

# RADIO & TELEVISION NEWS

ANC

MAY  
1952  
35¢  
In Canada 40¢

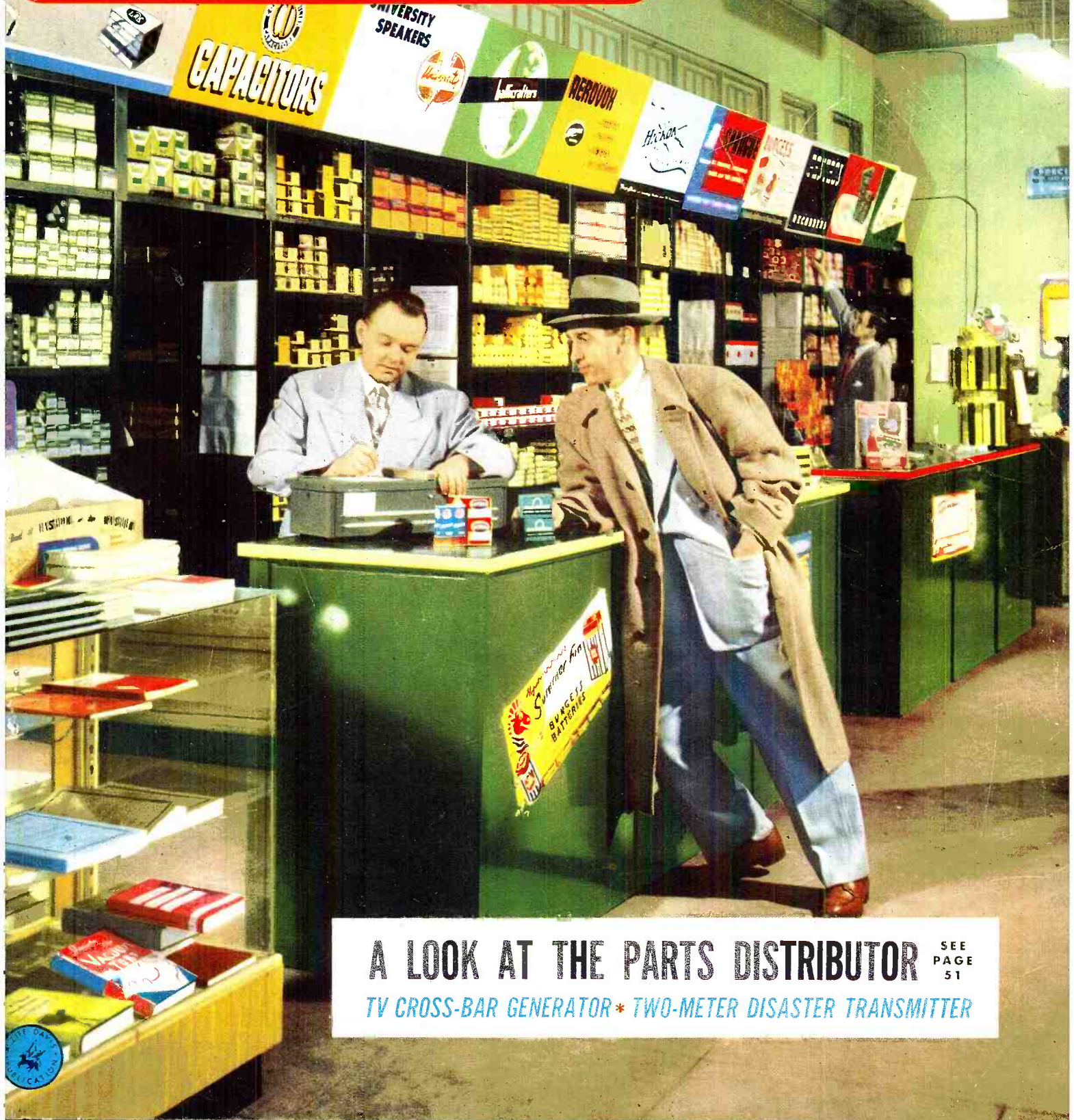

**A LOOK AT THE PARTS DISTRIBUTOR**

SEE  
PAGE  
51

TV CROSS-BAR GENERATOR \* TWO-METER DISASTER TRANSMITTER



**How we *spot* "shady characters"**

*before they can damage your business*

THE instrument you see is working for you. A sensitive light-measuring device, it is used like a doctor's stethoscope, to explore the surface of a picture tube for screen imperfections the unaided eye would fail to detect.

Employing a photosensitive surface and color filters, this device does two jobs. It checks not only the uniformity of brightness, but also the *color* values from center to edges of the faceplate.

Why is this important? It is important because RCA has learned, through long

experience in the manufacture of picture tubes, that the best picture—the picture having superior quality—calls for unusually rigid processing controls of the phosphor and its application. The light-measuring device spots any departure from RCA's established brightness and color standards. Result? "Shady characters"—those tubes that would produce pictures lacking in fine quality—*never reach your shop.*

This constant vigilance and *quality control* at all stages of manufacture assure

that RCA standards will be met. In this way, RCA guards its own reputation for quality . . . and yours as well.

With RCA Receiving Tubes, as well as RCA Kinescopes, **TOP-QUALITY CONTROL** makes the difference.



**RADIO CORPORATION of AMERICA**

**ELECTRON TUBES**

**HARRISON, N. J.**

## You Practice COMMUNICATIONS

I send you parts to build this transmitter



As part of my Communications Course you build this low power broadcasting transmitter, learn how to put a station "on the air," perform procedures demanded of Broadcast Station operators, make many tests.

This is just part of the equipment my students build. You keep all parts I send.

## You Practice Radio SERVICING

on this m build wit

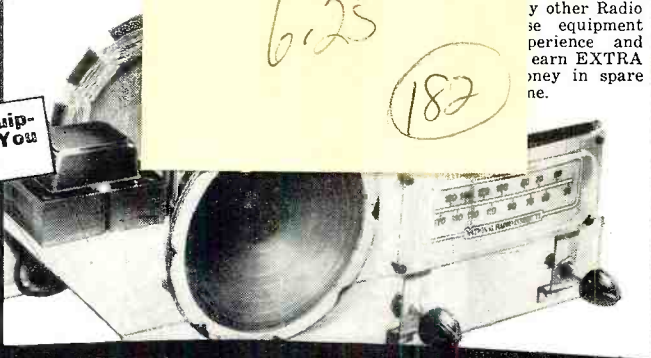

VF 5-52  
6.25  
182

servicing Course, speaker, tubes, power, loop antenna, you need them, powerful I also send you other Radio service equipment experience and earn EXTRA money in spare time.

# BE A RADIO-TELEVISION TECHNICIAN

**NOW! Advanced Television Practice**

New, special TV kits furnished to build high-definition SCOPE . . . RF OSCILLATOR with flyback power supply . . . complete TV set . . . many other units. You see pulse, trapezoidal, saw-tooth wave forms. Get valuable PRACTICAL EXPERIENCE locating and correcting TV troubles. Mail coupon for facts, pictures and prices!

## Learn Servicing or Communications Practice at Home in Spare Time



Do you want good pay, a job with a bright future and security? Would you like to have a profitable shop or store of your own? If so, find out how you can realize your ambition in the fast growing, prosperous RADIO-TELEVISION industry. Even without Television, the industry is bigger than ever before. 90 million home and auto Radios, 3100 Broadcasting Stations, expanding use of Aviation and Police Radio, Micro-wave Relay, Two-way Radio for buses, taxis, etc., are making opportunities for Servicing and Communications Technicians and FCC-Licensed Operators.

### Television is TODAY'S Good Job Maker

J. E. SMITH, President National Radio Institute In 1950, over 5,000,000 TV sets sold. By 1954, 25,000,000 TV sets estimated. Over 100 TV Stations now operating. Authorities predict 1,000 TV Stations. This means more jobs, good pay for qualified men all over the United States and Canada.

### Many Make \$10 Extra a Week in Spare Time

Keep your job while training. Hundreds of successful RADIO-TELEVISION TECHNICIANS I trained had no previous experience, some only a grammar school education. Learn Radio-Television principles from illustrated lessons. Get PRACTICAL EXPERIENCE—build valuable multimeter—experiment with circuits common to Radio and Television. Keep all equipment. Many students make \$5, \$10 extra a week fixing neighbors' Radios in spare time. SPECIAL BOOKLETS start teaching you the day you enroll.

### Send Now For 2 Books FREE—Mail Coupon

Send now for my FREE DOUBLE OFFER. You get actual Servicing lesson to show you how you learn at home. Also my 64-page book, "How to Be a Success in Radio-Television." Read what my graduates are doing, earning; see equipment you practice with at home. Send coupon in envelope or paste on postal. J. E. SMITH, President, Dept. 2EE, National Radio Institute, Washington 9, D. C. Our 39th Year.

## I TRAINED THESE MEN

 "I have been operating my own Servicing business. In two years, I did \$14,000 worth of business; net profit \$6,850. Have one full time employee, an NRI student."—PHILLIP G. BROGAN, Louisville, Ky.

 "Four years ago, I was a bookkeeper, with a hand-to-mouth salary. Now I am a Radio Engineer with a key station of the American Broadcasting Company network."—NORMAN H. WARD, Ridgefield Park, New Jersey.

 "When halfway through the NRI course, I made \$5 to \$8 a week fixing sets in my spare time. Am now selling and installing Television sets and antennas."—E. J. STREIT-ENBERGER, New Boston, O.

 "My first job was operator with KDLR, obtained for me by your Graduate Service Dept. I am now Chief Engineer of Police Radio Station WQOX. I never hesitate to endorse NRI."—T. S. NORTON, Hamilton, Ohio.

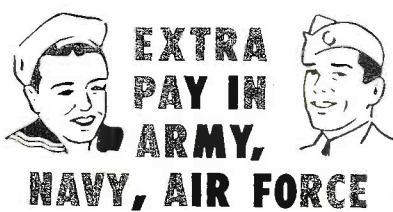

**EXTRA PAY IN ARMY, NAVY, AIR FORCE**

Knowing Radio, TV, Electronics can help you get extra rank, extra prestige, more interesting duty at pay up to several times a private's base pay. You are also prepared for good Radio-TV jobs upon leaving service. Mail Coupon TODAY.

## Have Your Own Business

Many N.R.I. trained men start their own Radio-Television sales and service business without capital. Let me show you how you, too, can be your own boss, have a good income from your own shop. Send coupon for FREE book now!

**Tested Way to Better Pay**

### The ABC's of SERVICING

## Good for Both—FREE

MR. J. E. SMITH, President, Dept. 2EE National Radio Institute, Washington 9, D. C.

Mail me Sample Lesson and 64-page Book about How to Win Success in Radio-Television. Both FREE. (No Salesman will call. Please write plainly.)

Name.....Age.....

Address.....

City.....Zone.....State.....

Approved for training under G. I. Bill

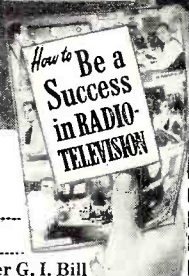

# RADIO & TELEVISION NEWS

Reg. U.S. Pat. Off.

Radio News Trademark Reg. U. S. Pat. Office • Television News Trademark Reg. U.S. Pat. Office.

*First in*  
radio-television-electronics  
Average Paid Circulation over 200,000

Editor  
**OLIVER READ, D.Sc., D.Lit.**

Managing Editor  
**WM. A. STOCKLIN, B.S.**

Technical Editor  
**H. S. RENNE, M.S.**

Midwest Editor  
**RAY FRANK, W9JU**

Associate Editor  
**HAROLD BECKER**

Service Editor  
**CHARLES TEPPER**

Assistant Editor  
**P. B. HOEFER**

Television Consultant  
**WALTER H. BUCHSBAUM**

Short-Wave Editor  
**KENNETH R. BOORD**

Staff Artist  
**FRANK SAYLES**

Advertising Manager  
**L. L. OSTEN**

Midwest Adv. Manager  
**JOHN A. RONAN, JR.**

Western Adv. Manager  
**JOHN E. PAYNE**

Color Art Editor  
**HERMAN R. BOLLIN**

## CONTENTS

## MAY, 1952

Mobility of Communications.....	<i>Lt. Col. Walter G. Wilson</i>	35
Horn-Loading Loudspeaker Enclosure.....	<i>Daniel J. Plach &amp; Philip B. Williams</i>	38
An Inexpensive TV Cross-Bar Generator.....	<i>Louis E. Garner, Jr.</i>	40
The Versatile 6BN6.....	<i>Fred P. Strother</i>	42
Interpreting that TV Pattern (Part 2).....	<i>Ken Kleidon</i>	43
Television Transmission Lines.....	<i>Walter Buchsbaum</i>	46
A Beat-Frequency Audio Oscillator.....	<i>John Potter Shields</i>	48
The New Philco 40 mc. I.F. Tuner.....	<i>Dan Lerner</i>	50
A Look at the Parts Distributor.....	<i>Harold Becker</i>	51
A Tubeless Saw-Tooth Oscillator.....	<i>E. G. Louis</i>	52
A Low-Cost 152-162 mc. Converter.....	<i>Hartland B. Smith, W8VVD</i>	54
Binaural Compensation in Single-Channel Reproduction.....	<i>Glen Southworth</i>	56
Audio-Frequency Ammeter.....	<i>W. D. Creviston</i>	59
Mac's Radio Service Shop.....	<i>John T. Frye</i>	60
A Two-Meter Miniature Disaster Transmitter.....	<i>Merritt Kirchhoff, W2FAR &amp; David D. Bulkley, W2QUJ</i>	61
Microwave Klystron Oscillators (Part 2).....	<i>Joseph Racker &amp; Lawrence Perenic</i>	64
Audio Simplified (Part 9).....	<i>David Fidelman</i>	68
A Simple Improvement for Regenerative Receivers.....	<i>Charles Erwin Cohn</i>	78
U. S. Television Stations and Network Links (Insert).....		83
Electronic Equipment Industry Advisory Subcommittees.....		126
Radio-TV Service Industry News.....		146
1952 Electronic Parts Show Program.....		174

## DEPARTMENTS

For the Record.....	<i>The Editor</i>	8	MARS .....	87
Spot Radio News.....		16	Manufacturers' Literature .....	94
Within the Industry.....		22	Technical Books .....	119
Short-Wave.....	<i>K. R. Boord</i>	67	Reel Review .....	132
What's New in Radio.....		80	New TV Products.....	158



COVER PHOTO: Almo Radio Company's Camden, New Jersey outlet is just one of six individually-operated stores in this chain serving the radio and electronics industry in the eastern states. (Ektachrome by Jay Seymour)

Chairman of the Board and Publisher  
**WILLIAM B. ZIFF**

President  
**S. G. DAVIS**

Secretary-Treasurer  
**G. E. CARNEY**

Vice-President  
**M. H. FROELICH**

**H. J. MORGANROTH**  
Production Director

**LYNN PHILLIPS, JR.**  
Advertising Director

**H. G. STRONG**  
Circulation Director

**LOUIS ZARA**

BRANCH OFFICES  
CHICAGO 111  
155 N. Webster, AN 3-5200  
LOS ANGELES 114  
875 S. Hill St., TUCKER 9213



VOLUME 47 • NUMBER 5



Member  
Audit Bureau of  
Circulations

Editorial and Executive Offices, 366 Madison Ave., New York 17, N. Y.  
RADIO & TELEVISION NEWS is published monthly by the Ziff-Davis Publishing Company at 185 N. Wabash Ave., Chicago 1, Illinois. Entered as second-class matter July 21, 1948, at the Post Office, Chicago, Ill., under the act of March 3, 1879. Entered as second-class matter at the Post Office Department, Ottawa, Canada. Postmaster—Please return undelivered copies under form 3589 to 64 E. Lake St., Chicago 1, Ill.  
SUBSCRIPTION RATES: RADIO & TELEVISION NEWS—in U.S., Canada, Mexico, South and Central America, and U.S. Possessions, \$4.00 for twelve issues; in British Empire, \$9.00; all other foreign countries, \$5.00 for twelve issues. RADIO-ELECTRONIC ENGINEERING EDITION—in U.S., Canada, Mexico, South and Central America, and U.S. Possessions, \$6.00 for twelve issues; in British Empire, \$7.00; in all other foreign countries, \$7.00 for twelve issues. SUBSCRIPTION SERVICE: All communications concerning subscriptions should be addressed to Circulation Dept., 64 E. Lake St., Chicago 1, Ill. CONTRIBUTORS: Contributors are advised to retain a copy of their manuscripts and illustrations. Contributions should be mailed to the New York Editorial Office and must be accompanied by return postage. Contributions will be handled with reasonable care, but this magazine assumes no responsibility for their safety. Any copy accepted is subject to whatever adaptations and revisions are necessary to meet the requirements of this publication. Payment covers all author's, contributor's, and contestant's rights, title, and interest in and to the material accepted and will be made at our current rates upon acceptance. All photos and drawings will be considered as part of the material purchased.

Copyright 1952 by Ziff-Davis Publishing Company. All rights reserved.

RADIO & TELEVISION NEWS

**NOW... GET EVERYTHING YOU  
NEED TO LEARN AND MASTER**

# TELEVISION

## RADIO-ELECTRONICS AT HOME!

Use REAL commercial-type equipment to get practical experience

Your future deserves and needs every advantage you can give it! That's why you owe it to yourself to find out about one of the most COMPLETE, practical and effective ways now available to prepare AT HOME for America's billion dollar opportunity field of TELEVISION-RADIO-ELECTRONICS. See how you may get and keep the same type of basic training equipment used in one of the nation's finest training laboratories... how you may get real STARTING HELP toward a good job or your own business in Television-Radio-Electronics. Mail the coupon today for complete facts — including 89 ways to earn money in this thrilling, newer field.

**D.T.I., ALONE, INCLUDES BOTH MOVIES and HOME LABORATORY** In addition to easy-to-read lessons, you get the use of HOME MOVIES — an outstanding training advantage — plus 16 big shipments of Electronic parts. Perform over 300 fascinating experiments for practical experience. Build and keep real commercial-type test equipment shown at right

**Get BOTH of these information packed publications FREE!**

**89 WAYS TO EARN MONEY IN TELEVISION RADIO ELECTRONICS**

**YOU GET ALL 6**

**MODERN LABORATORIES**

If you prefer, get all your preparation in our new Chicago Training Laboratories—one of the finest of its kind. Ample instructors, modern equipment. Write for details!

**MILITARY SERVICE!**

If you're subject to military service, the information we have for you should prove very helpful. Mail coupon today.

**ACT NOW! MAIL COUPON TODAY!**

DE FOREST'S TRAINING, INC. Dept. RN-5-1  
2533 N. Ashland Ave., Chicago 14, Ill.

Without obligation, I would like your Opportunity News Bulletin showing "89 Ways to Earn Money in Television-Radio-Electronics"; also, the folder showing how I may prepare to get started in this thrilling field.

Name.....Age.....  
Address.....Apt.....  
City.....Zone.....State.....



17 INCH TUBE

ABOVE: Build and keep a real 17 INCH commercial TV receiver. Optional after completing regular training at moderate added cost.

**Here's the REAL THING!  
SET UP YOUR OWN HOME LABORATORY**

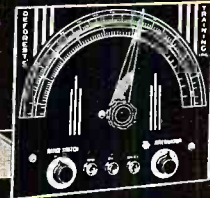

R-F Signal Generator

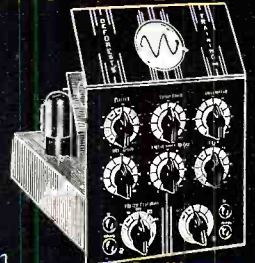

Oscilloscope



6-Tube Radio  
Home Movies



Multimeter

**"ONE OF AMERICA'S FOREMOST TELEVISION TRAINING CENTERS"**

**De FOREST'S TRAINING, INC.**  
CHICAGO 14, ILLINOIS  
A De VRY INSTITUTION

## Bill Clemens says—

Midget Radio Service (a 3-Man Shop)  
129 S. Elizabeth St., Lima, Ohio

*"TRIPLITT 660 saves us  
50 to 100 man hours  
per month."*

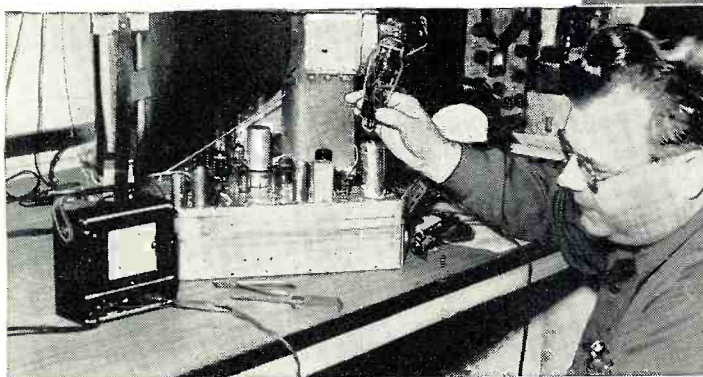

1. **ISOLATING THE TROUBLE**—Plug the power cord of the chassis into LOADCHEK and note the reading. With your eye on the large meter remove the rectifier tube and you can tell immediately which side of the tube the trouble is on. You have already eliminated 50% of your probing time.

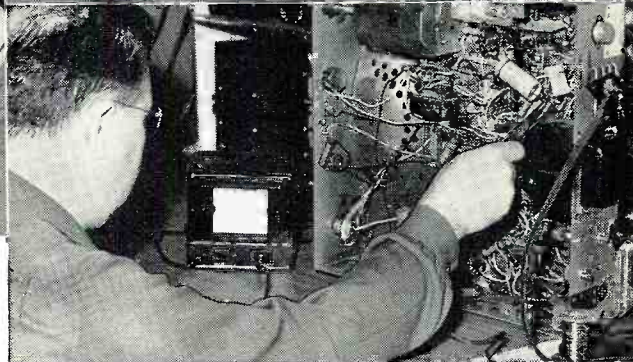

2. **LOCATING THE SHORT**—With Loadchek you can quickly check the shorted side, part by part, without laying down tools or picking up test leads. Here, the trouble was a short in the transformer, spotted without having to warm up set. Overloads are found the same way.

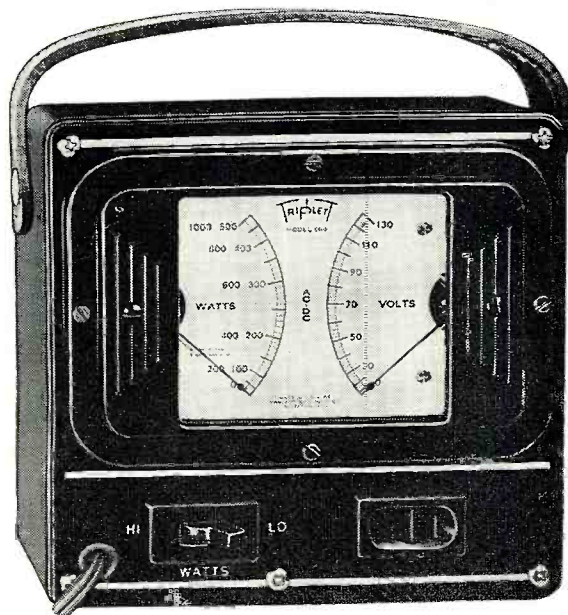

### Locates trouble in a hurry

The above pictures illustrate but one of the many time-saving uses of Triplitt 660 Loadchek. This versatile instrument accurately measures power consumption, enables you to see instantly any deviation from normal load, without disconnecting a single part... finds trouble in a hurry.

For Radio and TV servicing—for almost any kind of electrical trouble-shooting—LOADCHEK saves hours of painstaking work every day. At its moderate cost no service technician can afford to be without it. Try one today—and see! Write for free booklet.

TRIPLITT ELECTRICAL INSTRUMENT CO., BLUFFTON, OHIO, U. S. A.

SEE TRIPLITT 660 LOADCHEK AT YOUR DISTRIBUTOR



# Triplitt

RADIO & TELEVISION NEWS

# Military Performance and Dependability

## THE SX-73 COMMUNICATIONS RECEIVER

*"A Gibraltar of Stability"*

It is the ultimate in all-wave receivers . . . this jewel of precision craftsmanship! Refined in even the smallest detail, the SX-73 meets the tough military communications specifications.

Hallicrafters is proud to place its name on the SX-73.

PRECISION

# hallicrafters

## SX-73

### Frequency Range:

540 kc to 54 Mc in six turret-selected bands.

20 tubes, including rectifier, voltage regulation and ballast tubes.

Dual conversion, 455 kc and 6 Mc crystal controlled.

Receiver type: Single superheterodyne in tuning ranges of 540 kc to 7.0 Mc and dual conversion on tuning ranges from 7.0 to 54.0 Mc.

Types of signals: AM, CW, MCW, ICW, and Carrier Shift Tele-typewriter.

Frequency calibration: 2 tenths of one per cent or less at all frequencies.

Image rejection: Not less than 80 db at any frequency.

Front panel controls: R.F. gain, AC on/off; b.f.o. pitch; audio gain; crystal phasing; selectivity; V.F.O./Crystal; crystal vernier; band selector; frequency; receiver/send; CW/modulation; A.G.C./manual; A.N.L./off; antenna adjust.

FRONT VIEW  
SX-73

HALLICRAFTERS • WORLD'S LEADING MANUFACTURER OF PRECISION RADIO & TELEVISION  
CHICAGO 24, ILL.

# JETENNA

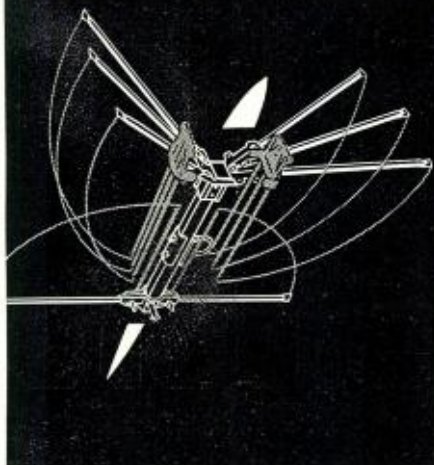

**no other fan conical  
assembles so fast  
performs so well!**

JFD JETENNA, the conical with the jet-action assembly, has absolutely no separate parts to put together—the slowest part is opening the carton! Just swing out the elements, tighten two “T” bolts and two wing nuts and it’s assembled! Front elements automatically fan out as they are swung forward. Reflector elements are spring-loaded to lock into position for tightening. 1” square seamless crossarm, seamless elements and element brackets are of high tensile strength aluminum—unbreakable head is of all weather, high dielectric material. Solid, unbreakable “vibration dampers” do not absorb moisture or swell and will not rot out. See your Jobber or write for further information about this revolutionary new antenna.



JFD MFG. CO.  
BROOKLYN 4, N. Y.  
BENSONHURST 6-9200  
world's largest  
manufacturer of TV antennas  
and accessories

## For the RECORD.

BY THE EDITOR

### TVI AND THE “DALLAS PLAN”

ONE of the important subjects discussed at a recent meeting of the *Radio-Television Mfrs. Assn.* (RTMA) was the problem of amateur radio interference to television service.

Such interference has been of major importance in many metropolitan areas, where crowded living conditions have placed hundreds of television receivers in close proximity to amateur stations. In some cases it has served to force the amateur off the air during television hours because of public wrath and indignation due to a misunderstanding of all the facts.

The desire of the public in fringe areas for television reception has also aggravated the interference problem. When receivers are used in areas of low signal strength, even the slightest interference from amateurs or other services becomes a major problem.

The *Amateur Radio Activity Section*, under the chairmanship of Al Kahn of *Electro-Voice*, discussed the correlation of the service managers' efforts and amateur activities. Both the RTMA and the FCC have set up standards for receiver performance dealing with radiation, images, etc.

It should be realized that the service industry has done a tremendous job overnight in acquainting service technicians with the many problems of the complex television industry. From a total of 10,000 receivers in 1945 to the present total of over 15,000,000 sets, it has been a tremendous job to train sufficient technical help to handle the servicing of these receivers with their many attendant problems.

In spite of the many excellent service manuals published by manufacturers, and the articles in various publications dealing with the problem of amateur interference, there has been little done to directly acquaint the technician with amateur interference and the remedies. Too often the technician is inclined to blame any type of interference on the neighboring amateur, especially if the amateur antenna is clearly visible. Some of this blame is due to misinformation or to inadequate training. In the majority of cases there has been no concerted effort on the part of technicians to work with the offending amateur to conduct tests designed to eliminate or reduce this interference to a negligible value.

Too often the ham has been blamed for interference from neon signs, electric razors, and other assorted interferences. Part of this is due to lack of education in recognizing amateur in-

terference, or confusing it with other types of interference.

A television receiver offers its own built-in analysis method for most troubles, and the problem boils down to interpreting what you see on the screen.

Too often, the general public regards the amateur as a person who pursues a hobby to the detriment of their entertainment. The many valuable services rendered by the amateur usually go unnoticed. Amateur radio is a vital part of the communications system of this country and has the full backing of government and military authorities. No other service can offer adequate emergency facilities, as attested by the sterling performance of amateurs in time of floods, hurricanes, and other disasters.

The *Federal Civilian Defense Administration* has recognized the amateur service's value and has made provisions for stations in this service to be operated in the event of national emergency. According to the FCDA, vital services such as these are not to be disrupted during time of emergency.

If the problem of amateur interference grows worse, a great many amateurs will either give up their hobby in sheer desperation or reduce their operating time to such an extent that their value will be considerably lessened.

The logical solution to this problem is cooperation between the amateurs and the service groups. Almost any town of appreciable size has a service organization as well as amateur clubs. If the amateurs will contact these service organizations, and arrange to have one of their technically qualified members attend service meetings, techniques for eliminating the interference can be readily worked out. Essentially this is the method commonly known as the “Dallas Plan,” and this plan has been eminently successful wherever tried. If this or some similar plan were widely used, the problem could soon be solved.

To further increase the supply of adequately trained technicians, the RTMA has recently taken steps to make good technical training available.

*RCA Institutes* is currently preparing a three-year syllabus for use in vocational high schools. This syllabus is designed to acquaint high school students with the vocational possibilities of television and will contain material on amateur radio.

(Continued on page 178)

**RADIO & TELEVISION NEWS**



the only complete catalog  
for everything in Radio,  
TV & Industrial Electronics

your 1952 **free!**  
**ALLIED** 212-page  
value-packed catalog



**Send for it today!**

Here's the *one* authoritative, complete, up-to-date Buying Guide to TV, Radio and Industrial Electronics. Make your selections from the world's largest stocks of quality equipment at lowest, money-saving prices. See the latest and most complete presentation of electronic apparatus: new TV, AM and FM receivers; High-Fidelity Custom Sound components; latest P.A. Systems and accessories; recorders; fullest selections of Amateur receivers and station gear; specialized industrial electronic equipment; test instruments; builders' kits; huge listings of parts, tubes, tools, books—the world's *most complete stocks* of quality equipment.

ALLIED gives you *every* buying advantage: speedy delivery, expert personal help, lowest prices, liberal time payment terms, assured satisfaction. Get the latest 1952 ALLIED Catalog. Keep it handy—and save time and money. Send for your FREE copy today!

**the world's  
largest stocks**

- Radio Parts Unlimited
- Test Instruments
- Television & Home Radios
- P.A. and Hi-Fi Equipment
- Amateur Station Gear
- Builders' Supplies
- Equipment for Industry

**quick, expert service**



**ALLIED IS YOUR TV and HI-FI HEADQUARTERS**



Count on ALLIED for the latest in TV! If it's made—we have it for quick delivery. We specialize, too, in High-Fidelity sound components—everything in amplifiers, speakers, tuners, phono gear and accessories. For TV or Hi-Fi—think of ALLIED!



**ALLIED RADIO**  
*the World's Largest Radio Supply House*  
EVERYTHING IN ELECTRONICS

**free**

**SEND TODAY FOR RADIO'S  
LEADING BUYING GUIDE**

ALLIED RADIO CORP., Dept. 1-E-2  
833 W. Jackson Blvd., Chicago 7, Illinois

Send FREE 212-page 1952 ALLIED Catalog No. 127.

Name \_\_\_\_\_

Address \_\_\_\_\_

City \_\_\_\_\_ Zone \_\_\_\_\_ State \_\_\_\_\_

# For the **clearest** picture of campaign progress...



## **Rauland** PICTURE TUBES

Man, what a year for TV—and TV service profits! The richest menu of regular attractions ever offered to viewers... PLUS the party conventions, the campaign, the elections and inauguration! When viewers need replacement picture tubes, they'll want them fast—and good.

So remember that Rauland alone

offers these replacement profit advantages:

- The *most complete* line of replacement picture tubes... a far better supplement for your regular tube line than a second line of receiver tubes.
- The faster, *surer* installation adjustment made possible by the patented Indicator Ton Trap.

• The dependable, uniform *extra* quality that so many smart service men depend on for assured customer satisfaction.

*Remember, Rauland research has developed more "firsts" in picture tube progress since the war than any other maker. And this leadership pays off... in your customers' satisfaction.*

### **THE RAULAND CORPORATION**



*Perfection Through Research*  
4245 N. KNOX AVENUE • CHICAGO 41, ILLINOIS



**RADIO & TELEVISION NEWS**

# TRAIN

# for Security! Good-Paying Jobs! MAKE THE MONEY YOU'VE ALWAYS DREAMED OF!



# LEARN RADIO -TELEVISION AND ELECTRONICS BY EASY SHOP METHOD TRAINING AT HOME!

**You get all the parts—even tubes!—** for this modern Superheterodyne Receiver. You learn to build it step by step. And you keep it! Get all the facts. Mail coupon now.

Let **NATIONAL SCHOOLS**—a resident-training school for nearly 50 years—train you at home for today's unlimited opportunities in Radio-Television-Electronics. National Schools is one of the largest schools of its kind. It is located in Los Angeles—the center of Radio and TV world! It has four large buildings of modern shops and labs. Its faculty is considered tops in the business.



You learn from lessons prepared by experienced instructors and engineers. Men who are successful Radio and Television technicians. Men who have trained 1000's of men like YOU!



## FREE BOOK TELLS YOU HOW!

Page after page—in color—tells you everything you want to know. Mail the coupon. Get this valuable book today. And if you hurry—YOU GET A FREE SAMPLE LESSON, TOO! Shows how easy National Schools Home Training is. Mail the coupon today.

### You Train At Home—In Your Spare Time

National Schools Shop Method Home Training gives you basic and advanced instruction in all phases of Radio-TV-Electronics. And remember—your training is based on resident school training principles. You learn fast from hundreds of diagrams and pictures. All instructions are written by experienced technicians who work in Radio and TV every day. All instructions have been developed and tested in National Schools' own labs and studios, which are equipped with the latest RCA equipment. No wonder this National Schools course is so up-to-date, practical, interesting. And so easy to learn! And no wonder it is held in such high regard by leaders of American industry! Approved for eligible Veterans.

### We Teach You How To Make Welcome Extra Money—While You Learn!

Many National Schools students—men like you—make plenty of extra dollars each week in spare time! Fixing neighbors' radios, appliances—and other ways we teach you. You start learning and earning from the day you enroll. From the very first lesson!

### WE SEND YOU LOTS OF PARTS LIKE THIS!

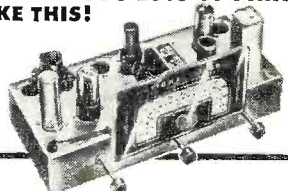

With National Schools Shop Method Home Training, you get basic principles and plenty of practical training. You learn by doing. No wonder you learn so fast! We send you many parts—all of professional, modern quality. You do lots of practical experiments. You advance day by day, step by step. Until you can even build the modern Superheterodyne Receiver you see above—plus other important testing units. The free book tells you all about it. The free sample lesson shows how easy the training is. Use the coupon. Send today — without fail!

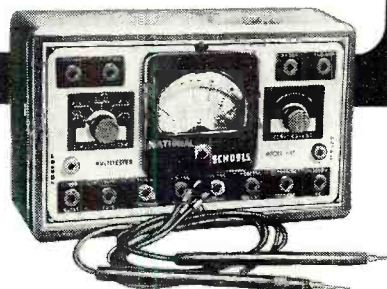

### Only National Schools Gives You This Professional Multi-Tester!

You get this amazing, new testing instrument—factory-made and tested—complete—ready to use! Simple to operate. Accurate and dependable. An instrument every Radio-TV man needs. Light enough to carry around—so you can use it at home or on service calls. You'll be proud to own this valuable equipment.

### Here are only a Few of the Good-Paying Jobs You Can Choose

Radio Station Engineer, District Service Manager, Aircraft Radio Inspector, Own Your Own Repair Shop, Inspector Technician, Service Specialist, Special Government Jobs, Complete TV Service, Sound Truck Operator. Many more! National Schools graduates have secure, good-paying jobs like these! So don't wait—mail the coupon today. Now—while you're thinking about it!

### Attention! Men Going into Service Soon!

National Schools' course quickly prepares you for many important jobs in the Armed Services. With National Schools Training you have an opportunity to get into special service classifications—with higher pay and grade—immediately!

### FREE SERVICE FOR GRADUATES

National Schools uses its great influence and prestige to help you find your place in the field of your choice. Don't put it off! Start yourself toward a skilled trade! Get the big pay you've always wanted!

## NATIONAL SCHOOLS

LOS ANGELES 37, CALIFORNIA • ESTABLISHED 1905  
In Canada: 193 Hastings St., Vancouver 4, B.C.

### Today's Shortage of Trained Technicians Creates Chance of a Lifetime For You!

Think of it! With guided missiles, radar, and other electronic devices so important to national defense! With big, new developments in TV. With over 90,000,000 home and auto radios, over 12,000,000 TV sets. With more than 3100 radio stations...over 100 TV stations—and more building every day...yes, imagine the great opportunity you have today! YOU are wanted in Radio-Television-Electronics! America's fastest-growing field. High-pay jobs—the kind you've always wanted—are waiting for YOU!

### Job Security! Big Money! For YOU! in Today's Expanding Industries!

Trained Radio and Television technicians really make important money these days. Thousands of National Schools graduates—men just like you—are earning good money all over the country. Why not you? And—National Schools graduates get the personal satisfaction of being highly-skilled technicians. Men people respect. Men who enjoy their work—rather than having to drag along in just any old job.

### National Schools Has Trained 1000's of Successful Men! Why Not YOU?

In almost every state—and many foreign countries—National Schools graduates are filling big jobs with famous companies. Or running their own successful businesses. What are YOU waiting for? National Schools training is complete training. So when you graduate you can take advantage of today's big opportunities in Radio-Television-Electronics—fast.

**DON'T PUT IT OFF!  
GET THE BIG SALARY YOU HAVE ALWAYS WANTED!**

### MAIL THIS COUPON TODAY—WITHOUT FAIL!

NATIONAL SCHOOLS, Dept. HR-52  
4000 South Figueroa Street  
Los Angeles 37, California

Mail in envelope or paste on penny post card.

Mail me FREE the book mentioned in this ad. Also a free sample lesson. I understand no salesman will call on me.

NAME \_\_\_\_\_ AGE \_\_\_\_\_

ADDRESS \_\_\_\_\_

CITY \_\_\_\_\_ ZONE \_\_\_\_\_ STATE \_\_\_\_\_

Check here if you were released from the Service less than 4 years ago.

# BUILD A BIGGER ON POWERFUL G-E



## AMERICA'S BIGGEST MAGAZINES PRESELL G-E TUBES!

● 35,000,000 people read G-E full-page tube ads. 35,000,000 TV owners and enthusiasts see *proof* month after month that General Electric tubes are superior!

● Every message emphatically directs these owners to you—the serviceman with the General Electric tube sign. The ads tell

why patronizing *your* shop means brighter, sharper, more lifelike television pictures in the home.

● Take advantage of the big local market that G-E tube advertising creates for you! Make real money by selling G-E tubes to a *presold* television public!

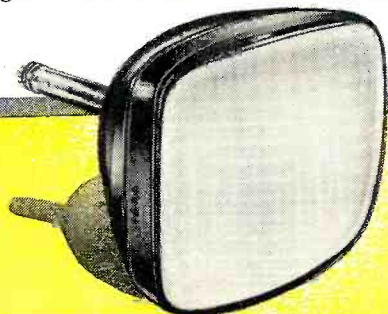

# BUSINESS "LIFE" AND "POST" ADS!



We install  
**Aluminized TV Picture Tubes**  
"up to 100% brighter"

AS ADVERTISED IN LIFE AND SATURDAY EVENING POST

**THIS SIGN PUTS G-E  
NATIONAL ADS  
TO WORK FOR YOU!**



**E**VERY MINUTE of every hour, people who have read G-E tube advertising pass your shop. They want to know where to go for service. Use these colorful gummed streamers to tell them *you* install G-E tubes!

**21" WIDE**, the streamer is just the right size for your door or window. Blow-ups of LIFE-POST ads, supplied from time to time, can be mounted beneath. For counter giveaway, or for display where space is limited, actual-size ad reprints are available to you regularly.

**YOUR G-E TUBE DISTRIBUTOR** will be glad to supply you with streamers and reprints. See, phone, or write him today! Get *all* the tube and service business "Up to 100% brighter!" will bring to your door! *Tube Department, General Electric Company, Schenectady 5, New York.*

GENERAL  ELECTRIC

151-1A2



**3 SIZES**  
 1/2, 1, and 2  
 WATTS



**RESISTANCE and  
 WATTAGE MARKED ON EVERY UNIT**

Every resistor is stamped and color-coded for quick, positive identification. All three sizes available in  $\pm 5\%$  or  $\pm 10\%$  tolerance. Standard RTMA values—10 ohms to 22 megohms. In the 1-watt size ( $\pm 10\%$  tol.), values as low as 2.7 ohms are available.

Wherever resistor reliability is important, use Ohmite Little Devils. These tiny, molded composition units have exceptional ruggedness, stability, and current-carrying capacity. They are completely sealed and protected by molded insulating plastic—and are rated at 70C, instead of the usual 40C. Little Devils dissipate heat rapidly, have a low noise level and low voltage coefficient. Under full continuous load for 1000 hours, their resistance change is less than 5%. Little Devil resistors meet JAN-R-11 specifications.

**OHMITE MANUFACTURING CO.**  
 4885 Flournoy St., Chicago 44, Ill.

Be Right with **OHMITE**

**RHEOSTATS  
 RESISTORS  
 TAP SWITCHES**

**RADIO & TELEVISION NEWS**

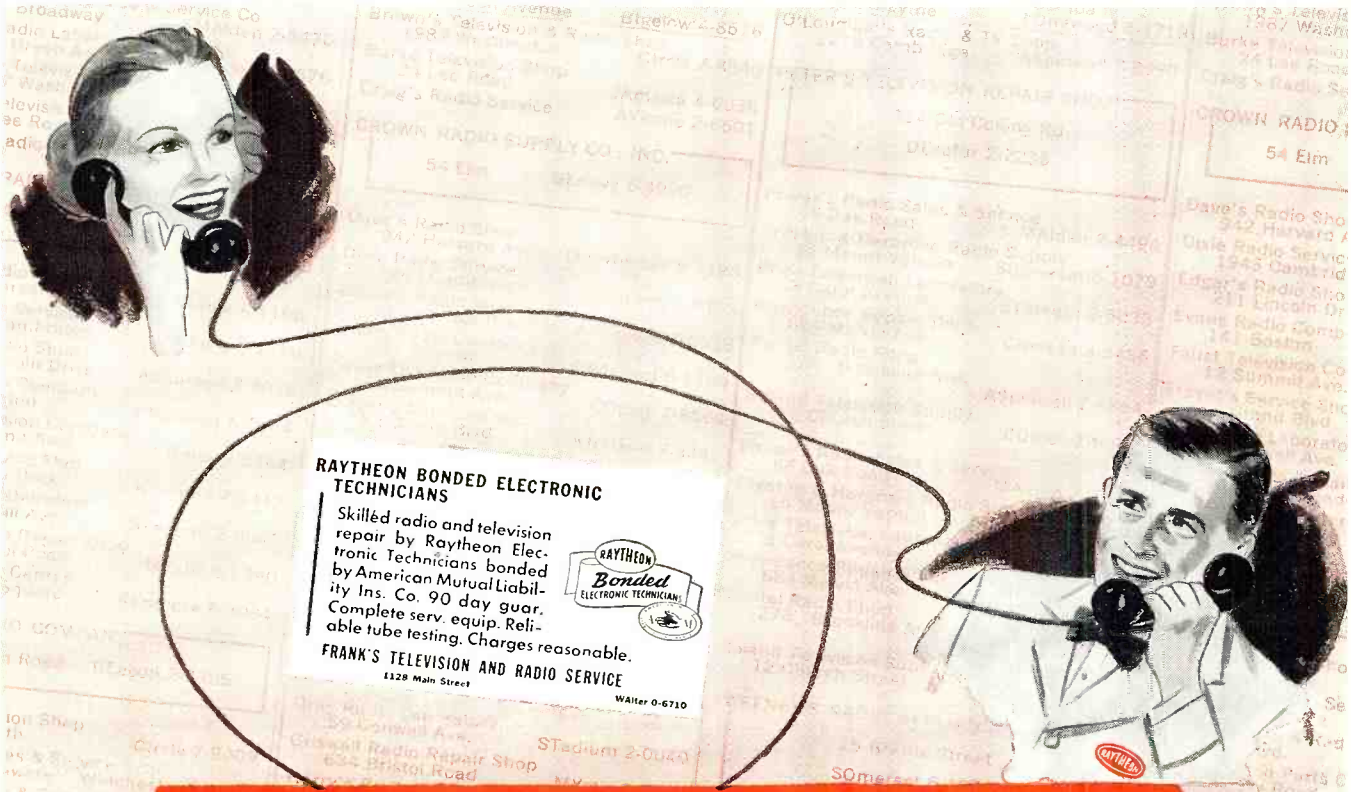

**RAYTHEON BONDED ELECTRONIC TECHNICIANS**

Skilled radio and television repair by Raytheon Electronic Technicians bonded by American Mutual Liability Ins. Co. 90 day guar. Complete serv. equip. Reliable tube testing. Charges reasonable.

**FRANK'S TELEVISION AND RADIO SERVICE**  
 1128 Main Street WALTER 0-6710

Here's another important way the

# RAYTHEON BONDED Electronic Technician Program

builds your business

A receiver fails and an upset customer scans the telephone directory. A sea of unfamiliar names — ah — here's a radio and television service dealer whose guarantee is cash-protected by a Bond. Result: another customer for a *Raytheon Bonded Electronic Technician*.

The Raytheon Bonded Dealer Decal on windows and doors; the Raytheon Creed Display; the Raytheon Bonded Dealer Certificate exert a similar influence on passers-by — wary customers choose you instead of the guy next door.

These are all part and parcel of Raytheon's *Bonded Electronic Technician Program* which costs you nothing yet gives you a mighty important advantage over your competitors.

Better ask your Raytheon Tube Distributor to show you how little it costs to use this exclusive business builder.



**RIGHT...FOR SOUND AND SIGHT**



**RAYTHEON MANUFACTURING COMPANY**

Receiving Tube Division  
 Newton, Mass., Chicago, Ill., Atlanta, Ga., Los Angeles, Calif.

*Excellence in Electronics*

RECEIVING AND PICTURE TUBES • RELIABLE SUBMINIATURE AND MINIATURE TUBES • GERMANIUM DIODES AND TRANSISTORS • RADIAC TUBES • MICROWAVE TUBES

# SPINTITE

REG. U. S. PAT. OFFICE



120  
STYLES  
and  
SIZES

THE  
ORIGINAL  
WRENCH  
WITH THE  
SCREWDRIVER  
ACTION

for

- ASSEMBLY WORK
- REPAIR WORK
- RADIO
- TELEVISION
- INDUSTRIAL
- AIRCRAFT



STEVENS WALDEN, Inc.  
WORCESTER 4, MASS.

## Spot Radio News

★ Presenting latest information on the Radio Industry.

By RADIO & TELEVISION NEWS'  
WASHINGTON EDITOR

**ALLOCATIONS, COLOR,** transit radio, and other thorny problems which have been crowding the headlines for quite a spell, found themselves soundly routed from this limelight post during the closing days of Spring, as Wayne Coy decided to leave his five-year chairmanship and become a consultant for a national news weekly, perhaps owner of one or more TV stations and, in addition, serve as a newspaper publisher.

The resignation caught everyone by surprise, for only a short while ago, the former headman had accepted a renewal on his term for another seven years. In stepping down from this key post, the ex-communications chief disclosed that he told the President that he had indicated from time to time that it would be necessary for him to . . . "leave the government for private employment" . . . since his . . . "meager resources are much too near the vanishing point for comfort." He pointed out that he now found it . . . "necessary to ask . . ." the President to accept his resignation . . . "in order that . . ." he may . . . "be free to make arrangements . . . for his future employment." Continuing, Coy said that he had told his former boss that his association with him for . . . "many years and particularly through . . . appointment . . . to membership on the Communications Commission . . ." were high marks in his public career. "I have valued your friendship beyond measure," said Coy to the President, "and I treasure above all else the support which you have given me and the Communications Commission when our decisions have been challenged."

In reply to Coy's letter, the President wrote: "Yours is the ironic story of so many key civil servants whose abilities and special skills must be lost to government because of the inadequacy of government salaries . . . It will not be easy to fill your place. You are one of those ideal government servants who place the public interest above every other consideration . . . The duties which you are now relinquishing were onerous and exacting. They required the patience of Job and the wisdom of Solomon, as well as judicial balance, tact, discretion, integrity, and common sense . . . All these you have exercised in such a way as to make your administration memora-

ble for efficiency and protection of the public interest . . . To you I say, as you leave office, well done. You have earned the acclaim which faithful performance of duty merits."

On the floor of Congress and in the offices of the Commission, there were also glowing tributes to the former official. Said his colleagues: "We honor you for your abilities, for your great qualities of mind and heart and your unflinching courage. We shall always recall with pleasure your helpfulness, understanding tact, and humor in many difficult situations. We are particularly appreciative of the encouragement which you have lent to expressions of and tolerance for individual viewpoints and philosophies on the part of all of us."

Senator Ed Johnson, who as chairman of the Senate Interstate and Foreign Commerce Committee, participated in the approval of Coy as chairman, praised the ex-headman on the Senate floor, declaring that . . . "His forthrightness, his great courage, his refusal to bow to all sorts of pressures which have been brought to bear, the fine leadership he has displayed, have been of such an unusual character that it will be truly a great loss to the country to have Mr. Coy give up his position as chairman of the Commission. . . . I know that for a good many months Mr. Coy has been considering retiring from his position because of poor health and because of what he feels is his obligation to earn more money for his growing family. So I am not in any way censuring him. He remained at his post through the thick of the battle for a long time, and he has fought a good fight."

The resignation set off a round of appointments. To succeed Coy, the President named Paul A. Walker who had been serving as a vice-chairman for years. In accepting this new post, Walker said that he realized . . . "the scope of the task to be accomplished and the importance to the public of how it is done . . . We have large responsibilities in fields other than radio and television broadcasting . . . We also have entrusted to us important functions, having to do with the national defense . . . Our activities are constantly expanding. Our great need is manpower. We are hopeful that Congress will acquiesce in the recommendations of the Budget Bureau to

RADIO & TELEVISION NEWS





**RCA**  
*Quality-Engineered Speakers*  
**COST NO MORE**

6" x 9" Field-Coil

5" PM

8" PM

12" PM

Famous RCA-515S2 15" Duo-cone high-fidelity speaker

## A complete line of quality speakers from one dependable source

RCA *quality-line* speakers employ *full-size Alnico V magnets* for top efficiency and performance... yet they are popularly priced for replacement needs. You'll find a PM or field-coil type to meet virtually every requirement for home and auto radios, for television receivers, as well as for public address and high-fidelity systems.

From the miniature 2"x3" to the superb 15" Duo-cone—each RCA *quality-line* speaker is skillfully designed, fabricated from the finest materials, and produced under the most rigid quality-control methods.

RCA *quality-line* speakers offer you a better selling potential, because they're backed by the greatest

name in radio—a name that insures unqualified customer acceptance.

Look to RCA—and your *RCA Parts Distributor*—as the dependable source for *all* your speaker requirements.

### Get the Handy RCA Flip-Up Speaker Index

Here are all the electrical and mechanical specifications on the complete line of RCA speakers—right at your fingertips. Get your free copy today from your *RCA Parts Distributor*.



**RADIO CORPORATION of AMERICA**  
**ELECTRONIC COMPONENTS**  
**HARRISON, N. J.**

# Famous Guns



**Deringer Percussion Pistol, Model 1843**, product of Henry Deringer of Philadelphia. Deringer's large caliber, short barreled pocket pistols were so popular that others imitated them—calling them "derringers".  
John Wilkes Booth used a Deringer to assassinate Lincoln.

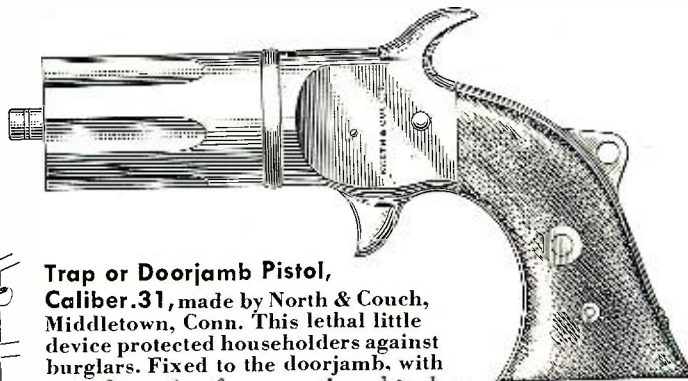
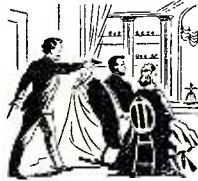

**Trap or Doorjamb Pistol, Caliber .31**, made by North & Couch, Middletown, Conn. This lethal little device protected householders against burglars. Fixed to the doorjamb, with a cord running from muzzle rod to door, the pistol fired all its barrels into any intruder.

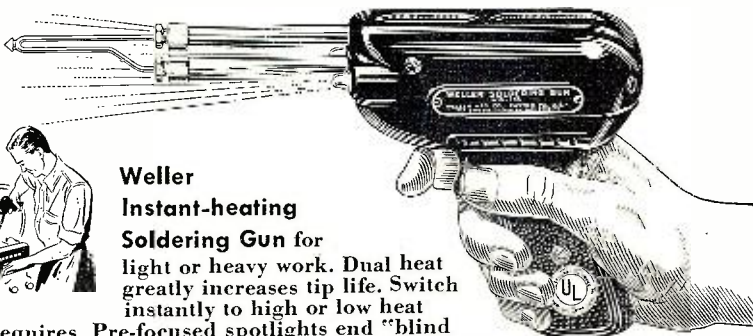

**Weller Instant-heating Soldering Gun** for light or heavy work. Dual heat greatly increases tip life. Switch instantly to high or low heat as job requires. Pre-focused spotlights end "blind soldering". Exclusive tip-fastening arrangement assures full, constant heat. High-impact plastic housing. Perfect balance. Low-cost replaceable tips. Pays for itself in a few months. See at your Distributor or write for Bulletin direct.

Get **SOLDERING TIPS**, new Weller Handy Guide to faster, easier soldering. 20 pages fully illustrated. Price 10c at your Distributor or order direct.



**Weller** BETTER FROM GRIP TO TIP!

**SOLDERING GUN** 810 Packer Street, Easton, Pa.

The Finest Soldering Tool for the Finest Craftsmen

enable us to acquire the personnel essential for the optimum job required of us."

Coincidental with the appointment of Walker, the President named Robert T. Bartley, nephew of Speaker of the House Sam Rayburn, as Commissioner to succeed Walker. In one of the speediest approvals from a Senate Committee, Bartley won an unanimous, or 13 to 0, vote for his accession to a seat on the Commission. Bartley was appointed for the remainder of the Coy term which terminates on June 30, 1958. The new Commissioner is far from a newcomer to the Washington scene and particularly the broadcast set, since he had been with the National Association of Broadcasters in '45 as director of war activities, and later became director of government relations. Subsequently he headed the FM department, when the FM Broadcasters merged with NAB. During the past four years he has been an administrative assistant to his uncle, the Speaker of the House. Bartley's broadcast experience dates back to '39 when he became assistant to John Shepard 3d, president of the *Yankee Network*. In '42 he became a vice president of the net. He had even seen service in the FCC, when he served as director of the telegraph division, in charge of the regulation of telegraph, land line, cable and radio carriers.

A host of celebrities attended the Bartley swearing-in ceremonies: Rep. Sam Rayburn, Associate Supreme Court Justice Tom Clark, Sen. Ernest W. McFarland, Judge Eugene Worley of the Court of Customs and Patent Appeals, Commissioner Wilson Cowen of the Court of Claims, Chief Judge Marvin Jones of the U.S. Court of Claims who administered the oath to Bartley, and former NAB Presidents Neville Miller and Justin Miller, with whom Bartley was associated during his NAB tenure.

The new appointees were feted during a luncheon party, hostessed by Madame Commissioner Frieda Hennock. Among those at the party were all the Commissioners and staff executives, as well as all of the examiners, division and office chiefs, women attorneys, and section chiefs.

To succeed Walker as vice-chairman, the Commissioners elected Rosel H. Hyde, who has been with the Commission since '46 when he was named to fill the unexpired term of the late William H. Wills.

Not only were there changes in the chief executive branch of the Commission, but in the engineering department, too, prompted by the realignment of divisions initiated some months ago. George S. Turner, known to many, many commercial ops as a former radio inspector and assistant radio supervisor in the days when the Department of Commerce supervised radio activities, was among those who were promoted in the shift. He was named chief of the field engineering and monitoring division in the office of

(Continued on page 164)

**RADIO & TELEVISION NEWS**

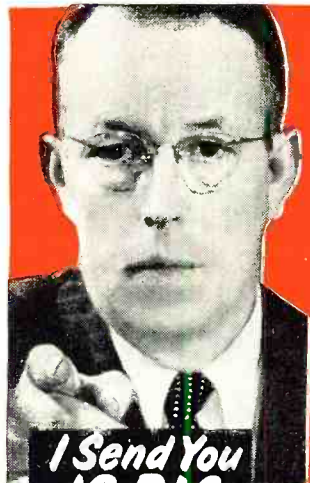

# Learn RADIO TELEVISION

**—New Package Unit Plan—PAY AS YOU LEARN  
NO MONTHLY PAYMENT CONTRACT TO SIGN!**

**I Send You  
18 BIG  
KITS  
OF RADIO-  
TELEVISION  
EQUIPMENT**

**TRAIN IN 10 MONTHS OR LESS  
At Home in Your Spare Time**

Now . . . be ready for Radio-Television's big pay opportunities in a few short MONTHS! Frank L. Sprayberry's completely new "Package" training unit plan prepares you in just 10 MONTHS . . . or even less! Equally important, there is NO monthly payment contract to sign . . . thus NO RISK to you! This is America's finest, most complete, practical training—gets you ready to handle any practical job in the booming Radio-Television industry. In just 10 months you may start your own profitable Radio-Television shop . . . or accept a good paying job in this fascinating expanding field at work you've always wanted to do. Mr. Sprayberry has trained hundreds of successful Radio-Television technicians—and stands ready to train you in less than one year, even if you have no previous experience. You learn by DOING . . . actually working with your hands with equipment of special design to illustrate basic theory instead of relying on books alone.

### VALUABLE EQUIPMENT INCLUDED WITH TRAINING

The new Sprayberry "package" plan includes many big kits of genuine, professional Radio-Television equipment. While training you actually perform over 300 demonstrations, experiments and construction projects. In addition, you build a powerful 6-tube standard and short wave radio set, a multi-range test meter, a signal generator, signal tracer, many other projects. All equipment is yours to keep . . . you have practically everything you need to set up your own service shop. The interesting Sprayberry book-bound lessons and other training materials . . . all are yours to keep.

### EARN EXTRA MONEY WHILE YOU LEARN!

All your 10 months of training is AT YOUR HOME in spare hours. Keep on with your present job and income while learning . . . and earn EXTRA CASH in addition. With each training "package" unit, you receive extra plans and ideas for spare time Radio-Television jobs. Many students pay for their entire training this way. You get priceless practical experience and earn generous service fees from grateful customers. Just one more reason why the Sprayberry new 10 MONTH-OR-LESS training plan is the best Radio-Television training in America today. If you expect to be in the armed forces later, there is no better preparation than good Radio-Television training.

## FREE 3 BIG RADIO TELEVISION BOOKS

I want you to have ALL the facts about my new 10-MONTH Radio-Television Training—without cost! Act now! Rush the coupon for my three big Radio-Television books: "How to Make Money in Radio-Television," PLUS my new illustrated Television Bulletin PLUS an actual sample Sprayberry Lesson—all FREE with my compliments. No obligation and no salesman will call on you. Send the coupon in an envelope or paste on back of post card. I will rush all three books at once!

**SPRAYBERRY ACADEMY OF RADIO**  
Dept. 25-J, 111 North Canal St., Chicago 6, Ill.

**SPRAYBERRY ACADEMY OF RADIO, Dept. 25-J  
111 North Canal St., Chicago 6, Ill.**

Please rush to me all information on your 10-MONTH Radio-Television Training Plan. I understand this does not obligate me and that no salesman will call upon me.

Name.....Age.....

Address.....

City.....Zone.....State.....

Please check Below About Your Experience  
 Are You Experienced?  No Experience

**Mail  
Coupon  
Today!**

**NO OBLIGATION  
No Salesman  
Will Call**

Approved for  
Veterans Under  
the G. I. Bill

**IF YOU ARE  
EXPERIENCED IN RADIO**

Men already in Radio who seek a short intensive 100% TELEVISION Training with FULL EQUIPMENT INCLUDED are invited to check and mail the coupon at the right.

# VEE-D-X

*proudly presents*

THE ALL CHANNEL

# Q-TEE



FEATURING

\* PATENTED BUILT-IN

*Electronic Channel Separators*

for

Super Power All-Channel Performance

VEE-D-X engineers have done it again! Here is the antenna that brings to all channel reception the brilliant performance and clean design of the famous VEE-D-X single channel arrays, the "JC" and the "Long John". Add the outstanding new feature, patented electronic channel separators, plus amazing newly engineered all-channel power, and it is easy to see why VEE-D-X is proud to present the Q-TEE. With these dramatic developments, the Q-TEE is destined to revolutionize broadband reception, not only in large metropolitan areas, but also in the near fringe and fringe with two and four stacked arrays. Your cue to brilliant TV reception is the Q-TEE.

THE LaPOINTE-PLASCOMOLD CORP., WINDSOR LOCKS, CONNECTICUT

ANOTHER VEE-D-X ORIGINAL—WITH PATENTED FEATURES

\* Lic. A.A. K. Pats. 2,422,458; 2,282,292; others pending.

# REVOLUTIONARY

## Engineering Achievement in Antenna Construction

### Q-TEE FEATURES

- All-channel Performance
- Ideal for Primary, Near Fringe and Fringe Areas
- Higher Average Gain Than Other Broadband Antennas
- Smaller, Lighter, Better Looking
- Higher Uniform Gain Over All Channels
- Better Front-to-Back Ratio
- Perfect 300 Ohm Match on Both High and Low Channels
- Lower Standing Wave Ratio Than Any Other Broadband Antenna
- More Easily Installed and Stacked
- VEE-D-X Pre-assembled Construction

### EASILY STACKED FOR FRINGE AREAS

#### SINGLE BAY for primary areas

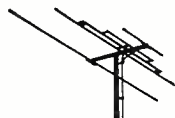

#### 2-STACK ARRAY for near fringe areas provides a gain increase of 40% or better

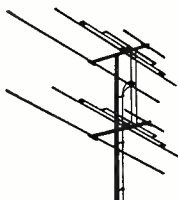

#### 4-STACK ARRAY for fringe areas provides a gain increase of 100% or better

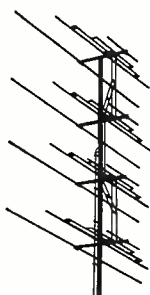

Q-TEE is shipped pre-assembled and the elements fold open into position. Portions of this antenna are manufactured under license of A.A.K. Patent Nos. 2,282,292 and 2,422,458. Other patents on this antenna pending.

## HOW THE Q-TEE FUNCTIONS

by Sydney E. Warner, VEE-D-X Chief Engineer

The Q-TEE is a new engineering approach to the all-channel TV antenna problem. Entirely new in design, this antenna incorporates a revolutionary feature, Electronic Channel Separators. The result is a unique antenna with better gain and directivity, higher front-to-back ratio, greater ease of assembly, increased mechanical strength and better appearance. Figure 1 shows the basic antenna assembly. On the low channels, elements (A-A) form a half-wave dipole, with elements (B-B) as the reflector. On the high channels, elements (C-C) form a full wave dipole with elements (E-E) as a half-wave director.

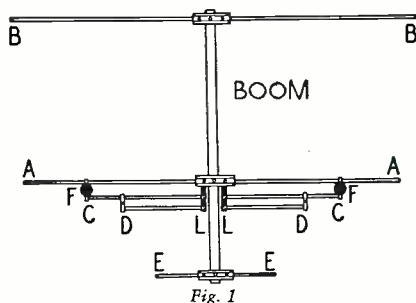

Fig. 1

Isolation filters (F-F) are anti-resonant at the center of the high channels (195 mc) and isolate the low channel dipole (A-A) from the high channel dipole (C-C). The center matching and phasing section performs a dual function and accounts for the unique operational characteristic of this antenna. In the high channels elements (D-D) are "T" match sections which tap the dipole (C-C) and provide a 300 ohm termination at (L-L). The high channel antenna is, therefore, a full wave antenna "T" matched, with a half-wave director. On the low channels the isolation filters (F-F) have a low impedance (inductive) since they operate below resonance. The high channel dipole (C-C) combined with element (D-D) form a double "T" match which taps dipole (A-A) to provide a 300 ohm termination at (L-L).

The close proximity of (A-A), (C-C) and (D-D) provides a driven element with very low "Q". This low "Q" in effect represents a driven element of a large electrical diameter and which in turn accounts for the broad (all-channel) frequency characteristics of the antenna.

Figures 2 and 3 show the horizontal directivity pattern of the Q-TEE. Note that the directivity is quite pronounced. The front-to-back ratio on the low channels will run from 6 db to as high as 12 db. This is an important consideration in those areas where co-channel interference problems exist. On the high channels, the front-to-back ratio is as high as 8 db on the center of the band.

The directional characteristics of the antenna give less noise pickup since signals off the side and back are rejected to a much greater degree than they are in a conical type antenna. Conicals designed for good response on the high channels are poor on the lows, while those designed for the low channels are poor on the highs. Q-TEE does not have these limitations.

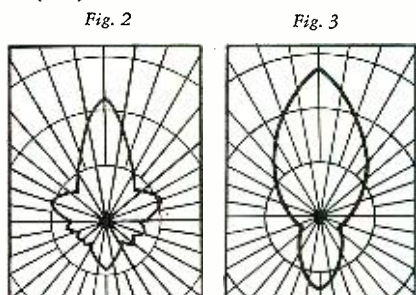

Fig. 2

Fig. 3



Mail coupon for full information on the Q-TEE.

THE LaPOINTE-PLASCOMOLD CORP.  
Windsor Locks, Conn.

Gentlemen:  
Send me full information on Q-TEE

NAME.....  
ADDRESS.....  
CITY.....ZONE.....STATE.....

# MERIT

tv full-line\*

components give  
universal coverage

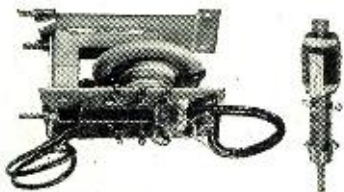

**NEW IMPROVED HVO-7**  
FOR GREATER COVERAGE  
Tapped AFC Windings, Covers Admiral Chassis 21-24 Series.

**MWC-1 UNIVERSAL WIDTH COIL**  
(3-27 MH) A Tapped Secondary For AGC or AFC.



**IF-RF COILS**  
Only complete line of TV replacements.



**"COSINE" YOKES**  
Complete with leads & network.

MATCHED FOR DIRECT DRIVE

MDF-30

HVO-8

A-3080 Vert. Mtg.  
A-3081 Horiz. Mtg.  
Autoformer



**KIT NO. 1000**  
MATCHED SET FOR SPEEDY  
PROFITABLE SERVICE!

**MERIT . . . HQ for PRACTICAL TV**  
Service Aids

MERIT'S 1952 Catalog No. 5211 with new  
MERIT IF-RF Coils.

Other MERIT service aids:

TV Repl Guide No. 404, 3500 models &  
chassis.

Cross Ref Data, IF-RF Coils, Form No. 14.  
See your Jobber or write: Merit Coil and  
Transformer Corp., 4425 Clark Street,  
Chicago 40.



These three MERIT extras help  
you:  
Exclusive: Tapemarked with  
specs and hook-up data.  
Full technical data packed with  
every item.  
Listed in Howard Sams Photo-  
facts.



\*Merit is meeting the TV im-  
provement, replacement and con-  
version demand with a line as  
complete as our advance in-  
formation warrants!

# Within the INDUSTRY

**EDWIN T. HERBIG, JR.** has been ap-  
pointed to the post of general sales  
manager for the *E. F. Johnson Com-  
pany*, electronic equipment manufac-  
turers of Waseca, Minnesota.



Mr. Herbig was  
formerly a director  
of the Alkaline Cell  
Division of the *Ray-  
O-Vac Company* and sales manager of  
the Audograph Division of *Gray Manu-  
facturing Company*.

He graduated from Massachusetts  
Institute of Technology in 1937 and  
served as an officer in the U.S. Army  
Signal Corps.

\* \* \*

**RTMA** has formed a government rela-  
tions section to provide a forum for its  
member-companies through which in-  
dustry problems may be presented to  
government officials. The new section,  
which consists of five task committees,  
is under chairmanship of Ben Edel-  
man, *Western Electric Co., Inc.*

The five task committees include:  
Patents and Copyright—Chairman A.  
L. B. Richardson, *Sylvania Electric  
Products Inc.*; Accounting and Cost  
Principles—Chairman G. T. Scharffen-  
berger, *Federal Telephone & Radio  
Corp.*; Termination and Renegotiation  
—Chairman Valentine Deal, *RCA Vic-  
tor Division*; Facilities and Govern-  
ment Property—Chairman Ernest  
Leathem, *Raytheon Manufacturing  
Co.*; and General Task Committee—  
Chairman L. A. Connelly, *RCA Victor  
Division*.

\* \* \*

**L. D. SHIPLETT**, formerly assistant ser-  
vice manager for the *Bendix* Television  
and Broadcast Receiver Division, has  
been upped to the  
post of service man-  
ager.



He has been with  
the company for the  
past eleven years,  
serving as inspec-  
tion supervisor in  
the Communications Division prior to  
his connection with the Television Di-  
vision. He is being succeeded by C. E.  
Bowers, former field service engineer  
of the company.

\* \* \*

**NARDA**, the national organization of  
appliance and radio-television dealers,  
has announced the removal of its ex-  
ecutive offices to new and larger quar-  
ters in the Merchandise Mart, Chicago.  
The association now occupies Suite  
1141 . . . **NUCLEAR INSTRUMENT &  
CHEMICAL CORPORATION**, 229 W. Erie  
Street, Chicago 7, Illinois has acquired

additional space in its present build-  
ing. The new plant area will allow  
the company 20 per-cent more floor  
space to devote to the manufacture of  
measuring instruments and radio-  
chemicals . . . **PHILIPS LABORATORIES,  
INC.** purchased the 44-room mansion  
and 13-acre estate at Irvington, N. Y.,  
which the laboratories have been oc-  
cupying on lease since 1944. Exten-  
sive remodeling will be undertaken to  
make the buildings more suitable for  
research and development purposes . . . **WESTINGHOUSE ELECTRIC CORPO-  
RATION'S** Transformer Division has  
begun production of "Hipersil" wound  
cores for electronic transformers at  
two recently leased plants in Green-  
ville, Pa. and Lima, Ohio . . . **THE  
GRAY MANUFACTURING COMPANY** of  
Hartford, Conn. has leased 23,000  
square feet of manufacturing space in  
Manchester, Conn. to provide addi-  
tional operating space for its wholly-  
owned subsidiary, **GRAY RESEARCH  
AND DEVELOPMENT COMPANY**.

\* \* \*

**ROBERT C. WALLACE** is the new mer-  
chandise manager for *Zenith Radio  
Corporation* of Chi-  
cago.



In addition to his  
new responsibilities  
which involve mer-  
chandising programs  
and products, he  
will continue his  
present duties in  
connection with the  
company's war contracts.

Mr. Wallace has been with *Zenith*  
for over thirteen years, joining the  
company's Chicago distributing corpo-  
ration in 1938.

\* \* \*

**STANDARD COIL PRODUCTS CO. INC.**  
has acquired the *Sherold Crystal Divi-  
sion* of **ESPEY MANUFACTURING COM-  
PANY**. **SHEROLD CRYSTALS, INC.** will  
become a wholly-owned subsidiary of  
**STANDARD COIL** for the manufacture  
of quartz crystal for the Armed Ser-  
vices and the electronics industry in  
general. The crystal company's plant,  
located in Kansas City, Kansas, is the  
sixth plant operated by **STANDARD  
COIL** in addition to the two plants  
of **KOLLSMAN INSTRUMENT CORPORA-  
TION**, another wholly-owned subsidi-  
ary . . . **THE JAMES KNIGHTS COM-  
PANY** of Sandwich, Illinois has pur-  
chased the Frequency Modulation  
Monitor Division of **DOOLITTLE RADIO,  
INC.** The manufacturing equipment  
and sales department, until now lo-  
cated in Chicago, is being moved to  
Sandwich . . . **LAPOINTE PLASCOMOLD  
CORPORATION** has acquired **PRESS  
WIRELESS MANUFACTURING CO., INC.**

(Continued on page 26)

**RADIO & TELEVISION NEWS**

# OOG BONGO WALSCO FR NGO

(Translation)

"WALSCO MODEL M ANTENNA OUT-PERFORMS ALL OTHERS IN FRINGE AREAS"

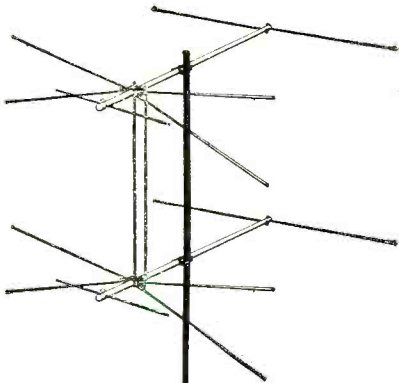

Almost anywhere, the WALSCO Model M Signal King will out-perform, out-last any competitive antenna. It's a fact... the Model M brings fringe areas closer to the TV transmitter... produces sharper, crystal-clear pictures.

And once you install... *that's all*. No costly call-backs that quickly eat up profit. Guaranteed sturdier, more dependable in *any climate*. Chromate-coated, magnesium cross-arms have a structural strength almost equal to steel, yet  $\frac{1}{3}$  lighter than aluminum. Positive corrosion resistance in severest weather. Elements are made of high-conductivity, super-strength aluminum alloy, reinforced with Swiss "Permalum." Here is quality you can trust *anywhere!*



## WALSCO

Walsco quality earned its reputation

**WALTER L. SCHOTT CO.**

3225 Exposition Place, Los Angeles 18, Calif.

Branch: Chicago 6, Illinois

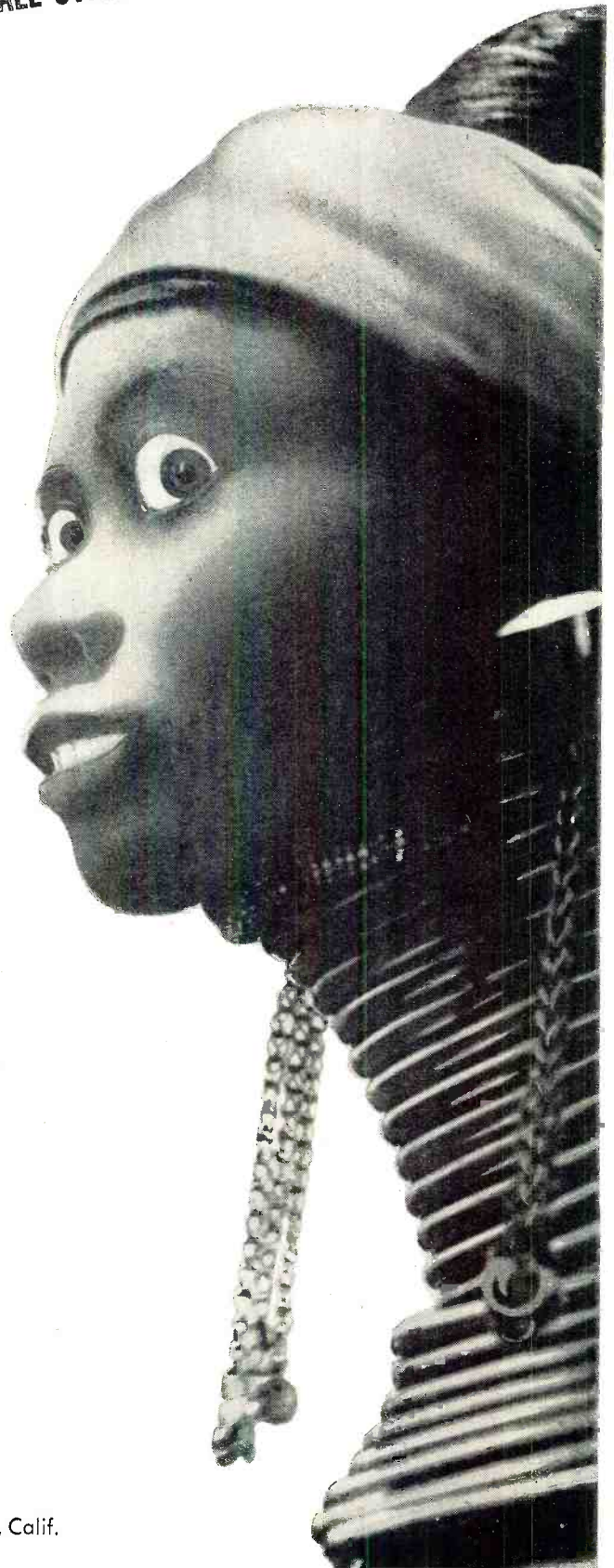

# DOUBLE-YOUR-MONEY- FOR SATISFACTORY FIT AND

No Shafts Too Short • No Switches Where Not Needed • No Reversing of Connections  
• No Improper Tapers • No Overlong Shafts • No Unsatisfactory Resistance Values

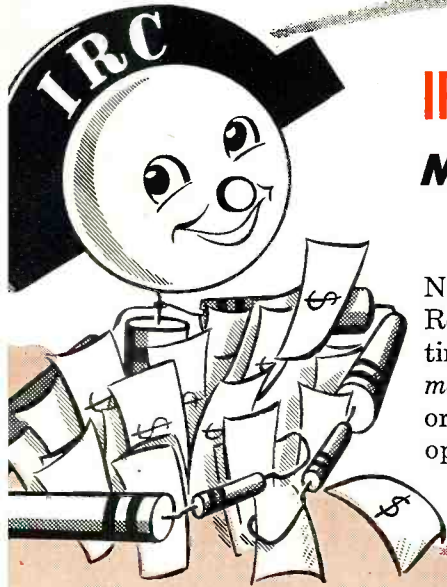

## IRC'S NEW UNIVERSAL REPLACEMENTS

**Must Fit and Operate Satisfactorily or  
Double Your Money Back!**

Never before has any manufacturer dared to guarantee Universal Replacements for satisfactory fit *and* electrical operation—without cutting or filing of shafts. IRC makes that guarantee now—*double your money back* if any IRC new Universal Replacement, employing K-2 or K-3 CONCENTRIKITS with Exact Duplicate Shafts, fails to fit and operate satisfactorily!

### LESS-THAN-A-MINUTE ASSEMBLY OF CARBON OR WIRE WOUND REPLACEMENTS USED IN OVER 5,000 TV MODELS

With IRC's two new, simplified, four-piece CONCENTRIKITS, you can actually assemble carbon or wire wound concentric duals in *less than a minute*—in home or shop—without special tools! And with a small stock of new CONCENTRIKITS—plus our Exact Duplicate Shafts and Base Elements—you can cover 416 Manufacturers' Concentric Dual Parts Numbers used in over 5,000 TV Models!

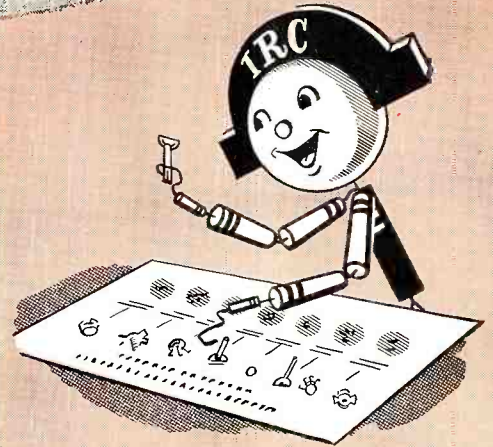

IRC's new pictorial instruction sheet makes Concentrikit assembly a snap.

### NEW IRC DEALER ASSORTMENTS GIVE WIDEST COVERAGE AT LOWEST STOCK COST

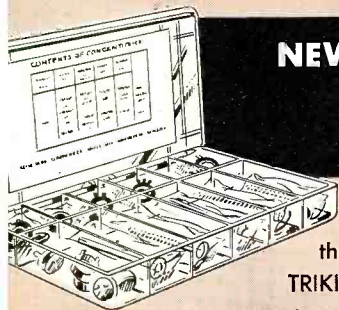

You'll tie-up less money in inventories—and lose less stock through obsolescence—when you buy IRC's new CONCENTRIKITS in low-cost, easy-to-stock CONCENTRIPAKS. These handy assortments include Base Elements, Exact Duplicate Shafts and Switches to suit specific brands of TV sets. And with them you get wide coverage at a fraction of the cost of factory-assembled controls. For example . . .

**CONCENTRIPAK for Philco—KC-1.** Replaces any of 13 Philco concentric dual controls—plus 21 others. Costs only \$10.20.

**CONCENTRIPAK for RCA—KC-2.** Replaces any of 14 RCA concentric dual controls—plus 38 listings among 15 other makes. Costs only \$7.44.

**CONCENTRIPAK for Admiral—KC-3.** Replaces any of 14 Admiral concentric duals plus others. Costs only \$7.80.

**IRC DEALER ASSORTMENT #14.** Wide-coverage, low-cost dealer stock of CONCENTRIKIT parts. Gives coverage of 240 concentric dual listings (which would require 149 different concentric duals). Supplies replacement coverage among 59 trade names, including the most popular and widely sold.

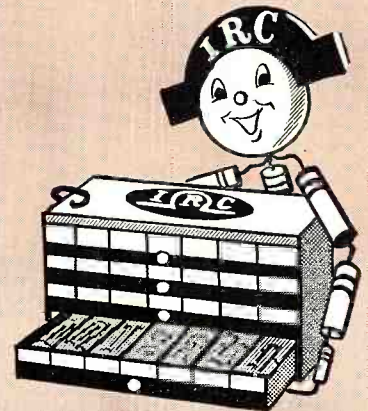



# BACK GUARANTEE OPERATION OF IRC TV CONCENTRIC DUALS

295

## IRC FACTORY-ASSEMBLED EXACT DUPLICATES Give Widest Replacement Coverage with Dependable, Guaranteed Specifications

IRC's new factory-assembled Exact Duplicates are sold with the same guarantee as the new IRC CONCENTRIKITS. *Double your money back* if mechanical fit and electrical operation are not satisfactory! The full line of 295 factory-assembled Exact Duplicate Controls covers 416 Manufacturers' Concentric Dual Parts Numbers used in over 5,000 TV Models. Both carbons and wire wounds are included. And all are designed and built to accurate specifications. No need to reverse connections or alter in any way!

## COMPLETE CONCENTRIC DUAL COVERAGE FROM ONE RELIABLE SOURCE

Whether you prefer Universal Replacements or Exact Duplicates, you can get your choice now from a single, dependable source. That's time and money saved—for now you can *schedule* your trips to your IRC Distributor. And regardless of the concentric dual units you buy, IRC's guarantee protects you—*double your money back if fit or operation are unsatisfactory!*

### GET THE FULL STORY TODAY

Mail the coupon today for full details of IRC's new, improved CONCENTRIKITS and FACTORY-ASSEMBLED EXACT DUPLICATE CONTROLS. Catalog Data Bulletin DC1C contains stock numbers, prices, TV sets covered and parts numbers. Yours without obligation.



**INTERNATIONAL RESISTANCE CO.**

401 N. Broad Street, Philadelphia 8, Pa.

In Canada: International Resistance Company, Ltd., Toronto, Licensee.

*Wherever the Circuit Says*

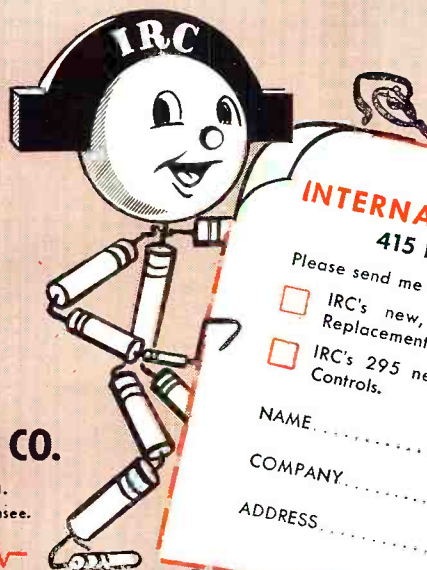

**INTERNATIONAL RESISTANCE COMPANY**  
415 N. Broad Street, Philadelphia 8, Pa.

Please send me full details of:—

- IRC's new, improved CONCENTRIKITS, with Exact Duplicate Replacement Shafts, Base Elements and Switches.
- IRC's 295 new Factory-Assembled Exact Duplicate Replacement Controls.

NAME .....

COMPANY .....

ADDRESS .....

CITY .....

STATE .....



# ... and TV ANTENNAS too!

Amphenol has long been recognized as one of the world's leading manufacturers of radar and communications antennas for civilian and military use. When Amphenol's famed team of engineers originated the Inline Antenna, they incorporated into their design the best in mechanical and electrical characteristics that years of antenna research had developed.

In the almost four years since the Amphenol Inline Antenna was originated, many other types of antennas have come into the TV market. Comparison with the manufacturers' own test data and reports reveal that the Amphenol Inline is still the superior all-channel TV antenna.

**AMERICAN PHENOLIC CORPORATION**  
1830 SOUTH 54th AVENUE • CHICAGO 50, ILLINOIS

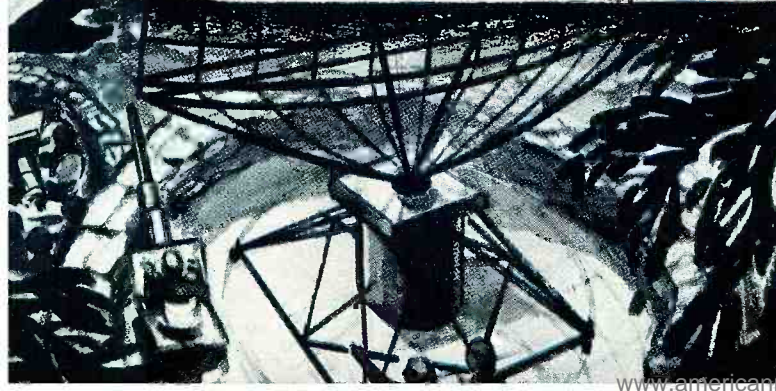
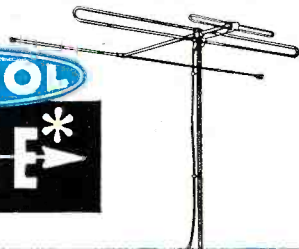

of Hicksville, N. Y. and also purchased a new four-story plant in Rockville, Conn. The new plant will be used to house the manufacturing facilities of **PRESS WIRELESS** which is in the process of being moved from Hicksville . . . **I.D.E.A.** of Indianapolis has purchased the *Ohm-Art Division* of the **CHICAGO DIAL COMPANY**. The new firm will be known as the **RADELL CORPORATION** and will have its headquarters at 55 N. New Jersey St. in Indianapolis.

\* \* \*

**WILLIAM L. ROLLINS** has been named vice-president in charge of industrial sales for *Crescent Industries, Inc.*, Chicago manufacturer of radio and TV loudspeakers, record changers, wire recorders, stampings, and other electronic equipment.



He has been associated with the radio business for more than 18 years, 13 of them with *Crescent*.

The company also announced the promotion of Edward M. Gietl to the post of manufacturing executive. He has been with the company since 1950 and will now be in full charge of speaker production, the manufacture of the company's three-speed intermix record changer, other record changers, wire recorders, and allied products.

\* \* \*

**NEDA** has announced details on its 1952 Convention and Manufacturers' Conference which has been scheduled for Atlantic City, September 22nd through 25th.

The Annual Board Meeting will begin the series of business sessions for the association on September 22nd. The program for the convention also includes the annual membership meet, a series of educational programs, and an exhibition of products.

An industry cocktail party and a well-rounded program of events for the wives of convention delegates are included among the purely social occasions scheduled.

Aaron Lippman is the convention chairman. Additional information on the convention is obtainable from NEDA headquarters at 221 N. LaSalle Street, Chicago 1, Illinois.

\* \* \*

**WILLIAM H. KELLEY** has been elected vice-president in charge of sales for the radio and television division of *Motorola Inc.*

He has been associated with the company for eight years during which time he has served as general manager of the firm. Before joining the company in 1944, he was with *Radio Corporation of America* for twenty-one years.



The company also announced the appointment of E. A. Holsten to fill the post of general merchandising manager for the division. He has served as the special merchandising manager for the firm since July 1951. He has been with the company since 1948. In his new capacity he will administer the advertising, sales promotion, sales training, and service departments.

\* \* \*

**PAUL A. HILTON**, formerly controller and assistant general manager of the *Crosley Distributing Corporation* of New York, has been named treasurer of the *Magna-Crest Corporation* of New York . . . **JAMES G. FLYNN, JR.** is the new director of the aviation and commercial sales division of *Collins Radio Company*. He retains his post as manager of the Dallas, Texas manufacturing division of the company . . . The election of **WILLIAM J. DOYLE** to the post of vice-president in charge of sales has been announced by *The Astatic Corporation* of Conneaut, Ohio. He was formerly general sales manager for the firm . . . **GEORGE E. McALLISTER** has been appointed division manager of the Norwood plant of *Workshop Associates*. He has been with *The Gabriel Company*, the parent firm, for 18 years . . . **Jerrold Electronics Corporation** has named **CAYWOOD C. COOLEY** to the post of sales manager with **CARL W. SCHMELZLE** serving as assistant sales manager . . . *Aerovox Corporation* has an- (Continued on page 92)



HOW TO PLEASE  
**1,000,000**  
MUSIC LOVERS

**WQXR Depends on G-E Pickups and Styli to Capture Full Brilliance of Recorded Music**

**Rated tops by professional users** like WQXR, the radio station of The New York Times, G-E audio equipment is at a peak of popularity with lovers of good music. The same superb cartridges and styli employed in WQXR studios are available for installation in home phonographs or sound systems—at prices your customers will appreciate.

**Highest sales in G.E.'s history** are being chalked up today by this outstanding line of high fidelity speakers, tone arms and pre-amplifiers. Don't miss your share of a fast-growing market that's currently rated in the millions! Call your General Electric distributor for full information.

**Ask Us for This New Free Phono Accessories Folder**

Complete line-up of G-E audio equipment is listed here. Write: *General Electric Company, Section 952, Electronics Park, Syracuse, New York.*



**GENERAL  ELECTRIC**



# You make more money selling and servicing **Olympic**

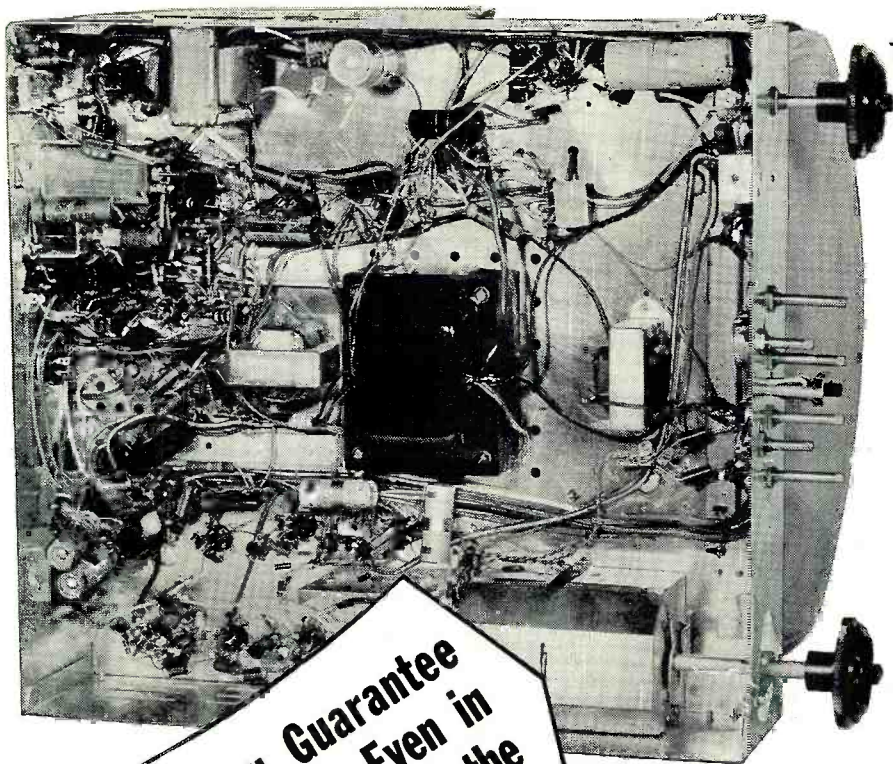

Olympic lets you Guarantee  
Sharp, Clear Pictures Even in  
Remote Fringe Areas with the  
amazing **ROCKET TV TUNER!**



**Olympic**  
*America's Favorite*  
**TELEVISION**

**Greatest Value in TV today!**

The Olympic Champion—5-way, 17-inch TV  
Combination priced to retail at \$299.95. Cash in!  
Sell this amazing profitmaker! See your Olympic  
distributor ... today!

... **because** Olympic has built into its brand new 1952 *Powerhouse Chassis* all those features that make servicing easier ... more profitable:

- Improved "Buzz Free" inter-carrier system
- "Cold" chassis—no shock hazard
- Heavy duty power transformer
- Single layer construction
- Simplified layout with Standard RMA color code
- Conveniently located test points
- Picture tube and chassis one unit—no need for extension leads when servicing
- Up to 200% safety factor
- Standard type components readily available from jobber stocks
- Standard receiving type tubes—no "trick" circuits
- Schematics readily available ... containing wave forms and voltages

**OLYMPIC RADIO & TELEVISION, Inc.** • Long Island City, N. Y.  
RADIO & TELEVISION NEWS

# Announcing the New **TRIO 'MINIT-UP'**

**STRONGEST TV ANTENNA EVER DESIGNED...**

## PLUS-ONE MAN/MINUTE ASSEMBLY!

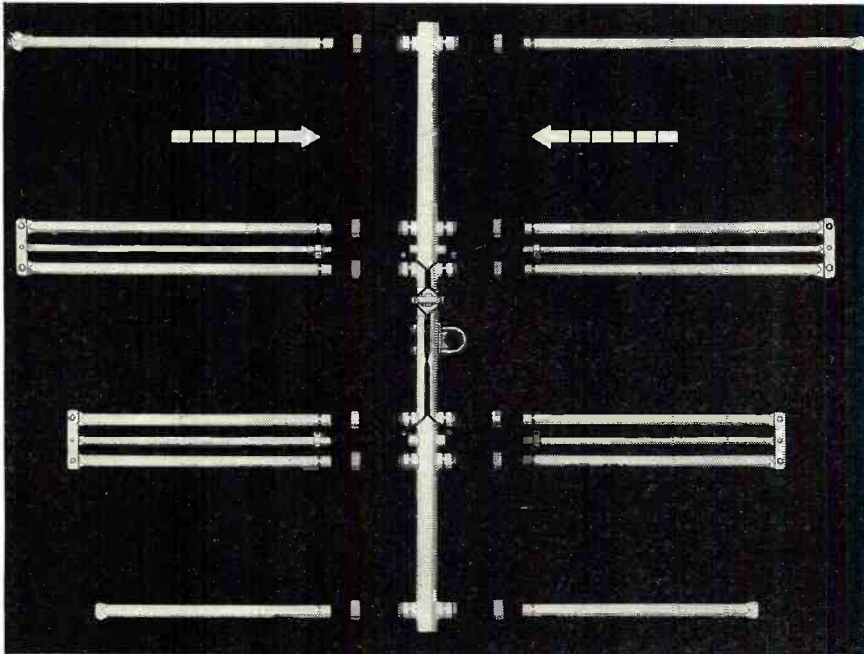

This — is it!

The new TRIO MINIT-UP... a revolutionary TV antenna that combines "minute quick" assembly with strength never before attained in *any* TV antenna!

Strong statements, to be sure — but absolutely true. Take a good look at the illustrations... see how simple, how fool proof, how "minute quick" assembly is! Note well, also, the many superior construction details that make the new TRIO "MINIT-UP" a veritable tower of strength!

**Feature upon feature makes this new TRIO MINIT-UP the biggest good news in TV antennas yet!**

This "exploded" view graphically illustrates the extreme simplicity of MINIT-UP's assembly. Note the color code bands that show instantly where each element is attached. Note the serrated connectors that provide a firm grip with hand or glove — in any weather. Here, indeed, is the last word in TV antennas. Featuring easy assembly, rugged strength — it's the New TRIO "MINIT-UP"!

Model 445MU High Gain MINIT-UP for channels 4 and 5  
Model 479MU High Gain MINIT-UP for channels 7 and 9

(TRIO's conventional single channel yagis also available with "MINIT-UP" construction)

Patent pending — no licensing arrangements granted for duplicating principle of this antenna.

### MINIT-UP STOPS ANTENNA "CALL BACKS"!

TRIO TV Antennas have long been recognized as "leaders in performance"! Now — with new design features and "minute quick" assembly — TRIO is, easily, the "leader in construction"!

Dealers and Installers will find TRIO's MINIT-UP the most profitable TV antenna they can install. MINIT-UP goes up fast — and stays up! Every detail of design and construction is employed to make MINIT-UP the most rugged TV antenna on the market today!

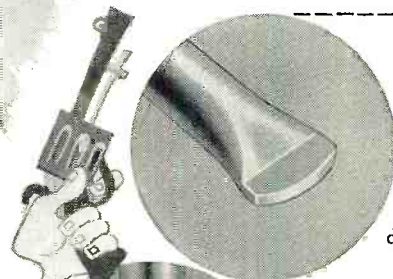

Yagi elements of .035" thick seamless aluminum, are full 5/8" in diameter. Ends are crimped for greater strength and to cut down vibration. Prevents entrance of dirt and moisture.

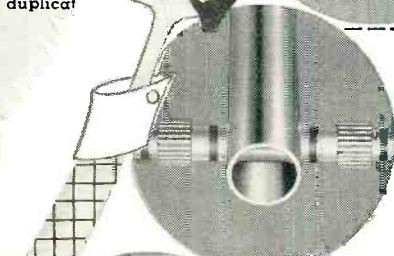

End view of the heavy gauge 1 1/4" boom showing how element inserts are swaged to completely eliminate vibrations and to provide tremendous strength.

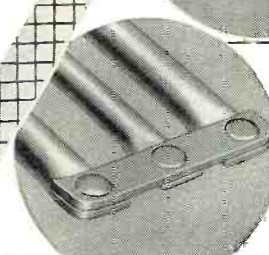

Double-folded dipole sections have heavy gauge aluminum brace bars securely riveted to element ends thus providing positive electrical connection and extreme rigidity. Workmanship throughout is of the highest order.



**TRIO** Manufacturing Company  
GRIGGSVILLE, ILLINOIS

# Largest Automobile Service Market!

Nearly half of all radio-equipped cars are equipped with Delco Radios . . . a total of more than 7 million. Think of this in terms of the service market.

There's big-volume opportunity right at your own front door when you are prepared to service this market with original equipment and universal parts.

Delco Radio parts are of uniform high quality—made and guaranteed by the world's largest maker of automobile radios.

Your nearby United Motors wholesaler can supply your requirements for Delco Radio service parts—promptly.



## DELCO RADIO PARTS

A GENERAL MOTORS PRODUCT



A UNITED MOTORS LINE

**DISTRIBUTED BY WHOLESALERS EVERYWHERE**

## DELCO RADIO

DIVISION OF GENERAL MOTORS CORPORATION  
KOKOMO, INDIANA



New CBS-Hytron  
cylindricals  
17LP4 and 21FP4A low-  
voltage electrostatics  
17QP4 and 21EP4A  
electromagnetics

## Facts

# YOU'LL WANT TO KNOW ABOUT NEW CBS-HYTRON Cylindricals

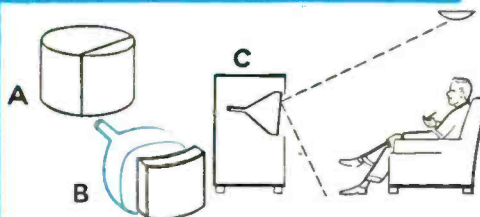

### WHY CBS-HYTRON CYLINDRICAL?

To eliminate reflected glare? How? Simple as ABC: A. Imagine a cylinder; slice it vertically. B. You now have the shape of the face plate of a cylindrical tube: curved horizontally; straight, vertically. C. Light falling on this surface at an angle from above is reflected at the same angle... downward. Tilting the tube directs glare downward even more, away from the viewer's eyes.



### WHY CBS-HYTRON SHIELDED LENS?

With this shielded lens in the electron gun, greater depth of field and better definition are achieved. Just as when you stop down the diaphragm of a large, fast camera lens ( $f/3.5$ ) to a small aperture ( $f/16$ ). Distortion caused by interaction of external electrostatic fields used to focus and accelerate the electron beam is avoided. Focusing is easier, less critical. Slight changes in voltages and currents do not cause drift.

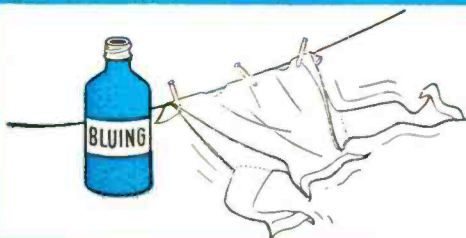

### WHY CBS-HYTRON BLUE-WHITE SCREEN?

Ever notice how a shirt laundered with bluing appears whiter? With the CBS-Hytron blue-white screen, whites appear whiter; blacks, blacker. Picture definition is crisper. In fringe areas, the expanded gray scale of the blue-white screen gives noticeably clearer pictures. No wonder CBS-Hytron's original blue-white screen is fast becoming the standard preferred by consumers for best definition.



These are just a few reasons why it's smart to demand CBS-Hytron... original studio-matched rectangulars. Try the new CBS-Hytron cylindricals yourself. Discover for yourself why 9 out of 10 leading set manufacturers pick CBS-Hytron.

MAIN OFFICE: SALEM, MASSACHUSETTS

# ANOTHER STANCOR "FIRST"



THOMAS AYOOB  
San Francisco, Cal.



R. A. BEEZLEY  
St. Louis, Mo.



ARTHUR M. BULLOCK  
Kansas City, Mo.



HAROLD CHASE  
Detroit, Mich.



WALTER S. COX  
Oklahoma City, Okla.



LOTHAR E. DIETEL  
Miami, Fla.



JOHN B. DONNER  
Brookline, Mass.



SIDNEY S. FLEISCHMAN  
New York, N.Y.



MAX FLEMING  
Portland, Ore.



FRANCIS R. GIBB  
Columbus, Ohio



ALBERT M. HAAS  
Philadelphia, Pa.



W. J. INMAN  
Dallas, Texas



IRVING J. KALUZNA  
Chicago, Ill.



GEORGE KELSO  
Denver, Colo.



STEADMAN LIDELL  
Staten Island, N.Y.



JOSEPH MARTIN  
San Pedro, Cal.



FRANK J. MOCH  
Chicago, Ill.



WILLIAM A. STEED  
College Park, Ga.



JAMES F. PINTO  
Buffalo, N.Y.



GERALD SOROKA  
Los Angeles, Cal.



ELMORE S. WALTER  
Milwaukee, Wis.

## the STANCOR SERVICEMAN ADVISORY BOARD

## Now...YOU'RE TELLING US!

**21 Top Servicemen from All Parts of the United States  
Will Tell Stancor What's Wanted at your Service Bench**

The members of the Serviceman Advisory Board have been chosen from the best men in their locality. They have an average of 4½ years experience in TV servicing (except those in non-TV areas) and over 17 years of practical experience in electronics. Most of them are officers or active participants in local servicing organizations.

**They know their business—and they know the serviceman's problems.**

These men have been retained to help Stancor do a better job for you. They will work for you by

advising Stancor on your replacement transformer problems. As we produce new components and publish new literature, the Serviceman Advisory Board represents YOU in our planning.

When new Stancor transformers are offered, they incorporate the practical suggestions of men like yourself, who are actively engaged in the servicing and maintenance of TV and radio equipment.

Here is another reason for you to "Specify Stancor" for the best in transformers.



**STANDARD TRANSFORMER CORPORATION**

3584 ELSTON AVENUE

CHICAGO 18, ILLINOIS



# G-E ALL-PURPOSE TEST EQUIPMENT CUTS TV SERVICING COST 4 WAYS

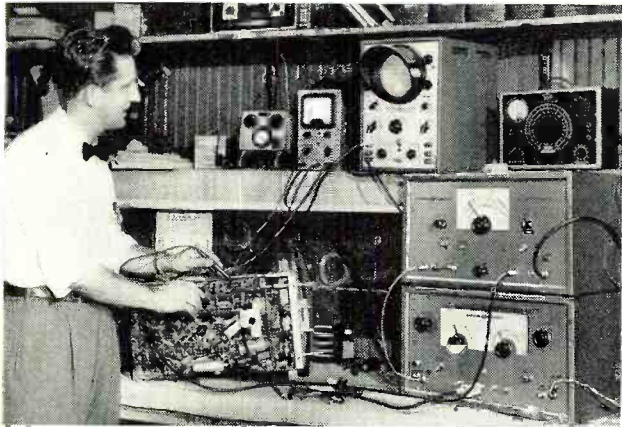

**1. Speeds shop work.** Increased volume means more profit to most TV servicemen. "Head-end troubles, hard to handle with ordinary test gear, are no match for the G-E units we installed 8 months ago. We've almost doubled our job completion score in the same period." *John Stowicki, Westbrook Radio, Westbrook, Conn.*

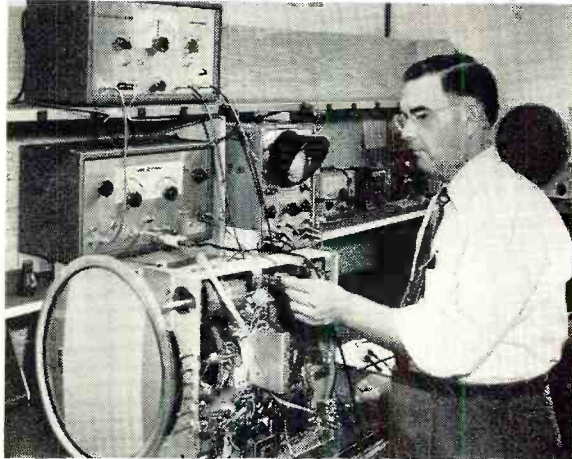

**2. Covers both VHF and UHF.** "Anything less than G.E.'s scope, sweep and marker would not do the servicing job I require. With one investment I can cover VHF plus UHF and cut my costs in half." *Ralph L. Crooks, Boulevard Radio & Television Co., Kansas City, Mo.*

**Basic investment in high quality service units pays dividends in efficiency, servicemen agree.**

**W**HEN you select television test equipment, profit from the experience of careful servicemen in almost every TV market area. They build their operation on 3 solid instruments built to last through years of VHF and UHF servicing: G.E.'s scope, variable permeability sweep, and marker generator. These multi-purpose units, unsurpassed for all-around accuracy and reliability, are particularly good at fringe area alignment work.

Your G-E Tube and Parts distributor will show you the complete equipment. Ask him about our easy payment plan, a great help to TV servicemen. Why not call him today?

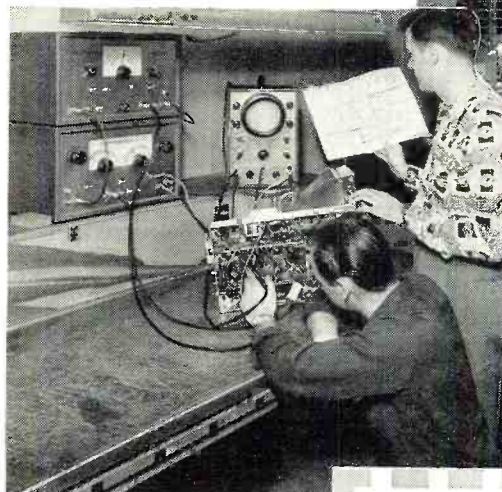

**3. Simplifies Training Problem.** Schooling technicians is no headache to this organization. "The simplicity of G-E test units has cut our training problems greatly, and helped boost our work output per man." *Phil Rudden, TV Lab Inc., San Jose, Calif.*

**4. Eliminates Guesswork.** "There's no substitute for G-E test equipment. Many service organizations bring their sets to us for precision alignments. This has increased our income tremendously." *J. H. Sampson, Sampson Television Inc., Dayton, Ohio.*

General Electric Company, Section 952  
Electronics Park, Syracuse, New York

Please forward your latest bulletins on G-E TV Test Equipment.

Name.....

Company or Title.....

Address.....

City..... State.....

**GENERAL**  **ELECTRIC**

# DEDICATED TO YOU!



This great new **EICO**  
**FACTORY...** these **NEWEST**  
**EICO INSTRUMENTS...**

**YOU** made them possible with your  
**CONFIDENCE** in EICO. We pledge to strive  
with all our power, product-wise and  
service-wise, to continue to merit your  
trust in us.

*Harry R. Ashley*  
President



## 6 NEW V-O-M KITS and Instruments

FOR LABORATORY PRECISION AT LOWEST COST

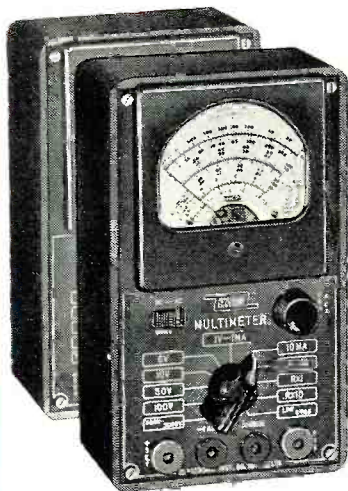

**New Model 536 —**  
**1000 Ohms/Volt Multimeter**  
Wired \$14.90. KIT \$12.90.

- 31 full scale ranges!
- DC/AC Volts: Zero to 1, 5, 10, 50, 500, 5000.
- DC/AC Current: 0-1 ma, 10 ma; 0.1 A, 1 Amp.
- Ohms: 0-500, 100K, 1 meg.
- 6 DB Ranges: -20 to +69.
- Large 3½" 400 ua meter movement.
- High-impact Bakelite case. 6¼ x 3¾ x 2".

**EICO New Model 526 1000 Ohms/Volt Multi-**  
**meter KIT \$13.90.** Wired \$16.90. As above, with 1%  
precision resistors.



**EICO New Model 566 1000 Ohms/Volt Multimeter KIT**  
**\$14.90.** Wired \$18.95. Ranges: same as Model 536 (left), plus  
7 output voltages. Large 4½" 400 ua meter movement.

**EICO New Model 556 1000 Ohms/Volt Multimeter KIT**  
**\$16.90.** Wired \$23.50. Ranges: same as Model 536 (left), plus  
7 output voltages. Large 4½" 400 ua meter movement and 1%  
precision resistors.

Compare these value-crammed EICO V-O-Ms with  
any others at any price—at your local jobber—and  
SAVE! Write NOW for FREE newest Catalog 5RA

— See the photographic proof of EICO's  
Performance Leadership on the Inside Back  
Cover of this magazine.

Prices slightly higher on West Coast. Due to unstable conditions, prices and specifications are subject to change without notice.



**New Model 565**  
**20,000 Ohms/Volt Multimeter KIT \$24.95.**  
Wired \$29.95.

- 31 full scale ranges!
- DC/AC/Output Volts: 0-2.5, 10, 50, 250, 1000, 5000.
- DC Current: 0-100 ua; 10, 100, 500 ma; 10 Amp.
- Ohms: 0-2000, 200K, 20 meg.
- 5 DB Ranges: -12 to +55.
- Large 4½" 50 ua meter movement.
- High-impact Bakelite case. 6¼ x 5¼ x 3"

**EICO New Model 555 20,000 Ohms/Volt**  
**Multimeter KIT \$29.95.** Wired  
\$34.95. As above, with 1% precision res-  
istors.

**ONLY EICO GIVES YOU ALL**  
**10 EICONOMICAL FEATURES**

- Laboratory Precision • Lowest Cost • Life-
- time Dependability • Speedy Operation
- Rugged Construction • Quality Compon-
- ents • Latest Engineering • Super-Simplified
- Assembly & Use Instructions • Laboratory-
- Styled Appearance • Exclusive EICO Make-
- Good Guarantee.



**ELECTRONIC INSTRUMENT CO., Inc. 84 Withers Street, Brooklyn 11, New York**

# MOBILITY OF COMMUNICATIONS



By  
**LT. COL. WALTER G.  
WILSON**

Deputy Chief of Staff,  
Communications, Civil Air Patrol

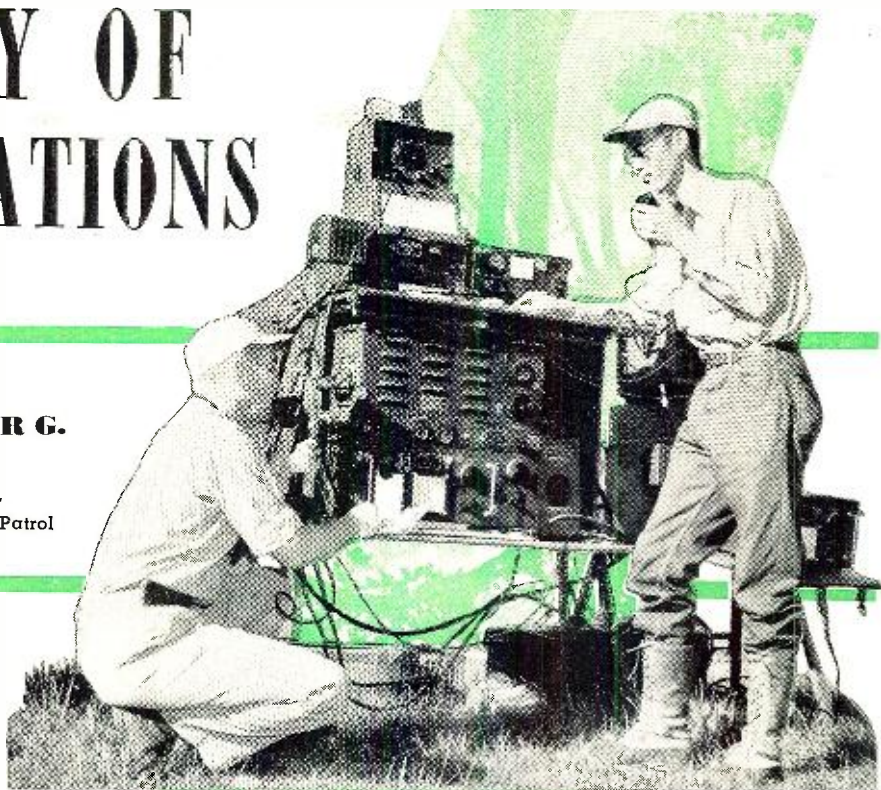

Radio played a vitally important role in the Civil Air Patrol maneuvers held recently at Boundary Peak in Nevada.

FROM both a military and civilian standpoint the United States can be justly proud of its communications systems—its vast telephone networks (both local and long lines), telegraph, and fixed radio nets from coast-to-coast. Together with highly developed air, rail, and highway systems, Americans are enormously “in touch” with one another at this Twentieth Century midpoint.

The only disturbing thought that enters into this rosy picture of communications efficiency is, “How vulnerable are these systems if subjected to all-out bombing attack?” It does not take an expert to realize that the possibility of communications severance is a strong one, where fixed types of any nature are concerned—resulting in communications “black-outs.”

The recent gas-main explosion at Brighton, N. Y., is an example of fixed communications failure in a real disaster. Brighton, for a time, was cut off from the world when explosions caused fixed communications failures. In last summer’s Midwest flood disaster fixed communications played a poor second to *mobile* communications in keeping traffic going. A year ago during a Mississippi ice storm, fixed communications again bowed to mobile types.

How, then, can the United States meet this problem?

Much thought was given the problem when the U.S. Air Force set forth the missions of Civil Air Patrol, official auxiliary of USAF. Among these missions, CAP was charged with the job of setting up a communications system characterized by high mobility and flexibility. USAF stated that the system, or network, would be at the disposal of civil defense agencies when not being called upon by the “mother” organization.

Over a period of a very few years Civil Air Patrol has developed a radio communications network of more than 9500 stations, of which approximately

7500 are *mobile*. While these figures may sound impressive, experience indicates that the communications coverage necessary in any widespread emergency could not be accomplished without a much larger network.

Civil Air Patrol envisions an organized net comprising 35,000 mobile v.h.f. stations controlled by 4000-5000 fixed control stations, with mobile control stations as a back-up in the event fixed facilities are rendered useless. The 35,000 mobile stations would afford a virtually complete communications coverage of the 48 states and the three Territories—Alaska, Hawaii, and Puerto Rico.

Plans are going forward to provide the mobile net with adequate types of equipment. In cooperation with Col. William P. Lear, communications advisor to Maj. Gen. Lucas V. Beau, National Commander, CAP is developing a means to meet requirements for a lightweight portable v.h.f. set. This set would consist of a four-channel, crystal-controlled v.h.f. transmitter and tunable receiver, with battery power incorporated. Output power would be low. The desire here is to limit the working range of the equipment so as to avoid mutual interference with adjacent CAP stations and traffic. It is

hoped that prototype tests can be made not later than May, 1952. The set will be transportable by light plane, car, boat, horseback, or hand.

At the present, CAP equipment consists of many different units, ranging in power from 500 watt a.c.-powered fixed stations to self-contained battery-operated transceivers of the .25 watt class. Much of this radio equipment is of the surplus military type, some is commercially-built equipment, while in other instances the gear is “home-brew”—like ham equipment.

Every conceivable type of power supply known to radio communications may be found operating in the CAP radio network. Such units as vibrator pack supplies, dynamotor supplies, a.c. rectifier units, and battery packs all play a prominent role in powering CAP equipment. The voltage outputs from these various supplies may range from 90 volts from the battery pack to as much as 3000 volts from the rectifier type supply, depending on its application and the equipment with which it is used.

Some of the transmitters in use as net control stations in the CAP are of the type designed for and used extensively by the military during World War II; the most popular of these is

Capt. Leonard J. Heinsen, Commander of Group 761, operates Station KONB in the CAP network. The Nebraska Wing now has five stations operating on 2374 kc.

This CAP radio unit at the Iowa Wing Headquarters in Des Moines can provide coverage for the entire state of Iowa.

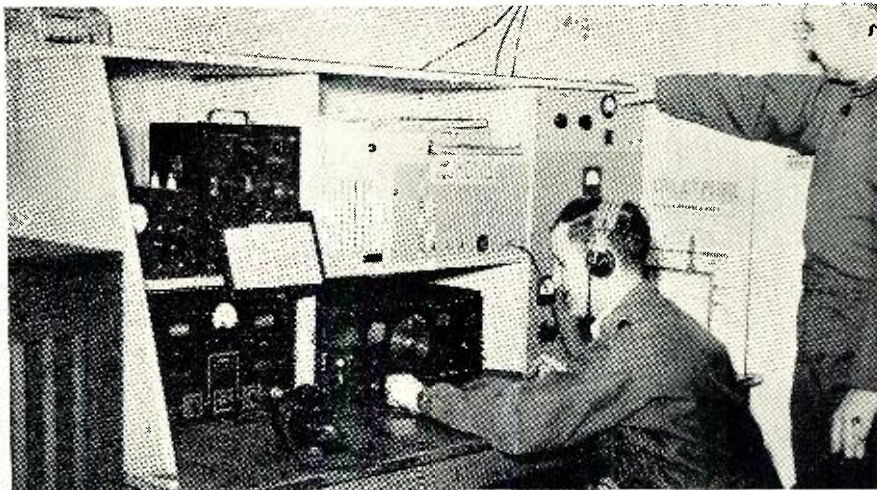
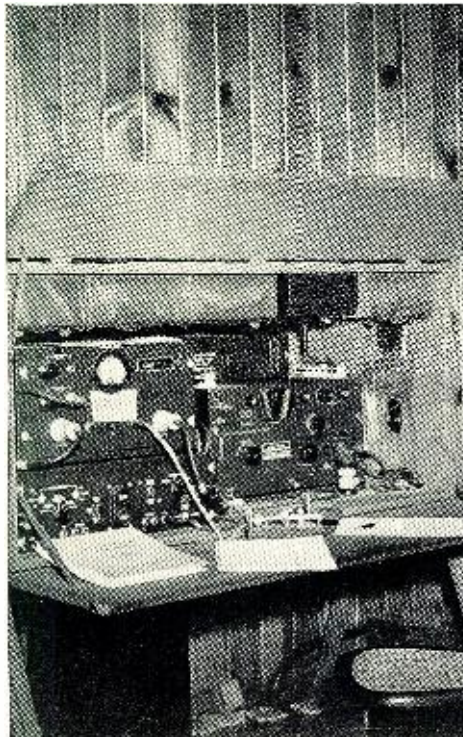

few years may be found at some CAP station.

Thus, the CAP is a vast and practical proving ground for all types of radio equipment, fixed or mobile.

The next logical query could be, "Does CAP have the organizational structure with which to man the proposed net and operate in a disciplined manner?"

Indeed, that is a primary consideration and one which Civil Air Patrol can fulfill. Such a network as CAP has now and the one which it envisions calls for a military or semi-military administration or command. CAP is semi-military in nature, although a completely civilian volunteer outfit. It has been so since December 1, 1941.

A brief study of the CAP framework indicates tremendous capabilities for control and communications coverage, in a truly disciplined manner. National Headquarters, at Bolling AF Base, D. C., actually is an Air Force headquarters, in that all personnel are USAF, from General Beau down through the ranks of some 70 officers and airmen. This headquarters serves to discharge the USAF obligation to CAP in providing administration, training aid, and general monitoring of the national program. The scheme is further enhanced by the Air Force liaison officers from this headquarters who serve in each Wing, or State, to promulgate the plans and policies of USAF-CAP.

From that point on CAP is "strictly CAP." A Wing is commanded by a CAP colonel, known as the "wing commander." The wing staff is similar to any "air staff" and performs the various duties required to keep the State program going. Among these staff officers is a communications director, such as the writer, a deputy commander, executive officer, public information officer, adjutant, and so on. There are 52 wings.

Following the Air Force pattern, the next level is the "group," of which CAP has 167, evenly distributed in such a way as to aid wing administration. Next are the 1400 squadrons. These nearly 1600 CAP units are not located just in the South, or the West, or overseas, or in close proximity

the BC-610 transmitter which is capable of providing both voice and telegraphic communications in the 500 watt class.

Other types of transmitters which are used as fixed base stations, mobile units (land portable and airborne) are listed in the table below.

As in the case of transmitters, there is a wide variety of receivers in use by CAP. Included are commercial types, surplus military units, and various "homemade" receivers. Among the surplus and commercial gear being used are the *National* NC-173, NC-183,

NC-125, and NC-57; the *Hallicrafters* S38B, S40B, SX-71, SX-22, SX-28, S-76, and S-72; *Hammarlund* receivers include the "Super Pro" and the HQ-129X; *RME* units are the RME-50, RME-45, and VHF-152; *Collins* is represented by the 75A1 and the 75A2; *RCA's* AR-88 is also used. Military-type receivers include the BC-348, BC-342, BC-312, BC-744, BC-779, and TC-107A.

These are only a few models that are being used daily in the vast CAP communications network. Actually, every type of receiver produced in the past

Tabulation of the transmitters currently being used by the Civil Air Patrol.

EQUIPMENT	POWER	POWER SUPPLY	EQUIPMENT	POWER	POWER SUPPLY
SCR-511	.75	V* or B*	SCR-542	75	D or R
SCR-522	6	D* (RA-62 or PE-94)	Siebhenthaler AW-50	50	D or R
SCR-193	75	D or R* (A.C.)	G-E 4G6B6	50	D or R
SCR-399	300	D (PE-95) or A.C.	Hadley TM-100	75	D or R
SCR-287	25	D (PE-73) or D.C. (2.4 v.)	Ranger 206	5	D or R
AN/TRC-2	25	G (hand)	Federal 167BY	75	D or R
ARC-4	10	D	Bendix TA-2-6	100	D or R
ARC-3	8	D	G-E 4G1C1	15	V (6 v.)
ARC-1	8	D	CG-20 (Coast Guard)	20	V (6 v.)
ARC-5	50	D	Meissner 150B	150	D or R
SCR-245	10	D (12 v.)	TRC-109	5	V
TC/128	10	V (6 v.)	Harvey-Wells TBS-50	50	D or R
150 CT (Comm.Cc.)	25	D	Lysco 140T	25	D or R
Letline 240	40	D or A.C. (110 v.)	TCS-12	30	D or R
Viking 1 (Johnson)	50	D	TCS-6	75	D or R
G-E T-22	10	R	TCS-5	20	D or R
ARC-13	100	D or R (A.C.)	T9 1/4	20	A.C. (110 v.)
RCA T-104	15	D or R (A.C.)	SCR-632	50	D (PE-99) or A.C. (110 v.)
RCA AVT-15	7	B (6 v.)	SCR-694	25	G (hand) or V
RCA AVT-112A	7	V or D	SCR-637	50	D (PE-99) or A.C. (110 v.)
HT-11 (Hallicrafters)	15	D or A.C.	SCR-583	5	G (hand)
WRL-406	40	D or R	SCR-284	15	G (hand)
TCS-9	25	D or R	SCR-536	.027	B (dry)
Bendix ATD	40	D or R	SCR-183	5	D or B

\* D is dynamotor; V is vibrapack; R is rectifier; B is battery.

to the metropolitan areas. They are to be found in every State and Territory—soon, CAP executives hope, in every county.

Through such an evenly-woven framework the organization is able to work some small miracles of public service. The reason: CAP is *there* when an emergency or disaster strikes. It doesn't have to travel a half day to get to the scene and go into operation. When floods ravaged Kansas, Missouri, Illinois, and Oklahoma last summer, CAP went in with the first relief, in many cases hours before other types. Communications in many instances were restricted to CAP's mobile radio units.

Likewise, this evenly-distributed organization affords a natural chain through which "command" may proceed. Also, following the Air Force pattern, CAP personnel perform their duties in a swift and precise manner, through this widespread organization of wings, groups, and squadrons.

Additionally, CAP has manpower. Personnel strength at this writing has passed the 75,000-mark with some 34,446 senior members and almost 43,000 cadets.

Added to that, CAP has mobility. The organization counts more than 5000 airplanes and 13,000 pilots, these backed up by thousands of pieces of various "rolling stock" and boats. Headed for the scene of an emergency or aerial search, CAP airlifts all possible personnel and stock, and moves the rest by truck, bus, car, or motorcycle. In the interest of mobility, CAP has horse, boat, and Jeep units in some parts of the country. You guessed it:

**A Civil Air Patrol field unit erects its transmitting antenna as high as possible to obtain the maximum signal coverage.**

**Jeeps of the Third Platoon, Cavalry Reconnaissance Squadron, test equipment at Boundary Peak, Nev., before starting a field problem. Radio equipment played a prominent role in all problems, coordinating the progress of the jeeps in mountain canyons. Units were controlled from portable transmitter units.**



May, 1952

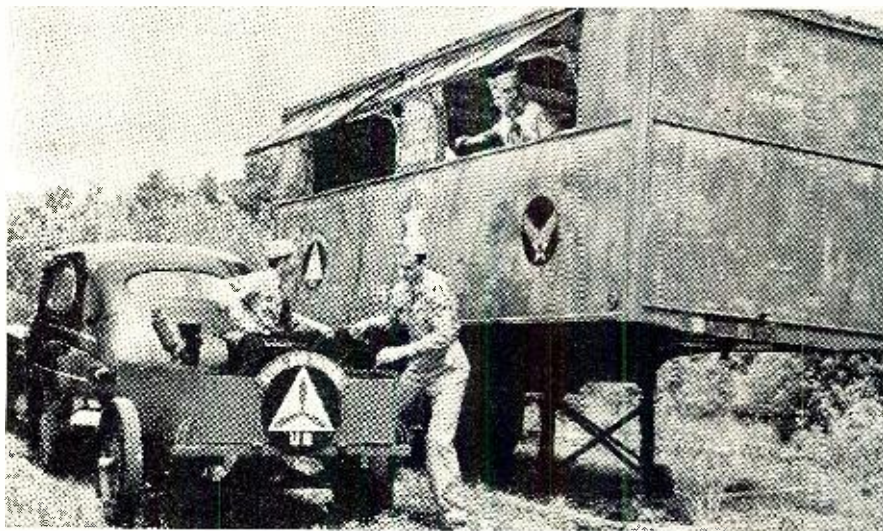

**Civil Air Patrol cadets set up a portable power unit for use during "Operation Flood." This simulated emergency operation was only one of the many such problems which are conducted to provide realistic training for members of the United States Air Force's auxiliary air arm—the Civil Air Patrol, known as CAP.**

in snowy climes, there also are ski and sled outfits.

But all is not plans with the Civil Air Patrol radio network. In existence today is a structure consisting of a national net, a regional net, and a wing net. The first consists of a National Headquarters' radio station (VPØ), serving as a net control station in scheduled operation with its eight regional net stations. Each regional station, in turn, serves as a net control station for the CAP wings in its prescribed area. A wing net consists of a wing control and satellite stations, after the above pattern. All of

these stations are of the fixed type.

The 7500 CAP mobile stations in all CAP levels of command operate independently or on a controlled basis, as the situation demands; but in no case is the mobile network rendered lifeless due to fixed failure for any reason.

At this point—in the early part of the 11th year of CAP history—the organization seeks to speedily fulfill its projected communications program, an ambitious undertaking calling for added manpower and leadership. You are invited to investigate Civil Air Patrol and the possibility of a berth in it for your "know-how." —30—

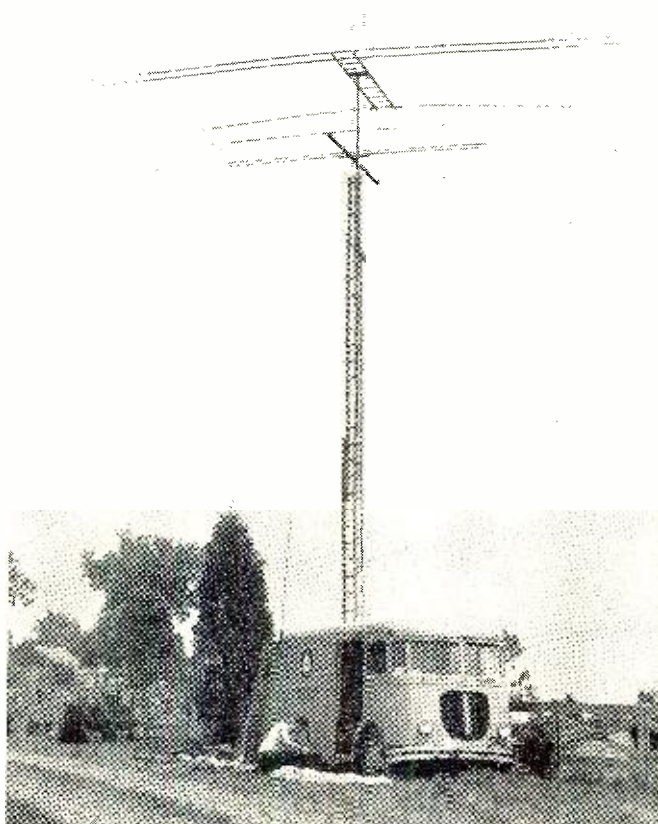

37

# HORN-LOADING

# LOUDSPEAKER ENCLOSURE

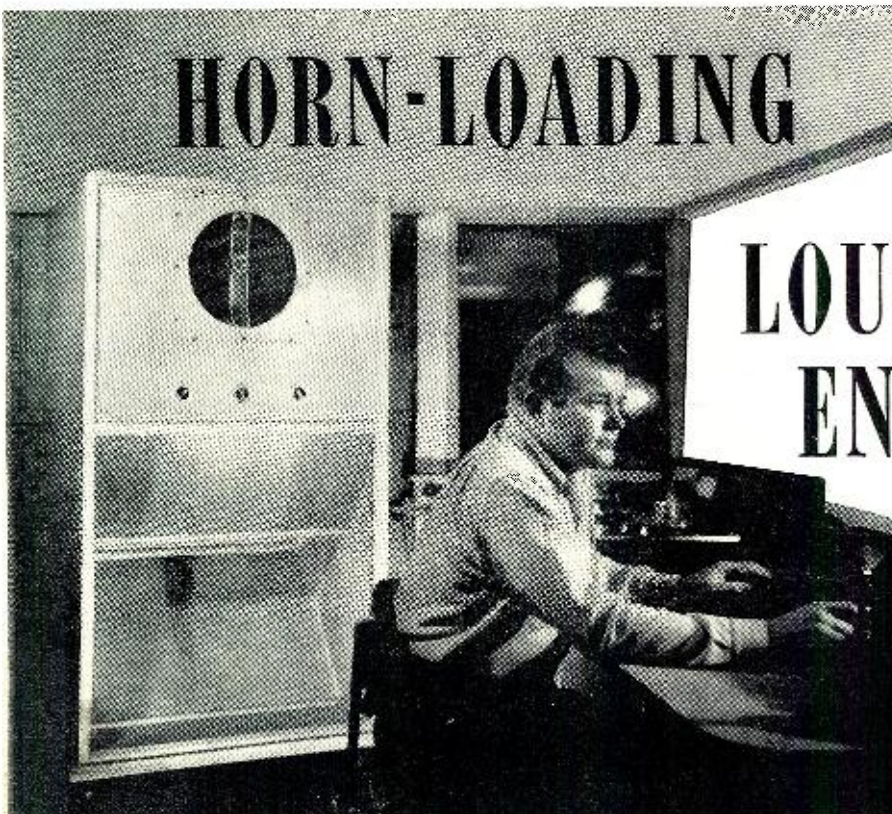

By

**DANIEL J. PLACH\***

and

**PHILIP B. WILLIAMS†**

Jensen Manufacturing Company

Fig. 1. Jensen back-loading horn enclosure installed in a recording control room.

**A discussion of horn loading and its effect on bass response. Details on building such a unit are given.**

FUNDAMENTAL research on compression driver horn-loaded loudspeakers has led to further and still further extension of the high frequency range with corresponding gains in polar characteristics, response smoothness, and transient behavior. While we cannot say positively that further improvements in the high end will not be worthwhile, nevertheless we have definitely reached the point of rapidly diminishing returns. It is now apparent that further high frequency extension will gain less in realism of reproduction than can yet be achieved at the opposite end of the spectrum. Another octave added to the top end of the best loudspeakers of today would carry their response far beyond the extreme upper limit of hearing. It now seems most worthwhile to exploit all possibilities of improving low frequency performance in order to enhance realism of sound from the reproducing system.

The evaluation of low end response is difficult for individuals who have become conditioned by listening to open backed radio consoles tending to emphasize the 100-200 cycle region, with resulting boomy or "one note thump" sound. This type of response is accepted by a large proportion of listeners as good low frequency reproduction, despite the very different characteristic the original sound may have had.

In this connection, extensive listen-

ing tests have been made with bass reflex enclosures housing identical high quality 15-inch speakers. One enclosure was tuned so as to have a 4 db rise at 100 cycles, with roll-off of 18 db per octave below that point. The other enclosure was tuned so as to give smooth response down to 45 cycles, with 18 db per octave roll-off below 45 cycles. For most program material, uncritical listener reaction was that the system with the 100 cycle rise had the better "low frequency" performance. Further tests with pipe organ recordings and with warbled sine wave input showed the 45-cycle enclosure to be definitely superior on this material over the first two octaves. So we cannot ignore the importance of program source material used in comparative judging, nor can we neglect the importance of response in the 100- to 300-cycle region in giving the sensation of bass loudness. To be most effective, a means of increasing bass output in a loudspeaker system must, therefore, increase the sound output over the whole range up to 300 or 400 cycles. An enclosure which adds only peaks at the extreme low end cannot be expected to give much subjective improvement in bass response. Yet, low distortion reproduction of the extreme lows is important when we are trying to push performance toward the ultimate.

For most applications, a properly ad-

\* Physicist.  
† Senior Engineer.

justed bass reflex cabinet offers an excellent means of obtaining good performance at modest cost down to the resonant frequency of the loudspeaker. For instance, moderate volumes such as 7-9 cubic feet afford smooth response at good efficiency as low as 50 cycles with a 15-inch speaker. Measurements show low distortion and absence of peaks when a loudspeaker of fairly high efficiency is operated from an amplifier of good regulation. With small space requirements and simple economical construction, this type cabinet probably will continue as the most generally useful type of enclosure for loudspeakers.

For some applications where substantially higher efficiency and greater power handling capabilities for the woofer are paramount, a horn-loading enclosure appears to be a logical method.

A horn can be considered as an impedance-transforming, high-pass filter that effectively matches the low impedance of the air at its mouth to the high impedance moving system at its throat. The design of the horn and loudspeaker system must be intimately correlated to obtain optimum performance. A properly designed horn-driver combination can increase the efficiency of the woofer 4 to 6 db over that of a conventional enclosure—no small matter when it is realized that this increase can reduce amplifier output requirements to as little as one-fourth, and where the reduction is most important—at the low end. The additional loading made possible by the impedance transforming property of the horn enables the woofer to handle

larger amounts of power for several reasons. Since the efficiency is increased, more power is radiated as sound, and less is used to heat the voice coil. The heavy loading lowers the resonant frequency of the moving system and decreases the amplitude of the cone movement, thus reducing whatever distortion arises from the non-linearity in the cone suspension. Because of the smaller cone excursion required for a given amount of power radiated, the voice coil has less movement out of a field of constant flux density, reducing still another factor causing distortion. Since horn loading presents to the speaker a better mechanical resistance-to-reactance ratio, less transient distortion can be expected.

There are four fundamental parameters that define a horn, namely, cut-off frequency, flare, throat size, and mouth size. The cut-off frequency is generally chosen as the lowest frequency which must be passed by the system. A low cut-off frequency requires a long path length to obtain the mouth area required for satisfactory performance. The choice of a lower cut-off frequency often is dictated by available path length. The flare determines the shape of the horn and the impedance characteristics of the horn throat in the vicinity of cut-off. While a variety of horn flares can be chosen, the "Hypex\*" flare results in a better resistance characteristic in the vicinity of cut-off, as compared to the conical or exponential types. Fig. 2 gives a comparison of the throat resistance characteristics of the "Hypex," exponential, and conical flares.

The choice of throat size is determined by constants of the loudspeaker moving system, and further by the power handling requirements for a prescribed amount of distortion.

Efficient radiation from a horn at low frequencies requires a mouth of large area to prevent resonances and reflections that produce dips and peaks in the response. Experimental work indicated that satisfactory performance could be maintained down to 40 cycles with a mouth size of approximately 1300 square inches.

Several types of commercial horn loading enclosures are available for use in corners of rooms. The horn path is so constructed that the corner is an approximation of the final section of the horn, with an extremely large mouth opening. These horns are folded, some in intricate fashion, to conserve space while providing the proper flare. One type of corner horn uses only the radiation from one side of the cone, radiation from the other side being buried in an air chamber. This type of horn is limited in upper frequency because of the roll-off due to the air chamber compliance, and response roughness caused by the tortuous path (with consequent impedance irregularities) necessary in folding the horn. Above 300 to 500 cycles, generally, an external high frequency unit is re-

quired. In another type, the radiation from the back side is horn loaded, and radiation from the front side of the cone ensues in the normal manner.

In a project at Jensen, intended to achieve near-ideal performance in reasonable space, it was decided to develop a back-loading horn in order to accommodate high quality, unitary multichannel loudspeakers such as the Jensen G-610 "Triaxial" and H-510 "Coaxial." Because of the all-too-frequent lack of a corner in which to put a loudspeaker enclosure, the design was to be such that a corner would not be required for proper operation.

The final horn design employs a "Hypex" flare of  $T = .7$ , take-off area of 125 square inches, and a mouth area of 1260 square inches developed in a path length of 62 inches. These constants, in combination with a loudspeaker chamber compliance, give a theoretical cut-off frequency of 40 cycles and a high frequency roll-off above 300 cycles. Actual cut-off frequency on the basis of useful output is somewhat below 40 cycles, a discrepancy to be expected when the characteristics of actual finite horns are compared to those of the theoretical infinite horn.

The sound take-off from the loudspeaker begins at two  $3\frac{1}{2}$ " x 17" slots located on the sides of the loudspeaker chamber. From these slots, the sound path follows two flaring sections which open into a vertical slot at the back of the upper part of the enclosure, this short slot opening into a section expanding downward at the back of the enclosure. The path direction is then forward as the passage rapidly flares to the mouth. Expansion is held very

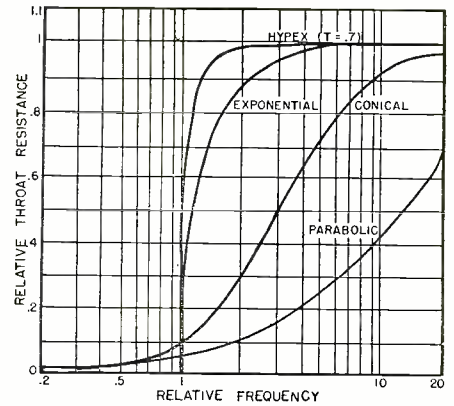

Fig. 2. Throat resistance of the "Hypex," exponential, conical, and parabolic horns.

closely to the specified "Hypex" flare along the whole path length by utilization of baffles as required.

The enclosure is constructed of  $\frac{3}{4}$ " plywood. In the model shown in Fig. 1, all the sections were solid enough to eliminate the necessity for further bracing, with the exception of the back of the enclosure. A brace had to be connected between the back and the bottom shelf of the sound chamber assembly. This brace is at right angles to the air passage, so offers no obstruction effect. A test for adequacy of rigidity of a section is to place the hand on the section during high level operation at low frequencies. Vibration should not be great at any frequency. If the section has much greater vibration than can be felt at other parts of the enclosure, additional bracing is required.

All joints and cracks are sealed  
(Continued on page 106)

Fig. 3. Mechanical details for constructing the horn-loading speaker enclosure.

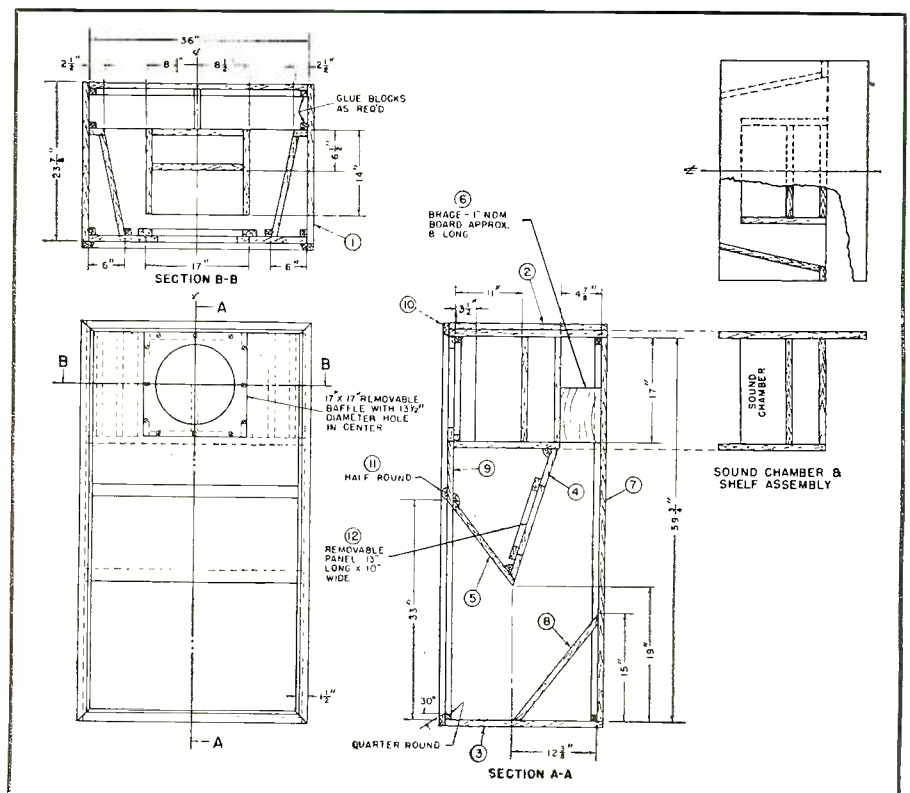

\* Salmon V.: Electronics, July, 1941.

# An Inexpensive TV CROSS-BAR GENERATOR

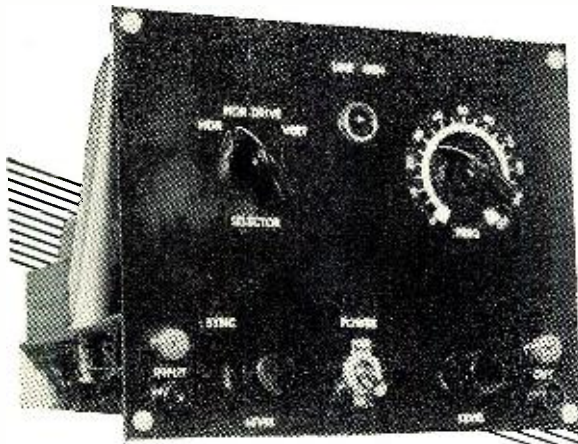

Fig. 1. Front and rear view of the home-built TV cross-bar generator.

**Details on a simple and effective test instrument designed for TV alignment and troubleshooting.**

**N**O SPECIAL blocking oscillator transformers are needed to build the simple and inexpensive TV cross-bar generator shown in Fig. 1. The TV technician or home experimenter can probably find all the necessary parts (with the possible exception of the selector switch) in his junk-box. Since only two tubes are used, the wiring can be easily finished in an afternoon or evening.

Once completed, the instrument can not only be used for making horizontal and vertical linearity tests in TV receivers but, more important, may also be used as a video signal source for signal injection tests in the video amplifier stages. Used in this fashion it speeds the isolation of defective stages in the video section of the receiver and also permits tests of relative gain. By adding an extra position on the "Function Selector" switch, provision has been made for obtaining a trapezoidal signal at the normal horizontal sweep frequency rate (15,750 cps), permitting the horizontal output stages of TV receivers to be checked independently.

## Circuit Description

As can be seen by reference to the schematic diagram (Fig. 2), a conventional power supply circuit is employed using a full-wave rectifier and a small receiver-type transformer. Adequate filtering is provided by the 10 henry filter choke ( $CH_1$ ) and the dual 10  $\mu$ fd. electrolytic condenser  $C_5$ - $C_6$ . Power supply voltage stability is aided by using a bleeder,  $R_8$ .

The generator itself consists of a twin-triode 12AU7 connected as a cathode-coupled Potter multivibrator. In this type of multivibrator, one grid (pin 2 in Fig. 2) may be grounded or may be used for introducing a sync signal to "lock-in" the oscillator with an external signal.

By  
**LOUIS E. GARNER, JR.**

To increase the versatility of the instrument (as we shall see later), provision has been made for introducing a sync signal and adjusting its level (by means of  $R_1$ ).  $C_1$  serves as a d.c. blocking condenser, permitting the sync signal to be obtained from the plate circuit of a tube.

Frequency of operation is determined by the  $R_2$ - $C_2$ - $C_3$ - $C_4$ - $R_3$ - $R_4$  combination. The value of  $R_2$  has been kept low and the combination  $C_2$ - $C_3$ - $C_4$  made adjustable by means of  $S_2$ . Thus, the setting of  $S_2$  determines whether *horizontal lines*, *vertical bars*, or a *horizontal sweep signal* is to be obtained, with the exact number of lines or bars (or exact frequency of the horizontal sweep signal) determined by the setting of  $R_5$ .

If the frequency of operation is greater than 60 cps (for a conventional black-and-white TV receiver), horizontal lines will be obtained, provided the signal is not equal to or greater than 15,750 cps. If greater than 15,750 cps (again, for a black-and-white TV receiver), vertical bars will be obtained.

To insure a good output waveform, the plate load resistor  $R_6$  has been kept low in value. This permits paralleling a comparatively small pot across  $R_6$  to serve as an output level control ( $C_7$  acting as a blocking condenser). At the high output frequency used to obtain vertical bars (over 100,000 cps), distributed capacities become increasingly important and will cause excessive attenuation and deterioration of

the signal should either  $R_7$  or output control  $R_8$  have a high resistance value.

Condenser  $C_7$  serves as an output d.c. blocking condenser, permitting the output lead to be connected directly to either the grid or plate of tubes in the TV receiver without danger of damaging the output control  $R_8$ .

Normally (with  $S_2$  in positions "A" or "C") the signal obtained from the multivibrator is a negative-going pulse. To change this signal into a trapezoid usable for horizontal deflection tests, discharge condenser  $C_8$  together with peaking resistor  $R_7$  are connected into the circuit by the second section of  $S_2$ .  $R_7$  is made adjustable, permitting the peak of the trapezoid (see Fig. 3C) to be varied at will.

## Unique Features

Although making provision for a trapezoidal output signal that may be used as a substitute horizontal drive signal is, in itself, an important feature, in the author's opinion the provision for an external sync signal is the one feature that really extends the usefulness of this cross-bar generator.

In many TV receivers employing a.f.c. in the horizontal sweep circuits, it is virtually mandatory that a horizontal sync pulse be present if any semblance of stability is to be maintained in the horizontal sweep. Without a sync pulse present, it is sometimes possible to obtain a pattern of vertical bars momentarily, but these soon shift and tear out of sync. This tendency has been overcome in at least

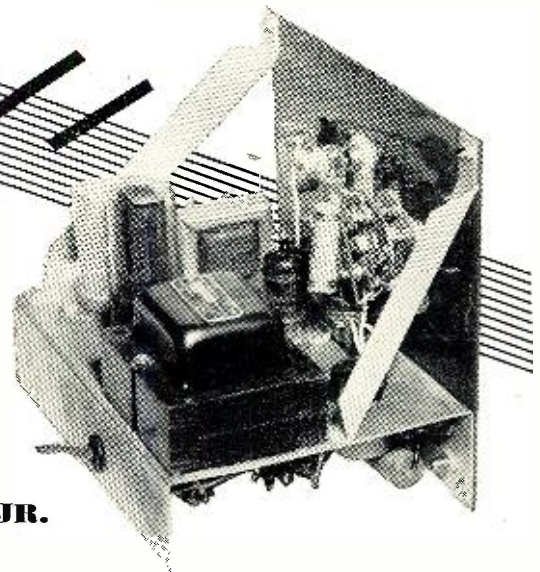



one commercially manufactured cross-hatch generator by providing a horizontal sync signal for the TV receiver in addition to the signal needed to form the vertical bars.

To eliminate the need for another oscillator to provide a 15,750 cps horizontal sync pulse, an external signal obtained from the horizontal sweep circuits of the receiver under test is used to lock-in the cross-bar generator. Thus the cross-bar generator is locked-in with the horizontal sweep of the TV receiver (instead of *vice versa*) and a stable pattern of vertical bars assured irrespective of drift of the horizontal sweep oscillator in the TV set.

The external sync signal may be obtained by capacitive-coupling to the plate of the horizontal output tube, or by direct connection to the grid of this tube or the plate of the horizontal sweep oscillator.

**Construction Hints**

Parts values are not critical and substitutions of the next RTMA size may be made for any parts given in the parts list. If the horizontal drive signal is not needed or desired by the builder,  $S_2$  may be replaced by a s.p.d.t. switch and parts  $C_3$ ,  $C_5$ , and  $R_7$  eliminated.

Wiring is not at all critical, but a reasonable amount of care should be taken to keep distributed wiring capacities low.

If desired, other tubes may be used in place of those shown. For example, a type 6SN7 tube may be substituted directly (socket change necessary, of course). If the builder wishes to vary part values slightly, either a 12AT7 or 6SL7 may be used as the twin triode. Should the builder use a larger chassis than that shown in Fig. 1, two single triodes (6J5, 6C5, 6C4, etc.) may be used in place of the twin-triode tube.

As far as the rectifier tube is concerned, a 5Y4, 5U4, 5Z4 or almost any similar type may be substituted with appropriate socket changes. The need for a 5-volt winding on the power transformer can be eliminated by using a type 6X4 or 6X5 tube.

Although a separate toggle switch was used as a power switch by the author, this switch may be placed on any of the controls in order to simplify the panel and save panel space.

The phone tip-jack type output terminals used in the model illustrated may be replaced with binding posts, coaxial connectors, banana jacks, or, for a low-cost model, simply by flexible leads brought through the front panel through rubber grommets.

$R_1$  can have any value from 50,000 ohm to 2 megohms, and a linear taper is not essential. Use whatever you have available.

Once the wiring is completed, the front panel may be "dressed-up" by using decals or commercial dial and name plates or, if the builder prefers, left "as-is."

Since the trapezoid peaking adjustment is seldom used, this control ( $R_7$ ) may be mounted on the back apron of

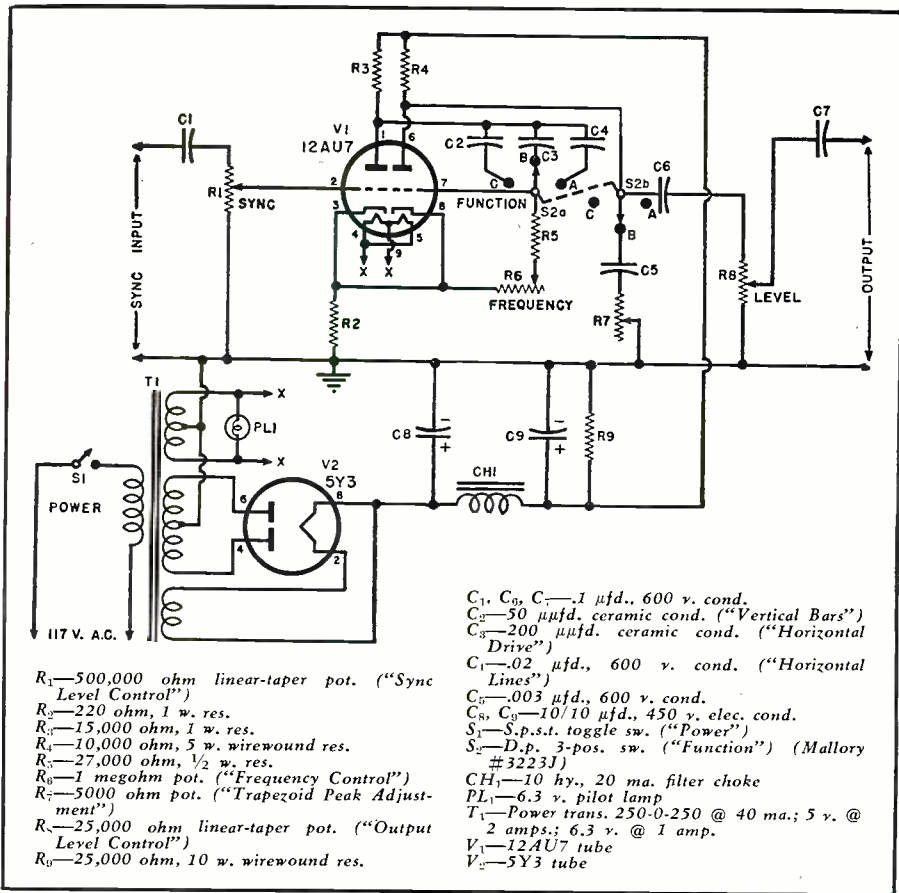

Fig. 2. Complete schematic diagram and parts list for the TV cross-bar generator.

the chassis, on top of the chassis, or wherever is convenient.

After completing the wiring and making an over-all visual check, turn on the power and make sure tubes light and d.c. voltages are obtained. If desired, a CRO may be used to observe the output signal. To do this, connect the output terminals to the vertical input terminals of the CRO. The various controls may then be varied and the changes in amplitude, waveform, and frequency in the output signal observed.

Familiarity with the use of the instrument may be gained more quickly by actually connecting it to a TV receiver, however. Refer to the block diagram of the video and sweep stages in a typical TV receiver as given in Fig. 4.

The ground lead from the cross-bar generator should be connected to the set chassis. Connect the "hot" output lead to the input of the first video amplifier stage (point "A" in Fig. 4).

Adjust the "Sync" control of the generator to minimum; turn the "Function" switch to the "Horizontal Lines" position (position "A" in Fig. 2); adjust the output "Level" control until horizontal lines appear on the screen of the CRT in the TV receiver as shown in Fig. 3A. Naturally, all the receiver controls should be properly adjusted to give a bright raster.

It may be found necessary to adjust the "Frequency" control of the generator or the "Vertical Hold" control of the TV receiver until a stable pattern of lines is obtained. Once a stable pattern is obtained, it will be found that either a white background with black lines (Fig. 3A) or a black background with white lines is obtained, depending on the internal connections in the TV receiver. Either pattern is suitable for all tests and adjustments.

The number of lines obtained may now be varied by adjusting the "Frequency" control ( $R_6$ ) of the generator. (Continued on page 102)

Fig. 3. (A) Horizontal pattern obtainable when "Frequency" control of generator is set correctly. (B) Vertical bar pattern. (C) Adjustable trapezoidal pattern.

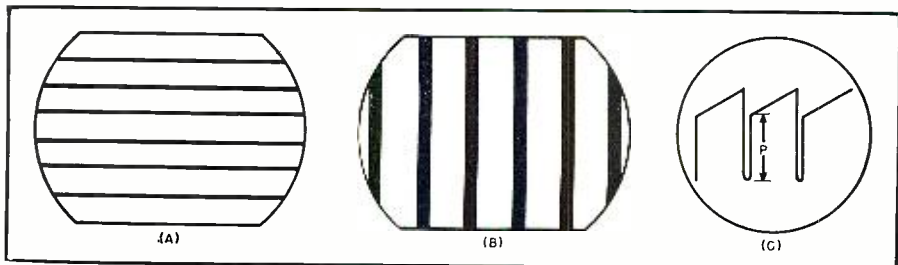

# The Versatile

# 6BN6

By  
**FRED P. STROTHER**

Head, Electronics Dept., Research Div.  
West Point Manufacturing Company

**Some interesting circuit applications employing the recently-developed 6BN6 gated-beam tube.**

**W**HENEVER a new type of vacuum tube is released, there is a mad rush by electronics men to secure all the available information and determine its suitability to their own special needs. This is a healthy condition, but all too often the tube is the same as a number of others already available, except that it has a different pin arrangement, filament voltage, or a new style bulb. Because of this, one loses interest and begins to pay less and less attention to the new releases. However, once in a great while a tube appears that is so entirely different that one's careful attention and study is warranted. Such a tube is the 6BN6 with its true beam characteristics, isolated control grids, and accelerator element. Here we have combined in one miniature envelope a tube with elements providing both positive and negative transconductance, as well as grids that effect a step function control. Best of all, the tube is in mass production, is available, and is cheap enough to allow its use when desired. Truly, the design-

ers and manufacturers of this tube are to be congratulated.

The 6BN6 tube was designed to replace the conventional limiter and discriminator in FM receivers, but its characteristics permit many other interesting circuit applications. These include its use as a pulse generator, RC oscillator, crystal oscillator, frequency divider, and multivibrator, to mention a few.

These circuits require only one tube, and the oscillators may be designed to provide various wave shapes from sine waves to pulses. A frequency standard which has an output very rich in harmonics may be easily built. None of these oscillators necessarily require a tuned circuit.

It would be only needless repetition to go into the workings of this tube in conventional receiver usage, as this has been well covered in the literature. Let us instead consider some of its lesser known applications, such as those to be described. In most cases we will find that the use of this tube permits a considerable simplification

of the circuitry required to do these jobs.

Fig. 1A shows a circuit for a crystal oscillator. With the values shown, a 100 kc. crystal oscillates nicely, giving essentially a sine wave output. By reducing the value of the normal control grid resistor  $R_2$ , the waveshape appearing at the plate is changed from a sine wave to negative pulses recurring at the crystal frequency. These pulses may be used as an accurate timing marker on a cathode-ray display, either for blanking or adding to the "Y" axis signal. Varying the values of  $R_2$ ,  $R_1$ , and  $C_1$  will give numerous other waveshapes, including a sawtooth, although the linearity is poor. Frequency doubling may be effected by increasing  $R_1$ .

Fig. 1B shows another crystal oscillator and frequency divider circuit. By varying the quadrature grid resistor  $R_2$ , a sine wave may be produced at the plate. A 100  $\mu\mu\text{f}$ . condenser  $C_2$  connected from the accelerator to the cathode improves the waveshape. Varying  $R_2$  after removing  $C_2$  will cause the circuit to divide, producing frequencies of  $\frac{1}{2}$ ,  $\frac{1}{3}$ , up to about  $\frac{1}{10}$ , although the higher orders of division are somewhat unstable. Such a circuit probably should find considerable use in a low-cost secondary frequency standard.

Frequently a source of negative pulses is required for tripping counters, multivibrators, and scaling circuits. Fig. 2 shows a simple circuit which fulfills these requirements adequately. For the values shown, the frequency is approximately 320 cps, and with a 150 volt supply the peak value is about 135 volts with less than a 1% duty cycle. The pulse is quite sharp. Its frequency can be varied, of course, by changing the values of  $C_2$  and  $R_6$ . Synchronization can be effected, as shown, by injecting a small amount of voltage of the desired frequency at point "A".

It is very apparent that a tube of this type lends itself nicely to the design of a square-wave generator. A circuit of this type is illustrated in Fig. 3. The values are not critical, and those given may be varied con-

(Continued on page 169)

Fig. 1. (A) Circuit for a crystal oscillator and (B) a crystal oscillator and frequency divider, using a 6BN6 tube.

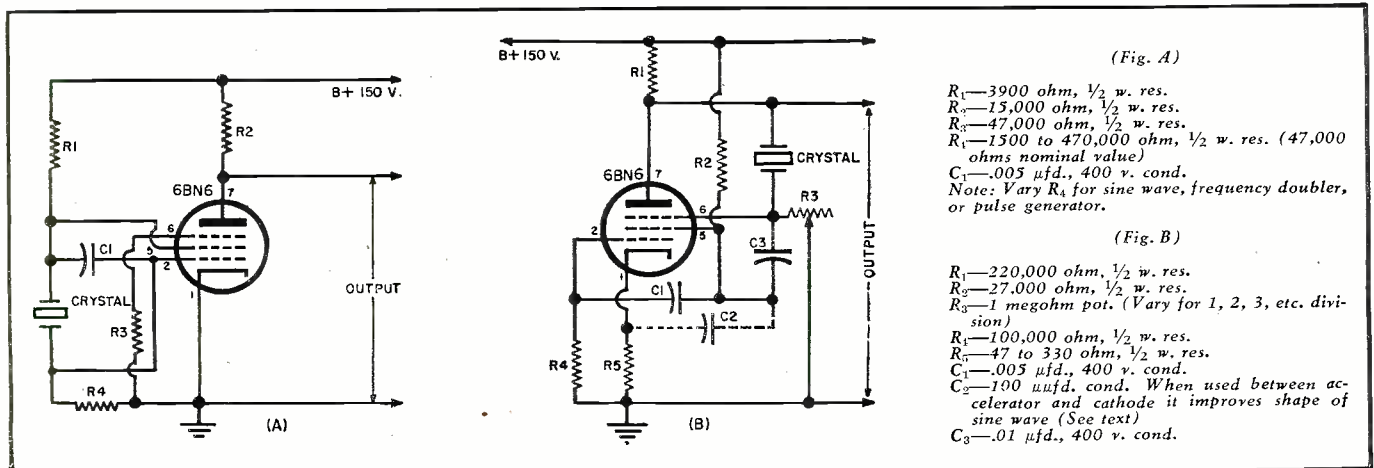

# INTERPRETING

By  
**KEN KLEIDON**  
Belmont Radio Corporation

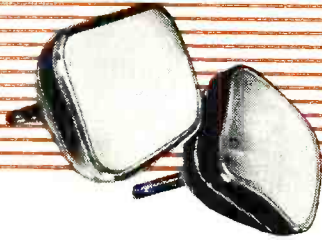

## that TV PATTERN

### *Part 2. Continuing the analysis of circuit faults by CR tube patterns.*

**T**HE use of the picture tube as an information source when servicing a television receiver will greatly aid in quickly determining which portion of the receiver is not functioning properly. By analyzing the deviations from a normal picture and having a basic understanding of how a television receiver operates, a technician can easily localize the defective stage and then proceed to locate the tube or components causing the trouble.

When analyzing the video information on the face of the picture tube it may also be helpful to determine whether the sound is operating normally. Since the majority of the present-day television receivers are of the intercarrier type, the sound and video information are amplified simultaneously by the tuner and i.f. amplifiers. Therefore if the sound is normal, it can be assumed that there are no defects in the tuner or i.f. amplifier stages. However, when a defective picture is accompanied by improper sound operation, the trouble is likely to be a defective tube or component in the tuner, i.f. amplifier, detector stage, or "B+" supply. A fast and simple check to localize the possible defective stage, when a no picture-no sound condition (raster normal) exists, is to turn the contrast or picture control to maximum and view the face of the picture tube. If the picture tube, at maximum setting, shows an increase in snow, first determine whether a signal is being transmitted, check the antenna or lead-in connections, and then check the tuner or first i.f. amplifier stages.

However, if no snow occurs check the second, third, and fourth i.f. amplifiers or the detector stage or any following stages before the sound take-off point. It is a good practice to substitute tubes in the particular circuit believed to be at fault before checking other components. This is one method to speed-up servicing. However, when substituting tubes be sure to replace the same tubes in the sockets from which the tubes have been removed. Disturbance of the alignment may result from rearranging tubes. A majority of tuner troubles is caused by open and high resistance solder connections, defective trimmers or coils, and defective contacts. These may cause an intermittent condition or loss of one or both bands.

Fig. 1 represents a no-picture condition which may result from station failure, the set being tuned to an off chan-

Fig. 1. No picture, raster normal. In this case no evidence of video information on the face of picture tube is similar to off-channel tuning. There may or may not be accompanying sound.

Fig. 2. Overloading. The picture is a "negative" with the black portions of the picture white and the white portions black. It may also have poor sync stability or horizontal displacement.

Fig. 3. Washout. Poor definition accompanied by a lack of contrast with the white dominating the black. This is a milder case of overloading than that shown in the pattern of Fig. 2.

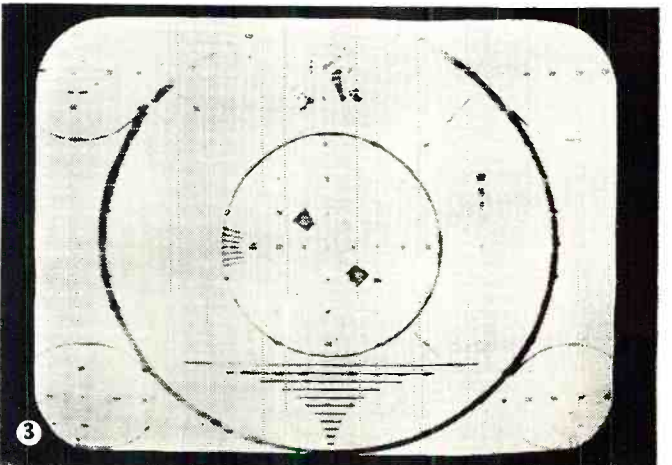
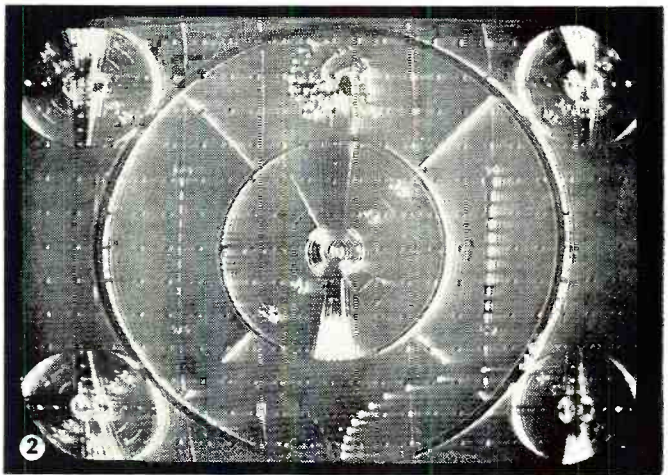
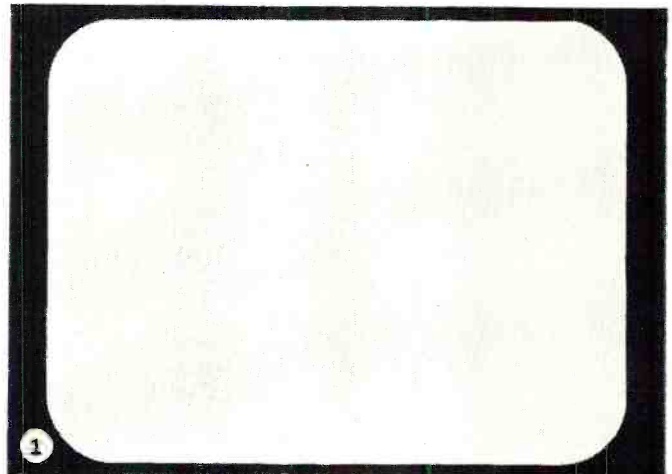

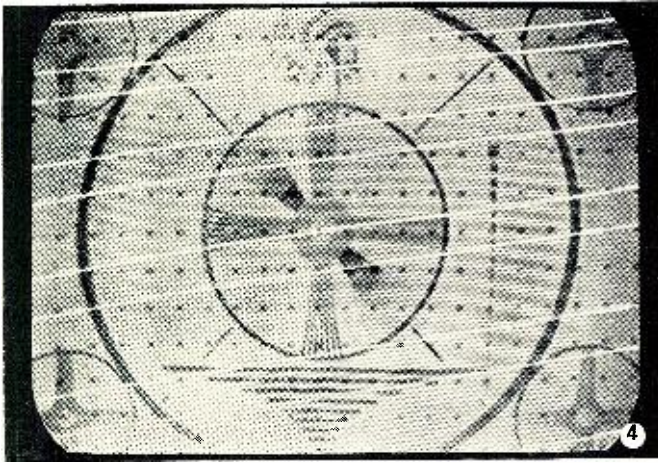

Fig. 4. This picture shows a lack of contrast or poor definition accompanied by white diagonal vertical retrace lines.

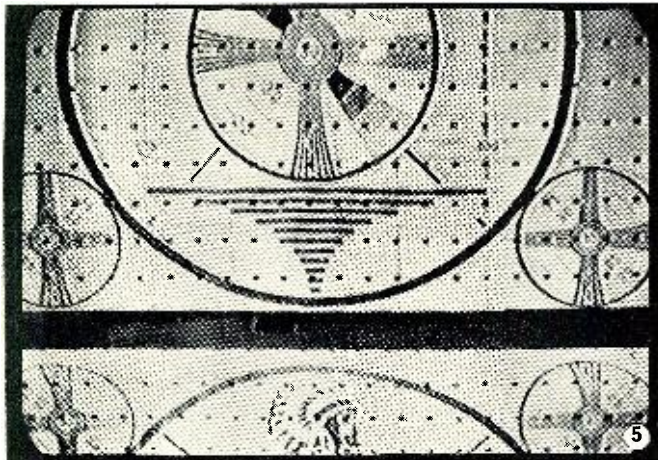

Fig. 5. An example of poor vertical sync. Flipping, picture rolling, or multiple frames characterize this condition. Photo shows vertical sync and vertical blanking references in the vertical dimension and equalizing pulses in the horizontal.

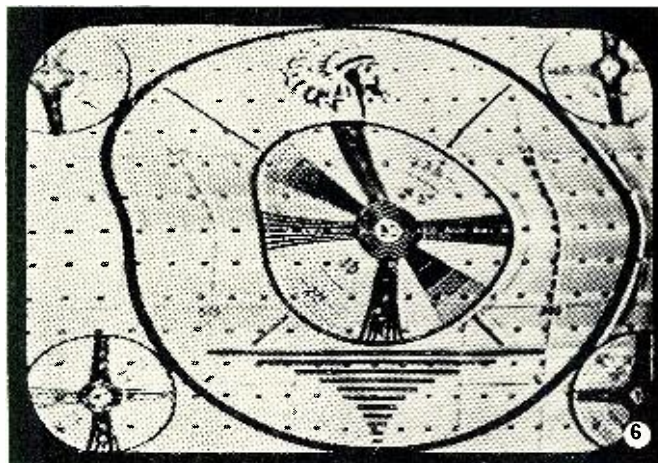

Fig. 6. Horizontal displacement. A portion of the picture is displaced horizontally and may vary with picture composition.

Fig. 7. Video amplifier used in a modern Raytheon TV receiver.

Fig. 8. The vertical deflection circuit of a Raytheon TV set.

nel, the antenna being disconnected or disabled, or defective tubes in following sections or the associated components; r.f. amplifier, oscillator-converter, i.f. amplifier, detector, and a.g.c. (using sound as a guide). A defective a.g.c. system will, in most receivers, not affect the sound but overload the video amplifier and cause very weak or no video information to be applied to the picture tube. A no-picture condition with normal sound would probably be caused by a defective video amplifier stage or a loss of a.g.c. If a rapid change of the contrast control setting or quickly inserting and removing the video output tube from its socket produces a brilliance fluctuation on the face of the picture tube, then it can be assumed that the video output stage is operative. This is one check to help localize trouble.

The picture of Fig. 2 shows a severe case of overloading which is usually caused by a loss of a.g.c. A failure in the a.g.c. will generally result in insufficient bias applied to the i.f. amplifiers and permit increased amplification or gain. The increased signal strength will overload and the video amplifier stage is unable to reproduce the video at the output, but due to stray capacities the signal may be coupled to the next stage. The signal applied to the grid of the picture tube will then be of incorrect polarity due to the overloaded stage and will result in a negative picture. Overloading may also result from gassy a.g.c. controlled grids, open or high resistance in the video detector, or a leaky video amplifier coupling condenser. A simple check for gassy a.g.c. controlled grids is to place a voltmeter across the a.g.c. decoupling resistors. A voltage drop will indicate a gassy grid.

Another condition of overloading, only in milder proportions, is washout, as shown in Fig. 3. Washout is usually due to insufficient a.g.c. and, in some cases, gassy i.f. or r.f. tubes. Washout may also be caused by a strong signal overloading the r.f. stage. Most receivers vary the amount of a.g.c. voltage to the r.f. stage, therefore when overloading due to a strong signal occurs, either decreasing the signal strength or connecting full a.g.c. to the r.f. stage should be made to prevent this condition.

A defective a.g.c. system in some receivers may affect both the horizontal and vertical sync besides overloading the video amplifiers. When the a.g.c. is suspected to be defective, a fast check can be made by measuring both the

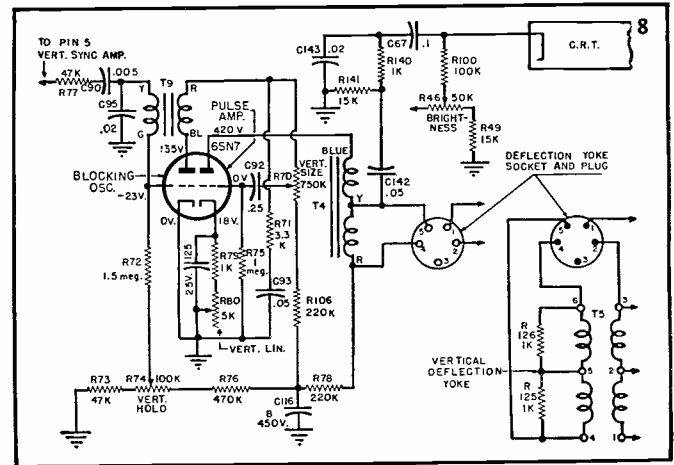
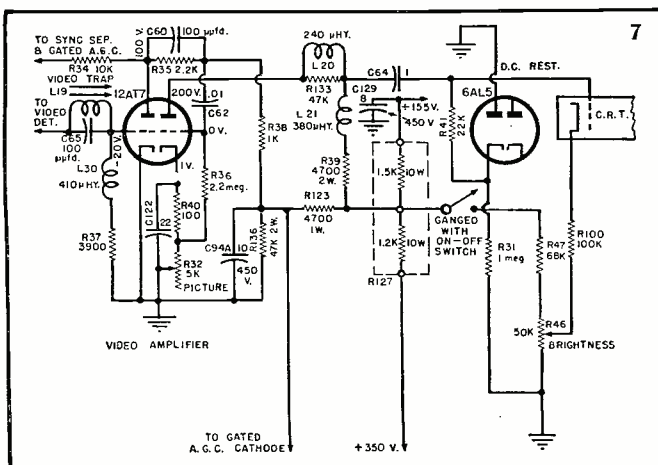

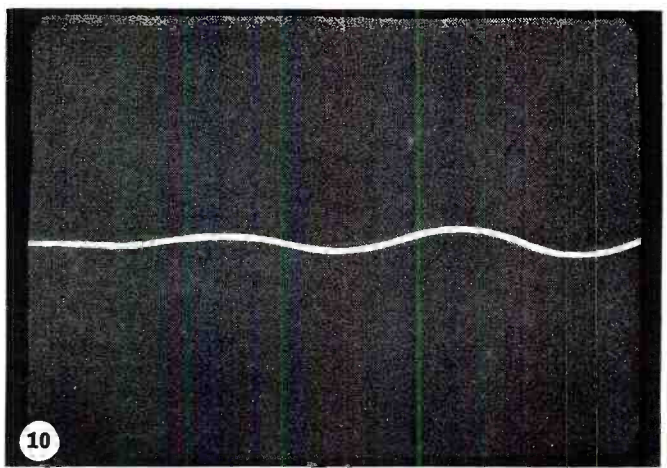
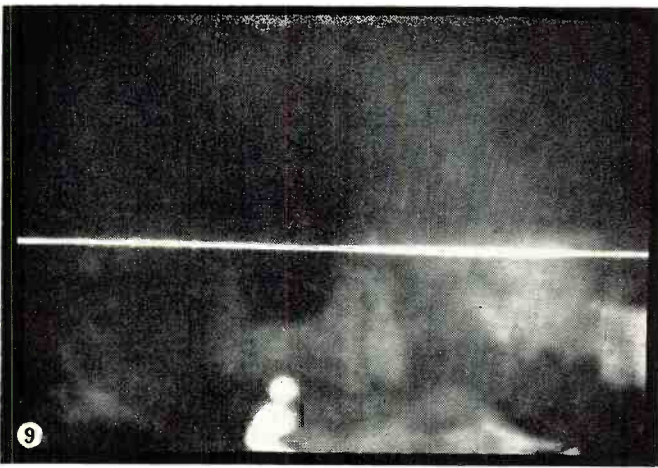

detector output and a.g.c. voltages. A defective or weak a.g.c. system will result in an increased detector output voltage and decreased a.g.c. voltage. Under normal operating conditions these two voltages should be approximately the same. Continuity checks should reveal any defective components.

Vertical retrace lines may, in some cases, appear as a result of washout due to overloading or sync washout in the video output. Other causes may be improper station programming, defective d.c. restorer, gassy video output tube or picture tube, defective retrace line elimination circuit, or, most commonly, misadjustment of the brightness control. Referring to Fig. 8, components  $R_{110}$ ,  $R_{111}$ ,  $C_{112}$ , and  $C_{113}$  comprise a network designed to eliminate retrace lines. The vertical flyback pulse is filtered and applied to the cathode of the picture tube. The pulse will bias the picture tube beyond illumination cut-off during the period of vertical retrace.

Conditions of improper vertical synchronization, such as rolling, flipping, or multiple frame troubles, can generally be traced to the sync separator, vertical sync amplifier, or the vertical integrating network. A picture that repeatedly rolls or flips indicates interruption of the sync by noise, misadjusted hold control, or improper sync separator operation. The proper procedure for setting the vertical hold control to reduce noise effects is to rotate the control until the picture is slowly moving upward and then just locks into place. A split or multiple frame picture indicates that the vertical oscillator is off frequency. A flickering background indicates the frequency is low. Check for improper values in the vertical time constant grid circuit and integrating network.

One fact to consider with regard to sync troubles is that the vertical sync signals are of low frequency and are part of the composite video signal amplified by the r.f., i.f., and video amplifiers. Poor low frequency response in the r.f., i.f., or video amplifiers may result in weak or poor synchronization. Therefore misalignment of the receiver may be one cause of sync troubles.

One convenient check point is to observe the vertical sync and blanking with brightness control turned up and the contrast or picture control operated at a low level. Rotate the vertical hold control to obtain a half-framed picture  
*(Continued on page 176)*

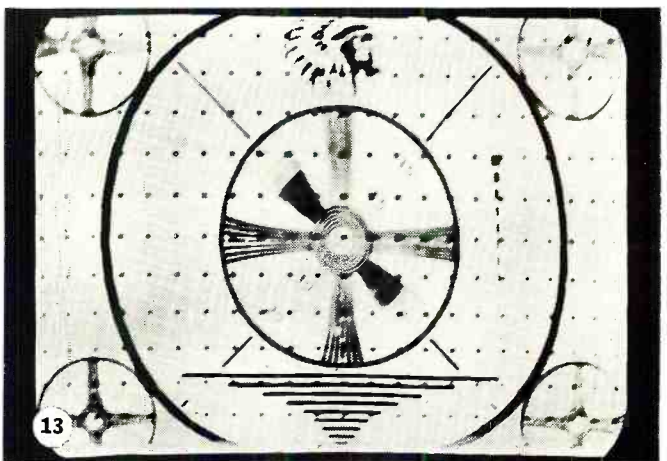
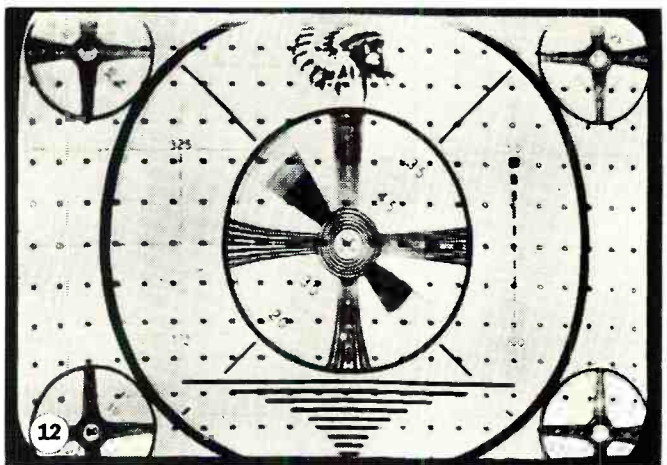
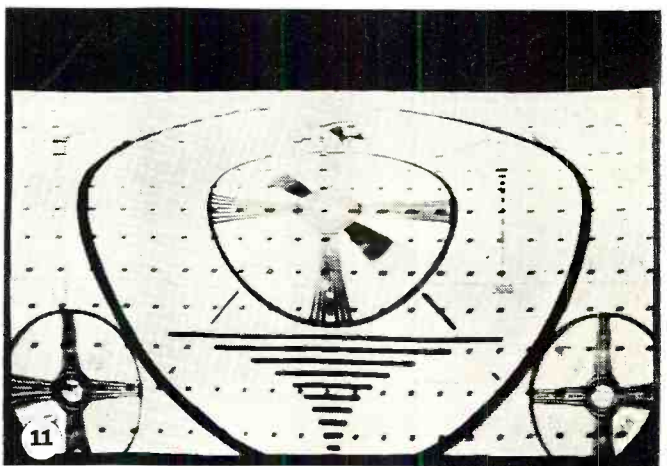

Fig. 9. Condition of no vertical sweep. A bright white horizontal line appears vertically in the center of the picture tube.

Fig. 10. Oscillatory "wobble." In this case a damped bright white horizontal line appears in center of the picture tube.

Fig. 11. Vertical misadjustment. Improper distribution or linearity in the vertical direction results in egg-shaped pattern.

Fig. 12. Top folding. A bright white horizontal line at the top of picture is accompanied by bunching of top scanning lines.

Fig. 13. Bottom folding. Bright white horizontal line at bottom of picture is accompanied by bunching of bottom scanning lines.

# TELEVISION

# TRANSMISSION LINES

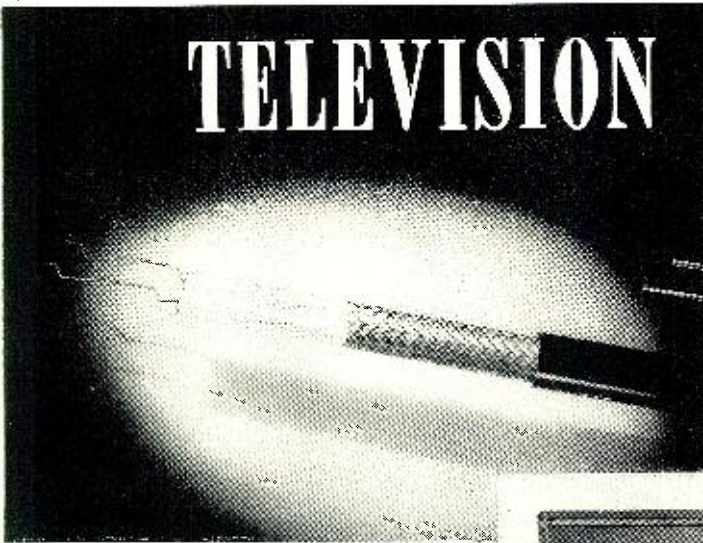

Fig. 1. Federal Telephone's recently developed 300-ohm shielded television cable.

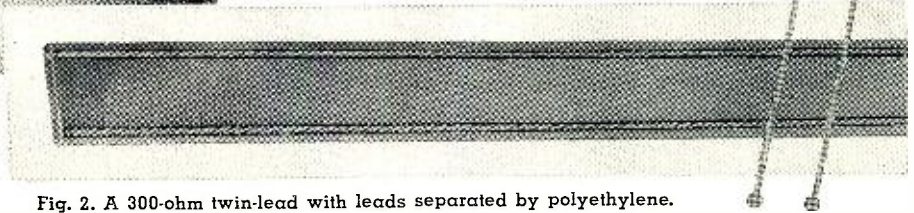

Fig. 2. A 300-ohm twin-lead with leads separated by polyethylene.

**B**ECAUSE of the complexity of the TV receiver itself and the variety of available antennas, these two items are usually the main considerations in installing a TV receiver. The proverb about the weakest link in the chain applies to television, especially in the case of the transmission line from the antenna to the receiver which is often the weakest link and therefore, a source of trouble. As the name indicates, the transmission line transmits the signal from the antenna to the receiver, but it is more than just a set of wires carrying electricity. It is our purpose to show the electrical characteristics, function, and requirements of television transmission lines together with their limitations and corrective measures.

Fig. 4 shows the electrical circuit of the antenna and the TV receiver input as well as the transmission line between the two. The antenna can be considered as an a.c. generator with an internal impedance  $R_A$  which works into a load  $R_L$ . The transmission line then has the function of delivering the output of the antenna to the load with a minimum of losses and distortion. To get maximum power transfer the internal impedance of the transmission line must equal that of the generator and, at the receiver end, that of the load. In other words, we must have correct impedance match both at the antenna and at the receiver to get maximum efficiency from this system. It is easy to see that in a weak signal area this efficiency can make the difference between a usable or unusable signal. Another effect of improper impedance match is reflections on the line which will be explained in detail later. These reflections appear as ghosts or multiple images on the screen and may be strong enough to completely ruin the picture as in Fig. 3. Excessive attenuation also results in weak pictures and must be avoided, especially in fringe areas.

The most frequently used type of television transmission line is the 300 ohm twin-lead shown in Fig. 2. It

By **WALTER BUCHSBAUM**  
Author, "Television Servicing"

## *A discussion of the principal considerations involved in selecting and installing TV lines.*

consists of two conductors of stranded copper wire set into a flat ribbon of polyethylene. Although polyethylene is a very good insulator some capacity exists between the two wires. When current flows through a wire a magnetic field is set up around it so even a perfectly straight wire must be considered as having some inductance. The complete transmission line then can be considered as having both inductance and capacity and its equivalent electrical circuit is therefore shown in Fig. 5. The first  $L$  and  $C$  at the left of the diagram represent the inductance and capacity per unit length; this could be per foot, yard, meter, or mile, and as long as we know the values and the unit we can calculate other useful characteristics. One of the most important is the characteristic impedance of the transmission line. This  $R_c$  is the impedance in which a particular transmission line must be terminated so as to deliver maximum

power and have no reflections. In the case of the twin-lead shown in Fig. 2, 300 ohms is the characteristic impedance and when this line is terminated by a 300 ohm resistor it will deliver maximum power and have no reflections and therefore no standing waves on the line. One formula for  $R_c$  is given in Fig. 5, another makes use of the physical dimensions of the line as shown in Fig. 6.

Where physical dimensions are concerned, a considerable difference exists between twin-lead and coaxial cable and a further variation depends on the type of insulating material used. Polyethylene, the material used for most TV lines, has a dielectric constant which is more than twice as high as air. Open wire lines must, therefore, have wider spacing between wires than those molded in polyethylene.

### **Standing Waves**

When a transmission line is terminated in anything but its characteristic impedance, some of the signal sent through it will be reflected back from the improperly terminated end. That this comes about can be proven mathematically and the truth of this statement verified experimentally. These reflected signals are usually out-of-phase with the original and therefore reduce the original signal strength at the receiving end. Another explanation for the loss in signal at the load is that when some of the transmitted energy is used up in reflections, less is available at the load. The reflected signal, together with the original signal, keeps up a constant

Fig. 3. Reflections appearing as ghosts or multiple images caused by line mismatch.

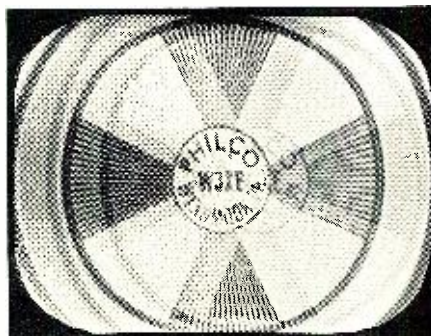

field around the transmission line, because each successive cycle produces the same reflection, and again the same instantaneous field. The total effect is that of a constant r.f. field of a pattern like that shown in Fig. 7. The distance between successive points of maximum or minimum is half the wavelength of the transmitted signal if the line is of the open-air type. If polyethylene is used, the distance between these peaks and valleys will be slightly less than half the wavelength. The Greek letter lambda ( $\lambda$ ) in Fig. 7 is the conventional symbol for wavelength. In laboratory procedure it is possible to get a better picture of this standing wave field by using a fairly strong r.f. signal and placing a small antenna probe and diode rectifier near the line. The rectified r.f. is then measured and by setting up a ratio between the voltage obtained at a maximum and at a minimum point, the standing wave ratio is obtained.

$\text{Standing-wave ratio} = E_{max}/E_{min}$   
 Thus if the s.w.r. is close to 1, this indicates that the line is terminated properly and no reflections take place. In television work it is desirable to get an s.w.r. as close to 1 as possible and practical values will range from about 1.05 to 1.2.

### Dissipation

Up to now we have assumed that the transmission line is composed entirely of inductive and capacitive elements and therefore would not have any dissipation. Although most types of TV lines have a fairly small d.c. resistance due to the copper conductors, some dissipation is encountered in every transmission line. By that we mean the loss in power due to heating up the copper conductors and the losses due to the dielectric between conductors. In the average TV installation these losses are negligible, but where lengths of  $\frac{1}{2}$  to 1 mile are concerned the dissipation losses present a serious problem. One way to overcome them is by means of open-wire lines. To reduce the d.c. copper loss the conductors are of larger size and to minimize dielectric losses the two wires are kept several inches apart by means of low-loss polystyrene spacers. Such a transmission line must be well removed from all grounded objects and suspended with suitable insulators.

The standing-wave pattern, shown in Fig. 7, holds true only for a line having no dissipation and such a line is not practically feasible. Therefore, the effects of dissipation on the standing-wave pattern must be considered, even though, just like the actual losses, this effect will be slight for TV transmission lines. Since the losses in the line reduce the signal strength as it travels down the length of the line, the reflected signal will also be reduced. For a line having considerable dissipation the standing-wave pattern will not be constant as shown in Fig. 7, but the height of each maximum point will be slightly less than the one before as the pattern progresses towards

the sending end. On very long lines this means that while the s.w.r. may be quite high at the improperly terminated receiving end, it may be negligible at the transmitting station. When specifying s.w.r. for longer lines the distance from either end of the line should be given.

### Tuned Line Effects

If a transmission line has exactly the same length as some multiple of the wavelength of the signal, we speak of a "tuned" line. The effects of such a tuned line length are quite similar to the effects of resonant or tuned circuits at the resonant frequency. The shortest multiples of the wavelengths which are practically usable are the quarter and half wavelength sections. A shorted half wavelength of transmission line or an open quarter wavelength act just like a series resonant circuit. Their input impedance is zero at the resonant frequency and they represent an effective short circuit to signals of that wavelength.

A shorted quarter wavelength or an open half wavelength, however, act just like a parallel resonant circuit. Their impedance at the resonant frequency is very high. These particular characteristics of transmission lines are quite useful in television work.

### Matching Stubs

One more aspect of transmission line theory merits discussion here because of its use in TV installations, that is, the impedance matching action of a quarter wavelength of line.

When it is desired to match different impedances, transformers are used in circuit work. In transmission line networks, a quarter-wave matching stub serves the same purpose. While in ordinary circuits the matching action of the transformer depends mainly on the turns ratio, the characteristic impedance of the matching stub is the critical factor here. As shown in Fig. 8, this characteristic impedance,  $R_{ST}$ , is the square root of the products of the two impedances to be matched. Assume that a 50-ohm antenna and a 300-ohm line are to be matched.  $R_{ST}$  equals the square root of 15,000 which turns out to be 122.5 ohms. Since the nearest commercially available value is 150 ohms for twin-lead, this can be used and a slight mismatch must be tolerated. The alternative would be to make up an open wire stub according to the formula in Fig. 6. By simple algebra we obtain the value of  $2D/d$ , then we need only select a convenient wire size for  $d$  and adjust the spacing  $D$  accordingly.

It should be noted that this impedance matching is not applicable to a broad band of frequencies, just as most high gain antennas are not equally effective on all TV channels. In most instances where separate high- and low-band antennas and lead-ins are used, the matching stub can be designed for the center frequency in each TV band. To use a single matching stub for both TV bands would hardly

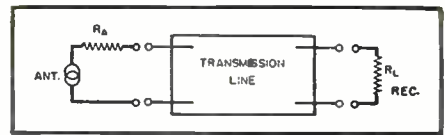

Fig. 4.

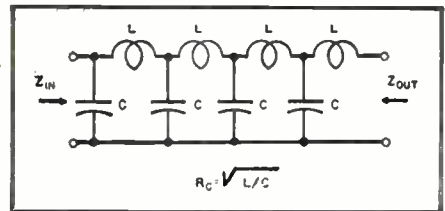

Fig. 5.

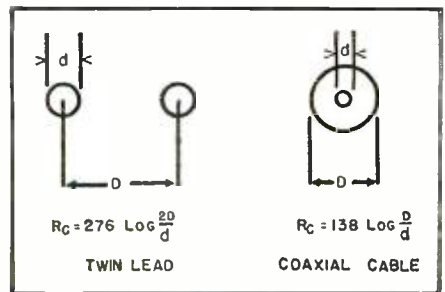

Fig. 6.

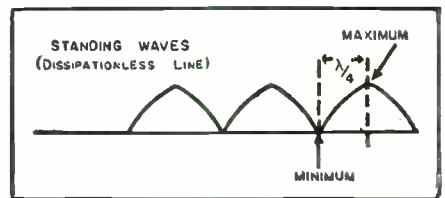

Fig. 7.

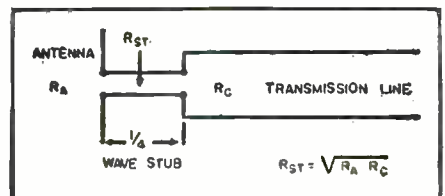

Fig. 8.

be useful since the mismatch at the off frequencies would be just as great as without the stub.

### Application of Theory in TV

Once we understand the fundamentals of transmission line theory, half of all problems connected with TV lines are solved automatically. Reviewing the major installation difficulties which can be overcome by proper manipulation of the transmission line, we find the following:

- Weak signal due to losses on the line
- Reflections or ghosts due to improper impedance match
- Over-all inefficiency of line
- Interference picked up by the antenna or line.

Foresight being better than hind-  
 (Continued on page 108)

# A Beat-Frequency AUDIO OSCILLATOR

By

JOHN POTTER SHIELDS

Over-all view of the home-built audio oscillator covering from 10 to 20,000 cps.

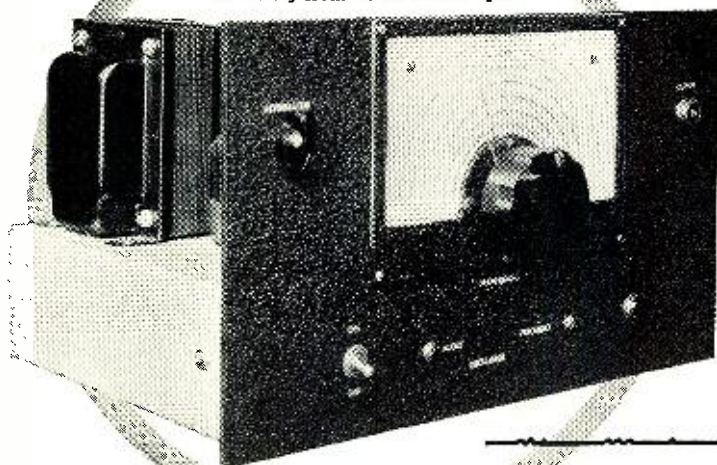

## Construction details on a continuous-tuning and stable generator which covers 10 to 20,000 cps.

**W**HEN the audio enthusiast begins designing and building various types of amplifiers and speaker systems, he soon finds that an audio generator is almost a necessity in his test equipment line-up. The audio generator to be described is believed to fulfill this need. It has the advantages of continuous tuning, good stability, with no critical parts such as precision resistors required in its construction, a frequency range of from 10 cps to over 20,000 cps, and last but not least, it is both easy and inexpensive to build.

The writer has constructed several resistance-capacitance tuned audio generators; however, it was decided that a beat frequency audio generator would be superior as continuous tun-

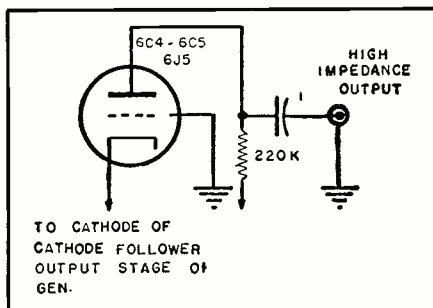
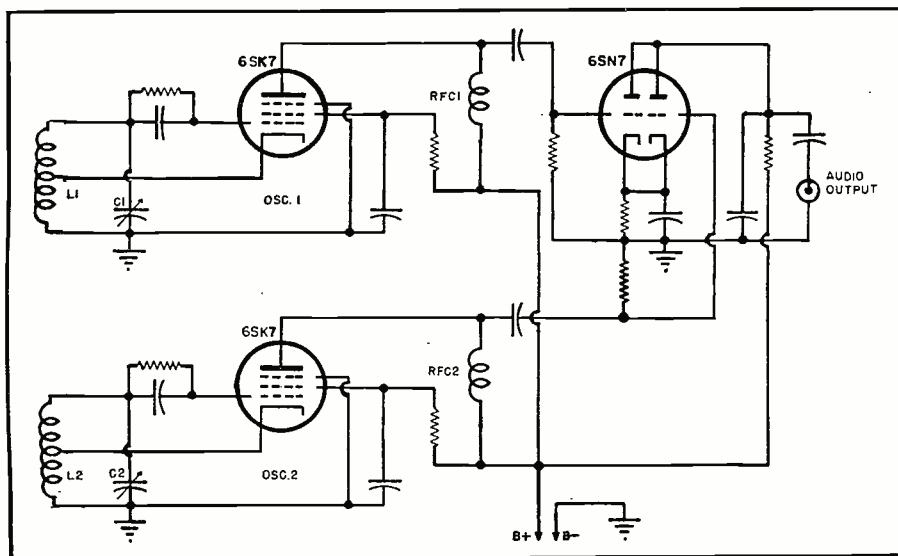

Fig. 1. A grounded-grid amplifier circuit.

ing could be easily achieved and no critical parts would be required. The schematic diagram of the breadboard setup appears in Fig. 2. The two oscillator coils,  $L_1$  and  $L_2$ , are identical

Fig. 2. Schematic diagram of the author's "breadboard" version of oscillator unit.



and consist of 80 turns of #30 enamel wire on a one inch form, tapped 20 turns from the bottom. The tuning condensers,  $C_1$  and  $C_2$ , are 365  $\mu\text{fd}$ . each. Electron-coupled oscillators are used as they are quite stable. The outputs from the two oscillators are fed into a duo-triode mixer where they beat together to form the audio signal. In operation, oscillator #1 is set at a fixed frequency and oscillator #2 is tuned. When both oscillators are operating at exactly the same frequency (zero beat) there will be no output from the mixer. However, when oscillator #2 is tuned either above or below the frequency of oscillator #1, an audio frequency output will be obtained from the mixer which will be the difference in frequency between the two oscillators. For example, if oscillator #1 is operating at 100 kc. and oscillator #2 is tuned to 99 kc. the resulting frequency obtained from the mixer will be 1 kc. Although the oscillators in this circuit drifted annoyingly and there was a tendency for the two oscillators to lock together, thus distorting the waveform at low frequencies, it showed that this type of oscillator had numerous advantages over the resistance-capacitance tuned type, and it was felt that the problems of oscillator drifting and locking could be solved.

Fig. 3 is a schematic diagram of the audio generator as it was finally constructed. The fixed frequency oscillator operates at 100 kc. and is crystal controlled to obtain a high degree of stability. The circuit shown effectively isolates the oscillatory circuit from the mixer. The 50  $\mu\text{fd}$ . trimmer condenser connected between grid and ground of this stage is used to tune the oscillator to exactly 100 kc. Both this oscillator and the variable frequency oscillator are operated at a relatively low plate voltage to minimize frequency drift. The output from the fixed frequency oscillator is taken from the plate and after passing



through the 500  $\mu\text{fd.}$  coupling condenser and 1 megohm isolating resistor, is applied to grid #1 of the 6SA7 mixer tube.

The variable frequency oscillator employs the Clapp circuit which is extremely stable and does not require a tapped coil. The trimmer condenser which is in parallel with the tuning condenser is used as the reset control. Its operation will be explained later. The output from this oscillator is fed through the 500  $\mu\text{fd.}$  coupling condenser and 1 megohm isolating resistor to grid #3 of the 6SA7 mixer tube.

The 6SA7 mixer tube was chosen for this circuit rather than a duotriode as its operation is more satisfactory. The output from the mixer is fed through the .1  $\mu\text{fd.}$  coupling condenser,  $C_{11}$ , and 1 megohm pot.  $R_{15}$ , to the grid of the 6C4 cathode-follower output stage. When a high impedance signal is fed through shielded cable, attenuation of the higher frequencies results due to the shunt capacity between the inner conductor and its shielding. With a low impedance output, this trouble is greatly minimized. The output voltage of this audio generator, with the attenuator set for maximum output, is 6 volts across 4000 ohms. If a high impedance output is desired, the grounded grid amplifier circuit shown in Fig. 1 may be incorporated.

An acceptance-type filter,  $L_2$ ,  $C_{12}$ , and condenser,  $C_{13}$ , are connected between the plate of the mixer and ground to remove any oscillator frequencies other than the desired audio signal which would otherwise appear in the output.

The power supply is conventional, using a single pi-section LC filter. The plate voltage for the two oscillators is regulated by two VR-75's (a single VR-150 may be used instead).

When constructing an oscillator of this type, great care must be taken with the mechanical details. The entire unit must be rigidly constructed as even a slight flexing of the chassis will cause the oscillators to change frequency. The tuning condenser should be shock mounted on rubber grommets and shock mounted tube sockets should be used for the oscillator tubes. All heat-producing components such as the bleeder resistor and dropping resistor for the voltage regulator tubes should be mounted on the outside of the chassis where their heat will not affect the stability of the oscillators. The power transformer and rectifier tube should likewise be mounted well away from the oscillator tubes and components. If these precautions are taken, this audio generator will produce a good, clean sine wave with practically no frequency drift.

When the audio generator is first completed, allow it to warm up for at least 15 minutes. Set the tuning condenser so that the plates are fully meshed (maximum capacity). Adjust the reset trimmer so that the two os-

(Continued on page 127)

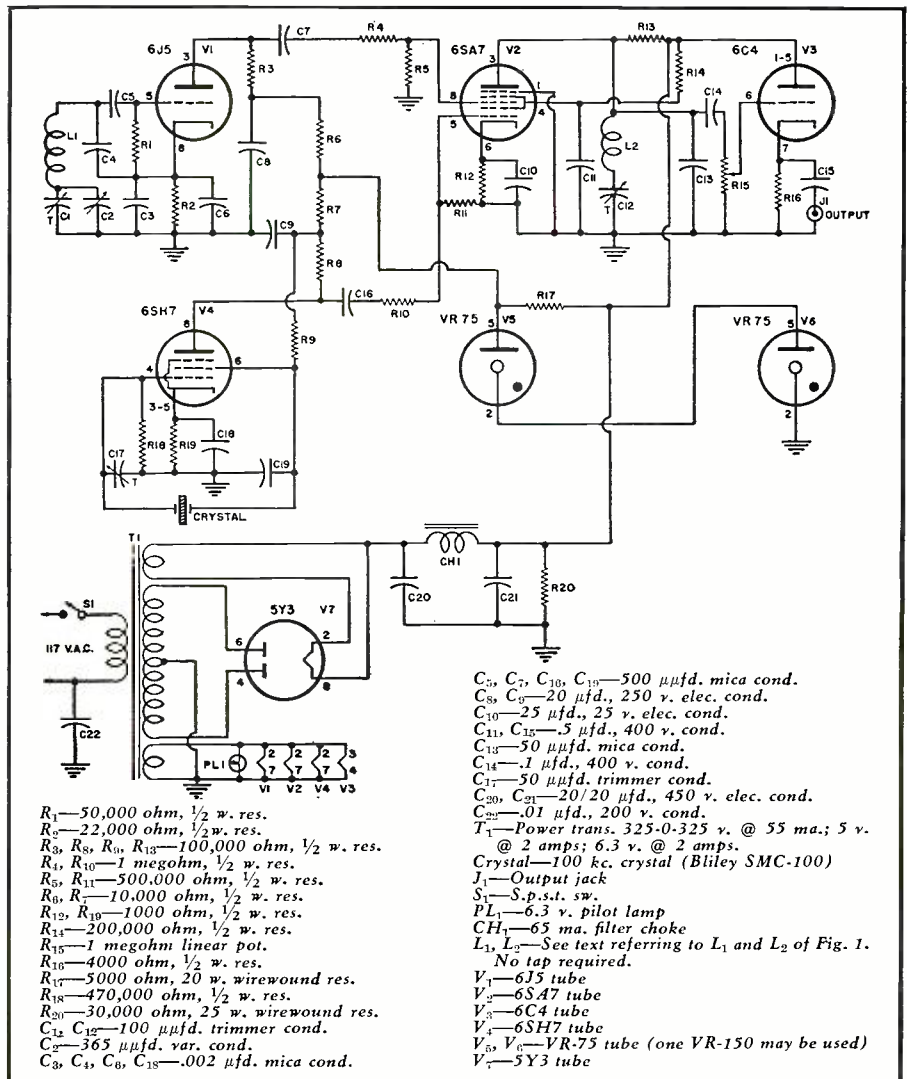
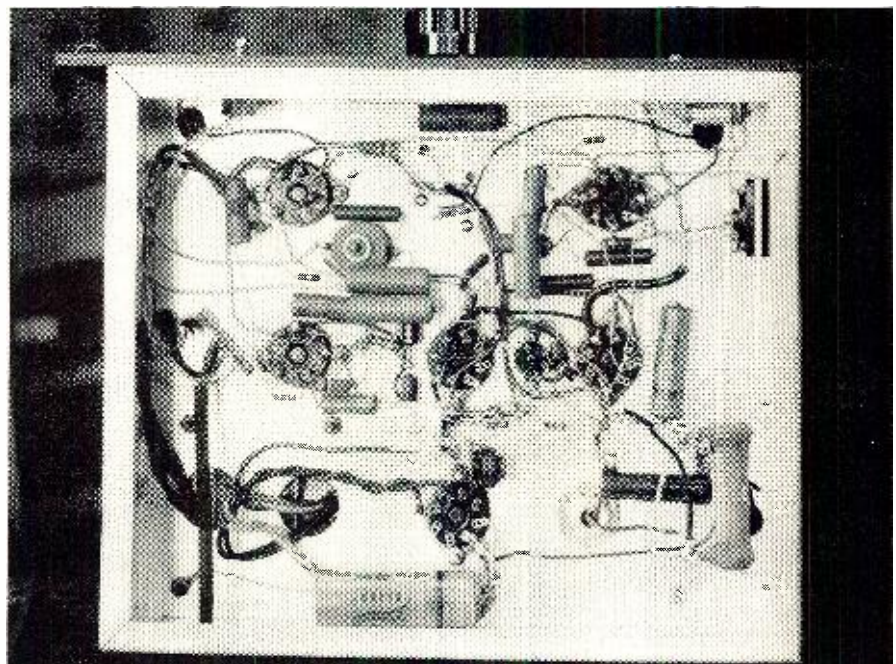

Fig. 3. Schematic diagram and parts list for the audio oscillator in its final form.

Under chassis view of unit showing correct parts layout and wiring technique.



# THE NEW PHILCO 40 MC. I.F. TUNER

By **DAN LERNER**  
Supervisor, Television Service, Philco Corporation

**Details on a new unit which has been designed to eliminate the effects of TV oscillator radiation.**

THE shift in i.f. design is definitely towards a relatively high (40 mc.) i.f. system. There are several advantages in this type of system, but perhaps the paramount reason is the reduction of the effects of local oscillator radiation. To illustrate this point let us examine the mathematical possibilities of interference on the TV channels when a local oscillator is operating 40 mc. above the incoming carrier. Channel 2 extends from 54 to 60 megacycles. The video carrier is thus at 55.25 mc. In the new 40 mc. system the local oscillator operates 45.75 mc. above the incoming video carrier or at 101 mc. This frequency falls on no existing TV channel. With a low frequency i.f. system, the local oscillator on Channel 2 will operate at 26.6 mc. above the incoming carrier or at 81.85 mc. This frequency falls in Channel 5 and in some cases can cause an interference pattern.

The same mathematics for other channels will show that there is no possibility of the local oscillator frequency falling in any TV channel.

The 40 mc. i.f. tuner used in some of the new Philco models contains some interesting features. To begin with, the tapered line section is somewhat different than that used in previous models. The incoming signal is not applied directly to the r.f. amplifier grid circuit but, instead, is coupled through inductively. See Fig. 1. There is no provision for switching to 72-ohm

Fig. 1. Inductive coupling in Philco tuner.

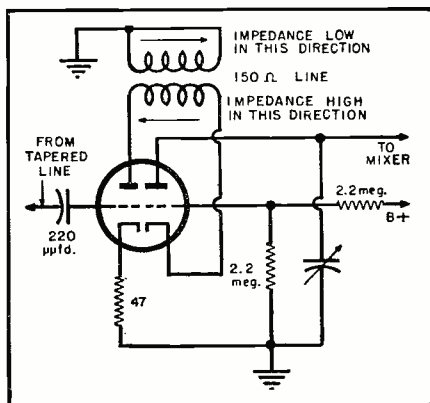
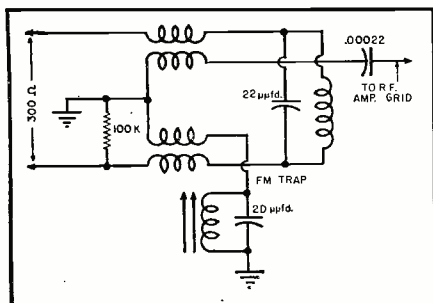

Fig. 2. Specialized circuits used to effect a constant neutralization over TV spectrum.

input in this section since the tuner is used exclusively with the line-connected type of receiver chassis. This means the danger of putting the antenna mast and folded dipole, if used, at above a.c. line ground potential must be considered.

One of the most interesting features in the new tuner is the use of unique neutralizing circuits. A special transformer, made up of a section of 150-ohm, open-wire transmission line wound on a coil form, is connected between the plate of the first triode and the cathode of the second triode. See Fig. 2. The neutralization effected by this transformer connection is constant over the TV spectrum. Its effect is to improve the over-all signal-to-noise ratio of the r.f. amplifier. It actually lowers the tuner noise figure by about 2 or 3 db. The section is not needed to prevent instability or regeneration. Neutralization is obtained in the circuit because attenuation through the line in a forward direction, that is, from first to second triode, is low. This is due to the low impedance termination afforded by the second triode cathode impedance. See Fig. 2. However, attenuation in the reverse direction, that is from second triode to first triode, is high. This is

due to the great mismatch afforded by the relatively high plate impedance looking from the cathode of the second triode to the plate of the first triode.

The mixer is one half of a 6J6. An interesting feature in this stage is the neutralizing circuit consisting of a coil and condenser connected from grid to plate. This resonant circuit serves to reduce the effect of the grid-to-plate capacity. It is needed in this stage because the 6J6 input impedance would cause the tube to regenerate for frequencies around 40 mc. Thus the circuit is required for television Channels 2 and 3. The r.f. output from the mixer is coupled to the 1st i.f. stage by means of a twisted pair in a link-coupling arrangement. See Fig. 3.

This type of coupling affords a low impedance and thus a low-noise feed system. Due to this system the tuner can be placed further from the i.f. strip than is normally possible with single wire type of feed-in.

### Aligning the New Tuner

Aligning the new tuner poses some seemingly formidable problems. In all of Philco's previous tuners, during alignment, the detected output was viewed with a scope by breaking the mixer "B plus" supply lead and inserting a load resistor in series with the lead to act as the detector load. In this application the mixer was made to function as a plate current detector.

In this particular tuner this type of detector load insertion is not possible because the mixer "B plus" supply lead does not come out of the tuner separately. Instead the "B plus" lead to the tuner supplies the r.f. amplifier and oscillator besides the mixer. A

(Continued on page 110)

Fig. 3. How mixer output couples to 1st i.f.

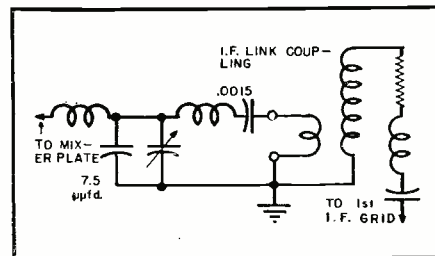

# A Look at the PARTS DISTRIBUTOR

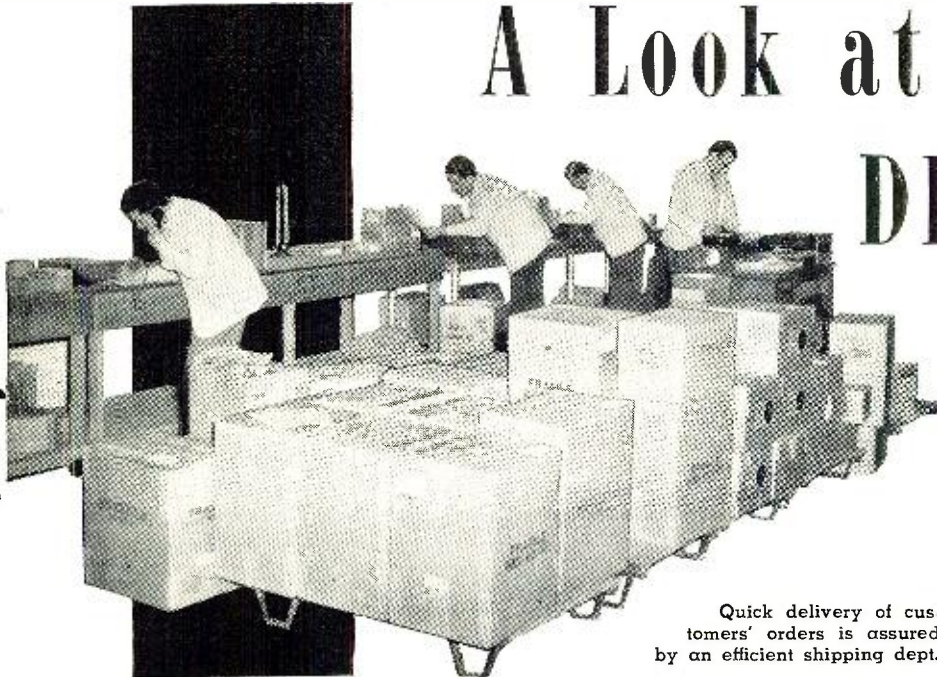

Quick delivery of customers' orders is assured by an efficient shipping dept.

***This unsung link in the distribution chain makes possible the fast and efficient handling of parts.***

THE month of May brings with it the annual Radio Parts Show - where the major emphasis of this Chicago conclave will be on distribution. An appraisal of the role of the parts distributor and his function in the service industry is, therefore, in order.

Today in the United States there are approximately 1500 parts distributors serving a variety of customers in service, communications, government, industry, and education. They serve as a source of supply for the products of more than five hundred manufacturers of electronic items. The requirements of the growing radio, television, and electronic industry have been such that parts distribution today is big business.

Typical of this growth is *Almo Radio Company* of Philadelphia, Pennsylvania. Within the last six years this organization, headed by Morris Green and Al Margolis, has mushroomed from a single outlet operation to a chain of six individually-operated outlets. This expansion was necessary to properly service their customers in an expanding market area.

The expansion of television and electronics in general has necessitated an increase in capital investment on the part of the present-day parts distributor. He must constantly be in a good inventory position in order to handle his growing volume of customers. Just consider television servicing alone, which today constitutes the major portion of the parts distributor's business. To handle this volume, the distributor must have on his shelf or in his warehouse a wide variety of parts.

In the *Almo* operation, each branch store carries a \$75,000 inventory at all times—backed up by a warehouse stock, valued at \$600,000, which feeds the various branches.

It is easy to see that without the parts jobber the individual service operator would be unable to offer his customer the service he does today. Imagine the chaos which would result if it were necessary to order every replacement resistor, condenser, or tube direct from the manufacturer! Time has proven that in the television service business of today the parts distributor performs an essential service both to the manufacturer and the service businessman, as well as to the customer indirectly. The parts distributor has, in reality, become the manufacturer's local outpost.

However, were it not for the manufacturer's representative, there would be little knowledge of the manufacturer's product story at the distributor level. His awareness of the problems inherent in the industry has made him doubly important to the parts distributor.

According to the *Almo* executives, many representatives actually make service calls with the distributor's salesmen to help introduce a new product or explain a sales campaign. Both Green and Margolis are unequivocal in their praise of the Mid-Atlantic Chapter of "The Representatives" whose members are providing so many "plus services" for their customers.

To further advance the manufacturer's product story, most distributors extend their liaison position by employing a number of outside salesmen. *Almo Radio* has twelve salesmen for its six stores, with the average salesman covering 200 accounts. Their function relative to the service customer includes the selling of merchandise, keeping the customer informed, helping to maintain good-will, assisting with the customer's credit problems, helping the customer promote his business, and providing the information required to make the customer a better over-all businessman.

*(Continued on page 168)*

The warehouse keeps branch stores supplied with fresh and up-to-the-minute stock.



# A TUBELESS SAW-TOOTH OSCILLATOR

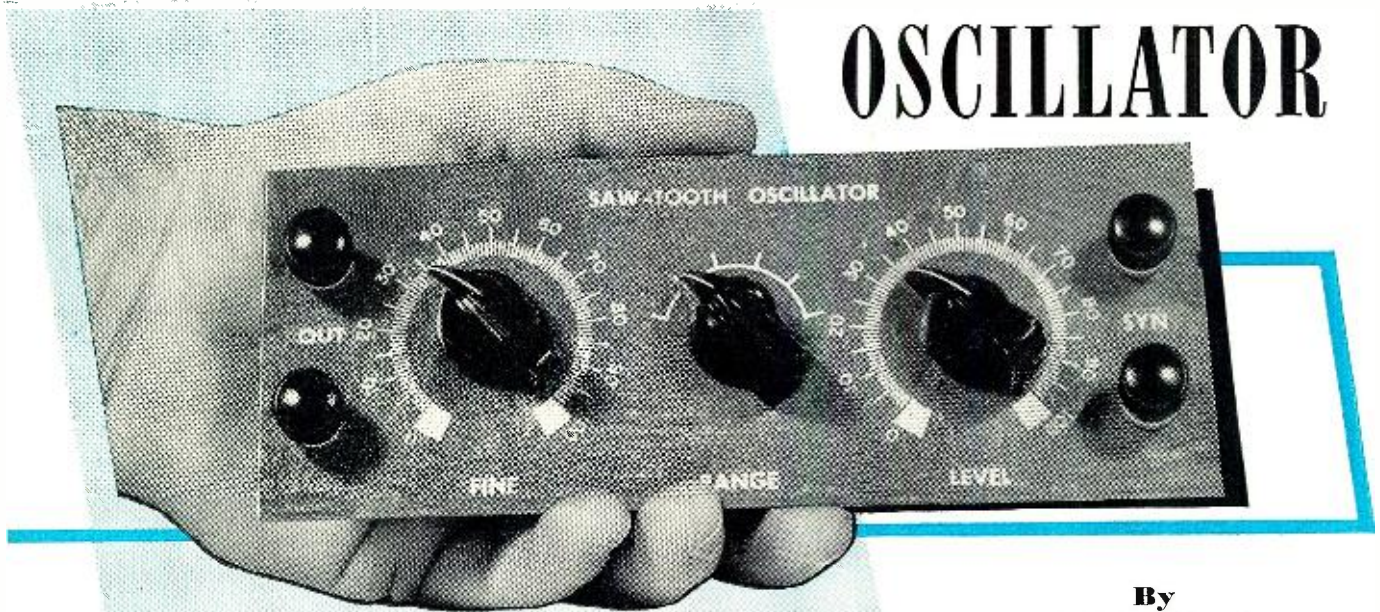

Fig. 1. Front view of the saw-tooth oscillator. The unit may be built into a standard metal utility box measuring 3" x 4" x 5" or 4" x 4" x 2".

By  
**E. G. LOUIS**

**An easily-built unit capable of supplying linear saw-tooth signals over the range 10 to 1500 cps.**

**I**F TEN the experimenter or technician will need a saw-tooth signal source, either for use as a linear sweep signal, to form an experimental raster, or as a substitute sweep source in a TV receiver. The need for such a signal source is generally not a continuing one, nor is the need usually urgent enough to warrant the purchase or construction of a special instrument for this purpose. Even though a particular experiment or piece of work may be simplified by having such a signal available, the technician will generally not want to spend the time punching a special chassis, mounting tube sockets, transformers, and other parts to build even a temporary signal source.

However, it is possible to build a very inexpensive saw-tooth oscillator which will supply a signal having sufficient amplitude and a satisfactory waveform for most experimental work—without using a special chassis, without using tubes (in the conventional sense), and requiring little more than an hour's work. Such an oscillator is shown in Fig. 1, while the schematic diagram is given in Fig. 2.

## Circuit Description

Referring to Fig. 2, the circuit is basically that of a conventional neon-bulb relaxation oscillator, but with a few important modifications. These modifications permit the frequency of operation to be easily changed, permit the oscillator to be "synced" with an external signal source (this is impor-

tant if the saw-tooth signal is to be used for sweep purposes), and permit the formation of a saw-tooth signal having reasonably good linearity.

Let us first consider the operation of the circuit with  $S_1$  ("Coarse Frequency Control") in the position shown in the schematic diagram, and with  $R_4$  ("Sync Level Control") turned so that the center arm is at ground potential.

Capacitor  $C_1$  is slowly charged through  $R_2$  and  $R_3$ . As soon as the voltage across  $C_1$  reaches the firing potential of the neon bulb, this tube conducts, discharging the capacitor quickly. The capacitor discharge drops the voltage applied to the neon bulb until it is no longer sufficient to maintain current flow and the tube is extinguished, permitting  $C_1$  to start charging again. The entire action is then repeated.

Since the time required for the voltage across  $C_1$  to reach the firing potential of the neon bulb determines the frequency of operation, and since this time period, in turn, depends on the time constant of the  $R_2$ ,  $R_3$ , and  $C_1$  combination, frequency can be easily changed by varying the electrical sizes of any of these three components.

In practice, changing the discharge capacitor serves as a coarse control on frequency, while adjusting the size of the series resistor permits a fine control. Thus,  $R_2$  becomes the "Fine Frequency Control," while any capacitor in a group of six ( $C_1$  to  $C_6$ ) may be chosen by  $S_1$ , the "Coarse Frequency Control."  $R_3$  is kept fixed so that the

amount of series resistance cannot be reduced to zero. If the series resistance is too low, or not present, the neon bulb glows continuously, and no signal is obtained.

By adding another resistor ( $R_4$ ) in series with the neon bulb, it is possible to supply an initiating signal pulse from an external source to "speed up" the operation of the oscillator slightly and thus to "lock-in" or "sync" the relaxation oscillator with the external signal.  $R_4$  is made variable and serves as a "Sync Level Control." A blocking capacitor,  $C_7$ , is connected in series with  $R_4$  to prevent the application of d.c. to the circuit.

When  $R_4$  is adjusted so that resistance is introduced between the lower electrode of the neon bulb and ground, the discharge time of the capacitor is increased, changing the waveform from a saw-tooth into a triangularly shaped wave which approaches an equilateral triangular waveform as the resistance is increased. This effect is not noticeable when an external signal is applied across  $R_4$  for sync purposes, but may cause trouble if  $R_4$  is turned up without a signal applied for sync.

Resistor  $R_1$  serves as an isolating resistor to minimize any loading of the saw-tooth oscillator by the external circuit. Although this reduces the available signal amplitude somewhat, sufficient signal is still obtained for most practical work.

## Construction Hints

The entire oscillator, together with all controls, may be assembled in one of the standard metal utility boxes (3" x 4" x 5" or 4" x 4" x 2"), on a small chassis, or on a flat piece of scrap metal. Only four holes are necessary

for the binding posts, and only three holes for the controls—all of these may be drilled, and no punched holes are required.

Parts are mounted directly on the controls, or to a common ground bus (see Fig. 4).

In the unit built by the author, a strip of scrap sheet metal approximately 2½" by 7" was used. After drilling, the front was finished with gray wrinkle enamel, and controls identified with decals. The final appearance is quite professional (Fig. 1) even though the total construction time, including the time taken for wiring and testing, was only an hour and a half. (Note that the "Coarse Frequency Control" is identified as "Range".)

Since the parts, including the neon bulb, may be laid flat against the front panel, the over-all depth can be kept quite small. In the model shown in the photos, the over-all depth (including knobs) is less than two inches.

### Substitutions and Modifications

With the components given in the parts list, frequency coverage is from less than 10 cps to about 1500 cps, in six ranges. The number of ranges necessary to cover these frequencies may be reduced by using a 10 megohm pot for  $R_2$  in place of the 3 megohm pot used by the author.

With a small neon bulb it is difficult to obtain a good saw-tooth waveform at frequencies appreciably higher than 1500 cps. This is sufficient for many types of experimental work, however.

Either a type NE-2 or NE-51 neon bulb may be used without modification of the circuit. The type NE-2 is preferred and was used by the author because it may be wired directly into the circuit. If the type NE-51 is used, a bayonet socket is required. For an interesting effect, a pilot light jewel (clear) type socket may be used so that the flashing neon bulb will serve as a pilot light. For frequencies below the "flicker rate" (a little over 20 cps), the individual flashes of the neon bulb may be followed as the bulb discharges the condenser. Above the flicker rate, the bulb appears to glow continuously.

The size of the "Sync Level Control" is not critical, and any value from 25,000 ohms to 100,000 ohms may be used. A linear taper is preferred, but not necessary. However, as pointed out before, it should be possible to adjust this control ( $R_4$ ) for zero resistance when the oscillator is used "free running" (without sync). If not, instead of a good saw-tooth signal (Fig. 3A), a triangular shaped wave with excessive flyback time will be obtained. See Fig. 3B.

Good quality condensers should be used in the discharge circuit. If any leakage is present, not only will the frequency of operation be affected, but a non-linear saw-tooth will be obtained. For the smaller condensers ( $C_3$ ,  $C_1$ ,  $C_5$ , and  $C_6$ ) use either ceramics or micas. Good quality paper condensers (or oil-

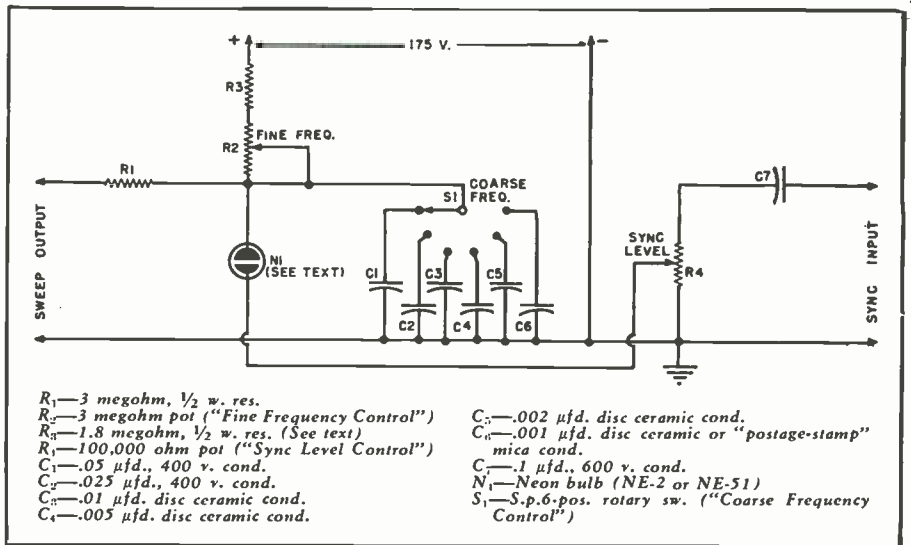

Fig. 2. Complete circuit diagram of the tubeless saw-tooth oscillator.

filled papers) may be used for  $C_1$  and  $C_2$ .

The "B" supply voltage is not critical and any value between 100 and 200 volts will give good results provided  $R_2$  is properly adjusted. The higher the d.c. supply voltage, the larger  $R_2$  should be. It is best to determine the size experimentally, as this will vary somewhat with the exact characteristics of the neon bulb used. If too high a "B" voltage is used, for the size of  $R_2$ , the neon bulb will glow continuously when  $R_2$  is adjusted for minimum resistance. The output signal will disappear under these conditions.

"B" power requirements are small (on the order of a milliamper or so) so that this voltage may be obtained in any manner desired, i.e., from series "B" batteries, from an experimental power supply, from an oscilloscope or other piece of test equipment, or, if desired, from a built-in power supply. Use a conventional selenium rectifier half-wave a.c.-d.c. circuit, taking care to use a polarized power line plug. Otherwise, the same type of circuit may be employed, using a 1:1 isolation transformer.

### Applications

It would be difficult to list, even briefly, all the possible uses to which an easily-built and inexpensive saw-

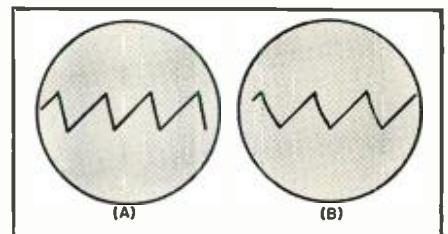

Fig. 3. (A) Saw-tooth wavelshape. (B) Triangular wavelshape indicating excessive flyback time in circuit. See text for details.

tooth oscillator may be put. These are best left to the individual experimenter. However, two interesting applications may be mentioned.

For educational purposes, this circuit may be used to demonstrate not only the basic operation of a relaxation circuit, but may also be used, in TV training, to demonstrate the formation of a raster, using an ordinary test oscilloscope. The built-in horizontal sweep of the scope is used for a line sweep, while this oscillator may be connected to the "Vertical Input" terminals to serve as a field sweep. It may be easily adjusted and synced to supply a 60 cps sweep.

In the ham shack, this circuit may be used, in conjunction with a single-

(Continued on page 173)

Fig. 4. Rear view of unit. Pencil points to the neon bulb indicator.



# A Low-Cost 152-162 mc. Converter

By  
**HARTLAND B. SMITH**  
WBVVD

**Designed for use with standard FM receiver, this unit is ideal for civil defense work and will cover police, taxi, etc. bands.**

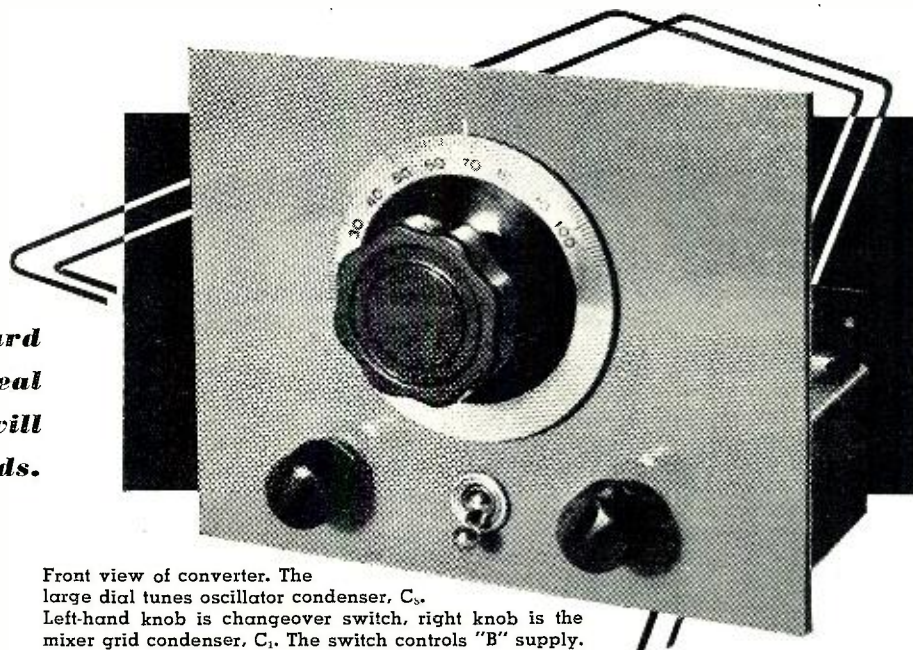

Front view of converter. The large dial tunes oscillator condenser,  $C_3$ . Left-hand knob is changeover switch, right knob is the mixer grid condenser,  $C_1$ . The switch controls "B" supply.

ACK in the middle '30's almost every family boasted at least one radio capable of receiving police calls. However, as the police frequency assignments climbed higher and higher in the spectrum, fewer and fewer people, even radiomen, possessed equipment that could be used to tune in on the local gendarmes. For several years, I was no exception to this rule. Finally, though, curiosity got the better of me. I just had to know where the fire trucks were headed, why an ambulance had been called, and whose dog was annoying the neighbors. Besides, I was interested in building a police receiver to round out the equipment roster of the local civil defense communications center.

I decided that the least expensive way to achieve my purpose was to build a converter for use ahead of an FM broadcast receiver. After carefully sorting through my junk box, and after an inexpensive visit to the nearest parts jobber, I was able to begin construction of a simple unit capable of tuning the 152-162 mc. band used by many police, taxi, and mobile telephone systems.

Several choices of intermediate and local oscillator frequencies presented themselves. For the sake of stability and freedom from drift, I chose to run the oscillator on the low side of the incoming signal. Working on the high side would have necessitated the design of a low drift oscillator operating in the 250 mc. region, and that was a job I definitely didn't wish to tackle.

Either 88 mc., the low frequency end of the FM broadcast band, or 108 mc., the high end, could have been used for the intermediate frequency. However, an 88 mc. i.f. requires an oscillator range of from 64 to 74 mc. Television Channels 3 and 4 occupy these frequencies and it seemed advisable to stay away from the 88 mc. intermediate frequency because of the possibility of TVI in neighboring receivers.

Therefore, I settled on a 108 mc. i.f. so that the oscillator would tune between 44 and 54 mc. With this arrangement, there is absolutely no interference to any TV channel.

Several of the converter's parts were found in the junk box. The aluminum chassis was originally from a surplus APN-1. The tuning condensers are inexpensive air padding condensers with  $\frac{1}{4}$  inch shaft extensions soldered on. The fancy planetary dial was picked up at a bargain sale and is not an absolute necessity. The converter's tuning range is so spread out that a knob, directly connected to the oscillator condenser, can be used if you want to hold cost to a minimum. The front panel is Masonite with a telephone gray lacquer finish applied by means of a fly sprayer.

Due not only to the nearness of the intermediate frequency to the signal frequency, but also to the high gain of the 12AT7 tube and the lack of shielding between input and output

circuits of the mixer stage, the mixer has a tendency to oscillate. In order to calm the unit, it proved necessary to use a fairly high value of cathode bias resistor for the mixer section of the 12AT7. The optimum value of this resistor will depend on the parts layout. Use the lowest resistance (250 ohms minimum) that will permit stable operation.

The antenna switching circuit is somewhat unconventional because the only switch I had on hand that would fit into the chassis lacked sufficient contacts. As a result, the converter's output coupling coil is across the FM receiver's input, even when the converter is switched for FM broadcast reception. The coil's reactance is high enough so that there is little shunting effect, however, and there seems to be no appreciable reduction in the strength of FM broadcast signals which might be blamed on the coil's presence.

Condenser  $C_2$  couples energy from the oscillator to the mixer grid and is made from a  $\frac{1}{4}$  inch piece of 75-ohm twin-lead. One wire of the twin-lead is connected to the grid end of oscillator coil  $L_6$  and the other wire is soldered to the grid end of mixer coil  $L_2$ . The capacity between the two wires provides sufficient oscillator injection. If 75-ohm lead is unavailable, two lengths of insulated hookup wire twisted together for an inch or two can be used instead.

As with any piece of equipment designed for use in the v.h.f. region, the converter must be wired with the shortest possible leads. All bypass condensers should be grounded at the center lug on the 12AT7 socket, after the lug has been well grounded to the chassis.

The amount of power required to  
**RADIO & TELEVISION NEWS**

Fig. 1. Antenna for use with converter.

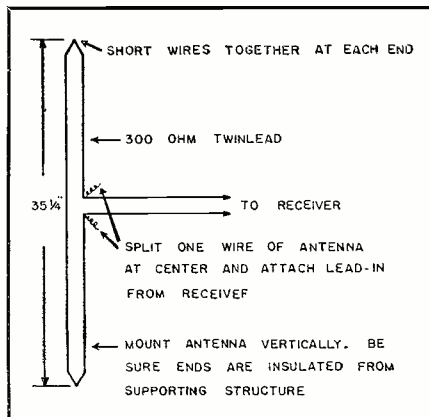

operate the converter is so small that it can probably be robbed from the power supply of the receiver with which the converter is being used. "B" voltage should be held fairly close to 200 volts in order to maintain the proper balance between sensitivity and tube heating.

To test the finished unit attach a suitable antenna and connect the output of the converter to an FM receiver by means of a short length of 300-ohm twin-lead. With power applied to the converter, and the oscillator tuning condenser at minimum capacity, the oscillator trimmer  $C_7$  should be adjusted until the second harmonic of the local oscillator is heard at 108 mc. on the FM set. The receiver should then be turned to 88 mc. and the oscillator tuning condenser  $C_6$  rotated until the oscillator can again be heard.  $C_6$  will probably not be at full capacity. Pull out a rotor plate and retune  $C_6$  to minimum capacity. Tune the FM receiver to 108 mc. and readjust trimmer  $C_7$  until the oscillator can once more be heard in the receiver. Keep removing rotor plates and readjusting  $C_7$  until the oscillator condenser's capacity range is just a little greater than required to tune the second harmonic of the oscillator from 88 to 108 mc. If this is done, the fundamental will then cover 44 to 54 mc.

When the oscillator range has been correctly adjusted, tune the FM receiver to 108 mc. Couple output coil  $L_1$  tightly to  $L_3$ . Tune  $C_4$  for maximum background noise in the FM receiver. Move  $L_4$  away from  $L_3$  until the mixer stage begins to oscillate as denoted by a loud thump in the speaker of the FM receiver. Then move  $L_4$  back toward  $L_3$  only far enough to kill the oscillation. Retune  $C_4$  for maximum noise. The converter will be most sensitive when the mixer is operating just below the point of oscillation. Oscillation can be controlled by changing the output loading, as described, and by using different values of  $R_1$ . Obviously, the higher the resistance of  $R_1$ , the less

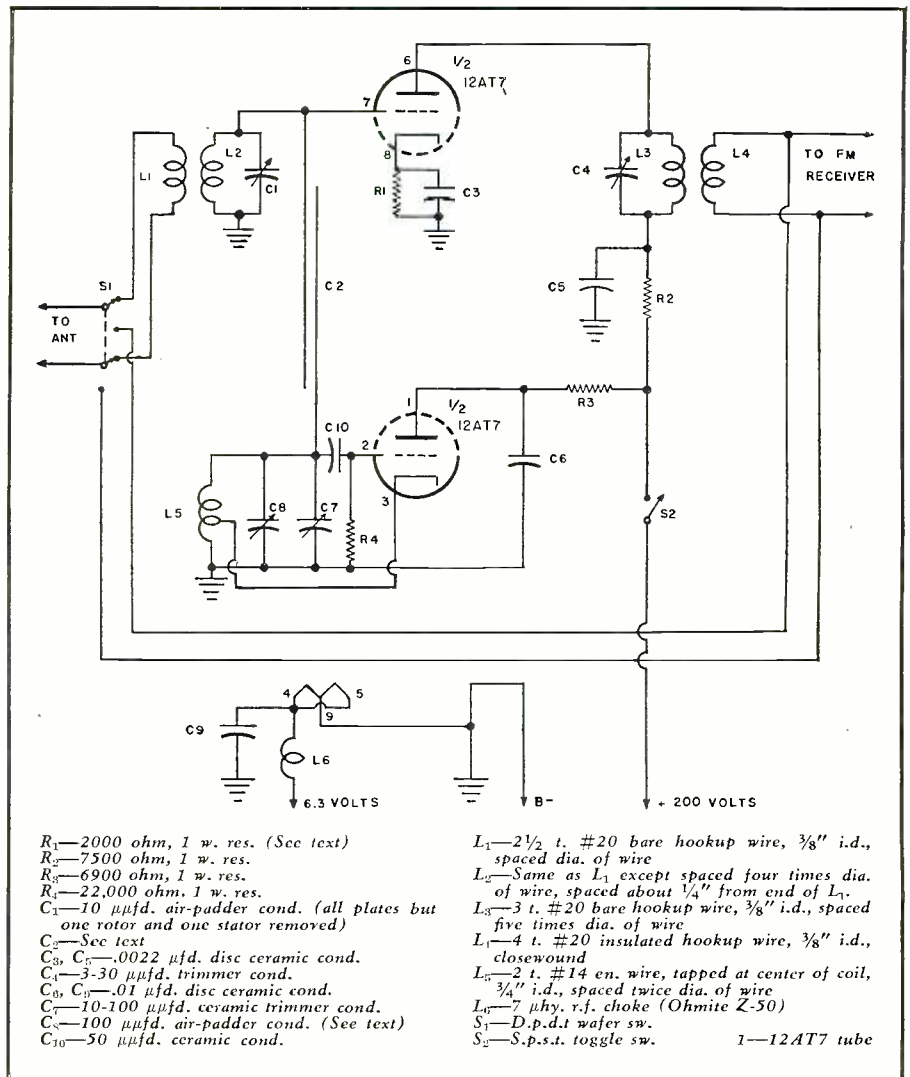

Diagram of the converter unit designed to permit reception of 152-162 mc. band.

will be the tendency toward oscillation.

While regeneration is not always desirable, it does serve a useful purpose in this particular unit because it increases the mixer gain to a point where incoming signals can override the noise

generated in the front end of the FM receiver. Without regeneration in the 12AT7, weak signals are lost in this noise.

$L_2$  can be most easily adjusted with  
 (Continued on page 123)

(Left) Rear view of converter showing how rotor plates have been removed from the oscillator tuning condenser,  $C_6$ . The antenna terminals are at the right with the output terminals at the left. The power cord runs through rubber grommets at the rear. (Right) Bottom view of chassis. Note that all of the coils are self-supporting.

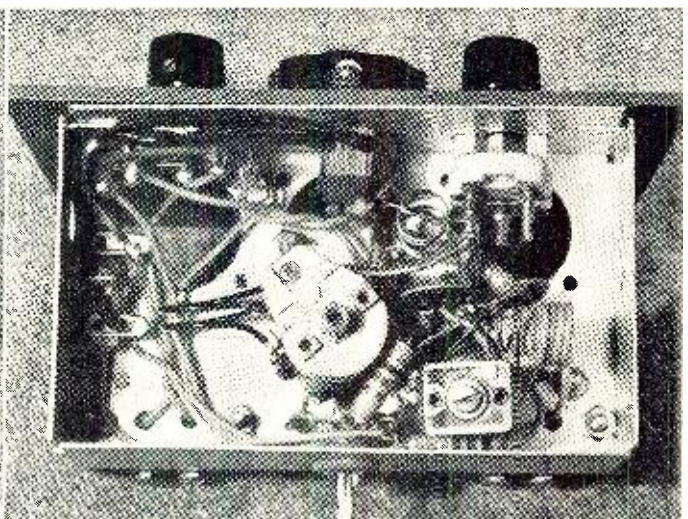
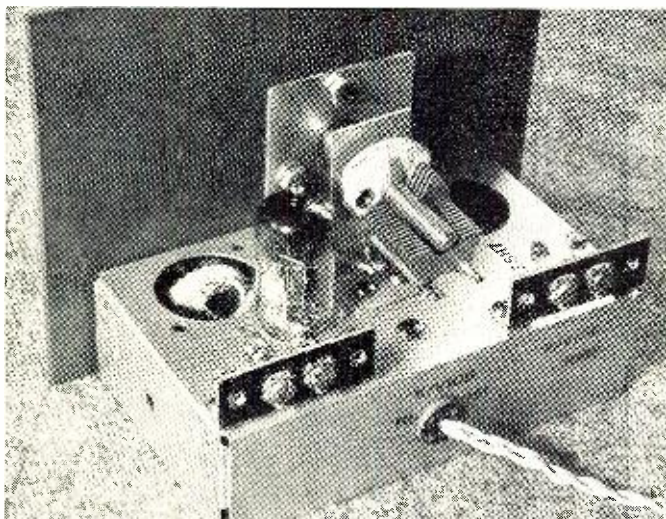

# BINAURAL COMPENSATION

## in Single-Channel Reproduction



By

GLEN SOUTHWORTH

Two-channel nonlinear amplifier designed for recording or broadcast work. For minimum hum level, the power transformer should be mounted on separate chassis.

***New ideas of considerable interest to the audio enthusiast—  
One point, though controversial, is covered, that is, the  
advisability of introducing nonlinear characteristics into  
an audio amplifier to obtain a more pleasing response. De-  
tails of experimental, two-channel amplifier are included.***

SINCE the early days of radio it has been recognized that monaural reproduction of sound has several unsatisfactory aspects, even though the highest available grade of reproducing equipment is used. The chief complaint is that a single channel or monaural system lacks the spatial perspective of natural sound and is, therefore, considerably inferior. Aside from the ability to localize the source of a particular sound, there is another valuable property of binaural hearing and that is the fact that under extreme conditions the human ears may be able to perceive sounds thirty decibels weaker under binaural listening conditions than, for example, sounds presented to only one ear by a headphone. As a result, a great deal of information or musical detail may be lost to the auditor when listening to a conventional monaural reproducing system, even though the system may be considered to be technically perfect.

This loss of sensitivity to very weak sounds sometimes leads to a seemingly paradoxical situation when monaural and binaural reproduction are compared in terms of listening sensations. In the case of monaural reproduction very unnatural effects may be observed. A normal-sized room may sound like a barn; speech may have a hollow sound and be difficult to understand. Various noises may appear unduly loud and objectionable and some normal sounds may be unrecognizable. These effects can lead the listener to

assume that monaural reproduction is "live-r" than binaural sound, while actually the decay period of the room will be less due to the poorer threshold sensitivity of monaural listening.

The explanation for the previously-mentioned effects of monaural listening appears to be that many of the sounds that the ears depend upon for the recognition of naturalness fall at or below the monaural threshold and are simply not perceived. If the level of the reproduction is raised from six

to thirty decibels, these low level components may once again be noticeable but high level voice transients, room reflections, noise pulses, or other disturbances will be intolerably prominent unless recourse is made to such measures as the common "close up" microphone technique and the sound deadened studio, and in these cases it is usually a question of improving intelligibility rather than naturalness.

It is well established that the human auditory apparatus is nonlinear in its operation, tending to greatly reduce the difference between very weak sounds and very strong ones in terms of relative loudness. This phenomenon leads to negative modulation or "masking" of a weak signal by a strong one, as well as the ability of the ears to perceive an enormous range of signal amplitudes. Binaural listening will, presumably, generate an auditory linearity curve in which very weak sounds are perceived at a level from six to thirty decibels higher than would be the case in monaural listening. As a result, by deliberately designing a nonlinear audio system to amplify weak signals to a greater extent than strong ones it would theoretically be possible to get binaural naturalness and detail from single channel reproduction and, in practice, this assumption appears to work out very satisfactorily.

At this point the current state of the audio art becomes pertinent inasmuch as it is desirable to know whether or not equipment is available which has a sensitivity to low level sounds comparable to the sensitivity of the ear. Unfortunately, harmonic or intermodulation distortion measurements are of little aid in settling this question, and inasmuch as it is calculated that, at the most favorable pitch, the ear

Fig. 1. (A) Block diagram of nonlinear, single-channel amplifier for correction of binaural-monaural differences or in-phase harmonic distortions in other parts of the reproducing chain. Variable equalizers are useful at both input and output of nonlinear amplifier, while amounts of nonlinearity may be varied by number of pentode stages used, strength of input signal, or biasing. (B) Typical damped sine wave train such as frequently occurs in noise or music. (C) Added duration produced by wall reflections and primary delay path in the Maxfield microphone technique. (D) Added duration produced by non-linear amplification of the input signal.

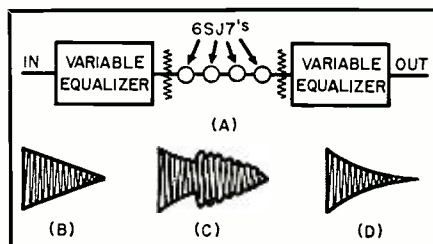



can hear tones that move the eardrum less than  $10^{-9}$  centimeter, or about one tenth the diameter of the smallest atom, a pretty rigorous set of requirements is laid upon a microphone or the following preamplifier. However, in practice, considerably less sensitivity is usually acceptable in reproducing equipment, but the necessity for accurate reproduction of low level signals still remains.

In general, it may frequently be desirable to increase the level of low intensity sounds above that which would be required for binaural simulation. This is due to the fact that imperfections often exist in the reproducing chain or acoustic environment which should be corrected. A fairly common example of this is an amplifier, speaker, pickup, microphone, or recording medium which has a linearity curve similar to that shown in *b1* of Fig. 2. In terms of wave analysis, such a curve will usually produce an in-phase third harmonic component in which the harmonics reinforce the fundamental. A linearity characteristic of this kind will cause the relative attenuation of low-level signals and positive modulation of high frequencies by bass tones. An amplifier with a curve of this kind would result in colorless, noisy reproduction even in a binaural system. An amplifier or other piece of equipment with a linearity curve such as shown in *c1* of Fig. 2 might measure identical harmonic distortion percentages, but would sound much different. In this case the linearity curve would give rise to the appearance of out-of-phase third harmonics in wave analyzer data, and the listening sensations in the case of monaural reproduction would be comparable to those achieved in a true binaural system, due to the fact that weak signals are emphasized with respect to strong ones. Similarly, any modulation products that take place are modulated in a negative sense and instead of appearing as disagreeable noise are masked by the lower tone, a characteristic of normal binaural listening. If such an amplifier were used in a binaural system, the results would be superior to live listening which will be discussed later.

The importance of linearity characteristics has long been recognized in the photographic field and a good analogy can be drawn between visual and audio reproduction. In photography, linearity characteristics are usually lumped under the term "contrast," and an example of the visual effects of this factor are shown in the accompanying series of photographs of the same scene. A print was made of the original negative, a negative then prepared from the print, another positive made from this and the process repeated for several cycles until the extremely "contrasty" result shown was achieved, the final picture being an almost cartoonlike black and white, devoid of detail and anything more than casual interest. This process may be likened to the amplification of an audio signal through a series of nonlinear vacuum tube stages, even to the polarity reversal with each stage, and the final result of the cumulative distortions producing a linearity curve similar to that of *b1* of Fig. 2.

In both photographic and audio practice a curve similar to that of *b1* of Fig. 2 may be corrected by generating an opposing characteristic such as that of *c1* (Fig. 2) and very satisfactory results may be obtained by this technique. However, in the case of a sharp bend in the linearity curve, such as would normally generate high-order harmonics in conventional audio measurements, it may be very difficult to secure compensation through use of the opposite type of linearity curve. In photographic usage the commonest form of contrast control is through the use of different types of printing or enlarging papers, while in audio practice out-of-phase harmonics may be generated in one part of the reproducing chain to compensate for defects elsewhere. For example, it is possible to compensate for deficiencies in pre-war shellac recordings with special equipment and the results are frequently very worthwhile.

Not only does the linearity curve of an audio system affect the amount of information presented to the ear but it greatly affects the tonal coloration of musical instruments. There are two

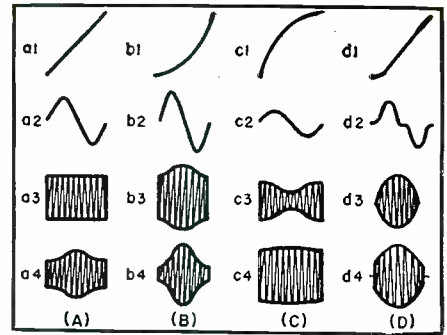

Fig. 2. (a1) Curve of a linear amplification system. (a2) Sine-wave input. (a3) High frequency carrier of a complex wave such as in intermodulation tests. (a4) Modulated wave input. (b1) Curve of nonlinear amplifier in which weak components are not amplified equally with strong signals. (b2) Sine-wave output shape. (b3) Positive modulation resulting from complex wave. (b4) Increase in modulation depth of modulated tone due to nonlinear characteristic. (c1) Curve of amplifier with out-of-phase third harmonic distortion and with a characteristic similar to that of binaural hearing. (c2) Sine-wave output shape. (c3) Negative modulation of high frequency carrier. (c4) Lowering of modulation percentages due to nonlinear characteristics. (d1) Curve of otherwise linear amplifier which cuts off sharply at low signal levels. (d2) Sine-wave output. (d3) R.f. envelope showing 100% modulation of a weak carrier. (d4) Deformation of a weak modulated tone.

reasons for this; first is the fact that very weak high-order harmonic or non-harmonic components may have a very audible influence upon the tonal qualities of a given instrument. Consequently, nonlinearity in reproduction appears in some instances to be a more important factor than frequency response in determining whether a natural sound is perceived. For example, if the amplitude of the sound lies below the hearing threshold it won't be detected even though a perfectly flat frequency response characteristic is maintained throughout the system.

A second important factor has to do with the fact that the tonal attributes of a continuous wave train are strongly affected by modulation. Although the common concept of modulation, as pro-

A photographic analogy of nonlinear distortion in audio equipment. (Left) The original photograph. (Center) Same photo after being passed through one nonlinear reprinting, corresponding roughly to the difference in quality between binaural and monaural sound. (Right) The result of several stages of nonlinear reprinting. This result corresponds to badly distorted monaural reproduction resulting from a linearity curve such as that shown in Fig. 2b1. Note the extreme lack of detail and the appearance of "noise" in the sky and foreground.



duced by a lower frequency, is considered to be of prime importance, the author's experience is that an objectionable type of tonal distortion occurs when modulation takes place without the masking effects of a lower frequency. This commonly occurs in two ways, the first being due to the fact that many instruments produce highly damped wave trains which may be much more highly damped by non-linearity or phase distortion. Secondly, modulations of continuous waves may be produced by out-of-tune instruments or by nonharmonic components produced by the instrument itself. For instance, instruments such as the triangle, gong, cymbals, etc., frequently produce two or more high-frequency tones separated by only a few cycles, with consequent strong beats. In either case, listening to a monaural system or a system having a curve such as that shown in b1 of Fig. 2 will result in a much higher apparent percentage of modulation, with consequent alteration or destruction of tonal color.

A rule of thumb used by the author is that tones having a duration of less than one twentieth of a second tend to be perceived as noise, particularly in the case of a single damped wave train, while in the case of a modulated wave train with no masking component a greater than fifty per-cent modulation may destroy the basic tonal characteristic, although, in practice, live room acoustics and high modulation rates may introduce modifications due to artificial hangover. In fact, the tonal attributes of many musical instruments are profoundly influenced by the acoustic environment, due both to phase interference effects and, more

desirably, the lessening of modulation percentages due to room reverberation, which brings out tonal attributes that would otherwise be lost.

To sum up the foregoing, the use of a deliberately nonlinear characteristic in sound reproduction has several important advantages if the curve resembles that of c1 in Fig. 2. These include the compensation for binaural effects in a monaural system, the ability to bring more actual information to the listener's ear, higher average efficiency from sound equipment, correction for either a high noise level or reproduction at levels below the original sound intensity, use in achieving certain aesthetic values in musical reproduction, and a number of interesting special applications.

Although a considerable amount of literature exists on the subject of reducing distortions in audio equipment, relatively little exists about the use of deliberately introduced nonlinear characteristics. In general, a system that introduces only third-harmonic distortion will tend to have a fairly smooth linearity curve, while high-order harmonics usually indicate a sudden and undesirable discontinuity. A useful characteristic would be a system which showed a constant percentage of third-harmonic distortion at all levels, but in practice the harmonic percentage is usually assumed to increase with increasing signal amplitude. In order to generate an input-output curve resembling that of Fig. 2C, a circuit which introduces negative resistance characteristics may be used. In this case an increase in input signal voltage does not produce a linear increase in current flow across the load resistor

and a form of instantaneous volume compression is achieved. In the experience of the author, certain voltage amplifier pentodes of the type 6SJ7, 6SK7, 6SD7, 6J7, and the older types 57, 77, or 6C6 will have a partial negative resistance characteristic due to secondary emission effects from the plate to the screen grid. This effect will vary from tube to tube and is also influenced by grid bias and relative plate and screen voltages, in some observed instances a relatively slight change in grid bias causing the low level gain of a single stage to vary as much as 10 db. In addition, the secondary emission characteristic may tend to disappear over a period of weeks or months of operation and these various inconsistencies have undoubtedly led to the reluctance of some designers to use pentodes.

By cascading a series of voltage amplifier pentodes, selected for the secondary emission characteristics, a useful amount of nonlinearity may be obtained. The block diagram of Fig. 1A shows a system of this kind. In order to prevent tube overload, the output of each tube is attenuated until the stage gain is approximately unity. The linearity curve of the system may be altered by changing the applied element voltages and the selection or number of tubes used. In extreme cases of tube selection, two pentodes may be all that are required to achieve adequate compensation for nearly any input signal, and preferably an even number of stages should be used in order to reduce second harmonic components. Of appreciable importance will be the characteristic of the input signal applied to this system. For example, a signal in which the highs were attenuated and the bass boosted would result in excessive masking of the highs. This is not necessarily undesirable since in the case of reproduction of worn phonograph records it tends to greatly reduce the apparent surface noise, although allowing solo instruments in the high register to come through with undiminished brilliance. On the other hand, if considerable hum or turntable rumble is present, the unnatural modulation of high frequency components may be very noticeable. In the block diagram of Fig. 1A, identical variable equalizer circuits are shown at both the input and output of the nonlinear amplifier and restored afterwards as this greatly reduces audible modulation of the highs. This will result in a much better and more natural reproduction.

Although very satisfactory results may be obtained by using a single nonlinear channel, this technique is limited by the normal masking characteristics of the ear and can only be carried to the point where the reproduction is slightly superior to normal binaural listening or the unnaturalness of a bleached out photograph will result, (Continued on page 122)

Fig. 3. Diagram of an experimental, two-channel, nonlinear amplifier for broadcast or recording work. A simple RC crossover network, which may be varied, is used. Impedance across input of network should be low or low-frequency boost will occur.

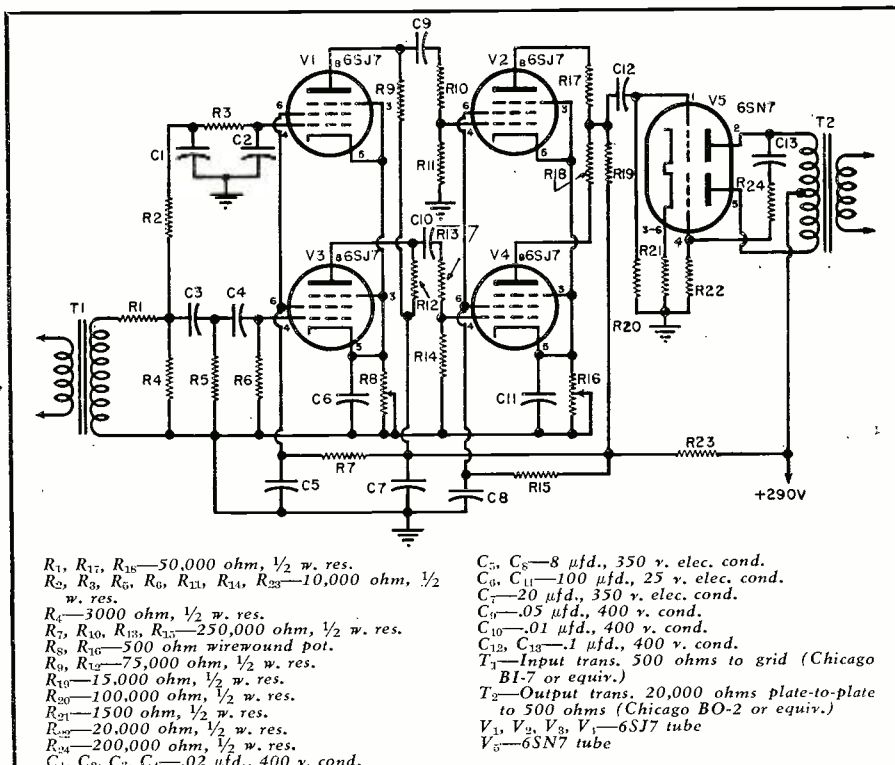

# AUDIO-FREQUENCY AMMETER

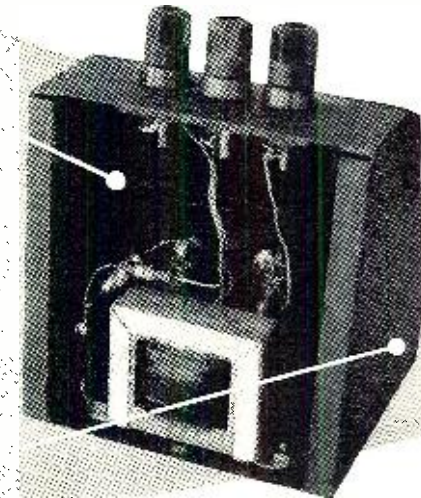
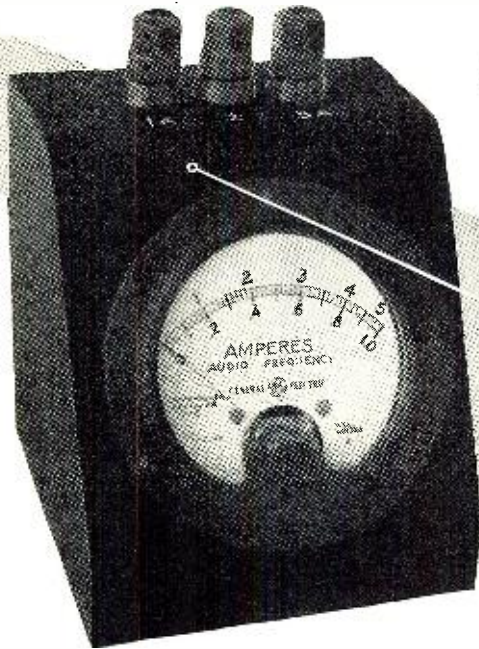

Front and rear views of an audio frequency ammeter. Response is flat from about 70 to 30,000 cycles and down 5 per-cent at 40 cycles. The unit is fairly easy to construct and adjustments may be made with a minimum of equipment.

By **W. D. CREVISTON**

**The technique of measuring current instead of the speaker voltage has several advantages in service work. It may be used in certain TV applications.**

AUDIO measurements are usually made on a voltage basis rather than by measuring a.c. current. It is as logical, however, to measure the output of an amplifier by means of an audio frequency ammeter in the voice coil circuit as it is to measure the voltage across the voice coil. Maybe more so, because the current reading will show up changes in the speaker impedance better than a voltage measurement. In amplifier tubes, the a.c. component of the plate current is as good an indication of how near we are to overload as is the voltage swing. Measuring audio frequency amperes or milliamps is useful in many industrial electronic applications. A good audio ammeter could "double in brass" as a line current ammeter for checking power drain.

The difficulty has been that a.c. current meters have generally had some drawback that prevented their more general use. For wide frequency range, thermal instruments have been about the only type available. Their square-law scale, lack of multiple ranges, and easy burnout have consigned them to the built-in, special-purpose class of meter. Iron-vane a.c. instruments are only rated for use up to a few hundred cycles, 2500 at most. Ordinary rectifier ammeters and milliammeters are non-linear and have too much voltage drop.

## Current Transformer Meter

A considerable advance over these instruments for a lot of practical uses is a combination of a small current transformer, a rectifier, and a d.c. milliammeter or microammeter. The current transformer can be made in less than an hour by replacing the voice coil winding on a suitable output transformer with a few turns of wire, or by winding a few turns over the winding of a 15 henry choke. A 1N34 crystal and a 0-1 milliammeter will do for the rest. No tubes or power supply are needed. Response is generally flat from about 40 to 30,000 cycles or more, and the scale is linear. A ten-times overload does no harm.

Current transformers are extensive-

Fig. 1. Complete circuit of current transformer ammeter of wide frequency range. The accuracy is  $\pm 5\%$  from 40 to 30,000 cycles.

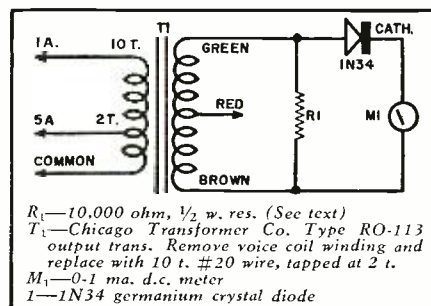

ly used in power work to step heavy currents down to convenient values for metering. The clamp-on type of ammeter uses this principle, too. Current-transformer-rectifier meters are not new for 60-cycle use either. It is odd, however, that there has been no general appreciation of the wide frequency range capabilities of such transformers until a recent article called attention to the fact.<sup>1</sup>

## Circuit

Fig. 1 is the circuit of a dual range instrument, 0/1/5 amperes, shown in the photographs. Response is flat from about 70 to 30,000 cycles, and down 5 per-cent at 40 cycles. Half-wave rectification is accomplished by the 1N34. A bridge rectifier would permit full-scale deflection with about half the current, and can be made with four 1N34's. A regular copper oxide instrument rectifier might do, but has not been tried; the high capacitance of the oxide discs may droop the high end, and the lower back-voltage limit might produce a non-linear scale effect.

The effect of the shunt resistor is twofold: it drops the over-all sensitivity and it flattens out the low-frequency response. The particular transformer indicated, with the low-impedance winding rewound as noted, should duplicate closely the results obtained by the writer; it is a small, inexpensive unit with characteristics very well suited for this use. The most important characteristic is the inductance of the high-impedance (secondary) winding. This will be discussed in detail later.

Fine adjustment of the full-scale sensitivity should be made by selecting  
(Continued on page 90)

# Mac's RADIO SERVICE SHOP

By JOHN T. FRYE

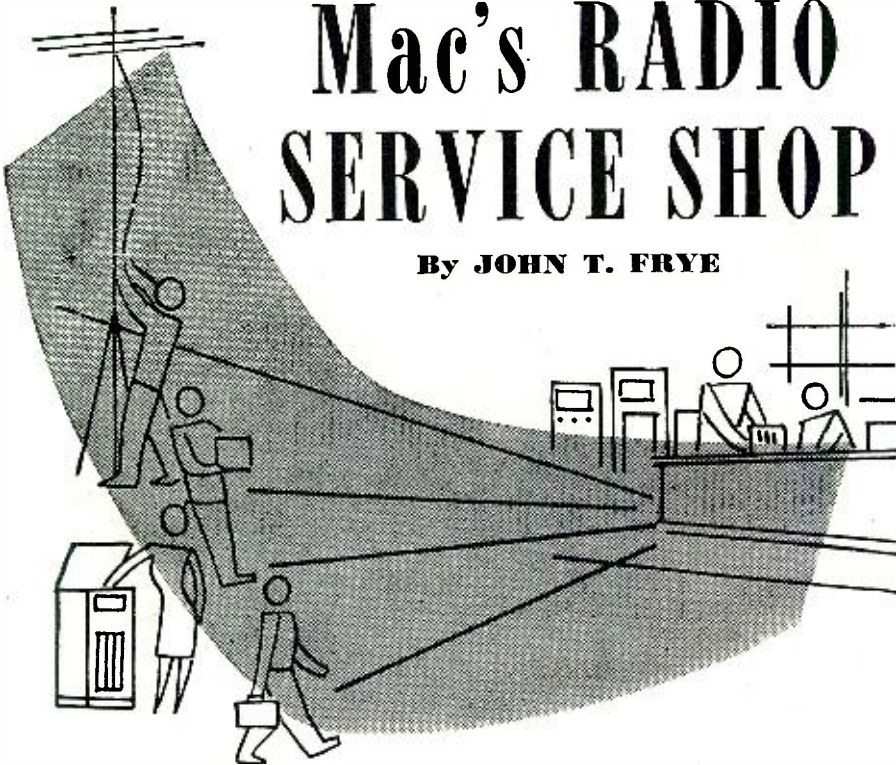

## "SATISFIED CUSTOMER INSURANCE"

**S**INCE mid-morning the doors of Mac's Radio Shop had been standing wide open, for this had been the first really warm day of the year. Even now in late afternoon the May sun shone down hot and bright. Children loitered on their way home from school, with their useless jackets slung carelessly across their shoulders. The first office workers were starting home, too; and they walked leisurely along with their topcoats draped over their arms and carrying their hats in their hands as though to show that the enjoyment of a warm spring day was not the sole privilege of children.

"You know something, Mac?" Barney called from where he looked out at the scene from the open doorway of the shop; "this is one time of year that I'm kinda glad my memory is not too good. Every winter I forget just how super an early summer day can really be; so each spring I have the fun of finding out all over again."

"Okay, Spring Fever," Mac said with assumed gruffness, "but don't forget you've still got a set here on the bench that you have been pawing over for the past couple of hours."

"All right, all right! Lay down the whip, Simon Legree," Barney said as he sauntered back into the service department. "To tell you the truth, however, that little cuss about has me whipped. The volume on it is way down, and it distorts; yet a check of all the usual causes of such a complaint turns up nothing. All voltages are within 5%; all tubes are good—and just to make sure, I've substituted for all of them; coupling condensers are neither open nor shorted; and the speaker magnet has plenty of stuff. A signal tracer shows everything to be

perfectly normal until you reach the plate of the output tube. It sounds a little fuzzy there, and when you listen across the voice coil it sounds even fuzzier. I thought it might be a shorted voice coil; so I unsoldered the output transformer secondary leads and clipped another speaker across them, but there was no improvement. Any suggestions will be gratefully received."

"If you found everything all right *until* you reached the output transformer, and if changing speakers revealed that the trouble was not *beyond* the transformer, it would seem that it might *be* the transformer," Mac commented.

"Neither winding is open," Barney objected. "Ohmmeter checks show the resistances to be about normal."

"How about some shorted turns in one of the windings?"

"I hadn't thought of that. I suppose it could happen, though. I'll try a new transformer; but I'm warning you now you had better be guessing right. Changing the output transformer on this little set is no small chore."

"You don't have to change the transformer to check it for shorted turns," Mac said as he switched on the audio oscillator and v.t.v.m. I'll set the oscillator to 400 cycles, and you connect these leads from it across the primary of the output transformer. Unsolder one of the secondary leads from the voice coil. Now check the audio voltage across the primary with the a.c. probe of the v.t.v.m. Hm-m-m, there doesn't seem to be any. You will notice, though, that when the leads are unclipped from the transformer primary, nearly four volts of 400-cycle voltage is present across them.

"And now," he went on as he removed a universal output transformer from its carton, "let's see what happens when we put this audio voltage across the primary of a transformer we know to be good. See there: the voltage drops only about half a volt; but look what happens when we short a couple of the output terminals: the voltage falls to zero. That's exactly why the voltage is zero across the primary of that transformer in the set. Some shorted turns in either the primary or the secondary are acting as an extremely heavy load and lowering the impedance of the primary so far that our audio oscillator cannot build up a voltage across it."

"Why bother with the audio oscillator? Why not just use a.c. from the line?"

"Two reasons: first, the impedance of the transformer would be much lower to 60-cycle current than to the 400-cycle current at which it is rated, and the resulting heavier current might cause even a good transformer to overheat if left on too long. Secondly, the output voltage of the oscillator has very poor regulation. By that I mean that an increasing load makes the voltage go down rapidly; and since our test requires a voltage that fluctuates with loading, this feature of the oscillator is made to order. On top of that, you know that I never approve messing around with dangerous line voltage unless it is absolutely necessary."

Barney soon had the transformer changed and, as the set warmed up, he had to grab the volume control and back it off in a hurry, as music shook the speaker cone with great volume. "Nothing the matter with the quality now," he remarked with a pleased grin as he cocked a critical ear.

"And so we'll have another satisfied customer," Mac observed; "which leads into another matter I've been wanting to talk over with you. I got to thinking last night that we ought to take out Satisfied Customer Insurance on every set we put out."

"Where would a guy buy insurance like that?" Barney wanted to know.

"You don't buy it; you build it into your service technique," Mac replied. "You see, the average customer measures the quality of the service job he gets by the length of time his radio or TV set plays before he has to call a technician again. We know that this is not strictly fair, for a lot of things can happen to a complex electronic machine that simply cannot be foreseen and prevented. The only real test of a service job is how well the radio or television set performs when it is delivered.

"However," he went on, "if you want to stay in business, you have to do your best to satisfy the *customer's* idea of good service; and there really are several things you can do to a set while it is on the bench that will go a long way toward reducing the likelihood of more trouble showing up in the imme-

(Continued on page 171)

# A Two-Meter Miniature Disaster TRANSMITTER

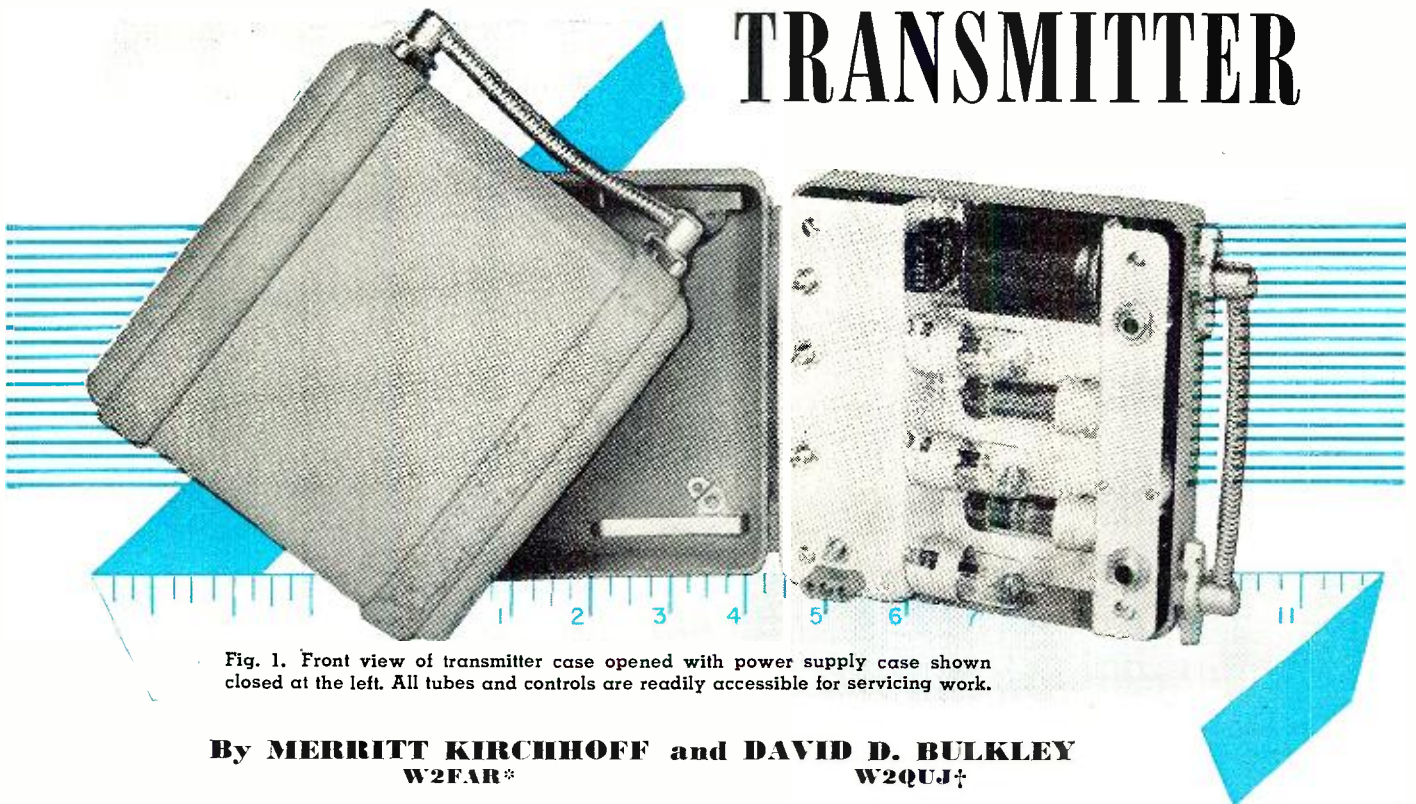

Fig. 1. Front view of transmitter case opened with power supply case shown closed at the left. All tubes and controls are readily accessible for servicing work.

By **MERRITT KIRCHHOFF** and **DAVID D. BULKLEY**  
W2FAR\* W2QUJ†

**Construction details on a compact transmitter that provides a modulated output of from 3 to 4 watts and is powered by a small selenium rectifier supply.**

**C**IVIL DEFENSE radio operation now takes its place alongside the various other recognized activities in the amateur radio field. Hundreds of Civil Defense radio networks interconnect towns, counties, and states throughout the nation. In cooperation with municipal and state agencies, amateur radio now provides the communication facility needed to insure that vital operations of relief agencies will not be hampered by delays in passing message traffic in the event of the failure of regular communication agencies during a local or national disaster or emergency.

Although the average amateur home station transmitter will provide adequate facilities for use as the network control station, somewhat specialized equipment is needed for remote communication activities such as operation directly from the scene of a disaster. Equipment of this type must embody certain features not found in average amateur transmitters. First, it must offer the utmost in portability and reliability, and second, it must be easy to operate. The transmitter described here is housed in a small compact carrying case only six inches square and three inches high, weighing three pounds. It provides a modulated r.f. output of from 3 to 4 watts, depending

upon the type of antenna used. This power is sufficient for most disaster and emergency network requirements.

Companion to the transmitter is a selenium rectifier power supply mounted in a second carrying case with the same dimensions as the transmitter. Built for 117-volt a.c. input, a small vibrator power converter, similar to the "Travellectric," may be used to obtain the required line voltage from any automobile or other six-volt source.

The transmitter, as shown in Fig. 1, is divided into two sections on a chassis-panel assembly made from sheet aluminum bent into the required shape. The left-hand portion of the case contains the r.f. section of the transmitter while the right-hand portion mounts the modulator section. All necessary tuning controls are easily accessible for adjustments, yet there is little possibility of their being knocked out of adjustment due to rough handling while operating in the field.

The rectifier unit consists of a full-wave doubler selenium rectifier circuit plus the necessary filament voltage transformers.

The three tubes which comprise the r.f. section of the transmitter are seen on the left-hand side of the chassis in

Fig. 1. At the top of the chassis, next to the crystal, is the 6J6 harmonic crystal oscillator/frequency doubler. Using a standard 8 megacycle crystal (still plentiful and inexpensive on the surplus market), one triode section of this tube is employed as a crystal oscillator providing 24 megacycle output while the second triode section of the tube doubles to 48 megacycles. This 48 megacycle signal is then fed to a second 6J6 used as a push-pull frequency tripler with 144 megacycle output to drive the 6J6 push-pull neutralized final r.f. amplifier.

At 144 megacycles it is necessary to neutralize the 6J6 final r.f. amplifier tube for it is operating as a straight-through amplifier. This is done very easily by using the capacity between the conductors in two short pieces of 72 ohm twin-lead. Details on this simple neutralization procedure will be covered later.

All tuning controls are screwdriver adjusted for convenience and safety. Starting at the top of Fig. 1, they are: crystal oscillator tuning, frequency doubler tuning, frequency tripler tuning, with the final amplifier tuning control located at the bottom of the panel next to the crystal socket used to connect the transmitter to the antenna.

The audio or modulator section of the transmitter is located on the right-hand side of the chassis in Fig. 1. The midget modulation transformer is mounted in the upper right-hand corner of the chassis. Directly below this

\* Columbia Broadcasting Company  
† International Telephone and Telegraph Corp.

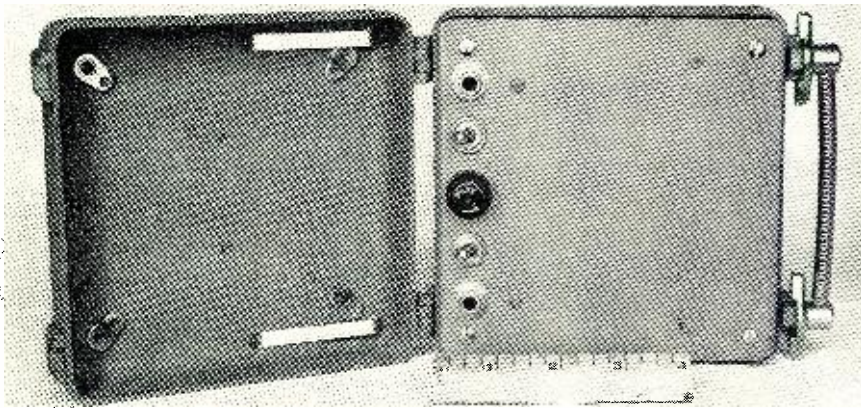

Fig. 2. Front view of the rectifier unit. Power input and power output jacks, primary line switch, and plate supply switch, in addition to the primary fuse, are mounted in such a way that the over-all appearance of the unit is pleasing.

are the two 6AQ5 modulator tubes. The power supply jack is mounted at the top of the panel while the microphone input plug is near the bottom. A single button carbon microphone provides ample output to drive the push-pull modulator stage without the need for additional speech amplification. No audio gain control is provided, as the modulator delivers sufficient audio to adequately modulate the r.f. amplifier when the operator speaks in a moderate voice approximately two inches from the microphone. The variation in percentage of modulation between persons having high-pitched voices and those having low-pitched voices is not great enough to warrant an audio gain control, thereby further simplifying the transmitter.

The underside of the transmitter chassis is shown in Fig. 6. All parts are mounted to provide short leads. In the photograph, the r.f. portion of the transmitter circuit is on the left, while the modulator is on the right. The microphone input transformer may be seen in the upper right-hand portion of the photograph.

Fig. 2 shows the front panel of the rectifier unit while Fig. 5 is the rear view. The front panel contains the 117-volt a.c. input jack at the top, with the primary toggle switch just below this, followed by the primary fuse, the plate voltage toggle switch, and the d.c. output jack. It will be noted that standard jacks are used for power supply connections. All these jacks must be in place before the line plug is plugged in and before the unit is tuned on, as a severe shock hazard exists otherwise.

### Transmitter Construction

The transmitter is mounted on a small chassis-panel assembly which is made from a piece of light sheet aluminum  $7\frac{1}{4}$  inches by  $5\frac{1}{2}$  inches. Four bends are made to provide a combination of the chassis and panels needed to mount the components. The transmitter panel is  $5\frac{1}{2}$  inches wide and  $1\frac{7}{8}$  inches high while the modulator panel is  $5\frac{1}{2}$  inches wide and  $\frac{7}{8}$ -inch high. The "U" is  $1\frac{1}{2}$  inches deep and the bottom of the "U" is  $5\frac{1}{2}$  inches wide and  $2\frac{3}{4}$  inches high. Reference to the

Fig. 3. Schematic and parts list for the power supply. It will be noted that both the power supply carrying case and the transmitter carrying case are effectively connected to the line, so the user must be careful not to touch either case while he is grounded, and there must not be a direct ground connection to either case.

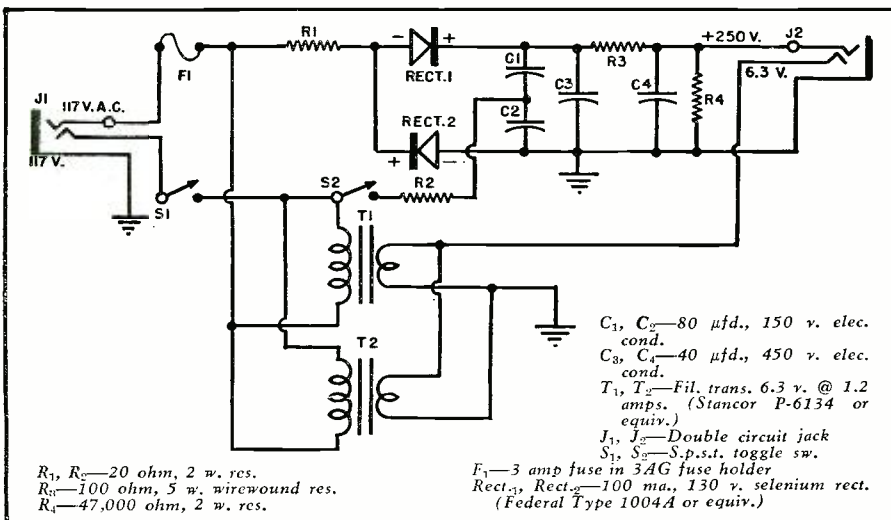

photograph will make the foregoing description quite clear.

All the miniature tube sockets are mounted on the chassis portion of the transmitter assembly so that their filament pins are at a  $45^\circ$  angle to the panel. This assures that the other pins on the sockets will provide short leads to the various components. The self-supporting coils are mounted directly on the variable condensers. Miniature variable condensers are used rather than standard midget variables in the interest of space conservation. The slight additional expense in employing this type of variable condenser is worth it since it permits much greater ease in the assembly of the tank circuits. A conventional condenser with semi-circular plates is used for the crystal oscillator tank, while butterfly-type condensers are utilized for the other tank circuits. Two small ceramic stand-off insulators are used as tie-points to which the resistors and r.f. chokes are mounted; these provide sturdy mounting facilities for the components.

The two neutralizing condensers  $C_{11}$  and  $C_{12}$  consist of two-inch pieces of 72 ohm twin-lead, each conductor soldered into place, leaving one end free. During the neutralizing operation, small pieces of twin-lead are snipped off the free ends of the twin-lead until correct neutralization is effected.

The modulator is mounted on the chassis-panel assembly, so that all components will fit into the small space provided. The "Ouncer" type microphone input transformer is mounted between the microphone input jack and the two modulator tube sockets to facilitate circuit wiring. Although the "Ouncer" microphone transformer used in the construction of this transmitter is of the commercial variety, a similar transformer has been seen on the surplus market, and might possibly still be obtained from some surplus dealer.

The midget modulation transformer seen in the upper right-hand corner of Fig. 1 is a surplus unit. The authors have obtained the commercial equivalent of this component and find it slightly larger than the unit available on surplus; however, it will fit on the chassis.

In order that space may be further conserved, the microphone battery has been replaced by a voltage divider circuit to provide the required voltage for the microphone. This circuit consists of  $R_5$  and  $R_{10}$ .

The transmitter chassis-panel assembly is mounted in its carrying case by means of four  $1\frac{1}{2}$  inch metal bushings secured to the case, one in each corner. This permits easy removal of the unit should maintenance become necessary.

The power supply is mounted on the rear side of the front panel as shown in Fig. 5. This panel is made from a  $5\frac{1}{2}$  by  $5\frac{1}{2}$  inch piece of aluminum. Along the bottom edge of the chassis will be found the toggle switches, fuse holder, and the two power connection

jacks. Directly above these components will be seen the two midget filament transformers mounted on a  $5\frac{1}{2}$  x  $1\frac{3}{8}$  inch aluminum bracket which has a  $\frac{1}{4}$ -inch lip to permit securing it to the chassis-panel assembly. These filament transformers are connected in parallel in order that sufficient filament current will be available to light all the tubes in the transmitter. In the upper right-hand corner of the photograph will be seen the two miniature selenium rectifiers; although only one rectifier is visible, the two units are mounted one atop the other. To the left of the selenium rectifiers are the electrolytic condensers and resistors which complete this compact power supply. Small yoke-shaped brackets are used to secure the electrolytic condensers in place. The power supply is mounted in its carrying case in the same manner as the transmitter.

### Operation

Tuning operations for this transmitter are quite simple inasmuch as all controls are located on the front panel. No metering facilities are included in the design of the equipment, for the voltages used in operating this transmitter are not sufficiently high to damage any of the tubes should out-of-resonance operation occur. Further, there is no danger of coupling the final amplifier tube too closely to the antenna. The average emergency antenna will not load the transmitter to the extent of creating any hazard of tube damage. To provide access to the coils, the transmitter should be removed from the carrying case during tuning operations. Initial tuning operations should be made with the aid of a grid dip oscillator or a sensitive r.f. indicating wavemeter. A  $\frac{1}{2}$ -watt neon lamp, however, may be used to indicate r.f. output from the various stages, to

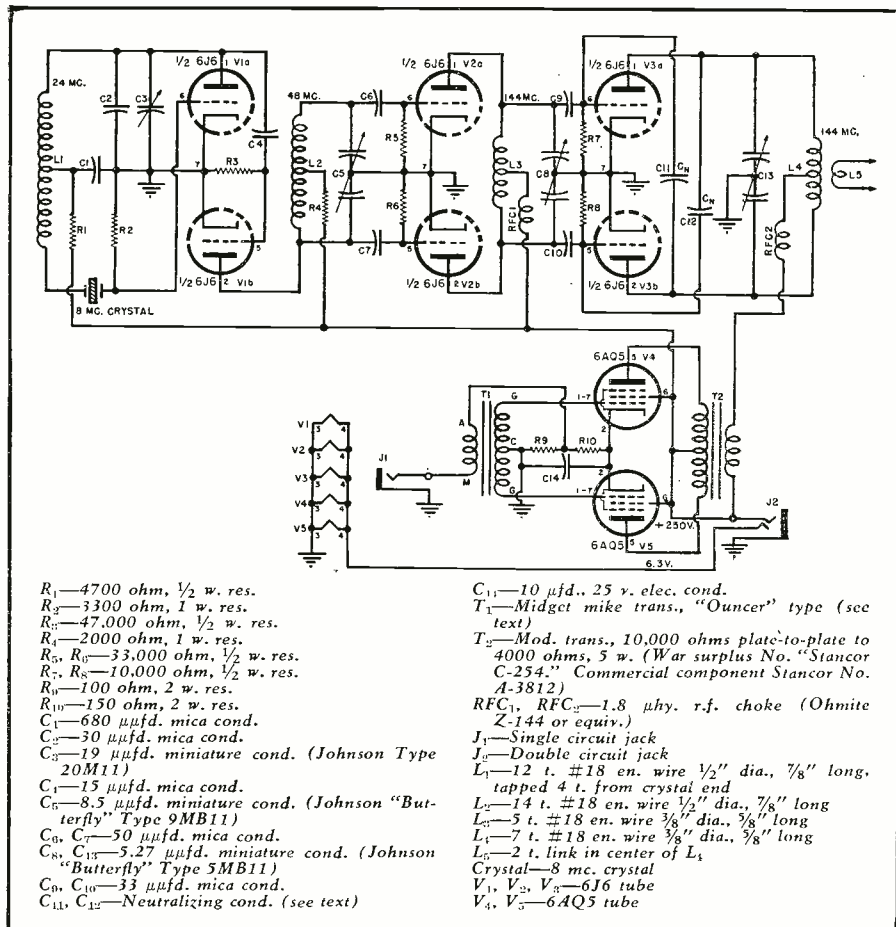

Fig. 4. Diagram of the transmitter section. A separate power supply (Fig. 3) is used.

periodically peak the various stages, or when changing the crystal for one of another frequency.

The first operation that should be performed in tuning the transmitter is neutralizing the final r.f. amplifier. As stated previously, neutralization is

accomplished by utilizing the capacity between conductors in two two-inch pieces of 72-ohm twin-lead. With the plate voltage applied to all tubes in the transmitter, but with the crystal removed from the crystal socket, the

(Continued on page 175)

Fig. 5. Rear view of rectifier unit. Although every bit of chassis space has been used, the parts layout is efficient and builders should experience no difficulty in assembling unit.

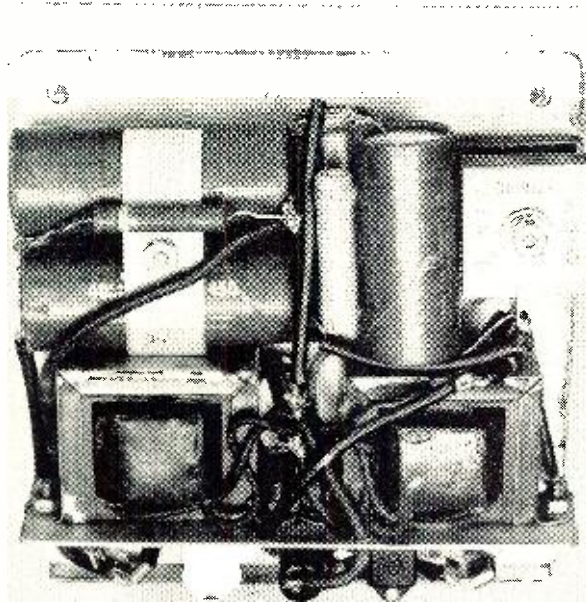
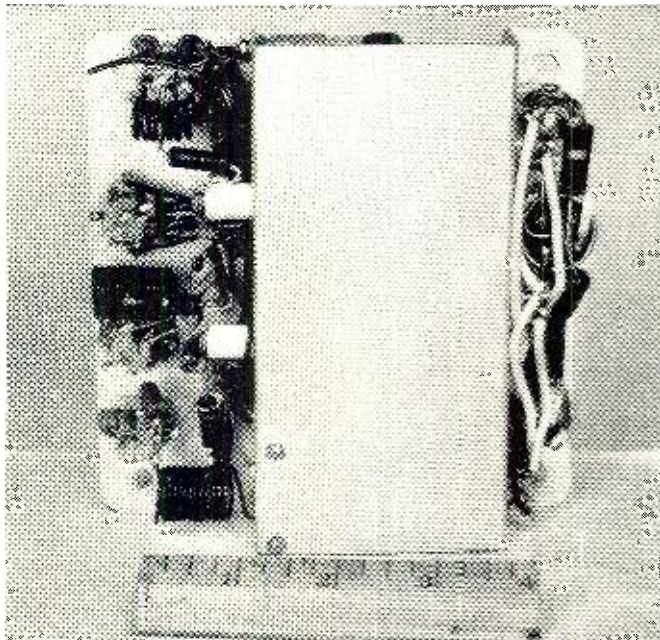

Fig. 6. Bottom view of transmitter. The r.f. portion is at left. Neutralization for 6J6 final r.f. amplifier is shown at upper left. Modulator on right uses an "Ouncer" mike transformer.



# MICROWAVE KLYSTRON OSCILLATORS

By  
**JOSEPH RACKER\***  
and  
**LAWRENCE PERENIC†**

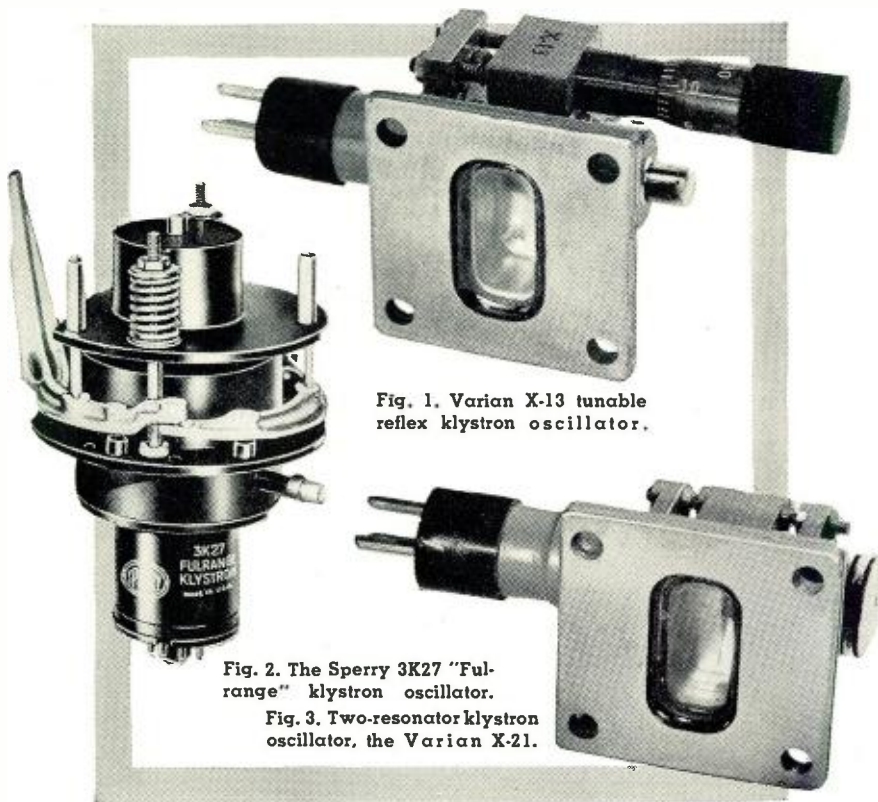

Fig. 1. Varian X-13 tunable reflex klystron oscillator.

Fig. 2. The Sperry 3K27 "Full-range" klystron oscillator.

Fig. 3. Two-resonator klystron oscillator, the Varian X-21.

## Part 2. Concluding article of this series covering the use of reflex klystrons in modern circuitry.

**W**HILE the two-resonator klystron, described last month, represents the simplest type for purposes of discussion and explanation, it is far from the simplest type to operate.

For instance, it was seen in Part 1 how the alternating voltage across the catcher had to be timed to retard the bunches of electrons as they arrived. Since the rate at which these bunches arrived was governed by the frequency of the alternating voltage across the buncher, it was evident that both the buncher resonant circuit and the catcher resonant circuit have to be tuned to the same frequency for proper operation. Now, inasmuch as the resonant circuits associated with all klystrons are actually high-"Q" cavities, it becomes difficult to keep two or more such circuits in tune, thus tuning of a two-resonator klystron represents a serious problem.

This problem of tuning is responsible, to a large extent, for the fact that of all forms of klystrons, by far the most common is the reflex klystron which utilizes only one resonant cavity. In the reflex klystron the same cavity is used for both bunching and catching. Instead of traveling only once through a straight drift-space, as in the two-resonator klystron, the beam is turned back on itself by a

retarding field. This field is produced by a reflector plate which is maintained at a negative potential with respect to the cathode, as shown in Fig. 4. The retarding field is strong enough not only to prevent the electrons from arriving at the reflector, but also to return them to the buncher.

Upon examining Fig. 4 it can be seen that the method of producing velocity-modulation in a reflex klystron is basically the same as that used in a two-resonator klystron. An electron which passes the center of the buncher at the instant the alternating voltage across the grids is passing through zero has the same net voltage acting on it as it had when it passed through the accelerator grid. It, therefore, leaves the buncher with the same velocity it had when it entered. An electron which passes through the center of the buncher a little later, however, when the alternating voltage is increasing in the positive direction, has a higher net voltage acting on it. As a result, this electron leaves the buncher

with a higher velocity than it had when it entered. It is seen, therefore, that in a manner similar to the one which took place in the two-resonator klystron, electrons passing through the buncher grids are either accelerated, decelerated, or remain unaffected by the buncher field, depending upon the phase and amplitude of the buncher voltage at the time they pass through.

### Reflector Bunching Action

As was stated previously, the retarding field of the reflector is made sufficiently strong not only to prevent the electrons from arriving at the reflector, but also to return them to the buncher. In this way it becomes feasible to use only one pair of grids and one resonant cavity to act as both buncher and catcher. Since there is no longer a field-free drift space in which the velocity-modulated electrons can become bunched, "reflector-bunching" is the mechanism by which density-modulation is achieved in the reflex klystron, and the operation is as follows:

An electron which passes through the buncher at a time when the alternating voltage across the buncher grids is going through zero is neither accelerated nor decelerated and, therefore, travels with unchanged velocity into the reflector region. As it enters the retarding field of the reflector it is slowed down more and more as it approaches the reflector, until it finally stops at a point in front of the reflector where the retarding field is sufficiently strong to return it to the buncher (which, in the reflex klystron, is also the catcher).

By contrast, an electron passing through the buncher a short time later, when the alternating voltage across the grids is such as to accelerate the electron, penetrates more deeply into

Fig. 4. Schematic diagram of reflex klystron.

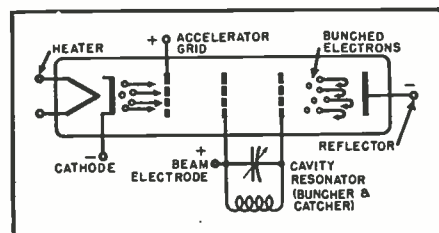

\* Pres., Joseph Racker Co.  
† Chief Electronic Engr., Bogart Manufacturing Corp.



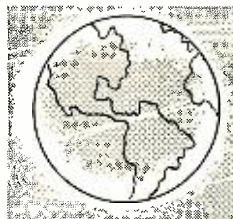

# International SHORT-WAVE

Compiled by **KENNETH R. BOORD**

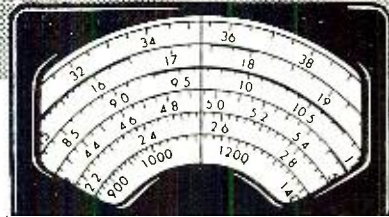

IT IS a pleasure to dedicate this month's *ISW DEPARTMENT* to "Call of the Orient," the missionary voice of the Far East Broadcasting Company, Manila, Philippines. Thanks go to Steve Brookner, Rhode Island, editor of the United Short-Wave Listeners of the World, who obtained this material from the FEBC for our use.

"To bring the Orient the Gospel of Christ," the Far East Broadcasting Company now has six transmitters operating daily. FEBC is "a work of faith, non-profit, non-commercial, interdenominational." It is a Christian organization incorporated December 20, 1945, under the laws of the State of California, USA. FEBC broadcasts from Manila in 32 languages and dialects.

Officials of the stations describe "Christian Radio City, Manila," as 12½ acres just seven miles north of Manila on which the FEBC stations are located and where some 40 staff members reside. "All broadcasting time is freely given to evangelical missionaries, native pastors, and Christian groups in order that they may reach the people with the Gospel in their own tongue. This tremendous enterprise is financed solely by the gifts of individual Christians upon whose heart the Lord has laid the burden of world evangelism plus the desire to help make the Name of Jesus known throughout every nook and cranny of the world by means of radio!

Into remote barrios, mountain-hidden, lying on far-off islands or in dense jungles, are pouring ambassadors of the FEBC in the form of short-wave radio receivers which FEBC refers to as "PM's" (Portable Missionaries). These battery-operated sets, made of special tropic-resistant construction, pre-tuned to the frequencies of FEBC outlets, are placed in the custody of missionaries, native workers, and pastors, whose sacred duty it is to see that through them multitudes throughout the Orient hear that "Jesus Saves"!

Officials of FEBC include John C. Broger, president; Robert Bowman, vice-president; Wm. J. Roberts, executive secretary; M. D. Atienas, assistant manager; and Ben Bengeo, chief engineer.

Stations include DZAS, 680 kc., 5 kw.; DZB2, 3,325, 1 kw.; DZH6, 6,030, 2 kw.; DZH7, 9,730, 2 kw.; DZH9, *new*, 11,855, 1 kw., and DZH8, 15,300, 2 kw. The two 1 kw. transmitters are to be increased to 2 kw. in the near future.

DZH6 has a four-element phased array; DZH7 uses an eight-element phased array; DZH8 has a three-element rotary antenna, while DZH9 is soon to have a 12-element phased array.

Programs in *English* are listed for 1600, 1830-2030, 0500-0600, 0300-0515, 0700-0900 weekdays; Sunday schedule includes *English* at 1600 and 1800 (Sat. *EST*), 0300-0530, 0630-1100. Announces "This is the Call of the Orient" or "This is the Far East Broadcasting Company, Manila, Philippines."

Verification is by QSL card—with photos of staff. FEBC QSL's 100 percent with a nice card—but all reports are very carefully checked for accuracy. QRA is P.O. Box 2041, Manila, Philippines.

\* \* \*

### Needs Recordings

*Radio Hollandia*, Dutch New Guinea, is badly in need of recordings for its record library. A station official recently wrote Oskay, N. J., and others: "Because of the poor state of our rec-

(Note: Unless otherwise indicated, all time is expressed in American EST; add 5 hours for GCT. "News" refers to newscasts in the English language. In order to avoid confusion, the 24 hour clock has been used in designating the times of broadcasts. The hours from midnight until noon are shown as 0000 to 1200 while from 1 p.m. to midnight are shown as 1300 to 2400.) The symbol "V" following a listed frequency indicates "varying." The station may operate either above or below the frequency given. "A" means frequency is approximate.

ord library, we cannot very well follow our schedule. We haven't more than a thousand records, many of them very old ones that should have been declared unfit for use long ago." The station official asked the help of radio clubs—as well as individuals—in securing some *usable* records, not necessarily new ones. QRA is Radio Omroep Nieuw Guinea, Sentani, Netherlands New Guinea.

\* \* \*

### Radio Club Notes

*Belgium*—Details about the Belgian Short Wave Club can be had by writing to 147 Rue Franklin, Brussels, Belgium. (Van Gilder, Mass.)

*England*—Bob Kenny of the World Friendship Society of Radio Amateurs writes—"Of special concern to us is our 'Bedfast Club,' and any support in the way of old books or magazines from anyone, anywhere will be quite welcome." QRA is Bob Kenny, 30 Churchbury Road, Enfield, Middlesex, England. This club has set up a "SWL Monitor Service" to consolidate reports which will be sent to short-wave broadcasters that now have regular DX programs; this service is in charge of Bill Harris, "Bridge Cottage," Gt. Bealings, Woodbridge, E. Suffolk, England.

*Japan*—The Japanese Short Wave  
(Continued on page 138)

The transmitter room of "Call of the Orient," the Far East Broadcasting Company, Manila. FEBC now has six transmitters on the air daily, the most recently added is DZH9, 11,855. All of the transmitters are home-made, station officials boast.

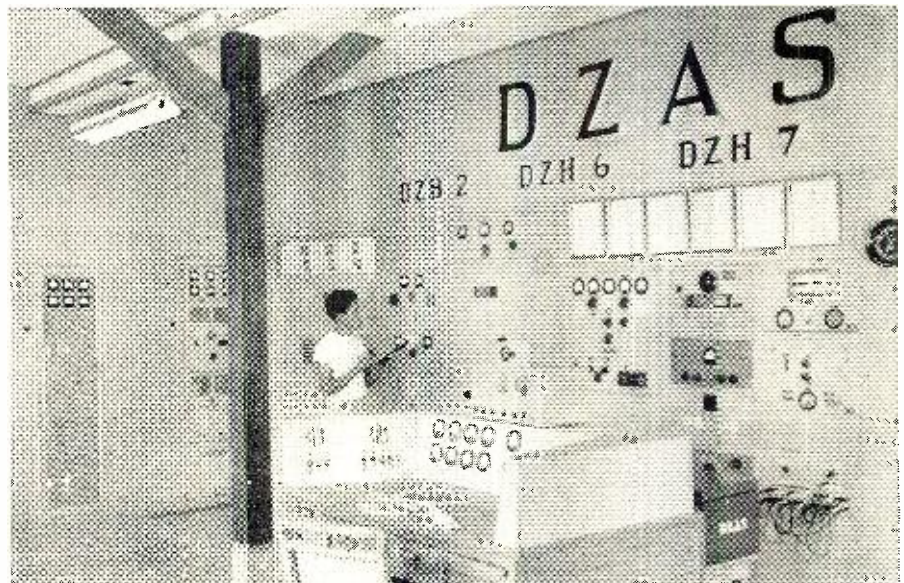

# AUDIO

# Simplified

By  
**DAVID FIDELMAN**

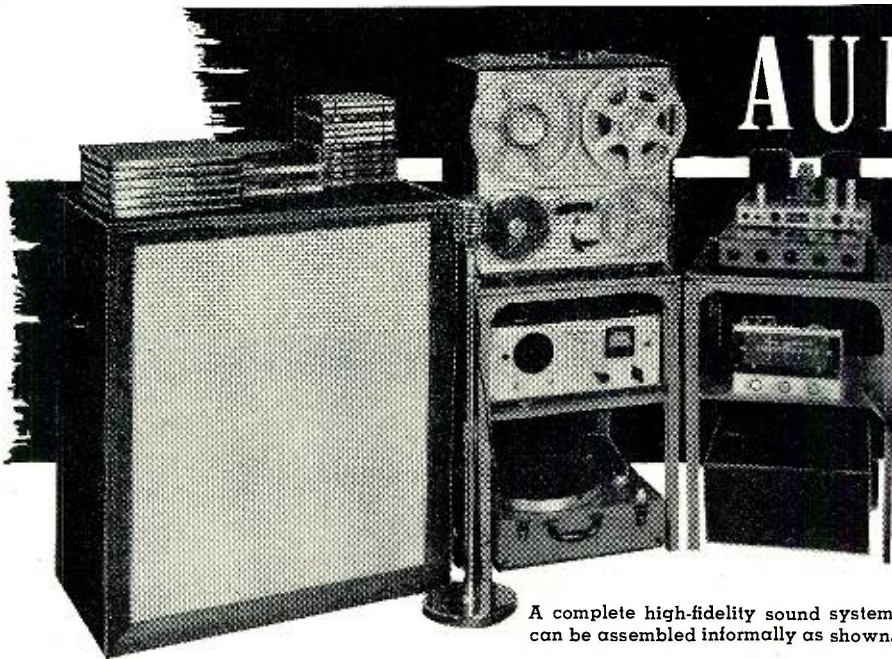

A complete high-fidelity sound system can be assembled informally as shown.

## Part 9. Concluding article presents a resumé of the most important features of an audio system.

THE complete sound reproduction system includes the microphone which converts the sound vibrations into electrical signals, the electronic system which transfers these signals in time or space either by recording or transmission, and the loudspeaker which converts the electrical signals back into sound. The electronic section may include a preamplifier

for low-level signals, a radio receiver or tuner, a voltage amplifier, tone controls and perhaps a noise filter and a volume expander or compressor, a power amplifier, and whatever switching or mixing networks are required for convenient operation. These components may be combined in different ways to perform a wide variety of functions, depending upon the interests of the individual experimenter. Systems may be set up for recording alone, for reproduction from records and radio broadcasts (which is the most common type of system), or as more versatile systems capable of simultaneous recording and reproduction.

Previous articles in this series have discussed in detail the various components and different sections of the sound reproduction system and described their design principles and method of operation. This final article will describe the manner in which they are combined into complete systems for recording or reproducing sound, and will indicate how the complete system is to be tested for quality and performance.

The basic systems for recording and reproducing sound consist essentially

of the components and setup shown in Fig. 1. Recording is accomplished by means of the system shown in Fig. 1A. A microphone converts the sound vibrations in the air into electrical signals which are then amplified by a low-level preamplifier. The frequency response may then be changed in any manner which is required by the recording process, and volume compression or limiting may be included. Further amplification provides the voltage and power to operate the particular transducer or converter which is used for the recording or transmission. The recording or transmission is played back by use of the system shown in Fig. 1B. It is converted into an audio-frequency electrical signal by the appropriate type of transducer (such as a phonograph pickup, radio receiver, or tape playback). This signal is then amplified and passed through an equalizer to give the required frequency response (and a volume expander, if desired). Further amplification provides the voltage and power for the loudspeaker to convert the electrical audio signal into sound again. These basic systems are quite general and form the basis for all types of sound recording and transmission, whether in the recording and broadcast studio or in the experimenter's home installation.

When greater flexibility is required, including simultaneous recording and reproduction, the system may be set up as shown in Fig. 2. The program material may be either direct sound picked up by a microphone, or may be taken from a recording or radio broadcast, and can be recorded and listened to simultaneously. (The monitoring facility is normally desirable even when the program is just to be recorded for playback at some future time.) This particular setup is quite simple and flexible in operation with a reasonable economy of equipment, and at the same time combines all the essential functions for both recording and reproduction.

The availability of simple and inexpensive  
**RADIO & TELEVISION NEWS**

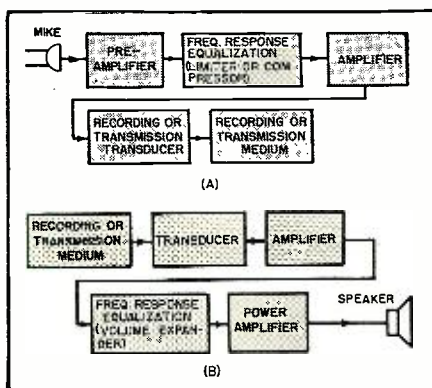
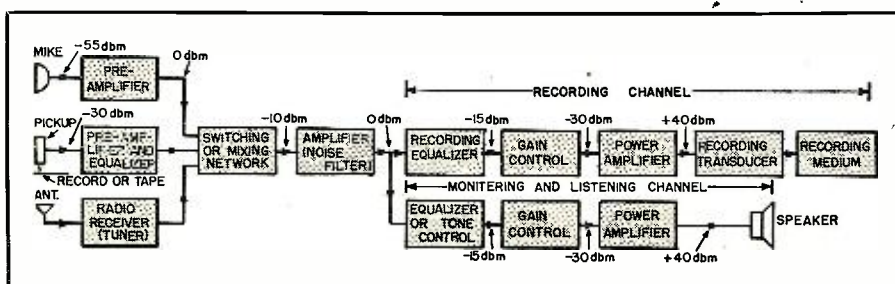

Fig. 1. (A) Basic system for recording or transmission of sound. (B) Basic system for reproduction of sound from a recording or from commercial-type transcriptions.

Fig. 2. Setup of system which can be used for the simultaneous recording and reproduction from either reproduced sound or from a direct pickup.



pensive disc recording equipment and the development of magnetic recording have made the recording process almost as simple as the reproduction process, therefore many serious listeners and experimenters are now very much interested in recording as well as in reproduction. However, by far the greatest interest at the present time is in systems for high-quality reproduction of sound from radio broadcasts and recordings—even among those who are also interested in making their own recordings. Therefore, to be of greatest usefulness, this article will concentrate on the discussion of practical systems for the reproduction of sound from radio broadcasts and recordings.

The basic system for reproduction of sound which has been recorded on discs or transmitted from a broadcast station is shown in the block diagram of Fig. 3. The input signal may originate in a phonograph pickup whose output is amplified (if necessary) by a low-level preamplifier, or in a radio tuner whose input is a modulated radio-frequency signal which the tuner converts into an audio-frequency signal. The particular signal which is to be reproduced is chosen by a switch or mixing network whose output is then applied to the input of the main amplifier channel. The output of the amplifier furnishes power to drive the loudspeaker to a sufficiently loud sound output. The main amplifier channel may include a tone control equalizer, a volume control, and volume expansion and noise filter circuits in addition to the necessary voltage amplifier and power amplifier. The various electronic sections of the reproducing system may be mounted on individual chassis in different locations, or they may all be mounted on a single chassis, depending upon the requirements of the individual installation.

A simple and adequate system which can be used for sound reproduction is shown in Fig. 4. This system consists of a separate radio tuner, a pickup for record playback, an amplifier which includes the switching and tone control circuits and the power amplifier, and the loudspeaker. The radio tuner may be any one of a number of good commercial tuners available for AM and FM reception which give appreciable voltage output to a high impedance load and are designed specifically for this type of application. The phonograph pickup should be either one of the good lightweight crystal pickups which have good frequency response and give an output voltage of about 1 volt into an impedance on the order of 1 megohm, or a good magnetic pickup. It may be mounted on one of the good three-speed record changers (that is, one that is relatively free from low-frequency rumble and speed variations such as wow and flutter) which can be used for playing records at 78, 45, or 33 rpm. (A different pickup or stylus will, of course, have to be used ac-

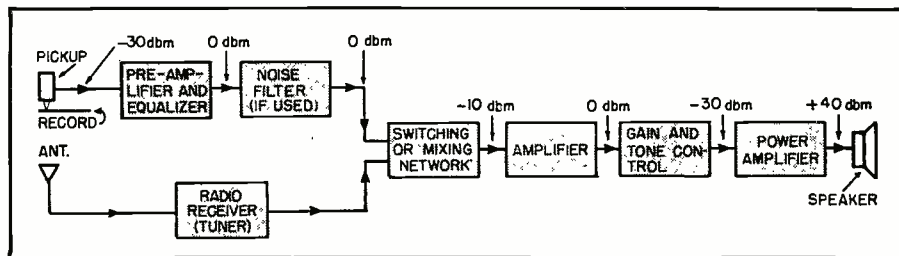

Fig. 3. Block diagram of a basic system for reproducing sound which has been recorded on discs or is transmitted from a broadcasting station.

ording to whether Microgroove or standard 78 rpm records are being played.)

The amplifier is shown in Fig. 7, and is based on the design principles which have been described in previous articles of this series. It contains a low-level preamplifier for use with magnetic phonograph pickups consisting of a dual-triode equalized two-stage amplifier which provides the required frequency correction and amplification for the pickup output. A mixing network selects either the radio tuner or phonograph pickup signal as the input to the amplifier. A single triode stage amplifies this input signal to the proper level for the adjustable tone control circuit, which has a 20 db insertion loss and provides up to 15 db bass and treble boost or attenuation. The output signal from the tone control circuit is further amplified by a single triode stage which feeds the driver section. The driver amplifier is a simple phase-inverter amplifier circuit which drives the grids of a push-pull 6V6 power amplifier. The output transformer may be any one of a number of good commercial transformers designed to be used with these tubes. Negative feedback is taken from the secondary of the output transformer to the cathode of the driver amplifier, and thus includes the entire power amplifier in the feedback loop. The feedback decreases the distortion in the power amplifier, improves the fre-

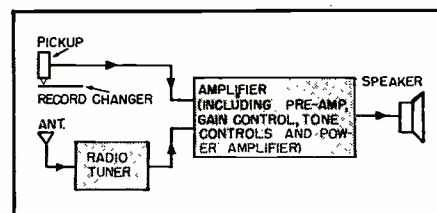

Fig. 4. Setup of a simple yet adequate system for sound reproduction, based on Fig. 3.

quency response, and lowers the output impedance to improve the transient response of the loudspeaker. This amplifier circuit will give quite good performance and its measured characteristics are well within the generally recognized limits for acceptable reproduction.

The loudspeaker should be a fairly good economical unit mounted in an appropriate cabinet or baffle. Since the amplifier is capable of delivering a maximum of about 12 to 14 watts, the loudspeaker should be capable of handling this power. A good 12 inch low-frequency speaker with a separate high-frequency tweeter, or a 12 inch coaxial dual unit, would be quite adequate. It may be mounted in a bass-reflex cabinet, a folded-horn corner cabinet, an infinite baffle, or any other of the acceptable baffles or cabinets which provide proper loading on the loudspeaker cone for good low-frequency response.

This sound reproduction system is a

A custom installation which houses a complete quality reproducing system inconspicuously. Variations of this arrangement can be made to suit the available space.

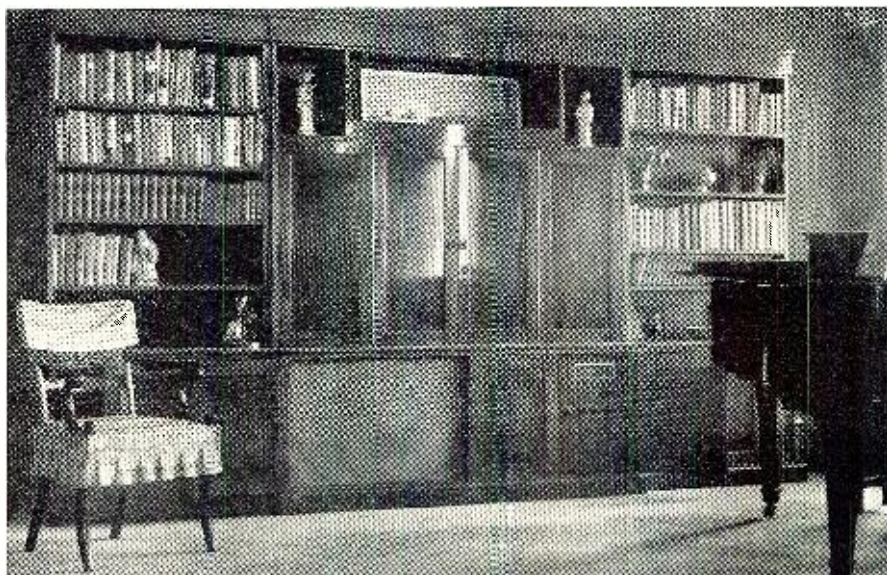

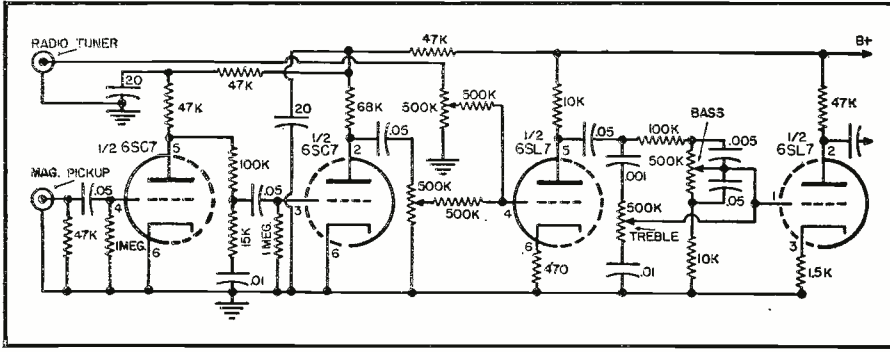

Fig. 5. Standard preamplifier which may be used in the sound system of Fig. 6.

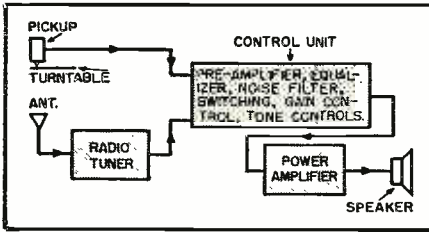

Fig. 6. Setup of high-quality sound reproducing system based on diagram of Fig. 3.

good, economical one for an average home installation, and will give very satisfactory reproduction. The measured characteristics will be within the recognized limits for acceptable reproduction, but there will still be present

certain amount of the various forms of distortion. The finest sound reproduction systems are those in which the distortions have been reduced to the lowest amounts possible with the present development of electronic engineering, and are to all practical purposes negligible. Such systems are, of course, extremely expensive since a considerable amount of care and effort must go into the manufacture of high-quality components.

The basic setup of such a system for the highest quality sound reproduction which is practical for reproduction in a home installation is shown in Fig. 6. This system includes a radio tuner, a disc playback turntable and pickup, a Williamson-type ampli-

fier with a separately located preamplifier containing most of the controls, and a high-quality loudspeaker system in a folded-horn corner enclosure. The radio tuner should be one of the commercial high-quality units, either for FM or AM-FM reception, which are available at the present time. The record playback unit should have a turntable which has very little wow and flutter, and a lightweight magnetic pickup with a wide frequency response. The turntable should either be one of the best three-speed record changers which have fairly good performance, or a single-record, high-quality turntable. The pickup may be any one of the various high-quality magnetic units.

The amplifier is based on the Williamson driver and power amplifier circuit, and has a separate preamplifier which selects the desired input and contains the volume and tone controls. (The radio tuner and the phonograph playback must, of course, be operated individually). The schematic circuit diagram of a typical amplifier which may be used for high-quality sound reproduction is shown in Figs. 7, 8, and 9. The basic preamplifier shown in Fig. 5 is similar to the one used in the system of Fig. 4, and is based on the design described in the article on preamplifiers. A modification of

(Continued on page 113)

Fig. 7. Schematic of typical amplifier which is suitable for use with the sound reproducing system shown in Fig. 4.

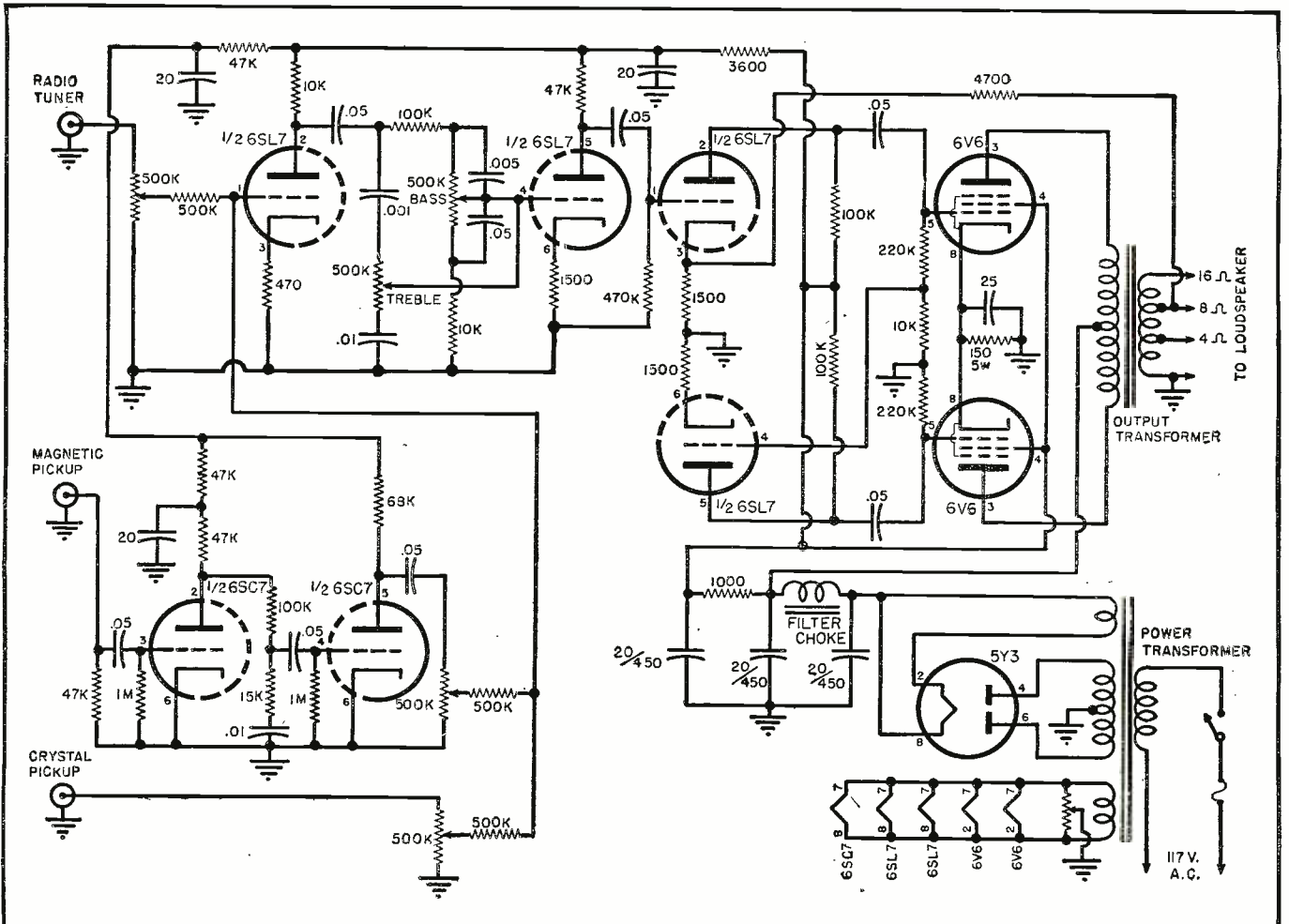

the retarding field of the reflector because it is traveling faster. As a result, it takes a longer time to return to the catcher because it has farther to travel. Similarly, an electron which passes through the buncher at a time when it is decelerated does not penetrate into the retarding field as much as those just considered, and takes a correspondingly shorter time to return to the catcher. By this process, electrons which initially pass through the buncher at equal intervals are made to return to the catcher in bunches.

### Conditions for Oscillation

In general, the condition for optimum operation of a reflex klystron is the same as for the two-resonator klystron, namely, the center of the bunches in the stream should pass through the catcher when the catcher field has its greatest retarding effect. Under this condition the greatest number of electrons lose the largest possible amount of power during the transit and the maximum power is extracted from the beam. In the case of the reflex klystron, which has no separate catcher, this means that the electron stream should be returned to the buncher when the buncher field has its maximum retarding effect.

It can be shown that this condition is satisfied if the total drift time of an electron, *i.e.*, the time it takes to travel from the buncher to the region of the reflector and return to the buncher, equals  $1\frac{3}{4}$  cycles. That is, any change in the total reflector transit time from this value of  $1\frac{3}{4}$  cycles results in a decrease in power delivered to the resonant circuit. If the total transit time is increased to  $2\frac{3}{4}$  cycles, however, optimum conditions will exist once more because the phase of the catcher field will again be such as to retard the returning electrons. Similarly, for other values such as:

$$(n + \frac{3}{4}) \text{ cycles}$$

where  $n$  is a whole number such as 1, 2, 3, etc., oscillations may exist.

This does not mean to imply that the reflex klystron will always oscillate if this transit time condition is met. If the d.c. beam current is too small, the power delivered by the bunched beam to the catcher may be less than the power dissipated in the buncher circuit. In this case there will be no oscillation. Therefore, a second condition is also necessary for oscillation to be maintained, namely, the d.c. beam current must exceed some minimum current, called the "starting current," which depends upon circuit and external load conditions. This starting current is inversely proportional to  $(n + \frac{3}{4})$ , that is, it is greater for transit times of  $1\frac{3}{4}$  cycles than it would be for, say,  $3\frac{3}{4}$  cycles. If both the conditions just discussed, *i.e.*, total transit time equal to  $(n + \frac{3}{4})$  cycles, and minimum starting current are satisfied, oscillations will always occur.

### Methods of Tuning

In actual practice there are several ways in which the transit time of a

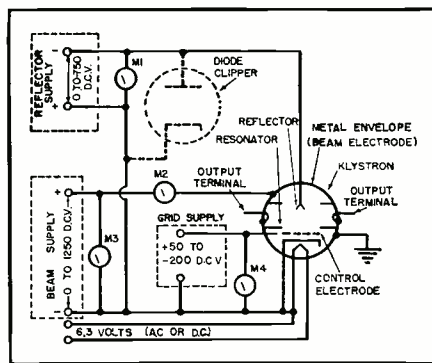

Fig. 5. Correct power supply connections for a reflex klystron oscillator.

reflex klystron may be adjusted to satisfy the first condition mentioned.

Fig. 5 shows, schematically, how such a klystron might be connected to power supplies in a typical oscillator circuit. Four separate supplies are indicated; a heater supply, a grid-bias supply, a beam supply, and a reflector supply. Of these, the latter two can be adjusted (either singly, or in combination) to vary the transit time and thus provide optimum operation. Most frequently, however, a change in reflector voltage rather than a change in beam voltage is used to control the transit time because a change in beam voltage produces two effects that tend to compensate each other. Increasing the beam voltage results in a higher velocity for the electrons, which tends to increase the time it takes them to return to the catcher; while at the same time it produces a greater potential difference between the cavity and the reflector, which tends to return the electrons in a shorter time. Since a change in reflector voltage produces only the second of these effects, about one-third as much change is needed in the reflector voltage as in the beam voltage for equal results. In addition, the reflector is a high-impedance electrode which draws no current and, therefore, the controlling elements (usually potentiometers) need not be capable of handling any appreciable amounts of power.

Since changing the transit time in a klystron is equivalent to varying the operating frequency, it is seen that by adjusting the reflector or the beam voltage of these tubes, the frequency may be changed. This behavior is known as "electronic tuning," and is utilized in practice to change the oscillating frequency by a comparatively small percentage. The main frequency controlling element in the reflex klystron is the resonant cavity which forms part of the buncher-catcher. By mechanically compressing the cavity, the volume of the cavity and the spacing of the grids connected to it are caused to change and, in this way, alter the oscillating frequency. This is called "mechanical tuning." In practice, both of the above methods are used, as follows:

The mechanical tuning is adjusted so that the operating point falls in a region of operation where the fre-

quency can be shifted a reasonable amount in either direction with electronic tuning without too much change in output power. The beam voltage and grid bias are adjusted to provide at least minimum starting current. Once the tube is oscillating, the reflector voltage is adjusted to optimize the transit time and thus provide maximum power output within a given "mode" of oscillation.

### Typical Behavior Curves

Klystron oscillators, in general, are characterized by the existence of discrete "modes of oscillation." (The word *mode* is used here to denote certain limited regions of electrode voltage within which oscillation occurs. Within a given mode, the frequency of oscillation changes continuously from one end of the mode to the other as the electrode voltage is changed.) The following are typical curves which illustrate this behavior:

Fig. 6 illustrates the so-called "reflector characteristics" of a reflex klystron, and shows both the variation of power output and the variation of frequency with reflector voltage. As can be seen from the lower curves, there are several discrete ranges of reflector voltage at which the tube will oscillate and supply power to the load. It is these ranges of operation which were previously defined as "modes." Inspection of the lower curves further reveals that the r.f. power outputs are not the same for all modes. In general, the maximum power output is greater at the higher reflector voltage modes. However, it is important to keep in mind that while the maximum power output obtainable may differ from one mode to the next, the frequency at the point of maximum output in each mode is exactly the same—being the resonant frequency of oscillation of the cavity.

In addition to showing the power output vs reflector voltage character-

Fig. 6. Characteristics of reflex klystron.

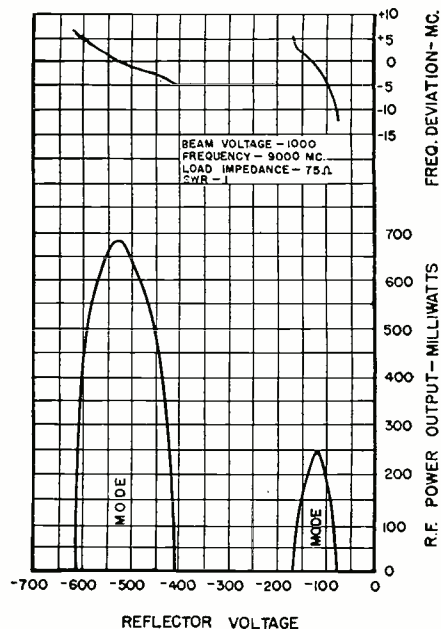

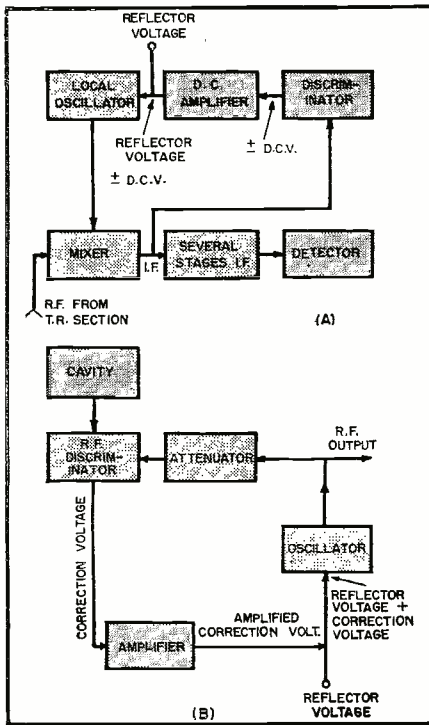

Fig. 7. (A) The difference-frequency type of a.c. system. (B) Block diagram of the absolute-frequency type of a.c. system.

istics just discussed, Fig. 6 also gives the frequency deviation vs reflector voltage characteristics of a typical reflex klystron. These curves are drawn in the upper portion of the graph and show the variation of output frequency with changes in the reflector voltage within any one mode. As was previously defined, this shifting of the operating frequency with reflector voltage is called "electronic tuning." The upper curves show that the range of tuning also varies with the mode, but in the opposite sense; in general, the range is smaller at the higher reflector voltage modes, making the operating frequency less susceptible to change for a given ripple in the reflector voltage supply. Since the modes with the highest output have the smallest electronic tuning range, a compromise must often be made between the value of reflector voltage which will yield the highest power output and a value of reflector voltage which will result in the greatest tuning range.

### Automatic Frequency Control

There are times when a very high degree of frequency stability is required and then some form of a.f.c. is usually employed. Most a.f.c. systems operate to minimize the difference between the frequency of the klystron oscillator and some standard of reference. In most radar applications, the standard of reference is the transmitter frequency plus or minus the intermediate frequency. This type of a.f.c. system can be thought of as a difference-frequency system. Another type of a.f.c. system used for the beacon local oscillator of an airborne radar uses a precision resonant cavity as the

standard of reference. This type of a.f.c. system can be thought of as an absolute-frequency system.

An example of the difference-frequency type of system is shown in the block diagram of Fig. 7A. The mixer, i.f. stages, and detector are similar to those found in any radar receiver. During transmission a portion of the "transmit-receive" section and is fed to the mixer in the same manner as would be a received signal. The mixer, in turn, produces an i.f. output which is applied to the discriminator of the a.f.c. system. The discriminator is able to distinguish between signals which are above the desired frequency and those which are below, and is able to produce an output voltage which is positive in one case and negative in the other. This d.c. voltage is amplified and added to the reflector voltage of the local-oscillator klystron in such a way as to maintain the output of the mixer at constant intermediate frequency.

In the absolute-frequency type of system, a high-"Q" reference cavity is employed as the standard. A block diagram illustrating the basic circuit is shown in Fig. 7B. As can be seen from the diagram, a portion of the r.f. output from the klystron oscillator is fed to an r.f. discriminator which is capable of producing an output voltage in proportion to the difference between the oscillator frequency and the resonant frequency of the cavity. This correction voltage is amplified and added to the reflector voltage of the klystron in such a way as to make the oscillator frequency the same as that of the reference cavity.

### Details on Reflex Klystron

Although all reflex klystrons behave electronically in a similar manner to that described in the foregoing paragraphs, in the past few years different mechanical design approaches have resulted in the development of several distinctive types of tubes. Since the most noticeable feature of a reflex klystron is its resonant cavity, a convenient grouping is according to the location of the cavity; that is, whether it is built into the tube (integral cavity), or external to it (external cavity).

The 3K27 reflex klystron, for example, is an integral cavity type and is illustrated in Fig. 2. The octal tube base serves to connect the proper operating voltages to the heater, grid, and buncher. Part way up the tube, pointing to the right, is a short length of rigid coaxial line which forms the

output lead. The microwave oscillations in the cavity are coupled out by means of an inductive pickup loop located inside the cavity and sent through this coaxial line to the output connector where it is available to do useful work. The cavity proper is the cylindrical portion of the tube which starts just below the coaxial output line and extends upward as far as the helical springs.

The mechanical tuning mechanism, not shown in the photograph, consists of helical springs, levers, tuning knob, screw, and a right-angle bracket. By rotating the tuning knob, the tuning screw moves either in or out of the bracket. This causes the levers, in turn, are connected to the movable wall of the cavity, the cavity shape becomes distorted and the frequency is changed to suit the new cavity dimensions. The 3K27 reflex klystron, with a full-range tuner, is capable of covering the entire frequency range of 770 to 1150 megacycles by rotation of a single knob, and with an average power output of about 1½ watts.

A second type of reflex klystron, known as the 2K28, uses an external cavity. In this type of tube the resonant cavity does not lie completely within the tube, but is chiefly external to it. In addition, the tube is constructed mainly of glass and does not have any tuning mechanism built in. The tube base is located at the bottom and serves to connect the proper operating voltages to the tube, as before. The electron gun occupies the region just below a lower copper disc which protrudes through the glass. This copper disc and the one above it form only a part of the cavity. The remainder of the cavity, whatever type it may be, must make contact with these two projecting discs. A typical cavity for the 8 to 12 cm region is shown in Fig. 8. The 2K28 fits in the hole in the center of the cavity with its discs making contact with the cavity walls.

Mechanical tuning is accomplished by turning the tuning knob, shown at the right-hand side of Fig. 8, which causes the sliding plunger (shown in the cutaway section) to move either toward or away from the klystron. This motion changes the volume of the cavity and thus the frequency of operation. The microwave oscillations are coupled out by means of an inductive pickup loop and fed through the short section of coaxial line shown on the left-hand side of the cavity. The 2K28 reflex klystron has a lead protruding through the top of the glass envelope which is used to connect the reflector voltage to the tube. Although the 2K28 was designed to operate in the 10 cm. range, oscillations have been obtained as low as 1000 mc. by using the proper external cavity. The average power output of this tube is about 70 mw.

Having discussed the theoretical aspects of satisfactory klystron operation and briefly described the physical

(Continued on page 130)

Fig. 8. Typical cavity for 8-12 cm region.

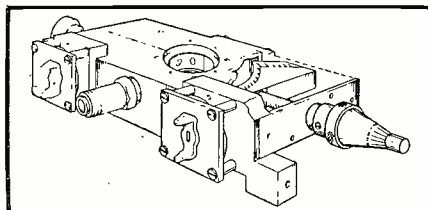

# the **BIG 10**

*is terrific!*

## **CHANNEL MASTER'S** fabulous new **10** ELEMENT YAGI

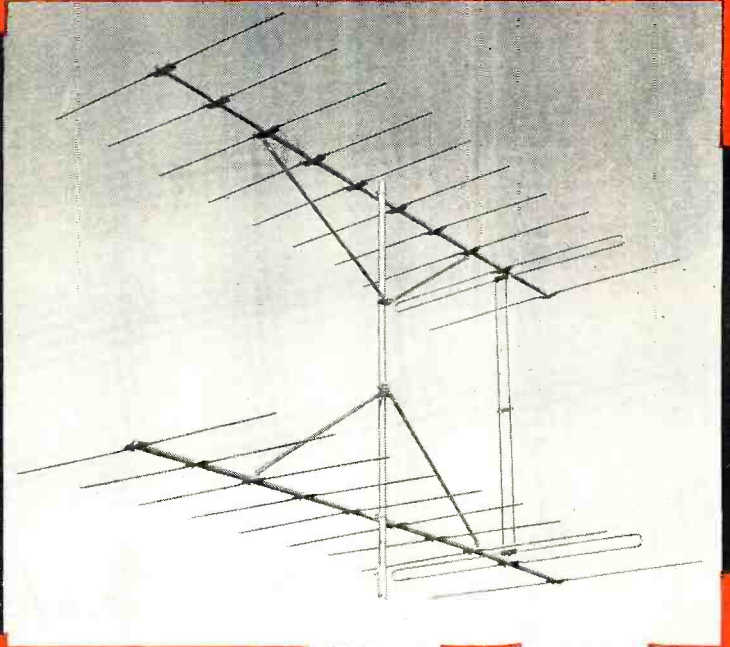

Highest Gains In TV History **12** DB single **14½** DB stacked

### COMPARE these 10 Terrific Features:

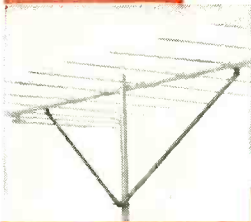

#### BOOM BRACING

Another original Channel Master development. Eliminates crossboom "bounce" — provides steadier pictures.

#### Amazing sensitivity!

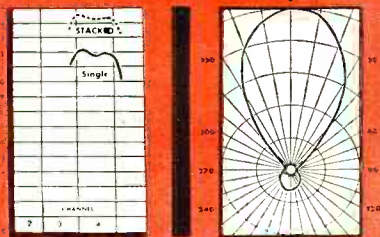

Channel 4 gain curves and polar pattern.

- 1 10 Elements—more signal, less noise, less rear pickup.
- 2 Highest gain of any Yagi ever developed.
- 3 Over 30% more gain than any 8 element Yagi.
- 4 This antenna **can be stacked**, with 78% additional gain over single bay.
- 5 Includes the famous Z-Match system.
- 6 You don't pay for stacking bars.
- 7 Excellent 300 ohm match in all installations.
- 8 "Boom Braced" to prevent crossboom "bounce" which causes picture flicker.\*
- 9 Two piece "Swej-Lok" crossboom for simplified stacking, handling, and installation.\*
- 10 Completely pre-assembled.

\*Low Band only.

List Prices	channel 7-13	<b>\$13<sup>88</sup></b>	channel 2 or 3	<b>\$31<sup>94</sup></b>
			channel 4 or 5	<b>28<sup>47</sup></b>
			channel 6	<b>25<sup>69</sup></b>

Write for name of your authorized distributor\* and complete technical literature.



## **CHANNEL MASTER CORP.**

NAPANOCH ROAD, ELLENVILLE, N. Y.

MEMBER



# The NEW 1952 Heathkit OSCILLOSCOPE KIT

MODEL O-7  
SHIPPING WT.  
29 LBS.

**\$435.00**

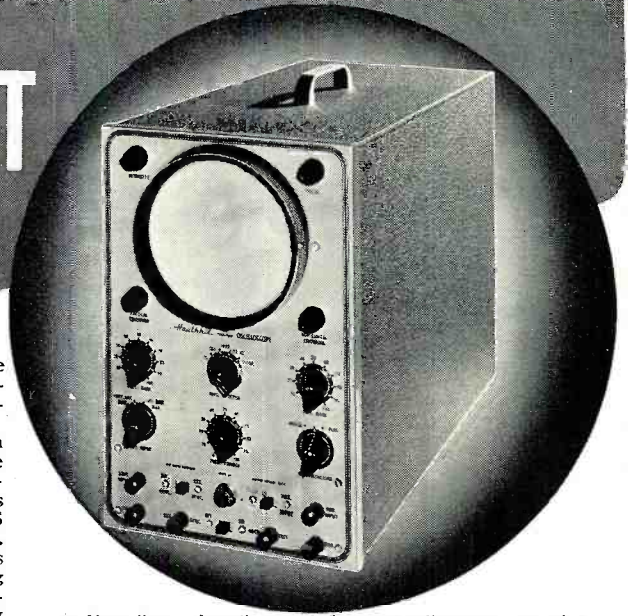

The Heathkit O-7 Oscilloscope with its 10 tube lineup (including CR tube) and carefully engineered circuit using highest quality components is truly the most outstanding scope value on the market today.

The "spot shape" (astigmatism) control working in conjunction with the focus control assures clear, sharp focusing . . . extended sweep range and faster retrace time permits the study of high frequencies . . . step-attenuated frequency-compensated cathode follower vertical input contributes to the excellent frequency response of the vertical channel . . . .03V RMS per inch vertical sensitivity makes weak input signals easy to study . . . push-pull operation of both vertical and horizontal deflection plates reduces pattern distortion . . . specially designed extra-wide CR tube mounting bracket places vertical cascade amplifier, vertical phase splitter, and deflection amplifiers near base of CR tube to reduce distributed wiring capacity and increase high frequency response.

Ideal for TV servicing—steep wavefronts encountered in TV work are easily handled. Fine for production line testing—rugged quality components can stand up under continuous hour-after-hour use. Excellent for laboratories—electrical performance comparable to scopes costing 4 and 5 times as much.

You'll like the complete instructions showing all details for easily building the kit—includes pictorials, step-by-step construction procedure, numerous sketches, schematic, circuit description. All necessary components included—transformer, cabinet, all tubes (including CR tube), completely punched and formed chassis—nothing else to buy.

- New "spot shape" control for spot adjustment—to give really sharp focusing.
- A total of ten tubes including CR tube and five miniatures.
- Cascaded vertical amplifiers followed by phase splitter and balanced push-pull deflection amplifiers.
- Greatly reduced retrace time.
- Step attenuated—frequency compensated—cathode follower vertical input.
- New mounting of phase splitter and deflection amplifier tubes near CR tube base.
- Increased frequency response—useful to 5 Mc.
- Tremendous sensitivity .03V RMS per inch Vertical—.6V RMS per inch Horizontal.

MODEL  
S-2

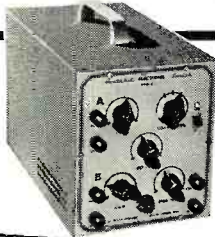

## Heathkit ELECTRONIC SWITCH KIT

SHIPPING WT.  
11 LBS.

**\$19.50**

The companion piece to a scope—Feed two different signals into the switch, connect its output to a scope, and you can observe both signals—each as an individual trace. Gain of each input is easily set (gain A and gain B controls), the switching frequency is simple to adjust (coarse and fine frequency controls), and the traces can be superimposed for comparison or separated for individual study (position control).

The kit is complete with tubes, switches, cabinet, power transformer and all other parts, plus a clear detailed construction manual.

## NEW Heathkit AUDIO FREQUENCY METER KIT

MODEL AF-1  
SHIPPING WT. 15 LBS.

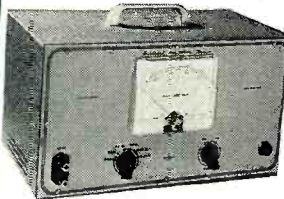

**\$34.50**

The ideal instrument for determining frequencies from 20 cycles to 100 KC. Set the selector switch to the proper range—feed the signal into the input terminals—and read the frequency from the meter—completely simple to operate, and yet dependable results.

Quality Simpson 200 microampere meter has two plainly marked scales (0-100 0-300). These scales read in conjunction with the seven position selector switch, give full scale readings of 100, 300, 1000, 3000, 10,000, 30,000, and 100,000 cycles. Convenient ranges for fast and easy readings.

For greatest accuracy, the 1-3-10 ratio of ranges is maintained and each range has an individual calibrating control.

A signal voltage anywhere between 2 and 300V can be fed directly into the instrument and a change in signal voltage between these limits will not affect the meter reading. In addition, input wave shape is not critical (the unit will read the frequency of either sine wave or square wave input).

The tube complement consists of a 6SJ7 amplifier and clipper, 6V6 amplifier and clipper, 6H6 meter pulse rectifier, 6X5 power supply rectifier, and OD3/VR150 voltage regulator.

Construction is simple, and quality components are used throughout.

## Heathkit INTERMODULATION ANALYZER KIT



MODEL IM-1  
SHIPPING WT. 18 LBS.

**\$39.50**

Intermodulation testing of audio equipment is rapidly being accepted by more and more engineers and audio experts as the best way to determine the characteristics of audio amplifiers, recording systems, networks, etc.

The Heathkit Intermodulation Analyzer supplies a choice of two high frequencies (approx. 3000 cycles and 7000 cycles) and one low frequency (60 cycles). Both 1:1 or 4:1 ratios of low to high frequencies can be set up for IM testing, and the ratios are easily set by means of a set up for IM testing, and the ratios are easily set by means of a panel control and the instrument's own VTVM. An output level control supplies the mixed signal at the desired level with level control supplies the mixed signal at the desired level with an output impedance of two thousand ohms. The Analyzer section has input level control and proper filter circuits feeding the instrument's VTVM to read intermodulation directly on full scale ranges of 30%, 10% and 3%. Built-in power supply furnishes all necessary voltages for operating the instrument.

**YOU SAVE BY ORDERING DIRECT FROM MANUFACTURER—USE ORDER BLANK ON LAST PAGE**

EXPORT AGENT  
ROCKE INTERNATIONAL CORP.  
13 E. 40th ST.  
NEW YORK CITY (16)  
CABLE: ARLAB-N.Y.

**The HEATH COMPANY**

**... BENTON HARBOR 15, MICHIGAN**



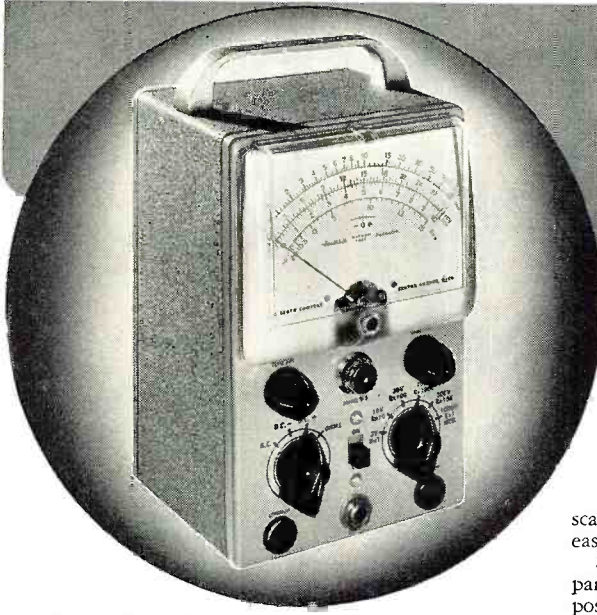

# THE *New* 1952 *Heathkit* VTVM KIT

MODEL V5-A  
SHIPPING WT. 7 LBS.

## \$24.50

Designed to take up a minimum of space, yet designed to be the most important and useful instrument on your workbench. Really handsome looking — note the rounded edges on front panel and rear cover. New compact size has cabinet dimensions of only 4 1/8" deep x 4 1/4" wide x 7 3/8" high.

Tremendous coverage — will read from 1/2 V to 1000V AC, 1/2 V to 1000V DC, .1 to over 1 billion ohms resistance, and Db. Meter scale has zero-set mark for FM alignment — all scales clearly marked for easy and fast readings and Db scale is in red for easy identification.

Simple to operate. Ohms adjust and zero adjust controls located on front panel along with selector and range switches. Selector switch has four positions: AC, DC-, DC+ and Ohms to set up the instrument for type of reading desired. DC- position allows negative voltages to be taken without reversing test prods. AC and DC voltage ranges are full scale 3V — 10V — 30V — 100V — 300V — 1000V and resistance ranges are RX1, X10, X100, X1000, X10M, X1 Megohm. Convenient ranges for fast and accurate readings.

Strictly highest quality components used throughout — 1% precision resistors in multiplier circuit, Simpson 200 microampere meter movement, sturdy cabinet, excellent positive detent smooth acting switches, etc. New miniature tube used in meter balancing circuit and new battery holding clamp and spring clip assure good contact to ohms string of resistors.

Kit comes complete — and the instruction manual with its step-by-step instructions, pictorials, figures, and schematic makes assembly a pleasure.

- New styling, — formed case for beauty.
- New truly compact size. Cabinet 4 1/8" deep by 4-11/16" wide by 7-3/8" high.
- Quality 200 microamp meter.
- New ohms battery holding clamp and spring clip — assurance of good electrical contact.
- Highest quality precision resistors in multiplier circuit.
- Calibrates on both AC and DC for maximum accuracy.
- Terrific coverage — reads from 1/2 V to 1000V AC, 1/2 V to 1000V DC, and .1 to over 1 billion ohms resistance.
- Large, clearly marked meter scales indicate ohms, AC Volts, DC Volts, and DB — has zero set mark for FM alignment.

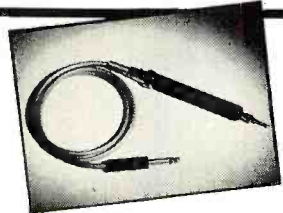

### *Heathkit* R F PROBE KIT

Extends range of Heathkit VTVM to 250 MC ± 10%. Designed for taking RF measurements. All parts furnished including probe housing and crystal diode detector. Shipping Weight 1 lb. **\$5.50**

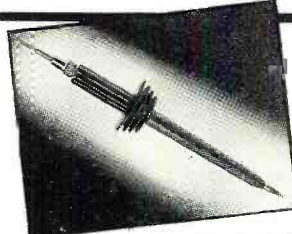

### *Heathkit* 30,000 V DC PROBE KIT

For taking readings up to 30,000 V DC when used with the Heathkit VTVM (or any standard 11 megohm VTVM). Comes with two color molded plastic probe body and all parts. Shipping Wt. 2 lbs. **\$5.50**

### *Heathkit* A. C. VACUUM TUBE VOLTMETER KIT

Now — as a Heathkit — at a price anyone can afford, an AC VTVM. Makes possible those sensitive AC measurements required by audio enthusiasts, laboratories, and experimentors. The kit audio men have been looking for. Ten ranges consisting of full scale .01, .03, .1, .3, 1, 3, 10, 30, 100, 300 volts RMS assure easy and more accurate readings. Ten ranges on DB provide for measurements from -52 to +52 DB. Frequency response within 1 DB from 20 cycles to 50 KC. The ingenious circuitry incorporates precision multiplied resistors for accuracy, two amplifier stages using miniature tubes, a unique bridge rectifier meter circuit, quality Simpson meter with 200 microampere movement, and a clean layout of parts for easy wiring. A high degree of inverse feedback provides for stability and linearity. Extremely compact, cabinet size — 4-1/8" deep x 4-11/16" wide x 7-3/8" high. Newly designed cabinet makes this the companion piece to the VTVM.



MODEL AV-1  
SHIP. WT. 5 LBS.  
**\$29.50**

### *Heathkit* SQUARE WAVE GENERATOR KIT

The Heathkit Square Wave Generator is an excellent square wave frequency source with features you won't want to be without. Especially notable is the wide range of the instrument — 10 cycles to 100 kilocycles continuously variable. This wide range makes it useful for television and wide band amplifier work as well as audio experimentation. The output impedance is low, and the output voltage is continuously variable between 0 and 20 volts. Because a multivibrator stage cannot be accurately calibrated, terminals on the front panel can be used for synchronization to an external source should it be desired.

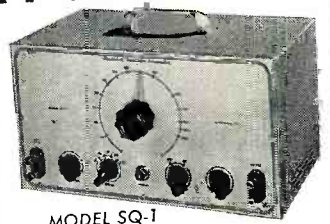

MODEL SQ-1  
SHIP. WT. 14 LBS.

## \$29.50

The circuitry consists of a multivibrator stage, a clipping and a squaring stage, and a cathode follower output stage. The power supply is transformer operated and utilizes a full wave rectifier tube with 2 sections of LC filtering. For a good, wide range, and low priced square wave generator, the SQ-1 just can't be beat.

**YOU SAVE BY ORDERING DIRECT FROM MANUFACTURER—USE ORDER BLANK ON LAST PAGE**

EXPORT AGENT  
**ROCKE INTERNATIONAL CORP.**  
13 E. 40th ST.  
NEW YORK CITY (16)  
CABLE: ARLAB.N.Y.

# The HEATH COMPANY

... BENTON HARBOR 15, MICHIGAN

# Heathkit SIGNAL GENERATOR KIT

Model SG-6  
Shipping Wt. 7 lbs.

The new Heathkit Signal Generator Kit has dozens of improvements. Covers the extended range of 160 Kc to 50 megacycles on fundamentals and up to 150 megacycles on useful calibrated harmonics; makes this Heathkit ideal as a marker oscillator for TV. Output level can be conveniently set by means of both step attenuator and continuously variable output controls. Instrument has new miniature HF tubes to easily handle the high frequencies covered.

Uses 6C4 master oscillator and 6C4 sine wave audio oscillator. The kit is transformer operated and a husky selenium rectifier is used in the power supply. All coils are precision wound and checked for calibration making only one adjustment necessary for all bands.

New sine wave audio oscillator provides internal modulation and is also available for external audio testing. Switch provided allows the oscillator to be modulated by an external audio oscillator for fidelity testing of receivers. Comes complete, all tubes, cabinet, test leads, every part. The instruction manual has step-by-step instructions and pictorials. It's easy and fun to build a Heathkit Model SG-6 Signal Generator.



## Heathkit CONDENSER CHECKER KIT

Only  
**\$19.50**

Model C-2  
Shipping Wt. 6 lbs.



Checks all types of condensers — paper — mica — ceramic — electrolytic. All condenser scales are direct reading and require no charts or multipliers. Covers range of .00001 MFD to 1000 MFD. A Condenser Checker that anyone can read. A leakage test and polarizing voltage for 20 to 500 V provided. Measures power factor of electrolytics between 0% and 50% and reads resistance from 100 ohms to 5 megohms. The magic eye indicator makes testing easy.

The kit is 110V 60 cycle transformer operated and comes complete with rectifier tube, magic eye tube, cabinet, calibrated panel and all other parts. Has clear detailed instructions for assembly and use.

## NEW Heathkit SIGNAL AND UNIVERSAL TEST SPEAKER KIT

**\$19.50**

Model T-2  
Shipping Wt. 7 lbs.



The popular Heathkit Signal Tracer has now been combined with a universal test speaker at no increase in price. The same high quality tracer follows signal from antenna to speaker — locates intermittents — finds defective parts quicker — saves valuable service time — gives greater income per service hour. Works equally well on broadcast, FM, or TV receivers. The test speaker has an assortment of switching ranges to match phones, pickups and PA systems. Also tests micro-60 cycle power transformer, tubes, test probe, all necessary parts, and detailed instructions for assembly and use.



Model TC-1  
Shipping Wt. 12 lbs.

**\$29.50**

## Heathkit TUBE CHECKER KIT

The Tube Checker is a MUST for radio repair men. Often customers want to SEE tubes checked, and a checker like this builds customer confidence. In your repairing, you will have a multitude of tubes to check — quickly. The Heathkit tube checker will serve all these functions — it's good looking (with a polished birch cabinet and an attractive two color panel) — checks 4, 5, 6, 7 prong Octals, Loctals, 7 prong miniatures, 9 prong miniatures, pilot lights, and the Hytron 5 prong types. AND IT'S FAST TO OPERATE — the gear driven, free-running roll chart lists hundreds of tubes, and the smooth, acting, simplified switching arrangement gives really rapid set-ups.

The testing arrangement is designed so that you will be able to test new tubes of the future — without even waiting for factory data — protection against obsolescence.

You can give tubes a thorough testing — checks for opens, shorts, each element individually, emission, and for filament continuity. A large BAD-?-GOOD meter scale is in three colors for easy reading and also has a "line-set" mark.

You'll find this tube checker kit a good investment — and it's only \$29.50.

YOU SAVE BY ORDERING DIRECT FROM MANUFACTURER—USE ORDER BLANK ON LAST PAGE

EXPORT AGENT  
ROCKE INTERNATIONAL CORP.  
13 E. 40th ST.  
NEW YORK CITY (16)  
CABLE: ARLAB-N.Y.

The **HEATH COMPANY**

... BENTON HARBOR 15, MICHIGAN

# NEW 1952 *Heathkit* BATTERY ELIMINATOR KIT



Model BE-3  
Shipping Wt. 17 lbs.

- Can be used as battery charger.
- Continuously variable output 0 - 8 Volts — not switch type.
- Heavy duty Mallory 17 disk type magnesium copper sulfide rectifier.
- Automatic overload relay for maximum protection. Self-resetting type.
- Ideal for battery, aircraft and marine radios.
- Dual Volt and Ammeters read both voltage and amperage continually — no switching.

The new Heathkit Model BE-3 incorporates the best. Continuously variable output control is of the variable transformer type with s-tooth wiper type contacts.

There are no switches or steps and voltage between 0 and 8 Volts is available at 10 Amperes continuous and 15 Amperes intermittent. Maximum safety from overloads and shorts provided by automatic overload relay which resets itself when overload is removed.

The new rectifier is a 17 plate Mallory magnesium copper sulfide type. This is the most rugged type available for long trouble-free use.

Output is continuously metered by both a 0 - 10 Volt Voltmeter and a 0 - 15 Amp Ammeter. Shorted vibrators indicated instantly by ammeter.

Equip now for all types of service — aircraft — marine — auto and battery radios — this inexpensive instrument vastly increases service possibilities — better be ready when the customer walks in.

## NEW *Heathkit* SINE AND SQUARE WAVE AUDIO GENERATOR KIT

Designed with versatility, usefulness, and dependability in mind, the AG-7 gives you the two most needed wave shapes right at your fingertips — the sine wave and the square wave.

The range switch and plainly calibrated frequency scale give rapid and easy frequency selection, and the output control permits setting the output to any desired level.

A high-low impedance switch sets the instrument for either high or low impedance output — on high to connect a high impedance load, and on low to work into a low impedance transformer with negligible DC resistance.

Coverage is from 20 to 20,000 cycles, and distortion is at a minimum — you can really trust the output wave shape.

Six tubes, quality 4 gang tuning condenser, power transformer, metal cased filter condenser, 1% precision resistors in the frequency determining circuit, and all other parts come with the kit — plus, a complete construction manual — A tremendous kit, and the price is truly low.

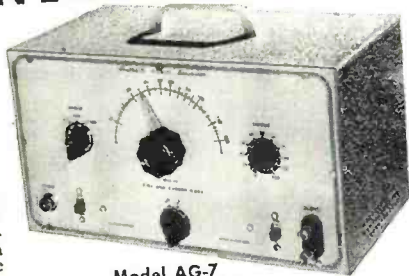

Model AG-7  
Shipping Wt. 15 lbs.

**\$34.50**

## NEW *Heathkit*

## T.V. ALIGNMENT GENERATOR KIT

Here is an excellent TV Alignment Generator designed to do TV service work quickly, easily, and properly. The Model TS-2 when used in conjunction with an oscilloscope provides a means of correctly aligning television receivers.

The instrument provides a frequency modulated signal covering, in two bands, the range of 10 to 90 Mc. and 150 to 230 Mc. — ALL ALLOCATED TV CHANNELS AS WELL AS IF FREQUENCIES ARE COVERED.

An absorption type frequency marker covers from 20 to 75 Mc. in two ranges — therefore, you have a simple, convenient means of frequency checking of IF's, independent of oscillator calibration.

Sweep width is controlled from the front panel and covers a sweep deviation of 0-12 Mc. — all the sweep you could possibly need or want.

And still other excellent features are: Horizontal sweep voltage available at the front panel (and controlled with a phasing control — both step and continuously variable attenuation for setting the output signal to the desired level — a convenient instrument stand-by position — vernier drive of both oscillator and marker tuning condensers — and blanking for establishing a single trace with base reference level. Make your work easier, save time, and repair with confidence — order your Heathkit TV Alignment Generator now!

Model TS-2  
Shipping Wt. 20 lbs.

**\$39.50**



## THE NEW *Heathkit* HANDITESTER KIT

A precision portable volt-ohm milliammeter. Uses only high quality parts — All precision 1% resistors, three-deck switch for trouble-free mounting of parts, specially designed battery mounting bracket, smooth acting ohm adjust control, beautiful molded bakelite case, 400 micro-amp meter movement, etc.

DC and AC voltage ranges 10 - 30 - 300 - 1000 - 5000V. Ohms range 0 - 3000 and 0 - 300,000. Range Milliamperes 0 - 10 Ma, 0 - 100 Ma. Easily assembled from complete instructions and pictorial diagrams.



**\$13.50**

Model M-1  
Shipping Wt. 3 lbs.

**YOU SAVE BY ORDERING DIRECT FROM MANUFACTURER—USE ORDER BLANK ON LAST PAGE**

EXPORT AGENT  
ROCKE INTERNATIONAL CORP.  
1314 40th ST.  
NEW YORK CITY (16)  
CABLE: ARAD-M T.

**The HEATH COMPANY**

**... BENTON HARBOR 15, MICHIGAN**

# Heathkit IMPEDANCE BRIDGE KIT



Model 1B-1B  
Shipping Wt. 15 lbs.

**\$69<sup>50</sup>**

This Impedance Bridge Kit is really a favorite with schools, industrial laboratories, and serious experimenters. An invaluable instrument for those doing electrical measurements work. Reads resistance from .01 Ohms to 10 meg., capacitance from .00001 to 100 MFD, inductance from 10 microhenries to 100 henries, dissipation factor from .002 to 1, and storage factor from 1 to 1000. And you don't have to worry about selecting the proper bridge circuit for the various measurements — the instrument automatically makes the correct circuit when you set up for taking the measurement you want. Bridge utilizes Wheatstone, Hay, Maxwell, and capacitance comparison circuits for the wide range and types of measurements possible. And it's self powered — has internal battery and 1000 cycle hummer. No external generator required — has provisions for external generator if measurements at other than 1000 cycles are desired. Kit utilizes only highest quality parts. General Radio main calibrated control.

Mallory ceramic switches, excellent 200 microamp zero center galvanometer, laboratory type binding posts with standard 3/4 inch centers, 1% precision ceramic-body type multiplier resistors, beautiful birch cabinet and ready calibrated panel. (Headphones not included.)  
Take the guesswork out of electrical measurements — order your Heathkit Impedance Bridge kit today — you'll like it.

## Heathkit LABORATORY RESISTANCE DECADE KIT

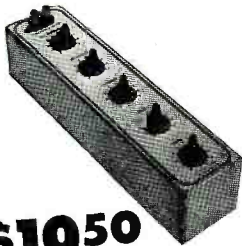

**\$19<sup>50</sup>**

Shipping Wt. 4 lbs.

An indispensable piece of laboratory equipment — the Heathkit Resistance Decade Kit gives you resistance settings from 1 to 99,999 ohms IN ONE OHM STEPS. For greatest accuracy, 1% precision ceramic-body type resistors and highest quality ceramic wafer switches are used.

Designed to match the Impedance Bridge above, the Resistance Decade Kit has a beautiful birch cabinet and attractive panel. It's easy to build, and comes complete with all parts and construction manual.

## Heathkit LABORATORY POWER SUPPLY KITS

*Limits:*

No load.....Variable 150-400V DC  
25 MA.....Variable 30-310V DC  
50 MA.....Variable 25-250V DC  
Higher loads: Voltage drops off proportionally



**\$29<sup>50</sup>**

Model PS-1.....Ship. Wt. 20 lbs.

Every experimenter needs a good power supply for electronic setups of all kinds. This HV supply has been expressly designed to act as a source. Voltage control allows selection of HV output desired (continuously variable within limits outlined), and a Volts-Ma switch provides choice of output metering. A large plainly marked and direct reading meter scale indicates either DC voltage output in Volts or DC current output in Ma. (Range of meter 0-500V D.C., 0-200 Ma. D.C.) Instrument has convenient stand-by position and pilot light.

Comes with power transformer, filament transformer, meter, 5Y3 rectifier, two 1619 control tubes, completely punched and formed chassis, panel, cabinet, detailed construction manual, and all other parts to make the kit complete.

## Heathkit ECONOMY... 6 WATT AMPLIFIER KIT

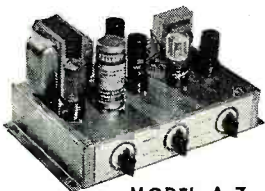

MODEL A-7  
Shipping Wt. 8 lbs.

**\$14<sup>50</sup>**

- Choice of 4-8-15 ohm output impedances.
- Response flat  $\pm 1\frac{1}{2}$  db from 20-20,000 cycles.
- 6 watts output.
- Good fidelity at low cost.
- Output tubes working in push pull.
- Volume, bass, and treble controls.
- Two separate inputs.

The purpose of this kit is to provide to the kit builder a low cost amplifier with excellent fidelity. The circuit consists of four tubes with following functions: a 12SL7, one section working as an amplifier and one as a phase splitter, two 12A6 output tubes working in push pull, and a 5Y3 rectifier in a full wave rectifier circuit.

The unit operates from a husky power transformer, and has good output transformer with a choice of 4-8-15 ohm output impedances. (Speaker not included).

The kit provides excellent listening pleasure and the price is really low. Compare it with all others. You won't find a better buy.

MODEL A-7: For tuner and crystal phono inputs. Has two position selector switch for convenient switching to type of input desired.

MODEL A-7-A: Has a 12SH7 preamplifier stage with special compensation network for operation with reluctance phono input. Shipping Wt. 8 lbs. **\$16.50**

## Heathkit HIGH FIDELITY 20 WATT AMPLIFIER KIT

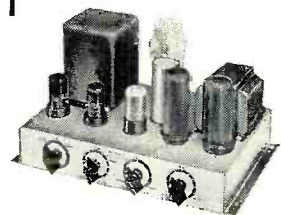

MODEL A-8  
Shipping Wt. 18 lbs.

**\$33<sup>50</sup>**

The A8 (or A-8A) is a high quality amplifier for those who want high fidelity output at moderate cost. Frequency response within  $\pm 1$ db from 20-20,000 cycles. Distortion at 3db below maximum power output (at 1,000 cycles) is only .3%. Kit has a Chicago power transformer in drawn steel case and a Peerless output transformer with output impedances of 4-8-16 ohms. Bass and treble controls permit listener to select output with tonal qualities of his own liking.

The tube lineup is composed of a 6SJ7 voltage amplifier, a 6SN7 amplifier and phase splitter, two 6L6's in push-pull output and a 5U4G rectifier. All parts furnished (speaker not included) and the construction manual makes assembly easy.

MODEL A-8: For tuner and crystal phono inputs. Has two position selector switch for convenient switching to type of input desired.

MODEL A-8A: Features an added 6SJ7 stage (preamplifier) for operating from variable reluctance cartridge phono pickup, mike input, and either tuner or standard crystal phono pickup. A three position selector switch provides flexible switching. Shipping Wt. 18 lbs. **\$35.50**

**YOU SAVE BY ORDERING DIRECT FROM MANUFACTURER—USE ORDER BLANK ON LAST PAGE**

EXPORT AGENT  
ROCKE INTERNATIONAL CORP.  
13 E. 40th ST.  
NEW YORK CITY (16)  
CABLE: ARLAB-N.Y.

**The HEATH COMPANY**

**... BENTON HARBOR 15, MICHIGAN**

# Heathkit RECEIVER & TUNER KITS for AM and FM



Model BR-1 Broadcast Model Kit covers 550 to 1600 Kc. Shipping Wt. 10 lbs.

**\$19.50**

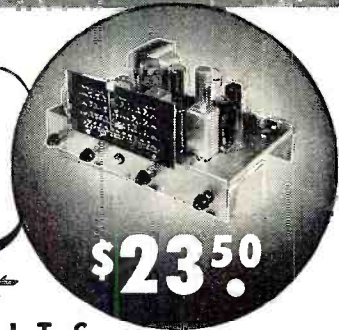

Model AR-1 3 Band Receiver Kit covers 550 Kc. to over 20 Mc. continuous. Extremely high sensitivity. Shipping Wt. 10 lbs.

**\$23.50**

## TWO HIGH QUALITY *Heathkit* SUPERHETERODYNE RECEIVER KITS

Two excellent Heathkits. Ideal for schools, replacement of worn out receivers, amateur and custom installations. Both are transformer operated quality units. The best of materials used throughout—six inch calibrated slide rule dial—quality power output transformers—dual iron core shielded. I.F. coils—metal cased filter condenser. The chassis has phono input jacks, 110 Volt output for phono motor and there is a phono-radio switch on panel. A large metal panel simplifying installation in used console cabinets is included. Comes complete with tubes and instruction manual incorporating pictorials and step-by-step instructions (less speaker and cabinet). The three band model has simple coil turret which is assembled separately for ease of construction.

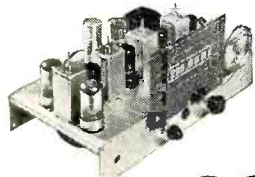

Model FM-2  
Ship. Wt. 9 lbs.

**\$22.50**

## TRUE FM FROM *Heathkit* FM TUNER KIT

The Heathkit FM Tuner Model FM-2 was designed for best tonal reproduction. The circuit incorporates the most desirable FM features—true FM. Utilizes 8 tubes: 7E5 Oscillator, 6SH7 mixer, two 6SH7 IF amplifiers, 6SH7 limiter, two 7C4 diodes as discriminator, and 6X5 rectifier. The instrument is transformer operated making it safe for connection to any type receiver or amplifier. Has ready wound and adjusted RF coils, and 2 stages of 10.7 Mc IF (including limiter). A calibrated six inch slide rule dial has vernier drive for easy tuning. All parts and complete construction manual furnished.



MAIL TO THE  
**HEATH COMPANY**  
BENTON HARBOR 15,  
MICHIGAN

### ORDER BLANK

From \_\_\_\_\_  
\_\_\_\_\_  
\_\_\_\_\_

SHIP VIA  
 Parcel Post  
 Express  
 Freight  
 Best Way

Quantity	Item	Price	Quantity	Item	Price
	Heathkit Oscilloscope Kit — Model O-7			Heathkit H.V. Probe Kit — No. 336	
	Heathkit VTVM Kit — Model V-5-A			Heathkit R.F. Signal Gen. Kit — Model SG-6	
	Heathkit FM Tuner Kit — FM-2			Heathkit Condenser Checker Kit — Model C-2	
	Heathkit Broadcast Receiver Kit — Model BR-1			Heathkit Handitester Kit — Model M-1	
	Heathkit Three Band Receiver Kit—Model AR-1			Heathkit Power Supply Kit — Model PS-1	
	Heathkit Amplifier Kit — Model A-7 (or A-7-A)			Heathkit Resistance Decade Kit — Model RD-1	
	Heathkit Amplifier Kit — Model A-8 (or A-8A)			Heathkit Impedance Bridge Kit — Model IB-1B	
	Heathkit Tube Checker Kit — Model TC-1			Heathkit A.C. VTVM-KIT — Model AV-1	
	Heathkit Audio Generator Kit — Model AG-7			Heathkit Intermodul. Analyzer Kit—Model IM-1	
	Heathkit Battery Eliminator Kit — Model BE-3			Heathkit Audio Freq. Meter Kit — Model AF-1	
	Heathkit Electronic Switch Kit — Model S-2			Heathkit Square Wave Gen. Kit — Model SQ-1	
	Heathkit T.V. Alignment Gen. Kit — TS-2				
	Heathkit Signal Tracer Kit — Model T-2				
	Heathkit R.F. Probe Kit — No. 309				

On Parcel Post Orders, include postage for weight shown and insurance. (We insure all shipments.)  
On Express Orders, do not include transportation charges—they will be collected by the Express Agency at time of delivery.

Enclosed find  Check  Money Order for \_\_\_\_\_  
Please ship C.O.D.  Postage enclosed for \_\_\_\_\_ lbs.

ALL PRICES SUBJECT TO CHANGE WITHOUT NOTICE

EXPORT AGENT  
**ROCKE INTERNATIONAL CORP.**  
13 E. 40th ST.  
NEW YORK CITY (16)  
CABLE: ARAS-N.Y.

**The HEATH COMPANY**  
... BENTON HARBOR 15, MICHIGAN

# A Simple Improvement for Regenerative Receivers

By

CHARLES ERWIN COHN

*By improving the antenna coupling, a regenerative receiver can be made to perform like a superhet.*

**T**HE regenerative receiver is capable of giving more performance per tube than any other known receiver circuit. However, it has certain disadvantages which have precluded its general adoption, the primary of these being its tendency to interfere with other receivers when in the oscillating condition.

Another disadvantage of these sets, while not as bothersome as the above, is their tendency to interact with the antenna, causing both frequency shift and erratic regeneration control. However, neither of these bad features is inherent in the regenerative circuit, but both are due to the fallacy of coupling to an antenna a circuit which is distinctly unsuited for such coupling. The fundamental idea of the regenerative detector is the feeding back of energy from the plate to the grid circuit, and the close control of that feedback in order to realize maximum gain. Now, obviously, the presence of an antenna in the circuit, which by its very nature tends to draw power, cannot help but upset the delicate bal-

ance necessary for the best performance. Also, when the set is run in an oscillating condition, which is a perfectly legitimate state of operation for band-searching or c.w. reception, the antenna draws out oscillator power and radiates it to interfere with the reception of others. In an attempt to reduce these effects, most regenerative receivers are loose-coupled to the antenna through a small condenser on the order of several micromicrofarads. Although that scheme does reduce these effects to some extent, it also reduces the efficiency of energy transfer from the antenna to the detector, and thus reduces the sensitivity of the receiver. In fact, no system of antenna coupling using passive elements alone can get away from this difficulty, due to the reciprocity theorem, that energy transfer through a passive network is the same in both directions.

Therefore, it is obvious that the type of antenna coupling needed is a "one-way" coupling which will allow maximum energy transfer from the antenna to the detector, but will prevent

transfer in the other direction. The obvious component to use for this purpose is a vacuum tube. Therefore, the circuit shown in Fig. 1A was designed. Essentially, it is an untuned r.f. amplifier. The only unconventional part of this circuit is the means of coupling to the detector. The r.f. plate is impedance-coupled to the plate side of the tickler winding, which then serves as an r.f. primary as well as giving regeneration. Of course, it is also possible to connect the output end of the .001  $\mu$ fd. coupling condenser to the top end of the grid coil, but I found that this connection causes a great loss in selectivity, making the receiver "swamp" on strong signals. The connection shown maintains the selectivity as well as giving efficient energy transfer. In receivers which use a cathode tap instead of a tickler for regeneration, the coupling condenser is connected to that tap. If a three-winding tuning coil is used, the third winding can be used for coupling.

If a remote cut-off tube is used in the r.f. stage, the untuned antenna connection is perfectly satisfactory in almost all cases. However, if there are extremely strong signals in the area, especially on the broadcast band, some "swamping" is likely to be noticed; the strong signals occupying an inordinate amount of dial space. If this is bothersome, it can be eliminated by using a tuned input circuit such as the one shown in Fig. 1B. Either a standard antenna coil and 365  $\mu$ fd. variable for the broadcast band, or a 140  $\mu$ fd. condenser and a standard plug-in coil with its tickler winding used as primary for all-wave operation is suitable. The tuning condenser for this circuit can either be tuned separately or ganged with the detector tuning condenser. In the latter case, the antenna and detector coils should be fairly well matched. Since this circuit tunes quite broadly, neither tracking nor separate tuning is any great problem. With it the selectivity is extremely good, and weak stations can be received quite close on the dial to strong ones. Resistors  $R_k$  and  $R_{s1}$  should be proportioned to provide the proper screen and bias voltage for the particular tube used.

Of course, if a detector is poor to start with, if it has abrupt or erratic regeneration control, or if it produces fringe howl, "squegging," or other spurious noises, this circuit will not make it a good receiver. However, with a good detector circuit, the addition will make a set rivaling many superhets, but sharing the regenerator's advantages of simplicity, economy, and low power drain. Even with the tuned antenna input, this r.f. stage is extremely stable, and can be installed without trouble. Its use is recommended, therefore, for every regenerative receiver, since it makes a great improvement in the sensitivity, besides reducing the bad effects of antenna interaction, and eliminating radiation to such an extent that it cannot be detected by another set.

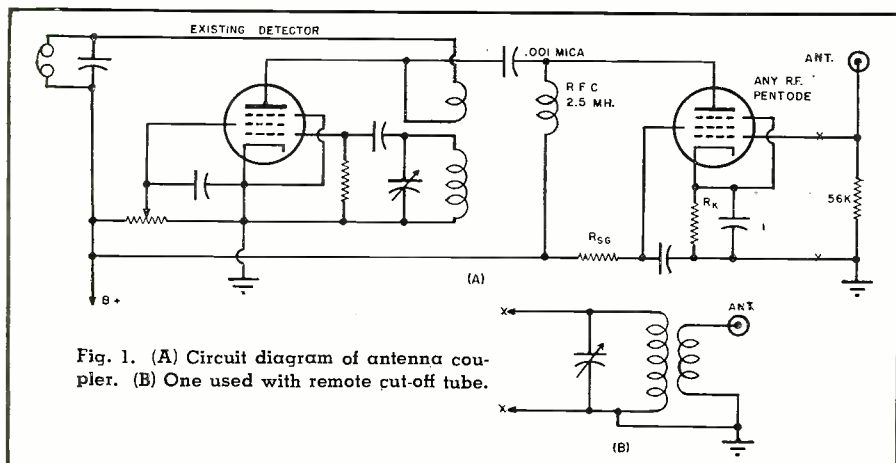

Fig. 1. (A) Circuit diagram of antenna coupler. (B) One used with remote cut-off tube.

if you use television picture tubes

# DU MONT PICTURE TUBE DATA CHART

## ELECTROMAGNETIC FOCUS TYPES

Type	Code	Model	Length	Beam Diameter	Beam Current	Beam Power	Beam Voltage	Beam Angle	Beam Spot	Beam Deflection	Beam Deflection Angle	Beam Deflection Rate	Beam Deflection Time	Beam Deflection Distance	Beam Deflection Angle	Beam Deflection Rate	Beam Deflection Time	Beam Deflection Distance
11P1	11P1	11P1	11P1	11P1	11P1	11P1	11P1	11P1	11P1	11P1	11P1	11P1	11P1	11P1	11P1	11P1	11P1	11P1

**Using the Data Chart**  
**CODE AND APPLICATION NOTES**  
 1. 11P1 is a standard picture tube.  
 2. 11P1 is a standard picture tube.  
 3. 11P1 is a standard picture tube.  
 4. 11P1 is a standard picture tube.  
 5. 11P1 is a standard picture tube.  
 6. 11P1 is a standard picture tube.  
 7. 11P1 is a standard picture tube.  
 8. 11P1 is a standard picture tube.  
 9. 11P1 is a standard picture tube.  
 10. 11P1 is a standard picture tube.  
 11. 11P1 is a standard picture tube.  
 12. 11P1 is a standard picture tube.  
 13. 11P1 is a standard picture tube.  
 14. 11P1 is a standard picture tube.  
 15. 11P1 is a standard picture tube.  
 16. 11P1 is a standard picture tube.  
 17. 11P1 is a standard picture tube.  
 18. 11P1 is a standard picture tube.  
 19. 11P1 is a standard picture tube.  
 20. 11P1 is a standard picture tube.  
 21. 11P1 is a standard picture tube.  
 22. 11P1 is a standard picture tube.  
 23. 11P1 is a standard picture tube.  
 24. 11P1 is a standard picture tube.  
 25. 11P1 is a standard picture tube.  
 26. 11P1 is a standard picture tube.  
 27. 11P1 is a standard picture tube.  
 28. 11P1 is a standard picture tube.  
 29. 11P1 is a standard picture tube.  
 30. 11P1 is a standard picture tube.  
 31. 11P1 is a standard picture tube.  
 32. 11P1 is a standard picture tube.  
 33. 11P1 is a standard picture tube.  
 34. 11P1 is a standard picture tube.  
 35. 11P1 is a standard picture tube.  
 36. 11P1 is a standard picture tube.  
 37. 11P1 is a standard picture tube.  
 38. 11P1 is a standard picture tube.  
 39. 11P1 is a standard picture tube.  
 40. 11P1 is a standard picture tube.  
 41. 11P1 is a standard picture tube.  
 42. 11P1 is a standard picture tube.  
 43. 11P1 is a standard picture tube.  
 44. 11P1 is a standard picture tube.  
 45. 11P1 is a standard picture tube.  
 46. 11P1 is a standard picture tube.  
 47. 11P1 is a standard picture tube.  
 48. 11P1 is a standard picture tube.  
 49. 11P1 is a standard picture tube.  
 50. 11P1 is a standard picture tube.  
 51. 11P1 is a standard picture tube.  
 52. 11P1 is a standard picture tube.  
 53. 11P1 is a standard picture tube.  
 54. 11P1 is a standard picture tube.  
 55. 11P1 is a standard picture tube.  
 56. 11P1 is a standard picture tube.  
 57. 11P1 is a standard picture tube.  
 58. 11P1 is a standard picture tube.  
 59. 11P1 is a standard picture tube.  
 60. 11P1 is a standard picture tube.  
 61. 11P1 is a standard picture tube.  
 62. 11P1 is a standard picture tube.  
 63. 11P1 is a standard picture tube.  
 64. 11P1 is a standard picture tube.  
 65. 11P1 is a standard picture tube.  
 66. 11P1 is a standard picture tube.  
 67. 11P1 is a standard picture tube.  
 68. 11P1 is a standard picture tube.  
 69. 11P1 is a standard picture tube.  
 70. 11P1 is a standard picture tube.  
 71. 11P1 is a standard picture tube.  
 72. 11P1 is a standard picture tube.  
 73. 11P1 is a standard picture tube.  
 74. 11P1 is a standard picture tube.  
 75. 11P1 is a standard picture tube.  
 76. 11P1 is a standard picture tube.  
 77. 11P1 is a standard picture tube.  
 78. 11P1 is a standard picture tube.  
 79. 11P1 is a standard picture tube.  
 80. 11P1 is a standard picture tube.  
 81. 11P1 is a standard picture tube.  
 82. 11P1 is a standard picture tube.  
 83. 11P1 is a standard picture tube.  
 84. 11P1 is a standard picture tube.  
 85. 11P1 is a standard picture tube.  
 86. 11P1 is a standard picture tube.  
 87. 11P1 is a standard picture tube.  
 88. 11P1 is a standard picture tube.  
 89. 11P1 is a standard picture tube.  
 90. 11P1 is a standard picture tube.  
 91. 11P1 is a standard picture tube.  
 92. 11P1 is a standard picture tube.  
 93. 11P1 is a standard picture tube.  
 94. 11P1 is a standard picture tube.  
 95. 11P1 is a standard picture tube.  
 96. 11P1 is a standard picture tube.  
 97. 11P1 is a standard picture tube.  
 98. 11P1 is a standard picture tube.  
 99. 11P1 is a standard picture tube.  
 100. 11P1 is a standard picture tube.

## ELECTROSTATIC FOCUS TYPES

Type	Code	Model	Length	Beam Diameter	Beam Current	Beam Power	Beam Voltage	Beam Angle	Beam Spot	Beam Deflection	Beam Deflection Angle	Beam Deflection Rate	Beam Deflection Time	Beam Deflection Distance	Beam Deflection Angle	Beam Deflection Rate	Beam Deflection Time	Beam Deflection Distance
11P1	11P1	11P1	11P1	11P1	11P1	11P1	11P1	11P1	11P1	11P1	11P1	11P1	11P1	11P1	11P1	11P1	11P1	11P1

**Electrostatic Focus Tubes**  
 The main reason for the development of electrostatic focus tubes is the need for a more compact and efficient design. These tubes are designed to provide a sharp focus and a long life span. They are available in a variety of sizes and types to meet the needs of different applications.



## RULE-OUTLINE INFORMATION

Type	Code	Model	Length	Beam Diameter	Beam Current	Beam Power	Beam Voltage	Beam Angle	Beam Spot	Beam Deflection	Beam Deflection Angle	Beam Deflection Rate	Beam Deflection Time	Beam Deflection Distance	Beam Deflection Angle	Beam Deflection Rate	Beam Deflection Time	Beam Deflection Distance
11P1	11P1	11P1	11P1	11P1	11P1	11P1	11P1	11P1	11P1	11P1	11P1	11P1	11P1	11P1	11P1	11P1	11P1	11P1

**CATHODE RAY TUBE DIVISION**  
**ALLEN B. DU MONT LABORATORIES, INC.**  
 750 BLOOMFIELD AVENUE  
 CLIFTON, N. J.

Teletrons  
 TELEVISION'S FINEST  
 PICTURE TUBES

Whether it's for TV receiver design, research, or servicing be sure to have one of these charts handy. At a glance you can see all the electrical and physical characteristics for any modern RTMA-registered TV picture tubes. This is the latest edition of the Du Mont tube chart incorporating the very latest tube types. Ask your local Teletron Distributor, or write...

# DU MONT

Teletrons\*



First with the Finest in Television Picture Tubes  
 Cathode-ray Tube Division,  
 Allen B. Du Mont Laboratories, Inc.  
 Clifton, N. J. \*Trade mark

# ATR

For  
**AC CURRENT  
ANYWHERE**



**STANDARD  
AND HEAVY DUTY  
INVERTERS**

For Inverting D. C. to A. C.  
Specially Designed for operating A. C.  
Radios, Television Sets, Amplifiers, Ad-  
dress Systems, and Radio Test Equip-  
ment from D. C. Voltages in Vehicles,  
Ships, Trains, Planes and  
in D.C. Districts.

NEW MODELS  
NEW DESIGNS  
NEW LITERATURE

ATR

"A" Battery, Eliminators, DC-AC Inverters  
Auto Radio Vibrators

See your jobber or write factory

**AMERICAN TELEVISION & RADIO CO.**  
Quality Products Since 1931  
SAINT PAUL 1, MINNESOTA-U. S. A.

## WHAT'S

*New in Radio*

For additional information on any of the items described herein, readers are asked to write direct to the manufacturer. By mentioning RADIO & TELEVISION NEWS, the page, and the issue number, delay will be avoided.

### EICO MULTIMETER

*Electronic Instrument Co., Inc.*, 84 Withers Street, Brooklyn 11, New York, has just introduced a new multimeter in its 1952 line of test equipment.

The Model 536 has 31 different 1000-



ohms-per-volt ranges. It is said to be the only multimeter of its type that offers a.c.-d.c. voltage ranges from 0-1 volt up to 0-5000 volts in six steps. There are four d.c. and a.c. current ranges; three resistance ranges from 0-500 ohms, 100,000 ohms, and 1 megohm; and six db ranges covering from -20 to +69 db. The instrument incorporates a large 3 1/2", 400  $\mu$ a. meter movement.

The Model 536 is available in either kit (Model 536-K) or factory-wired form. It is housed in a high-impact Bakelite case which measures 6 1/4" x 3 3/4" x 2". Complete assembly and operating instructions accompany each unit.

### CARBON MIKE

*Astatic Corporation*, Conneaut, Ohio, is now marketing a new, single-button carbon microphone which is especially suitable for a wide variety of mobile transmitter applications and other hand mike uses.

The manufacturer claims that this



new mike combines ruggedness and immunity to high temperatures and humidity with increased sensitivity and

good performance quality. Response is 100 to 4500 cps, sensitivity is rated at one volt for 100 dyne/cm<sup>2</sup>.

The Model 10M5 has a double-pole, single-throw switch, with relay and microphone circuits normally open. It will work into power output tubes without preamplifier stages with a step-up transformer.

The mike comes complete with a four-conductor, self-coiling cable with oil-resistant "Neoprene" rubber cover. It has a retracted length of 12 inches and extends to five feet. The conductors are color-coded, and the free ends are stripped and tinned. A coiled spring cable connector is mounted at the microphone.

### POWER AMPLIFIER

A new laboratory power amplifier has been added to the line of equipment being produced by *Hermon Hosmer Scott, Inc.*, 385 Putnam Avenue, Cambridge 39, Massachusetts as the Type 220-A.

This versatile and inexpensive unit has been designed for both laboratory and high-fidelity music reproduction work. Its rated power output is 20 watts and the frequency response is flat from 12 to 55,000 cycles.

Harmonic distortion is less than .5%

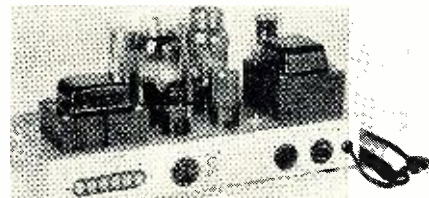

at the full 20 watt output, first-order difference-tone intermodulation component is less than .1% at full rated peak output, hum level is minus 90 db below full output, input for the full-rated 20 watt output is .5 volt on the low level input and 1.5 volts on the high level input, input impedance is .5 megohm for the low level input and 1.5 megohms for high level input.

A free bulletin on the Type 220-A is available on request.

### ELECTRICAL TUBING

A new type of electrical tubing which is said to possess exceptional flexibility and heat endurance has just been announced by the *Irvington Varnish and Insulator Company*, Irvington, New Jersey.

The new product is known as "silicone rubber-coated fiberglass tubing" and has been designed to withstand exposure of 200 hours at 200 degrees C without embrittlement.

The new tubing is manufactured by

**RADIO & TELEVISION NEWS**



using selected sizes of glass braid, which are coated with silicone rubber, using a special multiple coat process to insure uniform coating and roundness. It will meet the performance of the government specification Mil-1-3190 on Class "H" materials.

A preliminary data sheet on this tubing is available from the Sales Promotion Dept. of the company.

#### COMPACT V-O-M

Trade Associates, 128 South 1st Street, Brooklyn, New York is in production on a new compact volt-ohm-milliammeter which measures only 2¼" x 2¼" x 4".

The new unit is designed to test a.c. and d.c. voltages in the range 1, 10, 50, 100, 500, and 1000 volts, and d.c. mil-

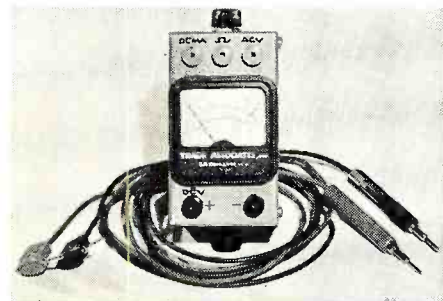

liamperes at 1, 10, and 100. Resistance ranges cover up to 1 megohm with 22,500 ohms center scale. Sensitivity is 1000 ohms-per-volt.

#### NEW HAM TUBE

A potent and versatile beam power tube, designed to handle 50 watts of power input at 175 mc., has been announced by the Tube Department of Radio Corporation of America, Harrison, New Jersey.

The new RCA-6146 provides large power output with small driving power and relatively low plate voltage and is, therefore, expected to find wide amateur application in the 2-meter band.

The tube is of the v.h.f. beam-power amplifier type and is designed for use in both mobile and fixed communications equipment. It can be employed as an r.f. power amplifier, oscillator, a.f. power amplifier, or modulator.

It can be operated in c.w. service with an input of 90 watts up to 60 mc. and with an input of 60 watts at 175 mc. It has a maximum plate dissipation rating of 25 watts under ICAS conditions in both modulator and c.w. services.

The tube measures 1¾" in diameter and is 3¾" long. Complete data on the RCA-6146 is now available from the company's tube distributors.

#### LEVER SWITCH

General Control Company, Boston 34, Massachusetts has developed a new, miniature, telephone-type lever switch which has been especially designed for use in instruments, radio equipment, and communications systems.

The Type MCS unit has a single-hole mounting which reduces assembly time  
(Continued on page 143)

# HERE'S THE "SECRET!"

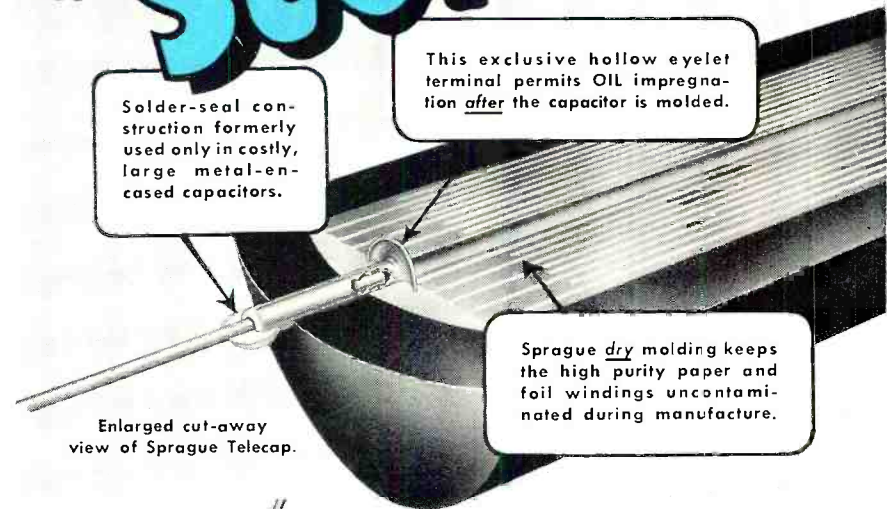

Solder-seal construction formerly used only in costly, large metal-encased capacitors.

This exclusive hollow eyelet terminal permits OIL impregnation after the capacitor is molded.

Sprague *dry* molding keeps the high purity paper and foil windings uncontaminated during manufacture.

Enlarged cut-away view of Sprague Telecap.

... that makes **SPRAGUE TELECAPS®** outperform and outlast other molded tubulars



Actual, on-the-job performance *proves* the superiority of Sprague "Black Beauties" beyond question. To find the secret that explains just why they're so much better, however, you've got to see inside of a Telecap itself.

The big feature is that every Sprague Telecap is molded into its sturdy Bakelite phenolic shell while its windings are still *dry*. Any chance of contamination by moisture or dust during manufacture is avoided. *After* molding, the capacitor is vacuum-impregnated with mineral oil through a tiny eyelet. The lead is then inserted, the terminal is solder-sealed—and you have a capacitor that has maximum resistance to heat and moisture... extra high insulation resistance and superior capacitance stability. *In short, a capacitor that brings you premium quality at no extra cost!*

... And that's the secret behind the fact that Sprague Telecaps are more widely used by leading television set makers... and why they're first choice of service technicians who value their reputations for good work!

Write for "Telecap" Bulletin. It's free!



**SPRAGUE PRODUCTS CO.**  
Distributors Division of Sprague Electric Co.  
51 Marshall Street  
NORTH ADAMS MASSACHUSETTS

**BLACK BEAUTY TELECAPS®**

TELEVISION'S MOST WIDELY USED MOLDED TUBULARS



**Airex... WHERE MERCHANDISE IS TOPS...**  
**PRICES ARE LOW... VALUES THE GREATEST**  
 NO FREE MERCHANDISE • OUR PRICES ARE LOW • QUALITY SUPREME

# NOW—THE FINEST "630" TV CHASSIS EVER—WITH THE AMAZING CASCODE TUNER

PERFECT FOR FRINGE AREAS • 4 microvolt sensitivity

This wonderful new Super DX handles all tubes from 10" to 24" . . . will bring in better reception up to 200 miles without the use of boosters and will work where other sets have failed. The NEW STANDARD COIL CASCODE tuner gives you greater sensitivity with less snow. This tuner utilizes the newly developed 6BK7 tube with the gold-plated grid . . . is fully shielded against radiation and has a newly designed converter circuit. Has new improved Mark flyback with keyed AGC for better picture control; 15 KV output; 3-stage sync separator; 6CB6 tubes in video IF; 5-hour minimum heat run at factory. Plasticized condensers; syncro lock; improved new Ferrite core width coil, for greater range of width. Armstrong FM sound system; improved linearity control. Factory wired, aligned and tested before shipment. Phono connection and switch on chassis. Complete with RCA Hi-Fi 12" Speaker. DIRECTLY ADAPTABLE FOR COLOR AND UHF STATIONS.

**\$ 49<sup>95</sup>**  
 Complete with 12" RCA Hi-Fi Speaker. Fed. Tax Included Less Picture Tube

Service Manual—\$1.00

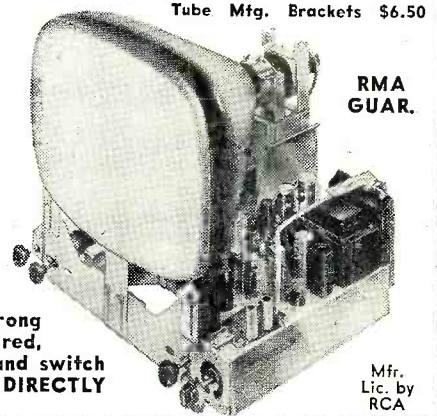

## SENSATIONAL SPECIAL OFFER OF THE AIREX SUPER DX COMPLETE TV SETS . . . THE FINEST SET VALUE IN ITS PRICE CLASS

These outstanding sets were specially designed to meet our rigid specifications to assure you many pleasant hours of trouble free TV at an unequalled price. The mfr. is licensed by RCA. RMA guarantee. All you have to do is plug in and play.

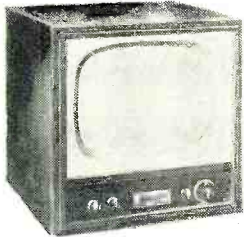

17"—\$154.95  
 20"—\$179.95

**24" TV CONSOLE**  
 1 Year Warranty on Tubes and Parts **\$299<sup>95</sup>**

### Check These Features

- Has standard coil Cascode tuner that brings in reception up to 200 miles • 20 tubes • Large HI-FI speaker • Hand rubbed, satin finished genuine mahogany cabinet • AGC • Moulded plastic condensers • Black, glareless picture tube, guaranteed for 6 months • Adaptable for UHF and color • Synchronized FM audio system • 5 hour heat run at factory • Factory wired, aligned and tested • Mounted in cabinet.



17"—\$174.95  
 20"—\$199.95

## Price Smashing Values in TV Cabinets for "630" Chassis

Beautiful, richly finished, hand rubbed mahogany cabinets to suit every taste. They are designed to house the "630" chassis, 12" speaker and up to 20" TV tube. The combination cabinets will hold up to a 20" TV tube, radio and Webster record changer, with ample record space.

All cabinets are equipped with mask and mounting brackets. The perfect chassis deserves a perfect cabinet. It will be a focal point of beauty in your home. Other models in stock. When ordering chassis and cabinet, no tube mounting brackets needed. Send for FREE circular.

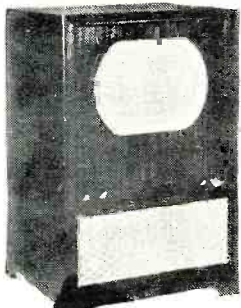

**ECONOMY**

38x22 1/2 x 22 1/2—16" and 17" tube . . . \$49.95  
 41x25x23—16" to 20". 59.95  
 45x28x25—24" tube . . 74.95  
 Blonde \$10 Additional

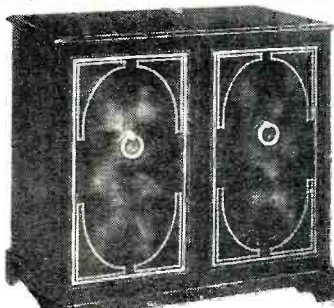

**ELITE**

Combination—39x40x23 1/2. Red antique gen. leather. Gold leaf hand tooling . . . \$149.95  
 In lined oak, gold colored leather 159.95



**STRATFORD**

40x28 1/2 x 23 1/2. Genuine crotch Mahogany doors for 20" only . . \$89.95

All merchandise is brand new, factory fresh & fully guaranteed. Mail & phone orders filled upon receipt of certified check or money order for \$25 as deposit on TV chassis, 20% on other items. Balance C.O.D., F.O.B. N. Y. Prices subject to change without notice. No Fed. taxes to pay. Prices lower than OPS Regs.

**AIREX RADIO CORP.** 171 Washington St., N.Y.C. 7, N.Y.  
 Phone Worth 2-4029

## TV TUBE EXTRA STANDARD BRANDS BLACK-GLARELESS Factory New—1st Quality Guaranteed 1 Year

14" Rectangular \$26.95 17" Rectangular \$32.95  
 16" Rectangular 29.95 20" Rectangular 39.95  
 16" Round . . . 33.50 21" Rectangular 44.95  
 24" Round Metal 69.95  
 Ring and sleeve for 24" tube . . . \$7.50

**TV GOLD, PLASTIC MASKS**  
 16" & 17", \$4.95; 20" & 21", \$7.95; 24", \$14.95

## TV ANTENNA BARGAINS

Following antennas can be used with our sets and are perfect for fringe area use. Complete with 10 ft. mast, 100 ft. wire, insulators, mounting brackets & lightning arrestors. Order now. Save 33 1/2 %.

Stacked Conical . . . . . \$19.95  
 Stacked Double Vee . . . . . 19.95  
 Single Conical . . . . . 15.95  
 Single Double Vee . . . . . 15.95

**PORTABLE PHONO—33 1/3 RPM**  
 2 tube amplifier. Tone control. Cases slightly imperfect . . . \$13.95

## RCA VICTOR AUTOMATIC CHANGER

Plays all 33 1/3 and 78 RPM Records, turnover cart, 2 needles, intermix and stops on last record. **\$19<sup>95</sup>**  
 MATCHING METAL BASE . . . \$3.95

## AIR KING 6-TUBE CHASSIS

Superhet, AC-DC for custom installation. Complete with loop antenna, all tubes and extra RF stage. Ready to play. Reg. \$25. **\$11<sup>95</sup>**  
 MATCHING PLASTIC CABINET. \$3.95

**Airex Special 5-Watt Amplifier**  
 3 Tubes, Phono Mike Input. Separate Bass & Treble Control. **\$19.95**

<b>300 OHM TV LEAD-IN WIRE</b> 14 strands each leg. Heavy duty. 100 ft \$2. 1000 ft \$17.95.	<b>FM TUNER</b> 5 tubes plus rectifier. New FM Band. <b>\$24<sup>95</sup></b>
---	--

**"NOW YOU CAN FIX YOUR OWN TV SET"**  
 Simplified book. Fix over 1,000 models listed by 39 manufacturers. **\$1<sup>00</sup>**

## SPECIAL BARGAINS

- Approved 10-Watt Amplifier . . . \$ 34.50
- Espéy 7C FM-AM Radio, 12 Tubes . . 69.95
- 2 Set TV Antenna Coupler . . . . . 3.69
- RCA Hi-fi speaker . . . . . 4.95
- Standard Coil Cascode Tuner . . . . 24.95
- Super Sonic Booster, MD1107 . . . . 14.95
- Regency Booster, Md1 DB410 . . . . 19.11
- Resistor Assortment—100 . . . \$2.49; 1000 . . . . . 21.50

COMPLETE LINE 630 PARTS  
 RADIO TUBES 50% TO 70% OFF LIST

SEND POSTCARD TO BE PUT ON FREE MAILING LIST

# Thunder Hunters

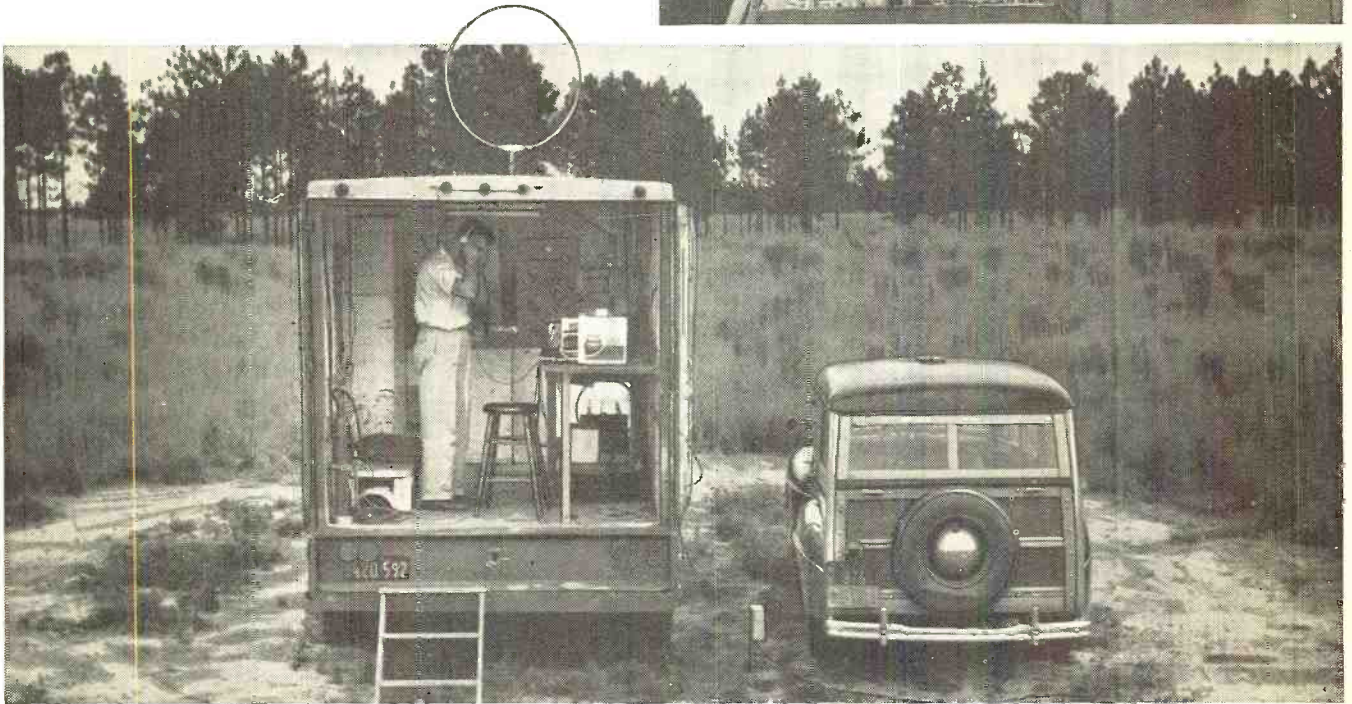
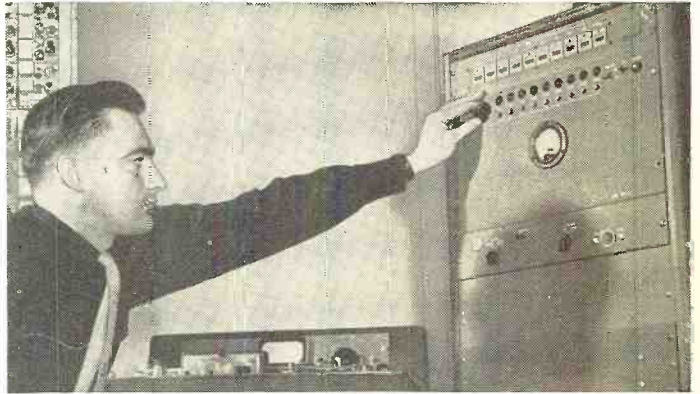

Thunder hunting equipment on location near Madison, Florida. Loop antenna on truck picks up static. The engineer in top picture is watching the indication of a circuit which registers how often the static exceeds a given level.

Many new telephone circuits have two jobs to do—carrying your voice and transmitting signals to operate dial exchanges in distant towns. And an old-fashioned thunderstorm can interfere with both!

“Rolling static” comes from many storms over a wide area and can interfere with clear telephone talk. A nearby lightning flash makes “crack static” which, unchecked, plays hob with dial system signals.

So Bell Laboratories scientists go “Thunder Hunting” in the storm centers of the United States — “capturing” storms by tape recorders. Back in the Laboratories, they recreate the storms, pitting them against their new circuits. This method is more efficient and economical than completing a system and taking it to a storm country for a tryout. It demonstrates again how Bell Telephone Laboratories help keep costs down, while they make your telephone system better each year.

## BELL TELEPHONE LABORATORIES



*Improving telephone service for America  
provides careers for creative men in  
scientific and technical fields.*

## TELEVISION STATIONS IN OPERATION

(as of May 1, 1952)

<b>ALABAMA</b>	
Birmingham	WBRC-TV — WAFM-TV
<b>ARIZONA</b>	
Phoenix	KPHO-TV
<b>CALIFORNIA</b>	
Los Angeles	KNBH, KECA-TV, KHJ-TV, KLCB-TV, KTLA, KNXT, KTTV
San Diego	KFMB-TV
San Francisco	KRON-TV, KGO-TV, KPIX
<b>CONNECTICUT</b>	
New Haven	WNHC-TV
<b>DELAWARE</b>	
Wilmington	WDEL-TV
<b>FLORIDA</b>	
Jacksonville	WMBR-TV
Miami	WTVJ
<b>GEORGIA</b>	
Atlanta	WSB-TV, WAGA-TV, WLTV
<b>ILLINOIS</b>	
Chicago	WNBQ, WBKB, WENR-TV, WGN-TV
Rock Island	WHBF-TV
<b>INDIANA</b>	
Indianapolis	WFBM-TV
Bloomington	WTTV
<b>IOWA</b>	
Ames (Des Moines)	WOI-TV
Davenport	WOC-TV
<b>KENTUCKY</b>	
Louisville	WAVE-TV, WHAS-TV
<b>LOUISIANA</b>	
New Orleans	WDSU-TV
<b>MARYLAND</b>	
Baltimore	WBAL-TV, WAAM, WMAR-TV
<b>MASSACHUSETTS</b>	
Boston	WBZ-TV, WNAC-TV
<b>MICHIGAN</b>	
Detroit	WWJ-TV, WJBK-TV, WXYZ-TV
Grand Rapids	WOOD-TV
Kalamazoo	WKZO-TV
Lansing	WJIM-TV
<b>MINNESOTA</b>	
Minneapolis-St. Paul	KSTP-TV, WTCN-TV
<b>MISSOURI</b>	
Kansas City	WDAF-TV
St. Louis	KSD-TV
<b>NEBRASKA</b>	
Omaha	WOW-TV, KMTV
<b>NEW JERSEY</b>	
Newark	WATV
<b>NEW MEXICO</b>	
Albuquerque	KOB-TV
<b>NEW YORK</b>	
Binghamton	WBNF-TV
Buffalo	WBEN-TV
New York	WNBT, WABD, WCBS-TV, WJZ-TV, WOR-TV, WPIX
Rochester	WHAM-TV
Schenectady	WRGB
Syracuse	WSYR-TV, WHEN
Utica	WKTV
<b>NORTH CAROLINA</b>	
Charlotte	WBTV
Greensboro	WFMY-TV
<b>OHIO</b>	
Cincinnati	WLW-TV, WCPO-TV, WKRC-TV
Cleveland	WNBK, WEWS, WXEL
Columbus	WLW-C, WBNS-TV, WTVN
Dayton	WLW-D, WHIP-TV
Toledo	WSPD-TV
<b>OKLAHOMA</b>	
Oklahoma City	WKY-TV
Tulsa	KOTV
<b>PENNSYLVANIA</b>	
Erie	WICU
Johans town	WJAC-TV
Lancaster	WGAL-TV
Philadelphia	WPTZ, WCAU-TV, WFIL-TV
Pittsburgh	WDTV
<b>RHODE ISLAND</b>	
Providence	WJAR-TV
<b>TENNESSEE</b>	
Memphis	WMC-TV
Nashville	WSM-TV
<b>TEXAS</b>	
Dallas	WFAA-TV, KRLD-TV
Ft. Worth	WBAP-TV
Houston	KPRC-TV
San Antonio	WOAI-TV, KEYL
<b>UTAH</b>	
Salt Lake City	KDYL-TV, KSL-TV
<b>VIRGINIA</b>	
Norfolk	WTAR-TV
Richmond	WTVR
<b>WASHINGTON</b>	
Seattle	KING-TV
<b>WEST VIRGINIA</b>	
Huntington	WSAZ-TV
<b>WISCONSIN</b>	
Milwaukee	WTMJ-TV
<b>WASHINGTON, D. C.</b>	
	WNBW, WMAL-TV, WTOP-TV, WTTG

# U.S. TELEVISION STATIONS

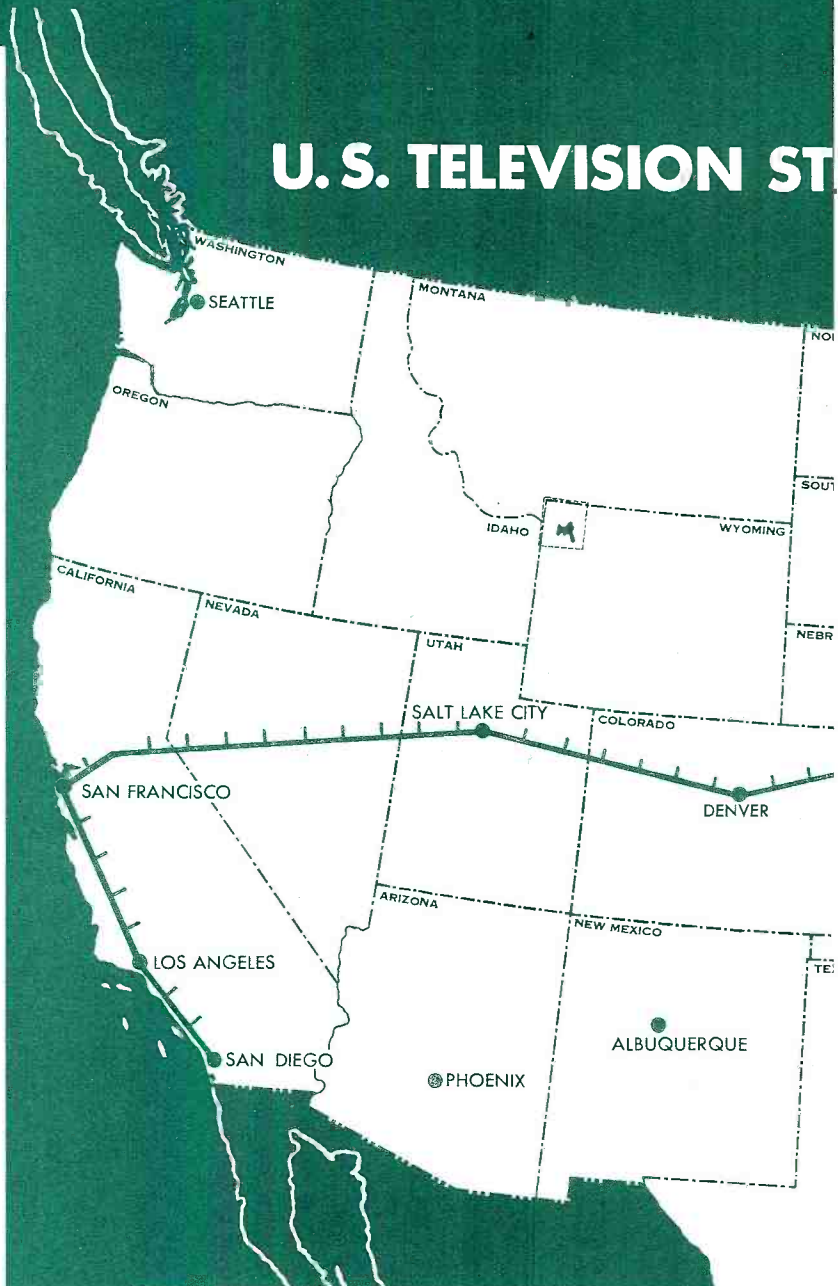

## LEGEND

Coaxial Cable in Service —————

Coaxial Cable Planned for 1952 —————

Microwave Relay in Service ————

Microwave Relay Planned for 1952 ————

Includes — Bell System  
and private relay links

Oklahoma City, Tulsa, Fort Worth, Dallas, Houston,  
San Antonio, New Orleans, and Miami will be  
connected to the networks by July 1st.

# ATIONS AND NETWORK LINKS

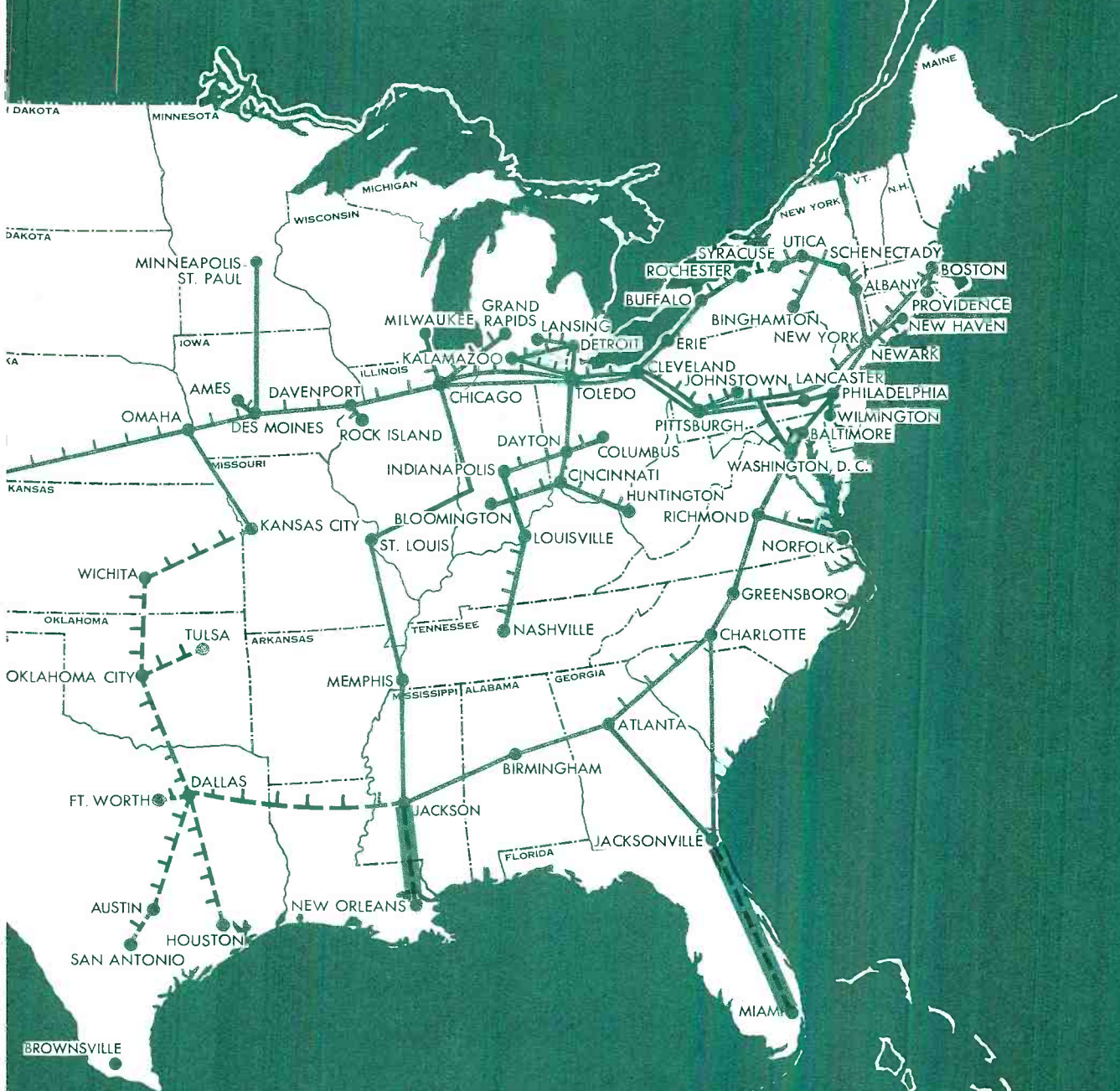

**RADIO &  
TELEVISION  
NEWS**

DATA-PRINT 1

(Copyright 1952)

## ANOTHER RADIO & TELEVISION NEWS FIRST

# DATA-PRINT

This is the first in a new series of RADIO & TELEVISION NEWS Data-Prints — designed to bring you up-to-date, pertinent reference data in an easy-to-read, graphic form.

Look for this new feature regularly. Make use of it. Put it up on your wall. Its attractive appearance will add distinction to your store or shop interior, plus always being in view as a ready reference.

### FUTURE ISSUES WILL INCLUDE:

Maps

Charts

Schematics

Tables

Nomographs

Exploded Diagrams

### VISUALLY DRAMATIZING SUBJECTS OF IMPORTANCE TO YOU:

Television Circuits

Product Engineering

Audio Design

Amateur Radio

Transmission and Reception

***Data-Print is one of the many NEW FEATURES in RADIO & TELEVISION NEWS.***

# MARS

# Station of the Month

### NOVICE AND TECHNICIAN CLASSES ELIGIBLE

Authority has now been granted to accept Novice and Technician class radio amateurs for membership in MARS.

According to the terms of the authority any Novice or Technician class radio amateur may apply for MARS membership. He must be a member of one of the Armed Services or the reserves or he must be a civilian who has attained the age of 21 yrs. and who has in his possession at the time of application the necessary equipment to operate on the MARS frequency, 3497.5 kc. The applicant must agree to operate, while on the military frequency, at such times and in such manner as the MARS Command Director may direct.

Full details on this new program are available either from MARS Headquarters (Army), Office of Chief Signal Officer, Washington 25, D. C. or MARS Headquarters (Air Force), Director of Communications, A. F., Washington, D. C.

**M**ARS Station AF2FAL at Headquarters EADF, Stewart Air Force Base, New York, has been named "Station of the Month" by Major Charles C. Mack, Chief MARS, USAF. Manned by MARS director, Major William A. Werber, W5RHK; assistant MARS director, Ted Arkin, W2SLL; station chief and maintenance man, Sergeant Frank Bohn; and chief operator, Pfc. John B. McKendrew, W2IVZ this station has accomplished much since its inception in January 1951. Active duty and civilian members assigned to EADF total approximately 150.

AF2FAL operates on 3307.5 kc., 7635 kc., and 14,405 kc. utilizing A3 emission and on 3497.5 kc. and 6997.5 kc. with A1 emission. K2FAL is quite active on the 80 and 40 meter bands as well as piling up many DX contacts on 20 meters. Now using two multi-band off-center-fed antennas with 20 meter doublet, 40 meter doublet, they expect to have a 10-20 meter, three-element beam installed within three months and, in the not too distant future, a sixteen-element 2-meter beam.

Due to limitation of personnel, the station is in operation only from 0800

to 1700 EST, Monday through Friday, and 0800 to 1200 EST on Saturday. Despite its limited time on the air, the station handles an average of 90 to 100 outgoing messages, 70 incoming messages, plus unrecorded informal messages each month. Those people, and there are many, who have had messages handled to and from their sons at West Point have reported that they have never had better service.

The station's contacts have been world-wide. Europe, Africa, South America, Canada, and the entire United States are represented in the log book.

Several months ago a family in Newburgh, New York, which is about 18 miles from the Base Station, wished to send a message to an infantry soldier in the Korean combat zone, relaying information on his son's illness. The message was delivered to the soldier and the reply received within 12 hours.

AF2FAL has also reported in on radioteletype and schedule is maintained daily 1000 to 1100 and 1600 to 1700 with Headquarters USAF, MARS, Pentagon Building, Washington, D. C. on 7635 kc. -30-

Ted Arkin, W2SLL, and Sgt. Frank Bohn are shown operating MARS station AF2FAL.

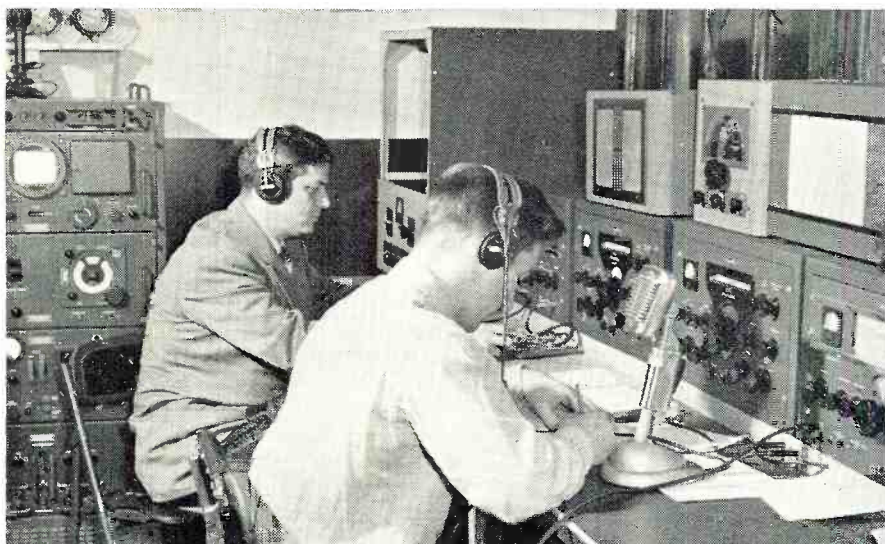

# HARVEY

is First with the Finest at Most Reasonable Prices!

### WILLIAMSON HR-15 AMPLIFIER KIT

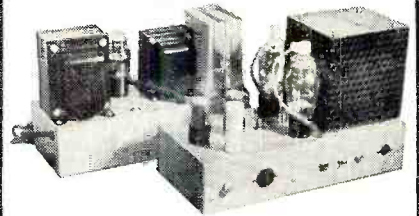

The famous Williamson HR-15 amplifier circuit... now available with the original Partridge transformers built to Williamson's specifications. Build this kit in 3 hours or less, and enjoy sound of a quality you never heard before. The HR-15 is a 2-Chassis power amplifier for use with tuners or other front ends having own volume and tone controls. All American triodes, 2-6SN7GT, 2-807 or 6BG6G in PP output, 5V4G rectifier. Response  $\pm$  .5 db, 10-100,000 cycles. Output impedances 1.7 to 109 ohms in 8 steps. Absolute gain 70.8 db. 20 db. of feedback around 4 stages and the output transformers. Kit is Complete with Tubes, Punched Chassis, Pre-wired Resistor Board, Sockets, Genuine Partridge Output Transformer, and All Necessary Parts.....\$76.50

As Above, with CFB Transformer.....\$90.00  
PARTRIDGE Output Transformers available separately WWFB, as used in above kit. \$26.50  
CFB Transformer, Hermetically sealed.....\$40.00

HR-15T A Williamson Kit with all TRIAD TRANSFORMERS... including power transformer, chokes and specially designed output transformer which is completely sealed in tar.  $\pm$  2 db. 10-100,000 cps. Harmonic Distortion less than .1% - 10 watts output. Output impedances 4-8-16 ohms .....\$69.50  
Both HR-15 and HR-15T Kits available with KT-66 tubes for \$3.00 extra.



### MORROW CONVERTERS



The latest in mobile converters... Easy to read... Easy to operate... Sturdy construction for long, trouble-free operation

Model 2BR for 10-75 meters, net .....\$54.95  
Model 2BRLN for 10-75 meters, net .....\$49.95  
Model 3BR for 10-20-75 meters, net .....\$64.95  
Model 3BRLN for 10-20-75 meters, net .....\$59.95  
The LN series converters are identical to the standard 2BR and 3BR converters, less the noise limiters.

### ELMAC A54

Under-dash Mobile Xmtr.



For Carbon Mike Input ..... Net \$139.00  
For Dynamic or Crystal Mike ..... Net 149.00  
Power Supply, 110 volts AC ..... Net 39.50

NOTE: In view of the rapidly changing market conditions, all prices shown are subject to change without notice and are net, F.O.B., N.Y.C.

Telephone  LUxemburg 2-1500

# HARVEY RADIO COMPANY, INC.

103 West 43rd St., New York 18, N. Y.

# New Super-Quality 15-inch COAXIAL SPEAK R Only \$24.95

BUY YOUR WIDE-RANGE COAXIAL SPEAKER AT McGEE



NEW 1952 MODEL  
12" COAXIAL P.M.

**\$12.95**

WHY PAY  
MORE?

McGee offers its new 1952 model 12" coaxial PM speaker. The finest that we have ever offered. Quality you would put in your finest sets if you were a manufacturer. Genuine Alnico V magnet 6.8 oz., in the 12" woofer. The tweeter is coaxially suspended inside the 12" and has a metal diffuser attached. The high pass filter is concealed under the pot cover, leaving only two wires to connect to your radio or audio amplifier. Why, buy an ordinary speaker, when you can have a 12" coaxial PM for only \$12.95? Input 8 ohms with 18 watt peak and 10 watts average. Shipping weight 8 lbs. Response from 30 to 17,500 cps. McGee's finest speaker value. Stock No. CU-14Y. Sale price, \$12.95 each.



15"  
COAXIAL  
P.M.  
SPEAKER  
**\$19.95**

Only \$19.95 buys a full 15" 20 watt coaxial PM speaker. Full range high tone high pass filter. Hook to any 8 ohm output on radio or amplifier. Response below 20 to 17,500 cps. Good bass response. A lucky purchase makes this price possible. Full 32 oz. magnet in the woofer. 5" tweeter. Model P15-9. Ship. wt. 11 lbs. Sale price, \$19.95.

## HALLICRAFTERS S-78 11-TUBE FM-AM CHASSIS

ONLY **\$89.50** WITH **\$99.50**  
LESS SPEAKER 12" COAXIAL SPEAKER

### ★ PUSH-PULL WIDE RANGE AUDIO

Hallcrafters S-78, 11-tube AM-FM radio receiver chassis, with push-pull 6K6 high fidelity audio system. A new model chassis for custom installation. Full range tone control, with bass boost. Input for automatic record changer. Output transformer has 3.2 ohm and 500 ohm connections. Chassis size, 12 3/4" x 10" x 7 3/4" high. Knobs and escutcheon plate are finished. Receives standard broadcast and FM. 88 to 108 mc. Shipping weight, 25 lbs. Model S-78, priced less speaker at \$89.50 net. S-78 11-tube AM-FM chassis with our 12" coaxial PM speaker, both for \$99.50. S-78 with 15" coaxial PM speaker, both for \$119.95. If you want a record changer, see our special listing below.

### DELUXE CAPEHART CABINET \$99.95

MADE FOR A \$1100.00 RADIO-PHONOGRAPHER Beautiful, top quality, walnut combination radio-phono cabinet. 42" high, 42" wide and 22" deep. Made for Capehart's finest combination. Highly polished matched walnut panels. Cabinet top is 1 1/2" thick. This cabinet weighs approximately 180 lbs. Both the radio and changer compartments and speaker grill have hinged doors. Radio compartment on the right-hand side is 14" high and 1 1/2" wide. Made to mount chassis vertically. The changer compartment is 14" high and 26 1/2" wide. Large enough to hold any record changer or recorder mechanism. Front 10" of top over the changer compartment is hinged to fold back for easy access to the changer. Both radio and changer compartments come with uncut panels. Speaker baffle is cut for 12" speaker and is completely enclosed. Shipping weight, 275 lbs. Stock No. K-275, Capehart combination cabinet. Net price, \$99.95.

## New Versatile Espey 12-TUBE FM-AM CHASSIS \$64.50

- ★ BUILT IN PRE-AMPLIFIER FOR G.E. VARIABLE RELUCTANCE PICKUP
- ★ WIDE RANGE AUDIO
- ★ MAY BE USED WITH A CRYSTAL MIKE AS A HOME P.A. SYSTEM

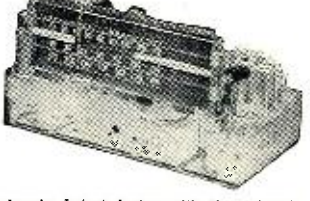

McGee's new 1951 model 12 tube FM/AM chassis. Latest design with phono inputs for all types of record players, crystal or G.E. variable reluctance. Receives standard broadcast 550 to 1700 KC and FM 88 to 108 MC. Wide range audio response (push-pull 7C5) and bass boost tone control. Loop antenna for broadcast and 300 ohm line type antenna, may be stapled in cabinet. Attractive lighted slide rule dial. Chassis size, 13 1/2"x9" high and 9" deep. Shipping weight 20 lbs. Stock No. 7-CX. Made to sell at a much higher price. McGee's sale price is \$64.50, less speaker (output matches 8 ohms). 7-CX chassis with our 12" coaxial PM speaker, both \$74.50. Espey 7-C chassis, 12" coaxial PM speaker and 3 speed VM changer with G.E. variable reluctance cartridge, \$104.95.

## TERRIFIC RADIO-PHONO SALE

12-TUBE ESPEY CHASSIS  
2—12" P.M. SPEAKERS  
\$200.00 VALUE WALNUT CABINET  
GE 2-SPEED CHANGER **\$179.95**

Buy this combination offer and have a fine radio-phono combination for less than the value of the cabinet alone. This beautiful walnut cabinet was intended for a Capehart \$800.00 combination and is the finest possible, furniture quality cabinet workmanship. 37" high, 40" wide and 21" front to back. Hinged top lifts in two sections. 25 1/2" lid covers the changer compartment and 14 1/2" covers the radio compartment. Changer mounting panel is furnished blank. Radio panel is shipped ready cut to fit the Espey 7-C chassis. Twin heavy duty 12" PM speakers are furnished. Espey 7-C chassis and General Electric 33 1/2 and 78 rpm, 2 speed automatic changer with G.E. variable reluctance cartridges. Stock No. MID-375 chassis. Espey 7-C chassis, 2 speed G.E. changer and 2 12" speakers. Sale price, \$179.95. 3 speed VM automatic changer with G.E. variable reluctance turnabout cartridge furnished for \$15.00 extra. Shipping weight 200 lbs. Shipped via truck, rail or express only. Capehart cabinet described above, furnished cut to fit the Espey 7-C chassis, cabinet only \$79.95.

## NEW SUPER QUALITY 15" COAXIAL SPEAKER

5" TWEETER

21 OZ. ALNICO V MAGNET  
THE FINEST COAX WE HAVE EVER OFFERED  
**\$24.95 TWO FOR \$47.95**



This is the finest 15" coaxial PM speaker value that we have ever offered. New 1952 production, of a famous manufacturer of fine speakers. The 15" speaker has a 21 1/2 oz. Alnico V magnet; equal 28 oz. of the Alnico 3 type magnet. The cone is free floating, is coaxially suspended and has a ridged cone to reproduce only the high frequencies. It will respond up to 17,500 cps. The high-pass filter is concealed under the pot cover, leaving only two wires to connect both the tweeter and woofer to any 8 ohm output transformer of a radio, or high fidelity music lovers' amplifier. Stock No. P15-CR, shipping weight 13 lbs. Net price, \$24.95; 2 for \$47.95.

## ELECTRONIC RADIO and TV TUBES

- 6 MONTHS' GUARANTEE • INDIVIDUALLY CARTONED
- IN RED AND BLUE DE LUXE VARNISHED CARTONS
- EVERY TUBE SET TESTED FOR YOUR PROTECTION

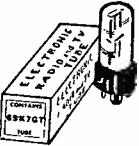

ORDER 50 ASSORTED—TAKE 10% OFF. Prices as Low as 39c

024	...	.59	6BA7	...	.59	6WA4T	...	.59	144A	...	\$.89
1B3	...	.79	6BC5	...	.59	6X4	...	.49	14B6	...	.99
1C6	...	.79	6BE6	...	.59	6X5GT	...	.49	14C5	...	1.09
1G	...	.99	6BE6	...	1.19	6Y7	...	.79	14H7	...	.79
1H5	...	.99	6BH6	...	.59	6ZY5G	...	.59	14D7	...	.99
1J6	...	.99	6BJ6	...	.59	7B6	...	.69	19T8	...	.89
1L4	...	.79	6BQ6GT	...	.59	7C5	...	.59	25B6GT	...	.79
1LA4	...	.79	6C4	...	.49	7E6	...	.89	25L6GT	...	.59
1LCS	...	.79	6C6	...	.59	7E7	...	.89	25Z6GT	...	.79
1L3	...	.99	6C7	...	.59	7H7	...	.79	50A6GT	...	.59
1L5	...	.79	6CD6G	...	1.49	7N7	...	.59	50B6GT	...	.59
1LN5	...	.79	6HG7	...	.59	7V7	...	.79	50L6GT	...	.59
1R5	...	.99	6K6	...	.59	8C5	...	.59	50P6GT	...	.59
1S5	...	.99	6K6GT	...	.49	7Y4	...	.74	35L6GT	...	.59
1T4	...	.59	6K7GT	...	.59	7Z4	...	.69	35W4	...	.49
1U4	...	.59	6K7G	...	.49	7A7	...	.59	35S6GT	...	.49
1U5	...	.59	6L6	...	1.09	12A7	...	.69	35S/51	...	.69
2X2	...	.89	6L7G	...	1.09	12AU7	...	.69	38	...	.59
3Q4	...	.69	6P5GT	...	.59	12X7	...	.69	39	...	.49
3Q4	...	.69	6R7	...	1.09	12AX4GT	...	.69	43	...	.79
3Q4	...	.69	6S4	...	.59	12AK7	...	.69	47	...	.89
4T4	...	1.49	6S4GT	...	.59	12AV6	...	.69	48B5	...	.89
5U4	...	.69	6SA7GT	...	.59	12BA7	...	.69	50C5	...	.59
5X4	...	.69	6SD7GT	...	.59	12BE6	...	.59	50L6GT	...	.59
5Y3	...	.49	6S7GT	...	.79	12B6G	...	.59	50P6GT	...	.59
6A4	...	.69	6S7P	...	.69	12J5GT	...	.69	57	...	.49
6A15	...	.69	6S7GT	...	.69	12J7GT	...	.69	58	...	.49
6A5	...	.69	6S7GT	...	.69	12J7GT	...	.69	58	...	.49
6A5	...	.99	6S7GT	...	.69	12J7GT	...	.69	58	...	.49
6A5	...	.59	6S7GT	...	.59	12Q7GT	...	.69	77	...	.69
6A5	...	.59	6S7GT	...	.59	12Q7GT	...	.69	77	...	.69
6A5	...	.59	6S7GT	...	.59	12SA7GT	...	.59	78	...	.69
6A75	...	.49	6S7GT	...	.59	12S6GT	...	.69	85	...	.69
6A8	...	.59	6S7GT	...	.59	12S6GT	...	.69	85	...	.69
6A8	...	.59	6S7GT	...	.59	12S6GT	...	.69	85	...	.69
6A8	...	.59	6S7GT	...	.59	12S6GT	...	.69	85	...	.69
6A8	...	.59	6S7GT	...	.59	12S6GT	...	.69	85	...	.69
6A8	...	.59	6S7GT	...	.59	12S6GT	...	.69	85	...	.69
6A8	...	.59	6S7GT	...	.59	12S6GT	...	.69	85	...	.69
6A8	...	.59	6S7GT	...	.59	12S6GT	...	.69	85	...	.69
6A8	...	.59	6S7GT	...	.59	12S6GT	...	.69	85	...	.69
6A8	...	.59	6S7GT	...	.59	12S6GT	...	.69	85	...	.69
6A8	...	.59	6S7GT	...	.59	12S6GT	...	.69	85	...	.69
6A8	...	.59	6S7GT	...	.59	12S6GT	...	.69	85	...	.69

## 3-SPEED CHANGERS ON SALE AT McGEE

WEBSTER CHICAGO MODEL 100-2 ONLY **\$26.95**

For the first time we offer the world famous Webster-Chicago, model 100-2. Features a newly designed spindle, that drops the records flat; air-cushioned to the turntable. Pickup arm sets down automatically after the last record plays. Plays all records automatically, 33 1/2, 78 and 45 rpm. New balanced tone arm with Electro-Voice Phono-Matic cartridge with dual magnets. Ordinarily cost over \$37.00. McGee offers them for only \$26.95 each. Base size 12"x12 1/4". Shipping weight 14 lbs.

### V.M. 3-SPEED MODEL 406 \$22.95

VM model 406, deluxe 3 speed automatic record changer. Plays them all. Internixes records of the same speed. Equipped with a flip over crystal pickup with twin needles. Base size, 12 1/4"x13". Shipping weight 12 lbs. VM-406. Net price \$22.95.

### G.I. 3-SPEED CHANGER WITH G.E. **\$22.95**

VARIABLE RELUCTANCE TURN-ABOUT CARTRIDGE Another tremendous McGee Scoop! Brand new General Instrument 3-speed automatic record changers. Complete with RPX-050 G.E. variable reluctance cartridge with turn-about stylus. Plays all speeds automatically; 7", 10" or 12" records. Has reject button. Repeats last record. Base size, 12"x12 3/4". Shipping weight 14 lbs. Stock No. 700-GE. Scoop price, \$22.95.

## SENSATIONAL 50 WATT BOOSTER AMPLIFIER

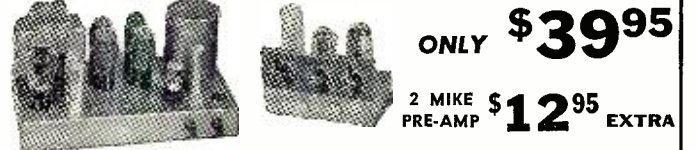

ONLY **\$39.95**  
2 MIKE **\$12.95** EXTRA  
PRE-AMP

50-WATT BOOSTER A sensational value, 50 watt booster amplifier with push-pull parallel 6L6 output tubes. Connect to your present amplifier as a booster or use with the PR-2X Pre-amp to add the use of 2 mikes and one low level input. The booster amplifier has one 400 ohm input with 1 volt input grids for stereo audio. Booster has a 6 lb. potted case high fidelity output transformer, matches speaker with 4-8-16 ohm voice coil, also 60 ohm and 250 ohm line. Booster has a 225 mill power supply with 51L4 rectifier. Price includes tubes: 4 6L6, 7N7 and 6U4. The two variable controls are for master volume control and base boost tone control. Size 8 x 6 1/2 x 14 1/2". Stock No. PA-55X. Shipping weight 26 lbs. Sale price \$39.95 ea.

2-MIKE PRE-AMP. Pre-amplifier plugs in directly to the PA-55X Booster amplifier. It enables use of 2 Crystal or Dynamic Mikes plus one low level input. Furnished with 4 for cables and plugs for remote control of the 50 watt Booster Amplifier. Small chassis size 5 x 3 1/4 x 4". Stock No. PR-2X, with tubes 7F7 and 7N7. Net price \$12.95.

## TERRIFIC VALUES IN SPEAKERS AND BAFFLES

8" PM  
AND  
LEATHERETTE  
BAFFLE  
**\$4.95**

\$4.75 IN LOTS OF 10

The finest Leatherette Baffle we have ever offered. New self-supporting plastic grill material. Baffle is covered tan with matching grill. Offered with a good heavy duty 8" Alnico V PM speaker with 3.2 ohm voice coil. Stock No. 818. Speaker and Baffle, \$4.95 ea.; lots of 10, \$4.75. 8" Baffle only. Stock No. NV-8, \$2.29 ea.; 10 for \$19.95.

High impedance dynamic mike with 12 ft. of cable for use preamp. No. 4-DT, \$8.95 ea. lots of 10, \$8.95 ea. Also on floor stand, \$5.88 extra.

12" PM  
AND  
WALNUT  
BAFFLE  
**\$9.95**

\$8.95 IN LOTS OF 3

The finest built 12" Walnut plywood wall baffle we know of. Factory cost of the famous juke box manufacturer exceeds \$7.00. We offer with a 12" PM for little more. You pay only \$9.95 in single lots, or \$8.95 in 3 lots for both a 12" Alnico V PM with 3.2 ohm voice coil and the beautiful wall baffle, 12" Speaker Baffle combination, Stock No. PS-12Q, \$9.95 ea.; lots of 3, \$8.95 ea. 12" Baffle only, #SEG-12, \$4.95 each.



# \$10.95 BUYS A GOOD TEL VISION BOOST R AT McG

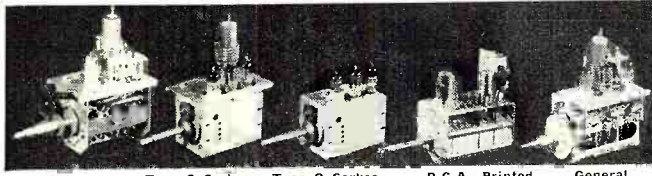

R.C.A. \$7.95 Type 3 Sarkes-Tarzian \$9.95 Type 2 Sarkes-Tarzian \$7.95 R.C.A. Printed Circuit \$19.95 General Inst. \$2.95

## RCA TV FRONT END WITH TUBES \$7.95

Terrific buy on this RCA TV tuner. We have a limited quantity of the famous original 201E1. 13 channel completely wired and tested TV front end tuners. Ready to connect to your TV video I.F. strip. Offered at a sacrifice. Price was originally \$44.00. Now only \$7.95 each, with tubes. You'll save plenty on this item. No RCA-13P TV front end tuner. Shaft length 3 3/8". From base of tuner. Converter coil type for separate sound, as used in the famous 630 chassis. Net price \$7.95 each, complete with 3-636 tubes.

## SARKES-TARZIAN TYPE 3-TUNER WITH TUBES \$9.95

This popular Sarkes-Tarzian TV front end is widely used today. 13 channel rotary type switch with individually tuned coils. Price includes a schematic diagram and 3 tubes; 6C4 osc., 6B116 RF and 6AG5 mixer. Regular factory cost is twice our price. Each tuner and its own tube sockets are wired, ready to hook up to a video and sound IF strip. May be used with either inter-carrier or separate sound IF circuits. Built in fine frequency control. Shipping weight 3 lbs. Type 3 Sarkes-Tarzian TV tuner with tubes. Net price \$9.95. Type 3 tuner and 205-XX video coil kit, both for \$16.95.

## 3-TUBE TUNER SCOOP—\$2.95 LESS TUBES

Type 4, Sarkes-Tarzian 12 channel TV tuner. Requires 2-6AG5 or 6BC5 and a 12A7. Has 1/4" diameter shaft, 2 3/8" long. Has screwdriver fine tuning adjustment. It differs from other tuners in that it has no concentric fine tuning shaft over the channel selector shaft. Very fine for experimental use, building field strength meters, etc. Sarkes-Tarzian Type 4, TV tuner. Sale price only \$2.95.

## RCA 12-CHANNEL PRINTED CIRCUIT TV TUNER \$19.95

Latest design RCA 12 channel printed circuit TV tuner. Rotary switch with snap-in printed circuit strip principle. This popular tuner used by Hallcrafters in inter-carrier circuit sets. Shaft length 3 3/8". Built in fine frequency control. Price includes tubes, 636 and 6CB6. A terrific value at \$19.95 each.

## GENERAL INSTRUMENT TV TUNER, LESS TUBES \$2.95

Completely wired, 13 channel selector incorporating fixed inductance and variable capacitance. To be coupled direct to separate sound and video IF's, 3-636 tubes are required. Built in fine frequency control. Original cost over \$20.00. Weight 4 lbs. Have been in sets, but guaranteed to be a good value. Stock No. GI-131T. General Instrument TV tuner, less tubes. Net price \$2.95 each.

## 2-TUBE SARKES-TARZIAN TV TUNER WITH TUBES \$7.95

Sarkes-Tarzian new two tube model, type WT-3A, 12 channel television tuner. This is the new 2 tube model requiring a 6J6 plus 6AK5, or 6AG5, or 6CB6 or 6AU6 RF tube. Pre-aligned by trained factory personnel. Input feeds 21 mc broadband band. Fine tuning control is over the channel selector shaft. Power requirements: 120 to 140 volts DC at 17 mills, plus 6.3 volts filament. This tuner is offered at a terrific saving to you. Stock No. WT-3A. Net price \$7.95. With tubes 6J6 and 6AUG. Available with 2 3/8", 5 1/2" or 7 1/2" shaft. Specialty shaft length desired.

# NEW 1952 MODEL 3-WAY PORTABLE RADIO KIT ONLY \$15.95

## 10-WATT HIGH FIDELITY AMPLIFIER KIT \$14.95

- ★ MIKE INPUT ★ PHONO INPUT
- ★ BASE AND TREBLE BOOSTER

A complete kit of parts, including tubes, diagram and instructions, to build a 10 watt high fidelity twin tone control audio amplifier, with bass and treble boost. Inputs for radio tuner, crystal mike and crystal phono pickup. Output transformer matches 8 ohms. Use with our 12" coaxial FM speaker, or any good 1M and have a beautiful sounding, yet low cost amplifier. Response from 50 to 15,000 CPS. Chassis is ready punched and a ventilated cover is furnished. A straight forward circuit with twin triode gain stages and 2-50L6 tubes in push-pull. New twin 150 ma. selenium rectifier voltage doubler; television type power supply. Price includes tubes; 12AX7, 12AU7 and 2-50L6, plus rectifiers. A good quality kit with matched parts. Size, 5 1/2" x 10" x 5 1/2" high, including cover. Stock No. AP-10R, shipping weight 8 lbs. Sale price \$14.95 each. 12" coaxial FM speaker, \$12.95, extra.

## T.V. FRINGE AREA DEALERS—ATTENTION FM AND TELEVISION BOOSTER SALE

ANOTHER  
MCGEE SCOOP  
**\$10.95**  
WHY PAY MORE?  
NOT A KIT BUT A FACTORY-BUILT BOOSTER



Sensational value. Continuously variable inductance type tuner, from channel 2, including the FM band, through channel 13. This booster is self covered for 110 volts AC operation. Incorporates a 6J6 tube. Input for 300 ohm TV line and 300 ohm output to the TV set. Single knob tuning. Attractive plastic case. McMurdo-Silver Super Sonic TVFM booster, Stock No. GB-6B. Shipping weight 5 lbs. McGee's terrific sale price \$10.95 each, two for \$20.00.

## COMPLETE 17" TO 20" T.V. KIT

- ★ AC-TRANS-TYPE
- ★ CONVENTIONAL CIRCUIT
- ★ READY WIRED 12 CHANNEL T.V. FRONT END
- ★ 70° DEFLECTION
- ★ KIT OF TUBES EXCEPT KINE \$16.95
- ★ CERAMIC FLYBACK
- ★ 20HP4 \$27.95 EXTRA



A complete kit of parts to build an AC transformer operated television chassis for use with a 16, 17 or 20 inch rectangular picture tube. The 12 channel Sarkes Tarzian tuner is ready wired. The 2 tube video IF strip is also wired. Circuit is of the conventional accepted design, with latest ceramic type flyback high voltage supply. Chassis is ready punched. Warning: Do not buy this kit unless you understand Television and electronics. It is difficult to wire. We furnish schematic and photos. Kit model WH 20 ship weight 40 lbs., less all tubes \$59.95. Kit of 19 tubes but less picture tube \$16.95 ext. 17 inch 17BP4A \$21.95 ext. 20HP4 \$27.95 ext. 20CP4 rect. tube \$37.00 ext.

## ELECTROSTATIC FOCUS CONVERSION KITS

The 17HP4 and 20HP4 are 17" and 20" black face picture tubes of the electrostatic deflection electrostatic type of focusing. Focusing is accomplished by a 5 meg. pot connected as a bleeder between ground and the cathode of the damper tube. We furnish schematic and photos. Kit model WH 20 CR tube, to apply a focus voltage of from 0 to 300 volts. This new type tube is called low voltage electrostatic focus. Very simple to use and operates from 8.5 KV to 14 KV. Most set makers are using this new tube in several models. The trend is almost completely to this type gun.

## 20" CONVERSION KIT \$32.95

The new 20HP4 blackface picture tube operates from 8 to 14KV, high voltage. It is the conventional 20" rectangular shape. A standard 70° yoke and single ion trap are required. Focusing is accomplished by electrostatic means, applying from 0-300 volts on the focus anode, pin No. 6. All other connections and characteristics are similar to a 20CP4. (No focus coil or focus magnet is needed.) You get the 20HP4 tube, a 20" rectangular plastic safety mask with gold trim, plus tube characteristics, all for \$32.95. Stock No. HPM-20, shipping weight 40 lbs.

## 17" CONVERSION KIT \$24.95

The new 17HP4 blackface picture tube operates from 8 to 14KV, high voltage. It is the conventional 17" rectangular shape. A standard 70° yoke and single ion trap are required. Focusing is accomplished by electrostatic means, applying from 0-300 volts on the focus anode, pin No. 6. All other connections and characteristics are similar to a 17BP4. (No focus coil or focus magnet is needed.) You get the 17HP4 tube, a 17" rectangular plastic safety mask, with gold trim, plus tube characteristics, all for \$24.95. Stock No. HPM-17, shipping weight 30 lbs.

7701-X. Universal flyback with connecting instructions. \$3.95. 70° Deflection Yoke. \$2.95. Width Coil. 69c. 5 meg. focus control. 59c.

7701-X. Universal flyback with connecting instructions. \$3.95. 70° Deflection Yoke. \$2.95. Width Coil. 69c. 5 meg. focus control. 59c.

## SELF POWERED AC Broadcast Tuner Kit, 3-Gang Tuning. Complete Kit, \$12.95

A self-powered, 3-gang superhet tuner kit with R.F. stage. When wired according to our diagram will make a top quality broadcast tuner (550 to 650 kc) for use with any amplifier. Don't class this with ordinary tuners; this has its own power transformer. This complete kit is furnished with a diagram, photos and tubes, 6AG6 R.F., 6BE6 oscillator R.F., 6AU6 I.F. detector, 6AL5 diode, AVC, plus rectifier. Connect to any audio amplifier. Ideal for use with our S-2020, TM-16 or 7-X amplifier kits. Chassis size, 4 1/2" x 4 1/2" x 4 1/2" high. Shipping weight, 7 lbs. Broadcast tuner kit Model BT-38X. Net price, \$12.95.



## 8-TUBE 22 WATT Wide Range Amp. Model Tx5 Kit Only \$37.95

A complete kit, including tubes (3-7E5, 2-7F7, 2-6A3, plus rectifier), diagram and photos. All triode circuit makes for minimum harmonic distortion. Inputs for radio tuner any kind of phono pickup (crystal or G.E. variable reluctance) and either crystal or dynamic mike. Output transformer matches 8 ohm voice coil. Twin electronic tone controls, bass and treble with range selector switch for either juke box quality with heavy bass response or brilliant symphonic range. The best quality amplifier kit we know how to make. Has a very wide range output and heavy power transformer. Response 15 to 20,000 CPS. 8 tube all triode amplifier kit, complete with tubes. Weight 25 lbs. Net \$37.95.



## 5-Tube Broadcast SUPERHET RADIO KIT \$12.95

Model RS-5 tube AC-DC superheterodyne radio kit. Has loop antenna and 2-gang condenser, with lighted slide rule dial and attractive plastic cabinet. Receives broadcast, 550 to 1650 kc. Full size dynamic speaker, matched 456 I.F.'s, automatic volume control. This is a complete radio kit. Everything furnished, including diagram, photos and tubes; 12K8 mixer, 12SK7 I.F., 12SQ7 detector, 1st audio, 50L6 output, 35Z5 rectifier. Shipping weight 7 lbs. Stock No. RS-5. Net price \$12.95.



## Build Your Own Phono-Mike Broadcaster \$7.95

Kit Model DE-6R. With this simple kit, you can build a 3-tube phono oscillator that also has a mike input. Will broadcast over any radio, within your home (about 75 feet) from 1000 to 1500 kc. Inputs for crystal mike or crystal phono pickup. Factor control fades from mike to record. Ideal for a home P.A. system, baby listener and home entertainment. A complete kit of parts including tubes, Kit Model DE-6R. Net price, \$7.95. DE-6RWT, wired and tested. Net price, \$9.95. Crystal mike and desk stand, \$4.95 extra. Concealed microphone unit, only 1" in diameter and 1/4" thick. Specify hidden mike when ordering. Stock No. T-001. Net, \$3.95 extra.



## 3-WAY PORTABLE RADIO KIT \$15.95

A NEW '52 MODEL New 1952 Model 3-way personal portable radio kit. Operates on 110 Volts AC-DC or 67 1/2 plus 1 1/2 volt self-contained batteries. Leatherette covered case size, 5 1/2" x 5 3/4" x 8". Receives broadcast 550 to 1650 kc. A conventional 2-gang superhet circuit with 456 KC iron core IF's. Incorporates the new super gain stick loop antenna. All plated chassis. Lab. approved circuit—matched parts. Price includes all parts, tubes, diagram, A1 in co. V. PM speaker. A factory quality kit. Stock No. PN-4T, shipping weight 7 lbs. The complete kit, less batteries \$15.95. 67 1/2 V. B. \$1.59, 1 1/2 V. A. 39c extra.



## 10-TUBE RADIO KIT \$29.95

- 3-GANG TUNING
- MIKE INPUT
- 12 WATT
- HI-FI AUDIO
- BASS-TREBLE BOOST



## A NEW 1952 ALL-PURPOSE RADIO KIT ALL-PLATED CHASSIS PARTS

10-Tube Broadcast (550 to 1700 kc) Radio Kit for custom builders. Features 3-gang superhet circuit with A.V.C., high gain IF circuit, 8" slide rule dial. Chassis size 12 1/2" long, 10" front to back, 6 1/2" high. Audio inputs for a crystal or dynamic mike, and record changer or player. Tone compensation for standard crystal pick-up or General Electric variable reluctance. Push-pull 6V6 output tubes, shielded high fidelity output transformer, matches 8 ohm PM speaker, husky power transformer, 2 tone controls for separate bass and treble boost. A complete kit, including tubes 6SK7 R.F., 6SA7 mixer, 6SK7 I.F., 6H6 detector, AVC, 6SQ7 1st audio, 12AX7 variable reluctance and mike amplifier, 12AX7 phase inverter, 2-6V6 outputs, plus rectifier, diagram and instructions. Shipping weight 18 lbs. Stock No. BK-R10. Net price \$29.95. 10" FM speaker, \$6.95 extra. Crystal mike and desk stand, \$4.95 extra. 12" coaxial speaker \$12.95 extra.

# McGEE RADIO COMPANY

Prices F.O.B. K.C. Send 25% Deposit with Order. Balance Sent C.O.D. With Parcel Post Orders, Include Postage

TELEPHONE VICTOR 9045. WRITE FOR FLYER 1422 GRAND AVE., KANSAS CITY, MISSOURI



your  
ear  
will  
tell  
you



**the performance  
of the TRIAD  
Hi-Fidelity  
Amplifier is equal  
to that of amplifiers  
costing much more**

Listening tests conducted before groups of critical music lovers have proved that the difference in reproduction qualities between the low cost Triad Amplifier and the other higher priced units is undistinguishable. Available in kit form only, with complete assembly instructions, the Triad HF-10 Amplifier provides valuable experience while affording substantial savings. In quality and performance it is a fitting companion to the finest sound system components available today.

**prices**

HF-10 Kit — Includes S-31A, R-14A, A-74J and C-10X Triad transformers, chassis, prints and assembly instructions.....\$43.00

HF-10A Kit — Same as above except for substitution of HS-81 output transformer for S-31A..\$63.50

Both of above available with 500/250/125 ohm output

Write for Catalog  
TR-52

2256 Sepulveda Blvd.  
Los Angeles 64, California

**A.F. Ammeter**  
(Continued from page 59)

or padding the shunt resistor  $R_s$ , Fig. 1. Adjustments of over 20 per-cent are made by changing the number of primary turns.

**Transformer**

A current transformer is a strange animal to one accustomed to thinking about audio transformers. The primary, made of a few, or even one turn of wire, looks into a high impedance—the source being measured. The secondary, having lots of turns and an inductance of perhaps 50 henrys, operates practically short-circuited. However, these apparently inverted conditions will give the same transformation ratio over a very wide frequency range, as long as the secondary feels that it is looking into a short circuit. In other words, the inductive reactance of the secondary must be high compared to the resistance of the load (meter and rectifier, etc.) across it at the lowest frequency to be measured. In the case of the present instrument, the secondary load appears to be a couple of hundred ohms, and the transformer secondary inductance measures approximately 50 henrys. If a transformer having less inductance is used, the low-end droop will start at a higher frequency. If the secondary load resistance were lower, less inductance could be used for the same frequency range, but most of the resistance is in the rectifier, and cannot readily be reduced.

High frequency errors start to appear around 50 kc., and quickly become rather large; the meter reads high, goes through a peak, then drops off. This applies to transformers with regular silicon steel cores and no interleaving of windings. How high one could go with alloy cores has not yet been determined.

The current transformation ratio is simply the inverse of the turns ratio, when the previously mentioned requirement of adequate inductance is met. With a 1-turn primary and a 1000-turn secondary, a primary current of 1 ampere will produce a secondary current of 1 milliamperere.

The more turns on the primary, the less primary current is required for full-scale deflection. That is, the primary ampere-turns is a constant for a full-scale reading for a given instrument. In the unit shown, 10 ampere-turns are needed for full-scale deflection. A 100-turn primary would provide a 100 ma. full-scale sensitivity.

The main purpose of the transformer is to provide sufficient voltage swing to operate the rectifier linearly and efficiently. The voltage drop across a current-measuring instrument should be low, much less than a volt. The primary drop across the instrument of Fig. 1 is about 0.25 volt. Such a low voltage applied to a rectifier meter results in a scale that is badly cramped at the low end. The amount of cramping depends on the characteristics of the particular rectifier used. With the transformer, the high impedance secondary winding is capable of delivering several volts of signal. Rectification is linear and changing 1N34's has almost no effect on calibration.

If the constructor wants to start out with a different transformer than the one specified, choose either a filter choke with an inductance of 15 or 20 henrys or an output transformer rated for a high primary impedance. The RO-113 is listed for 50,000 ohms plate-to-plate. If a choke is used, take out the core laminations and reassemble them interleaved, without an air gap. This approximately doubles the inductance.

**REFERENCE**

1. Fleming, Lawrence; "Current Transformers for Audio Measurements," *Electronics*, July, 1951.

—50—

The first studio control board at station CFRB, Toronto, with Jack Sharpe at the controls, is in marked contrast to the modern facilities now occupied by the 25-year-old Canadian station. CFRB was Canada's first "batteryless" station and was instrumental in popularizing "batteryless" radio receivers to the public.

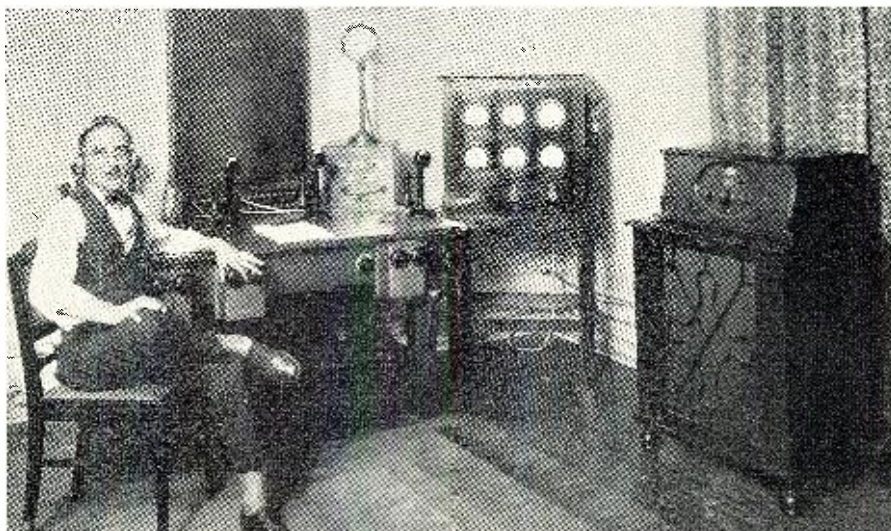

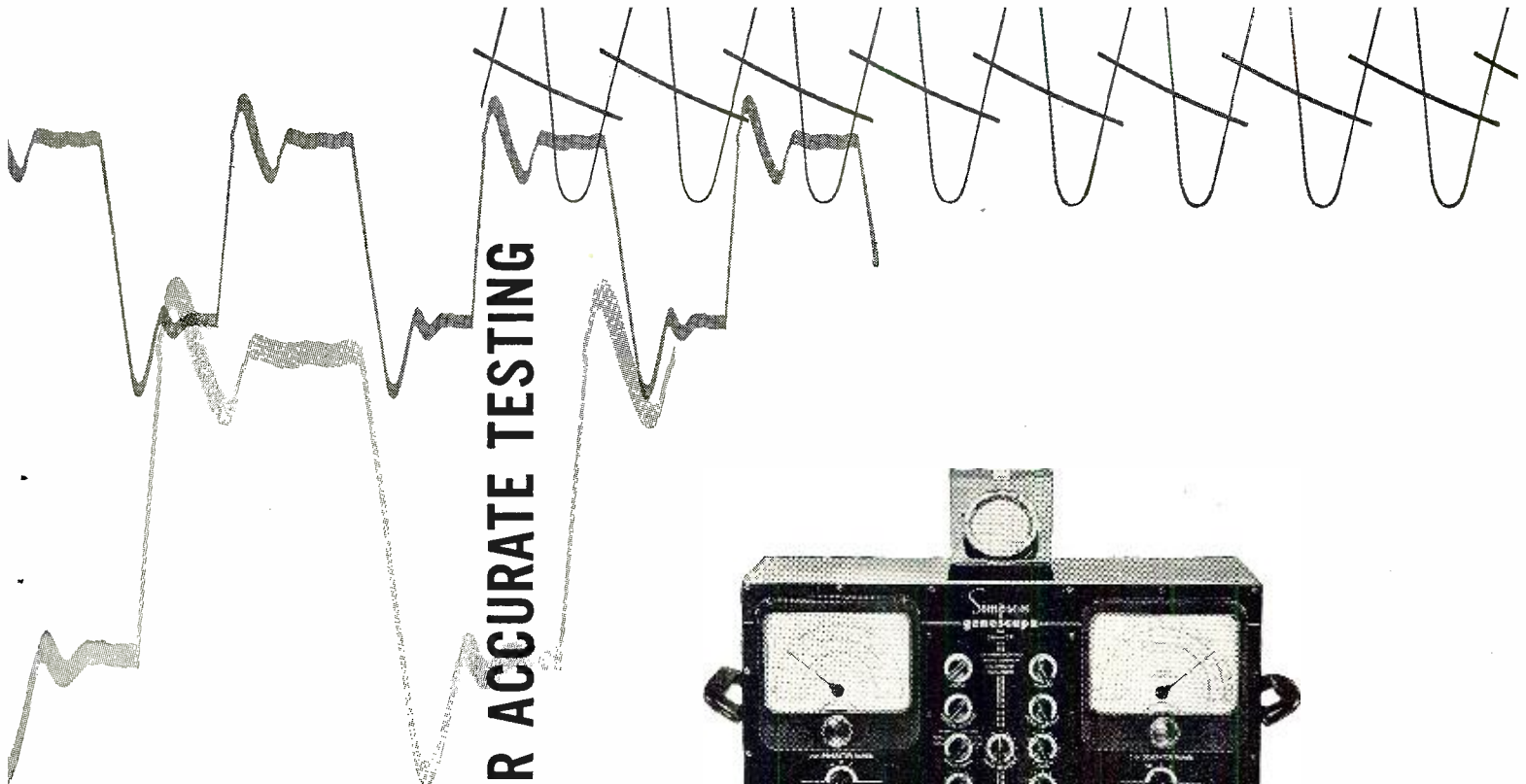

**SIMPSON MODEL 480 GENESCOPE FOR ACCURATE TESTING**

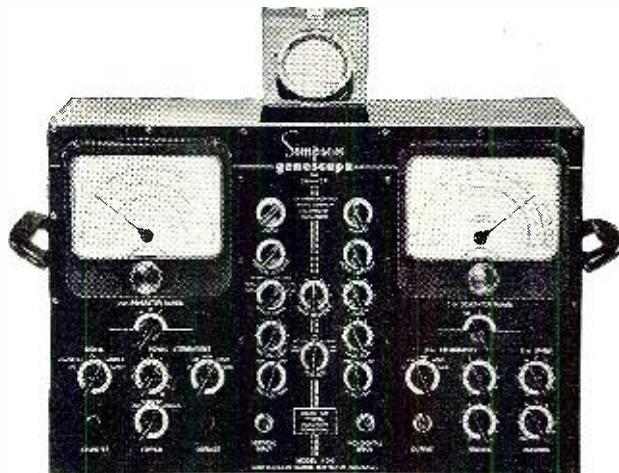

- Provides all the necessary signal sources for proper alignment and servicing of FM and TV receivers • Includes the Simpson High Sensitivity Oscilloscope, complete in every detail and equipped with a high frequency crystal probe for signal tracing • Independent, continuously variable attenuators and step attenuators for both AM and FM units offer complete control of output at all times—from the high level required for front end adjustment to extremely low levels for fringe area peaking operations • Multiple shielding, generous bypassing and adequate line filtering reduces signal leakage to a negligible factor • A 0-15 megacycle sweep is provided by means of a noiseless specially designed sweep motor based on the principles of the D'Arsonval meter movement for fine control and lasting accuracy • The exclusive Simpson output cable (illustrated on the right) includes a variable termination network which is quickly adapted to provide open, 75 or 300 ohm terminations—the addition of a pad provides attenuation and isolation. The use of appropriate resistors across certain terminals will provide any other termination required. A .002 MFD blocking condenser can be added on any termination for use on circuits containing a DC component • The FM generator output voltage is constant within .2 DB per MC of sweep. Model 480 \$395.00

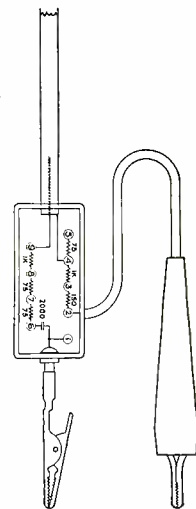

*approved by  
service managers of:*

- admiral*
- zenith*
- motorola*
- emerson*
- hoffman*
- hallicrafters*



Also available without the oscilloscope as Simpson Model 479 TV-FM Signal Generator. Model 479 \$269.00

Simpson Instruments That Stay Accurate Are Available From All Leading Electronic Distributors

## RADIO Surplus Buys

### CRYSTALS

... in FT 241-A Holders—1/2" Pin SPC. Marked in 5th OR 72nd Harmonic MC Freq. Listed below by fundamental frequency with fractions omitted.  
500 KC Crystals only. Limited Quantity...ea. **\$1.95**



372	411	487	400	462
374	412	488	440	463
375	413	490	442	464
377	414	491	444	466
379	416	492	446	468
381	418	493	448	470
383	420	494	450	472
384	422	495	451	474
385	423	496	452	475
387	424	497	453	476
388	425	498	455	477
390	427	499	456	479
391	429	500	457	480
392	431	501	459	501
394	432	502	461	505
396	433	503		
398	434	504		
401	437	509		
403	438	510		
405	439	511		
407	443	514		
409	448	523		

49c ea. or 10 for \$4.50

99c ea. or 10 for \$9.00

### TUNER FROM NAVY "BN" EQUIPMENT

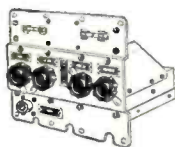

Simply modified into 2-meter converter for car or communications receiver. Uses 1-6J6, 1-6SH7, 1-3006, 1-6J5 (Not Furnished).

Slug is tuned from 157 to 187 Megacycles. Includes schematic diagram for "BN" equipment.

Now—A New LOW Price..... **\$4.95**

### SENSITIVE ALTIMETERS



Pioneer Sensitive Altimeters. Range 0-35,000 ft., calibrated in 100's of feet. Barometric setting adjustment. No hook-up required... mounts easily in auto or aircraft. Used. Good. Each **\$12.95** Postpaid

### ALTIMETER, AIRCRAFT



U. S. Navy surplus Altimeters, range 0-10,000 feet. Adjusts to sea level setting of terrain. Simply installed, requires no hook-up... for auto or aircraft installation. BRAND NEW..... Each **\$7.95** Postpaid

ALL EQUIPMENT F.O.B. PASADENA UNLESS OTHERWISE SPECIFIED. PLEASE ENCLOSE FULL AMOUNT WITH ORDER

## C & H SALES CO.

BOX 356..MT, East Pasadena Station, Pasadena 8, Calif.

## Within the Industry

(Continued from page 26)

nounced the formation of a new advertising department which will be in charge of **WILLIAM B. TANNER**... **LAVERN E. QUINNELL**, of *The Magnavox Company*, for over twenty years a leading figure in engineering and plant management passed away recently in Fort Wayne. At the time of his death, he was staff assistant to the general manager in charge of the government products division... **LOUIS H. NIEMANN** has been appointed eastern sales manager of *Hytron Radio & Electronics Co.*... *Philharmonic Radio & Television Corp.* of New Brunswick, N. J. has appointed **STANLEY I. MESSING** to the post of manager of the government contract division of the company... **JOSEPH MARESCA** has been named assistant to **BERNARD L. CAHN**, general sales manager of *Insuline Corporation of America*. He will also continue to act as manager of the sales order department... **JAMES N. RYAN, JR.** is the new sales manager for *Steelman Phonograph & Radio Co., Inc.*... **MAX GRAFF**, senior partner of the brokerage firm of *Townsend, Graff & Co.*, has been added to the board of directors of *Audio & Video Products Corporation*... **MORTON LEE** has joined the staff of *British Industries Corporation* as a sales engineer. He was formerly associated with *Reeves Sound Laboratories, Radio Receptor Company*, and *Amy, Acedes & King*... **C. K. KRAUSE** has been named division manager of the electronic products division of *Air Associates, Inc.*... **FRITZ P. PRICE** is the new manager of the cathode-ray tube division of *Allen B. Du Mont Laboratories, Inc.* He has been assistant manager of the division since 1950 and has been with the company since 1942... **HERBERT A. ELION** who was formerly

project engineer at *Freed Radio Corp.*, has been appointed to the research staff of *Paul Rosenberg Associates*, consulting physicist firm.

**E. W. GAUGHAN** is the new general sales manager for television and radio for the *Crosley Division of Avco Manufacturing Corporation*.



He heads the newly-created sales organization which has been set up to handle the broad expansion of the company's line. He was formerly an eastern divisional sales manager for the company.

Both this sales organization and the one set up to handle appliances are under the direction of W. A. Brees, vice-president of *Avco* in charge of *Crosley* sales.

-30-

## CBS SHOWS NEW COLOR TV

**THE** Columbia Broadcasting System recently demonstrated an all-electronic color television receiver operating with the CBS color television system.

The experimental receiver employed an RCA all-electronic color tube and contained no moving parts.

The demonstration which featured "Vericolor" industrial color television equipment (jointly displayed by Remington Rand Inc. and the CBS Laboratories Division) also included the showing of color television pictures of widely varied sizes ranging from a miniature monitor with a picture less than 7 inches wide to a projected color picture 30 inches high and 40 inches wide which, if produced for direct view, would require a tube over four feet in diameter.

According to CBS, although the demonstration receiver used the RCA tube, the unit may be used with any type of color tube yet conceived, including the "Lawrence" tube.

-30-

# Largest Selling Booster

AT ANY PRICE !

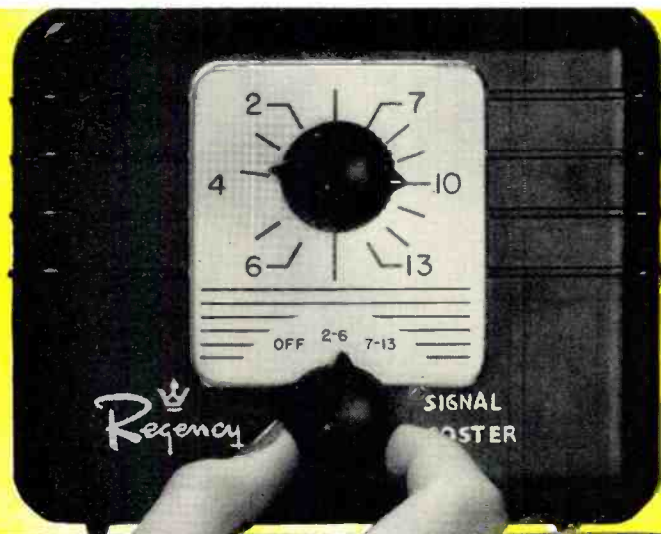

# Regency

# Here's your Opportunity

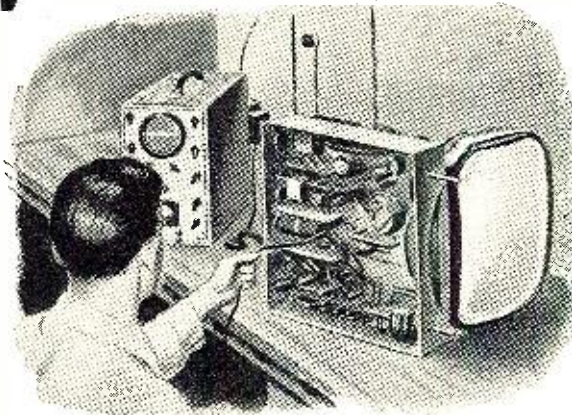

## to prepare for a good job or a business of your own in TV SERVICING

**There are today more good jobs** open in TV Servicing than there are trained and experienced men to fill them. Yes, thousands of opportunities exist now for good-pay jobs offering employment security for years and years to come. Thousands of TV Servicing jobs are going begging. Do you want one of them?

Experts agree, that because of the critical shortage of trained and experienced TV Servicemen, and the tremendous future growth of the industry, no vocational field today offers more opportunities than TV Servicing.

### The Big New Industry with a Great Future

Television is just in the beginning stages of its big industrial boom. Look at these amazing facts:

- Lifting the freeze on new TV stations will open many new TV areas and will improve the coverage of existing areas. The result will be an enormous demand for TV receivers.

- Within a few years over 1000 TV stations will be telecasting compared with 108 TV stations now on the air.

- Nearly one-half of all families living within the present TV areas do not yet own TV receivers.

- The new trans-continental video network plus better and more interesting programs plus larger viewing screens and color TV will increase the installation of new receivers, will induce present owners of 12-inch and smaller size viewing screens to buy newer model receivers.

- The power increases of many existing stations and improved reception range of current receivers will result in receivers being installed and serviced in the fringe areas of present stations.

- Under the FCC proposal, over 70 per cent of all communities will be served by UHF channels exclusively. This means TV servicemen must know UHF receivers before the new UHF stations in their area are opened.

- No one yet knows how great the industrial TV market will be.

### RCA Institutes Home Study Course prepares you for a Career in TV Servicing

The addition of the RCA Institutes TV Service Training to your present radio-electronics experience will qualify you to step out and grasp the golden opportunities that now exist in television—America's fastest growing industry.

Learn at home—in your spare time—while you study the practical *how-to-do-it* techniques with *how-it-works* information. Easy-to-read and easy-to-understand lessons under the supervision of RCA engineers and experienced instructors quickly train you to qualify for the many good jobs now waiting for trained TV servicemen. Don't pass up this lifetime opportunity for financial security and a bright future in TV. Learn TV Servicing from RCA—pioneers and leaders in radio, television and electronic developments.

RCA Institutes conducts a resident school in New York City offering day and evening courses in Radio and TV Servicing, Radio Code and Radio Operating, Radio Broadcasting, Advanced Technology. Write for free catalog on resident courses.



**RCA INSTITUTES, INC.**  
A SERVICE OF RADIO CORPORATION of AMERICA  
350 WEST FOURTH STREET, NEW YORK 14, N. Y.

## Send for FREE BOOKLET

Mail the coupon—today. Get complete information on the RCA INSTITUTES Home Study Course in Television Servicing. Booklet gives you a general outline of the course by units. See how this practical home study course trains you quickly, easily. Mail coupon in envelope or paste on postal card.



### MAIL COUPON NOW!

RCA INSTITUTES, INC., Home Study Department RN-552  
350 West Fourth Street, New York 14, N. Y.

Without obligation on my part, please send me copy of booklet "RCA INSTITUTES Home Study Course in TELEVISION SERVICING." (No salesman will call.)

Name \_\_\_\_\_ (please print)

Address \_\_\_\_\_

City \_\_\_\_\_ Zone \_\_\_\_\_ State \_\_\_\_\_

## INDISPENSABLE! PHOTOFACT BOOKS



**Photofact Television Course.** Covers TV principles, operation and practice. 216 pages; profusely illustrated; 8½ x 11". Order **TV-1**.....Only **\$3.00**

**Television Antennas. New 2nd edition.** Describes all TV antenna types; tells how to select, install, solve troubles. Saves time; helps you earn more. 200 pages; illustrated. Order **TAG-1**.....Only **\$2.00**

**Television Tube Location Guide. Volume 2.** Accurate diagrams show position and function of all tubes in hundreds of TV sets; helps you diagnose trouble without removing chassis. 224 pages; pocket-size. Order **TGL-2**. Only **\$2.00**

**Television Tube Location Guide. Vol. 1.** Over 200 pages of TV receiver tube position diagrams on hundreds of models. Order **TGL-1**.....Only **\$1.50**

**Making Money in TV Servicing.** Tested proved methods of operating a profitable TV service business. Covers all important phases. Authoritative, valuable guide to success. Over 130 pages. Order **MM-1**.....Only **\$1.25**

**Servicing TV in the Customer's Home.** Shows how to diagnose trouble using capacitor probe and VTVM. Short-cut methods help save time, earn more on outside service calls. Order **TC-1**.....Only **\$1.50**

**1949-1950 Record Changer Manual.** Vol. 3. Covers 44 models made in 1949, including multi-speed changers and wire and tape recorders. Original data based on actual analysis of equipment. 286 pages; 8½ x 11"; paper-bound. Order **CM-3**.....Only **\$3.00**

**1948-1949 Changer Manual.** Vol. 2. Covers 45 models made in 1948-49. Paper bound. Order **CM-2**. Only **\$4.95**

**1947-1948 Changer Manual.** Vol. 1. Covers 40 post-war models up to 1948. Order **CM-1**.....Only **\$3.95**

**Recording & Reproduction of Sound. 2nd Edition.** New, completely revised and vastly enlarged edition of the outstanding original volume. The most authoritative treatment of all phases of recording and amplification ever written. Over 800 pages. 6 x 9". Order **RR-2**. Only **\$7.95**



**Audio Amplifiers.** Vol. 3. Clear, uniform, accurate data on 50 important audio amplifiers, plus full coverage of 22 FM and AM tuners, produced during 1950. 362 pages, 8½ x 11". Order **AA-3**.....Only **\$3.95**

**Audio Amplifiers.** Vol. 2. A complete analysis of 104 well-known audio amplifiers and 12 tuners made 1949-50. 368 pages, 8½ x 11". Order **AA-2**.....Only **\$3.95**

**Audio Amplifiers.** Vol. 1. 102 amplifiers and FM tuners made through 1948. 352 p. Order **AA-1**.....Only **\$3.95**

**Auto Radio Manual.** Complete service data on more than 100 post-war auto radio models. Covers over 24 mfrs. 350 pages, 8½ x 11". Order **AR-1**.....Only **\$4.95**

**Communications Receiver Manual.** Complete analysis of 50 popular communications models. 246 pages, 8½ x 11". Order **CR-1**.....Only **\$3.00**

**Radio Receiver Tube Placement Guide.** Accurate diagrams show where to replace each tube in 5500 radio models, covering 1938-1947 receivers. 192 pages, pocket-size. Order **TP-1**.....Only **\$1.25**

**Dial Cord Stringing Guide.** Vol. 2. Covers receivers made from 1947 through 1949. Shows you the one right way to string a dial cord in thousands of models. Pocket-size. Order **DC-2**.....Only **\$1.00**

**Dial Cord Guide.** Vol. 1. Covers sets produced 1938 through 1946. Order **DC-1**.....Only **\$1.00**

Order from your Parts Jobber or write direct to  
HOWARD W. SAMS & CO., INC., 2201 E. 46th St., Indianapolis 5, Indiana

**HOWARD W. SAMS & CO., INC.**

# Manufacturers' Literature

Readers are asked to write directly to the manufacturer for the literature. By mentioning **RADIO & TELEVISION NEWS**, the issue and page, and enclosing the proper amount, when indicated, delay will be prevented.

## AUDIO ATTENUATORS

*Cinema Engineering Company*, 1510 W. Verdugo Avenue, Burbank, California has recently issued a new 16-page catalogue covering its line of audio attenuators.

The catalogue includes data on mixer controls, precision "T" attenuators, general purpose "T" attenuators, balanced "H" attenuators, vu meters, db meter range extending units, grid control pots, wirewound grid pots, turntable faders, speaker controls, variable impedance matching and load networks, fixed attenuators, and matching pads.

The material included also carries pad formulas, mixer circuit diagrams, technical data, and a voltage ratio table.

## RECORDING TAPES

*Audio & Video Products Corp.*, 730 Fifth Avenue, New York 19, New York has issued a one-page data sheet covering currently-available recording tapes.

Thirty-two different tapes ranging from ¼" to 1" and in a wide variety of lengths are listed along with prices and other pertinent data.

When requesting a copy of this data sheet, please specify publication 5202-17.

## REPLACEMENT GUIDE

*Standard Transformer Corp.*, 3581 Elston Avenue, Chicago, Illinois has issued a new television transformer catalogue and replacement guide which the company claims is the largest and most complete TV guide in the industry.

The new edition lists 2416 TV models and chassis made by 82 manufacturers and lists 107 transformers in the catalogue section. Set up for easy reference, the guide lists manufacturers alphabetically. All models and chassis are listed in numerical order and each replacement transformer is listed with the original manufacturer's part number for easy identification.

Copies of this new guide are now available at parts distributors or from the company direct.

## RHEOSTAT BULLETIN

*Rex Rheostat Company*, 3 Foxhurst Road, Baldwin, N. Y., has recently issued a new catalogue showing its complete line of rheostats, pots, and resistors.

Catalogue No. 5 also describes the company's new double rheostats and its line of resistors up to 2000 watt sizes, its new vernier-type rheostat for extremely fine adjustment, the new tubular rotary drive rheostats, graded

and taper-wound and non-inductive rheostats, and the company's miniature slide-wire units.

This 16-page catalogue is available only on letterhead request and all inquiries should be addressed to the company.

## GRAYBURNE CATALOGUE

The new 1952 electronic equipment catalogue recently released by *Grayburne Corporation*, 103 Lafayette Street, New York 13, New York, is now available for distribution to interested persons.

The four-page, two-color catalogue describes the company's complete line including a detailed analysis of the specific market potential for each product and specific recommendations for the exploitation of these markets.

Products described include the company's "Feri-Loopsticks" and "Vari-Loopsticks," TV interference filters, tube carriers, and TV i.f. signal boosters.

## DIRECT-MAIL BOOKLET

*Electronic Instrument Co., Inc.*, 84 Withers Street, Brooklyn 11, New York, now has available a direct-mail booklet for use by authorized parts jobbers.

The new booklet stresses to the technician the theme that the seven basic "Eico" test instrument kits will provide him with an efficient, low-cost TV-FM-AM test bench at minimum cost.

The booklet itself is printed in two colors on glossy stock. Ample space is provided for jobber imprinting.

Further details on "Form JB-152-100M" may be obtained by writing the company direct.

## AUTO AERIALS

*Ward Products Corp.*, Division of *The Gabriel Company*, 1523 East 45th Street, Cleveland 3, Ohio, has just released a new catalogue covering its line of auto aerials.

The new publication provides a complete description of the entire line, including the company's "8-ball," "Phantom," and "Air-King" series. It also describes available counter displays and other merchandising material for *Ward* aerials.

Free copies of this catalogue are now available from radio parts distributors or from the company direct.

## NEW "TRIPLE PINDEX"

The *RCA* Tube Department has released a revised edition of its "Triple Pindex" socket manual, in which are compiled, for ready reference by radio and television service dealers, socket-

# SURPLUS IS GETTING SCARCER!!



**NEW! SHIP-TO-SHORE BC-223 TRANSMITTER**  
A 30 watt Transmitter, ideal for ship-to-shore or Ham Rig. Crystal or MO control on four pre-selected channels. 2000 to 5250 KC. Use of 3 plug-in coils, five tubes: 2—801 and 3—46, and TU 17-18-25 tuning units.

TRANSMITTER ..... \$39.95  
TUBES ..... 6.95  
TUNING UNITS (TU-17 2000-3000 KC, TU-18 3000-4500 KC, TU-25 4500-5250 KC)—NEW  
IN ORIGINAL CASES ..... 5.50  
PE-125 POWER SUPPLY for BC-223, 12 or 24V output, 475V 150 ma—BRAND NEW ..... 20.95  
SPARE VIBRATOR and TUBE KIT for PE-125—NEW ..... 6.95  
NEW CABLE between TRANSMITTER and POWER SUPPLY—NEW ..... 3.95

### VHF Excellently Reconditioned Guaranteed

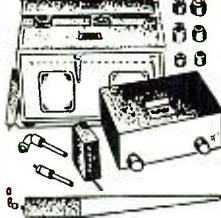

**SCR-522 AIRBORNE COMMAND EQUIPMENT**  
Frequency Range 100 to 156 mcs. in 4 channels receiver and transmitter. Crystal controlled. Complete equipment. Consists of trans/rec, control box BC-602, dynamotor PE-94, AN104 antenna, plugs, etc. Power input with PE-94 is 28 v.

Electrically Tested—Complete as Shown. **\$129.50**  
Only BRAND NEW—PRICES ON REQUEST

**TIME CLOCKS**  
12 and 24 hour cycle timing. Unlimited uses. Needs minor repairs. AN EXCELLENT BUY—HOW CAN YOU GO WRONG!  
**ONLY \$9.95**



**20 POUNDS OF ASSORTED RADIO PARTS**  
**\$2.79**  
A TERRIFIC BUY AT ONLY

**BC-221 Frequency Meter**  
Real Value! QUANTITY IS LIMITED—so first come, first served. They are just like new, with original calibration charts. Range 125-20,000 KC with crystal check points in all ranges. Complete with crystal and tubes ..... \$129.50  
MODULATED TYPE ..... \$159.50  
MODULATED TYPE WITH AC POWER SUPPLY ..... \$179.50  
These Frequency Meters are factory tested, checked for frequency alignment and GUARANTEED.



**MAY SPECIALS!!**  
**FL-8 RADIO FILTER**  
Range or Voice for 1020 cycles. Audio Switch mounted on Filter. Excellent for CW. First Class Condition. **SENATIONALLY PRICED AT ONLY 89c**

**LIMITED QUANTITY COMMAND SET BC-455-G to 9.1 MC.** Excellent. 95% completely wired—a few minor parts included require assembling. Instructions included. **ONLY \$7.95**

**COMMAND TRANSMITTER—Navy and Army Type** —3 to 4 MC. 75% complete spare parts—LIMITED QUANTITY **\$10.95**

**NOTE REDUCED PRICES!!**

**SCR-274N COMMAND and ARC-5 Equipment**

RECEIVERS	USED	NEW
BC-453—190 to 550 KC	\$20.95	\$29.95
BC-454—3 to 6 MC	8.95	9.95
BC-455—6 to 9 MC	9.95	11.95
BC-954—500 to 1500 KC (Broadcast Band)	24.95	27.95

TRANSMITTERS	USED	NEW
BC-458—5.3 to 7 MC	7.95	9.95
ARC5-T-19—3 to 4 MC	24.95	34.95
BC-459—7 to 9.1 MC	13.95	15.95

**ADDITIONAL EQUIPMENT**

BC-456 Modulator	2.49	2.95	5.95
BC-450 Control Box (3 Receiver)	1.49	1.95	2.75
BC-451 Control Box (Transmitter)	1.29	1.79	2.39
BC-442 Relay Unit (ANT)	2.39	2.89	3.69
Plugs: PL-147, 148, 151, 152, 153, 154, 156—EACH		1.25	
Flexible Shafting with gear to fit receivers			2.69
3 Receiver Rack	1.79	2.29	2.98
2 Transmitter Rack	1.69	2.39	3.97
Single Transmitter Rack			3.97
DM-32 Dynamotor for Command Set		3.95	5.95
DM-33 Dynamotor for Command Set		2.95	3.95
Shock Mounts for 3 Receiver Rack			
2 Trans. Rack, Modulator or Antenna Relay Unit	1.95	2.45	

**WHY PLATT'S RECONDITIONED SURPLUS EQUIPMENT IS SO HIGHLY DESIRABLE AND SUCH A TERRIFIC BARGAIN!!**  
Platt Electronics Corp. is presently engaged in manufacturing electronic equipment for the government. As you know, the standards required for this type of work are extremely high, and Platt applies these same standards in his Surplus Reconditioning Department. Guided by the Platt Engineering Staff, all work is done according to the latest methods of manufacturing. No expense is spared to supply you with perfectly reconditioned equipment at real bargain prices. And if you would like to prove to yourself how carefully all work is done, please accept this invitation from Mr. Platt to visit his plant.

**NEW SUPPLY ARRIVED! LIMITED QUANTITY TRANSMITTER-RECEIVER**  
**Navy Model ABA-1 (CG-43AAG)**  
**Army Model SCR-515A, known as the BC-465**  
**450 MC — 15 Tubes**  
**BRAND NEW—ORIGINAL CARTON**

Can be easily converted for phone or CW 2-way communication. Covering for the following bands: 420-450 MC ham band, 450-460 MC for fixed or mobile, 460-470 MC for citizens, 470-500 MC television experimental. Size 10 1/2 x 13 1/2 x 4 3/4. Contains 15 tubes: 4—7H7, 4—7HT, 2—7E6, 2—6F6, 2—955, 1—WE-316A door knob. Price includes Dynamotor, Control Box, Mount, Tubes. **\$42.95**  
Complete set of spare parts, tubes and plugs for above **\$29.95**

**HEADSETS**  
HS-23 low impedance with cord and plug, used, fine condition ..... \$2.79  
HS-23 high impedance, BRAND NEW with ear buds ..... 4.25  
HS-33 low impedance, BRAND NEW with ear buds, cord and PL-34 plug ..... \$4.95  
HS-30 with ear plugs, low impedance, used, good condition ..... 1.69  
CH-307A Cords 6'—NEW ..... .89  
H-16/U high impedance. Includes two receiving units ..... 3.95  
HS-16 high impedance—used ..... 2.49

**ARMY TEST UNIT 1-236**  
Meter is contained in a metal box 5 1/2" long x 3 3/4" wide x 3 1/4" deep. Comes complete with test leads and instruction book. Can be used for testing between AC and DC measuring resistances of circuits, checking fuses and testing capacitors. **SPECIAL \$4.19**

**Multimeter Foundation BIAS METER 1-97A**  
Contains a zero center 3 1/2" round Martin voltmeter, calibrated 0-1000 volts each side. Movement is one mill each side of center. The unit is mounted in a steel box 7" x 5" x 4 1/2" and contains 8 contact push button, line cord dual 100 MFD at 200 V DC condenser, a potentiometer 6 IRC 1 1/2 wire wound non-inductive resistors: one 400 ohm, two 2500 ohm, one 5000 ohm, one 10,000 ohm, one 15,000 ohm. Excellent for building a zero center multimeter with ranges of 1, 10, 100, 1000 volt. **COMPLETE BRAND NEW \$5.95**

**MM-26Y INSTALLATION MN-26Y Receiver**—Remote control commercial type navigational. Indicates direction of any desired transmitting station. Frequency range: 150 to 325 KC, 325 to 695 KC, 3.4 to 7 megacycles in 3 bands. Has 12—6V type tubes. **BRAND NEW (Original Cost \$860) YOUR PRICE ONLY \$18.95**

**CD 307A CORDS**  
with PL55 Plug and JK 26 Jack, long cord. **79c**  
SPECIAL

**Ranger Aircraft Interphone Receiver Model I14-C**  
A 6 tube super-heterodyne interphone receiver designed for operation directly from a 24 V battery. Frequency coverage: 200-550 KC, Audio output: 27 1/2 milliwatts. Weight of receiver and jack box: 2 lbs. 22 ozs. 2 cables are furnished—one connecting receiver to jack box and the other shielded cable for connecting receiver to battery. Set comes complete with receiver, jack box JB-2, cables, and operating manual. **BRAND NEW—LIMITED QUANTITY ONLY \$14.95**

**MINIMUM ORDER \$2.00**  
Immediate Delivery—Send 25% deposit on C.O.D. orders. All shipments F.O.B., N.Y.C. (N.Y.C. residents add sales tax to your remittance.)

This is probably no news to you. But, just like every other commodity, as the supply dwindles, prices tend to skyrocket. That's why Platt wants you to know that it is his practice to favor all his customers with the best possible prices based on present market conditions. Every item in this advertisement has been carefully priced at the usual minimum mark-up—and as always, the savings are passed along to you. So why not ORDER TODAY to be sure you get what you want at the price you can afford to pay!

**TURBO AMPLIFIER**  
4 tube Amplifier used by U. S. Air Force. 115 V. Input at 400 cycles. **BRAND NEW \$149**  
..... SPECIAL

TS-13 HANDSETS—BRAND NEW ..... \$9.95  
TS-9 HANDSETS—BRAND NEW ..... 6.95  
J-37 TRANSMITTING KEY—BRAND NEW ..... 1.79  
J-38 TRANSMITTING KEY—BRAND NEW ..... 1.39

**Field Telephones**  
Army surplus, plus, completely reconditioned, and electrically tested, using 2 flashlight cells and a pair of interconnecting wires. G U A R A N T E E D—like new. **\$20.95**

**FIRE EXTINGUISHER TIRE INFLATOR**  
Made by leading Detroit Auto Mfr. Especially recommended for oil, gas, and electrical fires. Guaranteed by mfr. against defects. Order two—one for your home; one for your car in case of flats or fires. **ONLY \$2.29 each**

**MINE DETECTOR SET SCR-625**  
A portable device capable of detecting all types of metals. Hundreds of uses: Agricultural, mining, etc. **SPECIAL! \$79.95**

**RA 10 DA 4 BAND RADIO COMPASS & COMMUNICATION RECEIVER**—Frequency range: 150 to 400 KC, 400 to 1100 KC, 2 to 5 MC, 5 to 10 MC. Input 28V DC—BRAND NEW ..... \$21.95  
RA 10 DB—Same specs. as above—Excellent Used 19.95

**T9/APQ-2 RADAR TRANSMITTER**  
80/115 V 400-260-26 VDC. Designed primarily for aircraft operation. **NEW \$23.95**

**RADIO SET SCR-583**  
Has following 3 installations: on pack animal, on the ground, in a motor vehicle. Designed to provide 2-way communication. Frequency Range: Transmitter 2 to 4.6 Mc. Receiver 2.2 to 4.6 Mc. Types of Signals emitted CW and Voice, Types of Modulation A.M.  
Distance Range  
Low Power ..... 10 15  
High Power ..... 35 65  
Auxiliary Power Supply ..... 4 80  
Complete, brand new, equipped for immediate installation **\$347.50**

**SPACE DOES NOT ALLOW US TO LIST ALL THE ITEMS WE HAVE AVAILABLE**  
—so if you are in the market for any of the equipment listed below, please write, wire or phone today for complete information and prices.  
SCR 694 BC 191 BC 224  
SCR 300 RA 34 Power BC 610  
SCR 536 Supply BD 71 Switchboard  
SCR 284 ART 13 BD 72 Switchboard  
SCR 510 ARC 1 Loops  
SCR 269G BC 348 Dynamotors  
ARM 7 BC 342 Plugs  
BC 375 BC 312  
All types of Teletype Equipment

**PLATT ELECTRONICS CORP.**  
DEPT. A, 489 BROOME ST., NEW YORK 13, N. Y.  
PHONES: WO 4-0827 and WO 4-0828

# WORLD' FASTEST SELLING VOLT-OHM MILLIAMMETER



## Model 770

is an accurate pocket-size V.O.M.  
Measures only 3 1/8" x 5 7/8" x 2 1/4"

Write Dept. RN-5 for catalog of complete line.



Manufactured and Guaranteed by  
**SUPERIOR INSTRUMENTS CO.**  
227 Fulton Street • New York 7, N. Y.

**Sensitivity**  
1000 ohms per volt

- ★ Uses latest design 2% accurate 1 Mil. D'Arsonval type meter.
- ★ Same zero adjustment holds for both resistance ranges. It is not necessary to readjust when switching from one resistance range to another. This is an important time-saving feature never before included in a V.O.M. in this price range.
- ★ Housed in round-cornered, molded case.
- ★ Beautiful black etched panel. Depressed letters filled with permanent white, insures long-life even with constant use.

The Model 770 comes complete with self-contained batteries, test leads and all operating instructions.

**\$14.90**  
NET

### Specifications:

- 6 A.C. VOLTAGE RANGES:  
0-15/30/150/300/1500/3000 Volts.
- 6 D.C. VOLTAGE RANGES:  
0-7.5/15/75/150/750/1500 Volts.
- 4 D.C. CURRENT RANGES:  
0-1.5/15/150 MA. 0-1.5 Amps.
- 2 RESISTANCE RANGES:  
0-500 Ohms 0-1 Megohm.

**AT  
YOUR  
RADIO  
PARTS  
JOBBER**

connection diagrams for more than 660 receiving tubes and kinescopes.

Specially designed to provide information at a glance, the book is divided into three identical horizontal sections, each connected to the same flip-over-type binding. This arrangement enables the technician to refer to a single composite page for simultaneous reference to any three of more than 660 socket diagrams, thus minimizing the necessity for leafing back and forth through the book.

The revised edition also contains a handy cross-index reference supplement which lists a variety of tube types used only occasionally.

The new publication is priced at 75 cents and is currently available from all RCA tube distributors or from the Commercial Engineering Division of the RCA Tube Department, Harrison N. J.

### INSULATOR DATA

M. Kirchner & Co., Inc., 1425 37th Street, Brooklyn, New York has issued two booklets covering its "Lava" insulators for the electrical and chemical industries.

Since these insulators are custom-designed, the booklet deals with technical data on properties, grades, thermal resistance, etc. instead of specific units.

The two booklets are entitled "Lava Insulators for Electronic Tubes" and "Lava for Industry." The first publication has been specially prepared for use in the electronic field while the second booklet treats the subject of insulation more generally, thus making it helpful in a number of industries.

### METAL COIL

The Coated Coil Corporation, 539 West 30th Street, New York 1, New York has recently issued a four-page folder describing the production advantages of "Enamelstrip," the metal coil pre-coated in color.

The folder lists the various metals which can be coated and suggests the uses for this product in various industries. Of interest to the radio-television-electronics industry are such applications as instrument parts, appliance accessories, batteries, various terminal plates, etc.

A copy of this booklet is available on request.

### VARIABLE RESISTORS

Chicago Telephone Supply Corporation, Elkhart, Indiana has issued a 38-page catalogue illustrating and describing in detail its new military and civilian lines of composition and wirewound variable resistors.

The new military line ranges from a 1/2 watt, 3/4" diameter miniaturized composition variable to a 4 watt, 1 1/32" diameter wirewound variable unit. Military resistors can be supplied to meet JAN-R-94 or JAN-R-19 requirements as well as other special requirements beyond these specifications.

The data included in the catalogue  
**RADIO & TELEVISION NEWS**

## AMPERITE

Studio Microphones  
at P.A. Prices

Ideal for  
**BROADCASTING  
RECORDING  
PUBLIC ADDRESS**

"The ultimate in microphone quality," says Evan Rushing, sound engineer of the Hotel New Yorker.

• Shout right into the new Amperite Microphone—or stand 2 feet away—reproduction is always perfect.

• Not affected by any climatic conditions.  
• Guaranteed to withstand severe "knocking around."

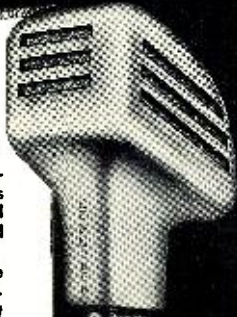

Models  
RBLG—200 ohms  
RBHG—Hi-imp.  
List \$42.00



"Kontak" Mikes  
Model SKH, list \$12.00  
Model KKH, list \$18.00

**Special Offer:** Write for Special Introductory Offer, and 4-page illustrated folder

**AMPERITE Company, Inc.**

561 BROADWAY • NEW YORK 12, N. Y.

Canada: Atlas Radio Corp., Ltd., 560 King St. W., Toronto

## PHOTOCON SALES

1062 N. Allen Ave. SYcamore 4-7156  
Pasadena 7, Calif. RYan 1-8271

### WRITE FOR OUR WINTER SURPLUS SALES CATALOGUE

WE WILL BUY YOUR NEW OR CLEAN USED ELECTRONIC SURPLUS: ARC-1, ARC-3, BC-224, BC-348, BC-312, BC-342, ATC, ART-13, APS-13, BC-221, LM's, TS-12, TS-13, TS-23, TS-34, TS-35, IE-19A, I-222, SCR-522, TS-100, or any BC, I, IE, TS, APR.

### WRITE FOR PRICES:

APR4, TS34/AP, TS13/AP, TS148/UP, ARC-1, ART13, APA11, TS18A, TS251, etc.

DuMont (208B) 5" Oscillograph	EXCELLENT	\$225.00
804CS Signal Generator 8-330 mc.	EXCELLENT	400.00
APN-1 Altimeter Indicator 0-1 ma. shunt, 250° dial.	NEW	2.95
LM & BC-221 Frequency Meter with cal. book, crystal, and tubes.	EXCELLENT	99.50
SCR-625 Mine Detector.	NEW	69.50
	USED	39.50
AN/APN4B Complete	EXCELLENT	150.00
PE-218 Inverter 400N.	NEW	29.50
Weston Model 545 Tachometer Meter	NEW	17.50
HS-33 600 ohm Headsets.	USED	3.50
	NEW	5.95
400 cycle Inverters—G.E. 5D21N3A Input 24V. DC. Output 115V. AC. 400 cycles 485 V.A.	NEW	24.50
DuMont 241 Oscillograph.	EXCELLENT	300.00
G.E. Oscillograph CRO5Y.	EXCELLENT	225.00
Drafting Machine single scale 16" Fulcrum less scale, Exc.		35.00
CRT-3 Two-Channel Gibson Girl.	NEW	75.00
DuMont 224 Oscillograph less front cover.	EXCELLENT	125.00
TS173/UP Freq. 90-180MC Freq. Meter	EXCELLENT COND.	600.00
Genescope—Superior 480.	NEW	340.00
196A Signal Generator.	LIKE NEW	375.00

NOTE: One of the largest and most complete electronic surplus stocks in the country. We have thousands of tubes, capacitors, plugs, accessories, transmitters-receivers, test equipment, etc. Send us your requirements.

TERMS: Prices F.O.B. Pasadena, California. 25% on all C.O.D. orders. Californians add 3% Sales Tax. Prices subject to change without notice.



# HERE'S HOW THE "OLE TIMER" DOES IT...

SAY, O.T., TELL US HOW YOU ARE ALWAYS ABLE TO HAVE THE LATEST NATIONAL EQUIPMENT.

THAT'S EASY, JUNIOR. I'VE BEEN DEALIN' WITH *Walter Ashe* FOR YEARS, AND I ALWAYS GET A CLEAN CUT DEAL.

.. AND THOSE WALTER ASHE "Surprise" TRADE-INS REALLY SAVE US MONEY!



## HERE IS THE NEW NATIONAL NC-183D Featuring DUAL CONVERSION with Steep Skirt Selectivity



HRO-50T1—Shpg. wt. 88 lbs. less spkr. Only \$383.50

Dual conversion on the 3 highest ranges including 6, 10, 15, 20 and 40 meter ham bands. Steep sided skirt selectivity made possible by three I. F. stages and 16 tuned circuits on the 3 high ranges; 12 on all other ranges. New crystal filter gives deeper phasing notch. Retains many time-tested features of NC-183 but has 1 more tube and 1 more I. F. stage. Also many other new features.

All prices f. o. b. St. Louis • Phone Chestnut 1125

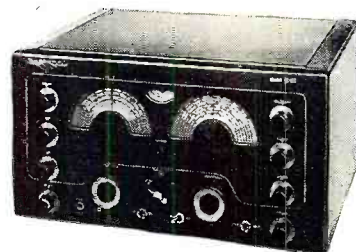

Shpg. wt. 64 lbs. Price on request.

**Walter Ashe**  
RADIO CO.  
1125 PINE ST. • ST. LOUIS 1 MO.

Walter Ashe Radio Co. RTN-52-5  
1125 Pine St., St. Louis 1, Mo.  
 O. K. Walter, Rush "Surprise" Trade-in-offer on my \_\_\_\_\_  
for \_\_\_\_\_  
(show make and model No. of new equipment desired)  
 Rush Free Copy of your new Catalog.  
NAME \_\_\_\_\_ ADDRESS \_\_\_\_\_  
CITY \_\_\_\_\_ Zone \_\_\_\_\_ STATE \_\_\_\_\_

**SEND  
FOR YOUR  
COPY  
TODAY!**

# OLSON HAS THE BIG BIG BARGAINS

## LAST CALL—12" CO-AXIAL SPEAKERS

12" Wide Range Co-Axial Speaker



To Make Way for New Model  
**SPECIAL \$10.95**

Stock No. S-160

of these fine PM speakers during this sale and save money. This is the same type of speaker you will find in \$300.00 combination radios. Each speaker consists of a 12" woofer section driven by a heavy 6.8 oz. magnet and this part delivers the bass notes. The 3" tweeter speaker is built into the center of the speaker and is driven by a 2.15 oz. Alnico 5 magnet. This part delivers the treble notes. The high pass filter is built into the speaker and the entire combination gives you tones you never dreamed possible. Only two wires connect to any radio or amplifier at the speaker. Voice coil impedance is 8 ohms. Shpg. wt. 10 lbs.

40 to 17,500 CPS Response

to connect to any radio or amplifier at the speaker. Voice coil impedance is 8 ohms. Shpg. wt. 10 lbs.

**CLOSE-OUT PRICE WHILE THEY LAST**

## STOCK UP



On These Popular Sizes—at These Low Prices

Don't hesitate—here's that opportunity to buy quality speakers at less than jobbers cost. Again Olson was Johnny-on-the-Spot. We had the cash and made the deal. Now you can get your share of the savings. All are PM with 3.2 ohm voice coils.

Stock No.	Size	Shpg. Wt.	Olson's Price
S-4	4"	2 lb.	\$1.50
S-5	5"	2 lb.	1.70
S-7	6"	2.20	2.20
S-96	8"	3 lb.	3.30
S-123	8"	3 lb.	3.30
S-97	10"	5 lb.	3.95
S-167	12"	7 lb.	4.95

## 4-DRAWER STEEL CABINET GIVEN WITH OLSON'S GIGANTIC, NEW AKRAD KIT

Olson's Price **\$16.95**

You get \$51.60 list worth of "AKRAD" Condensers plus the 4 drawer steel cabinet FREE, size 10"x11 1/2"x10". Shpg. wt. 11 lbs.

11 1/2"x10". Shpg. wt. 11 lbs.

**42 "AKRAD" By-Pass Condensers**

Qty.	Cap.	Volts	List ea.	Total
2	.001	600	\$25	\$50
2	.002	600	25	50
2	.005	600	25	50
5	.01	600	30	150
5	.02	600	30	150
10	.05	600	40	400
10	.1	600	45	450
2	.005	1600	55	110
2	.008	1600	55	110
2	.01	1600	60	120

**Also 27 "AKRAD" Electrolytic Condensers**

Qty.	Cap.	Volts	ea.	Total
2	10	25	\$1.00	\$2.00
2	25	25	1.00	2.00
5	20	150	1.20	6.00
5	40	150	1.35	6.75
4	20-20	150	1.65	6.60
5	8	450	1.25	6.25
4	16	450	1.40	5.60
69 Value				\$51.60



AS-46 KIT OF 20 **\$24.95**

**10 WATT RESISTOR KIT**

We mean to move 80,000 fine 10 watt wire wound resistors during this sale. REGULAR LIST PRICE OF THIS KIT IS \$15.00. Each kit contains 20 popular insulated resistors, with tinned copper leads. Shpg. wt. 2 lbs.

## Fairchild GRINDER TL-3

**\$9.98**

Every service man needs one of these handy tools made by Fairchild, famous manufacturer of precision electric grinders. Regular nationally advertised price is \$15.75. The set consists of 1-115 volt high speed, air cooled grinder, 6 assorted grinding wheels, 1 circular saw blade, 1 hardened steel reamer, 1 buffing brush, 1 abrasion stone and a natural finish wood case size 10"x5"x3" to house the grinder. Shipped in original factory sealed cartons.

## 3 SPEED PICK-UP ARM

**\$4.95**

Cartridge flips by means of a lever. Dual cartridge, one side plays 33 1/2 and 45 and other 78 RPM. Double needle. Special while they last

## A BIG VALUE COMBINATION OFFER

You get an Alliance Rim Drive 78 Photo Motor with turntable PLUS a Pickup Arm with high output Cartridge

## CRYSTAL MIKE

High output crystal mike for PA systems and recorders. Equipped with handie base and 7' shielded cable. Shpg. wt. 5 lbs.

**\$6.95**

## PHONO AMPLIFIER

A real high efficiency 3-tube amplifier of modern design. Connect to any crystal phono arm and speaker. Has volume and tone controls 7"x3 1/4"x2". Shpg. wt. 2 lbs.

**\$2.64**

## 15 WATT AMPLIFIER

Brand new, in factory sealed cartons. An all around amplifier to take care of most of your PA needs. Has an input for crystal mike and phono. Separate volume controls. Also tone control. Output impedances: 4-8-16-500. Equipped with handsome grey cover.

**\$24.75**

KIT OF TUBES FOR AMPLIFIER 12SQ7 50L6 35Z5 No. AS-22

embraces such information as electrical and mechanical characteristics, special features and construction, and dimensional drawings. A special information section on the new military line provides much valuable data of interest to design engineers.

## RESISTOR CATALOGUE

Tru-Ohm Products, Division of Model Engineering & Mfg., Inc., 2800 N. Milwaukee Avenue, Chicago 18, Illinois is currently offering copies of its new catalogue covering the various resistors made by the company.

The publication illustrates and describes the company's power rheostats, fixed and adjustable resistors, and its line of "Econohm" resistors. In addition, the new publication includes graphs, resistor mounting diagrams, terminal types, and other pertinent information.

The price of the revised edition is 45 cents and a money order must accompany requests for this booklet.

## "PROSPECTING FOR URANIUM"

A revised edition of the pocket-sized handbook for uranium prospectors, "Prospecting for Uranium," is now available from the Superintendent of Documents, U.S. Government Printing Office, Washington, D. C.

Published jointly by the U.S. Atomic Energy Commission and the U.S. Geological Survey, the new booklet contains eight color reproductions of common uranium bearing ores. The new revision also includes the latest official AEC price circular, including Domestic Uranium Program Circular 6 providing for the bonus for initial production of uranium ores from domestic mines, and a compilation of public land orders listing tracts withdrawn from public use.

The price of the revised edition is 45 cents and a money order must accompany requests for this booklet.

## ELECTRICAL PAPERS

Insulation Manufacturers Corporation, 565 West Washington Blvd., Chicago 6, Illinois has issued a new 12-page catalogue which covers rag, part rag, wood pulp, and rope papers, pressboards; and electrical fiber for electrical insulation.

The bulletin provides complete technical data on the various available types of electrical insulating papers along with information on the advantages, properties, and applications of each paper grade.

Copies of this catalogue are available from the company's Publications Department at the above address.

## CARRIER EQUIPMENT

A description of a broadband, single-sideband suppressed-carrier radio channelizing system designed to provide 24 voice and signal circuits over one wideband radio channel is included in the new folder just released by Lenkurt Electric Company, Inc., 1105 County Road, San Carlos, California.

Known as Form 33C-P, this publica-



**\$19.99**

**GIGANTIC CLOSE-OUT SALE!**  
Combination 33 1/2 and 78 RPM Changers. Genuine V.M. Intermix Record Changers Built for RCA. Factory sealed cartons. Worth \$45.00 List.

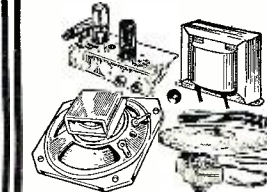

**Build Your Own Record Player**  
Kit contains a rim drive motor with velvet finish turntable, crystal pickup, all purpose needle, 4" PM speaker, matching output transformer, 1 tube AC-DC amplifier complete with tubes (55W4 and 50B5). Single Speed Model 78RPM. Complete Kit as described above. Shpg. wt. 8 lb. Stock No. AS-52 ..... **\$8.95**

## 10-WATT WIRE-WOUND RESISTORS

Olson bought over \$64,000 worth of the fine wire wound resistors (a famous manufacturer's entire stock). You can have them at 80% discount off list price. Stock up. Order whether you need them now or not. Regular list prices run from 75c to \$1.10 each. These resistors are unaffected by heat, cold, or fumes. Windings are rigidly held in place on asbestos core by special formula. Stands terrific overloads. Accuracy 0.6%. FULLY GUARANTEED. Equipped with tinned leads. TAKE YOUR CHOICE WHILE THEY LAST

Stock #R-16

OHMS	OHMS	OHMS	OHMS	OHMS
5	50	250	1250	3,500
20	100	750	1500	4,000
125	125	800	1750	4,500
33	150	1000	2000	7,500
35	200	1100	2250	8,000
40	225	1200	2500	8,500
				10,000
				16,000

Olson's Special **20¢ EA.**

## RECORDING TAPE—Famous Mfr's Close-Out!

Get the buy of your life. Save up to 64% on high quality RECORDING TAPE. A large manufacturer had to sell his inventory and he unloaded the whole deal. Olson now offers you this high grade recording tape at prices which defy competition. Standard 1 1/2" wide, 1200 ft. long. Frequency response 50 to 8,000 cy. Plastic Reel included with each.

PAPER BASE—1200 ft.	PLASTIC BASE—1200 ft.
Stock No. X-248	Stock No. X-249
Single each \$2.19	Single each \$2.19
Lots of 10, each <b>\$1.49</b>	Lots of 10, each <b>\$1.99</b>

**PRICES SLASHED ON EMPTY PLASTIC REELS**  
Finest Clear Plastic—Will Not Warp

5" Diameter—600' Size	7" Diameter—1200' Size
No. X-250	No. X-251
Single, ea. 39¢	Single, ea. 49¢
LOTS OF TEN, EA. <b>29¢</b>	LOTS OF TEN, EA. <b>39¢</b>

# OLSON RADIO WAREHOUSE • 275 E. Market St., Akron 8, Ohio





## STANCOR

**SAME AS P-6387**  
Step down Step up Isolation Transformer

500 Watts 28 lbs.  
Pri. 250-230-210  
Sec. 115  
Volts.....**21.95**  
List 49.50



BRAND NEW

## GALVONOMETER

LEEDS & NORTHRUP

Scale 0-25 In Oak Case. Used, in Good Condition... **7.95**

## RESISTOR KIT

100 asstd. 1/2 & 1 Watt. All standard brands... **2.99**

## Williamson Type High-Fidelity Output Transformer

Frequency Ranges—30cy to 20KC ± 1/2db. Used for Push Pull 807s or English KT66s 8 ohm Voice Coil.  
Terrific Value  
Made by Chicago Transformer Co.



**BETTER THAN 50% OFF LIST** On all Tubes. Standard Brands R.C.A., Sylvania, Kenrad, G.E., Tung Sol, National Union.  
Write for our tube price list

## The New CASCODE TUNER

For all 630 Sets. For all intercarrier sets... **22.89**

Standard Tuner For all 630, etc **18.95**

## RAM TV CONVERSION KIT

FOR ALL SETS. You can now make your 10" or 12" Set into any size up to 24". Consists of 16KV High Voltage Flyback Transformer, 70° Full Focus Cosine Yoke, Linearity Coil, Width Coil. Complete with instructions... **11.95**  
List 22.00

## CARTER DYNAMOTOR

Stock No. 4037 AS Input—6 VDC Output—400 V @ 375 mils. Brand new **26.95**

## PIONEER GENEMOTORS

Type E-3 Input 14VDC @ 8 amps. Output 550 V @ 120 mils. **8.95**  
SP-125 Input 28VDC @ 2.2 amps. Output 270 V @ 120 mils. **6.95**  
DS-125 Input 28VDC @ 1.2 amps. Output 260 V @ 60 mils. **4.95**

## BENDIX DYNAMOTOR

DA-1A— Input 28 VDC 1/2 1.6 amps. Output 230 V 1/8 100 mils. **5.95**

## 3 SPEED RECORD CHANGER

Made by General Instrument—VERY SPECIAL QUANTITY LIMITED **19.95**

## SIGMA SENSITIVE RELAY

Type 4F—8000 ohms SPDT... **2.95**

## 10,000 ohm SENSITIVE RELAY

SPDT—Adjustable Contacts Adjustable Tension **4.95**

## 2 1/2" SIMPSON

0-8 amps RF meter Complete with built in Thermocouple. Special... **3.29**

Phone WOrth 4-3270

**ACORN ELECTRONICS CORP.**  
76 Vesey St., Dept. N-5, New York 7, N. Y.

tion illustrates a typical equipment rack, provides block diagrams, and a frequency allocation chart which shows in detail how a simple and economical group modulation scheme is utilized to position three eight-channel groups in the spectrum between 10 and 135 kc.

## ANDREW PRODUCTS

Andrew Corporation, 363 East 75th Street, Chicago 19, Illinois has issued a new general price list covering its entire line.

Designated as Bulletin 10-E, the new catalogue includes double coaxial cables, transmission lines, wave guides, line and cable accessories, open wire lines, antennas for FM and TV, communications antennas, microwave antennas, tuning equipment, instruments, components, tower lighting equipment, and a comprehensive cross index.

## NEW PYRAMID DATA

Pyramid Electric Company, 1445 Hudson Blvd., North Bergen, New Jersey has released a new 8-page engineering bulletin covering its new metalized paper condenser line.

Designated Bulletin MP-1, the new publication carries general data; information on self-healing characteristics; voltage, derating, insulation resistance, life test, and application data;

and specific information on the various units in the line.

Types MT, MPG, MPT, and MPD are covered with ratings, diagrams, and important circuit data provided on each of these units.

Copies of this bulletin are available on request from the company.

## TAPE RECORDING

Pentron Corporation, 221 E. Cullerton Street, Chicago 16, Illinois is now offering copies of a new booklet, entitled "See, Hear! Tape Recording Offers You," to dealers for distribution to their customers.

This handy-sized, 8-page booklet, which is attractively printed in two colors, explains and illustrates the component parts of a tape recording system, outlines the advantages of tape recording, applications for the tape equipment, and a brief glossary of terms encountered in tape recording literature.

The explanatory material is written simply, in non-technical language and should help the layman to better understand the subject of tape recording.

Copies of this little booklet are now available from the company. You may obtain your copy without charge by writing direct to the firm.

-50-

## NOVEL MIKE STAND

By ARTHUR TRAUFFER

**T**HOUGH a little on the humorous side, radio amateurs and home recording fans will like the way this practical, economical, and easy-to-make microphone desk stand will protect the mike from vibrations, thumps and bumps, which can ruin an otherwise perfect transmission or recording.

Buy a brand new drain suction-cup with a wood handle. The writer uses a small mike so he bought a cup with a 4" diameter bottom. For larger mikes, buy a cup with a 5 1/2" bottom. Saw off the wood handle to the desired height. Bore an undersize hole in the end of the wood handle and twist in a 1/4"

diameter lag-screw securely. Saw off the screw so about 3/8" projects out of the handle. Remove the cable-protecting spring from a male mike cable connector, slip the connector over the lag screw, and tighten the set-screw in the connector. The threads on the cable connector are standard microphone 5/8"-27, which will fit the sockets in all U. S. microphones except those made by RCA. Give the wood handle a coat of black enamel, or soak it in a dark walnut or mahogany stain. The writer has often wished for an all-rubber desk stand for his mikes. Now he has one at a cost of only fifty cents!

-50-

Exploded diagram showing how desk mike stand can be assembled from drain plunger.

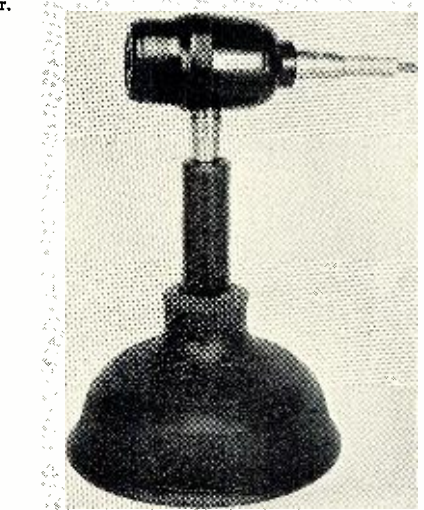
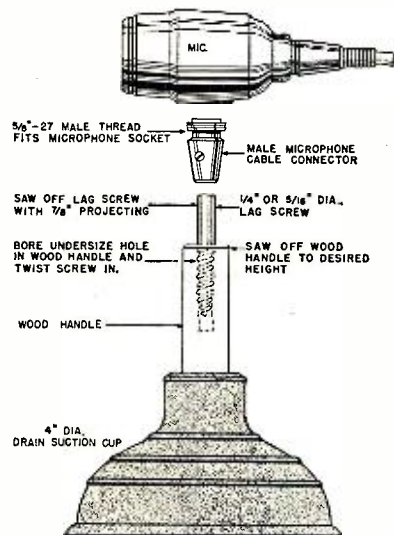

Over-all view of handy mike stand assembly.

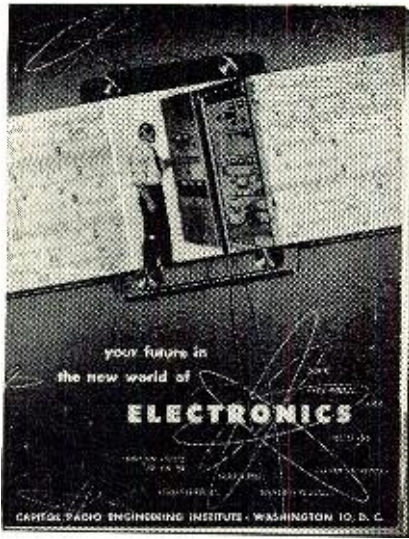

Many a well-paid man  
is grateful for this FREE  
fact-packed booklet, which details

## HOW YOU CAN BE SUCCESSFUL IN RADIO-TV-ELECTRONICS

← Send for it today

EVERY success in Electronics has a story behind it. Sometimes you hear it's "luck." Other times, "contacts." What do the successful men themselves say? *They give credit to training.* In addition, many men on the way up thank the day they sent for a booklet titled "Your Future in the New World of Electronics."

This is the eye-opening survey of the fast-growing world of Electronics. Many eager, ambitious men started their technical careers with a study of this booklet.

Expansion is phenomenal in this dynamic industry. There are over 100,000,000 radios in use! Experts predicted that by 1954 there would be 13,000,000 TV sets. That mark was passed a year ago. Today there are 16,184,000. 109 television stations are now in operation, and the lifting of the freeze will send 1500 to 2500 new stations scrambling for trained personnel—so urgently needed in every phase of electronics. That isn't the whole picture.

Consider the tremendous defense orders for electronic installations—consider the fire and police departments, the railroads, the cabs, the aircraft—all using radio. Consider radar. Consider the maritime world with its navigational aids, fathometers, ship-to-shore and ship-to-ship communications. Think of electronic heating, fax and ultra-fax, of electronic medicine, and all the other applications of electronic know-how.

Countless positions must be filled—in development, research, design, production, testing, inspection, manufacture, broadcasting, telecasting and servicing. Who can get those positions? You—if you prepare today—if you are alert and have the ambition to advance your knowledge. You—if you take 2 minutes to send for a free copy of "Your Future in the New World of Electronics."

This helpful booklet shows you how CREI Home Study leads to greater earnings through the inviting opportunities described above.

CREI, an accredited technical school, does not promise you a "bed-of-roses." You have to translate your willingness to learn into salable technical knowledge—via *study*. Since its

founding in 1927, CREI has provided thousands of professional radiomen with technical educations. During World War II, CREI trained thousands for the Armed Services. Leading firms choose CREI courses for group training in electronics at company expense, among them United Air Lines, Canadian Broadcasting Corporation, Trans Canada Airlines, Sears Roebuck & Co., Bendix Products Division, All-American Cables and Radio, Inc., and RCA-Victor Division.

CREI courses are prepared by recognized experts. Assignments are practical and easily-understood. You benefit from the individual supervision of CREI's Staff of Instructors. This complete training is the reason why CREI graduates

find their diplomas keys-to-success in Radio, TV and Electronics.

CREI alumni hold top positions in many of America's leading firms.

At your service is the CREI Placement Bureau, which finds positions for students and graduates. Although CREI does not guarantee jobs, requests for personnel currently exceed supply by far.

Talk to men in the field and check up on CREI's high standing in

electronics instruction. Determine for yourself right now that your earnings are going to rise with your knowledge—and that you get your rightful place in the Age of Electronics. All this CREI can promise you, provided you sincerely want to learn. Fill out the coupon and mail it today. We'll promptly send you your free copy of "Your Future in the New World of Electronics." The rest—your future—is up to you.

**CREI Resident Instruction (day or night) is offered in Washington, D. C. Here work is done with the latest equipment, in ideal surroundings, under close personal supervision. New classes start once a month. For a CREI Residence School catalog, check the last line of the coupon below.**

**MAIL COUPON FOR FREE BOOKLET**

**CAPITOL RADIO ENGINEERING INSTITUTE**

Dept. 115D, 16th & Park Rd., N.W., Washington 10, D. C.

Send booklet "Your Future in the New World of Electronics" and course outline.

CHECK FIELD OF GREATEST INTEREST

<input type="checkbox"/> TV, FM & Advanced AM Servicing <input type="checkbox"/> Practical Television Engineering <input type="checkbox"/> Broadcast Radio Engineering (AM, FM, TV)	<input type="checkbox"/> Aeronautical Radio Engineering <input type="checkbox"/> Practical Radio Engineering
---	---

Name .....

Street .....

City..... Zone..... State.....

If residence school in Wash., D. C., preferred, check here

**NOW . . . AT O-R . . .  
THE "BAY" MOBILE ANTENNA!**

Here is that new 75 meter mobile antenna that is providing such excellent performance for West Coast amateurs. The "Bay" utilizes a new method for center loading, a design that has repeatedly outperformed other good mobile antennas in direct comparative on-the-air tests. Completely streamlined, (maximum diameter is only 1 1/2") handsome in appearance, the top whip and center loading section are both completely protected by a Fibreglass sealed covering. It's weatherproof . . . you operate in any weather without detuning. All exposed parts are brass, beautifully chromed for permanent luster. Overall length is approx. 9' 3" when trimmed. Make your signal outstanding . . . use a "Bay." Only \$19.95 net.

**Power Supply for  
Any 274-N Receiver**

Just plug it into the rear of your 274-N RECEIVER . . . any model. Complete kit and black metal case, with ALL parts and diagrams. Simple and easy to build in a jiffy. Delivers 24 volts plus B voltage. No wiring changes to be made. Designed especially for the 274-N receiver. All necessary parts for conversion of set of receiver also included. ONLY \$8.95.

**Now available, the  
beautiful  
MORROW  
CONVERTER**

Model 3BR  
for 10-20-75

A truly outstanding converter specifically designed for highest stability under rough service. Chassis is fabricated from heavy aluminum, all parts rigidly mounted. Electrically, this unit is one of the finest available to the mobile user. Compare the following features, then select Morrow. 1 microvolt sensitivity—all bands. Tuned preselector, mixer, oscillator. Low drift, (temperature compensated) calibrated oscillator. I.F. amplifier with 4 tuned circuits. Output freq. 1525 kcs. Single point tuning, no images, no birdies. Antenna trimmer on front panel. AVC on preselector, no strong signal blocking. Automatic noise limiter built in. Full width dial—calibration accuracy 1%. Glare-free, edge illuminated dial. Units come complete with mounting hardware and instruction book. Dimensions, 4" high, 5 1/2" wide, 6 1/2" long. Model 3BR . . . . . \$64.95 net



**NOVICE 500V POWER SUPPLY KIT**

Here is all the makin's for a sweet little power supply suitable for 807's. Includes: Power transformer, 2—4mfd, 600V oil filled condensers, 1—10 henry choke, 1—5U4 rectifier, 1—socket, 1—chassis, line cord, power switch and terminal board. Supply output voltage is 500 volts at 200 ma. . . . . Only \$16.95 kit

**LOOK! NO HANDS!**

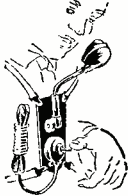

This mike leaves both hands free for mobile QSO's. Fastens to operator by simple snap strap. Adjustable. Double action sw. operates push-to-talk or holds on. Only \$2.00 ea. POSTPAID in U.S.A. and CANADA.

**TRANSFORMERS-CHOKES:**

920-0-920 or 740-0-740 AC @ 200 ma. Pri. 115V, 60 cycle, AC. Upright shielded case. Excellent for 807's. . . . . Only \$10.80 ea.

5V, 25A, Pri. 115V, 60 cy. AC. A real rugged job excellent for 304TL—4-250A etc. Limited quantity. Only \$4.50 ea.

10H, 200 ma choke. Hermetically-sealed steel case. Also has hum-bucking tap. A beautiful item only \$1.98.

Power transf. Pri. 115V, AC, 60 cy. Sec. 520-0-520 @ 200 ma. . . . . \$5.25 ea.

350-0-350 @ 300 ma. 6.3 @ 4A. 6.3 @ 8A. 5V @ 3A. Pri. 115V, 60 cy. AC. . . . . only \$7.95 ea.

450-0-450 @ 200 ma. Pri. 115V, 60 cy. AC. 5V @ 3A, 6.3 @ 5 amp. In shielded case. Only \$8.90 ea.

350-0-350 @ 350 ma. 6.3 @ 10A. 5V @ 6A. Pri. 115V, 60 cycle. Only . . . . . \$8.95 ea.

Minimum order \$2.00. All items subject to prior sale. All prices subject to change without notice. 20% deposit must accompany all orders, balance C.O.D.

**OFFENBACH &  
REIMUS CO.**

1564 MARKET ST.  
SAN FRANCISCO, CALIF.

**Cross-Bar Generator**

(Continued from page 41)

At least six lines (preferably more) should be used when making adjustments for vertical linearity.

To obtain vertical bars, leave the generator connected as previously and turn the "Function" switch ( $S_2$ ) to the "vertical bars" position (position "C" in Fig. 2).

If unable to obtain a stable pattern of vertical bars (Fig. 3B) by adjusting the "Horizontal Hold" control of the receiver, connect a lead from the input of the horizontal sweep oscillator to the "Sync Input" terminal of the cross-bar generator. Adjust the "Sync Level" control ( $R_1$ ) until a stable pattern is obtained. The sync signal may be obtained from point  $Y_1$  (Fig. 4).

Again, the vertical bars may be either black on white (Fig. 3B), or white on black, depending on the internal connections of the TV receiver. And, as before, the number of bars may be varied by adjusting the "Frequency" control (although some readjustment of the "Sync" control may also prove desirable).

To obtain a horizontal drive signal, the "Function" switch is set in its mid-position ("B" in Fig 2). The connections to the TV receiver should be changed, however.

Remove or disconnect the horizontal oscillator tube. Connect the sync input lead to the output of the sync amplifier (Point Z in Fig. 4), and connect the cross-bar generator output lead to the input of the horizontal output tube (Point  $Y_1$ , Fig. 4). The output "Level" control should be turned to its maximum position.

Next, tune in a TV station, adjusting the necessary controls on the TV receiver. Adjust the "Sync" and "Frequency" controls of the cross-bar generator until a stable pattern is obtained, and adjust the trapezoid peaking resistor ( $R_7$ , Fig. 2) until best linearity is obtained.

The cross-bar generator will supply a trapezoid signal having a peak-to-peak amplitude of from 60 to 90 volts,

depending on the "B" supply voltage, tube characteristics, and parts tolerances. This may not be sufficient to provide maximum drive for some TV receivers, but will still be enough to obtain an indication that the horizontal output stage and kick-back high voltage supply is operating satisfactorily.

Once the peaking control ( $R_7$ ) has been adjusted as outlined, its position may be left fixed. This is satisfactory for checking most sets.

Vertical and horizontal linearity tests and adjustments may be made without removing the TV chassis from its cabinet by using one of two methods. Probably the easiest method to use is to connect the output of the cross-bar generator to the "External Modulation" terminal of a signal generator, using it to modulate an r.f. signal adjusted to the TV i.f. value, or to one of the channel frequencies. When this technique is used, the signal generator may be connected directly to the antenna terminals of the receiver.

With many TV receivers it will not be necessary to apply an external sync signal to the cross-bar generator in order to obtain a stable pattern of horizontal or vertical bars. This is particularly true as far as the horizontal bars are concerned, for adjustment of the "Vertical Hold" control will usually permit the vertical sweep oscillator to lock-in with the cross-bar generator signal.

Where a sync signal is needed, it can be obtained from the deflection yoke . . . point  $X_2$  (Fig. 4) when horizontal bars are being used, and point  $Y_2$  when vertical bars are being used. The sync signal for vertical bars may also be obtained from the horizontal output stage by capacity coupling to the plate of the output tube ( $Y_2$  in Fig. 4).

If an r.f. signal generator is not available, the output of the cross-bar generator is sufficient to drive the picture tube directly. The output lead is connected to the "hot" signal lead of the CRT (cathode or grid lead, depending on the receiver). This may be done without difficulty by simply pushing a straight pin through the insulation of the "hot" lead and connecting the output lead from the cross-bar

Fig. 4. Test points on a standard television receiver. See text for explanation.

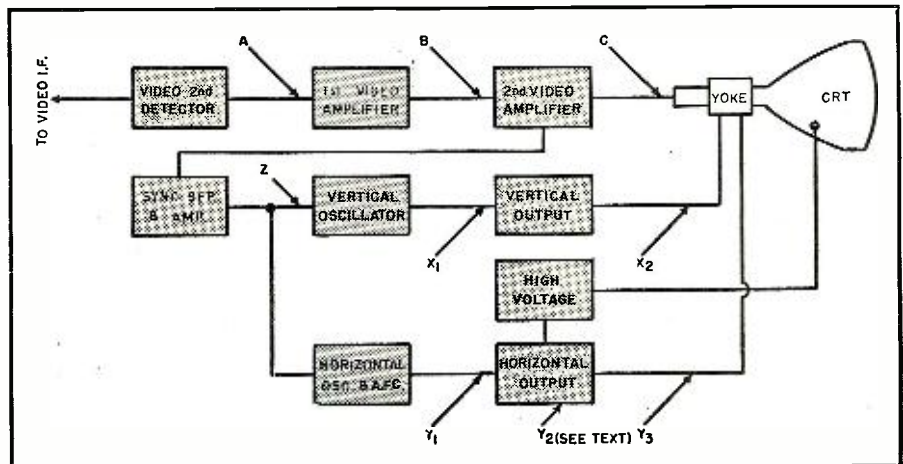

Be Sure of Your Installations . . . Use

*Aptitude-Tested*

**MULTIPLE CONDUCTOR**

**CABLE**

● You know what you are doing when you use Belden Multiple Conductor Cables — they're aptitude rated. They are designed to provide desirable electrical characteristics, and rigid control assures constant quality.

Specify Belden Radio Wires.

Belden Manufacturing Co., 4681 W. Van Buren St., Chicago 44, Ill.

To You, Belden's Golden

Anniversary Means

—product performance that can come only from a "know-how" that has grown through actual service since the inception of Radio.

—an ability to co-operate in pioneering new wires to meet or anticipate industry's growing needs.

In the years that follow

This Belden Program Is—

— TO BE CONTINUED

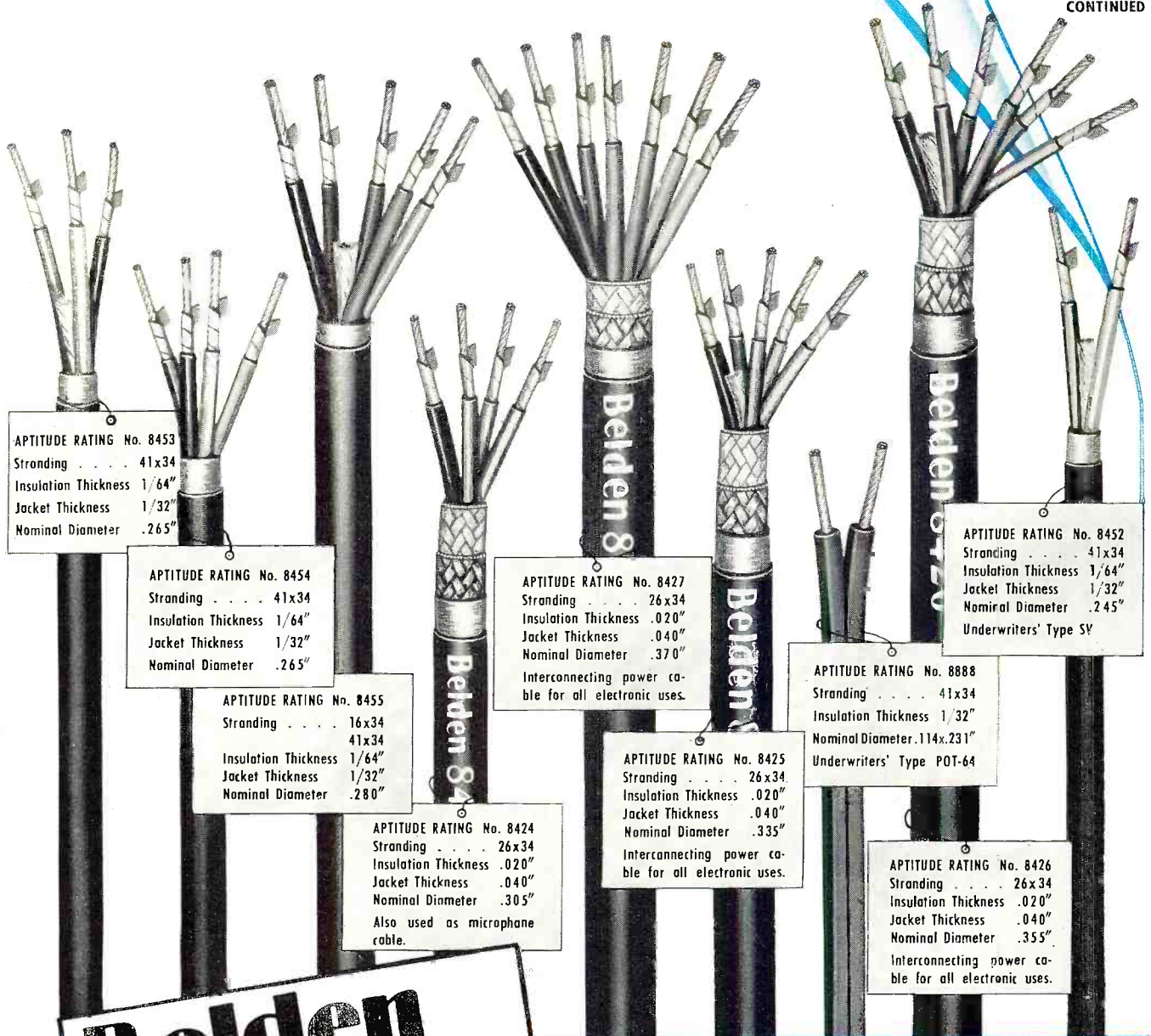

APTITUDE RATING No. 8453  
Stranding . . . . 41x34  
Insulation Thickness 1/64"  
Jacket Thickness 1/32"  
Nominal Diameter .265"

APTITUDE RATING No. 8454  
Stranding . . . . 41x34  
Insulation Thickness 1/64"  
Jacket Thickness 1/32"  
Nominal Diameter .265"

APTITUDE RATING No. 8455  
Stranding . . . . 16x34  
                          41x34  
Insulation Thickness 1/64"  
Jacket Thickness 1/32"  
Nominal Diameter .280"

APTITUDE RATING No. 8424  
Stranding . . . . 26x34  
Insulation Thickness .020"  
Jacket Thickness .040"  
Nominal Diameter .305"  
Also used as microphone cable.

APTITUDE RATING No. 8427  
Stranding . . . . 26x34  
Insulation Thickness .020"  
Jacket Thickness .040"  
Nominal Diameter .370"  
Interconnecting power cable for all electronic uses.

APTITUDE RATING No. 8425  
Stranding . . . . 26x34  
Insulation Thickness .020"  
Jacket Thickness .040"  
Nominal Diameter .335"  
Interconnecting power cable for all electronic uses.

APTITUDE RATING No. 8888  
Stranding . . . . 41x34  
Insulation Thickness 1/32"  
Nominal Diameter .114x.231"  
Underwriters' Type POT-64

APTITUDE RATING No. 8426  
Stranding . . . . 26x34  
Insulation Thickness .020"  
Jacket Thickness .040"  
Nominal Diameter .355"  
Interconnecting power cable for all electronic uses.

APTITUDE RATING No. 8452  
Stranding . . . . 41x34  
Insulation Thickness 1/64"  
Jacket Thickness 1/32"  
Nominal Diameter .245"  
Underwriters' Type S1

**Belden**  
*Radio WIRE*

The *Aptitude-Tested* **LINE**

# THE 3 Bs... BEETHOVEN, BRAHMS AND BACH

they're different

they're improved

they're better than ever!

Yes, Bach, Beethoven and Brahms are now better than ever—we don't mean we've improved their music, but we do mean we've improved the reproduction of their recorded music.

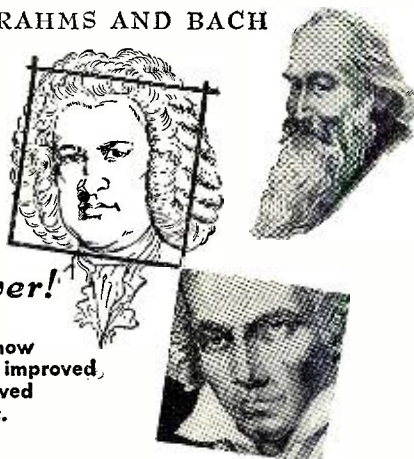

It's the new, improved Pickering Cartridges that give credence to this claim. Yes, Pickering Cartridges are different. They're improved. They're better than ever. Pickering patented Cartridges with Dynamic Coupling\* are superior in every way, by providing: HIGHER FREQUENCY RESPONSE • NEGLIGIBLE INTERMODULATION DISTORTION • BETTER TRACKING CHARACTERISTICS

### \*DYNAMIC COUPLING ASSURES

constant stylus contact with the record grooves over the entire audio spectrum (20-20,000 cps) • full frequency response • full transient response • no resonances • no mistracking • no grinding of groove walls

## PICKERING and company, incorporated



Pickering High Fidelity Components are available through leading Radio Parts distributors everywhere; detailed literature sent upon request. Address Department C

Oceanside, L. I., New York



generator to it. Sync connections, if necessary, are as before. (In Fig. 4, the "hot" lead of the CRT is indicated by point "C".)

If there are no defects in the sweep circuits, and if all linearity, drive, and other sweep adjustments are correct, the lines or bars on the screen of the CRT will be evenly spaced. Poor linearity is indicated by an unequal spacing of the lines or bars. Use horizontal lines to check vertical linearity; vertical bars to check horizontal linearity.

Where the TV chassis is on the bench for servicing, it is sometimes easier to obtain the sync signal from other points in the receiver (points X<sub>1</sub> for horizontal bars, Y<sub>1</sub> for vertical bars. Fig. 4).

Horizontal sweep defects resulting in non-linearity are readily found when the technique outlined is used and it is found that adjusting the linearity, drive, and width controls does not affect picture quality. In addition, a total lack of horizontal sweep may be isolated as a defect in either the horizontal oscillator or horizontal output stages simply by using the cross-bar generator as a substitute horizontal sweep signal source.

The frequency coverage afforded by R<sub>0</sub> is adequate so that a signal of the correct frequency (horizontal sweep) may be supplied to color TV receivers as well as conventional black-and-white sets.

Video amplifier defects resulting in a complaint of "raster, no picture" may be isolated to a specific stage by using the cross-bar generator for signal injection tests. Referring to Fig. 4, the signal may first be applied directly to the CRT to check this circuit, connecting to point "C." Next, the output lead is transferred back to the input of the last video amplifier stage (point "B"), and, finally, to the input of the first video amplifier stage (point "A".)

Video coupling condensers are checked by connecting the output lead first to the grid of the amplifier stage, then to the plate of the preceding stage.

Relative gain measurements in the video amplifier stages can be made by using an a.c. v.t.v.m. as an indicator and the cross-bar generator as a signal source. Referring to Fig. 4, connect the a.c. voltmeter to point "C." Note the signal level obtained when the cross-bar generator is connected to the same point. Transfer the generator output lead back to point "B" and again note the a.c. voltmeter reading. Dividing this reading by the former gives the relative gain of the second video amplifier stage.

A similar technique may be used for checking the over-all gain of all the video amplifier stages. Where several stages are being checked, adjust the output "Level" control of the cross-bar generator to avoid overloading any of the succeeding stages, thus preventing an accurate measurement of gain.

-50-

**MANUFACTURERS!  
EXPORTERS!  
PURCHASING AGENTS!**  
•HONESTY•INTEGRITY  
•QUALITY OF  
PRODUCT

- Radio and Receiving Tubes
- Transmitting & Special Purpose Tubes
- Radio and Electronics Parts and Equipment
- All Types of Electrical Wire, Magnet Wire, and Cable
- Authorized Distributors for Federal Telephone & Radio Corp. Co-Axial Cable.

Available from Stock!  
References: Dun & Bradstreet

**Electronic Expeditors**  
225 N. Wabash Ave., Dept. R, Chicago 1, Ill.  
Phone ANdover 3-0841

BRANCH OFFICES  
9015 Wilshire Blvd., Beverly Hills, Cal., CR 4-6237  
307 Fifth Ave., New York 17, New York, MU 7-0084

## COME TO THE UNIVERSITY OF HOUSTON FOR YOUR TECHNICAL AND VOCATIONAL TRAINING

ONE OF AMERICA'S LARGE AND MOST MODERN UNIVERSITIES

Select from these fascinating fields

- |   |   |
|---|---|
| <input type="checkbox"/> Aeronautics                        | <input type="checkbox"/> Industrial mechanics   |
| <input type="checkbox"/> Air conditioning and refrigeration | <input type="checkbox"/> Drafting               |
| <input type="checkbox"/> Automobile trades                  | <input type="checkbox"/> Machine shop           |
| <input type="checkbox"/> Body and paint                     | <input type="checkbox"/> Welding                |
| <input type="checkbox"/> Mechanics                          | <input type="checkbox"/> Woodworking            |
| <input type="checkbox"/> Upholstery and trim                | <input type="checkbox"/> Photography            |
| <input type="checkbox"/> Diesel                             | <input type="checkbox"/> Radio                  |
| <input type="checkbox"/> Electricity                        | <input type="checkbox"/> Stationary Engineering |
| <input type="checkbox"/> Electronics                        | <input type="checkbox"/> Television             |
| <input type="checkbox"/> Furniture upholstery               |   |

PREPARE FOR YOUR FUTURE NOW... with very latest methods and equipment, at modern U. of Houston College of Technology. Entrance: high school diploma, or over 18 and ability to profit from instruction. Beautiful campus—250 wooded acres in Houston, Texas—city of tomorrow. Full college activities, sports, social life. Day or night, short or longer courses. Co-op work-study programs... earn part of tuition and expenses with part-time job in your own career field, while you learn. Personal vocational counseling. Diploma on completion and all credits apply towards Bachelor of Applied Science Degree. Job placement assistance. June, Sept., Feb. semesters. Mail ad now for Free fully-illustrated brochure. No obligation. Mark X before choice of subject. Do it today!

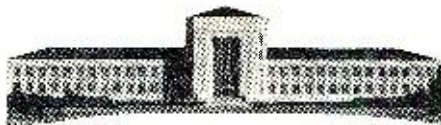

ADMINISTRATION BUILDING

University of Houston, College of Technology

DEPT. 552 — HOUSTON 4, TEXAS



IMMEDIATE DELIVERY OF

*Top Quality*

# MINIATURE SWITCHES

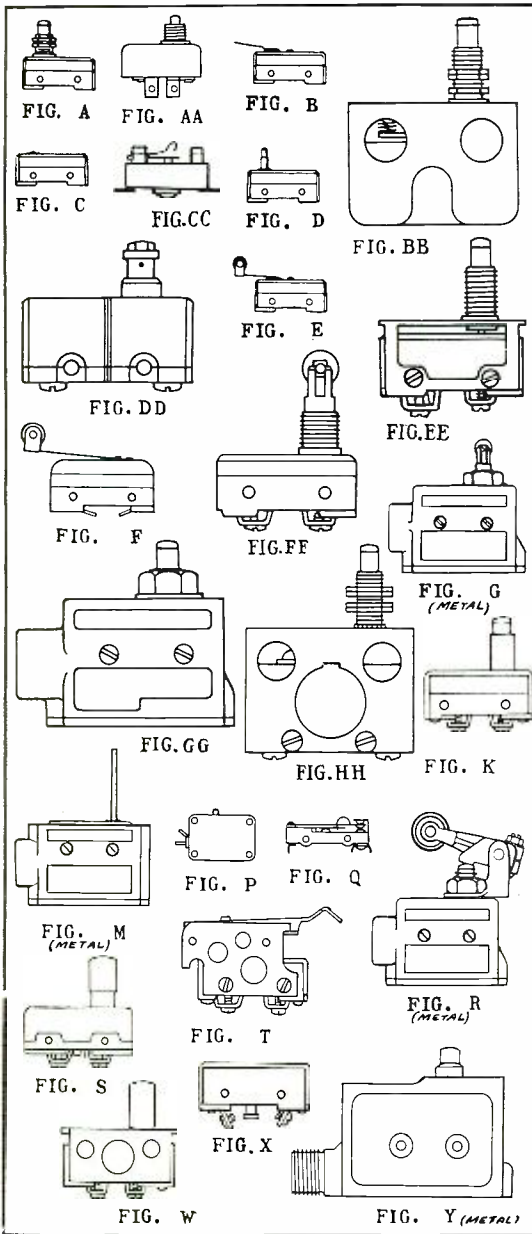

This list of brand new standard brand miniature switches represents only a few of many types in stock at Wells. Large quantities of most types are on hand for your immediate requirements. Write or wire for quotations on switches not listed.

Stock #	Mfr.	Type #	Contact	Fig.	Price	Stock #	Mfr.	Type #	Contact	Fig.	Price
4MC2	ACRO	2M03.1A	NO	P	.50	4MC27	MICRO	WZ2RST	NC	D	.55
4MM2	MU	AC2101BB	SPDT	W	.85	4MD16	MICRO	WZ7R	NC	C	.55
4MC17	MICRO	B-1	NC	Y	1.45	4MC15	MICRO	WZ7RQT2	NC	A	.70
4MC16	MICRO	B-1T	NC	DD	.90	4MD36	MICRO	WZ7RST	NC	D	.55
4MC7	MICRO	B-14	NO	HH	1.70	4MC23	MICRO	WZE7RQTN	NC	R	3.75
4MD62	MICRO	B-R	SPDT	C	.70	4MD54	MICRO	WZ8X	NC	X	.80
4MD63	MICRO	B-RS36	SPDT	D	.80	4MC9	MICRO	WZ831	NC	C	.65
4MD23	MICRO	BD-RL32	SPDT	B	.95	4MD57	MICRO	WZ831	NC	T	.70
4C51	MICRO	BZ2FTC1	SPDT	C	.75	4MD31	MICRO	WZ8D	NC	C	.55
4ML4	MICRO	BZ2RQ41	SPDT	W	.85	4MD19	MICRO	WZ8L8	NC	B	.70
4MD51	MICRO	BZ-R37	SPDT	C	.70	4ML3	MICRO	WZ8Q41	NC	W	.65
4MD2	MICRO	BZE7RQT2	SPDT	GG	1.70	4ML2	MICRO	WZV7RQ9T1	NC	G	2.25
4MD21	MICRO	BZ-7RST	SPDT	D	.80	4MC21	MICRO	X757	NC	C	.55
4MD38	MICRO	BZE2RQ9TN1	SPDT	G	2.65	4MD37	ACRO	XC1A	NC	C	.55
4MD6	MU	CUM 24155	NO	E	.80	4MC5	ACRO	XD45L	SPDT	B	.95
4ML1	MU	D	NO	BB	1.50	4MD4	MICRO	YZ	NO	C	.75
4MC12	MICRO	D in case	NC	Y	1.45	4MD40	MICRO	YA2RLE4D13	NO	B	.70
4MD60	MICRO	G-RL	NO	B	.80	4MD24	MICRO	YZ2YLTC1	SPDT	B	.95
4MC11	MICRO	G-RL 5	NO	B	.80	4MC1	MICRO	YZ2YST	SPDT	D	.60
4MD61	MICRO	G-RL35	NO	B	.80	4MD13	MICRO	YZ3R3	NO	C	.60
4MC32	ACRO	HRO 7.1P2TSP1	NO	K	.65	4MD56	MICRO	YZ3RLTC2	NO	B	.80
4MC19	ACRO	HR07.4P2T	NO	S	.60	4D79	MICRO	YZ3RT	NC	C	.60
4MD8	ACRO	HRRC 7.1A	NC	C	.55	4D127	MICRO	YZ3RW2	NC	F	.80
4MD27	ACRO	HRRO 7.1A	NO	C	.60	4MC14	MICRO	YZ3RW2T	NO	F	.90
4MC31	MICRO	LN-11 HO3	SPDT	M	1.70	4MD49	MICRO	YZ7RQ9T6	NO	FF	.85
4MC18	MU	MLB 321	SPDT	B	.95	4MD32	MICRO	YZ7RST	NO	D	.60
4MD1	MU	MLR 643	NC	B	.70	4MC13	MICRO	YZ7RA6	NO	EE	1.00
4MD55	PHAO	PS 2000	SPDT	C	.85	4C116	MICRO	YZRE4	NO	C	.65
4MC28	ACRO	RC71P2T	NC	A	.70	4MC20	MICRO	YZRQ4	NO	S	.60
4D129	ACRO	RD71AT2	SPDT	C	.75	4MC22	MU	Z	NC	Y	1.45
4MD22	ACRO	RO2M	NO	E	.80	4MD52	MU	Blue Dot	SPDT	E	.90
4MC28	ACRO	RO2M12T	NO	E	.80	4C73	MU	Blue Dot	SPDT	D	.80
4D87	ACRO	RO7 8586	NO	K	.70	4MC8	MU	Red Dot	NC	C	.65
4MC25	MICRO	R-RS	NC	D	.50	4MD18	MICRO	Open Type	SPDT	Q	.50
4MD9	MICRO	SW-186	NC	D	.50	4MD39	MU	Green Dot	NO	B	.80
4MC10	MICRO	WP3M5	NC	AA	.50	4MC29	MU	Green Dot	NO	D	.55
4MC4	MICRO	WP5M3	NC	AA	.50	4D84	MU	Green Dot	NO	B	.80
4MD53	MICRO	WP5M5	NC	AA	.50	4MD26	MAXSON	Precision	SPDT	B	.95

## SWITCHETTE

All Rated 10A-230 VAC



Stock #	Mfr. Type #	Contacts	Terminals	Price
41SF3	CR1070C103-A3	N.C.	SIDE	\$0.53
41SF2	CR1070C103-B3	N.O.	END	.53
41SF9	CR1070C103-F3	1-N.O. 1-N.C.	SIDE	.53
41SF12	CR1070C123-B3	N.O.	END	.53
41SF10	CR1070C123-C3	1-N.O. 1-N.C.	END	.53
41SF5	CR1070C123-D3	N.C.	SIDE	.53
41SF4	CR1070C123-J2	SPDT	END	.53
41SF11	CR107 C124-M4	SPDT	SIDE	.53
41SF1	CR1070C128-C3	1-N.O. 1-N.C.	END	.53

MANUFACTURERS  
AND DISTRIBUTORS:  
Write for Catalog

**SEELEY 8-4143**



833 W. CHICAGO AVE., DEPT. R, CHICAGO 22, ILL.

May, 1952

Order Direct or Through Your Local Parts Jobber.

**SO IMPORTANT** — it was  
 Featured in Special Article  
 in  
**The New York Times**

Jan. 28, 1952  
 FREE copy  
 of article on request

**UNIT REACTIVATES  
 TV PICTURE TUBES**

Small Electronic Device Tests  
 Sets at Home and May Add  
 Year or More of Use

By T. R. KENNEDY Jr.

A small electronic device that can be applied to home television receivers to test and reactivate the picture tube without removing the tube from the set, resulting in renewed brightness in many and considerably longer useful life, has been placed on the market for the first time by a New York manufacturer.

In some cases, it was said, the picture tube may be made almost as good as new and given as much as a year's useful life before replacement is necessary.

The instrument is small and compact. It weighs three pounds, costs little and is simple to operate. Picture tubes, some of them new and never in a receiver, have shown remarkable improvement in brilliance and definition after a few minutes of reactivation here in the last few days.

Although the principle of its operation is not new—cathode-ray tube manufacturers have used it for years in the initial making of picture tubes—the incorporation

The almost immediate urgent need for such an instrument, which also soon may be produced in kit form for home assembly, is apparent. Eight to ten million television picture tubes, Transvision engineers estimate, have now been in use for three to four years or more, and "probably are in need of test and reactivation to renew their brightness." Unfortunately, loss of brightness, it was pointed out, seldom can be detected short of comparing the old tubes with new ones in lately produced sets. Furthermore, picture tubes in their original cartons in stores may have lost some of their brightness, which has been described as a "kind of aging process" to which all large cathode-ray tubes and similar devices are subject. Many of these tubes, in the current surge in use today, cost from \$25 to \$40.

New picture tubes can be tested and reactivated without removing them from their cartons, and tubes from the receivers. It is done by attaching a standard picture tube socket to the tube, and linking by wire a switch on the instrument, turning a small neon bulb as a glow of a small neon bulb as a condition of the tube is indicated directly on a dial of the tester, meaning it is not turned on.

In some cases the test and reactivation is accomplished in less than ten minutes.

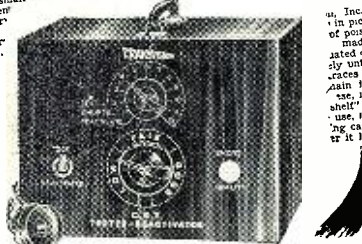

**TRANSVISION CR TUBE  
 TESTER - REACTIVATOR**  
 performs 2 vital functions:

- Tests Picture Tubes
- Renews Brightness of Dim Picture Tubes

**It's a TESTER:**

Without removing picture tube from set, you apply this precise instrument to:—

- Measure Cathode emission
- Locate shorts between elements
- Locate high resistance shorts or leakage as high as 3 megohms

**It's a REACTIVATOR**

for dim CR Picture Tubes

Revives dim TV Picture Tubes, without removal of tubes from sets. Reactivation works on tubes with low light output; if there's no mechanical break in tube, 110 V—60 cycles. Weighs only 3 lbs. One or two applications pays for instrument.

**SATISFACTION GUARANTEED** or money refunded if you return the instrument in 10 days in good condition. **\$19.95 NET**

—RUSH THIS COUPON—  
**TRANSVISION, INC.**  
 DEPT. RN5 NEW ROCHELLE, N. Y.  
 Send me CR Tube Tester-Reactivator(s).  
 Enclosed find \$\_\_\_ deposit. Balance C.O.D.  
 Enclosed find \$\_\_\_ in full. Send prepaid.  
 Name \_\_\_\_\_  
 Address \_\_\_\_\_  
 City \_\_\_\_\_ State \_\_\_\_\_

**Speaker Enclosure**  
 (Continued from page 39)

tightly with putty or cement. Special attention should be given the loudspeaker baffle mounting, to insure sealing. If there is possibility of air leakage between the baffle and the enclosure, a rubber gasket may be required. Air leaks around the loudspeaker baffle gasket also should be avoided.

Some otherwise waste space is available in the cavity at the center for placing a network or other apparatus. Controls may be mounted on the panel at the front of this cavity. In the model described, a removable cover (12) (Fig. 3) was placed at the rear of this cavity, and a G-610 "Triaxial" control network mounted on the cover and inside the cavity. The cable between the network and the loudspeaker was brought through the sound chamber bottom shelf, and the cable entrance hole sealed with putty. If the loudspeaker has no separate control network, leads can be brought through one of the horizontal sound passages at the top and through the back of the enclosure—again with all holes well sealed. Other arrangements are possible, such as mounting of terminal strips or sockets.

Structural or appearance changes are allowable, provided that the flare and length of the sound path are not changed appreciably. Neither should the changes involve modification of the sound chamber as its size is an important factor in the operation of the enclosure. For instance, in the model depicted in Fig. 1 a curved panel was substituted for the cavity baffle section (5), with little change in area. The half-round trim strip (11) could be replaced by any suitable trim, perhaps with bevelled edges. Joints can be mitered or banded as desired. Runners or furniture glides would be useful for a base to protect the bottom edges of the enclosure.

Concerning the actual details of assembly, two methods of fastening the sections together may be used with equal success. Glue blocks, nails, and screws can be used as required, but should not be visible from the outside for best finish appearance. Glue blocks may be used at joints as long as they do not form an obstruction to the air passage. Most of the blocks can be placed inside the cavities, with the exception of those at the top and sides at back section (7). The volume taken up by blocks at these points is small com-

pared to the total air passage volume. Glue blocks can be avoided by routing at the points of joining the sections. The latter method is somewhat fancier, probably more expensive, and requires use of routing equipment. Routed grooves should be approximately 3/8" deep.

Acoustically, the type of wood used is not important. Plywood is suggested. If a better material such as birch is used for front panel (9) and side sections (1) (Fig. 3) it should also be used for the baffle sections (5) and (8). The wood for the sides should be "sound" (free from blemishes) on both inside and outside surfaces, if a furniture finish is contemplated, as both surfaces are seen. Other sections do not show on both sides, so need to be sound only on one side. Trim strips can be of clear white pine, or any other suitable wood, bevelled or decorated in any manner desired.

Assembly of the horn may require joining the pieces in a certain sequence. While other constructional methods may be used, the enclosure shown in Fig. 1 was made by completing the sound chamber-shelf assembly and joining the larger pieces onto it.

To the sound chamber-shelf assembly were added the larger pieces in this order: Sides (1); Top (2); Bottom (3); Cavity back (4); Cavity baffle (5); Brace (6); Back (7); Bottom baffle (8); Front panel (9); and Trim (10).

At current prices for plywood, the total cost of the raw material for the enclosure should be in the neighborhood of \$40 to \$50.

Fig. 4 compares the total radiation from the horn and a bass reflex enclosure, using the same high energy 15-inch loudspeaker. Here it can be seen that up to 6 db gain can be obtained. Absolute efficiency is 50% over a considerable range, with substantial contribution as low as 30 cycles. Compared to conventional enclosures, five times the power can be handled at the same distortion percentage.

An enclosure of this type can comprise the framework for a small theater sound system, or for an extra quality monitoring or home entertainment installation. Construction is a good-sized project, but there are many instances where the time and expense are well justified.

The authors wish to acknowledge valuable suggestions by Ralph P. Glover, assistance in performance measurements by Andrew Gronkovsky, and mechanical design collaboration by Victor Johnson.

—30—

Fig. 4. Back-loaded horn enclosure vs bass reflex cabinet with 15" woofer unit.

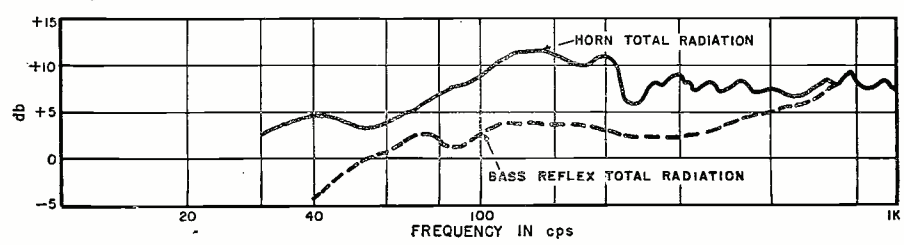

THE MIRACLE OF ELECTRONIC CONTROL

*Yours to Command!*

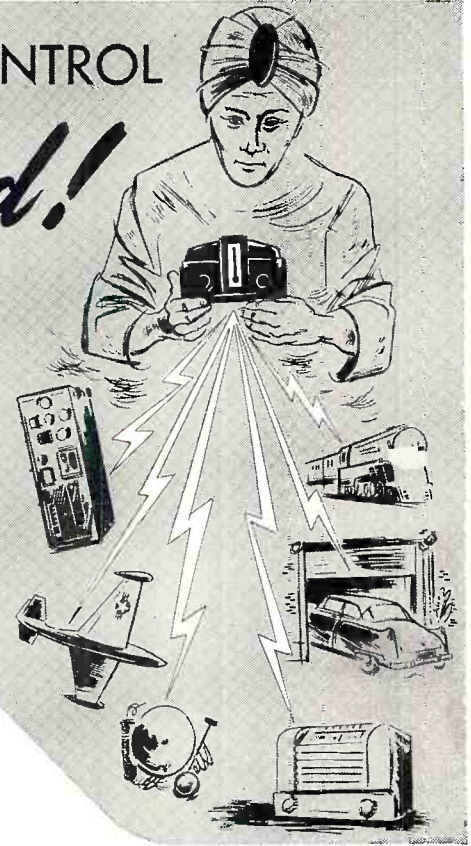
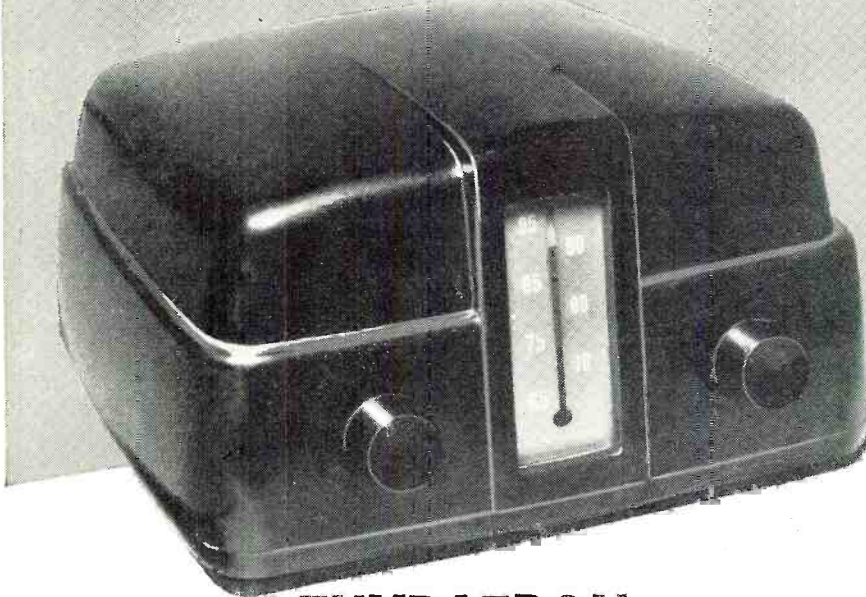

ADVANCED **THYRATRON** CIRCUIT  
**REMOTE CONTROL**

FOR 110 VOLTS 60 CYCLES AC

**Engineers — Hams — Students**  
**Servicemen — Hobbyists**

Here's the chance of a lifetime to own a genuine Thyatron Electronic Remote Control of your own at a fraction of its regular price! This mighty handful (only 5 3/4 x 5 x 3 1/4") of miracle control can be made to perform hundreds of practical, fascinating feats of remote control.

**PRECISION THYRATRON CIRCUITRY**

These amazing Thyatron precision thermostatic controls can easily and quickly be modified by you for electronic remote control of: Transmitters; Turn Radio and TV on and off; Open and Close Garage Doors from your car; Remote Control of Appliances, Machinery, Power Tools; Remote Controls for Model Railroads, Planes, Boats, Trucks; Burglar, Fire, Temperature and Rain Alarm Systems; Poultry Brooder Controls, etc., etc.

Your own ingenuity and inventiveness can devise many more interesting and practical uses which this remarkable unit can control for you. A complete schematic is furnished with each control.

**PARTS ALONE WORTH TWICE THE COST**  
Each control unit contains a highly sensitive plate circuit trigger relay, a 110 volt 60 cycle AC filament transformer, many condensers and resistors (including 1% precisions) and a host of other valuable parts worth twice or more our low, low bargain price. No matter how you use it it's a great buy!

Kit of 3 Tubes for Remote Control Unit, consisting of 6SN7GT, 6SL7GT and a GE Thyatron GL-5662 (net \$3.30 by itself). All 3, plus Bakelite Cabinet..... only \$4.95

No. C.O.D. Postpaid in U.S.A. Only  
(10 Days Net to Rated Firms)  
Send Check or Money Order to Dept. RT

**ATTENTION: Electronic Alarm Manufacturers!** These Thyatron controls are ideal for adaptation by you for FIRE, BURGLAR and other alarm systems you make. Increase your profits, make a better product by using this control or its components in your products. Let your engineers check a few and see for yourself. Terms: Net 10 days to rated firms.

**\$2.88**

only (Less Cabinet & Tube Kit)  
No. C.O.D. Postpaid in U.S.A. Only

Complete With Cabinet and Thyatron Tube Kit..... **\$7.50**  
No. C.O.D. Postpaid in U.S.A. Only

**POPULAR REMOTE CONTROL USES**

- ON-OFF for Transmitters, Radio or Television Sets
- Open and Close Garage Doors From Inside Your Car
- Model Railroads, Boats, Planes, Cars, Trucks
- ON-OFF for Appliances, Machinery, Power Tools
- Burglar, Fire, Temperature or Rain Alarm Systems
- Poultry Brooder Temperature Controls
- Remote Thermostatic Control

**MANUEL KLEIN COMPANY**

94 Chambers Street, New York 7, N. Y.  
REctor 2-6460



# "Centre-Kooled"

## SELENIUM RECTIFIERS

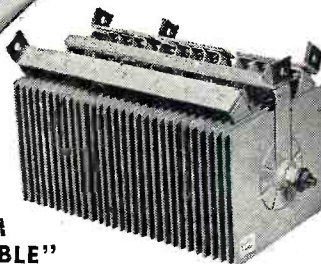

### THE SELENIUM RECTIFIER "BIBLE"

Most complete book of its kind ever published . . . 80 pages of valuable information about Selenium Rectifiers . . . 48 pages of Radio and Television circuit diagrams . . . 20 pages on Power Rectifiers . . . 3 pages on High Voltage Rectifiers . . . a 7 page cross index replacement guide. Send 50c for your copy or see your distributor.

**Sarkes Tarzian, Inc., RECTIFIER DIVISION**

Dept. R-3, 415 N. College Ave.  
Bloomington, Ind.



## TV Transmission Lines

(Continued from page 47)

sight it is wise to plan the installation in advance and try to avoid all of these defects. The most important item in that respect is the choice of the antenna and transmission line to match the input impedance of the receiver. Most modern sets have a 300-ohm input or else have provision for either 72- or 300-ohm input by means of a coupling transformer mounted near the tuner. 52-ohm input is rare, but some older receivers may have it. To match these impedances the most common type of line is the 300-ohm, ribbon-type, twin-lead. Coaxial cable comes in 72- and 50-ohm types and is often preferred over twin-lead because of its shielding effect against ignition and other noise. Recently, a special 300-ohm, shielded cable was made available by *Federal Telephone & Radio Corp.* This cable is shown in Fig. 1, and has the advantage of the 300-ohm impedance, combined with the shielding effect of the outer copper braid. When this type of line is used, connect the two inner conductors to the antenna terminals and connect the shield to the chassis by means of a .1  $\mu$ fd. condenser. This eliminates the danger of shorts should the chassis be connected to the power line. In addition to selecting the correct transmission line, the selection of the best antenna is quite important. The choice of antenna, however, will be guided by reception conditions, number of channels to be received, reflections, etc., rather than by impedance considerations. As a result, the impedance of the antenna is often quite different from that of the line. A few types such as the folded dipole, conical, and other broadband antennas have an impedance approaching 300 ohms. Most of the high-gain, narrow-beam types have impedances varying from 10 to 75 ohms. It is possible to get a higher impedance when the antenna connections are made a little further from the center, but this has the effect of loading the antenna and often cannot be done. The best procedure is to find out the nominal impedance of the antenna to be used from the manufacturer's data and then design a matching stub accordingly. As mentioned before, a separate matching stub for each TV band is a necessity and the ideal, of course, would be to have a separate antenna and matching stub for each channel. To keep the dissipation losses to a minimum and the efficiency of the system high, mount the transmission line well away from walls, gutters, and pipes, especially where twin-lead is used. The mounting studs should contain either porcelain or polyethylene to avoid further capacity to ground. Never use regular electrician's tape or paper tape on twin-lead since they have a much lower dielectric constant and therefore increase losses. Only poly-tape or a good grade of cellophane

## STAY ON THE AIR WHEN POWER FAILS...with an ONAN Electric Plant



**AUTOMATIC  
START & STOP**

Model 10EL, 10KW A.C.

When storms, floods, or fires interrupt electricity and force you off the air, you lose listeners and income. Guard against loss, assure vital public service during emergencies by installing an Onan Electric Plant. Onan Standby Electric plants serve many network and private stations. Automatic models to 35,000 watts.

### PORTABLE ELECTRIC PLANTS FOR MOBILE RADIO USES



Supply A.C. power for broadcasting at scene of events. Light in weight. Can be carried by hand or in trunk of car. A.C. models: 400 to 3,000 watts.

Write for **FREE Folder**



**D. W. ONAN & SONS INC.**  
4818 University Avenue  
Minneapolis 14, Minnesota

## South River ★★ NEWS ★★

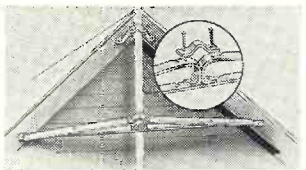

### EAVE MOUNT Model EM-1

Heavy steel of a novel, bridge-type, truss construction, hot dip galvanized. Upper bracket provides 4" clearance from eave; lower bracket, generous 48" spread. Complete with hardware.

South River Antenna Mounting Accessories are carried by every leading TV Parts Jobber from coast to coast.

New catalog mailed to all Dealers and Service Men. Write, if you haven't received yours!

**SOUTH RIVER METAL  
PRODUCTS CO., INC.**  
SOUTH RIVER, N. J.

PIONEER AND OUTSTANDING PRODUCER  
OF FINEST LINE OF ANTENNA MOUNTS

tape should be used. Another "don't" concerns the practice of concealing twin-lead near a molding, tacking it on and eventually painting over it. Invariably tacking and especially painting will completely wreck the impedance and dissipation characteristic.

Once an installation is made and exhibits some of the defects due to incorrect transmission line impedance or excessive losses, the remedy is naturally somewhat harder. To make sure efficiency is really down it would be necessary to install a new and properly matched line, unless it is possible to measure the signal strength at the antenna and again at the receiver. A loss of more than 20% for a 50 foot length would certainly be excessive. It is often possible to determine by inspection whether the impedance of the antenna is matched and whether a match exists at the receiver. To check for standing waves simply grasp the line in one hand and slide the hand along the line over at least five or six feet and observe if the picture changes as this is done. If the picture shifts, ghosts move, or the signal strength changes, standing waves are present and improper impedance match exists.

#### Interference Elimination

The effect of "tuned" transmission line lengths can often be used to eliminate interference before it reaches the TV receiver. As was shown earlier, a quarter-wavelength open line or a half-wavelength shorted line represents a short circuit at the resonant frequency. If, therefore, such a length were connected to the antenna terminals of the TV set, the resonant frequency would be shorted out, but other signals would not be affected too much. A good example would be the case of FM interference from a station at about 108 mc. which could be received by beating with the local oscillator set at 83 mc. and the receiver tuned to Channel 3. Connecting an open circuited quarter-wavelength section of transmission line at the antenna terminals would make this a short for the interfering signal. At the desired TV signal, however, this would be much less than a quarter-wavelength and would represent a high impedance. In practical applications the exact wavelength of the interfering signal need not be known, but only an approximate idea of it is necessary. Cut the open circuited stub longer than necessary and connect at the receiver. Then cut off 1/2 inch lengths until the interference is eliminated.

There is nothing mysterious about the behaviour of transmission lines and once the basic theory of this subject is understood the technician will find many applications in designing new installations and improving the performance of existing ones. Although not an active circuit element, the transmission line between the antenna and the receiver is a vital link in the over-all operation of TV reception.

there's no tower like an

# Alprodco

## ALUMINUM TOWER

TV • FM • AM  
BROADCASTING — RECEIVING

the height of perfection

easy to install

attractive and modern

low cost...

light weight

strong durable...

... NO PROFITS LIKE THOSE IN AN ALPRODCO TOWER, EITHER! For fringe areas and other difficult locations, these can't-be-beat antenna towers get the antenna up where the signal is — and keep it up without costly follow-up maintenance for you. Get full details from your local parts distributor now.

WRITE FOR NEW LITERATURE AND OTHER INFORMATION ... ADDRESS DEPT. B.

# Alprodco, Inc.

KEMPTON, INDIANA  
MINERAL WELLS, TEXAS DUBLIN, GEORGIA

See Us at Our PARTS SHOW Booth



# DOW SURPLUS

**TELECHRON SYNCHRONOUS MOTOR**  
Type C2M 115V-60 cycle Model 822 M.-6- RPM-Removed from new Surplus.....\$3.95

**MISCELLANEOUS ITEMS—ALL NEW**  
Rubber Grommets—100 asst. ....\$0.89  
BC 457—X-titters 4 to 5 mc net.....\$3.95  
TC 461 control box with counter..... 1.49 ea.  
144C mike and plug......95 ea.  
Leads & Nourous—Grand Paper, Type 578, 0 to Infinity. Boxed per Roll..... 1.50  
APC condensers, all sizes......49 ea.  
1000-ft. #W130 twisted Telephone wire..... 4.95  
50 Watt—Tube Sockets—new......95  
Antenna Insulators—10 for..... 1.00  
3 Asst. 24V Relays......89  
**FILAMENT TRANSFORMERS—110V-60 cycle** input, output 9V to 13V in 1V steps—output rated 3 amps......1.49  
G.E. Solenoids—14V DC-25 ohms—Nycalac arm, many applications—new......49

**GP7 TUNING UNITS, A TO F, for ECO, \$2.95 ea.**

**PANEL METERS**  
**NEW SURPLUS**  
STANDARD BRANDS  
4 SPECIAL SCALE  
5Q-SQUARE CASE  
3" METERS  
0-8V AC WES.....\$2.95  
0-130V AC.....5.95  
0-150V AC.....3.95  
0-15V AC.....3.95  
0-1.5V DC.....3.95  
0-2V DC.....3.95  
0-1 Mill DC SQ.....6.95  
100-0-100 DC Mill.....3.95  
0-800 Mill DC SQ.....3.95  
Freq. 350 to 450.....1.00  
115V.....17.95  
2" METERS  
0-1 RF Amp.....55.95  
0-8 RF Amp.....3.95  
0-3 DC Mill.....3.95  
0-150 Micro Amp.....8.25  
S Tuning D.C.....1.95

**RHEOSTATS**

Watts	Ohm	ea.
25	5	.98
25	10	.98
25	15	.98
25	25	.98
25	50	.98
25	100	.98
25	145	.98
25	200	.98
25	370	.98
25	1000	1.49
125	1000	1.95
125	5000	1.95
100	100	2.50
150	500	3.95
150	5000	3.95

**XMIT RF CHOKES**  
0-3 MH-100 mill.....29c  
0-150 Micro Amp.....25c  
S Tuning D.C.....1.95

**BUY TUBES HERE**  
**SURPLUS**  
13-4 Ballast \$0.19  
801A \$0.35  
843 \$0.39 4/1.35  
1625 .59 4/1.80  
1626 .39 4/1.35  
1629 .39 4/1.35  
HY615 .39 4/1.35  
RK73 .39 4/1.35  
958A .59 4/2.00  
65N7GT .79 4/3.00  
6J7 .79 4/3.00  
6AL5 .79 4/3.00  
1LD5 .59 4/2.00  
41 .79 4/3.00  
RKR73 .79 4/3.00  
GAKS 1.19 4/4.00  
219 1.19 4/4.00  
857 1.49 4/5.00  
15E 1.49 4/5.00  
34H7 1.49 4/5.00  
5F7 1.95 4/6.00  
1616 1.95 4/6.00  
807 1.69  
8012 1.49  
RK39 3.95  
860 3.95  
335 3.95  
12J1A 8.95  
5BP1 3.95  
8P4 3.95  
304TL 9.95  
3BP1 3.95  
250R 2.95  
804 6.95  
861 19.95  
849 19.95  
**KEYS**  
J-5A \$0.95  
J-30 1.25  
J-32 1.25  
J-38 1.25  
J-41A .99  
J-47 1.25  
J-48 1.25

**OIL CONDENSERS**  
**SPRAGUE #4884**  
32 mfd. Four 8 mfd. sections in one can 600V —oil—perfect for amplifiers.....\$4.95  
2 mfd 600V Round......79  
2X1 mfd 600V Round......89  
10 mfd 600V.....\$3.95  
.5 mfd 5000V-oil.....5.95  
1 mfd 6000V-oil.....6.95  
2 mfd 4000V-oil.....6.95  
GE23F47 Pryn-oil.....6.95  
90 mfd 120V-AC GE26F685 Pryn-oil.....6.95

**NEON INDICATORS**  
NE 48.....29c ea.  
NE 30.....37c ea.

**FUSES**

Amp.	Type	Each	10 for	100 for
1/2	8AG	\$0.03	\$0.25	\$2.95
1	8AG	.03	.25	2.95
3	3AG	.03	.25	2.95
3 1/2	3AG	.03	.25	2.95
4	4AG	.02	.25	2.95
5	5AG	.02	.25	2.95
5 1/2	5AG	.02	.25	2.95
6	6AG	.02	.25	2.95
10	10AG	.02	.25	2.95
15	15AG	.02	.25	2.95
20	20AG	.02	.25	2.95
25	25AG	.05	.40	2.95
4	4AG	.05	.40	2.95
10	4AG	.05	.40	2.95
35	4AG	.05	.40	2.95
40	4AG	.05	.40	2.95
20	5AG	.05	.40	2.95
40	5AG	.05	.40	2.95
70	5AG	.05	.40	2.95

**VARIABLE CONDENSERS—ALL NEW**  
Dual 35 mmd per Section. Miniature.....\$1.49  
Dual-100 mmd..... 1.49  
3 Gang 365 per Section..... 1.95  
4 Gang 147 mmd per Section..... 2.95  
5 Gang 365 per Section..... 2.95

5M ohm 20W...\$0.15  
5M ohm 50W... .69  
6M ohm 25W... .35  
10M ohm 10W... .15  
10M ohm 150W... 1.25  
250M ohm 2W, 3 for .10  
65M ohm 2W, 3 for .10

**JK26-PL54** Set \$0.49  
3 AG fuse post......25  
4 AG fuse post......25  
8 AG fuse post......25  
8 AG fuse HJM......25  
807 Tube Sockets......29  
Accorn Sockets......21  
WG153F.....\$149.50  
MG153F 3 Phase  
115V400 Cycle Out.....149.50

**SHOCK MOUNTS**  
Most Types. Send us your requirements for price.  
12V Soldering Iron.....\$2.95

**EDWARDS BUZZERS**  
#1892-115 V-60 cycle .05 amp.....\$0.98  
#15-size 0-12V DC works on 6V less cover. Fine for Code Practice Sets, Ea......69c  
10 for.....\$4.95

4 Speed Hobby Motors.....\$12.95  
Dry Air Pumps for Co-Ax Lines..... 4.95  
Voltage Regulators..... 2.49  
Microphone Cable, Per Set......04  
RH 28—Put-Put, 1500W 28 Volts DC..... 59.50  
30 ft. hook-up wire, Plastic Cover......10  
Luminous Paint Kit, For Dusting, Painting or Mixing, Glows in the Dark......79  
6 ft. AC line cords......15 ea.  
Single Hole mtg. Push Button Switch......19  
TS11 Hand Sets.....4.95  
Toggle P8A SPDT—center off.....3/1.00  
Toggle B1B SPDT.....3/1.00  
Toggle B11 SPDT Momentary.....3/1.00  
Micro Switch BZ-R041 SPDT......79  
Resistor Kit.....100/2.89  
A62 Phantom Antenna for 10 Meters, new......75  
35 FOOT STEEL ANTENNA MAST KIT, 7-Five foot sections—new..... 12.95  
Soldering Paste 1/2 lb. can......10

Write us for your meter wants. Over 3,000 in stock. Write for Our 16-Page Bulletin.  
**DOW RADIO, INC.**  
1759 E. Colorado St. Pasadena 4, Calif.  
PHONE: SYcamore 3-1196  
\$1.50 min. order 25% deposit with orders  
Send full remittance to save C.O.D. charges  
All merchandise fully guaranteed. Subject to prior sale.

## 40 mc. I.F. Tuner (Continued from page 50)

scope, when placed at this point, will therefore not give a true indication of the r.f. response.

There are two alternate methods which have been evolved which may be used to connect the scope so as to view the r.f. response. At the side of the mixer-oscillator tube there is a hole through which the top end of plate load resistor  $R_{310}$  (15,000 ohms) may be contacted. By the "top end" we mean the end closest to the i.f. link. See Fig. 4. The scope may be connected to this point through a series-isolating resistor of 100,000 ohms. The resistor should be covered with a piece of spaghetti to prevent shorting to the tuner shield.

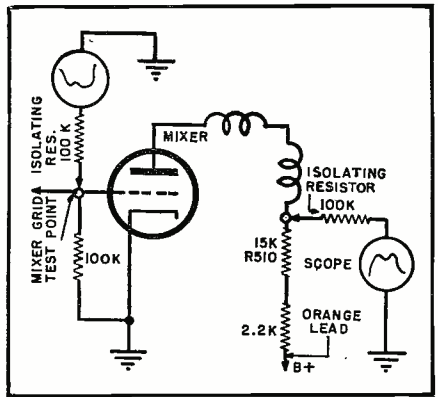

Fig. 4. One method of connecting scope and tuner for testing the new 40 mc. i.f. unit.

The scope may also be connected so as to view the r.f. response by connecting it to the mixer grid test point, which is readily accessible from the top of the tuner. A series resistor of 100,000 ohms must be used with the scope lead to keep from loading down the grid circuit. In this application the mixer serves as a grid leak detector in order to rectify the incoming r.f. sweep.

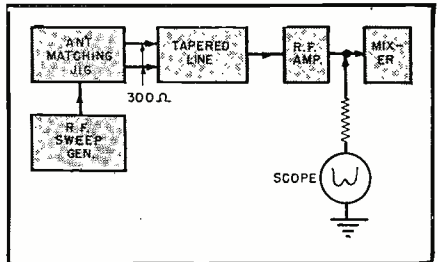

Fig. 5. Test setup for checking 40 mc. tuner.

In all cases, as with previous tuners, the sweep generator is connected to the input of the tuner through a 72-ohm to 300-ohm matching jig. See Fig. 5.

If the tuner is aligned in the chassis it is necessary to remove the first i.f. tube. It is also necessary to load the i.f. link with a 68-ohm resistor.

as that covered in earlier Philco service manuals. However there are some troubleshooting hints which perhaps would be valuable in servicing the new tuner.

Other than the above precautions and preliminaries the alignment of the new tuner is substantially the same

For easy reference the complete schematic diagram for the new tuner is shown in Fig. 6. Two important points must be remembered in troubleshooting this tuner.

1. In this tuner especially, the shunt capacity that is present between the tuner components-and-ground or com-

Fig. 6. Complete schematic diagram of the new Philco 40 mc. i.f. tuner unit.

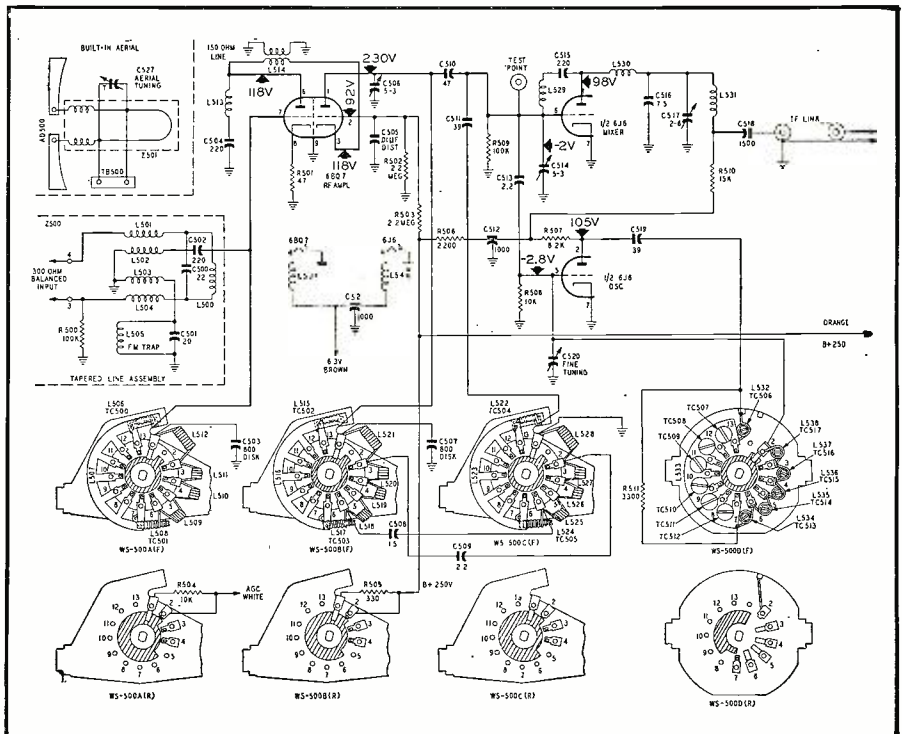

# BUY TEST EQUIPMENT ON THIS RADICALLY NEW TIME PAYMENT PLAN

**NO INTEREST!! - NO CARRYING CHARGES!!**

USE CONVENIENT TIME PAYMENT ORDER BLANK BELOW

## Superior's New JUNIOR SUPER-METER

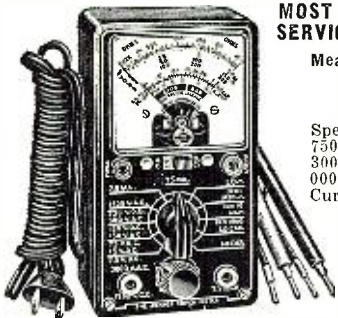

**MOST COMPLETE AND COMPACT MULTI-SERVICE INSTRUMENT EVER DESIGNED**

Measures: \* Voltage \* Decibels  
\* Capacity \* Resistance  
\* Current \* Inductance  
\* Reactance

Specifications: D.C. Volts: 0-7.5/75/150/750/1500 Volts. A.C. Volts: 0.15/150/300/1500/3000 Volts. Resistance: 0-10,000/100,000 ohms. 0-10 Megohms. D.C. Current: 0-7.5/75 Ma. 0-7.5 amps. Capacity: .001 Mfd.—2 Mfd. 1 Mfd.—20 Mfd. Electrolytic Leakage: Reads quality of electrolytics at 150 Volt test potential. Decibels: -10 Db to +18 Db. + 10 Db. to + 38 Db. + 38 Db. to + 58 Db. Reactance: 15 ohms—25 K ohms 15 K ohms—2.5 Megohms. Inductance: .5 Henry—50 Henries 30 Henries—10 K Henries. Plus Good-Bad scale for checking the quality of electrolytic condensers.

Handsome round cornered molded bakelite case 3 1/2" x 5 7/8" x 2 1/4" complete with all test leads and instructions .....

**\$2140**  
NET

## Superior's New Model CA-12 SIGNAL TRACER



The well known Model CA-12 is the only signal tracer in the low price range including both meter and speaker!!!

**SPECIFICATIONS:** • Comparative Intensity of the signal is read directly on the meter—quality of the signal is heard in the speaker. • Simple to Operate—only one connecting cable—no tuning controls. • Highly Sensitive—uses an improved vacuum-tube voltmeter circuit. • Tube and Resistor Capacity Network are built into the detector probe. • Built-In High Gain Amplifier—Alnico V Speaker.

Completely Portable—weighs 8 pounds—measures 5 1/2" x 6 1/2" x 9".

Model CA-12 comes complete with all leads and operating instructions .....

**\$3395**  
NET

## Superior's New Model 660—AN AC OPERATED SIGNAL GENERATOR

Provides Complete Coverage for A.M.—F.M. and TV Alignment

• Generates Radio Frequencies from 100 Kilocycles to 600 Megacycles on fundamentals and from 60 Megacycles to 240 Megacycles on powerful harmonics. • Accuracy and stability assured by use of permeability trimmed III-Q coils. • R.F. available or modulated by the internal audio oscillator. • Built in 400 Cycle sine wave audio oscillator used to modulate the R.F. signal also available separately for audio testing of receivers, amplifiers, etc. • Oscillator Circuit: Uses a miniature high frequency type of acorn triode in a Hartley circuit to insure a high degree of stability. By using the same type of triode as a buffer amplifier, complete and positive isolation between the R.F. oscillator and the attenuator is attained. • Attenuator: a 3 step ladder type of attenuator is used. Each step of the attenuator is controlled by a separate attenuator control thus providing intermediate level steps. • Tubes used: 955, as R.F. Oscillator, 955 as Modulated Buffer Amplifier.



6SN7 as Audio Oscillator and Power Rectifier.

The Model 660 comes complete with coaxial cable test lead and instructions .....

**\$4295**  
NET

## Superior's New Model TV-11 TUBE TESTER



• Uses the new self-cleaning Lever Action Switches for individual element testing. Because all elements are numbered according to pin number in the RMA base numbering system, the user can instantly identify which element is under test. Tubes having tapped filaments and tubes with filaments terminating in more than one pin are truly tested with the Model TV-11 as any of the pins may be placed in the neutral position when necessary. • Uses no combination type sockets. Instead individual sockets are used for each type of tube. Thus it is impossible to damage a tube by inserting it in the wrong socket. • Free-moving built-in roll chart provides complete data for all tubes. • Phono jack on front panel for plugging in either phones or external amplifier detects microphonic tubes or noise due to faulty elements and loose external connections.

Operates on 105-130 Volt 60 Cycles A.C. Hand-rubbed oak cabinet complete with portable cover .....

**\$4750**  
NET

## Superior's New TV BAR GENERATOR

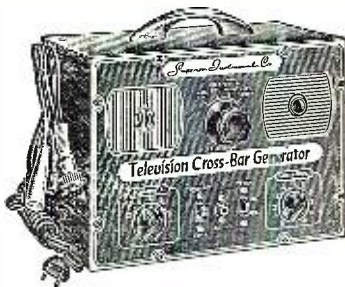

**Throws an Actual Bar Pattern on Any TV Receiver Screen!!!**

Two Simple Steps:

1. Connect Bar Generator to Antenna Post of any TV Receiver.
2. Plug Line Cord into A.C. Outlet and Throw Switch.

**RESULT:** A stable never-shifting vertical or horizontal pattern projected on the screen of the TV receiver under test.

TV Bar Generator comes complete with shielded leads and detailed operating instructions. Only .....

**\$3995**  
NET

## NEW TIME PAYMENT PLAN ORDER BLANK

MOSS ELECTRONIC DISTRIBUTING CO., INC.  
Dept. B-26, 38 Murray Street, New York 7, N. Y.

Please send me the units checked below. I am enclosing the down payment with order and agree to pay the monthly balance as shown. It is understood there will be no carrying, interest or any other charges. Provided I send my monthly payments when due. It is further understood that should I fail to make payment when due, the full unpaid balance shall become immediately due and payable.

- JUNIOR SUPER METER ..... Total Price \$21.40  
\$5.40 down payment. Balance \$4.00 monthly for 4 months.
- MODEL TV-11 ..... Total Price \$47.50  
\$11.50 down payment. Balance \$6.00 monthly for 6 months.
- MODEL CA-12 ..... Total Price \$33.95  
\$9.95 down payment. Balance \$4.00 monthly for 6 months.
- TELEVISION BAR GENERATOR ..... Total Price \$39.95  
\$9.95 down payment. Balance \$5.00 monthly for 6 months.
- MODEL 660 ..... Total Price \$42.95  
\$12.95 down payment. Balance \$5.00 monthly for 6 months.
- I enclose \$..... as down payment.
- Ship C.O.D. for the down payment.

Signature .....

Name .....

Address .....

City ..... Zone ..... State .....

**Save \$\$\$ On These TV BUYS OF THE YEAR**

**Rocket DIRECTRONIC MOTORLESS TV ANTENNA**

360° Electronically Switched Beam

- No Motors
- No Roof Orientation
- No Electric Power
- No Ghosts

AX-599 Directronic. As shown. . . . . **\$1695**

The Directronic 18-element, 360° antenna is the finest for ultrafringe or metropolitan reception. The HI-PAC molded insulator is a material of extreme tensile strength not affected by weather or temperature, either mechanically or electrically. Included in the AX-599 "Service-men's Array" are:

- 18 hi-tensile aluminum alloy elements.
  - 1 set of connecting studs (3).
  - Universal U Clamps for masts to 1 1/2".
  - Directronic Beam Selector.
  - 7 1/2 feet of Tri-X Cable.
  - 1 stacked array per carton.
- AX-599 Directronic, 9-element Single. . . . . \$10.35  
 All above prices include Tri-X Cable and Switch.  
 Extra Tri-X 3 Conductor Lead-In. . . . . 3c ft.  
**SOLD ONLY BY MAIL BY NATIONAL ELECTRONICS**

**Rocket YAGI**

**5 ELEMENT TV ANTENNA**

Excellent Pictures in Fringe Areas

**HIGH GAIN.** Clearer, sharper, steadier pictures in fringe areas. Minimum interference from ghosts and noise due to a directive pattern. Five elements include one folded dipole, three directors, and one reflector. Supplied less mast. MATCHES 300 OHMS IMPEDANCE. Molded insulator provides additional strength. Exclusive design mast clamp prevents antenna turning or canting under any conditions. **STURDY, TROUBLE-FREE CONSTRUCTION.** No return calls. No broken elements. Stands the test of severest weather. Elements of extra heavy aluminum-clamped top and bottom. **QUICK RIG.** Completely pre-assembled. Just swing elements into line and tighten wing nuts. Simple, quick, easy. Avail. for any channel, high or low band.

Channels 2 or 3. . . . . \$7.95 each  
 Channels 4, 5 or 6. . . . . \$6.95 each  
 Channels 7 to 13. . . . . \$3.95 each

EACH CHANNEL requires a DIFFERENT Yagi. When ordering specify exact channel number desired.  
**SOLD ONLY BY MAIL BY NATIONAL ELECTRONICS**

**OTHER ANTENNA BARGAINS**

ALL CHANNEL CONICALS.—  
 Single Bay. . . . . \$3.75 each  
 Stacked Array. . . . . \$3.75 each  
 ALL CHANNEL INLINE. . . . . \$3.75 each  
 ALL CHANNEL FOLDED DIPOLE. . . . . \$3.95  
 ALL CHANNEL DOUBLE VEE. . . . . \$3.75

**WORLDS LOWEST ACCESSORY PRICES**

<p><b>TWIN LEAD</b></p> <p>300 ohm ±70 Mill.          Solid. . . . . \$12.95          300 ohm ±60 Mill.          28 Stranded. . . . . \$7.95          300 ohm ±70 Mill.          Solid 1000'. . . . . \$12.50M</p>	<p><b>PANTHER TV LAMP</b></p> <p>21-Inch. Ebony or char- treuse. . . . . \$4.95</p>
<p><b>TELEMATIC Antenna Switch</b></p> <p>3 position. . . . . \$2.11          Low loss. . . . .</p>	<p><b>TELEMATIC COUPLERS</b></p> <p>Operates two 300-ohm receivers from one 300-ohm antenna. . . . . \$4.77</p>

- Mast Steel (Dunlsted 5' crimped) 1 1/4" O.D. . . . . \$1.05
- Mast Steel (Dunlsted 10') 1 1/4" O.D. . . . . \$1.95
- Mast Steel (Zinc Plated 10') 1 1/4" O.D. . . . . \$1.59
- Mast Conn. for 1 1/4" O.D. Mast—10' Long. . . . . 49c
- Chimney Mount Complete with Straps. . . . . \$1.59
- PART-9A Deluxe Chimney Mount. . . . . \$1.79
- Peak Roof Saddle (will take up to 1 1/2" O.D.). . . . . \$1.49
- Aluminum Guy Line 7/16 Stranded, 300ft. . . . . \$4.95
- Coil. . . . .
- Galvanized Guy Wire, 6 strand ±20. . . . . 1/2c ft.
- Galvanized Guy Wire, 11 strand ±20. . . . . 1/2c ft.
- Mast Stand-Off Insulators—3". . . . . \$8.50 C
- Stand-Off Screw Insulators—3". . . . . \$2.75 C
- Stand-Off Screw Insulators—2". . . . . \$5.50 C
- TC-8 3-Section Top Cowl 58" Auto Antenna. . . . . \$2.59
- C-3L 3-Section Side Cowl 63" Auto Antenna. . . . . \$1.95
- Lightning Arrester—TV. . . . . 69c

**SOLD ONLY BY MAIL BY NATIONAL ELECTRONICS**  
 Prices Subject to Change Without Notice  
**ALL PRICES F.O.B. CLEVELAND, OHIO**

Do not remit more than complete purchase price. Pay shipping charges on receipt of goods. 25% deposit on C.O.D. orders, please. Money-back guarantee.

**National Electronics OF CLEVELAND THE HOUSE OF TV VALUES**

105 Delco Building • Cleveland 3, Ohio

ponent-to-component becomes an important factor at r.f. frequencies.

2. When replacing a defective component, the lead length should be kept as short as possible in order to eliminate the extra inductance introduced.

**Oscillator Check:** Using a meter with a sensitivity of 20,000 ohms-per-volt or better, the voltage at the mixer grid should be checked.

If the oscillator is operating properly, that is, producing sufficient output, a negative reading of about 5 volts should be observed. The amount of negative voltage should increase as the channel selector is rotated to the high end of the band.

**Mixer Check:** Though the mixer stage is not designed primarily as an amplifier stage, its operation or lack of operation can be checked by making it perform as an amplifier stage and then checking its gain.

Since the oscillator injection voltage at the grid of the mixer causes a high negative bias to be developed, disabling of the local oscillator will allow the mixer to operate as an amplifier. This can be accomplished by unsoldering the grid lead of the local oscillator mixer tube. To isolate the mixer stage further, it is advisable to remove the 1st i.f. tube. The voltage gain of this stage can be easily measured by the following procedure.

1. Set the "AM-R.F." generator to 43 mc. and connect it to the grid of the mixer. Using a scope with good vertical sensitivity, connect a high frequency probe to the scope input. Connect the probe at the grid of the mixer. With this arrangement, the output of the generator is fed directly to the input of the scope.

2. Adjust both the output of the generator and the vertical gain of the scope until a small waveform appears on the scope. The exact height of this waveform must be registered since it will serve as a reference level to be compared with a change in level ob-

tained at the output of that stage. If there is a transparent graph on the scope, set the deflection of the waveform to one block.

3. With the output of the generator still connected to the grid of the mixer, place the high frequency probe at the grid of the 1st i.f. stage.

If the mixer stage is operating normally, a noticeable increase in waveform will be observed. The exact gain can be calculated by dividing the reference level into the increased level obtained through the amplifier stage.

**R.F. Amplifier Check:** The procedure for checking the r.f. amplifier is very similar to that of checking the mixer stage.

1. Remove the oscillator mixer tube from the socket.

2. Set the frequency of the "AM-R.F." signal generator to the carrier frequency of a given channel, making sure the channel selector corresponds to this frequency.

3. Connect the output of the signal generator and the scope using a high frequency probe to the antenna input terminals.

4. Adjust the signal generator output and the vertical gain of the scope for a small deflection to be used as a reference level.

5. Leave the generator connected to the antenna input and connect the scope through the high frequency probe to the mixer grid.

If the r.f. stage is operating normally, a noticeable increase in scope deflection will be observed.

The gain of the r.f. amplifier stage can be measured by dividing the units of deflection obtained at the mixer grid by the units of deflection obtained at the antenna input.

The amount of gain to be expected in the r.f. amplifier will vary from channel to channel; an average gain of eight over the entire band is considered normal.

—50—

While some gas companies operate in territories where water famine is experienced, there's occasionally too much Ohio River water in a portion of the West Virginia-Ohio area served by The Manufacturers Light and Heat Co. That's why when the Ohio spreads over its banks, this gas company brings into service a fleet of aluminum boats and has recently equipped some of them with two-way radio pack sets. This is the "flagship" of the fleet. It is equipped with a Johnson outboard motor and carries a Link transmitter-receiver mounted on special brackets in the bow. During flood conditions the boats enable gas men to reach otherwise inaccessible valves and regulators while maintaining communications with distribution headquarters.

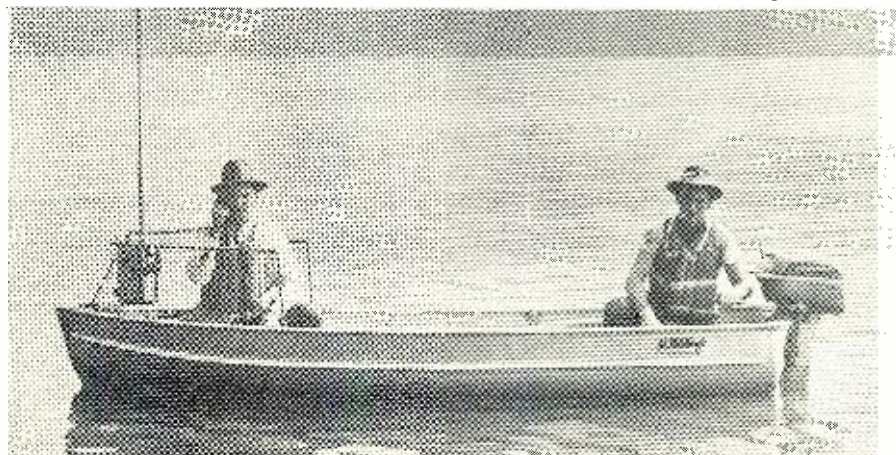



**Audio Simplified**  
(Continued from page 70)

this circuit includes a dynamic noise suppressor preamplifier for the magnetic pickup. This noise suppressor preamplifier is a commercial unit, the diagram of which is shown in Fig. 9. The circuit diagram of the Williamson driver and power amplifier is shown in Fig. 8. The basic circuit has already been described in a previous article in this series, but it is of interest to note again the use of direct coupling between the voltage amplifier stage and the cathode-follower phase inverter, and the feedback from the secondary of the output transformer to the cathode of the voltage amplifier. This amplifier delivers 10 watts of audio power with 0.3% distortion, which is quite adequate for home reproduction, and gives excellent performance suitable for use in the highest quality sound reproduction systems. If more power is desired, a 20-watt unit of similar design may be used.

The fine reproduction of which this system is capable can only be realized fully when a sufficiently good loudspeaker is used to produce sound from the electrical energy delivered by the amplifier, therefore, the loudspeaker should be the best that can be afforded. The loudspeaker should, of course, be one which has good frequency and transient response, has good efficiency and is capable of handling the maximum electrical power without distortion. The best loudspeakers are very expensive, but because of their extreme importance in determining the over-all quality of reproduction which can be obtained from a high-quality sound reproduction system, an effort should be made to use the best loudspeaker and enclosure that is economically practical.

**Testing Sound Systems**

Once the complete sound reproduction system has been set up, its performance should be evaluated according to the ultimate criterion that the reproduced sound should be exactly the same as the original sound. This condition is unattainable in actual practice, but the degree to which it is attained is a measure of the quality of reproduction. Since hearing is done by the ear, the best method of judging performance is a listening test, and the ear must always be the final judge of audio quality.

The most basic listening test applies a sound to the input of the system and, using the ear as the measuring instrument, compares the reproduction with the original. This test is actually the basic criterion against which all tests of audio quality must eventually be standardized. However, it is quite difficult to perform, since the original sound is generally not available for direct comparison. Furthermore, such a test is completely subjective and is

**The Masts that Stayed up—**

**when others went DOWN!**

**PERMA-TUBE**

**... the Steel Television Mast that's UP to STAY!**

... it was a *big blow*—the hurricane of November 1950 that hit the New York area with devastating force. Television masts were crumpled and flattened like straws in the path of the wind ... all but those made of PERMA-TUBE. PERMA-TUBE Masts *Stayed Up!* ... and why did PERMA-TUBE Masts *stay up?* For the very good reason that they're made of sturdy, corrosion-resistant steel ... Jones & Laughlin Tele-

vision grade PERMA-TUBE Steel ... a product that is pre-treated with Vinsynite and coated with a metallic-pigmented vinyl resin base *inside and outside.* ... what's more, they're easily, quickly and economically installed. Their new Fitted Joints can be slipped together in a matter of seconds. And you can obtain PERMA-TUBE in standard lengths, diameters and wall-thicknesses.

FOR COMPLETE INFORMATION—MAIL THIS COUPON TODAY!



Jones & Laughlin Steel Corporation  
495 Jones & Laughlin Building  
Pittsburgh 30, Pennsylvania

Without charge please send me:—

- Name of nearest distributor
- Complete information on Perma-Tube

NAME \_\_\_\_\_

COMPANY \_\_\_\_\_

ADDRESS \_\_\_\_\_

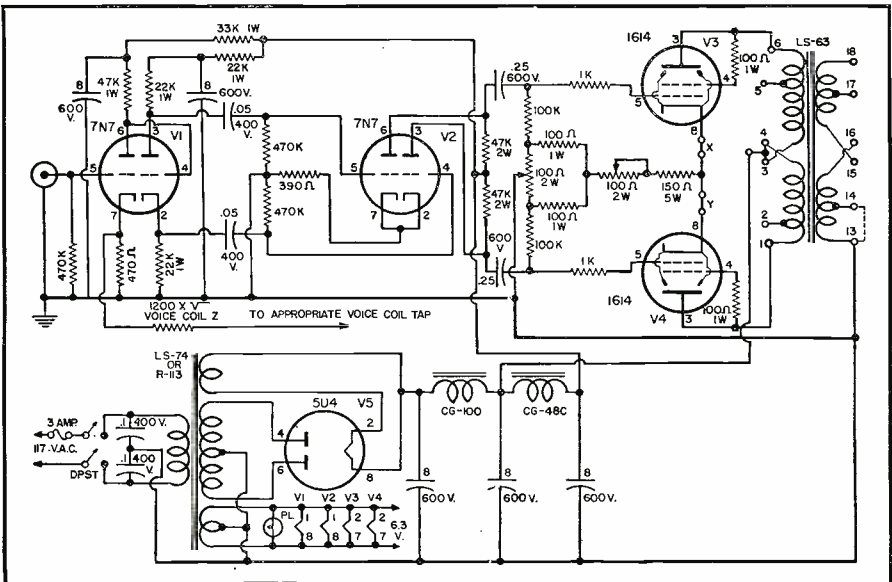

Fig. 8. Schematic of a Williamson-type driver and power amplifier which may be used in the sound reproducing system shown in the block diagram of Fig. 3.

RESPONSE OR DISTORTION BEING MEASURED	TYPE OF SIGNAL WITH WHICH MEASURED	GOOD REPRODUCTION	ACCEPTABLE REPRODUCTION
Frequency response	Steady sine wave	20-14,000 cps	40-10,000 cps
Noise level	zero	-60 db below full output	-50 db below full output
Harmonic distortion	Steady sine wave	2% total harmonics	2-5% total harmonics
Intermodulation distortion	Sum of high and low frequency steady sine waves	5%	10%
Transient response	Square wave or tone burst	No set standard	No set standard
Wow and flutter	Steady sine wave	0.1%	1%

Table 1. Tabulation of the acceptable limits of various distortions and the type of signal which can be employed to measure such distortions.

★ ★

Fig. 9. Schematic of a dynamic noise suppressor preamplifier for magnetic pickups.

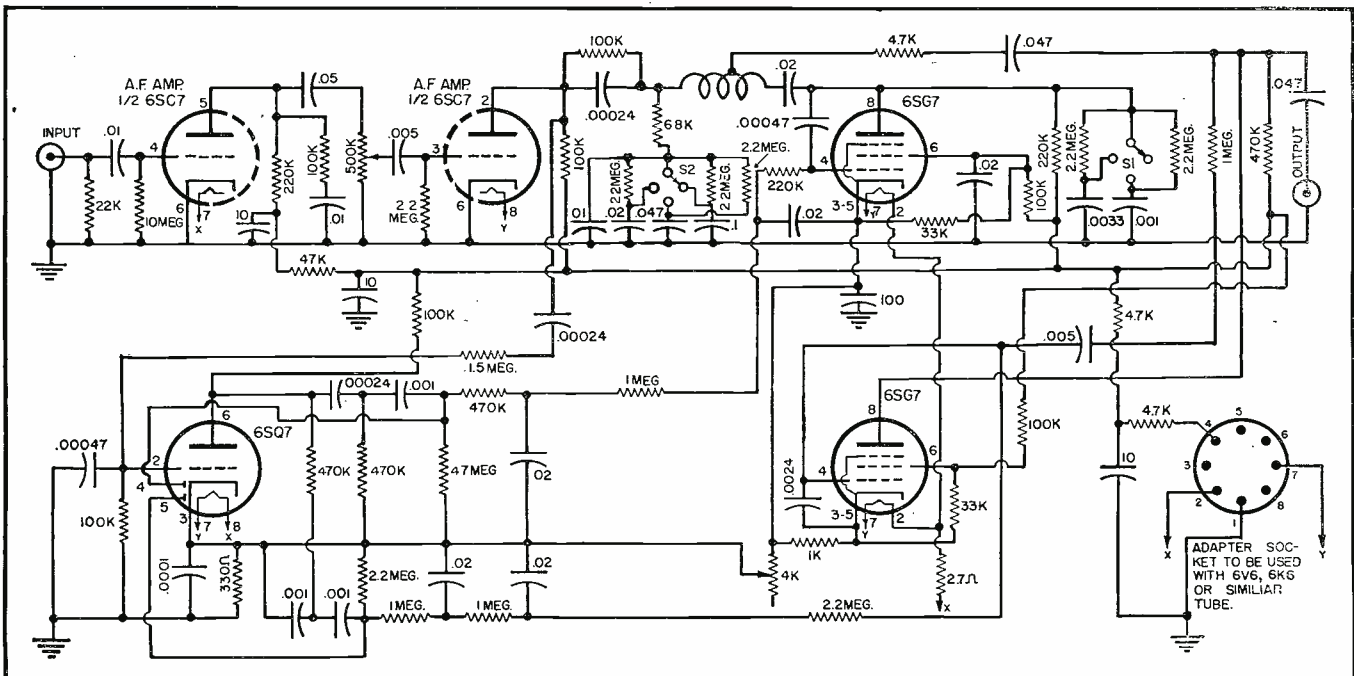

not capable of accurate quantitative measurements for comparison and evaluation under standardized conditions.

It is therefore necessary to find a quantitative measurement of the quality of sound reproduction which can be used as a basis for comparison and evaluation. However, for accurate measurements the average sound is much too complex a function to permit a ready determination of its characteristics. The sound must be simulated by simpler types of signals which are capable of direct measurement and which simulate the characteristics of the sounds which are of interest. The complete testing of an audio system requires measurements of several different types of input signals, in order to represent accurately the various factors known to be important in determining the quality of a complex sound. By using simplified signals which can be generated and measured fairly easily, the more complex relationships which occur in sound are separated and simplified into a form capable of exact measurement. A number of basic scientific investigations have been carried out with great numbers of people to determine the proper correlation of these simplified measurements with listening preferences. The results of these tests indicate that the various distortions should not exceed the limits shown in Table 1.

When carrying out such measurements, the tests can, in general, be performed either over the complete system<sup>1</sup> or for any individual component of the system. For example, the measurements may be performed over-all from microphone to loud-speaker, or over any individual phase

<sup>1</sup> Read, O., "The Recording and Reproduction of Sound" 2nd edition, Chapter 25.

**New Low Prices  
Largest Stock**

# TUBES and PARTS

**All TUBES** are guaranteed for one year . . . individually boxed.  
**10% DISCOUNT** on orders of 100 tubes or more, all brands.  
*Use this Order Blank!*

**TUBE SPECIALS!**

6AU6 . . . ea. 59c  
6V6GT . . . ea. 59c  
12AU7 . . . ea. 65c  
6SK7GT . . . ea. 58c  
6BQ6GT . . . ea. 85c  
6CD6G . . . ea. \$1.69

Quantity	Quantity	Quantity	Quantity	Quantity	Quantity
024 . . . 59c	6AB7 . . . \$1.15	6J5GT . . . \$ .54	7A6 . . . 73c	12BE6 . . . \$ .65	35B5 . . . 72c
024G . . . .65	6AC5GT . . . 1.31	6J6 . . . 1.04	7A7 . . . .73	12BF6 . . . .59	35C5 . . . .59
1A5GT . . . .99	6AC7 . . . 1.19	6J7G . . . .79	7A8 . . . .73	12BH7 . . . 1.08	35L6 . . . .45
1A7 . . . .95	6AG5 . . . 1.44	6J8G . . . 1.15	7B4 . . . .73	12C8 . . . 1.15	35W4 . . . .99c
1B3GT . . . .95	6AG7 . . . 1.40	6K5GT . . . .87	7B5 . . . .73	12F5GT . . . 65c	35Y4 . . . .54c
1B5 . . . .95	6AH6 . . . 1.08	6K6GT . . . .59	7B6 . . . .73	12H6 . . . .54	35Z3 . . . .95
1C7G . . . .95	6AK5 . . . 72c	6K7GT . . . .79	7B7 . . . .73	12J5GT . . . .54	35Z5 . . . .95
1E7 . . . .95	6AK6 . . . 72c	6K8GT . . . .87	7B8 . . . .73	12K7GT . . . .72	35Z6G . . . .79
1H6 . . . .95	6AL5 . . . 72c	6L5G . . . .95	7C4 . . . 1.30	12SA7GT . . . .72	35/51 . . . .41
1H5GT . . . .95	6AQ5 . . . 72c	6L7 . . . .87	7C5 . . . .73c	12SC7 . . . .79	42 . . . .72c
1H6G . . . 1.15	6AQ6 . . . .81	6N6G . . . 1.40	7C6 . . . .89	12SF5GT . . . 72c	43 . . . .72c
1J5GT . . . .95	6AR5 . . . .74	6N7GT . . . 1.08	7C7 . . . .89	12SH7GT . . . .79	45 . . . .59
1L4 . . . .29	6AT6 . . . .54	6P5GT . . . 1.08	7E6 . . . .89	12SK7GT . . . .72	46 . . . 1.04
1LA4 . . . .95	6AS5 . . . .90	6Q7GT . . . .65	7E7 . . . 1.07	12SL7GT . . . .87	47 . . . .79
1LA6 . . . .95	6AU5GT . . . 1.45	6R7GT . . . .95	7F7 . . . .81	12SN7GT . . . .99	50A5 . . . 1.21
1LC5 . . . 1.19	6AU6 . . . 59c	6S4 . . . .65	7F8 . . . 1.47	12SQ7 . . . .54	50B5 . . . 72c
1LC6 . . . .95	6AV6 . . . 1.44	6S7GT . . . 1.15	7G7 . . . 1.07	12S7GT . . . .79	50C5 . . . 1.04
1LD5 . . . .95	6B4G . . . .79	6S8GT . . . .95	7H7 . . . .89	12SQ7GT . . . .59	50L6 . . . .59
1LE3 . . . 1.19	6B5 . . . 1.44	6SA7GT . . . .72	7J7 . . . .89	12SR7GT . . . .79	50X6 . . . .79
1LH4 . . . 1.19	6B6G . . . .79	6SC7 . . . .99c	7K7 . . . .86	12Z3 . . . .95	50Y6 . . . .59
1LN5 . . . 1.19	6B8GT . . . 1.15	6SD7GT . . . 81c	7Q7 . . . .89	14A7 . . . .93	70L7 . . . 1.40
1N5GT . . . .72	6BA6 . . . .65	6SF5 . . . .59	7R7 . . . .89	14AF7 . . . .89c	71A . . . .87
1P5GT . . . .95c	6BA7 . . . .72	6SF5GT . . . .65	7S7 . . . 1.07	14B6 . . . .89c	75 . . . 1.10
1Q5GT . . . .95c	6BC5 . . . .72	6SF7 . . . .72	7V7 . . . 1.07	14B8 . . . .89c	77 . . . 1.45
1R5 . . . 72c	6BC7 . . . .79	6SH7GT . . . .79	7W7 . . . 1.07	14C5 . . . 1.07	78 . . . 1.45
1S5 . . . .95	6BD5GT . . . 1.15	6SJ7 . . . .81c	7X7 . . . 1.07	14C7 . . . .98	80 . . . .61
1T4 . . . .95	6BE6 . . . .65	6SJ7GT . . . .58	7Y4 . . . 73c	14F7 . . . .89	83 . . . 1.45
1U4 . . . .95	6BF5 . . . .99	6SK7GT . . . .87	7Z4 . . . 1.15	14F8 . . . 1.30	85 . . . .79
1U5 . . . .95	6BF6 . . . .73	6SL7GT . . . .54	12A7 . . . 1.15	16SJ7GT . . . .81	117L7 . . . 1.40
1X2A . . . 1.15	6BG6G . . . 72c	6SN7GT . . . .79	12A8 . . . .79	19BG6G . . . 2.15	117N7 . . . .54
2A3 . . . .79	6BH6 . . . 1.44	6SQ7 . . . .65	12AH7 . . . 1.45	19T8 . . . 1.04	117P7 . . . .79
2A5 . . . 1.19	6BN6 . . . .85	6SQ7GT . . . .72	12AT6 . . . .54	20 . . . 1.40	117Z3 . . . .54
3LF4 . . . .79	6BQ6 . . . 1.58	6SS7 . . . 1.15	12AT7 . . . 1.04	24A . . . .79	117Z6 . . . 1.55
3Q4 . . . .95	6C4 . . . 59c	6T8 . . . 1.10	12AU6 . . . .72	25AC5GT . . . 1.04	807 . . . 1.55
3Q5GT . . . 72c	6C5GT . . . 79c	6U5 . . . .79c	12AU7 . . . .65	25BQ6GT . . . 1.15	813 . . . 8.95
3S4 . . . .95	6C6 . . . .79	6U6GT . . . .65	12AV6 . . . .54	25L6GT . . . .59	1294 . . . 29c
3V4 . . . .95	6C8G . . . 1.15	6U7G . . . .59	12AV7 . . . 1.15	25W4GT . . . .72	1299 . . . .45
5T4 . . . .87	6CB6 . . . .72	6V6GT . . . .65	12AW6 . . . .95	25X5 . . . 1.04	1619 . . . .29
5U4G . . . .59	6CD6G . . . 1.69	6W4GT . . . .54	12AX7 . . . .87	25Z6GT . . . .79	1629 . . . 2.00
5V4G . . . .87	6D6 . . . .79	6X4 . . . .68	12BA6 . . . .65	32L7GT . . . 1.15	2050 . . . 1.15
5W4 . . . 59c	6D8G . . . 1.15	6Y6G . . . .81	12BA7 . . . .87	35A5 . . . .99	2051 . . . 1.15
5W4GT . . . .95	6E5 . . . .79	7A4 . . . .81			7193 . . . .87
5X4G . . . .45	6F5GT . . . 59c	7A5 . . . .89			VT51 . . . 29c
5Y3GT . . . .54	6F6GT . . . 59c				VT52 . . . .87
5Y4G . . . .81	6F8G . . . 1.15				
5Z3 . . . 1.15	6G6G . . . .95				
6A3 . . . 1.21	6H6 . . . .59				
6A7 . . . 1.21	6H6GT . . . .65				
6A8GT . . . .99					

**P. M. SPEAKERS**  
12" Coaxial PM Speakers **\$12.95** ea.  
High fidelity with high pass filter attached. 20 watt; 40-17500 cps. response; 8 ohm VC.  
Very best quality—NATIONAL BRANDS Individually Packed

3" . . . \$1.26 ea.	8" . . . \$3.23 ea.
4" . . . 1.36	10" . . . 5.10
5" . . . 1.59	12" . . . 6.54
6" . . . Special Price	1.59 ea.

**RESISTOR KITS**  
Insulated 1/2, 1 and 2 watt assortment of most used values, best brands. 100 for **\$4.95**  
50 asst.—\$2.95

**TUBE KITS**  
BEST BRANDS at BEST PRICES

3Q4, 1T4, 1R5, 1S5, List Value \$8.00. Tube Kit only . . .	<b>\$2.39</b>
3S4, 1T4, 1S5, 1R5, List Value \$7.80. 4 Tube Kit . . .	<b>\$2.39</b>
1U4, 3S4, 1S5, 1R5, List Value \$7.80. All Four Tubes for . . .	<b>\$2.39</b>
3V4, 1R5, 1S5, 1T4, List Value \$7.80. All for . . .	<b>\$2.39</b>
117Z3, 1U5, 3V4, 1R5, 1T4, AC-DC Portable Kit. All for . . .	<b>\$2.89</b>
12AT6, 12BA6, 12BE6, 35W4, 50B5, 5 Tubes for . . .	<b>\$2.95</b>
50L6GT, 35Z5GT, 12SQ7GT, 12SK7GT, 12SA7G, 5 Tubes for . . .	<b>\$3.22</b>

**TV PICTURE TUBES**  
Six month guarantee

10BP4 . . . \$13.95	16GP4 . . . \$29.95
12LP4 . . . \$18.95	16JP4 . . . \$29.95
12LP4A . . . \$22.95	16RP4 . . . \$23.95
14PB4 . . . \$22.95	16TP4 . . . \$24.95
7JP4 . . . \$16.95	17BP4A . . . \$24.95
16AP4 . . . \$29.95	19AP4A . . . \$39.95

**Fringe Area DOUBLE "V" TV ANTENNA KIT**  
High Gain, Best Pictures Possible . . . complete with 300 ohm line, insulators, guy wire, hardware, full size antenna with double length 9 ft. mast **\$7.95** complete kit

**TWIN LEAD**  
300 ohm twin lead 55 Web virgin polyethylene, in either clear or brown, the finest available.  
1000' \$18.50 | 100' \$1.95 ft.

**6 FOOT LINE CORD**  
UL apprvd. cord and plug—10 for \$1.95  
TV Tubular Capacitor .05 mfd, 6000-VDC Only . . . 79c ea.

Get our special sales bulletins . . . write TODAY!

**3 speed G. I. CHANGER** complete, ready to install **\$24.95**

**TV INLINE FOLDED DIPOLE ANTENNA**  
At this price we cannot mention manufacturer's name, complete with mast, ind. boxed. **\$6.95** each

**Premier RADIO TUBE CO.** 551 W. Randolph St. Chicago 6, Illinois ANdover 3-1590



# Special Offer On This Complete RADIO ENGINEERING LIBRARY

New, Up-To-Date Edition of Famous Library Covers Whole Field of Radio Engineering. Places Latest Facts, Standards, Data, Practice, and Theory At Your Fingertips.

THE five big volumes of the new edition of the Radio Engineering Library now include the very latest facts, standards, data, and practice. This Library will help solve hundreds of problems for designers, researchers, engineers, and students in any field based on radio.

Written by leading radio engineers, these books cover circuit phenomena, networks, tube theory, vacuum tubes, amplification, measurements, etc.—give specialized treatment of all fields of practical design and application. They provide you with a complete and dependable encyclopedia of facts.

5 Volumes • 3872 Pages • 2770 Illustrations

- Eastman's FUNDAMENTALS OF VACUUM TUBES, 3rd Edition.
- Terman's RADIO ENGINEERING, 3rd Edition.
- Everitt's COMMUNICATION ENGINEERING, 2nd Edition.
- Hund's HIGH FREQUENCY MEASUREMENTS, 2nd Edition.
- Henney's RADIO ENGINEERING HANDBOOK, 4th Edition.

## SEND NO MONEY

Special Low Price • Easy Terms

On this special offer you get this Library for \$34.50, instead of \$39.00. You save \$4.50 and may pay on easy terms. Mail coupon below to examine the Library FREE for 10 days. No obligation. These books are recognized as standard works; you are bound to need them. So take advantage of this special money saving offer. *Mail coupon at once!* McGraw-Hill Book Co., Dept. RTN-5-52, 327 W. 41st Street, New York City.

McGraw-Hill Book Co., Dept. RTN-5-52  
327 West 41st St., New York 18, N. Y.

Send for 10 days' FREE trial, the RADIO ENGINEERING LIBRARY. If not satisfied I will return books. Otherwise I will send \$4.50, plus delivery charges, then; and \$5 a month for 6 months. (Reg. price \$39.00; you save \$4.50).

Name.....

Home Address.....

RTN-5-52

City & State.....

WE'LL PAY DELIVERY CHARGES if you enclose \$4.50 first payment WITH coupon. Same return privilege for full refund.

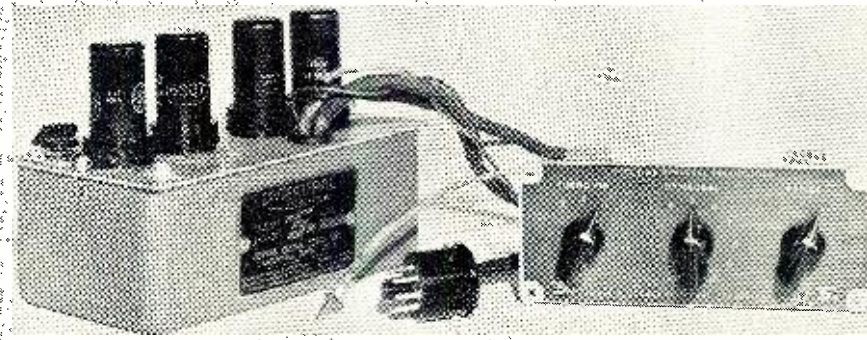

The H. H. Scott noise suppressor preamplifier shown schematically in Fig. 9.

of the system such as the amplifier, the phonograph pickup, the loudspeaker, etc. The over-all method is advantageous in that it measures the interactions as well as the characteristics of the individual components and gives an indication of the complete reproduction quality. However, the method of individual measurements has the advantage of being generally simpler and more convenient to perform and serves to localize any deficiencies which may exist. With this method each component should be carefully matched into the proper input and output impedances, to approximate as closely as possible its interactions with the over-all system. Then the over-all quality can be obtained by correlation of the individual measurements.

The basic setup for any type of measurement is shown in Fig. 10. A known input of the proper form is applied through a generator of the desired impedance to the input of the system, and the resulting output is measured across the desired load impedance. Each different type of audio unit will, of course, require the correct type of input signal and the output must be measured by the proper type of equipment. Great care must also be taken, in performing any measurements whatever, in the selection and characteristics of the test equipment itself. All equipment and instruments used for the measurements must be sufficiently better than the system under test so that their defects can reasonably be neglected. This factor should always be given careful consideration and if any auxiliary equipment must be used in making a particular measurement or set of tests, precautions should be taken that the equipment used should not introduce errors which might be large enough to make the readings unreliable or meaningless.

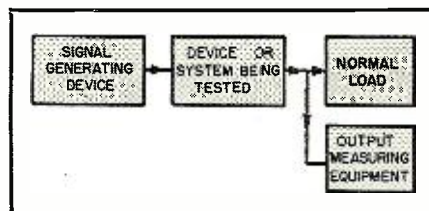

Fig. 10. Basic setup for making measurements.

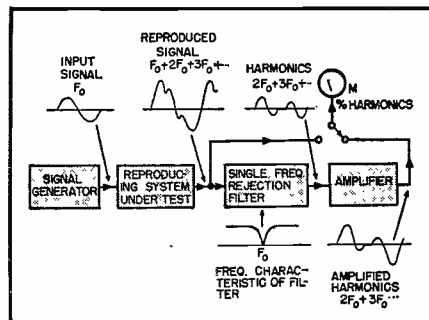
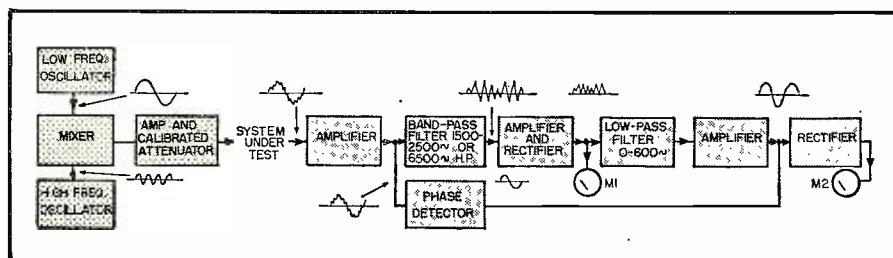

Fig. 11. General method of measuring total harmonic distortion introduced by system.

Frequency response is generally measured by applying a signal of constant amplitude to the input and measuring the output signal amplitude as the frequency of the input test signal is varied. Maximum power output is measured by increasing the input signal level (with the system set for full gain); and observing the output signal (either aurally, or visually by means of an oscilloscope or a meter) to determine the output power level at which the system overloads or becomes excessively distorted. The noise level is determined by measuring the output signal with zero input signal and the gain control of the amplifier wide open.

The general method of measuring the total harmonic distortion introduced by the reproducing system is

Fig. 12. Block diagram showing general method of measuring intermodulation distortion.



shown in Fig. 11. It consists of applying to the input a steady single-frequency pure sine wave (known to be relatively free of distortion) and then measuring the harmonic content of the output signal. The harmonics are measured by filtering out the fundamental component (which may be done by a single-frequency rejection filter such as the RC parallel-T type), and measuring the remaining signal as a percentage of the total. The general procedure is to first measure the total signal including the fundamental with a vacuum-tube voltmeter, then switch this output signal through the filter which attenuates the fundamental and permits the amplitude of the remaining harmonics to be measured and compared to the fundamental.

The intermodulation distortion which is introduced by the system is measured by applying two known frequencies simultaneously to the input and determining the amount of interaction distortion of these two frequencies by measuring the magnitude of the new frequencies generated in the system. The general method of performing this measurement is shown in Fig. 12. Two units are required: a signal generator which supplies the composite input signal and the analyzer which determines the amount of cross-modulation generated in the reproducing system. For the purpose of determining intermodulation, the composite signal effectively simulates those characteristics of a normal audio signal that are important in generating the intermodulation products which unpleasantly affect the quality of the reproduction. It consists of a low-frequency component between 40 and 150 cps and a high-frequency component which may be either about 2000 cps or between 7000 and 12,000 cps, with the amplitude of the low-frequency about 12 db. greater than the high-frequency component. The analyzer unit then measures the output signal from the system to determine how much the system has caused the high-frequency component to be modulated by the low-frequency component. This measurement is accomplished by passing the reproduced signal through suitable filters to separate the desired frequency components and measuring the percentage modulation of the high-frequency signal. Intermodulation distortion analyzers which are commercially available generally contain all of these various features in a single instrument. The amount of intermodulation which is measured using the two different frequencies in this manner can then be expected to be a measure of the amount of intermodulation that will be introduced into the more complex sounds of speech and music.

In performing any type of measurement on audio reproduction systems, it is extremely important that such measurements be performed extremely carefully and that proper attention be paid to the measurement techniques, otherwise the factors which

inside this package on your Jobber's shelf...



is the world's toughest transformer



#### S-TYPE

Steel base cover fitted with phenolic terminal board. Convenient numbered solder lug terminals. Flange-mounted unit.

there's nothing **TOUGHER**  
THAN CHICAGO "Sealed-In Steel" CONSTRUCTION



#### H-TYPE

Hermetic sealing meets all MIL-T-27 specs. Steel base cover is deep-seal soldered into case. Ceramic bushings. Stud-mounted unit



#### C-TYPE

With 10" color-coded leads brought out through fibre board base cover. Lead ends are stripped and tinned for easy soldering. Flange-mounted unit

CHICAGO "New Equipment" transformers (available in 3 mountings) feature one-piece drawn-steel cases—the strongest, toughest, best-looking units you can buy. The one-piece seamless design, enclosing an electronically perfect construction, provides the best possible electrostatic and magnetic shielding, with complete protection against adverse atmospheric conditions. For every application: Power, Bias, Filament, Filter Reactor, Audio, MIL-T-27, Stepdown—ask your electronic parts distributor for CHICAGO "Sealed-in-Steel" Transformers—the world's toughest with that extra margin of dependability.

#### Free "New Equipment" Catalog

Get the full details on CHICAGO'S New Equipment Line—covering "Sealed-in-Steel" transformers for every modern circuit application. Write for your Free copy of this valuable catalog today, or get it from your distributor.



**CHICAGO TRANSFORMER**

DIVISION OF ESSEX WIRE CORPORATION

3501 ADDISON STREET • CHICAGO 18, ILLINOIS



# INCREASE EARNINGS

## TESTING and SERVICING

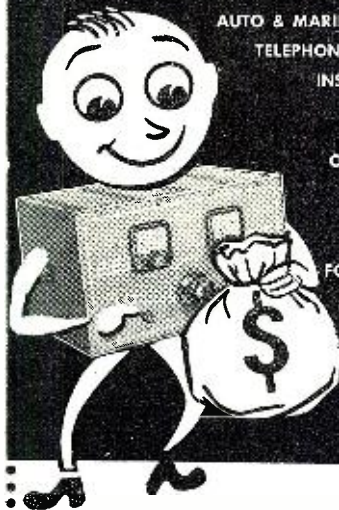

AUTO & MARINE RADIOS.  
TELEPHONE CIRCUITS.  
INSTRUMENTS.  
RELAYS.

OTHER LOW VOLTAGE DEVICES.

FOR PLATING & BATTERY CHARGING.

MODEL "BJ" JUNIOR

## ELECTRO LOW-COST FILTERED DC POWER SUPPLY

End costly storage battery failures . . . save time and money with the "BJ" JUNIOR. Exclusive EPL conduction cooling doubles rectifier power rating and provides lowest cost per ampere output over any other type. Dissipates over 3 times the heat and withstands high overloads. Top quality components assure dependability and long life. . . . . **Net \$37.50**

- 1 to 12.5 amperes 6 volts continuous output with a peak instantaneous rating of 25 amperes.
- 3 to 9 volts at other loads.
- Heavy duty selenium rectifiers, transformer and choke.
- AC ripple less than 0.4 volts at 6 volts DC 8 amperes.

**For Heavy Duty Applications**  
MODEL "B" 6 VOLTS DC  
1-20 AMPERES NET \$49.80

See Your Jobber Today!  
Write for New Folder!



**ELECTRO PRODUCTS LABORATORIES**  
4501 Nj Ravenswood Avenue, Chicago 40, Ill.

IN CANADA: ATLAS RADIO CORP. LTD., TORONTO

are to be measured may be completely masked by errors due to the methods of measurement. The input signals and the measuring equipment must themselves be sufficiently free from distortions to permit the measurement of the desired factors. This requirement can be met without too much difficulty when the electrical characteristics of the system are being tested, but many factors must be considered when the electro-acoustic sections of the system are being tested. If a microphone is being tested, the acoustics of the measuring room must be carefully planned to avoid acoustical resonances and the calibration of the loudspeaker used as the sound source must be accurately known. When testing recording heads and pickups, great care should be taken to keep the mechanical drive free from flutter and wow, and the characteristics of the records and recording materials must be taken into account. When the output of a loudspeaker is being measured, the same acoustical considerations are important as for microphones, and the characteristics of the measuring microphone must be accurately known.

If the various factors which affect the quality of reproduction are measured accurately and evaluated properly they will give a very good indication of how well the system will reproduce any physical sounds. The measurement data will correspond closely with the preferences of the human ear—which is, after all, the final judge and has up to now been the determining factor in acoustical progress. If the complete system has been properly set up, and properly conducted tests indicate it to be good, then subjective listening tests will confirm these measurements. Sound reproduced by a high-quality system will sound very much like the original sound in the studio or concert hall, with natural and distortion-free bass and high frequency response, good transient response and good definition of individual sounds and instruments. Such a system will have "presence," no fatigue will result even after many hours of continuous listening, and a great amount of enjoyment will be derived from listening to sound reproduced under the best conditions. —50—



"Now, Harry, this is the last one—let's get off on our honeymoon!"

## TV RECEPTION UP TO 200 MILES

ON ACTUAL FIELD TESTS WITH

### NEW DX630 CHASSIS

USING THE CASCODE TUNER

will operate in fringe areas or in localities remote from TV broadcast stations up to 200 miles.

HAS 4 MICROVOLT SENSITIVITY—10 times any other TV receiver. Will pick up distant stations without use of booster or special antenna arrays—and with less noise. Will operate any tube including 24", greater brilliance, improved keyed AGC circuit (eliminating flickering and fading). Uses the best materials with a high factor of safety to insure trouble-free operation. STD. RTMA GUARANTEE free replacement of defective parts or tubes for 90 days. Completely factory-wired chassis ready to operate with 12" P.M. Speaker. **\$144.50**  
Price Including Excise tax. . . . .

## TELEVISION PICTURE TUBES Standard Brands

ONE-YEAR GUARANTEE

12 1/2" (Black or White) . . . . .	\$22.50	Glass 16" Round (Black) . . . . .	\$28.50
Glass 14" Rectangular (Blk.) . . . . .	\$23.50	Glass 16" Rectangular (Blk.) . . . . .	\$27.25
17" Rectangular (Blk.) . . . . .	\$25.95		
19" Round (Blk.) . . . . .	\$39.95		
20" Rectangular (Blk.) . . . . .	\$28.35		
21" Rectangular (Blk.) . . . . .	\$42.95		
24" Metal . . . . .	\$67.25		

Console cabinet of beautiful design made of the finest veneers and good finish. Size 39" high x 24" wide x 22 3/4" deep. Finished in mahogany or walnut. Cut for 630 chassis with 12" speaker; will take either 16, 17, or 20" tube. (Please Specify Size.)

Price including mask and excise tax. . . . . \$43.95  
Extra for glass. . . . . \$2.75

For the various other cabinets in our large selection we will furnish photos and other NECESSARY INFORMATION, ON REQUEST.

## TELEVISION COMPONENT SPECIALS

"Faster Than Hotcakes!"

That's how these original 13-channel RCA Tuners are selling. Uses 3—6J6 tubes. Sold as is, less tubes, only **\$3.95**

## NEW STANDARD COIL CASCODE TUNER

The tuner that will give you stronger, better and clearer reception. Uses 1—6J6 and 1—6BK7 Intercarrier. **\$19.95**

- New—DuMont Tru Focus Conversion Kit
- Convert your old set for even focus over entire screen.
- DuMont 70° Yoke, Model Y2A1—distributed winding . . . . . \$6.57
- DuMont 70° Flyback Transformer Model H1A1 . . . . . \$6.57
- DuMont Linearity Control— for above units . . . . . \$0.75
- DuMont Width Coil—for above units. . . . . \$0.75

## AUTOMOBILE RADIOS

Custom-Built for any of the following 1949-1950-1951-1952 automobiles—Dodge, Plymouth, Chevrolet, Hudson, Studebaker, Henry J. and Ford 1949-1951. Every Radio is a powerfully built, 6 tube superhet with R.F. Stage and 3 gang condenser. Each radio is Custom Built and can be mounted in the dashboard within 4 minutes. Your price including aerial \$38.47 ea.

All Merchandise Subject to Prior Sale. All Prices Subject to change without Notice.

WRITE FOR COMPLETE CATALOG N-4

## EDLIE ELECTRONICS INC.

154 Greenwich St. New York 6, New York

## Technical BOOKS

**"MAKE MUSIC LIVE"** by Irving Greene, James R. Radcliffe, & Robert Scharff. Published by *Medill McBride Company, Inc.*, New York. 256 pages. Price \$4.50.

While the publishers of this text have characterized this book as a "practical guide for the assembly and installation of high fidelity music systems in the home," in reality, it falls short of its objective.

The text material is a popular treatment for the non-technically trained music lover and while the book contains many photographs and line drawings of custom installations, it lacks the requisite circuit data to actually perform such an installation.

Emphasis has been placed on cabinetry, hardware, TV antennas and accessories and while these are often important adjuncts to a home music system, their inclusion should not be at the expense of the more pertinent components, namely, the tuners, record players, tape recorders, amplifiers, speakers, etc., that comprise the heart of a high-fidelity music system.

There has been a general avoidance of the practice of "naming names" which is undoubtedly a prudent procedure from the commercial standpoint but it does leave the untutored music enthusiast a little at a loss as to the specific equipment he should purchase. Specifications for an "ideal" system are given but unless the reader has access to the catalogues of a great number of audio manufacturers he will have difficulty in locating a piece of equipment to meet the published specifications.

The material incorporated in the appendix is somewhat unrelated to the subject under discussion except for Appendix C which lists by price class the various components comprising a home sound system, to indicate the range of units available. No index is included—an essential component of any textbook.

\* \* \*

**"RADAR AND ELECTRONIC NAVIGATION"** by G. J. Sonnenberg. Published by *D. Van Nostrand Company, Inc.*, New York. 265 pages. Price \$6.00.

This is a practical handbook for those actively concerned with the operation of *Decca*, loran, and consol systems, radar, and echo sounding equipment.

The book is divided into six main sections covering general introductory material, the *Decca* system, loran, the consol, echo sounders, and radar. The first chapter covers the basic principles of such radiolocation systems, deals briefly with the subject of electric current and magnetism, plotting sine waves, vector diagrams, a discussion of the cathode-ray tube, the saw-tooth oscillator, magnetic deflection, etc. The other chapters deal with spe-

May, 1952

# 3 MICROPHONES DESIGNED FOR YOU...

BA-109... Flat frequency response from 40 to 10,000 cps. Nondirectional in the horizontal plane... output of 54 db below 1 volt/dyne/cm<sup>2</sup>. Fits standard stand. List . . . \$22.50.



BA-106... Essentially flat frequency response from 40 to 6,000 cps. Output level — 50 db below 1 volt/dyne/cm<sup>2</sup>. List . . . \$19.75.



BA-116 . . . Hand or desk model. Can be used with standard stand if desired . . . uniform response from 50 to 6,000 cps. Finest of the low priced microphones. List . . . \$14.75.



**No matter how good your ham rig, your P. A. system or your tape recorder, you can only get out of it what your mike puts into it. You want a sensitive, wide range mike with flat response, yet you want a mike that is sturdy and trouble-free.**

Brush had you in mind when they designed their line of microphones. Each Brush mike is engineered to do an outstanding job in its class. All use the exclusive **Metalseal Crystal\*** which assures protection from both high and low humidity.

The 3 Brush microphones illustrated as well as the **Brush Vibromike\*** and the **Brush Lapel** microphone are available from your local radio parts jobber.

Brush headphones—for the first time combine all the most wanted headphone features. See them at your dealer.

\*T. M. Reg.

THE **Brush**  
DEVELOPMENT COMPANY



Piezoelectric Crystals and Ceramics  
Magnetic Recording Equipment  
Acoustic Devices  
Ultrasonics  
Industrial & Research Instruments

3405 Perkins Avenue • Cleveland 14, Ohio

# Become an Electrical Engineer



## MAJOR IN ELECTRONICS



- B. S. Degree in 36 Months
- Radio-Television Technician Certificate in 18 Months

Experts predict that by 1954 there will be at least two positions for every engineering and technical graduate. This College offers a tested plan that permits you to enter these vast employment opportunities at an early date. First—you save a valuable year through optional year-round study. Second—you can receive advanced credit for prior training gained in the armed forces, other schools or field experience.

### ENTER BOTH RADIO AND TELEVISION THROUGH THIS PLAN

12 months or one-third of the B.S. degree course (Electronics major) — also brings you the *Radio Technician's* certificate. An added 6-month course qualifies you for the *Radio-TV Technician's* Certificate.

### The Famous "UNIT CHASSIS SYSTEM"



of teaching was developed here. It "breaks down" the TV set by stages. You learn every component of all types and makes—and are prepared for future design changes, including the advent of color.

### SPECIAL! Television Clinics

Ambitious Radio and TV Servicemen can enroll now in special one-month spring or summer clinics — to handle latest field service problems. Write for full details.

Over 48,000 former students from all states and 23 overseas countries. Faculty of trained specialists. Modern laboratories and equipment. Nonprofit technical institute and college 49th year.

## MILWAUKEE

SCHOOL OF ENGINEERING

• FOUNDED 1903 •

Terms open April, July, October, January

FREE — Write for "Occupational Guidance Bulletin," "Your Career" booklet, and Catalog.

Milwaukee School of Engineering  
Dept. RN-552, 1025 N. Milwaukee  
Milwaukee, Wisconsin

Without obligation send Catalog for Electrical Engineering, B. S. Degree, major in  Electronics;  Power;  "Your Career"; Occupational Guidance Bulletin on:  Radio-TV;  Electrical Power;  Welding;  Heating, Refrigeration Air Conditioning;  TV Service Clinic.

Name \_\_\_\_\_ Age \_\_\_\_\_

Address \_\_\_\_\_

City \_\_\_\_\_ Zone \_\_\_\_\_ State \_\_\_\_\_

If veteran, indicate date of discharge \_\_\_\_\_

cific equipment, the basic principles of operation, the circuits, applications, and actual examples of readings and results.

While most of the equipment described in the text and used as examples is of British manufacture, a discussion of some American-made equipment is included.

As a specialized study of a highly specialized subject, this book fills a definite place in the literature.

### "LOW-COST RADIO RECEPTION"

by Claude Mercier. Published by UNESCO by *Columbia University Press*, New York. 118 pages. Price \$0.65. Paper bound.

This booklet which was sponsored by UNESCO is an inquiry into the problem of providing low-cost radio equipment for the dissemination of knowledge in the underprivileged and backward areas of the world.

The author, who is the chief engineer of *Radiodiffusion Francaise*, was commissioned to make this study and devise equipment which would meet the economic conditions of the various areas, taking into consideration power sources, access to necessary radio components, facilities for assembling such low cost units, and the organization of "listening groups" to take advantage of the available equipment.

The book is divided into nine chapters dealing with generalizations on radio reception, a specific discussion of the technical conditions as they prevail throughout the world, individual reception requirements (including circuit diagrams for various low-cost receivers), collective reception, receiving antennas, special conditions for the construction of such equipment, maintenance of receivers, modern industrial

manufacturing procedures, and economic and commercial considerations.

Six appendices cover an extract from the report of the "Technical Needs Commission" (1948 and 1949), a reply from the British Radio Equipment Manufacturers' Association, details on the "Saucepan Special," information on the Delhi Rural Broadcasting Scheme, and notes on receiving sets.

"MICROPHONES" by the Staff of the Engineering Training Dept., British Broadcasting Corporation. Published by *Iliffe & Sons, Ltd.*, London. 111 pages. Price \$3.20. Available in the United States through The British Book Centre, 122 E. 55th Street, New York, N. Y.

Although originally written as a textbook for *BBC* engineers-in-training, this manual contains a wealth of material that is of interest to students, audio enthusiasts, and those working in various sound fields.

The text material is divided into six chapters and five appendices. A list of symbols as used in the body of the book precedes the text material proper. The book covers the use of microphones in broadcast service, the behavior of sound waves in air, operation forces, electro-acoustics, diaphragm operation, and studio microphones. The appendices contain various necessary mathematical formulas, a bibliography, and an index.

The text material is illustrated with 78 photographs and diagrams.

Although all of the equipment described in the text is of British origin and the application data applies to *BBC* operations, much of the material in this book is applicable to broadcasting operations in both this and other non-British countries.

This mobile television pick-up unit is shown being field-tested by engineers of Federal Telecommunication Laboratories, Inc., Nutley, N. J., prior to being shipped to Buenos Aires, where it is now part of LR3-TV, Argentina's first television station. The mobile unit, a studio-on-wheels, is entirely self-contained for remote operation and includes the latest technical advances. From a triple camera chain to microwave link, all necessary video and audio facilities are supplied for complete program coverage. The station has an effective radiated power of 45 kw., one of the highest of any TV station in the Western Hemisphere.





# Now, The Truth About easy tv servicing

## Learn how official service data direct from the set manufacturer's own engineering and testing laboratories can solve the most difficult tv repairs, quickly and permanently!

No one knows his receiver better than the manufacturer.

Isn't it common sense that the men who design and build the receiver know the most about it? They are responsible for the receiver's performance and when a weakness is discovered, they are the first to determine the necessary permanent correction. The servicing information issued by the manufacturer's engineering department is certainly the most complete; because it contains not only the whole story on each model but includes *changes* in the receiver which the service technician must know in order to make a permanent repair!

For example: A major set manufacturer found that a capacitor overheated and broke down. A conventional replacement of the defective capacitor would mean repeat calls and customer dissatisfaction because the overheating and eventual breakdown would reoccur. So he developed a permanent cure—rearrangement of the circuit wiring. You couldn't possibly know that by looking at the original schematic. The only way you could repair this manufacturer's set containing this trouble would be to have the *complete* factory data! When faced with these facts, and there are many, many more, isn't it surprising that some servicemen are still not taking advantage of the wealth of data developed by the manufacturer?

### How to get this vital information.

There are only two ways to get the complete unabridged manufacturers' servicing data: one way is to write the manufacturers direct. However, by doing this you run the risk of mail delay while your customer's set gathers dust, plus the difficulty of organizing the material once it's received.

The other way—the only practical way—is to buy this data in complete, easy-to-read published form. **THIS MEANS RIDER SERVICING DATA!** For 22 years Rider, and Rider alone, has been the only source for getting the whole story—the complete story, including all manufacturers' production changes—in accurate, organized, un-

edited form. You get large, easy-to-follow schematics . . . explanation of circuits . . . stage by stage alignment curves . . . page after page of trouble-shooting test patterns . . . waveforms . . . *complete* factory parts lists and values . . . clear, enlarged chassis views . . . circuit changes . . . and much, much more, all guaranteed to match the set you're working on. This has made servicing *easy* for countless thousands of service technicians.

### Rider servicing data designed to meet your needs.

Whether you are a part-time or full-time service technician — independent or employed — you can afford Rider servicing data; Because it's available two ways:

#### *Rider Manuals.* Volumes 1 through 9.

The greatest collection of manufacturers' servicing data ever published. Each volume covers all production runs for a certain period. The newest Rider Manual (TV9) contains servicing data for sets produced between October 1951 and February 1952. Each Rider manual contains an index listing the contents for all Rider manuals. The average volume contains more than 2000 (8½ x 11") pages bound in a permanent, heavy-duty binder. Perfect for shop use and permanent reference. Price \$24.00 each.

#### *Rider Tek-File.* Packs 1 through 56.

The newest way to get complete Rider servicing data. The *only* difference between Rider manuals and Tek-File is the package. In manuals you buy the data of many manufacturers in one volume. In Tek-File packs you buy the same data—but only for one, two, or a few manufacturers at a time according to your needs. Each numbered Tek-File pack contains standard file folders with all servicing data for the manufacturer's models printed on the pack's

tamper-proof label. These folders are designed for house calls and easy bench use in the shop. Perfect for the specialist on certain brands of receivers . . . the part-time service technician . . . the engineer and the independent or employed serviceman. Price only \$2.00 per pack.

As an additional Tek-File service, many packs contain Tek-File Handies. These are 3 x 5" index cards giving manufacturer-tested trouble cures plus production changes made by the manufacturer's own engineering department . . . Each Tek-File pack contains a coupon, 15 of which, plus a small handling charge, get you a permanent manual binder for Tek-File shelf use.

### DON'T BE SWITCHED!

There is only one Rider Tek-File. It is *not* the same as any other publisher's service. If your jobber doesn't carry Rider Tek-File DON'T BE SWITCHED . . . write us direct—we'll sell you! Please include your jobber's name.

Combat unfair press . . . combat national ads that say "fix your own set"! You can do this if you use Rider Manuals and Tek-Files because then you can tell your customers that you are using *factory-prepared, official, authorized, complete servicing information.*

**TRY A PACK!** Once you've tried Rider Tek-File we are convinced you'll never use any other service. Make this simple test. Use Tek-File for seven days—if you're not convinced, return it to us and receive full refund!

#### *Free Rider Tek-File Index.*

Rider Tek-File indexes covering all issued packs are available at your jobbers. If your jobber doesn't have Rider Tek-File Indexes—write us direct . . . it's free.

John F. Rider Publisher, Inc. 480 Canal St. New York 13, N. Y. West Coast office: 4216-20 W. Jefferson Blvd. Los Angeles, Calif.

new Jensen  
RP-302



## HIGH FREQUENCY UNIT\*

make a 3-way system from your coaxial or a 2-way from a single speaker

Improve the realism of your sound reproduction by adding this new compact advanced-design h-f unit to your present coaxial or extended range speaker. Sits atop cabinet or mounts flush on baffle or panel. Gives smooth, clean highs from 4,000 cycles to limits of audibility. List Price, \$56. Write for free illustrated folder EA, with complete installation data.

\*Same h-f unit used in famous Jensen G-610 Triaxial

# Jensen

JENSEN MANUFACTURING COMPANY  
DIVISION OF THE MUTER COMPANY  
6601 S. LARAMIE AVE., CHICAGO 38, ILLINOIS  
IN CANADA:  
COPPER WIRE PRODUCTS, LTD., LICENSEE



A-402 Crossover Network  
RECOMMENDED FOR USE WITH RP-302.  
TWO CHANNEL TYPE WITH 4,000 CYCLE  
CROSSOVER LIST PRICE, \$11.25.



## Binaural Reproduction

(Continued from page 58)

due to the fact that low level detail again tends to disappear in the presence of any stronger sound. Nevertheless, there are several practical reasons for wanting to carry this process farther. Probably the first of these is in communications work, where a weak signal, high noise level, or a combination of these factors make desirable the concentration of the maximum amount of detail or information into the signal. Similar considerations occur in musical reproduction at low levels, or in environments with high noise intensities.

A considerable increase in useful nonlinearity may be obtained by resorting to use of multiple channels. In this case the highs and lows may be compressed much more than normally without the intermodulation distortion, and consequent masking, that would occur if a single channel were used. Parenthetically, this characteristic seems to explain the popularity of some multiple speaker systems, as their tonal coloration may be almost perfectly duplicated by a single direct radiator fed from a dual-channel, nonlinear amplifier using a similar crossover frequency.

The photo shown on page 56 and the schematic of Fig. 3 cover an experimental two-channel nonlinear amplifier designed for broadcast or recording work. The results were very gratifying both in terms of superior naturalness and increased effective average modulation percentages. The crossover network is a simple RC system, and as in the case of loudspeakers, the crossover frequency is somewhat a matter of choice, although to some degree dependent upon the type of program material being handled. The network values shown are for approximately 800 cps as this falls approximately in between the "power" range of orchestral music and the region of the ears' maximum sensitivity.

The aural sensations of the nonlinear system are similar in many respects to those claimed for the Maxfield microphone technique, in that the reproduced sound does not appear to come from a point source but rather an area. Similarly, the location of the listener in respect to the speaker seems much less critical, and reproduction at higher or lower intensities than the original sound does not seem to have nearly as great an effect upon the tonal color as in a conventional system.

In practice, the use of nonlinear techniques appears to have several definite advantages over the multi-mike method. It does not require a large studio or as many microphones and has the very great asset that it may be applied to much existing program material, thus making it useful to the recording engineer or the individual listener.

-50-

## DUAL POWER SUPPLY

A completely wired, Dual Power Supply, delivers 600 volts DC at 200 ma and 250 volts at 75 ma. Both sections filtered with high grade capacitors and chokes. 115 volts—60 cycles primary fused and by-passed. Mounted on chassis shelf, 8" wide, 1 1/2" long. Has two extra filament windings of 6.3 volts at 5 amps. and 12.6 volts at 2.5 amps. Output brought out in 2-cole with provisions for external DC and HV switch. Ideal for low power transmitters and modulators. Complete, but less 5R4GY and 6X5GT rectifiers. Terrific value at.....\$14.95

## Power Transformer Bargains

115 Volt, 60 Cy. Primary  
800 Volts CT @ 250 MA., 6.3V @ 4A, 6.3V @ 4A, 6.3V @ 2A, 5V @ 2A, 5V @ 2A. Fully Cased. BRAND NEW,  
Wt. 14 Lbs. .... Only \$7.89 ea.

750 volts CT @ 200 MA, 6.3V @ 10 amps. 5V @ 3A. Fully cased, removed from TV equipment. Guaranteed. .... each \$3.75

SCOPE TRANSFORMER BARGAIN  
2500 V @ 20 ma, 2.5 V @ 2, 6.3 V @ 6 amp. Removed from TV equipment. Guaranteed. Terrific value @ ..... \$1.89

## SENSITIVE RELAY

D'Arsonval moving coil type, mounted in meter case. Adj. 700 microamps to 1 ma. Made by Triplett. .... ea. \$5.75

## H. V. OIL CAPACITOR BARGAINS

.5 MFD 10 KV DC \$6.95  
.5 MFD 7.5 KV DC 2.95

## PANEL METERS

### NEW GOV'T SURPLUS STANDARD BRANDS

#### \*Special Scale

2" METERS  
0-100 MA\* ..... \$2.45  
0-10 MA. AC ..... 2.95  
0-2 AMP RF ..... 2.95  
0-4 AMP RF ..... 2.95  
0-50 AMP ..... 3.25  
0-30 AMP DC ..... 2.95

3" METERS  
0-1 MA ..... 4.95  
0-2 MA ..... 4.50  
0-2.5 AMP RF ..... 5.95  
0-500 MA ..... 4.50  
0-100 VDC (1 MA). 5.95  
0-100 VDC (1 MA). 5.95  
0-250 VDC (1 MA). 5.95  
0-750 VDC (1 MA). 5.95  
0-150 VAC ..... 6.95

#### FILTER CHOKES

6 Hy 90 MA.....\$0.79  
10 Hy 250 MA..... 2.75  
6 Hy 500 MA..... 4.95

#### PIGTAIL MICAS

MMF: 5, 20, 50, 60, 100, 250, 300, 400, 500, 750, 800, 1000, 1000, 3000, 4000, 5000, 6000, 10000.....\$0.09 ea.

Silver Mica Capacitors  
MMF: 10, 50, 60, 340, 750, 780, 1000.\$0.12 ea.

#### OIL CONDENSER SPECIAL

4 mfd 600 vdc oil condenser in cylindrical can (CD TLA 6040 or equivalent). Brand New. Only \$1.19 each.

#### BAKELITE CASED MICAS

MFD	VDC	Price	MFD	VDC	Price	MFD	VDC	Price
.001	600	\$1.18	.024	1500	\$0.65	.001	5 KV	\$1.60
.002	600	.24	.033	1500	.75	.002	5 KV	1.60
.01	600	.26	.02	2 KV	.90	.005	5 KV	1.90
.02	600	.26	.005	2500	.55	.005	5 KV	2.50
.01	1 KV	.45	.002	2500	.15	.001	6 KV	2.50
.002	1200	.35	.0001	5 KV	.70	.002	6 KV	2.90

#### WIRE WOUND RESISTORS

5 watt ohms: 25-50-84-200-2500 ..... \$0.09 ea.  
10 watt ohms: 25-40-1325-2K-4K ..... .15 ea.  
20 watt ohms: 150-300-750-1K-1.5K, 2.5K-2.7K-10K-20K ..... .20 ea.  
30 watt ohms: 100-2500-5300-18K ..... .22 ea.  
100 watt ohms: 100-3750-1500-2K, 10K, 15K, 20K, 100K ..... .59 ea.

#### POWER SUPPLY KIT

1-UTC Power Transformer 700 VCT @ 60 ma, 5V @ 2A, 6.3V @ 1.2A.  
2-UTC 60 ma chokes. Transformer and chokes fully cased. Transf. and 2 Chokes, ..... SPECIAL \$3.95

#### ADJUSTABLE SLIDER RESISTORS

20 Watt: 1.5 Ohms ..... \$0.25  
50 Watt: 500 Ohms ..... .39  
75 Watt: 100, 150, 200 Ohms ..... .39  
100 Watt: 50, 3750 ..... .69

## PEAK ELECTRONICS CO.

188 WASHINGTON ST., NEW YORK 7, N. Y.

Phone COrtlandt 7-6443-4

## 152-162 mc. Converter

(Continued from page 55)

the aid of a grid dipper. The coil should be squeezed or stretched until the  $L_2C_1$  combination tunes from 152 to 162 mc. This adjustment should be made with the antenna connected. If you don't have a dipper, set  $C_1$  halfway between minimum and maximum capacity. Tune in a station around 157 mc. and adjust  $L_2$  for maximum signal strength. The response curve of  $L_2C_1$  is broad and so  $C_1$  needs resetting only once or twice as the converter is tuned across the band.

The antenna used with the converter should be vertically polarized and should be mounted as high and as far from surrounding objects as possible. A suitable folded dipole antenna may be easily constructed from 300-ohm twin-lead as shown in Fig. 1. Although a short length of twin-lead connected to the antenna terminals provides usable signals from stations 8 to 10 miles away, an outside antenna will be much more satisfactory and is definitely recommended.

Due to a fortunate choice of oscillator and i.f. frequencies, no complicated signal generator-frequency meter set-up is required for calibrating the converter's dial. If you wish to tune in a particular station and know its operating frequency, merely deduct 108 from the frequency in megacycles. Multiply the answer by 2 and tune the FM receiver to the resulting frequency. Tune the converter so that the local oscillator's second harmonic can be heard in the FM receiver. Then retune the FM set to 108 mc. If the receiver's dial is accurately calibrated, the converter will now be tuned to the frequency of the desired station.

### Example:

Desired frequency . . . . .	155.73 mc.
Deduct 108 . . . . .	108
	<hr/>
	47.73
Multiply by 2 . . . . .	×2
	<hr/>
	95.46

Set converter dial so that second harmonic of local oscillator can be heard at 95.46 on FM dial. Retune FM receiver to 108 mc.

Good frequency stability is an important police receiver characteristic. In small towns, especially, there may be intervals as great as a half hour or more when no transmissions take place. In this length of time an unstable oscillator could drift right off the station without the listener's knowledge. If either the converter oscillator or the receiver oscillator drifts to any extent, there is bound to be trouble. Luckily, most FM receivers are fairly stable after only a few minutes warmup. To test the converter's stability it was operated for several hours at a room temperature of 85°. At the end of this time the converter was carefully zeroed on the carrier of a police radio transmitter 8 miles dis-

# TV DIRECT FROM THIS GREAT FACTORY TO YOU

## BRINGS YOU

### Finest Quality at Lowest Prices



# TRANSVISION

TV KITS, WIRED CHASSIS, and SETS  
CABINETS, COMPONENTS, INSTRUMENTS, and ACCESSORIES

## SENSATIONAL OFFER

on Top Quality TV Picture Tubes:

### • FREE—VALUABLE PREMIUMS:

With every Transvision tube you buy, you get a Merchandise Premium Coupon of real value. Write for list.

### • TRADE-IN ALLOWANCE on old tubes:

Make from \$2.50 to \$5.00 glass allowance on each "dud."

### • FULL 2 YR. GUARANTEE:

Only Transvision gives you a Guarantee for 24 months.

COMPARE: Get the full details on the Transvision tube deal today.

**FREE BOOKLET: "INSIDE CRT, or What You Should Know About Picture Tubes."** Written by CRT experts, illustrated. It will MAKE MONEY FOR YOU. WRITE FOR IT NOW.



TRANSVISION Picture Tube PRICES

Type	Your Cost if no old tube is traded in—DEALER PRICE—	Allowance for old tube	Your FINAL COST, if old tube is turned in. DEALER NET.—
10BP4	\$17.95	\$2.50	\$15.45
12JP4	17.95	2.50	15.45
12LP4	19.95	3.00	16.95
14RP4	19.95	3.00	16.95
16DP4	27.95	4.00	23.95
17BP4	25.95	4.00	21.95
19AP4	37.00	5.00	32.00
20CP4	35.95	5.00	30.95

So IMPORTANT is this great instrument, that on Jan. 28 the N. Y. TIMES devoted a feature article (copy on request) to the TRANSVISION

## TESTER-REACTIVATOR

FOR PICTURE TUBES

Tests Picture Tubes and Renews Brightness of Your Dim Picture Tubes. Without removing picture tube from set, measure Cathode emission . . . locate shorts between elements . . . locate high resistance shorts or leakage as high as 3 megohms. Then, REACTIVATE dim picture tubes if there's no mechanical break in tube. 110V-60 cycles; weighs 3 lbs.

**\$19.95** net  
Fully Guaranteed.



## FIELD STRENGTH METER AT NEW LOW PRICE

Improve TV installations; save half the work with the Transvision Field Strength Meter. **\$59** net  
Model FSM-1, complete with tubes.



## BEAUTIFUL TV CONSOLES

Ideal for Custom-Building or Conversion. Factory prices start from \$49. Send for Cabinet Catalog now.

## MULTI-SET CONNECTORS

feed up to 5 TV Sets from 1 Antenna  
Prices: Multi-Set Conn. for 2 sets. . . . \$4.95 list\*  
For 3 or 4 sets. . . . . 7.95 list\*

\*Dealers, write for discounts



Want to Make More Money in TV?  
Write for the Transvision Factory Agent Plan  
and Complete Illustrated Literature

**FREE:** EXTRA INCOME EVERY MONTH from hints in "TV and Electronics Notes." Request sample copy. Or send 50¢ to cover cost of addressograph plate and mailing for FREE Subscription. Monthly issues are gold mines of info on New Products, Sales, Service, Conversion, etc. **WRITE DEPT. RN5 TODAY!**

TRANSVISION, INC. NEW ROCHELLE, N. Y.

# WE'RE CRAZY



LIKE A FOX . . .  
FOR WE PROVED  
THAT OUR POLICY OF  
"PROFIT IN PENNIES"  
HAS PAID OFF. WE HAVE  
THOUSANDS OF THRIFTY-  
MINDED CUSTOMERS WHO  
BUY ONLY FROM US.

WE BUY BY THE CARLOAD  
AT RIDICULOUSLY LOW  
PRICES AND PASS ON  
THE SAVINGS TO YOU.

BELOW ARE TYPICAL  
BARGAINS IN OUR  
LATEST CATALOG!



**FAMOUS  
ROLA 12"  
SPEAKERS**

Model G12  
• 1000 ohms  
field coil •  
Complete  
with Push-Pull 6L6 output.  
Ideal for P.A. Systems.

**\$8<sup>95</sup>**

**STANDARD BRAND**

**16 HP4 \$19<sup>95</sup>  
KINESCOPE**

**19 AP4 \$25<sup>95</sup>  
KINESCOPE**

Both Fully Guaranteed

Mail Coupon At Once  
Your copy is waiting for you!

STEVE-EL ELECTRONICS CORP.  
61 Reade St., New York 7, N. Y.

N-5

Send me the advertised bargains at once.

Rola Speakers  16HP4  19AP4

Check or money order encl.-ed.  Send C.O.D. (20% deposit)

Name \_\_\_\_\_

Address \_\_\_\_\_

City \_\_\_\_\_ Zone \_\_\_\_\_ State \_\_\_\_\_

Send latest BARGAIN CATALOG.

tant. The unit was shut off and 15 hours later it was turned on with a room temperature of 65°. As soon as the filaments warmed up, the carrier of the same police transmitter could again be heard. Although the modulation appeared a little weak, the converter had definitely not drifted far enough to lose the station. When one takes into consideration the frequencies being employed and the simplicity of the circuit, this amount of drift seems well within reason.

Despite a poor receiving location,

fixed stations twenty miles away are received with excellent strength. Mobile stations can be heard at distances of from two to ten miles, depending on intervening terrain and transmitter power. These results are obtained with an antenna which is surrounded by trees and houses and is mounted only 25 feet above ground.

If you're looking for an inexpensive, easy-to-build device that will enable you to keep in touch with the local constabulary, this converter should admirably fill the bill.

-30-

## NEWS FOR AMATEUR OPERATORS

THE FCC has given notice that it will consider amending Section 12.111 of the Commission's Rules and Regulations to authorize stations in amateur service to operate, commencing May 1, in the 21,000-21,450 kc. band of frequencies using type A-1 emission only.

The Commission also proposes to institute further rule-making proceedings to determine what type of emission

should be permanently authorized for this band, how the band should be apportioned among those types of emission, and the classes of licenses required when using each type of emission.

The band was allocated for amateur service under the Atlantic City Table of Frequency Allocations which was ratified by the U.S. in June 1948.

-30-

## REDUCING PICTURE SMEAR

THE Service Division of Admiral Corporation in tracing down reports of picture smear or poor picture definition has found that the receivers in question were being tuned incorrectly due to 4.5 mc. beat interference present in the picture when the tuning control was set for the best picture position. They found that the natural tendency was to tune the set to eliminate the 4.5 mc. interference in the picture but this resulted in incorrect setting of the fine tuning control for best picture.

To reduce or eliminate 4.5 mc. interference when it occurs in the Admiral 21B1 series, the following steps are recommended. See Fig. 1.

1. Remove peaking coil L<sub>304</sub> (part #73A5-9) and replace it with peaking coil, part #73A11-1. This latter component has a three-pi winding. If a #73A11-1 is not available, use two 73A5-9 peaking coils connected in series (with short leads) so that the coils are not more than 3/4" apart. Connect a 22,000 ohm, 1/2 w. resistor across this two-coil assembly.

2. Remove peaking coil L<sub>303</sub> (part #73A5-13) and replace it with peaking coil, part #73A5-14. This unit is coded with a blue dot. If this part is not available, part #73A5-13 should be left in the

receiver and a 33,000 ohm, 1/2 w. resistor should be wired across it.

3. Connect a series resonant trap L<sub>305</sub>, part #72B99-3 (used in 20T1 receivers) between pin 4 of V<sub>305</sub> (a 6AC7) and chassis ground. Mount the trap in the chassis hole located between tubes V<sub>305</sub> (6AC7) and V<sub>403</sub> (12AU7) with the 6.8 μfd. condenser C<sub>322</sub> connected to pin 4 of V<sub>305</sub>.

4. The trap should be tuned by watching the picture and adjusting the slug for minimum 4.5 mc. interference. If greater accuracy is required, the trap should be adjusted as follows: (a) Using clip leads, short-circuit pin 1 of V<sub>201</sub> (6AU6) to chassis ground and connect a 50 μfd. condenser between pin 8 of V<sub>305</sub> and pin 7 of V<sub>201</sub>. (b) Set the channel selector to a TV station having the strongest signal. Tune the fine tuning control for loudest signal. Using a non-metallic alignment screwdriver, carefully adjust the trap slug for minimum sound. **WARNING:** Do not attempt to adjust the 4.5 mc. trap by using a grid dip meter since the reading will not be correct.

Some of the later production sets in the 21B1 series have these changes incorporated.

-30-

Fig. 1. Recommended circuit changes to reduce picture smear in Admiral 21B1 sets.

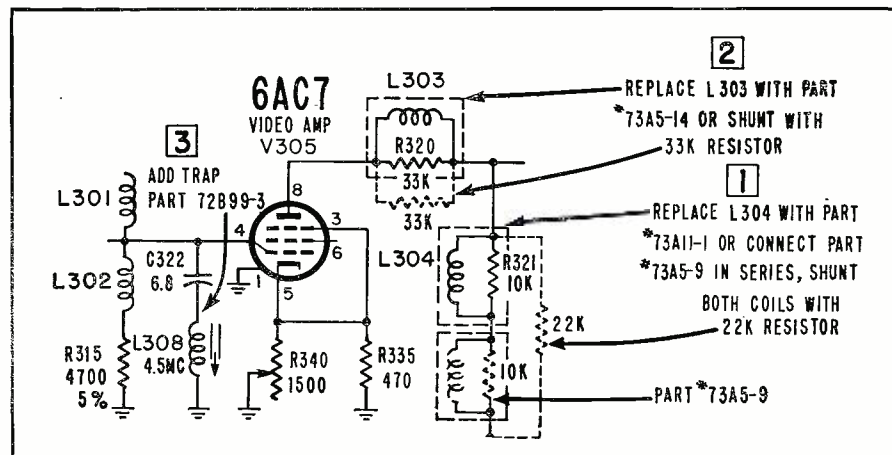

# Which Do You Want?



Better Pay



A Nice Home



A New Car

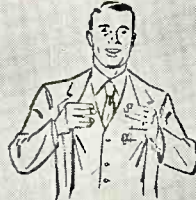

Greater Security



Happy Vacations and Travel

Get Your FCC Ticket  
Then Use Our  
Amazingly Effective  
Job-Finding Service  
To Get a Better Job

Add Technical Training to Your Practical Experience and

# Get Your FCC COMMERCIAL RADIO OPERATOR LICENSE

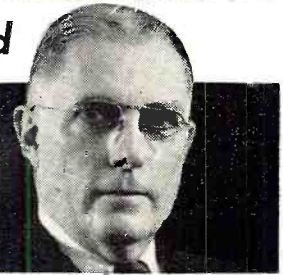

I can train you to pass your FCC License Exams in a minimum of time. If you've had any practical radio experience—amateur, Army, Navy, radio servicing or other. My time-proven plan can help put you, too, on the road to success.  
Let me send you FREE the entire story. Just fill out the coupon and mail it. I will send you, free of charge, a copy of "How to Pass FCC License Exams," plus a sample FCC-type Exam, and the amazing new booklet, "Money Making FCC License Information."  
Edw. H. Guilford,  
Vice President

in a Minimum of Time

Get this Amazing Booklet FREE

TELLS HOW— WE GUARANTEE

TO TRAIN AND COACH YOU AT HOME  
IN SPARE TIME UNTIL YOU GET

**YOUR FCC LICENSE**

If you have had any practical experience—Amateur, Army, Navy, radio repair, or experimenting.

TELLS HOW— Employers Make

**JOB OFFERS Like These  
to Our Graduates Every Month**

Letter from Chief Engineer, Broadcast Station, North Carolina. "Need men with radiotelephone 1st class license, no experience necessary. Will learn more than at average station for we are equipped with Diesel Electric power, transmitting and studio equipment."

Telegram from Chief Engineer, Broadcast Station, Wyoming. "Please send latest list available first class operators. Have November 10th opening for two combo men."

Letter from Chief Engineer, Broadcast Station, Texas. "Please send list of latest license graduates."

**HERE'S PROOF FCC LICENSES ARE OFTEN SECURED  
IN A FEW HOURS OF STUDY WITH OUR  
Coaching AT HOME in Spare Time**

Name and Address	License	Lessons
Lee Worthy 2210 1/2 Wilshire St., Bakersfield, Calif.	2nd Phone	16
Clifford E. Vout, Box 1016, Dania, Fla.	1st Phone	20
Francis X. Foerch, 38 Boucler Pl., Bergenfield, N. J.	1st Phone	38

**CLEVELAND INSTITUTE OF RADIO ELECTRONICS**  
Desk RN-41, 4900 Euclid Bldg., Cleveland 3, Ohio

May, 1952

TELLS HOW—

Our Amazingly Effective  
**JOB-FINDING SERVICE**

Helps CIRE Students Get Better Jobs

Here are a few recent examples of Job-Finding Results

**GETS BROADCAST JOB**

"I wish to thank your Job-Finding Service for the help in securing for me the position of transmitter operator here at WCAE, in Pittsburgh."

Walter Koschik, 1442 Ridge Ave., N. Braddock, Pa.

**GETS AIRLINES JOB**

"Due to your Job-Finding Service, I have been getting many offers from all over the country, and I have taken a job with Capital Airlines in Chicago, as a Radio Mechanic."

Harry Clare, 4537 S. Drexel Blvd., Chicago, Ill.

Your FCC Ticket is recognized in all radio fields as proof of your technical ability.

OURS IS THE ONLY HOME STUDY COURSE WHICH SUPPLIES FCC-TYPE EXAMINATIONS WITH ALL LESSONS AND FINAL TESTS.

**Get All 3 FREE**

**MAIL COUPON NOW**

**CLEVELAND INSTITUTE OF RADIO ELECTRONICS**  
Desk RN-41—4900 Euclid Bldg., Cleveland 3, Ohio  
(Address to Desk No. to avoid delay)

I want to know how I can get my FCC ticket in a minimum of time. Send me your FREE booklet, "How to Pass FCC License Examinations" (does not cover exams for Amateur License), as well as a sample FCC-type exam and the amazing new booklet, "Money-Making FCC License Information."

Tell me how I can get your Free Television Course.

Name .....

Address .....

City..... Zone..... State.....

Paste on 2-cent postcard or send air mail.

## HERE'S A REAL BUY

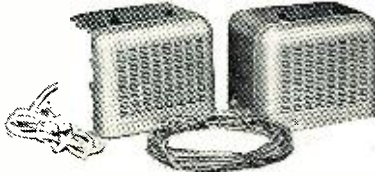

### Two Station Intercom System

Less than half the original price. Built for America's leading dept store chain, whose name we cannot mention because of this low price. Consists of master station, remote station and 20 ft. of 3 conductor wire. Can be used as a private or non-private system. 115V AC or DC. Brand new. Now only \$17.95. Additional wire per ft.—5c.

**BRAND NEW**  
now only  
**\$17.95**

### Clearance Sale! Display Models

		Reg.	Now
McMurdo	911 Sweep Gen.	\$78.50	\$44.95
McMurdo	909 Sweep Gen.	48.50	29.95
McMurdo	910 Test Spkr.	22.70	14.95
McMurdo	700 144/240 MC		
	XTMR less tubes	36.95	21.95
Vision	TSW 50 Sweep Gen.		
	and TM-10 Marker	89.50	45.00
Philco 507	Cross Hatch	49.95	17.50
RCP.	Tube Tester Kit	32.50	22.50
Hickok	288 Sig. Gen.	186.00	125.00
Hickok	505 Scope	208.70	140.00

### General Instruments 3-Speed Automatic Record Changer

\$34.95

BRAND NEW

**\$19.97**



With all purpose cartridge & needle. Plays 33 1/3-45 and 78 RPM records automatically.

NOTE: Do not send money for postage on above items, we ship best way—charges collect.

#### LOW FREQ. XTALS-FT 241A

For SSB, lattice filter, etc. 1/2" spc. 54th or 72nd harmonic channels listed by fundamentals. Fractions omitted.

SCR 522		Xtals		BC-61	
1/2" ins		1/2" ins		2 banana plugs	
1/2" spc.		1/2" spc.		3/4" spc.	
374	405	436	506	400	463
375	406	437	507	440	464
377	407	438	508	441	466
379	408	441	509	442	468
380	409	443	511	446	470
381	411	484	514	447	472
383	412	485	515	450	474
384	413	487	516	452	475
385	414	488	518	455	476
386	415	490	519	459	477
387	416	491	520	461	478
388	418	492	522	462	480
390	419	493	525		7930
391	420	494	526		2320
392	422	495	530		2360
393	423	496	531		2390
394	424	497	533		2415
395	425	498	537		
396	426	503	538		
397	427	504			
398	431				
401	433				
403	435				
404					
	49c ea.			\$1.29	
	10 for			each	
	\$4.50				
		SPECIAL			
		200 Kc xtals		\$1.29	
		without holders		each	
		69c each			
		3 for \$2.00			

#### HAM XTALS-FT 243 HOLDERS—1/2" pin spc.

4190	6773	7873	1015	5800	6306	6573	7506	7650
5030	6873	7906	1129	5806	6325	6575	7540	7673
5485	6906	7940	2045	5825	6340	6600	7573	7706
6040	7140	7973	3735	5840	6373	6606	7606	8240
6073	7773	8273	5305	5850	6406	6625	7640	
6106	7806	8306	5677	5873	6440	6640		
6125	7840		5706	5875	6450	6673		
6140			5725	5906	6473	6706		
6173			5740	5940	6475	6740		
6175			5760	5973	6506	7440		
6206			5773	6273	6540	7473		
	49c ea.						99c ea.	
	10 for						10 for	
	\$4.50						\$9.00	

Add 20c for each 10 xtals or less for postage and handling.

**TERMS**—All items F.O.B., Washington, D.C. All orders \$30.00 or less, cash with order. Above \$30.00, 25 per cent with order, balance C.O.D. Foreign orders, cash with orders, plus exchange rate.

**SUN RADIO**  
OF WASHINGTON, D. C.  
938 F STREET, N. W. WASH. 4, D. C.

## Electronic Equipment Industry Advisory Subcommittees

Revised listing of the eleven Industry Advisory Subcommittees in the field of electronics. The subcommittees serve the Munitions Board, Department of Defense. All members serve without compensation and assist the Board by advising and making recommendations on military aspects of industrial mobilization.

#### CAPACITORS

Col. T. M. Natt, USAF, Gov't. Chairman  
Paul McK. Deeley, Cornell-Dubilier Electric Corp., South Plainfield, N. J.  
G. R. Fryling, Erie Resistor Corp., Erie, Pa.  
J. F. Gudeman, Gudeman Co., Chicago, Ill.  
Louis Kopinski, John E. Fast & Co., Chicago, Ill.  
Larry Kunz, Sangamo Electric Co., Springfield, Ill.  
W. M. Owen, Aerovox Corp., New Bedford, Mass.  
W. S. Parsons, Centralab Div. of Globe-Union Inc., Milwaukee, Wis.  
Gordon Peck, P. R. Mallory & Co., Inc., Indianapolis, Ind.  
J. K. Sprague, Sprague Electric Co., North Adams, Mass.  
F. G. Stebbins, General Electric Co., Pittsfield, Mass.  
Ed Tyler, Micamold Radio Corp., Brooklyn, N. Y.

#### DYNAMOTORS

Col. T. M. Natt, USAF, Gov't. Chairman  
John Bentia, Alliance Mfg. Co., Alliance, Ohio.  
C. T. Button, Holtzer-Cabot Co., Boston, Mass.  
Robert W. Carter, Carter Motor Co., Chicago, Ill.  
W. A. Gothard, Gothard Mfg. Co., Springfield, Ill.  
R. C. Hanna, General Electric Co., Fort Wayne, Ind.  
R. L. Irvin, Westinghouse Electric Corp., Lima, Ohio  
H. K. Mann, Bendix Aviation Corp., Red Bank, N. J.  
Max L. Robinson, Jannette Mfg. Co., Chicago, Ill.  
E. I. Winquist, Continental Electric Co., Inc., Newark, N. J.  
Andrew Wylie, Redmond Co., Inc., Owosso, Mich.

#### RECEIVING TUBES

Col. T. M. Natt, USAF, Gov't. Chairman  
John Q. Adams, Hytron Radio & Electronics Corp., Salem, Mass.  
R. E. Carlson, Tung-Sol Electric Inc., Newark, N. J.  
Richard W. Cotton, Philco Corporation, Philadelphia, Pa.  
Norman B. Krim, Raytheon Mfg. Co., Newton, Mass.  
J. M. Lang, General Electric Co., Schenectady, N. Y.  
Frank Mansfield, Sylvania Electric Products Inc., New York, N. Y.  
Carl F. Miller, Westinghouse Electric Corp., Bloomfield, N. J.

#### METERS

Col. T. M. Natt, USAF, Gov't. Chairman  
Roscoe A. Ammon, Marion Electrical Instrument Co., Manchester, N. H.  
H. A. Bernreuter, Simpson Electric Co., Chicago, Ill.  
E. J. Boland, General Electric Co., West Lynn, Mass.  
G. T. Deaney, Weston Electrical Instrument Corp., Newark, N. J.  
J. M. Heggy, Westinghouse Electric Corp., Newark, N. J.  
Norman A. Triplett, Triplett Electrical Instrument Co., Bluffton, Ohio

#### QUARTZ CRYSTALS

Thomas A. Perrott, Gov't. Chairman  
Karl John, James Knights Co., Sandwich, Ill.  
Luther McCoy, Standard Piezo Co., Carlisle, Pa.  
August E. Miller, Miller Laboratories, North Bergen, N. J.  
Samuel Ryesby, Hunt Corp., Carlisle, Pa.  
J. H. Sweeney, General Electric Co., Syracuse, N. Y.  
R. A. Sykes, Bell Telephone Laboratories, Inc., Murray Hill, N. J.  
George E. Wright, Bliley Electric Co., Erie, Pa.

#### RELAYS

Col. T. M. Natt, USAF, Gov't. Chairman  
G. A. Bering, North Electric Mfg. Co., Galion, Ohio  
R. T. Brengle, Potter & Brumfield Co., Princeton, Ind.  
Carl Clare, C. P. Clare & Co., Chicago, Ill.  
F. H. Clark, Westinghouse Electric Corp., Beaver, Pa.

Joseph F. Clark, Leach Relay Co., Los Angeles, Calif.  
George T. Deaney, Weston Electrical Instrument Corp., Newark, N. J.  
Richard Fischer, Sigma Instruments, Inc., Boston, Mass.  
Edward Gillette, Allied Control Co., New York, N. Y.  
Emory Howe, Comar Electric Co., Chicago, Ill.  
A. C. Keller, Western Electric Co., New York, N. Y.  
H. W. Pfeffer, Struthers-Dunn, Philadelphia, Pa.  
James Roughan, Price Electric Co., Frederick, Md.  
John Rowell, Guardian Electric Co., Chicago, Ill.

#### RESISTORS

Col. T. M. Natt, USAF, Gov't. Chairman  
G. F. Benkelman, Continental Carbon, Inc., Cleveland, Ohio  
Harry A. Ehle, International Resistance Co., Philadelphia, Pa.  
Andrew Kaul, Speer Carbon Co., St. Marys, Pa.  
D. S. W. Kelly, Allen Bradley Co., Milwaukee, Wis.  
W. M. Kohring, Wilkor Products Co., Cleveland, Ohio  
Roy S. Laird, Ohmite Mfg. Co., Chicago, Ill.  
Leon Podolsky, Sprague Electric Co., North Adams, Mass.  
D. H. Shallcross, Shallcross Mfg. Co., Collingdale, Pa.  
J. H. Stackpole, Stackpole Carbon Co., St. Marys, Pa.  
B. S. Turner, Chicago Telephone Supply Co., Elkhart, Ind.

#### STEATITE

Thomas A. Perrott, Gov't. Chairman  
E. H. Fritz, Stupakoff Ceramics Mfg. Co., Latrobe, Pa.  
Wm. S. Parsons, Centralab Div. of Globe-Union Inc., Milwaukee, Wis.  
G. E. Richter, American Lava Corp., Chattanooga, Tenn.  
Joe Schemerhorn, National Ceramics & Steatite Corp., Trenton, N. J.  
C. L. Snyder, General Ceramics & Steatite Corp., Keesbey, N. J.

#### TEST EQUIPMENT

Col. T. M. Natt, USAF, Gov't. Chairman  
H. A. Bernreuter, Simpson Electric Co., Chicago, Ill.  
G. T. Deaney, Weston Electrical Instrument Corp., Newark, N. J.  
R. H. Denton, Radio Frequency Laboratories, Inc., Boonton, N. J.  
George A. Downsbrough, Boonton Radio Corp., Boonton, N. J.  
L. A. Goodwin, Jr., RCA Victor Division, Camden, N. J.  
R. D. Hickok, Hickok Electrical Instrument Co., Cleveland, Ohio  
Harry W. Houck, Measurements Corp., Boonton, N. J.  
Stephen D. Lavoie, Lavoie Laboratories, Inc., Moravia, N. J.  
A. J. W. Novak, Brush Development Co., Cleveland, Ohio  
David Packard, Hewlett-Packard Co., Palo Alto, Calif.  
J. P. Smith, Jr., The Daven Co., Newark, N. J.  
R. R. Stoddart, Stoddart Aircraft Radio Co., Hollywood, Calif.  
A. E. Thiessen, General Radio Co., Cambridge, Mass.  
R. L. Triplett, Triplett Electrical Instrument Co., Bluffton, Ohio  
E. C. Williams, Allen B. Du Mont Laboratories, Inc., Clifton, N. J.  
Frank Zayac, Ballantine Lab., Inc., Boonton, N. J.

#### TRANSFORMERS

Col. T. M. Natt, USAF, Gov't. Chairman  
F. E. Baker, Westinghouse Electric Corp., Sharon, Pa.  
Monte Cohen, F. W. Sickles Co., Chicopee, Mass.  
Louis R. Duman, Advance Transformer Co., Chicago, Ill.  
K. W. Gordon, Raytheon Mfg. Corp., Waltham, Mass.  
J. J. Kahn, Standard Transformer Corp., Chicago, Ill.

Louis Howard, Triad Transformer Mfg. Co., Los Angeles, Calif.  
 Laurence A. King, Rola Co., Inc., Cleveland, Ohio  
 Leslie Muter, Muter Coil Co., Chicago, Ill.  
 L. S. Racine, Chicago Transformer Division, Chicago, Ill.  
 J. B. Schaefer, New York Transformer Co., Inc., Alpha, N. J.  
 P. M. Staehle, General Electric Co., Fort Wayne, Ind.  
 Wm. E. Wilson, Acme Electric Corp., Cuba, N. Y.

**TRANSMITTING TUBES**

Col. T. M. Natt, USAF, Gov't. Chairman  
 Henry Argento, Raytheon Mfg. Co., Waltham, Mass.  
 C. E. Burnett, Radio Corporation of America, Harrison, N. J.  
 Thomas Clinton, Thomas Electronics, Inc., Passaic, N. J.  
 Charles E. Cohn, Arcturus Electronics, Inc., Newark, N. J.  
 W. A. Hayes, Westinghouse Electric Co., Bloomfield, N. J.  
 G. W. Henyan, General Electric Co., Schenectady, N. Y.  
 H. J. Hoffman, Machlett Laboratories, Inc., Springdale, Conn.  
 L. C. Jarvis, Western Electric Co., Allentown, Pa.  
 H. Kuthe, Kuthe Laboratories, Newark, N. J.  
 J. A. McCullough, Eitel-McCullough, Inc., San Bruno, Calif.  
 A. L. Milk, Sylvania Electric Products Inc., Washington, D. C.  
 Sam Norris, Amperex Electronic Corp., Brooklyn, N. Y.

All subcommittee correspondence and business will be conducted with the Office of Electronic Programs, Room 2D845, Pentagon Building, Washington 25, D. C. Telephone Liberty 5-6700, Ext. 56098 or 71587.

**Audio Oscillator**  
 (Continued from page 49)

illators zero beat at this point (zero audio output from the unit) and mark this point on the dial scale. Later, when the tubes age and the output frequency does not correspond with that marked on the dial, it is only necessary to set the pointer to the zero beat mark on the dial scale and adjust the reset control for zero beat. The output frequency will then again correspond to that marked by the dial.

There are several possible ways of calibrating the finished audio generator. One is to compare the frequency of it with that of a calibrated generator. The setup for this is shown in Fig. 4. When the output frequencies of the two generators are equal, a circular trace will appear on the scope. Then, it is only necessary to transfer the frequency reading of the calibrated generator to the uncalibrated generator. If no calibrated generator

Fig. 4. Setup for calibrating the oscillator.

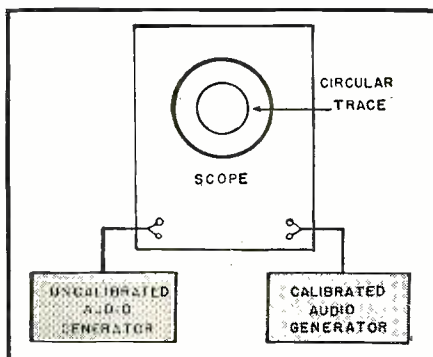

A. A. GHIRARDI  
 Radio-TV servicing's  
 greatest instructor

**SPECIAL COMBINATION OFFER!**

Get these NEW Ghirardi service books at the special price of only \$12.00 for the two (regular price \$12.75)! Have complete, modern service data at your finger tips! Be prepared for faster, more profitable handling of every job! Books contain 1489 pages of helpful, how-to-do-it service data. Use coupon to order SPECIAL COMBINATION OFFER today for 10-day free examination.

**Learn to service ANY RADIO OR TV SET EVER MADE!**



It pays to know all about circuits when it comes to handling tough jobs in less time! ... only \$6.00



The complete "know-how" of Radio-TV service by money-making professional methods only \$6.75

**Ghirardi's New Radio & Television Receiver CIRCUITRY & OPERATION**

Know modern circuits from A to Z, and you'll be pleasantly surprised how much easier it is to handle even the toughest jobs—how much faster you can go right to the seat of the trouble. Guesswork is eliminated. Laborious testing can be reduced to an absolute minimum—and you won't have to depend on set manufacturer's data and manuals!

Starting with a clear explanation of AM and FM processes, Ghirardi's 669-page Radio and Television Receiver Circuitry and Operation brings you a complete understanding of all basic circuits in today's home equipment. You learn how each one operates; how to recognize it quickly; what troubles to look for; and how to service it. By making it easy for you to understand each circuit and its relations to other circuits, Mr. Ghirardi helps you locate troubles much faster and with far less effort. You know what to look for—and you know exactly how to go about repairing the troubles when you find them!

**A BOOK TO HELP YOU GET THE BIG-MONEY JOBS!**

In the characteristic, easily understood style that has made his books famous throughout the entire world, Mr. Ghirardi not only explains the comparatively few basic circuits in use, but likewise tells all about their many and often complicated variations. In short, this is a book for servicemen who want to forge ahead—and who know that the best way to earn more is to learn more! Read it for 10 days at our risk and see for yourself how much it can mean to you!



**Pass service licensing exams WITH FLYING COLORS!**

Even the toughest servicing license examinations now required by many cities won't "stump" you—not if you fortify yourself with the knowledge in these great books! Ghirardi service books are recognized throughout the trade as the finest, most complete of their kind!

**Ghirardi's New Radio & Television Receiver TROUBLESHOOTING AND REPAIR**

Nowhere else will you find troubleshooting and service procedures explained so clearly, so conveniently and as completely as in this brand new 820-page Ghirardi book!

Fully modern, profusely illustrated, Radio & Television Receiver TROUBLESHOOTING AND REPAIR shows you how to service all types of radio, television and record-playing equipment—also communications receivers. You learn to locate troubles faster—how to repair them more efficiently in a fraction of the usual time. Best of all, the book teaches you to work professionally—not as an underpaid "screwdriver" mechanic!

**LET GHIRARDI GIVE YOUR EARNING POWER A BIG BOOST!**

Any radio or TV is simply a network of components—and this big book first analyzes each component type individually. From here, you forge ahead rapidly to troubleshooting methods including static and dynamic tests using signal tracing and injection techniques. You learn to interpret data—how to make dozens of invaluable troubleshooting short cuts. The troublesome procedures of realigning TV, AM and FM are made amazingly clear. Television servicing is explained so simply that even newcomers will find it easy to understand. Parts repair as well as parts replacement are fully covered and there are hundreds of tips on handling difficult service jobs. Unique step-by-step charts show exactly what moves to make in checking specific trouble symptoms. Nothing has been omitted. Each subject is covered with the remarkable clarity that, for over 20 years, has made Ghirardi service books the most widely used of their type in schools, for military training and for home study. Read it for 10 days at our risk!

**10-DAY EXAMINATION OFFER**

Dept. RN-52, Rinehart Books, Inc., Technical Division, 232 Madison Ave., New York 16, N. Y.

Send the following books for 10-day examination. If I like the books, I will then promptly remit the price indicated, plus a few cents postage. Otherwise I will return books postpaid in good condition and owe you nothing.

- Ghirardi's Radio & Television Receiver TROUBLESHOOTING AND REPAIR, \$6.75
- Ghirardi's Radio & Television Receiver CIRCUITRY AND OPERATION, \$6.00
- SPECIAL COMBINATION OFFER—both of above big books—1489 pages of helpful service data—Price only \$12.00 for the two

Name \_\_\_\_\_

Address \_\_\_\_\_

City, Zone, State \_\_\_\_\_

Employer's name & address \_\_\_\_\_

OUTSIDE U.S.A.—\$7.25 for TROUBLESHOOTING REPAIR; \$6.50 for CIRCUITRY & OPERATION or \$13.00 for COMBINATION OFFER. Cash only—money back if you return books in 10 days.

# Finest TV CHASSIS complete with TUBE!

**12 1/2"** picture tube with complete chassis including:

- beautiful bronze metal mask
- permanent magnet 12" speaker
- all tubes aligned perfectly
- ideal for fringe area... works better than other receivers and where others can't
- ultra-sensitive fringe area tuner
- standard 90-day guarantee on all tubes and parts
- full band reception and output
- gated AGC—finest automatic gain control
- COMPLETE... READY TO OPERATE

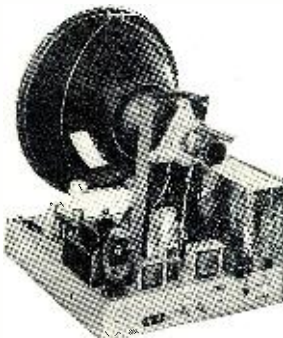

**16"** picture tube with complete chassis including:

- gated AGC—finest automatic gain control
- full band reception and output
- standard 90-day guarantee on all tubes and parts
- ultra-sensitive fringe area tuner
- ideal for fringe areas... works better than other receivers and where others can't
- all tubes aligned perfectly
- permanent magnet 12" speaker
- beautiful bronze metal mask
- COMPLETE... READY TO OPERATE

Complete, including the picture tube, licensed by R C A..... **\$89.50**

Fringe Area Double "V" TV ANTENNA... complete with all hardware, 300 ohm line and 9 ft. mast..... **\$7.95**

Complete, including the picture tube, licensed by R C A..... **\$129.50**

## CUSTOM-BUILT CABINETS

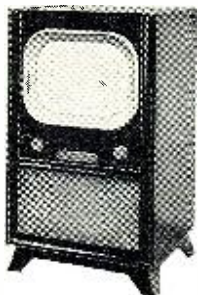

Beautifully designed console cabinets with luxurious mahogany finish... dimensions: 38" High x 22 1/4" W. x 18 1/4" D. Fits 12 1/2" and 16" tube (specify size when ordering)..... **\$44.95**

20% deposit with order; balance C.O.D. Shipped F.O.B. Chicago. SATISFACTION GUARANTEED. Illinois residents add 2% Sales Tax. ... THERE IS A LIMITED QUANTITY ...

**ORDER TODAY!**

**Concert Master Radio & Television Co.**

551 W. Randolph Street  
Chicago 6, Illinois  
ANdover 3-1591

## The TURNTABLE is the HEART OF YOUR HIGH FIDELITY SYSTEM

You may own the finest pickup, amplifier and speaker that money can buy... yet you'll get poor reproduction if your TURNTABLE has excessive wow, hum or rumble!

REK-O-KUT offers a complete range of 12" Turntable models to match your present high-fidelity equipment and your own pocketbook. Not every sound system requires the most expensive turntable... your turntable must be chosen to complement your other components. Each REK-O-KUT Turntable carries an engineering specification which enables you to select the appropriate unit to match your other components. Quality and workmanship of every REK-O-KUT Turntable is identical... price differential depends solely on type of materials used.

### MODEL LP-743

#### 3-Speed 12" Turntable

Induction type motor, designed for smooth, vibration-free operation. Instantaneous speed changes without stopping turntable or removing disc..... **\$54.95 Net**

### MODELS T-12H & T-43H - 2-Speed 12" Turntables

Recommended for use with ULTRA HIGH FIDELITY Amplifiers and Speaker Systems. The only 12" Turntable that meets N.A.B. specifications for speed regulations and Wow content.

MODELS	MOTOR	DB Noise Level	SPEED	PRICE
T-12 H*	Hysteresis Synchronous	-50DB	78-33 1/3	\$119.95
T-43 H*	Hysteresis Synchronous	-50DB	45-33 1/3	\$119.95
T-12	4 Pole Induction	-40DB	78-33 1/3	\$84.95
T-43	4 Pole Induction	-40DB	45-33 1/3	\$84.95

\* Delivery limited due to short supply of Hysteresis motors

## REK-O-KUT CO.

38-05 Queens Blvd., Long Island City, N. Y.

EXPORT DIVISION: 453 Broadway, New York City, U. S. A.

CANADA: 67-15 5431 20th. L.D., 350 King St. W., Toronto 25, Ontario

## ANOTHER Editors and Engineers PUBLICATION



### BRAND NEW 9TH EDITION WORLD'S RADIO TUBES

(BRANS' VADE MECUM)

Over 15,000 transmitting and receiving tubes from 253 manufacturers. The only book of its kind in the world. Available in 16 languages.

\$5.00 PLUS ANY TAX

**BUY IT FROM YOUR DISTRIBUTOR**

ADD 10% ON DIRECT MAIL ORDERS TO EDITORS AND ENGINEERS, LTD. BOX 689A, SANTA BARBARA, CALIF. Bookstores order from BAKER & TAYLOR, Hillside, N.J.

## ANOTHER Editors and Engineers PUBLICATION



### RADIO HANDBOOK

**734 PAGES!**

Reference data galore, the latest in theory and practice, and a wealth of information on the operation of vacuum tubes as amplifiers in all frequency ranges. Profusely indexed for easy finding, clearly illustrated and described for easy reading.

**\$6.00 AND WORTH IT!**

**BUY IT FROM YOUR DISTRIBUTOR**

ADD 10% ON DIRECT MAIL ORDERS TO EDITORS AND ENGINEERS, LTD. BOX 689A, SANTA BARBARA, CALIF. Bookstores order from BAKER & TAYLOR, Hillside, N.J.

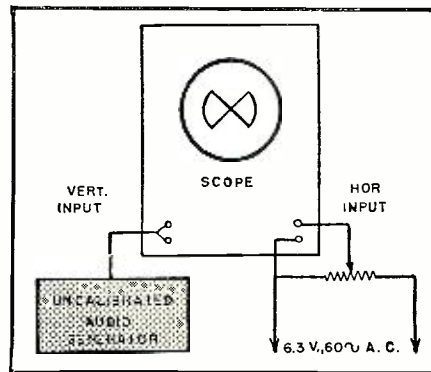

Fig. 5. Calibrating with Lissajous figures.

is available, this unit may be calibrated by the use of Lissajous figures, as is shown in Fig. 5. Two or three volts of 60 cycle a.c. are fed into the horizontal input. When the output frequency of the generator is exactly 60 cycles, a circular trace will appear on the scope. When the output frequency of the generator is twice the frequency of that fed to the horizontal input, in this case 120 cycles, a figure similar to that in Fig. 5 will appear on the scope, having two loops along the horizontal edge and one loop along the vertical edge. As the frequency of the generator is increased, an increasing number of loops will appear along the horizontal edge, while the number of loops along the vertical edge will remain constant. Hence, the unknown frequency of the generator may be computed by the formula  $f_2 = (m_2/m_1) f_1$ ; where  $f_2$  is the unknown frequency,  $m_1$  is the number of loops along the horizontal edge,  $m_2$  is the number of loops along the vertical edge, and  $f_1$  is the known frequency applied to the horizontal input of the scope. As the frequency of the generator is increased, it becomes increasingly difficult to count the number of loops along the horizontal edge as they become quite closely spaced at higher frequencies. Therefore, it is advisable to use higher known frequencies such as 400 cps and 4000 cps to calibrate the higher ranges of the generator. These frequencies are broadcast by radio station WWV and can be received at practically any hour, on any communications receiver.

If it is desired to increase the frequency range of this generator beyond 20,000 cps, a higher capacity tuning condenser can be used in the variable frequency oscillator.

-30-

## HAM CONTACTS O.K.'D

THE FCC has been notified by the International Telecommunication Union that the Netherlands Antilles no longer forbids the exchange, internationally, of amateur contacts.

The Commission's Public Notice of Dec. 21, 1950, which lists countries which have notified the Union that they object to such ham contacts has now been amended to delete the Netherlands Antilles.

-30-



**WANTED! WANTED!**

**MILITARY TEST SETS & EQUIPMENT**  
 TS-12, 13, 35, 14, 15, 146, 174, 175, 263, 268, etc. APR, ARC, ART, APS, APA, SCR, BC equipment and parts. Also TUBES, any quantity. WRITE, WIRE OR CALL.



Coaxial Relay K-101 SPDT-24v DC 5 4.95  
 Set of 83-1SP Coax-Connectors for Above... 1.35  
 1000 K Crystal Bit cut... 3.95  
 VS-2 Vacuum Switch... 6.95  
 Sigma Plate Relay 8000 ohm SPDT... 2.49  
 RG59/U Coaxial Cable-75 ohm  
 150' roll... \$11.95 300' roll... 22.50  
 3" Scope Shield... 1.29  
 Voltmeters 2 1/4" sq. 0-20v & 0-40v DC... 2.49  
 15 HY @ 800 MA Choke... 6.95  
 2 mfd 3000 V Condenser... 4.25

**TUBES!! BRAND NEW! STANDARD BRANDS! NO SECONDS! COMPARE! TUBES!!**

0A3 4V75 51.23	3C33 510.95	215A 50.15	811 52.85	8008 55.95	0A2 51.25	5Z3 50.85	6SK7GT 50.72	12S17GT 50.65
0A3/V100 1.19	3C34 246G 7.95	216A 8.49	812 2.75	8011 1.59	0A4G 1.15	5Z4 81.85	6SL7GT 75	12SK7GT 80
0C1/AR105 1.19	3C37 7.95	227A/5C27 4.59	813 7.95	8012 2.65	0B2 1.48	6A3 75	6SN7GT 80	12ST7GT 85
0D3 V1150 2.95	3C31/C11 16.95	249C 3.69	814 2.69	8014 28.75	0I1 65	6AL5 82	6SR17GT 65	12SQ7GT 72
1B23 9.75	3CP1 1.95	250TH 21.95	816 1.05	8020 .98	0A3 70	6A7 89	6S87 80	12Z6 98
1B24 9.75	3CP1S1 1.95	250TIL 18.95	820 8.95	8021 1.65	0A4 75	6AB7 98	6SU7GT 2.75	14A4 75
1B26 16.95	3DP1 4.45	274 1.75	820B 10.95	9002 1.65	0A6 85	6AC5GT 1.05	6T6 98	14AT 85
1B29 2.45	3DP1-S2A 8.95	276A 1.75	820B 12.95	9003 1.65	0A7 85	6AD7GT 1.29	6TV 1.05	14B 85
1B32 4.75	3DP1A 1.65	283A 2.69	820B 2.75	9004 1.65	0A8 79	1AB5 69	6U5 82	14F7 85
1B36 19.95	3K29 13.95	294A 3.95	832 8.95	9005 1.85	1B3/3016 1.19	6AE6G 72	6U6GT 85	14H7 85
1B38 28.75	3KP7 1.75	300B 9.95	832A 9.45	9006 1.85	1B4 82	6AG5 82	6U7G 85	14J7 85
1B42 4.75	3K39 10.45	301A 8.95	834 42.50	C1JA 9.95	1B5/2518 .82	6AG5 82	6V1 85	14M7 85
1N1 1.19	3M7 3.45	304TIL 9.95	836A 3.49	C6B 8.95	1B6GT 1.19	6AG7 1.29	6V6GT 65	14N7 85
1N21 1.59	4-65A 19.95	305A 34.95	837 8.45	CK1000 1.49	1C7 89	6AG7 1.29	6V7 65	14P7 85
1N21A 1.19	4AP10 4.45	307A RR7 4.45	845 4.25	CK1000 1.49	1C7 89	6AG7 1.29	6V8 65	14R7 85
1N22 1.45	4AP10 4.45	308A 23.95	845 4.25	CK503AX 2.95	1D7 85	6AG7 1.29	6V9 65	14S7 85
1N23 2.45	4B22/E15H 10.45	321A/B 23.95	845 4.25	CK503AX 2.95	1D7 85	6AG7 1.29	6V9 65	14T7 85
1N24 1.19	4-250A 39.95	327A/5C37 4.75	845 4.25	CK503AX 2.95	1D8GT 85	6AG7 1.29	6V9 65	14U7 85
1N24H 4.95	4B24/131C 7.95	328A 8.95	851 27.50	CK503AX 2.95	1E6GT 85	6AG7 1.29	6V9 65	14V7 85
1N26 6.95	4B25/6CF 8.95	329A 8.95	851 27.50	CK503AX 2.95	1E7G 75	6AG7 1.29	6V9 65	14W7 85
1N27 1.19	4B26/200H 8.95	331A 11.95	851 27.50	CK1002 1.98	1E7G 75	6AG7 1.29	6V9 65	14X7 85
1N34A .97	4B28 4.95	350A 7.95	860 3.95	CK1002 1.98	1F4 65	6AT6 1.19	7A5 XX1 75	31 55
1P21 45.00	417/V09 16.45	350B 3.95	861 22.50	CK1002 1.98	1G4 65	6AU6 6.95	7A6 75	32 55
1P21A 1.79	4C23 32.50	371A 1.65	865 1.98	CK1006 3.25	1G4GT 65	6AV6 65	7A7 75	33 55
1P24 2.69	4K27/257H 18.95	371B 1.65	866A 1.29	EF50 72	1H6GT 85	6B4 75	7A8 75	34 55
1P21 1.19	5AP 3.45	388A 1.65	866A 1.29	EF50 72	1H6GT 85	6B4 75	7A8 75	34 55
2AP1 10.95	5AP4 3.45	393A 7.95	869B 35.00	F123A 2.95	1I4 67	6B4 75	7A8 75	34 55
2C21/RK33 4.45	5BP1 3.45	394A 7.95	874 1.19	F123A 2.95	1I4 67	6B4 75	7A8 75	34 55
2C22 7/108 3.45	5BP1 3.45	394A 7.95	874 1.19	F123A 2.95	1I4 67	6B4 75	7A8 75	34 55
2C26A .18	5CP1 4.59	434A 27.50	878 1.27	FG00 37.50	1I4 67	6B4 75	7A8 75	34 55
2C34/RK34 32.55	5CP1 4.59	446A 3.75	884 1.75	FG17 4.89	1I4 67	6B4 75	7A8 75	34 55
2C40 8.49	5D21 24.25	450TH 38.75	885 1.39	FG27A 4.95	1I4 67	6B4 75	7A8 75	34 55
2C43 14.95	5GP1 2.85	450TH 38.75	885 1.39	FG27A 4.95	1I4 67	6B4 75	7A8 75	34 55
2C44 3.45	5GP1 2.85	450TH 38.75	885 1.39	FG27A 4.95	1I4 67	6B4 75	7A8 75	34 55
2C46 7.95	5P1 2.45	527 12.45	900 3.25	FG81A 3.45	1I4 67	6B4 75	7A8 75	34 55
2C41 6.95	5P2 22.50	559 97.50	919 2.79	FG172 33.50	1I4 67	6B4 75	7A8 75	34 55
2D21 1.19	5P2 12.25	575A 13.45	922 1.25	FG140 8.95	1I4 67	6B4 75	7A8 75	34 55
2E22 4.69	5P2 12.25	575A 13.45	922 1.25	FG140 8.95	1I4 67	6B4 75	7A8 75	34 55
2E24 2.45	5P2 12.25	575A 13.45	922 1.25	FG140 8.95	1I4 67	6B4 75	7A8 75	34 55
2E30 2.15	5P2 12.25	575A 13.45	922 1.25	FG140 8.95	1I4 67	6B4 75	7A8 75	34 55
2J21A 8.95	5P2 12.25	575A 13.45	922 1.25	FG140 8.95	1I4 67	6B4 75	7A8 75	34 55
2J22 9.95	5P2 12.25	575A 13.45	922 1.25	FG140 8.95	1I4 67	6B4 75	7A8 75	34 55
2J23 2.45	5P2 12.25	575A 13.45	922 1.25	FG140 8.95	1I4 67	6B4 75	7A8 75	34 55
2J24 2.45	5P2 12.25	575A 13.45	922 1.25	FG140 8.95	1I4 67	6B4 75	7A8 75	34 55
2J25 2.45	5P2 12.25	575A 13.45	922 1.25	FG140 8.95	1I4 67	6B4 75	7A8 75	34 55
2J26 2.45	5P2 12.25	575A 13.45	922 1.25	FG140 8.95	1I4 67	6B4 75	7A8 75	34 55
2J27 2.45	5P2 12.25	575A 13.45	922 1.25	FG140 8.95	1I4 67	6B4 75	7A8 75	34 55
2J28 2.45	5P2 12.25	575A 13.45	922 1.25	FG140 8.95	1I4 67	6B4 75	7A8 75	34 55
2J29 2.45	5P2 12.25	575A 13.45	922 1.25	FG140 8.95	1I4 67	6B4 75	7A8 75	34 55
2J30 2.45	5P2 12.25	575A 13.45	922 1.25	FG140 8.95	1I4 67	6B4 75	7A8 75	34 55
2J31 2.45	5P2 12.25	575A 13.45	922 1.25	FG140 8.95	1I4 67	6B4 75	7A8 75	34 55
2J32 2.45	5P2 12.25	575A 13.45	922 1.25	FG140 8.95	1I4 67	6B4 75	7A8 75	34 55
2J33 2.45	5P2 12.25	575A 13.45	922 1.25	FG140 8.95	1I4 67	6B4 75	7A8 75	34 55
2J34 2.45	5P2 12.25	575A 13.45	922 1.25	FG140 8.95	1I4 67	6B4 75	7A8 75	34 55
2J35 2.45	5P2 12.25	575A 13.45	922 1.25	FG140 8.95	1I4 67	6B4 75	7A8 75	34 55
2J36 2.45	5P2 12.25	575A 13.45	922 1.25	FG140 8.95	1I4 67	6B4 75	7A8 75	34 55
2J37 2.45	5P2 12.25	575A 13.45	922 1.25	FG140 8.95	1I4 67	6B4 75	7A8 75	34 55
2J38 2.45	5P2 12.25	575A 13.45	922 1.25	FG140 8.95	1I4 67	6B4 75	7A8 75	34 55
2J39 2.45	5P2 12.25	575A 13.45	922 1.25	FG140 8.95	1I4 67	6B4 75	7A8 75	34 55
2J40 2.45	5P2 12.25	575A 13.45	922 1.25	FG140 8.95	1I4 67	6B4 75	7A8 75	34 55
2J41 2.45	5P2 12.25	575A 13.45	922 1.25	FG140 8.95	1I4 67	6B4 75	7A8 75	34 55
2J42 2.45	5P2 12.25	575A 13.45	922 1.25	FG140 8.95	1I4 67	6B4 75	7A8 75	34 55
2J43 2.45	5P2 12.25	575A 13.45	922 1.25	FG140 8.95	1I4 67	6B4 75	7A8 75	34 55
2J44 2.45	5P2 12.25	575A 13.45	922 1.25	FG140 8.95	1I4 67	6B4 75	7A8 75	34 55
2J45 2.45	5P2 12.25	575A 13.45	922 1.25	FG140 8.95	1I4 67	6B4 75	7A8 75	34 55
2J46 2.45	5P2 12.25	575A 13.45	922 1.25	FG140 8.95	1I4 67	6B4 75	7A8 75	34 55
2J47 2.45	5P2 12.25	575A 13.45	922 1.25	FG140 8.95	1I4 67	6B4 75	7A8 75	34 55
2J48 2.45	5P2 12.25	575A 13.45	922 1.25	FG140 8.95	1I4 67	6B4 75	7A8 75	34 55
2J49 2.45	5P2 12.25	575A 13.45	922 1.25	FG140 8.95	1I4 67	6B4 75	7A8 75	34 55
2J50 2.45	5P2 12.25	575A 13.45	922 1.25	FG140 8.95	1I4 67	6B4 75	7A8 75	34 55
2J51 2.45	5P2 12.25	575A 13.45	922 1.25	FG140 8.95	1I4 67	6B4 75	7A8 75	34 55
2J52 2.45	5P2 12.25	575A 13.45	922 1.25	FG140 8.95	1I4 67	6B4 75	7A8 75	34 55
2J53 2.45	5P2 12.25	575A 13.45	922 1.25	FG140 8.95	1I4 67	6B4 75	7A8 75	34 55
2J54 2.45	5P2 12.25	575A 13.45	922 1.25	FG140 8.95	1I4 67	6B4 75	7A8 75	34 55
2J55 2.45	5P2 12.25	575A 13.45	922 1.25	FG140 8.95	1I4 67	6B4 75	7A8 75	34 55
2J56 2.45	5P2 12.25	575A 13.45	922 1.25	FG140 8.95	1I4 67	6B4 75	7A8 75	34 55
2J57 2.45	5P2 12.25	575A 13.45	922 1.25	FG140 8.95	1I4 67	6B4 75	7A8 75	34 55
2J58 2.45	5P2 12.25	575A 13.45	922 1.25	FG140 8.95	1I4 67	6B4 75	7A8 75	34 55
2J59 2.45	5P2 12.25	575A 13.45	922 1.25	FG140 8.95	1I4 67	6B4 75	7A8 75	34 55
2J60 2.45	5P2 12.25	575A 13.45	922 1.25	FG140 8.95	1I4 67	6B4 75	7A8 75	34 55
2J61 2.45	5P2 12.25	575A 13.45	922 1.25	FG140 8.95	1I4 67	6B4 75	7A8 75	34 55
2J62 2.45	5P2 12.25	575A 13.45	922 1.25	FG140 8.95	1I4 67	6B4 75	7A8 75	34 55
2J63 2.45	5P2 12.25	575A 13.45	922 1.25	FG140 8.95	1I4 67	6B4 75	7A8 75	34 55
2J64 2.45	5P2 12.25	575A 13.45	922 1.25	FG140 8.95	1I4 67	6B4 75	7A8 75	34 55
2J65 2.45	5P2 12.25	575A 13.45	922 1.25	FG140 8.95	1I4 67	6B4 75	7A8 75	34 55
2J66 2.45	5P2 12.25	575A 13.45	922 1.25	FG140 8.95	1I4 67	6B4 75	7A8 75	34 55
2J67 2.45	5P2 12.25	575A 13.45	922 1.25	FG140 8.95	1I4 67	6B4 75	7A8 75	34 55
2J68 2.45	5P2 12.25	575A 13.45	922 1.25	FG140 8.95	1I4 67	6B4 75	7A8 75	34 55
2J69 2.45	5P2 12.25	575A 13.45	922 1.25	FG140 8.95	1I4 67	6B4 75	7A8 75	34 55
2J70 2.45	5P2 12.25	575A 13.45	922 1.25	FG140 8.95	1I4 67	6B4 75	7A8 75	34 55

**RADAR—COMMUNICATIONS—TEST EQUIPMENT**

AN/APA10 Panoramic Adapter	5175.00
AN/APA11 Pulse Analyzer	39.95
AN/APN-4B Receiver	39.95
AN/APR4 Radar Search Receiver	375.00
AN/APR5 Radar Search Rec. 1000-3.100 mes.	875.00
AN/APR5A Radar Search Receiver	99.50
AN/APR5 X-Band R.F. Head.	149.50
AN/APR5 300-1500 mes. Xmitter	149.50
AN/CRT3 Dual Freq. Vetrology Girl	129.50
Complete YJ Beacon Installations	19.95
AN/PPN-1 Portable Radar Beacon	149.50
BC221AK Freq. Mtr. with Modulation	3.95
BC-433G Compass Receiver	285.00
BC-639 Receiver	1300.00
BC-640B 100-156 mes ground xmitter.	29.95
BC-733D Receiver	459.50
BC-1016 Tape Code Recorder	24.95
BC-12	

high  
**HICKOK**  
sensitivity

5 Inch  
**SCILLOGRAPH**  
with DC  
**AMPLIFIERS**

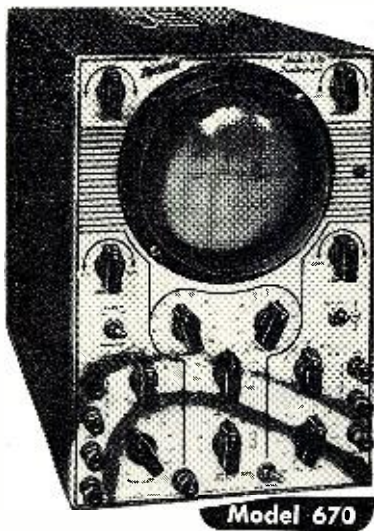

Model 670

Accurate television service requires a GOOD "Scope". This HICKOK 670, designed with D. C. amplifiers provides perfect square wave response on low frequency. The extra sensitivity—to 10 MV per inch—in this HICKOK 670, properly shows the response curve, even when TV receiver is far out of alignment.

**Features . . .**

Wide band vertical amplifier useable beyond 2MC. Polarity reversing switches. Push-pull amplifiers. Direct connections to horizontal and vertical plates. Fixed sweep frequency for accurate viewing of wave forms 30 and 7875 cycles. Recurrent linear sweep 3 to 50,000 cycles. Astigmatic focus control for sharper trace. Horizontal amplifier 0 to 100 KC. Sweep oscillator 3 to 50 KC.

You'll like this Model 670. It's a perfect companion to the 610A for accurate TV alignment; or the Model 630 for accurate wave form analysis. Write for complete technical details.

**THE HICKOK ELECTRICAL INSTRUMENT CO.**  
10524 Dupont Avenue • Cleveland 8, Ohio

**Klystron Oscillators**

(Continued from page 66)

details of some external and integral-cavity types, this article concludes with some notes on the construction of an actual oscillator.

Fig. 11 shows a 2K39 reflex klystron, an integral-cavity type, mounted directly on the wave guide with which it is to be used. The tube is supported by means of a metal bracket to a wave guide-to-coax transition. This transition, or adapter, consists of a section of wave guide 1" x 1/2" in cross-section, shorted at one end, and with a probe projecting into the guide as shown in Fig. 9. The upper end of the probe ends in what is known as an "SKL" fitting,\* which mates with the "SKL" fitting on the output line of the klystron. Use of such a direct me-

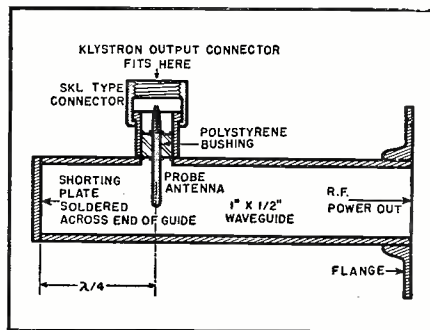

Fig. 9. Simple wave guide-to-coax transition.

chanical coupling between the klystron and wave guide eliminates the annoying tendency of the output power to vary—which occurs when non-rigid coaxial lines are used at these frequencies. Moreover, the power output obtainable from the oscillator is greater due to the decrease in length of the coupling line.

To operate the oscillator shown, two additional items are required: the first

\* Sperry Gyroscope Co., Trademark

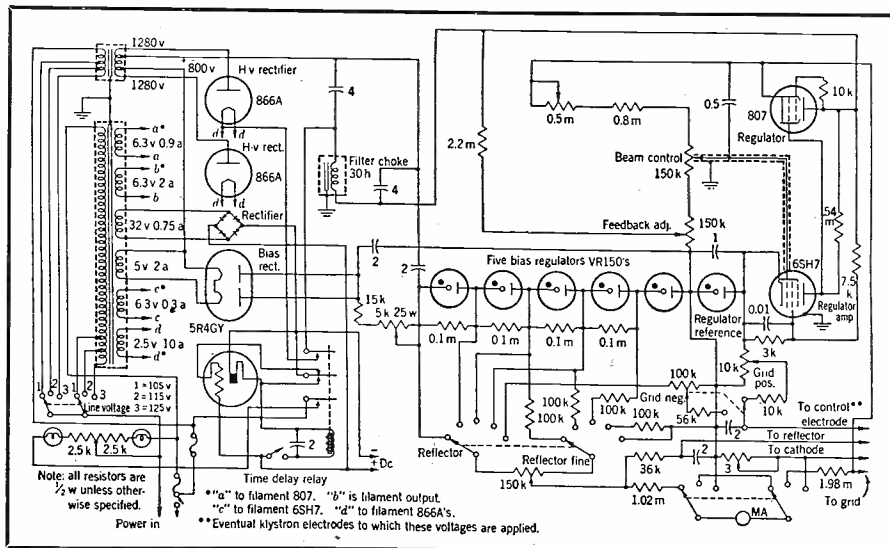
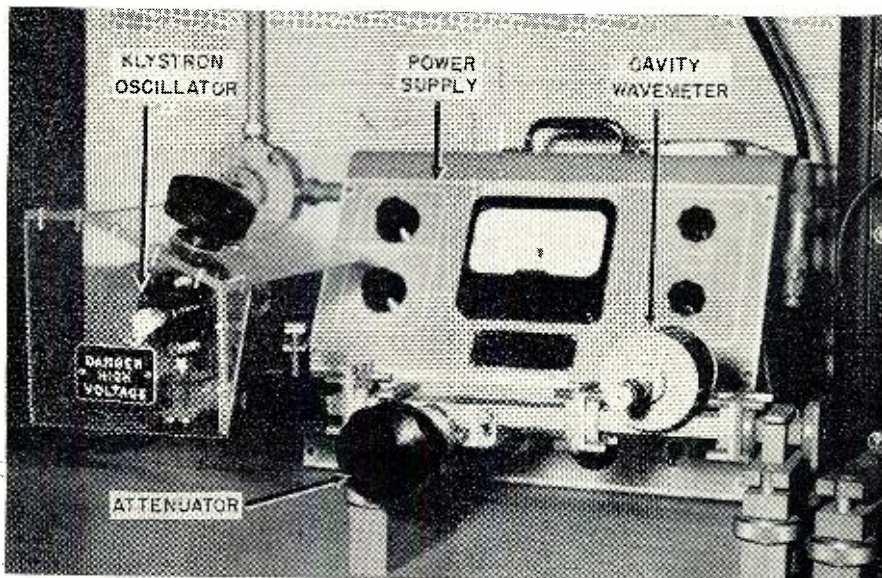

Fig. 10. Schematic diagram of a satisfactory power supply for reflex klystrons.

Fig. 11. A 2K39 reflex klystron mounted on wave guide with which it is used.



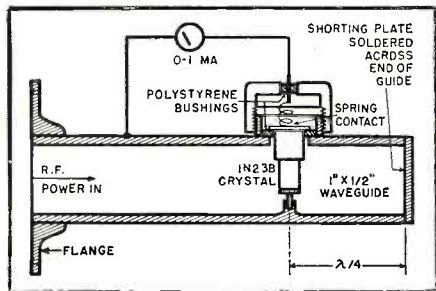

Fig. 12. Simplified crystal detector circuit.

is a power source capable of supplying the voltages previously discussed, the second is a blower of approximately 50 cfm (cubic feet-per-minute) capacity to cool the klystron at maximum ratings and to improve the frequency stability. Although several excellent supplies are available commercially, the experimenter who wishes to construct his own will have to exercise particular care with the reflector supply. The supply should be designed to have a low impedance to reverse current to prevent a transient condition or modulating voltage from driving the reflector positive—a condition which can seriously damage the tube. A satisfactory supply should not have more than a 50,000 ohm bleeder across its output. In addition, all three d.c. supplies should be characterized by very low ripple content. The reflector supply variation, in particular, must be held to better than a small fraction of one volt, while the beam supply need be only one-half as good (on a percentage basis). Fig. 10 gives the schematic of one of many supplies which has been found to give satisfactory performance. Note in particular that the reflector supply is exceptionally well regulated.

This oscillator may be tuned to any frequency in the 7500 to 10,300 megacycle range with a power output of better than 300 mw. In the event a power bridge is not available, oscillation can be detected by means of a crystal rectifier and d.c. milliammeter arrangement shown in Fig. 12. Adjusting the reflector voltage for a maximum indication on the 0-1 milliammeter is about the most feasible way of getting started. Further refinements will almost suggest themselves.

-30-

### S.T.E.N. CONVENTION

THE South Texas Emergency Net will hold its seventh annual convention at Kerrville, Texas, May 9, 10, and 11.

The group has planned three days of varied activities designed to interest hams, CD personnel, and radio hobbyists. The committee has scheduled a series of get-togethers, lectures, transmitter hunts, contests, and programs of entertainment for the event.

Persons in south Texas who are interested in attending the convention are asked to register with Cedrig Toler, Blue Bonnet Hotel, Kerrville, Texas. Hotel or motor court reservations can be arranged. Registration fee is \$2.50.

-30-

May, 1952

# LOW PRICE is Proved by FIGURES NOT BY WORDS!

Compare **PENN'S**  
**current price list**  
**with that of any**  
**other Tower Maker**



Today, almost every television tower advertisement contains the words "low price." So—Teletower invites you to judge by the actual figures as shown on the price lists. Get Penn's current prices—and make your own comparison.

Teletower keeps the lead in tower sales because it incorporates design and construction advantages while holding its edge in price. Here are some Teletower "firsts":

(1) adjustable roof mount that saves money and weight (2) universal motor mount adaptable to all antenna rotors (3) straight top section for easier climbing (4) built-in base that permits raising tower after fastening base to roof (5) pilot hole that automatically aligns sections when just one leg is properly fitted.

Find out who gives you what for your money . . . and what you really pay to get it. Remember the prices on your Penn price list include delivery to your door—all freight paid. Mail the coupon now.

CANADIAN REPRESENTATIVE: Atlas Radio Corp., Ltd.,  
560 King Street, W. Toronto, Canada

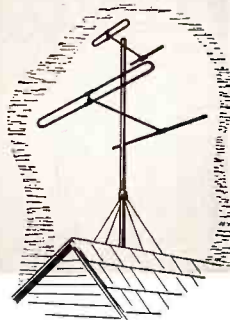

### Penn Tele-Poles with Exclusive Base Mounts

Made of high grade steel tubing. PBM 5 base permits mounting on peak of ridge so erection can be made either from ridge or side.

Penn Boiler & Burner Mfg. Corporation,  
Department N, Lancaster, Pa.

Please send me complete information on Penn Teletowers, including most recent price list.

Name .....

Address .....

.....

**PENN**

Teletowers  
Lift towers  
enna-Mast  
Hardware

PENN BOILER & BURNER MFG. CORP., LANCASTER, PA.



WITH THE SENSATIONAL NEW

# ROGER-PHILLIPS

FIVE ELEMENT ALL CHANNEL

# YAGI

- ALL CHANNEL COVERAGE
- HIGH FRONT TO BACK RATIO
- REDUCES CO-CHANNEL INTERFERENCE
- COSTS LESS THAN DOUBLE STACKED ARRAYS
- RUGGED CONSTRUCTION...EASIER TO INSTALL
- PROVIDES EQUAL GAIN ON ALL CHANNELS
- PERFECT MATCH FOR 300 OHM LINE
- PRE-ASSEMBLED...LIGHT WEIGHT

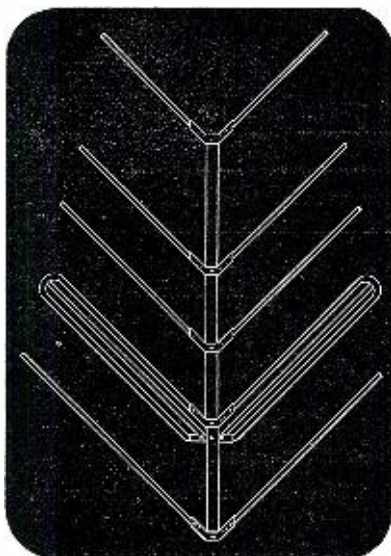

Model AC-5

(1/4 Wave Stacking Bars Built-in...Ready for Use)

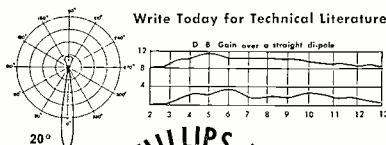

717-RA NO. LAKE AVE., PASADENA 6, CALIF.



## NEWS, TRENDS, AND A REVIEW OF MAGNETIC TAPE RECORDING

**M**ORE and more, magnetic tape is becoming the "final" as well as the "original" sound recording medium. Private enterprises, professional recording companies, broadcasters, foundations, institutions, and other organizations who make use of sound reproduction for profit or philanthropy are finding ways and means of using magnetic tape for education and entertainment.

About two years ago, a few institution-owned, non-profit radio stations began an experimental exchange of recorded programs. Out of this experiment, there has grown the National Association of Educational Broadcasters Tape Network.

The philosophy behind the Tape Network was evolved at a conference of 22 educational broadcasters who met for a two-week round-table at the University of Illinois in July 1949. There they discussed the ways and means of economically advancing their efforts towards the improvement of educational radio stations which, for the most part, are owned and operated by colleges and universities. One of the conclusions was a plan for an "interchange of resources."

After the seminar, Mr. Seymour Siegel, director of New York City's Station WNYC, conferred with Mr. Richard Hull, director of the University of Iowa's Station WOI. At that time Mr. Hull was president of the NAEB. Mr. Siegel recommended the use of magnetic tape as an economical means for the "interchange of resources." The cost of telephone lines prohibited the actual establishment of a network similar to those used in commercial radio practices. Mr. Siegel got the go-ahead and called upon Cooper Union in New York City for funds with which to buy magnetic tape stock which would be used to circulate WNYC's forum discussions among the National Association of Educational Broadcaster (NAEB) stations. Some funds were granted and the tape network began operations.

The recorded programs were "bicycled" around from one station to another. Each broadcaster paid only for the postage involved in mailing the programs to the next station on the NAEB itinerary. At the end of the routing, the tapes were returned to WNYC for erasing and recording new programs.

The tape network grew rapidly. Whereas early in 1950 only 4 or 5 stations were using the taped programs, six months later almost 40 stations were on the mail itinerary.

It was a dramatic development. The stations were thirsty for good programs and more of them. The catalogue grew to include such things as a series of "We Human Beings" which originated at the Lowell Institute in Boston, "Music For The Connoisseur" moderated by David Randolph, and, adding an international note, a series of concerts from Canada, and the BBC's "World Theatre."

Almost 90% of WNYC's resources were being devoted to the tape network. This was becoming too big a project to be handled on a part-time basis by WNYC's small staff. In January 1951, the Tape Network headquarters were moved to the University of Illinois where it was given office space and administrative and financial aid by the Institute of Communications Research.

In June 1951, through Seymour Siegel's efforts, the W. K. Kellogg Foundation in Battle Creek, Michigan, donated \$250,000 to the NAEB Tape Network. The Ford Foundation then donated \$300,000 for the origination of a series of four public service programs covering public affairs, international affairs, the American Heritage, and some aspects of the nature of man and human behavior. To date, 900 commercial radio stations have requested that the Tape Network permit them to use some of these recorded programs.

At present, the NAEB is offering 10 hours of broadcasting time a week to 80 stations across the nation. The mechanics of distribution are much like the original "bicycle" technique, with 10 legs of 8 stations each circulating the programs. The Network will soon resort to mass tape duplications to enable programs to be released simultaneously, eliminating the present delay, make the programs more timely and even expanding the number of hours of programs offered.

Seymour Siegel is now president of the spirited NAEB. The officials and the staff of NAEB, headquartered at the University of Illinois, are delivering UNESCO programs originating in Paris, transcriptions of the *New York Herald Tribune's* Forum, Budapest

# COMMUNICATIONS EQUIPMENT CO.

## RACK-PANEL TYPE DESK



Heavy Duty Standard Panel, 19" x 10 1/2" W x 1 1/2" H, tough steel supporting metal desk well for that new contact ring. Ideal for that new contact ring. Space saving panel may be used to support extra equipment. Attractive gray finish. **\$4.95**

## POWER RESISTORS

Res.-Ohms	Price	Res.-Ohms	Price
2.5*	55c	198*	35c
2 1/2*	35c	225*	30c
30*	45c	250*	45c
32.5*	35c	300*	35c
40*	30c	450*	65c
50*	45c	500*	40c
70*	45c	630*	55c
100*	75c	750*	50c
125*	35c	8,000*	90c
125*	45c	160,000*	65c

\* Tapped to give 10 equal sections with 9 taps.

## SPECIALS

SA-4/A/APA-1-MOTOR DRIVEN ANT. SWITCH-NEW	\$14.95
BC 305 ANTENNA TUNING UNIT, NEW	6.95
IR1/APN-1, New, With Tubes	75.00
IR1/APN-1, New, With Tubes and Crystal	75.00
Superionic Crystal Head, M-2, 22.2K HC HI-2	27.45
Underwater Microphone, Model JR, Z=50W	24.50
DYNAMIC Mike & Headset Combo. B-19, New	3.75
HS-30 Inserts, M-300	53.50
Synch. Motors, 3RPM-115V, 60 Cy.	1.85
Synch. Motors, 1RPM, 115V, 60 Cy.	2.35
ART-13 Driver Trans. 6V6 to P-P	1.29
811's	
DM 34 Dynamotor, 14V In. 220V, 80 MA out.	
Sens. Relay, 3.5MA, 13K Ohms	1.29
Klixon Breaker, Thermal, 35A.	.69
T-30 Carbon Mike, New	.89
Motor, 24VDC, 3HP, 3800 RPM, New	89.75
Supersonic Rochelle Xds, 1000-Ft. Loss	.50
T-Y Lead-in, 300 Ohms, HI-Q, Roll	17.50
Gibson Gift, Emerg. Kit	12.95
Screen Mod. Trans. for 807's	1.19
3-4 MC Coils for ARC-5 = 6020	
# 7247	2.75

## AUDIO TRANSFORMERS

AT501 HI-Fi Special: PRI: 3000 Ohms P.P. Sec: 4/10/12/50/200 Ohms	\$2.49
AT152 HI-Fi Driver Pri: 10,000 Ohms Sec: 40,000 Ohms PP Grids 50-15 KC/1 db.	\$4.95
AT063 Output to H.S. or line PRI: 14,200 Ohms SEC: 3000/600 Ohms	\$1.19
AT449 HI-Fi Driver (5000 Ohms to P.P. output grids (4,000 Ohms) 100-10,000 CY 10 W. 6V6 to PP 806's)	\$2.39
AT656 Intercon. Line: 30K (4-8 Ohms to grid (250,000 Ohms))	\$0.69
AT415 Plate (18,000 Ohms C.T.) to line (125 Ohms) 175 W.-200-600 CY	\$1.95
AT858 Plate (10,000 Ohms C.T.) to line V.C. (500/125/30 Ohms) HI-Fi	\$6.95
AT070 Mike-or-Line (250 Ohms) to grid (250,000 Ohms C.T.)	\$1.20
AT765 Mike-or-Line (600 Ohms) to grid (50,000 Ohms C.T.)	\$0.89
AT694 HI-Fi Output 3 Watts, 8500 Ohms P.P. V.C. (15 Ohms) 1.5-15KC PM 1 db.	\$1.49
AT4-A1: Mike (35 Ohm Carbon) to Line 2300 Ohm/200 Ohm	\$1.19
AT649: Line (500 Ohms) to Grid (75K Ohms)	\$0.89
AT748 Line (600 Ohms) to V.C. (6-8 Ohms) 17 db Level	\$1.19
AT621: Mike-or-Line (200 Ohms) to Simple or P.P. Grids (30K Ohms)	\$0.59
AT718: Line (300 Ohms) to line (600/30 Ohm) Response 50-20KC P.M. 1 db.	\$0.49

## DYNAMOTORS



Type	Input	Output	Radio
PE86	28 1.25	250 .060	RC36
DM416	14 6.2	330 .170	RU 19
DW33A	28 7	540 .250	BC 456
PE101C	13/26 12.6	400 .135	SCR515
		6.3	800 .020
BD AR 93	38 3.25	375 .150	APN-1
	27 1.75	475 .075	APN-1
ZAO515	12/24 4.2	500 .050	
B-19 pack	12 9.4	275 .110	MARK11
D-10A	12 12	225 .100	
DA-34	28 10	440 .200	SCR522
		300 .060	BC 375
		150 .010	
S053	28 1.4	250 .060	APN-1
PE73CM	28 19	1000 .350	
CW21AAX	13 12.6	400 .135	
	26 6.3	800 .020	

## POWER TRANSFORMERS

Comb. Transformers—115V/50-60 cps input			
CT-07 760VCT 300A	5V/3A, 6.3VCT/7A	\$5.95	
CT-15A 550VCT 085A	6.3V/6A, 6.3V/1.8A	2.35	
CT 164 4200V/002A/12KV Test, 5VCT/3A/12		12.95	
CT-341 105V/10 MA.—625V @ 5 MA, 26V @	4.5A, 2x2.5V/3A, 6.3V @ 3A	22.50	
CR-825 360VCT .340	6.3VCT/3.6, 6.3VCT/3A	3.95	
CT-626 1100V .160	2.5/12, 30/100	9.95	
CT-071 150V .200	33/200, 5V/10,	2.5/10	4.95
CT-378 2300V	4 MA 2.5/2, 2.25	6.95	
CT-367 580VCT .050	5VCT/3A	2.25	
CT-721 550VCT .010	6.3/1.2, 2.5VCT/2	2.95	
CT-99A 2x110VCT .010	6.3/1A, 2.5VCT/7A	3.25	
CT-403 350VCT .025	MA 5V/3A	2.75	
CT-931 585VCT .036	5V/3A, 6.3V/6A,	4.25	
CT-610 1250V .002	MA 2.5V/2.1A, 2.5V/1.75A	4.95	
CT-137 350VCT .026	MA 5V/3A	2.75	
CT-866 330V .065	6.3V/1.2, 6.3V/600	1.75	
CT-456 390VCT 30	MA 6.3V/1.3A, 5V/3A	3.45	
CT-160 800VCT 100	MA 6.3V/1.2A, 5V/3A	4.95	
CT-931 585VCT 86	MA 5V/3A, 6.3V/6A,	4.95	
CT-442 525VCT 75	MA 5V/2A, 10VCT/2A, 50V/200 MA.	3.85	

## FILTER CHOKES

Stock	Description	Price
CH-917	10H/450 MA-10KV	\$12.95
CH-366	20H/3A	6.95
CH-8-19	SWING .006H/5A-.035H/5A .032	
	Ohm DCR, 1KV TEST	3.95
CH-776	1.28H/130 MA/75 Ohms	2.25
CH-344	1.5H/145 MA/1200V Test	2.35
CH-43A	10 HY/15 MA—850 Ohms DCR.	1.75
CH-999	15 HY/15 MA—400 Ohms DCR.	1.95
CH-511	6 H/80 MA—310 Ohms DCR	2.45
CH3-501	2x.5H/400 MA	2.79
CH-189M	5 HY 200 MA	1.75
CH-488	10 HY 030A	1.19
CH-791	Dual 1.75-125 HY 100 MA	1.27
CH-981	15 HY 110A	1.59
CH-22-1	1 HY 100A	1.17
CH-779	5 HY 400A	1.25
CH-25A	SW .09/.018 HY 3/3A	8.95
CH-043	2.2 HY 80 MA	.98
CH-89A	2 X 1.52H @ .167A	1.39
CH-69A	Mult. Choke	
	SECT. 1. Swing 3-12H/52-.05A	
	SECT. 2. Smooth 5H/52A	
	SECT. 3. Swing 3.25-18H/138-014A	
	SECT. 4. Smooth 3.4H/138A	\$17.95

## SELENIUM RECTIFIERS

UP TO 18 VAC IN—	IN—			
UP TO 14 VDC OUT	OUT			
2A	4.00			
JA	4.00			
6A	6.00			
12A	7.50			
12A	9.00			
24A	18.00			
UP TO 36 VAC IN—				
UP TO 28 VDC OUT				
1A	5.00			
2A	5.00			
4A	8.00			
10A	14.50			
12A	15.00			
24A	36.00			
UP TO 54 VAC IN—				
UP TO 42 VDC OUT				
2A	5.50			
4A	8.50			
UP TO 120 VAC IN—				
UP TO 100 VDC OUT				
10A	\$11.00			
12A	45.00			
12A	60.00			
Special Rectifiers				
On Request				
Hi-Current Chokes				
1 HY — 12 Amp — 40				
Ohms	\$4.95			
10 HY — 2.5 Amp				
Cased	\$2.25			
LO-VOLT. XFORMS				
Primaries 115V, 60 Cycle				
36V.40V at 3.5	\$3.75			
24V-1.5A	1.95			
18V-1.5A	.98			
16V-5A	3.75			
12V-3A	3.75			
HI CAP FILTER				
Cap. WVDC	Price			
800 .15	\$1.35			
2000 .6	1.85			
500 .200	2.00			
250 .150	1.45			
CONDENSERS				
Stock	Res	Coil		
No.	(ohms)	(D.C.)		
RY 107	20	4-12	1A-20 Amp	\$1.65
RY 1P3	100	12	2C	1.45
RY 12S	13,500	48	1A-1B	1.49
RY X32	120	18-24	2-B	.97
RY X27	120	18-24	2-B	.97
RY 80-2	100	20-24	2-A	.89
RY 834	90	3 (Can)	1-B	1.75
RY 613	150	24	5-C	1.29

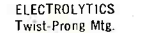

## ELECTROLYTICS

Cap. Mid	WVDC	Price
30	300	.18
40	450	.38
50	400	.36
60	300	.21
80	150	.25
80	500	.43
8-8	450	.24
30-20	25	.16
20-10	150	.23
80-80	300	.21
90-10	350	.21
80-10	450	.49
150-50-25	150	.49
80-10-10-10	350	.21
40-40-20-2	150	.28
30-15-15-15	300	.28
80-10-10-10	350	.32
40-10	450/350	.56
40-20	150/25	.21
40/50	400/300	.28
80/50	450/50	.65
250/1000	10/6	.30

## INTERCOM.

Interphon used on tanks. Amplifier converts easily for operation on 110V. AC. 60 Cy. Ideal for garages, homes, factory. Nussey-brand New, with Complete Conversion Data. **\$4.75**

## RELAYS

Relay No.	Coil Res (ohms)	Coil Vols (D.C.)	Contacts	Price
RY 107	20	4-12	1A-20 Amp	\$1.65
RY 1P3	100	12	2C	1.45
RY 12S	13,500	48	1A-1B	1.49
RY X32	120	18-24	2-B	.97
RY X27	120	18-24	2-B	.97
RY 80-2	100	20-24	2-A	.89
RY 834	90	3 (Can)	1-B	1.75
RY 613	150	24	5-C	1.29

Mail orders promptly filled. All prices F.O.B. New York City. Send money order or check. Only shipping sent C.O.D. Rated concerns send purchase order. All Merchandise Subject to Prior Sale. Prices Subject to Change Without Notice.

**131 LIBERTY STREET, NEW YORK, N. Y. . DEPT. K-5 PHONE DIGBY — 9-4124**

NOTE: PARCELS IN EXCESS OF 20 LBS. WILL BE SHIPPED RAILWAY EXPRESS OR CHEAPEST MOTOR FREIGHT.

## Now... Get ALL Your DRIVERS FROM



Only Vaco offers you the complete, fine quality line of drivers that daily is proving its superiority in service shops and on factory production lines . . . in terms of performance at low cost. Made of specially heat treated chrome vanadium blades mounted in break-proof, shock-proof plastic handles, Vaco drivers are the choice of experts in TV and radio.

## SPECIAL RADIO AND TV DRIVERS

Investigate Vaco's new non-metallic aligners, non-magnetic beryllium copper focalizer screw drivers and other unusual products. They are made especially for radio and TV and have proved themselves most practical in delicate adjustment work.

## NEW 27 PIECE TV SERVICE KIT

Also available from Vaco is a new 27-piece TV Service Kit made up at the request of TV men. You'll find a full description of this kit and other Vaco products in the new Vaco 3-color catalog. Send for it, today.



At Your Supplier or Write to:  
**VACO PRODUCTS COMPANY**  
 317 East Ontario Street, Chicago 11  
 In Canada: Vaco-Lynn Products Co., Ltd.,  
 204 Laurier Ave., W., Montreal 6, Quebec

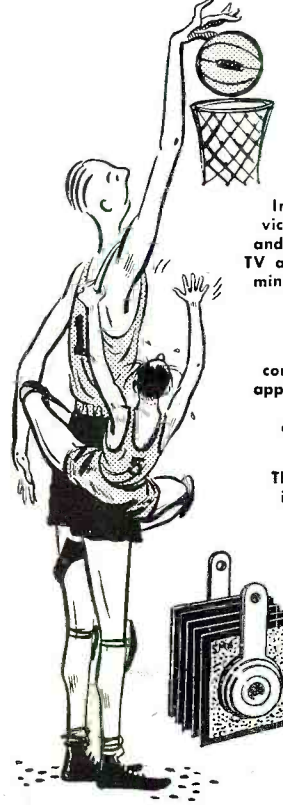

**High score every time with "Safe Centers!"**

In Basketball there's no better assurance of victory than a lengthy lad jumping center . . . and there is nothing that scores higher in radio, TV and other electronic circuits than SELETRON miniature rectifiers with "Safe Center" plates.

When you specify SELETRON Selenium Rectifiers you eliminate arc-over danger, short circuits and heating at the center contact point. Assembly pressure, or pressure applied in mounting the rectifier cannot affect its performance—a SELETRON feature accomplished by deactivating the area of the plate under the contact washer.

The millions of SELETRON Selenium Rectifiers in satisfactory service as original equipment in the products of leading manufacturers are millions of reasons why you can specify SELETRON and be safe!

Look for Howard W. Sam's Red Book Supplement listing SELETRON replacements . . . and write for Bulletin No. 104-N-2



SELETRON DIVISION  
**RADIO RECEPTOR COMPANY, INC.**  
 Since 1922 in Radio and Electronics  
 Factory: 84 North 9th St., Brooklyn 11, N. Y. • Sales Department: 251 West 19th St., New York 11, N. Y.

# USE PHOTOFAC

the world's best Radio and TV Service Data...



WE'LL PROVE YOU'LL SAVE TIME and EARN MORE WITH PHOTOFAC

**FREE** Service Technicians: We'll send you any Photofact Folder listed in the "PF INDEX and Technical Digest." If you haven't an Index, get a free copy from your local Photofact distributor or write for it today. To obtain Free Folder, be sure to state Photofact Set and Folder Number as shown in the Index.

NOW—learn for yourself how PHOTOFAC makes your Radio and TV work quicker, easier, more profitable! Just get and use an actual PHOTOFAC Folder. Discover why over 35,000 successful service technicians count on this invaluable data daily. No other service gives you PHOTOFAC's completeness, accuracy, uniformity and lowest cost. PHOTOFAC is the only Radio-TV service data prepared from laboratory analysis on the actual equipment. Get your FREE Folder now. Examine, use, compare. See why you can't afford to be without PHOTOFAC!

**NOTE:** Our FREE Folder offer is limited to Service Technicians only. Attach coupon below to your letterhead and mention your jobber's name. Experimenters and others may obtain the Photofact Folder by remitting amount shown below.

## HOWARD W. SAMS & CO., INC.

HOWARD W. SAMS & CO., INC.  
2201 E. 46th St., Indianapolis 5, Ind.

I am a Service Technician. Send me Free Folder No. .... which appears in Photofact Set No. .... (as listed in the PF Index).

I am an Experimenter. Enclosed \$..... Send me Folder No. .... which appears in Photofact Set No. .... (TV—\$1.00. AM/FM—50c. Record Changer, or Communication Receiver—75c)

Name.....

Address.....

City.....Zone.....State.....

**EASY PAY PLAN!**

**PAY AS YOU EARN!** Ask your distributor about this amazing plan. Only \$18.39 puts the entire profit-boosting Photofact library in your shop now!

String Quartet concerts, Amsterdam's Concertgebouw Orchestra, and an ever increasing array of cultural material.

Tape recording is also playing a wonderful role in therapy by bringing diversion and entertainment to hospitalized G.I.'s. Fifty Veteran Administration Hospitals have formed their own Tape Network.

In these hospitals, small bedside radios with earphones are provided. In addition to tuning the broadcast band for local stations, the bedside radios pick up a signal which originates inside the hospital and which is fed from a tape recorder. Talent for the hospital "broadcasts" is supplied by the hospitalized G.I.'s themselves. Many of them find that participation is an excellent distraction and are therefore eager to cooperate. Top-name motion picture, stage, radio, and TV entertainers visit the hospitals regularly. Although they broadcast "live" to the men in only one hospital at a time, their shows are simultaneously put on tape and circulated among other Veterans' hospitals.

Typical of the patient-produced, tape recorded shows is "Minot Varieties," which is done at the Minot VA in North Dakota. "The Old Country Store" is a light disc jockey show created by veterans in Jefferson Barracks, Missouri. The Tape Network doesn't just accept anything or everything that has been recorded. Officials make certain that only the choice shows are circulated.

Tape has been a wonderful boon to these boys in helping them recover from their illnesses and it is doing it at an amazingly low cost. Almost all of the hospital owned tape recorders were used for transcription, lectures, conferences, and seminars when the Network was formed. Now they are also used for recording and playing back shows for the VA Tape Network. Actually the only cost involved is the purchase of the magnetic tape and the small postage for mailings to other hospitals. Of course, the tape is re-used after it has made the circuit.

Allied Record Mfg. Co. tells us that Allied has been engaged in the development of a direct re-record duplicator for the past two years and will soon announce the specifications and characteristics of the unit. When the information is released, we will try to bring you all the details on this equipment.

### Tapes of the Month

A-V Tape Libraries, Inc. of 730 Fifth Avenue, New York supplied us with five reels of their pre-recorded magnetic tape for review this month. The comments on the individual reels are included below the listings.

A label on the back of the box lists the selections included on the enclosed reel. A-V has designed a unique label for the reels which bears an identifying number for the reel in the same manner that records are identified. In addition, a tab of adhesive is attached

## 17 Jewel Swiss CHRONOGRAPH

For Men Who Demand Precision

\$29.95 Including Tax.

Importer's Price

- 1/5 Second STOP WATCH
- 3 Separate Dials
- TACHOMETER
- TELE-METER
- 17 JEWELS
- Anti-Magnetic
- Shock Resistant
- PRECISION Time Keeper



Imported from Switzerland

Swiss Craftsmen designed this 17 Jewel Recipro-Register Chronograph for men whose work or hobbies require a versatile, precise timepiece.

**GUARANTEED**  
Full 2 YEAR Written Guarantee with each watch. Absolutely NO CHARGE during this period for any repairs necessary, excluding parts. COMPLETE SATISFACTION OR MONEY BACK!

This outstanding multi-purpose, multi-function synchronized Recipro Register answers all needs... at a price that can't be matched! We sincerely believe there is no greater watch value anywhere. Prove to yourself why other Hams have found this to be the best watch they've ever owned... at an unmatched \$29.95 price (tax incl.)... only because this is a DIRECT IMPORTER'S OFFER! Wear it, test it, compare it. Remember, our money back guarantee protects you... you must be 100% satisfied.

### CHECK THESE FEATURES

- Split-Second STOP WATCH calibrated to 1/5 Second.
- Contact clutch assures instantaneous start.
- Brake clutch freezes results. • It "remembers" results.
- Separate dials record seconds and minutes.
- Sweep-second hand ERASES BACK TO ZERO. 2-clutch reset movement plus extra perimeter calibrations give you simplified TACHOMETER and TELE-METER readings. Now measure speed or distance as easily as telling time!

Swiss Movement is encased in Chrome and Stainless Steel for shock resistance. A shatterproof crystal protects hands, raised luminous numerals and dials against dust, dirt and moisture. Recording hands are all SYNCHRONIZED; Jewel movement is ELECTRONICALLY TIME TESTED for positive isochronism. For men who work with electricity, it's ANTI-MAGNETIC!

**ORDER NOW AND SAVE** while we can hold this low. **LOW IMPORTER'S DIRECT OFFER PRICE.** Send \$29.95 (this includes all taxes and postage). Or send only \$2.00, pay postman balance (\$27.95) plus C.O.D. charges. Same Money Back Guarantee for cash or C.O.D. (Note: Deluxe Rolled Gold identical watch—\$34.95. Same terms as above.) SEND NOW to:

THE NASSAU CO., Dept 203  
Box 792, G.P.O. 1, N. Y. C.

REMEMBER HIM FOR FATHER'S DAY

## SAVE 1/2!

On This New, Improved **GAR-DIPPER GRID DIP METER KIT**

**\$14.95** Postpaid in U.S.A.

### CHECK THESE FEATURES:

- Self-contained power supply using a power transformer
- High quality components
- Complete with Instruction Manual
- Precision 1-mil meter
- Easy-to-read dial
- NOTHING ELSE TO BUY

### MONEY-BACK GUARANTEE

Accurate precision instrument tells where your equipment is in the radio spectrum. Range 3 to 170 megs. Operates on 115 AC, 60 Cy. Complete with plug-in coil form and simple instructions, FB for ham stations. TV technicians, experimenters—makes a fine photo monitor, field strength meter, signal generator. Indispensable for TVI elimination.

**ALVARADO SUPPLY CO.**

NEW ADDRESS: Dept. R-1, 4665 Melrose Ave. Los Angeles 29, California

RADIO & TELEVISION NEWS

to the leader tape to permit the reel to be sealed, thus avoiding "loose ends."

**A-V #1010 (CONCERT HALL SERIES)**

Part 1. Symphony #4 in B Flat Major (Beethoven)

Austrian State Symphony Orchestra, George Singer, conductor

Part 2. Symphony in C Major, KV 200 (Mozart)

Salzburg Mozarteum Orchestra, Paul Walter, conductor

Minuette and Gavotte (Mozart)

Austrian State Orchestra,

Kurt Woss, conductor

(Available as 7.5" single-track—2 reels; 7.5" double-track—1 reel; or 3.75" double-track—1 reel)

Like the other two "Concert Hall" reels reviewed this month, this recording further convinces the listener that the true role of magnetic tape is that of the "final" medium rather than that of the "middleman" in bringing music to the aesthete's loudspeaker. An added comment on this reel is that this particular program was recorded with a somewhat more "live" acoustic quality than the others, a quality which makes listening more pleasant. Lovers of Mozart will find this particular reel a rewarding one.

**A-V #1007 (CONCERT HALL SERIES)**

Part 1. Fifth ("New World") Symphony (Dvorak)

Austrian State Symphony Orchestra, George Singer, conductor

Part 2. Fifth ("New World") Symphony (Dvorak) Concluded

"Haffner" Symphony in D Major (Mozart)

Conducted by Hans Wolf

(Available on 7.5" single-track—2 reels; 7.5" double-track—1 reel; or 3.75" double-track—1 reel)

Here is a reel that deserves acclaim. It is literally a "concert" with two balanced symphonic works on the same program. The critic was delighted on all scores with this one. The true value of music-on-tape is demonstrated positively on this reel. It has excellent dynamic range, the *piano* passages are truly hushed and free from extraneous and distracting noises and the *forte* passages are clean and distortionless.

**A-V #1002 (CONCERT HALL SERIES)**

Part 1. Symphony #7 in C Major (Schubert)

Austrian State Symphony Orchestra,

Kurt Woss, conductor

Part 2. Symphony #7 in C Major (Schubert) Concluded

Ballet Selections (Delibes)

Austrian State Symphony Orchestra,

Max Schonherr, conductor

(Available as 7.5" single-track—2 reels; 7.5" double-track—1 reel; or 3.75" double-track—1 reel)

This reel was originally recorded in Europe on magnetic tape with an *Ampex* professional magnetic tape recorder. A full symphony orchestra was employed for the sessions. The orchestra performs as a group of seasoned musicians who have long played together. The microphones were apparently placed for pickup with considerable presence. The tape duplication is excellent, free from distortion

**LOOK—NO NOISE!**

Boosts the signal . . . not local lead-in noise!

Gives higher signal-to-overall-noise ratio!

Exclusive broadband circuit gives uniformly high all-channel gain!

Eliminates effect of external interference

**Tenna-Top TV BOOSTER**

AUTOMATIC SELF-TUNING

SINGLE TWIN-LEAD LINE\* CARRIES POWER UP—AND SIGNAL DOWN

**Pictures are Sharper, Brighter! Sound is Clearer!**

You can *see* and *hear* the difference when you hook up the TENNA-TOP. Because it is mounted at the antenna ahead of the lead-in...it amplifies only the wanted TV signals, not any local noise interference produced by automobile ignition systems, neon signs, diathermy, or other external noise picked up by the lead-in. You have the further advantage of E-V low-noise circuit. All this guarantees the best possible results with any TV set anywhere...even in toughest fringe areas or in all noisy locations. The TENNA-TOP is completely automatic. Turns "On" or "Off" with the TV receiver switch. It is easy to install, highly stable, trouble-free.

Model 3010 Tenna-Top TV Booster. List Price . . . \$88.00



**Tune-O-Matic TV BOOSTER**

Famous E-V broadband booster—proved in thousands of installations! Uniform high gain—low noise circuit. Automatic self-tuning for all channels. Easily concealed.

Model 3000, 4-stage, List \$57.50  
Model 3002, 2-stage, List \$39.50

**Electro-Voice**

TV BOOSTERS • MICROPHONES • HI-FI SPEAKERS • PHONO-PICKUPS

Send for Free Bulletin

Electro-Voice, Inc., Dept. N5-52  
410 Carroll St., Buchanan, Michigan  
Send Free Bulletins 163-165

Name \_\_\_\_\_ (PLEASE PRINT)

Address \_\_\_\_\_

City \_\_\_\_\_ Zone \_\_\_\_\_ State \_\_\_\_\_

Serviceman  Installer  Dealer  TV Fan

\*Patent Pending

Enjoy "LIVING SOUND" with a

# McIntosh

Build your custom installation  
around the world's  
finest amplifier!

Unquestioned in its superiority, the McIntosh 50-watt amplifier reproduces every sound source without adding to, or subtracting from, the original. Only the McIntosh, with its unique, patented design, can reproduce your musical library with less than 1% harmonic or inter-modulation distortion, over the entire audible range, and at full power.

Listen to the McIntosh at your dealer's . . . compare it with any amplifier at any price—for only then can you judge the truly superior quality of the McIntosh! Write today for free catalogue and name of nearest dealer.

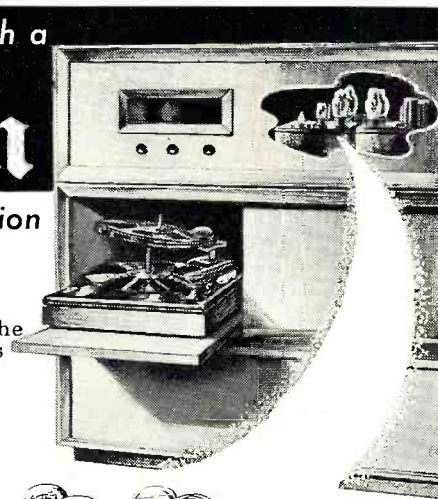

50W-2 Amplifier  
50 Watts (Peak: 100)

**MCINTOSH LABORATORY, INC.**  
322 Water St., Binghamton, N. Y.

or any artificial qualities which might give it away as a re-recording of an original.

**A-V #801 (WESTERN SQUARE DANCES)**  
Arkansas Traveler—Soldier's Joy—Old Kentucky Home—Golden Slippers—Draggin' The Bow—Pig Angle Rag—Red Wing—Listen to the Mocking Bird—Fiddlin' the Blues—Haste to the Wedding—Eddie's Polka—Little Brown Jug—Candy Kisses—Turkey in the Straw. (Available as 7.5" single-track; 7.5" double-track; or 3.75" double-track)

This reel contains a continuous medley of some of the best-known "hop tunes". Played by the old favorite combination of accordion, steel guitar, bass, traps, and that characteristic trio of violins with *glissando*, this reel was recorded without vocals, according to the manufacturer, so that the user can do his own "calling". The musicians are not identified and probably are a "pickup group". However, they do a good job of performing the "toe-tap-pin" kind of music.

**A-V #604 (ORGAN REVERIES)**  
Goin' Home—The Lord's Prayer—I Hear You Calling Me—Nearer My God to Thee—I Shall See Him Face to Face—Prelude (Chopin)—Oh, My Father—Sweet Hour of Prayer—Shall We Meet—Jesus, Lover of My Soul. (Available as 7.5" single-track; 7.5" double-track; or 3.75" double-track)

Here is a reel of devotional music performed quite warmly on a cathedral organ. The artist isn't identified; however, he apparently knows the emotional powers of his instrument. The quality of this particular reel is not as good as the others reviewed this month. There is a deficiency of bass and the treble tones have an artificial quality, but the tender performance still makes this reel a good one. The manufacturer informs the critic that the original recording was also made on magnetic tape.

We hope to have more tapes available for review in the near future. We'll keep you posted as the new items hit the market.

-30-

### NEW FT. DIX SERVICE

**THE MARS** station, AA2WAO, at Fort Dix, New Jersey has announced a new service for military and civilian personnel living near or at the base.

According to Lt. William A. Winant, radio officer at the base, the MARS station will undertake to relay personal messages throughout the United States and on a world-wide basis without cost to the sender or the recipient.

The Fort Dix station was opened on January 25th to assume control of the Burlington, Ocean, and Monmouth County net of the New Jersey State MARS control net.

According to word from the base, persons interested in sending messages should phone 3207 or go direct to building T-29-80, located adjacent to the Signal Property Office near the Wrightstown circle at Fort Dix.

The MARS station at the base is interested in building up traffic and will, therefore, welcome the opportunity to serve Fort Dix personnel and interested civilians.

-30-

**THIS PRODUCT**



**WILL SAVE YOU**

**TIME, MONEY**

AND

**HEADACHES**

ITS MAGIC ACTION  
STOPS NOISY OPERATION OF

**TV & RADIO**

CONTROLS & SWITCHES  
AND ALL OTHER MOVING PARTS

**WITHOUT**

REMOVAL FROM CHASSIS

"IF IT MOVES OR ROLLS USE"

**QUIETROLE**

Order from Your Distributor

MFD. BY

**QUIETROLE COMPANY**

SPARTANBURG

SOUTH CAROLINA

Prerequisite to

*Natural Reproduction  
of Music*

THE **BROOK**  
ALL TRIODE HIGH QUALITY  
AUDIO AMPLIFIER

The BROOK will play at extremely low volume, yet retain full naturalness of tone; or, recreate in your home the full volume of a symphony, or dance band, clear and clean. You will hear and FEEL live music and voices.



Write for technical data, booklet.

"Better Listening"

and name of local dealer. Dept. RE-2.

**BROOK ELECTRONICS, INC.**

34 DeHART PLACE, ELIZABETH 2, N.J.



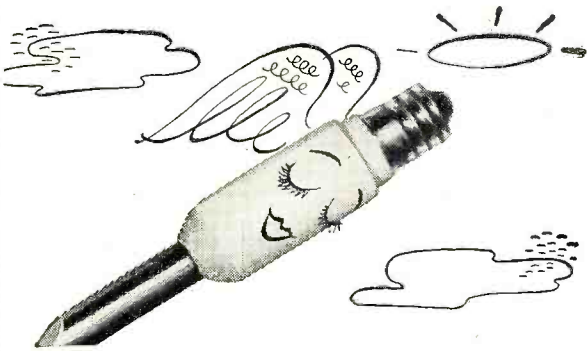

For a Heavenly Soldering Job, Insist on

*Ungar's little Angels*

Need we say more?

No. 537-5 1/8" PENCIL TIPS, 20 Watts

For Light Duty Work. Recommended for small meters and instruments, small joints and hard-to-reach points on radio and TV. printed circuits, delicate electronic assemblies, aircraft instrument repair, hearing aid assembly and repair.

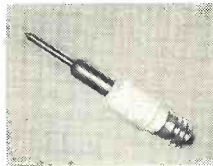

Write for Catalog No. 400

**Ungar** ELECTRIC TOOLS, INC., Los Angeles 54, Calif.

**'S SH ME**  
to throw away  
that beautiful old  
Console . . . replace the  
obsolete radio with a  
modern, easily-installed

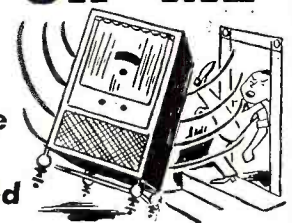

**ESPEY AM/FM CHASSIS**

and your console is "right-up-to-date"



It is not necessary to spend a large sum of money to modernize your old radio or to become a "High Fidelity" enthusiast. ESPEY chassis provide the Highest Quality at moderate prices.

Fully licensed under RCA and Hazeltine patents. The photo shows the Espey Model 511-C, supplied ready to play. Equipped with tubes, antenna, speaker, and all necessary hardware for mounting.  
**NEW FEATURES**—Improved Frequency modulation circuit, drift compensated • 12 tubes plus rectifier, and pre-amplifier pick-up tubes • 4 dual purpose tubes • High quality AM-FM reception • Push-pull beam power audio output 10 watts • Switch for easy changing to crystal or variable reluctance pick-ups • Multi-tap audio output transformer supplying 4—8—500 ohms.

Write Dept. RN-5 for literature and complete specifications on Model 511-C and others.  
Visit our Booth No. 673 at the PARTS Show in Chicago.

**ESPEY** Makers of fine radios since 1928  
E. L. Trafalgar 9-7000  
**MANUFACTURING COMPANY, INC.**  
528 EAST 72nd STREET, NEW YORK 21, N. Y.

**GIANT TV SALE Save on Chassis, Tubes, Cabinets, Accessories, etc.**

**NEW—THE SENSATIONAL 630-DX CHASSIS**

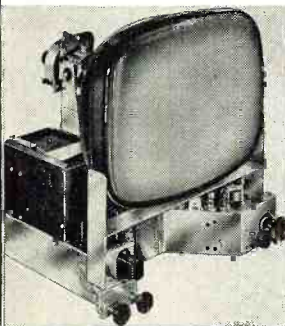

Amazing Low Price!  
**New Cascade Tuner**  
1952 Model—30-Tubes—  
For 16" to 24" Picture Tubes.  
FINEST CHASSIS AVAILABLE At Any Price! For long range and best reception up to 200 miles without a complicated booster or antenna, this new, advanced 630 DX Chassis gives 3-times normal reception. Special extra-high gain standard coil tuner offers greater sensitivity, top performance on any channel; aligned & tested for 5 hours; modded condensers; 4 microvolts sensitivity; FM sound system; horizontal & linear lock and is directly adaptable for color and UHF. This is the very best chassis buy—order NOW at this low-price! You can't beat it!

**RMA Guaranteed—Factory Wired**  
Complete, ready to play including 12" speaker, hardware and knobs:

Special Price—Limited time only **\$149.50** (Incl. Fed. Tax—less CRT)  
**ORDER NOW and SAVE!**

**FREE!** With any chassis, a copy of the famous "TV Trouble Shooting Method" locate all troubles in a jiffy. Complete with illustrations and hundreds of rapid checks. Get yours NOW—FREE!

**TV TUBE ACCESSORIES—ANTENNAS**  
Each Specially Priced!

- |                                    |   |
|------------------------------------|---|
| Universal Mounting Bracket. \$5.95 | <b>Famous Conical "Fan-Tenna"</b><br>Finest antenna made at any price. Completely pre-assembled. All seamless aluminum doweled elements & crossarm. Regular list: \$12.43. Save more than half! |
| Sleeve & Ring for 16" Metal 3.85   | <b>\$6.19 ea. \$5.59</b> ea. lots of 6  |
| Sleeve & Ring for 19" " 4.04       |   |
| Sleeve & Ring for 24" " 7.95       |   |

**LUXURIOUS, NEW TV CABINETS**

For 630 Chassis, 17", 19", & 20" Picture Tubes

Model 100 Reduced to <b>\$39.50</b>		Save 45%! Custom Styled	Model 200 Now only <b>\$49.50</b>
---	--	----------------------------	---

Blonde finish add \$10

Every beautiful cabinet, in richly finished, hand rubbed mahogany will stand out in any room. Made special to house the 630 chassis, they will carry a 17", 19", 20" or 21" picture tube. Every cabinet is custom styled, made by craftsmen and guaranteed perfect. Includes safety glass, mask and mounting brackets. Order Now and Save 45%!

**All Prices Reduced! CRYSTAL CLEAR LUCITE MASKS**

Framed in Rich Gold Leaf Finish

RO—Round Tubes	
RE—Rect. Tubes	
14" RE 10 1/2" x 13 1/4" . . . . .	\$4.49
16" RE 12 1/2" x 15 3/4" . . . . .	5.79
16" RO 13 1/2" x 17" . . . . .	5.89
17" RE 13 1/2" x 17" . . . . .	5.89
19" RO 15 1/2" x 20" . . . . .	7.69
20" RE 16 1/2" x 20 1/2" . . . . .	7.69
24" RO 21" x 25" . . . . .	13.95

**TV PICTURE TUBES**

6-Months Guarantee—non pro-rata  
Black Face—Brand New—Standard Brands—Sealed Cartons

10BP4 Round-Glass. \$24.95	16HP4 Round-Glass. \$33.95
12LP4 Round-Glass. 24.95	17BP4 Rect.-Glass. 29.95
14BP4 Rect.-Glass. 24.95	19AP4A Round-Metal 37.95
16GP4 Round-Metal. 31.95	20CP4 Rect.-Glass. 37.95
21" Rect. 39.95	24AP4 Round-Metal. 69.95
Cylindrical face.	

NOW! Write for FREE Catalog including new complete line of tubes, parts, accessories for radio & TV, plus test instruments.

MINIMUM ORDER: \$5.00. 25% deposit with order, balance C.O.D. Include postage with order. All merchandise subject to prior sale, F.O.B. New York City. Prices subject to change without notice.



**THE ROSE COMPANY**

98 Park Place

Dept. R-5, New York 7, N. Y.

CORtlandt 7-6195

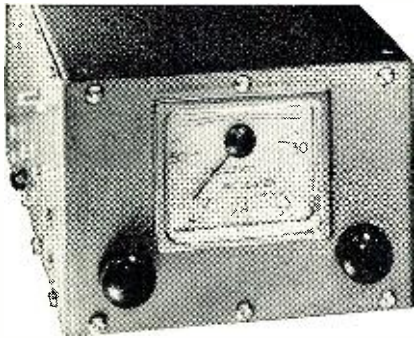

## Model M-51

# for emergency communications

USED BY HUNDREDS OF MUNICIPALITIES FROM BOSTON, MASS., TO ALHAMBRA, CAL.

## POLICe ALARM

## MONITOR RADIO

5 Models For All Systems

6 VOLT MOBILE

M-51

Tuneable 30-50 MC

M-101

Tuneable 152-163 MC

115 VOLT AC-DC

PR-31

Tuneable 30-50 MC

PR-8

Tuneable 152-163 MC

AIRCRAFT

AR-1

AM Tuneable 108-132 MC

115 Volt AC-DC

Says S. L. Grant, City Manager, Winchester, Virginia . . .

"I think you have a receiver that is well built, and I see no reason why it should not be in demand by all public works departments that have a transmitter available."

Users of FM 2-Way Radio Communications equipment throughout the entire nation, find Polic-Alarm and Monitorradio a welcome innovation to low-cost mobile communications radio .

For Complete Information: See Your Jobber—Or Write Us Today

**RADIO APPARATUS CORPORATION**

55 N. NEW JERSEY ST., INDIANAPOLIS 4, IND., PHONE: ATLANTIC 1624

## International Short-Wave

(Continued on page 67)

Club, c/o Kenro Wada, Secretary, Kitagobancho 48, Sendair, Japan, is eager to hear from SWL's. (URDXC)

*Norway*—The Arctic Listeners Club, Postboks 170, Tromsø, Norway, now issues a house organ regularly. (Radio Sweden).

*Sweden*—The Malo Kortvagsklubb (Malmo Short-Wave Club) now publishes a bulletin called "Malmo DX-aren;" has tips in *English* as well as in Swedish; *English* section is compiled by Gunnar Persson; officers of the club include Bror Otto Svenburg, Gunnar Persson, Lars Ingvar Nilsson, Arne Svensson, and Gunnar Friberg; QRA is Malmo Kortvagsklubb, Ystadsgatan 31, Malmo, Sweden.

\* \* \*

### This Month's Schedules

(NOTE: Some stations will be changing to Summer Time now; in such cases, schedules may be one hour earlier than listed herein.—K.R.B.)

*Afghanistan*—Radio Kabul, 9.975, noted Sundays signing on 1118A and running to 1200A; on week-days runs only 1110-1120A. Starts with newscast. (Pearce, England; Ridgeway, South Africa)

*Albania*—ISWC, London, says Radio Tirana has news 1615 over 7.850 and 6.560 (new). Confirmed by Pearce, England; has bad CWQRM on 6.560; carries Italian news 1515.

*Algeria*—Radio Algerie, 7.280, is good signal some days from around 1645 to sign-off with "La Marseillaise" 1800. (Bellington, N. Y., others) Noted by Pearce, England, on 6.145 signing off 1800 with "La Marseillaise;" heard as early as 1430.

*Argentina*—LRT, 11.840, Tucuman, noted around 2000 with all-Spanish program. (Niblack, Ind.) Latest SIRA schedules are listed—LRA, 1030-1230, Portuguese for Brazil, 17.720; 1235-1530, French for France, 17.720; 1600-1700, German for Germany, 9.690; 1730-2030, *English* for Eastern USA, 17.720; 2100-0100, Spanish for Caribbean, 15.345. LRU, 1300-1400, Spanish for Latin America, 15.290; 1400-1545, *English* for England, 15.290; 2100-2300, Spanish for Latin America, 15.290, and 2300-0100, *English* for Western USA, 15.290. LRS, 0800-1300, Portuguese for Brazil; 1300-1400, *English* for England; 1400-1500, Swedish for Sweden; 1500-1600, Italian for Italy; 1600-1700, German for Germany, and 1700-2230, Portuguese for Brazil, all on 11.880.

*Australia*—Radio Australia's current schedules for North America include 2330-0045 to West Coast on VLA15, 15.200; 0700-0900 to East Coast, 0900-1000 to Central and Mountain Zones, and 1000-1115 to West Coast over VLA11, 11.810.

VLM4, 4.9175, Brisbane, noted 0600-0730 at good strength in Missouri. (Boggs)

*Azores*—CSA92, 11.090, Ponta Delgada, noted with Portuguese program

**RADIO & TELEVISION NEWS**

**NOW... quickly, easily**  
cut **SQUARE** and  
**OBLONG** openings  
in radio chassis

**WITH THE GREENLEE No. 731**  
**SQUARE RADIO CHASSIS PUNCH**

Now, in 1½ minutes or less you can do hole-cutting jobs that might take an hour with old "drilling and filing" methods. Simply insert GREENLEE Punch and turn with an ordinary wrench . . . a square or oblong opening is cut immediately. An indispensable, timesaving tool that pays for itself in a hurry.



In sizes 5/8", 3/4" and 1"

**GREENLEE**

Write today for facts and prices on this handy Punch. Greenlee Tool Co., 1885 Columbia Ave., Rockford, Ill.

138

**STAR SPECIALS**  
NEWEST ITEMS! LOWEST PRICES!

**GENERAL INSTRUMENT 3-SPEED CHANGER**  
Same model used in popular TV-Radio-Phono combinations. Plays 33½, 45 and 78 rpm records in 7", 10" and 12" sizes. Perfect for custom installations or modernizing old-type consoles. Brand new, packed in original factory carton, a real buy at only. . . . . <sup>A-1749</sup> **\$17.95**

—LATEST TEST EQUIPMENT—

**SIMPSON 276 OSCILLOSCOPE CALIBRATOR**  
Adapts any oscilloscope for quick and accurate voltage measurements by comparative methods. Big 4½" meter. Reads RMS 0.06 to 90, peak 0.1 to 125, and peak-to-peak 0.2 to 250 volts; all measurements in 6 ranges. Black molded bakelite case identical to Simpson 269; carrying handle. Operates from 105-125 volts, 50-60 cycles. . . . . **\$28.91**

**TV PICTURE TUBE REACTIVATOR**  
Restores most low emission tubes up to 80% of original brilliance; adds 50% to picture tube life. Rejuvenates pure barium coating on surface of tube cathode. Cannot harm picture tube. Brightens up old sets. . . . . **\$14.65**

SEND FOR OUR BIG BARGAIN CATALOG!

**STAR ELECTRONIC DISTRIBUTORS, INC.**  
Dept. RN-5-7736 S. Halsted, Chicago 20, Ill.

1500-1600 at usually good level. (Dary, Kans.) May be on *summer* schedule of 1400-1500 by now.

**Bechuanaland**—ZNB, 8.230, Mafeking, noted recently 1310 with recordings to 1430 when closed with "God Save the Queen." (Pearce, England)

**Belgian Congo**—A DX program in Swedish is now radiated at 1410 every second Friday over OTC2, 9.745. (WRH) Is recorded by the Teknikens Varld's Radio Club, Sveavagen 53, Stockholm, Sweden. (Radio Sweden) The 9.745 channel noted 1735-1755 with steady signal. (Precourt, N. Y.)

OTM1, 6.295, and OTM2, 9.385A, now close 1600 weekdays instead of 1500; carry news in Flemish 1545; French is used from 1100 for first part of session, then Flemish in second half of period to closedown; these are "home" programs. (Ridgeway, South Africa) The 9.385A outlet was logged 0121-0130 sign-off; announcements in Flemish and French. (Patterson, Ga.)

**Bolivia**—CP38, 9.505, La Paz, *Radio La Cruz del Sur*, is scheduled weekdays 0600-0730, 0930-1245, 1800-2115; Sundays 0700-0800, 1100-1530; news in Spanish weekdays *only* 0700, 1230, 1830, 2100. (WRH)

**Brazil**—ZYB7, 6.095, and ZYB8, 11.765, were noted in dual recently 1950 tune-in. (Bellington, N. Y.) PRN9, 9.294, noted 1805 with music, fair level in England. (Catch)

"Brazil Calling," presented in *English* by *Radio Jornal do Comercio*, Recife, has now returned to a weekday schedule of 2005-2030, and Sundays is still 1625-1655, over ZYK3, 9.565; is now using ZYK3 on 11.825 for the 0355-1100 period, widely reported. *Radio Borborema*, 3.325, Campina Grande, is now on the air 1600-2030 with 1 kw. ZY220, *Radio Relogio Federal* (Standard Time Service Station), Rio de Janeiro, has been delayed in the opening of its 4.905 transmitter due to construction difficulties—but by now may have begun operations. (Serrano, Brazil, via WRH)

**British Guiana**—ZFY, 5.980A, Georgetown, noted 0530 at fair level. (Golden, Mass.) Good signal in Indiana around 1930-2000. (Niblack)

**British New Guinea**—VLT7, 7.280, Port Moresby, has good signal daily around 0730. (Dary, Kans.) VLT9, 9.520, fair 0145-0150 with classical music; announced "ABC." (Lane, Wyo.) Signed off 0300.

**Bulgaria**—In verifyng, Sofia listed *English* on 6.070 at 1500-1514, 1600-1629, and on 9.700 at 2000-2029, 2300-2315; listed channels of 6.070, 9.700, 15.330, 7.670, 827 kc., 593 kc., 1233 kc., and 1124 kc. (Dary, Kans.; Scott, W. Va.)

**Burma**—*Radio Rangoon*, 9.543A, now appears to close 1015 with *its own* National Anthem; heard well in South Africa from around 0915; news 1000. (Ridgeway) Current schedule is 2000-2130 on 9.540; 0030-0230, 6.035, 9.540; 0700-1015, 4.775, 9.540; *English* at 2015-2030, 0115-0145, 0915-1015 (news 1000). (Radio Sweden)

**Cape Verde Island**—CR4AA, 5.885A, Praia, noted 1651-1702 when signed off

May, 1952

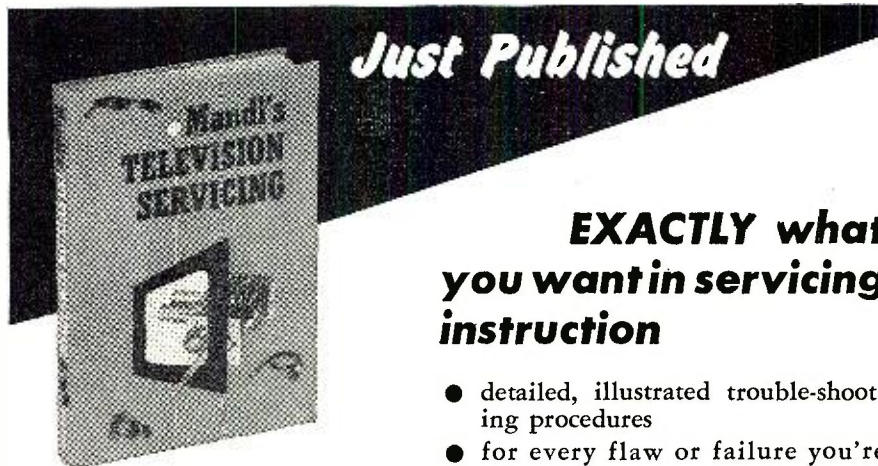

## EXACTLY what you want in servicing instruction

- detailed, illustrated trouble-shooting procedures
- for every flaw or failure you're likely to encounter in any TV receiver
- completely and clearly indexed for quick reference

### You'll find

Handy lists of troubles that may occur in each section of the TV receiver and the exact procedures for correcting each.

Large clear block diagrams of typical commercial circuits for tuners, focus control systems, R-F voltage supply, sync separator systems and all other basic TV receiver circuits.

New original photographs showing actual symptoms of trouble on TV screens to aid identification.

Full explanation of unusual, hard-to-find troubles and how to fix them, as well as all ordinary defects.

Complete instruction on the use of testing equipment, and oscilloscope patterns to facilitate the checking of test results.

Ways of improving overall performance; how to improve gain, reduce ghost reception, minimize interference.

Special servicing instruction for color TV and for VHF and UHF receivers.

Whatever the trouble, in picture or sound, you'll be able to put your finger on it quickly and accurately with the aid of this book. More important, you'll KNOW HOW TO FIX IT, without guesswork or trial and error, and with full assurance that the trouble is REALLY CORRECTED.

A complete master index, in clear, convenient tabular form, lists over 100 trouble symptoms—all the various hums, sound distortions, streaks and bars on picture, focus defects and all others that you're likely to find—with the probable causes of each and the page on which full servicing instruction for that particular fault is given.

You won't have to thumb through batches of manufacturers' notes, never sure that you have the right directions for the latest improvements or changes. Here are the instructions you need for correcting trouble in each circuit in any set, and the CLEAR UNDERSTANDING of each circuit you need in order to BE SURE that the adjustments you make will achieve the desired results.

300 illus.

A handy 421-page, fact-packed guide

Are these top-ranking aids on your working reference shelf?

### Fischer's RADIO & TV MATHEMATICS

"An extremely useful reference," wrote *Radio News* about this unique book. Here are step-by-step solutions, showing what formulas to use and what numerical values to substitute, for HUNDREDS of typical radio and TV servicing, construction, and operational problems, arranged under radio topics for quick reference.

### Noll & Mandl's TELEVISION & FM ANTENNA GUIDE

A basic course on antenna theory combined with a complete handbook on antennas and their installation. Shows how to pick the right antenna for the site, determine the best position for it, install transmission line for maximum efficiency and all other practical details for getting the most out of the antenna system.

### Noll's TV FOR RADIOMEN

Explains very clearly and fully all basic principles of television reception, the essentials of TV transmission, and the construction and operation of each part of modern TV receiving systems; and gives step-by-step instruction in installation, adjustment, alignment, and basic trouble-shooting procedures. A basic book for anyone in television servicing, noted for clarity and completeness. Here are all the fundamental why's and how's by a man known throughout the country as a leading authority on the technical aspects of television.

See them ON APPROVAL

Look them over, if you're not entirely satisfied you may return the books without further obligation.

The Macmillan Co., 60 Fifth Ave., New York 11

- |  |        |   |
|--|--------|---|
| <input type="checkbox"/> Mandl's TV Servicing  | \$5.50 | Please send me the books checked at left. I will either remit in full or return the books in 10 days. |
| <input type="checkbox"/> TV for Radiomen       | \$7.75 |   |
| <input type="checkbox"/> Radio & TV Math.      | \$6.75 | Signed .....  |
| <input type="checkbox"/> TV & FM Antenna Guide | \$6.25 | Address .....   |

*more TV set outlets  
per dollar!*

with easy-to-install  
**Blonder-Tongue**

**ALL-CHANNEL  
MASTER  
ANTENNA  
SYSTEMS**



Distribution Amplifier  
8 TV Set Outlets  
Model #DAB-1-M List Price \$87.50



Distribution Amplifier  
2 TV Set Outlets  
Model #DA2-1-M List Price \$39.50



Commercial Antensifier (30 Times  
Gain) Use As Pre-Amplifier, Line  
Amplifier or de-luxe Booster  
Model #CA-1-M List Price \$77.50

**More Gain Per Dollar!**

B-T Home Antensifier Model HA-2-M  
Finest All-Channel TV Booster, Fully  
Automatic, 16 Times Gain. In Metal  
Cabinet List Price \$57.50

See your local distributor  
or write to Dept. RN5



**Blonder-Tongue Labs., Inc.** Mt. Vernon, N. Y.

... and Now  
the NEW

**B-T  
MIXER-  
AMPLIFIER  
SYSTEM**

for ALL

**TV Channels**

&

**UHF**

See us  
in Chicago  
Booth 6

with "A Portuguesa;" identified with "Aqui Praia, Radio Clube de Cabo Verde." (Patterson, Ga.) Verified by QSL card; listed frequency as 5.895 (measured 5.8535) and schedule as 1530-1700. (Oskey, N. J.)

*China — Radio Peking, measured 10.261, noted 1820-1830. (Ballou, Calif.) Heard parallel on 10.200A, 10.260A for English starting 0400; announced 6.100, 10.260, 11.690, 15.060, 15.170. A station heard on 3.660A in Chinese around 0650-0750 may be a new Shanghai outlet; has time pips 0700; is parallel with Shanghai on 5.985 and other Chinese outlets on 6.155, 6.320, 6.500 for Chinese news relay from Peking 0700; is parallel 5.985 and 6.320 after 0730 but not with 6.155, 6.500; good signal. (Rosenauer, Calif.)*

Chinese on approximately 6.225 appears to sign off 0705; during Nationalist regime, this was the channel of XNEC, Tsinan, North China; Shanghai has been noted on 6.345A in parallel with 5.985; 8.265V is a new outlet for *Radio Peking*, used chiefly in the International Service; heard with bad QRM on West Coast after 1900, and also mornings around 0900; is parallel with 15.060V; while these open 1700 (with *English* to 1730A, they seldom have been audible until around 1900; sign off 2030; Shanghai, 91325V, directed to Taiwan, is scheduled 0500-0800 in parallel with Nanking, 9.733A. (Dilg, Calif., via URDXC)

*Dutch New Guinea — Although "Down Under" sources report Radio Hollandia has moved to 7.170, a letter from the station to Oskey, N. J., indicates the regular channel is still 7.1266, and that by this time should be testing on approximately 6.000; power is 350 watts. Heard recently on 7.126A by Dary, Kans., at 0530 with time signal of chimes; fair level.*

*France — Paris, 15.242, noted in French talk 1515. (Dary, Kans.) Heard on 7.240 at 0315 with "The French Have a Word For It" to 0330 sign-off; like a local. (Niblack, Ind.) Paris, 6.200, broadcasts nice dance music 0645-0700 Sats. (Radio Sweden) Paris noted on 5.966 at 1627-1645 in French and Portuguese; identified as "Aqui Paris" and "Ici Paris." Heard on 6.200 around 0243-0319 in French. (Patterson, Ga.) Paris, 6.145, noted 0100-0133; first five minutes in French, then American recordings with announcements in *English*; at closedown 0133 announced this is a "regular Friday night" feature. (Oestreich, Washington State)*

*Greece — Pearce, England, has heard a Greek Armed Forces Station on 3.710A in parallel with 6.340 around 1500; signed off 1700 with Greek National Anthem; no *English*.*

*Greenland — OXI, 7.094, Godthaab, noted with fairly good signal around 1740; heard another day signing on 1630; has been heard to 1840 fade-out; sent QSL card; relays 633 kc. (Pearce, England)*

*Holland — Radio Nederland has changed its schedules to this line-up—*

**PREMAX**

**FIRST...**

**TO DEVELOP AND  
INTRODUCE**

- 75-Meter Center-Loaded Mobile Antenna
- Built-in Co-axial Shielding
- Universal Ball Mounting
- Consolidated Spring Mounting



Premax can supply a complete line of vertical and mobile antennas for marine and amateur use or for CD. Send for new Bulletin.

**PREMAX PRODUCTS**  
DIVISION CHISHOLM-RYDER CO., INC.

5205 Highland Ave., Niagara Falls, N. Y.

**BUYING ANTENNAS?**

Buy by This Mark—  
The Seal of Quality Products  
and Sound Business Practices



**C. & M. MANUFACTURING CO.**  
Eastondale, Mass.

**CAMBURN, INC.**  
Woodside, L. I., N. Y.

**CHANNEL MASTER CORP.**  
Ellenville, N. Y.

**THE FINNEY CO.**  
Cleveland 3, Ohio

**HY-LITE ANTENNAE, INC.**  
New York 51, N. Y.

**JFD MANUFACTURING CO., INC.**  
Brooklyn 4, N. Y.

**RADELCO MANUFACTURING CO.**  
Cleveland 25, Ohio

**THE RADIART CORPORATION**  
Cleveland 2, Ohio

**RADIO MERCHANDISE SALES, INC.**  
New York 59, N. Y.

**WALTER L. SCHOTT COMPANY**  
Los Angeles 18, California

**SNYDER MANUFACTURING CO.**  
Philadelphia 40, Penna.

**T-V PRODUCTS CO.**  
Brooklyn 5, N. Y.

**WARD PRODUCTS CORP.**  
Division of The Gabriel Co.  
Cleveland, Ohio

**THE WORKSHOP ASSOCIATES**  
Division of The Gabriel Co.  
Needham Heights 94, Mass.

*English* (weekdays only) 1100-1140 to South Asia and Africa, 15.22, 11.73, 6.025; 1630-1710 to Europe and North America, 11.73, 9.59, 6.025; 2130-2210 to North America, Australia, New Zealand, 11.73, 9.59. The "*Happy Station*" Programs, produced and presented by Eddie Startz, are listed for Sundays (only) at 0530-0700, 21.48, 17.775, 15.22, 6.025 to Far East, Pacific, Europe; 1100-1230, 11.73, 9.59, 6.025 to Near and Middle East, Europe; 1630-1800, 11.73, 9.59, 6.025 to South and Central America; 2130-2300, 9.59; 6.025, to North America.

*India*—AIR, 11.85, noted signing on 1830 with native program; strong signal. (Fuller, R. I.) Has news 1730-1740.

AIR, 15.190, noted with native music 0810-0815 when announced and closed down. Heard on *measured* 7.175 with news 0730. (Ferguson, N. C.) Logged on 17.830 at 0245 with musical program and at 0300 with news. (Sanderson, Australia) Delhi noted signing on 1130 on 5.990 in *English*; program in native for Afghanistan followed; heard 1400-1515 with *English* for Europe on *announced* 7.170, 7.190, 5.990; later channel often has severe QRM from *Radio Andorra*; noted 0445 closing in *English* to South East Asia on 15.380, when announced program for 0830-0945 would be parallel on 15.380, 17.740. (Pearce, England)

*Indo-China* — *Radio France-Asie*, *measured* 7.228, noted 0715-0745 sign-off; had native program. (Ballou, Calif.) Has moved from 11.830 to 11.924 where is noted with news 2030; news in French 2045. (Sanderson, Australia, others) Heard on 11.924 irregularly mornings, noted with *English* talk 1025 one day, fair level. (Balbi, Calif.) At the time this was compiled, RFA was considering the possibility of moving to 15.430 for the 0400-0530 transmission (*English*) to South Pacific. (Radio Australia) Noted on 9.730A with news in French 0715, fair level. (Ferguson, N. C.)

*Japan*—*Radio Japan*, JOA, 7.180, some days is fair 0700 with *English* news. (Ferguson, N. C.) Heard testing on 9.675 to North America 0000-0100 in *English* and Japanese. (Hultman, Calif.) Balbi, Calif., says this is now on 6.069 in parallel with 11.705 (good).

*Kenya Colony*—Forces Broadcasting Service, East Africa Command, 7.265, Nairobi, noted on Saturdays signing on 2259 with trumpet fanfare; relays BBC news 2300; from 2315 uses recordings. (Kary, Pa.)

The Forces Broadcasting Service, *Middle East*, has ceased to operate on short-wave and is now using only m.w., according to a letter from Forces Broadcasting Service, East Africa Command, No. 2 Forces Broadcasting Station, P.O. Box 4040, Nairobi, Kenya. Schedules for FBS, *East Africa Command*, Nairobi, on 1420 kc. and 7.265, both 250 watts, were listed weekdays 2200-0000, 0430-1500, and Sundays and public holidays 2300-1500 (that Sunday start would be Saturday 2300 EST).

May, 1952

# Announcing:

**Rudy Weiss, former President of ARROW SALES, INC., announces his new firm name**

**... same location ... same courteous service**

**... same guarantee of quality.**

## I. D. 6B/APN4

### LORAN INDICATOR SCOPE

less tubes, like new	ONLY	<b>\$29.95</b>
<b>R9/APN4</b> , complete with tubes, like new		<b>\$17.95</b>
<b>BC 624</b> receiver (SCR 522), less tubes,		used <b>\$14.95</b>
<b>BC 625</b> transmitter (SCR 522) less tubes,		used <b>14.95</b>
<b>SCR 522</b> transceiver, complete in case with top bracket, less tubes		<b>29.95</b>
<b>BC 376H</b> Test Oscillator, new		<b>69.50</b>
<b>TS170/ARN5</b> glide path test set, new		<b>69.50</b>
<b>RS/ARN7 ADF</b> receiver, excellent		<b>74.50</b>
less tubes, used		<b>59.50</b>
<b>BC-1033</b> Marker Beacon Receiver (convertible to BC-1333), exc. cond.		<b>19.95</b>
<b>LP21LM ADF</b> loop, excellent cond.		<b>79.50</b>
<b>MC124</b> Flexible Cable, per length		<b>2.95</b>
<b>10/APN</b> Altimeter Test Set, new		<b>19.95</b>
<b>TS16/APN</b> Altimeter Test Set, new		<b>24.95</b>
<b>TS184/AP</b> Signal Generator, new		<b>89.50</b>
<b>TS51/APG4</b> Test Set for bomb release equip.		new <b>89.50</b>
<b>TS251</b> Loran Test Set, less crystal, BUT NEW		<b>100.00</b>

### SCR 625 Famous Army Mine-Detector

For Prospectors, Miners, Oil Companies, Plumbers, etc.

This unit is being offered now at a considerable reduction in price. Recently advertised at \$79.50 it is now available in the same brand new wrappings in suitcase style carrying case (less batteries) at **\$59.50** WHILE THEY LAST! Used, like new, \$39.50

### MIKES and HEADSETS

<b>HS 23</b> High Impedance Headset	new	<b>\$4.95</b>
<b>HS-33</b> Low Impedance Headset	exc.	<b>\$2.95</b> new <b>5.50</b>
<b>CD-307</b> Ext. cord for HS 23-33	like new	<b>.95</b>
<b>T-32</b> Desk Stand microphone		<b>2.95</b>
Good used cond.		
<b>Throat Mike</b> —T 30	New	<b>.98</b>
<b>Lip Mike</b> —Navy Type	New	<b>.98</b>
<b>Extension Cord</b> and Switch Assembly for lip and throat Mikes	New	<b>.98</b>
<b>CW 49505 High Impedance headset</b> complete with leather headband and rubber cushions.	Used	<b>98c</b>
<b>RS-38</b> , Microphone	new	<b>\$4.95</b>
<b>TS 10</b> sound powered HAND SET	new, ea.	<b>9.95</b>
	used, ea.	<b>5.95</b>
<b>HS-38</b>	exc.	<b>\$1.95</b> new <b>2.29</b>
<b>HS-30</b> , miniature headset	new	<b>2.49</b>
	used	<b>1.49</b>
<b>HB-7</b> Headband, used, exc.		<b>1.25</b>

### WOBULATOR

See page 43—December "Radio News" **\$5.95 ea.**

### REAL BUYS!

	Used	New
<b>RL 42</b> Antenna Gearbox Motor and Reel		<b>\$ 4.95 \$7.50</b>
<b>PE-101</b> Dynamotor		<b>2.75</b>
<b>BC-1023</b> Marker Beacon Receiver, complete with tubes, shock mount and instruction manual		<b>9.95</b>
<b>PE 206</b> Inverter		<b>4.95</b>
Scott Hi-Fi output transformer		<b>1.49</b>
<b>PE-218</b> Inverter		<b>29.95</b>
<b>SCR-522</b> , transceiver, less tubes		<b>29.95</b>
<b>BC-709</b> , battery operated, lt. wt., inter-phone amplifier, complete with tube, shock mount and manual, brand new, ea.		<b>\$3.95</b>

## COMMAND (SCR 274 N) EQUIPMENT

	Used	New
<b>BC-453</b> , with tubes	<b>\$19.95</b>	
less tubes	<b>14.95</b>	
<b>BC-454</b> , 3-6 mc receiver, less tubes	<b>7.95</b>	
<b>BC-455</b> , 6-9 mc receiver, with tubes	<b>9.95</b>	<b>\$14.95</b>
less tubes	<b>7.95</b>	
<b>BC-457</b> , 4-513 mc transmitter, less tubes	<b>5.95</b>	
<b>BC-458</b> , less tubes	<b>5.95</b>	
<b>BC-459</b> , less tubes	<b>12.95</b>	
<b>T-23 ARC 5</b> , 100-156 mc xmtr		<b>49.50</b>
<b>BC-496</b> , 2 position Rec. Control Box		<b>1.95</b>
<b>MC-215</b> Mechanical Drive Shaft, per length		<b>2.45</b>
<b>BC-450 3</b> Receiver Remote Control		<b>2.95</b>
<b>BC-451</b> Transmitter Control Box	<b>.69</b>	<b>1.50</b>
<b>BC-442</b> Antenna Relay, less condensers—used		<b>1.95</b>

### MONTHLY SPECIAL!

**BC 604 FM Transmitter**—20-27 mc. 10 Channel crystal controlled push-button, excellent for conversion to 10 and 11 meters, small quantity on hand, in good used condition, less dynamotor, some missing side covers, etc.—otherwise complete, including tubes—**\$7.95**

### CATHODE RAY TUBES

**16JP4**—\$19.95    **16DP4**—\$19.95  
90-DAY GUARANTEE

### COMPASS INDICATORS

**I 81 3"** 360 degree compass indicator and Selsyn Indicator... used **\$6.95 ea.**  
**I 82 5"** (description as above)... used **6.95 ea.**

### VIBRATORS

**2 Volt**—7 Prong Synchronous... **49c**  
10 for **\$4.25**  
**6 Volt**—4 Prong Non-synchronous... **79c**  
10 for **7.00**

### SCR 508 EQUIPMENT

**BC 604** Transmitter L/dyn... **\$12.95** Exc. Used  
**FT 237** Mounting... **9.95** Exc. Used  
Crystals, Set of 80... **19.95**

### RA 52—RECTIFIER

A transtat controlled rectifier to produce high voltage DC from 110 VAC 60 cycle source. Up to 11,500 volts DC at 50 watts. Metered high voltage (0-15KV) and current (0-20 MA). **\$74.50**

Some available with small repair or minor part replacement, less tube... only **\$49.50**

Shipments FOB warehouse. 20% Deposit on orders. Minimum order \$5.00. Illinois residents, add regular sales tax to remittance.

Prices subject to change without notice.

# R W ELECTRONICS

Dept. N, 1712-14 S. Michigan Ave., Chicago 16, Ill.

PHONE: HARRISON 7-9374

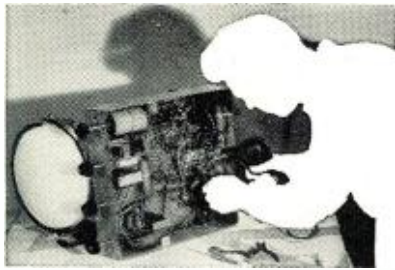

Let MILTON S. KIVER Help  
You Prepare For U.H.F.-  
TV And...

**TELEVISION  
SERVICING**

**TRAIN AT HOME  
This Practical Way!**

Men with the right training in Television Servicing are in big demand... pull down big pay. T.C.I. TRAINS YOU RIGHT with easy-to-follow technical training designed by servicemen, for servicemen! You learn practical, professional type Television Servicing without leaving your present job. Included are money-making extras such as set conversion, master antenna installation, U.H.F.-TV and field servicing short cuts. You can start earning Television money after the first few lessons. You learn to test, trouble shoot and repair all types of TV sets the proven, practical way!

**HERE'S HOW YOU GET EXPERIENCE!**

You train on your own large screen modern television receiver, furnished as part of your course. This set is yours to keep! As an optional feature you get two weeks of actual field experience going on service calls and on the repair bench for Chicago's largest independent servicing organization. You learn Television Servicing by actually doing Television Servicing... you get the practical know-how you need to qualify for BIG MONEY in this fast-growing field! Age is no barrier. Many TCI students are over 40!

ACT NOW! Fill out and mail coupon for FREE Catalog and SAMPLE LESSON. Write TODAY!

**YOU GET** and keep modern large screen Television receiver.

**YOU DO** actual testing, servicing, trouble shooting and repairing

**TV BROADCASTING COURSE  
READY NOW!**  
Train at home for these big pay studio jobs! Video engineers, cameramen, microwave engineers, etc. Easy non-mathematical training covers all phases. Write!

**MAIL NOW FOR FREE BOOKLET**

MILTON S. KIVER, President  
TELEVISION COMMUNICATIONS INSTITUTE

205 W. Wacker Dr., Dept. 1-W, Chicago 6, Ill.

Rush full facts on the course checked below. I am not obligated. Salesman will not call.

( ) TV Servicing ( ) TV Broadcasting

Name.....Age.....

Address.....

City.....Zone.....State.....

( ) BEGINNERS check here for information on Pre-Tel Radio Course.

Mexico—A Mexican outlet noted on 7.350 has been identified as the seventh harmonic of XEG, 1050 kc. (Stark, Texas)

XEHH, 11.88, noted some afternoons (EST) with race track results in English. (Niblack, Ind.) XEBR, 11.820, Hermosillo, is heard daily to about 2300; sends nice QSL card. (Robertson, Mass.) XEBT, 9.625, is good strength 0900-1300. (Boggs, Mo.)

Nicaragua—Radio Colonial, 5.942, believed YNDG, noted in QRM to 2130. Radio Sport logged on 7.850 at 1845. (Stark, Texas) Machwart, Mich., says the 5.942 one is YNDG "en Leon," according to announcement. YNXW, 8.195, heard 2028 when man identified as "Radio America en Managua." (Machwart, Mich.) YNOW, 6.055, noted at good level around 2345-2400 sign-off; closes with march.

Nigeria—Radio Nigeria, 7.255, Lagos, is believed to be the station heard relaying BBC's General Overseas Service to 1700, then in native to around 1716 when signs with "God Save the Queen." (Kary, Pa.)

North Korea—Koreans on 6.235 and 4.400A heard recently 0800, in parallel, with news in Korean at dictation speed; weak on 6.235, good on 4.400A; the 6.235 is heard as early as 0445 with good signal, at 0630 with Moscow chimes; signal drops rapidly after 0730; 4.400A has considerable CWQRM. (Rosenauer, Calif.)

Northern Rhodesia—ZQP, Lusaka, informs Pearce, England, that it broadcasts to Africans in English on Tuesdays 0900-1230, Sundays 0300-0600; on other days uses African languages 0900-1230; frequencies are 3.914, 7.220; both are omni-directional; 3.914 is 2.5 kw.

Norway—Tromsøe has moved from 9.540 to 9.550, heard around 0700. (Radio Sweden) LLK, 11.850, noted 0830 with a little QRM. (Brown, N.Y.) The 21.670 channel noted 0645 with musical program, then news in Norwegian. (Sanderson, Australia)

Outer Mongolia—Ulan Bator Choto, 5.265, heard 0900-1000 relaying Radio Moscow. (Malmo DX-aren, Sweden)

Pakistan—Radio Pakistan, 11.674A, still noted 1015 with news; signs on 0830 with Burmese program for Burma. (Ferguson, N. C.) Noted parallel on 7.096 and 7.147A with news 0730. (Saylor, Va.) The 7.096 channel has news also 2130.

APK3, 11.885, noted 2030 with program to South East Asia in news, music. APDI, 15.335, heard 2045 in parallel with 11.885 in local program. (Sanderson, Australia) Heard on 15.621 at 0730-0740 with news. (NNRC) Radio Pakistan is still testing to the United Kingdom 1515-1600, to Turkey 1430-1515 on 7.010 and 6.035 (replacing 6.235); both heard by Pearce in England. Lahore, 4.807, noted with native music at 1110 by Catch, England; poor level.

Panama—HOJA seems to be on 9.645 now rather than 9.640. (Bellington, N. Y.) When this was written,

(Continued on page 151)

**WEBSTER-VM-G.I.**

3-SPEED RECORD CHANGERS

Fully automatic. Plays all size records 7", 10", 12". BRAND NEW.

G. I. CHANGER

OUR PRICE **\$15.95**

Immediate Delivery

\$47.50 List. 12"x12 3/4" Long life needle incl. ORDER YOURS TODAY. Comes with RCA plug to attach to your radio or TV set. Metal base for above \$3.50. Fully guaranteed. Original factory cartons.



NOT MANY LEFT AT THIS PRICE  
**REPLACE YOUR OLD CHANGER NOW!**  
3 tube amplifier 5" speaker volume and tone controls with tubes. Ready to operate. Same as used in portable units. **\$ 8.95**

VM #950 Flip Cart. 3 speed..... **22.95**

WEBSTER #100 Flip Cart..... **23.95**

WEBSTER 100 with G.E. Triple Play Reluctance Cartridge..... **29.95**

VM #950 with G.E. triple play variable reluctance cartridge..... **28.95**

Pre-Amp with tube for G.E. Cart..... **4.95**

METAL BASE for Webster or VM..... **3.50**

VM Triomatic Radio Phonograph Comb. in carrying case..... **56.95**

Send for descriptive literature. Please include shipping charges.

Come in or order by mail—\$10 on C.O.D. orders.

**JAN ELECTRONIC DIST. CO.,** Dept. RN

218 Fulton St. New York 7, N. Y. WO. 4-0632

**\$5.00** YOU SHOULD OWN A **MICRO CIRCLE CUTTER**  
A well built tool for those odd size holes. Cuts through 1/2 inch of steel. Has MICRONATIC SIZE ADJUSTOR. Comes complete with tool steel cutting bit for extra long service.  
Specify round (7/16") or square shank. See your local distributor or write us. **PRECISE MEASUREMENTS CO.**  
942 Kings Highway  
Brooklyn 23 New York

**SPEAKER RECONING**  
Complete line Cones, Spiders, Rings and Voice Coils. Custom Built Voice Coils. Low prices. Write for Parts List and Reconing information.  
**WESTERN ELECTRONICS CO.**  
3164 West Colfax Denver 4, Colo.

**EVERY RADIOMAN**  
Can Use These **SERVICE HINTS!**  
Valuable Manual Yours—FREE!

Every page of "How to Simplify Radio Repairs" is packed with on-the-bench, practical ideas. Contains photos, charts, diagrams—no fluff—no vague theory. In plain every-day language it gives you priceless suggestions—new servicing ideas. You'll use and benefit from the experience of experts. Partial list of contents: How to Localize Trouble; How to Service Amplifiers; How to Test for Distortion; How to Test Audio Circuits; How to Test Speakers; How to Find Faults in Oscillators; How to Test Radio Parts—and it's all yours—FREE! No obligation.

**FEILER** SEND COUPON OR PENNY POSTCARD FOR YOUR FREE COPY TODAY!

FEILER ENGINEERING CO., Dept. 5H2  
8026 N. Monticello Ave., Skokie, Ill. (Suburb of Chicago)

Please RUSH my FREE copy of "How to Simplify Radio Repairs."

Name.....  
Address.....  
City.....Zone.....State.....

## What's New in Radio

(Continued from page 81)

and simplifies panel design. The switch may be mounted in any position. Lever action is smooth and positive, incorporating lock, non-lock, and no-throw positions. The lever handle is of black bakelite. Back-of-the-panel depth is only  $2\frac{1}{16}$ " while contact build-ups are  $\frac{5}{16}$ " in width. Weight averages less than 1 ounce.

### CIRCUIT TESTER

Neo-Lite Manufacturing Company, 915 Taylor Avenue, Rockford, Illinois is now marketing a new pocket-size circuit tester which has been designed to locate shorts and grounds on appliances or lines from 90 to 550 volts a.c. or d.c.

Tradenamed the "Dandy-Lite," the unit operates on the neon glow prin-



ciple, with two test prods connected to the lamp in series. According to the manufacturer, the tester can be used on cords, appliances, signals, etc., and will test for grounded lines or line polarity.

### R.F. CHOKE COILS

A new series of r.f. choke coils featuring small size and a wide range of inductance is now in production by Jeffers Electronics, Inc., Dubois, Pa.

Made with insulated copper wire, the coils have a rugged molded jacket made of a mineral-filled thermosetting compound which permits use under the most severe service conditions.

The coils, made in types 101, 102, and 104, have no shorted end turns and the windings are soldered to the leads. A new standardized test method is being used on the coils which, according to the manufacturer, is basically fundamental in contrast to previous test methods.

### R.F. CHOKES

Grayburne Corp., 103 Lafayette Street, New York 13, New York has introduced a new line of miniature r.f. chokes which can be supplied in inductances ranging from 500 microhenrys to 250 millihenrys, with either pi or solenoid windings.

These new units have been designated "Ferri-Chokes" because they employ ferrite as the core material. Features of these new chokes include in-

The sensational new

# GONSET "RADARRAY"

High gain on all 12 channels

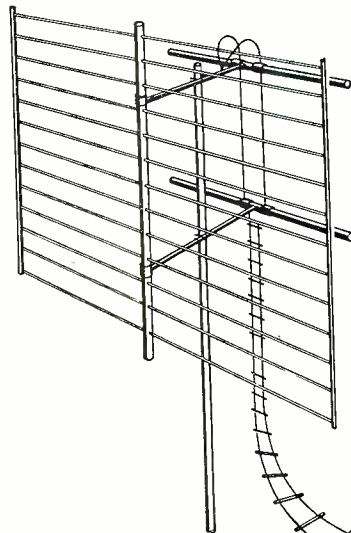
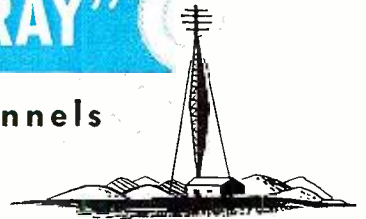

## No Better Antenna for FRINGE AREA RECEPTION...

The Gonset Model C "Radarray" is the first choice by manufacturers, TV Stations and technicians for bringing in a strong signal in areas where reception is difficult. No other antenna offers higher gain on all 12 channels (over 10 DB). This means greater rejection of ghosts and all types of interference, giving a clear, steady picture with a minimum of "snow."

### GONSET LINE The Original "Low Loss" Open Wire Line

GONSET LINE has the lowest loss characteristics of any line manufactured (less than  $\frac{1}{2}$  the loss of molded ribbon). It is the ideal line for use where high efficiency is required — fringe TV areas, beach areas and long runs. The impedance is 450 ohms and will substitute for 300 ohm ribbon.



See your jobber or write for circular and further details to

## GONSET CO.

801 S. Main St. • Burbank, Calif.

## revive weak picture tubes

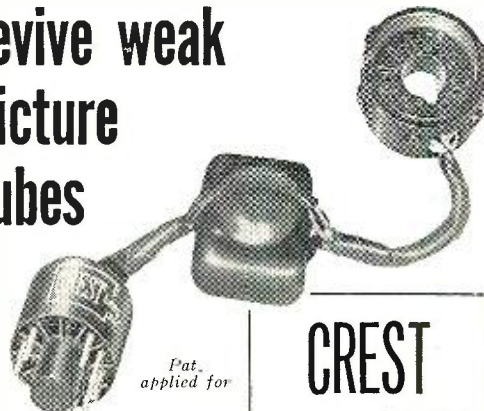

Pat. applied for

# CREST

JOBBER INQUIRIES INVITED

LABORATORIES, INC.

Whitehall Building, Far Rockaway, N. Y.

- Simple Plug-In
- Permanent Hook-Up
- Applicable to all size tubes
- Save on service contracts
- Automatically operated
- Only \$3.85 dealer net

**TOP QUALITY! LOW COST!**

# FISHER

## HIGH QUALITY Phonograph Preamplifier

■ Here is the *top* quality, *reasonably priced* preamplifier you have always wanted. The FISHER provides exact equalization for low-level magnetic pickups of *any* make, such as GE, Pickering, Audax, Clarkstan and others; also used as a microphone preamplifier.

List \$20.95

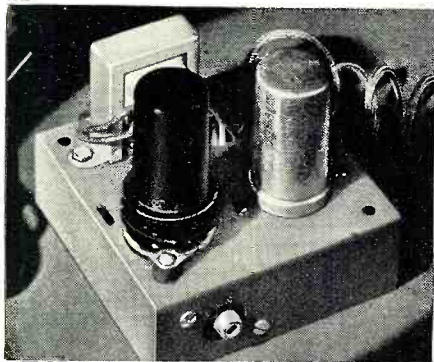

### Outstanding Features:

- Uniform response, 30 to 20,000 cycles.** Self powered. Two stages of triode amplification. Extremely low hum.
- Full low-frequency equalization.** High gain. Completely enclosed chassis with bottom cover. Plugs supplied.
- Output cable can be up to 50 feet in length.** size: 3 $\frac{3}{4}$  x 3 $\frac{3}{8}$  x 3 $\frac{3}{8}$  high.

WRITE FOR FULL DETAILS

**FISHER RADIO CORPORATION**  
39 E. 47TH ST., NEW YORK

creased "Q", an important reduction of d.c. resistance, a significant reduction of distributed capacity, and a marked reduction in weight, according to the company.

Four standard models of these chokes are now available. The Model F-25 is a 2.5 mhy., 125 ma. unit; the Model F-50 is a 5 mhy., 125 ma. choke; the Model F-100 a 10 mhy., 125 ma. unit; and the Model HD-25 a 2.5 mhy., 300 ma. choke.

Complete data on these models as well as information on chokes available on special order can be obtained from the company on request.

### NEW TUBE TESTER

*Electronic Measurements Corp.*, 280 Lafayette Street, New York, N. Y. has recently added a new tube tester to its line of test equipment.

The Model 205 is designed to give

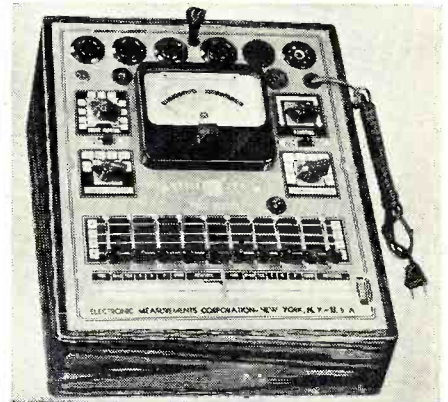

test readings for all tubes including noval and subminiatures, from .75 volt to 117 filament volts by means of the standard emission method of testing.

This instrument, using four-position level-type switches and individual sockets for each tube base type, is available in either bench-type or portable models. The portable unit is designated as the Model 205P.

### 18" WOOFER

*C. S. Manufacturing Co.*, 4089 Lincoln Blvd., Venice, California is in production on a new 18" woofer which is being marketed in the moderate price class.

The speaker has a heavy cast aluminum frame, uses a 2 $\frac{1}{2}$  pound Alnico V magnet, and measures 18 $\frac{1}{4}$ " over-all diameter with a baffle opening of 16 $\frac{1}{2}$ ". The depth behind the mounting panel is 8".

Impedance of this unit is rated at 12 ohms. The resonant frequency of the cone is from 27 to 31 cps.

Complete details on this new woofer are obtainable from the manufacturer on request.

### SMALL STROBE UNIT

*The Berkshire Laboratories*, 566 Beaver Pond Road, Lincoln, Massachusetts has developed a new small, lightweight, and inexpensive stroboscope unit for test and service work.

Known as the Model 18 "Labstrobe," the new unit gives 60 flashes-per-second when connected to the 60-cycle

**RADIO & TELEVISION NEWS**

**SELLS ON DEMONSTRATION**  
**DuKANE**  
**MAGNETIC TAPE RECORDER**



**THE FINEST IN  
HIGH FIDELITY  
RECORDING**

*at  
LOW  
COST!*

**DEALERSHIPS AVAILABLE NOW!**  
**MAIL COUPON FOR INFORMATION TODAY!**

**DUKANE CORP.** Dept. RTN-52, St. Charles, Ill.

Please send information on the DuKane Magnetic Tape Recorder.

I am interested in a dealership.

Name \_\_\_\_\_

Address \_\_\_\_\_

City \_\_\_\_\_ State \_\_\_\_\_

ESTABLISHED AS "OPERADIO" 1922

## SENSATIONAL VALUE!

**#630 SUPER 30 TUBE CHASSIS**  
Mfr. Licensed under R. C. A. Patents

Complete with  
21" first quality  
tube

AND  
Beautiful hand-  
rubbed Mahog-  
any Console  
Cabinet.  
COMPLETE PRICE  
**\$259.95**



slightly higher  
with full doors

the latest 1952 model with all the newest electronic improvements . . .

- peak sensitivity for fringe areas
- synchrolock tuning
- keyed A G C
- 15,000 volts under load
- 12-inch RCA speaker
- can be adapted to color & UHF
- high quality parts

A set—NOT A KIT

Completely wired, Factory Engineered, aligned and tested. RMA Guaranteed

**1 YEAR GUARANTEE ON TUBE**

A half-hour to mount; ready for operation. Saves up to \$150.

Compare this anywhere for high quality—low price!

Write Dept. F for further information. Phone and mail orders filled on receipt of money order for 25% as deposit . . . the balance C.O.D., f.o.b. N. Y.

**NEW ENGLAND TELEVISION CORP.**  
75 CHURCH STREET NEW YORK, N. Y.



a.c. line. The lamp is a standard neon bulb which is easily replaceable. The instrument itself is housed in a chrome plated case which is the same size as a standard two-cell flashlight. An aluminized reflector directs the light forward to increase the illumination.

Power consumption is less than 1 watt and the unit may be used to determine the speed of rotation of motors, machines, phonograph turntables, and other standard units.

### DETECTOR KIT

Allied Radio Corporation, 833 W. Jackson Boulevard, Chicago 7, Illinois is currently offering a new radioactivity detector in kit form—the *Knight "Super Scout"*.

Designed to provide low-cost radiation detection for schools, laboratories, civil defense applications, and prospectors, the new unit may be assembled by anyone who is mechanically inclined.

The Geiger counter will detect the presence of gamma rays, medium-to-high energy beta rays, as well as cosmic and x-rays. A sensitive Geiger-Mueller tube is used and power is obtained from a built-in vibrator supply which operates from two self-contained standard flashlight batteries.

To simplify construction, some of the parts are supplied premounted, including the battery clip, the G-M tube clips, and the "on-off" switch. A single 1T4 tube is used, rectifier-connected.

The entire unit weighs 3 pounds when assembled. It comes complete with all necessary tubes, parts, batteries, etc. The case measures 7 3/4" x 4 3/8" x 2 1/4".

### GEIGER COUNTER

Precision Radiation Instruments, 4113 W. Jefferson Blvd., Los Angeles 16, California has developed a low-cost Geiger counter for civilian defense work, prospecting, and scientific work.

The Model 107 (the "Professional") has a three-range meter, a neon flasher, and earphones as the means



of indication. It has ranges of .2, 2, and 20 milliroentgens-per-hour full scale and is accurate within 10% on all ranges. The unit is completely waterproof and is housed in a 4" x 4 1/2" x 6 1/2" cabinet. The counter weighs approximately 5 pounds.

May, 1952

# PRICES ARE DOWN HERE NO INFLATION!!!

### 160-80 METER MOBILE RECEIVERS

MOBILE RECEIVER which will operate in your boat or car from 6 Volts D.C. and will cover the 160 METER BAND. Ship to Shore and Police Bands. Prefixed frequency only or by slugging will cover its complete frequency range. Comes in 2 separate units: Receiver and External 6 Volt Vibrator Power Supply Unit. The equipment is used, but is in excellent condition complete with tubes.

PRICE FOR COMPLETE UNIT WITH POWER SUPPLY \$24.95  
 Separate RECEIVER \$22.50  
 Unit 6 VOLT POWER SUPPLY 7.95

### COAXIAL CABLE

52 OHM Transmission Cable. Made to J.A.N. Specification. 1P349 Same as RG-5U. All unused. On Reels of approximately 1,000 Ft.

100 Ft.	9c per Ft.
1,000 Ft.	8c per Ft.
10,000 Ft.	7c per Ft.

### ARC 5 EQUIPMENT:

#### TRANSMITTERS

3 to 4 MCS	\$14.95
4 to 5.3 MCS	8.95
5.3 to 7 MCS	7.95

All above complete with all tubes and crystal. In excellent condition.

T-23 ARC-5 WAVE TRANSMITTER-100-156 MCS Chassis, Less Tubes and Crystals. Each \$12.95

#### RECEIVERS

190 to 550 KC	\$16.95
3 to 6 MCS	9.95
6 to 9 MCS	9.95

All above Receivers complete with all tubes and dynamotor. In excellent condition.

R-4/ARR-2 RECEIVER-234-258 MCS Complete with all tubes and dynamotor. Excellent condition \$19.95

#### SOUND POWERED HEAD AND CHEST SET

Use same way as Hand Set except you have freedom of hands. No Batteries or power source required for operation. Excellent Condition. \$11.95

#### PROP PITCH MOTORS

For your Beam Antenna: 20 Volt to 32 Volt A.C. or D.C. 1/2 H.P. Motor; 1 1/4 RPM Gear Reduction, 7000 to 1. ALL BRAND NEW. Each \$13.95

1/4 H.P. PROP PITCH MOTORS (Small Size) 20 to 32 Volt A.C. or D.C. Gear Ratio: 9000 to 1. All Brand New. \$16.95

#### 2 VOLT VIBRATORS

VBSA Synchronous Type. Used in all portable radios having 2 Volt wet cell supply. All new. Ea. \$1.50

#### TANK PERISCOPES

Type M9 Contains 2 glass prisms, one at each end of the peepscope. Use them for looking over crowds at parades, ball games, races, etc., or use prisms separately for optical work. Low priced. All Brand New. \$1.95

#### MICA CAPACITORS

CAP.	W. VOLTS	PRICE
.003	3000	\$1.50
.005	3000	1.00
.008	3000	2.50
.010	3500	1.25
.00015	5000	1.50
.0002	5000	1.95
.0003	5000	1.75
.00032	5000	2.25
.000375	5000	2.50
.0004	5000	2.35
.0005	5000	2.75
.0006	5000	3.25
.00072	5000	3.35
.00075	5000	2.75
.0008	5000	3.25
.001	5000	3.25
.0011	5000	2.95
.0015	5000	3.25
.002	5000	3.25
.004	5000	3.50
.005	5000	3.75
.006	6000	3.50
.001	7500	3.50
.0001	7500	2.95
.001	6000	3.50
.01	1200	.75
.001	1200	.65
.005	1200	.50
.0015	2500	1.00
.002	2500	1.00
.00025	2500	.65
.0005	2500	.75
.00005	2500	.75

CAP.	W. VOLTS	PRICE
.00015	600	.35
.01	1200	.75
.001	1200	.65
.005	1200	.50
.0015	2500	1.00
.002	2500	1.00
.00025	2500	.65
.0005	2500	.75
.00005	2500	.75

All Mail Orders Promptly Filled, F.O.B. San Francisco. All California Orders—Add 3% Sales Tax. Do not send postage stamps. Write for new 1952 free booklet listing Radio, Electronics, Tools, Hardware, Motors, Wire, Meters, Batteries, Aluminum Sheets, etc. 20% Dep. on all C.O.D. orders. All items subject to prior sale and prices subject to change without notice.

### MODEL GO-9 TRANSMITTER

All Brand New. 100 Watts CW or MCW emission. Operates from 110 V., 800 Cycle, easily converted to 60 Cycle. Panel or Motor Control. Low frequency range, 300 KC. to 600 KC. High frequency 3,000 KC. to 18,000 KC. using an E.C.O. We furnish complete conversion data with each transmitter. Complete with schematics. \$59.95

TELEGRAPH KEYS  
 J-48 Standard Hand Key enclosed in box with cord and PL 55 Plug. All new. Ea. \$1.25  
 J-5A Flameproof Key. Ea. \$0.79

### BRASS SELSYNS

Heavy Duty Bendix Selsyns, 110 Volt 60 Cycles AC.  
 TYPE II-2 similar to type 6 Selsyns—New Cond. Pr. \$35.00

### BC 375 TUNING UNITS

200 KC-500 KC; 4500 KC-6200 KC; 6200 KC-7700 KC; 7700 KC-10000 KC; 10000 KC-12500 KC. With Variable Dial and many parts which alone worth 3 times our Low Price of \$2.95 per unit

### G.P.7 TUNING UNITS

5 Ranges: A-350-800 KC., B-800-1500 KC., D-3000-4525 KC., E-4525-6500 KC., F-6200-9050 KC. Also contains Capacitors, Resistors, Vernier Dials and many other parts. REAL BUY while they last. Each unit range \$4.95

### BD-LQ-61 DC VOLTAGE CONTROL PANEL

3 Circuit Voltage Distribution for use on up to 50 Volts D.C. Generator. Can be used as Battery Charger Control Panel or Motor Control. Has one 300 V. D.C. Meter; three 0-15 Amp. D.C. Meters; three 10 Amp. Rheostats; three 10 Amp. Magnetic Breakers. The Panel is mounted in a steel box with 2 doors. Each \$35.00 ALL NEW.

### SCR-522 TRANSCEIVER

100-156 MCS—HOTTEST 2 METER BUY OF THE YEAR. VIB. MOBILE or FIXED. Complete with all Tubes and 24 Volt Supply. Excellent Cond. \$62.50

#### CAPACITORS • FIXED • OIL FILLED

Solar, Pyranol, C.D., Etc.

#### ALL D.C. VOLTAGE RATINGS

Capacitor	Price	Capacitor	Price
2 MF. 400 V.	1.95	8 MF. 1000 V.	3.95
3X3 MF. 400 V.	2.95	10 MF. 1000 V.	4.50
10 MF. 400 V.	2.95	1 MF. 1500 V.	2.50
1 MF. 600 V.	1.95	4 MF. 1500 V.	2.25
4 MF. 600 V.	1.95	6 MF. 1500 V.	2.95
5 MF. 600 V.	1.95	1 MF. 2000 V.	1.95
7 MF. 600 V.	1.95	2 MF. 2000 V.	1.95
8 MF. 600 V.	1.95	3 MF. 2000 V.	3.50
8X8 MF. 600 V.	2.25	4 MF. 2000 V.	3.95
12 MF. 600 V.	2.25	1 MF. 3000 V.	3.95
15 MF. 600 V.	2.95	4 MF. 3000 V.	5.95
20 MF. 600 V.	2.95	1 MF. 5000 V.	5.95
1 MF. 1000 V.	1.00		

#### CAPACITORS TRANSMITTING VARIABLE

K 1 MMFD. to 75 MMFD. 1/4" Spacing	\$1.95
*D 12 MMFD. to 125 MMFD. 3000 V. Peak	3.50
1 28 MMFD. to 110 MMFD. 5000 V. Peak	3.95
*F 12 MMFD. to 150 MMFD. 3000 V. Peak	3.50
A 7 MMFD. to 80 MMFD. 1500 V. Peak	1.00

\* With National Vernier Vernier Dial.  
 All New Hammerlund, Carver, Etc.

#### RADIO DIRECTION FINDER

MODEL DZ-20, tunes from 15.7 KC. to 170-1750 KC. Complete Radio Direction Finder Unit ready for installation and operation on 28 Volts D.C. Receiver Loop Assembly and Pedestal and 28 Volt Dynamo. \$75.00 Set motor, all included. All Brand New.

#### DU-1 MANUAL DIRECTION FINDERS

Tunes to broadcast, High house and beacon bands—easy to convert for use on marine bands. True bearing immediately. For use with any loop input receiver. Complete with 2 tube pre-amplifier. Used good condition. Specify 12 V. D.C. or 24 V. D.C. Excellent Condition. Each \$19.95

#### MIDGET SELSYNS

AYC type operates from 6-12 Volts 60 Cycle. Use as both transmitter and receiver. These compact little units draw almost no current and work fine for all remote position indicating applications. OD 2 1/4 x 2 1/4 x 2". Has spring return shaft. All New (Apprx. Wt. 1 lb.). Each \$2.50

AY-1 Type or AY-5 Type, same as above but has a continuous rotating shaft. These compact units are all new. \$4.95

#### CANNED FRICTION TAPE

3/4", 82 1/2 Ft., 6 Rolls to Can. \$1.25 per Can

#### TAPE IN INDIVIDUAL BOXES

RUBBER TAPE, 3/4", 15 Ft., 15c Roll. SCOTCH TAPE, 1", 50 Yds., 35c Can. FRICTION TAPE, 3/4", 82 1/2 Ft., 15c Roll. MICA TAPE. 25c Roll

#### 6 GANG TUNING CONDENSER

Variable with National 201 Worm Drive. 300 MMFD. per section. Each rotor insulated from frame. A TERRIFIC VALUE. Each \$7.95

#### REVERSIBLE MOTOR

1/40 H.P. Ball-bearing 3450 R.P.M. in Blast-proof case. Needs only a capacitor for starting. All Brand New. 110 V., 60 Cycles. Special Low Price. \$4.95 Starting Capacitor. \$0.69 Ea.

## STANDARD SURPLUS 1230 Market St., San Francisco 3, Cal. Telephone Hemlock 1-3106



**ENCYCLOPEDIA on CATHODE-RAY OSCILLOSCOPES and THEIR USES**

by Rider and Uslan

1. The most complete source of practical, usable knowledge concerning the oscilloscope ever published. Covers practically every kind of scope manufactured during the past ten years. Hundreds of pages alone are devoted to actual application plus complete, detailed treatments of auxiliary equipment, measurements, waveforms, visual alignment of AM-FM-TV receivers and more, much more. A "must" for anyone using an oscilloscope. Completely indexed, with 992 pages (8½ x 11") 3,000 illustrations...\$9.00
2. **VACUUM-TUBE VOLTMETERS**, by Rider & Barber. Completely revised. Covers theory, functions, operation and applications of the VTVM in detail. Typical chapters: Triode Vacuum-Tube Voltmeters; Probes for DC & RF; Calibration and Testing. 432 pp. (5½ x 8½") ill.....\$4.50
3. **TV AND OTHER RECEIVING ANTENNAS**, by Bailey. is a source book on antennas of all types. Typical chapters: The Center Fed Zero DB Half-Wave Antenna; Parasitic Element Antennas; The TV Signal and Its Bandwidth; Vertically Polarized Antennas. 606 pp. (5½ x 8½") ill.....\$6.60
4. **TV INSTALLATION TECHNIQUES**, by Marshall. A practical timely "how-to-do-it" book on antenna installation and receiver adjustment. Typical chapters: Materials and Methods Used in Installations, High Mast and Tower Installations; Municipal Regulations Governing TV Installations. 336 pp. (5½ x 8½") 270 ill.....\$4.50
5. **TV MASTER ANTENNA SYSTEMS**, by Kamen & Dorf, covers all popular distribution systems now in manufacture, with schematics, performance figures and design data. Typical chapters: Installing Master Antenna Systems; Basic TV Antenna Systems; The Need for Master Systems. 356 pp. (5½ x 8½") ill. \$5.00
6. **RECEIVING TUBE SUBSTITUTION GUIDE BOOK**, by Middleton. Lists 2,500 radio, TV and electronic tube substitutions in numerical sequence for quick reference. Gives performance ratings and any necessary wiring changes. Also RTMA color codes, transformer and condenser substitutions. 225 pp. (8½ x 11") .....\$3.00
- 6a. **FIRST SUPPLEMENT TO ORIGINAL GUIDE BOOK** lists 650 completely new and different tube substitutions. Includes wiring instructions and illustrations of original and substitute tube sockets. 48 pp. (8½ x 11").....\$99

Buy these books now at your jobbers... leading bookstores...or—

MAIL THIS COUPON—TODAY—

JOHN F. RIDER, Publisher, Inc.  
480 Canal Street, New York 13, N. Y.

Please send me book(s) circled. I understand, if not satisfied, I may return them within 10 days for full refund.

1   2   3   4   5   6   6a

NAME \_\_\_\_\_

ADDRESS \_\_\_\_\_

CITY \_\_\_\_\_ ZONE \_\_\_\_\_ STATE \_\_\_\_\_

(Please Print) RN-5

# RADIO-TV Service Industry News

AS REPORTED BY THE TELEVISION TECHNICIANS LECTURE BUREAU

LESS than a year ago the Joint Electronic & Radio Committee on Service was formed in Philadelphia as an over-all industry effort to study and solve the problems of service in that area. The JERCS Committee, as it is known, is composed of representatives of all segments of the radio-television industry in Philadelphia with officers and members of both the Television Contractors Association and the Philadelphia Radio Servicemen's Association actively participating in the planning of its programs.

Recently the Better Business Bureau of Philadelphia reported that as a result of the program launched by the JERCS committee in cooperation with the BBB, the number of complaints concerning the merchandising and servicing of television receivers has been "reduced by 85%."

In citing the fact that complaints to the Better Business Bureau had dropped from an average of 800 a month to about 70 since the JERCS committee started to function last summer, Albert M. Haas, president of the Television Contractors Association, pointed out that extensive consumer education is necessary to acquaint the TV public with the extent and nature of the tremendous job the service industry has done.

In commenting on the success of the JERCS program in the Philadelphia area, Mr. Hugh L. Smith, general man-

ager of the Better Business Bureau, said:

"Problems always arise on the consumer level with the sale of a new commodity. The industry's cooperation with us brought about a greatly improved condition. Although we still receive some complaints concerning television sets and their sale, their number is now proportionate to the complaints we normally receive regarding other appliances which have been on the market for many years.

"Every major industrial development attracts fringe opportunists who want to get an easy ride or make a fast buck while the going is good, and the television industry has been no exception."

Mr. Smith noted that the decrease in the number of consumer complaints during the past year took place while television sales and service were undergoing an increase. "There are approximately 275,000 more sets in use in the Philadelphia area than there were at the beginning of the industry-wide program," he said.

"There is still much to be done but we have made real progress. One of the remaining abuses about which the BBB is concerned, is the flamboyant, exaggerated advertising by some retail dealers. Our next objective is to make this advertising more accurate and trustworthy."

The JERCS committee educational

More than 150 TV service contractors, dealers, and technicians attended the lecture on "Test Instrument Applications" presented in Atlantic City, N. J. under the sponsorship of the Almo Radio Company. This is one of a series of lectures prepared by Edward M. Noll of the Television Technicians Lecture Bureau under the sponsorship of prominent parts distributors and RADIO & TELEVISION NEWS.



campaign is being carried out via radio skits, brochures, and lectures to acquaint the public with the fact that television receivers are delicate instruments that require expert attention when they need adjustments or repairs.

The JERCS program is intended to accomplish six objectives:

1. Develop a consumer program which will tell the set buyer and user just what can be reasonably expected from his television receivers.

2. Create a means whereby the consumer can recognize the responsible, ethically-operating service technician, servicing dealer, and service contractor.

3. Develop an understanding of warranty problems locally, and when possible, throughout the industry. This will tend to bring about an abatement of practices which have been found objectionable by the entire service industry.

4. Inspire an understanding among manufacturers that over-selling and over-advertising are not conducive to the best interests of either the purchasers or the industry.

5. Find a suitable method for resolving consumer complaints as quickly as possible and develop means to avoid their undue repetition.

6. To encourage the development of business-managed service outlets, whether among dealers, contractors, or technicians, which will tend to reduce business failures and particularly those that result in service contract holders being left without service for which they paid in advance.

To launch the technical training program that was planned as a vital part of the JERCS committee activity, arrangements were made with the Television Technicians Lecture Bureau to present a series of lectures on the most needed servicing subjects. The first of these lectures selected for this series was on the subject of u.h.f. television. This was prepared and presented by Edward M. Noll of the Lecture Bureau staff to an overflow crowd of technicians in the Franklin Institute auditorium in Philadelphia.

#### Launches Consumer Program

The Dallas Radio Sales & Service Association recently appropriated funds for an advertising program that is designed to educate the consumer about radio and television service dollars and to build the prestige of the association and its participating members.

According to Bill Inman of the *Inman Radio Sales & Service Company*, and president of the Dallas Association, \$300.00 per month has been tentatively appropriated to start this advertising program but he also added that, "when the ball gets rolling, this amount will undoubtedly be increased."

Joe Buch of the *Joe Buch Electronic Service Company*, was selected by the senior members of the association as chairman of a committee to study service problems and to devise an ad-

*The BEST BUY in* **Recorders!**

Complete PUSH-BUTTON CONTROL



CUT TAPE COSTS IN HALF

OUT PERFORMS EVERYTHING IN ITS PRICE CLASS

HIGHEST QUALITY & RESPONSE  
EVER BUILT INTO A PORTABLE

15,000 cps at 15 & 7½ inches per second

**AMPEX**

AMPEX ELECTRIC CORPORATION  
Redwood City, California

*Advanced Series 400-A*

Write for Bulletin A-211

AX-77



**solves a basic problem  
for the service man**

**the ERIE  
413 "UNIVERSAL"  
HV FILTER  
CERAMICON<sup>®</sup> for TV**

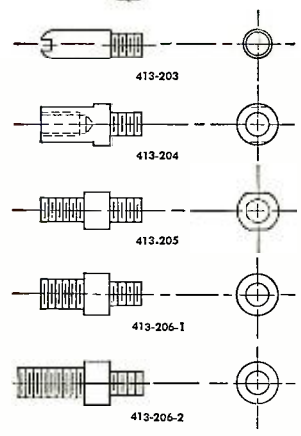

• You stock *one* body type of Ceramicon. An assortment of terminals such as illustrated at the left enables you to replace any one of a multitude of terminal combinations as found in receivers of different manufacturers.

With a fraction of the inventory otherwise required you are able to service practically any receiver on the market rated at 20 KV or lower . . . quickly and profitably.

Booth 318, Electronic Parts Show  
Display Room 536A, Conrad Hilton Hotel, Chicago

*Electronics Division*  
**ERIE RESISTOR CORP., ERIE, PA.**  
LONDON, ENGLAND . . . TORONTO, CANADA  
Ciffside, N.J. • Philadelphia, Pa. • Buffalo, N.Y. • Chicago, Ill.  
Detroit, Mich. • Cincinnati, Ohio • Los Angeles, Calif.

**Beautiful  
TV CABINETS**  
*For Custom-Built  
Sets or Conversions*

Series 503 TV Cabinets accommodate all 630, Radio Craftsmen & similar Chassis, all round & rectangular tubes. Complete with all mountings for tube & yoke. Fidelity-styled in Period, Traditional & Modern; hand-rubbed to high lustre in Mahogany, Walnut, Ebony or Blonde. 40" h, 24" w, 24" d.

Series 505 TV Combination Cabinets have identical features plus separate compartments for all FM-AM radio chassis, record changers & record storage. 40" h, 40" w, 24" d.

**Series RP3  
RADIO-PHONO  
COMBINATION  
CABINETS**

Compartments for record changer, radio chassis, record storage and 15" or 12" speaker. Fidelity-styled in Period, Traditional & Modern; hand-rubbed to high lustre in Mahogany, Walnut, Ebony or Blonde. 36" h, 34" w, 19" d.

Write NOW for literature and prices.  
**STANDARD WOOD PRODUCTS CORP.**  
43-02 38th St. Long Island City 4, N. Y.

**WALDOM**  
**SUPERIOR  
COMPONENTS**

WALDOM CONES...R.M.A. warranty, true low frequency response, unconditionally guaranteed.

Waldom also supplies quality CRONAME parts



TUBE SOCKETS  
Standard and J.A.N. Types

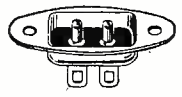

INTERLOCK ASSY.



TV ANODE CONNECTORS



KNOB

**WRITE  
FOR FREE  
CATALOGS**

**WALDOM ELECTRONICS, INC.**  
911 N. Larrabee St., Chicago 10, Ill.

vertising campaign to educate consumers about the value of the service dollar. Other members selected to serve on this committee include Harry Ernstrom, *Ernstrom's Radio*; Roger Dickey, *Floyd and Dickey*; Frank Prarie; and Raymond Spross, *Oak Cliff Appliance Sales & Service*.

**Service Operators Organize**

Motivated by the desire to protect the TV public from the "gyp" TV technicians who have crept into the business of serving the 17,000 TV set users in this fringe area locality, responsible TV-technicians of Manchester, N. H. have formed an organization which will strive to stabilize service business operations. Since there is not a Better Business Bureau in Manchester to which TV set owners can refer their complaints about unethical service business practices, the radio-television service businessmen in the area feel that a strong service association can do much to police servicing activities and in educating the public as to what they are entitled for the dollars they spend on television adjustments and servicing.

In discussing the plans and purposes of the new organization, its chairman, Frank Lavoie of Epping, said "This organization will serve the dealers, technicians, and the public. It will give the technicians a chance to exchange information and thus save the customer money when solving localized problems.

"The organization's code of ethics will make for equitable prices and discourage members from charging excessive prices. Also, there will be a campaign to educate the public in our problems and to sponsor a program whereby they will better understand the operation of their own sets.

"Many TV owners in this area have had a scalping. For example, some dealers who never sold radios before now sell and service TV sets. I've seen them for sale in grocery stores. This leads to a lot of people having to pay for labor which cannot be done competently."

**San Fernando Valley**

A new organization of radio and television technicians was recently formed in the San Fernando Valley area in California which has attracted the interest of technicians in that section. The recently chartered association is known as the Society of Radio and Television Technicians Incorporated and is said to be an outgrowth of the old San Fernando Valley chapter of the Radio Technicians Association which disbanded some time ago.

According to Dell Davis, chairman of the Public Relations Committee of the new organization, the programs which were developed for their semi-monthly meetings, and to which they strictly adhere, have attracted capacity crowds of technicians. The meetings are all held in the banquet room of the Airline Cafe, 2704 North Hollywood Way, Burbank, California, and

are conducted by practicing technicians for their fellow television service technicians. Members who are unable to make the dinner portion of the meeting arrive later for the first session—a fifteen minute period devoted to the discussion of the business phases of radio-television servicing.

After the business sessions, the balance of the meetings, which adjourn at 10:15 p.m. sharp, is confined to the discussion of the practical phases of television servicing and the solution of common installation and service headaches. Each speaker is assigned a time limit and must hold his discussion strictly within this limit.

An interesting facet in the conduct of their meetings is that any member who interrupts a speaker or engages in a *sub rosa* conversation during a talk is fined for his indiscretion. These fines, in the form of one dollar bills, are attached to a clothes line strung across the room. At the conclusion of each meeting one name is drawn from a box containing the names of paid up members. If the lucky member is present he "takes down the wash"—if the member is not present the money is carried over for the next week's drawing.

The society of Radio and Television Technicians has invited all interested persons in that section of California to attend its meetings. Associate memberships are open to non-practicing technicians, jobbers and their salesmen, and it is particularly interested in contacting and encouraging television service apprentices.

### Discontinue Consumer Servicing

It was recently announced that the *Philco Distributors, Incorporated*, New York, will no longer accept television installation and service contracts on any basis but "will direct such business to *Philco* dealers and members of the *Philco* factory-supervised service organizations."

In explaining the move the *Philco* organization's letter to its dealers stated, "In January, 1951, *Philco Corporation* inaugurated their national factory *Philco*-supervised service program. Since that time, over 50,000 *Philco* dealers, service contractors, and independent technicians have participated and have proved conclusively that good service rendered through the dealer produces a consumer satisfaction and this is reflected by an increase in sales.

"*Philco Distributors, Inc.*, New York division is wholeheartedly in agreement with this program and has no desire to maintain service facilities which will be in competition with *Philco* factory-supervised service members.

"Therefore, in a sincere effort to contribute to the furtherance of our program, the company has chosen its announced course. This is your assurance of plus business and the continued and rightful maintenance of your contact with your customers.

"Our service division," the announcement concluded, "is fully pre-

# ORDER BY MAIL FROM WHOLESALE RADIO

Low Prices • Complete Stocks • Fast Shipments

## Brand New Time & Money Savers for Servicemen!

### Check Pix Tube Circuits on-the-Spot

#### New! RMS PIX-EYE

\$5.97

Eliminates time, labor and danger of unnecessary removal of picture tube. Makes instant checks of brightness control, video, contrast control, low voltage and filament voltage circuits.



### Adapt Your Present Tube Checker to Test Picture Tubes!

\$9.95

#### CR-ADAPTERS

For shorts, relative emission, slow heater, filament continuity.

CR-1—For Jackson  
CR-2—For Hickok  
CR-3—Precision 10-00 Series  
CR-4—Precision 9-00 Series  
CR-6—Precision 6-00 Series

## Outstanding Buys in TV Antennas & Accessories!

### Get Snyder's Amazing New

# 360° MOTORLESS TV AERIAL

Same Clear Pix As Motor Rotating Aerial Systems Costing Triple This Price

FOR FRINGE AREA Only \$16.95

Complete with beam selector switch and 75 ft. 3 conductor cable.

Electronically beams in complete 360° rotation to give clear picture on all channels. You choose direction with Directronic selector switch mounted on or near TV set. Complete double-stacked arrays with 18 hi-tensil double-alloy aluminum elements.

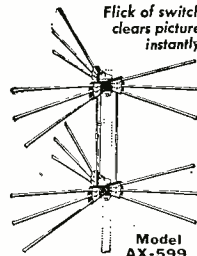

Flick of switch clears picture instantly

Model AX-599

## YAGI TV ARRAYS

### For Fringe & Ultra Fringe



High Channels 7-RY7  
8-RY8  
9-RY9  
0-RY10  
1-RY11  
2-RY12  
3-RY13

Highly directional and closely tuned to each channel. Cuts interference and noise to a minimum. Five elements; one folded dipole, three directors and one reflector. Individual array for each channel desired.

\$7.95

\$4.95

TIE RODS for stacking 2 Yagi Arrays

85c

Specify III or Lo band pair

## TV ANTENNA ACCESSORIES

STEEL EXTENSION POLES. Weather treated.  
10 ft. long 1 1/4" di. Crimped end ..... \$2.19  
5 ft. long 1 1/4" di. Crimped end ..... 1.35  
3 1/2 ft. long 1 1/4" di. Crimped end ..... 1.19  
CHIMNEY MOUNT BRACKETS  
CW-100 complete with strap ..... Pr. 1.59  
HEAVY DUTY MAST BRACKETS WB-2  
Adj. to 18" from wall ..... 3.75  
ANTENNA SWIVEL BASE. Aluminum  
Fits 1 1/4" O.D. mast section ..... .39  
300 OHM TWIN LEAD—Per ft.—3c; 100 ft. .... 25.00  
DOUBLE POLE DOUBLE THROW KNIFE SWITCH  
ANTENNA WALL MOUNTS  
PAM-1 For poles 1"-1 1/2" di. 6" from mast to wall ..... 1.15  
PAM-4 For poles 1"-1 1/2" di. Up to 12 1/2" from wall ..... 1.80  
PAM-6 For poles 3/4"-1 1/2" di. Adj. 1" to 19" from wall ..... 3.45

## SAVE with "Automatic" Custom Built Auto Radios!

All with 6 Tubes! 3 Gang Condensers! New for '52



	Net Dealer
F-100 '49, '50 Ford	\$38.47
D-200 '49, '50 Dodge-Plymouth	38.47
C-300 '49, '50 Chevrolet	41.97
F-151 '51 Ford	38.47
F-152 '52 Ford	38.47
D-251 '52, '51 Dodge	38.47
C-351 '52, '51 Chevrolet	38.47
H-451 '52, '51, '50, '49, '48 Hudson	38.47
S-551 '52, '51, '50 Studebaker	38.47
P-651 '52, '51 Plymouth	41.97
K-751 '51 Henry J.	38.47

FOR ALL PASSENGER Cars & Trucks  
Five tubes \$26.37  
Universal Mtg.

### Lick the Fringe Area! MASCO SKY CHIEF TV BOOSTER

Accommodates 300 ohm twin lead or 75 ohm coaxial. Has two 616 tubes and sel. rect. —only one tuning control—AC switch — pilot light — AC convenience receptacle — neutral booster position—U-L approved.

\$24.30



## ROOF MOUNTS

PEAK ROOF MOUNTS  
PRA-148 For peak roofs, flat roofs, side walls. Masts 3/4" to 1 1/2".  
\$2.69

BASE MOUNT  
BMA-136 For sloping or flat roofs, side walls. Masts 3/4" to 1 1/2".  
\$1.79

## Only VTVM Kit with 7 1/2" Meter

Precise Deluxe Model 907  
\$38.98  
Factory Wired \$57.98

Meter can be mounted for vertical or horizontal use. Etched panel; 1% ceramic resistors; amphenol connectors; separate 5 V AC scale. Tubes: 6AL5, 6X5, 6SN7; true zero adjust; huge 7 1/2" meter for more accurate readings. Complete with construction book, battery, and test lead. Ranges: Plus DC: 0-5-25-250-500-1000 v. Minus DC: 0-5-25-250-500-1000 v. AC: 0-5-25-250-500-1000 v. Ohms: Rx1, Rx10, Rx1000, Rx10,000, Rx1,000,000 ohms. DB: from -20 to -55 DB.

## MARKER GENERATOR RF—AF—TV KIT

FUNDAMENTALS THRU 110 mc 350 mc HARMONICS  
Audio: 20-20,000 cycles. Cathode follower. Output: Variable per cent modulation. Stepping attenuator. External Modulation. Speech amplifier. Crystal marker.  
With preassembled RF head. 630 KA. 38.95  
Completely factory wired. 630 W. 53.95  
630 K Kit 33.95

Address Orders to Dept. RN-5 Write for Free FYI Bulletin

# WHOLESALE RADIO PARTS CO., Inc.

311 W. BALTIMORE ST., BALTIMORE 1, MD.

**An Invitation  
to see and hear  
BRITAIN'S FINEST  
AUDIO PRODUCTS**

**CHICAGO AUDIO FAIR**  
Conrad Hilton Hotel, Rooms 700-701A

**GARRARD**

Model RC80,  
3-Speed Record  
Changer



\$42.30 net,  
less cartridges.

Model M,  
3-Speed  
Manual  
Record  
Player



\$25.95 net,  
less cartridges.

World's finest automatic record players!  
Competitively priced! Automatic stop.  
Heavier turn-table. Four-pole motor for  
accurate speed... no wows, wavers, rum-  
ble or disturbing resonance. RC-80 muting  
switch eliminates noise between records.

**LEAK "POINT ONE"**

Distortion. 0.1%

Complete  
\$192.00 net

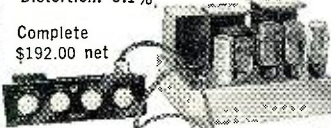

The new model of Britain's best audio  
amplifier, with pre-amplifier which has  
compensated settings for all records.  
The ultimate in clarity and frequency  
response... pure, undistorted musical  
reproduction. Certified tests by British  
Nat'l Physical Lab. (equiv. U.S. Bureau of  
Standards) prove this triple loop power  
amplifier and pre-amplifier exceed manu-  
facturer's performance claims.

**WHARFEDALE**

Super 12/CS/AL  
\$61.95 net



Surpasses many  
multi-speaker  
combinations.

Magnificent speakers, yet inexpensive,  
with remarkable response. Acclaimed for  
wide range, natural sound and pleasing  
listening quality. Built by Wharfedale  
Wireless Works under the direction of  
world-famous engineer, G. A. Briggs.  
Brilliant performance approaching living  
sound. Endorsed by B. B. C.

At your dealer or write to Dept. 5N  
**BRITISH INDUSTRIES CORP.**  
164 Duane St., New York 13, N. Y.

pared to assist you in establishing  
Philco factory-supervised service fa-  
cilities for your business. We suggest  
you review your present facilities and  
if they are inadequate, we invite you  
to request assistance from our service  
division. We will be glad to afford edu-  
cational training, technical informa-  
tion, and shop clinic assistance. We  
will also make available the names of  
qualified Philco factory-supervised  
service accounts that can capably and  
efficiently handle your service re-  
sponsibility."

**Large Volume Expected**

The chairman of the retail service  
division of the Electric League of Los  
Angeles, Inc., George Korntved of  
Service, Inc., predicted at a board  
meeting of that group that "service  
and parts sales will exceed new prod-  
uct sales through retail stores in from  
six months to a year in this area."

Mr. Korntved, in calling for more  
comprehensive trade recognition of  
the service function in major appli-  
ance and television merchandising,  
made these observations in connection  
with the recommendation that a ser-  
vice division of the league be formed.

The service executive suggested the  
establishment of an adequate stand-  
ards program, adequate training pro-  
gram, qualification program for  
personnel, educational program for  
consumers, central office for service  
complaints, employment office, and  
technical information center. He also  
emphasized that an associate member-  
ship offer be made to all personnel of  
service organizations, despite the fact  
that all such personnel are already in-  
vited to attend general meetings of  
the league.

"Service is the most mistreated  
word in the trade," Mr. Korntved  
stated. "That's the reason we want to  
open up this division."

**Home Repair Book Criticized**

A "fix-it-yourself" television service  
book for set owners is being widely  
advertised in some sections of the  
country through newspapers and over  
some radio stations. The phraseology  
of the copy leads the technically un-  
informed reader to the conclusion that  
a television receiver is so simple that  
he does not need to employ a techni-  
cian—he can fix it himself.

Quoting from a full page ad which  
appeared in the *Philadelphia Daily  
News* explanatory copy reads:

"Why we publish this information.  
A frank statement to TV owners...  
TV buyers. During the next year—no  
matter what brand or model or con-  
dition of your TV set you will prob-  
ably waste \$30-\$100 on it!

"You will waste this money," the  
copy continues, "for one reason—be-  
cause you do not know the truth about  
your television set. Because you do  
not realize that \$400,000,000 worth of  
research has gone into simplifying  
that set—into making it so simple that  
you yourself can keep it in perfect  
condition—without a repairman."

**YOU CAN BUY  
PICTURE  
TUBES**

(magnetic deflection types only)

**WITH A ONE YEAR GUARANTEE**

for

**\$ 1.30 PER  
INCH**

Tubes smaller than 12" @ \$15.60 minimum.  
Add \$1.50 per tube for all metal tubes.

Send us your dud picture tubes. We will  
return them completely factory rebuilt with  
all scratches removed, new gun, coatings and  
screen and guarantee them for 1 year. Broken  
neck tubes must have at least 2" of neck.  
Send them prepaid, packed securely and  
insured. Include full payment with order  
and we will ship in 48 hours. Otherwise  
allow 1 week C. O. D. All shipments collect.

EXAMPLE: 16" TUBE X \$1.30 = \$20.80  
if metal tube add 1.50

**PACKING?** Send a \$2.00 deposit and we'll send  
you a shipping carton. Deposit will apply to  
order. Be sure to include tube type and size.  
**DEALERS:** Save money—don't hang on to duds—  
turn them into new stock.

All prices subject to change without notice

**VACTRON**

398 ASHFORD AVE., DOBBS FERRY, N. Y.

**MARINE RADIO BARGAINS  
THE NEW G.L. MARINER  
Model 100A**

Here is the 1952 version of the famous G.L.  
MARINER 100 watt transmitter. Designed to conform  
with all new F.C.C. regulations. New features include  
built-in harmonic suppressor, panel mounted R.F.  
meter, 150 watt input, 100 watts to antenna. Four-  
channel, crystal controlled. Contains break-in relay  
for receiver in addition to antenna switching relay.  
Modulated. Contains break-in relay. 18 1/2" long,  
5 1/2" wide, 7 1/4" high. With dynamotor, R.F. meter,  
modulator, microphone, connecting cords. \$349.50  
specify) . . . . . \$349.50

**G.L. MARINER  
Model 50B**

Perfect for small boat installations where inches  
count. 50 watts, four-channel crystal controlled. This  
popular conversion of the Navy ATA 2-1-3 mc trans-  
mitter includes a startlingly effective post war modu-  
lation system. Minimum 50 watts into antenna, 95%  
modulated. Contains break-in relay. 18 1/2" long,  
5 1/2" wide, 7 1/4" high. With dynamotor, R.F. meter,  
modulator, microphone, connecting cords. \$189.50  
12 or 24 volts . . . . . \$189.50  
(Add \$20.00 for 32 volt system)

**G.L. MARINER REMOTE CONTROL RECEIVER**

All you need in your cabin is a small control box  
and a speaker. Tunes 200-1100 kc and 2-10 mc.  
Continuous variable tuning, accuracy better than 1%.  
Remote choice of AVC, M.V.C. or CW. Remote control  
box is only 5 1/2" wide, 6" high, and 2" deep. Re-  
ceiver itself is 11" wide, 8 3/16" high, 18 1/2" long,  
with built-in dynamotor. Complete, including tubes,  
plugs, flexible shaft and control cable. \$159.50  
12 volts . . . . . \$159.50  
24 or 32 volts . . . . . \$169.50

**G.L. MARINER RECEIVER, MARINE ONLY**

This is famous Navy model ARA command receiver,  
1.5 to 3 mc, giving lots of spread in Marine band.  
Is companion set to our Model 50B transmitter, but  
may be used with any transmitter. We calibrate the  
dial for instant setting to frequencies you specify.  
Furnished in mounting rack with break-in leads and  
leads to power the DU-1 loop if desired. Requires  
external speaker. With tubes and dynamotor. Marine  
Band: 24 or 32 volts. \$49.50; 12 . . . . . \$59.50  
12 volts . . . . . \$59.50  
Long Wave Band: 24 or 32 volts \$59.50; 12 . . . . . \$69.50

**DU-1 MANUAL DIRECTION FINDER**

Goes ahead of any receiver. We convert it to marine  
band. Still retains lower half of broadcast band, and  
all the lighthouse and beacon band. 2 tube phasing  
circuit, no 180° ambiguity. Gives true bearing in 3  
seconds! We furnish schematic and complete instruc-  
tions. 12, 24 or 32 volts. . . . . \$47.50

**G.L. MARINER SPEAKER**

In neat bulkhead mounting haffle, wired with trans-  
former, cord, and plugs, to match 4000 ohm \$5.95  
output of G.L. MARINER receivers. . . . . \$5.95

**BE SURE TO SPECIFY WHETHER  
POS. OR NEG. GROUNDED SYSTEM**

For complete listing, including Model 100A, G.L.  
Mariner Model 200A, Automatic Direction Finder, etc.,  
send for our catalogue.

**G.L. ELECTRONICS**

905 S. Vermont Ave. Los Angeles 6, Cal.  
25% required on C.O.D. orders. Calif. Buyers add  
Sales Tax.

When this advertisement appeared in a Chicago newspaper, Frank J. Moch, president of the National Alliance of TV Electronic Service Associations, sent the following wire to the service manager of the Radio-Television Manufacturers Association: "Imperative you vigorously protest acceptance by any paper, magazine, radio or TV station of untrue advertising encouraging sales chiseling, jeopardizing lives of set owners and the future of television by encouraging slipshod service. See back page, first section, *Chicago Daily News*, February 21, ad on TV owners' book."

In response, Albert Coumont, service manager for the Radio-Television Manufacturers Association issued a strong protest against the promotion of such material and called for campaigns on the local level to discourage papers, magazines, radios, etc., from accepting such ads.

Mr. Coumont's reply objected to "misleading and unfactual statements used in belittling need for specialized skills in servicing TV receivers as well as to implications that TV service men are incompetent and fraudulent."

He felt that the books had "inconsequential technical value" and could endanger a home owner who tried to tinker with a set according to the instructions in such manuals. Another result of the use of such books that Mr. Coumont foresaw was the possible voidance of manufacturers' warranties and ultimately higher repair bills.

He urged members of RTMA's service committee to keep their protests on the local level, enlisting the help of Better Business Bureaus, manufacturers, service representatives, and other interested groups. —50—

### International Short-Wave

(Continued from page 142)

*Radio Programas Continental* was being heard on 5.996 to 2300. Is a "mover." (Stark, Texas)

*Paraguay*—ZJA1, 6.278, *Radio Nacional de Paraguay*, noted 2132-2200 with light popular music; clock strikes at 2200. (Lane, Wyo.) *Radio Paraguay*, 9.45A, noted to 0000 sign-off recently; all-Spanish. (Baugh, Quebec)

*Peru*—*Radio El Sol*, 15.105A, noted at fair level 0940; at 1000 identified in Spanish as "Radio El Sol en Lima, Peru;" man announcer. This one noted by Ferguson, N. C., around 1930-2030 or later.

*Radio Nacional del Peru*, 9.562 (listed), noted 1915-1930 with rather heavy QRM. (Niblack, Ind.) Heard 2323 announcing "Radio Nacional, La Voz de Peru en El Mundo." (Stark, Texas) *Measured* 9.5613; heard 2220 in Spanish. (Oskay, N. J.) OAX4J, 9.33, noted recently at good level 0120 with Latin American music; at 0130 man announced in Spanish as *Radio Colonial* and music continued; only slight CWQRM. (Bellington, N. Y.)

*Poland*—By now, *Radio Warsaw* should have added a Swedish broad-

# Do You Know?

# G-C MAKES 3,521 SERVICE NEEDS

## FOR RADIO TV SERVICING



**GENERAL CEMENT MANUFACTURING COMPANY**

904 Taylor Avenue

Rockford, Illinois

See Us — Booth 419 — Parts Show!

### RADIO - TV CHEMICALS

In the G-C chemical line alone, there are more than 85 different products. Every one's designed to help the serviceman do a better job faster, easier, more profitably.

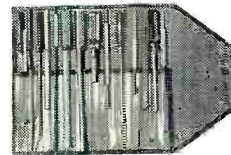

### ALIGNMENT TOOLS AND EQUIPMENT

Virtually every type of servicing tool for the bench or on the job is available at G-C, both separately and in kits. "Whatever you need, G-C makes" might well be the G-C motto!



### ACCESSORIES AND SERVICE AIDS

There are literally hundreds and hundreds of in-demand items in this G-C category. Switches, terminal strips, knobs, belts, dial drives, cables, recording wire and tape are included.

### RADIO HARDWARE



Nuts, bolts, set screws and all the rest of these indispensable items are conveniently packaged by G-C in jars, boxes, envelopes, displays and racks. And the line is both big and complete.

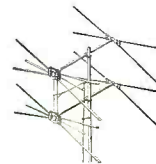

### TV ANTENNAS AND HARDWARE

The G-C Master-Line Antenna line-up is America's finest. In addition, there's a matching line of accessories — stand-offs, chimney and wall mounts, connectors, and the rest — to guarantee the success of every installation.

**G-C MEANS QUALITY!** Though our line is a big one, we've never forgotten that Quality is the first essential of any merchandise. That's why . . . no matter what you need . . . it will pay you to insist on G-C products every time you buy!

**FREE!** 80-PAGE G-C CATALOG shows every G-C product. Fully illustrated. Write for your copy today!

**PERFORMS THE BEST IN EVERY TEST!**

**THE TACO  
ANTENNA**

**Supercharger**

Proven in installations  
all over the country.

TV, FM, AND AM ANTENNAS

**TACO**

TECHNICAL APPLIANCE CORP.

SHERBURNE, N. Y. • IN CANADA: STROMBERG-CARLSON CO. LTD.  
TORONTO 4, ONTARIO

**NOW...**

**NEW MODEL No.  
1628-4½ RECEIVES  
CHANNELS 4 and 5!**

cast. (WRH) Warsaw noted with *English* 1230-1300 on 6.220, 7.205; at 1315-1345 on 6.115, 9.525; 1350-1420 on 6.230; 1545-1615 on 7.205; 1615-1645 on 9.525, 6.115. (Pearce, England)

*Portugal*—Lisbon noted on new channel of 12.033A (measured 12.0258 by Oskay, N. J.) in parallel with 11.963A and 11.995A signing off 1530. (Niblack, Ind.) Heard opening 0730 on 15.130, good level. (Saylor, Va.) *Radio Renascencea*, 6.154A, noted R7-8 at 1800 recently; Lisbon logged on 6.360 with popular recordings around 1325. (Pearce, England)

*Portuguese China*—*Radio Vila Verde*, 9.500, Macau, is reported signing on 0600. (ISWC, London) *Not confirmed.*

*Portuguese Guinea*—CQM4, 5.840A, Bissau, noted 1748-1759 with music; signed off 1800 with "A Portuguesa;" bad QRM. (Harris, Mass.)

*Portuguese India*—*Emissora da Goa*, 9.610, noted 0954 with Portuguese music and announcements; at 1030 said in *English*, "Good evening, we now present 'Bringing Christ to the Nations,'" which followed in *English*; at 1100 announcer said all communications regarding the broadcast should be sent to P.O. Box 1637, Madras, India; continued with "Bringing Christ to the Nations" in a native dialect; on another Sunday same program was noted. (Pearce, England) Also heard by O'Sullivan, England.

*Saudi-Arabia*—Djeddah, 5.975, is now signing on a little after 2330; noted around 2330 playing interval tune. (Bellington, N. Y.) Heard closing down 0010. (Ferguson, N. C.) Djeddah, 11.95, was recently noted opening 1230 with march tune, followed by reading from the Koran; formerly opened 1200 and closed 1345. (Ridgeway, South Africa) Noted recently by Pearce, England, at 1125 and closing 1147; again heard when tuned 1310 to sign-off 1325; he hears Djeddah on 11.950, 11.850, 5.975 in parallel.

*South Africa*—"SABC Calling Africa," 11.937, noted with news 1200; signs off 1505. (Pearce, England) Cape Town, 5.890A, noted 0015-0100 when was covered by CWQRM; had recordings with Afrikaans announcements. (Saylor, Va.) SABC, 9.679, noted from 2345 with setting-up exercises to 2400, then news; has heterodyne. (Stark, Texas) Noted on 4.895 in Afrikaans 0010-0035, weak level. (Patterson, Ga.) Heard from 2345 sign-on. (Saylor, Va.)

*South Korea*—HLKA, 7.93A, noted occasionally around 0700-0730 with fair level; native program. (Saylor, Va.)

*Southern Rhodesia*—Salisbury is now scheduled on 3.320, 7.285, and 9.490 weekdays 0055-0110 (not on 9.490); daily 0400-0700; weekdays 1000-1500 and Sundays 1100-1500; QRA is Broadcasting House, Manica Road, P.O. Box 8, Causeway, Southern Rhodesia. (Radio Sweden) Heard on the 3.320 channel at 1300 with BBC news relay, weak, bad CWQRM. (O'Sullivan, England) Noted on 7.285

It **COUNTS**  
and **CARRIES**  
your **TUBES**



Television  
tube caddy

Specially designed for the television serviceman. Makes work easier and quicker—and YOU more efficient.

You take **INVENTORY AT A GLANCE**—and always have the right tube with you.

Thin, easy-to-carry leatherette cabinet, 20½" x 14" x 9" deep. Holds up to 249 tubes, or less with space for **TOOLS** and **METER**. Clips in cover for price list or mirror.

\$13.50

Net to Dealer—  
Higher on West Coast

Ask your parts jobber how it can **PAY FOR ITSELF** in 3 WEEKS, or write

Also TV Cabinets,  
Wall Baffles

**ARGOS PRODUCTS CO.**

310 MAIN STREET • GENOA, ILLINOIS

It's...  
**KESTER**  
FLUX-CORE  
**SOLDER**



**IN DEMAND**

**IN DEMAND** and used by the manufacturers of original equipment... Best for you, what could be better... Kester Rosin-Core, "Resin-Five" and "Specialized" Solders!

**KESTER SOLDER COMPANY**  
4235 Wrightwood Ave., Chicago 39  
Newark 5, N. J. • Brantford, Can.

**KESTER  
SOLDER**

**RADIO & TELEVISION NEWS**



at 1117-1205 with concert, then light music; S7, light QRM. (Flynn, Calif.) Usually fades (weekdays) after 1030; tuning signal comes on 0955, sounds like chimes of a carillon; weak Sundays at 1100 opening. (Rosenauer, Calif.)

*Spain*—EAJ9, 7.021, Malaga, noted from 1400 with Spanish music in Home Service; calls "Radio Nacional de Espana" at 1500; heard to after 1600, good level in South Africa. (Ridgeway) *Radio Juventud*, 7.200, Cadiz, noted 1730-1800 sign-off. (Radio Sweden) EDV10 was recently measured 7.0874, noted 1515 with musical program. (Oskay, N. J.) "La Voz de Falange," 7.380, Madrid, good from around 1430 tune-in to close 1530; also heard again from 1700. (Pearce, England) Madrid, 9.363, has strong signal in *English* to North America daily 1800-1840. (Wade, Fla.)

*Surinam*—The Department of Education is broadcasting news in *English* and Spanish for the Caribbean and South America after the close of the regular session of AVROS in Paramaribo; newscasts begin 2040 and end around 2110; frequencies are 5.752, 15.400A; requests reports to Department van onderwijs en Volksonwikkeling, Paramaribo, Surinam. (WRH)

*Sweden*—*Radio Sweden*, 11.880, is good signal with *English* for Eastern North America 0700-0715. (Robertson, Mass.) Latest schedules of *Radio Sweden* are listed—*To Eastern Seaboard of North America—English* 1900-2000, Swedish 2000-2145, 9.535; *English* 0700-0715, Swedish 0715-0745, 15.155. *To Western Seaboard of North America—English* 2300-2315, Swedish 2315-2345, 11.705; *English* 1600-1630, Swedish 1630-1700, 11.705. *To South America—English* 1900-2000, Swedish 2000-2100, 11.705; *English* 0600-0615, Swedish 0615-0645, 15.155; *English* 1800-1815, Swedish 1815-1900, 11.705. *To Far East—English* 0800-0815, Swedish 0815-0845, 15.155; *English* 1800-1815, Swedish 1815-1845, 9.535. *To Southeast Asia and Western Australia—English* 2300-2315, Swedish 2315-2345, 15.155; *English* 0900-0915, Swedish 0915-0945, 15.155; *English* 0945-1030, Swedish 1030-1100, 15.155. *To Middle East—English* 2200-2215, Swedish 2215-2245, 9.535; *English* 1200-1215, Swedish 1215-1245, 9.535. *To Africa—English* 0000-0030, Swedish 0030-0100, 15.155; *English* 1300-1315, Swedish 1315-1345, 15.155. *European Service*—Swedish 1400-1430, German 1430-1500, *English* 1500-1530, French 1530-1545, 6.095. *Swedish Home Service*—0000-0500 (Sundays 0000-0400), 6.065; 0500-1110 (Sundays 0400-1110), 11.705; 1110-1745, 6.065. *Radio Sweden* wants reports on reception, especially on International Service, to Radio Sweden, Stockholm 7, Sweden.

*Switzerland*—Berne, 6.165, is good level around 2245 in *English*. (Littlefield, Mass.) Noted on 11.865 at good strength around 1200 in *English*. Bishop, Ohio, reports the 15.305 channel at good level to South Africa in *English* from 1030. Hoffman, N. Y.,

# ARROW HAS MOVED! →

ARROW SALES, INC., formerly of 1712 S. Michigan Ave., Chicago, wishes to announce its new location in California . . . to continue to serve you with fine merchandise at the right prices.

## MN26C BENDIX RADIO COMPASS

. . . complete with tubes, MN28C control box, loop transmission cable, MN20E loop, flexible cables, plugs, etc. . . . . **\$89<sup>95</sup>**

## SCR 625 Famous Mine Detector

For Prospectors, Miners, Oil Companies, Plumbers, etc.

This unit is being offered now at a considerable reduction in price. Recently advertised at \$79.50 it is now available in the same brand new wrappings in suitcase style carrying case (less batteries) at

**\$59.50** WHILE THEY LAST!

### Look at these items—write for best prices!

ARN7 AUTOMATIC DIRECTION FINDER . . . complete installation  
SCR269F AUTOMATIC DIRECTION FINDER . . . comp. inst.  
SCR269G AUTOMATIC DIRECTION FINDER . . . comp. inst.  
SCR522 VHF transmitter and receiver, available as a complete installation or just transceiver  
BC733D LOCALIZER RECEIVER, complete with tubes and crystals  
DM53A DYNAMOTOR for above  
FT293 MOUNT for 733  
BC732 CONTROL BOX for 733  
PLUGS for 733  
R89/ARN5 GLIDE PATH RECEIVER  
R57 GLIDE PATH RECEIVER  
AN/APS4 Complete RADAR SET  
BC638A Frequency METER  
BC376H Test OSCILLATOR  
ID6/APN4 Loran INDICATOR

R9/APN4 Loran RECEIVER POWER SUPPLY  
IE36 TEST SET for SCR 522  
I 139 Meter p/o IE36, available separately  
MD4/APS2 Modulator Unit  
TS10A/APN Altimeter TEST UNIT  
TS16/APN Altimeter TEST UNIT  
TS51/APG4 TEST SET for bomb release equipment  
TS170/ARN5 Glide Path TEST SET  
TS184/AP Signal GENERATOR  
TS251 Loran TEST SET  
RT34/APS13 420mc Tail-warning TRANSCEIVER  
BC788 TRANSCEIVER  
BC1023 Marker Beacon RECEIVER  
BC1033 Marker Beacon RECEIVER  
BC1206 Beacon RECEIVER  
TPS10 Receiver

## COMMAND (SCR-274N) EQUIPMENT

	used	new
BC-442 Antenna Relay, complete . . . . .		\$ 3.95
BC-451 Transmitter Control Box . . . . .		1.50
BC-450 3 receiver remote control box . . . . .		2.95
MC-215 Mechanical Drive Shaft, per length . . . . .		2.95
BC-496 2 position Rec. Control Box . . . . .		2.95
T-23 ARC5, 100-156 mc xmtr. . . . .		49.50
BC-459, less tubes. . . . .	12.95	
BC-458, less tubes. . . . .	5.95	
BC-455, 6-9 mc receiver, with tubes . . . . .	9.95	14.95
less tubes . . . . .	7.95	
BC-453, with tubes . . . . .	19.95	
less tubes . . . . .	14.95	

## FLAP PITCH MOTOR

24 VDC, will operate on AC-3300 or 11,000 R.P.M. Complete with gear box and limit switches, excellent, used **\$4.95** each

All shipments F.O.B. warehouse . . . California residents add sales tax with your remittance. 20% deposit on all orders. \$5.00—minimum order accepted.

## MONTHLY SPECIAL

BC457 command transmitter covering 4-5.3 mc, shipment just received, limited quantity, less tubes and crystals, exc. cond. . . . . **\$5<sup>25</sup>**

## PHONE EQUIPMENT

HS-23 High Impedance Headset . . . . .	new \$4.95
HS-33 Low Impedance Headset . . . . .	5.95
CD-307 Ext. cord for HS-23-33, like new . . . . .	.95
Throat Mike—T-30—new . . . . .	.98
Lip Mike—Navy Type—new . . . . .	.98
Extension Cord and switch assembly for lip and throat mikes, new . . . . .	.98
RS-38 Microphone, new . . . . .	4.95
HS-38, new . . . . .	2.29

We have a very complete list of all types of tubes . . . write today . . . please specify quantity desired.

**ARROW SALES, INC.** 7460 N. Varna, North Hollywood, Calif.

# STEEL TOWERS and MASTS

## Tubing - Roof Mounts - Guy Rings

### PRODUCTS

#### for T-V and ELECTRONICS



Model 100—  
Kwick Climb Tower

This light weight tubular steel tower comes in 10' sections with slip joints that require no bolting. Safe and easy to climb. Top section has sleeves for up to 2 1/4" mast. Base adaptable to any pitch roof. Additional sections may be added to 100 feet. 30' tower complete with base weighs 80 lbs. Additional sections 22 lbs. each.

MODELS 130 and 140, 30 foot and 40 foot Manually Telescoping Masts. Priced for that inexpensive installation.



Pat. Pending

Model 115—  
Krank Up Mast

27' telescoping crank up mast complete with all hardware. Cranks to any positive position from 10' to 27'. Made of sturdy 2", 1 1/2" and 1 1/4" tubing. Easily installed.

Model 125—  
Krank Up Mast

47' telescoping crank up mast complete with all hardware. Same as Model 115 in construction. Will telescope to any positive position from 20' to 47'. Weight 45 lbs.

A locking device on both of the above models removes all the strain from the cable.

### ROOF MOUNTS

Model A-5—Apex Roof Mount  
A sturdily constructed Roof Mount with 4-way swivel. Fully adaptable to any type of mounting. Will take up to 2 1/4 inch tubing.

### ALSO

MODEL S, Rotary 4-way T-V mast base mount  
MODEL P, 2-way swivel T-V mast base mount  
RUGGEDLY CONSTRUCTED MOUNTS - LOW PRICED

QUALITY PRODUCTS SOLD THRU  
RECOGNIZED JOBBERS

JOBBERS and DISTRIBUTORS  
WRITE FOR PRICES AND LITERATURE

JONTZ MANUFACTURING CO.  
1101 E. MCKINLEY AVE.  
MISHAWAKA, INDIANA

notes the monthly DX session at 1400 on first Wednesday of the month on 9.665. Berne is logged on 7.210 by Lackey, Pa., around 2030-2210.

HBQ, 6.675, Geneva, *United Nations Radio*, noted 1330 with news; news in French 1345; woman announcer said news is given Mondays and Fridays; strong signal in Britain. (Catch)

Tahiti—*Radio Tahiti*, 6.135, Papeete, noted around 2320 to after 0015; fair level, slight QRM from AFRS on 6.140. (Dary, Kans.)

Taiwan—Taipeh, 6.095, noted recently with "Bible Hour" in *English*, 0515. (Balbi, Calif.) Fox, N. Z., reports BED21, Taipeh, on 9.335 at 0330-0415; announced "This is BED21 on the air testing." Announced in *English* 0330, 0400.

"Voice of Free China," 15.235, noted strong 2300-2400 with news, commentary, music; announced 11.735 as parallel. (Leary, Calif.) BED7, 7.133A, noted at good level 0625-0720 or later; no *English* heard. (Ferguson, N. C.) Now signs on 0430 instead of 0530; gives calls of BED2, BED7, BED6 in that order. (Rosenauer, Calif.) Noted on 11.735 at 2315 with news; BED26, 10.070, heard 0430 with clear signal in Western music, Chinese announcements; BED36, 7.334, noted 0630-0645 with Western music, then news in Chinese. (Sanderson, Australia)

Tangiers—Saylor, Va., recently heard *Pan-American Radio*, 15.048, at fair level 1330-1415 when was blanketed by CWQRM; had nice signal when first tuned.

Thailand—During *English* session 0530-0625, *Radio Thailand*, 6.240, Bangkok, announced as using 11.910 and 6.240; fair level; had commentary 0545-0550, news 0615-0625. (Rosenauer, Calif.) Heard on 11.910 with news 0515. (Sanderson, Australia)

Trans-Jordan—Hashemite Jordan Broadcasting Service, 7.065, is scheduled 0000-0100 in Arabic; 0600-0630 *English*; 0630-0730 Arabic; 0930-1030 *English*; 1030-1330 Arabic. (ISWL, London)

Trinidad—*Radio Trinidad*, 3.275, noted to 2200 sign-off; usually has bad QRM. Verified this 90-m. outlet, giving frequency as 3.275, used 1500-2200; listed 9.625 for 0430-1515; 1295 kc. broadcasts continuously, according to schedules received. (Kary, Pa.) I recently noted *Radio Trinidad* (as did Saylor, Va.) one morning on 9.685A but on subsequent occasions was found on its old channel of 9.625 around 0700 when man gave local announcements.

Turkey—TAP, 9.465, Ankara, still noted with *English* for Western Europe 1600-1645 daily; heard Thursdays with program "The Way We Live In Turkey;" announces TAS, 7.285, as parallel; closes down 1655 in Turkish. (Baitzel, N. J.)

TAT, 9.515, continues at good level to North America in *English* session daily 1815-1900. (Mast, N. Y., others) Each Saturday at 1845 has a tourist information program called "Come to Turkey." (Bellington, N. Y.)

Uruguay—CSA19, 11.835, Monte-

## IF YOU BUY ON SPECIFICATIONS



and tops in value, you'll buy the

## TWIN-TRAX\* TAPE RECORDER

"Choice of Engineers Everywhere"

Compare the guaranteed specifications of a Twin-Trax Tape Recorder with any other recorder in any price class. You'll find that Twin-Trax gives you more features, better all-around performance and more value for your money.

Complete specifications, performance ratings and direct factory prices in our catalog 5109. Send for it today.

\*Trademark Reg.

## AMPLIFIER CORP. of AMERICA

398 Broadway, New York 13, N. Y.

### New • Electronic Materials • Guaranteed Relay Specials

SIGMA =41F, 8000 Z/04 watt sensitive plate circuit type SPDT, a scan 15t	\$2.95
SIGMA =2F, 2-65 ohm coils, SPDT, operates 2-24 VDC, makes sensitive overload or underload control, increased, \$2.45; cased, . . .	3.45
SIGMA =4F 3000 Z/4 ma, 5-prong plug-in, hermet. sealed . . . . .	3.25
GM BK-50 super sensitive, 10000 Z operates @ 500ua SPDT, mtd. on bakelite base. . . . .	4.50
LEACH 107BF, 160 ohm coil (24V) ceramic base over . . . . .	1.75
ALLIED B0D35, 200 ohm coil (24V) 4PDT, 10A. . . . .	2.75
ALLIED D09D2S, 14 ohm coil (6V) 3PDT, 10A. . . . .	1.95
ALLIED BL, 42 ohm coil (6V) SPNO, miniature . . . . .	.65
OIL CAPACITORS	
2 MPD/600V . . . . . \$ .75	10 MPD/600V . . . . . \$2.45
4 MPD/600V . . . . . 1.25	15 MPD/600V . . . . . 3.95
4 MPD/600V TLAD 1.14	20 MPD/600V . . . . . 4.75
SELENIUM RECT. FWB MINI, 115 vac/15 ma. . . . .	.69
SELENIUM RECT. FWB, 90 VAC in/150 ma. . . . .	1.25
SELENIUM RECT. FWB, 36 VAC in/250 ma. . . . .	.95
5 AMP 115 AC KILOWATT HR METER. . . . .	1.95
HI FI PP INPUT TRANS. CT pri. & sec. cased. . . . .	1.45
HI FI PP OUTPUT TRANS. 5000Z CT/4. 8. 250Z VC, RCA mfr. 10V. . . . .	1.95
SPECIAL POWER S U P P L Y KIT, HERMET. SEALED, 700VAC CT/125 ma 130VAC CT/50 ma bias wind, 6.3/6A, 6.3/5A, 5/2A-2 cased filter chokes, 8 hvy-dual 8 mtd oil capacitor, 16 mtd/450 tubular, complete kit with desk type console cabinet, a bargain. . . . .	10.95
DRY CHARGED PLASTIC CSD STORAGE BAT. 40A 6V-\$4.95; 40A 4V-\$3.95; 20A 2V . . . . .	.95
QUALITY KITS AT BARGAIN PRICES	
100 INSULATED RESISTORS, 14 gain prices	\$2.75
50 RF CHOKE COILS, useful assort., 2 circuit. . . . .	1.45
25 PRECISION WW RESISTORS, useful values	2.25
15 POTS, carbon & wv, incl. 1/2 mtr units	2.25
50 CERAMIC COND., over 25 useful values. . . . .	2.25
50 BY-PASS COND., tubular, 400 & 600V units	2.75
2 LB. HOOK-UP WIRE ASSORT., 58c; two for 1.00	1.00
SPECIAL BONUS-1 KIT FREE (choice) with 5 asstd.	

ELECTRONIC SPECIALTY SUPPLY CO.  
56D Lispenard Street New York 13, N. Y.

## WANTED!

ALL TYPES AIRCRAFT, RADAR, RADIO SETS, COMPONENTS, DYNAMOTORS AND ASSOCIATED EQUIPMENT, such as ART-13, EC-011, Test Equipment, ARC-1, ARN-6, ARN-7, RTA-1B, Etc.

WE PAY TOP DOLLAR!

WEST REGION ELECTRONICS, Dept. RW  
1437 South Norton Ave., Los Angeles 19, California

## RADIO ENGINEERING IN 27 MONTHS

Radio engineering is a big field. There's room for you in it—if you're good. Get first-class training at Indiana Tech. Intensive specialized course, including strong basis in mathematics and electrical engineering, advanced radio theory and design, television, electronics. Modern laboratories. Low rate. Also B.S. DEGREE IN 27 MONTHS in Aeronautical, Chemical, Civil, Electrical and Mechanical Engineering. G.I. Gov't approved. Enter June, Sept., Dec., March. You can earn part of your expenses right here in Fort Wayne while you are studying.

## INDIANA TECHNICAL COLLEGE

952 E. Washington Blvd., Fort Wayne 2, Indiana  
Please send me free information on B.S. Engineering Degree in 27 months as checked.

Radio-Television  Aeronautical  
 Civil  Mechanical  Electrical

Name \_\_\_\_\_  
Address \_\_\_\_\_

## RADIO & TELEVISION NEWS

video, logged 1700 with announcements in Spanish, French, *English*. (O'Sullivan, England)

**USA—Radio Free Asia** program noted on 8.910A signing off 0910; requested correspondence to P.O. Box 3161, Manila, Philippines; is *RCA*, San Francisco, to Manila for relay over DZ13, 6.110 (from 0700). (Kary, Pa.) Confirmed the 8.910 outlet for Flanders, Mass.

**USI (Indonesia)**—YDF, 6.045, noted closing 1030 with anthem and chimes for 2300 Indonesian Time; high level in South Africa. (Ridgeway)

**Radio Angkatan Udara di Djakarta**, the Indonesian Air Force Station on 11.945, was recently recorded at 0630. (Radio Australia) Broadcasts educational programs in Indonesian 0430-0630; verifies via airmail. (Cushen, N. Z.)

Djakarta uses 11.770 and 15.150 for *English* 0930-1030 to South Asia. (Radio Sweden) YDA3, 4.945, Bandung, heard 0745-0815; one gong for interval; is Home Service. (Flynn, Calif.) New 7.5 kw. transmitters have arrived in Indonesia and from the increased signal strength of YDE, 11.770, Djakarta, it may be that at least one of the new transmitters is now in operation. (Radio Australia)

**USSR—Moscow**, 15.360, noted 0925 with good level, clear signal. (Duxbury, R. I.) Moscow was heard recently with *English* talk 0810 on 15.502. (Oskay, N. J.) Noted on 9.723 at 1530-1600. (Geisel, W. Va.)

"Monitor," house organ of ISWL, London, comments that for those who collect QSL cards it may be of interest that there are no fewer than eleven separate countries within the USSR for QSL purposes—Minsk, White Russia; Kharkov or Kiev in Ukraine; Tbilisi in Georgia; Erevan in Armenia; Baku in Azerbaijan; Alma Ata in Kazak; Tashkent in Uzbek; Ashkabad in Turkmen; Stalinabad in Tadzhik; Frunze in Khirgiz, and Petrovovsk in Karalia.

**Vatican**—HVJ, 9.646A, noted 1445-1530; fair level in N. Y. (Precourt) This channel noted 1315-1330 in *English*; returned at 1345 with French session. (Bellington, N. Y.) Heard signing off on this channel 1630. (Stark, Texas) Has news 1000. OTC2, Belgian Congo, says the Vatican has started operation of a new 50 kw. transmitter. (Bellington)

**Venezuela**—YVKB, 4.89A, noted 2305-2330; fair level but with some QSB. (Oestreich, Washington State) **Radio Valencia**, 3.460, 1 kw., is on the air 0530-2230 with call of YV4RE. (WRH) The Latin heard on 9.94 to 0230 sign-off is harmonic of YVLK, 4.97. (Bellington, N. Y.)

**Yugoslavia**—**Radio Yugoslavia**, 6.100, now has news 1145, 1400. (ISWL, London)

\* \* \*

#### Press Time Flashes

"Voice of Free Hungary" (Freedom Station), 9.090A, heard with fine level 1550-1600 sign-off; man talked to 1600, then had short musical selection. (Har-

SEE LEO FIRST FOR . . .

# hallicrafters

I can SAVE you money . . . Liberal Trade-ins

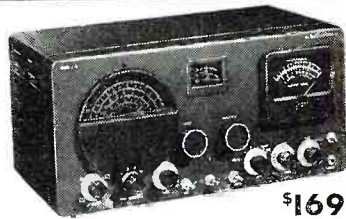

\$169.50

### New S-76 RECEIVER

Extra selectivity with double super-heterodyne circuit. One RF, two conversion and 3 IF stages. Range 550-1550 Kc, 1.7-34 Mc in four bands. 8 tubes plus voltage regulator and rectifier. Complete with tubes, less speaker.

R-46 SPEAKER \$19.95



\$199.50

### SX-71 RECEIVER

Double Conversion sharp selectivity, plus built-in NBFM at moderate cost. 11 tubes plus voltage regulator and rectifier. Low down payment.

R-46 Speaker \$19.95

NAME YOUR TERMS • LOW DOWN PAYMENTS • PERSONALIZED SERVICE

## HALLICRAFTERS RECEIVERS AVAILABLE FOR IMMEDIATE SHIPMENT

S-38B . . . . .	\$49.50	S-72 Portable . . . . .	\$109.95
S-40B . . . . .	\$99.95	SX-62 . . . . .	\$289.50
S-81 . . . . .	\$49.50	S-78A . . . . .	\$89.50
S-82 . . . . .	\$49.50	S-76 . . . . .	\$169.50
		R-46 Speaker . . . . .	\$19.95

## Famous WRL RADIO REFERENCE MAP 25c



CU on 10-20 & 75 Meters

## NEW LOG BOOK 25c

For mobile or fixed station. Spiral binding. Full column log listing all FCC required info. Will accommodate 1,525 stations. "Q" signals, phonetic alphabet, amateur international prefixes.



## JUST OFF THE PRESS!

### WRL 1952 CATALOG

Send for your copy today. Contains everything new in radio and television. Jam-packed with bargains. Leo I. Meyerson, WØGFQ



FREE

PHONE 7795

WRITE—WIRE



WORLD RADIO LABORATORIES R-5  
744 West Broadway  
Council Bluffs, Iowa

Please send me:

- Radio Map  SR-75 Info  
 New Catalog  SX-71 Info  
 Used Equipment List  New Log Book

Name . . . . .

Address . . . . .

City . . . . . State . . . . .

# MOSLEY FLUSH SOCKETS

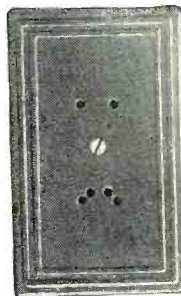

Cat. No. F-14

Now better than ever! New molded polystyrene sockets and face plates are more efficient, more attractive—easier to install!

There's a MOSLEY FLUSH SOCKET for every installation need—single or dual lead-in and combination lead-in and rotator cable sockets. Also, a combination lead-in socket and 3 position switch for multi-antenna installations.

For terminating standard 300 ohm transmission line in standard electrical box. May be mounted on non-plastered wall with fittings supplied. See the complete MOSLEY line of low-loss TV Antenna Transmission Line Accessories at your radio parts jobber.

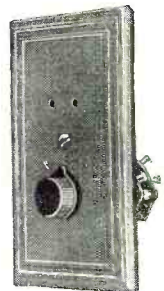

Cat. No. F-10

We're looking forward to meeting you at the May show. Visit us in Space 119.

## MOSLEY ELECTRONICS

2125 Lackland Road

Overland, Missouri

THIS AD IS YOUR ORDER BLANK

OUTSTANDING HIT!

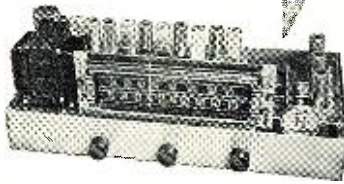

Above: Collins FM-AM Pre-Fab Tuner After You've Assembled It. Total Kit Cost, \$69.

# COLLINS AM-FM "PRE-FAB" TUNERS

Join thousands developing a fine radio hobby with inexpensive COLLINS FM-AM Pre-Fab Tuners — best buy in radio tuners since the crystal set! Thrilling experience in economical way to high fidelity radio reception. Radio building's a snap with COLLINS wired and tested components! Buy direct from COLLINS factory. and POCKET THE SAVINGS!

Collins — the only company devoted exclusively to manufacture of radio tuners and tuner kits . . . continuously producing finer kits at LOWER COST with the SAVINGS GOING DIRECTLY TO YOU!

CLIP AND MAIL WITH YOUR ORDER



FM Tuning Unit  
88-108 MC   
\$15.25

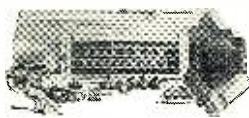

U.C.-2 Universal  
Chassis Kit  \$14.75



AM Tuning Unit  
(Includes IF & Audio Amplifier)  \$19.25  
Am-4 Tuning Unit  
(With Tuned RF Stage & 3-gang Condenser for Higher Sensitivity)  \$24.50



FM-IF Amplifier  
10.7 MC  \$19.75

Tuning Eye Kit  
6U5-G  \$2.85



All Pre-Fab units assembled, wired, tested and aligned at factory. Prices include tubes. Chassis Kit includes all necessary parts, nothing else to buy. Instruction Manual with detailed step-by-step procedure, pictures and schematic diagrams included. Chassis measures 8" x 17" x 2 1/2". Overall, tuner assembled measured 8" x 17" x 6". Expertly engineered for utmost satisfaction.

COLLINS AUDIO PRODUCTS CO., Inc.  
P. O. Box 368, Westfield, N. J.

Enclosed please find check  money order   
for items checked in this ad.

Amount enclosed \$ \_\_\_\_\_

Name \_\_\_\_\_

Address \_\_\_\_\_

City \_\_\_\_\_ State \_\_\_\_\_

Another Outstanding Jobber  
**OLYMPIC ELECTRONICS SUPPLY**  
1440 W. OLYMPIC BLVD.  
LOS ANGELES 15, CALIF.  
**EICO** has all 17 KITS  
& INSTRUMENTS  
in stock!  
3" SCOPE KIT \$44.95  
5% higher on West Coast  
See EICO ad on Page 183

**WE'LL PAY SWEET PRICES for Your  
RADIO & AIRCRAFT EQUIPMENT**  
We want to buy your parts or equipment—and we'll pay top dollar to get it! Just send us the dope on your equipment, its type and condition—and your asking price. You'll get fast, profitable action. It's just like taking "Candee" from a baby! Write today.  
**CANDEE-AIRCO, Dept. T-1**  
3306 Burbank Blvd. Burbank, California

**THE MOST COMPLETE LINE OF  
TV CABINETS IN THE COUNTRY**

River Edge...superb quality by skilled craftsmen. All cabinets are custom made, all with hand-rubbed finishes...table models, open face consoles, combinations, with bars, sliding doors, swivel bases, and many other fine features.

A typical example is the M-III shown, which will accommodate up to 27" tube with or without record drawer, made of solid mahogany and mahogany veneers. A complete line of conversion cabinets available with adaptable masks made to fit all name brand chassis. River Edge Industries defies all competition with complete price range retailing from \$40 to \$400. **Write for catalog**  
See us at the Parts Show, Conrad Hilton Hotel, Room 652A.  
New territories open for Representatives, Distributors and Jobbers.

**RIVER EDGE INDUSTRIES**  
River Edge, New Jersey, ORadell 8-0900  
N. Y. Showroom: 192 Lexington Ave., CHickering 4-2120

W 36" x D 25" x 4"

ris, Mass.) Also reported by Sutton, Ohio, at 1530-1600.

OTC2, Belgian Congo, in a recent DX session, reported a Czech Freedom Station, located in France, heard on 9.25 around 0515-0730. (Bellington, N. Y.)

According to press dispatches, the ancient kingdom of Yemen on the Red Sea is installing a *General Electric* short-wave transmitter so it can communicate with its United Nations delegation in New York; one of the Arab nations since 1946, the Yemen government plans to use the 25 kw. transmitter also for broadcasting to other Islamic countries. The 150-kw. *G-E* generator which will provide power for the transmitter will be the largest power source in Yemen. (Lund, Iowa)

Direct from an official of *Radio Omdurman*, Anglo-Egyptian Sudan, Bellington, N. Y., learns that Omdurman now broadcasts daily 1130-1430 continuously instead of 1130-1300 and then 1400-1430 as formerly; uses 9.737; has left the 16.6-m. band and is now experimenting on 7.325A, the official said.

Rosenauer, Calif., flashes that *Radio France-Asie*, Saigon, Indo-China, has moved again—from 9.750 to 9.720A; heard there with excellent signal 1000; also notes "Voice of Vietnam," Indo-China, has moved to 7.080A from 7.090, good level 0800. Balbi, Calif., also notes change to 9.720A, heard there signing off 1030. In verifying for the 7.230A channel for Kary, Pa., RFA listed other channels as 11.920, 11.830, 9.750, 6.116. Pearce, England, hears the 7.230A outlet at 1830 with news in French.

When this was written, Stark, Texas, reported TGWB, Guatemala, had moved from 6.440 to 6.180A; heard opening 0730 announcing TGWA (15.170) and TGWC (1520 kc.) in parallel.

The WRH DX Contest, conducted in November in conjunction with the ISWL, London, has again been won by the 1950 winner, Arthur Cushen, Invercargill, New Zealand. (Radio Australia, others)

Officials of *Radio Brazzaville*, Fr. Equatorial Africa, have informed Kary, Pa., that installations of *Radio Brazzaville* are used for three different programs—(1) an international program over *Radio Brazzaville*, French National Broadcasting Station; (2) a local program over *Radio A.E.F.*; and (3) a program in Arabic over *Radio Chad* for the Moslem populations of Africa, particularly those in the territory of Chad (one of four territories making up the Federation of Fr. Equatorial Africa).

A letter received at press time from Isamu Yamazaki, Chief, International Broadcasting Section, Broadcasting Corporation of Japan, Tokyo, Japan, says "in the near future, we hope to increase the broadcasting hours, with expansion to many other countries in the world." Wants reception reports.

Pyongyang, 4.400, North Korea, is fairly good at times, but suffers from QRM; best on West Coast from around

0600; relays Moscow's Far East Service when using Korean; some days has English 0815-0830; heard on 6.240A in parallel (slightly above Bangkok, 6.240, Thailand, and stronger). Chinese station, 6.225A, may be Sinkiang as parallels Sinkiang on 7.055A, sign-off appears 0730. ZQP, 7.220, Northern Rhodesia, is fairly good level at times; noted 1030 to fade-out after 1200; uses various dialects and some English; Salisbury, 7.285A, Southern Rhodesia, is fairly good level but suffers from selective fading, noted around 1100 and later. Armed Forces transmitter, 7.575, Makassar, Celebes, Indonesia, is good level but with bad QRM to 0900 sign off. North China, 9.040V is noted around 1900 parallel with Peking on 10.200A and 10.260A; these are Peking Home Service outlets; 9.040V is also audible mornings around 0800 and later. Harbin, 15.130, Manchuria, is not audible lately on this channel and may have returned to 15.170. (Dilig, Calif., via URDXC)

### Acknowledgement

Thanks for the many fine reports. Keep them coming to Kenneth R. Boord, 948 Stewartstown Road, Morgantown, West Virginia, USA. Good listening! . . . . . K.R.B.

## "ALASKA CALLING"

STATESIDE hams have been called upon by the USAF Air Weather Service to assist in solving a difficult morale problem which has been encountered in Alaska.

At lonely Eielson Air Force Base in central Alaska near Fairbanks, the men of the 58th Strategic Reconnaissance Squadron of the Air Weather Service are stationed in cold isolation. Away from personal contact with their families in the States, like men in all remote bases, the personnel of the 58th eagerly grasp any opportunity to communicate with parents, wives, and children back home in the U. S.

An answer to the morale problem—an answer in which all U. S. hams can cooperate—has been suggested by Captain Dean Mohr, communications officer for the 58th. Captain Mohr has called upon all Stateside hams to monitor as often as possible the 10, 20, and 75 meter bands for possible relay of messages to families in their localities.

Eielson Air Force Base's ham outfit is a branch of MARS which was established at the Alaskan base by Captain Mohr in the summer of 1950. Operating as AKIAG, the Eielson station has a power of 500 watts.

The men of the 58th continue to fly their weather reconnaissance missions every other day over the top of the world to the North Pole and back again to Eielson. The big Boeing WB-29 Superforts of the Air Weather Service have flown nearly 600 of these over-the-pole missions across the lonely frozen vastness of the Arctic, flashing back vital weather information for the Air Force and Army. It is easy to see why the squadron's morale is of real importance to the Armed Forces of the United States.

Here is a chance for hams at home to give a boost to some of their buddies in Alaska.



## DYNAMOTORS:

**DYNAMOTOR  
And BLOWER**  
9 Volts DC input.  
output 450 Volts 60  
MA., 4500 RPM. At  
6 Volts DC input.  
output 260 Volts 65  
MA., 3000 RPM.  
Price.....\$4.95

INPUT:	OUTPUT:	STOCK No.:	PRICE:
14 V. DC	600 V. 300 MA.	BD-86	\$9.95
12 V. DC	220 V. 70 MA.	DM-375	6.95
12 V. DC	220 V. 100 MA.	DM-18	4.95
12 or 24 V. DC	440 V. 200 MA. & 220 V. 100 MA.	D-104	9.95
14 V. DC	375 V. 150 MA.	DM-375	8.95
14 V. DC	330 V. 135 MA.	DM-330	7.95
14 V. DC	500 V. 500 MA.	PE-59	14.95
12 or 24 V. DC	275 V. 119 MA.	USA/0516	3.95

ALSO—PE-78; PE-86; DM-53; DM-33; 5055; DM-416; PE-101, etc.

## METERS:

0-150 Volt, 400 cycle, 2 1/2" Rd.	\$3.95
0-5 Amp. AC, 3" Rd., 0-75A Scale	3.95
0-5 Milliamp DC, 2 1/2" Sq., 0-5 Scale	3.95
0-1 Milliamp DC, 2 1/2" Rd., 0-150 Scale	3.95
0-500 Microamp, 2 1/2" Rd., 0-15 & 0-600 DC	3.95
TUNING METER 1-70B Reverse Scale, Weston #606 for Compass Control Boxes	3.95

## MOUNTINGS AND CLAMPS:

FT-154 for BC-348 Receiver	\$2.50
FT-470 Mounting & Clamp	1.00
MC-476 Maple Ball for above-ft/fairlead	1.00
MC-390 Wood Clamp for Fairlead	1.75
M-235 Bobbin & 250 Ft. W-106 Antenna Wire	3.50
WT-7 Weight for Trailing Antenna	1.50

## BLOWERS:

115 Volt 60 cycle BLOWER (pictured), approx. 100 CFM Dis. 2 1/4" intake; 2" outlet. Quiet running. Motor size: 2 1/2"x3 1/4". NEW—not Gov't surplus. **\$7.99**



**DUAL BLOWER**—Same as RN-520 above, except has blower assembly on each side of motor. Order No. RN-800.....\$12.95

## POWER SUPPLIES:

**VIBRATOR TYPE**—6 Volt DC input; output 230 Volt DC 50 MA.—not filtered—w/tube. Ideal for Command Receiver operation as receiver is filtered internally. Size: 4 1/2"x4 1/4"x3 3/4".....\$4.95

**PE-157 POWER SUPPLY**—2 Volt Vibrator Supply, operates from BB-54 2 Volt Battery mounted in Case. Output voltage 1.4 V. 1/2 Amp 125 V. 50 MA. Less Battery, Speaker, & External Power Cord—with Vibrator. **\$4.95**

**BB-54 2 Volt Dry Battery**.....2.95

## PLUGS AND CONNECTORS:

PL-112 Plug for LP-21 Loop	\$1.25
PL-P-103 Plug for BC-348	1.50
MC-211 Rightangle Adapter for Comm. Sets	.50
AF-359 Rightangle Coaxial Connector	.25

## CONTROL BOXES:

	NEW:	USED:
C-87/ART-13-f/ART-13 Trans.	\$ 6.95	\$4.95
MR-9C/Control Box f/RA-10 Rec. w/Mtg.	12.95	9.95
BC-454 for ADF	3.95	3.95
BC-732 for Localizer	2.95	1.95
BC-646 Control Box f/BC-645	2.00	
BC-461 Reel Control Box w/Counter	2.95	

## AUTOSYN TRANSMITTER:

Autosyn Transmitter from LP-21A Loops, used with I-81 or I-82 Indicators. Operates from 26 Volt 400 cycle. With calibrated Dial and Correction Pointer. MC-507.....\$6.95 MC-217.....\$5.95

## GEAR TRAIN MOTOR

Ball bearings, low inertia reversible type, 588 RPM. Extra large gear, 1/2 RPM operates 26 Volt 400 cycle or 12 Volt 60 cycle. Removed from LP-21 Loops. Type—10047-2-A.....\$4.95

## CORDS—CABLES

CD-501 Cord f/GN-45 Generator	\$2.00
CD-318 Cord w/PL-68 & SW-141 & JK-48F	
f/Throat or Lip Mic.	.89
f/Throat or Lip Mic.	.89
CD-307 Cord—6.5 Ft. w/PL-55 & JK-26	.89
CD-604 Cord w/C-410 Trans. & PL-54 Plug	.89
BC-375 or 191 Cable w/PL-64, 61, or 59 each end	2.50
CD-365 Cord for LP-21 Loop	1.75
MC-215 Tuning Shaft for 274N	2.00

Address Dept. RN • Minimum Order \$5.00 • Prices F.O.B., Lima, O. • 25% Deposit on C.O.D. Orders

## TRANSFORMERS AND CHOKES

TRANSFORMERS—110 V. 60 CYCLE PRIMARIES:

Sec. 6.3 Volt 1 Amp.	\$1.25
Sec. 24 Volt 1/2 Amp.	1.50
Sec. 24 Volt 1 Amp.	1.95
Sec. Two 12 V. 4 A. windings—gives 12 V. 8 A. or 24 V. 4 A.	2.95
Sec. 6.3 V. 6 A.—6.3 V. 4 A.	5.95
Sec. 24 Volt 6.5 Amp.	5.95
115 V. Sec. 440 VCT/70 MA—5 V/2 A—6.3/4 A.	3.35
115 V. Sec. 700 VCT/120 MA—5 V/3 A—6.3/4 A. 32V/2 A.	4.75
115 V. Sec. 490 VCT/60 MA—5 V/2 A—6.3/4 A. 6.3/2 A.	3.25
115 V. Sec. 460 VCT/90 MA—5 V/3 A—6.3/4 A.	3.75

## CHOKES

8 Henries 500 MA Filter, 5000 V. Ins.	\$8.95
7.5 Henries—400 MA., 60 ohms, 5000 Ins.	6.95
6.2 Henries—300 MA., 82 ohms, 5000 Ins.	4.95
15 Henries—300 MA., 260 ohms.	4.75
8 Henries—500 MA., 80 ohms, 5000 Ins.	8.95
4-12 Henries—300 MA., 110 ohms, 1000 Ins.	3.95

## BC-223 TRANSMITTER



30 Watt transmitter with Crystal or AIG control on four pre-selected channels. CW, MCW cover frequency range 2000-5200 KC. by use of plug-in coils. Complete with tubes and choice of one Tuning Unit (listed below). Less Mtg.—Prices: NEW: \$32.50

USED **\$26.50**  
(Gov't. Reconditioned)

CABLE—Trans. to Power Supply.....\$2.00  
TUNING UNITS: TU-17—2000-3000 KC.; TU-18—3000-4500 KC.; TU-25—3500-5250 KC. **\$3.50 EACH**  
Spare VIBRATOR & TUBE KIT f/PE-125BX.....\$ 5.95  
PE-125BX POWER SUPPLY f/BC-223—12/24 Volt input; output 475 Volts 150 MA. NEW: **14.95**  
SPARE TUBE KIT in metal box. f/BC-223 NEW: **5.95**  
OPERATING MANUAL for BC-223AX.....2.50  
SHOCK MOUNTING for PE-125.....1.50  
FT-173 MOUNTING for BC-223.....2.50  
BC-223 TRANSMITTER—Incomplete, for parts. No front panel or meters. Price—As is.....\$4.95

85 KC IF COIL—BC-453.....\$1.50 Ea.

BFO—85 KC.....75c 1415 KC—IF.....\$1.50 Ea.  
300 KC—IF.....\$1.50 Ea.  
TU-7-8-9-10-26 for BC-191/BC-375.....Used: **\$3.95**

## AERIAL WIRE

Aerial Wire—Phosphorous Bronze #16 Stranded, 200 lb. test. Weather-Proof. 150 feet on Reel. RL-3 with Clips...\$1.50

## WIRE—HEAVY DUTY RUBBER COVERED

2/16—20 Ft. Length.....\$1.25  
2/12—10 Ft. Length.....1.00  
1/16—Shielded, 15 Ft. ....1.50  
1/8—Shielded, 7 1/2 Ft. ....75  
1/2—Shielded, 8 Ft. ....1.00  
1/8—Cotton covered—Per Foot .....06  
1/14—Shielded, Rubber Covered, 50 Ft. Length.....\$2.75  
Or Per Foot at.....06

TELEPHONE WIRE—3 Conductor, copper and steel, 525 feet.....\$5.95

## ANTENNA EQUIPMENT

### MAST BASE—INSULATED

MP-132 BASE—as illustrated at left. 1" heavy coil spring. 2" insulator. Overall length: 11 1/2". Weight: 2 1/2 lbs. Price.....\$3.95

### MAST SECTIONS FOR ABOVE

BASE—Tubular steel, copper coated, painted, in 3 foot sections, screw-in type. MS-53 can be used to make any length, with MS-52-51-50-49 for taper. Price for any section.....50c Ea.

AN-104A Antenna—100-156 MC.	\$2.00
AN-117 Whip Steel—6 Ft. length	1.50
AN-109A Whip Steel, 5 Ft. w/Base	1.50
AS-27/ARN-5 Ram's Horn, 110 MC.—USED	5.95
LP-21-A Loop for ADF equip.—Used, tested.	9.95
AT-37/APT Stub—113-150 MC.	6.95
AT-42/APT-3 or APT-1 Stub—113-150 MC.	6.95
AS-97/ARQ-8 Spike with coaxial lead in base.	4.95
AS-61/ARN-5 Half-Wave Dipole—335 MC.	3.95

## MISCELLANEOUS

Leg and Seat Assy. for Hand Generator...\$ 3.50  
BC-230 Transmitter, with Tubes.....4.95  
T-20 ARC-5/BC-457 Trans.—4 to 5.3 MC. New: 14.95  
R-1/ARR-1 Rec. f/conversion to 220 MC.....4.95

# FAIR RADIO SALES

132 SOUTH MAIN ST.  
LIMA, OHIO

Visit the RADIO & TELEVISION NEWS Staff, in Suite 1606, Conrad Hilton Hotel, Chicago, during the Parts Show, May 19-21, 1952.



**FIND OUT WHY—**

Radio men all over the country sell their new and used radio gear to Columbia. The reason? If we want your equipment, WE ABSOLUTELY GUARANTEE TO TOP ANY OFFER. Just tell us the price you want for it. Send a fast letter—get a good deal!

**MARINE GEAR—SUPER SPECIALS!**

**COLUMBIA MARINER:** 100 W. 4-channel x-tal control. The best darn 100 W. marine unit on land or sea! FCC approved, too! Will match any antenna. Complete with all crystals, cables, dynamotor and mike. Specify frequencies desired and also whether you want 12 or 24 V. NEW, FULLY GUARANTEED, WITH INSTRUCTION. ONLY ..... \$249.50

**JOHNSON MARINE TRANSMITTER:** 90 W. NO dials, meters, loading switches or special procedure to worry about. Has only two (2) controls! These are on-off switch and a 4-position channel selector. Neon lamp indicates output and modulation. Think of it! EASIER TO OPERATE THAN A COMMON RADIO! Covers any four frequencies in the 2-3 mcs. marine band. FCC approved as to output and harmonics. Size: 10 x 17 x 13. Complete with mike, crystals, dynamotor and antenna. NOTHING ELSE TO BUY. Specify (4) frequencies desired and whether you want 12, 24 or 32 V. input. 30 DAY GUARANTEE! ..... \$299.95

**BC-223 TRANSMITTER:** 25 W. 12 or 24 V. Complete with power supply, tubes and cables. Excel. cond. MOST PARTS BRAND NEW! The Hottest Buy in Surplus!!!! JUST ..... \$85.00  
CRYSTALS FOR ABOVE, EACH ..... 20.00  
Set of 4 Crystals ..... 20.00

**ARB RADIO-COMPASS RECEIVER:** Covers 190-9,000 kcs. This set is dynamite for beacon standard broadcast, marine and amateur use. 24 V. input. Complete with remote control box, all plugs, flex cable and tuning control. IN REALLY SWELL SHAPE. Goin' to our boys for ONLY ..... \$85.00

**DU-1 DIRECTION FINDING LOOP:** Swell for use with ARB Receiver. Excel. cond. PLUS FREE SCHEMATIC. ONLY ..... \$27.50

**5 W. MARINE RADIO TELEPHONE**

Jefferson-Travis Emerson Radio Corp. Freq. 2-3 mcs. 2-channel, x-tal control. Complete with mike, speaker, 110 V. charging unit, all tubes and instructions, 6 V. input or will run 8-10 hrs. on own battery pack. BRAND NEW, BOXED (Less xtals & batteries). ONLY ..... \$89.95

**MN26-C RADIO COMPASS:** Complete with tubes, loop, flex cables, plugs and control box. Excel. cond. .... \$69.95

**AIRCRAFT EQUIPMENT**

Wild Blue Yonder Boys—Check These!

ARN-7 MN-26C SCR-269 ARR-7  
ARR-7 HS-32 Headset VIF ARC-5 ARR-5 224C  
APN-9 ARC-1 ARC-3 Loop (CAA)  
ART-13 RTA-1B SCR-522 APR-4 APR-5

**SCR-284 TRANSMITTER & RECEIVER:** Freq: 3800-5800 kcs. BRAND NEW. Write for information and prices.

**MOBILE EQUIPMENT**

For You Men of the Open Road  
**ARC-4 VHF TRANSMITTER:** Two ranges: 140-144 mcs. Fine for 2-meter, novice, CAP, 12 or 24 V. input. WITH tubes, less dynamotor. Excel. cond. Excel. price ..... \$32.50

**MOBILE TRANSCEIVER:** BC-559, 10-meter, FM. With all tubes, 6, 12, or 24 V. power supply. Includes mike, headset, and antenna. Fair condition—but sensational price ..... \$55.00

**ARC-5 OR 274-N TRANSMITTERS**

2-1-3 mcs. New ..... \$19.95  
2-1-3 mcs. Used ..... 14.95  
3-4 mcs. Used, excel. cond. .... 14.95  
4-4-1 mcs. Used, good cond. .... 6.95  
4-3-1 mcs. .... 5.99  
7-9-1 ..... 12.50

**ARC-5 OR 274-N RECEIVERS**

19-55 mcs. Used ..... \$14.95  
25-1.3 mcs. Brand new ..... 49.50  
55-1.3 mcs. Used, (Broadcast) ..... 24.95  
1-7-3 mcs. Brand new ..... 24.50  
6-9-1 mcs. Brand new ..... 11.95

**RACK FOR DUAL TRANSMITTER (274-N)** 3.95  
**RACK FOR DUAL TRANSMITTER ARC-5** 3.95  
**TRIPLE RECEIVER RACK** 5.00  
**BC-442-A ANTENNA RELAY with 50 mmfd. condenser. Excel. cond.** 3.95

**APN-1 FM WOBULATOR SECTION ONLY:** With schematic ..... \$6.95

TUBES	TUBES	TUBES
2AP1 .. \$10.95	6J5 .. \$0.75	813 .. \$9.95
3AP1 .. 10.95	6K7 .. 1.10	829B .. 9.95
5BP4 .. 4.95	6L6M .. 2.50	832A .. 9.95
6AC7 .. 1.50	6X5 .. .75	1625 .. .59
6AG7 .. 1.25	807 .. 1.25	

NOTE: WE HAVE A WAREHOUSE FULL OF NEW AND USED PREMIUM SURPLUS MERCHANDISE. DON'T BE SHY—TELL US WHAT YOU NEED. SURE, WE'LL MAKE A DEAL!

All orders F.O.B. Los Angeles. 25% deposit required. All items subject to prior sale.

**COLUMBIA ELECTRONIC SALES**

522 South San Pedro Street  
LOS ANGELES 13, CALIFORNIA

# NEW TV PRODUCTS on the Market

**REPLACEMENT "CERAMICONS"**

Erie Resistor Corporation of Erie, Pa. has released a new high voltage "Ceramicon" which has been designed with the needs of the technician in mind.

The Style 413 "Ceramicon" instead of the conventional terminals, has threaded sockets into which various types of terminals may be screwed to match the terminal combinations found in any of the different manufacturers' sets.

According to the manufacturer, this new unit will enable the service technician to reduce his inventory of high voltage filters and at the same time have a greater assurance of being able to give immediate service on practically any receiving set on the market, rated at 20 kv. or lower.

The Style 413 is insulated in low-loss thermostetting plastic which provides an efficient moisture seal. Ring convolutions are molded into the surface to provide a check against surface leakage often resulting from conducting deposits in ordinary handling.

**TV TUBE RACK**

The Tube Department of General Electric Company, Schenectady, N. Y. has developed a new tube rack which is designed to facilitate radio and TV servicing.

The new technician's aid, known as a "tubesaver," contains holders for as many as 52 tubes, including 22 seven-pin miniatures, 10 nine-pin miniatures, and 20 octal base tubes. A special tempered rubber insert in each tube

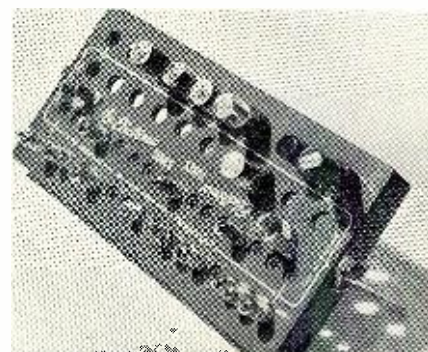

holder secures the tubes tightly no matter which way the unit is tipped.

The unit also includes pin straighteners for seven- and nine-pin miniatures. The "tubesaver" can be set flat on the table or tilted into an easel position with the help of the carrying handle which can also be used to support the "tubesaver" at an angle.

The unit can be used on the service bench as a holder for the technician's test tubes, it can be used as a tube holder at the tube tester, or can be

employed to maintain correct tube order when testing all tubes in a TV receiver.

**V.H.F.-U.H.F. TURRET TUNER**

Standard Coil Products Co. Inc., 2329 N. Pulaski Road, Chicago 39, Illinois

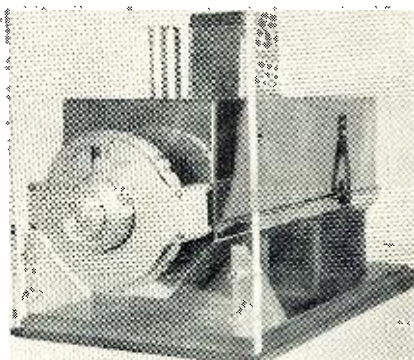

has developed a new tuner unit which covers both the v.h.f. and u.h.f. bands in one compact unit.

Employing the "spot" or "detent" principle, the new unit covers all 82 prospective television channels. Channel selection is made simply by turning the dial until the desired channel number appears in the dial window. The new unit will, when available, be pre-tuned at the factory so that it will not be necessary for the technician to make any station adjustments.

The selection dial of the new unit consists of three superimposed knobs. To get the station desired, the viewer turns one knob for the tens digit, another for the units digit, and a third knob for the fine tuning, the number of the selected station appearing in the dial window.

**CHANNEL SEPARATOR**

Technical Appliance Corporation of Sherburne, New York is now offering a new channel separator which has been designed for use with the "Tacoplex" master antenna distribution system in community installations.

The new unit is available as a two-channel model which has been designated as Catalogue No. 1512 or as a three-channel model which is known as the 1513.

The new channel separators feature a high transfer of energy with extremely low loss. The purpose of these units is to separate the television channel signals traveling along a common transmission line, and feed the separated signals through individual outputs to their respective amplifier strips. Such units are employed in a community system at all "booster stations."

These units are housed in a compart-

mented metal housing that completely shields each individual channel filter. Each channel section is a pi section type bandpass filter.

#### TOWER AND MAST

*Mallard Manufacturing Company*, 6025 North Keystone Avenue, Chicago 30, Illinois has introduced a new TV tower and telescoping mast which has been especially designed to provide easy installation and simplified servicing.

The new tower weighs just 30 pounds and can be carried up a ladder by one man. It can be set up and secured to any type roof in a matter of minutes. Installation of the telescoping mast and rigging of the antenna and guys can all be performed from the safety of the roof or from the ladder-type cross braces on the tower sides. The mast weighs 30 pounds and the entire assembly is completely self-supporting during erection.

Complete data on this new tower and telescoping mast combination is available from the company.

#### PM FOCUSING DEVICE

*Heppner Manufacturing Company* of Round Lake, Illinois is in production on a new television PM focusing device which may be installed in a matter of seconds.

Designed for use with the new low-energy magnetic focus tubes, the unit is slipped over the tube neck and tightened by means of a clamp. No brackets or special mounting devices are required. Because the entire unit weighs only 5 ounces, including the 1 1/4 ounce Alnico permanent magnet, it cannot damage the neck of the tube.

Two turns of the adjusting screw are sufficient to cover the entire focus

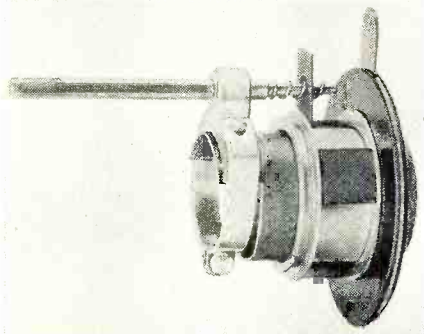

range. Other features include a built-in picture positioning device and the fact that there is no interference magnetically or mechanically with other components.

#### U.H.F. POWER TUBE

A new power triode, which is of particular interest to the designers of u.h.f. transmitting equipment, has been announced by the Tube Department of *Radio Corporation of America*, Harrison, N. J.

Intended for u.h.f. service in television and c.w. applications, the new Type 6161 is very compact, having a diameter of 1 1/4" and a length of 3 1/4".

The new triode has a maximum plate

# You can' go wrong with a TURNER TV BOOSTER



**THE TURNER BOOSTER**  
List Price . . . . . \$57.50

For television viewing you want the finest possible picture—whatever your receiving conditions. You don't want to compromise for anything less than a bright, clear picture, no matter where you are in the fringe area. And with the Turner Television Booster you don't need to compromise! The Turner Booster gives you the superior picture that's a delight to watch—the crisp, natural sound you've always wanted.

If it's a better picture you're after . . . if it's the finest possible performance you want from your TV set . . . don't settle for less than a Turner Booster!

**YOU CAN'T GO WRONG WITH A TURNER TV BOOSTER!**

## THE TURNER COMPANY

900—17th Street N.E.

Cedar Rapids, Iowa

IN CANADA: Canadian Marconi Co., Ltd. Toronto, Ont., & Branches  
EXPORT: Ad. Auriema, Inc., 89 Broad St., New York 4, New York

### RADCOM Special!

- PHONO KIT . . . 78 rpm . . .  
Consists of: 9" Table and Motor, pickup with astatic L-70-A cartridge, 6" Cone Speaker. NEW . . . . . **\$9<sup>95</sup>**
  - TOTE LITE . . .  
Fluorescent Hand Lantern Excellent for Service Men, Camps, Car, Less Batt. NEW . . . . . **\$4<sup>75</sup>**
  - TUBES . . . 6AL5  
**5 for \$2.60**
- INQUIRIES INVITED

### WANTED

RADCOM pays highest prices for surplus equipment, parts and tubes. We need TCS-7 and up; SCR 274-N; SCR 399 equipment; BC 312, 342 and 348 Receivers; SCR 522 equipment; SCR 211 frequency meters and RA-34 rectifiers.

*Always Right With Earl White*

**RADCOM Engineering Co.** 8 Livingston St. Newark 3, N. J.



EVERYTHING you buy from KEY is fully guaranteed. If you are not satisfied you may return your purchase for credit or refund as you prefer. NO questions asked. All merchandise offered subject to prior sale. Minimum order \$2.00. All prices are FOB Baltimore, Maryland. Shipment will be made by Railway Express Collect unless otherwise specified. Include 25% with all COD orders. The prices shown in this ad supersede all previously published prices.

SARKES TARZIAN TUNERS. Uses 1-6C4, 2-6AG5. Good condition. As is, less tubes 2.98 ea.

**FILTER CHOKES**

Stock No.	Description	Price Ea.
647	5.6 Henries, .085A., 900V. ins. ....	\$0.89
794	5.0 Henries, .090A., 900V. ins. ....	.95
8350	10.0 Henries, .225A., 500V. ins. ....	4.98
TANK CIRCUIT 150-200 Mc. Uses 2-2E8's. In Metal Shield Box, complete w/tubes...\$7.95 ea.		

**TRANSFORMERS, 117 V., 50/60 C. Primaries**

Stock No.	Description	Price
1159	Sec #1-650 V.C.T. @ 150A; Sec #2-6.3V @ 2.1A; Sec #3-5V @ 3A Jefferson...	\$4.95
1160	Sec #1-1450 V.C.T. @ 100A; Sec #2-6.3V @ 1.2A; Sec #3-5V @ 3A Jefferson...	5.95
8398	Sec #1-6.3V @ 10.0A; Sec #2-6.3V @ 1.5A; Sec #3-5V @ 3A.C.T.; Sec #4-860V @ .141 A.C.T. Westinghouse, Tuffnell Insulated...	7.95
1158	Sec. 4000Y @ .025A Jefferson...	8.95
1157	Sec #1 4V @ 16.0A; Sec #2 2.5V @ 1.75A Jefferson...	5.75

**AUDIO OUTPUT TRANSFORMERS**

900 V. Insulation 60 ma primaries. Secondaries match 3.2 ohms nominal.

Stock No.	Primary Impedance	Price Ea.
987	2,000 ohms	\$0.49
775	2,400 ohms with bucking winding	.59
247	2,500 ohms	.49
178	2,500 ohms with bucking winding	.59
656	5,000 ohms	.49
376	6,000 ohms	.49
868	8,000 ohms	.49
430	1,100 ohms with bucking winding	.59

**AMP "Champ" Hand Tool**

Shears bolts and machine screws!  
Cuts and strips wire!  
Crimps solderless terminals!

**\$3.95**  
Each  
postpaid in U.S.A.

**OIL-FILLED CAPACITORS**

Capacity	Voltage	Price ea.
0.1 mfd	1,000 V.D.C.	\$0.19
2 mfd	1,000 V.D.C.	1.49
3.5 mfd	220 V.A.C.	.69
4 mfd	3,000 V.D.C.	5.95
6 mfd	1,000 V.D.C.	3.29
7 mfd	220 V.A.C.	1.39
7 mfd	600 V.D.C.	2.69
8 mfd	1,000 V.D.C.	3.69
8 mfd	330 V.A.C.	2.75
10 mfd	1,000 V.D.C.	3.99
12 mfd	400 V.D.C.	3.50
16 mfd	330 V.A.C.	3.98

**PAPER CAPACITORS, TYPE TTR**

Capacity	Voltage	Price Ea.
0.02 mfd	.005 mfd, .01 mfd.	10 for \$0.49
1.0 mfd	400 V.D.C., C-D RM4100	.39
2.0 mfd	400 V.D.C., C-D RM4200	.49
4.0 mfd	400 V.D.C., C-D RM4400	.89

**FP CAPACITOR**

40/30/10/10 mfd. @ 500/350/350/300 V.D.C.W.V. \$1.00 each.

**MICA CAPACITOR**

Aerovox type 1460 .006 mfd, 500 V.D.C.W.V. 10 for \$1.00, postpaid in U.S.A.

**ATTENTION INDUSTRIAL USERS!!!!**

We have large stocks of the following items:  
Amphenol Connectors  
Allen Bradley Potentiometers  
T & B "Sta-Kon" Terminals  
Tube Sockets  
High-vacuum and Gas-filled Condensers  
Compression Type Trimmer Capacitors  
Magnet Wire  
AMP Terminals  
Burdny Hytugs  
Fiberglass Yarn  
We invite your inquiries. We will reply the same day your query is received.  
Write, wire, or phone.

Phone No. Wilkens 6300

**Key Electronics Division**

1801 N. LONGWOOD ST. BALTIMORE 16, MARYLAND

dissipation of 250 watts in both television and c.w. service. It can be operated with full plate voltage and full input at frequencies up to 900 mc. Compensating reduction in ratings permits operation at frequencies up to 2000 mc.

A forced-air-cooled, grounded-grid tube, the new unit is designed for use particularly with coaxial-cylinder circuits. The tube features a design which provides low-inductance, large-area r.f. electrode terminals for insertion in cylinders, thus permitting effective isolation of the plate from the cathode.

**TRANSMITTING TUBE**

The Tube Department of the General Electric Company, Schenectady, N. Y. has introduced a new air-cooled transmitting tube (Type GL-6183) which has been especially developed for use in u.h.f. television service.

The new tube is designed to operate at up to 900 mc. with a peak output of 1 kw. It is a companion unit to the company's GL-6019, a 1 kw. tube for u.h.f. which utilizes a water cooling system.

An important factor in the new tube is its ceramic-and-metal envelope. Use of ceramic in the envelope is said to increase the tube's resistance to high temperatures and shock and minimize the problem of high-frequency losses. Losses are also reduced through the use of gold-over-silver plating on all metal parts.

In television service, the new tube can be used in class B as a grounded-grid broadband amplifier, where it has

**OLSON HAS BIG, BIG BARGAINS**

**G-E Magnetic Cartridges Triple Play—RPX-050**  
Stock No. XC-48  
**\$5.99** ea.

Variable reluctance cartridge that plays all records. Equipped with baton style dual sapphire-tipped needle .001" tip for 33 1/3 and 45 RPM. Also .003" tip for 78 RPM. Requires pre-amplifier. Not affected by humidity and high temperatures. Supplied with knob to fit most tone arms. Complete with dual needle. Reg. list price \$13.95.

SEE OLSON'S BIG ADS ON PAGES 98 & 99

**OLSON RADIO WAREHOUSE**  
277 E. Market St., Akron 8, Ohio

*Unlimited Opportunities in*

**RADIO ENGINEERING**

**DEGREE IN 27 MONTHS**

Complete Radio Engineering course, including Telev., U.H.F. and F.M. Bachelor of Science Degree also in Mech., Civil, Elect., Chem., and Aero. Eng.; Bus. Adm., Acct. Extensive campus, modern buildings, well equipped labs. Low cost. Prep courses. Personalized, practical instruction. Founded 1884. Placement service. Growing shortage of engineers. Prepare now for unlimited opportunities ahead. Enter September, January, March, June. Write for catalog.

**TRI-STATE COLLEGE**  
1652 College Ave. ANGOLA, INDIANA

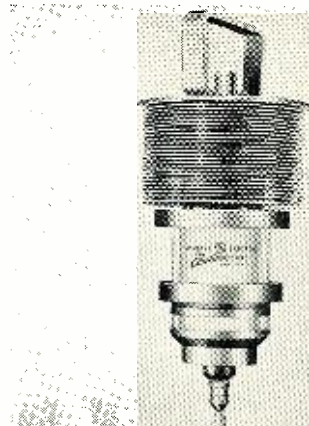

a power gain factor of 10, or in narrowband class C service as an amplifier or oscillator.

The tube is now in production and complete details on the new Type GL-6183 are available from the company.

**ANTI-CORONA COMPONENTS**

Todd-Tran Corp., 156 Gramatan Avenue, Mount Vernon, New York is now in production on a new line of anti-corona components.

Among the components currently available are a sealed-in-plastic fly-back transformer, and a sealed-in-plastic deflection yoke. This type of construction is said to minimize corona

**MAKE THIS YOUR HOME FOR IMPORTANT WORK UNDER IDEAL CONDITIONS!**

- TEST & INSPECTION ENGINEERS
- ELECTRONIC ENGINEERS
- TV RECEIVER DESIGN ENGINEERS
- FIELD ENGINEERS
- LAB. TECHNICIANS

NEEDED TO WORK ON: YOU BENEFIT FROM high wages, a modern, air-conditioned plant, paid vacations and holidays, group insurance and a good chance for advancement. Housing immediately available in the beautiful suburban and country areas that surround the Bendix Radio plant.

Write, Phone or Wire Mr. E. O. COLE, Dept. O

**Bendix Radio**  
DIVISION OF BENDIX AVIATION CORPORATION  
BALTIMORE 4, MARYLAND



radiation and breakdown due to dust particles attracted to or precipitated by deflection components.

A universal mounting bracket is used for the flyback transformer so that it can be mounted either vertically or horizontally.

#### U.H.F. CONVERTER

RCA Victor Division of Radio Corporation of America, Camden, New Jersey has unveiled initial models of



its u.h.f. converter which will be available as soon as the higher TV frequency bands are open.

The equipment shown includes a multi-channel converter designed to receive programs on all channels in the u.h.f. band, and simple, low-cost, one-channel and two-channel converters which may be added to v.h.f. receivers in areas where one or two u.h.f. stations go on the air. All three of the new converters can be used with any make of television set. The all-channel model measures 11 1/8" x 8 3/4" x 8 1/8".

#### RECEIVING TUBES

General Electric Company's Tube Department, Schenectady, New York has introduced two new receiving tubes for television applications.

The 6BK5 when used in conjunction with a 6BN6 in the sound circuit of television receivers will result in the elimination of two additional tubes, associated components, and several assembly operations.

The new 6BK5 is a power output pentode, while the 6BN6 is a combination limiter and discriminator. Used together, they eliminate use of a first audio amplifier tube and a limiter tube.

The second tube is an r.f. amplifier which is designed to be used in tuning units to cover the entire TV band. Because it has been developed specifically for u.h.f. tuner applications, improved performance is expected.

This tube, as yet undesignated, is not in commercial production at the present time. Full ratings and specifications are expected to be released later.

#### "CR-ADAPTER"

Pomona Electronics Co., Pomona, California has introduced a new television test instrument which has been trademarked the "Peco CR-Adapter".

This small-sized unit checks cathode-ray tubes for shorts, relative emission,

# Tube Prices SMASHED!

Dependable performance and economical service are two outstanding features overshadowing even these sensationally low-low priced, high quality, fully guaranteed tubes. Every tube must pass rigid tests in our plant. You can compare RAD-TEL tube performance and quality with any standard tube anywhere.

80% to 90% off list!

All Tubes Individually Boxed! Same Day Service!

Check this list for Fully Guaranteed Tubes

Type	Price	Type	Price	Type	Price	Type	Price	Type	Price
1A6	.59	5AZ4	.39	6BF5	.41	6SG7GT	.41	12SK7GT	.48
1A7GT	.47	5U4G	.40	6BF6	.37	6SJ7GT	.41	12SL7GT	.47
1AB5	.59	5V4G	.54	6BG6G	.94	6SK7GT	.41	12SN7GT	.52
1B3GT	.49	5X4	.40	6BH6	.46	6SL7GT	.48	12SQ7GT	.44
1B5	.59	5Y3GT	.32	6BJ6	.39	6SN7GT	.52	12SR7	.49
1B7GT	.59	5Y3G	.32	6BL7	.59	6SQ7GT	.37	19BG6G	.95
1C5GT	.43	5Y4G	.35	6BQ6GT	.59	6SR7	.37	19T8	.79
1H5GT	.40	5Z3	.39	6BQ7GT	.72	6T8	.56	25BQ6GT	.62
1L4	.46	6A3	.59	6C4	.37	6U5	.44	25L6GT	.39
1L6	.43	6A7	.59	6C5GT	.39	6V6GT	.39	25Z5	.40
1LC5	.51	6A8	.50	6C86	.44	6W4GT	.44	25Z6GT	.37
1LC6	.48	6AB4	.44	6CD6G	1.11	6W6GT	.44	32L7	.85
1LN5	.51	6AG5	.43	6E5	.48	6X4	.37	35B5	.40
1N5	.46	6AJ5	.90	6F5GT	.39	6X5GT	.37	35C5	.39
1P5	.57	6AK5	.75	6F6G	.39	6Y6G	.48	35L6GT	.41
1R5	.45	6AL5	.38	6F6GT	.37	7X6	.39	35W4	.37
1S5	.39	6AQ5	.39	6G6G	.52	12A8GT	.46	35Z5GT	.37
1T4	.45	6AQ6	.37	6H6GT	.41	12AL5	.37	41	.42
1T5	.53	6AR5	.37	6J5GT	.37	12AT6	.37	42	.42
1U4	.45	6AS5	.46	6J6	.52	12AT7	.56	43	.55
1U5	.39	6AT6	.37	6J7G	.43	12AU6	.38	45	.55
1X2	.63	6AU6	.38	6K5GT	.48	12AU7	.43	50B5	.39
2A5	.47	6AV6	.37	6K6GT	.37	12AV6	.39	50C5	.39
2X2	.59	6AX4	.53	6K7G	.44	12AV7	.59	50C6	.59
3A4	.45	6B4G	.64	6K7GT	.44	12AX4	.48	50L6GT	.41
3E5	.46	6B5	.64	6L6G	.64	12AX7	.48	50X6	.53
3Q4	.48	6BA6	.39	6L6GA	.64	12BA6	.38	50Y7	.50
3Q5GT	.49	6BA7	.57	6Q7G	.45	12BA7	.46	70L7GT	1.09
3S4	.46	6BC5	.44	6Q7GT	.45	12BE6	.39	75	.41
3V4	.47	6BD5GT	.59	6S4	.38	12BH7	.52	76	.44
5AX4	.37	6BE6	.39	6S8	.53	12K7GT	.46	78	.47
				6SA7GT	.43	12Q7GT	.46	80	.35
				6SD7GT	.41	12Q7G	.39	117L7	.89
						12SA7GT	.44	117Z3	.37

#### A Rad-Tel Super-Special Value!

Super savings on branded R.C.A. & Philco tubes in original containers! Only while they last!

Type	Price	Type	Price	Type	Price
841	.39	2C26	.39	3D6	.44
954	.34	35/51	.39	3A8	.39
1625	.39	34	.34	2A6	.34
1626	.39	33	.34	3C6/XXB	.49
9006	.39	6U7G	.54	56	.39
8011	.39	6J7G	.54	12Z3	.44
RL34	.39	6K7G	.54	12F5GT	.44

#### PICTURE TUBES . . .

14BP4... 14.50    16RP4... 19.50  
17BP4... 19.50

#### TERMS

A 25% deposit must accompany all orders—balance C. O. D. All shipments FOB Newark warehouse. Orders under \$5—\$1.00 Handling Charge. Subject to prior sale.

32 BEECHER STREET  
NEWARK, NEW JERSEY



## ELECTRONICS

### TRAIN FOR A SUPERVISORY POSITION

Through 2-year course covers electrical circuits and machinery, basic electronics and industrial electronics. Franklin Technical Institute graduates are in demand as junior engineers for research and test work, sales engineering, supervisory work on production lines and drafting room design work. Other engineering and technical courses. Coed. Day, evening. 44th year. Write for catalog.

#### FRANKLIN TECHNICAL INSTITUTE

46 Berkeley Street    Boston 16, Mass.

**CODE SENDING SPEED**  
HIGH SPEED WITHOUT NERVOUS TENSION  
REVEALING BOOK shows how "radio" operators develop high speed and proficiency. Learn code for Amateur or Commercial Radiotelegraph License, or improve your sending and receiving with the Candler System which develops radio-telegraph experts and code champions.  
CANDLER SYSTEM CO. FREE BOOK  
Box 928, Dept. 2-E. Denver, Colo.

# BASS REFLEX

## EQUIPMENT CABINETS

### KITS

by **Cabinart**

**DIMENSIONS**  
33 1/2" high  
23" wide  
16" deep

**LUMBER**  
3/4" thick  
Fir Ply

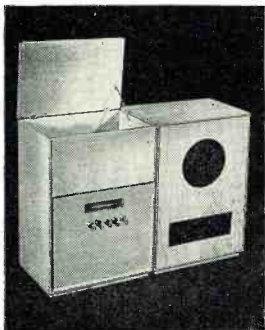

Equipment cabinet accommodates any WEBSTER, GARRARD or REK-O-KUT changer, and any combination of standard tuners or amplifiers. Tuner compartment inside dimensions: 20" high x 21 3/4" wide x 15 1/4" deep. Bass reflex cabinet volume: 6 cu. ft.

#### ASSEMBLED CABINETS

(Sanded smooth, ready for finishing)

- MODEL 70 (Equipment cabinet) . . . 36.00\*
- MODEL 7115 (12" speaker cabinet) . . . 24.00\*
- MODEL 7112 (15" speaker cabinet) . . . 24.00\*

#### CABINET KITS (Ready for assembly)

- MODEL 80 (Equipment kit) . . . 27.00\*
- MODEL 8112 (12" speaker kit) . . . 18.00\*
- MODEL 8115 (15" speaker kit) . . . 18.00\*

Speaker Cabinets also furnished in a smaller size for 8" or 12" Speaker. Dimensions: 30" high x 18 1/2" wide x 12" deep.

- |   |   |  |  |
|---|---|--|--|
| <b>MODEL 758</b><br>Assembled<br>8" speaker<br>18.00* | <b>MODEL 7512</b><br>Assembled<br>12" speaker<br>18.00* | <b>MODEL 858</b><br>8" speaker kit<br>15.00* | <b>MODEL 8512</b><br>12" speaker kit<br>15.00* |
|---|---|--|--|

#### All kits include:

- Lumber Cut to Size
- Baffle Pre-cut for 12" or 15" Speaker
- Saran Plastic AcoustiCloth
- Hardware • Plastic Wood
- Sandpaper • Glue
- Kimsul Acoustic Insulation
- Assembly Instructions
- Finishing Instructions

**ALSO AVAILABLE**  
**KITS FOR CORNER FOLDED HORN ENCLOSURES**

<b>MODEL 61</b> 12" Speaker 19.95*	<b>MODEL 63</b> 15" Speaker 23.95*
--	--

\*Sold only through radio parts distributors. Net prices, slightly higher West and South.

G & H WOOD PRODUCTS COMPANY • 75 NORTH 11th STREET • BROOKLYN 11, NEW YORK

slow heater, and filament continuity. The adapter permits the use of regular tube testers in checking CR tubes. Two models are currently available—the CR-1 for use with Jackson testers and the Model CR-2 for Hickok units.

With this unit the picture tube can be checked either in or out of the set under test.

#### INDOOR ANTENNA

Snyder Manufacturing Company of Philadelphia has introduced a new low-cost indoor television antenna to the trade.

Known as the P-TZ, the new unit is an all-channel model with all-way orientation. It comes complete with a 42" twin-x cable and features four telescopic dipoles, mirror finish, and topple-proof heavy cast base of modern design.

The antenna is now in the hands of the company's distributors.

#### LIGHTNING ARRESTER

Insuline Corporation of America, Long Island City 1, New York is marketing a new molded phenolic television lightning arrester which has been designed to withstand all extremes of weather.

This new unit can be installed in a few minutes without cutting the TV lead-in. Contact to the latter's wire is made by means of cup-shaped washers with serrated teeth.

This UL-approved arrester is now available in two styles. The No. 6113

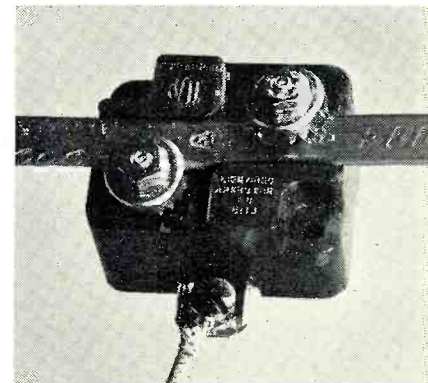

has a binding post for a ground wire while the No. 6114 has a ground strap which fits around the usual metal pipe of the TV antenna.

#### ALL-CHANNEL ANTENNA

The LaPointe Plascomold Corporation of Windsor Locks, Conn. has just introduced a new all-channel antenna, the "Q-Tee."

The new unit is designed primarily for use in metropolitan areas and incorporates an entirely new principle, i.e., electronic channel separators. This principle permits the antenna to be broadbanded with the elements performing dual functions on both the high and low channels. The same principle permits the antenna to be peaked on specific channels in any metropolitan areas.

Designed to replace conicals and other broadband types, the "Q-Tee" has a uniform response across both

## SPRING SALE PRICES SLASHED

Don't Buy Tubes until you get our prices.

- Westinghouse Kuprox Rectifier 0.64 Amp. 28 Volts. Reg. \$11.00 ea. Special . . . \$1.95
- 12 BRAND NEW 10" PHONO RECORDS—Ass't Jazz—Popular. Please specify . . . \$1.79
- Single Pole—10 Pos. 2 Gang Switch . . . 29c
- 2 piece, 5 pole Male and Female separable Amphenol plugs. Both with Flex. shielded cables. Approx. 3 ft. long. 35c pair. . . . 3 pr. for \$1.00
- Grind your own Crystals. Pure Brazilian Quartz. Various sizes and thicknesses. 1/2 lb. pkg. . . . \$1.00
- 4 Tube Drilled Chassis, 4 1/2"x6 1/2"x1 1/2". 29c each
- 4 inch P.M. SPEAKER . . . \$1.50
- 5 in. 450 ohm Dynamic Speaker . . . \$1.35
- Signal Corps Phones—2 M. Ohms (8 M. Ohms Imp.) . . . \$1.25
- 2 Ft. Ext. Cord (and Plug) . . . 40c

#### TOBE TUBULAR ELECTROLYTICS

- 20-20 MFD. 150 V. . . 49c
- 30-30 MFD. 150 V. . . 57c
- 40-40 MFD. 150 V. . . 59c

- |   |                                    |
|---|------------------------------------|
| Low-Loss Short Wave Lock Type Air Trimmer Variable Condensers | 3 GANG T.R.F. VARIABLE CONDENSERS  |
| 5 Pl.—20Mmfd. . . 14c   | 0.00365 Con. 65c                   |
| 7 Pl.—25-30 Mmfd. . 15c                                       | D.P.D.T. SLIDE TOGGLE SWITCH . 15c |
| 8 Pl.—30-35 Mmfd. . 16c                                       |                                    |
| 14 Pl.—56 Mmfd. . . 24c                                       |                                    |

- 1,000 OHM WIRE WOUND POTENTIOMETER . . 15c
- 30 HY-FILTER CHoke SHIELDED . . . 3 for \$1.25
- CARTER WIRE WOUND C.T. VARIABLE 20 OHM RESISTORS . . . 85c per doz.

PIEZO CRYSTAL HOLDERS, 12 for \$1.00—\$6.00 per C

- RCA Bang Switches—3 gang, 3 pos. 3 band. 30c 6 gang, 4 pos. 4-5 band. 40c
- Trimmer-Padder Ass't—all isolantite—singles, duple, triples—100 asst. pieces. . . . \$2.25
- Philco push button Rotary Switch Double Pole . . . 35c
- ATTENTION: Prospectors, Explorers for Hidden Treasures! Construct a U.S. Army Type of Metallic Mine Detector Amplifier. Amplifier unit, only (less tubes and batteries) with cables, headphone cord, and jack. Army wiring diagram. Type AN/PRS-1 . . . \$1.95
- RCA Ass't Mica By-Pass Cond. .001, 100 for . . . 95c
- 8 or 9 Gang Push Button Switch . . . 49c

- DILLED CHASSIS FOR 5-6 tubes 5"x10"x1 1/2". . 25c
- PHONE JACKS—OPEN & CLOSED AUTO. . . 18c
- 156-1 RATIO VERNIER DIALS—4 in., 3/8 in. Hub. 35c
- SALE—PHONO RECORD ALBUMS—12"—3 comp. 15c; 10"—3 comp. 18c; 4 comp. 20c; 12 comp. 69c
- VULCAN HEAVY DUTY 100 WATT SOLDERING IRON. Built for U.S.N.—Brand New—Equiv. sells for \$8.50 . . . OUR PRICE \$2.99
- AMERTRAN AUDIO OUTPUT XFORMER—Pri. 10,000 @ 15 MA. Sec. 300, 6-1 Ratio. . . . \$1.49

MINIMUM ORDER \$3.00—NO C.O.D.  
SHIPMENTS—PLEASE INCLUDE POSTAGE  
NEWARK SURPLUS MATERIALS CO.  
Dept. MY  
324 Plane Street NEWARK 1, N. J.

## Trav-Electric miniature Converter

Input 6 Volts D.C.—  
Output 110 V. 60 Cycle 40 Watts



Size—  
2 1/2" x 2 1/2" x 3 1/2" \$15.95 List Price

#### Operates—

- Radios—Short and Broadcast Band
- Phono—Turntables
- Small Dictating Machines
- Test Equipment
- Electric Shavers
- Incandescent Lights

#### Just Plug in Cigar Lighter

THOUSANDS IN USE  
Fully Guaranteed

See Your Dealer or Jobber—or Write Direct

**TERADO CO.** 1068 RAYMOND AVE.  
ST. PAUL 8, MINN.

high and low bands, with higher gain and improved front-to-back ratio.

The impedance is matched to 300-ohm twin-lead over both bands. The unit may be double stacked for near-fringe and 4-stacked for the fringe areas.

#### INDOOR TV ANTENNA

*Spiraling Products Co., Inc.*, 62 Grand Street, New York, N. Y. has recently introduced a "Super-Phantom" indoor television antenna, the Model TV-503.

Featuring an exclusive "Adjusta-Knob" control and matching stub, which matches the impedance of any television set, the new unit is solidly built and inconspicuous.

At the present time the company is promoting the antenna nationally by means of radio, television, and newspaper ads, in addition to participating in department-store demonstrations on a cooperative basis.

Additional details on the Model TV-503 are available from the company on request. Price lists will also be furnished.

#### JFD "BALINE"

*JFD Manufacturing Company, Inc.* of 6101 Sixteenth Avenue, Brooklyn 4, N. Y. has introduced a new ten-element yagi antenna which has been tradenamed the "Baline."

The new antenna features an exclusive matching transformer system. The design of these matching transformers has completely eliminated the

conventional and impedance lowering jumper bars and similar devices. In this way the antenna provides a 300-ohm impedance match which guarantees the maximum transfer of a clean signal.

Precision cut to exact channel wavelengths, the new units are constructed of seamless aluminum. In both single-bay and stacked models these yagis provide ultra high gain across a full 6 mc. bandwidth. The narrow beam width produces a very high signal-to-noise ratio plus a sharp directivity, according to the company. The elimination of possible co-channel interference is insured by special factory-tuning of the units.

Literature has been prepared on the new "Baline" antenna. In addition to explaining the installation and functional advantages of the antenna, the brochure describes the "Quik-Pivot" installation method.

#### 27" GLASS BULB

*Corning Glass Works*, Corning, New York has introduced a 27" rectangular all-glass bulb for use in the manufacture of television picture tubes. Samples of the new bulb were recently distributed to the industry with volume production scheduled for this month.

The largest piece of molded glass manufactured anywhere in the world on automatic production equipment, the new 27" bulb offers a 375 square inch picture, which is approximately 50 per-cent larger than the present 21"

size. It features the new cylindrical face design that successfully eliminates annoying light reflection.

#### PENTODE BOOSTER

*Radio Merchandise Sales, Inc.*, 1165 Southern Boulevard, New York 59, New York has developed a new pentode television booster which features an external gain control.

The Model SP-6's gain control permits the maximum utilization of the unit's gain without danger of overload. The company is recommending this unit particularly for extreme fringe areas where every bit of power

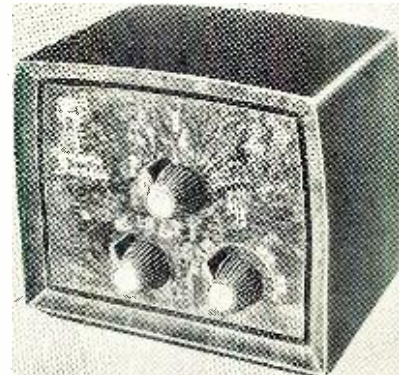

is needed to obtain maximum picture clarity.

The unit is housed in a plastic cabinet with functional tuning knobs for easy tuning. The booster carries UL approval.

-50-

# LEARN Practical RADIO AT HOME

COMPLETE ONLY... **\$19<sup>95</sup>**

## BUILD 15 RADIOS

ABSOLUTELY NO PREVIOUS TRAINING NEEDED  
EXCELLENT BACKGROUND FOR TELEVISION

**10-DAY MONEY-BACK GUARANTEE**

**WHAT THE 1952 PROGRESSIVE RADIO "EDU-KIT" OFFERS YOU:**

This is a practical home radio course. You learn theory, construction, operation, trouble shooting, code. You build RECEIVERS, TRANSMITTERS, AMPLIFIERS, CODE OSCILLATOR, SIGNAL TRACER.

You start with a simple radio circuit, and gradually advance to more complex circuits. No previous background is required. No instructor is needed. All parts and instructions are included and every single step is clearly explained.

All parts are guaranteed, individually packaged, identified, and explained.

There is nothing extra to buy. You receive all parts, tools and instructions at once. You keep everything; there is absolutely nothing you return to us.

You can easily pay for the kit in a short time by repairing radios. Use the tester and signal tracer for servicing. The signal tracer alone is worth more than the price of the entire kit.

**USED BY RADIO SCHOOLS AND GOVERNMENT AGENCIES!**

The Progressive Radio "Edu-Kit" includes tubes, paper condensers, mica condensers, electrolytic condensers, variable condensers, selenium rectifiers, chassis, hardware, tie strips, tube sockets, solder, wire, soldering iron, tubing, coils, instruction book, radio trouble-shooting guide, radio tester, television trouble-shooting manual, etc.; in brief, everything you need in a practical radio course.

*Order your "Edu-Kit" today, or send for further information.  
Postage prepaid on Cash orders—C.O.D. orders accepted in U.S.A.*

GET A WELL-PAYING JOB

GO INTO A PROFITABLE BUSINESS AND PLAN FOR A FUTURE

## PROGRESSIVE ELECTRONICS CO.

497 UNION AVE. DEPT. RN-5 BROOKLYN, NEW YORK

# NOW'S THE TIME TO BUY GREYLOCK TUBES

AT THESE TERRIFIC LOW PRICES!

ALL TUBES listed below carry 6-month guarantee—exception only burnouts and breakages. At these seasonally low prices, these tubes must be ordered in quantities of AT LEAST 10 ASSORTED TYPES. Add 10% for orders under 10 tubes. All individually boxed in attractive Greylock Cartons.

SPECIAL OFFER: Additional 5% discount on all shipments of 100 tubes or more assorted!

OZ4M	.59	6BH6	.79	7N7	.79
1A7GT	.89	6BJ6	.79	7X7	.79
1B3GT	.89	6BL7GT	1.09	807	1.79
1H5GT	.69	6BN6	1.09	12A8GT	.49
1L4	.49	6BQ6GT	.79	12A15	.79
1LA4	.89	6BQ7	1.49	12A16	.49
1LC5	.79	6C4	.49	12A17	.79
1LD5	.99	6C5GT	.49	12A18	.49
1LN5	.89	6C6	.49	12A17	.79
1N5GT	.69	6CB6	.49	12A16	.49
1R5	.59	6CD6G	1.49	12A17	.79
1S5	.49	6E5	.79	12AX4GT	.69
1T4	.59	6F6GT	.59	12AX7	.59
1U4	.49	6H6	.59	12AZ7	1.29
1U5	.49	6J5	.49	12BA6	.49
1X2	.89	6J6	.89	12BA7	.99
3A4	.59	6J7	.49	12BE6	.49
3A5	.79	6K6GT	.59	12BH7	.99
3LF4	.99	6L6G	1.19	12J5GT	.59
3Q4	.49	6L6GA	1.19	12Q7GT	.69
3S4	.59	6S4	.49	12SA7GT	.79
3V4	.49	6S8GT	1.29	12SK7GT	.59
5U4G	.69	6SA7GT	.69	12SN7GT	.79
5V4G	.89	6SC7	.99	12SQ7GT	.69
5X4G	.59	6SD7GT	.79	12S8GT	.79
5Y3GT	.49	6SG7	.89	14A7	.89
5Y4G	.69	6SH7	.79	14B6	.79
6AB4	.69	6SJ7GT	.69	14Q7	.99
6AC7M	1.09	6SK7GT	.49	19BG6G	1.29
6AG5	.79	6SL7GT	.59	19T8	.99
6AG7M	1.19	6SN7GT	.59	25BQ6GT	.79
6AH6	1.29	6SQ7GT	.59	25L6GT	.59
6AK5	.89	6SR7	.89	25W4GT	.49
6AL5	.49	6T8	.79	25Z5	.49
6AQ5	.49	6U4GT	.59	25Z6GT	.69
6AQ6	.69	6U5	.69	35B5	.59
6AR5	.59	6V3	1.59	35C5	.59
6AR6	2.49	6V6GT	.49	35L6GT	.69
6AS5	.69	6W4GT	.49	35W4	.49
6AT6	.49	6W6GT	.79	35Y4	.69
6AU6	.49	6X4	.49	35Z5GT	.49
6AV6	.49	6X5GT	.49	41	.69
6AX4GT	.69	6Y6G	.79	45	.69
6AX5GT	.79	7A4	.69	50B5	.59
6BA6	.49	7A8	.89	50C5	.59
6BC5	.69	7B6	.59	50L6GT	.49
6BD5GT	1.09	7B7	.89	80	.49
6BE6	.49	7C6	.89	11T73	.49
6BF5	.69	7C7	.89	FM1000	.89
6BG6G	1.29	7L7	.99	7JP4	16.50

MANY ADDITIONAL VALUES. In Radio, TV and Electronic components and accessories! Send for our Great New Bargain Catalog N-100-3. All Prices F.O.B. NYC. Please include postage and insurance with your remittance. 25% Deposit required on all C.O.D. orders.

**GREYLOCK ELECTRONICS SUPPLY CO.**  
115 Liberty Street - New York 6, N. Y.

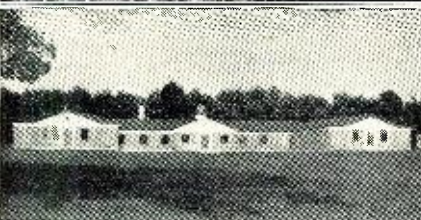

## RADIO ENGINEERING TELEVISION ELECTRONICS

Thorough training in all phases of radio and electronics, open to high school and junior college graduates. Old established school specializing in Radio training exclusively. Modern laboratories and courses. Enrollments limited. Approved veteran training.

**VALPARAISO TECHNICAL INSTITUTE**  
Dept. RD Valparaiso, Ind.

## Spot Radio News

(Continued from page 18)

the chief engineer. An attorney, who entered radio through the doors of hamdom, Turner has had a wealth of experience in radio. He has participated in several international radio conferences, was a member of the United States delegation to the International Radio Consultative Committee in Stockholm in '48, and was vice-chairman of the CCIR conference in Geneva in '51. To assist Turner, the Commission named Frank M. Kratokvil, who will also serve as chief of the bureau's field operating division. In that post, he will supervise the operations of 24 district offices, 6 sub-offices, 3 ship offices and 19 monitoring stations, functioning under 9 regional field offices. Kratokvil, also a radio entry through the ham world, is a veteran inspector too, having served in that capacity with the Department of Commerce in '28.

**SHORTLY BEFORE** his appointment as chairman, Paul Walker delivered a resounding address, the fervor of which appeared to be truly prophetic of the leadership he was soon to assume. Following the vigorous campaign of program criticism waged by his predecessor, Walker told an audience in Cleveland that . . . "It is regrettable that much of what we hear on the radio and see on television does not help . . . the situation . . ." which prevails in programming today. Quoting from an address on modern programs, the new FCC headman said: "In contrast to the official pattern of the American dream, and its world peace and progress in which people get along with each other, the American day dream (and nightmare) of the media of mass entertainment is acted out in a world in which the human relations are opened and settled by daggers, whips, tommy guns, or atomic exterminators." This critic also declared, according to Walker, that the pattern was often directed . . . toward destruction rather than creation, toward hate rather than love, toward aggression rather than understanding, toward death rather than life."

Noting that the foregoing review represents . . . "an extreme point of view," Walker said, "we must honestly admit there is a great deal of truth in what he says."

"It is easy to point the finger of criticism and scorn at broadcasters," the chairman added, but it is . . . "unfair and over-simplifies the problem to put all the blame on them for inferior program service. . . . The fact is that networks and broadcasting stations have been looking for a formula which will hold the attention of the greatest number of people, and to a large extent the average level of radio and television programs reflects our immature wants and interests, quite as much as it fosters them." In the

## Finest FRINGE AREA Antenna

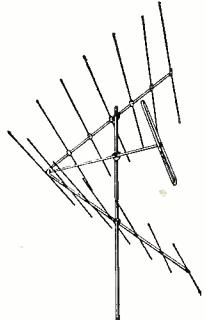

# VELA

- CORNER REFLECTOR**
- HIGH GAIN 12 db
  - BROAD BAND CHANNELS 2 to 6
  - HIGH FRONT TO BACK RATIO
  - RUGGED CONSTRUCTION

**ORDER NOW!**

Immediate delivery LIST

**\$54.50**

## VIDEO ELECTRONICS

1220 1/2 Grand Ave. Des Moines, Ia.

## TELEPHONE EQUIPMENT & PARTS

Reconditioned & tested Army EES Field tele-phones . . . . .	each	\$20.00
New T59 handsets with flip switch for EES telephone . . . . .	each	6.50
Rebuilt T59 handsets with new shell . . . . .	each	4.75
Rebuilt like new solid handsets, A.E. W.E., Kolozz, new 3 Conductor cord . . . . .	each	4.95
New W.E. Operator's Head & Chest sets . . . . .	each	6.00
New W.E. Chest Sets with F1 transmitter—T-26 . . . . .	each	4.00
New W.E. T-30Q Throat Mikes . . . . .	each	.50
New C-105 Induction Coils . . . . .	each	.75
C-114 Loading Coils . . . . .	each	1.00
New A.E. type 41 transmitters, low impedance . . . . .	each	1.50
New A.E. Sound power transmitters . . . . .	each	2.00
New Kellogg 4 Conductor cords 6' for telephone handset . . . . .	each	.50
3 Cond. each Upright desk telephones, tested, reconditioned, for intercoms, extensions, etc. . . . .	each	2.95
W.E. transmitter for up-right telephones . . . . .	each	.50
New BD62C switchboards . . . . .	each	25.00
Switchboards BD 129 . . . . .	each	60.00

Component Parts of EES Field Telephone  
Many, many more items.  
Terms: Check with Order F.O.B., Brooklyn 5, N. Y.  
**EASTERN TELEPHONE CO.**  
321 Vanderbilt Ave. Brooklyn 5, N. Y.

## New All-Channel BOOSTER

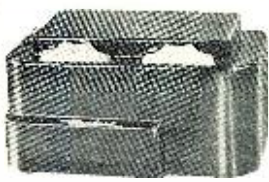

**YOUR COST \$10<sup>95</sup>**  
12 or More \$10.50 Ea.

Here's a new booster that uses Printed Circuit inductors to give accuracy of tuning and tracking. A detent on the channel selector switch gives positive selection of any T.V. channel. No separate switch is required to change from high to low channels. An antenna bypass feeds directly to the T.V. receiver, when the booster is off. Self-contained A.C. power supply. Handsome plastic cabinet.

10% Cash with Order

**ALMO RADIO CO.**  
509 ARCH ST. & 6205 MARKET ST. Philadelphia, Pa.  
6th & ORANGE STS. • Wilmington, Del.  
4401 VENTNOR AVE. • Atlantic City, N. J.  
1133 HADDON AVE. • Camden, N. J.

opinion of the Commissioner "... if radio and television, as well as other public media, are going to be most effective in promoting good human relations, there must be a cooperative effort on the part of all important elements in our society."

**THEATER TV**, struggling for recognition for nearly a year, received another shut-in sentence a few weeks ago, when the Commission issued an order declaring that the project will now have to wait until May before hearings will be held. Allocation problems were blamed for the delay, the Commission noting that it will be impossible to conduct any hearings before that late Spring date with any dispatch.

The sessions are expected to be raging affairs, with definite claims being set for exclusive channels. Specifically, the movie folks want six 60-megacycle wide 7000-megacycle channels for closed-circuit operations. These channels, according to a theater group, would serve some 20,000 theaters throughout the country, and permit the birth of a new industry whose worth might be \$500-million.

In an analysis of the needs of the theater industry, should the channels be allowed, one motion picture executive said that each theater would have to spend from \$20 to \$25,000 for equipment alone, while industry would have to provide broadcasting facilities, which would include intercity, intracity, and pickup gear.

Some of the burning issues which are expected to be raised at the hearings are: Will the new service build theater audiences at the expense of the stay-at-homers? Will the new medium be offered as an inducement to prospective sponsors, thus introducing a problem of competition for the broadcasters? Will the theater exhibitors or operators control the closed circuits?

Sparks will really fly when the long-delayed theater TV hearings begin during those days in May.

**COLOR SET MAKING**, restricted some months ago by an order from NPA, will, it definitely appears now, not be allowed for quite awhile. However, as forecast in these columns, a modified version of the order, known as M-90, will be issued permitting the production and use of theater color-projection equipment. The order may also permit the production of receivers which are capable of receiving both color and black and white, assuming that only circuitry changes are required to provide the pickup. This is the interpretation such companies as *Chromatic* seek; they feel that it is possible to include their color tube in chassis of the type being made now and simply include modified circuitry for the color tube.

The over-all ban on color home sets will not be lifted, it is said, because too many engineers would be required to develop and design the new gear. This

*Newcomb*  
The sound line  
that quality built...

KX-25

There's a Newcomb quality amplifier for every sound need, from the low cost STANDARD E SERIES, through the superb DELUXE H SERIES, to the incomparable CUSTOM K SERIES illustrated.

*Write for literature*

**NEWCOMB AUDIO PRODUCTS COMPANY**  
DEPT. F 6824 LEXINGTON AVE.  
HOLLYWOOD 38, CALIFORNIA

*hermetically sealed  
miniature and sub-miniature  
audio transformers*

actual size

**CREST**  
LABORATORIES, INC.  
Whitehall Building, Far Rockaway, N. Y. • FA 7-2732

- **MANUFACTURED** to meet most exacting MIL-T-27 specifications.
- **GLYPTOL** impregnation prior to potting assures quiet operation and long life under all adverse conditions.
- **MU-METAL** core assures a light weight, compact unit with full efficiency and wide frequency response.
- **PRODUCTION SAMPLES** submitted for your inspection on approval.
- **SENSIBLE DELIVERY** send your B/P specifications for quotations and delivery schedule.
- **JOBBER LINE** immediate delivery on full line of oincer and suboincer type miniatures.

# VIS-U-ALL TUBE and TOOL CASE

Only 16 x 13 1/2 x 7 1/2 in.,  
closed. Weighs only 7 1/2  
lbs. (21 lbs. when full)



® TRADE MARK REGISTERED

Holds 107 Tubes  
and All Tools for  
TV Home Service

## EVERYTHING IN FULL VIEW WHEN CASE OPEN

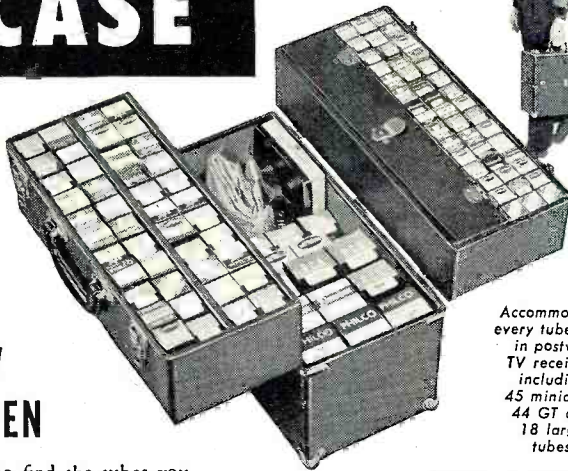

Accommodates  
every tube used  
in postwar  
TV receivers  
including  
45 miniature  
44 GT and  
18 large  
tubes

NET PRICE

**\$14.95**

Case Only

Send check or money  
order. We will ship  
day order is received.

No hidden tubes. Easy to find the tubes you want, *when you want them*. Saves time. Holds tubes snugly and protects them against breakage. Tool compartment, 15 1/2 by 3 by 2 1/2 inches in size; accommodates all tools ordinarily needed for home service calls. Case is made of strong plywood with durable leatherette covering. Sturdy clasp fasteners and convenient luggage-type handle. Handiest case you ever saw, and a real boon to busy service men. Order yours *now!* If not satisfied, return within ten days and your money will be refunded.

## TELEVISION ENGINEERS, INC.

1539 W. Harrison Street • Chicago 7, Illinois

© Copyright, January 1, 1952

# This CR ADAPTER

FOR YOUR  
TUBE TESTER

CHECKS...

Cathode Ray Tubes

For:

- ✓ SHORTS
- ✓ RELATIVE EMISSION
- ✓ SLOW HEATER
- ✓ FILAMENT CONTINUITY

FEATURES...

- EASE TO USE... Tube can be checked in or out of the set.
- COMPACTNESS... Can be carried with tube tester.

995

Only... Net to Dealer

SEE YOUR JOBBER—OR WRITE DIRECT TO:

**POMONA ELECTRONICS CO.**

524 WEST FIFTH AVENUE

POMONA, CALIFORNIA

MODEL CR-1  
Use with Jackson 648

MODEL CR-2  
Use with Hickok Tester

MODEL CR-3  
Use with Precision 10-00

MODEL CR-4  
Use with Precision 9-00

MODEL CR-6  
Use with Precision 6-00



## SCARCE VALUES

### METERS

CARRIER LEVEL, 2" Sq. Marion, 3 Ma. "R" units 0-9+. Transparent Scale for Rear Illumination. NEW—\$ 2.95  
D. C. MILLIAMPS, 2" Round 0-15 Ma. Bakelite Case. NEW—\$ 2.75  
FOUNDATION "ET E" 4" x 4 1/2" Sq. (Wetche.) A.C.-D.C. Volts, Ohms and Milliampers, 600 Microamps. F. S. Knife edge pointer, 3/8" Rd. Mtg. with A.C. Rectifier. NEW—\$ 7.95

### KITS

MICA CONDENSERS—1/2 postage stamp size. Ruby & Silver Mica. All color coded—500 V. NEW—\$ 1.35  
BY-PASS CONDENSERS—Tubular & Moulded Paper. 100-600 V. Popular sizes. NEW—\$ 1.65

CARBON RESISTORS—Popular Mfg. & Values —ALL NEW—1/2 W. 100 for \$2.95; 1 W. 100 for \$4.95; 2 W., 100 for \$6.95; Assortment of 1/2, 1 and 2 Watts, 100 for \$4.95. Assorted Foreign—Uninsulated 1/2 to 2 W. NEW—\$ 1.19

NEON BULBS—1/4 Watt Double Contact Bayonet Base, 105-125V. with 30K Ohm Ext. Res. NEW—\$ 1.29

RS/ARN 7—A.D.F. COMPASS RECEIVER. New with complete set of tubes. NEW—\$ 99.50

MODULATION TRANSFORMER—A 3571 Prim. 4500 Ohms; 60 Ma. Sec. 8500 Ohms; 50 Ma. 10 Watts (single 6L6) Upright shielded. Ideal for mobile transmitter. NEW—\$ 1.69

OUTPUT TRANSFORMERS—SPECIAL T-22 S 84-5 WATTS. Prim.: 500 to 2000 Ohms, tapped. Sec.: 3.2 to 15 Ohms tapped. NEW—\$ 1.95

TS-24 S 61-8 Watts. Prim.: 4M, 7M, 8M, 10M, & 14M Ohms CT. Sec.: Tapped from 1 to 20 Ohms. NEW—\$ 1.19

T-22 S 58-8 Watts. Prim.: 5M or 7M Ohms CT. Sec.: 3.2 to 8 Ohms. NEW—\$ 1.49

POWER TRANSFORMERS 710-4013—Flush mtg., completely shielded. 6.3 V.C.T. @ 2.5 Amps., 5 V. @ 2 Amps., 650 V.C.T. @ 90 Ma. D.C. NEW—\$ 2.75

SPECIAL REACTOR T-17 C 40-1500 Hys. @ 3 Ma. D.C. 12,000 V.D.C. Ins. Upright mtg., shielded. Ideal for audio work, etc. NEW—\$ 3.75

500 Kc. STANDARD XTAL—Type DC-23—1/2" spacing, 7/16" x 1-1/16" NEW—\$ 2.95

B & W AMATEUR COILS—ALL NEW.

HVL	HDL	BCL	BEL	JCL
10	10	5	5	5
40	15	15	20	15
160	20	40	40	20
	80	40	80	40

Price... 30% Off Catalog Net

COMMAND RECEIVER PARTS

I.F. Transformers—2850 Kc. . . . . 3 for \$1.00

R.F. Coil Set—6-9.1 Mc. (R.F. Osc. & Mixer) . . . . . \$ .79 ea.

Audio Choke—Potted mica ins. . . . . 3 for 1.00

Tuning Gang—for BC-455 . . . . . 1.00 ea.

WRITE FOR OUR LATEST CATALOG

Material subject to prior sale. 25% dep. with all orders. Bal. C.O.D. Orders received less postage shipped express. Min. order \$3.

FOREST SALES CO.

702 Madison St. Euclid 6-1663, Oak Park, Illinois

engineering talent is necessary, Washington has declared, for military electronics, which before the end of the year will become a \$3-billion item for industry.

Permission to produce theater systems will make it possible to process several types of gear, one of which is the Swiss *Eidophor* projection setup, which it is said can be used for monochrome or color.

**A MAJOR FREQUENCY PROGRAM**, governing the use of frequencies by all government agencies and the right of transfer from one group to another, has been developed by the executive committee of the technical policy steering committee, which consists of representatives of the FCC, State Department, the Interdepartment Radio Advisory Committee for the military, and others concerned with the government use of the airwaves.

The plan, which has been submitted to Haraden Pratt, telecommunications advisor to the President (who is also chairman of the policy steering committee which originated the plan) notes that . . . "Any rights of any agencies of the United States to operate in any radio frequencies are considered to be a vital national resource." Accordingly, it was said, such rights . . . "shall be regarded as rights held by the United States as a whole, and they may be transferred by this government from one user to another, as required in the over-all national interest."

Declaring that the current philosophy is . . . "not compatible with an expeditious and adequate solution to problems . . ." the committee cited as an example the many problems now in the 4 to 27.5 megacycle bands which will require solution in view of the growing international needs for these frequencies.

**HORSE-RACING INFORMATION** broadcasts, long an irksome problem and of deep concern to the Commission, received a lashing in an official memo from the FCC, directed to those stations who are involved in such broadcasting or telecasting. The Commission said that in their opinion such broadcasts serve the interest of gamblers. "It is common knowledge," declared the FCC, "that bookmakers whose activities are in most states illegal, operate too during the afternoon while racing is in progress . . . The ease with which the afternoon dissemination of horse-racing information through the facilities of broadcast stations can be of aid in illegal gambling activities has become evident, and there is good reason to believe that the possible use of such information is not avoided by such alleged safeguards as delays in announcing results for a fixed period of time . . . Accordingly, the Commission has been gravely concerned in considering applications for renewal of station licenses from licensees, who as a regular prac-

tice engage in the broadcasting of horse-racing information during the afternoon, when such information would apparently be of particular value to illegal gambling activities."

Stations now broadcasting racing copy are being asked to detail to what extent and the manner in which broadcasts have been made and whether it is proposed to continue such broadcasting, providing such information as: entries, scratches, probable jockeys, jockey changes, winning jockey, weights, selections, offtime, next post-time, track conditions, weather conditions, time of race, mutuels or prices paid, results of race, results in code, post positions, running account of race and pre-race betting odds. The Commission has also asked for sources that are used to provide the foregoing information.

All stations cited as racing broadcasters will undoubtedly cease such broadcasts rather than jeopardize their license renewal possibilities. One station in New York City, which has actually featured racing information broadcasts, has already notified the Commission that it will drop continuing broadcasts and hereafter offer only a summary once a day, at the end of the afternoon.

The recent crime hearings, during which horse-race broadcasts were constantly referred to as a gambler's source of betting information, were cited as one of the reasons for the renewed effort to ban all such broadcasting.

**TV BROADCASTING**, which had been a deficit operation for years, has now become a striking item on the profit side of the ledger. According to a financial report issued by the Commission, for the first time, networks derived a greater proportion of their total revenues and income from TV than from AM. Specifically, TV produced \$132.2-million revenue, while AM resulted in only \$100.4-million. In '50, TV network losses were nearly \$10-million; in '49, the loss was \$12.1-million; and in '48, the loss was over \$14-million. Ninety-three TV stations, excluding the 15 network owned and operated stations, reported total revenues of \$107.3-million, which was more than double the '50 revenues of \$50.4-million. Of the 106 TV stations, including all but two of the network owned and operated stations, 93 reported profitable operations during '51. TV has really begun to fulfill those dreamy promises painted for this bustling new industry. . . . L.W.

### REGIONAL MEET

**T**HE Denver Radio Club is again sponsoring the Rocky Mountain Division ARRL Convention which will be held this year at Estes Park, Colorado on June 14th and 15th.

Headquarters for the event will be at Elkhorn Lodge. All correspondence regarding this event should be addressed to the Denver Radio Club secretary, Walter M. Reed, WØWRO, 1355 E. Amherst Avenue, Denver, Colorado. —50—

May, 1952

## Sam's Surplus Sells For Less

### COMMAND AND/OR ARCS TRANSMITTERS and RECEIVERS

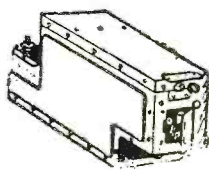

3-6 MC Receiver. Used \$ 7.95 New 17.95  
6.9-1 Receiver. Used \$ 6.95 New 12.95

Triple Receiver Rack \$1.95  
V.H.F. ARC5 Transmitter or Receiver, Complete w/tubes. Used \$24.95 New

2.1-3 MC Transmitter with tubes 14.95  
4-5.3 MC Transmitter with tubes 6.95  
5.3-7 MC Transmitter with tubes 6.95  
7-9.1 MC Transmitter with tubes 9.95 \$19.95  
3-4 MC Transmitter with tubes 18.95  
28V Receiver Command Dynamotors \$0.97

### MODULATORS

BC-456 with Tubes, less dyn. 2.95  
MD-7/ARC5 Plate Modulator. 9.95  
MD-7 Modulator Dynamotor, 28V 2.95  
BC-433 Receiver—with tubes. \$24.95  
MN-26C Compass Receiver. 24.95 \$39.50  
MN-26Y Compass Receiver. 39.50 49.50  
BC-357 Marker Beacon Rec. W.O. Tube 5.95



BC-223 Transmitter. 30 watt. Ideal for Ship-to-Shore or Ham Rig. Crystal or MO control on four pre-selected channels. 2000 to 5250 KC. Use of 3 plug-in coils. Five tubes: 2-801, and 3-36, and TU 17-18-25 tuning units.

Transmitter—\$39.95. Tubes—5.75. Tuning Units—\$4.95 Amp Meter. No. 60-0-60. New—1.29.

### CIVIL AIR DEFENSE or 2 METERS

ARC-4. W/tubes. Good, used. \$29.95  
522 Trans.-Receiver. W/tubes. Good, used \$6.50  
Modulation Transformer. BC-375. New. 2.49  
BC-375 Trans. 100 Watt Voice, CW, MCW, freq. range 200 kc to 12 mc, uses Plug-in Tuning Units listed complete with tubes, less Tuning Units. \$29.95

### Tuning Units for BC-375 or 191 Trans:

TU- 7 4500- 6200 kc ..... \$2.49  
TU- 8 6200- 7700 kc ..... 2.49  
TU- 9 7700-10000 ..... 2.49  
TU- 10 10000-12500 ..... 2.49  
TU-26 200-500 kc ..... each 4.50

FT-151 Shock Mounting for BC-375 or 191.... 2.95  
BC-306 Antenna Loading ..... 1.95  
GP-7 Navy Transmitter: 100 watt master os. Can use on any freq. from 350-9050 kc. by using proper plug-in. With 1 tuning unit. \$13.33

### LOOP ANTENNAS

DU-1 2 tube amplifier. New \$25.95  
MM-20-E ..... New 7.95  
LP-21 A ..... New 16.95  
Rotatable Loop Unit — Type MN-20E. 8" diameter—used with MN-26 Compass and RA 10 DB. By Bendix. Only \$7.95

FL8 Filters—A's, B's, C's ..... New 1.95  
FL5 Filters ..... New .95  
Hand Keys—J-38 ..... New 1.19

TSC Transmitter & Receiver with 12V Power Supply and Cables. Good—used. \$179.50  
Heineman Circuit 115 V., 20 amp. 1.39  
Breakers 115 V., 5 amp. .97  
Prop Pitch Transformer, only new 6.95  
RT-7PN-1 Transceiver w/o tubes. Used 9.95

Cash with order. Prices subject to change without notice. California orders please include 3 1/2% Sales Tax. Please include approximate postage—Excess will be refunded. What Have You in Surplus? Submit

1306 BOND STREET, at PICO  
**ESEGE SALES COMPANY INC.** LOS ANGELES 15, CALIFORNIA

### "S" METER



### "S" METER

"S" METER — SAM'S SPECIAL. Illuminated face (supplied with miniature lamp). Full scale reading of 5 ma. A standard value for most "S" Meter Circuits. Dia. across face — 2 3/8". Black bakelite face. Reverse-set pointer. New \$2.49  
Vibrators—Mallory. For use on 12 V battery. New \$0.97

### TRANSFORMERS

12V 24V 2am 110V primary. \$2.95  
ARC-4 2 Meter Transceiver, tubes, good, used \$29.95  
BC-434 Control. Used—\$1.95 New 2.95  
Code Tapes for TG-10 15 rolls. New. 7.95  
BC-906 Absorption Type Freq. Meter Range 150-225 mc. 0.500 DC Microm. Used \$11.50  
Field Phones E-E 8's. Used \$29.95 pr.

Relay. SP-ST. Leach 6 V or 12 V. New 1.49

### CRYSTALS—CR 1A/AR

8036.25—8001.43 \$1.19 ea. 3 for \$2.95

### DYNAMOTORS

PE103 New Case \$29.95  
DM-32A Input 28V. Output 250 DC. .06 amps. Used 1.95  
PE-73 29V @ 20 amps. output 1000V @ .350 amps. New 8.95  
PE-77 14V @ 40 amps output 1000V @ .350 amps. New 19.95  
PE-94 or SCR—522 24V. Used—\$5.95 New 14.95  
PE-94 Dynamotor only ..... 4.95  
DM-34 12V @ 2.8 amps. Output 220V @ 160 amps ..... New 9.95  
SPEC. 9V @ 450V output @ 80 ma. New 8.95  
SPEC. 12V @ 320V output @ 80 ma. New 4.95  
SPEC. 6V @ 250V output @ 80 ma. New 8.95  
SPEC. 12V @ 440V output @ 200 ma. New 15.95  
ARC-1 DY-9/ARC-1 ..... Used 11.50  
14 Volt Input—425 Volt Output at 163 mils. Starting Filter and Relays in base. Like New 5.95

PE-94 or SCR—522 24V. Used—\$5.95 New 14.95  
PE-94 Dynamotor only ..... 4.95  
DM-34 12V @ 2.8 amps. Output 220V @ 160 amps ..... New 9.95  
SPEC. 9V @ 450V output @ 80 ma. New 8.95  
SPEC. 12V @ 320V output @ 80 ma. New 4.95  
SPEC. 6V @ 250V output @ 80 ma. New 8.95  
SPEC. 12V @ 440V output @ 200 ma. New 15.95  
ARC-1 DY-9/ARC-1 ..... Used 11.50  
14 Volt Input—425 Volt Output at 163 mils. Starting Filter and Relays in base. Like New 5.95

### OIL CONDENSERS

#### Standard Mikes—New

2 mfd 600V \$0.49  
4 mfd 600V 1.39  
1 mfd 1000V .69  
3 mfd 4000V 7.95  
5 mfd 2500V 1.49  
10 mfd 600V 2.95  
2 mfd 2500V 3.95  
2 mfd 5000V \$ 8.95 2 mfd 7500V 29.59  
T-30 Throat Mikes ..... Used—3 for \$0.50  
CD-307 Head Set Extension Cord ..... 1.19

### HEAD SETS

HS-30 ..... New \$1.95  
HS-23 ..... Used—\$1.95; New 2.95  
Matching Transformer for HS-30 ..... .69

RG-7U Coax Cable, 97.5 ohms ..... foot .08  
MIKE CHEST SET "F-1" button ..... New .99

### DECK INSULATORS

Bowl & Flange type. Heavy galv. metal flange—10 1/2" dia. Porc. bowl set in rubber gaskets. Top bell—7 3/4" dia. Brass feed thru rod L insul. dist. between top bell and flange—6 1/2". New \$2.95  
Cash with order. Prices subject to change without notice. California orders please include 3 1/2% Sales Tax. Please include approximate postage—Excess will be refunded. What Have You in Surplus? Submit

## IRMC TRANSCRIPTION PLAYER



16" Synchronous  
Model TP16E \$126.00  
Model TP16D \$84.00  
Model TP12H \$50.50  
(F.O.B. Port Chester, N. Y.)

Export: Rocke International Corporation.  
13 East 40th Street New York 16, N. Y.

### FOR HIGH FIDELITY RECORD REPRODUCTION

Meets the rigid demands of Army-Navy requirements, even Navy salt-spray test. Used by U. S. Signal Corps all around the world. Standard equipment in Veterans' Hospitals, and most radio stations, transcription services, etc., for realistic reproduction of transcription records up to 16 inches, 78 and 33 1/3 r.p.m.

Descriptive Bulletin HS3-1, upon request.  
Available Through Authorized Jobbers.

## RADIO-MUSIC CORPORATION

PORT CHESTER NEW YORK

for dependable sound,  
**INDUSTRY** relies on  
**ATLAS**



DR Double-Reentrant Projectors



Paging & Talk-Back Speakers



ALINCO-V-PLUS Driver Units



Dual Speakers



FULL-GRIP, VELVET-ACTION Mike Stands

**DEPENDABLE QUALITY:**

The latest electro-acoustic research and engineering—and over 20 years of manufacturing know-how—are behind every ATLAS product.

**DEPENDABLE SERVICE:**

Coast-to-coast and around the world today—in every Industrial, Marine, Railroad, Military, Educational, Civic, U.S. and Foreign Government application—under every kind of climate and noise condition—ATLAS sound equipment is famous for highest efficiency and durability. That's the proof of ATLAS performance dependability.

**DEPENDABLE DELIVERY:**

Yes, ATLAS gives our Government highest priority. And yes, we too feel the pinch of material shortages. But our customers will continue to get our usual dependable delivery—because we believe in equitable and dependable distribution to all ATLAS users.

**DEPENDABLE PROFITS:**

Completeness of line, excellence of product, dependable delivery, right prices—that's the ATLAS combination that means high, steady Industrial Sound profits for You!

JUDGE for yourself, COMPARE ATLAS at your local Jobber today. See why ATLAS is the preferred line for utmost dependability. Write NOW for FREE latest Catalog[551].

**ATLAS SOUND CORP.**  
1446-39th Street, Brooklyn 18, N. Y.  
In Canada: Atlas Radio Corp., Ltd., Toronto, Ont.

**LEARN TELEVISION**  
ELECTRONICS and RADIO  
Engineering Laboratory and Classroom Training. Day and Evening Classes.  
Write for illustrated Catalog  
**ELECTRONICS INSTITUTE, Inc.**  
21 HENRY, DETROIT 1, MICH.

QUALITY · SERVICE · DEPENDABILITY  
**DUMONT** PERFECTLY CENTERED  
COMPLETELY MOLDED **CAPACITORS**  
Sold and Preferred Everywhere  
**DUMONT Electric Corp.**  
308 Dyckman Street, New York 34, N. Y.

**Parts Distributor**  
(Continued from page 51)

Each salesman and counterman employed by the parts distributor is a veritable gold mine of information for the service customer. On a normal day in any distributor outlet, countermen will answer a battery of questions concerning every phase of the business from product information to schematic queries.

In a brochure recently released by the National Electronic Distributors Association, entitled, "What Is An Electronic Parts Wholesaler," the publication said of the distributor employee:

"Because of the complex technical nature of the various electronic applications electronics parts distributors are called upon to serve, their employees are, to a great extent, technical. They are required to interpret incoming orders, to be able to make substitutions and recommendations involving the use of more or less stock items in place of special equipment that might take months to obtain and which might be much higher in cost . . . and they render this exceptional technical service and advice as a matter of everyday course."

Both Morris Green and Al Margolis summarize their contribution as parts distributors to service customers as follows: Stand behind and guarantee the manufacturer's merchandise, evaluate his product requirements, keep him abreast of current happenings, provide increasing support for the sale of his services to the consumer, and help make him a better businessman.

-30-

**GAIN CONTROL GADGET**

By HUGH LINEBACK

WHEN operating a public address mixer in a darkened auditorium, the man at the controls has some uneasy times with the gain settings while following a stage performance. The kink shown in the photograph was cooked up as an emergency measure at the start of a show, and it has proved to be very valuable since.

Scotch drafting tape was split and rolled into a small pellet. This little lump was then attached to the edge of the gain control knob with a narrow strip of tape. Thus the position of the knob could be judged by feel.

Gain control adapted for "riding blind."

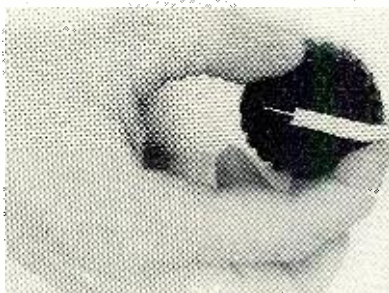

**TUBES AT LOWEST PRICES**

1A7	\$.79	6C4	\$.48	12AT7	\$.95
1B3	.85	6CB6	.55	12AU6	.65
1L4	.59	6H6M	.58	12AU7	.65
1L6	.55	6J5M	.65	12AV7	.85
1L8S	.90	6J6	.85	12AX7	.65
1R5	.59	6K6	.65	12BA6	.55
1S5	.80	6N6	1.50	12BA7	.80
1T4	.75	6N7	1.10	12BE6	.50
1U4	.65	6S4	.55	12J5GT	.80
1U5	.55	6S7M	.95	12SA7GT	.75
2Z3	.70	6S7M/GT	.75	12X7	.70
3V4	.65	6SC7	.95	12SK7M	.65
5Y3	.35	6SH7M/GT	.70	12SQ7	.75
6Z3	.65	6S17M/GT	.80	12SN7	.85
6AB4	.65	6SK7M/GT	.55	12SR7	.70
6AC7	.90	6SL7	.65	14BE	.85
6AG5	.80	6SN7	.65	19T9	.95
6AL5	.48	6SQ7GT	.65	25Z6GT	.59
6AQ5	.65	6T8	.95	23W4	.70
6AT6	.48	6V6GT	.45	35L6	.53
6AU6	.58	6W1	.49	35W4	.45
6AV6	.65	6X4	.40	35Z5	.48
6AB6 GNS	.90	6X5	.40	50B5	.55
6BA6	.55	6Y6	.70	50C5	.55
6BC5	.65	7AD7	1.20	50L6	.55
6BE5	.60	7A6	.60	59	.90
6BF5	.75	12A6	.45	89Y	.75
6BF6	.70	12AT6	.45		

**IMMEDIATE DELIVERY!**

Write for quotations, many other types available. 20% Deposit with order, balance C.O.D. All tubes subject to prior sale. Prices subject to change without notice.

**WRITE, WIRE, CALL—TODAY!**

We Buy Anything in Electronics—large or small Quantities!

**NAT ADELMAN**

168 Washington St. New York 6, N. Y.  
CO. 7-6091

**OLSON HAS BIG, BIG BARGAINS**  
**FAMOUS BRAND**  
3-SPEED AUTOMATIC RECORD CHANGER  
Sorry, we can't mention the manufacturer's name. Automatic plays 7, 10 and 12" records. Plays all type discs—all speeds, 33 1/3, 45 and 78 RPM.  
**\$19.99**  
One of the most famous brands in automatic changers. Brand new. Precision built—with Astatic Ceramic Cartridge and long-life sapphire needle. Operates on 115 volts, 60 cycles AC. Base 12 x 12 1/2, 5 1/8" above plate and 3 1/2" below. Shpg. wt. 15 lbs.  
SEE OLSON'S BIG ADS ON PAGES 98 & 99.  
**OLSON RADIO WAREHOUSE**  
277 E. Market St., Akron 8, Ohio

**EASY MONEY!!**  
If you don't get our postcards telling the cash we'll pay for that surplus gear you bought when the buying was good, then YOU ARE LOSING MONEY! So send us your name and address NOW and GET ON OUR MAILING LIST!  
**G. L. ELECTRONICS**  
905 S. VERMONT AVE., LOS ANGELES 6

**LEARN CODE**  
TWO DOTS MAKE LETTER 'I'  
No matter how difficult it has been for you to learn code before, I guarantee that you will memorize the Morse International Code in two hours or return method within 5 days and I will refund your money. Get in on the fun of 'easy license' civilian radio. Send one dollar for complete method. **NOTHING ELSE TO BUY!**  
**OTTO LUTHER, NEW PRESTON, CONN.**

**RADIOS**  
1, 2 & 3 band Electric and/or battery  
**TELEVISION**  
AC/DC Operation  
**TEST INSTRUMENTS**  
Write for FREE Catalog  
**ARKAY—Radio Kits, Inc.**  
120 Cedar St., New York 6, N. Y.



**The Versatile 6BN6**  
(Continued from page 42)

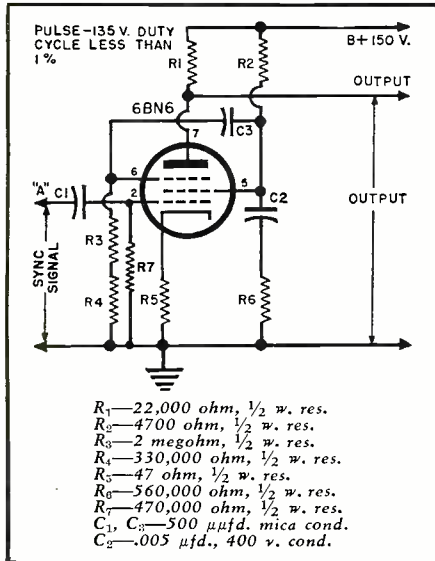
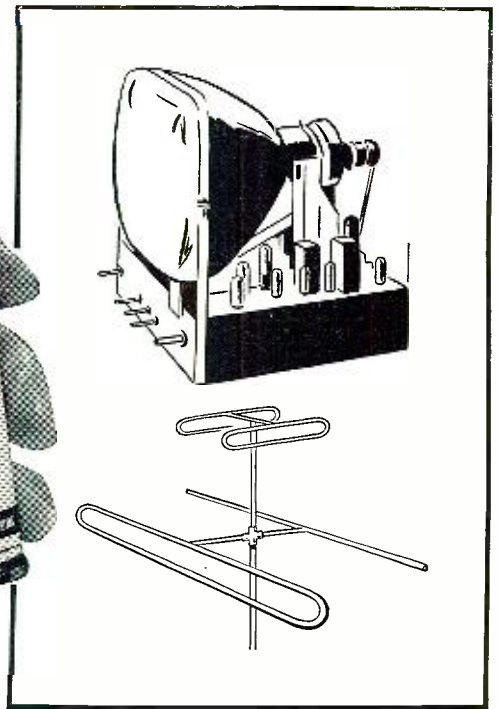
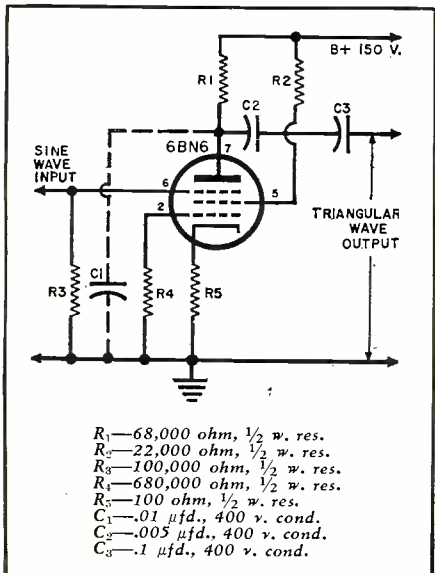

Fig. 2. Circuit for supplying negative pulses.

siderably. If a small condenser is connected from plate to ground, the circuit will produce a nice triangular wave. Using this square-wave generator to drive the quadrature grid of a second 6BN6, we obtain an electronic switch which will control any voltage of suitable magnitude applied to the control grid. One use of this arrangement would be to apply a sine wave to the control grid with a suitable frequency square wave applied to the quadrature grid. We would obtain "bursts" of the sine-wave voltage, which are very nice for testing the transient response of audio amplifiers, etc. The chief advantage of using the 6BN6 in this manner lies in the reduction of the number of tubes and other components which would be required to give the same result.

Fig. 3. Wiring diagram of a square-wave generator using the new type 6BN6 tube.



**PREVENT CORONA**  
in high voltage circuits with



**ACRYLIC SPRAY**

Advertised in  
The SATURDAY  
EVENING POST

**Spray on antenna and lead-in terminals, too; Krylon prevents corrosion and pitting**

Krylon is an acrylic spray—not a vinyl plastic. Spray it, right from the 12 oz. aerosol can, on the high voltage coil and insulation... in the socket of the high voltage rectifier... on component parts of the high voltage rectifier circuit. Krylon dries in a few minutes to form a permanent protective coating of high dielectric strength.

Both inside the set and on the antenna, Krylon seals and protects... makes TV sets perform better, longer... cuts down service calls... builds customer good will. Two types—clear (list \$1.95) and nonconducting aluminum (list \$2.25). Also in gallons for application by brushing or dipping. See your jobber, or write direct.

**KRYLON, Inc. Dept. 527**  
2601 North Broad St. Phila. 32, Pa.

**SALE!**

- HEADSETS**  
HS 30—BRAND NEW ..... \$1.75  
HS 33—BRAND NEW ..... 3.50
- LOOPS**  
LP 21—NEVER USED ..... \$9.50  
AN 104A—NEW ..... 1.25  
MN 20E—BRAND NEW ..... 4.50
- CORDS**  
CD 307 with PL55 and JK26—  
BRAND NEW ..... \$ .75  
CD 365 with PL108 each end.. 1.00
- TEST SETS**  
TS 10—NEW ..... \$20.00  
TS 16—NEW ..... 20.00
- TEST SET SPARES**  
TS 34—NEW ..... \$100.00

- TUBES**  
6C21—NEW ..... \$ 7.50  
864—NEW ..... .20  
PL 55 PLUGS—used..... .35
- BALLOONS**  
Inflate to 2 ft. .... \$1.00  
Inflate to 3 ft. .... 1.50  
Inflate to 4 ft. .... 2.00  
Inflate to 6 ft. .... 3.00
- KITES—ARMY—LARGE TYPE ... \$2.50**

ASK FOR OUR FREE CATALOG  
Write, Wire, Phone Today!

**TALLEN COMPANY, INC.**  
159 CARLTON AVE., BROOKLYN 5, N. Y.  
PHONE: TRIangle 5-8241

We Have Over 1 Million Plugs, AN Connectors, Amphenols and Cannons in Stock

**SALE!**

**SALE!**

# EBCO

Mfrs. of  
**PICTURE TUBES**  
and  
**ELECTRONIC**  
**EQUIPMENT**

Sold only thru Radio Parts Jobbers

17" Rectangular C.R.T. .... net \$21.95  
with Glass Allowance

20" Rectangular C.R.T. .... net \$29.95  
with Glass Allowance

Prices include tax

**EIGHTEEN MONTHS GUARANTEE!**

## "EBCO" Dual-Purpose CHECKER-REACTIVATOR

for TV Picture Tubes

**A MONEY MAKER  
FOR SERVICEMEN:**

Check picture tubes for shorts, cathode emission, leakage, etc., without removing tube from TV set. Also PUT NEW LIFE into weak tubes with the REACTIVATING power of this instrument. Lightweight, portable; 110V-60 cycles. Factory-guaranteed. **ASK YOUR JOBBER.**



Model 10 net \$19.95

### FIELD STRENGTH METER

Want better antenna orientation? Better TV performance? Want to save time and money? Then use the NEW "EBCO" FIELD STRENGTH METER. Measures field strength from 50 to 50,000 microvolts at the 300 ohm input terminals. Many other great features. net \$64.95

### 2-SET CONNECTORS

Two-set Connector for TV. .... Net \$2.95

Four-set Connector, operates 3 or 4 sets from 1 antenna. .... Net 4.95

**ASK YOUR JOBBER!**

## ELECTRONIC BEAM CORP.



923 Old Nepperhan Ave.  
YONKERS, N. Y.  
Phone: YOnkers 3-3514

# STAN-BURN McKee

### ANTENNAE SPECIALS

DOUBLE V 3/4"	1-11	Or More
DOUBLE V 3/4" Dowel	\$2.98	\$2.20
DOUBLE V 1/2" Dowel	3.45	2.45
DOUBLE V 1/2" Dowel	3.95	2.95
10 Element Conical 3/4"	3.55	2.55
Folded 111 Straight Low Quick Rig 1/2" elements	4.25	3.25
WINDOW CONICAL MASTS	4.95	3.75
5 FOOT SWEGGED	.79	.69
10 FOOT PLAIN	1.39	1.29
TV WIRE		
55 MIL. 300 OHM	\$15.95 M Ft.	
72 OHM COAXIAL	\$2.50 M Ft.	

### CATHODE RAY TUBE SPECIALS

10BPA	ZETKA	\$14.95	17BPA	FEDERAL	23.00
10BP4	N. U.	19.95	17BP4	DUMONT	26.00
10BP4A	N. U.	19.95	19AP4	SHELDON	29.95
12LP4	ZETKA	18.95	19AP4A	G.E.	39.95
12LP4A	THOMAS	19.95	19BP4A	THOMAS	39.95
16AP4	ZETKA	26.00	20CP4A	DUMONT	39.95
16AP4A	G.E.	38.00	20CP4A	SHELDON	37.00
16OP4A	THOMAS	28.80	21EP4A	DUMONT	42.95
16GP4A	RAULAND	33.00	23AP4A	SHELDON	63.00
16GP4	ZETKA	26.00	24AP4A	G.E.	75.00
16JP4A	THOMAS	28.80			
16RP4A	GE & NU	26.00	Single Ion Traps	1.39c	
16TP4A	DUMONT	\$26.00	Double Ion Traps	.59c	

CHASSIS 600 REGAL with Cascade Tuner	\$139.50
211 T3 FLY BACK (similar to RCA)	2.98
OPEN FACE CABINET	39.00

### TRANSFORMERS

Nationally Advertised	
RCA type for 16" to 24" X032	\$3.85
G.E. type for 16" to 24" X045	3.85

These are very special prices while they last!

### DEFLECTION YOKES

COSINE FERRITE TODD YOKE 70"	\$1.20
------------------------------	--------

### SPECIALS

G1 3 speed Changer—Model 700F33-45	\$19.50
G1 3 speed Changer—Model 407-31	22.50

### AUDIO DEVICES, DISCS AND TAPE IN STOCK

12" Heavy Slat Speaker	Special \$4.98
500 MMFD Barrel Type—20,000 KV—Screw end	75c
Plain end	Special while they last 55c

### WIRE RECORDERS IN STOCK

PENTRON—Model 9T3C—2 speed Tape Recorder	\$116.68
Net	\$99.97
WILCOX GAY—Model 2A10	89.97
4 Prong Vibrators each	1.19
Lots of 12 or more	1.19

Standard TV Tuners (with tubes)	\$18.95
Cascade Guaranteed Tuners (with tubes)	21.95
SPECIAL: While they last	21.95

**AUTHORIZED DISTRIBUTORS for:** General Electric, Kenrad, Tung-Sol, National Union, Jewel, De Wald, Regal, Automatic and Setchen, Carlson.

We carry a complete line of popular makes of Radio and TV tubes, at 50% discount. Also many other special purpose and transmitting types, and all electronic parts and equipment at lowest prices. Send us a list of your requirements for prompt quotations. Terms: 20% with order. Balance C.O.D. All prices FOB, NEW YORK Warehouse. Minimum order \$5.00. Write for our latest price list to Dept. RNS

# STAN-BURN RADIO and ELECTRONICS CO.

(C.B.S. THEATRE BLDG.)  
1697 BROADWAY • NEW YORK 19, N.Y.

The main purpose of this article is not to present any exact circuits but rather to indicate the versatility of the 6BN6 tube. A large number of variations on the circuits shown are possible. Although designed primarily as a substitute for the more conventional limiter-discriminator, it is entirely possible that other uses may become more important. The two isolated control grids and the negative transconductance of the accelerator element give promise of some very interesting applications. The circuits shown have all been tried out on breadboard hook-ups, and no one should experience any difficulty in duplicating the results. Obviously one must adhere to the usual rules of good circuit layout and design. The circuits all operate nicely at 150 volts and require only a few mils of current.

-30-

## ANOTHER DEALER SCORES

By WAYNE ALBIN

I FOUND the article "No Television in Your City?" in the December 1951 issue of particular interest as out here in Lamar, Colorado we have been carrying on the same type of experiment. We have been having fairly good luck but with different equipment and a few variations in results.

We have been DX-ing TV since the spring of 1950. We pioneered television here in Lamar and since that time we have logged a total of 100 stations with 29 different contacts.

Unlike Longmont, Colorado, we are situated in the Arkansas River Valley, right out on the open plains of South-eastern Colorado, approximately 150 air miles southeast of Denver and 30 miles west of the Kansas line on US 50. We have to rely on tropospheric conditions entirely.

It is interesting to note a few of the differences between our operation and that of Mr. McKee. He found that in 1950 the best time for reception was after 12 noon and in the evening while our experience was that reception was best between 9:30 in the morning and noon. Afternoon and evening reception was rare. In 1951 the morning hours proved to be best in Longmont while there was practically no late evening reception. Our experience was very similar except that we had very good afternoon and evening reception a number of times. We have found that on clear days we can receive programs all through the day.

We are using a 16" standard 26-tube Stewart-Warner table model. We have a single-stage Anchor booster we use occasionally. Under most conditions the booster is not necessary as the Stewart-Warner set is sensitive enough to receive the weakest signal without any trouble. The quality of the picture is remarkable considering the conditions under which the set operates. The sound always comes in with the picture and is uniformly good. We are using a two-bay X-type conical, all-channel antenna mounted on a Cornell-Dubilier rotator. This antenna has been giving excellent results on all channels we have had occasion to use. The antenna is approximately 60 feet in the air.

-30-

# TRIPLEX WAVE MASTER

**YOUR BEST TV ANTENNA BUY!**

PROVEN UNDER  
ACTUAL TESTS!

- ✓ GHOST-FREE RECEPTION—ALL CHANNELS
- ✓ MATCHES ANY OHM WIRE 75—150—300
- ✓ USERS REPORT UP TO 300-MILE RECEPTION
- ✓ TRIPLE DIRECTORS
- ✓ EASY TO INSTALL

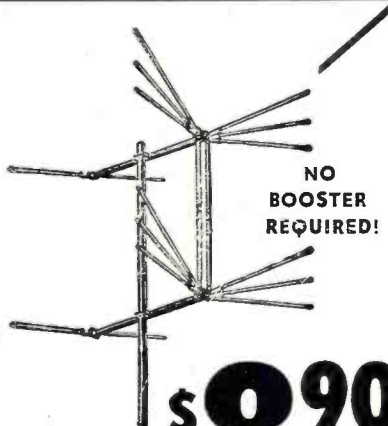

NO BOOSTER REQUIRED!

**\$8.90**  
Lots of 3 \$8.45 each

YOUR COST NOW ONLY . . .

Approximate Weight . . . 9 lbs.

20% deposit on all C.O.D. orders

# RAY CO.

**SOLD DIRECT! WRITE . . . WIRE**  
OR CALL FAIRFAX 9171  
441 SUMMIT ST., TOLEDO, OHIO

**Mac's Service Shop**  
(Continued from page 60)

diate future. These are the things that I want you to include as a part of regular checking routine of any radio you put on the bench."

Barney perched himself on the service bench stool and entwined his long legs through its supports. Pulling a pencil and scratch-pad from the pocket of his service coat, he moistened the lead with the tip of his tongue and poised the pencil over the pad.

"Shoot!" he commanded out of the corner of his mouth in his best Humphrey Bogart imitation.

"Well, first, I want you to make certain none of the controls are on the verge of causing trouble. Check volume and tone controls while the set is cold, for often trouble will show up in variable resistors then, but will disappear when the set is warm. If the change in volume or tone is not smooth and quiet, if there are any abrupt changes in control action or any tendency to create scratching sounds or whistles when the knob is moved, change the control. Do not try to doctor it with cleaning fluid."

"Check," Barney acknowledged.

"Try the tuning action for slippage while the set is cold and again after it has warmed up. Some dial cords and belts will slip when warm; others, only when cold. While you are checking, move the knob very slowly and note if the pointer responds immediately and positively to every slight movement of the knob. If it does not, if you have to jerk the knob or press it up or down or sideways to start the pointer, correct this condition; and the best way to start is by installing a new cord. Do not increase the cord tension beyond normal or roughen the shaft or use dope on the cord, for usually such measures are only temporary cures, and the trouble will soon show up again."

"Check!"

"Use the v.t.v.m. to check bias voltage between cathode and signal grid of each output tube. If this voltage is not up to rating, find out why. A leaky coupling condenser is frequently the cause; so clip the grid end of the condenser loose and check it for positive voltage. If any is present, change the condenser. Sometimes an output tube will develop a positive-creeping voltage on the grid even when the coupling condenser is cut loose and the grid-supply voltage stays the same. Such a tube is defective and should be replaced. With these precautions you will often be able to nip trouble in the bud before any actual audio distortion can be noticed.

"Use the vacuum tube voltmeter to check the grids of tubes controlled by automatic volume control for the development of a good a.v.c. voltage when a local station is tuned in. Leaky bypass condensers on the a.v.c. line will cause strong stations to overload, and

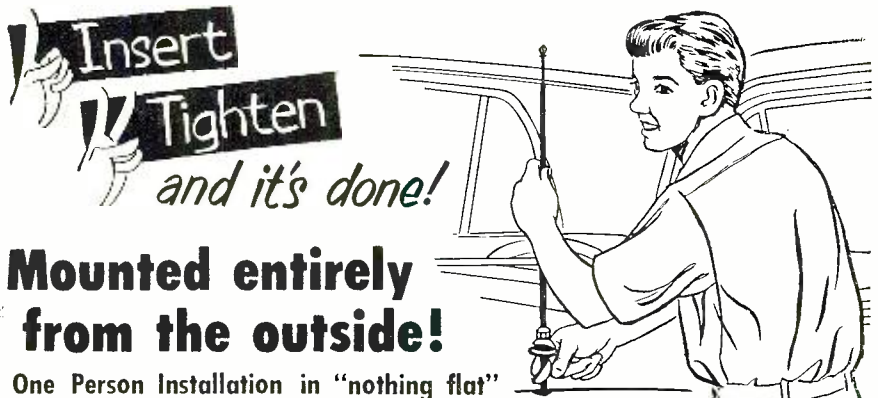

**Mounted entirely from the outside!**

One Person Installation in "nothing flat"

**"Solo-mount" New Improved**  
**TOP FENDER & COWL AUTO RADIO ANTENNA**



Cat. No. 4583-B

Here's the antenna that takes time-consuming, expensive drudgery out of antenna installation, once and for all. One man, in no time at all, inserts the antenna lead and special rocker into the hole, pulls up against the rocker and tightens the top nut. All from the outside!

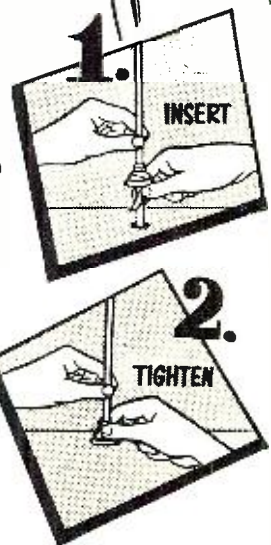

**Simplest to install—precision engineered**

- ✓ 36" HI-Q low loss cable—inner polyethylene insulation
- ✓ Three sections — extends to 60 inches
- ✓ Guaranteed rust proof — rattle proof
- ✓ Gleaming chrome-plated admiralty brass
- ✓ Noise free reception
- ✓ Streamline, modern design
- ✓ Readily conforms to contour of any car

Visit our Booth No. 206 at the Radio Parts and Electronic Equipment Show May 19-22 Chicago

**insuline CORPORATION OF AMERICA**  
INSULINE BUILDING • 36-02 35th AVENUE • LONG ISLAND CITY, N. Y.  
West Coast Branch and Warehouse: 1335 South Flower Street, Los Angeles, Calif.  
Exclusive Canadian Sales Agents: CANADIAN MARCONI COMPANY, Toronto

**PEN-OSCIL-LITE**  
Extremely convenient test oscillator for all radio servicing; alignment • Small as a pen • Self powered • Range from 700 cycles audio to over 600 megacycles u.h.f. • Output from zero to 125 v. • Low in cost • Used by Signal Corps • Write for information.

**GENERAL TEST EQUIPMENT**  
38 Argyle Buffalo 22, N. Y.

**RADIO and TELEVISION ELECTRONICS**  
in all Technical Phases  
New Classes (Day and Evening) Start 1st of Dec., Mar., June, Sept.  
Free Placement Service for Graduates  
For Free Catalog write Dept. RN-52  
**RCA INSTITUTES, INC.**  
A Service of Radio Corporation of America  
350 WEST 4th ST. NEW YORK 14, N. Y.

**MARK THESE VALUES!** TOP STANDARD BRANDS ONLY—100% GUARANTEED

1B3GT ... 89c	6AG5 ... 79c	5U4 ... 59c	6J6 ... 89c	12AT7 ... 99c
0Z4 ... .59	6AC7 ... \$1.16	6AG6 ... 1.48	12SK7 ... .72	50L6 ... .67
1L4 ... .73	6AK5 ... 1.29	6BE6 ... \$1.89	12SQ7 ... .64	957 ... .29
1R5 ... .78	6AL5 ... .59	6BG6 ... .78	35Z5 ... .54	958A ... .39
1X2A ... .95	6AU6 ... .64	6BQ6 ... \$1.29	6SN7 ... .79	6W4 ... .65
5Y3 ... .46	6BA6 ... .67	6BK6 ... .64	6SL7 ... .88	12AU7 ... .79
6AB4 ... .79	6BC5 ... .78	6BS7 ... .79	6T8 ... .89	12AV7 ... 1.34
			6V6 ... .99	12BA6 ... .77

1000 Kc CRYSTALS, uncased, ..... \$1.35  
1000 Mf/15 mv ELECTROLYTIC "WP" ..... .79  
Write for Your Free Bargain List Now!

**MARK electronics** 1888 Randall Ave. New York 72, N. Y.

**NOW! The KLIPZON MINI-PROD CONNECTOR**  
 IT'S A MINIATURE CLIP . . . it's a MINIATURE TEST PROD, too!  
 STREAMLINED FOR MODERN ELECTRONICS

FOR LABORATORY, SERVICE SHOP, PRODUCTION LINE TESTING



Type B

**SELF HOLDING**  
 For Every Test Application

CLIPS ONTO WIRE IN HARD-TO-REACH PLACES	FITS INTO BUNDLING PORTS
NEEDLE-SHARP POINT PERMITS INSULATION	CLIPS ONTO CLOSE SPACED LUGS AND TERMINALS
IFES INTO PHILADELPHIA	CONNECT EASILY TO EACH OTHER FOR EXTENSION OF LEADS
CLIPS ONTO MINIATURE SOCKET TERMINALS	EASY TO WIRE SOLIDTLESS CONNECTION IN PLASTIC HANDLE

**KLIPZON SELF-HOLDING POINTS**  
 bring greater time-saving and convenience on many other KLIPZON TEST accessories

ASK YOUR DISTRIBUTOR ABOUT:

- KLIPZON HIGH FREQUENCY CRYSTAL PROBES that bring V.H.F. versatility to your V.T.V.M., or V.O.M.
- KLIPZON LOW CAPACITY-LOW LOSS SHIELDED LEADS that reduce pickup in A.F. and R.F. testing.
- KLIPZON STREAMLINED TEST PRODS and LEADS for more convenient testing of miniaturized circuits.
- KLIPZON JUMBO TEST PRODS and LEADS for heavy duty testing on larger sized wires.
- KLIPZON ADAPTERS, in three types that SLIP ON to your old style prods and convert them to SELF-HOLDING.
- KLIPZON TEST PROD HANDLES for wiring your own SELF-HOLDING PRODS.

Write for **FREE FOLDER #22** describing **MINI-PRODS** and Other KLIPZON Products.

**United Technical Laboratories**  
 Engineers MORRISTOWN, N. J. Manufacturers

**RADIO COURSES**

- RADIO OPERATING • CODE
- RADIO SERVICING • ELECTRONICS
- F.M. TELEVISION
- PREPARATION FOR CIVILIAN, MARITIME, ARMY AND NAVY LICENSE REQUIREMENTS.

Write for Catalog T.S.

Y.M.C.A. **TRADE & TECH. SCHOOL** 15 W. 63 St., N. Y. 23 ENdicott 2-8117

From the earliest days of Radio . . . to the present era of Television . . .

**CORNISH WIRES**

"Made by Engineers for Engineers"

CORNISH WIRE CO., Inc. — 50 Church St., N. Y. C. 7

they are often overlooked in routine servicing unless they develop direct shorts.

"Next feed a modulated signal into the receiver and use the a.c. scales of your v.t.v.m. to check the push-pull output stage for balanced input and output. You will be amazed how unbalanced you will find some of these. Correction is usually a matter of changing tubes, coupling condensers, or resistors that have changed value. A lopsided output stage is incapable of really good quality."

"Check," Barney repeated as Mac stopped for breath.

"Be sure and check for hum. Listen to the set tuned to a dead spot on the dial with various settings of the volume control. A slight increase in hum as the volume control is advanced is normal, but at no setting of the control should the hum be more than barely noticeable. Incidentally, always listen for hum with your ear directly in front of the speaker. If you listen at certain critical angles off to one side, the hum vibrations from the front and back of the speaker will cancel and the hum will not be heard. Always find the cause of excessive hum and remove it. Do not try to kid yourself that the set 'has probably always sounded like that.'

"I think you'll find that checking filter condensers by measuring the pulsating voltage across them with the a.c. portion of the v.t.v.m. is better than bridging with another condenser. This last practice produces a surge that often temporarily cures the hum and makes it impossible to be sure as to what was the cause. The v.t.v.m. probe does not do this, and after a little practice you will be able to tell by reading the meter whether or not the condenser is doing the filtering job it should.

"You have to keep in mind, however, that open grids, cathode-to-filament shorts, and other less-common conditions can produce hum. For example, one kind of hum is only heard when a strong station is tuned in. A nasty characteristic of such a tunable hum is that often it will be very bad on a particular station when the set is used in one electrical outlet but will disappear altogether when another outlet is used. In the latter case, though, it will usually be found that the hum will reappear on another station carrier at a different portion of the dial. That is why it is a good idea to listen to three or four strong stations at different parts of the dial when checking for such a hum. As you know, a very common cause of this condition is a defective line-bypass condenser.

"And finally," Mac finished after stopping to draw a long breath, "always give each set a ten-minute run at 125 line volts and then another ten minutes at 105 volts. If nothing shows up at these voltages, we can rest assured we have done our best to anticipate any trouble in the immediate future."

"How much are we going to tack on

**Unused ELECTRONIC COMPONENTS**

- 39 pieces BC-957-A RADAR INDICATOR
- 22 pieces TA-12B TRANSMITTER
- 24 pieces RA-10-DB RECEIVER
- 32 pieces BC-605-D INTERPHONE AMPLIFIER

PLUS

Large stock of AN connectors in most sizes . . . big assortment electronic components; plugs, resistors, condensers, potentiometers and other parts.

★ Available for inspection at our Baltimore warehouse

★

**COMMERCIAL SURPLUS SALES CO.**  
 4101 Curtis Avenue  
 Baltimore 26, Maryland  
 TELEPHONE: CURTIS 3300

**OLSON HAS BIG, BIG BARGAINS**

**FREE! BIG BARGAIN BOOK**

Get Olson's LOWER - than - wholesale prices from this famous book. **STANDARD BRANDS—FRESH STOCK—Immediate delivery.** Send for your copy today and buy your radio parts the right way—from **OLSON.**



SEE OLSON'S BIG ADS ON PAGES 98 AND 99.

**OLSON RADIO WAREHOUSE**  
 277 E. Market St., Akron 8, Ohio

**WALKIE TALKIES \$4.99** Complete Set of 2

POCKET SIZE —ELECTRONIC VOICE POWERED

No tubes, batteries, adjustments, license or permit needed!

Guaranteed to work anywhere up to 1/4 mile with extra wire. Swell for garage to house, etc. Your own private, talk-listen phone. Not war surplus. Brand new. Solid Aluminum Case. Two complete units with wire—**READY TO USE! SEND ONLY \$1.00** deposit and pay postman \$3.99 C.O.D. or send \$4.99 for P.P. delivery. Sold only by mail from: **MIDWAY CO., Dept. WRT-5, KEARNEY, NEBRASKA.**



**SCHEMATICS—CONVERSIONS FOR SURPLUS GEAR**

**NEW LIST! MANY ADDITIONS!**

Send stamped, self addressed envelope for List B. Add 25c for chart explaining AN nomenclature.

**R. E. GOODHEART** BOX 1220 BEVERLY HILLS, CAL.

**SELL Jensen PHONO NEEDLES for Any Type Record Player**

Please send me **FREE** Jenselector. Picks the proper replacement needle.

Name \_\_\_\_\_

Address \_\_\_\_\_

City \_\_\_\_\_ State \_\_\_\_\_

Jensen Industries, Inc., 336 S. Wood St., Chicago 12

to our usual service charge for making these extra checks?" Barney asked.

A quick frown creased Mac's face. "Not a nickel!" he said emphatically. "If you insist on looking at it from the what's-in-it-for-me angle, the thorough checking will doubtless turn up additional needed repair work, and the increased customer-satisfaction should bring in more repeat business; but when I was thinking about the matter, my only concern was how we could do a better job of servicing.

"This present tendency to concentrate on the reward instead of the work is beginning to get under my hide a little," he went on. "I'm just old-fashioned enough to believe that if we put all our efforts into doing a really fine job of servicing, our income will take care of itself. Right now, when everybody is beginning to complain that it is impossible to find a workman who is conscientious and takes pride in his work, is a pretty good time to start proving them wrong."

"Check!" Barney agreed.

-30-

### Saw-tooth Oscillator

(Continued from page 53)

stage RC amplifier, to provide horizontal sweep for a basic "monitor" type of oscilloscope (one that normally does not have a built-in sweep or amplifiers), permitting observation of audio signal waveforms. Its simplicity and small power requirements well suit it for such a use.

#### Conclusion

Although the saw-tooth oscillator circuit described and shown is quite simple and easy to build, for special applications it may be simplified still further. For example, if saw-tooth signals over a very limited range of frequencies (or at one frequency only) are needed,  $S_1$  may be eliminated and one of the discharge condensers ( $C_1$  to  $C_6$ ) left permanently connected in place. If external sync is not needed,  $R_1$  and  $C_1$  may be eliminated, and the lower electrode of the neon bulb connected directly to ground.

The average experimenter will find it quite interesting to develop other applications and modifications of the circuit shown.

-30-

### TV TROUBLESHOOTER

By HENRY MILLER

A TRICK automotive mechanics use in car repair is readily adapted to tracking down arcing in the large tubular condensers in television receivers.

When arcing is suspected in these, use a long plastic alignment tool with a plastic screwdriver type handle. Place one ear against the handle, touch the other end to the body of each condenser—one at a time. When the tip is touched against the defective condenser, a distinct popping noise will be heard very clearly through the handle of the improvised stethoscope.

-30-

May, 1952

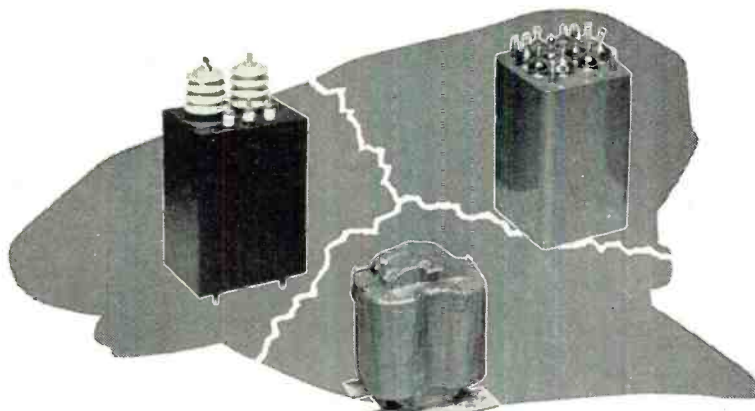

## ★ FOR MILITARY SERVICE

Today most Peerless transformers are assigned for military service. They are being used in Radar, Sonar, guided missiles, radio communications and many other applications. Peerless is building transformers today to meet all JAN-T-27 and MIL-T-27 specifications. If you have transformer requirements for government apparatus you will find it profitable to contact Peerless for engineering and manufacturing. Below are a few general facts on some transformers now in production in the Peerless plant.

- TYPES:** High voltage filament and plate supply, charging chokes, saturable reactors, pulse transformers, etc.
- POWER RANGE:** From microvolts to 30,000 volts. From 1 milliwatt to 25 K. V. A.
- CONSTRUCTION:** Hermetically sealed, oil filled, heliarc case construction. Hermetically sealed, potted type, solder sealed metal cases. Fosterite treated with thermosetting resin.



### PEERLESS Electrical Products

A Division of

9356 Santa Monica Blvd., Beverly Hills, Calif. • 161 Sixth Ave., N. Y. 13, N. Y.



New  
**WILLIAMSON  
TYPE**

**AMPLIFIER Features**

- First Williamson Type Amplifier supplied with matching preamplifier
- Uses Altec Lansing Peerless output transformer.
- Practically distortionless — Harmonic and intermodulation distortion both less than 1/2 of 1% at 5 watts output.
- Frequency response ± 1 db from 10 cycles to 100 kc.
- Output impedance 4, 8, or 16 ohms.

The new Heathkit Williamson Type Amplifier kit is the best obtainable in amplifiers today — the choice of the really discerning listener. You can hear the difference and measurements actually bear out the superb performance. Frequency response ± 1 db from 10 cycles to 100 kc allow you to hear the highs and lows with equal crispness and clarity. Harmonic and intermodulation distortion both less than 1/2 of 1% at 5 watts output eliminate the harsh and unpleasant qualities which contribute to listening fatigue.

The circuit is similar to the one published in Audio Engineering Magazine for November, 1949, and is considered by engineers throughout the audio field as one of the best ever developed. The Main Amplifier (which may be purchased separately) consists of a voltage amplifier and phase splitter using a 6SN7, a driver stage using a 6SN7, and a push-pull output stage using a pair of 807 tubes. The output transformer is manufactured by the Peerless Division of Altec Lansing and is built to their highest standards. Output impedances of 4, 8, and 16 ohms are available. The power supply uses a separate chassis with husky Chicago Transformer power transformer and choke, and 700V Mallory filters for long hum-free operation. A 5V4G rectifier is used.

The main amplifier and power supply are each on a chassis measuring 7" high by 5 1/2" wide by 11" long.

**PREAMPLIFIER AND TONE CONTROL UNIT KIT**

The preamplifier kit consists of: a 12AX7 (or 12AV7) dual triode first amplifier stage with a turn-over control for LP or 78 record types, and a 12AU7 amplifier stage with individual bass and treble tone controls which each provide up to 15db of boost or attenuation. A switch on panel selects either magnetic, crystal, or tuner inputs. Preamplifier also is well suited to custom installations — it will operate in either vertical or horizontal position, and special notched shafts of the controls and switches allow a variety of shaft lengths to be selected. Dimensions: 2 1/4" high by 10 1/4" wide by 7 1/4" deep.

**WRITE FOR Free CATALOG**

**The HEATH COMPANY**  
BENTON HARBOR 15,  
MICHIGAN

**Heathkit AMPLIFIER KIT**

WA-A1 Amplifier kit — Combination 1 — (Main Amplifier and Power Supply) complete with WA-P1 Preamplifier kit. Total Ship. Wgt., 34 lbs. (Shipped Express only) **\$69.50**

WA-A1 Amplifier kit only — Combination 4 — (Main Amplifier and Power Supply). Less WA-P1 Preamplifier. Total Ship. Wgt., 29 lbs. (Shipped Express only) **\$49.75**

WA-P1 Preamplifier Kit only. (less power supply) (Tubes included). Total Ship. Wgt., 7 lbs. (Shipped Express or Parcel Post) **\$19.75**

*You SAVE BY ORDERING DIRECT*

*this is it—  
this is the tuner  
you designed!*

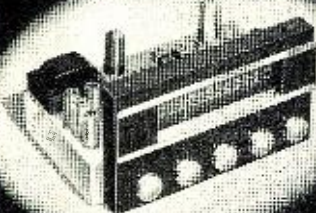

*the*  
**craftsmen 10**

**High Fidelity  
FM-AM Tuner**

Maybe you had a hand in designing this magnificent tuner. A lot of our friends did. Their questions and suggestions made sense because they came from people who knew what they needed. The superior flexibility and performance of the C-10 proves it. And we think it will answer your rigid requirements, too.

- Two cathode followers furnish both audio output and detector output for remote installations.
- Built-in pre-amplifier, compensated for variable reluctance pick-ups.
- Automatic Frequency Control entirely eliminates drift, simplifies tuning.
- 5 microvolts sensitivity on both FM and AM.
- 10 kc filter on AM eliminates interstation squeal.
- Bass and treble tone controls for boost, cut, or 20—20,000 cycle flat response.

Write for information—or send 50c for instructions and schematics

THE RADIO  
**craftsmen** INC.  
Dept. R-5, 4401 N. Ravenswood Ave., Chicago 40, Ill.

# 1952 ELECTRONIC PARTS SHOW PROGRAM

**CONRAD HILTON HOTEL, CHICAGO, MAY 19-22, 1952**

Sponsored by the Radio Parts & Electronic Equipment Show, Inc.  
Headquarters: 11 So. LaSalle St., Chicago 3

Sponsoring groups: Radio—Television Manufacturers Ass'n.  
National Electronic Distributors Ass'n.  
Ass'n. of Electronic Parts & Equipment Mfrs.  
Sales Managers Club Eastern Division.  
West Coast Electronic Mfrs. Ass'n.

## SHOW BOARD OF DIRECTORS:

President—Charles A. Hansen, Jensen Mfg. Co., Chicago  
Vice-Pres.—Samuel L. Baraf, United Transformer Co., New York  
Secretary—W. D. Jenkins, Radio Supply Co., Richmond, Va.  
Treasurer—Lew W. Howard, Triad Transformer Mfg. Co., Los Angeles  
Jerome J. Kahn, Standard Transformer Corp., Chicago  
Louis W. Hatry, Hatry & Young, Hartford, Conn.  
Herbert W. Clough, Belden Mfg. Co., Chicago  
J. M. Kirshbaum, Precision Apparatus Co., Elmhurst, L. I.  
John H. Cashman, Radio Craftsmen, Inc., Chicago  
Byron C. Deadman, Northern Radio & Television Co., Green Bay, Wis.  
A. J. Dybowski, Dymac, Inc., Buffalo  
Arthur C. Stallman, Stallman of Ithaca, Ithaca, N. Y.  
V. N. Zachariah, Zack Radio Supply Co., San Francisco  
H. E. Ruble, Srepco, Inc., Dayton, O.  
Show Manager—Kenneth C. Prince, Chicago

Exhibition Hall and display rooms 5th and 6th floors

## MONDAY, May 19th

- 10:00 A.M. Exhibition Hall and Display Room Area Open.  
6:00 P.M. Exhibition Hall Closes. Watch Service Withdrawn from Display Room Area. (Attendance on this day confined to Exhibitors, Sales Representatives, and Distributors Only.)  
7:00 P.M. Industry Dinner in the Grand Ballroom of the Stevens Hotel.

## TUESDAY, May 20th

- 9:30 A.M. to 1:00 P.M. Educational Program for Distributors.  
1:00 P.M. Exhibition Hall and Display Room Area Open.  
9:00 P.M. Exhibition Hall Closes. Watch Service Withdrawn from Display Room Area. (Attendance on this day confined to Exhibitors, Sales Representatives, and Distributors Only.)

## WEDNESDAY, May 21st

- 9:30 A.M. to 1:00 P.M. Educational Program for Distributors.  
1:00 P.M. Exhibition Hall and Display Room Area Open.  
6:00 P.M. Exhibition Hall Closes. Watch Service Withdrawn from Display Room Area. (Attendance on this day confined to Exhibitors, Sales Representatives, and Distributors Only.)

## THURSDAY, May 22nd

- 10:00 A.M. Exhibition Hall and Display Room Area Open.  
6:00 P.M. Exhibition Hall and Display Room Area Closes. Show Closes. (Attendance is confined to Exhibitors, Sales Representatives, Distributors, Industrial Buyers, Industrial Engineers, Government Agencies.)

## EDUCATIONAL SESSIONS:

Tuesday, 9:30 A.M. to 12:30 P.M. (Sales Course 9 A.M. to 12:00 N.)  
Wednesday, 9:30 A.M. to 12:30 P.M. (Sales Course 9 A.M. to 12:00 N.)  
Thursday, \_\_\_\_\_ (Sales Course 9 A.M. to 12:00 N.)

## MANAGEMENT SEMINARS:

(Times to be set by Group Leaders)

## NOVICE BARGAINS

### NOVICE 80 METER CW XMTR

Here's a neat and compact surplus item which converts very simply to 3700-3750 KC crystal controlled. Condition? Guaranteed suitable. Instructions? Yes, we furnish them! Complete, comprehensive, step-by-step; nothing left to guesswork. This is 5,3-7, the command transmitter which has been such a favorite with old-timers. By the time this ad appears, the BC-457, described in November QST, will be all gone, so we worked out the conversion on 5-3-7. It had to be converted anyway, why not convert the lowest priced and available unit? Just as easy. Now don't wait until these are all gone! ONLY.....\$7.95

#### 2-METER VOICE XMTR-RECEIVER

ARC-4 A standard for two meter conversion. Excellent used, all tubes, conversion instructions. Less Dynamotor.....\$42.50  
12 or 24 volt ARC-4 dynamotor.....\$12.50

### 80 METER RECEIVER

3-6 MC Command, with schematic, excellent electrically, but shop worn. Satisfaction guaranteed. \$14.95

### BROADCAST BAND & AERO

**MN-26-C Remote Controlled navigational direction finder and communications receiver.** Manual DF in any one of three freq. bands, 150 to 1500 KC. 24 V. Self contained dynamotor supply. Complete installation, including receiver, control box, loop, azimuth control, Left-Right Indicator, plugs, loop transmission line, and flex. shafts. **\$69.50**  
**BRAND NEW, ORIG. PACK.....\$39.50**  
**MN-26-C alone, New.....\$39.50**  
**MN-20-E Loop, Brand new.....6.95**  
**MN-52 Crank drive, New.....2.50**

### COMMAND EQUIPMENT

With free dope sheets and schematics 3-6 mc. (see above) \$14.95

#### RECEIVERS

BC-455, 6-9 mc. NEW \$12.95 GOOD USED.....\$7.95  
**TRANSmitters**  
T-19/ARC-5, 3-4 mc. Excellent.....\$17.95  
BC-457 or T-19/ARC-5, 4-3 mc. Like new.....\$24.95  
BC-458 or T-21/ARC-5, 5.3-7 mc. Excellent used 7.95  
MOD BC-456, Brand new \$5.95. Excellent used 2.49  
As is, for parts.....1.29  
**274N PLUG.** 7-prong male plug to fit back of command rxvrs. and xmtrs. This is the same plug as used in the ricks. NEW, each 21c, five for \$1.00  
Local Control Adapter Parts for 274N or ARC-5 rxvrs. Exact pot, switch, knobs, etched plate, and instruction data. Ready to mount.....\$1.29  
**SPRINE TUNING KNOB......79c**

### VHF COMBINATION BARGAIN

Here's your two meter setup. Includes T-23/ARC-5 4-channel 100-156 Transmitter, R-28/ARC-5 combination Receiver, MD-7/ARC-5 Modulator, C-30/ARC-5 push-button control box, schematics. Weight 35 lbs. Excellent used, with all tubes.....\$82.50  
Add for 24 v dynamotors.....7.45

### BUILD TV-FM-AM SWEEP GENERATOR

(See Dec. Radio & TV News)  
Now you can build that "VERSATILE SWEEP FREQUENCY GENERATOR" We've managed to acquire only 100 of the APN-1 magnetic units. So HURRY! With reprint of the article.....\$6.95

### 4 USES—4 DOLLARS

The most versatile dynamotor in surplus! The best dynamotor for conversion to 6 v. Multiple windings! After conversion you get choice of 120 v. at 60 MA or 250 v at 100 MA. No brushes to shift around, no mechanical work. Or use it as a 2:1 or 1:2 step-up or step-down transformer. Or use it as a 5:1 or 1:5 transformer. Or use it as a GENERATOR. Turn with motor, get 12 v DC at 12.5 A or 24 v DC at 6.25 A. Our original Navy lot includes easily removable self-contained 800:1 sealed-in oil gear reduction unit. Complete dope sheet furnished. **BRAND NEW.....\$4.00**

### SUPER HI-FI HEADSET BUY!

Uses annular-grooved plastic flute cones with voice coils as in speakers, and padded chamois ear muffs to obtain spacing for correct acoustic phase. Gives finest music reproduction, flat far beyond upper and lower limits of auditory perception. Pair in series has measured impedance of 600 ohms at 1,000 cycles obtained with built-in high quality transformers. However, severe mismatching makes no apparent difference. Far superior to crystal phones. Best manufacturer's price is \$45.00 per pair! (Each unit can also be used as high quality dynamic mike with 200 ohm output impedance.) They come to you clean in their original Navy lot chamois pads in cellophane bag. Our original Navy lot sold out immediately, but we managed to locate more in Hawaii. Seems that's all that's left, so better not wait! Get yours now.....\$7.95

### NEW CARBON MIKE

A little gem! Same impedance as T-17, but hold in the palm of your hand. Nice flexible cord with standard 3-circuit plug. Press-to-talk switch. New shipment. **BRAND NEW.....\$2.79**

### PORTABLE POWER KITS

1. Includes 2 volt, 20 AH wet cell, lightweight transparent plastic, fibrite separators, 3 ball hydrometer, 4" x 3" x 5 1/2" high, shipped dry; also 2 volt synchronous vibrator, no tube needed; also 2 volt charger, 115 v 50/60 cy 1/2". This high quality unit uses step-down transformer and dry disc rectifier, with pilot lamp in output to indicate and regulate charging rate. With crossover type battery filler and instructions. **ALL 4 ITEMS, BRAND NEW.....\$4.95**  
2. Three 2 volt 20 AH wet cells and box CH-291 made for them. This box is made of metal, has a lightweight construction, and includes inter-cell wiring and vent tube. Set-up gives you six volts. Boxes may be snapped together for multiple units. **ALL NEW.....\$6.95**  
3. Six volt Vibrapack kit. Vibrator plus non-synch transformer with two for plates, 15 v for bias. With schematic. **BRAND NEW.....\$2.95**

**ANTENNA MAST SECTIONS, MS-49, 50, 51, 52, 55. New, original packing.....Each 39c**

### AUDIO SUPER-SPECIALS

**SUPER HI-Q** high cut choke, 0.65 H, 55 ohms DC. Tune with 0.004 MF. ONLY.....98c  
**LOW CUT,** 5 H, 284 ohms. Tune with 1 MF. Or use as 50 ma filter choke. ONLY.....98c  
**QUINCEY Transformers,** one for mike to push-pull triodes, flat 30 to 15,000 CPS; other for push-pull or output-tapped sec., turns 14:1. In unit with resistors, condensers, etc. **BOTH FOR ONLY.....\$1.29**  
**OR PHASE SPLITTER.** Has 3 windings, each exactly 1:1 to any other, essentially flat 100-15,000 CPS. **BRAND NEW, ONLY.....69c**

### G.L. ELECTRONICS

905 S. Vermont Ave., Los Angeles 6, Calif.  
All Prices F.O.B. Los Angeles Calif. Buyers Add Sales Tax  
SEND FOR OUR CATALOGUE.

## Disaster Transmitter

(Continued from page 63)

grid dip oscillator or wavemeter is tuned to 144 megacycles and held close to  $L_1$ . It will be noted that an r.f. indication is obtained on the meter of the instrument, showing that the stage is self-oscillating. Then, small pieces are "snipped" off each piece of twin-lead, 1/4 inch at a time, until the r.f. indication reaches zero. This should take place when the twin-lead is exactly 1 1/2-inches in length. Plate voltage should be turned off momentarily during the snipping operation.

Now the appropriate crystal may be placed in the crystal socket, and we may proceed with resonating the various stages of the transmitter. With the wavemeter or grid dip oscillator tuned to 24 megacycles, the pickup coil is placed close to  $L_1$  while  $C_1$  is rotated slowly until an r.f. indication is seen on the meter. This indicates that the harmonic crystal oscillator section of the first 6J6 is providing output on 24 megacycles. The wavemeter or grid dip oscillator is then adjusted to approximately 48 megacycles and placed close to  $L_2$ ; condenser  $C_2$  is then slowly rotated until an indication is seen on the meter of the r.f. indicating device, assuring 48 megacycle output from the second or frequency doubler section of the first 6J6 tube. The frequency tripler is then resonated in a similar manner, with the wavemeter or grid dip oscillator adjusted to 144 megacycles and held close to  $L_3$  and  $C_3$  is slowly rotated while watching for the r.f. maximum as shown on the meter.

The final amplifier is resonated by placing the grid dip oscillator, tuned to 144 megacycles, close to  $L_1$ , while  $C_1$  is tuned for a maximum reading on the meter.

The antenna may now be connected to  $L_2$  through the output socket of the transmitter.  $L_2$  should be adjusted to provide maximum output by bending it closer to or further away from  $L_1$ , while observing the meter on the grid dip oscillator, which should be held close to the r.f. transmission line.

### Antenna

A word might be said about antennas at this point. For emergency work, the most easily erected antenna should be chosen. However, after experimenting with numerous types of antennas, both simple and complex, it was found that a simple folded dipole using 300-ohm twin-lead for both the flat top and the transmission line will give satisfactory results; it is the simplest, most easily transported radiation medium available. The length of the antenna flat top should be 38 inches. The folded dipole type of antenna is sufficiently broadband to enable coverage of the 144 to 148 megacycle amateur band. Of course, for every-day operation more complex beam antennas will give extremely good results.

Now you can believe everything you hear!



## the CRAFTSMEN 500 ULTRA FIDELITY audio amplifier

Even we were amazed when we tested this remarkable amplifier. Never before, in our experience (or yours) has such remarkable performance been recorded. The C-500 is 99.99+%\* distortion-free. We had to think of a new word to describe it. The word is ULTRA-FIDELITY. Hear the "500" and you'll know why.

### C500 Amplifier Features

- **FAMOUS WILLIAMSON** all-triode circuit.
- **FREQ. RESPONSE:**  $\pm 0.1$  db., 20 cps to 20,000 cps;  $\pm 2$  db., 5 cps to 100,000 cps.
- **POWER RESPONSE:** 12 watts  $\pm 2$  db., 10 cps to 50,000 cps.
- **TOTAL H DISTORTION:** Less than 0.1% at 10 watts, at mid-freqs.  
\*0.01% at av. listening level below 1 watt.
- **TUBE COMPLEMENT:** (2) 6SN-7GTA; (2) KT66 power output; 5V4G rectifier.

Sold by leading radio parts distributors everywhere or write to

THE RADIO  
**craftsmen INC.**  
Dept. R-5, 4401 N. Ravenswood Ave.  
Chicago 40, Ill.

✓ On-the-Spot News  
 ✓ Sidewalk Interviews  
 ✓ Conference Recording  
 ✓ Courtroom Reporting  
 ✓ Traveling Secretary  
 ✓ Salesmen's Reports  
 ✓ Confidential Recording  
 ✓ Lecture Note-taking  
 ✓ Missionary Work  
 ✓ Testimony Recording

*If your Recording Jobs  
 are like these...you need*  
**THE MAGNEMITE\***  
*The 10-Pound Portable*  
**BATTERY-OPERATED TAPE RECORDER**

The MAGNEMITE\* offers convenience in field recording never before attained. This unusual unit measures only 11½ x 8½ x 5½ inches, and weighs only 9¾ lbs., including its self-contained batteries which last 100 operating hours. At 1½ in. per sec. tape speed, 2 full hours of recordings are accommodated on standard 5 in. reels of tape. Constant tape speed is assured by means of a governor-controlled spring-wound motor that runs 15 minutes per winding. Recordings can be made up to a distance of 100 feet from the microphone. The same instrument may be used for playback through earphones or external amplifier. For any recording, in or away from home, office, or studio, it's the MAGNEMITE\*!

Net  
**Factory Price \$189.50**  
 Complete with batteries,  
 microphone, and earphones.

\*Trade Mark Reg.      Order today, or write for additional literature to:

**AMPLIFIER CORP. of AMERICA**  
 398 Broadway      New York 13, N. Y.

**"WE'RE TEARING  
 OUR HAIR OUT..."**



to buy desperately needed equipment such as ART-13, BC-348, BC-224, BC-342, BC-312, ARC-1, BC-788, I-152, T-17MICS, BC-221, R5/ARN-7 or components. In fact, we'll buy any parts or accessories no matter how small. For speedy, efficient service and a real honest deal, phone, wire or write:

**V & H RADIO & ELECTRONICS SUPPLY CO.**  
 2033 W. Venice Blvd., Los Angeles 6, Calif.  
 Telephone: REpublic 3-1127

**BRAND NEW TUBES**

0A2	\$ 1.25	SJP1	\$24.50	723A/B	\$16.50
0A3/VR75	1.25	SJP5	24.50	724B	2.75
0B3/VR90	1.10	8R4GY	1.50	725A	5.95
0C3/VR105	1.25	6AN5	4.95	807	1.59
0D3/VR150	1.10	6A56	2.79	810	9.50
1B22	2.95	6C21	24.50	813	8.50
1B23	8.95	6F4	5.50	829	10.95
1B24	12.50			829R	13.50
1B27	17.95			832A	9.95
1B38	29.95			833A	37.50
1N21B	3.50			836	3.75
1N22	1.25			837	1.49
1N23	1.25			838	2.95
1N23A	2.75			866	3.95
1N23B	4.95			866A	1.59
1N43	1.45			872A	2.75
1N54	.89	6J4	\$ 6.95	874	.98
1N55	2.75	7BP7	5.95	884	1.75
1N56	.89	717	1.15	914A	5.95
1P42	5.70	1E6	1.75	955	.40
2AP1	9.95	250R	9.95	958	.60
2C39	29.50	250TH	22.50	1616	.90
2C40	8.50	304TH	9.95	1624	1.50
2C43	24.50	304TL	9.95	1625	1.45
2C51	5.75	307A	3.95	1631	1.25
2C52	4.50	702A	2.95	1632	.89
2D21	1.49	703A	4.95	1644	1.80
2E50	1.98	707B	14.95	2051	1.50
2K25	32.50	713A	9.95	5654	4.50
3B24	4.50	715R	8.95	5654A	5.95
3C23	8.95	715C	22.50	5670	2.95
3C33	12.50	717A	1.39	5694	2.10
4C35	27.50			5703	4.95
4E27	16.50			5726	4.25
4X150A	35.00			5751	4.50

**YOUR SURPLUS WANTED!**  
 We Pay Highest Prices!

**Vacuum Capacitors**  
 50-15...\$ 5.95    9001... 1.75  
 12-25... 12.50    9002... 1.50  
 50-32... 12.50    9003... 1.75  
 5G1... 3.95

Complete Line of Transmitting & Receiving Tubes.  
 Send Cash With Order and Save C.O.D. Charges!  
**J. S. H. SALES CO.**  
 Dept. R-12 7552 Meirose Ave., Los Angeles 46, Calif.

**The Sign of Top Quality**

The sign of highest efficiency at most reasonable cost... when buying TV wire, look for the Orange and Blue J.S.C. Sign of Quality.

More than a thousand distributors from coast to coast... more than a million TV sets installed with J.S.C. 300 Ohm TV Lead-in wire... more than one hundred million feet in use.

Visit us at Booth No. 115 at the May Parts Show.



**Jersey Specialty Co.**  
 LITTLE FALLS, NEW JERSEY  
 All phones: Little Falls 4-0784, 1404, 1405



**Interpreting TV Patterns**  
 (Continued from page 45)

picture as shown in Fig. 5. If the sync does not appear blacker than the blanking portion of the picture, the trouble is probably overloading or clipping (check a.g.c. bias or plate voltages). However, if it appears blacker, the sync trouble probably lies in the circuits between the sweep oscillators and sync separator.

Horizontal displacement, as shown in Fig. 6, will generally vary in vertical positioning with changing picture composition. This is generally due to improper operation of the sync separator. Check the plate voltage and the vertical waveform at the sync separator output. The waveform should not show signs of pedestal or video information. Displacement may also be the result of overloading (check diode waveform for sync compression).

No vertical sweep, as evidenced by a white horizontal line in the center of the picture tube, is usually caused by a defective sweep oscillator or output tube, defective transformers or components. Continuity and voltage checks should easily find the trouble. A simple method to localize the trouble is to quickly rotate the vertical linearity control back and forth while observing the face of the picture tube. If the horizontal line fluctuates, it can be assumed that the vertical output tube is functioning properly. Next, quickly rotate the vertical size control and observe the results. If the line fluctuates it can be assumed that there are no defects in the plate circuit of the sweep oscillator. The grid circuit of the sweep oscillator should then be checked for a faulty component. If one of these checks does not produce the expected results, the trouble is then localized and continuity or voltage measurements should find the bad component.

Fig. 10 shows the result of no vertical sweep due to a broken wire in the vertical winding of the deflection yoke. The oscillatory wiggle is caused by horizontal pulse-induced currents in the undamped portion of the vertical winding.

Vertical misadjustments (Fig. 11) evidenced by an egg-shaped test pattern and improper vertical distribution while receiving a program is one of the most common customer complaints. This condition usually results from replacement or aging of tubes, variations in power-line voltage, other external conditions, or from incorrectly adjusting the centering control and then adjusting the vertical size and linearity controls to fill the entire screen in a vertical direction. Once the centering control is misadjusted, proper vertical distribution cannot be obtained. Centering should be attempted only while receiving a test pattern, however, this is not always convenient. One method proved to be successful while receiving a program is to either remove the vertical output tube to produce no vertical



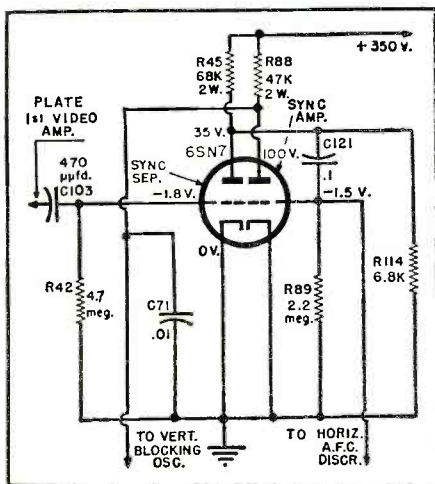

Fig. 14. Sync separator and vertical sync amplifier of a modern Raytheon TV set.

sweep or rotate the vertical size and linearity controls to minimum to produce the smallest vertical picture. The centering control should then be adjusted until the picture, or horizontal line, is in the vertical center of the screen. The size and linearity controls are then adjusted until the picture just fills the screen. One interesting point to remember is that the vertical linearity control affects the upper portion of the picture while the size control affects the over-all size, especially the lower portion of the picture. Both the controls should be adjusted simultaneously until the picture is symmetrical and fills the entire screen vertically. When allowing the vertical to roll slowly, the blanking area dimension should not change thickness as it goes from top to bottom.

The condition of vertical top folding illustrated in Fig. 12 shows the result of a long retrace time whose appearance may vary with station blanking. This condition may result from an improper turns-ratio impedance match due to miswiring of the vertical output transformer, or the use of an incorrect type of deflection yoke, or incorrect circuit wiring or adjustments. If the centering control is misadjusted and the linearity control is adjusted beyond the receiver's scan reserve to fill the top of the screen, top folding may result. Correctly readjusting the controls should correct this condition. Referring to Fig. 8, components  $R_{77}$ ,  $C_{90}$ ,  $C_{93}$ , and  $T_5$  may also cause a similar condition.

Bottom folding (Fig. 13) may result from misadjustment of the centering, vertical size, and linearity controls. Other causes may be a weak tube, low line voltage, low "B+", low deflection yoke or vertical output transformer efficiency, and the following components,  $C_{92}$ ,  $T_4$ ,  $T_5$ , and the cathode bypass condenser of the 6SN7 (Fig. 8).

(To be continued)

NOTE: In part 1 (April issue), page 37, the eleventh line of the second paragraph states: "An interfering signal approximately 3 mc. above the video carrier is illustrated in Fig. 3." About one-half megacycle is actually shown.

## Men who know *Quality* .. know **TECH-MASTER**



C. G. McPROUD,  
Editor of *AUDIO*  
*Engineering*, writes:

"I assembled my own home TV receiver from a standard Techmaster kit. I was amazed at the speed and simplicity with which this could be done. So gratifying was the result, that I have since

been obliged to assemble several more Techmaster receivers for friends who marvelled at the picture quality of my own. In each case the results were excellent and have provided their owners with uninterrupted top quality, trouble-free performance..."

### Experts Everywhere Concede the Superiority of the Techmaster 630 Type Circuit!

The TECHMASTER 630 has been advanced in every detail of modern engineering and design. Every component is the best available, and rigid factory and test standards are your assurance of years of trouble-free performance. Prefabricated unit construction, factory pre-adjusted and pre-aligned make assembly an utterly simple and enjoyable procedure with a minimum of tools.

More leading engineers and technicians have chosen Techmaster Kits and Techmaster Chassis, than any other television.

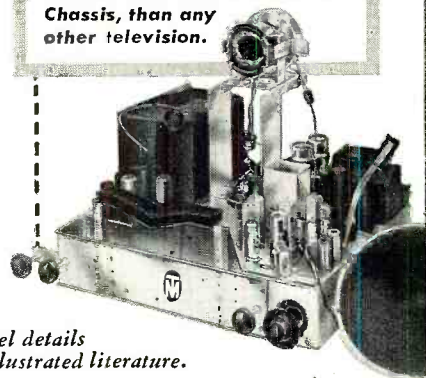

See your local Jobber for model details or write direct to factory for illustrated literature.



**TECH-MASTER PRODUCTS COMPANY** • 443-445 BROADWAY, N. Y. 13, N. Y.



**NEW!**

### Transformer Catalog and TV Replacement Guide

Haldorson's new one-source catalog has the components you need, well classified for easy use.

This highly active line has been super-charged with 114 new items. Special attention is given to TV replacements. A self-contained guide section tells you where they are used.

Here's extra value, too. Haldorson prices actually have been reduced, but Haldorson quality is even better than ever.

Ask for a copy at your distributor, or write direct.

**The HALLDORSON COMPANY**  
4500 N. Ravenswood Ave, Dept. N-5  
Chicago, 40, ILL.

**Haldorson**  
QUALITY Transformers SINCE 1913



### Low Cost Powerful P.A.!

COMPLETE • READY TO USE

Tops for powerful indoor-outdoor use; ideal for electioneering. Easy portability. Covers 4,000 persons indoors, up to 25,000 sq. ft. outdoors. Full 30 watts usable output; 2 high-imp. mike inputs, 1 phono input, each with separate volume control; tone control; fidelity  $\pm 2$  db from 40-20,000 cps. Complete system includes: 30 watt amplifier and tubes, Electro-Voice "Cardax" unidirectional mike with adjustable floor stand and 20' cable; 2 General Electric 12" PM speakers, each with 30' cable; portable carrying case holds all, 16 $\frac{3}{4}$  x 12 $\frac{1}{2}$  x 25". For 110-130 v., 60 cy. A.C. Shpg. wt., 75 lbs. Complete, less only phono top.

93-372. Complete 30 Watt System. Only \$119.75  
93-340. 3-Speed Phono Top for above. Only \$16.95  
Available on Easy Terms—write for details

**FREE** See the 212-Page ALLIED Catalog for other Sound Systems, ranging from 8 to 80 watts. Write for Free copy of Radio's leading Buying Guide today.

**ALLIED RADIO**

833 W. Jackson Blvd., Dept. 1-EE-2 Chicago 7, Ill.

# FRINGE AREA & DX PROBLEM SOLVED with NEW DAVIS SUPER-VISION ANTENNA

"THE ONLY TV ANTENNA SOLD WITH A  
MONEY-BACK GUARANTEE"

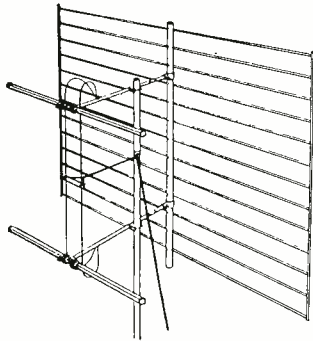

## 10 OUTSTANDING FEATURES:

1. EXCELLENT FOR FRINGE AREA and DX RECEIVING—and broad band receiving with high gain on all channels—2 through 13.
2. CLEARER PICTURES UP TO 125 MILES OR MORE—from the station.
3. GHOST PROBLEMS REDUCED or eliminated due to excellent pattern.
4. PROVIDES 10 DB OR MORE GAIN ON HIGH CHANNELS where gain is needed most.
5. EXCELLENT FRONT TO BACK RATIO on all channels. Eliminates co-channel interference.
6. MINIMIZES INTERFERENCE: Airplane Flutter—Diathermy and Ignition—F.M.—Neon Signs—X-Ray—Industrial—Etc.
7. ELIMINATES DOUBLE STACKED ARRAYS, and out-performs 2 bay yagis on low band and 4 bay yagis on high channels.
8. ONLY ONE TRANSMISSION LINE NECESSARY.
9. NO WORRY OVER POSSIBLE CHANNEL CHANGES on either high or low channels.
10. CAN BE TIPPED WITHOUT TILTING MAST to take advantage of horizontal wave lengths.

AT YOUR JOBBERS, OR WRITE TO:

DAVIS ELECTRONICS 1-7  
3047 W. Olympic Blvd., Los Angeles 6, California  
SIRS: RUSH INFORMATION TO ME AS CHECKED BELOW:

Send Free Technical Data on new SUPER-VISION ANTENNA.

Send Name and Address of NEAREST JOBBER.

Name \_\_\_\_\_

Street \_\_\_\_\_

City \_\_\_\_\_

State \_\_\_\_\_

## WANTED

4 TS-172 Echo Boxes

New or used if in good condition

Will pay top price

Reply wire collect—John McKiernan

Department 70—Bendix Radio Division

Towson 4, Maryland

## THIS AD MAY BE SMALL—BUT IT CAN MEAN B-I-G MONEY TO YOU!

I want to buy BC-348, BC-342, BC-312, ARC-1, BC-788, I-152, T-17A11C'S, ART-13, BC-221 or any parts thereof, no matter how small. In fact, I'll buy anything. I'm not kidding! Let me prove it!

Wire or write: BOB SANETT  
4668 Dockweiler, Los Angeles, Calif.  
Telephone: YOrk 4637

## For the Record (Continued from page 8)

The RTMA is very cognizant of the interference problem and is willing to furnish manufacturers with many suggestions for improvement of receiver performance. It is very helpful to the service technician if the manufacturer's service manual contains information on the types of amateur interference and methods of recognizing them, as well as suggested cures.

There is also a movement among manufacturers to include a built-in, high-pass filter in the receiver. In many cases, a high-pass filter has not eliminated interference due to improper installation, and this can be effectively controlled if the filter is installed at the time of manufacture.

Onowa, Iowa recently passed an ordinance making it illegal to operate an amateur transmitter, diathermy machine, or any other device causing interference to television or radio regardless of where the fault lies. Such an ordinance is obviously invalid, but it will require a concerted effort plus a great deal of expense to make a test case of this or similar ordinance and prove its invalidity. While this ordinance, in itself, is not too important, it does indicate the type of opposition faced by amateur radio, due to misinformation. . . . . O.R.

## SERVICE MEETINGS

WIDESPREAD dealer acceptance of the Raytheon TV service forums, incorporating the techniques outlined in Ken Kleidon's series "Interpreting that TV Pattern" currently appearing in RADIO & TELEVISION NEWS, has encouraged the company to schedule a large number of these meetings for distributors and service dealers throughout the United States.

These meetings, sponsored jointly by the company's TV Service Department and the Replacement Tube Department, include a showing of the Raytheon "Bonded Program" movies and a lecture on servicing techniques. —50—

## PHOTO CREDITS

Page	Credit
35, 36, 37 (bottom)	Civil Air Patrol
37 (top)	U. S. Air Force
38	Jensen Manufacturing Company
43, 44, 45	Belmont Radio Corporation
46 (top left)	Federal Telephone & Radio Corp.
46 (top right)	Anaconda Wire & Cable Co.
46 (bottom)	Philco Corporation
51	Almo Radio Company
64 (Figs. 1 and 3)	Varian Associates
64 (Fig. 2)	Sperry Gyroscope Company, Inc.
67	Far East Broadcasting Company
68, 69	Electronic Workshop Sales Corp.
87	MARS
90	Station CFRB, Toronto
112	The Manufacturers Light and Heat Co.
116	Hermion Hosmer Scott, Inc.
120	Federal Telecommunication Laboratories, Inc.

\* \* \*

## ERRATUM

In the circuit diagram of Fig. 4A, page 74 of the March issue ("Audio Simplified") the cathode resistor for the 6SN7 tube should be 470 ohms instead of 470,000 ohms.

## SALE of ELECTRONICS

### NOTICE TO PROSPECTIVE BIDDERS:

The State of Wisconsin, Department of Public Instruction, Division of Surplus Property, offers for sale the following items:

Description and Location:	Govt. Code No.	Article	No. Units
	564050	Autotone Head	350
	564099	Keying relay	200
	564051	Emission relay	135
	564030	Output relay	1,000
	564533	Voice relay	1,220
	564532	Guardian relay	200
	2B1630V (T-30)	Microphone	2,850
	1B23	Vacuum tube	32
	RI6-S-6745-83	Oper. Spares AN/APN-1	370

This property may be inspected by applying to Mr. Harold Reed, State Surplus Property warehouse, Building 1007 at Truax Field, Madison, Wisconsin. Hours of inspection: 8 a.m. to 5 p.m., Monday through Friday. Closing date for bids: 2 p.m., C.S.T., Monday, May 19, 1952.

**METHOD OF SALE:** Sales shall be by sealed bids to the highest responsible bidder.

Specifications and bid forms may be obtained upon application to the Department of Public Instruction, Division of Surplus Property, Room 147, North, State Capitol, Madison 2, Wisconsin.

This sale authorized by U.S. Government Federal Security Agency.

FALMER O. JOHNSON  
Supervisor, Surplus Property

## OLSON HAS BIG, BIG BARGAINS



**COMBINATION DEAL**  
14,000 VOLT FLYBACK  
AND 70° YOKE

**BOTH FOR \$488**

Stock No. X-273

Change over small picture TV sets to large kinescopes at a low price. You get a high efficiency 14,000 volt Ferrite horizontal flyback Transformer like the General Electric RTO-085 (7711) and one 70° Powdered Iron Ferrite Yoke. Can convert sets to 19" pictures and larger.

See Olson's big ads on pages 98 & 99

**OLSON RADIO WAREHOUSE**  
277 E. Market St., Akron 8, Ohio

## Moody Kit TOOLS ARE A MUST

**IN RADIO, T.V. AND ELECTRONICS**

Your tool box is incomplete if it lacks Moody Kit precision small tool sets. The PA-5 Kit shown contains five interchangeable Allen type and Phillips head screw drivers. Ask to see the complete Moody line at your local stores.

SEND FOR FREE DESCRIPTIVE BOOKLET

**Moody MACHINE PRODUCTS CO., INC.**  
4 Culver Street, Providence 5, Rhode Island

\*\*\*\*\*

**NOW!** SEE YOUR 2nd RADI PARTS SHOW

WRITE TODAY FOR CIRCLE'S NEW FREE PARTS & EQUIPMENT CATALOG

- RADIO • ELECTRONICS
- TELEPHONE & TELETYPE

**CIRCLE SALES CORP.**  
113 GREEN ST., N.Y. 12, N.Y. WOrth 4-1541-2

## ON THE SPOT BATTERY RECORDER

**WALKIE-RECORDALL** 8 lb. miniature BATTERY RECORDER-PLAYBACK

Continuous, permanent, accurate, indexed recording at only 5c per hr. Instantaneous, permanent playback. Picks up sound up to 80 ft. Records conferences, lectures, dictation, 2-way phone & sales talks; while walking, riding or flying. Records in closed briefcase with "hidden mike"! Write for Detailed Literature.

**MILES REPRODUCER CO., INC.**  
812 BROADWAY Dep't RN-6 NEW YORK 3 N.Y.

## RADIO & TELEVISION NEWS

# Classified

Rate 50c per word. Minimum 10 words

## RADIO ENGINEERING

COMPLETE radio, electronics theory & practice: television; broadcasting; servicing; aviation; marine, police radio, 12 or 18 month. Catalog. Valparaiso Technical Institute, Dept. N, Valparaiso, Ind.

### SALE

HALLICRAFTERS SX28, BC610, BC639, SCR211-AF. Excellent. Carmichael, 7 Locust, Dayton, Ohio.

LARGE stock of surplus electronic parts and equipment. Write us your needs. K & L Radio Parts Co., 1406 Venice Blvd., Los Angeles 6, Calif.

REK-o-kut-G1-16" transcription turntable, induction motor, brush PL-20 pickup. Complete, \$100.00. Gutman, 7002 Somerled, Montreal, Quebec.

HALLICRAFTERS Communications Receiver SX-43 with R-41 matching speaker, 11 tubes, 6 bands, including FM, phono input. \$214 list. Excellent condition. Sacrifice. Redfield, 643 W. 246th, New York 71.

HEARING aids, used. Zeniths, less accessories, \$7. One-piece Nationals, \$10. One-piece overhauled, with accessories, \$20.00. Shelby Instrument, 321 W. 7th St., Long Beach, Calif.

TUBES, surplus, bought-sold. Free list. Betz, 73 Caroline Ave., Yonkers, N. Y.

DIAGRAMS Radio. Record Changers, Recorders, 75c; Television with Service Data, \$1.25 up. State manufacturer and model number. Kramer's Radio Service, Dept. N8, 36 Columbus Ave., New York 23, N. Y.

RECORD changer parts for leading makes. We ship everywhere. Friend's Wholesale Distributors, 106 N. 6th St., Philadelphia 6, Pa.

TV and FM Antennas. Yagi, Conical, Bow-Tie. Mounts, accessories. Lowest prices. Wholesale Supply Co., Dept. H, Lunenburg, Mass.

PLYWOOD machined to order for baffles, enclosures. Corner enclosure, bass reflex kits, \$17.50 up. Hamilton's, 424 Kittitas, Wenatchee, Washington.

TUBES and equipment bought, sold, and exchanged. For action and a fair deal, write B. N. Genster, W2LNL, 136 Liberty, N. Y. 6, N. Y.

HIGH Fidelity Bargains. Free list. Skalamer, 435 E. 74 St., N. Y. C. 21.

ENJOY television with a 3 color filter screen. Thirty seconds to attach. Reduces glare, blur, and snow. Send only \$1. Mention screen size. Zingo Products, Dept. B, Johnstown, N. Y.

### WANTED

WANTED. Top prices paid. Navy Selsyns 1F, 1G, 1CT, 5F, 5G, 5CT and BC-348, BC-221, AN/ART-13, AN/ARC-1, AN/ARC-3, RTA-1B. Electronic Research, 719 Arch St., Philadelphia.

AN/APR-4, other "APR-," "ARR-," "TS-," "IB-," ARC-1, ARC-3, ART-13, everything surplus; Tubes, Manuals, Laboratory equipment. Describe, price in first letter. Littell, Farhills Box 26, Dayton 9, Ohio.

WANTED. New, complete EE-108 sound powered field telephone sets. Wire prices and quantity, collect. Coastal Corp., 447 Calvert Ave., Alexandria, Virginia.

INVENTIONS wanted for license to manufacturers. Patent Eng. Development Co., 624 Southern Standard Building, Houston, Texas.

### CORRESPONDENCE COURSE

USED Correspondence Courses and Books sold and rented. Money back guarantee. Catalog free. (Courses bought.) Lee Mountain, Pisgah, Ala.

RADIO Servicing Course shows latest short cut methods. Lessons easy to follow. Only \$3.00, postpaid in U.S.A. Buyers Syndicate, 30 Taylor St., Springfield, Mass.

REPAIR your own radios. Tells how. \$1.00 postpaid. Information free. Slate's Radio Service, Corsicana, Tex.

### MISCELLANEOUS

SPEAKERS repaired, wholesale prices, guaranteed workmanship. Amprite Speaker Service, 70 Vesey St., New York City 7.

"SUBSTITUTE" beats tube shortage. 900 direct-interchangeable tubes listed. Chart, 50c. Alexander, 750 E. 214th St., New York City.

## BEFORE YOU SPEND MONEY FOR A LOUDSPEAK R or AMPLIFI R

consult the pages of

# High Fidelity

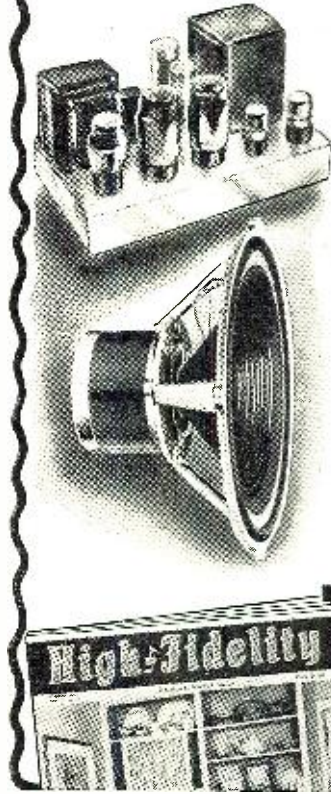

HIGH-FIDELITY is filled with articles and advertisements showing the latest developments in speakers and amplifiers, as well as tuners, recorders, turntables, microphones, and all the other equipment for fine musical entertainment from radio, records, and tape.

In non-technical language, with elaborate illustrations, HIGH FIDELITY will help you select, install, and use your equipment to best advantage, whether you plan an elaborate or inexpensive installation for your home.

You'll save money and avoid disappointment if you make it a rule to consult HIGH-FIDELITY for the latest information before you buy any type of radio, record, or tape equipment. See for yourself! Use the coupon below to order a subscription to this fascinating magazine.

HIGH-FIDELITY is a large magazine, handsomely illustrated, and beautifully printed on fine paper. Published quarterly by Milton B. Sleeper.

Mail Coupon Today!

Mr. Charles Fowler, Editor, High Fidelity Magazine  
14 Audio Building, Great Barrington, Mass.

Please enter my subscription to High Fidelity Magazine:  
 \$6.00 for three years (SAVE \$6)  \$3.00 for one year (SAVE \$1)

Name \_\_\_\_\_

Address \_\_\_\_\_

Add 50¢ per year for Canada, \$1.00 foreign countries

### SELENIUM RECTIFIERS—FULL-WAVE BRIDGE TYPES

Current (Continuous)	18/14 Volts	36/28 Volts	54/42 Volts	130/100 Volts
2 Amps.	\$2.20	\$3.60	\$6.50	\$10.50
4 Amps.	3.75	6.75	8.75	.....
6 Amps.	5.50	9.00	14.00	36.00
10 Amps.	6.75	12.00	20.00	45.00
12 Amps.	8.50	16.00	25.50	52.50
20 Amps.	13.25	24.00	36.00	.....
24 Amps.	16.00	31.00	48.00	.....
30 Amps.	18.50	36.00	.....	.....
36 Amps.	25.50	45.00	.....	.....

We now stock over 100,000 plates and can manufacture standard and special types of rectifiers and rectifier supplies. Low prices... 48-hour service.

#### Selenium Rectifier Specials

110 V., 1/2 Wave..... 65 ma..... only 59c each  
110 V., 1/2 Wave..... 450 ma..... only \$1.65 each

#### New, Selenium Rectifier Transformers

PR: 115 V. 60 cycle in. 4 Amps..... \$ 8.75  
SEC: 9, 12, 18, 24, and 12 Amps..... 16.75  
36 Volts. 24 Amps..... 35.75

### QUALITY, TESTED TUBES

NEW & GUARANTEED, in Stock Now;  
Many Others Not Listed (XMTG, etc.)

—Write for Low, Low Prices.

0A2	\$1.00	GAB7	\$0.98	125F5	\$0.70
0B2	1.10	GAC7	.98	125M7	.95
0Z4	.65	GAJ5	1.65	125J7	.75
1A7GT	1.00	GAK5	2.95	125L7GT	.75
1B3GT	.85	GAN5	.98	125R7	.75
1A4E	1.10	GAQ6	.90	GE 211	.75
1N23-A	2.50	GR06GT	1.70	813	9.25
1N23-B	3.75	6C4	.65	GE 872-A	3.95
1N34	.85	6F6	.98	1280	.80
1A4-A	.90	6F7	.98	1280	4.95
1X2-A	.90	6F8-G	.98	1604	.75
1N54	.75	6J5	.55	1624	1.40
2E24	3.95	6J7	.95	1625	.40
2E26	3.25	6K7	.75	1625	.40
3A4	2.35	6L7	.80	1629	.30
3A4A	.85	6R8	.80	2050	1.50
3AP1	1.05	6S7M	.98	2051	1.25
3BP1	6.75	6S7	.98	5808-A	2.95
3BP11	10.00	6SH7	.70	5910	.75
3D4	.90	6S17GT	.75	9004	.44
3Q5GT	1.00	6SN7GT	.70	9006	.44
5P7	1.95	6V6GT	.60	VR-105	1.25
5U4	5.25	6X5GT	.45	VR-150	.90
5V4G	1.05	12A6	.75	7C30	95.00
5X4	.85	12C8	.85	AND MANY	
5Y3	.49	12BD6	1.25	MANY OTHER	
5Z3	.95	12H6	.75	TYPES—ORDER	
				OR WRITE"	

## BARRY ELECTRONICS CORP.

136 Liberty Street, N. Y. 6, N. Y. Rector 2-2563  
Terms: 25% with order, balance C.O.D.—Send a few cents for postage—All merchandise guaranteed, F.O.B. N.Y.C. Remember, you can order tubes not listed at same savings.

# Television-Radio Electricity

## REFRIGERATION-ELECTRONICS

IN THE GREAT SHOPS OF COYNE

### TRAIN QUICKLY! OLDEST, BEST EQUIPPED SCHOOL OF ITS KIND IN U.S.

Draft Age and Older Men...  
Come to the Great Shops of Coyne in Chicago. Get practical training in TELEVISION-RADIO or ELECTRICITY—vital in Defense Program. Prepare now for a better job or better service rating.

START NOW—PAY LATER  
You can finance most of your tuition, pay for it later in easy monthly payments. Special plan for men of Draft Age. Part time employment service available.

FREE BOOK  
Clip coupon for Big Free Illustrated Book. Indicate below, course that interests you. No salesman will call. Act NOW.

## COYNE SCHOOL

ELECTRICITY ★ TELEVISION  
RADIO ★ REFRIGERATION ★ ELECTRONICS

B. W. COOKE, Pres.  
COYNE School  
500 S. Paulina St., Chicago 12, Ill. Dept. 52-85H  
Send FREE BOOK and full details on:  
 TELEVISION-RADIO  ELECTRICITY

NAME \_\_\_\_\_  
ADDRESS \_\_\_\_\_  
CITY \_\_\_\_\_ STATE \_\_\_\_\_

Designed for Discriminating Users  
**NORTHEASTERN**  
**F.M.-A.M. 13 Tube Chassis**  
**HIGH FIDELITY**

Complete, ready to plug in  
 —including amplifier with  
 all tubes and 10" or 12"  
 P.M. Speaker. **\$67<sup>50</sup>**  
 list \$139.50

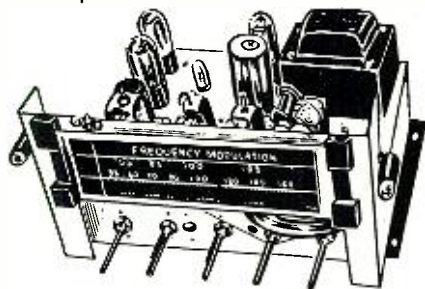

- FM tuning range 88 Megacycles-108 Megacycles.
- AM tuning range 535 Kilocycles-1650 Kilocycles.
- Individual circuit de-coupling insures minimum circuit drift.
- Dial large, easy-to-read multi-color slide rule type.
- Tone range covers all tones from 30 cycles to 15000 cycles.

Brand new, original factory sealed carton. Built-in pre-amp. for reluctance pickup and XTAL input. Push-Pull audio output approx. 14 watts. Volume tone and bass controls. Antenna, folded FM aerial, knobs, plus, etc. Instructions incl. 12 1/2" x 10 1/2" x 7 3/4" high. Will accommodate 2 speakers.

WEBSTER #100—Changers with GE Triple Play Cartridge **\$29.95**  
 VM #950—With GE Cartridge **\$28.95**

Console Cabinet avail. to fit Chassis & Record Changer. **IMMEDIATE DELIVERY—FULLY GUARANTEED**  
 Send for descriptive literature.  
 Order direct from this ad—\$10 on C.O.D. orders.  
 Address mail and C.O.D. orders to Dept. RN.

**JAN SOUND EQUIPMENT CO.**  
 218 Fulton St., New York 7, N. Y.  
 Worth 4-0632

Depend On . . .

Insist on . . .

**ASTRON**  
 CAPACITORS



You can depend on ASTRON for a complete line of multi-layer dry electrolytic and molded paper tubular capacitors for every radio and television replacement job. For quality next time insist on ASTRON.

Write for catalog AC-3

**ASTRON CORPORATION**  
 255 Grant Avenue, E. Newark, N. J.

MAY  
 1952

**INDEX OF Advertisers**

While every precaution is taken to insure accuracy, we cannot guarantee against the possibility of an occasional change or omission in the preparation of this index.

NAME	PAGE
Acorn Electronics Corporation	100
Adelman, Nat	168
Airex Radio Corporation	82
Allied Radio Corporation	9, 177
Almo Radio Corporation	164
Altec Lansing Corporation	173
Aluminum Products Corporation	109
Alvaradio Supply Company	134
American Phenolic Corporation	26
American Television & Radio Co.	80
Amperite Company, Inc.	96
Amp Electric Corporation	147
Amplifier Corporation of America	154, 176
Antenna Manufacturers Assn., The	140
Argos Products Company, Inc.	152
Arkay Radio Kits, Inc.	168
Arrow Sales of California	153
Ashe Radio Co., Walter	97
Astron Corporation	180
Atlas Sound Corporation	168
Audel & Company, Theo	181
Barry Electronics	179
Belden Manufacturing Company	103
Bell Telephone Laboratories, Inc.	86
Bendix Radio	160, 178
Blonder-Tongue Labs.	152
British Industries Corp.	150
Brook Electronics, Inc.	136
Brush Development Company	119
C & H Sales	92
Candee-Airco	156
Candler System Co.	161
Capitol Radio Engineering Institute	101
Channel Master Corporation	71
Chicago Transformer Company	117
Circle Sales Company	117
Cleveland Institute of Radio Electronics	125
Collins Audio Products	156
Columbia Electronic Sales	158
Commercial Surplus Sales Company	172
Communication Equipment Company	133
Concert Master Corporation	128
Cornish Wire Company	172
Coyne Electrical School	179
Crest Television Laboratories	143, 165
Davis Electronics	178
DeCray & Association, Frank W.	180
DeForest's Training Inc.	5
Deleo Radio Parts	30
Dow Radio Inc.	110
Du Kane	144
Dumont Electric Corporation	168
DuMont Laboratories, Inc., Allen B.	79
Eastern Telephone Company	164
Editors & Engineers, Ltd.	128
Edlie Electronics, Inc.	118
Electro Products Laboratories	118
Electro-Voice Inc.	135
Electronic Beam Corporation	170
Electronic Expeditors, Inc.	104
Electronic Instrument Co., Inc.	34, 156, 3rd Cover
Electronic Specialty Supply Co.	154
Electronics Institute, Inc.	168
Erie Resistor Corporation	148
Esege Sales Co., Inc.	167
Espey Manufacturing Company, Inc.	137
Fair Radio Sales	157
Feller Engineering Company	142
Fisher Radio Corporation	144
Forest Sales	166
Franklin Technical Institute	161
Fretco Television Company	181
G & H Wood Products	162
G. L. Electronics	150, 168, 175
General Cement Manufacturing	151
General Electric Company	12, 13, 27, 33
General Test Equipment	171
Goodheart, R. E.	172
Gonsert Company	143
Greenlee Tool Company	138
Greylock Electronics Supply Co.	164
Halldorson Company	177
Hallcrafters Company, The	7
Harvey Radio Company, Inc.	87
Heath Company	72 thru 77, 173
Hickok Electrical Instrument Co.	130
High-Fidelity Magazine	179
Hytron Radio & Electronics Co.	31
Indiana Technical College	154
Instructograph Co.	180
Insuline Corp. of America	171
International Resistance Company	24, 25
J. F. D. Manufacturing Company	8
J. S. H. Sales Company	176
Jan Sound Equipment Co.	142, 180
Jensen Industries, Inc.	172
Jensen Mfg. Co.	122
Jersey Specialty Company	176
Jones & Laughlin Steel Corporation	113
Jontz Manufacturing Co.	154
Kester Solder Company	152
Key Electronics Division	160
Klein, Manuel	107
Krylon, Inc.	169

**RESISTOR KIT \$3.00**

100 Assorted Insulated 1/2, 1 and 2W Standard RMA Values (Not Surplus). Kit Contains 20 Values in 5%, 10%, 20% Tolerances.

**T-V TUNERS—\$4.75**

Continuous Tuning Printed Circuit Type  
 All new units. Uses 6J6 tubes in very efficient Hi-Q circuit. Has eight tuned circuits with individual compensation. Built in 5:1 Vernier Drive. Can be readily converted to a Hi-Gain, Low Noise booster. Schematic and instructions furnished. Shipped less tubes.  
**WITH TUBES \$6.75**

Television receiving tubes—latest types in stock at "terrific discounts." Write for price list.

**MINIATURE TUBE SOCKETS \$1.00**  
 7 pin wafer type, 25 for . . . . .

**FOCUS POTS 10K W.W. 4 WATT \$1.00**  
 THREE FOR . . . . .

**WRITE FOR CATALOGUE**  
**POSTAGE PAID CASH WITH ORDER**

**FRANK W. DE GRAY AND ASSOCIATES**  
 P. O. BOX 1276 CULVER CITY

**OLSON HAS BIG, BIG BARGAINS**



**5" HI-FI SPEAKER**



**MADE IN FRANCE**  
 1 1/2 lb. Magnet-PM  
**\$1.98**  
 EA.  
 3 for \$5.75  
 S-166

Made by French Craftsmen for the critical user. Worth \$10.00 List.  
**SEE OLSON'S BIG ADS ON PAGES 98 & 99**

**OLSON RADIO WAREHOUSE**  
 277 E. Market St., Akron 8, Ohio

**EASY TO LEARN CODE**

It is easy to learn or increase speed with an Instructograph Code Teacher. Affords the quickest and most practical method yet developed. For beginners or advanced students. Available tapes from beginner's alphabet to typical messages on all subjects. Speed range 5 to 40 WPM. Always ready—no QRM.



**ENDORSED BY THOUSANDS!**  
 The Instructograph Code Teacher literally takes the place of an operator-instructor and enables anyone to learn and master code without further assistance. Thousands of successful operators have "acquired the code" with the Instructograph System. Write today for convenient rental and purchase plans.

**INSTRUCTOGRAPH COMPANY**  
 4711 SHERIDAN ROAD, CHICAGO 40, ILLINOIS

\*\*\*\*\*  
**WANTED WE NEED YOUR Surplus Electronic Equipment**  
**WE PAY TOP \$\$\$ FOR:**  
 Radio Receivers | An Connectors  
 Transmitters | Clamps  
 ARC-1 | Plugs  
 ARC-3 | Cords  
 ART-13 | Relays  
 Control Boxes | Telephone Materials  
 Indicators | **WE BUY ANYTHING!!**  
**WRITE, WIRE TODAY!**  
 TELL US WHAT YOU HAVE  
**TALLEN COMPANY, INC.**  
 Dept. RN, 159 Carlton Ave.  
 Brooklyn 5, N. Y.  
 \*\*\*\*\*

NAME	PAGE
LaPointe Placemold Corporation	20, 21
Leotone Radio Co.	181
Luther, Otto	168
MacMillen Company	139
McGee Radio Company	88, 139
McGrath-Hill Book Company	143
McIntosh Laboratory, Inc.	136
Mallory & Co., P. R.	4th Cover
Mark Electronics	171
Merit Coil & Transformer Corporation	22
Midway Company	172
Miles Reproducer Company, Inc.	178
Milwaukee School of Engineering	112
Moody Products, Inc.	178
Mosley Electronics	155
Moss Electronics	111
Nassau Company	131
National Electronics	120
National Radio Institute	3
National Schools	11
Newark Surplus Materials	162
Newcomb Audio Products	165
New England Television Corporation	141
Offenbach & Reimus Company	102
Ohmite Manufacturing Company	14
Olson Radio Warehouse	98, 99, 168, 172, 178, 180
Olympic Radio & Television, Inc.	28
Onan & Sons, D. W.	108
Peak Electronics Company	122
Penn Boiler & Burner Mfg. Company	131
Photocon Sales	96
Pickering and Company, Inc.	104
Platt Electronics	95
Pomona Electronics	166
Precise Measurements Company	142
Prenax Products	140
Premier Radio Tube Co.	115
Progressive Electronics Company	163
Quietrol Company	136
RCA Institutes, Inc.	93, 171
R W Electronics	141
Radcom Engineering Company	159
Radio Apparatus Corporation	138
Radio Corporation of America	17, 2nd Cover
Radio Craftsmen, Inc.	174, 175
Radio Ham Shack, Inc.	129
Radio-Music Corporation	167
Radio Receptor Co. Inc.	133
Rad-Tel Tube Company	164
Randall Corporation, The	10
Ray Mfg. Co.	170
Raytheon Manufacturing Company	15
Regency	92
Rek-O-Kut Company, Inc.	128
Rider, Publishers, Inc., John F.	121, 146
Rinchart Books, Inc.	127
River Edge Industries	156
Roger-Phillips Research Labs.	132
Rose Company, The	137
Sams & Company, Howard W.	94, 131
Sanett, Bob	178
Sarkes-Tarzian, Inc.	108
Schott Company, Walter L.	23
Simpson Electric Company	91
South River Metal Products	108
Sprague Products Company	81
Spraberry Academy of Radio	19
Stan-Burn Radio & Electronics	170
Standard Surplus	145
Standard Transformer	32
Standard Wood Products Corporation	118
Star Electronics Distr., Inc.	138
State of Wisconsin	178
Steve-El Electronics	121
Stevens-Waldon, Inc.	16
Sun Radio of Washington D.C.	126
Superior Instrument Company	111
Tab	182
Tallen Company	169, 180
Technical Appliance Corporation	140
Tech-Master Products Company	177
Television Communications Institute	142
Television Engineers, Inc.	166
Television Workshop	181
Terado Company, The	162
Transvision, Inc.	106, 123
Triad Transformer Mfg. Company	90
Tri-M Manufacturing Company	29
Triplett Electrical Instrument Company	6
Tri-State College, The	160
Turner Company	159
Ungar Electric Tool Company, Inc.	137
United Technical Laboratories	172
University of Houston	104
V & H Radio & Electronics	176
Vactron	150
Vaco Products Co.	133
Valparaiso Technical Institute	164
Video Electronics	164
Waldom Electronics Inc.	148
Weller Electric Company	18
Wells Sales, Inc.	105
Western Electronics Company	142
West Region Electronics	154
Wholesale Radio Parts, Inc.	149
World Radio Laboratories, Inc.	155
YMCA Trade & Technical School	172

**Be a TELEVISION CAMERAMAN**

Work with "live" equipment in station-size studios. TRAIN with "Big Name" TV instructors. Graduates employed at leading TV stations. Easy payment plan. Free National Placement Service. Housing accommodations secured. Approved for Vets.

Send for FREE Booklet  
**TELEVISION WORKSHOP**  
1782 Broadway, New York 19, N. Y. PLaza 7-3721

**INTRODUCING**

# THE NEW AMAZING FRETARAY TV Antenna

**AT LAST! THE ALL-CHANNEL ANTENNA**

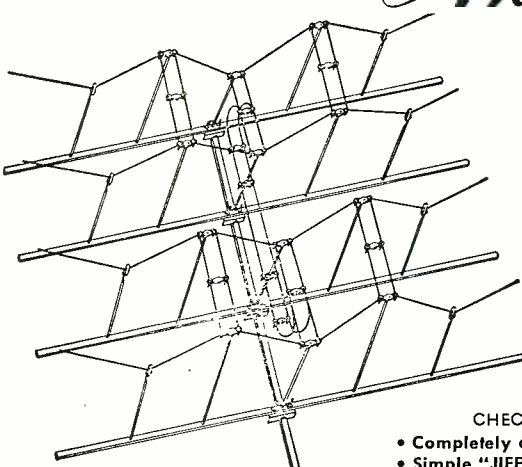

**FOR Matchless FRINGE AREA RECEPTION**

CHECK THESE SURE SALES FEATURES

- Completely assembled
- Simple "JIFFY" installation
- Sturdy all aluminum construction
- No co-channel interference
- Clear pictures up to 300 miles
- Only one transmission line necessary

Another product of FRETCO, INC. manufacturers of FRET-LINE, the world's leading transmission line.

See us at the Chicago show—Booth No. 126

**FRETCO**  
INCORPORATED

1041 FORBES STREET  
PITTSBURGH 19, PENNSYLVANIA

**!! CABINETS! CABINETS !!**



Sturdy wood; slide-rule dial  
Type "A"—Ivory. Inside: 10 1/4 x 6 3/4 x 5 1/2. Dial: 1 3/4 x 3 3/8. . . . \$1.49  
Type "B"—Mahogany. Inside: 17 x 8 1/4 x 10 1/4. Dial: 1 1/2 x 10 1/4. . . . 2.49  
Type "C"—Mahog. Inside: 14 1/4 x 6 3/4 sq. Dial: 1 3/4 x 6 3/8. . . . 1.95  
Type "D"—MIDGET CABINET & CHASSIS. Pol. walnut, Exc. for small radio. Amplif. Oscill. Intercoms, etc. Inside: 7 x 5 1/2 x 4". Punched 4 min. tube chassis—set. 2.00  
Type "E"—Red Marbleized heavy moulded plastic. 3 holes on front. Uses as in Type "D"—Inside: 8 1/2 x 5 3/8 x 4 1/2. . . . 1.49  
**PORTABLE RADIO-AMPLIFIER CABINET**—steel, Walnut finish; hinged, twist-lock front. Brand New. Exc. also for Test Equip., Med. or Indust Eqp. 14" x 8" sq. . . . 2.49

**Leotone**

**RADIO-HARDWARE TREASURE FULL LB.**  
CANS. Nuts, screws, Washers, Lugs, etc. 69c; . . . . . 3 lbs./\$1.98

**RADIO-TV BUILDERS LIBRARY** for Hams. Servicers. .15 asstd. TV. B'cast & S.W. diags. . . \$ .98  
1N21 CRYSTAL DIODES . . . ea. 69c; 10/ . 6.50  
115V. POWER TRANSFORMERS . 60cy. 700V. CT. 90ma; 6-3V. 3A. 5Y/3A. half-shell. . . . 2.95  
HI-FREQ. 6 VOLT BUZZER, adjust. ea. 69c; 10/ 6.50  
T-30 THROAT MIKE w/neckband. Pl. 291. . . 69c  
EXT. CORD & SWITCH for T-30 mike. Less Pl. 68 49c  
HANDY CARBON MIKE (RS-83). Press to talk. 1.79  
TUBE CARTONS . plain white. Prices per 100. Min. 1" sq. x 2 3/4" —\$1.20; 6T (1 1/2" sq. x 3 1/4") —\$1.45; Med. (1 1/2" sq. x 4 3/8") —\$1.65; Large (2" sq. x 5") —\$1.98; Extra Large (2 1/4" sq. x 6 1/2") . . . 3.95  
115V. AC INDUCTION MOTOR . 175. R3M3, fract. H.P. Dbl. 1/4" shaft. 2 7/8" O.D. x 1 3/4" . . . 1.75  
RM-4 RECORDING MOTOR . Hvy. duty. 115V. AC 3 3/8" sq. x 2 3/4" . Less T.T. mtg. plate. . . . 4.95

**7 ACCESSORIES!**  
UNIVERSAL CHIMNEY MOUNT KIT . . . \$1.79  
WALL MOUNT BRACKETS . 4" standoff. Pr. . . 69  
300 OHM TWIN LEAD std. brown . . . 1.00 ft. 1.89  
TV LEAD-IN INSULATORS . 175. R3M3  
HI-FREQ. FOLDED DIPOLE & REFLECTOR. . . 98

**!! BARGAINS IN KITS!!** . . . NEW "JUMBO RADIO PARTS KIT" 17 FULL LBS. OF: COILS, WIRE, HARDWARE, SWITCHES, RESISTORS, CHASSIS, SOCKETS, CONDENSERS, ETC., ETC. \$3.95  
3" PM SPEAKER KIT . incl. Cone, Voice Coil, Spider, Dust Cap, Spkr. Frame & Magnet. With instr. ONLY . . . . . 98  
SPEAKER CONE KIT . 4" to 12" incl. Free-edge. Less voice coils. Kit of 12 asstd. . . . 1.98  
SPEAKER REPAIR KIT. A PROFESSIONAL AS-SORTMENT OF: SPIDERS, C. FORMS, RINGS, FELT, CHAMOIS LTHR, CEMENT, SHIM KIT & INSTRUCTIONS . ALL FOR . . . . . 2.49  
SPECIAL! BOTH CONE & REPAIR KITS: . . . 3.95  
MOULDED BAKELITE CONDENSERS .00001 to .2 mfd. 200-600V. Kit of 50 assorted. 1.98 Min. Order \$3.00. Only 20% deposit req. on all C.O.D.'s. Full remittance with foreign orders. Please add sufficient postage—excess refunded.

**EOTONE** RADIO CORP.  
67 Dey Street  
New York 7, N.Y.

**TELLS HOW TO SOLVE TV TROUBLES AND ANSWERS TV QUESTIONS**

**AUDEL'S TELEVISION SERVICE MANUAL**

**1001 FACTS 19 CHAPTERS**

Placement of Television Receivers—Receiver Controls, Test Patterns & Adjustments—Television Interference—Interference Traps—Television Antennas & Transmission Lines—Master Antenna Systems—Antenna Installation Procedure—Television Broadcasting—Television Receiver Fundamentals—Circuit Description of Typical Receiver—Television Picture Tubes—Projection Type Receivers—Television Testing Instruments—Television Servicing—Trouble Shooting—Color Television—Television Terms.

**\$2 POST PAID**

**7 DAYS FREE TRIAL**  
GET THIS PRACTICAL ASSISTANCE FOR YOURSELF—MAIL COUPON TODAY—

**AUDEL Publishers, 49 W. 23rd St., N.Y.**  
Mail me postpaid for 7 Day examination  
**AUDEL'S TELEVISION SERVICE MANUAL (Price \$2).**  
If O.K. I will mail you \$2, otherwise I will return book.

Name \_\_\_\_\_  
Address \_\_\_\_\_  
Employed by \_\_\_\_\_



"WILLIAMSON" 10W HI-FI KIT

10 to 20000cycles with Ease! Internationally Famous; For HiFi enthusiasts. Inc. Pwr supply, selected parts; Balanced resistors... \$29.95

DYNAMOTORS PE103 in 6 & 12v out 500V/160MA \$29.95 DM37C in 28V/9.2A out 625V/220ma 9.98

SELENS 2J11G GE As Is No Returns... 2 for 49c 2J11H GE Selens... 2 for \$6.98

ALLEN BRADLEY POTENTIOMETERS 1000 ohm Type J 3/4" Flatted Shaft... \$1.45

TABOGRAM WRITE FOR IT

WE STOCK LARGE VARIETY OF COMPONENTS. TELL US YOUR NEEDS. SELL US YOUR TUBES & EQUIPMENT.

Table of electronic components and their prices. Columns include part numbers (e.g., 0A2, 0B2, 0C3) and prices (e.g., \$0.98, \$1.23, \$1.25).

"TAB" THAT'S A BUY

OIL CAPACITORS table with columns for capacitance (600wvdc, 800 wvdc, 2000wvdc) and voltage (150V, 250V, 500V).

HIGH CURRENT MICA CONDRS. CYLINDRICAL SIMILAR TYPE G. Table with columns for Mfd., Kv, Amps, Mc, and Each.

RHEOSTATS table with columns for resistance (15 ohm, 25 ohm, 50 ohm, 100 ohm, 250 ohm, 500 ohm, 1000 ohm) and price.

STORAGE BATTERIES table with columns for voltage (36 Volt Willard Mini-BRAND, 2 Volt, 6V, 6V, 6V), capacity (10.6Ah, 1.2Ah, 1.2Ah, 1.2Ah), and price.

SELENIUM POWER SUPPLY

0-12 VDC Amps. Un-cased Variable supply & completely built-in 115 VAC input. Usable for lab. filament DC.

CIRCUIT BREAKERS Heilmann Magn Bkrs. Amps; 0.22, 2, 3, 5, 7, 9, 12, 15, 20, 30, 35, 40, 50, 60, 75.

TRANSFORMER 2500V For CRT 6.3V/6A, 2.5V/7.5V, 5V/15V, 10V/30V, 20V/60V, 30V/90V, 40V/120V, 50V/150V, 60V/180V, 70V/210V, 80V/240V, 90V/270V, 100V/300V.

FILAMENT XFMRs 6.3vct/4A (rud 6.5A) H'Sld HVins. \$ 2.69 2.5v/2A 79c 6.3V/6A... 1.98

"TAB" TESTED & GUARANTEED

PRICES SUBJECT TO CHANGE Table listing various tube types and their prices, such as 6X4, 6X5, 6X6, 6X8, 6X9, 6X9A, 6X9B, 6X9C, 6X9D, 6X9E, 6X9F, 6X9G, 6X9H, 6X9I, 6X9J, 6X9K, 6X9L, 6X9M, 6X9N, 6X9O, 6X9P, 6X9Q, 6X9R, 6X9S, 6X9T, 6X9U, 6X9V, 6X9W, 6X9X, 6X9Y, 6X9Z.

Top Dollar Paid for Your Surplus Tubes—Send List and Prices.

Large table of tube types and prices, including 6X4, 6X5, 6X6, 6X8, 6X9, 6X9A, 6X9B, 6X9C, 6X9D, 6X9E, 6X9F, 6X9G, 6X9H, 6X9I, 6X9J, 6X9K, 6X9L, 6X9M, 6X9N, 6X9O, 6X9P, 6X9Q, 6X9R, 6X9S, 6X9T, 6X9U, 6X9V, 6X9W, 6X9X, 6X9Y, 6X9Z.

866A KIT AND XFORMER

2 Tubes, Sekts, Xmptr 115v 60cyc Imp. outpt 2.3vct/10A... \$6.98

SELENIUM RECTIFIERS We specialize in Rectifiers and Pwr supplies to your specifications. Immed. delivery.

SELENIUM RECTIFIER XFMRs 18-19-20-24-31V 12 amp... \$12.98 31-32-34-36 Volts/12 amp... 16.49

TAB "SUN-FLASH" LAMPS table with columns for No. Replaces, W.v., and Price.

BALL BEARINGS table with columns for ID, OD, Thickness, and Price.

Large table of tube types and prices, including 6A4, 6AG5, 6AL5, 6AR5, 6AV6, 6AV7, 6AV8, 6AV9, 6AV10, 6AV11, 6AV12, 6AV13, 6AV14, 6AV15, 6AV16, 6AV17, 6AV18, 6AV19, 6AV20, 6AV21, 6AV22, 6AV23, 6AV24, 6AV25, 6AV26, 6AV27, 6AV28, 6AV29, 6AV30, 6AV31, 6AV32, 6AV33, 6AV34, 6AV35, 6AV36, 6AV37, 6AV38, 6AV39, 6AV40, 6AV41, 6AV42, 6AV43, 6AV44, 6AV45, 6AV46, 6AV47, 6AV48, 6AV49, 6AV50, 6AV51, 6AV52, 6AV53, 6AV54, 6AV55, 6AV56, 6AV57, 6AV58, 6AV59, 6AV60, 6AV61, 6AV62, 6AV63, 6AV64, 6AV65, 6AV66, 6AV67, 6AV68, 6AV69, 6AV70, 6AV71, 6AV72, 6AV73, 6AV74, 6AV75, 6AV76, 6AV77, 6AV78, 6AV79, 6AV80, 6AV81, 6AV82, 6AV83, 6AV84, 6AV85, 6AV86, 6AV87, 6AV88, 6AV89, 6AV90, 6AV91, 6AV92, 6AV93, 6AV94, 6AV95, 6AV96, 6AV97, 6AV98, 6AV99, 6AV100.

THAT'S A BUY THAT'S A BUY DEPT. 5RN, SIX CHURCH ST. NEW YORK 6, N.Y., U.S.A. CORNER CHURCH & LIBERTY STS. ROOM 200

Money Back Guarantee (Cost of Mdsd Only) \$5. Min. Order: F05 CC. Add S.C. Charges & 25% Dep. Tubes Gtd. via R-Exp. only. Price subject to change Without Notice. Phone: Worth 2-7230.

# EICO

TEST INSTRUMENTS

guards

*Majestic*  
HIGH STANDARDS OF  
TELEVISION PRODUCTION QUALITY

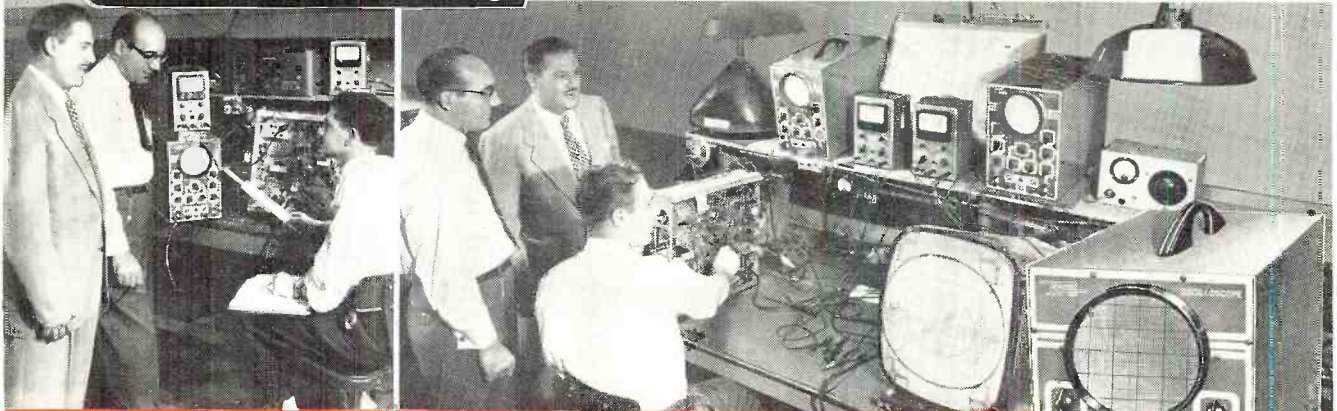

In the Majestic design laboratories, Frank J. Dieli and assistant, Paul Smith, discuss with Harry R. Ashley, some important prototype-circuit measurements just taken with the 425 Oscilloscope, #221 VTVM and #HVP-1 HV Probe.

Frank J. Dieli, Majestic's Chief Engineer, and Harry R. Ashley, President of EICO, inspecting the use of the EICO Model 425 5" Push-Pull Oscilloscope, Model 221 Vacuum Tube Voltmeter and Model HVP-1 High Voltage Probe at the important Final Test Position on the Majestic Television production lines.

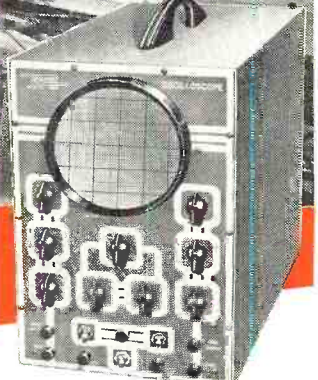

NEW 425K 5" PUSH-PULL SCOPE KIT \$44.95. WIRED \$79.95

## KITS - Wired Instruments

For Laboratory Precision at Lowest Cost—the Leaders Look to **EICO!**

**WHY** does The Majestic TV Division of The Wilcox-Gay Corp., another one of America's leading TV manufacturers, specify EICO Test Instruments on both its production lines and in its design laboratories?

**BECAUSE**—like Emerson, Tele-King, Tele-Tone, CBS-Columbia and many another famous TV manufacturer coast to coast, Majestic knows that

- ONLY **EICO** TEST EQUIPMENT DELIVERS ALL 10 **EICO** NOMINAL FEATURES
1. Laboratory Precision
  2. Lowest Cost
  3. Lifetime Dependability
  4. Speedy Operation
  5. Rugged Construction
  6. Quality Components
  7. Latest Engineering
  8. Super-Simplified Assembly and Use Instructions
  9. Laboratory-Styled Appearance
  10. Exclusive EICO Make-Good Guarantee

Before You buy any higher-priced equipment, be sure You look at the **EICO** line—in Wired as well as Kit form! Each EICO product is jam-packed with unbelievable value. YOU be the judge—compare, see **EICO** instruments today—in stock at your local jobber—and SAVE! Write NOW for FREE newest Catalog 5-R.

FOLLOW THE LEADERS... INSIST ON EICO!

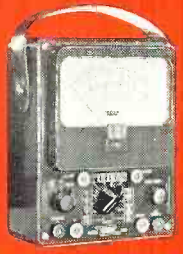

NEW 555K MULTIMETER KIT \$24.95 WIRED \$29.95. 20,000 ohms/volt

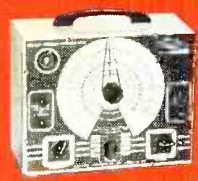

NEW 950K R-C BRIDGE & R-C L COMP. KIT \$19.95 WIRED \$29.95



320K SIG. GEN. KIT \$19.95. WIRED \$29.95  
NEW 322K SIG. GEN. KIT \$23.95. WIRED \$34.95

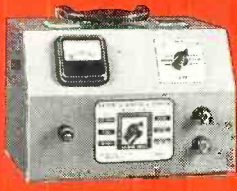

NEW 1040K BATTERY ELIM. KIT \$25.95. WIRED \$34.95



511K VOM KIT \$14.95 WIRED \$17.95



NEW 536K MULTI METER KIT \$12.90 WIRED \$14.90 1000 ohms/volt

NEW 1171K RES. DECADE BOX KIT \$19.95 WIRED \$24.95

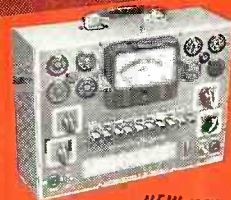

NEW 625K TUBE TESTER KIT \$34.95 WIRED \$49.95



145K SIG. TRACER KIT \$19.95 WIRED \$28.95



NEW 315K DELUXE SIG. GEN. KIT \$39.95 WIRED \$59.95

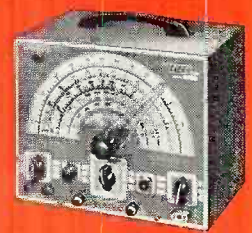

360K SWEEP GEN. KIT \$24.95 WIRED \$49.95



NEW 221K VTVM KIT \$25.95 WIRED \$49.95



HIGH VOLTAGE PROBE \$6.95



ELECTRONIC INSTRUMENT CO., Inc.  
84 WITHERS STREET, BROOKLYN 11, NEW YORK

Prices 5% higher on West Coast. Due to unstable conditions, prices and specifications are subject to change without notice.



Preferred by Servicemen everywhere . . .

## MALLORY VIBRATORS

There are three big reasons why servicemen prefer Mallory vibrators over all other brands combined. They count on Mallory vibrators for long dependable service because they give . . .

- 1— Slow contact impact for minimum wear
- 2— High contact pressure for low resistance
- 3— Fast contact break for reduced arcing, pitting

That combination—available only from Mallory, with its patented, tuned mechanism—means real performance for you and your customers. That's why more Mallory vibrators are used as original equipment than all other makes combined. Put these features to work for you. When you order vibrators . . .



Service 47 Radio Makes  
With ONE of Mallory's  
Special Vibrator Deals

Ask your distributor about these Mallory specials. They help keep your inventory down. You can service 47 radio makes with the 6 Mallory vibrators in one of these deals. And you get a handy parts cabinet at no additional cost when you buy at your regular discount price. Call your distributor today for details.

## Make Sure! Make it Mallory!

P. R. MALLORY & CO. Inc.  
**MALLORY**

CAPACITORS • CONTROLS • VIBRATORS • SWITCHES • RESISTORS  
• RECTIFIERS • VIBRAPACK\* POWER SUPPLIES • FILTERS

\*Reg. U.S. Pat. Off.

**APPROVED PRECISION PRODUCTS**

**P. R. MALLORY & CO., Inc., INDIANAPOLIS 6, INDIANA**