

RADIO & TELEVISION NEWS

ANC

FEBRUARY

1951

35¢

In Canada 40¢



**AUTOMATIC SEALING DEVICES SPEED
PRODUCTION OF TV PICTURE TUBES**

PAGE 38

THE QUALITY OF RCA TUBES IS UNQUESTIONED

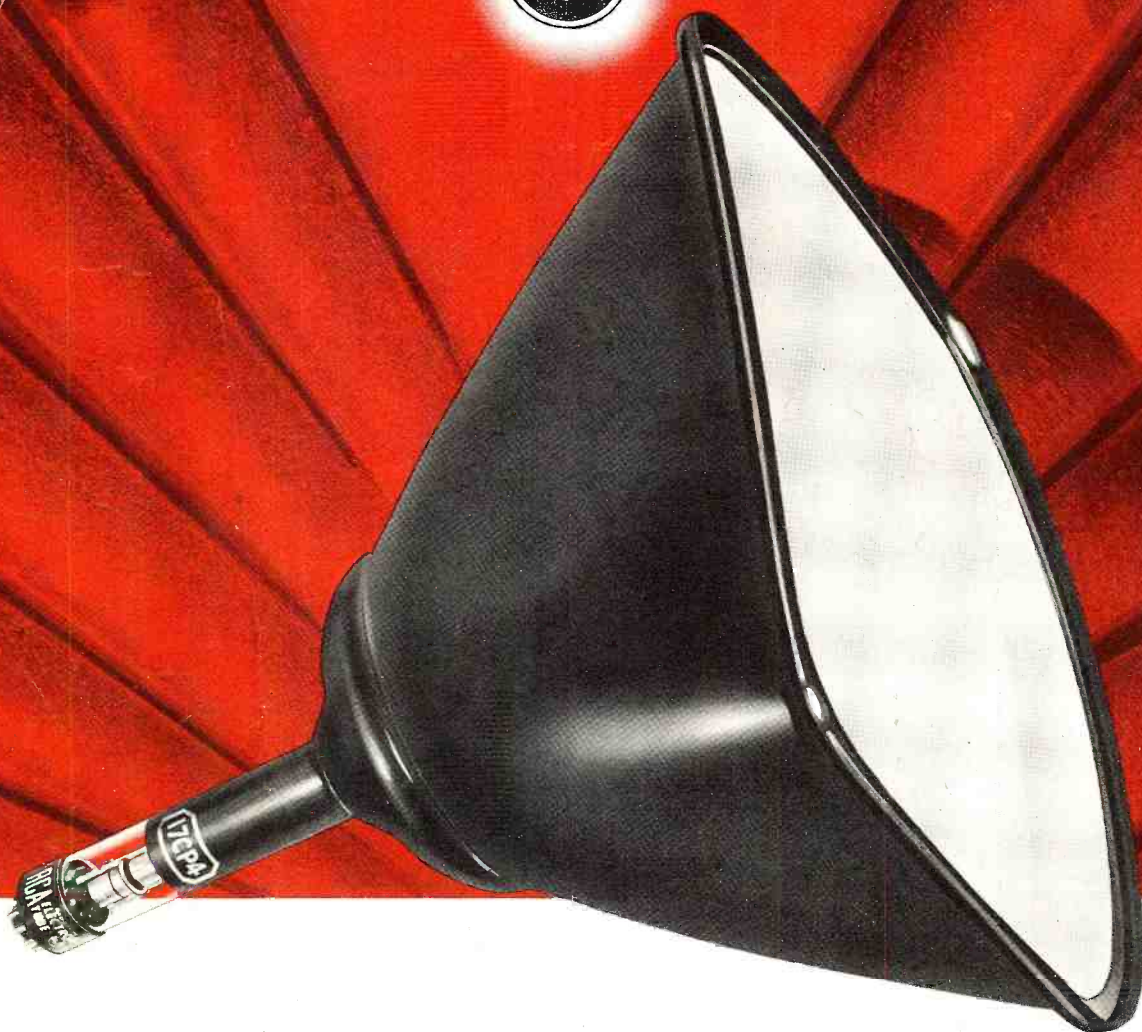

ANOTHER MILESTONE IN

Television Progress

...the new RCA-17CP4

metal shell

rectangular kinescope



The new RCA-17CP4 *metal-shell* rectangular kinescope is the first of its type—and represents a notable engineering advancement in the design of television picture tubes.

In addition to the practical advantages of the rectangular shape, use of the metal shell substantially reduces the weight of the tube and permits the use of a higher-quality faceplate than is commonly used on all-glass types.

Other features of the new RCA-17CP4 include an improved funnel-to-neck section which facilitates centering of the yoke . . . short overall length . . . an ion-trap gun which requires only a single-field, external magnet . . . and a frosted Filterglass faceplate.

RCA's engineering leadership adds *value beyond price* to the RCA tubes you sell. And you benefit directly from this continued research by the new products which it creates.

Keep informed...stay in touch with your RCA Tube Distributor



RADIO CORPORATION of AMERICA
ELECTRON TUBES HARRISON, N. J.

You Practice COMMUNICATIONS

I send you parts to build this transmitter

As part of my Communications Course you build this low power broadcasting transmitter, learn how to put a station "on the air," perform procedures demanded of Broadcast Station operators, make many tests.



This is just part of the equipment my students build. You keep all parts I send.

You Practice Radio SERVICING

on this modern radio you build with parts I send

As part of my Servicing Course, I send you the speaker, tubes, chassis, transformer, loop antenna, EVERYTHING you need to build this modern, powerful Radio Receiver! I also send parts to build many other Radio circuits. You use equipment for practical experience and to earn EXTRA money in spare time.

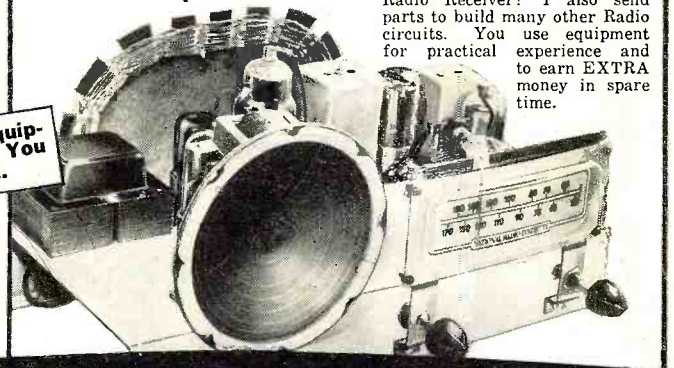

BE A RADIO-TELEVISION TECHNICIAN

NOW! Advanced Television Practice

New, special TV kits furnished to build high-definition SCOPE . . . RF OSCILLATOR with flyback power supply . . . complete TV set . . . many other units. You see pulse, trapezoidal, saw-tooth wave forms. Get valuable PRACTICAL EXPERIENCE locating and correcting TV troubles. Mail coupon for facts and pictures.

Learn Servicing or Communications Practice at Home in Spare Time



Do you want good pay, a job with a bright future and security? Would you like to have a profitable shop or store of your own? If so, find out how you can realize your ambition in the fast growing, prosperous RADIO-TELEVISION industry. Even without Television, the industry is bigger than ever before. 90 million home and auto Radios, 3100 Broadcasting Stations, expanding use of Aviation and Police Radio, Micro-wave Relay, Two-way Radio for buses, taxis, etc., are making opportunities for Servicing and Communications Technicians and FCC-Licensed Operators.

Television is TODAY'S Good Job Maker

J. E. SMITH, President National Radio Institute In 1950, over 5,000,000 TV sets sold. By 1954, 25,000,000 TV sets estimated. Over 100 TV Stations now operating. Authorities predict 1,000 TV Stations. This means more jobs, good pay for qualified men all over the United States and Canada.

Many Make \$10 Extra a Week in Spare Time

Keep your job while training. Hundreds of successful RADIO-TELEVISION TECHNICIANS I trained had no previous experience, some only a grammar school education. Learn Radio-Television principles from illustrated lessons. Get PRACTICAL EXPERIENCE—build valuable multimeter—experiment with circuits common to Radio and Television. Keep all equipment. Many students make \$5, \$10 extra a week fixing neighbors' Radios in spare time. SPECIAL BOOKLETS start teaching you the day you enroll.

Send Now For 2 Books FREE—Mail Coupon

Send now for my FREE DOUBLE OFFER. You get actual Servicing lesson to show you how you learn at home. Also my 64-page book, "How to Be a Success in Radio-Television." Read what my graduates are doing, earning; see equipment you practice with at home. Send coupon in envelope or paste on postal. J. E. SMITH, President, Dept. 1BE, National Radio Institute, Washington 9, D. C. Our 38th Year.

Good for Both—FREE

The ABC's of SERVICING

MR. J. E. SMITH, President, Dept. 1BE National Radio Institute, Washington 9, D. C.

Mail me Sample Lesson and 64-page Book about How to Win Success in Radio-Television. Both FREE. (No Salesman will call. Please write plainly.)

Name.....Age.....

Address.....

City.....Zone.....State.....

Check if Veteran Approved for training under G. I. Bill

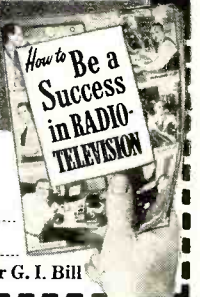

I TRAINED THESE MEN



"I have been operating my own Servicing business. In two years I did \$14,000 worth of business; net profit \$6,850. Have one full time employee, an NRI student."—PHILLIP G. BROGAN, Louisville, Ky.



"Four years ago, I was a bookkeeper, with a hand-to-mouth salary. Now I am a Radio Engineer with a key station of the American Broadcasting Company network."—NORMAN H. WARD, Ridgefield Park, New Jersey.



"When halfway through the NRI course, I made \$5 to \$8 a week fixing sets in my spare time. Am now selling and installing Television sets and antennas."—E. J. STREIT-ENBERGER, New Boston, O.



"My first job was operator with KDLR, obtained for me by your Graduate Service Dept. I am now Chief Engineer of Police Radio Station WQOX. I never hesitate to endorse NRI."—T. S. NORTON, Hamilton, Ohio.

Veterans

Get this training under G. I. Bill.

MAIL COUPON

Have Your Own Business

Many N.R.I. trained men start their own Radio-Television sales and service business without capital. Let me show you how you, too, can be your own boss, have a good income from your own shop. Send coupon for FREE book now!

Tested Way to Better Pay

Editor
OLIVER READ, D. Sc., D. Litt., W9ETI

Managing Editor
WM. A. STOCKLIN, B.S.

Technical Editor
H. S. RENNE, M.S.

Associate Editor
RAY FRANK, W9JU

Eastern Editor
HAROLD BECKER

Television Consultant
MILTON S. KIVER

Short-Wave Editor
KENNETH R. BOORD

Editorial Assistants
I. M. CARROLL

E. V. HITZEL

P. B. HÖEFER

Staff Artist
R. S. KUPJACK

Advertising Manager
L. L. OSTEN

Midwest Adv. Manager
JOHN A. RONAN, JR.

Art Director
HERMAN R. BOLLIN

RADIO & TELEVISION NEWS

First in
radio-television-electronics

Average Paid Circulation over 200,000

Radio News Trademark Reg. U.S. Pat. Office No. 521506 • Television News Trademark Reg. U.S. Pat. Office No. 517468
Radio & Television News Trademark Reg. U.S. Pat. Office No. 517025

CONTENTS

FEBRUARY, 1951

1950—Banner Year for TV.....	Harold Becker	31
Induction Heating.....	Ed Bukstein	35
An Inexpensive Pulse Generator.....	Louis E. Garner, Jr.	36
Metal Sealing Techniques for Large Television Tubes.....	William L. Hyde	38
Is the One Man TV Shop Doomed?.....	Paul Wendel	40
Novel Tester for Checking Radio Control Equipment.....	Guy Dexter	42
Simplified Reproduction of Drawings for Small Lab or Home Shop.....	Walter S. Rogers	44
A V-O-M and Grid-dip Oscillator.....	Milton White	45
Ham Converter for 2-6-10-15 Meters.....	H. J. Harris, W1PFF	48
There's Money in Cartridge Replacements.....	John D. Harper	51
Loudness and Power in Audio Systems.....	James A. Mitchell	52
A Direct Reading Electronic Audio Frequency Meter.....	Rufus P. Turner, K6AI	54
An Electronic A.C. Voltmeter.....	Lawrence Fleming	56
Television Synchronizing Circuits (Part 2).....	J. Racker and P. Selvaggi	58
Mac's Radio Service Shop.....	John T. Frye	61
A Flexible Record-Reproduce System (Part 3).....	Oliver Read	62
Ten Tips to Tax Thrift.....	Fred Merish	65
A Vacuum-Tube Transformer.....	Richard H. Dorf	112
The Ad-Viser (Part 6).....	Irving Settler	144
Radio-TV Service Industry News.....		150

DEPARTMENTS

For the Record.....	The Editor	8	Manufacturers' Literature.....	82
Spot Radio News.....		14	Technical Books.....	88
Within the Industry.....		24	MARS.....	102
Short-Wave.....	K. R. Boord	66	New TV Products.....	128
What's New in Radio.....		68	AFCA News.....	136

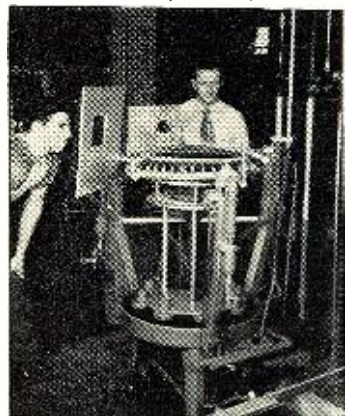

COVER PHOTO: The high temperature fusing of glass to steel in the manufacture of television tubes as performed in the tube plant of the Allen B. Du Mont Laboratories, Inc. (Kodachrome by Norman Germond)

Chairman of the Board and Publisher
WILLIAM B. ZIFF

President
B. G. DAVIS

Secretary-Treasurer
ARTHUR T. PULLEN

Vice-Presidents
MICHAEL H. FROELICH
Dir. Eastern Div.

H. J. MORGANROTH
Production Director

LYNN PHILLIPS, Jr.
Advertising Director

H. G. STRONG
Circulation Director

BRANCH OFFICES

NEW YORK (17)

366 Madison Ave., Murray Hill 7-8080

LOS ANGELES (14)

815 S. Hill St., Tucker 9213

Manager, WILLIAM L. PINNEY



COPYRIGHT 1951
ZIFF-DAVIS PUBLISHING COMPANY
185 North Wabash Ave., Chicago 1, Ill.
VOLUME 45 • NUMBER 2



Member
Audit Bureau of
Circulations

RADIO & TELEVISION NEWS is published monthly by the Ziff-Davis Publishing Company at 185 N. Wabash Ave., Chicago 1, Ill. Entered as second-class matter July 21, 1948, at the Post Office, Chicago, Ill., under the act of March 3, 1879. Entered as second-class matter at the Post Office Department, Ottawa, Canada, under the act of March 3, 1879. U. S. Canada, Mexico, South and Central America and U. S. Possessions, \$4.00 for twelve issues; in British Empire \$5.00; all other foreign countries, \$5.00 for twelve issues. RADIO-ELECTRONIC ENGINEERING EDITION SUBSCRIPTION RATES: in U. S., Canada, Mexico, South and Central America and U. S. Possessions, \$6.00 for twelve issues; in British Empire \$7.00; all other foreign countries, \$7.00 for twelve issues. Subscribers should allow at least two weeks for change of address. All communications about subscriptions should be addressed to the Director of Circulation, 185 N. Wabash Ave., Chicago 1, Ill. CONTRIBUTIONS: Contributors are advised to retain a copy of their manuscripts and illustrations. Contributions must be accompanied by return postage and they will be handled with reasonable care, but this magazine assumes no responsibility for their safety. Any copy accepted is subject to whatever adaptations and revisions are necessary to meet the requirements of this publication. Payment covers all author's, contributor's and contestant's rights, title, and interest in and to the material accepted and will be made at our current rates upon acceptance. All photos and drawings will be considered as part of the material purchased.

RADIO & TELEVISION NEWS

**NOW... GET EVERYTHING YOU
NEED TO EARN AND MASTER**

TELEVISION

**RADIO-ELECTRONICS
...AT HOME!**

**Use REAL commercial-type equip-
ment to get practical experience**

Your future deserves and needs every advantage you can give it! That's why you owe it to yourself to find out about one of the most COMPLETE, practical and effective ways now available to prepare AT HOME for America's billion dollar opportunity field of TELEVISION-RADIO-ELECTRONICS. See how you may get and keep the same type of basic training equipment used in one of the nation's finest training laboratories... how you may get real STARTING HELP toward a good job or your own business in Television-Radio-Electronics. Mail the coupon today for complete facts — including 89 ways to earn money in this thrilling, newer field.



**Here's the
REAL THING!**

**SET UP YOUR OWN
HOME LABORATORY**



Oscilloscope

R-F Signal
Generator

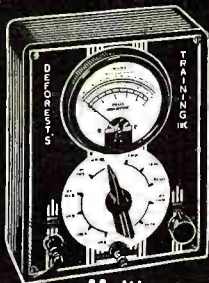

Multimeter

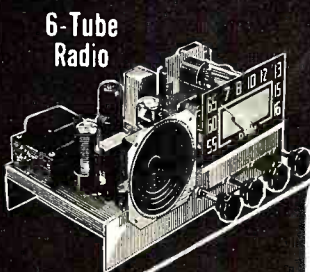

6-Tube
Radio

**HOME
MOVIES**

ABOVE: Build and keep a real 16 INCH commercial TV receiver. Optional after completing regular training at slight additional cost.

D.T.I., ALONE, INCLUDES BOTH MOVIES and HOME LABORATORY

In addition to easy-to-read lessons, you get the use of HOME MOVIES — an outstanding training advantage — plus 16 big shipments of Electronic parts. Perform over 300 fascinating experiments for practical experience. Build and keep real commercial-type test equipment shown at left.

MODERN LABORATORIES

If you prefer, get all your preparation in our new Chicago Training Laboratories—one of the finest of its kind. Ample instructors, modern equipment. Write for details!

MILITARY SERVICE!

If you're subject to military service, the information we have for you should prove doubly interesting. Mail coupon today.

**Get BOTH of these
information packed
publications FREE!**



ACT NOW! MAIL COUPON TODAY!

DeFOREST'S TRAINING, INC., Dept. RN-2-H
2533 N. Ashland Ave., Chicago 14, Ill.

Without obligation, I would like your late News-Bulletin showing 89 ways to earn money in Television-Radio-Electronics... and how I may prepare to get started in this thrilling field.

Name..... Age.....
Street..... Apt.....
City..... Zone..... State.....

De FOREST'S TRAINING, INC.
CHICAGO 14, ILLINOIS
A De VRY INSTITUTION

Never Before a Sales Boosting Campaign Like This—all for You!

This SYLVANIA star-studded program will keep your service business booming during 1951



Appealing Life-Like Window Displays

You'll find prompt expert television and radio service Right Here!

Colorful Counter and Store Displays

You'll find prompt expert television and radio service Right Here!

Call us for top quality television and radio service

Marie Wilson says: "I rely on this Emblem for dependable Radio and Television Service"

Doreen Lynn says: "For Reliable Radio and Television Service I Depend on this Emblem!"

We Use SYLVANIA Radio and Television Tubes



We Use SYLVANIA Radio and Television Tubes

We Use SYLVANIA Radio and Television Tubes

Bright window streamers

Marie Wilson says THIS EMBLEM IS MY ASSURANCE OF FINE RADIO AND TV SERVICE

If your Radio or Television set needs expert attention

We Use SYLVANIA Radio and Television Tubes



Sales-getting postal cards



New giant mailers



It's ready and waiting for you now . . . the most colorful and appealing Service Dealer advertising campaign ever planned!

Featuring famous stars of screen, television and radio, it ties in with the national advertising your customers will see in *The Saturday Evening Post*, *Life*, *Look*, and *Collier's Magazine*, and with Sylvania's weekly CBS-TV Show, "Beat The Clock"!

So, win with Sylvania in '51. Send for this material NOW . . . and display it prominently. It identifies you as the expert with the super-fine Sylvania tubes . . . the tools and the know-how for the finest radio and TV service.

All of the display material, stickers and radio spots are FREE. You pay only 1¢ apiece for the four mailing pieces you send to your prospects. So, see your Sylvania Distributor or mail coupon NOW!

Reminder stickers for every set you service



Radio spot announcements for every month



RADIO TUBES; TELEVISION PICTURE TUBES; ELECTRONIC PRODUCTS; ELECTRONIC TEST EQUIPMENT; FLUORESCENT TUBES, FIXTURES, SIGN TUBING, WIRING DEVICES; LIGHT BULBS; PHOTOLAMPS; TELEVISION SETS

SYLVANIA ELECTRIC

Sylvania Electric Products Inc.
Dept. R-2102, Emporium, Pa.
Please send me full details about Sylvania's great 1951 Dealer Promotion Campaign.

Name _____
Street _____
City _____ Zone _____ State _____

RADIO & TELEVISION NEWS

YOUR OPPORTUNITY IS HERE NOW! LEARN

TELEVISION RIGHT AT HOME!

By the new method of **TRANSPONDENCE**

training on film and tape recordings

Now the De Forest-Sanabria Corporation—a division of the world's largest television training school—brings *class-room instruction* to you right in your own home! You actually hear your instructor's recorded voice. At the same time you watch "blackboard" size projected pictures, diagrams and illustrations. It's the quick, easy way to equip yourself for the big earnings in television—today!

LOOK . . . You get the tape recorder and projector right at the start of your course!



HEAR your instructor

It's even better than the classroom, because you can repeat the instructor's lectures until they're thoroughly understood.

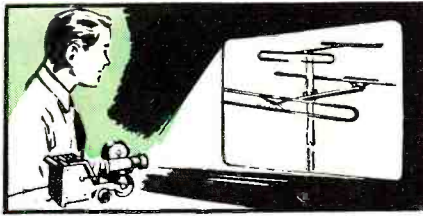

SEE 2000 illustrations

You learn quicker when you see diagrams and illustrations in black-board size.



READ from reference library

You receive complete books, pamphlets and manuals to supplement your instructor's lessons.



ASK your questions on tape

Tell your instructor about anything that puzzles you and get his answers back pronto.



BE A SUCCESS . . . ACT NOW!

Millions of television set owners are demanding qualified television technicians to service their sets. There is a tremendous shortage of such qualified men today and will be for many years to come. Get in on the ground floor of this booming industry and be prepared to accept a steady, big pay job for life. We can qualify you quickly, easily, surely—and help get you a job when you complete your course. Send for illustrated booklet that gives the complete details.

The De Forest-Sanabria Corp.

An affiliate of American Television, Inc.

5050 North Broadway, Chicago 40, Illinois

MAIL COUPON TODAY!

De Forest-Sanabria Corporation **FREE BOOK**
Dept. RN-2
5050 Broadway, Chicago 40, Ill. **TELLS HOW**

Dear Sirs:

Please send me copy of your free illustrated booklet which describes the new TRANSPONDENCE method of learning television at home under the direction of Dr. Lee de Forest and U. A. Sanabria.

NAME _____ AGE _____

ADDRESS _____

CITY _____ STATE _____

(Mail in envelope or paste on a postcard.)

For the RECORD.

BY THE EDITOR

MECHANICAL ROBOTS AND PRODUCTION OF ELECTRONIC EQUIPMENT

ENGINEERS and production experts have dreamed for years of the day when raw materials would be fed in at one end of a factory and completed pieces of electronic equipment, such as television receivers, would come out of the other end, with few, if any, production personnel being required. Several developments of recent years bring this dream much closer to reality than most of us realize. Since this matter is of vital interest to the military, service technicians, engineers and experimenters it might be well to discuss some of these developments, and perhaps anticipate a trend in future construction.

A number of different methods have been developed for producing the basic wiring of an electronic circuit. Probably the method that is best known in this country is the printed circuit technique, which has been widely publicized and needs little discussion. Another system of mass production, developed in England, makes use of a molded plastic plate with grooves for the wiring. This plate was sprayed with metal, usually silver, and the top surface milled off, leaving the conducting paths as desired.

Another technique involves attaching a thin copper sheet to a plastic base by means of a suitable binder, then etching away the undesired portions of the copper with acid, after the circuit paths are protected by some suitable material. In still another technique, a master die is made in accordance with the desired circuitry, and this die embeds the copper sheet into the plastic where conducting paths are desired, the remainder of the copper sheet obviously being discarded.

Assembly of components onto this basic wiring poses many problems. In some cases, resistors may be printed on by a silk screen process and a suitable paint, and if the base material is ceramic, some of the condensers may be formed by means of a conducting plate on each side of the ceramic. However, it appears more likely that some process for feeding the components from a hopper direct to the plate will be developed. This involves components with right-angle leads dropping through eyelets or other suitable terminations on the base plate. Once all components are in place, the back side of the plate could be dipped in solder to make the components electrically and mechanically secure. Tape resistors having acceptable accuracy have been developed and can be placed

over the conductive pattern and "fired" in place.

It should be mentioned at this point that in many cases coils, particularly for use at higher frequencies, may be applied in spiral form in the same manner that the base wiring is applied. Such coils can be held to very close tolerances in production, and can be made to have a relatively high "Q". Successful attempts have been made to "print" windings for transformers by applying metallic spirals on impregnated paper and folding.

So far in our discussion, the primary emphasis has been on the production of a complete assembly. The problem can be greatly simplified by the preparation of plug-in subassemblies which may or may not be cast in one of the casting resins recently developed. For example, a TV receiver may be made up of several subassemblies such as r.f., mixer, i.f., and video stages. Mass production of these individual subassemblies would be much simpler than production of the complete receiver, and final assembly would consist merely of plugging in the proper units in the proper places. This technique is particularly adaptable to military equipment, since it greatly simplifies the servicing problem and decreases tremendously the number of spare parts that must be provided. With the use of subminiature tubes and miniaturized components, such complete subassemblies would not be much larger than conventional tubes.

It is obvious that with the tremendous needs of the military in this emergency, and with the huge civilian market for electronic equipment, techniques must be developed and put into practice which will eliminate, to a very large extent, the present hand-wiring and hand-assembly processes which seem to be so wasteful of manpower (and womanpower). When this revolution comes about, engineers and service technicians will be faced with problems considerably different from those encountered at present.

* * *

AUDIO MAGAZINE POSTPONED

BECAUSE of the National Emergency and the resulting transition of our Industry into military production, the editors of RADIO & TELEVISION NEWS have altered their plans to publish "Audio," as announced for March 1951 publication.

The very excellent audio material prepared for the new magazine will appear in the regular edition of RADIO & TELEVISION NEWS. . . . O.R.

THIS HANDBOOK MAKES SOLDERING EASY!

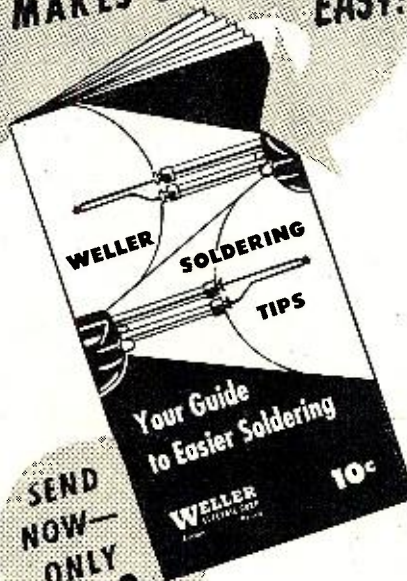

SEND NOW— ONLY 10¢

Learn the soldering tricks of experts—without any

hard study. This revised and up-to-date, 20-page handbook leads you step-by-step to real soldering skill. Time-saving methods, DO's and DON'T's, difficult operations, fluxes and solders, all made clear by 43 easy-to-understand illustrations. NOT a catalog, but a real professional's pocket manual. Send only 10 cents in coin.

GET NEW WELLER SOLDERING GUN CATALOG, TOO



When you send for your copy of SOLDERING TIPS, be sure to ask about the new Weller Soldering Guns. Fastest, handiest soldering tools you've ever seen—just point, pull, and solder!

WELLER ELECTRIC CORP.

810 Packer Street, Easton, Pa.

Weller Electric Corp., Easton, Pa. N

Enclosed find 10 cents in coin, for which please send me my up-to-date copy of revised Weller "Soldering Tips."

I am also interested in the new Weller Soldering Guns. Please send Free Catalog Bulletin.

Name _____

Address _____

City _____ State _____

RADIO & TELEVISION NEWS

new.

1951 ALLIED catalog

free!

the only complete
up-to-date catalog for
Everything in Radio, Television
and Industrial Electronics

212 value-packed pages

Send for it today!

Here's the only *complete, up-to-date* Buying Guide to TV, Radio and Industrial Electronics—packed with the world's largest selections of quality equipment at lowest, money-saving prices. See the latest in TV, AM and FM receivers; radio-phonos; new Sound Systems and P.A. equipment; High-Fidelity Custom Sound components; recorders and accessories; full selections of newest Amateur receivers and station gear; test instruments; builders' kits; huge listings of parts, tubes, tools, books—the world's *most complete stocks* of quality equipment.

ALLIED gives you *every* buying advantage; speedy delivery, expert personal help, lowest prices, assured satisfaction, liberal time payment terms. Get the latest 1951 ALLIED Catalog. Keep it handy—it will save you time and money. Send for your FREE copy!

ALLIED IS YOUR TELEVISION HEADQUARTERS



To keep up with TV, depend on ALLIED! Count on us for the latest releases and largest stocks of picture tubes, component parts, antennas and accessories—plus the latest in TV tuners and kits. If it's *anything* in TV—we have it. So remember —for TV—it's ALLIED First!

ALLIED RADIO
the World's Largest Radio Supply House
EVERYTHING IN ELECTRONICS

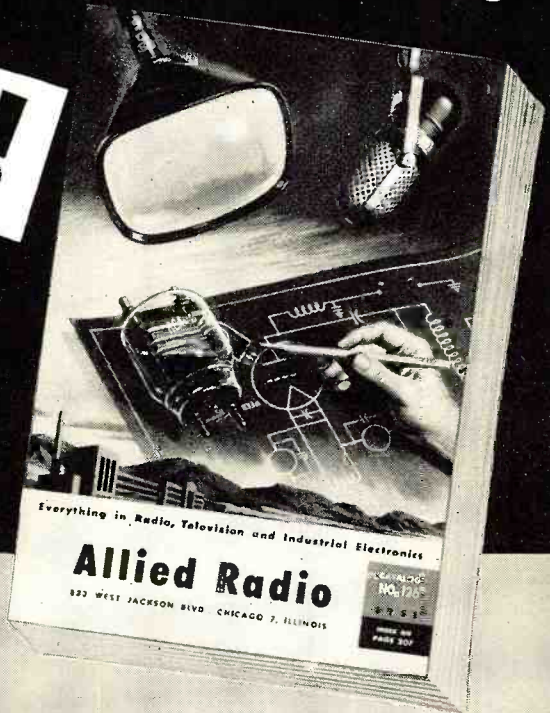

THE WORLD'S LARGEST STOCKS

Radio Parts Unlimited
Test Instruments
Television & Home Radios
P.A. and Hi-Fi Equipment
Amateur Station Gear
Supplies for Industry

QUICK, EXPERT SERVICE

SEND TODAY FOR RADIO'S LEADING BUYING GUIDE

free

ALLIED RADIO CORP.
833 W. Jackson Blvd., Dept. 1-B-1
Chicago 7, Illinois

Send FREE 212-page 1951 ALLIED Catalog No. 126

Name _____

Address _____

City _____ Zone _____ State _____

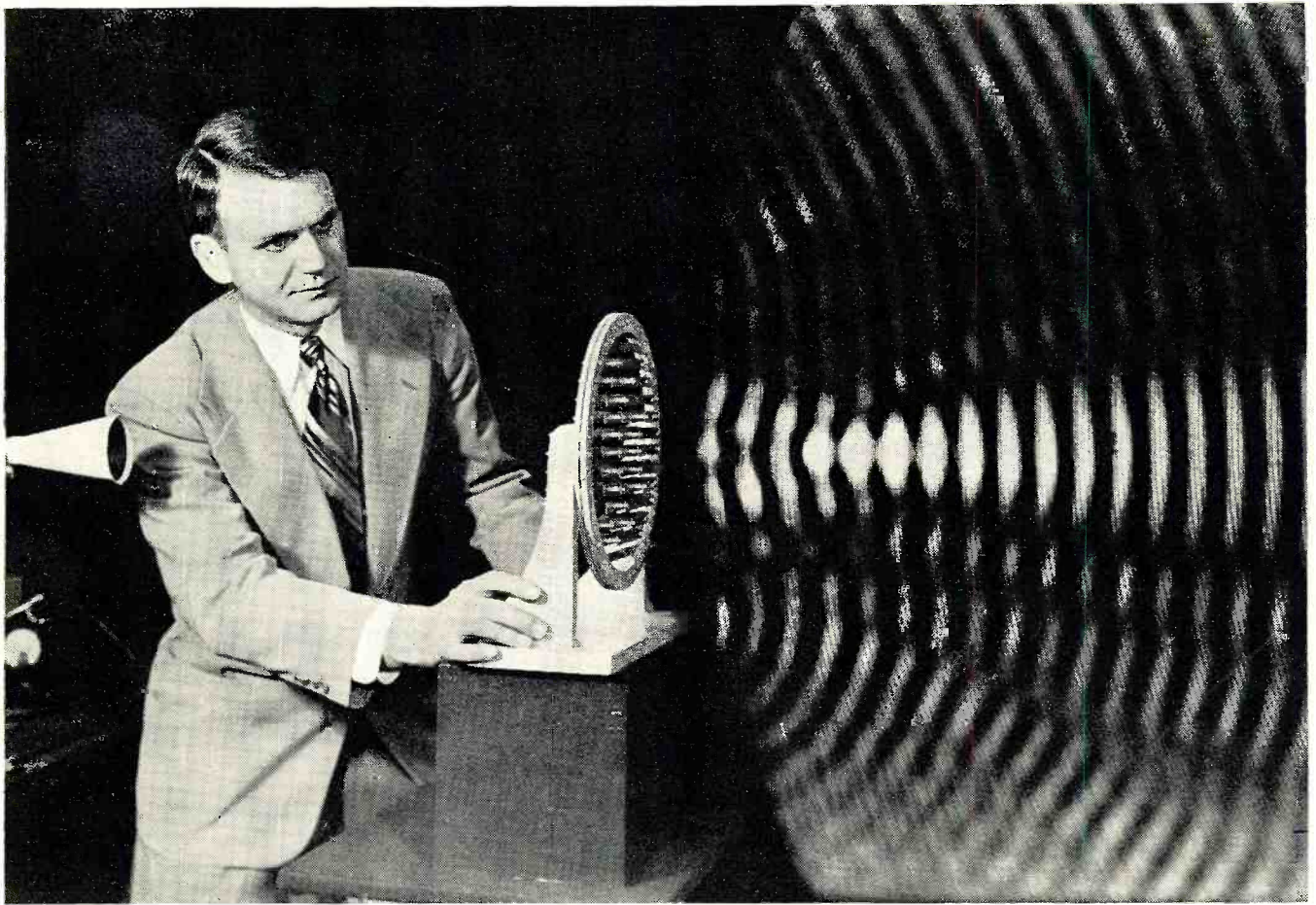

WAVE MAKING

*—for better
telephone
service*

Waves from the sound source at left are focused by the lens at center. In front of the lens, a moving arm (not shown) scans the wave field with a tiny microphone and neon lamp. The microphone picks up sound energy and sends it through amplifiers to the lamp. The lamp glows brightly where sound level is high, dims where it is low. This new technique pictures accurately the focusing effect of the lens. Similar lenses efficiently focus microwaves in radio relay transmission.

At Bell Telephone Laboratories, radio scientists devised their latest microwave lens by copying the molecular action of optical lenses in focusing light. The result was a radically new type of lens — the array of metal strips shown in the illustration. Giant metal strip lenses are used in the new microwave link for telephone and television between New York and Chicago.

The scientists went on to discover that the very same

type of lens could also focus sound . . . thus help, too, in the study of sound radiation . . . another field of great importance to your telephone system.

The study of the basic laws of waves and vibrations is just another example of research which turns into practical telephone equipment at Bell Telephone Laboratories . . . helping to bring you high value for your telephone dollar.

BELL TELEPHONE LABORATORIES



- WORKING CONTINUALLY TO KEEP YOUR TELEPHONE SERVICE ONE OF TODAY'S GREATEST VALUES

**"MY CUSTOMERS BUY IT
WITH CONFIDENCE!"**

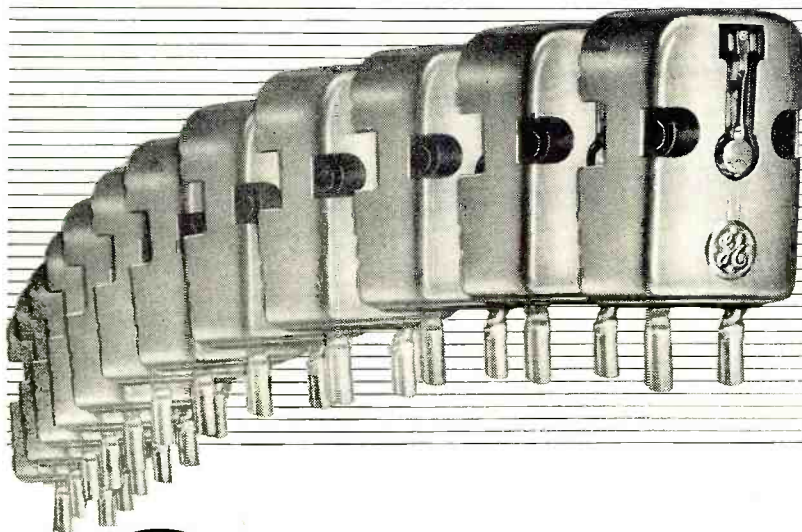

VARIABLE RELUCTANCE CARTRIDGE

MORE than 100,000 sold in 1950! Outsells all other brands of VR cartridges combined. That's why dealers like to sell it — people like to buy it; it's dependable, it offers more listening pleasure per dollar than any other cartridge on the market.

Orders from manufacturers are way up — you will see more and more G-E

cartridges in new record players and combinations. Dealers and servicemen, too, are placing orders now for adequate stocks of these quality cartridges. Your customers deserve the best audio equipment you can give them. Phone or wire your distributor today, or write: *General Electric Co., Electronics Park, Syracuse, New York.*

NEW CATALOG...GET YOURS FREE!

Every dealer and serviceman needs one of these catalogs... complete specs and photos on G-E cartridges, styli, tone arms, pre-amps.

General Electric Company — Section 921
Electronics Park, Syracuse, New York
Rush me the new G-E Phono-Accessory Catalog.

NAME _____
ADDRESS _____
CITY _____ STATE _____

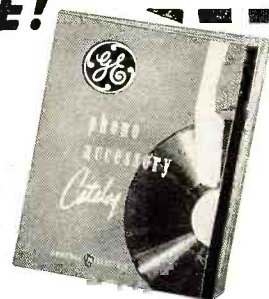

GENERAL  ELECTRIC

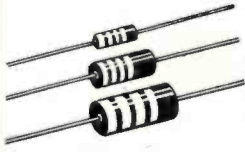

LITTLE DEVIL COMPOSITION RESISTORS

Resistance and wattage are clearly marked on every one of these tiny, rugged insulated composition resistors. Three sizes: 1/2, 1 and 2-watt in all RMA resistances. Tolerance $\pm 5\%$ and $\pm 10\%$.



CLOSE CONTROL RHEOSTATS

Insure permanently smooth, close control. Widely used in industry. All ceramic, vitreous enameled; 25, 50, 75, 100, 150, 225, 300, 500, 750, and 1000-watt sizes.



DUMMY ANTENNA RESISTORS

For loading transmitters or other r.f. sources. New, rugged, vitreous-enameled units are practically non-reactive within their recommended frequency range. 100 And 250-watt sizes, 52 to 600 ohms, $\pm 5\%$.

TYPE AB POTENTIOMETER



It's quiet! This Type AB Potentiometer has a resistance unit that's solid molded. As a result, the noise level often becomes less with use. Has a 2-watt rating, good safety factor.



BROWN DEVIL WIREWOUND RESISTORS

Dependable vitreous-enameled units, in a size small enough to fit most installations. Easily mounted by 1 1/2" tinned wire leads. Three sizes: 5, 10, and 20 watts. Tolerance $\pm 10\%$.

If it's made by

OHMITE

IT'S DEPENDABLE!

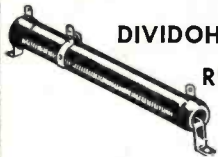

DIVIDOHM ADJUSTABLE RESISTORS

These wirewound resistors, with one or more adjustable lugs, provide a convenient means of obtaining odd resistance values. Stock units made in 10, 25, 50, 75, 100, 160, and 200-watt sizes, in many resistance values.

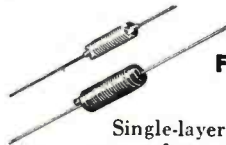

RADIO FREQUENCY CHOKES

Single-layer wound on low power-factor steatite or bakelite cores, with moistureproof coating. Seven stock sizes for all frequencies, 3 to 520 mc. Two units rated 600 ma, others rated 1000 ma.

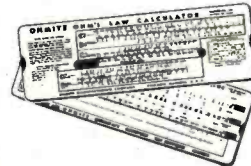

OHM'S LAW CALCULATOR

25¢

Favorite of engineers everywhere! Solves Ohm's Law problems with one setting of the slide. Also has parallel resistance and slide rule scales.

To countless thousands of technical men all over the world—engineers, designers, and servicemen—the name OHMITE has become synonymous with *dependability*. There is good reason for this overwhelming opinion. Every OHMITE product is carefully designed and constructed to give *extra* performance and long life under severe service conditions. When you need dependable resistance components, play safe and specify OHMITE.

Write FOR STOCK CATALOG



OHMITE MANUFACTURING CO., 4883 Flournoy St., Chicago 44, Ill.

Be Right with **OHMITE** RHEOSTATS RESISTORS TAP SWITCHES

ALLIANCE TENNA-ROTOR

RINGS THE BELL for smart TV dealers!

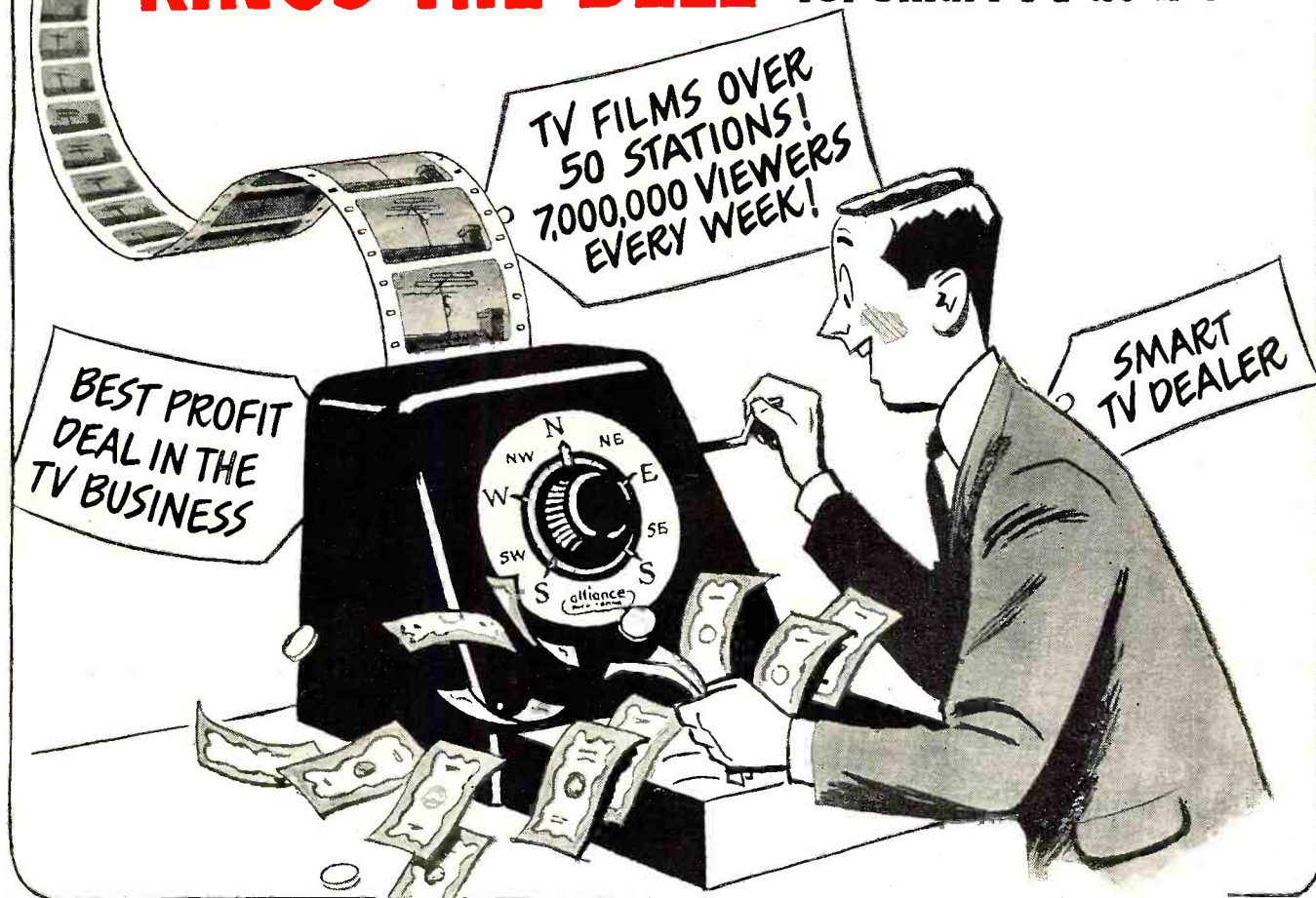

Be Sure You Have This Winning Combination



Model HIR Tenna-Rotor

TENNA-ROTOR

The only fully automatic rotor. Just set it and forget it! Set the pointer . . . the antenna turns to that position and stops. North—East—South—West—direction indicator dial shows exact antenna position at all times.



Tenna-Scope

ALLIANCE TENNA-SCOPE

The new TV booster with one simple control. Gives maximum uniform high gain on all channels. Automatic on-off switch. Easy to install. An excellent companion item to Tenna-Rotor.

THE SALES ARE 'SET UP' FOR YOU!

**Nation-wide TV Advertising delivers
Thousands of Sales—Every Week!**

Seven million viewers see Alliance Tenna-Rotor demonstrated on 50 key TV stations every week. Tenna-Rotor is the only TV accessory backed by a consistent, powerful national TV campaign. Hundreds of thousands of Alliance Tenna-Rotors are in use! ● Alliance Tenna-Rotor offers faster installation with 4-conductor "Zip" cable. Works in all weather. Guaranteed for one year. Approved by Underwriters Laboratories.

NEW DELUXE MODEL HIR IS FULLY AUTOMATIC!

ALLIANCE MANUFACTURING COMPANY • Alliance, Ohio



FREE!

This New TV REPLACEMENT Capacitor MANUAL by SPRAGUE

From A to Z, from Admiral to Zenith, this 16-page book is jam-packed with complete replacement recommendations for critical TV capacitors in 497 television sets from The Technical Service Division of Sprague, world's largest capacitor maker.

Get your copy FREE from your SPRAGUE DISTRIBUTOR or send 10c directly to Sprague to cover handling and mailing costs.

Remember! Avoid costly call-backs in your service work by sticking to Sprague — the capacitors you can depend upon.

SPRAGUE
PRODUCTS COMPANY
DISTRIBUTORS' DIVISION OF THE SPRAGUE ELECTRIC COMPANY
51 MARSHALL ST., NORTH ADAMS, MASS.

Spot Radio News

★ Presenting latest information on the Radio Industry.

By RADIO & TELEVISION NEWS'
WASHINGTON EDITOR

RADIO AND TV has once again become a dominant factor in a national emergency. As in World War II, these essential services have been given a poignant role to fill and there is no doubt anywhere that there will be complete fulfillment, with many pluses.

Described on the Congressional floors and in meetings of the official family as a medium of vaulting import to the nation, radio-TV's possibilities have been closely reviewed during special meetings of the Senate and House Armed Services committee considering a civil defense act, as proposed by the President in his 162-page civil defense report. According to the report the . . . "nerve system of civil defense is communications." It is imperative, the study reveals, that effective and rapid communications be maintained between federal and state and between state and local civil defense organizations and within these organizations if they are to function when needed. Accordingly, we are told, every contingency must be provided for, and sound flexible plans developed so that in any emergency, communications in some form will be available.

Detailing the types of communications required, the report says that all forms must be embraced including facsimile, AM, FM, and TV, and planning must include provisions for equipment for communications between ground stations, and between air and ground. All existing communications facilities and services will have to be used to their fullest extent, and in addition, it will be necessary to provide for emergency services as alternate means of transmission and reception, the presidential statement discloses. Mobile two-way and ham services are cited as two important emergency services which will be required. The amateurs are described as possessing facilities which can make . . . "an important contribution to civil defense communications."

Commenting on the role of broadcasting in the critical days which may lie ahead, the report states that stations of all types, including TV, can be utilized as . . . "an important medium to inform the public of its responsibility to civil defense." Through the use of broadcast facilities, it will be possible to present to a maximum audience vital informational and educa-

tional material, the defense review continues, material which will cover the . . . "location of shelters, advice on how to prevent jamming of thoroughfares . . ."

So that broadcasters will be fully familiar with emergency procedures, a series of classified regulations, prepared under the joint direction of the Department of National Defense and the FCC, are now being issued. According to a notice from the Commission, the defense-emergency authorizations, which will require special experimental operations, will not be made public. However, the stations directly affected by the rulings will be informed as fully as possible consistent with security regulations.

Some states have already organized their own emergency broadcaster's program. In New York and New Jersey, for instance, a bi-state committee, including David Driscoll of WOR, serving as chairman, and Seymour N. Siegel of WNYC, named as co-chairman, recently set up plans for the mobilization of broadcasting personnel and facilities. During a meeting of the group, three basic areas were cited as essential to the stations: New Jersey, upstate New York and Greater New York City. Technical arrangements were made for the complete coordination of all major networks and channels of independents in case of atomic attacks.

Plans are also on file in Washington for the restoration of a State Guard Radio Service, similar to the one that was operative during World War II. During that period, nearly thirty state guard authorizations were outstanding, covering in each instance operation of from 40 to 200 or more low-power portable or mobile stations by state guard personnel only. Present patterns call for the sharing of the Special Emergency Radio Service frequency of 2726 kilocycles and for the handling of emergency communications relating to public safety and the protection of life and property. It appears at this time that the reactivation will become an actuality in a matter of weeks.

TV'S PART in education found itself quite a featured attraction during a long hearing session of the FCC. The meeting, scheduled as part of the overall allocation discussion, was highlighted by prior comments of Madame Commissioner Frieda Henneck, who



ALL RANGES WITH THIS ONE CONTROL

**Model
630**

Just *one* knob—extra large—easy to turn—flush with the panel, controls all ranges. This one knob saves your time—minimizes the chances of “burn-outs” because you don’t have to remember to set another control. You can work fast with Model 630 with your eyes as well as your hands. Look at that scale—wide open—easy to read, accurately. Yes, this is a *smooth TV* tester. Fast, safe, no projecting knobs, or jacks, or meter case. Get your hand on that single control and you’ll see why thousands of “Model 630’s” are already in use in almost every kind of electrical testing



ONLY \$39.50 AT YOUR DISTRIBUTOR

In Canada: Triplett Instruments of Canada, Georgetown, Ontario

FOR THE MAN WHO TAKES PRIDE IN HIS WORK

Triplet

TRIPLETT ELECTRICAL INSTRUMENT COMPANY • BLUFFTON, OHIO, U.S.A.

for Greatest
TV Picture Quality

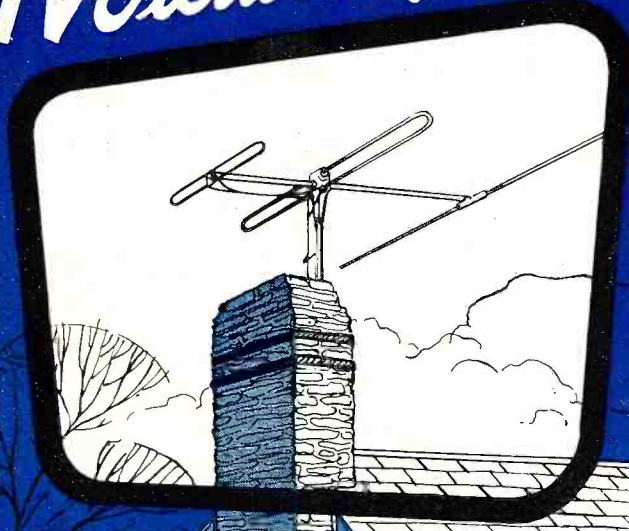

AMPHENOL
—INLINE—
TV ANTENNA

* Reissue Patent Number 23,273

Manufacturer, dealer, serviceman alike benefit when the customer receives the greatest picture quality that his set can produce. Customers expect a good picture on all channels when they purchase a TV set—but even the most expensive set cannot produce a better picture than the antenna brings to it.

Exhaustive laboratory and field tests have proved that the AMPHENOL Inline Antenna gives higher, more uniform gain over the entire TV spectrum. Its full 12-channel coverage insures fine reception for all future, as well as all existing, stations in any area.

Give your customer TV picture quality right from the time of installation by recommending an AMPHENOL Inline Antenna and you will build customer satisfaction.

Send for "The Antenna Story"—a sincere discussion of TV antennas based on actual field tests.



YOURS FOR THE ASKING . . .

AMPHENOL

AMERICAN PHENOLIC CORPORATION

1830 SO. 54TH AVENUE

CHICAGO 50, ILLINOIS

has been a staunch supporter of extra channels for education. In a prepared statement during a broadcast, she not only bluntly repeated her earlier demands that at least 25% of all TV channels should be assigned to educators, but struck out against commercial broadcasters, declaring that she did not . . . "think that our commercial broadcasters ever have accepted or ever will accept the full-time responsibility for educating our listening and viewing public." In her opinion, such acceptance could not prevail because . . . "selling soap or toothpaste is not a qualification for, or in any way compatible with teaching history, physics, or literature on television."

Television channels, she emphasized, represent one of America's most valuable natural resources, the airwaves. "The airwaves," she added, "belong to the people. Unlike any of the other mass communications media, such as newspapers, magazines, or motion pictures, the radio and television airwaves are in the public domain."

"Television is at the crossroads," said the Commissioner. "There are about 2000 TV frequencies remaining to be handed out, and once these are gone there will be no more to be had," the FCC air jurist declared. She said that she hoped that the Commission will take a far-sighted view of the great potential value of TV as a medium of public education and set aside certain channels exclusively for the use of non-commercial stations. It was her belief that education . . . "cannot do a decent job when it is subject to the vicissitudes of commercial broadcasting. . . . Education should be handled by educators skilled and trained in that field. Commercial broadcasters are not qualified in the field of education and have never even made such a pretense."

Quite an illuminating study of the potentialities of TV in education was offered by WNYC Headman Seymour N. Siegel during the official hearings. Citing the value of TV in covering such subjects as baby care, Siegel said that only television can tell the story. For instance, he said, you cannot tell anybody . . . "how to hold a baby or how to diaper a baby, or how to give a baby a bath. . . . You have to show them." Oddly enough, he continued, no station in New York City, has ever demonstrated the proper method of diapering a baby.

Cooking and the kitchen were also described as unfortunate victims of the commercial tactics. He pointed out that one of the . . . "major difficulties in teaching the housewife how to buy food is the one describing various cuts of meat." He claimed that most women don't know what they are buying when they visit the butcher shop. "You cannot tell people about the different grades and parts of a steer," he said. "You have got to show them!"

Turning from the domestic scene to the political arena, Siegel said that our highly developed communications system is . . . "not doing everything necessary to raise the culture and the reasonableness of the American people." In his opinion, there is too great an idea lag between the high-level policy makers and the majority of the voting public which has the ultimate power over these policy makers. He felt that the lag . . . "is a frightening one . . ." and the hope . . . "lies in non-commercial educational TV."

The direct problems of allocation and education were reviewed by quite a few witnesses during the sessions. In a particularly complete brief, we were told by Telford Taylor, counsel for the joint committee on educational TV, (representing the American Council on Education, Association for Education by Radio, Association of Land Grant Colleges and Universities, National Association of Educational Broadcasters, National Association of State Universities, National Council of Chief State School Officers, and the National Education Association) that inasmuch as all of the receivers now in the hands of the public are designed for operation on the very-high channels, and since the technical prospects in the ultra-high bands are as yet uncertain, only the v.h.f. allocations were of immediate concern to them. The committee felt that because of the technical difficulties and the cost factors, educational TV must be granted space in the present channels. Unless such a program is adopted, added Taylor, and educational institutions

(Continued on page 113)



Train at Home in Spare Time for **RADIO** and **TELEVISION**

**I Send You
18 BIG
KITS
OF RADIO-
TELEVISION
EQUIPMENT**

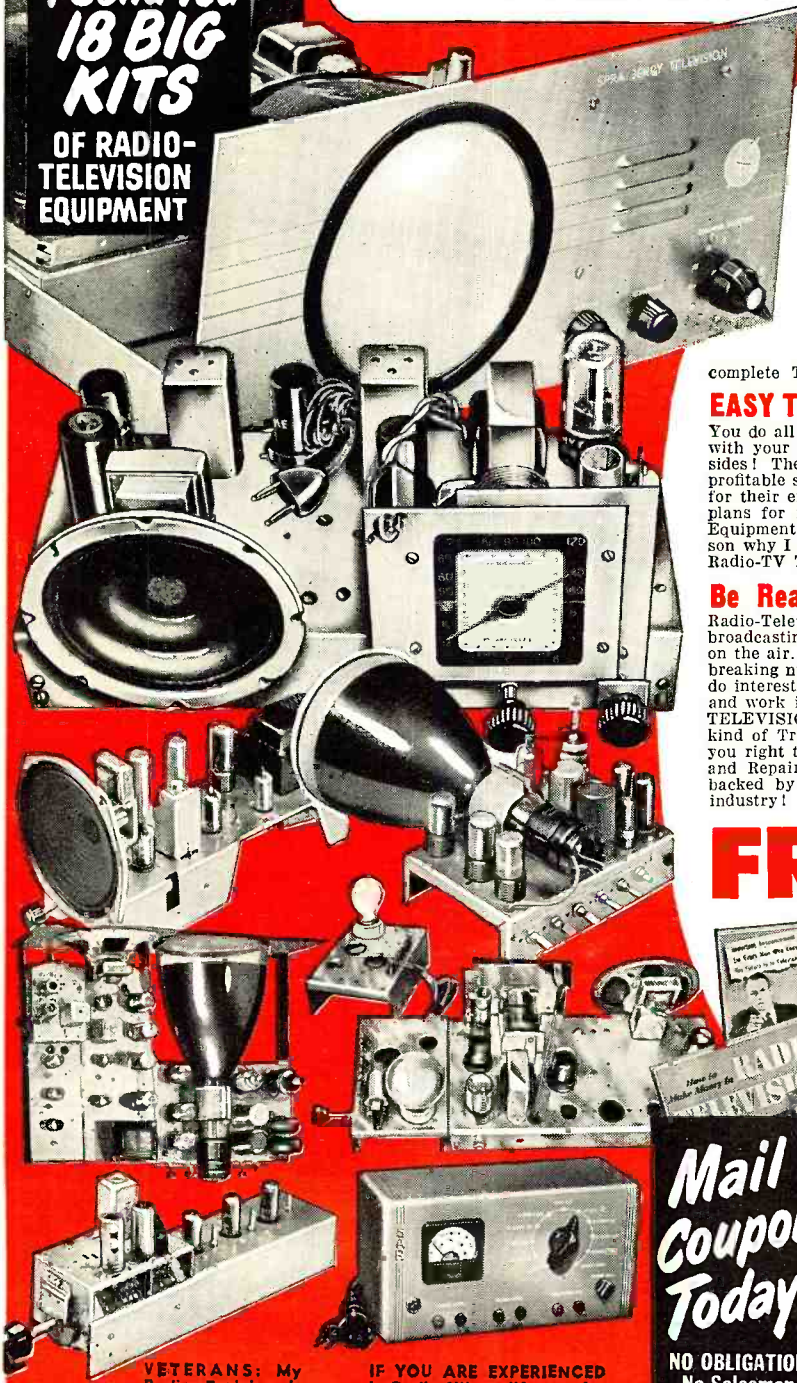

**My Famous Training System Prepares
You in Double-Quick Time for a Good
Job or Your Own Profitable Radio-
Television Business**

Radio-Television is now America's greatest opportunity field! Trained men are needed to fill good jobs and handle profitable Radio-Television Service work. I have trained hundreds of men for success in Radio-Television—and I stand ready to Train you too, even if you have no previous experience. My training is 100% practical—designed to give you the knowledge and experience you need to make money in Radio-Television in the shortest possible time. I Train you with up-to-the-second revised lessons—PLUS many big kits of Radio-Television equipment. You actually do over 300 demonstrations, experiments and construction projects. In addition, you build a powerful 6-tube 2-band radio, a multi-range test meter and a complete Television receiver! All equipment is **YOURS TO KEEP.**

EASY TO MAKE EXTRA MONEY WHILE YOU LEARN

You do all your training with me **AT HOME** in spare hours. Keep right on with your present job and income while learning—and earn extra cash besides! The day you enroll I begin sending you plans and ideas for doing profitable spare-time Radio-TV work. Many of my Sprayberry students pay for their entire training this way! You get priceless experience and many plans for making extra money. You build all your own Radio-TV Test Equipment from parts I send you—nothing else to buy. Just one more reason why I believe I offer the ambitious man the biggest value in top notch Radio-TV Training available anywhere in America today.

Be Ready for Top-Paying Radio-Television Jobs

Radio-Television is growing with amazing speed. More than 2000 Radio broadcasting stations PLUS an additional 102 Television stations are now on the air. Radio sets and TV receivers are being made and sold in record-breaking numbers. If you enjoy working with your hands . . . if you like to do interesting and varied work . . . if you really want to make good money and work in an industry that has a future . . . **YOU BELONG IN RADIO-TELEVISION.** But you **MUST** have good Training to "cash in" . . . the kind of Training that starts you out with basic fundamentals and carries you right through every circuit and problem of Radio-Television Servicing and Repair. In a word . . . that's Sprayberry Training . . . the course backed by more than 20 years of association with the Radio-Television industry!

FREE 3 BIG RADIO-TELEVISION BOOKS

I want you to have **ALL** the facts about my complete system of Radio-Television Training! Act now! Rush the coupon for my three big Radio-Television books: "How to Make Money in Radio-Television," PLUS my new illustrated Television Bulletin PLUS an actual sample Sprayberry Lesson—all **FREE** with my compliments.

No obligation and no salesman will call on you. Send the coupon in an envelope or paste on back of post card. I will rush all three books at once!

**Sprayberry Academy of Radio, Dept. 25-T
111 North Canal St. Chicago 6, Ill.**

**Mail
Coupon
Today!**
**NO OBLIGATION
No Salesman
Will Call**

**SPRAYBERRY ACADEMY OF RADIO, Dept. 25-T
111 North Canal St., Chicago 6, Ill.**

Please rush to me all information on your Radio-Television Training Plan. I understand this does not obligate me and that no salesman will call upon me.

Name..... Age.....

Address

City..... Zone..... State.....

Please Check Below About Your Experience

Are You Experienced? No Experience

VETERANS: My Radio Training is Approved for Veterans.

IF YOU ARE EXPERIENCED in Radio I'll qualify you for Television in 4 to 8 weeks. Rush coupon.

ON LONG ISLAND

817 **EXPERTS**

SPECIFY



PETE CHANKO SAYS:
Chanrose Distributors
Jamaica, N. Y.

Servicemen and Service Dealers are our customers and we carry the products they want. From the very beginning, we have featured N. U. tubes because N. U. pioneered in designing and building tubes to meet the serviceman's strictest requirements. Uniform, reliable, properly designed for interchangeability, N. U. tubes solve every service problem. And, backed by N. U.'s cooperative management, helpful service aids and advertising, N. U. tubes are profit-makers for both us and our 817 customers.

renew
with **N.U.**
premium quality tubes

- RADIO AND TELEVISION RECEIVING TUBES
- VIDEOTRON TELEVISION PICTURE TUBES
- PANEL LAMPS
- TRANSMITTING AND SPECIAL PURPOSE TUBES



NATIONAL UNION RADIO CORP.

Main Office: 350 Scotland Rd., Orange, N. J.

Research Division: Orange, N. J. • Plants: Newark, N. J. —Hatboro, Pa.

New Du Mont Steadibeam* . . .

always a clinching sales point

One of the pet peeves of television set owners is the program disturbance sometimes caused by moving planes, trains, autos, buses, trolleys, or tropospheric disturbances.

This is where the new Du Mont Steadibeam comes to the rescue. All Du Mont Telesets* without exception have this automatic signal compensator, the most advanced form of automatic gain control in the television industry today.

The Du Mont Steadibeam positively insures uniform signal strength, whether the station is distant or nearby. It compensates automatically for rapid or slow variations in signal, due to any of the hazards mentioned above as well as many others. It retains picture brightness, for example, despite variations as great as 100 to 1!

It is an advantage that makes Du Mont Telesets easier to sell. It is one of those wanted features that a set owner brags about to his friends and neighbors. And that means more Du Mont sales for you.

The new Du Mont Steadibeam, like the Du Mont Sensituner,* the Du Mont Signalock,* the Du Mont Extra tubes, is one of the many Du Mont plus values that result in better performance, longer set life, lower service cost, more satisfied customers.

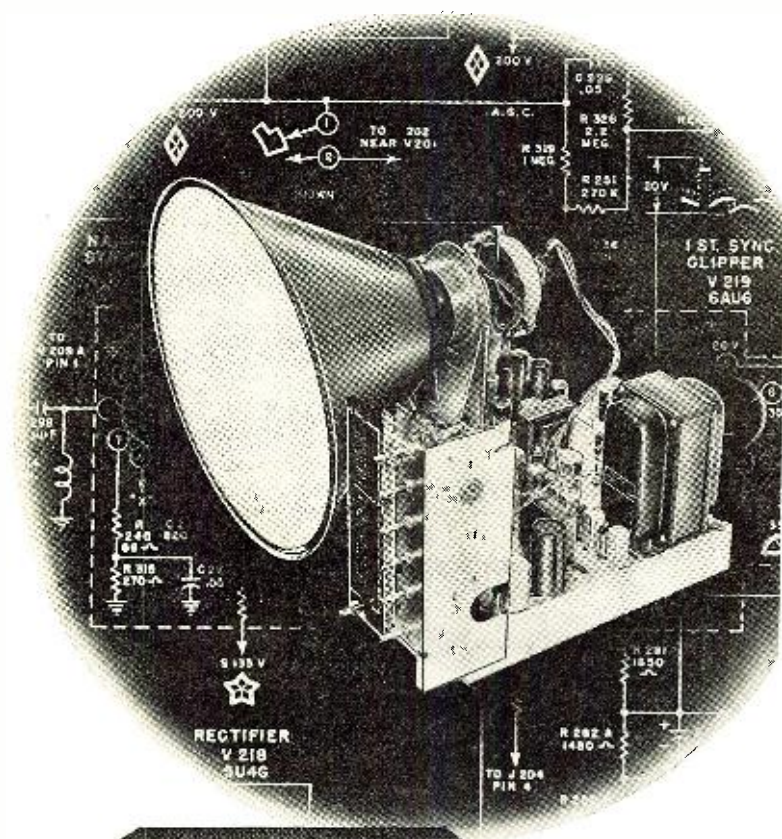

The DU MONT TARRYTOWN, with 17 inch Rectangular tube, combining TV, AM-FM radio, 3-speed phonograph.

You'll do better with Du Mont—Television's most coveted franchise

DU MONT *first with the finest in Television*

*Trade Mark

Copyright 1950, Allen B. Du Mont Laboratories, Inc., Television Receiver Division, East Paterson, N. J. and the Du Mont Television Network, 515 Madison Avenue, New York 22, N. Y.

MADE OF STAINLESS STEEL . . .

**Metal-shell tubes mean
better picture quality
and
fewer service calls**



ASK any dealer or serviceman. He'll tell you that a high-quality picture means a satisfied television customer. And it means fewer call backs for service, too.

Metal-shell picture tubes are a long step forward in giving television owners the kind of performance they want. This type of construction lends itself to the use of face plates with improved optical characteristics, and results in clearer, sharper pictures.

Tube manufacturers now have the ideal material for metal-shell construction in U·S·S 17-TV Stainless Steel . . . developed especially for this type of application.

Light weight and high structural strength—two of Stainless Steel's outstanding characteristics—contribute immensely to the advantages of metal-shell construction. Stainless tubes

weigh from one-third to one-half less than all-glass tubes, materially reducing handling, packing and shipping costs. And Stainless Steel's extra strength greatly reduces the danger of breakage and implosion.

You'll find metal-shell tubes of U·S·S 17-TV Stainless in many of the new 1951 television receivers. Their performance is an added sales point for the dealer and distributor and a big help to the serviceman, too.

AMERICAN STEEL & WIRE COMPANY, CLEVELAND • COLUMBIA STEEL COMPANY, SAN FRANCISCO
NATIONAL TUBE COMPANY, PITTSBURGH • TENNESSEE COAL, IRON & RAILROAD COMPANY, BIRMINGHAM • UNITED STATES STEEL COMPANY, PITTSBURGH
UNITED STATES STEEL SUPPLY COMPANY, WAREHOUSE DISTRIBUTORS, COAST-TO-COAST • UNITED STATES STEEL EXPORT COMPANY, NEW YORK



U·S·S STAINLESS STEEL

SHEETS • STRIP • PLATES • BARS • BILLETS • PIPE • TUBES • WIRE • SPECIAL SECTIONS

1-317

UNITED STATES STEEL



Service Clinic!

Latest information to help you better service Raytheon TV

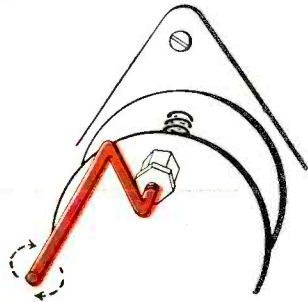

HOW RAYTHEON'S SIMPLIFIED TV PICTURE-CENTERING WORKS

NO SCREWDRIVER NEEDED
WRENCH NEEDED
BACK COVERS TO REMOVE

All you do is move the extended iris control arm

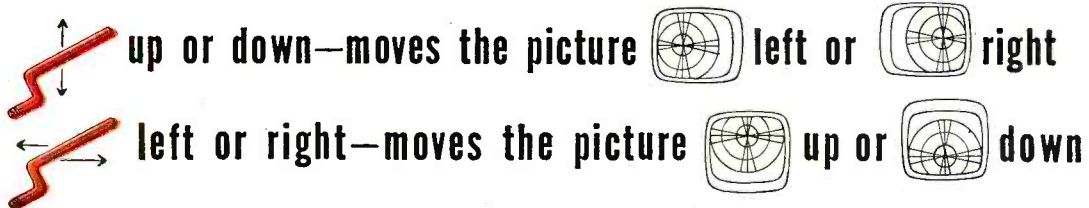

IT'S SIMPLE TO USE. Just move the extended iris control arm. Precise iris control of the magnetic field in the focalizer provides the correct axial alignment of the beam to give perfect picture centering.

IT'S ONE OF MANY EXAMPLES of how important Raytheon engineering considers "servicing ease" among its specifications of quality.



Dependably Built for Dependable Performance



THE STARLIGHT—Model RC-1720

Belmont Radio Corporation, 5921 W. Dickens Ave., Chicago 39, Ill.
Subsidiary of Raytheon Manufacturing Company

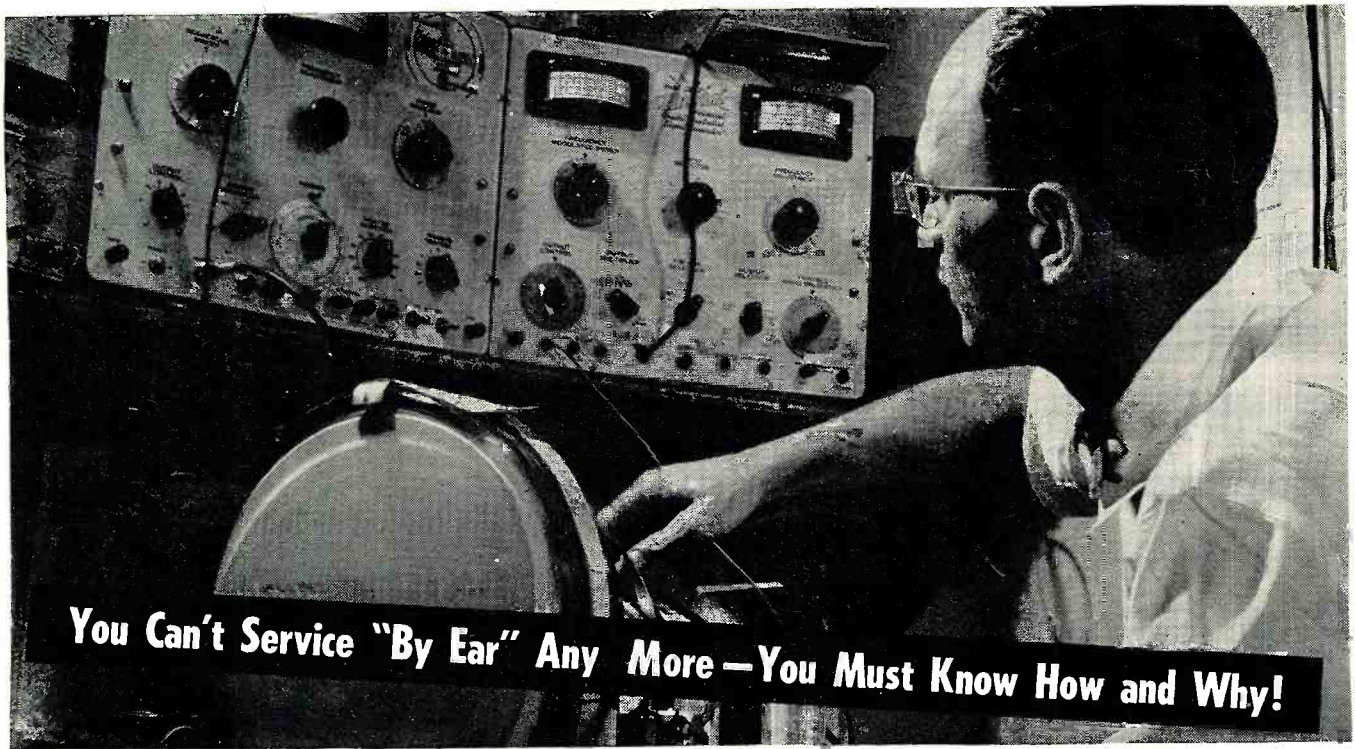

CREI Technical Training Qualifies You for "Tough" Jobs—at Better Pay—in TELEVISION & FM SERVICING!

Screwdriver mechanics could get by in the old days of radio—but no longer. TV's complicated circuits call for skilled men—capable of using modern test equipment. Anyone in the field—if he is to stay in business—needs to know how a TV set works, why it works, and how to make it work better. Hit-and-miss methods are not only inefficient; they are unsuccessful and unprofitable.

As one manufacturer's service manager says, "If you are a TV man who can repair a set only by slow and plodding work—watch out. Pretty soon a youngster will come along with training and skill. He'll do a given job in one-quarter the time. He'll be paid twice as much per hour as you get—but the customer will still get off at half-price."

Opportunities for profitable servicing work are practically unlimited. With partial—or complete—mobilization of the electronics industry a definite possibility, a qualified serviceman will be

in line for one of two things: increased and profitable work as a civilian, either in his own shop or in essential industry; or military service, where technical electronics ability is immediately rewarded with supervisory jobs at extra pay. So, in or out of the armed services, you'll be better off with *good* technical training.

That's why more and more service men are using CREI's practical home-study course in TV-FM servicing. Designed by top-notch teachers, taught by practical TV instructors, reviewed and checked by qualified experts, kept up-to-date through direct contact with manufacturers, dealers, and service specialists, the CREI course equips you with the right "tools" to earn more money.

Start *your* preparation while there is still time! The next few months can be all-important—don't put it off. It costs you only a few minutes' time to get the facts. Mail the coupon below for complete details.

THE THREE BASIC CREI COURSES:

- ★ **PRACTICAL RADIO ENGINEERING**
Fundamental course in all phases of radio-electronics
- ★ **PRACTICAL TELEVISION ENGINEERING**
Specialized training for professional radiomen
- ★ **TELEVISION AND FM SERVICING**
Streamlined course for men in "top-third" of field

ALSO AVAILABLE IN RESIDENCE SCHOOL COURSES

CAPITOL RADIO ENGINEERING INSTITUTE

An Accredited Technical Institute Founded in 1927

Dept. 112C, 16th Street & Park Road, N. W.
Washington 10, D. C.

Branch Office:
San Francisco (2) 760 Market St.



SEND FOR
FREE BOOKLET

CAPITOL RADIO ENGINEERING INSTITUTE
Dept. 112C, 16th & Park Rd., N. W., Washington 10, D. C.

Gentlemen: Send me complete details of the TV and FM Servicing home study course. Also send brochure that explains the CREI self-improvement program and gives complete details and outline of course. I am attaching a brief resume of my experience, education and present position.

- Check the Field of Greatest Interest
- TV, FM & ADVANCED AM SERVICING
 - PRACTICAL TELEVISION ENGINEERING
 - PRACTICAL RADIO ENGINEERING
 - AERONAUTICAL RADIO ENGINEERING
 - BROADCAST RADIO ENGINEERING (AM, FM, TV)
 - RADIO-ELECTRONICS IN INDUSTRY

NAME _____ AGE _____

ADDRESS _____

CITY _____ ZONE _____ STATE _____

SEND DETAILS ON RESIDENCE SCHOOL.

"The Set the Experts Own"

hallicrafters

precision television



TELEVISION CAMERAMAN!



TELEVISION DEALER!



TV SERVICE ENGINEER!

ONLY
HALLCRAFTERS
HAS THE
\$2,000,000
**dynamic
tuner**

For their *own* homes .
for their *personal* television
pleasure, the experts buy
Hallicrafters!

Their judgment is by comparing,
with *their own eyes*. *You*, too, can see
what the experts see, PRECISION performance!

Hallicrafters exclusive "Dynamic Tuner" brings you
television's **CLEAREST** picture, with 2 to 4 times greater
sensitivity than other leading sets.

hallicrafters TV
THE SET THE EXPERTS OWN!

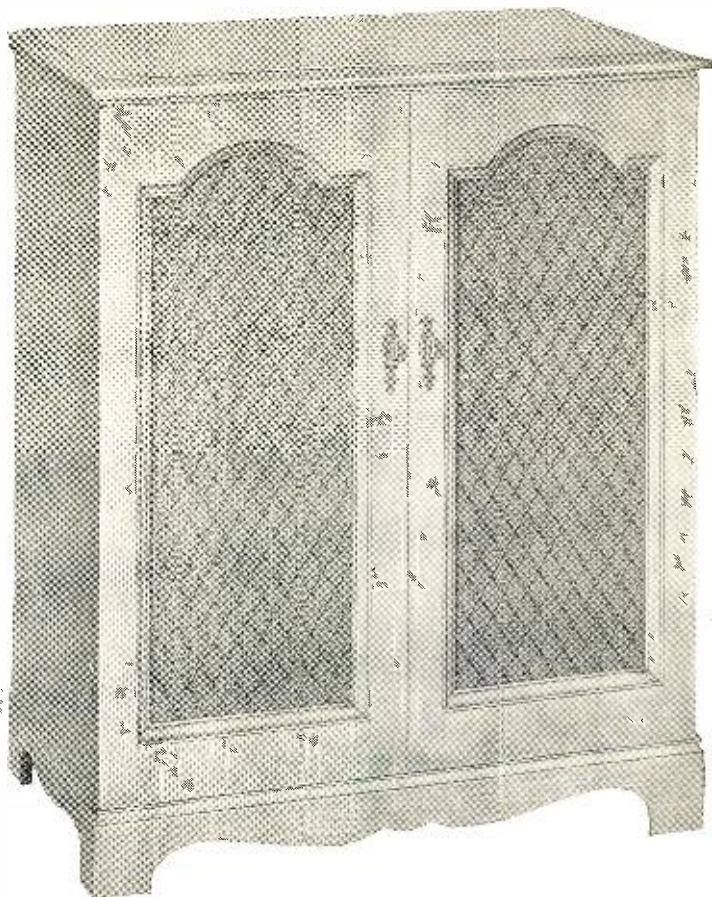

The 890 "PROVINCIAL"
in Honeyed Maple

20" Rectangular
Black Tube TV
—AM Radio
—3-Speed
Phonograph

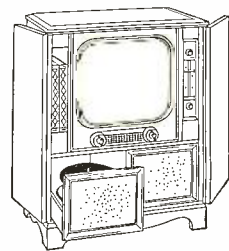

the hallicrafters co.

WORLD'S LEADING MANUFACTURER OF PRECISION RADIO & TELEVISION • CHICAGO 24, ILLINOIS
February, 1951

hear!
hear!



PYRAMID

"HEARING-AID"

TYPE 65 PTR

**TUBULAR PAPER
CAPACITORS**

for 65° C
applications—
150 v.d.c. rating

- Small, compact and sturdily constructed.
- Designed for continuous operation at D.C. voltage rating
- Will withstand a 5-second test of 300 V.D.C.
- Will meet standard RMA humidity test.

WRITE FOR COMPLETE LITERATURE
Representatives and Distributors
throughout the U.S.A. and Canada



PYRAMID

PYRAMID ELECTRIC COMPANY

1445 Hudson Boulevard

North Bergen, N. J., U. S. A.

TELEGRAMS: WUX North Bergen, N. J.
CABLE ADDRESS: Pyramidusa

Within the INDUSTRY

OTTO B. BLACKWELL, retired assistant vice-president of the *American Telephone & Telegraph Co.*, has been awarded the 1950 Edison Medal for "his pioneer contributions to the art of telephone transmission" by the American Institute of Electrical Engineers.



The Edison Medal which was established in 1904 is awarded annually to a resident of the United States or Canada for meritorious achievement in electrical science, electrical engineering, or the electric arts.

Mr. Blackwell is a former vice-president of the AIEE and retired last year after 43 years with the *Bell System*. He is associated actively with the American Association for the Advancement of Science, the Institute of Radio Engineers, the Acoustical Society of America and the American Physical Society. He is a fellow in the AIEE and the IRE.

* * *

LANSDALE TUBE COMPANY, a subsidiary of *Philco Corporation*, has purchased a new plant site at Frederick, Maryland for the manufacture of electronic tubes. The plant is expected to be in operation before the end of this year . . . **EUTECTIC WELDING ALLOYS CORPORATION** is building a new Engineering Services Building at the site of the company's No. 2 plant in Flushing, Long Island. Completion is expected shortly . . . **MEASUREMENTS CORPORATION** of Boonton, New Jersey has recently moved all of its manufacturing department, laboratories, and offices into a new plant on Intervale Road in Boonton. The new plant provides 25,000 square feet of usable floor space . . . **BEST VUE PRODUCTS**, manufacturer of television antennas and accessories, has moved its factory and offices to 240 North 10th Street, Brooklyn, New York . . . **UNITED STATES ELECTRONICS CORP.** is now located at 2038 Broadway, Santa Monica, California. The firm formerly had headquarters in Los Angeles . . . **TRACER-LAB, INC.** has contracted to purchase a building site in West Concord, Massachusetts. A building to house the engineering, manufacturing operations, and certain phases of its radiochemical program will be built at the new location . . . Construction has begun on the first 50,000 square foot addition to the **PACKARD-BELL** factory in Los Angeles. An additional 70,000 square feet of manufacturing area is in the blueprint stage and work will be started

shortly . . . **MINNEAPOLIS-HONEYWELL REGULATOR COMPANY** is expanding its industrial production and operating facilities in Philadelphia with the purchase of the Thomas M. Royal plant for its **BROWN INSTRUMENTS DIVISION . . . GENERAL CEMENT MANUFACTURING COMPANY** of Rockford, Illinois has recently completed a new plant which will be devoted to the manufacture of television accessories . . . **GENERAL ELECTRIC COMPANY** has begun work on a new million dollar electronics plant at Auburn, New York. Completion is expected in the late summer or early fall . . . **ALTEC LANSING CORPORATION** has recently opened a new plant in Beverly Hills, California to supplement its production facilities in Los Angeles and New York. The new plant is located at 9356 Santa Monica Boulevard . . . **RAYTHEON MANUFACTURING COMPANY** of Newton, Massachusetts recently laid the cornerstone for a new \$100,000 industrial cafeteria at its Receiving Tube Plant on Chapel Street in Newton.

* * *

HAROLD BECKER recently rejoined the staff of **RADIO & TELEVISION NEWS** as Eastern Editor with headquarters at 366 Madison Avenue in New York.



In his new position, Mr. Becker will contact authors and potential authors not only for this publication but also for the Radio-Electronic Engineering Edition of **RADIO & TELEVISION NEWS**. He will also cover industry events taking place on the east coast and represent the magazine at conventions and press conferences. Because of his varied experience in the radio field, Mr. Becker is particularly well qualified to gather and interpret trends in the manufacturing and servicing branches of the industry.

Before joining the *Ziff-Davis Publishing Company* organization Mr. Becker was associated with the Press Division of *Radio Corporation of America*.

* * *

THE BRITISH INDUSTRIES FAIR, the British Empire's annual industrial show, will be held this year from April 30 through May 11.

The heavy industry exhibits will be centered in Birmingham and other trades will display their merchandise in London. Exhibit space will occupy more than a million square feet and over 90 industries will be represented by 3000 exhibitors. Advance inquiries

RADIO & TELEVISION NEWS

WHAT YOU GAIN WHEN YOU BUY...

HYTRON
Studio-Matched
RECTANGULARS

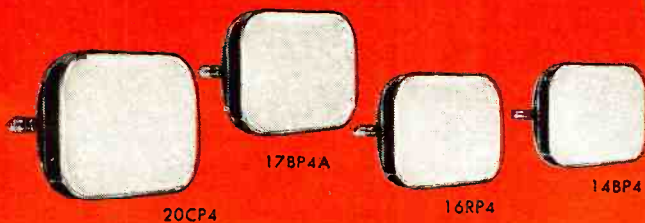

LEADING TV SET MANUFACTURERS PICK HYTRON RECTANGULARS:
ADMIRAL • AIR KING • BENDIX • CROSLY • EMERSON
HALLICRAFTERS • HOFFMAN • MOTOROLA • NATIONAL
OLYMPIC • SENTINEL • SETCHELL-CARLSON • SPARTON
STROMBERG-CARLSON • TRAV-LER • WESTINGHOUSE
AND OTHERS

1 You get THE ORIGINAL. The *studio-matched* rectangular tube is Hytron's baby. Its logically designed screen matches the 4 by 3 aspect ratio of the studio picture. Quite naturally, Hytron's new rectangular is fast becoming the most popular picture tube.

2 You get UNIFORMITY. Hytron's new picture-tube plant is the most modern in the world. It was designed especially to mass-produce Hytron *studio-matched* rectangulars of uniform dependability.

3 You get A COMPLETE LINE. Hytron offers you 14-, 16-, 17-, and 20-inch *studio-matched* rectangulars. All the popular rectangulars (and the popular types of round tubes too).

4 You get THE QUALITY LEADERS DEMAND. Nine out of ten leading TV set makers choose Hytron. More and more leading service-dealers pick Hytron. Because their own experience proves Hytron *studio-matched* rectangulars give "amazingly clearer, sharper, more brilliant pictures." Demand this same performance for yourself. Demand original Hytron *studio-matched* rectangulars.



MAIN OFFICE: SALEM, MASSACHUSETTS

ASTATIC IS FIRST IN PERFORMANCE FIRST IN CABINET STYLING

Booster Model BT-1
List Price \$32.50

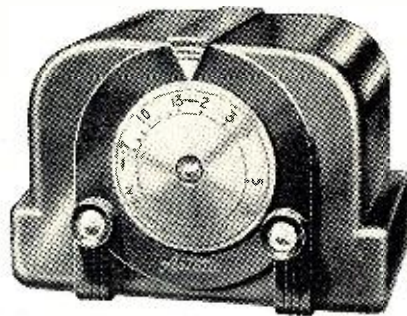

Booster Model BT-2
List Price \$34.95

Compare:
the ability to
improve reception
of these two NEW
ASTATIC TV and FM
BOOSTERS with ANY
others

Note these Quality Features

- 1 Mallory Inductuner for continuous variable tuning.
- 2 High gain, very uniform on both high and low channels.
- 3 Simplified controls—single tuning knob with continuous tuning through both TV and FM bands.
- 4 Band width adequate over entire range.
- 5 Low noise design and construction.
- 6 No shock hazard to user.
- 7 Off-on switch for easily cutting in and out of circuit.
- 8 Selenium rectifier.
- 9 Single 6AK5 Tube.
- 10 Provide for either 72 ohm or 300 ohm impedance input and output.
- 11 Model BT-2 has handsome, dark brown plastic cabinet.
- 12 Model BT-1 has metal cabinet in rich mahogany woodgrain finish.
- 13 Large dial face is easy to see in tuning.
- 14 Model BT-2 has recessed pilot light to show when booster is on.

● Yes, forget their low cost, and make your own comparison of these new Astatic Boosters with others at any price! You'll be amazed at the difference . . . the higher gain and greater reduction of interference and distortion . . . provided by the Astatic BT-1 and BT-2. Astatic engineering leadership has given these new units an unequalled ability to improve both TV and FM reception. But, the final proof is in your own results. Why not put them to the test and see why these new low-cost models are taking the field by storm?



from United States business firms indicate that the number of American buyers attending this year's show will exceed the 1950 record, which was 50 per-cent higher than the registration in 1949.

Radio, television, and radar equipment will be shown at the Olympia hall in London while the electronic, electrical, electromagnetic appliances and devices will be on display in Birmingham.

The British Information Services at 30 Rockefeller Plaza, New York 20, New York is handling U. S. inquiries regarding the fair.

* * *

J. D. VAN DER VEER has been named sales manager of the Electron Tube Initial Equipment department of *Tung-Sol Lamp Works Inc.*



The new sales manager attended the University of Michigan and Armour Institute and served as an engineer with the CAA in the development of Air Navigational Aids. In 1942 he joined the Signal Corps as an engineer in the development of army communications equipment. He was chief of the Radio Branch of Coles Laboratory and left the Army with the rank of Captain in 1945.

Mr. Van der Veer joined *Tung-Sol* in 1945 as Western Sales Manager for Electron Tube Initial Equipment in Chicago. He will now make his headquarters at the company's home office in Newark, New Jersey.

* * *

FREDERICK A. HESS has been named sales manager for the *Vee-D-X* line of TV antennas and accessories . . . *Philco International Corporation* has appointed **FREDERICK J. WILLARD** as vice-president in charge of sales and **F. LEROY SHERMAN** vice-president in charge of foreign operations . . . **H. ALLEN WHITE** has been appointed sales service engineer for the Radio Tube Division of *Sylvania Electric Products Inc.* . . . **FRED A. LYMAN**, assistant national sales manager, has been named director of sales training for the receiver sales division of *Allen B. DuMont Laboratories, Inc.* He will also continue his sales duties . . . **WARREN FREBEL**, formerly purchasing agent for *Majestic Radio & Television*, Division of *The Wilcox-Gay Corporation*, has been appointed purchasing director of the firm . . . **ROBERT H. PASCHALL** is the new vice-president in charge of sales for the *Universal Electronics Sales Corporation* of Philadelphia . . . **LESLIE M. NORMAN** has been elected president of the *Browne TV Laboratories* of Los Angeles. He is also president of *Precision Radiation Instruments, Inc.* of that same city . . . **CARL BROOKS**, eastern manager of *General Dry Batteries, Inc.* has been named general sales manager of the company with headquarters in Cleveland . . . **R. S.**

(Continued on page 105)

RADIO & TELEVISION NEWS



Lectures by
M. N. Beitman,
engineer, author
& serviceman.

Use my 19 years of
Radio Experience
To Double Your Earning
Cut Servicing Time in 1/2

30 LECTURES
COMPLETE \$3.00
ONLY

HERE IS WHAT YOU GET

BOOK 1. How to operate a radio shop. Right location. Store arrangement. New ideas on getting more business. Plans for model shop. Lecture on how and what to charge. Getting repeat business.
BOOK 2. Twelve practical lectures on using all types of test equipment, such as: simple meters, vacuum tube voltmeters, tube testers, signal generators, oscilloscope, signal tracers, point-to-point technique, condenser testers, bridges, etc.
BOOK 3. Fourteen more lectures on radio circuits, trouble-shooting, and servicing. Includes all types of sets—auto, home, portables, F.M., and Television.

GET AHEAD OF OTHERS

By simply reading these 30 lectures and examining the hundreds of interesting illustrations, slides, and diagrams, you add 19 years to your own radio experience. This is real practical knowledge to place you above competition. Facts to help you improve your shop, how to obtain free advertising. Learn what faults are most common to various circuits, how to find these faults quickly, and what instruments to use. Material on every important radio servicing topic including F.M. and TV. See column at right, top.

AMAZING BARGAIN OFFER

Add years of valuable experience to your radio knowledge by using ideas and tricks of an expert. Use this new 3-in-1 giant-size 30-lecture manual to polish up your radio servicing ability, so that toughest jobs will be as easy as replacing a filter condenser. Learn the cause of every puzzling radio defect. Use Beitman's 19 years of successful radio experience to your own advantage.

A \$60 VALUE, YOURS FOR ONLY \$3

Think what it would cost to attend in person the 30 lectures completely printed in **ADVANCED RADIO SERVICING** manual. Perhaps \$60, plus carfare. But in this mammoth volume you have every word of all lectures, illustrations of every slide used, and many additional photographs and charts. The special bargain price for the complete 30-lectures in the giant manual is only \$3, postpaid, full price, nothing else to pay. Send coupon at bottom of page to try this material for 10 days without risk under our guarantee. Read about other Supreme manuals, below.

RADIO-ELECTRONICS HOME-STUDY COURSE

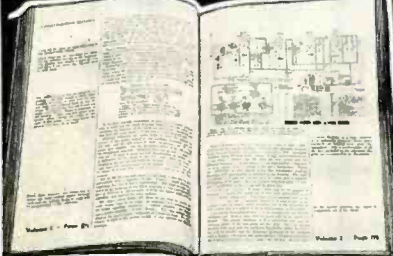

ONLY \$3.95
COMPLETE 3 VOLUMES
53 Lessons

NEW AMAZING OFFER

Here is the most amazing bargain in radio training. The price scoop of the year. For only \$3.95 (full price) you receive a complete radio-electronics course of 53 large, fact-packed lessons. Covers every topic of radio fundamentals, practical servicing, TV, FM, audio, and industrial electronics. Published in three giant books, bound in one super-mammoth volume. Printed in 1951. Compares lesson by lesson with the best \$200 home-study correspondence courses; but here you get all lessons at one time at the unheard-of bargain price of only \$3.95; nothing further to pay or buy.

THREE COURSES IN ONE

The complete training of these 53 large lessons is really **THREE** distinct courses on: (1) Practical Radio, (2) Applied Electronics, and (3) Radio Servicing. The lessons are clear, practical, easy to master and use. Early lessons will make fundamentals clear even to a beginner, while other lessons will give you the practical "know-how" of an expert. Notice in the illustration of the manuals, at top, that the wide column on each page has the text, while the narrow column contains pertinent explanations usually supplied by a teacher. These teacher comments guide you over the hard parts, stress points of importance, tell you how to perform practical experiments using any home radio. There are hundreds of review self-testing questions, 427 drawings, pictures, diagrams, and over a thousand service hints.

YOURS TO TRY FOR 10 DAYS

Just send no-risk coupon, at right, and receive the 3-volume COURSE for a free examination. Use all this material a full 10 days in your own home. Read a few lessons, examine the hundreds of illustrations, apply some of the hints to fix a couple of radios. Only then, if you are pleased, the complete course of 53 lessons, in three volumes, is yours to keep for only \$3.95, full price; otherwise, it costs you nothing for the use and examination. Fair enough? Please rush coupon or ask your jobber while your special price is still only **\$3.95**

Supreme Publications
Sold by All Leading Radio Jobbers

February, 1951

Supreme TV & RADIO Manuals

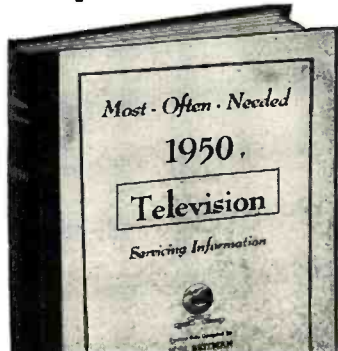

1950 TELEVISION VOLUME

This newest giant volume of the series covers 1950 factory data on all popular television sets of all makes. There are circuit explanations, 144 pages of alignment procedure, test patterns, response curves, pages of waveforms, voltage charts, service hints, and ten mammoth 11x15" blueprints. Manual-style. Available at your jobber or postpaid. **\$3** See coupon below, price only.

1949 T-V Manual. Similar to the volume listed above. Has 160 extra-large pages, plus 9 double-spread giant blueprints. **\$3** To order see coupon below, only.

1948 T-V Manual. Earlier volume has material on all popular TV sets of this period. Large size: 8 1/2 x 11". Remarkable value. **\$3** Including 8 fold-out blueprints, only.

1947 F.M. and T-V Manual. Covers popular F.M. and television sets including R.C.A. 630T's. Data on 192 pages. Only **\$2**

SUPREME RADIO DIAGRAM MANUALS



1950 1949 1948 1947 1946 1942 1941 1940 1939
SUPREME Most-Often-Needed RADIO DIAGRAMS
Each Manual \$2. ('49, '50 at \$2.50); 192 pages of diagrams, alignment data, voltage values, parts lists, and service hints; large size, 8 1/2 x 11". To order, see coupon below. **1926-1938 RADIO Diagrams 240 Pages Price \$2.50**

NO-RISK TRIAL ORDER COUPON

SUPREME PUBLICATIONS, 3727 W. 13 St., Chicago 23, ILL.

Send on trial the manuals checked below and at right. You guarantee complete satisfaction.

Advanced Radio Servicing, 30 lectures. \$3.00
 Radio & Electronics Course, 53 lessons. \$3.95
 1950 Television Manual, \$3. 1949 TV, \$3.
 1948 TV, \$3. 1947 TV & F.M., only \$2.
 I am enclosing \$..... Send postpaid.
 Send C.O.D. I am enclosing \$... deposit.

Name:
 Address:

Most-Often-Needed Radio Diagram Manuals

New 1950 Manual, \$2.50
 1948 Radio Manual, \$2.50
 1948
 1947
 1946
 1942
 1941
 1940
 1939
 1926-1938 Manual, \$2.50

PRICED AT ONLY \$2 EACH

The MOST CHINESE COPIED *TUNER on the Market Today...

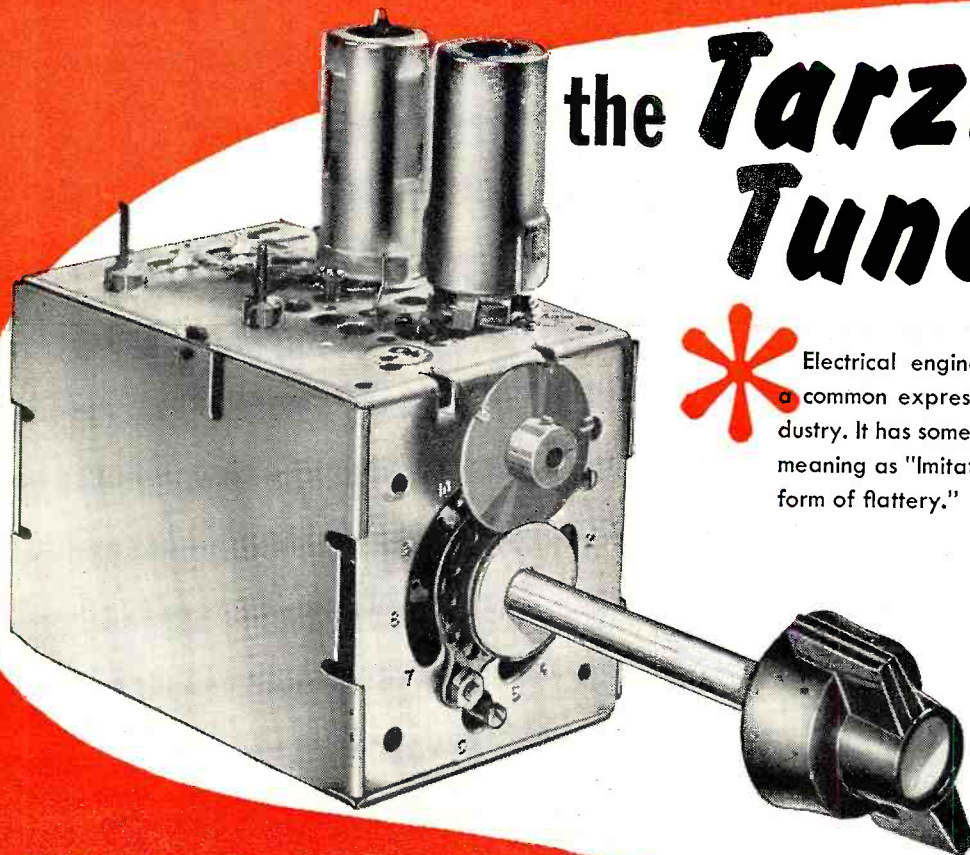

the *Tarzian* Tuner!



Electrical engineers tell us that's a common expression within the Industry. It has something of that same meaning as "imitation is the greatest form of flattery."

Only the TARZIAN front-end TUNER has ALL of these desirable features

- Low oscillator radiation
- High gain and low noise
- Designed for 21 or 41 megacycle I.F. systems
- Insulated shaft design available at low cost
- Anti back lash, air dielectric fine tuning, giving uniform coverage on low and high channels
- Three tube performance with two tubes
- Each channel individually aligned for maximum performance
- Good input balance—no tracking difficulties
- Completely shielded
- Oscillator tube shield provides rigid horizontal and vertical positioning of the tube
- Extra terminals provided for tie-points

Write for complete information, specs and technical data. Engineering service available upon request.

Sarkes Tarzian, inc.

TUNER DIVISION, DEPT. TV-1

537 South Walnut Street • Bloomington, Indiana

The SARKES TARZIAN
stations in Bloomington

WTTS-WTTV

5000 Watts

Channel 10

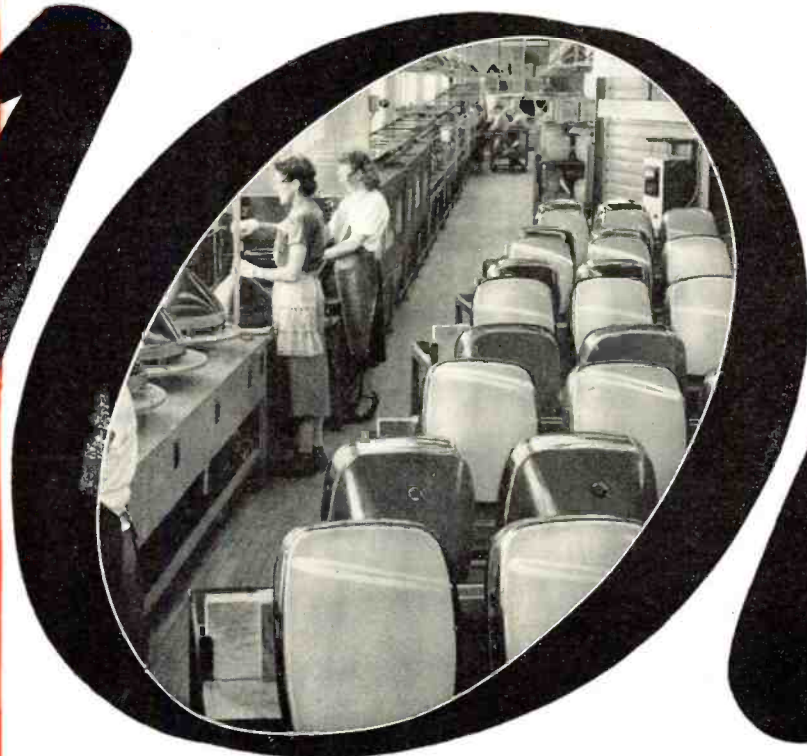

Quality checks and tests make
RAYTHEON PICTURE TUBES
Right for Sight!

Raytheon Television Picture Tubes must pass 101 rigid tests and inspections before a tube is allowed to be shipped. Every component, every assembly and every tube is precision tested for quality of material, accuracy of dimensions, and electrical performance by skilled workers using the finest checking and control system.

That's why Raytheon picture tubes are Right for Sight — right for you to choose and use for replacements and conversions.

101 basic tests make Raytheon Picture Tubes mechanically and electrically perfect; Raytheon's vast background in the pioneering and manufacture of almost every type of electronic tube keeps them ahead of the field in design and performance. Use Raytheon picture tubes with complete confidence that you are giving your customers the finest quality Picture Tubes money can buy.

See your Raytheon Distributor today.

RAYTHEON

®

Excellence in Electronics

**RAYTHEON
MANUFACTURING COMPANY**

Receiving Tube Division

Newton, Mass., Chicago, Ill., Atlanta, Ga., Los Angeles, Calif.

RADIO AND TELEVISION RECEIVING TUBES • CATHODE RAY TUBES
SPECIAL PURPOSE TUBES • SUBMINIATURE TUBES • MICROWAVE TUBES

COPYRIGHT 1951

EICO ITS
and INSTRUMENTS

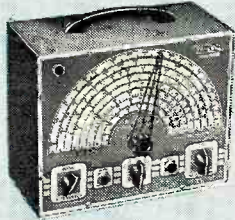

320K SIG. GEN. KIT \$19.95
Wired \$29.95

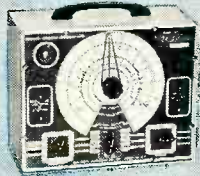

New 950K COND.-RES. COMP.
BRIDGE KIT \$19.95 Wired \$29.95

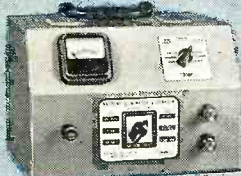

New 1040K BATTERY ELIM.
KIT \$25.95 Wired \$34.95



511K VOM KIT \$14.95
Wired \$17.95

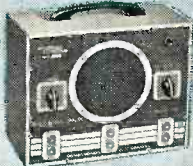

145K SIG. TRACER KIT \$19.95
Wired \$28.95



HV PROBE
(Wired only) \$6.95

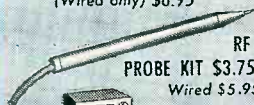

RF
PROBE KIT \$3.75
Wired \$5.95



C-5 SMC
CRYSTAL
KIT \$3.95

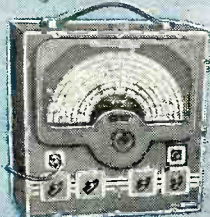

New 315K DELUXE SIG. GEN.
KIT \$39.95 Wired \$59.95

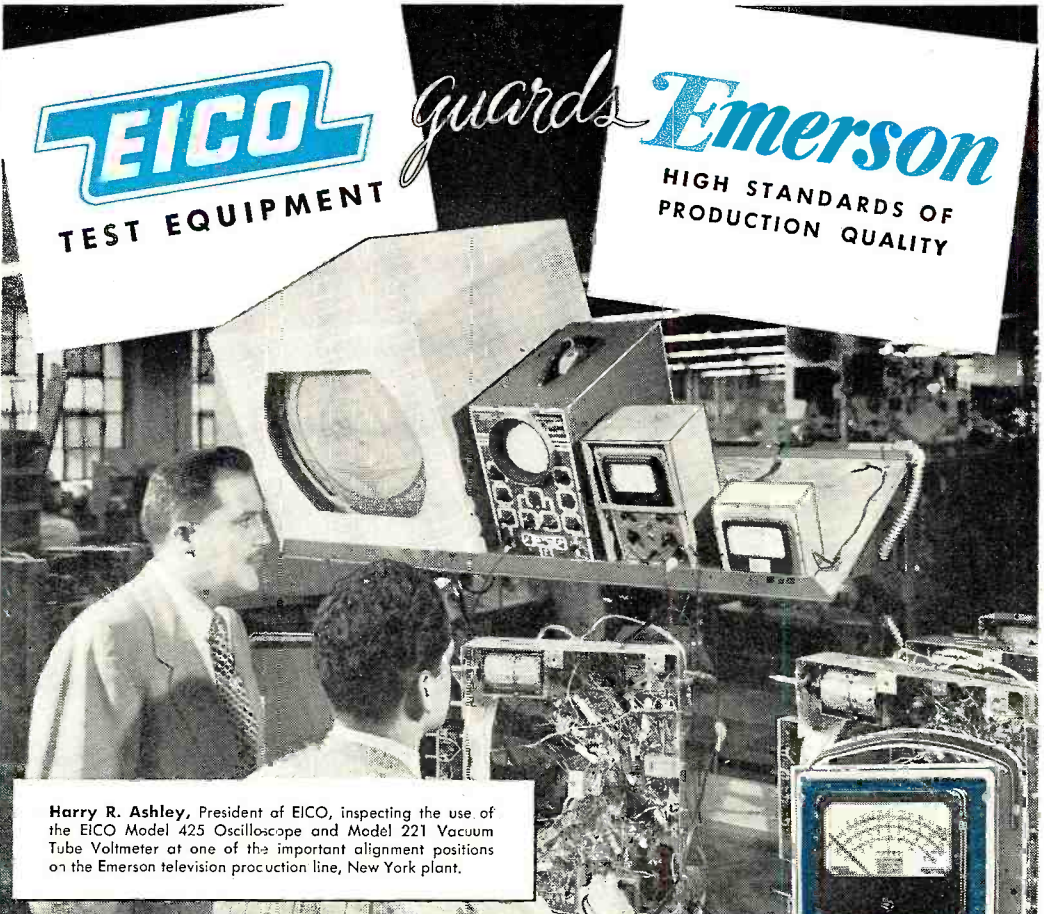

Harry R. Ashley, President of EICO, inspecting the use of the EICO Model 425 Oscilloscope and Model 221 Vacuum Tube Voltmeter at one of the important alignment positions on the Emerson television production line, New York plant.

For Laboratory Precision at Lowest Cost—the Leaders Look to EICO!

FOR electronics test equipment, there's no tougher proving ground than the factories where TV sets are made. There's where the pace is fastest, precision requirements the highest, costs the tightest—and day-after-day dependability an absolute *must*.

In both the giant New York and New Jersey television plants of the Emerson Radio & Phonograph Corporation — at the many critical constant-duty testing positions along the production line—EICO instruments stand guard. For Emerson has found that for speed, accuracy and trustworthiness, at lowest cost, EICO instruments always deliver the fullest measure of value.

From coast to coast, in one leading TV factory after another, this is the experience—*this is the proof of EICO superiority*—that is repeated again and again. The top-flight TV set makers have discovered—and over 50,000 servicemen have learned—that *for the industry's greatest instrument values, at the industry's lowest costs—it's EICO!*

Be sure you look at the *EICO* line *before* you buy any higher-priced equipment! Each *EICO* product is jam-packed with unbelievable value. **YOU** be the judge—compare *EICO* at your local jobber today—and **SAVE!** Write **NOW** for free newest Catalog 2-R.

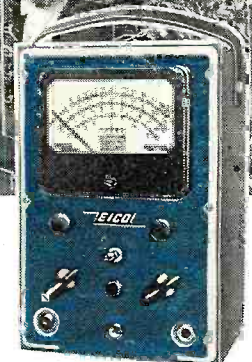

New 221K VTVM KIT \$25.95
Wired \$49.95



New 425K 5" SCOPE KIT \$44.95
Wired \$79.95

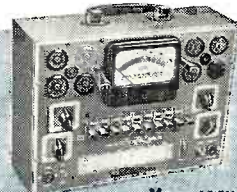

New 625K
TUBE TESTER KIT \$34.95
Wired \$49.95

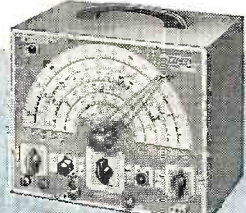

360K SWEEP GEN. KIT \$34.95
Wired \$49.95



ELECTRONIC INSTRUMENT CO., Inc.
276 NEWPORT STREET, BROOKLYN 12, NEW YORK

© 1950, Electronic Instrument Co., Inc.

Prices: 5% higher on West Coast. Due to unsettled conditions, prices and specifications are subject to change without notice.

1950- BANNER YEAR FOR TV

Record production and the color turmoil highlighted 1950. Restrictions and parts shortages will hold 1951 video receiver production below the five million mark.

By
HAROLD BECKER
Eastern Editor
RADIO & TELEVISION NEWS

IN December of 1949, television manufacturers were asked to estimate the volume of television receivers to be produced in 1950. The prognostications ranged from 2½ million to 7 million. Based upon these rough estimates, the industry figured it would produce four million receivers. But even this average goal seemed far fetched considering the component and tube requirements necessary to carry out such a schedule. Most industry observers felt that there just weren't enough kinescope manufacturing facilities to meet anything but a four million figure.

It probably would be fair to say that practically everyone in January, 1950 felt that a four million year was in store—that is everyone but the buying public. The consumer fever for television was so great that it put new meaning in the word "expansion." For in the year 1950, television receiver production became a billion dollar business. There were approximately seven and a half million television receivers produced, far more than were produced from 1946 through 1949.

Today there are more than ten million receivers in the country, with an estimated viewing audience of 92 million people. There are 107 stations in 63 trading areas, reaching approximately 62% of the total population.

The tremendous growth of the tele-



The CBS color receiver. Although FCC approved the CBS color system, an injunction is in force until April 1st forbidding commercial colorcasts by CBS.

vision industry primarily manifested itself in set production. Here is where manufacturers themselves underestimated the part they were to play in 1950.

As of the beginning of 1950, consumer demand for television exceeded existing production facilities of television manufacturers. In a market where a television set was paramount, most consumers held no trademark allegiance, but rather were willing to purchase the set they could get at the time they wanted it.

What motivated this consumer demand?—television itself and its function as an entertainment medium. To see television was to be sold on it. For the first time the consumer was offered an opportunity to view the world within his own living-room. The demand was unquestionably there. It was up to the television manufacturers to meet this demand.

Parts and Tubes

One of the basic deterrents to all-out production of television receivers

(Left) Special conveyors at the Du Mont plant. Many such devices were adopted by manufacturers to increase production. (Center) RCA color camera with cover removed. The long drawn-out color battle ending with FCC approval of CBS system was 1950's big surprise. (Right) Green Radio Distributors sales floor. With many commonly-used components in short supply by end of 1950 distributors were being hard pressed and 1951 will find the situation even more acute.

at the beginning of 1950 was the tight situation to be found in parts and tubes. This situation became increasingly worse as the year progressed, so much so that manufacturers literally hunted down overseas vendors.

Undoubtedly the greatest story in the advancement of commercial television lies in what the parts and tube manufacturers did to increase their production. In equipment that contains as many tubes, condensers, resistors, etc. as a television set, you can well imagine the production necessary to meet the 1950 consumer demand for 7½ million receivers.

The production story of the television kinescope is, in itself, a marvel of creative productive genius. Unless you have seen the manufacturing facilities necessary to produce a television kinescope, you cannot possibly imagine the difficult position the industry was in to meet the requirements for picture tubes. Yet, here again, kinescope manufacturers met the demand. They converted every possible bit of floor space to production and added new

INTERCITY TELEVISION NETWORKS

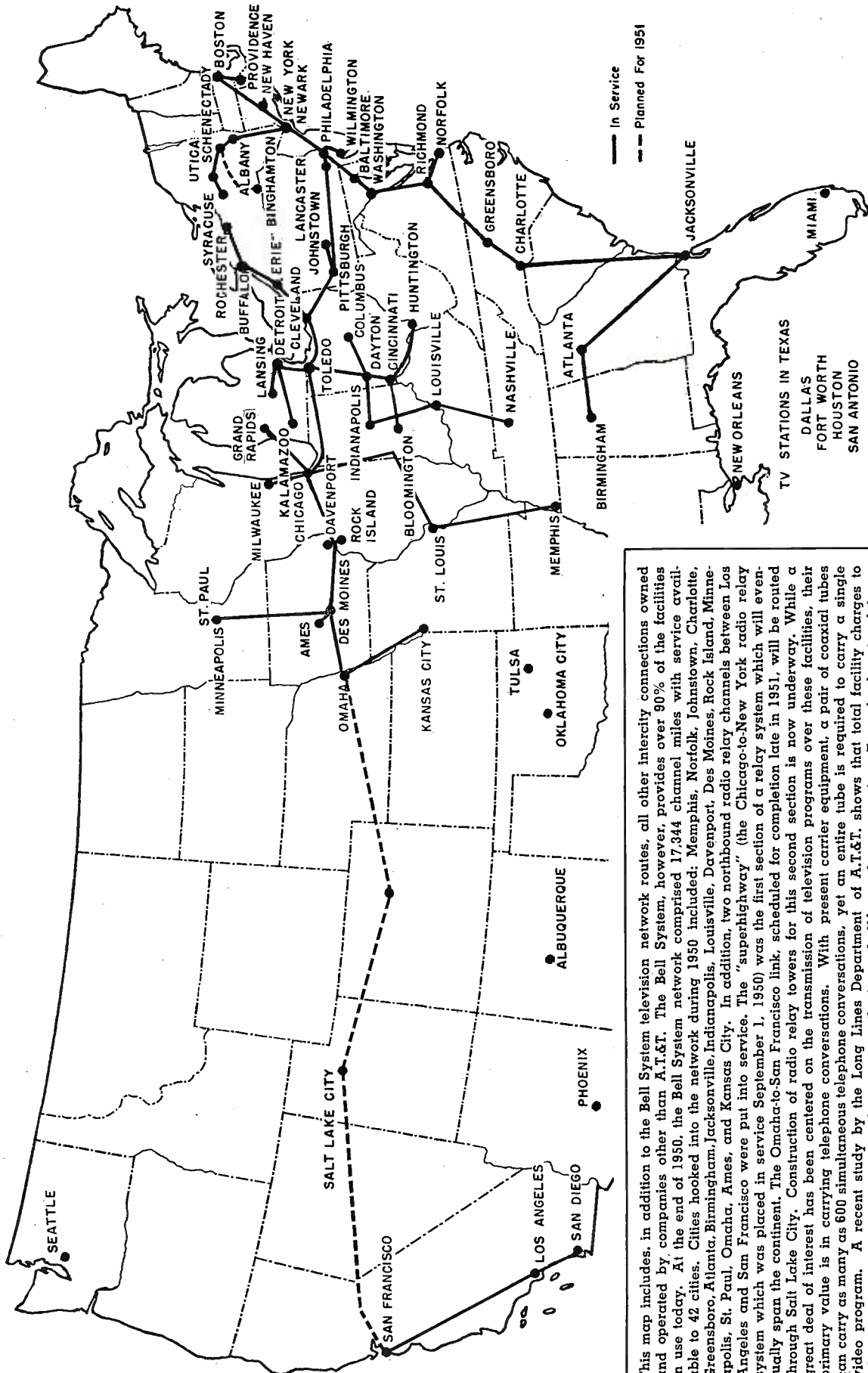

This map includes, in addition to the Bell System television network routes, all other intercity connections owned and operated by companies other than A.T.&T. The Bell System, however, provides over 90% of the facilities in use today. At the end of 1950, the Bell System network comprised 17,344 channel miles with service available to 42 cities. Cities hooked into the network during 1950 included: Memphis, Norfolk, Johnstown, Charlotte, Greensboro, Atlanta, Birmingham, Jacksonville, Indianapolis, Davenport, Des Moines, Rock Island, Minneapolis, St. Paul, Omaha, Ames, and Kansas City. In addition, two northbound radio relay channels between Los Angeles and San Francisco were put into service. The "superhighway" (the Chicago-to-New York radio relay system which was placed in service September 1, 1950) was the first section of a relay system which will eventually span the continent. The Omaha-to-San Francisco link, scheduled for completion late in 1951, will be routed through Salt Lake City. Construction of radio relay towers for this second section is now underway. While a great deal of interest has been centered on the transmission of television programs over these facilities, their primary value is in carrying telephone conversations. With present carrier equipment, a pair of coaxial tubes can carry as many as 600 simultaneous telephone conversations, yet an entire tube is required to carry a single video program. A recent study by the Long Lines Department of A.T.&T. shows that total facility charges to television stations averages about 10 cents a mile for a half-hour of program time. For a hookup involving a station in each of the 42 cities served by the existing Bell System facilities, the charges per station for a half-hour of program time would run approximately \$10.

facilities in a kinescope expansion program. Thus, television picture tubes were produced in quantities heretofore considered impossible, and television was given sight.

Labor

Television manufacturers were indeed fortunate in that an existing mass production labor market was available in the radio industry. The orientation of a radio production worker was easily accomplished without too much time expended in training. Thus a study of the effect of television manufacturing upon the general labor market will indicate that the rise of workers involved in television production has closely paralleled the radio market.

Receiver Design

More than anything else, competition and consumer demand influenced the design of television receivers. Manufacturers were forced to take the high cost out of television receiver design and to translate design into mass production.

The most outstanding design change was in the increased use of the intercarrier sound system. For example, in the 1949-1950 models manufacturers were using the common split i.f. method of sound reception. However, in their 1950-1951 models the trend was reversed, with the majority of television set manufacturers resorting to the use of the intercarrier sound system. The fact is that today only two of the leading television manufacturers (*Du Mont* and *RCA Victor*) do not use intercarrier sound in any of their models.

Design engineers were also faced with the large screen trend. Whereas in 1949 the average television receiver employed a 12 inch picture tube, the 1950 models incorporate larger tube sizes with the average 16 inches.

This trend toward increased tube size brought with it a newly designed cathode-ray tube, rectangular in shape. As the year progressed, more and more manufacturers added rectangular designs, principally to cut down cabinet size. However, round tubes were still holding their own at the end of the year.

To maintain proper cost levels, manufacturers resorted to various low-cost, high-efficiency deflection systems. These systems allowed the manufacturer to cut down on the number of receiving tubes usually required to achieve the necessary deflection and voltage.

A mass television market stimulated the production of new and varied models. Television manufacturers in 1950 at least doubled the number of models and in some cases went so far as to triple their 1949 figure. The ingenuity exhibited in the design of television receivers, coupled with the efficiency of mass production, brought down the cost of the average television receiver approximately \$30.00 within one year. In 1949 the average television receiver cost \$193.00. In

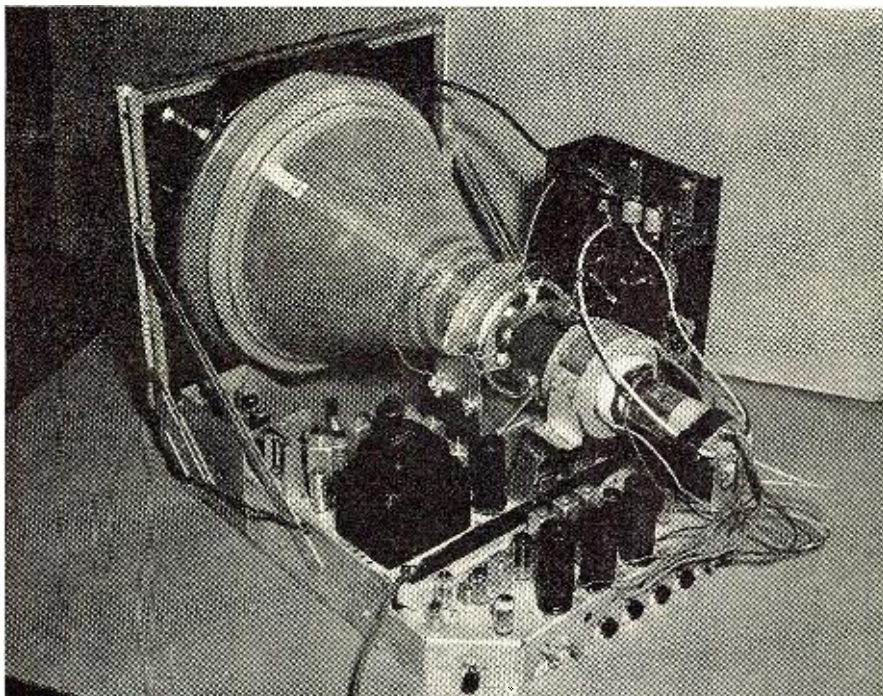

A standard television receiver converted for color under the RCA color system. The conversion unit is shown at the rear. The set utilizes RCA's tri-color picture tube.

YEAR	SETS MADE	WHOLESALE VALUE
1946 (and before)	15,000	\$ 2,900,000
1947	196,955	55,000,000
1948	953,511	225,000,000
1949	2,896,676	560,000,000
1950 (estimate)	7,500,000	1,250,000,000

Television receiver production by years and approximate wholesale value of these sets.

1950 this figure was reduced to \$169.00. When you realize that the lower cost brought with it a larger picture tube, as well as many engineering advances, the triumph of 1950 television design can be seen in its proper perspective.

The pattern of expansion in television broadcasting has, of necessity, been far more restricted than receiver production. Whereas tremendous markets already existed for receivers, the telecasting phase of the business was

Stations and sets in the 63 television cities and their "primary" service areas (up to 40 miles). NBC reports show 9,169,300 video sets were in use as of November 1, 1950.

CITY	No. OF STATIONS	No. OF SETS	CITY	No. OF STATIONS	No. OF SETS
Albuquerque	1	5,400	Louisville	2	60,300
Ames	1	24,500	Memphis	1	60,200
Atlanta	2	66,700	Miami	1	40,000
Baltimore	3	240,000	Milwaukee	1	177,000
Binghamton	1	26,100	Minneapolis-St. Paul	2	163,000
Birmingham	2	28,700	Nashville	1	12,600
Bloomington	1	11,000	New Haven	1	110,000
Boston	2	580,000	New Orleans	1	41,100
Buffalo	1	149,000	New Orleans	7	1,825,000
Charlotte	1	36,200	New York	1	38,700
Chicago	4	710,000	Oklahoma City	1	54,600
Cincinnati	3	196,000	Omaha	2	42,000
Cleveland	3	349,000	Philadelphia	3	695,000
Columbus	3	104,000	Phoenix	1	21,000
Dallas	2	46,600	Pittsburgh	1	180,000
Davenport-Rock Island	2	28,000	Providence	1	95,600
Dayton	2	98,000	Richmond	1	47,400
Detroit	3	356,000	Rochester	1	56,200
Erie	1	35,000	Salt Lake City	2	31,500
Ft. Worth	1	36,000	San Antonio	2	32,200
Grand Rapids	1	65,400	San Diego	1	62,000
Greensboro	1	30,500	San Francisco	3	115,000
Houston	1	49,700	Schenectady	1	116,000
Huntington	1	27,500	Seattle	1	50,100
Indianapolis	1	84,000	St. Louis	1	207,000
Jacksonville	1	21,000	Syracuse	2	80,900
Johnstown	1	45,000	Toledo	1	57,000
Kalamazoo	1	27,500	Tulsa	1	48,200
Kansas City	1	73,600	Utica	1	27,900
Lancaster	1	68,500	Washington	4	189,000
Lansing	1	30,000	Wilmington	1	48,900
Los Angeles	7	735,000			

TOTAL OPERATING STATIONS (107) IN 63 MARKETS
TOTAL TV SETS: 9,169,300

considerably slowed down by the FCC freeze. Thus in 1950 only 9 stations were opened, bringing the total of stations operating to 107.

Undoubtedly television broadcasting made its greatest strides in 1950 in the field of network transmission. The *Bell System* coaxial line continued its geographic expansion by going as far south as Jacksonville and as far west as Omaha. Sixteen new communities were placed on the coaxial line to receive network shows, with six others added for private station-to-station relays. Today 48 communities can enjoy network television through coaxial and microwave relay links.

To provide increased network service, the New York to Chicago coaxial link was supplemented by a microwave

relay system. These facilities provide a total of six channels, four from New York to Chicago and two from Chicago to New York. Two of the westbound channels are carried via the cable and two via microwave relay. The eastbound channels are microwave.

The economic strides that television has made can best be emphasized by the fact that although only 107 stations are on the air, television revenues amount to almost 25% of the AM radio revenue from its more than 2200 stations. Network television sponsorship has already surpassed radio. Considering the high production cost one can well imagine the drawing power of television as a sales medium as evidenced by the enthusiastic support it has received from advertisers.

1950 can undoubtedly be considered television's year of achievement, for this was the year that television receiver sales went over the billion dollar mark and the size of the viewing audiences foretold the success of television broadcasting as a competitive advertising medium.

Service and Technicians

The ever-increasing television market brought with it serious service problems. Too many consumers were unaware of the complexities inherent in the reception and transmission of television. The technician was often blamed for poor picture quality in cases over which he had no control. The few instances where technicians were shown to be improperly trained the press hullabaloo was all out of proportion to the complaint. Soon the TV servicing problem was built up until its solution became a community witch-hunt. To supposedly protect themselves, many communities considered the passage of local ordinances governing television technicians. The Better Business Bureau made the public television servicing conscious by publishing a "primer" for television owners. The booklet critically evaluated reception difficulties and generally cleared the air for the individual television technician.

The business failure of large numbers of television service contractors provided the servicing field with its greatest headache. Although the fault, in most cases, was due to inefficient operation, the consumers involved rapped television service as a whole, not realizing that business failures were possible in any enterprise. However, a careful examination of the field of contractual servicing seems to indicate that too many organizations sold their service short. The crying need of such organizations was, and is, a sound understanding of cost analysis. Those companies that were operated efficiently proved that television servicing could be "big business."

Television's Future

The one thing that we can be certain of in considering the television picture for 1951 is that 1950 was a peak year for television receiver production—a distinction it is liable to hold for some time to come. As we get into 1951, the television industry will be faced with component and tube shortages unparalleled in commercial production. With basic materials such as cobalt and copper being stockpiled by the government, scarcity of these materials will, in turn, lead to higher prices. Most observers believe that 1951 production will approximate at the most half of what was achieved in 1950, with low price table models and consolettes making up the bulk of most manufacturers' lines. The field of television broadcasting will undoubtedly remain as of 1950, except for tying in a number of stations to

(Continued on page 104)

Call letters, location, and channel numbers for commercial TV stations now in operation.

CALL LETTERS	CITY & STATE	CHANNEL	CALL LETTERS	CITY & STATE	CHANNEL
WAFM-TV	ALABAMA			NEBRASKA	
WBRC-TV	Birmingham	13	KMTV	Omaha	3
	Birmingham	4	WOW-TV	Omaha	6
	ARIZONA			NEW JERSEY	
KPHO-TV	Phoenix	5	WATV	Newark	13
	CALIFORNIA			NEW MEXICO	
KECA-TV	Los Angeles	7	KOB-TV	Albuquerque	4
KFI-TV	Los Angeles	9		NEW YORK	
KLAC-TV	Los Angeles	13	WNBF-TV	Binghamton	12
KNBH	Los Angeles	4	WBEN-TV	Buffalo	4
KTLA	Los Angeles	5	WABD	New York City	5
KTSL	Los Angeles	2	WCBS-TV	New York City	2
KTTV	Los Angeles	11	WJZ-TV	New York City	7
KFMB-TV	San Diego	8	WNBT	New York City	4
KGO-TV	San Francisco	7	WOR-TV	New York City	9
KPIX	San Francisco	5	WPIX	New York City	11
KRON-TV	San Francisco	4	WHAM-TV	Rochester	6
	CONNECTICUT		WRGB	Schenectady	4
WNHC-TV	New Haven	6	WHEN	Syracuse	8
	DELAWARE		WSYR-TV	Syracuse	5
WDEL-TV	Wilmington	7	WKTV	Utica	13
	DISTRICT OF COLUMBIA			NORTH CAROLINA	
WMAL-TV	Washington	7	WBTV	Charlotte	3
WNBW	Washington	4	WFMY-TV	Greensboro	2
WOIC	Washington	9		OHIO	
WTTG	Washington	5	WCPO-TV	Cincinnati	7
	FLORIDA		WKRC-TV	Cincinnati	11
WMBR-TV	Jacksonville	4	WLW-TV	Cincinnati	4
WTVJ	Miami	4	WEWS	Cleveland	5
	GEORGIA		WNEK	Cleveland	4
WAGA-TV	Atlanta	5	WXEL	Cleveland	9
WSB-TV	Atlanta	8	WBNS-TV	Columbus	10
	ILLINOIS		WLWC	Columbus	3
WBKB	Chicago	4	WTVN	Columbus	6
WENR-TV	Chicago	7	WHIO-TV	Dayton	13
WGN-TV	Chicago	9	WLW-D	Dayton	5
WNBQ	Chicago	5	WSPD-TV	Toledo	13
WHBF-TV	Rock Island	4		OKLAHOMA	
	INDIANA		WKY-TV	Oklahoma City	4
WTTV	Bloomington	10	KOTV	Tulsa	6
WFEM-TV	Indianapolis	6		PENNSYLVANIA	
	IOWA		WICU	Erie	12
WOL-TV	Ames	4	WJAC-TV	Johnstown	13
WOC-TV	Davenport	5	WGAL-TV	Lancaster	4
	KENTUCKY		WCAU-TV	Philadelphia	10
WAVE-TV	Louisville	5	WFIL-TV	Philadelphia	6
WHAS-TV	Louisville	9	WPTZ	Philadelphia	3
	LOUISIANA		WDTV	Pittsburgh	3
WDSU-TV	New Orleans	6		RHODE ISLAND	
	MARYLAND		WJAR-TV	Providence	11
WAAM	Baltimore	13		TENNESSEE	
WBAL-TV	Baltimore	11	WMCT	Memphis	4
WMAR-TV	Baltimore	2	WSM-TV	Nashville	4
	MASSACHUSETTS			TEXAS	
WBZ-TV	Boston	4	WFAA-TV	Dallas	8
WNAC-TV	Boston	7	KRLD-TV	Dallas	4
	MICHIGAN		WBAP-TV	Fort Worth	5
WJBK-TV	Detroit	2	KPRC-TV	Houston	2
WWJ-TV	Detroit	4	KEYL	San Antonio	5
WXYZ-TV	Detroit	7	WOAI-TV	San Antonio	4
WLAV-TV	Grand Rapids	7		UTAH	
WKZO-TV	Kalamazoo	3	KDYL-TV	Salt Lake City	4
WJIM-TV	Lansing	6	KSL-TV	Salt Lake City	5
	MINNESOTA			VIRGINIA	
KSTP-TV	Minneapolis-St. Paul	5	WTAR-TV	Norfolk	4
WTCN-TV	Minneapolis-St. Paul	4	WTVR	Richmond	6
	MISSOURI			WASHINGTON	
WDAF-TV	Kansas City	4	KING-TV	Seattle	5
KSD-TV	St. Louis	5	WSAZ-TV	Huntington	5
				WEST VIRGINIA	
			WTMJ-TV	Milwaukee	3

INDUCTION HEATING



Fig. 1. Electronic induction heating used to harden coil spring. The heating coil acts as a primary and induces currents in the spring, causing it to heat. After a predetermined time, a "trap door" opens, dropping spring in oil bath.

NO OTHER phase of the diversified field of electronics has so challenged and excited the imagination as its industrial applications. Industrial electronics, once the little brother of the electronics family, has already outgrown its elders and shows no signs of stopping. Even today, more radio power is used in industry than in broadcasting.

In an almost countless variety of industrial and manufacturing processes, heat must be applied to the product. When this heat is developed and controlled electronically, production time and cost are drastically reduced and the products are of uniformly high quality. Electronic heating falls into two categories: *induction* and *dielectric heating*. The former is used when the material to be heated is a conductor of electricity,

By **ED BUKSTEIN**

The r.f. oscillators used in these industrial units generate powers ranging from 2 to 200 kw. at frequencies of 50 kilocycles to 3 megacycles.

and the latter is used for heating non-conductors.

In the induction heating system, the metal to be heated is placed inside of a coil, through which an r.f. current is passed. This coil acts as the primary of a transformer and the material to be heated acts as a secondary. The currents thus induced in the metal cause it to become heated. The effect is similar to the heating of transformer cores by eddy currents. It is noteworthy that the system does not involve the transfer of heat to

the work. Only electrical energy is transferred—the heat is developed within the work itself. As a result, the surrounding air remains relatively unaffected and working conditions are cool and clean.

Surface Hardening

If the frequency is increased, the currents induced in the metal tend to flow on the surface due to skin effect. As a result, the surface of the metal becomes heated while the in-

(Continued on page 92)

Fig. 2. The induction heating unit is similar to a transmitter except that it has no modulation circuits. This is a 10 kilowatt, 450 kilocycle unit made by Westinghouse Electric Corp.

Fig. 3. Inside view of induction heating unit. The oscillator tank coil may be seen near top of cabinet, while the 3-phase, full-wave rectifier circuit occupies the lower part of cabinet.

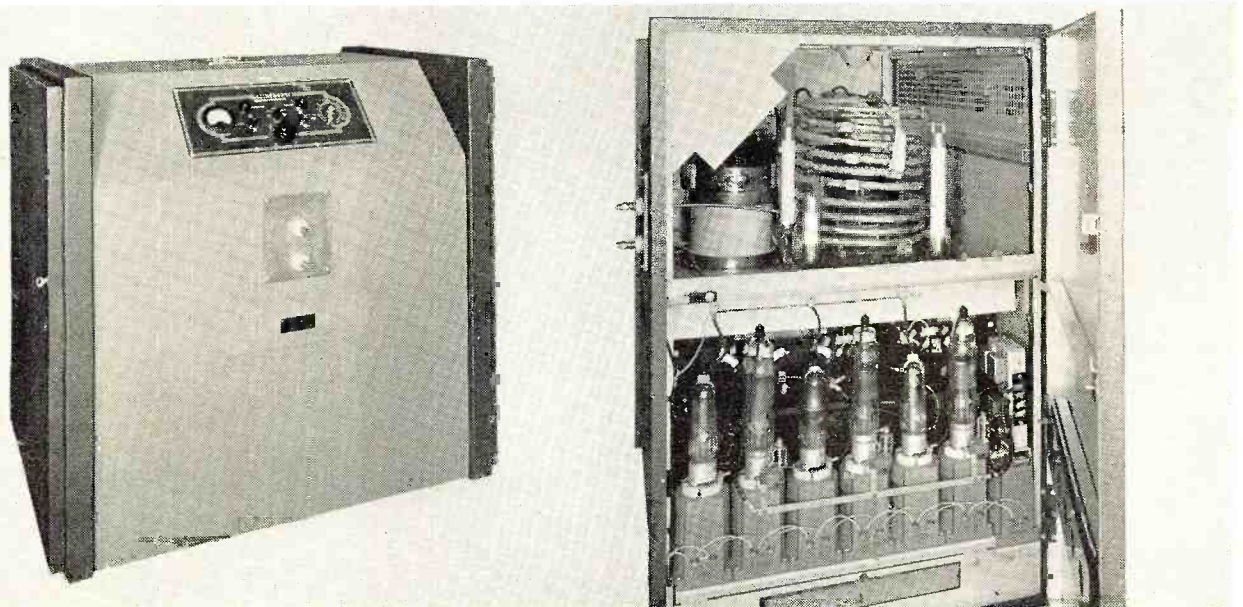

An Inexpensive PULSE GENERATOR

By
LOUIS E. GARNER, JR.

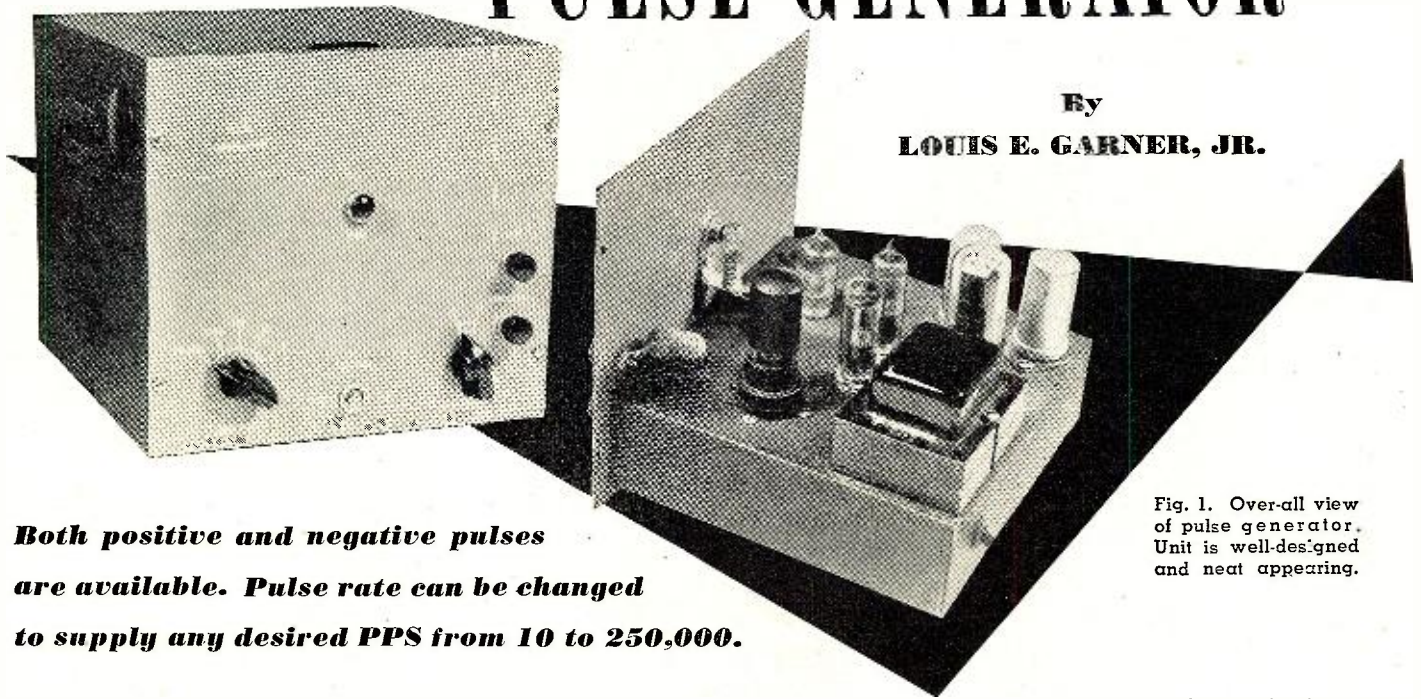

Fig. 1. Over-all view of pulse generator. Unit is well-designed and neat appearing.

Both positive and negative pulses are available. Pulse rate can be changed to supply any desired PPS from 10 to 250,000.

SCILLOSCOPES, r.f. signal generators, vacuum tube voltmeters, and similar pieces of electronic test equipment are generally found in the laboratories of home experimenters and smaller manufacturers as well as in the more elaborate commercial research and development labs. There is one quite useful piece of equipment that is found in almost all large laboratories, but is seldom, if ever, found in the lab of the average home experimenter, namely, a pulse generator.

Usefulness and versatility are certainly not lacking in the pulse generator, for not only may it be used for direct circuit work, syncing, timing, saw-tooth formation, etc., but it is also valuable for applications such as retrace blanking, frequency measurement, and other test techniques. Therefore, it is safe to conclude that the chief reason for the pulse generator not being used more is the comparative high cost of commercial instruments. This, in turn, is probably due to the many special features incorporated in commercial pulse generators which, while useful for some types of advanced development work, are not too important to the experimenter or engineer requiring pulse signals for only certain applications. Such features include variable pulse width, extremely short rise time, and an unusually wide range of pulse rates, generally with continuous frequency coverage. If a compromise is made between special features and cost, it is possible to build a comparatively inex-

pensive pulse generator which will amply serve the needs of the home experimenter and will even prove useful to schools (for demonstration work) and smaller industrial laboratories.

The final pulse generator may be easily finished as a professional appearing instrument, rivaling many commercial instruments in over-all appearance (Fig. 1).

The pulse generator shown in Figs. 1 and 2 is completely self-contained and no external signal source is required. Positive or negative pulses are available from the output terminals, and either may be obtained by simply turning a switch. The pulse amplitude remains essentially constant over the entire range, irrespective of whether positive or negative pulses are obtained. Pulse rate is selected by means of a step switch, and may be easily changed to supply any PPS from 10 to 250,000. Rise time depends on pulse rate, and is comparatively short.

Referring to Fig. 2, V_1 is connected as a Potter multivibrator with the pulses appearing across load resistor R_1 , being fed through C_1 to the phase split-

ter V_2 . The frequency of operation is determined by the size of R_3 , R_2 , and the grid condenser connected between pins 6 and 2 of V_1 . The grid condenser is changed by selector switch S_1 , and this acts as the frequency control for the generator.

Positive-going pulses appear across plate load resistor R_4 , while negative-going pulses appear across cathode resistor R_5 , and either may be selected by S_2 and fed to the output binding posts through C_2 , which serves as a d.c. blocking condenser.

Resistors R_4 and R_5 are chosen so that both positive and negative pulses have equal amplitude, the difference in electrical size being due to degeneration in the cathode circuit. Both resistors are under 1000 ohms so that a low output impedance may be maintained.

In order to maintain stability with different line voltages and with line voltage fluctuations, a regulated power supply is provided.

The output pulses obtained are shown in Fig. 3. Those on the left show the positive-going pulses while those on the right illustrate the negative-going pulses for each range. These waveform patterns were traced from the screen of a Tektronix 5" cathode-ray oscilloscope Model 511AD. The output pulse for each range is given, with A, B, C, D, and E corresponding to the output frequencies obtained with selector switch S_1 in positions 5, 4, 3, 2, and 1, respectively. Although the total time of the sweep in microseconds for each range is given, this

Table 1. The five-position switch used in author's design covers a pulse rate from 100 pulses to 200,000 pulses per second.

SWITCH POSITION	PULSES PER SECOND (PPS)	TIME BETWEEN PULSES
1	200,000	5 μ sec.
2	100,000	10 μ sec.
3	10,000	100 μ sec.
4	1,000	1,000 μ sec.
5	100	10,000 μ sec.

must be considered approximate, due to slight differences in syncing with positive and negative pulses. Actually, the output frequency of the pulse generator remains constant whether positive or negative pulses are obtained.

As can be seen, the pulse width depends on the pulse repetition rate. This is desirable for some types of work, such as saw-tooth formation and scope retrace blanking. The peak pulse amplitude is approximately 10 volts.

With the condenser values given, the pulse repetition rates for each position of selector switch S_1 are shown in Table 1.

The selector switch calibration on the model is in terms of microseconds between pulses, but the builder may use any calibration scheme desired.

Condenser C_1 is a trimmer and may be adjusted so that the highest range is exactly on frequency. If desired, C_2 may also be made variable and the two highest frequency ranges thus can be set exactly.

The frequency determining condensers, C_1 through C_5 , were selected experimentally, and the values given in the parts list are the marked values. The actual values may be found to be somewhat different from those given, depending on tolerances of R_2 and R_3 and distributed wiring capacities. If exact frequencies are required, parallel and series combination of condensers may be used to obtain the right value, or either R_2 or R_3 may be changed in value.

Circuit Modifications

In the model, only five different output frequencies are provided. If a greater number of output frequencies are required, a selector switch (S_1) with more contacts may be used, and additional condensers provided in the switch circuit. Frequencies as low as 10 PPS and as high as 250,000 PPS may be easily obtained.

When lower frequencies are required, it is best to increase the size of R_2 as well as the size of the coupling condenser. This resistor should not be made too large (over 2 megohms), however, as this will result in a certain amount of instability.

If, for any reason, single polarity pulses are required, then S_2 may be eliminated, and a direct connection made to the output binding posts through C_5 . For positive-going pulses, obtain the output from the plate of V_2 . Negative-going pulses are obtained from the cathode.

The pulses obtained may be synced with an external source, if desired, by applying the signal to the grounded grid of V_1 (pin 7). Removing this grid from ground potential will change the frequency of operation somewhat, and it may be necessary to readjust the values of parts in the frequency determining circuit.

Hints On Construction

The entire unit may be easily assembled on a standard 7"x7"x2" metal chassis. Layout is not critical, but the

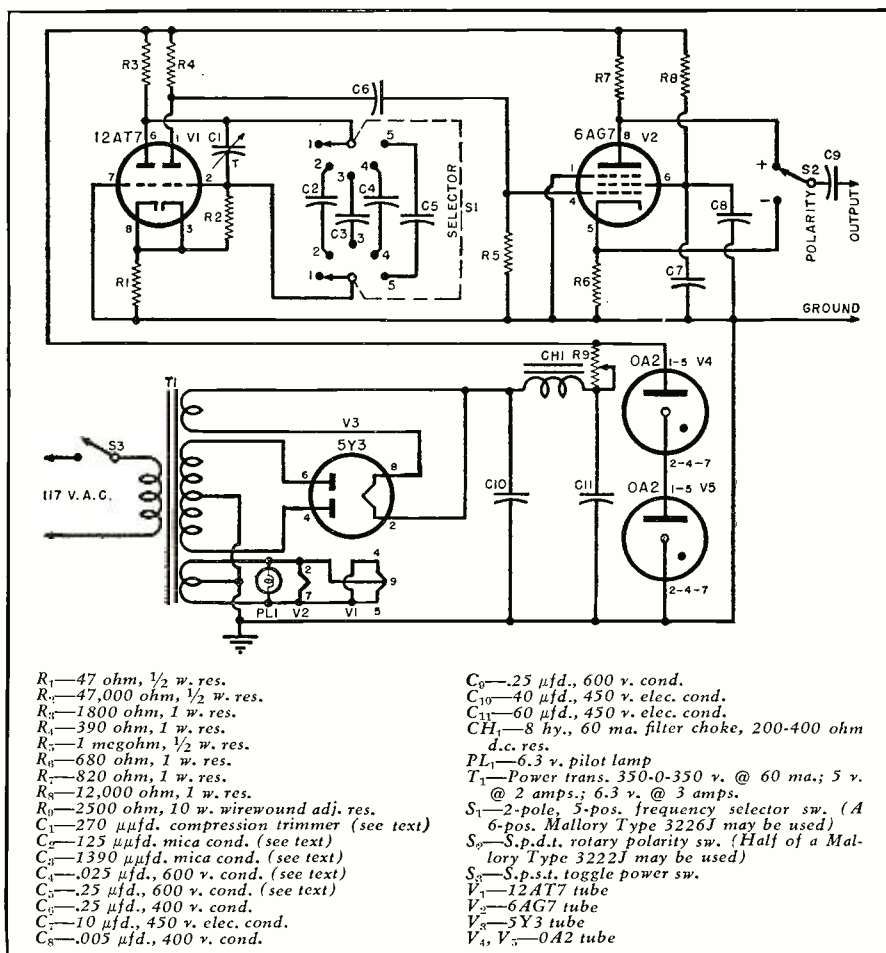

Fig. 2. Schematic diagram of pulse generator. A multivibrator-type oscillator is used.

electrolytic filter condensers should not be mounted too close to the rectifier or output tubes. The interior photo (Fig. 1) gives some idea of the layout used by the author. Both voltage regulator tubes and the rectifier are located close to the transformer. The filter condensers are on the far side of the rectifier tube (in the photo), while the 12AT7 multivibrator is located as far from the power supply and output as is practicable.

When wiring the generator, keep leads as short and direct as possible in order to avoid high distributed capacities and hum pickup. Particular care should be taken in the multivibrator circuit since high distributed capacities tend to lower the maximum frequency of operation and to "round" the pulses, as well as increasing the rise
(Continued on page 142)

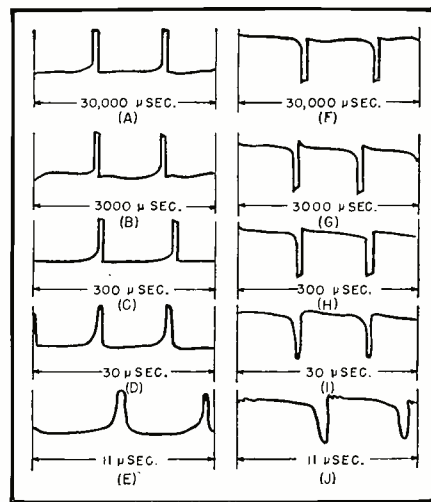
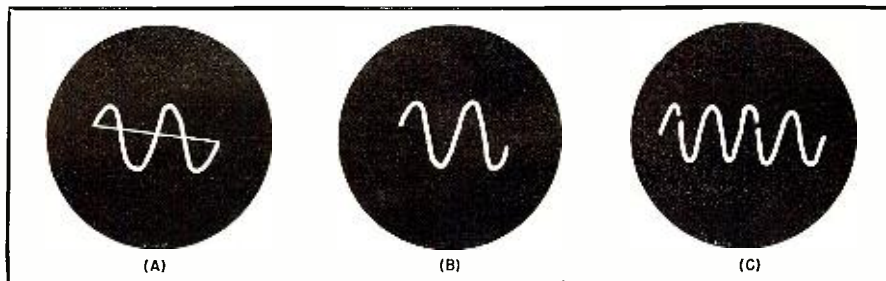

Fig. 3. Output pulses available. See text.

Fig. 4. Pulses can be used for retrace blanking in an oscilloscope. (A) Without, and (B) with retrace blanking. (C) Frequency measurements by observing dashes in pattern.



Metal Sealing Techniques for Large Television Tubes

By **WILLIAM L. HYDE**

Tube Engineering Department
Allen B. Du Mont Labs., Inc.

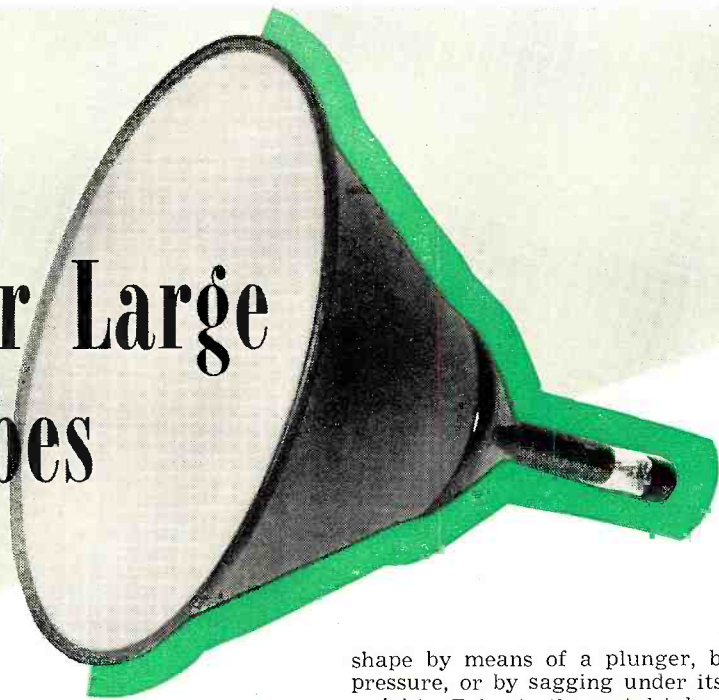

Metal-to-glass seals have been made for many years, but it is only with the development of metal television picture tubes that large seals have been made on production basis.

ONE of the most spectacular operations in a television tube plant is the high temperature fusing of glass to steel when the envelope of a metal tube is assembled. The operation as performed at *Du Mont* is shown on the cover this month.

With the trend toward larger picture sizes, the metal tube is becoming increasingly important. Among its advantages are light weight, strength, and the excellent optical quality of the face. The metal tube is attractive to tube manufacturers; since unfinished tubes can be warehoused as component parts in a fraction of the space required to store raw glass bulbs. Shipping costs are lower for both the unassembled parts, which can be com-

pactly nested, and for the completed tube, which is rugged and light in weight.

Before it is seen how the various parts of the tube envelope are assembled, let us find out how the components are made. The face of the tube starts out as a sheet of high-quality, drawn glass. If the glass is to be used in a 19AP4A, it is cut into twenty-inch squares and sent to a manufacturer who shapes the glass into a portion of a sphere. This operation is called bending or convexing.

To make the face plate, a circular disc is cut from the twenty-inch square. The disc is heated to the plastic or sagging point in a large oven or lehr. The glass is then forced into a rounded

shape by means of a plunger, by air pressure, or by sagging under its own weight. Prior to the metal tube, glass benders worked mainly with clock faces, convex mirrors, and decorative glass. With the coming of convexed face plates, the bending industry has been called upon for a new high in precision since the television face must be held to an accurate curvature to prevent picture distortion.

The main structural part of the metal tube is the cone. It is made of a special type of chromium-iron alloy steel. Originally, this part is a flat sheet of steel a tenth to an eighth of an inch in thickness. The sheet steel is cut into discs slightly larger than the diameter of the finished cone at the face. The cone itself is formed by spinning—an operation which resembles the way a potter shapes clay on his wheel. The center of the disc is clamped against a rotating metal form which has the same shape as the inside of the completed cone. Rollers, under many tons of force, press against the rotating disc and shape it over the form just as if it were made of wax. Final operations are trimming and cleaning.

The last element of the tube is the glass funnel and neck. It is made by the glass manufacturer from what looks much like a small kitchen mixing bowl and a piece of straight tubing. The glass manufacturer cracks or sears off the small end of the bowl and splices on the neck tubing.

At *Du Mont* the first step in assembling the parts is to seal the funnel and neck to the small end of a cone. Prior to sealing the cone has been cleaned and sandblasted. The sandblasting provides a roughened surface for the glass to adhere to. It also improves picture contrast by reducing internal light reflections.

In the sealing operation the glass funnel and neck are held above the metal cone while each is gradually heated. Before the rim of the funnel

A specially built machine is used to seal the funnel and neck to 19-inch metal cone.



is allowed to come in contact with the small end of the metal cone, the temperature of the metal sealing surface is raised to about 1200° C. with directed gas and oxygen flames. At this temperature the metal glows with a bright orange color over a band of about an inch and a half. When the glass has been heated sufficiently to make the edge of the funnel plastic, it is pressed down against the hot metal. Intense gas-oxygen fires play against the metal-glass junction, melting the glass so that it wets the metal. After the melting has been completed, the assembly is cooled gradually by passing through groups of flames which lessen in intensity.

In a laboratory this sealing operation can be performed on a glass working lathe where the heating flames are controlled manually. In a factory where thousands of units must be produced each day, automatic equipment such as that shown in the picture is used. Here the assembly passes through a number of positions, each set to give the correct amount of heat.

It could now be asked why does the glass stick to the metal. When the chromium-iron steel is heated to a temperature of from 1100° to 1200° C. in the proper atmosphere produced by the enveloping flames, an oxide layer is produced which is rich in chromium. Glass, when melted, readily wets this oxide forming a solution of the oxide in the glass. The melting action is so strong that fluid glass will flow on the surface under the influence of capillary action. When the correct conditions of oxide and temperature are used, the glass-metal bond is very strong. A test of pulling the glass from the metal seldom fails at the glass juncture.

Adherence of the metal and glass is not sufficient to insure a good strain-free seal. Glass, when cool, is very brittle. It is important in this case that the metal and glass contract uniformly when they cool. This is accomplished by choosing a glass with a coefficient of expansion close to that of the metal. When this is done the strain remaining after gradual cooling is slight and a mechanically strong assembly is assured.

After sealing the funnel and neck to the small end of the metal cone, the assembly is turned over with the large open end of the cone facing upwards. The curved face plate is inserted and the unit placed in the face plate sealing machine shown on the cover of this issue. As the tube envelope rotates slowly on its axis, gradually increasing heat is applied to the face plate and the cone.

At first low flames play on the face, heating it uniformly to a temperature which will prevent breakage in later operations. Intense flames are then brought to play on the rim of the metal where the glass face seats. As the brilliant blue circle of gas-oxygen fires hit against the metal, a dull red glow appears. The color rapidly changes to a bright orange representing a tempera-



Metal cone being checked for quality.



Inspecting face plate for a 19" tube.

ture of about 1200° C. The glass face, which remains solid and hard in the central area, begins to melt where it is in contact with the heated metal. As the heat continues, the edge of the glass melts completely and flows out into the rim of the cone. While the glass is melting, low pressure air is pumped in through the neck of the tube to support the face and to prevent it from sagging down into the cone. After the seal is completely wetted out, the metal and glass are allowed to cool slightly so that the face will not distort at the seal region under its own weight. The completed envelope is then placed in an annealing oven where temperatures are equalized and strain removed. The temperature inside this oven is about 600° C. After the cone and face temperature have stabilized, the whole assembly is brought out into air at normal room temperature and allowed to cool rapidly. In most glass operations this would be very bad practice; since severe strains are set up by this treatment. However, the very strength of the metal tube depends upon developing a controlled strain in the face. Glass has the property of being very strong in compression but weak in ten-

sion. The rate of expansion and, therefore, the rate of contraction of the metal cone is designed to be slightly greater than that of the glass face. When the hot tube comes out of the annealing oven, the metal cone tends to contract or squeeze the face as it cools to room temperature. This places a compressive strain in the glass.

Furthermore, it tends to bend the face out into a more convex shape; so that the force of the atmosphere on an evacuated tube will be balanced. Atmospheric pressure on the face of a round nineteen-inch tube exceeds a ton and a half or about the same as the weight of an average automobile.

Additional strength of the face is obtained by a semi-tempering of the glass surface. This occurs when the outer layers of glass cool more rapidly than the center layers. The strengthening strain produced is similar to that in tempered glass. Automobile rear windows, all-glass doors, and shatter-resisting tumblers are familiar examples of tempered glass.

The tube envelope is now complete. Before it reaches the television set it will pass through many carefully controlled operations such as washing, screen application, and exhaust. —30—

An eight-position machine for sealing the funnel and the neck of a 19" metal tube.

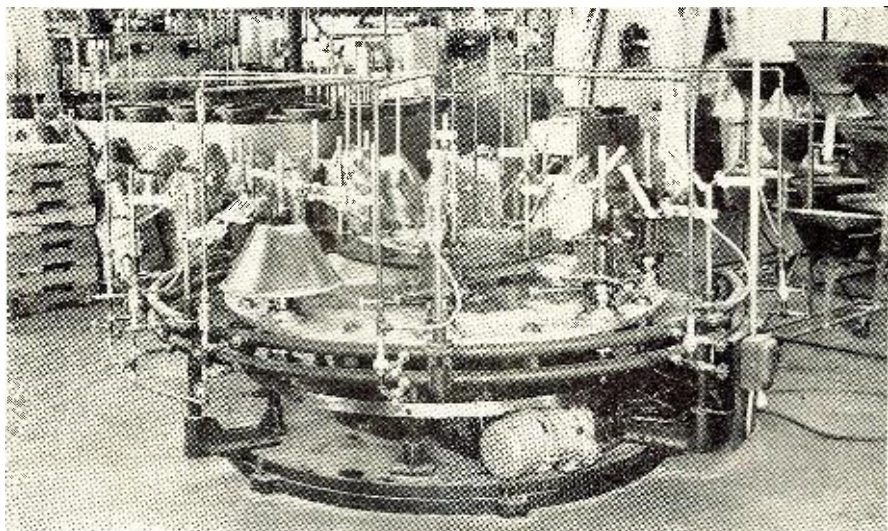

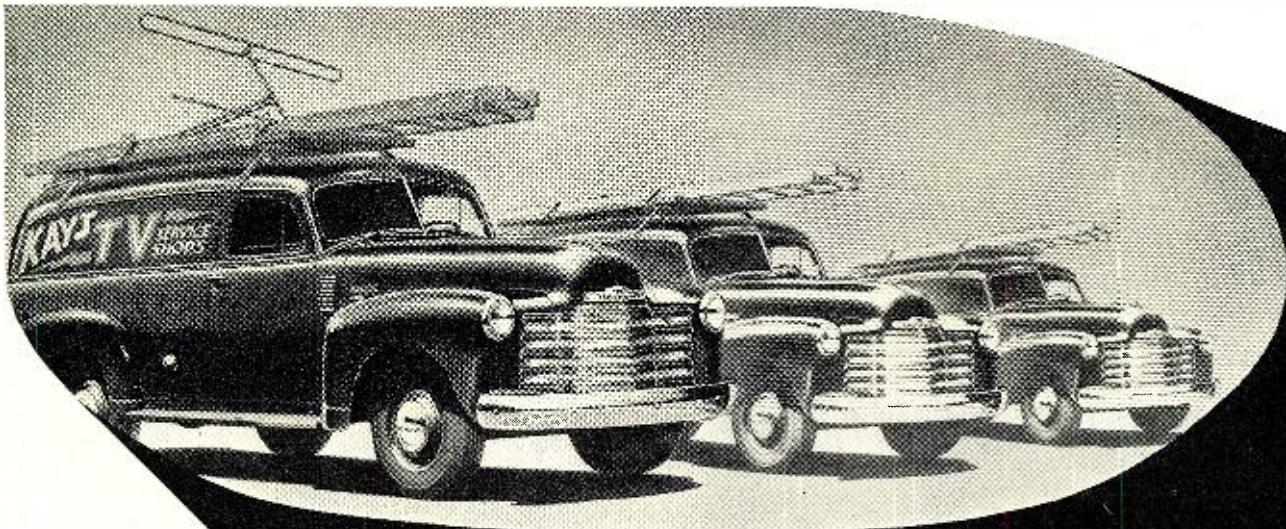

Is The One Man TV Shop Doomed?

By

PAUL WENDEL

Television Technicians Lecture Bureau

With 10 million sets in use, television servicing today is "Big Business." Considering installations, house calls, service policies, etc., can the one man shop show a worthwhile profit?

WHEN you grab a crystal ball with the idea of charting the future course that a business activity will probably take, it is a good plan first to turn your attention to and examine the roads it traveled to get where it is today. What sort of a business was it yesterday and what made it that kind of a business? Is it different today? If it is different, what factors brought about the change and are those factors fundamental or transient? Are they here to stay?

For quite a number of years the backbone of the independent radio servicing industry was the one man radio service operation. Sometimes it was located in a store in a traffic location, or perhaps it was a business location on a side street with living quarters attached, or again it might be found in the basement, front room, or garage at the operator's home. It was and is a business of rugged individualists, men who find a peculiar fascination in struggling with the continuing stream of problems associated with the maintenance and repair of radio circuits. It was never a stable, profitable business except for those rare individuals whose natural talents were a combination of technical skill and business acumen and who were ambitious enough to put this combination of abilities to work to build a dual service-sales business in some branch of the radio-sound field.

For many years the controlling factor in the radio service business was the a.c.-d.c. circuit. These sets provided from seventy to eighty per-cent of the over-all volume of radio service business. The inexpensive table models were the most widely sold and used in the home and thus were responsible for a high percentage of the service volume. They were easy for the owners to carry to the radio repair shop so they gave the shop operator the bulk of his work in over-the-counter transactions.

The a.c.-d.c. table model sets were price merchandise. Chain drug, jewelry, and department stores featured some numbers that you could carry home for a ten dollar bill and get some change. These low prices also put a psychological ceiling on all radio service charges. A sporadic "fader" or "intermittent" could eat up more service hours than it would cost for a new receiver if the service operator had charged a just rate for his time. But he didn't and so he would take a loss on that kind of service jobs.

Television swept into the service picture in the metropolitan areas shortly after radio sales and service had taken a fast nosedive from their postwar peaks. Television brought with it the business of antenna installation and of maintenance insurance in the form of twelve-month service contracts. It also introduced an important new user fac-

tor—video. The human eye is a critical organ. Our vision will not make the compensation for bad pictures that our hearing will for poor sound.

The user who would put up with a radio that poured out a distorted version of all sounds that were broadcast would raise Old Ned if these same defects were present in the video section of his television receiver. He would see them in the form of a distorted picture and his eyes would cry for relief.

The critical visual factor alone has been responsible for basic changes in the entire servicing industry in television areas. It will bring about these same changes nationally whenever television programs are universally available.

The prospective bonanza of having a service business with an annual gross income of from fifty thousand dollars (for an average of 175 service and installation contracts per month) to a quarter of a million dollars (for an average of 700 installation and service contracts per month) attracted practically all of the more aggressive radio service operators—and a host of outsiders—to the TV installation and service contract business in television-served areas. However, this business proved to be anything but all peaches and cream and in the course of time most of the inefficient and the "fast dollar" operators folded up. This has left a substantial group of efficiently-managed installation and service organizations in the metropolitan areas which are handling the bulk of the new business originating in those areas.

These businesses were built primarily on annual service contracts. Under

RADIO & TELEVISION NEWS

reasonably normal conditions the 12-month maintenance contract is sound business both for the independent service contractor and for the set user. In a soundly-managed organization built up to handle the average volume of contracts the organization is geared to sell, the management is assured of a fixed monthly income to meet its payroll and operating expenses. Seasonal fluctuations do not affect it so the company can offer job security and stability of employment to its employees. This is seldom possible in a service business operating on the income from day-to-day requirements for C.O.D. service. It also insures the contract buyer of capable service performed by qualified technicians whenever his receiver needs it.

These operators are able to build up their files of service notes on the receivers they handle under contract which, in itself, will insure the user of quicker, better service than he could hope to get from a free-lance technician who plays the field. In the long run the continuance of the 12-month contract plan will give the public a much better type of television service than if it is permitted to drift into the category of prewar radio service.

FCC's TV station freeze effectively set limits on television broadcast coverage until the problems of propagation are solved or, at least, a pattern of development is agreed upon that will permit the construction of new stations. This created a competitive situation on receiver sales and service that for a time threatened to create havoc with even the best managed television service operations. However, the current emergency in which many skilled service technicians are being absorbed by the services, industry, and the Government plus the extremely critical parts and equipment shortages will "freeze" the service industry more or less in its present state until the parts and manpower problems are solved.

However, the lifting of the station freeze, the development of color and u.h.f. television, and the easing of parts shortages will put a fire under the transition of the service industry on a national scale and we will see an expansion of the contract type of service operation.

There are four factors that television brought to the servicing industry that will be the determining factors in the type of service business that will prove most efficient in handling the maintenance needs of television receivers in the home. These four factors are: 1. The antenna and the attendant problems of its installation and maintenance; 2. The critical requirements of sight; 3. Multiple coordinated circuits; and 4. Size.

Considering these elements in relation to a one man service operation this service operator may elect to handle only the servicing of the receivers and leave the antenna installation to an installation contractor. But suppose the service call he receives re-

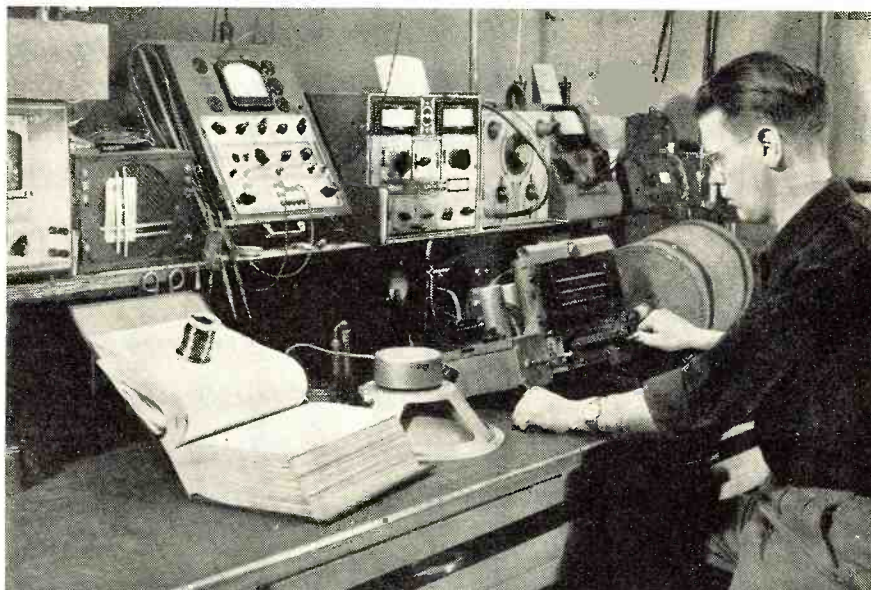

The skilled technician who in addition to his knowledge of radio and television circuits is required to be a bookkeeper, salesman, and manager often finds the task too arduous for one individual. Since the time he can devote to servicing at his work bench is the only profitable part of the operation, most technicians are finding it increasingly difficult to make money with a one man service shop.

quires work on the antenna system, will he attempt to do this work himself or will he call in an antenna specialist? If he calls in an antenna specialist will the customer be willing to pay for the time of two skilled technicians (the service technician and the antenna specialist)? The question here, of course, is whether the solo operator would or could carry the investment in ladders, tools, antenna, and transmission line parts to handle antenna maintenance when such service is necessary to restore receiver performance.

The requirement for the reproduction of good pictures plus the technical problems involved in the rapid and proper adjustment and alignment of television receiver circuits demands the use of precision-type service test equipment. This makes necessary a

substantial investment—especially for one man's use—in test equipment which should be amortized out of service income over a reasonably short period of time.

Added to this investment is that of maintaining an adequate working stock of replacement tubes, parts, and supplies. Time wasted in frequent, quick trips to set and parts distributors' stores to pick up the parts necessary to complete "in process" service jobs is a definite loss of income to the service technician who is operating as an independent.

Finally we come to "size" as a factor in TV receiver servicing and its influence on a service business operation. Statistics gathered from a number of TV service contract organizations indi-

(Continued on page 140)

Inventory control used to be a comparatively simple procedure for the one man shop operator. Today's television installation and service contractor has a big investment in installation and maintenance parts and supplies. Unless the owner maintains a well-balanced stock and accurate inventory records substantial losses will result.



Novel Tester for Checking Radio Control Equipment

By
GUY DEXTER



External view of field tester. The entire unit is small enough to be carried in the pocket.

Construction details on a combination field strength meter and d.c. voltmeter designed for field checking radio-controlled model airplanes and similar units.

WHEN radio control equipment for model aircraft goes out of commission or fails to operate properly in the field, a few simple tests will localize the trouble quickly in transmitter or receiver. The essential instruments required for quick, on-the-spot trouble shooting are; (1) an indicating field strength meter or wavemeter for determining if the transmitter is *working* and whether its frequency is correct, and (2) a d.c. voltmeter for checking the batteries or power supply. It is unlikely that the model aircraft man will lug these instruments to the flying field as a matter of routine if his control equipment has been behaving properly of late.

The instrument described in this article is a combination field strength meter and d.c. voltmeter designed especially for the model airplane enthusiast. For some time, there has been a demand for a single instrument of this kind which would be simple to operate and easily transportable. Light in weight and small in size, it can be carried in a coat pocket if necessary. Over-all dimensions are 6" x 3½" x 2".

The field strength measuring portion of the device may be tuned to the transmitter frequency. The transmitter signal is picked up for test purposes by an antenna consisting of a foot or less of stiff wire plugged into a jack on the front panel of the instru-

ment. No direct connection to the transmitter is required. If the transmitter is radiating a signal, the indicating meter of the instrument will be deflected as the signal is tuned in. The amount of deflection obtained indicates the relative strength of the signal, that is, how well the transmitter is "putting out." A simple precalibration of the tuning knob or dial will enable the operator to determine if the transmitter frequency is inside the band. The method of making this calibration is explained later in the article.

The voltmeter portion of the device uses the same indicating meter as the field strength portion. The meter may be switched at will from one section of the instrument circuit to the other. The d.c. voltage ranges provided are 0-10, 0-100, 0-1000 volts. These ranges are adequate for checking all batteries used in airplane receivers, and power supplies employed in portable field transmitters.

The instrument is ready for instant use, since no batteries, tubes, or power supply of any kind are employed.

Circuit Description

Fig. 1 shows the complete circuit diagram. The coil L_2 and the condensers C_1 and C_2 have been chosen to tune from 48.5 to 65 megacycles. This range includes the 50-54 mc. amateur band which is widely used for model aircraft control. Coil L_2 consists of 2

turns of No. 20 bare copper wire, ⅝ inch in diameter and spaced to a winding length of ½ inch. This is a self-supporting "air-wound" coil. The antenna coupling coil, L_1 , is a single ⅝ inch diameter turn of insulated, solid hookup wire mounted as close as possible to one end of coil L_2 . All tuning is done by means of the miniature 50 μ fd. variable condenser C_2 .

The detector is one of the new glass-enclosed 1N34-A crystal diodes (*Sylvania*). This simple detector operates quite satisfactorily in this circuit.

The indicating meter, M_1 , is a miniature 0-100 d.c. microammeter. Some individual builders may prefer to use a less expensive 0-1 d.c. milliammeter. This will be satisfactory. However, the increased sensitivity of the microammeter allows the instrument to be operated at an appreciable distance from the transmitter. The microammeter also gives a substantial reading when testing low-powered transmitters.

Referring to Fig. 1; when switch S_1 is thrown to its "R.F." position, the meter is connected to the detector and is deflected upward whenever a signal is tuned in. When the switch is thrown to its "V" position, the meter is removed from the detector circuit and is connected into the voltmeter circuit. Resistors R_1 , R_2 , and R_3 , respectively, adapt the meter to read 1000, 100, and 10 volts d.c. full-scale. The voltage is read directly on the 0-100 scale of the meter by adding or subtracting mentally the required number of ciphers when necessary.

Connections are made to the instrument through insulated pin-type panel jacks. Into one jack is plugged the short length of stiff wire which acts as a pick up antenna when making transmitter checks. The jacks labeled with voltage figures in Fig. 1 are connected to the positive terminal of the battery or power supply being tested. The jack labeled "NEG." is connected to the negative terminal. Regulation meter test leads and pencil-type test prods may be plugged into the jacks when the instrument is used as a voltmeter.

RADIO & TELEVISION NEWS

Switch *S*, completely disconnects the radio circuit when voltages are being measured, and completely disconnects the voltmeter when signals are being tuned in. This switching feature protects the 1N34-A crystal from destructive voltages when the voltmeter section is in use. It also prevents interference between the two portions of the instrument circuit.

Mechanical Construction

The photographs show arrangement of the parts. The pickup antenna jack may be seen in the panel view just above the meter. Switch *S*₁ is to the right of the meter. Just below the meter is the finger-grip knob for the tuning variable condenser *C*₂. The voltage jacks are spaced along the lower edge of the panel. The instrument is housed in a standard painted aluminum radio utility box, 6 inches long, 3½ inches wide, and 2 inches deep.

The under chassis view shows the internal arrangement of parts. Note that coil *L*₂ (seen to left of the meter) is soldered directly to the two connection lugs of the tuning condenser *C*₂. The pigtail leads of the ceramic condenser, *C*₁, are also soldered to these two lugs. Coil *L*₁, spaced just slightly below *L*₂, is connected to a lug "grounded" to the instrument case, and to the antenna input jack near the meter. The tiny glass-enclosed crystal diode may be seen slanting upward to the right from one end of coil *L*₂. Voltmeter multiplier resistors *R*₁, *R*₂, and *R*₃ may be seen soldered directly to the voltage input jacks. The common connection between these three resistors is secured by joining all of their free pigtail leads to the single lug of an insulated terminal strip.

Resistors *R*₁, *R*₂, and *R*₃ must have the exact resistance values specified in Fig. 1. If higher accuracy is desired than can be obtained with carbon resistors, use precision wirewound instrument-type resistors. If a 0-1 d.c. milliammeter is used instead of the microammeter, the following resistance values will be required: *R*₁-1 megohm, *R*₂-100,000 ohms, and *R*₃-9900 ohms.

The only precaution in wiring the instrument is to keep all leads in the radio section rigid and as short as possible. For this purpose, use *solid* radio hookup wire, instead of the flexible type. Observe carefully the polarities of both crystal and meter, otherwise the meter will kick backward when a signal is tuned in.

Frequency Calibration

After the instrument has been completed, a frequency calibration must be made. This can be done with any one of the several types of test oscillators or signal generators used by radio technicians. The generator must tune at least as high as 65 megacycles. The following calibration procedure is recommended.

1. Connect the "high" output terminal of the signal generator to the antenna pickup jack of the test gadget.

2. Connect the "low" output terminal of the signal generator to the metal case of the gadget by means of the "NEG." jack. 3. Set the gadget tuning knob to its lowest-frequency position. This is the setting with the tuning condenser plates completely meshed. 4. Set switch *S*₁ to its "R.F." position. 5. Switch-on the signal generator and allow about 5 minutes warmup time. 6. Set the generator output to maximum and slowly tune the generator frequency dial until an upward swing of the microammeter occurs. Retune carefully for peak (maximum) meter reading. Read the frequency from the signal generator dial and inscribe a line and this value on the panel of the gadget. 7. Set the generator, in steps, to higher frequencies spaced a few megacycles apart, and tune the gadget to each of these frequencies. At each peak deflection of the meter, inscribe a new line on the panel and mark in the corresponding frequency. 8. Repeat the procedure until the entire tuning range of condenser *C*₂ has been covered. 9. An alternative method, which is the system employed by the author, consists of inscribing only two lines on the panel—one to indicate the 50 mc. low-frequency limit of the amateur band; the other to indicate the 54 mc. high-frequency limit. This marking will be sufficient in most cases, since the exact operating frequency often is not as important as whether or not the transmitter is well inside the legal band.

While most model airplane activity seems to center in the 50-54 mc. amateur band, individual operators may prefer other bands. For higher-frequency bands, reduce the number of turns in and diameter of coil *L*₂ until the desired frequencies are covered by the tuning condenser.

The voltmeter section of the instrument requires no calibration, provided resistors *R*₁, *R*₂, and *R*₃ are chosen to have the exact values specified in Fig. 1.

Transmitter Checking. Switch on the transmitter. Plug a length of stiff

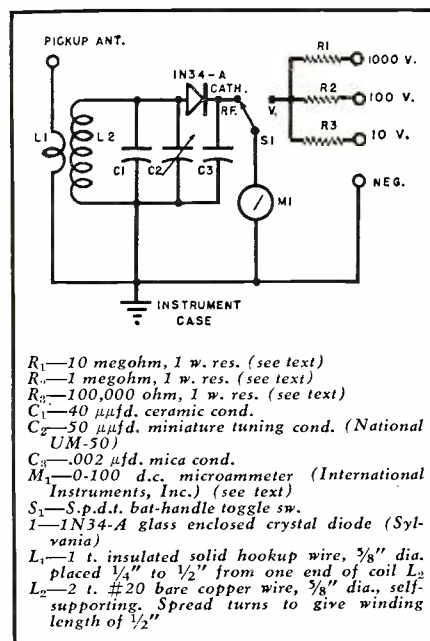
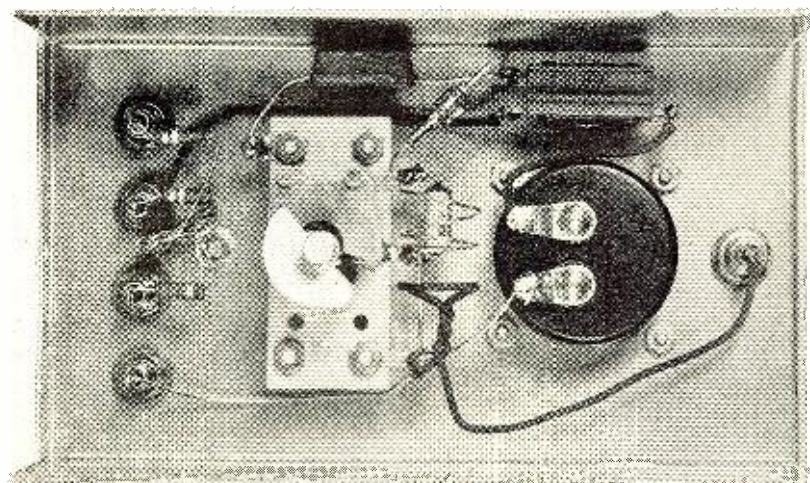

Fig. 1. Circuit diagram of field test unit.

wire (No. 14 bus wire will do) into the pickup antenna jack of the test gadget. In most cases, even when the transmitter is quite low-powered, this wire will not need to be more than about 1 foot long. Hold the instrument in the hand so that the pickup antenna wire is vertical. Move in about 1 foot from the transmitter. Throw switch *S*₁ to its "R.F." position and adjust the tuning knob, while watching the meter for deflection. If no deflection is obtained, move the pickup antenna closer to the transmitter and retune the gadget. At the point of peak deflection of the meter, determine the frequency from the setting of the tuning knob. If no deflection is obtained with the pickup antenna close to the transmitter, the latter is out of operation. If the deflection is forceful enough to drive the meter pointer hard against the right-hand stop, cut the pickup antenna to a shorter length or move the instrument (Continued on page 135)

Interior view of instrument showing wiring and correct placement of parts.



Simplified Reproduction of Drawings for Small Lab or Home Shop

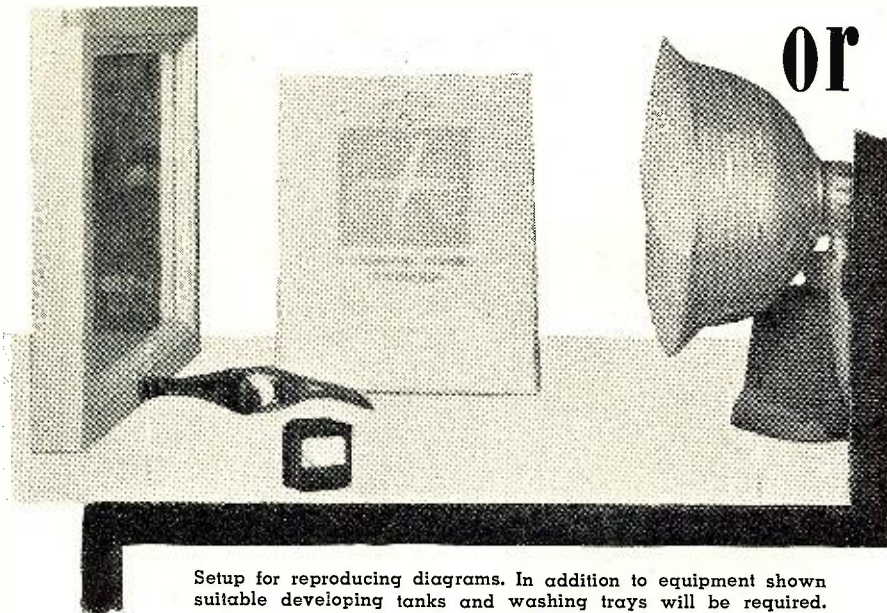

Setup for reproducing diagrams. In addition to equipment shown suitable developing tanks and washing trays will be required.

By **WALTER S. ROGERS**

An economical method for duplicating diagrams from the original drawings or the printed page.

✓ CIRCUIT and layout drawings in the small laboratory or home shop usually can be held to letter-size tracing paper (8½ by 11 in.), although larger drawings can be printed if needed. For the most part, however, this "A" size drawing will be adequate for the "official" shop size. This, then, brings up the need for copies of such data as surplus diagrams, or even a page in *RADIO & TELEVISION NEWS* (for shop use only—not for sale due to copyright laws) so as to retain the original intact. After due trial, the writer has formulated a copy method which appears to be the easiest and most economical.

A try at blueprinting with sun lamps, photofloods, and other light sources produced an unsatisfactory copy. A stab at another method requiring ammonia vapor in a crude home-brewed outfit gave similar results. It was finally discovered that the *Kodak* "Autopositive" method, released only last year, gave results which, under the crudest conditions, were often snappier and better than the originals.

The "Autopositive" process is covered in a booklet called "How to Use Reproduction Materials." Also included is data on other papers and processes which are not of interest, and

therefore a bit confusing to the layman. A call at the *Eastman Kodak* store found several trained engineer-photographers who had used the "Autopositive" paper and who were most helpful in furnishing the missing data.

This "Autopositive" paper is an extremely high-contrast, self-reversing, and reasonably fast paper which yields positive photocopies from positive originals upon exposure through a yellow filter, followed by the conventional photographic paper processing. It is extra thin but uses paper stock which does not tear easily. This permits it to be exposed from either front or back and thus, if necessary, it can be used for reflex copying.

The image is black—blacker than

Fig. 1. Contrast characteristics of "Autopositive." Note that no additional contrast can be obtained after rise to the peak.

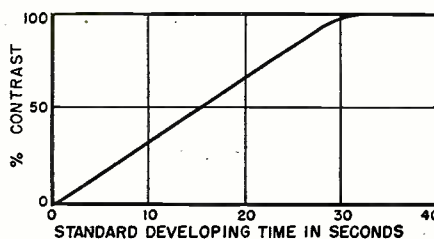

other methods tested so far—and therefore the copy usually is better than the original. Because the paper is extra thin, the prints curl less than anything I have used as photographic paper. This means that special drying care is not necessary.

Since the sensitivity is such that special lights (like carbon arcs or super intensity sources) are not needed, the print can be developed in a reasonably well-illuminated room where over 10 footcandles does not reach the print for a considerable time. The paper is most sensitive after exposure and thus requires more light care after exposure until it has been developed and immersed in the fixing bath.

A word about developing is in order. *Kodagraph* Developer and Fixer is recommended for the cleanest and most consistent results with this type of paper. But, realizing that the results will not be quite so good, any paper developer may be used. Normal development reaches its peak in about 30 seconds at proper temperature, see Fig. 1; fixing, after recommended short stop, normally takes 5 to 10 minutes; and a thorough washing, about 30 minutes.

With this information, I looked about for what was at hand in my home shop. I came up with two large trays, two small bottles of ready mixed chemicals for paper developing, no short stop, a makeshift but strong 8½ by 11 inch printing frame with no felting or rubber backing, a No. 2 photoflood in a reflector, and a *G-E* lightmeter. The printing equipment was set up on one of the electronic work benches. The photoflood at 24 inches from the printing frame gave a reasonably flat light field of about 400 footcandles. Test strips showed that 30 seconds to one minute provided the required data on exposure for copying through a rather poor and abused pencil tracing.

The development equipment was just as crude. Two trays were placed on a board on top of the fixed laundry tubs. The developer, "FR" paper developer, was mixed according to directions and poured into one tray. It probably should have been diluted more. The "FR" fixing solution was mixed and added to the other tray. An enamel pail under the cold water tap of the other laundry tub was the washing contraption.

(Continued on page 78)

A V-O-M and Grid-dip OSCILLATOR

By
MILTON WHITE

*A combination of test instruments,
each of which incorporates within
itself some unusual design features.*

THIS is a small test instrument which, because of the number and variety of tasks it will perform, does a big job.

The volt-ohm-milliammeter and the grid-dip oscillator have been basic test instruments from the early days of the radio industry and they will probably hold this position for as long a time as can be foreseen.

The combination of these instruments, as described in this article, gives to the radio amateur and technician test equipment that for rugged construction, operating conveniences, and appearance is tops.

In addition, the construction is such that the unit may be expanded to take care of extraordinary requirements where specialized test instruments may be needed. This v-o-m may be considered as a foundation unit around which such special equipment may be built. The microammeter and the 45 volt battery terminals are available to any specially built device for which they are suitable and which can be constructed in a manner that will allow the attachment of such a device.

Anticipating that additional connections to the v-o-m circuit might be required for some special instrument, two spare contacts are provided for the purpose in the receptacle used for connections. See the Jones connector, Fig. 2.

Six d.c. voltage ranges of 20,000 ohms-per-volt sensitivity to 750 volts and 5 resistance ranges from .2 ohm to 100 megohms form the volt-ohmmeter sections.

The high values of resistance so frequently used in modern equipment make the high sensitivity and the 100 megohm range desirable although such features are not, as a rule, found in pocket size instruments.

The convenience of a meter polarity reversing switch is also provided.

Another feature of the v-o-m, ex-

plained later in the text, is the method used to obtain an extra range from the circuit selector switch.

Fig. 1. The complete test instrument. The grid-dip meter plugs directly into the v-o-m, providing a more flexible and practical instrument.

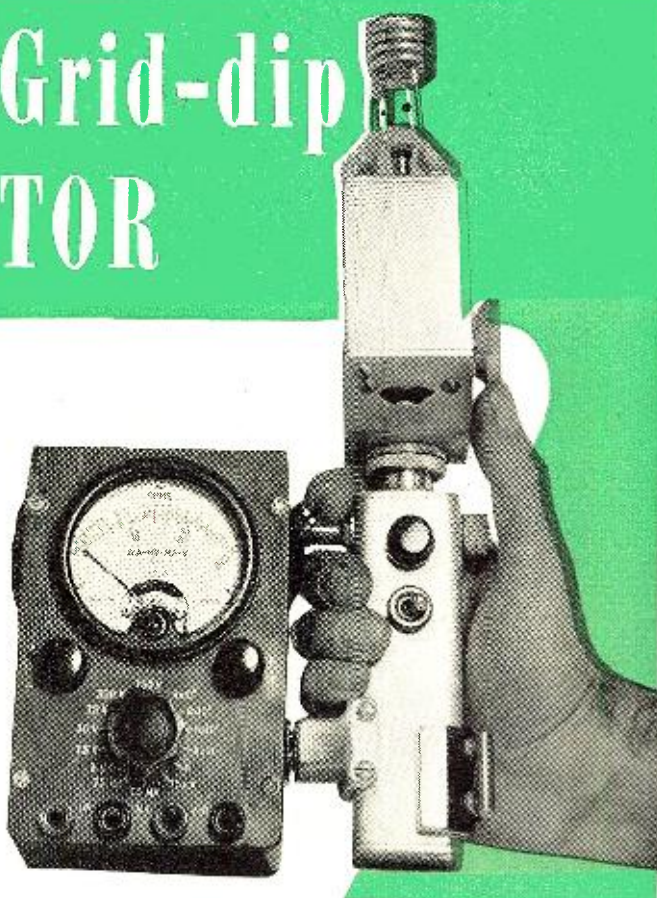

With proper design a grid dip oscillator can cover the broadcast field, being useful as a wavemeter, oscillating detector, etc., so that its only limitation is the ability of the user.

To cover this broad field the instrument must be arranged with means for modulation, listening-in, adjustable meter sensitivity, diode detection and, of particular importance, the oscillator tuning section must be built as a small separate unit and provided with a connecting cord so that it may be used in cramped quarters. See Fig. 3.

The mechanical coupling of all units must be secure and a handle should be provided for antenna applications so that the device may be held by one hand, leaving the other free to grasp some firm support. After careful design and rigid testing of several models, the oscillator described meets all the necessary requirements.

The parts layout of the entire device is straightforward except for the tuning unit. This is pictured withdrawn from its case to make its assembly clear. See Fig. 4.

In these photographs a geared drive for the tuning condenser can be seen. This drive was cut from an old condenser, make unknown or it would have been specified, but many of the anti-backlash, right-angle drives used on auto radios will do.

To use the condenser dial and the

vernier graduations on the tuning knob, as shown in Figs. 5B and 5C, the gear drive must have a ratio of 20 to 1. This is how it figures.

The tuning condenser dial has five graduations for the 90 degrees through which the butterfly condenser turns. At the gear ratio specified, five turns of the tuning knob will be required to turn the tuning condenser through its range. With the tuning knob given fifty graduation marks, each mark will indicate 1/50 of 1/5 or 1/250 part of the tuning range. One complete rotation of the knob will bring a dial graduation to the reading point. Each dial graduation should therefore be read as 50. For fractions of a knob revolution, add the number indicated on the knob to the dial reading. The second and fourth dial graduations from 0 represent 100 and 200 but are numbered 1 and 2 because of space considerations. For other gear ratios or types of drive the calibration and construction will have to be changed to fit. By the use of the vernier, closer readings can be obtained than ordinary dials calibrated over 180 degrees will give, so that the objection to crowded readings for the butterfly condenser is overcome.

Figs. 5G and 5H show the special banana jacks used for the plug-in coils. Attention is called to the angularly drilled hole in Fig. 5H. The tuning condenser stator bar is soldered into this hole, which should be located and drilled at assembly. Three nuts for the coil jacks will be needed. The regular

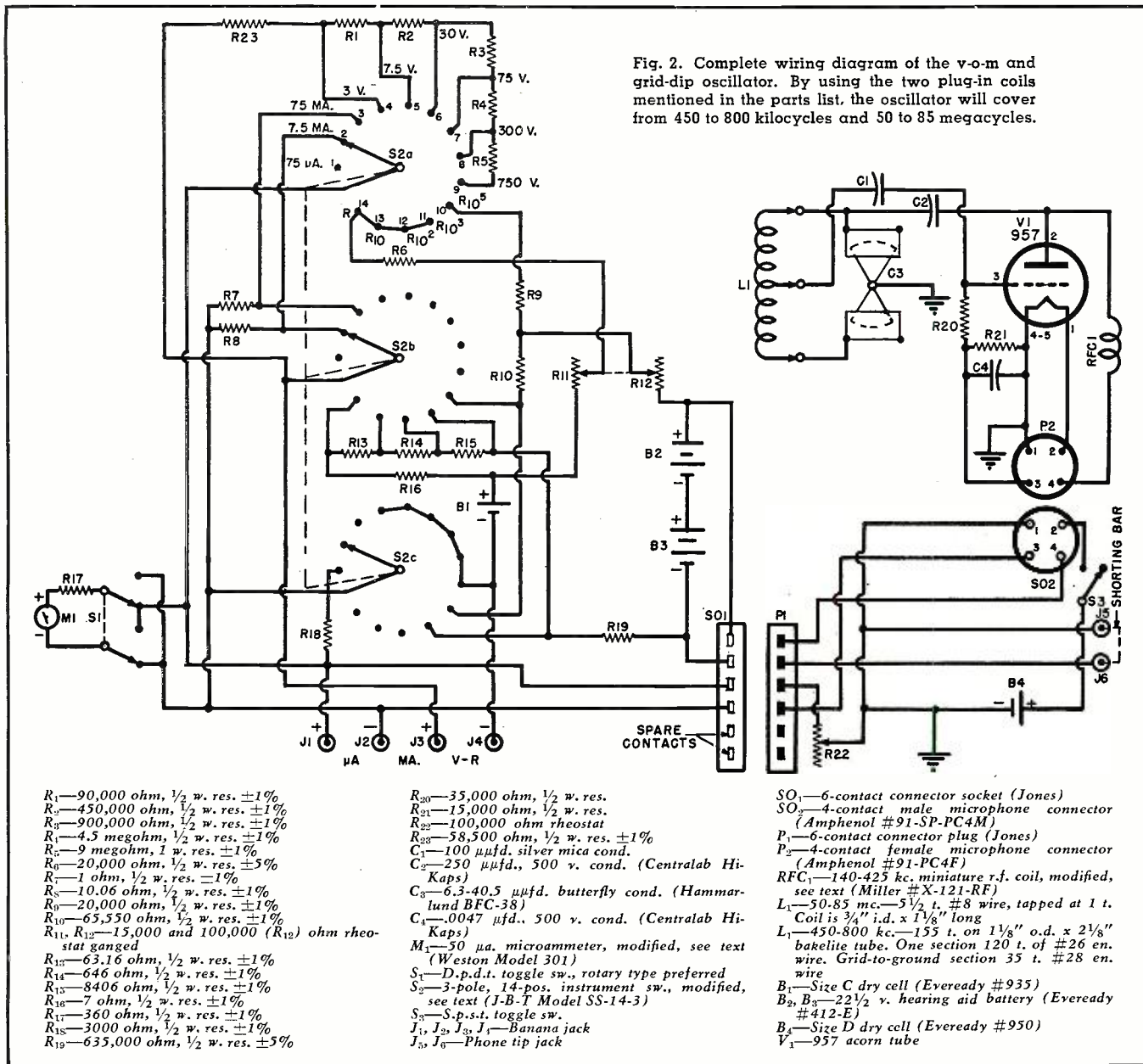
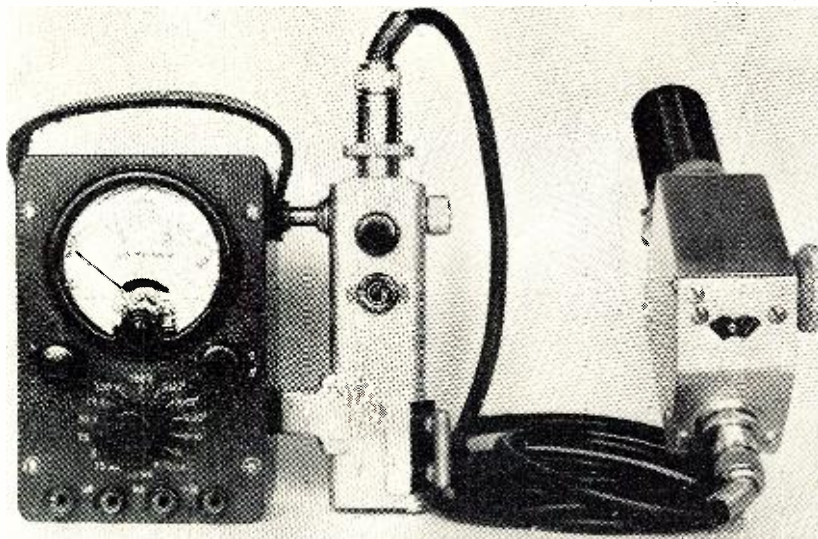

Fig. 3. The complete instrument showing the 450-800 kc. coil and the interconnecting cord in place. "Window" on the end panel is to allow observation of tuning dial.



1/4 inch nut being too large for the purpose, these were made by drilling and tapping standard 8-32 nuts for a 1/4-32 thread.

An important factor in the stability of an oscillator is the loading of the tank circuit, due to the internal capacities of the vacuum tube which also restrict the frequency range of the coil. By connecting the vacuum tube across only part of the coil, this effect is minimized. To accomplish this, the tank circuit coils are tapped for connection to the vacuum tube grid. Specifications for coils to cover the ranges that the author required are given in the parts list, but coils may be wound for any frequency. The required winding data can be obtained from a radio handbook, except for the location of the grid tap which must be found by experiment. This tap should be made to the turn of the coil which gives the most constant reading on the meter over the frequency range of the coil being wound. While the position of the

tap is not critical, a little care in placing it will pay dividends in the form of good frequency range and "Q." A frequency chart should then be prepared for each coil. Details of the coil base are shown in Fig. 5E.

A Miller X-121-RF coil is used for the radio frequency choke. The iron core and the can in which it comes must be removed. The coil is then cemented to the oscillator front panel. See RFC₁, (Fig. 2) and the photographs of Fig. 4.

A square duralumin tube forms the connecting member between the v-o-m and the tuning unit. It also serves as the handle and contains the Eveready size D dry cell for the 957 tube filament. The oscillator "On-Off" switch and the meter sensitivity control are mounted on this handle in such a position that they, together with the tuning knob, may be operated by the thumb of the holding hand as shown in Fig. 1. At the other end of the handle, mounted on a raising block, are the phone tip jacks to which phones may be connected for listening-in or a modulating voltage for the oscillator applied. When using the device as a c. w. oscillator a shorting bar is placed across these jacks. For diode operation, removal of this bar breaks the oscillator plate circuit. On the other side of the handle opposite the phone tip jacks, the Jones plug is mounted in an aluminum block which has been cut out to fit it. This plug does double duty as a radial support for the v-o-m as well as making the required electrical connections to the 45 volt battery and the microammeter. A special 10-32 screw with a knurled knob head (shown under the thumb joint in Fig. 1), passing through the handle and mating with a threaded bushing (See Fig. 5D) in the v-o-m case serves to hold these two units together. To separate the units it is only necessary to release this one screw. They may then be pulled apart.

Additional use is made of the threaded bushing by having it serve as one support for a strap handle on the v-o-m, the other end being held to the v-o-m case by a 10-32 screw.

When separated from the oscillator, the v-o-m is ready for use as an independent instrument with the following ranges: 3, 7.5, 30, 75, 300, and 750 volts d.c.; 75 μ a., 7.5 ma., and 75 ma.; 7, 70, 700, 7000, and 700,000 ohms center scale; 1000, 10,000, 100,000 ohms, 1 megohm, and 100 megohms full scale.

Resistors R₁₁ and R₁₂ serve to give a 75 mv. drop to the current ranges. This voltage drop, being readable on the scale, adds another range to the instrument. It should be read from the 75 μ a. range and used only when the characteristics of the circuit being measured will not be affected by the current drain.

A new dial scale, calibrated for the ranges listed, will be required. The calibration of the voltage-current scale, which is evenly divided, may be marked off directly. The ohmmeter scale must

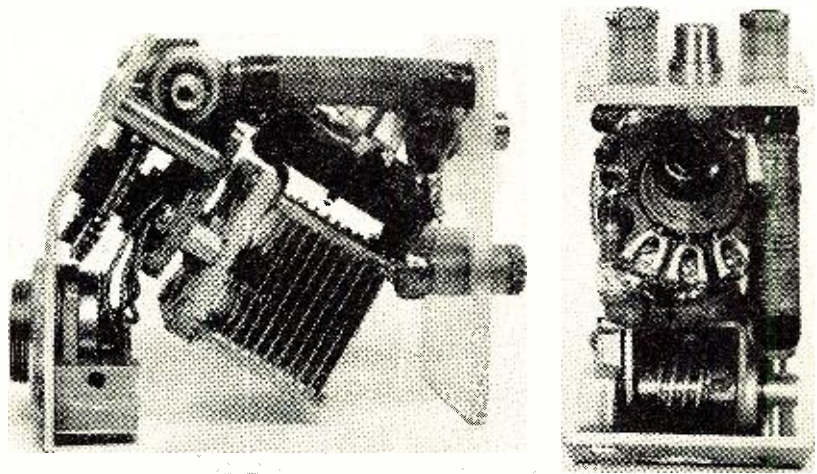
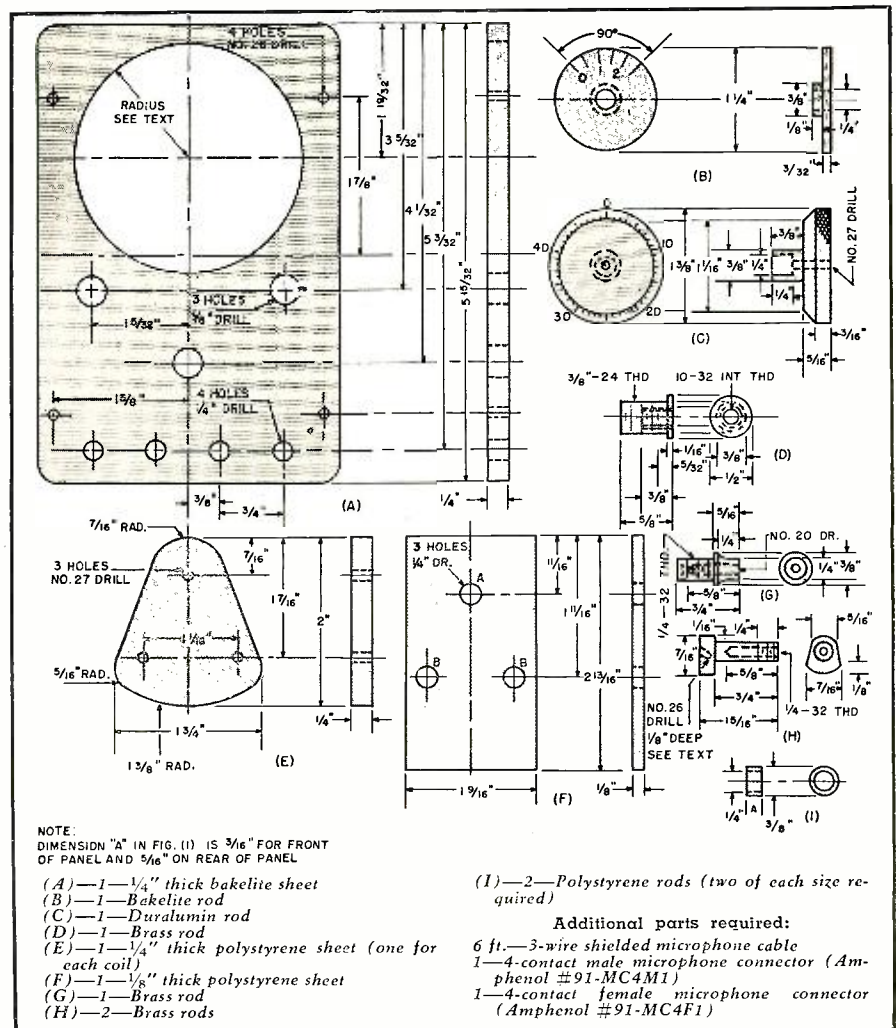

Fig. 4. (Left) Side view of the oscillator. Note the angular position of the 957 tube socket and the tuning condenser. The drive gear and dial are directly behind the left end panel on which is mounted the female microphone connector. (Right) Top view showing position of the coil jacks, the 957 tube, and worm of the gear drive. C₁ is shown directly in front of worm gear. R₁₁ in the top center, and RFC₁ at lower side.

be checked against standards to locate the calibrating points or these points may be transferred with dividers from the ohms scale of a Weston Model 697

instrument if one is available. Checking the calibration of the new scale will show that the Weston ohms scale (Continued on page 100)

Fig. 5. Mechanical details of parts required. (A) the v-o-m panel. (B) oscillator dial. (C) oscillator tuning knob and vernier. (D) threaded bushing. (E) plug-in coil base. (F) oscillator panel. (G) oscillator plug-in coil (used at center tap of coil L₁, Fig. 2), (H) oscillator plug-in coil (outside terminals of coil L₁, Fig. 2), (I) spacers used with part H. Dimension A is 3/16" for front of panel and 5/16" for the rear of the panel.



Ham Converter for 2-6-10-15 Meters

By

H. J. HARRIS, W1PFF

Construction details on a compact, well designed ham converter. Output is 5 mc.

THE converter about to be described was first dreamed up by the writer nearly two years ago. Needless to say the original idea was somewhat different than the final version as presented here. In fact two previous models were discarded before the project was considered as finished. Throughout the period of development work devoted to the construction of this unit, two goals were sought above all else. First, its operation must not be restricted to one band. Second, its performance must be uncompromised. Then came in order stability, ease of operation, and appearance.

This is definitely not a "junk box" converter. Nor can it be duplicated for ten dollars. It may be well to mention at this point that construction of a unit of this type probably should not be attempted by the uninitiated. A little experience with v.h.f. construction techniques would be most helpful. Lead lengths and shielding are, of course, extremely important. The r.f. circuit wiring should be copper ribbon, preferably silver plated.

The writer claims nothing new or original in so far as the circuit of this unit is concerned. There is nothing unusual about the r.f. stage except that the 6AK5 is employed in a manner that actually gives 6AK5 performance. Adequate shielding is the principal factor contributing to this performance, the r.f. grid and plate circuits being contained in completely isolated compartments. To eliminate coupling between the r.f. grid and plate coils on top of the chassis, a removable shield can was used to cover the grid coil. The shield can used here is a National H-522 with grounding cup H-563-2. The top view photograph shows this shield can removed. Cathode lead

inductance and its associated ills has been eliminated by grounding both cathode connections and using a pair of Mallory bias cells for grid bias. The tuned-grid, tuned-plate r.f. stage has been used for years and is still used widely in preselectors and "front ends" where top performance is demanded.

So many articles have appeared in recent months regarding the superiority of the triode as a mixer that it seems hardly necessary or worthwhile to go into any details regarding this stage. Suffice it to say that its sensitivity is adequate, the noise level is a very minimum, and the input capacity is low enough so that the size of the r.f. plate coil is not appreciably affected, even for the 2-meter range. A portion of the i.f. transformer primary tuning capacity was connected directly from the mixer plate to ground to provide a short path for any signal frequency that might appear at this point.

The oscillator was chosen for stability and simplicity. By operating the heater and cathode at the same r.f. potential, hum modulation of the oscillator output is eliminated. Also, frequency variation due to heater temperature changes and vibration is minimized. The oscillator operates on the "high side" on all ranges and sufficient mixer injection is obtained by stray coupling.

A jumper included in the appropriate coils short circuits half of the split-stator tuning condensers, thus doubling the amount of tuning capacity across the coil. Reference to the schematic diagram should be made in order to better understand this method of changing the tuning rate to obtain the desired coverage and band-spread for the various amateur bands.

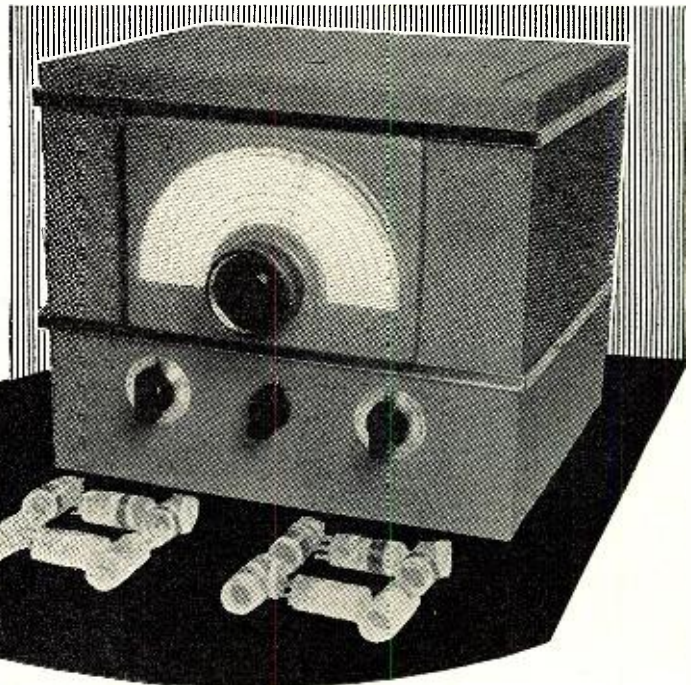

Front view of unit. Controls below main tuning dial are: r.f. grid tuning, receiver input switch, power supply, and the standby switch.

No doubt many will question the selection of 5 mc. for the converter output. Much thought was given to this part of the project and the following reasoning has proven to be sound in practice. First, 5 mc. is high enough to eliminate images in the amateur bands covered. Second, it is low enough so as to not present any oscillator mixer tracking problem. Third, a standard signal is always available (WWV) for setting up the receiver, thus assuring that the converter calibration can be reset. If the receiver shielding is adequate no trouble should be experienced from the WWV signal. However, if trouble should be encountered it can easily be eliminated by tuning off 5 mc. slightly. Fourth, "birdies" from the receiver oscillator are, for all intents and purposes, eliminated. The converter has been demonstrated on numerous receivers and in all cases it has been necessary to hunt for the 27th harmonic of the receiver oscillator which lands at about 147.2 mc. This is the only harmonic which lands in the amateur bands covered by this unit. If an i.f. of 10.7 mc. had been used, the 13th harmonic of the receiver oscillator would land at about 145 mc. which is in the heavily populated end of the 2-meter band and could be expected to be considerably stronger than the 27th harmonic.

After much experimenting with the commonly-used link output for connection to the receiver input, it was decided that this method was not practical for the average home workshop project. It is not easy to determine if the link impedance is correct to match the antenna coil or if it is coupled properly to the i.f. coil. This can be determined without too much

effort if you are fortunate enough to have a "Q" meter available. A simpler method appeared to be the use of a regular i.f. transformer with critical coupling and a cathode follower output tube. The transformer used here tunes with 220 $\mu\text{f.d.}$ The output impedance of a triode cathode follower is only slightly less than the d.c. resistance of the cathode resistor, so for all practical purposes the output impedance of the converter as described may be considered to be 500 ohms.

The tuning condensers used by the writer are a new type made by Millen under their part number 21906D. These condensers are small physically, of the split-tube type, are double-spaced, have two stator and two rotor plates per section, and have the shaft extended sufficiently for ganging. The capacity range, stator-to-stator, is approximately 1.8 to 3.5 $\mu\text{f.d.}$ Similar condensers have been seen on the surplus market.

For the oscillator and r.f. plate tuned circuits, which are ganged, one rotor and one stator plate were removed from the grounded section of these condensers to reduce the range. This, of course, is optional. Since the r.f. grid circuit is not ganged but is tuned separately, in the manner of an antenna trimmer, this condenser was used as is. A pair of pulleys and string drive allows this circuit to be tuned from any panel position that might be required in order to obtain a symmetrical layout.

Complete coil data is given in the coil table. The 2-meter coils are self-supporting and are mounted inside the coil forms. The antenna coil for this range is covered with tubing and inserted between the first and second turns of the grid coil at the cold end. The forms for the 6-meter coils were grooved to facilitate even spacing of the winding. With the exception of the 2-meter coils, all coils are wound with a loop on the inside for minor inductance adjustment. This method of coil winding is described in most amateur handbooks. The 2-meter coils may be adjusted by squeezing or

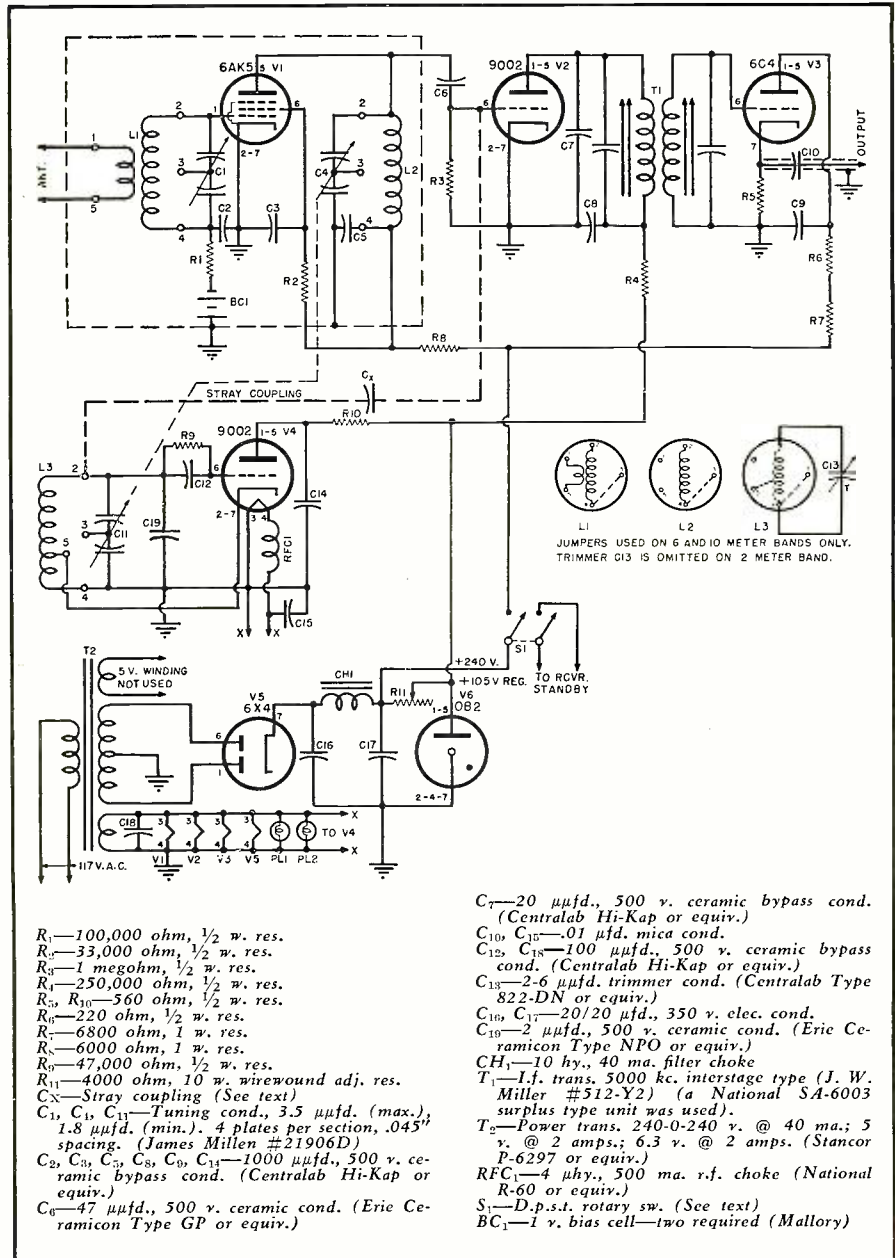

Schematic diagram of 2-6-10-15 meter converter. Complete winding specifications for the various plug-in coils required are given on the following page.

Bottom view of converter with bottom plate removed. Note the right angle brackets securing bottom edge of shield partitions.

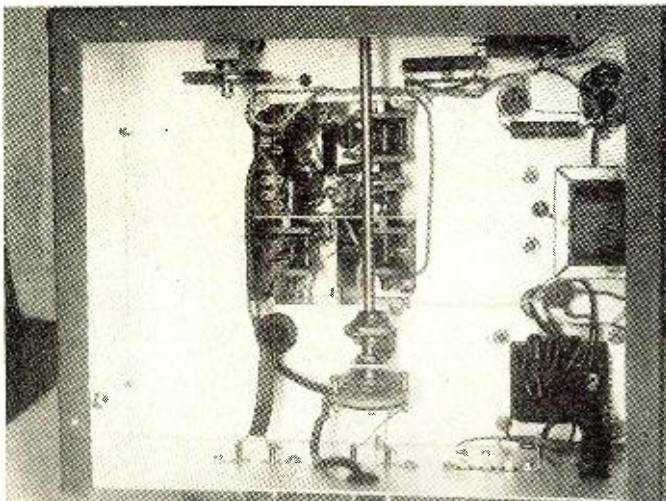

Top view with shield can removed from r.f. grid coil. The xtal holder and socket are used for antenna connection to converter.

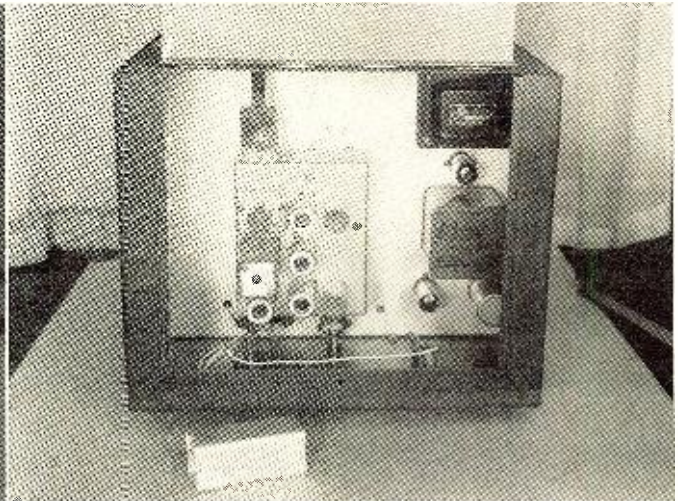

spreading the turns slightly and they will stay put. No trimmers were used except on the three lowest frequency oscillator coils and these are ceramic 2-6 μfd . trimmers mounted on the side of the form and held there merely by pulling the connecting leads down taut.

Coil forms are of the *Amphenol* miniature ($\frac{3}{4}$ " dia.) polystyrene type, 5-prong. Special polystyrene sockets for these forms are also made by *Amphenol*. A word of caution is in order regarding the use of these forms. Don't try to solder the pins with a soldering iron. The method used by the writer was as follows; make up the coils and try them first without soldering. Sufficiently good connection can be made for testing by slightly bending the wires where they pass through the pins. After it has been determined that the coils are satisfactory, apply a small amount of non-corrosive soldering paste to the ends of the pins. Then dip into a hot solder pot to about half the length of the pins, count to ten rapidly, remove from solder and immediately dip into a pan of alcohol and clean. Possibly someone knows of a better way to handle these forms. Finally, the coils should be given a coating of coil dope.

The antenna coils were designed for 50 ohms input inasmuch as this line is being widely used for feeding v.h.f. beams. If 300 ohm line is used it is suggested that a simple tapped coil impedance matching device be used to match the antenna to the converter input. This may be adjusted most simply by tapping the converter input onto the coil at a point which permits the r.f. grid tuning condenser to give a definite peak.

The under chassis photograph shows the shielding inside the chassis. These shields are made from 1/16 inch aluminum. The shield between the r.f. grid and plate circuits has a square cutout which straddles the 6AK5 socket. A small square piece of copper is then notched to fit snugly over the socket and in a manner which will allow it to be soldered to the grounded socket connections. This copper insert is then bolted securely to the alumi-

num shield and closes the aforementioned cutout. The schematic diagram indicates clearly the location of shielding and the components contained in each compartment.

The converter proper is a very compact assembly and may take on any final form to suit the needs and taste of the builder. Since the writer planned to use the converter as a companion unit to a NC200 receiver it was desirable that the final form should be similar in appearance and appropriate in dimension. This allowed plenty of space for including a power supply. The power supply is conventional and needs no description. A double-pole "B plus" standby switch was included, one pole being used for the converter and connected in a manner which permits the oscillator to run continuously. The other pole of this switch is terminated on the back of the chassis and is connected to the remote standby terminals on the NC200 thus permitting the converter and the receiver to be controlled from one switch. A single-pole, two-position wafer switch, not shown in the diagram, is also used in the converter and is wired to connect either the converter output or the low frequency antenna into the receiver, the low frequency antenna now being connected permanently to terminals on the converter chassis. This has been most convenient since the receiver is always ready to go, either separately or with the converter.

The dial used is a *National* ICN, the bezel of which happened to be the same size as the dial window opening on the NC200 receiver. This dial does not have to be dismantled to remove or replace the calibration charts so it is very convenient. The knob-to-pointer tuning ratio is very satisfactory with the amount of bandspread used. Tuning is a little bit stiff but perfectly smooth and without backlash. The final dial calibration was printed on by a friend with a *LeRoy* letterer and really looks professional.

It is essential that an insulated coupling be used between the two sections of the tuning condensers C_4 , C_{11} .

The same precaution applies be-

tween the condenser shaft and the dial. The rotors of these condensers are above ground and must be left floating electrically.

The condenser C_4 in the grid circuit of the 6AK5 tube is driven by a string and pulley arrangement. Care should be taken to see that the string or dial cord used is non-conducting.

When construction has been completed a 0-50 ma. meter should be temporarily inserted in the lead at one side of the 0B2 tube. The resistor R_{11} should then be adjusted to give a current of approximately 15 ma. through the tube with S_1 in the closed position.

It is not essential that the power supply be included with the converter and if the receiver has sufficient excess capacity, the converter may be powered from the receiver supply. About 20 ma. at 250 volts is necessary plus 6.3 volts at .9 amps.

It is recommended that the oscillator be supplied with regulated voltage for the greatest stability and freedom from drift.

Calibration of the converter was found to be no problem when using harmonics of a signal generator plus a 100 kc. crystal beat to WWV. Referring to the 0-100 scale of the ICN dial the following bandspread of amateur bands was obtained; 2-meter band—39 to 68, 6-meter band—29 to 81, 10- and 11-meter bands—29 to 94, (includes new 11-meter band) 15-meter band—48 to 71.

Standard laboratory equipment and methods were used to measure the gain of the converter and the following data was obtained; 2-meter band gain—37.7 db., 6-meter band gain—43 db., 10- and 11-meter band gain—47 db., 15-meter band gain—47 db. Since the measurements were made with a 1000 μv . i.f. setup, the lowest input to the converter was 4.5 μv . At this level the signal-to-noise ratio (modulation on and off) could not be read accurately by going down 20 db. with the output meter so a conservative estimate of signal-to-noise ratio would appear to be 30 db. This is exceptionally good in view of the fact that a common specification for signal-to-noise ratio is 10 db. for 5 μv . input.

If you are wondering now just what the above gain figures could mean to you in the way of performance, probably the best way to interpret them is by means of comparison. If you happen to own one of the better communications type receivers with two r.f. stages you may get 20 db. of r.f. gain on the 10-meter band, somewhat less if your receiver has only one or no r.f. stage.

If you are secretly dissatisfied with your present converter because it's built for one band only, or because the converter noise pushes your "S" meter up to 8 or 9, or if your receiver has "heavy images" on 10 meters and you can't hear the DX that your bosom pal across town works, then this converter can be the answer to all of your problems.

Coil table. For additional notes on final assembly, see the schematic diagram.

BAND	ANTENNA	L_1	L_2	L_3
2-m.	1 t. (See text)	3 t. #14 tinned. $\frac{5}{16}$ " i.d. Space twice wire dia. Mount $\frac{1}{4}$ " above bottom of form. See text.	Same as L_1	Same as L_1 . Tap $\frac{1}{2}$ t. from gnd. end.
6-m.	2 t. #19 tinned. One space from cold end of L_1 . Space same as L_1 .	6 t. plus $\frac{1}{2}$ t. loop, #19 tinned. Space 13 t. per inch.	Same as L_1 only with 5 t.	Same as L_1 only with $4\frac{3}{4}$ t. Tap $\frac{7}{8}$ t. from gnd. end.
10-11-m.	3 t. #22 en., closewound. $\frac{1}{16}$ " from L_1 at cold end.	$10\frac{1}{2}$ t. plus $\frac{1}{2}$ t. loop, #22 en. closewound.	Same as L_1 only $8\frac{1}{2}$ t.	Same as L_1 only $7\frac{3}{8}$ t. Tap $1\frac{1}{3}$ t. from gnd. end.
15-m.	3 t. #22 en. closewound. $\frac{3}{32}$ " from L_1 at cold end.	15 t. plus $\frac{1}{2}$ t. loop, #22 en. closewound.	Same as L_1 only 13 t.	Same as L_1 only $10\frac{2}{3}$ t. Tap 2 t. from gnd. end.

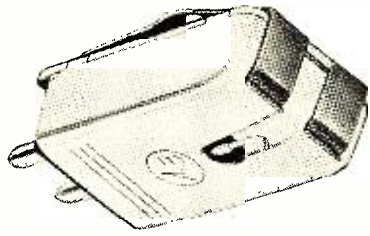

Electro-Voice's Models 10, 12, and 14 Torque Drive units, for 78 r.p.m. and microgroove.

There's Money in Cartridge Replacements

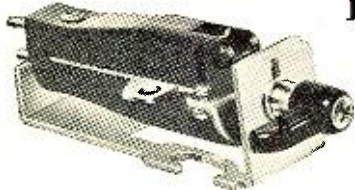

Electro-Voice Torque Drive turnover cartridge, the Model 96-T.

Shure's lever-type series cartridge.

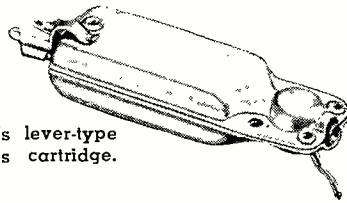

Shure "Vertical Drive" cartridge, Series W20. It is designed for all records.

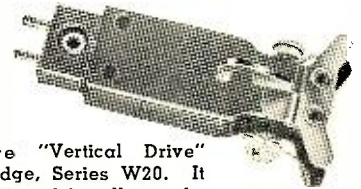

Electro-Voice's Torque Drive Models 30, 32, 33, and 34, for single or three speeds.

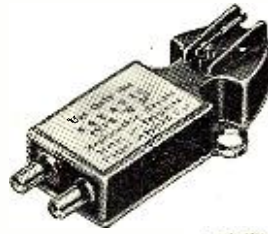

Astatic's CAC-J crystal cartridge. It is available in both 78 r.p.m. and LP models.

Astatic's Model ACD-2J turnover crystal cartridge assembly.



SEVENTY million dollars! It would seem rather difficult to ignore a market as tremendous as this. Yet, that is just what radio and TV technicians are doing every day.

The phono-cartridge replacement, or better, phono-cartridge modernization market totals 70 million dollars in direct sales alone. But the goodwill and customer satisfaction technicians can build by replacing old style, stiff-acting cartridges with modern, compliant models can be valued at several times this amount. Only the technician's habit of making exact replacements and then only after the original cartridge has gone completely dead prevents him from fully exploiting the profitable phono-cartridge market and making it one of his main sales efforts.

Owners of record players frequently buy one or more replacement needles a year. It has been estimated that the average phono-needle turned in for replacement has from 50 to 75 per cent of its usable life remaining. This poses an embarrassing question for cartridge manufacturers and technicians. Why is the record fan willing to replace his phono-needle at least once a year when he usually expects the phono-cartridge to last the life of his set? The answer lies in the sales and promotional techniques of manufacturers and retailers of phonograph needles. The same successful and useful techniques can and should be applied to the sales of phono-cartridges.

Examine the psychology behind these sales and promotional techniques and the reason for their success is apparent. The fans who purchase audio systems for their home, whether they be changers or single play sets, radio-phono combinations or custom-built high-fidelity systems, enjoy listening

By JOHN D. HARPER
Electro-Voice Incorporated

Why modern replacement cartridges mean more business for the service technician. Major postwar design changes make units manufactured prior to 1945 obsolete. Even replacing early LP cartridges will help materially in providing top performance.

to music. The enjoyment of music is simply an emotional experience, one that appeals to the senses. It cannot be evaluated by a standard set of rules or measurements. But it is one that demands to be enjoyed to the fullest. That's why audio enthusiasts want better recordings by the most talented artists, and have stimulated the present boom in the sale of high-fidelity sound systems and components.

It is to this highly emotional appeal that phono-needle promotions have been directed. The average record fan has been convinced that he will get more enjoyment from his records, in both superior reproduction and longer record life, when he replaces the phono-needle frequently. And maxi-

mum enjoyment from his musical hobby is what he wants!

But even this brilliant sales campaign could not have been successful without the aggressive backing it has received from retailers. How many times have you seen in record bars attractive displays asking, "Have you replaced your phonograph needle lately?" It is this consistent campaign at all marketing levels that has made the audio hobbyist aware of the needle in his record player.

The same hobbyist probably doesn't know the function of the cartridge in which he inserts the needle. To him the cartridge is merely a chuck which supports the needle.

(Continued on page 96)

Fingertip compliance test. The more recent models, giving better performance, are compliant, as shown in (A). The old prewar models were, in most cases, rather stiff (B).

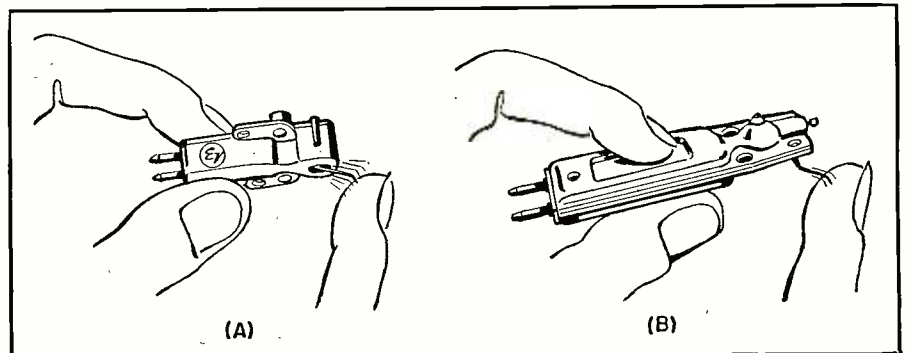

LOUDNESS and POWER

In Audio Systems



By
JAMES A. MITCHELL

How loud do you want your audio system to sound? Here are some of the factors involved.

HOW much power does it take to produce a sound of a given loudness in a certain room? This is a question which causes the amateur sound enthusiast a lot of head scratching. It's an important question too with a lot of dollars involved in the answer. Thirty watt amplifiers cost a lot more than ten watt models. Speaker prices run up into big figures as the wattage ratings rise. How can we make an estimate of the amplifier and speaker requirements, as far as loudness is concerned, in a certain installation?

Most sound engineers have acquired enough experience to make good estimates of these requirements and equipment manufacturers try to supply packaged units to fit different types of situations. The amateur can usually take these recommendations and obtains the desired results. However most inquisitive sound men will want to be able to make their own estimates. The present science of acoustics provides a basis for calculating the acoustic and electrical power required to produce a given sound intensity in different types of rooms. A few simple equations are all that is involved and these have been combined into a simple nomograph which will be described. With this graph the power required to produce any sound level in nearly all types of rooms can be estimated in a few seconds.

It should be stated that the accuracy of the graph is limited. This is not the fault of the equations involved but because of the difficulty of defining sound levels and due to the lack of accurate data on speaker efficiency. Even so, the graph will allow some useful estimates and, with a suitable safety factor, amplifier wattage ratings may be selected. The graph is also a very revealing source of information on the change in amplifier output at different sound levels and in different types and sizes of rooms.

The first question is the measurement of loudness. How loud is the average human voice? How loud is a symphony orchestra in the climax of

a Beethoven Symphony? Or in the softest violin solo? How loud is a swing band when all the boys stand up and hit the beat? Pretty loud you might say but an acoustic engineer would express it in decibels. Actually loudness is a sensation in the mind of the hearer and is a rather complicated matter but it is generally related to sound pressure or intensity. A great many measurements have been made of the sound intensities produced by various noises and musical instruments. A little study of this data will provide a measuring stick by which we may refer to various degrees of loudness. Fig. 1 shows several of these measurements on the standard decibel scale. These decibel ratings are obtained by measuring the intensity of the sound waves and by using the formula: *Sound intensity in decibels* = $10 \log_{10} (I/I_0)$ where *I* is the intensity being measured and *I*₀ is the standard

Fig. 1. Loudness levels of everyday sounds shown in db. and sound intensity ratios.

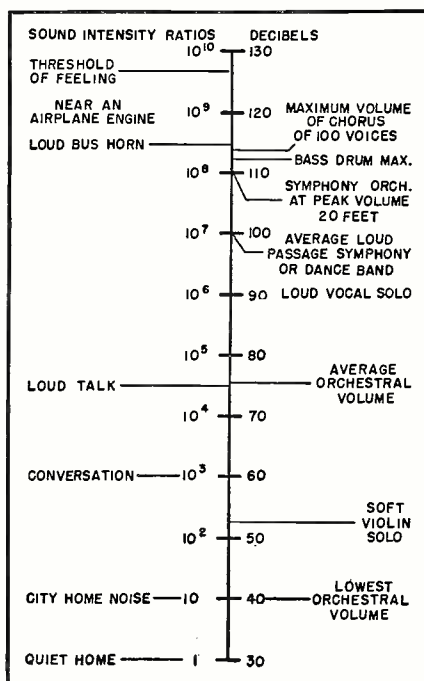

sound intensity. This standard is usually selected as the weakest 1000 cycle tone that can be heard by a normal ear in a silent room. This is a sound intensity of 10^{-16} watts per square centimeter. Since the logarithm of one is zero this standard level is expressed as 0 on the decibel scale. The decibel scale is a ratio scale and this is especially useful in loudness measurements because the ear responds to sound intensity in approximately a ratio function. That is, each time the sound level doubles in intensity it sounds approximately like an increase in equal steps of loudness. Thus an increase in sound intensity from 35 to 40 decibels sounds about the same as an increase from 55 to 60 decibels. In both cases the sound power increases by a ratio of about 3 but the actual power increase is 100 times greater in the second case.

Fig. 1 shows the relationship between the sound intensity in acoustic power ratio versus the decibel notation. The graph covers a range of 10 billionfold in sound pressures, from 30 decibels, the sound level of an average quiet home, to 130 decibels, the threshold of feeling or pain. Note the decibel ratings of the different sound levels that your audio system will be called upon to reproduce and the tremendous sound intensity ratios which this represents. It should be remembered that most of these sound measurements have been made with sound instruments which have a certain time lag. With complicated sounds the instantaneous sound pressure may be considerably higher. Engineers generally recommend that a system be capable of producing sound levels 6 decibels above the maximum sound meter readings. In Fig. 1, 113 decibels is the loudest musical sound measurement made, but instantaneous sound peaks may extend to 120 decibels and this safety margin should be kept in mind.

Now how loud do you want your audio unit to sound? In its design you must plan for the maximum level that will be required. Most home radios reproduce music at about 20 to 40 decibels lower than the real thing. Of course it makes a difference if the music is to be a background for conversation or if it is an occasion for serious listening or dancing. High fidelity and music fans often listen at normal volume levels and a few even run up the volume on everything except the loudest passages. For serious listening it is reasonable to design a system to reproduce normal volume levels even though the program is not always played that way. Dance bands and symphony orchestras have a characteristic sound because people enjoy that kind of loudness and most listeners have similar preferences when low distortion audio is available and listening conditions permit. Now normal volume level is not the same thing as putting a symphony orchestra in a small living room. That would be much too loud. We simply want to recreate

the loudness heard in the symphony hall in the living room. Naturally much less acoustic power will be required. In reproducing music at lower-than-normal levels there are not the savings in power requirements that might be expected. This is because of the increased bass boost needed for compensating the loss in aural sensitivity to bass notes at low volumes. The Fletcher-Munson curves show that if a musical passage, normally heard at an 80 decibel level, is reproduced at a 40 decibel level about 30 decibels of bass boost at 50 cycles is required for balanced listening. Since the bass tones contain much of the peak power this 40 decibel reduction in listening level will allow a reduction in power requirements of only 10 decibels. Normal loudness levels are, therefore, a reasonable requirement for high fidelity audio equipment designed for listening to music. For other purposes different loudness requirements must be met and these will have to be decided by the designer. The graph will aid in calculating power requirements for any sound level.

In the open air sound intensity diminishes with the distance from the source of the sound but in a room or small hall there is a great deal of reflection so that a source of sound builds up the loudness to a fairly uniform level. The ability of the sound source to produce a given sound intensity in a room depends on the size of the room and the amount of sound reflection or absorption in the room. The size of the room is a simple matter of calculation but this absorption business takes a little more thought. The properties of a room affecting the reflection or absorption of sound are measured by the reverberation time. This has been defined as the time required for a sharp sound to die away to one millionth of its original intensity. If we had a machine that would make a sharp noise at a 90 decibel level and would time the decay of the sound down to the 30 decibel level, we would have a measurement of the reverberation time. The reverberation time of most living rooms is within $\frac{1}{3}$ of a second to 1 second. Small halls may go up to $2\frac{1}{2}$ seconds. Values of about $\frac{1}{2}$ to 1 second are considered quite good acoustically for living rooms or small halls.

There is a simple method for calculating the reverberation time of a room by summing the effective absorption areas of the entire room. Each area of the room of different absorption surfaces is multiplied by the coefficient of absorption for that material and the total for the entire room is obtained and is called A. The reverberation time in seconds is therefore: $T = .05V/A$ where V is the volume of the room. Table 1 shows a typical calculation of this sort. This calculation was made on the room to estimate the amplifier requirements.

It is possible to make a shrewd guess of the reverberation time of a room with a little practice at clapping and listening. The method is to make

sure the room is quiet, clap the hands loudly and sharply and listen for the time of die-away. Careful listening will reveal a noticeable time of die-away even in a heavily draped room. It is surprising how different rooms can be in this respect. A stop watch is helpful in learning to estimate fractions of a second. The clap should be loud at about 90 or 100 decibels. Since the noise level of the room will be about 30 or 40 decibels the sound will be masked by the room noise after it has dropped about 60 decibels or the standard one millionth of its original loudness. Check your first listening estimates against the set of calculations shown in Table 1.

Well, we now have the reverberation time and the volume of the room. The power required to produce a loudness or sound intensity of 120 decibels is: $P = 0.00012 V/T$ where P is the power in watts and V is the volume of the room in cubic feet and T is the reverberation time in seconds. Other sound intensities require proportionately different power levels. It must be remembered that the power referred to in this equation is the acoustic power, the sound power actually put out by the speaker, not the power put into the speaker. In the room used in the calculations of Table 1 the acoustic power required to produce this sound level of 120 decibels is: $P = 0.00012 \times 1872/0.75 = 0.30$ watts

This brings us to the point of loudspeaker efficiency. Speaker systems differ a great deal in efficiency, covering a range of about 2 to 40%. Few speaker manufacturers specify the efficiency of their speakers in a way which allows a calculation of power input to acoustic output but a little experience on this point can aid in making estimates. If you are fortunate to live in a city with a good comparative speaker listening studio it is possible to make a pretty good list of

ABSORPTION COEFFICIENTS	
Glass	.025
Plaster, Brick, Linoleum	.03
Wood Panel	.08
Carpets, Rugs	.40
Draperies, Upholstered areas	.50
Wood Chairs, Small Tables (each)	.3
Persons (each)	4.0
$T = .05V/A$	
T = Reverberation time in sec.	
V = Volume of room in cu. ft.	
A = Absorption power of room in effective sq. ft.	
EXAMPLE	
Small living room (13' x 16' x 9')	
Plaster (1061 sq. ft. \times .03)	31.8
Wood areas (56 sq. ft. \times .08)	4.0
Carpet area (120 sq. ft. \times .40)	48.0
Draperies and upholstery (57 sq. ft. \times .50)	28.5
Wood chairs and small tables (5 \times .3)	1.5
Persons (3 \times 4.0)	12.0
	125.8
$T = .05 (13 \times 16 \times 9)/125.8 = .75$	sec.

Table 1. Calculating reverberation time.

efficiencies. Play some music and switch back and forth between two speakers, one with a known efficiency and, with an attenuator calibrated in decibels, cut the level of one until they are equal. The decibel attenuation allows a simple calculation of efficiencies. The speaker enclosure affects the efficiency and comparisons should be made while the speakers are housed in the type of cabinet which you expect to use.

As a general rule the more expensive the speaker the higher its efficiency, but this is not always true. Large magnets and light voice coils increase efficiency. Unfortunately good bass response does not go with light voice coils and diaphragms and when we demand good bass we must pay for more magnet without increased efficiency because of the heavier moving mass. Efficiency is also improved by good coupling of the speaker with the air as in horn systems and bass reflex cabinets. Standard speakers in the \$10 class are gen-

(Continued on page 156)

Fig. 2. Nomograph for calculating loudness and power requirements. See text for details.

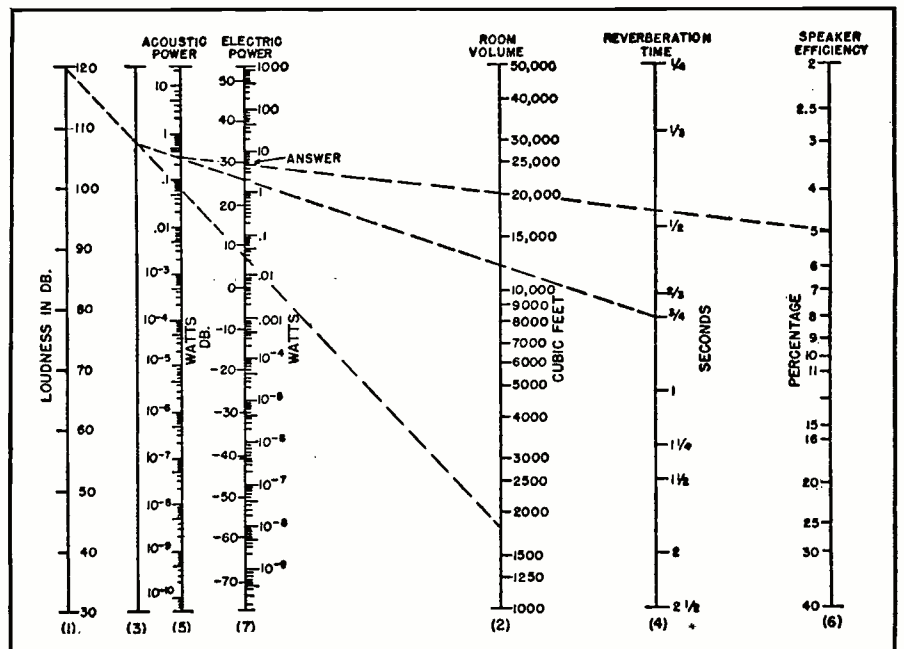

By
RUFUS P. TURNER
K6AI



Fig. 1. External and internal views of the home-built audio frequency meter. The large meter, reading directly in frequency, is easy to use.

A Direct Reading ELECTRONIC AUDIO FREQUENCY METER

Construction details on a simple instrument which gives direct indications of frequency up to 50,000 cycles. The response is independent of signal waveform and is not affected by signal voltage fluctuations between 1-300 v.

IN BOTH professional and amateur laboratories, it very often is necessary to check unknown audio frequencies. A common method is to compare the unknown frequency with some known frequency, using Lissajou's patterns. This method requires an audio oscillator and an oscilloscope, and demands some skill on the part of the operator. Moreover, it is a relatively slow process and cannot give direct indications of fluctuating frequency values. Another method is to feed the unknown frequency into an "audio frequency bridge," usually of the Wien type, and to set the bridge to null. At balance, the unknown frequency generally is read from the bridge potentiometer dial or from a chart or graph based upon that dial. This method also is relatively slow, requires some know-how on the part of the operator, entails use of one extra piece of equipment—a null detec-

tor, and cannot give direct indications of fluctuating frequency values.

The best arrangement of all for rapid, direct frequency checking is an audio frequency meter. Used with the same speed and simplicity as a voltmeter, this instrument merely is connected to the source of signal voltage and the unknown frequency is read directly from the meter deflection. No adjustments, other than setting a range switch, are required. This instrument accordingly can be operated successfully by non-engineering personnel.

Commercial, direct-reading audio frequency meters are expensive. Most of the circuits described in the literature either use gas triodes, whose deionization time limits frequency coverage to about 5000 cycles, or a combination of rather complicated amplifying, limiting, and shaping circuits which the non-engineer does not feel

equal to duplicating. Furthermore, most of these circuits employ sensitive d.c. microammeters as the indicating devices.

The direct-reading audio frequency meter described in this article will appeal to technicians who desire the utility and simplicity of a meter-type instrument but who wish to avoid circuit complication and expense. Six frequency ranges are provided: 0-100, 0-500, 0-1000, 0-5000, 0-10,000, and 0-50,000 cycles. The indicating instrument is a 0-1 d.c. milliammeter. By using this relatively inexpensive meter, the 100-, 1000-, and 10,000-cycle ranges may be read directly on the 0-1 scale by adding mentally the proper number of ciphers. The 500-, 5000-, and 50,000-cycle ranges are read by mentally multiplying the milliammeter readings by 5 and adding the proper number of ciphers. Response of the instrument is linear, so that only one point need be calibrated in each range. The frequency readings are not influenced by variations in signal strength between 1 and 300 volts r.m.s. Thus, the signal voltage may swing to any values between 1 and 300 without causing any change in the frequency meter reading. Response of the instrument is also reasonably free from waveform of the applied signal. Input impedance is high (the input circuit consisting of 0.1 microfarad and $\frac{1}{4}$ megohm in series) so that the instrument presents negligible loading effect to the circuit under test. Extensive tests of the instrument under a variety of operating conditions have shown no drift effects, therefore excellent stability may be expected.

Operating Principle

The circuit (See Fig. 3) consists of an overdriven 6SJ7 voltage amplifier followed by an overdriven 6V6 triode-connected power amplifier. By driving the tubes to saturation by means of the applied signal voltage, clipping action takes place in both stages, very largely so in the 6V6 stage, and the output of the 6V6 consists of constant-voltage square waves. The 6V6 output voltage is applied through a coupling condenser to a 6H6 double-diode switching tube which actuates the d.c. milliammeter. Since the output signal is a train of constant-amplitude pulses, the meter reading will be proportional only to the number of pulses passing through the meter each second. Thus, the meter deflection is proportional to the frequency of the applied signal voltage. A variable resistor of appropriate value in the milliammeter circuit will allow this circuit to be calibrated so that full-scale deflection of the meter occurs at a desired frequency. As a result of complete clipper action in the amplifier circuit, the signal voltage can fluctuate consider-

ably without changing the amplitude of the 6V6 output pulses and, accordingly, the meter deflection.

The Circuit

The complete frequency meter circuit is shown in Fig. 3. The amplifier section varies from the conventional arrangement only in the direct grounding of the 6V6 cathode and the use of current limiting resistors in the control grid circuits. R_2 and R_8 limit grid current drawn when the grid signal amplitude swings high on positive half-cycles.

The 0D3/VR150 tube serves to regulate the 6V6 plate voltage and also to provide bias for the 6H6 switching tube.

Range switch S_2 selects an output coupling condenser (C_6 to C_{11}) and at the same time switches a calibration rheostat (R_{12} to R_{17}) in parallel with milliammeter M_1 . The rheostats are preset individually, as will be explained later under *Adjustment and Calibration*.

The power supply section is entirely conventional, being a small transformer-type unit with a two-section condenser-input filter.

Construction

The audio frequency meter, as it is shown in the accompanying photographs, is built into a standard metal "shield" box 6" wide, 9" high, and 5" deep. All components, including tube sockets, are mounted on a snug-fitting vertical chassis plate which may be seen in Fig. 1. The right-angle lips of this plate are bolted to the sides of the box. The tubes are supported horizontally and point toward the front panel of the instrument.

Rheostats R_{12} to R_{17} are mounted directly on the chassis plate and are provided with slotted shafts for screw-driver adjustment, since these controls are set during the initial calibration and need only infrequent readjustment to compensate for the aging of tubes and circuit components.

Transformer T_1 and filter chokes CH_1 and CH_2 are mounted as far as possible from the 6SJ7 tube, to prevent hum pickup. These three components should also be well separated from the milliammeter.

A four-inch milliammeter, *Triplet Model 420*, has been used here for good readability.

In the instrument shown, one of the points on a spare third wafer of switch S_2 was used for the "On-Off" power line switch S_1 . However, most builders undoubtedly will prefer a separate toggle switch for this purpose and will follow the scheme shown in Fig. 3 for making and breaking the power input.

There are no special wiring tricks. All leads in the 6SJ7 stage must be kept as short as possible to prevent oscillation and hum pickup. Also to prevent hum pickup, tube heater leads and powerline leads should be twisted together and pressed flat against the chassis. Run all of the ground returns in the 6SJ7 stage to one lug on the chassis, and later connect this lug

to "B-minus" by means of a length of No. 14 solid wire. Do not depend upon the chassis for a trouble-free performance as a conductor.

Adjustment—Calibration

After the instrument is completed, inspect the wiring carefully for errors. If none are found, it will be safe to proceed with adjustment and calibration.

First, set the range switch, S_2 , to its 100-cycle position. Do not connect anything to the "Signal Input" terminals. Switch on the power and allow about 2 minutes for the tube heaters to come up to normal operating temperature. There should be no steady deflection of the meter at this time. If the meter gives a reading, however slight, hum pickup or circuit oscillation is present and must be corrected.

The most accurate calibration will be secured by feeding in a signal (of voltage higher than 1 v.) corresponding to the highest frequency in each range and adjusting the corresponding calibration rheostat for full-scale deflection of the meter. The calibrating frequencies may be obtained from an accurate audio test oscillator. (1) With range switch S_2 set to its 100 cycle range, feed in a signal of 100 cycles and adjust rheostat R_{12} so that meter M_1 reads exactly 1 ma. (2) Switch S_2 to its 500 cycle position, feed in a 500 cycle signal and adjust rheostat R_{13} for 1 ma. deflection of meter M_1 . (3) Switch S_2 to its 1000 cycle position, feed in a 1000 cycle signal, and adjust rheostat R_{14} for 1 ma. deflection of meter M_1 . (4) Switch S_2 to

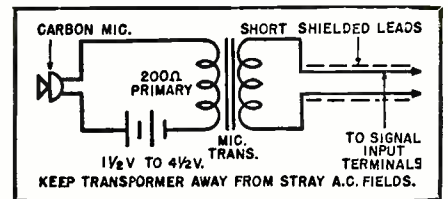

Fig. 2. Suggested test setup for testing the frequencies of various sounds.

its 5 kc. setting, feed in a 5000 cycle signal, and adjust rheostat R_{15} for 1 ma. deflection of meter M_1 . (5) Switch S_2 to its 10 kc. setting, feed in a 10,000 cycle signal, and adjust rheostat R_{16} for 1 ma. deflection of meter M_1 . (6) Switch S_2 to its 50 kc. setting, feed in a 50,000 cycle signal, and adjust rheostat R_{17} for 1 ma. deflection of meter M_1 .

Somewhat less accuracy is obtained when the calibration is made at some frequency less than the full-scale value in any range. However, this method can be used when the full-scale frequencies are not available. For example, a 60 cycle signal may be tapped off the ungrounded tube heater terminal and fed into the high "Signal Input" terminal. With S_2 set to its 100 cycle position, R_{12} then may be adjusted for a meter deflection of 0.6 ma. corresponding to 60 cycles. And with S_2 set to its 500 cycle position, R_{13} may be adjusted for a meter deflection of 0.12 ma., also corresponding to 60 cycles. A 120 cycle signal voltage not in excess of 300 v. may be taken from the output of an unfiltered

(Continued on page 149)

Fig. 3. Complete circuit diagram and parts list for the direct reading frequency meter.

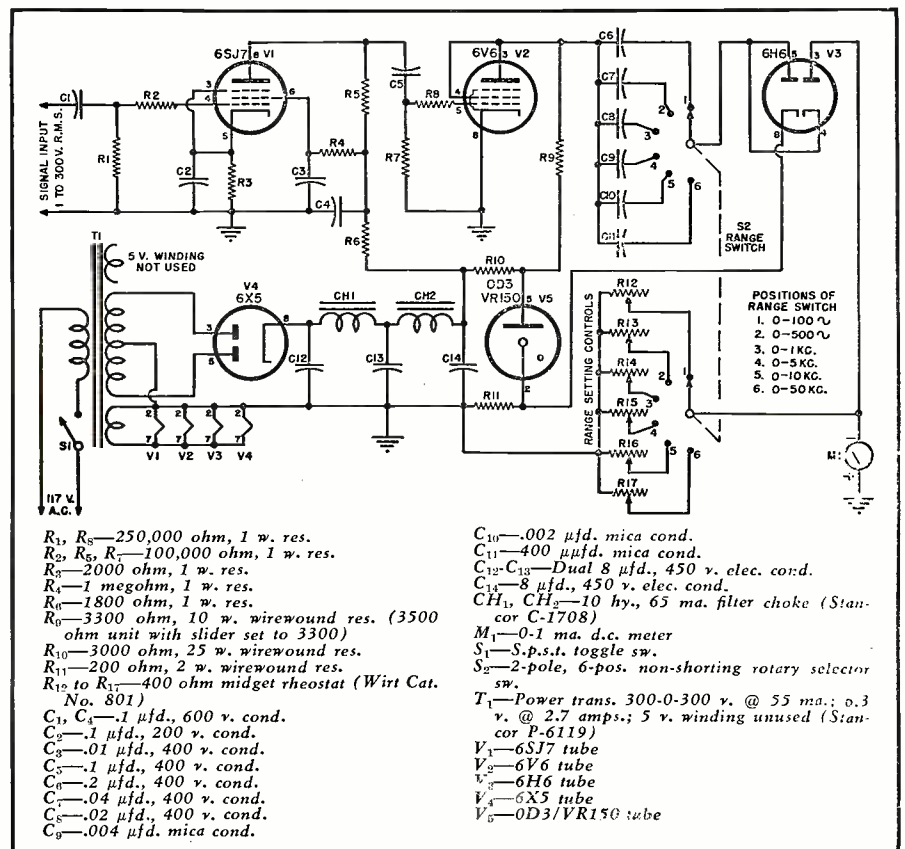

An Electronic A.C. Voltmeter

By

LAWRENCE FLEMING

This instrument measures a.c. volts from 1 mv. to 100 v., has an input impedance of .5 megohm, and is flat to within five per-cent from 10 to 50,000 cycles per sec.

THE three indispensable instruments for making real audio measurements are: an oscillator; an oscilloscope; and a wide-range, high-sensitivity a.c. voltmeter. All can be built at home at small cost. Many articles have appeared describing the construction of good oscillators and scopes, and good kits are available. But a really versatile, high-gain voltmeter is a rare item outside of a full-fledged development laboratory.

The instrument to be described will measure a.c. voltage from 1 millivolt to 100 volts. Its input impedance is 0.5 megohm and it is flat within 5 per-cent from 10 to 50,000 cycles.

Some of the uses of such a meter are: 1. Measuring audio gain and loss; 2. Measuring frequency response of any amplifier, equalizer, or filter; 3. Checking balance of phase inverters and push-pull stages; 4. Measuring turns ratios of audio and power transformers; 5. Measuring output of microphones and phonograph pickups; 6. Use as a preamplifier for an oscilloscope; and 7. Measuring distortion of amplifiers, in conjunction with a suitable rejection filter.

Commercial voltmeters of this sort are found in nearly every electronics laboratory. Their cost runs upwards of two-hundred dollars, which is a bit out of the reach of most of us, but such instruments, i.e., the *Ballantine* 300A and the *Hewlett-Packard* 400A are so useful that larger laboratories often have a dozen or more.

These commercial meters cover a wider frequency range than the unit to be described, and their circuits are a great deal more complicated. The *Ballantine* meter is flat to 150 kc. and

the more recently designed *Hewlett-Packard* goes up to 1 megacycle. Successful duplication or even approximation of these circuits is very difficult. Fortunately there is a way out, by means of a circuit that was first proposed, the writer believes, by Howard L. Daniels of *Engineering and Research Associates, Inc.* while he was at the Naval Ordnance Laboratory in Washington in 1944. This circuit achieves very respectable results with the utmost simplicity, and with freedom from critical adjustments or any tendency toward instability.

A good many v.t.v.m.'s for measuring audio have been described in print, but nearly all have followed the design originally described by Stuart Ballantine in 1938. Sensitivity is normally 0.1 volt full-scale on the most sensitive range. Microphone and variable-reluctance pickup outputs will not show up on such a meter, and small percentages of distortion cannot be measured. Flexibility in general is severely limited. This old arrangement consists of a two-stage voltage amplifier, followed by a 6H6 half-wave rectifier with a load resistor of around 50,000 ohms, a d.c. microammeter, and feedback over-all.

To increase the sensitivity, it has heretofore been necessary to resort

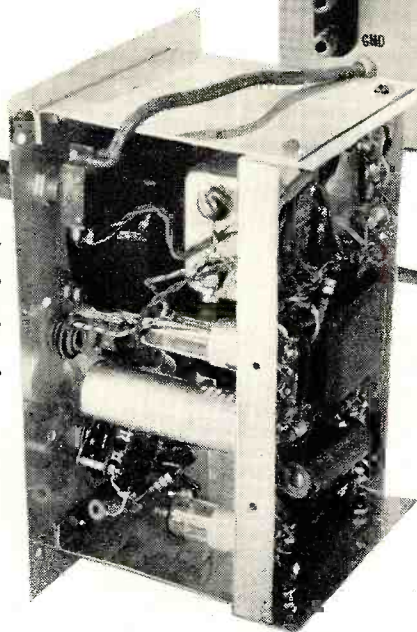
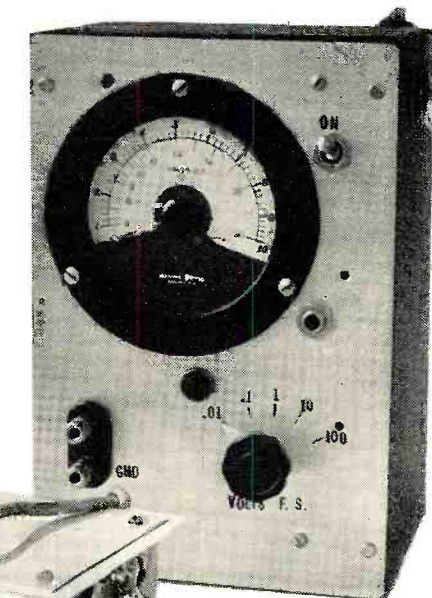

Two views of the unit. It uses just two tubes and a power rectifier. Unit can be made from junk box parts.

to a three-stage amplifier, as is done in the *Ballantine* meter. While this instrument is unequalled among electronic laboratory gear for all-around accuracy and dependability, its circuit has a lot of components, and its excellence is the result of extremely painstaking over-all design. Engineers who use these instruments send them back to the factory when repairs other than tube replacements are needed.

The Daniels Circuit

The *Daniels* circuit, by means of an ingenious trick, makes it possible to get the very most out of two tubes in a v.t.v.m. circuit. Using this principle, together with modern high-gain miniature tubes and crystal diodes, it is possible to get 10-millivolt full-scale sensitivity with plenty of negative feedback, and the whole thing is as free of "bugs" as a code-practice oscillator.

The trick is that the tube which feeds the rectifier-meter circuit is operated as a *current* amplifier rather than a conventional voltage amplifier. The effective a.c. load impedance to the last stage is much lower than the plate resistance of the tube, and consists of the rectifier-meter circuit itself. The negative feedback is current

feedback, and acts to stabilize and make more linear the meter current with respect to the input voltage—which is just what is wanted. In addition, full-wave rectification is employed. The meter deflection is proportional to the *average* full-wave value of the input voltage, giving a truer indication on square waves, and other non-sinusoidal waveforms.

The use of 1N34 germanium crystals as signal rectifiers eliminates zero drift of the meter due to diode contact potentials, and so no zero or bucking adjustment is needed.

Elementary Circuit

A simplified schematic is shown in Fig. 1. The circuit doesn't look unusual, but it is. The first stage, V_1 , is an ordinary voltage amplifier. The current amplifier is the second stage, V_2 . Its load consists of a resistor R_L in parallel (for a.c. currents) with the metering circuit, which consists of a bridge rectifier, the meter, a large coupling condenser (C), and the feedback resistor, R_f . The impedance of this combination is not over a thousand ohms or so, and it is through this that practically all the a.c. component of the plate current of V_2 flows. All that resistor R_L does is to pass the d.c. plate current of the tube V_2 . R_L should be high in resistance compared to the meter circuit, to avoid shunting it too much. It is also convenient to choose R_L and the bias on tube V_2 so that the d.c. plate current is 1.5 or 2 times the current required for full-scale deflection of the indicating meter. In this way the meter will not be banged around too much by overload voltages.

Gain and Feedback

The gain of this circuit (before feedback is applied) is expressed in milliamperes-per-volt. It is equal to the voltage gain of the first stage V_1 , multiplied by the transconductance of the second stage tube V_2 . For example, if the first stage is a pentode with a voltage gain of 200, and the second stage tube has a transconductance of 1 milliamperes-per-volt (1000 micro-mhos), the over-all gain is $200 \times 1 = 200$ milliamperes-per-volt. Hence if our indicating meter has a sensitivity of 1 ma. full-scale, the input signal required for full deflection will be $1/200$ volt, or 5 millivolts. If a 500 micro-ampere meter is used, the full-scale sensitivity will be 2.5 millivolts. A feedback factor of 4 can then be applied to obtain a full-scale sensitivity of 10 millivolts.

The negative feedback factor is proportional to the resistance R_f in Fig. 1. The feedback voltage, which is proportional to the a.c. current through the meter rectifiers, appears across this resistor, and is thereby injected into the grid-cathode circuit of the first tube V_1 . The design was started by choosing a tube lineup that would give several times the desired sensitivity, then adjusting the feedback resistor R_f until the gain was exactly the desired value. In the practical circuit described later, the constants

are as follows: 1. The a.c. current for full meter deflection—700 microamps; 2. Gain without feedback—about 550 ma./volt; 3. Sensitivity without feedback—1.3 millivolts; 4. Sensitivity with feedback—10 millivolts; 5. Feedback factor at mid-band—8.

Circuit Details

Fig. 2 is the circuit of the practical electronic voltmeter shown in the photographs. The input terminals go directly to a step attenuator, set up to give five decade ranges of .01—0.1—1—10—100 volts full scale. This attenuator or voltage divider is made up of precision composition resistors wired around a single-circuit, five-position rotary switch. Wirewound resistors, even the so-called non-inductive type, should not be used, because they were found to introduce peaks in the high-frequency response due to their residual inductance.

The first stage is a 6AU6 pentode voltage amplifier of conventional design, uses "contact potential" bias and has a gain of around 300. The screen bypass condenser should be no smaller than 2 μ f. Decoupling of the "B" supply to this stage is necessary, as indicated on the diagram, for stability at low frequencies. The second stage is a 6AT6 diode—high- μ —triode, only the triode being used. "Contact potential" bias is used here, too. The load resistor of 100,000 ohms limits the plate current under overload conditions to a safe value for the meter. The high- μ triode is preferable to a lower- μ tube because of its higher

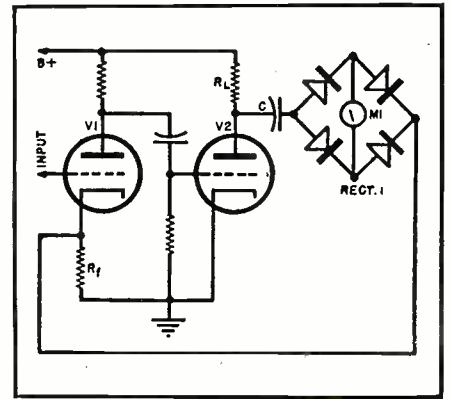

Fig. 1. Simplified Daniels voltmeter circuit.

transconductance at low plate currents.

A 2 μ f. paper condenser C_1 couples the plate of this triode to the rectifier circuit. In this case a half-bridge is used, consisting of two 1N34 crystals and a pair of 4700-ohm resistors R_{12} , R_{13} . The d.c. current through the meter M , with this half-bridge arrangement is exactly half the value it would be with a full bridge (as in Fig. 1), for the same a.c. current flowing into the rectifier circuit. A 500-micro-ampere meter will give the same results with a half-bridge as a 1 ma. meter with a full bridge, and so on. It is just a matter of convenience, and a question of whether one's parts collection is blessed with more 1N34's than meters, or *vice-versa*.

The particular meter used by the
(Continued on page 93)

Fig. 2. Complete circuit diagram of the electronic audio voltmeter unit.

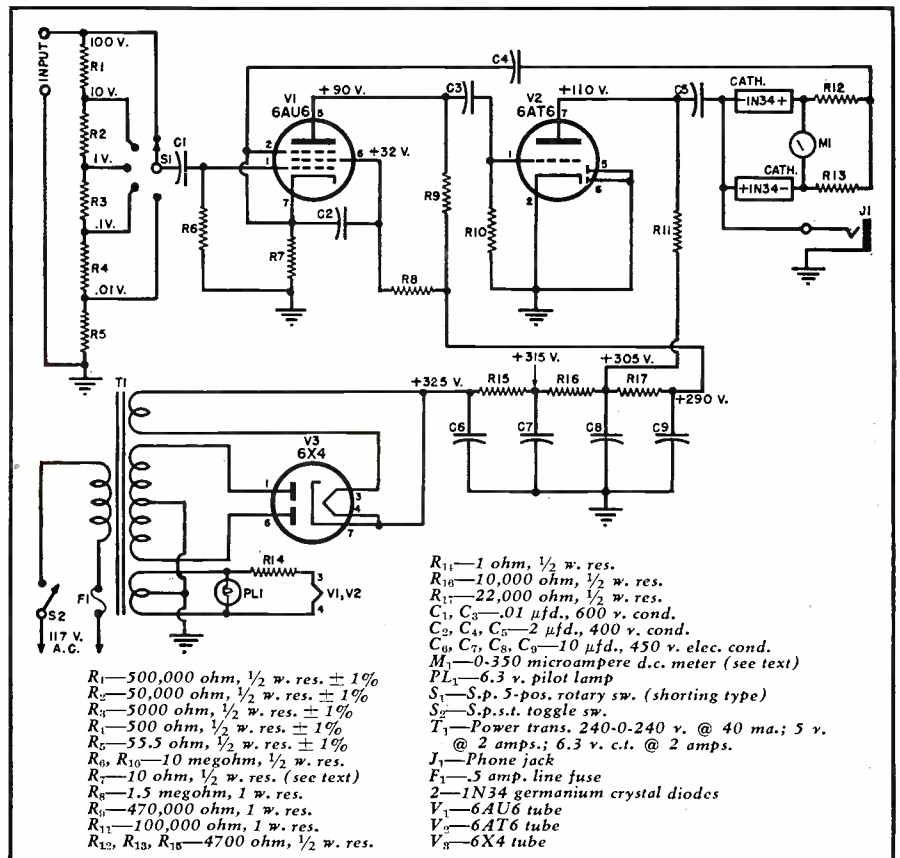

- R_{11} —1 ohm, $\frac{1}{2}$ w. res.
- R_{12} —10,000 ohm, $\frac{1}{2}$ w. res.
- R_{13} —22,000 ohm, $\frac{1}{2}$ w. res.
- C_1 —.01 μ f., 600 v. cond.
- C_2, C_4, C_5 —2 μ f., 400 v. cond.
- C_3, C_6, C_7, C_8, C_9 —10 μ f., 450 v. elec. cond.
- M —0.350 microampere d.c. meter (see text)
- PL_1 —6.3 v. pilot lamp
- S_1 —S.p. 5-pos. rotary sw. (shorting type)
- S_2 —S.p.s.t. toggle sw.
- T_1 —Power trans. 240-0-240 v. @ 40 ma.; 5 v. @ 2 amps.; 6.3 v. c.t. @ 2 amps.
- J_1 —Phone jack
- FL_1 —5 amp. line fuse
- 2—1N34 germanium crystal diodes
- V_1 —6AU6 tube
- V_2 —6AT6 tube
- V_3 —6X4 tube

TELEVISION SYNCHRONIZING CIRCUITS

By

J. RACKER and P. SELVAGGI

**Part 2. A discussion of flywheel circuits
and automatic frequency control circuits
found in commercially available TV sets.**

IN PART 1, appearing last month, we discussed the blocking oscillator and its improved version, the comparison system, which is used in conjunction with a blocking oscillator.

This blocking oscillator circuit as described is particularly applicable to the 30 cycle sweep circuits where conventional tuned circuits would be bulky and expensive. However, for the horizontal sweep, which operates at a frequency of 15.75 kc., standard tank circuits can be used. These circuits are known as "flywheel" circuits.

Fig. 8 shows the simplest type of flywheel oscillator. Tank A of this circuit operates at 15.75 kc., while tank B operates on the third harmonic (47.25 kc.). The tube is biased beyond cut-off so that only a positive pulse appears at its plate, as shown in Fig. 9. This positive pulse is then used to drive a saw-tooth generator as in the case of the blocking oscillator.

The sync pulses are applied to the grid circuit through the transformer. These pulses drive the tuned circuits at the sync frequency. When the sync frequency coincides with the tank A frequency, the resultant output is in-phase with the sync pulse.

However, when there is a frequency difference, the pulse appearing in the plate circuit will be out-of-phase with the sync pulses, the degree of phase difference being proportional to the frequency difference and the "Q" of the tuned circuit. The higher the "Q" the greater the phase difference between sync and saw-tooth waveform. For the very high "Q" circuits the phase shift may be as high as 50 percent and the blank space, making the center of the image.

On the other hand, the higher the "Q" the smaller the effect of random noise on the circuit. Thus to minimize phase shift, the "Q" should be made low, but to minimize random noise effects the "Q" should be high. In a very weak signal area, the gain of the receiver must usually be turned up which also increases the noise am-

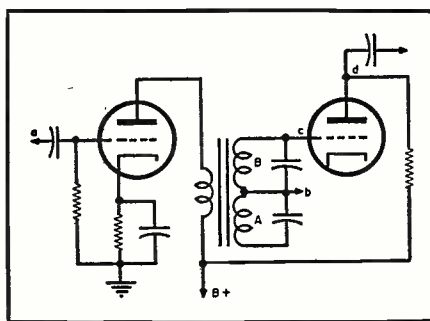

Fig. 8. Basic diagram of flywheel circuit.

plitude and hence a high "Q" is desirable. In strong signal areas, where the gain can be kept low, noise is not a serious problem and the "Q" can be made lower. It is rather difficult to increase the "Q" of a tank circuit in a set, unless an entirely new tuned circuit with a high "Q" is used to replace an existing one. Lowering the "Q" is a much simpler problem however which can be accomplished by placing a resistor across the tank. It is recommended that the technician use a 10,000 ohm potentiometer and vary the resistance across the tank until best performance is obtained.

From the foregoing it can be seen that it would be desirable to employ a tank circuit that would have a high "Q" for weak signals and a lower "Q" for strong signals. A circuit that reacts in this manner is the locked-in oscillator shown in Fig. 10. The sync pulses are injected across the resistor r_s . These pulses add to the signal developed by the resonant circuit so that a positive pulse appears at the plate of the tube as shown in Fig. 10B.

The ability of a flywheel circuit to stabilize synchronization may be expressed in terms of the time it takes to respond to a disturbance. If the circuit takes a long time to respond to a disturbance it means that random effects will not disturb the synchronization very much as they will disappear before the circuit can change appreciably. Such a circuit will, therefore, only respond to repeated impulses. This action is suitable for television synchronization. At the start the repeated impulses are the sync pulses themselves and although a circuit with a long time constant takes a long time to reach equilibrium, it will also take a long time to fall out of synchronization.

Fig. 9. Voltages at the various points designated in the flywheel schematic of Fig. 8.

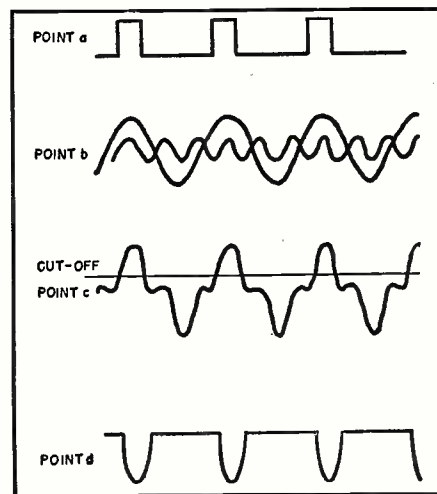

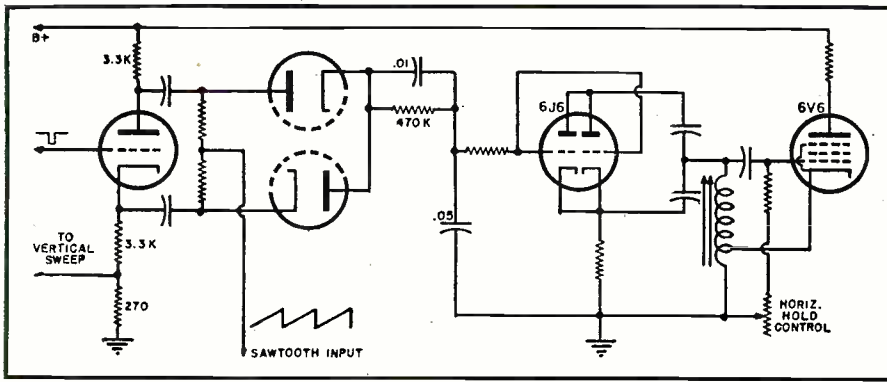

Fig. 12. Simplified schematic of the sync circuit used in several Admiral models.

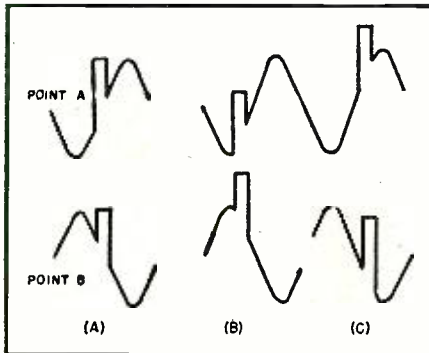

Fig. 13. Voltages across the diodes shown in Fig. 11. (A) With sync centered, (B) sync frequency low, and (C) sync frequency high.

point will not necessarily be at the center position since at this point the discriminator voltage would be zero and the circuit would revert to the original conditions. As a result there may be some phase difference between the sync and sine wave, but, when the circuit is operating properly, it will not be very serious.

R_1C_1 is the discriminator comprising a low pass filter which prevents momentary changes in error voltage, caused by random noise effects, to be

applied to the grid of the reactance tube. In some localities the sync pulses are phase modulated due to poor transmitter operation. Such a condition will cause poor synchronization in the automatic frequency control system because of the slow response to the changes in sync phase. To minimize this effect a large condenser (about $0.5 \mu\text{fd.}$) should be placed in parallel with C_1 . This will permit the circuit to readjust itself rapidly to changes in sync phase but, at the same time, it will also allow noise to affect the circuit to a larger extent.

Another important point to remember in servicing this circuit is that the most critical element in maintaining correct operation is the reactance tube. If this tube has aged to the point where it cannot increase or decrease the frequency of the resonant circuit enough to cover the extreme frequency differences, the circuit may go out of sync frequently. Even if a bad reactance tube allows synchronization it might require such a large error voltage (the lower the amplification of the tube the larger the error voltage required to maintain equilibrium) that the equilibrium position

Fig. 14. Sync circuit used in some G-E television sets. (A) Simplified schematic, (B) sync at center, (C) with sync at left (higher frequency), and (D) sync at right (lower frequency).

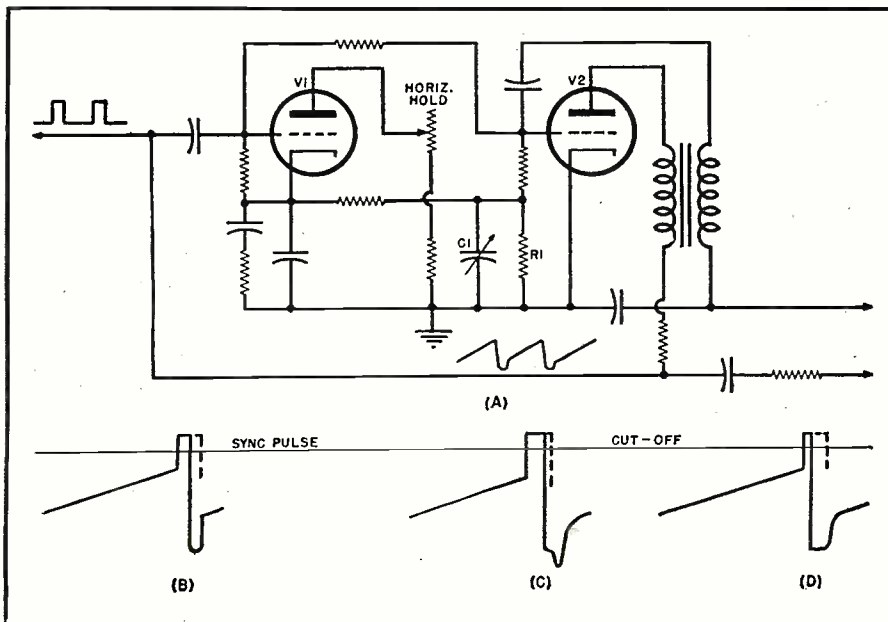

of the pulse with respect to the sine wave will be closer to the peaks than to the center. This will manifest itself on the screen as a shift of the image to the left or right.

This effect may not be due to the 6AC7 alone but can also be caused by an aging 6K6. If any replacement of tubes is required or it is desirable to retune the tank circuit, the 6AL5 diode should be removed first. The tank circuit is then tuned until the picture is synchronized horizontally. The phasing may not be correct, but this procedure assures correct oscillator tuning so that all the automatic frequency system must do is correct the phasing between the sync and resonant circuit.

Admiral Sets

The basic principles embodied in the four circuits described are used in virtually all sync systems of present day receivers. In some cases the circuits used are identical to those described, for example most RCA and RCA-licensed sets use the automatic frequency control circuit shown in Fig. 11. Other companies use variations of these circuits. It would be impossible to cover all of these in this article; however, the author believes that by describing several typical systems the reader will find it simpler to analyze those not covered.

Fig. 12 is a schematic diagram of a sync circuit used in some Admiral models. This circuit utilizes a Hartley oscillator running at 15.75 kc. A 6J6 reactance tube is used to correct any frequency and phase differences between the horizontal sweep and incoming sync pulses. This circuit differs from the RCA circuit in the fact that comparison is made with respect to the saw-tooth generator output rather than the sine wave, using the principles shown in Fig. 5 (Part 1). The correcting voltage is then applied to the reactance tube which varies the resonant frequency. This circuit is somewhat more sensitive than the sine wave type because the slope of the saw-tooth voltage is steeper than that of the sine wave so that small changes in the time position of the sync pulse will be translated into relatively large voltage amplitudes.

Several minor modifications can be noted in this circuit. Instead of using a center-tapped transformer, the sync pulses are fed into the grid of a 6SN7 which provides two out-of-phase outputs, one at the plate and the other at the cathode. The load on the dual diode tube (Fig. 12) is made up of a 470,000 ohm resistor in parallel with a $.01 \mu\text{fd.}$ condenser, both in series with a $.05 \mu\text{fd.}$ condenser. This type of load eliminates the need for the two condensers in series with the diodes. When the current through one diode is equal to that flowing through the other one, the net charge across the $.01 \mu\text{fd.}$ unit is zero. When the current through one diode is greater than that through the other, due to a difference in amplitude, the condenser will

charge up to the difference voltage with a polarity that is a function of the heavier conducting diode. The .05 μ f. condenser acts to bypass random effects.

Since the output of the discriminator is zero at proper synchronization, the only bias on the 6J6 reactance tube is that obtained through the cathode resistor. If the tube ages or becomes defective, the new equilibrium condition will detune the tank circuit to a certain extent and the circuit may require a large correction voltage with an accompanying phasing error even though there would be no frequency difference under normal operating conditions. Similarly this circuit assumes that the plate and cathode resistors in the 6SN7 are of the same value, to give equal and opposite sync pulses, and both diodes have the same characteristics. These conditions should exist to within 10 per-cent, otherwise a large correcting voltage would be necessary to overcome the unbalance.

General Electric Circuit

Fig. 14 is the schematic diagram of a sync circuit used in some *General Electric* sets. V_2 in this figure is a blocking oscillator in which the plate-to-grid driving voltage is fed through the secondary of a transformer and coupling condenser. The grid bias is determined by the time constant of R_1C_1 and the voltage developed at the cathode of V_1 . This latter voltage is a function of the amount of current flowing through V_1 , and hence the frequency of the blocking oscillator is proportional to the V_1 current.

The voltage applied to the grid of V_1 is the sum of the saw-tooth voltage obtained from the saw-tooth generator and the sync pulse which, for no frequency difference, is the position at the top of the saw-tooth as shown in Fig. 14B. V_1 is biased beyond cut-off and will conduct only during that portion of the time that the sync pulse plus saw-tooth extends the voltage beyond cut-off. For zero frequency difference, the tube would conduct over one-half the sync duration. When the sync pulse moves to the left, for example, the tube would conduct over a longer period of time, as indicated in Fig. 14C, which increases the tube current and hence the frequency of oscillation, tending to move the sync pulse to the right. Similarly when the sync moves to the right, the frequency of oscillation will decrease, driving it toward the center position.

There are many similar modifications of the four basic circuits described. The author believes that with the clear understanding of these circuits, plus the examples of how they may be modified given, most technicians will be able to determine the operation of most sync systems. There are a few sets that employ systems that have not been covered but these represent only a small percentage of the total used.

-30-

Mac's RADIO SERVICE SHOP

By JOHN T. FRYE

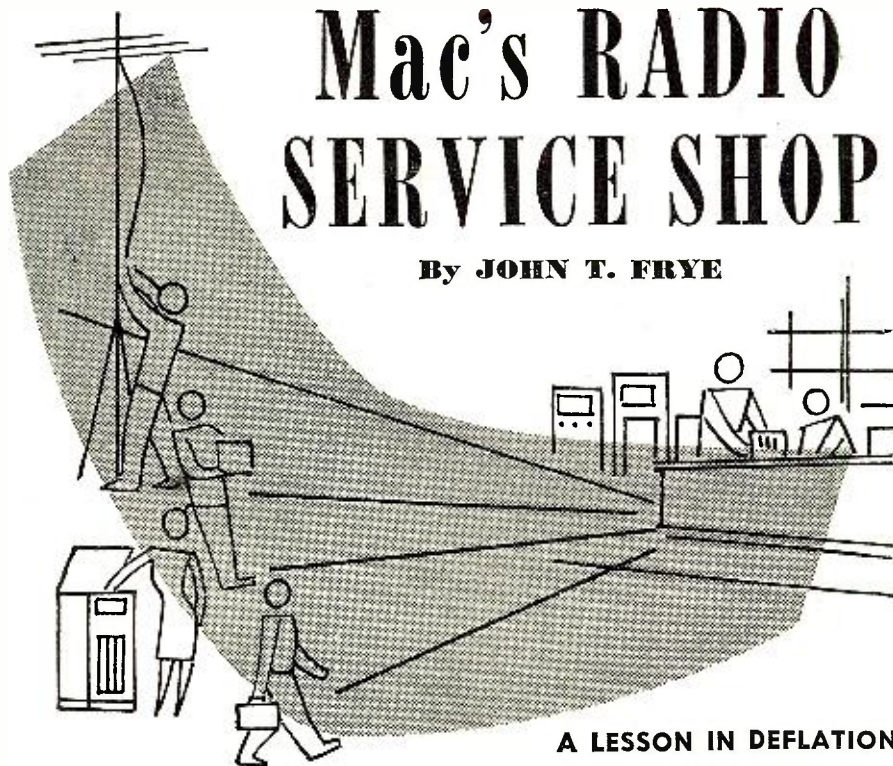

A LESSON IN DEFLATION

"**H**O hum!" Barney, the number-two boy at Mac's Radio Service Shop, smothered a prodigious yawn as he stared morosely out of the store window at the automobiles slithering around in the dirty February slush outside.

"Bored with it all?" Mac called sympathetically from the service department.

"A little," the youth confessed. "It's partly the mid-winter heebies; but then, too, I haven't run across a service job that presented a real challenge to my service ability for the past couple of months."

"That's the price you have to pay for becoming an expert," Mac blandly consoled him. "That's why poor old Alexander the Great sat down and wept after he had conquered—or so he thought—the whole world."

"Now don't get me wrong. I don't want you to think I know it all," Barney said modestly as he strolled back into the service room. "There are still probably a few things about radio and TV servicing that I do not know; but it is a fact that I can fix ninety-nine out of a hundred of the radios that come into this shop with my eyes closed. Hey!" he suddenly broke off, "that set you have there certainly disproves the old saying."

"What old saying?"

"That lightning never strikes in the same place twice. That charred antenna coil is a replacement. Obviously, this is the second time the set has been hit."

"Obviously," Mac mimicked him. "But then we have so many terrific thunderstorms up here during the winter that only lightning could have done this."

"Hm-m-m," Barney reflected, "it is a little odd to have lightning damage in February."

"I rather suspect that the fellow who put in this replacement antenna coil was servicing with his eyes closed, too," Mac said gently. "If he had been thinking about what he was doing, he would have checked this condenser that goes from one side of the line to the chassis."

Mac placed the test leads from the ohmmeter across the condenser, and the pointer indicated a direct short.

"Instead," Mac continued, "he just put in a new antenna coil; and it worked quite well until the customer happened to plug the set in so that the side of the line shorted to the chassis was the 'hot' side and at the same time he happened to ground the antenna terminal. That's when the 110 volts burned the antenna coil to a crisp, and it would do the same thing with new antenna coils as long as you wanted to put them in. The technician was just lucky it was only a coil that was bridged from the hot chassis to ground instead of the customer, his wife, or one of his kids. I don't want to catch you letting a set out of the shop without making a resistance check from both sides of the line to the chassis."

"In an a.c.-d.c. set, you will usually find a resistance of about a quarter megohm from one side of the line to the chassis; but in a transformer set, the resistance should be away up in the megohms. Any time you run across a resistance below 100,000 ohms, even in an a.c.-d.c. set, find out why."

"Aye, aye, Sir!" Barney said as he put a little three-way portable on the bench and started to work on it; but Mac noticed out of the corner of his

(Continued on page 146)

A Flexible RECORD-REPRODUCE SYSTEM

By **OLIVER READ**
Editor, RADIO & TELEVISION NEWS

Part 3. Covering design data on the bridging bus and including important considerations for optimum loading.

THE main point of distribution in the record-reproduce system under discussion is called the bridging bus. By maintaining a constant impedance of 600 ohms, various circuits may be added to the bridging bus and accurate measurements may be made where the impedance is established at 600 ohms.

This applies particularly to the use of standard volume indicator meters (Fig. 1) which are designed and calibrated to give accurate readings when connected across a source impedance of 600 ohms. The bridging bus as shown in Fig. 3 is unbalanced and no ground connection is employed. A fixed level of plus 4 dbm. is maintained on the bridging bus. A volume indicator (vu. meter) is permanently connected across the bridging bus so that a level of plus 4 dbm. may be set (Fig. 1).

The design of the bridging bus is rather simple. Our first requirement

Fig. 1. Standard NAB vu. meter indicating +4 dbm. See text for explanation.

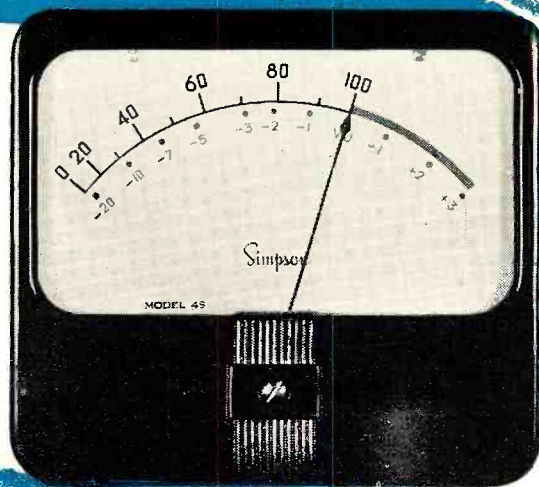

is to place all permanently connected units across the bridging bus and to determine, by Ohm's Law for parallel resistance, the total net impedance of all units. For bridging purposes transformers (other devices are also used) which normally connect across the 600 ohm bridging bus, are designed to have a primary impedance of from 5000-10,000 ohms. When adding several of these in parallel the net impedance will be too low and will disturb the normal 600 ohm impedance of the bridging bus. Therefore it is necessary to use what are known as

build-out resistors (Fig. 4) in a network terminating to the primary of the input transformers of the amplifiers.

The McIntosh 50W2 amplifier (Fig. 2) has built-in provision for a 20,000 ohm bridging input. To accomplish this, two 10,000 ohm resistors are connected in series with the primary of the input transformer to the preamplifier.

Our monitor amplifier was modified for bridging input purposes. The Radio Craftsmen RC-2 amplifier normally has an input direct to a 6J5 grid shunted with a 1 megohm resistance. See Fig. 5. A UTC type LS26 input transformer was added to the amplifier. Normally this transformer has a rated primary impedance of 5000 ohms. To make it suitable for bridging purposes, two resistors, having values of 7500 ohms each, were added in series with each side of the primary. See Fig. 4A. This results in a load impedance of 20,000 ohms to the bridging bus.

So far, we have two parallel circuits, both 20,000 ohms. These are normally connected across the bus either for recording or for playback.

Another item that must be considered when designing the bridging bus is the impedance presented by the volume indicator (vu. meter). As it comes from the factory, the standard NAB vu. meter (Fig. 1) has an internal impedance of 3900 ohms. This value is too low for bridging purposes. Therefore a 1/2 watt resistor of 3600 ohms is added in series with one side of the meter to bring the total impedance to 7500 ohms.

It is good engineering practice to avoid any load across the bridging bus

Fig. 2. A record-reproduce amplifier that provides ideal characteristics and adequate power.



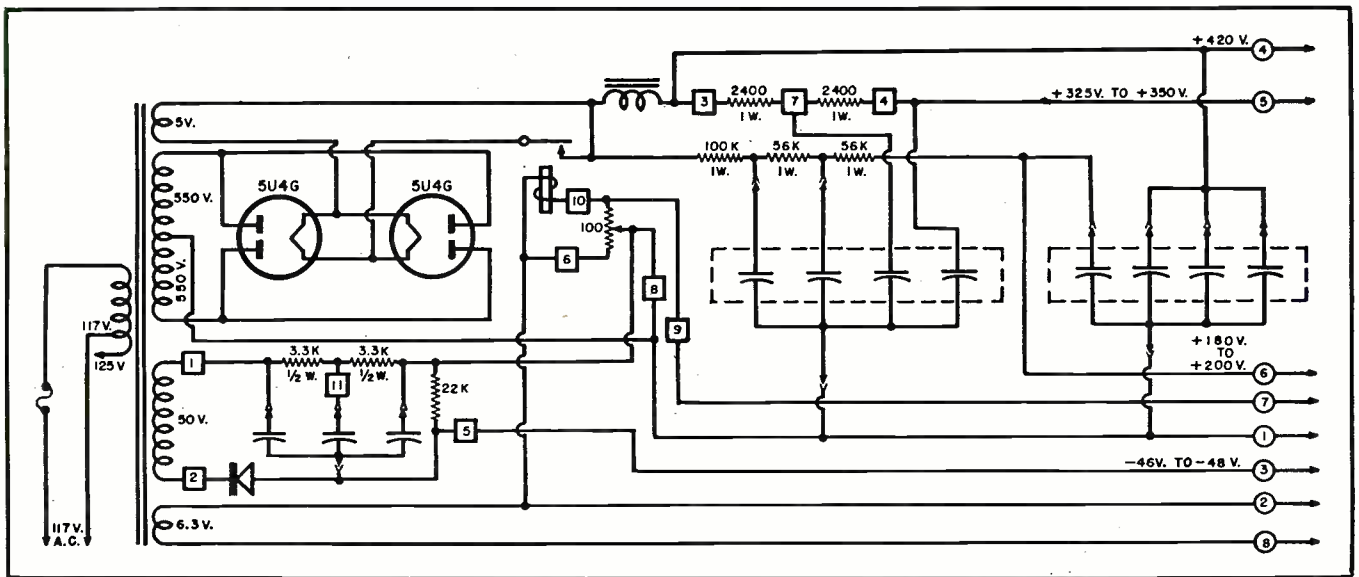

Fig. 6. Complete schematic diagram of the power supply used with the 50 watt record-reproduce amplifier.

where db. refers to a 6 mw. reference level. In recording it is an accepted practice to employ the term dbm. whenever the reading is taken with a vu. meter across a load of 600 ohms.

The Monitor Amplifier

The author had on hand a *Radio Craftsmen* RC-2 amplifier and it was decided to employ this unit for purposes of monitoring. As previously explained an input transformer was added for bridging purposes. See Fig. 5. Another modification includes the addition of a .25 μ fd. condenser between the 50,000 ohm loading resistor across the secondary of the transformer and the input grid of the RC-2 amplifier. The fixed resistance R_1 was replaced with a .5 megohm gain control so that a preset level could be made

to the input of the amplifier and further adjustment made when required to either raise or lower the monitoring volume level.

The output of the amplifier has a 500 ohm tap. This represents the highest impedance available from the output of the amplifier. Normally, it is connected in the circuit to feed a 600 ohm line to a monitoring loudspeaker. Note: Reference is often made to a 500/600 ohm line. Usually it makes no difference what rating is employed. Most amplifier outputs are rated at 500 ohms rather than 600 ohms, and in all cases either one is suitable.

The Recording Amplifier

Certain basic conditions must be taken into account in selecting audio amplifiers and associated equipment for

high quality recording-reproduction. The design features of the system must provide a frequency range at least equal to the original sound and be able to reproduce it at a desirable level.

Very thrilling and realistic reproduction of sound has been achieved when the listener, with his eyes closed, cannot differentiate between the recording and the original sound. This desideratum can be closely approached with equipment now available, even with systems designed for the home. This realism is tied in with several basic factors: Distortion defined in three ways—harmonic, intermodulation, and phase. These are virtually interrelated and if, for instance, the intermodulation distortion which is distortion caused by the mutual effect of two or

(Continued on page 134)

Fig. 7. Diagram of the main or record-reproduce amplifier with the various plug-in units identified.

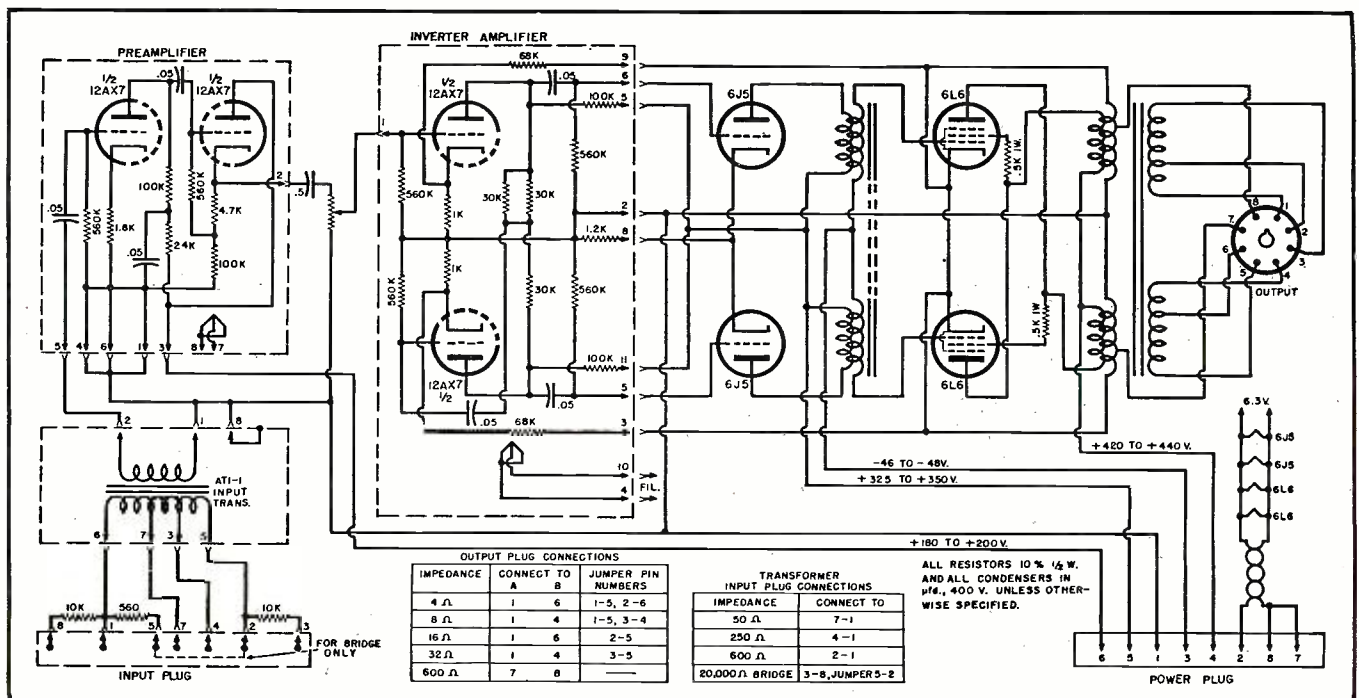



TEN TIPS

To Tax Thrift

By

FRED MERISH

Are you taking advantage of all the deductions the law allows you? Read this article and save.

INCOME tax is now a high-bracket expense and it is destined to go higher, yet, many radio and television dealers fail to take advantage of all legitimate tax savings available to them.

These suggestions will help keep tax expense at minimum.

1. Do not wait until the day before filing time to prepare a return. In your haste, essentials to tax economy may be overlooked. Omissions are costly. Keep the tax in mind throughout the calendar year and keep a check on the toll when analyzing each monthly profit and loss statement. It is as important to consider means of minimizing the tax toll as it is to curtail other items of expense as they are reviewed from month to month. Once the taxable year has passed into history, a taxpayer can seldom apply correctives because the proper action must be taken when the transaction occurs or during the taxable year. So, preview the records during the year or around the close of the year to see that all transactions have been handled and entered so that maximum benefits are obtained.

2. Deduct sufficient depreciation each year. A taxpayer is not permitted to take any depreciation allowance in a subsequent year to recompense him for failure to take an adequate allowance in prior years providing he had the facts that would have permitted the proper valuation. If you short-change yourself on depreciation when you file a return, you cannot retrieve the loss in a subsequent year so check the depreciation deduction carefully each year. The computation of depreciation is more an accounting problem than one of tax. Use the depreciation method that most accurately reflects wear and tear. A taxpayer is not limited to any one method as long as the depreciation allowance is reasonable.

3. Figure inventory conservatively,

cost or market, whichever is lower. Dealers often pay too much tax because they guess at the inventory. Take a physical count at the end of the year. Check it carefully. Record the details and file away. If the inventory is inflated in value, profits will be higher on paper and taxes will be higher in real money. There are numerous ways to figure the value of inventory. The "cost or market, whichever is lower" valuation is recommended. It is dependable, simple, and will keep the tax down to minimum. During a period of rising prices, cost is the inventory valuation. In a period of decreasing prices, the inventory valuation is the market or current bid price for the merchandise prevailing at the date of inventory.

The Treasury permits a deduction for loss on inventory due to deterioration of one kind or another, which compels the taxpayer to dispose of merchandise at reduced prices or scrap it entirely. Keep a separate record of such items on an inventory sheet. However, to get credit for a loss of this kind on inventory, the goods must be offered for sale within 30 days after the inventory is taken at the reduced list prices.

4. Do you contemplate repairs and improvements during the coming year? If so, be sure to earmark which is which. You can deduct repairs and maintenance as an expense but not improvements. Often the two overlap when you do a remodeling or reconditioning job. If so, get separate bills for repairs, otherwise the Treasury may consider the entire job as an improvement and refuse a deduction for the repairs.

5. Deduct all petty cash outlays. Often small expenses are paid in cash and never recorded. Sometimes these expenses are paid out of pocket, hence, they may not be deducted from gross

income. In the aggregate, over a year, these petty cash outlays may total a sizable sum, increasing tax expense. These petty cash disbursements should be handled systematically by means of a petty cash fund. The small- and moderate-sized dealer is most remiss in this. The standard accounting procedure is to open a petty cash account, set aside a certain sum for cash payouts and put it in a separate cash box. Pay all cash items out of this fund and place petty cash slips in the cash box covering the expenses.

6. Deduct for bad debts promptly. Many taxpayers hold worthless accounts indefinitely when they could reduce their tax payments by writing them off. Be sure to deduct for a bad debt in the year it is ascertained worthless, otherwise it will not be allowed.

7. If you trade in old equipment for new and the unrecovered cost on the books is more than the trade-in allowance offered, sell the equipment for cash and then the loss can be recorded on the books and deducted on the return. If you trade in the old equipment without a clean-cut sales transaction of this kind, the unrecovered cost (original cost less the depreciation deductions taken to date) is added to the net price of the new equipment (total price with trade-in allowance deducted) and the entire sum is then depreciated over the years, which does not give the taxpayer as much relief as the cash sales method. Using the cash sales method he may deduct in full for the unrecovered cost, whereas, using the other method he gets the deduction over a number of subsequent years.

8. If returns are filed on a cash basis (the cash you take in less the cash you pay out), try to pay all current bills during the taxable year so that these expenses may be deducted from the income of that year. Sometimes the economies thus effected make it advisable to borrow to meet these obligations. The tax savings amount to

(Continued on page 116)

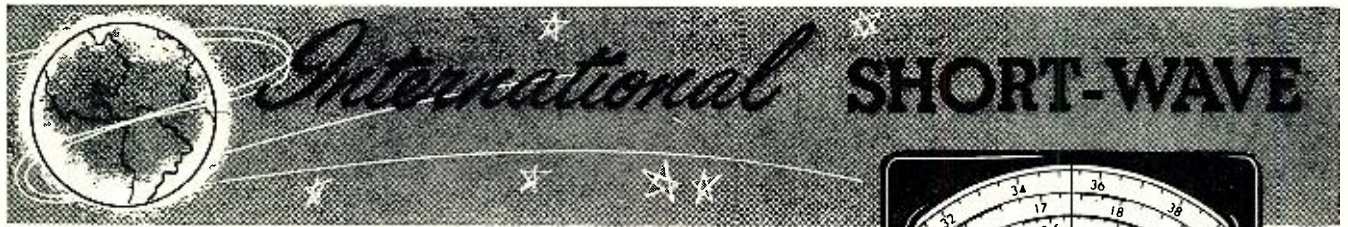

Compiled by **KENNETH R. BOORD**



IT IS a pleasure this month to dedicate the *ISW DEPARTMENT* to radio station TGNA, a new missionary voice in Guatemala City, Guatemala, Central America. Several U. S. DX-ers have cooperated in furnishing this data:

TGNA ("Telling the Good News Abroad") is being operated as the "Radio Voice of the Central American Mission." The station is owned by the Central American Benevolent Association of Dallas, Texas. It is a non-commercial and non-political station carrying cultural, educational, and gospel programs and is sustained by free-will offerings of friends of this type of work both in Central America and in the United States.

From 0630 to 0800 and again from 1627 to 2057, TGNA's programs are radiated in the Spanish language on a m.w. channel of 1180 kc. and in the 49-m. band s.w. on 6.040. At 2100, the 1180 kc. channel is changed to 9.660 in the 31-m. band and parallels 6.040 for the *English* language releases of the evening; schedule recently was extended to 2230 closedown.

H. Leslie Garrison, technician-in-charge, says that "eventually, we shall have in use from 2100 both 9.660 and 11.850, as soon as our final tanks are tuned. Later, we hope to use 6.040 for Spanish releases at the same time that 9.660 and 11.850 are in use for *English* periods." Frequencies have

been varied slightly of late, in order to avoid interference and when satisfactory channels are found, the operators may ask the Guatemalan government for frequency changes. (The station is primarily interested in reaching the huge Spanish-speaking audience in Texas, New Mexico, California, and so on—as well as in Latin America.)

At present, TGNA is operating a dual transmitter manufactured by Clarence C. Moore, chief engineer of the *International Radio & Electronics Corporation* of Elkhart, Indiana. This is a bandchanging transmitter with three bands in each bay. One bay has the m.w. plus the 31- and 19-m. bands; the other bay has the 49-, 25-, and 16-m. bands. Two bands are operated simultaneously—such as m.w. and 49-m., or 31- and 49-m. Output is approximately 4 kw. in each bay, but ultimate operation calls for 5 kw. in each band. TGNA employs eight *Eimac* tubes (No. 4...1000A).

For m.w. radiation, TGNA has been using a vertical antenna on a 166-ft. tower. Later, on this tower there will be four cubicle stacked quad antennas for the 25-m. band. On the other two towers, when completed, will be two 31-m. cubicle stacked quads, three 19-m. stacked quads, and two 16-m. stacked quads, all directional. At present, only one such stacked quad is in use for the 31-m. band; this includes the radiator and its reflector.

The quads were designed by Mr. Moore and are leased to TGNA under contract.

Reception reports are desired and correct ones are now verified by mimeographed letter. QSL cards are being made up, however, and will be ready soon. QRA is TGNA, Apartado 601, Guatemala City, Guatemala.

Our best wishes go to the staff of TGNA—"Telling the Good News Abroad!"

* * *

This Month's Schedules

Anglo-Egyptian Sudan—Radio Omdurman still is heard in Arabic 2315-2345 on 9.747; also noted afternoons to 1430 closedown; all-Arabic program. (Cox, Delaware, others) Should have *English* on Fridays around 1230-1300.

Angola—Occasionally, *Radio Clube do Huambo*, 11.925, Nova Lisboa, can be heard in California around 1115-1145; all-Portuguese. (Neeley)

Argentina—LRS2, 9.320, Buenos Aires, fair level when tuned 0050; musical program in Spanish. (Cox, Delaware) LRA, 9.69, still noted in *English* for North America daily 1900-0000.

Australia—At the time this was compiled, *Radio Australia* still was using VLC7, 11.81, to North America mornings 0700-1115, news 0715, 0815, 0930, 1030. However, by this time may be using 9.540 or some other 31-m. outlet.

Austria—KZCA, 9.617, Salzburg, noted with good signal when tuned 0117, giving news; weather forecast 0129. (Ferguson, N. C.)

Barbados—Bridgetown, 7.547, Cable and Wireless station, is on the air *only* two or three times a year; the only time it operates is when a cricket match or horse race meet is being held. During the transmission on Nov. 11, it was announced that the station would not be transmitting again until *February* 1951, when a cricket match between Barbados and Trinidad will be played. (Mercer, England, via Radio Sweden) The Berne List gives VP918 as 7.547. SWL's who are desirous of verifying Barbados might watch for
(Continued on page 118)

(Note: Unless otherwise indicated, all time is expressed in American EST; add 5 hours for GCT. "News" refers to newscasts in the English language. In order to avoid confusion, the 24 hour clock has been used in designating the times of broadcasts. The hours from midnight until noon are shown as 0000 to 1200 while from 1 p.m. to midnight are shown as 1300 to 2400.) The symbol "v" following a listed frequency indicates "varying." The station may operate either above or below the frequency given. "A" means frequency is approximate.

This 16-year-old DX-er is David Dary of Manhattan, Kansas. He uses an RME-45 receiver and three long-wire antennas, each 100 feet long, running E-W, NE-SW, and NW-SW. All are at least 70 feet high. Dave hopes to add a DB22A preselector to his Listening Post soon. A high school junior, Dave is a member of ISWC, ISWL, N.Z. Radio DX League, and other groups. He has logged 49 countries on the short-wave bands in the last six months.

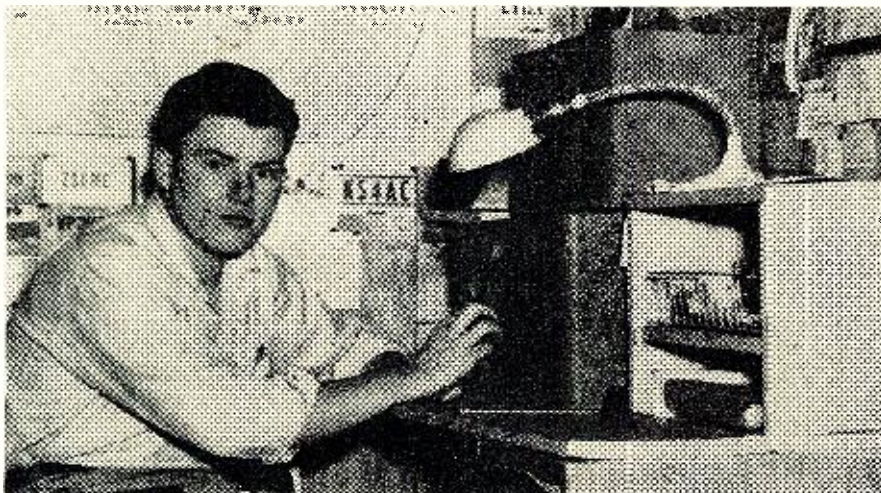

Sure, TUBES ARE TIGHT

... but the man with this sign
remains your best friend!

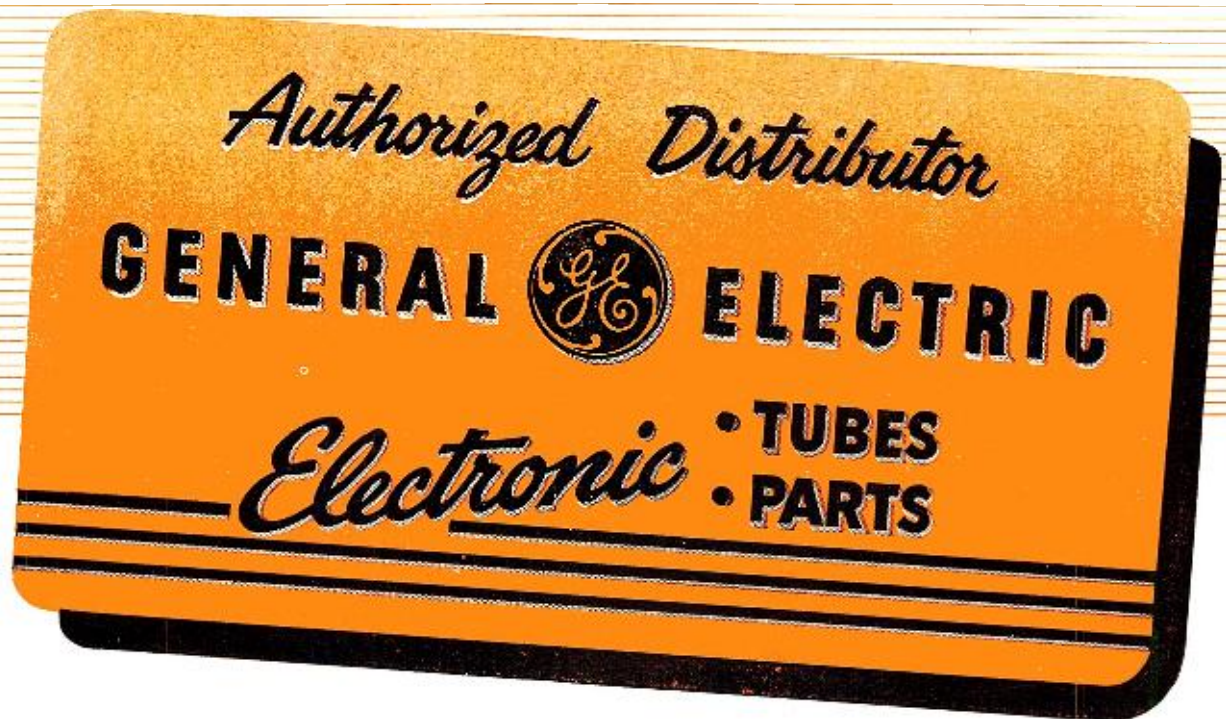

YOUR G-E tube distributor is interested, first of all, in supplying you, as a serviceman, with the tubes you need—or, when these can't be had for love or money, with types you may substitute.

However, he's under a handicap. Let's be frank: nobody... but *nobody*... is getting all the tubes they want. That's true also for radio-TV set manufacturers... broadcast stations... communications and industrial users. Allocation is the order of the day. New millions invested by General Electric in more tube facilities, are helping G-E distributors and dealers—aiding the whole industry. Yet the work

horse, production, can't match speed with a pair of track sprinters, TV popularity and national defense needs, that have taken the bit in their teeth.

Tube shortages exist, and will continue. Meanwhile, your customers count on you to keep their sets operating. Grappling with these facts that oppose each other, isn't easy.

Your G-E tube distributor wants your business tomorrow, next year, five years from now. He'll see you through! That's his job... and that's his pledge. *Electronics Department, General Electric Company, Schenectady 5, New York.*

You can put your confidence in—

GENERAL  **ELECTRIC**

181-KA2

USE PHOTOFAC

the world's best Radio-TV service data—it pays for itself every working day



Try **PHOTOFAC!**

FREE We'll send you any Photofact Folder listed in the Photofact Cumulative Index

WE'LL PROVE YOU'LL SAVE TIME and EARN MORE WITH PHOTOFAC

NOW—learn for yourself—at our expense—how PHOTOFAC makes your Radio and TV work *quicker, easier, more profitable!* Examine an actual PHOTOFAC Folder. Use it. You'll learn first-hand why over 35,000 successful service technicians use PHOTOFAC daily. You'll learn that no other service gives you PHOTOFAC'S *completeness, accuracy, uniformity, and lowest cost.* PHOTOFAC is the *only* radio and TV service data prepared from laboratory analysis of the actual equipment. Know the facts—get your **FREE** Folder now. Examine, use, compare—learn why no modern service shop can afford to be without PHOTOFAC!

WRITE FOR FREE INDEX

PAY AS YOU EARN! Ask your distributor about this amazing plan. Only \$18.39 puts the entire profit-boosting Photofact library in your shop now!

NOTE: Our **FREE** Folder offer is limited to Service Technicians only. Attach coupon below to your letterhead and mention your jobber's name. If you have no letterhead, send coupon to your jobber. Experimenters and others may obtain the Photofact Folder by remitting amount shown below.

HOWARD W. SAMS & CO., INC.
2201 E. 46th St., Indianapolis 5, Ind.

- Send **FREE** Photofact Cumulative Index
 Send Full Easy-Pay Details

I am a Service Technician:

- Send **FREE** Folder for set model.....

I am an Experimenter: Enclosed \$.....

- Send Folder for set model!.....

TV-\$1.00. Record Changer or Comm. Receiver-75c. AM/TM-50c

Name.....

Address.....

City.....Zone...State.....

What's New in Radio

For additional information on any of the items described herein, readers are asked to write direct to the manufacturer. By mentioning RADIO & TELEVISION NEWS, the page, and the issue number, delay will be avoided.

D.C. POWER SUPPLIES

Opad-Green Co. of 71 Warren Street, New York 7, New York has recently introduced a new series of general purpose, low voltage d.c. power supplies.

Featuring continuously variable outputs on all models, these units carry continuous duty ratings of 10 amperes. They are available in ranges of 0-8 volts, 0-12 volts, and 0-28 volts, d.c. The a.c. input requirements are 115 volts, 60 cycles, single phase.

A variable voltage transformer and a fixed ratio transformer insure minute and precision control of the d.c. output, according to the company.

The d.c. voltage and current may be read directly on two 3" meters. The ammeter is calibrated in steps of 200 ma. and has a full scale value of 10 amperes. Bench space requirements are 8" x 16 3/4".

RECTIFIER TUBE

National Electronics, Inc. of Geneva, Illinois has recently developed a new quick-heating, 15 ampere rectifier tube for heavy-duty industrial applications.

Designated the NL-643, the new

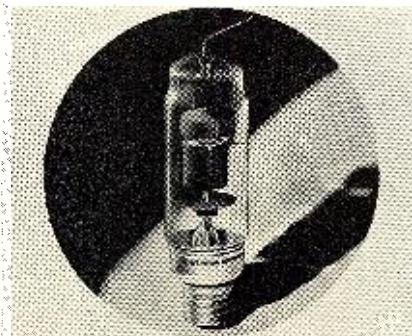

tube is mercury-vapor filled and is designed as a substitute for conventional 15 ampere tubes where higher voltage, higher overload capacity, or extremely long life are required.

The peak inverse voltage rating of 700 volts is 40 per-cent higher than conventional mercury rectifiers. Other ratings include a filament voltage of 2.5; filament current of 23 amperes; filament heating time, 120 seconds; and maximum peak current, 90 amperes.

Complete data on this tube is available in the form of a catalogue sheet which is available on request from the company.

PISTON-TYPE VARIABLES

The JFD Manufacturing Co., Inc. of 6101 Sixteenth Avenue, Brooklyn 4, New York has announced production of a new piston type variable trimmer condenser which provides the minimum capacities required for accurate

and stable electronic adjustments.

Tubular in design, it delivers continuously uniform change of capacitance in relation to rotation. Except-

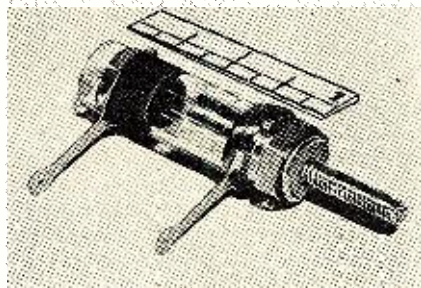

tionally compact, the new unit is only one inch in length. In addition, the new trimmer has approximately zero temperature coefficient, a "Q" of over 1000 at 1 mc., 55 to 100 degrees C operating temperature, 10,000 meg-ohm insulation resistance, and a single-unit movable electrode and adjustment screw made of a special alloy with low temperature coefficient of expansion.

Three units are available in the new line at the present time, the Nos. VC3, VC5, and VC11. The company will supply specifications on the units upon request.

ELECTRONIC MIXER

A new professional type electronic mixer for all audio systems is now being offered to the public by *The Pentron Corporation* of 221 East Cullerton Street, Chicago 16, Illinois as the "Audio-Mix."

Although designed especially for audio engineers in the professional field, the new Model MM-1 is priced for the non-professional user as well. The unit has four individual controls which permit a wide range of audio blending applications on each of its four channels simultaneously. A com-



bination plug and screw type coupling on the output cord assures easy connection to any audio system.

The mixer has six high impedance inputs—four microphone and two phono; a microphone gain of 8 db. and a phono gain of -22 db. It uses a se-

YOU'RE FIRST IN LINE!

FOR TOP VALUES IN TV, RADIO & ELECTRONICS

TYPICAL CONCORD BUYS

When your name is on Concord's Mailing List you're first to receive news of the Latest and Best Buys in TV, Radio and Electronics Parts and Equipment. This will be especially true in 1951 for Concord is going to issue periodically special

THE MODERN CONTROL MECHANISM

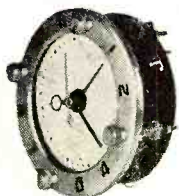

Sessions SWITCH TIMERS

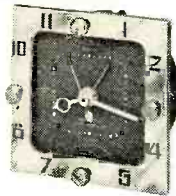

Especially designed for turning radios, TV sets, Air Conditioners, and other common household appliances on and off automatically. Offers the best in clock-radio movements. Easily installed as replacement unit in old clock-radios. All controls, including on-off, switch set, time set, and "Sleep Selector" are conveniently located on front of attractive clock face. "Wake-up" feature turns your radio on in the morning or turns on any desired program at any pre-set time within a 12 hr. period. Special safety feature turns off controlled appliance within 1-1/2 to 2 hrs. should you forget to turn it off manually. "Sleep Selector" lets you go to sleep with your radio playing and turns it off at a pre-set elapsed time up to 90 min. Has low speed, long life motor. . . built compactly, neat in appearance extremely quiet in operation. . . no buzz or whine of high speed gears. Size: 3-1/2" dia., 2" deep from clock face. Bezel finished in bronze. Shipped complete with mounting bracket, and mounting and operating instructions. Switch rating 10 amps at 115 V. For 110 V, 60 cycle AC. UL approved.

- 33-25472 - Model W-31, Shpg. wt. 3 lbs. **6.50**
- 33-25492R - As above except with 3-1/2" square face and bezel. \$6.50
- Model W-26, same as W-31 except without "Sleep Selector" and has switch rating of 15 amps at 115 volts.
- 33-25473R. \$5.50
- 33-25493R - As above except with 3-1/2" square face and bezel \$5.50

MOBILE HIGH VOLTAGE PWR. UNIT

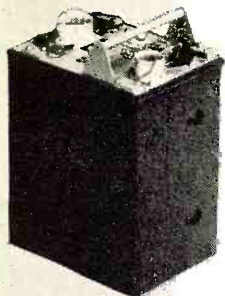

For mobile radios, amateur equipment, PA amplifiers, and many other types of equipment. Well built made of the finest materials available to meet strict specifications. Especially adapted to furnish plate supply for above mentioned units. Input 12 volts at 10 amps. Output consists of two volt ranges. (1) 275 volts at 10 ma., 12 volts @ 3 amps. (2) 500 volts at 50 ma. Contains two nationally known permanent magnet dynamotors, complete with all hash filters. Each high voltage range individually fused and the input has an "on and off" switch and an indicating pilot light assembly. Olive drab wrinkle finish. Size: 8-3/8" x 6-1/4" x 11-5/8".

- 99-9513R - Shpg wt. 27 lbs. **9.95**
- PERMANENT MAGNET DYNAMOTOR
- Input 12/24 volts @ 3/4 amps., Output 12/275 volts @ 3/.110 amps.
- 99-9589R - Shpg wt. 10 lbs. \$4.95

RECORDING TAPE



- Best Recording Tape Buy on the market! Made by a famous national manufacturer to Concord's strict specifications. 1200' long, 1/4" wide with uniform coating of red oxide particles on kraft paper base. Magnetic coating wound facing in. Plastic reel included. Order while our supply last.
- 35-16297R - 1200' Kraft Paper Base Tape. **1.49**
 - As above but on stronger more efficient plastic base for more uniform output and lower noise level.
 - 35-16296R - 1200' Plastic Base Tape. \$2.25

BUYER'S GUIDES

jam-packed from cover to cover with TV, FM and AM receivers, phonos, high-fidelity sound components, amateur equipment, servicemen's supplies, tubes and other critical parts. All listed as they are available and ready for immediate shipment to you.

CONCORD BUYER'S GUIDE IT'S YOUR KEY TO

- Complete Listings of Available Merchandise
- Current Low Prices
- Prompt Expert Shipment
- Satisfaction Plus

PUT YOUR NAME ON CONCORD'S MAILING LIST **NOW!**

CONCORD RADIO

Mail Order Center and Showroom
901 W. Jackson Blvd., Chicago 7, Ill.
Branch Showroom: 265 Peachtree St., Atlanta 3, Ga.

EXPORT

For PROMPT Service on Export Orders & Inquiries Address to CONCORD RADIO CORP., EXPORT DIVISION, 901 West Jackson Blvd., Chicago 7, Illinois.

CONCORD RADIO CORP., Dept. RB-51
901 West Jackson Blvd., Chicago 7, Illinois

Please forward your latest Buyer's Guide

Name.....

Address.....

City..... Zone... State.....



BUILT
TO
TAKE IT

... BUT the goalie is not expected to join the play in center ice. He is physically conditioned and equipped for one job — to "stay put and take it". It's different with a Thomas picture tube ...

For a Thomas tube is a flashing performer as well — it produces finely shaded contrasts and clear, steady pictures which make it the all-season star of hundreds of thousands of TV receivers.

Getting a Thomas tube means getting all the endurance and staying power, and all the top-flight performance which are built into the Thomas product.

So, see that your customers get the best — recommend a Thomas picture tube!

THOMAS ELECTRONICS, Inc.

118 Ninth Street
Passaic, New Jersey



WE HAVE LARGE QUANTITIES OF RADIO TUBES

TYPE	TYPE	TYPE	TYPE	TYPE	TYPE	TYPE	TYPE
5U4G	6AL5	6H6	6K7GT	12SG7	805	9005	6SK7
5Y4G	6C4	6J7	6SG7	12SK7	807	1R5	12SR7
6AB7	6C5GT	6J5GT	6SH7	42	813	1S4	
6AC7	6D6	6K6GT	6SN7GT	803	866A	6J5	

Packed in Original Cartons
PRICES ON REQUEST

SUBSTANTIAL DISCOUNTS ON LARGE ORDERS

All tubes are brand new standard brands. This offer subject to change without notice and prior sale. Terms: 25% deposit with order, balance C.O.D. \$25.00 minimum order.

MANUFACTURERS: WANT MORE EXPORT SALES? CONTACT: MICHEL LEVIT
Domestic Division: TUBE DEPARTMENT

METROPOLITAN OVERSEAS SUPPLY CORPORATION
1133 Broadway, New York 10, N. Y. Telephone: CHelsea 3-1105

lenium rectifier and two tubes and may also be used with the new 12AY7 low noise level tubes for extremely technical applications. The frequency response is 20 to 20,000 cycles and the power consumption is 8 watts.

The entire unit weighs 4½ pounds and measures 8"x6"x5". Literature on the Model MM-1 "Audio-Mix" is available from the company.

PREAMP-EQUALIZERS

Brociner Electronics Laboratory, 1546 Second Avenue, New York 28, New York has introduced two new models of preamplifier-equalizers for magnetic (constant velocity) phonograph pickups.

The Model A100 and the A100P are



improved versions of the company's Model A65 unit. Both are mechanically similar to the older unit but include several new features among which are: an additional turnover step for exact low frequency equalization of LP records; increased gain which permits the use of new low output dynamic pickups; a screwdriver adjusted gain control for setting of gain to suit the pickup used; lower output impedance which allows the use of longer cable for output without loss of highs; a three-stage amplifier; and the use of the new 12AY7 low hum, non-microphonic dual triode for initial stages and the 6C4 for the output stage.

The units have a power socket to fit under the 6L6 or 6V6 output tubes with a special socket available for triode amplifiers. The Model A100P has an integral power supply on the same size chassis as the A100. This power supply uses a selenium high voltage rectifier.

PLUG-IN UNITS

Berkshire Laboratories, 504 Lexington Road, Concord, Massachusetts has begun marketing the "Labcase" which permits any three or four terminal networks to be made into a convenient plug-in unit.

Now available for general use, the new unit can be used for housing wave filters, wave shaping circuits, and other special or standard circuits. The resulting plug-in units can be added to or removed from an experimental setup for comparison purposes. The input terminals of one unit may be plugged into the output terminals of another. Thus any number of similar or different units may be combined in tandem arrangements.

The housing, which is 4" long and 1½" in diameter, is made of aluminum tubing with a gray hammered-type paint finish. The over-all length is approximately 4 1/8".
(Continued on page 106)

*You GET
THE BEST IN
Heathkits*

Heathkits are the Quality Line of TEST INSTRUMENT KITS

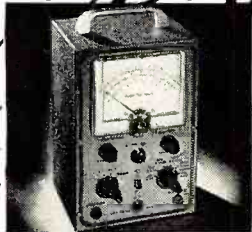

Modern STYLING KITS THAT MATCH

Heathkits are styled in the most modern manner by leading industrial stylists. They add beauty and utility to any laboratory or service bench. There is a complete line of Heathkit instruments allowing a uniformity of appearance.

An attractive service shop builds a feeling of confidence. Many organizations have standardized on Heathkits providing uniform service departments.

There is no waste space or false effort to appear large in Heathkits — space on service benches is limited and the size of Heathkit instruments is kept as small as is consistent with good engineering practice.



Accuracy ASSURED BY PRECISION PARTS

Wherever required, the finest quality 1% ceramic resistors are supplied. These require no aging and do not shift. No matching of common resistors is required. You find in Heathkit the same quality voltage divider resistors as in the most expensive equipment.

The transformers are designed especially for the Heathkit unit. The scope transformer has two electrostatic shields to prevent interaction of AC fields.

These transformers are built by several of the finest transformer companies in the United States.

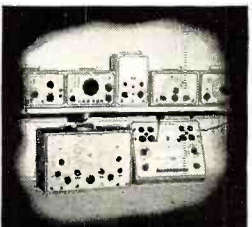

Used BY LEADING MANUFACTURERS

Leading TV and radio manufacturers use hundreds of Heathkits on the assembly lines. Heathkit scopes are used in the alignment of TV tuners. Impedance bridges are serving every day in the manufacture of transformers. Heathkit VTVM's are built into the production lines and test benches. Many manufacturers assemble Heathkits in quantity for their own use thus keeping purchase cost down.

Manufacturers assemble Heathkits in quantity for their own use thus keeping purchase cost down.

Famous HEATHKIT PARTS

- MALLORY FILTER CONDENSERS
- WILKOR PRECISION RESISTORS
- GRIGSBY ALLISON SWITCHES
- ALLEN-BRADLEY RESISTORS
- GENERAL ELECTRIC TUBES
- CHICAGO TRANSFORMER
- CENTRALAB CONTROLS
- SIMPSON METERS
- CINCH SOCKETS

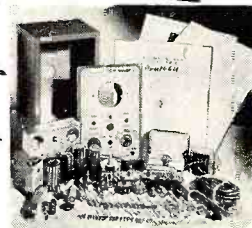

Complete KITS WITH PARTS THAT FIT...

When you receive your Heathkit, you are assured of every necessary part for the proper operation of the instrument.

Beautiful cabinets, handles, two-color panels, all tubes, test leads where they are a necessary part of the instrument, quality rubber line cords and plugs, rubber feet for each instrument, all scales and dials ready printed and calibrated. Every Heathkit is 110 V 60 Cy. power transformer operated by a husky transformer especially designed for the job. Heathkit chassis are precision punched for ease of assembly. Special engineering for simplicity of assembly is carefully considered.

Complete INSTRUCTION MANUALS

Heathkit instruction manuals contain complete assembly data arranged in a step-by-step manner. There are pictorials of each phase of the assembly drawn by competent artists with detail allowing the actual identification of parts.

Where necessary, a separate section is devoted to the use of the instrument. Actual photos are included to aid in the proper location of wiring.

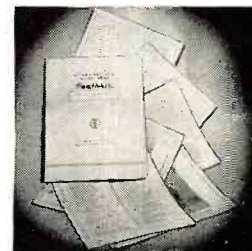

Used BY LEADING UNIVERSITIES

Heathkits are found in every leading university from Massachusetts to California. Students learn much more when they actually assemble the instrument they use. Technical schools often include Heathkits in their course and these become the property of the students. High schools, too, find that the purchase of inexpensive Heathkits allows their budget to go much further and provides much more complete laboratories.



YOU SAVE BY ORDERING DIRECT FROM MANUFACTURER—USE ORDER BLANK ON LAST PAGE

EXPORT AGENT
ROCKE INTERNATIONAL CORP.
13 E. 40th ST.
NEW YORK CITY (16)
CALL: ARLAB-N.Y.

The HEATH COMPANY

... BENTON HARBOR 15, MICHIGAN

12 Improvements IN NEW 1951

MODEL O-6

PUSH-PULL

Heathkit OSCILLOSCOPE KIT

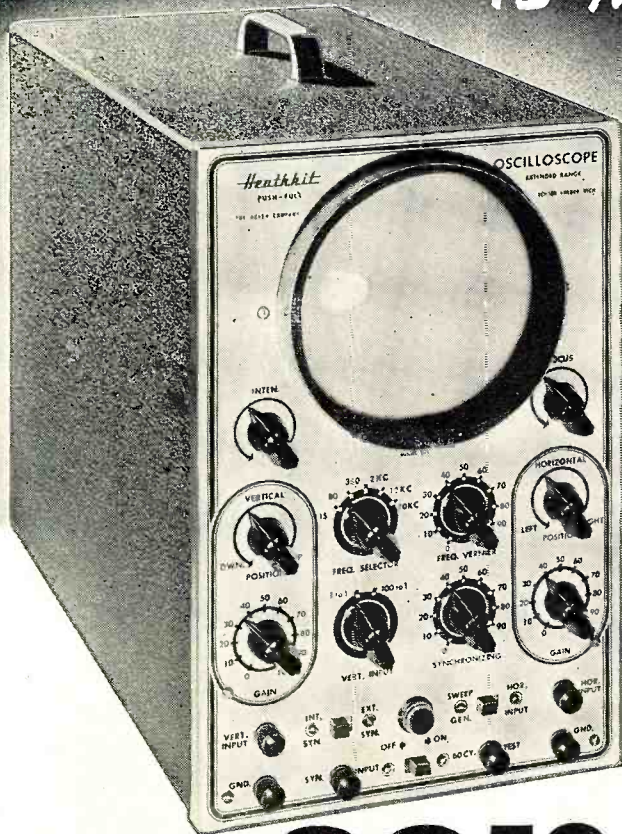

- ★ New AC and DC push-pull amplifier.
- ★ New step attenuator frequency compensated input.
- ★ New non frequency discriminating input control.
- ★ New heavy duty power transformer has 68% less magnetic field.
- ★ New filter condenser has separate vertical and horizontal sections.
- ★ New intensity circuit gives greater brilliance.
- ★ Improved amplifiers for better response useful to 2 megacycles.
- ★ High gain amplifiers .04 Volts RMS per inch deflection.
- ★ Improved Allegheny Ludlum magnetic metal CR tube shield.
- ★ New synchronization circuit works with either positive or negative peaks of signal.
- ★ New extended range sweep circuit 15 cycles to over 100,000 cycles.
- ★ Both vertical and horizontal amplifier use push-pull pentodes for maximum gain.

Only **\$39.50**

New INEXPENSIVE MODEL S-2 ELECTRONIC SWITCH KIT

Twice as much fun with your oscilloscope — observe two traces at once — see both the input and output traces of an amplifier, and amazingly you can control the size and position of each trace separately — superimpose them for comparison or separate for observation — no connections inside scope. All operation electronic, nothing mechanical — ideal for classroom demonstrations — checking for intermittents, etc. Distortion, phase shift and other defects show up instantly. Can be used with any type or make of oscilloscope. So inexpensive you can't afford to be without one.

Has individual gain controls, positioning control and coarse and fine switching rate controls — can also be used as square wave generator over limited range. 110 Volt transformer operated comes complete with tubes, cabinet and all parts. Occupies very little space beside the scope. Better get one. You'll enjoy it immensely. Model S-2. Shipping Wt., 11 lbs.



Only **\$19.50**

The new 1951 Heathkit Push-Pull Oscilloscope Kit is again the best buy. No other kit offers half the features — check them.

Measure either AC or DC on this new scope — the first oscilloscope under \$100.00 with a DC amplifier.

The vertical amplifier has frequency compensated step attenuator input into a cathode follower stage. The gain control is of the non frequency discriminating type — accurate response at any setting. A push-pull pentode stage feeds the C.R. tube. New type positioning control has wide range for observing any portion of the trace.

The horizontal amplifiers are direct coupled to the C.R. tube and may be used as either AC or DC amplifiers. Separate binding posts are provided for AC or DC.

The multivibrator type sweep generator has new frequency compensation for the high range it covers; 15 cycles to cover 100,000 cycles.

The new model O-6 Scope uses 10 tubes in all — several more than any other. Only Heathkit Scopes have all the features.

New husky heavy duty power transformer has 50% more laminations. It runs cool and has the lowest possible magnetic field. A complete electrostatic shield covers primary and other necessary windings and has lead brought out for proper grounding.

The new filter condenser has separate filters for the vertical and horizontal screen grids and prevents interaction between them.

An improved intensity circuit provides almost double previous brilliance and better intensity modulation.

A new synchronization circuit allows the trace to be synchronized with either the positive or negative pulse, an important feature in observing the complex pulses encountered in television servicing.

The magnetic alloy shield supplied for the C.R. tube is of new design and uses a special metal developed by Allegheny Ludlum for such applications.

The Heathkit scope cabinet is of aluminum alloy for lightness of portability.

The kit is complete, all tubes, cabinet, transformer, controls, grid screen, tube shield, etc. The instruction manual has complete step-by-step assembly and pictorials of every section. Compare it with all others and you will buy a Heathkit. Model O-6. Shipping Wt., 30 lbs.

YOU SAVE BY ORDERING DIRECT FROM MANUFACTURER — USE ORDER BLANK ON LAST PAGE

EXPORT AGENT
ROCKE INTERNATIONAL CORP.
13 E. 40th ST.
NEW YORK CITY (16)
CABLE: AR143-N.Y.

The **HEATH COMPANY**

... BENTON HARBOR 15, MICHIGAN

New 1951 • • MODEL V-4A

Heathkit VTVM KIT

HAS EVERY EXPENSIVE Feature

- ★ Higher AC input impedance, (greater than 1 megohm at 1000 cycles).
- ★ New AC voltmeter flat within 1 db 20 cycles to 2 megacycles (600 ohm source).
- ★ New accessory probe (extra) extends DC range to 30,000 Volts.
- ★ New high quality Simpson 200 microampere meter.
- ★ New 1/2% voltage divider resistors (finest available).
- ★ 24 Complete ranges.
- ★ Low voltage range 3 Volts full scale (1/3 of scale per volt).
- ★ Crystal probe (extra) extends RF range to 250 megacycles.
- ★ Modern push-pull electronic voltmeter on both AC and DC.
- ★ Completely transformer operated isolated from line for safety.
- ★ Largest scale available on streamline 4 1/2 inch meter.
- ★ Burn-out proof meter circuit.
- ★ Isolated probe for dynamic testing no circuit loading.
- ★ New simplified switches for easy assembly.

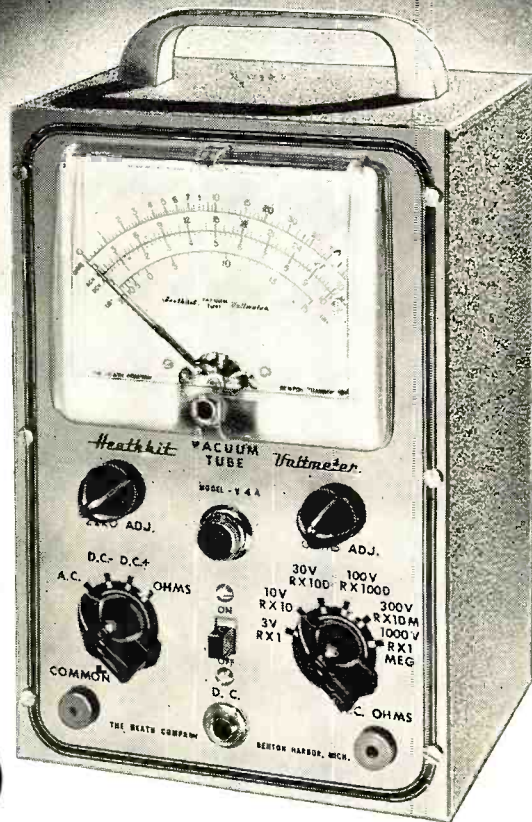

New
LOW PRICE **\$23.50**

The new Heathkit Model V-4A VTVM Kit measures to 30,000 Volts DC and 250 megacycles with accessory probes — think of it, all in one electronic instrument more useful than ever before. The AC voltmeter is so flat and extended in its response it eliminates the need for separate expensive AC VTVM's. + or - db from 20 cycles to 2 megacycles. Meter has decibel ranges for direct reading. New zero center on meter scale for quick FM alignment.

There are six complete ranges for each function. Four functions give total of 24 ranges. The 3 Volt range allows 33 1/3% of the scale for reading one volt as against only 20% of the scale on 5 Volt types.

The ranges decade for quick reading.

New 1/2% ceramic precision are the most accurate commercial resistors available — you find the same make and quality in the finest laboratory equipment selling for thousands of dollars. The entire voltage divider decade uses these 1/2% resistors.

New 200 microampere 4 1/2" streamline meter with Simpson quality movement. Five times as sensitive as commonly used 1 MA meters.

Shatterproof plastic meter face for maximum protection Both AC and DC voltmeter use push-pull electronic voltmeter circuit with burn-out proof meter circuit.

Electronic ohmmeter circuit measures resistance over the amazing range of 1/10 ohm to one billion ohms all with internal 3 Volt battery. Ohmmeter batteries mount on the chassis in snap-in mounting for easy replacement.

Voltage ranges are full scale 3 Volts, 10 Volts, 30 Volts, 100 Volts, 300 Volts, 1000 Volts. Complete decading coverage without gaps.

The DC probe is isolated for dynamic measurements Negligible circuit loading. Gets the accurate reading without disturbing the operation of the instrument under test. Kit comes complete, cabinet, transformer, Simpson meter, test leads, complete assembly and instruction manual. Compare it with all others and you will buy a Heathkit. Model V-4A. Shipping Wt., 8 lbs Note new low price, \$23.50



New 30,000 VOLT DC PROBE KIT

Beautiful new red and black plastic high voltage probe Increases input resistance to 1100 megohms, reads 30,000 Volts on 300 Volt range High input impedance for minimum loading of weak television voltages. Has large plastic insulator rings between handle and point for maximum safety Comes complete with PL55 type plug.

No. 3366 High Voltage Probe Kit.
Shipping Wt., 2 pounds.

\$550

Heathkit RF PROBE KIT

Crystal diode probe kit extends range to 250 megacycles = 10% comes complete with all parts, crystal, cable and PL55 type plug.

No. 309 RF Probe Kit.
Shipping Wt., 1 lb.

\$550



YOU SAVE BY ORDERING DIRECT FROM MANUFACTURER—USE ORDER BLANK ON LAST PAGE

EXPORT AGENT
ROCKE INTERNATIONAL CORP.
13 E. 40th ST.
NEW YORK CITY (16)
CABLE: ARLAB-N.Y.

The **HEATH COMPANY**

... BENTON HARBOR 15, MICHIGAN

NEW Heathkit T.V. ALIGNMENT GENERATOR KIT



Shipping Wt., 16 lbs.

\$39.50

- ★ New simplified circuit for easy calibration and assembly.
- ★ New 2 band built-in marker covers 19 to 75 Mc.
- ★ New dual spider sweep motor for long life.
- ★ New blanking circuit gives base line for better alignment.
- ★ New variable oscillator gives high output fundamentals on high TV band.
- ★ New standby switch keeps instrument ready for instant use.
- ★ New 6 to 1 slow speed drive on both master oscillator and marker tuners.

The new Heathkit TV Alignment Generator incorporates the new developments required for modern TV servicing. An absorption marker circuit covering all possible IF bands and even several of the RF bands. The new blanking circuit provides a base reference line which is invaluable in establishing proper traces. The new sweep motor incorporates dual spiders in the speaker frame assuring better alignment and long life. The mounting of the speaker sweep motor has been simplified for easy alignment.

The variable master oscillator covers 140 to 230 Mc. thus giving high output fundamentals where they are most needed. Low band coverage 2 Mc. to 90 Mc.

A new step attenuator provides excellent control of output.

Planetary 6 to 1 drives on both oscillator and marker provides smooth easy control settings.

A standby position is provided making the instrument always instantly available.

Horizontal sweep voltage with phasing control is provided. No other sweep generator under \$100.00 provides all these features — comes complete with instruction manual. Model TS-2.

Heathkit CONDENSER CHECKER KIT

Only **\$19.50**

Features

- Power factor scale.
- Measures resistance.
- Measures leakage.
- Checks paper-mica-electrolytics.
- Bridge type circuit.
- Magic eye indicator.
- 110 V. transformer operated.
- All scales on panel.

Checks all types of condensers over a range of .00001 MFD to 1,000 MFD. All on readable scales that are read direct from the panel. NO CHARTS OR MULTIPLIERS NECESSARY. A condenser checker anyone can read. A leakage test and polarizing voltage for 20 to 500 Volts provided. Measures power factor of electrolytics between 0% and 50%. 110 V. 60 cycle transformer operated complete with rectifier and magic eye tube, cabinet, calibrated panel, test leads and all other parts. Clear detailed instructions for assembly and use. Model C-2. Shipping Wt., 7 lbs.

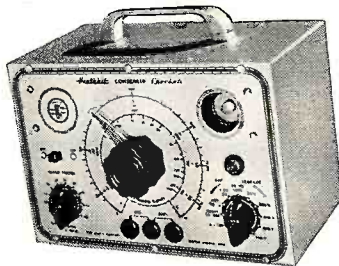

NEW Heathkit SIGNAL TRACER AND UNIVERSAL TEST SPEAKER KIT

\$19.50

Features

- High sensitivity
- Complete set of speaker impedances
- Tests microphones and PA systems
- Tests both single and push-pull speaker circuits

The popular Heathkit Signal Tracer has now been combined with a universal test speaker at no increase in price. The same high quality tracer follows signal from antenna to speaker — locates intermittents — defective parts quicker — saves valuable service time — gives greater income per service hour. Works equally well on broadcast — FM or TV receivers. The test speaker has assortment of switching ranges to match push-pull or single output impedance. Also test microphones, power transformer — tubes, test probe, all parts and detailed instructions for assembly and use. Model T-2. Shipping Wt., 8 lbs.

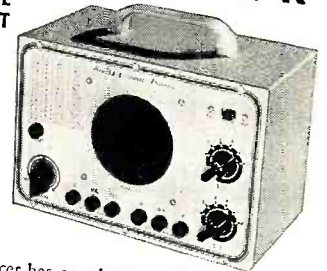

Heathkit TUBE CHECKER KIT

Features

Sockets for every modern tube — blank for new types.

Fastest method of testing tubes — saves time — makes more profit.

Rugged counter type birch cabinet.

Test your tubes the modern way — dynamically — the simplest, yet fastest and surest method — your Heathkit has a switch for each tube element and measures that element — no chance for open or shorted elements slipping by, all the advantages of the mutual conductance type without the slow cumbersome time consuming setups.

Your Heathkit Tube Checker has all the features — beautiful 3 color BAD-GOOD meter — complete selection of voltages — roller chart listing hundreds of tubes including the new 9 pin miniatures — finest quality Centralab lever switches for each element — high grade birch counter type cabinet — continuously variable line adjust control — every feature you need to sell tubes properly. The most modern type tube checker with complete protection against obsolescence. The best of parts — rugged oversize 110 V 60 cycle power transformer — finest of Mallory and Centralab switches and controls, complete set of sockets for all type tubes with blank spare for future types. Fast action brass gear driven roller chart quickly locates the settings for any type tube. Simplified switching cuts necessary testing time to minimum and saves valuable service time. Short and open element check. Simple method allows instant setup of new tube types without waiting for factory data. No matter what the arrangements of tube elements, the Heathkit flexible switching arrangement easily handles it. Order your Heathkit Tube Checker Kit today. See for yourself that Heath again saves you two-thirds and yet retains all the quality — this tube checker will pay for itself in a few weeks — better assemble it now. Complete with instructions — pictorial diagrams — all parts — cabinet — ready to wire up and operate. Model TC-1 Shipping Wt., 12 lbs.

Gear driven roller chart gives instant setup for all types.

Tests each element separately for open or short and quality.

Beautiful 3 color meter — reads good-bad and line set point.

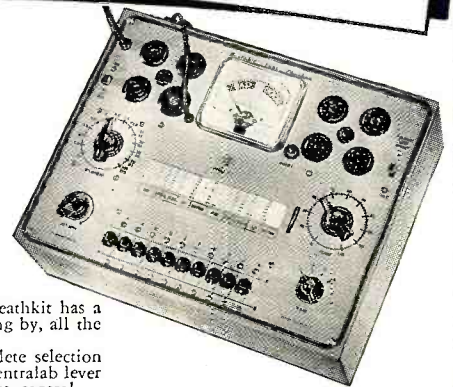

\$29.50

YOU SAVE BY ORDERING DIRECT FROM MANUFACTURER — USE ORDER BLANK ON LAST PAGE

EXPORT AGENT
ROCKE INTERNATIONAL CORP.
13 E. 40th ST.
NEW YORK CITY (16)
CABLE: ARAB-N.Y.

The HEATH COMPANY

... BENTON HARBOR 15, MICHIGAN

RADIO & TELEVISION NEWS

NEW 1951
Heathkit

SIGNAL GENERATOR KIT

Features

- Sine wave audio modulation.
- Extended range 160 Kc. to 50 megacycles fundamentals.
- New step attenuator output.
- New miniature HF tubes.
- Transformer operated for safety.
- Calibrated harmonics to 150 megacycles.
- New external modulation switch.
- 5 to 1 vernier tuning for accurate settings.

A completely new Heathkit Signal Generator Kit. Dozens of improvements. The range on fundamentals has been extended to over 50 megacycles; makes this Heathkit ideal as a marker oscillator for T.V. New step attenuator gives controlled outputs from very low values to high output. A continuously variable control is used with each step. New miniature HF tubes are required for the high frequencies covered.

Uses 6C4 master oscillator and 6C4 sine wave audio oscillator. The set is transformer operated and a husky selenium rectifier is used in the power supply. The coils are precision wound and checked for calibration making only one adjustment necessary for all bands.

New sine wave audio oscillator provides internal modulation and is also available for external audio testing. Switch provided allows the oscillator to be modulated by an external audio oscillator for fidelity testing of receivers.

A best buy — think of all the features for less than \$20.00. The entire coil and tuning assembly are assembled on a separate turret for quick assembly — comes complete — all tubes — cabinet — test leads — every part. The instruction manual has step-by-step instructions and pictorials. It's easy and fun to build a Heathkit Model SG-6 Signal Generator. Shipping Wt., 7 lbs.



\$19.50

Heathkit SINE AND SQUARE WAVE AUDIO GENERATOR KIT

Either sine or square wave.
Stable RC bridge circuit.
Covers 20 to 20,000 cycles.
Less than 1% distortion.

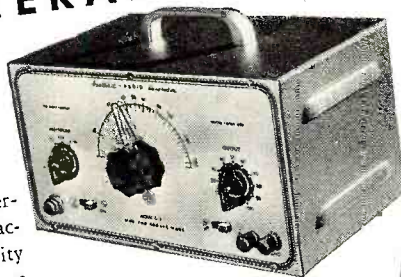

\$34.50

Hundreds of Heathkit Audio Generators are used by speaker manufacturers—definite proof of their quality and dependability. The added feature of square wave opens up an entirely new field of amplifier testing. Uses the best of parts, 4 gang condenser, 1% calibrating resistors, metal cased filter condensers, 5 tubes, completely calibrated panel and detailed instruction manual. One of our best and most useful kits. Model G-2. Shipping Wt., 12 lbs.

THE NEW Heathkit HANDITESTER KIT

- Beautiful streamline Bakelite case.
- AC and DC ranges to 5,000 Volts.
- 1% Precision ceramic resistors.
- Convenient thumb type adjust control.
- 400 Microampere meter movement.
- Quality Bradley AC rectifier.
- Multiplying type ohms ranges.
- All the convenient ranges 10-30-300-1,000-5,000 Volts.
- Large quality 3" built-in meter.



\$13.50

A precision portable volt-ohm-milliammeter. An ideal instrument for students, radio service, experimenters, hobbyists, electricians, mechanics, etc. Rugged 400 ua meter movement. Twelve complete ranges, precision dividers for accuracy. Easily assembled from complete instructions and pictorial diagrams. An hour of assembly saves one-half the cost. Order today. Model M-1. Shipping Wt., 2 lbs.

NEW Heathkit BATTERY ELIMINATOR KIT

Features

- Provides variable DC voltage for all checks.
- Locates sticky vibrators-intermittents.
- Voltmeter for accurate check.
- Has 4000 MFD Mallory filter for ripple-free voltage.

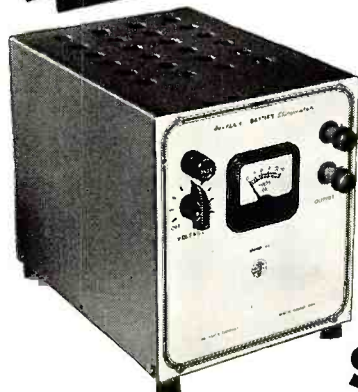

\$22.50

Even the smallest shop can afford the Heathkit Battery Eliminator Kit. A few auto radio repair jobs will pay for it. It's fast for service, the voltage can be lowered to find sticky vibrators or raised to ferret out intermittents. Provides variable DC voltage 5 to 7½ Volts at 10 Amperes continuous or 15 Amperes intermittent. Also serves as storage battery charger. Ideal for all auto radio testing and demonstrating.

A well filtered rugged power supply uses heavy duty selenium rectifier, choke input filter with 4,000 MFD of electrolytic filter for clean DC. 0-15 V. voltmeter indicates output which is variable in eight steps. Easily constructed in a few hours from our instructions and diagrams — better be equipped for all types of service — it means more income. Model BE-2. Shipping Wt., 19 lbs.

YOU SAVE BY ORDERING DIRECT FROM MANUFACTURER—USE ORDER BLANK ON LAST PAGE

EXPORT AGENT
ROCKE INTERNATIONAL CORP.
13 E. 40th ST.
NEW YORK CITY (16)
CABLE: ARLAB-N.Y.

The **HEATH COMPANY**

... BENTO HARBOR 15, MICHIGAN

New
**LABORATORY
INSTRUMENT KITS**



HUNDREDS OF LABORATORIES USE
Heathkit **IMPEDANCE BRIDGE** as *Standard*

Features

- Measures inductance 10 microhenries to 100 henries
- Measures resistance .01 ohms to 10 megohms
- Measures capacitance .00001 MFD to 100 MFD
- Measures "Q" and power factor.

Measures inductance from 10 microhenries to 100 henries, capacitance from .00001 MFD to 100 MFD. Resistance from .01 ohms to 10 megohms. Dissipation factor from .001 to 1. "Q" from 1 to 1,000. Ideal for schools, laboratories, service shops, serious experimenters. An impedance bridge for everyone — the most useful instrument of all, which heretofore has been out of the price range of serious experimenters and service shops. Now at the lowest price possible. All highest quality parts. General Radio main calibrated control. General Radio 1,000 cycle hummer. Mallory ceramic switches with 60 degree indexing — 200 microamp type binding posts with standard 3/4" centers. Beautiful birch cabinet. Directly calibrated "Q" and dissipation factor scales. Ready calibrated capacity and inductance standards of Silver Mica, accurate to 1/2 of 1% and with dissipation factors of less than 30 parts in one million. Provisions on panel for external generator and detector. Measure all your unknowns the way laboratories do — with a bridge for accuracy and speed.

\$69.50

Internal 6 Volt battery for resistance and hummer operations. Circuit utilizes Wheatstone, Hay and Maxwell circuits for different measurements. Supplied complete with every quality part — all calibrations completed and instruction manual for assembly and use. Deliveries are limited. Model IB-1. Shipping Wt., 15 lbs.

**NEW Heathkit LABORATORY
RESISTANCE DECADE KIT**

Features

- 1/2% Accuracy
- Birch Cabinet
- Ceramic Switches
- Covers 1 ohm to 99,999 ohms

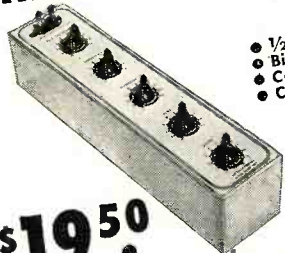

\$19.50

The new Heathkit Resistance Decade is a handy tool for laboratory, school and service shop. Ideal for test setups, calibrating instruments, bridge measurements, selecting multipliers, etc.

Uses the finest Centralab ceramic switches, 1/2% ceramic decade resistors and heavy birch cabinet matching other laboratory equipment. The range is 1 ohm to 99,999 ohms in one ohm steps.

Finest quality throughout to withstand school usage — heavy aluminum panel — laboratory type binding posts — the fine decades are extremely simple to assemble — complete kit. Model RD-1. Shipping Wt., 4 lbs.

**NEW Heathkit LABORATORY
POWER SUPPLY KIT**

Features

- Supplies 6.3 V. AC at 4.5 Amps.
- Heavy duty construction.
- Handy for schools, labs., and service shops.
- Supplies variable DC 50-300 Volts.
- Shows voltage or current on 3 1/2" meter.



\$29.50

This new Heathkit Variable Power Supply Kit fills hundreds of needs — use it for experimental circuits — no need to build a separate power supply — use it for a test voltage to determine proper coefficients in unknown circuits — calibrate instruments with its variable voltage, etc. This new Heathkit supplies 50 to 300 Volts continuously variable DC together with an AC filament voltage of 6.3 Volts at 4.5 Amperes. A built-in 1 MA 3 1/2" meter has proper shunts to read 0-500 Volts and 0-200 Milliampers. The circuit uses a 5Y3 rectifier, two 1G19 tubes as electronic control 7/8" x 13" x 7 1/4". Has instruction manual for assembly and use. Model PS-1. Shipping Wt., 18 lbs.

Heathkit **RECEIVER & TUNER KITS for AM and FM**

**TWO HIGH QUALITY Heathkit SUPERHETERODYNE
RECEIVER KITS**

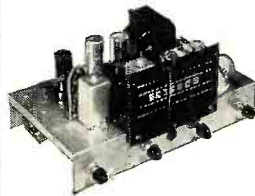

Model BR-1 Broad-cast Model Kit covers 550 to 1600 Kc. Shipping Wt., 10 pounds.

\$19.50

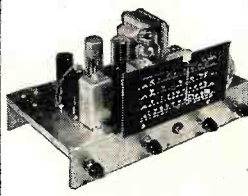

Model AR-1 3 Band Receiver Kit covers 550 Kc. to over 20 Mc. continuous. Extremely high sensitivity. Shipping Wt., 10 lbs.

\$23.50

Two new Heathkits. Ideal for schools, replacement of worn out receivers, amateurs and custom installations.

Both are transformer operated quality units. The best of materials are used throughout — six inch calibrated slide rule dial — quality power and output transformers — dual iron core shielded I.F. coils — metal filter condensers and all other parts. The chassis has phono input jack — 110 Volt outlet for phono motor and there is a phono-radio switch on panel. A large metal panel simplifying installation in used console cabinets is included. Comes complete with tubes and instruction manual incorporating pictorials and step-by-step instructions (less speaker and cabinet). The three band model has simple coil turret which is assembled separately for ease of construction.

**TRUE FM FROM Heathkit
FM TUNER KIT**

\$22.50

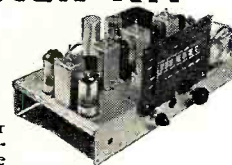

The Heathkit FM Tuner Model FM-2 was designed for best possible tonal reproduction. The circuit incorporates the most desirable FM features — true FM — ready wound and adjusted coils — 3 stages of 10.7 Mc. I.F. (including limiter).

Tube lineup: 7E5 oscillator, 6SH7 mixer, two 6SH7 I.F. stages, 6SH7 limiter, two 7C4 diodes as discriminator, 6X5 rectifier.

The instrument is transformer operated making it safe for connection to any type receiver or amplifier. The R.F. coils are ready wound — mounted on the tuning condenser and the condenser is adjusted — no R.F. coils to wind or adjust.

A calibrated six inch slide rule dial has vernier drive for easy tuning. The finest parts are provided with all tubes, punched and formed chassis, transformers, condensers and complete instruction manual. Model FM-2. Shipping Wt., 10 lbs.

EXPORT AGENT
ROCKE INTERNATIONAL CORP.
13 E. 40th ST.
NEW YORK CITY (16)
CABLE: ARLAB-N.Y.

The **HEATH COMPANY**

... BENTON HARBOR 15, MICHIGAN

ENJOY MUSIC AT ITS *Finest* WITH *Heathkit* AMPLIFIERS

NEW *Heathkit* HIGH FIDELITY 20 WATT AMPLIFIER KIT



\$21.50

Features

- Push-pull 6L6's.
- Full 20 Watts output.
- Fully enclosed chassis.
- Provisions for reluctance pickup compensation stage.
- Cased high fidelity output transformer.
- Treble and bass boost tone controls.
- Full range of output impedances 3.2 ohms to 500 ohms.

The finest amplifier kit we have ever offered — check the features. This inexpensive amplifier compares favorably with instruments costing five times as much. Nothing has been spared to provide the best reproduction — an ideal amplifier for the new Heathkit FM Tuner listed below.

Dual tone controls for control of both treble and bass. Bass control is of the boost type for maximum listening pleasure. Optional preamplifier stage for use with G. E. reluctance pickup or microphone. Uses inverse feedback to give excellent response over entire range. Tube lineup: 6SJ7 preamplifier stage, 615 phase splitter stage, two 6L6's in push-pull and 5Y3 rectifier. (6SC7 as optional compensation stage).

Uses highest quality Chicago Transformer Corporation cased output transformer with taps of 3.2, 8, 15, 60 and 500 ohms to match any speaker combination. Power transformer is conservatively rated for continuous operation in sound systems. Tone control gives maximum bass boost of 6 db at 70 cycles. Amplifier has maximum gain of 75 db. Response within 3 db 20 to 20,000 cycles. Shipping Wt., 17 lbs. Complete with all parts, tubes and instruction manual.

Model A-5A Amplifier with preamplifier for G. E. cartridges or microphone **\$23.50**
12" 20 Watt Speaker, No. 326..... **7.50**

Heathkit ECONOMY 6 WATT PUSH-PULL AMPLIFIER KIT



\$12.50

No. 304,
12-inch Speaker... **\$6.95**

This new Heathkit Amplifier was designed to give quality reproduction at a very low price. Has two preamp stages, phase inverter stage and push-pull beam power output. Comes complete with six tubes, quality output transformer (to 3-4 ohm voice coil), husky cased power transformer and all other parts. Has tone and volume controls. Instruction manual has pictorial for easy assembly. Six watt output with response flat $\pm 1\frac{1}{2}$ db from 50 to 15,000 cycles. A quality amplifier kit at new low price. Better-build one. Model A-4. Shipping Wt., 7 lbs.

Heathkit RECEIVERS and TUNER CABINETS



\$4.95

Order No. 350 for FM tuner

Blonde birch veneer cabinet for either the receivers or tuner. Modern styling is an asset to any room. 5" speaker fits in end of cabinet when used with receivers. Size 7 x 13 $\frac{1}{2}$ x 8 $\frac{3}{4}$ inches. Shipping Wt., 5 lbs. Order No. 345 for either receiver

Metal professional type communications receiver cabinet. Finished in deep grey to fit the panel supplied with Heathkit BR-1 and AR-1 Receivers (panel shown not included with cabinet). 5" speaker mounts in end of cabinet. Gives professional appearance to Heathkit receivers. Size 7 x 14 x 7 $\frac{3}{4}$ inches. Shipping Wt., 6 lbs.

5" Permoflux Speaker for either cabinet for use with either Heathkit Receiver No. 320 5" Speaker..... **\$2.75**

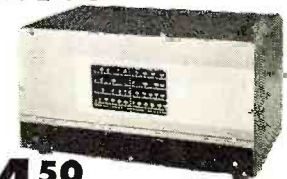

\$4.50

No. 335 Cabinet for receivers only.

ORDER BLANK

To HEATH COMPANY
BENTON HARBOR 15,
MICHIGAN

From

SHIP VIA

- Parcel Post
 Express
 Freight
 Best Way

(PLEASE PRINT)

Quantity	Item	Price	Quantity	Item	Price
	Heathkit Oscilloscope Kit — Model O-6			Heathkit VTVM Kit — Model V-4A	
	Heathkit T.V. Alignment Gen. Kit — TS-2			Heathkit R.F. Probe Kit — No. 309	
	Heathkit FM Tuner Kit — FM-2			Heathkit H.V. Probe Kit — No. 336	
	Heathkit Broadcast Receiver Kit — Model BR-1			Heathkit R.F. Signal Gen. Kit — Model SG-6	
	Heathkit Three Band Receiver Kit — Model AR-1			Heathkit Condenser Checker Kit — Model C-2	
	Heathkit Amplifier Kit — Model A-4			Heathkit Handitester Kit — Model M-1	
	Heathkit Amplifier Kit — Model A-5 (or A-5A)			Heathkit Variable Power Supply Kit — Model PS-1	
	Heathkit Tube Checker Kit — Model TC-1			Heathkit Resistance Decade Kit — Model RD-1	
	Heathkit Audio Generator Kit — Model G-2			Heathkit Impedance Bridge Kit — Model IB-1	
	Heathkit Battery Eliminator Kit — Model BE-2			Heathkit Signal Tracer Kit — Model T-2	
	Heathkit Electronic Switch Kit — Model S-2				

On Parcel Post Orders, include postage for weight shown and insurance. (We insure all shipments.)

On Express Orders, do not include transportation charges — they will be collected by the Express Agency at time of delivery.

Enclosed find Check Money Order for _____

Please ship C.O.D. Postage enclosed for _____ lbs.

REPORT AGENT
ROCKE INTERNATIONAL CORP.
13 E. 40th ST.
NEW YORK CITY (16)
CALL: AREA 4-N.Y.

The **HEATH COMPANY**

... BENTON HARBOR 15, MICHIGAN

*this is it—
this is the tuner
you designed!*

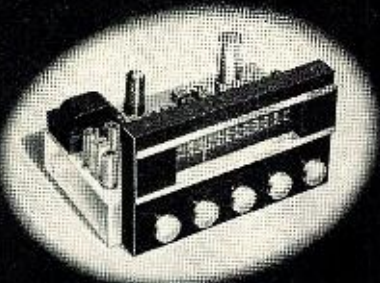

the
**CRAFTSMEN RC-10
HIGH FIDELITY
FM-AM TUNER**

This new tuner was your idea. It is the precisely engineered answer to hundreds of questions . . . the solution to scores of problems . . . the outgrowth of countless suggestions we've received from you. Developed from your ideas—and a few of ours—the RC-10 retains every feature of the famous RC-8. And it offers a host of innovations.

- Built-in pre-amplifier compensated for reluctance pickups.
- Automatic Frequency Control entirely eliminates drift, simplifies tuning.
- 5 microvolt sensitivity on both FM and AM.
- 10 kc filter on AM eliminates inter-station squeals.
- Base and treble tone controls for boost, cut, or 20—20,000 cycle flat response.

SEE . . . the RC-100A ultra-sensitive, custom TV with built-in booster.

HEAR . . . the RC-2 high fidelity amplifier. All units finished in chrome.

Write for information—or send 50¢ for instructions and schematics.

THE RADIO
craftsmen
INCORPORATED

Dept. R 11, 1617 S. Michigan Ave., Chicago 16, Ill.

Diagram Reproduction

(Continued from page 44)

This paper must be exposed through Kodak "Sheeting Yellow" to obtain consistent contrast and proper light values. This comes in the sizes of the paper to be used. Exposure, due to the self-reversing process, is the reverse of regular paper in action. Underexposure gives *too black* a paper print—and too much exposure makes it *too white*. Using the recommended exposures or test strips will show this reverse action.

The process is quite simple. After wiping the printing frame glass to remove fingerprints, the "Sheeting Yellow" is placed in first. The light must pass through this filter first. Then the pencil tracing is placed in proper position with the drawing face down. The "Autopositive" paper comes next, emulsion down, and the frame back is then fitted into place.

This frame was exposed for slightly over one minute as indicated. The "Autopositive" was removed and covered with the developer as rapidly as possible. In about 15 seconds (rather fast I was told) the print was fully developed. I then removed the print and put it in the fixing tray. No short stop was at hand. After about 5 minutes, the print was dropped into the pail for washing. The resulting print, from a very poor pencil tracing, was good.

With a better frame or light box and a more convenient developing layout, it is reasonable to expect that one person can make 25 to 50 8½ by 11 prints per hour after the equipment is set up. Larger copies require larger frames. Kodak recommends that for larger prints the paper be folded so as to use smaller trays.

Reflexing, or copying by illuminating

through the print paper, can be done so as to obtain copies of printed matter, one side at a time. It is essential that even illumination be available for this reflex printing. Several smaller No. 1 photoflood (or, better still, the 3200° K. lamps) are recommended for the tungsten-light bank. The No. 1 bulbs should be on about an 8 inch center-to-center layout, while the larger, longer-lasting 3200° K.'s should be on 17 inch centers. An opal or ground glass should be placed about half-way from the lamps to the glass of the printing frame. For reflection, high temperature aluminum paint can be used on the inside of the light box.

The exposure is made by using the usual "Sheeting Yellow" first on the frame, next the "Autopositive" emulsion down, then the typed page or printed matter last. If the magazine, drawing, or other matter to be copied is at all transparent or translucent, and the surface away from the "Autopositive" is not to be copied, it should be covered with black paper sheeting. The light must pass through the "Sheeting Yellow," the emulsion, and the type or material to be copied. The contrast of the "Autopositive" does the rest. The light source *must be intense* and the book or material to be copied held very firmly in place.

It can be seen that very simple equipment is all that is required for the "Autopositive" copy method. The paper in "A" (letter) size costs less than 5c per sheet in lots of 50. Setting the fixed and washed prints face up on newspapers constituted the drying mechanism. Thus, with this most elementary equipment, I can knock out those needed copies quickly and economically. For electronic circuits and layouts, this "Autopositive" copy system seems to be the answer to a long-felt want.

—30—

Schematic diagram of a test unit for checking selenium rectifiers. The table included below shows correct switch position for various types of rectifiers. Voltage readings shown are those that should be obtained when testing rectifiers. This suggested test unit was designed by the Selenium Rectifier Division of Sarkes Tarzian, Inc.

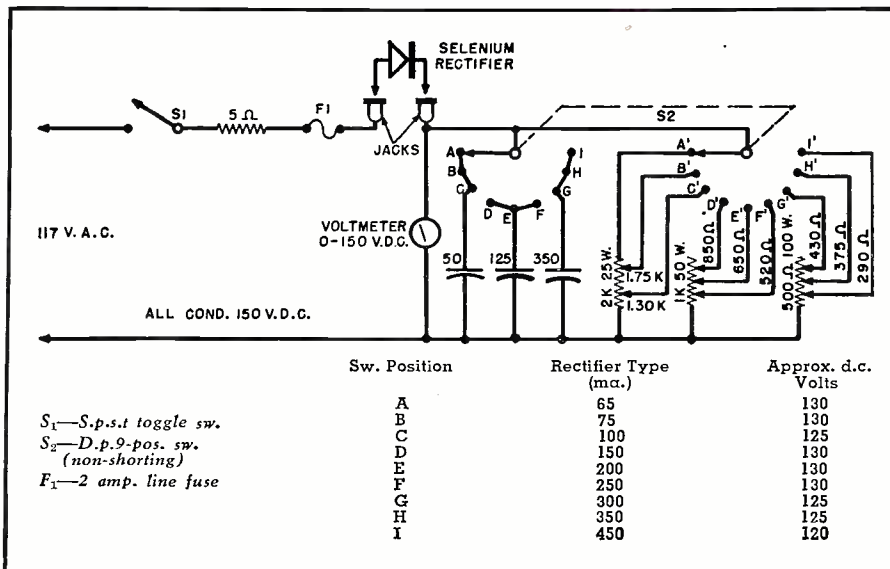

Guarantee

NIAGARA'S GUARANTEE
of Satisfaction
All items ordered must meet with full approval or your money back!

Nobody undersells NIAGARA

CHECK THESE

GUARANTEED VALUES.

NIAGARA—ONE OF AMERICA'S GREAT ELECTRONICS STORES

Extra Special!
SELENIUM RECTIFIER
AC-DC POWER UNIT

A versatile foundation power supply kit, providing 6 to 24 V. D.C. at 5 Amps., 110 V. A.C. or D.C. input. Kit contains: 1—Multiamp Trans., 2—5 Amp. Selenium Rect., 1—ACDC Ammeter, 1—6 point heavy duty tap switch, 1—DPDT toggle switch, 10—6 Amp. cartridge fuses, 10—3 Amp. cartridge fuses, circuit diagram, parts list. All waterproof packed for overseas shipping in wood cases. All this for less than the price of the Selenium Rectifiers! Shpg. Weight 50 lbs. **\$1295**
SPECIAL



RECEIVING TUBE
VALUES!

Guaranteed New—Branded

1B5/ \$0.88	1LH4 \$0.64	6K7 \$0.48
255 1.06	1LH5 .66	6K8 .78
1B7GT 1.06	1S5 .89	6L7 .78
1C5GT .66	1T4 .98	6L7G 1.16
1C6 .88	1T5GT .78	6N7 .78
1C7G .88	2V6G .98	6R7 .78
1D5GP .96	3A4 .36	6SD7GT .68
1D7G .88	3B7 .35	6SF5GT .89
1D8GT .94	3D6 .34	6S6GT .88
1E5GT 1.38	3Q5GT 1.10	6SH7 .48
1E7G 1.56	3S4 .98	6S7 .80
1F4 .74	3T4 .88	6SL7GT 1.20
1F5G .74	6A3 1.28	6SR7 .56
1F6 1.56	6A6 .88	6S57 .89
1F7G 1.56	6A7 .68	6T4 .88
1G4GT .68	6B7 .78	7B5 .72
1G6GT .68	6AD6 .88	7B6 .58
1H4B .68	6C5 .88	7C4 .58
1H5GT .63	6B7 .88	7C6 .72
1H6G .86	6BB .88	12A6 .18
1J6GT .88	6BBG 1.28	12B8 .58
1L4 .54	6C4 .46	12SH7 .34
1LA4 .78	6C6 .56	12SL7GT .58
1LA6 .88	6C8G .68	12SR7GT .48
1LB4 .86	6C9 .46	19 .97
1LC5 .78	6F7 .38	76 .38
1LC6 .56	6G6G .88	9001 1.90
1LD5 .78	6S5 .78	9005 1.90
1LE3 .88	6J8G 1.28	
1LG5 .88	6KS5GT .96	

ARC-5/R-28 (Plus \$2.50 BONUS)*
Hottest 2-Meter Receiver Ever Built!

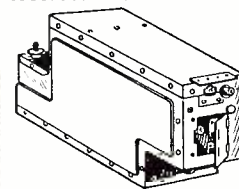

Here is the 2-meter superhet you have been looking for! Absolutely the BEST available today! Tunes from 100 to 158 Mcs. in four crystal channels. (Easily converted to continuous tuning.) Tube lineup is as follows: 717A—Mixer, 2-12SH7—1st and 2nd I.F. (6.9 Mc.), 12SL7—1st audio-squelch amplifier, 12A6—2nd audio, 12SH7—R.F. Osc.—4th Harmonic Gen., 717A—Tripl. 12th Harmonic Gen., 717A—Dblr.—12th harmonic Gen. A highly desirable superhet, made of rigidly inspected parts and contained in a louvered aluminum cabinet measuring 7 5/8" x 4 1/2" x 1 1/4". Complete with all tubes in original sealed cartons. **\$1995**

***FOR A LIMITED TIME ONLY!**

With each order for ARC-5/R-28 Receivers, one copy of Vol. 2 "Surplus Radio Conversion Manual" (Regular price \$2.50) will be shipped at no additional cost! This volume contains circuit diagram and full description of above receiver, plus a wealth of additional conversion data on many other popular items of surplus equipment. ACT NOW, for YOUR \$2.50 BONUS!

IMPORTANT NOTICE: Minimum Order \$5. Quantity prices on request. All items in stock now—subject to prior sale—prices subject to change without notice. 20% Deposit with orders unless rated. All prices F.O.B. our N.Y.C. Warehouse.

TRANSFORMER
BARGAINS
PLATE

511-T1	330-0-330 600MA	\$5.75
A-10	1025-0-1025V 500MA	17.95
D-161813	2500V 4MA. (TV or Scope)	3.95
GE9126	612-593-0-593-612V 200MA.	9.95

FILAMENT

P-3061	2.5V-5A, 7.5V, 4A.	2.60
T-2	2.5V 10A	4.95
52B049	5 VCT-3A, 5 VCT-10.5A, 6.3 VCT-3.5V	4.50
475-T201	5 VCT-15A	5.95
14749	Three 6.3 VCT-4A. Each	4.80
T-47164	6.4 V-8A	2.05
P-4091	7.5 V-5A	2.49
D-161917	6.3 V-3A, 2.5V-2A	2.85

POWER

T-47177	75-0-75V-250MA., 5V-3A	\$4.25
511-T2	350-0-350V-150MA., 6.3V-6A	2.15
475-T301	245-0-245V-70MA., 6.3V-6.2A	2.25
466-T1R	110-0-110V-225MA., 5V-3A	1.95
PC-110	300-0-300V-125MA., 6.3V-3.8A, 5V-3A	2.95
P-6010	325-0-325V-40MA., 6.3 VCT-2A,	2.49
P-6001	325-0-325 40MA., 5 VCT-2A,	2.25
P-6009	275-0-275 70MA., 5V-5A, 2.5V-10.5A	3.00
T-47165	135-0-135 90MA., 5V-3A, 5V-3A	2.49

MODULATION

ARC-3	807 R.F. to PP 6L6	\$2.49
A-3866	200, 500 OHMS to 5, 6, 7, 8, 9, 10 K OHMS-150MA	4.49
900716	P.P. 813 R.F. to P.P. 211 (R.C.A.) 500 Watts	4.95
T-47171	"AB" P.P. 807 to "C" 425V-240MA.	3.50

DRIVER

A-4413	200, 10,000 OHM Plate to Single Grid	\$0.79
A-4205	10,000 OHM Plate to Single Grid	.89
A-4406	P.P. 45, 2A3, etc., to P.P. 210, 801.	1.95
A-4404	P.P. 6L6, 2A3, etc., to P.P. Grids	1.65

OUTPUT

SP-10	6V6 to 2, 4, 8 OHMS	\$0.69
SP-12	P.P. 6V6 to 8 OHMS	.79
T-46255	P.P. Par. 6N7 "B" to 8000 OHMS	1.49
511-T1	6V6 to 8 or 600 OHMS	.85
11666	6V6 to Voice Coil or 500 Ω Line	1.89

INPUT

T-47368	600 OHM C.T. to 300 OHM Mike	\$1.29
---------	------------------------------	--------

MIKE TO LINE

A-4350	Pri. & Sec. 50, 200, 330, 500 OHMS	\$4.49
T-47369	30 OHM Mike to 600 OHM C.T. Sec.	1.65

CHOKES

5-16885	.875 HY	2.5. AMPS	\$8.95
L-143	1.72 HY	4 AMPS	8.95
C-2303	2.5	100 MA.	1.10
475-CH301	3.8	75 MA.	1.25
	4	40 MA. (AC-DC)	2.35
32584	8	200	3.49
10634	10	180	
	40	90	Dual
2647	10	200	2.49
A 13567	12	150	1.75
RC-72	15	125	1.60
14010	15	200	2.65
L-554	20	125	1.75

AC-DC
AUDIO
AMPLIFIER

Complete with speaker and 3 tubes. Ideal for use as Public Address or for Phonopickup. Volume controls. Amplifier with 5" speaker... Same as above with 8" speaker...



\$8.95
\$9.95

Single and Dual BLOWERS

All 110 V.A.C. Single Section Blowers illustrated ideal for many cooling applications—Approx. 100 cubic ft. per min. 2 1/2" intake, 2" outlet 3200 RPM motor, available in either 25 or 60 Cy. Special... Single Section Blowers somewhat smaller than above. Approx. 50 C.F.M. 60 Cy. only. **\$9.95**
SPECIAL... \$6.95
Dual Blowers—100 C.F.M. per section—mounted side by side with 60 Cy. motor in center. Otherwise same as single section illustrated above. 60 Cy. only. **\$14.95**



RPM motor, available in either 25 or 60 Cy. Special... Single Section Blowers somewhat smaller than above. Approx. 50 C.F.M. 60 Cy. only. **\$9.95**
SPECIAL... \$6.95
Dual Blowers—100 C.F.M. per section—mounted side by side with 60 Cy. motor in center. Otherwise same as single section illustrated above. 60 Cy. only. **\$14.95**

HEART
OF THE
BC-221

FREQ. METER

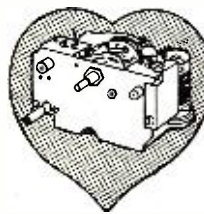

This VFO Sub-Assembly, used in BC-221 Freq. Meter, is ideally suited for home construction of: 1—Amateur V.F.O. 2—Freq. Mtr. Foundation, 3—Portable Transmitter. 4—Replacement for BC-221.

Unit contains two temperature and moisture compensating coils, wafer switch, 3 variable condensers, carbon resistors and silver mica condensers. FULLY WIRED and mounted on sturdy aluminum sub-chassis, ready for installation. Brand new—in original packing. **N-276.**
New Low Price... **\$4.95**

New Low Price

Niagara Famous High Pass Filter



Banish Interference with Niagara's High Pass filter! Positive protection against interference from amateur transmitters, diathermy, and all other devices generating radio frequency interference below 40 MCS. Designed for 300 ohm leadin. No loss in brightness or clarity. Wired and tested. **\$2.50**
Postpaid if entire amount is included with order.

BC-459A—28 MEG. V.F.O.
CONVERSION KIT



Complete Kit of Parts required to convert any BC-457A, or ARC-5 equivalent, to a fixed or mobile, 6 volt, 10-meter V.F.O. Transmitter. Kits contain: 1 copy—Vol. II "Surplus Radio Conversion Manual" (Containing full conversion instructions and worth \$2.50 by itself!), all 6V tubes (807, 6V6, 6J5) sockets, slug-tuned coils, resistors, condensers, wire, etc. Absolutely COMPLETE. ONLY **\$995**

Niagara Radio Supply Corp.

Phone
Dlgbly 9.
1132-3-4

Dept. N-21

160 Greenwich Street, New York 6, N. Y.



Olson Radio Warehouse, Inc.

73 E. Mill St. • 2nd Fl. • Akron 8, Ohio

FREE—SEND FOR OUR LATEST RADIO AND TELEVISION BARGAIN CATALOG

TV BOOSTER KIT RA-26
\$9.95
 Complete. Build your own TV-FM booster. Improves reception on low-signal "fringe" areas. 3 to 5 db gain in signal to noise ratio. All channel tuning. Complete with 6AK5 tube, pre-aligned coils, etc. Shpg. wt. 5 lbs.

TV COMPONENTS
 Deflection Yoke for use with 10BP4, 12 1P4, 16AP4 and all similar kinescopes, same RCA 201D1. WT. 2#. **T-84, Olson's Price only \$3.59**
 Deflection Yoke for use with kinescopes requiring 70 degree magnetic deflection such as rectangular 14BP4, 14CP4, 16RP4, 16TP4, 16KP4 and round 16CP4. WT. 2#. **T-85, Olson's Price, only \$4.49**

Hi-Voltage Flyback output transformer for 10" & 12" kinescopes. Same as RCA 211T1. WT. 4#. **T-82, Olson's Price, only \$3.99**

300-Ohm Lead-in
 High grade, low loss. For all TV installations. Shpg. wt. 3 lbs. **W-68, 100 ft. coil \$4.00**

PANEL LAMPS
 Western Electric and Tung-Sol bayonet panel lamps of a type to the box.
 Price
 Stock No. Type No. per 100
 X-161 47 \$5.59
 X-174 44

Battery Eliminator
 Converts portable battery sets to all electric AC. Will give years of dependable, trouble-free service. Supplies 1.4 volts "A" and 90 volts "B" power for 4 to 6 tube sets.
MODEL AS-20 \$10.95
 Each

4 Drawer Steel Cabinet FREE
 with OLSON'S
Gigantic AKRAD CONDENSER KIT
 Olson's Price AS-20 **\$16.95**
 You get \$45.20 (list) worth of "AkRAD" condenser plus cabinet, 8 1/2" x 7 1/2" x 10 1/2".

42 "AkRAD" By-Pass Condensers!
 List
 Qty. Cap. Volts ea. Total
 2 .001 600 \$25 \$50
 2 .002 600 25 50
 2 .005 600 25 50
 5 .01 600 30 150
 5 .02 600 30 150
 10 .05 600 40 400
 10 .1 600 45 450
 2 .005 1600 55 110
 2 .008 1600 55 110
 2 .01 1600 60 120
 69 Total List Value \$45.20

BATTERY CHARGER RA-55
\$8.50
 Highly efficient storage battery charger. Automatically decreases charging rate as battery becomes charged. Housed in sturdy steel case with 117 volt AC cord, plug and battery leads with heavy-duty clips.

H & H TOGGLE SWITCH
 Single pole, single throw, 6 amp, 125 V. Regular 60c.

Olson's Special NEW CRYSTAL MIKE
 Nationally famous make. Smart New Design, easy to hold. Used in many tape, wire and disc recorders. Can be used on P. A. systems, amplifiers, etc.
\$4.29
 M-71

MUSICAL INSTRUMENT MIKE
 Famous quality! Sells for twice our price. Easily attached. Delivers brilliant tone from string instruments. With 4' shielded cable and volume control.
\$6.95
 M-61

\$34.95
 RA-23 Olson's Price
 Less Tubes
30 WATT AMPLIFIER
 • Factory Built
 • Latest Design

A real commercial amplifier which looks good and performs well. Not a kit. Gain, mike, 130DB, phono 80DB. Has dual tone controls, base for bass and the other for treble tone. Output impedances 4, 8, 15 and 500 ohms. Input for two mikes and one crystal pickup. Shpg. wt. 20 lbs. Tubes re-former 3-68Q7, 1-68C7, 2-6L6G, 1-5V4G.

RECORDERING TAPE
 Fine magnetic recording tape. Frequency response 50 to 8,600 cycles at 7 1/2" per second. Uniformly coated with red oxide. Available in paper base and plastic base recording tape from Olson. Get the best for less.

Stock No.	Size	Type	Price ea.
X-203	1/4"x600 ft.	Paper	\$1.35
X-204	1/4"x600 ft.	Plastic	2.10
X-205	1/4"x1200 ft.	Paper	2.10
X-206	1/4"x1200 ft.	Plastic	3.30

RADIO CHASSIS
79c
 each X-228
 Real value for the experimenter. Each chassis contains at least 5 sockets, and one output transformer to match single tube to 3.2 ohm voice coil. Approximate dimensions 4 x 10 x 1 1/2. Transformer alone is worth 79c, but Olson's price is 79c for everything.

HOOK-UP WIRE KIT
 AS19. 500 feet \$4.95
 How can we give you so much for so little? Olson bought all the wire in sight and is passing the savings on to you. Kit contains 5 rolls, each 100 ft.—total 500 ft. Various colors, rust proof, plastic and rubber insulation; solid and stranded copper. Shpg. wt. 3 lbs.

4 Prong Universal VIBRATORS
 Stock No. VB48 **\$1.49**
 The most popular vibrator in use today. Replaces Mallory 294, 859, 901H, Radiator 3401. Size 1 1/2" dia. by 2 7/8" high. Reg. list price \$4.10. Brand new individually boxed. Shpg. wt. 8 oz.

Build a Receiver Set of Basic Components AS-38 ONLY **\$1.89**
 You get this kit of 5 basic parts to build an AC-DC set or portable. Reg. List Price Loop \$0.95 R. F. Coil \$1.10 I. F. Transformer (456 KC) \$1.60 Input \$1.60 Output \$1.60 Oscillator \$1.60 List Price of Set, 6.00 Use any 365 mfd variable for tuning. Covers 535-1625 KC.

ASTATIC MICROPHONE
 High output crystal mike for PA systems and recorders. Equipped with handle and base and 7' shielded cable. Shpg. wt. 5 lb.
\$5.95
 M-67, each
\$6.95 with on-off switch built into handle.

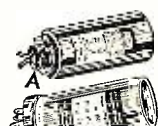

Close Out Entire Stock CORNELL-DUBILIER CONDENSERS

Save big money during Olson's big C-D close-out sale. Over 35,000 brand new shiny electrolytic condensers will be purchased by Olson's customers. Be sure of getting your share. Order early.

Stock	No.	Fig.	Capacity	Volts	Close-out Price
C-530	A		450	450	\$.59
C-510	B		350	350	.39
C-501	B	10-10-20	450-450-25	450	.39
C-617	B	20-10-10-10	450-450-450-450	450	.39
C-502	C		350	350	.39

Cornell Dubilier Paper Filter Block

Hard to get, but Olson has these 4 MFD 400 volt tough condensers. Not Electrolytic. Dry construction throughout. Size 3 3/4" x 2" x 1". Reg. list price \$2.95.
C-523, each \$4.95

SUPERIOR PRECISION-BUILT ELECTRONIC INSTRUMENTS

SIGNAL GENERATOR
 Provides Complete Coverage For A.M.—F.M. and TV Alignment
MODEL 660 \$39.95

Complete with coaxial cable, test lead and instructions. **SPECIFICATIONS:** The Model 660 generates Radio Frequencies from 100 kilocycles to 60 megacycles and fundamentals and from 60 megacycles to 240 megacycles powered harmonics. Accuracy and stability are assured by the use of permeability trimmed HI-Q coils. All calibrations are etched in large easy-to-read type on a vernier rotating dial. R. F. is available separately or modulated by the internal audio oscillator. Provision has also been made to modulate the R. F. by external source. The built-in 400 cycle sine wave audio oscillator used to modulate the R. F. signal is also available separately for audio testing of receivers. The built-in oscillator aids, etc. **OSCILLATOR CIRCUIT:** The Model 660 uses a miniature high frequency type of acorn triode in a Hartley circuit to insure a high degree of stability. By using the same type of triode as a buffer amplifier, complete and positive isolation between the R. F. oscillator and the attenuator is attained. **ATTENUATOR:** A 3-step attenuator type of attenuator is used. Each step of the attenuator is controlled by a separate attenuator control thus providing intermediate level settings to match the input of most receivers.

TUBE USED: 955 as R. F. Oscillator. 955 as Modulated Buffer Amplifier, 6N7 as Audio Oscillator and Power Rectifier.
POWER SOURCE: Operates on 110-125 Volt 50 to 60 cycle A.C.

SUPERIOR ALL-PURPOSE TUBE TESTER

Speedily, efficiently tests every type of receiving tube made in the past plus new types since TV and FM! Specifications: Tests all tubes including 4, 6, 7, Octal, lock-in, Peanut Bantam, Miniature Hearing Aid, Tyratron, Miniatures, 9B Miniatures, Novalis, etc. Will also test Pilot Lights. Tests by the well established comparison method for tube quality, directly read on the scale of the tester. "Shorts" and "leakages" up to 5 Megohms. Uses the new self-cleaning Lever Action Switches for individual element testing. Because all elements are numbered according to pin-number in the RMA base numbering system, the user can instantly identify which element under test. Tubes having tapped filament and tubes with filament terminating in more than one pin are truly tested. All tubes. Newly designed Line Voltage Control compensates for variation of any line voltage between 165 and 130 volts. The Model TV-10 operates on 105-130 Volt 60 cycle A.C.

Comes to you housed in a beautiful hand-rubbed oak cabinet complete with portable cover, Model TV-20. **\$39.50**

SUPERIOR ACCURATE POCKET SIZE VOLT-OHM MILLIAMMETER

(SENSITIVITY: 1000 ohms per volt)
 MODEL 770
 Compact, it measures 3 1/8" x 5 7/8" x 2 1/4". Uses latest design for accurate D.C. or A.C. voltage measurement. Same zero adjustment holds for both resistance ranges. It is not necessary to readjust when switching from one resistance range to another. This is an important feature never before included in a V.O.M. in this price range. Housed in rounded, molded case. Beautiful black etched panel. Depressed letters filled with permanent white, insures long life even with constant use. Specifications: 6 A.C. Voltage Ranges: 0-15/30/150/300/1500/3000 volts • 6 D.C. Voltage Ranges: 0-7 1/2/15/75/150/750/1500 volts • 4 D.C. Current ranges: 0-1 1/2/15/150 Amps • 2 Resistance Ranges: 0-500/0-1 Megohm • Comes to you complete with self-contained batteries, test leads and all operating instructions. Model 770. **\$14.90**

4-DRAWER STEEL CHEST

For small parts, etc. Knob on each drawer; various size compartments. Each drawer 1 1/4" deep. Size: 6 1/2" H. 5 3/4" W. 8 1/8" D. Shipping weight 5 lbs.

MATCHED PAIR AM-FM CONDENSERS

Beautifully built! 3-gang. Build a X-201 tuner or AM-FM set. AM sections are 365 MMFD; FM is 15 MMFD per section. Can be operated by push-buttons, tone. Shaft 3/8" dia. Condenser 3" x 1 1/2" x 1/4". Shpg. wt. 3 lbs. X-201. Only at OLSON'S. **Pair \$6.95**

KIT OF THREE VARIABLE CONDENSERS

A \$3.50 value! Perfect for the experimenter. Brand new stock. Quantity limited. Get a kit containing 3 assorted variable condensers. Popular X-226 values. 2-gang and 3-gang. Carton contains 3 trimmers, vernier of 3 drives, AM and FM styles. **\$1.29**

By-Pass Condenser Kit

Assortment of 50 popular values, 200 to 1700 volts, capacities from .0002 to .25 mfd. Quantity limited. Shpg. wt. 3 lbs. **\$1.59**

FP CONDENSER KIT

Assortment of 15 popular values, 200 to 1700 volts, triple sections. Capacities from 10 mfd to 50 mfd; Shpg. wt. 3 lbs. **OLSON'S Bargain \$3.98** AS-24, each.

PHONOGRAPH RECORDS

"TIME TO SLEEP" A 12" 78 RPM, unbreakable disc in album form recorded by World Famous magician Ralph Slater. Designed to put anyone to sleep. Save money. Thousands sold at \$3.75. Shpg. wt. 3 lbs. X-242, your cost, per album only. **\$1.29**

GENUINE ASTATIC PICK-UP ARM

With crystal cartridge... at less than you'd normally pay for the cartridge alone.
OLSON'S Special M-58... \$2.99

GE RPX-040

Variable Reluctance Cartridge with Removable Stylus
 Regular price is \$9.95 on this GE Phono Cartridge with removable 3 mil Stylus for 78 RPM discs. Stylus pressure 3/4 oz. XC-45. **\$3.49**

ASTATIC "TURNOVER" PICK-UP ARM

Cartridge turns by means of knob on front. One side plays 3 1/2" and 4 1/2" RPM records and other side plays 78 RPM. Only 8 grams needle pressure. Employs the famous ASTATIC LQD-1 Double needle cartridge. Die cast curved arm. Equipped with 2 long life needles. Frequency response 50-7000 cps output 1.2 volts. Shpg. wt. 2 lbs. Reg. list price \$15.00. **\$4.95** M-64

RIM DRIVE PHONO MOTORS

Famous Makes! Real bargains at these low prices. Self-starting; complete with turntable. All parts included. Shpg. wt. 4 lbs. M-52, 78 rpm for 115 volts AC. **\$3.79**

PHONO AMPLIFIER

Connect to phono or speaker or just the thing for a portable. Uses: 2-500, 7-50L6, 35Z5 tubes, 2 controls on/off volume and tone. 7" x 3 1/4" x 2". Shpg. wt. 2 lbs. **\$6.95** RA-19

BUILD 15 RADIOS At Home

WITH THE NEW IMPROVED 1951
PROGRESSIVE RADIO "EDU-KIT"

\$19.95

ONLY ...
FREE TOOLS
WITH KIT

ABSOLUTELY NO
KNOWLEDGE OF
RADIO
NECESSARY

NO
ADDITIONAL
PARTS
NEEDED

EXCELLENT
BACKGROUND
FOR TELEVISION



10-DAY MONEY-BACK GUARANTEE

WHAT THE PROGRESSIVE RADIO "EDU-KIT" OFFERS YOU

The Progressive Radio "Edu-Kit" offers you a home study course at a rock bottom price. Our Kit is designed to train Radio Technicians, with the basic facts of Radio Theory and Construction Practice expressed simply and clearly. You will gain a knowledge of basic Radio Principles involved in Radio Reception, Radio Transmission and Audio Amplification.

You will learn how to identify Radio Symbols and Diagrams; how to build radios, using regular radio circuit schematics; how to mount various radio parts; how to wire and solder in a professional manner. You will learn how to operate Receivers, Transmitters, and Audio Amplifiers. You will learn how to service and trouble-shoot radios. In brief, you will receive a basic education in Radio exactly like the kind you would expect receive in a Radio Course costing several hundreds of dollars.

THE KIT FOR EVERYONE

The Progressive Radio "Edu-Kit" was specifically prepared for any person who has a basic knowledge of the English language, and has the desire to learn Radio. The Kit appeals to persons of all ages, by young and old in all parts of the world. It is not necessary that you have even the slightest background in science or electronics.

The Progressive Radio "Edu-Kit" is used by many Radio Schools and Clubs in this country and abroad. It is used by the Veterans Administration for Vocational Guidance and Training.

The Progressive Radio "Edu-Kit" requires no instructor. All instructions are included. All parts are individually packaged, so that you can easily photograph and diagram. Every step involved in building these sets is carefully explained. You cannot make a mistake.

PROGRESSIVE TEACHING METHOD

The Progressive Radio "Edu-Kit" comes complete with instructions. These instructions are arranged in a clear, simple and progressive manner. The theory of Radio Transmission, Radio Reception and Audio Amplification is clearly explained. Every part is identified by photograph and diagram; you will learn the function and theory of every part used.

The Progressive Radio "Edu-Kit" uses the principle of "Learn By Doing." Therefore you will build radios to illustrate the principles which you learn. These radios are designed in a modern manner, according to the best principles of present-day educational practice. You begin by building a simple radio. The next set that you build is slightly more advanced. Gradually, in a progressive manner, you will find yourself constructing still more advanced radio sets, and doing work like a professional Radio Technician. Altogether you will build fifteen radios, including Receivers, Amplifiers and Transmitters.

THE PROGRESSIVE RADIO "EDU-KIT" IS COMPLETE

You will receive every part necessary to build 15 different radio sets. This includes tubes, tube sockets, variable condensers, electrolytic condensers, mica condensers, paper condensers, resistors, tie strips, coils, tubing, hardware, etc. Every part that you need is included. In addition, these parts are individually boxed, and identified by name, identify every item.

TROUBLE-SHOOTING LESSONS

Trouble-shooting and servicing lessons are included. You will be taught to recognize and repair troubles. While you are learning in this practical way, you will be able to do many a repair job for your neighbors and friends, and charge fees which will far exceed the cost of the Kit. Here is an opportunity for you to learn radio and have others pay for it.

FREE EXTRAS IN 1951

- ELECTRICAL AND RADIO TESTER
- ELECTRIC SOLDERING IRON
- BOOK ON TELEVISION
- RADIO TROUBLE-SHOOTING GUIDE
- MEMBERSHIP IN RADIO TELEVISION CLUB
- CONSULTATION SERVICE
- QUIZZES

The Progressive Radio "Edu-Kit" is sold with a 10-day money-back guarantee. Order your Progressive Radio "EDU-KIT" Today, or send for further information.

PROGRESSIVE ELECTRONICS CO.

497 UNION AVE.
DEPT. RN-2 BROOKLYN 11, N. Y.

Manufacturers' Literature

Readers are asked to write directly to the manufacturer for the literature. By mentioning RADIO & TELEVISION NEWS, the issue and page, and enclosing the proper amount, when indicated, delay will be prevented.

CR TUBE BOOKLET

Sylvania Electric Products Inc. of Emporium, Pa. has just issued a new 12-page booklet which lists characteristics of 194 cathode-ray tubes for television receivers, oscilloscopes, and radar applications.

The CR tubes described include 103 designed for magnetic deflection and 91 electrostatic types with screen sizes ranging from 2" to 22". The data provided includes current and voltage, nominal dimensions, basing, persistence and fluorescence of screen, maximum design center ratings, and typical operating conditions.

Copies of the publication, "Sylvania Television Picture Tubes," may be secured from the advertising department of the company at Emporium.

BAKELITE BOOKLET

The new "Guide to Improved Packaging with Bakelite and Vinylite Plastics," recently issued by the *Bakelite Division of Union Carbide and Carbon Corporation*, is of particular interest to manufacturers.

This idea-provoking booklet cites the advantages of using various forms of Bakelite and Vinylite plastics in packaging and display. Properties of the specific form of the plastic or resins employed are listed with each application and illustrations showing one or more typical examples are given.

Copies of this 8-page booklet are available from the company at 300 Madison Avenue, New York 17, New York.

COMPONENT CATALOGUE

Allied Electric Products Inc. of 68-98 Coit Street, Irvington 11, New Jersey is currently offering a copy of its Catalogue 161 covering a variety of components.

The new 24-page catalogue covers attachment plug caps, cube adapters, cube taps, extension cord sets, fluorescent units, female connectors, various types of lamps, rectifier bulbs, spring-action contacts, and a line of television picture tubes.

This handy reference booklet contains complete specifications and ordering data on products manufactured both by *Allied* and its *Sheldon Electric Co. Division*.

INSULATOR DATA

American Lava Corporation of Chattanooga 5, Tenn. has issued a new bulletin, No. 502, on internal insulators for electronic tubes.

This bulletin discusses the require-

ments for vacuum tube insulators and outlines the main facts about various technical ceramics especially adapted to those requirements.

A chart gives detailed physical characteristics of the five most frequently used ceramic compositions. The chart also gives, for the first time, complete and detailed characteristics on the company's "AlSiMag 548".

Copies of Bulletin No. 502 will be sent on request and samples of the material can be made available for tests.

CABINET CATALOGUE

The company's complete line of television cabinets and five-way combination console cabinets is described and illustrated in the new 14-page catalogue just released by *Standard Wood Products Corporation* of 43-02 39th Street, Long Island City 4, New York.

The cabinets described comprise all types of modern, traditional, period, and custom styling and are designed to accommodate 16, 17, 19, and 20 inch rectangular and round picture tubes.

Free copies of this catalogue are available from the company.

PRECISION CATALOGUE

Precision Electronics, Inc. of 641-643 Milwaukee Avenue, Chicago 22, Illinois has announced publication of its Catalogue No. 6449, covering beam power amplifiers manufactured by the firm.

Included in the new catalogue are details on the company's Model PE-80 8-watt amplifier, the Model PE-180 18-watt unit, the Model PE-300 30-watt amplifier, the Model PE-100PG 10-watt music amplifier, the Model PE-600 60-watt unit, and the Model PE-30MP 30-watt mobile amplifier.

Complete specifications and performance details are provided on all of these units.

PHONO ACCESSORIES

A new phono accessory catalogue, complete with descriptions and data on variable reluctance cartridges, replacement baton styli, tone arms, and preamplifiers, is presently available from the Parts Section of the Receiver Division of *General Electric Company*.

Copies of this new catalogue, which are free of charge, may be secured from the company by writing to Syracuse, New York.

AUDIO EQUIPMENT

A new edition of the company's audio equipment catalogue is currently available for distribution, according to

Six Months from Today Which will YOU hold?



ADD TECHNICAL TRAINING TO YOUR PRACTICAL EXPERIENCE

GET YOUR FCC LICENSE IN A HURRY!

THEN—Use Our Amazingly Effective JOB-FINDING Service

Get this Valuable Booklet **FREE**



TELLS HOW—

WE GUARANTEE

TO TRAIN AND COACH YOU AT HOME IN SPARE TIME UNTIL YOU GET

YOUR FCC LICENSE

If you have had any practical experience—Amateur, Army, Navy, Radio repair, or experimenting.

TELLS HOW—

Employers make

JOB OFFERS Like These to Our Graduates Every Month

Letter, August 4, 1950, from Communications Supt., Airlines, Missouri, "There is an opening at present for the position of radio operator with this Airlines here in St. Louis. Would like to have a list of your available graduates here in St. Louis. Must have 2nd class phone license."

Telegram, Sept. 7, 1950, from Chief Engineer, Broadcast Station, Georgia, "Have immediate opening first phone engineer. Prefer one with usable voice, experience not necessary. Prefer man from small town. Beginning pay \$48 for 48 hours."

These are just a few samples of the job offers that come to our office periodically. Some licensed radioman filled each of these jobs . . . it might have been you!

HERE'S PROOF FCC LICENSES ARE OFTEN SECURED IN A FEW HOURS OF STUDY with OUR Coaching AT HOME in Spare Time.

Name and Address	License	Lessons
Lec Worthy 2210 1/2 Wishire St., Bakersfield, California	2nd Phone	16
Clifford E. Vogt Box 1016, Davin, Florida	1st Phone	20
Francis X. Foerch 38 Beueler Pl., Bergenfield, New Jersey	1st Phone	38
S Sgt. Ben H. Davis 317 North Roosevelt, Lebanon, Illinois	1st Phone	38
Albert Schoell 110 West 11th St., Escondido, California	2nd Phone	23

CLEVELAND INSTITUTE OF RADIO ELECTRONICS

Desk RN-26, 4900 Euclid Bldg., Cleveland 3, Ohio
Approved for Veteran Training Under G.I. Bill

TELLS HOW—

Our Amazingly Effective JOB-FINDING SERVICE Helps CIRE Students Get Better Jobs

Here are a few recent examples of Job-Finding results:
GETS FIVE JOB-OFFERS FROM BROADCAST STATIONS

"Your 'Chief Engineer's Bulletin' is a grand way of obtaining employment for your graduates who have obtained their 1st class license. Since my name has been on the list I have received calls or letters from five stations in the southern states, and am now employed as Transmitter Engineer at WMMT."

Elmer Powell, Box 274, Sparta, Tenn.

GETS CIVIL SERVICE JOB

"I have obtained a position at Wright-Patterson Air Force Base, Dayton, Ohio, as Junior Electronic Equipment Repairman. The Employment Application you prepared for me had a lot to do with me landing this desirable position."

Charles E. Loomis, 4516 Genesee Ave., Dayton 6, Ohio

GETS JOB WITH CAA

"I have had half a dozen or so offers since I mailed some fifty of the two hundred employment applications your school forwarded me. I accepted a position with the Civil Aeronautics Administration as Maintenance Technician. Thank you very much for the fine cooperation and help your organization has given me in finding a job in the radio field."

Dale E. Young, 122 Robbins St., Owosso, Mich.

OURS IS THE ONLY HOME STUDY COURSE WHICH SUPPLIES FCC-TYPE EXAMINATIONS WITH ALL LESSONS AND FINAL TESTS.

Your FCC Ticket is always recognized in all radio fields as proof of your technical ability

Get All 3 FREE

MAIL COUPON NOW

CLEVELAND INSTITUTE OF RADIO ELECTRONICS
Desk RN-26 — 4900 Euclid Bldg., Cleveland 3, Ohio
(Address to Desk No. to avoid delay)
Approved for Veteran Training Under G.I. Bill

I want to know how I can get my FCC ticket in a minimum of time. Send me your FREE booklet, "How to Pass FCC License Examinations" (does not cover exams for Amateur License), as well as a sample FCC-type exam and the valuable booklet, "Money-Making FCC License Information."

NAME

ADDRESS

CITY..... ZONE..... STATE.....

Veterans check for enrollment information under G.I. Bill.

the **chicago**

V.T.V.M.

ELECTRONIC MULTITESTER

A versatile new Chicago Vacuum Tube Volt Meter with more ranges and greater utility—at the lowest price in the industry!

\$39⁰⁰
net

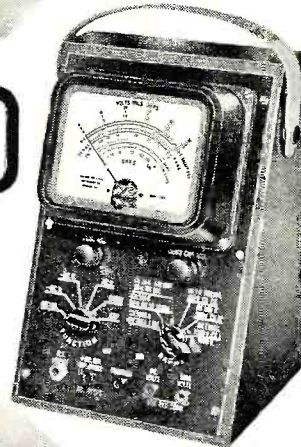

RANGES

DC VOLTS

0-5, 10, 50, 100, 500, 1000, 5000. Input impedance: 20 megohms (including 10 megohms in the DC probe);

AC VOLTS

0-5, 10, 50, 100, 500, 1000, 5000
Input impedance: 10 megohms

OHMS

0 to 1000 megohms in 6 ranges with center scale readings of 10, 100, 1000, 10K, 1Meg., 10Meg.

CAPACITANCE

50 MMF to 5000 MF in 6 ranges. Low voltage-power source enables testing of electrolytic condensers.

MILLIAMPERES

DC 0-1, 10, 100, 500
(Not electronic) 50 millivolt drop.
Operates on 115 V.A.C. Dimensions: 6 3/4" Wide x 9 1/2" High x 6" Overall Depth

The big 5 1/2" meter is mounted in a handsome brown Hammerloid case slanted for easy reading.

See Your Parts Distributor or Write for Complete Information

CHICAGO INDUSTRIAL INSTRUMENT CO.

536 W. ELM ST. • CHICAGO 10, ILL.

TOUGH CONSTRUCTION

...The Key to the "top" performance of

JFD "COMMANDAIR"
TV CONICALS

ALL ALUMINUM!
RUST PROOF!
CORROSION PROOF!

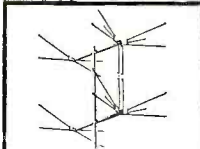

JFD No. C671

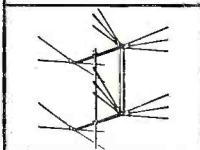

JFD No. C681

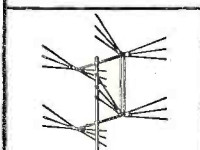

JFD No. C691

Available with 1/4" 61ST6 Solid Aluminum Elements or Dowel Reinforced 3/8" Aluminum Elements!

All-Aluminum Construction!
Retains full strength, eliminates rusting and corrosion.

Unique Bracket Flexibility!
Takes any combination of element arrangements to suit location.

Reinforced Elements!
Sturdy 8-inch wood dowels eliminate whip and vibration. Pressure-sealed, howl-proof ends prevent interior corrosion.

Solid Aluminum Elements!
No. SR660 and SR661 arrays utilize elements made of 61ST6 1/4" OD solid aluminum rods. Break-proof! Howl-proof! Vibration-proof!

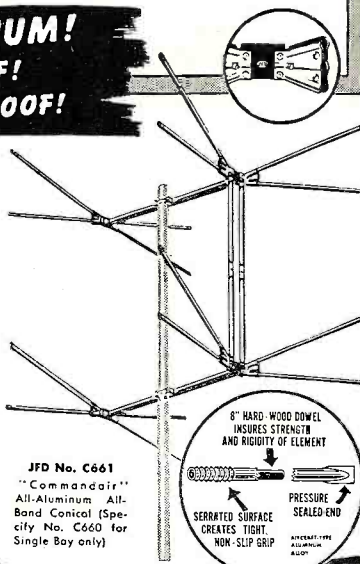

JFD No. C661

"Commandair"
All-Aluminum All-Band Conical (Specify No. C660 for Single Bay only)



8" HARD WOOD DOWEL INSURES STRENGTH AND RIGIDITY OF ELEMENT
SERRATED SURFACE CREATES TIGHT, NON-SLIP GRIP
PRESSURE SEALED END
ALUMINUM TYPE ALUMINUM



MANUFACTURING CO., Inc.

6105B 16th Avenue, Brooklyn 4, N. Y.

FIRST IN TELEVISION ANTENNAS AND ACCESSORIES

Write for FREE literature completely describing the JFD "Commandair" Line of All-Aluminum TV Conicals.

word received from *Sun Radio & Electronics Co., Inc.* of 122-124 Duane Street, New York, New York.

This revised catalogue contains a wealth of technical information on the principles involved in fine music reproduction. As with the previous edition the material is presented in easy-to-understand form. A large section of this 100 page book is devoted to questions and answers most common to high fidelity owners. The balance of the handbook contains listings, prices, and information on hundreds of components and subassemblies relative to high fidelity music reproduction in the home or public places.

Copies of the 1951 edition of "Audio Equipment, A Handbook for Music Lovers" may be secured from the company without charge.

PLUNGER RELAYS

H-B Instrument Company has recently issued its Catalogue No. 17 which explains in detail how relay maintenance can be eliminated by using the company's Mercury Plunger Relays.

In addition to providing complete specifications on normally-open and normally-closed tubes and relays with various mountings, the new catalogue features diagrams and cut-away illustrations showing how these relays work.

A copy of Catalogue 17 may be secured by writing Dept. MP31 of the company at 2633 Trenton Avenue, Philadelphia 25, Pa.

POWER SUPPLIES

Kepeco Laboratories, Inc. of 149-14 41st Avenue, Flushing, New York is making available copies of its new brochure on voltage regulated power supplies to interested electronic technicians.

Data sheets on the Models 315, 510, 515, and 500 R have just been released and will be supplied on request. Each sheet carries a picture of the unit and complete specifications and performance details.

Any or all of these sheets will be furnished. Please specify which model data sheets you require.

SERVICE UNITS

The Simpson Electric Company, 5200 W. Kinzie Street, Chicago 44, Illinois is offering a new, illustrated folder covering six of its instruments for FM and television servicing.

Included are descriptions of the company's Model 335 plate conductance tube tester; the Model 488 field strength meter; the Model 476 "Mirrorscope," the Model 303 v.t.v.m.; the Model 260 a.c.-d.c. volt-ohm-milliammeter; and the Model 480 "Genescope." Detailed descriptions on all of these instruments is given, along with photographs of the units and physical dimensions.

Parts jobbers have supplies of these booklets available for distribution or copies may be obtained from the company direct.

OUTSTANDING VALUES NOW AVAILABLE

POST INVENTORY CLEARANCE SALE

G I—13-CHANNEL TELEVISION TUNER

For replacement or construction work. Capacity type tuner with fine tuning control. Using 3—6J6 tubes. Input for 300-ohm line. One of the finest front ends ever built.

Each **\$5.95** less tubes
Lots of 3 **\$5.50** each

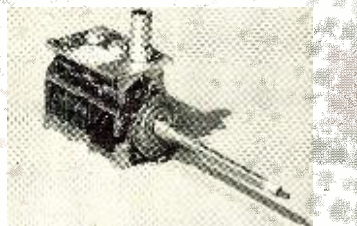

GALVANIZED STEEL GUY WIRE

50 ft. hanks, 4 strand #20. **.49c** ea.
1000 ft. rolls, 4 strand #20. **\$5.25** ea.
1000 ft. rolls, 6 strand #20. **\$5.95** ea.

GUARANTEED RECTANGULAR PICTURE TUBES

A real bargain for these first-rate tubes.

16"—16RP4. **\$28.50** each
17"—17BP4. **\$29.95** each
20"—20CP4. **\$52.50** each

PHONO CARTRIDGES—Brand New—Will replace 95% of all cartridges.
1 volt—Standard Mounting. **\$1.75** ea.
3 volt—Standard Mounting. **\$1.85** ea.

150 Watt Soldering Iron— $\frac{3}{8}$ " Plug-in-Tip. Standard. **\$1.95** each

PLATE CONDENSERS

40x20 Mfd—150V	} 49c each	
15x15 Mfd—350V		
60x40 Mfd—150V		
40x40x20 Mfd—150V		
200 Mfd—10V		
30 Mfd—150V		
15x10 Mfd—400V		
40 Mfd—25V		
10 ass'td		\$4.25

NOW! LARGE 14" or 16" PICTURE FROM YOUR 10" or 12" TELEVISION SET

Servicemen: Convert customers' sets for extra profits! 90% of all conversions can be made by use of the RAPARCO conversion kit.



Includes 14BP4 CR tube, 70° deflection yokes, and attractive lucite mask. Complete, only. **\$34.95**

CONICAL TV ANTENNAS

Featuring 8 inter-changeable elements. Hi-tensil Aluminum Alloy. Just insert elements and lock.

Universal U Bolt. **\$4.25** each
Stacked conicals, including stacking bars. **\$8.00** each

TV ANTENNA MASTS — Heavy Gauge Steel—Rust Proof.

5 ft. **\$1.25** each 10 ft. **\$2.59** each

12 ft. TV ANTENNA MAST—Heavy Gauge Aluminum. **\$2.95** each

CHIMNEY MOUNTS—2 piece heavy-duty, rust-proof brackets. No drilling or guy wire needed. Includes strapping. **\$1.45** each 12 for **\$1.30** each

UNIVERSAL MOUNT—Can be used for Chimney Mount, Wall Mount or Base Mount. Heavy-duty, rust-proof steel.

\$1.65 each. 12 for **\$1.50** each

INDOOR TELEVISION ANTENNA



Now TV reception without the outdoor antenna. Effective range 20 to 25 miles from station. Excellent reception. Easily installed—takes 5 seconds. Easily orientated. Heavy base—will not tilt. Attractive. Friction clutch-type action on the rods. Complete with lead in. **\$2.49**
Case lots of 25. **\$2.25**

Standard Manufacture—All New—All Guaranteed. All these parts are used constantly in repair or conversion work.

Flyback transformer for 12½" set. **\$2.75** ea.

14" attractive Lucite Square Mask. **\$3.95** ea.

16" attractive Lucite Square Mask. **\$4.50** ea.

Single Magnet Beam Bender. **.39c** ea.

Double Magnet Beam Bender. **.75c** ea.

500 MMFD 10 KV. **.69c** ea.

For stronger TV signal with an indoor TV antenna, use a BEACON HI-LO spiral antenna. No orientation necessary with change of station. Attractive, well-constructed.

Now only **\$4.59** ea. 10 for **\$42.50**

70° Deflection Yoke—Includes Resistors and Condensers. **\$3.65** each

Radio Parts Company, 614 RANDOLPH ST., CHICAGO 6, ILL.

COMPLETE RADIO AND AMPLIFIER KITS FOR SCHOOLS AND CUSTOM BUILDERS

7-TUBE FM-AM TUNER

★ AC SELF POWERED

★ 3 GANG TUNING ★ A COMPLETE KIT

\$29.95

McGee has ready for delivery, this self powered AC, 7 tube FM and AM superhet tuner kit. Build yourself a professional looking tuner that may be connected to any audio amplifier. Receives broadcast 550 to 1650 kc and FM 88 to 108 mc. A 3 gang tuning condenser is used on both FM and AM. This extra stage of TRF makes a smoother working tuner. 2 IF stages on FM and one IF stage on AM (I.F. frequency 456 and 497 mc). Lighted slide rule dial with metal escutcheon plate. Own lab designed and wired an original tuner using these parts. Chassis is ready punched and painted. Everything furnished including tubes and diagrams. Shipping weight 12 lbs. Stock No. KAL-8, net price \$29.95.

5-TUBE BROADCAST SUPERHET RADIO KIT \$12.95

Model NS-5X 5 tube AC-DC superheterodyne radio kit. Has loop antenna and 2 gang condenser, with lighted slide rule dial and attractive plastic cabinet. Receives broadcast, 550 to 1650 kc. Full size dynamic speaker, matched 456 I.F.'s, automatic volume control. This is a complete radio kit. Everything furnished, including diagram, photos and tubes: 14B6, 14Q7, 14A7, 50B5 and rectifier. Shipping weight 7 lbs. Stock No. NS-5X. Net price \$12.95.



Build Your Own \$7.95

Phono-Mike Oscillator Kit
Kit Model DE-6X. With this simple kit, you can build a 4 tube phono oscillator that also has a mike input. Will broadcast over any radio within your home, (about 75 feet) from 800 to 1500 kc. Inputs for crystal mike or crystal phono pickup. Fader control fades from mike to record. Ideal for a home P.A. system. Baby listener and home entertainment. A complete kit of parts including tubes. Kit Model DE-6X. Net price, \$7.95. DE-6XWR, wired and tested. Net price, \$9.95. Crystal mike and desk stand, \$4.95 extra. Concealed microphone unit, only 1" in diameter and 1/4" thick. Specify hidden mike when ordering. Stock No. T-001. Net, \$3.95 extra.

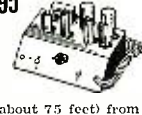

MODEL ME6-2 \$19.95 NEW MODEL 6-TUBE, 2-BAND RADIO KIT A FULL 2 GANG SUPERHET RECEIVES 550-1600 KC PLUS 6-18 M.C.

McGee's new 1951, 6 tube; AC-DC 2 band radio kit. Receives broadcast, 550 to 1600 kc and short wave, 6 to 18 mc. A straight forward superhet circuit with 2 gang tuning condenser, 456 kc I.F. transformers, etc. 3" PM speaker illuminated slide rule dial. Everything furnished, including tubes, diagram and a photo showing view of underside of completely wired chassis. The chassis pan and dial parts are factory production. With this kit, you can build a commercial looking and factory quality 2 band radio, housed in a streamlined plastic cabinet. Size: 13 x 6 3/4 x 6 1/4". Stock No. ME6-2, shipping weight 10 lbs. Net \$19.95.



SELF POWERED AC Broadcast Tuner Kit, 3-Gang Tuning, Complete Kit, \$12.95

A self powered, 3 gang superhet tuner kit, with I.F. stage. When wired according to our diagram will make the best possible broadcast tuner. Built on a 500 kc (or use with any amplifier). Has a G lighted slide rule dial. Don't class this with ordinary tuners, this has its own transformer. The complete kit is furnished with a diagram and tubes: 6SK7 R.F., 6SA7 converter, 6SK7 I.F., 616G detector, 6X4 rectifier. Connect to any audio amplifier. Ideal for use with our 7.5, TM-16 or S-2020 amp. kits. Massive size: 9 1/4 x 8 1/4 x 4 1/2" high. Shipping weight 8 lbs. Broadcast tuner kit. Model BT-38. Net price \$12.95.

8-TUBE 22 WATT Wide Range Amp. Model 7x5 Kit Only \$37.95

A complete kit, including tubes (3-7E5, 2-7F7, 2-6A3 or W.E. VT-52, plus rectifier), diagram and photo. All triode circuit makes for minimum harmonic distortion. Inputs for radio tuner any kind of phono pickup (crystal or G.E. variable reluctance) and either crystal or dynamic mike. Output transformer matches 8 ohm voice coil. Twin electronic bass and treble with range selector switch for either juke box quality with heavy bass response or brilliant symphonic range. The best quality amplifier kit we know how to make. Has a very wide range output and heavy power transformer. Response 18 to 20,000 CPS. 8 tube all triode amplifier kit, complete with tubes. Weight 25 lbs. Net \$37.95.



New 16 Watt Utility \$16.95 Amp Kit

Kit Model TM-16, push-pull wide-range 16 watt amplifier kit. Ideal for a high quality record player, as a P. A. system or recording amplifier. Matched component parts, ready punched chassis. One control fades from phono to mike. Input compensation for G.E. variable reluctance, or crystal pickup, fully shielded. Output matches 8 ohm voice coil, 100 mil power transformer. Complete with tubes, photos and diagram. 2-7G5, 7-7F and rectifier. Variable tone control. Model TM-16. Weight 10 lbs. Net \$16.95.

3-SPEED RECORD PLAYER KIT \$13.95

Complete record player kit to build a 3 speed player. Heavy 3 speed phono motor, universal crystal pickup, all parts and tubes to build a 70L7 type amplifier in an attractive walnut case with grill for speaker cut on top. Kit model D-3378, net price \$13.95.



BUY YOUR WIDE RANGE COAXIAL SPEAKER AT MCGEE

12" COAXIAL PM \$12.95
A \$32.50 retail value, 20 watt, 12 coaxial PM speaker of quality used on radios of the \$300 to \$400 bracket. Hook up like any PM speaker. High pass filter. 10,000 ohm plate to 8 ohm voice coil. Upright, shielded. Matches push-pull 6V6 or 10,000 ohm plate to 8 ohm voice coil. Weight 2 1/2 lbs. Stock No. K9-4241. \$3.95.

15" COAXIAL PM \$17.95

Only \$17.95 buys a full 15" 20 watt coaxial PM speaker, with built-in high pass filter. Hook to any 8 ohm output of radio or amplifier. Response below 20 to above 17,500 CPS. magnet in the woofer. A lucky purchase makes this price possible. Full \$2.02, magnet in the woofer. 5 tweeter. Model P-5-9. Weight 14 lbs. Sale price, \$17.95, or two for \$34.00.

PUSH PULL TRIODE OUTPUT TRANS. \$4.95

High fidelity push-pull 2A3 to 8 ohm voice coil transformer. Wide range response, upright mounting. Use with push-pull 2A3 or 6A3 tubes. 3,000 ohms plate to plate. No. K-94157. Weight 2 1/2 lbs. Net \$4.95. High fidelity push-pull 6V6 output transformer to 8 ohm voice coil. Upright, shielded. Matches push-pull 6V6 or 10,000 ohm plate to 8 ohm voice coil. Weight 2 1/2 lbs. No. K9-4241. \$3.95.

HIGH FREQUENCY TWEETER 750 TO 17,500 CPS. \$10.95

1051 model high frequency speaker, designed for reproduction from 750 to above 17,000 CPS. Use with any high quality cone speaker as a woofer for putting a 2 mid condenser in series with high frequency tweeter. Has removable 8 ohm driver. Bell diameter 4 3/4" length 1 3/4". Model HF-5 speaker, \$10.95 each.

MAHOGANY BAFFLE \$32.95

Mahogany arched height speaker baffle for 12 and 15 inch speakers. 24" high, 27" wide and 16" deep. Specialty wood baffle is needed for 12 or 15" speaker. Beautiful mahogany, furniture quality finish. High quality, non-rattle construction. D. B. F. No. L8-A, weight 49 lbs. Net price \$32.95.

McGee's Super High Fidelity Best Value in U.S.A. OUTPUT TRANS. 20-20,000 CPS. \$7.95

Model A-403 High fidelity output transformer. Why pay \$20 or \$30 for an output, when our A-403 is available at \$6.95? Impedance, 6600 ohms plate to plate, (for PP 6L6 or 6V6) 100% feedback winding, 4-8-15-250 and 500 ohm secondary. Housed in a potted case. Net weight 6 lbs. Recommended for all amplifiers up to 34 watts. Size 3 7/8 x 1 1/2 x 3". Suggested diagram furnished. Shipping weight 8 lbs. Net price A-403 \$7.95.

G.E. RECORD PLAYER ATTACHMENTS SALE PRICE \$6.95

General Elec. 78 RPM Record Players to attach to any radio or amplifier. Heavy duty motor and standard crystal phono pick-up. Volume control and on-off switch. Shipping weight 8 lbs. (No motor included). 78 RPM Model, Stock No. GE-78. \$6.95.

RED HOT PRICES ON 15-INCH PM'S

MODEL 15LS \$24.95
MODEL 15KR \$14.95

15-inch Cinaudagraph speaker with a 12-oz. Alnico V magnet and 8 ohm voice coil. Ideal as a low frequency woofer and general use. Only 100 to sell at this low \$14.95 price. Stock No. 15-KR, ship. wt. 10 lbs. Net, \$14.95.
15-inch Cinaudagraph speaker with 2 1/2-oz. Alnico V magnet and 8 ohm voice coil. This is a super quality heavy duty speaker with a retail list value of \$60.00. It will take 35 watts of audio with ease. Stock No. 15-LS, ship. wt. 12 lbs. Net, \$24.95.

BUY YOUR TELEVISION MATERIAL AT MCGEE

20 MATCHED VIDEO COIL KIT \$7.95

20 matched TV video and sound I.F. coils, intended for use with the RCA circuit. You get 6 peaking coils, 4-25.75 mc picture I.F.'s, 2-21.25 mc sound I.F.'s, discriminator converter coil and 3 filament chokes. Stock No. 20S-XX, weight 3 lbs. Net price, \$7.95. \$9.95 if purchased with a Sarkes-Tarzian TV tuner; all coils identified.

SARKES-TARZIAN TV TUNER \$7.95

Sarkes-Tarzian 13 channel television front end tuner. Factory-wired. Controls switch to a popular today on many TV sets. Also good for building purposes. 6C4 oscillator, 6BH6 IF and 6AG5 mixer. Output of tuner feeds your converter coil. I.F.'s, etc. Stock No. ST-1E, weight 3 lbs. Iccs tubes, Net, \$5.95; with converter coil kit, \$6.95 extra, when ordered with tuner.

BRAND NEW GENERAL INST. TELEVISION FRONT END-TUNERS Sale Price \$7.95

All completely wired, brand new and pre-aligned. 13 channel selector incorporating fixed inductance variable capacitance. Converter output transformer is attached to be coupled direct to separate sound and video I.F.'s. 3 6J6 tubes required. Shift length 2 1/4". Built in fine frequency control. Original factory cost over \$20.00. Weight 4 lbs. Stock No. GI-13P, less tubes. Net price \$7.95.

TV BOOSTERS AND ROTORS

Regency DB-410 television booster. A real engineering unit, small and compact. SUG tuned, using 1-6B6 tube as neutralized push pull amplifier. Dollar for dollar, your best booster buy. 53% extra for 110 volt AC operation. Weight 6 lbs. Net price \$19.10.
Astatic AT-1, "Channel-Chief" booster. Two tuned circuits and two broad circuits on all channels. Dual controls tune sound and picture independently. 8 1/2 x 6 1/2 x 7 1/4". Weight 6 lbs. Net price \$29.10.
Astatic BR-1 television booster. Continuous variable tuning on all channels; simplified single knob tuning; low noise design, uses single 6AK5 tube and selenium rectifier. For either 72 or 300 ohm input and output. Woodgrain metal cabinet. Weight 4 lbs. Net \$19.10.
"Tee-Deemer" antenna rotator will carry any weight antenna with 3/4 to 2" mast. Take winds up to 80 mph. Positive action push-button control. Uses heavy instrument with machine cut gears and electrical stops. Net \$28.95.

T.V. FLYBACKS YOKES, ETC.

52 degree deflection yokes, for 10, 12 and 16" round tubes, \$2.95 each. 70 degree deflection yokes for 14, 16, 17 and 19" rectangular tubes, \$3.49 each.
New small horizontal output (flyback) 14000 volt, \$3.99. Philip 12 or 16" horizontal output (flyback), \$3.49. Vertical output transformer, strap mounting, \$1.95. Vertical oscillator transformer, strap mounting, \$1.95. Single magnet ion trap, 49c. Double magnet ion trap, 89c.

MOLDED TUBE MASKS

Picture tube masks. Molded plastic; decorative and neat looking, to dress up your TV set and for conversion. 16" rectangular, \$4.79. 16" round, \$6.49. 16" rectangular, \$6.19. 17" rectangular, \$7.49. 19" round, \$9.95. 12 1/2" round, \$4.95.

G.E. variable reluctance pickup for 1 and 3 mil needles for playing all records. General Electric ball bearing pickup for 1 and 3 mil needles. UFX-004 with RPX-004 groove variable reluctance cartridge and replaceable 1 mil stylus; furnished with an extra 3 mil G.E. stylus for playing 78 RPM records, at no extra charge. Total value over \$11.00. Stock No. 0042. Net price \$5.95. 3 speed phono motor and turntable, for 3 3/4, 4 1/2 and 78 RPM \$5.95 extra.

McGEE RADIO COMPANY Prices F.O.B. K.C. Send 25% Deposit with Order, Balance Sent G.D.B. With Parcel Post Orders, include Postage **TELEPHONE VICTOR 9045. WRITE FOR FLYER 1422 GRAND AVE., KANSAS CITY, MISSOURI**

USE The HANDBOOKS The EXPERTS use

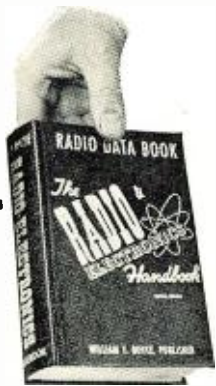

Let The RADIO & ELECTRONICS HANDBOOK Solve Your Problems

This Handbook assists you in every operation in Radio and Electronics. Gives you the fundamentals, complete ground work, understanding of all types of radio and electronic gear and their circuits, including theory of operation. Shows you expert methods of planning, building, installing, operating, testing, adjusting and servicing. The know-how of radio and electronics presented in plain language and simple terms with easy to understand drawings and working diagrams.

You get 900 pages of basic knowledge, methods, and data of radio and electronics completely illustrated with over 1500 drawings and diagrams.

A complete Data Section provides you with handy reference to all radio symbols, codes, tables, standards and laws of radio and electronics.

Written by the Boyce-Roche experts who make electronic manuals for the U. S. Signal Corps. Over 25,000 in use.

Send for yours today. **\$5.95**

The VIDEO HANDBOOK

teaches television and provides complete handbook reference on all phases with full sections on principles of television, receivers, antennas, test equipment, servicing, pattern interpretation, transmitters, show production and more.....**\$5.95**



SPECIAL OFFER

Save one dollar. Send for the RADIO & TELEVISION LIBRARY SET and get The RADIO & ELECTRONICS HANDBOOK and The VIDEO HANDBOOK in handsome slip case for only **\$10.90** (Regularly \$11.90)

10-DAY FREE EXAMINATION COUPON
(Good only while special Library Set offer lasts)

BOYCE-ROCHE BOOK CO.
CALDWELL 22, NEW JERSEY

Send () Radio & Electronics Handbook @ \$5.95
() Video Handbook @ \$5.95
() Library Set @ \$10.90

In ten days I will send you price plus postage or I will return book (\$) postpaid. (Offer good only in U. S.)

Name.....

Address.....

City, Zone, State.....

Employed By.....

Save Postage! We pay postage if you enclose full price (\$) now. Money back on same return privilege.

Technical BOOKS

"RADIO AND TV INDUSTRY RED BOOK" by the Sams Staff. Published by *Howard W. Sams & Co., Inc.*, Indianapolis, Ind. 623 pages. Second edition.

This new edition of the "Industry Red Book" covers AM, FM, and television receivers and radio-phonograph combinations. Like its predecessor volume, the new book provides accurate replacement parts data on thousands of radio and television receiver models. The replacement parts represent the products of nineteen leading manufacturers in the radio field.

This book includes all of the listings found in the First Edition plus data on the majority of the radio and television models which have appeared since September of 1948.

The manual is divided into eight sections each of which covers specific years and thus facilitates the location of the desired diagram. Installation notes covering applications of the first seven sections are given in Section 8.

Since most technicians are now familiar with this handy manual, little further needs to be said except that this is an even bigger and better "Red Book" than the First Edition.

* * *

"ENCYCLOPEDIA ON CATHODE-RAY OSCILLOSCOPES AND THEIR USES" by John F. Rider & Seymour D. Uslan. Published by *John F. Rider Publisher, Inc.*, New York. 974 pages. Price \$9.00.

This book has been well named as it is truly encyclopedic. The authors have performed a prodigious feat in assembling such a vast amount of material on the topic of cathode-ray oscilloscopes and the resulting text should fill a crying need for an authoritative work on this subject.

This volume is divided into twenty-two chapters, three appendices, and a bibliography. The first chapter is a survey of the different types of cathode-ray tubes, the general principles of operation, types of commercially available oscilloscopes and their applications. Other chapters deal with the principles of electrostatic and electromagnetic deflection and focusing, mechanical characteristics, the electron gun, deflection systems in CR tubes, screens, spot displacement, linear time bases, the basic oscilloscope and its modifications, synchronization, phase and frequency measurements, nonlinear time bases, auxiliary equipment, the testing of audio frequency circuits, the visual alignment of AM, FM, and television receivers, waveform observation in television receivers, transmitter tests, electrical measurements in scientific and engineering applications, complex waveform patterns, special purpose cathode-ray tubes, commercial oscilloscopes and related equipment. The appendices cover the characteristics of cathode-ray

tubes, RMA CR tube basing chart, and a discussion of photographing techniques. An extensive bibliography is a particularly valuable addition to the text material.

Engineers, service technicians, students, hams, schools, and technical colleges will all find this book an invaluable source book for the answers to all cathode-ray oscilloscope questions.

* * *

"EFFECTIVE RETAIL ADVERTISING" by Irving Settel. Published by *Fairchild Publications, Inc.*, New York. 202 pages. Price \$4.75.

This handy little volume, written by the author of the "Ad-Viser" series running in this magazine, has been designed to assist the small retailer in making the most of his advertising dollar.

The author has discussed the techniques of advertising thoroughly enough so that even if the retailer is setting up his own advertising without agency assistance he can prepare effective, dynamic copy.

The entire text is thoroughly practical and step-by-step instructions are given on all phases of advertising preparation including newspaper ads, direct mailing pieces, radio program material, and other forms of publicity. Illustrative material is used generously so that the subject matter is crystal clear. The avoidance of "agency lingo" and unfamiliar trade expressions also characterizes this book and makes it particularly suitable for the lay audience.

Radio retailers and service technicians can profit from an understanding of what a carefully thought out advertising program can do for their business and this little book provides the answers.

* * *

"MOVIES FOR TV" by John H. Battison. Published by *The Macmillan Co.*, New York. 369 pages. Price \$4.25.

Since literally hundreds of hours of TV program time each week are devoted to the showing of films, the subject is of more than mere academic interest to station personnel, program directors, and technicians.

This is a practical handbook which clearly explains the various types of movie cameras and allied equipment used in making pictures and the various types of units used for projecting such films. Technical details on lighting effects, lenses, filters, and other accessory equipment, how to make still and moving titles, how to make fades, dissolves, and other special effects are all covered in this handbook.

Considerable space has been devoted to the problem of program planning and production. Specific examples of successful and unsuccessful commercials are given, along with details on comparative costs of different types of productions.

We believe TV stations will find this book a valuable adjunct to their reference libraries.

-30-



HALLICRAFTERS SX-71
Shpg. wt. 33 lbs....Only **\$199⁵⁰**

But buy it for less by applying our liberal trade-in allowance against the purchase price.

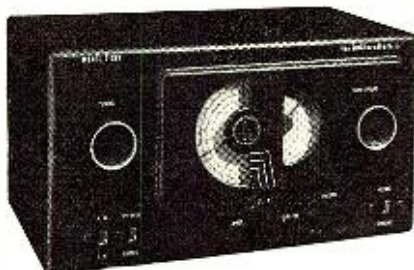

HALLICRAFTERS S-38B
Shpg. wt. 14 lbs.
Price Only **\$49⁵⁰**

Buy it at a substantial saving with a Walter Ashe "Surprise" Trade-in deal. What do you have to trade?

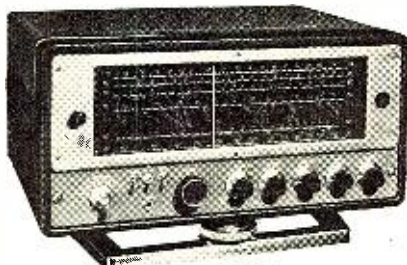

HALLICRAFTERS SX-62
But you can buy it for less when you take advantage of a "Surprise" trade-in allowance.
Shpg. wt. 70 lbs. Only **\$289⁵⁰**



Hallicrafters S-72
Shpg. wt. 16 lbs.
Price Only **\$109⁹⁵**
(less battery)

This all-purpose portable radio is ready to go places! Offers outstanding performance anywhere... anytime. Get it now with a "Surprise" trade-in deal.



For the very Thr-r-iffiest way to buy your NEW...

hallicrafters

COMMUNICATION RECEIVER

Get A *Surprise* Trade-In Allowance on your Used Test and Communication Equipment

Aye, laddie, there's savings aplenty for the bargain-wise buyer who gets a Walter Ashe "Surprise" Trade-In Allowance on used (factory-built) test or communication equipment toward the purchase of a brand new Hallicrafters Receiver. So pick the instrument you want. Tell us what you have to trade. We'll come right back with our money-saving offer. Wire, write, phone or use the handy coupon.

All prices f. o. b. St. Louis

Phone CHestnut 1125

FREE! *New 164 page*

CATALOG

Just off the press!

The "Treasure Chest"

of values. *Don't delay.*

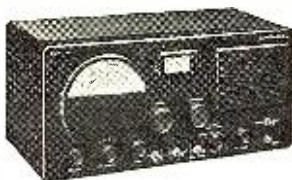

HALLICRAFTERS S-77
For amazing savings apply our "Surprise" Trade-In Allowance against this price.

Shpg. Wt. 32 lbs. Only **\$99⁹⁵**

Walter Ashe
RADIO CO.
THE HOUSE OF "SURPRISE" TRADE-INS
1125 PINE ST. • ST. LOUIS 1, MO.

Walter Ashe Radio Co.
1125 Pine St., St. Louis 1, Mo. RN-51-2

O. K. Walter, Rush "Surprise" Trade-in offer on my _____
(describe used equipment)

for _____
(show make and model No. of new equipment desired)

Rush Free Copy of your new 164 page Catalog.

NAME _____
ADDRESS _____
CITY _____ Zone _____ STATE _____





SUPERIOR'S
new model 770

AN ACCURATE POCKET-SIZE VOLT-OHM MILLIAMMETER

(SENSITIVITY: 1000 OHMS PER VOLT)

FEATURES

- ★ Compact—measures 3 1/8" x 5 7/8" x 2 1/4".
- ★ Uses latest design 2% accurate 1 Mil. D'Arsonval type meter.
- ★ Same zero adjustment holds for both resistance ranges. It is not necessary to readjust when switching from one resistance range to another. This is an important time-saving feature never before included in a V.O.M. in this price range.

★ Housed in round-cornered, molded case.

★ Beautiful black etched panel. Depressed letters filled with permanent white, insures long-life even with constant use.

The Model 770 comes complete with self-contained batteries, test leads and all operating instructions.

SPECIFICATIONS

6 A.C. VOLTAGE RANGES:
0—15/30/150/300/1500/3000 VOLTS

4 D.C. CURRENT RANGES:
0—1.5/15/150 MA. 0—1.5 AMPS.

6 D.C. VOLTAGE RANGES:
0—7.5/15/75/150/750/1500 VOLTS

2 RESISTANCE RANGES:
0—500 OHMS 0—1 MEGOHM

\$14⁹⁰
NET

Superior's new model 670

SUPER-METER

A COMBINATION VOLT-OHM MILLIAMMETER
PLUS CAPACITY REACTANCE INDUCTANCE
AND DECIBEL MEASUREMENTS

SPECIFICATIONS

D.C. VOLTS: 0 to 7.5/15/75/150/750/1,500/7,500 Volts

Megohms

A.C. VOLTS: 0 to 15/30/150/300/1,500/3,000 Volts

CAPACITY: .001 to .2 Mfd. .1 to 4 Mfd. (Quality test for electrolytics)

OUTPUT VOLTS: 0 to 15/30/150/300/1,500/3,000 Volts

REACTANCE: 700 to 27,000 Ohms 13,000 Ohms to 3 Megohms

D.C. CURRENT: 0 to 1.5/15/150 Ma. 0 to 1.5 Amperes

INDUCTANCE: 1.75 to 70 Henries 35 to 8,000 Henries

RESISTANCE: 0 to 500/100,000 Ohms 0 to 10

DECIBELS: -10 to +18 +10 to +38 +30 to +58

ADDED FEATURE: The Model 670 includes a special GOOD-BAD scale for checking the quality of electrolytic condensers at a test potential of 150 volts.

The Model 670 comes housed in a rugged, crackle-finished steel cabinet complete with test leads and operating instructions. Size 5 1/2" x 7 1/2" x 3".

\$28⁴⁰
NET

Superior's
Model CA-12

SIGNAL TRACER

THE WELL KNOWN MODEL CA-12 IS THE ONLY
SIGNAL TRACER IN THE LOW PRICE RANGE
INCLUDING BOTH METER AND SPEAKER!!!

SPECIFICATIONS

★ Comparative Intensity of the signal is read directly on the meter—quality of the signal is heard in the speaker.

★ Simple to Operate—only one connecting cable—no tuning controls.

★ Highly Sensitive—uses an improved vacuum-tube voltmeter circuit.

★ Tube and Resistor Capacity Network are built into the detector probe.

★ Built-In High Gain Amplifier—Alnico V Speaker.

★ Completely Portable—weighs 8 pounds—measures 5 1/2" x 6 1/2" x 9".

Model CA-12 comes complete with all leads and operating instructions.

\$29⁹⁵
NET



-----USE CONVENIENT RUSH ORDER FORM ON OPPOSITE PAGE----->

GENERAL ELECTRONIC DISTRIBUTING CO. DEPT. RN-2, 98 PARK PLACE
NEW YORK 7, N. Y.

Not a kit, but a complete chassis assembled and checked by professional experts

14 reasons why our **RCA type 630** chassis is your best TV buy!

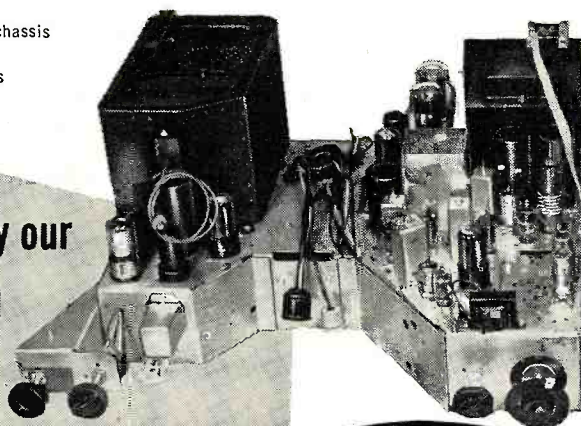

Contact us immediately for low price of this unbelievable buy!

manufactured by

TRAD TELEVISION CORP.

sold by **Tradtel DISTRIBUTORS, INC.**

a division of **TRAD TELEVISION CORP.**

Dept. N 2, 1001 First Avenue Asbury Park, New Jersey
Asbury Park 2-7447. In New York, Worth 4-1197

1. 30 tubes—27 tubes, 3 rectifiers
2. AFC horizontal hold, featuring Syncrolok
3. High voltage doubler circuit
4. Maximum brilliance with any picture size up to 19"
5. Co-channel sound, featuring good limiting for maximum noise immunity
6. Keyed AGC (using extra 6AU6 tubes), minimizes airplane flutter, keeps picture level constant and uniform when switching from channel to channel
7. Overall band width four m. c. for maximum definition and picture crispness
8. Original 630 sync chain for maximum picture stability
9. Molded condensers throughout
10. Full complement of electrolytics as specified in original design
11. Focus coil and yoke assembly with removable plugs for easy servicing
12. Top quality video amplification assuring good contrast range for full "blacks and white"
13. Same chassis used in highest-priced sets and custom installations
14. Complete with mounting hardware ready for installation

Induction Heating

(Continued from page 35)

terior remains relatively cool. This technique is widely used for surface hardening of gears, bearings, cams, etc. Prior to the introduction of electronic heating, surface hardening was accomplished by heating the part in a furnace to a specified temperature and then quenching it in an oil bath. Induction heating now performs the same job in less time and with more uniform results. Since skin effect is a function of frequency, the metal may be hardened to any desired depth by proper choice of frequency. Fig. 1 shows a coil spring being hardened by this method. At the end of a preset length of time, an automatic timing device opens a "trap door" and allows the spring to fall into an oil bath. The springs are heated and quenched at a rate of one every eleven seconds. Furnace and open flame methods could never compete with this speed. The heating coil is usually made of hollow copper tubing. Water is sometimes circulated through the coil as a cooling agent.

Soldering and Brazing

A similar system is used to solder the lids on metal containers such as canned foods and can-type condensers. The lid and a ring of solder are placed in position and the heating coil is then brought down over the container. In a matter of seconds, the lid is sealed with a smooth and uniform coating of solder. The heating is so localized and so rapid that the operation is completed long before the material inside the container can be affected.

Brazing is similarly accomplished. The system is especially advantageous in those cases where the heat must be confined to a small area of a large structure. In brazing aircraft propellers, for instance, the operation is completed before the heat can distort the metal and alter its critical shape.

Tin Reflowing

Tin reflowing is another industrial problem to which induction heating has been applied with gratifying results. A continuous strip of steel passes through a specially shaped heating coil, and a smooth layer of tin, 30 millionths of an inch thick, is flowed on its surface. With this arrangement, the steel strip is tin plated at a rate of 1000 feet per minute. Formerly, the steel was tin plated by hot-dipping. This meant that the material had to be handled as single strips rather than as a continuous roll. The process was slow and the cost high. The old method required 1.5 pounds of tin for every hundred feet of steel. Induction heating reduces this requirement to one-half pound of tin per hundred feet of steel.

R.F. Oscillator

The oscillators used to develop the r.f. energy are so conventional that

NOW BETTER, BRIGHTER PICTURES

insuline
new "BI-CON"
TELEVISION ANTENNA

Single Type and Stacked Array for fringe areas

An engineering triumph by Insuline . . . proved outstanding by actual test. Pre-assembled sections for quick installation.

- * Peak ALL-Channel reception.
- * Suitable for ANY make TV set.
- * Exclusive—separate High Frequency and Low Frequency dipole-reflector elements.
- * Popularly priced.

FREE! New Catalog

Thousands of items including metal goods, radio parts, TV indoor and outdoor antennas and accessories, tools, hardware, etc. Write Dept. RN-2.

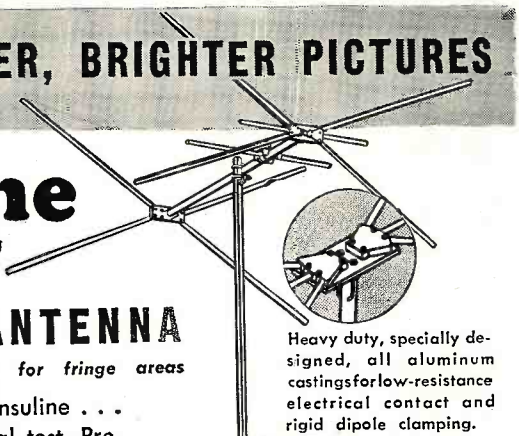

Heavy duty, specially designed, all aluminum castings for low-resistance electrical contact and rigid dipole clamping.

insuline
"meteor"
INDOOR TV ANTENNAS

Installed in a jiffy and quickly adjustable to all channels. Supplied complete with 300 ohm connecting lead and open-end mounting lugs. Not Necessary 300 ohm cable available for all INSULINE TV antennas.

insuline CORPORATION OF AMERICA

INSULINE BUILDING • 36-02 35th AVENUE • LONG ISLAND CITY, N. Y.
West Coast Branch and Warehouse: 1335 South Flower Street, Los Angeles, Calif.
Exclusive Canadian Sales Agents: CANADIAN MARCONI COMPANY, Montreal

their circuits will not be considered here. The Colpitts, Hartley, TGTP and other standard circuits are used. The induction heating unit is like a transmitter without any modulation circuits. Stray radiation must, of course, be held to a minimum to comply with the FCC limitation of 10 microvolts-per-meter at a distance of one mile. An automatic timing circuit is included to permit exact control of the amount of heat developed in the work. Commercially built induction heating units generate powers ranging from 2 kw. to 200 kw., at frequencies ranging from 50 kc. to 3 mc.

A representative induction heating unit is shown in Figs. 2 and 3. This is a 10 kw. generator operating at 450 kc. The oscillator plate coil is visible in the upper portion of the cabinet in Fig. 3. The full-wave, bridge-type rectifier occupies the lower portion of the cabinet. The oscillator tank circuit is tray mounted for ease of removal. Other tank circuits can be substituted for operation at other frequencies.

—50—

A.C. Voltmeter

(Continued from page 57)

writer is a 4-inch round surplus *Western Electric* instrument with a 350 microampere movement. It has a 270° pointer travel, and hence a very long scale. For this reason it was satisfactory to provide a scale in steps of 10, rather than smaller steps. With a smaller meter, more scale ranges may be needed to get good accuracy of reading. In such a case, the input voltage divider could be arranged to give, say a series of ranges like this: .01—.02—.01—.02—1—2—10—20—100.

With the arrangement shown in the photographs, a db. scale was drawn on the meter face in red ink, and is extremely convenient. Fig. 3 gives the relative voltage points on the scale at which to mark decibels, over a 10 to 1 range of voltage.

Imitating the *Ballantine* 300A meter, the scale was calibrated only from 10% to 100% of full-scale, the lower 10% being suppressed because it is read on the next lower range anyway. The mechanical zero adjustment was set so that the meter read correctly at 10% of full scale, and that was that. No further adjustment has even been needed. If a good, big meter is used, this type of scale is extremely convenient.

Power Supply

The power supply is entirely conventional. The "B" voltage is not critical. A resistor is included to drop the filament voltage to about 5.9, for longer tube life and lower hum. Since the total "B" drain is only around 4 milliamperes, the resistance-capacitance filtering used is fully adequate, and the 6X4 rectifier is quite contented with its heater connected to the 5-volt winding of the power transformer. The actual heater voltage on

TRAIN for TELEVISION

FOR BETTER JOBS... FOR BETTER PAY

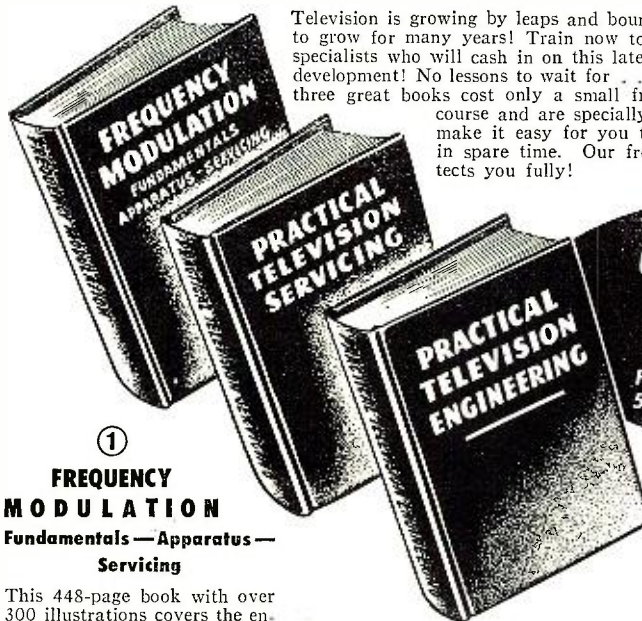

Television is growing by leaps and bounds—and should continue to grow for many years! Train now to be one of the well-paid specialists who will cash in on this latest and greatest electronic development! No lessons to wait for... no wasted time! These three great books cost only a small fraction of the price of a course and are specially designed and written to make it easy for you to learn quickly at home in spare time. Our free examination offer protects you fully!

ONLY \$15.50
FOR ALL 3 BOOKS
5 MONTHS TO PAY

5 Months to Pay!

Learn At Home... Learn FAST... Learn Right with the RINEHART TV LIBRARY

These 3 great books offer you a really outstanding, AMAZINGLY LOW-PRICED OPPORTUNITY to get ahead in the greatest, fastest-growing electronics field of all—TELEVISION!

Presupposing a knowledge of basic radio, **FREQUENCY MODULATION** (Book No. 1) provides up-to-the-minute training in the circuit system that has made modern television possible. **PRACTICAL TELEVISION SERVICING** (Book No. 2) trains you to install and service television receivers. Each part of the work is clearly explained step by step. Book No. 3 (**PRACTICAL TELEVISION ENGINEERING**) offers invaluable advanced training in the form of an intensely practical background in the engineering, design and broadcasting end of the business.

Read singly, each book is an authentic, easy-to-understand guide to an essential phase of modern TV. Add all 3 together and you have a specialized training that can help fit you for a good job, better pay or even a business of your own in this vast industry!

SAVE \$1... PAY AS YOU LEA

Use the attached mail order coupon. Read any or all of these outstanding books for 10 days AT OUR RISK! Buy them singly if you like. Better yet, why not save \$1 by ordering the complete set of 3? The regular price

of the 3 books is \$16.50. On our special Rinehart TV Library offer you get them for only \$15.50—with 5 months to pay. Our 10-day free examination offer protects you fully. YOU CAN'T LOSE!

10-DAY FREE EXAMINATION

Dept. RN-21, RINEHART BOOKS, INC., Technical Division
232 Madison Avenue, New York 16, N. Y.

TO ORDER BOOKS SINGLY

Send me the following books on your 10-day FREE EXAMINATION OFFER. In 10 days, I will either send you the price indicated for each book or return the books to you postpaid.

- FREQUENCY MODULATION** \$5 (\$5.50 outside U.S.A.) **PRACTICAL TELEVISION SERVICING** \$4 (\$4.50 outside U.S.A.)
 PRACTICAL TELEVISION ENGINEERING \$7.50 (\$8.00 outside U.S.A.)

SAVE \$1—ORDER THE COMPLETE SET!

Send me Rinehart's TV Library—all three of the above books—on your 10-day FREE EXAMINATION OFFER. If the books are not what I want, I will return them postpaid in 10 days. If I decide to keep them, I will send you \$3.50 as my first installment and will also send you \$3 a month for the next four months until the special price of \$15.50 is paid.

Name
Address
City, Zone, State.....
Your Employer's Name and Address.....

① FREQUENCY MODULATION Fundamentals—Apparatus—Servicing

This 448-page book with over 300 illustrations covers the entire field of Frequency Modulation—the system on which modern Television as well as many other important developments are based. Basic FM theory, circuits, transmitters, receivers and mobile FM are clearly explained. Other subjects include FM circuit peculiarities; tuning indicators; antennas; test units; alignment; general servicing procedure, etc. Price \$5.00 separately.

② PRACTICAL TELEVISION SERVICING

Here is a 334-page complete guide to installing and repairing television receivers. Includes dozens of case histories, full explanations of wiring, repair and component replacement techniques; antennas, testing tips, improving picture linearity, fringe area reception and other vital TV service data. Tells what to do—how to do it. Price \$4.00 separately.

③ PRACTICAL TELEVISION ENGINEERING

This 700-page book with its 385 illustrations can help pave your way to a good-paying job in TV manufacturing, laboratory or broadcast studio work! Starting with picture transmission fundamentals, it guides you through all phases of TV equipment and station engineering. Helpful data includes a full explanation of the cathode ray tube; TV camera chains; telecasting techniques; studio problems; lenses; lighting; oscilloscopes; camera tubes; synchronizing generators; video amplifiers; regulated power supplies and dozens of others. Price \$7.50 separately.

HARVEY

For Variety... Dependability
...and Value!

WILLIAMSON HR-15 AMPLIFIER KIT

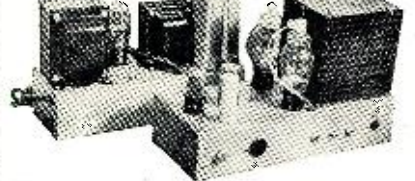

The famous Williamson HR-15 amplifier circuit... now available with the original Partridge transformers built to Williamson's specifications. Build this kit in 3 hours or less, and enjoy sound of a quality you never heard before. The HR-15 is a 2-Chassis power amplifier for use with tuners or other front ends having own volume and tone controls. All American triodes, 2-6SN76GT, 2-807, or 6BG6G in PP output, 5V4G rectifier. Response $\pm .5$ db, 10-100,000 cycles. Output impedances 1.7 to 109 ohms in 8 steps. Absolute gain 70.8 db. 20 db. of feedback around 4 stages and the output transformers. Kit is Complete with Tubes, Punched Chassis, Pre-wired Resistor Board, Sockets, Genuine Partridge Output Transformer, and All Necessary Parts...\$75.00



TECHMASTER

America's Finest
TV Chassis

Made by Techmaster Products Co. 630 circuit RCA licensed. For all size Kinescopes, Full-rated high voltage

round or rectangular. Improved AGC... advanced turret 12-channel tuner... molded tubular condensers... perfect linearity... four tube split sound circuit... full 4 Mc bandwidth... hi-fidelity FM TV sound.
1630 Chassis—Turret Tuner\$189.50
1930 Chassis—Turret Tuner\$189.50
1930T Chassis—With Push-Pull Audio...\$199.50
1930D Chassis—With Push-Pull Audio...\$199.50

NEW AC-DC KIT

Now available for the first time! Simple—Complete with step-by-step instructions. Can be assembled within 8 hours. Complete with all tubes, but less Kine\$ 89.50
Chassis Prices Are Less Kine

- 16AP4\$ 44.00
 - 19AP4\$ 68.25
 - 17AP4 (Rectangular Tube)\$ 44.00
- (All Tubes Are Black Face)

KOLLSMAN Remote



Reading THERMOMETER

There are thousands of applications for this BRAND NEW (Aircraft Surplus) unit. Complete with 12 ft. of tubing in woven copper sleeve. Black Face, Illuminated Dial. Temperature Range from -40° to $+120^{\circ}$ F. At a fraction of initial cost\$ 4.95

RCA 201-EI (KRK-2) FRONT END TV TUNER — as used in the RCA 630 chassis. Brand new, and complete with tubes\$ 18.50

20" COLOR WHEEL for CBS Type Color Broadcast Reception, \$22.50. Color Conversion Manual 50c

G.E. #77J1—High Voltage Transformer, 14,000 volts output. TODD #70W85-70" Yoke. Specially Priced. Both for only\$ 10.95

Prices Subject To Change Without Notice

Telephone: LUxemburg 2-1500

HARVEY

RADIO COMPANY INC

103 West 43rd St., New York 18, N. Y.

the 6x4 is about 5.5 volts, due to the light load.

The only adjustment to make, once the wiring is complete, is the value of the feedback resistor R_7 . Merely connect the input posts in parallel with a trustworthy a.c. voltmeter as a standard, and apply a.c. thereto. Then select and/or pad the resistance at R_7 until the v.t.v.m. reads the same as the standard. If the standard is a rectifier-type meter, any test frequency up to 2000 cycles should be OK. If an iron-vane type standard is used, the test frequency should not be over about 100 cycles. If calibration is done with 60 cycle a.c., it is a good plan to take the average of two readings—one with the v.t.v.m. terminals reversed. This is to average out an error of 1 per-cent or so which may be caused by the phase relation of the residual hum in the v.t.v.m. to the power frequency.

If the value of R_7 comes out more than 30 per-cent off of 10 ohms, something is probably wrong, and the circuit constants and voltages need checking.

Provided the input attenuator is wired correctly with accurate resistors, calibration at only voltage level is all that is needed; the rest will take care of itself.

The circuit has very high inherent linearity. Small deviations from linearity are probably due to the d.c. meter itself. Large deviations, such as crowding at the top of the scale, are probably caused by insufficient d.c. plate current in tube V_2 , or to defective 1N34's. Below 10 per-cent of full scale, a little tapering-off may be expected. This is inherent in any rectifier-type meter, but the tail end of the scale should not have to be used anyway. Proper procedure is to calibrate at 10 per-cent and at full scale, and let the zero go hang.

Physical Layout

There is nothing fussy about the physical layout. One should not go out of his way, of course, to introduce long leads and stray coupling in high-impedance signal circuits. Still, this circuit is considerably more tolerant of such matters than most audio amplifiers.

The cabinet is a standard 5" x 6" x 9" utility box. A special chassis was bent out of sheet aluminum and supported by homemade brackets about 3 3/4" below the panel and parallel to it. The 6AU6 first stage is approximately underneath the input binding posts, and the 6AT6 below the range switch. Power supply components are located on the middle and upper portion of the chassis. This is about the

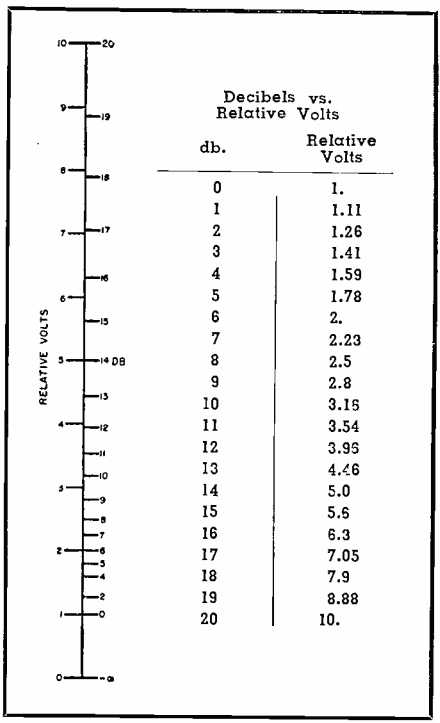

Fig. 3. Graphic and tabular representation of decibels versus relative voltages.

most compact layout that can be realized with standard parts, and the cabinet used has the advantage of taking up very little bench space. A sloping-front cabinet could be used just as well.

Oscilloscope Jack

The phone jack J_1 in the diagram of Fig. 2 is for plugging in a scope, to check the waveform of the voltage under measurement. It is very useful when distortion measurements are being made, and the use of a scope is advisable as an auxiliary to most audio measurements anyway, in order to see that one is measuring the real signal, and not hum or noise. The jack is convenient because changing ranges on the v.t.v.m. also changes the effective gain to the scope, and it is not necessary to twiddle the scope gain control. The meter reading is not disturbed by connection of the usual 0.5 megohm oscilloscope input to this jack. Phones can be plugged in here too, but headphones will shunt the meter circuit appreciably and make the reading erroneously low. The output level is ample for a scope, but not too high for phones, being of the order of 0.2 to 2 volts.

REFERENCE

Ballantine, Stuart; "Vacuum Tube Voltmeter Using Feedback," *Electronics*, September 1938.

-30-

Fig. 4. Graph of the frequency response of the electronic audio voltmeter.

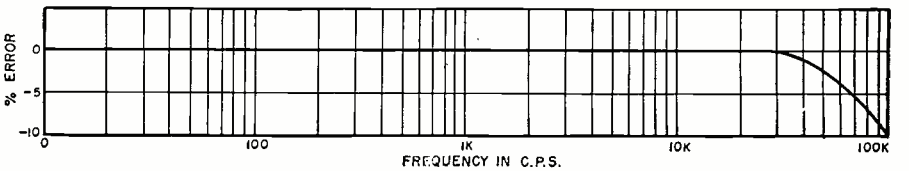

- TRANSMITTING
- RECEIVING
- INDUSTRIAL
- SPECIAL PURPOSE

TUBES

*Guaranteed
by
WELLS*

Many Types Are Now Scarce At These Low Prices. Check your requirements at once for your own protection. All tubes are standard brand, new in original cartons, and guaranteed by Wells. Order directly from this ad or through your local Parts Jobber.

WIDE SELECTION OF ELECTRONIC COMPONENTS AT

WELLS

Tubes • Resistors • Condensers • Wire and Cable • Volume Controls • Co-ax Connectors • Relays • Rectifiers • Transformers • Chokes • Micro Switches • Toggles • Antennas • Accessories • Electronic Assemblies • Dial Light Assemblies

TYPE	PRICE EACH	TYPE	PRICE EACH	TYPE	PRICE EACH	TYPE	PRICE EACH	TYPE	PRICE EACH	TYPE	PRICE EACH
1ASGT.....	\$ 0.85	3D6/1299.....	\$ 0.30	7Y4.....	\$ 0.80	CRP-72.....	\$ 0.85	446A.....	\$ 1.15	841.....	\$ 0.70
1B1.....	1.00	3D21A.....	1.65	9-3 Ballast.....	.35	CYN-72.....	1.62	GL-451.....	1.90	843.....	.35
1B4P.....	1.90	3DP1.....	3.75	10 Acorn.....	.55	RKR-72.....	.90	GL-471A.....	2.75	849.....	29.75
1B27.....	2.90	3FP7.....	1.95	10 Spec. VT-25-A.....	.53	RKR-73.....	1.23	507AX.....	9.90	851.....	33.00
1B22.....	7.75	3FP7A.....	2.25	REL-10.....	.80	77.....	.80	527.....	12.85	860.....	6.00
1B32/532A.....	1.85	3GP1.....	4.95	10T1 Ballast.....	.50	VR-78 British.....	.65	WL-530.....	12.20	864.....	0.35
1B42.....	6.75	3H-1-7 Ballast.....	.45	10Y (VT-25).....	.45	FG-81-A.....	3.95	WL-531.....	1.75	865.....	1.40
1B48.....	9.90	3HP7.....	2.80	12AN7GT.....	1.25	83V.....	1.20	WL-532.....	1.85	866A.....	1.35
EL-C1A.....	3.95	3Q4.....	1.25	12C8.....	1.25	89.....	.30	532A.....	1.85	869.....	19.75
CE-1C/918.....	1.45	4B24/CE224.....	3.25	12F5GT.....	.75	89Y.....	.35	559.....	2.10	869B.....	23.35
EL-1C.....	4.85	4B25/CE221.....	7.85	12J7GT.....	.82	100R.....	.85	KU-610.....	6.90	872A.....	2.45
CE-1-D/918.....	1.45	4B26/CE226.....	1.90	12K8.....	.80	100TH.....	11.50	HY-615.....	.35	876.....	.35
1D8.....	1.75	4B27/CE201A.....	2.40	12K8Y.....	.85	101/837.....	1.35	WL-632A.....	8.75	878.....	1.00
1E7GT.....	1.45	4B28/CE225.....	2.40	12KSF7.....	.70	101/837.....	14.95	700B.....	17.95	879/2X2.....	.05
1G6.....	1.30	4B35/CE212B.....	7.65	12XS25 (2 Amp Tungar).....	1.45	104.....	9.75	700C.....	17.95	884.....	1.50
1G6GT.....	1.30	5AP1.....	3.75	13-4 Ballast.....	.35	114B.....	.45	700D.....	17.95	918/CE-1C.....	1.45
1H4C.....	.80	EL-C5B.....	4.25	R-15-A/CE235 (15 Amp Argon Rectifier).....	6.00	114B.....	1.20	701A.....	2.90	920/CE23D.....	2.40
1J6G.....	1.20	5BP1.....	2.95	15R.....	.55	VT-127 British.....	.35	702A.....	2.60	923/CE23D.....	1.10
1LH4.....	1.25	5BP4.....	3.95	FG-17/CE-309.....	3.90	YR-127A.....	2.95	703A.....	2.35	927/CE25D.....	1.25
1N21 (Xtal Diode).....	1.20	5CP1.....	2.45	19.....	1.20	YR-150.....	.85	704A.....	1.00	930/CE30C.....	1.20
1N21A (Xtal Diode).....	1.40	5D21.....	18.80	20-4 Ballast.....	.45	YR-158.....	.95	705A.....	.85	931A.....	3.05
1N22 (Xtal Diode).....	1.40	5FP7.....	1.75	CE-20D/927.....	1.25	FG-172.....	19.25	706AY.....	17.50	954.....	.30
1N23 (Xtal Diode).....	1.30	5GP1.....	2.95	CE-21-D/920.....	2.40	CE-201A/4B27.....	2.40	706CY.....	18.90	955.....	.45
1N23A (Xtal Diode).....	2.25	5H-4 Ballast.....	.45	REL-21.....	2.10	205B.....	1.35	707A.....	12.95	957.....	.25
1N27 (Xtal Diode).....	3.25	B-5H-4 Ballast.....	.45	21-2 Ballast.....	.45	211.....	4.45	707B.....	14.45	958A.....	.50
1N29 (Xtal Diode).....	3.25	5HP4.....	4.75	CE-23-D/923.....	1.10	215A.....	19	708A.....	3.45	991/NE-16.....	2.00
1Q5GT.....	1.25	5J29.....	12.85	CE-21-D/920.....	2.40	215A.....	7.85	709A.....	3.95	1005.....	.30
1R4/1294.....	.95	5MP1.....	3.75	CE-22D/924.....	1.20	CE-221.....	1.75	710A.....	.80	CK1059.....	3.00
1T4.....	1.40	5NP1.....	3.75	CE-23-D/923.....	1.10	221A.....	3.25	713A.....	.75	CK1090.....	2.00
2B7.....	1.20	6-4 Ballast.....	.35	23D4 Ballast.....	.45	CE-224.....	2.40	714AY.....	3.25	1148.....	.25
2B22/GL-559.....	.70	6-7 Ballast.....	.35	HK24/3C34.....	.45	CE-225.....	2.40	715A.....	6.25	1201.....	.45
2C21.....	.75	6A3.....	1.60	24G/3C24.....	.45	CE-226.....	2.45	715B.....	6.55	1203A.....	.65
2C22/7193.....	.55	6A6.....	1.21	CE-25D/927.....	1.25	227A.....	1.20	715C.....	20.50	1204.....	.25
2C26.....	.28	6AF6G.....	1.30	25T/3C34.....	.40	231D.....	1.20	717A.....	.90	1209.....	.30
2C26A.....	.30	6B7.....	1.50	30.....	.40	RX-233A.....	1.95	721A.....	2.20	1290A.....	.60
2C34/RK34.....	.40	6B8.....	1.30	30/VT-67.....	.58	CE-235.....	6.00	724A.....	9.50	1296A.....	.70
2C40.....	5.25	6B8G.....	1.20	CE-30-C/930.....	1.20	268A.....	2.95	724B.....	3.85	1616.....	.35
2C44.....	1.25	6C8G.....	1.30	34.....	1.00	274A.....	5.40	725A.....	2.50	1619.....	1.35
2J21.....	7.95	6G12 Ballast.....	.45	35/51.....	.90	274B.....	2.65	726A.....	6.45	1624.....	.95
2J21A.....	7.95	6H16 Ballast.....	.45	37.....	.90	282B.....	7.95	730A.....	4.50	1625.....	.35
2J32.....	12.85	6J5.....	1.30	38.....	.40	287A/722A.....	9.50	801.....	8.50	1626.....	.35
2J33.....	18.75	6J8G.....	1.45	RK-34/2C34.....	.40	293A.....	2.95	801A.....	.40	1629.....	.35
2J34.....	17.50	6K7.....	1.50	35/51.....	.90	304TH.....	12.95	801B.....	.65	1630.....	2.25
2J36.....	95.00	6K7G.....	1.30	37.....	.75	307A.....	6.85	803.....	3.00	1638.....	.60
2J37.....	12.75	6R7G.....	1.10	38.....	.75	CE-309.....	3.90	804.....	6.40	1641.....	.80
2J38.....	9.85	6R7GT.....	1.20	39/44.....	.75	316A.....	.85	805.....	5.75	1642.....	.55
2V3G.....	.60	6U7G.....	.65	41.....	.75	327A.....	2.50	808.....	1.65	1960.....	.75
2X2/879.....	.65	7-7-11 Ballast.....	.35	45 Spec. 7 Volt Fil.....	.30	331A.....	12.85	814.....	2.20	2051.....	.75
3-16 Ballast.....	.45	7A4.....	.65	46.....	.90	W1-332 (X-Ray).....	90.00	815.....	2.20	7193.....	.55
3A4.....	.35	7B8.....	.80	EF-50.....	.65	356B.....	4.95	826.....	.75	8011.....	1.95
3B7/1291.....	.25	7C4/1203A.....	.35	56.....	.75	368AS/703A.....	3.75	830B.....	3.00	8012.....	2.25
3B22.....	1.95	7E6.....	.75	59.....	1.75	371A.....	.59	832.....	5.50	8013.....	1.25
3BP1.....	3.45	7F7.....	1.10	RK-60/1641.....	.80	371B.....	.59	834.....	5.75	8020.....	1.50
3C21.....	4.85	7H7.....	1.80	VT-62 British.....	1.00	388A.....	1.60	835/38111A.....	1.00	8025.....	3.65
3C24/24G.....	.45	7L7.....	1.33	VR-65 British.....	1.00	HX-408-U.....	.30	836.....	1.45	9003.....	.95
3CP1-S1.....	1.95	7N7.....	1.50	CEQ-72.....	1.45	417A.....	8.90	837.....	1.35	9004.....	.50
								838.....	2.30	9006.....	.50
										3811A/835.....	1.00

Many Other Types in Stock. Send Us Your Requirements. Order From Your Parts Jobber or Directly From Wells.

**WRITE FOR NEW
WELLS CATALOG**

World's Largest Display of Radio and Electronic Components. 9000 Square Feet of Display All on One Floor.



320 N. LA SALLE ST. DEPT. R, CHICAGO 10, ILL.

February, 1951

SAVE \$ ON SUN SURPLUS AND STANDARD SPECIALS!

CRYSTALS FOR S.S.B. EXCITER As in Nov. '50 QST—Lo. Freq.

Also many other uses—in FT 241-A Holder— $\frac{1}{2}$ " Pin SPC. Marked in 54th OR 72nd Harmonic MC Freq. Listed Below by Fundamental Frequency. Fractions Omitted.

412 429 446 485 497	390 401	372 381	450 530
413 431 447 487 503	391 402	374 383	452 531
414 433 448 488 504	392 403	375 384	461 533
415 434 462 490 506	393 404	376 386	485 536
416 435 468 491 507	394 405	377 387	526 537
418 436 472 492 509	395 408	379 388	529 538
419 437 473 493 511	396 409	380	
420 438 474 494 516	397 411		
422 440 475 495 518	400		
423 441 477 496 519			
424 442 479			
425 443 481	EACH	EACH	
426 444 483	49¢	79¢	
427 445 484			

Special—200 KC XTALS without Holders.
 $2\frac{1}{2}$ " x $2\frac{3}{32}$ "
69¢ EA. 3 for \$2

HAM CRYSTALS

FT-243 Holders—$\frac{1}{2}$" SPC. Fractions Omitted	
4190 6106 6873 7840	3735 5775 5906 6406 6573 7340 7573
5030 6140 6906 7873	5305 5806 5925 6425 6606 7373 7640
5485 6173 6973 7906	5677 5825 5940 6440 6640 7406 7573
6006 6206 7740 7973	5706 5840 5973 6450 6673 7440 7706
6040 6773 7773 8273	5740 5850 5975 6473 6705 7473 7806
6073 6840 7806 8306	5750 5873 6273 6475 6740 7506 8340
	5760 5875 6340 6506 6806 7540
	5773 5900 6373 6540 7306

49¢ EACH 10 for \$4.50 **99¢ EACH 10 for \$9.00**

SCR-522 XTALS	BC-610 XTALS	2 Banana Plugs	$\frac{3}{4}$ " SPC.
5910 6610 7580	2045 2220 2360	2557	3520
6370 6750 7810	2105 2258 2390	3202	3550
6450 7480 7930	2125 2260 2415	3215	3570
6470	2145 2282 2435	3237	3580
6407.9	2155 2300 2442	3250	3945
6522.9	2305 2532	3322	3955
6547.9	2320 2545	3510	3995

EACH \$1.29

Payments must accompany order. Enclose 20c for Postage & Handling. Crystal shipped packed in cloth bags. All Shipments Guaranteed.

Bendix 100 Watt Transmitter



4 separate ECO's with tubes, 3-807, 4-12SK7. Complete instructions for converting to 10, 20, 40, and 80 meters supplied. Only a few left at this low price!

\$29.95 LIKE NEW | \$19.95 USED

MODERNIZE YOUR OLD PHONO WITH A NEW 3-SPEED AUTOMATIC RECORD CHANGER

WEBSTER—100-1 , with turnover crystal cartridge.....	\$37.24
100-27, less cartridges.....	\$34.50
—Base Dimensions 12" x 12 1/2"	
356-1 , with turnover crystal cartridge.....	\$41.36
356-27 , less cartridges.....	\$37.83
—Base, Dimensions 14 1/4" x 14 1/4"	
GARRARD—RC-80 , less cartridges.....	\$39.00
—Base Dimensions 13 1/4" x 15 1/2"	
Turnover crystal cartridge in head for above... \$5.10	
MAGNETIC CARTRIDGES FOR USE WITH WEBSTER	
100-27, 356-27, and GARRARD RC-80.	
General Electric Variable Reluctance.	
RPX-040 .003 stylus.....	\$5.85
RPX-041 .001 stylus.....	\$5.85
RPX-050 Triple Play, less stylus.....	\$8.20
RPJ-010 .001 & .003 stylus for RPX-050.....	\$3.51
Picking Cartridges for use with Webster and Garrard Changers.	
S120M Sapphire .003.....	\$9.90
S140S Sapphire .001.....	\$15.00
D120M Diamond .003.....	\$24.90
D140S Diamond .001.....	\$36.00
Picking Adapter Clip, for use in Webster Changers.....	
	\$1.15

TERMS: All items F. O. B., Washington, D. C. All orders \$30.00 or less, cash with order. Above \$30.00, 25 per cent with order, balance C.O.D. Foreign orders cash with orders, plus exchange rate.

SUN RADIO
 OF WASHINGTON, D. C.
 938 F STREET, N. W. WASH. 4. D. C.

Cartridge Replacement

(Continued from page 51)

It is this lack of understanding or appreciation of the important role the phono-cartridge plays in determining the ability of the hobbyist's record player to bring him all the enjoyment he demands that has handicapped the technician in effectively exploiting the profitable cartridge market. In the past, manufacturers and distributors have given the technician only limited assistance in telling the public about phono-cartridges. However, under the stimulus of rapidly increasing public interest in home audio systems, cartridges are coming more and more into the spotlight of public attention. Manufacturers and distributors are becoming aware that audio fans want to know more about all the factors in the reproduction of sound. Radio and television journals and even a few national "mass circulation" magazines, alert to trends in the electronic market, are already devoting additional space to explanation of phono developments and installation.

The introduction of microgroove records and the profound effect they have had on phono-cartridge design has given the technician an important and compelling sales message to tell his customers. Actually, in performance and operation, the new, modern cartridges are less like their predecessors than the modern automobile resembles the "horseless carriage" of another era. It is important to note that the new improvements were not limited to microgroove cartridges but were applied to 78 r.p.m. cartridges as well. Unfortunately, the average record fan is not aware of the thorough overhauling of phono-pickup techniques nor what it means to him in superior sound reproduction, longer life from his records, and less record and needle wear. But the music enthusiast who treasures his library of records, often accumulated over a period of years and consequently including many 78 r.p.m. recordings, is particularly receptive to a cartridge guaranteed to bring him more brilliant reproduction from his records while extending their life many times over. *And this is just what the technician has to offer him.*

Ten million record players still use old-fashioned, heavy, stiff cartridges. Permitting the record fan to continue using these cartridges, which actually detract from his ability to fully enjoy his record player, is a disservice to him. The average list price of a modern cartridge replacement is \$7.00. Scarcely has the technician had so much value to sell at so little cost. *In no other component of a sound system, regardless of cost, have more significant improvements been made in recent years than in phono cartridges.* The features that guarantee less record wear and better reproduction—light weight, high compliance, and reduced tracking pressures—are inherent in

OUTSTANDING - TV - VALUES

MODEL #300
 Folded dipole complete with reflector and d high frequency adapter. Covers 13 channels. All aluminum construction. Less mast. Shpg. wt. 7 lbs. **PRICE..... \$4.95**

MODEL #200-D
 Stacked array. Consists of 2 complete conicals and connecting bars. Very rigid construction. Covers all 13 channels. Matches 300 Ohm or 72 Ohm. Center impedance 150 Ohm. Ideal for low signal areas. An outstanding buy. Shpg. wt. 12 lbs. **SENSATIONAL \$9.75** OFFER at, less mast.

MODEL #200-S
 Single array. Same construction as above. Shpg. wt. 7 lbs. **PRICE, less mast..... \$4.50**

MODEL #500
 All-band folded dipole antenna. Ideal for rotator use. Maximum gain on any channel. All aluminum construction. Less mast. Shpg. wt. 8 lbs. **Price..... \$4.95**

MODEL #Y-100
 5 element Yagi Hi-Gain beam designed specifically for fringe area use. All aluminum construction. Cut to specific channels. Shpg. wt. 4 lbs. Channel #7, \$3.80; Channel #9, \$5.20; Channel #11, \$4.60; and Channel #13, \$4.00. The prices are less mast. "Y" type antenna. **Price \$4.25**

ANTENNA ACCESSORIES

CM-100 Chimney Mount.....	\$ 1.50
WM-104 Wall Mount.....	1.25
WM-107 Wall Mount.....	1.25
U-100 "Universal" Ant. Mtg. Bkt. Offset to U-200 Same as U-100 but Offset to 12".....	3.95
Price.....	6.95
3-ft. 1 1/2" OD Steel Mast. Plated.....	90
3-ft. 1 1/2" OD Alum. Mast.....	1.25
3 1/2" 300-ohm stand-off insulators fit coax cable). Per 100, \$3.00; per 500, \$12.00; per 1000, 20.00	
Best Quality 300-ohm twin lead—Send for prices.	
High Quality 72-ohm Coax Cable—Send for prices.	
Folded Dipole Hi-Frequency Adapters.....	1.50
Conical Hi-Frequency Adapters.....	1.50
Straight Dipole Hi-Frequency Adapters.....	1.50

TERMS: All shipments F.O.B. Newark, New Jersey. 25% deposit with orders, balance C.O.D. Minimum order \$2.00. include ample postage.

Prices Subject to Change Without Notice
EAST COAST ELECTRONICS
 40 St. Francis Street Newark 5, New Jersey

MOSLEY LOW-LOSS TV ACCESSORIES

Provide Better TV Pictures Through More Efficient Installation!



F-10 Socket-Switch

Provides easy, instant change-over to any one of three antennas plus convenient plug-in connection of set to lead-in. Features constant impedance 3 position switch. Made of low loss acrylic plastic with non-ferrous metal parts. Recesses in standard electrical outlet box. Takes standard double receptacle plate.

301 Transmission Line Plug

For efficient connection of 300 ohm transmission line from receiver to MOSLEY Socket-Switch.

A Single Source of Supply

MOSLEY ELECTRONICS manufactures the only complete line of antenna transmission line connectors, plugs, sockets and other accessories. MOSLEY products are solderless and designed for maximum electrical efficiency. Install MOSLEY accessories with complete confidence. Write for new Catalog No. 50-51.

MOSLEY ELECTRONICS
 WOFQY 2125 Lackland, Overland, Missouri

the design of modern cartridges and they can be demonstrated dramatically and convincingly.

Modern cartridges weigh only one-fifth as much as old style cartridges. Let the record fan compare the weight of the old cartridge in his record player with that of a modern replacement. When he understands that the weight of the cartridge is a factor in determining the force with which the needle presses against the record groove, he'll know why the modern cartridge will not wear the record or needle as rapidly.

The compliance of a cartridge is one of the most important determinants of record and needle life and quality of reproduction. Compliance is the lightness of needle movement on the record. Just what this means can be demonstrated by letting the record fan move the needle of the old cartridge with his finger and then test the modern replacement cartridge in the same manner. The flexibility of the modern needle system is instantly apparent. The stiff, non-compliant needle system of old fashioned cartridges is not free to follow displacements of record grooves and much of the sound pressed into the record is not reproduced.

But the stiffness of the needle system has a second, more serious effect. The oppressive force with which the needle tip is forced against the groove walls rapidly wears them down, eliminating various tones so that reproduction merely approximates the original.

The hobbyist will easily understand why the flexibility or compliance of modern cartridges means less needle pressure against the record groove walls and greater ability to follow displacements of the grooves. He will know why his records will last longer and sound better when played by a modern pickup.

Old style cartridges require a force of 28 to 56 grams (1 to 2 ounces) to keep them from mis-tracking. Modern cartridges track perfectly at 5 to 12 grams pressure. By reducing the force with which the needle pushes against the record groove to a whisker touch, modern cartridges add months and months of usefulness to the life of records and needles.

These benefits were made possible by greatly improved phono-cartridge harness or drive systems. The high voltage output-to-compliance ratios offered by these drive systems marks their innate superiority over previous methods in which compliance and tracking pressure were virtually ignored as factors in cartridge design. An example of the radically new approach made to the problem of driving a piezoelectric generating element by a needle is the "Torque Drive" system of *Electro-Voice* cartridges. By this system, needle movement is transmitted to the generating element through a rotary motion. "Torque Drive" acts as a mechanical transformer and provides the right "gear ratio" between the record groove and crystal. It multiplies needle force to

CHICAGO

the preferred transformers

for every circuit application!

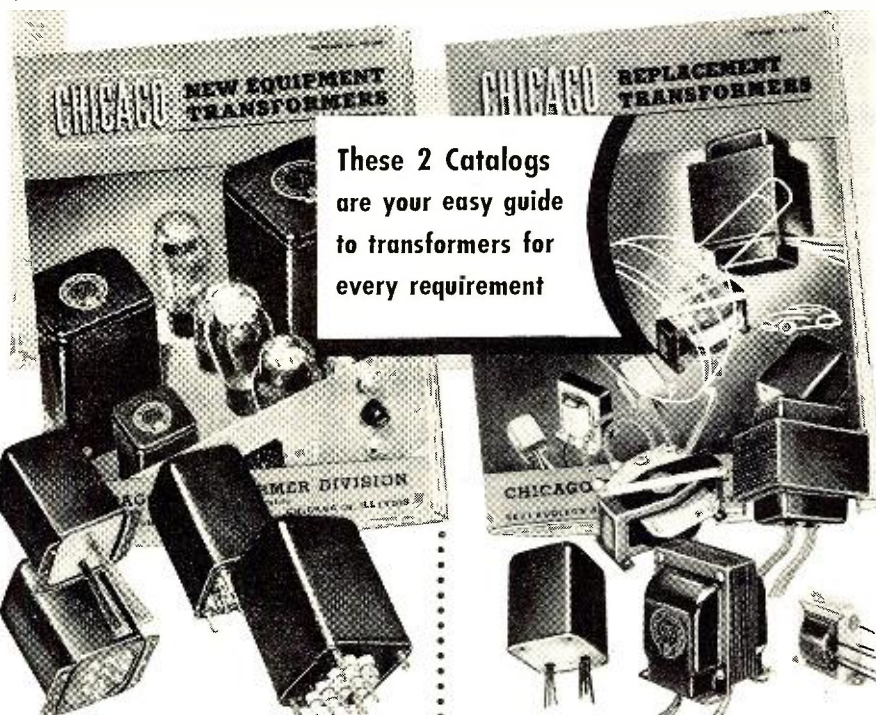

These 2 Catalogs are your easy guide to transformers for every requirement

New Equipment Line

Famous Sealed-in-Steel Units

- POWER TRANSFORMERS
- BIAS TRANSFORMERS
- FILAMENT TRANSFORMERS
- FILTER REACTORS
- AUDIO TRANSFORMERS
In 3 Ranges: Full Frequency, Public Address & Communications
- JAN-T-27 TRANSFORMERS
- HIGH-Q CHOKES
- SPLATTER CHOKES
- LOW PASS FILTERS
- STEPDOWN & ISOLATION UNITS

Replacement Line

Preferred by Service Technicians

- TELEVISION TRANSFORMERS
POWER, FILTER REACTOR, VERTICAL BLOCKING, HORIZONTAL DEFLECTION OUTPUT, HIGH VOLTAGE, VERTICAL SCANNING OUTPUT
- RADIO REPLACEMENTS
POWER, FILAMENT, AUDIO, DRIVER, VIBRATOR

ASK FOR **CHICAGO**—THEY'RE BETTER REPLACEMENTS—YET THEY COST NO MORE!

FREE SEND TODAY FOR THESE 2 IMPORTANT CATALOGS! SEE YOUR DISTRIBUTOR FOR **CHICAGO TRANSFORMERS!**

CHICAGO TRANSFORMER
DIVISION OF ESSEX WIRE CORPORATION

3501 ADDISON STREET • CHICAGO 18, ILLINOIS



acclaimed

an achievement...

ALTEC
21B

...the world's finest microphone

* The only microphone ever selected to receive the "Electrical Manufacturing" award for "outstanding achievement in product design, engineering and development"...the Altec 21B again proves that it deserves the title of "the world's finest microphone."

* Setting a new standard in microphone performance in every field...broadcast, recording, motion picture, television and public address.

* If you still haven't heard this amazing condenser microphone call your Altec dealer for a demonstration and the 21B will prove that it is "the world's finest microphone." Immediate deliveries on all models: stand, chestplate and lapel.

ALTEC
LANSING CORPORATION

9356 Santa Monica Blvd., Beverly Hills, Calif.
161 Sixth Avenue, New York 13, New York

crystal 20 times so that the cartridge produces ample voltage output with high needle compliance. All rubber pads and viscoloid damping materials which tend to stiffen in time and to lower compliance, have been eliminated.

The story of modern pickup cartridges is an interesting one for the audio enthusiast and one that will appeal to his desire for the most enjoyment possible from his record player. It is firmly implemented by facts to whet his scientific curiosity.

The cartridge modernization market can be one of the technician's most important sales areas. In it he is preeminently well equipped to render outstanding service. His technical know-how is unmatched by any of the other

factors active in the market. Cartridge manufacturers are eager to make available to the technician charts which list the modern cartridges they recommend to replace older, inferior models. Installation is easy because standard tone arm mounting dimensions and wiring arrangements are employed throughout most of the industry. Accurate, easy-to-read installation instructions are a part of each cartridge package. The replacement of old style cartridges in 10 million record players still using them presents the technician with the opportunity to make one of his most significant contributions to the development of home audio systems—and can be, at the same time, one of his most profitable sales activities.

A SYNC SIGNAL INVERTER FOR THE SCOPE

By WILBUR J. HANTZ

IN the course of oscilloscope measurement procedures it often becomes imperative to observe test signals of either polarity. This is usually an impossible attempt with ordinary scopes. It is somewhat annoying when one must plot an a.f. curve or observe sync pulses upside down.

The circuit shown in Fig. 1, was designed for the scope owner who doesn't have the cash to trade the old one in for a gold-plated special. Here the synchronizing voltage, whether it is of positive or negative polarity, internal or external, is applied to the first half of V_1 which is a phase inverter. Any amount of signal can be selected from either the plate or cathode for feeding the second half of V_1 by means of the center-tapped control R_5 . The IN52 crystal diode was added to function as a peak limiter to prevent the sync volt-

age from exceeding a set level thus avoiding a premature firing of the 884 due to too much input signal. The control R_5 is a small screwdriver adjustment and may be located at the rear of the chassis or wherever convenient. In use, this is set so the diode conducts when the signal exceeds the bias. If desired, this control can be replaced by a 47,000 ohm, 1/2-watt resistor which was used in the author's final model.

The 884 sweep oscillator is along conventional lines and was shown just to indicate the addition of the sync signal inverter. In most cases any of the scopes will stand the addition of this extra tube which can be either a 6SN7 or a 12AT7. Several different size controls were tried instead of the center-tapped 500,000 ohm linear control shown but this pot works the best.

Fig. 1. Schematic diagram of the reverse polarity sweep circuit.

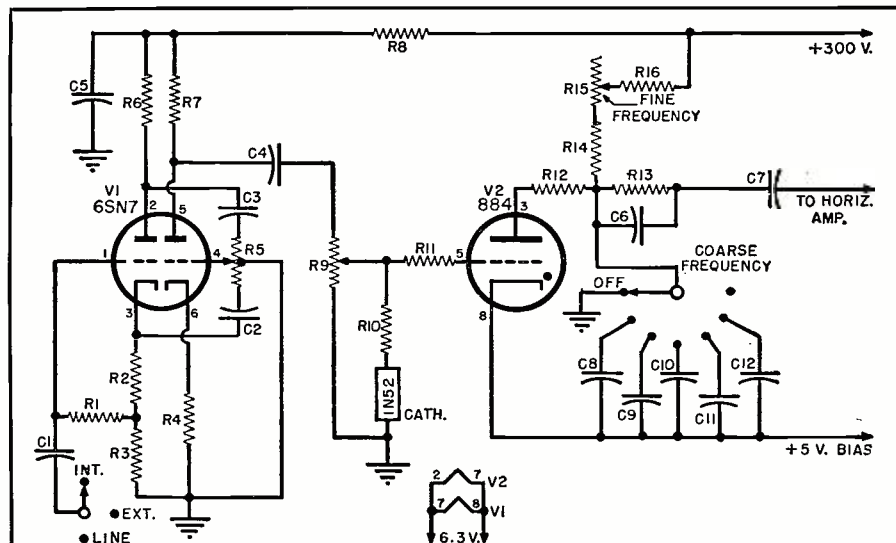

R_1 —220,000 ohm, 1/2 w. res.
 R_2 , R_3 —2200 ohm, 1/2 w. res.
 R_4 , R_6 , R_7 , R_{10} —47,000 ohm, 1/2 w. res.
 R_5 —500,000 ohm linear taper pot., tapped at 250,000 ohms
 R_8 —100,000 ohm, 1/2 w. res.
 R_9 —50,000 ohm, linear taper pot., Shaft for screwdriver adjustment
 R_{10} —150,000 ohm, 1/2 w. res.
 R_{11} —27,000 ohm, 1/2 w. res.
 R_{12} —470 ohm, 1/2 w. res.
 R_{13} —1.8 megohm, 1/2 w. res.
 R_{14} —470,000 ohm, 1/2 w. res.

R_{15} —4 megohm pot. ("Fine Frequency" control)
 C_1 , C_7 , C_8 —.25 μ fd., 600 v. cond.
 C_2 , C_3 , C_4 —1 μ fd., 600 v. cond.
 C_5 —20 μ fd., 450 v. elec. cond.
 C_6 —5 μ fd., 500 v. ceramic cond.
 C_9 —.045 μ fd., 600 v. cond.
 C_{10} —0.008 μ fd., 600 v. cond.
 C_{11} —0.01 μ fd., 500 v. mica cond.
 C_{12} —220 μ fd., 500 v. mica cond.
 I —IN52 crystal diode
 I —S.p. 3-pos. sw.
 V_1 —6SN7 or 12AT7 tube
 V_2 —884 tube

CONDENSERS



DS Filter Condensers

40-20	135	10c
2k20	150	29c
2k30	150	29c
2k40	150	29c
2k50	150	29c
2k60	150	29c
2k70	150	29c
2k80	150	29c
2k90	150	29c
2k100	150	29c
2k110	150	29c
2k120	150	29c
2k130	150	29c
2k140	150	29c
2k150	150	29c
2k160	150	29c
2k170	150	29c
2k180	150	29c
2k190	150	29c
2k200	150	29c
2k210	150	29c
2k220	150	29c
2k230	150	29c
2k240	150	29c
2k250	150	29c
2k260	150	29c
2k270	150	29c
2k280	150	29c
2k290	150	29c
2k300	150	29c

Many Others



ELECTROLYTICS
Prong Mount
D. Y. Type
29c ea.
10 for \$2.75

MFD.	VOLT	PRICE
20	25	.10
20	35	.10
20	45	.10
20	50	.10
20	60	.10
20	75	.10
20	100	.10
20	150	.10
20	200	.10
20	250	.10
20	300	.10
20	350	.10
20	400	.10
20	450	.10
20	500	.10
20	550	.10
20	600	.10
20	650	.10
20	700	.10
20	750	.10
20	800	.10
20	850	.10
20	900	.10
20	950	.10
20	1000	.10

AC COND.

13-15	220	\$1.20
20-24	110	1.25
26-30	220	1.35
43-45	110	1.25
43-48	110	1.25
50-75	110	1.25
53-60	220	1.50
60-70	110	1.25
64-72	110	1.25
72-87	110	1.25
75-84	110	1.25
88-106	110	1.25
107-129	110	1.25
150-157	110	1.25
130-140	70	1.50
180-180	110	1.85
158-181	110	1.85
161-180	110	1.78
189-210	110	1.95
200-220	110	1.95
270-300	110	2.15
324-300	110	2.40
378-420	175	3.00
432-480	110	2.75
485-540	110	2.85

MINICAPS
PIGTAIL

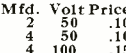

Mfd. Volt Price

2	50	.10
4	50	.10
4	100	.15
4	150	.18
4	220	.18
5	25	.10
5	50	.10
5	150	.10
5	25	.15
8	100	.18
8	150	.18
8	350	.20
10	50	.18
10	100	.20
12	450	.23
16	100	.22
16	300	.30
16	450	.40
20	25	.10
20	50	.15
20	80	.18
20	350	.30
24	350	.30
25	25	.10
25	30	.10
25	30	.25
30	450	.30
40	150	.22
40	450	.40
50	25	.22
50	50	.25
50	150	.30
100	50	.40
250	15	.50
500	8	.60
500	25	.75
1000	6	1.20
2000	6	1.35
1200	1.5	1.10
8-8	450	.60
8-16	450	.65
10-10	150	.30
10-10	450	.35
10-10	500	.40
20-20	150	.40
20-20	450	.55
50-50	150	.40
50-50	150	.40
50-50	150	.40
70-70	175	.85

SCR274
See spec. Mod.
XPR for pair of
807's PP-PP
or Parll Sidetone
Windg. .95c

ARC 5
MODULATOR

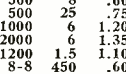

MD7/ARC5 w/dyna-
motor complete w/
Tubes 1-1255. 2-1625.
1-VR50. Good cond.
Price \$8.95

ARC 5
REPEATER

Used to extend range
of field telephones.
Simplex Teleg. and
20 cycle ringing pos-
sible over lines
equipped with unit.
Supplied w/305 tube.
Phone supplied.
(Featherweight) \$9.49

THRU-PANEL
INSULATOR

Insulator 2 1/2" H x
1 1/4" dia. & Mod.
ware. Glazed Ceram.
Insulator. 5 for 45c

TEST METERS

Model 542 Supreme Sensitivity. 5,000
Ohms/v x 3V square meter. Reads D.C.
volts. 6-150-300-1,500; A.C. volts. 6-30-
150-600; D.C. ma. 0.3-6-30-150; Ohms.
2-200-20,000-100,000. 2 mess; db. -4 to
+50; Output. 6-30-150-600 volts. Bakelite
case. 5/8x3-1/16x2 1/8". Shpg. wt. 2 lbs.
\$8.95 ea. Model 442 Radio City. Same as
above. \$8.95 ea.
Model 666-SC565 Triplett VDC 3/30/300/
600/1500 VDC ohms 1000/10000/
10000/10000. Price \$7.95 ea.
Model Same as above Chicago. \$7.95
All above meters sold as is. No refund
minor repairs required.

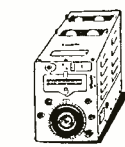

274N
(ARC5)
Transmitters
40 Watt
Output

These Famous
V.F.O.
Drivers
Available

2-1-3M.C. . . . \$14.95
3-4M.C. 9.95
4-5-3M.C. . . . 5.95
5-3-7M.C. . . . 5.95
7-9-1M.C. . . . 13.95

Used Good Cond.



ARC 5
MODULATOR

MD7/ARC5 w/dyna-
motor complete w/
Tubes 1-1255. 2-1625.
1-VR50. Good cond.
Price \$8.95



ARC 5
REPEATER

Used to extend range
of field telephones.
Simplex Teleg. and
20 cycle ringing pos-
sible over lines
equipped with unit.
Supplied w/305 tube.
Phone supplied.
(Featherweight) \$9.49

TEST METERS

Model 542 Supreme Sensitivity. 5,000
Ohms/v x 3V square meter. Reads D.C.
volts. 6-150-300-1,500; A.C. volts. 6-30-
150-600; D.C. ma. 0.3-6-30-150; Ohms.
2-200-20,000-100,000. 2 mess; db. -4 to
+50; Output. 6-30-150-600 volts. Bakelite
case. 5/8x3-1/16x2 1/8". Shpg. wt. 2 lbs.
\$8.95 ea. Model 442 Radio City. Same as
above. \$8.95 ea.
Model 666-SC565 Triplett VDC 3/30/300/
600/1500 VDC ohms 1000/10000/
10000/10000. Price \$7.95 ea.
Model Same as above Chicago. \$7.95
All above meters sold as is. No refund
minor repairs required.

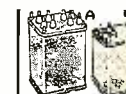

TRANSFORMERS

These XFRMRS are Army
Spec. All Underrated.

Comb. Transformers—115V/50-60 cps input

Item	H.V.	Amps.	Filaments	Price
CT-861	2100VCT	.175	7.5VCT/4A, 2.5V/10A.	\$7.29
CT-142	645VCT	.060	5V/2A, 6.3V/1.2A.	4.25
CT-825	360VCT	.340	6.3VCT/3.6, 6.3VCT/3A.	3.95
CT-076	600V	.100	2 x 12.6V/1	1.95
CT-626	1500V	.160	2.5/1.2, 3.0/100.	3.95
CT-624	350VCT	.070	6.3/2.6, 6.3/1.8, 3 lbs.	2.95
CT-071	110V	.200	33/200, 5V/10, 2.5/10.	4.95
CT-378	2300V	4 MA	2.5/2.	6.95
CT-367	580VCT	.050	5VCT/3A.	2.25
CT-721	550VCT	.100	6.3/1, 2.5VCT/2.	2.95
CT-98A	2x110VCT	.010	6.3/1A, 2.5VCT/7A.	3.25
CT-91A	72V	.100	5V/3A, 6.3/3.5.	3.25
CT-080	700VCT	.205	5V/3, 5V/2A.	3.95
CT-441	50V	.200	5V/2.4, 5V/1.2.	2.29
CT-408	350VCT	.026 MA	5V/3A.	2.75
CT-468	1100VCT	.400 MA	6.3V/1.6.	6.95
CT-931	585VCT	.088	5V/3A, 6.3V/6A.	4.25
CT-602	1250	.002 MA	2.5V/2.1A, 2.5V/1.75A.	4.95
CT-137	350VCT	.026 MA	5V/3A.	2.75
CT-102	1080VCT	.055	25V/3A, 6.3V/1.8A, 6.3V/1.2A.	9.95
CT-866	330V	.065	6.3V/1.2, 6.3V/600 MA.	1.75
CT-319	330VCT	.085	2.5/2, 6.3/7.5, 6.3/3	3.25
CT-526	510VCT	.025	12.5/900 MA, 6.3/5A.	1.95

Filament Transformers—115V/50-60 cps input

Item	Rating	Each
FT-852	23V 35	\$1.79
FT-308	58V/2.2A	2.25
FT-599	78V/300, 6.3V/2A	1.95
FT-719	1.3V/6A	.79
FT-029	13.5V/11A	.79
FT-014	2.5V/10A, 6.3/9A	1.79
FT-346	5VCT/13.5, 5VCT/6.75, 5VCT/6.75.	5.95
FT-781	866 Trans. 2 x 2.5/5A	2.25
FT-511	3.4V/300A, 7 1/2 H x 10 1/2 W	14.95
FTG-31	2.5V/2.5, 7V/7A (Tape @ 2.5V/2.5A), 16 lbs.	9.95
FT-674	8.1V/15A	1.10
FT-157	4V/16.5, 2.5V/17.5A	1.10
FT-391	6.4V/3A	1.10
FT-736	2 x 6.3VCT/3.2-1.2A.	1.49
FT-461	2 x 6.3VCT/1A.	1.10
FT-899	2x5 V/5.5A 29000 Rms.	12.95
FT-418	6.3VCT/1A, 6.3VCT/7A.	1.75
FT-042	6.3VCT/6.5A, 6.3VCT/1A.	1.75
FT-101	6V/25A	1.69
FT-738	6.3VCT/1A, 5V/2A.	1.79
FT-774	6.3V/1.6A.	.79
FT-589	9V/1.6A.	.49

Plate Transformers—115V/50-60 cps input

Item	Rating	Each
PT-976	Auto: 120VCT/10 MA.	\$6.99
PT-31A	2 x 300V/5 MA	.79
PT-46A	4080VCT N.L. 3 1/2 x 1 3/8" H x 6" W x 7" L. 20 lbs.	29.95
PT-033	4150V/400 MA 1 1/8 x 9/16" W x 7" L. 70 lbs.	49.95
PT-75-2	3780/3446/3112VCT/77 MA.	10.95
PT-28-1	4600VCT/077.	12.95
PT-703	Auto 7V/1A	2.95
PT-160	1120VCT/770 MA, 590VCT/82 MA, 25 lbs.	24.95
PT-170	Auto: 156/146/137/128-71A.	3.29
PT-848	3140VCT/750 MA for BC545, BC1069A.	69.95
PT-139	42V/46V/50V/55V/15.2A 7 1/2" W x 6 1/4" H.	10.95
PT-104	60V/20 MA.	2.95
PT-61-1	62V/3.5A.	2.95
PT-12A	280VCT/11.2A.	2.95
PT-104	60V/450 MA.	4.95
PT-054	980V/450 MA.	5.25
PT-997	78V/.00754 KVA. AUTO.	1.49

SPECIAL TYPES

Item	Pri.	Output	Price
STF-946	210/220/230	2.5V/4.3 1/2" H x 2 1/4" x 2 1/4" D.	1.25
STF-443	220/440	11VCT 12 1/2" 6 1/2" L x 6 1/2" x 8 1/2" 15 lbs.	15.95
STF-638	230	5V/9A 5 1/2" H x 4 1/2" x 3 3/4"	1.25
STF-05A	115/230	2 x 5V/7.5 7" H x 7" x 5" D.	4.25
STF-682	220	30-25-20V/1 MA.	.69
STF-368	230	2.5V/6.5A.	1.10
STF-455	220/115	5V/12.9A.	2.95
STF-630	220/440	3 x 2.5V/5A, 2.5V/15A, 5 1/2" x 5 x 4 1/2"	5.25
STF-619	110/220	2.5V/500A, 7 x 5 1/2 x 5.	19.95
STF-11A	220	2 x 40V/.05/2 x 5V/6A, 12.6/1A.	2.95
STF-631	230	2 x 5V/27A 2 x 5V/9A, 103/4H x 5 x 7 3/8 lbs.	24.95
STF-608	220	24V/60V/5V/3A, 2 x 6.3V/1A.	2.25
STF-45A	43/78/90	2 x 2.5/6.5, 6.3V/4 7 Few.	3.25
STF-306	100/120/200/240	5VCT 10 amp 20000 V Test.	13.95

SPECIAL PLATE TRANSFORMER

STP-945	210/20/30	1100VCT/300 5/4 x 4 x 3 1/2	\$5.95
STP-444	230/460	230/105/115/125 15 lbs.	14.95
STP-613	230	2 x 2.5/15.	2.95
STP-823	137V	222VCT/300 MA.	2.95
STP-780	82V	4000V/.002.	1.29
STP-088	50V	2 x 7.50V/1 MA.	.98
STP-311	30/35/40	95 NL-50VFL 1 Amp.	.59
STC-627	230V	1500/160, 110V/200, 3.3V/200, 5V/10, 2.5-1.4/10.	\$5.95
STC-611	230V	200V/200, 4 x 6.3V/9.	2.95
STC-16A	220V	260V/.03, 100V/1, 6.3V/4.2.	2.95
STC-607	220V	700VCT/75 MA, 40VCT/100, 15/10/15V/100 MA.	3.95
STC-612	230V	400V/30, 150/30, 2 x 5V/2.5 w/2-866 Socket.	3.95
STC-622	230V	250V/100, 2 x 5V/2-9-2-4 Png. Sockets.	4.25
STC-407	200V	700V/80 MA, 110/80 MA, 24V/80 MA, 2 x 6.3/3-1A, 5V/3, 5V/5A, 2.7/5A.	4.95

Ferrule	20w	360w	6000w	MS-49
Resistor	25w	375w	7000w	and
Class	50w	400w	7500w	MS50
Type & Vitreous	90w	500w	10,000w	Fish Pole
	120w	700w	15,000w	Antenna,
	14			

Our Survey at the Audio Fair Showed that.....

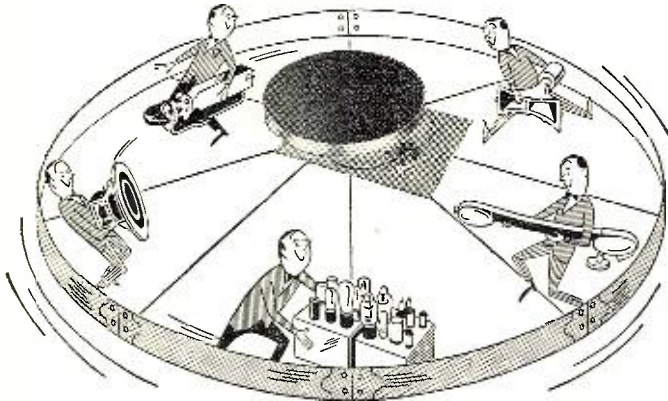

EVERYTHING REVOLVES AROUND REK-O-KUT TURNTABLES

At the recently held AUDIO FAIR in New York City...the following companies used REK-O-KUT Turntables to bring out the best reproduction in demonstrating their own components.

ALTEC LANSING
AUDAK COMPANY
BELL SOUND SYSTEMS
ELECTRONIC WORKSHOP
HARVEY RADIO CO.
HUDSON RADIO & TV

LEONARD RADIOD
MARK SIMPSON MFG. CO.
McINTOSH ENG. LABS.
PANORAMIC RADIO PROD.
PICKERING & COMPANY
RCA-VICTOR DIVISION
REEVES SOUNDCRAFT

SAT. REVIEW OF LIT.
STEPHENS MFG. CORP.
SUN RADIO & ELECTRONICS
TETRAD CORP.
TRIAD TRANS. MFG.
UNIVERSITY LOUDSPEAKERS

This line-up of famous names in the Sound Reproduction Industry is, indeed, an outstanding tribute to the quality of REK-O-KUT Turntables. Since the turntable is the "heart" of the reproduction you, too, should insist on the best — insist on REK-O-KUT.

REK-O-KUT Turntables, Phonographs and Disc Recorders are Sold by Leading Music Stores, Radio Parts Distributors, and Audio-Visual Dealers. Write for Literature.

REK-O-KUT Co., Inc. 38-05 Queens Blvd.
Long Island City 1, N. Y.

V-O-M and Grid-Dip

(Continued from page 47)

is used with the value of its calibrations doubled. Instead of 3.5 ohms as the value of the center calibration mark, the new scale will have a value of 7 ohms at this point with a corresponding increase throughout the scale.

All of the fixed resistors may be of the carbon type, selected from standard RTMA sizes by checking a few units of the nearest standard size to the value required. The tolerance of the 10% units will usually allow a resistor of the right size and accuracy to be found.

The 9 megohm unit should be of 1 watt rating, not because of the load it carries, but on account of the voltage drop across it. The regular 1/2 watt unit is rated at 350 volts drop. As this is the drop across this resistor when 750 volts are under test, the larger resistor is used to provide a safety factor.

No matter how many ranges a selector switch may have it always seems that more could be used. By a little trick one extra range was added to the switch in this v-o-m circuit. To get it, the make and type of switch specified should be used. Remove the rear deck and replace it upside down. With the switch re-assembled as directed, the rotating contact of the reversed deck will be one position out of line with the rotating contacts of the other decks. This is shown in the schematic diagram (Fig. 2) where with the selector switch drawn in what would normally be the "Off" position, the 75 μ a. range is now connected to the panel jacks. This range is also connected to the Jones socket and should always be in when the oscillator is attached.

To build a device of this type into a cabinet this size requires that some fitting of parts will be necessary. There is not enough space on the v-o-m panel for the broad flange of the Weston meter. It was necessary, therefore, to turn down this flange to a diameter of 2 7/8 inches. This operation removes the screw holes provided for fastening the meter to the panel, so that other means had to be found. The job was finally done by boring out the meter hole in the panel (Fig. 5A) to a hand press fit against the meter case. To securely lock the meter in place, a little shellac is run in around the inside edge of the hole.

A standard panel bearing, shown under the index finger in Fig. 1, serving as a spacer and a support for the binding screw, will require modification. Various shaft lengths are supplied with these bearings. Select one that can be cut to a length of 1 1/2 inches from the rear of the bearing and cut it to length. Remove the shaft from the bearing. Then put the bearing into position. Note the excess of threads beyond the binding nut. These threads are unsightly and should be turned off. Next, the shaft which will now become the binding screw between the handle and

TECH-MASTER

TELEVISION

New TECH-MASTER developments!

LO-PRICED
Universal KIT

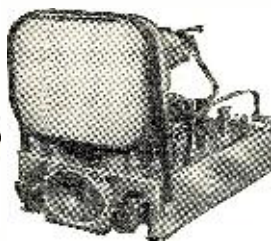

FOR TUBES UP
TO 14" RECT.

First LOW-COST TV Receiver Kit completely engineered by TECH-MASTER. Features 2-knob control and small, lightweight chassis.

Model 5016

Resale Price \$89.50

Advanced
630 Type KIT

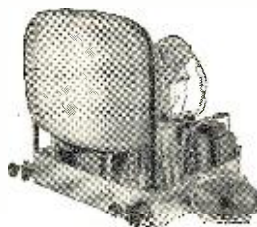

FOR ALL TUBES
12" Rd. to 20" Rect.

The greatest advance in TV—developed by top TECH-MASTER engineering! Model 630D19 (DeLuxe) Principal components assembled.

Resale Price \$159.50

Model 630S19 (Standard) Unassembled.

Resale Price \$154.50

All 3 Kits supplied with all tubes (less Kine), parts, speaker and six tube mounting brackets.

CONTACT YOUR JOBBER or write Dept. RN-2 for literature.

TECH-MASTER PRODUCTS CO.

443-445 Broadway, New York 13, N. Y.

More leading engineers and technicians have built Tech-Master for their own use than any other Television Kit.



the v-o-m must be turned down and threaded at the front of the bearing end with a 10-32 thread $\frac{5}{16}$ inch long. The bearing and screw may then be assembled in the handle.

Cases for the separate units are made from material easily adapted to fit. For the v-o-m the case of the Weston Model 697 instrument is used. The tuning unit requires a rectangular aluminum tube $3\frac{1}{4}$ inches long x 3 inches high x $1\frac{1}{4}$ inches wide x .093 wall. A piece of 24 ST square aluminum tubing with rounded corners $4\frac{1}{4}$ inches long x $1\frac{1}{2}$ inches each side x .050 wall is used for the handle. If this wall thickness can not be secured, a $\frac{1}{16}$ wall, which is a more common size, may be used. The thicker wall will have to be filed out at the lower end of the handle to accept the single dry cell that must be placed here.

One picture has been given the value of 10,000 words. This being so, the construction and assembly of those parts not detailed in the drawings may be judged from the photographs, since these parts, such as the raising block, binding screw knob, etc., do not have to be held close to size or position.

The pleasure to be obtained from working with any device of your own construction depends to a great extent upon its appearance. For this reason the required lettering on the panel and dials should be engraved and the high frequency coils silver-plated for the gain in "Q" as well as the improved appearance that the plating gives. Do this and build carefully. You will have a job you can be proud of. —30—

ION TRAP ERASER

By M. KALASHIAN, WINXT

MANY times a tape or wire will be over-modulated to the extent that it cannot be successfully erased by the recorder, as evidenced by the over-modulated portion being heard in the background.

A very handy item to use to erase the portion in question is an ion trap of the single, permanent magnet variety used on picture tubes in television receivers. Merely hold the magnet of the ion trap next to the tape or wire (as the case may be) and operate the recorder. As the tape or wire runs past, the magnet will completely erase everything—including that over-modulated portion. —30—

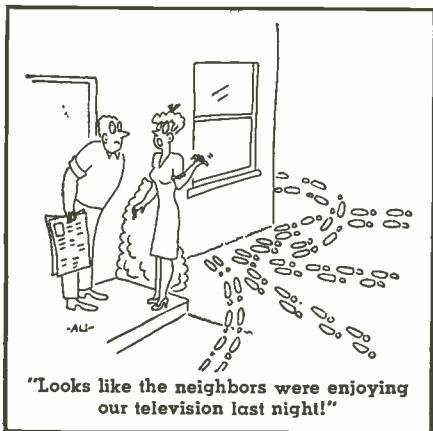

February, 1951



It takes an RCA Original... to insure top TV performance



Performance-proved in millions of television receivers of many makes—RCA "original" TV components will cut your service call-backs and insure customer satisfaction. That's because RCA TV components are designed to work perfectly with the tube types and circuits used in the top television receivers...and rated to withstand abnormally high peak voltages.

When replacements are called for...play safe...use genuine RCA television components...they cost no more than substitutes.

SEE YOUR LOCAL RCA PARTS DISTRIBUTOR
FOR "ORIGINAL" RCA TV COMPONENTS



RADIO CORPORATION of AMERICA
ELECTRONIC COMPONENTS

HARRISON, N. J.



VIBRATORS!
By every test

ATR

is Best!

ATR
AUTO RADIO
VIBRATORS

have Ceramic Stack Spacers



A COMPLETE LINE OF VIBRATORS . . .

Designed for Use in Standard Vibrator-Operated Auto Radio Receivers. Built with Precision Construction, featuring Ceramic Stack Spacers for Longer Lasting Life. Backed by more than 19 years of experience in Vibrator Design, Development, and Manufacturing.

ATR PIONEERED IN THE VIBRATOR FIELD.

NEW MODELS NEW DESIGNS
NEW LITERATURE

"A" Battery Eliminator, DC-AC Inverters
Auto Radio Vibrators

See your jobber or write factory

AMERICAN TELEVISION & RADIO CO.

Quality Products Since 1931

SAINT PAUL, 1, MINNESOTA-U. S. A.

MARS

Station of the Month

MARS OPENS RANKS TO CIVILIAN HAMS

The Department of the Army has announced that it will accept civilian members in its MARS program. Civilians interested in joining the system are invited to contact the Signal Officer of their nearest Army installation. Authorization for civilian membership in MARS-Army insures the continued use of the net as a back-up communication system if activities and reserves of the Army are mobilized. MARS membership does not affect draft status, the Army emphasized.

Civilian members must be 21 years of age or older and must hold a valid FCC amateur radio station license. They must also agree to operate their stations in accordance with rules and regulations prescribed for the MARS by the Army. Only amateurs who own stations, in operation at time of application for MARS membership, can be considered. No radio equipment can be furnished civilian amateurs under existing law.

NESTLED in the Lake Tahoe Valley, 6250 feet above sea level, is military amateur radio station A6GMX, named MARS Station of the Month by the Chief of MARS-Army, Captain E. L. Nielsen.

The station is owned and operated by E. R. (Bob) Horwinski, a former Signal Corpsman who vowed, during the war, that "if I ever get home I will take my radio gear to the mountains and live my own life."

He has taken to the mountains, true. But his activities as net control station on the MARS 4020 kc. net, serving as communications officer for Lake Tahoe Coast Guard Flotilla #61, working with forest rangers and with air-rescue service, indicate that Bob's life is not exactly carefree.

To get equipment for all these assorted services, A6GMX has "scrounged" the surplus market thoroughly. His home station transmitters are a pair of AT-20's, purchased from the Australian Government as surplus and shipped to California at Bob's expense.

Horwinski also operates a 1 kw. mobile station mounted in an armored truck. Police sirens and a beachmaster speaker system are mounted on the truck to help attract attention or direct other search parties when the unit operates with rescue crews. The Coast

Guard boat furnished for his use is completely equipped for maritime mobile operation on Lake Tahoe. (Lake Tahoe is 21.5 miles long by 12 miles wide with 75 miles of shoreline. Twenty-three postoffices serve the Lake Tahoe valley, according to A6GMX, and the valley is serviced by two major highways, U.S. 40 and U.S. 50.)

A6GMX is presently crusading for location of a weather station at Lake Tahoe. According to his observations, Lake Tahoe is "similar to the bottom of a pan, with mountains up to 12,000 feet all around it. U.S. 50 comes into this bowl over Spooner Summit Pass at 7140 feet, skirts the south end, and goes out over Echo Summit Pass at 7340 feet."

Horwinski's argument is that the area generates its own weather, which is not indicated by any other weather station now in existence. Because of the tremendous volume of tourists and visitors annually, Horwinski feels many lives might be saved by an at-the-scene weather charting service.

When winter sets in and the region is no longer open to motor traffic, Bob covers the valley by means of dog sled. You guessed it—he has emergency portable radio equipment aboard!

If he finds time hanging heavy on his hands, A6GMX can take to the air. He has a surplus P-40 aircraft, and is

A6GMX's mobile communications truck which started life as an armored express vehicle.

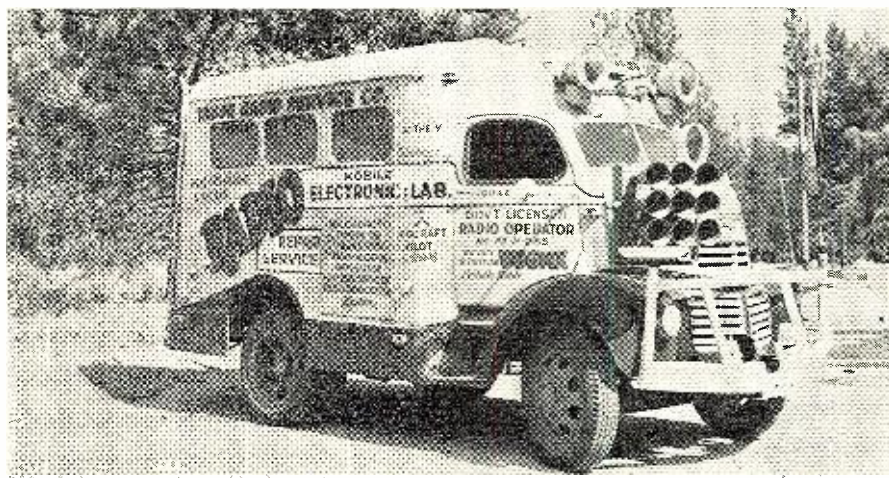

PARTS and TUBES

TUBES—Radio and TV

OZ4\$0.83
OZ4G90
1A5GT90
1A61.60
1A7GT1.00
1B3GT1.33

1C5GT	\$.110	6AB4	\$.100	6J8G	\$.160	7A7	\$.090	125H7	\$.110	35Z4GT	\$.075
1C6	1.60	6AB7	1.60	6K5GT	1.20	7A8	.90	125H7GT	1.10	35Z5GT	.75
1C7G	1.60	6AC5GT	1.45	6K6GT	.83	7A7	.90	125J7	.90	35Z6G	1.33
1C8GP	1.95	6AC7	1.45	6K7G	.83	7B4	.90	125J7GT	.90	36	1.33
1D7G	1.60	6AG5	1.33	6K8GT	1.20	7B5	.90	125K7	.90	39/44	1.33
1D8GT	1.95	6AG7	1.60	6K8	1.20	7B6	.90	125K7GT	1.00	41	.83
1F4	1.33	6AH6	1.95	6K8GT	1.20	7B8	.90	125L7GT	1.20	42	.83
1F5G	1.33	6AK5	1.95	6L5G	1.33	7C4	1.60	125N7GT	1.10	43	.83
1G4GT	1.33	6AK6	1.20	6L6	1.78	7C6	.90	125Q7	.75	45	.83
1G6GT	1.33	6AL5	1.00	6L8G	1.78	7C7	.90	125Q7GT	.83	45Z5GT	.90
1H6G	1.60	6AL7GT	1.33	6L8GA	1.78	7E5	1.60	125R7	1.10	46	1.33
1J5G	1.33	6AQ5	1.00	6N6G	1.95	7E6	1.10	125R7GT	1.10	50	1.95
1J6G	1.60	6A06	.90	6P5GT	1.20	7F7	1.10	1223	1.33	50A5	1.10
1J6GT	1.60	6A07GT	1.20	607	1.00	7F8	1.33	14A7	1.10	50C5	1.00
1LA4	1.33	6AR5	1.33	6Q7GT	.90	7G7	1.33	14AF7	1.20	50C6G	1.45
1LC5	1.33	6AS5	1.00	6R7GT	1.33	7J7	1.33	14B6	1.10	50L5GT	1.00
1NSGT	1.00	6AT6	.75	6S4	.90	7K7	1.33	14B8	1.10	50X6	1.10
1P5GT	1.33	6AU5GT	1.33	6S7GT	1.60	7L7	1.33	14E6	1.10	50Y6GT	.90
1Q5GT	1.33	6AU6	1.00	6S8GT	1.33	7N7	.90	14F7	1.10	56	.90
1R5	1.00	6AV6	.75	6SA7	1.00	7Q7	.90	14F8	1.33	57	1.00
1S5	.90	6AX5GT	.68	6SA7GT	1.00	7R7	1.10	14G8	1.33	58	1.00
1T4	1.00	6B4G	1.60	6S7	1.00	7S7	1.33	14H7	1.33	59	1.78
1T5GT	1.33	6B5	.75	6S7GT	1.45	7T7	1.33	14J7	1.33	70L7GT	1.95
1U4	1.00	6B8GT	1.60	6S8GT	1.60	7X7	1.33	14K7	1.33	71A	1.00
1U5	.90	6BA6	.90	6S9GT	.90	7Y4	.90	14L7	1.33	75	.83
1V	1.10	6BA7	1.20	6S9GT	1.00	7Z4	.90	14Y4	1.20	76	.83
1X2	1.33	6BC5	1.00	6S9GT	1.10	12A	1.83	1986GG	1.10	77	.83
2A3	1.60	6BC7	1.10	6SH7	1.10	12A6	1.45	1988	1.45	78	.83
2A5	1.10	6BE6	.90	6SH7GT	1.10	12A9	1.45	20	1.95	79	1.33
2A7	1.33	6BF5	1.10	6S7	.90	12A8GT	1.00	24A	1.60	80	.68
2E5	1.33	6BF6	.83	6S7GT	1.00	12AT6	.75	25A7GT	3.00	82	1.33
3A8GT	2.40	6BF6	.83	6S7GT	1.45	12AT7	1.45	25AC5GT	1.45	83	1.33
3B7 1291	1.33	6BH6	1.00	6S7GT	1.10	12A6	1.00	25B0GT	.75	84	1.00
3C4	1.33	6BJ6	1.00	6S7	.75	12AU7	1.20	25C6G	1.45	85	1.10
3FL4	1.33	6BN6	1.60	6S7GT	.83	12AV7	1.60	25D8	1.95	89V	1.10
3V4	1.00	6C6	1.60	6S7	.90	12AX7	1.20	25W4GT	1.00	117L	1.95
30S5GT	1.20	6C4	.83	6S7	1.60	12B6	.90	25Y7	1.45	117N7GT	1.95
354	1.00	6C5GT	.83	6T7G	1.60	12BA6	1.00	25Z5	1.45	117P7GT	1.95
3V4	1.00	6C6	1.60	6S7GT	1.00	12B7G	1.00	25Z6	1.45	117Q7GT	1.95
5T4	1.95	6C8E	1.00	6U5	1.00	12BE6	.90	25Z6GT	.75	117Z3	.75
5U4G	.83	6CDEG	3.00	6UG5GT	1.00	12BF6	.83	26	.90	117Z6GT	1.20
5V4G	1.20	6C6	1.60	6V7	1.00	12C7	.90	27	1.50	117Z7GT	1.50
5W4	1.33	6D8G	1.60	6V6GT	1.00	12H6	.90	30	1.00	482B	.30
5W4GT	.83	6F5GT	.83	6V7G	.90	12J5GT	.75	31	1.33	483	.30
5X4E	.90	6F6GT	.83	6V7G	.90	12K7GT	.90	32	1.33	159V	.30
5X4GT	.68	6F8G	1.60	6W6GT	.90	12Q7GT	.90	33	1.60	807	1.50
5Y4G	.75	6G6G	1.33	6X4	.75	12S8GT	1.33	35 51	1.00	813	6.75
5Z3	.90	6H4GT	1.33	6X4GT	1.20	12S7	1.00	35B5	1.00	1549	1.00
6A3	1.60	6H6GT	.83	6V7G	1.60	12S7GT	1.10	35C5	1.00	1622	1.75
6A4	1.60	6J5GT	.75	7A5	1.60	12S7	1.10	35LEGT	.90	2050	2.25
6A7	1.60	6J6	.75	7A5	1.10	12S7GT	1.00	35W4	.90	2051	1.75
6A8GT	1.00	6J7G	1.00	7A6	.90	12SF7	1.00	35Y4	.90	713	.83
				7A7	.90	12SG7	1.00	35Z3	.90	9001	.36

ORDER from PREMIER
Your reliable source
since 1926

SPEAKERS Very Best Quality—
NATIONAL BRANDS—
Ind. Packed

10 or more each	Price Each
3"	\$1.14
4"	1.55
5"	1.75
6"	2.94
8"	4.74
10"	5.10
12"	5.94

5 x 7\$2.25 ea. 6 x 9\$3.25 ea.

5" PM with 50L6 o. p. Xformer.....\$1.99

SPECIAL—6" PM Speakers, big Alnico 5 magnet, in lots of 10.....each \$1.55

Individual.....1.67



World's Best Indoor TV Antenna
A beautiful antenna which is the ultimate in reception, highest signal gain, nothing to adjust.

List price \$9.95 Each **\$4.78**

TV Antennas:
Hi-Low Conical with 8-ft. mast\$5.94

WORLD'S BEST DELUXE CONICAL\$10.74
with 9-ft. mast and heavy cast fittings.

100 ft. of twin lead with any TV antenna\$1.98

RED HOT VIBRATOR SPECIAL!
Standard small size, 2 1/2" in height (the popular small size), bright and shiny, Stock up while they last, all 4-prong Universal Vibrators. **\$1.29** each

Standard replacement crystal cartridge L70-172\$1.96

NYLON IJ CARTRIDGE\$2.59

OUTPUT TRANSFORMERS STANDARD REPLACEMENT

For 50L6, 35L6, 50A5, 35A5, 117L747c ea.

For 6V6, 6F6, 3Q5, 3Q4, 35A, 3V4, 41, 42, 6K6, 2A3, 45, 6L654c ea.



UNIVERSAL OUTPUT TRANSFORMERS SPECIAL
Up to 12 watts to any speaker (while they last).....ea. **\$1.18**

VOLUME CONTROLS

VERY BEST BRANDS	10 or more	Price Each
1/2 meg. or 1 meg. or 1/10 meg. with switch—long shaft.....	52c	59c
2 meg. for battery sets—switch, long shaft.....	52c	59c
1/2 meg., 1 meg., 1/10 meg. or 2 meg., long shaft, less switch.....	24c	28c
1000 ohm.....	19c	23c
5000 ohm.....	19c	23c
1/2 meg. with 6" shaft.....	59c	71c

Special on #47, #44 and #51
100 PILOT LIGHTS... \$4.74
Box of 10.....59c

PILOT LIGHTS #40 #41 #46 \$5.88
100 Bulbs
Box of 10 Bulbs.....65c

TV Discriminator Transformers.....ea. .83

TV Screen Filters with suction cups—best quality INDI-VIDUALLY BOXED for 10".....1.40

highest re-sale value 12".....2.34

OSCILLATOR COILS for any 5-tube AC-DC 23c
HOOK-UP WIRE—100 ft.59c

OCTAL SOCKETS10 for 59c

7-PIN MINIATURE SOCKETS.....10 for 59c

9-Pin Miniature Sockets.....10 for 59c

Local Sockets.....10 for 59c

TV PICTURE TUBES

10BP4 Slightly Used But Perfect \$ 8.95	16RP4 NEW \$29.95
12LP4 NEW \$19.95	16TP4 NEW \$29.95
14BP4 NEW \$22.95	17BP4A NEW \$31.95

FILTER CONDENSERS

Very best brands. Fresh stock

450 Working Volts	150 Working Volts	40-40-150 V
8-450 V.....ea. 29c	8-150 V.....ea. 23c	20-25 V.....ea. 47c
10-450 V.....ea. 35c	8-8-150 V.....ea. 23c	50-30-150 V.....ea. 47c
20-450 V.....ea. 47c	10-150 V.....ea. 23c	20-16-16-350 V.....ea. 47c
30-450 V.....ea. 59c	10-10-150 V.....ea. 29c	Sprague type.....ea. 47c
30-450 V w/ 20-20-25 V.....ea. 35c	10-10-10-150 V.....ea. 35c	25-25-150 V-200-10 V.....ea. 47c
10-10-450 V.....ea. 52c	15-150 V.....ea. 25c	15-15-40-20.....ea. 35c
20-20-450 V.....ea. 59c	20-150 V.....ea. 30c	150 V-25 V.....ea. 35c
10-10-10-20.....ea. 59c	30-150 V.....ea. 35c	20-20-150 V-25 V.....ea. 47c
450V-150-25 V.....ea. 59c	40-150 V.....ea. 35c	30-30-200-150 V-10 V.....ea. 47c
30-30-400 V-350 V.....ea. 47c	15-15-150 V.....ea. 35c	20-16-16-150 V.....ea. 47c
30-30-25-400 V-25 V.....ea. 47c	20-10-150 V.....ea. 35c	Cathode Condensers
	20-20-150 V.....ea. 35c	10-25 V.....19c ea.
	30-20-150 V.....ea. 47c	20-20-25 V.....19c ea.
	30-30-150 V.....ea. 47c	20-20-20-25 V.....19c ea.
	35-35-150 V.....ea. 47c	30-50 V.....19c ea.
	40-20-150 V.....ea. 47c	100-25 V.....29c ea.
	40-40-150 V.....ea. 47c	

BY-PASS CONDENSERS

100 Condensers assorted in package.....**\$7.14**

.001 6c	.0005	} 7c SPECIALS MICA
.002 6c	.0025	
.005 6c	.005	
.01 8c	500 mmf	
.02 8c	250 mmf	
.05 10c	100 mmf	} 18c
.1 11c	50 mmf	

BYPASS SPECIAL—SOLAR
In lots of 25 or more.....ea. 11c
.25 mfd. 600 V.....Less than 25 ea. 14c

400-VOLT BY-PASS CONDENSERS
.05 mfd.....ea. 7c
.2 mfd.....ea. 7c
.25 mfd.....ea. 12c
.5 mfd.....ea. 18c

BUFFER CONDENSERS
.005 mfd. 1600 WV.....ea. 18c
.008 mfd. 1600 WV.....ea. 18c
.01 mfd. 1600 WV.....ea. 18c

VARIABLE CONDENSERS
Two-gang for superhet or TRF.....ea. 83c

IF TRANSFORMERS

Standard Replacement Regular.....ea. 35c

Midget 455 Kc.....ea. 47c

Midget 10.7 AM-FM.....59c

SPECIAL CONDENSER KITS

Kit of 50 BY-PASS CONDENSERS very best, assorted sizes.....\$1.98

6-FT. LINE CORDS

Good Rubber with plug.....\$1.50

Underwriters' Approved, 10 for.....\$2.03



Order Today

Premier RADIO TUBE CO.

551 West Randolph St.
Chicago 6, Illinois
Phone: ANdover 3-1590

**You Can't Beat Wholesale Radio
for Quality and Price**



**Get the Genuine!
GENERAL ELECTRIC
TV COMPONENTS**



**Horizontal Sweep Output
and HV Transformer**

RTO-085. For 66 to 70 degree tubes such as 14CP4, 16GP4, 19AP4, 24AP4. Max. HV to CRT anode 15KV. **\$7.05**
RTO-092. For 52 to 60 degree tubes, Max. HV 15KV to load. Long leads. **\$6.90**

**DEFLECTION YOKE RLD-024
To sweep 70 degree tubes—\$7.17**

EM-PM FOCUS COILS—\$4.50

RLF-026 for 10"-52" tubes
RLF-028 for 12"-52" & 16"-53" tubes
RLF-038 for 16"-70" round and rect. tubes

**RTO-064 VERTICAL SWEEP OUTPUT
TRANSFORMER (10:1 Ratio) \$3.60**

WIDTH & LINEARITY COILS—78c

RLD-014—Width/Linearity—1.27 Mh
RLD-016—Linearity—1.3-11.5 Mh
RLD-019—Width—6.5-40 Mh
RLD-020—Linearity—0.3-3 Mh

HORIZONTAL OSCILLATOR COIL

RLC-091 Ferrite core oscillator coil is center-tapped for use in sine wave horiz. oscillator circuit with AFC. **\$1.05**

SINGLE ION TRAP MAGNETS 93c

RET-005 for 10" and 12" round 11KV and 19" round 14KV. Gauss—35
RET-003 for 14" and 16" rect. 13 KV and 24" round 18 KV. Gauss—42

**Hi-Gain For Fringe Areas!
Snyder Double V
TV ARRAY**



Only \$4.75

Less Mast
Easiest installed hi-gain array. Four hi-tensil 3/8" Aluminum Alloy elements. Two 1/2" Aluminum Alloy cross arms. Completely assembled. Model AR-55.

**Sensational Antenna Buy!
SNYDER HI-LO ARRAY**

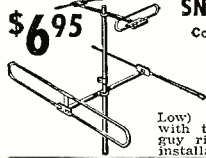

Model TV 21

We don't believe you'll find a finer antenna anywhere near this low price. Two folded dipoles (High and Low) with reflectors. Complete with two 3/2 ft. mast sections, guy ring. Ready for easy, quick installation.

**Lowest Price Conical Array!
Can Be Stacked for Fringe Areas**

Covers complete TV-PM band. Hi-tensil 3/8" aluminum alloy elements. Includes mast clamp for use with poles up to 1 1/2". Can be used with any type lead-in 72 to 300 ohms. Model KA-44. **\$4.95**
Less Mast...

TV ANTENNA ACCESSORIES

- STEEL EXTENSION POLES.** Weather treated.
10 ft. long, 1 1/4" di. Crimped end. \$2.19
5 ft. long, 1 1/4" di. Crimped end. 1.35
3 1/2 ft. long, 1 1/4" di. Crimped end. 1.19
ANTENNA SWIVEL BASE. Aluminum
Fits 1 1/4" O.D. mast section.45
GUYWIRE. 6 strand No. 20. Per 50 ft.39
24 reels, 50 ft. each, interconnected. 6.00
CHIMNEY MOUNT BRACKETS. Complete with strap
3" 300 OHM STAND OFF INSULATORS 1.59
Wood screw-in TWIN LEAD INSULATORS 2.95
SNAP ON TWIN LEAD INSULATORS
Fit 1 1/4" masts. Each06
JFD LIGHTNING ARRESTORS (AT-102) 1.35
JFD LIGHTNING ARRESTOR (AT-105)
Connects to baseboard.75
TIE RODS for double V type antenna. Pr.85
TIE RODS for conical type antenna. Pr.85
TIE RODS for inline type antenna (TR-29). Pr.85
10" MAST COUPLINGS for 1 1/4" masts.90
8" MAST COUPLINGS for 1 1/4" masts.45
48 STACKING ASSEMBLY. 4 rods and a center tie point. For stacking 2 double VX arrays. 1.95
PEAK ROOF MOUNTS for all type antenna installations. Fits wall, flat roof, any angle peaked roof. For masts 3/4" to 1 1/2". 2.69
HEAVY DUTY MAST BRACKETS WB-2. Adjustable up to 18" from wall. For masts 1" to 1 1/2" di. Pr. 3.75

Write for Free F. Y. I. Flyer
Address Orders to Dept. RN-2
or call Mulberry 2134

**WHOLESALE
RADIO PARTS CO., Inc.**
311 W. Baltimore St.
BALTIMORE 1, MD.

a licensed pilot. "Only thing is," he mused recently, "the darn thing really eats up gasoline, and my income is pretty small. In the summer I live by the process of repairing radios—we have a lot of tourists—but in the winter the source of ready cash disappears. Confidentially, I'm preparing to put a commercial broadcast station on the air to give me a year 'round income so that I can pursue my hobbies the way I want to." —30—

**1950—TV Year
(Continued from page 34)**

either the network coaxial or the microwave relay. Material shortages will make it practically impossible to construct new television stations even if FCC ends the freeze. However, commercial television should continue to flourish as a result of the exploitation of the new markets which will open up as the network expands.

Color Television

The FCC's decision late in 1950 to accept the CBS standard for color transmission has had very little effect on the industry as a whole. Although the initial reaction of the public was to hold off on the purchase of television receivers, this feeling was only short-lived and as of the end of the year receiver sales were normal. The future of color television is today a purely academic question. The conflict as to what system of color transmission will survive the test of time will undoubtedly continue in the coming year. No color system can be expected to achieve a "commercial" status within the foreseeable future. Manufacturers and broadcasters face too many difficulties in connection with existing black and white production and transmission to worry about color.

Servicing Business 1951

Considering that 1951 offers a ten million television set servicing market, the future of the replacement business should remain a bright one. The big question mark, however, is one of supply, that is, providing the lower level of distribution—the technician—can obtain an adequate supply of parts and tubes to complete his servicing job. In this period of component shortages manufacturers will have to determine for themselves whether new sets are to receive a greater priority than those sets already in the field. The manufacturer must remember that his name and reputation is at stake when a set in the field is left inoperative due to an inadequate supply of components or tubes. At a recent meeting, Ernest A. Marx, general manager of the Du Mont Receiver Division, said that his company would give a component and tube priority to those sets already in the field. It is his contention that manufacturers must keep faith with the customers that have already been sold. What manufacturers in general will do will determine to a great part the

PHOTOCON S LES

Mail Order Address: 106-2 N. Allen Ave. Pasadena 7, Calif. SYcamore 4-7156 RYan 1-8271
Retail Sales Store: 1240 East Colorado St. Pasadena 1, Calif. SYcamore 6-7217

**February Specials
Write for Our Latest Sales Bulletins**

PLUGS
PLQ-171, PL-172, PLQ-60, PLQ-63, PL-147, PL-148, PL-151, PL-152, PL-153, PL-154, PL-156, PLQ-103. Plugs for ARC-1, ARC-3, ARC-5, BC-375, SCR-522, BC-348, GP-6, GP-7, LM Frequency Meters and many others.

HS-23 Hi Imp. Headset with plug and ear cushionsNEW \$2.45
HS-33 Headset, Low Imp. less headband. 1.75

We have thousands of Tubes, High Voltage Oil Capacitors, Mica Capacitors, Transformers, and Miscellaneous Items. Please send us your requirements.

FL-8 Range FilterNEW \$ 1.95
1. mfd. 15,000 W.V.D.C. GE Oil Capacitor—475 availableNEW, each 14.95
APN-1 Altimeter Indicator basic movement 0-1 ma. 5 ma. shaft 270° dial. An excellent basic movement for constructing your own meters. BRAND NEW 1.95
IE-19A Test Set for SCR-522 complete with manual 4.NEW 325.00
LM Frequency Meter with cal. book, crystal, tubesEXCELLENT 79.50
BC-221 Frequency Meter with calibration book, crystal, tubes.EXCELLENT 79.50
TS-323/UR Frequency Meter Calibrated, completeNEW 400.00

BC-348, ATC, T47/ART-13, T47A/ART-13, 4IN26C, BC-343, BC-312, BC-324, RT18/ARC-1, R5/ARNT, SCR-522, SCR-625, BC-375, BC-323, BC-684, BC-464, RA10, and many others. Prices on request.

Weston Tachometer Generator Model 724, Type CGOOD USED \$12.95
Weston Electrical Tachometer Model 545 for use with 724 Generator. Speed 0-2000 R.P.M. Ratio 2:1NEW 14.50

We will buy new or clean used ARC-1, ARC-3, ART-13, BC-348 original condition or converted 10 115V. A.C. BC-312, BC-342, Test Equipment, etc. All letters will be answered promptly. Please list equipment, condition, and lowest price.

TERMS: Prices f.o.b. Pasadena, Cal. 25% on all C.O.D. orders. Californians add 3% sales tax.

Are You Missing This "Plus" Business?



Sell Extension Speakers, when you install TV in Bars, Cocktail Lounges, Etc.

There are additional profit possibilities in every commercial TV installation, when you sell the advantages of extension speakers—and LOWELL Speaker Baffles! Many Bar and Restaurant owners are now buying larger TV screens, to provide good visibility for more patrons; be sure you emphasize the importance of extending the sound range too!
Lowell Extension Speaker Baffles are ideal for the purpose—easily installed, low in price, attractively designed and finished in any colored lacquer to match surroundings. Lowell Speaker Baffles assure UNIFORM SOUND REPRODUCTION in all directions, give excellent low level response, have "floating conical action." Lowell Baffles are available in all sizes from 6" thru 15", in AL (for low ceilings) and BL (normal ceilings) Models, shown above.
For complete details and prices, write for new catalog covering complete line of Lowell Baffles, for all sound installations.

Lowell Metal Products Corporation
1531 Branch Street, St. Louis 7, Mo.

state of the servicing business in 1951. The supplying of servicing organizations with needed parts and tubes will mean both an expanded servicing business and ever-operative television receivers, which in the final analysis is the most important factor in the success of television broadcasting.

-50-

Within the Industry

(Continued from page 26)

LAWTON who has served as assistant to the president of *Sentinel Radio Corporation* for three and one-half years has been elevated to the post of secretary of the company . . . **ROBERT B. BARNHILL** is the new manager of mobile radio sales for *Bendix Radio Communications Division* . . . **RALPH J. CORDINER** has been elected president of the *General Electric Company* to succeed Charles E. Wilson who was recently named chairman of the government's new Defense Mobilization Board . . . **EDWARD J. HANLEY** has been named president and **CLARK W. KING** executive vice-president of *Allegheny Ludlum Steel Corporation* . . . **DAVID R. HULL** has been elected a vice-president of *Raytheon Manufacturing Company* by the board of directors . . . **ROBERT K. ROULSTON** has been appointed assistant to the president of *Air King Products Company, Inc.* and will coordinate the company's new expansion program . . . **RAY F. SPARROW** has been named senior vice-president of *P. R. Mallory & Co., Inc.* He has been vice-president in charge of sales since 1931 . . . **M. J. ALEXANDER** has joined *Thomas Electronics, Inc.* of Passaic, New Jersey as director of the TV tube firm's sales and advertising programs.

* * *

KURT APPERT, vice-president and chief engineer of *Lenkurt Electric Co.* of San Carlos, California, has been named director of engineering for the firm.



Associated with the company since its founding in 1934, Mr. Appert will be actively engaged in the engineering of

the firm's line of wire-line and radio carrier equipment for telephony, teletography, telemetering, and control.

The post of chief engineer, vacated by the promotion of Mr. Appert, is being filled by George M. Lebedeff. He was formerly chief engineer at *Heintz and Kaufman* and was associated with the *Federal Telegraph Company*.

* * *

MURRAY HILL BOOKS, INC., publishers of technical books, is now operating as the Technical Division of **RINEHART BOOKS, INC.** The company will continue to maintain offices at 232 Madison Avenue in New York . . . **SLIDE-CROSS TELETABLE COMPANY** has been

February, 1951

ENTER RADIO-TV thru *This Plan*—

As a young man with a career to build, you may *today* be interested primarily in training for Radio — and perhaps for TV. But — *who knows* . . . you may some day have both the desire and opportunity to climb further and become an Electrical Engineer! Here, then, is a world-renowned educational *plan* that permits you to use your Radio training as a *major stepping-stone* to an even greater career.

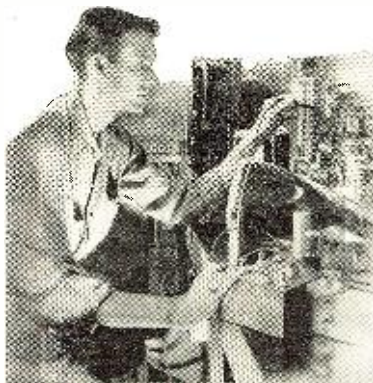

IN 12 MONTHS... become a RADIO TECHNICIAN

You are trained here for functions such as Radio shop operator or Serviceman, Supervisor of service personnel, and Serviceman for Mobile Receivers and all types of Transmitters. The Radio Technician's certificate is awarded. You may then advance immediately or at any future date into courses described below.

IN 6 ADDITIONAL MONTHS you become a RADIO-TELEVISION TECHNICIAN

On completion of the Radio-TELEVISION Technician's course, you are equipped for opportunities in Television — America's fastest growing industry. You are trained for such work as Radio-TV Service—Audio, Transmitter or Communication Technician—and Broadcast Operator (upon passing FCC examination).

ALSO...your radio course is full credit toward a B.S. degree in ELECTRICAL ENGINEERING

Your Radio Technician's course, while complete in itself, is also *one-third* of the program necessary to achieve the B.S. degree with an Electronics major. In the final stage of this college program you receive an added, important service . . . your aptitudes and interests are analyzed scientifically—thus guiding you to choose specialized preparation for design and research—manufacturing and production—or engineering sales and management.

• Over 2300 students, from all states and 23 foreign countries, annually enrolled in this 47-year-old non-profit school. Over 35,000 alumni. Faculty of 85 specialists. Terms open *APRIL, JULY, OCTOBER, JANUARY.*

• Military, practical or prior academic training will be evaluated for advanced credit. Preparatory and refresher courses available. Laboratory training, on modern equipment, is given immediately and in each term.

MILWAUKEE SCHOOL OF ENGINEERING

Technical Institute • College of Electrical Engineering



FREE—
Write today for helpful "Occupational Guidance Bulletin" and 1951 catalog. If possible, state course having your interest.

MILWAUKEE SCHOOL OF ENGINEERING,
Dept. RN-251, 1020 N. Broadway, Milwaukee, Wis.
Without obligation, mail Occupational Guidance Manual on: Radio-Television Electrical Power. Refrigeration, Heating, Air Conditioning Welding. Also 1951 Catalog for Electrical Engineering, B.S. degree Electronics or Power.

Name _____ Age _____

Address _____

City _____ Zone _____ State _____

Check if World War II Veteran



Music—sweet music to his ears!

And why not? A satisfied customer has telephoned—yes, actually telephoned—to thank this service-dealer for the swell repair job on his TV sets.

Your customers may not take the trouble very often to do this, but you can bet your last dime that a *dissatisfied* customer will lose no time in telling you what he thinks. This means call-backs on which you lose time, money, and reputation.

The trick, of course, is to eliminate call-backs. Unfortunately, you can't eliminate them *all*. But, you can keep them to a minimum by using only parts on which you can stake your reputation.

Look at any tube marked TUNG-SOL. There is the same tube—the same performance standards—the same dependability which eight out of ten leading set manufacturers use for initial equipment. All TUNG-SOL tubes are made to meet their requirements. So, when you make replacements with TUNG-SOL tubes, you're putting back into the set the same high quality with which it left the factory.

This TUNG-SOL "one standard" policy safeguards your service work, your prestige and your profit.

Tell your distributor's salesman you'd rather have TUNG-SOL tubes.

TUNG-SOL LAMP WORKS INC., NEWARK 4, N. J.
Sales Offices: Atlanta, Chicago, Dallas, Denver, Detroit, Los Angeles, Newark



ONE STANDARD—*The best that can be made*
For Initial Equipment and Replacement

recently organized to manufacture and distribute a new and specially-designed table to handle all sizes of table model television receivers. The company has showrooms and sales offices at 225 West 57th Street in New York . . . **LEWIS & KAUFMAN, INC.** of Los Gatos, California has purchased the entire capital stock of **TAYLOR TUBES, INC.** of Chicago. Jack Kaufman, president of the parent firm, will direct operations for both companies . . . Formation of a new company under the name of **ANCHOR INDUSTRIAL CO.**, 533 Canal Street, New York, N. Y., has been announced by Richard A. Fisch, owner of the concern. The new organization will take over all sales in the television field from **ANCHOR PLASTICS CO., INC.** in order to expedite service to the television industry.

* * *

O. O. SCHREIBER has been named assistant to the president of *Philco Corporation* in addition to his duties as assistant secretary of the company.



He has been associated with *Philco* for the past 17 years, joining the parent company as controller of *Philco Distributors, Inc.* in New York. He has since held various positions in the financial, production, and contract divisions of the company until his appointment to the post of assistant secretary in 1949. At the same time he was named secretary of the Management Policy Committee and of the Management Operations Committee, two responsibilities which he will continue to discharge.

* * *

RTMA reports that production of TV picture tubes in November continued at its peak fall rate, running slightly above October.

A total of 851,872 tubes were sold to manufacturers in November and 914,804 were produced for all purposes.

* * *

FRANK H. URIELL has been named vice-president and general counsel for *Admiral Corporation* of Chicago.



A well-known tax attorney, Mr. Uriell ended a 25 year association with the law firm of *Pope and Ballard* to accept his new post. He joined the law firm in 1922, later resigning when he was named Assistant to the Chief Counsel of the Bureau of Internal Revenue in 1933. He rejoined *Pope and Ballard* in 1937.

Mr. Uriell's first association with *Admiral* came about in 1942 when he was retained to handle a tax case for the company. From that time until the present he has handled the company's legal matters, an affiliation which led to his present position. —30—

What's New in Radio

(Continued from page 70)

proximately 5½ inches. The output binding posts may be used with leads having single or double banana plugs, spade tips, or plain wire ends. Input terminals are of the banana type with standard ¼" inch spacing.

NEW KNOBS AND DIALS

The *E. F. Johnson Company*, Waseca, Minnesota, is currently marketing a new series of knobs and dials in a wide variety of sizes and calibration markings.

Available with or without black

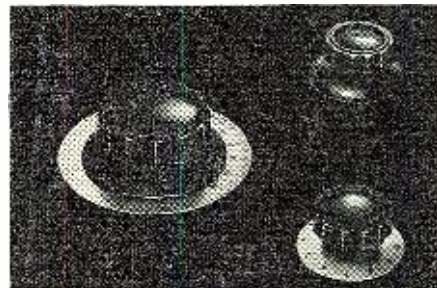

phenolic skirts or satin chrome dials, the new knobs are designed with extra thick walls for added strength. All types have heavy brass inserts. Twelve flutes instead of eight enhance the attractiveness of the knobs by eliminating the octagonal effect. This feature, plus slightly tapered sides, provides better and more comfortable gripping surface, according to the company.

In addition to standard types, the company can supply modified versions of the knobs and dials on special order in quantity production lots. Inquiries should be addressed to the company direct.

CORNER SPEAKER

The Audio Engineering Department of *Sun Radio & Electronics Co., Inc.* of 122-124 Duane Street, New York, New York has developed a new corner speaker system which is being marketed under the tradename "The Realist."

The new unit features a woofer and a tweeter placed back to back. This unique arrangement has the 12½ inch woofer facing out and the 8 inch tweeter facing the corner. According to the company, this arrangement results in no hangover of the bass notes while the treble tones are reflected from the corner and distributed throughout the room with clearer definition.

A wide selection of speakers of various manufacture is available with this system. The impedance matches amplifier outputs of 4 to 16 ohms. Designed primarily for the small room, the system may be used in larger rooms with good results. The cabinet is available in either modern or traditional styling and measures 36" high, 30" wide, and 18" deep. Standard finishes include cordovan mahogany, wal-

1000 KC crystal BT cut. \$3.95
 3" scope shield. 1.29
 2 speed dial drive for 3/4" shaft ratios 5-1 to 1 . . . 1.29
 ATC 100 mmfd air trimmer screwdriver shaft.29
 Sigma Sens. Relay 8000 Ohms. 1.98
 Centralab 850 S 50MMF 5KV BUTON COND. 39
 500 watt 12.5 ohm power rheostat. 3.49



50 mmfd 5 KV vacuum condenser. \$1.49
 6v. 12v vibrators any type.98
 Rotary switch Mylexal, 2 deck SP3T.39
 1 mfd 5000v oil condenser. 2.98
 2 mfd 3000v oil condenser. 3.25
 3 mfd 4000v oil condenser. 3.95
 24 mfd 1500v DC 3KV flash. Excellent for speed lamp 3.95

TUBES!! BRAND NEW! STANDARD BRANDS! NO SECONDS! COMPARE! TUBES!!

0A3/VR75	\$1.29	3C23	\$ 9.95	204A	\$69.50	809	\$ 2.45	8012	\$ 3.95	0A2		6SN7GT		12S17	
0B3/VR30	1.29	3C24	2.25	211	.69	810	9.95	8013	2.95	0A4G		68Q7		12S17	
0C3/VR105	1.49	3C30	2.95	212E	49.50	811	2.95	8014	29.95	0B2		68I7GT		12S17	
0D3/VR150	1.29	3C31/C1B	1.50	215A	3.10	812	2.95	8015	4.29	0Z4		68J7		12S17	
1H23	12.50	3CP1	2.25	227A/5C27	5.95	813	8.95	8025	5.95	01A		68T7		12S17	
1H24	6.95	3CP1-S1	2.25	250R	12.95	814	3.95	9001	2.25	1A3		68U7GT		12S17	
1H26	2.95	3CP1	4.95	250T	11.50	815	3.95	9003	1.49	1A4P		68V7		12S17	
1H27	24.50	3DP1	6.95	250TH	21.50	816	1.19	9004	2.45	1A6		617G		14A4	
1H29	2.75	3DP1-S2A	8.95	250TL	21.50	817	8.26	9006	.29	1A7GT		618		14A7	
1H32	1.35	4-63A	3.95	274A	2.98	818	3.95	9008	1.49	1A8		619		14B6	
1H36	24.96	3E29	14.95	274B	2.65	819	12.95	C1A	9.95	1A9		619		14B6	
1H38	32.50	3EP1	5.95	276A	9.95	820B	14.95	C6A	6.95	1B3/8016		619		14B6	
1N21	1.95	3EP1	3.95	276B	2.98	821	3.95	C6B	6.95	1B4		619		14B6	
1N21A Xtal	2.25	3CP1	4.75	294A	5.75	822	5.95	C6T	6.95	1B5/25S		619		14B6	
1N21B Xtal	3.25	3HP1	3.95	300B	9.95	823	8.95	C100	2.95	1B7GT		619		14B6	
1N22 Xtal	2.25	3HP1	3.95	300C	27.50	824	8.95	CK502AX	2.95	1B7GT		619		14B6	
1N23 Xtal	2.25	4-125A	26.95	304TL	29.95	825	3.95	CK503AX	2.95	1C7G		619		14B6	
1N23A Xtal	3.25	4-250A	29.95	305A	34.95	826	1.69	CK506AX	2.25	1D5GP		619		14B6	
1N23B Xtal	4.25	4-300A	34.95	307A/RK75	5.95	827	2.95	CK507AX	2.25	1D7G		619		14B6	
1N27	1.69	4B22/EL5B	9.95	310A	8.95	828	.45	CK512AX	2.25	1D8GT		619		14B6	
1N34	1.05	4B24/EL3C	7.95	316A	24.65	829	.45	CK517AX	8.45	1E5GT		619		14B6	
1N34A	1.05	4B25/WCF	8.95	327A/5C37	4.95	830	29.50	CR1005	.89	1F4		619		14B6	
1N37	1.35	4B26/2000	8.95	328A	12.95	831	69.50	EL148	.39	1F5G		619		14B6	
1P24	1.79	4B28	4.95	329A	12.95	832	8.95	EP50	.69	1G6GT		619		14B6	
1P36	2.95	4B34	9.95	350B	2.95	833	29.50	F122A	2.50	1H4G		619		14B6	
1S21	6.95	4B37	9.95	350C	2.95	834	29.50	F123A	2.50	1H5G		619		14B6	
2A1	6.95	CV92	49.50	350D	2.95	835	29.50	F124A	2.50	1H6GT		619		14B6	
2A1P	6.95	4C33	12.95	350E	2.95	836	1.39	F125A	2.50	1H6GT		619		14B6	
2C21/RK33	8.95	4C34	12.95	350F	2.95	837	1.39	F126A	2.50	1H6GT		619		14B6	
2C22/7193	4.9	4D32	14.95	350G	2.95	838	1.39	F660	79.50	1J6GT		619		14B6	
2C26A	4.9	4E27	17.95	350H	2.95	839	1.39	FG17	3.95	1K4		619		14B6	
2C31/RK34	4.9	4E27	17.95	350I	2.95	840	1.39	FG27A	7.95	1L4		619		14B6	
2C39	24.50	5AP1	3.69	350J	2.95	841	1.49	FG37	14.95	1L5G		619		14B6	
2C40	4.95	5AP4	3.69	350K	2.95	842	1.49	FG41	14.95	1L6G		619		14B6	
2C41	1.49	5BP4	5.95	350L	2.95	843	1.49	FG45	14.95	1L7G		619		14B6	
2C42	1.49	5BP4	5.95	350M	2.95	844	1.49	FG502A	91.50	1L8G		619		14B6	
2C43	1.49	5BP4	5.95	350N	2.95	845	1.49	FG502A	91.50	1L9G		619		14B6	
2C44	7.50	5CP1	4.95	350O	2.95	846	1.49	FG502A	91.50	1L9G		619		14B6	
2C51	1.79	5C22	49.55	350P	2.95	847	1.49	FG502A	91.50	1L9G		619		14B6	
2D1	1.95	5D21	24.50	350Q	2.95	848	1.49	FG502A	91.50	1L9G		619		14B6	
2D2	1.95	5D21	24.50	350R	2.95	849	1.49	FG502A	91.50	1L9G		619		14B6	
2D3	1.95	5D21	24.50	350S	2.95	850	1.49	FG502A	91.50	1L9G		619		14B6	
2D4	1.95	5D21	24.50	350T	2.95	851	1.49	FG502A	91.50	1L9G		619		14B6	
2D5	1.95	5D21	24.50	350U	2.95	852	1.49	FG502A	91.50	1L9G		619		14B6	
2D6	1.95	5D21	24.50	350V	2.95	853	1.49	FG502A	91.50	1L9G		619		14B6	
2D7	1.95	5D21	24.50	350W	2.95	854	1.49	FG502A	91.50	1L9G		619		14B6	
2D8	1.95	5D21	24.50	350X	2.95	855	1.49	FG502A	91.50	1L9G		619		14B6	
2D9	1.95	5D21	24.50	350Y	2.95	856	1.49	FG502A	91.50	1L9G		619		14B6	
2D10	1.95	5D21	24.50	350Z	2.95	857	1.49	FG502A	91.50	1L9G		619		14B6	
2E1	1.95	5D21	24.50	350AA	2.95	858	1.49	FG502A	91.50	1L9G		619		14B6	
2E2	1.95	5D21	24.50	350AB	2.95	859	1.49	FG502A	91.50	1L9G		619		14B6	
2E3	1.95	5D21	24.50	350AC	2.95	860	1.49	FG502A	91.50	1L9G		619		14B6	
2E4	1.95	5D21	24.50	350AD	2.95	861	1.49	FG502A	91.50	1L9G		619		14B6	
2E5	1.95	5D21	24.50	350AE	2.95	862	1.49	FG502A	91.50	1L9G		619		14B6	
2E6	1.95	5D21	24.50	350AF	2.95	863	1.49	FG502A	91.50	1L9G		619		14B6	
2E7	1.95	5D21	24.50	350AG	2.95	864	1.49	FG502A	91.50	1L9G		619		14B6	
2E8	1.95	5D21	24.50	350AH	2.95	865	1.49	FG502A	91.50	1L9G		619		14B6	
2E9	1.95	5D21	24.50	350AI	2.95	866	1.49	FG502A	91.50	1L9G		619		14B6	
2E10	1.95	5D21	24.50	350AJ	2.95	867	1.49	FG502A	91.50	1L9G		619		14B6	
2E11	1.95	5D21	24.50	350AK	2.95	868	1.49	FG502A	91.50	1L9G		619		14B6	
2E12	1.95	5D21	24.50	350AL	2.95	869	1.49	FG502A	91.50	1L9G		619		14B6	
2E13	1.95	5D21	24.50	350AM	2.95	870	1.49	FG502A	91.50	1L9G		619		14B6	
2E14	1.95	5D21	24.50	350AN	2.95	871	1.49	FG502A	91.50	1L9G		619		14B6	
2E15	1.95	5D21	24.50	350AO	2.95	872	1.49	FG502A	91.50	1L9G		619		14B6	
2E16	1.95	5D21	24.50	350AP	2.95	873	1.49	FG502A	91.50	1L9G		619		14B6	
2E17	1.95	5D21	24.50	350AQ	2.95	874	1.49	FG502A	91.50	1L9G		619		14B6	
2E18	1.95	5D21	24.50	350AR	2.95	875	1.49	FG502A	91.50	1L9G		619		14B6	
2E19	1.95	5D21	24.50	350AS	2.95	876	1.49	FG502A	91.50	1L9G		619		14B6	
2E20	1.95	5D21	24.50	350AT	2.95	877	1.49	FG502A	91.50	1L9G		619		14B6	
2E21	1.95	5D21	24.50	350AU	2.95	878	1.49	FG502A	91.50	1L9G		619		14B6	
2E22	1.95	5D21	24.50	350AV	2.95	879	1.49	FG502A	91.50	1L9G		619		14B6	
2E23	1.95	5D21	24.50	350AW	2.95	880	1.49	FG502A	91.50	1L9G		619		14B6	
2E24	1.95	5D21	24.50	350AX	2.95	881	1.49	FG502A	91.50	1L9G		619		14B6	
2E25	1.95	5D21	24.50	350AY	2.95	882	1.49	FG502A	91.50	1L9G		619		14B6	
2E26	1.95	5D21	24.50	350AZ	2.95	883	1.49	FG502A	91.50	1L9G		619		14B6	
2E27	1.95	5D21	24.50	350BA	2.95	884	1.49	FG502A	91.50	1L9G		619		14B6	
2E28	1.95	5D21	24.50	350BB	2.95	885	1.49	FG502A	91.50	1L9G		619		14B6	
2E29	1.95	5D21	24.50	350BC	2.95	886	1.49	FG502A	91.50	1L9G		619		14B6	
2E30	1.95	5D21	24.50	350BD	2.95	887	1.49	FG502A	91.50	1L9G		619		14B6	
2E31	1.95	5D21	24.50	350BE	2.95	888	1.49	FG502A	91.50	1L9G		619		14B6	
2E32	1.95	5D21	24.50	350BF	2.95	889	1.49	FG502A	91.50	1L9G		619		14B6	
2E33	1.95	5D21	24.50	350BG	2.95	890	1.49	FG502A	91.50	1L9G		619		14B6	
2E34	1.95	5D21	24.50	350BH	2.95	891	1.49	FG502A	91.50	1L9G		619		14B6	
2E35	1.95	5D21	24.50	350BI	2.95	892	1.49	FG502A	91.50	1L9G		619		14B6	
2E36	1.95	5D21	24.50	350BJ	2.95	893	1.49	FG502A	91.50	1L9G		619		14B6	
2E37	1.95	5D21	24.50	350BK	2.95	894	1.49	FG502A	91.50	1L9G		619		14B6	
2E38	1.95	5D21	24.50	350BL	2.95	895	1.49	FG502A	91.50	1L9G		619		14B6	
2E39	1.95	5D21	24.50	350BL	2.95	896	1.49	FG502A	91.5						

IT'S **NEW!**

IT'S A **NATIONAL!**



\$49⁹⁵

SW-54

*the most compact
general coverage
receiver
ever built!*

- 540kc — 30mc
- VOICE
- MUSIC
- CODE

Designed especially for the shortwave fan, the new SW-54 covers ship, police, amateur, foreign and standard broadcast bands. Yet it's housed in a smart, modern, unbreakable metal cabinet that measures only 11" x 7" x 7". Uses new miniature tubes in superheterodyne circuit, for astonishing sensitivity. Unique adjustable plastic bandsread dial assures logging accuracy over entire range. AC/DC operation. Write for details and name of nearest supplier to Dept. C.



nut, natural mahogany, and blonde. Platinum, walnut, and maple finishes are available at additional cost.

PULSE TRANSFORMERS

Engineering Research Associates, Inc., 1902 West Minnehaha Avenue, St. Paul W4, Minnesota has recently put a new line of pulse transformers on the market.

Designed to be used in applications such as triggering and counting circuits and blocking oscillators in addition to use for d.c. isolation, inversion, pulse shaping, and pulse transmission circuits, the new line consists of three types of units.

The Type 100A2 may be used for interstage coupling of pulse amplifiers where no impedance change is desired. The use of the transformer eliminates the necessity for an inverting ampli-

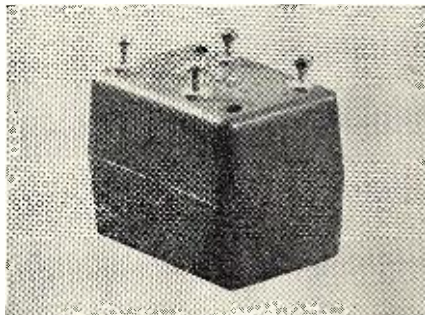

fier stage. It may also be used as a blocking oscillator transformer, for d.c. isolation or for other circuits where pulse polarity inversion and/or d.c. level change is desired without change of impedance.

The Type 101A2 can be employed as an output transformer for a pulse amplifier to match impedance into a coaxial transmission line, or as an output transformer for a pulse amplifier where power must be delivered to a low impedance load, as terminating elements for a pulse transmission line where impedance transformation is required, for d.c. isolation, or other circuit where a change of impedance level is required in pulse circuits.

The Type 102A2 is applicable for matching magnetic reading heads to the input of reading amplifiers and for stepping up voltage from the reading head, for d.c. isolation, or for coupling any low-level, low-impedance voltage source to the input amplifier.

POTENTIAL TAP

Of interest to service technicians as well as laboratory personnel is the new device recently announced by Industrial Devices, Inc. of Edgewater, New Jersey.

The new test device permits a voltage measurement to be made across a load without the usual "breaking in" on the line. The new #400PT consists of a wafer-thin plate which slips over the prongs of standard Edison plugs and provides two tip jacks that receive standard phone tips. The appliance to be checked is plugged through the potential tap into the power receptacle. A standard voltmeter with

**STAY ON THE AIR
WHEN POWER FAILS...with
an ONAN Electric Plant**



**AUTOMATIC
START & STOP**

Model 10E1, 10KW A.C.

When storms, floods, or fires interrupt electricity and force you off the air, you lose listeners and income. Guard against loss, assure vital public service during emergencies by installing an Onan Electric Plant. Onan Standby Electric plants serve many network and private stations. Automatic models to 35,000 watts.

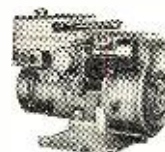

**PORTABLE ELECTRIC PLANTS
FOR MOBILE RADIO USES**
Supply A.C. power for broadcasting at scene of events. Can be carried by hand or in trunk of car. Weigh as little as 80 pounds. A.C. models 350 to 35,000 watts.

Write for **FREE Folder**

Onan PRODUCTS **D. W. ONAN & SONS INC.**
4811 Royalston Avenue
Minneapolis 5, Minnesota

FREE! Just for Examining **COYNE'S** New 5-Volume Set **APPLIED PRACTICAL RADIO-TELEVISION**

Get this Book of TV PICTURE PATTERNS & WAVE FORMS... FREE! Gives you dozens of actual TV Test Patterns and wave forms—tells how to use them to shoot trouble and repair TV sets quicker easier. A money-making short cut that helps you get ahead in Television... and it's yours FREE!

Complete Practical Up-to-Date!
This book is our gift to you for examining Coyne's brand new 5-volume set APPLIED PRACTICAL RADIO-TELEVISION. Here is the most completely up-to-date set of reference books in America! 1500 easy-to-understand pages; 1000 illustrations. Covers all phases of radio and television. Tells you how to install, service, trouble shoot, align all types of radio and television sets. "Break-down" photos help you understand quicker.

Sensational Free Book Offer Send No Money!
Mail coupon now to get this great new 5 volume set and the FREE Book of Picture Patterns. Use the set 7 days. If you keep the set, pay just \$3.00 after 7 days and \$3.00 a month until \$15.50 plus postage is paid. (Cash price \$15.00.) If not 100% satisfied with set send it back and owe us nothing. EITHER WAY THE BOOK ON TV PICTURE PATTERNS IS YOURS FREE. Coupon is just a request to see set and get Free book of picture patterns. This sensational offer is limited. ACT NOW!

MAIL COUPON NOW!
COYNE ELECTRICAL & TELEVISION-RADIO SCHOOL
500 S. Pauline St., Dept. 21-T3, Chicago 12, Ill.
Rush "APPLIED PRACTICAL RADIO-TELEVISION" on 7 days' FREE TRIAL, per offer above.

NAME..... Age.....
Address.....
City..... Zone..... State.....
Where Employed.....

Check here if you want set sent C.O.D. You pay Postman \$15.00 plus C.O.D. postage. Same money-back guarantee of satisfaction.

phone tip leads may then be used to check the voltage with the appliance on or off. In this manner the voltage drop with the load on may be read immediately, without the inconvenience of removing the plug from the line and wiring in the instrument.

FRACTIONAL H.P. MOTORS

The Cyclohm Motor Corporation Division of Howard Industries, Inc. of Racine, Wisconsin is currently in pro-

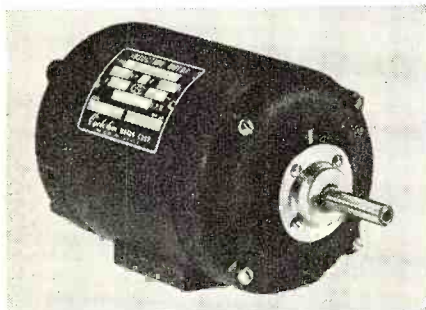

duction on a new fractional h.p. motor for tape recording applications.

The Model 2900 is a two-speed hysteresis motor which is rated at 1/100 to 1/15 horsepower. The same unit is also available as a non-synchronous capacitor motor and a torque motor with high resistance rotors.

The company will supply complete data and literature on the Model 2900 on request.

PHONO PICKUP

Two additions have recently been made to the line of phonograph pickups being manufactured by Sonotone Corporation of Elmsford, New York.

The new "Titone" units include the "Playal" with replaceable needle and the "Super Titone Turnover" unit.

The "Playal" can be used with three types of needles. With a 3 mil sapphire needle, it plays 78 r.p.m. recordings. A 1 mil sapphire needle is used with 33 1/3 and 45 r.p.m. recordings. All three types of recordings can be played with a 2.3 mil truncated osmium needle.

Either a diamond or sapphire needle is used with the "Turnover" model which plays all three speeds. The

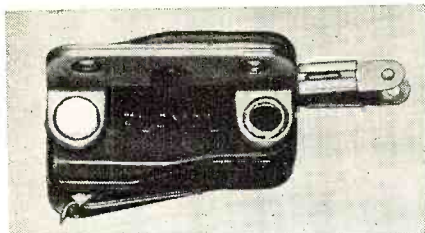

turnover design provides two separate points, a 1 mil for 33 1/3 and 45 r.p.m. recordings and a 3 mil point for 78 r.p.m. The desired point can be put in position by flicking a clearly marked lever.

NEW RECORDING TAPE

Amplifier Corp. of America, 398-2 Broadway, New York 13, New York, has recently added a new sound recording tape to its line.

February, 1951

Money-maker with A Fast Pay-Off . . . Keeps Income Up When Sets Get Scarce

Mail Coupon
for
NEW Bulletin



1. Fixed pole provides mount adaptable to all antenna rotors.
2. Top plate provides guy holes for easy guying.
3. New straight TXT eliminates bending under heavy stack load.

Scarce sets aren't making scarce sales for dealers who push Teletowers! They're selling *improved reception* to present set-owners . . . and collecting a quick pay-off. Penn Teletowers and Thriftowers . . . advertised hard and merchandised hard . . . are now No. 1. on the "Hit Parade" of consumer tower acceptance.

NEW, cost-cutting engineering improvements are now incorporated in Teletowers. You're not up-to-date on your tower engineering until you've read Penn's new, free bulletin. Mail coupon or write today!

Penn Boiler & Burner Mfg. Corp.—Dept. N-1
Lancaster, Pa.

Please send me free bulletin describing structural improvements in Teletowers and Thriftowers.

Name

Address

Canadian representative: J. R. McVITY & CO.,
53 Dalewood Road, Toronto, Ontario, Canada.

PENN Teletowers Thriftowers

PENN BOILER & BURNER MFG. CORP.
LANCASTER, PA.

Service-Dealers: DO A

\$50,000

TV BUSINESS
ON A \$500 INVESTMENT

WITH THE
TRANSVISION

Factory Agent Plan

Why this Plan is BEST FOR YOU:

- You have NO INVENTORY PROBLEM because you work from our MILLION-DOLLAR stock.
- You get SPECIAL PRICES to enable you to undersell competition at a profit.
- You get EXCLUSIVE TERRITORY benefits.

REQUIREMENTS: You must be a Radio-TV Technician (experienced only); and you must have a presentable business place.

The TRANSVISION TV LINE is of the finest quality. Has the famous "A" chassis, housed in beautiful cabinets. 28 models. 17" or 19" Tubes.

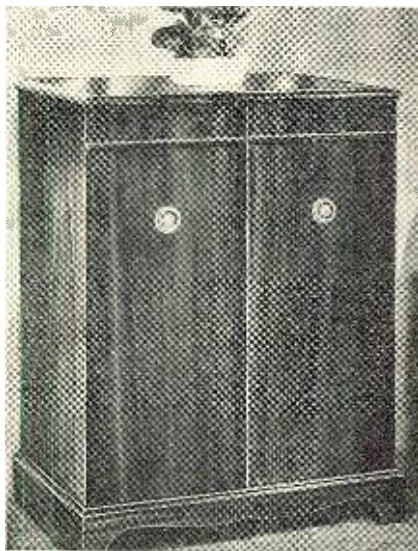

Write for Details on
FACTORY AGENT PLAN today!

TRANSVISION, INC.

Dept. RN NEW ROCHELLE, N. Y.

The new "Magneribbon" Premium Sound Recording Tape is currently available in four types: Red Oxide (medium coercive) with paper and plastic base and Black Oxide (high coercive) with paper and plastic base. All tapes are of standard ¼ inch width and come in 1200 foot lengths, wound on non-warping tempered aluminum 7" diameter metal reels that fit all standard recorders. A metal leader is furnished with the tape to facilitate threading onto standard takeup reels.

The company claims that the new tape offers excellent quality over a wide response range with unusually fine high frequency response.

A descriptive circular is available from the Accessories Division of the company at the address given.

RADIO SWITCH-TIMERS

The Sessions Clock Co. of Forestville, Conn. has recently announced a series of new switch-timer movements for radio applications.

These new units feature the "Tru-Bel" ten-minute reminder, a low-speed quiet motor, and "Sleep-Selector" switch to turn the radio off automatically at a preset time up to 90 minutes, automatic radio shut-off 1½ to 2

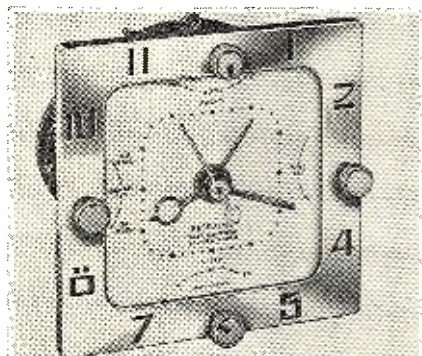

hours after the timer turns on (for the forgetful), and UL Approved 10 and 15 ampere switches.

Radio manufacturers have a choice of front or back controls, round or square bezel, and etched or screened numerals, luminous or in color. Dial and hand styling can be furnished to suit the user.

The new switch-timer catalogue covering these and other units in the Sessions line is available from the Timer Division, Dept. 21, of the company.

PAGING SPEAKER

University Loudspeakers, Inc. of 80 South Kensico Ave., White Plains, N.Y. has developed a new paging-type speaker, the "Cobra-12."

With power input capacity of 12 watts continuous, and a frequency response of 250 to 10,000 c.p.s., it is capable of unusually wide-angle dispersion of sound in the horizontal plane, while limiting the vertical dispersion to the optimum degree for paging and talk-back purposes.

The new design permits efficient and economical installation since it offers acoustic possibilities which cope with reverberation and ambient noise prob-

lems, as well as reducing the number of speakers required for various installations.

ANTENNA TURNER

Neo Products Corporation of Erie, Michigan has developed a new low-cost, hand-operated antenna rotator

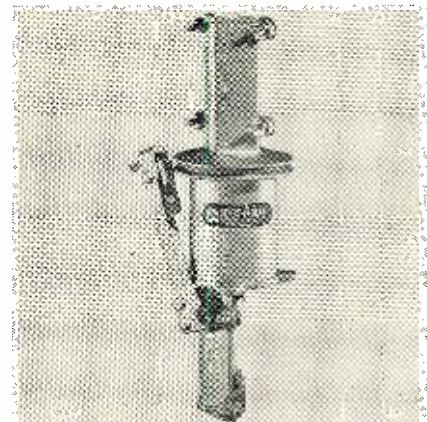

which may be used for either ham or TV applications.

Tradenamed the "Select-a-Beam," the new unit is constructed of aluminum and is rustproof, corrosion resistant, and comes equipped with weather-sealed ball bearings. The rotator is said to be practically foolproof and is factory-lubricated for life. A small worm-gear control box for attachment to the outside of the house turns the antenna 360 degrees in seconds and may be operated from either the outside or inside. Positions lock automatically but for additional speed and ease in turning to chosen stations, a simple mechanical metering device has been provided.

PLAYBACK MACHINE

Audio-Master Co. of 341 Madison Avenue, New York 17, New York has redesigned its transcription playback machine for greater flexibility and versatility.

The new '51 plays all speeds, 33½, 45, and 78 r.p.m. and all size records from 7 to 17½ inches and all kinds of discs including transcriptions. Important new features of the unit include a four-tube, high-gain amplifier, a de-



tachable 8" loudspeaker with a 10 foot cord, and a twist crystal cartridge fitted with two permanent needles.

A special jack has also been added to the design to provide p.a. service when used with a mike. The machine may also be supplied with earphones if desired.

-30-

RADIO & TELEVISION NEWS

... AND NOW FOR A WORD FROM BUFFALO RADIO SUPPLY

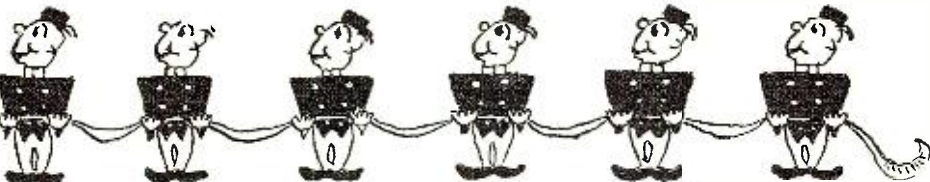

TRANSFORMERS

AUTO-TRANSFORMER—Steps up 110V, or steps down 220V to 110V—\$2.95.
FIL. TRANS.: 6.3V, 1 Amp—\$1.00; Universal Output Trans., 8 Watt—89c; 18 Watt—\$1.29; 30 Watt—\$1.69. **AUDIO TRANSFORMER**: S. Plate to S. Grid, 3:1—79c; S. Plate to P.P. Grids—70c; Heavy Duty Class AB or B, P.P. Inputs—\$1.49; Midjet Output for AC-DC sets—69c; **MIKE TRANSFORMER** for T-17 Shure microphone, similar to UTC cancer type—\$2.00. Stancor SB or DB mike to line or grid—\$1.95.
POWER TRANSFORMERS—Half-shell type, 110V, 60 cy. Centertapped HV winding. Specify either 2.5 or 6.3V filament when ordering.
 For 4-5 tube sets—650V, 40MA, 5V & 2.5 or 6.3V..... \$1.75
 For 5-6 tube sets—650V, 45MA, 5V & 2.5 or 6.3V..... 1.90
 For 6-7 tube sets—675V, 50MA, 5V & 2.5 or 6.3V..... 2.35
 For 7-8 tube sets—700V, 70MA, 5V & 6.3 or 2.5..... 3.00
 For 7-8 tube sets—700V, 70MA, 5V & 6.3 (25 Cycles)..... 4.50
 For 8-9 tube sets—750V, 80MA, 5V, 3A, 2.5V-3.5A, 2.5-10.5A..... 3.50
 For 9-11 tube sets—700V, 5V & 6.3V-4.7..... 3.50
 For 9-15 tube sets—600V, 150MA, 5V & 6.3V..... 4.00



WE ARE LOOKING FOR TUBES
 and other surplus.

Large or small quantities. Send your list for our bid.

We especially want BC654 and SCR284 components.

HEAT GUN

Streamlined pistol grip heat gun. Vivid red glow. 20 cubic feet per minute blast of hot air at 160° Fahrenheit. Ordinary blowers have small fan motors but this has a lifetime-lubricated AC-DC motor of the rugged vacuum cleaner type, that produces a hurricane of either hot or cold air. Blow out dirt or dust from radio chassis. Dry out ignition systems. Heat carburetors. Quick-dry paint. Thaw out radiators or water pipes, etc. Warning—Keep this away from your wife. She will use it to dry her hair because it will do it in half the time of her ordinary hair dryer, to say nothing of her using it to dry stockings or clothing, or defrost the refrigerator instantly. Only \$12.95. Satisfaction guaranteed or money refunded if returned prepaid within 5 days.



Universal 4 lead broadcast band oscillator coil (can be converted to 3 lead type by addition of jumper). Ten for.....\$1.00



PHONO SCRATCH ELIMINATOR

Consists of 2 condensers and powdered iron core choke connected in filter network. Same as used in most jukeboxes. Connects instantly between pick-up and amplifier.....\$2.00

CERAMIC INSULATED VARIABLE AIR CONDENSERS

10, 15 or 23 mmf—\$.35, 10 for \$2.90, 100 for \$23
 25 mmf—\$.40, 10 for \$3.40, 100 for \$28
 50 mmf—\$.45, 10 for \$3.70, 100 for \$30
 75 mmf—\$.50, 10 for \$4.40, 100 for \$33
 100 mmf—\$.55, 10 for \$4.50, 100 for \$39
 140 mmf—\$.80, 10 for \$7.40, 100 for \$64
 160 mmf—\$1.00, 10 for \$8.50, 100 for \$75
 Buttery condensers, rotor has double ball bearings and 9/16" shaft.
 15 mmf. per section \$.50, 10 for \$4.50, 100 for \$40
 30 mmf per section \$.60, 10 for \$5.50, 100 for \$50
 50 mmf per section \$.70, 10 for \$6.50, 100 for \$60

SUPER SPECIAL!

2 gang midjet superhet tuning condensers with 1/4" shaft and trimmers, .9 for \$2.50
 2 gang 140 mmf—\$1.60, 10 for \$12.50, 100 for \$100

350 mmfd 5 gang—\$1.95
 3 gang—\$1.29

Manufacturers and Distributors: Write for prices on larger quantities. WE HAVE OVER 250,000 VARIABLE CONDENSERS IN STOCK.

All sales final and no returns unless otherwise specified in ad of item. Right reserved to change prices and specifications at any time. Cable address BUFRAD

SENSATIONAL TV BOOSTER KIT

Latest circuit utilizing greatly improved push-pull circuit for maximum gain.

Perfect operation on higher channels where other boosters fail. 3 tubes. Ceramic butterfly condensers. Coil sets for either low or high channels. 110V 60 cycle. Built up \$29.95. Save half by buying the kit and wiring the parts together from the schematic and pictorial diagrams furnished. Kit \$14.95.

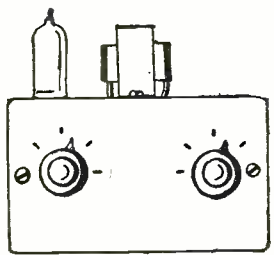

ASSORTMENTS

- Wire Wound Resistors, 12 Asst., including adjustable.....\$1.00
- Knobs, Assorted, 30 for..... 1.00
- Sockets, 9, 8, 7, 6, 5 prong, 25 for..... 2.00
- Coil Forms, Large & Small Asst., 20 for..... 1.00
- Rotary Switches, Asst., 6 for..... 1.75
- Resistors, Asst., 100 for..... 2.95
- Insulators, Asst., 20 for..... 1.00
- Bathub Oil Condensers Asst., 6 for..... 1.00
- Solder Lugs, Asst. Types, 300 for..... 1.00
- Asst. Oscillator Coils, 7 for..... 1.00
- Asst. Toggle & Slide Switches, \$3.00 value, 5 for..... 1.00

SAVE HOURS OF HARD WORK

Do the job in minutes with a BUFRAD Socket Hole Punch. Cut clean accurate holes for sockets, plugs, connectors, etc. Cutting holes in radio chassis is as simple as cutting butter with a hot knife with a BUFRAD punch. Just insert the punch in a 1/2" hole and turn with an ordinary wrench. In a minute or less you can complete a job which often takes an hour with the old "drilling, reaming, and filing" method. With BUFRAD punches you can make 13 different sizes of openings from 1/2" to 2 1/4" diameter.
 1/2", 5/8", 3/4", 7/8".....\$2.08
 1", 1 1/8", 1 1/4", 1 1/2", 1 3/4", 1 7/8", 2", 2 1/8", 2 1/4" sizes.....\$2.42
 1 3/8", 1 1/2" sizes..... 3.10
 2 1/4" size..... 5.95



CONDENSERS

Below is designated the quantity of nationally known tubular condensers that you can buy for a DOLLAR BILL.
 *.0005-15, *.001, *.002 or *.005-11, *.01, *.02 or *.03-10, *.05-9, *.1-8, *.25-6, *.5-4.

GENERAL ELECTRIC 150 WATT TRANSMITTER

COST THE GOVERNMENT \$1800.00

COST TO YOU—BRAND NEW—EXPORT PACKED \$100.00

This is the famous transmitter used in U.S. Army bombers and ground stations during the war. Its design and construction have been proved in service, under all kinds of conditions, all over the world. The entire frequency range is covered by means of plug-in tuning units which are included. Each tuning unit has its own oscillator and power amplifier, coils and condensers, and antenna tuning circuits—all designed to operate at top efficiency within its particular frequency range. Transmitter and accessories are finished in black crackle, and the milliammeter, voltmeter, and RF ammeter are mounted on the front panel. Here are the specifications: FREQUENCY RANGE: 200 to 600 KC and 1500 to 12,500 KC. (Will operate on 10 and 20 meter band with slight modification for which diagrams are furnished. OSCILLATOR: Self-excited, thermo compensated, and hand calibrated. Equipped with antenna coupling circuit which matches practically any length antenna. MODULATOR: Class "B" uses two 211 tubes. POWER SUPPLY: Supplied complete with 2 dynamotors which furnish 100V at 350 MA, from either 12 or 24 volts. Complete instructions are furnished to operate set from 110V AC. SIZE: 21 1/2 x 23 x 9 1/4". Total shipping wgt.—350 lbs., complete with all tubes including a full set of spares besides those necessary for operation, dynamotor power supply, seven tuning units, antenna tuning unit and the essential plugs.

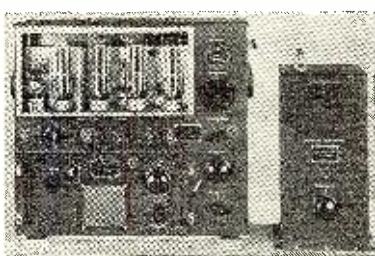

COMPRESSED AIR INSTANTLY ANYWHERE

Portable Air Compressor and storage tank. Ruggedly built of best materials using lifetime lubricated ball bearing on connecting rod and oil-impregnated main bearing on shaft. Unusual design forever eliminates valve trouble, the most common fault in air compressors. **PATENTED** unique air intake system increases efficiency tremendously over other compressors so that a larger output is much greater than that from larger compressors powered by heavier motors. Will deliver approximately 3500 cubic inches of air per minute at maintained pressure of 30 lbs., or will inflate a 90 lb. truck tire in less than one minute. Comes complete with 100 lb. gauge, although finger-tip adjustment allows setting of output pressure at any value, which will automatically be maintained. Works from any 1/4 H.P. motor. Useful for spraying paints or lacquers, disinfectants, insecticides, annealing or brazing with natural gas, inflating tires, etc. Price \$4.50 postage prepaid anywhere in the U. S. Efficient, completely adjustable siphon type spray gun complete with 12 ft. of 100 lb. tested hose available for only \$7.75 with pint container, also prepaid, 25% required on all C.O.D. orders.



SPAGHETTI

Terrific Bargain in Spaghetti at lower than carload lot prices. Plastic Spaghetti made to U.S. Air Force Specs. Safe for 10,000 volts.
 3/8" to 1 1/2" diam..... 1c per ft.
 5/16" to 3/8" diam..... 1 1/2c per ft.
 7/16" to 1/2" diam..... 5c per ft.
 1" to 1 1/2" diam..... 10c per ft.
 We can supply continuous lengths up to 100' clear or black in most sizes.

MICROPHONES

Super Special—High-quality all chrome bullet shaped CRYS-TAL MIKE of top-flight nationally known brand—\$5.95. Bullet DYNAMIC MIKE—\$7.95. MIKE Jr.—60c. PUSH-TO-TALK MIKE with switch on handle—98c. LAPEL MIKES—(Specify whether carbon or magnetic)—93c.



AUDIO AMPLIFIER

Brand new, dual triode amplifier having 2 of the valuable and scarce ounce type audio transformers that sell for \$12.80 apiece. Neat aluminum case, fully enclosed (largest dimension 6 in.). Perfect for intercom systems, phono amplifiers, mike amplifiers, or signal tracer amplifier for testing radio sets. A sensational bargain at only, each..... \$3.40

"P.M. SPEAKERS"

Latest type PM Speaker in a fully-enclosed finished metal cabinet. This speaker and case match communication receivers, and in addition make perfect intercom remote stations. Our price \$4.50. Including output transformer.....\$4.95



1000 CYCLE AUDIO FILTER

With TOROID Coils

Navy PD52010-1 low pass audio filters as mentioned in the "Peaked Audio" article in June CQ, and designated by the above number, are the exact electrical and physical equivalents of commercial audio filter units selling for \$35.00 wholesale. They are infinitely better than the surplus "Radio Range Filters" being sold for reducing QRM, and at 2 KC off resonance, for example, a 2 section filter using PD52010-1 is capable of twice the selectivity available through the use of the Q5-er (the BC453 section of the 274N which has provided the amateur's previous highest standard of interference elimination). **EXTRA SPECIAL—NAVY PD52010-1 with diagram.....\$2.00**

MIDGET 1 WATT TRANSMITTER supplied complete with polystyrene coil forms for 3 ham bands. Size overall 3 1/2" x 2 1/2" high. Includes practically all necessary parts. Your Cost.....\$1.50

BUFFALO RADIO SUPPLY, 219-221 Genesee St. Dept. RN-2, BUFFALO 3, N.Y.

A Vacuum-Tube TRANSFORMER

A simple circuit, superior to cathode follower, eliminates costly transformers when coupling high-impedance output to low-impedance device.

By
RICHARD H. DORF
Audio and TV Consultant

ANY occasions arise where the outputs of low-level amplifiers must be coupled to low-impedance devices. Typical instances are microphone and phonograph preamplifiers feeding low-impedance mixers or lines in broadcast stations, recording studios, p.a. systems, and high-quality residence installations. If transformers are used, high prices must be paid for output transformers which will not introduce frequency, phase, or intermodulation distortion.

Replacement of the transformer with a vacuum tube is the first thought that comes to mind, and the cathode follower circuit seems the obvious one to use. In many cases it is satisfactory and the impedance-matching cathode followers presented by Leon G. Wilde in the December, 1949, issue of RADIO & TELEVISION NEWS fill the bill.

There is one drawback, however, when a cathode follower is loaded by a low impedance. Fig. 1, for instance, shows a cathode follower with a 500-ohm output impedance feeding a 500-ohm load. The blocking condenser *C* must have a large capacitance, at least 50 μ fd. for a 500-ohm system and proportionately more for lower-impedance units, which means that it must be an electrolytic. And being an electrolytic, it has appreciable d.c. leakage, even if it is of the highest quality. There is, thus, some d.c. in the load.

The writer has found from experience that even this small amount of d.c. is enough to produce bad effects. If a variable attenuator—wire-

wound or step-type—is the load, the slightest imperfection in the contact of the rotating arm with the resistance network makes a loud pop. If the load is the primary of an input transformer, the d.c. may be enough to damage the frequency response, though it is not likely to saturate the core. If there is a switch of any kind between the cathode follower and its load, each opening and closing of the

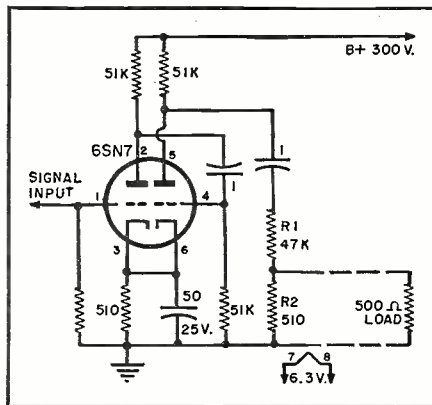

Fig. 2.

switch sounds like a pistol shot—and there is no way of “de-clicking” the system. Where a switch is used, there is some advantage in placing a permanent resistor, about 10 times as large as the load, between the negative end of the condenser and ground; this keeps the condenser charged, at least. It does not solve the problem.

A solution is offered by the circuit of Fig. 2. At the cost of one extra tube or the replacement of the single cathode follower triode by a duotriode, d.c. is entirely eliminated from the load and added gain is secured.

The problem solved in the writer's case was that of coupling the outputs of microphone and phonograph preamplifiers to 500 ohm lines leading to the inputs of a 500 ohm mixer system. The output circuit of Fig. 2 is simply a pair of cascaded triodes, with the output line tapped across the last 500 ohms of the resistance which ordinarily would be across the grid of the following stage. This approach may seem less ingenious than the cathode follower, aside from the question of blocking d.c., but a look at the following figures will change that impression.

The voltage gain of each triode is 13; gain of the two stages from input ohms. The voltage appearing across grid to the second plate is 169 or 45 db. R_1 and R_2 constitute a voltage divider; the effective value of R_2 in combination with the load is about 250 R_2 and the load is, therefore, about 1/200 of that on the second plate, a loss for purposes of impedance matching of about 46 db. Since the gain of both stages is 45 db., net loss from input grid to 500 ohm load is about 1 db.

The d.c. blocking condenser *C* is in series with 47,000 ohms instead of with 500 ohms as in the cathode follower of Fig. 1. It can, therefore, be much smaller. The value of 1 μ fd. shown in Fig. 2 is adequate for the most exacting bass response. It is, of course, a paper unit (or metallized paper for smaller size), so does not pass any detectable d.c.

The loss of 1 db. in this circuit compares with a somewhat greater loss in the cathode follower. It is also interesting to compare this circuit with a standard transformer-loaded triode stage. Voltage gain of the latter may be around 10, or about 20 db., from grid to plate, but the stepdown loss in the 10,000-500 ohm output transformer is about 4.5, or 13 db., leaving a net voltage gain for the stage of only 7 db. The use of the circuit of Fig. 2, therefore, entails a loss of only about 8 db. compared with a standard transformer scheme. But not only is it cheaper to add the gain needed with another tube (and usually the 8 db. difference is not important), but no transformer can perform as well for high-quality work as a straight vacuum-tube circuit.

Decibel calculations should usually, of course, be corrected for the differences in input and output impedances. Here, however, we are dealing strictly with voltage, so impedances do not introduce real errors.

The limitation on the circuit of Fig. 2 is that it is usable only in low-level applications. Maximum permissible input voltage to the first triode grid is 0.17 volt and maximum output is 0.14 volt or about -22 db. (6 mw. reference level in 500 ohms). The circuit may be used for 600-ohm circuits by simply replacing R_2 with a 620 ohm resistor. Maximum output level in this case will be roughly -15 v.u. (1 mw. reference level in 600 ohms).

These values are quite satisfactory in most audio systems consisting of preamplifiers, high-level mixer, and program or line amplifier. In addition to the low cost and high performance compared to transformer coupling, the R_1 - R_2 voltage-divider effect affords a 46 db. isolation of the outgoing line from tube noise and hum. In cathode followers the direct coupling to a tube element often gives great difficulty from these factors, especially from hum, when a low-level circuit is being fed. This is true even with very well filtered power supplies and may be due to the close proximity of the cathode to the heater.

Fig. 1.

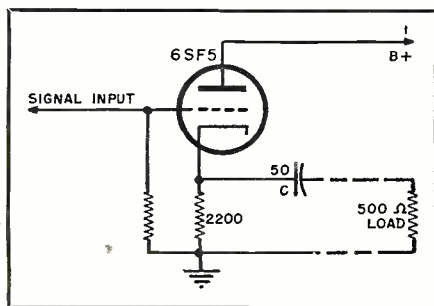

Spot Radio News

(Continued from page 16)

are permitted to develop both technical and programming experience . . ." there is scant prospect that they will be ready and able to exploit ultra-high television when it comes of age."

COLOR plunged into one of the dramatic events of the year during the closing days of '50, when RCA presented its improved version of compatible electronic red, green, and blue viewing. In accordance with its earlier promise to unveil a system that would feature many improvements, the gentlemen from Princeton displayed models using tri-color tubes with the number of dots increased from 351,000 to 600,000, and with new red and blue phosphors which added to picture brightness and eliminated the need for an optical filter.

Everyone was enthusiastic about the results. During a demonstration before licensees, several large-plant owners declared that the pictures were very striking. In the opinion of Dr. Allen B. DuMont, the system now offers substantial brilliance and no longer is there any flicker. The fidelity was also very good, he said.

The reduction in chassis size was particularly noticeable. When the color demonstrations were held about two years ago, there were about 100 tubes in the model and three picture tubes were set up in an elaborate mirror system. The newest set has only 43 tubes and a single three-color picture tube. Incidentally, the picture available now is about 13½ inches, but it is expected that this will be increased to at least 16 inches very soon. A 13-tube converter was also demonstrated, along with a slave-type chassis.

Describing the operation of the system, technical staff members said that each primary color is directed to one of three camera tubes. The pictures on the three tubes are then scanned by electronic beams simultaneously and each image is thereby dissected into 525 lines, the entire process being repeated 30 times per second. The outputs of the three-camera tubes consist of three simultaneous picture signals, each representing one of the three primary colors. After the signals leave the camera tubes, they are combined to form a black and white picture, which contains mixed highs, a principle based on the fact that the eye cannot distinguish color in fine detail. At the same time, the three primary color signals pass through a color sampler and are multiplexed to permit their transmission over a standard TV band. The black and white signal containing the mixed highs is added to the sampled or multiplexed color signals in an electronic unit called an "adder," and the result is a combined high-detail video signal.

The incoming television signal passes through standard receiver circuits.

February, 1951

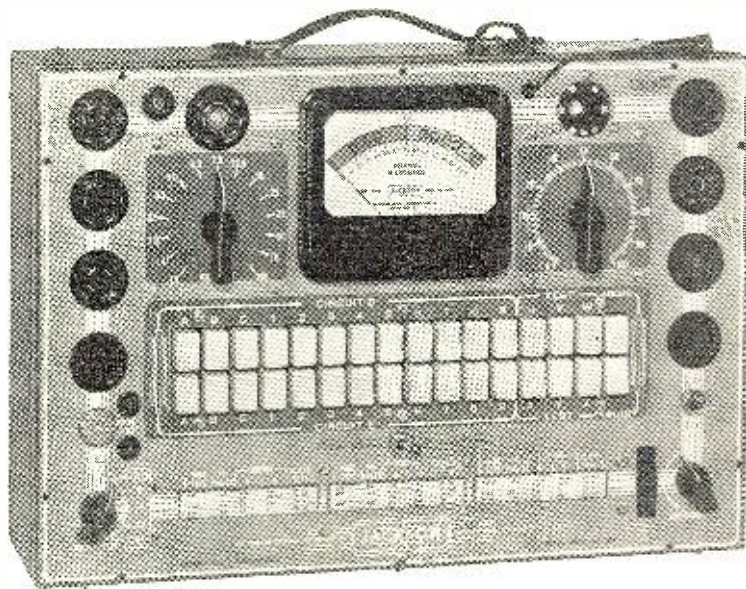

Dependable—Simple—and, "Service-Engineered"

JACKSON "Dynamic" Tube Tester

Here is the tube tester used and recommended by manufacturers, laboratories and smart service organizations. Uses the "Dynamic" principle, pioneered by Jackson. Here are just a few of its major features.

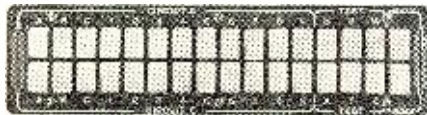

Sequence Switching—no obsolescence with this amazing switch. Simple to use. Tube elements not connected together. Each element gets the right load or the right voltage.



Complete Shorts and Noise Tests

You test every element for shorts. Because tube elements are tested separately, you get a true picture of tube operation. Switch position shows which element is shorted—helps you locate source of circuit trouble.

Life-Line Indicator

Reduces normal heater or filament voltage. Tells you if tube is approaching the end of its life. Helps avoid troublesome call-backs. Insures more satisfied customers.

There are many more advantages to this fine Jackson tube tester—big, 4" meter—sockets for every type of tube, including sub-miniatures, blanks for future types—built-in roll chart. For the complete story, fill in and mail coupon today.

Available in bench, counter, or portable styles. Prices as low as

\$94⁵⁰

Jackson Electrical Instrument Company
Department 48
16-18 S. Patterson Blvd.
Dayton 1, Ohio

Gentlemen:
Please send information on:

- Model 648 Tube Tester Complete Jackson Line
 Low Cost Challenger Line TV Instruments

NAME _____

ADDRESS _____

CITY _____

ZONE _____

STATE _____

MY DISTRIBUTOR IS _____

JACKSON

"Service-Engineered"
Test Equipment
Dayton 1, Ohio

Tube Testers—Television Generators—
Oscilloscopes—AM-FM Generators—
Audio Oscillators—Condenser Check-
ers—Vacuum Tube Voltmeters.

*TM REGISTERED U. S. PATENT OFFICE

SAVE 98% NOW

COMMAND AND OR ARC5 TRANSMITTERS AND RECEIVERS

	USED	NEW
BC-442 Antenna Relay	\$ 1.85	
BC-450 3 Receiver Control	.97	\$1.95
BC-454 Receiver 3-8 mc	3.55	7.95
BC-455 Receiver 6-8.1 mc	3.55	9.95
BC-457 Transmitter 4-5.3 mc	3.55	
BC-458 Transmitter 5-5.7 mc	3.95	
BC-606 Transmitter 3-4 mc	18.95	
BC-433 200-1750 kc Receiver	19.95	
Above all with tubes.		

	USED	NEW
BC-1206C Receiver 200-400 kc.	\$ 5.95	\$ 7.95
BC-357 Marker Beacon Rec. W.O. Tubes		3.95
TA-12 Transmitter		39.50
BC-733 Excellent condition	9.95	
BC-375 Transmitter 100 Watt Voice, CW, MCW, covers frequency range 200 kc to 12 mc by the use of Plug-in Tuning Units, as listed below. Complete with tubes, less Tuning Units.		

Used, \$15.95; New \$19.95
 GP-7 NAVY TRANSMITTER: 100 watt master oscillator type. Can be used on any freq. from 350 to 9050 kc. By using proper plug-in tuning unit. Type S03 P. A. and built-in, 115 V. 400 cycle power supply using a pair of 1616 rectifiers. Comes with 1 tuning unit. \$12.39
 Additional Tuning Units. Ea. 3.50

TUNING UNITS FOR BC-375 or BC-191 Transmitters listed below.		
TU-6 3000-4500 kc		
TU-7 4500-6200 kc	TU-10 10000 to 12500	
TU-8 6200 to 7700 kc	TU-22	
TU-9 7700 to 10000 kc	TU-26 200-500 kc	

BC-306 Antenna Loading	\$1.95
FT-151 Shock Mounting for BC-375-191	2.95

LOOP ANTENNAS

DU-1 MDF Has 2 tube amplifier.	\$25.95
New	
MIN-20-E New	\$7.95
L/P-21A New	7.95

FLS Filters. New	\$1.09
FL5 Filters. New	.97
Iland Keys J-38. New	.89
TCS Transmitter & Receiver and Power supply and cables, good. Used	\$19.50
Heinemann Circuit Breakers, 115 v 20 amp	1.35
Prop Pitch Motors, New. \$13.95. Transformer for same	5.95
RT 7 APN-1 Transceiver, used, \$6.95. New	9.95
BC-1066 B-150-225 mc portable receiver. Used, \$9.95. New	12.95

TRANSFORMERS

3200 V 300 ma NCT	\$8.95	\$15.95 pr
12V 24V 2 am 110 V. primary		\$2.95

TUBES

5 GPI \$4.95; 5 RPT \$1.95, 3 BPI \$3.95, 5 HV4, \$1.95, 3 P17 \$1.95.
--

ARC-4 2 Meter Transceiver complete with tubes. Excellent condition	\$39.00
BC-239 Indicator	4.95
BC-434 Control for ARN-7 used \$1.95. New	2.95
Code practice Tape for TG-10 15 Rolls. New	6.95
BC-655 Signal Generator 17.5 to 160 mg 400 cy mod. Battery oper. New	24.95
MD-7 ARC-5 Push Pull Mod. Used	7.95
BC-506 Abruptly Dying Meter. In black crackle case with handle, frequency range 150-225 mc. Uses 4-500 DC Microammeter for indicator. Used \$10.95. New	13.95
Mobile Generator Noise Filter PL-19-55A-30 VDC. Original Cost \$15.00. Works wonderfully	1.19
Field Phones E-E S's, Used \$7.95 ea. pr \$14.95. New	\$24.95 a pair

DYNAMOTORS

DM-53-A 24 volts at 1.4 amps output 220 @ .08 amp	\$1.95
DM-33-A 28 volts @ 2.7 amps output 500 v @ 100 mills. Used	2.95
PE-73 29 volts @ 20 amps output 1000 v @ 370 amps. New	4.95
BD-77 14 volts @ 450 amps output 1500 v @ 350 amps. New	6.95
PE-94 For SCR-322 24 v. New	4.85
PE 04 Dynamotor only	3.95
PE-101	2.95
DM 34 12 volts @ 2.8 amps output 220 v. @ 160 amps. New	8.95

683 FM Receiver 26 to 39 mc FM Receiver with tubes \$29.95 used. New \$39.50
 RL-42A Antenna Reel Assembly. Excel for rotating, small beam. Less wire. New 4.95

OIL CONDENSERS

2 mfd 600 v . . . \$.19	10 mfd 600 v . . . \$ 1.15
4 mfd 600 v85	2 mfd 2500 v . . . 2.48
1 mfd 1000 v85	2 mfd 4000 v . . . 4.35
3 mfd 4000 v . . . 5.95	2 mfd 5000 v . . . 6.95
2 mfd 10000 v 24.95	paper 19.95

STANDARD MAKES

T-30 Throat Mike. Used	\$0.19
RM-29A Remote control unit for telephone or phone patch	8.95
CD-307 Head set extension cord	.85
Chokes 5 h. 50 mil.	.37

HEAD SETS

HS-30 New	\$1.49
HS-23 Used	1.19
HS-33 Used	1.19
Matching Transformer for HS-30	.41

BC-348 Mounting Base	\$2.49
BC-348 Outlet Plug	.69
RG-7U Coax 17. ohms	11.06
Cash with order. Prices subject to change without notice.	
Many more items too numerous to list. Inquiries invited.	

SAM'S SURPLUS

1380 Bond St. Los Angeles, Calif.

The black and white signal containing the mixed highs is separated or subtracted and at the same time the color signals pass to an electronic unit known as the color-receiver sampler, where the original three primary color signals are simultaneously produced. The black and white signal containing the mixed highs is then added to each of the primary color signals. Each primary color signal thus produced is then directed continuously to one of the electron guns in a direct-view picture tube. Each gun produces a complete color picture in its own primary color.

Confidence in the improved technique was so sturdy, that a statement was issued declaring that the corporation is willing to back this assured feeling with its money and reputation. The assertion was made in a brief filed before the three-judge court in Chicago, before whom a color-injunction motion had been made against the FCC.

"The confidence of RCA and NBC in the RCA color system is not based on laboratory work alone, but upon actual experience," the brief said. "It is based on months of field testing under conditions which the record shows closely approximate normal commercial broadcasting conditions."

The brief also cited the lack of success CBS has had in finding an engineering solution to the problem of incompatibility after devoting, as it claims, ten years of research to its method. Compatibility, the brief explained, should be . . . "dealt with as a research expense of the company which sponsors a color system. It should not be dealt with at the expense of the public. But the adoption of the CBS system is an attempt to transfer the expense of compatibility to the public, which must buy adaptors, at a cost of half a billion dollars, to overcome the defect of incompatibility in that system."

According to the legal reply of the electronic proponents, compatibility is . . . "an engineering matter to which RCA devoted its attention with success and with respect to which CBS must admit complete and absolute failure."

SMALL BOAT OWNERS received a bit of good news during the closing days of the old year, when they learned that the popular frequency of 2638 kilocycles, would still be available. Because of a rule-making procedure which had indicated that maritime rule revisions, calling for frequency and use restrictions, would be probed before the year was out, some small craft operators thought that the 2638 channel would be cancelled. Actually, according to the Commission, plans are afoot to provide comparable additional frequencies in the 2000 to 3500-kilocycle band. At present, there are no frequencies in this band available for immediate substitute assignment. Therefore, it will be necessary to continue the use of the 2638 frequency for

general radiotelephone communications until substitute frequencies are made available.

The FCC said that they heartily approve the use of small-craft communications for not only essential contact, but for social purposes, too.

RAILROAD RADIO'S communication possibilities were demonstrated to members of the Commission recently, during a run of over 200 miles by the *Erie Railroad*, between Susquehanna, Pennsylvania and Jersey City, N. J., a test route over which newspaper and magazine writers were taken a few months prior.

The Commissioners saw a four-way train-radio network in operation, which includes 51 wayside transmitting stations spaced at intervals ranging from six to thirty miles, operating on the standard very-high frequencies allotted for train-radio operations. Between Susquehanna and Port Jervis, N. Y., the train traveled over 104 miles of rugged terrain and through valleys of the Susquehanna and Delaware Rivers. Eleven base stations provided point-to-point contact at all times. Between Port Jervis and Croxton Freight Yards in Jersey City, the train traveled over an 87-mile highly industrialized route in which power and structural interference had to be overcome. The results were excellent, the Commissioners found. During this portion of the trip, six base stations provided contact.

Among those who were on the trip were FCC Chairman Wayne Coy and Commissioners Paul Walker, Edward Webster, Robert Jones, and Rosel Hyde. Colonel Edwin L. White, chief of the safety and special services bureau, George Turner assistant chief engineer and Marshall Orr, chief of the enforcement unit were also on board.

The system was hailed as a milestone in railroading and communications, providing an all-important point-to-point link along a vital transportation route.

AS DOWNTOWN AND MIDTOWN WASHINGTON hum with political and legal activity, on the outskirts, or specifically Connecticut Avenue and Van Ness Street, there is a beehive of scientific motion. For here stands the National Bureau of Standards, where 15 scientific and technical divisions divided into more than 100 sections, are engaged in a round-the-clock investigation of every facet of science. It is here where the divisions of electricity, electronics, ordnance development, propagation, missile development, and other related units are seeking to provide the answers to problems which will further elevate our standards of living and strengthen our leadership in education, research, and industry. It is here where much of the nation's striking progress has been recorded and where we can look for even greater strides in these moments of national emergency . . . L.W.

FIRST IN RADIO TELEVISION-ELECTRONICS



**RADIO &
TELEVISION
NEWS**



Broad coverage of the entire field! Alert! Authoritative! Keeps you posted on today's trends and prepares you for tomorrow's vital developments! Every monthly issue an indispensable guide for any man interested in any technical phase of radio and television.



USE THIS ORDER CARD

ZIFF DAVIS PUBLISHING COMPANY
185 N. WABASH AVE., CHICAGO 1, ILL.

February, 1951

115

Timely Specials—
Prices Still Way Down!

While they last!
400 Cycle Motor Generators!

Holtzer Cabot type MG 218
 Motor: 115 Volts D.C. @ 2.3 Amperes, 1/4 HP,
 3430 RPM
 Generator: 110 Volts A.C., 400 Cycles @ 1
 Ampere
 Complete with hash-filters, etc.
 Price **\$49.50**

PRECISION RESISTORS

These are standard **NATIONALLY ADVERTISED BRANDS** priced ridiculously low. All are brand new, non-inductive, non-aging wire-wound types, insensitive to wide temperature variations. Sizes not listed below can readily be made up by series, and/or parallel arrangements at a fraction of the cost of precision resistors available elsewhere.

Following sizes are \$.25 each; \$19.50/100

220,000 2% WW5	7,500 1% WW3
95,000 1% WW1	5,000 1% WW3
92,000 1% WW3	4,300 2% WW3
84,000 2% WW4	4,000 1% WW3
	2,200 1% WW3
80,000 1% WW4	1,500 1% WW5
50,000 1% WW4	1,000 1% WW3
46,000 1% WW3	750 1% WW3
33,000 2% WW3	500 1% WW3
25,000 1% WW4	130 1% WW3
20,000 1% WW3	125 1/2% WW3
17,000 1% WW3	30 1% WW3
15,000 1% WW3	22 1/10% WW4
12,000 2% WW3	20 1% WW4
11,000 1% WW4	14 1% WW4
10,000 1% WW4	12 1/10% WW4
8,000 1% WW1	

Following sizes are \$.35 each; \$27.00/100

800,000 1% WW5	600,000 1% WW4
750,000 1% WW5	125,000 1% WW5
700,000 1% WW5	120,000 1% WW3

Following sizes are \$.15 each; \$12.50/100

700,000 3% WW5	4,285 1/10% WW3
399,000 3% WW5	2,500 5% WW3
268,000 1% WW5	2,230 1% WW3
109,000 1% WW5	280 1/10% WW3
54,500 1% WW3	235 2% WW3
50,000 3% WW5	110 5% WW3
	70 5% WW3
26,500 1% WW3	50 5% WW3
22,000 5% WW3	35 5% WW4
20,000 1/4% WW3	30 5% WW3
17,000 1/10% WW5	6.0 3% WW4
14,460 1/4% WW4	4.0 5% WW3

500,000 1% WW4.....\$0.55
 100,000 1% WW4......55

Following sizes are \$.10 each; \$8.50/100

53.96 3/4% WW4	4.35 1% WW3
53.32 3/4% WW4	4.3 1% WW4
33.22 3/4% WW4	3.94 3% WW4
23.29 1% WW4	3.5 5% WW4
13.52 3/4% WW3	2.56 1/4% WW4
13.333 1% WW4	1.563 1% WW4
10.2 2% WW4	.29 3% WW4
5.1 1% WW4	.25 5% WW4

PRECISION METER SHUNTS—MULTIPLIERS

4 Ohm.....\$0.15 15,000 Ohm.....\$0.15
 Both above are wire-wound units

New! Flexible TV Flashlight!

Consists of a thin 7" flexible gooseneck attached to small battery case with a pre-focused bulb at end of gooseneck. Light can be directed in the finest corners, around obstructions, inside grill, etc. The gooseneck can be clamped around pipes to direct light without holding lamp—leaving hands free—or stuck out of your pocket, etc.

One of the handiest flashlights we have ever seen and sold at a price of only **\$.95** with batteries.

WRITE FOR COMPLETE CATALOG N-2

EDLIE ELECTRONICS INC.

154 Greenwich St. New York 6, New York

Ten Tax Tips
 (Continued from page 65)

more than the interest paid on the borrowed funds.

9. If returns are filed on an accrual basis, using inventory valuations at the beginning and the end of the year, all accrued items, which are expenses, due but not yet paid, should be pro-rated to the end of the taxable year and deducted. Make each year's return complete in itself. Any expenses and liabilities overlooked in one year cannot be deducted from the next year's return. In general, the income tax law is concerned with losses or gains for the taxable year and the taxpayer should make the proper recordings in the year the transactions occur. All deductions must be evidenced by closed and completed transactions, fixed by identifiable events, bona fide and actually sustained during the taxable period for which allowed. That is why it is so important to preview your return some time before filing time and not prepare it in a hurry a few days before March 15. You may overlook certain important factors that might have given you tax benefits. You'll pay more tax than you should and you may not get a refund.

10. Keep accurate accounts and the necessary supporting records. The heavy taxes that will be levied from now on make it an economy measure to review your accounting set-up to make sure that it provides means for recording all business figures accurately. Errors and omissions will be far more costly today than in the days before Pearl Harbor. In too many establishments, particularly in the small- or moderate-sized shops, the records are vague and incomplete, in which case, the figures cannot be recorded on the return with any assurance that they will give the taxpayer maximum benefits. The taxpayer will be in a bad way if an income tax auditor checks his books and finds the records inaccurate or inadequate. Then the revenue man may have to estimate, and in such cases, he may figure high and penalize accordingly. Even if it means installing a new set of books, it will pay to do it in these high-tax days.

As for auxiliary records, the taxpayer should retain all invoices from suppliers, cancelled checks and bank statements, cash register tapes, receipts for paid taxes, inventory sheets detailing the valuation of inventory by item, transcripts of bad debts written off, cancelled notes for money borrowed, all papers and documents that support the recordings in the books. It is surprising how many taxpayers do not keep such supporting records, either destroy them, lose them, or file them in the wrong places so that they cannot be found when needed. Too many dealers use a desk drawer or some other inadequate receptacle as a catch-all for some important papers that

NEW PRECISION ELECTRONICS SIGNAL TRACERS

MODEL 201 A \$34.50
MODEL 251 A \$49.75

Write for literature and name of your nearest Jobber

PRECISION ELECTRONICS, Inc.
 641-643 MILWAUKEE AVENUE
 CHICAGO 22, ILLINOIS

SIGNAL TRACER SPECIALISTS

MIDWEST
 Presents its NEW 1951 Line of
Mammoth New 19 1/2-Inch TELEVISION
 and
5 WAVE BAND RADIOS
 In Beautiful Console and Complete Chassis

MAMMOTH 19 1/2-Inch 19 1/2 PICTURE

30 DAYS TRIAL

EASY TERMS
 Midwest offers a complete line of 19 1/2" and 16 1/2" Television models in consoles, console combinations, and ready-to-use chassis complete with 12" speaker. Don't buy any radio or television receiver until you've seen the new 1951 Midwest line—the finest in 31 years.

BUY DIRECT FROM THE MIDWEST FACTORY

SEND THIS COUPON ON 1c POST CARD FOR NEW 1951 FREE 4-COLOR MIDWEST CATALOG

MIDWEST RADIO & TELEVISION CORP.
 Dept. 37-H, 909 Broadway, Cincinnati 2, Ohio

NAME _____
 ADDRESS _____
 CITY _____ ZONE _____ STATE _____

would help justify certain tax deductions and when they want them, they have disappeared. Retain all such records systematically in a file.

Many dealers assume that the savings on tax lie in the transference of the figures from the books to the return and their listing in the proper place on the form. This procedure covers only the mechanics of income tax. The real savings lie behind the figures on the return, in the supporting records you keep, the way you handle certain transactions and record them, the method of figuring inventory and depreciation, the recording of all expenses and liabilities during the taxable year, in a detailed explanation of all transactions of the unusual type—and such savings are not made at filing time, they are effected throughout the taxable year. In fact, when filing time comes around, it is often too late to effect all possible savings because the method by which transactions have been recorded or handled cannot be revised after the year is over. The Treasury is concerned with actual gains or losses that were duly recorded within the taxable year, not at some time during the following year.

Accurate book work in journals and ledgers plus the supporting records needed to justify the entries are a "must" if the dealer wants to keep his tax expense at minimum in the hectic days to come when taxes are destined to go to an all-time high. —30—

CLAMP TUBE-MODULATOR

By C. M. MORENUS, W5RX

SOME OF the readers who have built the modulator described by W6-CXM (September issue, page 38) may be interested in the circuit shown in Fig. 1 in which the 6Y6 tube functions as either a modulator or clamp tube depending on whether phone or c.w. is being used.

With the addition of a double-pole, double-throw toggle switch, which can be installed in a few minutes, it permits instant shift from phone to c.w. and turns off the speech amplifier tubes while c.w. is being used. —30—

Fig. 1.

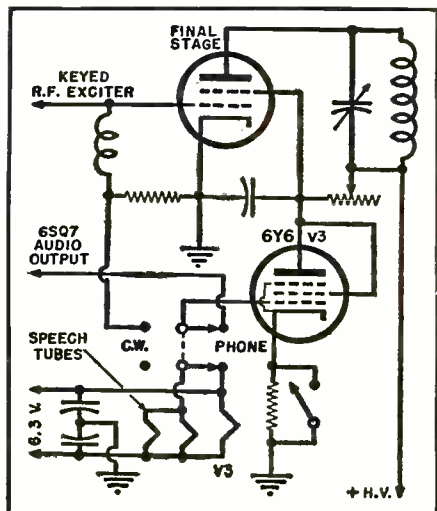

February, 1951



A. A. GHIRARDI

GHIRARDI SCORES AGAIN.

JUST OUT!

Price only
\$6.00

Here's what it contains:

Amplitude Modulation & AM Signals • Frequency Modulation & FM Signals • RF Amplifiers & TRF Receivers • AM Superheterodyne Receivers • AM Detectors & AVC Systems • FM Receivers • Push-Button Tuning & AFC Systems • Audio Frequency Amplifiers • Loudspeakers • Radio Receiver Power Supply Systems • Television Receivers • Receiving Antenna Systems • Home Recorders • Phono Pickups & Record Players • Automatic Record Changers • Mechanical Construction of Receivers • Glossary of Terms.



COMPLETE TRAINING FOR BETTER JOBS... The GHIRARDI Library

These 4 world-famous books so clearly cover radio-television theory, trouble-shooting and servicing that, in short order, you can train to handle repairs on any type of equipment. Order the complete set today at the special bargain price! See coupon.

1—RADIO PHYSICS COURSE

Most highly praised basic training in radio-TV-electronic fundamentals for beginners—36 courses in one. 972 illustrated pages make everything easy to understand. Price \$5.

2—MODERN RADIO SERVICING

This giant 1300-page book teaches radio-electronic service by truly professional methods. Explains instruments, circuit analysis, trouble-shooting—and dozens of other subjects plus how to start a service business. Price \$5.

3—RADIO TROUBLE-SHOOTERS' HANDBOOK

Ghirardi's great 744-page manual-size handbook that contains time-saving, money-making trouble case histories for over 4800 receiver models plus a gold mine of other service data. Price \$5.

4—RECEIVER CIRCUITRY AND OPERATION

The latest Ghirardi book as described here. To be issued on or about Feb. 15. Price \$6.

Bought singly, these fact-packed books would cost \$21. Under our special offer (SEE COUPON) you save \$2 and pay in easy installments. No waiting for monthly lessons! You learn fast—and right!



Here is a completely new book planned by the best-known radio-electronic writer and instructor of them all—A. A. GHIRARDI! Years of experience, plus hundreds of talks with radio and TV service technicians proved to Mr. Ghirardi the urgent need for a book that got right down to earth to explain the design and circuitry fundamentals of modern radio and TV receiving equipment. This great new book by Ghirardi & Johnson is the result. A typical "GHIRARDI" book, it is chock-full of helpful, easily understood information that can pave your way to faster, more efficient work and better pay.

MAKES COMPLEX CIRCUITS EASY TO SERVICE

Actually there are only a few really basic circuits in modern radio and TV. Learn these from A to Z, and even the most complicated of the countless modern circuit variations won't bother you!

RADIO AND TELEVISION RECEIVER CIRCUITRY AND OPERATION starts with a clear explanation of AM and FM processes and characteristics. Then it progresses to ALL basic circuits; shows how they operate, how to recognize them quickly; Guesswork is minimized, laborious testing often eliminated. By making it easy to understand each circuit and its re-

lation to other circuits, this unique book speeds up trouble-shooting and repair—helps you keep abreast of "new" developments with less time, money and effort.

Why is a high-transconductance, low-capacitance tube best for TV and FM receiver r-f amplifiers? How is a grounded-grid r-f amplifier connected? Why is this circuit popular in TV? What is a "squish" system? How many types of discriminators are used in FM receivers, and what are their circuits? Such are just a few of the thousands of questions answered!

THE ONLY BOOK OF ITS KIND!

Circuit analysis, trouble-shooting and repair are made a whale of a lot easier if you have the knowledge of CIRCUITRY this book can give you. Complicated service problems are greatly simplified! In short, Ghirardi's RECEIVER CIRCUITRY AND OPERATION can help you handle more jobs—better—in less time!

Let this world-famous instructor help you build a brighter, richer future—just as he has helped so many thousand others! Read this great new book for 10 full days AT OUR RISK! If not more than satisfied, return it and your \$6 will cheerfully be refunded.

YOU CAN'T LOSE! 10-DAY Money Back Guarantee

Dept. RN-21, RINEHART BOOKS, Inc., Technical Division, 232 Madison Ave., New York 16, N. Y.

Enclosed find \$6 (\$6.50 outside U.S.A.) for Ghirardi's new RADIO AND TELEVISION RECEIVER CIRCUITRY AND OPERATION. Or send C.O.D. for this amount plus postage. If book is not satisfactory, I will return it in 10 days and you guarantee to refund my \$6.

THE COMPLETE GHIRARDI LIBRARY (4 books as listed)

Send me Ghirardi's complete radio-TV-electronics library as advertised. I enclose \$4 and will send you \$6 a month for 5 months until the total special price of \$19 is paid. If not satisfactory, I will return books in 10 days, postage paid, and you guarantee to return my \$4 and cancel the remaining installments. (NOTE: Any of the Ghirardi books may be ordered separately at prices indicated.)

Name _____
Address _____
City, Zone, State _____
Name of Employer _____
Address _____

LOOK! IT'S A WHALE OF A SALE at PLATT

Stop in at Our Store at
489 Broome St., N. Y. C.

FREE! WRITE FOR OUR BIG 1951 CATALOG



SCR-27N COMMAND and ARG-5 EQUIPMENT



RECEIVERS	USED	NEW
BC-453-190 to 550 KC	\$12.95
BC-451-3 to 6 MC	5.95
BC-455-6 to 9 MC	10.95
R-23-ARC 5-190-550 KC	21.95

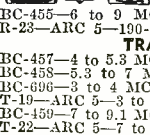

TRANSMITTERS	USED	NEW
BC-457-4 to 5.3 MC	5.95
BC-458-5.3 to 7 MC	8.95
BC-459-3 to 4 MC	24.95
T-19-ARC 5-3 to 4 MC	24.95
BC-450-7 to 9.1 MC	24.95
T-22-ARC 5-7 to 9.1 MC	24.95

ADDITIONAL EQUIPMENT

BC-456 Modulator	2.25	3.25
BC-450 Control Box (3 Receiver)98	1.95
BC-451 Control Box (Transmitter)89	1.49
BC-442 Relay Unit (ANT)	1.95	2.95
Plugs: PL-147, 148, 151, 152, 153, 154, 155—EACH75	
Flexible Shafting with gear to fit Receivers		1.69
3 Receiver Rack	2.25	
2 Transmitter Rack	1.69	

TURBO AMPLIFIER

4 tube Amplifier used by U.S. Air Force. 115 V. input at 400 cyc. With tubes—**BRAND NEW**—\$3.95 Without tubes—**BRAND NEW**—\$1.49

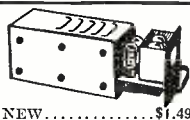

APN-2 COMPLETE AIRBORNE NAVIGATIONAL RADIO UNIT

Consists of transmitter, receiver and power supply. Frequency range of receiver: 214 and 234 MC. Maximum operating range: 100 miles. Power requirement: 115 VAC—400 cyc. Contains a considerable amount of excellent parts.

ONLY \$6.95 less tubes

SPECIAL!! A BUNDLE OF KITS

Unfortunately space does not allow us to list all the individual parts of these sensational kits, but take Platt's word—they're value-packed!

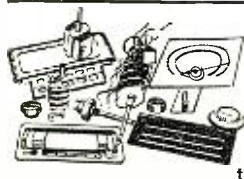

- 1 Kit of 25 assorted metal and plastic ES-CUTCHEON PLATES.....\$2.49
- 1 Kit of 25 assorted DIAL FACES, finished in various stages and used on present high priced broadcast receivers. (Can be used with above kit)..... 2.79
- 1 Kit of 100 assorted RADIO KNOBS—push-on, screw-on, pointer-type, long neck..... 3.89
- 1 Kit of 12 assorted SWITCHES—many uses: TV, electrical, circuit breakers, wafers, etc. 3.49
- 1 Kit of 25 assorted COILS AND CHOKES—IP's, antenna, broadcast and short wave..... 1.79

20 POUNDS OF ASSORTED RADIO PARTS

Transformers, Chokes, Wire, Condensers, Knobs, Sockets, Switches, Dynamotor.

ONLY \$3.39

BEACON RECEIVER BC-1206-C

Manufactured by Satchell-Carlson

Frequency Range—195 KC to 420 KC, IF Frequency—135 KC Receiver Sensitivity—3 Microvolts for 10 Milliwatts output. Output Impedance—300 Ohms and 4000 Ohms to be selected internally. Power Output—230 Milliwatts. Volume Control—RF Gain Control, Power Supply—24-28 Volts Aeroplane Battery, Current—75 Amperes.



\$795

HEADSETS

- HS-33 low impedance with cord and plug, used, fine condition.....\$0.79
- HS-23 high impedance, BRAND NEW with ear pads..... 2.75
- HS-33 low impedance, BRAND NEW with ear pads, cord and PL54 plug..... 2.75
- TH-37A—1200 ohms with dual plugs..... 2.95
- HS-16 high impedance with cord and pin plugs, BRAND NEW..... 1.95
- HS-30 with ear plugs, low impedance, used, good condition..... .89

MINIMUM ORDER \$2.00

Immediate Delivery—Send 25% deposit on C.O.D. orders. All shipments F.O.B., N.Y.C. (N.Y.C. residents add sales tax to your remittance.)

PLATT ELECTRONICS CORP.

Dept. A, 489 Broome St., N. Y. 13, N. Y.
PHONES: WO 4-0827 and WO 4-0828

International Short-Wave

(Continued from page 66)

this station during February. It is suggested that newscasts from VP4RD, 9.625, Trinidad, be followed for announcement as to when the cricket match between Barbados and Trinidad is to be carried.

Belgian Congo—OTC3, 11.645, Leopoldville, noted parallel with OTC2 to around 2030 lately. (Leary, Indiana, others) OTM2, 9.400, heard with music 1448, news in French 1450-1500 sign-off; woman announcer. (Cox, Delaware)

Bolivia—CP2, 9.497, La Paz, weak signal noted 1855; terrific QRM from XEWW, 9.500, Mexico City; seldom heard. (Cox, Delaware)

Brazil—PRL7, 9.72, heard signing off 2304, fair signal but usual CWQRM from TGZ. (Neeley, Calif.) PRA8, 6.015, Recife, noted 1702 in Portuguese. ZYK3, 9.565, Recife, good level on Sundays 1630 with "Brazil Calling" (English). ZYB9, 15.155, Sao Paulo, noted 1240 with musical program in Portuguese; strong signal. (Cox, Delaware)

Burma—Radio Rangoon, 6.035, is still on old schedule 0900-1015; news 1000. (Neeley, Calif.)

Canada—CHNX, 6.130, Halifax, Nova Scotia, has Mail Bag on Saturdays 1900. (Dary, Kans.) CJCX, 6.010, Sydney, Nova Scotia, heard daily 0530-2230; reports are verified by QSL card; IRC required; QRA is CJCX, Eastern Broadcasters, Ltd., Radio Building, 318 Charlotte St., Sydney, Nova Scotia, Canada. (Kroll, N. Y.)

Latest CBC International Service schedules are—*European Service*—0850-1130, CKNC, CKCX; 1130-1330, CKNC, CKCS; 1330-1345, CKCS; 1345-1400, CKCS, CHOL; 1400-1420, CHOL; 1420-1645, CHOL, CKLO; 1645-1700, CKLO; 1700-1830, CKLO, CKRZ. *Australasian Service*—2330-0005 (except Sat., Sun.) commentaries from UN, CHOL, CKLO; 0340-0450 (Sun. and Wed. only), CHOL, CKLO. *Caribbean and Latin-American Service*—1850-2235 (English 2100-2130), CKRA, CKLO. *North West Territories* (Northern Messenger) *Service*—2320-0005 (Sun. only), CKLO, CKOB; sign-off varies slightly. Outlets are CKNC, 17.82; CKRA, 11.76; CKCS, 15.32; CHOL, 11.72; CKOB, 6.09; CKCX, 15.19; CKLO, 9.63, and CKRZ, 6.06.

Cape Verde Islands—CR4AA, Praia, announces it works on 5.895; heard recently 1600-1630 with program of "mornas" (typical music of Cape Verde); good reception in Portugal. (Mesquita e Sousa) Measured as 5.8925 recently at 1630 by Oskay, N. J.

Ceylon—Radio Ceylon's Commercial Service is scheduled 0630-1130 on new channels of 11.975, 7.190, and 3.320; the 11.975 and 7.190 channels are directed to India-Pakistan, while the Tropical Band outlet of 3.320 is intended for reception in Ceylon. The 21.620 outlet

is heard at good strength in New Zealand at 1830-2030 with program of request items from 2000. (Cushen) The 25-m. outlet was measured by Oskay, N. J., at 0650 recently as 11.9762.

Chile—CE118, 12.005, Santiago, fair level in Spanish with music 2030. (Cox, Delaware)

China—Hankow, 6.645, noted at good strength 0900; believed to come on the air 0530. (Dilg, Calif.) Heard in Australia at 0600 with Western recorded music, then news in Chinese. (Sanderson)

Mukden, Manchuria, 5.915A, opens around 0500. (Dilg, Calif.)

The Chinese station on approximately 8.005 is heard irregularly; location is unknown; at times relays Peking at 0700. (Dilg, Calif.)

Radio Peking, 10.260, noted in England 1840 with Chinese music, good signal. (Catch) Is heard in Eastern USA erratically from before 1800 to sign-off which varies 1920-1930.

Colombia—HJEX, 6.054, Radio Pacifico, Cali, closes 2210 Sundays, at 2300 on Mon.-Sat. (Grove, Ill.)

Costa Rica—Radio Attenea, San Jose, formerly battling Radio Brazzaville on 11.972, lately has been noted on 11.980. (Stark, Texas)

Cuba—Radio Salas, COBZ, 9.030, Havana, verified with nice QSL in English (Callarman, Oregon)

Curacao—PJC2, 2.460, Willemstad, weak to fair around 1917 parallel 5.010; at times has news 1930-1932. (Cox, Delaware)

Cyprus—Sharq-al-Adna noted Sundays 1045-1115 with dance music, then Arabic; heard well on 9.65, 11.72, 6.79. (Pearce, England)

Czechoslovakia—Prague noted on new 9.504 channel with news 1415 and 1530; call is probably OLR3B. (Bellington, N. Y., others) OLR2C, 6.115, weak signal 1538 with musical program. (Cox, Delaware) Noted on 11.84 with news 0645-0730. (Pearce, England)

Dominican Republic—La Voz Dominicana, 9.735, has English Mon., Wed., Fri. 1900-1915. (Neeley, Calif.)

Ecuador—HC1AC, 6.210, Quito, heard signing off in Spanish 0015. (Whitman, Ill.)

Egypt—SUX, 7.863A, Cairo, is widely reported erratically in Eastern USA around 1500-1600 or later. (Cox, Delaware; Bellington, N. Y., others) Also noted in Australia by Sanderson.

France—Paris broadcasts now to the United Kingdom on 6.145, 6.200 at 1345-1400 (French lesson), and 1445-1609 (general program). (Catch, England) The 6.200 channel noted with popular music 0225; French-English lesson 1530-1545 sign-off. The 15.350 outlet heard with excellent signal 1245 in French. (Cox, Delaware)

Paris has been carrying out a number of tests in English—daily 0300-0315 on 7.240; 1345-1400 on 6.200; Saturday 0845-0900 on 7.240, 9.560; Sundays 0815-0845 on 7.240, 9.560. (Patrick, England)

French Equatorial Africa—Radio Brazzaville, 11.972, has news 1100. (Rosenauer, Calif., Ferguson, N. C.)

the new
Smitty Jr.
saves time
and temper!

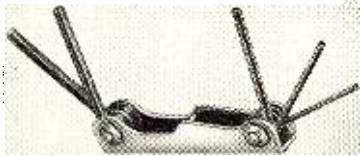

Designed to save radio and television mechanics' time and temper, the new Smitty Jr. has combined the six sizes of socket head wrenches you need most in one sturdy knife-like handle.

No wasted time looking for the right sized wrench... it's always handy. The unique design and huskiness of the Smitty Jr. gives you greater leverage at every angle.

Made from high quality, tempered steel... sizes .050", 1/16", 5/64", 3/32", 1/8", 5/32". Get yours today!

H. D. HUNTER COMPANY
3499 E. Fourteenth Street • Los Angeles 23, California
Dealers: Write for name of nearest jobber.



WALSCO
—in any
climate,
anywhere...

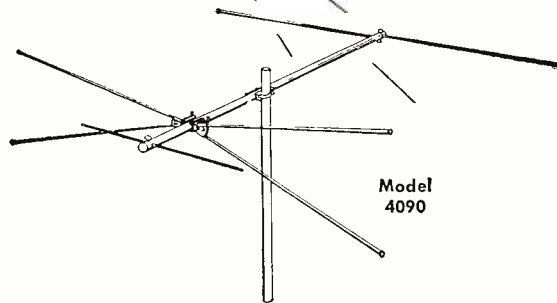

Model 4090

INSTALL IT
and **FORGET IT**

new WALSCO SIGNAL-KING

No fear of costly "call backs" that eat up a dealer or installer's profit. In any climate, anywhere... the new WALSCO Signal King antenna provides sharper, clearer response over entire TV spectrum. Rugged aluminum alloy construction for elements, cross-arm and mast. Corrosion resistant. All steel parts are cadmium plated to AN specifications.

NOTHING LIKE IT ANYWHERE...

- High gain on all channels — no weak spots. Excellent for fringe areas.
- Entirely new insulator guaranteed unbreakable under all operating conditions. Outstanding and lasting dielectric properties.
- Marine type aluminum alloy elements, reinforced and closed ends.
- Assemble in a jiffy (less than 2 minutes).

Write for Information Bulletin No. 51-N

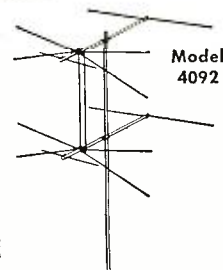

Model 4092

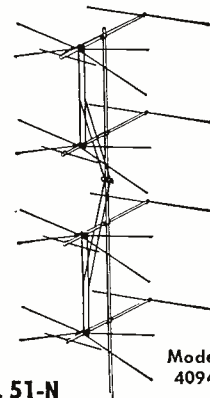

Model 4094

WALTER L. SCHOTT CO. Beverly Hills, Calif. • Chicago 6, Ill.

SAVE

THAT GOOD LOOKING OLD CONSOLE—
REPLACE YOUR OBSOLETE RADIO

with a modern, easily installed

ESPEY AM/FM CHASSIS

and your favorite console is "right-up-to-date"



Rated an excellent instrument by America's foremost electronic engineers. Fully licensed under RCA and Hazeltine patents. The photo shows the Espey Model 511-B, supplied ready to play. Equipped with tubes, antenna, speaker, and all necessary hardware for mounting.

NEW FEATURES—Improved Frequency modulation circuit, drift compensated • 12 tubes plus rectifier, electronic tuning eye and pre-amplifier pick-up tubes • 4 dual purpose tubes • High quality AM-FM reception • Push-pull beam power audio output 10 watts • Switch for easy changing to crystal or variable reluctance pick-ups • Multi-tap audio output transformer supplying 4—8—500 ohms.

Makers of fine radios since 1928.

Write for literature RN for complete specifications on Model 511-B and others.

ESPEY
MANUFACTURING COMPANY, INC.
528 EAST 72nd STREET, NEW YORK 21, N. Y.

40 MC TO 220 MC TV AMPLIFIERS



With the Model 212TV Amplifier—SKL — introduces for the first time a single broad band booster capable of amplifying all 13 television channels simultaneously. Because of its stability and reliability — a tube failure means only a slight loss of gain, not amplifier failure — the Model 212TV Amplifier can be safely left unattended for long periods of time. Its low noise level, high output, and low impedance make the Model 212TV Amplifier ideal for television distribution systems in hotels, apartment houses, sales rooms and television stations and manufacturers' plants.

Write today for further information

SPECIFICATIONS

BANDWIDTH

40 MC—220 MC

● IMPEDANCE

200, 52 and 72 ohm unbalanced, 300 ohm balanced

● GAIN.....20 db

● OUTPUT VOLTAGE

4 volts RMS maximum

● RESPONSE

± 2 db over bandwidth

● LIST PRICE

\$366.00 f.o.b. Cambridge, Mass.
Trade Discounts Available

SKL SPENCER-KENNEDY LABORATORIES, INC.
186 MASSACHUSETTS AVE., CAMBRIDGE 39, MASS.

FOR BETTER TOWERS AT LOWER COST! Ask about AERO

• COST LESS

Because Aero Towers are aircraft-designed, lower manufacturing costs offer you a lower price. Lower weight and lower shipping costs are passed on as savings to you.

• LAST LONGER

Coated INSIDE and OUT. DIP-COATED process keeps Aero Towers bright and new. Rust resistant. Will not brown.

• EASY TO CLIMB AND SERVICE

Strong electric aircraft welds at EACH joint (not just one or two) prevents sway. Provides sturdy safe ladder-like cross members.

• QUICKER TO INSTALL

Aircraft precision tolerances assure accurate fit of components. Light and easy to erect. Strong durability assures customer satisfaction.

Jobber Territories Open

Dealers—Write for FREE Booklet

AERO TOWER DIVISION
Knepper Aircraft Service
1016 Linden Street
Allentown, Pa.



COLOR CONVERTER- ADAPTER KITS

Convert TV set to receive CBS Color



Write today for complete data

COLOR SALES CO.
88 Merrick Road, Amityville, Long Island

French Morocco—Rabat, 6.006, noted 1435 with French program; weak level. (Cox, Delaware)

Germany—*Deutschlandsender*, Berlin, broadcasts on 6.115, 7.150; is in Russian Zone. (Bachman, Pa.)

Radio Free Europe, 6.130, is now heard coming on the air with bells at 1020; may run as late as 2300; uses various Eastern European languages. (Pearce, England)

Greece—The General Broadcasting Station of the Greek Armed Forces, Athens, sent further letter verification and schedules via airmail; has new 1 kw. transmitter in operation, scheduled in Greek 2330-0200, 0500-0800, 1030-1615; in *English* 1615-1630; operates on 6.330; asked for further reports. (Pearce, England)

Radio Athens has been testing over 9.607 at 1430-1445 and 2000-2058; part is *English*. (Stark, Texas; Bellington, N. Y., others)

The Home Service now is heard from 1000 on 6.175. *Radio Epiros*, 6.224, Janina, is on the air weekdays 1430-1600, Saturdays and Sundays 1430-1700. (Radio Sweden)

Larissa, 6.745, is heard 1300-1600 or later. (Peddle, Newfoundland)

Greenland—OXI, 5.944, Godthaab, heard in England 1630 with half-hour newscast in Danish; fair level. (Catch)

Guatemala—TGOA, Quezaltenango, verified in 20 days; sent QSL card and letter; frequencies were listed 1450 kc. and 6.400. Will add *English* programs soon. (Dary, Kans.)

Holland—Hilversum, 17.775 and 15.220, noted 0645 with news. (Fried, Mich.)

Honduras—HROW, 6.02, strong 0700, QRM'g Kuala Lumpur's 6.025 channel. (Balbi, Calif.)

Hong Kong—ZBW3, 9.525, noted signing off 1030. (Lane, South Dakota, others)

Hungary—The *English* periods at 0030 and 2300 are now radiated to North America over 6.248, 7.222, 9.833. (Bellington, N. Y., others)

India—Delhi recently tested on 21.680 around 0230-0330. (Cushen, N. Z.) According to *Radio Sweden*, AIR now uses only 7.270 and 9.575 for the transmission in *English* for Europe 1400-1500.

Indo-China—*Radio France Asie*, Saigon, has recently changed schedules and has been testing. Reports are conflicting. I hope to have new schedules by next month. However, is heard mornings to around 1030 sign-off on 11.780 and 9.520A, with news 0900; also noted evenings around 1700-1926 on 9.520A, news 1725. Should have news 0500 on 11.830. The 9.520A channel is announced as 9.524. Riggie, Ohio, hears the 11.78 channel as early as 0515. Balbi, Calif., says has moved its 49-m. outlet from 6.165 to 6.095, heard 0500 with news in French, bad QRM; 6.165 is now occupied by "Voice of Vietnam" which signs on 0500 parallel with 9.62, formerly this one also used 7.265 which may have been replaced by 6.165; should have *English* around 0830-0930.

WHY

See **WHY Rider Manuals are BEST BY TEST.** See **WHY they are most economical in the long run.** See **WHY they are most popular with competent servicemen.**

RIDER TV MANUALS

➔ Offer you the very same information which the service department of the original receiver manufacturer uses. There is no greater **accuracy, authenticity, completeness of detail.** NOBODY, but RIDER, can make this statement!

➔ Include understandable descriptions of the circuit action. In the five RIDER TV MANUALS there are **731 pages of such extremely valuable instructional information**—telling you **HOW** the circuit functions. NOBODY, but RIDER, furnishes so much of this kind of data . . . all of it necessary for successful and profitable TV servicing!

➔ Presents you with no less than **293 pages of signal waveforms**—so vital to rapid trouble diagnosis in picture i.f., sound i.f., video, sweep and sync circuits. NOBODY, but RIDER, offers you anywhere near this amount of absolutely indispensable information!

➔ Incorporate fully **337 pages of official, accurate unpacking and installation data.** NOBODY, but RIDER, brings you as many of these helpful, time-saving instructions!

➔ Give you the **most complete coverage of the manufacturers' receiver output**—not just pilot models—but **ALL** production runs with **ALL** of the changes. NOBODY, but RIDER, puts all of the data . . . so thoroughly, so completely . . . at your fingertips!

Prove, To Yourself, That Rider Manuals

ARE BEST COMPARE!

Check the completeness of RIDER MANUALS. The five RIDER TV MANUALS contain 10,544 pages. Compare them with any other service. Compare not only listings of model numbers, but all of the information contained which is of value in servicing a receiver. RIDER AM-FM MANUALS contain 31,382 pages. The PA MANUAL contains 2,024 pages.

John F. Rider Publisher, Inc.
480 Canal Street New York 13, N. Y.

Complete your Rider Manual Library! If any volumes are missing, order a replacement today!

Radio Hue, 7.21, heard irregularly 0400-0555 sign-off; weak to fair only. (Balbi, Calif.)

Ireland—Dublin, 17.84, has news daily 1330 now instead of former 1230. (Cox, Delaware) Usually has QRM from *Radio Brazzaville*, on low side.

Jamaica—*Radio Jamaica*, Kingston, appears to have moved from 4.950 to approximately 3.360 (although announces 3.480) for its evening program around 1600-2300 sign-off; still noted mornings around 0700, however, on 4.950. (Stark, Texas; Lane, South Dakota, others)

Japan—Current schedules for NHK programs are JKI, 4.91, 0355-0930; JHK, 7.257, 1525-0930; JKI2, 9.655, 1525-1725; JKM, 4.95, 0255-0800; JKJ, 7.285, 1625-0800; JKM2, 9.695, 1625-0330; JBD, 9.505, JBD2, 9.560, and JBD3, 15.225, used irregularly. No *English on any of these.* (Tsuji-kawa, Japan, via Bachman, Pa.)

JBD3, 15.225, heard with fair level 1800 in Japanese; also heard 15.235 in parallel, but weaker. (Cox, Delaware)

AFRS schedule from Tokyo now is JKL2, 9.605, 1600-0300; JKL, 4.86, 0345-1000; JK13, 6.175, 1700-1845, 0315-0700; JK14, 11.800, 1900-0300. (Neeley, Calif.)

BCOF, 6.105, Kure, heard signing off 0930 with "God Save the King." No longer mentions call-sign WLKS, but does give m.w. frequency of 1470 kc.; announces only as BCOF (British Commonwealth Occupation Forces). (Neeley, Calif.)

Korea—Seoul's 2.510 outlet is much better in California early mornings than the 7.933 channel. (Dilg) The 7.933 station is best after 0700. (Balbi, Calif.) Heard with no *English* except call-sign HLKA which is given at about 30-minute intervals. (Rosenauer, Calif.)

Lebanon—Beirut, measured 8.031, noted 1510 with musical program. Oskay, N. J.) Noted leaving air 1600. (Bellington, N. J.) Heard in New York as early as 2350, late as 0030 in its "morning" program. (Bellington) Heard by Ferguson, N. C., at 0030 with news in French. Noted by Pearce, England, with *English* period 1030.

Luxembourg—*Radio Luxembourg*, 15.3526, measured 0730. (Oskay, N. J.)

Madagascar—*Radio Tananarive* still noted with French program on 9.515 from 2230. (Cox, Delaware)

Malaya—K u l a L u m p u r, 6.025, *Radio Malaya*, heard signing off 1030 after program of popular music; fair to good level in California. (Neeley)

Malta—FBS, Middle East, now signs on 2330 on 7.220, 6.015, and 6.140; announces *only* m.w. 1478 kc., and s.w. channels of 7.220, 6.015, so the 6.140 may be an African relay outlet.

Mexico—Whitman, Ill., recently heard a Spanish-speaking station announcing as "La Voz de Mexico" testing around 2045-2145 on approximately 8.500.

Mozambique—*New* schedule for *English* sessions is 2300-0100 on 11.764, 4.925; 0100-1100 on 11.764, 7.260A; 1100-1300 on 11.764, 4.925; 1300-1600 (Sats. to 1700), 7.260A, and possibly

Beat the Tube Shortage!

This Sensational New RIDER Book Shows You HOW to Do It!

RECEIVING TUBE SUBSTITUTION GUIDE BOOK

by H. A. Middleton

For AM-FM-TV Receivers and Allied Equipment!



URGENT! Receiving tubes are very scarce . . . and will get scarcer. There is a wide scramble for every type of tube, and you can't always get what you need. What can you do when you can't find a tube replacement? How can you get a set working again? How can you substitute one tube for another?

HERE!

HERE Are The Answers To All Tube Problems!

- 2500 Radio And TV Tube Substitutions Are Listed!
- TV Receiver Filament Wiring!
- Heater Substitution Wiring Instructions!
- Tube Types Classified By Functions!
- And A Wealth Of Other Priceless Data!

Here the serviceman will find 2500 radio and TV tube types systematically listed in numerical sequence with accompanying wiring instructions for making the substitutions. There are views of original and substitute tube sockets, and clear explanations for whatever changes may be necessary. In this, one of the most important servicing books ever published, and certainly a most timely one right now, the serviceman will find the way to turn out jobs that would otherwise remain on the shelf because of lack of proper tubes.

EXTRA! EXTRA! In addition to tube information . . . this sensational book contains material on Cathode-Ray Tube Characteristics, Complete Tube Characteristics Chart, Ballast Tube Data, Pilot Light Information, Resistors—Capacitors—Transformer Color Codes, Transformer Substitution, Fixed Condenser Substitution, and Converting Farm Radio for Electrified Operation.

208 Pages in Heavy Durable Paper Cover. 8 1/2 x 11 inches. Only **\$2.40**

10 DAY MONEY BACK GUARANTEE
Make this book **PROVE** its value!
Unless you agree that it is the best investment you've ever made—return it, and we will refund your money.

Rush This Coupon Today

JOHN F. RIDER PUBLISHER, INC.
480 Canal Street, New York 13, N. Y.

Please send me copies of "RECEIVING TUBE SUBSTITUTION GUIDE BOOK" at \$2.40 per copy. I am enclosing check money-order in the amount of \$ If, within 10 days, I am not satisfied—I will return the book(s) in good condition, for refund.

Name _____

Address _____

City _____ Zone _____ State _____

CRYSTAL CALIBRATOR

MEASUREMENTS CORPORATION

Model 111

FREQUENCY RANGE: .25Mc.—1000 Mc.

FREQUENCY ACCURACY:

±0.001%

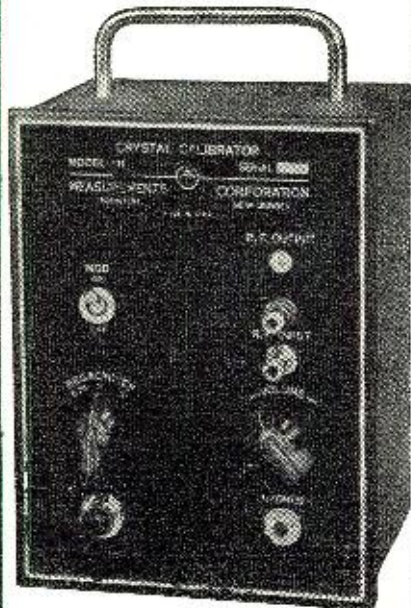

A Dual-Purpose Calibrator

- CRYSTAL-CONTROLLED OSCILLATOR
 - BUILT-IN DETECTOR
- 2 Microwatt Sensitivity

Designed for the Calibration and Frequency Checking of Signal Generators, Transmitters, Receivers, Grid-Dip Meters and other equipment where a high degree of frequency accuracy is required.

Harmonic Range:

- .25 Mc. Oscillator: .25-450 Mc.
- 1 Mc. Oscillator: 1-600 Mc.
- 10 Mc. Oscillator: 10-1000 Mc.

117 volts, 50/60 cycles; 18 watts, 6" wide, 8" high, 5" deep; 4 lbs.

MEASUREMENTS CORPORATION



Boonton

New Jersey

4.925. (Hannaford, South Africa, others) The 7.260A outlet noted signing off 1100. (Neeley, Calif.)

New Caledonia—Radio Noumea was noted testing recently on 15.180 at 0200; and on 11.750 around 0400 calling Paris. (Cushen, N. Z.) FK8AA has been heard lately on 6.0346, signing on 0200. (Saylor, Va.)

New Zealand—ZL4, 15.28, heard with BBC news relay 1400; at 1545, ZL3, 11.78, signs on in parallel with ZL4, according to announcement made at that time. (Balbi, Calif.)

Pakistan—Radio Pakistan recently made changes in schedules. I hope to have complete new schedules soon. At the time this was compiled, the 0700 news was heard at good strength on 7.140; 17.770 is reported to parallel. Radio Australia says the 17.770 outlet is now in use 0300-0330, 0700-0730.

Panama—HOLA, 9.505 has English 1200-1430 daily. (Dary, Kans.) Also has English at various other times; uses commercials widely.

HP5B, 6.030, Panama City, noted with Spanish news by man 1950; HORT, 6.060, fair signal with Spanish music 2100. (Cox, Delaware.)

Paraguay—ZPA3, 11.850, heard with choral music 1915, fair level. (Cox, Delaware.)

Peru—OAX6A, 6.043, Arequipa,

weak signal with musical program in Spanish 1943; QRM. OAX4W, 9.360, Lima, noted 1448 with comedy show in Spanish. (Cox, Delaware) OAX1B, 5.706, Lima, noted around 2200. (Leary, Indiana) OAX4Z, 5.895, Lima, noted 2035 in Spanish. (Gerran, N. Y.)

Philippines—DYH2, The Voice of Cebu, 6.140, heard 0845 with news; DUH2, The People's Station, 6.170, heard 0900 with AP news; DZH4, The Voice of Manila, 6.000, heard 1000 with news; DZH6, The Far Eastern Broadcasting Company, 6.030, signs off 1030, says will return at 1800, and announces "We salute you from the Philippine Republic, 7000 beautiful islands where the Pacific Ocean meets the China Sea;" DZ13, the Republic Broadcasting System, 6.110, heard around 1015 announcing DZ13 and DZBB, Manila; DZH2, The Voice of the Philippines, 9.640, has news and maritime warnings 0315; DZH3, Radio Philippines, 9.503, noted around 0400 with fair signal. (Neeley, Calif.)

Daveo, Mindanao, now uses the call-sign DXB2; operates on 3.950. The Far Eastern Broadcasting Company, Manila, uses 3.320 at 0300-0900; 6.030 and 15.300 at 1800-2000, 2300-0100, 0300-1015; has Mail Bag on Thursdays 0645. (Cushen, N. Z.) Has Mail Bag Program on Fridays 1000; reports seem to

FM INTERFERENCE

By KEN MAXWELL

DID YOU ever buy a tape recorder and find it equipped with a built-in FM receiver? Operation of portable amplifiers and tape recorders in the vicinity of an FM transmitter is often made difficult by interference of the amplitude and frequency modulations of the high frequency transmitter. Usually after spreading the equipment out on the bench, the purchaser tries various grounding and shielding tricks until the interference is eliminated. He solders in the shield, congratulates himself, and rises to get the case only to be greeted with a new burst of FM program material. Probably his work has only provided sufficient out-of-phase signal to cancel the interference until some nearby object is moved.

In the conventional input circuit the grid-to-cathode capacitance resonates with the inductance of the grid lead at a frequency near that of the transmitter. Any non-linearity in the grid circuit or in the transfer characteristic of the tube will cause detection of any ampli-

tude modulation present in the radio frequency signal. Assuming that this circuit resonates either above or below the transmitter frequency, it will convert frequency excursions into amplitude modulation causing them to also appear in the amplifier output.

A resistor of 10,000 ohms or any similar value placed in series with the grid wire with one side connected directly to the tube socket terminal will lower the "Q" of the grid circuit at the resonant frequency sufficiently to eliminate the interference. The resistor will have little effect on the desired signal. Grid impedance of a tube is very high at audio frequencies; consequently there will be negligible voltage lost across this resistor. Fig. 1A shows a conventional amplifier circuit. Fig. 1B represents the same circuit as it appears to the high frequency signal. Fig. 1C shows the suggested modification while Fig. 1D gives the high frequency equivalent of the modification.

-30-

Fig. 1.

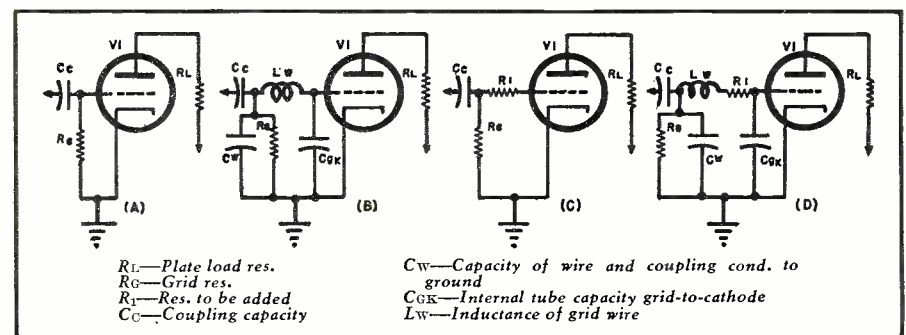

be mostly from the Pacific Area. (Neeley, Calif.) News-cast noted 1930 on the 15.300 channel. (Hansen, Oregon) DYH4, 6.055, heard 0200-0500; QRA's Silliman University, Dumaguette City, Philippines. (DX Radio, Sweden)

Poland—Warsaw III, 6.115, now carries three programs to USA daily; each lasts an hour, first half is *English*; opens 1930, 2300, 0030. (Bellington, N. Y., others) Woman announcer says "This is Warsaw Calling"

Noted on 7.205 with weak signal, music, 0118. (Cox, Delaware)

Portugal—Lisbon more recently has been using 15.380 parallel 11.040 around 1215-1800.

Portuguese Guinea—Bissau is currently operating on 5.838, according to QSL's received by Sluter, Pa., and Mesquite e Sousa, Portugal. Confirms earlier reports by Bellington, N. Y., and Oskay, N. J., that had been heard around 5.840 at 1630-1800 when closed with "A Portuguesa."

Portuguese India—Radio Goa has been noted on 9.610 at 1030 on Sundays with "Bringing Christ to the Nations" (*English*). (Cushen, N. Z.) May have higher-powered transmitter soon.

Roumania—Bucharest, 9.252, still has news 1500; off 1600. (Cox, Delaware)

Sao Tome—CR5SC, 4.805, noted from 1520 to 1600 when signs with "A Portuguesa." (Pearce, England) This station uses *only* Portuguesa.

Saudi-Arabia—Djeddah noted on 5.975 opening 2300 with music; off 2330; parallel on 11.75, 11.95, 11.85. (Cox, Delaware). Heard now at 1200-1230 sign-off.

Southern Rhodesia—Peddle, Newfoundland, recently heard Salisbury on 3.320 (best) and 9.490 until closing 1500. Pearce, England, reports Salisbury with BBC news relay 1300; local news and South African news 1315.

Spain—Radio Murcia, Emisora del Frente de Juventudes, is a new station on approximately 7.160; starts 1557. (Radio Sweden) Radio Falange de Alicante, 7.940, usually signs off 1800 but extends its broadcasts on Sundays to

(Continued on page 124)

High score every time with "Safe Centers!"



In Basketball there's no better assurance of victory than a lengthy lead jumping center . . . and there is nothing that scores higher in radio, TV and other electronic circuits than SELETRON miniature rectifiers with "Safe Center" plates.

When you specify SELETRON Selenium Rectifiers you eliminate arc-over danger, short circuits and heating at the center contact point. Assembly pressure, or pressure applied in mounting the rectifier cannot affect its performance — a SELETRON feature accomplished by deactivating the area of the plate under the contact washer.

The millions of SELETRON Selenium Rectifiers in satisfactory service as original equipment in the products of leading manufacturers are millions of reasons why you can specify SELETRON and be safe!

Look for Howard W. Sam's Red Book Supplement listing SELETRON replacements . . . and write for Bulletin No. TN-4



SELETRON DIVISION
RADIO RECEPTOR COMPANY, INC.
Sales 1122 St. Radio and Electronics
Factory: 14 North 9th St., Brooklyn 11, N. Y. • Sales Department: 291 West 10th St., New York 11, N. Y.

SIGMA SENSITIVE RELAY

S.P.D.T. adjustable from 700 Microamps to 1.5 MA, 8000 ohm coil.

\$2.29 ea.

PEAK ELECTRONICS CO. COMPONENTS

SELECTED AND GUARANTEED SURPLUS AT A FRACTION OF ORIGINAL COST.
188 WASHINGTON ST., NEW YORK 7, N. Y.

POWER TRANSFORMER BARGAIN

740 Volts CT @ 185 MA
6.3V @ 4.5 Volts @ 3A
10 V, 60 cy. pri. Half-shell mount.

\$3.49



PANEL METERS

GE—General Electric
WH—Westinghouse
W—Western
S—Simpson
SU—Sun *—Special Sale
SQ—Square Case



2" Meters

0-5 MA, S, SQ . . . \$2.95
0-5 MA, GE . . . 2.45
0-20 MA, S* . . . 1.95
0-25 MA, SU* . . . 1.95
0-50 MA, SU*, SQ . . . 1.95
0-1 AMP RF, S, GE . . . 2.95
0-2 AMP RF, S, SQ . . . 2.95
0-4 AMP RF, GE . . . 2.95
0-9 AMP RF, WH . . . 2.95
0-250 MA AC, GE . . . 3.50
0-20 VOLT DC, W . . . 2.95
0-30 AMP DC, GE . . . 2.50
RC100B Consisting of
BC768, 769, 770, RA52
and Cabinet . . . \$119.00

3" Meters

0-1 MA, S* . . . \$4.95
0-2 MA, WH, S . . . 4.50
0-5 MA, GE, SQ . . . 3.95
0-10 MA, WH* . . . 2.95
0-20 MA, S, WH . . . 3.95
0-20 MA, GE, SQ . . . 3.95
0-30 MA, GE, SQ . . . 3.95
0-2 AMP, WH . . . 3.95
0-10 VAC, GE, SQ . . . 3.95
0-15 VOLT AC, GE . . . 3.95
0-30 VOLT DC, BA . . . 2.75
0-3 KV DC, GE, SQ . . . 8.95
0-5 KV DC, GE . . . 10.95

METER MULTIPLIERS

2 Meg 1/5 of 1% Cage Enclosed 2 KV . . . \$3.95
4 Meg 1/2 of 1% Tubular 4 KV . . . 2.95
2 Meg 1/2 of 1% Tubular 4 KV . . . 3.75

PANEL METER KIT

Here's what you get:

- 2" Sq. bakelite cased meter, Gov't. Surplus
- Scales for all the following ranges: 0-50 ma, 0-100 ma, 0-200 ma, 0-500 ma.
- Pre-calculated shunt sizes for all ranges.
- Complete instructions. Only \$2.50 ea. . . 3 for \$6.75



WESTON PORTABLE AC VOLTMETER
Model 433, 0-150 Volts AC, 25 to 2400 cycles, 3/4%, mirrored hand calibrated scale. Bakelite case with leather handle . . . \$27.50

PRECISION 1% W. W. RESISTORS

Ohms: 2K, 5K, 8500, 50K25 ea.
100 WATT NON-INDUCTIVE RESISTORS
Ohms: 250, 500, 12,500 . . . \$0.75

WIRE WOUND RESISTORS

5 watt ohms: 25-50-200-2500 . . . \$.09 ea.
10 watt ohms: 25-40-84-100-325-2K-4K15 ea.
20 watt ohms: 50-70-100-300-750-1K-1.5K20 ea.
2.5K-2.7K-5K-16K-20K22 ea.
30 Watt Ohms: 100-250-5300-18K22 ea.
100 Watt Ohms: 100-250-1500-2K, 10K, 20K, 25K-50K, 75K59

2 KVA SOLA CONSTANT VOLTAGE TRANSFORMER

2 KVA, 17.4 Amps. Input 95-135 Volts, 60 cy., 1 Phase. Constant Output 115 Volts. Type 4. 3 1/2" L, 9 1/2" H, 7 7/8" W. \$137.00 ea.

HIGH WATTAGE ANTENNA RELAY
110/220 volt 60 cycle Solenoid. D.P.D.T. Heavy duty paralleled contacts rated 5000 Volts @ 15 Amps. Sturdy Construction. Insulantite insulation . . . \$18.50
As above but DPST . . . 12.50
As above but SPDT . . . 12.50

GUARDIAN LATCHING RELAY
SPDT, 110 V 60 cy Coil, 15 Amp Contacts . . . \$1.95

RAYTHEON SWINGING CHOKE
2 to 12 Henrys, 1 Amp to 100 MA, 15 Ohms DC fully cased. High voltage insulation, ceramic insulators. Very conservatively rated. Weight 60 Lbs. . . \$16.95 ea.

CHOKE BARGAINS

O-Open Frame		C-Cased	
6 Hy, 50 MA, O \$0.39	6 Hy, 400 MA, C \$3.95	10 Hy, 80 MA, C .69	6 Hy, 250 MA, C 2.95
8 Hy, 175 MA, C 1.75	5 Hy, 170 MA, C 1.25		

ADJUSTABLE SLIDER RESISTORS

20 Watt: 1, 5, 50, 300 Ohms25
50 Watt: 500 Ohms35
75 Watt: 100, 150, 200 Ohms39
100 Watt: 20, 50, 75, 100, 500 Ohms49

MISCELLANEOUS BARGAINS

25 ohm 675 watt Rheostat \$2.95
50 ohm 35 watt Resistor99
250 mfd Midget Var, Ceramic Ins. . . .69
15 mmf Midget Var, Ceramic Ins. . . .39
4PST Lever Switch Mossman89
Ceramic RF Switch SP 11 Post. . . .89
4PDT Relay, 4500 Ohm DC Coil. . . .1.95
.02 600V Tubulars15 for .99
.05 600V Oil Tubular12 for .99
10K, 15K Pots4 for .99
50 Watt Sockets w/shell69
300 Ohm 50 W. Rheostat59
16 mfd 450 V. Electrolytic. . . .39
5-20 mmf Ceramic Variable24
1.5-7 mmf Ceramic Variable24
SPST Push Button Switch29
5 S MFD 400 VDC Oil39
1 1 1 MFD 1200 VDC59
100 mmf Air Paddle APC 10049
50 mmf Air Paddle APC 5039
PE 9YC Dynamotor2.75
Inst. Knob 2 5/16 Dia. w/pointer . . .39



HIGH CURRENT MICAS

Type G Ceramic Case, Tolerance 5%.

TYPE G4		TYPE G1		TYPE G3		TYPE G5	
CAP Amps	KV	CAP Amps	KV	MFD	DC	Price	Each
0.00024	4	.0006	10	20		\$15.50	
0.0008	4	.0008	12	20		16.50	
.003	25	.003	25	15		19.95	
.037	45	.0001	6	35		\$32.50	
.02	40	.00015	10	35		37.50	
.0075	39	.0005	20	35		42.00	
		.003	40	25		47.50	

CERAMICONS

MMF: 1.5, 3, 8, 20, 22, 120, 50005 ea.

SILVER MICA CAPACITORS

MMF: 10, 50, 60, 340, 750, 780, 100012 ea.

PIGTAILED MICAS

MMF: 5, 20, 50, 60, 100, 250, 300, 400, 500, 750, 800, 1000, 2000, 3000, 4,000, 5,000, 6000, 10000, 50,09 ea.

BAKELITE CASED MICAS

MFD	VDC	Price	MFD	VDC	Price	MFD	VDC	Price
.001	600	\$.18	.024	1500	\$.65	.00045	5 KV	\$1.10
.002	600	.24	.033	1500	.75	.001	5 KV	1.60
.01	600	.26	.005	2500	.55	.0015	5 KV	1.60
.02	600	.26	.002	2500	.45	.003	5 KV	1.90
.027	600	.26	.004	2500	.50	.005	5 KV	2.50
.01	1 KV	.45	.005	3 KV	1.00	.0003	8 KV	2.50
.002	1200	.35	.0001	5 KV	.70	.0005	8 KV	2.90

OIL CONDENSERS

1.75 mfd 400 vdc . . . \$0.39
4 mfd 600 vdc39
6 mfd 600 vdc95
8/8 mfd 600 vdc . . . 1.79
10 mfd 600 vdc . . . 1.95
10 mfd 1500 vdc . . . 3.95
2 mfd 2000 vdc . . . 2.50
10 mfd 2000 vdc . . . 4.95

2 mfd 4000 vdc . . . \$4.90
1 mfd 5000 vdc . . . 4.50
1/2 mfd 7000 vdc . . . 2.95
.05 7000 vdc85
1 7500 vdc1.25
1 mfd 6000 vdc . . . 9.95
2 mfd 7500 vdc . . . 12.75
.65 mfd 12,500 vdc . . . 12.95

POWER TRANSFORMERS

Fully Cased, Pri. 110 Volts 60 cy.
1110 volts CT 60 MA, 920 Volts CT 160 MA, 6.3V, 18A, 6.3V, 1.25V, 5V2A, 5V2A . . . 4.95 ea.
300 volts CT 300 MA, 2.5V7A, 2.5V7A, 0.3V, 1.5A
940 Volts CT 425 MA, 65V BIAS2.75
4400 V @ 4.5 MA, 5V 3A 15 KV INS . . . 4.95
Vibrator Trans. 6V in, 300V @ 100MA Out . . . 2.95

FILAMENT TRANSFORMER

110 V 60 CY. Primary—Full Casing
2.5V 20A, 2.5V 20A . . . \$6.95

Insist on VEE-D-X

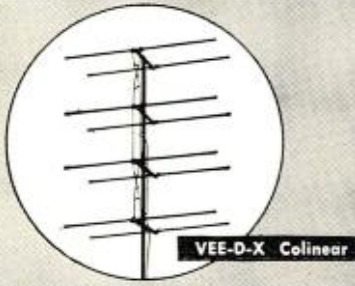

VEE-D-X Colinear

THE WORLD'S

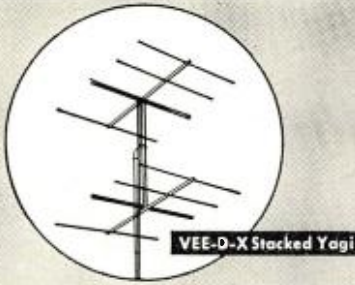

VEE-D-X Stacked Yagi

MOST POWERFUL



VEE-D-X Yagi

TV ANTENNAS

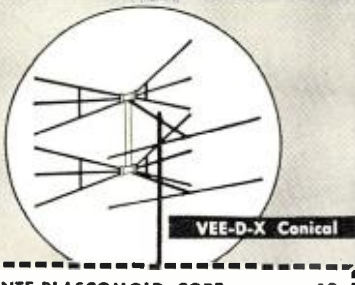

VEE-D-X Conical

LaPOINTE-PLASCOMOLD CORP. 10
WINDSOR LOCKS, CONN.

Please send me new 1951 catalog of VEE-D-X
antennas and accessories.

NAME _____
STREET _____
CITY _____ ZONE _____ STATE _____

1830 with a program of dance music. (Catch, England) Recently noted *Radio SEU*, Madrid, at 0900 on 7.170 with "Diario Hablado" (news in Spanish); station sent nice QSL card and photo; QRA is Radio SEU, Calle de Diego de Leon, 49, Madrid, Espana. (Mesquita e Sousa, Portugal)

Radio Nacional de Espana, 15.625, Madrid, noted signing off 1147; good signal. (Ferguson, N. C.) *Radio Mediterraneo*, 7.036A Valencia, now broadcasts in *English* each Tue. and Fri. 1445. (Patrick, England)

Surinam—Station noted on 10.97 recently around 1655 is definitely PZR; was in dual with PZH5, 5.76; may be used at times instead of 15.405. (Bellington, N. Y.)

Tahiti—*Radio Tahiti*, 6.980, heard 2300-2345, weak and usually with severe CWQRM; the 12.080 channel not heard lately. (Neeley, Calif.)

Taiwan—*Taipeh*, 7.133, signs on weekdays 0430, Sundays 0530. (Balbi, Calif.) Still has news 0630.

The 11.735 outlet noted in *English* 2310; weak. (Stark, Texas)

Trinidad—VP4RD, 9.625, Port-of-Spain, noted with news 1845-1858, then weather forecast. (Cox, Delaware)

Turkey—TAV, 17.840, Ankara, noted testing 0715. (Cushen, N.Z.) TAP, 9.465, noted with news 1445. (Bellington, N. Y.) The new 100 kw. transmitter, which had been testing for some months, was officially inaugurated in early December. Program time is expected to be expanded.

TAV, 17.840, noted 0500 with program for Forces in Pacific Area. (Sanderson, Australia)

Uruguay—CXA30, 6.035, heard with dance music 1945-2000; identified in Spanish. (Cox, Delaware)

USI—YDE, 11.77, Djakarta, noted with news 1000; considerable heterodyne. (Cox, Delaware)

USSR—Khabarovsk, 5.940, noted with weak signal in England 0915 with Russian program. (Catch) Yakutsk, 5.970, tuned 0405; commentary in foreign language by man and woman alternately. (Russell, Calif.) Petropavlosk, 6.075, noted in Chinese 0530-0615, in native from 0300, late as 0930. The 4.275 channel irregular relays the Chinese transmission in parallel with Petropavlosk. (Balbi, Calif.)

Vatican—HVJ, 17.765, noted recently with news 1000. (Oskay, N. J.) Noted recently with *English* 1315-1330 on 11.740. (Peddle, Newfoundland)

Yugoslavia—Belgrade, 6.100, heard in foreign language 1525; weak signal. (Cox, Delaware)

* * *

Last Minute Tips

Radio Sweden reports an unidentified station on 7.540 with call-sign DIV2; announces as "The International Broadcasting System" and gives Central European Time, with opening around 0200; loaction is believed somewhere in Germany.

Radio Moscow now operates to South-East Asia in *English* 0900 on 9.60, 11.84, 15.18. (Fried, Mich.)

Polskie Radio, Warsaw, broadcasts

RCA VICTOR Camden, N. J.

Requires Experienced Electronics Engineers

RCA's steady growth in the field of electronics results in attractive opportunities for electrical and mechanical engineers and physicists. Experienced engineers are finding the "right position" in the wide scope of RCA's activities. Equipment is being developed for the following applications: communications and navigational equipment for the aviation industry, mobile transmitters, microwave relay links, radar systems and components, and ultra high frequency test equipment.

These requirements represent permanent expansion in RCA Victor's Engineering Division at Camden, which will provide excellent opportunities for men of high caliber with appropriate training and experience.

If you meet these specifications, and if you are looking for a career which will open wide the door to the complete expression of your talents in the fields of electronics, write, giving full details to:

National Recruiting Division
Box 120, RCA Victor Division
Radio Corporation of America
Camden, New Jersey

FOR Greater
EARNINGS...

Learn
RADIO-
ELECTRONICS



Train for Success in TELEVISION, RADIO, RADAR and ELECTRONICS. Learn the application of RADIO-ELECTRONICS to Aviation, Petroleum Exploration and other industries.

You learn on the finest equipment. You build equipment. You may join Spartan's "Ham" Club. Many large organizations call on Spartan regularly for graduates. Often, students are hired months before graduation.

Spartan offers two complete, thorough courses, preparing you for Federal Communication Commission license tests—first class radio telephone, second class radio telegraph or class

"B" radio amateur.

SPARTAN
SCHOOL OF RADIO AND ELECTRONICS
TULSA, OKLAHOMA

Write Today!

MAIL COUPON TODAY

Spartan School of Radio and Electronics
Tulsa, Oklahoma, Dept. RTN-21

Please send complete information.

Name _____ Age _____

Street _____ City _____ State _____

G. I. Approved—Write Today

in English on 6.115 at 1245-1315; on 6.220 at 1230-1300, 1400-1425, and on 7.205 at 1600-1630; also noted on 9.570 signing off 0915 or 0930. (Radio Sweden)

A new station in northeastern Brazil is *Radio Arapuan* in Joa Pessoa, capital of the State of Paraiba; was report as operating in the 60-m. band (exact channel not known) with powerful harmonic in the 10 meter amateur band in Rio de Janeiro, but ceased test transmissions by request of the Brazilian Amateur League and of the Technical Radio Commission. However, it may resume transmissions soon. *Radio Record*, Sao Paulo, is now using 6.055, 15.135; no longer uses 9.505 which belongs to *Radio Nacional* in Rio de Janeiro; PRL7, 9.72, by this time likely will have moved to 9.505 to escape QRM from *Radio Moscow*. *Radio Quitandinha*, Petropolis, is now on the air daily on 5.045 with test transmissions at 1230-1400 and sometimes at night. Petropolis, in the State of Rio de Janeiro, is a famous summer resort—2700 feet in altitude—on the highway between Rio and Belo Horizonte; is located 35 miles north of the nation's capital, 60 miles by highway! *Radio Nacional* now is using its 250 watt transmitter on 11.720; the channel used by this particular transmitter is not announced. (Serrano, Brazil)

Riggle, Ohio, reports *Radio Rangoon*, Burma, opening 0000 on approximately 15.050; after opening "chanting," had news in English.

At the time this was compiled, Balbi, Calif., said the only Peking outlets he was hearing around 0330-0510 were 10.260 and 6.040, in parallel.

BED26, 10.06, Taipeh, Taiwan, noted 0430 with Western recorded music, then Chinese news; BCSF, 7.334, also Taipeh, heard 0700 with recorded music, then Chinese news. (Sanderson, Australia)

According to *Radio Australia*, at the time this was compiled, Ankara, Turkey, was to test with 20 kw. on any of these channels—6.000, 7.240, 11.760, 17.720; and with the new 100 kw. transmitter on possibly 7.285, 9.515, 11.880, 15.160, 17.840, or 21.660.

Menado, Celebes, USI, more recently has been noted on 9.680 at 0630 with recorded musical program for Forces. (Sanderson, Australia)

Press Time Flashes

AIR, Delhi, airmailed me these schedules for English periods—2130, 11.760, 9.670, 9.565, 7.225, 6.110; 2315, 17.780, 15.160; 0230, 21.700, 17.740; 0300, 17.760, 15.290, 9.670; 0530 (Sat., Sun. only), 17.760, 15.160; 0730, 17.760, 15.290, 11.870, 9.670, 9.630, 9.590, 9.575, 9.565, 7.290, 7.275, 7.260, 7.255, 6.110, 6.010, 4.960, 3.435, and 3.365.

Real values on hard-to-obtain items

"S" METER . . . An outstanding buy!



Here is a beautiful instrument exactly suited for use as an "S" meter. Illuminated face, (supplied with miniature lamp) with a full-scale reading of 5 ma, a standard value for most "S" meter circuits. Diameter across face is 2 3/4", black bakelite case, reverse-set pointer. New, surplus . . . limited quantity. Only . . . \$1.95 ea.

836 hi-vacuum rectifiers. 2 for . . . \$1.50

TRANSFORMERS-CHOKES:

2.5V, 10A. 10KV insulation. Suitable for 866, 836, etc. Reduced to \$2.79 ea.
10H, 200 ma choke. Hermetically-sealed steel case. Also has hum-bucking tap. A beautiful item only \$1.98.

10H, 50 ma choke. Strap mounting. Handy for dozens of applications. Reg. 98c, reduced to 65c. Charger or fil. trans. Pri. 110V, 60 cycle. Secondary, 9-10-11-12-13 volts @ 1.2 A. Fully cased. A buy at \$1.49.

Vibrator transformer. 6V imp. Secondary 345-0-345 @ 150 ma. Also has bias winding. Fully cased. Bargain at \$1.49 ea.

Power transformer. 780V, CT @ 200 ma. 2.5V at Sa. 5V at 8A. 6.3V at 6A. Pri. 115V, 60cy. AC. Has electrostatic shield. Upright mount. Shipping weight 11 lbs. Only \$4.95.
5V, 25A transf. Cased, upright mtg. A buy at \$3.95 ea.

MICROPHONES:

RCA Hand Mike. Hi-grade, single button. Bronze colored w/cord and plug. NEW. Were \$1.98, now reduced to 98c ea.

TELEPHONE EQUIPMENT:

EES9 Repeaters (see previous ads). Only a few left. NEW! Regularly \$9.95 ea. . . now \$6.95 ea.
T5-10 Sound powered handsets. A limited quantity only. BRAND NEW! . . . \$25.95 pair
Handset hanger. Beautiful cast aluminum shell finish'd in black wrinkle. Takes all makes and models. An extremely useful, well-made item only \$1.95 ea.

STORAGE BATTERIES:

2 volt. Willard. Dry packed. Very special at \$1.19 ea.
36 volt storage bat. Consists of 18, 2V units in sturdy case. Here is really a bargain! Only \$17.95.

RECEIVERS:

SCR-522 Receiver. Used, good condition. With tubes \$14.85 ea.

LOW FREQUENCY CRYSTALS

Precise units in holders. Ideal for oscillators as markers, BFO, etc. Can also be used as resonators for crystal filters. 450, 453.70, 457.4, 464.81, 466.66, 468.51, Freq. in KC. These are an excellent buy at only . . . 89c ea.

CRYSTAL SETS FOR SSB FILTERS

Three crystals, 450, 451.85, 453.7 kc. See QST, Nov. 1950, page 11. Set of three . . . \$2.60 set.

SPECIAL PLUGS & CONNECTORS

RS-ARNS. Two special plugs. . . \$1.00 set
PL-109 fits into BC-248—new. . . 75c ea.
PL-58 fits into EE-8 telephones and many switchboards—new . . . 30c ea.
PL-106 fits RM-14 telephones and others—new . . . 45c ea.
8 pr. Female. Fits SCR-284 equip. . . 35c ea.

HS-30 Phones. NEW in boxes. Only . . . \$1.29
HS-16 phones. Used, with headband and 6' cord. A hot buy at . . . 98c

BC-454 RECEIVERS

Frequency range, 3 to 6 mcs. Good condition. An astonishing low close-out price. . . \$3.95 ea.
Less tubes . . . \$3.95 ea.

CONDENSER TESTER

• One of our best sellers! Useful, versatile laboratory item, in kit form. Simple, and easy to build in less than an hour. Checks condenser leakage and continuity up to 8 megs. Will test any paper, electrolytic, mica or oil capacitor from 50 mmf. to 50 mfd. Self-contained power supply and neon bulb indicator with socket and bezel. Drilled metal cabinet. Complete instructions and diagrams included with each kit. Only \$4.85.



THE WELL-KNOWN "Q5'er"!!

Special purchase on this outstanding unit. Frequency range 190 to 550 kc. 85 kc I.F. Complete with full tube complement.
Used, good condition. . . only \$10.95 ea.
New . . . only \$12.95 ea.
R-23-ARC/5. Identical receiver to above except has switch to change from antenna to direction finding loop. Makes a wonderful L.F. direction finder. With tubes.
Used, good condition. . . only \$10.95 ea.
New . . . only \$12.95 ea.

GRAIN-OF-WHEAT LAMPS

The smallest of the small. Overall, 3/8", diam. 3/16". Operates on 3 volts. Wonderful for receivers, models, etc. . . . only \$.15 ea.
12 for \$1.50

DOUBLE-POTS

Carbon, small size, two-gang. Made by A-B. One section, 12,000 ohms, one section 22,000 ohms. A buy at . . . \$.50 ea.

15 OHM RHEOSTATS

Rated at 25 watts. Ohmite Type "II." Only \$.50 ea.

SCOPE COMBO OFFER

The makings for an excellent scope. Includes: 1-5NP1 C-R tube, transformer for hi-voltage and fil. for 2X2 rectifier, circuit diagram. Only \$7.95

FL-8 Filters, New. only 98c ea.

ULTRA-VIOLET LIGHT SOURCE

FOR TELEVISION AND C/R TUBE EXAMINATION

O-R now presents . . . new . . . an 8-watt, ultra-violet, "black-light" source! Here is a highly effective and time saving device for checking burn spots and other defects in phosphors of C/R tubes. C/R tube face fluoresces when exposed to this special black-light to give visual indication of condition of phosphor. Reflected light from C/R tube face is negligible and tube does not have to be in operation. An invaluable device for TV service shops, schools, laboratories. Also used in medical, chemical, foods, stamps, criminology . . . a thousand uses.

In kit form including Sylvania 8 watt, black-light tube, ballast, starter, mounting panel, tube clips, reflector, line cord/plug, hardware, instructions. Simple shadow box for outer housing is easily made. Complete kit (less outer housing) . . . only \$4.95

1/2 WAVE TVI FILTERS

Assure yourself of success with the highly effective 1/2 wave TVI filters described in G-E HAM NEWS. Kit consists of drawn aluminum case, 11" long, 2 7/8" deep and 2 3/4" wide, finished black wrinkle. (Surplus.) Also three 150 mmf variable capacitors with transmitting type shunting mica where required in the circuit. Two air-wound inductors set to approximate inductance are supplied. Combination makes it possible to set internal circuits for exact resonance for optimum harmonic reduction and minimum interaction on transmitter. Instructions for assembly and tuning are supplied. Kits available for either 10 or 20 meters (specify). For 52 ohm line. Complete kit as above. . . . only \$5.95

TU-10 B TUNING UNITS

The best of the BC-375 tuning units. Has three, transmitting type variables. H.V. mica, RF chokes. Velvet Vernier tuning dials, worm-gear reduction. Really a wonderful source of excellent components only \$1.75 ea.

SMALL PRECISION LATHE—110-V. AC

Now with Larger Motor \$44.50

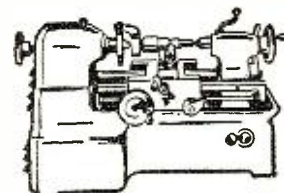

A small lathe for radio shops, jewelers, laboratories, dentists, hobby-crafters, model makers, machine shops, schools, etc. Automatic Feed. Work capacity 3" between centers. Swing over bed 2". Constructed of steel and cast iron. Accurately machined and finished. Fan-Cooled Motor mounted inside the base. Complete with 1 1/4" face plate, 2 lathe centers, tool post and rocker, one lathe dog, one tool-bit and test rod.

COMPLETE ACCESSORY KIT

Including 4-jaw chuck, drill chuck, center counter-sink drill, 2 tool-bits, 2 lathe dogs, 1 face plate with 8 drilled and tapped holes, 4 collets, 1 collet chuck, 1 Allen wrench. \$24.50

MINIMUM ORDER \$2.00. ALL ITEMS SUBJECT TO PRIOR SALE.

ALL PRICES SUBJECT TO CHANGE WITHOUT NOTICE.

20% DEPOSIT MUST ACCOMPANY ALL ORDERS, BALANCE C.O.D.

OFFENBACH & REIMUS CO.

372 ELLIS ST.

SAN FRANCISCO, CALIF.

PHONE Ordway 3-8551

INDISPENSABLE! PHOTOFAC BOOKS



Photofact Television Course. Covers TV principles, operation and practice. 216 pages; profusely illustrated; 8 1/2 x 11". Order TV-1 Only \$3.00

Television Antennas. New 2nd edition. Describes all TV antenna types; tells how to select, install, solve troubles. Saves time; helps you earn more. 200 pages; illustrated. Order TAG-1 Only \$2.00

Television Tube Location Guide. Accurate diagrams show position and function of all tubes in hundreds of TV sets; helps you diagnose trouble without removing chassis. 200 pages; pocket-size. Order TGL-1 Only \$1.50

1949-1950 Record Changer Manual. Vol. 3. Covers 44 models made in 1949, including multi-speed changers and wire and tape recorders. Original data based on actual analysis of equipment. 286 pages; 8 1/2 x 11"; paper-bound. Order CM-3 Only \$3.00

1948-1949 Changer Manual. Vol. 2. Covers 45 models made in 1948-49. Paper bound. Order CM-2. Only \$4.95

1947-1948 Changer Manual. Vol. 1. Covers 40 post-war models up to 1948. Order CM-1 Only \$4.95

Recording & Reproduction of Sound. A complete authoritative treatment of all phases of recording and amplification. 6 x 9". Order RR-1 Only \$5.00



Post-War Audio Amplifiers. Vol. 2. A complete analysis of 104 well-known audio amplifiers and 12 well-known tuners made in 1949-50. 368 pages, 8 1/2 x 11". Order AA-2 Only \$3.95

Post-War Audio Amplifiers. Vol. 1. Covers 102 amplifiers and FM tuners made through 1948. 352 pages. Order AA-1 Only \$3.95

Auto Radio Manual. Complete service data on more than 100 post-war auto radio models. Covers over 24 mfgs. 350 pages, 8 1/2 x 11". Order AR-1 Only \$4.95

Communications Receiver Manual. Complete analysis of 50 popular communications models. 246 pages, 8 1/2 x 11". Order CR-1 Only \$3.00

Radio Receiver Tube Placement Guide. Accurate diagrams show where to replace each tube in 5500 radio models, covering 1938-1947 receivers. 192 pages, pocket-size. Order TP-1 Only \$1.25

Dial Cord Stringing Guide. Vol. 2. Covers receivers made from 1947 through 1949. Shows you the one right way to string a dial cord in thousands of models. Pocket-size. Order DC-2 Only \$1.00

Dial Cord Guide. Vol. 1. Covers sets produced 1938 through 1946. Order DC-1 Only \$1.00



The Famous "Radio and TV Industry RED BOOK"

New 2nd Edition. The complete one-volume guide to TV and Radio replacement parts for 22,000 sets made from 1938 through 1950.

Covers all 22 major components; 19 leading part manufacturers. Gives original part number, proper replacement numbers, valuable installation and service notes. Over 600 pages; 8 1/2 x 11". Only \$3.95

Order from your Paris Jobber or write direct to
HOWARD W. SAMS & CO., INC., 2201 E. 48th St., Indianapolis 5, Indiana
HOWARD W. SAMS & CO., INC.

Prague, Czechoslovakia, noted with news 1415 and 1530 on 9.504; at 1715-1730 on 9.504, 6.170; at 1900 on 6.170, 9.550. Nova Lisboa, 11.925, Angola, good afternoons to 1530 when closes with "A Portuguesa." (Bellington, N. Y.)

4VEH, Haiti, at times now is using 9.730; noted there 1930. (Bellington, N. Y.; Stark, Texas, others) Mulvey, Conn., says moves from 9.745 to 9.730 at 1830 when is in *English*.

Monte Carlo, 6.035, 9.785, now noted signing on 0030 instead of former 0100. (Bellington, N. Y.)

HROW, Honduras, noted on new spot around 6.650 or 6.670; signs off 2330. (Stark, Texas; Bellington, N. Y.)

VLT5, 7.280, Port Moresby, British New Guinea, heard 1800 with BBC news relay. (Sutton, Ohio)

British Antarctic amateurs VP8AJ and VP8AK have been heard recently around 7.001-7.010 at 2000-2045. (Mulvey, Conn.)

YDC, 9.553.8 (measured), Makassar, Celebes, USI, noted recently 0450 with program of Hawaiian recordings. (Treibel, Washington State)

Damascus, 12.000, Syria, logged 0712 with native language, musical program; has *English* 0600; fair signal but with some CWQRM. Limassol, 6.170, 6.135, 6.790, and 9.650, Cyprus, noted from tuning 2345 with Arabic program. Tel Aviv, 6.830, Israel, heard 0015 with musical program in Hebrew, weak to fair; also heard 1525 with talk or news in Hebrew, weak. (Cox, Delaware)

During 1951, *Radio Norway*, Oslo, may use any of these channels—LLQ, 21.730; LLP, 21.670; LLN, 17.825; LKW, 17.755; LLM, 15.175; LKV, 15.170; LLK, 11.85; LKQ, 11.735; LLH, 9.645; LLG, 9.610; LKJ, 9.540; LLR, 7.240; LLS, 7.210; LLI, 6.185, and LKF, 1578 kc. Latest schedule is—*For Norwegians Abroad* (daily)—to North America and North Atlantic, 2000-2100, LKV, LKQ, LLG; to Far East, Antarctic, 0600-0700, LLP, LLM, LLK, LLG; to Indian Ocean, 0800-0900, LLP, LLM, LLK, LLG; to African Waters, Europe, 1400-1500, LLP, LKV, LLK, LLG; to South America, Antarctic, 1800-1900, LKV, LKQ, LLG, LKF. To these sessions, a 15-to-20-minute program in *English* ("Norway This Week") is added on Sundays *only* (at end of each of these transmissions). The last 15 minutes of the daily one-hour broadcast *For Norwegians Abroad* usually consists of Norwegian music or music by Norwegian artists; this section is introduced in both *English* and Norwegian. *Home Service*—to African Waters, Europe, Antarctic, 0115-0230 (Suns. 0255-0550), LLP, LLN, LLM, LLK; 1300-1400 (Sats. 1200-1400, Suns. 1000-1400), LLP, LKV, LLK, LLG; 1500-1700 (Suns. 1515-1700), LLP, LKV, LLK, LLG. *Home Service Over Tromsø Short-Wave Transmitter*—to North Atlantic, North Sea, 0115-0230 (Sats. 0115-0320, Suns. 0255-0320), LKJ; 0520-0740, LKJ; 1045-1700 (Sats. 0930-1700, Suns. 1015-1700), LLS. On Sundays, Wednes-

STOP

those costly service calls with ...

ELECTRO ANTENNA KOTE

A newly developed Chemical compound of various Resins, Gums and Synthetics, ANTENNA KOTE is recommended for safely coating all exposed exterior television connections.

Dielectric Strength — Volts/Mil 1050.
(May be used for arrest of voltage leakage)
Dries hard in 8 hours.
(A non-electrical conductor)
Eliminates rust and corrosion.
(Does away with the use of tape)
Excellent resistance to heat, oil, acid, salt water, chemicals and moisture.

A Complete Line of Electronic Chemicals
Exclusive territories for sales representatives.
write for particulars . . .

DAKOLINE CHEMICAL CO., INC.
ELECTRONIC CHEMICALS DIVISION
357 Atlantic Ave., Brooklyn 2, N. Y.

For Clearer, Sharper Pictures . . .

For Easier, Faster Installations

PHOENIX Speed TENNAS . . . Speed MOUNTS . . . and HARDWARE

PHOENIX ELECTRONICS INC. LAWRENCE, MASS.

days and Thursdays (or Fridays), there usually is a symphony concert in the Home Service at 1400. (Halvorsen, Norway.)

World Radio Handbook (1950 Edition) is available now at \$1.25; the new guide, *How To Listen To The World*, by the same publisher—O. Lund-Johansen, Copenhagen, Denmark—is 30 cents; both can be had for \$1.50; prices are *postpaid*; send orders *direct* to the American representative—Ben E. Wilbur, 32 Whittlesey Ave., East Orange, New Jersey. *Both books are in English.*

BCOF, Kure, Japan, noted recently testing on 6.105 to 1030 sign-off; excellent signal in California; regular schedule is 1630-0930. (Necley.)

Vatican Radio, 17.840, is coming in well in Virginia on Tuesdays 1030-1045 with news in *English* for the Far East. (Saylor.)

Salisbury, Southern Rhodesia, says it rarely uses calls, but lists these—ZFAE, 2.500; ZFAF, 3.320; ZFAH, 4.890; ZFAJ, 6.120, and ZFAK, 7.290. (*Short Wave News*, London.)

Sutton, Ohio, says V3USE, 15.060, Forestside, Mauritius, is heard with BBC news relay 2330; seldom heard due to poor band conditions lately; signs off 0015 now.

Lisbon, Portugal, is using 11.980 in parallel with 11.027 until closing at 1530; and re-opening 1600. (Radio Australia.) Also noted by Bellington, N.Y., others, on 11.980 which they thought might be image.

A French-speaking station noted on 9.960 at 1230-1500 gives call that appears to be *Radio AEF*; is believed to be a low-powered transmitter operated by *Radio Brazzaville*, French Equatorial Africa. (Radio Sweden, others.) Heard in New York. (Bellington.)

Radio Nigeria, Lagos, is at present using *only* 6.035 but soon will transmit on 7.255 at 0100-0230, 0600-0700; on 9.655 at 0100-0230, 0600-1300; on 4.990 at 1300-1700; will drop the 6.035 channel. (*Short Wave News*, London.)

HCJB, "The Voice of the Andes," also now known as the "International Missionary Station," is scheduled with these *English* releases daily *except* Mondays—*Morning In The Mountains*, 0630-0730, 12.455, 9.958; *Southern Cross Salute*, 1430-1530, 17.890, 15.115; *Ecuadorian Echoes*, 1700-1800, 15.115, 12.455, 9.958; and *Moon Over the Andes*, 2100-0030, 15.115, 12.455, 9.958, and from 2300 over 5.993. Foreign language programs are listed—*Spanish*, daily 0600, 1230, 1730; *Russian*, daily 0600, 1100; *Swedish*, daily 1200; *French*, daily 1600; *German*, Tue.-Thu.-Sat. 1400, Sun. 0845; the foreign language releases are over one or more of these outlets—17.890, 12.455, 9.958, 5.993, 974 kc. Power is 10 kw. (Dary, Kans.)

Acknowledgement

Thanks, fellows, for the fine cooperation! I'm eager to receive reports from *anyone*, *anywhere* in the world—to 948 Stewartstown Road, Morgantown, West Virginia, USA. . . . KRB.

February, 1951

The NEW Automatic Radio

RECORD SMASHING VALUES!

CUSTOM-BUILT AUTO RADIOS

1949, 1950 and 1951 FORD AUTO RADIOS

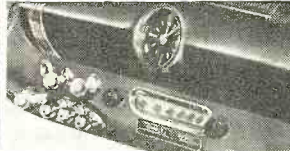

List Price.....\$54.95

1949, 1950 and 1951 PLYMOUTH-DODGE RADIOS



List Price.....\$54.95

1949, 1950 and 1951 CHEVROLET RADIOS



List Price.....\$54.95

ATTRACTIVE DISCOUNTS TO DEALERS

CAPACITORS UPRIGHT MOUNT

	EA.	TEN
2X.25MFD	400 VDC	\$.30
7.5MFD	400 VDC	.35
1MFD	400 VDC	.40
2X.05MFD	600 VDC	.40
.35MFD	600 VDC	.40
2X.1MFD	600 VDC	.45
1MFD	600 VDC	.45
.5MFD	600 VDC	.45
1MFD	600 VDC	.45

BATH TUB

40MFD	25 VDC	.40
4MFD	50 VDC	.45
1MFD	100 VDC	.55
2MFD	200 VDC	.60
3X.1MFD	400 VDC	.40
2MFD	400 VDC	.55
.25MFD	600 VDC	.40
.25MFD	600 VDC	.40
1MFD	600 VDC	.45
2MFD	600 VDC	.60
2X.1MFD	600 VDC	.60
2X.1MFD	1000 VDC	.65

OIL FILLED AND GE PYRANOL

.5-.5MFD	400 VDC	\$.45
1MFD	500 VDC	\$.50
1MFD	600 VDC	\$.55
2MFD	600 VDC	\$.60
4MFD	600 VDC	\$.70
5MFD	600 VDC	1.00
1MFD	600 VDC	2.25
3MFD	1000 VDC	1.60
2MFD	1000 VDC	.90
.5MFD	2000 VDC	1.70
.25MFD	2000 VDC	2.50
.5MFD	3000 VDC	2.45
1MFD	7500 VDC	7.50
1MFD	10000 VDC	12.00
1MFD	12,000 VDC	12.95
.0005MFD	15,000 VDC	12.50
.045MFD	16,000 VDC	7.95

PAPER

8-SMFD	600 VDC	\$2.25
3-SMFD	600 VDC	\$2.55
8-S-1MFD	650 VDC	2.45
160-160MFD	150 VDC	1.50

ELECTROLYTICS

2500MFD	3 VDC	\$.30
5000MFD	12 VDC	\$.85
25 MFD	25 VDC	\$.30
30MFD	25 VDC	\$.30
1000MFD	25 VDC	\$.85
1500MFD	50 VDC	\$.40

SPECIALS

80.80 KC Crystal with Holder. \$1.50
 KC-501A Cord Connects BC-654 Transceiver to GN-45 Gen. 1.50
 Balloon with Hydrogen Gen. 2.59
 Gibson Gift Box Kit 17"x17"x36" 2.25
 33-440 MMF Variable Condenser .79
 7-100 MMF Variable Condenser .79
 24-750 MMF Tapered Rotor Plates .90
 American Blower and Motor .90
 GE 1/8 HP 115V 1 Phase 60 cy 1725 RPM. Brand New. 24.95

CHECK THESE VALUES

BC-709 Interphone Amplifier ideal for aircraft-booster tele. phone. New. \$4.00
 MN-26V Radio Compass Receiver, 150-325KC, 325-695KC, 3.47-7.0 MCs, 28 Volt Bendix Brand New. \$44.50
 RA-100B Receiver Bendix New \$39.95
 BC-733D Receiver New Less Dynamotor. \$14.95
 Used w/ Dynamotor. \$59.95
 BC-224 Receiver New Less Mtr. \$100.00
 BC-412 5" Radar Oscilloscope. \$59.95
 RS/ARN-7 Radio Compass Receiver w/tubes. Used. \$39.95
 BC-433G Radio Compass Receiver. Used. Excel. Cond. w/ tubes. \$39.95

TUBES

2C24	1629	\$.30
6X2/879	2051	.30
6C24	7193	.30
7C4/1203A	8011	2.40
10Y	9006	.95
15R	40	9.75
203A	CPQ-2	1.40
29/44	CK-70	3.50
45 SIFEC	CR-72	1.40
203A	EL148	.30
218	IV-615	.70
713A	VR-68	21.00
W1-531	4.95 RK-73	.45
702B	2.50 VT-127A	3.00
801A	3.60 3BP1	3.45
803	4.25 5BP4	4.25
804	3.50 5BP7	1.95
834A	3.60 8A4	.60
864	4.45 1J6G	.95
860B	23.95 6SG7	1.75
CK1005	.95 6SJ7	1.45
CK1007	.90 35	.55
1626	.35	.55

RELAYS

6 VDC DPST Contacts 6A Coil 33 Ohms. \$.65
 12 VDC DPST Allied Control 2 Box 32. 1.25
 12 VDC DPST 64 Ohms. 1.25
 24 VDC 3 PDT 8 Amp. .95
 24 VDC Solenoid Operates 2 1.25
 45 Switchlets CNA 1970. .80
 40 VDC DPST-SPDT 1000 ohm .80
 110 VAC DPST 1 Amp Contacts 3184 Strath's Dunn. 1970. 3.65
 110 VAC DPST 25 Amp Contacts Ward Leonard. 3.95
 113 VAC DPST Strath's Dunn. 3.65
 CNA 1957. 1.25
 220 VDC DPST Strath's Dunn CX2122. 4.50

TIME DELAY SWITCHES

1 Minute 115 VAC 60 Cy Ene. in Waterproof Metal Case. New. \$5.25
 3 Micro Switches Make Contact at 40-41-42 Sec. Time Delay. 1.10
 VAC Motor. New. \$4.00
 Thermo Switch 50° to 300° F 115 VAC @ 6A, 230 VAC @ 5A Breaks @ Contact with Increase of Temperature. New. \$1.35
 30-40 Second Mercury Time Delay Relay 110 VAC Adlake. New. \$6.50

TRANSMITTING MICA

.0099MFD	2500 VDC	\$.35
.01MFD	2500 VDC	.70
.0075MFD	5000 VDC	1.25
.000375MFD	5000 VDC	1.45
.003MFD	5000 VDC	1.80
.002MFD	5000 VDC	2.00
.001MFD	6000 VDC	2.25
.005MFD	5000 VDC	7.50
.006MFD	6000 VDC	8.50
.002MFD	6000 VDC	7.50
.0012MFD	20,000 VDC	23.50

ROUND PANEL METERS

0-5 RF Amps Weston.	3 1/2"	\$ 4.50
0-300 MA DC Simpson	2 1/2"	3.75
0-300 MA DC Weston	2 1/2"	3.75
0-5.0 MA DC Weston with 50 MA Shunt	3 1/2"	4.25
0-50 Amps DC Weston	3 1/2"	4.75
0-100 Amps DC Hoyt	3"	3.50
0-3 Volts DC Sun	2 1/2"	1.95
0-15 Volts AC GE	3 1/2"	4.95
0-2500 Volts DC Simpson with multiplier	3 1/2"	5.95
0-5 KV DC 0-10 MA DC	3 1/2"	\$ 5.50
0-150 Volts DC Hoyt	3 1/2"	3.50
10-0-16DB Weston	2 1/2"	4.50

PORTABLE METERS

0-10 Amps DC Weston	489	7.50
0-3-6-30 Volts DC Weston	280	17.50
0-100 Amp DC Weston with 100 Amp Shunt	269	19.95
0-25 Amps AC Weston	433	29.95
0-15 Volts AC Outputmeter Weston	571	12.00

LINEAR POTENTIOMETERS WW

OHMS	WATTS	MFG'R	EA.	TEN
200	2	Chicago Tel.	\$ 40	\$.35
1000	2	Trefz	.50	.45
3000	2	Chicago Tel.	.40	.35
10,000	2	Chicago Tel.	.40	.35
5000	3	Trefz	.50	.45
7500	3	Trefz	.45	.40
10,000	3	Trefz	.55	.50
25,000	3	Wirt	.55	.50
50,000	4	Trefz	.70	.65
15	25	DeJeur	.75	.70
25	25	Ohmite	.75	.70
25	25	DeJeur	.75	.70
50	25	DeJeur	.75	.70
100	25	DeJeur	.85	.80
200	25	DeJeur	.85	.80
1000	25	DeJeur	.90	.85
3000	25	DeJeur	.95	.90
15,000	25	DeJeur	1.20	1.10
20,000	25	DeJeur	1.30	1.25
150	Switch	AN 3155-50	1.10	.90
200	W Switch	50 IRC	1.10	.90
800	50	Ohmite	1.10	.95
10,000	50	DeJeur	1.75	1.50
15	60	Ohmite	2.45	2.25
15	75	IRC	2.45	2.25
750	100	Ohmite	3.25	3.00
Heipot	20,000	Ohms	7.50	—
20,000	5W 5%	Muter 433 AC	8.50	—
5000	General	Radio 410	1.95	—
6000	Muter	314A	2.25	—

POWER EQUIPMENT

Voltage Regulator Raytheon 95/130 V 60Cy 1.25 Amp Output 115V 60 Watt. New. \$12.50
 Generator Voltage Regulator 115V 1000Cy GE CBA-200C New. \$14.95
 Vibration VEG 360 12 VDC Output 250V @ 70MA Synchronous Motor New. \$5.95
 ATR Inverter and Regulator 110 VDC to 110 VAC 50/60 Cy 150 Watt Model 15B New. \$19.95
 Vibrator ATR 2410 24 VDC Output 110V 100W. New. \$2.50

VALUES

De-ion Line Starter DPST 115V 60 Cy 15A 1 HP Rating Westinghouse. New. \$4.95
 Genuine Upright Desk Telephone and Ringing Box. New. \$4.95
 1 Micro Second Delay 15 KV A 400 Cy 50 Ohm. New. \$14.95
 T-17 Microphone. Used. \$1.25
 Tap Stand Mercury TS 915. \$1.45
 T-30 Throat Slike. New. \$1.25

TERMS: Minimum order \$5.00—All orders promptly filled—All prices F.O.B. Boston, Mass. Send M.O. or check. Shipping charges sent C.O.D. 25% deposit required with all C.O.D. orders.

Prices Subject to Change without Notice

COMET ELECTRONIC SALES CO.

22 Washington St. Brighton 35, Mass.
 Beacon 2-7863

Inquiries from Dealers, Schools and Industrial Firms Invited

www.americanradiohistory.com

127

Watch
MERIT
for TV in '51

Merit is meeting the rapidly rising demand for TV replacements with a TV line as complete as current and advance information will permit
TRY MERIT FIRST FOR TV CONVERSION OR REPLACEMENT!



HV06—Universal Ferrite core "FLYBACK" permits widest coverage.



MDF70—70° high efficiency Ferrite yoke for tubes up to 19"



MWC-1—Width linearity control with AGC winding (Automatic Gain Control).

FOCUS COILS



Free!

Write today for:

- MERIT TV REPL GUIDE AND CATALOG**
Dec. 1950 issue. Up-to-date listing of all replacements.
- MERIT 1951 CATALOG No. 5111**
Show specs. on complete line of TV, Radio, Amateur and Industrial Transformers.

REFER TO MERIT'S LISTING IN HOWARD SAM'S PHOTOFACTS



TAPE-MARKED TO HELP YOU!
Handy tape marking on every Merit Transformer shows permanent hook-up data for quick reference. ORIGINALATED BY MERIT.



MERIT
TRANSFORMER CORP.

4437 NORTH CLARK ST., CHICAGO 40, ILL.

NEW TV PRODUCTS on the Market.

NEW TV TUBE

The Tube Divisions of the *General Electric Company*, Schenectady, New York have announced that production is currently underway on an aluminized 19" round metal picture tube (the 19AP4C) which will provide improved picture brightness, contrast, and detail.

This is the second large picture tube to be aluminized within the past month by the company, the other being the 16" glass rectangular unit. The 19AP4C tube features an electron gun designed to be used with an external ion-trap magnet. The aluminized screen allows the tube to be operated at a lower anode voltage than is feasible with the non-aluminized version of the tube.

Electrical characteristics of the tube include a heater voltage of 6.3 volts; and heater current of .6 ampere plus or minus 10%. Maximum ratings are anode voltage 19,000 volts and grid-No. 2 voltage 410 volts.

CR TUBE TESTER

Precision Apparatus Company, Inc. 92-97 Horace Harding Blvd., Elmhurst, Long Island, New York has developed a new cathode-ray tube tester, the Model CR-30.

The new unit is a complete, self-contained instrument which will test

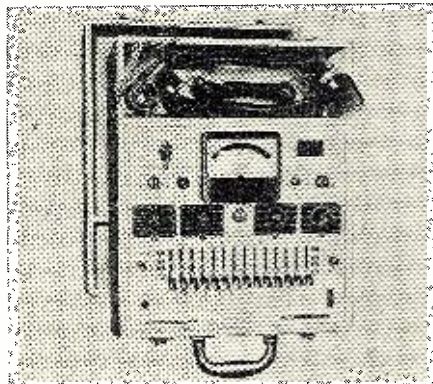

all TV picture tubes (electrostatic as well as electromagnetic), scope tubes, and industrial CR tubes, including special tests for all tube elements.

The CR-30 performs such tests without removing the tube from the TV set or the tube carton. The unit features a true beam current test circuit which checks all CR tubes with the electron gun in operation, giving accurate indication of proportionate picture brightness and tube condition. A voltage-regulated, bridge-type v.t.v.m. provides super-sensitive CR tube quality indications. With test circuits at high sensitivity position, a beam current change of only 1/10th of one microampere will create a change in

meter indication of approximately five divisions on the 120 division scale.

Full details on the Model CR-30 are available direct from the company.

SWEEP GENERATOR

Eastern Electric Company, P.O. Box 175, Valley Stream, Long Island, New York is currently in production on a

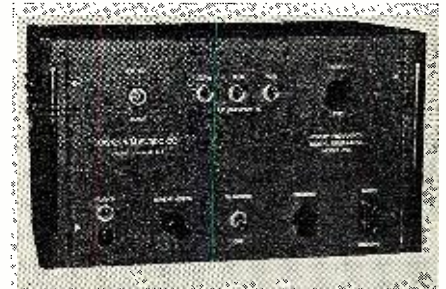

sweep frequency signal generator that is especially designed for television work.

The new Model 100 is an all-electronic, fundamentally-operated television i.f. generator for production alignment in the 20 mc. range. The maximum sweep width is 16 mc. at a center frequency of 25 mc. The amplitude variation is .1 db. per mc. with frequency linearity within 2%. The swept r.f. output is .5 volt across a 100 ohm terminated cable. Three steps of 20, 20, and 10 db. plus a linear vernier attenuator are available at the front panel with blanking, phasing, and sweep width controls and horizontal scope source. The unit incorporates no moving parts.

A data sheet on the new Model 100 is available on request.

"QUAD LOOP"

Square Root Manufacturing Corporation of 391 Saw Mill River Road, Yonkers 3, New York is currently introducing a new television antenna for indoor applications.

This top-of-the-set "Quad Loop" provides selective directivity without mechanical rotation on the top of the set, a single control which substantially reduces ghosts and selects the strongest signal, full 360 degree electronic rotation, and the reduction of unwanted interference. The unit is housed in a crackle finish cabinet which blends with any set.

A data sheet on the new "Quad Loop" is available on request.

NEW TV-FM BOOSTER

Industrial Television Inc. of 359 Lexington Avenue, Clifton, New Jersey has begun production on a new and fully automatic TV-FM booster.

The new "Autobooster" amplifies the entire TV and FM band thus elim-

RADIO & TELEVISION NEWS

inating the need for any tuning or switching. The unit turns on and off with the receiver by means of a magnetic relay. It employs two 6CB6 tubes for a 9X gain on the low and a 5X gain

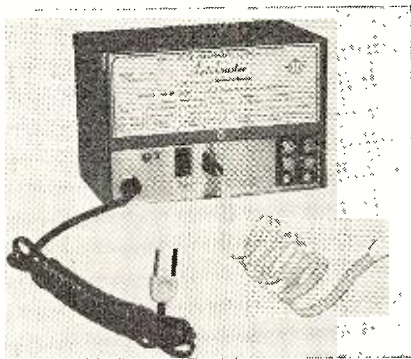

on the high TV channels with provision for field realignment to supply even higher gain on troublesome channels.

The booster provides for either single or double input, thereby permitting separate high and low frequency antennas and transmission lines without the usual manual switching. Because of its automatic feature the new "Autobooster" may be mounted in the rear of the television receiver out of sight of the viewer.

SIGNAL GENERATOR

The Hickok Electrical Instrument Company of 10514 Dupont Avenue, Cleveland 8, Ohio has developed a new universal, all-band microvolt signal generator, the Model 292X.

The new generator has been designed specifically for television, mobile radio, and AM-FM applications. It covers all of these frequencies in seven ranges and is crystal controlled. The modulated and unmodulated output from .2 to 100,000 microvolts is available through a 10 to 1 attenuator. The unit may be externally modulated from 15 to 10,000 c.p.s.

The instrument incorporates a decibel meter for faster servicing, to indicate reference level. It measures both input and output of units under test.

A data sheet covering complete specifications on the Model 292X is available on request.

NEW TV TUBE

A new television receiving tube, designed primarily for vertical oscillator and amplifier service with large wide-angle picture tubes, has been announced by the Tube Divisions of General Electric Company, Schenectady, New York.

The tube, the Type 12BH7, is a 9-pin miniature double triode having semi-high perveance units. In addition to its application in TV receivers, the 12BH7 may be used in applications where two similar triodes in a single envelope are desirable from the viewpoint of space conservation and cost reduction.

The new tube is designed to withstand relatively high peak positive plate potentials, and accordingly is specifically rated for use in the ver-

USE E-V 34"

FOR BEST CARTRIDGE REPLACEMENT

IN RCA "45"

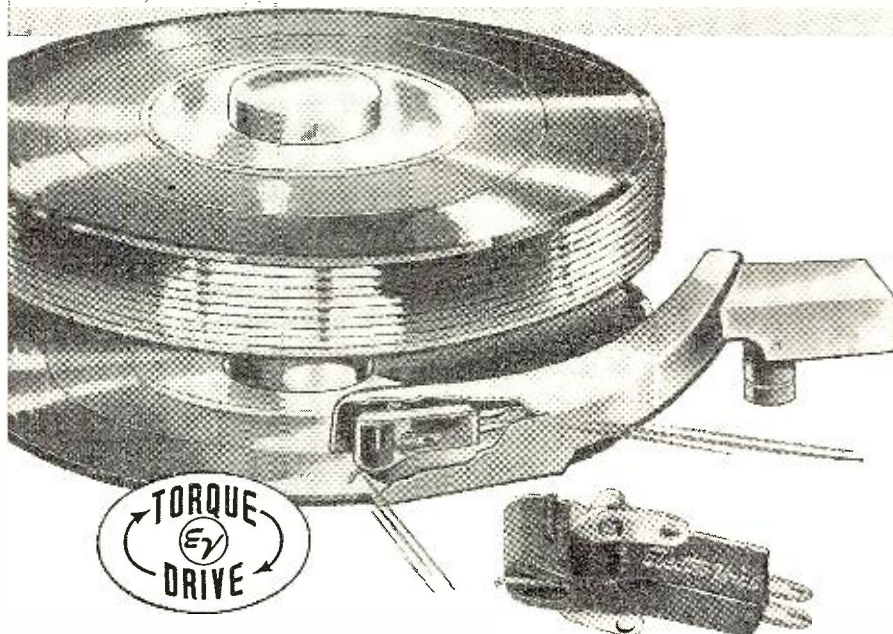

NO OTHER CARTRIDGE so clearly demonstrates the high calibre of your service. Gives unsurpassed fidelity.

And it's so simple to install. $\frac{1}{2}$ " and $\frac{5}{8}$ " hole spacing saves you time and work. Ideal for replacement in RCA type "45" rpm changers. Just as good, too, for $33\frac{1}{3}$ rpm changers.

Has high compliance, wide range, low-tracking pressure and other TORQUE DRIVE advantages. Replaceable needle.

Model 34. With Osmium tip needle, List Price, \$6.50

Model 34-S. With Sapphire tip needle, List Price, \$7.50

Replace now. Your customers will approve. Order from your E-V Distributor.

FREE!
Send for complete easy-to-use REPLACEMENT CHART

E-V MODEL 34 REPLACES		
ASTATIC	SHURE	
AC-J	W53MG	P73R
CQ-J	P93MG	P73AR
CQ-AG-J	P95MG	P73
CAC-J	W21AR	P73A
R.C.A.	WEB. ELEC.	AMERICAN
74067	F13M	CR5

Electro-Voice

410 CARROLL STREET • BUCHANAN, MICHIGAN
Export: 13 E. 40th St., New York 16, U.S.A. Cables: Arlab
PHONO PICKUPS • MICROPHONES • HI-FI SPEAKERS • TV BOOSTERS

RADAR, COMMUNICATIONS AND SONAR TECHNICIANS W-A-N-T-E-D For Overseas Assignments

Technical Qualifications:

1. At least 3 years practical experience in installation and maintenance.
2. Navy veterans ETM 1/c or higher.
3. Army veterans TECH/SGT or higher.

Personal Qualifications:

1. Age, over 22—must pass physical examination.
2. Ability to assume responsibility.
3. Must stand thorough character investigation.
4. Willing to go overseas for 1 year.

Base pay, Bonus, Living Allowance, Vacation add-up to \$7,000.00 per year. Permanent connection with company possible.

Apply by Writing to
**D-4, P.O. Box 3575,
Philadelphia 22, Pa.**

Men qualified in RADAR, COMMUNICATIONS or SONAR give complete history. Interview will be arranged for successful applicants.

COAXIAL CABLE CONNECTORS



83-1AP	\$.30	83-1SP	\$.45	83-168	\$.15
83-1F	1.30	83-1SPN	.40	83-185	.15
83-1H	.09	83-1T	1.12	UG-27/U	.68
83-1J	.80	83-22AP	1.10	UG-38/U	.63
83-1R	.40	83-22R	.48	UG-85/U	.88

Others in stock. Write for prices.

1N34 CRYSTAL..... 79c

VERNIER DIAL or DRUM (from BC-221)

DIAL—25/4" dia. 0-100 in 360°. Black with silver marks. Has thumblock. DRUM—0-50 in 180°. Black with silver marks.....either 85c

SELSYN 21G1—Brand New—400 Cyc..... \$1.85

SOUND POWERED Handsets—Including 6 ft. cord with each.....\$17.60 pr.

THROAT MIKE (MT S1-A), 2 mikes in leather zipper case with 56" cord & PL68—Brand New.....59c

CARBON MIKE T-17, slightly used—Guaranteed—Has 5 ft. cord and PL68.....89c

OIL FILLED CONDENSER SPECIALS

MFD	VDC PRICE	MFD	VDC PRICE	MFD	VDC PRICE
4	800 \$.79	3	1,000 \$.80	8	2,000 \$4.50
8	800 1.60	8	1,000 1.95	2	3,000 2.35
10	600 1.95	4	2,000 3.85	2	4,000 2.50

GEAR ASST.—100 small sizes. Mostly stainless steel or brass. Experimenters' dream!.....Only \$6.50

AN Connectors—all numbers available for immediate delivery. Let us know your requirements. Minimum Order, \$3.00—All Orders F.O.B. Philadelphia

RELIANCE Merchandizing Co.

2221 Arch Street Philadelphia 3, Pa.
Telephone: Rittenhouse 6-4927

ANOTHER OUTSTANDING JOBBER
VARIETY Electric Co., Inc.
601 BROAD STREET
Newark 2, New Jersey

HAS THE
SENSATIONAL NEW
5E10D 425-K 5" SCOPE KIT
IN STOCK!



RADIO and TELEVISION

Thorough Training in All Technical Phases

APPROVED FOR VETERANS

WEEKLY RATES DAYS—EVENINGS

FREE PLACEMENT SERVICE FOR GRADUATES

For Free Catalog write Dept. RN-51
RCA INSTITUTES, INC.

A Service of Radio Corporation of America
350 West 4th St., New York 14, N. Y.

tical deflection amplifier socket as well as being rated for usual Class A1 applications. The ratings of the tube for Class A1 amplifier include a heater potential (a.c. or d.c.) of 12.6 or 6.3 volts; maximum d.c. plate potential of 300 volts; maximum plate dissipation of 3.5 watts per section; and maximum peak heater-cathode potential of 180 volts.

Ratings for the tube when used as a vertical deflection amplifier are a maximum d.c. plate potential of 500 volts; maximum d.c. negative grid potential of 50 volts; and maximum peak heater-cathode potential of 180 volts.

FIELD STRENGTH METER

The Simpson Electric Company of 5200-18 West Kinzie Street, Chicago 44, Illinois has recently introduced a

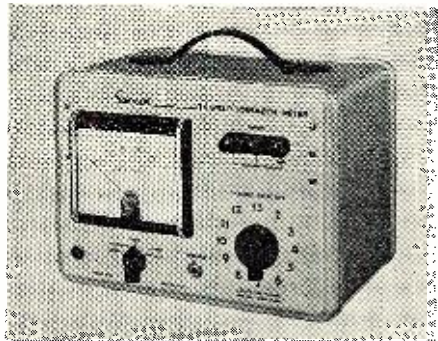

television field strength meter which will measure TV signals in any locality and in all types of installations.

The Model 488 incorporates a 12 channel television tuner with each channel separately adjustable for maximum flexibility and uniform results. There are four ranges of sensitivity, i.e., 50 microvolts full scale range for fringe area installations, a 500 microvolt range, a 5000 microvolt range, and a 50,000 microvolt range. A phone jack is included for making audible tests so that the operator can quickly identify the type of signal being measured.

The unit has a 4½ inch modernistic meter which can be easily read from a considerable distance. All controls and connections are arranged for greatest accessibility. The meter is housed in a gray hammerloid case with a leather handle.

GUY ANCHOR

Technical Appliance Corporation of Sherburne, New York is in production on a new guy anchor that allows free rotation of the mast after the guy wires are attached.

Designated as catalogue No. 867, the new guy anchor is made of heavy gauge steel and provides the strength necessary for high installations where guy wires are required for steadying the antenna while the antenna is oriented.

Without removing any of the guys, it is possible to rotate the antenna mast without relocating guy wires on the roof. When the guy wire turn-buckles are tightened the circular plate is pulled down on the mast col-

TRIPLEX WAVE MASTER

TRIPLE DIRECTORS

¼ Wavelength Stacked

Conical with 3-Element Dipole

GHOST FREE RECEPTION ALL CHANNELS

NO BOOSTER REQUIRED

YOUR COST \$770

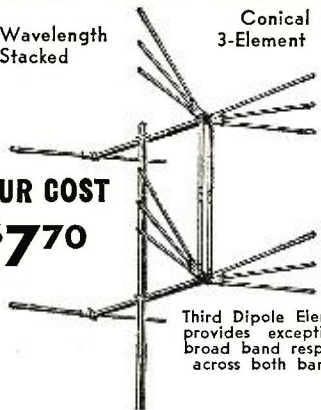

INSTANT ASSEMBLY

MATCHES ANY OHM WIRE
75-150-300

Third Dipole Element provides exceptional broad band response across both bands.

EASY INSTALLATION APPROX. WT. 7 POUNDS

Price List \$2690

UNDER ACTUAL TESTS...PROVED!

- Most advanced design to date.
- 30% more gain than former 4X antennas.
- Reception available in fringe and formerly unsatisfactory locations, all channels.

- Easier tuning, added selectivity on any receiver.
- These tests conducted in fringe areas and locations up to 250 miles from transmitting stations—not by meter or laboratory tests, but under average home installation.

SOLD DIRECT—WRITE—WIRE—CALL—FAIRFAX 9171

RAY MFG. CO.

441 SUMMIT ST.
TOLEDO, OHIO

lar, thus acting as further assurance of direction stability in addition to the mast mount.

17" TV TUBE

National Union Radio Corporation of Orange, New Jersey has added a 17 inch rectangular tube to its line of "Videotron" picture tubes.

The new Type 17B04A is a direct-view picture tube providing a 11 1/4" x 14 1/4" rectangular picture having the standard 3x4 aspect ratio. It features a face plate having an integral neutral gray filter which increases the contrast ratio when viewed under ambient light conditions.

The tube utilizes the new tilted-beam type gun to obtain improved picture detail. It requires only a single field ion trap. The new tube is electrically similar to the company's 16KP4/16RP4 and is a suitable replacement in new set designs where the larger dimensions can be accommodated.

NEW MOUNTING UNITS

Anchor Industrial Company of 533 Canal Street, New York 13, New York has developed a new type of mounting and insulating "Ring" and "Sleeve" for 17" rectangular metal television tubes.

The "Ring" and "Sleeve" incorporate several new improvements over the general types now available, according to the company, but may be used in the same applications. Specially engineered models are available for all round and rectangular metal

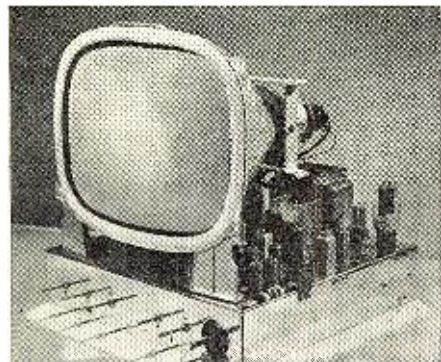

picture tubes. Details on these custom models as well as the standard model are available from the company.

20" TV PICTURE TUBE

Production has begun on a 20" rectangular picture tube at the Tube Divisions of General Electric Company in Schenectady, New York.

Designated the 20CP4, the new tube is a magnetic focus and deflection, direct-view, all-glass picture tube for television applications. It has a screen area of 217 square inches.

Features of the 20CP4 include an electron gun designed to be used with an external single-field ion trap magnet for the prevention of ion spot blemish, a high quality neutral density faceplate to increase picture contrast and detail under high ambient light conditions, and a space-saving rectangular face shape.

February, 1951

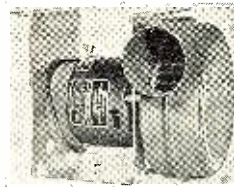

BLOWERS:

Brand New 115 Volt 60 cycle blowers, as illustrated, approx. 100 CFM. Dis. 3 1/4" intake, 2" outlet. Motor size: 3 1/2" x 3". 1525 RPM. Complete with mounting bracket. Gov't. surplus. Individually boxed. Order P.C. Dis. No. RN-3604 **\$9.95**

BLOWER—115 Volt 60 cycle, approx. 100 CFM. 2 1/4" intake, 2" outlet. Motor size: 2 1/2" x 3 1/4". Quiet running. NEW—not Gov't. surplus. Order No. RN-520. **\$7.99**
DUAL BLOWER—Same as RN-520 above, except has blower assembly on each side of motor. Order No. RN-800. **\$12.95**
L-R #2 Blower Assembly, Plastic Housing 3"x1 1/2", Blower Wheel 2"x1 1/4"—3/4" shaft. (No Motor)... **\$1.95**
L-R #2 1/2"—Same as above. Housing 3 1/2"x1 1/2". **\$2.00**
L-R Blower Wheel only, 3"x2"—3/8" shaft.... **\$1.00**

GASOLINE ENGINE GENERATORS:

HOMELITE Gasoline Engine Generator—30 Volt DC 50 ampere (1500 Watts) generator driven by single cylinder, two cycle air-cooled gas engine approx. 3 HP. Rope or electric starting. From unused Gov't. vehicles, reconditioned. Shipping Wt. 150 lbs. **\$59.50**
 Price.....

GUY CABLE

Regular Aircraft Control Cable, 3/32"—7x7—49 Strands galvanized weatherproof. 920 lb. Test. Ideal for television or radio mast guying.
2 1/4¢ per Ft.—1000 Ft. or more: 2¢ per Ft.

DYNAMOTORS:

INPUT	OUTPUT:	STOCK NO.	PRICE
9 V. DC @ 6 V. DC	450 V. 60 MA.	DM-9450	\$3.95
12 or 24 V. DC	275 V. 50 MA. w/Blower		
	440 V. 200 MA. & 220 V. 100 MA.	D-104	9.95
12 V. DC	600 V. 300 MA.	BD-86	7.95
12 V. DC	330 V. 150 MA.	BD-87	5.95
12 V. DC	375 V. 150 MA.	BD-83	6.95
12 V. DC	1000 V. 300 MA.	BD-77	7.95
PERMANENT MAGNET FIELD DYNAMOTORS:			
12 or 24 V. DC	275 V. 110 MA.	USA/0516	\$3.95
12 or 24 V. DC @ V. DC	500 V. 50 MA.	USA/0515	2.95
	240 V. 50 MA.		

Tell Us Your Dynamotor, Inverter, & Motor Needs!

TRANSFORMERS

110 V. 60 CYCLE PRIMARIES:

SEC.:

24 V. 1/2 amp. **\$1.50**

24 V. 4 1/4 amps. **3.95**

36 V. 2 1/2 amps. **2.95**

RG-8/U COAXIAL CABLE

(W/PL-259 Plugs, ea. end):

65 Foot length... **\$4.95**

50 Foot length... **3.95**

35 Foot length... **2.95**

Junction Connectors for PL-259's... **75¢**

WHIP ANTENNA EQUIPMENT

MAST BASES—INSULATED:
 MP-132—(Illustrated) 1" heavy coil spring, 2" insulator. Overall length: 11 1/2". Weight 2 3/4 lbs. Price... **\$3.95**
 MP-22—Spring action direction of bracket, 4"x6" mounting. Price... **\$2.95**

MAST SECTIONS FOR ABOVE BASES:
 Tubular steel, copper coated, painted, 3 foot sections, screw-in type. MS-53 can be used to make any length, with MS-52-51-50-49 for taper. Price—any section... **Ea. 50¢**
 MS-54—Larger section than MS-53... **75¢**
 BAG BG-56 for carrying 5 Mast Sections... **50¢**

WIRE—HEAVY DUTY, RUBBER COVERED:

2/#1620' **\$1.25**
 2/#1210' **1.00**
 1/#6 Shield, 15' **1.50**
 1/#6 Shield, 7 1/2' **.75**
 4/#16 St. Wrap. Per Ft. **.08**

CONTROL BOXES:

C-87 / ART-13 f / ART-13 Transmitter... **\$9.50**
 MR-9 f/RA-10 14 Volt Receiver... **\$12.50**
 MN-52-F f/Azimuth Control... **\$1.95**
 BC-602 f/SCR-522 **2.00**
 BC-732 f/BC-733. **2.00**

Address DEPT. RN • Minimum Order \$2.00 • Prices F.O.B., Lima • 25% Deposit on C.O.D. Orders

BC-223 TRANSMITTER

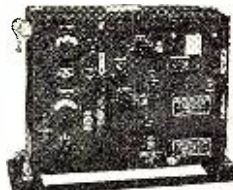

30 Watt transmitter with Crystal or MO control on four pre-selected channels. CW, MCW cover frequency range 2000-12000 KC. by use of plug-in coils. Complete with tubes and choice of one Tuning Unit (listed below). Less Mtg.—Prices:

NEW: **\$29.95**

USED: **\$23.50**

CABLE—Trans. to Power Supply... **\$2.00**
TUNING UNITS: TU-17—2000-3000 KC.; TU-18—3000-4500 KC.; TU-25—3500-5250 KC. **\$3.50 EACH**
SPARE TUBE KIT in metal box, f/BC-223... **\$4.95**
OPERATING MANUAL for BC-223... **\$2.50**
PE-125 POWER SUPPLY f/BC-223—12/24 Volt input; output 500 Volt 150 MA. **NEW: \$11.95**
SPARE VIBRATOR & TUBE KIT f/PE-125... **\$4.95**
SHOCK MOUNTING for PE-125... **\$1.50**

RECEIVER (MOBILE-BOAT-AIRCRAFT)

BENDIX RA-10 RECEIVER—\$ Tube Set covering frequency range 150 to 1100 KC. and 2000 to 10000 KC. in four bands by use of remote control unit. Set size: 18 1/2" L. x 10 1/2" W. x 8 3/4" H. Wt. 3 1/2 lbs. Comes complete with remote control unit, dynamotor, and plugs. BRAND NEW.
 Order RA-10 CA f/ 14 Volt DC operation. **\$49.95**
 Order RA-10 DA f/ 28 Volt DC operation.

BC-645-A TRANSCEIVER

15 Tube Transceiver, ideal for conversion to 460 MC. Citizens Band. Frequency coverage 435 to 500 MC. With conversion instructions. **\$16.95**
 Price: New and Boxed BC-645-A.....

COMMAND TRANSMITTERS and RECEIVERS with SCHEMATICS

	USED:	NEW:
BC-453 Receiver—190-550 KC. ...	\$11.95	
BC-454 Receiver—3 to 6 MC....	5.95	
BC-455 Receiver—6 to 9.1 MC....	6.95	
BC-457 Transmitter—4 to 5.3 MC.	5.95	
BC-458 Transmitter—5.3 to 7 MC.	5.95	
BC-459 Transmitter—7 to 9 MC....	14.95	\$24.95
T-20/ARC-5 Trans.—4 to 5.3 MC	8.95	
T-23/ARC-5 Trans.—100 to 156 MC	29.50	

BC-375 TRANSMITTER

BC-375 Transmitter—100 Watt Voice, CW, MCW covers frequency range 200 KC. to 12 MC. by the use of Plug-in Tuning Units, as listed below. Complete, **\$18.95** with tubes, less Tuning Units. USED: **\$13.95**
TUNING UNITS FOR BC-375 OR BC-191 TRANSMITTERS (Listed Below):..... **\$3.95 EA.**
 TU-5—1500 to 3000 KC. TU-9 — 7700 to 10000 KC.
 TU-6—3000 to 4500 KC. TU-10 —10000 to 12500 KC.
 TU-7—4500 to 6200 KC. TU-26 — 200 to 500 KC.
 TU-8—6200 to 7700 KC. BC-306—Antenna Loading
 FT-151 Shock Mounting for BC-375-191... **\$2.00**
 CABLES F/BC-375-191 w/PL-64, 59, or 61 ea. end... **\$2.00 EA.**

ATD TRANSMITTER

50 Watt, 540 to 9050 KC. MO control. CW and Phone complete with tubes (4/6L6G, 1/814, 128L7, 6X4, 6X5), 24 V. Dynamotor, Control Boxes, Spare Tubes, Parts, etc. BRAND NEW... **\$150.00**

TDQ TRANSMITTER

45 Watt, 115 to 156 MC. Crystal control, MCW and Phone complete with Tubes, 110/220 Volt 60 cycle Power Supply, and Instruction Book. **LIKE NEW \$450.00**

3/4 RPM ANTENNA ROTATOR MOTOR

High torque, reversible motor—operates directly from 110 Volt 60 cycle by use of condenser. Light weight, quiet running, ruggedly built, positive stop, easily mounted. Normally operates from 110 Volt 400 cycle. Complete—with instructions. NEW... **\$4.95**
 10 MFD 400 Volt Cond., \$1.00. SPST Momentary Switch, 35¢. DPDT Momentary Switch, 75¢. Resistor, 100 ohm 25 Watt, 50¢. 4 Wire Cable, 5¢ per ft.

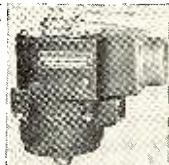

FAIR RADIO SALES 132 SOUTH MAIN ST. LIMA, OHIO



COLOR TONE ON YOUR TELEVISION

Simply attach Telecolor Filter to front of your set and enjoy your favorite programs in many shades of a glorious color tone instead of dull black and white. Telecolor Filter is guaranteed to work on every make or size set. Find new happiness in color depth and contrast, less eyestrain and glare. Free Information. Dept. RN-1.

ORDER BY MAIL:
 10 inch. **\$ 3.00**
 12 inch. **4.00**
 16 inch. **6.00**
 19 inch. **10.00**

HARVARD LABORATORY • 659 FULTON STREET • BROOKLYN 1, N. Y.

NEW!

RECTANGULAR BLACK TUBE

16 in. TELEKIT

PRICES BEGIN AT **49.95** LESS TUBES

**JOBBER: WRITE FOR CONFIDENTIAL
PRICE INFORMATION**

16 BR Telekit

\$79.95 Less
Tubes

Console Cabinet shown
\$39.95

You can build this fine 16 in. rectangular black tube TV set. All you need is pliers, screw driver, and soldering iron. It's easy to assemble; no previous knowledge of TV is required. The tuning unit and hi-voltage supply are factory wired and tested for you. A big 54 page illustrated instruction book guides you through easy assembly. Satisfactory results are **GUARANTEED** by Factory Service Plan and Warranty. Write today for complete information.



12-B Telekit

\$69.95

8-B Telekit
\$49.95

Both Less Tubes

Exciting new low prices on Telekits let you have a fine 8 1/2 or 12 1/2 inch set for a price far lower than comparable commercial sets. Over 35,000 Telekits have been successfully assembled by following the big illustrated Telekit instruction book. No previous knowledge of TV is required. Satisfactory results are **GUARANTEED** under the Telekit Factory Service Plan. Write for full information.

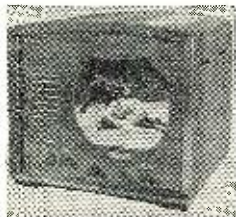

12 Channel Tuner

\$12.95

Pre-built, factory aligned. Stage of R.F. amplification. Telekit 12 channel tuner equips any TV set with video I.F. of 25.75 to 26.1 Mc and sound I.F. of 21.25 to 22 Mc. Not a kit. Complete with tubes. Only 4 wires to connect.



Telekit Booster

\$12.95

Brings in TV signals bright and clear. Especially helpful in fringe areas. For use with any TV set. NOT A KIT. Completely assembled with tubes.



TELEKIT

ELECTRO-TECHNICAL INDUSTRIES

1432 N. BROAD ST. DEPT. R. PHILADELPHIA 21 PA.

Maximum ratings of the tube include an anode voltage of 18,000 volts; a grid No. 2 voltage of 410 volts; a



grid No. 1 voltage with a negative-bias value of 125 volts and a positive-bias of 0 volts; and a positive-peak value of 2 volts.

CABLE FITTING

Jerrold Electronics Corporation of 121 North Broad Street, Philadelphia 7, Pa. is currently marketing a new solderless coax fitting for RG-59/U cable.

The new fitting, the C-51, is a male connector for RG-59/U cable and mates with two other of the company's coax fittings, the Model C-61 heavy duty female receptacle and the Model C-81 cable coupler which is used to splice two RG-59/U cables.

All of these fittings may be assembled in the matter of seconds and make positive contact. These fittings use the inner conductor of the coax cable for the male pin. Fittings, individually packaged in sealed cellophane bags, are made of brass and plated with silver.

"CATHO-CHEK"

Thomas Electronics, Inc. of 118 Ninth St., Passaic, N. J. has just announced a new TV service instrument, the "Catho-Chek."

The new unit permits the technician to establish or eliminate the CR tube as the source of trouble in one simple, 60-second operation without removing the tube from the chassis.

The instrument is connected to the terminals at the tube base and indicates the condition of the tube in checking emission, gas ratio, shorts, leakage, etc. The lead wires on the unit are equipped with snap-on test clips which eliminates the need for removing, loosening, or shifting the tube on the chassis.

The unit comes complete in a grey, wrinkle-finish cabinet and weighs 14 pounds. A carrying handle is provided for easy portability.

"CLAMP-ON" ANTENNA

Channel Master Corp. of Napanoch Road, Ellenville, New York has just developed a "Clamp-On" television antenna which may be clamped any-

REPORT ON SIGNAL CORPS SUPPRESSOR TESTS

THE long-time argument on the effect of resistor-suppressors on motor performance is seemingly resolved with the release of a report from the U.S. Signal Corps on the results of a series of extensive tests recently completed.

According to the report, the use of resistor-suppressors by no means brings on horsepower loss or reduced engine economy. In addition, the Signal Corps discovered that suppressors do not hinder cold weather starting but, on the contrary, they actually improved it.

In order that field conditions might be simulated in the tests, a used Army vehicle was employed. The vehicle selected was a quarter ton four-by-four truck which had already clocked 21,335 miles. Its pre-test performance was below par.

Doing away with the use of such starting aids as primers and heaters, the engine used in these experiments was started 18 times out of 18 tests at temperatures from minus 30 to minus 40 degrees F with resistor-suppressors applied in the spark plugs, distributor, or both, in an average cranking time of 57.3 seconds and at an average of 77 per-cent rated primary voltage during cranking.

With no resistor-suppressors in the ignition system, the engine started only once (at minus 30 degrees F) out of 13 attempts in the same temperature range, with an average cranking time of 215 seconds and at an average of 79.2 per-cent rated primary voltage.

The principal effect of inserting a resistor-suppressor of approximately 10,000 ohms at the spark plug appeared to be smoothing out the inductive

reactance component, allowing the energy stored in the inductance of the secondary to dissipate uninterruptedly through the gap.

Nor did suppressors at the distributor outlets, in addition to those at the spark plug, have any apparent effect on engine starting ability. Shielding on the ignition cables with suppressors in the spark plugs appeared to further improve starting.

On the basis of these tests, Signal Corps engineers have concluded that the effect of resistor-suppressors on the starting ability of engines, even at low temperatures, is beneficial rather than detrimental.

-30-

Cutaway view of integrally suppressed shielded spark plug, showing integral suppressor.

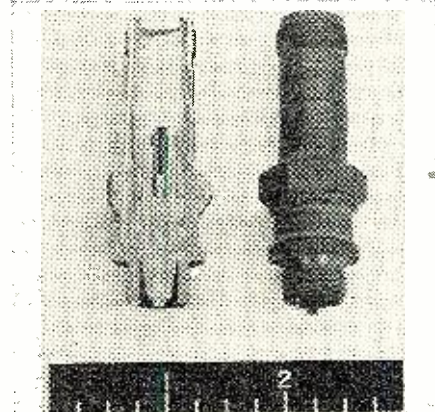

where, thus solving many antenna installation problems.

Designed to be speedily affixed to furniture, fixtures, windows, etc., the new unit takes a positive grip anywhere. The ball-mounted, telescoping dipoles swing out in a 360 degree arc. The elements can be set to form a horizontal "V" for any channel, in any direction.

LIGHTNING ARRESTER

LaPointe-Plascomold Corporation of Windsor Locks, Conn. has added a new

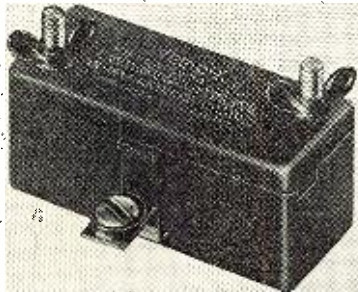

lightning arrester to its line of "Vee-D-X" TV antennas and accessories.

The new unit which is similar in design to the company's four-wire RW-204, is constructed with only two saw-tooth contact points instead of four. The new RW-200 provides positive protection for all standard installations and lists in the moderate price class. -30-

HUM IN PICTURE TUBES

By M. KALASHIAN, WINXT

If a TV set with electrostatic deflection (usually a 7" set) comes into the shop for repairs because the raster is shaped as though it has hum in it—don't always be too eager to rip into the filter condensers. In several rare cases they haven't been the trouble!

First check the sweeps feeding the picture tube by means of a scope and if they look OK—don't go ahead and check the filter condensers until you have tried a new picture tube. Sometimes the deflection plates in the picture tube get bent and produce effects similar to that of hum in the raster. This tip is the result of several hours spent on a 7" set trying to cure the hum. -30-



BRINGS IN THE PICTURE!

Bright... Clear and Without Interference

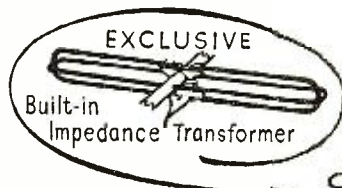

WARD YAGI

Fringe and Super-fringe

ANTENNA

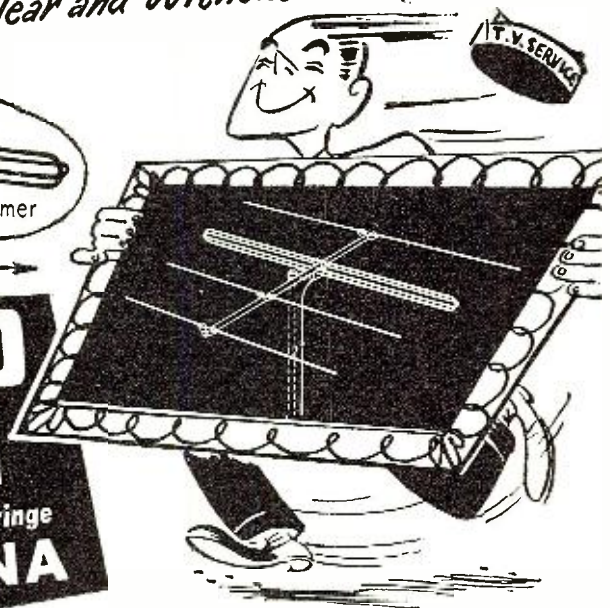

DR. YAGI,
Originator of
Yagi Antenna
PRAISES
WARD
ENGINEERING

"The low numerical value of Voltage Standing Wave Ratio as recorded is... the proof of the exact matching between circuit elements. In this regard, I highly esteem the excellent ability of your engineers."

Yours very truly,
I/s/Hidetugu Yagi

WARD YAGIs are producing amazing results! In many cases, acceptable pictures now enthuse set owners, where no image could be obtained by other antennas. Increased sensitivity and exceptionally high gain is developed through Ward's exclusive built-in impedance transformer. Having perfect match to a 300 ohm line, full signal strength is transmitted to the set. Designed with high front to back ratio, a clear, sharp signal is picked up, without co-channel interference. Being closely tuned to each channel, this highly directive antenna has a narrow, angular pattern cutting foreign interference and noise to the minimum.

Ward's Yagi is a highly specialized antenna, designed without compromise specifically for long distance TV reception. In distant areas, and areas intermediate between transmitting centers, where weak signals and co-channel interference obstruct reception, stacking of Ward Yagis enables the selection and maximum energy reception of the desired station.

Order a supply of Ward Yagis today. Satisfied customers make WARD your most profitable antenna.

only WARD OFFERS
TV-FM-AUTOMOTIVE-AM-SPP
ANTENNAS

THE WARD PRODUCTS CORP.

Subsidiary of the Gabriel Co.

1523 East 45th St., Cleveland 3, Ohio

SENSATIONAL NEW BOOK

ELEMENTS of SINGLE and DUAL
TRACK MAGNETIC TAPE RECORDING
and 1001 APPLICATIONS

by A. C. Shaney

INFORMATIVE! INSTRUCTIVE! INTERESTING!

ONLY
\$1.00
POSTPAID

The book that brings you up-to-date on tape recording. Complete history, theory, design and uses. 144 pages of FACTS!

Order today. Remit with order, please. Booklet mailed same day.

AMPLIFIER CORP. of AMERICA
398-2 Broadway, New York 13, N. Y.

RADIO HANDBOOK

IN TWO EDITIONS

11TH EDITION: The standard work on practical and theoretical aspects of all radio communication.

12TH EDITION: Detailed constructional information on a wealth of radio communication equipment; all brand-new.

BOTH these top-notch books are a necessity for everyone interested in radio communication. There is little overlap in coverage; each is a perfect companion volume to the other.

FOR EITHER EDITION

\$3.00

By mail, \$3.25 postpaid. Foreign \$3.50.

AT YOUR FAVORITE DEALER
OR DIRECT BY MAIL FROM
Editors and Engineers
1902 KENWOOD ROAD, SANTA BARBARA, CALIFORNIA

by the addition of the AT1-1 input transformer connected as shown. There follows a preamplifier employing a 12AX7. The output of the preamp feeds through a gain control to the input of the inverter amplifier. This is also of a plug-in construction to facilitate servicing.

One of the unusual features of the *McIntosh* design is to be found in the method of employing extremely close coupling and specially designed transformers. This results in very low generator impedance which makes it ideally suited to recording amplifier applications. A 600 ohm winding is available at the output of T_3 . This is usually connected through a pair of "normal" jacks to a 600 ohm line, driving the playback speaker, or in the case of recording, is patched into a 500 ohm *Presto* 1C cutter.

The amplifier power supply (Fig. 6) also includes several plug-in components such as the bias supply, the delay relay which withholds the application of high voltage until the filaments are thoroughly warmed, and various high voltage condensers which may require occasional replacement.

(To be continued)

Novel Tester

(Continued from page 43)

farther from the transmitter. It is a good idea to check the radio-control transmitter initially at some time when it is known to be operating correctly. A note then should be made of the distance between transmitter and instrument, length of the pickup antenna, and the meter reading. When the transmitter subsequently is checked under the same conditions, a decreased meter reading will show that the transmitter output has fallen—an indication of failing tubes or batteries.

Somewhat more stable operation of the instrument, in transmitter checking, often can be obtained by grounding the instrument case. This is true especially when the gadget is placed at a good distance from the transmitter. The best grounding method consists of connecting a short length of flexible, insulated hookup wire from the "NEG." jack to a spike or rod driven into the earth.

Voltage Checking. Throw switch S_1 to its "V" position. Plug test leads into the "NEG." jack and one of the voltage-range jacks. Touch the two test prods to the terminals of the voltage source and read the voltage on the scale of the meter. When checking an unknown voltage, protect the meter by always starting with the highest-voltage range and then transferring the positive test lead successively to each lower range jack until the unknown voltage can be read. Batteries and power supplies always should be checked under full-load conditions. If this rule is not followed, the batteries may appear in better condition than they really are.

-30-

THOUSANDS CHELSEA'S *New* BETTER-THAN-EVER C-4 CHASSIS

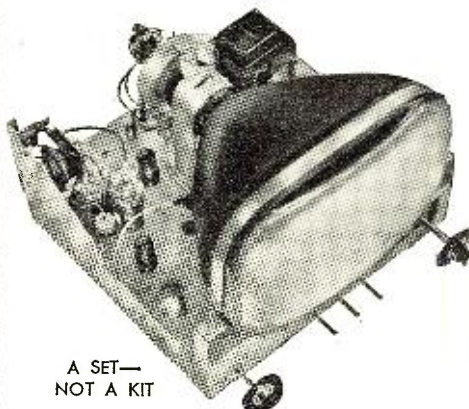

A SET— NOT A KIT

Advanced 1951 Circuits
Improved I-Knob Control
Phono-Jack Switch

JUST PLUG IT IN— AND IT WORKS!

In the last few months our engineers have achieved still greater triumphs in the construction of this famous C-4 Chassis . . . its quality-controlled features are now at the peak of operational perfection, yet the price remains incredibly low.

- Factory-engineered, aligned and tested
- Completely wired superpower circuit
- Improved AFC—Keyed AGC
- 13K Anode Voltage
- Improved Front End down to 45 microvolts
- Brilliant all-station performance
- Functions on indoor antenna in most areas
- Long range reception—even in fringe areas

FOR LESS CRT
17" —C4-11— \$119⁹⁵
round or plus Fed.,
rect. tube Excise Tax

FOR LESS CRT
20" —C4-13— \$129⁹⁵
round tube plus Fed.,
Excise Tax

**FULL RMA Guarantee
FREE Chelsea Warranty**

**ALSO AVAILABLE
630 TYPE CHASSIS**

GUARANTEED FACTORY-FRESH PICTURE TUBES in sealed cartons:			
16"— round,	\$40	17"— rectangular,	\$42⁵⁰
16"— rectangular,	\$41	19" round, 20" rect.,	\$69⁹⁵

Write Dept. Z for latest literature and prices—AND COMPARE!

Phone and mail orders filled on receipt of certified check or money order for \$25 as deposit —balance C.O.D., F.O.B., N. Y. All offerings subject to prior sale. Prices and models subject to change without notice.

The House of Bargains

CHELSEA TELEVISION CENTER, INC.

Office and Showroom: 130 West 42nd Street, near Broadway
New York 18, N. Y. Longacre 5-2254-5-6

RADIO COURSES

- RADIO OPERATING • CODE
 - RADIO SERVICING • ELECTRONICS
 - F.M. TELEVISION
 - PREPARATION FOR CIVILIAN, MARITIME, ARMY AND NAVY LICENSE REQUIREMENTS.
- Write for Catalog T.S.

YMCA

TRADE & TECH. SCHOOL 229 W. 66 St., N. Y. 23
#ndicott 2-8117

COUPON-OF-THE-MONTH

- SAPPHIRE PHONO NEEDLES (LIST \$2.50) 2 for \$0.99
- A. C. CORD & PLUG SET 6PT. 5 for .99
- VOL. CONTROLS—STD. BR. .5 Meg. W. SW. 3 for .99
- CONDENSERS—40-20 MFD 150V (FP) 2 for .99
- CONDENSERS—20-20 Mfd. 150V. 3 for .99
- LOOP ANTENNA—HI GAIN (5"x8") 3 for .99
- OUTPUT TRANSFORMERS (FOR 50L6) 2 for .99
- OSC. COILS 455 KC (for 12SA7) 4 for .99
- BY PASS COND. KIT—18 Asstd.99
- DIAL CORD KIT—100 ft. Asstd. & 6 Springs99
- GRILLE CLOTH—6 Asstd. 6"x6" & 10 Knobs99
- COMBINATION KIT—All Above Items—Only 10.00

WITH THIS COUPON—ORDER AT ONCE
Write for Monthly Coupons and Bulletin

RADIO DISTRIBUTING CO., Pasadena 18, Cal.

No Experience Needed To PRINT YOUR OWN POST CARDS

The GEM STENCIL DUPLICATOR saves money . . . gets results quickly! Hundreds of uses for every type of business and organization. We ship the GEM complete with all supplies. Guide Board for accurate printing and 60-page Book of Ideas at the special low price of only **\$8.50** (a \$15.00 value)

FREE TRIAL OFFER

Use the GEM FREE at our expense! SEND NO MONEY. Write and complete GEM outfit will be sent you postpaid. After ten days, send us only **\$8.50** or return the GEM. You must be satisfied! WRITE TODAY.

BOND EQUIPMENT CO. Dept. 52
6633 Enright • St Louis 5, Mo.

Lowest prices!



SYNCHRON MOTOR
Model 600, 1 RPM, 115 Volts,
60 cycles. Brand New.
Special Price \$2.75 each



BEAM INDICATOR
1-82F Compass Indicator.
0-360°-5 in. dial. 26 v 400
cy. 8-12 v. 60 cy. Ideal
position indicator. Brand
new.
Price \$3.95 each

**C-1 AUTOPILOT
VERTICAL GYRO**



May be used to conduct many interesting and amusing experiments. Operates from 24 V. DC or may be operated for short periods on 110 V. AC. Gyro will run for approx. 15 minutes after actuating. Size—approx. 8" x 8 1/2" x 8 1/2". Less Amphenol Connector. Removed from new aircraft. Special \$4.95



**C-1 AUTOPILOT
AMPLIFIERS**

Three channel servo amplifier consisting of many valuable electronic parts including 6 relays, 7 tubes.
With Tubes \$5.95
Less Tubes \$3.95

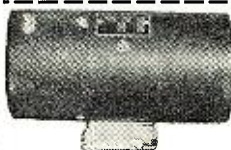

DYNAMOTOR
WinCo Type 41S6.
Input 13 volts DC
at 13 amps. Total
output 250 volts at
0.060 amps. and
300 v. at .225
amps.

Price Only \$5.95 Each

SWITCHES



Mallory Water type. Double Water. 3 Position. Special 29c each.
Mallory Single water. Three Position. Special 29c each.
Hi-Detent—Heavy duty—4P.3T. Pos. #1, 3 on, 1 off. Pos. #2 all off. Pos. #3, 2 on, 2 off. Special low price 39c each.
Push button Switch—Enclosed—s.p.s.t. Metal housing for panel or chassis mtg. Special 19c each.



CONTACTOR RELAY
Cutler Hammer 6041H30B.
12 v. dc. (50 amps. contacts).
Special at \$2.95 Each



**PUSH-BUTTON
SWITCH SPECIAL**
D.P.D.T. Momentary type.
Special at 59c Each

TERMS: 20% cash with order—balance C.O.D. Orders accompanied by payment in full must include sufficient postage, otherwise shipment will be made via Railway Express collect. Minimum order \$2.00.

Electro Devices
INCORPORATED
247 BROADWAY PATERSON, N.J.

AFCA NEWS



NATIONAL NEWS

1951 National Convention

CHICAGO is now definitely set as the site of the AFCA national annual meeting for 1951. April 19 and 20 will be the dates.

AFCA's Chicago Chapter will be host for the convention and plans are already well under way for an excellent show. Industry, instead of one of the armed services, will provide the displays, and from the start already made by the Chicago Chapter it is assured that something outstanding of interest will be presented.

CHAPTER NEWS

Atlanta

George M. Phillips, director of civil defense for the Atlanta Metropolitan Area, was the principal speaker at the Atlanta Chapter's winter dinner-meeting on December 4th at the Fort McPherson Officers' Mess. Details of the plans for civil defense for Atlanta and vicinity were explained to the 185 members present, and at the conclusion of the talk, Chapter President Ralph S. Grist of *Southern Bell Tel. & Tel.* pledged the full support of the chapter in rendering any assistance necessary to further the civil defense program.

Lt. Robert F. Malsby, formerly of the 34th Infantry, 24th Division, who went through the first 40 days in Korea, gave a short commentary on his experiences in Korea. The meeting closed with a showing of the film "The First Forty Days," a 21-minute portrayal of the Korean saga.

Over 185 members and guests attended the meeting. Among those present were Major General William C. Chase, Deputy Commanding General, Third Army; Col. Henry J. Hort, president of AFCA's Augusta-Camp Gordon Chapter; Major Harry Young, Communicator, 14th Air Force, Robins Air Force Base; and Captain Elwell T. Deagle, representing Brig. General George H. Weems, chief of the Georgia Military District.

Baltimore

The *Bendix Radio Div., Bendix Aviation Corp.*, was host to the Baltimore Chapter on December 5th at its Towson, Maryland, plant.

Special emphasis was placed on the vital question of civil defense with Paul Holland, director of public works, and of civil defense, Baltimore City, as the speaker of the evening. Mr. Holland outlined the civil defense program for the city and stated that it is being covered in three big phases, namely: (1) educating the people as early as

This Association is a patriotic non-profit organization, with chapters in most of the larger cities, dedicated to developing and maintaining efficient personnel, commissioned, enlisted, civilian, for the supply (including design and development), installation, maintenance, and operation of communications and electronic equipment for Army, Navy, and Air Force and their supporting civilian activities. It publishes a magazine "SIGNALS" at its national headquarters in Washington. Every American interested in any way in communications is eligible and invited to join. Dues are \$5.00 per year. Application should be submitted to the secretary at 1624 Eye St., N. W., Washington 6, D. C., who will furnish details upon request.

possible, (2) conducting trial runs and drills in fire fighting, first aid, communications, transportation, etc., and (3) the development of an organization of 40 groups of civilian defense officers under the direction of a police sergeant in each of the 40 areas. With communications being of utmost necessity, Mr. Holland requested the assistance of the Baltimore Chapter.

Amateur radio will play an important role in Baltimore's program, said Mr. Holland. The city will be divided into 7 sectors—each sector having a complete transmitting station housed in a public building and operated solely by amateur radio operators. In addition, adequate underground communication facilities will be available to maintain contact between the stations at all times.

Col. George P. Dixon, AFCA national executive secretary, was a special guest of the chapter and reported on the over-all progress of the association in its membership and advertising programs.

At the conclusion of the dinner meeting, the members were conducted on a guided tour of inspection of the *Bendix* plant.

Boston

The Boston Chapter sponsored the exhibit of the Signal Corps, "The Signal Corps in Peace and War," at the 1st Cadet Armory, Boston, during the period December 12th-16th. Occupying some 6000 square feet and attended by a unit of Signal Corps personnel, the exhibit depicted some of the outstanding developments of the era.

Invitations to attend the exhibit were sent to all communications and electronics companies in the Boston area by Boston Chapter President T. F. Halloran of the *General Communication Company*.

Chicago

The *Zenith Radio Corporation* was host to the Chicago Chapter for its October 26th meeting. An instructive

talk by J. E. Brown, asst. vice-president and chief engineer of *Zenith* on "Zenith Operations in Peace and War" was followed by a guided tour of the plant.

The program was concluded with the showing of the film, "Functional Photography in Industry," which has been made available to AFCA chapters through the courtesy of the *Eastman Kodak Company*.

Fort Monmouth

"Color" was the featured subject on the program of the Fort Monmouth Chapter meeting on December 7th. Ralph M. Evans, superintendent of the color control department of the *Eastman Kodak Company*, gave an excellent talk supplemented by 100 slides which proved many of the points of his lecture by dynamic demonstration. He was assisted in the demonstration by a number of AFCA members who are instructors in the Photographic Division, Enlisted Department, The Signal School.

The chapter's annual elections were held with Col. E. A. Kenny selected as the new president; L. F. Christianson, 1st vice-president; Philip T. Boone, 2nd vice-president; Lt. Col. Mervin C. Bowers, secretary; and Esther M. Fernau, treasurer.

New York

Brig. General Peter C. Sandretto, USAFR, assistant technical director of *Federal Telecommunication Laboratories*, presented a demonstration-lecture on "Electronics in Aerial Navigation" at New York's November 15th meeting.

The many advances in the art of aerial navigation, both for military and civilian applications, were described and photographs of various equipments currently used to locate and plot positions of airplanes were shown, together with a motion picture in color depicting an actual landing using the I.L.S. method.

Another interesting feature of General Sandretto's lecture was a demonstration of the latest type "VOR" or omni-directional v.h.f. radio range beam, developed by the *Federal Telecommunication Laboratories* for the CAA. Signals from FM broadcasting stations in the 88-108 mc. band were tuned in and this device indicated the direction of the station. It was an impressive demonstration of the accuracy of this electronic direction finder. General Sandretto also described the *F.T.L.* "Naviar System" of controlling airplane traffic enroute and at airports.

Two new films were made available for the meeting by the Continental Air Command. One depicted the effects of the atomic bombs on Japan during the past war and the other film described the important part to be played by civilian defense in any future emergency.

Philadelphia

Father Bernard R. Hubbard, the Glacier Priest, author, explorer, and photographer, who had just returned from

February, 1951

THE MEASURE OF MICROPHONE VALUE

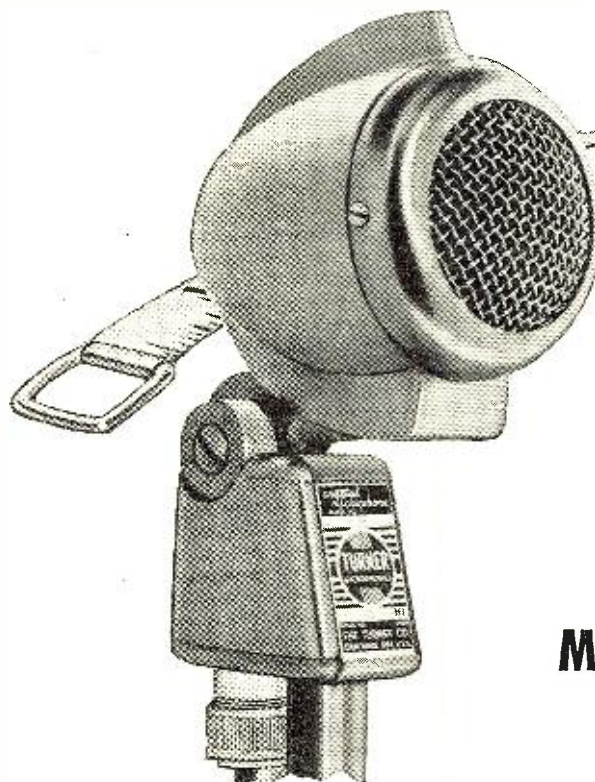

MODEL 22

EVERY INCH A SOUND PERFORMER

An all around value. Right for performance, style, dependability and price. Specified as the standard by leading manufacturers of communications, sound, and recording equipment. For standards of comparison Turn to Turner crystal, dynamic, cardioid, ceramic and carbon microphones.

Write for Literature. **THE TURNER COMPANY**
900 17th Street N. E., Cedar Rapids, Iowa

In Canada: Canadian Marconi Company, Toronto, Ontario

Export: Ad. Auriema, Inc., 89 Broad Street, New York 4, N. Y.



Crystals licensed under patents of the Brush Development Company

NOW!
AT *Hy-Grade!* the **SKY-HIGHEST VALUE** in Television Today!

World Famous Quality

630

TV CHASSIS
only

\$159.95 All Taxes Included
less CRT

Yes, you can believe your eyes! Here's the exact duplicate of the incomparable RCA 630TS Circuit—television's unmatched standard for super-sensitivity and stability—now with all the newest features of trigger-fast Keyed AGC, Voltage Doubler, Standard Tuner, molded condensers, plus the finest quality components, Yoke, Focus Coil, Mounting Brackets, plus 30 tubes. Supplies 13 to 14KV under load for full brilliance and width for all rectangular and round 12 1/2, 16 and 19" tubes. At only \$159.95 this is the TV super-value you can't afford to miss! Order several NOW! Immediate Delivery! 25% deposit with order, balance C.O.D., f.o.b., Brooklyn, N. Y.

for SKY-HY VALUES
at rock-bottom costs—
it's **HY-GRADE!**

Hy-Grade Electronics, inc.
1509 EAST NEW YORK AVE., BROOKLYN 12, N. Y.

National Distributors
of Electronic Parts
and Equipment

These Men are Getting PRACTICAL TRAINING

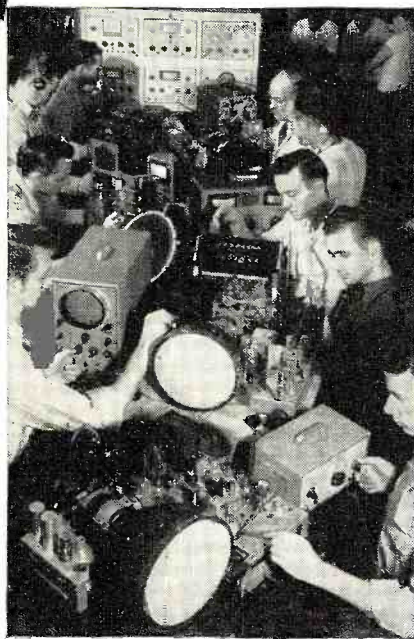

IN TELEVISION-RADIO ON REAL TELEVISION SETS RADIO RECEIVERS F.M. RECEIVERS IN THE GREAT SHOPS OF COYNE

Big opportunities are waiting for men who know the practical and technical end of Television and Radio. That's what you get at COYNE—besides practical Shop Training in F.M., Electronics and other branches of this giant field. Remember, Television is the fastest growing opportunity field today, and Radio is one of the biggest.

NOT "HOME STUDY" COURSES

All Coyne Training is given in our mammoth Chicago training shops. We do not teach by mail. You train on actual equipment, under friendly instructors. Previous experience unnecessary. Hundreds of firms employ Coyne trained men.

START NOW—PAY LATER

Come to the Great Shops of Coyne in Chicago. Established 1899—now in our 52nd Year. Oldest, largest, best equipped school of its kind in America. Fully approved for G.I. training. Finance plan for non-veterans.

MAIL COUPON FOR FREE BOOK

Send today for big new book packed with large pictures taken in Coyne Shops. No obligation. No salesman will call. Get the facts now!



COYNE B. W. Cooke, Pres.
ELECTRICAL & TELEVISION-RADIO SCHOOL
An Institution not for Profit
500 S. Paulina St., Chicago 12
Dept. 21-1K

B. W. COOKE, Pres.
COYNE Electrical & Television-Radio School,
500 S. Paulina Street, Dept. 21-1K, Chicago 12, Ill.

Send FREE BOOK and full details on Television-Radio Course.

NAME.....
ADDRESS.....
CITY.....STATE.....

Alaska where he is Chaplain to the 10th Rescue Squadron, addressed the Philadelphia Chapter meeting on November 16th.

"Bering Sea Patrol," the title of Father Hubbard's illustrated lecture, highlighted photography and communications in the strategic Alaskan Peninsula. Not only did he present some breath-taking pictures of disintegrating glaciers and ice floes, but also a first-hand account of the work that has been and is being done by the U. S. Air Forces in that area.

While the major part of Father Hubbard's lecture was confined to Alaska, he also presented some interesting views regarding the European and Korean situations.

A record audience of 500 attended the meeting. Guests of the chapter were members of the American Ordnance Association, 9555th ORTSU, Naval Aviation Supply Depot, Frankford Arsenal, Reserve Officers' Association and the Quartermaster Depot Officers' Club.

Pittsburgh

The *Copperweld Steel Company*, Glassport, Pa., was host to the Pittsburgh Chapter for its dinner-meeting on November 14th.

After a turkey dinner in the *Copperweld* dining room, the 118 members and guests were divided into groups of five to seven and conducted on a two-hour tour of the plant. The tour was most complete, following the processes of making *Copperweld* products from the casting department through to the shipping room.

Rochester

Members of the working committee attended a special meeting at the Genesee Valley Club, Rochester, on November 2nd to confer with Col. George Dixon, AFCA national executive secretary, on organizational plans for the new chapter.

Those present were: Joseph C. Wilson, president of *The Haloid Co.* and chairman of the committee; Rufus Rosenbloom, president of *Ilex Optical Co.*; Edward A. Springer, president of *Wolensak Optical Co.*; J. A. Whittle, manager of the Contract Sales Div., *Eastman Kodak Co.*; and Kenneth E. Reynolds, *Bausch & Lomb Optical Co.* The president of *Graftex, Inc.*, and Howard A. Schumacher, vice-president, had planned to attend the meeting but were called out of town.

Plans were made for an organizational meeting to be held December 13th at which time the new Rochester Chapter of AFCA would be officially launched.

Sacramento

Mayor Bert Geisreiter of Sacramento was one of the speakers at the Sacramento Chapter's November 1st meeting where an over-all picture of disaster relief plans for the Sacramento area was presented.

At the meeting Col. Milton G. Mauer announced that he had found it neces-

TESCO

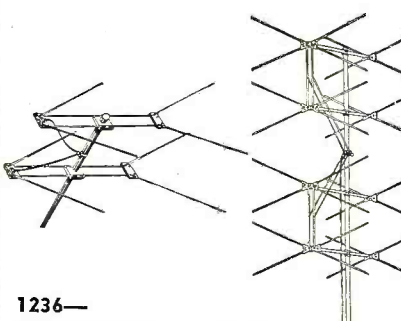

- 1236—**SINGLE BAY..... \$4.58**
- 1237—**DOUBLE BAY..... \$9.15**
- No. 1231 **\$20.85**
- 1230—Double Bay Conical.....\$9.56
- 1215—Swift Rig Folded Hi Folded Low... 5.37
- 1814—Economy Chimney Mount.. Dozen Lots 1.32
- 1302 to 1306—Five El. Yagi any Lo Channel 13.62
- 1307 to 1313—Five El. Yagi any Hi Channel 5.45
- 1219—Swift Rig Folded Hi Straight Low... 4.92
- 2113—Deluxe Indoor Antenna..... 2.48
- 1860—Chimney Mount.....Dozen Lots 1.54
- 1905—3 1/2" Mast Snap-On Standoff, per 100 4.00
- 1873—3 1/2" Mast Standoff Insulator, per 100 6.50
- 1872—4" Nail-In Insulator, Lots of 250... .025
- 1870—3 1/2" Wood Screw-Eye Insulator
- Lots of 250025
- 1229—Single Bay Conical..... 4.58
- 1231—Four Bay Conical.....20.85

Send for quantity prices and complete list
TELEVISION SUPPLY CO.
Box 213 Gracie Square Station
New York, N. Y.

The ONLY truly high-fidelity high-performance tape recorder in the popular price field!

Concertone RECORDER



Model 1401
"just like being there!"
Has every feature of the most expensive professional equipment. Ready for console installation. Write for Bulletin #102. **\$345.00** USER'S NET COST

Manufactured By
Berlant Associates
4917 W. Jefferson Boulevard
Los Angeles 16, California

sary to resign his office as chapter president due to the press of increasing military activities related to his engineering work at the Pacific Tel. & Tel. Co. He was serving his second term as president. It was then announced that the chapter board of directors had selected Major Paul W. Carrington, USAR, to succeed Col. Maurer.

The motion picture "Atomic Power" was shown at the opening of the program and served as an effective introduction for Mayor Geisreiter and the other speakers on disaster relief.

Col. Joe Plato, director of disaster relief for Sacramento, outlined the various phases of the Sacramento disaster relief plan. The important part that would fall to communications should a disaster strike was described by Moody M. Jorgensen, chairman of the communications committee on disaster relief. He asked for the assistance of the Sacramento Chapter in inventorying communications equipment which would be required and available in case of disaster. The chapter readily agreed to assist in this matter and a committee is being appointed to work with Mr. Jorgensen's committee. Mr. Francis S. Smith of the McClellan Air Force Base discussed the "Atomic Effect on Industrial Areas" and outlined some of the medical aspects relative thereto.

Mayor Geisreiter described the overall disaster plan for Sacramento, pointing up the work that had already been accomplished and emphasizing the fact that considerable team work and planning remained to be done in order to perfect a workable and effective plan, Mayor Geisreiter also related some of the interesting highlights of a mayors' conference on disaster relief which he had recently attended in Washington, D. C.

Retiring President Mauer's term of office was marked by the chapter's achievements in the national Chapter of the Year contest, in which the Sacramento Chapter won second place for 1950 and is currently in the lead for the 1951 contest. Major Carrington, who succeeds to the presidency, was one of the original founders of the chapter back in 1946 and is well grounded in both the local and national activities of the AFCA. He is an official with the Sacramento municipal utility district and a member of the reserve unit at the Sacramento Signal Depot.

Seattle

"Far East Customs and Habits" was the subject of a talk by Major John D. Flewelling of the Alaska Communications System before the Seattle Chapter meeting of November 8th. He pointed out that the Japanese attitude has changed greatly since 1945 because under the occupation they have found freedom and individuality. The freedom educational program for the Japanese, he said, was accomplished quickly due to the extensive radio nets and newspapers.

Major Flewelling stated that Japa-

SAVE UP TO 95% SENSATIONAL SURPLUS VALUES!

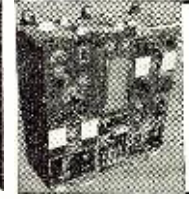

GO-9 XMITTER. Frequency range 3-18 MC and 300-600 KC. Band switching 100 w output. Brand new in original mtg. crates. Comes complete with tubes and spare parts kit. Comes in three units; high and low frequency xmitter and rectifier. Dimensions: 14" deep x 27" long x 29 1/2" high. Net wt. 137 lbs. Shpg. wt. approx. 250 lbs. Finished in black crackle, shock mounted. Has 7 meters for indicating plate and grid current, also antenna current. Operates 110V 800 cycles. Single phase and 24V DC. Contains 2-803 tubes, 1-807, 1-801, 2-837, 1-523, 2-1616. Comes with maintenance manual and test data. **\$72.50**

EXPORT QUANTITIES AVAILABLE. Write for complete information.
SURPLUS RADIO CONVERSION MANUAL NO. 2 containing conversion information for GO-9 to 10 meters and 110V 60 cycles. Contains 18 other popular conversions and complete information. **\$2.50**

SPECIAL FOR FEBRUARY ONLY! Low Freq. Section of TBW3 TRANSMITTER. Tunes from 350 to 1000 KC. Contains 0 to 9 Amp. RF Meter and 0 to 100 Millimeter. This unit originally used 801 oscillator, 807 buffer and 803 final. Chock full of capacitors, sockets, coils, switches. Unit is completely enclosed, less tube. FEB. ONLY **\$12.50**

ATTN: AIRLINE OPERATORS

APN-9 with MG-149F or PE-206	TS-19
T-47A/ART-13	BC-611
DY 11	0-17/ART-13 LFO Unit
DY 12	0-16/ART-13 LFO Unit
DY 17	SCR-509
RC-103	PPF-35/TRC-2
R 99B/ARN-5	AT-49/APR-4
TA-2124	BC-929
ARC-1, 10 or 20 Channel	BC-800
SCR-522C	APN-2
SCR-269 ADF Systems	SO-7 Parts
1-96 VHF Test Sets	RC-75A
SCR-718	ARG-13A APG-134
BC-376	CP-11/AP5-15
AN ARN-8	R-5A/ARN-7
APS-15	MT-283/ART-13
APS-13	MT-284/ART-13
APS-4	T-30 Microphone
APS-6	APN-1 Allimeter
SCR-717	BC-221 AK
SCR-729	LM Freq. Meter
TBS	RTA-1B
HS-33	TA-12
TS-226A	ARC-4 Complete
IE-56A	SCR-274N
ARC-4	BC-1023
SCR-274 N	BC-357
ARC-5 VHF Set	BC-348-L New
AN/ARN-5	Plus many others
TS-23/APN-1	

COMMAND RECEIVERS
Tested Before Shipping

190-550 KC Used. Orig. \$40. Now...	\$12.50
3-6 MC Used. Orig. \$30. Now...	4.95
3-6 MC New. Orig. \$35. Now...	7.95
6-9-1 MC Used like new	7.95
1.5-3 Meg Brand New...	24.50
ARR-1, brand new	9.95

COMMAND XMITTERS

T-22 ARC 5 MC. Used. SAME as BC-459...	\$ 9.95
T-22 ARC-5.7-9.1. New. Orig. \$50. Now...	12.75
3-4 MC. Used. Orig. \$50. Now...	12.50
T-23/ARC-5100-156 Megs. 4 channel Xtal. Used.	25.00
MD7/ARC5 Modulator Plate & Screen for T23ARC5, with Dynamotor	15.00
T-21 ARC-5.3-7 MC. New. Orig. \$40. Now...	8.95
4-5.3 MC. Used. Orig. \$30. Now...	9.95
2-1.3 MC. LN. Orig. \$40. Now...	16.95

BC-906 ABSORPTION-TYPE FREQ. METER

Freq. range 150-225 Mc. Uses 0-500 DC Microammeter for indicator. In black crackle carrying case with handle. 12 1/2" x 6 1/2". Net 18 lbs. With tubes and calibration chart. New... **\$14.95**

IMPORTANT
NO ORDER LESS THAN \$5.00. Send 30% deposit on cost of item or full amount to save C.O.D. charges. Do not send shipping costs. It will be C.O.D. only. Shipments sent via Railway Express unless other instructions given. Merchandise subject to prior sale. Prices subject to change at any time.

BC-611 HANDIE-TALKIE, part of SCR-536, Freq. 3.6 Mc. Attn: Construction men, builders, surveyors. Perfect for short distance communication. Weighs only 5 1/2 lbs., hand-held like a hand set. Pre-set to your frequency. Push-button controlled. Transmitter and rcvr. in same case. 15 1/2" x 3 3/8" x 5 7/8" sturdy aluminum case. Complete with tubes, xtals, 1 set batteries. Extra batteries, accessories available. Models B, C, D, E, F available. PRICE ON REQUEST.

FREQ. METER. LAVOIE VHF, type 105 SM. Tunes from 375-725 MC 1%. **\$59.95**
Brand new complete.

VARIAC, GR. 0 to 130 volts, AC 60 cy. 5 amps. 7 1/2 intermittent. New **\$17.95**

BC-347 INTERPHONE AMPLIFIER. Contains 6F8 Dual Triode and matching transformer. New... **1.49**
HS-33 HEAD SETS... Used **1.50**
TBY VIBROPACK for TBY Transceiver. Supplies all voltages. Operates on 4-volt source. Brand new. Only... **\$12.50**
T-85/APT-5 VHF TRANSMITTER. New, 350 to 1200 meg. 5 to 30 watts output. Brand new complete with tubes... **\$59.50**

BC-620 FM TRANSCIEVER AND PE 120 VIBROPACK
20 to 20.9 Megacycles. Xtal Controlled. Part of SCR-509. Includes PE-120 Vibrator Power Supply Battery Case, Shock Mounting. Used... **\$22.50**
but in excellent condition.

NEW STANDARD BRAND CHOKES

HY	BRAND	SWINGING CHOKES		PRICE	VOLTAGE	CASE	WT.
		MILS	OHMS				
8-40	Stancor	175	100	2.75	3KV	Closed	3.5
8-30	Stancor	200	80	3.25	3KV	Closed	4.5
5-25	UTC	200	100	4.95	2KV	Closed	5
5-25	UTC	300	90	9.95	5KV	Closed	18
8-25	Stancor	300	80	5.95	5KV	Open	8 1/2
5-25	Stancor	300	80	4.95	3KV	Open	4
5-25	UTC	500	60	12.95	7KV	Closed	28
8-40	UTC	1 amp	50	39.95	10KV	Closed	58

HY	BRAND	SMOOTHING CHOKES		PRICE	VOLTAGE	CASE	WT.
		MILS	OHMS				
5	UTC	500	600	4.95	2KV	Closed	4
7	Stancor	150	200	1.25	2KV	Open	2
10	UTC	500	60	12.95	7KV	Closed	28
12	Stancor	300	80	5.95	5KV	Closed	9
12	Thordarson	375	105	3.95	5KV	Closed	8
12	Thordarson	400	400	6.95	2KV	Closed	15
15	Stancor	200	120	2.95	3KV	Open	4.5 lbs.
20	Stancor	300	80	4.95	3KV	Closed	9 lbs.
20	UTC	300	90	4.50	4KV	Closed	10 lbs.
20	UTC	400	85	5.95	5KV	Closed	14 lbs.

HY	BRAND	SMOOTHING CHOKES WITH HUM BUCKING TAP		PRICE	VOLTAGE	CASE	WT.
		MILS	OHMS				
20 Series	UTC	1A	50	39.50	10K	Closed	20
5 Parallel	UTC	2A	12.5				
16 Series	UTC	175	96	5.95	2.5K	Closed	15
4 Parallel	UTC	350	24				
26 Series	UTC	200	112	6.95	3.5K	Closed	15
6.25 Parallel	UTC	400	28				

VACUUM CONDENSERS

50 MMFD 5 Amps. 5 KV.....	\$1.15	100 MMFD 20 KV.....	\$7.95
12 MMFD 20 KV.....	5.95	150 MMFD 20 KV.....	7.95
50 MMFD 20 KV.....	6.95	200 MMFD 20 KV.....	7.95

While They Last!
PORTABLE FM XMITRS AND RCVRs!
Operate on 6V DC, 34 MC varied either direction depending xtals, xmtmr and Rcvr has aluminum case with antenna relay. Xmtmr uses 1073, 125 KC extral in osc. stage followed by 4 doublers and 1 fin. amp. all using HY 65 tubes. Mike amp. and Fre. Mod. use 1C7G tubes. Xmtmr stages have metering jacks. Rcvr is superhet. Xtal cont. local osc at 8060 KC. Power Supply on chassis using Carter 6v gen. output 450 v. 250 ma 6v vibrator power supply for receiver. All tubes inst. heating. Included is control box, hand set, 8" speaker **\$45.00** and extra microphone. Used, complete set only.

EXPORT INQUIRIES INVITED
Large stock of airline equipment, test equipment and radar sets, etc. Write for complete information. All inquiries answered immediately!

V&E RADIO & ELECTRONICS SUPPLY
DEPT. R-18, 2033-37 W. VENICE BLVD.
LOS ANGELES 6, CALIFORNIA

RADIO ENGINEERING IN 27 MONTHS
DEGREE IN 27 MONTHS

Radio engineering is a big field. There's room for you in it—if you're good. Get first-class training at Indiana Tech. Intensive specialized course including strong basis in mathematics and electrical engineering, advanced radio theory and design, television. Modern laboratory. Low tuition. Also 27-month courses in Aeronautical, Chemical, Civil, Electrical and Mathematical Engineering. Approved for G.I.'s. Enter March, June, September, December. You can earn part of your expenses right here in Fort Wayne while you are studying.

INDIANA TECHNICAL COLLEGE
911 E. Washington Blvd., Fort Wayne 2, Indiana
Please send me free information on E.S. Engineering Degree in 27 months as checked.

Radio-Television Aeronautical
 Civil Mechanical Electrical

Name.....
Address.....

antenna manual

The most practical, comprehensive book on antennas. 300 pages of down-to-earth help on antenna, feed line, radiation and propagation for all frequencies up to 1000 Mc. Including FM and TV. Plain language; no need to brush up on math. A necessity for everyone interested in transmission or reception.

\$3.50 PER COPY —
By mail, \$3.65 postpaid. Foreign, \$3.75

AT YOUR FAVORITE DEALER
OR DIRECT BY MAIL FROM
Editors and Engineers
1302 KENWOOD ROAD, SANTA BARBARA, CALIFORNIA

INVENTORY SALE

ALL PRICES CUT TO BONE

Don't Buy Tubes until you get our prices.
Large Stock, Low Prices

TELEVISION TUBES

6CD6—\$2.75, 6BG6—\$1.95

All Other Types at Vast Reductions

Westinghouse Cuxpro Rectifier 0.64 Amp. 28 Volts. Reg. \$11.00 ea. Special \$1.95
35c TUBE SALE—2 50-2A7-35-27-85-31-56-57, 6 for \$1.75; OZ4, 79c; 117P7, 95c; 6SL7, 35c

12 BRAND NEW 10" PHONO RECORDS—Ass't. Jazz—Pop.—Hillbilly—Polkas. Please specify. \$1.79

3 Ft. 5 Wire Shielded Cable with Amphenol Connection, 8 for \$1.00
7 Wire Shielded Cable, 24 in. with Octal Plug, 6 for \$1.00

U. S. ARMY GAS MASKS

Has O.D. covered case suitable for lunch or tool bag and charcoal container for use in refrigerators to eliminate fish or other odors.
Brand new—49c each; 3 for \$1.25

TRANSMITTING PLATE TRANSFORMERS

A pair of Signal Corps transformers connected in series to 110-125 Volts, AC, will deliver approximately 750 to 800 Volts, DC, 200 mls. when connected to a rectifier tube and filter condenser. Cost Uncle Sam \$23.00—our price per pair, \$2.98. Shipping weight 33 lbs.

Signal Corps Phones—2 M. Ohms (8 M. Ohms Imp.) \$1.00
2 Ft. Ext. Cord (and Plug), 40c

OIL FILLED FILTER CONDENSERS

1.—MFD—1000 working volts. 6/99c; 12/\$1.75

TOBE TUBULAR ELECTROLYTIC

20-20 MFD. 180 V. 35c 30-30 MFD. 150 V. 37c
40-40 MFD. 150 V. 39c

Low-Loss Short Wave Lock Type Air Trimmer Variable Condensers

3 GANG T.R.F. VARIABLE CONDENSERS .000365 Con. 65c
3 Pl.—12-15 Mmfd. 12c
7 Pl.—25-30 Mmfd. 15c
8 Pl.—30-35 Mmfd. 16c
10 Pl.—40 Mmfd. 17c
14 Pl.—56 Mmfd. 24c
27 Pl.—100-110 Mmfd 35c



D.P.D.T. SLIDE TOGGLE SWITCH 15c

4 PR. WAFER SOCKETS—\$1.49 per C. each 36
5-6 PRONG WAFER SOCKETS \$2.50 per C
100 ASST. SOCKETS—4-5-6-7 \$3.50 per C
1,000 OHM WIRE WOUND POTENTIOMETER 15c
30 HY-FILTER CHOKE SHIELDED 3 for \$1.25
UNSHIELDED 3 for 1.00
2,000 ohm Wire Wound Rheostats \$1 per doz.
CARTER WIRE WOUND C.T. VARIABLE 20 OHM RESISTORS 85c per doz.
GEN. ELEC. WESTINGHOUSE, etc. 60 CYCLE WATT HOUR METERS slightly used, perfect condition, same as used in your home. 110-125 volts. 5 Amps. \$2.95; 10 Amps \$3.95

PIEZO CRYSTAL HOLDERS. 12 for \$1.00—\$6.00 per hundred—\$50.00 per thousand
Grind your own crystals—Pure Brazilian Quartz, all sizes and thicknesses—1/2 lb. package \$1.00

RCA Band Switches—3 gang, 3 pos, 3 band. 30c 6 gang, 4 pos. 4-5 band. 40c
Trimmer-Padder Ass't.—all isolantite—singles, dual, triples—100 asst. pieces \$2.25

Philco push button Rotary Switch Double Pole 35c
ATTENTION: Prospectors, Explorers for Hidden Treasures! Construct a U.S. Army Type of Metallic Mine Detector Amplifier. Amplifier unit only (less tubes and batteries) with cables, headphone cord, and jack. Army wiring diagram. Type AN/PRS-1 cost \$1.95

RCA Ass't Mica By-Pass Cond. .001, .002, .0025, 100 for 95c
8 or 9 Gang Push Button Switch 49c

DRILLED CHASSIS FOR 5-6 tubes 5"x10"x1 1/2" .25c
PHONE JACKS—OPEN & CLOSED AUTO. 18c
NATIONAL 20 MFD—450 VOLT CAN FILTER CONDENSER 25c
EBY SPEAKER VOL. CONTROL—80 OHMS 15c
SALE—PHONO RECORD ALBUMS—12" 3 comp. 15c; 10" 3 comp—15c; 4 comp. 20c; 12 comp. 49c

IRC—300 Watt—300,000 OHM Wire Wound Res. 95c
6 Prong Amphenol Sockets \$4.00 per C

AMERTRAN FILAMENT TRANSFORMER—0.3 V. 1 Amp. Encased Isolantite Terminal Posts \$1.50

AMERTRAN XMITTING AUDIO XFORMER—For Class B or Modulator, Pri. 6400/1600—Sec. 5760 @ 160 MA. Cost \$75.00 SPECIAL \$2.49

AMERTRAN AUDIO OUTPUT XFORMER—Pri. 10,000 @ 15 MA: Sec. 300, 6-1 Ratio. \$1.49

AMERTRAN MIXER AUDIO XFORMER—Pri. 600-10,000 Ohms \$1.00

156-1 RATIO VERNIER DIALS—4 in., 3/8 in. Hub. 35c

LINE VOLTAGE NOISE ELIMINATOR—Plugs in Between Radio and Elec. Socket 35c

12 in. MAGNAVOX SPEAKER, 2500 Ohms \$2.95
HEARING AID CORDS—Assortment of 12 for \$1.00

BY-PASS COND. ASST.—25 Cans. Bake., Paper, etc. \$1.00

MINIMUM ORDER \$2.00—NO C.O.D.
SHIPMENTS—PLEASE INCLUDE POSTAGE

NEWARK
SURPLUS MATERIALS CO.

Dept. FE

324 Phone Street NEWARK 1, N. J.

nese electronic technicians do an excellent job but lack the know-how for efficient production. Despite the handicaps of shortages of essential materials, he said, they have accomplished a number of radio developments.

The dinner meeting was held at the Chamber of Commerce Building. Special guests of the evening were representatives of the U. S. Navy.

Southern California

The Executive Committee of the Southern California Chapter met on November 9th to discuss the practicality of present plans to establish lines of communication for civilian defense. A report on the conclusions reached at the meeting was forwarded to AFCA national headquarters by Chapter President Arthur C. Hohmann, Deputy Chief of Police of Los Angeles.

Washington

The Washington Chapter's second meeting of the season on November 16th brought out a large attendance of AFCA members and guests to hear Rear Admiral Stanford C. Hooper, USN (Ret.) recount the first days of radio in the Navy and the birth of broadcasting.

Admiral Hooper, the "Father of Navy radio communications," had with him at the chapter luncheon his "First Team," a group of radio pioneers who had worked with him in the early days. The group of ten were honored guests at the meeting.

The "First Team" included one particularly well known AFCA member, former FCC Commissioner E. K. Jett, who was president of the Baltimore Chapter last year. Others were W. A. Eaton, R. A. Lavender, C. H. Maddox, T. A. M. Craven, R. E. Gillmor, Charles S. Range, Morris E. Eason, Arthur O'Brien, and Lloyd S. Quynn.

Admiral Hooper's recollections of his early efforts to have radio accepted in the Navy as a practical medium of communication proved highly amusing to the AFCA members present because of the many incidents related wherein doubt of radio's reliability caused reactions which seem comic now.

—30—

One Man Shop Doomed?

(Continued from page 41)

cate that about sixty per-cent of the television service jobs are completed in the owners' homes. In other words, out of every five service calls three are handle television units to and from "pulled" to the shop for repairs. To handle television units to and from customers' homes the service operator must have some kind of a truck, which represents another investment in operating equipment.

Of course, there are many other elements that are serious obstacles to the successful operation of a one-man television service business in competition with organizations of skilled specialists. The larger organizations usually specialize in the receivers of a limited number of manufacturers. Normally they frown upon or refuse to service an "orphan" set or one they do not handle in volume. The reason is obvious. Experience on any given circuit is additive. Knowledge of a receiver's eccentricities or peculiarities, gained from experience in servicing it, reduces the servicing time per unit.

In the final analysis the question resolves itself into—How far can one individual effectively "spread" his time and abilities in a business that requires such a wide variety of techniques?

Successful television service businessmen in cities of all sizes agree that an organization of skilled technicians is required to handle television service efficiently, economically, and profitably. They also agree that there is manpower minimum below which the business will lose money. This minimum size varies from four men to seven men depending upon the size of the city and the trade area where it operates. It also presumes that the owner is himself a skilled technician capable of performing any phase of the service activity. The size of any service organization in manpower is determined by many things, but chiefly these: 1. The managerial ability of the owner; 2. The finances available for investment in capital equipment such as trucks, test equipment, replacement tubes and parts stocks, operating supplies and equipment, etc.; 3. Knowledge of effective sales promotion methods on the part of the management to insure a uniform volume of business to keep personnel profitably employed.

All right, you say, suppose the one-man service operator passes up television service; he can still make a good living servicing FM and AM radios.

It's highly questionable whether any man ever made a "good living" consistently out of a one man service business. But let's assume that under current conditions and possessing a fairly good stock of hard-to-get tubes and replacement parts, the solo operator is able to take a good living out of his business. How long will it last?

The easing of the present emergency coupled with the development of color



"It's the only way he can enjoy television!"

and u.h.f. television will give the green light to a rapid spreading of the type of television installation and service organization that has proven most successful in the metropolitan areas. Men who have acquired the management "know how" by working for successful metropolitan service businesses will seek opportunities to develop businesses of their own. They will turn their attention to smaller cities where a minimum-sized organization requiring a comparatively nominal investment can get a business foothold. We saw this development in a small way in cities that got television stations a year or more after the metropolitan areas were opened. The TV station freeze and the more recent tightening up in the skilled technical manpower situation caused a temporary suspension in this perfectly normal development in a new industry.

Successful television service contractors have developed sales promotional campaigns to maintain and expand their volume of business and through necessity have learned the fundamentals for maintaining good customer relations. One example of the excellent sales promotional material that service contractors are using is a fourteen-page brochure prepared by *Whittingham Brothers, Inc.*, of Philadelphia, containing a pictorialized story of their organization and facilities. This brochure is distributed to the company's customers and prospective customers. It has helped materially to increase their volume of service business and also created an especial appreciation of the company on the part of their service contract customers.

Time and experience will eventually determine the cycles of television service. It will be only natural for TV service businessmen to explore ways and means for adding service business during their slack TV periods. AM and FM radios, record changers and players, and home recorders can provide this added volume. These companies have the equipment, the skilled manpower, and the "know how" to handle the servicing of any type of electronic vacuum tube equipment. They know how to "sell service." As a matter of fact, quite a number of contract organizations in metropolitan areas had perfected plans for going after AM and FM radio service business, plans which were temporarily shelved in the face of the tightening situation on replacement tubes and parts.

Perhaps the most promising field of activity for the individual technician who wants to work alone in his own business is that of television receiver conversions. TV set owners have shown a decided preference for having their receivers converted to include later developments over trading them in on new models. In most areas a brisk business has grown up in converting 7" and 10" picture tube sets to 12½", 14", 16", and 19" picture tubes.

A skilled technician with a flair for selling or dealing with people can build

STANCOR *High Fidelity* OUTPUT TRANSFORMERS

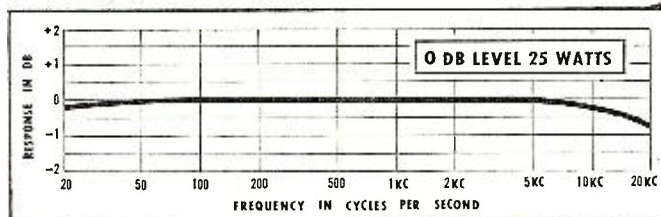

Curve represents an average response of the ten transformers in this series. Units used for this test were drawn at random from current Stancor stock.

±1 db FROM 20 TO 20,000 cps

Premium Quality at Low Cost

Stancor has taken advantage of the most advanced design and manufacturing practices to bring you a series of output transformers combining outstanding audio response with very moderate cost.

Extensively interleaved "trifilar" windings, extremely tight coupling, and careful electrical balance result in audio fidelity to please the most critical specialist. An inexpensive, but thoroughly practical, type of mounting is used since elaborate shielding is not required at the audio output power level.

Listed part numbers have a maximum power level rating of 50 watts and provide a wide selection of impedances for popular amplifier applications.

PART NO.	PRI. IMP. (P-P) IN OHMS	SEC. IMP. IN OHMS*	MAX. PRI. D. C. PER HALF	NET PRICE
A-8050	1500	8, 16	200 ma	\$10.86
A-8051	2500	8, 16	150 ma	10.86
A-8052	3000	8, 16	175 ma	10.86
A-8053	5000	8, 16	150 ma	10.86
A-8054	9000	8, 16	100 ma	10.86
A-8060	1500	500	200 ma	10.86
A-8061	2500	500	150 ma	10.86
A-8062	3000	500	175 ma	10.86
A-8063	5000	500	150 ma	10.86
A-8064	9000	500	100 ma	10.86

For complete specifications and prices of more than 450 stock part numbers, including other high fidelity transformers, see the current Stancor catalog. Ask your distributor for a copy or write direct.



STANDARD TRANSFORMER CORPORATION 3584 ELSTON AVENUE, CHICAGO 18, ILLINOIS

WALKIE TALKIES \$3.99 PER SET OF 2

POCKET SIZE
—Electronic
Voice Powered



No tubes, batteries, adjustments, license or permit needed! Should last for years.

Guaranteed to work anywhere up to 2 1/2 mile with extra wire. Clear tone. Swell for room to room—garage to house, etc! Your own private, talk-listen phone. Not war surplus. Brand new. Solid Aluminum Case. Guaranteed. Two absolutely complete units with wire—READY TO USE! SEND ONLY \$1.00 deposit and pay postman \$2.99 plus postage charges on arrival. Ideal gifts for boys—girls. Order Now! Today! THE MIDWAY COMPANY, Dept. WRT-5, KEARNEY, NEBRASKA.

Consecrated to Quality Output and Golden Rule Service

Fixed Capacitors and RF Interference Filters

Write for catalogue

ASTRON CORPORATION — 253 Grant Ave., East Newark, N. J.



RADIO ENGINEERING TELEVISION ELECTRONICS

Thorough training in all phases of radio and electronics, open to high school and junior college graduates. Old established school specializing in Radio training exclusively. Modern laboratories and courses. Enrollments limited. Approved veteran training.

VALPARAISO TECHNICAL INSTITUTE
Dept. RD Valparaiso, Ind.

Ready in January



TELEVISION AND FM ANTENNA GUIDE

by E. M. Noll & M. Mandl

Here is all the information and practical instruction you need in order to be sure of getting the most out of any antenna system, with a minimum of testing and readjustment. It gives—

- The characteristics, dimensions, and special advantages and disadvantages of ALL VHF and UHF antennas and allied equipment.
- NEW information on NEW types of antennas recently tested by the authors.
- Definite installation procedures—how to determine the right type of antenna for the particular site; how to locate space loops; how to determine signal strength, etc.
- Practical directions for mounting antennas on different types of roofs or on window sills; how to install transmission lines to minimize noise and avoid standing waves; use of booster amplifiers, input systems, etc.
- Clear, practical explanation of all essential principles—impedance matching, loss factors, etc. Handy tables and all other information useful in selecting and installing any type of antenna for best results.

Have you seen



RADIO & TELEVISION MATHEMATICS

A Handbook of Problems and Solutions

by Bernhard Fischer

Completely worked-out samples of every calculation commonly required in radio, television, and industrial electronics work of all kinds. Shows what formulas to use, what numerical values to substitute, each step in solution. Conveniently arranged and fully indexed for quick reference on any problem.



TELEVISION FOR RADIOMEN

by E. M. Noll

The outstanding book on television for servicemen. Clear, non-mathematical explanations of the operating principles and function of every part and circuit; complete instruction in installation, alignment, adjustment, and trouble-shooting.

SEE THEM ON APPROVAL

The Macmillan Co., 60 Fifth Ave., New York 11

Please send me a copy of the books checked below. I agree to remit in full or return the books within ten days without further obligation.

- TV & FM Antenna Guide, \$5.75 (prob.)
- Radio & Television Mathematics, \$6.00
- Television for Radiomen, \$7.00

Signed.....

Address.....N

a nice business for himself in converting TV receivers. By specializing in one model at a time he can operate a one-man production line in his shop and regulate his selling and shop work time to keep himself profitably occupied as many hours a day as he wants to work. The u.h.f. and possible color television will create a vast new market for set conversion and many skilled technicians who possess business management ability will build nice businesses specializing in this type of work.

The present radio service shop operator who hopes to build good television service business someday would do well to study the business operating practices of the television service contractors who have made a success of the business. While skilled technical ability is vitally necessary, so is experienced management "know how." By adding the proven experience of successful operators to his own practical experience he will be able to avoid many of the pitfalls that threw so many of the early companies into failure.

Television service is big business. It will be bigger business in the years to come. Whether such servicing operations prove to be profitable or become disastrous failures is something only time can tell.

—30—

Pulse Generator

(Continued from page 37)

time. The new miniature "metallized" paper condensers may be used to good advantage for coupling purposes since their small physical size reduces the distributed capacities to ground. They may be used for C_5 , C_6 and C_8 .

Once the construction job is completed, the unit may be mounted in a standard metal utility cabinet, and decals used to identify controls. When "dressed up" in this manner, the completed generator looks like a commercially-built piece of equipment (Fig. 1).

Use and Adjustment

Where exact frequencies are required, the output terminals of the completed pulse generator should be connected to an oscilloscope, and the frequency determining condensers (C_1 thru C_5) adjusted to give the desired results.

It is important that an oscilloscope having good high frequency response in the vertical amplifier be used if the pulse waveforms are to be observed without distortion. Pulsed signals contain harmonics as high as the tenth harmonic of a signal represented by the pulse-width (not pulse rate). Thus, a 10 kc. pulse rate, with the pulse-width equal to $\frac{1}{10}$ of the total time for a cycle, represents a frequency of 50 kc. and contains harmonics to 500 kc. For most work, a scope having a "flat" response to 2 megacycles should be satisfactory. The Tektronix 511AD,

More TV Protection

with the New Improved... R. L. DRAKE



Completely redesigned—

the New Improved R. L. Drake High Pass Filter affords the video amplifier, I. F. bandpass and signal channels more protection against strong radio frequency interference (zero to 50 mc.) generated by:

- Amateur Radio Transmitters
- Shortwave Broadcast Stations
- X-ray and Diathermy
- Industrial R. F. Heating
- Auto Ignition and Motors
- Neon Lights, Appliances, etc.

Two models available—TV-300-50HP for 300-Ohm Twin Lead and TV-72-50HP for Small 72-Ohm Coax.

\$5.95 LIST
Discounts to dealers, servicemen and amateurs

R. L. DRAKE CO.
11 Longworth St., Dayton 2, O.

See them at your distributor or write us for details

TUBE—OHM—CAPACITY TESTER!

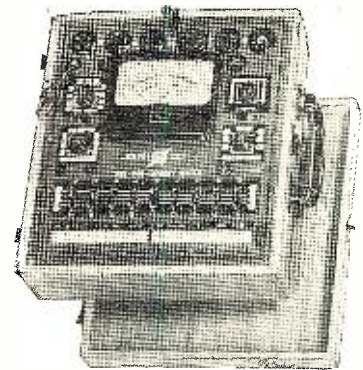

MODEL 202

- Line Voltage Control.
- Checks shorts and leakages.
- Checks resistance to 4 megs.
- Checks capacity from .01 to 1 Mfd.
- Checks condenser leakage to 1 megohm.
- Individual sockets for every type tube base.
- Built-in roll chart.
- Tests tubes from .75 volts to 117 filament volts.

Complete in sturdy, hand-rubbed portable oak case with carrying handle. **\$46.50 ONLY**

Add \$6.00 for 220V operation
Export Dept., 303 W. 42nd St., N. Y. C.
Write Dept. A-2 for Free Catalog

Gives More Measurement Value Per Dollar



ELECTRONIC MEASUREMENTS CORPORATION

423 Broome Street, New York 13, N.Y.

RADIO & TELEVISION NEWS

used to obtain the waveforms shown in Fig. 3, is reasonably flat to about 10 mc.

When connecting the pulse generator to other equipment, it is best to use short connecting leads, particularly when high pulse repetition rates are used. Open leads are preferable to coax unless hum pickup in the connecting leads becomes too severe.

Applications

Pulses are particularly valuable for syncing multivibrators, blocking oscillators, relaxation oscillators, and scope sweeps. Whether positive or negative pulses are to be used depends upon the exact circuit to be "locked-in," and both should be tried.

A positive pulse may be used to form a saw-tooth signal when applied to a vacuum tube biased to cut-off, with an RC circuit in the plate circuit of the tube. The condenser is connected to ground and charges through the plate load resistor. When the positive pulse is applied to the grid the tube conducts, acting to discharge the condenser.

Pulses are also valuable for retrace blanking in a cathode-ray oscilloscope. When some scopes are used at high sweep rates, the retrace becomes visible and interferes with proper interpretation of the observed waveform, as illustrated in Fig. 4A.

To apply retrace blanking to the scope, connect the output of the pulse generator to the "Intensity Modulation" terminals of the scope, as shown in Fig. 5. Whether positive or negative pulses are required for proper blanking depends on the design of the scope, and both should be tried. When the retrace is properly blanked out, the scope pattern shown in Fig. 4A will appear as in Fig. 4B.

For proper blanking, the pulse rate should be equal to the scope sweep rate.

When the pulse rate is higher than the sweep rate, small "dots" or "dashes" will appear in the observed signal, as shown in Fig. 4C.

Under such conditions, the pulse generator is useful for frequency measurement. As an example, if there are two complete cycles of the signal being observed between the "dashes" represented by the pulses, as in Fig. 4C, then the frequency of the observed signal is twice the pulse rate. Similarly, if there are three or four complete cycles between pulses, then the frequency of the observed signal is three and four times the pulse rate, respectively.

-30-

Fig. 5. Setup for applying retrace blanking.

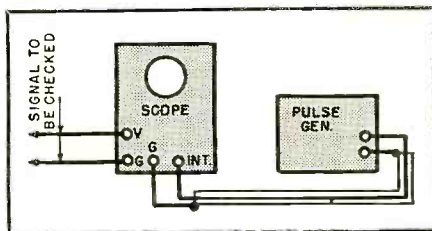

February, 1951

ARROW "The Home of Values!"

TUBE SPECIALS!

211	\$0.39	813	\$6.95
307A	5.50	832	2.95
703A	1.89	832A	7.95
723A B	12.95	837	1.19
724B	1.89	841	.49
803	2.89	860	4.95
805	3.29	864	.24
807	1.89	5D21	9.95

MISCELLANEOUS SPECIALS!

	Used	New
RA 10 DA Receiver	\$17.50	\$24.95
RT7/APN1 Transceiver	6.95	9.95
APN 1 Complete		24.50
BC 347 Interphone Amplifier		2.95
I-70 Tuning Meter		.89
BC 461 Veeder Root Counter		.59
BC 442 Less Condenser	1.49	1.95
APS 13 UHF Antenna, Pair		.98
FL 8 Filter		2.95
I-97 Bias Meter	3.95	4.95
RL 42 Antenna Gearbox Motor and Reel	4.95	7.50
TS 10—Sound powered phones		6.50
BC 1066 B—150 to 225 MC Portable Receiver adaptable to many amateur uses. In Canvas Carrying Bag. Used.		\$5.95
One Tube Interphone Amplifier—Small compact aluminum case fully enclosed. 2 1/4" x 3 3/4" x 5 3/4". Less Tube		.79c
BC 709 Battery operated lightweight interphone amplifier. Complete with tube and shock mount, but less battery.		New \$3.95
40 Amps Circuit Breaker		New 59c
220 M.A. Circuit Breaker		New 59c
Collins VFO Dial—5 calibrated ham bands from 3.2 Mc to 32 Mc; complete with pointer, gears, logging dial and flywheel. Scale 6" on 8" plate. New		each 95c
C-18—Antenna coil assembly slug tuned used in BC 603 receiver. Frequency range 20-27.9 Mc.—fully shielded.		New. 10 for \$1.95
I 82 F—Five Inch 360 degree compass indicator and Selsyn receiver.		New \$4.95
A-81-2 Transmitter selsyn for I82 indicator.		2.45
(Both I82F & Trans. Selsyn for \$7.00)		
T23/ARC5 Transmitter		Brand New \$29.95
RC 100—Complete or components parts available—Price upon request.		

MONTHLY SPECIAL

BC-457, 4 to 5.3mc command transmitter in very good condition. Complete with tubes and crystal. \$3.95 Both for \$7.00
BC-458, 5.3 to 7mc. 3.95

AS-138/ARN—10 inch streamline loop as used with direction finding receivers. Fixed position, it is ideal for planes, boats, auto-mobiles. New \$1.95

TS-293/CPA 5 Range Calibrator

designed for testing Radar set AN/CPA5, it contains a good 110 volt, 60 cycle power supply, plus other circuits. Tubes have been removed, but the power supply alone is a terrific buy at \$3.95 each

O-27 CPA5 Range notch generator is similar to the above described TS/293/CPA5 and will be substituted when necessary.

Note: At this low price we are unable to answer technical inquiries or furnish other information on these two above items.

SNI/APQ 5 Synchronizer Unit Chassis consists of resistors, condensers, sockets, relays and other salvageable parts. Less tubes. each \$2.95

PP12A/APS—3 Power Pack used to supply many voltages for APS 3 equipment from an 800 cycle source. A good parts buy. Less tubes. \$1.49

All shipments FOB warehouse. 20% Deposit required on all orders. Minimum order accepted—\$5.00. Illinois residents, please add regular sales tax to your remittance.

COMMAND (SCR 274 N) EQUIPMENT

	Used	New
BC-454	\$ 5.95	
BC-455	7.95	\$ 9.95
BC-456		2.95
BC-457	5.95	
BC-458	5.95	8.95
BC-696	14.95	24.95
BC-450—3 Receiver Remote Control	.89	1.95
BC-442		2.95
3 Receiver Rack	1.95	
2 Transmitter Rack	1.50	

1D6/APN4 Scope unit complete with 5CP1 cathode ray tube and shield and all parts except smaller tubes and crystal. Used. \$9.95 ea.

RT7/APN1 TRANSCEIVER UNIT—

Used as an altimeter, it may be converted for signaling control circuits, etc. Complete with 14 tubes and dynamotor they are in good used condition at \$6.95—the amazingly low price of.....



MN 26 Y Compass Receiver, twelve stage superhet covering frequencies of 150 to 325 KC; 325 to 695 KC; and 3400 to 7000 KC in three bands. These units are brand new but with Dynamotor, Band switch motor and tubes removed. Schematic Furnished. While they last. each \$4.95

BC-604 Transmitter FM 20-28 MC

11 and 15 meters. Can be operated on 10 meters—10 channel push button crystal. With all tubes and meter but less dynamotor. Excellent Condition. \$19.95 Crystals—Set of 80. 19.95

BC 603

Receiver—Good. Used. \$24.95 Complete SCR-508 Installation available—price and information upon request.

SURPRISE PACKAGE

20 lbs. Ass't radio parts. A \$25.00 value for only \$1.95

Flap Pitch Motor

24 VDC. Will operate on AC—3300 or 11,000 R.P.M. Complete with gear box and limit switches. each \$2.95

BC 620

Receiver-Transmitter—2 crystal channels—20 to 27.8 MC FM—13 tubes. Metered, Plate and Filament. Used \$9.95

PE 97 or PE 117 or PE 120 Power Supply for above 6-12 volt vibrator type.

Used less tubes, vib. & con. \$2.95

Used, complete. 6.95

FT 250 Mount for both BC 620 and PE 97 New 1.50

ARROW SALES, Inc.

Dept. N
1712-14 S. Michigan Ave., Chicago 16, Ill.
PHONE: Harrison 7-9374

SOLAR CONDENSER TESTER

Model CBB:—Not just another condenser tester but the best ever made. This is a must for TV servicing. Will test any and all types of condensers for capacity, power factor, leakage and voltage. Will test resistors from 100 ohms to 7 megs. Has self contained power supply from 100 to 500 V D C which can be used for external testing. Operates on 115 V 50-60 CPS.

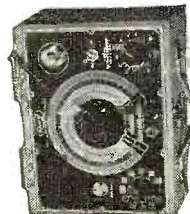

Complete with tubes, test leads and instruction manual. Shipping weight 9 lbs. \$42.49

20% deposit with order. Balance C.O.D. JOBBERS—WRITE FOR DISCOUNTS
ARCEE ELECTRONICS CO.
Dept. A 96 WARREN ST., N. Y. CITY, N. Y.

RADIO ENGINEERING

B.S. DEGREE IN 27 MONTHS

Complete Radio Engineering course incl. Telev., U.H.F., and F.M. BS Degree Courses also in Mech., Civil, Elect., Chem. and Aero Eng.; Bus. Adm., Acct. Extensive campus, modern buildings, well equipped labs. Low cost. Prep courses. Personalized instruction. Heavy demand for graduates. Placement service. Founded in 1884. Prepare now for the civil and military opportunities ahead. Enter March, June, Sept., Jan. Write for Catalog.

TRI-STATE COLLEGE

1621 COLLEGE AVE. ANGOLA, INDIANA

TIME and STOCKS are running out ... BUY NOW!

VHF TRANSCEIVER. Ideal substitute for SCR-522. Xmitr is crystal controlled, 100 watts. Recvr has two individual RF sections feeding a common 3 stage 10 mc IF. Both RF sections may be operated simultaneously or individually. Recvr uses 5 tubes. Xmitr is straightforward, uses 7 tubes, including 832 final modulated by push-pull 6L6's. In one neat case. Excellent used, less tubes, xtals, dynamotor. We furnish complete conversion and power supply instructions. A steal at only... **\$6.95**

R-9A/APN-4. 160-meter Loran receiver plus high (for scope) and low voltage power supply. Three chans. tunable 1.6-3.3 mc. 1 chan. tunable 7.58-11.75 mc. With schematic and instructions for 60 cy. Excellent used, less tubes... **\$4.50**

FREQ. METER BC-438. Easily converted to precision lab. xtal calibrated heterodyne-type freq. meter and sig. gen., 50 to 440 mc with audio modulation. We furnish simple instructions for conversion and calibration. Has power supply, tubes, and lab. standard xtal. Start where your BC-251 or LM ends. Excellent cond., complete as described. While they last... **\$27.50**

LOOK WHAT \$2.65 WILL BUY!

The most versatile dynamotor in surplus! The best dynamotor for conversion to 6v. Multiple windings! After conversion you have choice of 190 or 350 v at 50 MA or 250 v at 100 MA. No brushes to shift around, no mechanical work. Or use it as a 2:1 or 1:2 step-up or step-down transformer for DC voltage. Changes 6 to 12, 12 to 24, or vice versa, up to 3 A. Or use it as a GENERATOR. Turn with motor, get 12 v DC at 12.6 A or 24 v DC at 6.3 A, plus high voltage. Includes easily removable self-contained 800:1 geared-in-vol gear reduction unit. Complete dope sheet furnished. **\$2.65**

MARINE SPECIALS

G.L. "MARINER" TRANSMITTER. 180 w input, 120 w to antenna, 90% modulated, 4 channel xtal cont, 12 or 24 v input with dynamotor, connecting cord, xtals, tubes, mike, all aligned and ready to operate. (Specify volt. and freq. when ordering.) Contains break-in relay for recvr in addition to antenna switch. Dimensions: 8 1/2" x 8 1/2" deep, 17 1/4" wide, 19 1/2" high. Tubes included: 10Y speech amp., two 211 mod., 12J5 osc., 1625 IPA, two 814 parallel PA. We add \$130 worth of skilled engineering and parts to equipment which cost U.S. over \$1200 to start with. How can you lose? With our \$1200 instructions, FCC license approval guaranteed. **\$275.00**

G.L. "MARINER" RECEIVER. Long wave, broadcast, marine and short wave receiver, converting to 160 meter finest Navy surplus! All controls, vernier tuning, BFO ON-OFF and AVC-MVC on entirely new front panel. Coaxial type speaker, 8" diameter, 16 ohm, 100 watt, 1/2" of rear to battery to power a DU-1 loop, and to kill B-1 with xmitr break-in relay. 12 or 24 v DC. Only 15 1/2" long, 8" wide, 8 1/2" high. No need for a speaker. No need. With 6 tubes, 2 neon voltage limiters, and dynamotor. Requires an external speaker. Alignment instructions and schematic furnished. Specify... **\$69.50**

BC-223 TRANSMITTER. 15 to 25 w output, 4 chan xtal control. To modify for FCC approval, just remove a few knobs and put one metal screw into panel to keep channel selector switch from being turned off. No connection. WE CHECK THEM OUT! With tubes, 12 v dynamotor PE-55, connecting cable, 4 marine freq. xtals, mike, and schematic. Don't forget to specify... **\$89.50**

Additional plug-in unit for above, with custom-ground 4 mc ship-shore band xtal. Get through when lower band is busy. Brand new, specify freq. **\$6.19**

CORD WITH PLUGS. PE-55 to BC-223... **\$2.50**

NAVY TYPE ARA (SCR-274N) 6-tube receiver, 1.5-3 mc. We rewired it for 12 v. with dynamotor mid on back, and with phone plug and all for Marine band. Still retains original Navy surplus! All controls, vernier tuning, BFO ON-OFF and AVC-MVC on entirely new front panel. Coaxial type speaker, 8" diameter, 16 ohm, 100 watt, 1/2" of rear to battery to power a DU-1 loop, and to kill B-1 with xmitr break-in relay. 12 or 24 v DC. Only 15 1/2" long, 8" wide, 8 1/2" high. No need for a speaker. No need. With 6 tubes, 2 neon voltage limiters, and dynamotor. Requires an external speaker. Alignment instructions and schematic furnished. Specify... **\$32.50**

Same as above, but for 24 v. **\$27.50**

DU-1 Manual Loop Direction Finder. 12 or 24 v. Goes ahead of the L. "Mariner", ARA or any other receiver. We convert it to the Marine band. Still retains lower half of broadcast band, and all the lighthouse and beacon band. 2-tube phasing circuit, no 180° ambiguity. Gives true bearing in seconds! No schematic and complete instructions furnished. **\$32.50**

NAVY WATERPROOF BULKHEAD SPEAKER with universal matching transformer, cord and phone plug. **\$9.95**

RA-10-DB DIRECTION FINDER AND RECEIVER. 24 v, 150-1100, 2000-10,000 KC. Very hot. Brand new, complete with Loop, cords, plugs, control box, flex cable and technical manual. **\$98.50**

We're stuck with a lot of Salt Water Soap! Navy detergent powder in 30 lb. Kegs. Clean-out price per keg **\$2.95**

COMBINATION SPECIAL

See our January ad! Angular Position Transmitter of the Eastman-Kodak Co. with 24 v. Tuning Coil, PWS BC-347-C excellent used amplifier with tubes, PLUS Sensitive Relay closes on 2 ma... a perfect assortment for your "come-in-handy" box... totals \$4.50. **\$3.98**

TU-25 80-meter plug-in tuning unit for xmitr BC-223. 3500-5250 KC. Use as foundation for xmitr or a feast for parts, including ant. coupling, ant. inductance, xtal selection switches, coils, condensers, etc. With schematic. **\$1.29**

6 V STORAGE BATTERY. New! Consists of three Willard 2v. 20 amp. hr., spill-proof batteries, dry charged, and Battery Box CH-291 with plastic windows to see built-in hydrometer balls. A neat little set-up! **\$4.95**

OIL FILLED 4X8 mfd. 600 v. condenser, in one case, common ground, with nut hooks, as used in Army G-1 Super-Pro power supply. **\$2.89**

APS-13 Tail-warming Radar xmitr-recvr. 410-420 mc, 5 stage, 30 mc IF. Brand new, with schematic, less tubes **\$9.95**

CITIZEN'S BAND ANTENNA with director, radiator, reflector hardware and nut. Two complete sets. **\$98c**

TAPPED POWER! Here is the depot-spares replacement main transformer which enabled the RA-34-F and -G recvr to furnish COMPLETELY VARIABLE 0-1200 v DC at 400 ma in steps of 1 v. Variable hi-voltage is obtained by using the coarse and fine taps to feed the primary of a 1:10 hi-voltage transformer (not included). Furnished with 3 heavy-duty 1000 v. 1/2" wire. In addition, it has 4 outputs to feed dry rectifier which put out 12 v, 2.4 A and an AC output of 12-14 v at 14 1/4 A. Input is 115 or 230 v 60 cy. With schematic of RA-34-F show... **\$17.50**

See our large ad, Page 125, Jan. Issue

WANTED!

Your Spare Surplus Equipment and Tubes, Dynamotors, Recvrs., Xmitrs., Test Equipment. Send List, stating condition and rock bottom price.

G.L. ELECTRONICS

905 S. Vermont Ave., Los Angeles 6, Cal.
All Prices F.O.B. Los Angeles. Calif. Buyers Add Sales Tax

THE AD-VISER

DIRECT MAIL ADVERTISING

By

IRVING SETTEL

FOR the radio and television retailer, direct mail advertising can be an extremely important medium. Many successful businesses have been built by employing this mode of promotion almost exclusively. Others have utilized direct mail to supplement newspaper and radio advertising. In almost every case, it has proved to be a substantial business getter. Its importance cannot be over-emphasized. Let us, therefore, probe into direct mail advertising to see what makes it tick.

Basically, direct mail consists of any advertising matter which is sent through the mails directly to potential customers. The message may be carried in the form of postcards, letters, leaflets, booklets, folders, broadsides, or catalogues. In contrast with other media such as newspapers, magazines or radio, direct mail is not accompanied by any "interest" or editorial material. Its success depends upon its own merits and its biggest competitor is the wastepaper basket. The recipient must be attracted to the mailing piece immediately or the costly advertising matter becomes scrap. Even with this important obstacle, direct mail possesses some intrinsic advantages, most important of which are as follows:

1. Direct mail costs are more flexible than the costs of other media. You can spend as little or as much as you desire.
2. Direct mail can be used with a minimum "waste" circulation. The advertiser selects the list of prospects to whom the piece will be sent.
3. Direct mail advertising results can be checked accurately. Each recipient is known by the sender and can be subjected to various types of copy approaches. This means that after testing, advertising matter can be improved.
4. The advertiser controls his direct mail circulation as to amount, distribution, and quality. He establishes and maintains his own list. He can send a personalized message and can devote more space to the recipient's individual problems. In other words, he can sell his merchandise in terms of his customers' specific desires and needs. Probably the most important element in successful direct mail adver-

tising is the list or the names to whom the pieces are directed. It is the advertiser's task to establish his own list, upon which depends the success of his campaign.

Building the Mailing List

Obviously, just any list of names would not serve too well as a source for potential customers. For example, you wouldn't direct a mailing piece offering expensive television sets to a lower income group of customers. Their interest in such an item would probably be negligible and their purchasing power low. You wouldn't choose a list of children for similar reasons. You would desire a list, however, of persons possessing the purchasing power and potential desire for your product.

Building a good list is not a difficult job. It requires, however, rigid adherence to certain basic rules which are listed below:

1. *The Names Must Be Potential Customers.* The people on the list must be logical prospects for the radio and television sets advertised. The recipient must be in a present or future position to adapt the ideas you are trying to impart.
2. *The List Must Be Up-to-Date.* Most people are in a constant state of flux. They are always moving. They get married. They have children. They die. A good list changes with similar regularity.
3. *The List Must Be Accurate.* One of the surest ways to antagonize a customer is to misspell his name or call him "Mrs." instead of "Mr." When you are gathering your list, it is essential to get correct information as to spelling and other details. This, too, must be kept up-to-date to insure accuracy.
4. *The List Must Be Complete.* It should contain complete data which will enable the advertiser to know his prospects well. If possible, a list should contain age, education, financial status, and any other pertinent information which can be obtained.
5. *The List Should Be Free of Duplication.* In gathering lists from separate sources, it is important that there is no duplication of names. If one person receives two identical mailing pieces, the effect of both may be lost entirely.

Gathering the Names

Mailing lists can either be bought or built. There are companies which specialize in compiling and selling lists.

You can buy a list of names in practically any desired quantity and grouped in many varied categories. You can purchase names of people in your own town listed according to income bracket groups, neighborhoods, educational qualifications, etc. Remember, however, that "canned" lists can be obtained by anyone who is willing to pay the price—and that includes your competitor. "Home made" mailing lists, though more difficult to obtain, are usually more effective, for they represent a more carefully selected group of people whose names make up a list available to no one else.

For the radio and television merchant, great opportunities exist to build an excellent mailing list in his business. Following are a list of convenient sources:

1. Charge account customers whose names and addresses you already have in your account books.
2. Present and past customers. Salesmen and deliverymen should take the time to write down all necessary information.
3. Answers to advertisements soliciting mail orders. The use of a coupon at the bottom of your newspaper advertisement will facilitate the ordering and give you the information you desire.
4. Names of friends submitted by established customers. Inexpensive gift items offered for each name submitted will stimulate action.
5. Names from newspaper announcements of births, engagements, weddings, graduations, etc.
6. Municipal records of licenses and permits usually available at the city hall of your town.
7. Payroll lists of local companies, sometimes available.
8. Convention rosters, membership lists of commercial, professional, and social clubs.
9. The main and classified sections of local telephone directories.
10. The exchange of lists with non-competitive but allied retailers. Radio and television merchants can often find effective lists in the possession of a neighborhood record store or furniture store.

The chief precaution to take in the use of directories is to guard against the use of out-of-date books. It often takes months to compile a printed directory and during this period many changes may occur.

The compiling of an effective direct mail list, though not too difficult a job, requires care, patience, and resourcefulness.

Classification

After the names have been gathered in sufficient quantity, it is wise to give thought to the information which has been compiled. Correct classifications will keep your list alive and accurate. Most important is to divide your list into "active" and "inactive" groups. After subjecting your "active" customers to a predetermined number of mailing pieces, unresponsive names



Performance

WHEREVER YOU ARE
with *Telrex*
"CONICAL-V-BEAMS"*

America's Finest TV Antenna —

Telrex "Conical-V-Beams" are engineered to perform where others fail, whether near or far from the TV station.

ACTUAL PERFORMANCE COUNTS!

It takes more than extravagant claims to produce results. That's why Telrex has over a million "Conical-V-Beam" installations all over the nation.

Install a "Conical-V-Beam" today — you'll be installing them every day thereafter because you can



MODEL
4X-TV

"See the Difference"

*REGISTERED TRADE MARK

Conical-V-Beams are produced under Patent No. 2518297



telrex INC.
CONICAL-V-BEAMS



AMERICA'S STANDARD OF COMPARISON
ASBURY PARK 7, N. J.

THE SKILL TO DESIGN
THE FACILITIES TO PRODUCE
THE ABILITY TO DELIVER

GREYLOCK TUBES

MORE THAN 400 TYPES LISTED

**We're STILL DELIVERING
Better Than 90%!**

Complete stocks of Standard Brand Lines, including	
AMPERITE—Micro-phones	WALSCO—Chemicals & Tools
EICO—Instrument Kits	HOWARD SAMS—Photofacts
X-CELITE—Tools	TV Antennas & Accessories
EBY—Parts	

Write TODAY for our Complete Catalog Dept. N-2

GREYLOCK ELECTRONICS SUPPLY CO.

115 Liberty Street New York 6, N. Y.

LEARN DAY and EVENING CLASSES

TELEVISION

ELECTRONICS-RADIO
Modern Laboratory Instruction in

- SERVICING
- BROADCAST OPERATING
- ELECTRONIC and TV ENGINEERING

G.I. APPROVED

WRITE FOR CATALOG

ELECTRONICS INSTITUTE, Inc.
21 HENRY, DETROIT 1, MICH.

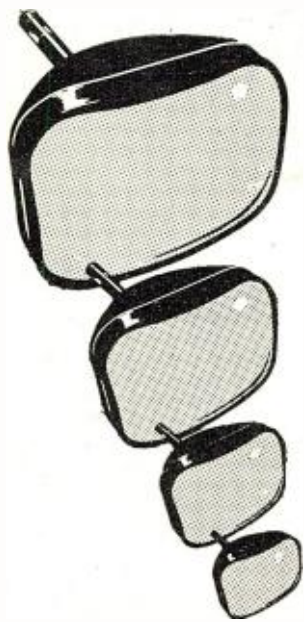

ELECTRONIC BUSINESS MACHINES

That's what we call the 16", 17" and 20" rectangular neutral-density-filter tubes that Reeves Soundcraft Corp. is manufacturing as successors to Remington Rand's TV Picture Tube Division.

IT IS GOOD BUSINESS to INCORPORATE Reeves Soundcraft "TRULUMES" as the BUSINESS end of TV sets you manufacture, service, convert, or for which you stock tubes.

In the coming months more and more of these fine rectangulars will become available. An inquiry NOW will enable us to tell you how YOU may sooner become one of our happy kinescopic beneficiaries.

Dictate an inquiry today.

Reeves — 20 YEARS WITH ELECTRONICS IN PEACE AND WAR: Optical and magnetic film sound recording facilities, equipment, and supplies; "acetate" discs and magnetic tape; transformers; projection TV; crystals; electronic computers.

REEVES Soundcraft CORP.

COLORCRAFT PICTURE TUBE DIV.
35-54 36th STREET, LONG ISLAND CITY 6, N. Y.

SUCCESSORS TO REMINGTON-RAND TELEVISION PICTURE TUBE DIV.

Leotone

CABINET & CHASSIS FOUNDATION modern, plastic (Walnut, Flow, Orchid or Black), & 5-tube punch on chassis. 9" x 7" x 1 1/2" . . . \$1.79

CABINET DRAW SLIDES . . . \$2.10; 15" (11") \$2.25; 16 1/2" (12 1/2") \$2.39
Heavy Duty, all-steel 16 1/2" / 12 1/2" . . . 3.25

DYNAMIC HEADSET & HAND-MIKE (B19-MkII) . . . 2.49

MICA PADDERS—TRIMMERS . . . Kit of 15 assd.59

WAFER SOCKETS . . . 4 to 8 pin. Kit of 12 assd.25

KNOBS . . . Setscrew, spring. Kit of 25 assd.98

DIAL WINDOWS . . . Glass, acetate, 12 assd.1.29

DIAL SCALES . . . Acetate, glass, P.M. AM, 25 assd. . . . 2.49

DIAL ESCUTCHEONS . . . Ring, slide-rack, 25 assd. . . . 2.49

MOULDED BAKELITE CONDENSERS (Micamold)

.00001 to .2mfd, 200-600WV. Kit of 50 assd. 1.98

SPEAKER PARTS SPECIALS!! (less V.C.)

4" CONES . . . 9/16" I.D. 3/4" deep . . . \$46/M; 100/\$7.25

5 1/4" CONES . . . 9/16" I.D. 13/16" deep . . . \$50/M; 100/\$7.95

6" CONES . . . 24" I.D. 1 1/8" deep . . . \$65/M; 100/\$9.95

KITS OF 12 ASSD. CONES . . . less voice coils, 4" O.D.—98c

kits 5" —\$1.25; 6" —\$1.49

4" to 12" ASSORTMENT (incl. free-edges)12 for \$1.98

SPEAKER REPAIR KIT . . . Liberal assortment, of: Spiders, Rings, Shims, V.C. forms, Cement, Felt, Chamois Leather & Instructions. . . \$2.49

!SPECIAL!—\$1.98 CONE & REPAIR KIT . . . 3.95

18 FT. WHIP ANTENNA . . . 6 steel screw sects. \$2.49

MINI-JACK & PLUG PL291/JK-49 . . . Pr. 39c; 3/1.00

50W-25 OHM "DIVIDOHM" adj. resistor. 29c; 4/1.00

POWERFUL "ALNICO MAGNETS" . . . "U" type for: Tape or Wire Erase, TV, 3/4"x9/16" sq. . . . 39c; 15/5.00

ALNICO MAGNET KIT . . . assortment of powerful Bar, Block, "U," Ring. Kit of 10 magnets. 1.98

(WRITE FOR "ALNICO MAGNET" SUPPLEMENT)

DM-36D DYNAMOTOR . . . 24V-220VDC, 80 ma, \$1.39

HIGH FIDELITY CRYSTAL MIKE . . . HI-imped. rubber shock-mtd. 1 3/4"x3/4". Less housing.98

ALUMINUM HOUSING for xtal mike.15

T-44A MAGNETIC MIKE . . . brand new. . . 69c; 3/1.98

HANDY CARBON MIKE (HSS3) Pres-to-lark. 98c; 6/5.00

EXPERIMENTAL TUBES . . . for Testing, Research. Fil. tested, 20 assd. receiving types. 1.00

IMMERSION LIQUID HEATER (GE) 2TV, 54W . . . 1.95

BENDIX AMPLIFIER (LINE OF SIGHT) . . . "Gold Mine" of parts. Metal Cased: 7"x6"x4" . . . 1.00

.05-600V. OIL CONDENSERS . . . 12c; 10/1.00

.230 PE MAGNET WIRE . . . 400 ft. roll. . . 23c; 5/1.00

4" RND. DIAL . . . 0-100CCW, 1/4" shaft hole. . . .39

D.P.D.T. ANTI-CAPACITY SWITCH . . . Red knob. . . .49

GENERATOR VOLTAGE REGULATOR (G.E.)

2GBD-1A-18, incl. 24 cont. adj. relay. . . . 1.49

MACHINE SCREWS (Phillips) . . . Cad. plate.

5/4x3/8, 7/16, 1/2, 5/8 or 1"gross59

4/48x3/4, 5/16, 7/16 or 3/4"gross49

DPDT TOGGLE (CH) 3at, lum. tip, sprg. ret.39

2 1/2" SQ. PANEL METERS . . . 0-5V, DC1.29

6-100 AMPS. DC. With shunt.98

JK-24 PHONE JACK for PL-55. Long frame.29

1 1/2" V. FIL. XMF8 . . . 113V. Pr. 23c; 12/1.35

FACTORY SPEAKER REPAIRS SINCE 1927

Min. Order \$3.00 . . . 20% deposit on all C.O.D.'s

Full Remittance with foreign orders

Please add sufficient postage—excess refunded

EOITONE RADIO CO.
63 Day Street
New York 7, N. Y.

FOR THE "GOLDEN EAR" CROWD

THE STRAIN-SENSITIVE PHONOGRAPH PICKUP

Here's why this truly faithful reproducer appeals to people gifted with the "Golden Ear" . . . why the STRAIN-SENSITIVE PICKUP developed by the PFANSTIEHL CHEMICAL COMPANY brings out the brilliance of great voices and orchestras . . . the latent music on your records that other pickups leave untouched.

- The STRAIN-SENSITIVE PICKUP is an amplitude transducer with a CONSTANT RESISTANCE of about 250,000 ohms.
- Signal output is at a practically CONSTANT IMPEDANCE LEVEL.
- Excellent Transient Response.
- NO DISTORTION, phase shift or evidence of intermodulation is audible.
- LINEAR RESPONSE, free from peaks or resonances.

Cartridges are available for both standard and micro-groove, and can be had with Famous PFANSTIEHL M47B Precious Metal Alloy or diamond tipped styli.

A special preamplifier is necessary to provide the correct D.C. voltage for the pickup element and to provide the first stages of signal gain. Four styles are ready, or, if you prefer, you can build your own from the circuit in the literature.

Ask your radio supply man, or write today for complete FREE INFORMATION.

PFANSTIEHL CHEMICAL COMPANY
101 Lake View Avenue, Waukegan, Illinois

should be transferred to the "inactive" file. This will keep your list alive with customers who react favorably to your selling appeals. Other possible groupings include marital status, age, financial ability, etc.

Both the careful gathering and the accurate classification of your lists are almost useless unless these names are continuously maintained. Data changes will occur from time to time. These changes should be noted. Address changes are probably most frequent. Changes in marital status rank second. Intelligent "direct" advertisers diligently inspect their lists, making frequent changes. Care and patience in the tending of a "live" list will pay off in huge dividends.

-30-

Mac's Service Shop

(Continued from page 61)

eye that the boy was doing some heavy thinking. He was trying to estimate just how many sets he had let slip without this routine check in the past!

"Here is a good example of those open-and-shut servicing cases I was talking about," Barney said a few minutes later. "This little job works all OK on the battery, but it is weak and has a loud hum on a.c. Any dope would know that the input filter condenser was weak or open. All we have to do is bridge a good condenser across the input section, like this, and the set will straighten out and fly right."

To his deep chagrin, the boy found that connecting the new condenser caused the set to go completely dead at first and then slowly return to its weak and noisy playing.

"What do you know!" he exclaimed as his ears turned a brick red. "That's not it. Well, it must be the resistor that drops the d.c. voltage for the filament string has increased in resistance and made the filament current too low. The tubes all check extra good on emission."

Mac said nothing, and a few minutes later the little set made a noticeable increase in volume. "There," Barney announced triumphantly; "reducing the resistance of the dropping resistor a couple of hundred ohms did the trick."

Without making a reply Mac reached over and cut the output of the line isolation transformer from 117 volts to 105 volts. Instantly the little receiver went dead.

"I seem to remember telling you that all of the sets had to keep playing when the line voltage was dropped to 100 volts before they were ready to leave the shop," he observed quietly.

"But if I reduce that resistance any more, I am afraid the tubes will get too much current when the line voltage is up," Barney protested.

"Maybe you are barking up the wrong tree. How does the rectified voltage ahead of the dropping resistor check with the value given in the service manual?"

"It's about ten per-cent low at 117 volts in the line."

"Then why don't you check the rectifier?"

"Because (a) the rectifier is a selenium job and they never give any trouble, and (b) I know of no way of checking that type of rectifier."

"Replying to 'a,'" Mac said, "never" and "always" are two words that just do not belong in the vocabulary of a technician. If he has been in this game long enough, he has seen everything happen, at least once. Those selenium jobs do give very little trouble, but some of them have been in service long enough now to begin to weaken a little. I replaced three last week. As for 'b' you are going to learn right now a quick and practical way of checking them."

Mac picked up the solder gun and unsoldered one lead from the rectifier. Then he connected an ohmmeter, set to its lowest range, across the selenium unit. When the leads were connected in one way, the meter pointer barely flickered; but when the leads were reversed, a resistance of around six hundred ohms was indicated. Next he took several new selenium rectifiers from a parts cabinet and showed Barney that each of them, in the conducting direction, presented a resistance of only fifty ohms or less.

"Be sure and notice the particular ohmmeter and the particular scale we are using for this test," Mac cautioned, "for that fifty-ohm figure will not hold good unless you employ the same setup. What we are really testing is the amount of current passed by the rectifier for a given voltage, and the applied voltage—and consequently the current—will be different for other ohmmeter circuits; but as long as you stick to this particular meter and range, the check will be all OK. A very high resistance in the non-conducting direction and a low resistance to current moving in the conducting direction is the mark of a good rectifier."

"I suppose a fellow could use the low-resistance, high-current range of any ohmmeter to establish a similar acceptable resistance by taking the average of several new rectifiers, couldn't he?" Barney asked.

"That's right," Mac agreed as he removed the old rectifier and soldered the new one into place. Immediately the set started to play loudly and without hum, and it continued to play that way even when the line voltage applied was only ninety-five volts.

"That has taught me a lesson," Barney vowed. "From now on I am going to consider every radio part guilty until it has been proved innocent. I'm going to be as suspicious as a bubble-dancer at a bean-shooters convention."

"While you are in this rare chastened mood, I want to mention a couple of other matters," Mac said. "In that set you left on the bench last night and which you said was ready to go back in the cabinet, you had re-

← CHECK THESE MONEY-SAVING SURPLUS "BUYS"!

COMPLETELY CONVERTED AND READY FOR USE! 80 METER EXCITER OR 75 METER PHONE RIG

These are BC457's converted and retracked to 3-4 Megs—at a fraction of cost—and we've done all the work for you. Only the crystal frequency is different. Calibrated to 3.5 to 4 mcs. It's all complete—ready to add the power supply and easily a \$25 value! The buy of a lifetime. **READY FOR USE WITH MODULATOR.**
F.B. FOR MOBILE AND HOME STATION USE..... \$10.95
POWER SUPPLY KITS for the above transmitter. Complete, nothing else to buy. Chassis, transformer, sockets, tubes, etc. \$14.95
Power Supply already wired and tested..... add \$3.50



HERE IS AN IDEAL LOW PRICED 10 METER RECEIVER—A BC 454 3-6mc converted to cover the entire 10 meter band. All brand new, converted for you by expert lab technicians at a fraction of the cost. Complete with tuning knob. Just add the power supply and it's the hottest 10 meter receiver you've ever used. Volume control and head phone jack on front panel. **POWER SUPPLY FOR ABOVE RECEIVER.** Plugs on receiver in place of original dynamotor. Complete kit with all parts and diagrams. No wiring changes necessary..... **\$7.95**
Completely wired and tested..... add \$3.00

TRANSFORMER VALUES!

THORDARSON T21F20 FILAMENT TRANSFORMER. Primary 115 V 60 cycles, Secondary 5 V center tapped. 15 amps. 10,000 VA. **\$3.95**
STANCOR P-4086 FILAMENT TRANSFORMER. Secondary 2 volts CT 14 amps. Cased. Heavy duty. 10 KV insulation. **\$4.95**
HERMADOR J-29 FILAMENT TRANSFORMER. Secondary 5 V CT 20 amps. 10 KV insulation. Cased, heavy duty. **\$5.99**



SCOPE TRANSFORMERS

THORDARSON T17-HERCULES. 115 V, R32, Primary 115 V 60 cycles primary, V 60 cycles, Secs. 1800 V, Secondary ordinary 2300 V. **\$3.95**
V, 2 1/2 V. Shielded..... \$3.95

THERMADOR SPECIAL TRANSFORMERS

Built for Gov't lab use. All hermetically sealed with glass terminals.
 • CS5727. 900, 700 V CT at 150 MA. 3 filament windings: 6.3-5A, 6.3-5A, 5-3A. Shpg. wt. 20 lbs. **\$3.50**
 • CS9728. 800 V 650 CT at 150 ma. 3 filament windings: 6.3-4A, 6.3-1.5A, 5-2A. Shpg. wt. 14 lbs. **\$3.95**
 • CS5729. 1000 V 850 V CT at 250 MA. 3 filament windings: 6.3-4A, 6.3-4A, 5-3A. Shpg. wt. 25 lbs. **\$4.50**

• **STANCOR ISOLATION & STEP-DOWN TRANSFORMER** No. P-3063, Primary 220-250 volts, 50-60 cycle. Secondary 110-125 volts, 250-300 WATTS.
 • **THORDARSON T18V22 LINE VOLTAGE REGULATOR** 95, 105, 125 V to 15 V 60 cycle. Complete with cord and plug, 250 VA.
 • **THERMADOR CS 10535 ISOLATION TRANSFORMER** 105, 115, 125 V to 115 V cy-cycles. Complete with cord and plug, 250 VA.
YOUR CHOICE \$6.69 Ea. BRAND NEW

Weston Aircraft Meters
 1 Milliampere, zero center. FB for field strength meters, grid-dip or tuning meters; beam antenna indicators, vacuum tube volt indicator.
 catars. Brand new **\$1.95 ea.**



ARR-1 RECEIVERS

Complete with 4 RCA 954 Acorn Tubes (Reg. \$5.65 ea.), Schematic Diagrams and Conversion Information.
1000's Already Sold!
WHILE THEY LAST! POSTPAID IN U.S.
\$4.95
 Includes the Receiver, 4 tubes, schematic diagrams and a reprint of "A 220 mc Converter from the Surplus R-1/Arr-1" by Leroy W. May, Jr. (W5A JG) an article from RADIO & TV NEWS, Jan. 1947. Ideal for 50, 14, 220 mc Converters or Pre-Selectors. Also TV boosters. FB for helping up the SCR-522 Receiver on 2 meters.



ARR-5 RECEIVER
 Airborne version of VHF S-36, 27-144 MC. Easily padded into 2 meter band. Used, good condition..... **\$94.50**

TELEVISION, HAM BEAM MOTOR KITS

With instruction sheet and data
\$5.95
 Each POSTPAID IN USA



Complete less the connecting cable. Consists of motor, phasing condenser and switch.
 MOTOR ONLY, \$3.95. Postpaid. A 1947 value in '51!

MARK II AIRCRAFT COMPASS
 Orig. Gov't Cost appr. \$75
\$9.95

Ideal for planes, boats, autos. Illuminated with 12 or 24 V bulb, but can be changed to cheap 3 V auto bulb without modification. Accurate floating-in-alcohol dial reads directly from the front.

Everyone Can Afford This GRID DIP METER KIT

For home stations, TV Technicians, experimenters. Know where your equipment is in the radio spectrum. 955 OSC. Range approx. 3 to 170 meg. Also ideal for Phone or CW monitor, Harmonic indicator, absorption wavemeter, measures tuned circuits, antennas, etc. Ideal for TVI checking. Power Requirements 6.3 filament, 150 V dc. Easily obtained from your receiver, etc. Complete with Instructions on Calibrating Coils, etc.
 Compare this price! **\$7.95** Postpaid in USA



ORDER DIRECT FROM THIS AD!
 Prompt, speedy shipment. Cash with order. Minimum order \$3.00. Order deposit on C.O.D. truck. Shipments by collect, Calif. buyers please add state sales tax. All prices subject to change. All merchandise subject to prior sale.

ALVARADIO SUPPLY CO.

DEPT. A-10, 341 S. VERMONT, LOS ANGELES 5, CALIF., DUkirk 8-2211

Read RADIO & TELEVISION NEWS Every Month

EASY TO LEARN CODE

It is easy to learn or increase speed with an Instructograph Code Teacher. Affords the quickest and most practical method yet developed. For beginners or advanced students. Available tapes from beginner's alphabet to typical messages on all subjects. Speed range 5 to 40 WPM. Always ready—no QRM.



ENDORSED BY THOUSANDS!
 The Instructograph Code Teacher literally takes the place of an operator-instructor and enables anyone to learn and master code without further assistance. Thousands of successful operators have "acquired the code" with the Instructograph System. Write today for convenient rental and purchase plans.

INSTRUCTOGRAPH COMPANY

4711 SHERIDAN ROAD, CHICAGO 40, ILLINOIS

BARGAINS!

We still have plenty of them—but, we are doing so much business that we are afraid we won't have anything left to sell in a few months. Most of the material we have been advertising is still available—check with us for current prices.

WANTED!

• Right now we are more interested in buying than selling. We want to buy large or small quantities of new or used electronic components, equipment, tubes, etc., gov't or mfrs. surplus. Cash or trade for standard test equipment or electronic material of your choice.

ELECTRONIC RESEARCH LABS

1021-R Collowhill St. Phila. 23, Pa.

World Headquarters for TV ★ RADIO ★ ★ INDUSTRIAL ★ Test Equipment and Supplies

- ★ Dumont
- ★ Simpson
- ★ Sprague
- ★ Supreme
- ★ Eico
- ★ Superior
- ★ Jackson
- ★ Precision
- ★ Hickok
- ★ R.C.A.
- ★ R.C.P.
- ★ E.M.C.
- ★ Silver
- ★ Weston



Famous Simpson Model 260 Portable Tester

Black bakelite roll top safety case prevents injury or damage to meter or tester. Ranges: Volts AC and DC 0-2.5/10/50/250/1000/5000 a t 20,000 ohms/volt DC and 1000 ohms/volt AC. Output AC Volts 0-2.5/10/50/250/1000/5000. DC micro-amperes 0-100, milliamperes 0-10/100/500. DC amps 0-10. Decibels -10 to plus 52 db. Resistance 0-2000/200,000 ohms and 0-20 megohms. With test leads. Shipping weight 3 lbs. \$45.96
Same as above but less roll-top case features **\$38.17**



RCP Model 447B Multifester

1000 ohms/volt. DC volts: 0-5/50/250/500/2500. DC ma: 0-1/10/100/1000. DC amps: 0-1/10/AC volts: 0-10/100/500/1000. Ohms: 0-10M/1 meg/10 Meg ext. DB -8 to plus 55 db. Output ranges same as AC volts. Open-face hardwood case, test leads, battery. 3x5 1/2 x 3 1/2. Shpg. wt. 4 lbs. **\$15.63**
Model 447 BP in portable hardwood case. Shpg. wt. 5 lbs. \$19.55



Sensational F.M. Signal Generator

- Stable
- High Output
- Accurate
- Good Attenuation

Complete with tubes, shielded output cable line cord and plug ready to operate—attractive hamstone, grey case and panel. Size 3x8x2 3/4 inches. Weight 2 lbs. **\$14.95**

20% Deposit with Order Required, Balance C.O.D.

VARIETY ELECTRIC CO., INC.
601 BROAD ST. NEWARK 2, N. J.

ON-THE-SPOT BATTERY RECORDER

WALKIE-RECORDALL 8 lb. miniature BATTERY RECORDER-PLAYBACK

Continuous, permanent, accurate, indexed recording at only 5c per hr. Instantaneous, permanent playback. Picks up sound up to 60 ft. Records conferences, lectures, dictation, 2-way phone & sales talks; while walking, riding or flying. Records in closed briefcase with "hidden mike"! Write for details.

MILES REPRODUCER CO., INC.
812 BROADWAY Dep't RN-3 NEW YORK 3, N. Y.

BARGAIN HUNTING? RADIO SERVICEMEN!

Write for SENSATIONAL CATALOG

HENSHAW RADIO SUPPLY
3619 TROOST KANSAS CITY, MO.

placed the condenser that was shorted, but you did not replace the resistor that had had its paint blistered by this short."

"But I checked the resistance of the resistor, and it was well within ten per-cent of the rated value," Barney explained.

"That's not the idea. A resistor that has been subjected to that much of an overload is very likely to have developed structural strains that will cause it to become noisy. On top of that, a burned resistor in a set will cause the next technician who works on it to think that the charring has been done recently, and he may waste a lot of time trying to figure out why."

"I never thought of that," the red-headed youth admitted. "You know, I am beginning to wonder if I wasn't jumping the gun a little when I decided that I had about outgrown radio servicing. Maybe there are still a few tricks I can learn."

"Maybe," Mac agreed with a grin. "As some guy put it, all you need to keep you humble is *enough* egotism. If you are content to compare your mastery of servicing with that of your not-too-bright competitor down the street, it is easy to feel pretty smug about yourself; but if you are willing to stack your knowledge of radio up against all there is to know about the subject—well, you are not going to be too impressed with your own brilliance."

-30-

CIRCUIT IMPROVEMENT

By JIM KIRK, W6DEG

ADDING a noise localizer to your signal tracer, as suggested by William Tretter on page 44 of the October 1950 issue of RADIO & TELEVISION NEWS, is a bright idea.

However, a radio technician has enough on his mind, what with intermittent sets and customers, without adding one more burden. I am specifically referring to the injunction that you should "be sure and turn that switch to 'Off' when you are using the crystal probe."

I am afraid of anything that makes me think, so before I burned out my Ferris (a high-priced job) and not after—I made such an occurrence impossible. The diagram (Fig. 1) shows how one must remove the signal tracing probe to plug in the noise localizing section. You may also use the ohmmeter function together with the signal tracer or independently.

-30-

Fig. 1

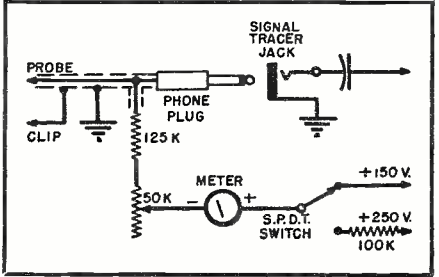

music lovers

Unless you hear recorded music recreated by a fine record playing system, you cannot enjoy the realism, the beauty, the concert hall quality inherent in modern recordings.



PICKERING Audio Components are the choice of leading audio engineers, lovers of fine music, record critics and specialists who design and build the better music systems.

PICKERING Pickups, Preamplifiers, Compensators, Arms and Speakers are available through leading jobbers and distributors everywhere; detailed literature will be sent upon request.



PICKERING & CO., Inc.
Oceanside, L. I., N. Y.
Address Department C.

ATTENTION ALL ELECTRONIC- TELEVISION ENGINEERS

For more than 6 years RADIO-ELECTRONIC ENGINEERING, a special edition of RADIO & TELEVISION NEWS, has kept alert engineers dependably and thoroughly informed on all that's really important in electronic engineering. Selected and exclusive articles and other specialized features of practical and lasting value to electronic engineers are added to the content of the regular edition of RADIO & TELEVISION NEWS.

Subscribers to the regular edition may change to the RADIO-ELECTRONIC ENGINEERING edition by remitting an extra dollar for each 6 months of the unfulfilled portion of their subscriptions. *New subscribers please use the lower half of order card in this issue. The RADIO-ELECTRONIC ENGINEERING edition is available only by subscription.*

RADIO-ELECTRONIC ENGINEERING

edition of
RADIO & TELEVISION NEWS
185 N. Wabash Ave.
Chicago 1, Ill.

RADIO & TELEVISION NEWS

Frequency Meter

(Continued from page 55)

full-wave power supply and fed into the instrument for calibration of the 1000 cycle range. A 440 cycle signal may be taken from across the loud-speaker voice coil of a radio receiver tuned to WWV standard frequency broadcasts and used to calibrate the 440 cycle points in the 500 and 1000 cycle ranges. WWV also provides a tone frequency of 600 cycles (0.6 ma. on the 1000 cycle range).

Once the calibration rheostats have been set, it is advisable to lock their shafts in position with a drop of sealing wax or service cement.

Operating the Instrument

Use of the frequency meter is straightforward. Simply switch on the power and allow the tubes to heat up. Set the range switch to its 50 kc. position. Then connect the source of unknown frequency to the "Signal Input" terminals. If the frequency is too low to produce a deflection on the 50 kc. range, switch S_2 successively to each lower range until the unknown frequency is read near the top of one of the ranges.

The frequency of a sound may be checked by means of a carbon microphone circuit connected as shown in Fig. 2. If a crystal or dynamic microphone is used, an external high-gain pre-amplifier will be required, but the transformer shown in Fig. 2 will not be necessary. The volume of the sound need not be constant, since the frequency meter reading will not change with variations in volume, as long as the voltage delivered by the secondary winding of the transformer does not drop below 1 volt. This scheme can be used to check the frequency of single-tone whistles, bells, chimes, buzzers, horns, tuning forks, pitch pipes, and the like.

CORD PLUG FOR TV SETS

WHEN the backs of many TV sets are removed, the line plug is also removed as a safety measure.

Another cord with plug is necessary to allow the technician to energize the set with the back removed.

It is worthwhile to carry the cord and plug used on most electric razors, as such a plug will often fit the TV prongs.

An electric razor cord and plug assembly can be used to energize most TV sets when the back panel is removed for servicing.

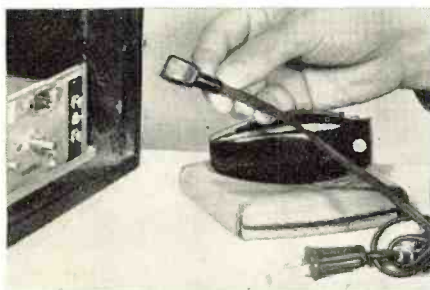

SELENIUM RECTIFIERS AND SPECIALIZED ELECTRONIC COMPONENTS

SINGLE PHASE Full Wave Bridge

Input: 0-18 VAC		Output: 0-12 VDC	
Type No.	Current	Price	
B1-250	250 Ma.	\$.98	
B1-1	1.0 Amp.	2.99	
B1-1X5	1.5 Amp.	2.95	
B1-3X5	3.5 Amp.	4.50	
B1-5	5.0 Amp.	5.95	
B1-10	10.0 Amp.	9.95	
B1-20	20.0 Amp.	15.95	
B1-30	30.0 Amp.	24.95	
B1-40	40.0 Amp.	27.95	
B1-50	50.0 Amp.	32.95	

Input: 0-36 VAC		Output: 0-26 VDC	
Type No.	Current	Price	
B2-150	150 Ma.	\$.98	
B2-250	250 Ma.	1.25	
B2-300	300 Ma.	1.50	
B2-2	2.0 Amp.	4.95	
B2-3X5	3.5 Amp.	6.95	
B2-5	5.0 Amp.	9.95	
B2-10	10.0 Amp.	15.95	
B2-20	20.0 Amp.	27.95	
B2-30	30.0 Amp.	36.95	
B2-40	40.0 Amp.	44.95	

Input: 0-115 VAC		Output: 0-90 VDC	
Type No.	Current	Price	
B6-250	250 Ma.	\$ 2.95	
B6-600	600 Ma.	5.95	
B6-750	750 Ma.	6.95	
B6-1X5	1.5 Amp.	10.95	
B6-3X5	3.5 Amp.	18.95	
B6-5	5.0 Amp.	24.95	
B6-10	10.0 Amp.	36.95	
B6-15	15.0 Amp.	44.95	

Full Wave Center Tap

Input: 10-0-10 VAC		Output: 0-8 VDC	
Type No.	Current	Price	
C1-10	10.0 Amp.	\$ 6.95	
C1-20	20.0 Amp.	10.95	
C1-30	30.0 Amp.	14.95	
C1-40	40.0 Amp.	17.95	
C1-50	50.0 Amp.	20.95	

THREE PHASE Full Wave Bridge

Input: 0-234 VAC		Output: 0-250 VDC	
Type No.	Current	Price	
3B13-1	1.0 Amp.	\$22.00	
3B13-2	2.0 Amp.	32.00	
3B13-4	4.0 Amp.	56.00	
3B13-6	6.0 Amp.	81.50	
3B13-10	10.0 Amp.	105.00	
3B13-15	15.0 Amp.	120.00	

RECTIFIER MOUNTING BRACKETS

For Types B1 through B6, and Type C1, \$.35 per set
For Types 3B 1.05 per set



POWERSTATS

Smooth, efficient voltage control 0 to 135V. output from 115V. AC line.
Type 20 3 Amps. \$12.50
Type 116U (illustrated) for panel mfg. 7.5. amps. \$18.00
Type 1126 15 Amps. ... 46.00
Type 1136 45 Amps. ... 118.00

Also available for 230 volt input. Write for descriptive literature

POWER SUPPLIES



GENERAL PURPOSE low voltage DC power supplies, with variable outputs. Rugged—Dependable—Precision Control.

- ✓ Long life FULL WAVE SELENIUM RECTIFIERS
- ✓ Output voltage continuously adjustable from zero to maximum
- ✓ 3" Voltmeter and Ammeter—2% accuracy
- ✓ Stepless control
- ✓ Instant Power—no warm-up period
- ✓ Dimensions: 8 3/4" x 10 1/2" x 3 1/2"
- ✓ Assembled and Ready to Operate
- ✓ For 115 VAC 60 cycles

Model	Write for descriptive bulletin	Current	Price
GPA810	0-8 VDC	10 Amps.	\$69.50
GPA1210	0-12 VDC	10 Amps.	75.00
GPA2810	0-28 VDC	10 Amps.	85.00

RECTIFIER CAPACITORS

Type	Capacity	Voltage	Price
CF-1	1000 MFD	15 VDC	\$.98
CF-2	2000 MFD	15 VDC	1.69
CF-20	2500 MFD	15 VDC	1.95
CF-6	4000 MFD	30 VDC	3.25
CF-19	500 MFD	50 VDC	1.95
CF-16	2000 MFD	50 VDC	3.25
CF-21	1200 MFD	90 VDC	3.25
CF-9	200 MFD	150 VDC	1.69
CF-10	500 MFD	200 VDC	3.25

Mounting clamps for above capacitors 15c ea.

RECTIFIER TRANSFORMERS

Type No.	Volts	Amps.	Shpg. wt.	Price
XF19-12	15	12	7 lbs.	\$ 3.95
TXF36-2	36	2	6 lbs.	4.95
TXF36-5	36	5	8 lbs.	6.50
TXF36-10	36	10	12 lbs.	9.95
TXF36-15	36	15	20 lbs.	11.95
TXF36-20	36	20	25 lbs.	17.95
XFC18-14	18 VCT	14	10 lbs.	6.95

All TXF Types are Tapped to Deliver 32, 34, 36 Volts. XFC Type is Tapped to Deliver 16, 17, 18 Volts Center-tapped.

RECTIFIER CHOKES

Type No.	Hy.	Amps.	DC Res.	Price
HYX6	.055	600MA.	2.0	\$ 1.50
HY5A	.028	5	.20	5.25
HY10A	.014	10	.04	9.95
HY20A	.007	20	.02	13.95

ATTENTION MANUFACTURERS

We are in a position to furnish Selenium Rectifiers, in quantity, to specifications. Excellent delivery, prompt quotations.

All prices FOR our N. Y. C. warehouse. Send M.O. or check. ONLY shipping charges sent COD. Rated concerns send P.O., Terms Net 10 days.

OPAD-GREEN COMPANY

71-3 WARREN ST., NEW YORK 7, N. Y. PHONE: BEekman 3-7385-6

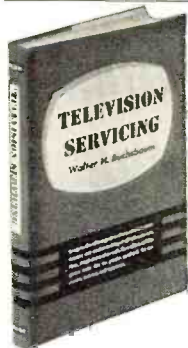

Published by Prentice-Hall, Inc.

HOT off the press!

Easy to understand, practical, up-to-date "Know How" on TELEVISION SERVICING. No Knowledge of Higher Mathematics Needed! Covers the newest designs and servicing techniques. Chock full of illustrations, diagrams and schematics. Very latest circuit data.

If you are interested in television

servicing YOU NEED THIS BOOK. All your questions answered by Walter H. Buchsbaum, author of many TV articles.

NO RISK. Send for your postpaid copy today. If not satisfied, return within 10 days and your money refunded. Free descriptive folder giving full details available.

CENTRAL ELECTRONICS CO., P.O. Box 55, Rego Park, N. Y.

Enclosed find \$5.35 for my TV SERVICING, postpaid

Send descriptive folder

NAME _____
ADDRESS _____
CITY _____ ZONE _____ STATE _____

MAIL COUPON TODAY 10 DAY MONEY-BACK GUARANTEE

POWER SUPPLY KITS

- 700 VCT @ 110 V 60 Cy Input
- 2 chokes, 7HY 125MA, 5V 3A, 6.3V 3A trans,
- 8S8 MFD, 600 VDC.....\$6.50
- 700 VCT @ 125MA 2.5V 10A, 5V 3A trans,
- 1 FH Trans 6.3V 4A, 6.3V 4A, 2 chokes
- 7 HY 125MA, 1 Dual Oil Capacitor 8X8 MFD
- 600 VDC.....\$8.50

- WESTERN ELECTRIC 104A Two Tone Signaling Selector** for mobile use. Unit contains 600 CY & 1500 CY Filter Units, Relays, etc. Used, Excellent Condition.....\$49.50
- Superior Powerstat Model 116U..... 18.00
- 6 HY 70 MA WOKS, 2 for..... 1.98
- 12 HY 160 MA CHOKES \$1.25 ea., 2 for..... 1.98
- SOLA Constant Volt Trans 115 V 50 CY, OIL, 115 V 250VA..... 39.50
- ART/13 Mod. Trans PP 811 to 813..... 9.95
- ART/13 Audio Driver Transformer..... .99
- Beachmaster Output Transformer 250W..... 9.95
- Wagge Tube Heaters, 110 V 100 W, 2 5/16" Inside Diameter, 2 for..... 3.90
- IRC 50K 10W fixed, 2.5K 100W ADJ. P..... 1.25
- Counter Type Instrument Dial, 3"x3", 1/4" to 1/4" Shaft, 3 Digit Counter..... 1.95
- 8S8 Dual MFD 600 V Oil Cap..... 1.95
- 1MF 600 V Metal Cased Oil Tub. Cap. 10/Aerovox Type 484 .5MF 400 V Tube Cap.10/..... 2.50
- Four Quadrant Phasing Capacitor..... 3.50
- C-H Luminous Tip Bulb Handle Aircraft..... 5.95
- SW., SPDT, 5A 125 V 10 for..... 1.98
- 5 Way Binding Post, Red or Black.....ea. 1.40
- 100KC Precision Crystal..... 5.95
- 100KC xtal \$3.95; 5 Mc xtal..... 3.50
- APN-1 Allimeter Transceiver, New..... 27.50
- R89/ARN5 Receiver, New..... 32.50
- BC221 Freq. Meters, excellent cond. 79.50

METER SPECIALS

- RD 3 1/2" O-20 ua (O-100 Scale) WH \$14.50
- SO 3 1/2" O-200 ua DC..... 6.50
- SO 3 1/2" O-1 MA..... 3.95
- SO 2 3/4" O-9 VDC..... .79
- SO 2 3/4" O-100 AMP DC with shunt..... .99

3" METERS

- O-50 ua.....\$14.50
- 100-0-100 ua..... 8.95
- O-500 ua GE..... 9.95
- O-1 MA Scale..... 3.95
- O-1 MA DC..... 5.95
- O-5 MA SP Scale..... 4.50
- O-15 MA DC GE..... 4.50
- O-20 MA DC WH..... 4.50
- O-20 MA DC GE..... 4.50
- O-50 MA DC WH..... 4.50
- O-80 MA DC WE..... 4.50
- O-100 MA DC..... 4.50
- O-150 MA DC WH..... 4.50
- O-200 MA DC GE..... 4.50
- O-300 MA DC..... 4.50
- O-500 MA DC..... 4.95
- O-1 AMP DC WH..... 4.95
- O-2 Amp DC Simp..... 5.95
- O-300 VDC..... 7.95
- O-750 VDC..... 7.95
- O-8 VAC WES 476..... 4.50
- O-15 VAC GE..... 4.50
- 10-45 DB WES..... 3.01
- O-150 VAC..... 5.95
- 30-0-30 AMP DC..... 5.95
- O-50 AMP AC WH..... 55.95
- O-75 AMP AC Trip..... 5.95
- JBT 31 MF..... 7.95

2" METERS

- O-500 ua SP Scales \$3.95
- O-1-2 MA 306..... 3.45
- O-5 MA SP Scale..... 2.49
- O-30 VDC, 120 A and shunt..... 4.95
- O-30 MA SP Scale..... 2.49
- O-50 MA..... 2.49
- O-25 MA SP Scale..... 2.49
- O-300 MA DC..... 3.50
- O-30 VDC..... 3.50
- O-30 VDC..... 3.50
- O-10 VAC GE..... 4.95
- O-300 VAC..... 4.95
- O-2 AMP RF SO..... 3.50
- O-4 AMP RF GE..... 3.50
- O-9 AMP RF WH..... 3.50

CO-AXIAL RELAYS

- Allied Control Type RA, SPDT, 6 VDC, Uses Standard Co-Ax Connectors..... \$3.95 ea.; 10 for \$35.00
- Above Relay for 24 VDC..... \$6.50 ea.; 10 for 60.00
- Set of 83-1SP Co-Ax Connectors for above..... .99
- Cramer Time Delay Relay, 120 Sec 120 VAC..... \$9.95
- Pat-Brom. Time Relay, 6 VAC, DPST..... 1.95
- 24 VDC Relays, 5 for..... .99

CHOKES

- 200 HY 6MA 620 OHM, Cased.....\$ 0.99
- 8 HY 50 MA..... .89
- 10 HY 80 MA 240 OHM..... .89
- 7 HY 125 MA, Cased..... \$1.10 ea.; 2/..... 2.00
- 10 HY 150 MA 140 OHM..... 3.49
- 7 HY 200MA 100 OHM, Cased..... 3.49
- 4-16 HY 200 MA 140 OHM Swinging CH..... 4.25
- 3 HY 250 MA 60 OHM, Herm Seal..... 1.25
- 15 HY 250 MA 60 OHM, Cased..... 3.49
- 3-14 HY 300 MA 80 OHM Swinging CH..... 6.20
- 6 HY 300 MA 80 OHM, Cased..... 4.95
- 8 HY 300 MA 80 OHM, Cased..... 6.90
- 6 HY 350 MA 72 OHM, Cased..... 5.50
- 4 HY 400 MA 80 OHM, Cased..... 5.95
- 6 HY 450 MA 80 OHM, Cased..... 6.50
- 7 HY 750 MA 40 OHM, Cased..... 11.50

115V FILAMENT TRANSFORMERS 60 CY

- 2.5 VCT 10 A, 10KV Insulation..... \$3.95
- 2.5 V @ 6 Amp, 2.5 V @ 6 Amp..... 3.45
- 5 VCT 3A, 2.5 KV Insulation..... 2.35
- 3 V 20 A, 2.5 KV Insulation..... 6.25
- 6.3 V 1.2 A..... .85
- 6.3 V 3 Amps..... 2.14
- 6.3 V 1.2 Amps..... 3.95
- 6.3 V 4 Amps..... 3.95
- 6.3 V 3.5 A, 2 x 2.5 V 3 Amps ea..... 3.95
- 6.3 V 3A, 2 V 6 AMP Herm Seal..... 3.49
- 6.3 V 3 Amps..... 5.55
- 10 VCT 10 A, 2.5 KV Insulation..... 5.55
- 6.3 V 12A, 6.3 V 2 A Herm Seal..... 4.50

115 V POWER TRANSFORMERS 60 CY

- 435 VCT 145 MA, 6.3 V 3A, 5V 3A..... \$ 2.49
- 700 VCT 90 MA, 6.3V 4A, 5V 3A..... 3.50
- 700 VCT 150 MA, 5V 3A..... 2.95
- 610 VCT 160 MA, 6.3V 3A, 5V 3A..... 4.50
- 800 VCT 200 MA, 6.3V 4A, 5V 3A..... 6.50
- 800 VCT 300 MA, 6.3V 10.5A, 5V 6A, 5V 2A..... 8.95
- 750-600-0-600-750 225 MA..... 8.95
- 3200 VCT 450 MA..... 24.50
- 115 V, 230 V TAP, PRI.....850 VCT 280 MA -36V 7A-6.3V 3A-5V 3A, Cased..... 12.50

OIL CAPACITORS

- 7 MF 330 VAC.....\$0.95
- .5 MF 600 VDC..... .45
- 2 MF 600 VDC..... .79
- 4 MF 600 VDC..... .90
- 6 MF 600 VDC..... 1.05
- 10 MF 600 VDC..... 2.49
- 2 MF 1000 VDC..... .99
- 5 MF 1000 VDC..... 1.95
- 10 MF 1KV DC..... 3.25
- 15 MF 1KV DC..... 3.95
- 2 MF 1.5 KV DC..... 1.75
- 4 MF 1.5 KV DC..... 2.75
- 6 MF 1.5 KV DC..... 2.95
- 1 MF 2000 VDC..... 1.79
- .25 MF 2000 VDC..... 1.95
- 1 MF 2000 VDC..... 2.10
- 2 MF 2000 VDC..... 2.75
- 4 MF 2000 VDC..... 4.50
- 8 MF 2000 VDC..... 5.95
- .5 MF 2500 VDC..... 1.39
- 1 MF 3000 VDC..... 2.25
- .5 MF 3000 VDC..... 1.49
- 4 MF 3000 VDC..... 8.95
- 4 MF 4000 VDC..... 3.95
- 1 MF 5000 VDC..... 5.50
- 2 MF 5000 VDC..... 8.95
- 4 MF 5000 VDC..... 11.50
- 1 MF 7500 VDC..... 1.25

TERMS: 25% Deposit with order, balance C.O.D. Rated firms open account

POLY-TECH
919 Dawson St., New York 59, N. Y.
Tel. Murray Hill 6-2650

RADIO-TV Service Industry News

TROUBLE • CONFUSION • FAILURES

AS REPORTED BY THE

TELEVISION TECHNICIANS LECTURE BUREAU

Trouble Brews for Independents

THE extent of the public's interest and concern in any problem affecting a large segment of the population is always reflected in the amount of space devoted to it by magazines with general national circulation and by the daily newspapers. And when newspapers get their teeth into a subject and a wide variety of reporters and columnists start to interpret a business as heterogeneous as that of television servicing they brew the ingredients for a violent explosion of public resentment that can hurt every honest man engaged in that business.

In a recent issue of "Pageant" magazine the lead article, "Beware the TV Gyms," detailed a number of case histories of the racketeering being practiced by some unscrupulous set dealers and so-called service operators. Of particular interest and significance in this article is the author's statement emphasized in italics that, "The BBB's (Better Business Bureaus) in most of these cities (referring to the cities where the author made a personal investigation) re-

ported a larger volume of public howls about television receivers and service than for any single item of merchandise in their history."

Undoubtedly many other magazines with national newsstand circulation will pick up the ball on this subject and there will be a plethora of articles exposing the faults and failures of television retailing, installation, and maintenance activities. While all of the writers take great pains to point out that the majority of TV set buyers are fairly and honestly treated by the dealers and service operators with whom they deal, a flood of articles of this nature will incline the average reader to look with suspicion on every organization and technician engaged in independent television servicing unless the ethical operators find an effective publicity voice to proclaim what they are doing to obliterate the sharpshooters and the incompetents. Honest-dealing service operators cannot safely take the attitude "Let's you and him fight," and stand on the sidelines while the magazines, newspapers, and BBB's wage the campaigns to clean up

A capacity crowd turned out in York, Pa. to hear the lecture on color television presented by the Television Technicians Lecture Bureau. Similar groups in Harrisburg, Lancaster, Reading, and Philadelphia evidenced their interest in the subject by appearing in force to hear Edward M. Noll lecture on this vital topic.



the TV retailing and servicing activities. It is in their best interests to get together and help.

As reported in this department last month, the Better Business Bureau of New York City recently launched a campaign to inform the public about how they can protect themselves against sharp-dealing and dishonest retailers and service operators. More recently in the Philadelphia area "The Bulletin" (the evening newspaper which, they say, almost everyone reads) launched a news campaign to alert their readers to the dishonest practices that are being employed by some television dealers and service technicians in Philadelphia with the idea of weeding out chiselers and racketeers with the help of an informed public.

Based on figures supplied by the Philadelphia Better Business Bureau "The Bulletin's" initial article pointed out that more than one thousand complaints had been received by the BBB so far and that this organization could not adequately cope with the situation with its present staff. While this record of complaints in Philadelphia is far below that of most other major cities, it is significant that concerted action is being taken to correct it.

It was noted that the Better Business Bureau had consulted with representatives of the Philadelphia Radio Servicemen's Association (PRSMA) and the Television Contractors Association (TCA) both of which were lending every possible assistance in the campaign to drive out the incompetent and the unscrupulous service operators in the Philadelphia area.

Quoting Paul V. Forte, executive secretary of TCA, the news account states that, "TCA welcomes a complete airing of this disgraceful situation.

"Such an inquiry will help the ethical and reputable men and firms in the field and will aid the public by teaching them to distinguish between legitimate individuals and concerns and the racketeers who have drifted into the business.

"Some retailers sell sets at cost and depend upon a 'kickback' for their profit from the service contractor with whom they place the policy. If the service contractor has to turn back part of the money to the retailer it is impossible for him to set aside any reserve funds to take care of the service over the life of the contract.

"Should he find himself in a position where he has to make any considerable outlay, he winds up with his back against the wall and can only go out of business. Then the users who paid their money for policies with him also become victims."

Along with the well-written, ably documented articles and news stories that are popping up in publications across the country, there are other writers who are putting out just plain drivel on the subject of TV servicing. Typical of these is the following excerpt from one columnist's "brilliant" coverage of current service conditions:

February, 1951

SEE LEO FIRST . . .

for hallicrafters!

HALLICRAFTERS SX-71 RECEIVER



Double Conversion sharp selectivity, plus built-in NBFM at moderate cost. 11 tubes plus voltage regulator and rectifier.

\$199.50

Low Down Payment
Hallicrafter S-38B Receiver \$49.50

HALLICRAFTERS S-77 RECEIVER

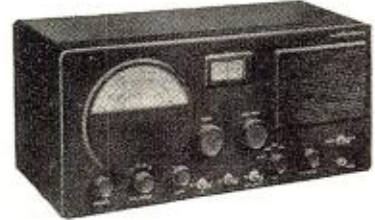

Improved AC-DC version of the famous S-40 B. One r-f, two i-f stages. Temperature compensated. Series type noise limiter. Micro-set iron core i-f coils. Separate electrical bandspread. Improved cabinet construction. Built-in PM speaker. 7 tubes plus rectifier.

Only **\$99.95**

Low Down Payment



WRITE FOR DETAILED SPECIFICATION EQUIPMENT SHEETS



RADIO REFERENCE MAP
CU ON 10-20 & 75 METERS
Just right for your control room walls. Approximately 25" x 36". Contains time zones, amateur zones, monitoring stations. Mail coupon today and... **25c**

FREE

Send for the 1951 complete WRL Catalog containing everything new in radio and television. Deal with the "World's Most Personalized Radio Supply House."



PHONE 7795

WRITE—WIRE



WORLD RADIO LABORATORIES
744 West Broadway
Council Bluffs, Iowa

R-2

Please send me:

- Radio Map SX-71 Info
 New Catalog S-77 Info
 List of Guaranteed Used Equipment

Name

Address

City State

POWER!

Your ad in the Classified Section of RADIO & TELEVISION NEWS is read by the largest audience in the field—monthly circulation—over 200,000.

RECEIVERS SUP HET 2 RF 4 IF'S 15 TUBES 19½ MC IF COILS CONVERTS TO 2-5-10 MTR'S & 420 band now tunes 195-210 MC

115 VAC 60 cycle 15 tube 2 RF & 4 IF stages on one chassis 25"x11"x8" in a metal case with the following tubes and main parts PWB, trans. Thor. 70R02 chokes 4 Thor. 13C50 filter cond. 4 Aerovox S-8 oil filled, IF & IF coils and tubes shielded. 2 plate tuning cond. has following tubes: 1-953, 5-954, 4-6SK7, one for each stage IF 2-6S47, 2-6N7, 1-5T4 Rect. This is a super Het circuit, each unit cost the Govt. \$292.95; orig. tunes 195 to 210 megs. we have converted one to 2 meters & plenty hot, orig. print with ea. unit, we furnish you with a print of our changes for 2 meters, all minor changes. Condensers are mica or silver mica. Tubes, except the accorns, are metal. Check Feb. issue CQ 1946 for hot 10 meter write-up. This Hot 10 Meter Write-up with Print is Available free with ea. unit. The 115 VAC pwr. unit has four section filter capacitors and chokes in place of the usual one; this cannot be beat. These are a new lot just received, a large quantity of both the 40B and 406A, the only difference in the 40B and the 406A is there is a 115 VAC motor .65 RPM forward and reversible used for variable freq. control, this motor can be used for a geared beam, plenty of torque. 75 ounce inch units are later model with the same circuit and all like new. Send your order in early; send check or money order for the receiver but do not send the shipping charges; we will ship the units F.O.B. by freight; this is the greatest \$ value on the surplus market; sold on a money-back guarantee. Each unit with orig. print; we furnish conversion instructions and print for 2 meters and 10 meters free.

MFG. W.E. COST GOV'T. \$292 BC406 \$14.95 BC406A \$17.95

McCONNELL'S 3834 Germantown Ave., PHILA., Penna. RA 5-6033 WITH ALL TUBES

QUAM Adjust-A-Cone SPEAKERS



LOOK FOR the U-Shaped COIL POT

**FIRST IN REPLACEMENT FIELD
FIRST FOR ORIGINAL EQUIPMENT**

You can always tell a Quam Adjust-A-Cone Speaker by the U-Shaped Coil Pot—and its superior performance!

This exclusive coil pot design provides an unbroken path for the magnetic lines of force, producing a stronger magnetic field, increasing efficiency and improving performance.

It's another one of the superior features that service-men consider when they

REPLACE WITH QUAM

WRITE FOR CATALOG of complete QUAM line
Also Makers of Quam Focalizer Units and ION Traps

QUAM-NICHOLS COMPANY

522 E. 33rd Place, Chicago 16, Illinois

MAKERS OF QUALITY SPEAKERS FOR 27 YEARS, UNDER THE SAME MANAGEMENT

Advance with ELECTRONICS CITY

You need firm grasp of fundamentals to keep pace with these complex, fast-growing fields. In thorough 2-year course learn electricity, electronics, physics, mathematics, drafting, etc. Employers want Franklin graduates. Coed. G.I. approved. Day, evening, 43rd year. Write for Catalog.

FRANKLIN TECHNICAL INSTITUTE
46 Berkeley Street Boston 16, Mass.

SCHEMATICS—CONVERSIONS FOR SURPLUS GEAR

NEW LIST! MANY ADDITIONS!

Send stamped, self addressed envelope for List B. Add 25c for chart explaining AN nomenclature.

R. E. GOODHEART 345 1/2 N. PALM DRIVE BEVERLY HILLS, CALIF.



T. L. Clarkson of Harrisburg, vice-chairman of the Federation of Radio Service Associations of Pennsylvania; Fred J. Schmidt of Steelton, treasurer of the Mid-State Radio Service Association; and Fred W. Brown, member of the board of directors of the Harrisburg association, get a first hand explanation of one of the circuits covered by Ed Noll in his color television lecture. The meeting where Mr. Noll spoke was sponsored by Mid-State group of Harrisburg.

"So if your television set goes on the fritz, just be pleasantly surprised if you get it fixed promptly and don't get a bill that makes you count to 10 before starting to ask questions.

"Remember, too, it could be worse. A number of sets have a 'nerve center' in which the wires have to be just so long down to a zillionth of an inch. If that goes haywire, according to servicemen, it's about \$5 cheaper to buy a new set than to fix the old one.

"Buck up! Maybe a pair of pliers and a screwdriver, plus a repairman's know how, can have your set perking again in jig time."

Radio service and television contract organizations in a few of the large cities are playing a vital role in unified campaigns to place independent television servicing on a sound, substantial basis as an honorable business activity. Unfortunately, there are far too few of these organizations in existence. If the existence of strong, local service organizations was the rule rather than the exception—as it is now—this entire problem could eventually be successfully whipped on a national scale.

However, local organizations can be influential and effective only on the limited scale of the trade area in which they are located. In the areas where there is no co-ordinated thinking among ethical service operators they may discover that some of this extensive news coverage of TV service failings may result in abortive city ordinances and licensing arrangements before they can develop an organization to protect their interests.

Major Contractors Fail

The legitimate service operators are plastered with their worst black eyes when honestly conducted but poorly managed service organizations go broke and leave thousands of service contract owners to make out as best they can for service on their sets. The failure of the *Prudential TV Service Company* operating in New York and New Jersey is a case in point.

The complete history of the *Prudential* story was ably reported in "Retail-

TRIPLE POLE DOUBLE THROW KNIFE SWITCH

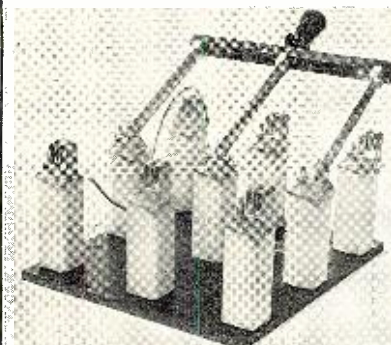

Mounted on 7"x8"x1/4" bakelite. Steatite insulators. Heavy duty copper blades with double contact copper spring receptacle to match. Mfg. Square D Co. as Signal Corps Antenna Switch, SW-225. Brand new in original packing. Shipping wt. approx. 3 1/2 lbs.

Original cost—more than \$10.00.
NET PRICE—\$1.75 EA.
4 for \$6.25
DAVID GROSSMAN CO.
3510 Devonshire Dr. Baltimore 15, Md.

TELEVISION

PREPARE FOR A GOOD JOB!
BROADCAST ENGINEER
COMMERCIAL OPERATOR (CODE)
RADIO SERVICEMAN

Television Servicing

(Approved for Veterans)
SEND FOR FREE LITERATURE
BALTIMORE TECHNICAL INSTITUTE
1425 EUTAW PLACE, BALT. 17, MD.

AD-VANTAGE

Take advantage of the world's biggest Classified Ad opportunity—Your ad in RADIO & TELEVISION NEWS Classified Section will get more action—more inquiries—quicker, and at less cost than in any other magazine. Monthly net paid circulation over 200,000.

PEN-OSCIL-LITE

Extremely convenient test oscillator for all radio servicing; alignment • Small as a pen • Self powered • Range from 700 cycles audio to over 600 megacycles u.h.f. • Output from zero to 125 v. • Low in cost • Used by Signal Corps • Write for information.

GENERAL TEST EQUIPMENT
38 Argyle Buffalo 22, N. Y.

ing Daily," a publication that has been doing a commendable reporting job on the day-to-day activities of the television servicing industry.

Prudential suspended operations because they were unable to meet their payroll, said to be more than twenty thousand dollars per month. "Retailing Daily" reported the following four reasons as the basic causes for the company's failure:

1. Failure of dealers to escrow service contract monies. Prudential accepted contract commitments by telephone from dealers who, in turn, were required to mail the contract fees to the bank which acted as the escrow agent.

2. Receivers badly made, poorly inspected, and shipped with parts missing. This required service time that was not contemplated in the annual maintenance contract price.

3. Dealer "kickbacks." A portion of the service contract fee given to the dealer.

4. Inability of service technicians working in the greater New York City area to park at or even near customer's home. This cut the daily average of field service calls below the break-even point.

While it is claimed that ninety percent of Prudential service contract owners are protected because of the company's escrow arrangement on contract service monies, the transfer of service accounts from a defunct company to another is never accomplished without a great deal of customer disappointment and dissatisfaction.

But while the Prudential service customer will get some sort of a continuation of service on their contracts, this is not true with failures like that of Supreme Television Service Company, Inc., of Philadelphia, which failed with thousands of contracts on their books. This company offered to settle with their creditors on the basis of ten cents on the dollar so it is obvious that thousands of set owners were left holding the bag for the balance of the service due on their contracts.

Several service organizations are studying plans for creating an insurance "pool" that would provide the means for fulfilling any member's service commitments in the event his business failed. Such a plan would solidly cement the relations of the organization's membership and it would provide the service contract customer with added assurance of uninterrupted service from any of the member organizations.

On the other hand, members of the Television Installation Service Association of Chicago pledge themselves to abide by a very strict Code of Ethics which, if followed to the letter, will almost insure that every member's business will prosper.

TISA Code of Ethics

As a member of TISA, we recognize our responsibility to the set purchaser for whom we are doing television installation and/or maintenance and to

February, 1951

Get Speedy Service & Top Values at



ACORN

30-TUBE 630 TV CHASSIS
TAKES ALL PICTURE TUBES FROM

16" to 20"

ROUND OR RECTANGULAR

- Licensed by RCA
- Can be Readily Adapted for Color

This remarkable chassis incorporates ALL THE SUPERIOR FEATURES and ENGINEERING ADVANCEMENTS that have been made to date! Designed to bring in sharp, clear pictures, even in fringe areas. This unexcelled unit features keyed AGC—complete noise immunity; FM traps; 15 KV under normal picture load; full four megacycle overall picture band width.

Factory aligned, ready-to-play, less CR tube

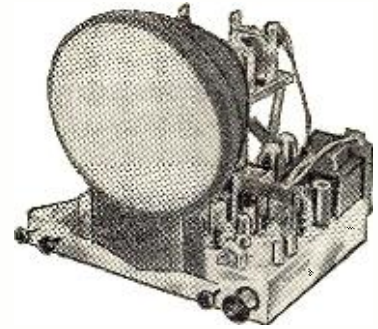

\$169⁵⁰* Complete with
12" RCA
SPEAKER

AVAILABLE WITH **DUMONT IMPUTUNER** covering FM BANDS **\$179⁵⁰**** PRICES INCLUDE ALL EXCISE TAXES

DUMONT 4-CIRCUIT INPUTUNER

Series T-3A

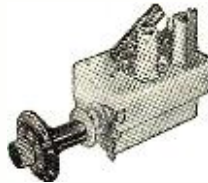

Featuring FM BAND reception, as well as 13 TV channels. Fits into dual channel IF system, Type 630 receivers, without alterations. Higher gain 2-to-1 ratio on high channels, low noise, input impedance 300 ohms. 21.25 mc sound center IF. Continuous tuning. Complete with TUBES and KNOBS. **\$29⁹⁵**

DYNAMOTORS

PIONEER GEN-E-MOTOR

Type E-3: Input 14 VDC @ 8 amps DC.
Output 550 V @ 120 mils. **\$14.95**

SP-125: Input 28 VDC @ 2.2 amps DC.
Output 270 V @ 120 mils. **\$ 6.95**

DS-125: Input 28 VDC @ 1.2 amps DC.
Output 260 V @ 60 mils. **\$ 4.95**

CARTER GENEMOTOR

Stock No. 4037AS

DC input 6VDC; output 400 V @ 375 mils DC. Perfect for mobile communications in car, plane or boat.
BRAND NEW
—List \$68. **\$24⁹⁵**
OUR PRICE.

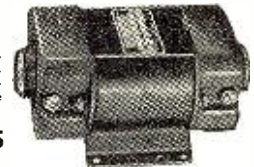

Phone WOrth 4-3270

ACORN ELECTRONICS CORP.

76 Vesey St. Dept. N-2 New York 7, N. Y.

TERMS: 20% cash with order, balance C.O.D. All prices F.O.B. our warehouse in N. Y. C. Minimum order \$5. NOTE: Due to conditions beyond our control, prices are subject to change.



HENRY HAS THE NEW hallicrafters MODEL SX-71 NOW!



This new type of receiver—the first of its kind on the market—has extra sensitivity, selectivity, and definitely superior image rejection. Continuous AM reception from 538 kc to 35 Mc, and 46 to 56 Mc. One RF, 2 conversion, and 3 IF stages. 105-125 volts AC. 11 tubes plus voltage regulator and rectifier. Only \$199.50. (R-46 matching speaker only \$19.95)



LOW-COST HALLICRAFTERS MODEL SR-75

A completely new transceiver. Receives on 540 kc through 32 Mc, transmits on 10, 11, 20, 40 or 80 meter bands. 10 watts input to final amp. Receiving section substantially same as S-38B. Transmitting section uses electron coupled Xtal oscillator plus output tube of receiver. Xmt controls on rear: tuning, coupling adj., doubler coil switch (10 meters) and adjustment, power switch with interlock, phone tip jacks, socket for tuning meter or tuning, bulb and for key. Size 12 3/4" wide, 7" high, 7 3/4" deep. For 115 volts, 50/60 cycle AC. Shipped with coils less crystals, \$79.95.

I have a complete stock of Hallicrafters receivers and transmitters. I'll make you the best deal on a trade-in for your communications receiver. I give you prompt delivery, and 90-day FREE service. Nobody can beat Bob Henry on a trade-in, and I offer you the world's lowest credit terms. Write, wire, phone, or visit either store today for the best deal. Export orders solicited.

Bob Henry
WPARA

Buffalo 2, Missouri

HENRY RADIO STORES

11240 Olympic Blvd
LOS ANGELES 25
CALIF.

"WORLD'S LARGEST DISTRIBUTORS OF SHORT WAVE RECEIVERS"

CUT ACCURATE HOLES IN RADIO CHASSIS

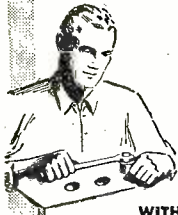

WITH A GREENLEE
RADIO CHASSIS PUNCH

● Make smooth, true holes quickly this easy way. Just turn GREENLEE punch with an ordinary wrench and have an accurately-sized opening for plugs, sockets, and other receptacles. No reaming or filing. A GREENLEE Punch for each of these sizes: 1/2"; 5/8"; 3/4"; 7/8"; 1"; 1 1/16"; 1 1/8"; 1 1/16"; 1 3/16"; 1 1/4"; 1 3/8"; 1 1/2"; 2 1/4". Also GREENLEE Knockout Punches and Cutters for conduit and meter holes up to 3 1/2". Get facts now. Write Greenlee Tool Co., 1882 Columbia Avenue, Rockford, Illinois.



NOW! SPEED UP ALL SOLDERING WITH UNGAR FEATHER-LIGHT SOLDERING PENCILS WITH HI-HEAT TIPS

INCREASED WATTAGE

TIPS



For use with No. 776
Handle & Cord Set

Stop wrestling with big irons. New HI-HEAT TIPS in your Ungar Electric Soldering Pencil produce a really versatile tool that'll perform on a par with the big, bulky 100-150 watt irons. If you can't get immediate delivery, please be patient; for production hasn't yet caught up with demand. Ask your supplier for No. 1236 Pyramid or No. 1239 Chisel. List price, \$1.25 each.

Ungar
ELECTRIC TOOL CO., Inc.
LOS ANGELES 54, CALIFORNIA

the rest of the industry and other television service contractors. We further realize that any act on our part is a reflection upon every other member of this profession. We must, therefore, conduct our business in such fashion as to render honest services at honest rates.

In recognition of the above requirements, we pledge ourselves to abide by the following code of ethics. We fully agree that violation of any part of this code of ethics or any additions to this code which may be authorized from time to time through established means, will be just cause for expulsion of this company from TISA. We further agree that upon expulsion or termination of our membership through other means that we will immediately cease to use any TISA emblem or device. Further, we agree to hold TISA blameless for notification to other members of the industry of expulsion or termination of membership.

WE AGREE TO:

1. Employ qualified personnel to assure proper service. Each employee will be examined and graded by a TISA approved independent examiner. Test based upon industry approved questionnaire.
2. Present to TISA a certified copy of a CPA's report on proper arrangements for the protection of reserve funds on contracts. Supply the association with bond to assure fulfillment of all contractual obligations.
3. Present to TISA a certificate of insurance showing adequate insurance coverage.
4. Employ approved methods of doing installations and maintenance.
5. Issue a standard guarantee.
6. Have available sufficient and proper test equipment to assure a good job.
7. Maintain an adequate service data library.
8. Render service no later than 48 hours.
9. Be honest, courteous and treat each client in a professional manner.
10. Adhere to TISA approved service rates. We recognize that these rates were adopted after an exhaustive study of service requirements. We further recognize that lower rates would of necessity lower standards to the disadvantage of the purchaser of service. We agree that the payment of any commission other than that already agreed upon or the issuance of any special services, awards, credits, premiums, compensations, gifts or rebates is detrimental to the best interests of the average purchaser of a contract and we agree to refrain from such practices. We reserve the right to apply to TISA for a reduction of rates provided we can give sufficient proof of our ability to render adequate service at reduced rates.

Confusion in National Groups

The diversity of opinion as to the type of association that would be most acceptable to the average service oper-

TWIN- TRAX TAPE RECORDERS



...give you more

MORE MODELS

the most complete variety of recorders for professional, semi-professional and experimenter use.

MORE FEATURES

for better quality, smoother performance and easier operation.

MORE VALUE

because our direct sales policy saves you dealer markups.

Send today for our catalog 5109 which lists complete technical specifications and performance ratings for all recorder models and accessories. *Trademark Reg.

AMPLIFIER CORP. OF AMERICA
398 Broadway New York 13, N. Y.

STAR SPECIAL!

DON GOOD TVI ELIMINATORS

\$2.32 Each

- For TVI caused by amateurs, diathermy and x-ray, appliances, neon signs, etc. Easily attached to TV set. Low-loss polystyrene cases.
- A-1072 High-pass (#300) for 500-ohm line.
- A-1073 High-pass (#72) for 72-ohm line.
- A-1074 Variable Teletrap (R-301 FM) for nearby 88-110 mc FM station interference.
- A-1075 Variable Teletrap (R-302 DA) for diathermy and amateur TVI in 26-32 mc range.
- A-1076 Channels 5-6; variable trap for amateur station antenna feedline (T-301 LB).
- A-1077 Channels 7-13 ditto (T-302 HB).

KRYLON PLASTIC SPRAY

Clear plastic coating stops corrosion of TV antenna connections due to water, smoke, etc. Protects and insulates radio, auto and other wiring. 1000's of practical uses. 12-oz. sprayer can. List price \$1.95.

A-1078

\$1.47 ea.

COMPLETE STOCKS

All Standard Brands

Just off the press
BIG BARGAIN BULLETIN



ELECTRONIC
DISTRIBUTORS, INC.

Dept. RN 2-7736 S. Halsted, Chicago 20, Ill.

CODE SENDING RECEIVING SPEED



WITHOUT NERVOUS TENSION

REVEALING BOOK shows how "crack" operators develop high speed and proficiency. Learn code for Amateur or Commercial Radiotelegraph License, or improve your sending and receiving with the Candler System which develops radiotelegraph experts and code champions.

CANDLER SYSTEM Box 928, Dept. 2-B,
Denver, Colorado

**SEND POWERED
PHONES RCA-MI-2454**
Complete with 24' of Rubber Covered Wire.
NEW EXPORT PACKED
Shipping weight 6 lbs.
\$6.45 PER SET
2 FOR \$12.50
EACH SET GUARANTEED
Brand New, Gov't. Cost, \$42.00
INCLUDE POSTAGE WITH ORDER
McCONNELL'S
3834 Germantown Ave.
Phila., Pa. RA 5-6033

ator and technician has resulted in a situation that is reminiscent of the story about the man who "jumped on his horse and rode off in all directions."

In this department last month we reported the formation of the National Alliance of Television & Electronics Service Associations (NATESA) headed up by Frank J. Moch, president of TISA in Chicago. This organization was created in Washington, D. C., at a meeting of representatives of television service groups from nine cities in various parts of the country.

Subsequently a meeting was called in New York City by the Empire State Federation of Electronic Technicians Associations to discuss the formation of a national association or federation of state associations of radio and television service technicians. The end result of this meeting was the selection of a committee with Dave Krantz as chairman and Norman Chalfin as secretary, to develop a plan for a national organization. The plan as developed by this committee will be presented to the delegates of all associations which are represented at a meeting to be held in Washington, D. C., early in 1951. Mr. Krantz is chairman of the Federation of Radio Service Associations of Pennsylvania and Mr. Chalfin is executive secretary of AR-TSNY.

There are two distinct schools of thought prevalent in the service industry about the kind of a national organization the service industry needs. The one opinion holds that a national organization should be made up of local associations of radio and electronic maintenance and service businessmen while the other insists that it must be made up of state associations or federations of radio and television service technicians.

Unfortunately, there are not enough active local associations or state federations to provide a nucleus for either type of national organization to justify their speaking with authority for the entire servicing industry.

Since most of the aggressive radio and television service association activities have been concentrated in the metropolitan areas, organization thinking is geared to the problems peculiar to the closely populated areas and not especially applicable to service activities in the smaller cities and rural areas where a large percentage of the successful independent service businesses are located.

A third philosophy of associated activity by radio and television technicians is that represented in the Radio Technicians Guilds of New England. These guilds which function under the simple creed of good fellowship and the exchange of ideas and information have quietly flourished down through the years without any fanfare or involvement in the political squabbles that have many times destroyed good service organizations.

More recently the Electronic Technicians Guild of Pennsylvania, fathered by PRSMA, was launched with a

University

LOUDSPEAKERS

WITH A TRADITION FOR

Quality and Dependability

... designed by
**PROGRESSIVE
ENGINEERING!**



MODEL 6201
COAXIAL SPEAKER



The 6201 must be heard to be appreciated.

You'll find no compromise in the model 6201—a true coaxial system, completely self-contained with LC network and attenuator, at a sensible price. Full range response 45 to 15,000 cps, power capacity 25 watts. Highest quality construction throughout—separate Alnico V tweeter driver, exclusive UNIVERSITY "W" shape Alnico V "woofer" magnet, special cone edge treatment for longer life, minimum distortion; and even the famous UNIVERSITY wide angle "Cobra" tweeter horn for uniform dispersion of the "highs." Variable attenuator adjusts "balance" to personal preference.

Every UNIVERSITY product is built to traditional standards of quality that have earned a world-wide reputation for absolute dependability. Highest quality materials, skillfully fabricated, result in unsurpassed performance and extra reliability. "Progressive Engineering" assures the latest design improvements in every piece of UNIVERSITY equipment.

Ask for your free copy of the
TECHNOLOG

Handy technical catalog, published for engineers, installers, service men. Request yours today—write Desk 15.



UNIVERSITY
LOUDSPEAKERS • INC
80 SO. KENSICO AVE., WHITE PLAINS, N. Y.



Whether you're in the Armed Services or in Industry **ELECTRONICS TRAINING PAYS OFF**

WITH INTERESTING JOBS AND HIGHER EARNINGS

CREI Residence School training offers quick promotion in uniform as well as profitable civilian careers

IN or out of the armed services, the best jobs go to the men with technical training. If you are prepared with electronics training, you're fortified for the future, whether you're headed for a berth in the armed services or a career in essential industry. Because of the critical shortages that exist today in the electronics industry, the qualified technicians and engineers can practically choose their own futures. Because of the dependence of modern armies, navies, and air forces upon electronics—for radar, communications, and navigation—the man with even limited knowledge of electronics gets ahead quickly in uniform. In case you're called to active duty before completion of your CREI course, you'll still be way ahead, for the armed services will choose you for further electronics training in place of the completely un-trained man.

At CREI you'll work with the latest equipment—over 120,000 square feet of modern class rooms, TV and radio broadcasting studios, transmitters, control rooms, and experimental labs. Here you're grounded in the fundamentals required for work in guided missiles, TV, and all the other important fields of communications and electronics. CREI's experience in training thousands of men for the Army, Navy and Coast Guard in World War II, coupled with pioneering background in technical education and close industry connections, assure you of the best in technical preparation. To insure your training ACT RIGHT NOW. Send today for free Residence School catalog.

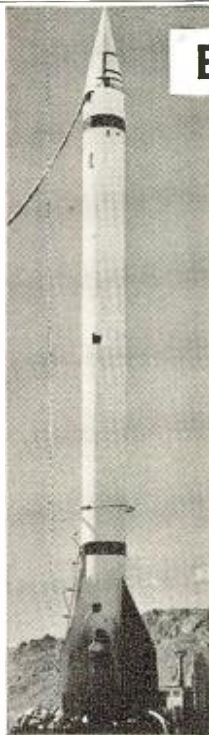

APPROVED FOR VETERANS — New classes start twice a month. High level home study training also available for professional radio men.

CAPITOL RADIO
ENGINEERING INSTITUTE
16th Street and Park Road
Dept. 132C, Wash. 10, D. C.

FOR FREE CATALOG, MAIL COUPON NOW!

CREI—16th & Park Rd., Washington 10, D. C.

Please send free Residence School Catalog.

Name.....

Street.....

City..... Zone..... State.....

Veteran..... Non-Veteran..... Age.....

Send details about Home Study Courses 132C

IN DETROIT IT'S AARON

LAND BASED SURFACE MARINE RADAR SCR-296-A 700 MC—100,000 YDS. MAX. RANGE—115 V. 60 CYCLE—10 KVA. POW. SUPPLY. Complete with following components:
 Cabinet BC-82-A
 Modulation Generator BC-720-A
 Radio Receiver BC-716-A
 Power Control Panel BP-108-A
 Radio Transmitter BC-717-A
 High Voltage Rectifier RA-50-A
 Duplexing Panel BP-106-A
 Indicating Equipment
 Range Oscilloscope BC-719-A
 Range Unit BC-723-A
 Azimuth Oscilloscope BC-718-A
 Azimuth Indicator I-110-A
 Regulated Rectifier RA-49-A
 Antenna Equipment
 Control Unit RM-36-A
 Motor Amplidyne Generator MG-16-A
 Magnatron Tube 700 Western Electric
TECHNICAL MANUAL TM-11-1105-A, covering entire equipment.
 Information and price on request

The following are extra components from the SCR-296 which we wish to dispose of

8 units BC-716 at	\$50.00 each
4 units BC-717 at	\$50.00 each
4 units BC-719 at	\$50.00 each
4 units BC-723 at	\$25.00 each
2 units BC-726 at	\$15.00 each
1 unit I-110 at	\$4.00
2 units RA-49	\$50.00 each

PRESSURIZING CPR-101198B PUMP—used to pressurize ASD & ASG AIRBORNE RADAR—GAGE CALIBRATED 0-30 LBS. —N.E.W.—Oversize wrapped in box—write for price and quantity.

ABK-1 NAVY IFF RECEIVER—similar to BC-966 IFF—contains: (6) 6SH7, (2) 6HG & dynamotor \$ 9.95
RE-1 ARR-1 HORN RECEIVER—DIO NEWS tells how to convert this revr. to Hi-Freq. converter for use with your present revr.—contains 4 acorn tubes—24 Volt operation 4.95
MN-26 C or Y BENDIX RADIO COMPASS RCVR.—with tubes 22.50
ALTIMETER RT/APN-140 MC RCVR.—contains 14 tubes—(3) 1 meg. resistors—dynamotor—numerous other valuable parts 9.95
T-26/APT-2 RADAR—400-2600 cycle & 20 VDC—660-day-44—contains following tubes: (2) 5R4, (2) 6AC7, (1) 22 (1) 807 (1) 6A7—new w/ manual 19.95
BC-645 TRANSCEIVER—430-500 MC—can be converted to Citizens & Ham Bands—New 14.95
SCR-522 TRANSCEIVER—430-500 MC—in good condition—with tubes 37.50
RADAR INDICATOR BC-704—From Radar SCR-521 (ASB) with 7 tubes—less 15V CR tube & shield—makes excellent scope—New in a 30x 13x10" chest 12.95
R-25/AP5-2 CONTROLS—22 tubes—includes (1) 5FP7, (1) 2AP1 CR tubes—with blower-motor, etc. 42.50
OSCILLOSCOPE BC-403 C—Made in RCA for Army—110 VAC 60 cycle—complete w/ tubes 69.95
ALTIMETER INDICATOR APN-1—0-1 MA movement/5 MA shunt/270° scale—New 2.75

274-N COMMAND EQUIPMENT
BC-442-A Antenna Relay—With RF meter—less 50 mmid vacuum conds. \$ 1.75
BC-453 Receiver—100-350 KC 9.95
BC-454 Receiver—2-6 MC 5.50
BC-455 Receiver—6-9.1 MC 6.75
BC-456 Modulator 2.50
BC-457 Transmitter 4-5 MC 5.95
BC-458 Transmitter 5-3.7 MC 5.95
BC-459 Transmitter 7-9.1 MC, New 14.95
DM-23-A Dynamotor for BC-456 MC 1.00
BC-450 Control Box—for 3 revrs. 1.50
NAVY RECEIVER CBY-46104—1.5 to 3 MC—New in cartons—w/dynamotors 16.95

PHONO AMPLIFIER—partially wired—with output xfrms.—less 10-15V CR tubes (1) 35Z5, (1) 50A5, (1) 14BB \$ 0.75
BC-212 INTERPHONE AMPLIFIER—contains (2) 6E5 tubes—New 2.95
BC-347 INTERPHONE AMPLIFIER—contains (1) 6E5 tube & output xfrm. 1.50
SERVO AMPLIFIER—10-15V CR tubes—8 neon sockets—8 relays—hundreds of other parts 4.95
MINNEAPOLIS-HOWE TUBE WIRING FIGURE—contains following tubes: (2) 7C5, (1) 7F7, (1) 7Y4—1-1 mfd. 1000 VDC conds.—7 resistors—2 fuses—400 cycle 1.95
I-198-A SIGNAL GENERATOR—6-15 MC—New 19.95
FREQUENCY METER BC-906-D—Cavity Type—Range 14.5 to 23.5 MC—NEW—in crackle carrying case—w/calibrator—crackleshipped in wooden carrying case 14.95
BATTERY CHARGER 115 VAC—50 cwt.—100 amp—changes 8-cell storage batteries—starts at 6 amps, tapers to 3 amps—New—(9 1/2" high x 3 3/4" wide x 3 3/4" deep) 9.95
ABC POWER SUPPLY Model 24—500 W—260 V INPUT; 24 VDC 8 amps—OUTPUT: 1.5 V .3 amps 65 V .01 amps and -6 V—Made by Setchell-Carlson—New 4.95
MINE-DETECTOR SCR-625—New—w/manual 69.95
RANGE CALIBRATOR I-178—for BC-436 Range Unit—110 VAC operation—contains (7) (1) 6J5, (1) 6F6, (1) 5Y3 in unit—Plus: (2) 6SR7, (1) 6J5, (1) 6F6, (1) 5Y3 spares—with 3 cables w/plugs—14 peanut sockets, 7 1/2 55 plugs & alligator clamps—New, in wooden box 35.00
RANGE UNIT BC-436-A—with 110 VAC Power Supply—New 17.50
RELAY BOX BC-616—New—contains the following: (1) 1K ohm Keving Relay, (1) 2.5K ohm Time Relay, (1) 1K ohm Channel Selector Relay, (1) Capacitor (Paper—150 mfd @ 50 VDC), 1 Terminal Block, 2 resistors, 700 1.50
BC-746-A TUNING KIT—complete with 2 crystals (4855 & 5300 KC), RF Coils, 4855 KC—can be converted for 1 Watt transmitter—New 1.00
COIL ASSY BOX—1st Detector for BC-314G and R.F. Oscillator for BC-342N 1.75
COIL SET & CRYSTALS FOR RT-TX BC-721-B on freq. of 3500 KC (5300 & 4955 sta. ant. & tank coils)—New79
BUTTERFLY CONDENSERS—with silver-plated loop attached—9x13 1/2"49
98-156 MC \$0.38
100-300 MC49
J-38 BREAK-IN-TELEGRAPH-KEY—on Bakelite Base—43"x8"x1 1/2"—with 1000 ohm contact closing switch—1 1/16" keving contact, etc.39

WELL-KNOWN TV CHASSIS—Cadmium plated steel—16 3/4"x13"—will take 7-10-12 tube—Cutouts for 14 peanut sockets, 8 octal sockets—plus numerous condensers, xfrms. & other mounting cutouts—Control cutouts front and rear—complete with sub-assembly tuner chassis 7"x3 3/4"x3"—Cutouts for 3 peanut tubes and interstage xfrm. \$1.69
SAME CHASSIS, but with sub-tuner wired and CR tube yoke mount 1.99

All items USED unless otherwise stated. ALL orders F.O.B. Detroit. Michigan customers add 3% sales tax. 25% payment must accompany ALL MERCHANDISE SUBJECT TO PRIOR SALE.

AARON ELECTRONIC SALES
 3400 CREWE, DETROIT 7, MICHIGAN LOrain 8-9986

constitution that theoretically provided an association haven for every level of the various categories of radio, television, sound, and electronics maintenance that we normally lump together as the "service industry." Since its introduction at a mass meeting of technicians held in Philadelphia several months ago nothing has been announced about the progress of this new guild.

Loudness and Power

(Continued from page 53)

erally about 2 to 3% efficient. Wider range speakers costing up to about \$30 are generally not more efficient, the extra cost usually going into better bass and high frequency response. A number of speakers in the \$40 to \$70 class are about 4 to 6% efficient. These usually have magnets of 2 or 4 pounds as compared with ounces in the lower cost models. Top efficiency for a speaker unit seems to go to the *Altec* 604B which has an efficiency of about 8% according to my measurements. This is a pretty good standard for comparison. Higher efficiencies are obtained on some types of speaker systems using horn loading. The *Klipsch* corner horn system claims an efficiency of the order of 30% and some checks I have made seem to confirm this.

To return to the example of Table 1, the room was to be equipped with a coaxial speaker of good efficiency in a bass reflex cabinet. An efficiency of 5% was estimated for this model and so the electrical power calculated to produce the sound intensity of 120 decibels is: $Electrical\ power = Acoustic\ power / Speaker\ efficiency; P_e = 30/.05 = 6\ watts.$

It is informative to calculate the power that will be used in this installation under different listening levels. At 113 decibels (top loudness of a symphony orchestra) the electrical power is 1.2 watts. Of course the instantaneous peaks may be above this level by a 6 decibel factor, or at the 6 watt output already calculated. The average loudness of a symphony orchestra will use only about a thousandth of a watt and lower volume levels will be down to a millionth of a watt and less.

It was reasoned that a 10 watt amplifier would suffice for this installation and as this agreed with other engineering advice a suitable unit was installed. Later some output measurements of the amplifier in various loudness levels were made and readings of the following type were obtained.

	Calculated	Measured
Loud symphonic peak	1.2 w.	.6 w.
Average loud passage1 w.	.08 w.
Average music	1 mw.	2.4 mw.

The agreement is closer than would be expected from the estimates involved.

The calculations outlined in this article can be performed on the simple nomograph shown in Fig. 2. The



COMPLETE DELUXE
T-V ANTENNA
 KIT WITH 45'
 TWIN LEAD

Ten bar conical or flying arrow type—30 ft. of guy wire—8 ft. mast—base a n d guy ring—standoff insulators a n d roof hooks included with complete instruction sheets. Add 5c. for additional lead-in if needed.

7.95

NOTHING ELSE TO BUY
 20% Deposit on C.O.D. orders. Include postage.
 Shipping weight 7 lbs.

THE WEST'S LEADING
T-V ANTENNA MAIL ORDER HOUSE

Davis
TELEVISION
SUPPLY CO.
 3037 W. OLYMPIC BLVD. LOS ANGELES 6, CALIF.

BETTER TV RECEPTION

THE "Fringe Area TV" Reference Book



TV signal propagation, evaluation of TV antenna, making a TV signal survey, types of masts and towers and recommended installation practices. Full data on rhombics, how to use open-wire feed line, how to eliminate ghosts, minimizing fading, TVI, etc.

By W. W. Smith and R. L. Dawley

\$2.50 PER COPY — By mail, \$2.60 postpaid.

AT YOUR FAVORITE DEALER
 OR DIRECT BY MAIL FROM
Editors and Engineers
 LIMITED
 1302 KENWOOD ROAD, SANTA BARBARA, CALIFORNIA

RADIO and TELEVISION

Over 30 years N.E. Radio Training Center. Train for all types FCC operators' licenses. Also Radio and Television servicing. FM-AM broadcasting transmitters at school. Send for Catalog M.

MASS. RADIO SCHOOL
 271 Huntington Avenue Boston 15, Massachusetts
 Lic. by Comm. Mass. Dept. Educ.

DO YOU WANT TO STOP TOBACCO?



Banish the craving for tobacco as thousands have with Tobacco Redeemer. Write for free booklet telling of injurious effect of tobacco and of a treatment which has relieved many men.

In Business Since 1909
 300,000 Satisfied Customers
THE NEWELL COMPANY
 462 Clayton Sta., St. Louis 5, Mo.

FREE BOOK

CONDENSERS
OUR SPECIALTY
OIL FILLED TYPES

All Values and Voltage Ratings
 We Invite Your Inquiries

TECHNICAL RADIO PARTS CO.
 557 McDonald Ave., Brooklyn 18, N. Y.

method is as follows. Select the loudness level which you wish to produce in the room in question. Place a straightedge on this point on line 1 and also on the point on scale 2 corresponding to the volume of the room. Mark the crossing of the straightedge on line 3. Connect this point to the reverberation time of the room on scale 4. The intersection on scale 5 gives the acoustic power required. To change this to electrical output connect the point on scale 5 to the speaker efficiency on scale 6. The intersection on scale 7 shows the electrical power required. The right hand of the scale reads in watts and the left hand side gives the answer in decibels with a zero reference of .006 watts.

This nomograph has been used in estimating power requirements in a number of different applications. It has proven to be very useful and even more educational. The limitations of the graph are the estimates involved in the reverberation time and the speaker efficiency. These factors must be used in any system of figuring power requirements plus an added safety factor which must be large enough to cover all contingencies. However by the methods described it is usually possible to come within 50% of the actual power required.

It is amazing the tremendous range of power which an amplifier has to deliver. Peak power is needed only a very small fraction of the time. The average power required is only about a thousandth of the peak power. Amplifiers must have the needed reserve power for those times when musical peaks occur, power must be clean and low in distortion or else the thrill of musical volume is supplanted by a sound causing a wince and a shudder. A good audio system must be designed around the power requirements of the installation if it is to be free from overloading on the one hand or over powered with resulting extra costs on the other hand.

REFERENCES

Hausmann & Slack: "Physics," Chaps. 21, 22, D. Van Nostrand Co.
 Smith, F. L.: "Radiotron Designer's Handbook," Third Edition, The Wireless Press
 "Frequency Range and Power Considerations in Music Reproduction," Jensen Technical Monograph No. 3, Jensen Mfg. Co.
 Klipsch, P. W.: "The Klipsch Sound Reproducer," FM-TV Magazine, Sept. 1947
 Olson, H. F.: "Elements of Acoustical Engineering" Second Edition, D. Van Nostrand Co.

-30-



February, 1951

FITS ANYWHERE.

- ★ Only 15/16" in dia.
- ★ Features Clarostat stabilized element.
- ★ Tapers. Also with one tap.
- ★ Knurled aluminum shaft, standard.



THE TINY CONTROL FOR THE FULL-SIZED JOB!

★ Just the thing for extra-tight spots — Clarostat's 15/16" control. Quite a lot smaller than the usual carbon controls but handles the load.

And typically Clarostat construction:

No-wiggle no-wobble aluminum knurled shaft; velvety-smooth rotation; longest-wearing element; special alloy contact arm; easy-to-solder tinny terminal lugs; and QUIET! It's a honey!

★ Ask your Clarostat jobber for these 15/16" controls. Ask for latest Clarostat catalog — or write us.



Controls and Resistors

CLAROSTAT MFG. CO., INC. • DOVER, NEW HAMPSHIRE • In Canada: CANADIAN MARCONI CO., LTD. Montreal, P. Q., and branches

Believe It Or No

FAMOUS R.C.A. 630TS

31 TUBES—Latest Features.
 Complete with all Knobs, Dial
 Plate, Mounting For Picture
 Tube 12" Speaker.

\$179

Complete with

16" PICTURE TUBE

17 INCH PICTURE TUBE . . \$184

20 INCH PICTURE TUBE . . \$199

RMA Guarantee on Chassis—Tube (Tax Included)
 25% WITH ORDER — BALANCE C. O. D.

UPSTATE

107 DUANE AVE., SCHENECTADY, N. Y. — Tel. 4-3008

EVERYBODY'S RUSHING to RED ARROW FOR BIGGER and BETTER BARGAINS

We specialize in Ceramicons, Resistors and Condensers. If you don't see what you want listed, be sure to write. (Manufacturers: ask for our quantity prices.)

FILTER UNIT

This unit is an excellent buy for the parts alone. Some parts are worth more than we're asking for the whole unit.

- 1-1000 MFD @ 450V
- 1-1000 MFD @ 12V
- 1-.5 MFD @ 400V
- 2-.5 MFD @ 50V
- 1-.01 MFD @ 400V
- 2-20 Watt Resistors
- 2-Filter Chokes
- 3-RF Chokes
- 1-DPST Toggle Switch
- Miscellaneous hardware, wire, etc.



FP TYPE CONDENSERS

- 10 MFD @ 400 V, 20-20 MFD @ 50 V.....49c
- 1000 MFD @ 15 V, 49c 10 MFD @ 250 V, 39c

TUBES • Brand New

- Standard Brands
- Immediate Delivery

- VT25A/10Y39c 162639c
- 3C24/24G59c 872A\$1.75

SLEEVEING, various colors and sizes

- 3 ft. lengths10 for 25c
- (100 for \$2.00)

MINIMUM ORDER—\$2.00. Send 25% deposit with order, balance C.O.D. Shipped F.O.B., N.Y.C. (N.Y.C. residents add 2% sales tax.)

HS33 HEADSETS—Used, excellent condition.

\$1.19 pair

TRANSMITTING MICAS

- .0001 @ 5000 V39c each
- .00025 @ 5000 V39c each
- ANY MICA LISTED BELOW29c each
- .001 @ 1200 V004 @ 600 V
- .008 @ 1200 V005 @ 600 V
- .01 @ 1200 V01 @ 2500 V
- .027 @ 1200 V04 @ 600 V

SOLDERING PASTE — 8 oz. cans — U.S.N. Specification

51-FLB.....29c ea. (10 for \$2.50)

SPECIAL! 300 OHM TWIN LEAD TV LINE

\$3.89 per hundred ft. \$35.00 per thousand ft.

TERRIFIC KIT SALE

Kit of 50 Assorted KNOBS\$1.19

Kit of 100 Assorted PAPER TUBULAR CONDENSERS, 200 to 800 V5.75

Kit of 10 Assorted VOLUME CONTROLS2.79

CORDS CD478—5 ft. long with Alligator Clips, can be used as test leads.....19c pair

CD307A with PL55 and JK26.....69c each



BATHTUB CONDENSERS

- 20 MFD @ 350 VDC14c each (\$12.50 per hundred)
- 2 x .25 MFD @ 600 VDC
- .5-5 MFD @ 100 VDC
- 3 x 1 MFD @ 400 VDC

RED ARROW SALES

Dept. A 63 East Broadway, N.Y.
Phone COrlandt 7-5425

COLUMBIA Distributors, Inc.

ROUTE 8 (opp. school), COLUMBIA, N. J.

CARRIES THE ENTIRE LINE OF



and factory-wired instruments



425-K
5" SCOPE
KIT
\$44.95



221-K
VTVM
KIT
\$25.95



625-K
TUBE
TESTER
KIT
\$34.95



HVP-1
HIGH VOLTAGE
PROBE (wired)
\$6.95

Write us about your TV needs!

BUY DIRECT

From Factory

New Improved RCA

Licensed-630

32 Tube Chassis

• Complete with NEW, Electro-scope Magic-Eye Tuning indicator

• Completely wired and aligned by expert technicians

• Keyed automatic gain control

• Latest type Standard Coil tuner

NEW SENSATIONAL MODEL 622

22 Tube Chassis — AGC — Standard coil tuner — co-channel sound (not intercarrier)

\$144.95

Fed. Tax Incl. (Less CRT)

All above chassis designed for 16", 17", 19" or 20" tubes

ALL TUBE SIZES AVAILABLE

Regular RMA guarantee on all tubes and chassis

Beautiful cabinets for above—available

Terms: \$25.00 deposit on all orders—Balance C.O.D.

F.O.B.—N. Y. Factory

Prices subject to change without notice

IMMEDIATE DELIVERY Visit our showrooms

AD-RITZ MFG. CORP.

158 Grand Street

New York, N. Y.

Phone WO 4-6763

SAVE!!

\$179.95

Fed. Tax Incl. (Less CRT)

Classified

Rate 50c per word. Minimum 10 words

RADIO ENGINEERING

RADIO Engineering Broadcasting, Aviation and Police Radio, Servicing, Marine Operating and Electronics taught thoroughly. Expenses low. Write for catalog. Valparaiso Technical Institute, Dept. N, Valparaiso, Ind.

PANELS for electronic, nucleonic construction projects. Complete service for designers, custom builders. Circular upon request. Gilpin Instrument Works, P. O. Box No. 8, Mt. Clemens, Mich.

SALE

ONE new Radio Tower, 136 foot height. Still in crate. For additional information, write County of Lake, Court House, Waukegan, Ill.

REK-O-KUT G2 16" Transcription Turntable, brand new. Brush PL20 Reproducing Arm, also McElroy Code Equipment. Canadian inquiries, Gutman, 7000 Somerled, Montreal, Canada.

RADIO and Television Tubes. We have all numbers. They're all new at good discounts. Write us for your needs. Immediate response. Beacon Stores, Inc., Anderson Ave., Grantwood, N. J.

HOTTEST surplus list in the country. Electronics-Hydraulics, Aircraft-Gadgets. Dick Rose, Everett, Wash.

RADIO Diagrams 50c; Record Changers, Recorders 60c; Television Diagrams with service data \$1.00 up. State Manufacturer and model number. Kramer's Radio Service, Dept. RX, 36 Columbus Ave., New York 23, N. Y.

COLOSSAL bargain in radio parts, over 150 assorted radio parts including resistors, condensers, controls, coils, etc. All new, \$75.00 value, guaranteed satisfaction or money refunded, postpaid in U. S. A., \$2.50. Write for catalog. Buyers Syndicate, 30 N. Taylor St., Springfield 3, Mass.

4 G.E. Type 4A1 Frequency Modulator Mobile Units (complete). Frequency adjusted to 31.5 MC for operation on 6 V. battery. 1 G.E. Type 4GE1AC F.M. Central Station unit complete. 31.5 MC for operation on 115-V. 60 cycles. 1 Bowling Frequency Meter. Best offer. All in good condition. Village of Maywood, Illinois.

53 OHM coax, prices reasonable. Inquire: Harry H. Van Dick, Little Falls, N. J.

5% PRECISION 8-8mfd/600wv Oil Filtermite, Plug-in, new, 69c. 100 Mica Condensers, \$4.98. Add postage. Free bargain list. No dealers. Betz, 73 Caroline Ave., Yonkers 5, N. Y.

WANTED

AN/APR-4, other "APR-", "ARR-", "TS-", "IE-", ARC-1, ARC-3, everything surplus. Special tubes, Tech. Manuals, Lab. quality Test Equipment, etc. Describe, price in first letter. Littell, Farhills, Box 26, Dayton 9, Ohio.

HELP WANTED

WANTED: "Aircraft Radio Technician to take over Aircraft Radio maintenance of small mid-west airline. Good starting pay and opportunity for advancement." Write to Box 508, % Radio & Television News, 185 N. Wabash Ave., Chicago 1, Ill.

PATENT ATTORNEYS

LANCASTER Allwine & Rommel Registered Patent Attorneys. Patent practice before U.S. Patent office. Validity and Infringement investigations and opinions. Booklet and form "Evidence of Conception" forwarded upon request. Suite 414, 815 15th St., N.W. Washington 5, D.C.

HERMAN Lewis Gordon, Registered Patent Attorney. Patent Investigations and Opinions. Warner Building, Washington, D. C.

CORRESPONDENCE COURSE

USED Correspondence Courses and Books sold and rented. Money back guarantee. Catalog free. (Courses bought.) Lee Mountain, Pisgah, Ala.

USED Correspondence Courses and Educational Books bought, sold, rented, catalog free. Educational Exchange, Summerville, Ga.

MISCELLANEOUS

ELECTRONIC Research. Equipment designed or built to specifications. Inventors, experimenters, inquiries invited. E. A. K. Research Laboratory, Box 62, Tarrytown, N. Y.

15 TESTED One-tube circuits 25c, including "Radiobuilder," catalog. Laboratories, 411-H Capitol Hill, Reno, Nev.

PHONOGRAPH Records cheap. Catalogue free. Paramount, CG-313 E. Market, Wilkes-Barre, Pa. VIBRATORS rebuilt. \$1.00. Guaranteed. Bevisor Co., Box 5802, Cleveland 1, Ohio.



MAGNAFILTER'S Top Sales Prove

• CUSTOMERS DEMAND MAGNAFILTER • BIGGER PROFITS FOR YOU!

MAGNAFILTER'S A HIT with TV set owners because it provides easy-on-the-eyes, non-glare, distortion-free enlargement. The image is filtered, enlarged and has a third dimensional effect. MAGNAFILTER combines brilliance with balance... complete full vision.

Made of finest quality materials... selected and fabricated to give ideal contrast in light values and the greatest magnification without distortion. A SURE SELLER—MAGNAFILTER!

Write Today For Literature and Prices

RUSSELL LENS CO., 11056 Cumpston St., North Hollywood, Calif.

CR TUBE LEAKAGE

By M. KALASHIAN, WINXT

A TV set may come into the shop because of no horizontal and vertical sync or lack of brightness control—full brilliance consistently.

If you have finished checking the circuits in the video amplifier, d.c. restorer, etc., and have found nothing, then suspect the picture tube for your next check. Usually when this trouble occurs there is leakage inside the picture tube between the control grid and grid number two—which is usually positive by about 300-400 volts. This fault will usually place a positive voltage on the control grid (the exact value depending on the amount of leakage); and it should be measurable with the set running, and the reading obtained should be checked with the instruction manual or properly interpolated to the circuit in the particular set. However it is doubtful if the leakage can be measured with an ohmmeter across the tube prongs, because the leakage is usually due to foreign particles "floating around in the tube" which have lodged in the right spot to do harm.

Sometimes the trouble can be cured by knocking the neck of the picture tube with the handle of a screwdriver a few times, for this may jar the foreign particles loose. If that isn't successful then try burning the particles with the high voltage from the set. Simply disconnect the high voltage lead from the picture tube, put an extension lead on it and arc it to the various pins on the base of the picture tube for several minutes. If a good looking arc does not take place—then try arcing to one pin at a time while all the others are temporarily grounded.

If several attempts of the above does not clear things up, then a new picture tube might be in order.

NEW AMATEUR RULES

ACCORDING to a directive from the FCC dated December 21, 1950, radio amateurs are reminded of the regulation forbidding communication with amateurs in countries that have banned such contacts.

These countries now include: Japan (except for amateur stations of the Allied Occupation forces as authorized by the Supreme Commander, Allied Powers); Indo-China; Iran; Lebanon; Netherlands Antilles; Thailand; Australia (except for experimental purposes and the administrations of which permit such communications); and Austria (reception permitted but transmissions forbidden by Allied Control authorities).

Since this entire matter is covered by international treaty, hams are warned to conform.

PHOTO CREDITS

Pages	Credit
31 (left), 38, 39	Allen B. Du Mont Laboratories, Inc.
31 (center), 32, 33	Radio Corporation of America
31 (right)	Green Radio Distributors
31 (lower center)	Columbia Broadcasting System
32	Illinois Bell Telephone Co.
35	Westinghouse Electric Corp.
40	General Motors Corporation
41, 150, 152	Paul Wendel
51	Electro-Voice Inc.
51	Shure Brothers, Inc.
51	Astatic Corp.
62 (top)	Simpson Electric Co.
62 (bottom)	McIntosh Engineering Laboratories, Inc.
102	MARS
132	U. S. Army Signal Corps

Let MILTON S. KIVER Help You Prepare For COLOR TV And...

TELEVISION SERVICING

Easy to TRAIN AT HOME This Practical Way!

Men with the right training in Television Servicing are in big demand . . . pull down big pay. T.C.I. TRAINS YOU RIGHT with easy-to-follow technical training designed by servicemen, for servicemen! You learn practical, professional type Television Servicing without leaving your present job. Included are money-making extras such as set conversion, master antenna installation, COLOR TV and field servicing short cuts. You can start earning Television money after the first few lessons. You learn to test, trouble shoot and repair all types of TV sets. You learn **COLOR CONVERSION** too!

HERE'S HOW YOU GET EXPERIENCE!

You train on your own large screen RCA 630TS type television receiver, furnished as part of your course. We loan you test instruments. As an optional feature you can get two weeks of actual field experience out on service jobs and on the repair bench for Chicago's largest independent servicing organization. You learn Television Servicing by *actually doing* Television Servicing . . . you get the *practical* know-how you need to qualify for **BIG MONEY** in this fast-growing field! Age is no barrier, Many TCI students are over 40!

ACT NOW! Fill out and mail coupon for FREE Catalog and SAMPLE LESSON. Write TODAY!

TELEVISION COMMUNICATIONS INSTITUTE
205 W. Wacker Dr., Dept. 1-E, Chicago 6, Ill.

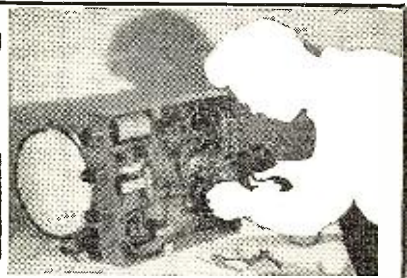

YOU GET and keep famous RCA 630 TS type Television receiver.

YOU DO actual testing, servicing, trouble shooting and repairing.

FOR THE BEGINNER
TCI offers a low-cost Pre-Television Course in Radio, especially designed to prepare you for television in just 5 to 7 weeks. Everything you need from basic radio through servicing . . . to Television.

MAIL NOW FOR FREE BOOKLET

MILTON S. KIVER, President
TELEVISION COMMUNICATIONS INSTITUTE
205 W. Wacker Dr., Dept. 1-E, Chicago 6, Ill.
O. K. Mr. Kiver! Rush FREE Catalog on your practical home study course in Television Servicing, including COLOR TV. Include FREE Sample Lesson. I am not obligated. Salesman will not call.

Name Age
Address
City Zone State
() BEGINNERS check here for information on Pre-Television Course.

The HIT of the AUDIO FAIR!

Plays 10 1/2" Reels!



\$345⁰⁰

Complete, for console installation with single or dual track heads:

CONCERTONE

■ The professional quality tape recorder you have been waiting for! NAB standards; triodes throughout; 40-15000 cycles at 15", 40-8000 cycles at 7 1/2". Three motors; flutter less than 0.1%; signal-to-noise better than 50 db. Three heads for simultaneous erase, record, playback. Quick change from single to dual track. Write for booklet.

FISHER RADIO CORPORATION • Distributors • 39 E. 47th St., N. Y.
MAGNETIC RECORDERS CO., 7120 MELROSE AVE., L. A. 46, CALIF.

**LIGHTEST WEIGHT,
HEAVIEST DUTY
SOLDERING GUN
EVER ENGINEERED!**

FLASH

SOLDERING GUN

Just think, only SIX OUNCES in weight, yet Flash Soldering Guns deliver practically infinite heat in just six seconds—no soldering job too big for this feather-weight champion!

Operates off 110 volt AC source through step-down transformer, or six to 12 volts AC or DC (25 amperes) supply. Can be used with any standard car battery.

Finger tip control—perfect balance. Built for years of trouble-free, heavy duty service. Two models—SF-100 for fine and general soldering; HF-150 for heavy duty work with $\frac{3}{8}$ inch tip and extra heavy element together with heavy duty barrel.

For full illustrated details on complete Phillips Soldering tool line, write today!



Phillips Mfg Co.

2816 Aldrich Ave. S., Minneapolis, Minn.

EXPORT DIV.—PAN-MAR CORP.
1270 Broadway—N. Y. 1, N. Y.



**EVERY
RADIOMAN**

Can Use These
SERVICE HINTS!

Valuable Manual Yours—FREE!

Every page of "How to Simplify Radio Repairs" is packed with on-the-bench, practical ideas. Contains photos, charts, diagrams—no fluff—no vague theory. In plain every-day language it gives you priceless suggestions—new servicing ideas. You'll use and benefit from the experience of experts. Partial list of contents: How to Localize Trouble; How to Service Amplifiers; How to Test for Distortion; How to Test Audio Circuits; How to Test Speakers; How to Find Faults in Oscillators; How to Test Radio Parts—and it's all yours—FREE! No obligation.



SEND COUPON OR PENNY
POSTCARD FOR YOUR
FREE COPY TODAY!

FEILER ENGINEERING CO., Dept. 2M1
1601 S. Federal St., Chicago 16, Illinois

Please RUSH my FREE copy of "How to Simplify Radio Repairs."

Name
Address
City Zone State

**INDEX
OF**

Advertisers

FEB
1952

While every precaution is taken to insure accuracy, we cannot guarantee against the possibility of an occasional change or omission in the preparation of this index.

ADVERTISER	PAGE	ADVERTISER	PAGE
Aaron Electronic Sales	156	Metropolitan Overseas Supply Corp.	70
Acorn Electronics Corporation	153	Midway Company, The	141
Ad Ritz Mfg. Corp.	158	Midwest Radio & Television Corporation	116
Alliance Manufacturing Company	13	Miles Reproducer Company, Inc.	148
Allied Radio Corporation	9	Milwaukee School of Engineering	105
Altec Lansing Corporation	98	Mosley Electronics	96
Alvaradio Supply Co.	147	McConnell's	151, 154
American Phenolic Corporation	16	McGe Radio Company	86, 87
American Television & Radio Co.	102	MacMillen Company	142
Amplifier Corporation of America	133, 154	National Company, Inc.	108
Arcee Electronics Company	143	National Radio Institute	3
Arrow Sales, Incorporated	143	National Schools	Third Cover
Ashe Radio Company, Waller	89	National Union Radio Corp.	18
Astatic Corporation, The	26	Newark Surplus Materials Co.	140
Astron Corporation	141	Newell Company, The	156
Baltimore Technical Institute	152	Niagra Radio Supply Corporation	79
Bell Telephone Laboratories	10	Oak Ridge Products	134
Belmont Radio Corp.	21	Offenbach & Reimus Co.	125
Berlant Associates	138	Ohmite Mfg. Company	12
Bond Equipment Company	135	Olson Radio Warehouse, Inc.	80, 81
Boyce-Roche Book Company	88	Onan & Sons, Inc., D. W.	108
Brook Electronics, Incorporated	134	Opad-Green Company	149
Buffalo Radio Supply	111	Peak Electronics Company	123
Candler System	154	Penn Boiler & Burner Mfg. Corp.	109
Capitol Radio Engineering Institute	22, 135	Pfanstiel Chemical Company	146
Carnegie Illinois Steel Corporation	28	Phillips Manufacturing Company	160
Central Electronics Company	149	Phoenix Electronics, Inc.	126
Chelsea Television Center	135	Photocon Sales	104
Chicago Industrial Instrument Company	84	Pickering Company, Inc.	148
Chicago Transformer Company	97	Platt Electronics Corporation	118
ClaroStat	157	Poly-Tech	150
Cleveland Institute of Radio Electronics	83	Precision Electronics, Inc.	116
Color Sales Co.	120	Premier Radio Tube Co.	103
Columbia Electronic Sales	134	Progressive Electronics Company	82
Comet Electronic Sales Company	127	Pyramid Electric Company	24
Communications Equipment Company	99	Quam-Nichols Company	152
Concord Radio Corporation	69	R C A Institutes	130
Coyne Electrical & Television-Radio School	108, 138	Radio Corporation of America	Second Cover, 101, 124
Dakoline Chemical Company, Inc., The	126	Radio Craftsmen, Inc., The	78
Davis Television Supply Co.	156	Radio Distributing Company	135
De Forest-Sunabria Corporation	7	Radio Ham Shack, Inc.	107
DeForest's Training, Inc.	5	Radio Parts Company	85
Drake Company, R. L.	142	Radio Receptor Company, Inc.	123
Du Mont Laboratories, Allen B.	19	Ray Manufacturing Company	130
East Coast Electronics	96	Raytheon Manufacturing Company	29
Editors & Engineers, Ltd.	133, 139, 156	Red Arrow Sales	158
Eddie Electronics, Inc.	116	Reeves Soudercraft Corporation	146
Electro Devices, Incorporated	136	Rek-O-Kut Company, Inc.	100
Electro-Technical Industries	132	Reliance Merchandizing Company	130
Electro Voice, Inc.	129	Rider, Publisher, Inc., John F.	121
Electronic Instrument Company, Inc.	30, 130, 158	Rinehart Books, Inc.	93, 117
Electronic Measurements Corp.	142	Russell Lens Company	158
Electronics Institute, Inc.	145	Sams & Company, Howard W.	68, 126
Espey Manufacturing Company, Inc.	119	Sam's Surplus	114
Fair Radio Sales	131	Sarkes-Tarzen, Inc.	28
Feiler Engineering Company	160	Schott Company, Walter L.	119
Fisher Radio Corp.	159	Spartan School of Radio & Electronics	124
Franklin Technical Institute	152	Spencer-Kennedy Laboratories, Inc.	120
G. L. Electronics	144	Sprague Products Company	14
General Electric Company	11, 67	Sprayberry Academy of Radio	17
General Electronic Distributing Co.	90, 91	Standard Transformer Corporation	141
General Test Equipment	152	Star Electronics Distributors, Inc.	154
Goodheart, R. E.	152	Sun Radio of Washington, D. C.	96
Greenlee Tool Company	154	Supreme Publications	27
Greylock Electronics Supply Co.	145	Sylvania Electric Products, Inc.	6
Grossman, David	152	Tab	161, 162
Halliercrafters Company, The	23	Tech-Master Products Company	100
Harvard Laboratory	131	Technical Radio Parts Company	156
Harvey Radio Company	94	Television Communications Institute	159
Heath Company, The	71 thru 77	Television Supply Company	138
Henry Radio Stores	153	Telrex, Incorporated	145
Henshaw Radio Supply	148	Thomas Electronics, Inc.	70
Hunter Company, H. D.	119	Trad Television Corporation	92
Hy-Grade Electronics, Inc.	137	Transvision, Incorporated	110
Hytron Radio & Electronics Corp.	25	Tri-State College	143
Indiana Technical College	139	Triplet Electrical Instrument Co.	15
Instructograph Company	147	Tung-Sol	106
Insuline Corporation of America	92	Turner Company	137
J.F.D. Manufacturing Co., Inc.	84	Ungar Electric Tool Company, Inc.	154
Jackson Electrical Instrument Co.	113	United States Steel	20
Knepper Aircraft Service	120	University Loudspeakers Incorporated	155
La-Pointe Plascomold Corporation	124	Upstate Distributors	157
Leetronic Research Laboratories	147	V & H Radio & Electronics Supply	139
Leotone Radio Company	146	Variety Electric Company, Inc.	148
Lovell Metal Products Corporation	104	Valparaiso Tech. Institute	141
Mallory & Company, P. R.	Fourth Cover	Ward Products Corp.	133
Mass. Radio School	156	Weller Electric Corp.	8
Measurements Corporation	122	Wells Sales, Inc.	95
Merit Transformer Corporation	128	Wholesale Radio Parts	104
		World Radio Laboratories, Inc.	151
		YMCA Trade and Tech. School	135



Learn RADIO TELEVISION, ELECTRONICS

by
SHOP METHOD HOME TRAINING

Let NATIONAL SCHOOLS, of Los Angeles, a practical Technical Resident Trade School for almost 50 years, train you for today's unlimited opportunities.

You receive all parts, including tubes, for building this fine, modern Superheterodyne Receiver. This and other valuable standard equipment becomes your property.

these two FREE books will tell you how



WE BRING NATIONAL SCHOOLS TO YOU!

GOOD JOBS AWAIT THE TRAINED RADIO TECHNICIAN

You are needed in the great modern Radio, Television and Electronics industry! Trained technicians are in constant and growing demand at excellent pay—in Broadcasting, Communications, Television, Radar, Research Laboratories, Home Radio Service, etc. National Schools Master Shop Method Home Study Course, with newly added lessons and equipment, can train you in your spare time, *right in your own home*, for these exciting opportunities. Our method has been proved by the remarkable success of National Schools-trained men all over the world.

You Learn by Building Equipment with Standard Radio Parts We Send You

Your National Schools Course includes not only basic theory, but *practical* training as well—you learn by doing. We send you complete standard equipment of professional quality for building various experimental and test units. You advance step by step until you are able to build the modern superheterodyne receiver shown above, which is yours to keep and enjoy. You perform more than 100 experiments—build many types of circuits, signal generator, low power radio transmitter, audio oscillator, and other units. The Free Books shown above tell you more about it—send for them today!

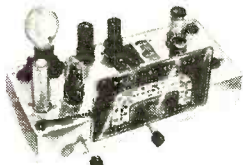

NOW! NEW PROFESSIONAL MULTITESTER INCLUDED

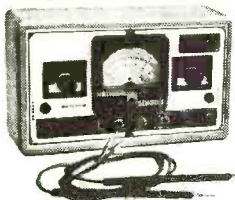

This versatile testing instrument is portable and complete with test leads. Simple to operate, accurate and dependable. You will be able to quickly locate trouble and adjust the most delicate circuits. You can use the Multitester at home or on service calls. It is designed to measure AC and DC volts, current resistance and decibels. You will be proud to own and use this valuable professional instrument.

GET THE DETAILS - SEND THE COUPON →

Lessons and Instruction Material Are Up-to-date, Practical, Interesting

National Schools Master Shop Method Home Training gives you basic and advanced instruction in all phases of Radio, Television and Electronics. Each lesson is made easy to understand by numerous illustrations and diagrams. All instruction material has been developed and tested in our own shops and laboratories, under the supervision of our own engineers and instructors. A free sample lesson is yours upon request—use the coupon below.

TELEVISION TRAINING A complete series of up-to-the-minute Television lessons is an integral part of your course, covering all phases of Television repairing, servicing and construction.

Here are just a few of the interesting facts you learn with the **FREE SAMPLE LESSON**

1. How radio receivers operate.
2. How the antenna circuit is constructed.
3. Converting signal currents into sound.
4. How the R-F transformer handles the signal.
5. How the tuning circuit functions.
6. The Radio "bands."

APPROVED FOR VETERANS
Check coupon below.

NATIONAL SCHOOLS

LOS ANGELES 37, CALIFORNIA EST. 1905



MAIL OPPORTUNITY COUPON FOR QUICK ACTION

National Schools, Dept. 2-RN
4000 South Figueroa Street
Los Angeles 37, California

(Mail in envelope or paste on penny postcard.)

Mail me FREE the book "Your Future in Radio-Television" and the sample lesson of your course. I understand no salesman will call on me.

NAME _____ AGE _____

ADDRESS _____

CITY _____ ZONE _____ STATE _____

Check here if veteran of World War II

Don't gamble with comebacks!

Hundreds of servicemen, interviewed in a recent survey, say that to avoid comebacks they use Mallory Vibrators. For right-the-first-time jobs, their rule is . . .



Make Sure! Make it Mallory!

We called on every serviceman in the phone book—in widely scattered cities—talked to every one we could find in his shop. We found that servicemen prefer Mallory vibrators in a ratio of two to one over any other brand!

Why? Better performance! Longer life! Less service trouble!

Mallory vibrators give you the performance you want because of experience dating back to the first commercial vibrator development—because of a patented design that gives you positive starting, quiet operation, long life. Mallory gives you a better vibrator, available in a complete line, meeting original equipment specifications . . . and you pay no more.

Don't just order vibrators. Order Mallory! Get the benefit of the precision quality that is the reason for more Mallory vibrators being used in original equipment than all other makes combined.

Depend on your Mallory Distributor for precision quality at competitive prices.



P. R. MALLORY & CO. Inc.
MALLORY

CAPACITORS • CONTROLS • VIBRATORS • SWITCHES • RESISTORS
• RECTIFIERS • VIBRAPACK† POWER SUPPLIES • FILTERS

*Reg. U. S. Pat. Off.

APPROVED PRECISION PRODUCTS

P. R. MALLORY & CO., Inc., INDIANAPOLIS 6, INDIANA