

FEBRUARY

1946

35c

In Canada 40c

# RADIO NEWS

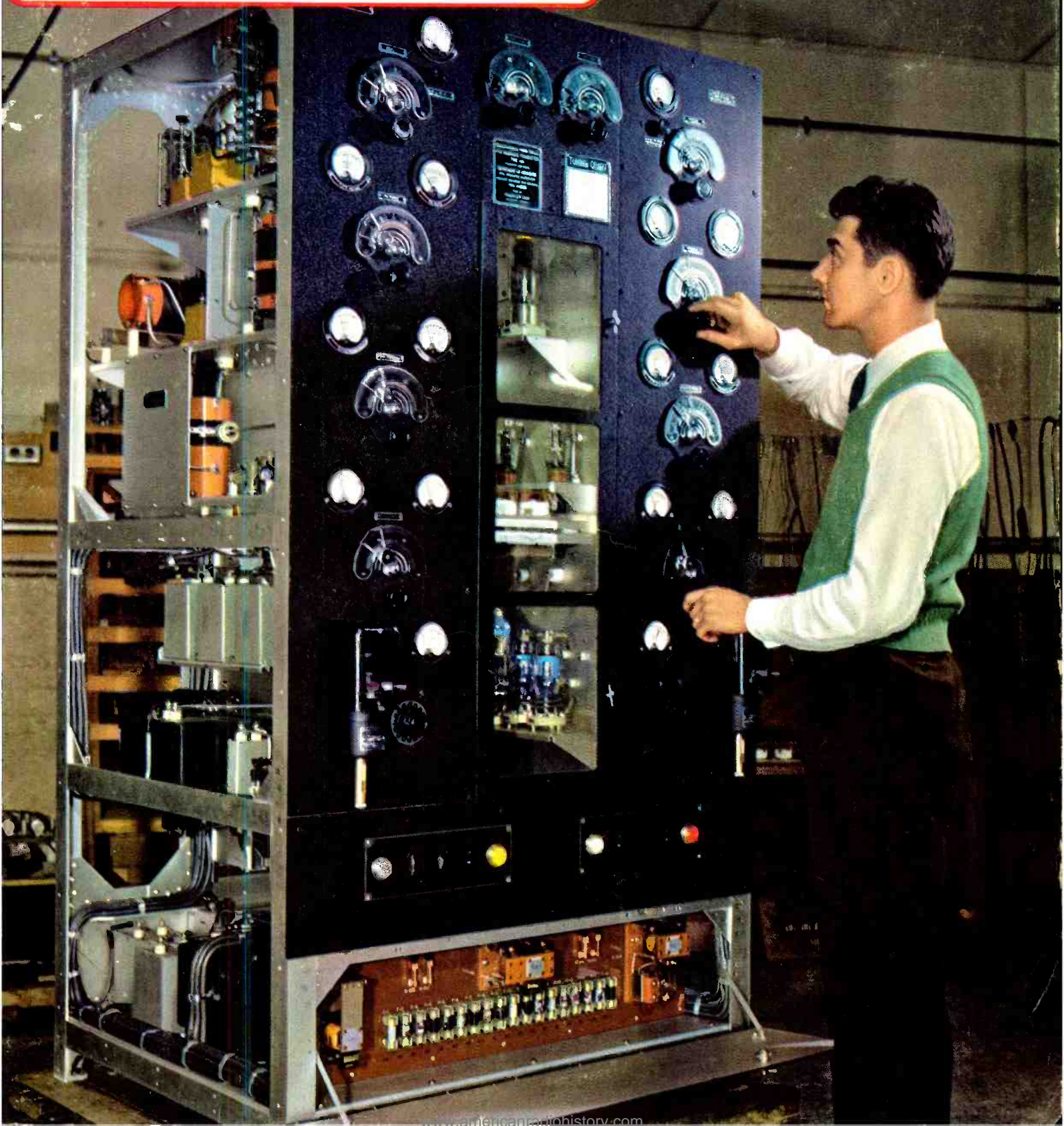

# New!

## Series 200

# A RELAY BY GUARDIAN with Interchangeable Coils

### BUILT IN TWO PARTS

A.C. Coil Assemblies available for 6 v., 12 v., 24 v., 115 v.  
D.C. Coil Assemblies available for 6 v., 12 v., 24 v., 32 v., 110 v.

★ Two basic parts—a coil assembly and a contact assembly—comprise this simple, yet versatile relay. The coil assembly consists of the coil and field piece. The contact assembly consists of switch blades, armature, return spring, and mounting bracket. The coil and contact assembly are easily aligned by two locator pins on the back end of the contact assembly which fit into two holes on the coil assembly. They are then rigidly held together with the two screws and lock washers. Assembly takes only a few seconds and requires no adjustment on factory built units.

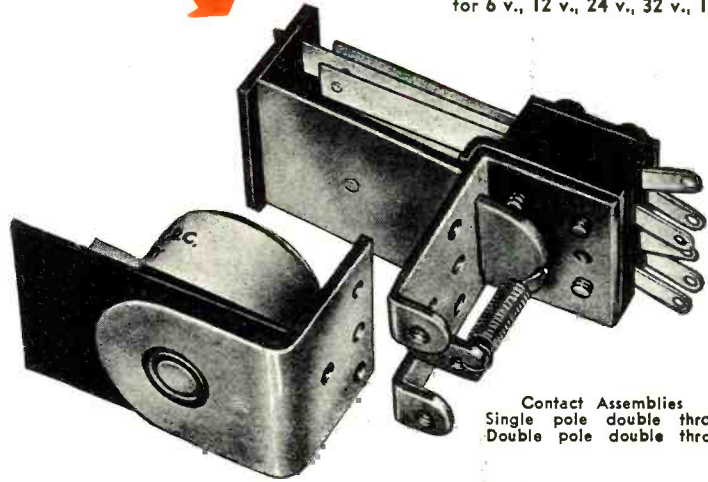

Contact Assemblies  
Single pole double throw  
Double pole double throw

SERIES 200 RELAY

## On Sale at Your Nearest Jobber NOW!

See it today! . . . this amazing new relay with interchangeable coils. See how you can operate it on any of nine different a-c or d-c voltages—simply by changing the coil. Ideal for experimenters, inventors, engineers.

### TWO CONTACT ASSEMBLIES

The Series 200 is available with a single pole double throw, or a double pole double throw contact assembly. In addition, a set of Series 200 Contact Switch Parts, which you can buy separately, enables you to build dozens of other combinations. Instructions in each box.

### NINE COIL ASSEMBLIES

Four a-c coils and five d-c coils are available. Interchangeability of coils enables you to operate the Series 200 relay on one voltage or current and change it over to operate on another type simply by changing coils.

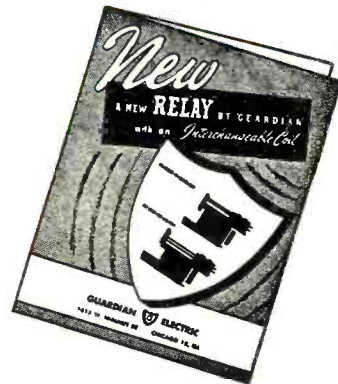

Your jobber has this sensational new relay on sale now. Ask him about it. Or write for descriptive bulletin.

# GUARDIAN ELECTRIC

1630-B W. WALNUT STREET CHICAGO 12, ILLINOIS  
A COMPLETE LINE OF RELAYS SERVING AMERICAN INDUSTRY



**RADIO SERVICING** pays good money for full time work. Many others make \$5. \$10 a week EXTRA fixing Radios in spare time

Building this **A. M. SIGNAL GENERATOR** gives you valuable experience. Provides amplitude-modulated signals for test and experiment purposes.

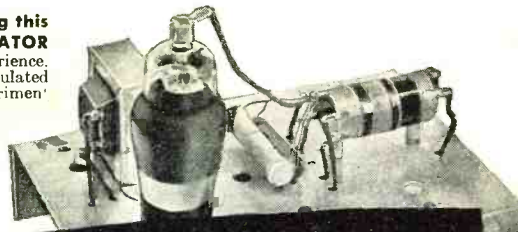

# Learn RADIO by PRACTICING in Spare Time

## with 6 Big Kits of Radio Parts I Send You

Let me send you facts about rich opportunities in Radio. See how knowing Radio can give you security, a prosperous future. Send the coupon for FREE 64-page book, "Win Rich Rewards in Radio." Read how N.R.I. trains you at home. Read how you practice building, testing, repairing Radios with SIX BIG KITS of Radio parts I send you.

**Future for Trained Men is Bright in Radio, Television, Electronics**

The Radio Repair business is booming NOW. There is good money fixing Radios in your spare time or own full time business. Trained Radio Technicians also find wide-open opportunities in Police, Aviation, Marine Radio, in Broadcasting, Radio Manufacturing, Public Address work, etc. Think of the boom coming now that new Radios can be made! Think of even greater opportunities when Television and Electronics are available to the public!

**Many Beginners Soon Make \$5, \$10 a Week EXTRA in Spare Time**

The day you enroll I start sending EXTRA MONEY JOB SHEETS to help you make EXTRA money fixing Radios in spare time while learning. You LEARN Radio principles from my easy-to-grasp Lessons—PRACTICE what you learn by building real Radio Circuits with Radio parts I send—USE your knowledge to make extra money in spare time.

**Mail Coupon for Free Copy of Lesson and 64-Page Illustrated Book**

I will send you FREE a sample lesson, "Getting Acquainted with Receiver Servicing," to show you how practical it is to train for Radio in spare time. With it I'll send my 64-page, illustrated book, "Win Rich Rewards in Radio." Just mail coupon in an envelope or paste it on a penny postal. **J. E. Smith, President, Dept. 6BR, National Radio Institute, Pioneer Home Study Radio School, Washington 9, D. C.**

MY COURSE INCLUDES TRAINING IN **TELEVISION • ELECTRONICS**



You build this **MEASURING INSTRUMENT** you sell early in the course—use it for practical Radio work on neighborhood Radios to pick up EXTRA spare time money!

You build this **SUPERHETERODYNE CIRCUIT** that brings in local and distant stations. You get practical experience putting this set through fascinating tests.

## BE A SUCCESS in RADIO I Will Train You at Home

### Sample Lesson FREE



Gives hints on Receiver Servicing, Locating Defects, Repair of Loudspeaker, I. F. Transformer, Gang Tuner, Condenser, etc., 31 illustrations. Study it—keep it—use it—without obligation! Mail Coupon NOW for your copy!



## GET BOTH 64 PAGE BOOK FREE SAMPLE LESSON

**MR. J. E. SMITH, President, Dept. 6BR NATIONAL RADIO INSTITUTE, Washington 9, D. C.**

Mail me FREE, without obligation, Sample Lesson and 64-page book about how to win success in Radio and Television—Electronics. (No salesman will call. Please write plainly.)

Name..... Age.....  
Address.....  
City..... Zone..... State..... 4FR



**AMATEUR**

A Resonant Cavity Wavemeter.....*Jordan McQuay* 36  
 Self-Synchronous Transmission System.....*Erik Hansen* 38  
 Wide-Range Converter-Receiver.....*Lt. Col. Byron E. Hargrove* 40  
 Velocity Modulation.....*James E. Kauke* 44  
 Analysis of Parasitic Oscillations in  
 Radio Transmitters.....*John S. Jackson, W9DZR* 68

**SERVICE**

Universal Test Instrument.....*McMurdo Silver* 32  
 As I See It!.....*John Rider* 35  
 Multi-Range Milliammeter.....*Rufus P. Turner* 49  
 Practical Radio Course.....*Alfred A. Ghirardi* 50  
 Phase Inverters.....*Harold A. Bustard* 57

**GENERAL**

For the Record..... 8  
 Spot Radio News..... 12  
 Future of Electronics in Aviation...*John D. Goodell & Donald J. Coleman* 25  
 Spotting and Repeating Record Player.....*R. H. Bailey* 29  
 A Writing Cathode-Ray Tube.....*Lt. Hugh Lineback, USNR* 30  
 International Short-Wave.....*Kenneth R. Boord* 43  
 Television Must Sound Right.....*Richard Hubbell* 46  
 QTC.....*Carl Coleman* 48  
 Let's Talk Shop.....*Joe Marty* 53  
 Saga of the Vacuum Tube.....*Gerald F. J. Tyne* 54  
 What's New in Radio..... 64  
 Within the Industry..... 124  
 Letters from Our Readers..... 138

**EDITORIAL**

**OLIVER READ, W9ETI**  
*Editor*

**WM. A. STOCKLIN**  
*Ass't to the Editor*

**HAROLD S. RENNE**  
*Technical Editor*

**RAY FRANK, W9JU**  
*Amateur Radio*

**FRED HAMLIN**  
*Washington Editor*

**E. H. SEHNERT**  
*Chief Draftsman*

**R. S. KUPJACK**  
*Staff Artist*

**ADVERTISING**

**L. L. OSTEN**  
*Advertising Mgr.*

**JOHN A. RONAN, JR.**  
*Midwest Adv. Mgr.*

**WM. L. PINNEY**  
*Western Adv. Mgr.*



Cover Photo  
 By FRANK ROSS

COPYRIGHT, 1946 ZIFF-DAVIS PUBLISHING COMPANY  
 185 N. Wabash Ave., Chicago 1, Ill.

BRANCH OFFICES: NEW YORK, WASHINGTON, LOS ANGELES, TORONTO

**WILLIAM B. ZIFF**  
*Publisher*

**B. G. DAVIS**  
*General Manager*

**C. R. TIGHE**  
*Ass't to the Publisher*

**GEORGE BERNER**  
*Advertising Director*

**HERMAN R. BOLLIN**  
*Art Director*

**H. G. STRONG**  
*Circulation Director*

**H. J. MORGANROTH**  
*Production Director*

Transmitter used in the simultaneous radio range equipment manufactured by the Wilcox-Gay Corp. for CAA peace-time airways. Feature of the equipment is that a single dial telephone operates the complete equipment. Frequency of this service is between 200 to 400 kc. and has a service area of approximately 200 miles in diameter.



RADIO NEWS is published monthly by the Ziff-Davis Publishing Company, 185 N. Wabash Ave., Chicago 1, Ill. Subscription Rates: in U. S. \$3.00 (12 issues), single copies 35 cents; in Mexico, South and Central America, and U. S. Possessions, \$3.00 (12 issues); in Canada \$3.50 (12 issues), single copies 40 cents; in British Empire, \$4.00 (12 issues); all other foreign countries \$4.00 (12 issues). Subscribers should allow at least 2 weeks for change of address. All communications about subscriptions should be addressed to: Director of Circulation, 185 N. Wabash Ave., Chicago 1, Ill. Entered as second class matter March 9, 1938, at the Post Office, Chicago, Illinois, under the Act of March 3, 1879. Entered as second class matter at the Post Office Dept., Ottawa, Canada. Contributors should retain a copy of contributions and include return postage. Contributions will be handled with reasonable care but this magazine assumes no responsibility for their safety. Accepted material is subject to whatever revisions and by-line changes that are necessary. Payment, made at our current rates, covers all authors', contributors', or contestants' rights, title, and interest in and to accepted material, including photos and drawings.

Other Ziff-Davis Publications: Radio & Appliances, Radio-Electronic Engineering, Plastics, Flying, Popular Photography

# hallicrafters *new Model* S-40

New beauty and perfect ventilation in the perforated steel top

Separate electrical bandspread with inertia flywheel tuning.

Tuning range from 540 kc to 42 Mc continuous in four bands

Self-contained, shock mounted, permanent magnet dynamic speaker

All controls logically grouped for easiest operation. Normal position for broadcast reception marked in red, making possible general use by whole family.



Automatic noise limiter

3-position tone control

Standby receive switch

Phone jack

**New design, new utility in a great new communications receiver . . .**

(APPROXIMATELY)

**\$79<sup>50</sup>**

Here is Hallicrafters new Model S-40. With this great communications receiver, handsomely designed, expertly engineered, Hallicrafters points the way to exciting new developments in amateur radio. Read those specifications . . . it's tailor-made for hams. Look at the sheer beauty of the S-40 . . . nothing like it to be seen in the communications field. Listen to the amazing performance . . . excels anything in its price class. See your local distributor about when you can get an S-40.

**INSIDE STUFF:** Beneath the sleek exterior of the S-40 is a beautifully engineered chassis. One stage of tuned radio frequency amplification, the S-40 uses a type 6SA7 tube as converter mixer for best signal to noise ratio. RF coils are of the permeability adjusted "micro-set" type identical with those used in the most expensive Hallicrafters receivers. The high frequency oscillator is temperature compensated for maximum stability.

*From every angle the S-40 is an ideal receiver for all high frequency applications.*

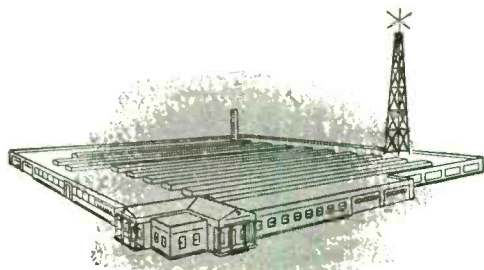

COPYRIGHT 1945 THE HALLICRAFTERS CO.

February, 1946

## hallicrafters RADIO

THE HALLICRAFTERS CO., MANUFACTURERS OF RADIO AND ELECTRONIC EQUIPMENT, CHICAGO 16, U. S. A.

Sole Hallicrafters Representatives in Canada: Rogers Majestic Limited, Toronto - Montreal



# 1946



As the bright hope of the New Year lights up the horizon, we turn our vast facilities . . . the pent-up good will accumulated over a quarter of a century of radio leadership . . . to the task of making 1946 the most spectacular sales year in the history of FADA dealers.

FADA has done great things in the past. But they are only a stepping stone to what the future will bring. And — we'll fortify this exciting line of radio receivers with a wall-packed program of dealer helps that will bring more and more customers into the sales rooms of FADA dealers.

Illustrated here are two more point-of-sale helps . . . a beautiful and sturdy stand for the display of FADA radios and a colorful window or store door decalomania designed to get immediate attention. A few FADA dealer franchises are still available. We suggest that you communicate with your distributor or with us, now!



YOU CAN ALWAYS DEPEND ON

# FADA Radio

OF THE FUTURE

*Famous Since Broadcasting Began!*

**FADA RADIO AND ELECTRIC COMPANY, INC., LONG ISLAND CITY, N. Y.**

# I'LL SHOW YOU HOW TO SUCCEED IN RADIO

Here's the right training for Big Post-War Pay!



F. L. Sprayberry, one of the country's foremost Radio Teachers.

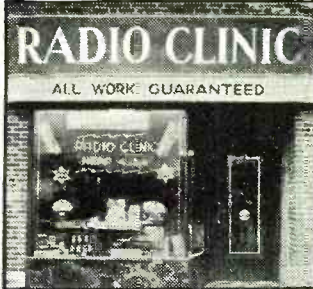

A RADIO SERVICE BUSINESS OF YOUR OWN

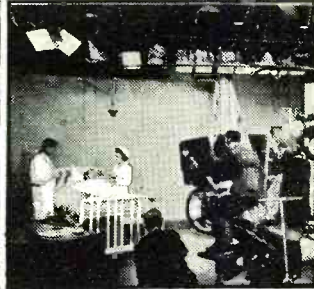

A GOOD JOB IN RADIO & TELEVISION BROADCASTING

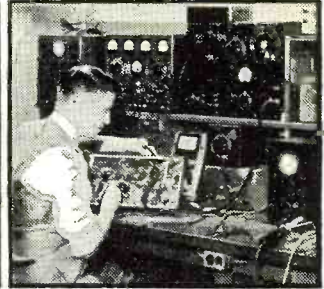

RADIO-ELECTRONIC SERVICE ENGINEER

## BE A RADIO-ELECTRONICIAN

NOW YOU CAN PREPARE AT HOME IN SPARE TIME FOR AMAZING OPPORTUNITIES AHEAD IN RADIO — ELECTRONICS — TELEVISION



I SUPPLY A FULL RADIO SET for practical easy LEARNING

SPRAYBERRY TRAINING GIVES YOU BOTH TECHNICAL KNOWLEDGE—SKILLED HANDS

There's only one right way to learn Radio Electronics. You must get it through simplified lesson study combined with actual "shop" practice under the personal guidance of a qualified Radio Teacher. It's exactly this way that Sprayberry trains you... supplying real Radio parts for learn-by-doing experience right at home. Thus, you learn faster, your understanding is clear-cut, you acquire the practical "know how" essential to a good-paying Radio job or a Radio business of your own.

I'll Show You a New, Fast Way to Test Radio Sets Without Mfg. Equipment

The very same Radio Parts I supply with your Course for gaining pre-experience in Radio Repair work may be adapted through an exclusive Sprayberry wiring procedure to serve for complete, fast, accurate Radio Receiver trouble-shooting. Thus, under Sprayberry methods, you do not have one cent of outlay for manufactured Test Equipment which is not only expensive but scarce.

DON'T PUT IT OFF!

Get the facts about my training—now! Take the first important step toward the money-making future of your dreams. All features are fully explained in my big, illustrated FREE Catalog which comes to you along with another valuable FREE book you'll be glad to own. Mail Coupon AT ONCE!

ATTENTION VETERANS!

The Sprayberry Radio-Electronics Home Study Course has been fully approved for Veterans Training under the G.I. Bill of Rights. This is important to you! It's your opportunity to get our complete Radio Training through Government grant. Find out about your eligibility AT ONCE!

The offer I make you here is the opportunity of a lifetime. It's your big chance to get ready for a wonderful future in the swiftly expanding field of Radio-Electronics INCLUDING Radio, Television, Frequency Modulation and Industrial Electronics. Be wise! NOW'S the time to start. Opportunities ahead are tremendous! No previous experience is necessary. The Sprayberry Course starts right at the beginning of Radio. You can't get lost. It sets the various subjects across in such a clear, simple way that you understand and remember. And, you can master my entire course in your spare time. It will not interfere in any way with your present duties. Along with your training, you will receive my famous BUSINESS BUILDERS which will show you how to make some nice profits while learning.

Prepares You for a Business of Your Own Or Good Radio Job

My training will give you the broad, fundamental principles so necessary as a background, no matter which branch of Radio you wish to specialize in. I make it easy for you to learn Radio Set Repair and Installation Work. I teach you how to install and repair Electronic Equipment. In fact, you'll be a fully qualified RADIO-ELECTRONICIAN, equipped with the skill and knowledge to perform efficiently and to make a wonderful success of yourself.

JUST OUT! FREE!

"How to Read Radio Diagrams and Symbols" a valuable new book which explains in simple English how to read and understand any Radio Set Diagram. Provides the quick key to analyzing any Radio circuit. Includes translations of all Radio symbols. Send for this FREE book now, and along with it I will send you another big FREE book describing my Radio-Electronic training.

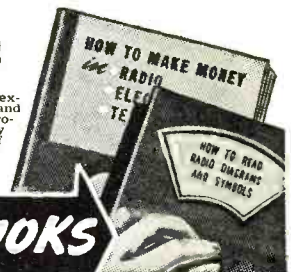

GET FREE BOOKS

SPRAYBERRY ACADEMY OF RADIO  
F. L. Sprayberry, Pres.  
Room 2526

Pueblo, Colorado

Please rush my FREE copies of "HOW TO MAKE MONEY IN RADIO, ELECTRONICS and TELEVISION" and "HOW TO READ RADIO DIAGRAMS and SYMBOLS."

Name ..... Age.....  
Address .....  
City ..... State.....  
Tear off this coupon, mail in envelope or paste on penny postcard.

# AUDAX

RELAYED-FLUX  
Microdyne

## The Importance of SPECIALIZATION

Aside from outstanding and long-acknowledged technical skill—our "Specialization Formula" is probably as fully responsible for the world-renowned AUDAX quality as any other single factor.

We proudly concentrate all our energies and resources upon producing the BEST pick-ups and cutters. Because we are specialists in this field, much more is expected of us. Because the production of fine instruments like MICRODYNE is a full time job, it stands to reason that we could not afford to jeopardize our reputation—EVER—by making pick-ups a side-line.

Now that Victory is ours, you may expect AUDAX improvements, refinements . . . master-touches to heighten the marvelous facsimile realism of AUDAX reproduction.

**AUDAX COMPANY**  
500-N Fifth Ave., New York 18, N. Y.

Creators of Fine Electronic-Acoustical Apparatus Since 1915

Send for complimentary copy of our Informative

"PICK-UP FACTS"

★ BUY WAR BONDS

"The Standard by Which Others Are Judged and Valued"



## For the RECORD.

BY THE EDITOR

THE confidence implied by letters we are receiving from hundreds of our ex-fighting men readers asking for advice in solving their problem of reconversion to civilian life is flattering but frightening. We have coming across our desk a reflection of the high hopes of our American youth combined with a puzzlement created by the fact they are staring reality in the face without fully recognizing it.

To be perfectly frank, we too are baffled. We know the radio industry is rich in potentialities. Engineering, manufacturing, selling, distributing, retailing, servicing—all branches of our great industry will need the same inspired effort in peacetime which made us the electronic masters of warfare. The question is how, where, and when will the individual ex-soldier fit into the gigantic pattern. For us to answer these questions at this writing date would require the wisdom of a Solomon. Why? The industry is at a standstill, frozen to a full stop by the bleak situation which engulfs the major portion of our entire national economy. No parts to assemble, cumbersome pricing formulae, labor problems, are all factors which are contributing to the reconversion stalemate.

To you who are eager to get into the harness of peacetime radio activity, we can only recommend that you spend your time, until the industrial log jam breaks, studying all sections of the industry in relation to your own ambitions and capabilities.

Here's a suggestion for organizing your thinking and developing a campaign. Get lots of paper and plenty of pencils. Jot down all the jobs you think you might be able to handle based on your training. Now check off those you'd most like to have. Do you want to work with a manufacturer in production work, or in research work, or in sales work? Maybe you'd like to get into sales engineering. This is a tough job because you're always in the middle. You have to prove to customers that your company's product is right without arousing the customer's ire by inferring that his product is wrong. If you find your company is wrong, you have to convince them without angering your own engineering or production people.

We heard some statistics the other day which were astounding to us. At one army separation center of 20,000 men only 18 expressed a desire to get into sales work. This condition is almost incredible as it is an established fact that the need for good salesmen is an eternal want of indus-

try and the rewards are rich for those who succeed.

Perhaps you'd like to work with a distributor selling or servicing? It could be that retailing appeals to you because you like direct contact with the public? Here again you may either sell or service or combine both activities. After you have made your selections and set your objectives, make a list of companies where you think you'd like to work. If possible, find out the name of the executive in charge of the department or division where you'd like to land. Write him a letter or, better yet, if he's nearby call him on the phone. When you write or call him, don't tell him you're looking for a job. Tell him, or his secretary, you've been given to understand that he might be willing to give business advice to a veteran considering the radio industry as a life work. Tell him that you know he's busy and have no intention of taking more than five or ten minutes of his time and "by the way I'm not taking any jobs until I've had the opportunity of talking with a number of executives like yourself."

Don't get discouraged. Keep on seeking interviews with as many executives as possible. Don't let a few rebuffs dishearten you. These men are all caught in the log jam. They may not intend to be cold or impolite, but business pressures have made many jittery. You will find, on the average, the business executive who is really a big man mentally will spare the time to advise you.

This process of investigation will familiarize you with the many aspects of the industry and if you'll review your findings calmly and analytically, it may change your whole idea of what you'd like to do. You may even be offered a job. Don't turn it down just because it does not pay much. Make your decision to accept or reject it on how well you like the atmosphere of the company and the character of the man who offers it to you. Many business executives will offer low pay to test your metal. Advancements usually come rapidly to the fellow who devotes his best brain power and physical power to the task at hand without wasting energy on trying to get a raise.

We hope the thoughts we have set forth here will help some of you to clarify your thinking. We are all feeling our way in a mist of uncertainties these days. These mists will lift in the next few months and we can but hope that our compass setting will have steered you to the harbor of a successful future in the radio industry. . . . . O. R.



# ORDER YOUR NEW COMMUNICATIONS RECEIVER

NOW from ALLIED.. For Earliest Delivery

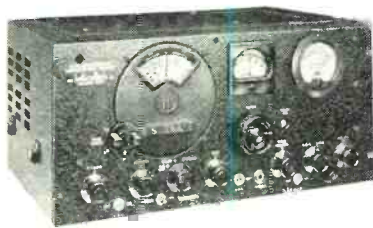

## HALLICRAFTERS S-36A

Hallicrafters' most advanced development in very - high - frequency, high-fidelity receivers. Combines AM, FM, and CW reception. Frequency range 27.8 Mc. to 143 Mc. continuous in 3 bands. Covers old and new FM bands. RF stage with acorn tube. Push-pull high fidelity output

stage. Four position tone control with bass boost. Sharp-broad selectivity switch. Dual purpose "S" and tuning meter. Oscillator compensated for frequency drift. Hermetically sealed transformers and reactors. Beat frequency oscillator, pitch variable from panel. Designed for service in any climate. Net..... \$415

PM23 Speaker, Net..... \$15.00



## HALLICRAFTERS SX-28A

Famous Super Sky-Rider. Frequency range 550 kc. to 42 Mc. continuous in 6 bands. Main tuning dial accurately calibrated in megacycles. Separate calibrated bandspread dial. Two r.f. stages. Lamb type 3 stage adjustable noise limiter.

Six position i.f. and crystal filter selectivity switch. Oscillator temperature compensated for frequency drift. Inertia flywheel tuning and pre-loaded gear drive on main and bandspread dials. Push-pull 8 watt output stage. Net..... \$223

PM23 Speaker, net..... \$15.00



## ECHOPHONE EC-1A

Popular low-cost communications-type short-wave and broadcast receiver, with many new features. Covers entire tuning range from 550 kc. to 30 Mc. in 3 bands. For 115-125 volts AC-DC. Electrical bandspread on all bands with separate tuning control and dial. Dial calibrated in megacycles. Beat frequency oscillator

for CW reception. Automatic noise limiter. Built-in PM dynamic speaker. Headphones or speaker selected by panel switch. Housed in metal cabinet with gray wrinkle haked-on finish. Net..... \$29.50

Available on Time-Payments  
Trade-ins Accepted

BE ONE OF THE FIRST to own and enjoy one of these celebrated receivers. All models cover amateur, short-wave, and broadcast bands. War-proved features . . . plus latest engineering developments. Allied is a leader in the distribution of communications receivers. Place your order now for earliest delivery.

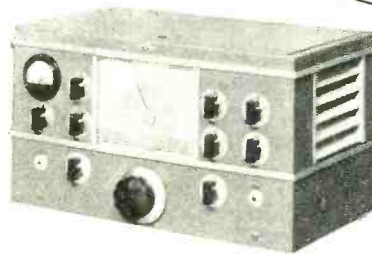

## NATIONAL NC-2-40C

One of National's top receivers. 490 kc. to 30 Mc. range in 6 tuning bands. Definite, accurate calibration for all bands. Actual single dial control.

Stable high frequency circuits. Frequency drift reduction to a negligible value by temperature compensation. Automatic voltage stabilization. Wide range adjustable series-valve-noise limiter. Flexible crystal filter. Phonograph or high level microphone pick-up jack. Special r.f. coupling circuits maintain full sensitivity. Net..... \$225

Speaker in matching cabinet, net..... \$15.00



## HAMMARLUND HQ-129X

Designed to meet the most critical demands of professional operators. Full range .54 to 31 Mc., accurately calibrated. 4 calibrated Ham bands and one arbitrary scale. Variable selectivity crystal filter. Low-drift beat oscillator for code and

locating stations. Antenna compensator. Voltage regulation. Compensated oscillator to reduce drift during warm-up. Automatic noise limiter. Earphone jack. 3 i.f. amplifier stages. 2 audio stages. For phone or CW. Net..... \$129

Speaker, net..... \$10.50

### Other well-known receivers such as:

Hallicrafters SX-25 .....	\$ 94.50
Hallicrafters S-20R .....	60.00
Hallicrafters S-22R .....	74.50
Hallicrafters S-39 .....	110.00
National HRO .....	197.70
PM23 Speaker .....	15.00

Net, F.O.B. Chicago  
(All prices subject to possible change)

# ALLIED RADIO

Everything in Radio and Electronics

833 W. Jackson Blvd. • Chicago 7, Illinois

SEND YOUR ORDER TODAY FOR EARLIEST DELIVERY

ALLIED RADIO CORP., L. M. Dezettel W9SFW  
833 West Jackson Blvd., Dept. 1-8B-6  
Chicago 7, Illinois

Please enter order for

Date.....

Model.....

Enclosed \$ .....  Full Payment  
 Part Payment (Balance C.O.D.)

Please send full information on Communications Receivers and Time Payment Plan, without obligation.

Name.....

Address.....

City..... Zone..... State.....

# DON'T SETTLE FOR LESS THAN:

*the Best*

When you must service any and all models of radio sets, only Rider Manuals can fill the need.

For sixteen years Rider Manuals have been furnishing complete and authentic servicing data on American radio receivers. Today they represent the only single source upon which you can depend for all the information you need on such vital material as voltage data, alignment data, resistance values, chassis layouts and wiring, trimmer connections—in fact all the things that lead to a quick diagnosis of troubles in ailing receivers.

—And they're complete! Since the publication of Volume I over 42,000 models have been covered—only Rider Manuals contain wiring diagrams on Scott receivers. (These diagrams were received officially from the E. H. Scott Radio Labs., Inc.)

There are good reasons why better servicing shops have waited during the war until they could get their Rider Manuals. There are better reasons today why you should not settle for less than "The Best." For, the flow of Rider Manuals is again approaching normal.

See your jobber and place your order today to guarantee fastest possible delivery.



(See Prices Below)

## GET ON THE MAILING LIST FOR "SUCCESSFUL SERVICING"

A monthly paper, dedicated to the financial and technical advancement of the electronic and radio maintenance man. Free distribution—Just

### MAIL COUPON

JOHN F. RIDER PUBLISHER, INC.  
404 (a) FOURTH AVE., NEW YORK, N. Y.

NAME \_\_\_\_\_

ADDRESS \_\_\_\_\_

CITY \_\_\_\_\_

STATE \_\_\_\_\_

### YOU MUST STUDY TO KEEP UP TO DATE

<b>RIDER MANUALS (14 VOLUMES)</b>	<b>Frequency Modulation</b> Gives principles of FM radio . . . \$2.00	<b>Automatic Frequency Control Systems</b> —also automatic tuning systems . . . \$1.75
Volumes XIV to VII . . . \$12.50 each volume	<b>Servicing by Signal Tracing</b> Basic Method of radio servicing . . . 4.00	<b>A-C Calculation Charts</b> Two to five times as fast as slide rule . . . 7.50
Volumes VI to III . . . 9.50 each volume	<b>The Meter at Work</b> An elementary text on meters . . . 2.00	<b>Hour-A-Day-with-Rider Series—</b>
<b>Abridged Manuals I to V</b> (1 volume) . . . . . \$15.00	<b>The Oscillator at Work</b> How to use, test and repair . . . . 2.50	On "Alternating Currents in Radio Receivers"
<b>Automatic Record Changers and</b> <b>Recorders</b> . . . . . 7.50	<b>Vacuum Tube Voltmeters</b> Both theory and practice . . . . 2.50	On "Resonance & Alignment"
<b>The Cathode Ray Tube at Work</b> Accepted authority on subject . . . 4.00		On "Automatic Volume Control"
		On "D-C Voltage Distribution" . . . 1.25 each

**JOHN F. RIDER PUBLISHER, INC. 404 FOURTH AVE., N. Y. 16, N. Y.**

Export Division: Rocke-International Electric Corp. 13 E. 40th Street, New York Cable: ARLAB

*—and Don't  
Forget*

# RIDER MANUALS

*are Now Complete  
in 14 Volumes*

They Provide Schematics and Essential Servicing Data on American Made Radio Receivers.



## TYPE 162-C Rider Chanalyst

HOW this  
RCA CHANALYST helps  
you test radios faster

**T**HE RCA Type 162-C *simplifies and speeds* up many types of radio trouble-shooting, testing, and repair jobs—saves worry, work, and time.

Because it analyzes the *signal* itself in any part of a radio receiver, the same method of analysis can be used with *all* receivers, old or new, simple or complicated. You can locate quickly and without guesswork the precise stage where distortion, hum, noise, low sensitivity and other defects first appear.

This instrument even helps to solve the

problem of intermittent troubles by indicating how far the signal has passed through the receiver when the intermittent develops. All tests can be made without introducing distortion or otherwise interfering with the operation of the set.

Service records show that several months' use more than pays for the cost of this labor- and money-saving instrument. Be sure to get your name on your RCA Distributor's reservation list so that you will be among the first to get one of the Chanalysts now in production.

### GET OUT THE SCISSORS—TODAY

Radio Corporation of America  
Test and Measuring Equipment Section  
Box 70B, Camden, New Jersey

Please send me your publication on the RCA 162-C Chanalyst which tells what this instrument does and how to use it.

Name \_\_\_\_\_

Street Address \_\_\_\_\_

City \_\_\_\_\_ Zone \_\_\_\_\_ State \_\_\_\_\_

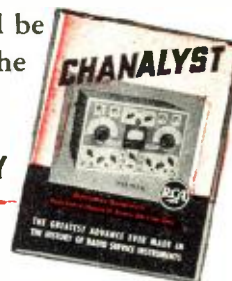

TEST AND MEASURING EQUIPMENT

**RADIO CORPORATION  
of AMERICA**

ENGINEERING PRODUCTS DIVISION, CAMDEN, N. J.

February, 1946

Designed for



Application

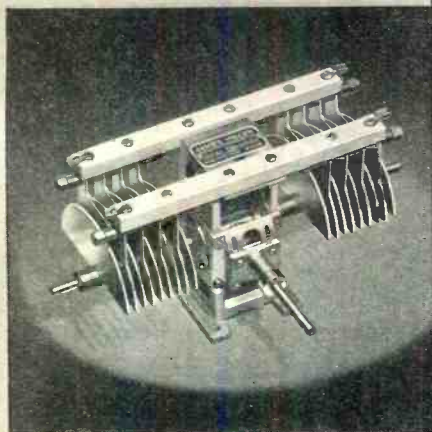

### 04000 Series Transmitting Condensers

A new member of the "Designed for Application" series of transmitting variable air capacitors is the 04000 series with peak voltage ratings of 3000, 6000, and 9000 volts. Right angle drive, 1/1 ratio. Adjustable drive shaft angle for either vertical or sloping panels. Sturdy construction, thick, rounded, polished aluminum plates with 1 3/4" radius. Constant impedance, heavy current, multiple finger rotor contactor of new design. Available in all normal capacities.

## JAMES MILLEN MFG. CO., INC.

MAIN OFFICE AND FACTORY  
MALDEN  
MASSACHUSETTS



# Spot Radio News

★ Presenting latest information on the Radio Industry.

By **F. D. WALKER**

Washington Reporter

**THE FEDERAL COMMUNICATIONS COMMISSION** made radio history early in December when it authorized Garwood Irrigation Company of Texas to construct a radio system for use in the operation of irrigation networks serving 100,000 acres of rice and other crops. It was the first such application filed with FCC.

The company operates 200 miles of canals and many miles of irrigating ditches for the benefit of approximately 100 ranches, and without these waterways no crops could be raised in that section of Texas. The radio system will be substituted for the present methods of communication—messengers traveling on horseback or by automobile. These methods are so slow that much damage can be done to crops by either too much or too little water.

Currently, three men continuously patrol the entire system in cars. Canal riders must be in touch with each other and with the pumping plants, so the plants know how much water to pump and the canal riders know how to distribute it. For years, the only way a canal rider could communicate with the plants, another canal rider, or a water patrol was to drive until he could meet the person he sought. All that will be changed when the shift to radio is made. The FCC authorization permits the Garwood company to build a land station and two 50-watt portable and mobile units and four 35-watt mobile units. The frequency assigned is 35.46 mc., and the equipment is FM Link, Model 50, UFS.

**OPA HAD ADVANCED** early in December to a fairly satisfactory pricing program for the reconversion period, and the first of a series of weekly reports on specific retail price tags for radio sets and portable phonographs was issued three weeks before Christmas. The price approvals are handled through the OPA's housewares and accessories price branch.

Few sets reached the Christmas holiday buying market, and R. C. Cosgrove, president of *Radio Manufacturers' Association*, predicted that radio sets would not be in "free supply" before the middle or latter part of 1946. He attributed the delay to "inexcusable" OPA delays in ironing out the pricing problem which could have

been solved more than three months ago. He accused OPA of failing to make "a determined effort to arrive at an equitable solution."

But Cosgrove is optimistic, as this statement proves: "There never has been in the past any handicap that hasn't been overcome. While many handicaps have faced the industry, this last one has been man-made and is, therefore, inexcusable. However, I have yet to find the manufacturer who isn't aggressively swinging with both fists, and determined to move up in this industry and get a larger share of the business than he received before; and I have yet to find a manufacturer who doesn't confidently believe he will make and sell a great deal more products than ever before."

His optimism is shared by the Civilian Production Administration, which estimates that employment in the radio manufacturing industry by June, 1946, will reach a peace-time peak almost 2 1/2 times above the 1939 level and only 20 per-cent lower than the first quarter of 1945, when it rose to 550,000.

**FCC HAS REORGANIZED** its engineering department to help expedite its sharply increased postwar load. The broadcast division has been re-named the broadcast branch and it is headed by John A. Willoughby, who had been assistant chief engineer in charge of the broadcast division. The broadcast branch will comprise three divisions as follows: standard broadcast division, James A. Barr, acting chief; FM division, Cyril M. Braun, acting chief; television division, Curtis B. Plummer, acting chief.

There are to be three other branches in the engineering department: safety and special services branch, consisting of the marine and general mobilization division, aviation division, emergency, and miscellaneous division; field and research branch, consisting of the field and monitoring division, technical information division, frequency allocation division and laboratory division; common carrier branch, consisting of the domestic division, international division, rate division, and the field division.

Charles A. Ellert has been appointed chief of the laboratory division and Paul D. Miles is chief of the allocation division of the field and research branch.

**RADIO NEWS**

*Finer in Performance AND NOW – Smarter in Appearance with*

# INTERCHANGEABLE COLORED FLANGES

**ROUND OR SQUARE... AT NO EXTRA CHARGE**



## ***Marion Glass-to-Metal Truly Hermetically Sealed 2½" and 3½" Electrical Indicating Instruments***

- Smart styling, sleek lines, more color are invading the radio and electronic industry... bulky packaging and drab blacks and grays are no longer in step with the times... appearance now takes equal rank with performance in consumer demand.
- Sensing this important trend, we here at Marion present a "beauty treatment" for radio and electronic equipment in our new and attractive interchangeable colored flanges. There are 12 different iridescent shades, including blue, red, green, silver, gold and others—in both round and square shapes.
- Manufacturers who specify Marion hermetically sealed instruments will find that the eye-appeal of these new flanges will give added sales value to their products. Amateur radio operators and experimenters will especially welcome the idea because the interchangeability feature will help reduce instrument costs by permitting universal application of Marion "hermetics" when building or modernizing their equipment.

Marion "hermetics" sell for no more than most competitive unsealed instruments... and they're being delivered in ever-increasing quantities. Write for our 12-page brochure.



**MARION ELECTRICAL INSTRUMENT CO.**  
MANCHESTER, NEW HAMPSHIRE

EXPORT DIVISION 458 BROADWAY · NEW YORK 13, N. Y. U. S. A.  
CABLE ADDRESS: MOR-HANEX

George P. Adair, chief engineer of the commission, pointed out that the need of meeting unprecedented expansion in all phases of electrical communications is throwing a tremendous burden on the engineering department and the lack of staff is retarding the processing of applications.

In the broadcasting field alone, the commission has on file 463 applications for new standard stations, 211 applications for changes in existing standard stations, 707 FM applications, and 142 television applications. In addition, the commission is receiving many applications for experimental authorizations, all of which will definitely require careful study.

Of the AM applications on file, FCC has designated 231 for hearings in 61 consolidated proceedings, and consolidated nine more applications requiring four additional hearings. Because of the heavy load, hearing dates for these cases have been set on a staggered basis over a period of four months. Late in November, the commission placed in the pending files another group of 18 AM applications involving breakdowns of existing clear channels and notified the interested parties that their applications would not be further processed until after the clear channel hearing, starting Jan. 14, has been concluded.

Among the AM applications on which no action has yet been taken, a considerable number probably can be granted without a hearing. Where it develops, however, upon a detailed examination that a hearing is necessary, an effort will be made to sandwich the hearing dates in among the groups to be heard during the next four months. The commission has made 174 conditional FM grants and designated 11 FM applications for hearing. The remaining 522 applications for FM stations will be processed rapidly.

**MANY FM APPLICANTS** and other members of the public have asked FCC for information on the cost of entering the FM industry. Because of this interest, FCC has addressed telegrams to equipment manufacturers to determine the probable cost of FM equipment.

From replies to the telegrams, the commission hopes to be able to furnish more reliable estimates of the cost of building an FM station. In the absence of price quotations on equipment to operate in the 88-108 mc. band, FM applicants necessarily have been forced to use cost estimates made during the war and based on prewar prices for equipment built to operate in the 42-50 mc. band.

**ACCORDING TO AN FCC ANNOUNCEMENT**, tests by its engineering laboratory at Laurel, Md., have established the exact opposite of the Zenith Radio Corporation claim that FM operation in the higher band allocated requires substantially more

power. Excerpts from the FCC report follow:

"Field intensity measurements of a low-band FM station and a high-band FM station of comparable power, both located in Washington, D. C., showed negligible difference in signal strength at the FCC laboratory, a distance of approximately 20 miles, in spite of the fact that the low-band station W3XO (43.2 mc.) enjoys a distinct advantage in having an antenna more than 200 feet higher than W3XL (99.8 mc.). The commission engineers are of the opinion that if the two antennas were of the same height, the field strength of the station operating in the new high FM band would exceed that of the old low FM band station.

"It is recognized that neither the commission tests nor the Zenith tests are conclusive on the question of power. Subsequent tests may establish that somewhat higher power might be desirable in the new band. However, there is no warrant for any such conclusion on the basis of the limited data now available. From what is known today, it appears that the power requirements for the new band will be substantially the same as requirements for the old band.

"The FCC tests show that the conclusions which have been drawn from the Zenith tests are not sound. Moreover, it is misleading to discuss only one phase of the problem, namely, power, which can be greatly reduced if antenna structures are designed for high gain and placed at high locations. For example, a New York station whose antenna is located on the top of the Empire State building need only use 1.6 kilowatts of power to render service comparable to that of a 20 kilowatt transmitter feeding an antenna at a height of 500 feet."

The commission stressed that its reason for moving FM broadcasting from the 40 to 100 mc. region was to minimize sky-wave interference. The important point is that no sporadic E interference of the type found in the old band has been observed in the new FM band. This will benefit listeners, particularly in rural areas.

**VARIABLE CONDENSER MANUFACTURERS** have won their fight for a higher price increase factor. The OPA, which on Oct. 11, established 13.5 per-cent as the increase factor on such radio condensers, early in December upped the figure to 16.5 per-cent. Reason for the change is that when increase factors for other radio parts were set, makers of variable condensers had not furnished satisfactory cost data to OPA.

**MANUFACTURERS OF RADIO SETS** are overwhelmingly in favor of using the FCC channel number designations, rather than frequency wavelengths, on dials of new FM radio receivers. The FCC adopted the new system of numbering channels after a con-

(Continued on page 130)

RADIO NEWS

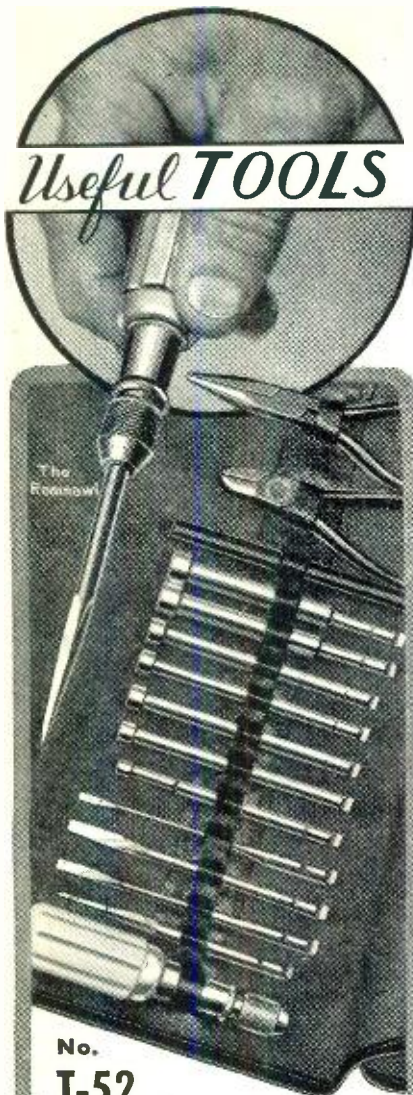

No.

T-52

**SPINTITE SET.**

Chuck Type Handle with Reamawl, 3 Screw Drivers, 7 SPINTITES, Insulated Neutralizing Alignment Wrench, and 2 Pliers, all in a Leatherette Roll. . . .

**A Positive need in every RADIO, HOME and ELECTRICAL SHOP.**

A Fascinating, Fast-Moving Item for thousands of stores. Your good jobber has it. . .

Send for Catalog No. 141 picturing a full line of Automobile, Aircraft and Radio Tools.

**WALDEN WORCESTER**

**WRENCHES**

**STEVENS WALDEN, INC.**

468 SHREWSBURY STREET

**WORCESTER, MASSACHUSETTS**

# Now You can Use.



## ALL OF THESE RADIO PARTS

to help You learn

# RADIO

## FASTER—EASIER

## AT HOME

### YOU CAN BUILD **133** FASCINATING EXPERIMENTS

At home—in your spare time—you get real Radio experience from these many *interchangeable* Radio parts and sub-assemblies. DeForest's handy "Block System" eliminates unnecessary mechanical work; the convenient spring clip connections save a great deal of time. You quickly build Radio circuits that work. You experiment with Photo-Electric Cell "Magic" . . . a 5 tube Superheterodyne Receiver . . . a Radio Telephone, and scores of other fascinating projects. Little wonder learning Radio at home is so practical . . . effective and real fun—with DeForest's modern "Home Laboratory."

### YOU USE "LEARN-BY-SEEING" MOVIES!

Think of the pleasure, as well as help you get from the use of this DeVERY Motion Picture Projector and exciting "movie" TRAINING FILMS. You will be surprised how much faster . . . easier . . . Home Movies help you understand Radio-Electronic fundamentals. Here's a preferred training method of tomorrow—yours today. See the principles of what you're learning—in motion . . . ANIMATED! See circuit actions otherwise hidden from the eye. You get this big Radio home training advantage—exclusively with DeFOREST'S. So act now! Mail coupon for complete details.

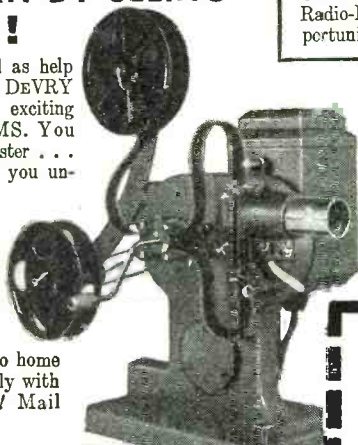

#### VETERANS!

Big things are happening at DeForest's for veterans! See how we can prepare you WITHOUT COST for a GOOD JOB or a BUSINESS OF YOUR OWN in the vast Radio-Electronic opportunity field.

See how DeForest's fascinating SHOP METHOD Radio Training at home can help you toward a good start in the Billion Dollar Radio-Electronic Field. Write for DeForest's BIG FREE book, "VICTORY FOR YOU!" that has helped many to good pay jobs. You'll be surprised at the opportunities ahead in F.M. Radio, Aviation Radio, Broadcast Radio, a Profitable Business of Your Own, Motion Picture Sound Equipment, Electronics—plus the exciting future possibilities ahead of Television, Radar, etc.

#### YOU Get "ALL THREE" With DeFOREST'S

Where else can you get such a combination of PROVED MAJOR training features as—(A) modern loose-leaf lessons prepared under the supervision of Dr. Lee DeForest, often called the "Father of Radio;" (B) the use of "Learn by Seeing" home movie films and a genuine 16 mm. DeVERY

MOVIE PROJECTOR—and (C) eight big kits of "Home Laboratory" Radio parts to give you valuable practical Radio experience—at home.

You Also Get EFFECTIVE EMPLOYMENT SERVICE . . . to help you get started toward a Radio-Electronic job or a business of your own. Residential training in our Chicago laboratories also available! DeFOREST'S TRAINING INCLUDES INSTRUCTION IN MOTION PICTURE SOUND EQUIPMENT, FM RADIO AND TELEVISION . . .



DeFOREST'S TRAINING, INC., Dept. RN-C2  
2535-41 N. Ashland Ave., Chicago 14, Illinois, U.S.A.  
Send—FREE and WITHOUT OBLIGATION—illustrated book, "VICTORY FOR YOU" and KIT SUPPLEMENT, showing how Home Movies and Home Laboratory can speed my preparation for a place in the Radio-Electronics industry.

Name \_\_\_\_\_ Age \_\_\_\_\_  
Address \_\_\_\_\_  
City \_\_\_\_\_ Zone \_\_\_\_\_ State \_\_\_\_\_

If under 16, check here for special information.  
 If a discharged veteran of World War II, check here.

# DeFOREST'S

## TRAINING, INC.

CHICAGO, ILLINOIS

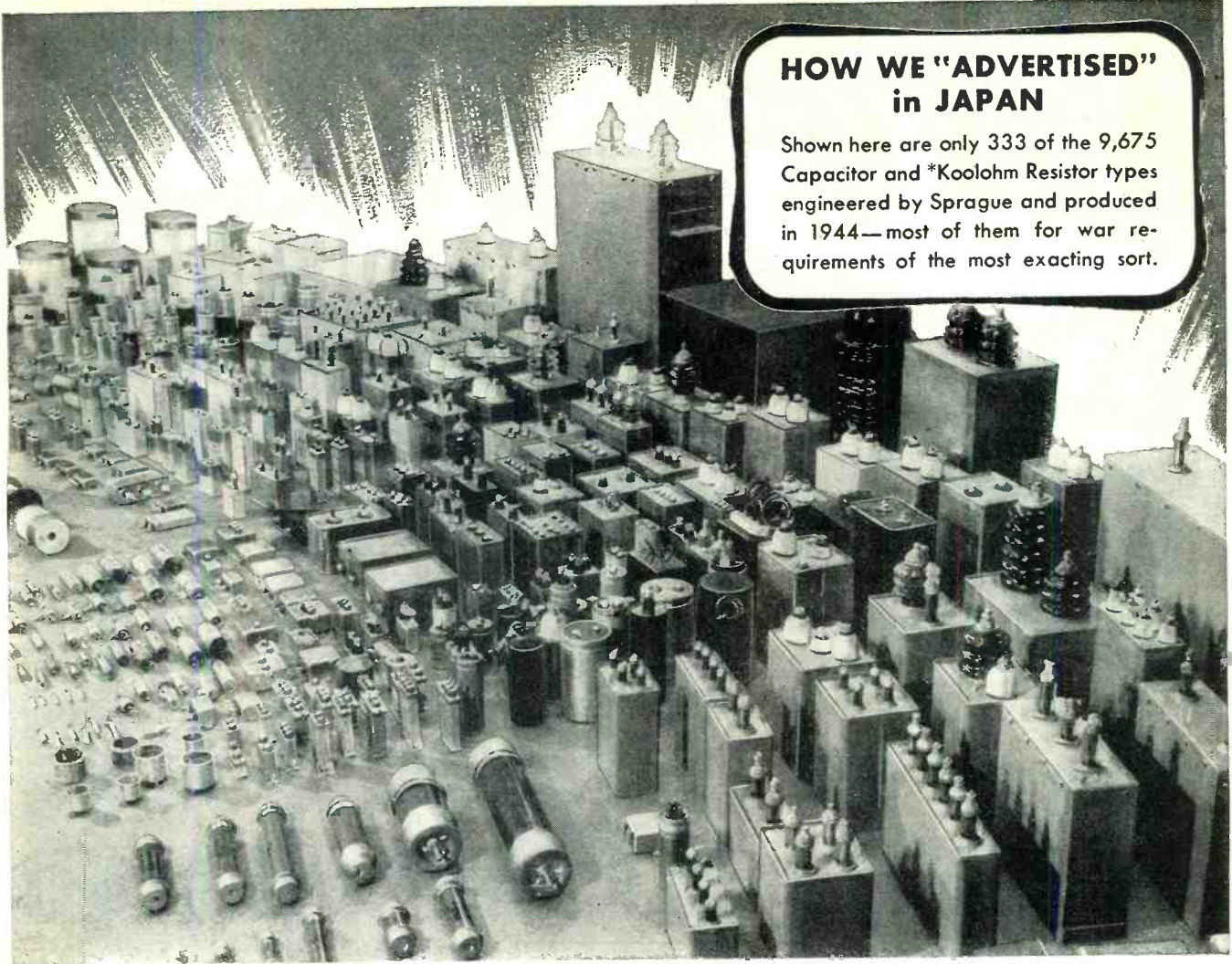

**HOW WE "ADVERTISED"  
in JAPAN**

Shown here are only 333 of the 9,675 Capacitor and \*Koolohm Resistor types engineered by Sprague and produced in 1944—most of them for war requirements of the most exacting sort.

**FROM RADAR TO THE ATOM BOMB AND VT FUZE**



How good are Sprague Capacitors and \*Koolohm Resistors? Ask the Germans! Ask the Japs! From radar to the atom bomb and VT (radio-controlled) fuze, those nations got the most convincing evidence of electronic component quality the world has ever seen. And were they convinced!

Today with Sprague Capacitors and \*Koolohm Resistors coming back on the civilian market in goodly quantities you'll also be convinced—but in a much more pleasant way. Every Sprague unit you now buy brings you full benefit of a wartime engineering record unsurpassed in the entire component field. Sprague Capacitors and \*Koolohm Resistors are "tops"—because an unparalleled program of engineering makes them that way.

\*Trademark Reg. U. S. Pat. Off.  
**SPRAGUE PRODUCTS COMPANY, North Adams, Mass.**  
(Jobbing Distributing Organization for Products of the Sprague Electric Co.)

**SPRAGUE**

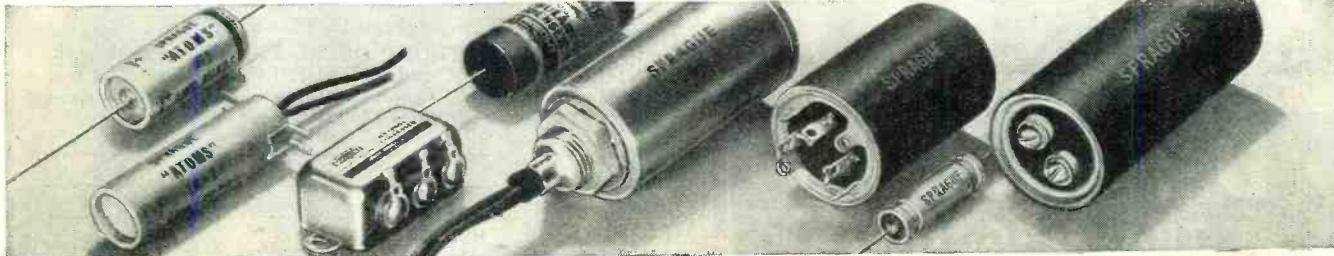

**CAPACITORS FOR EVERY SERVICE, AMATEUR AND EXPERIMENTAL NEED**



# N. U. BATTERIES

*by the Carload!*

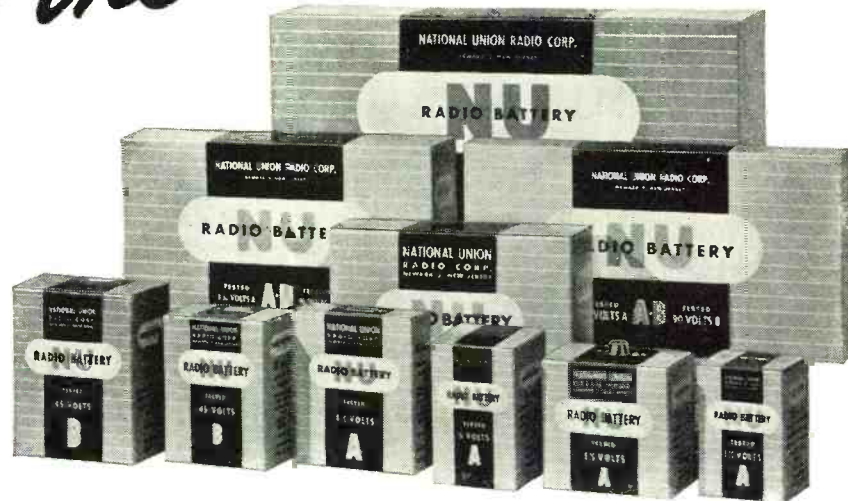

## Get Immediate Deliveries of All Types for Standard Radio and Other Replacements

Now you can bring many thousands of good, serviceable battery-powered radio sets *back to life*. Portables—Farm Radios—"carry-about" sets! Here are the batteries you need to bring in this flood of profitable service and parts business. Order now and *tell* your customers to come on the run for the batteries they need.

In batteries as in other products, N. U. quality helps you build for the future. The patented construction of N. U. Batteries permits more active materials—more service hours per dollar. Every N. U. Battery is engineered to the highest initial equipment standards and is designed for universal replacement.

**PLACE YOUR BATTERY ORDER TODAY—with YOUR N. U. DISTRIBUTOR**

*Renew with N. U.* . . . the quality line that brings repeat sales at full profit to radio service men!

NATIONAL UNION RADIO CORPORATION, Newark 2, New Jersey



## NATIONAL UNION RADIO TUBES AND PARTS

Transmitting, Cathode Ray, Receiving, Special Purpose Tubes • Condensers • Volume Controls • Photo Electric Cells • Panel Lamps • Flashlight Bulbs



*New* **Jensen**  
**PM SPEAKERS with**  
**ALNICO 5**

Newly designed in every detail . . . magnets, housings, magnetic structures, voice coils and cones . . . and incorporating the new and powerful **ALNICO 5** magnet material, this new family of PM speakers will add an imposing and important series of speakers to the **JENSEN** line.

These new models are now being tooled for production and, when ready, complete specifications and prices will be issued to the trade in Data Sheet TD-133. . . Watch for other postwar innovations soon to come from the **JENSEN** laboratories.

**JENSEN RADIO MANUFACTURING COMPANY, 6617 S. Laramie Ave., Chicago 38, Ill.**  
IN CANADA: Copper Wire Products, Ltd., 138 Oxford St., Guelph, Ont.



**Jensen**  
SPEAKERS WITH

**ALNICO 5**

*Specialists in Design and Manufacture of Fine Acoustic Equipment*

# Felix strikes a happy note-

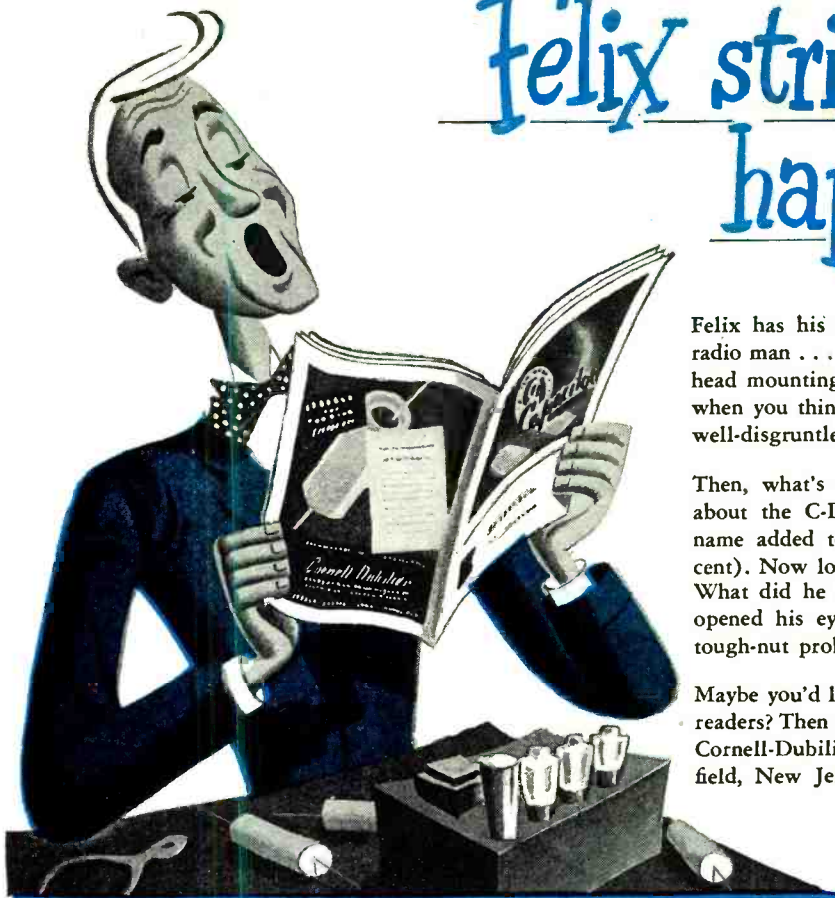

Felix has his share of worries, just like every other radio man . . . work piling up, parts hard to get; overhead mounting, hours shrinking into minutes. In fact, when you think about it, this should be a picture of a well-disgruntled service man.

Then, what's the smile for? Last month Felix read about the C-D Capacitor and straight 'way had his name added to our mailing list. (Didn't cost him a cent). Now look at him, after reading only one issue! What did he discover? A practical service story that opened his eyes to a quick, easy way of cracking a tough-nut problem. What a break!

Maybe you'd like to join our happy family of Capacitor readers? Then do as he did. Write to "The Capacitor", Cornell-Dubilier Electric Corporation, South Plainfield, New Jersey.

## COLOR-CODE CHARTS FOR YOU!



Another C-D help. These charts are available in two useful sizes; one for your wall and one for your pocket. Both include Army-Navy coding and RMA standards. Ask your local jobber for a set.

## DO YOU HAVE THIS CATALOG?



Here at your fingertips is all the information you need on capacitors. Smart servicer's remember only one line . . . one name for their capacitor needs: Cornell-Dubilier. Send for Catalog #195.

## STOUT HEARTED BEAVERS



Small in physical dimensions; giants in quality. Even when you use them in heat and high humidity, these little Blue Beavers are "all there". They're Johnny-in-the-spot for small space mounting, too. Ask your jobber.

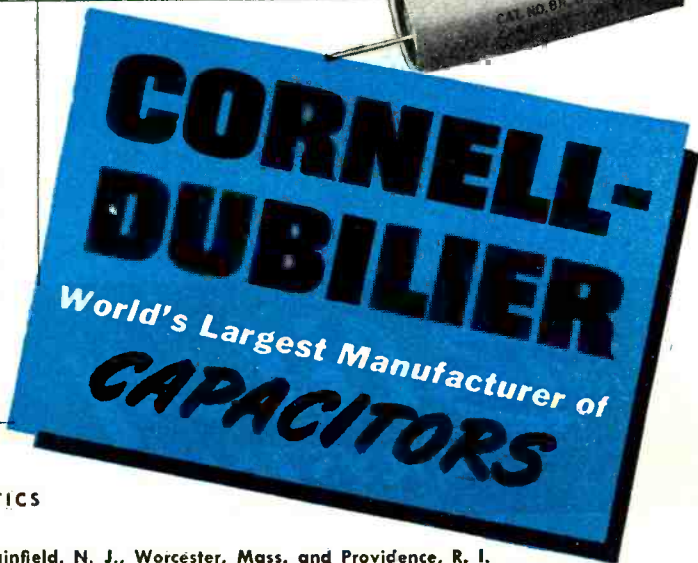

MICA • DYKANOL



PAPER • ELECTROLYTICS

JOBBER DIVISION: NEW BEDFORD, MASS. Other plants at So. Plainfield, N. J., Worcester, Mass. and Providence, R. I.

February, 1946



## It's a mark of quality in any equipment when the frequency source is a **BLILEY CRYSTAL**

Anyone familiar with radio frequency applications knows that the name Bliley on a crystal means original engineering for a specific job. True—Bliley builds crystals by the million—but Bliley craftsmanship was never gained through mass production.

Fifteen years of interpreting the needs of communications engineers, personalized attention to their individual problems, has provided the engineering background and experience that has

made possible consistent quality production.

In the current line of Bliley Crystals all that proved good in wartime models has been retained, with important refinements for peacetime applications. New types have been added—more are on the way.

Make it a habit to consult Bliley engineers on all of your frequency control problems. You will benefit from this mark of quality in your equipment.



**TYPE TC91**—This new Temperature Stabilizer is just one of many products described in a new Bliley bulletin. Write for your copy.

Ask for bulletin **RN-27**



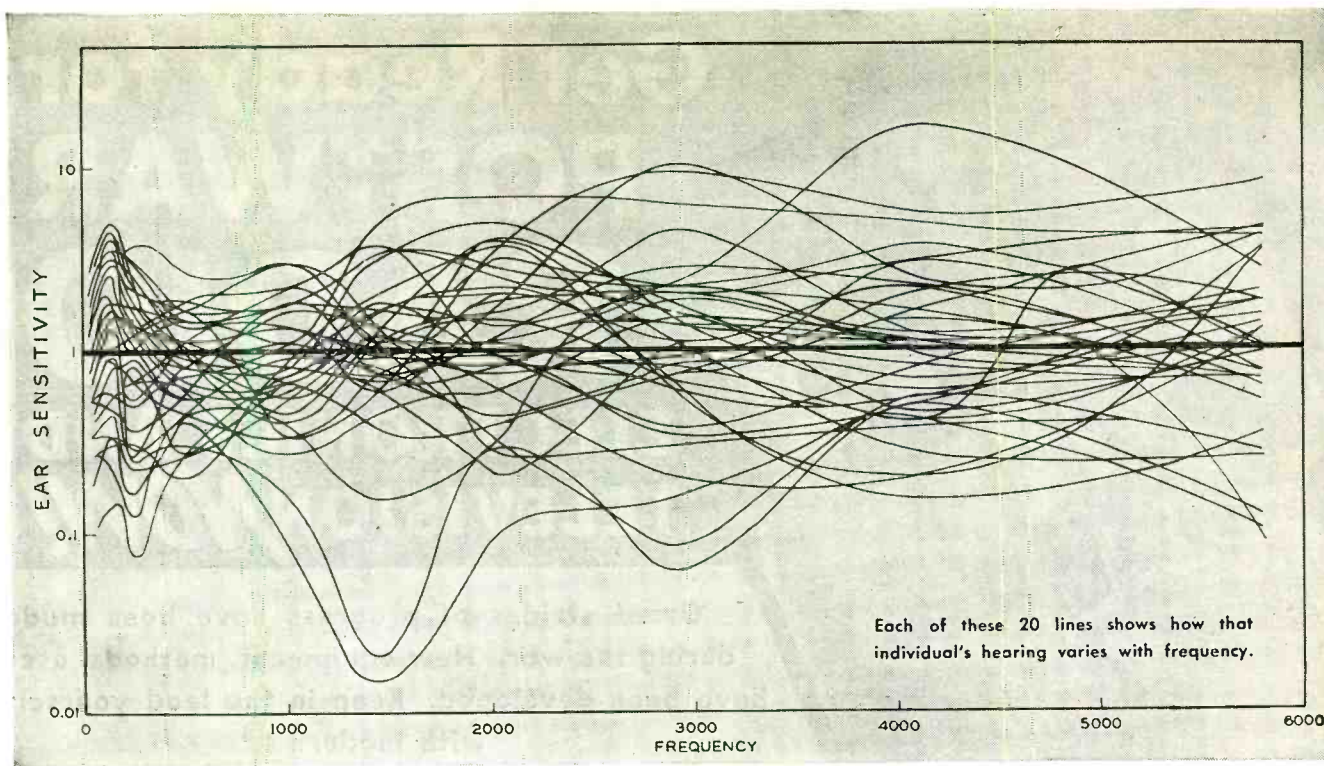

## To measure is to know

Twenty-five years ago, one standard of sound power was the ticking of a watch, another was the clicking of two coins; and the measure was how far away the tick or the click could be heard. That test was made in measuring people's hearing, a field of interest to the Bell System scientists because the ear is the end-point of every talking circuit.

Accustomed to exact measurements, Bell scientists proceeded to develop a method of measuring hearing-sensitivity in terms which could be precisely

defined and reproduced. After plotting hundreds of runs like those above, they decided on a particular sound intensity, representing an average "threshold of hearing," as a starting point.

The sounds delivered by a telephone line had previously been evaluated by listeners who compared their loudness with that of a standard source. There were wide variations in ears, as the chart shows, so the engineers replaced them by electrical instruments. When later their associates developed the

Western Electric radio and public address systems, the necessary measuring circuits were promptly forthcoming. Addition of a standard microphone made a noise meter, widely used in quieting airplanes and automobiles.

"Through measurement to knowledge," said a famous Netherlands scientist. The principle finds wide application in Bell Laboratories, whether the quest be for a way to measure sound, a new kind of insulation, or more economical telephone service.



Hearing was first measured reliably by engineers in the Bell Telephone Laboratories



For good reception, program loudness must stay within certain limits. Volume-meters help to hold it there

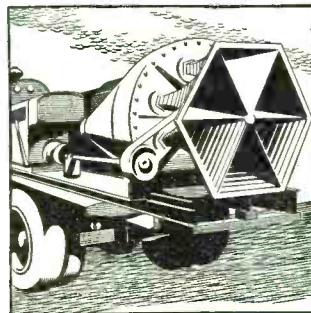

From the throat of this mighty air-raid siren comes the loudest sustained sound ever produced

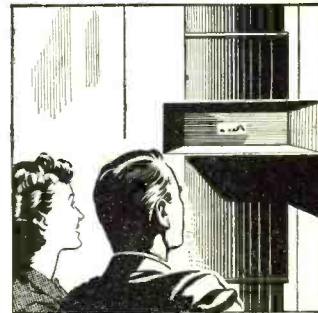

Visible Speech, result of telephone research, turns sound into "pictures" that the deaf can read

**BELL TELEPHONE LABORATORIES**



*Exploring and inventing, devising and perfecting for continued improvements and economies in telephone service*



# Get Ready for POSTWAR RADIO ELECTRONICS AND TELEVISION *NOW!*

Great strides of progress have been made during the war. New equipment, methods, uses have been developed. Keep in the lead yourself with modern

## SHOP METHOD HOME TRAINING

BY A GREAT ESTABLISHED RESIDENT SCHOOL



NATIONAL SCHOOLS HAS BEEN BRINGING OPPORTUNITY TO AMBITIOUS MEN FOR MORE THAN A THIRD OF A CENTURY. Above and to the right are two departments in this great school where modern developments are analyzed to provide National students with first-hand knowledge of short cuts and trade secrets. For full details fill out the coupon.

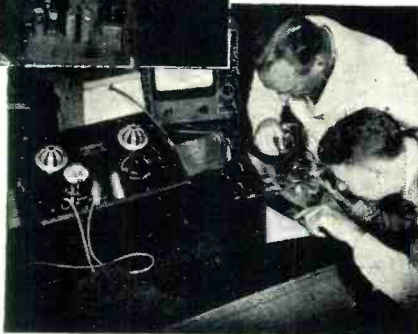

Take your place in the forefront of Radio, Television and Electronic progress. Get your share of the NEW business. War inventions and improvements—walkie-talkies, radar, aircraft control and communications—will quickly be adapted to civilian use. F.M. is winning almost universal acceptance and use.

Everywhere you turn new and important changes in the field of Radio are being put into operation every day. Television is rapidly being perfected. Electronics is being applied to industry and better living. The successful technician **MUST KEEP UP WITH PROGRESS** if he is going to be sure of his job—**GET AHEAD IN BUSINESS.**

National Schools presents a Radio and Electronic training system geared to the rapid advancement of the industry itself. Here is an exclusive home training system based on the shop methods as practiced in one of the World's foremost vocational education centers—the actual shops and experimental laboratories of this National institution. Send the coupon on the next page for complete details. Only National can bring you this type of training for only National has the shops, equipment and experimental laboratories for the development and extension of the system.

## Use This Modern Electronic Laboratory



The very essence of National Shop Method Home Training is **EXPERIENCE**. You get to know Radio and Television circuits by building them yourself. You get

first-hand knowledge of how instruments work by a sound analysis and construction system.

You build a beautifully toned, high fidelity, long distance modern superheterodyne re-

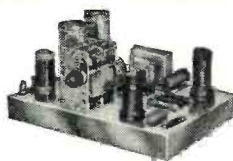
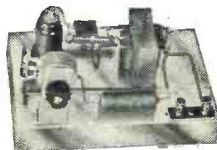

ceiver from the parts furnished with your course. In this way you have a thorough understanding of the superheterodyne principle.

You learn modulation, beat frequency and

signal generation by building yourself a small, operating radio transmitter with National parts. You get to know and understand the process of creating

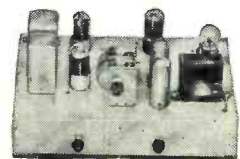

audible signals by electronic means by conducting experiments with a National Audio Oscillator.

You conduct cathode ray experiments to gain a first-hand knowledge of the operation, repair and maintenance of Television equipment. Hundreds of experiments may be performed to gain first-hand experience with your National laboratory equipment.



## New Fields

Electronics is already a most important factor in industry. Many manufacturing processes depend on electronic controls—employ electronic processes. In medicine and agriculture too, electronics is being used extensively. Are you ready to cash in on this development in a field that is so close to radio?

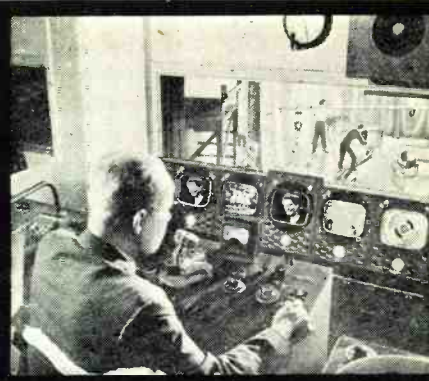

## New Equipment

Every day you learn of new types of radios and improved television—new electronic devices. Fac-simile, F.M., Radar, Sonor—all present new problems of manufacture, operation and maintenance that demand training and experience. Consider your advantages if you have the necessary preparation to tackle this work.



## New Hook-Ups

The relatively simple wiring of the radio receiver of a few years ago is as out-of-date today as one of the first automobiles. The new Radio and Television sets, and Electronic devices demand a thorough knowledge of new principles. National brings its students the results of continuous research and improved methods.

# NEW OPPORTUNITIES

Think what all this great progress in Radio, Electronic power and control and Television means to YOU PERSONALLY—you who are already in Radio or have a natural inclination toward it. The greatest opportunity of a lifetime is right within your grasp.

Compare the job you now have or expect to get when you are out of service or your present war job with the great future presented you by the broad field of Electronics.

Literally tens-of-thousands of technicians are needed in Radio and Television stations and communications companies all over the country—to operate, maintain and repair equipment. The man who knows modern methods and equipment is welcome almost at his own price.

Latest figures show that Radio represents a 5-billion dollar industry and, in the opinion of experts, it is a secure, well established, basic type of business offering steady employment. Television, according to authorities, offers half a million openings right at the start. The man trained

in modern Electronics CAN CHOOSE THE KIND OF INDUSTRY HE WANTS—THE PART OF THE COUNTRY HE PREFERS AND THE KIND OF POSITION MOST SUITABLE.

### You Want Action

With this amazing speed-up training you can progress just as quickly as you wish—start taking advantage of your new found knowledge and experience in a very short time. Send the coupon below and learn the facts about this great educational development. Try out the FREE SAMPLE LESSON and see for yourself what you can accomplish so quickly and easily with the remarkable SHOP METHOD HOME TRAINING.

In a few months—perhaps only weeks—you may start making good money; maybe accept a BIG PAY JOB in industry—GET INTO A PROFITABLE, LIFETIME BUSINESS OF YOUR OWN, with little or no capital investment.

Take the first step now. Fill out and mail the coupon below.

# FREE LESSON



## Get this BOOK

Here is an interesting forecast of the future of Radio and the opportunities present for you in this, and allied fields right now. It is profusely illustrated and describes the jobs waiting for trained men everywhere. Send the coupon below for your copy.

## Here Are Some Samples of Success in Radio by National Graduates

National Shop Method Home Training wins good jobs, independence and security quickly. Take the word of National men who have established records in their favorite Radio, Television, or other branches of Electronics:



Joseph Grumich, Lake Hiawatha, New Jersey writes: "My latest offer was \$5,800.00 as Radio Photo Engineer but I'm doing well where I am now engaged. I am deeply indebted to National."

Here's a statement from R. R. Wright, Blackfoot, Idaho: "Due to my training at National, I was selected to instruct in the laboratory work of Navv and Marines."



Robert Adamsen Kearney, Nebraska, National graduate, has two radio jobs—makes double pay as a radio instructor and as engineer at Station KGFV. He writes: "I am proud of my National training and appreciate the cooperative spirit."

Read what hundreds of other enthusiastic students have written about National Training. Send in your coupon today.



From O. K. Ivey, Washington, D. C. comes this endorsement: "I believe National offers the best course to be had... Keep up the good work."

## NATIONAL SCHOOLS

LOS ANGELES 37, CALIFORNIA EST. 1905



### MAIL OPPORTUNITY COUPON FOR QUICK ACTION

National Schools, Dept. RN-2  
4000 South Figueroa Street, Los Angeles 37, California

(Mail in envelope or paste on penny post card)

Mail me FREE the two books mentioned in your ad including a sample lesson of your course. I understand no salesman will call on me.

NAME ..... AGE.....

ADDRESS .....

CITY..... STATE.....

Include your zone number

Try  
it!  
Compare  
it!

**\$129\***  
AMATEUR NET  
LESS SPEAKER

# HQ-129-X



Price subject  
to change  
without notice.

Frequency  
31—.54  
Megacycles

Try—then compare, and you'll agree that this professional receiver is an outstanding value. It is built by craftsmen who specialize in communication equipment. The HQ-129-X has endless improvements which are fully described in an eight-page booklet.. Write today for complete technical information.



# HAMMARLUND

THE HAMMARLUND MFG. CO., INC., 460 W. 34<sup>TH</sup> ST., NEW YORK 1, N. Y.  
MANUFACTURERS OF PRECISION COMMUNICATIONS EQUIPMENT



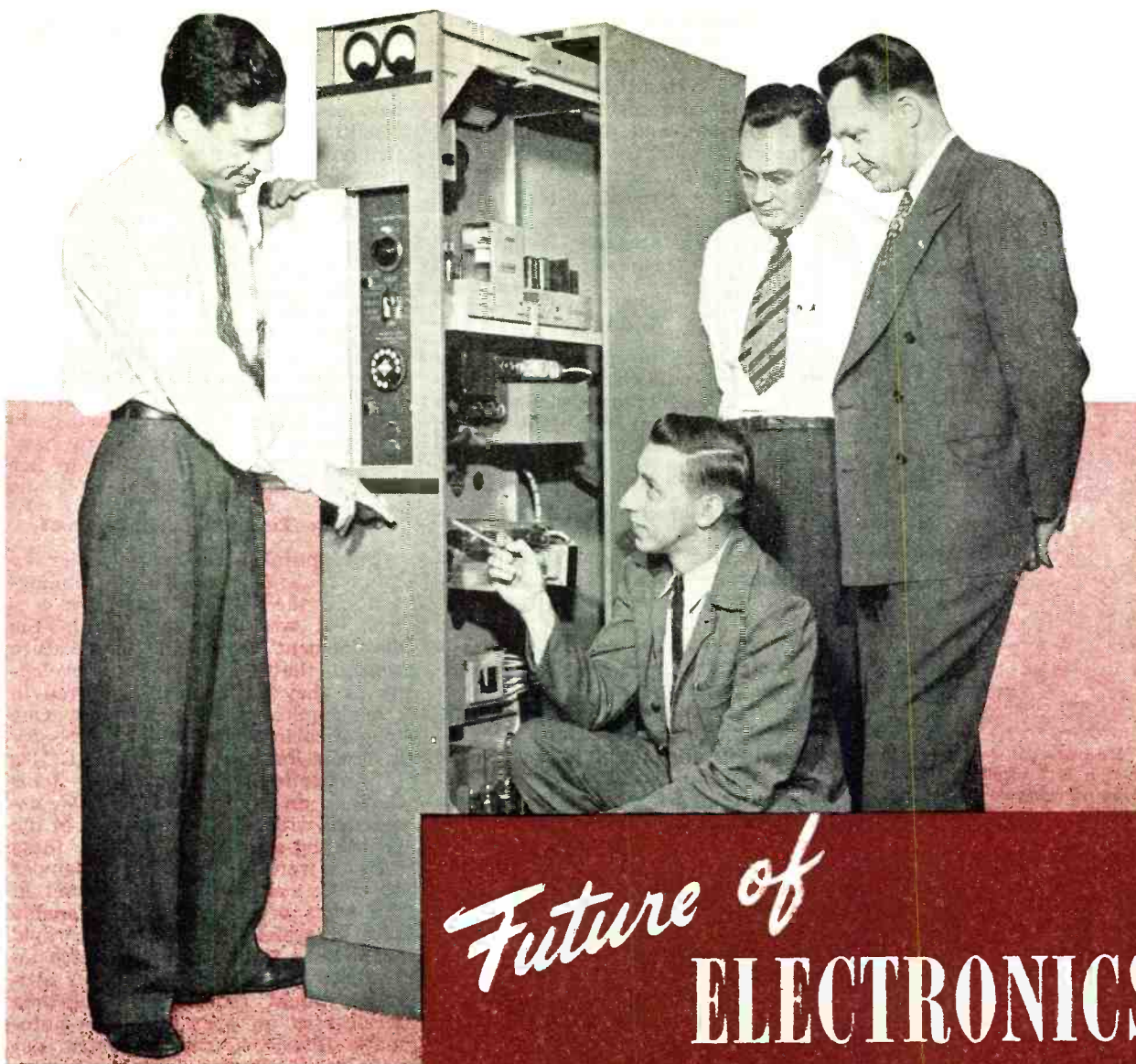

Fig. 1. TWA electronic specialists examine the first of v.h.f. transmitter and receiver units that are to be installed over its transcontinental route to form a nationwide communication network.

## Future of ELECTRONICS in AVIATION

**Aviation industry opens up a rapidly expanding field for electronic equipment and personnel. Authors discuss the various applications of the innumerable wartime electronic developments in this field.**

**I**NNUMERABLE new devices have been contributed as a result of wartime accelerated research programs and it is not possible in a single article to do more than review the highlights of this fertile field.

In commercial operations, as well as in private planes, the radio set is a considerably more important piece of equipment than it is in the field of entertainment. In aviation it is an instrument upon which life itself depends. If civilian flying expands to the extent anticipated, traffic control at airports will be a serious problem and constant communication with every ship will be vital. For this rea-

son, airborne radio equipment should never be permitted to enter into a price competitive situation that will lead to undependable construction. It should be the concern of federal lawmakers, insurance companies, and the entire radio industry to see that action is taken along the lines of licensing the manufacturers in accordance with established specifications.

By  
**JOHN D. GOODELL**  
and  
**DONALD J. COLEMAN**

The C.A.A. *Approved Type Certificate* issued to manufacturers whose equipment has been tested by that organization is an excellent basis for a rigid program, but the people who think in terms of immediate profits can be controlled only by legal restraint.

It is important that designers provide convenient methods of rapid servicing. Flying is a means of accelerated travel; the emphasis is constantly on speed, and commercial schedules are bound to become more intense under increased competition. Private flyers will inevitably become careless of the upkeep of their equipment, precisely as they are of the

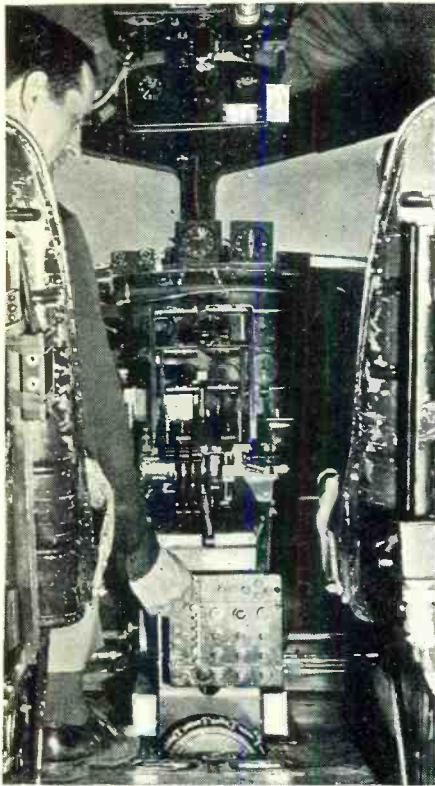

Fig. 2. A Honeywell test pilot in the cockpit of a B-17 airplane. He is shown making adjustments on the control panel of the electronic Autopilot.

brakes on their automobiles. In the development of radio and radar sets for the armed forces, a great deal of pressure has been applied to secure convenient servicing arrangements. A little consideration of these problems in the physical layout of components and the deliberate introduction of standard test points will save

endless hours of wasted effort in maintenance work. The intelligent placement of a shorting switch to check specific circuits, the installation of hinged chassis compartments for ease of inspection, and plug-in design of complete circuits are examples of the approach to these problems. It is obvious that a convenient test will be made more often than a laborious one. Preventive maintenance is the most important program of the aircraft radio technician.

### Radars

With regard to the application of this highly publicized field of electronics in peacetime practice, it is worthy of mention that many aspects that are invaluable for warfare would be an inefficient approach to problems of commercial and private flying. In devices developed primarily for combat conditions, the entire purpose is to locate and destroy enemy ships that are doing everything possible to evade detection. This involves intricate circuits and equipment that is physically large and heavy, as well as costly. The economic factor is of little consequence if even a small advantage over the enemy is gained, but considerations of extreme accuracy are not likely to be of equal importance in the postwar use of similar devices. Commercial and private planes flying in peacetime are *not* trying to evade detection. On the contrary, they may be equipped with simple transmitting devices that will automatically make their presence known.

This does not mean that radar will not play an important part in peacetime aviation programs. It is intended only to indicate that the problems are very different and that the planning must be in different terms.

Fig. 3. Honeywell Formation Stick, as installed in a B-24. It is a one-hand, electronically operated control device enabling the pilot to maintain closer flight formation with less fatigue.

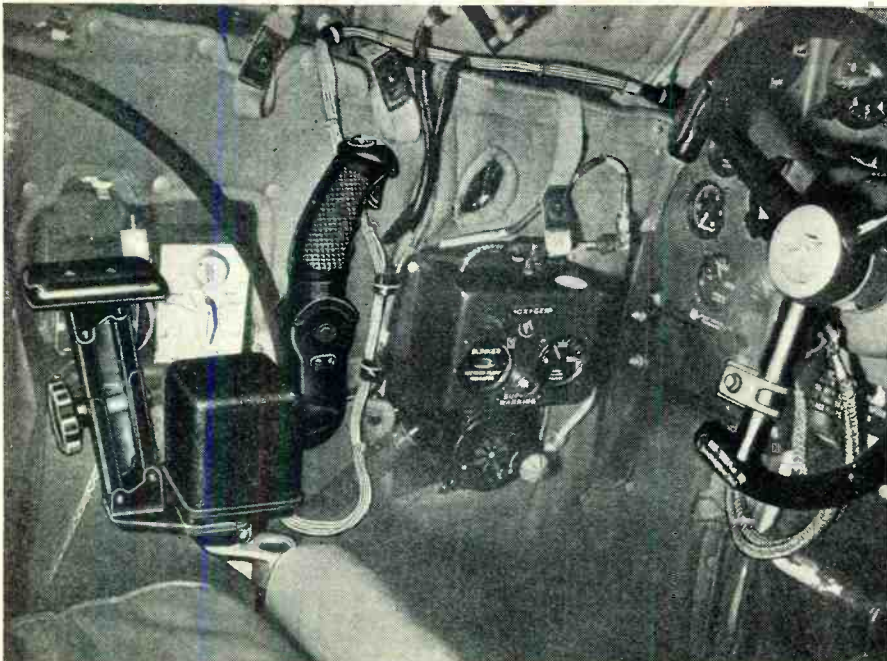

Certainly it is true that devices developed on radar principles for detecting the presence of obstacles, particularly in mountainous regions, will have the same value in flying under conditions of poor visibility as they will have in maritime navigation. Radar equipment at airports will probably be required by law for purposes of traffic control, even under conditions of excellent visibility. By no other means would it be possible for a traffic control supervisor to be presented with so complete and accurate a dynamic picture of events.

However, some of the projects that have been publicized as future radar possibilities are as ridiculous as Billie Burke's comment in a recent radio program that she planned to have radar control over the soap in her postwar bathtub.

### Cabin Temperature Control

The initial use of electronics by *Minneapolis-Honeywell* was, quite logically, in the field of temperature control. It was their interest in the development of cabin temperature controls that led to the many developments they have since pioneered in other applications of electronics. One type of cabin temperature control now in use is installed on Douglas DC-3's in connection with heating systems that use an exhaust heated boiler associated with a steam radiator in the ventilating air duct. Originally these systems were controlled by a damper adjusted manually from a panel in the front of the cabin. To enable such a system to follow the rapid changes in temperature to which an airplane is subjected at various altitudes would require the full-time services of an operator. The automatic *Honeywell* control system not only readjusts the damper continuously but actually makes the adjustments required by outside temperature changes *before* the effect of these changes is felt inside the cabin.

This system operates on the temperature coefficient of special alloy resistance wire. The temperature sensitive components are connected so as to balance fixed resistors (of zero temperature coefficient) in a Wheatstone bridge with an amplifier connected across the bridge. If the resistance of the control elements increases, the output of the amplifier drives a motor that operates the damper in a closing direction until a balancing potentiometer restores the bridge to balance. The reverse operations take place if the resistance of the control elements is less than normal. The temperature sensitive resistances are placed in a *Cabinstat* and two *Ductstats*. The *Cabinstat* is affected by the temperature of the air in the cabin; one *Ductstat* is operated by the temperature of the outside air entering the heater, and the other by the heated air as it enters the cabin. These components are connected in an interrelated manner so that the damper is continuously adjusted to

produce the correct balance between the outside air temperature and the temperature of the air fed into the cabin so that cabin temperatures will be held constant. The accurate construction of the temperature sensitive devices and the high sensitivity of the amplifier contribute to maintaining the cabin temperature to within one degree of the value for which the apparatus is set by a selector control.

### Autopilots

Automatic devices for accomplishing the task of a pilot during flight have been in use for a number of years. The early instruments employed mechanical, hydraulic, and pneumatic drives of various types, all of which had disadvantages. It was not until the introduction of electronic controls, developed and manufactured by *Minneapolis-Honeywell*, that the *Autopilot* became an instrument capable of more accurate control of flight than a human pilot.

The location of various components is illustrated in Fig. 6. The horizontal (directional stabilizer) gyro, which functions to provide intelligence regarding left and right deviations from the course, is mounted in the bombardier's compartment. The vertical-flight gyro develops information with respect to pitch and roll around the longitudinal and lateral axes. Both gyros are so mounted that their enclosures move with the plane while their rotors maintain themselves level at all times. When an angle of the plane deviates from normal, the arm of a potentiometer fixed to the rotor of the gyro, corresponding to the axes of motion, acts to unbalance the electrical control system. This unbalance is fed through an amplifier to the corresponding servo motors. The servo motors operate the cable drums, and the cables adjust the necessary control surfaces to compensate for the shift from level flight. The electrical relationships in this circuit consist of a Wheatstone bridge arrangement, and the servo motors also operate potentiometers to equalize the unbalance produced by the gyro system. Thus the amount of correction applied through the control cables automatically follows the electrical unbalance of the gyro systems, which is a function of the displacement of the gyro enclosures from their normal relationship to the rotors. As the plane returns to level flight, the gyro potentiometers gradually return to their initial setting and this intelligence, transmitted to the servo motors, causes readjustment of the entire system, including the control surfaces, back to normal.

The foregoing is, of course, a simplified description of the basic operation. The system is capable of operating rapidly enough to make a correction in less than one-fifth of a second. This instrument is not subject to emotional reactions or lapses in reflex time, as is a human pilot; furthermore, it doesn't get tired.

February, 1946



Fig. 4. Typical electronic de-icer timer. This control unit may be adjusted to automatically operate the de-icer boots in cycles, timed to suit various conditions of ice formation and flight altitudes. The de-icer boots are periodically inflated and deflated to break up the ice.

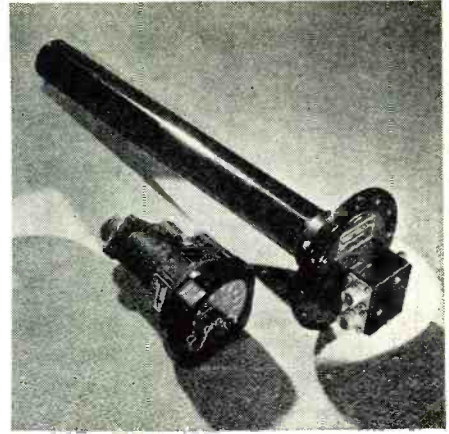

Fig. 5. Units of the electronic gasoline gauge. Tube at right is the tank unit which is mounted within a fuel cell and immersed in the gasoline. Depth of gasoline is electronically measured and transmitted to the gauge at left, which is mounted on the plane's instrument panel.

Actually it is capable of far more consistently accurate control of flight than any human pilot and, consequently, is used during bombing runs where the success of the bombardier's aim is dependent on the precision with which flight control is accomplished. The *Norden Bombsight* and stabilizer are associated with the *Autopilot* in such a manner that during bombing runs the bombardier's adjustment of the bombsight applies electrical signals to adjust the *Autopilot* controls in accordance with his tracking of the target.

The control panel for the *Autopilot* includes facilities for making automatic turns, and associated devices

produce the degree of bank appropriate to the sharpness of the turn.

The value of the electronic *Autopilot* in peacetime applications includes relief for pilots from fatigue and strain, and considerably greater comfort for passengers because of the constant correction for pitch and roll.

### Electronic Formation Stick

The most recent addition to the facilities associated with the electronic *Autopilot* is the *Minneapolis-Honeywell* electronic control stick. This pistol grip formation stick is shown in Fig. 3 mounted in a *Consolidated Liberator B-24*. It has subsequently been installed in the *B-29 Superfor-*

Fig. 6. How autopilot units control airplane. With the development of this electronically operated instrument, it is possible that the flight of a plane can be more accurately controlled than if a human pilot were in charge. Drawing shows: (1) directional stabilizer, (2) p.d.i. pot, (3) dash pot, (4) directional panel, (5) banking pot, (6) rudder pick-up pot, (7) p.d.i., (8) autopilot control panel, (9) turn control, (10) vertical flight gyro, (11) elevator pick-up pot, (12) aileron pick-up pot, (13) skid pot, (14) up-elevator pot, (15) aileron servo, (16) amplifier, (17) rotary inverter, (18) rudder servo, (19) elevator servo.

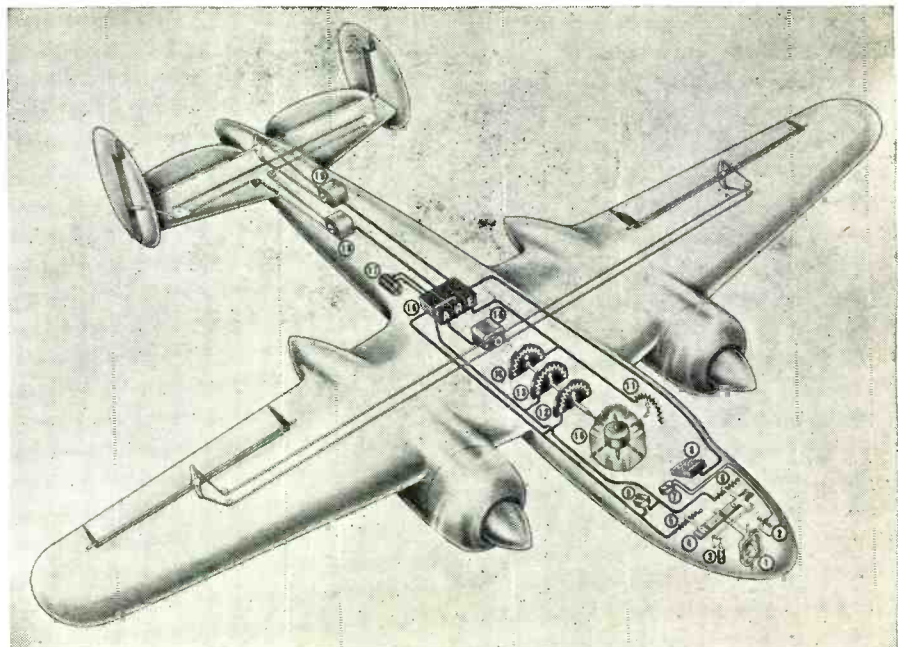



Fig. 7. Test bench set-up in the maintenance shop of one of our major air lines.

press and other large aircraft. This device is fully automatic and is so designed that the *Autopilot* accepts intelligence from the motion of the stick and acts to adjust the proper control surfaces. The greatest advantage of this method is that the pilot is no longer called upon to exert great strength in order to move and hold the controls under difficult flight conditions. A one-pound pull with one hand accomplishes tasks that previously required a force of approximately 100 pounds exerted with hands and feet. By reducing pilot fatigue and increasing the sensitivity of control, this method should result in greater safety during peacetime operation of large transport planes.

One of the important considerations in close formation flying is the increased turbulence of the air and the consequent difficulty of maintaining accurate flight control. It is sometimes necessary to maintain forma-

tions so compact that the wing tips of the planes are almost in contact. This involves conditions that may require the full strength of both pilot and co-pilot to hold their proper formation position, with the result that they arrive over the target in a state of fatigue and are unable to function with full efficiency.

The electronic control stick and its associated components are so designed that only a few minor wiring changes are necessary to make installations on any aircraft already equipped with the *Autopilot*. An interesting feature of the design includes a mechanism to provide the necessary physical reaction to the pilot so that he can *feel* the action of the controls.

#### Ceilometer

It is interesting to note that electronics is an art that may be thought of as a sort of *problem solver* for other sciences. The *Ceilometer* (Fig.

9) which is used to determine cloud heights accurately for the information of pilots, is an excellent example. Previously, cloud heights were determined at night by training a searchlight vertically to produce a bright spot of light on the clouds. Then an observation was made at a known distance from the searchlight to obtain the angle necessary to solve for the height by simple triangulation. In daytime the background light obscures the image and the method is useless. In the *Ceilometer* the ingenious application of electronic circuits has solved the problem while retaining the same basic principles.

A beam of light approximating 32 million candlepower is produced from a mercury arc quartz tube of cigarette dimensions in a special projector provided with forced air-cooling nozzles. This narrow beam of light, modulated over 90% at 120 cycles-per-second, is projected straight upward. A thousand feet away the *Ceilometer* is located and operated so that it scans the light beam vertically. When the light beam is reflected from a cloud, a portion of its modulated energy is received by the photoelectric cell in the *Ceilometer*. The total output from the photocell includes the voltages generated as a result of the daylight as well as the 120-cycle signal energy. All of this is fed through a pre-amplifier to an amplifier with a 100-cycle bandwidth. The amplified output is then applied to a discriminator circuit that functions as an electronic commutator by chopping the total input into pulses that are synchronized with the positive half of the 120-cycle component. This means that all other components retain a negative and positive swing. An RC circuit with a long time constant integrates the 120-cycle component while the interference, which averages

(Continued on page 131)

Fig. 8. Airplane engine, showing detonation pick-up unit which can be attached to cylinders without piercing walls.

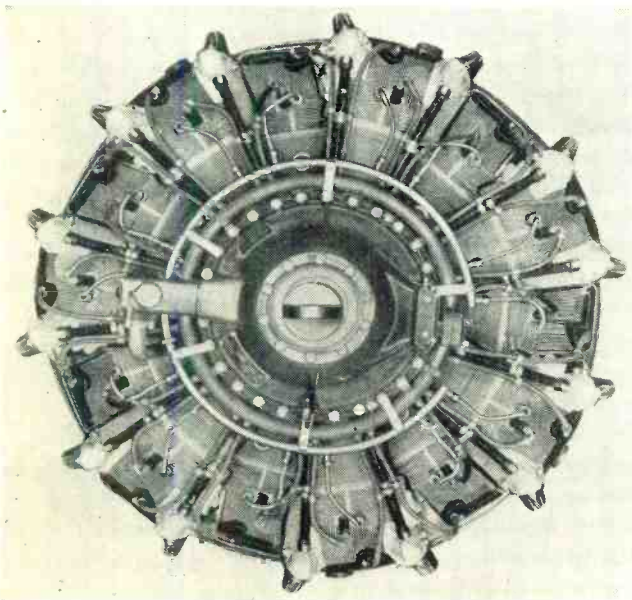
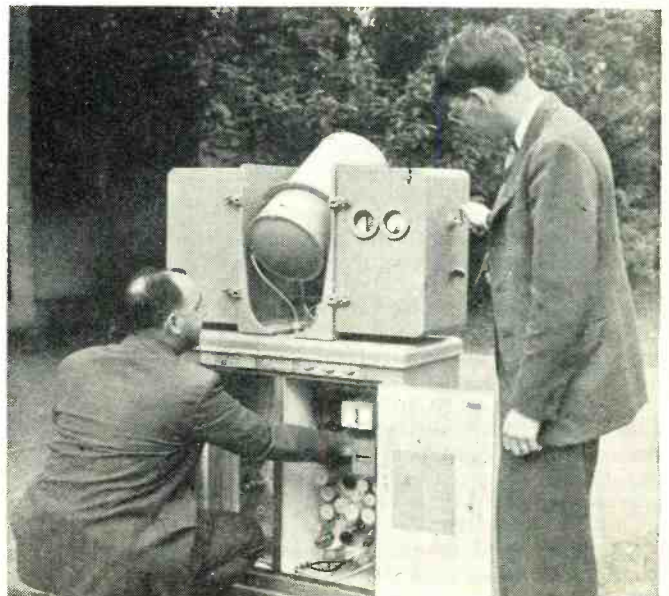

Fig. 9. G.E. "Novalux" Ceilometer. This instrument is used to determine cloud heights with extreme accuracy.



# Spotting and Repeating RECORD PLAYER

**A simple, low-cost combination word spotter—record player is now ready for the nation's schools and colleges.**

**By R. H. BAILEY**

Fairchild Camera & Instr. Corp.

**T**HIS new classroom teaching accessory, known as the *Language Master*, is basically a record player with a device that permits accurate spotting and repeating of any desired passages on a record for analysis. Thereby it eliminates playing entire records through.

For classroom, library, or private study use, it can, if desired, be used with a pair of crystal headphones without amplifier, so as not to disturb other occupants of the room. It can also be plugged into a radio without any re-wiring necessary, for record-playing.

The record player comes complete with synchronous motor driving the turntable at 78 r.p.m., standard crystal pick-up, spotting mechanism, 3-tube amplifier, and 5-inch permanent magnet dynamic speaker. The amplifier is optional.

Its design was conceived shortly before the war by *Dr. Wentworth D. Fling*, then a young professor of romance languages at Hamilton College. In teaching his students, he made extensive use of sound recordings. These foreign language records, he found, enabled the pupils to play back intricate phrases and sentences again and again until mastered. Nothing startlingly new, this method is an invaluable short-cut in obtaining aural education in the languages being studied.

Unfortunately, however, his students were forced to waste time, when playing the records, in searching for difficult passages they needed to play often. They naturally could not hit the exact grooves they wanted on the records without considerable trial and error. Frequently they had to repeat an entire record two or three times before they were successful. Eventually the college's valuable collection of foreign language records became exceedingly scratched and worn.



This record player features a 78 r.p.m. synchronous motor, standard crystal pick-up, three-tube amplifier, and a five inch permanent magnet dynamic speaker.

This annoyed Dr. Fling, so he began investigating the market for a so-called *word-spotter* that would mark out the desired portions on a record, enabling the student to quickly and accurately play them. The only devices of this kind, he soon discovered, were costly, highly elaborate machines so cumbersome and unwieldy they were impractical for classroom use.

Being of an inventive turn of mind, and knowing the general principles of radio and phonograph construction, Dr. Fling decided to build a word-spotter of his own. After months of work and experiment, he rigged up a simple combination of record player plus spotting mechanism that evolved into the present commercial model.

Besides his initial model for his students' use, Dr. Fling has built several such record players, adding improvements from time to time, and these home-made units are in use at such institutions as Columbia University and the Hill School, Pottstown, Pa., where they have been of help in language and music classes since. Word rapidly got around that here was an unusual and practical teaching device.

The war interrupted Dr. Fling's ambitious plan to manufacture his device commercially, even though it had be-

gun to sell at an accelerated rate. But the record player was never forgotten, even though material shortages prohibited its manufacture.

While at Hamilton, Fling conducted several interesting experiments with his invention. Making use of the college's extensive record library, he indexed all passages he especially wanted his students to note throughout each semester. This was a time-saver. When lecturing before his classes, he was able to place the record on the turntable and, by means of the spotting device on the record player, to pick out the specific sections he wanted to comment on. Eventually the students used the same technique by tabulating any additional passages they needed to brush up on occasionally.

When he was able to build several record players for his own classroom, Dr. Fling constructed them so that all were uniform, in that tabulations applying to grooves on a record used on one specific machine would apply equally accurately on a second and a third machine. This interchangeable feature remains in this record player's design.

By use of records and the spotting  
(Continued on page 127)

By  
**Lt. HUGH LINEBACK,**  
**USNR**



Fig. 1. Illustrating the clearness of the writing as it appears on the center of the cathode-ray oscilloscope.

*Although novel, this writing cathode-ray tube helps in teaching students the development of 'scope patterns.*

# A Writing CATHODE-RAY TUBE

**E**VEN though many pieces of equipment using the cathode-ray tube do not require that the operators have technical training, it is helpful for the user to understand how the patterns on his 'scope are formed. For demonstrating this tube to operator's classes, the apparatus described here gives an effective presentation. After an introduction covering briefly the construction and

theory of these tubes, the electron spot is shown on an oscilloscope and movement by changing voltages demonstrated. Then suddenly what appear to be random motions on the screen begin to make sense by tracing out a word—in handwriting. This novel presentation has a bit of theatrical atmosphere and never fails to bring forth exclamations of surprise from the class. Fig. 1 is a photograph of

such a pattern. The writing appears fuzzy here because of voltage changes during the exposure.

Fig. 5 shows the device for providing just the proper voltages to the proper plates at the proper times. It consists of a rotating transparent disc carrying two *sound tracks* which are scanned by light beams. Photoelectric cells cause voltage variations which correspond to the vertical and horizontal components of the written word.

Plotting the tracks for the *record* is the most tedious part of building the apparatus. First the word is written in fairly large letters on squared paper. Points about half an inch apart are marked off along the trace and numbered consecutively, as in Fig. 3A. On a large circle, a section of which is illustrated in Fig. 3B, two bands several inches wide are laid out and the width of each band divided into tenths. The circumference is then divided into equal parts to give as many segments as there are points on the original graph. Each one of these points has a certain value for its

Fig. 2. Circuit used in the operation of the photoelectric cells. A regulator tube is provided to maintain a constant voltage on the photoelectric cells.

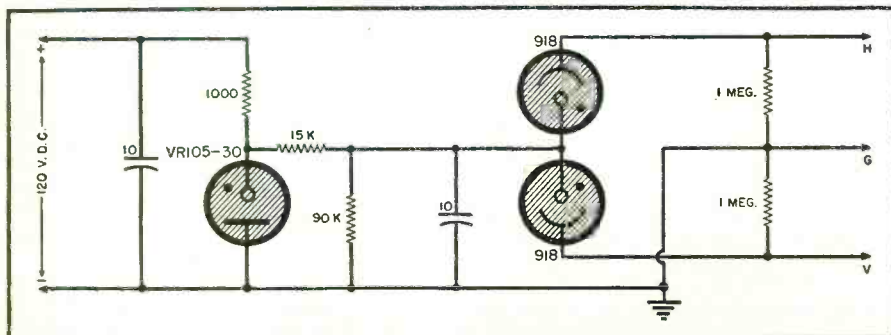

height and another value for its distance from the left edge. All of the horizontal components are plotted in one track and the vertical in the other. For example, the horizontal component of the starting point in Fig. 3A has a value of 1. On the circular band of Fig. 3B this point would be plotted at the start of the divisions and its distance from the edge would be 1 unit. In the same manner, point number 1 would be plotted on the first division line of the circle and its value would be 1.2 units. Point 2 would be 1.4 units out on the second division line, and so on for each point.

The second band is used for the vertical components and the plot should be started 180 degrees from the beginning of the horizontal track, since the photoelectric cells are mounted diametrically opposite. The vertical value for the starting point in Fig. 3A is 7.8; for point 1 it is 7.3; and for point 2 it is 6.7.

When all the points are plotted, and the points in each band connected with smooth lines, one side of each plot is inked in solid black. A completed circular graph is shown in Fig. 4. With the guide lines erased, the circle is photographed in reduced size, so that the track width is not over  $\frac{3}{8}$  of an inch. The film is mounted between clear plastic discs on the shaft of a small motor. Several circles drawn around the center of the plot will aid in mounting the film accurately. A motor speed of 1800 r.p.m. was used, and this speed gives a flickerless trace.

Fig. 2 shows the circuit used on this particular model. As 120 volt d.c. mains were available, a separate power supply was unnecessary. The regulator tube gives a constant voltage for the cells and the condensers bypass the ripple of the d.c. line. Small 115 volt lamps were used for the light source and, since the photoelectric cells are sensitive to red, the lamps were connected in series to reduce the heat in the enclosure. The width of the slit for scanning the track was not found to be critical. The wider the slit, the greater the output and a sixteenth of an inch seemed to give as sharp a reproduction as narrower beams. For an a.c. line a power supply could be used for the photoelectric cell voltages, with a battery for the exciter lights. Automobile bulbs or some types of dial lamps might be used, the filaments being aligned with the slits.

In this model, the amplifiers in the oscilloscope were used. If preamplifiers are used at the photoelectric cells the load resistors would have to be moved to the other side of the cells or the writing would appear backwards.

On a large 'scope it might be desired to write more than one word. A third track and photoelectric cell would provide for blanking out the spaces. Fig. 6 is a circuit which includes this feature.

When most observers see this display they begin speculating on some

(Continued on page 126)

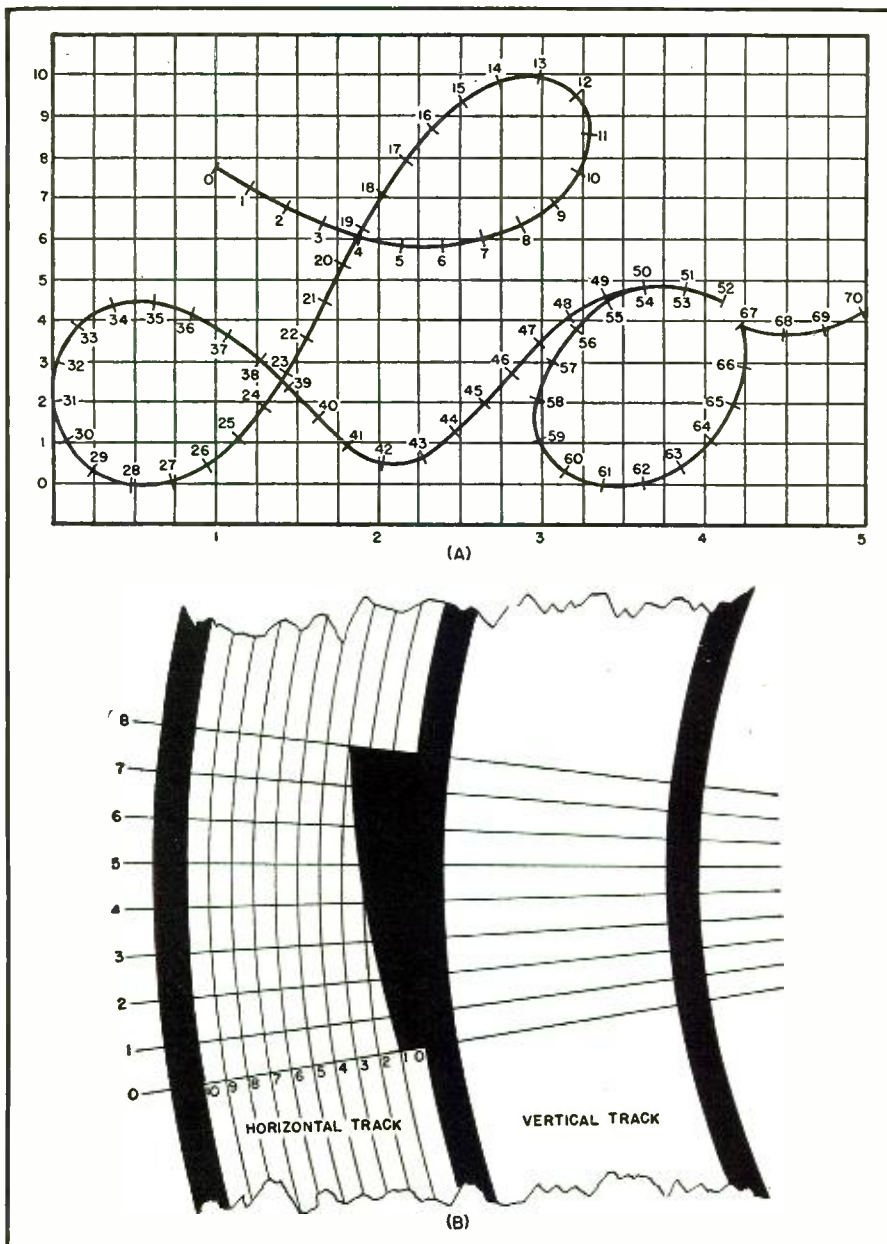
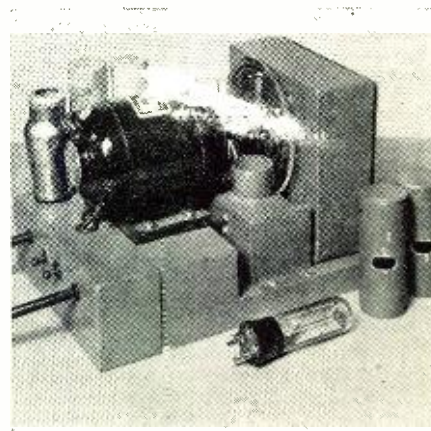

Fig. 3. (A) All letters are first plotted on squared paper and properly numbered. (B) In plotting the tracks for the final "record," two large circles are employed. This is the most tedious part of the work. Photoelectric cells are then used to apply proper voltages to the horizontal and vertical sweeps of the 'scope.

Fig. 4. Completed circular graph of the word "Loran" after guide lines are erased.



Fig. 5. Motor is used to rotate transparent disc in the final scanning process.



# Universal TEST INSTRUMENT



By  
**McMURDO SILVER**

*This versatile instrument enables service technicians to measure every voltage in AM, FM, and television receivers.*

Fig. 1. This new improved v.t.v.m. provides fifty-one total ranges of d.c. and a.c. volts to above 100 mc., ohms through 2000 megohms, current from 1.2 ma. through 12 amperes, db. from -10 through +50.

**T**HE known history of mankind reveals his increasing mastery of the elements. The price of such increasing mastery has been an accompanying increase in complexity of life. Radio receivers alone illustrate this point effectively. Thirty years ago the best imaginable receiver consisted of a one-tube regenerative detector followed by two stages of audio frequency amplification. The components were so few, their functions so free of interactive effects, that trouble shooting in such a receiver was simple. Replacement of dry "B" and recharging of storage "A" batteries, substitution of new tubes for old, and a cursory knowledge of operation of a few simple circuits was all the service technician needed to set up shop.

Receivers of immediately prewar vintage were a far cry from such simplicity, not to mention the even more marked simplicity of precedent "one-slide tuning coil and crystal detector" days. A typical high-quality 1940/1 broadcast receiver might include one or more stages of r.f. amplification, a first detector or mixer, a heterodyne oscillator, one or more stages of i.f. amplification, an a.v.c. system linking most of the above circuits, a second or audio detector, one or more stages of a.f. voltage amplification, a push-pull a.f. power amplifier, a power supply rectifier and filter system, and a dynamic loudspeaker with separate signal and field-energization circuits. Ten or more substantially different yet closely inter-linked and inter-related circuits, each with a multiplicity of coils, condensers, resistors, switches,

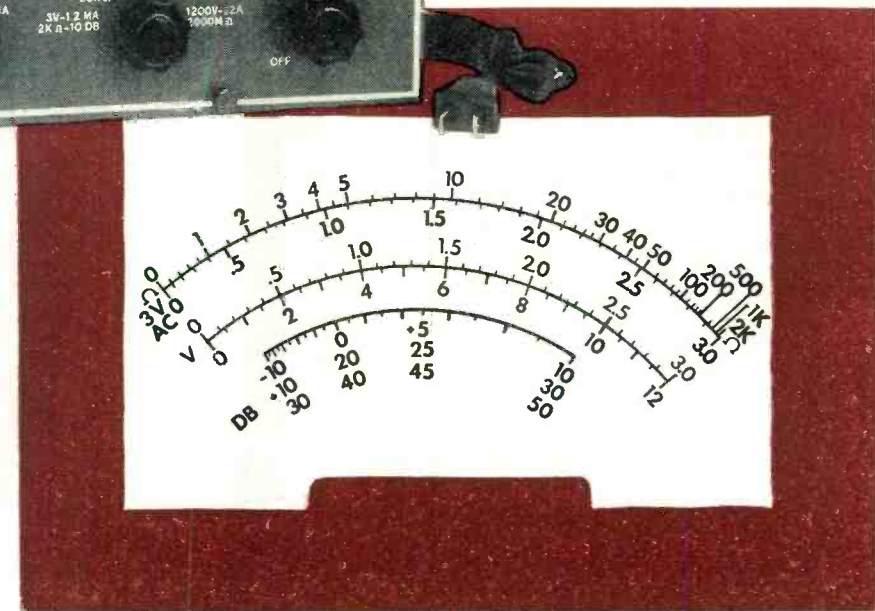

Fig. 2. These basic meter scales cover 39 of 51 possible ranges. The remaining 12 high-voltage d.c. ranges are read by multiplying center scales by 2.5.

and tubes confronted the service technician. An FM receiver might include, in addition, limiter, discriminator, and de-emphasis circuits—while a.f.c., amplified a.v.c., and volume-expander circuits were not infrequently encountered. Television receivers were, and will be, even more complex.

It seems safe to state that with the increasing complexity in receiver construction necessary to yield the improvements in performance expected in postwar receivers, be they AM, FM, television, facsimile, or combinations thereof, prewar service techniques and instruments will be inadequate. The old methods of interchanging tubes, measuring a few power-supply and heater voltages, possibly checking alignment, must of necessity give place to a thorough understanding of circuit conformation, interlinkage and functioning, and test instruments adequate to localize troubles, reveal their character, and so permit repair.

Specializing in receiver design and

production since the crystal detector days of long ago, the writer has watched the progressive development of more and more complex receivers with horrified fascination at the increasing burden such development has placed upon the service technician and his equipment. Long ago he recognized the inadequacy of available test equipment and techniques to cope with the situation in a logical manner. In the design laboratory, where cost of equipment is of quite secondary importance and time was not invariably of the essence, techniques direct and effective when applied by skilled engineers possessed of long training were developed and successfully applied. These involved investigation of the behavior of each individual circuit making up one of many cascaded and inter-linked sections in a receiver. Equipment necessary to such analysis was costly, complicated, and difficult of operation due to inherent instability which had to be compensated for by



frequent check and calibration of the test equipment itself against even more costly and complicated fundamental equipment standards.

The signal is the common denominator of the majority of circuits in every radio receiver. Signal voltage should appear in amplified form in each successive circuit of a properly functioning receiver. Detectors do not usually amplify the signal, but rather convert it to a new frequency. They may be checked by observing the amplitude of the converted signal in terms of gain or loss at their output. It is apparent that if the service technician could apply the laboratory technique of measuring signal voltages, plus every other voltage present in a receiver, he would be provided with a rapid and almost infallible system of servicing. Resistance, and occasionally capacitance, measurements would also be neces-

sary, plus alignment of ganged or cascaded tuned circuits. Alignment is possible using a signal generator and output meter. It is also possible to obtain alignment by employing signals at today's broadcast stations which are, in many cases, even more stable in frequency than the usual signal generator. The matter of providing for complete measurement of every significant voltage found in radio receivers has proved much more difficult of practical, everyday solution. Yet, if servicing and maintenance of complex multi-circuit receivers is to be rapid, simple, and modern, it must presuppose as a fundamental requirement the ability to measure every type and magnitude of voltage encountered in postwar receivers.

In the course of over six years devoted to direction and supervision of design, development, and production

of a wide variety of military radio equipments, the writer was early driven face-to-face with this basic need of accurate and complete voltage measurements.

Ordinary volt-ohm-milliammeters leave much to be desired. Their d.c. input resistance can seldom practically exceed 20,000 ohms/volt, while the usual practice of employing copper-oxide rectifiers to convert a.c. voltages into d.c. for actuation of the usual d.c. meter movement results in even lower meter resistance. Such low meter resistances automatically eliminate any possibility of measuring signal voltages, or even d.c. vacuum tube operating voltages directly, since such voltages are almost invariably applied to tube elements through high resistance circuits. Copper-oxide rectifiers are practically useless above relatively low audio frequencies, and become in-

Fig. 3. Employing only four tubes, this instrument in its entirety has been based on latest commercial design principles.

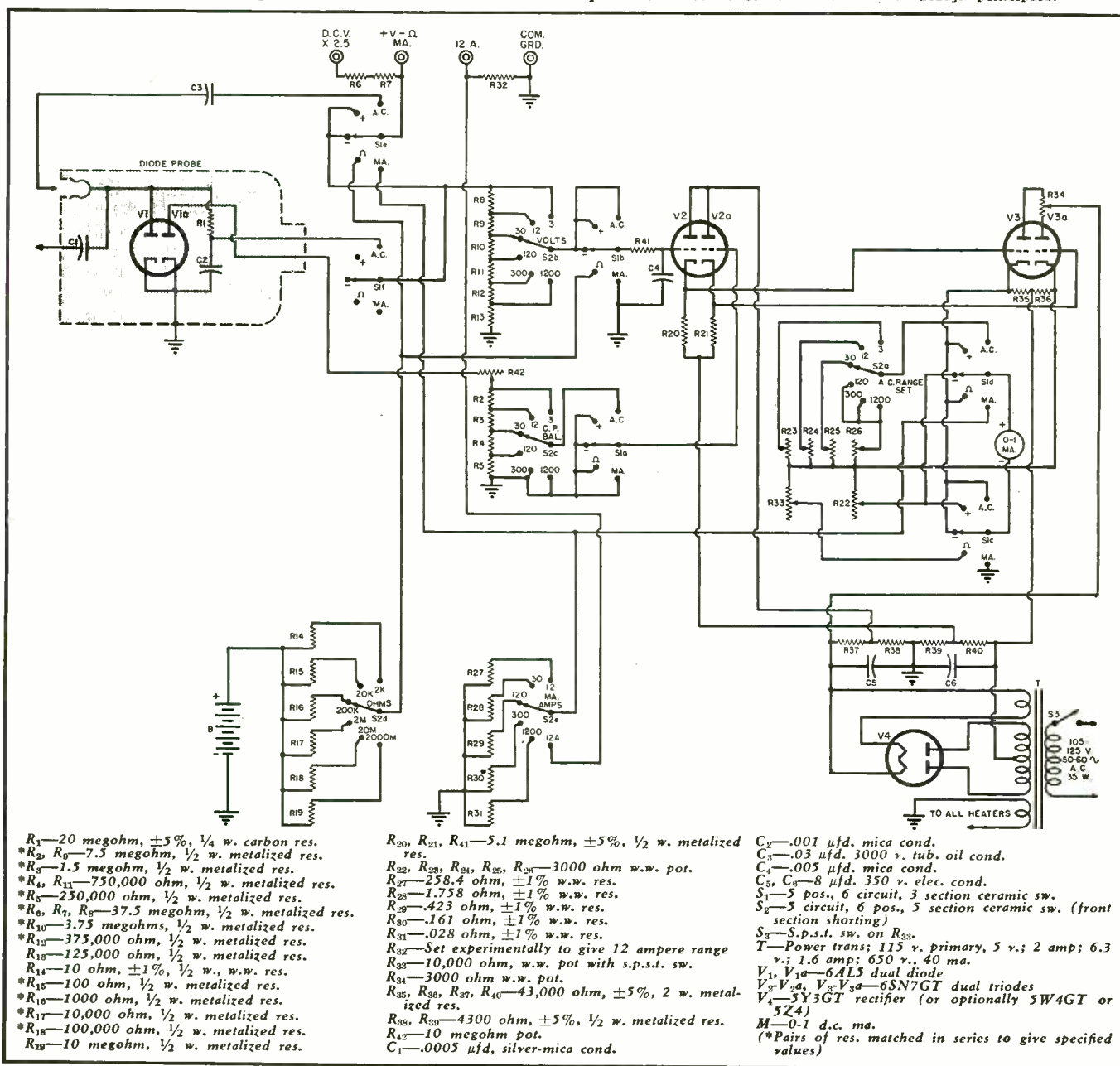

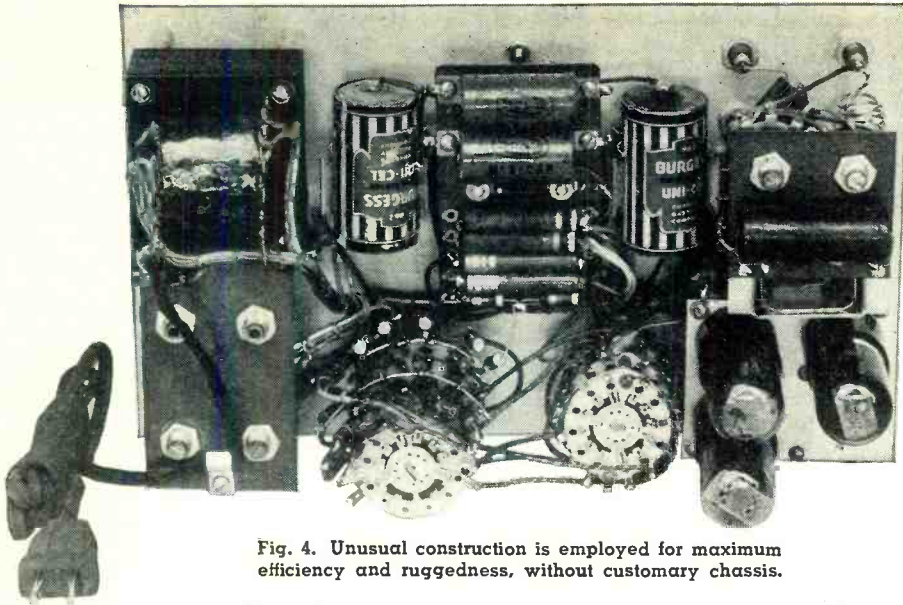

Fig. 4. Unusual construction is employed for maximum efficiency and ruggedness, without customary chassis.

creasingly inaccurate as frequency is raised above usual power line values.

The use of vacuum tubes as coupling agents between a.c., d.c., or r.f. voltages present in high resistance circuits and low resistance power consuming meter movements is an obvious solution at first glance. Yet, anyone familiar with the instability, undependability, and general untrustworthiness of vacuum-tube voltmeters, heretofore available, has shunned all but the most expensive laboratory types or had to be content with an approximation of desired performance. All were of decidedly limited utility in their inability to provide accurately all required voltage measurements. The unsolved problem, as it appeared to the writer, was the inability to produce a universal test instrument capable of high accuracy and truly negligible circuit loading when functioning as a voltmeter over the full range of voltage and frequency essential to modern receiver design and servicing, as well as ability to function accurately as a power output meter, milliammeter, and ammeter (as for auto radio input currents) and to provide accurate resistance measurements over the great range required in postwar radio servicing.

It is believed that the instrument herein described and illustrated fully satisfies these heretofore unsatisfied requirements. It is a perfected vacuum-tube volt-ohm-db.-ma.-ammeter possessing practically the absolute stability and dependability of the meter movement and associated multiplier/shunt resistors. Product of years of research and development, in it has been accomplished that end so essential to universal satisfaction—the practically complete divorcement of the inescapable vagaries of vacuum tubes from affecting operational accuracy. This has been accomplished not at the expense of meter resistance but with what is believed to be the highest effective meter resistance, d.c., a.c., and signal tracing r.f. yet obtained in any stable instrument.

Stemming out of the laboratory type of v.t.v.m. described in the September, 1943 issue of RADIO NEWS, this new instrument goes far beyond predecessor types to provide some 51 ranges and functions—more than heretofore available in any equally compact meter, and of truly extraordinary dependability and accuracy. Six d.c. voltage ranges of 3, 12, 30, 120, 300, and 1200 volts are provided at 50 megohms input resistance, plus the same six in reverse polarity at the turn of a knob. Six more dc. ranges at 125 megohms input resistance, of 7.5, 30, 75, 300, 750, and 3000 volts full-scale, are also doubled by the polarity reversing switch. Six a.c. ranges at 6.6 megohms effective input resistance are had at 3, 12, 30, 120, 300, and 1200 volts full scale. Withdrawing the r.f. diode probe from the instrument panel, as for direct contacting without intervening connecting leads to r.f./i.f. circuits for voltage measurement up through over 100 megacycles, gives the same ranges in r.f. at 6.6 megohms effective input loading shunted by approximately  $8 \mu\text{mf}$ . (The detuning due to this shunt capacitance is eliminated in r.f./i.f. voltage measurements by momentary retuning of the circuit under measurement.) Three of the a.c. ranges are calibrated in decibels (0 db. = 1 milliwatt in 600 ohms). Six direct-reading, zero-left vacuum-tube resistance ranges have full-scale values of 2000, 20,000, 200,000 ohms and 2, 20, and 2000 megohms. Six direct current ranges of 1.2, 30, 120, 300, 1200 ma., and 12 amperes complete a total of 51 useful ranges—enough to service almost any conceivable type of radio receiver in terms of every voltage from antenna input right on through the heretofore almost-impossible-of-accurate-measurement a.v.c., a.f.c., limiter, discriminator, and plate and grid voltages in resistance-coupled amplifier stages, on through power output and even a.c. power input.

The effects of variation in the a.c. line voltage used to power the instru-

ment are almost completely washed out by balanced circuit design. The variation in the behavior of any one vacuum tube due to line voltage variation is balanced out by an equal and opposite effect produced by its complementary balancing tube. The effects of diode contact potential (generated within a diode when its cathode is heated for electron emission) are balanced out by a companion diode and new circuit arrangement. The usual diode meter reading error at low frequencies is eliminated by automatic substitution of an input capacitor large enough to prevent low-frequency attenuation. This capacitor is replaced by a low-inductance, silver-mica unit for r.f. usage equally automatically. The effects of change in vacuum tube characteristics with aging and use is washed out practically 100% by degeneration in each circuit so heavy as to actually permit exchange of an old tube for a new tube with negligible effect upon meter calibration! Burn out of meter through 1000-times overload is eliminated in all but current ranges. The meter is completely protected by so designing its actuating circuits that total meter current in the presence of overload is limited to a value insufficient to burn out the meter movement.

#### Grid and Gas Current Errors Eliminated

Grid current, the besetting sin of practically all v.t.v.m.'s, is completely eliminated. The importance of this feature cannot be overlooked. It is what causes the usual v.t.v.m. to read higher than zero when its input jacks are open, fall to zero when they are short-circuited—as the instructions almost invariably require the operator to do to set zero. This is all right if the voltage source to be measured is of low resistance. If it is of high resistance, the usual case in radio receivers for all except power circuit measurements, then removal of the input short-circuit lets the meter read above zero once again when a not easily predictable amount of this error will add to the voltage to be measured if it is present in the usual high resistance grid, plate, or a.v.c. circuit.

The importance of the complete elimination of grid current effects (caused with ordinary vacuum tubes whenever the grid circuit resistance is high, hence the manufacturers' specifications of maximum permissible grid resistance for tube types which may be damaged thereby) cannot be emphasized too much. It is the source of error and inaccuracy invalidating any attempt at precise measurements with any v.t.v.m. which will not hold the same zero reading with input either open or short-circuited. It is the limitation upon the maximum value of input resistance which may be attained; and the only reason for using vacuum tubes is to obtain an input resistance so high as not to affect circuits which must be measured. Only when grid current effects, plus the

(Continued on page 104)

**W**ITH the official eyes of the nation on the future, it would not be out of step to look critically at the radio repair industry and try to resolve, if possible, the problems of the future. "Why?" you may ask. For the very simple reason that the time has come for major changes.

We are anxious to make the radio repairman think and, in that way, pave the way for the action which must follow. No doubt some who read these lines will say *alarmist* or *fear psychologist*. If such be the reaction, we'll accept the indictment. We are bent upon rousing men deep in lethargy. Our fervent hope is that enough men in this nation, even if comprised of only small groups in the various communities, will heed the warning and take the necessary steps to lead the rest. Entirely too many repairmen in this nation have been lulled into a false sense of security by a condition which obviously is unhealthy. We are speaking about the three years of profitable servicing during the war days and the anticipated two more years of like activity in the immediate future.

Making money in the radio repair business during war days was no trick. It was wholly a seller's market. The public pleaded to have its sets repaired. War hysteria combined with a shortage of replacement merchandise and high war wages made money plentiful. The picnic is still on and will be for about two more years. It will take about this much time for radio receiver manufacturers to produce sufficient new receivers as replacements for old equipment, which will have an effect upon repair activity.

Normally, one would say that two years is a long time. Whether it is or not depends upon what must be accomplished and the time available to complete the job. According to our reasoning, two years is not too much time, for less than a total of five years is available for the required transformation of the radio repair industry. It is, indeed, fortunate that these two years of fairly secure prosperity will be available, for it will provide the luxury of time needed to place this vital plan into operation. To be successful it must be in full operation within five years, and since it took a war to create the approaching favorable two years, the opportunity cannot be missed by the repair group. If the world's efforts to set up a peace machine will bear fruit, never again will such a beneficial opportunity for a required change present itself. If those who, by all rights of sufferance, are entitled to be the electronic maintenance industry of the approaching generation of electronics, miss this opportune period and think only of making money with a total disregard of all else, it will be a sure road to non-existence in the future.

\* Lt. Col. USA (ret'd)

February, 1946



## Let's Look to the Future of RADIO SERVICING

Without meaning to criticize past effort, we cannot help but say that the repair industry made only half-hearted attempts, during the decade prior to the war, to solidify its position. Just why this happened is not important now. It made the mistake once; it should not repeat it a second time. A complete change is required in the repair industry. It must become technically competent to deal with commercial applications or the technological development of the war, and remain so; it must establish trust in the mind of the public; it must develop cooperation within the industry; and last, but not least, it must remain a financially successful institution. The creation of this complete state is no mean task. It is deep within the realm of possibility but will require constancy of purpose, steadfastness of pursuit, and, above all, cooperation and understanding among the men.

We admit that in the light of the multitude of quotations about prosperity which are making the front pages of the press, our prophecy of dire possibilities seems very much out of place. At the same time, it is wise not to overlook the condition that a nation as a whole can be prosperous for years, and not be affected by changes in a minor industry, or by the transposition of an activity from one group of people to another which becomes better suited to carry on the effort under the existing conditions. Stated differently, although not fully

at the moment, it is not inconceivable that the operations of the independent radio repair shops will be taken over by the established radio set dealers or even local representatives of the manufacturers. Which of these it would be would depend to a large measure upon the type of equipment involved.

This type of threat to the welfare of the radio repairman existed prior to the war, although it never materialized into anything definite. Neither did the program at that time have as much weight behind it as it has today, nor were the conditions then as conducive to the change as they are at present. To build hopes upon a foundation of past performance is not very healthy business practice. To be optimistic is a good trait, but to be optimistic with total abandon of common sense as a limiting agency is, to say the least, very dangerous. It is granted that nothing but impairment of the national economy can stop the swelling of the coffers of the radio repair industry during 1946 and 1947. Major reduction of the national income does not loom in the offing, so that a temporary state of security is assured.

What gave rise to the conditions we say must be changed? This, in itself, is a long story which cannot be covered in one article. For that matter, maybe it is best not to resurrect the past in all its detail. Let it suffice to say that it is a combination of short-

sightedness and the war. About the former we intend saying very little; about the latter, a great deal. To lay the blame for lack of foresight by the repair industry in the lap of its individuals only would not be fair. All who had dealings in any form with that group of men can shoulder part of the responsibility in that all contributed to the meager emphasis placed upon the need for advancement in technical understanding. The accent was placed upon the sales rather than the (Cont. on page 118)

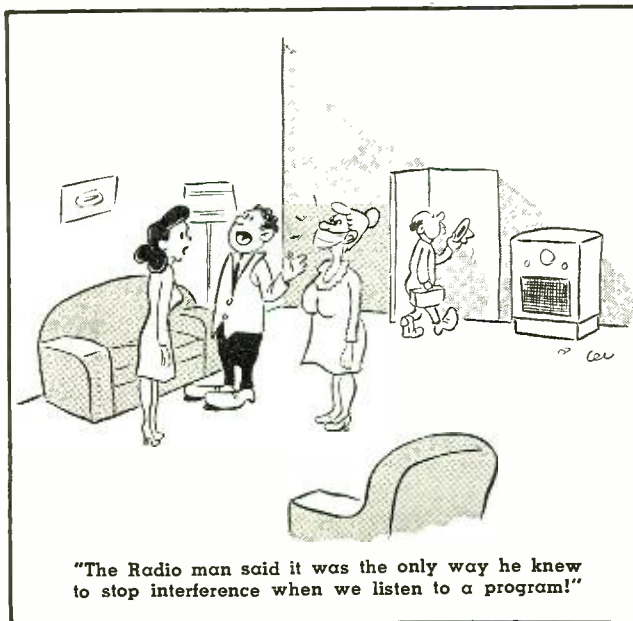

"The Radio man said it was the only way he knew to stop interference when we listen to a program!"

# A Resonant-Cavity WAVEMETER

*Amateurs who look towards the u.h.f. and the s.h.f. ham bands will find the cavity-resonator an accurate instrument for measuring centimeter wavelengths.*

By  
**JORDAN McQUAY**



Differing only in that it is cylindrical in shape, this cavity resonator with coaxial feed has extremely high "Q". In all other respects it is identical to the rectangular type illustrated on opposite page.

**M**EASURING the wavelength of u.h.f. energy above 1000 megacycles is extremely difficult with most conventional means of high-frequency measurement, such as open-rod Lecher or coaxial lines. But recent developments of the *wave guide* as a means of energy transmission have also brought about somewhat of a new philosophy of u.h.f. measurement: the use of resonant sections of wave guides. And this measuring method produces some startling results!

Fundamental theory of all u.h.f. measurement is based on the reflection of these microwaves by certain known lengths of transmission line. Procedure consists simply of measuring the distance *d* between positions of a movable short-circuit on a transmission line for successive maximum readings of an indicator loosely coupled to the transmission line.

Length of the wave is then determined by:

$$\lambda = 2d \left[ 1 + \left( \frac{R}{2\omega L} \right)^2 \right] \dots \dots \dots (1)$$

where *d* = distance between points of successive maximum readings  
*R* = total resistance per unit length of transmission line, measured in: ohms × cm.<sup>-1</sup>  
*L* = inductance per unit length of transmission line, measured in: henrys × cm.<sup>-1</sup>

In the region of u.h.f. operation above 1000 megacycles, however, the only efficient type of transmission line is the wave guide. Energy traveling within these guides may have any of various types of electromagnetic field configurations or *modes*. But in *other* respects, particularly since there is no center conductor, wave propagation is considerably simplified. As for these wavelengths of 30 centimeters or less, equation (1) also is simplified. Effects of resistance and inductance (per unit length of wave guide) are so minute, the equation becomes:

$$\lambda = 2d \dots \dots \dots (2)$$

where *d* = distance between points of successive maximum readings.

Analogous to similar use of Lecher and coaxial lines, a short section of wave guide can be made to resonate when both ends are closed or partitioned in such a manner that reflections occur within the device. When u.h.f. energy is introduced into one end of a closed section of wave guide, standing waves will be set up within the guide whenever it is terminated in an impedance differing from its characteristic impedance. If this termination can be made variable—by use of a moving partition, or plunger arrangement—the interior of the wave guide section can be made to resonate at any value within a considerable range of ultra-high frequencies. In this way, the section of wave guide becomes a *resonant cavity*. When a suitable indicator is added

for determining the points of maximum energy at resonance, the section of wave guide is known as a *resonant-cavity wavemeter*.

A fundamental—but typical—resonant-cavity wavemeter is shown in Fig. 1. Cross-section and plan views are shown in Fig. 2.

Energy of unknown ultra-high frequency is introduced into the wavemeter by means of a coaxial cable and a small coupling loop. Then, if the length *L*—from input to plunger—is *not* equal to a whole number of half waves of the unknown frequency, standing waves will *not* be established within the cavity, because reflected waves from the plunger will cancel the incoming waves. This condition of *non-resonance* will be evident by the absence of a bright glow from the neon lamp, regardless of its position along its narrow, rectangular slot.

However, if the tuning plunger is moved back and forth slowly, a position will be found where resonance takes place inside the wave guide. There is a condition of resonance *only* when the length *L* is equal to a half wave or a whole number of half waves of the unknown frequency—when the energy waves reflected by the plunger *aid* the incoming u.h.f. waves instead of cancelling them. This optimum position of the tuning plunger is indicated by a glow from the neon lamp, regardless of the position of the lamp along its narrow slot.

After finding the optimum position of the plunger, however, the position

of the neon lamp may be varied, when desired, to obtain a brighter glow. Lamp will be brightest when it's located about one-quarter wavelength from the input—measured at resonance, on the *inside* of the guide. But this distance is not critical and will not greatly influence relative measurements.

The desired length  $d$  of the unknown wave *within the guide* can be determined by actual measurement of the physical distance between points of successive maximum indications of the neon lamp as the tuning plunger is moved back and forth. Or, for very short wavelengths, the plunger may remain fixed at resonance and the position of the neon lamp varied to determine points of successive maximum energy. These maximum points require hair-splitting adjustment of the plunger, and, unless a good deal of care is taken, they may be passed over easily.

A calibrated scale, in centimeters, can be applied to one side of the serrated tuning arm. Wave measurement can thus be obtained directly and quickly. If the movable neon lamp is to be used to measure very short wavelengths, a centimeter calibration should also be appended alongside the lamp's rectangular slot.

Within the wave guide section, a very low-resistance contact must be maintained between the plunger and the inner surface of the guide. Often the plunger may be operated in a region of maximum voltage where contact resistance can be more easily broken down. To solve this problem, it's generally desirable to construct a low-loss multiple-spring *contact sleeve* around the plunger and extending into the cavity about one-half inch beyond the face of the plunger.

Total length  $D$  of the wavemeter is, of course, largely dependent upon the range of centimeter waves to be investigated. Length is rarely more than the value of four wave lengths of the longest microwave likely to be measured.

Other dimensions of the wavemeter are also dependent upon the longest and shortest centimeter waves to be measured. Selecting an *average wavelength* from the proposed operating range, width  $A$  of the wave guide should be slightly less than one-half wavelength, and height  $B$  should be slightly less than one-fifth of the average wavelength.

Although the neon lamp gives satisfactory and critical definition in measurement, greater accuracy can be achieved by substituting an r.f. voltmeter mounted on a similar sliding base—so that it can be moved back and forth along the rectangular block. A tiny probe extends down through the meter base for coupling out of the guide a small amount of u.h.f. energy.

In this arrangement, maximum points of the standing wave due to the electric field at resonance can be determined with greater precision. The distance  $d$  between any two successive

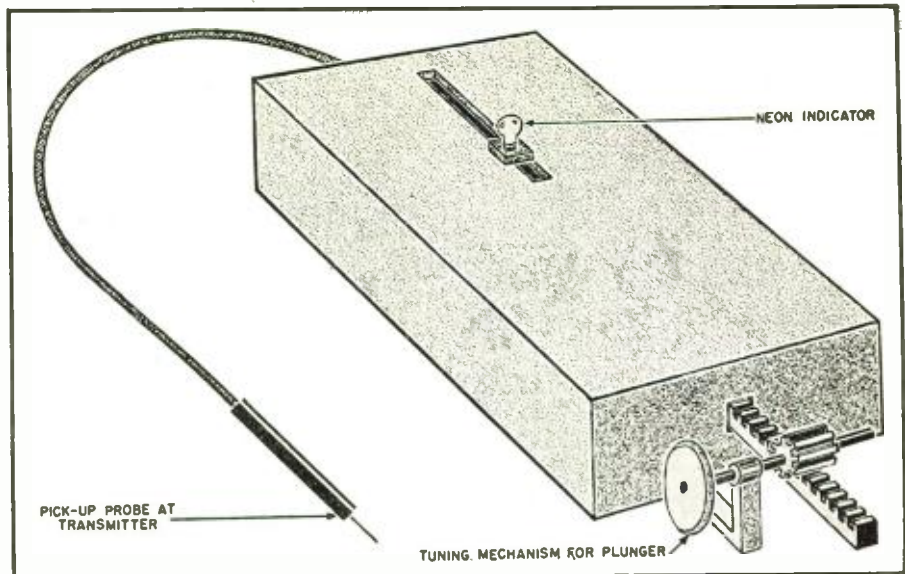

Fig. 1. External view of a rectangular type resonant-cavity wavemeter.

points of maximum r.f.-voltage indicates the length of a half wave within the guide.

The meter can be visualized as a high-impedance device. Therefore, maximum deflection will take place when the meter probe is located one-quarter wavelength from the cavity input.

*It's important to note that these measurements are made of u.h.f. waves when they are within the resonant section of wave guide. Their behavior in a resonant cavity differs from their behavior in free space. Measurement results are often hard to believe because it appears that waves inside a resonant wave guide travel faster than the speed of light!*

Assume the existence of a centimeter wave, *having a known length*. When this energy is applied to a resonant-cavity wavemeter, careful and precise measurement of the wave *indicates an increase in length of about 20 per-cent*. In other words, for a given ultra-high frequency, the measured length of a half wave in the

resonant wave guide appears to be greater than the length of a half wave in space.

Velocity of radio waves is approximately 300,000,000 meters-per-second, or the speed of light. For a given radio wave, the relation between frequency and wave length is expressed by the familiar equation:

$$\lambda \text{ (in meters)} = \frac{\text{velocity}}{f \text{ (in cycles)}} \dots\dots\dots (3)$$

which can also be stated as:

$$\text{Velocity} = f \text{ (in cycles)} \times \lambda \text{ (in meters)} \dots\dots\dots (4)$$

Thus, when a wave of fixed frequency is measured by a resonant-cavity wavemeter and found to have increased about 20 per-cent in length, it would appear (from equation 4) that the velocity of the wave increased within the resonant section of wave-guide. This would mean that the velocity of a wave in a resonant guide exceeded the velocity of light, thus stubbornly contradicting laws of physics which state that *neither matter*

(Continued on page 74)

Fig. 2. Cross-sectional view showing mechanical construction of wavemeter.

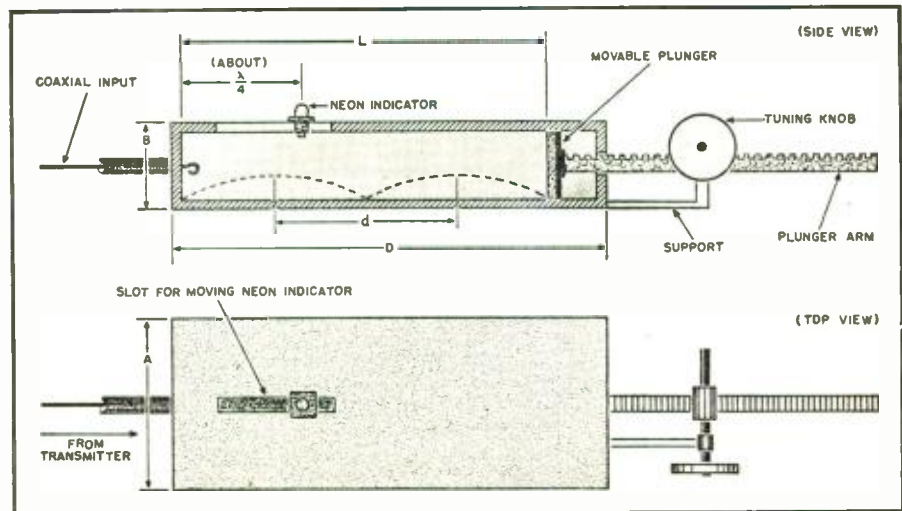

# Self-Synchronous TRANSMISSION SYSTEM

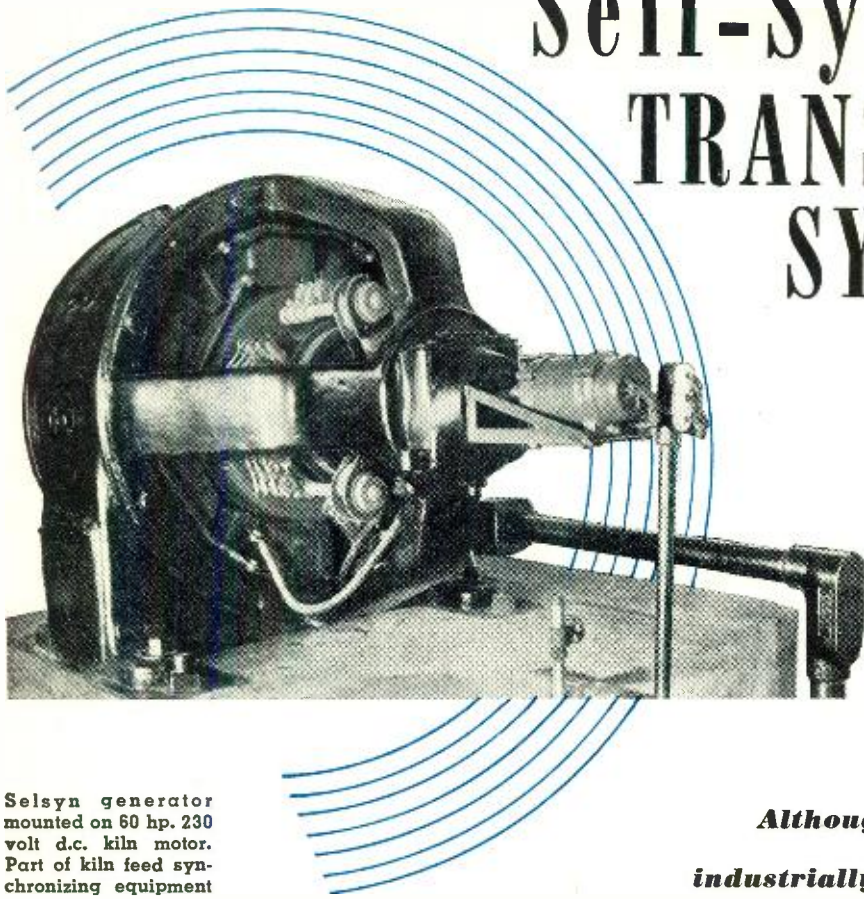

Selsyn generator mounted on 60 hp. 230 volt d.c. kiln motor. Part of kiln feed synchronizing equipment manufactured by GE.

By  
**ERIK HANSEN**

**Although selsyn motors are widely used industrially, they will find many amateur applications, particularly in rotating highly directional antennas to a predetermined position.**

**W**ITH the invasion of electronics into many fields of industry, there is a concurrent increase in the need for transmitting, by electrical means, a signal that may be represented by angular position. Industrial electronic devices have been developed to indicate information which is read on a dial and it is often necessary to repeat this information simultaneously in another room or even in another building. One of the simplest and most efficient methods of communicating these dial readings to a central board or control headquarters is by a self-synchronous transmission system.

The transmitting unit of the system has been called a *selsyn* (self-synchronous), teletorque, autosyn, or synchro, but all mean the same thing—a generator. The receiving unit—a motor—is similarly named with the word *repeater* or *follower* added. The system thus becomes the familiar *motor-generator* set but of a special sort which will be explained later.

The electrical operation of all types of synchros is the same although manufacturers vary as to mechanical details. There are, in general, two types of rotors, the more common being the salient pole or *dumbbell* type used in most transmitters and repeaters. It

has a machine wound, single-phase spool winding, the synchro primary, with two slip rings associated with it. The other type has a cylindrical rotor commonly called a wound rotor, slotted and laminated, carrying either a single or three-phase winding with two or three slip rings respectively. Stators are cylindrical, slotted, laminated structures with a distributed 3-phase Y connected winding which is the secondary of the synchro. The winding is not three phase, in the usual sense, as all induced voltages are in phase with each other. The three circuits of the stator winding, however, are displaced 120 degrees from each other similar to the conventional 3-phase winding.

The operation of a synchro or selsyn motor is based on the control of shaft position by varying a voltage as shown in Fig. 1A. Recalling the fundamentals of electrical solenoids, a study of the diagram makes it obvious that the magnet in the center will point to  $S_2$  or zero position. Likewise, the magnet will rotate to a fixed position pointing to  $S_3$  or  $S_1$  when  $S_2-S_1$  or  $S_2-S_3$  are connected to the negative terminal with the positive voltage applied to the remaining open  $S$  lead.

If the circuit is changed slightly to

Fig. 1. (A) Magnet turns to 0° position. (B) Magnet moves from 60° to 0° as voltage between  $S_2$  and  $S_3$  is increased.

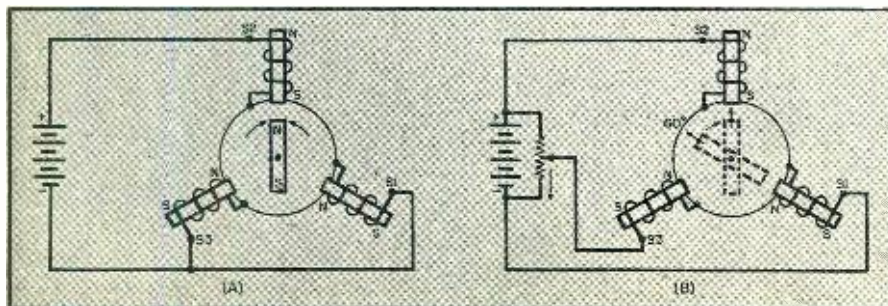

that in Fig. 1B, it is evident that the magnet in the center will rotate as the voltage between  $S_2$  and  $S_3$  is increased from 0 to maximum. In other words, the magnet points to the left at sixty degrees with no voltage between  $S_2$  and  $S_3$  but turns clockwise to zero when the two voltages are equal. Thus, it is possible to make the magnet rotate to any position merely by adjusting the voltages applied to the three coil leads.

Since in practice, alternating current is supplied to the motor, it now becomes necessary to understand what happens to the center magnet or rotor under a.c. conditions shown in Fig. 3A. The rotor coil can be considered as rotating around an axis with the arrow pointing to its electrical position. This position is determined by the phase relationship of the rotor to the stator coils. From the figure, it is evident that the rotor is in phase with coil 2, and the  $R_1$  end of the rotor is strongly attracted to the lower end of coil 2; the  $R_2$  end is attracted equally to the upper end of coils 1 and 3, and the resultant magnetic force turns the rotor to zero.

It has been explained how a variation of d.c. voltage will change angular position and this principle still holds when a.c. is used (Fig. 3B). Here a fixed voltage between  $S_1$  and  $S_2$  is in phase with the rotor coil voltage since both are from the same a.c. source. A variable tap permits another in-phase voltage to be applied between  $S_2$  and  $S_3$ , and this can be decreased from the a.c. source potential to zero. The rotor points to sixty degrees with no voltage between  $S_2$  and  $S_3$ , and turns to zero when the voltage between  $S_2$  and  $S_3$  reaches that from  $S_2$  to  $S_1$ .

To obtain the proper voltages required to position the motor shaft, a synchro generator is used. This unit is almost identical to the motor in construction except that no inertia damper is needed, this being provided by mechanically coupling the generator to its source of shaft motion. Both motor and generator leads are marked in the same way, that is,  $R_1$  and  $R_2$  are the rotor leads;  $S_1$ ,  $S_2$  and  $S_3$  are the stator leads. Coil windings are similar in the two units and electrical zero for the generator is shown in Fig. 2. The maximum voltage is induced in coil 2 since the rotor coil is in line with it. This value is 52 volts on a 115 volt a.c. system as the turns ratio between rotor and any one stator coil of a synchro generator is a little more than two to one. Values of 26 volts, in the other two stator coils, result since the voltages induced in these are one half maximum. This, of course, is due to the rotor not being lined up with these coils.

The vectorial addition of the voltages results in values needed to position a motor to electrical zero as was shown in Fig. 3A. By connecting the rotor and stator leads of the two units, a simple synchro transmission system results (Fig. 4). Here it must be remembered that since motor and gen-

erator are electrically similar, the former also induces a voltage in its stator coils. However, the voltages are in opposite phase and, by tracing the circuit, it is evident that no current flows through the motor stator windings and both rotors are positioned electrically at zero. If we now move the generator rotor 30 degrees counterclockwise, different voltages appear and current flows in all three stator leads. This current produces a turning torque on the motor shaft and brings it around to the 30 degree position of the generator. In other words, the motor follows the generator due to voltage unbalance and a synchro repeating system results.

Selsyns are usually energized by 60 cycle, 115 volt single-phase alternating current and draw but little power from the line. Although designed for continuous excitation, a limiting factor is the allowable temperature rise in the unit. The displacement angle must never exceed 20 degrees for very long as excessive heating with a resulting burned out coil may follow. Torque requirements should thus be carefully studied in applying selsyn systems. For instance, in the case of a compass repeater the load on the motor must be very small and the impedance of the windings and connecting wires must be kept to a minimum. In this case the repeating accuracy is usually about one half a degree either way.

A generator can operate several motors in parallel, provided it can supply a sufficient current without too much voltage drop. The motor shafts should, of course, be free to turn so that the stator current is relatively low. The amount of current available to make each motor turn depends on the impedance of the generator and the current used by the motors.

Although no adjustments are made to selsyns themselves, it is necessary to adjust the unit with respect to the instrument in which it is mounted. The generator rotor must be set at electrical zero although this may not mean the zero position on the dial attached to the shaft. The reading depends on the function of the unit in the instrument.

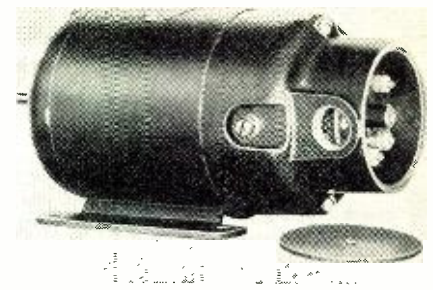

Totally enclosed single-phase selsyn motor.

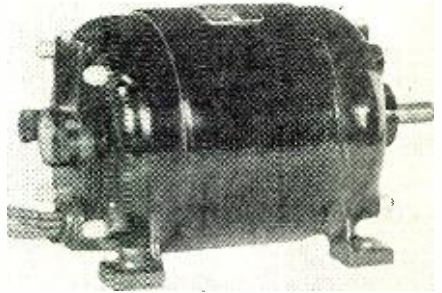

Selsyn transmitter to drive scanning mechanism of textile weft straightening control.

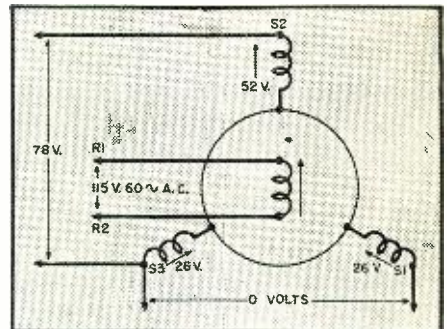
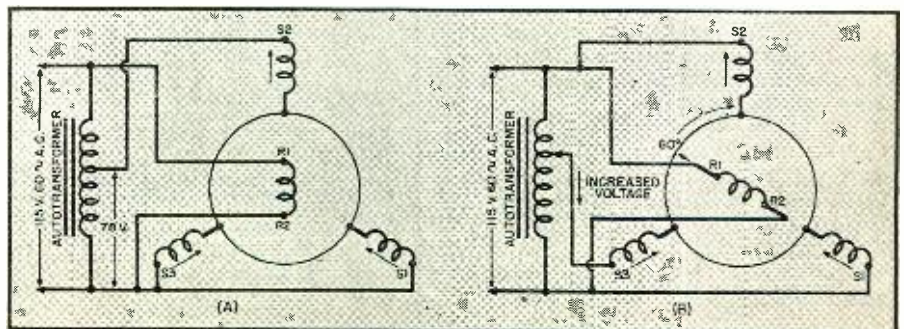

Fig. 2. Showing voltages induced in stator windings when  $R_1$  and  $R_2$  are connected across a 115 volt a.c. power supply.

The electrical zero position of a motor or generator is the position of the rotor relative to the stator when the unit is connected, as in Fig. 5. If the unit is rated at 100 volts, 87 volts should be impressed across the stator; if rated at 90 volts the proper impressed voltage is 78 volts. These should be obtained from an auto-

(Continued on page 142)

Fig. 3. (A) The  $R_1$  end of the rotor is attracted to the lower end of coil 2. The  $R_2$  end is attracted equally to the upper ends of coil 1 and coil 3. Hence, the rotor turns to 0°. (B) With no voltage between  $S_2$  and  $S_3$ , the rotor turns to 60°. Increasing the voltage causes the  $R_2$  end of the rotor to be attracted more and more toward coil 3. The  $R_1$  end reaches the zero position when the voltage from  $S_2$  to  $S_3$  equals that from  $S_2$  to  $S_1$ .



# Wide-Range

# CONVERTER-RECEIVER

By LT. COL.

BYRON E. HARGROVE

AUS. W9LFU

**Complete construction details for a combined superregenerative receiver for 112 mc. and a 14, 21, 28, and 50 mc. converter.**



Front panel view of the completed unit. The controls from left to right are antenna changeover switch  $S_1$ , regenerative control  $R_1$ , and  $S_2$ , band set condenser  $C_3$ , filament switch  $S_3$ , and r.f.-mixer condenser  $C_1$ ,  $C_2$ . Main knob controls tuning of oscillator condenser  $C_{12}$  and superregenerative condenser  $C_{17}$ .

**H**AVING an excellent communications receiver whose upper frequency range is 20 megacycles, the author desired a converter that would provide superlative performance at the higher frequencies.

A superregenerative receiver for 112 mc. was added as an afterthought and may be omitted, if desired. However, the cost of such a receiver is considerably reduced due to saving in power supply, chassis, dial, cabinet, etc.

The following specifications were adopted as musts for the converter:

1. Extreme sensitivity with high signal-to-noise ratio.
2. No images, no spurious signals in the amateur bands.
3. Good stability.
4. Ease of operation.

In order to provide maximum sensitivity with minimum noise, it was decided to take advantage of the new tubes developed during the war. Accordingly, a 6AK5 was selected as the r.f. amplifier and another as a mixer. These tubes when operated with 180 volts on the plate, 120 volts on the screen, and a bias resistor of 200 ohms, have a transconductance of 5100. Also, they handle as easily at 50 mc. as a 6K7 does in the broadcast band. A corresponding miniature triode, the 6C4, was chosen as the oscillator tube and results proved that the choice was a good one.

In order to be absolutely sure there would be no images, it was decided to use a high intermediate frequency. Any frequency above 7 megacycles

would probably have been satisfactory but since there was a complete set of FM intermediate frequency transformers for 12 mc. in my junk box and the possibility of using the converter as the front end of an FM receiver was rather attractive, 12 mc. was chosen as the intermediate frequency. Since the receiver with which the converter is to be used has an i.f. of 465 kc. this means that the h.f. oscillator is on 12,465 kc. when the receiver is tuned to 12 mc. Checking the various harmonics of the receiver h.f. oscillator showed that they would always fall outside the amateur bands. If another i.f. is chosen, a check should be made to determine that the harmonics of

the receiver h.f. oscillator will not fall in the amateur bands.

In order to insure good stability, care was taken to make the assembly mechanically rigid. To minimize drift, the power transformer, rectifier tube, and voltage regulator tube were placed well away from the oscillator components. The voltage regulator tube holds the voltage on the oscillator plate constant at 150 volts. Very light loading of the oscillator is accomplished by using a very small coupling condenser  $C_6$  to the mixer tube. Actually  $C_6$  consists of about  $\frac{3}{4}$ " insulated hookup wire soldered to the grid of the 6AK5 mixer and two turns of a similar piece of wire twisted around it and then soldered to the grid end of the oscillator coil.

In order to obtain ease of operation, and at the same time obtain maximum performance, the oscillator tuning condenser is not ganged to those of the mixer and r.f. stages. This makes it quite easy to get all circuits working on the nose. Actually the r.f.-mixer control is tuned for the middle of the band in use and then peaked for weak signals only. The r.f. and mixer condensers are ganged. Tracking can be checked by tuning in a signal, then slowly rotating the r.f. and mixer tuning condensers for maximum signal,

**EDITOR'S NOTE:** Many amateurs have receivers giving excellent performance at frequencies up to about 20 mc. but which either do not cover the higher frequencies or do not perform as well on the higher bands. This involves no criticism on the part of the manufacturers but is rather the natural result when a receiver is called upon to cover too wide a frequency range. Also, the proposal to include 21-21.5 mc. as a new amateur band leaves many amateurs with receivers providing band-spread on 80, 40, 20, and 10 meters but which either do not cover 21-21.5 mc. or else provide only general coverage with no means of spreading this narrow band. The converter described adequately surmounts any of the difficulties mentioned.



then checking to see if there is another point of maximum signal. This process is easily accomplished if the receiver has an *R* meter or tuning eye. If there are two points, the r.f. and mixer are not tuning to resonance at the same point and turns on one of the coils should be altered accordingly. The mixer tunes the sharpest and causes the greatest change in signal when detuned. This makes it easy to determine which coil needs changing. For example, suppose after tuning the main control  $C_1C_2$  to a signal,  $C_1C_2$  is rotated from minimum toward maximum capacity and a rise in signal strength is found. Then on continuing the rotation, a second setting is found which gives a more pronounced rise in signal strength, and which tunes more sharply than the first. This indicates that the first setting was resonance for the r.f. stage and the second for the mixer. The cure is to add more turns to the mixer coil or remove turns from the r.f. coil. The first is the preferred solution since the lower the *C* and the higher the *L*, the more gain.

In this connection, it was found that the 21 mc. coils would also tune to 14 mc. and the 28 mc. to 21 mc. However, even this small increase in the amount of *C* in the circuit makes a substantial difference in the performance so that separate coils for each band are strongly recommended.

Incidentally, the oscillator always works on the high frequency side of the incoming signal. Since the comparatively large band-set condenser, used on the oscillator for stability purposes, enables it to be set on either the high or low frequency side on some bands, care should be taken to see that it is always set on the high frequency side, if the dial calibration is to be maintained. Otherwise the oscillator may be used on either side of the incoming signal.

The 9002-6C5 superregenerative receiver for 112 mc. (or 144 mc. after the band is moved) is straightforward. The 9002 tuning condenser is ganged to  $C_{12}$ . The antenna connections are two small *Fahenstock* clips mounted on the tuning condenser  $C_{17}$  bracket.

In construction, a 7"x9"x2" chassis of heavy gauge should be chosen in order to insure good rigidity. If the layout shown in the illustrations is followed no trouble should be had with oscillations in the r.f. and mixer stages. If the layout has been followed and the r.f. does oscillate, increase the number of turns in  $L_1$ . If this fails, increase  $R_2$  to 30,000 ohms. It should be noted in this connection that the 14 mc. coils can be tuned to the intermediate frequency of 12 mc. If so, a violent oscillation takes place. (This is normal and the cure is to avoid tuning to the intermediate frequency.) This layout allows extremely short r.f. leads, the lead to the oscillator band spread condenser and that from the oscillator to the mixer for coupling being the only leads more than 1" long.

Band	$L_1$	$L_2$	$L_3$	$L_4$	$L_7$	$L_8$
14 mc.	8 t. No. 22 enamel close wound at bottom of form.	14 t. No. 22 enamel close wound spaced $\frac{1}{16}$ " from $L_1$ .	10 t. No. 22 enamel close wound at bottom of form.	17 t. No. 22 enamel close wound spaced $\frac{1}{16}$ " from $L_3$ .	2 t. No. 22 enamel close wound at bottom of form.	$3\frac{3}{4}$ t. No. 18 d. c. c. close wound $\frac{1}{8}$ " above $L_7$ . Tap 1 turn from grid end.
21 mc.	6 t. No. 22 enamel close wound at bottom of form.	15 t. No. 22 enamel space wound to $\frac{3}{4}$ ", bottom turn beginning $\frac{1}{16}$ " from $L_1$ .	$6\frac{1}{2}$ t. No. 22 enamel close wound at bottom of form.	16 t. No. 22 enamel space wound to $\frac{3}{4}$ ", bottom turn beginning $\frac{1}{16}$ " from $L_3$ .	$1\frac{7}{8}$ t. No. 24 d. c. c. close wound at bottom of form.	$3\frac{1}{8}$ t. No. 18 bare, space wound to $\frac{1}{2}$ ", beginning $\frac{3}{16}$ " from $L_7$ . Tap $\frac{1}{16}$ " of turn from grid end.
28 mc.	6 t. No. 22 enamel close wound at bottom of form.	$9\frac{1}{2}$ t. No. 22 enamel space wound to $\frac{5}{8}$ ", bottom turn beginning $\frac{1}{16}$ " from $L_1$ .	$6\frac{1}{2}$ t. No. 22 enamel close wound at bottom of form.	11 t. No. 22 enamel space wound to $\frac{3}{4}$ ", bottom turn beginning $\frac{1}{16}$ " from $L_3$ .	$1\frac{3}{4}$ t. No. 24 d. c. c. close wound at bottom of form.	3 t. No. 18 bare, space wound to $\frac{3}{4}$ ", beginning $\frac{3}{16}$ " from $L_7$ . Tap at grid end.
50 mc.	4 t. No. 22 enamel close wound at bottom of form.	5 t. No. 18 d.c.c. space wound to $\frac{7}{8}$ " bottom turn beginning $\frac{1}{16}$ " from $L_1$ .	$4\frac{1}{2}$ t. No. 22 enamel close wound at bottom of form.	5 t. No. 18 d.c.c. space wound to $\frac{5}{16}$ ", bottom turn beginning $\frac{1}{16}$ " from $L_3$ .	$1\frac{7}{8}$ t. No. 24 d. c. c. close wound at bottom of form.	$1\frac{3}{4}$ t. No. 18, space wound to $\frac{1}{2}$ ", beginning $\frac{3}{16}$ " from $L_7$ . Tap at grid end.

Coil data for converter. All coils are wound on  $\frac{3}{4}$ " 5-prong polystyrene forms.

All wiring to the r.f. and mixer sockets must be made before mounting  $C_1C_2$ , which is a dual 25  $\mu$ fd. midget. The 6AK5 tubes have two cathode connections. All grounds from the grid circuit should be made to one of these connections and those from the plate circuit to the other as shown in the schematic diagram. The chassis should not be depended on for ground in any r.f. circuit. Leads of about two inches in length are soldered to the grid of the 6AK5 r.f. and 6AK5 mixer. Then  $C_1C_2$  is mounted, the leads soldered in place, and the

excess clipped off. A vertical shield about 3"x4", separates the r.f. coil from the other coils.

The oscillator band spread condenser  $C_{12}$ , is made by removing all but one rotor and one stator plate from a *Hammarslund* MC type midget, and is tapped down on coil  $L_8$  to give the desired band spread.

It is best to wind coils for the 14 mc. band first even though the receiver covers this band with good performance. By comparing the converter-receiver performance with that of the receiver itself on this band, an idea

Top view of the completed receiver. The entire assembly is mechanically rigid and all stages are well shielded to prevent any interstage coupling.



can be obtained as to how well the combination is working. Actually this receiver was checked on the 15 mc. broadcast band, which is easily reached with the 14 mc. coils by resetting the oscillator band set condenser. In this case, employing a receiver widely used, both by commercial services and the military, generally acknowledged as one of the finest receivers available and having a measured sensitivity of about 1.4 microvolts per meter at 15 mc., the converter-receiver combination gives about one R point better performance than the receiver alone, and with an accompanying worthwhile improvement in the signal-to-noise ratio.

The coils are wound on  $\frac{3}{4}$ " diameter, 5 prong, polystyrene coil forms. Extreme care must be used in soldering to the prongs as excessive heat will cause the form to soften and the prong to bend over out of line. If held in place by a pair of pliers, however, the form soon hardens and is as good as ever. Slightly roughen the ends of the prongs with a file and apply the solder with a pointed iron for

just long enough to flow the solder. Be sure a good connection is made, however, as a poor connection will result in erratic operation or a failure of the high frequency oscillator to oscillate at all.

Connections to the coil sockets should be made with consideration for the shortest possible leads and the coils wound accordingly. The antenna changeover switch is a 4-pole, double-throw type which permits connecting the antenna to the receiver or to the converter.

Small coaxial cable, if available, should be used to make connections from the doublet antenna terminals to the antenna changeover switch, from the switch to  $L_1$ , from  $L_6$  to the switch, from the switch to the output terminals, and thence to the receiver or 12 mc. intermediate frequency amplifier. However, if coax is not available, twisted hook-up wire will do and was actually used in the construction of this converter.

To operate the converter, first be sure that each tube is seated properly in its socket. Then insert the set of

coils for the desired band. (It is best to begin with the 14 mc. set because of the abundance of signals always available in this range). Throw  $S_3$  (first control on left) so that the antenna is connected to the converter. Throw  $S_2$  (second control from right) so that the converter tube filaments are connected to  $T_1$ . Turn  $S_1$  (second control from left) until it just clicks. Set  $C_{12}$  (main dial) to about half scale. Rotate  $C_{13}$  (center control) until a signal is heard. Then peak the signal with  $C_1C_5$  (first control on the right).  $C_1C_5$  may be used as a volume control on extremely strong signals. Usually this is done with the controls on the receiver.

To operate the superregenerative receiver, merely throw  $S_2$  so that the receiver filaments are connected to  $T_1$ .  $S_1$  and  $R_{13}$  are combined into a single unit (the second control from the left).  $R_{13}$  should be advanced until the oscillator breaks into oscillation. The band is spotted by adjusting  $C_{15}$  with a screwdriver and then all tuning is done with the main tuning dial.

(Continued on page 140)

Schematic diagram of the complete unit. The converter employs two 6AK5 tubes and a 6C4. The power supply employs an 80 and a VR-150. The 112 mc. receiver is made up of two tubes, a 6C5 and a 9002. The VR-150 prevents any change in the 150 v. "B" supply.

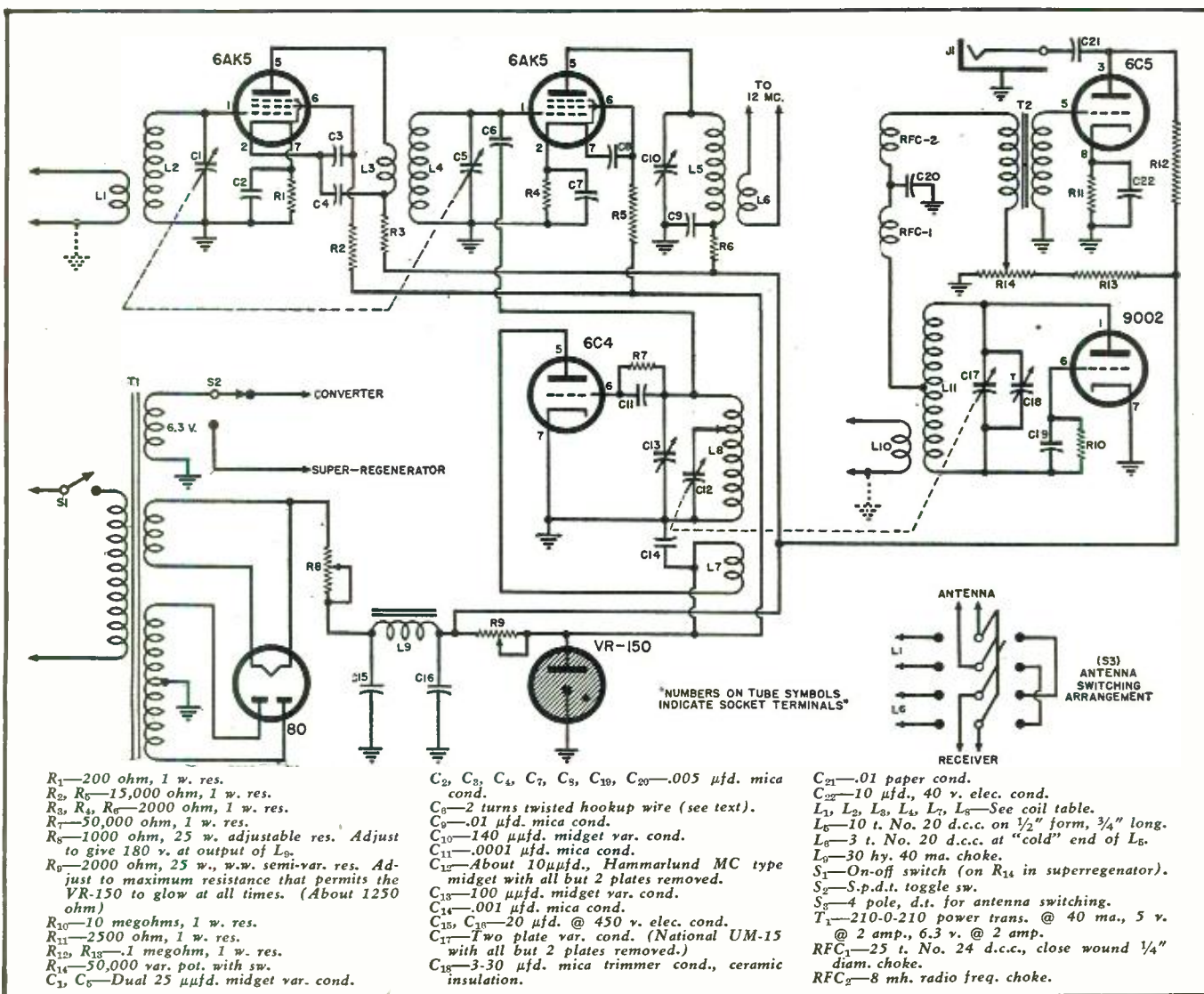



# International SHORT-WAVE



Compiled by **KENNETH R. BOORD**

**T**HIS month our congratulations and best wishes go to Director William W. "Bill" Harris and his capable staff of *The West Indian Radio Newspaper* which on February 1, 1946, marked its third anniversary.

Sponsored by the Anglo-American Caribbean Commission, this thirty-minute broadcast beamed to the Caribbean area has taken to the airwaves each evening at 5:15-5:45 p.m.<sup>1</sup> since February 1, 1942, over the Boston facilities of the World Wide Broadcasting Foundation, through powerful transmitters WRUW, 11.73 in the 25-meter band and WRUL, 15.29 in the 19-meter band.

The Newspaper, presented in English, originates in Washington, D. C., is sent by wire line direct to Boston where it flashes out into the ether from transmitters beamed in a V-angle to blanket completely the Caribbean area. Yet, with the wide and sometimes uncontrollable range of short-wave radio signals, the West Indian Radio Newspaper is heard clearly in Europe, Africa, South America, the Pacific, Central America, the United States, and Canada. The fame of the West Indies and the work of the Anglo-American Caribbean Commission is thus spreading daily to the far corners of the world through this medium.

Station ZFY, 6.000, Georgetown, British Guiana, relays the broadcasts daily except Saturday; Re-Diffusion, Port-of-Spain, Trinidad, relays the broadcasts daily except Tuesday and Sunday; and Radio Distribution, Bridgetown, Barbados, rebroadcasts the Newspaper daily except Thursday, Saturday, and Sunday. ZNS, Nassau, the Bahamas (640 kc. and 6.090 on short-wave), has rebroadcast the Newspaper intermittently, and ZQI, 4.700, Kingston, Jamaica, has been given the green light to rebroadcast the radiations when diversity of receiving equipment has been made available.

The West Indian Radio Newspaper was established as "a method for the carrying out of the cultural and educational opportunities for the initiation and successful accomplishment of projects dealing with the welfare of the territories and colonies of the United States and Great Britain in

the Caribbean area," through a half-hour international short-wave radio program designed especially for the peoples in the lands of the Caribbean. The Newspaper devotes itself purely and simply to items of essential interest to the Caribbean area, primarily the British West Indies, the colonies of British Honduras and British Guiana, and the territories of Puerto Rico and the Virgin Islands of the United States.

The West Indian Radio Newspaper is, as its name implies, a newspaper of the air. In order to give flexibility in programing, the Commission decided to produce the broadcast in the format of a newspaper, starting with the headline news of the world and continuing through the radio newspaper with such feature pages as were applicable to the programs, such as the editorial page, music, travel, sports, entertainment, women's world, and others. The name of the broadcast has proved itself so realistic in construction that listeners have written in asking for subscription rates!

While programs are subject to change without notice, typical features include Sunday, West Indian Story Page, Caribbean Newsletter, Concert Gems; Monday, Creole Cook, Story of Great Composers; Tuesday, Caribbean Quiz; Wednesday, Letters

from the West Indies, World of Postage Stamps; Thursday, Caribbean Theater of the Air; Friday, This is Puerto Rico, ATS Guest; and Saturday, Once Upon a Time (15-minute program). In addition to these features, each program contains musical selections and closes with a Review of the News of the Caribbean.

The most popular feature of the Newspaper, according to mail response and a recent survey of that area, is the Caribbean News Page which broadcasts the latest news of all the lands of that region, thus providing the peoples with information on inter-island happenings. Such information tends to break down insular barriers and prejudices.

Special wartime campaigns were carried on extensively and successfully by the Newspaper, such as "Grow More Food," through "The Victory Gardener," "The Creole Cook," and "The Livestock Farmer."

"Bill" Harris, who has so ably directed these fine broadcasts, tells me that plans have been made to carry on for an indefinite period. "We will elaborate upon our program to the extent of international forums and programs of a broader nature that display Anglo-American cooperation, and perhaps we'll do a series of dramatic

*(Continued on page 78)*

Recent photo of the staff of the West Indian Radio Newspaper, which recently observed its third anniversary. Seated (left to right): Gerard de Freitas, Caribbean News Commentator; Jean Russ Kern, Dramatic Script Writer; Peggy Boyd, The Creole Cook; Jane Hart, Actress-Writer; Jack Lawrence, Announcer. Standing (left to right): Warren Matts, Master of Ceremonies; Frank Randall, Announcer; William Harris, Director; Arnold Low, Producer.



<sup>1</sup> Unless otherwise indicated, all time herein is EST.

# VELOCITY MODULATION

By  
JAMES E. KAUKE

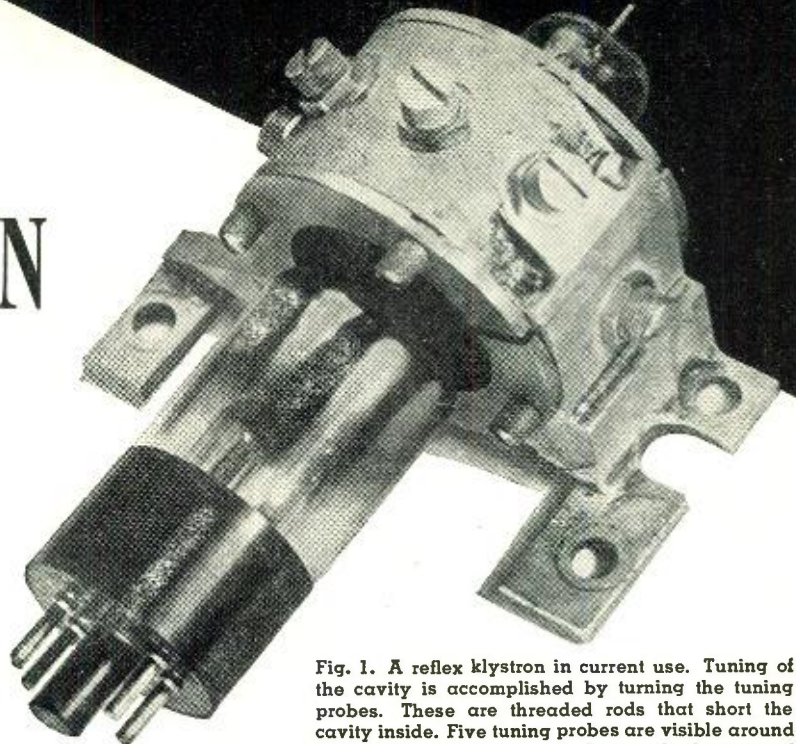

Fig. 1. A reflex klystron in current use. Tuning of the cavity is accomplished by turning the tuning probes. These are threaded rods that short the cavity inside. Five tuning probes are visible around the periphery of the cavity. Since only the internal shape of the cavity is important, the outside is fitted with mounting feet for efficient assembly.

**With the opening of higher frequency bands to the amateurs, advantage must be taken of radically different types of tubes—one of these, the klystron, is covered in this text.**

THE action that goes on inside of a velocity-modulated type of oscillator is not difficult to understand if the analogy of traffic-control is used. Velocity modulation makes use of the transit time of the electron stream—the same transit time that formerly prohibited the investigation of the centimeter frequencies.

Initially, the klystron oscillator consisted of two cavity-resonators, separated by a *field-free* drift space, and coupled together magnetically. The reflex klystron evolved from the original, and is essentially the same with the exception that the second cavity, called the *catcher*, is eliminated because the electron stream is turned back upon itself and lands on the same cavity, thus eliminating the need for the catcher cavity.

The cavities in a klystron are called *rhumbatrons* because the word *rhumba* is the Greek word for rhythm. In Fig. 2, the double cavity klystron, the lower cavity is the *buncher rhumbatron* and the top cavity is called the *catcher rhumbatron*.

The analogy to traffic control is as follows: While the stop-light is red, cars coming up the street at a regular pace will slow down and wait at the intersection. When the light turns

green, these cars will move past the intersection, but since they were either stopped or slowing, (the last few cars will be arriving just as the light changes and may not come to a complete stop) they will move slower than those arriving when the light is full green. The last few cars, knowing that the light is about to change to red, will speed up, ending with that last fellow who races through with the light snapping red as he crosses the mark. The slower speed of the first cars require them to take longer to reach the next street. The higher speed cars, coming later, will catch up. If their speeds are right, and the distance is correct, there will be a large bunch of cars arriving at the next intersection. The spaces between bunches will be regular and relatively free of traffic.

It is the hope of traffic control that car-bunching will occur. Once such bunching takes place, the flow of cars from one end of the street to the other will be regular, with the cars not stopping; with each street stop-light changing to green as the bunch approaches. That is what they hope when they say *traffic timed to 24 m.p.h.*

With such bunching, the intersection four miles down the road will re-

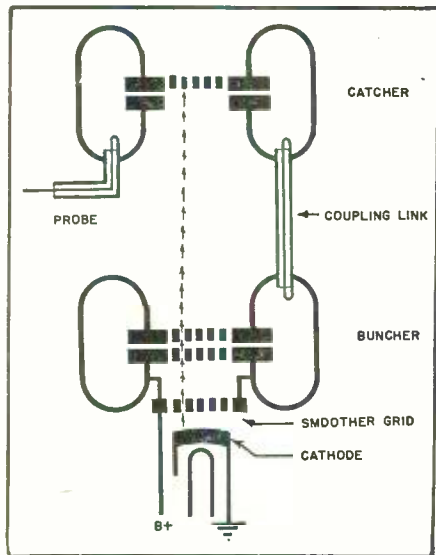

Fig. 2. Schematic of double-cavity klystron. The stream of arrows indicates the electron-flow through the elements of the tube. The coupling link is a properly-terminated concentric line inductively coupling the two cavities. The probe takes the output of the driven cavity to external circuits.

ceive or *catch* bunches with the same frequency as the initial *buncher*. Any individual car will require ten minutes to cover the four miles, though the lights may be set at thirty-second intervals.

The rhumbatron is a sort of electron traffic control. It will speed up or slow down the velocity of an electron, depending upon the instant of passage. Since the cavity resonator is nothing more than a specialized type of resonant circuit (Fig. 4), the voltage across the cavity will be a sine wave at resonance—the frequency of which is equal to the resonant frequency of the cavity.

Electrons flowing from the cathode are accelerated by the voltage between the cathode and the bottom grid of the buncher cavity. Since this bottom grid is maintained at a constant voltage with respect to the cathode, the electron velocity will be constant throughout this space. In some klystrons, a *smoother* grid is placed between them, acting as a sort of *sifting* screen that smoothes out minor irregularities in the electron stream.

In Fig. 5, the slope of any line is a measure of velocity, since it shows the distance moved (upward) for a given interval of time (horizontal from start to instant). From cathode to the bottom grid the velocity is constant, hence the slopes are all parallel.

The buncher, however, is resonating. Therefore, the space across the two grids will develop an alternating voltage in synchronism with the resonant frequency of the cavity.

Since the bottom grid is maintained at a constant voltage with respect to the cathode, the top grid will oscillate above and below the voltage of the bottom grid.

The electron stream passes through these grids and enters the *drift space* between the cavities.

An electron crossing the gap between the top and bottom grids of the cavity is acted upon by the instantaneous voltage across the cavity. An electron arriving when the voltage is positive will be accelerated. An electron arriving when the cavity voltage is negative will be retarded. And, of course, when the voltage across the cavity is *crossing the line* no field acts upon the electron and so its velocity is unchanged.

The sine wave voltage across the cavity is shown along the dotted line of Fig. 5. The slope or velocity of the electrons changes across this space.

Electrons passing when the cavity is negative are retarded and, at some distance above the cavity, they are joined by electrons passing later when the cavity voltage has risen to zero. As time goes on, the cavity voltage increases and the electron velocity also increases, and the electrons all *bunch* together at some distance above the cavity. Those passing first are slowed, and those passing later are speeded up by enough to make up for the time between passages.

They arrive at the upper cavity, or *catcher rhumbatron* in bunches. The frequency of arrival is the same as the resonant frequency of the cavity, and so if the catcher rhumbatron is tuned to the same frequency, these heavy densities of electrons will excite the catcher rhumbatron into oscillation.

In Fig. 5, the catcher grid is shown below the position of the best bunching. However, if this best position were used, the phase of the catcher rhumbatron would be such that the coupling of its oscillation to the buncher would not be correct and no oscillation would result. By a change in the main accelerating voltage between the bottom grid and cathode, the initial velocity can be adjusted so that the best bunching would occur right at the catcher grid. This is a problem in design, as is the proper spacing of the cavities. It is possible to arrive at secondary bunching, in which an accelerated electron from *cycle one* will catch up with the unaffected electron from *cycle two*, and simultaneously be met by the electron retarded from *cycle three*. In terminology, these periods of operation are known as *modes*. Mode 1 is the single bunching; mode 2 is double bunching, and so forth. The higher the mode, the less efficient is the oscillator, and so the initial mode is normally used.

The twin-cavity klystron requires careful tuning of the cavities to the same frequency. To eliminate this difficulty, the *reflex* klystron was developed. A diagram of this is shown in Fig. 6. The plate above the cavity is the *repeller* plate and it operates at a negative voltage with respect to the cathode. It, therefore, repels the electron stream, which returns to the top grid of the cavity.

The bunching diagram of the reflex klystron is shown in Fig. 7. Since the field between the top grid and the repeller plate is constant, the effect of the individual electron is similar to a baseball thrown upward. The harder it is thrown, the higher it will go and the longer it will take to return. The total journey may be con-

(Continued on page 72)

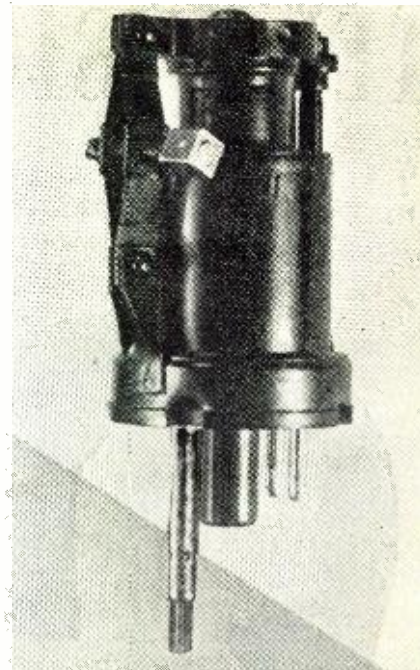

Fig. 3. A reflex klystron. Turning the nut between the struts spreads them apart, drawing the top of the tube down along the "shelf." This oil-canning of the tube-top changes the electrical dimensions of the cavity, permitting the setting of the resonant frequency of the cavity to that desired. The top cap, which is barely visible, is connected to the repeller plate; the pins below are filament, cathode, and cavity as shown in Fig. 6. The probe is a concentric line coupled to the cavity.

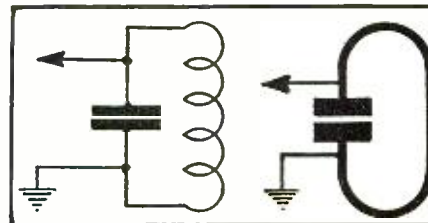
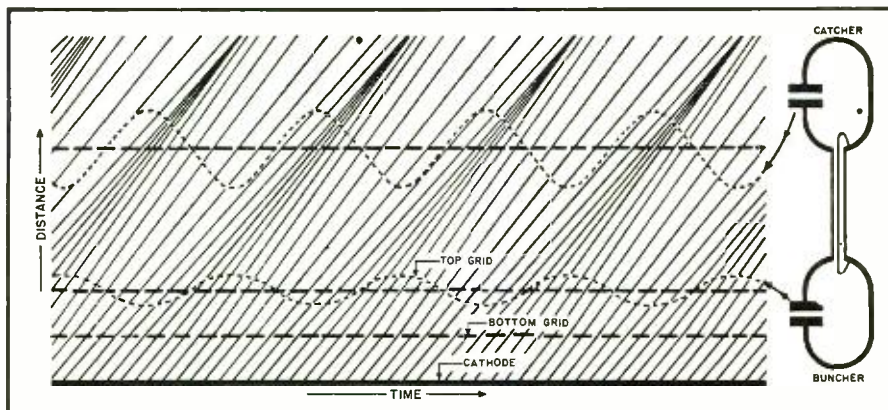

Fig. 4. The resonance-voltage relations across a cavity show that it is similar to a more conventional inductance-capacitance tuned circuit.

\* \* \*

Fig. 5. Graph of electron-flow with "time" plotted against "distance." This shows the effect of "bunching." Note that the sine wave indicating voltage is taken from where the time-distance or "velocity" lines cross the heavy lines indicating the grid. A slight lag in coupling is due to phase-differences that prevail along the coupling link.



# TELEVISION Must Sound Right

By RICHARD HUBBELL\*

Crosley Corp.



Richard Hubbell, television consultant and production manager of the Crosley Corporation, Broadcasting Division, who has charge of the program end of their television developments.

**H**AVE you taken even a slight look at television recently? If so, you cannot help but have noticed that present-day studios are somewhat less than perfect. In fact, they often are cramped, ill-ventilated, poorly lighted, and range from acoustical monstrosities up to a low mediocre.

Such studios have been a major handicap to pioneer television producers. The reasons for these lamentable facilities include the fact (publicity releases to the contrary) that there has never been a really serious attempt to develop commercial television broadcasting. This cannot be blamed entirely on wartime necessities. Part of the blame rests on prewar bickering within the industry, artificial restrictions of one sort or another, and a general lethargy induced by a highly profitable *status quo* in old-fashioned, blind radio.

Only one company built a real television studio, *Don Lee* in Hollywood.

This studio—a highly attractive layout on top of a mountain—was not completed when the war broke out. All the other television broadcasters took halfway measures, adapted portions of existing structures to their needs. That in itself was reasonable, since no one knew what a television studio should be. Unfortunately these adapted buildings left much to be desired and that situation has placed producers squarely *behind the eight ball*.

New and spacious studios must be built before any serious attempt to promote television can be expected to succeed. They must be designed, not only by engineers and builders but also by practical production experts. A studio plant may be a gorgeous item architecturally and electronically, and may also be sales-promotion-wise, but unless it meets the needs of the program producers it will prove an expensive white elephant. And don't think this hasn't happened!

**Many fallacies in studio design and equipment must be corrected before commercial television broadcasting can reach its ultimate goal.**

In designing these new studios, broadcasters are bound to be pre-occupied with the problems of lighting, video equipment, and providing for maximum mobility and flexibility in camera dollies. They are likely to put less thought on the problems of the audio—the *sound*. This has been the case in television studios to date.

A parallel is found in early talking pictures. Hollywood film companies were so absorbed with the problems of introducing talkies that they forgot a lot of what had been learned in silent movies. Result—the first talkies were not too good. As we begin to get television moving, let's hope that broadcasters do not forget too much of what has been learned in aural radio.

For these reasons, it might not be a bad idea to take a quick survey of some of the basic audio problems and procedures in television.

In a radio studio, designed for sound pickups only, the microphone is placed in the best acoustical position, and the cast is grouped around it without regard for visual considerations. Everything is balanced for sound. In a television studio, as in a motion-picture sound stage, the visual aspects, setting, and position of cast are dictated by the camera requirements. The cast must act visually as well as aurally. It is hardly desirable to have each actor saying his lines into one or more microphones standing in the middle of a set.

To be invisible, the microphone must be placed outside the frame area of the camera. It is difficult to get the best possible pickup, and exclude background noise and echoes, since the actors move about, and it is necessary

\* Mr. Hubbell is the author of "Television Programming and Production" and "4000 Years of Television."

to follow them with the microphone as well as with the camera.

The primary problem of the audio is, therefore, to get a good pickup at all times without dropping the microphone into view. The microphone not only must be kept out of the picture, but it also must not get in between lights and visible objects and thus cast shadows. This is not as simple as it might seem at first glance, for many productions use three, four, or more cameras viewing from different angles. There is also a battery of lights shooting from various positions. The microphone, mounted on the end of a long, telescopic boom, is moved from character to character and from one side of the set to the other. Inevitably it casts shadows somewhere. The trick is to make sure they are not cast squarely across the heroine's face, the sponsor's product, or some equally vital point.

On rare occasions, the problem can be eliminated by hiding microphones inside lamp shades or bowls of flowers, or behind some books close to the actors—provided the actors are going to remain rooted in one spot for some length of time. Usually, however, actors will be moving about and will get out of range of a microphone.

The type of sound system presents another problem; the television studio is monaural—all sounds going through a single sound system and coming out of one source, the loud-speaker. Unlike the human hearing system, the microphone cannot be exposed to a number of different sounds and yet focus only on the desired sound. Therefore, unwanted noises must be eliminated before the microphone makes its pickup.

The two classifications of unwanted sound are *extraneous* and *reverberant*.

Extraneous noises are those which have nothing whatever to do with the program content. By way of providing a check list for studio builders, these may be divided into two groups—noises originating within the studio and those leaking in from the outside.

The latter group, external noises, are by far the easier to control. They include the rumble of nearby machinery, trains, trolley cars, airplanes, storms, and particularly fire engine sirens if your studio is located next to a busy street.

Noise is also created by the opening and closing of the entrances to the studio. A sound lock is essential, but it must be big enough to permit the passage of large pieces of scenery.

Extraneous noises originating in, or heard inside of, the studio include the hiss of air conditioning, the splutter or hum of lighting equipment and the hum of current in power cables, the sounds caused by the moving of props, scenery, lights, cameras, microphone booms, in addition to the general noise level created by the moving and breathing of many people.

All of this leads to the inevitable conclusion that the walls and ceiling of a television studio should be com-

pletely dead, acoustically speaking. This is necessary in order to soak up as much as possible of the inevitable background noise level. Acoustics of each given program can be controlled by the scenery or by synthetic means.

Control of reverberant or *echo* sound is more complex. A certain amount is desirable according to the requirements of the particular scene. If there is no reverberation, the sound will seem dead and lifeless, particularly in the case of music. If there is too much, the sound may become confused and unintelligible, especially in the case of speech.

Because of the loss of *focusing powers* in monaural hearing, echo is much more noticeable than in binaural hearing. This can be illustrated by placing two people in an empty, *live* room with bare walls and no rug. They can converse without difficulty and can understand what is being said. But, put a nondirectional microphone between them, listen on a loud-speaker, and you will find it a strain to follow the conversation because of the excessive reverberation.

The further a microphone is from a source of sound, the greater is the ratio of reverberant or reflected sound to direct sound. *Direct sound* is that which comes direct from the source to the microphone without being reflected one or more times from the walls, or floor, or ceiling, or properties. If sound is reflected, successful sound waves reach the microphone a fraction of a second later than the direct sound wave. This time lag produces an echo.



The microphone shown in this setting has a broad pickup beam on its "live" side. It will pick up, without frequency distortion, the four characters at the right. The character sitting at extreme left is on the "dead" side of the microphone; the side facing the camera is "dead" over an angle of about 130 degrees. This suppresses unwanted noises caused by camera movements and the like. However, should the character at extreme left speak, he probably would be heard softly. There are, however, enough hard, reflective surfaces in the scenery and on the floor to "bounce" his voice around and into the "live" side of the microphone.

When many varying echoes—of different pitches and with different time lags—go into a microphone, they produce a reverberant effect. (Reverberation may be defined as the persistence of sound, caused by repeated and varied reflections.)

(Continued on page 135)

Note the position of the two microphones in this photograph. Microphone at left, mounted on mobile, telescoping boom, is used to pick up ensemble. Its broad, 150 degree beam more than covers spread of the choir. Microphone hanging at right, in a fixed position, is used to pick up soloist who will not be moving around. Closeness of soloist to microphone will put him in an acoustical "closeup" in comparison with voices of ensemble. Lights overhead are of the Birdseye type, used in some prewar studios. Because of their extreme heat and undesirable color temperature (predominance of red and infra-red) they are unlikely to be extensively used in the future. Camera at lower right is a prewar type, RCA Iconoscope, mounted on an "ironman" stand. Only semi-mobile, this type of mount does not permit the operator to "dolly" the camera across the floor while he is "on the air." However, it does permit camera to be raised and lowered on the air, in addition to pans and tilts. Camera is painted silver color to reduce absorption of heat from lights.





By **CARL COLEMAN**

**C**OMMODORE E. M. WEBSTER, chief of the Communications Division of the U. S. Coast Guard, spoke at the American Merchant Marine Conference held in New York during mid-October, on the general subject of *Postwar Navigational and Rescue Networks*, and said:

"Coast Guard Headquarters is charged with the direction of a system of communication devices, a major function of which is the promotion of safety at sea and the assistance of persons in distress, in addition to serving the communication needs of the rescue organization itself. Included in the facilities which we operate is a network of primary and secondary radio stations, a land line organization linking the various activities of the Coast Guard and connecting them with Army, Navy, and commercial facilities, and strategically located nets of medium-frequency and high-frequency direction-finder stations. The reason for the existence of all these facilities and the conduct of all these activities is the promotion of safety at sea and in the air.

"In this connection I should mention the development in the field of high-frequency direction finding. Of course, the use of direction finders in the high frequencies is not a new thing. However, the war has given us equipment which, for the first time, has been sufficiently dependable and accurate to justify the organization of large nets of these stations for use as a navigational and rescue aid.

"The development has been primarily in the field of shore-based direction finders which can supply bearings on positions to ships and aircraft. While improvements have been made in shipboard devices in this connection, the fact that a sky-wave rather than a

ground-wave is employed necessitates the application of judgment to the plotting of bearings, which must be based on extensive training. For this reason and because of the large size of this equipment which has to be used to get accurate results, shipboard direction finding in high-frequency range is not very practical at present.

"The Coast Guard is now operating several networks of these stations. We have one in the Atlantic (really consisting of several nets) which, together with the Canadian network with which it is integrated, extends from Greenland to Brazil. In addition there is a Gulf net, a West Coast net extending from California to the Aleutian Islands, and several nets not yet permanently organized in the Pacific. Because of the great range at which these stations can take bearings, these networks will be able to give substantially one hundred per-cent coverage in the Atlantic and Pacific shipping and flight lanes. These stations are, at present, guarding 8280 kilocycles, which has been used during the war as a high-frequency distress channel, and are connected by teletype with rescue centers, as well as with each

other, by teletype and radio circuits so that they are prepared to switch on notice to any other frequency that a distressed ship or aircraft may be employing. While, at present, their activities are confined largely to distress generally and to potential distress of lost aircraft, it is expected that eventually their services will be extended to the supplying of general navigational assistance. In connection with this, we are working on the preparation of new procedures for the use of these stations as a navigational aid, which will be incorporated in the new communications convention.

"With the development of this system, the loran system, and other navigational devices, it is my present opinion that the medium-frequency direction-finder net will fail to serve a need sufficiently great to justify its continued existence. We have not made a final decision in this matter and are naturally interested in any comments which may be made by those who might make use of it."

**J**OSEPH MILLER shipped out of Boston aboard a collier recently . . . Ed Donnelly is up and about again and ready to ship out . . . George Dill growing pumpkins down east on his Maine farm. George has been pounding brass as a marine operator for twenty-eight years . . . Robert Mayhew is back again after his rush to the hospital down in Australia . . . Charlie Hollison, former instructor at Gallups Island, was expecting to return to sea at the last report . . . Louis Pinkerton, Jack Naughton, Joe Konrad, and John Yanik were all in Baltimore recently. Joe has already shipped out again . . . Arne Hanson and Van Ordstrand both back from trips down through the Indian Ocean and both disgusted with that part of the world . . . Dave Cintron married recently, congrats . . . Al Pierce, another oldtimer, is now around again after a long spell in the hospital . . . Mort Grove back from a South America jaunt.

**W.** C. (BILL) SIMON of TRT and VWOA, noted recently that it might be well to point out that the men returning from the armed forces who are intending to get into marine radio, either as marine radio oprs. or as shore servicemen, must have an FCC license. It is necessary that you hold a 2nd-class radiotelegraph license or higher for this type of work . . . Incidentally, at this writing, really experienced men in the marine service field are few and far between. If you are just out of the armed forces and interested in marine radio, get after that ticket; it's the first thing you will be asked for when seeking employment in the seagoing or shore berths.

**F**RED HOWE, general secretary-treasurer of ROU, sends along a copy of the ROU-Pan American-Grace (Continued on page 129)



"Place your left hand on the bible, your right in the air; now tell me what was wrong with my radio?"



# Multi-Range MILLIAMMETER

By **RUFUS P. TURNER**  
Consulting Eng., RADIO NEWS

***This practical 0-1-10-100-1000 d.c. milliammeter can be home constructed from junk-box parts. All hard-to-obtain, odd-sized, low-resistance shunts, so often used, are purposely eliminated.***

Fig. 1. Two views of the completed instrument. Note, in the under-chassis view, the screw-driver-tuned rheostats and large  $R_1$  resistor.

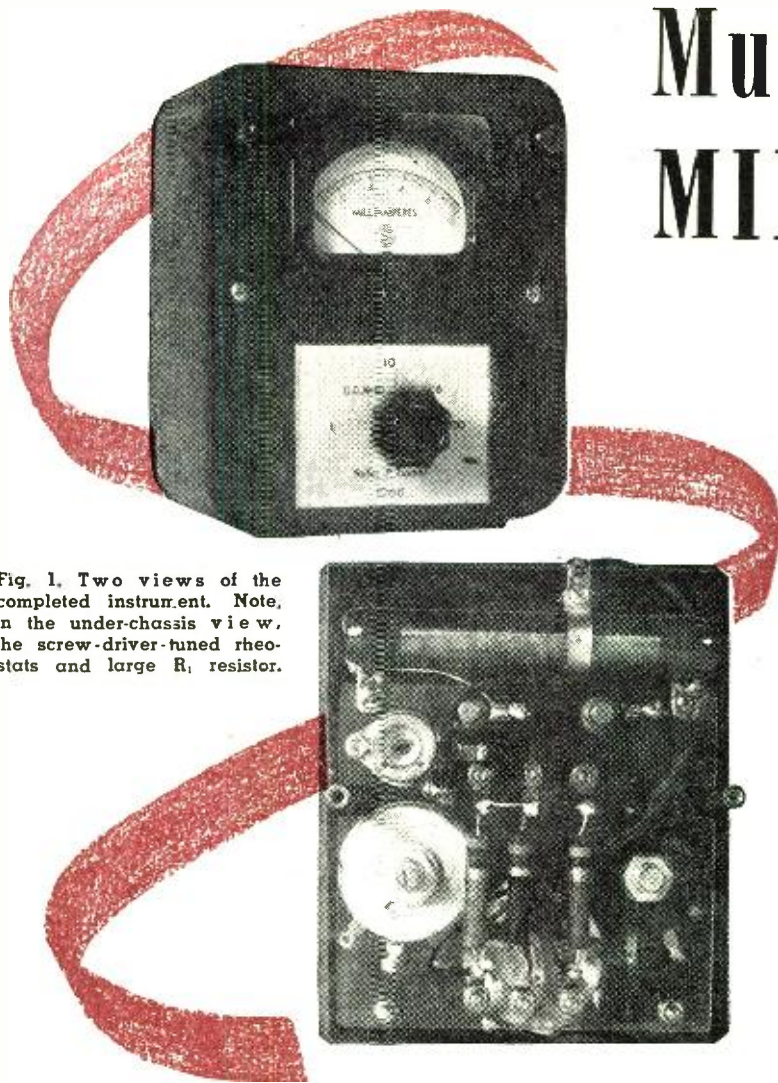

**T**HERE is no question that a small-sized, multi-range d.c. milliammeter separate from the regular volt-ohm-milliammeter is very useful in shop, station, and laboratory. The uses of such an instrument are many and varied. Familiar applications include checking current and tuning in grid and plate circuits of transmitters; drain checking and load measurements in test instruments, power supplies, and industrial electronic gear; and substitution for damaged milliammeters. The common multi-range milliammeter consists simply of a low-range instrument, such as a 0-1 ma. model, with some arrangement for switching shunt resistors across the meter to change its range.

That more experimenters and servicemen do not build multi-range milliammeters from spare parts is due chiefly to difficulties arising (or expected) from switch contact resistance and to the hard-to-get odd resistor values required.

In order to get a bird's-eye view of the conventional arrangement, see Fig. 2. This circuit is based upon the common 0-1 d.c. milliammeter. The value of each shunt is equal to  $R_s = R_m/f-1$ .

$R_m$  is the internal resistance of the meter and  $f$  is the factor whereby the basic 0-1 scale is to be multiplied.  $R_m$  will have a value between 30 and 110 ohms for 0-1 d.c. milliammeters, the exact value depending upon the make and type of meter.  $R_m$  for a particular model may be obtained with sufficient accuracy from the manufacturer's catalogue. As an illustrative example; if  $R_m$  equals 100, the shunts for the several ranges shown in Fig. 2 will have the following values:  $R_1$  11.11,  $R_2$  1.01, and  $R_3$  0.100 ohms. For a 60-ohm meter movement, these values become:  $R_1$  6.666,  $R_2$  0.606, and  $R_3$  0.060 ohms. And for a 30-ohm value of  $R_m$ , the shunt values are:  $R_1$  3.333,  $R_2$  0.303, and  $R_3$  0.030 ohms. Resistors having these values are difficult to obtain unless the builder is willing to invest in precision instrument shunt resistors or make his own from resistance wire, with the aid of a precision Wheatstone bridge. When such resistors are home-made they usually have a poor temperature coefficient unless extraordinary precautions are taken. A further disadvantage of the conventional circuit, as given in Fig. 2, is the fact that the

switch contacts are in series with the shunt resistor and meter. While contact resistance is extremely low in ohmage, it becomes of concern when it is in series with resistances as low as those employed as meter shunts. Consider the effect of switch contact resistance in series with the .06- and .1-ohm shunts. The only remedy in the conventional circuit is to employ an expensive, low-resistance instrument-type switch.

The arrangement in Fig. 3A makes it possible to use standard resistors and a common rotary selector switch in a multi-range milliammeter. Here, the unknown current flows through a resistor,  $R_1$ , across which it develops a voltage drop. The meter then is connected (as a voltmeter) across  $R_1$  through a suitable multiplier resistor, (Continued on page 141)

Fig. 2. Conventional type multi-range d.c. milliammeter circuit.

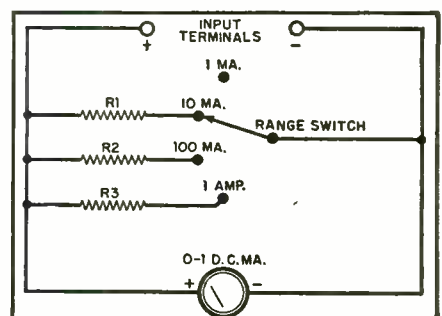

# Practical RADIO COURSE

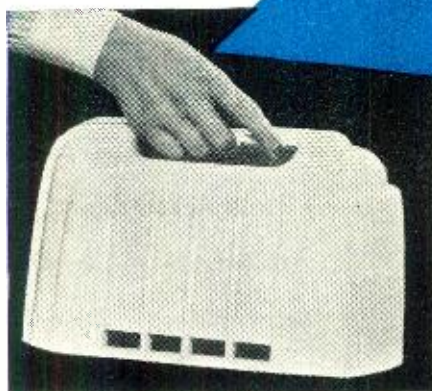

Novel new trend in plastic radio receiver design. This one-piece cabinet with built-in handle and dust-proof enclosed back will be the first of Bendix Aviation Corporation's radios to be made available to the public.

By  
**ALFRED A. GHIRARDI**

## **Part 41. Analysis of the various causes of drift in the resonance frequency of tuned circuits and in the frequency of the superheterodyne oscillator.**

**A** PRELIMINARY discussion of the frequency, and frequency stability of vacuum tube oscillators was presented in an earlier chapter<sup>1</sup> in this series and should be reviewed at this point, if possible.

Any oscillator circuit component whose capacitive, inductive, or resistive characteristics change even slightly with:

1. Change of temperature
2. Change of humidity
3. Change of operating voltage
4. Shock or vibration
5. Age

contributes to drift of the oscillator frequency; likewise, for the effect of any component in the i.f. amplifier tuning circuits, upon the resonance frequency of the i.f. amplifier.

The subject of frequency drift assumed great importance in the design of the various types of radio equipment that had to be perfected for military use under especially difficult operating conditions in all parts of the world. Such equipment had to be

constructed to operate satisfactorily under ambient temperature conditions ranging from the arctic to the tropical—from approximately  $-40$  degrees Centigrade to  $+85$  degrees Centigrade. It often had to function in humidity up to 100 per-cent and at unprecedentedly high altitudes. It had to withstand the severe mechanical vibration incidental to operation in aircraft, tanks, and other vehicles, and the repeated shock and rough handling encountered in combat conditions. The large amount of research that was directed toward solution of

the many difficult problems involved in the design of stable equipment intended for operation under such severe conditions has thrown much light on the causes and magnitudes of frequency drift caused by various components, as well as practical methods for effectively reducing it to negligible values.

### **Causes of Temperature Changes in Receivers**

In home and auto-radio receivers the effects of temperature variations are usually of greatest importance since they are present under all operating conditions of the receiver. In some receiver applications they assume extreme importance. For example, some services (military aircraft, etc.) require working under ambient temperatures which may vary as much as  $100^{\circ}$  C. during a relatively short period of time.

Temperature changes that affect the components of a receiver result from two causes:

(1) Changes in temperature of the receiver's surroundings.

(2) Rise in temperature caused by the heat produced by the various tubes, resistors, transformers, and other heat-generating components in the receiver and by the flow of current through the critical components themselves during normal operation.

Cause (1) is most likely to be a fairly limited day-to-day, or even season-to-season, temperature variation for fixed receivers operated un-

**Fig. 1. Curves illustrate the effect of coil form material upon frequency drift.**

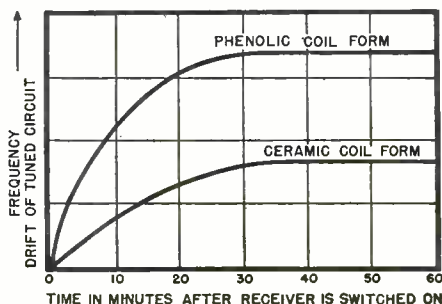

<sup>1</sup> Page 120 of Part 33 of *Practical Radio Course* which appeared in the April, 1945, issue of *RADIO NEWS*.

der sheltered conditions indoors. Contrasted to this are, of course, the cases of portable receivers operated both indoors and outdoors, and the various types of mobile receivers operated in vehicles, aircraft, boats, etc.—all under widely varying temperature and humidity conditions. For example, air temperature at an altitude of 42,000 ft. is reasonably constant at about  $-55^{\circ}\text{C}$ . The rate of temperature change experienced by descending aircraft may be as high as  $5^{\circ}\text{C}$ . per minute, but the actual rate of temperature change of apparatus is lower, possibly from  $2^{\circ}\text{C}$ . to  $3^{\circ}\text{C}$ . per minute.

Cause (2) needs no explanation because the receiver chassis with its accompanying oscillator and i.f. amplifier circuit components go through a fairly wide temperature change that starts the moment the receiver is switched on. A rapid rise in temperature occurs during the first fifteen or twenty minutes; after that the increase proceeds more slowly until a state of some stability is reached after an hour or so. It is not at all uncommon for the ambient temperature in an ordinary home receiver to rise as much as  $30^{\circ}\text{C}$ . or more during the first fifteen minutes after the receiver is switched on. In the smaller, extremely compact types of a.c.-d.c. table-model receivers the tuning coils and capacitors must necessarily be mounted so close to heat-generating tubes, voltage-dropping resistors, etc., and ventilation is so restricted, that temperature increases much greater than this frequently occur in them.

### Effects of Temperature Changes on the Tuning Coils and Capacitors

A complete list of all the temperature-initiated causes that tend to make the inductance of the oscillator and i.f. amplifier tuning coils and the capacitance of all the tuning capacitors associated with them change in value, would include dozens of items and probably would make the reader wonder how a signal of any steady carrier frequency can be continuously received at all. Fortunately, since many of the effects of these changes have opposing trends, and so introduce some compensation, it is possible for the receiver designer to assist by taking advantage of every expedient that will make unavoidable drift effects tend to cancel.

### Effects of Temperature Changes Upon Tuning Inductors

Changes of temperature produce variations in the inductance, resistance, and self-capacitance of a coil. However, under ordinary conditions of operation of home receivers, the last two are not large enough to be important in comparison with the change produced in the inductance.

Increase of temperature causes the copper wire comprising each turn of the coil to expand, so the length of the winding increases and the radius of the coil also increases. The relative

amounts of these two increases depends upon many factors, among which are the tension at which the wire was originally wound, expansion rate of the coil-form material, thickness and expansion rate of the wax impregnation on the coil, etc. Review of the formula for the inductance of a solenoid-type winding indicates that increase of winding length *decreases* the inductance in almost simple ratio, whereas increase of radius *increases* the inductance in square ratio. The net result then is an *increase* in coil inductance as the temperature is raised. Designing the coil so it has suitably different rates of radial and axial expansion is a possible means of reducing the temperature effect. However, because of the unavoidable commercial variations in the materials being dealt with, it is difficult to achieve zero coefficient of inductance with temperature by this method in quantity production.

Another effect is present in multi-layer coils; the radius of the first few layers of the winding may be influenced by the expansion of the form, but that of the rest of the layers depends on the expansion rate of the copper.

When coil windings are impregnated with wax, the length of the winding after heating depends on the expansion of the wax, while the diameter depends largely on the expansion of the copper. Also, the expansion rate changes appreciably if a thin impregnation is used instead of a thick one.

The material used for the coil form assumes importance from two viewpoints. First, its expansion coefficient affects the radial and axial expansions of the coil. Also, the change of its dielectric constant with temperature affects the self-capacitance of the coil.

In general, unless special design tricks have been resorted to, the overall effect of increasing the temperature of a coil is to *increase* its inductance. By controlling the various contributing factors already reviewed here it is possible to control the amount of this increase. In fact, it actually is possible to produce coils whose inductance *decreases* with increase in temperature. For example, if the temperature of a powdered-iron core type tuning coil is increased, the different rates of expansion of the coil-form material and the material of the screw mounting the core slug will

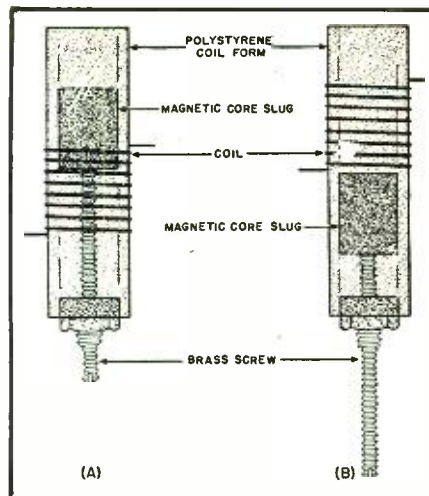

Fig. 2. Powdered-iron core type tuning coils. Winding and core arranged for (A) positive temperature coefficient of inductance and (B) negative temperature coefficient of inductance.

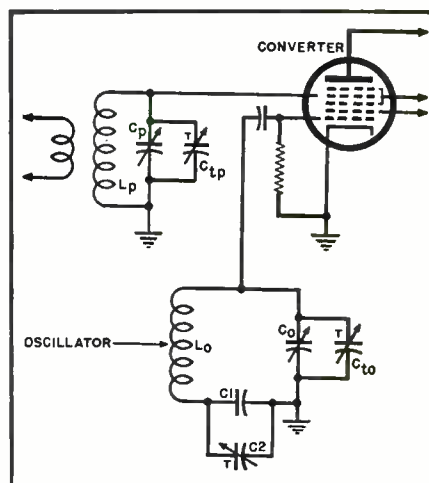
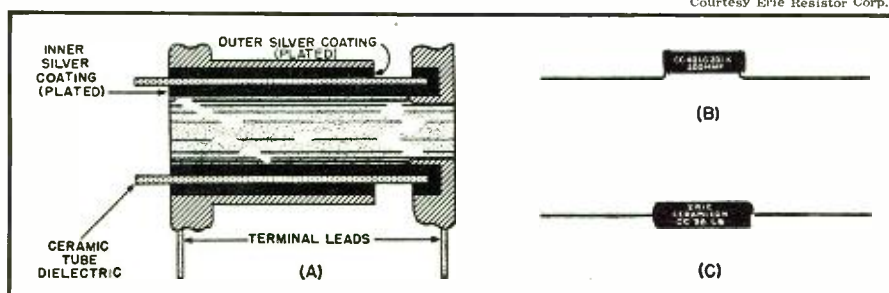

Fig. 3. Standard oscillator and pre-selector tuning circuits used in manually tuned superheterodyne receivers. The circuit shows inductors, adjustable trimmers, and fixed capacitors employed. All of these components can affect the frequency stability.

cause the core slug to move *relative* to the coil winding by an amount depending on the difference between these two expansion rates. If the coil and core are so arranged that increase of temperature causes the two to move *toward* each other, the inductance will *increase* with rise of tem-

Fig. 4. Various types of commonly used capacitors. (A) Cross-section of a fixed ceramic capacitor. (B) Commercial uninsulated capacitor. (C) Insulated type capacitor.



Courtesy Erie Resistor Corp.



Fig. 5. Illustrating how rubber shock mountings are used on all aircraft receivers.

perature. If they are arranged so they move apart, the inductance will *decrease* with rise of temperature. In the coil arrangement illustrated at (A) of Fig. 2 the core slug moves in accordance with the expansion rate of the brass screw, but the winding moves at a greater rate, in accordance with the expansion rate of the polystyrene coil form. Hence, temperature increase causes them to move toward each other, and the inductance *increases*. In the arrangement illustrated at (B) the greater rate of expansion of the polystyrene coil form causes them to move apart, so the inductance *decreases*.

It is frequently found that the variation of coil inductance with temperature is non-cyclical, *i.e.*, if the coil undergoes temperature change cycles the inductance will not follow the temperature changes exactly but will vary irregularly and will not return to its initial value when the temperature returns to normal. This is apparently the result of mechanical

changes such as result from slippage of the wire over the coil form and permanent changes in physical dimensions occasioned by the relieving of initial stresses and strains in the winding and coil form.

As illustrated in Fig. 1, the use of a ceramic coil form results in less inductance drift due to temperature changes than when a similar coil wound on a phenolic form is employed. This is due to the smaller coefficient of expansion of ceramics and the fact that the distributed capacitance of the coil is smaller and less affected by temperature when the ceramic form is used than it is when a higher-loss phenolic type material is employed.

#### Effect of Temperature Change on Air-Dielectric Tuning Capacitors

The principal factors that may cause the capacitance of an air-dielectric tuning capacitor to change with temperature are:

1. Differential expansion of different portions of the capacitor; partic-

ularly those effects that cause twisting and bending of the plates.

2. Linear expansion that causes changes in electrode surface areas, etc.

3. Changes in dimensions and dielectric constant of the insulation used for mounting the stator plate assembly.

4. Changes in residual stress with temperature that give rise to deformations.

Depending upon their design, the temperature coefficient of capacitance of ordinary air-dielectric tuning capacitors may vary over as wide a range as from +150 to -65 parts per million per deg. C. Unless precautions are observed in the design, the capacitance variation may be non-cyclic, *i.e.*, the capacitance may not return to its original value when the temperature comes back to normal. However, air-dielectric tuning capacitors with very small positive temperature coefficients (capacitance *increases* with *increase* of temperature) and cyclic behavior can be realized by proper design. The air gap between rotor and stator plates should be relatively large so the capacitance will not be affected greatly by small deformations in the plates. One way of controlling the exact temperature coefficient of such capacitors is by controlling the axial position of the rotating plate assembly with respect to the fixed plate assembly by means of metal rods of a second material having a suitably different coefficient of expansion. In this way, it is possible to obtain zero temperature coefficient of capacitance; or one can even obtain either a positive or a negative temperature coefficient, as desired, by using a greater or less displacement from the initial position than that required for zero coefficient. In general, the per-cent frequency instability caused by variable tuning capacitors of the air-dielectric type in receivers is negligible, provided good electrical and mechanical design has been followed.

#### Effect of Temperature Changes on Fixed Mica Capacitors

Fixed capacitors of the mica-dielectric type have been used in the oscillator tuning circuits of manually-tuned superhets mainly for the purpose of providing a lumped padder capacitance  $C_1$  (Fig. 3) across which an adjustable trimmer is shunted. Such mica capacitors contain minute air pockets between their plates and the mica dielectric. Increase of temperature causes expansion of the materials, resulting in greater pressure that tends to force the metal plates into more intimate relationship with the layers of mica. This causes the capacitance to *increase*.

#### The Silvered-mica Fixed Capacitor

This effect has been greatly decreased by a special method of capacitor construction. Instead of employ-

(Continued on page 88)

Fig. 6. Construction details of one of the many ceramic variable trimmer capacitors. This particular type may be adjusted by means of a screwdriver.

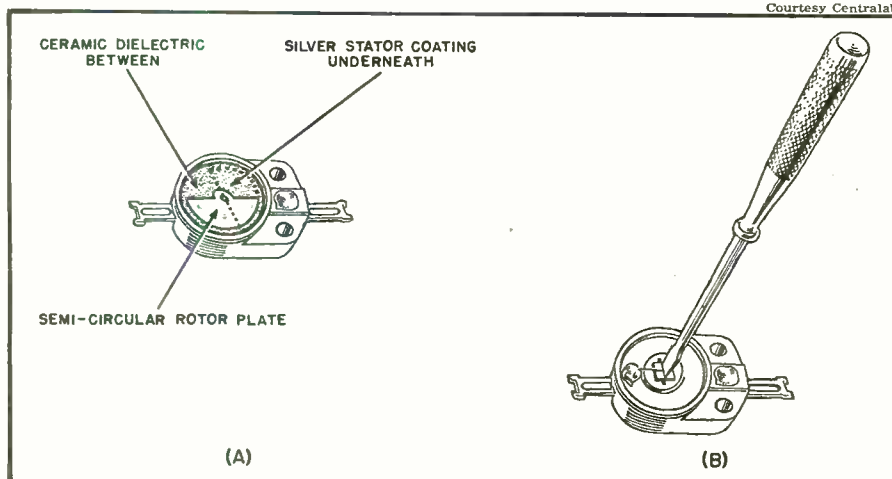



# LET'S TALK SHOP

With **JOE MARTY**

Associate Editor, RADIO NEWS

**T**HE time has come in the affairs of most servicemen to become very objective in the operation of their businesses. We now can definitely see an end to the enormous amount of service work which has been created by the lack of sets available during the war. In short, the honeymoon is over. I see a distinct threat to the independent serviceman, as such, in conditions which will prevail in the radio industry, unless he takes steps to protect himself.

First and foremost, the trend of business will definitely be away from the independent serviceman who does not sell sets, due to the obvious fact that the average dealer who employs a serviceman will be getting more and more of the independent customers now that new sets are becoming available. The dealer, by his comprehensive advertising and sales techniques and backed up by his set distributor and manufacturer, is going to make an unprecedented drive for new business. This, coupled with the fact that many people are only waiting until sets are available before they buy, will naturally bring them to the outlet where sets are being displayed. Industry analysts have estimated that it will be necessary for the average retail outlet to sell at least twice, and in many cases four times, as much merchandise as has originally been sold by them in order that the enormous demand may be satisfied.

The two types of competition which the independent serviceman faces are a combination from the standard radio and appliance retail stores and other outlets who handle radio as a department of a large national operation. These little department stores in the specialty field are definitely sales-minded and are determined to get their share of the business. The third type, and probably the one which will make its effect felt on the independent more actively than the others, is the operation by oil and gasoline companies which will sell radios and service directly to customers who will drive into stations for oil and gasoline. This will be a very hard type of competition to combat as far as the average small serviceman is concerned, due to the fact that these gasoline stations have the advantage of tremendous traffic from which to draw their customers. It requires no master mind to see the effect on Mrs. Jones when the gas station attendant, instead of saying, "May I check your oil?" will be saying, "May I check your radio?" or, "How is your radio performing?" And it is only a step

further to have Mrs. Jones bring in all sorts of radios for repair to these stations.

The fourth reason that the trend is away from the independent serviceman, is the fact that new services, such as FM and television, require quite a bit more in the way of servicing equipment than the independent has heretofore been called upon to provide. For that reason alone, many dealers cannot afford to be without a serviceman and, therefore, must maintain a service department. In addition, many large manufacturers are refusing to enfranchise dealers as retail sales outlets unless they can prove they do have an adequate service department, and they can install and maintain the new equipment that is coming on the market.

All of the above add up to just one thing—if the independent serviceman is to survive, he must become sales-minded; he must, by all means, arrange to become a seller of radios and prepare himself technically and otherwise to perform better service jobs.

The time to do some very hard thinking is *now*. It is well to plan three years in advance. In order to do this, you will first have to take

stock of yourself, and please do not hesitate to be brutally honest. Your entire customer list should be gone over and a segregation made of those customers whom you feel you can depend upon for service in the next year or so. All customers about which you are doubtful should be contacted immediately and you should sell yourself over again to these doubtful ones. New customers should be continually added to the list from whatever source you get your prospects. If you have committed the many sins which have been laid at the serviceman's door during the war, such as over-charges, "the customer is always wrong" attitude, and other business errors, please make a complete confession to yourself at once and take whatever steps are necessary to rectify these business killers.

There has been a great shift in populations in practically all communities in the United States, due to the war. Therefore, one of the first things you should do is to analyze your community figures to find out if the population has increased or decreased, if such changes are permanent, and what steps it will be necessary for you to take in order that you can shift your position or take advantage of the new situation which has arisen. It might be well to canvass the various industries in your area to see whether or not they have any peace-time chances of prosperous operation. Many new industries have been created as a result of the war and the tendency of most manufacturers is to locate in smaller towns and cities, wherever possible. This, of course, means more people employed and, therefore, more potential customers for you. A check-up with your Chamber of Commerce or other local business group will enable you to know what is expected to happen in your community within the next year. All of these factors should be taken into consideration in planning your operation. Bear in mind that if there has been an increase in manufacturing facilities in your neighborhood as well as an increase in population, the large chain outfits, as well as the other merchandising factors, are well aware of this and are moving at this time to take advantage of it. A third way in which you should immediately move is along technical lines. As all of you know, the servicing and installation of high frequency

(Continued on page 128)

"Defective Radar Beam! Didn't reflect!"



# Saga of the VACUUM TUBE



Fig. 223

## Part 21. Vacuum tube developments that were carried on in France and Germany during the first World War.

By **GERALD F. J. TYNE**

Research Eng., New York

**V**ACUUM tube development on the Continent during World War I was carried on chiefly in France and Germany, although the Dutch and Russians were also active. The work in France, as has previously been mentioned, was done almost entirely by the French Military Telegraphic Service under the able guidance of Colonel (later General) Ferrie.

Early in the war, the French realized the manifold advantages of wireless telegraphy as a medium of communication in military work. Since military stations, of necessity, must be portable, the transmitters and receivers must be light weight, which necessitates a minimum of power consumption. The need for reliable communication under all conditions could be met by using high power transmitters and relatively low sensitivity receivers. Since the weight and bulk of transmitting equipment increases rapidly with the requirements for radiated power, this solution was not a satisfactory one. The use of low or medium power transmitters in conjunction with high sensitivity receivers was much more desirable, even necessary. To increase receiver sensitivity some form of amplifying device must be used. The three electrode vacuum tube was, by far, the best device available.

In August, 1914, the French Military Telegraphic Service instituted an intensive development program with a view to obtaining a vacuum tube suitable for military applications.

While development of a number of types was followed, problems of supply and distribution dictated the provision of a *universal* tube, one which could be used as high or low frequency amplifier, detector, or oscillator.

The design of such a tube was settled upon early in the program and quantity production was undertaken in 1915-1916.<sup>301</sup> It was a *hard* tube, known usually as the *French tube*, although it was also designated as the *Type S* tube. There were minor variations in construction, depending on the manufacturer.

Fig. 224 shows one of these tubes.

The element assembly was of the concentric cylindrical type, mounted with the axis of the assembly horizontal. The anode was a cylinder of sheet nickel, .59 inch long and .39 inch in diameter. The filament was of pure tungsten about .83 inch long and when operated at the normal voltage of 4 volts ran at a temperature of about 2400° K. The variations in construction of models, made by different manufacturers, were chiefly in the helical grid structure. In the *Lampe Fotos*, the grid was of .008 inch molybdenum wire, wound with a pitch of .051 inch and of 12 turns, the total

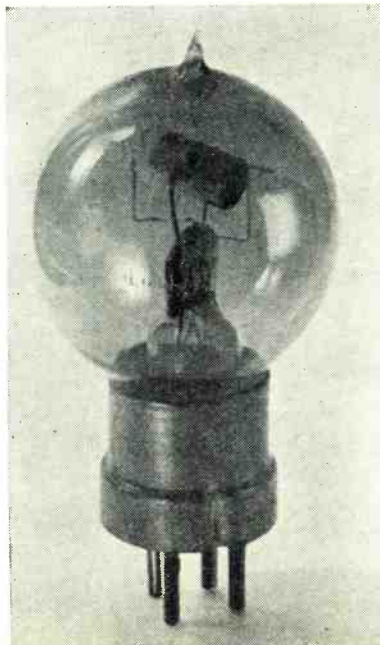

Fig. 224

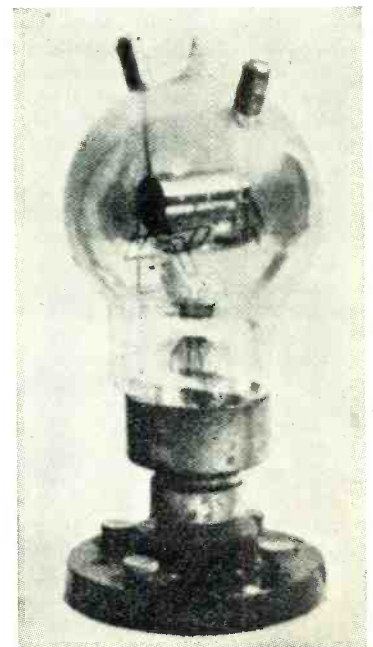

Fig. 225

length being .63 inch. Its diameter was about .18 inch. In the *Lampe Metal*, the grid was of .011 inch diameter nickel wire wound with a pitch of .067 inch and had 11 turns, with a total length of .75 inch. The diameter of the helix was about .16 inch.<sup>302</sup> The base was usually of sheet metal with a ceramic insert which carried the pins. The fastening arrangement for the pins was not a very secure one, and they frequently worked loose in the base. The bulb was about 2.2 inches in diameter.

This tube was operated for receiving applications at its normal filament voltage of 4 volts, and filament current of .6 to .8 ampere. When used for transmitting purposes, the filament voltage was increased to 5 or 5.5 volts with consequent increase in output and reduction in operating life. The maximum permissible anode voltage, when used for transmitting, was 400 volts, while anode voltages of 15 to 50 were used in receiving.

When attempts were made to utilize this tube in a multistage radio frequency amplifier, difficulties were encountered. The amplifiers used at that time were of the resistance-capacitance coupled type and the high input capacitance (15  $\mu\text{fd.}$ ) of this tube limited its use to frequencies below about 600 kc. This upper limit was extended to about 1500 kc. by the use of a modification of this tube known to the French as the *Lampe aux cornes*, and to others as the *horned valve* or *Kamerad valve*.<sup>303</sup> One of these tubes is shown in Fig. 223. The grid and anode are supported from wires which are embedded into projections on the press, and the electrical connections are brought to caps on the top of the bulb, separated by a considerable distance. This construction considerably reduced the tubes input capacitance.

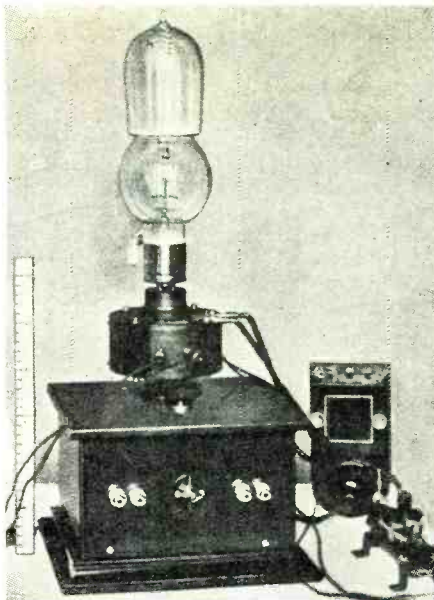

Fig. 226.

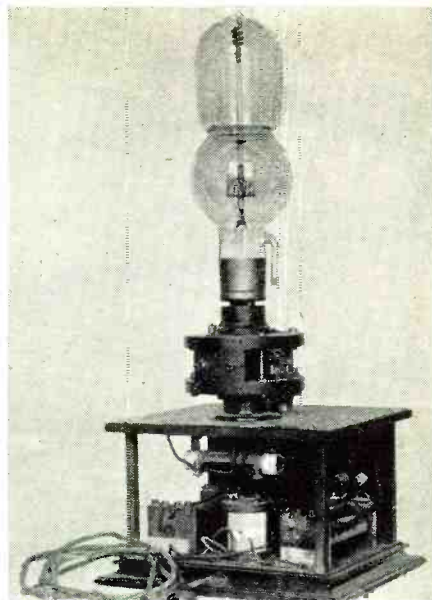

Fig. 227.

There were also a number of other and higher-powered tubes of this same general construction developed for military transmitter applications. One of these is the 50-watt output transmitting tube shown in Fig. 225.

In Germany, the first attempts at the use of tubes for radio work were conducted with the von Lieben-Reisz-Strauss tube known as the *LRS Relay*, which was described in a preceding article. The LRS Relay was employed both as an oscillator and as a high-frequency amplifier in addition to its originally intended use, that of an audio-frequency amplifier. Fig. 226 shows the general arrangement for using this tube as a high-frequency amplifier and Fig. 227 shows a close-up of the assembly with some of the box covers removed.

The first German high-vacuum tubes were developed shortly before the beginning of World War I and their refinement and improvement were greatly accelerated by military necessity. One of the first uses to which they were put was that of *listening-in* devices used to pick up enemy conversations. The first of these tubes, known as the Siemens & Halske Type A, is shown in Fig. 228 in its various stages of development.<sup>304</sup> It followed, in general, the construction of the de Forest Audion and like it was a very inefficient device. Unlike its progenitor however, it was quite free from noise and microphonic action, chiefly because of its mechanical construction. The circular disk anode and spiral grid were held rigidly in place by means of glass spacers into which

(A)

(B)

Fig. 228.

(C)

(D)

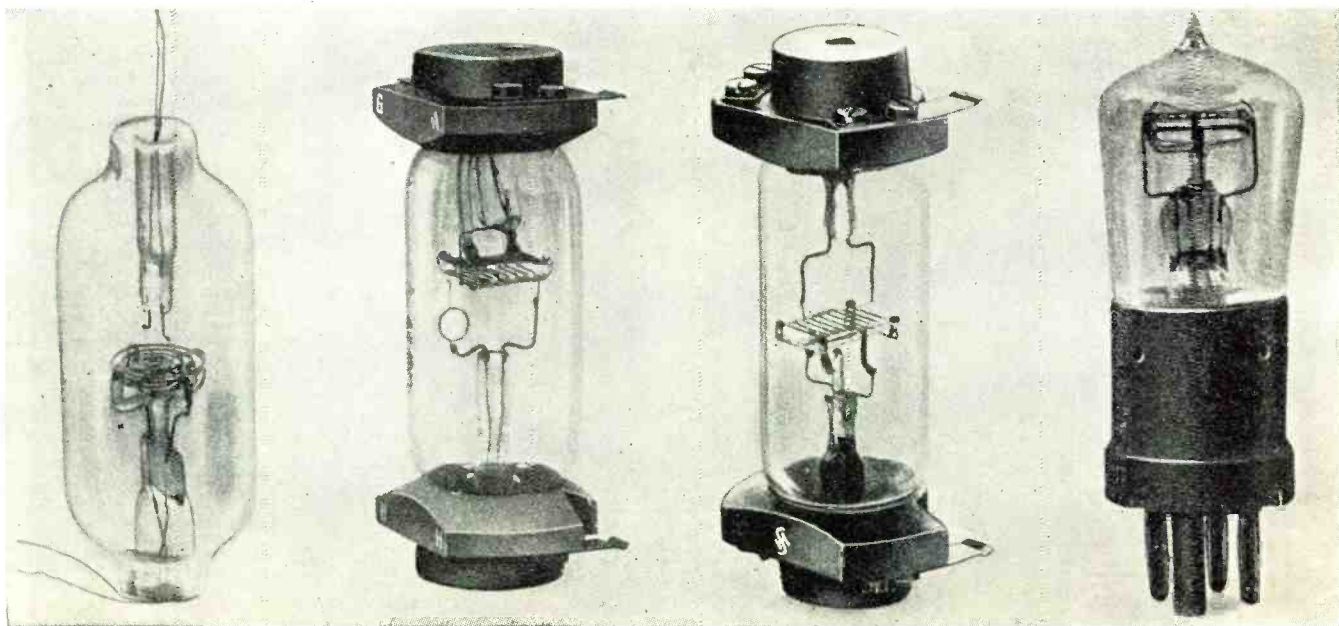



Fig. 229.

the elements were pressed. The bowed filament operated with .52 ampere at about 2.2 volts; the tube had an amplification factor of about 15 and an anode resistance of about 120,000 ohms. It had the advantage of taking a very small anode current, so that the anode batteries could be small and light.

While Fig. 228A shows the earliest stage of development, the tube as actually used in field equipment, even at this stage, was fitted with end mountings similar to those shown in Fig. 228B.<sup>305</sup>

Fig. 228B shows the second stage (attained in 1916) in the evolution of this tube. In it is shown the first step toward the punched grid which was finally used. The grid has been changed from spiral to zig-zag, still mounted in glass supports; the anode is rectangular to conform to the changed shape of the grid, and the filament has been changed to one parallel with the plane of the grid and equipped with a tensioning spring. The next step, shown in Fig. 228C, which was attained in 1917, utilizes a punched grid to replace the zig-zag wire. The final stage in this series is shown in Fig. 228D, in which the tube has been changed to single-ended construction with a single press, and a conventional 4-pin base employed.

Another early type, made by A.E.G. (*Allegemeine Electricitats Gesellschaft*), followed more closely the de-

sign of the original de Forest Audion. It too was double-ended and had end fittings similar to the Siemens & Halske Type A. In the A.E.G. tube the hairpin shaped filament was surrounded by a zig-zag grid wound on formed glass arbors, and both filament and grid were supported from the bottom press. The anode was shaped like an inverted U, was supported from the upper press, and fitted rather closely over the filament-grid assembly. This tube was identified as the A.E.G. K3 tube, and was used in the final stages of the A.E.G. K4 Amplifier, shown in Fig. 229.<sup>306</sup>

The Telefunken laboratories, as distinguished from those of Siemens & Halske and A.E.G., had been working on high-vacuum tubes since about the middle of 1913 and by early 1914 had standardized on the use of the high-vacuum tube for radio reception.<sup>307</sup>

These tubes had a construction similar to the Siemens & Halske tube described above; that is, plane anode, spiral grid, and bowed filament, in this case of helically wound tungsten wire. The EVN129 was provided with metal plates on each side of the filament in order to prevent the emitted electrons from reaching the walls of the tube, to which they might be impelled by the magnetic field resulting from the filament current.<sup>308</sup>

The first application of the EVN94 was in the EV89 Amplifier shown in Fig. 230. This amplifier was first produced in July 1914.<sup>309</sup> The EVN129 was originally developed for use as a heterodyne oscillator but was also used as a low-powered transmitting tube in sets of the type shown in Fig. 231, which were first made in June of 1915. The designation EVN indicates that the tube was intended for use in a receiver (*E = Empfänger*) as an amplifier (*V = Verstärker*) at low frequencies (*N = Niederfrequenz*).<sup>310</sup>

Another tube also intended for use in low-frequency amplifiers was the EVN171, shown in Fig. 232. This tube operated with a filament current of .5 to .55 ampere at 2.7 volts and used 80-100 volts on the anode. It had an amplification factor of about 10, a mu-

tual conductance of about 100 micromhos, and an internal resistance of about 100,000 ohms.<sup>311</sup>

By 1914 the Telefunken engineers had decided to change over to a cylindrical element assembly and one of the first of the new type tubes, intended for use in the EVE211 Amplifier, was designated EVE173. This tube is shown in Fig. 233. It was intended to duplicate the characteristics of the EVN171 and, for a time, both tubes were made, eventually the EVN171 being abandoned. Like its predecessors, the earlier EVE173s used nickel in the anode and the grid. The grid was of thin nickel ribbon with a stiffening rib applied longitudinally. Later production of this tube, about 1918, influenced by the shortages of material which had developed in Germany by that time, had anodes of copper, and sometimes grids of copper as well. The copper used was chemically treated to eliminate surface impurities and make the tubes uniform in their operating characteristics.

#### CAPTIONS FOR ILLUSTRATIONS

Fig. 223. French Kamerad type, in display socket. Photograph courtesy Bell Telephone Laboratories.

Fig. 224. French Type "S" made by Fotos. Photograph courtesy Radio Corporation of America.

Fig. 225. 50 watt transmitting tube of the Horned type. Photograph courtesy R. McV. Weston and Electric Communication.

Fig. 226. High-frequency amplifier using LRS Relay. Reproduced from "Handbuch der drahtlosen Telegraphie und Telephonie" by Eugen Nesper.

Fig. 227. Close-up of LRS Relay used as a high frequency amplifier showing interior of apparatus. Photograph courtesy Clark Historical Library.

Fig. 228. Development series of Siemens & Halske Type "A" Tube. Reproduced from "Veroffentlichungen aus dem Gebiete der Hachrichtentechnik"—1935.

Fig. 229. A.E.G. Type K4 Amplifier, showing use of type K3 tubes in last stages. Reproduced from Zenneck-Rukop "Lehrbuch der drahtlosen Telegraphie"—1925.

Fig. 230. Telefunken EVN89 Amplifier using EVN94 tubes. Reproduced from Zenneck-Rukop "Lehrbuch der drahtlosen Telegraphie"—1925.

Fig. 231. Telefunken transmitter made in 1915, using EVN129 tube. Reproduced from Zenneck-Rukop "Lehrbuch der drahtlosen Telegraphie"—1925.

Fig. 232. EVN171 tube. Reproduced from Telefunken Festschrift—1928.

Fig. 233. EVE173 tube. Reproduced from Telefunken Festschrift—1928.

#### References

301. Ferrie, General—"L'emploi des audions ou lampes a trois electrodes pendant la guerre." *Revue Generale de l'Electricite*, Vol. 6, No. 26, December 27, 1919, pp. 933-935.

(Continued on page 130)



# PHASE INVERTERS

**A thorough discussion of the design and operation of many types of phase inverters. Most of the circuits discussed are widely used while others are quite novel in operation.**

**T**HE grid excitation requirements of a push-pull audio amplifier are such that it is necessary to excite each grid, or bank of grids, with the same amount of audio voltage, but the voltage on one side of the balanced amplifier must be opposite in phase to that on the other side of the amplifier, if the voltages from each side of the amplifier are to mix properly in the plate transformer. That is, the voltage applied to one grid or bank of grids, must reach its positive peak in the a.c. cycle at the same instant that the voltage applied to the other grid or bank of grids reaches its negative peak in the a.c. cycle.

A brief glance at the action of the output transformer will reveal why this action is necessary. If the grid voltages were in phase, the plate current through the two tubes would rise or drop simultaneously, and their effects would cancel in the output transformer, resulting in no output. However, if the grid voltages were 180° out of phase, the current in one tube would be rising while that in the other tube would be falling, with the result that the induced voltage in the secondary of the output transformer would be twice that for one tube.

A good interstage transformer, with a center-tapped secondary, is the simplest and best method of obtaining this excitation voltage, since the voltages at the opposite ends of this secondary winding are 180° out of phase. However, good transformers are too expensive, as well as too large, for use in the modern midget receivers and the low powered sound systems and, since the coming of high fidelity transmissions some ten or twelve years ago, most manufacturers have reverted to resistance-coupled phase inversion. This electronic method of satisfying the excitation requirements of push-pull audio amplifiers was chosen for several reasons. The fidelity of the resistance-coupled phase inverter is as good as, if not better than, that of most transformers. The space that a phase inverter consumes is only one-third to one-half as great as that of a transformer. The original cost is a great deal less, since it is made up of a tube and a few inexpensive resistors and condensers whose electrical values are not too critical. Furthermore, it is possible to attain a higher frequency response and, in some circuits, a higher voltage step-up than it is possible to get from low price interstage transformers. A good transformer has the

advantage that it has much higher inherent stability than the phase inverter and, for this reason, it is used in commercial communications work. Another advantage of a good transformer is that the impedance in the grid circuits following the driver can be high while the d.c. resistance can be kept low, and this condition is almost necessary in the case of a class-A prime amplifier where grid current flows over a portion of the cycle. It is necessary to keep the next stage grid resistors comparatively high when using a phase inverter, in order to prevent loading of the inverter, which would cause unbalance because of changes in the excitation voltage to the inverter tube grid. Also, it would

By  
**HAROLD A. BUSTARD**

seriously impair the frequency response at the higher frequencies.

The purpose of the phase inverter, then, is to provide two voltages which are equal in magnitude and 180° out of phase, which can be utilized to drive a push-pull amplifier. There are numerous methods of accomplishing this but the basis of operation of the majority of the systems is that a small portion of the output voltage from either the driver stage or the output stage is coupled to a similar driver tube, or to the grid of the other output tube, through a suitable coupling arrange-

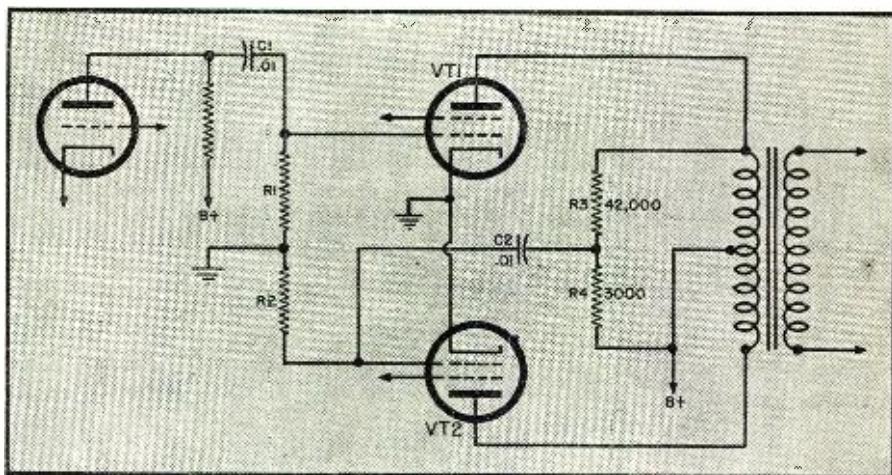
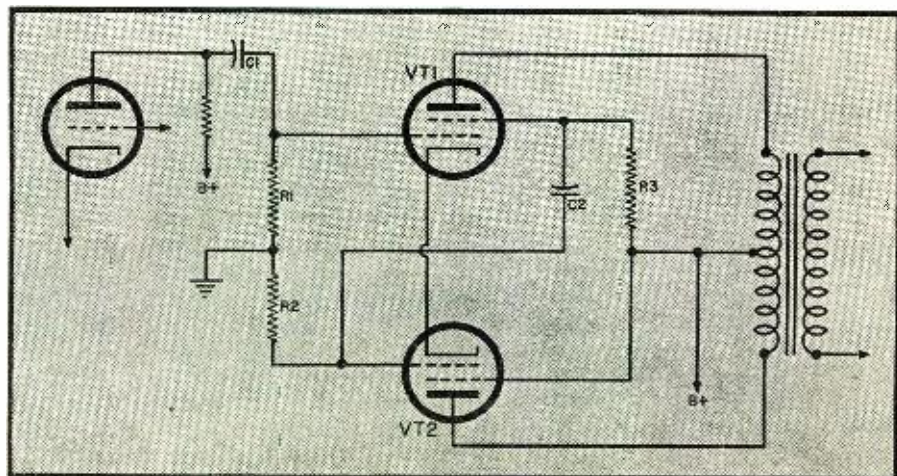

Fig. 1. Phase inversion takes place in the output stage. This system has the advantage of not requiring an inverter tube or additional transformers.

Fig. 2. Similar in operation to Fig. 1, with the exception that advantage is taken of changes in the screen grid current in order to obtain phase inversion.



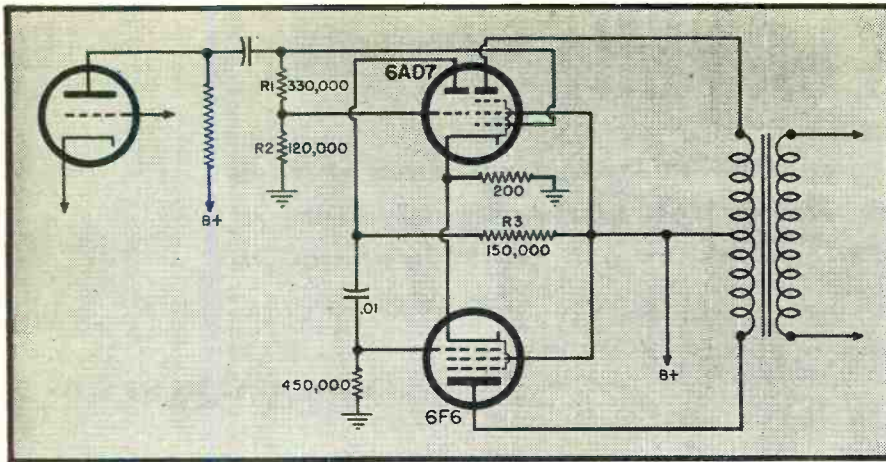

Fig. 3. A 6AD7 triode-pentode is used as an output tube. The pentode section is used for push-pull operation and the triode section is used as an inverter.

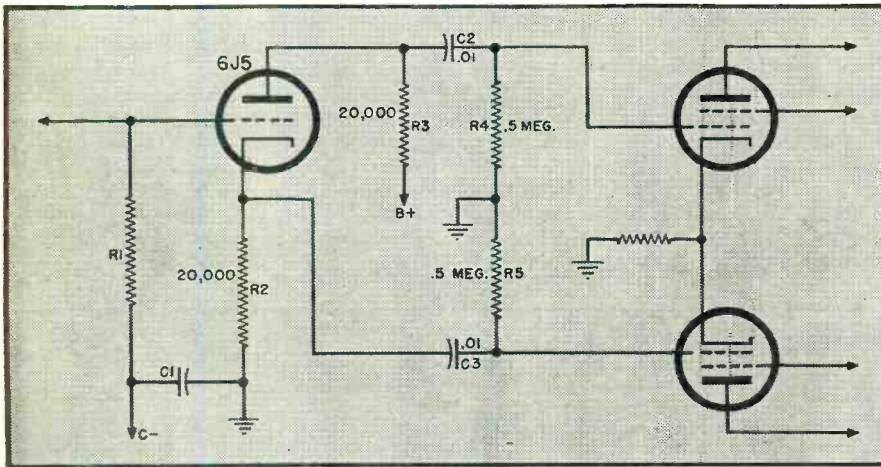
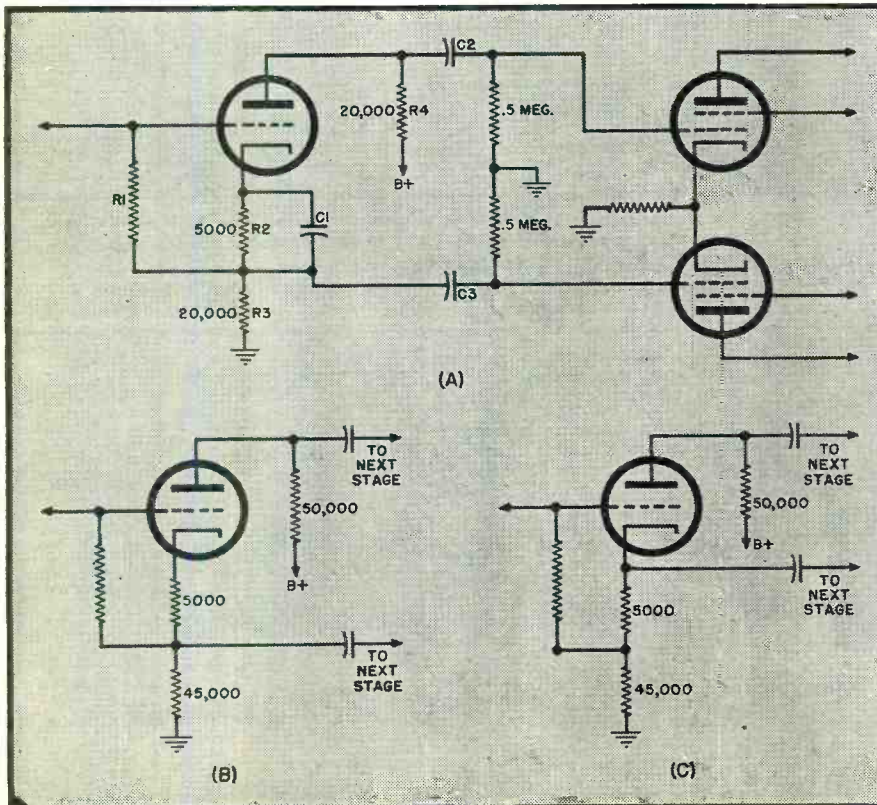

Fig. 4. The 180° phase shift, necessary for proper phase inversion, is obtained by taking advantage of the signal voltage on the cathode of the 6J5 triode tube.

Fig. 5. Similar in operation to Fig. 4, with the exception that the 6J5 is now self-biased which will eliminate the addition of a bias voltage source.



ment to provide the necessary excitation voltage for the push-pull tubes.

The systems where the phase inversion takes place in the output stage itself are perhaps the most simple and are all adaptable for use in the service shop where it is necessary to get around shortages of inverter tubes and transformers.

One of the first phase inversion systems ever used was of this type and is shown in Fig. 1. Two resistors,  $R_2$  and  $R_1$ , are connected in series across the first half of the output transformer primary. The grid voltage for the second output tube is taken from the junction of these two resistors and fed to the grid of the second tube through coupling condenser  $C$ , whose value is generally  $.01 \mu\text{fd.}$  and is always the same as that of  $C_1$ . When first looking at the circuit, it is difficult to see how such an arrangement can satisfy the requirements of a phase inverter. However, the voltage developed across  $R_2$  and  $R_1$  is 180° out of phase with that developed across  $R_1$ , because of the 180° phase shift in  $V_1$ , and the size of  $R_2$  and  $R_1$  are adjusted so that the magnitude of the voltage fed to the grid of  $V_2$  is the same as that appearing at the grid of  $V_1$ . Thus, the two grid voltages are equal in magnitude and 180° out of phase. In Fig. 1, it is assumed that  $V_1$  has a gain of 15, so  $R_2$  and  $R_1$  are so proportioned that one-fifteenth of the output voltage of  $V_1$  is fed to  $V_2$ .

Other values of resistors could be used proportionately. However, we find that if the total resistance is very far below a critical value of fifty thousand ohms, the transformer will be loaded with a resultant reduction in power and fidelity, while, if the total resistance is much higher, the balance will be affected on high frequencies due to the effects of stray capacities in wiring, transformer distributed capacities, and the output and input capacities of the tubes. The values of  $R_1$  and  $R_2$  are standard for the type of tubes used and, of course, they should both have the same value. The parts values are not very critical, and, as in the case of most electronic equipment, a tolerance of ten percent is allowable which gives one a chance to use standard replacement parts if the exact size is not available. The small mismatch that could be caused with this tolerance is easily balanced out in the output transformer with no ill effects other than a slight reduction in the output voltage, which will be less than five volts in most cases. This circuit is almost entirely independent of tube characteristics in that, if the excitation voltage to  $VT_1$  drops or if the emission in  $VT_1$  drops, there will be a similar reduction in the voltage drop across  $R_1$ . Therefore, the excitation voltage to  $VT_2$  will be reduced accordingly. Under these conditions, only the characteristics of  $VT_2$  can really greatly affect the fidelity of the amplifier.

The circuit has the definite advantage that it is simple and uses only

# OHMITE

## RITEOHM PRECISION RESISTORS

*Non-Inductive... Pie-Wound... 1% Accurate*

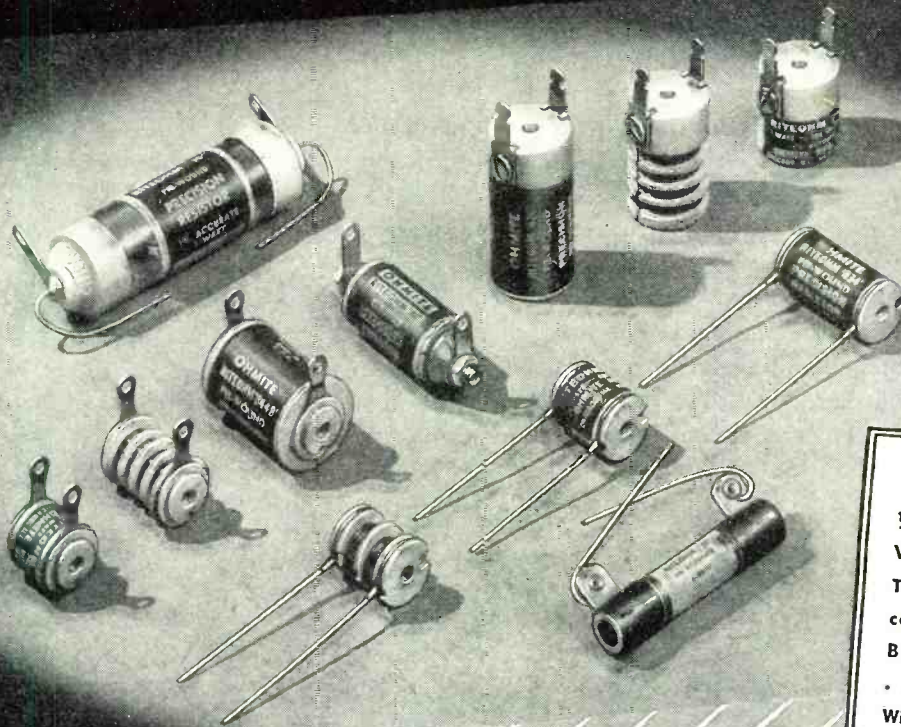

### NEW

1/2 Watt and 1 Watt  
Vacuum Impregnated  
Types... Hole in  
center for Through-  
Bolt Mounting  
... Equipped with  
Wire Leads or Lugs

### Available from Stock... or Made to Order

OHMITE presents a *new* line... a *full* line... of finer precision resistors! Every type... every size... ready for every need! Each Riteohm is designed and built with all the specialized skill and experience that have made OHMITE units the standard in this field. However critical the application... consistent accuracy and reliability are assured. In these Riteohms, you get *time-proved protection against humidity, temperature and corrosion.*

Ideal for use in voltmeter multipliers, laboratory equipment, radio and electrical test sets, attenuation pads, and in electronic devices requiring *extremely accurate* resistance components.

AVAILABLE FROM STOCK in 1/2 watt and 1 watt units in a wide range of values, in various types of mountings and terminals... or made to order. Complete line of 6 different series includes non-inductive pie-wound vacuum impregnated units... single-layer wound vitreous enameled units... and non-inductive pie-wound hermetically glass sealed units. Some units are in a range of 0.1 ohm to 2,000,000 ohms. *Get full facts today!*

OHMITE MANUFACTURING CO., 4884 Flournoy St., Chicago 44, U. S. A.

### Send for Bulletin No. 126

This handy Riteohm Bulletin makes it easy for you to select the exact units for your needs. Gives complete data... lists stock units and made-to-order units... includes dimensional drawings. Write for it now.



Be Right with **OHMITE**

**RHEOSTATS • RESISTORS • TAP SWITCHES • CHOKES • ATTENUATORS**

**Design by STANCOR**  
**MEANS MAXIMUM ADAPTABILITY**  
**AT AN**  
**ECONOMICAL PRICE...**

**MAKE** your transformer replacements more profitable by specifying STANCOR Uni-dapt units. More adaptable because over 80% of all radio transformers now in use are replaceable with a standard Uni-dapt item.

It's this adaptability that makes STANCOR design complete, fulfilling the exact needs of radio serviceman, amateur, and electronic engineer in an economical manner.

For transformer replacements think first of STANCOR.

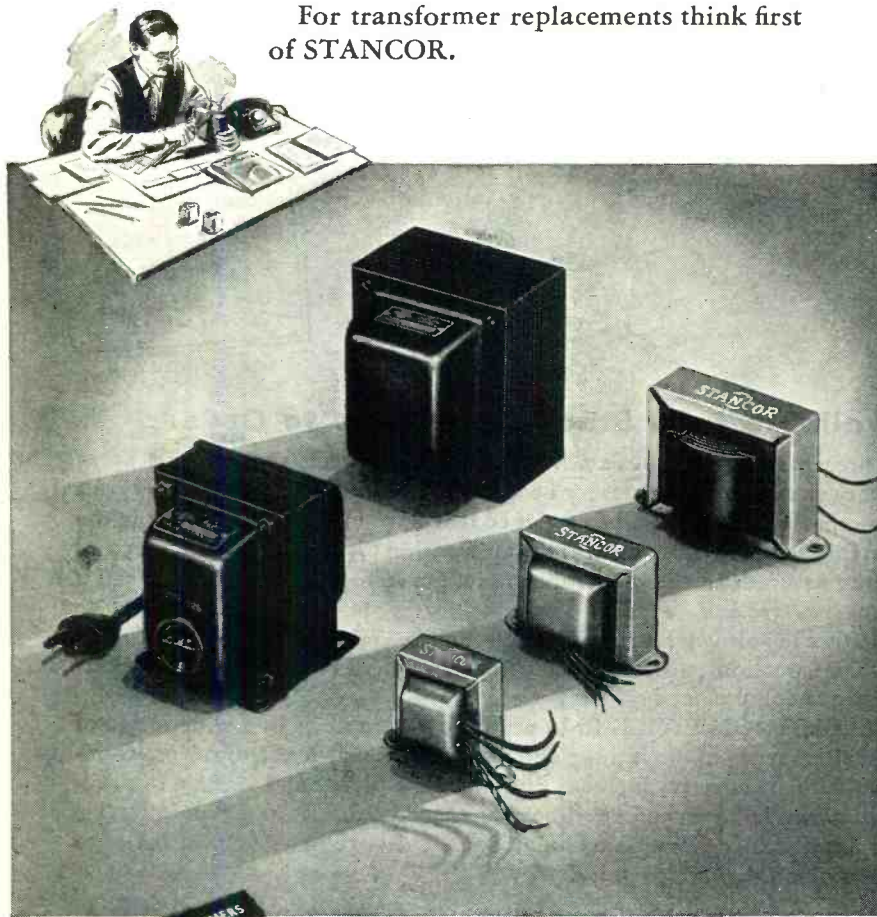

**STANCOR**

**STANDARD TRANSFORMER CORPORATION**  
 1500 NORTH HALSTED ST., CHICAGO 22, ILLINOIS

the regular output tubes, so no additional space is consumed. Its disadvantages are slight and may be neglected in most receivers; the resistors across the transformer primary have a loading effect on the transformer, regardless of their value, and they take part of the power off of the first half of the transformer. This loading effect reduces the output slightly (less than ten per-cent) and hinders the fidelity. It seems to flatten the high frequencies and the cut-off point for low frequencies is around 100 c.p.s. The circuit is however, adaptable to all types of output tubes, whether they are triodes, pentodes, or tetrodes.

In Fig. 2, we have a similar circuit, but here we have taken advantage of the changes in the screen grid current which are similar to the plate current changes and we have placed a resistor in the screen grid circuit of  $VT_1$ . The voltage drop across this resistor is  $180^\circ$  out of phase with the input voltage and is proper for the excitation of  $VT_2$ . The value of resistor used depends, of course, on the tubes used. Each tube, of course, has slightly different screen grid current variations when the tube is working. What is meant is that the screen current in one tube may rise from 10 ma., no signal value, to 15 ma., peak signal value, while another type may have a 20 ma. no signal value, and will rise to 40 ma. on peaks. This information can usually be found in the manufacturers' data, as can the following necessary conditions. The peak grid volts necessary for the tube to work at full output is usually equal to the manufacturers' grid bias voltage rating. The peak a.c. voltage drop across  $R_s$  will be equal to this grid voltage. The exact value of resistor  $R_s$  can then be calculated from Ohm's law, remembering that the changes in current corresponding to the audio signal will be the only current changes that will develop an a.c. voltage which is needed. Therefore, if the manufacturers' data shows the no signal current as 10 ma. and the peak current as 15 ma., the difference between the two will be the value to use in calculating the value of  $R_s$ .

In the event that you cannot find this data, approximate values of  $R_s$  for the two popular classes of output pentodes and tetrodes are for 41, 6K6, 7B5, and others requiring high excitation values on the order of twenty volts, use a resistor of 3800 to 4000 ohms. For tubes such as the 42, 6F6, 6V6, and 7C5 whose amplification factor is higher and grid voltage lower, a resistor of 3500 ohms will be found to work satisfactorily.

As in the case of all push-pull amplifiers, any small amount of unbalance will be unnoticeable, since it will be balanced out in the output transformer at a slight loss of power. Small differences may be made up by proper choice of coupling condensers, but this is slightly out of the technician's field and, as differences in coupling con-

**RADIO NEWS**

# Greater Maximum Range

FM AND TELEVISION RECEPTION IS STRONGER AND CLEARER  
with **AMPHENOL** antennas

As distance from the transmitter increases, antennas of the highest efficiency are essential. Amphenol's FM and Television Antennas are engineered to provide the most satisfactory, noise-free reception in zones of low signal strength.

Note the many superior Amphenol features of these antennas... high strength, lightweight seamless tubular aluminum

elements—durable molded bakelite insulator—rugged steel mast and cadmium plated fittings. These factors, coupled with Amphenol engineering and precision workmanship, result in long life, durability and top performance.

**AMERICAN PHENOLIC CORPORATION**  
Chicago 50, Illinois  
In Canada • Amphenol Limited • Toronto

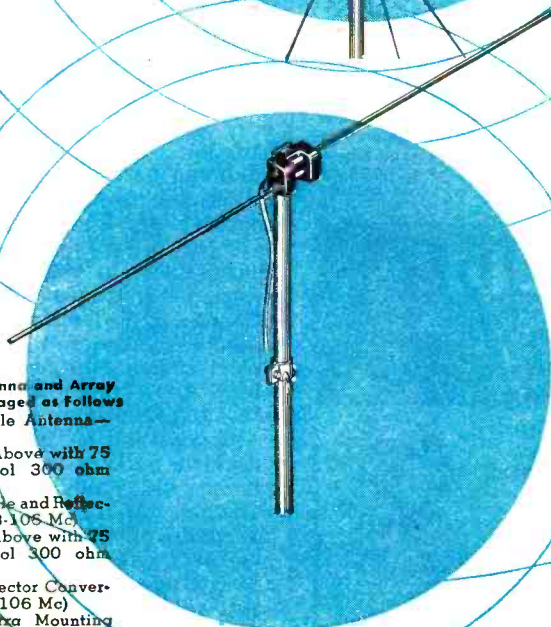
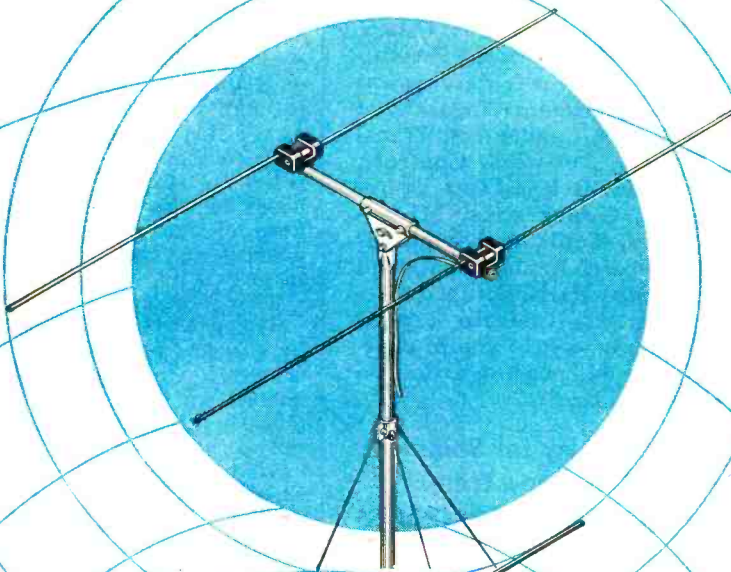

#### Amphenol Antenna and Array Equipment Packaged as follows

- 107-114 Dipole Antenna—(88-106 Mc)
- 107-104 As Above with 75 Feet Amphenol 300 ohm Twin-Lead
- 107-113 Dipole and Reflector Array—(88-106 Mc)
- 107-103 As Above with 75 Feet Amphenol 300 ohm Twin-Lead
- 107-109 Reflector Conversion Kit—(88-106 Mc)
- 107-110 Extra Mounting Bracket (When Required for Side Mounting)

#### AMPHENOL FM ANTENNAS PROVIDE

- High gain assures better reception.
- Directional array eliminates interfering signals.
- Improved reception in the FM bands.
- Swivel feature on mounting bracket and mast head permits polarization adjustment in two planes.
- Swivel feature on mounting bracket allows installation on peak roof as well as flat roof. Two mounting brackets recommended for side mounting installation.
- Innovation in parallel low-loss transmission line for antenna to receiver connection.
- Exploded view of all parts on direction sheet facilitates easy, proper assembly.



U. H. F. Cables and Connectors • Conduit • Fittings  
Connectors (A-N, U. H. F., British) • Cable Assemblies  
Radio Parts • Antennas • Plastics for Industry

# RADIO PARTS

## ELECTRONIC EQUIPMENT



### Mail Coupon NOW for **CONCORD** Victory Clearance Flyer . . . FREE!

● Ready now! 32 Bargain-packed pages listing thousands of standard-make, top-quality radio parts and electronic supplies—now available without priority at low VICTORY CLEARANCE prices. The values listed at the left are typical of the important savings offered in Meters, Condensers, Transformers, Resistors, Controls, Switches, Relays, Test Equipment, Generators, Microphones, Tools, and hundreds of Repair, Replacement, and Accessory Parts. On special requirements, Concord experts are ready to help you in expediting and speeding action on essential needs.

### Order Today for Shipment Tomorrow from **CHICAGO OR ATLANTA**

Huge stocks in TWO convenient warehouses—one in CHICAGO and one in ATLANTA—are ready to supply you quickly with needed parts of dependable, nationally-known quality—and at VICTORY CLEARANCE prices that mean real savings. Mail the coupon below NOW for your FREE copy of CONCORD'S VICTORY CLEARANCE Flyer.

### Check These Typical **CONCORD VALUES**



**D. C. Milliammeters**  
2½" flange mtg. type. Metal case dull black finish. G. E. 0-200 M. A. C10650. Specially Priced . . . . . \$4.95



**Plate Power Transformer**

Pri. tapped at 115, 117 and 120 V.A.C. Sec. output 850 V. at 200 ma. c. t. 4½" L x 3½" W x 3¼" H. 5B5035. Your cost . . . . . \$4.29

**Output Transformer**  
Hermetically sealed. Six studs. 1, 2, and 3 are pri. 4, 5, and 6 the sec. Pri. ind. at 5 V. 1000 cy.: .20 H. Ratio sec. to pri. 3.02:1. size: 3¼ x 2 41/64" 5B5045. Your cost . . . . . \$1.95



**Dry Electrolytic Condenser**  
Hermetically sealed. Size, 1½" x 3". Can negative. Cap.: 40 mfd. at 475 volts; 15 mfd. at 350 volts; 15 mfd. at 150 volts; 20 mfd. at 25 volts. 5B3161. Each . . . . . 59c



**Mobile High Voltage Power Unit**  
Input 12 V. at 10 amps. Output consists of two voltage ranges: (1) 275 at 110 ma. (2) 500 at 50 ma. 5B9518. Your cost . . . . . \$39.50



**300 Watt Rheostat**  
Wire wound. Vitreous enameled. Cast aluminum base. 6" dia. 2½" deep. 1400 ohms. 5B9517. Your cost . . . . . \$3.95

## CONCORD RADIO CORP.

LAFAYETTE RADIO CORPORATION  
CHICAGO 7, ILL. ★ ★ ATLANTA 3, GA.  
901 W. Jackson Blvd. 265 Peachtree Street

CONCORD RADIO CORPORATION  
901 W. Jackson Blvd.  
Dept. E-26  
Chicago 7, Ill.



Please RUSH FREE copy of CONCORD'S new 32-page VICTORY CLEARANCE Flyer.

Name . . . . .  
Address . . . . .  
City . . . . . State . . . . .

denser values also tend to reduce the fidelity of the amplifier, it is suggested that small unbalances be left up to the output transformer which will take care of them very adequately.

Another method of phase inversion in the output stage is shown in Fig. 3. In this circuit, a 6AD7 triode-pentode is used as one output tube. The pentode section of the 6AD7 is identical to a 6F6 and is used in conjunction with one in a push-pull amplifier. The triode section is used as an inverter, and gets its grid voltage from a voltage dividing arrangement,  $R_1$  and  $R_2$  in the pentode section grid circuit. The resistors in the voltage divider are so proportioned that, when used with resistor  $R_3$ , the voltage on the 6F6 grid is equal in magnitude but opposite in phase to that which is on the grid of the pentode section of the 6AD7. Since the characteristics of the pentode section of the 6AD7 and the 6F6 are identical, if the excitation voltages are equal, the output will be well balanced and fidelity very high. The output of the amplifier is entirely dependent on the emission of the 6AD7 because, as the emission of the 6AD7 drops, the excitation voltage on the grid of the 6F6 will fall accordingly with the result that the output from the 6F6 will always be equal to that of the 6AD7. Since the 6AD7 is the only tube of its kind, the parts and tubes are standard and should be adhered to whenever possible. A tolerance of ten per-cent is permissible when necessary. This circuit is found in several popular radios.

The foregoing have been circuits that can be used in low power amplifiers such as are found in small receivers. All are simple and can be hooked up in a few minutes in the average service shop. Therefore, they are very handy for servicemen who have to get around a tube shortage problem or can't find a replacement interstage transformer. Following are circuits that are adaptable to higher powered amplifiers. In these systems, the phase inversion takes place in the driver stage. In most instances, a separate or special inverter tube is used. Therefore, more voltage is generally available for the push-pull grids that follow and the circuits are far more sensitive.

In Fig. 4, we have what is probably the simplest of these inverter-driver systems. A simple triode such as a 6C5, 6J5, or 76 is used. The plate and cathode resistors are made equal. When a signal is applied to the grid of the tube, over the positive half of the a.c. cycle, the current in both resistors,  $R_2$  and  $R_3$ , increases. This increase in current naturally causes an increase in voltage drop across these resistors. As a result, the voltage at the plate of the tube becomes more negative with respect to ground and the voltage at the cathode becomes more positive with respect to ground. When the two resistors are of equal value, the peak negative voltage at

(Continued on page 98)

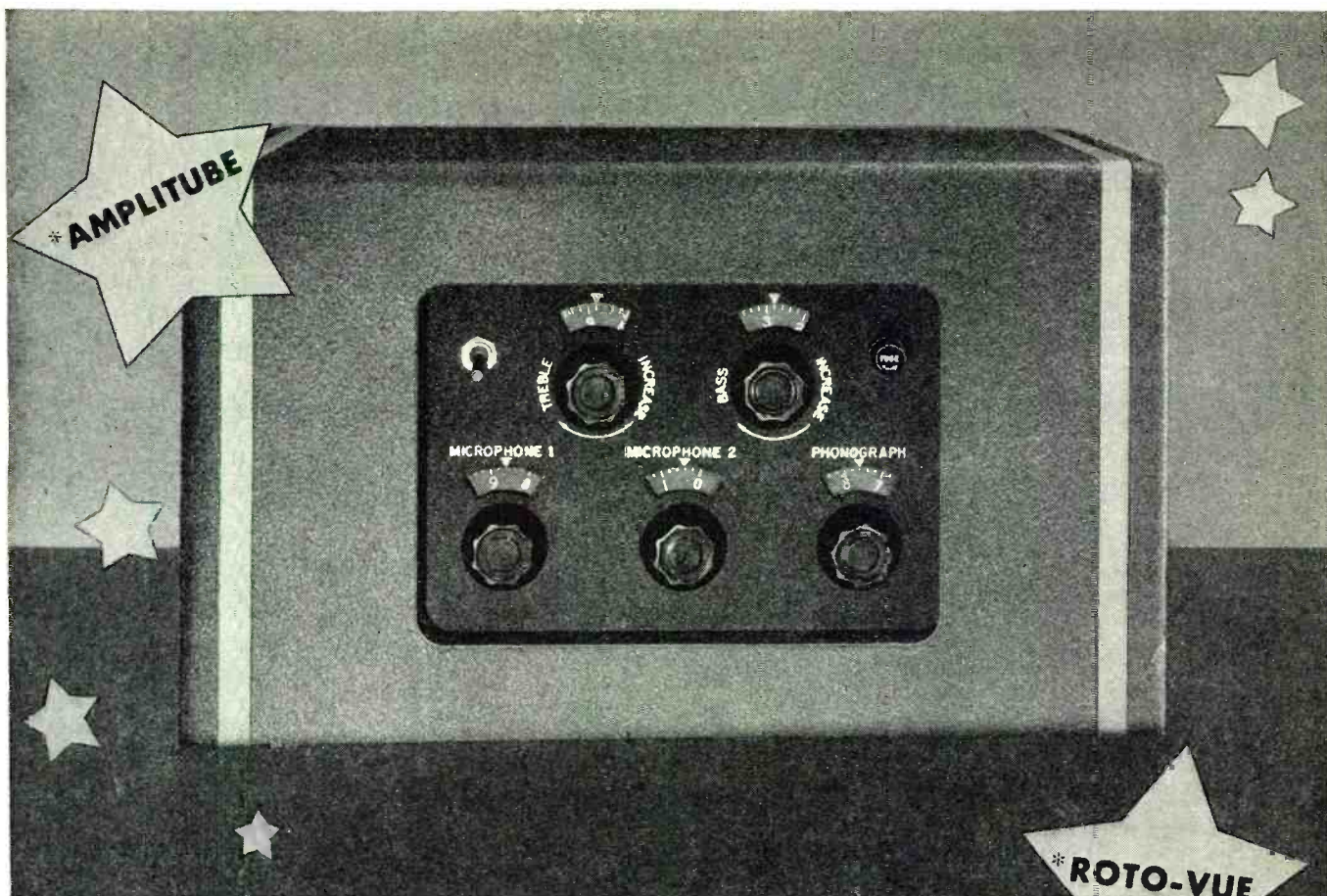

# *Ethical Engineering* is the Basis of

## Eastern's 21 STAR FEATURES

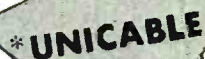
  **\*UNICABLE**



Ethical engineering at Eastern is the history of many years in the service of sound amplification. The 21 Star Features are the result of intensive experience dating back to the early days of radio—the pioneer 20s! Today this engineering background accounts for the many innovations we have designed for the new 1946 Eastern Amplifiers—the 21 Star Features that produce Eastern's

famous *Quality Performance*. No other amplifiers, regardless of price, incorporate so many novel and useful features. . . . For complete information and price list—for the first edition of our 1946 Catalog—write today! . . . Eastern Amplifier Corporation, 794 East 140th Street, New York 54, N. Y. Dept. 2E.

  **RECESSED CONTROLS**

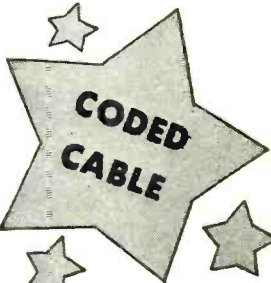
  **CODED CABLE**

**EASTERN**   **AMPLIFIERS**

\*U.S. Reg'n Applied For.

# WHAT'S NEW IN RADIO

## ENCLOSURES FOR ELECTRICAL COMPONENTS

*Electrical Industries, Inc.*, is now offering a new line of enclosures for electrical components including relays, coils, transformers, etc.

Round or square cans are available with or without equipment mounting bridges attached to the can interior

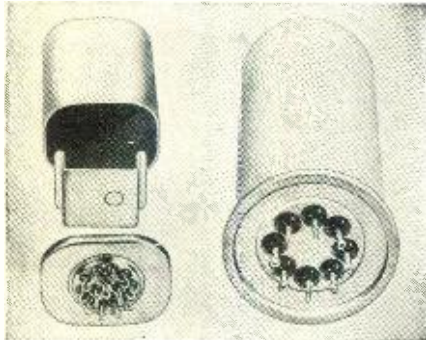

and terminals are brought out through sealed headers in the base. The headers can be supplied for plug-in use. Round cans can have any number of contacts up to a maximum of eight, and square cans have a maximum of fourteen leads.

These new enclosures offer a compact, economical and efficient method of encasing components. Units so housed are easily replaced or serviced and complete protection from dust, dirt, and moisture, as well as mechanical damage, is afforded.

Details of these enclosures may be had upon request to *Electrical Industries, Inc.*, 42 Summer Avenue, Newark 4, New Jersey.

## MEGOHM METER

A new model 1500 Megohm Meter with a range from 400,000 ohms to 100,000 megohms in five ranges on single-scale, four-inch meter has been developed by *Communication Measurements Laboratory*.

Weighing only eight pounds, this new unit has a wide variety of applications including measuring of leak-



age resistance of insulation materials, condensers, coaxial cables, wiring harness, motor, and transformer windings. Model 1500 may also be used

for determination of moisture content of wood, paper board, plastics, textiles, and other materials in which electrical resistance is a function of moisture content.

This new Megohm Meter has a line voltage of 115 volts, 60 cycles and is available for immediate delivery without priorities. Descriptive bulletins are available from the Meter Division, *Communication Measurements Laboratory*, 120 Greenwich Street, New York 6, N. Y.

## "LITTLE DEVIL" RESISTORS

*Ohmite Manufacturing Company* has announced a new series of small size, insulated, fixed composition resistors known as "Little Devils." They are full 1/2 watt, 1 watt, and 2 watt resistors, yet the size of the 1/2 watt is only 3/8" long x 9/64" diameter; the 1 watt, only 9/16" long x 7/32" diameter; the 2 watt, 11/16" long x 5/16" diameter.

Ratings for maximum continuous r.m.s. voltage drop are high: 500 volts for the 1/2 watt unit, 1000 volts for the 1 watt unit, and 3500 volts for the 2 watt unit. They are completely sealed and insulated by their molded plastic

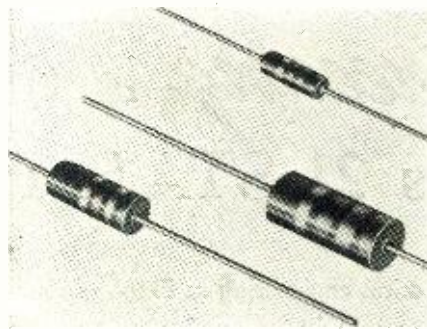

construction. Leads are soft copper wire, hardened immediately adjacent to the resistor body, strongly anchored, and hot solder coated. All these resistors are color coded and available from stock in RMA standard values (10% tolerance) from 10 ohms to 22 megohms and can be used for regular replacement or for special applications even in the smallest equipment.

For complete information, write for Bulletin No. 127 to *Ohmite Manufacturing Company*, 4835 Flournoy Street, Chicago 44, Illinois.

## VOLTAGE REGULATORS

*R-B-M Manufacturing Company*, division of *Essex Wire Corporation*, Logansport, Indiana is now producing improved 3-unit, vibrating type, heavy-duty voltage regulators for low voltage d.c. generator application.

These regulators are compactly de-

signed, sturdily constructed, and are especially suitable for stationary or mobile gas engine or motor driven generators. All three units (reverse

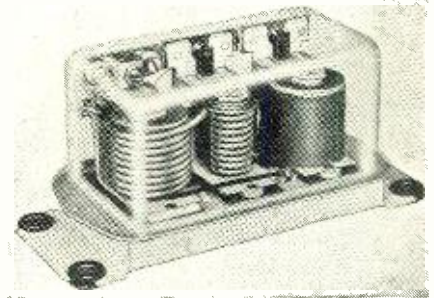

current relay, voltage control, and current limiter) are designed to work in any position and withstand external vibration and shock normally encountered in mobile apparatus.

These voltage regulators are available in maximum capacities of 30 amperes at 6 to 32 volts and 45 amperes at 6 to 12 volts d.c. Maximum field current rating, 3 amperes at 6 volts; .5 amperes at 32 volts d.c. Approximate dimensions are; width, 7 3/4"; depth, 4"; height, 3 1/2". Average weight, 3.25 lbs.

In order to secure detailed information regarding definite applications, it is necessary to consult the engineering department of the *R-B-M Manufacturing Company* as these voltage regulators must be calibrated as to settings and resistance values to match generator specifications.

## MICROPHONE JACKS AND PLUGS

Two new, completely redesigned microphone jacks and plugs have been issued by *Kings Electronics Company* of New York.

Model M-150, now available in quantities for immediate delivery, is a standard jack, heavily nickel plated with silver plated contact pins. Model M-151, now in production, is an improved microphone jack and plug combination. This combination has solid contact pins, heavily silver plated, and can be soldered to the cable while assembling. This is a precision connector in which all noise and vibration, due to wear on the soldered contact, is eliminated.

*Kings Electronics Company* is located at 372 Classon Avenue, New York.

## THYRATRON ELECTRONIC TUBE

*General Electric Company* has announced a new all-metal "midget" thyatron electronic tube, GL-502 A, having a net weight of two ounces.

The GL-502 A is an inert-gas-filled, double-grid thyatron with negative



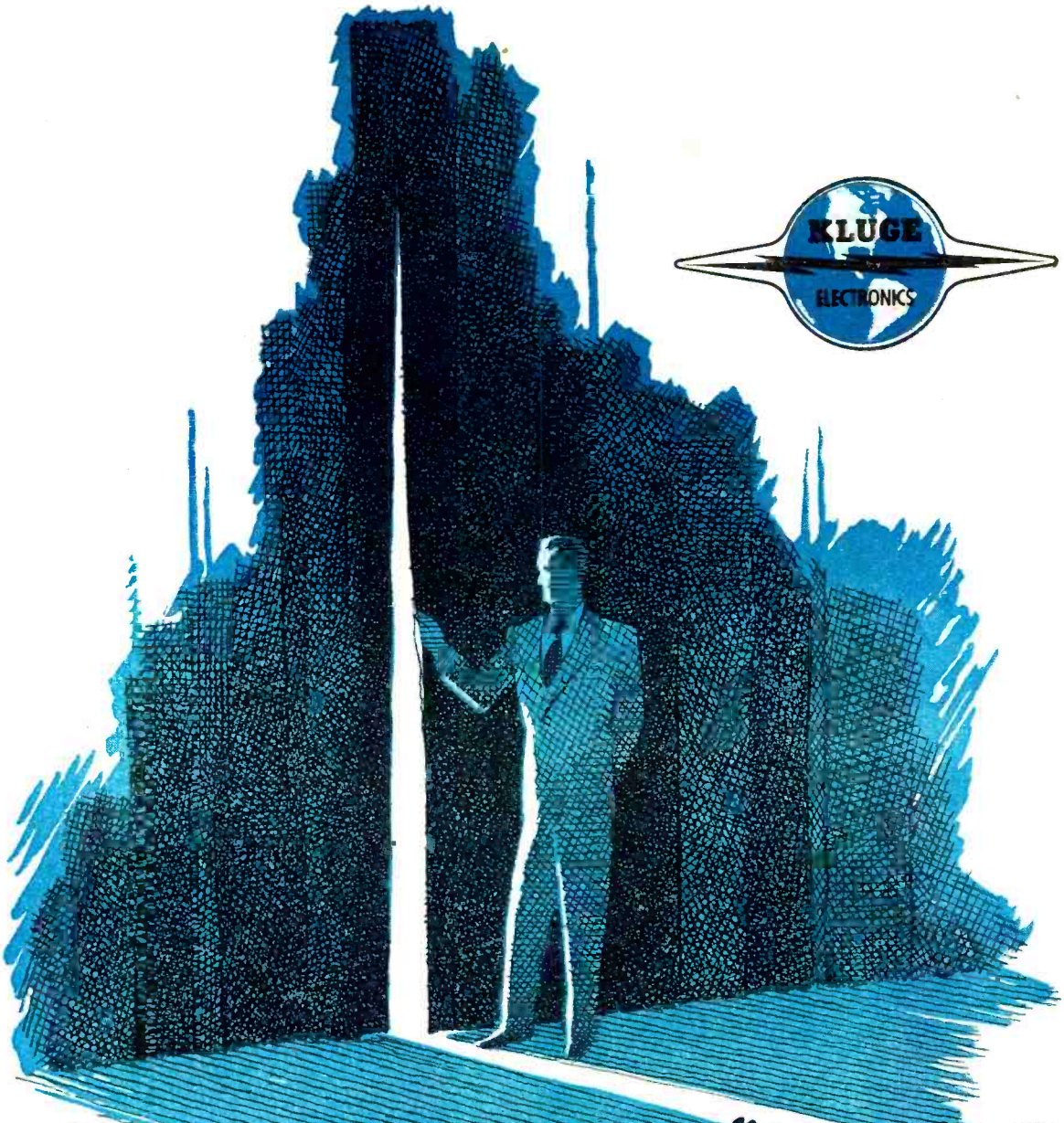

## *Soon... A New "Ham" Era*

The curtain is rising on a remarkable "new era" development for the "hams" and *potential* hams of the world! It's so logical... so ingenious, in its use of advanced electronics and ultra-modern principles of design that we have kept the secret for showings in *all parts of the country*, at the same time. Dealers will be ready soon. Don't miss their KLUGE "Premieres" ... It won't be long!

**KLUGE**  
ELECTRONICS  
C O M P A N Y

1031 NORTH ALVARADO STREET • LOS ANGELES 26, CALIFORNIA  
February, 1946

# The Answer TO YOUR INSTRUMENT PROBLEMS

# Burlington

## PANEL INSTRUMENTS

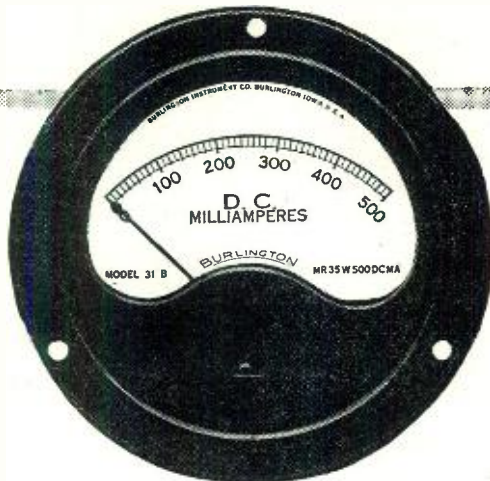

Burlington Panel Instruments are designed and built to give dependable service with guaranteed accuracy. They are available in a complete line of AC or DC Ammeters, Voltmeters, Milliammeters, and Microammeters. The wide selection of sizes and case styles offer instruments that are ideal for your particular application.

Write today for full details — our engineers will recommend the precision Burlington Instruments required to solve your instrument problems.

### BURLINGTON INSTRUMENT CO.

902 Fourth St., BURLINGTON, IOWA



PANEL INSTRUMENTS • VOLTAGE REGULATORS • AUTOMATIC SYNCHRONIZERS • FREQUENCY REGULATORS

control characteristics. The control characteristic of this tube is independent of ambient temperature over a wide range. It has high sensitivity characteristics because the grid current is low enough to permit the use of a high resistance in the grid circuit. Because of its low grid-anode capacitance, the thyratron is relatively unaffected by line-voltage surges.

Further technical data may be obtained on request to Electronics Publicity, *General Electric Company*, Schenectady 5, N. Y.

#### X-RAY TUBE

*Machlett Laboratories, Inc.*, of Springdale, Conn., has produced experimentally a new x-ray tube which emits x-radiation from a hemispher-

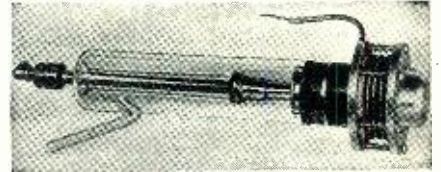

ical window throughout the entire 180° solid angle, with an intensity in excess of five million roentgen units per minute.

A smaller version of the tube, providing over two million roentgen units, is already commercially available.

#### VOLT-OHM-MILLIAMMETER

A new model 2405 Volt-Ohm-Milliammeter with d.c. volt ranges at 25,000 ohms-per-volt has been announced by *The Triplet Electrical Instrument Company*.

This unit will provide for voltage, current, and resistance analysis where extreme sensitivity is required. Model 2405 ranges are: d.c. volts: 0-10-50-250-500-1000, at 25,000 ohms per volt; a.c. volts: 0-10-50-250-500-1000, at 1000



ohms per volt; d.c. amperes: 0-10; a.c. amperes: 0-0.5-1-5-10; d.c. milliamperes: 0-1-10-50-250; d.c. microamperes: 0-50; ohms-megohms: 0-4000-40,000 ohms, 4-40 megohms. Batteries are self-contained and leads furnished.

This new Volt-Ohm-Milliammeter is a product of *The Triplet Electrical Instrument Company*, Bluffton, Ohio.

-30-

RADIO NEWS

# Tops in the Field

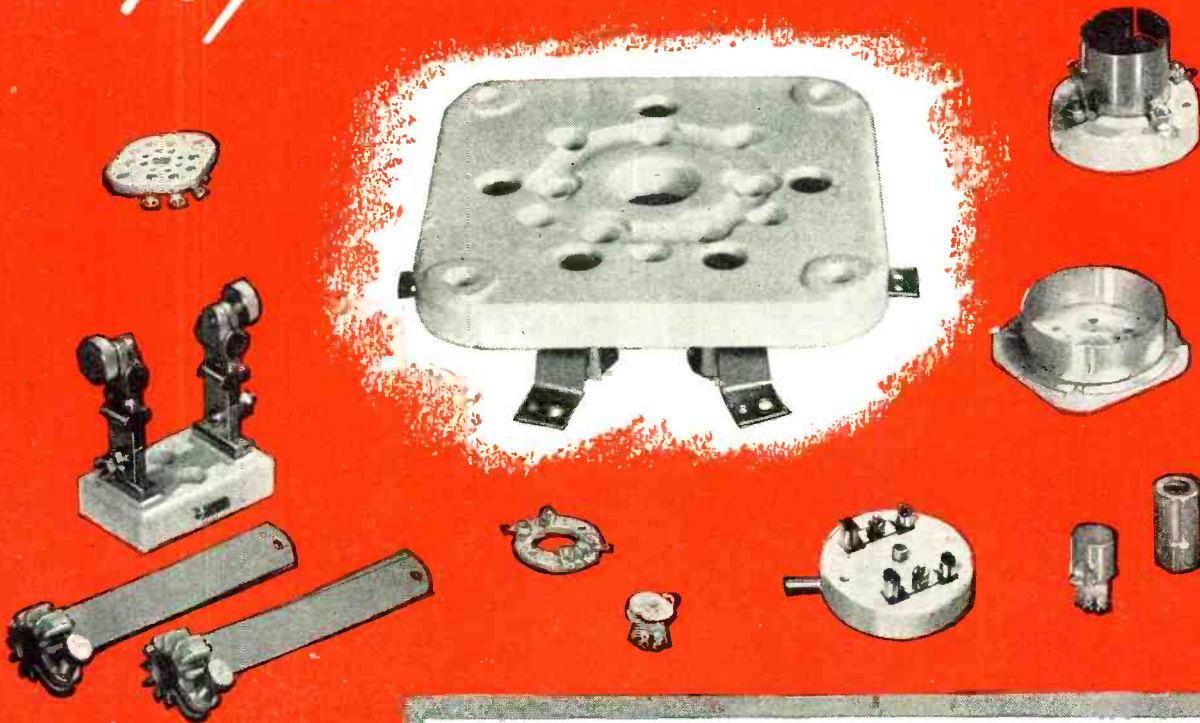

Write for  
**TUBE SOCKET  
GUIDE**

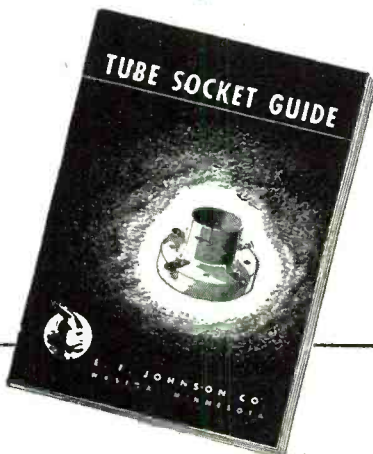

Johnson sockets are stocked by leading radio-electronic parts jobbers.

The latest addition to the famous line of Johnson tube sockets is the 275, Giant Five Pin tube socket with all the outstanding features which have made other Johnson sockets superior. A special feature of the 275 is the provision that has been made to allow forced ventilation from below the chassis, as required for the recently announced Eimac 4-125A and 4-250A. This socket may also be used for other Giant Five Pin tubes when a wafer type socket is desired.

Johnson sockets are engineered to meet the most exacting requirements of industrial, commercial broadcast and "ham" applications. For more than 20 years Johnson engineers have designed, and Johnson production lines have produced, transmitting components known throughout the industry as tops in the field. With this background and the close association with tube manufacturers, Johnson is continually leading the way with tube sockets designed to meet the rigid requirements of present day electronic circuits and equipment.

If you have a special tube socket problem, write Johnson, today.

## JOHNSON

*a famous name in Radio*



E. F. JOHNSON COMPANY • WASECA • MINNESOTA  
February, 1946

# Analysis of PARASITIC OSCILLATIONS In Radio Transmitters

**Review of the many undesirable factors of parasitic oscillations, their causes, and methods employed for their elimination.**

By  
**JOHN S. JACKSON,**  
W9DZR

**W**ITH the construction of that long-dreamed-of *postwar* transmitter well under way, it won't be long before amateurs all over the nation flip on the standby switch for the first *on-the-air* trial, their chests swelled with pride and expectations high, only to let out an agonized groan upon finding that the buffer and final amplifiers are working, not as amplifiers, but as self excited oscillators at some frequency totally unrelated to the crystal frequency.

Such oscillations as these are termed *parasitic oscillations*. The name is quite apt, for these oscillations do waste power that would otherwise be available for use on the desired frequency. However, this is but one of the undesirable factors of operation

with parasitics. They also cause rough notes; even in a well filtered, crystal controlled transmitter, they create unusually severe key clicks over a wide band of frequencies; they cause severe splatter and radiation of spurious side bands; they can create high r.f. voltage stresses in unexpected places in the circuit, a factor of no little importance in amateur transmitters incorporating inexpensive, low voltage, components.

We shall now analyze a conventional single-end class C r.f. amplifier to see how parasitic oscillations may develop in such a circuit. Figure 2A shows a class C amplifier, with plate neutralization. The tuned circuits  $L_g-C_g$  and  $L_p-C_p$  are the grid and plate tank circuits respectively, tuned to the nominal frequency of operation.

At the resonant frequency of these tuned circuits, the inductive reactance of the grid circuit coil  $L_g$  is exactly equal to the capacitive reactance of the grid circuit tuning condenser,  $C_g$ . At a higher than resonant frequency, however, the reactance of the coil increases, becoming, in effect, an open circuit at very high frequencies; while the reactance of the condenser decreases, becoming a virtual short circuit at very high frequencies. Bearing in mind these alterations in circuit impedances at high frequencies, we can redraw the circuit of Fig. 2A as shown in Fig. 2B. It will be noted that  $L_g$  and  $L_p$  have been replaced by open circuits,  $C_g$ ,  $C_p$ , and  $C_n$  by short circuits. This new circuit is what the class C amplifier *looks like* to a very high frequency. Inspection shows this to be a tuned plate-tuned grid oscillator, the grid circuit being tuned by the grid-filament capacity of the tube,  $C_{gf}$ , and the plate circuit being tuned by the plate-filament capacity,  $C_{pf}$ . The plate tank coil,  $L_p$ , in this instance, is the inductance of the plate circuit wiring. The grid tuning inductances,  $L_g$  and  $L_n$ , consist of the grid circuit wiring ( $L_g$ ) in parallel with the neutralizing circuit wiring ( $L_n$ ). With such small capacitances and inductances, it can be seen that the frequency of parasitic oscillations in such an amplifier will be extremely high. Ultra-high frequency parasitics arising in this manner can be prevented by the insertion of a small non-inductive resistance (100 ohms,  $\frac{1}{2}$  watt is typical) in series with the grid, directly at the tube socket. This resistance greatly reduces the  $Q$  of the parasitic tuned circuit, while leaving unaffected the  $Q$  of the  $L_g-C_g$  circuit. Another preventative for ultra-high frequency parasitics is the use of a parasitic choke connected directly at the plate terminal of the tube socket. A commercial form of such a choke consists of eight turns of heavy wire, wound  $\frac{5}{8}$ " in diameter and spaced to  $1\frac{3}{4}$ " in length. The exact physical dimensions are not critical, the object in its use being to tune the plate to a lower

Fig. 1. (A) Diagram of push-pull class "C" amplifier. (B) Actual circuit of high-frequency parasitic oscillations (Ultraudion). (C) Actual circuit of low-frequency parasitic oscillations (tuned plate-tuned grid).

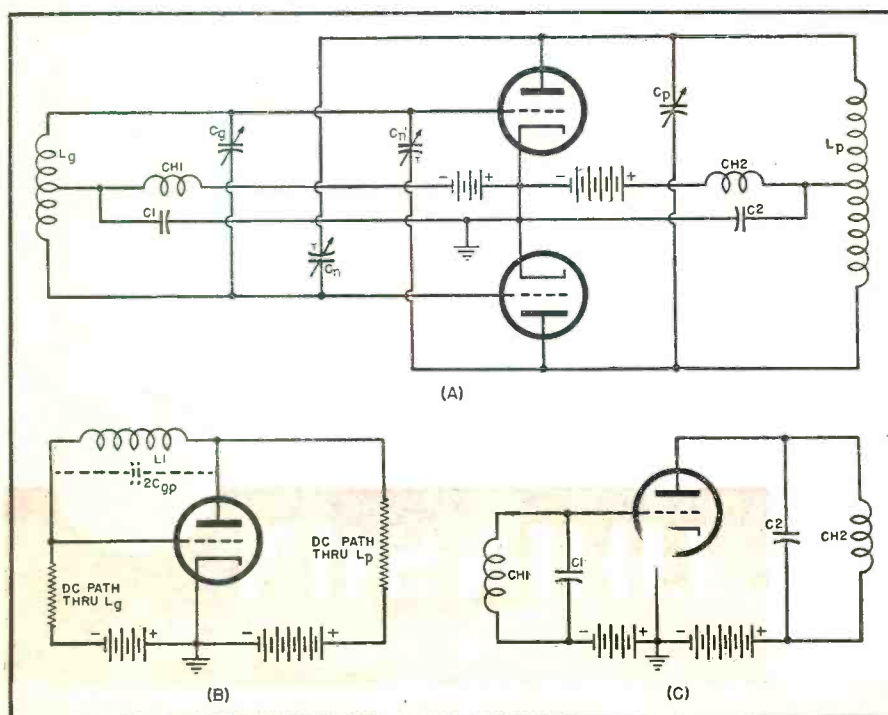

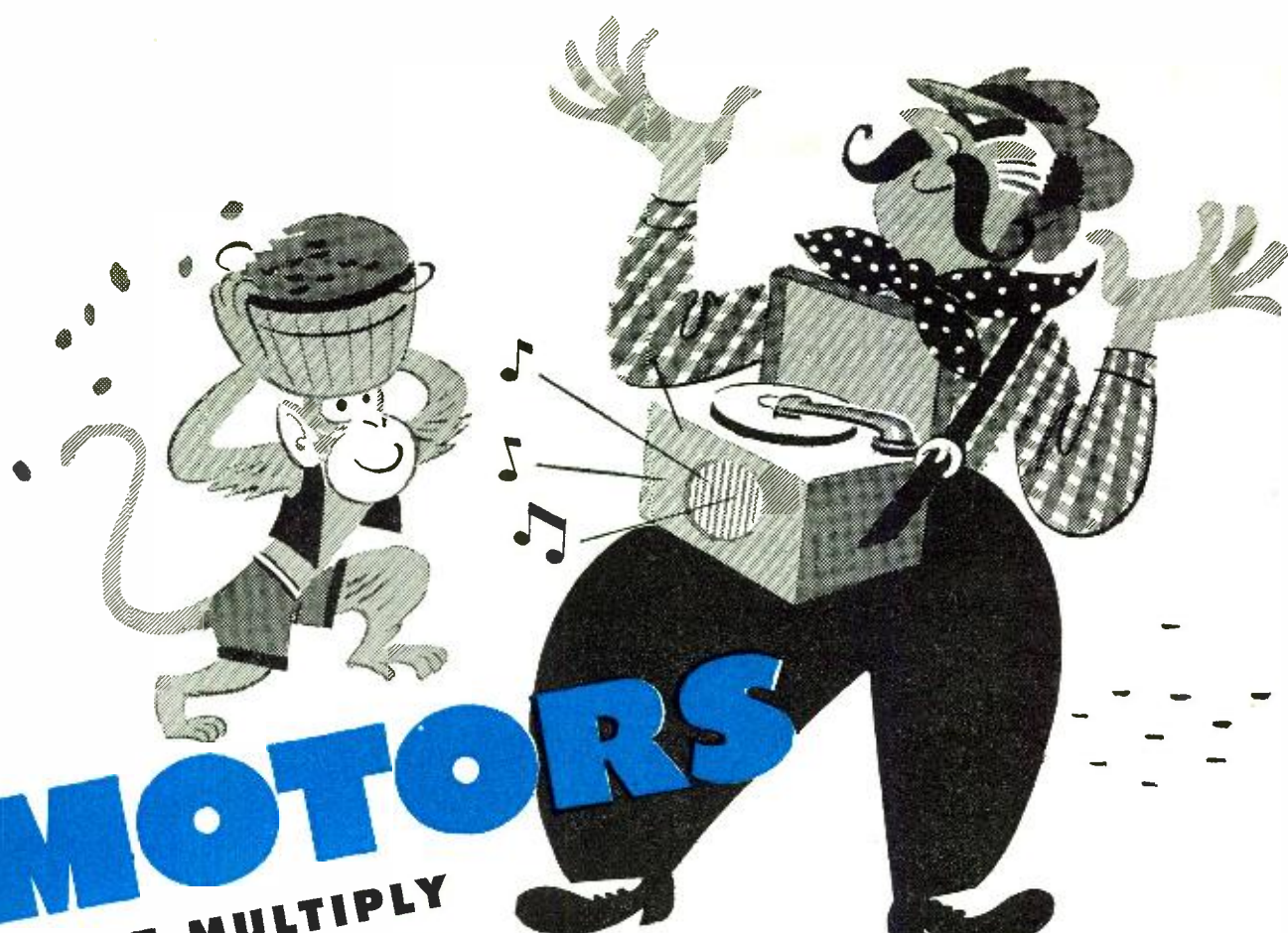

**MOTORS**  
THAT MULTIPLY  
YOUR TURNOVER

Sweet music—the kind that makes satisfied customers—yours when Alliance phonomotors drive your turntables, record changers and recorders.

Manufacturers, retailers and service shops everywhere like to “make ‘em move” with Alliance. That’s because Alliance is the recognized leader when it comes to turning out little motors in large quantities at low cost.

For original equipment or replacement the years have proved that Alliance assures trouble-free performance and long life!



**WHEN YOU DESIGN... KEEP**

**alliance**  
IN MIND

**THE NEW MODEL 80** “Even-speed” phonomotor is smooth, cool running and quiet. Larger bearings with ample oil reservoirs prolong life. New shock mountings almost eliminate vibration of motor and idler plate. Equipped with 60 cycle friction rim-type drive.

**NEW USES**—For automatic and non-automatic electronic control devices and the power sources to actuate mechanical or push-button controls, Alliance motors offer the most practical engineering economy in advanced designs.

**ALLIANCE MANUFACTURING COMPANY • ALLIANCE, OHIO**  
February, 1946

# LAKE'S

## RADIO CABINETS & PARTS



Portable Phonograph case in brown leatherette covering. Inside dimensions 17 1/4" long, 13" wide, 7 1/2" high. Has blank motor board and opening for speaker. As illustrated at left, specially priced at.....

**\$7.95**

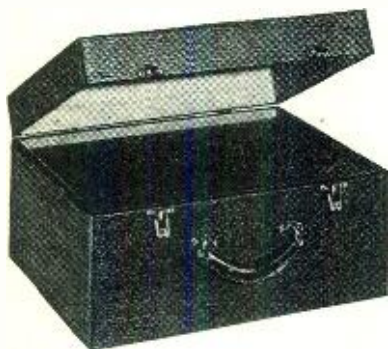

Portable Phonograph case, of sturdy durable plywood, in handsome brown leatherette finish. Inside dimensions 16 1/4" long, 14" wide, 9 1/4" high. Has blank motor board. As illustrated above, specially priced at.....

**\$6.95**

### NOW AVAILABLE!

#### Postwar 2 Post RECORD-CHANGER

In luxurious brown leatherette portable case, 15" L x 15" W x 10" D. Latest electronic developments make this modern record-changer the finest on the market today!

List price ..... \$49.95  
Dealers' Net ..... \$29.97

\*Also blank table cabinets of walnut veneer in the following sizes, with speaker opening on left front side: (\*Note: \*7 has center speaker grill.)

#1	— 8 1/4"	L x 5 1/2"	H x 4"	D \$1.95
#2	— 10 1/4"	L x 6 3/4"	H x 5"	D \$2.75
#3	— 13 1/2"	L x 7 5/8"	H x 6 1/4"	D \$3.25
#7*	— 10 3/4"	L x 7 7/8"	H x 5 1/2"	D \$2.50
#8	— 17"	L x 9"	H x 9 3/4"	D \$4.50
#9	— 21"	L x 9 1/4"	H x 10 1/2"	D \$5.50

\*Speaker Opening in center of front side. Cabinets available in Ivory color and Swedish Modern. Write for prices.

All types of radio cabinets and parts are available at Lake's Low prices. A large stock is listed in our catalog.



SERVICEMEN—RETAILERS  
Join our customer list today.

Dept. A

Write for our NEW, 12 page, illustrated, elaborate catalog!  
Order from Lake!  
You'll make no mistake!

**Lake Radio Sales Co.**  
615 W. Randolph Street  
Chicago 6, Ill.

parasitic frequency than the grid.

In the case where pentodes are used as amplifiers, it may be necessary to insert *losser* resistances in both the grid and screen leads. In using parasitic chokes, however, use one in the plate circuit only, as its use in both plate and grid circuits would defeat its purpose.

Now let us consider the neutralized push-pull class C amplifier shown in Fig. 1A. Circuit constants are the same as in Fig. 2A, with the addition of r.f. chokes and by-pass condensers in the grid and plate d.c. return leads. Note that  $C_g$  and  $C_p$  are single stator, not split stator, condensers. At very high frequencies,  $L_p$  and  $L_g$  appear as open circuits, as explained above; similarly,  $C_p$  and  $C_g$  appear as short circuits, shorting the grids of the two tubes directly together and the plates together, causing the tubes to operate in parallel as a single tube.

The resulting *high frequency circuit* is shown in Fig. 1B. Note that this is an ultraudion oscillator, the frequency determining tuned circuit being formed of the inductance in the neutralizing circuit wiring, tuned by the sum of the grid-plate capacities of the two tubes. It will be seen that while  $L_p$  and  $L_g$  are virtually open circuits at the parasitic frequency, they form good d.c. return paths. It should be mentioned that the circuit of Fig. 1B is over-simplified, but it does give an indication of the mode of parasitic oscillation present when single stator condensers are used. The use of split stator condensers, as in the plate circuit in Fig. 2A, would have resulted in a push-pull tuned plate-tuned grid ultra-high frequency parasitic oscillator, similar to the single end oscillator shown in Fig. 2B.

It can readily be seen that the ultraudion type of parasitic oscillation is not amenable to the parasitic choke method of suppression, since this would do no more than increase the tuning inductance,  $L_1$ , thus reducing the frequency of the parasitic and making it, perhaps, *more efficient in operation*. The proper cure for this type of parasitic is the use of a parallel tuned *wave trap* connected directly at the plate terminals of both tubes. Such a wave trap is adjusted to resonate at the parasitic frequency and, in construction, consists of five turns, heavy wire wound to 1/2" diameter and spaced to the total length of 1", tuned by a 30  $\mu$ fd. mica trimmer condenser connected directly across the ends of the coil. These dimensions are only approximate and some experimentation may be necessary to get the trap tuned to the parasite frequency. Note that the resonant frequency of the trap can be *increased* by stretching the coil out or by removing turns.

It should be mentioned that the parasites resulting from the tuned plate-tuned grid mode of oscillation can be cleared up by the use of the above described trap method, though not as simply as by the use of a parasitic choke.

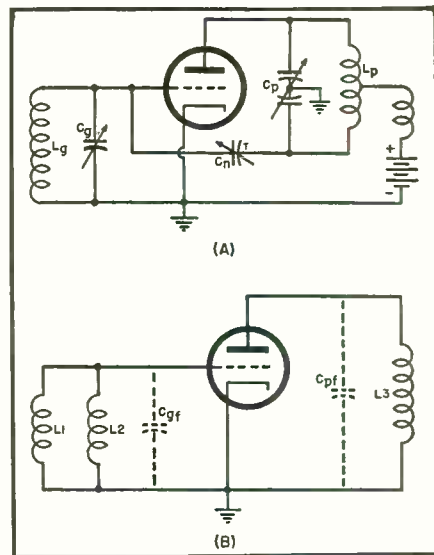

Fig. 2. (A) Circuit diagrams of class "C" amplifier. (B) Actual circuit of parasitic oscillations.

Consider again our push-pull amplifier of Fig. 1A. Fig. 1B illustrates how this circuit appears to a high-frequency parasite. Let us now investigate the production of low-frequency parasitic oscillations by the same circuit.

At a low frequency,  $C_g$ ,  $C_p$ , and  $C_n$  will appear as virtually open circuits, while  $L_p$  and  $L_g$  will appear as short circuits, shorting grid to grid and plate to plate as shown in Fig. 1C. Examination of the resulting *low frequency parasitic circuit* shows it to be of the tuned grid-tuned plate type, the tuning elements being comprised of the r.f. choke,  $Ch_n$ , and by-pass condenser,  $C_b$ , in the grid circuit and the corresponding choke and condenser in the plate circuit. Since these inductances and capacitances are large, the frequency of oscillation will be low.

This type of parasitic oscillation can best be attacked by arranging the circuit to eliminate one of the chokes. Alternatively, a large value grid bias resistor, unbypassed, can be connected in series with the grid choke, thus reducing the Q of the grid circuit for the low frequency parasite.

Although mentioned in the above illustrative cases in relation to a push-pull amplifier, ultraudion and low frequency parasites do not occur solely in this type of amplifier; they may arise in single end amplifiers as well and parallel operation of tubes is particularly susceptible to parasites. Specifically, the split stator tuning condenser amplifier, whether push-pull, single end, or parallel, is favorable to the tuned plate-tuned grid mode of high-frequency parasitic oscillation, whereas the single stator tuning condenser circuit most easily gives rise to the ultraudion type of high-frequency parasites. Low-frequency parasitic oscillations are caused, almost invariably, by r.f. chokes and associated by-pass condensers, and can occur in any type of amplifier, push-pull or

(Continued on page 86)

# "CLUTCH HEAD SCREWS STEPPED UP PRODUCTION 20%"

*Say*

## LINDSAY & LINDSAY

Chicago manufacturers of the famous Lindsay Structure for all-metal truck body assemblies . . . serving America's largest fleet owners through a Nationwide organization of Distributors and Builders.

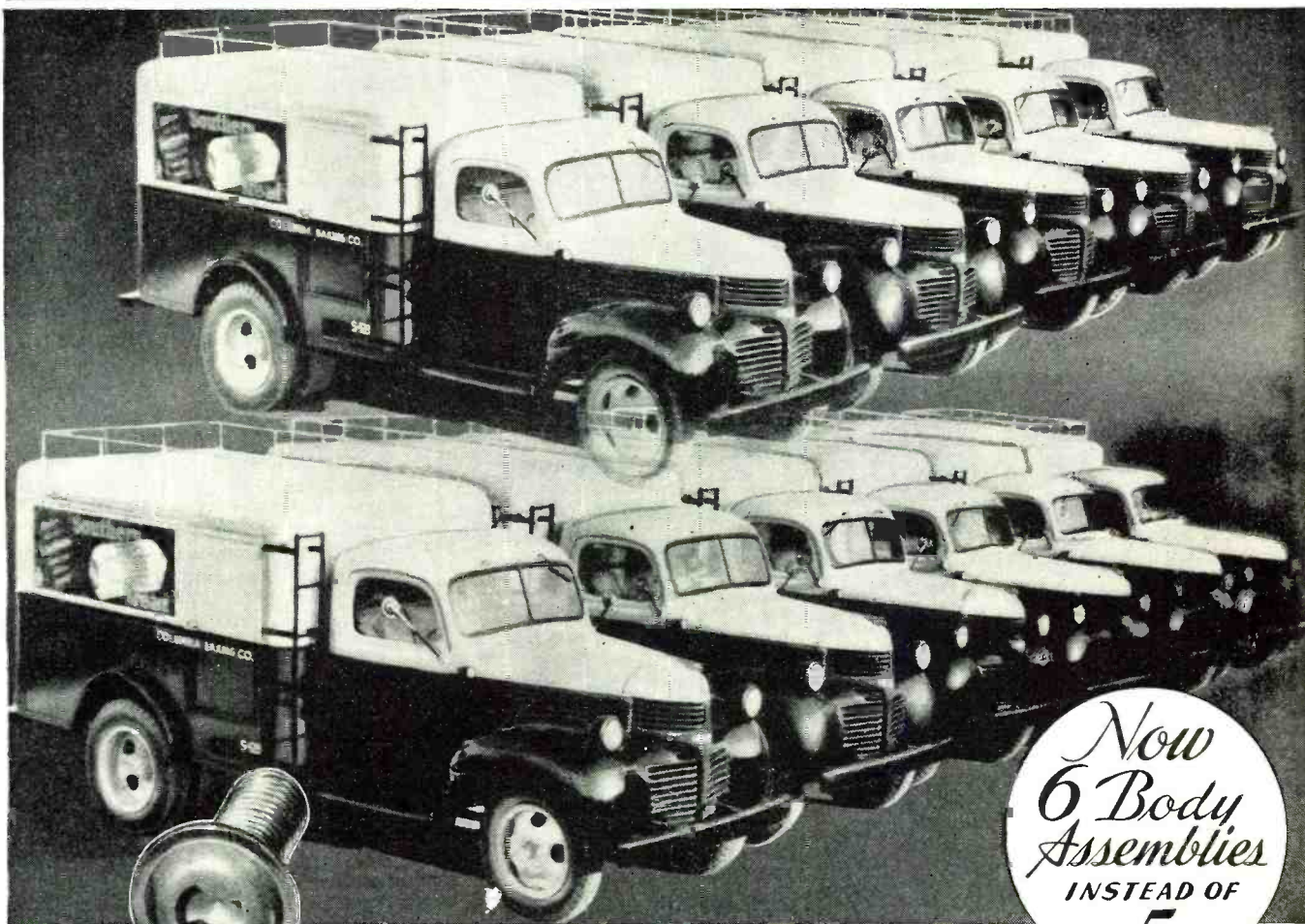

*Now  
6 Body  
Assemblies  
INSTEAD OF  
5*

*This Increase* is definitely accredited to CLUTCH HEAD as compared with the use of other recess head screws in the regular assembly schedule . . . the result of exclusive features that contribute to faster, safer, easier, and smoother power driving. It will pay you to investigate these factors.

**HIGH VISIBILITY** . . . Wide roomy recess is an easy-to-hit target. Substitutes operator confidence for slow-down hesitation. Saves "breaking-in" period.

**AUTOMATIC STRAIGHT DRIVING** . . . No driver canting because the Center Pivot column guides the bit into full-depth dead-center engagement.

**NO CHEWED-UP HEADS** . . . to stop or slow down the line. Definite grip protects manpower and material against slippage.

**EFFORTLESS DRIVING** . . . With CLUTCH HEAD the driving contact of bit and recess walls is all-square. No ride-out or "kick-back" as set up by tapered driving.

**ABSENCE OF END PRESSURE** . . . disposes of a fatigue factor and a slippage hazard. Steps up speed for smoother higher production . . . no end-of-shift lagging.

**DRIVE EXTRA THOUSANDS OF SCREWS** . . . with the rugged Type "A" Bit . . . without interruption for tool change.

**NEW BIT LIFE IN 60 SECONDS** . . . No back-to-the-factory shipment for reconditioning. A simple 60-second application of the end surface to a grinding wheel restores this bit to its original efficiency . . . *time and time again.*

**THE CLUTCH HEAD LOCK-ON** . . . A reverse turn of the bit in the recess unites screw and bit as a unit for easy one-handed reaching to hard-to-get-at spots. With the Type "A" Hand Driver for field use, this Lock-On enables service men to withdraw screws undamaged and held safely for re-use.

**OPERATES WITH ORDINARY SCREWDRIVER** . . . This is the only modern screw basically designed for operation with a flat blade which need only be reasonably accurate *in width.* Simplifies field service problems.

*The many advantages of CLUTCH HEAD Screws and of the Type "A" Bit are self-evident upon examination. You may convince yourself by sending for package assortment of screws, sample of the Type "A" Bit, and illustrated Brochure. Mailed to you without obligation.*



**UNITED SCREW AND BOLT CORPORATION**

CLEVELAND 2

CHICAGO 8

NEW YORK 7

# PHONO-AMPLIFIER

**Now Ready for Immediate Delivery!**

List Price ..... \$ **3.50**  
(less tube)

A compact phonograph amplifier —ONLY one tube, but comparable to most 3-tube amplifiers. Built into sturdy metal chassis.

The amazing efficiency of this small amplifier will pleasantly surprise and satisfy you.

Two, three, and four-tube amplifiers also available.

\* \* \*

We also manufacture all types of coils and pick-ups. Send your specifications and we will gladly quote prices.

\* \* \*

Write for our new, illustrated literature.



## LECTROLAB PRODUCTS

Manufacturers and Designers of Electronic Devices

2806-10 W. HARRISON STREET • CHICAGO 12, ILLINOIS

# First Choice

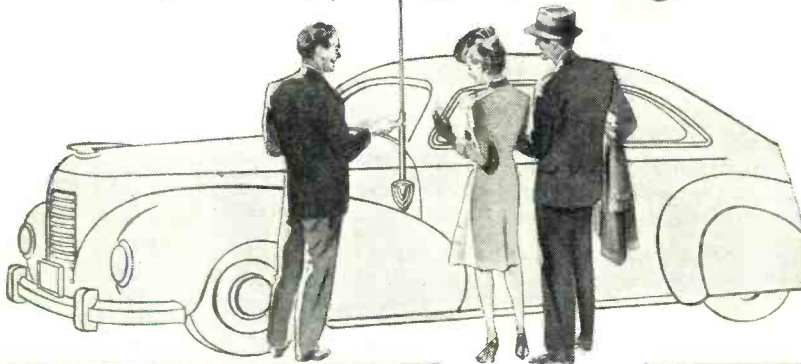

### ... OF AMERICA'S AUTO DEALERS

The same precision workmanship and the same fine quality mark Ward Antennas now as before the war. But now there are added reasons of new design and newly-engineered efficiency which will give Ward Antennas an even greater margin of preference with America's auto dealers. For extra profits that satisfied customers always bring, order Ward—world's finest antennas for car and home.

Buy Victory Bonds  
**THE WARD PRODUCTS CORPORATION**  
1523 E. 45th St., Cleveland 3

# WARD

## Antennas

## Velocity Modulation

(Continued from page 45)

trolled by the negative voltage on the repeller; this is comparable to adjusting the distance between the cavities in the twin job. Then by tuning the cavity to the right frequency, adjusting the main accelerating voltage, and adjusting the repeller voltage, the electron bunches will cross the gap, flow into the drift space, and be turned back to hit the top grid of the cavity, thus exciting it directly. The electrons never reach the repeller plate, but are always turned back before they hit.

Two of the types of reflex klystrons used in radar equipment are shown. Fig. 3 is used with extremely short wavelengths and has an internal cavity. The cavity is tuned by turning the nut, which has an expanding double-thread that spreads the struts. This causes the top of the tube to *oilcan* and changes the size of the cavity inside of the tube.

Fig. 1 shows a klystron used with a slightly longer wavelength. This has an external cavity which is tuned by running *tuning probes* into the cavity. These probes are the screw-studs that appear around the body of the cavity. Fig. 8 shows the tube with half of the cavity removed. The tuning probes are shown part way in, which changes the electrical shape of the cavity. The electrodes that act upon the electron stream are inside of the tube and connect to the cavity by means of a pair of connecting rings sealed in the glass. Changing tubes with the internal cavity klystron changes the entire circuit, while

Fig. 6. Reflex klystron, showing the electron stream in repulsion from the repeller plate. Cavity is excited by the electron stream that is modulated by its own excitation.

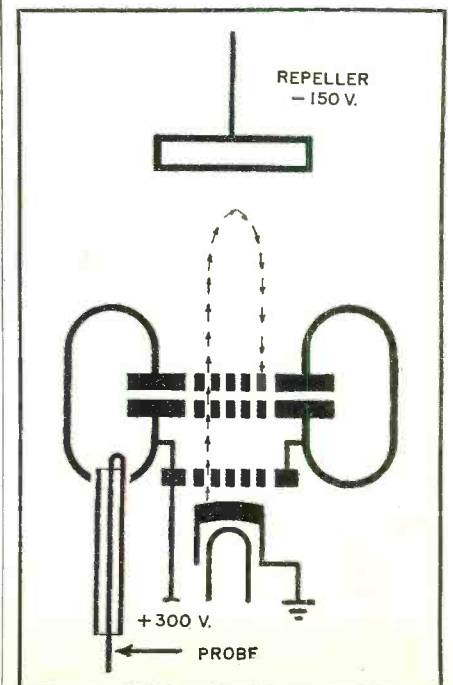



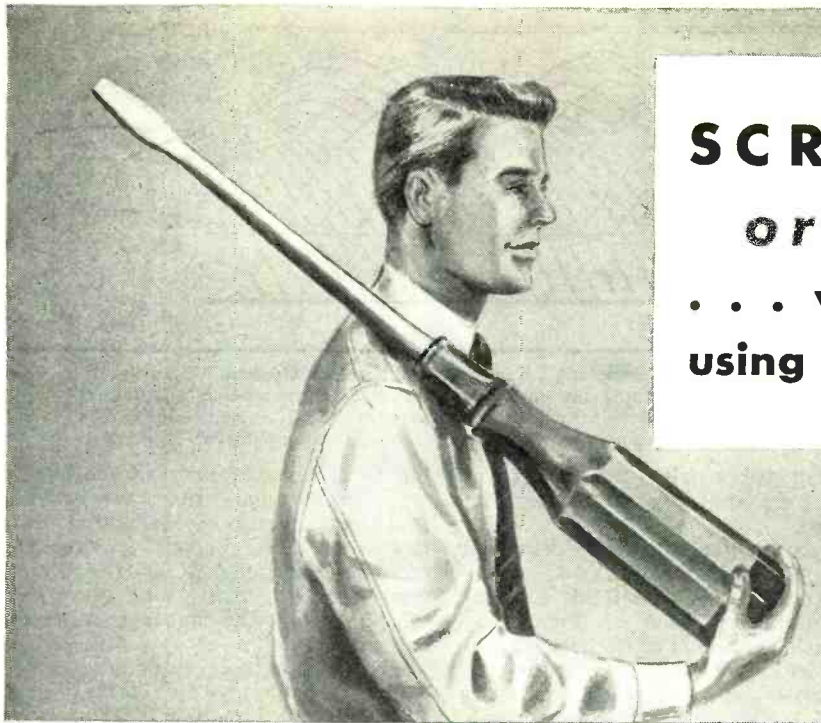

## SCREWDRIVER or SLIDERULE

. . . which will YOU be  
using 2 years from now?



### What's Ahead for You? Add CREI Home Study Training to Your Present Experience—Then Get That BETTER Radio Job You Want

Face the facts! Thousands of new men entered the radio-electronics industry during the war. Now, many more thousands are returning as they are being discharged from the Services.

Where will you fit into this picture? What are your chances of holding down a good-paying job—of advancing to a better one?

No matter what your past radio-electronics experience has been—no matter what your training—you must start anew to add to your store of radio-electronics knowledge—to improve your ability by keeping pace with the rapid developments that have been taking place in the industry.

You must keep pace with such new developments as U.H.F. Circuits, Cavity Resonators, Wave Guides, Klystrons, Magnetrons and other tubes.

All these largely revolve around U.H.F. applications, and here is where CREI technical training can help you—by providing you with

the know-how and ability to keep pace with these new developments and to keep ahead of competition for the good jobs.

In our proved method of instruction you learn not only *how*—but *why*! Easy-to-read-and-understand lessons are provided well in advance, and each student has his personal instructor who corrects, criticizes and offers suggestions on each lesson examination. This is the basis of the CREI method of training for which more than 10,000 professional radiomen have enrolled since 1927.

It's up to you to decide if you will be a "screwdriver" mechanic or a real technician in a responsible engineering position. Let CREI train you now to trade that "screwdriver" for a slide rule. Our proved program of home study training should increase your technical ability and equip you to advance to the better-paying jobs that offer security and opportunity.

*The facts are in the free booklet. Send for it today.*

**• WRITE  
TODAY for  
FREE  
BOOKLET**



**"Your Opportunity in the  
New World of Electronics"**

If you have had professional or amateur experience—let us prove to you that we have something you need to qualify for a better radio job. To help us to intelligently answer your inquiry—PLEASE STATE BRIEFLY YOUR BACKGROUND OF EXPERIENCE, EDUCATION AND PRESENT POSITION.

## CAPITOL RADIO Engineering Institute

HOME STUDY COURSES IN PRACTICAL RADIO-ELECTRONICS  
ENGINEERING FOR PROFESSIONAL SELF-IMPROVEMENT

Dept. RN-2, 3224—16th Street, N. W., Washington 10, D. C.

Contractors to U. S. Navy—U. S. Coast Guard—Canadian Broadcasting Corp.  
Producers of Well-trained Technical Radiomen for Industry.

Member: NATIONAL COUNCIL OF TECHNICAL SCHOOLS



## this shouldn't happen TO YOU!

Why take chances on getting into the wrong band? Today, with frequency multipliers in practically all transmitters, it is too easy to hit the wrong Harmonic. The positive way to tell which band you are on, is by using an absorption type wave meter.

The New Bud WM-78 Wave-meter covers all amateur bands from 160 to 5 METERS . . . accomplishing this by bandswitching. Due to its sensitivity the BUD WM-78 can also be used as a neutralizing indicator.



\$6.90 your cost at your radio supply dealer. If he cannot supply you, write direct for further information.

**BUD Can Supply  
All Your Needs! . . .**

. . . with the latest types of equipment including: condensers — chokes — coils — insulators — plugs — jacks — switches — dials — test leads — jewel lights and a complete line of ultra-modern cabinets and chassis.



**BUD RADIO, INC.**  
CLEVELAND 3, OHIO

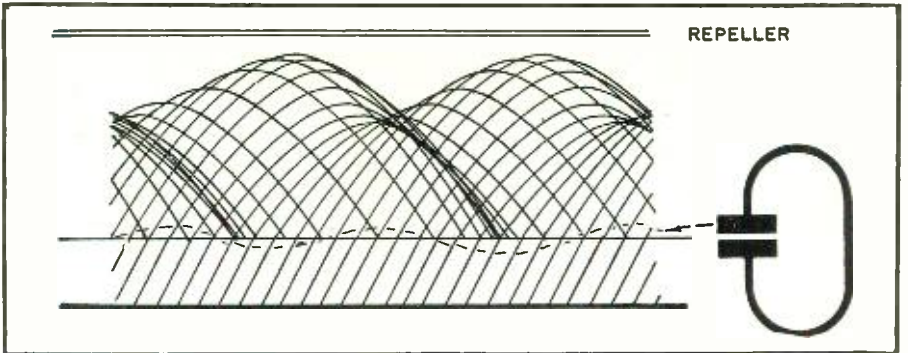

Fig. 7. The "bunching" diagram of the reflex klystron. Here the electrons return to the cavity top; the time interval being dictated by their initial velocity through the cavity; a high velocity electron taking a longer time than a slower electron because it travels farther.

changing tubes with the latter requires only that the tube itself be replaced.

The cavity itself is the "U" shaped portion of the inside. Since the magnetic and electrostatic fields are enclosed entirely inside of the cavity, the outside shape is of no importance. Therefore, in the external cavity klystron, the outside of the cavity is used as the mounting. The mounting feet are shown in Fig. 1. Contact to the cavity from the internal elements is made by the metal rings sealed in the walls of the glass tube. Contact-springs clamp the rings to the cavity ends.

Another form of the klystron is the multiple cavity amplifier. In this, many cavities appear in cascade along the drift tube, each one tuned to resonance, and each cavity adding, bit by

bit, to the compactness of the bunching. In the diagrams there are but few electrons shown. In actual practice there are hordes leaving the cathode every second. Since each electron has its own field, stray-field effects spoil the perfect velocity-control in the acceleration space between the cathode and the smoother grid and the cavity bottom grid. Therefore, the bunching is not as clean as it appears on the diagram. With many cavities lying along the drift tube, the wild electrons are either hastened into the bunch ahead or slowed back into the bunch behind so that at the far end of the tube a clean, high efficiency output is achieved.

To the present, the upper limit of velocity modulation has not been explored. Since the controlling frequency factors are electron velocity and cavity size, without a doubt, the upper limit of frequency will lie where phase reversal takes place in the interval during which the electron crosses the cavity-gap. Higher voltage will cut this time, and possibly the limiting factor will be the mechanical construction of a cavity. This will have to be done with microscopic techniques before velocity modulation has reached its upper limit of frequency.

-30-

### Cavity Wavemeters

(Continued from page 37)

nor energy can travel faster than the speed of light!

But there is an explanation of this minor phenomenon.

Reverting briefly to wave guide theory—when a section of guide is supplying u.h.f. energy to a source or load, the *E* and *H* waves are in time phase. When a section of wave guide is resonant, however, and a small amount of energy is expended (as in the neon lamp, or r.f. voltmeter), the *E* wave and the *H* wave are in time quadrature.

At resonance there is no energy velocity within a waveguide section because no energy is being delivered to a source or load terminating the guide.

Apparent energy velocity, observed by the wavemeter, is actually a phase

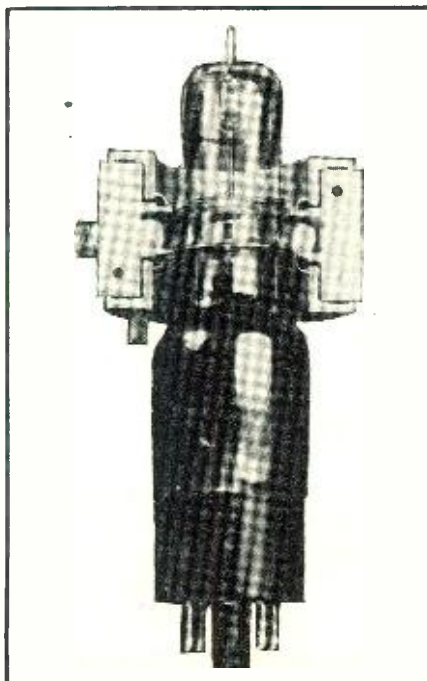

For TRANSMISSION and RECEPTION Rely on

# Aireon

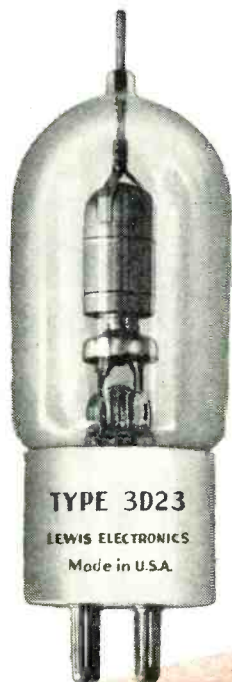

## 3D23

A remarkable new **TETRODE** for Fixed or Mobile Operation of Radio Transmitters.

*This is the Tube you are seeking to install in your postwar transmitters*

A remarkable new **TETRODE** for fixed or mobile operation

Filament Voltage . . . 6.3 AC or DC Volts  
 Filament Current . . . . . 3.0 Amperes  
 Amplification Factor . . . . . 65  
 Mutual Conductance . . . . . 2,750  
 Plate Dissipation . . . . . 35 Watts  
 Medium 4 Pin Ceramic Base  
 Maximum Power Output . . . 130 Watts  
 Approx. Driving Power . . . . 4.5 Watts

**Inter-Electrode Capacities**

Input to Plate . . . . . .2 MMFD  
 Input, 6.5 MMFD . . . . Output, 1.8 MMFD

Licensed under R. C. A. Patents

Catalog Sheet and Tubes Now Ready for Distribution.

## Cinaudagraph Speaker

*The Speaker of Tomorrow*  
**TODAY**

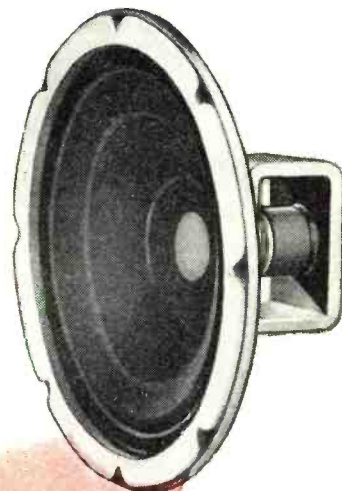

The Aireon Cinaudagraph Speaker is a product of deft engineering, vast experience, daily profound research and proven performance. It has an international reputation for tone, stamina and perfection. The plus features that you get in Aireon Cinaudagraph Speakers are inherent—born of the highest standards of inspection and use of the finest materials. You'll need these extras—these plus factors to help you do the better job you now require.



All P.M. Models of Aireon Cinaudagraph Speakers use Alnico 5, the miracle metal that gives you 4 times the performance without size or weight increase. No set-up is complete without at least one—write for information.

**Lewis Electronics**  
 Los Gatos, Calif.

Subsidiaries of

**Aireon**

MANUFACTURING CORPORATION

**Cinaudagraph Speakers, Inc.**

3911 SOUTH MICHIGAN AVENUE  
 CHICAGO, ILLINOIS

# I'LL HELP YOU TO EQUIPMENT EVER

**ALFRED A. GHIRARDI**  
the man who has started  
thousands of students on suc-  
cessful careers by making Ra-  
dio-Electronics easy to learn

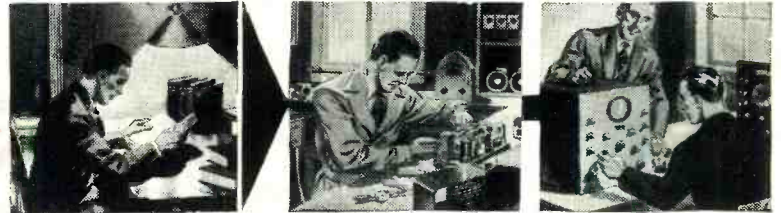
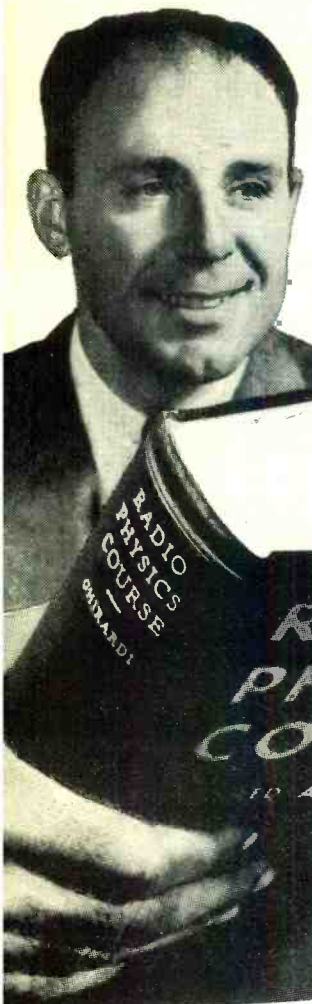

A FEW NIGHTS OF **THIS** CAN PAVE THE WAY TO A PROSPEROUS FUTURE OF **THIS**

## Ghirardi's COMPLETE BASIC RADIO-ELECTRONIC TRAINING for beginners



The Book that Makes it Easy to Learn at Home

No matter what phase of ELECTRONICS-RADIO-TELEVISION work you plan to enter, a knowledge of the basic fundamentals is absolutely essential—and Ghirardi's world-famous RADIO PHYSICS COURSE, all complete in this one big 4-pound, 972-page book, gives you exactly what you need—at a price you can afford to pay! No previous electrical, radio, or electronic training is necessary to enable you to understand every word of it! Remember! RADIO PHYSICS COURSE has given more beginners their start in Radio-Electronics than any other book or course! Let it do the same for you!

RADIO PHYSICS COURSE starts your training right at the very beginning—with Basic Electricity. Then it takes you step by step through the entire field of RADIO-ELECTRONICS-TELEVISION to the latest, most modern developments. Nothing is omitted, nothing condensed. Everything is clearly and thoroughly explained. Everything is made as simple as A-B-C. Ask any

for only \$5 (\$5.50 foreign)

Radio-Electronic man about it. He'll know the book—because he probably got started from it himself!

This single, fully-illustrated 972-page volume is a miracle of modern Radio-Electronic training written by an author who has devoted years to making radio easy for beginners. Actually, it gives you the scope of 36 different courses in one. If broken into "course" form and sent to you in the form of monthly lessons, you'd regard it as a bargain at \$50 or more! Instead, you buy it for only \$5—and you progress as fast as spare reading time permits you. Many students have completed it within a few weeks!

If you're just starting in Radio and want to get started right **THIS IS THE BOOK FOR YOU**—and we back it with our 5-DAY MONEY-BACK GUARANTEE that makes you the sole judge of whether or not you will want to keep it! You cannot lose!

**NO PREVIOUS TRAINING NEEDED!**

**Covers Basic Radio-Electronics Like a Blanket**

**36 Big Courses in One! Here are a few of the things about which it teaches you:**

- |                       |                        |
|-----------------------|------------------------|
| Sound, Speech, Music  | Detector & Amplifier   |
| Electron Theory       | Tube Action            |
| Electric Current      | Radio-Frequency        |
| Electric Circuits     | Amplifiers             |
| Resistance            | Superheterodynes       |
| Batteries             | Audio Amplifiers       |
| Electromagnetism      | Power Supplies         |
| Electromag-Induction  | Loud Speakers          |
| Condensers, Coils     | Auto & Aircraft Radio  |
| Alternating Currents  | Aviation Radio         |
| Transformers          | Public Address Systems |
| Filters               | Phototubes, Cathode    |
| Measuring Instruments | Ray Tubes              |
| Radio Waves           | Sound Pictures         |
| Vacuum Tubes          | Television, etc., etc. |

Radio Physics Course is more widely used for home study, by more Signal Corps, Navy, and civilian schools and colleges than any other book of its kind!

**HERE'S PROOF!**

**Compares it with a \$150 Radio Course**

"I had already taken a \$150 radio course but since I've read RADIO PHYSICS COURSE, I put the other one away. RADIO PHYSICS COURSE is the real book I need, because it teaches so clearly."  
Gerard Champagne, Montreal, Canada.

**"Easiest for Beginners"**

"One of the clearest, easiest books for the beginner I have ever read."  
Jerome Feld, Brooklyn, N. Y.

"I have read quite a few texts on Radio-Electronics. Now after reading RADIO PHYSICS COURSE, I can see that I wasted my time on the other ones!"  
C. W. Redish, Astoria, Oregon.

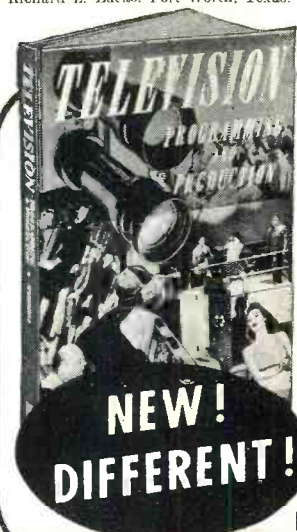

## Learn all about TELEVISION PROGRAMMING and PRODUCTION

Not since the early days of the movies or of Radio itself has there been such a glowing opportunity to get in on the "ground floor" of a vast new industry as Television now presents. Television's technical problems are fast being solved. Today, the crux of its development problems is the matter of producing the right kind of programs—and in his new book TELEVISION PROGRAMMING AND PRODUCTION, Richard Hubbell, Production Manager and Television Consultant of Crosley Corp., not only explains for you every phase of this important new field in tele-

vision work, but outlines potential developments as well.

Technical limitations and possibilities are discussed from the all-essential program standpoint. Writing — acting — directing — advertising — production — designing — and Television's relation to the theatre and the movies are but a few of the subjects covered. Fifty selected photos illustrate the different production techniques and provide in themselves a complete, graphic course in this latest of the Arts. The very first book of its kind! 207 pages. Price \$3 (\$3.25 foreign).

**ENJOYABLE—INSTRUCTIVE—EASY TO UNDERSTAND**

# GHIRARDI TRAINING TO SAVE YOU LEARN EASIER, BETTER, FASTER...

# REPAIR ANY RADIO-ELECTRONIC MADE ... AND GUARANTEE TO REFUND EVERY CENT OF YOUR MONEY IN FIVE DAYS IF YOU'RE NOT SATISFIED!

## THIS 4½ LB. HANDBOOK SHOWS EXACTLY HOW TO REPAIR OVER 4,800 RECEIVER MODELS

*A Definite, Dependable Guide for Diagnosing, Locating and Repairing the Common Troubles in Almost Every Receiver Ever Made*

**GHIRARDI TELLS YOU WHAT TO DO—EXACTLY HOW TO DO IT**

Whether you repair radios for a living or work with them only occasionally, Ghirardi's **RADIO TROUBLESHOOTER'S HANDBOOK** will help you do the jobs better AND TWICE AS FAST. Eliminates useless testing! Saves time—helps you make more money! When a receiver comes in for repairs you simply turn to the 404-page Case History section of the Handbook. Look up the notes on that particular make and model—and, chances are, you'll find EXACTLY the information you require. The Handbook tells you what the trouble is—how to remedy it. Just the thing for training and speeding up the work of new service helpers—handling tough jobs in half the usual time—repairing cheap sets rapidly.

The tabulations on hundreds of additional pages give you invaluable data on Color Codes, Tubes, I-F alignment and transformer troubles, tube substitutions, etc., and the literally dozens of charts, graphs, diagrams, data and helpful hints will save you money every day you use them!

"Thanks to Ghirardi's Handbook, I repaired my radio in one hour after it had been returned as

'unrepairable' from a local shop," writes J. L. Fizzell, Kansas City, Mo.

"I would not take ten times the price my Handbook cost me," says C. E. Daniels of Florida.

"Started to work for me the first day I bought it. The Case Histories take you right to the trouble and save headaches and hours of testing," says Julius Siske, Jr., Curtis Bay, Maryland.

Ghirardi's big Handbook weighs 4½ lbs., contains 744 big manual-size pages. Only \$5 complete—on our 5-Day Money-Back Guarantee offer!

### STOP GUESSING MISTER!

Don't guess! Don't waste time! Turn to Ghirardi's big Radio Troubleshooter's Handbook—let it tell you in a jiffy WHAT to do and HOW to do it.

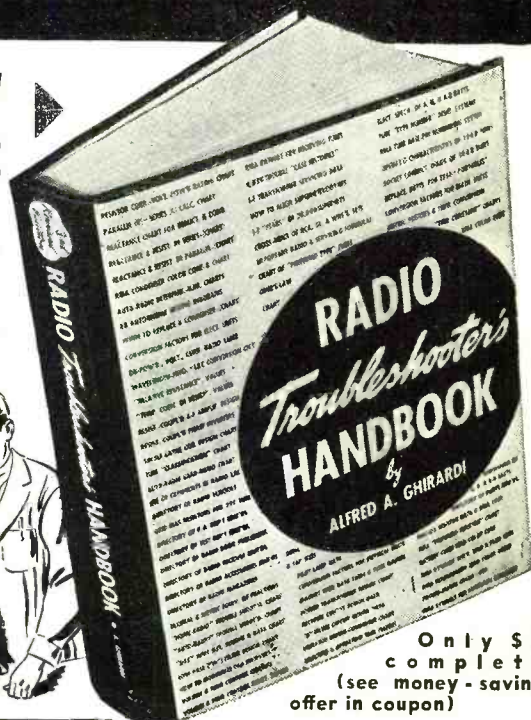

**Only \$5 complete**  
(see money-saving offer in coupon)



## GET A COMPLETE MODERN Professional SERVICE TRAINING ... at Home Without an Instructor

Now, as never before, the call is for PROFESSIONALLY TRAINED men who really KNOW radio repair work.



A. A. Ghirardi's MODERN RADIO SERVICING is the finest, most complete instruction book on Radio-Electronic service work for either the novice or the professional serviceman—bar none! Actually, it gives a COMPLETE MODERN EDUCATION in truly professional service work of the kind that will be your "Open Sesame!" to the real opportunities in Radio-Electronic servicing springing up on every side. Remember! The call is now for HIGHLY TRAINED men having a broad knowledge of modern test equipment and testing techniques—NOT for "screw-driver" mechanics of limited technical understanding! Read from the beginning. MODERN

RADIO SERVICING is a complete servicing course from A to Z. Used for reference, it is an invaluable refresher course on any type of work that puzzles you. Explains all types of test instruments used in Radio-Electronic service work—also how, when, why and where to use each one; how to make preliminary trouble checks and perform circuit analysis; how to repair or replace parts or make substitutions—and literally hundreds of additional subjects, including How to Start and Operate a Successful Service Business of Your Own. 1300 pages, 706 clear illustrations, 720 self-test review questions.

**Only \$5 complete**  
(See money-saving offer in coupon)

### START A SERVICE BUSINESS ... OR, GET A BETTER-PAYING JOB!

There's a real future for you in servicing—and A. A. Ghirardi's MODERN RADIO SERVICING is just the book to start you on it without delay. And remember: Radio itself only represents the beginning of this big book's usefulness to you. What it teaches you about Radio Servicing, Test Instruments and Modern Scientific Technical Procedure is exactly the training you need to fit you to "grow up" with the fast-expanding Electronics profession in all of its servicing phases.

The amount of Radio and Electronic equipment that will be manufactured and sold both to industry and the public within the next few years will be tremendous. All of it must be serviced—and there'll be rich rewards for competently trained men who can fill the bill!

MODERN RADIO SERVICING gives you real Professional service training—complete in every respect—easy to understand—and priced at only \$5 complete!

## FIVE DAY UNRESTRICTED MONEY BACK GUARANTEE

MURRAY HILL BOOKS, Inc., Dept. RN-26,  
232 Madison Ave., New York 16, N. Y.

- Enclosed find \$\_\_\_\_\_ for books checked; or,  send C. O. D. (in U.S.A. only) for this amount plus postage. In either event, I may return the books for refund of my money within 5 days if not fully satisfied.
- RADIO PHYSICS COURSE \$5 (\$5.50 foreign)  TELEVISION PROGRAMMING & PRODUCTION, \$3 (\$3.25 foreign)
- MODERN RADIO SERVICING \$5 (\$5.50 foreign)  RADIO TROUBLESHOOTER'S HANDBOOK, \$5 (\$5.50 foreign)
- MONEY-SAVING COMBINATION OFFER: Modern Radio Servicing and Troubleshooter's Handbook—both big books—\$9.50 (\$10.50 foreign).

Name \_\_\_\_\_  
Address \_\_\_\_\_ State \_\_\_\_\_  
City & Dist. No. \_\_\_\_\_

## TIME & MONEY

Mail coupon now!

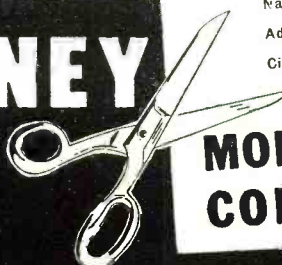

### MONEY-SAVING COMBINATION

Make your servicing library complete! Get BOTH Ghirardi's RADIO TROUBLESHOOTER'S HANDBOOK and MODERN RADIO SERVICING at the special Money-Saving Combination-price of only \$9.50 for both (\$10.50 foreign). Use coupon today!

**SOUND VALUES at  
TERMINAL RADIO**

**TRANSFORMER  
Specials!**



**Fully Cased  
and  
Shielded!**

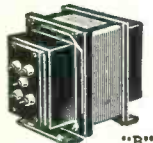

**Guaranteed  
Top  
Quality!**



Illustration "A"

**POWER TRANSFORMER**

Type TR589. AC voltage: 300-0-300 volts @ 125 Ma. DC; 6.3 volts C.T. @ 4.5 amps.; 5 volts @ 3 amps. Size: 5" H x 3 7/8" W x 5" L. Special..... **\$4.95**

**POWER TRANSFORMER**

Type TR586. AC voltage: 450-0-450 volts @ 325 Ma. DC; 6.3 volts C.T. @ 8 amps.; 5 volts @ 6 amps. Size: 9" H x 7 1/2" W x 7" L. Special..... **\$9.60**

**FILAMENT TRANSFORMER**

Type TR547. 10 volts or 11 volts @ 4 amps. Insulation voltage 5000 volts. Size: 3 3/8" H x 3" W x 4 1/2" L. Special..... **\$2.98**

**FILAMENT TRANSFORMER**

Type TR540. 5 volts @ 8 amps. Insulation voltage—2500 volts. Size: 3 3/8" H x 3" W x 4 1/2" L. Special..... **\$3.49**

**FILAMENT TRANSFORMER**

Type TR569. Four secondaries: 6.3-7.5 volts C.T. @ 3 amps.; 5 volts @ 3 amps.; 5 volts @ 3 amps.; 6.3 volts @ 4 amps. Insulation voltage—2500 volts. Size 5" H x 3 3/8" W x 5" L. Special..... **\$4.00**

Illustration "B"

**PLATE TRANSFORMER**

Type TR501. Input voltage 115 or 230 volts, 50-60 cycles. DC voltage after filter 500 or 400 volts @ 250 Ma. 40 volt bias tap. Size: 5" H x 4 1/2" W x 5" L. Special..... **\$7.95**

**PLATE TRANSFORMER**

Type TR043. Delivers 750 or 600 volts DC @ 300 Ma. after filter. 40 volt bias tap. Size: 7 1/2" H x 6 1/8" W x 8" D. Special..... **\$13.50**

**PLATE TRANSFORMER**

Type TR027. Delivers 1250 or 1000 volts DC @ 500 Ma. after filter. Size: 7 3/8" H x 7 3/8" W x 9" D. Special..... **\$18.75**

**PLATE TRANSFORMER**

Type TR509. Input voltage 115 or 230 volts, 50-60 cycles. Delivers 2000 volts DC @ 250 Ma. after filter. Size: 8 1/2" H x 11 3/4" W x 14" L. Special..... **\$23.75**

Illustration "C"

**FILAMENT TRANSFORMER**

Type TR089. 6.3 volts C.T. @ 6 amps. Insulation voltage—2500 volts. Size: 3 3/8" H x 2 1/8" W x 3 1/8" D. Special..... **\$2.79**  
25% deposit required on C.O.D. orders.

**TERMINAL Radio Corporation**  
85 CORTLANDT STREET • NEW YORK 7, N. Y. • WOH 2.4415

velocity because of the 90 degree phase angle between the *E* wave and the *H* wave within the guide. This phase velocity may be greater than the velocity of light (300,000,000 meters-per-second) without conflicting with the laws of physics.

For this reason, the length of a wave measured within a cavity-resonator wave guide is greater by about 20 percent than the actual length of the wave as measured in free space.

All measurements of centimeter waves should compensate for this phase velocity characteristic of a resonant waveguide cavity.

—30—

**International Short-Wave**

(Continued from page 43)

sketches on 'Now it can be told' stories, depicting the great deeds of the war," he says. For a long time, postwar plans for the Newspaper have been in the making in order that the broadcasts may play a most vital and influential role during peacetime. The Newspaper will further the long-range aspects of its program, and the Anglo-American Caribbean Commission, through the Newspaper, will be able to discuss fully, in its advisory capacity, the expansion of Caribbean trade and communications, public works, health, plant and animal quarantine, development of fisheries, sugar, transportation, and travel. The Newspaper is preparing to assist in tourist and travel development of the area in the years to come for, as has been proved, there is no greater or more potential way of publicizing the islands than by radio, Mr. Harris points out.

Remember—The West Indian Radio Newspaper takes to the air daily, 5:15-5:45 p.m., and dial settings are WRUW, 11.73, and WRUL, 15.29, Boston. Any correspondence concerning these radiations should be addressed to *The West Indian Radio Newspaper*, Washington, D. C.

\* \* \*

**RADIO RANGOON**

From Political Warfare Broadcasting Unit No. 1 Area, Southeast Asia Command, Rangoon, Burma, *Paul Dily*, Monrovia, California, one of the first to report reception of Radio Rangoon some months ago, has received this letter, dated October 27, 1945:

"We were very much interested to receive your report from California and the information you give is of considerable value to us. We broadcast in English on the 49-meter band at 0745 to 0830 and from 1245 to 1330 and in the 25-meter band from 0930 to 1000, from 1345 to 1415, and from 2000 to 2130; all time given is Burma Standard Time which is 6 1/2 hours ahead of GMT." The letter was signed by the Director of Programs, P.W. Broadcasting Unit, and came airmail from a post office address in Washington, D. C.; it is presumed the British Embassy received it via London.

Converted to EST, these English schedules of Radio Rangoon are 8:15-9 p.m., 1:15-2 a.m. in the 49-meter band (approximately 6.040); and 10:10-30 p.m., 2:15-2:45 a.m., and 8:30-10 a.m. in the 25-meter band (approximately 11.860).

Latest report on Radio Rangoon indicates it is now heard on 11.845 rather than 11.860, between 8:30 and 10 a.m., with severe interference from WGEA. English news has been reported at 8:45 a.m. and 9:45 or 9:55 a.m.

\* \* \*

**THE BAHAMAS**

From K. P. Brown, Secretary of Broadcasting, Telecommunications Department, P.O. Box 48, Nassau, Bahamas, we learn that Station ZNS, located in Nassau, the Bahamas, is owned and operated by the Telecommunications Department of the Bahamas Government "as a social service and educational station." The two transmitters carry the same programs. Neither is directional. ZNS operates on 640 kc. in the BCB with a power of 5000 watts, while ZNS-2 may be found on 6.090 in the 49-meter band, using a power of 600 watts.

Hours of operation are listed as 7:45-8:15 a.m., Morning Melodies, local news, BBC news relayed from London, and weather report; 11:45 a.m.-12:15 p.m., luncheon music and BBC news; 6:30-10 p.m., Evening Transmission, including "Calling the Out Islands," BBC Radio Newsreel, Children's Program, Evening Symphony, and BBC news. Usually the station does not close down until 10:15 p.m. on Sundays. These stations will verify, Mr. Brown states.

\* \* \*

**BELGIAN CONGO SCHEDULES**

From *L. Le Roye*, director, Radio-diffusion Nationale Belge, Leopoldville, Belgian Congo, comes the following schedules of RNB:

First Transmission—17.770 (16.88 meters)—5-6:30 a.m., Belgium speaks to Belgians in South Africa and the Netherlands Indies (Dutch); 6:30-8:30 a.m., to the French Empire (French); 8:30-9:30 a.m., to the British Empire (English), with world and Belgian news at 8:30 a.m. and a news resumé at 9:25 a.m.

Second Transmission—17.770 (16.88 meters)—11:30 a.m.-12:15 p.m., to the Allied Occupation Forces (English), with world and Belgian news at the beginning of the transmission; 12:15-1 p.m., musical variety program presented in French.

On 9.785 (30.66 meters), 1-1:30 p.m., Belgian Congo Hour (Dutch); 1:30-2 p.m., Belgium speaks to the Netherlands (Dutch); 2-2:30 p.m., Belgians speak from the Congo (French); 2:30-4:15 p.m., Belgium speaks to France and Switzerland (French); 4:15-4:30 p.m., change in antenna direction; 4:30, Spanish transmission to Spain; 5 p.m., French transmission to Canada, with French news at 5 p.m.; 5:45 p.m., Portuguese transmission to North and South America; 6:30 p.m., Spanish transmission to North and

# AMPLICALL

FINEST PAGING, TWO-WAY COMMUNICATION  
AND PUBLIC ADDRESS SYSTEMS FOR INDUSTRY

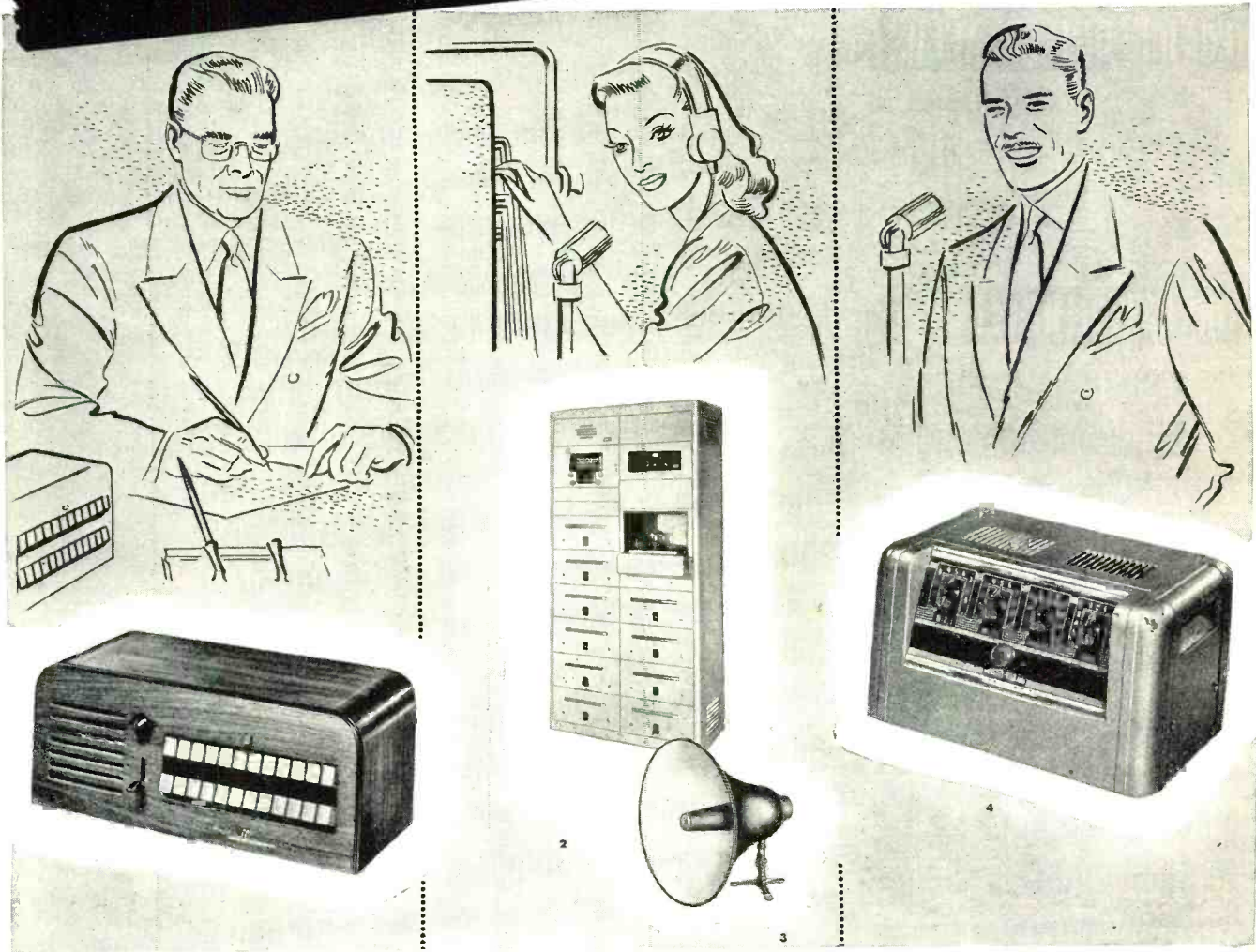

Thousands of Rauland AMPLICALL Systems are serving industry today with a performance dependability second to none! Engineering, quality materials and craftsmanship have been combined to insure AMPLICALL's dependability . . . multiple uses, flexibility of design, superb tonal quality, low maintenance cost and trouble-free operation are additional reasons for its preferred rating. Whether you need an adequate Paging, Intercommunication or Public Address System, or all three, be sure to check AMPLICALL . . . you'll find a system of the exact design and capacity to answer all of your requirements perfectly.

1. **AMPLICALL** Intercommunication unit, available for two-way communication between multiple stations.
2. **AMPLICALL** Paging Control Unit.
3. **AMPLICALL** Weatherproof Speaker.
4. **AMPLICALL** Audio Amplifier unit for laboratory, test equipment and general applications.

RADIO • RADAR • SOUND

## Rauland

COMMUNICATIONS • TELEVISION

*Electroneering is our business*

THE RAULAND CORPORATION • CHICAGO 41, ILLINOIS

# FOR EVERYTHING IN RADIO

WRITE  
**Leo, W9GFQ**  
For Fast Delivery!



Get Leo's own personal, sudden service on your radio and electronic needs. Quick delivery, lowest terms, liberal trade-in allowances.

## SERVICE DEALER NEEDS



**WRL MULTITESTER**  
Steel case with 30-60° angle  
Cat. No. 16-491  
Less Leads .. **\$1875**

Handles AC DC Voltmeter, DO Milliammeter, high and low range Ohmmeter. 3" meter with sturdy D'Aronval movement. Size 5½x8x3¼.

A complete stock of tools, replacement parts, test equipment, intercom and public address systems . . . everything for the progressive service dealer.

## FOR EXPERIMENTERS

### PHONO AMPLIFIER KITS



Complete with tubes, speaker, stamped chassis, and all resistors and condensers.

Cat. No. 7-271 . . . . . \$9.50 ea. Lots of 3, ea. **\$915**

Crystal sets, Antenna Kits, Code Oscillator Kits, Transmitter Kits, and many other items for the experimenter and radio enthusiast.

## TUBES NEEDS

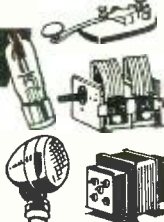

Transmitting tubes, condensers, mikes everything for the Ham. One of the country's largest stocks of Ham equipment. Write Leo, W9GFQ, today, and be first with the latest. We invite inquiries for special equipment of all kinds.

## TRANSMITTERS

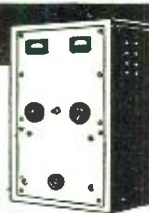

For peak performance and more dollar for dollar value, get a WRL Transmitter Kit . . . designed in Leo's own laboratories . . . tested and proven. Available in 15, 35, 70, and 150 watt kits as well as kits custom built to your own specs. Write Leo today for complete details, prices and terms.

## RECEIVERS



Here are just a few of the many well-known receivers offered by Leo:

- Hallcrafters SX-25 . . . . . \$ 94.50
- Hallcrafters S-20R . . . . . \$ 60.00
- Hallcrafters SX-28A . . . . . \$223.00
- Echophone EC-1A . . . . . \$ 29.50
- Hammond H10-129X . . . . . \$129.00
- National NC-2-40C . . . . . \$225.00

Write for details of our trade-in plan and easy terms



### NEW POST WAR 52 PAGE FLYER

52 pages packed with real buys in radio, electronic, and general merchandise. Write for your free copy today.

- Send for these exclusive items:
- Tube and Circuit Book . . . . . 10c
- Giant Radio Reference Map (size 3½"x4½") . . . . . 15c
- Handy Tube-Base Calculator . . . . . 25c

Depr. RN-2  
**COUNCIL BLUFFS, IA.**

*Wholesale*  
**RADIO LABORATORIES**

South America; 7:15 p.m., English transmission to North and South America, with news in English at 7:15 and 8:10 p.m.; relays the North American Service of the BBC to the Americas, 8:15-11:45 p.m. (NOTE: This listed 9.785 is subject to frequent changes, and is currently listed by the BBC as 9.745. It is readily identified by the *tom-tom* interval signal used.)

\* \* \*

### RADIO AUSTRALIA

Radio Australia has decided to continue its transmission beamed to the Eastern States of North America, over VLC5, 9.54, Shepparton, Victoria, with studios in Melbourne, 8-8:45 a.m. News is still heard at 8:01 and 8:35 a.m. This transmitter is reported throughout the U. S. and Canada as sending one of the strongest and most consistent short-wave signals to America.

The evening transmission over VLC4, 15.315, also Shepparton, beamed also to the East Coast, has been temporarily discontinued.

\* \* \*

### HAWAII DATA

Norbourne E. Smith, Acting Chief, Central Pacific Operations, OWI, Honolulu, T. H., writes that KRHO, Honolulu, "is in the process of a change. The following languages are heard over this station between the hours of 4-9:45 a.m. on a frequency of 6.120: Japanese, Burmese, Korean, Thai, French, Annamese, and English. Japanese programs are also heard over KRHO on a frequency of 17.800 from 4-5 p.m. Armed Forces Radio Service programs follow this period from 5-7:15 p.m. This AFRS block is followed by programs in Chinese, Thai, and English." Mr. Smith comments that "none of the programs heard over this station are designed for listening in the United States or Canada. Station KRHO *does* send verification cards to listeners."

KRHO on both 6.120 and 17.800 (the latter frequency being heard usually to 11:30 p.m.) is reported as well received throughout the United States and Canada, however.

\* \* \*

### NEWS FROM ZFY

G. V. de Freitas, of ZFY, 6,000, Georgetown, British Guiana, writes that he has returned to The B. G. United Broadcasting Company, Ltd., after a stay of 7 months in the United States with the Radio Section of the Anglo-American Caribbean Commission. While in this country Mr. de Freitas availed himself "of the chance to see something of the American radio industry both from a production as well as an operating standpoint. Also I was able to acquire some fine studio equipment for ZFY to replace what was lost in the disastrous fire of February last."

"Most of this new material has now arrived in Georgetown and is now installed in our present broadcasting headquarters," he continues. "We have moved from the Masonic Lodge of which I told you in a previous let-

ter, to a fine colonial residence in another part of Georgetown which we have adapted to suit our requirements. It is an improvement on our old studios and offices—but naturally, it leaves much to be desired from a technical point of view. We are planning to get some really up-to-date premises in a few years' time, when building materials become available. . . . I would be glad if you would state that we are again answering reports and are sending QSL cards to all listeners who send International Reply Coupons. Since the cessation of censorship, we have received a number of reports from U. S. DXers which were held up by the Office of Censors since 1942-43. These have now been answered and we trust that DXers will continue to send reports for verification."

Mr. de Freitas sent along a verification card of "The Voice of Guiana, ZFY," which is a (buff) postal card. ZFY's current schedule is 5:45-7:45 a.m., 9:45-11:45 a.m., and 2:15-7:20 p.m., or later.

\* \* \*

### NEW

C. W. Havlena, Washington, D. C., has received a letter from "Ceskoslovensky Rozhlas" (Czechoslovak Short-Wave Station), Praha (Prague), Czechoslovakia, stating that broadcasts in English are now regularly short-waved on 31.41 meters (approximately 9.551) at 2230 hours Praha Central European Time (4:30 p.m. EST).

I recently heard VLK3, 8.095, Sydney, Australia, at 5 a.m., Sunday, calling San Francisco, strong signal; this station operates on 16 kw. power.

The BBC is now using GRC, 2.880, to North America, 9:30-11:45 p.m.; strength is very good as it was last winter.

Since AFN, London, has vacated 6.080, AFN, Munich, Germany, is heard on 6.078, 11:58 p.m.-8 p.m. next day; relays AFN on 1,249 kcs.; signal strength is reported poor to fair.

Recently heard DPGH, Nuremberg, Germany, calling New York City at 3:10 p.m. on a new frequency of 9.100, with excellent signal strength; also reported heard at 6:40 p.m.; other frequencies reported are 7.390, 8.787, 14.780, and 10.615.

PFS, 14.845, Amsterdam, Holland, is being used to phone Curacao and Surinam; apparently, there is no regular schedule set up.

A new Moscow frequency of 11.890 is heard opening at 10 p.m., runs to 2 a.m.; this probably replaces 11.918, heard some months ago.

A station on 9.695 (frequency varies), believed to be Taihoku, Formosa (Taiwan), frequently contacts XGOY, and relays XGOY's English news at 9 a.m.; from 9:15 to 9:55 a.m. has what appears to be news dictation in Chinese; heard as early as 6 a.m., and signs off about 10 a.m., announcing two calls. A parallel station has been located on about 6.017; one may be XGPA. (Balbi, Dilg.)

**RADIO NEWS**



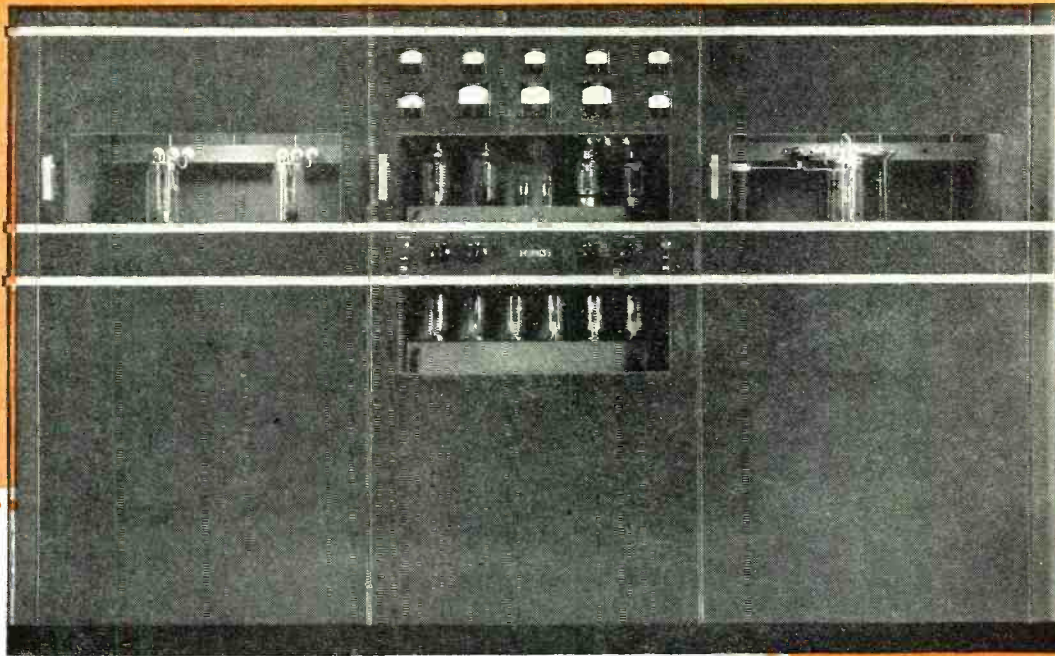

## Why WAAT bought its new 5 kw transmitter from Collins

The Bremer Broadcasting Corp., owners of WAAT, had had previous experience with Collins equipment. Mr. Frank V. Bremer, Technical Director, puts it this way:

"It is with interest and pride that I bring to your attention the performance of the Collins 20K one kilowatt AM transmitter installed at Kearny on April 14, 1941.

"This transmitter has been on the air a total of 39,000 hours, as of October 15, 1945, with a total elapsed lost time of only fifteen minutes.

"This makes a most remarkable record, since our station is on the air twenty-four hours per day, seven days per week, and it speaks well for your transmitter.

"According to the logs checked by Anthony Castellani, transmitter supervisor, the fifteen minutes total of lost air time was caused by defective bias tubes and a coupling

condenser in the audio circuit.

"At no time in the period of operation of the 20K have we had to make a refund or make up allowance to any sponsor due to lost air time.

"As director of the engineering department of WAAT and FM-WAAW, I give credit for this remarkable performance to your efficient design and to the capable operating supervision by our transmitter staff."

(Signed) Frank V. Bremer

With this background of satisfaction, the Bremer Broadcasting Corp. ordered a new 21A 5 kw AM Collins transmitter as soon as military restrictions were lifted in the fall of 1945. An illustrated bulletin, fully describing this transmitter, will be sent you on request.

FOR BROADCAST QUALITY, IT'S . . .



Collins Radio Company, Cedar Rapids, Iowa; 11 W. 42nd St., New York 18, N. Y.

**Now an entirely new line!**

*Quality  
sound equipment  
by  
Newcomb*

**P**RESENTING our newest line of amplifiers... they offer you greater excellence in sound reproduction than has ever before been available to the public address field. Designed and produced by an organization devoted exclusively, for more than seven years, to the perfection of fine sound equipment, they embody all the practical benefits of today's

most advanced electronic achievements.

*Send for the catalog... compare Newcomb with others... you'll find no other amplifier has so many advantages.*

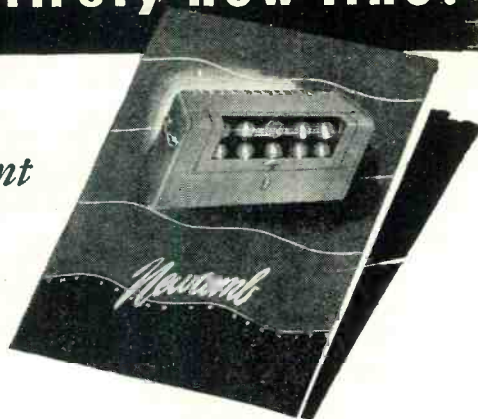

T H E   S O U N D   O F   Q U A L I T Y

*Newcomb*

**AUDIO PRODUCTS CO.**

MANUFACTURERS

DEPT. F 2815 S. HILL STREET, LOS ANGELES 7, CALIFORNIA

GARRARD costs a bit more because it's the finest

GARRARD

GARRARD

GARRARD

GARRARD

automatic record changer

WRITE FOR NEW CATALOG: GARRARD SALES CORP., 401 BROADWAY, N. Y.

An unidentified Chinese station on approximately 6.051, which signs off at 10:30 a.m., may be old XGOW at Hankow, which used to be on 6.055.

GQB, 12.695, *H.M.S. Recluse* in Chinese waters, is being used for broadcast relays at various times in the early morning.

The Delhi, India, transmitter VUD6 is reported to have been replaced by a new transmitter, VUD11, on 6.010, 9.680, and 11.830; the 9.680 frequency has been heard signing on at 5:59 a.m., with a Japanese program at 6 a.m., switching to Burmese at 6:30.

A new Tokyo Home Service frequency is reported heard well irregularly from 11:45 p.m. to 12:15 a.m. on 9.497; may be JLG2 drifting from its assigned frequency of 9.505.

A station believed to be Bangkok, Siam, is heard daily on 6.000 from before 8 a.m. to sign-off at 8:45 a.m.; severe CW interference. (Dilg.)

Warsaw, 6.100, Poland, is reported in the East as heard regularly with English news, 4-4:20 p.m., and with English news at dictation speed, 6-7 p.m.

In the East, Bucharest Radio, 9.252, Rumania, is reported in French and Rumanian from fade-in around 4 p.m. to 5 p.m. sign-off; weak signals.

The new U.S.S.R. station at Kiev, 6.012/6.005 varying, is reported afternoons to 7 p.m. sign-off; at 8-9:20 p.m. in the Siberian broadcast; and opening the day's broadcast, which is all relayed from Moscow, at 10 p.m. in parallel with Moscow on 9.650, 11.780, 11.900, 12.112, 12.170, 12.260, and 15.270, and Leningrad on 9.710.

A new station in the Cape Verde Islands has been reported with a one-hour program in Portuguese daily, 4:30-5:30 p.m. on 6.400; this is not to be confused with the more powerful Lisbon, Portugal, transmitter on adjacent 6.370. The Cape Verde transmission includes music, news, and talks, and the location is believed to be Praia; signals vary, poor to good.

A station announcing as ZLT, 10.980, Wellington, New Zealand, has been reported with tests at 11:40 p.m.; good signal strength.

COBQ, 9.238, *La Voz de Cuba*, Havana, has returned to the air after a long absence, is reported 8 p.m.-12 midnight.

A new Ecuador transmitter with the call of HCHAC, 10.313, is reported operating weakly 5-10 p.m. from Guayaquil, using the slogan, *Radio Palagra*. Has a bad carrier hum.

A new station in Guatemala, *La Voz del Pacifico*, is reported on 6.276, with the call TGLA, 5:30-6:30 p.m. and 8:30-10:30 or 11:30 p.m.; the exact location has not been determined; and there is QRM from ZPA1.

\* \* \*

**CHANGES**

The North American transmission from Radio Paris is now heard on 9.54 (announced) instead of 9.52 (100 kw.) and on 11.847 (25 kw.), 8:55-10:45 p.m. The English period, called *Atlantic Program*, runs from 9-9:20

PLEASE PLACE YOUR ORDER WITH YOUR REGULAR RADIO PARTS JOBBER. IF YOUR LOCAL JOBBER CANNOT SUPPLY YOU, KINDLY WRITE FOR A LIST OF JOBBERS IN YOUR STATE WHO DO DISTRIBUTE OUR INSTRUMENTS OR SEND YOUR ORDER DIRECTLY TO US.



## The New Model CA-11 SIGNAL TRACER

Simple to operate . . . because signal intensity readings are indicated directly on the meter!

Essentially "Signal Tracing" means following the signal in a radio receiver and using the signal itself as a basis of measurement and as a means of locating the cause of trouble. In the CA-11 the Detector Probe is used to follow the signal from the antenna to the speaker — with relative signal intensity readings available on the scale of the meter which is calibrated to permit constant comparison of signal intensity as the probe is moved to follow the signal through the various stages.

### Features:

- ★ SIMPLE TO OPERATE — only 1 connecting cable — NO TUNING CONTROLS.
- ★ HIGHLY SENSITIVE — uses an improved Vacuum Tube Voltmeter circuit.
- ★ Tube and resistor-capacity network are built into the Detector Probe.
- ★ COMPLETELY PORTABLE — weighs 5 lbs. and measures 5" x 6" x 7".
- ★ Comparative Signal Intensity readings are indicated directly on the meter as the Detector Probe is moved to follow the Signal from Antenna to Speaker.
- ★ Provision is made for insertion of phones.

**\$18<sup>75</sup>.**

The Model CA-11 comes housed in a beautiful hand-rubbed wooden cabinet. Complete with Probe, test leads and instructions. . . . . Net price

## The New Model 450 TUBE TESTER

### Specifications:

- Tests all tubes up to 117 Volts including 4, 5, 6, 7, 7L, Octals, Loctals, Bantam Junior, Peanut, Television, Magic Eye, Hearing Aid, Thyratrons, Single Ended, Floating Filament, Mercury Vapor Rectifiers, etc. Also Pilot Lights.
- Tests by the well-established emission method for tube quality, directly read on the scale of the meter.
- Tests shorts and leakages up to 3 Megohms in all tubes.
- Tests individual sections such as diodes, triodes, pentodes, etc., in multi-purpose tubes.
- New type line voltage adjuster.
- NOISE TEST: Tip jacks on front panel for plugging in either phones or external amplifier will detect microphonic tubes or noise due to faulty elements and loose internal connections.
- Works on 90 to 125 Volts 60 Cycles A.C.



**SPEEDY OPERATION** assured by newly designed rotary selector switch which replaces the usual snap, toggle, or lever action switches.

The model 450 comes complete with all operating instructions. Size 13"x12"x6".

Net weight 8 lbs. **\$39<sup>50</sup>**  
Our Net Price. . . . .

## The Model PB-210 MULTI-METER

### Features:

- ★ SPEEDY!
- ★ PUSH-BUTTON OPERATION!

### Measures:

- ★ A.C. Volts
- ★ D.C. Volts
- ★ D.C. Current
- ★ Low Resistance
- ★ High Resistance
- ★ High Capacity
- ★ High Decibels

### Specifications:

- 5 A.C. VOLTAGE RANGES: 0 to 10/50/250/500/1000 Volts
- 5 D.C. VOLTAGE RANGES: 0 to 10/50/250/500/1000 Volts
- 5 OUTPUT METER RANGES: 0 to 10/50/250/500/1000 Volts
- 4 D.C. CURRENT RANGES: 0 to 1/10/100 Ma. 0 to 1 Amp.
- 2 CAPACITY RANGES: .0005 Mfd. to .3 Mfd. .25 Mfd. to 100 Mfd.
- 3 DECIBEL RANGES: —10 to +15; +10 to +35; +30 to +55
- 4 RESISTANCE RANGES: 0 to 2,000/20,000/200,000 Ohms. 0 to 20 Megohms

Model PB-210 comes housed in hand-rubbed oak portable cabinet, complete with cover, self-contained battery, test leads and instructions. Net Price. . . . .

**\$35<sup>75</sup>**



# SUPERIOR INSTRUMENTS CO.

Dept. RN 227 FULTON ST., NEW YORK 7, N. Y.

**Standard**  
HAS IT  
IN STOCK!

FOR AT ONCE DELIVERY

**ORDER NOW**

• You bet! Standard Radio & Electronic Products Co. has the goods. We will make PROMPT shipments. Large complete stocks now on hand.



**SIMPSON  
MODEL 260**

The new "HIGH SENSITIVITY" MULTI-METER for television and radio servicing. 20,000 ohms per volt.

**33.25**

AT ONCE DELIVERY

**HEAVY DUTY  
12" Utah P.M.  
SPEAKERS**  
for Public  
Address



This fine public address speaker is now available in the following models . . . immediate delivery.

Model	Nominal Watts	Peak Watts	Magnet Weight	Price
E12P	13	20	20 oz.	10.89
F12P	16	24	31 oz.	11.76
G12P	17	26	46 oz.	16.51
GS12P	20	30	4 lb.	23.67
H12P	22	33	7 lb.	29.04



**Crystal Phonograph Pickup**

ASTATIC (CURVED ARM)	D9	2.97
SHURE (CURVED ARM)	No. 93A	3.30
ASTATIC (TANGENT HEAD)	CL407	3.90
BRUSH	PL20	27.00



**SPECIAL!**

Geared Head  
**MOTOR**  
**1.49**

Operates from toy train transformer. 12 volts AC or DC. Has many uses.

**Standard**  
RADIO & ELECTRONIC  
PRODUCTS COMPANY

135 E. SECOND ST., DAYTON 2, OHIO

MAIL ORDERS GIVEN PROMPT  
ATTENTION! WRITE US FOR  
INFORMATION ON ALL PARTS  
20% DEPOSIT ON ALL MAIL ORDERS

p.m., and is followed by a repeat in French to 9:40 p.m. The Latin American broadcast is heard 6:25-8:40 p.m. on 11.730 (100 kw.), 9.620 (25 kw.), and 11.847 (25 kw.). Paris on 11.886 is heard irregularly relaying the French National Program, 3:30-6 p.m. or later.

OIX2 has moved six kilocycles higher to 9.506 and is heard with improved strength most hours of the morning and early afternoon; has English news at 7:15 a.m. and mentions stations in the 19- and 25-meter bands (probably OIX4, 15.190, and OIX3, 11.78) as being in parallel; announces further newscast for 8:25 a.m.; location is Lahti, Finland.

According to printed schedules, GSL carries the BBC's North American Service, 6:15-11:45 p.m., but listeners report it as on only 7:15-11:15 p.m.

The Armed Forces Network stations in London (6.080 and 8.565) have discontinued operations.

CSW7, Lisbon, Portugal, has shifted to 9.735, still is well heard, free of interference, 7-8 p.m.; CSW, 11.035, now opens to Portuguese Africa at 12:30 p.m., shuts down at 3:02 p.m.

HVJ, 17.445, is heard in English on Tuesdays, 10:15-10:40 a.m., is beamed to India that day, 10-11 a.m. This same frequency of Vatican City is used on Wednesdays, Fridays, and Saturdays, 8:45-9:45 a.m. in various languages.

Luanda, Angola, has moved from 11.735 to 11.002 where it is being heard 2-3:30 p.m. in parallel with CR6RA, 9.470, also Luanda.

EAJ-43, Tenerife, Canary Islands, apparently has shifted frequency to 7.582, a big improvement.

SUX, 7.863, Cairo, Egypt, is now heard 1:30-5 p.m. sign-off with Arabic program; SUX2, 16.737, is heard irregularly around 8 a.m. with relays for the U.S. networks, but when radiating on Sundays, is heard at 9 instead of 8 a.m.

VLC4, 15.315, Radio Australia, has replaced VLC7, 11.84, at 1-1:40 a.m. VLG6, 15.230 has been heard signing off at 11 p.m. instead of 10 p.m., and was carrying the Forces Program in parallel with VLA6, 15.200, and VLC4. VLQ2, 7.215, has excellent signals at 4:30 a.m.; request reception reports on VLQ frequencies, asking that they be sent to the Superintendent, G.P.O., Sydney; stations in the VLQ series are at Brisbane. VLG7, 15.160, is reported as heard at 4:15 p.m. with news.

Radio Southeast Asia Command, Colombo, Ceylon, ZOI, is now being heard 4-9:15 or 9:30 a.m., and 1-2:30 a.m. on a frequency of 15.120 which has replaced former 15.220; this is a separate transmitter from that which operates on 11.810 and 15.275; another Colombo transmitter is reported as scheduled on 3.495, but has not been reported as heard here.

Chungking's XGOY has replaced 9.810 with the winter frequency of 6.135 (announced, but actually operating on 6.140); schedule remains

6:35-11:35 a.m., in parallel with 7.153, with English news at 9 a.m.

FK8AA, 6.208, Noumea, New Caledonia, now signs on at 2:04 a.m. and has French news at 4 a.m. (Balbi).

Petropavlovsk, U.S.S.R., 6.070, no longer relays Moscow, 7:40-8:15 a.m. to North America; but is still heard irregularly on Sundays, 3:30-4:30 a.m.

Vienna's latest move is from 7.160 to 7.135.

Portugal's time change has moved Ponta Delgada (Azores) broadcasts to 3-4 p.m. on 11.090 and 5-7 p.m. on 4.043; both broadcasts are now heard very well.

The Prague, Czechoslovakia, transmitter in the 49-meter band is reported to have changed from 6.037 to 6.010, but the frequency varies slightly; interference is severe.

Allied control of Radio Luxemburg ended on November 11.

Lisbon, Portugal's CSW7 has been lowered in frequency from 9.740 to 9.726 to get away from Leopoldville; is heard 7-8 p.m.

Radio Bissau, Portuguese Guinea, has not been reported lately and is assumed to be off the air at present.

Radio Tangier, 7.098, is reported as sending a fair signal to the East, 4-6:30 p.m. sign-off; still uses Spanish but no longer closes with the Falange March and Spanish Anthem.

The frequency of LRY, Radio Belgrano, Argentina, has been moved from 9.640 to 9.690, while LRX1 has moved up again to its former frequency of 6.120.

A late report indicates that powerful Mexico City has discontinued its 15.160 daytime frequency and is again using 9.500 throughout; heard widely most of the day and night.

OAX1B, Piura, Peru, has changed its frequency from 5.576 to 5.530; heard evenings.

\* \* \*

**BEST BETS FOR BEGINNERS**

From Dorchester, Massachusetts, William Cotter passes along these Best Bets:

VONH, 5.970, St. John's, Newfoundland, 5-10 p.m., 300 w.; GSL, London, 6.110, London, 7:15-11:45 p.m.; CHNX, 6.130, Halifax, Nova Scotia, good all day but best around 4 p.m.; GSU, 7.260, London, 4:15-11:45 p.m., excellent; FZL, 9.440, Radio Brazzaville, English news at 6:30 p.m.; OPL, 9.745, Leopoldville, Belgian Congo, relays BBC's North American Service, 8:15-9 p.m. and 9:15-11:45 p.m.; HEF4, 9.185, Bern, Switzerland, 8:30-10 p.m. nightly, except Saturday; and HCJB, 12.455, Quito, Ecuador, best 5-6 p.m.

\* \* \*

**REPORTS FROM ABROAD**

Australia — Cleve Maher, Sydney, reports XGOY, 11.910, Chungking, as heard 5:55-6:30 a.m., with news in English at 5 a.m., and foreign languages following. Radio Saigon on 11.775 to 11.780, is heard in English at 5:15 a.m. and has English news at 5:30 a.m.; in this morning radiation languages used include French, Annamese, English. Singapore Radio on

IT'S  
A **Snap-on**

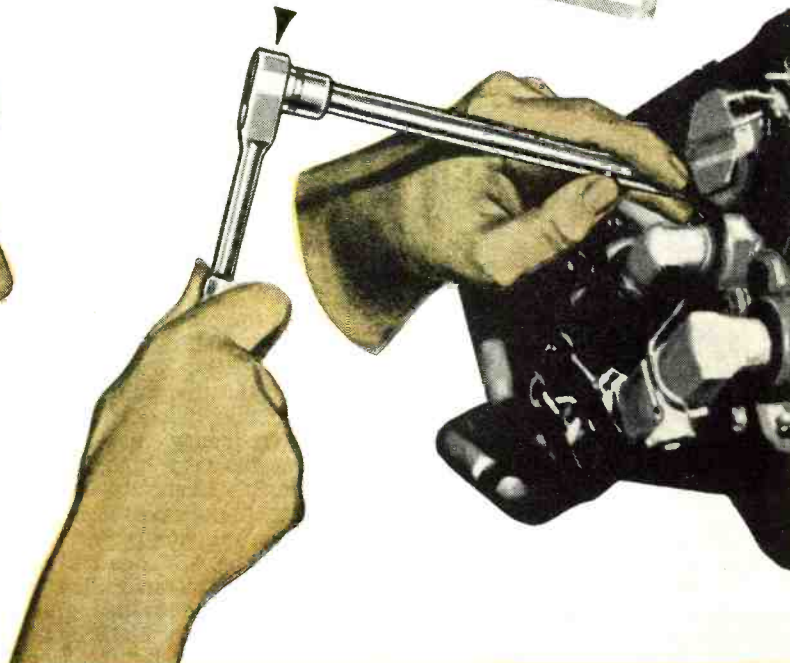

**-THE NAME THAT**

**SAYS "QUALITY"**

**ON 3,000**

**TOOLS**

To a vast army of skilled mechanics the brief phrase, "It's a Snap-on", sums up all they care to know of tool quality. Better tools mean added earning power, and they know that the Snap-on name on any tool pays off in speed and accuracy, in dependability and durability. Not only are Snap-on tools "the choice of better mechanics", but they are the choice of industry, widely used in every phase of production, assembly and maintenance. Write for catalog of 3,000 Snap-on tools.

### THIS UNIQUE, NATION-WIDE ORGANIZATION SERVES TOOL USERS EVERYWHERE

Snap-on's own distributing organization provides direct, personal service to tool users throughout America. Snap-on's branch offices and warehouses in 38 principal cities cover all major industrial areas. From factory branches a force of trained tool specialists bring Snap-on tools and service right to the work bench in shops and factories. The helpfulness and efficiency of this 25-year old service have won the endorsement of tool users everywhere. Write today for catalog and address of nearest factory branch.

**SNAP-ON TOOLS CORPORATION**  
8120-B 28th Avenue Kenosha, Wisconsin

February, 1946

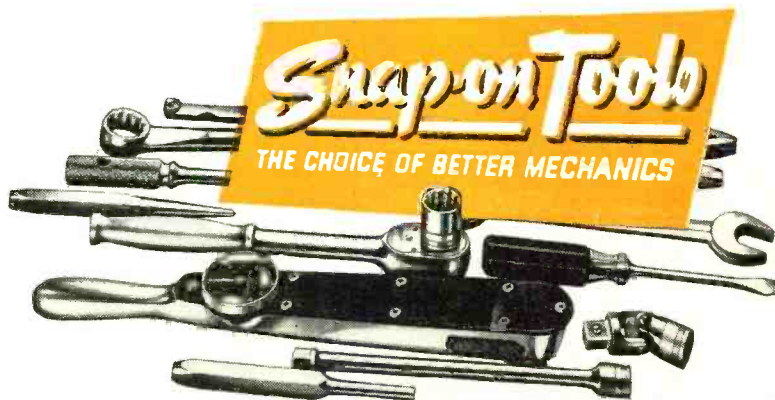

# Attention GI JOE!

## Here's Your Opportunity to be First to Start Your Own RADIO SERVICE SHOP

Complete Starting-in-Business  
Package Stocks of

TEST EQUIPMENT  
TUBES, PARTS, TOOLS

**\$350 up**

Act quickly! Meet the pent up demand for radio service. Turn your special service training into a profitable business of your own. No fuss. No worry. Here's everything you need—\$350 up. Details upon request! Write, wire or phone



### TRIPLETT Volt-Ohm-Milliammeter

**A. C.-D. C. Volts**  
0-10-50-250-1000-5000  
at 1000 ohms per volt.  
**D. C. Milliampores**  
0-10-100-500  
**Ohms** 0-300-250,000  
0-10-100-500  
Case Black molded  
3 1/4" x 5 1/8" x 2 1/8".

**\$16.00 net**

## Good News! ALL PRIORITIES LIFTED

### HALLICRAFTERS SX-28A



**\$223**

SUPER DEFIANT .....	SX25	\$94.50
SKY CHAMPION .....	S20R	60.00
SKYRIDER MARINE .....	S22R	74.50
SKY RANGER .....	S39	110.00
ECHOPHONE .....	EC1A	29.50

ORDERS FILLED AS RECEIVED!!!

### AMPLIFIERS



Complete with tubes.	
17 Watt	30.30
25 Watt	42.60
35 Watt	54.60
50 Watt	70.50
17 Watt with Phono-top .....	42.30
25 Watt with Phono-top .....	52.20
35 Watt with Record-changer .....	89.10

### PHILCO BEAM OF LIGHT

Selenium Cell only, no holder ..... 1.80

20% deposit required on all C.O.D. orders. 2% transportation allowance on orders of \$25.00 or more accompanied by payment in full.

Write for  
FREE CATALOG

**RADIO SUPPLY &  
ENGINEERING CO., Inc.**  
129 SELDEN AVE. DETROIT 1 MICH

11,850 (to 11,860), 7,220, and 300 meters, carries English news at 5:30-5:45 and 8 a.m.; English is used to 9:15 a.m. when a foreign program is presented to closedown at 10.05 a.m.; a daily program outline is given after the news at 5:45 a.m. On 9.550, Singapore Radio has a two-hour program of music for the Forces at 7-9 a.m. ZOJ, 15.275, Colombo, Ceylon, is heard in English and Eastern languages "most of the afternoon, Australian time," with English news at 10 and 11:30 p.m. EST. The best signals from Delhi, India, are at 6:30 a.m. when news, commentaries, and music are presented in the program called "The Voice of Britain Calling the Far East," in the 19-, 25-, 31-, and 41-meter bands; the 19- and 25-meter band transmitters are heard best in Australia. Mr. Maher lists English news from Delhi on VUD3, 15.290, 5:30 a.m.; VUD8, 15.350, 6:30 a.m.; and VUD9, 11.870, 8 a.m. VLZ-3, 13.340, Sydney, is a point-to-point station which calls ZLT-4, Wellington, New Zealand at 7 p.m. daily. The call and frequency are given then; they transmit on one note, this being a good opportunity for frequency check since their accuracy is very high; this station also calls San Francisco irregularly.

Mr. Maher passes along the information that for more than a year and a half the ABC has had nothing to do with the Overseas Short-Wave Service from Radio Australia (as it now announces). "Material is compiled and produced by the Department of Information (same as your OWI), and the transmitters, land-lines, etc., are provided and operated by the Post-Master General's Department, Treasury Gardens, Melbourne, C2, Victoria." These short-wave transmitters of Radio Australia include VLG, 9.58; VLG3, 11.71; VLG4, 11.84; VLG5, 11.88; VLG6, 15.23; VLG7, 15.16; VLG 10, 11.76, all at Melbourne. VLA, 7.28; VLA4, 11.77; VLA6, 15.21; VLC2, 9.68; VLC4, 15.315; VLC5, 9.54; VLC6, 9.615; VLC7, 11.84, all at Shepparton.

It is further stated that letter verifications are now being sent by Radio Australia, since no QSL cards are available at the present; possibly more cards will be printed soon, Mr. Maher believes. Latest schedules of the ABC's Domestic Short-Wave Service follow: VLR3, 11.880, Saturday, 3:45 p.m.-2:45 a.m., other days, 4:20 p.m.-2:45 a.m.; VLR, 9.580, Saturday, 3 p.m.-4:10 p.m., other days, 3 a.m.-7:30 a.m.; VLQ, 7.240, Saturday, 3:45-7:45 p.m., other days, 3-7 p.m.; VLQ2, 9.660, Saturday, 8 a.m.-2:15 a.m., other days on 7.215, 2:30 a.m.-8:30 a.m.; VLQ3, 7.215, Sundays, 2:30 a.m.-8:30 a.m., other days, on 9.660, 8:45 p.m.-2:30 a.m.; VLG7, Saturdays, 3:45-5:15 p.m., other days, 3-5:10 p.m. (NOTE: These schedules are subject to change, but are as accurate as can be obtained at this time.)

From the ABC Weekly, Mr. Maher sent these tips: English news—ZOJ, 11.810, Colombo, Ceylon, 5:30, 7:30, 9:30 a.m.; Delhi, 9.630, 10:50 a.m.;

TAP, 9.465, Ankara, Turkey, 12:45 p.m.; Vatican City, HVJ, 9.660, 1:15 p.m.; Warsaw, Poland, 6.115, 3 p.m.; TAP, 9.465, Ankara, Turkey, Mon., Tues., Fri., 4:30 p.m.

From Rex G. Gillett, DX Editor of Radio Call, Adelaide, South Australia, we have just received these interesting tips: XMEW, 16.540 and 8.700, Kunming, China, is heard in English irregularly with popular U.S. shows and announces, "This is XMEW, the American Forces Station in Kunming, China." He lists ZOJ, Headquarters Radio Southeast Asia Command, Colombo, Ceylon, as now using 11.765 rather than listed 11.810, with a popular program for the Armed Forces at 8:30 a.m. A station announcing as VUZZZ, 14.870, believed to be in India, (Continued on page 143)

## Parasitic Oscillations

(Continued from page 70)

single end. A good rule to keep in mind when designing an amplifier which is to be free of low-frequency parasitics is stay away from chokes and coupling condensers. Always use link coupling between stages wherever possible, but never, under any circumstances, use shunt feed in the input and output circuit of the same tube, as this is just asking for trouble.

The methods of parasite suppression discussed in detail are here summarized for convenience:

1. Use small resistor connected directly at control grid terminal.
2. Use small resistor connected directly at screen grid terminal.
3. Use parasitic choke connected directly to plate terminal.
4. Use wave trap connected directly to plate terminal.
5. Eliminate as many r.f. chokes as possible.
6. Connect the unbypassed grid bias resistor in direct series with the grid r.f. choke.
7. Eliminate capacitive coupling. Use link coupling instead.
8. Avoid stray capacitive or inductive coupling between circuits. Shield or rearrange components where necessary.

If parasitic oscillations still persist after all these methods of suppression have been attempted, the logical procedure is to sketch the circuit diagram of the amplifier being used, making particular note of the physical dimensions and arrangement of the r.f. paths. The next step is to analyze the circuit for probable modes of parasitic oscillation, as has been done here in the case of two amplifiers. Having found a possible parasitic circuit, determine which components affect its frequency of oscillation and then apply some means of stopping the oscillation. It can be eliminated either by placing a lossy resistor in series with the parasitic tuned circuit (be careful not to introduce losses in the amplifier's nominal tuned circuits), or by placing a parallel tuned circuit in such

# SYLVANIA NEWS

## RADIO SERVICE EDITION

FEB

Published by SYLVANIA ELECTRIC PRODUCTS INC., Emporium, Pa.

1946

### RADIO SERVICEMEN KNOW THEIR BUSINESS; HAVE COUNTRY'S COMPLETE CONFIDENCE, SURVEY SHOWS

#### National Research Bureau Reports Findings to Sylvania

A recent nationwide, independent survey — conducted by one of America's leading market research organizations — reveals that not only do 93% of the thousands of set owners interviewed firmly believe that the radio serviceman does a good

job, but also that 89% say he charges a fair price for his work!

That's a flattering record — since the ground covered was scientifically selected, both from the geographical distribution standpoint and income group.

#### WHAT THIS MEANS TO YOU

To radio servicemen this means they are virtually assured of the continuance of this public trust in the busy years ahead. For, if this confidence was main-

tained throughout the past *difficult* period, it certainly may be expected to continue — and grow — in the following years, when the millions of radio tubes and parts needed will be *available*.

All of this spells opportunity for the radio serviceman. Knowing that he has the public confidence, he can combine the other ingredients of quality components and high class equipment, backed by aggressive promotion, to form an unbeatable recipe for success.

**SYLVANIA  
SERVICEMAN  
SERVICE**

by  
**FRANK FAX**

Now that the war's over, radio tube production is rapidly getting into its stride. All the pre-war tubes should be available gradually — and along with them will come the newly developed tubes, or improvements and modifications of some of the older ones.

So to keep you in step with the latest tube characteristics and base diagrams, we at Sylvania are having prepared a brand new Radio Tube Characteristics Sheet as well as an up-to-date Base Chart.

You can get both your copies — free — from your Sylvania Jobber or send your request direct to me at Emporium, Pa.

**YOU SAY  
WE DO GOOD WORK**

A NATIONWIDE SURVEY  
CONDUCTED FOR US  
AMONG THOUSANDS OF  
RADIO SET OWNERS REVEALS...

**93% SAY**  
REPAIRS MADE ON THEIR  
RADIOS WERE SATISFACTORY

**89% SAY**  
THE CHARGES FOR THE  
SERVICE WERE REASONABLE

**LET US SERVICE YOUR RADIO  
EXPERT WORK AT REASONABLE COST  
WE USE SYLVANIA RADIO TUBES**

This is the  
special poster — in color —  
mailed to radio servicemen with Sylvania News

# SYLVANIA ELECTRIC

Emporium, Pa.

MAKERS OF RADIO TUBES; CATHODE RAY TUBES; ELECTRONIC DEVICES; FLUORESCENT LAMPS, FIXTURES, WIRING DEVICES; ELECTRIC LIGHT BULBS

February, 1946

87

**ALWAYS  
GETS A HAND**

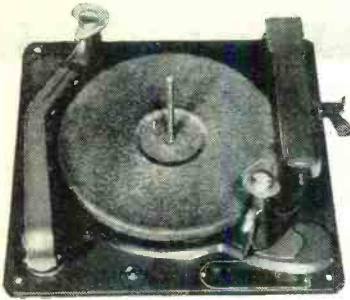

Combination record-changer recorder  
Model GI-RC130

Users and the trade have always given hearty applause to General Industries phonograph mechanisms. Owners like the fine fidelity of every note or syllable—and sales and service departments are strong for their reliability and freedom from maintenance troubles.

You'll get this same oldtime satisfaction from our *Smooth Power* turntable motors, recording assemblies and record changer-recorder combinations. As always, General Industries equipment will earn your approval.

**THE GENERAL INDUSTRIES CO.**  
Dept. M • Elyria, Ohio



a position as to break up the parasite's circuit, or, still again, by detuning the resonant frequency of one of the parasitic tuned circuits.

In any high powered r.f. amplifier one can expect parasitics as a matter of course. Do not look upon trouble of this type dismally as an *Act of God*. Parasitic oscillations take place in strict accordance with the laws of circuit theory and, by the application of these laws, the difficulty can be resolved.

—50—

### Practical Radio Course

(Continued from page 52)

ing a stack of ordinary metal plates interleaved by mica sheets, the plates consist of a thin layer of metal (silver) sprayed or otherwise applied *directly* to the mica dielectric and fired at high temperature. This insures a positive, intimate bond between each conducting silver electrode or plate and the mica. Since no intervening air pockets can form, the capacitance is not affected later by any temperature-caused variation in pressure between the stacked mica sheets when assembled. Also, the coefficient of expansion of the mica itself is almost balanced by the change in its dielectric constant when heated. As a result, this type of *silvered-mica* fixed capacitor has a very low *positive* temperature coefficient of capacitance averaging about .002% to .003% per degree C. It also has excellent cyclic characteristics and practically no capacitance drift with time. Consequently, its effect on oscillator frequency drift is practically nil. The

units are heat treated, aged, and wax impregnated for protection against moisture, and are also available in molded phenolic or ceramic cases. Where capacitance change as a result of temperature variation is to be reduced to a very low value, such capacitors are widely used instead of the ordinary type of fixed mica capacitors.

### Ceramic-Dielectric Fixed Capacitors

Carrying the idea of the silvered-mica capacitor one step further, we have the ceramic-dielectric type. In this, two tubular silver plates are electroplated directly on a thin-wall ceramic tube, one on the inside and one on the outside of the tube, as illustrated at (A) of Fig. 4. Wire leads, soldered to the plates, are brought out for connection. This forms a single 2-plate fixed capacitor in which the ceramic is the dielectric, and in which no mechanical movement that might change the distance between the two plates is possible. An important characteristic is that the temperature coefficient of capacitance of these capacitors is determined by the ingredients of the ceramic dielectric, so by employing the proper ceramic mixtures it is possible to produce capacitors that have either a *positive*, *zero*, or *negative* coefficient of capacitance. Furthermore, the coefficient can be controlled in manufacture within very close limits. For example, one manufacturer offers such capacitors in a range from 1 to 1100  $\mu\text{fd.}$ , available in ten standard coefficients ranging from +.00012 to -.00075 per degree C. Thus, in addition to units with zero temperature coefficient that are among the most temperature-stable of all

Artist's conception of the new radio skyway between Chicago, Cleveland, and New York—a skyway which features the use of very-high frequency radio range transmitters. According to officials of United Air Lines, which is installing equipment aboard its planes for use in connection with these radio ranges, the Chicago-New York route is the first in the country to be equipped with such facilities by the Civil Aeronautics Administration. Equipment of other routes will follow. At top is a map showing location of the new ranges; at bottom, an illustration of the manner in which these so-called "line-of-sight" radio directional beams overlap to give pilots a straight, true, and "static-free" radio skyway from Chicago to New York.

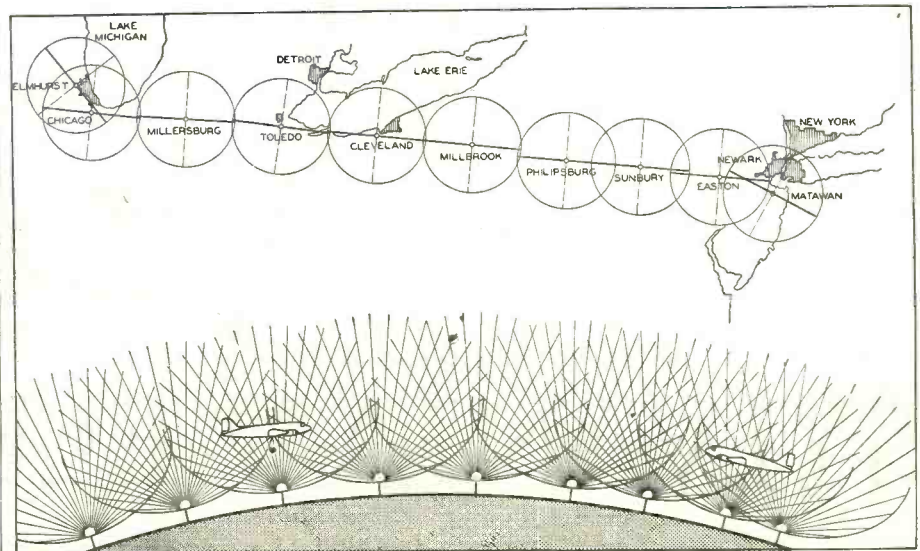





# GOOD NEWS!

for RADIO STATION ENGINEERS...MANAGERS

...and for those who plan a "Dream Station"

**SOON  
AVAILABLE**

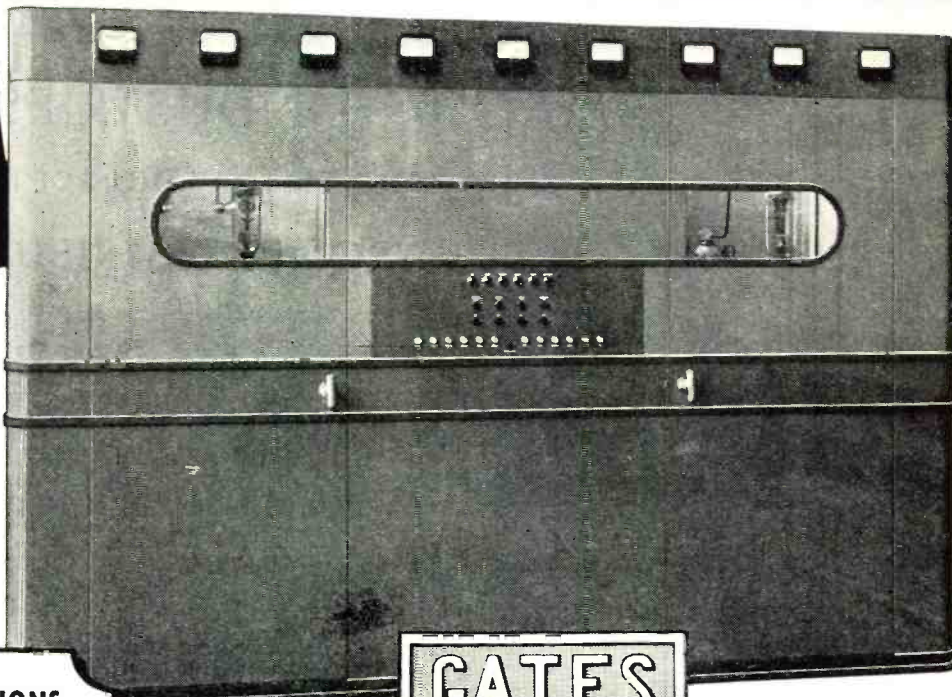

**GATES**

## NOTE THESE SPECIFICATIONS

Carrier Frequency Stability	Plus or minus 10 cycles maximum.
Audio Distortion	Less than 3%, 95% modulation, 50 to 7500 cycles.
Audio Frequency Response	Plus or minus 1½ Db., 30 to 10,000 cycles.
Carrier and Hum Level	Better than 60 Db. below 100% modulation, unweighted.
Power Supply	230 volts, 3 phase, 60 cycles.

## 5 AND 10 KILOWATT TRANSMITTERS

They're modern—with built-in technical features that fulfill every demand for versatile 5 and 10 Kilowatt Transmitters—and they'll soon be available, both for stations now operating or for that "dream station" you may be planning.

Engineered by skilled GATES men with 24 years of "know-how" back of them, these new models (BC-5, BC-10) afford not only a perfected broadcasting technique, dependability, and efficiency but a prideful investment in engineering distinction and prestige.

**Install them for Engineering Perfection . . .  
Dependability . . . Efficiency . . . Versatility!**

WRITE FOR COMPLETE DETAILS

. . . *Everything for Radio Broadcasting from the Plans to the Completed Station* . . .

NEW YORK OFFICE  
9th Floor, 40 Exchange Place

**GATES RADIO CO.**  
**QUINCY, ILLINOIS**

SOLE IN CANADA BY  
Canadian Marconi Co., Ltd.,  
Montreal

**EXCLUSIVE MANUFACTURERS OF RADIO TRANSMITTING EQUIPMENT SINCE 1922**

**ANOTHER IMPORTANT  
FROM MAGUIRE**

FOR FASTER, BETTER AND MORE COMPLETE SERVICE  
TO ALL CUSTOMERS

**MAGUIRE INDUSTRIES, INC.**

ANNOUNCES THE FORMATION OF ITS NEW

**ELECTRONIC DISTRIBUTOR**

and

**INDUSTRIAL SALES DEPARTMENT**

THIS NEW DEPARTMENT WILL ASSUME ALL

**MERCHANDISING**

**SALES**

and

**CUSTOMER RELATION**

DUTIES AND RESPONSIBILITIES ESSENTIAL IN  
MARKETING THE COMBINED PRODUCTS OF THE

**THORDARSON DIVISION**

**MEISSNER DIVISION**

**RADIART CORPORATION**



**ELECTRONIC DISTRIBUTOR AND  
INDUSTRIAL SALES DEPARTMENT**

# ANNOUNCEMENT

## INDUSTRIES, INC.

*THESE SUPERIOR PRODUCTS NOW  
AVAILABLE FROM A SINGLE SOURCE*

**THORDARSON**

### TRANSFORMERS

Precision engineered and quality built transformers for all requirements...replacement, communications, sound amplifier, industrial, experimental and amateur.

### TRU-FIDELITY AMPLIFIERS

In new, modern designs featuring advanced tone compensation, conservative ratings, ample ventilation, low hum level, multiple input channels and maximum flexibility of controls.

 **Meissner**

### COMPONENTS

Precision-built components including antenna, R. F. and oscillator coils; standard, plastic and Ferro-cart transformers; windings, coils, chokes and accessories.

### SERVICE INSTRUMENTS

Meissner Analyst—operates by "signal tracing" method, fastest and most reliable—furnished complete. Signal Calibrator—a portable self-contained unit.

**Radiart**

### VIBRATORS

Radiart Correct Replacement Vibrators are individually engineered to meet exactly the physical as well as the electrical requirements of each application.

### RUST-PROOF AERIALS

A complete line of newly designed aerials to fit all cars; 3 and 4 section models—cowl, fender and under hood types... all made of finest materials.

### SEE FOR YOURSELF!

See the outstanding products of the Electronic Divisions of Maguire Industries, Inc., at the Winter Meeting of the I. R. E. at the Hotel Astor, New York on January 23 to 26.

# MAGUIRE INDUSTRIES, INC.

936 NORTH MICHIGAN AVENUE, CHICAGO 11, ILLINOIS



# LIGHT AS A FEATHER

## UNGAR SOLDERING PENCIL

... handles like a fountain pen and is a demon for speedy precision on intricate hard-to-reach jobs. And it takes plenty of punishment... weighs only 3.6 ozs., perfectly balanced; length 7 inches... heats in 90 seconds and draws only 17 watts. Unit complete with any of the four tips pictured sells at less than \$2.

No. 538 Chisel Tip, made from Elkaloy A, Tip 1/8 dia.



No. 539 Extra Hot, made from Tellurium

No. 536 Standard Tip, made from Hard Drawn Copper



Please order from your nearest Electronics distributor.

**Ungar**  
Electric Tools, Inc.  
Formerly Harry A. Ungar, Inc.  
LOS ANGELES 54, CALIF.

Part	Temp. Rise (receiver) °C	Capacitance Change (μμfd.)	Temp. Coeff. (μμfd. per °C)
Osc. tube (internal structure).....	—	.03	—
Tube base.....	30	.03	.001
Socket (wafer type).....	30	.03	.001
Other circuit elements.....	15	.20	.017
TOTAL.....	—	.29	—

Table 1. The effect of temperature rise on various portions of a 6J5 oscillator circuit.

commercial types of fixed capacitors, others with a uniform rate of *negative* change (capacitance *decreases* with increase of temperature) are available to compensate for the normal positive drift of other circuit components. When made in uninsulated form, these units are of small size, light weight, and small mass that readily follow temperature changes when used for compensation. They are also available with axial leads and the unit sealed in a steatite tube (Fig. 4). The use of fixed capacitors of this type for frequency-drift compensating purposes in oscillator circuits will presently be explained.

### Titanium Dioxide Capacitor

The titanium dioxide type of fixed capacitor is characterized by its negative temperature coefficient that gives it approximately 2 per-cent capacitance change for the thirty degree C. rise in temperature between 30° and 60° C. Silver electrode surfaces are coated on the surface of the titanium dioxide dielectric and fixed at high temperature. By combining the titanium dioxide with other ceramics, other temperature coefficients between fairly wide limits may be obtained. This type of capacitor has been used for temperature compensation applications in some domestic receivers.

### Effect of Temperature Changes on Adjustable Mica Trimmer Capacitors

In manually-tuned receivers, adjustable trimmer capacitors are employed for trimming preselector and oscillator tuning circuits ( $C_{1p}$  and  $C_{1o}$  in Fig. 3), for oscillator padding ( $C_2$ ), and for the main tuning in the i.f. amplifier tuned circuits. In push-button operated receivers, they also are often employed as the main tuning capacitor in either the preselector or oscillator tuning circuits (or both) for each push button.<sup>2</sup>

The type that has been most popular in the past for all-round use is the mica-dielectric compression trimmer consisting of metal plates separated by thin sheets of mica 1½ to 3 thousandths of an inch thick and held under tension by an adjusting screw. Increase of temperature can cause the capacitance of such capacitors to increase considerably. This results from the effect of the temperature increasing the plate area and the dielectric constant of the dielectric, and causing mechanical expansion of the insulat-

ing material used for the base. This effect is offset somewhat by the elongation which occurs in the adjusting screw that holds the plates under tension but, unfortunately, the two effects do not exactly balance.

There is another cause of capacitance drift in such capacitors—the drift that occurs after mechanically adjusting the trimmer to a new capacitance value. It is due to the relatively high coefficient of friction between the electrode plates and mica sheets held under compression by the adjusting screw. This friction prevents them from sliding into their final positions immediately upon changing the setting of the adjusting screw. The largest amount of this adjustment drift takes place in the first few minutes after a capacitance adjustment has been made (while the electrode plates and mica sheets are sliding toward their final positions), but it continues at a slower rate for several hours. This difficulty has been overcome by one manufacturer by coating the surfaces of the electrode plates with graphite in order to make them more slippery.

### Necessity for Trimmers Having High Capacitance Stability

Particular care is necessary in the choice of the oscillator high-frequency trimmer capacitor ( $C_{1o}$  in Fig. 3) which, being shunted directly across the main oscillator tuning capacitor  $C_o$ , can have a very appreciable influence on the oscillator frequency as the temperature varies. This is especially important in short-wave and communications type receivers. The ordinary mica-compression type trimmer capacitors, if well made, are usually quite satisfactory for use as ordinary trimmers in a manually-tuned broadcast-band receiver. However, the permissible frequency variation in communications type receivers and in those push-button tuned oscillator stages where the trimmer entirely controls the tuning, is much smaller. Accordingly, a more stable type of adjustable capacitor is desirable for such receivers.

Either the conventional well-designed midget, air-dielectric, variable capacitors, or the more compact and mechanically rugged ceramic type variable trimmers, fulfill these require-

<sup>2</sup> See the push-button receiver preselector and oscillator circuit arrangements illustrated in *Practical Radio Course* Part 39 in the November 1945 issue of *RADIO NEWS*.

# Men! You Need "All-Around" Training for Tomorrow's Better Jobs in



# RADIO-ELECTRONICS and TELEVISION

*"Learn by Doing"*

**— 12 FASCINATING WEEKS of STREAMLINED TRAINING**

You like Radio work. But if you're really serious about making it your lifetime career, **GET PRACTICAL TRAINING NOW.** Don't be satisfied to putter along in a "one-operation" no-future job. Prepare for better pay and advancement with **Coyne all-around training in Radio-Electronics-Television.**

### Many Branches Included

Here in the great shops of Coyne in Chicago, you're trained in everything from basic principles and Radio construction, to F. M. (frequency modulation), electronic controls, public address systems, television and radio-phonographs. You can even get valuable **extra training in Industrial Electronics and Electric Refrigeration** at no extra cost, for still more opportunities in the years ahead. Coyne gives "all-around" training!

### Work on Real Equipment

You work on real actual equipment and expert instructors give you necessary theory in blackboard lectures and demonstrations. In **12 WEEKS OR SO—** you're ready for a real future!

### Starting Your Own Radio Shop

Want to be your own boss, with a fine-paying radio shop of your own? We show you how to set one up and operate it successfully. Hundreds of Coyne graduates are doing it. You can, too. Send now for details.

### Get the Facts — FREE!

My new giant Radio Opportunity Book has dozens of shop pictures, facts about Radio and Television jobs, my plans to help you. Rush coupon today. No obligation; no salesman will call. You alone will decide. But don't delay. Act NOW.



H. C. Lewis

## Send for Details on My STUDENT FINANCE PLAN

If you don't have much cash, I'll arrange to finance most of your tuition and you can pay it back in easy monthly installments after you graduate. We'll even help you get a part-time job if you wish, so you can **EARN WHILE LEARNING.** My **LIFETIME EMPLOYMENT SERVICE** is free to Coyne Graduates. Coyne Training is the finest investment you can make.

### MEN WITH PHYSICAL DISABILITIES

Also facilities for men with physical disabilities, whether due to war or other causes. Check coupon for special information.

THE HOME OF COYNE



**VETERANS!** Coyne is also equipped to train those who qualify for training under the G. I. Bill of Rights. Check the coupon for special G. I. Bulletin.

H. C. LEWIS, Pres.

Founded 1899

# COYNE ELECTRICAL SCHOOL RADIO-ELECTRONICS DIV.

500 So. Paulina Street, Dept. 26-1K CHICAGO 12, ILLINOIS

H. C. Lewis Pres., Radio-Electronics Div.,  
 COYNE ELECTRICAL SCHOOL,  
 500 S. Paulina St., Dept. 26-1K  
 Chicago 12 Ill.

I want to build a REAL FUTURE for myself. Send your big FREE BOOK on Radio-Electronics, also details of your Student Finance Plan. Check if you are interested in information on the following:

Send special G. I. Bulletin  
 Send details on Physical Disability

NAME.....

ADDRESS.....

CITY..... STATE.....

# HEINS & BOLET

68 CORTLANDT ST.  
New York 7, N.Y. Rector 2-7600

FACTORY DISTRIBUTORS FOR  
HAMMARLUND RADIO  
RME RADIO

Public Address Systems  
CINAUDAGRAPH  
SPEAKERS  
PRESTO

Recording Machines  
ELECTROVOICE MIKES  
FOR IMMEDIATE DELIVERY  
SHURE MIKES &  
CRYSTALS  
ELECTRONIC A.C.-D.C.  
Inverters

## HAMMARLUND

HQ 129X RECEIVERS

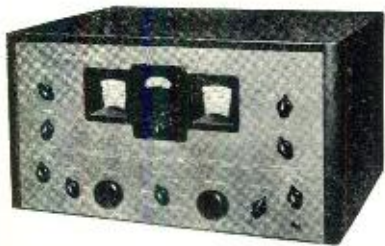

## 12" SPEAKER BAFFLES



OUR  
PRICE  
\$2.95

## Lightweight PICKUPS

INCLUDING CRYSTALS

List Price \$5.50  
OUR PRICE \$2.97

20% DEPOSIT Required  
ON ALL C.O.D. ORDERS

WE CARRY A FULL LINE OF  
STANDARD RADIO PRODUCTS

Inquiries Invited on Products Not  
Advertised

Write for Free Literature  
on Standard Products

## HEINS & BOLET

68 CORTLANDT ST. NEW YORK

ments much more satisfactorily. The former type of trimmer has been used extensively in communications type receivers where some latitude is possible in available space and capacitor cost. The latter type does not rely on compression or on variable distance between the plates for its variable capacitance. It is of the rotary-vane air-dielectric type, and no mica is used in its construction.

### Variable Trimmer Capacitors Employing Ceramic Dielectrics

The construction of a small and inexpensive design of ceramic dielectric variable trimmer that has been successfully used on late-production peacetime radio equipment, is illustrated in Fig. 6. The base is made of a ceramic having a high dielectric constant, in order to obtain the widest possible capacitance range. Silver is fired and then burnished to the under side in a variable pattern determined by the capacitance range desired. This becomes the stator plate and is electrically connected to the stator terminal by a rivet. The upper surface of the base is ground optically flat and on this surface is rotated a half-moon shaped piece of metal which acts as the rotor plate. The rotor is held firmly against the optically-flat top surface of the base by a bronze spring also formed to provide the adjusting slot. A rivet through the base holds this assembly and connects it to the rotor terminal.

As the rotor plate presses firmly against the optically flat top surface of the ceramic dielectric at all times, it eliminates any variable air film between the parts. The method of adjustment, see (B) of Fig. 6, and capacitance change is similar to that of a variable air condenser, with a special high dielectric constant ceramic substituted for the air to separate the rotor from the stator plate. In the maximum-capacitance position, the metal of the rotor is directly over that of the stator. The full capacitance range is obtained with 180° rotation, and equal stability is maintained at any position from minimum to maximum. Thus, less total range is needed than on trimmers of the *book* or *variable-pressure* type. Since the rotor is of small mass and is always in mechanical balance and under heavy, uniform spring pressure, the setting is stable even under extreme vibration without need for any special shaft-locking device. Also, the unit can easily be designed to provide a definite, fixed capacitance minimum that makes a separate fixed capacitor unnecessary in some circuit applications.

These capacitors have the same feature of controlled temperature coefficient common to the ceramic-dielectric type fixed capacitors previously described. The temperature coefficient is controlled by the basic mixture of the ceramic dielectric. Some designs are available with either *positive* temperature coefficient of .0002 per degree C, *zero* temperature coefficient, or

with a *negative* temperature coefficient of .0005 per degree C. The latter type is helpful in compensating many circuits. Others are only available with positive or negative temperature coefficient. Those with negative temperature coefficient have the largest capacitance range, because the particular ceramic mixture employed in them has the highest dielectric constant.

### Effect of Humidity on Frequency Stability of Components

Although the chief cause of variation of the inductance, capacitance, and resistance of the tuning circuit and its associated components is usually temperature change, *humidity* can have a more serious effect if care is not taken to properly moisture-proof the coils and fixed capacitors—especially when the equipment is to be operated in humid climates. Increase of humidity has much the same effect as increase of temperature, *i.e.*, it increases the self-capacitance of a coil and increases the capacitance of an ordinary mica-type trimmer capacitor, thus reducing the oscillator frequency. The increase in capacitance is due to the displacement of air in the insulating material by water vapor, which has a much higher dielectric constant. For example, since the dielectric constant of water is 85, while that of mica is approximately 5, it is readily seen that even a minute quantity of moisture will appreciably increase the capacitance of a mica trimmer capacitor if it finds its way between the plates. Frequency drifts due to humidity are extremely troublesome because they cannot readily be compensated for, since the humidity and resulting drift varies from day to day, or season to season.

No humidity compensator has, as yet, had any commercial acceptance. Precautions to reduce the injurious effects of humidity are still the best expedient. By use of non-hygroscopic insulating materials, and intelligent use of high-grade, moisture-proofing waxes or varnishes wherever necessary, humidity variations can generally be reduced to a second order effect. It must be remembered, however, that some precautions taken to overcome the undesired effects of humidity (especially over-thick wax impregnation of tuning coils) can seriously *increase* the frequency drift caused by temperature change in these components. In general, however, the use of good insulating materials and proper moisture-proofing of coils, trimmers, etc., reduces the humidity-caused frequency shift to a low value.

### Effect of Aging & Vibration on Frequency Drift

Shift caused by changes in electrical properties of components due to *aging* can be troublesome, especially if mica trimmer capacitors or poorly designed coils that change values after going through many heat cycles are employed.

The right connections always put you  
**IN THE LEAD**

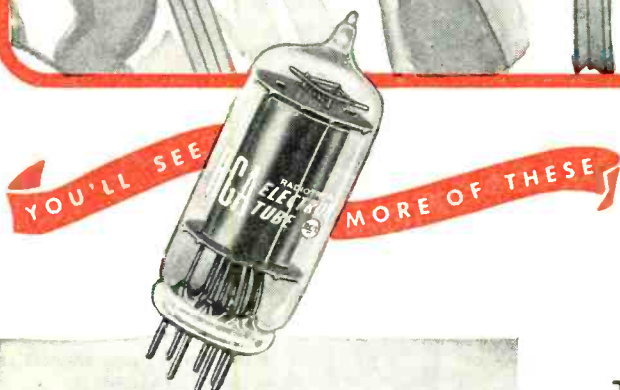

... and always see your  
**RCA Tube Distributor for  
BATTERIES, TUBES,  
PARTS, TEST EQUIPMENT**

*The Fountainhead of Modern  
Tube Development is RCA*

**P**EOPLE naturally seek out products of earned reputation. That's why the RCA Electron Tubes you sell enjoy such wide customer acceptance—for RCA has become a household word.

What's more, your identification with RCA lends prestige to your business—brings more people to your shop for other things, too.

So, push RCA Electron Tubes and watch your business grow!



**TUBE DIVISION**

**RADIO CORPORATION of AMERICA**

**HARRISON, N. J.**



**FREE**

**TO YOU**

**COLOR CODE  
and OHMS LAW CALCULATOR**

**Great Time Saver**

Burstein-Applebee of Kansas City offers you this great convenience **FREE**. Easy to work. Solves many problems in a jiffy. **FREE** to Radio men, electronic engineers and others in the business. Attach coupon to your letterhead.

**MAIL COUPON NOW**



BURSTEIN-APPLEBEE CO.  
1012 MCGEE ST.  
KANSAS CITY 6, MO.  
Send me **FREE** Color Code and Ohms Law Calculator along with latest catalog.

I am \_\_\_\_\_  
STATE CONNECTION IN INDUSTRY  
NAME \_\_\_\_\_  
ADDRESS \_\_\_\_\_  
TOWN \_\_\_\_\_ STATE \_\_\_\_\_

**Crystalab AMATEUR CRYSTALS  
IMMEDIATELY AVAILABLE!**



**CRL-20**  
14,075 to  
14,725 KC

7,038 to  
7,362 KC

**CRL-16**  
14,075 to  
14,725 KC

7,038 to  
7,362 KC

for frequencies released Nov. 15th by F. C. C. for Amateurs

• These units are supplied at frequencies between the limits set by the F. C. C.; exact crystal frequency is marked on each holder. The 14 meg. crystals can be used by doubling directly to operating band. The 7 meg. crystals are at 1/3 of operating frequency. All units are low drift, precision cut crystals. CRL-16 has 1/2" between pins (plug-in type — fits std. octal socket) CRL-20 can be soldered in place — Soldering will not affect performance of unit.

See your local radio dealer, or write to;



**CRYSTAL RESEARCH LABORATORIES**

INCORPORATED  
LABORATORIES AND MAIN OFFICE: 29 ALLYN STREET, HARTFORD 3, CONN  
New York Office: 15 E. 26th Street, New York 10, N. Y Phone MU 5 7957

Many manufacturers give their components initial *aging* or *heat cycle* treatments to eliminate stresses set up in the materials during the process of manufacture and factory adjustment, thus improving them from the standpoint of subsequent aging.

*Mechanical vibration* can seriously affect the frequency stability of an oscillator if the design of the individual components is such that movement of parts and wires is not prevented. This usually shows up as a frequency modulation of the oscillator output signal. The vibration can be due to external causes, or to audio vibrations set up by the receiver's loudspeaker itself. The components in the frequency-determining circuits of the oscillator should be well designed and mounted as close together as practicable to provide short leads. Right-angle bends in connecting leads should be avoided, as they are especially susceptible to vibration effects. The variable tuning capacitor should have a comparatively wide plate spacing, light plates, and good bearings that do not permit end-play. It may be necessary to mount it so it *floats* on properly designed live-rubber cushions. If adjustable trimmer-type capacitors are used, the ceramic dielectric type (Fig. 6) will be found to possess the advantage of having its capacitance adjustments unaffected by vibration. Vibration is especially prevalent in aircraft, and much about good vibration-proof (and shock-proof) receiver design practice can be learned by detailed examination of successful aircraft receivers.

Sudden *shock* may also affect the frequency stability—especially in receivers employed in military vehicles, etc., where the components not only are subjected to shock from the natural action of the carrying vehicle but also that due to gunfire, explosions, etc. Effective receiver shock-mountings of live rubber are available for reducing the effects of such shock upon the oscillator components. Fig. 5 illustrates the use of such mountings in an aircraft receiver.

**Effect of the Tube on Oscillator Frequency Stability**

When the tube is added to the tuned circuit and the other components necessary to make up an oscillator, several factors that affect frequency drift are introduced. The effect of the heat generated within the tube itself (oscillator or converter tube) changes its input capacitance (which shunts the oscillator tuning circuits) slightly, due to expansion of some of the tube elements with respect to others. The effect of this capacitance variation can be reduced by employing a comparatively large C/L ratio in the oscillator tuning circuit (in grid-tuned oscillators). Variations in the tube capacitance will then have less effect on the tuning of the oscillator grid circuit since they will be very small in comparison with the oscillator tuning capacitance already in the grid circuit. Too low a value, however, tends to



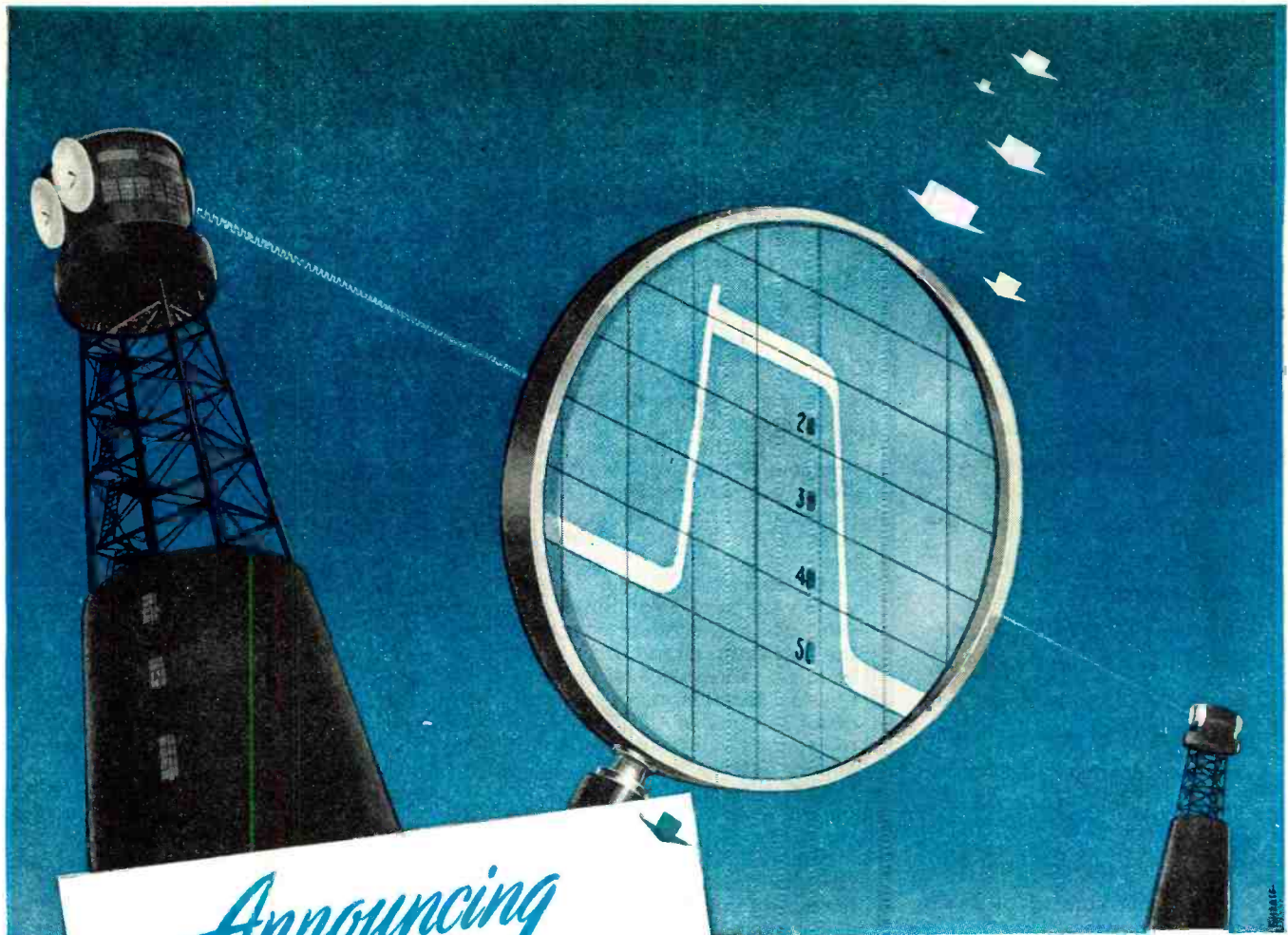

*Announcing*  
**THE NEW**  
**SPERRY Microline\***

As a reading glass aids visual search, so MICROLINE test and measurement equipment provides means for making all measurements at microwave frequencies.

Sperry announces a comprehensive line of microwave test and measurement equipment for labora-

tory and field use. The new line... the MICROLINE... is the outgrowth of years of research and experience in modern microwave techniques beginning with the development of the Klystron.

Write our Special Electronics Department for further information.

**Available now:**

**WAVEMETERS • WATTMETERS  
 BARRETTOR ELEMENTS  
 AND MOUNTS  
 DIRECTIONAL COUPLERS  
 KLYSTRON SIGNAL SOURCES  
 STANDING WAVE DETECTORS  
 ATTENUATORS  
 IMPEDANCE MATCHING  
 EQUIPMENT  
 WAVEGUIDE AND COAXIAL  
 COMPONENTS**

\*TRADE MARK

**SPERRY GYROSCOPE COMPANY, INC. GREAT NECK, N. Y.**



*Division of the Sperry Corporation*

★  
 LOS ANGELES • SAN FRANCISCO • SEATTLE • NEW ORLEANS  
 CLEVELAND • BROOKLYN • HONOLULU

**GYROSCOPICS • ELECTRONICS • RADAR • AUTOMATIC COMPUTATION • SERVO-MECHANISMS**

February, 1946

97

## RADIO AND ELECTRONIC

### ACCESSORIES

# SEEKING INSTALLATION!

Let Radionic's experienced personnel help you with your radio and electronic requirements.

At your call are large and varied stocks at lowest possible prices—prompt personal service, with all merchandise guaranteed! For a quarter-century, Radionic's management has specialized in serving Repair Dealers, Amateurs, Equipment Builders, Laboratories, etc.

So, send today for your free copy of our catalog of Radio and Electric parts—a valuable buying guide for dealers and amateurs.



Radionic Equipment Co., Dept. W2  
170 Nassau Street  
New York 7, N. Y.

Gentlemen:  
Please send me, without charge, your new catalog.

Name.....

Address.....

City.....State.....

Nature of Business.....



make oscillation difficult. Also, with the exceptions of those push-button operated receivers that do not employ a conventional variable tuning capacitor for optional manual tuning, and band-spread receivers with fixed-signal tuning, the values of  $L$  and  $C$  that can be used are pretty much fixed by oscillator-preselector circuit tracking consideration, and there is a limit to the amount of  $C$  that can be used in the oscillator tuning circuit, especially on the higher frequencies. Another method is to reduce the tube load on the tuning circuit by tapping down on the tuning coil.

The frequency drift caused by the variation in oscillator tube input capacitance resulting from thermal expansion of the tube elements, while appreciable, usually is quite rapid, since the tube reaches a stable temperature within a comparatively short time. The oscillator tube usually comes up to within 90 per-cent of its final normal operating temperature within the first 15 minutes of operation, while the other components in the oscillator circuit may require an hour or more, depending upon their physical location, mass, and other factors. Because of this, it is fairly safe to assume that any oscillator frequency drift encountered during the first few minutes of operation after the receiver is switched on is due to the tube.

Frequency drift caused by the oscillator tube usually does not account for more than a third of the total drift of the complete receiver, and part of this  $\frac{1}{3}$  is usually due to the change in the tube socket capacitance that results from the change in dielectric constant of the insulating material of the socket when it warms up. This is illustrated by the following approximate analysis of the temperature rise, capacitance change and temperature coefficient occurring in the various portions of the 6J5 oscillator circuit of a typical well-designed receiver (Table 1).

Since fluctuations in the oscillator plate voltage affect the internal plate resistance of the tube and hence the oscillation frequency, it is important that the  $B+$  supply to the oscillator be adequately decoupled and smoothed. One method of reducing the influence of changes of plate resistance is to use loose coupling between the tube and the tuned circuit, such as by tapping across a part instead of the whole tuning inductance. However, in high-frequency receivers where need for constancy of oscillator frequency is most urgent, loose coupling is not compatible with stable and strong oscillation. Accordingly, a compromise must be effected in their oscillator design.

Fortunately, the frequency stability (with nominal values of supply-voltage fluctuations) of an oscillator using normal circuits is sufficiently good so as to cause little trouble from this source. It becomes a problem only in those types of receivers that employ extremely sharp tuning in the

intermediate amplifier, or whose line or plate voltage supply undergoes appreciable voltage variation.

(To be continued)

## Phase Inverters

(Continued from page 62)

the plate is equal to the peak positive voltage at the cathode. Since these two voltages are of opposite polarity, or, in other words, they are 180 degrees out of phase, they may be utilized to drive a push-pull amplifier.

The exact values of resistors  $R_2$  and  $R_3$  are not very critical and any value from twenty thousand ohms upwards to fifty thousand ohms is satisfactory as long as both values are the same, the higher value giving slightly higher output voltage. The circuit could also be adapted to the high gain type triodes such as a 6F5, 6SF5, 6SQ7, etc., but the plate resistance of these tubes is so much higher that, in order to keep the plate resistor values above the plate resistance value a sufficient amount to keep the operation linear, the resistor values would be in the 100,000 ohm class with the result that the small amount of plate current in these tubes would be reduced nearly to zero.

The circuit has the advantage that it is simple. It is also entirely free from the effects of tube emission changes, since a change in the current in one resistor will likewise affect the current in the other resistor. The voltage drop across the resistors will be similar regardless of the condition of the tube and the phase inversion process will go on unaffected by any change in the voltages. As the circuit is the cathode follower type, considerable degeneration is present which tends to reduce distortion. Some method must be provided for obtaining bias for the tube, however, and the output of the circuit is very low—1.8 times the input voltage for resistor values of twenty thousand ohms and this rises to about 3 with the higher values of resistors. This small amount of voltage is usually insufficient except for the smaller tubes such as the 25L6, 7A5, and other tubes which require less than 7 or 8 volts driving power for full output. The circuit can be utilized, however, to drive push-pull triode driver tubes with very good results and, because of the balance and low distortion, it is highly recommended for this type circuit, if some external bias voltage is available.

In Fig. 5, this circuit has been modified to provide self bias. Fig. 5A shows the basic circuit as it was first used. Cathode resistor  $R_2$  is heavily bypassed by  $C_1$ , and the grid return resistor  $R_3$  is connected to the junction of  $R_2$  and  $R_3$ , where the next stage audio voltage is also taken off. Because  $R_2$  is heavily bypassed, very little audio voltage is developed across it and, therefore, no degeneration takes place. This accounts for the high gain of the circuit. Theoretically

GET HIGH FIDELITY, BI-DIRECTIONAL ADVANTAGES

with *Electro-Voice*

# Velocity Microphones

Flat Frequency Response  
Insures True Reproduction

Dead at Sides, Top, Bottom—  
To Reduce Unwanted Sounds

Wide-Angle Pick-up—  
Greater Pick-up Range

Usable Front and Back  
at the Same Time

Model V-1



Years of special E-V "know how" make possible the full utilization of the ribbon velocity's high fidelity characteristic.

In Model V-1, you get true reproduction without imposed peaks and dips. Pole pieces are designed to insure adequate high frequency reproduction and provide ample output. One-piece frame and internal mounting structure is exclusively E-V—jars and mechanical shocks cannot shift parts.

Bi-directional polar pattern provides equal front and back pick-up, zero pick-up at sides, top, and bottom. Proper tilting reduces feedback and unwanted sounds.

Excellent for solo or orchestra—for individual or chorus—for single speaker or groups . . . in public address, broadcasting, and recording.

Substantially flat from 40-9000 cps. May be used with any modern amplifier designed for crystal or dynamic microphones. Handy size. Easily tilted. Standard 5/8"-27 thread. "On-Off" switch.

**Model V-1** Hi-Z (direct to grid), 50, 200, 250 or 500 ohms. List Price . . . . . **\$30**

Model V-2 List Price \$37.50      Model V-3 List Price \$50

AUTHORIZED DISTRIBUTORS EVERYWHERE

No finer choice than

# Electro-Voice

## M I C R O P H O N E S

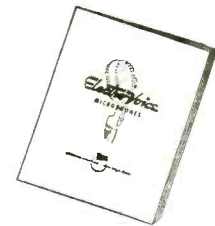

SEND FOR CATALOG

Valuable data on Microphones for Communications, P. A., Broadcasting, Recording. Includes Reference Level Conversion Chart.

ELECTRO-VOICE, INC., 1239 South Bend Ave., South Bend 24, Indiana  
Export Division: 13 East 40th St., New York 16, N.Y., U.S.A.—Cables: Arlab  
February, 1946

# LEOTONE MONTHLY SPECIALS

Brand New R.C.A. UX200 tubes in sealed cartons (detector & Ampl.) . . . 8 for \$1.00  
 Following tubes in perfect condition but not in sealed cartons. Guaranteed for 90 days.

Nos. 26, 27, 46 & 56	ea.	.29
Nos. 120, 250 & 6A3	ea.	.95
Nos. 77 & 42	ea.	.49
Majestic 90 Bronze Dial Plate. Exact K.C. calibration. O.D. 5/4" Shaft hole 3/8"	ea.	1.50
Fada Drum Dial & Scale. No. 871 MP. 1/2" shaft hole, O.D. 4 1/2". Specify zero at top or bottom of scale	ea.	1.50
Crosley Pinion Gear for Dial Drive. Specify model No. 3/16" shaft hole	ea.	.70
Screen Grid Caps. 7" stranded leads att'd		
Fits No. 24 tubes etc. 100 for		2.00
8" turntables, 3/8" shaft hole. Flocked	ea.	.89
Same as above—Unflocked	ea.	.49
Stranded shielded wire for phonograph pickups. O.D. 3/32" 100 ft. spool		2.75
12 Ohm, 20 Watt resistors 2" long	ea.	.10
100 Ohm, 150 Watt resistors 5 3/4" long	ea.	.69
Standard voltage dividers. Kit of 20		5.00
Assort. Grid Leaks. Kit of 12		.35
Bakelite tubing for coils. 15 assort. lengths	1.00	
Heavy duty Horseshoe magnets. 4" long. Ship. wt. 20 oz.	ea.	.29
6 prong wafer sockets. Mfg. 1 1/2" . . . 35 for	1.00	
Magnavox carbon mikes. (Ant. Noise XMTR)	ea.	1.75
1 MFD Dubilier paper wound Condenser. D.C. flash test 800 v	ea.	.10
Oval loop antennas 12" x 8"	ea.	.39
Midget Alnico magnets 1 1/16" long	ea.	.35
Heavy duty brass binding posts. Nickel plated	ea.	.06
Chassis Cradle. Holds radio in position for testing, rep. etc.		4.75
Duplex twisted stranded tinned wire. Both wired (black & red) Vinylite covered and enclosed in Vinylite jacket. Ideal for Comm. system, long and short wave aerial, television and line work. O.D. 1/4", 3 1/2 c per ft. 250 ft.		5.00
Dial scales. Aeroplane & slide-rule type (acetate & glass incl.) set of 25 assorted.		2.98
3/8" blank celotex. 14 1/4" x 14 1/2"	ea.	.19
4 MFD 600 V. transmitter condensers. 4 3/4" x 3 1/2" x 1 1/2". Paper & tinfoil wound	ea. 49; 5 for	2.00
Brown porcelain aerial insulators. Heavy duty. 1" O.D. 4" long.	20 for	1.00
Green or brown 12" turntable felts.	ea.	.23
Interstage push-pull trans. 2 3/4" high, 2" wide, 2" deep. Primary—8 M Ohm, C.T. Secondary—250 Ohms C.T.	ea.	.89
Green rubber insulated No. 21 B & S hook up or bell wire	100 ft. roll.	.49
Cone Assortment Kit of 12 popular cones—4" to 12". Molded & frill edge		2.00
Multi phone plugs for coupling 4 pairs of phones	ea.	.35
Slotted ball on-off toggle switch. 12 for	1.00	
12 assorted shields for tubes or coils		1.00
Flexible copper mesh roof antennas. Brocade covered	ea.	.49
4 prong ribbed short wave coil form. O.D. 1 3/8"	ea.	.12
Assorted electrolytic condensers. . . kit of 10		1.25
Yaxley 40 Ohm wire wound controls	ea.	.23
Complete kit of parts for slide coil type crystal set. Inc. isolantite base crystal detector		1.95
Bendix 4 tube 5 Watt Amplifier using the following tubes K55B, 25Z6, 25L6, 6J7		8.50
Completely encased in crackle finish cabinet. DIM—7 1/2" long, 6 5/8" high, 3 1/2" deep.		
W. E. platinum point telegraph key		.49

**20% DEPOSIT REQUIRED ON ALL ORDERS—PROMPT SERVICE ON ALL SPEAKER REPAIRS**  
 Write Dept. RN-2

**LEOTONE RADIO CO.**  
 MAKERS OF CONES AND FIELD COILS  
 65-67 DEY STREET, NEW YORK 7, N.Y.  
 WORTH 2-0284-5  
 12,000 SQ. FT. OF RADIO PARTS

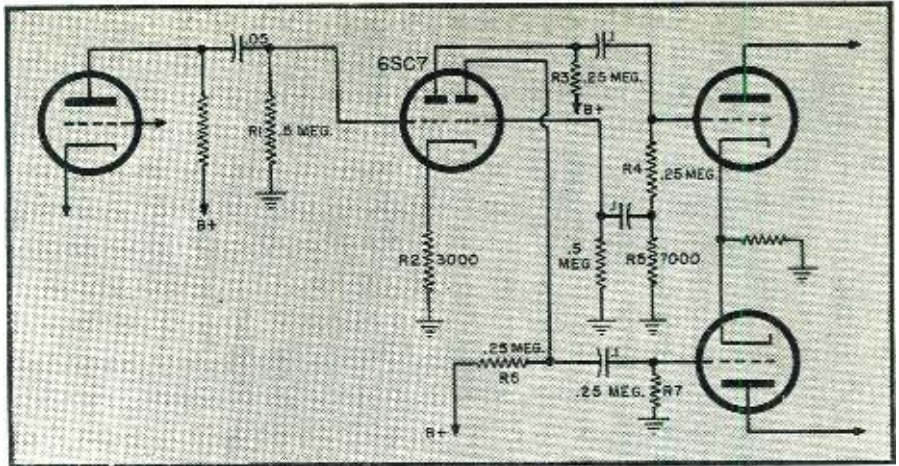

Fig. 6. Basic circuit used extensively in commercial sound systems.

cally, this circuit is not so good for phase inversion because of the stray capacities that are across  $R_3$ , i.e., the output wiring capacities of the preceding stage, which include coupling and decoupling condensers and tube output capacity. These capacities, it seems, would seriously affect the balance on high frequencies but they seem to affect it very little in practice.

In Fig. 5B, this basic circuit has been altered again. This time the total resistance of both plate and cathode resistors has been raised to fifty thousand ohms. The cathode condenser has been eliminated with the result that a small amount of degeneration is allowed. This degeneration lowers the gain of the tube with the result that the gains are similar to that obtained in the basic circuit, shown in Fig. 4. The values shown, when used with a 37 or 6J5 tube, give adequate voltage to more than drive a pair of 42's or 6F6's to full output of ten watts. In the two previous circuits (Figs. 4 and 5A) the value of  $R_2$  was the same as  $R_3$  in Fig. 4, and  $R_3$  the same as  $R_4$  in Fig. 5A, with the result that the added value of  $R_2$  (Fig. 5A) caused an unbalance in the circuit.

A method of getting around this unnecessary unbalance of resistance, as well as avoiding the effects of stray capacities across  $R_3$ , is shown in Fig. 5C. Here, the 50,000 ohm resistor is used in the plate circuit as before.  $R_2$  is made 5000 ohms and  $R_3$  is 45,000 ohms. The audio voltage for the next stage is then taken off the cathode of the tube. Much better fidelity and balance is obtained.

Although a great many assortments of resistor values may be used in these foregoing circuits, a plate resistor value of 50,000 ohms seems to give the best results of any tried. This value gives a wide frequency response, the high frequency cut-off point is well above the audio range and the low frequency response is excellent. Because the value is high enough to place it well above the plate resistance value of any of the common triodes that may be used, the circuit conditions are ideal for class-A operation.

In Fig. 6, we have the basic circuit

used in most commercial sound systems. A dual triode, such as a 6SC7, 6SN7, 6C8, or 6N7, is used for the inverter tube. The input voltage applied to the first grid of the 6SC7 is amplified and applied to the grid of the next stage across resistors  $R_4$  and  $R_5$ . The ratio of these resistors determines the grid voltage to the second section of the inverter tube and is equal to the output voltage of the first section, divided by the input voltage. Since the gain of this circuit, using a 6SC7, is 36, the ratio of  $R_5$  to the total value of  $R_4$  plus  $R_5$  will be 36 and, in this case, the values of resistors are 250,000 ohms for  $R_4$  and 7000 ohms for  $R_5$ , which gives us a voltage across  $R_5$  which is approximately  $1/36$  of the output voltage or, to be exact, it is equal to  $7000/257,000$  of the output voltage and this is also approximately equal to the voltage on the grid of the first section. Since the plate resistors  $R_3$  and  $R_4$  are equal, as are the next stage grid resistors, the voltages applied to the next stage grids are equal in magnitude and 180° out of phase.

Because of the high gain, the stage is very sensitive. The input voltage must be kept well below two volts to avoid complete plate current cutoff with this particular tube. Any of the tubes mentioned may be used in this circuit. However, the others are less sensitive and, unless the voltage divider is adjusted, the balance will be affected. The balance of the two sections of the tube also affects the balance of the following stage. With the coupling condensers shown, the amplifier is rather "bassy" and, for better response, smaller condensers could be used. The high-frequency cutoff, however, is rather high, as in the case of all triodes.

In Fig. 7, we have a similar circuit. In this case we use a 6C8 inverter and operation is essentially the same. The tubes used in the previous circuit may well be used in this one and the choice of tubes will depend largely upon the necessary output voltage. The 6C8 or 6F8 have a top cap connection, while the others are single ended. The 6F8 is essentially two 6J5's in one envelope

# Stock only **4** AUTO-RADIO VIBRATOR MODELS!



Model 1703  
serves 738  
auto-radios



Model 2089  
serves 237  
auto-radios



Model 2041  
serves 75  
auto-radios



Model 2088  
serves 72  
auto-radios

## **4** Vibrator Models cover 95% of all auto-radio replacement demand! Faster Turnover... Greater Profits

Think of it! To serve the 1122 auto-radio models comprising 95% of the replacement demand, you need stock only 4 models of E-L Vibrators. This is a *real standardization plan* that means increased profits for E-L dealers and distributors. Save on shelf space too! Not only fewer models to stock but E-L Vibrators are smaller in size than other makes as well.

### 33% Longer Life

E-L engineers devoted many months of thorough research to determine the exact requirements of auto-radios... and adapting to them E-L models whose design and exclusive features have been proved in the toughest of proving grounds... military service.

These E-L Vibrators synchronous and non-synchronous are of balanced resonance construction designed especially for heavy duty service. Tests show that they provide 33% longer vibrator life, with output and starting voltages held virtually constant at all times.

### See Your E-L Distributor

With your order, you'll receive your copy of the new E-L Auto-Radio Vibrator Replacement Guide. Designed to hang on your wall, it will tell you instantly which E-L Vibrator to use for most auto-radios as far back as 1936. See your E-L distributor!

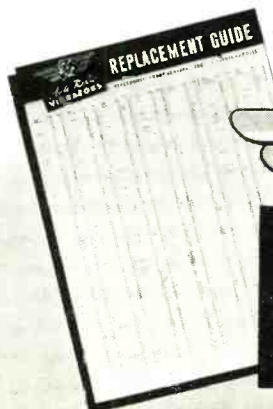

**Electronic**  
**LABORATORIES, INC.**  
INDIANAPOLIS

VIBRATORS AND VIBRATOR POWER EQUIPMENT FOR LIGHTING, COMMUNICATIONS, ELECTRIC AND ELECTRONIC APPLICATIONS

# HENRY RADIO

We are delivering these models as fast as available:

Skyrider Jr. S41 . . . . .	\$ 33.50
Hallicrafters S20R . . . . .	60.00
Hallicrafters S22R . . . . .	74.50
Hallicrafters S39 . . . . .	110.00
Hallicrafters SX-25 . . . . .	94.50
Hallicrafters SX-28A . . . . .	223.00
Hallicrafters S36A . . . . .	415.00
Hallicrafters S37 . . . . .	591.75
EC1A . . . . .	29.50
National N-2-40-C . . . . .	225.00
National One-Ten . . . . .	56.10
National HRO Sr. . . . .	197.70
RME-45 . . . . .	166.00
Hammarlund HQ129X . . . . .	129.00
Hammarlund Super Pro . . . . .	318.00
HT-9 Transmitter . . . . .	225.00
T350XM Transmitter . . . . .	850.00

**DEMAND** for some models exceeds supply. A few models we ship at once. Enter your reservation for earliest delivery. You can trade in your receiver. You can order on our 6% terms. Write for information. We specialize in receivers and transmitters but also have crystals, transmitting tubes, microphones, test equipment, etc. Your inquiries welcomed.

## HENRY RADIO

BUTLER, MISSOURI AND  
LOS ANGELES 25, CALIF.

"WORLD'S LARGEST DISTRIBUTORS  
OF SHORT WAVE RECEIVERS"

and is a very good inverter tube where low gain is desirable.

The proper choice of resistors here is made in the same manner as in Fig. 6. Although the values in the diagram should be 240,000 ohms and 10,000 ohms respectively, we make the plate resistor 250,000 ohms as that value is standard. When designing inverters, it is best to go over the resistor stock and choose a value which is as close to the correct value as is possible. Since a tolerance of ten per-cent is almost always allowable without serious unbalance, in a resistor of this size, twenty thousand ohms does not affect the operation very much. The circuit has the definite advantage over that of Fig. 6 that it avoids the effects of coupling condenser and the input capacity of the following tubes, as the inverter grid voltage is taken off the driver tube plate circuit.

In Fig. 8, we have a modified arrangement of Fig. 6, which compensates for a part of the unbalance that might otherwise occur. The modification consists of breaking the 7000 ohm voltage divider into two 3500 ohm resistors,  $R_2$  and  $R_3$ . Another 3500 ohm resistor,  $R_4$ , is placed in the grid return of  $VT_2$ . Thus, the total grid voltage for  $VT_1$  is formed across points A and B and the total grid voltage for  $VT_2$  is formed across points B and C but each of these voltages is opposed by a bucking voltage that is formed across  $R_3$ . This occurs because the signal voltages from each grid return circuit must pass through  $R_3$ . Therefore, when considering the positive half cycle of the signal voltage, it is necessary to realize that the negative half cycle is being formed across  $R_3$  as well. This, then, results in a balancing action because any difference in output voltage from one half of the phase inverter will be counterbalanced by an increase or decrease, as the case may be, of the opposing voltage from the other half of the inverter. Thus, a degree of automatic balancing takes place which will compensate for small voltage differences in the output voltage of the phase inverter. The circuit is slightly degenerative, reducing

the gain slightly, but improved performance compensates for the loss in driving power and distortion in the output stage is reduced sufficiently so that the amplifier may be run wide open to make up the difference in driving power.

This circuit is applicable not only to dual triodes but also single triodes operating in similar circuits and, not long ago, it was tried in an amplifier in which two resistance coupled triode driver tubes were used, operating from a pair of similar tubes, and the balancing action was very good, even when not used with a phase inverter-driver. In that amplifier, it was necessary to use a 6SC7 inverter driving a pair of 6C5's which in turn were used to drive a pair of 6J5's in class-A and these were transformer coupled to four 6L6G's, class-AB<sub>2</sub>. The balancing circuit was used in the 6J5 grid return circuit since a more suitable resistor network presented itself.

In Fig. 9, we have a circuit where the phase inversion takes place in the second detector stage of the receiver. Two .1 megohm resistors are connected across the audio output of the second detector with their common tap grounded. The effect is essentially the same as a center tapped transformer, the demodulated output of the second detector dividing itself equally across these resistors. Two condensers  $C_1$  and  $C_2$  having a value of 250  $\mu$ fd. are used as r.f. filter condensers to reduce the r.f. potential left in the demodulated second detector output. Coupling condensers  $C_3$  and  $C_4$  may be of any value, .01  $\mu$ fd. being the value generally used.

This circuit, while of low output, has the advantage of perfect balance since the output is not dependent on the tube characteristics. The output, however, is so low that it cannot be utilized to drive a power stage. However, it could be used with tubes such as 6J5's to provide driving power for a high power amplifier. The output would then be sufficient to drive a pair of 6F6's to full output or it could drive 6L6's to about fifteen or eighteen watts if the receiver over-all gain were high

Fig. 7. A dual triode is used as an inverter tube. Like Fig. 6, no transformers are needed in its operation. The 6C8 is considered a good inverter tube.

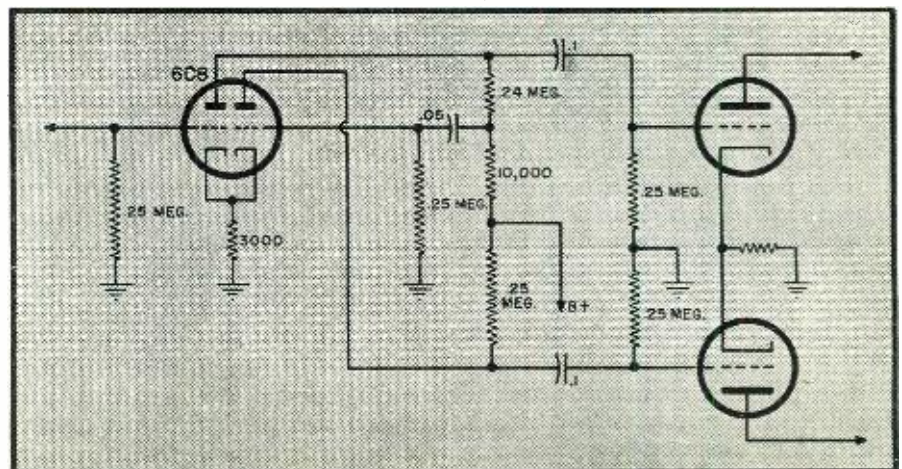

**THERE IS ONLY ONE**

# **RIGHT WAY TO TRAIN FOR TELEVISION**

**First**

See Television.

**Second**

Learn television from engineers who work in the industry.

**Third**

Train with real up-to-the-minute television broadcasting and receiving equipment. Be expert in servicing, operating, and engineering, so that you are capable of taking a job in the industry.

**Finish**

By working with real television studio production experts with actual performances and with television manufacturing engineers in a large, up-to-date laboratory, so that you can become expert in the branch of television you are most capable of following. This is the right way to get into television and the way of

**AMERICAN TELEVISION LABORATORIES, INC.**

**433 E. Erie St., Chicago 11, Illinois**

*Where there are day or evening classes, full or part time*

**A NATIONAL ORGANIZATION**

**APPROVED FOR GI TRAINING**

**AMERICAN TELEVISION INSTITUTE**

**Division of American Television Laboratories, Inc.**

**433 E. Erie Street**

**Chicago 11, Illinois**

Please send me information regarding television training.

Name ..... City .....

Address ..... State .....

**Test Instrument**  
(Continued from page 34)

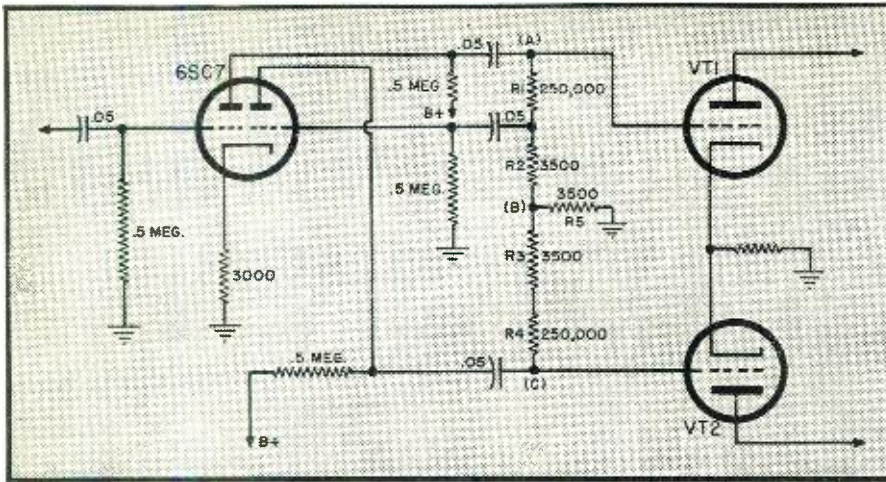

Fig. 8. Modified arrangement of Fig. 6. This circuit compensates for part of the unbalance that might otherwise occur.

enough to provide approximately two volts at the driver grids.

This about covers the assortment of phase inverters that are very useful at present. A few facts to remember about phase inverters are, never bypass the cathode resistor unless specified. The system usually is necessarily designed in such a manner that the output would be highly distorted were it not for the degeneration that takes place when the cathode is left unbypassed. Other than for the bypass condenser, the inverter is usually designed like a regular class-A amplifier. Ordinarily, the resistor values used are the same as they would be in the case of an ordinary class-A amplifier stage and are split up accordingly in the voltage dividers. Remember, the audio voltage will divide itself across a resistor in the same manner d.c. voltage does. Whenever designing or servicing a phase inverter system, where two tubes are used or if a dual triode is used, make sure they both have identical emissive characteristics or are as close to being identical as it is possible to get them.

Although a good tube tester and an ohmmeter is all the equipment that is necessary when designing and servicing phase inverters, a signal tracing

unit such as a chanalyst is desirable, since it is possible to measure the actual balance of voltages. An oscilloscope, of course, can be used for the same purpose and with it, you can also observe the phase relationships of the voltages. The balance of the voltages is always dependent on the resistors, the values of the coupling condensers, and tube characteristics. As long as the resistor values are chosen correctly, the coupling condensers are identical and the tube characteristics are identical, the operation of the two sides of the amplifier will be identical. Distortion in a phase inverter can usually be traced to unbalance caused by one or more of those parts changing value enough to impair operation. The resistors have a tendency to change value as some of them have a rather high audio voltage across them and run rather hot.

The phase inverter is a handy system for the serviceman in these days of shortages, since one can be hooked up in the average shop in a few minutes. As the fidelity is high, the customer is well pleased and the serviceman can make a neat profit on a job that he otherwise would have to refuse because of unavailability of parts or tubes.

other points set forth above, are completely eliminated, may really dependable, stable and continually accurate results be had.

The instrument possessing these vitally required features is illustrated in Figs. 1, 3 and 4, while its pleasingly open and non-confusing meter scale appears in Fig. 2. This latter is worth serious consideration, for in routine design and service work it is only too easy to confuse the selected meter scale when the meter face is crowded with many scales, thus making serious errors. The ability to reduce so many different functions to so few scales provides assurance of functional uniformity and identity, in themselves most important. It will be noted in Fig. 2 that all voltage ranges, a.c., d.c., and r.f. are read upon but two scales, that the slope of all is identical except for the 3-volt a.c. range. Here the unavoidable slope in diode operation at low input voltages necessitates a separate scale. Had the lowest range been made approximately 5 volts, this non-linearity would have been swamped out, exactly as it is on all but this one range. Yet, a 3-volt range is more useful in r.f., i.f., and a.f. amplifier work than is one of almost twice its magnitude, since it permits measurement of much smaller signal voltages and signal tracing is one of the features which postwar service technicians simply cannot be without. It will be noted that the six resistance ranges require but one scale, the range switch simply indicating the number of zeros to be added to the observed resistance reading. The two center scales, differing only in figures above and below the line, take care of all voltage ranges but the 3-volt a.c. range, again by adding zeros to the observed reading as indicated by the range switch (or by multiplying by 2.5 and adding appropriate zeros for the 12 d.c. ranges at 125 megohms input resistance). The three db. ranges require but one scale, with three sets of range figures in the ample space below the db. scale. There is little point in detailing here the work required to simplify the meter scale to this degree, tying back as it does to complex circuit behavior, but only to hope that it may prove a welcome relief to overworked technicians.

**One Zero Setting for 51 Ranges**

Another important operating point is the simplicity of zeroing this instrument. One zero knob, and one single adjustment thereof, sets zero at start of operation for every voltage-db. range. One single ohms adjust knob sets each resistance range to full scale at start of measurement with but a single adjustment. Zero does not shift about when ranges are changed but is set once and for all by one adjustment, as it should be in any properly de-

(Continued on page 114)

Fig. 9. Circuit diagram of a phase inverter which is somewhat unusual. Phase inversion takes place in the second detector stage of receiver.

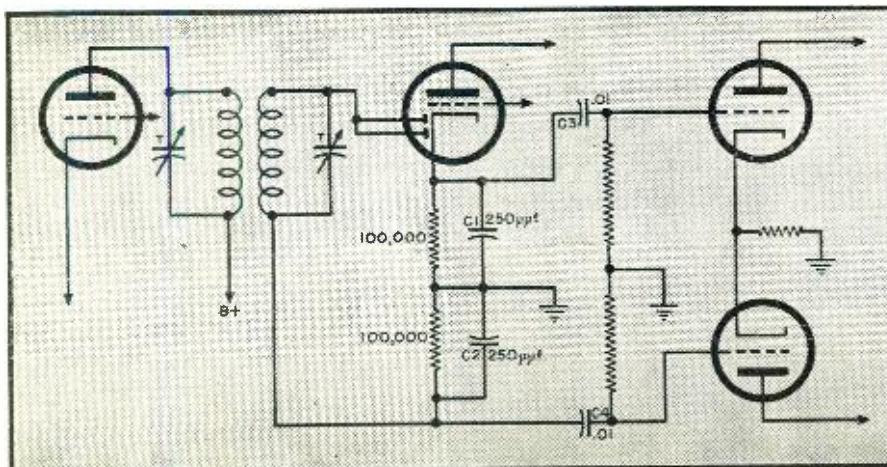



# SILVER



## "VOMAX"

Leaving far behind the limitations of conventional testers and electronic voltmeters, "VOMAX" blazes new trails to make the serious service technician the master . . . no longer the victim . . . of service and design problems. With "VOMAX" you can measure every voltage found in radio receivers.

What this means in time saved . . . work better done . . . increased profits . . . is conclusively proved by overwhelming acceptance of "VOMAX". Since V-J Day the military, university research groups, atomic bomb laboratories, service technicians by the thousands have forced production up . . . and again up.

Read the briefed specifications at right, and you will realize why "VOMAX" is the primary "must" for every service technician. Built to rigid specifications . . . using finest of parts . . . no wonder OPA ceiling is much the higher than \$59.85.

Your favorite jobber can supply "VOMAX" . . . make you master of your trade, for only \$59.85 if you order now.

OVER 34 YEARS OF RADIO ENGINEERING ACHIEVEMENT

*McMurdo Silver Company*

1240 MAIN STREET, HARTFORD 3, CONNECTICUT  
February, 1946

### Measures EVERY Voltage

1. Brand new post-war design . . . positively not a "warmed-over" pre-war model.
2. More than an "electronic" voltmeter, VOMAX is a true vacuum tube voltmeter in every voltage resistance db. function.
3. Complete visual signal tracing from 20 cycles through over 100 megacycles by withdrawable r.f. diode probe.
4. 3 through 1200 volts d.c. full scale in 6 ranges at 51 and in 6 added ranges to 3000 volts at 125 megohms input resistance. Plus-minus polarity reversing switch.
5. 3 through 1200 volts a.c. full scale in 6 ranges at honest effective circuit loading of 6.6 megohms and 8 mfd.
6. 0.2 through 2000 megohms in six easily read ranges.
7. -10 through +50 db. (0 db. = 1 mw. in 600 ohms) in 3 ranges.
8. 1.8 ma through 12 amperes full scale in 6 d.c. ranges.
9. Absolutely stable—one zero adjustment sets all ranges. No probe shorting to set a meaningless zero which shifts as soon as probes are separated. Grid current errors completely eliminated.
10. Honest factual accuracy: ±3% on d.c.; ±5% on a.c.; 20Ω through 100 megacycles; +2% of full scale, -1% of indicated resistance value.
11. Only five color-differentiated scales on 4" D'Arsonval meter for 51 ranges (including d.c. volts polarity reversal) eliminate confusion.
12. Meter 100% protected against overload burnout on volts ohms db.
13. Substantial leather carrying handle. Size only 12" x 7" x 5 7/8".

Send postcard for free catalog of measurement and communication equipment.

# "VOMAX"

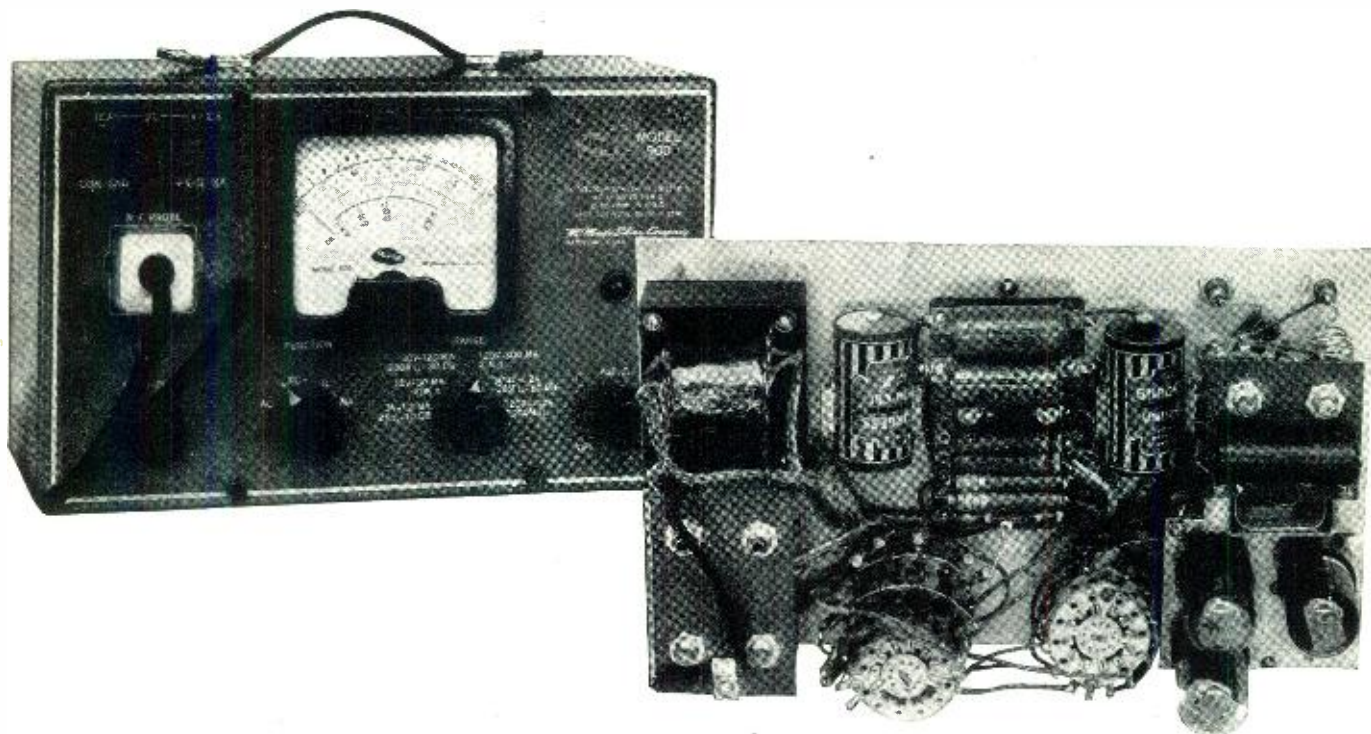

- As time-seasoned designers and manufacturers of high-quality radio and electronic components, we take understandable pride in the regular selection of our products by the world's greatest engineers . . . their specification for the world's finest equipments.
- We are particularly proud of the specification of our components for the outstanding "VOMAX" by such a respected and seasoned engineer as McMurdo Silver. In it we find that unusual versatility and breadth of performance which makes "VOMAX" truly a post-war instrument of almost unlimited capability . . . a tremendous boon to serious laboratory and maintenance technicians.
- "VOMAX" is more than good. — It is extraordinary . . . a truly universal vacuum-tube voltmeter incorporating the full benefits of visual dynamic signal tracing all the way up to above 100 megacycles. It already serves in renowned research laboratories — in service organizations by the thousands.
- The specification of our products for such a new and advanced instrument as "VOMAX" . . . by such an internationally respected engineer as McMurdo Silver . . . is more than a recommendation. It is proof positive that you, too, will always get that *extra* measure of merit and value in our radio-electronic components.

**SOLAR MFG. CO.**  
285 Madison Ave., New York 17, N.Y.

**ALPHA WIRE CORP.**  
50 Howard St., New York, N. Y.

**BEEDE ELECTRICAL INSTRUMENT CO.,**  
Penacook, N. H.

**CLAROSTAT MFG. CO., INC.**  
130 Clinton St., Brooklyn 2, N. Y.

**HYTRON RADIO & ELECTRONICS CORP.**  
Salem, Mass.

**DIAL LIGHT CO. OF AMERICA INC.**  
900 Broadway, New York 3, N. Y.

**INSULINE CORP. OF AMERICA**  
36-02 35th Ave., L. I. City 1, N. Y.

**AMERICAN RADIO HARDWARE CO.**  
152-4 MacQuesten Pkwy So., Mt. Vernon, N.Y.

**INTERNATIONAL RESISTANCE CO.**  
401 No. Broad St., Philadelphia, Pa.

**PREMIER METAL ETCHING CO.**  
21-03 44th Ave., L. I. City, N. Y.

# "VOMAX"



## THE UNIVERSAL V.T.V.M. YOU'VE ASKED FOR

We and you, our customers, have waited a mighty long time for that meter we knew you must have to be equipped for post-war work. At last we have it . . . in "VOMAX". It will directly measure every type and kind of receiver voltage and resistance, but accurately. Yet it's only \$59.85 net.

**PROMPT DELIVERY  
FROM 8  
CONVENIENT  
BRANCHES**

### MASSACHUSETTS

**BOSTON**  
42 Cornhill Lafayette 2546  
**LAWRENCE**  
639 Essex St.

### CONNECTICUT

**HARTFORD (Main Office)**  
203 Ann St. Tel. 7-3183  
**NEW HAVEN**  
1172 Chapel St., Tel. 5-6607  
**BRIDGEPORT**  
544 E. Main St. Tel. 5-3471  
**WATERBURY**  
89 Cherry St. Tel. 4-0009  
**STAMFORD**  
525 Main St. Tel. 4-7595  
**NEW LONDON**  
363 Bank St. Tel. 6684

# HATRY & YOUNG

The ELECT in Electronics

# "VOMAX"

### WILL INCREASE YOUR PROFITS, TOO

Without correct tools the greatest expert is "stumped" in service — wastes valuable time, loses profits. This needn't be you if you have "VOMAX". Measuring every type of receiver voltage, "VOMAX" speeds work to give you more profit. We suggest a quick order for early shipment. Only \$59.85

## R. G. SCELLI & CO.

317 Asylum Street, Hartford, Conn.  
84 Elm Street, Bridgeport, Conn.

# "VOMAX"



### OUTSTANDING FEATURES

D.C. Volts at 51 and 126 megohms.  
A.C. and r.f. volts at 6.6 megs.  
Resistance .2 ohms to 2,000 megs.  
D.C. current 1.2ma. through 12 amperes.  
D.B. — 10 through +50.  
PLUS visual dynamic signal tracing.

In our critical opinion these features establish "VOMAX" as standard of comparison. Early shipment at only \$59.85 net — as long as price holds.

**RADIO EQUIPMENT  
DISTRIBUTORS**  
709 SO. MAIN ST.  
LOS ANGELES 14, CALIF.

# "VOMAX"

### UNIVERSAL V.T.V.M. PLUS VISUAL SIGNAL TRACING

It's news to discover a meter truly universal — that will measure any and every type of receiver voltage, resistance, d.c. ma. and amperes, even capacity. But when it includes visual dynamic signal tracing too, we recommend it as the "buy" of buys. Prompt shipment at only \$59.85 net.

## SCOTT RADIO SUPPLY

265 ALAMITOS AVENUE  
LONG BEACH 2, CALIFORNIA

# "VOMAX"

IN CANADA  
\$90.00

# PAYETTE

& COMPANY LIMITED  
910 BLEURY, MONTREAL

# "VOMAX"

### EVERY MEASUREMENT, YET NO CIRCUIT LOADING.

Only with "VOMAX" can you measure every type of voltage in receiver servicing. Meter resistance is so tremendously high that "VOMAX" doesn't upset circuit operation even when used as visual dynamic signal tracer. No other instrument gives you this exclusive advantage. Price now only \$59.85, shipment fast on early orders.

**ARROWHEAD RADIO &  
TELEVISION SUPPLY CO.**  
1216 "D" St., San Bernardino, Cal.

# "VOMAX"

### MEASURES EVERY RECEIVER VOLTAGE

All those vital measurements you've never been able to make are "duck soup" to "VOMAX". At meter resistance so high as not to upset circuits you can now directly measure r.f., i.f., a.f., a.c., d.c. — all voltages — visual dynamic signal tracing on operating receivers. "VOMAX" makes you the master. Only \$59.85.

## UNIVERSAL RADIO SUPPLY CO.

715 So. Seventh, St. Louisville, Ky.

# "VOMAX"

### WILL INCREASE YOUR PROFITS, TOO

Without correct tools the greatest expert is "stumped" in service — wastes valuable time, loses profits. This needn't be you if you have "VOMAX". Measuring every type of receiver voltage, "VOMAX" speeds work to give you more profit. We suggest a quick order for early shipment. Only \$59.85.

**WELCH RADIO SUPPLY**  
408 9th St., South St. Petersburg, Fla.

# "VOMAX"

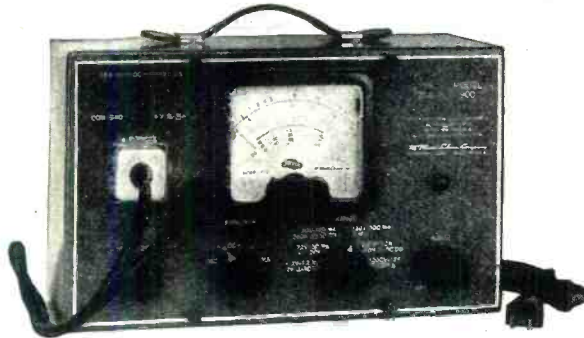

## WILL INCREASE YOUR PROFITS, TOO

Without correct tools the greatest expert is "stumped" in service — wastes valuable time, loses profits. This needn't be you if you have "VOMAX". Measuring every type of receiver voltage, "VOMAX" speeds work to give you more profit. We suggest a quick order for early shipment. Only \$59.85.

## RADIO PRODUCTS SALES CO.

1237-16th ST. CH. 6591  
DENVER 2, COLORADO

# "VOMAX"



### OUTSTANDING FEATURES

D.C. Volts at 51 and 126 megohms  
A.C. and r.f. volts at 6.6. megs.  
Resistance .2 ohms to 2,000 megs.  
D.C. current 1.2 ma. through 12 amperes.

D.B. — 10 through +50  
PLUS visual dynamic signal tracing.

In our critical opinion these features establish "VOMAX" as standard of comparison. Early shipment at only \$59.85 net — as long as price holds.

## LUKKO SALES

CORPORATION  
5024 IRVING PARK BLVD.  
CHICAGO 41, ILL.

# "VOMAX"

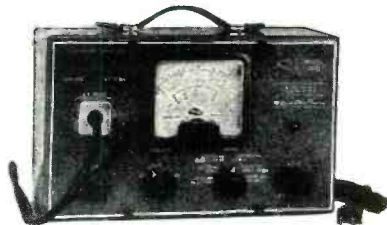

### OUTSTANDING FEATURES

D.C. Volts at 51 and 126 megohms  
A.C. and r.f. volts at 6.6 megs.  
Resistance .2 ohms to 2,000 megs.  
D.C. current 1.2 ma. through 12 amperes.

D.B. — 10 through +50.  
PLUS visual dynamic signal tracing.

In our critical opinion these features establish "VOMAX" as standard of comparison. Early shipment at only \$59.85 net — as long as price holds.

**WALKER-JIMIESON, INC.**

311 SOUTH WESTERN AVE., CHICAGO 12, ILL.

Phone CANal 2525

# "VOMAX"

## UNIVERSAL V.T.V.M. PLUS VISUAL SIGNAL TRACING

It's news to discover a meter truly universal — that will measure any and every type of receiver voltage, resistance, d.c. ma. and amperes, even capacity. But when it includes visual dynamic signal tracing too, we recommend it as the "buy" of buys. Prompt shipment at only \$59.85 net.

## Lurtz Electric Co.

210 NORTH ILLINOIS ST.  
BELLEVILLE, ILLINOIS

# "VOMAX"

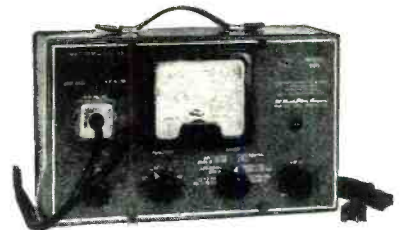

### OUTSTANDING

#### FEATURES

D.C. Volts at 51 and 126 megohms  
A.C. and r.f. volts at 6.6 megs.  
Resistance .2 ohms to 2,000 megs.  
D.C. current 1.2 ma. through 12 amperes.

D.B. — 10 through +50.  
PLUS visual dynamic signal tracing.

In our critical opinion these features establish "VOMAX" as standard of comparison. Early shipment at only \$59.85 net — as long as price holds.

## Newark ELECTRIC Company

115-117 W. 45th St., New York 19, N. Y.  
323 W. Madison St., Chicago 6, Ill.

# "VOMAX"

## A.C., D.C. and R.F. VACUUM TUBE VOLT-METER

True v.t.v.m. on a.c., d.c., ohms, db., all frequencies from 20 cycles to over 100 megacycles, "VOMAX" is what you have been asking for. With it you get resistance, capacity, power output, even power input. Demand is increasing every day. An immediate order will obtain prompt shipment. Only \$59.85 net.

## TRI-CITY RADIO SUPPLY

1919 4th AVE.  
ROCK ISLAND, ILLINOIS

# "VOMAX"

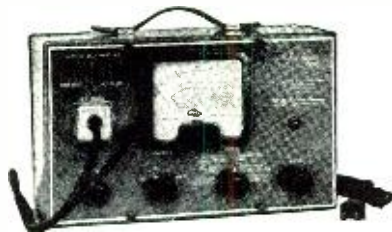

## OUTSTANDING FEATURES

D.C. Volts at 51 and 126 megohms  
 A.C. and r.f. volts at 6.6 megohms.  
 Resistance .2 ohms to 2,000 megohms.  
 D.C. current 1.2 ma. through 12 amperes.  
 D.B. -10 through +50.  
 PLUS visual dynamic signal tracing.

In our critical opinion these features establish "VOMAX" as standard of comparison. Early shipment at only \$59.85 net — as long as price holds.

ADDRESS — LEO, W9GFQ  
 COUNCIL BLUFFS, IOWA



# "VOMAX"

## NEW POST-WAR

### V.T. V-O-DB-MA METER

Pre-war meters weren't complete enough for pre-war servicing. Why accept less than complete measurements — r.f., i.f., a.f., a.c., d.c., a.v.c., a.f.c., etc., — including visual dynamic signal tracing 20 cycles through over 100 megacycles. "VOMAX" gives you this mastery. Prompt shipment. Only \$59.85.

**FULTON RADIO**  
 SUPPLY CO.  
 707 S. BLACKSTONE ST.  
 JACKSON, MICHIGAN

# "VOMAX"

## EVERY MEASUREMENT, YET NO CIRCUIT LOADING.

Only with "VOMAX" can you measure every type of voltage in receiver servicing. Meter resistance is so tremendously high that "VOMAX" doesn't upset circuit operation even when used as visual dynamic signal tracer. No other instrument gives you this exclusive advantage. Price now only \$59.85, shipment fast on early orders.

**NORTHWEST RADIO**  
 109 EAST FIRST ST.  
 DULUTH 2, MINN.

# "VOMAX"

## MEASURES EVERY RECEIVER VOLTAGE

All those vital measurements you've never been able to make are "duck soup" to "VOMAX". At meter resistance so high as not to upset circuits you can now directly measure r.f., i.f., a.f., a.c., d.c. — all voltages — visual dynamic signal tracing on operating receivers. "VOMAX" makes you the master. Only \$59.85.

**WARE RADIO**  
 SUPPLY COMPANY  
 913 CENTER ST.  
 BROCKTON 11, MASS.

# "VOMAX"

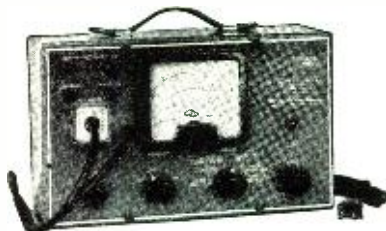

## OUTSTANDING FEATURES

D.C. Volts at 51 and 126 megohms  
 A.C. and r.f. volts at 6.6 megohms.  
 Resistance .2 ohms to 2,000 megohms.  
 D.C. current 1.2 ma. through 12 amperes.  
 D.B. -10 through +50.  
 PLUS visual dynamic signal tracing.

In our critical opinion these features establish "VOMAX" as standard of comparison. Early shipment at only \$59.85 net — as long as price holds.

## LEW BONN COMPANY

1211 LaSalle Ave. 141 W. 7th St.  
 MINNEAPOLIS ST. PAUL  
 MINN. MINN.

# "VOMAX"

## MEASURES EVERY RECEIVER VOLTAGE

All those vital measurements you've never been able to make are "duck soup" to "VOMAX". At meter resistance so high as not to upset circuits you can now directly measure r.f., i.f., a.f., a.c., d.c. — all voltages — visual dynamic signal tracing on operating receivers. "VOMAX" makes you the master. Only \$59.85.

**EVANS RADIO**  
 18 N. MAIN ST.  
 CONCORD, NEW HAMPSHIRE

# "VOMAX"

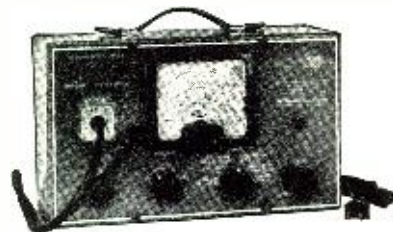

## OUTSTANDING FEATURES

D.C. Volts at 51 and 126 megohms  
 A.C. and r.f. volts at 6.6 megohms.  
 Resistance .2 ohms to 2,000 megohms.  
 D.C. current 1.2 ma. through 12 amperes.  
 D.B. -10 through +50.  
 PLUS visual dynamic signal tracing.

In our critical opinion these features establish "VOMAX" as standard of comparison. Early shipment at only \$59.85 net — as long as price holds.

## BURSTEIN-APPLEBEE COMPANY

1012-1014 McGEE ST.  
 KANSAS CITY, MISSOURI  
 Phone — VICTOR 7998

# "VOMAX"



## PROMPT SHIPMENT

Buy from the home of friendly service — close to your home! Our central location means fast shipment, better service and lasting satisfaction!

## WALTER ASHE RADIO CO.

1125 PINE ST. ST. LOUIS 1, MO.

# "VOMAX"

## UNIVERSAL V.T.V.M. PLUS VISUAL SIGNAL TRACING

It's news to discover a meter truly universal — that will measure any and every type of receiver voltage, resistance, d.c. ma. and amperes, even capacity. But when it includes visual dynamic signal tracing too, we recommend it as the "buy" of buys. Prompt shipment at only \$59.85 net.

**RADIO EQUIPMENT CORP.**  
326 E. LA STREET . . . BUFFALO, N. Y.

# "VOMAX"



## EQUIPS YOU FOR POST-WAR SERVICE

In complex post-war servicing profits go to the best equipped. That spells "VOMAX", basic tool of the biggest, best service organizations. You, too, can be up front with "VOMAX". We'll ship promptly this much - higher - OPA - ceilinged universal V.T.V.M. — if you order now — for only \$59.85.

**FISCHER  
DISTRIBUTING  
COMPANY**  
222 FULTON ST.  
NEW YORK 7, N. Y.

# "VOMAX"

## THE KEY TO SERVICE PROFITS

No technician can make his rightful profit without proper tools to work with. And what a tool is "VOMAX"! It insures you maximum profit by making "pipes" out of the "toughies", for it will measure directly every voltage, signal, power, etc., etc. Prompt shipment, and what a bargain — at \$59.85.

**DAVIS RADIO  
DISTRIBUTING CO.**  
66-70 E. THIRD ST.  
MOUNT VERNON, N. Y.

# "VOMAX"

## OPA CEILING FAR HIGHER

We can't see how "VOMAX", custom-built of the very top-quality parts, can be sold at only \$59.85 net. Performancewise it's unequalled — in a class by itself.

**METROPOLITAN  
ELECTRONICS & INSTRUMENTS CO.**  
258 BROADWAY  
NEW YORK, N. Y.

# HARRISON! HAS IT!



# "VOMAX"

PROMPT DELIVERY! IN STOCK!  
\$59.85

**NEW YORK CITY**  
12 WEST BROADWAY  
227 GREENWICH ST.  
Barclay 7-9854

**JAMAICA, LONG ISLAND**  
172-31 HILLSIDE AVE  
Republic 9-4102

**SINCE 1925 —**  
ELECTRONIC PARTS AND  
EQUIPMENT DISTRIBUTORS

**HARRISON  
RADIO CORPORATION**

# "VOMAX"

## IN STOCK FOR IMMEDIATE SHIPMENT

Instantly acclaimed as the standard of comparison by our customers, carrying our highest recommendation, our entire problem has been not sales, but shipments. Our stock is replenished. We can ship your "VOMAX" promptly. But the demand is heavy. We recommend immediate ordering. Still only \$59.85.

**HARVEY RADIO  
COMPANY**  
103 WEST 43rd ST.  
NEW YORK 18, N. Y.

# "VOMAX"



## THE UNIVERSAL V.T.V.M. YOU'VE ASKED FOR

We and you, our customers, have waited a mighty long time for that meter we knew you must have to be equipped for post-war work. At last we have it . . . more than we expected . . . in "VOMAX". It will directly measure every type and kind of receiver voltage and resistance, but accurately. Yet it's only \$59.85 net.

*Radio Wire  
Television Inc.*

100 Avenue of the Americas  
(formerly Sixth Avenue)  
New York 13

Boston, Massachusetts

Newark, New Jersey

Originators and Marketers  
of the famous

*Lafayette Radio*

# "VOMAX"

**EVERY MEASUREMENT, YET  
NO CIRCUIT LOADING.**

Only with "VOMAX" can you measure every type of voltage in receiver servicing. Meter resistance is so tremendously high that "VOMAX" doesn't upset circuit operation even when used as visual dynamic signal tracer. No other instrument gives you this exclusive advantage. Price now only \$59.85, shipment fast on early orders.

**CONTINENTAL  
SALES COMPANY**  
195-197 Central Ave. Newark, N. J.

# "VOMAX"

**A.C., D.C. and R.F.  
VACUUM TUBE VOLT-  
METER**

True v.t.v.m. on a.c., d.c., ohms, db., all frequencies from 20 cycles to over 100 megacycles "VOMAX" is what you have been asking for. With it you get resistance, capacity, power output, even power input. Demand is increasing every day. An immediate order will obtain prompt shipment. Only \$59.85 net.

**RADIONIC EQUIPMENT  
COMPANY**  
170 Nassau St. New York 7, N. Y.

# "VOMAX"

**IN STOCK FOR  
IMMEDIATE SHIPMENT**

Instantly acclaimed as the standard of comparison by our customers, carrying our highest recommendation, our entire problem has been not sales, but shipments. Our stock is replenished. We can ship your "VOMAX" promptly. But the demand is heavy. We recommend immediate ordering. Still only \$59.85.

**CAROLINA  
RADIO EQUIPMENT CO.**  
105 E. Martin St. Raleigh, N. C.

# "VOMAX"

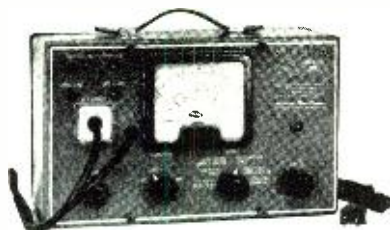

**PROMPT  
SHIPMENT**

## NIDISCO

*Radio Parts Distributors*

**JERSEY CITY 6, Journal Sq.**  
713 Newark Ave. 2-5543

**TRENTON, N. J. Trenton**  
147 N. Warren St. 3-4536

**PASSAIC, N. J. Passaic**  
205 Madison St. 2-4962

**CLIFFSIDE, N. J. Cliffside**  
658 Anderson Ave. 6-0510

# "VOMAX"

**IN STOCK FOR  
IMMEDIATE SHIPMENT**

Instantly acclaimed as the standard of comparison by our customers, carrying our highest recommendation, our entire problem has been not sales, but shipments. Our stock is replenished. We can ship your "VOMAX" promptly. But the demand is heavy. We recommend immediate ordering. Still only \$59.85.

**STAN-BURN RADIO  
& ELECTRONICS CO.**  
1697 Broadway 558 Coney Island Ave.  
New York 19, N. Y. Brooklyn 18, N.Y.

# "VOMAX"

**THE CHOICE OF  
ELECTRONIC EXPERTS**

You can't go wrong by duplicating the choice of the University of California, Johns Hopkins, Princeton, Monsanto Chemical, Lapp Insulator, the Army, the Navy, etc., etc. In "VOMAX", standard of comparison, you get the unequalled universal v.t.v.m.-signal tracer for only \$59.85, if you order now.

**HANS A. SOMS**  
Westchester Electronic Supply Co.  
333 MAMARONECK AVE.  
WHITE PLAINS, N. Y.

# "VOMAX"

**NEW POST-WAR  
V.T. V-O-DB-MA METER**

Pre-war meters weren't complete enough for pre-war servicing. Why accept less than complete measurements — r.f., i.f., a.f., a.c., d.c., a.v.c., a.f.c., etc., etc. — including visual dynamic signal tracing 20 cycles through over 100 megacycles. "VOMAX" gives you this mastery. Prompt shipment. Only \$59.85.

**KLADAG RADIO  
LABORATORIES**  
105 WEST ERIE ST.  
KENT, OHIO

# "VOMAX"

**VALUE FAR  
ABOVE \$59.85 COST**

Come in and examine "VOMAX". Look over its superb quality of parts, husky construction. You'll wonder, as we do, how its maker can price it only \$59.85. With OPA-approved ceiling far higher, we suspect today's give-away price may rise any minute. Better order quick at only \$59.85.

**MATTSON'S**  
519-521 W. BROAD ST.  
RICHMOND, VA.

"The choice of Electronic Experts"

# "VOMAX"

**Outstanding Features:**  
D.C. volts at 51 and 126 megohms; A.C. and r.f. volts at 6.6 megs; Resistance .2 ohms to 2,000 megs; D.C. current 1.2 ma. through 12 amperes; D.B. — 10 through +50 . . . . PLUS  
VISUAL DYNAMIC SIGNAL TRACING. **\$59.85**  
Prompt shipment, net.

**TERMINAL Radio Corporation**  
85 CORTLANDT STREET • NEW YORK 7, N. Y. • WOrth 2-4415

# "VOMAX"

**IN STOCK FOR  
IMMEDIATE SHIPMENT**

Instantly acclaimed as the standard of comparison by our customers, carrying our highest recommendation, our entire problem has been not sales, but shipments. Our stock is replenished. We can ship your "VOMAX" promptly. But the demand is heavy. We recommend immediate ordering. Still only \$59.85.

**METROPOLITAN**  
Electronics & Instruments Co.  
258 BROADWAY  
NEW YORK, N. Y.

# "VOMAX"

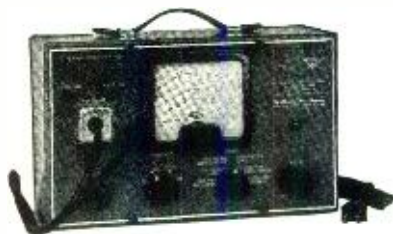

**PROMPT  
SHIPMENT**

## RADIO ELECTRIC SERVICE COMPANY

**PHILADELPHIA (Main Office)**  
701 Arch St. Lom. 6177

**PHILADELPHIA**  
5133 Market St. All. 7751

**PHILADELPHIA**  
3145 N. Broad St. Bal. 5900

**CAMDEN, NEW JERSEY**  
513 Cooper St. Emerson 0239

**ALLENTOWN, PA.**  
1042 Hamilton St. 3-5284

**WILMINGTON, DEL.**  
219 W. 8th St. 8864

**EASTON, PA.**  
9 N. 2nd St. 2-1551

# "VOMAX"

### MEASURES EVERY RECEIVER VOLTAGE

All those vital measurements you've never been able to make are "duck soup" to "VOMAX". At meter resistance so high as not to upset circuits you can now directly measure r.f., i.f., a.f., a.c., d.c. — all voltages — visual dynamic signal tracing on operating receivers. "VOMAX" makes you the master. Only \$59.85.

*J. V. Duncombe*  
COMPANY

1011 WEST 8th ST. ERIE, PA.

# "VOMAX"

### THE CHOICE OF ELECTRONIC EXPERTS

You can't go wrong by duplicating the choice of the University of California, Johns Hopkins, Princeton, Monsanto Chemical, Lapp Insulator, the Army, the Navy, etc., etc. In "VOMAX", standard of comparison, you get the unequalled universal v.t.v.m.-signal tracer for only \$59.85, if you order now.

**The GEORGE D. BARBEY  
COMPANY**  
432 WALNUT ST. READING, PA.

# "VOMAX"

### UNIVERSAL V.T.V.M. PLUS VISUAL SIGNAL TRACING

It's news to discover a meter truly universal<sup>1</sup> — that will measure any and every type of receiver voltage, resistance, d.c. ma. and amperes, even capacity. But when it includes visual dynamic signal tracing too, we recommend it as the "buy" of buys. Prompt shipment at only \$59.85 net.

**RADIO SERVICE  
COMPANY**  
346 SO. MAIN ST.  
WILKES-BARRE, PA.

# "VOMAX"



### OUTSTANDING FEATURES

D.C. Volts at 51 and 126 megohms  
A.C. and r.f. volts at 6.6 megs.  
Resistance .2 ohms to 2,000 megs.  
D.C. current 1.2 ma. through 12  
amperes.

D.B. -10 through +50.  
PLUS visual dynamic signal tracing.

In our critical opinion these features establish "VOMAX" as standard of comparison. Early shipment at only \$59.85 net — as long as price holds.

### RHODE ISLAND DISTRIBUTING CO.

19 DEXTER ST.  
PAWTUCKET, R. I.

# "VOMAX"

### THE STANDARD OF COMPARISON

When we examined, tested, "VOMAX" we realized that here was radio's outstanding. "buy". Our customers say it's unbeatable. From big industrial laboratories to one-man service stations they're enthusiastic. We can ship your "VOMAX" promptly at only \$59.85. But act fast — avoid delay and possible price rise.

**VALLEY RADIO  
DISTRIBUTORS**  
408 N. APPLETON ST.  
APPLETON, WIS.

# "VOMAX"

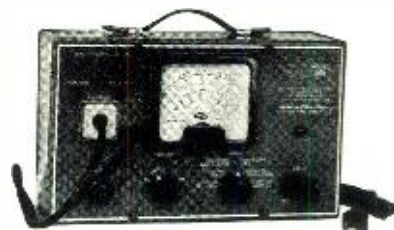

### THE UNIVERSAL V.T.V.M. YOU'VE ASKED FOR

We and you, our customers, have waited a mighty long time for that meter we knew you must have to be equipped for post-war work. At last we have it . . . more than we expected . . . in "VOMAX". It will directly measure every type and kind of receiver voltage and resistance, but accurately. Yet it's only \$59.85 net.

**RADIO & APPLIANCE  
CORPORATION**  
4 CUMMINS STATION  
NASHVILLE 3, TENN.

# "VOMAX"

### A.C., D.C. and R.F. VACUUM TUBE VOLTMETER

True v.t.v.m. on a.c., d.c., ohms, db., all frequencies from 20 cycles to over 100 megacycles, "VOMAX" is what you have been asking for. With it you get resistance, capacity, power output, even power input. Demand is increasing every day. An immediate order will obtain prompt shipment. Only \$59.85 net.

### WILKINSON BROS.

2406-2408 Ross Avenue  
DALLAS 1, TEXAS

# "VOMAX"

### UNIVERSAL V.T.V.M. PLUS VISUAL SIGNAL TRACING

It's news to discover a meter truly universal — that will measure any and every type of receiver voltage, resistance, d.c. ma. and amperes, even capacity. But when it includes visual dynamic signal tracing too, we recommend it as the "buy" of buys. Prompt shipment at only \$59.85 net.

*Wheeling Radio Supply*  
924 MARKET ST.  
WHEELING, W. VA.



# "VOMAX"

## NEW POST-WAR V.T. V-O-DB-MA METER

Pre-war meters weren't complete enough for pre-war servicing. Why accept less than complete measurements — r.f., i.f., a.f., a.c., d.c., a.v.c., a.f.c., etc., etc. — including visual dynamic signal tracing 20 cycles through over 100 megacycles. "VOMAX" gives you this mastery. Prompt shipment. Only \$59.85.

G. M. POPKEY CO.  
MARINETTE, WIS.  
DULUTH, MINN.  
GREEN BAY, WISC.

# "VOMAX"

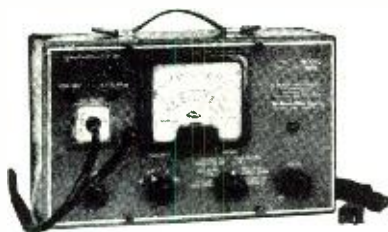

## OUTSTANDING FEATURES

D.C. Volts at 51 and 126 megohms  
A.C. and r.f. volts at 6.6 megs.  
Resistance .2 ohms to 2,000 megs.  
D.C. current 1.2 ma. through 12  
amperes.  
D.B. -10 through +50.  
PLUS visual dynamic signal trac-  
ing.

In our critical opinion these features establish "VOMAX" as standard of comparison. Early shipment at only \$59.85 net — as long as price holds.

*Arrow Electronics  
Company*

82 CORTLANDT ST.  
NEW YORK 7, N. Y.

# "VOMAX"

## MEASURES EVERY RECEIVER VOLTAGE

All those vital measurements you've never been able to make are "duck soup" to "VOMAX". At meter resistance so high as not to upset circuits you can now directly measure r.f., i.f., a.f., a.c., d.c., — all voltages — visual dynamic signal tracing on operating receivers. "VOMAX" makes you the master. Only \$59.85.

## RADIO PARTS CO.

536-538 WEST STATE ST.  
MILWAUKEE 3, WIS.

February, 1946

One OF THE Reasons VOMAX  
IS DEPENDABLE . . .

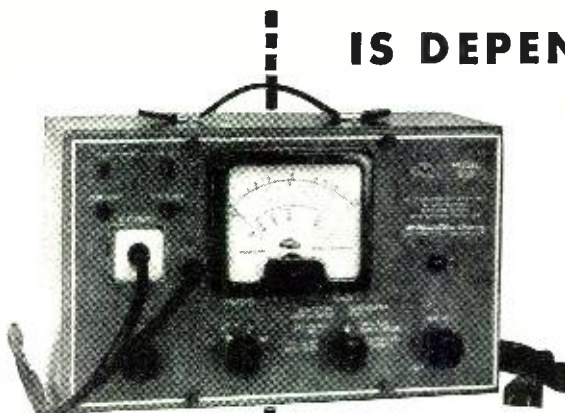

For new set construc-  
tion or replacement,  
insist on FREED Trans-  
former Types for  
every Electronic  
purpose.

FREED TRANSFORMERS  
ARE USED IN ITS CON-  
STRUCTION—Your as-  
surance of quality and  
dependability.



**FREED**  
TRANSFORMER CO.  
72-N SPRING ST., N. Y. C.

# "VOMAX"

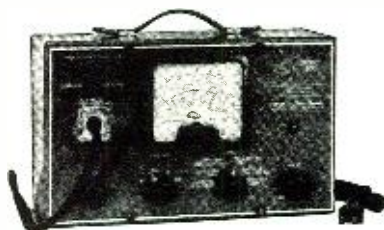

## OUTSTANDING FEATURES

D.C. Volts at 51 and 126 megohms  
A.C. and r.f. volts at 6.6 megs.  
Resistance .2 ohms to 2,000 megs.  
D.C. current 1.2 ma. through 12  
amperes.  
D.B. -10 through +50  
PLUS visual dynamic signal trac-  
ing

In our critical opinion these features establish "VOMAX" as standard of comparison. Early shipment at only \$59.85 net — as long as price holds.

## MAC'S RADIO SUPPLY

8320 LONG BEACH BLVD.  
SOUTHGATE, CALIFORNIA

Over 34 Years of Radio  
Engineering Achievement



*McMurdo Silver Co.*

1240 MAIN ST.  
HARTFORD 3, CONN.

# "VOMAX"

## THE POST-WAR SERVICE STATION

Measuring every type and kind of voltage in receiver servicing, resistance, power input, db. output, our long experience tells us "VOMAX" is tops. In it you exclusively get new visual dynamic signal tracing. We've been heavily oversold, but can now ship promptly — if you order at once — at only \$59.85.

## CHARLES E. TURNOCK COMPANY

336 WEST STATE ST  
MILWAUKEE 3, WIS.

113



## EVERYTHING IN RADIO AND ELECTRONICS

R. W. T., world's oldest and largest Radio Supply House is ready again with tremendous stocks of sets, parts and equipment. You can depend on our quarter-century reputation for quality, sound values and super-speed service. Orders shipped out same day received. All standard lines already here or on the way, including: National, Hammarlund, R. C. A., Hallicrafters, Bud, Cardwell, Bliley and all the others you know so well.

Originators and  
Marketers of  
the Famous

*Lafayette Radio*

## Radio Wire Television Inc.

100 Avenue of the Americas  
(Formerly 6th Ave) New York 13  
Boston, Mass. • Newark, N. J.

SEND  
TODAY!

**R. W. T.** DEPT. RB-6, 100 AVENUE OF THE  
AMERICAS, NEW YORK 13, N. Y.

I want your big new post-war Catalogue.

NAME \_\_\_\_\_

ADDRESS \_\_\_\_\_

HAM?  (CALL LETTERS) \_\_\_\_\_

ENGINEER?  SERVICE MAN?  STUDENT?

### Test Instrument (Continued from page 104)

signed instrument. All this, despite the ability to perceive less than a 1/10th per-cent change in zero on the large, open-faced 4 $\frac{1}{8}$ " Alnico-magnet meter. The meter itself is of 0-1 ma. range, sturdy and rugged as microammeters seldom are, yet, in this new v.t.v.m., only 3 volts across 50 megohms—miniscule power and infinitesimal circuit loading—drives the meter to full-scale 1 ma. deflection.

The simplicity of operating controls, all located upon the 12" long and 7" high panel of 3/32" thick reverse-etched aluminum, is clearly illustrated in Fig. 1. At the lower left is the *set zero knob*, adjusted but once to set meter zero for all functions and ranges. Immediately above it is the removable shielded diode r.f. probe. This is the *signal tracing probe* with which signal voltages may be followed from antenna right through every signal circuit to speaker voice-coil by contacting the probe tip and shell to successive grid and plate circuits and ground. Its construction is such as to require no connecting leads worthy of the name either within the probe itself or between it and the circuit to be measured—the reason, among others, why the instrument is usable well above 100 megacycles, at which frequency it is still highly accurate. For low-frequency measurements, test leads with special prods are inserted into the two insulated jacks immediately above the probe, the probe inserted in its socket as illustrated, and measurements made in the usual manner. The same test leads in the same two jacks serve for a.c. and d.c. volts, ohms, decibels in output meter operation, and milliamperes/ampere. There is no need to shift test leads about for different functions or for reversal of d.c. polarity, except for the 12 ampere current range and for the 3000 volt d.c. range (the upper right jack together with the *com.-gnd.* jack, provides all twelve of the x25 d.c. voltage ranges). The reasons for not handling the 3000 volt and 12 ampere ranges through the two basic input jacks is because of the extra insulation required for high voltages, and to keep the heavy current of the 12 ampere range out of the *range switch* contacts, both desirable precautions in conservative design.

#### Special Construction

The panel arrangement of Fig. 1 is so self-explanatory as to require little special mention. The rear view of Fig. 4 is a different matter, as is the schematic diagram of Fig. 3. The construction of Fig. 4 is distinctly military/commercial, in contrast to usual test instruments. The usual chassis has been dispensed with entirely in favor of the more substantial and efficient location of every component part directly upon the back of the heavy panel itself, exactly as in the Navy

low-frequency transmitter described in the May, 1944 issue of RADIO NEWS. At the upper left of Fig. 4 is the power transformer, *T*, of Fig. 3, through which all operating voltages are provided for plates, grids, and heaters. Below it is a linen bakelite panel carrying the four factory-adjusted, wire-wound a.c. range set resistors  $R_{25}$ ,  $R_{21}$ ,  $R_{25}$ , and  $R_{20}$ , one for each of the three lowest voltage a.c. ranges, and a fourth for the three higher voltage a.c. ranges. Immediately to the lower right is the 5-gang ceramic *range switch* directly carrying the many 1% matched pair metalized and wire-wound current multiplier resistors. To its right is the *function switch*, 6-circuit, 5-position ceramic also. These ceramic switches, as well as the special construction employed, are essential to preserve constant the very high meter resistance now available throughout wide variations in temperature and humidity. At top center is the meter itself, its terminals carrying a stable linen—in contrast to usual paper—base phenolic panel which supports the power supply voltage divider resistors, degenerative cathode resistors  $R_{35}$  and  $R_{36}$ , and the two electrolytic filter capacitors  $C_5$  and  $C_6$ . These are metal-cased, hermetically sealed units of high quality and ample voltage rating.

At the extreme lower right of Fig. 4 is the socket plate carrying the three vacuum tubes  $V_2$ ,  $V_3$ , and  $V_1$ —but more of these later. This sub-panel is mounted sufficiently behind the front panel on plated brass studs to give easy access to *zero* adjusting potentiometer  $R_{31}$ , exactly as its companion a.c. range resistor plate at the extreme lower left is similarly supported behind *ohms adjust rheostat*  $R_{32}$ . To right and left of the meter panel are the two ohmmeter dry batteries. Dry batteries are employed as a voltage source for resistance measurements simply because of their low cost, long life, and convenience. In this function, constancy of voltage is most important. Any attempt to draw such voltage from the main power supply would entail excessive cost for special voltage regulators, while such good regulation for other meter functions is obtained directly through the balanced circuit design.

At upper right of Fig. 4 is visible the linen-phenolic panel carrying the d.c. range set and the a.c. diode contact-potential balance rheostats  $R_{22}$  and  $R_{12}$  respectively. This panel is mounted upon the rear of the r.f. diode probe socket and carries low-frequency a.c. input capacitor  $C_1$ , as well as socket pin, through which it is directly connected, to the measurement plate of the 6AL5 ( $V_1$ ) dual u.h.f. diode

### COMING NEXT MONTH

"Radio in Arctic Oil  
Exploration"

By

JOHN H. ROBERTS

mounted in the plug-in probe shield. Immediately above this assembly are visible the four input jacks, with the two 1% matched pair high d.c. voltage multiplier resistors as well as the heavy, coil-type 12 ampere direct current shunt visible between them.

### New Circuits Explain Improved Results

The secrets of the extraordinarily high input resistance, extreme frequency range, and absolute stability of this new instrument lie not alone in the mechanical construction and unusually high quality of parts above described, but in the new and advanced circuit of Fig. 3. A detailed analysis of its development would be excessively lengthy, and detract emphasis from the essential points of practical usefulness of the finished instrument which it has been sought to bring out herein. For easy understanding tubes  $V_1$ ,  $V_2$ , and  $V_3$  may be thought of as the actual measurement channel, with  $V_{11}$ ,  $V_{21}$ ,  $V_{31}$  as the complementary balancing channel.  $V_1$  is, of course, the power supply rectifier. Starting with  $V_1$ , which with its associated components is housed in the removable aluminum-shielded, ceramic-headed r.f. probe,  $V_1$  is the a.c. measurement rectifier. For r.f. and high a.f. operation it employs the 500  $\mu$ fd. silver-mica insulating capacitor  $C_1$  housed in its shield. Capacitor  $C_2$ , .03  $\mu$ fd., is automatically substituted when the probe is in its socket. Resistor  $R_1$  and capacitor  $C_2$  are the filter, removing a.c. ripple from the rectified a.c. which actuates the meter. Since  $V_1$  delivers d.c. output in close proportion to the peak value of any a.c. voltage to be measured,  $R_1$  is made 20 megohms so that only 100/140 of the rectified d.c. (1.41 x r.m.s. value) is applied to the d.c. load  $R_2$  through  $R_3$  of 50 megohms total (to yield r.m.s. a.c. meter indication). Function switches  $S_{1c}$  and  $S_{1r}$  cut the diode a.c. rectifier into or out of the circuit as required.

As soon as  $V_1$  is heated, its cathode emits electrons which impinge upon its plate. A self-generated d.c. voltage results. This must be balanced out. This has been a problem defying really satisfactory solution when the range-establishing voltage-divider follows the diode—as it must if any of the usefully wide a.c. voltage/frequency range is to be covered. So a second, or balancing, diode  $V_{1s}$  is brought into play having in its output circuit load resistors  $R_2$  through  $R_5$ . Across these resistors is developed a second contact-potential, regulated to exactly equal that generated within  $V_1$  by rheostat  $R_{1s}$ . This voltage, usually around 1 volt, must, as a.c. ranges are changed, be divided down in step with that generated by  $V_{1s}$ , hence, the tapping of its load resistors by switch  $S_{2c}$ . (All  $S_{1-}$  and  $S_{2-}$  switches are ganged,  $S_{1-}$  being function,  $S_{2-}$  range. By this new technique, the problem of contact-potential is nicely solved, and the instrument stays zeroed without adjustment over all a.c. ranges. Contact-

Here's a soldering iron with . . .

**HEAVY  
POWER**  
(225 WATTS)

**LIGHT  
WEIGHT**  
(14 OUNCES)

made possible by  
**KWIKHEAT'S  
BUILT-IN  
THERMOSTAT**

- \* HEATS IN ONLY 90 SECONDS
- \* MAINTAINS PROPER HEAT
- \* CAN'T OVERHEAT
- \* LESS RETINNING NEEDED
- \* TIPS LAST LONGER
- \* COOL, SAFE HANDLE
- \* LIGHT WEIGHT

The Kwikheat Soldering Iron has ample reserve power for your soldering jobs—225 watts held in check by a thermostat built right into the iron\*—maintaining ideal temperature for perfect soldering—preventing overheating (which causes deterioration in other irons)—prolonging life of tips and eliminating the need for constant retinning. Besides these big advantages, the Kwikheat Iron is hot, ready to use only 90 seconds after plugging in. It is extremely light (14 ounces), well-balanced, and has a safe, cool handle. No wonder Kwikheat is a sensation wherever it is used. Ask your jobber. With choice of #0, 1, 2, 3, or #5 tips. \$11.00

### 6 INTERCHANGEABLE TIP STYLES

					
#0 \$1.25	#1 \$1.25	#2 \$1.25	#3 \$1.25	#4 \$1.75	#5 \$1.25

VANATTA

\*patented



**kwikheat**  
THERMOSTATIC SOLDERING IRON  
A Division of  
Sound Equipment Corp. of Calif. • 3903 San Fernando Rd., Glendale 4, Calif.

**Now Delivering  
TEST EQUIPMENT**



## The New RCP 802N Combination Tube and Set Tester

- ★ 4 1/2-inch Rectangular Meter
- ★ Easy to Operate
- ★ AC and DC Reading Coincide
- ★ Test All Tubes and Ballasts

### METER RANGES:

DC voltmeter 0/10/50/500/1000  
at 1000 ohms per volt.

Four range AC voltmeter 0/10/50/  
500/1000.

DC milliammeter 0/10/100/1000  
DC Ammeter 0/10.

D.B. Meter—8-15/15 to 29/29 to  
49/32 to 55 decibels.

Four Range Output Meter—same  
as AC volts.

Model 802N is supplied in handsome hard-  
wood case, which has a special compart-  
ment for small tools, test leads (included).

Size: 12 3/4 x 12 x 5 1/4

Weight: 11 1/2 lbs.

Complete with self contained batteries,  
ready to operate.

Quantity limited—Order now. Price \$57.50

FEDERATED PURCHASER, INC. is at  
your service. Our large and com-  
plete stock of radio and electronic  
parts makes it possible for us to  
offer you immediate delivery on  
most types of equipment.

**FEDERATED PURCHASER INC.**  
NATIONAL DISTRIBUTORS OF ELECTRONIC PARTS  
80 PARK PL. N. Y. 7, N. Y.

potential compensation is required individually only for the four a.c. voltage ranges of 120 volts and below, since a possible 1-volt error on 300 and 1200 volt ranges is insignificant in percentage.

$V_3$  and  $V_{3a}$  are the voltmeter tubes proper, in that variations in their grid voltages are what produce changes in meter readings. This portion of the new instrument follows very closely indeed the teachings of the writer's article in the September, 1943 issue of RADIO NEWS. Variations in plate current of measurement triode  $V_3$ , due to variations in line voltage and tube aging, are balanced out by equal and opposite changes in  $V_{3a}$ . Note that dual tubes are used in each successive circuit as, produced identically, their section uniformity versus voltage and time is believed to be materially better than for the case of separate tubes.  $V_3$  and  $V_{3a}$  see an effective plate-cathode voltage of only half the 400 volts generated by the power supply due to the very heavy degeneration and large voltage drop occasioned by their 43 kilohm cathode resistors  $R_{23}$  and  $R_{36}$ . The other half of the power supply voltage is included in their grid circuits to buck out the heavy negative grid bias developed across  $R_{10}$  and  $R_{36}$ . The net result is class-A operation with grids approximately 8 volts negative with respect to cathodes, yet with the very heavy degeneration necessary to stability. The meter is connected from cathode-to-cathode to avoid useless voltage drop across unnecessary plate resistors, and in such manner as to limit the total current flow to the meter and so give protection against overload for up to 1000 times rated input voltage. Switches  $S_{1c}$  and  $S_{1d}$  reverse meter connections to yield the several different polarities required in a.c., d.c., and ohms measurement. Range switch section  $S_{2a}$  selects the 4 appropriate factory-set a.c. and 1 d.c. range setting resistors—all except  $R_{30}$  for ohms, which is front-panel adjustable to permit compensation for gradual fall-off in ohms battery "B".

### New Cathode Follower Eliminates Grid Current

Were voltages to be measured to be applied directly to  $V_3$  grid through a.c. filter  $R_{11}$  and  $C_1$  from 50 megohm range "stick" and switch  $S_{2b}$ , the change in grid resistance so occasioned would result in varying orders of grid current in  $V_3$ , and so the unstable zero, usual to vacuum tube voltmeters, plus the error caused by addition of the initial meter reading error to the applied voltage. The only way to escape this most serious drawback is to reduce plate voltage to around 18 volts or less, below which grid and gas current will not show up. But grid current is not bothersome at usual  $E_p$ , and may be washed out in initial zero setting if the resistance in the grid circuit is held constant. These requirements conflict, and a new solution had to be created to produce a stable, high-resistance instrument. This new solu-

## Unusual Buy Cathode-Ray Tubes



New, Factory sealed, for  
**TELEVISION & OSCILLOSCOPES**  
RCA 5BP4 price . . . . . \$18.00  
Dumont 5BP1 price . . . . . \$15.00  
N-U 3AP1 price . . . . . \$ 9.00  
Other CR Tubes 3" to 12"

### Amphenol Coaxial Cables

Polystyrene beaded & Polyethylene solid dielectric, for low losses and freedom from interference.  
Type 21B-290-7/26-XXV, 72 Ohm., List price \$0.85, your price \$0.25 p. ft. Many other types. Ask for list.

### TELEVISION PARTS

RCA Deflection yokes compl. with hardware and cable . . . . . \$19.50  
RCA High and Low Voltage complete in one unit Television power supplies, oversize unit . . . . . \$90.00  
AEROVOX Type 3009 Capacitor .5 MFD. 3000 Volt Working . . . . \$ 2.40  
DUMONT Wide Band Oscilloscope Type 241 . . . . . \$458.00

All types of ceramic, mica and oil CAPACITORS. Many other television parts.  
Send 50 cents coin/stamps for complete list including diagrams for TELEVISION sets RCA, GE, DUMONT, ANDREA. Free with order \$5.00 or more.

RCA Parts and Equipment Distributors  
WORLD'S FIRST SPECIALIZED HOUSE IN TELEVISION  
**ELECTRONICS SERVICE & SUPPLY**  
262 West 40th Street, New York 18, N. Y.

## MORE SMASH BUYS at National Radio Distributors

### IMMEDIATE DELIVERY

#### RMS REPLACEMENT CABINETS

PA-10 portable electric phono for 10-inch records and 5-inch speaker . . . . . \$7.75  
PA-12 portable electric phono for 10-in. and 12-in. records and 6-inch speaker . . . . . \$9.95  
PAC-100 portable automatic record changer (will accommodate any make) . . . . . \$8.95

Replacement Cabinets to Suit Any Requirement.  
**WESTINGHOUSE EQUIPPED FLUORESCENT LIGHTS**  
2-light 20-watt kitchen unit ready to plug in \$3.25 ea. In lots of 10 . . . . . \$4.77  
2-light 40-watt standard industrial fixture 48 inches long \$11.95 each. In lots of 10 . . . . . \$11.25

Prices do not include lamps.  
Also Fluorescent Desk and Bed Fixtures. \$5.85 each (including lamps)

**EXTRA SPECIAL!—CONDENSER KIT (By-Pass)**  
Consists of 100 Tubulars (all 600 Volt) in the following sizes: .001, .002, .006, .01, .02, .03, .05, .1 Mfd. Per Kit . . . . . \$5.95

**RADIO KNOB KIT**  
Contains 50 assorted styles set screw knobs for 1/4" shaft. A beautiful assortment of the most popular styles in present use. Per Kit . . . . . \$3.95

**INSULATED RESISTOR KIT**  
Contains 100 most popular sized DELUXE assortment of 1/4, 1/2 and 1 Watt, R.M.A. color coded, some Gold Band Per Kit . . . . . \$2.75

**AERIAL KITS** (individually boxed) complete, including full instructions . . . . . 75c

**RADIO KITS** 4-tube TRF (including Tubes), SPECIAL \$10.75

5-tube SUPERHET (including Tubes) . . . . . \$17.95

Please include at least 25% with all C.O.D. orders  
Write for Our Latest Complete Catalog. Just Out!

## National Radio Distributors

140 A West 42 St., New York 18, N.Y.

tion is the use of a cathode follower, operated at plate voltage low enough to banish the last traces of grid and gas current effects, located between input voltage divider "stick" and the meter-actuating tube requiring high enough plate voltage to provide a 1 ma. current change for a 3-volt grid bias change.

By this new device, it becomes possible to utilize high enough plate voltage on the actual meter-actuating tube to obtain ample plate current shift for a small grid voltage change to allow employment of a rugged meter carrying no excessive price premium, all without any of the usual deleterious grid and gas current effects. The measurement cathode follower is  $V_2$ , its companion balancing tube (in the same single 6SN7GT bulb) is  $V_{2a}$ . Each tube has a 5.1 megohm cathode resistor,  $R_{2a}$  and  $R_{2b}$ , with the excessive grid bias developed thereacross bucked out by the opposing drop across  $R_{2c}$ , similar to  $V_3$ ,  $V_{3a}$ . Here again class-A operation obtains, as is essential if the grid voltage range is to be linear in both positive and negative directions for a voltage greater than the basic 3-volt range. This is necessary to permit d.c. polarity reversal by simple shift of the *function* switch.

The 125 megohm x2.5 d.c. voltage ranges of 7.5 through 3000 volts in six steps are obtained by placing the two 37.5 megohm resistors  $R_6$  and  $R_7$  in series with the 50 megohm meter input provided by the basic voltage range "stick"  $R_8$  through  $R_{10}$ . This multiplies the voltage ranges by 2.5 times and provides for an interesting check for absence of grid current. For example, if 3 volts d.c. be applied between *com.-gnd* and *+9-MA* jacks the meter should read 3 volts and its zero should not shift when these jacks are open or short-circuited. But, if grid current is present, applying 3 volts d.c. between *com.-gnd.* and x2.5 jacks will not result in the proper voltage division to yield a meter reading of 1.2 volts, as it should. The fact that it does exactly this in the instrument described is proof positive of the complete elimination of grid and gas current effects.

#### V.t.v.m. Signal Tracer Is Self-Testing

One very interesting and useful feature is the resemblance of the new instrument to a lathe—reputed to be the only machine tool which can duplicate itself without the aid of other tools in the process. Using the d.c. voltmeter section, every d.c. operating voltage within the instrument itself can be checked! The a.c. input and power transformer a.c. secondary voltages may be checked using the a.c. voltage ranges. Using the resistance ranges the values of range multiplying resistors may be measured. So complete are the tests and checks of the instrument by its own functions, and so independent is it of changes due to minor variations in its own operating voltages, that it may almost be regarded as self-testing. By simple means set forth in the commercial in-

## Meet the Demand for Duotone's Duodiscs and Cutting Needles!



The mushrooming market in home-recording demands that all dealers be prepared to meet the needs of these enthusiasts. Give them the best—Duotone's Duodiscs for greater fidelity, longer wear and noiseless reproduction. Coated with nitrate on a base of aluminum, these Duodiscs will sell and then resell themselves. Follow up with Duotone Cutting Needles and you can't miss. Write now for specific prices and details.

**RELATED PRODUCTS:** *Duotone Hardening Fluid* which preserves the recording; the *Duotone "Star" Sapphire*; *Shadowgraphed Transcription Needles* for quality playbacks.

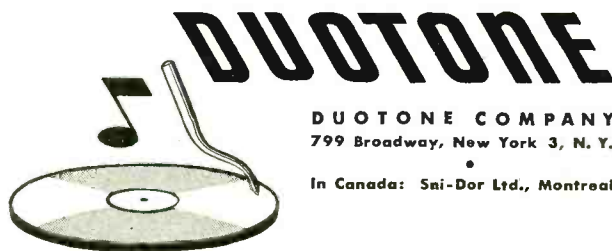

**DUOTONE COMPANY**  
799 Broadway, New York 3, N. Y.

In Canada: Sai-Dor Ltd., Montreal

# CURRENT CONVERSION WITH ATR QUALITY PRODUCTS



## ATR "A" BATTERY ELIMINATORS

For Converting A.C. to D.C.

Designed for Testing D.C. Electrical Apparatus on Regular A.C. Lines. Equipped with Full-Wave Dry Disc Type Rectifier, Assuring Noiseless, Interference-Free Operation and Extreme Long Life and Reliability.

- Eliminates Storage Batteries and Battery Chargers.
- Operates the Equipment at Maximum Efficiency at All Times.
- Fully Automatic and Fool-Proof.



## ATR LOW POWER INVERTERS

For Inverting D.C. to A.C.

For Operating Small A.C. Motors, Electric Razors, and a Host of Other Small A.C. Devices from D.C. Voltage Sources.



## STANDARD AND HEAVY DUTY INVERTERS

For Inverting D.C. to A.C.

Specially Designed for Operating A.C. Radios, Television Sets, Amplifiers, Address Systems, and Radio Test Equipment from D.C. Voltages in Vehicles, Ships, Trains, Planes, and in D.C. Districts

WRITE for LATEST ATR CATALOG—  
Just off the press!

**AMERICAN TELEVISION & RADIO CO.**  
Quality Products Since 1931  
ST. PAUL 1, MINN. U. S. A.

struction book capacitances of usual values of paper and electrolytic capacitors may be measured with that order of accuracy possible to other than bridge measurements, as may be a.c. and r.f. currents, not to mention insulation resistances ranging up to thousands of megohms.

While the instrument herein described is basically a voltmeter, its extraordinary frequency range and multiple functions make it much more than the usual V-O-M. It is a visual dynamic signal tracer, which, with its other advanced characteristics, at last gives to the service technician in simple usable form the ability to rapidly perform measurements upon receivers impossible without costly and complex laboratory equipment—an essential key to the door of postwar profits.

-30-

**As I See It**  
(Continued from page 35)

technical phase of the industry. Now we are faced with the situation wherein the lack of technical knowledge will tend to throttle the sales capabilities, if not the very existence of the service shop, unless we do something about it.

To do this *something*, we must understand fully another influence which is at work. This is the end of the war. War does many strange things. It produces a victor and a vanquished, but even the victorious nation experiences changes in the habits and thinking of its people. It is true that everybody remains rational, but the general feeling, especially in commerce, is that the end of the war is the equivalent of a rebirth; people can start afresh. This comes about from the condition that the prosecution of war interrupts the normal flow of commodities to the people through the usual channels; therefore, the usual train of commercial actions and ways of thinking are interrupted. The end-product of profitable enterprise is still the aim, but the manner in which this will be accomplished usually is subject to much transformation. This discontinuity is accepted during war, but when it comes time to rejoin the broken threads, the past seldom is the pattern for the future.

New technical development, new manufacturing techniques, and new concerns born during the war, create numerous changes in the commercial life of the nation, especially with respect to competitive effort. The zone of influence of these changes encompasses the radio repair man just as it does many other groups of people. To attempt to swim against the tide is ridiculous; to recognize the truth as it exists makes much more sense.

### The Threat by the Set Dealer

Examine the advertisements in the trade papers. You will note that the radio manufacturer of the past is spreading horizontally in the items he

## REPAIR ANY RADIO QUICKLY-EASILY with the help of FEILER SIGNAL TRACER TS-1



Locates causes of dead or weak sets, noise, hum, poor sensitivity. Locates speaker defects, short tuned or open coupling condensers, open or shorted antenna coils, loops or transformers.

Checks faults due to faulty condensers or resistors. Simple instructions explain procedure for point-to-point signal tracing and how to recognize cause of trouble. An important time saver for service men.

Model TS-1 Complete with Tube, \$9.85  
But Less Batteries and Phones

B-4794 Headphones for Above \$ 1.45

B-4745 Batteries for Above \$ .79

Write for Free Parts Catalog



731 West Washington Boulevard—Dep't N  
CHICAGO 6, ILLINOIS

## AMATEURS AND RADIO REPAIRMEN

DISTRIBUTOR FOR

Advance—Aerovox  
Amphenol—B & W  
Burgess—Cinaudograph  
Clarostat—Eimac  
Eisco—Hammarlund—ICA  
Millen—National  
Premax—Shure  
Speedex—Superior  
Supreme—Taylor—Turner  
UTC—Universal  
HAMMARLUND  
NATIONAL AND R.M.E.  
Receivers in Stock

EXCLUSIVE DISTRIBUTORS  
FOR STROMBERG-CARLSON  
AMPLIFIERS

Stanton Radio Supply

W9PSP W9JKE  
521 State St. HAMMOND, INDIANA  
Phone 2314

Intends producing. His new plans call for the production of not only radio receivers but, in many cases, also washing machines, refrigerators, and other home electrical appliances. These will be sold through established radio dealers who, incidentally, are anxious to get these lines because they know that the public's pocketbooks are bulging with money to be spent for such items. The new school of thought among these manufacturers is that the radio dealer who receives a franchise must install a service department, for proper service is one way of protecting the product which has been sold and, in that way, the brand name. The food for thought is that with this new arrangement the old threat of radio set dealer versus independent service shop is revised.

A flash reaction to this situation is antagonism against the manufacturer, but such an attitude is wrong. The organization which sets up such a program is entirely within its rights; it is simply supplying a need which the public demands and will do so in the most logical manner consistent with the existing conditions. The manufacturer feels that his brand name must be made secure. Such being the case he feels that his direct representatives (his dealers) should perform the service on *all* his items, rather than upon a few of them. From the viewpoint of the radio set dealer, the arrangement is favorable, for no longer is he faced with the problems of making radio servicing alone pay for his service shop. This he always considered a thorn in his side. Now he has a much wider field of activity and it can be made to produce a profit much more easily than operations within a narrower field.

Of course there are two sides to every story. Many radio manufacturers will make only radio receivers, but competition will force these to establish policies which conform with the general trend. Then again, some dealers may contract for their repair service, so that this entire situation is not beyond solution. That it will tend to limit the activities of the independent radio repair shops and, in that way, reduce income cannot be denied. Let us stop here for the present. It is not all we have to say about the subject, but it is sufficient for the moment. Later we shall integrate it with the other factors which must be considered in working out the future.

#### The Television Situation

Let us now consider a second major issue, which in one form is very close on the heels of the repair group; in general, it is the matter of technical developments born during the war. This is a very broad subject and will receive a great deal of attention as this story unrolls, for it is of extreme importance in the formulation of a comprehensive program which we shall suggest.

To become specific, for the moment,

## Big News About Small Speakers

Permoflux leads again with the development of a new permanent magnet dynamic speaker providing maximum performance with minimum magnet weight.

With less than a 1½ ounce Alnico Five magnet weight, Permoflux now achieves performance only obtainable before by using a much heavier Alnico Five magnet.

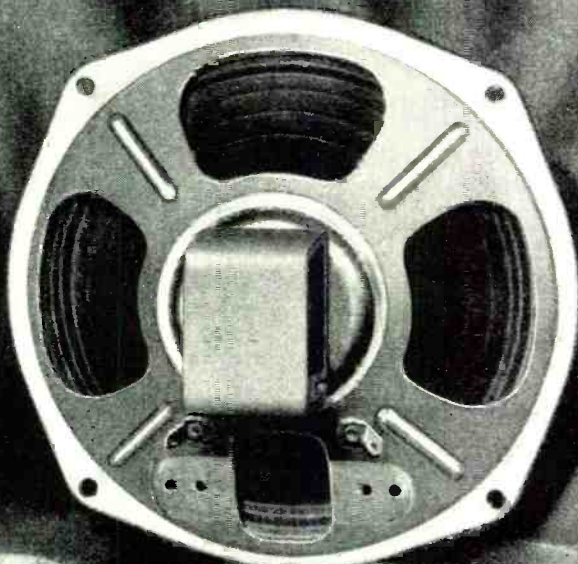

Setting a new standard for speakers up to 6", this new unit is particularly adaptable to portables and farm radios—in fact to all receivers, battery or power line operated, wherever weight is an important factor.

TRADE MARK  
**PERMOFLUX**  
 PERMOFLUX CORPORATION  
 4900 WEST GRAND AVE., CHICAGO 39, ILL.

PIONEER MANUFACTURERS OF PERMANENT MAGNET DYNAMIC TRANSDUCERS

# Now! Get COPIES of Anything, in a Jiffy!

... Right in your own office or plant! New, low-cost, error-proof method saves typing, drafting, checking—**TIME!**



Amazing New Unit—  
**The APÉCO PHOTOEXACT**

Copies anything written, typed, printed, drawn, or photographed

Photo-Copier  
**\$55**  
Copies up to 18" x 22"

Also continuous cabinet models for prints of any length, up to 42" wide.

Quickly, Easily copy  
**BLUE PRINTS, TRACINGS, WIRING DIAGRAMS, SPECIFICATIONS, DRAWINGS, GRAPHS, CHARTS, LETTERS**  
(over 100 others)

Make accurate permanent copies of *anything* at 1-a-minute speed—for less than the price of a phone call! No darkroom or technical knowledge needed. Anyone can operate APÉCO—"America's Most Widely Used Photocopy Equipment." Get full information, **TODAY!**

**MAIL COUPON NOW for this FREE book**



American Photocopy Equipment Co.  
2849 N. Clark St., Dept. HK26  
Chicago 14, Ill.

Send, without obligation, your 20-page illustrated book on Photocopying and its savings in time, money and labor.

NAME.....  
COMPANY.....  
TITLE.....  
ADDRESS.....  
CITY & STATE.....

## BUILD YOUR OWN! FAST FREEZER PLANS \$190

It's easy to build this household appliance and profitable to use. Save up to 75%. Operates on 110 or 32 volts. Plans show 5 sizes and are easy to follow. **ENJOY MAKING ONE OF** these freezers from new or used parts. No expert knowledge needed. Mail \$1.00 bill or check for complete plans and catalog. **LE JAY MFG. CO., 454 Ledy Bldg., Minneapolis 8, Minn.**



### PLUG-IN TEST LAMP

**Tests Everything Electrical Speeds Up Trouble-Shooting**

Used by Radio Men, Electricians, Mechanics and Experimenters. Tests continuity, open circuits, etc. **ALWAYS READY! PLUGS INTO ANY OUTLET!** Only \$1.50 Postpaid. **FREE CIRCULAR.** (Pat. Pend.). **HANLAN CO., 1419-R, West Jefferson, Los Angeles 7, Calif.**

let us select television. The radio industry, as a whole, has not yet reached a concert of thought upon the many phases of this development; much conflict rages behind the scenes on numerous issues. Color versus black and white, cost of stations, and other details will delay major national activity. However, it is definite that programs will be put on the air and receivers will be sold in the very near future in those places where transmitters exist or are being erected.

The settlement of the technical aspects of television is only of minor significance to the repair field at the moment, but the dilemma which faces the vendors of the home receiving equipment will have a much greater meaning. Who will install and service this new equipment? That is the *sixty-four dollar question!* What does it mean to radio repair industry? It is the impending consequences resulting from the general dissatisfaction voiced years ago when the first batch of television receivers were installed and serviced in different cities of the nation. Apparently they were not installed or serviced to the entire satisfaction of the public. This statement is not made as an indictment of the organizations who made these installations or as a reflection on their technical qualifications. Many receiver purchasers did not fancy the installation costs or the kind of service they received at times. As far as this writer was concerned, he was entirely satisfied and the same can be said for some of his friends, but it is true that even a few swallows don't make a summer.

To bring this to a head, the general talk is that because of the anticipated great demand for television equipment the manufacturers intend to offer both installation and repair service, if competent service is available. Much imagination is not required to realize that this would mean the installation and servicing of virtually all such sales, for the path of least resistance when a customer desires installation and repair is to go to the organization which sold the equipment.

The manufacturers justify their stand beyond contradiction. Their contention is that when equipment is available, its sale will be in large numbers. The number of technically qualified service organizations required to make these installations and render the necessary highly technical service are too few—entirely inadequate to cope with the situation. . . . Let's recognize the truth when we hear it. They are right. It is doubtful if 15 out of every 1000 independent repair shops are sufficiently well versed in television technique to do the job properly and economically. Remember, before you comment about installation that the physical erection of the antenna is only part of the job and even that part of the work is closely associated with adjustments upon the equipment itself. Such adjustments are not simple.

## FOR IMMEDIATE DELIVERY! RECORD PLAYERS COMPLETE—SIMPLY INSTALL YOUR OWN MOTOR AND TURNTABLE!



Record Player Complete without motor & turntable  
**\$32.50**  
per unit

PLAYER CONTAINS:

- Large electro-dynamic speaker
- Tone Control • Volume Control
- A. C. Amplifier with power transformer, and connecting cords
- 3 tubes—1-6V6, 1-6CS, 1-5Y3
- Astatic pickup with arm rest
- Permanent needle—Knobs
- Acoustically-built cabinet
- All in a handsome, leatherette-covered, sturdily-constructed case, 14" wide, 7½" high, 16¾" long.

DEALERS—Write for quantity discounts!

**UNION RADIO CORPORATION**  
1636 W. VAN BUREN ST., CHICAGO 12, ILL.

## JOB AHEAD

...and we're equal to it!  
Each day we are shipping more for civilian use.



# WIRES

MADE BY *Engineers*  
FOR *Engineers*

## cornish

WIRE COMPANY, INC.

15 Park Row,  
New York City





All this does not mean that such work will forever remain beyond the capabilities of the recognized radio repair shop. Given time, the man can acquire the necessary knowledge . . . At the moment, however, there are not enough trained men to go around and it is doubtful if the number of qualified people will increase to an appreciable extent after a lapse of even six or nine months, if that much time will pass before these receivers appear upon the market in substantial numbers. So it is not entirely unreasonable for the manufacturer to view this problem differently than he did before.

The seriousness of the situation is not the loss of a limited amount of business installing and repairing television receivers. This is aggravated enough, it is true, but the major issue of immediate concern is the implication of such a relationship between the manufacturer and the set owner. Since the latter does not know exactly what is at fault when something is wrong, and his television receiver will, without doubt, be a multi-band broadcast and short-wave receiver as well, the call for any and all kinds of repair will be made to the agency designated for television work. Whether it be the manufacturer, his jobber, or his set dealer, it is difficult to see how any one of these can refuse to respond to the call for service just because the set owner cannot identify the fault as being in the television portion of the apparatus. If what we said before about the set dealer comes to pass, then that organization will more than welcome such calls for any kind of repair. Moreover, the human being is a creature of habit and if he becomes accustomed to calling a certain outfit to repair his television receiver, he will call that outfit to repair other receivers despite differences in brand, name, or function. The net result will be a decline in business of all kinds to the independent repair shop and, to a certain extent, a general discrediting of his technical ability, regardless of how successfully he may have handled the usual run of AM or FM receivers in the past. The manufacturers' viewpoint is that such special service will be relinquished as soon as adequate outside facilities become available, but how much harm will have been done by that time to the regular business of the repair man? That is the unknown quantity, but most certainly one which must not be neglected when the eye is to the future.

Where to place the blame for the development of such a condition, that is difficult to decide. There is no use crying over spilt milk. Condemning the repair industry for not preparing itself technically during the years past will accomplish nothing. Very little effort would be required to defend the case by developing extenuating circumstances. Thus we arrive at the crux of the matter, namely *what to do now* and, like the serial story, we will not give the version of the answer at this time. The solution is long and

February, 1946

## DON'T CHANGE THE CARTRIDGE— CHANGE THE ARM TO *Glider*

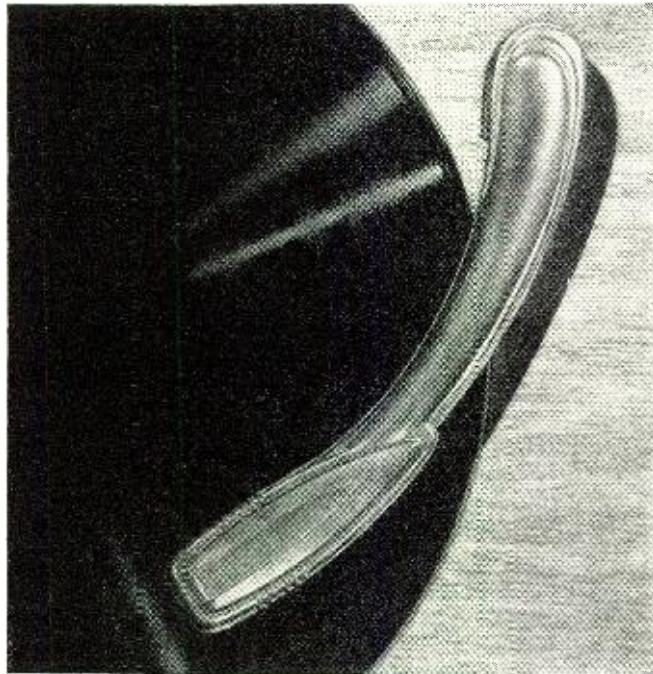

### THE SHURE *Glider* MAKES IT POSSIBLE . . .

Now—for the first time—you can replace old, heavy Crystal Pickups with modern light-weight Shure "Glider"—with no practical loss of output voltage. The "Glider" can be installed as easily as changing a Cartridge—and at an additional price of only \$1.50 list. You will have your customers' lasting good-will when they hear their Phonographs brought up-to-date with better tone—less surface noise—the opportunity to use a permanent-point needle.

The "Glider" has been the selection of leading set Manufacturers for their post-war Phonographs—definite evidence of the most advanced Pickup engineering achievement: the new Shure lever-type Cartridge and aluminum Tone Arm.

**MODEL 93A — \$5.50 LIST**  
(Needle not included)

Immediately Available at Shure Distributors Everywhere

Patented by Shure Brothers. Licensed under the Patents of the Brush Development Company

# SHURE BROTHERS

*Designers and Manufacturers of Microphones and Acoustic Devices*

225 West Huron Street, Chicago 10, Illinois  
Cable Address: SHUREMICRO



represents the answer to only one part of a complicated equation, so we deem it best to hold the answer in abeyance until we present all the factors. In the meantime, you can think about it'

**Other Technical Developments**

Television is the closest of the technical problems but it is not the only one which must be located in its proper place in this jig-saw puzzle of the future. Each month more and more of the wartime developments are being declassified by the military and naval authorities. These will appear in new costume for use by the civilian market, industrial and individual. Maybe three or five years or longer

will pass before many of these will see this new light of day, but some of them will come much sooner. When they come, where will they fall in the pattern of the future of this service group? What will it mean to the present-day radio repairman? . . . A conservative statement is that it will mean as much as the response he displays to the analysis of requirements within the repair industry. This is one man's opinion, it is true, but we hang our hat on it and await criticism. The technological advancements of the war embrace thousands of different commercial applications ranging from electronic eyes for the blind man, a sort of optical radar, through every

form of mechanical and safety control device becoming electronic, to sight and sound communication linking all peoples and all places . . . Who will repair this equipment? The answers to these and many more related questions must be given soon, if the radio repairman is to be in business for more than the next two prosperous years.

Some may feel that it is a foregone conclusion that the radio repairman will automatically get in on the ground floor of this repair work. Don't build your hopes too high! As everyone knows, much activity is expected in private flying. In turn, private flying will be permitted only with adequate radio communication facilities as well as other electronic safeguards. But if you listen to the talk going on in this field, a rude awakening is due. Very much thought is being given to the idea that radio equipment manufacturers provide the necessary repair facilities. The reasons are numerous and sound. They include the problem of technical proficiency, the high cost of the test equipment required to test aircraft radio apparatus properly, unscrupulous repairmen (remember Reader's Digest), and the like . . . So, the radio repairman can't just sit by idly and wait for things to fall into his lap. Project this kind of thinking on the part of these equipment manufacturers to such fields as industrial electronics, private boat navigational equipment, microwave traffic control—and the view does not look too rosy . . . Much thinking followed by much action is the only satisfactory answer. The radio repair field must prove its merit!

**And the Discharged GIs**

For a change of pace, let's gaze upon another unknown quantity which must be resolved into something definite. This is *manpower*. How about the discharged servicemen (thousands of them) who were trained as radio or radar maintenance men in the armed forces? Are they going into the radio repair field? What is going to be the effect of such an influx of men—and women—many of whom have spent years working with equipment which is totally unfamiliar to the practicing repairman? Will they dislocate or even displace the presently operating repair organizations? How much more or less do they know than those now in business and what are the relative merits of technical knowledge and business experience?

**The Output of Correspondence Schools**

This question of manpower is not limited to discharged military personnel; it involves the correspondence schools as well. It is highly significant to note that the national enrollment in correspondence schools, teaching the various phases of electronics, is the *highest ever* in the history of the industry . . . Can the repair industry absorb all these people? Will an abun-

# ELECTRICITY



**FOR RADIO AND ELECTRONIC APPLICATIONS**

**• ONAN ELECTRIC GENERATING PLANTS**  
supply reliable, economical electric service for electronics applications as well as for scores of general uses.

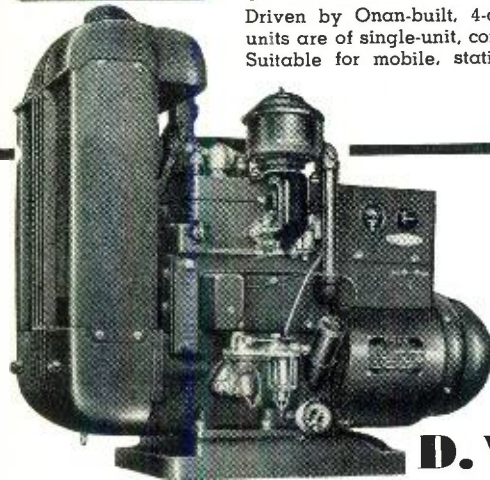

Driven by Onan-built, 4-cycle gasoline engines, these power units are of single-unit, compact design and sturdy construction. Suitable for mobile, stationary or emergency service.

---

Models range from 350 to 35,000 watts. A.C. types from 115 to 660 volts; 50, 60, 180 cycles, single or three-phase; 400, 500 and 800 cycles, single phase; also special frequencies. D.C. types range from 6 to 4000 volts. Dual voltage types available. Write for engineering assistance or detailed literature.

Model shown is from W2C series, 2 and 3-KW, 60-cycle, 115 volt; powered by water-cooled 2-cylinder engine.

**D. W. ONAN & SONS**  
MINNEAPOLIS 5, MINN.

2169 Royalston Avenue

## SPEED UP REPAIRS WITH THESE G-C AIDS!



**FREE STEEL CABINET**

**G-C Dial Belt Kits**

Every Serviceman needs a G-C Dial Belt Kit. Save money—be ready for that repair job. Finest woven fabric replacements. Easy to install—no stretch—no adjustments. Supplied in kits of 25, 50, 100, 200 or 300 Belts in sturdy metal box with slide-in drawer. Free Belt Guide and measuring device



**G-C Dial Drive Cables**

G-C has a complete line of Dial Drive replacement cables. Available by the spool for prompt servicing of all sets. Every Serviceman should have a complete assortment Best quality—extra strength. Preferred by Radio Men everywhere.



**G-C Radio Service Cement**

The best Cement for Speaker and Radio Work. Especially suitable for cementing replacement cones and repairing rattling and torn cones. Also used on glass, to seal adjustments, hold wires in place, etc. Dependable, vibration proof, water-proof and fast drying.

Write for New G-C Catalog No. 146 and G-C Dial Belt and Service Book

**Immediate Delivery on all G-C Products**

Order From Your Radio Parts Jobber  
**ALWAYS ASK FOR G-C PRODUCTS**



**GENERAL CEMENT MFG. CO.**  
ROCKFORD, ILLINOIS

dance of supply cause chaos? These are problems born of the war but they must be answered if we are to develop some idea of how the future appears in order to do some planning.

### Increased Operating Life

Still another unknown quantity of great influence born of the war is the life of the new radio apparatus, if, and when, delivered. The Army and Navy and the other services required apparatus which would continue in operation under the most trying conditions. This meant much research of many kinds . . . And it produced results! Condensers, tubes, resistors, and transformers are better than they were . . . More is known about the mounting of equipment against shock and vibration . . . Moisture proofing technique made tremendous strides . . . In every way the industry has learned the means of producing a more stable, better, longer-lasting piece of radio equipment . . . Statistics developed prior to the war years disclosed that a radio set was on the average about 12 to 16 months old before it required service . . . Will these new sets extend this period to 20 months or perhaps longer? What effect will this have on the future income of the repair shop? How many repairmen will be required to take care of the nation's radio equipment? These questions must be answered.

### A Standardized Repair Charge List?

Let's go right into the repair shop. The nation as a whole is waiting for a standardized repair charge list. The task of preparing such a chart is tremendous. It has been attempted upon occasion without too much success . . . That does not mean that it cannot be done!

Maybe, in order that such a standardized chart be created, it is first necessary to mechanize the diagnosis of faults in radio equipment and to develop a production-line method of repairing equipment—that is, separate diagnosis from repair. This may tend to limit operations to certain types of shops. Who knows? Maybe a new approach is required . . . That is another of the problems.

### The Midget Set

Then there is our friend the midget set . . . The relationship between the original cost of the receiver and the repair charge may not have been of any moment during the war days but it certainly will loom large again during peace . . . Everyone will agree that the determination of this intriguing situation, so fraught with difficulties and as much as anything else responsible for the creation of ill will between the repair field and the public, is vital . . . How can it be solved? Will higher original sales prices solve it; or will it call for the development of special equipment designed to do that type of job specifically? Or will it be a matter of a fixed charge re-

gardless of the fault, taking into account the probability of defects and the frequency of their recurrence? Whatever form it may take in the end, the fact remains that an answer must be found, for it too will play a definite part in the days to come.

We hope that by this time you agree that the future of the radio-repair industry can't be viewed through glasses made rosy by the simple expedient of imagining profitable charges. Profitable operation is the end result. Like the rabbit pie, for which you must first catch the rabbit, to make service charges profitable, you first must have the customer. We have presented a number of major factors, which appear to the writer as destined to exert the most profound influence upon the life of the repair industry. As you can see, by the many questions associated with all of these major issues, the complete puzzle has very many pieces.

It is possible, yes even probable, that many will not agree with our forecasts

or the solutions we will suggest. That is the chance—every person must take when he prognosticates. Fortunately for us, some of the situations are so close as to be clearly visible, even if not within immediate reach; in other words, we're not sticking our chin out in every case. For that matter, we've pushed it out before, so it is nothing new . . . Perhaps as the result of what will be said in other articles, better and more practical suggestions may appear. If that happens, this effort will not have been in vain, as we said before, the fundamental reason for this dissertation is to make people think, to awaken the radio repair group to what faces it, and, finally, to suggest the means of building an electronic maintenance industry which will live for a long time and be free from repeated threats of extinction because it will be equipped to cope with whatever technical and commercial problems arise.

-30-

**in TUNE with the TIMES!**

This is an era of scientific progress. Radio performance which satisfied the amateur operator of 1941 is not going to satisfy him now—and it need not! RME is in tune with the times! While building new and better communications equipment for the exacting demands of war, RME has at the same time perfected even finer equipment for the amateur. Let's examine a few . . .

**THE NEW RME 45**

1. The new RME-45 is so engineered that it delivers peak performance on ALL frequencies—from 550 to 33,000 KC —is the VHF-152 converter.
2. New in the radio field—and a most welcome addition —is the VHF-152 converter.
3. For the ham with wings, RME has carefully designed a practical, feather weight and highly efficient receiver transmitter.
4. And the DB-20 is now one of the most well-known units in existence.

With RME equipment, the amateur can be confident that he possesses the most carefully designed, painstakingly built, and most brilliant performing equipment modern science and pride in manufacture can produce.

**THE RME SPEAKER**

**THE AT-12<sup>7</sup> A RECEIVER-TRANSMITTER FOR THE PRIVATE PILOT**  
(Normal ten mile range)  
Receiver Specifications:  
180 to 420 KC—For Range Station  
550 to 1500 KC—For Broadcast Stations  
278 KC—For Tower Frequency Position.  
Power from small dry cells for both units. Optional equipment, 6 and 12 volt input with external power supply.\*

**THE VHF-152 CONVERTER\***  
For exceptional performance on 28 to 30 MC, 50 to 54 MC and the new 144 to 148 MC bands. With the VHF-152, you can work these frequencies through the double detection method—with economy!

**THE DB-20 PRESELECTOR**  
20 to 25 db gain achieved throughout tuning range of 550 to 33,000 KC. Two highly efficient RF stages provide very high signal to noise ratio.

**SINCE 1933**

\*Units now in preparation

LITERATURE ON REQUEST

**RME RADIO MFG. ENGINEERS, INC.**  
P.O. Box 111, Chicago, U.S.A.

## Radiomen's Headquarters BUFFALO RADIO SUPPLY

219-221 Genesee St., Dept. N  
Buffalo 3, New York

Almost All Kinds of Radio Tubes In  
Stock at Best Wholesale Prices

Mail in your orders for all types needed,  
not just the critical numbers, and we'll  
try to fill them completely.

**BALLAST TUBES**—Nationally known quality, any  
type 39c ea..

**CONDENSERS**—Guaranteed 1 year. Prices in lots  
of ten, either 1 type or assorted. 100 Mfd. 25V—  
35c 50 Mfd. 150V—.45; 20-30 Mfd. 150V—.40;  
20-20 Mfd. 150V—.30; 25 Mfd. 25V—.20; 10-10  
Mfd. 450V—.45; 20 Mfd. 150V—.20; 16 Mfd. 450V  
—.40; 12 Mfd. 150V—.15; 10 Mfd. 450V—.27; 10  
Mfd. 50V.15; 8 Mfd. 450V—.23; Following paper  
condensers in 600V size. 25 Mfd.—.15; 1 Mfd.—  
.10; .05 Mfd.—.09; .02 Mfd.—.08; .01 Mfd.—.08;  
.008 Mfd.—.05; .005 Mfd.—and smaller capacities—  
.07 ea. 100 ass't new but outdated condensers,  
average over 15 lbs., no guarantee—\$.90.

Highest grade standard 3-section auto antennas,  
with leads; 66"—1.50; 96"—2.50. Volume controls,  
\$.58; with switch, \$.87—any standard resistance.  
Speaker Specials—Permas Dynamics—2 1/2"—\$1.45;  
4"—\$1.35; 5"—\$1.25; 6"—\$1.15; 8"—\$1.05; 10"—  
\$.95; 12"—(21 oz. Magnet) \$7.95. Electrody-  
namics—4, 5, or 6"—\$1.50.

115V. 60 Cycle, Half-Shell Power Transformers at  
prices that can't be beat.

For 4 or 5 tube sets: 650V, 40Ma HV; 5V  
Fil and either 6.3 or 2.5V Fil. .... \$1.40  
For 5 or 6 tube sets: 650V, 45Ma HV; 5V  
Fil and either 6.3 or 2.5V Fil. .... 1.55  
For 6 or 7 tube sets: 675V, 50 Ma HV; 5V  
Fil and either 6.3 or 2.5V Fil. .... 1.70  
For 7 or 8 tube sets: 700V, 70Ma HV; 5V  
Fil and either 6.3 or two 2.5V Fils. .... 2.05  
For 9 to 11 tube sets: 700V, 100Ma HV; 5V  
Fil and either 6.3 or two 2.5V Fils. .... 2.75

Filter Chokes, Cadmium Plated Straps, 2" Mount-  
ing; 200, 300, 400 or 500 ohms—\$.49. Universal  
Audio Output Transformers, tapped for various  
impedances—\$.79; Single or double-burton mike  
transformers—\$.69.

Gold-Plated Single-Button Midset Carbon Micro-  
phone with stretched duraluminum diaphragm.  
Works in any position. Made for Signal Corps.  
Perfect for lapel mike or concealed or secret pick-  
ups. Waterproof-Super-Special \$.95 ea. Bullet  
Crystal Mikes—\$.45; Bullet Dynamic Mikes—  
\$.45.

Bargains in Wire: No. 18 POSI 2 conductor ap-  
proved parallel Zipcord, 250' spool, \$4.25; No. 18  
FF (suture wire), 1000' or 2000' spools, \$6.95 per  
M; No. 18 SV round rubber-covered double wire  
for electric drills, wash machines, etc., 250'  
for \$5.95; No. 16 single conductor stranded with spun  
glass 5000V insulation, per ft.—\$.02; No. 18 PO  
brown rayon covered parallel lamcord, 250' spool,  
\$.45. Hook-up wire, per 100 ft.—\$.60. Radio  
and appliance Plugs-Bakelite, 100 for \$2.00; Heavy  
lubber, 100 for \$4.50.

Operate any 1 1/2 Volt portable or farm radio on  
110V AC, with the new GTC Portapower Unit.  
Complete for \$8.95.

Our latest price list is just off the press. Send for  
your free copy now.

LOWEST PRICES • COMPLETE STOCKS  
FAST SERVICE  
STANDARD MERCHANDISE!

**LF's** Correspondence Courses in  
**RADIO & ELECTRICAL ENGINEERING**

**ELECTRICAL ENGINEERING** Get good  
electrical field, prepare yourself at Low Cost, for secure  
future. Modern courses. So simplified anyone can understand quickly.

**RADIO ENGINEERING** Extrafine course in radio, public  
address, address, photo-electric work. Trans  
you to be super-service man, real vacuum-tube technician. Services  
needed badly. Diplomas on completion.

**WRITE** Send postcard or letter for Free  
Copies of school catalogues, full  
details, all about deferred pay-  
ment plan etc. **SEND NOW!**

**LOW \$25** Either  
**AS** Course

**LINCOLN ENGINEERING SCHOOL, Box 921-R86, Lincoln 2, Nebr.**

**Ted McElroy**  
World's Largest Manufacturer of  
Wireless Telegraphic Apparatus  
COMPLETE CENTRAL OFFICE EQUIPMENT  
**McElroy Manufacturing Corp.**  
82 Brookline Avenue • Boston, Massachusetts

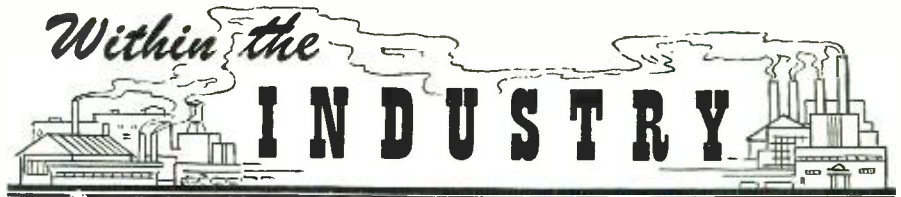

**ANSLEY RADIO CORPORATION**, makers  
of *Ansley Dynaphones* and *DynaTones*,  
are now located in their new offices  
at 41 St. Joes Avenue, Trenton, New  
Jersey.

\* \* \*

**D. L. WARNER, W9IBC**, has returned  
to *Allied Radio Corporation*, Chicago,  
after 42 months'  
service with the  
A.A.F. He will re-  
sume his former  
prewar activities as  
director of Amateur  
Equipment and  
Sales Division.



Early in 1942, Mr.  
Warner, serving as  
Captain, assisted in organizing the  
coastal Aircraft Warning and Defense  
System and later was assigned to  
training bases as a Staff Officer to  
supervise radio and communications  
training for combat crews of medium  
and heavy bomber aircraft.

Mr. Warner plans to begin operat-  
ing his own station shortly and to re-  
sume his participation in the activities  
of various amateur clubs throughout  
the country.

\* \* \*

**FEDERAL TELEPHONE AND RADIO COR-  
PORATION**, manufacturing affiliate of  
the *International Telephone and Tele-  
graph Corporation*, has appointed W.  
P. Short chief engineer and H. A.  
Snow senior engineer of *FTR's* newly  
created home radio receiver depart-  
ment. Mr. Short was formerly chief  
engineer of the *Research Construction  
Company* and staff member of the Ra-  
diation Laboratory of the Massachu-  
setts Institute of Technology. Mr.  
Snow developed the "variable mu"  
tube while with the *Boonton Research  
Corporation*.

Appointment of Robert H. Freeman,  
recently of the Army Air Forces, as  
sales manager of pulse time modula-  
tion radio equipment and systems,  
has also been announced.

\* \* \*

**RAY H. DE PASQUALE** has been elected  
vice-president of the newly organized  
*Press Wireless  
Manufacturing Cor-  
poration*, a subsidi-  
ary of *Press Wire-  
less, Inc.* Mr. de  
Pasquale was direc-  
tor of manufacturing  
for *Press Wire-  
less* and has been  
associated with the  
radio industry since 1921. Other offi-  
cers elected to the same positions in  
the manufacturing corporation as they  
now hold in *Press Wireless* are: James  
Humphry, Jr., treasurer, and James



E. Denning, secretary. Alfred G.  
Greany was elected assistant secre-  
tary.

The main executive and sales office  
of the manufacturing corporation will  
be at 1475 Broadway, Times Square,  
New York City.

\* \* \*

**RICHARD H. BAILEY**, formerly public  
relations director for the *Fairchild  
Camera and Instrument Corporation*,  
has joined *G. M. Basford Company*,  
New York advertising agency. Mr.  
Bailey will continue to handle public  
relations for *Fairchild* and its two  
subsidiaries, *Fairchild Aerial Surveys,  
Inc.*, and *Photogrammetric Instru-  
ments, Inc.*

Announcement is also made of a  
change in address of the general of-  
fices and all manufacturing facilities  
of *Fairchild Camera & Instrument  
Corporation*. They are located at  
88-06 Van Wyck Boulevard, Jamaica 1,  
New York.

\* \* \*

**JULIAN LOEBENSTEIN** has been ap-  
pointed sales manager in the new  
Selenium Rectifier  
Division of *Radio  
Receptor Co., Inc.*,  
New York.



Mr. Loebenstein  
has been associated  
with *Radio Recep-  
tor Company* for  
the past four years  
in the capacity of  
production manager. Other new ap-  
pointments include the following sales  
agents for the Selenium Rectifier Di-  
vision: E. T. Turney, Jr., of *Turney  
& Beale*, N. Y., and *J. E. Oliphant  
& Company*, Marion, Ohio.

\* \* \*

**INTERNATIONAL DETROLA CORPORA-  
TION** has announced the sale of its  
machine tool manufacturing interests  
to *Gisholt Machine Company*, Madison,  
Wisconsin. The sale includes transfer  
of the manufacturing of *Fastermatic*  
turret lathes and superfinishing ma-  
chines, but excludes the equipment,  
lands, and buildings of *Detrola's* Elk-  
hart, Indiana, plant, which will be  
prepared for machining and assembly  
work under sub-contracts.

\* \* \*

**LEE R. KEMBERLING** has become asso-  
ciated with *The Lifetime Sound Com-  
pany*, Toledo, Ohio, and will be in  
charge of the amateur radio equip-  
ment division.

Mr. Kemberling has been actively  
engaged in radio work for many years  
and is well-known in the amateur ra-  
dio field. He has held a federal com-  
mercial operator's license since 1930  
and, at the present time, is holder of

**RADIO NEWS**

amateur radio operator's and station license W8ESN and W8IZZ. Mr. Kemberling is a member of many radio clubs and associations in Ohio and Michigan and is commanding officer of Civilian Amateur Radio Monitoring and Relay System.

**S. D. MAHAN** has been selected vice-president of *The Crosley Corporation* and general sales manager of the of the manufacturing division.



Mr. Mahan came to *Crosley* in 1943 after two and one half years with the U. S. Treasury Department as director of advertising and promotion for the War Bond program. All commercial activities, including export and domestic sales, advertising and service will come under Mr. Mahan's direction. *Crosley* has also announced the promotion of Norman C. Macdonald to vice-president and general manager of the New York branch.

**RADIO CORPORATION OF AMERICA**, New York, has elected E. W. Engstrom as vice-president in charge of research of *RCA* laboratories division and E. C. Anderson as vice-president in charge of the commercial department. C. B. Jolliffe, vice-president in charge of *RCA* laboratories, was promoted to executive vice-president.

The election of five officials of the

*RCA Victor* division as vice-presidents in charge of their respective departments was also announced. They are Joseph B. Elliott, home instruments; Meade Brunet, engineering products; L. W. Teegarden, tubes; J. W. Murray, records, and J. H. McConnell, vice-president and general attorney of *RCA Victor*. Thompson H. Mitchell, vice-president and general manager of *RCA Communications, Inc.*, was elected executive vice-president.

**HAROLD V. NIELSEN**, formerly chief engineer of the radio division for *Sparks-Withington Company*, has joined *United States Television Manufacturing Corporation* as chief engineer, in charge of all radio, television, and special product design and production.

**HAROLD E. KARLSRUHER**, general manager of *Emerson Radio and Phonograph Corporation's* Reconstruction Finance Division during the past four years, has been appointed eastern regional sales manager for the company. Mr. Karlsruher will cover the Metropolitan New York area, New Jersey, Eastern Maryland, Baltimore, and Washington.

**HAROLD L. OLESEN** has been named general sales manager of the *Weston Electrical Instrument Corporation*. H. L. Gerstenberger who formerly served in that capacity will continue as vice-president in charge of sales.

Mr. Olesen has been associated with

*Weston* since 1931 and has been in charge of radio sales, assistant general sales manager, and sales promotion manager.

**GEORGE C. TANTY**, who has been merchandise manager in the Middlewest and Pacific Coast area for *The Crosley Corporation*, has been appointed Southwest regional sales manager. Mr. Tanty was previously associated with the *Philco Radio & Television Company* and also with the *Majestic Radio Corporation*.



*Crosley* has also announced the appointment of Inwood Smith as regional sales manager in the central district. Mr. Smith has been connected with the Office of Price Administration as state board operating executive in Ohio.

**NATIONAL ELECTRIC PRODUCTS CORPORATION**, Pittsburgh, has moved its New England sales office to 270 Albany Street, Cambridge, Mass. Wallace A. Card is manager of the New England office.

**BEVERLY F. FREDENDALL** is now associated with *Frederick Hart & Co.*, subsidiary of *American Type Founders*, in the design and manufacture of Recordgraph and Martron recording equipment. Mr. Fredendall was pre-

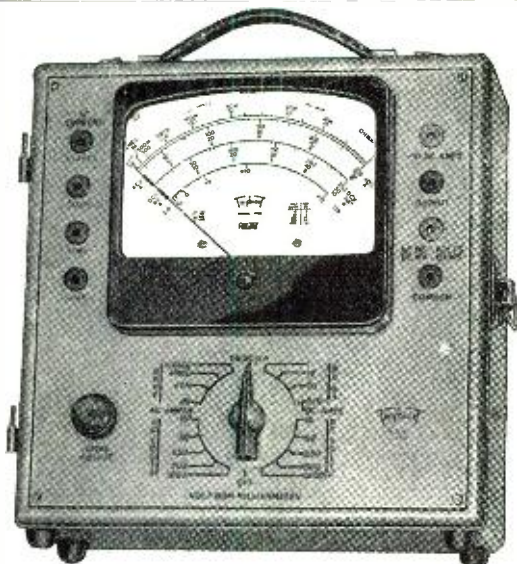

## MODEL 2405 Volt•Ohm•Milliammeter

25,000 OHMS PER VOLT D.C.



### SPECIFICATIONS

NEW "SQUARE LINE" metal case, attractive tan "hammered" baked-on enamel, brown trim.

■ **PLUG-IN RECTIFIER**—replacement in case of overloading is as simple as changing radio tube.

■ **READABILITY**—the most readable of all Volt-Ohm-Milliammeter scales—5.6 inches long at top arc.

■ **RED•DOT LIFETIME GUARANTEE** on 6" instrument protects against defects in workmanship and material.

### NEW ENGINEERING • NEW DESIGN • NEW RANGES 50 RANGES

Voltage: 5 D.C. 0-10-50-250-500-1000 at 25000 ohms per volt.

5 A.C. 0-10-50-250-500-1000 at 1000 ohms per volt.

Current: 4 A.C. 0-.5-1-5-10 amp.

6 D.C. 0-50 microamperes—0-1-10-50-250 milliamperes—0-10 amperes.

4 Resistance 0-4000-40,000 ohms—4-40 megohms.

6 Decibel -10 to +15, +29, +43, +49, +55  
Output Condenser in series with A.C. volt ranges.

*Model 2400 is similar but has D.C. volts Ranges at 5000 ohms per volt.*

Write for complete description

# Triplet

## ELECTRICAL INSTRUMENT CO.

BLUFFTON OHIO.

Available Immediately  
PORTABLE, 2 WAY  
**RADIO TRANSMITTER  
AND RECEIVER SETS**

No. 5CR-583

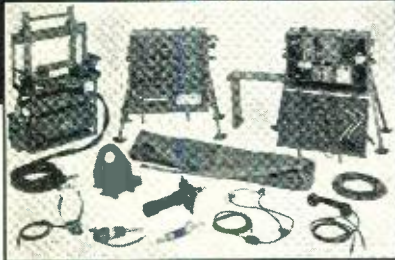

**COMPLETE with War Dept. Manual  
and READY TO OPERATE . . .**

For pack, vehicular or ground operation. Entirely waterproofed; can be operated in driving rain. Power output up to 40 watts. Distance range to 80 miles. 12 Transmission Bands, Frequency range from 2.2 to 4.6 mc. Receiver 2.2 to 4.6 mc.

Government paid Approx. \$1775 for set . . .  
**OUR PRICE while quantity lasts**

**\$215<sup>00</sup>**

Plus Crating  
F O B Chicago

**EQUIPPED WITH**

- Radio Transmitter and Receiver Set with Tubes
- Accessory Chest
- Antenna and Roll Bag
- Power Unit and Power Converter Unit
- Mast Bracket
- Head Sets
- Built-in Speaker
- Microphones
- Hand Sets
- Plugs
- Cables
- Code Key

**ONLY 23 LEFT**

**LEONARD ASHBACH  
Company**

**ELECTRONICS DISTRIBUTORS**  
Phone Whitehall 2065  
152 W. HURON ST. • CHICAGO 10, ILL.

**MASCOT SLIDE  
RULE**

Fits the pocket. Quickly solves any problem in multiplication, division, proportion. Gives the square, the square root, logarithm and reciprocals of all numbers. Trig scales give sines and tangents of numbers. Fine black graduations on white celluloid. Complete with instructions. Price in fabricoid case \$1.00, in leather case \$1.25. Money back if not satisfied. Special offer to agents and dealers.



**MONITOR SLIDE RULE - 6" Dia.** Made in white Vinylite. Same scales as Mascot Slide Rule. Complete with instructions. Without case, \$2.95. Leatherette case, 75c additional.

**TAVELLA SALES CO.**  
25-SB West Broadway, New York 7, N. Y.



**Photo Electric Unit**

For numerous control applications such as burglar alarms, industrial safety controls, automatic counters and in conjunction with a chime or bell to announce entrance of people in stores and offices. For AC. Complete with all tubes and SPDT control relay. Net

**\$9<sup>45</sup>**

**ADSON RADIO CO.**  
221 FULTON ST., NEW YORK 7, N. Y.

viously associated with *NBC* for six-teen years.

\* \* \*

**LOUIS J. WRONKE** has been named chief mechanical engineer and director of design for *The Hallicrafters Company*, Chicago, following the merging of the personnel of the *Louis J. Wronke, Inc.*, Oak Park, with that of *Hallicrafters*.



Prior to the merging of the firms' personnel, Mr. Wronke and his staff had taken part in the designing of postwar lines of radio cabinets for *Hallicrafters* and other large radio companies.

\* \* \*

**FARNSWORTH TELEVISION & RADIO CORPORATION** has moved its Chicago distributing branch from 540 North Michigan Avenue to its new office and show rooms in suite 535-B of *The American Furniture Mart*, 666 Lake Shore Drive, Chicago 11, Illinois.

\* \* \*

**JACK MOULTHROP** has joined *Radio Television Supply Company*, Los Angeles, as vice-president and general manager to replace Mitchell Hirsch who recently retired from the company.



For the past ten years, Mr. Moulthrop has been manager of the Electronics Department of the San Francisco Division of the *Leo J. Meyberg Company*.

\* \* \*

**AMERICAN TRANSFORMER COMPANY**, Newark, N. J., has announced several changes in their executive personnel. Walter Garlick, Jr., vice-president,

will be in charge of sales and related activities. A. A. Emlen, vice-president, will be in charge of engineering and W. R. Smith, works manager, will relieve Mr. Emlen of all supervision and responsibility in connection with factory operations.

\* \* \*

**R. CLARK**, formerly chief purchasing agent, has been appointed to the *Shure Brothers* sales staff. He will contact engineers and purchasing agents at manufacturers of communications and audio equipment, phono-



graphs, and radio sets throughout the country.

Mr. Clark (right) is shown displaying the company's newest lightweight "Glider" Phonograph Pickup to S. N. Shure, general manager (center) and J. A. Berman, sales manager (left).

\* \* \*

**MILO RADIO & ELECTRONICS CORPORATION** is a newly organized firm specializing in radio and electronic components, featuring leading brands of test, sound, and recording equipment.

Louis H. Grossberg and Milton Puterman, both well known in distributing and manufacturing circles, supplement the staff of trained technicians. Offices of this new company are located at 200 Greenwich Street, New York City.

-30-

**Cathode-Ray Tube**

(Continued from page 31)

practical use of these educated elec-

trons. Perhaps one of the best ideas was that of the operator who suggested, "When our indicating units won't work right at sea, why doesn't the scope just write 'out of order'?"

-30-

Fig. 6. If it is desired to write more than one word, a third track and photoelectric cell can be added. Circuit shown includes this feature.

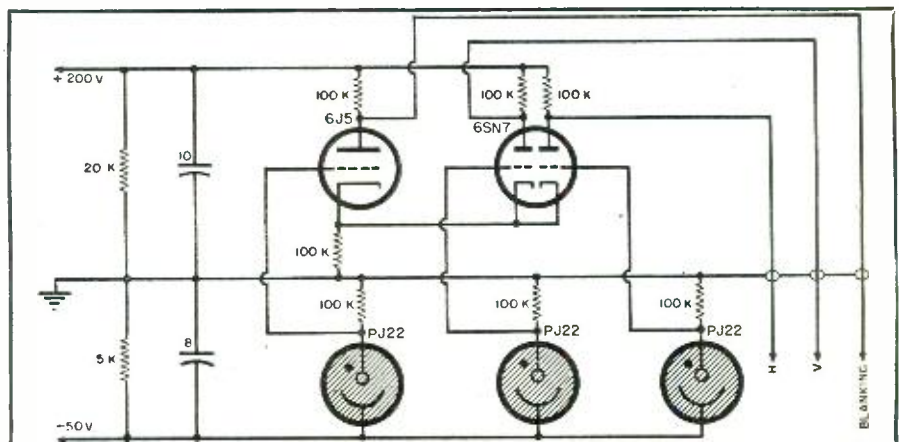

**Record Player**  
(Continued from page 29)

technique, Dr. Fling's students developed the ability to understand and speak two foreign languages, French and Spanish, in one-fourth the time that would have been required in standard practice. An aid in this work was special off-the-air recordings of foreign news broadcasts. Students were eventually able to transcribe, learn, and speak the texts of entire broadcasts by making use of this record player.

Using these experiments as evidence, Dr. Fling now maintains that 50% of the possibilities of foreign language records cannot be realized without constant repetition of short, difficult passages. In no other way can students firmly grasp the material being studied.

The record player is a simple, compact unit, complete in itself. It is portable and weighs less than 20 pounds. It can be used on both 110 volt 60 cycle a.c. as well as 110 volt/50 a.c., making it available for both the domestic and foreign market. Its amplifier is mounted in a carrying case and its response matched to the case to produce crisp speech and brilliant music.

Its most novel feature, of course, is the spotting mechanism. The spot-

ting arm is directly beneath the turntable panel. When the pickup is playing the record, the spotting arm rests free. As the student wishes to repeat a word or sentence, he depresses a lever that actuates the arm, and the pickup is instantly lifted clear of the record. With this lever still depressed, the student moves the spotting arm and, by means of it, re-positions the pickup on the part of the record he wants to hear.

All this can be done accurately within one groove on the record. There is an illuminated position-indicator to the right of the turntable panel, showing the pickup's exact location on the record as it travels across it. The scale of 0-100 on the position indicator, showing number of grooves on the record, is expanded by the use of five consecutive pointers, to allow for coverage of discs up to 12-inch size.

The first of these position-pointers is straight and the scale can be read directly. Thus, when it points to 79, the 79th groove of the record has been reached. The four other pointers that follow are notched, and 100 is added to the scale reading for each notch on the pointer. Thus, if the pointer with 3 notches indicates 50 on the scale, the groove on the record is known to be No. 350. Such readings are uniform on all machines.

At no time does the operator of the record player touch the pickup itself. It is entirely controlled by the spotter-

arm, which lifts the pickup so that it does not damage the record. The spotter arm, incidentally, can be operated with the ease of a telegraph key. The student's hand rests easily on the desk or table, on which the record player is set, while controlling it.

It has many actual and potential uses. During the war material was transcribed from domestic and foreign broadcasts, much as an office Ediphone machine is used—stopping and starting the records at will for taking words off it. The Army is to use this machine in its educational and recreational divisions.

Schools of music can make extensive use of the machine. Much as in the teaching of languages, indexing can be made of symphonies, concerts, chamber music, to indicate themes, recapitulations, and other measures and phrases that must be studied and analyzed. It can be skillfully used in transcribing the folk songs and other music of the Negroes, the hill billies, the American Indians, and all native groups here—and abroad. The 'Library of Congress is currently building up a library of such music, and is to use this record player as an aid.

Because of its low cost, it is available to students for use in their homes, both as a record player and as an accessory to improved study. Other potential users include dance studios, business offices, radio stations.

The record player is inexpensive,

# FIX ANY RADIO

## Amazing New Invention



Find radio faults with a new simplified method. Repair all radios in minutes instead of hours. Revolutionary, different Comparison technique permits you to do expert work almost immediately. Most repairs can be made without test equipment. Simple point-to-point, cross-reference, circuit suggestions locate faults quickly and easily.



**CHARTS, BLUEPRINTS; TESTS, PICTURES; HINTS, JOB-SHEETS**



Learn time-saving trouble-shooting short-cuts; find any radio fault with ease. Follow the tests shown on 24 large circuit blueprints. Over 1,000 practical repair hints. Hundreds of simplified tests using a 5¢ resistor and any filter condenser. Introductory material for beginners and to serve as review for experienced radio men. Several chapters on test equipment. Complete plan in manual form, 64 job sheets, data on all tubes, large size: 8½x11 inches. Schematics, pictures, charts. Sold on no-risk trial. Use coupon to order.

**NO TESTERS NEEDED**

**REPAIR ANY RADIO IN MINUTES**

This newly developed method tells you how to locate the source of trouble in any radio set without equipment. Make needed tests, measure voltage, trace the signal, by using only a 5¢ resistor, small condenser, and a crystal detector. Inject signals without any signal generator. Test parts by the new Comparison method. Test tubes without equipment. Repair any radio expertly following simplified picture plans. Improve your radio servicing ability. Data on all sets, portables, AC-DC, FM, recorders, intercoms, P.A. Examine and apply the plan for 10 days without obligation or risk. Send trial coupon today →

**NO RISK TRIAL ORDER COUPON**

**SUPREME PUBLICATIONS**

9 S. Kedzie Ave., Chicago 12, Illinois

Ship postpaid the new complete Simplified Radio Servicing by Comparison Method manual for 10 days' examination. I am enclosing \$1.50, full price. I must be entirely satisfied or you will refund my total remittance.

NAME: ..... RNF

ADDRESS: .....

simple, foolproof, long-lasting, and does a precision job. Its valuable aid to teaching is proved. For the work it can do, one would ordinarily expect both a complicated and delicate mechanism. But it is so simple and rugged that it can be carried around as easily as a portable radio.

-30-

**Let's Talk Shop**  
(Continued from page 53)

equipment is much more complicated than the servicing and installation you have had to do on old-time equipment. Therefore, you should immediately

take steps to train yourself and your personnel in the operation of high-frequency signal generators and measuring equipment. Operating procedures and service methods should be very carefully studied and the entire personnel should be brought up-to-date with these instructions. Perhaps the best way to start would be with the test equipment manufacturers. They all have in production now, or in projected production, new types of tube testers, signal generators, and output indicators and they will be glad to furnish you with as much information as is available at the moment. As rapidly as time will permit, we at RADIO NEWS will have this information

for you in our pages each month.

From a practical standpoint, it appears that the independent serviceman will be shortly divided into two groups, one group which will stick definitely to service for other retail and wholesale outfits and which functions as the agent for groups of dealers in one or several communities and the other group which will, no doubt, become more sales-minded and actually go into the sales of all types of equipment, thereby becoming dealers, rather than independent servicemen, as we know them.

If, after study of your problems, you believe that the super-service station type of operation more nearly fits your picture, you should immediately begin to make contacts with prospective dealers who can use that service. Do not leave the details entirely up to the dealer, but go in to him with a complete plan of operations based upon what you know you can do. This should include such things as the rate of payment, discounts applicable to the dealer based upon the volume of work, the pick-up and delivery of repairs, and all other necessary details of the arrangements should be thoroughly in mind in order that you have as little trouble as possible in proving to the dealer that a tie-up with you will be a profitable operation.

If you decide that your best bet for the future lies in becoming a retail outlet yourself, you should immediately make contact with whatever jobbers or distributors you think necessary in order that a complete line of radios and appliances can be available to you as quickly as possible. It might be well, at this time, to consider not only radios but some small traffic appliances, which will increase your store traffic and volume. Financial plans should be carefully gone over and the advice of either your banker, or some other person in whom you have complete confidence, should be taken. Remember that if you do decide to go into the retail store business, you may, of necessity, have to become two persons, one that is definitely interested only in the sale of new and used equipment and radios, and the other who is only interested in the service end of the business. This is quite a hard combination to find in any one person and that is one reason care is necessary before you are in it too deeply.

Any of our readers who have any specific questions regarding the operation of either of these two types of businesses are requested to get in touch directly with the author by letter for more details regarding any personal problems. From the above remarks, it can readily be seen that a complete reorientation of thinking, as well as operation, will be necessary beginning now for the independent serviceman who intends to stay in business and who further intends to make a profit on his operations in ensuing years. While we do not expect service work to drop off entirely, cer-

**RADIO NEWS**

# UNIVERSAL

## Model 501

# RADIO TUBE TESTER

• Advanced Styling — Finest Quality Materials and Workmanship.

Designed to give lasting service and priced to **SAVE YOU MONEY.**

WRITE TODAY for SPECIFICATIONS and PRICES.

---

Please rush me full details and specifications on UNIVERSAL Radio Service Instruments.

Name.....

Street.....

City.....

**PRECISION ELECTRONIC INSTRUMENTS**



**UNIVERSAL INSTRUMENT CO.**  
306 E. McMILLAN STREET CINCINNATI 19, OHIO

## *Announcement*

EFFECTIVE JANUARY 1st., 1946 . . . ALL CATALOG COIL PRICES WILL BE INCREASED 26.3%



## **J. W. MILLER COMPANY**

5917 SOUTH MAIN STREET  
LOS ANGELES 3, CALIFORNIA



tainly there will be a general slackening in the next year and a larger slackening in the years to follow until such time as new radio sets, now on the market, will require servicing. Make the most of your opportunity and get busy today.

-30-

**QTC**

(Continued from page 48)

Airways agreement. It certainly is clear-cut and to the point—reason for both the Panagra and other airways men to be proud. Panagra deserves congrats for the co-operation in this contract. Fred also reports a new agreement with the U. S. Lines which shows a substantial increase in wages.

**WE BELIEVE** that most men, being interested in new developments in the maritime field of safety, will be interested in the previous statements by Commodore Webster and will also be interested in the highlights on *loran* noted by Captain Lawrence M. Harding at the same meeting:

"Although it is an electronic device quite close kin to radar, it offers all of the important advantages of the conventional celestial navigation, and the time required is considerably less. *Loran* uses a wavelength which is not greatly different from the range of wavelengths used for long-range radio communications; thus its waves are reflected from the ionosphere and follow around the earth's surface as do the familiar radio broadcasting waves. . . . The range and accuracy of *loran* establish it as a basic sound navigational system. Its freedom from many common equipment errors bespeaks its reliability. Changes in weather, darkness, etc., are unknown to *loran*. The fact that the Coast Guard maintains *loran* transmitting stations in most areas of the world marks it as a navigational device that can be installed on commercial ships and put to good use immediately. Only one item of equipment is necessary. This is a receiver-indicator which is installed on the bridge, where it may be used constantly as a navigational aid. . . . The cost of a *loran* receiver will probably be slightly higher than for a good communications receiver. Various estimates have been made which indicate that the cost of buying and installing all necessary equipment will be in the neighborhood of five hundred dollars."

The equipment will be approximately the size of a communications receiver.

If you are interested in reports of these new developments as they are coming out, let us know and we will obtain as much information as possible for your enlightenment. . . . When this type of equipment becomes a reality aboard your ship, it's you who will have to do the necessary *out-at-sea* repairs. . . . 73

February, 1946

**33 well overlapped ranges . . . plus long-life dependability!**



**WESTON**

(Model 665 Type 1)

**VOLT-OHM-MILLIAMMETER**

Its compactness, versatility and rugged dependability make Model 665 the ideal instrument for use in the field, or in the shop . . . whether servicing communications equipment, testing electrical components in production, or research or maintenance work. Provides 33 AC and DC voltage, DC current, and resistance ranges . . . with simplified switching arrangement for rapid operation. Built to WESTON standards to assure dependable measurement accuracy throughout the years. Full details on request. Weston Electrical Instrument Corporation, 658 Frelinghuysen Avenue, Newark 5, N. J.

**WESTON Instruments**



**SALESMEN FOR CITY AND COUNTY**

*Nationally Known Manufacturer*

Build up a **business of your own** with Nationally Advertised Products bearing Underwriters' label. Sell to schools, factories, service stations, warehouses, hotels, restaurants, public institutions, truck and bus companies, grain elevators, house trailers, autos, farms, homes, etc. **Capable man can earn real money.** Established in 1916. Write letter with details, age, experience, etc.

**THE FYR-FYTER CO.,**

Dept. 22-14

Dayton 1, Ohio

**EASY TO LEARN CODE**

It is easy to learn or increase speed with an Instructograph Code Teacher. Affords the quickest and most practical method yet developed. For beginners or advanced students. Available tapes from beginner's alphabet to typical messages on all subjects. Speed range 5 to 40 WPM. Always ready—no QRM.

**ENDORSED BY THOUSANDS!**

The Instructograph Code Teacher literally takes the place of an operator-instructor and enables anyone to learn and master code without further assistance. Thousands of successful operators have "acquired the code" with the Instructograph System. Write today for convenient rental and purchase plans.



**INSTRUCTOGRAPH COMPANY**

4709 SHERIDAN ROAD CHICAGO 40, ILLINOIS

129



**Silver Soldered  
Connections in  
LECTROHM RESISTORS  
is another Plus Value**



Here again—as in firing, winding, and rating—Lectrohm has devised a special process of silver soldering all connections (not by torch method of brazing) to assure perfect electrical bond always. This special method of silver soldering means added dependability and service life—because, the silver soldered connection is not subjected to remelting, oxidation and other weakening conditions when vitreous enamel is fired. You know you receive the ultimate in dependable service life, accurate rating and solid integral units when you use Lectrohm Resistors. The Lectrohm Line is complete with every style and capacity you may need—write for complete data.



5131 West 25th St., Cicero 50, Ill.  
Division of The National Lock Washer Co.  
Newark, N. J.

**IMMEDIATE DELIVERY!  
SIGNAL CORPS  
TELEGRAPH KEY**



Genuine U. S. Signal Corps key with switch to close contacts, polished durable enameled metal base mounted on a bakelite base, key lever is nickel-plated brass-silver contacts; packed in new, original boxes. Shipping weight, 1 lb. . . . **95c ea.**  
10 for \$8.50

**Army-Navy Type HEADPHONES  
Type HS-23**

Save up to 70% on genuine U.S. Signal Corps headphones. These are the better \$10.00 headphones for only \$2.95. Leather-covered headband, detachable rubber cushions, lightweight construction, impedance 8000 ohms. Ea. **\$2.95**



Plus Shipping Charges  
Order from your jobber or write direct.  
Write for our illustrated literature featuring all types of radio parts.

**ARROW RADIO CO.**

2205 W. Division St., Dept. C, Chicago 22, Illinois

**Saga of the Vacuum Tube  
(Continued from page 56)**

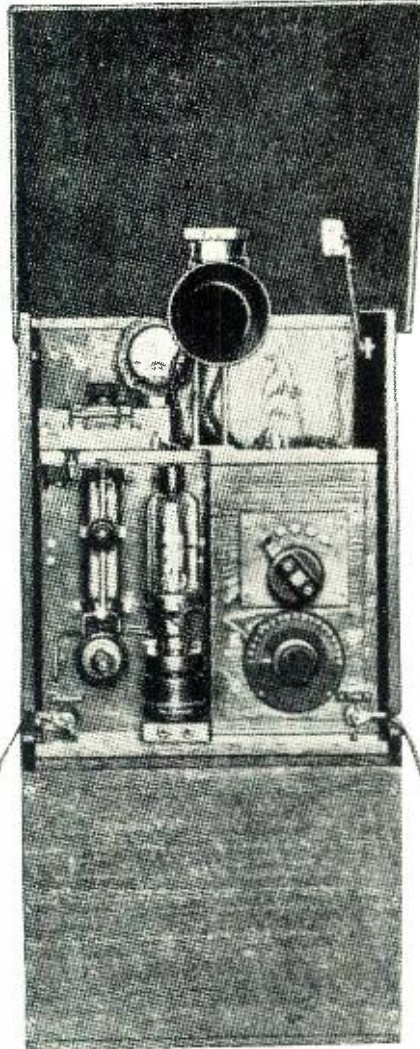

Fig. 231

302. Gutton, C.—“La lampe-valve a trois electrodes.” *Revue Generale de l'Electricite*, Vol. 5, April 26, 1919, pp. 629-640.  
See also Gutton's “La lampe a trois electrodes” *Librairie Scientifiques Albert Blanchard—Paris—1925*, pp. 23-24.

Fig. 232



Fig. 233



303. “Notice sur les lampes-valves a 3 electrodes et leurs applications” *Ministere de la Guerre—Etablissement Central du Materiel de la Radiotelegraphie Militaire—April 1918.*  
304. Nebel, C.—“Die Entwicklung der Siemens Fernsprechröhre” *Veröffentlichungen aus dem Gebiete der Nachrichtentechnik—1935*, Vol. 5, No. 4, pp. 215-226.  
305. Stanley, Rupert — “Textbook of Wireless Telegraphy, Vol. II—Valves and Valve Apparatus” 2nd edition, Longmans Green—1919, p. 182.  
306. Zenneck, Jonathan and Rukop, Hans — “Lehrbuch der drahtlosen Telegraphie” 5th edition, 1925, Verlag von Ferdinand Enke—Stuttgart, p. 787.  
307. Meissner, A.—“The development of tube transmitters by the Telefunken Company” *Proceedings I.R.E.*, Vol. 10, February 1922, pp. 3-23.  
308. See reference 307, p. 5.  
309. Rukop, Hans—“25 Jahre Telefunken — Die Telefunkenröhren und ihre Geschichte” *Telefunken Festschrift*, 1928, p. 115.  
310. See reference 309, p. 118.  
311. Groszkowski, J. — “Les lampes a plusieurs electrodes et leurs applications en radiotechnique” *Etienne Chiron—Paris—1925*, p. 126.

(To be continued)

**Spot Radio News  
(Continued from page 14)**

ference with representatives of the National Association of Broadcasters. Under that system, the first channel frequency (88.1 mc.) will be numbered 201; the second frequency (88.3 mc.) will be numbered 202, and so on up to and including channel number 300 (107.9 mc.). This will give all FM stations in the 88-108 mc. band, and in probable extensions of that band, channel numbers with three digits. Incomplete returns from a questionnaire sent to set manufacturers by RMA show that all but a few manufacturers intend to adopt the channel numbers.

**ALTHOUGH THE RECONSTRUCTION FINANCE CORPORATION** expects a large assortment of surplus handie-talkie and walkie-talkie transceivers, William L. Foss, chief of the electronics division, says no practical disposition of them has been developed. Contrary to general public belief, these military sets cannot be used in the proposed FCC citizens' community services because they were made to transmit and receive on frequencies assigned to and held by the military services. Some military handie-talkies were put on the market several months ago, but RFC stopped all sales when it was discovered they were of no use to civilians.

Radio and electronic war surplus so far declared is small, Foss reports. About 100 million dollars worth, on the basis of original price, has been made available to RFC. The first supply of radio receivers, the SX-28, while equipped to tune in the broadcast and international short-wave bands, are not likely to be converted into home sets. But they may be adapted for use by communications operators.

Radio tubes, both transmission and receiving, are moving well from the surplus stocks to consumers through manufacturer-agents. The transmitter tube market has been flooded, Foss reports, and a large number of the re-

ceiver tubes are being used in civilian home sets.

**Personals**

Chairman **Lee McCanne** of the RMA amplifier and sound equipment division has appointed heads of the five sections of the division under its recent reorganization: Acoustic, **Roy Anderson**, *Stromberg-Carlson Co.*; commercial sound equipment, **A. K. Ward**, *RCA*; intercommunication equipment, **Fred Wilson**, *Operadio Manufacturing Co.*; marine equipment, **H. L. Parker**, *Remler Co., Ltd.*; recording equipment, **Edgar Ellinger, Jr.**, *Jefferson-Travis Corp.* **Sam I. Cole** has resigned as a director of RMA and his terminated his connection with *Aerovox Corp.* **W. J. Haligan**, president of *Hallcrafters Co.*, has been named head of the new amateur radio activities section of the RMA parts division. First meeting of the section was scheduled for late January.

-30-

**Electronics in Aviation**

(Continued from page 28)

out to zero, is eliminated. This detected signal is applied to the grid circuit of the final amplifier, which drives a meter for instantaneous visual observations and also operates a continuous recorder to provide permanent records.

While pilots are immediately interested only in accurate observations of cloud ceilings around 1000 feet and lower, considerable information of value in weather prediction may be obtained at greater heights. The *Ceillometer* has located cumulus clouds with interference from reflections of direct sunlight at levels as high as four miles, using only a small portion of the total sensitivity.

**Detonation Indicator**

In connection with electronic instruments, the primary problem is usually one of devising a suitable pickup to supply the initial information required by the indicating or control apparatus. This was solved in the *M.I.T. Sperry Detonation Indicator* (Fig. 8) with the use of a vibration pickup, of which there are two designs—one operated with a diaphragm and permanent magnet, the other on principles of magnetostriction.

This device was originally developed for purposes of determining detonation characteristics of aircraft engines under test-bench conditions. The pickups are mounted directly on the cylinder heads and the electrical output fed to an amplifier. After rectification the output of the amplifier is used to flash a neon bulb, which is set to flash only when the pickups provide enough energy to indicate that detonation is taking place. In the operation and test of automobile engines it is possible to recognize detonation by

listening for the familiar *pinging* sound, but in aircraft engine operation other associated noises mask this *ping* and the ear cannot differentiate it.

In the process of design and development, it was found that the instrument could be built into a plane as a portion of its standard equipment so that the pilot would have the information available during routine flight. Detonation is a limiting factor on the use of optimum lean fuel mixtures, and it has previously been common practice to use an excessively rich carburetor setting in order to insure avoidance of detonation and its associated effects on engine life. With the *Detonation Indicator* available, the pilot may reduce the fuel mixture and increase the throttle openings until optimum operating conditions are attained. Thus, a 10% to 15% saving in fuel may be accomplished and, what is more important, the pay load of the plane may be increased by the amount of the reduction in fuel weight. A single flight of a DC-3 between Chicago and New York would be able to reduce its gasoline consumption sufficiently to increase the payload by approximately 240 pounds.

Associated with the operation of this instrument is a commutator, by means of which the pilot may choose between observing conditions in all cylinders or any individual cylinder. It is also possible to include the entire cycle of operations in the indications,

# Fahnestock Clips

## RADIO'S GREATEST CONVENIENCE



### FAHNESTOCK SPRING BINDING POST GRIPS THE WIRE BY THE ACTION OF A SPRING

Grips the wire with just the right pressure for good electrical contact without least injury to the wire. NO TOOLS REQUIRED TO MAKE THE CONNECTION. Simply press down on the spring, insert the wire and let go. The end of the wire does not have to be bent or twisted, consequently the connection can be made or unmade as often as desired, without the end of the wire breaking off.

Positive contact; cannot jar loose.

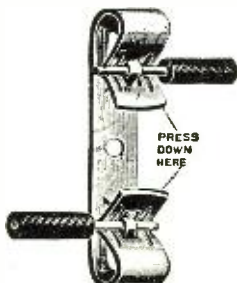
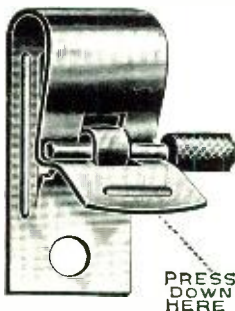

### FAHNESTOCK ELECTRIC COMPANY, Inc.

46-44 ELEVENTH STREET  
LONG ISLAND CITY 1, N. Y.

Please send me at once, Descriptive Literature, Prices and Delivery Schedule on

### FAHNESTOCK CLIPS

Name .....

Address .....

City..... State.....

# PHONOGRAPH RECORDS

FOR TESTING AND DEMONSTRATION WORK

Use them in your engineering dept.—for demonstration work, sales booths, etc. Current popular numbers—slightly used but guaranteed playable.

1000 for \$150<sup>00</sup>

SATISFACTION GUARANTEED

**STARK'S** 509 So. State St. Chicago 5, Ill.



**BIG SAVINGS**  
Hundreds of specials for RADIO SERVICEMEN

- CATHODE RAY TUBES
- POWER & TRANSMITTING TUBES
- HEADPHONES, etc.
- HARD-TO-FIND TEST METERS



### 7 LB. RADIO PARTS ASSORTMENT

A "gold mine" for the radio serviceman, handyman and repairman. Hundreds of valuable radio, radar and electronic parts, screw machine parts, bushings, sub assemblies, etc. More than your money's worth every time. An amazing value. Money-back guarantee.

**K130R — FULL 7 POUNDS ONLY \$179**

War Surplus Bargain Book  
Page after page of war surplus and other bargains for the radio serviceman; also specials for home, shop and outdoors.  
**IT'S FREE! WRITE TO-DAY**

**FREE CATALOG**

**STARK'S** Dept. RN246 509 So. STATE STREET CHICAGO 5, ILLINOIS

## SPEAKERS RECONED!

4" — \$1.15    6" — \$1.35    10" — \$2.25  
5" — \$1.25    8" — \$1.85    12" — \$2.50

Plus Transportation

Prompt Service—Expert Workmanship

**York Radio**

DISTRIBUTING COMPANY

Quality Parts for the Radio Profession

545 No. Water St. DECATUR 21, ILL.

# RADIO

RADIO Technician and Radio Communications courses. Register now for new classes starting first MONDAY of each month. Day and Evening Classes.

**AMERICAN RADIO INSTITUTE**

101 West 63d St., New York 23, N. Y.  
Approved under GI Bill of Rights.

or to limit the operation of the circuits to the time of combustion. This latter feature is important in eliminating extraneous noises caused by valve seating.

Under laboratory test conditions the use of an oscilloscope makes even more accurate diagnosis possible and, when the entire cycle of events is included in the measurement, faulty operation of the valves and other components may be observed and corrected before serious damage is done.

### Navigation

Radio navigation has long ago graduated from its original position as a novelty, and assumes a place today where it is not inconceivable that celestial navigation will soon take second place.

The *Air Position Indicator* manufactured by the *Pioneer Division of Bendix Aviation* provides a continuous indication of latitude and longitude, air miles flown, and true heading with readings on a single dial face. The system includes an air mileage pump, a computer and a remote reading compass. The amplifier functions to build up necessary signals and serves as the coupling unit between the *Air Position Indicator* and the *Gyro Flux Gate* or *Magnesyn Compass*.

The *RCA Radio Altimeter*, now installed on the *Avenger* for purposes of critical control of altitude when torpedoes are being dropped, should provide additional safety for all future navigation, particularly at low altitude over uneven terrains.

There are many other varieties of navigational radio-electronic aids, such as radio range, beacon and marker stations, direction finders, etc. Continued developments will be along the lines of simplification and increased accuracy, but the practical importance of these instruments has been established beyond any question.

### Traffic Control

Traffic control is one of the most important problems of future aviation developments and a great deal of careful planning is necessary to provide optimum rules, regulations, and facilities at airports. Many ingenious electronic devices have been proposed to aid in this program and, as traffic increases, unforeseen problems will doubtless arise to indicate the development of methods not yet conceived. It has been suggested that voice communication is sometimes distracting to the pilot and that automatic visual indicators might be preferable. In this arrangement color coded lights on the instrument panel would convey certain basic traffic control instructions from the control tower, such as "Proceed," "Climb," "Taxi," "Take off," etc. Collision warning indicators, which would provide the pilot with evidence of any other craft within a certain distance, would prevent many accidents. Ground stations to report automatically the presence and altitude of any aircraft passing over them

to a central station have been suggested, but it is likely that radar sets would provide this information more efficiently. It is certain that electronic devices will be the basis for traffic control operations and it will not be difficult to design instruments to provide almost any intelligence that might be required by the pilot or the control tower operator for either visual or instrument landing.

### Private Flying

It is estimated that between 100,000 and 450,000 privately owned airplanes in the United States will eventually require radio equipment. These installations will range from simple receivers to elaborate communications systems, radio direction finders, and other navigational aids, as well as electronic conveniences such as cabin temperature controls. It is easy to conceive that every modern airport will become a major source of business for radio service shops with technically qualified and licensed technicians available. There are more than 3000 airports in the United States today, and this number will likely double in the five years immediately following the war. The potentialities are very large indeed.

### Manufacturing

Electronics plays an important role not only in the operation of airplanes but also in their manufacture. Electronic welding controls in aluminum welding have been of incalculable value in speeding production. Radio frequency heating has improved the quality of aircraft plywood and has reduced the time required to dry (polymerize) the resin glue used in a multi-laminated wood spar from approximately eight hours to twenty minutes. This process has also made it possible to use shorter lengths and more glue joints with results that compare in strength with prewar metal spars of extruded aluminum or nicalumin.

An electronic piston ring inspector determines periphery tolerances to .0001 inch. An x-ray inspection of castings, raw materials, welded assemblies, etc., reveals faults that might otherwise pass undetected. *General Electric's Thy-Mo-Trol* drive controls, installed on an automatic contour milling machine, designed and built by *Onsrud Machine Works, Inc.*, reduces the finishing time in machining aluminum spar beams for plane wings from 13½ hours to 5 minutes.

These are only a few of the important applications of electronics to aircraft production.

### Special Controls

No single article could describe even briefly all of the electronic controls used in aviation. The devices already developed with proven value in operation include solutions to more problems than would ever occur to technicians not fully familiar with the field. One example of this is a device

**RADIO NEWS**

used in connection with systems for eliminating ice formations on the leading edges, wings, and tail surfaces of aircraft. This may be accomplished with rubber boots mounted symmetrically which are periodically inflated and deflated to break up the ice. For this system to be completely successful, it is necessary that the accretion of ice be permitted to develop adequate tensile strength to overcome adhesion between the ice and the De-Icer boot. The *Eclipse Electronic De-Icer Control*, manufactured by the *Eclipse-Pioneer Division of Bendix Aviation Corporation*, is shown in Fig. 4. This control unit may be adjusted to operate the De-Icer boots automatically in cycles timed to suit various conditions of ice formation and flying altitudes.

Among the many instruments developed by *Minneapolis-Honeywell* is an indicator that measures the thickness of ice on an airplane wing by determining the capacitance between two plates on the wing surface. The electronic turbo-supercharger regulator uses a pressure sensitive pickup which, in conjunction with a suitable amplifier, aids in controlling pressure, and is influenced by both speed and acceleration. Their most recent instrument is an electronic aircraft gasoline gauge shown in Fig. 5.

The potentialities are endless and it would appear that electronic methods are ideally adapted to all the control requirements of aircraft.

When one branch of electronics grows to the magnitude attained by

aviation applications, the development of special instruments for purposes of calibration and maintenance becomes an important industry. The catalog from *Televiso Products, Inc.*, is an indication of the increasing scope of this specialized field. Included in the list are Gyro Continuity Tester, Vertical Gyro Final Test, Rotor Vibration Indicating Amplifier, High Potential Test Panels, Aircraft Autosyn Voltage Calibrator, and Polarity Indicator, etc., etc.

The growth of aviation and the resulting increase in requirements for electronic equipment means a greatly expanded field, not only for newly designed test instruments but also for all the standard tools of the radio technician—oscilloscopes, signal generators, vacuum tube voltmeters, etc. (Fig. 7).

#### Viewpoint of the Airlines

In a recent survey of the present and anticipated uses of electronics in connection with commercial airline operations, the forward thinking of many of these organizations is well demonstrated. *TWA* expresses the belief that, while communicating equipment will continue to be the largest single application, this will be only a small part of the total use of electronics in aviation of the future. This large airline has, for a number of years, used electronic devices as a major means of navigation and position location. In the near future they expect to have improved facilities and equipment that will provide pilots with

continuous and extremely accurate indications of position, direction, speed, and altitude from electronic measurements. They expect the long-heralded instrument landing to be available soon for use on commercial aircraft. This is a typical example of equipment that was originally designed with the cooperation of all airlines and diverted for use by the armed forces at the start of the war. As a result of extensive use by the Army and Navy, the methods have been greatly improved. Developments in the microwave region indicate that a plane may be landed much more accurately by radio and electronic devices than by a human pilot.

Apart from the operational phase of aviation, plans for the use of radio and electronics include provisions for passenger entertainment. *TWA* pioneered in the installation of passenger radios several years ago. The radios were installed on a demonstration basis to get passenger reaction, and the results were such that installation on all future transport planes is planned. Telephone service for the executive who wishes to maintain constant telephone contact with his home office is another possibility. While the cost of this accommodation would be almost prohibitive on relatively short trips by commercial aircraft now in operation, it is believed to be entirely feasible in larger transport airplanes on transcontinental and global flights.

Gyroscopic instruments with associated electronic controls are expected to improve the stability of aircraft

**ANTENNAS**

**SNYDER**  
MANUFACTURING CO.  
22nd & ONTARIO STS., PHILA. 40

MANUFACTURERS • START TO FINISH

**AUTOMOBILES**      **BOATS**      **HOMES**      **HANDY-TALKIE**

The advertisement features a large, stylized graphic of an antenna extending from the top left towards the bottom right. The word "ANTENNAS" is written in large, spaced-out letters across the top. Below the antenna, there are four illustrations: a car with an antenna, a boat with an antenna, a house with an antenna, and a man in a suit holding a radio. The Snyder Manufacturing Co. logo and address are prominently displayed in the center.

# NOW—A REALLY HIGH-POWERED— Radio Engineering Library

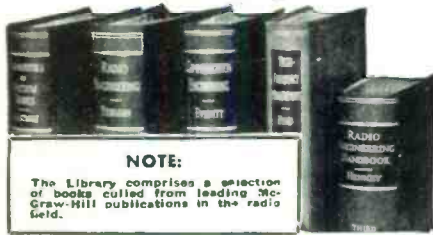

**NOTE:**

The Library comprises a selection of books culled from leading McGraw-Hill publications in the radio field.

- especially selected by radio specialists of McGraw-Hill publications
- to give most complete, dependable coverage of facts needed by all whose fields are grounded on radio fundamentals.
- available at a special price and terms

THESE books cover circuit phenomena, tube theory, networks, measurements and other subjects—give specialized treatments of all fields of practical design and application. They are books of recognized position in the literature—books you will refer to and be referred to often. If you are a practical designer, researcher or engineer in any field based on radio, you want these books for the help they give in hundreds of problems throughout the whole field of radio engineering.

- 5 VOLUMES. 1559 PAGES. 2558 ILLUSTRATIONS**
1. Eastman's FUNDAMENTALS OF VACUUM TUBES
  2. Terman's RADIO ENGINEERING
  3. Everitt's COMMUNICATION ENGINEERING
  4. Hund's HIGH FREQUENCY MEASUREMENTS
  5. Henney's RADIO ENGINEERING HANDBOOK

10 days' examination. Easy terms. Special price under this offer less than books bought separately. Add these standard works to your library now; pay small monthly installments, while you use the books.

**10 DAYS' FREE EXAMINATION—SEND COUPON**

**McGraw-Hill Book Co.,**  
330 W. 42nd Street, New York 18, N. Y.

Send me Radio Engineering Library, 5 vols., for 10 days' examination on approval. In 10 days I will send \$3.00 plus few cents postage, and \$3.00 monthly till \$24.00 is paid, or return books postpaid. (We pay postage on orders accompanied by remittance of first installment.)

Name .....

Address .....

City and State .....

Company .....

Position .....

**I Guarantee this Book will**

**Earn You**

**5 TIMES**

**ITS COST!**

**Or It's Yours FREE!**

Here's a book that will make money for you. Let me prove it with one of the greatest satisfaction guarantees in technical book history. COYNE TROUBLE SHOOTING MANUAL is 4 great books in 1. 610 large pages packed with over 500 valuable wiring diagrams, plans, etc. Shows you new methods for shooting trouble on motors, appliances, refrigerators, automotive devices, air conditioning and diesel equipment.

**SEND NO MONEY**

Here's my sensational offer—Fill in and mail the coupon below. Send no money. Look the book over 7 full days FREE—then decide if you want to keep the book. If you keep the book you can pay \$3.00 cash or send \$3.00 after 7 days and \$3.00 a month until \$24.00 is paid. And further I GUARANTEE that the book must earn 5 times its cost in one year or I'll refund every cent you paid and you keep the book FREE. You can't possibly lose on an offer like that—the book must pay its cost 5 times over or your money is refunded. Offer Limited—Act Now! Send 7-day trial coupon today!

H. C. LEWIS, Pres., COYNE ELECTRICAL SCHOOL, Dept. 26-T3  
500 S. PAULINA STREET, CHICAGO 12, ILLINOIS

Send me the COYNE TROUBLE SHOOTING MANUAL for 7 days FREE examination. After 7 days I'll either return the book and owe nothing or send \$3.00 and \$3.00 per month until \$24.00 is paid or I'll pay cash price of \$3.00. You agree to refund my entire payment if this book does not earn 5 times its cost in one year.

NAME ..... Age .....

ADDRESS .....

TOWN ..... Zone ..... STATE .....

IF YOU WANT BOOK sent C.O.D. (you pay postman \$3.00) check here. Same satisfaction guarantee or your money back.

with regard to pitch and roll, direction, and altitude, and would function in coordination with electronic auto-pilots. Engine controls are subject to electronic control methods. TWA's fleet of five Boeing *Stratoliners* have electronic apparatus now installed for maintaining room temperature regardless of whether the plane is flying in the frigid atmosphere of high altitudes, or the heat of the ground when landing on a warm day. As the craft passes from one zone of temperature to another, the electronic controls establish proper room temperatures within 50 seconds. Finally, this organization plans the use of automatic position recording equipment whereby information regarding location, altitude, speed and direction of flight may be automatically transmitted to a central control office on the ground which permits all aircraft flights to be coordinated to a common agency.

A letter from *Continental Air Lines* states that their use of electronics, in common with most airlines, is mainly for the navigation of and communication with aircraft. Each of their ships is equipped with one transmitter, two automatic direction finders, one v.h.f. marker receiver, and shortly will be equipped with a localizer receiver for instrument landing, a v.h.f. transmitter and receiver for communications purposes and, when developed and available, a v.h.f. radio range receiver. They have 20-odd ground stations, all equipped with a transmitter and two or more receivers, and operating in the medium-high frequency band. To this they plan to add, in the very near future, v.h.f. transmitters and receivers, all for communication with aircraft.

*United Air Lines* state that they are keeping abreast of all the latest developments in radio and electronics and are preparing to make numerous improvements in their operations procedures by taking advantage of new devices tested in the crucible of war. Mr. W. C. Mentzer, chief engineer, states that the four-engine 240- and 300-mile-per-hour luxury liners which United has ordered for the immediate postwar period will be equipped with the electronic automatic pilot as well as the electronic compass. Improvements in remote control equipment for ground station receivers are planned to provide rapid and flexible operation through the use of dial telephone type instruments.

The automatic radio compass, which indicates the direction from the plane to a fixed point on the ground, will be supplemented with newly developed electronic compasses for orientation with regard to north. The latter device will replace the presently used magnetic compass which may be deviated by magnetic fields set up within the plane. Mr. Mentzer is quoted as follows: "Much of the advancement of commercial aviation during the past quarter century can be traced

# TOWARD NEW HORIZONS

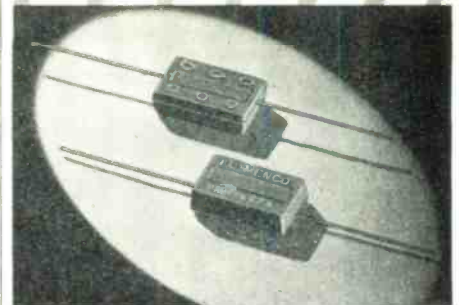

Tested and proved in every important theatre of war, El Menco Capacitors will soon be serving with equal merit in the products of peace. Insure the correctness of this important part of your post-war product by specifying El Menco Capacitors.

Write on your firm letter-head for catalog.



**THE ELECTRO  
MOTIVE MFG. CO.**  
Willimantic, Connecticut

FOR

*Perfection*

IN PERFORMANCE  
AND CLARITY OF TONE

USE —

**PERFECTION** Brand  
**SPEAKERS**  
embodying  
**ALNICO 5**

**PERFECTION**  
**ELECTRIC COMPANY**  
829 SOUTH STATE STREET  
CHICAGO 5, ILLINOIS

directly or indirectly to improvements in radio and electronic devices. In the future, with increasing emphasis on the speed of air transportation, electronics will provide the key for all-weather, on-schedule airline operations."

Considering the number of commercial airlines already in operation, this information forms a fairly impressive answer to the pessimists who fear that the Army and Navy are training more technicians than the industry will be able to absorb after the war. When this potential employment is added to the maintenance requirements for private aircraft and expanded commercial services, and when the use of electronic equipment in the actual manufacture of aircraft is included in the analysis, it becomes evident that electronics in aviation industries will provide employment for an unprecedented number of technicians.

-30-

### Television Must Sound Right (Continued from page 47)

One technique for the control of unwanted sound is that of using a directional microphone—one which picks up sound from preselected directions only. Of course, if the studio walls, floor, and ceiling have a high degree of acoustic reflection, unwanted sounds may be bounced around the room away from the *dead* side of the microphone, into the *live* side, and thus transmitted.

As a general rule, the higher frequencies of sound tend to go in straight lines only, like light. Therefore, they are easier to control than very low tones, which, unlike light, tend to go *around corners*. For this reason, many microphones are directional at higher frequencies and not at low. Even if a microphone is theoretically directional at all frequencies, it loses its directional properties in the lower frequencies whenever there are sufficient reflective surfaces to bounce the sound waves around to the *live* side of the microphone.

Reflection of sound can be cut down or eliminated by acoustically deadening all flat surfaces in the studio, particularly the walls, ceiling, and, where possible, the floor and scenery. Another way to suppress unwanted sound is to place the microphone very close to the source of sound, so that a great volume of direct sound will reach the microphone and the indirect, or reflected, sound will be correspondingly smaller.

The basic method of microphone handling requires the use of a mobile boom, similar in type to that used in motion-picture studios. This makes possible the movement of the microphone in three dimensions: up and down, around in circles, and forward and backward as the boom is telescoped in and out. These booms, usually mounted on a wheeled tripod, can be moved about with ease, especially if a *pusher* handle is attached to one

# NEW SOLDERING GUN

## THE SPEED IRON\*



Patent Applied For

100 Watts 115 Volts 60 Cycles

## Soldering Heat in 5 Seconds

Wherever you have a soldered joint in radio, electrical or electronic repair and service work, the Speed Iron will do the job faster and better.

The transformer principle gives high heat—in 5 seconds—after you press the trigger switch. Convenient to hold with a pistol grip handle, the compact dimensions of this new soldering tool permit you to get close to the

joint. The copper loop soldering tip permits working in tight spots. The heat is produced by the high current flowing through the soldering tip—permitting direct and fast transfer to the soldered connection.

If you want to save time on soldering jobs with a tool that is ready to use in 5 seconds, get a Speed Iron today. See your radio parts distributor or write direct.

\*T.M. Reg. U. S. Pat. Off.

# WELLER MFG. CO.

DEPT. RN-1 • EASTON, PA.

## IT'S NEW! IT'S HERE!

A Truly 100% Vacuum Tube

# VOLTMETER



\$5250

Immediate Delivery

### SPECIFICATIONS:

D.C. Electronic Voltmeter  
6 ranges—0 to 3, 10, 30, 100, 300, 1000 volts  
Input Resistance 11 megohms  
Sensitivity—3 volt scale  
—3,666,666 ohms per volt  
A.C. Electronic Voltmeter  
6 ranges—0 to 3, 10, 30, 100, 300, 1000 volts  
Input Impedance—10.5 megohms shunted by 5 micro-micro farads  
Frequency response flat from 20 cycles to 2—K.C.  
Electronic ohmmeter:  
6 ranges—0.1 ohm to 1000 meg. ohms

Meter:  
200 micro amperes, D.C. of rugged construction  
Accuracy—or —2% of full scale  
TUBES:  
1—6SN7, 1—6HG, 1—6X5  
EQUIPMENT:  
1—cable "D.C." shielded with connector and probe  
1—cable "A.C." ohms with plug and probe  
1—cable "common" with plug and clip  
POWER SUPPLY:  
105/120 volts, 60 cycle

## 96" AUTO ANTENNAS

1. Seamless Brass Tubing
2. High polished Chromium Plating
3. Stainless Steel "Snap Back" Top Rod
4. Heavily Insulated Shielded Loom Lead
5. 100% Low Loss Construction
6. Sturdy Quality Design and Workmanship

\$3.49 ea. 10 or more \$3.25 ea. Lots of 100 \$3.00 ea.

## Complete line of Resistance Type Line Cords

Complete line of Resistance type line cords standard 3 terminal AC-DC resistance line cords. Prompt delivery. Flexible, sturdy cords, 3 terminal type with color coded tinned leads.

135 - 160 - 180 - 200 - 220 - 250 -	45c each
290 - 300 - 330 - 350 - 390 ohms	10 or more 42c each

## JUST RELEASED! FINEST BALLAST TUBES

L42B	K55B	165R4	39c Each
L42C	K55C	165R8	
K42B	L55B	185R	35c Each
K42C	L55C	185R4	
K49B	K90B	185R8	lots of 10 or more
K49C	K90C	250R	
L49B	K80C	100-77	
L49C	100S79	200R	
L49D	100S70		

## 2 Burner Electric Hot Plate

### 3 HEAT

High Quality materials used throughout.

\$650 each



A complete line of Public address systems, Microphones, speakers, hard to get radio parts—everything to meet your requirements.

F. O. B. Chicago—Write Dept. N. for our latest catalogue. All foreign orders payable in U. S. funds.

# RADIO PARTS COMPANY

612 W. Randolph Chicago 6, Illinois



PREFERRED  
BY ENGINEERS

# BURGESS BATTERIES

RECOGNIZED BY THEIR  
STRIPES - REMEMBERED  
BY THEIR SERVICE

**NEW TINY POCKET SIZE  
RADIO!**



Slips in your pocket or purse—Wt. only 3 ozs.! Complete READY TO PLAY as shown with self-contained phone for personal use. Beautiful black plastic case. Has a patented fixed Crystal-Slide Tuning Dial. NO TUBES, BATTERIES, OR ELECTRIC PLUG-IN REQUIRED. U.S. & A.L.Y. RECEIVES LOCAL BROADCASTS without outside aerial wires.

**GUARANTEED TO WORK** when connected and used according to instructions. Can be used in homes, offices, hotels, cabins, in bed after hours, etc.

SEND ONLY \$1.00 (cash, money order, check) and pay postman \$2.99 plus delivery fees on arrival or send \$3.99 for postpaid delivery. IDEAL GIFT FOR CHILDREN OR ADULTS ALIKE! Get your PA-KETTE RADIO NOW for real enjoyment. Dealers in most cities.

PA-KETTE ELECTRIC CO., Dept. RN-2, Kearney, Nebr.

**FILMGRAPH PAT'D**

## Conference Recorders

UNINTERRUPTED  
Longtime (up to 12 hours) Conference  
& Telephone Recordings on Safety Film  
Models for Dictation "TALKIES"

ECONOMICAL  
PERMANENT  
INSTANTANEOUS  
PLAY-BACK

MILES REPRODUCER CO., INC. 812 BROADWAY, N.Y.3 NN-2

### PEN-OSCIL-LITE

Extremely convenient test oscillator for all radio servicing alignment. Small as a pen. Self powered. Range from 700 cycles audio to over 800 megacycles u.h.f. Output from zero to 125 v. Used by Signal Corps. Write for information.

GENERAL TEST EQUIPMENT CO.  
38 Argyle Buffalo 9, N. Y

of the wheels so that it can be pushed and steered by one man.

Auxiliary methods of microphone placement include the hanging of microphones in semipermanent positions over the set in cases where action is limited or where it is inconvenient to use a boom, as well as the hiding of microphones in the set as mentioned earlier.

A special type of *hidden* microphone is the so-called lapel microphone, a very small instrument which hooks on to the lapel of the wearer's jacket and is connected to the control room by a thin wire which can be run down the inside of the jacket and then out across the floor of the set. With a little practice satisfactory results can be attained. Because the microphone is so close to the speaker's mouth, almost all background noise can be excluded. On the other hand, the quality is inferior to standard microphones, and the sound volume is subjected to unexpected drops when the speaker turns his head too far to one side. This, however, may be partly corrected by using two microphones, one on each lapel.

Other types of microphones which offer promise are the so-called *line microphone* and *parabolic reflector* developments. These obtain extremely high directional characteristics at medium and high sound frequencies, so that a person's voice may be picked up out of a crowd. Prewar models, under development by both *Western Electric* and *RCA*, never thoroughly satisfied the engineers who built them, although broadcasters have reported successful use. This type of microphone, which can effect pickups from twenty-five to one hundred and fifty feet from the source of sound, would seem to have a definite place in television, particularly when perfect sound quality is unnecessary in picking up parades or sporting events, public forums, and programs involving audience participation. In short, these *line microphones* are to the audio of television what the telephoto lens is to the video.

Summing up, the main factors to be considered in making the audio pickup of a television production are:

The over-all acoustics of your sound stage. If your studio is spacious and dead, your noise level and echo effects will be reduced to a minimum.

By a dead studio, it is meant one in which the treatment of the walls and ceiling will absorb all frequencies from 16 to 16,000 cycles-per-second. This will always be difficult because the floor, which must be reasonably hard to support the weight of equipment, will be highly reflective. So will the surfaces of equipment and scenery, unless the latter is constructed out of materials which will absorb sound waves as desired. This, of course, has been standard practice in motion picture studios for some time.

And even in a dead studio, the moving of people and equipment, the rush

## TELEVISION TECH CORRESPONDENCE COURSE

**WANTED:** Radiomen to take a specialized television course. Instructions begin and end with television. Course has been written for the Radio Serviceman who wishes to learn television repair, and the radio commercial operator who wishes to prepare for this new field. A knowledge of basic radio is assumed.

**PREPARATION:** The authors of a large portion of this course are Edward M. Noll and O. J. Jimerson. Mr. Noll is author of the present television series in *Radio News* and a former member of the television department of a major radio corporation; Mr. Jimerson, a former senior radar inspector and a former member of the same television staff.

**ADDED FACILITIES:** Widespread interest in this course has encouraged us to enlarge our facilities to handle more students.

## TELEVISION TECH ENTERPRISES

**BOX 94 HATBORO, PA.**

## Roehr Distributing Company

**St. Louis' Radio  
Mail Order House**

ANTENNAS (Auto and Home)

CONDENSERS

RESISTORS

MICROPHONES

TUBES

PHONO MOTORS

BATTERIES

(All Types—  
AB Packs)

PHONO NEEDLES

TRANSFORMERS (All Types)

VOLUME CONTROLS

(Complete Stock Carbon  
and wire wound)

ALL R. M. S. CABINETS IN STOCK

Write for our list of tubes,  
catalog package, and in-  
formation on how to secure  
a Speedex Tube Base Chart  
free of charge.

**ST. LOUIS 3, MISSOURI**



of air, and the very sound of people breathing will tend to build up standing echoes and a bothersome noise level. The problem will be increased when groups of visitors are present on the set. It has been found very helpful to have large, mobile, sound gobos and a system of traveling curtains, which serve partially to isolate a playing area and, thus, break up these unwanted sound waves.

The desirability of having a spacious studio, as already mentioned, means something similar to a standard motion picture sound stage, large enough to give complete flexibility and mobility to the lights and cameras. The only existing studio approaching this size is the CBS television studio in New York.

The second factor to be considered is the acoustics of the production set in which the action is staged. The walls, floor, ceiling if any, and props will be fairly close to the microphones and the source of sound. For this reason, they will give short *slap-back* reverberation with a short time lag. By giving a reasonable amount of attention to position and shape of the scenery and properties and to the acoustical properties of the materials used, satisfactory acoustic perspective can be attained. Unfortunately, this has not been the case in most television programs to date. The tendency has been to forget all about acoustic perspective, permitting the audio to sound as though it were originating in a cave or rain barrel. To be sure, this not as disturbing as it would be in a radio program, for the ear tends to be less discriminating when a viewer's attention is concentrated on the pictures. Nevertheless, it is far from satisfactory.

The third factor to be considered in the audio pickup is the characteristics of your microphone—the sensitivity at various frequencies and its degree of directivity. Corollary to this is the way in which the microphone, or microphones, are placed and moved about.

One final note on microphones. In practical television studio use certain general qualities are desirable. These include:

- (1) High fidelity quality.
- (2) Maximum control of directional characteristics for easy adaptation to varying acoustical conditions.
- (3) A high signal-to-noise ratio.
- (4) Small in size and light in weight, with a dull, neutral gray finish to avoid reflecting light and distracting the actors.

At the CBS studio in New York, the old *Western Electric* 618-A dynamic microphone was selected for general use, because of its high signal-to-noise ratio, and its particular sensitivity to the higher frequencies. This tended to minimize the problem of low frequency rumble which plagues this studio. (It is located in Grand Central Terminal and is subject to severe vibration from the moving trains underneath it.)

# SMASH!

**VALUES!**  
SAVE MONEY ON  
HARD-TO-GET  
**RADIO PARTS**

## FIRST LINE BRANDS ELECTROLYTIC CAPACITORS

Cap. MFD	DC Voltage	Net Price	Net Price for 10
100	25	\$ .43	\$3.90
10	50	.28	2.50
20	150	.37	3.40
20-20*	150	.61	5.60
50	150	.49	4.60
10	450	.51	4.50
10-10*	450	.74	6.90

\*Common Cathode

## TUBULAR PAPER CAPACITORS

Cap. MFD	Net Price	Net Price 24 or more
.001	\$.09	\$.08
.002	.09	.08
.005	.09	.08
.01	.09	.08
.02	.09	.08
.05	.11	.10
.1	.13	.12
.25	.18	.16

Toggle Switch—STDT— $\frac{1}{4}$ " Stem. Each .37c  
 Mercury Coil Dope—6 oz. can—Each .69c  
 Aerial Wire—7 strand-50 ft. roll. Each .27c  
 10 for \$2.49  
 Aerial Kits—Includes stranded copper wire, ground clamps, porcelain insulators, etc. Each 99c

## SPECIAL

Universal Velocity Microphone—40,000 Imp. 25 ft. cable, each . . . \$14.70  
 Army Headphone  
 DC Resistance—17000 Ohms . . . 2.95  
 Simpson Multi-range Output Meter. Model 427 . . . 10.95  
 Weston  $3\frac{1}{2}$ " Rd. Meter—Model 476-0-150V AC . . . 4.95  
 Mercury Model Z Selenium Rectifier type  $1\frac{1}{2}$  V and 90V Battery Eliminator . . 8.65  
 Dual Tr. I.F. Input or Output Transformers—455 KC. . . . . Each 55c

Philmore Headphones—Single 1000 Ohms. \$1.29  
 Double 2000 Ohms . . . 1.89  
 Knob Kit—50 De Luxe Plastic Set Screw Knobs 4.35  
 Volume Controls—10M, 25M, 500M, 1 Meg, 2 Meg—All with switch 2 to  $2\frac{1}{2}$ " standard shaft. Each. 69c . . . 10 for 6.75  
 Single Cond. Rubber Mike Cable. Foot . . . 7c  
 Per 100 ft. . . . . 5.95  
 Shielded Phono Wire. 50 ft. coil . . . . . 99c  
 100 ft. . . . . 1.79  
 Spaghetti Kits, 25-3 ft. lengths assorted sizes and colors . . . . . 1.95  
 Antenna Hanks. 25 ft. each . . . . . 18c

Order direct from this ad—or write Dept. RN-12 TODAY for BIG FREE Catalog of HARD TO GET RADIO PARTS AVAILABLE NOW!  
 Our Terms are Cash. All C.O.D. orders must be accompanied with a deposit of 25% or more. We pay all shipping charges only on prepaid orders of \$25.00 or more.

CENTRALLY LOCATED TO SERVE THE NATION  
 NATIONAL ELECTRONIC SUPPLY  
 622 WEST KINZIE STREET • CHICAGO 10, ILLINOIS



## FOR SAFETY'S SAKE

Safety first for personnel is of the utmost importance.

This protection can be guaranteed through the use of G-E Interlock Switches on radio transmitters, X-ray and therapeutic machines, burglar alarms, and signal controls for fire doors.

Safety first for equipment is important, too. G-E Indicator Lamps give visual evidence of what is going on inside equipment, and circuit troubles can be corrected before they become serious. Write: *Electronics Department, General Electric Company, Syracuse, New York.*

**GENERAL  ELECTRIC**  
100-E1

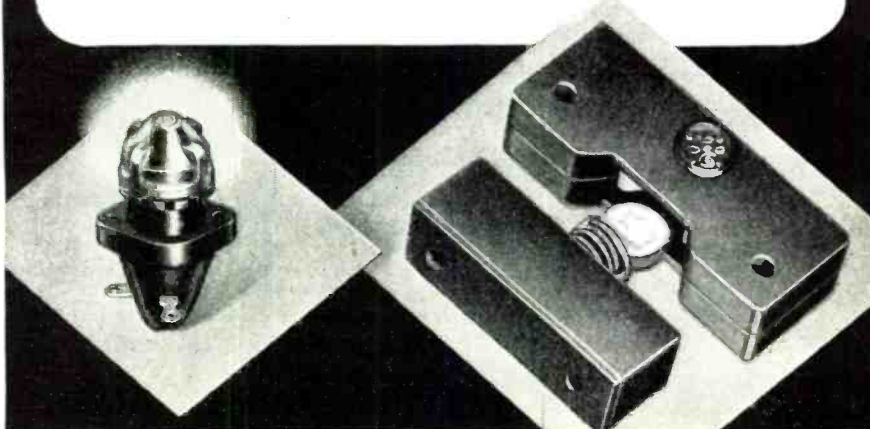

## CLARK PA-30 AMPLIFIER



With patented electronic equalization providing both bass and treble boost and attenuation over range of -12 db to +18 db.

Frequency Response—± 2 db, 50-10,000 Cycles. Overall Distortion—Less than 5%. Hum—55 db Below Full Output. Finish—Metalized Bronze Gray.

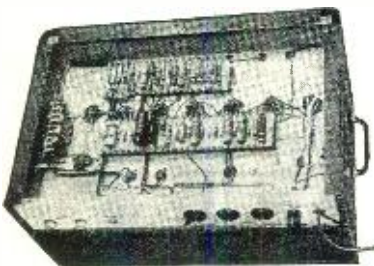

CLARK RADIO EQUIPMENT CORP.  
4313 North Lincoln Avenue  
Chicago 18, Illinois

# 7 Days Free Examination

## PRACTICAL RADIO INFORMATION

Including Frequency Modulation—Television, etc.

Inside Radio Information for all Servicemen—Aircraft Pilots, Students. AUDELS RADIO-MANS GUIDE contains 772 Pages, 400 Diagrams & Photos is complete—gives Authentic Principles & Practices in Construction, Operation, Service & Repairs. Covers clearly and concisely Radio fundamentals—Ohm's Law—Physics of sound as related to radio science—Measuring Instruments—Power supply—Resistors—Inductors—Condensers—Transformers and examples—Broadcasting stations—Radio Telephony—Receivers—Diagrams—Construction—Control systems—Loud speakers—Antenna systems—Auto Radio—Phonograph pickups—Public Address Systems—Aircraft & Marine Radio—Radio Compass—Beacons—Automatic Radio Alarms—Short Wave—Coil Calculations—Testing—Cathode ray oscillographs—Static Elimination—Trouble Pointers—Underwriter's standards—Units and tables—Frequency Modulation—REVIEW QUESTIONS & ANSWERS. Ready Reference Index.

**\$4 COMPLETE • PAY ONLY \$1 A MO.**  
Get this practical information in handy form for yourself—Fill in and MAIL COUPON TODAY—

AUDEL Publishers, 49 W. 23rd St., N.Y. Mail AUDELS NEW RADIO-MANS GUIDE for free examination. If O.K., I will send you \$1 in 7 days; then remit \$1 monthly until \$4 is paid. Otherwise I will return it.

Name \_\_\_\_\_  
Address \_\_\_\_\_  
Occupation \_\_\_\_\_  
Reference \_\_\_\_\_ R.N.

# ..... LETTERS ..... FROM OUR READERS

**T**HE editors have received many letters from readers regarding Tony Wayne's article in the November issue entitled, *Radio Jobs for GI Joe*. Evidently his was a popular topic, since the letters ranged all the way from requests for help in finding jobs to ones in which he was taken to task for alleged misstatements of fact. The author, Tony Wayne, has gone through a long period of training and activity in radar and, as he puts it himself, "have practically lived, eaten, and slept radar for a number of years." His experience includes service with such outstanding firms as Philco, Farnsworth, Raytheon, Westinghouse, and the airlines. He worked both in the U. S. Navy Bureau of Aeronautics and in television research and development on airborne equipment at Wright Field. He has had experience at sea as a radio officer. Some of the manuals he prepared were used as instruction books in Army and Navy training schools to assist military personnel in the operation, theory of operation, and maintenance of radar equipment.

We are sure you will agree with us that his background qualifies him to write authoritatively on radar matters. The editors believe that both our readers and Tony Wayne are viewing the vast project of radar that came out of the war from two different viewpoints. We know that Tony Wayne did not mean to discredit or belittle the efforts of even a single individual in this matter. According to his experience, there is abundant proof that the civilian engineering expert did render invaluable service to the cause of radar at a time when there were not very many trained men available. As schools began to train more men and as new manpower became available, the situation underwent changes from conditions mentioned in Tony Wayne's article to a point where more installation and service was turned over to the trained personnel of the Army and Navy. During the latter months of the war, the activities of these roving civilian technical experts were at a minimum. When the yardstick of time is applied to conflicting statements of this nature, it can readily be seen that both can be right. We feel that the above explanation of attitude on the part of Tony Wayne should go far toward clarifying the thinking of all concerned.

\* \* \*

### RADIO BIBLE

**E**VER since RADIO NEWS was first published (I believe I read my first copy of it as far back as 1920) I have found it to be a very excellent, up-to-date, clearly understandable,

and exceedingly helpful and instructive *radio bible* for any amateur, commercial, dyed-in-the-wool radioman, serviceman, or radio enthusiast of any degree whatsoever.

"I have been especially interested in the clearly understandable, progressive methods in the past half dozen issues of your explanation of radar principles of theory and operation.

"I have been in the radio game since World War I and have been a serviceman, an amateur radio operator (W8BJY, Mars, Pa.), a commercial operator, and during World War II I have been a radio inspector (civilian) for the Navy Department at both the Navy Yard at Philadelphia and, for over the past year, the Naval Aviation Modification Unit at Johnsville, Pa., present rating CAF-8.

"Have had occasion to inspect all latest types of Naval radar and television and radio control and confidential equipment and I can truthfully state that much of what I have learned through reading RADIO NEWS magazines has been of great beneficial value to me and others like me."

Louis A. Hunt, Jr.  
Hatboro, Pa.

\* \* \*

### APPRECIATION

**H**AVING now read and enjoyed over a year's copies of RADIO NEWS, I feel it is about time I let you have some intimation of my appreciation of the fine material contained in this magazine.

"To my mind you have set a very fine balance in the types of articles included in the various copies—developments, experimental work, servicing and constructional articles, and notes and news all find a place in your pages. One series that particularly interests me is *International Short Wave* and I am pleased to note that this is to continue. I also, as an Englishman, find much of interest in the *Spot Radio News* from Washington. Other features which interest me greatly are the *Practical Radio Course*, *Practical Radar*, *Let's Talk Shop*, and the series now concluded, *Theory and Application of U.H.F.* I also enjoy the *Saga of the Vacuum Tube* series. Could this not be collected and published in one volume?

"I was pleased to see, in recent issues, that amateur features are beginning to appear regularly again. I was not an amateur before the war, but I intend to open up an amateur transmitter on my release from the service sometime next year so I find all such material very interesting. I hope that, in due course, when amateur equipment is released in America, ham features will again attain predominance in your magazine. I first made my acquaintance with RA-

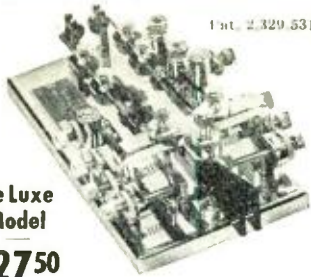

Pat. 2,329,531

De Luxe Model

\$2750

## THE MELEHAN VALIANT

Automatic Dots PLUS Automatic Dashes  
 • Permits sustained high speed transmission  
 • Fifteen to eighty WPM • No vertical play in handle unit • Eliminates "glass arm" condition • Length and speed of dots and dashes individually adjustable • Handle elevation, leverage action and spring tension fully adjustable • Purely mechanical in operation, self-contained and self-sufficient • Outstanding in design and craftsmanship • Massive base and cradle unit • Light, balanced working parts assure that precision movement and split-second response so essential to true super-speed sending • Completely chromed • Base 4x1/2x7 • Shipping weight 7 1/2 pounds •

**MELVINE E. HANSON**

(W6MFY)

MELEHAN RADIO 821 Main Street  
 HUNTINGTON BEACH, CALIFORNIA

## Electronics RADIO ENGINEERING

### NEW COURSES FOR MODERN NEEDS

RADIONICS, the science of electronic applications, is widening its horizon hour by hour. There's a secure future in this field for YOU—provided you put OUR TRAINING ON YOUR must list NOW.

Needed at once are specialists in Marine Radio, Police Radio, Aviation Radio, Broadcasting, Television, Frequency Modulation, High Frequency Broadcasting, and Commercial Radio Telegraph. That need will continue.

Our school is co-educational. It offers to women as well as men streamlined elementary and advanced courses for Radio Servicemen, Radio Engineering Assistants, Radio Test and Maintenance men. The work is thorough, practical, void of frills. The courses are approved by State Vocational Departments, Major Airlines, State Police Systems, Radio manufacturers, and hundreds of Broadcasting Stations.

Credit is given for Army Radio courses on 1 experience toward any of our courses. High school graduation or its equivalent necessary for advanced courses. Tuition at pre-war levels. Send for catalog today.

MAIL THIS COUPON NOW!

VALPARAISO TECHNICAL INSTITUTE,  
 Dept. R., VALPARAISO, Ind.

NAME.....

P. O. ADDRESS.....AGE.....

CITY and STATE.....

CATALOG REQUEST—RADIO NEWS

DIO NEWS in South Africa, while on my way out here, and in those days RADIO NEWS seemed to me to be an amateur's magazine par excellence.

"I would like to congratulate you on the inclusion of *Letters From Our Readers* as a regular feature. It has already produced plenty of 'rag-chewing' (notably on licenses for servicemen) and I trust will produce a lot more in the future.

"The advertisements too are a revelation after the cramped pages of the English radio journals. We are very restricted by paper rationing, but even before the war our advertisement pages could not equal yours.

"Yes, Mr. Editor, you have a fine magazine in RADIO NEWS. I've no complaints at all. If I might make some requests for future material, then I would like to see plenty of amateur material, plenty of u.h.f. features and more articles on television (especially amateur) and FM. Apart from that, I'm well satisfied. Keep up the good work and you'll keep the admiration of one 'Limey' at least. Thanks and 73."

John O. R. Garner  
 South East Asia

Many thanks OM. There's plenty of top-notch amateur material "in the works" by authors who have the experience and "knowhow" to write on all phases of ham radio.

\* \* \*

### G. I. JOE RADIO JOBS

"MAY I be one to congratulate RADIO NEWS on the publication of Tony Wayne's article entitled *Radio Jobs for G.I. Joe*. Such articles, I believe, are of inestimable value to servicemen who have been or are to be discharged and who expect to enter into any phase of the radio or electronics industry. As a whole, there is a very big question in their minds on the selection of suitable positions and on how to go about getting into what they want. I would like to see more of these articles from those who have been in a position to know the industry.

"I consider myself a typical serviceman, had typical service training during the little more than ten years I have been in the Navy. I hope to return to civilian industry in about two years. Through instructing in schools and duty where I came in contact with a great number of these men, I know many of their problems. They all know that success in the future will be because they have what it takes to get ahead. They, too, realize that there will be an abrupt change from military service to civilian employment, methods of doing jobs and, in general, *tricks of the trades* that they do not know. Those are some of the things that have confronted me in my mind.

"Mr. Wayne made one statement with which I am not in complete agreement. My opinion is not substantiated by records or statistics but from day to day observation of men doing technical work. That was in

for **SPEEDIER** testing, calibration and radio servicing see the NEW...

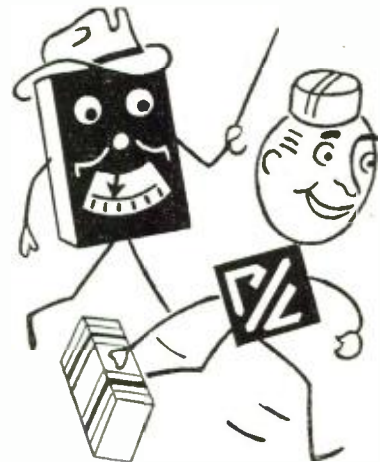

# Clippard

## Electronic and Electrical TEST INSTRUMENTS

Electronic  
 Volt-Ohmmeter  
 Model 406



Incorporates features and accuracy of expensive custom-built laboratory equipment—yet priced within reach of all wanting the best. Low capacity, high impedance input. Balanced circuit. Wide Audio, H.F. and V.H.F. response. New small-diameter diode probe reaches difficult places with minimum lead length. Full scale sensitivity of 1 volt. Determines resistances from fraction of 1 ohm to 1000 megohms. Decibel scale for measuring audio gain. Sturdy oak case. Handy carrying handle. Write for details.



60 Cycle Decade  
 Voltage Supply

A sturdy self-contained laboratory instrument, Weston metered, for calibration and test of A.C. meters and vacuum tube vol-

ometers. Highly accurate source of known voltage in 1/10 volt steps from 0 to 111, or in 1 to 1110 volt model. Engraved panel. Quartered oak case. Write for details.

Electrical Test & Service Instruments  
 High-speed production of precision R.F. Coils, Electro-Magnetic Windings and Sub-Assemblies for discriminating manufacturers.



1440 CHASE AVE.

CINCINNATI 23, O.

**IF YOUR SPEED IS LESS THAN 50 W.P.M. SEND TODAY FOR THIS 52 PAGE FREE BOOK**

**— FOR AMATEURS AND COMMERCIAL RADIO OPERATORS**

**CANDLER SYSTEM BOOK & FACTS**

It shows that "crack" operators rely on something besides practice to develop their high speed and proficiency; it explains the

"knack" of sound-sense and sound-consciousness—the secret of speedy sending and receiving. Once you acquire these mental processes, reading code becomes almost second nature to you, just as the rhythm of a dance band becomes automatic to musician and dancer.

Champions endorse the Candler System. It is used in training Commercial Operators, Amateurs, and Radiotelegraph Specialists in Signal Corps, Airlines, Broadcast Studios, Police Inter-City Communications. Wherever the fastest, most efficient operators are found, there you will find Candler trained men.

If you want s-p-e-e-d, if you have any difficulties in operating technique, if 40-50, and more, wpm seem fantastic speeds to you—send for this revealing 52-page Book now. It's yours without cost or obligation. Simply send your name and address to—

**CANDLER SYSTEM COMPANY**  
Dept. 2-B, Box 928, DENVER, COLO., U.S.A.  
And at 121 Kingsway, London, W. C. 2, England



**Champion Endorses CANDLER SYSTEM**

T. R. McElroy, Official Champion Radiotelegraph Operator of the world with a speed of 75.2 w.p.m., claims his success is due to the Candler System.

## CAPACITORS -

**OIL, PAPER and ELECTROLYTIC**



**Illinois CONDENSER COMPANY**  
1160 N. HOWE ST. • CHICAGO 10, ILL.

his paralleling service jobs to civilian jobs relative to radar. . . .

"This is not to criticize Mr. Wayne's statement or his excellent article but to add my views to help the serviceman returning to civilian employment as much as I possibly can. Such articles no doubt will be a very great help to us."

I. E. Hollingworth, CRM, USN  
Overseas

-30-

### Converter-Receiver

(Continued from page 42)

Vary the coupling of  $L_{10}$  to obtain best operation.

If it is desired to use the receiver which serves as the intermediate frequency amplifier without the converter, simply turn the converter off and throw  $S_2$  so that the antenna feeds directly to the receiver.

The National ACN dial has a beautiful action and may be calibrated by the user. To do this, a signal generator of good accuracy should be used. The coils shown in the table provide complete coverage of each amateur band with a slight overlap at each end for those DX stations just outside the band.

With this converter and a reasonably good receiver (it works very well with one selling for \$36.75 before the war), 10 and 5 meters become just two more bands and not something where you strain trying to pick that elusive signal out of the noise. Using a hunk of wire for an antenna and using the 50 mc. coils with the band set condenser adjusted for reception in the neighborhood of 40 mc., it is possible to hear W2XMN at Alpine, New Jersey, on 42.8 mc. from a location near Washington, D. C. Police stations near the 10 meter band and their squad cars pour in.

-30-

Bottom view of converter-receiver, showing placement of component parts.

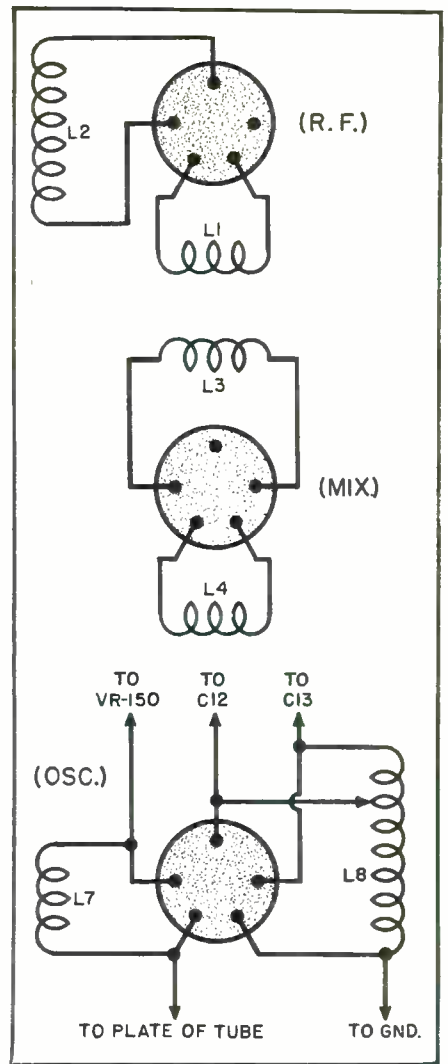

Connections to coil forms. Bottom views are shown.  $L_1$ ,  $L_2$ ,  $L_3$ , and  $L_4$  cannot be connected wrong as long as coils are wound in the same direction and proper coil prongs used. However,  $L_7$  and  $L_8$  must be connected correctly to obtain oscillation.

\*

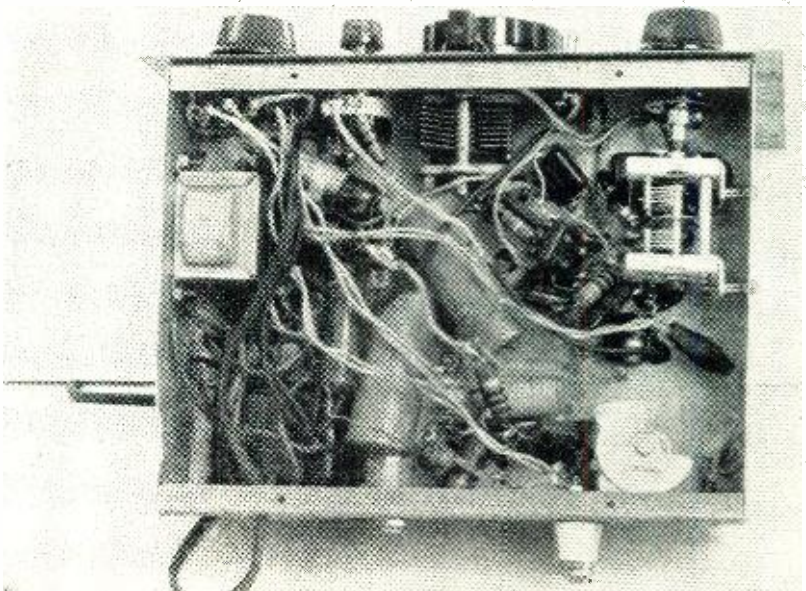

## Multi Range Ma. Construction

(Continued from page 49)

$R_2$ , to measure this drop. By proper choice of  $R_1$  and  $R_2$  values, the regular current scale of the meter may be used and milliamperes will be read in the regular manner. A convenient value for  $R_1$  is 50 ohms. 10 milliamperes flowing through this resistance will produce a drop of  $\frac{1}{2}$  volt. The meter then will give full-scale deflection (as a 0- $\frac{1}{2}$  d.c. voltmeter), corresponding to 10 milliamperes, if  $R_2$  is made 500 ohms. In the same way, 1000 milliamperes (1 ampere) will produce a drop of 50 volts, and  $R_2$  must be 50,000 ohms. In order to switch meter ranges, it will be necessary only to switch  $R_2$  values.  $R_1$  remains the same for all except the 0-1 range.

The resistors have standard integral values and, accordingly, are easily obtainable but they must be selected carefully to be as close as possible to specified values.  $R_1$  will have to be large enough to dissipate the power resulting from flow of 1 ampere. This sets the minimum rating at 100 watts. All series multiplier resistors may be 1 watt, however. Exact values may be obtained in the series resistors, if desired, by employing, in each case, a combination of fixed resistor and small wire wound rheostat in series. The rheostats may be set to give exact value to the total.

In order to use the basic 0-1 ma. range, some arrangement must be made to switch  $R_1$  out of the circuit and the meter directly across the input terminals. This may be accomplished by means of a second pole on the range switch, as shown in Fig. 3B.

Exact values are given in Fig. 3B for 0-1, 0-10, 0-100, and 0-1000 ma. ranges.  $R_2$  may be a 1000-ohm rheo-

Fig. 3. Practical circuit of the instrument described by the author. Note lack of odd-sized resistors.

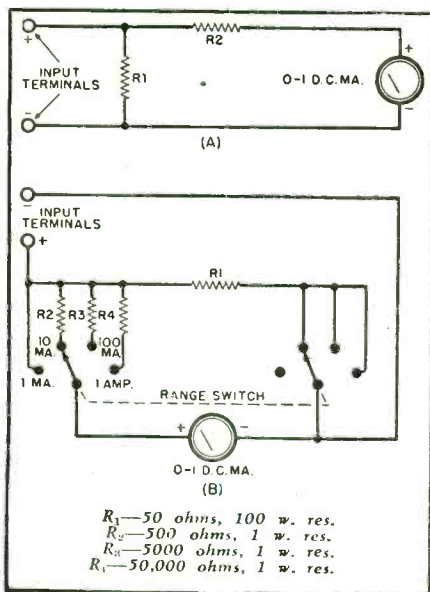

February, 1946



R. C. (Dick) Hall  
WSEIB

## R. C. & L. F. HALL

1015-17 Caroline St.  
Telephone C-9731  
Houston 2, Texas

### WE WANT TO EXPRESS OUR APPRECIATION

to the many new customers who have written us in response to our December advertisement in Radio News. We want to emphasize the desirability of stating clearly whether you are interested in service dealer or amateur bulletins, as most of you did. To give you

### BETTER SERVICE

Six technically qualified veterans of World War II have been added to our staff recently.



L. F. (Lillian) Hall  
WSEUG

### "ACROSS THE SERVICE BENCH"

is the title of our Service Dealer bulletin and our January issue is currently going into the mail (December 17, 1945). Our stock of replacement parts is at a new all time high and our tube allocation continues on the basis of two a month, one hundred tubes each. When you write, be sure to ask for our "new customer" allocation.

### "ACROSS THE OPERATING TABLE"

is the title of our Amateur bulletin. We could list a number of leading communication receivers (we handle them all) with prices and statement that we were delivering. Actually, we have been delivering Hallicrafters and RME communication receivers and by the time you read this we may have a stock built up, since we have placed large orders with the factories and are getting good deliveries although Hammarlund and National will probably not ship anything before January. If you want a new communication receiver or transmitter advertised by any leading manufacturer, get in touch with us. We give allowances on used equipment, easy terms and a guaranteed trade-in on the new receiver you buy from us, when traded in on new equipment in the future. Your special attention is called to the new RME VHF-152 converter for operation on 28-30 MC, 50-54 MC, 144-148 MC and will probably have them in stock as you read this. We have a

### LARGE PARTS STOCK

in which you will find the products of the manufacturers listed below. Write, phone or wire us for what you want.

### INDUSTRIAL PURCHASERS

usually find our service helpful. Wire, write or phone.

### FLASH

We will have our share of Army released Hammarlund Super-Pro receivers. Wire, write or call if interested.

### A FEW OF THE MANUFACTURERS WHOSE PRODUCTS WE DISTRIBUTE

Aerovox	Dumont	Hytron	Les Logan	Pioneer	Stancor
Amphenol	Echophone	Instrucograph	Littelluse	Precision	Taylor
Astatic	Finac	Insuline	John Meck	Premax	Thermador
R&W	Electronics Lab.	Jensen	Messner	Patel	Thordarson
Belden	Erie	JFD	Miller	RCA	Trim
Biley	Gammatron	Johnson	Mueller	RME	Triplett
Bud	General Cement	Kaar	National	Sangamo	Turner
Centralab	GE	Kelnor	Ohmite	Setchell-Carlson	Vaco
Cinaudagraph	Hallicrafters	Leah	Peerless	Silver	Waisco
Clarostat	Hammarlund	Lectrohm	Petersen	Speed-X	Ward
Drake					

**It's NEW! - Yet PROVED!**

**SUPREME MODEL 576 OSCILLATOR**

Incorporates Proved Features of Model 571. New Features Added

- **SIMPLE OPERATION**... all ranges read on two basic scales.
- **DUAL TUNING RATIO**. One for speed... one for vernier adjustments.
- **ELECTRON** coupled circuit giving greatest stability. Iron core coils.
- **LADDER ATTENUATOR** minimizes leakage.
- **DOUBLE SHIELDING**

**SPECIFICATIONS**

**R. F. RANGES**  
 65-205 KC.; 205-650 KC.; 650-2050 KC.;  
 2050-6500 KC.; 6.5-20.5 MC.; Harmonics to 82 Megacycles.

**AUDIO FREQUENCY:**  
 400 cycle—Voltage output continuously variable from minimum to maximum.

**POWER SUPPLY** 115 Volts—60 cycles. Special voltage and frequency on request.

**EXTERNAL MODULATION:**  
 R. F. Carrier modulated at approximately 50%.

**EXTERNAL MODULATION:**  
 Jack provided for external audio modulation.  
 Size 9 1/2" x 8-11/16" x 7-3/8"

**SUPREME INSTRUMENTS CORP.**  
 GREENWOOD, MISSISSIPPI

## 110-VOLTS AC from DIRECT CURRENT

with KATO KONVERTERS Furnish standard 110-volt AC from 32, .110, or 220-volts DC. Good deliveries on sizes 350 through 1500 watts.

PIONEERS IN THE BUILDING OF SMALL ROTARY CONVERTERS



Katolight Rotary Konverter 225 Watt

Good deliveries on 5, 7½, 15 and 25 KW AC generators. Mfg.'s DC generators, motor generators, frequency changers, high frequency generators.

Special motors and generators 25 to 800 cycles.

KATO ENGINEERING CO.  
120 Rock Street Mankato, Minnesota

## SERVICE MEN'S HEADQUARTERS FOR QUICK DELIVERY!

THIS MONTH'S SPECIAL

VOLT-OHM MILLIAMMETER



Model 697

Illustrated

\$24.00 net

Weston Analyzer

Model 772 type 6

\$49.50 net

Weston Tube

Checker Model 777

\$49.50 net

## ORDER TODAY WHILE THEY LAST

We carry a complete line of standard:

TESTING EQUIPMENT  
AMPLIFIERS  
RECORDING DEVICES  
PHONO PICKUPS  
MICROPHONES

and ALL Hard-to-Get EQUIPMENT for which you have been waiting. Many standard Sound Systems available for Immediate Delivery at \$100 and up, complete with tubes

Sound Advice and Sound Estimates Cheerfully Given • SEND US YOUR PROBLEM

Jack Greene

79 CORTLANDT, NEW YORK 6, N. Y.

142

stat,  $R_3$  a 2500-ohm resistor and 5000-ohm rheostat in series, and  $R_4$  a 25,000-ohm resistor and 50,000-ohm rheostat in series. Each of these combinations will give the specified resistance value at center-scale setting of the rheostat. Screwdriver adjustment may be provided for each rheostat; and when once set, the shafts may be locked in place permanently with a drop of sealing wax.

Fig. 1 shows outside and inside views of a multi-range d.c. milliammeter of the type just described, built by the author.

-30-

## Self-Synchronous Transmission Systems

(Continued from page 39)

transformer with a 78 or 87 volt tap. When the circuit is energized using a generator, the undamped rotor may spin. This can be prevented by grasping the shaft lightly until the rotor comes to its normal rest or electrical zero position.

If it is impractical to disconnect the mechanism driving a generator in order to obtain the electrical zero setting, a standard selsyn motor can be used. Such a motor has a dial or balanced pointer mounted on its shaft to indicate the rotor position of the motor when at electrical zero. By this method the generator is disconnected from its working circuit and connected to the corresponding  $R$  and  $S$  leads of the motor.

With both rotors energized, the generator shaft is rotated until the standard motor dial indicates electrical zero. Then a jumper is put momentarily across  $S_1$  to  $S_2$ . If the indication of the standard motor does not change when this connection is made and broken, the generator setting is considered to be accurate. For a finer adjustment, the generator  $S$  leads should be open with  $R_1$  and  $R_2$  across the 115 volt, 60 cycle line. Then a 2000 ohm set of phones or a sensitive a.c. voltmeter across the  $S_1$  and  $S_2$  leads will indicate a minimum sound or voltage when at electrical zero. It is important to remember that this indication is the same at 180 degrees and, for this reason, the zero position should be approximated before using the meter or phones.

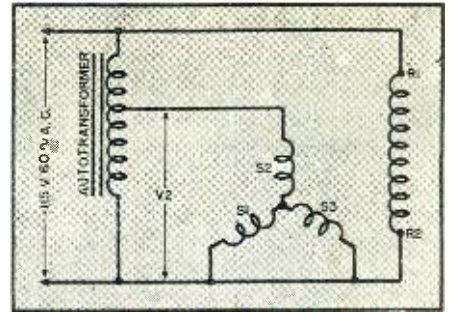

Fig. 5. Circuit for obtaining electrical zero position. For unit with 90 v. secondaries,  $V_2$  is 78 v. For units with 100 v. secondaries,  $V_2$  is 87 v.

Incorrect circuit connections will result in obvious errors in operation. If the generator  $R_1$ - $R_2$  leads are interchanged, all the controlled motors will assume the 180 degree position when the generator is at electrical zero. Interchanging the  $R_1$ - $R_2$  leads of a motor will likewise cause that motor to be 180 degrees out of phase although the direction of rotation is not affected in either case. The effect of interchanging motor or generator  $S$  leads will cause the unit to reverse its direction. If the  $S$  connections of a generator are rotated, the rotors of all motors controlled will be 120 or 240 degrees from the generator electrical zero. Similarly, if the motor stator leads are rotated, a 120 or 240 degree displacement between motor and generator positions will result.

An open rotor lead is indicated by a low motor torque and there are usually two points 180 degrees apart at which the motor comes to rest. If a stator lead is open there are two positions 180 degrees apart at which the operation is satisfactory. At other positions, the torque will be low and the motor will come to rest at two points 60 to 120 degrees apart.

Shorted leads in the motor or generator stator will cause the motor to assume one of two positions 180 degrees apart and each will be maintained through half a revolution of the generator rotor. If the rotor leads are shorted the 115 volt line circuit will, of course, blow out.

Jerky movements of the motor shaft are generally due to sticky bearings. A very light oil should be applied sparingly to each bearing in this case. Heavy oil or water leaking into the

Fig. 4. Typical circuit for synchronized transmission system.

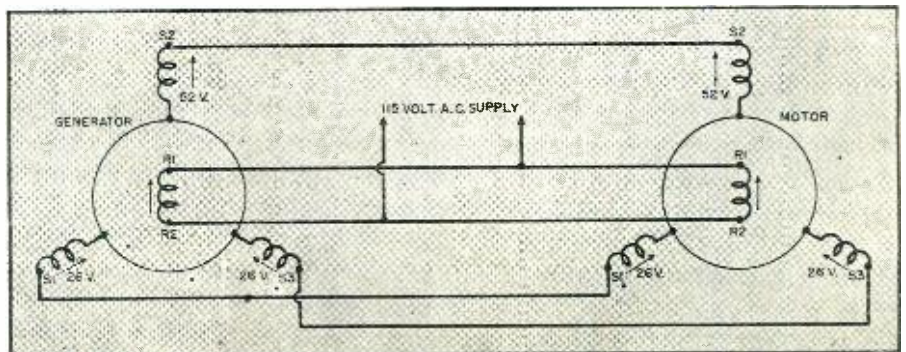

RADIO NEWS

*Attention!* **HAMS**  
... FINISH YOUR OWN  
CRYSTALS



**NEW**  
**Complete Crystal  
Finishing Kit**

**only \$4.95**  
postpaid

Meet F.C.C. regulations for frequency control with Quartz Crystals. Finish your own crystals to meet your individual requirements. It's fun—it's easy—it's economical. Kit contains four AT or BT low drift Quartz Crystals cut to U.S. Signal Corps wartime specification. Complete accessories including a holder with stainless steel hand lapped electrodes and special device for making limited frequency adjustments—flat glass grinding plates—coarse and fine special grinding abrasives—cleaning brush and syntex beads and complete instructions. Be sure to specify frequency desired so we can send blanks within easy grinding range.

**ALL AT AMAZING LOW COST—**  
Send money order, check or cash for your kit today.

**COMMERCIAL  
EQUIPMENT CO.**  
Dept. C  
1416 McGee Street  
Kansas City 6, Missouri

**FREE  
INSTRUCTION**

**ATTENTION!!  
MANUFACTURERS**

We are Looking for Additional  
Lines to Satisfactorily Serve Our  
Increasing Clientele of Radio  
Dealers and Servicemen.

**Consolidated Radio Sales Co.**

768 Amsterdam Avenue  
NEW YORK 25, NEW YORK

**DISTRIBUTORS OF:**

RADIOS, RADIO PARTS, TUBES,  
SPEAKERS, CABINETS AND  
PHONOGRAPH ACCESSORIES

**ELECTRICAL TRAINING**

8 months intensive residence course in fundamentals of industrial electrical engineering, including radio, electronics. Prepares for technician, engineering aides. Approved for veteran training. Classes begin February 25, July 8. 53rd year. Catalog.

**BLISS ELECTRICAL SCHOOL**  
202 Takoma Ave., Wash. 12, D.C.



February, 1946

housing will cause the unit to overheat or act sluggish and may burn out the windings.

To keep synchros in good condition, a regular routine of cleaning and oiling must be established. Slip rings and brushes should be cleaned monthly with grain alcohol. Bearings should be oiled. Care in handling the parts is essential in order to preserve proper brush tension. The units are inherently of a trouble-free nature and will last indefinitely if handled with reasonable care.

—30—

**International Short-Wave**

(Continued from page 86)

is heard in French at 4:30 a.m. The Jaffa, Palestine, transmitters on 6.130, 6.710, and 6.790 open at 12 noon in Eastern languages; no English heard, but open with 19 notes on a stringed instrument as identification. HVJ, 17.840, Vatican City, has been heard testing at 9:15 a.m. in English and Italian, as well as on 15.120 at 10 a.m. PCJ, Hilversum, Holland, has been heard by Gillett on both 15.220 and 9.590. A "very fine level" is heard from the AFRS stations in Tokyo, 7.551 and 9.503 (I believe he means 9.605), 4:30 p.m.-9 a.m. The AFN, London (now closed down), was good at 4 a.m. Radio Belgrade, 9.420. Yujoslavia, has English news at 2:15 a.m.; Radio Belgrade may be heard in foreign languages about 3:30 p.m. on 6.150 and 6.100. Gillett confirms Rangoon's frequencies as 6.035 and 11.860. He reports a Chinese station, announced as XGTA, on 11.650, with English news at 8 a.m., believed to be Shanghai (may be Canton).

Mr. Gillett reports KU1M, 10.590, U.S.S. Iowa, as heard from about 6.30 a.m. frequently contacting KU5Q, Guam. Radio Somali, 7.126, Hargeisa, British Somaliland, relays BBC news daily except Monday at 10 a.m. "The Voice of Free Indonesia," 18.535 (announced), has been heard 7-8 a.m. in native and English; actual callsign used was ABC. He lists Radio Saigon, 11.780, 2-8 a.m.; announces as operating in 25-, 62-, and 285-meter bands. Mr. Gillett has received a verification—after about a year—from PZC, 15.405, Paramaribo, Surinam, using a power of 5,000 watts; the station has not been heard lately. Other recent veries were Bern, Switzerland, on 11.615; CKXA, Sackville, Canada, on 11.705; ZLM-5, 15.500, Wellington, New Zealand; and VPD2, 6.130, Suva, Fiji.

\* \* \*

**EAST COAST REPORT**

A newcomer to ISW, *Jean-Marie Gauvreau*, of Quebec City, Canada, reports HH3W, 10.130, Port-au-Prince, Haiti, evenings; HCJB, 9.958, Quito, Ecuador, very weak; HEK3, 7.380, and HEF4, 9.185, Berne, Switzerland, both with very good volume, 8:30-10 p.m., except Saturdays; Paris on 9.540, opening with English news at 9 p.m., and in French from 9:20-9:40 p.m.,

**FOR  
Easy  
LISTENING**



**MURDOCK  
RADIO PHONES**

MURDOCK Radio Phones are built by sound manufacturing methods to give service—traditionally outlasting ordinary radio phones by years of service.

No other listening experience is like hearing through the "Ears-of-a-Nation"—produced by MURDOCK. Thousands are now listening without strain or discomfort. They get the message right . . . the first time . . . all the time!

MURDOCK Radio Phones have been a FIRST for over 40 years with unusual features that mean effective, easy listening. Be sure to consult with MURDOCK for sturdy, solid-built HEAD PHONES!

Write for Catalog

**JOBBERS!**

MURDOCK RADIO PHONES are now available to you in greater quantities. Write us for full information.

**WM. J. MURDOCK CO.**  
202 Carter St., Chelsea 50, Mass.

For Soldering in  
Tight Places...

**DRAKE**

No. 400 Soldering Iron

Smallest Industrial Iron  
Ever Designed

60 Watts—1/4 in. Tip

Only 9 in. long—Wt. only 8 oz

This mighty mite is backed by DRAKE'S 25 years of soldering iron manufacturing experience. The high quality and long service of DRAKE Soldering Irons have made them outstanding favorites with all types of radio men everywhere. The DRAKE No. 400 is an outstanding value at



Only \$4<sup>50</sup>  
List

Drake Has an Iron  
for Every Purpose.  
Ask Your Radio  
Ports Jobber.



**DRAKE ELECTRIC WORKS, INC.**

3656 LINCOLN AVE., CHICAGO 13, ILL.

**CAREER**

**Radio**

FOUR INTENSIVE  
COURSES

Each one a chance for ambitious men and women to increase earning capacity and promote permanent employment.

1. RADIO TECHNICIAN. A general course including FM and Television. Students learn by constructing electronic and radio equipment under expert supervision.
2. RADIO COMMUNICATIONS. Prepare for FCC licenses. Leads to position as merchant marine or flight radio officer.
3. AIRLINE COMMUNICATOR. Of special interest to YOUNG WOMEN. Prepares for employment in airport flight control offices.
4. RADIO & TELEVISION SERVICE. Employment as repairman on home-type equipment including standard broadcast and FM, as well as Television receivers.

MELVILLE RADIO INSTITUTE  
"The radio school managed by radio men"



CLIP THIS COUPON

SEND ME FREE INFORMATION

NAME .....

ADDRESS .....

MELVILLE RADIO INSTITUTE  
45 W. 45th St.  
New York 19, N. Y.

usually is best around 10 p.m.; VLC5, 9.54, Melbourne, Australia, 8-8:45 a.m., received every morning with a QSA-5 signal; HJDE, 6.145, Medellin, Colombia, evenings; OTC, 9.745, Leopoldville, Belgian Congo, 7-8 p.m., with news in English at 7:15 p.m., signal is sometimes very good but is usually QRM'd by CSW7, Lisbon, Portugal; FZI, Brazzaville, French Equatorial, Africa, on 9.440 and 11.970, are usually weak, female announcer, French is generally used; XEWW, 9.500, and XEQQ, 9.680, Mexico City, are fair; CSW7, 9.735, Emissora Nacional, Lisbon, Portugal, heard on 9.735 or 9.740 with fair signal, in Portuguese only; HJCAB, 9.690, Bogota, Colombia, in Spanish; Radio Nacional de Espana, 9.370, Madrid, evenings, Spanish only, news and commentaries, light music. Mr. Gauvreau explains that his receiver is built entirely from junk-parts; is a three-tuber—a 6C8G as regenerative-detector and first audio, one 43 as power output, feeding an 8" PM speaker, and a 25Z6GT rectifier; he uses phones most of the time, connected in the first audio-stage; his antenna is only 30' long and very badly situated; however, all the stations listed come in with good volume, as well as do 29 stations in the U. S., 6 in Canada, and 7 in England. Not bad with a homemade 3-tuber!

From Roxbury, Boston, John J. Kernan submits WXFJ, 12.255, Adak, Aleutians, 11-11:30 p.m. with (English) servicemen's program, calls WVD and home service, good signals; NWU, 10.255, U. S. Navy, Bermuda, calls NSS, 7 and 8 a.m.; Radio Somali, 7.126, British Somaliland, 10:30-11:30 a.m., with BBC news relay at 11 a.m.; Radio Cameroons, 11.53, Douala, 10-11:30 p.m. in French; EAJ-43, 7.570 (now 7.582), Santa Cruz de Tenerife, Canary Islands, 5-6:05 p.m.; TIPG, 9.620, San Jose, Costa Rica, 9-11:30 p.m., relays NBC news at 11 p.m.; Radio Macau, 7.530, logged a recent Sunday, sign-off at 10 a.m.; VONH, 5.970, St. John's, Newfoundland, 3-8 p.m.; LKJ, 9.54, Oslo, Norway, 1:45-7 a.m. and 10 p.m., in Norwegian; Egyptian Sudan on 9.220, 4:30-5 p.m. in Egyptian; CJCX, 6.010, Sydney, Nova Scotia, 5 p.m. on in French and English; COHI, 6.455, Santa Clara, Cuba, 8 a.m.-2 a.m. next day, Cuban and English, with English news at 5, 7, 10 p.m.; DHTC, 14.425, Berlin, Germany, heard testing with RCA at 3 p.m.; Radio Guadeloupe, 7.215, 7-8:30 p.m. in French; TFJ, 12.235, Reykjavik, Iceland, Sundays, 9-10 a.m. in Danish, and 4-7:30 p.m. on Saturdays; Funchal, Madeira, 7.100, 5:40-6:30 p.m., native; CR7BE, 9.710, Mozambique, 3:55-4:30 p.m., all native.

From New York City, Frank Bogdan reports HCJB, 9.958, Quito, Ecuador, R9; TGWA, 9.790, Guatemala City, R8-9, evenings; Leopoldville, 9.745, Belgian Congo, relaying BBC evenings; ZEQQ, 9.680, Mexico City, R7-8, evenings; LRX, 9.66, Buenos Aires, Argentina, R7-8, evenings; Radio National Francais, 9.560, R8 at 1:15 a.m.,

and on 9.54, R6 in evening transmission at 9 p.m.; Moscow, 9.480, sign-off at 1 a.m.; TAP, 9.465, Ankara, Turkey, heard at 1:40 p.m. (Sun.); Belgian Congo on 9.425, heard at 1 a.m., and Radio Belge, 9.375, heard at 1:30 a.m.; Radio Nacional de Espana, 9.370, heard at 7:30 p.m.; Bern, Switzerland, 9.185, R7-8, evenings; FZI, 11.970, Brazzaville, R8, evenings; HH3W, 10.130, Port-au-Prince, Haiti, English announcement at 12:30 p.m.; JCKW, 7.220, Jerusalem, Palestine, come on the air at 11:30 p.m., R7-8; also tests Saturday afternoons to 8 p.m. Radio Brazzaville, 17.530, afternoons, very good; Bern, Switzerland, 15.875, very good at 2:30 p.m.; GSP, 15.310, London, terrific signals afternoons; HCJB, 15.095, Quito, Ecuador, good afternoons, and on 12.455, very good "as ever;" GRF, 12.095, and GRV, 12.040, London, excellent, afternoons; Radio Brazzaville, 11.970, fine signal at 7 p.m.; PRL8, 11.720, Rio de Janeiro, Brazil, very good at 9:30-9:55 p.m.; GRH, 9.825, and GSB, 9.510, London, very good evenings, also GRI, 9.410; COCX, 9.270, Havana, good evenings; GSU, 7.260, London, terrific signals, evenings; PJCI, 7.250, fair signal to 9:30 p.m.; GWL, 7.205, GRK, 7.185, GRT, 7.150, and GRW, 6.150, all London, fine signals evenings; Havre, France, on 15.915, has been heard recently with special broadcast messages at 11:40 p.m.; Radio Levant, 8.020, FXE, heard at 1:30 a.m.

We have received the following fine log from Gilbert L. Harris, North Adams, Massachusetts:

YNDG, 7.66, Leon, Nicaragua, heard at 7:54 p.m. with music; YNLAT, 7.615, Granada, Nicaragua, heard at 7:58 with music, very weak; Radio Centre, 7.560, Moscow, heard signing on at 8 p.m.; XEQQ, 9.680, Mexico City, heard at 6:45 p.m.; ZYC8, 9.610, Rio de Janeiro, Brazil, heard at 7:45 p.m.; Radio Brazzaville, 9.440, heard signing off at 7:57 p.m.; RNF, 11.845, Paris, heard signing on at 8:57 p.m. and had English 9-9:20 p.m.; a Guatemala City station on 7.170 has been heard signing off at 10:58 p.m.; GSW, 7.230, London, heard signing on at 11:15 p.m., had Far East music, presumably was beamed to the Far East in the Pacific Service of the BBC; GRJ, 7.320, and GRS, 7.075, heard with English news at 11 p.m.; GWL, 7.205, and GSU, 7.260, have English news at 11:30 p.m.

RNB, 9.745, Leopoldville, heard at 11:30 p.m. relaying BBC English news, signed off at 11:45 p.m.; GRY, 9.600, London, has English news at 3:45 p.m., strong signal; HP5G, 11.780, Panama, heard at 4:05 p.m. A station near 9.945 was heard at 9:11 p.m. a recent evening, had chimes at 9:15 p.m. and left the air; Bern on 9.185 and 7.380 heard nightly except Saturday, 8:30-10 p.m.; CE1180, 12.00, Santiago, Chile, heard at 10:08 p.m.; GVW, 11.700, London, heard signing on at 11 p.m., had English news, and is in parallel with GSB, 9.51, and GRY, 9.60. PRL7, 9.720, Rio de Janeiro,



Brazil, heard at 5:55 p.m.; Moscow on 15.75 has been heard R9-plus recently, signing on at 11 a.m., had news to sign-off at 11:23 a.m., also heard well around 8 a.m.; VLC5, 9.54, Sheparton. Australia, in first transmission to Eastern States of North America, 8-8:45 a.m., very good signal; VLC6, 9.615, Radio Australia, heard signing on at 9 a.m. with English news; Radio Dakar, 6.917, heard at 3:45 p.m.; Radio Eireann, 17.840, Dublin, Eire, heard from 12:40-12:50 p.m. sign-off, with English news, ask for reception reports; CSW6, 11.040, Lisbon, Portugal, heard 12:30-3 p.m. and 4-6 p.m.; HVJ, 17.445, Vatican City, heard at 10:20 a.m. in English, with sign-off at 10:41 a.m.; WJS, 15.700, Hicksville, New York, heard at 11:10 a.m. calling Germany; GRP, 17.870, London, heard at 10:45 a.m. calling Africa, had English news at 11 a.m.; TAP, 9.465, Ankara, Turkey, heard a recent Tuesday from 6:04 to 6:13 p.m. talking to WLW (Cincinnati); Alicante, 7.950, Spain, heard signing off a 6 p.m.; Radio Brazzaville, 17.530, heard signing on at 11 a.m.; SDB-2, 10.780, Stockholm, Sweden, heard at 1 p.m.; Bern, Switzerland, on 15.875, heard signing off at 2:51 p.m.; HI1Z, 6.135, Ciudad Trujillo, Dominican Republic, heard signing off at 10:31 p.m.; SBT, 15.155, Stockholm, Sweden, heard signing off at 10:58 a.m., signed back on at 11 a.m.; TAP, 9.465, Ankara, Turkey, is being heard at 1 p.m. with English news; Radio Maroc, 9.095, CNR3, Rabat, French Morocco, heard at 4:48 p.m. in French, with music at 4:51 p.m., and sign-off at 5:01 p.m.; TGWA, 9.790, Guatemala City, heard at 6:10 p.m. with fine musical (marimba) program; Radio Portuguesa, 12.400, Parede, Portugal, heard signing off at 6:31 p.m.; Radio National Belge, 17.770, Leopoldville, heard signing on at 11:29 a.m., followed at 11:30 a.m. by English news; FXE, 8.025, Radio Levant, Beirut, Lebanon, heard at 3:55 p.m. with Near East music, sign-off was at 4:17 p.m.; JLG4 (WVTR), 7.551, Tokyo, Japan, AFRS, heard signing on at 4:30 p.m., runs to 9 a.m. next day; CSW7, 9.725, Lisbon, Portugal, heard 7-8 p.m. sign-off; Moscow on 7.300 heard with English news at 8:20 p.m.; YNBH, 7.008, Managua, Nicaragua, heard at 9:45 p.m.; Radio Dakar, 7.210, heard at 3:40 p.m.; HP5A, 11.692, Panama, heard at 6 p.m.; a Cuban station on approximately 9.245 is heard evenings, announcing as "The Voice of Cuba," Havana (probably is COBQ, 9.238, recently returned to the airwaves).

From Toledo, Ohio, Charles S. Sutton reports HBF, 18.450, Geneva, Switzerland, English program, 10-11:30 a.m.; PMC, 18.135, Indonesia-Java, "Control of Free Indonesia Forces," was heard calling "Java Calls United States of America," asking for support of the "Free Indonesia Republic," used various languages and American recordings, heard 5:30-7 p.m.; OIX2, 9.506, Lahti, Finland, English and Finnish news, 7:15-7:35 a.m.; Radio

February, 1946



• THE HALLDORSON COMPANY has continuously manufactured for industry since 1913. Since inception, this firm has been and is still an individual firm . . . not a subsidiary or branch of another company.

Each and every HALLDORSON transformer is backed by 33 years of experience, research and actual field knowledge. A new and more complete line of transformers is now being developed in the HALLDORSON laboratories. Soon . . . we hope, in the very near future . . . these transformers will be available.

JOBBER: Get on our mailing list today!

**THE HALLDORSON COMPANY**  
SINCE 1913  
4500 Ravenswood Avenue • Chicago 40, Illinois



**HALLDORSON Vacuum Sealed TRANSFORMERS**



## Special Low Price! AUTO ANTENNA

- Triple Chrome Plated Brass
- Shielded Cable Included!
- Extends to 68 Inches!
- Fine Construction!
- Gasket Seals!

**\$1.79**  
PLUS 10c POSTAGE  
(No C.O.D.s)

This 3-section side cowl Antenna fits most cars. Shielded lead-in, equipped for Motorola or Bayonet Radio connection. A super value!

Send for our free Bargain Bulletins.

This offer good only in U. S. A.



### RMA RESISTOR COLOR CHART

Printed on 3"x5" plastic card. Shows old and new color codes, tolerances, ruler, Ohms Law formulas!

**5¢**

Clip and mail this coupon today!

## OLSON RADIO WAREHOUSE

73 E. MILL ST., DEPT. 7, AKRON, OHIO

Please send me . . . Auto Antennas @ \$1.79 plus 10c postage.

Also RMA Color Chart for 5c. I enclose \$.....

NAME .....

ADDRESS .....

*Inside Facts About*  
**ROHM No. 7**  
**PERMANENT MAGNET**

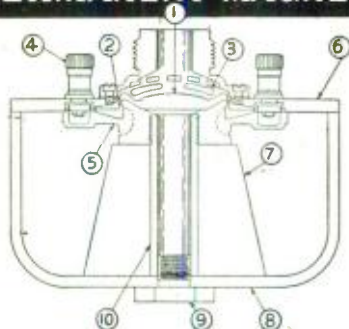

- 1—One-piece meta. diaphragm. Voice coil wound on diaphragm.
- 2—Horn mounting accurately centered.
- 3—Perforated die-cast palate.
- 4—Cadmium plated heavy-duty binding posts.
- 5—Flange molded to inner pole piece.
- 6—Outer pole piece of special alloy.
- 7—Heavy ALNICO permanent magnet.
- 8—Bowl of heavy gauge steel.
- 9—Brass assembly nut binds all parts.
- 10—Inner pole piece made of brass.

Write for circular RN-246 giving complete detail.

**ELECTRONICS DIVISION**

**ROHM Industries**  
 3120 MONROE ST., TOLEDO 6, OHIO

**ATTENTION!**  
**STUDENTS • SERVICE MEN • HOSPITALS**  
*Build Your Own*  
**RADIO**  
*It's Easy . . . We Show You How*



We manufacture complete radio kits. Send for details.

- Four tube T.R.F. Kit complete with tubes . . . . . **\$10.95**
- Six tube Superheterodyne Kit complete with tubes . . . . . **\$17.95**

**MULTI-TESTER**

All the parts you need plus complete detailed instructions to enable you to build a multi-tester which parallels commercial meter construction. . . . . **\$14.95**

**Special for This Month**

**12" P.M. Speaker (Heavy Slug) . . . \$4.95**

Available at Once  
**GOVERNMENT SURPLUS**  
 Transmitters • Receivers  
 Test Equipment

We carry a complete stock of parts.  
 Export Inquiries Invited.

**RADIO KITS COMPANY**  
 Dept. K 120 Cedar St. New York 6, N. Y.

Levant, 8 035, Beirut, Lebanon, heard 4-4:17 p.m. with English news, also 12:15-1:15 a.m. in French, Arabic, and other languages; Khabarovsk, U.S.S.R., 13.190, heard in Russian, 8-8:40 p.m.; EAJ-43, approximately 7.550, Tenerife, Canary Islands, heard in Spanish and musical program, 5:30-6:02 p.m. sign-off with Anthem; KU1M, 7.680, U.S.S. Iowa, calls KEB, 6.890, and KES-2, 8.930, 7-715 a.m.; Ponta Delgada, Azores, 4.043, heard 4-6 p.m.; Radio Singapore, 7.220 (heard announce 7.230), relayed BBC news at 8:30 a.m.; Radio Rangoon, 11.860, heard at 9:55 a.m. with English news.

\* \* \*

**MID-WEST REPORT**

H. H. Seckler, Radio Editor of the Times, Leavenworth, Kansas, sends us his log: KHE, 17.980, Kahuku, Hawaii, 8-8:45 p.m., English, good; KRHO, 17.800, Honolulu, Hawaii, with English news at 8-9-10 p.m., good; VLC4, 15.315, Shepparton, Australia, 10-12 midnight, weak; JVV4 (?), 15.235, Tokyo, contacts from 6 p.m. on, heard strong at 8 p.m. recently calling San Francisco; HCJB, 15.095, Quito, Ecuador, 1:30-7 p.m. with English news at 6 p.m., good, and on 12.455, 5-10 p.m. with English news at 9 p.m., good; Radio Centre, 12.170, Moscow, 6-8:15 p.m., some English, bad CW QRM; CE1180, Santiago, Chile, heard 4-11 p.m. in Spanish, with English news at 10 p.m., only fair signal; Radio Brazzaville, 11.970, heard with clear signal at 7 p.m.; TGWA, 9.790, Guatemala City, 10 a.m.-12 midnight, fine marimba music; VLC5, 9.54, Shepparton, Australia, 8-8:45 a.m., fine reception in Middle-west; HEF4, 9.185, Bern, Switzerland, 8:30-10 p.m., with HET3, 7.360 heard 5:30 p.m. on (may be HEK3, 7.380); HC1CQ, 7.239, Quito, Ecuador, 11 a.m.-10:30 p.m. in Spanish mostly, but with English at 10-10:30 p.m., very entertaining; JLG4, 7.551, Tokyo, heard in English 8-8:30 a.m.; JVT, 6.750, Tokyo, heard contacting San Francisco, 6:30-7 a.m.; HP5H, 6.122, Panama City, 6-10:30 p.m. in Spanish and English, with English news at 9 p.m.; XEOI, 6.015, Mexico City, in Spanish, usually has good orchestras. Mr. Seckler comments that his location is bad due to power lines, and proximity to highway—he is considering a "move out into the woods and getting a SX-28-A."

Paul H. Massey, River Forest, Illinois, lists CSW7, 9.740, Lisbon, Portugal, 7-8 p.m., S5; PRL8, 11.720, Rio de Janeiro, Brazil, 9:30-10:45 p.m., except Saturday and Sunday, with English news at 9:45 p.m., S8; HCJB, 9.958, 12.455, 15.100, Quito, Ecuador, 6-10 a.m., 2-10:30 p.m.; English news at 5 p.m., with signals of frequencies coming in S5, S6, and S5, respectively; RNF, 9.540, Paris, 9-10:45 p.m., with English at 9 p.m., S5; HEF4, 9.185, Bern, Switzerland, 8:30-10 p.m. with English news at 8:45 p.m., and messages from soldiers on furlough in Switzerland, at 9:45 p.m. except Fridays, S6; VLC5, 9.54, Shepparton, Aus-

tralia, 8-8:45 a.m., S9; OTC, 9.745, Leopoldville, Belgian Congo, noon-12:45 a.m., with English news at 7:15 and 8:10 p.m., S7; PRL7, 9.720, Rio de Janeiro, Brazil, 3:10-9 p.m. in Portuguese, S7.

Jim Johnson, Chicago, reports Brazzaville, 11.97, with excellent signals there afternoons, particularly good at 5:15 p.m. in English news period; RNF, 9.540, Paris, sends good signals from 8:55-10:45 p.m.; Radio Centre, 15.75, Moscow, heard well 7:30-8:15 a.m.; TAP, 9.465, Ankara, Turkey, is coming through on Mondays and Thursdays, 4:30-5 p.m., fair signals but plenty of QRM; KU5Q, 9.670, Guam, heard contacting San Francisco, Manila, XGOO (Shanghai), and others between 8-8:30 a.m., arranging network schedules; XEWW, 9.500, Mexico City, sends excellent signals to Chicago afternoons and nights; Spanish only, but popular U. S. music is used; Manila on 9.30, Press Wireless Communications, talks to San Francisco around 8:15-8:45 p.m., irregularly; VONH, 5.970, St. John's, Newfoundland, 500 watts, comes in fair; Canada's International Service Stations CKCX, 15.19, and CHOL, 11.72, are heard nicely in Chicago.

Also from Chicago, Larry Gutter says he's getting a "lot of kick" from listening to the 10-meter amateurs from all over (Spain, Puerto Rico, Canada, U.S., Hawaii, etc.). He has been picking up SBT, 15.155, Stockholm, Sweden, 10 a.m.-1:15 p.m. with English news at 10:05 a.m. and at 12:40 p.m. (almost an identical repeat of 10.05 a.m. news); SBT is strong, but is hampered sometimes by WNBI on 15.150; at all times is readable; SDB-2, 10.780, is in dual with SBT, 12:15-1:15 p.m., and continues in Swedish, believed to sign-off at 5 p.m. Stockholm uses 11 notes on a Novachord as identification in between some programs.

Other stations listed by Mr. Gutter include VLQ2, 7.215, Brisbane, Australia, heard 3-5 a.m. with fair signals broadcasting the "Queensland Program" of the Home Service, English news at 4 a.m.; VLC6, 9.615, Melbourne, good, with news at 4 a.m.; Radio France, 12.12, Algiers, heard at 1 p.m. in French with good signal; LRR, 11.88, Rosario, Argentina, Radio Rosario, puts in a good signal, 7-8 p.m.; HJCT, 6.198, Bogota, Colombia, Radio Nacional de Colombia, is the strongest, clearest Latin American at night on 49 meters, signs off at 11:15 p.m., uses chimes for identification much like NBC's; for entertainment, GSW, 7.23, London, is recommended for after 1 a.m. in the General Forces Program, terrific signals, beamed to Near East; GBU, 9.95, Rugby, England, heard for network correspondent contact at 5 p.m.; Brazzaville on 17.56 (600 watts) is heard before 10 a.m., off at 10:30 a.m. and back on at 11 a.m., continues to 5:30 p.m., news in English at 1:45 p.m., is stronger than on 11.97 which is in dual at that time, signals are strong all afternoon,

## Calibrate your 'Scope to 1% with Voltascope



**PROVIDES** three standard voltages—.1, 1.0 and 10.0 peak to peak volts. AC operated and adaptable for all make oscilloscopes. The magnitude of an unknown signal may be determined rapidly and accurately. No warm-up time makes the Voltascope ready for immediate use.

A self-contained instrument—no bigger than your hand. Fool-proof—no tubes. Easy to operate. Net price, F.O.B. New York City

**\$15.00**

**POLARAD ELECTRONICS COMPANY**  
135 LIBERTY STREET • NEW YORK 6, N. Y.  
Phone: REctor 2-0534



## Radio TUBES

Standard Brands  
ALL GUARANTEED

Available for Immediate Delivery

80.....69¢	35Z5.....84¢	3Q5.....\$1.51
6K7.....69¢	6Q7.....98¢	0Z4.....\$1.51
6C5.....69¢	6A8.....98¢	11Z76.....\$1.59
6F6.....69¢	50L6.....\$1.09	117L7.....\$2.29
12SK7.....89¢	12SQ7.....\$1.09	117P/N7.....\$2.29
5Z3.....89¢	35A5.....\$1.27	11L5.....\$2.29
5U4.....89¢	1N5.....\$1.27	

And hundreds of other types. Send postal for free complete catalog of radio parts, tubes, batteries, record players, etc. Orders filled as received. We ship anywhere. Dept. M.

## FLANAGAN RADIO CORP.

Philadelphia's Largest Stock of Radio Tubes  
N. E. Cor. 7th & Chestnut Sts., Phila. 6, Pa.

## RADIO COMMUNICATIONS

... ON LAND ... ON SEA ... IN THE AIR

Radio communications offers a wide variety of employment opportunities unequalled in radio-electronics. Practical, semi-professional, residence courses conform to FCC and NAB technical standards. Send for free booklet "Lifetime Careers in Radio Communications."

APPROVED FOR VETERANS

**Western Radio Communications Institute**  
Specialists in Radio Communications  
106 W. Third St. (C), Los Angeles 13, Calif.

## RADIO ENGINEERING!

EX-SERVICE MEN can complete work here in shortest possible time. Special Prep. Dept.

Also Refresher Courses. Courses also in Civil, Electrical, Mechanical, Chemical, Aeronautical Engineering; Business Administration, Accounting, Secretarial, Science. Tuition, living costs low. 63rd year. Cosmopolitan student body. Enter Mar., June, Sept., Jan. Catalog  
**TRI-STATE COLLEGE** 1626 College Ave.  
ANGOLA, INDIANA

DEGREE IN  
27 MONTHS

February, 1946

beamed on Near East, Africa, and Europe; FGY, 7.210, Radio Dakar, French West Africa, heard very well with French news at 2:15 a.m., bulletin usually runs to about 2:25 a.m., carrier identifies before start of transmission with constant tone, varying between three pitches for 2 seconds each, and there is a burst of typical French band music at beginning and end of the radiation; KU5Q, 9.67, heard with phenomenal signals, 8-9 a.m., in contact with KEB (6.89) and KES-2 (8.93), San Francisco; JZK, 15.16, Tokyo, audible some evenings around 7 p.m. with spot pickups, in contact with RCA, San Francisco; Leopoldville, 17.770, Belgian Congo heard 11:30 a.m.-12:15 p.m. to Europe and Britain, news in English at 11:30 a.m., uses much classical music; HP5K, 6.005, Colon, Panama, relays BCB HOK, has a resumé of the week's news (English) at 9 p.m. Saturdays, strong but occasionally QRM comes up out of the background and smotherers the signal.

Mr. Gutter further reports the Press Wireless transmitter in Manila on 9.30 is PY5, heard well around 8 a.m. in contact with KG57, Press Wireless, Los Angeles, which shares a frequency of 10.01 with WJQ, Press Wireless, New York; KXI, 17.40, RCA, Manila, heard about 5 p.m. contacting San Francisco; other RCA Manila transmitters which frequently go unreported are KXG, 10.70, and KXD, 16.215; another Manila station mentioned is KXE, frequency unknown; a telephone contact station at Bogota, Colombia, HJAH, 10.04, is heard well evenings using scrambled speech most of the time, strong signals, calls WNC and WNC-4, Hialeah, Florida; PSH, 10.22, Rio de Janeiro, heard signing off with strong signal at 6 p.m., following a program with male and female announcers in Portuguese; Moscow's new transmitter on 15.32 is heard well in French and Spanish, 8:30-9 a.m.; Moscow on 15.23 is very good evenings, 5:47-7:30 p.m., heard best with the 7 p.m. English news period; according to announcement heard at 8 a.m. over 15.75, the Moscow morning set-up is on the air at 7:20 a.m. with 9.48, 11.63, 11.83, and 15.75, and is joined at 7:35 a.m. by 6.07 and 9.56; in the morning, Moscow's 15.75 has been heard with "blind" pickups for the networks; always a good signal at 15.75.

From Butlerville, Indiana, James A. Green reports pickup of ZLT7, 6.715, Wellington, New Zealand, 4:30-4:45 a.m. with English news period, good signal strength but sometimes noisy, at closed down announces, "Station ZLT7 will now cease transmission until 9:30 tonight" (presumably local time); RNB, 9.745, Leopoldville, Belgian Congo, heard well with English news at 7:15 p.m., and relaying BBC after 8:15 p.m., clear; VLC6, 9.615, Shepparton, Australia, heard mornings in English, Dutch, Malay, English news at 5:30 a.m., good signal strength; VLC5, 9.540, Shepparton, 8-8:45 a.m.,

# HARVEY HAS IN STOCK QUALITY SHALLCROSS MEASURING INSTRUMENTS

Trust HARVEY to supply you with hard-to-get Shallcross Measuring Instruments when you need them. The models described below are on our shelves now. Delivery information concerning Shallcross products not listed herein can be obtained by writing directly to us. Remember, HARVEY carries the lines of many other leading American radio and electronic manufacturers, too. Tell us what you need. We promise efficient, courteous service—prompt deliveries.

### SHALLCROSS MODEL 637 KELVIN-WHEATSTONE BRIDGE

An extremely accurate and versatile bridge for the measurement of resistance over a wide range. Range is from .001 ohm to 11.1 megohms. Built-in galvanometer with a sensitivity of 1 microampere per millimeter division is supplied with the instrument. The rheostat arm consists of three decades variable in steps of 10 ohms when used as a Wheatstone bridge, or 10 micro-ohms when used as a Kelvin bridge. Accuracy of component resistors is 0.1%, except 1 ohm resistors, on which the accuracy is 0.25%. Portable; weight approximately 7 lbs. \$80.00

### SHALLCROSS MODEL 638-2 KELVIN-WHEATSTONE BRIDGE

Combining both Kelvin and Wheatstone networks in a single, portable unit, the Model 638-2 provides a range of resistance from 0.0001 ohm to 11.11 megohm. Separate keys are provided for the battery and resistors in circuit. Accuracy of component resistors is 0.1%, except the 1 ohm resistors, on which accuracy is 0.25%. For laboratory, school use, maintenance work, field investigations, and many forms of production line testing, this compact instrument is supplied with built-in galvanometer, sensitivity 0.25 microampere per m.m. Weight approximately 9 lbs. \$120.00

### SHALLCROSS MODEL 630 WHEATSTONE BRIDGE

A basic electrical measuring instrument for laboratory and industrial use, providing accurate and direct electrical resistance measurements from 0.1 to 11,000,000 ohms in between 10 ohms and 1,000,000 ohms is normally better than 1 percent. Supplied with built-in galvanometer having a sensitivity of 1 microampere per millimeter division. Weight approximately 6 lbs. \$60.00

### SHALLCROSS DECADE RESISTANCE BOXES

Used extensively as laboratory standards, A.C. and D.C. bridge and ratio arms, voltage dividers, etc. The accuracy adjustment of resistors as follows: 0.1 ohms—1%; 1 ohm—0.25%; all others—0.1%.

No. 544—One dial; 1.0 ohm steps; 10 ohms total resistance... \$13.50  
Model 550—One dial; 1,000,000 ohm steps; 10,000,000 ohms total resistance... \$45.00

Telephone: LOnacre 3-1800

# HARVEY RADIO COMPANY

103 WEST 43rd ST., NEW YORK 18, N. Y.



**STANDS UP  
IN HARD  
SERVICE**



**CERAMIC  
CAPACITORS**



**WIRE WOUND  
RESISTORS**

**CHOKE COILS**



**ELECTRICAL REACTANCE  
CORPORATION  
FRANKLINVILLE, N. Y.**

**POST-WAR  
Special**



**6 TUBE "SUPER HET"  
RADIO KIT**

Complete, Including Attractive Walnut Cabinet. Diagram Furnished. Uses 2-6SJ7-6SQ7-6SJ7-5SK7-25L6-25Z6.

**ALL PARTS MOUNTED**

To assemble, all one needs is a soldering iron and 30 minutes of your time.

**\$16<sup>95</sup>** LESS TUBES

Limited Quantity on Hand

TERMS: 10% DEPOSIT WITH ORDER—BALANCE C. O. D.

**LIBERTY SALES CO., INC.**

115 WEST BROADWAY • NEW YORK 13, N. Y.

excellent signal; VLQ2, 7.215, Brisbane, good signal but noisy; reception from Australia is usually good to about 9:30 or 10 a.m., VLC5, 9.54, and VLW7, 9.52, are heard regularly with good signals.

**WEST COAST REPORTS**

This month *August Balbi*, Los Angeles, lists VLC4, 15.315, Shepparton, Australia, 1-1:40 a.m. in French to Fiji Islands, and 1:50-2:25 a.m. in English, with English news at 2 a.m.; both radiations are in dual with VLG3, 11.71, Melbourne. Radio Saigon on 11.778, French Indo-China, is heard 6:30-7 p.m. in French, but is QRM'd by San Francisco; on 11.778 and 4.81, Radio Saigon is scheduled 4-9:15 a.m. in French and native mostly, but has English news at 5:15 and 9 a.m.; only the 4.81 frequency is now being heard on the West Coast; PMH, 6.72, Bandoeng, Java, 5:30-9:30 a.m., native, but with English news at 7:30 a.m., heard at intervals; Macau, 7.53, 5:15-9 a.m. and irregularly to 10 a.m., mostly in Portuguese, but with English news read by a woman at about 7:40 a.m., often is QRM'd. XGOY, now on 6.14 for the winter, Chungking, 6:35-11:35 a.m., with English news at 9 a.m., is in dual with 7.153. A station believed to be Taiwan (Formosa), 9.69, is heard 6-10 a.m., in contact with XGOY, Chungking, and relays English news from Chungking at 9 a.m. XPSA, 7.01, Kweichow, China, 8-10 a.m., relays XGOY's English news at 9 a.m.

Mr. Balbi reports JCKW, 7.22, Jerusalem, Palestine, heard recently 11 p.m.-1:30 a.m., with recordings, announcements in English were by a woman; OTC, 17.77, Leopoldville, Belgian Congo, heard 11:30-12:15 p.m., with English news at 11:30 a.m., good signal. Brazzaville, 11.97, heard 10:05-10:30 a.m., 11 a.m.-8 p.m., some QRM around 10:07 a.m. RNF, Paris, has replaced 9.52 by 9.54 and is heard in dual with 11.845 (listed 11.847), 8:55-10:45 p.m.; the 25-meter band frequency is weak on West Coast.

*Evan H. Curtiss, Jr.*, San Diego, reports Komsomolsk, 9.565, as nearly buried under KWID until KWID's sign-off at 11:05 p.m.; is on evenings, around 9 p.m. to sign-off at 12 midnight in Russian only, very good signal; on 15.23, Komsomolsk is heard from 6 p.m. to sign-off at 7:30 p.m., relaying Moscow's English program to North America, with English news at 7 p.m.; RNF, 9.54, coming through nicely with English at 9 p.m., followed by French at 9:20 p.m.; Brazzaville, 11.97, has also been heard on approximate frequency of 11.000 and on 8.46, which may be a harmonic; WXA, approximately 9.93, Juneau, Alaska, phones WVD, Seattle, irregularly; WVLC, 8.96, has been heard calling JLS/JVT, Radio Tokyo, mornings; HCJB, 12.455, 9.958, heard signing off at 10:35 p.m.; Mr. Curtiss lists a Melbourne frequency of 10.8 as heard on the 11 a.m. program to West Coast of North America, very strong and clear.

*Paul Dilg*, Monrovia, California,

**JUKE BOX  
RECORDS**

**LATEST & HARD-TO-GET BACK NUMBERS**

Some slightly used and some brand new—Victor, Bluebird, Columbia, Okeh, Decca, Capitol, etc. Such artists as Glenn Miller, Benny Goodman, Harry James, Bing Crosby, Frank Sinatra, Gene Autry, Duke Ellington, Fats Waller, Guy Lombardo, Andrews Sisters, Kate Smith, Ink Spots, Mills Bros., etc.

**BIG PROFITS** Your opportunity to cash in on this new field that is sweeping the country. Specify the type of music that sells best in your territory such as Swing, Sweet Music, Cow-boy, Hill-billy, Polkas, Blues, etc. Your price \$13.90 per 100 records, f.o.b. Chicago, 2% off for cash with order. All shipments made within 48 hours.

CHAS. HOODWIN CO.

4419 Broadway, J-15, Chicago 40, Illinois  
World's Largest Dealers in Used Records

**UTICA TOOLS**



ALL TYPES  
FOR MORE TOOL  
MILEAGE

Ask Your Dealer



**UTICA** DROP FORGE & TOOL CORP.  
★ UTICA, N. Y. ★

**LOCATES TROUBLE INSTANTLY  
IN ALL ELECTRICAL DEVICES**



**HANLAN  
APPLIANCE TESTER**

In this single unit are combined all the necessary tests for examining every appliance. Checks thermostats under actual working conditions. Tells instant it opens or closes. Controls the heat on soldering irons—prevents overheating. Tests continuity of open circuits, etc. Checks automatic irons, vacuum cleaners, motors, shavers, bulbs, fuses, appliances with 3-way switches, etc. Great time, effort and money saver! Only \$9.50

Pat. Pend.

complete. WRITE FOR CIRCULAR. **HANLAN Co.**,  
1419-R West Jefferson Los Angeles 7, Calif.  
**FREE** with each Tester. New, Complete, Practical  
Course in electrical appliance repairing.

**CRABTREE'S  
WHOLESALE RADIO**

2608 Ross Ave.

**DALLAS 1 TEXAS**



**RCA Institutes, Inc.**

Offer thorough training courses in all technical phases of Radio and Television

WEEKLY RATES DAILY—EVENINGS

**VETERANS:** RCA Institutes is approved under G. I. Bill of Rights

For Free Catalog write Dept. RT-146

**RCA INSTITUTES, Inc.**

A Service of Radio Corporation of America  
75 Varick St., New York 13, N. Y.

Order Your New  
Communication  
Receiver at . . .

## TERMINAL RADIO

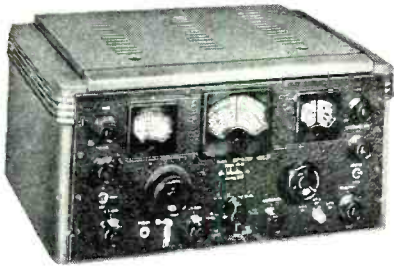

### HALLICRAFTERS

SX-28A, less speaker.....	\$223.00
SX-25, less speaker.....	94.50
PM-23, speaker.....	15.00
S-20R, Sky Champion.....	60.00
S-22R, Skyrider Marine.....	74.50
S-39, Sky Ranger.....	110.00
EC-1A Echophone.....	29.50

### NATIONAL

NC-240C, less speaker.....	225.00
HRO, less power supply and speaker.....	197.70
HRO power supply.....	17.70
HRO speaker.....	10.95

### RADIO MFG. ENGINEERS

RME-45, complete.....	166.50
-----------------------	--------

### HAMMARLUND

HQ-129X, less speaker.....	129.00
SP-210X, less speaker.....	318.00
SC-10, speaker in cabinet.....	10.50
\$10.00 deposit required on C.O.D. orders.	

**TERMINAL Radio Corporation**  
85 CORTLANDT STREET • NEW YORK 7, N. Y. • Wom 2-4415



## Export for Profit

Roburn Agencies, Inc. have represented leading manufacturers of radio and electrical equipment, parts and accessories. In world-wide markets since 1935 Extensive facilities relieve you of all export headaches — correspondence, advertising, sales, finance, packing and shipping. A few additional clients seeking experienced, reliable representation are invited. Write for information on Profits Through Exports

**Roburn Agencies, Inc.**  
115W Fulton Street New York 7, N. Y.

sends us a fine log and reports that WVLC seems to be back again in Japan waters; this is a ship and was called Apache while in Philippine waters. Early in September it must have moved to Tokyo waters and was in parallel with the Tokyo Signal Corps stations; then they must have sailed to new fields—probably China or Korea—for they talked with Tokyo, but now seem to be back in Japan waters. Frequencies announced were 9.28 afternoons, and 18.53 around 6-8 p.m.; Tokyo recently gave the call of a 16-meter afternoon frequency as JAG, approximately 17.84, maybe a little lower; JZK, 15.16, is the other frequency used afternoons and early evenings; at times, in mornings, Tokyo uses JVP, 7.51, with JLS, 9.655, and JVT, 7.65, but does not announce JVP.

Mr. Dilg reports that ZFY, 6.000, Georgetown, British Guiana, is being heard early mornings on West Coast now, but fades out around 6:40 a.m.; Radio Macau, listed as 7.530, but coming in on about 7.525, through terrific CW, with English news at 7:40 or 7:45 a.m. (usually read by a woman), following a talk in Portuguese at 7:30 a.m. (by a man), the remainder of the program being chiefly recordings; on Mondays, Wednesdays, and Fridays they have Chinese at 9 a.m., and daily Chinese may be heard around 5-6 a.m. Guam's KU5Q on 9.67 has not been working San Francisco much lately, and when they are not on it is possible to hear India on the same frequency; the trouble with the Indians is that they have so many breaks; the 9.67 frequency is one of the best on West Coast around 6 a.m. and 9.59 is also good at that time. Hong Kong has been again among the missing, probably blocked out by London beamed to the Far East; Tokyo's JZK, 15.16, used to networks afternoons and early evenings, is not so hot on West Coast, may be the season or the direction of antenna installation. A station believed to be Leningrad, U.S.S.R., on 9.713 is being heard 9-10 a.m.

Mr. Dilg uses CFRX, 6.07, Toronto, Ontario, as a key station in the 49-meter band mornings. Baghdad, Iraq, Y15KG, 7.085, has been heard again—but fades out before 11 a.m. when English news relay from BBC is scheduled, heard at peak by Dilg at 9:15 a.m. JLS, 9.655, Tokyo, parallels JVT, 6.75, in network contacts, mornings. GSH, 21.470, London, heard around 10:15 a.m. and before, weak; the signal builds up as the sun comes up and is strong when they sign off at 10:45 a.m. Brazzaville on 17.53 comes through mornings, news at 1:45 p.m., good signal.

Moscow has been heard recently around 11.88 at about 7 p.m. and is also heard on 11.63 early mornings, the signal probably coming over the North Pole. Petropavlovsk, U.S.S.R., 6.07, is not heard every day, but when heard seems to be in parallel with 9.565 relaying a news commentator around 8 a.m. to NBC, New York, in the 7:40-8:15 a.m. period from Radio

for everything in  
**ELECTRONICS**  
and **EQUIPMENT**  
follow

# ARROW!

## "VOMAX"



Choice of Electronic Engineers!

### NEW POST-WAR V.T. V-O-DB-MA METER

D.C. volts at 51 and 126 megohms A.C. and r.f. volts at 6.6 megs. Resistance 2 ohms to 2,000 megs. D.C. current 1.2 ma. through 12 amperes. D.B.—through + 50 . . . plus visual dynamic signal tracing. In our critical opinion these features establish "VOMAX" as standard of comparison. Prompt shipment. Your cost only . . .

**\$59<sup>85</sup>**



### Supreme Model 542 MULTIMETER

5000 ohms per volt

Compact, accurate all-purpose tester, weighing only 23 ozs. — 24 ranges. Tests current, voltages, resistance, etc. Full size 3" square meter with rugged, accurate 200 microampere movement and knife-edged pointer. Black molded bakelite case.

**\$20<sup>75</sup>**

Complete with batteries, your net price

### BRUSH

#### Transcription Type CRYSTAL PICKUP

Plays 16" records. Wide-range frequency response (flat within plus or minus 2.5 db. from 50 to 6,000 cps.; slight rise to 10,000 cps.). Complete with high impedance equalizer used for commercial "Constant Velocity" recordings. Your net price . . .

**\$26 46**

#### Special . . . RESISTOR ASSORTMENT

Assortment of 100 popular resistors. All standard IMA color-coded. An exceptional value.

Bargain at **\$1 65**

Write to us for anything in ELECTRONIC PARTS and EQUIPMENT. Get on our mailing list and keep informed as merchandise becomes available.

# ARROW

## ELECTRONICS COMPANY

82 CORTLANDT ST., NEW YORK 7, N. Y.

COrtlandt 7-2935 — 2998

# CUT HOLES

3/4" TO 3 1/2"



## in radio chassis

Punch cuts through chassis, die supports metal to prevent distortion, cap screw is turned with wrench to cut clean, accurate holes for sockets, plugs, and other receptacles. Saves hours of work—no reaming, filing or drilling! 3/4" to 3 1/2" sizes. Get complete data now from Greenlee Tool Co., 1882 Columbia Ave., Rockford, Illinois.

WRITE FOR FREE FOLDER S-119



## Alsam's REGENCY Striped Cases



**Model RC-250** Portable Automatic Phonograph Record-Changer Case  
Covered in attractive striped leatherette. Dimensions: 22 5/8" L x 15 1/2" W x 10 3/4" H. Takes record-changers with base plates up to 14 1/2" square. Mounting board also accommodates chassis and controls. Grilled front opening for 5" or 6" speaker; grilled opening in rear for acoustics and ventilation. Blank motor and insert boards included.



**Model P-512** Portable Phonograph Case  
Covered in attractively designed leatherette. Dimensions: 17" L x 14" W x 7 3/4" H. Will play 12" records with lid closed. Offset lid type. Grilled front opening for 5" or 6" speaker; grilled opening in rear for acoustics and ventilation. Blank motor and insert boards included.  
Other cases and cabinets available for open face record-changers, portable phonographs, table model radios, open face record-players, wall baffles.

Write for illustrated literature and prices.

ORDER FROM YOUR JOBBER!

### ALSAM PRODUCTS COMPANY

805 MILWAUKEE AVE., CHICAGO 22, ILL.

Centre, Moscow, to North America. Java on 12.275 was heard once some weeks ago for a short peak at 8:15 a.m., in dual with 6.72. Radio Saigon now signs at 9:15 a.m.—has news at 5:30 and 9 a.m. A station believed to be Madras, India, on 7.255, has been picked up around 9:45 a.m. and later, and a station on 6.15 with news at 8 a.m. is believed to be Bombay.

Mr. Dilg reports a Chinese station on approximately 7.500, 5-6 a.m., probably on earlier; a woman talks Chinese for a solid hour and signs at 6 a.m. or shortly thereafter with a call that sounds like XGOI; if true, this might be Shanghai, since Shanghai did broadcast in that vicinity while controlled by the Japanese. Java on 6.72 has been a little better in strength and of fair quality, they evidently come on around 5:30 a.m. and leave at 9:30 a.m., has English news at 7:30 a.m.; Java has silence breaks, a great deal like the Indian transmitters.

Korea, 2.510, gives a call of JODK and works Tokyo after the end of their transmission at 8:30 a.m., contacting JVT, 7.650; from broadcasts, it appears this is the only transmitter there; with one exception, all the engineers are natives. The transmitter believed to be Formosa, 9.695, but lower not long ago, is now on to about 9:57 a.m.; formerly signed after giving the Chungking news at 9 a.m., sign-off being approximately at 9:20 a.m.; but now after the news relay, some chap starts spilling Chinese or Formosian "lingo" in a rather slow manner; each phrase is immediately repeated, evidently is news, since names of cities are recognized, he will mention "Hong Kong, Hong Kong," or "Chungking, Chungking," and other names the same way; at conclusion at 9:55 a.m. he talks more rapidly and after the National Anthem of mixed voices he announces two sets of call letters—which sound different each day—one has been sensed most often as XGUA and XGUE; recently heard this chap reading the same material on approximately 6.017, so this is apparently the dual Formosa transmitter.

Perth's VLW7, 9.52, remains on a half hour longer on Saturdays with sign-off at 11 a.m., but the woman announcer signs off the medium-waves at 10:45 a.m. Manila, Press Wireless, on 18.56 (announced), PY10, calls KDE, Press Wireless, on approximately 17.90, around 6-8 p.m.; PY10 has a real "sock," better than KDE, Los Angeles, only 18 miles away.

While Mr. Dilg reports he has not been hearing Hong Kong's ZBW lately, he has received a letter from Singapore acknowledging his reception report, the letter having been signed by A. D. Peterson, Deputy Head of P.W. Division. From the letterhead, it appears that Radio Singapore is being operated by A.H.Q., Political Warfare Division, No. 2 Area, Southeast Asia Command. Mr. Dilg comments that the envelope was the most interesting part of the communication,

# Classified

Rate 20c per word. Minimum, 10 words

## RADIO ENGINEERING

RADIO Engineering, Broadcasting, Aviation and Police Radio, Servicing, Marine Operating and Electronics taught thoroughly. Expenses low. Write for catalog. Valparaiso Technical Institute, Dept. N, Valparaiso, Ind.

## RADIO EQUIPMENT

RADIO Service men and experimenters send for our giant radio catalogue. Save dollars. United Radio Co. (1000M) Newark, N. J.

RADIO Tubes, parts. Write for bulletin. Henshaw, 3313 Delavan, Kansas City, Kan.

## FOR SALE

RECTIFIERS—Halfwave, 5 Amperes, \$4.50, 2.2 Amperes, \$2.25; 1.5 Amperes, \$1.85. Fullwave, 1 Ampere, \$2.50; .5 Ampere, \$1.85. Maximum 18 volts input. List free. Milton Bursma, Route 5, Grand Rapids, Mich.

BUZZER Code Practice set complete with key, battery and instructions. Sends real wireless signals. Only \$1.65. Two sets \$3.00. Guaranteed. Rathert Electric, Dept. N Cresco, Iowa.

LOWEST Prices. Radio Tubes, parts. Bargain lists 3c. Potter, 1314 McGee, Kansas City 6, Mo.

ARMY Aircraft Surplus! R14 Headphones, \$2.50; throat mikes, \$4.50; hand mikes, \$6.50; headphone cushions, pair, 95c; bushel basket electrical & radio gadgeteer's lot, damaged, used, only \$4.95 shipped express. Aero Instrument Company, Municipal Airport, Houston, Texas.

ELECTRONIC Continuity Tester. Newly designed circuit with radical var developments. Range from 0 ohms to 50 megohms; test condensers; uses 60 cycle A.C.; cost of construction, \$4.00. Circuit diagram, \$.75. Paul Anthony Laboratories, 571 Chestnut St., Manchester, N. H.

CRYSTAL frequency control units. All kinds, including 1000 KC calibrating crystals. Also blanks. High quality. Low price. Prompt delivery. Standard Piezo Company, Box 164, Carlisle, Pa.

U.S. NAVY Aircraft Surplus Control Boxes. Two types, both for \$2.00 postpaid. Radio parts worth \$10.00. Van Sickle Radio Supply, Indianapolis 6, Indiana.

AMPLIFIERS—Hallcrafters. Masco MA-35, 35 W. Amplifier, \$45.50; Masco MA-25, 25 W. Amplifier, \$35.50; Bogen E-30, 30 W. Amplifier, \$46.88; Universal KO Microphone, \$8.13; Floor Mike Stands, \$3.70; Turner Guitar Pick-Ups, \$7.25; Turner Guitar Pick-Ups with Volume Control, \$8.25; Hallcrafters SX-28 with Speaker, \$190.40; Hallcrafters S-39, \$88.00. Munroe's Radio Service, 215 Commerce Street, Kingsport, Tennessee. Telephone 2120.

## CORRESPONDENCE COURSES

USED Correspondence Courses and Educational Books sold or rented. Inexpensive. Money-back guarantee. Write for Free Catalog listing 4000 bargains.—(Courses Bought.)—Lee Mountain, Pisgah, Ala.

CORRESPONDENCE Courses and self-instruction books, slightly used. Sold, rented, exchanged. All subjects. Satisfaction guaranteed. Cash paid for used courses. Complete information and 100-page illustrated bargain catalog FREE! Write Nelson Company, Dept. 2-59, Chicago 5.

USED Correspondence courses, Educational and Technical Books, bought, sold, rented. Catalog Free. Educational Exchange, Henagar, Ala.

AMATEUR radio licenses. Complete code and theory preparation for passing amateur radio examinations. Home study and resident courses. American Radio Institute, 101 West 63rd Street, New York City.

## SITUATIONS WANTED

RADAR-RADIO Technician. Navy trained, desires position. Garland C. Baker, 3025 W. Kilbourn Ave., Milwaukee 8, Wis.

## WANTED

URGENTLY Needed: Riders Manuals IX to XIII. Write John W. Day, 23 1/2 E. Wisconsin Ave., Tomahawk, Wis.

## PATENT ATTORNEYS

RANDOLPH & Beavers: Registered Patent Attorneys, 231 E. Columbian Building, Washington, D. C. In order to protect your invention and reap the reward that should be yours, Patent your invention without delay, and at the same time have Rights to sell as Manufacturers convert to Civilian Production. Write for information and Record Form Today.

INVENTORS—Before disclosing your invention to anyone, send for Form "Evidence of Conception"; "Schedule of Government and Attorneys' Fees" and instructions. Sent free. Lancaster, Allwine & Rommel, 414 Bowen Building, Washington 5, D. C.

PATENTS SECURED. Two valuable booklets sent free. Write immediately. Victor J. Evans & Co., 148-B Merlino Bldg., Washington 6, D. C.

**MISCELLANEOUS**

**EXPORT to Denmark.** Leading Danish firm in the radio and electrical industry wants to take over the representation for Denmark of American firms. We are particularly interested in Novelties and Specialties, but also in other products in the above lines. Submit quotations to TO-R Radio A/S, Howitzvej 11, Copenhagen F, Denmark.

**MANUFACTURERS' sales agents** will represent your company in the Chicago area on radio or electrical parts and equipment. We are reputable, progressive and financially responsible. Write full details. Box 425, % RADIO NEWS.

**Amateur Radio WRITERS WANTED**

To write articles on transmitters, receivers, antennas, test equipment, and any material of general interest to amateurs. Articles should be typewritten, between 2000 and 2500 words in length, accompanied by suitable diagrams, photos, and parts lists. Liberal payment made upon acceptance.

Address all communications to

Box 419

**RADIO NEWS**

185 North Wabash Avenue, Chicago 1, Illinois

**RADIO BOOKS by mail**

**FAST SERVICE:** 98% of all orders filled same day as received. We have one of the U.S.A.'s most complete stocks of electronic books. If you don't know the price, we'll send C.O.D. or remit sufficient and we'll refund excess.

Send stamp for catalog

**EDITORS AND ENGINEERS**

1420 North Highland Ave., Los Angeles 28, Calif.

**RADIO COURSES**

- RADIO OPERATING
- RADIO SERVICING — ELECTRONICS
- REFRIGERATION SERVICING

Personal Counselling Services for Veterans  
Write for Latest Trade & Technical Catalog  
**Y.M.C.A. TRADE & TECHNICAL SCHOOLS**  
7 W. 64th Street New York City

**CHICAGO REPRESENTATION**

Established Chicago distributor desires several part-time exclusive established lines; commission or resale; or special assignment or follow-up work. Local sales and service address for nominal charge.

Box No. 424

% RADIO NEWS, 185 N. Wabash Ave. Chicago 1, Ill.

the stationery evidently having formerly been that of a Singapore firm, with an address printed on the back flap; when the Japanese took possession, they blocked out the name and printed on a long line of Japanese letters down the back; then, when the British regained Singapore, they used the same envelopes, merely scratching out the Japanese lettering with a pen. The letter may have been flown to the U. S. by our planes since it was stamped A.P.O. Army Postal Service. While the letter stated that the operators of ZBW "are always interested to receive comments of this nature which are most useful to us," schedules or frequencies of Radio Singapore were not listed.

Calcutta, India, 3.305, and VUD2, Delhi, 3.495, are heard as early as 8:45 a.m. and later. Although the schedule of India on 7.24 is not known, this transmitter is heard around 9 a.m. in dual with VUD on 9.67; India on 6.010 opens at 8:30 a.m., all native as long as heard. A U.S.S.R. transmitter on approximately 6.765 is heard mornings around 9 a.m. and after 10 a.m. in Russian. (This transmitter has been reported as heard mornings in the East.)

\* \* \*

**ACKNOWLEDGEMENTS**

AUSTRALIA—Gillett, Maher. BAHAMAS — Telecommunications Department (Nassau). BELGIAN CONGO — Radiodiffusion Nationale Belge. BRITISH GUIANA—Mr. de Freitas, ZFY. CALIFORNIA—Balbi, Dilg, Curtiss. CANADA—Gauvreau, Quebec. COLORADO—Woolley. DISTRICT OF COLUMBIA — William Harris, West Indian Radio Newspaper; Havlena. HAWAII—OWI, Central Pacific Operations, Honolulu. HOLLAND—Koelmans. INDIANA—Green. ILLINOIS—Gutter, Johnson, Massey. IRELAND—Dowling. KANSAS—Seckler. MASSACHUSETTS—Cotter, Harris, Kernan, Florentine. MISSOURI—Kierski. NEW YORK—Atwood, Bogdan, AEC, BBC, Yates. NEW ZEALAND — Milne, Cushen. OHIO—Berg, Sutton. PENNSYLVANIA — Black. SWEDEN — Ekblom. VIRGINIA, Howe, URDXC. WEST VIRGINIA—Gonder.

-50-

**ERRATUM**

It has been called to our attention that an error appeared in the schematic diagram, page 38, of the article "5 Inch Oscilloscope Design," August, 1945, issue of RADIO NEWS. There should be an electrical connection from the plate of the V<sub>1</sub> tube to the filament of the V<sub>2</sub> tube.

**Photo Credits**

Page	Credit
25	TWA
26, 27 (top right)	Minneapolis-Honeywell Regulator Co.
27 (top left)	Eclipse Pioneer
28 (top), 28, 29	United Air Lines
28 (bottom left), 74	Sherry Gyroscope
28 (bottom right), 38, 39	General Electric
29	Fairchild Camera & Instrument Corp.
32, 34	McMurdo Silver
46	Crosley
47	NBC
50, 52	Bendix Aviation Corp.



**New MODEL 450 TUBE TESTER**

Designed especially for the service man who wants to give better service. Speedy operation is assured by newly designed rotary selector switch which replaces the usual snap, toggle or lever action switches. Tests all tubes up to 117 volts including 4, 5, 6, 7L, Octals, Loctals, Magic Eye, Hearing Aid, Thyratrons, Single Ended, Floating Filament, Mercury Vapor Rectifiers, also Pilot Lights. Tests shorts and leakages up to 3 Megohms in all tubes. Tests both plates in rectifiers. Has many other new features and advantages that any good service man will appreciate after five minutes' use. Immediate Delivery.

Only \$39.50

Write for latest bulletin showing hundreds of other hard-to-get items at money-saving prices.

*Lifetime*  
**SOUND EQUIP. CO., Dept. 43**  
911-913 JEFFERSON AVE., TOLEDO 2, OHIO

**RADOLEK**  
Radio-Electronic Service Parts

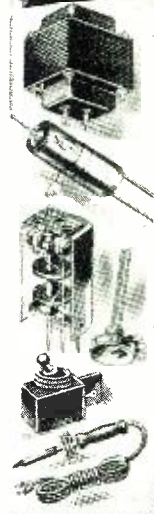

Large stocks assure the finest and most complete selections of all available items at lowest prevailing prices. Thousands of active buyers depend on us for their entire Radio repair and replacement requirements. Because we understand service problems, every order is expedited for delivery in double quick time. Everything we do is planned for convenience and satisfaction to our customers. You will find it profitable to make Radolek your buying headquarters.

**FREE BUYING GUIDES**

Because of existing conditions we keep our customers right up to the minute on available merchandise by releasing supplements frequently instead of sending our regular Big Profit Guide once a year. Send the coupon now to get these Free Buying Guide Supplements as they are issued.



**FAST SERVICE!**  
RADOLEK CO., Dept. B-111  
601 W. Randolph St., Chicago 6, Ill.  
Please send FREE Buying Guide Supplements

NAME \_\_\_\_\_  
ADDRESS \_\_\_\_\_

**ORDER FROM RADOLEK**

ADVERTISER	AGENCY	PAGE
Adson Radio	Mitchell Advertising Agency	126
Aerovox Corporation	Austin C. Lescarbours & Staff	153
Aireon Manufacturing Corp.	R. J. Potts-Calkins & Holden	75
Alliance Manufacturing Company	Foster & Davies, Inc.	69
Allied Radio Corporation	Henry H. Teplitz	9
Alsam Products Company	Sander Rodkin Adv. Agency	150
American Phenolic Corporation	Evans Associates	61
American Photocopy Equipment Co.	Arthur Meyerhoff & Co.	123
American Radio Institute	Sternfield-Godley, Inc.	132
American Television Institute		103
American Television & Radio Co.	Firestone Advertising Agency	118
Arrow Electronics Company	Mitchell Advertising Agency	149
Arrow Radio Co.		130
Ashbach, Leonard Company	Lieber Advertising Company	126
Audak Company	Hart Lehman Advertising	8
Audel Publishers	Grant & Wadsworth, Inc.	138
Bell Telephone Laboratories	N. W. Ayer & Son	21
Biiley Electric Company	Hardy Advertising	20
Bliss Electrical School	N. W. Ayer & Son	143
Bud Radio, Inc.	Allied Advertising Agency	74
Buffalo Radio Supply	International Advertising Agy.	124
Burgess Battery Company	Howard H. Monk & Associates	136
Burlington Instrument Co.	Weston-Barnett, Inc.	66
Burstien-Applebee Co.	Frank E. Whalen Advertising	96
Candler System Company	Van De Mark Advertising	140
Capitol Radio Engineering Inst.	Henry J. Kaufman Advertising	73
Clark Radio Equipment Co.		138
Clippard Instrument Laboratory	Savage & Talley	139
Collins Radio Company	McCann-Erickson, Inc.	81
Commercial Equipment Company	Abbott Kimball Co., Inc.	143
Concord Radio Corporation	E. H. Brown Advertising	62
Consolidated Radio Sales Co.		143
Cornell-Dubilier Electric Corp.	Reiss Advertising	19
Cornish Wore Co.	Hart Lehman Advertising	120
Coyne Electrical School	McJunkin Advertising Agency	93
Coyne Electrical School	Phil Gordon Agency	134
Crabtree's Wholesale Radio		143
Crystal Research Laboratories	Post & Johnson, Inc.	96
DeForest's Training, Inc.	McDonald-Cook Company	15
Drake Electric Works, Inc.	William Hoffman & Associates	144
Duotone Company	Maxon, Inc.	117
Eastern Amplifier Corp.	Roberts & Reimers, Inc.	63
Editors & Engineers		151
Electrical Reactance Corp.	Scheel Advertising Agency	148
Electronic Laboratories, Inc.	Burton Browne Advertising	101
Electronic Service & Supply	Burke & Wayburn Advertising	116
Electro-Motive Manufacturing Co.	Cory Snow, Inc.	134
Electro-Voice, Inc.	Henry H. Teplitz	99
Fada Radio & Electric Co., Inc.	Sternfield-Godley, Inc.	6
Fahnestock Electric Company, Inc.		131
Federated Purchaser, Inc.	Burke & Wayburn Advertising	116
Flanagan Radio Corp.	Stewart-Jordan Corp.	147
Freed Transformer Co.	Franklin Advertising Service	113
Fyr-Fyter Company	Dan De Mark Advertising	123
Garrad Sales Corp.	Reiss Advertising Agency	82
Gates Radio Co.	Ridgeway Company	89
General Cement Mfg. Co.	Turner Advertising Agency	122
General Electric Co.	Maxon, Inc.	137
General Industries Company	Fuller & Smith & Ross, Inc.	88
General Test Equipment Co.	Suzanne B. Hayman	136
Greene's Jack, Radio & Television Co.	Burke & Wayburn Advertising	142
Greenlee Tool Co.	Howard H. Monk & Associates	153
Guardian Electric Company	Kennedy & Company	Second Cover
Haldorson Company	Sander Rodkin Adv. Agency	143
Halicrafters, Inc.	Burton Browne Advertising	5
Hammarlund Mfg. Co., Inc., The	Roeding & Arnold, Inc.	24
Hanlan Company		120, 143
Harvey Radio Company	Shappe-Wilkes, Inc.	147
Heins & Bolet	Sternfield-Godley, Inc.	94
Henry Radio	Burton Browne Advertising	102
Hoodwin, Chas Co.	J. L. Stewart Advertising	148
Illinois Condenser Company	Sander Rodkin Advertising Agy.	149
Instructograph Company	Turner Advertising Agency	129
Jensen Radio Manufacturing Co.	Burton Browne Advertising	18
Johnson, E. F., Company	David, Inc.	67
Kato Engineering Co.		142
Kluge Electronics Company	Wookey & Roman Advertising	65
Lake Radio Sales Co.	Sander Rodkin Advertising Agy.	70
Lectrohm, Inc.	Merchandising Advertisers	130
Lectrolab Products	Sander Rodkin Advertising Agy.	72
Leday Manufacturing Co.	Frizzell Advertising Agency, Inc.	120
Leotone Radio Company	Altomari Advertising Agency	100
Liberty Sales Co.	Sternfield-Godley, Inc.	148

ADVERTISER	AGENCY	PAGE
Lifetime Sound Equipment Co.	Miller Agency Company	151
Lincoln Engineering School	Buchanan Thomas Adv.	124
Maguire Industries, Inc.	Park City Advertising Agy.	90, 91
Mallory, P. R. Co., Inc.	The Aitkin-Kynett Co. Third Cover	
Marion Electrical Instrument Co.	Shappe-Wilkes, Inc.	13
Melehan Radio		139
Melville Radio Institute	Seidel Advertising Agency	144
Miles Reproducer Co., Inc.	Altomari Advertising Agency	136
Millen, James Mfg. Co.	James Millen Inc.	12
Miller, J. W. Company		128
Murdock, Wm. J. Company	John A. Smith & Staff	143
Murray Hill Books, Inc.	Harry P. Bridge Advertising	76, 77
McElroy Mfg. Corp.	Shappe-Wilkes, Inc.	124
McGraw-Hill Book Co.		134
McMurdo Silver Company	Stanton Company	105 thru 113
National Company	Graydon Smith Advertising	154
National Electronic Supply	McDonald-Cook Company	137
National Radio Distributor	Burke & Wayburn Advertising	116
National Radio Institute	Vansant, Dugdale & Co., Inc.	3
National Schools	Mayers Company	22, 23
National Union Radio Corp.	Hutchins Advertising Agency	17
Newcomb Audio Products Co.	Gail Hall Advertising	82
Ohrnite Manufacturing Co.	Henry H. Teplitz	59
Olson Radio Warehouse	Jessop Advertising Agency	145
Onan, D. W. & Sons	Graves & Associates	122
Pa-Kette Radio Company	Arrow Advertising Agency	136
Perfection Electric Company	Schram Company	134
Permoflux Corporation	Turner Advertising Agency	119
Polarad Electronics Co.	Mitchell Advertising Agency	147
Radio Corporation of America	J. Walter Thompson Co.	11, 95
RCA Institutes, Inc.		143
R. C. & L. F. Hall		141
R-L Electronics Corp.	R. S. Wittenberg Advertising	118
Radio Kits Company	Edward Hamburger Adv. Co.	146
Radio Manufacturing Engineering	Rudolph Bartz Advertising	123
Radio Parts Company	Sidney S. Lovitt	135
Radio Supply & Engineering	Karl G. Behr Advertising	86
Radio Wire Television, Inc.	S. T. Seidman Co.	110, 114
Radionic Equipment Co.	Hirshon-Garfield, Inc.	98
Radolek Co.	Turner Advertising Agency	151
Raytheon Manufacturing Co.	Burton Browne Adv. Fourth Cover	
Rausland Corp.	Roy D. Zeff Associates	79
Rider, John F. Publisher, Inc.	Lansford F. King	10
Roburn Agencies, Inc.	Reiss Advertising	149
Roehr Distributing Company		136
Rue Industries	Miller Advertising Agency	148
Shure Brothers	Phil Gordon Agency	121
Snap-On-Tools Corporation	Scott-Telander Advertising	85
Snyder Manufacturing Co.	Abner J. Gelula & Associates	133
Sound Equipment Corp. of Calif	Beaumont & Hohman, Inc.	115
Sperry Gyroscope Co., Inc.	Chas. Dallas Reach Co.	97
Sprague Products Company	Harry P. Bridge Advertising	16
Sprayberry Academy of Radio	Harry P. Bridge Advertising	7
Standard Radio and Electronic Products	Hutzler Advertising Agency	84
Standard Transformer Corporation	Burnet-Kuhn Advertising Agy.	60
Stanton Radio Supply		118
Stark's	A. L. Addison Advertising	132
Stevens Walden, Inc.	Howard-Wesson Co.	14
Superior Instrument Corporation	Mitchell Advertising Agency	83
Supreme Instruments Corp.	O'Callaghan Advertising Agy.	141
Supreme Publications	Henry H. Teplitz	127
Sylvania Electric Products, Inc.	Newell-Ermmett Company	87
Tavella Sales Co.	Reuben Barkow Advertising	126
Television Tech Enterprises		136
Terminal Radio Corp.	Mitchell Adv. Agy.	78, 111
Triplett Electrical Instrument Co.	Western Advertising Agency	125
Tri-State College	Clem J. Steigmeyer Adv.	147
Ungar Electric Tools, Inc.	Milton Weinberg Advertising	92
United Radio Corp.	Craig Dennison	120
Union Screw & Bolt Corp.	Fred W. Mellis	71
Universal Instrument Co.		128
Utica Drop Forge & Fuel Co.	Devereux & Company	143
Valparaiso Technical Institute	Smith, Benson & McClure, Inc.	139
Ward, Products Co.	Burton Browne Advertising	72
Weller Manufacturing Co.	Beaumont, Haller & Sperling, Inc.	135
Western Radio Communications Institute		147
Weston Electrical Instrument Corp.	C. M. Basford Company	129
Wholesale Radio Laboratories	Pfeiffer Advertising Agency	83
YMCA Trade & Technical Schools	Cecil & Presbrey, Inc.	151
York Radio Distributing Co.		132



✓✓✓✓ from **START** to **FINISH** insures **AEROVOX**  
**PAPER-CAPACITOR** *Craftsmanship*

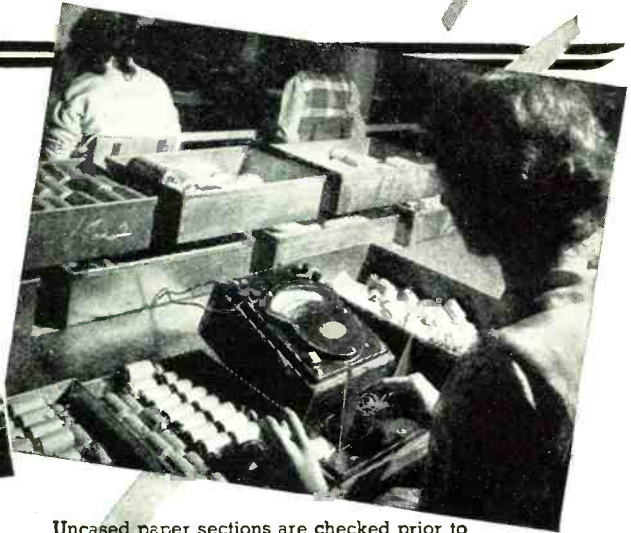
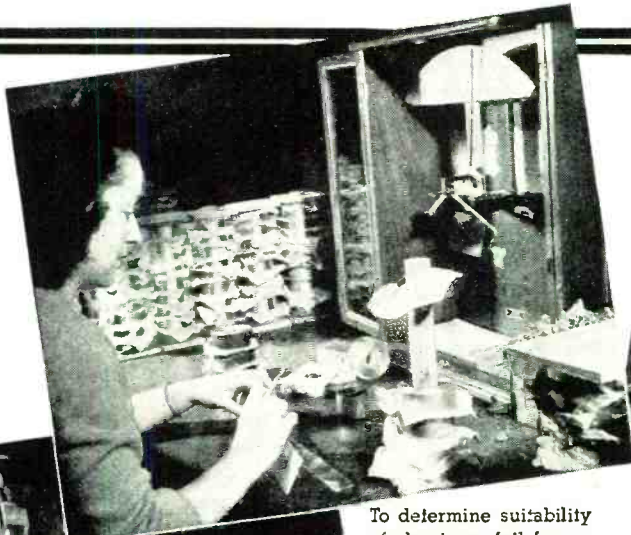

To determine suitability of aluminum foil for capacitor use, every lot is tested for thickness, unit weight and electrochemical characteristics.

Uncased paper sections are checked prior to impregnation. Completed units are tested for capacitance, power factor, insulation resistance, terminal-to-terminal and terminal-to-can, as well as for dielectric strength and tightness of seal.



The porosity of paper dielectric is important. This porosity test is made on each roll of paper.

● A paper capacitor can be no better than its several layers of paper dielectric, the quality of the impregnant, and the thoroughness of the impregnation and sealing.

That is why there are so many routine check-ups in Aerovox paper capacitor production. Paper tissues, metal foils, oils and sealing compounds, are critically checked. Sections are checked before impregnation and casing. Completed units are subjected to a final check-up and inspection.



Production control of impregnating materials. Electrical test is preceded by careful checking of temperature of oils.

"Individually-tested" is no idle boast as applied to Aerovox capacitors. It means precisely what it says. And to the capacitor user, it is a guarantee of dependable and long-lasting and economical service for the smallest and cheapest quite as well as the largest and costliest of types that bear the Aerovox label.

● Write for engineering literature. Submit your capacitance problems.



**FOR RADIO-ELECTRONIC AND INDUSTRIAL APPLICATIONS**

**AEROVOX CORPORATION, NEW BEDFORD, MASS., U. S. A.**

SALES OFFICES IN ALL PRINCIPAL CITIES • Export: 13 E. 40th St., NEW YORK 16, N. Y.

• Cable: 'ARLAB' • In Canada: AEROVOX CANADA LTD., HAMILTON, ONT.

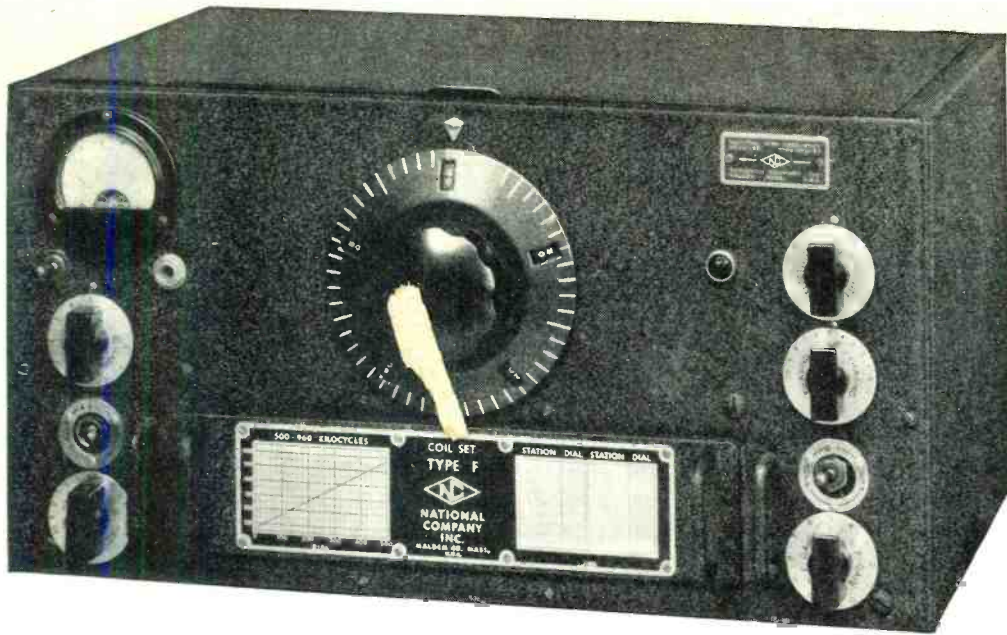

## THE HRO-5TA

Your old friend, the HRO, has seen active service all over the world with the armed forces of the United States and our allies. Much has been learned, and the HRO has emerged from its trial by fire an even better receiver than the superb receiver you knew before the War.

The HRO-5TA (table model) and the HRO-5RA (rack mounting) are new receivers incorporating design improvements based on field reports from all over the world. They are superb performers of extreme reliability.

*The new National catalogue lists the new HRO-5A receivers and their accessories together with a versatile group of parts you will need in your new rig. Ask your dealer for a copy.*



**NATIONAL COMPANY, INC.**  
MALDEN, MASSACHUSETTS, U.S.A.

MALDEN  
MELROSE  
★★★★

# The Right Replacement Control for Every Job

With Mallory plug-in shafts, you're sure of having "exact duplicate" controls for every service requirement... and your entire equipment can be carried in a small-sized kit!

Plug-in shafts, originated and developed by Mallory, do two things: they either replace the original shaft exactly—or they can be made into exact replicas by simply cutting to length.

For household receivers, a kit of eight shafts will answer most of your needs

(SS 1, 2, 5, 16, 18, 22, 25, 26). Automobile radios require, at most, twenty-two shafts (SS 1, 2, 3, 4, 6, 10, 11, 12, 14, 15, 17, 19, 20, 21, 23, 24, 27, 28, 29, 30, 31, 32). And remember—all these plug-ins fit Mallory UM, TM and DTM controls, each available in a complete range of resistances and tapers.

What a set-up for a busy service engineer! Then, too, because the line is simplified, your Mallory distributor is *never* out of stock. Let him help you select the proper kit to answer *your* service needs.

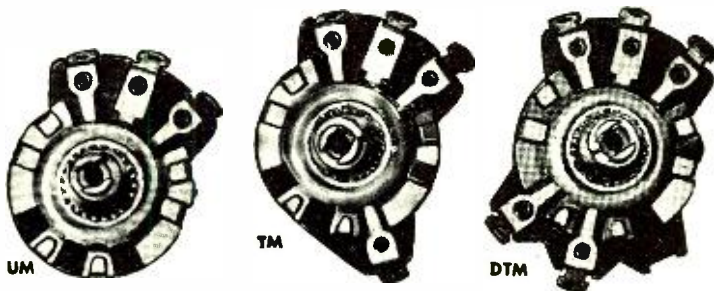

For your convenience, an SS-1 shaft is included with all UM, TM and DTM volume controls.

**NO WOBBLE**—*this ring prevents it!*

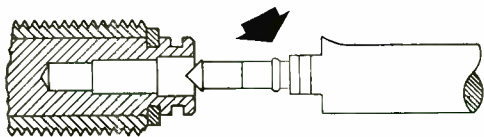

All Mallory plug-in shafts are now made with a small ring as shown in the drawing above. That's why they can't wobble or work loose — why they fit as securely as a fixed shaft.

*Shaft illustrations are approximately 1/2 actual size.*

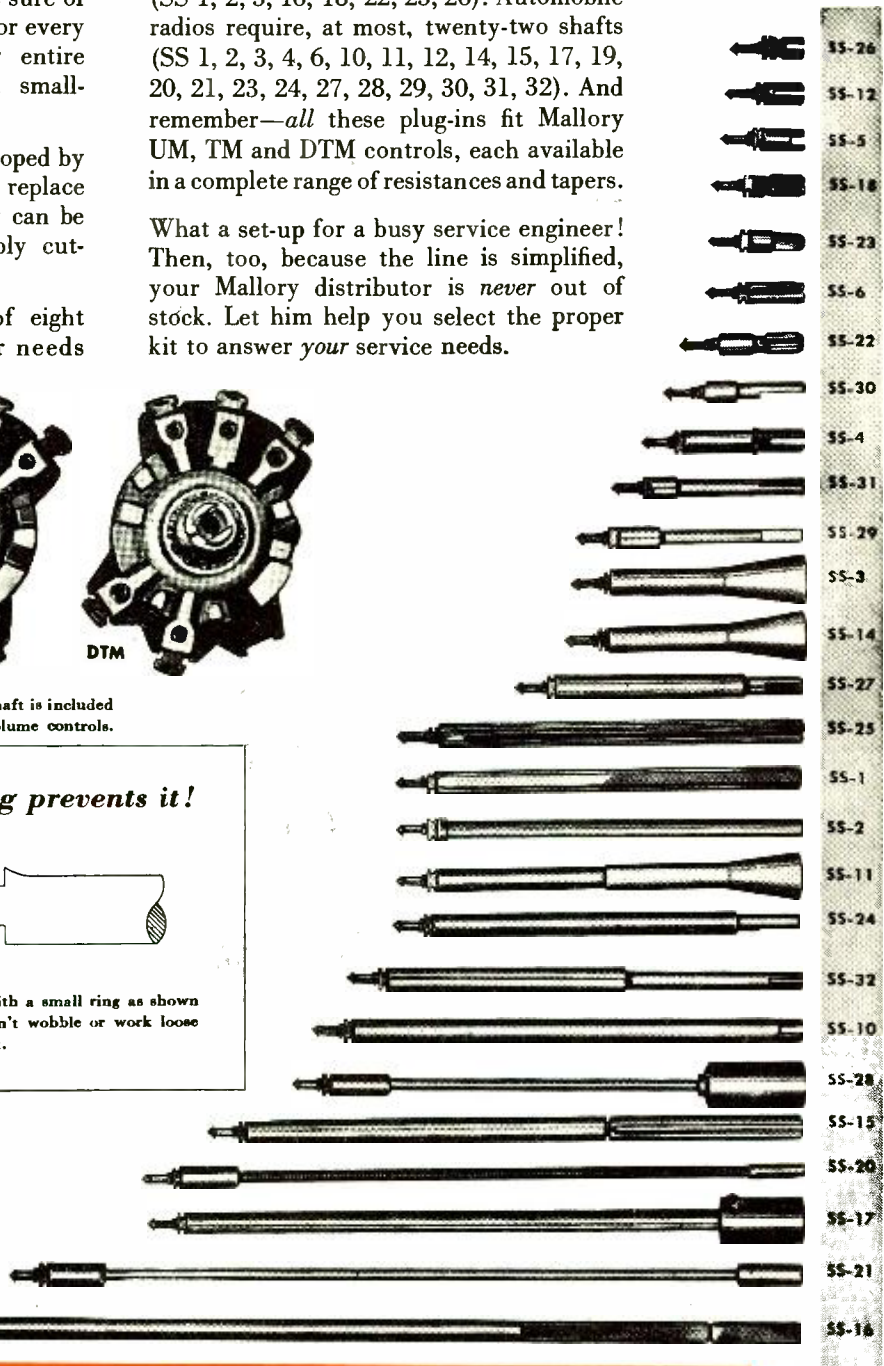

**P. R. MALLORY & CO. Inc.**  
**MALLORY**  
 APPROVED PRECISION PRODUCTS  
 VIBRATORS... VIBRAPACKS\*... CAPACITORS... VOLUME CONTROLS  
 ... SWITCHES ... RESISTORS ... FILTERS ... RECTIFIERS ...  
 POWER SUPPLIES. ALSO MALLORY TROPICAL\* DRY BATTERIES,  
 ORIGINALLY DEVELOPED BY MALLORY FOR THE U. S. ARMY.  
 \*Reg. U. S. Pat. Off.  
**P. R. MALLORY & CO., Inc., INDIANAPOLIS 6, INDIANA**

AC RADIO SERVICE

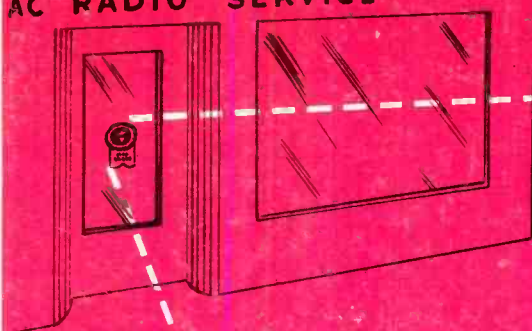

Here's  
where  
your  
profits  
start!

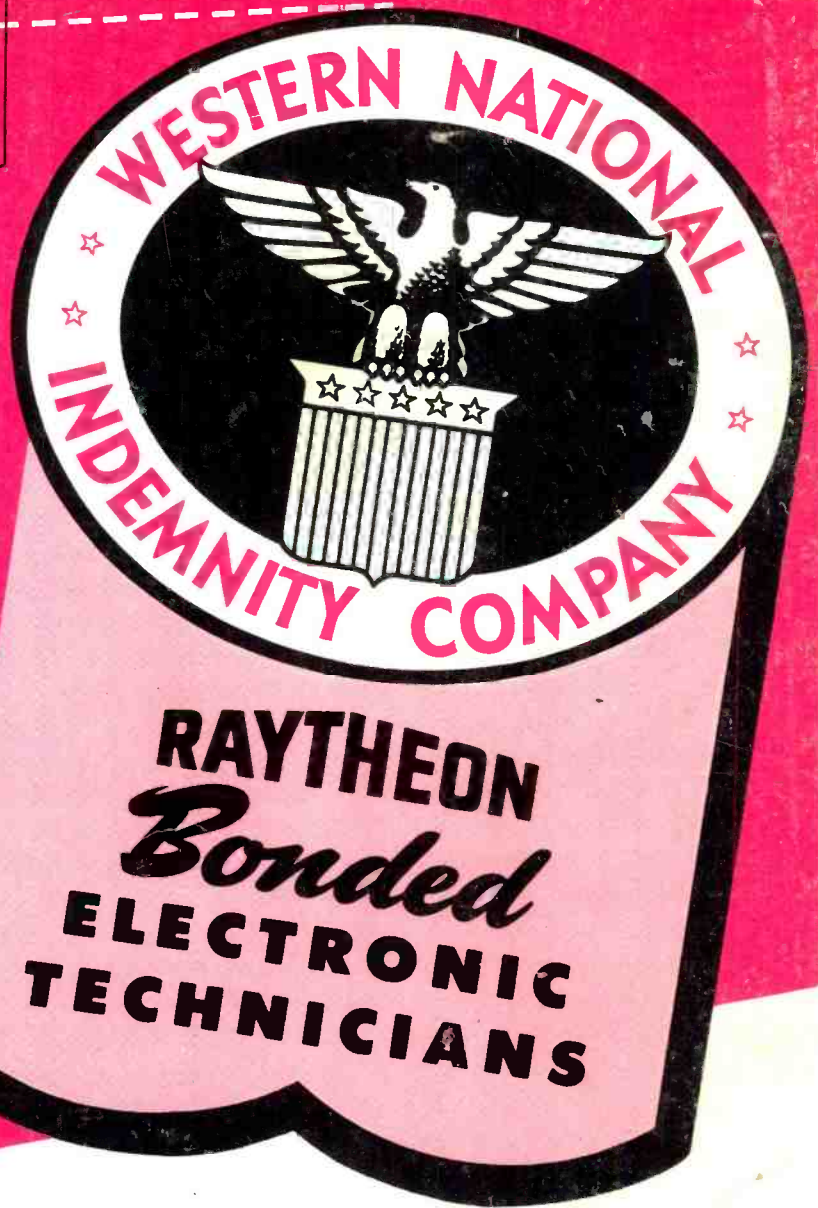

Right on your door, every visitor will see this smart, modern decal — and know your shop is operated by Bonded Electronic Technicians. Here, where your profits start, your doorway becomes a sales-aid. And this is only the beginning. Wall banners, displays, job record cards—the Raytheon Bonded Electronic Technician will have plenty of these to help build a substantial, money-making radio service business. See your Raytheon distributor today. Find out how you can qualify to become a Bonded Electronic Technician. Join the practical, responsible business men known to their communities as Bonded Electronic Technicians.

Another reason why it pays to qualify as a Raytheon Bonded Electronic Technician.



**RAYTHEON**  
MANUFACTURING COMPANY

*Excellence in Electronics*  
RADIO RECEIVING TUBE DIVISION  
NEWTON, MASS. • NEW YORK • CHICAGO