

RADIO NEWS

OCTOBER
1940
25c
In Canada 30c

Plane Spotting
via Uncle Sam's
New Transceivers
See Page 8

U. S. ARMY BLITZKRIEG RADIO

BUILD YOUR OWN
AUDIO OSCILLATOR

★ CRYSTAL
SIMPLE

PORTSMOUTH OHIO
NAVVO STA
A J ALLEN
RN-20-JS1924-DMR-11 A

Also the Latest on TELEVISION ★ F-M ★ UTILITY RADIO

DAVEGA - AMATEUR DIVISION - 63 CORTLANDT STREET, NEW YORK, N. Y.

SMASHING LOW PRICE!

McMURDO SILVER 15-17

New r.f. amplifier equalizes gain at all wave lengths and provides in single stage, selectivity and gain heretofore available only in best two stage r.f. amplifiers. Four bands. Special Jensen-Silver 15" Giant electro-dynamic speaker. 30 to 8000 cycles. Heavy welded one piece chassis, 20" by 12 3/4".

Regular Price **\$20500**
 Price **\$109⁵⁰**
 SALE PRICE
 You Save **\$95.50**
 MCMURDO SILVER MASTERPIECE VI—Reg. Price \$355. Sale Price \$199.50



LATEST R.C.A. MODEL A.R. 77

Dual R.F. alignment, negative feedback, variable selectivity, new type dial.

\$139⁵⁰

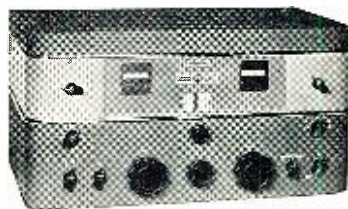

LATEST HALLICRAFTER TRIUMPH

Model S.X.28. 15 tubes, 2 R.F. stages, calibrated band-spread, high fidelity, high image rejection.

\$159⁵⁰

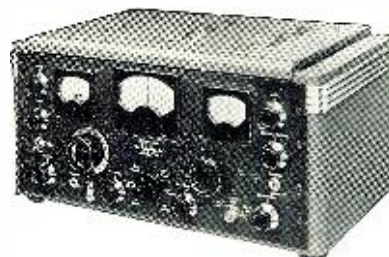

NEW HALLICRAFTER UNIVERSAL S-29 SKY TRAVELER 553-9.85 Meters

A.C.-D.C. battery operation, self charging unit built in. Self contained antenna, electrical bandspread.

\$59⁵⁰

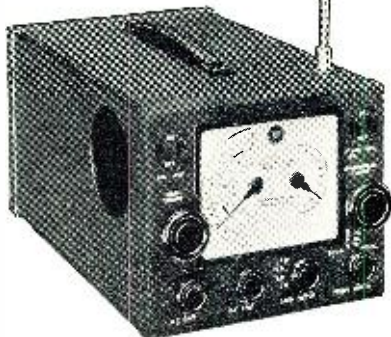

THE NEW WONDERBOX

Model E.C. 1
 6 tubes, A.C.-D.C. self contained speaker, three bands, direct calibration, headphone jack, beat oscillator.

\$19⁹⁵

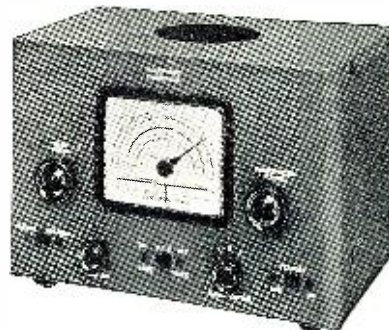

HALLICRAFTER

DUAL DIVERSITY

25 tubes; most famous set built; two eight-gang condensers; fading minimized; finest tone; best D.X.; regular \$750.00; special \$450.00.

\$90⁰⁰ DOWN
 12 payments \$34.50



ACR-III COMMUNICATION RECEIVER



MADE TO SELL FOR **\$18950**

\$8950

The ACR-III employs a single-signal, 16-tube Superheterodyne circuit with two tuned r.f. stages, constant-percentage electrical band-spread, individual carefully isolated oscillators, two I.F. amplifier stages, crystal filter, calibrated input-signal strength indicator (electron-ray tube), noise limiter, noise suppressor, audio driver stages, push-pull power-output stage, and an integral power supply.

HALLICRAFTER

DEFIANT

Calibrated band spread; variable crystal; complete coverage 8 to 550 meters; superior workmanship. \$69.50.

\$13⁹⁰ DOWN
 12 payments \$6.25



DAVEGA

AMATEUR DIVISION, 63 CORTLANDT ST., NEW YORK, N. Y.

"World's Largest Retail Radio Dealer"

**Men NOW in Radio
who Don't Think
they know it All
Read This**

You don't want to see younger, better trained men push ahead of you, I know. You don't want Radio's new technical developments to baffle you either, I am sure. You want to get ready to "cash in" on Television, Frequency Modulation, too. I have helped many already in Radio to win promotions, to make more money. Read my message below.

J. E. SMITH, President
NATIONAL RADIO INSTITUTE
Established 25 years

He has directed the training of more men for Radio than anyone else—has helped men already in Radio to get ahead, and men not in Radio to get into Radio and win success.



**If You're NOT
Working in Radio Now
Read This**

Do you want to make more money? Do you want to cash in on your present interest in Radio, Television, Frequency Modulation? Do you want a full-time job with good pay in one of Radio's many fascinating branches? Or do you want to make extra money in your spare time to boost your present income? If you want to do either of these things—you owe it to yourself to find out how I have trained hundreds of men for jobs in Radio. MAIL THE COUPON BELOW—TODAY.

Make Me Prove I Can Train You at Home for RADIO and TELEVISION

Clip the coupon and mail it. I'm certain I can train you at home in your spare time to be a Radio Technician. I want to send you a sample lesson free; to examine, read. See how clear and easy it is to understand. See how my Course is planned to help you get a good job in Radio, a young, growing field with a future. You don't have to give up your present job, or spend a lot of money to become a Radio Technician. I train you at home nights in your spare time.

**Many Radio Technicians Make
\$30, \$40, \$50 a Week**

Radio broadcasting stations employ operators, technicians, and pay well for trained men. Radio manufacturers employ testers, inspectors, servicemen in good-pay jobs with opportunities for advancement. Radio jobbers and dealers employ installation and servicemen. Many Radio Technicians open their own Radio sales and repair businesses and make \$30, \$40, \$50 a week. Others hold their regular jobs and make \$5 to \$10 a week fixing Radios in spare time. Automobile, police, aviation, commercial Radio; loudspeaker systems, electronic devices, are newer fields offering opportunities to qualified men. My Course includes Tele-

vision and Frequency Modulation which promise to open good jobs soon. Charles F. Helmuth, Atlantic City, N. J., writes: "I started Radio in the Marines. Later I took the N. R. I. Course. Now I am my own boss, and get jobs over others. I owe plenty to N. R. I. Training." James E. Ryan, Fall River, Mass., writes: "I was working in a garage when I enrolled with N. R. I. I am now Radio service manager for the M—Furniture Co. for their four stores."

**Many Make \$5 to \$10 a Week Extra
in Spare Time While Learning**

The day you enroll, in addition to my regular Course, I start sending you Extra Money Job Sheets—start showing you how to do actual Radio repair jobs. Throughout your Course I send plans and directions which have helped many make \$5 to \$10 a week extra in spare time while learning. I send special Radio equipment; show you how to conduct experiments, build circuits. My 50-50 training method makes learning at home interesting, fascinating, practical. I devote more than 10 Lesson Tests exclusively to Television, and in addition Television fundamentals are covered by my regular Course.

You Get This Servicing Instrument

This instrument makes practically any test you will be called upon to make in Radio service work on both spare time and full time jobs. It can be used on the test bench, or carried along when out on calls. It measures A.C. and D.C. voltages and currents; tests resistance; has a multi-band oscillator for aligning any set, old or new. You get this instrument to keep as part of your N. R. I. Course.



Get Sample Lesson and 64-Page Book Free

Act today. Mail coupon now for Sample Lesson and 64-page Book. They're FREE. They point out Radio's spare-time and full-time opportunities and those coming in Television; tell about my Course in Radio and Television; show more than 100 letters from men I trained, telling what they are doing and earning. Read my money back agreement. Find out what Radio offers you. Mail the coupon in envelope or paste on penny postcard—NOW!

J. E. SMITH, President, Dept. OKR,
National Radio Institute, Washington, D. C.

SAMPLE LESSON FREE

I want to prove that my Course gives practical, money-making information; is easy to understand—is what you need to master Radio. My sample lesson text, "Radio Receiver Troubles—Their Cause and Remedy" covers a long list of Radio receiver troubles in A.C., D.C., battery, universal, auto, T. R. F., super-heterodyne, all-wave, and other types of sets. And a cross reference system gives you the probable cause and a quick way to locate and alignment, set troubles. A special section is devoted to receiver checkup and testing. Get balancing, neutralizing and testing. Get this lesson FREE. No obligation. Just mail coupon.

**GOOD FOR BOTH 64 PAGE BOOK
AMPLE LESSON FREE**

J. E. SMITH, President, Dept. OKR
National Radio Institute
Washington, D. C.

Dear Mr. Smith: Mail me FREE, without obligation, your Sample Lesson and 64-page book "Rich Rewards in Radio" which tells about Radio's spare-time and full-time opportunities and explains your 50-50 method of training men at home to be Radio Technicians. (No salesman will call. Write plainly.)

(Please Check) I AM doing Radio work
 I am NOT doing Radio work

Age.....

Name

Address

City State..... 14X1

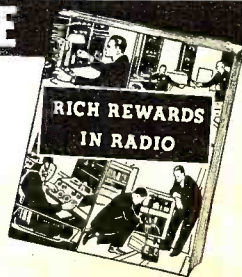



BY THE EDITOR

THOSE of us who are in radio can see day by day how this grand and glorious country of ours is getting better prepared. Just the other day we saw a young feller shooed off a flying field where he was innocently trying to take a picture of a *National Guard Radio Field Station*. No one supposed that the youngster was a 5th Columnist nor a spy. But it just goes to show that Uncle Sam means business, and that censorship is tight—so tight that you cannot get a picture of radio equipment used by the armed forces. It is a good thing too, since experts can learn much from such a picture. You may inquire how newspapers and even how RADIO NEWS gets its pictures for the stories such as appear on page 8. These are released by the Signal Corps and associated Government agencies. They have been studied by our counter-espionage units and have been labeled “harmless and non-informative.” Note how really little technical information you can get from them. That’s the sort of thing that makes an editor tear his hair . . . but as a patriotic regulation, it should have been in effect years and years ago.

* * *

HERE’S one for the books. The *Associated Press* reports that the Telephone Companies and their subsidiaries have been virtually placed on a war-time footing. At the suggestion of the National Defense officials, extra precautions have been taken to protect the vital communications centers. This protection is in the form of armed guards recruited from ex-marines and approved by the FBI. The guards are posted 24 hours a day and visitors to the plants have been sharply restricted. In some places where there were nothing but women working, schedules have been changed so that there are always some men on duty with the women, it being feared that an all-woman shop would be easy to “intimidate” or “destroy.” The Telephone Companies have even gone further and have issued questionnaires to over 40,000 employees inquiring about their citizenship. Yes sir, war is with us . . . at least in the primary stages.

* * *

ARE there any of us in the radio field, professionally, who can’t remember back, say, about three years? That was when we went from factory to factory, from radio store to radio store, from ship to ship. Always the same story, “Sorry, no jobs today!” How that has changed? At least where the factory is concerned and also in the Government, too. Three years ago you couldn’t get a Government radio job for love nor money. But now!!!

(Continued on page 57)



Trade-Mark Registered

Including Articles on POPULAR TELEVISION

The Magazine for the radio amateur
 experimenter, serviceman & dealer
 VOL. 24, NO. 4

Contents for October, 1940

FEATURES

- An Open Letter on Preparedness** Senator Claude Pepper **7**
- U. S. Army Blitzkrieg Radio** Alfred Toombs **8**
 Third after men and ammunition, radio plays an important part in the army.
- Sixty Simple Watts** William D. Hayes, W6MNU **11**
 An extremely cheap but very efficient CW rig for the beginner.
- Build Your Own Audio Oscillator, Part 1** . . Rufus P. Turner, W1AY **12**
 A detailed description of an excellent laboratory instrument.
- Crystal Shifter** Paul V. Trice, W8QHS **15**
 Changing of bands, though crystal controlled, is easy with this gadget.
- Installation and Maintenance of Aircraft Radio Equipment, Conclusion** Staff Sgt. Charles J. Schauers **16**
 Giving the fundamentals of this type of radio service.
- As I See It!** John F. Rider **19**
 The author answers a letter, and incidentally makes a very good point.
- Capacity Tester** R. K. Wheeler **20**
 In reality an AC-DC bridge, not too expensive, but very handy to have.
- Poorman’s High Fidelity Receiver** James Fulleylove **25**
 A fine receiver for the man whose pocketbook is rather flat.
- The Design of An 8 Tube Superhet** Ray E. Morrow **29**
 Showing how you could build yourself a nice single-control set.

Cover picture from Official U. S. Signal Corps.

DEPARTMENTS

- | | | |
|--|------------------------------|---------------------------------------|
| Book Review 40 | QRD? 37 | Serviceman’s Experiences 26 |
| What’s New in Radio . . 32 | Bench Notes 27 | Serviceman’s Cases . . . 44 |
| Radio Physics Course . . 44 | Manufacturer’s Literature 40 | The Video Reporter . . . 31 |
| Hamchatte 35 | For Immediate Release . 34 | Mikes-Heads-Pickups . . 22 |
| Servicemen’s Legal Advice 24 | Cuffings 28 | Ringin’ the Bell 23 |
| | Utility Radio 18 | |

Copyright, 1940
 ZIFF-DAVIS PUBLISHING COMPANY
 Member of the Audit Bureau of Circulations

RADIO NEWS is published monthly by the Ziff-Davis Publishing Company at 608 S. Dearborn St., Chicago, Ill., William B. Ziff, Publisher; B. G. Davis, Editor; J. Fred Henry, Vice-president; Karl A. Kopetzky, W9QEA, Managing Editor; Oliver Read, W9ETI, Technical Editor; Herman R. Bollin, Art Director; John H. Reardon, Circulation Director; S. L. Cahn, Advertising Manager. New York Office, 381 Fourth Ave. Subscription \$1.50 per year, single copies 25 cents; foreign postage \$1.00 per year additional except Canada. Entered as second class matter March 9, 1938, at the Post Office, Chicago, Illinois, under the Act of March 3, 1879. Contributors should retain a copy of contributions. All submitted material must contain return postage. Contributions will be handled with reasonable care, but this magazine assumes no responsibility for their safety. Accepted material is subject to whatever adaptations, and revisions, including “by-line” changes, necessary to meet requirements. Payment will be made at our current rates upon acceptance and, unless otherwise specified by contributor, all photographs and drawings will be considered as constituting a part of the manuscript in making payment.



Lafayette's LATEST GREATEST FREE CATALOG

196 PAGES

of amazing radio values!

BIGGEST IN EVERYTHING IN RADIO

RADIOS

Lafayette challenges the radio world with 64 brilliant new models—each one tops in its class for style, performance, value. Portables, table models, consoles, phono-combinations — every type for home, farm, camp and car—5 to 15 tube sensations! Check Lafayette's famous 30-day Home Trial. Consumer Test Laboratories consistently vote Lafayette "Best Buy."

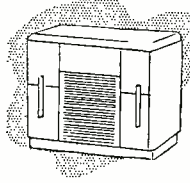

RADIO PARTS

Lafayette's huge stocks are complete to the tiniest accessory. All the newest tubes are here, as well as equipment and tools. Thousands upon thousands of items, including many hard-to-get today. All the famous names are here at Lafayette's amazing rock-bottom prices. Check Lafayette's bargain parts pages for super values that can't be beat anywhere.

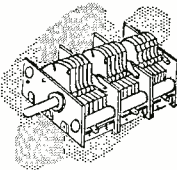

SERVICEMEN SAVE REAL MONEY

HAM EQUIPMENT

Lafayette, long-recognized "ham" headquarters, has an even greater amateur Radio Section in this great new catalog. See the latest receivers—the complete line of ham equipment — all nationally advertised — all at tremendous savings. Now you can get the "rig" you've always wanted on Lafayette's New Easy Pay Plan. Why wait—Lafayette saves you time and money, too.

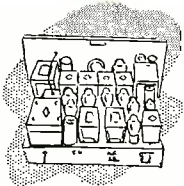

TEST EQUIPMENT

Lafayette's matchless line of test equipment defies comparison. Pocket and portable testers, leading set testers and combinations, modern all-purpose test instruments, precision panel meters—everything you need at startling Lafayette prices. And to help you, Mr. Serviceman: a new time payment policy that makes it easy to own up-to-the-minute equipment.

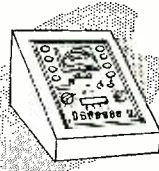

NEW TIME PAYMENT PLAN

SOUND SYSTEMS

Lafayette P.A. is years ahead in engineering, styling, matchless performance. This big new catalog section features 3 complete lines of streamlined sound systems for every purse and purpose—standout Lafayette values that have the whole trade talking. Only Lafayette offers the sensational 30-day trial on P.A. plus time payments. Don't miss it!

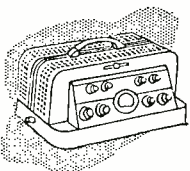

BUILD-IT-YOURSELF KITS

Radio's biggest thrill is in building your own receiver. Let Lafayette help you—and save money. Here you'll find complete equipment—popular, handy Lafayette Build-It-Yourself Kits for both radio and television. experiment, plus an amazing new kit for FM—hottest news in radio today! Lafayette is headquarters for homebuilders.

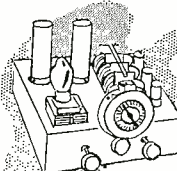

RUSH COUPON FOR FREE COPY

COMPLETE SELECTION

Lafayette's tremendous selection brings you the convenience and economy of "one place" buying. If there happens to be something you can't find in the catalog, we'll get it for you at lowest dealer prices. It pays to make Lafayette your source of supply.



FASTEST SERVICE

Lafayette renders the fastest and most efficient service in the entire industry. Huge stocks are maintained at strategic centers. Orders are teletyped to the nearest shipping point for immediate attention.



LOWEST PRICES

Lafayette will NOT be undersold! Our impressive buying power brings you the best in radio at Lafayette's bed-rock prices. Compare Lafayette radios, parts and equipment feature for feature, dollar for dollar. See if you can match the value!



Lafayette Radio

NEW YORK 100 SIXTH AVE. CHICAGO 901 W. JACKSON BLVD. ATLANTA 265 PEACHTREE ST.
BOSTON NEWARK BRONX, N. Y. JAMAICA, L. I.
110 FEDERAL ST. 24 CENTRAL AVE. 542 E. FORDHAM RD. 90-08 166TH ST.

LAFAYETTE RADIO CORP.
Dept. 2K—100 Sixth Ave., New York, N. Y.
or 901 W. Jackson Blvd., Chicago, Ill.

Rush FREE Catalog No. 82.

NAME.....

ADDRESS.....

CITY..... STATE.....

FREE

DOUBLE FEATURE

Smash Hits *NOW SHOWING AT* SUN RADIO

THE NEW 1941
SUPER

Skyrider

**BUILT TO
GOVERNMENT SPECIFICATIONS**

15 tubes, 6 bands, 540 kc. to 43 mc. 2 stages preselection. Adjustable noise limiter. Push-pull high fidelity audio. Band pass audio filter. New crystal filter circuit. New noise limiter. Standard relay rack panel 1/8 inch thick. Machine tool, dark gray wrinkle steel finish. Super Skyrider (Model SX-28) complete, less speaker, cash price..... **\$159.50**

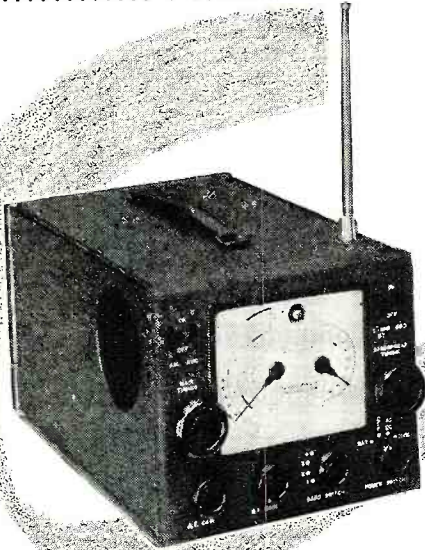

PORTABLE COMMUNICATIONS RECEIVER

The new Hallicrafters Model S-29 Sky Traveler is an entirely new idea. It is a real communications receiver operating on its own self-contained batteries or on 110v AC or DC power. Covers 542 kc. to 30.5 mc. (553 to 9.85 meters) on 4 bands. Built-in collapsible antenna extends to 3 feet. Battery life prolonged through self-contained charging circuit. Automatic noise limiter, electrical bandspread, built-in speaker, etc. Weighs only 18 lbs. Dimensions only 7 in. high, 8 1/2 in. wide, 13 1/4 in. deep. Complete with tubes and batteries, cash price..... **\$59.50**

Write for
Complete
1941
Hallicrafters
Catalog

**LARGEST STOCK of HALLICRAFTERS in the EAST
NEW YORK'S OLDEST "HAM" HOUSE
W2JEH W2DXC W2LFV W2CLH**

Cut and Paste on Penny Postcard

**P. A.
MEN**
Send for Sun's
New Sound
Catalog!

24 Pages chockful
of Public Ad-
dress Values.

SUN RADIO CO.
212 Fulton St., Dept. RN, New York City

RUSH Literature as checked.
 SUN SOUND SYSTEMS CATALOG
 1941 HALLICRAFTERS CATALOG

NAME.....
ADDRESS.....
CITY.....
STATE.....
 AMATEUR
 SHORTWAVE LISTENER
 P.A. ENGINEER SERVICEMAN

SUN RADIO CO.

212 FULTON STREET • NEW YORK CITY

ESTABLISHED 1922

CABLE ADDRESS "SUNRADIO"

100,000 RADIOMEN NEEDED FOR NATIONAL DEFENSE!

AN OPEN LETTER FROM SENATOR CLAUDE PEPPER,
U. S. SENATOR FROM FLORIDA

KEY PITTMAN, NEV., CHAIRMAN
PAT HARRISON, MISS.
WALTER F. GEORGE, GA.
ROBERT F. WAGNER, N. Y.
TOM CONNALLY, TEX.
ELBERT D. THOMAS, UTAH
FREDERICK VAN NUYS, IND.
JAMES E. MURRAY, MONT.
LEWIS B. SCHWELLENBACH, WASH.
CLAUDE PEPPER, FLA.
THEODORE FRANCIS GREEN, R. I.
ALBEN W. BARKLEY, KY.
ROBERT R. REYNOLDS, N. C.
JOSEPH P. GUFFEY, PA.
GUY M. GILLETTE, IOWA
BENNETT CHAMP CLARK, MO.

HIRAM W. JOHNSON, CALIF.
ARTHUR CAPPER, KANS.
ROBERT M. LA FOLLETTE, JR., WIS.
ARTHUR H. VANDENBERG, MICH.
WALLACE H. WHITE, JR., MAINE
HENRIK SHIPSTEAD, MINN.
GERALD P. NYE, N. DAK.

EDWARD J. TREMWITH, CLERK
JAMES A. WHITE, ASST. CLERK

United States Senate
COMMITTEE ON FOREIGN RELATIONS

August 19, 1940

Editors of RADIO NEWS,
608 S. Dearborn St.,
Chicago, Illinois.

Gentlemen:

I am writing to you as the editors of one of the largest, if not the largest, magazines in the field of technical radio, calling your attention to the fact that it is becoming increasingly apparent that the communications systems of the United States will have to be enlarged should an emergency arise. Such an emergency might easily come about over night, or might, on the other hand, develop slowly. I am fully confident that American industry can produce the necessary radio equipment sufficient to equip our armed forces adequately. I am not so sure, however, that we have available the trained personnel to man this equipment in the time of emergency. The demand is certainly imperative for a very large number of persons of unqualified patriotism who can be depended upon to ferret out and give information on fifth column and subversive group activity which, to the best of my knowledge, has been and will be rampant from coast to coast in the time of emergency and is in fact actually occurring right now.

Briefly, this country needs approximately 100,000 trained radio men. It also needs many thousands of patriotically minded citizens who will spend time at their radio sets listening for any dangerous or subversive material in communication channels. We know that there are a great number of broadcasts in foreign tongues and our patriotic foreign-born citizens could perform a real service by listening to these broadcasts in languages which they understand. The equipment of our armed forces at the time of emergency is but one step in the maintenance of our communications. There is always the problem of the maintenance of the equipment itself. This must be undertaken by men trained in the widely diversified radio field.

I think it would be a patriotic and helpful service to this country if RADIO NEWS were to bring these facts to the attention of its readers and encourage them to become an alert and effective organization dedicated to the preservation of our democracy. Thus they can use their technical information and their abilities, together with whatever equipment they may each possess, toward the furthering of our common goal of national unity and preparedness.

Just exactly how this is to be done I leave to your deep knowledge and understanding of publication work. But I again urge upon you that the situation is sufficiently grave to demand immediate attention and action if the United States is to be able to defend democracy against the despised dictatorships.

Very truly yours,

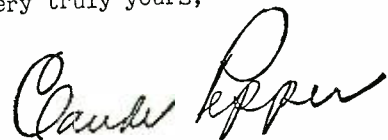

[We have always felt that the situation was grave enough that immediate organization of a group such as Senator Pepper suggests was needed. Accordingly, plans have been laid for the establishment of the RADIO MINUTEMEN OF AMERICA, a peace-time force of trained radiomen, each of whom will dedicate himself to the preservation of our democracy by following the lines indicated by the Senator's letter. Full details on the plan will be presented next month. The Editors.]

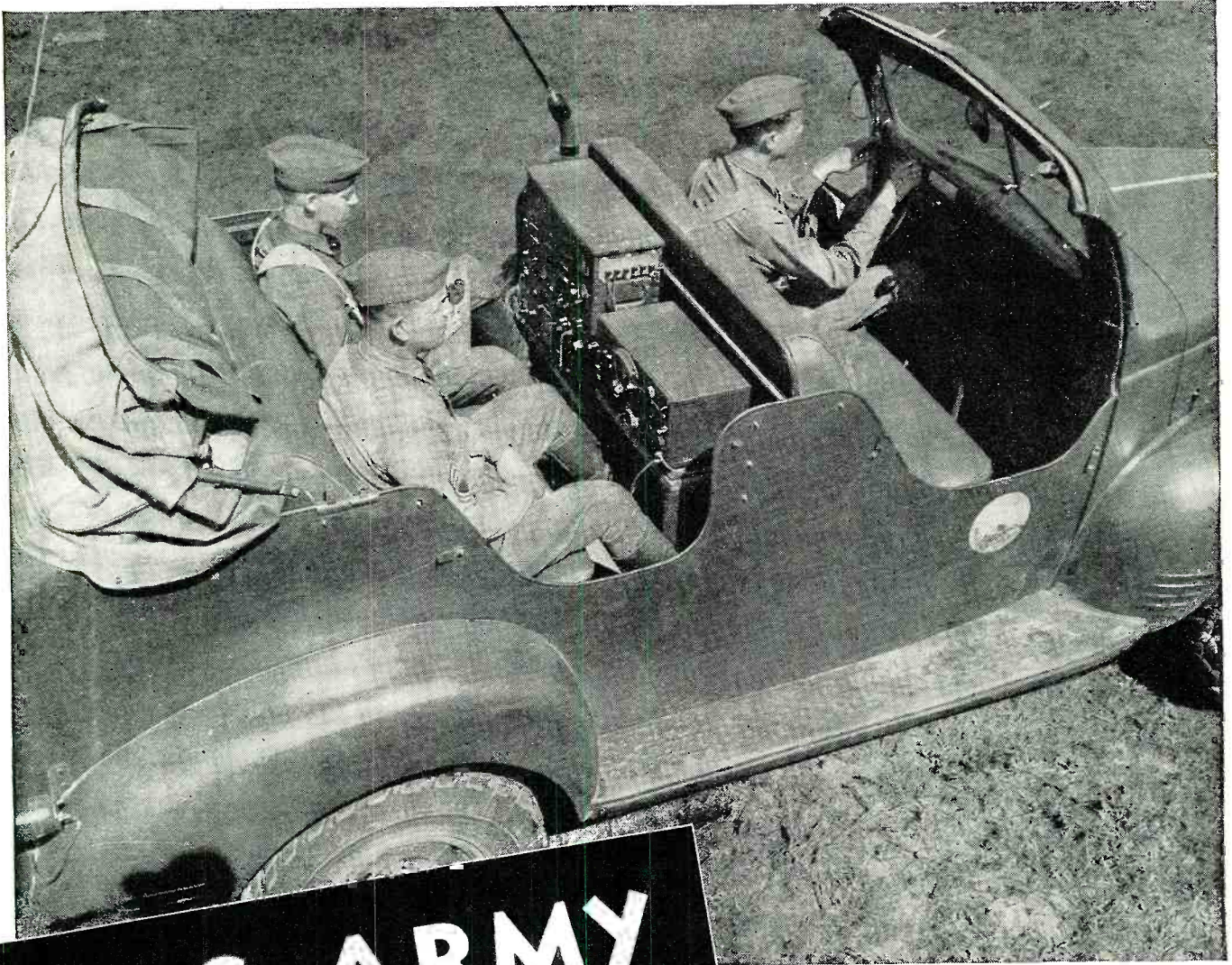

Heart of the mechanized troops of the U. S. Army Blitzkrieg Technique is this fast-moving radio car which keeps in communication with the advance attacking force of tanks and armored trucks.

U. S. ARMY Blitzkrieg Radio

by **ALFRED TOOMBS**,
Special Washington Correspondent for RADIO NEWS.

Radio communication in the Army has become so vital a necessity, that no campaign can be successfully waged without it.

JUST what has been done by the United States Army to prepare our armed forces to counter-attack a "Blitzkrieg." How great a part will radio play in the new technique developed by our Government? The answer is interesting because it shows that while a war can be won with communications, it cannot be won without them. Of all of them, radio is getting to play a more and more important part. It is a well-known fact that the French debacle was at least partly due to the fact that reliable French communications were totally broken down, while the radio system of the Germans operated over great distances and most efficiently. The author discusses the problems which confront our Army, and the solutions which have been discovered. He tells how the Signal Corps has now furnished the finest in radio communications to our Army.

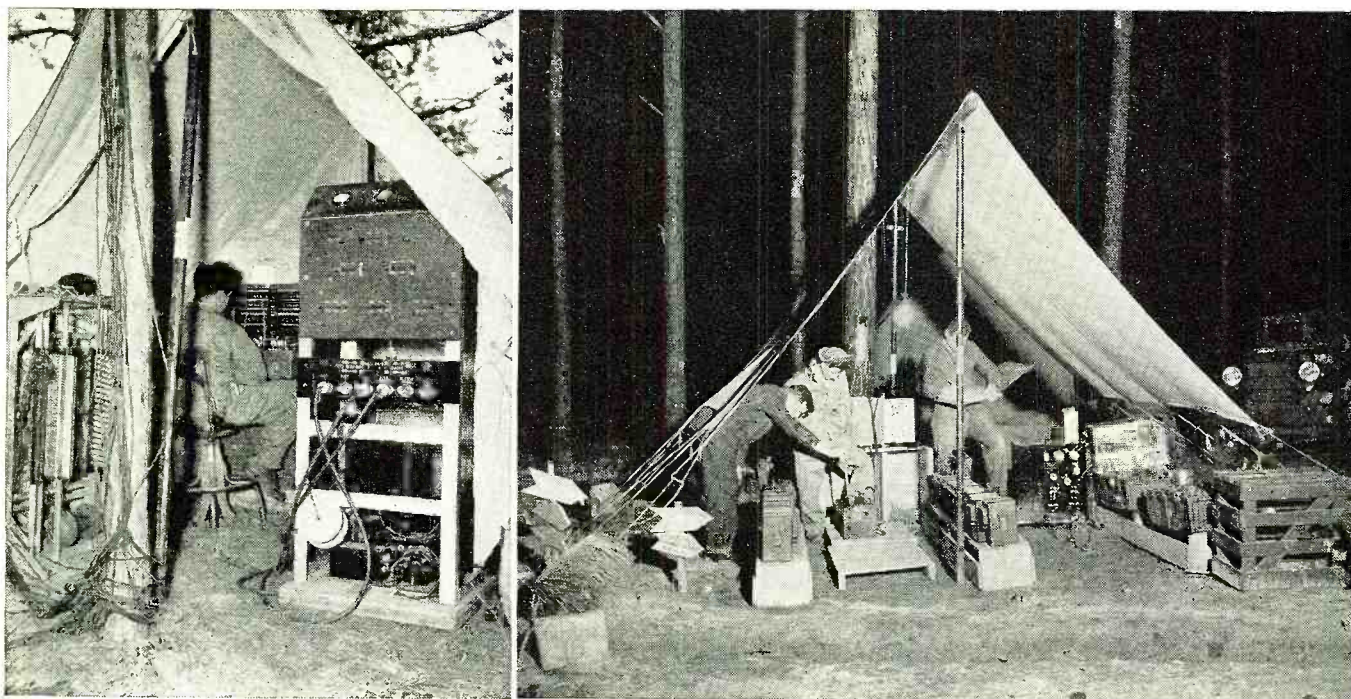

Not only radio is used to keep up the communications, but also telephone. This is "Central."

Batteries must be charged and kept up to snuff. This is done at a special point where a trained group of experts watch over these all-important units.

YOU can't win a modern war with radio. But you can't win one without it. And because this is so, the United States Army as part of its modernization and expansion program is investing millions of dollars in radio equipment and enlisting thousands of men to operate it.

In preparing its own particular brand of blitzkrieg, the Army is basing its design on the existence of a mobile, rapid means of communication—in other words, radio. The sharp, crisp signals that come from hundreds of field sets enable the Army field command to know at every instant exactly where its speeding units are and what they are up against. Orders for advances or withdrawals, calls for reinforcements or warnings of the approach of strong enemy forces can be flashed back over miles of battleground in a split second.

Of all the modern inventions—the airplane, the gasoline motor, the camera, the rapid firing weapon—which have affected the conduct of war, it is doubtful if any has been more integral a part of the new way of battle than the radio. Our Army men have never lost sight of this and as a consequence our military tactics have been revised to take into consideration the use of the very best and latest radio equipment. We are prepared for war on the ether.

The Signal Corps of the Army is charged with maintaining radio and other communications. It has, in other years, developed signal flags, carrier pigeons, telephone and telegraph systems for the vital task of maintaining communications between various battle units. In many respects, the radio has rendered these other methods obsolete, although for many purposes they

are the most practical. The strength of the Army Signal Corps, officers and enlisted men, is about 4,000 in the regular Army; 2,000 in the National Guard, and 2,000 in the Organized Reserves. In a war time Army of the strength we would need, this Corps would include no less than 75,000 men. And they would virtually all be experts in radio communication.

It is in the new mechanized divisions of the Army that the radio has been most extensively used and developed. The armored units are built to move fast, to strike hard. They seek out enemy concentrations, hit them without warning and open the way for the powerful, more ponderous units. These fast striking corps must maintain contact with each other and with the other battle units.

They move too fast to set up lines for telephone or telegraph and they get too far ahead to depend upon visual communications or messengers. So, quite naturally, these units have a radio net which is their nerve system.

The first unit in the Army's fast striking division is the reconnaissance plane. When the mechanized division goes into action, the plane flies ahead, reporting its observations back by radio. On the ground, swift armored scout cars race toward the objective—acting as feelers for the forces which follow. These scout cars are each equipped with a compact, long range transmitter, powered by a generator. These sets have a range of from 20 to 70 miles. In addition to maintaining contact with the units which follow,

In actual warfare no radio field station would be operated out in the open like this one; but the equipment is much the same. Note the "one-man power."

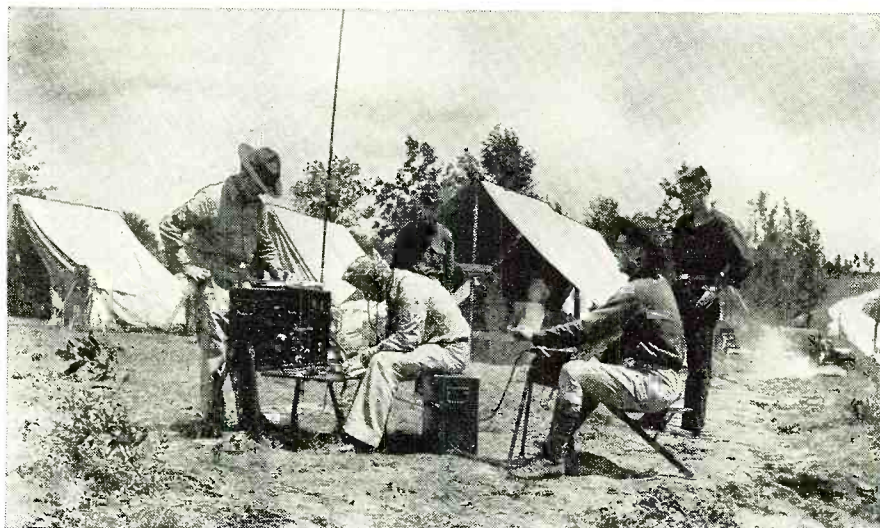

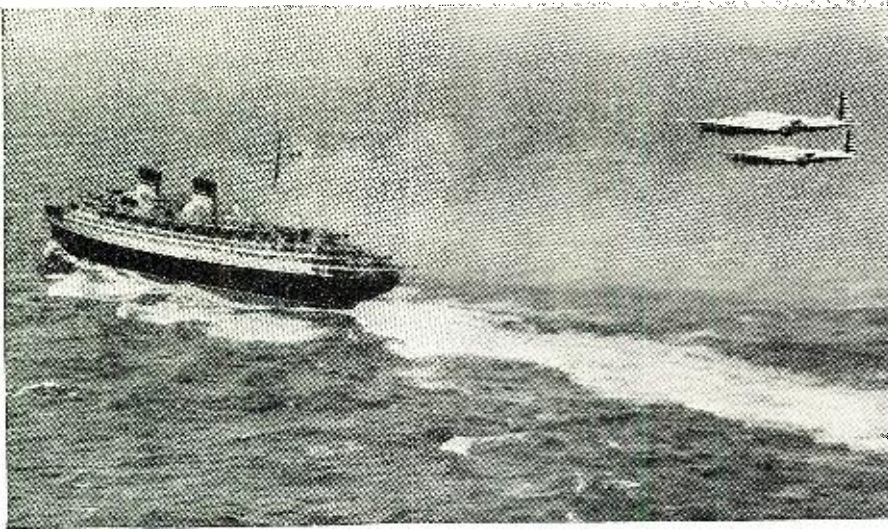

One of the slickest pieces of radio-directed flying that the Army ever did, was when they sent bombers to locate the Italian ship, *REX*, 776 miles at sea.

the scout cars keep in touch with the observation planes.

The tanks which come along behind the reconnaissance planes and cars are equipped with one radio for about every four tanks. The officer in this radio tank receives orders for his unit and gives visual signals to the other three. The exact descriptions of the Army's radio equipment, realistically enough, is not discussed by its officers. They say, however, that the difficulties which made transmission and receiving from tanks virtually impossible a few years ago has been overcome. Tank static has been virtually eliminated by electrically bonding certain metallic parts of the vehicle. Difficulties with aerials and with breakage to sets in the bouncing behemoths have been overcome, making laughable the predictions of officers who said no less than ten years ago that it would be impossible to install radios in tanks.

The strength and location of enemy units is radioed back to the division headquarters and the commanding officer can quickly make his decisions. He then radios orders to the combat vehicles, to the artillery and machine gun units and to the infantry. Within a short time, the whole furious attack is moving against the surprised enemy.

This is perhaps the most spectacular use of radio in modern battle. But in the every day life of the Army, in peace or in war, it is performing a vital function. The Signal Corps divides its radio activities into two spheres—the fixed stations and the field stations.

The fixed stations form a great radio network which has its center in an air-conditioned room in the low, white War Department building in Washington, D. C. In this room, at long rows of desks sit the men who operate the transmitters which reach every Army post in the continental United States and in our possessions. There are about 18 transmitters under *WAR*, one for each of the nine Army Corps areas and for stations in Hawaii, Puerto

Rico, etc. The power of these transmitters is from one to ten kw., depending on the distance of the station with which it connects.

Almost all sending and receiving is automatic, at a rate of about 125 words a minute and about 5,000 messages a day go through *WAR*. In the Corps areas, there are other message centers which tie in with stations at every Army post. Messages from these posts, if they are directed to Washington or to another post in another Corps area, must be transmitted to the area message center, thence to Washington, and back to the other post via *WAR*.

The Army, as part of its fixed work, has established the Army Amateur Radio System, whose members hold regular drills. This system could quickly furnish a reservoir of operators trained to the Army's way of doing things in event of an emergency. Members could be called to Army duty, or could be assigned to establish a station in some area where the Army had found it necessary to establish a concentration. The mobile units owned by these or other hams could be used by troops, for instance, who might be guarding oil storage tanks against sabotage. The value of a hamnet in case of invasion or insurrection, when other methods of communication fail, is obvious.

To the field outfits is assigned the bulk of the Army's radio equipment. The smallest, most common set is the portable "walkie-talkie." This six-meter set, which can be carried on a man's back, is much like the transceiver which the broadcasting companies use. Eight of these sets are assigned to each infantry regiment and they are used to maintain communication between units, to direct artillery or machine gun fire, to warn against surprise gas or infantry attacks, etc. Their range is about 2½ miles.

In addition, a regiment of infantry has a number of small loop sets, with hand generators, and the divisions have the larger vehicular sets. At the

corps command headquarters behind the lines, there are more powerful sets, radio trailers, etc. Artillery units have ten hand pack sets and scattered through the field force are a number of other low-powered, short-wave and high-frequency sets, equipped for voice and c. w. transmission. They are used for everything from directing artillery fire to directing traffic.

All these sets are integrated into nets and the different nets are tied together. The walkie-talkies won't work well if there are more than three on a net. With larger sets, there are more transmitters on a single net. Each net has one transmitter which is designated as a control station, and a second designated as an alternate in case the control station is put out of action. The stations on a single net communicate only with the control station, except in emergency when they may talk directly with another set on their net or to another net.

When an outfit goes into action, the staff command will assign a different frequency to each net. The orders will probably tell one outfit to stay on a certain frequency until midnight, then change to another frequency for twenty-four hours, then change again. This is to confuse enemy listeners.

At the headquarters of a staff command which may have a dozen different nets working with outfits under its control, there will be a set tuned in on each frequency, with an operator listening every second for signals. He will hear all messages between the control and other stations, will receive queries from and transmit orders to the control station.

Stations must be set up in quiet places, whenever possible. You'd have a hard time getting a weak signal if you were sitting next to a machine gun while it was going. Likewise, care must be exercised not to set up near sources of interference, nor to screen the set behind a high hill.

In combat areas, the operator must listen to make sure the air is clear before he starts transmitting, only being allowed a break-in for an emergency. Messages must be terse and must be sent slow enough for the slowest man on the net to get them and a 15-second silence must follow the "end."

Each station has its own call letters and the first station set up in a combat zone is designated as the control station. Whenever possible, stations in these tactical nets are calibrated before combat action begins. As the various stations report it, it may be necessary to adjust the dial setting to strengthen the signals of a secondary station. If a station has an urgent message to transmit to another net, it learns the frequency of that net by some means other than radio, if possible. If it is an emergency, a direct call up is permissible, but this is likely to give the enemy the location of the other net.

In addition to the tactical nets,
(Continued on page 49)

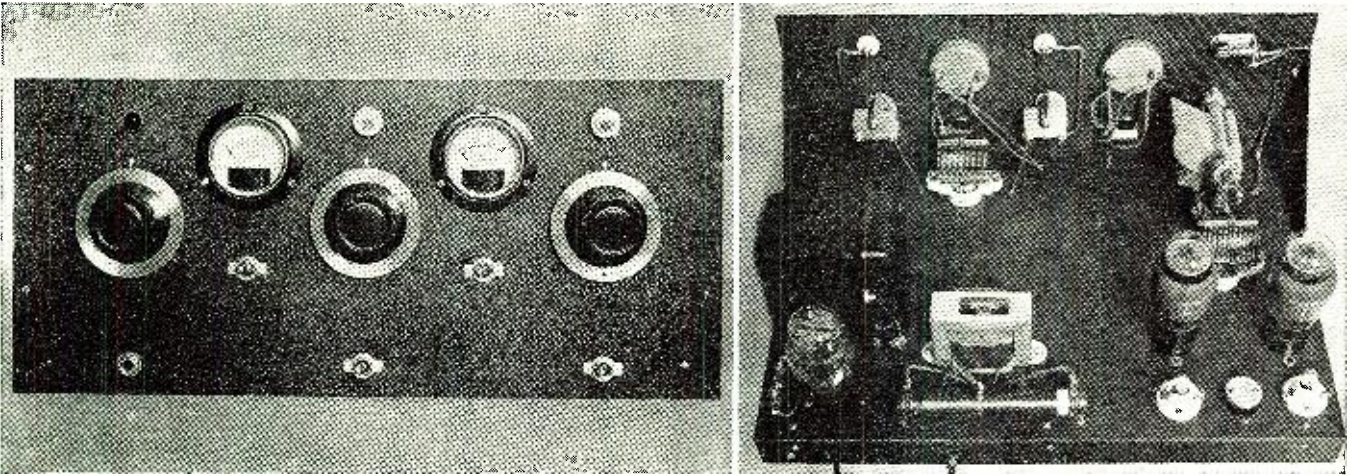

This is a simple, but highly efficient and good-looking 60-watt cw rig.

60 SIMPLE WATTS

SIMPLE transmitters are the need of our Government in time of emergency. This little unit, which can be assembled in one evening, would make an ideal set for code work. It will pay the experimenter, and the serviceman as well, to familiarize himself with the circuit and the operation, since transmitters may some day be needed rapidly; and several thousands like this one could come into existence practically over night. A prepared radioman is a distinct asset to our Government—so have some transmitter information at your finger-tips, even if you are *not* a licensed ham.

by **WILLIAM D. HAYNES, W6MNU**

Oakland, California

Sixty watts to a pair of 6L6G's is what the little transmitter consists of; but harnessed to a good antenna, it will really go places.

HAVE you ever had difficulty in neutralizing an r.f. amplifier? Or in preventing feedback from the amplifier to the oscillator? Or maybe you've had some trouble in adjusting the amplifier excitation to just the right value. If you've ever had these difficulties, and nearly every hamateur has at one time or another, then you should appreciate the little rig described in this article. It eliminates the difficulties of the oscillator-amplifier type of transmitter in a very ingenious way, by omitting the amplifier.

Circuit

The rig consists of a pair of 6L6G's in pushpull, with about sixty watts input. It is quite possible to run considerably more power to a pair of

these tubes, but sixty watts is a good compromise between power output and tube life.

Whenever anyone contemplates running more than a few watts to a crystal oscillator, the first question that arises is "what about crystal current?" Well, in the case of this little rig, the crystal can relax. The *Bliley B5* forty meter crystal which is used is rated at 135 ma., and the crystal current is only about 45 ma. with the oscillator loaded, or about 90 ma. to spare. With the oscillator unloaded, the current is about 60 ma. The two 60 ma. pilot bulbs in series with the crystal give a rough indication of the crystal current and also act as fuse protection for the crystal should the current rise to excessive values. When the bulbs are lit to full brilliancy, the crystal current is slightly over 60 ma. due to the by-passing effect of the pilot-bulb sockets. At high keying speeds, it may be found necessary to short out the lamps, but at twenty words per minute they cause no trouble whatsoever.

The tubes operate with a plate voltage of 500 and a screen voltage of 250; with full load the plate current is 120 ma. and the screen current is only about 7 ma. Currents given are for two tubes. The meters are shorted out by means of two toggle switches

while the transmitter is being keyed. Meters of the type shown are serviceable and dependable if treated with

(Continued on page 61)

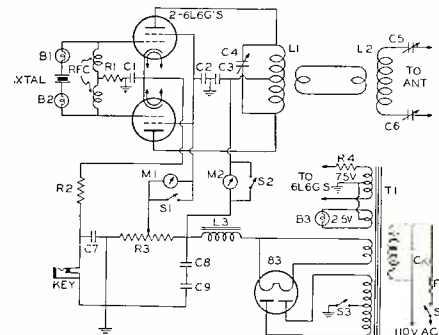

- $C_1, C_2, C_3, C_7, C_{10}$ —.01 mfd. 600 v. paper (Sprague)
 C_4 —125 mmfd. double-spaced (National)
 C_5, C_6 —140 mmfd. midget (Hammarlund SM-140)
 C_8, C_9 —8 mfd. 500 v. paper (Girard-Hopkins)
 R_1 —10,000 ohms, 10 w. (Ohmite)
 R_2 —200 ohms, 10 w. (IRC)
 R_3 —20,000 ohms, 50 w. (Atlas or equivalent)
 R_4 —0.7 ohm (resistance wire) see text
 L_1, L_2 —Air-wound plug-in coils (Bud OCL)
 L_3 —30 hy., 110 ma. (Stancor C-1001)
 T_1 —Thordarson T-6878 (see text), 1,200 v. c.t. with suitable filament windings
 RFC—2.5 mh. r.f. choke (Millen)
 B_1, B_2 —2 v. 60 m.a. pilot bulbs (GE)
 B_3 —2.5 v. 500 m.a. pilot bulbs (GE)
 Xtal—Bliley B5
 M_1 —0-25 milliammeter (Readrite)
 M_2 —0-150 milliammeter (Readrite)
 J_1 —Closed circuit jack (Yasley)
 S_1, S_2, S_3, S_4 —S.P.S.T. toggle switches (Arrow)
 F_1 —3 amp. fuse (Buss)
 Feed-through insulators (Johnson Alsmag)
 Tubes: 2 6L6G's, 1 83 (RCA)

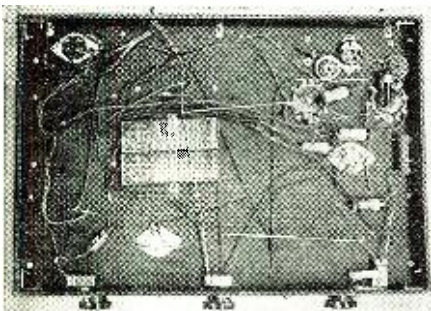

Under chassis view.

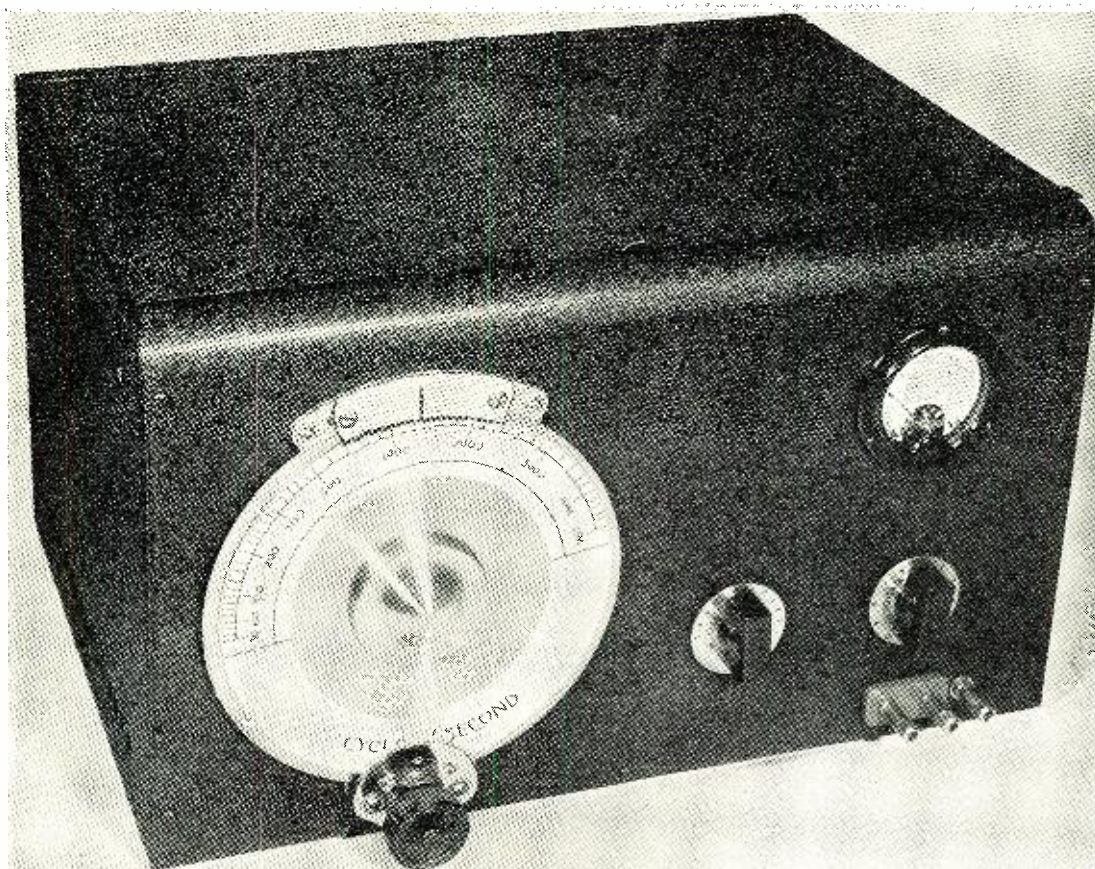

This unit will give good sinusoidal wave forms of from 30 to 15,000 cycles per second.

Build Your Own AUDIO OSCILLATOR

MOST audio men, and servicemen as well, have no audio oscillator. There are many reasons for this,—but when the instrument is needed, it is needed badly. There is nothing that will take the place of a good audio oscillator for testing gain or percentage distortion in a P.A. System. The unit developed by Rufus P. Turner is at once inexpensive and efficient. Anybody handy with tools and a reasonable knowledge of radio can build it. Why be without this instrument any longer? You will find that if you are a serviceman, it will pay for itself many times over for the few evenings devoted to its construction.

by **RUFUS P. TURNER, W1AY**
Cambridge, Massachusetts

*Last month we ran a simple audio oscillator;
but here is a precision instrument for the
most exacting public address serviceman.*

JUST a few years back, *audio* signal generators were to be found only in actual laboratories or in the sanctums of "amateur engineers." Indeed, as recently as ten years ago there was no pointed workaday demand for the instrument in service shops; and when it did very infrequently appear in those places, the user like as not was charged with harboring a costly instrument which,

while interesting enough, was a dubious profit booster and certainly not a "must." If signal chasing became necessary in the audio end of a receiver, the repairman very likely obtained his signal from a common buzzer.

Today, however, a different picture is viewed of essential equipment. The newer horizons of the radio service profession, the increasing complexity

of modern diagnosis, and the robust growth of amateur technical interest dictate more complete instrumentation.

P. A. testing and repair have been embraced by the serviceman's money-making program. And to the lot of that expert also falls the task of checking the response of high-fidelity equipment. Even the up-to-date radio ham seeks quantitative data on his

amplifier and modulator units. All substantial reasons why the beat frequency audio oscillator is now as necessary an electronic tool as the r.f. test oscillator. (And we rate the latter as indispensable as the radio man's right arm.)

An abbreviated idea of the utility of the instrument may be gained from these running considerations—that a good beat frequency oscillator covering the entire audio spectrum with controllable output and low distortion enables the serviceman to diagnose trouble in loud speakers, P.A. amplifiers, and receiver audio stages; to check the fidelity of those systems and actually to measure their overall and per-stage gain; by direct modulation of the r.f. signal generator, to study the overall characteristic of receivers; and to locate disturbing resonant points in speakers, chassis, and cabinets. The advanced radio amateur is enabled to perform the same operations on his receivers and audio gear, improving his design and manipulation of his equipment. The broadcast technician may make frequency runs and transmission efficiency measurements on studio program circuits, including lines. And the laboratory engineer is able in addition to performing any of the foregoing operations in his line of work, to adapt the audio oscillator to any application where a reliable source of a.f. voltage is indicated—such as for accurate bridge measurements, modulation processes, and other tests and studies requiring alternating voltages of low distortion and continuously-variable frequency of known accuracy.

The beat frequency audio oscillator is equally invaluable in design and test procedure and no institution boasting slightest resemblance to an adequately equipped laboratory can long maneuver without it. As a source of known audio frequencies, it finds ready application in shop, lab, and shack in the accurate determination of inductance and capacitance.

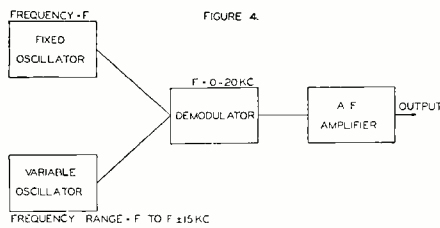

Block diagram of the oscillator.

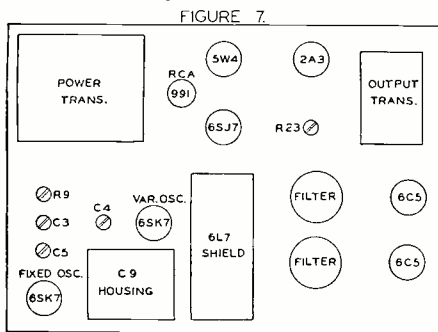

CHASSIS SIZE 14 X 10 X 3
Chassis layout details.

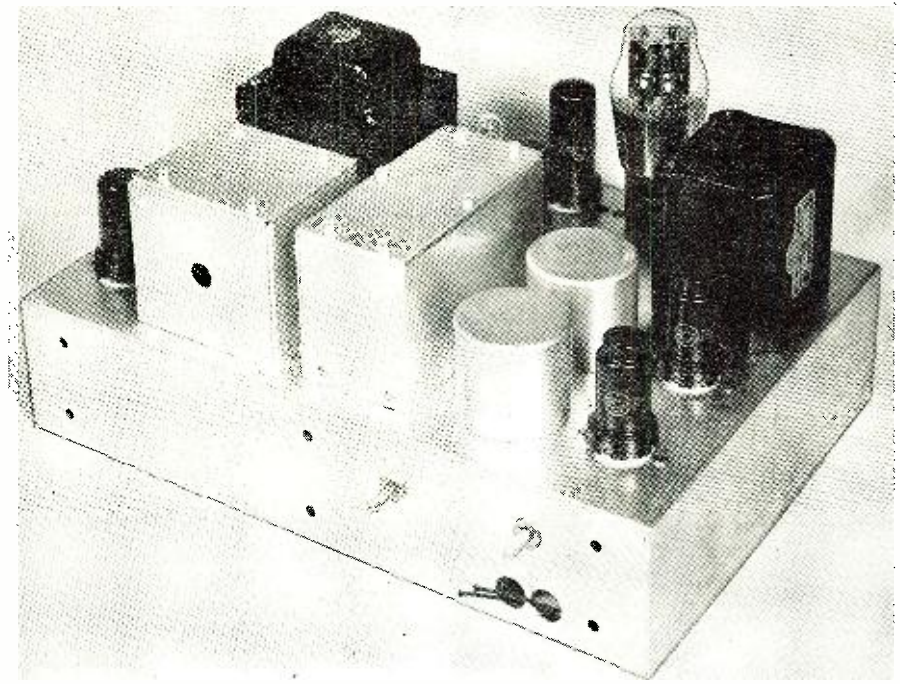

Notice the extreme care that has been taken in the matter of shielding. The author explains why this must be done in order to get good results.

There are still numerous technicians who have sufficient reason to build their own equipment. That more of them have not attempted the beat frequency oscillator is due largely to the fact that the completed article is by no means as simple as its explanatory block diagram, and this fearful fact is apparently widely publicized. At the

same time, some previously published building directions have casually called upon the home-maker to fabricate special coils, condensers, and the like for which manufacture he would have neither the highly specialized facilities nor particular abilities.

It is primarily to these individuals with the patience carefully to build

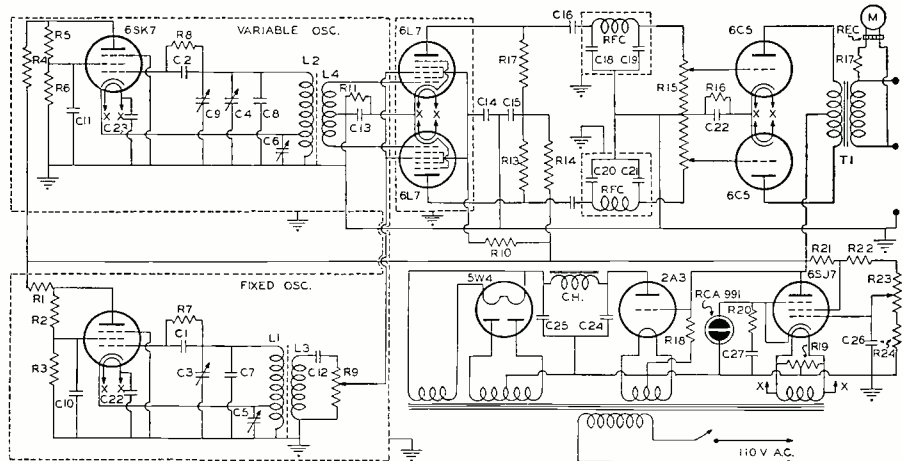

A larger diagram will be presented next month. This is for study, only.

- C₁, C₂—0.01 mfd. midget mica. Aerovox
- C₃, C₄—100 mmfd. National UM100
- C₅, C₆—35 mmfd. National UM35
- C₇, C₈—100 mmfd. silvered mica. Cornell-Dubilier
- C₉—Special BFO, 5-58 mmfds. RCA 31333
- C₁₀, C₁₁—0.1 mfd. 400 v. tubular. Aerovox
- C₁₂—0.0005 mfd. midget mica. Aerovox
- C₁₃—25 mfd. 50 v. electrolytic. Aerovox
- C₁₄—0.1 mfd. 400 v. tubular. Aerovox
- C₁₅—1.0 mfd. 400 v. paper. Aerovox
- C₁₆, C₁₇—1 mfd. 400 v. tubular. Aerovox
- C₁₈, C₁₉, C₂₀, C₂₁—0.0005 mfd. midget mica.
- C₂₂—25 mfd. 50 v. electrolytic. Aerovox
- C₂₃—1 mfd. 400 v. tubular. Aerovox
- C₂₄, C₂₅—16 mfd. 450 v. midget electro. Aerovox
- C₂₆—0.02 mfd. midget mica. Aerovox
- C₂₇—0.1 mfd. midget mica. Aerovox
- R₁, R₂, R₃, R₄, R₅, R₆—1 meg., 1/2 w. IRC
- R₇, R₈—50,000 ohms, 1/2 w. IRC
- R₉—1,000-ohm tapered potentiometer. Yaxley
- R₁₀—50,000 ohms, 1 w. IRC
- R₁₁—1,000 ohms, 1 w. IRC
- R₁₂—Dual 500,000-ohm potentiometer. Yaxley
- R₁₃—500 ohms, 1 w. IRC
- R₁₄—10,000-ohm non-inductive precision resistor, type WW4. IRC
- R₁₅—250,000 ohms, 1 w. IRC
- R₁₆—60-ohm wirewound, center-tapped
- R₁₇—50,000 ohms, 1 watt. IRC
- R₁₈—10,000 ohms, 2 watts. IRC
- R₁₉—25,000 ohms, 2 watts. IRC
- R₂₀—15,000-ohm heavy-duty wirewound potentiometer. Mallory
- R₂₁—5,000 ohms, 1 watt. IRC
- L₁, L₂—1 millihenry tapped at approximately one-third. National R300U r. f. choke with tap made between bottom and middle pins
- L₃—Fixed oscillator coupling coil (see text)
- L₄—Variable oscillator coupling coil (see text)
- RFC—250-millihenry r. f. chokes. National 1-10
- T₁—U. T. C. LS-51
- T₂—350-0-350 v., 95 ma.; 5 v., 3 a.; 6.3 v., 4.5 a.; 2.5 v., 5 a. U. T. C. Type R3
- CH—15 henries, 100 ma. U. T. C. R19
- M—0-1 d. c. Milliammeter. Triplett Model 221
- REC—Triplett C-4 copper oxide rectifier

and adjust a fine test instrument that this constructional article is addressed. The beat frequency oscillator described is the outcome of more than a modicum of painstaking cut and try, of building and wrecking, and patient bug-removing. Ease of duplication, minimum expense (not to be confused with skimping), and final superior performance were the aims that guided the development throughout. It should not be difficult for anyone who can follow directions to make a Chinese copy of both instrument and results.

Principle of Operation

A brief explanation is opportune here as to the method of obtaining audio frequencies with the type of instrument under discussion.

The beat frequency oscillator makes use of the well-known heterodyne principle; which is to say that it utilizes the *beat note* between alternating voltages of two different frequencies. Reducing to a definite example: if two radio-frequency oscillators are so arranged that their output voltages may be *mixed* in a suitable output circuit common to both oscillators, and if the oscillators are adjusted to two

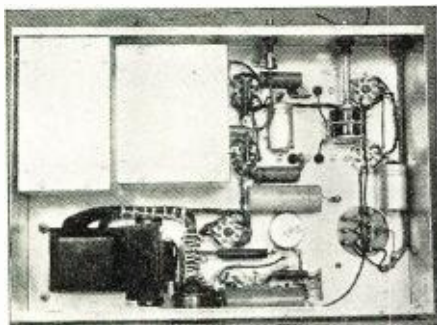

Underside the audio oscillator.

different frequencies, a third frequency numerically equal to the difference between the two oscillator frequencies may be detected in the output circuit voltage.

This difference frequency is the *heterodyne beat note* which may be increased or decreased by accordingly increasing or decreasing the separation between the two oscillator frequencies. When the two oscillators are operating on the same frequency, the condition of zero beat obtains, or the heterodyne beat note reduces to zero.

If the numerical difference between the two oscillator frequencies is less than 20,000 cycles, the beat note is of audible character and may be detected (demodulated) and amplified. And it should be readily apparent that the frequency of this audio beat note may be changed at will simply by shifting the frequency of one oscillator by the desired amount, thereby creating a new frequency difference.

This is the precise manner in which an audio-frequency signal is obtained in a beat frequency oscillator. However, in actual practice one oscillator is operated on a fixed frequency (see figure 4), while the frequency of the

(Continued on page 41)



Conscription !!!

WASHINGTON, turning its full attention to conscription, is preparing to call on almost everyone in the radio field for a very special effort. For when the draft gets going in earnest, radio people are going to find that Uncle Sam has a definite interest in: (1) Getting them into the armed forces, or (2) Keeping them out of the armed forces.

You won't be like bank clerks or shoe salesmen or truck drivers, whose assignment to duty will be routine. You will enjoy a very intensive going over by the selective service boards. For radio experts, and even semi-experts, are going to be desperately needed to supply, operate and repair the military communications system.

The draft, which need not worry you much at this time if you have dependents or are out of the age limits set forth, is designed to turn this country into an efficient military power. We are going to have a big Army and we are going to have the industrial organization to keep it going. Radio, the voice of the modern army, is as much a part of battle as shot and shell. And we are just about as short on radio men as we are on shot and shell.

Therefore, when we begin building the army, we are going to need the services of all our experienced radio people. Inquiry at the places where these plans are being worked out indicates that the selective service will work out this way for radio people:

If you are a ham, a commercial operator in a field which is not essential for defense, or a serviceman, you will be greeted with open arms and put to work on military radio.

If you are a worker in a plant turning out military radio equipment, you will be sent back to your job with orders to stay there.

If you are a commercial operator in a field which is essential to defense preparation, you will stay at your post, at least until substitutes can be trained. Then you'll probably become an instructor.

Those draft registration blanks have places where you indicate not only your profession—past or present—but your hobby and other interests. If either of these are radio, you will be assigned to radio work in the military organization. It is highly unlikely that a limited, first draft would turn up enough experienced radiomen for the job to be done. What then?

The military command will send out word to the selective service boards which will be set up in every community, calling for more radio men. These boards will advertise for volunteers to come in under "voluntary induction," whereby they will be allowed to choose their own branch of the service in return for joining early. And if this doesn't work, the draft board can reach out and call to service anyone it needs.

Those who are now engaged in the vital job of turning out the millions of dollars worth of radio equipment the military needs will be kept at their task. But if war comes, these men may expect to be drafted within a short time. The Labor Department, in fact, has already quietly made a study of the radio manufacturing industry, to see how much of the work can be done by women. They have put the industry on the list of those which can largely be taken over by women, if the men are needed elsewhere.

Radio Operator Shortage

GOVERNMENT officials have discovered that the shortage of radio operators and servicemen is about as acute as the shortage of airplane pilots. Chairman Fly of the FCC gave voice to this worry at a recent press conference, in discussing the difficulty

the Commission was having obtaining the 500 men needed to man the new anti-fifth column monitoring system. The Commission, you will remember, announced that it would hire amateur operators with five years experience, as well as commercial license holders.

But there was no rush to the colors, on the part of either the hams or commercial men. Mr. Fly said that such a situation worried him, because it was indicative of the scarcity of operators. He said he didn't quite know what to do, since he was hesitant to conduct any raid for operators on the industry, which he understood was just barely getting what it needed.

The Maritime Commission ran up against the same problem when it started looking for the operators it needed for the expanding Merchant Marine. So it has taken 200 CCC boys and is training them as operators in a school at Boston.

It's not been announced yet, but you can look for the Government to begin a vast training program for radio men for the defense forces. It will be much like the pilot training program. Plans have already been drawn up for a training schedule which every six months will produce 10,000 operators who can handle Morse at 30 words per minute. It will probably be administered by the National Youth Administration or the C. C. C.

If you are anxious to join the nation's radio defense services, there are spots open in the Army and Navy ham systems, in the National Guard and even a few reserve second lieutenancies. And there are the FCC monitoring jobs, which pay \$1,620 and \$1,800 a year. The Civil Service Commission handles applications for these.

Radio Equipment Deliveries

OF course, the need for men is not yet as acute with the military as the need for equipment.

The Army, Navy and Defense Commission are pretty secretive about the amount and type of radio equipment they are buying. They don't have much time for idle chatter, for one thing. And for another, they are afraid that by telling too much they might attract a flock of salesmen.

However, they are hopeful of getting quick delivery of most of the stuff they need. The radio industry, like every other, was caught a little short on the defense program. Just as the airplane manufacturers and the shipyards had to take a little time to get the right tools in, the radio industry had to do a quick expansion. So it will be a while before production gets under way on a mass scale.

But the Army is expecting its first deliveries within three months. The smaller sets will be the first received and production will step up so that the biggies are rolling in within a year.

FM—"Teacher's Pet"

YOU can see a subtle change these days in the attitude of normally skeptical Government officials toward new developments in the radio field. The television industry, which has been getting its knuckles rapped by the FCC pretty regularly, found itself basking in smiles from Washington the other day. And the FM boys are getting every help. You see, these new developments have their defense values—and they're being encouraged.

The FM short wave work is being watched closely by FCC engineers. Temporary permits have been issued to several police forces for establishment of FM systems. The Connecticut State police are reported to have in-

(Continued on page 65)

C R Y S T A L S H I F T E R

WHILE not new, here is a method of mounting several crystals in a transmitter so that crystal-switching is made easy. The unit is compact and works very well. We have had many types of band-switching, but most of them had to be built into the transmitter from the start. Here is a unit that can be added to the present rig to increase its efficiency.

THE device here described was designed and built after the author had tried to include crystal switching in several "single crystal" rigs but was unable to because of limited space and the design of the transmitters. To use it requires only that there be a space of several inches all around the crystal socket in the transmitter. It will not require any changes whatsoever in the transmitter and will provide optional use of up to six crystals. Moreover, it is a plug-in unit and can be used in any rig which has provision for at least one xtal.

Although the unit here described is made of tempered *Masonite* 1/8" thick, and has proven very satisfactory in use, a deluxe unit having better efficiency could be made using polystyrene or some other such insulation.

The front and back pieces are each 2" x 6" and the side pieces are 1" x 6". For the top and bottom pieces, soft wood 1" x 1 3/4" x 1/4" thick was used in order to eliminate the necessity of tapping the *Masonite* for machine screws.

All pieces are drilled as shown in the diagram, and care should be used in order that the *Masonite* does not chip while drilling. It would probably be a good idea to make a metal template for this work.

For holding the crystals in the unit, six-five prong wafer-type sockets of the smallest over-all dimensions possible were obtained. (Some of the newer two-point crystal mountings

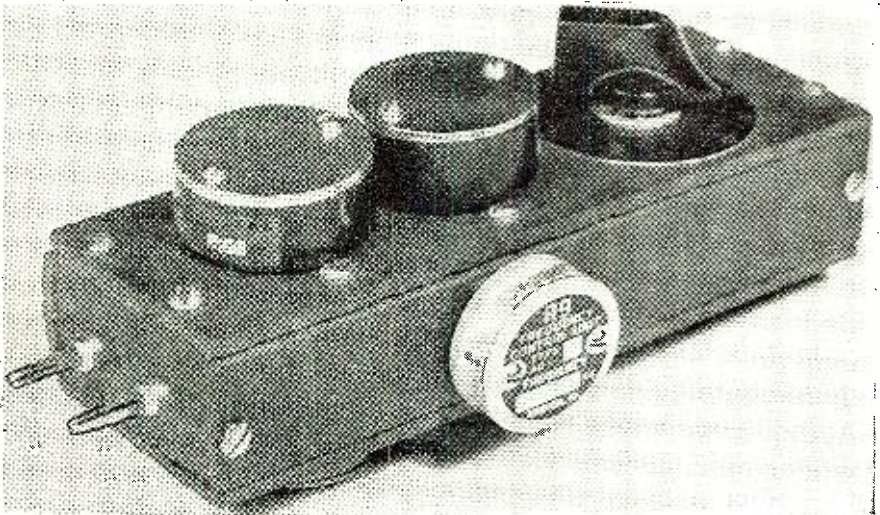

The completed crystal shifter ready to install in the transmitter.

by **PAUL V. TRICE, W8QHS**
Sharon, Pennsylvania

Without disturbing your transmitter, you can build this crystal shifter and insert it in the old crystal socket. Takes up to 6 crystals.

might do better. Ed.) These had the mounting holes in line with the cathode and plate connections of the socket. The soldering lugs for the grid and filaments are then broken off and the contact points can then be removed with a pair of pliers. The socket is then cut with a hacksaw so that only the original plate and cathode connections remain and the strip is only slightly wider than the contacts and mounting holes. No screw holes are shown in the diagram for mounting the socket pieces inasmuch as the size sockets obtained will differ.

Once the drilling has been completed, the socket pieces and the crystal switch (which is a Mallory 6-point single-contact type) can be bolted into place, using small machine screws. If it is possible to obtain a midget switch

of the type required, the unit can be slightly reduced in size.

The front and side pieces are then screwed to the top and bottom pieces, using small wood screws. Two GR plugs bolted to the bottom piece serve to plug the unit into the crystal socket of the transmitter.

The unit is now ready for wiring and is wired as shown in the diagram. When this is finished, the back piece is screwed into place and the job is completed.

One advantage of mounting the switch at the top of the unit is that it stands out above the oscillator coil form and other small apparatus, and is readily accessible.

-30-

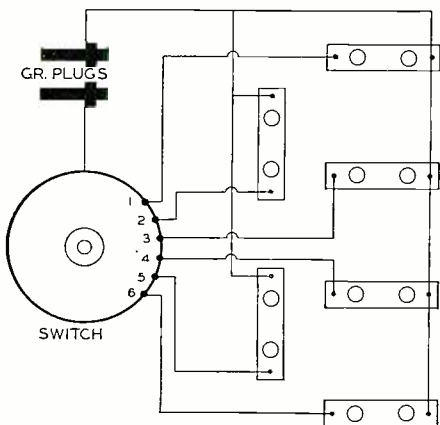

The hook-up of the crystal shifter.

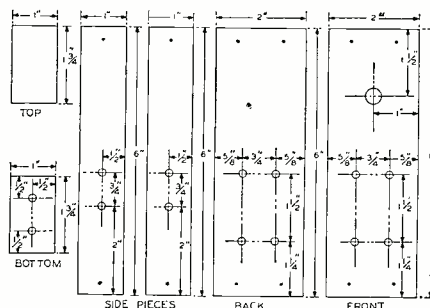

Constructional details of the unit.

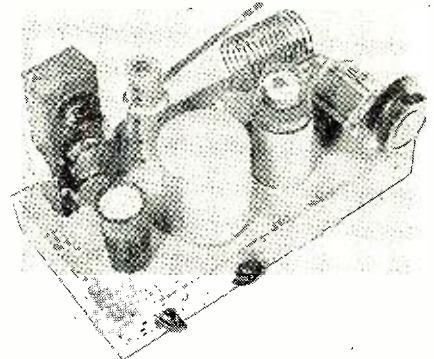

The crystal shifter installed in set.

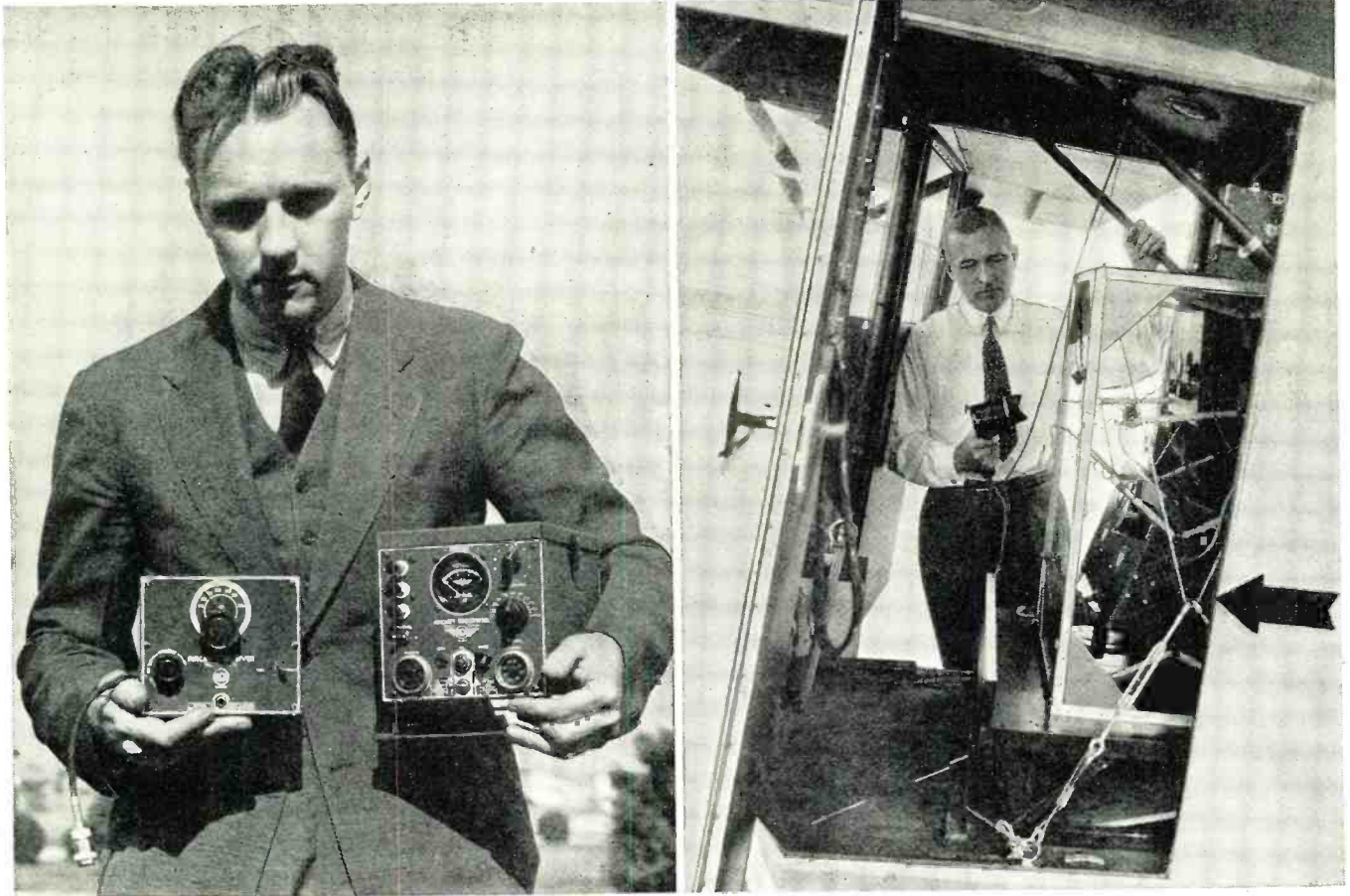

These two pictures serve to show how radio in the airplane has advanced in the last eleven years. Compare the modern two-way radio at right with the oldtime transmitter indicated by arrow at the left.

INSTALLATION and MAINTENANCE o AIRCRAFT RADIO EQUIPMENT

by Staff Sgt. CHARLES J. SCHAUERS

Communications Chief, 73rd Bomb. Sqdn., (M) GHQ,
McChord Field, Tacoma, Washington.

The author takes up the installation of the receiver, transmitter, antenna, and all the component parts of an airplane two-way radio.

Conclusion

THIS article completes the series on radio in aircraft. It will pay every person interested in radio to read it. The information contained is complete and, with the first part which was run last month, gives the fundamentals of aircraft installation. With conditions as unsettled as they are, who knows but that any of us might be asked to assist in National Defense by doing aircraft radio installation work?

THE second part concerns itself with the installation of the receiver, transmitter, and component parts.

When choosing a receiver location there are three factors which must be considered. First, the antenna-lead-in location; second, accessibility to removable components of the receiver for service; and third, proper weight distribution.

The first factor is a major problem with most installations in custom built aircraft because of the variety of design; and the various ideas of pilots.

When installing the receiver, it should always be installed as close to the lead-in insulator as possible; this is very important, because by running the lead-in several feet within the fuselage before connection to the receiver, a capacity effect can be created which is undesirable from the standpoint of dielectric loss encountered at high frequencies. Small standoff insulators should be used if the lead-in to the receiver is over twelve inches away.

By using copper wire as the "runner lead-in" and making it as short as

possible, consistent with strength, a very good internal connection will result, and most undesirable factors will be eliminated. Co-axial cable is now used to a very large extent for the lead-in and should be used where practicable.

The location of the receiver for accessibility is also very important, due to the fact that frequent inspections are necessary to keep the set operating correctly. The receiver should be located in such a position that maintenance work may be performed without removing a large amount of additional

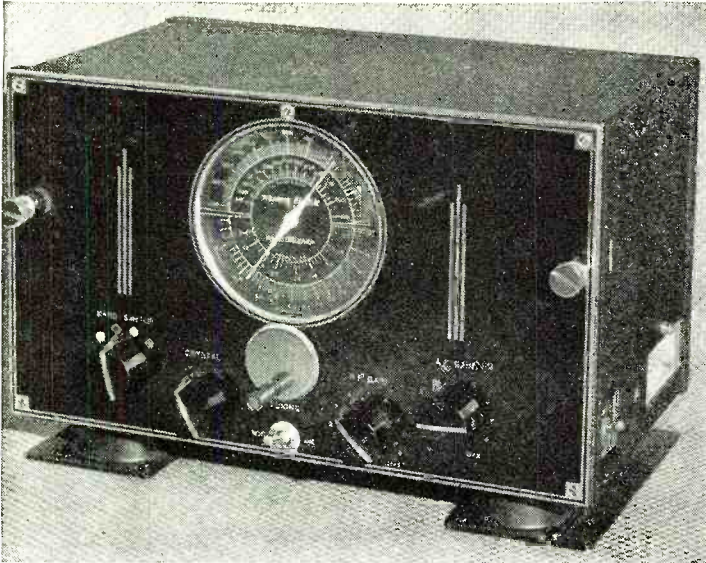

This is one of the many types of private flyer's receivers with which the prospective aviation radio serviceman must be familiar.

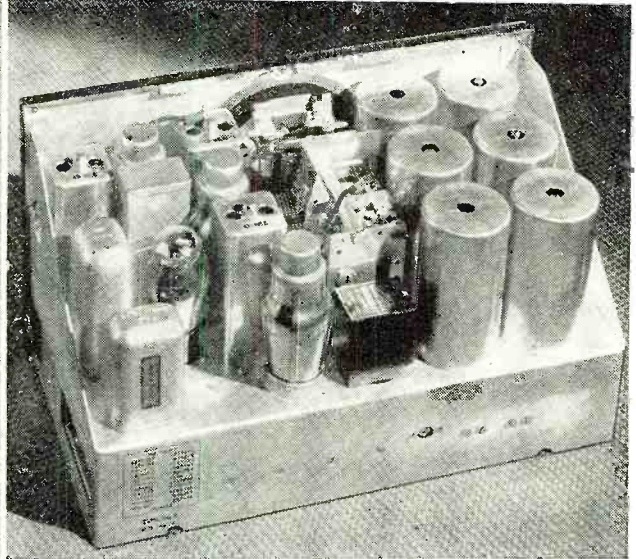

Rear view, with the cabinet removed, of the same unit showing the clean-cut, compact method of construction.

equipment and the panel coverings.

With the advent of new radio receiving equipment, it will be noted that most receivers are directly tuned by the pilot, no remote tuning cables being used. These receivers are usually mounted near the pilot's instrument panel where the tuning controls are readily accessible for receiver operation.

It should also be mentioned here, that all radio control boxes necessary for receiver and transmitter control should be located as close to the pilot or using personnel as possible, without interfering with other controls of the aircraft.

If remote tuning cables are utilized, the main tuning mechanism should be as near the pilot as is consistent with good installation, care being taken that all cables are securely clamped and insulated with tape to cope with vibration which may cause receiver noise. They should be fastened to the airplane structure at points not in excess of twenty inches by utilizing metal braid, soldered to the controls, in order to give a good bonded connection, for noise prevention. However, if the cables can be suspended by means of clamps (suspension clamps) every two or three feet,

the usual taping and shellacking will not be necessary.

Proper weight distribution for both transmitter and receiver will be treated later.

In choosing a receiver for any airplane the following should be taken into consideration: Frequency bands covered, how covered; sensitivity; selectivity; weight; tuning ease; service difficulties; *frequency stability*; construction; and whether or not the proper certificate has been issued by the authorities authorizing it for communication purposes in aircraft.

Radio receiving headsets should be purchased from a reputable manufacturer, and should be so constructed that they are light in weight, with a maximum amount of sensitivity, and a certain amount of damping characteristics.

I have always been a strong exponent of crystal receivers.

Their light weight, coupled with their inherent sensitivity, make them ideal for aircraft radio installations. However, there are a few precautionary measures which must be taken before putting them into service.

They *cannot* stand high voltage (direct current), so when installing them in an aircraft, the schematic diagram of the receiver should be inspected to ascertain whether or not d.c. is present in the output or not. If so, a small blocking condenser is necessary, which

is connected in series with the phones. This allows the audio to "filter" through and blocks the direct current component of the output.

If stray radio frequency currents are present it is sometimes necessary to install a small $\frac{1}{4}$ watt resistor in the phones for effective r.f. blocking.

The magnetic type phones are very efficient, and may be purchased for much less than the crystal phones. However, the added cost warrants the purchase of crystal phones.

There are many ways which may be used in connecting crystal phones into receiver circuits. However, the manufacturer usually supplies the necessary diagrams and recommendations for installation.

The actual weight of the receiver should be taken into consideration, and should be as small as design permits.

There are many manufacturers today who build receivers which are quite inexpensive for the service that they render. Some are battery operated, some use vibrators, some dynamotors for high-voltage supply, but in most cases the plane's battery is used as the primary power source.

There is a receiver manufactured today which may be used for radio compass work as well as liaison com-

(Please turn the page)

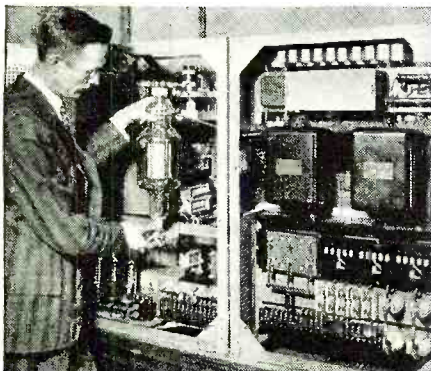

One of the big airport transmitters.

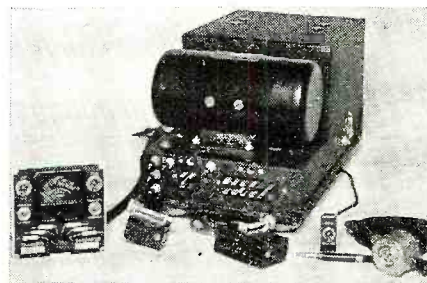

A private flyer's transmitter.

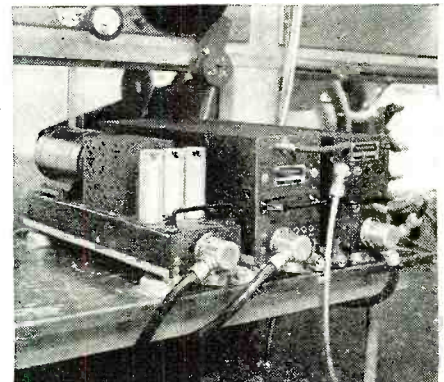

Specialized radio-altimeter unit.

munication, and which performs the functions of two receivers.

When purchasing a receiver the main *consideration* should be *dependability*. If a receiver fails at a critical moment and the pilot of the aircraft "squeezes" out of the "tight-spot," a safe bet of ten to one can be placed upon the pilot purchasing another receiver, or having the old receiver completely overhauled. Radio communication, consistent, is that important.

The transmitter location should always be chosen with the thought in mind that accessibility to its components are of prime importance. Due to frequent operating checks which must be made prior to flight, the transmitter must be so located that a hasty check may be made without too much loss of time. Regular maintenance adjustments must also be made, therefore it is necessary that the transmitter be located in an accessible spot. Nearly all airplane man-

CHART NUMBER TWO

AIRCRAFT RADIO EQUIPMENT MAINTENANCE CHART				
COLUMN INDICATED	WORK PERFORMED	DATE	TECHNICIAN	

CHART NUMBER ONE

AIRCRAFT RADIO EQUIPMENT MAINTENANCE CHART															
A	B	C	D	E	F	G	H	I	J	K	L	M	N	O	
42	1940	X	X	X	X	1940	X	X	X	1940	1940	1940	1940	1940	KC

KEY TO MAINTENANCE CHART

- A—AIRCRAFT NUMBER
- B—DATE
- C—TRANSMITTER CHECKED
- D—TRANSMITTER FREQUENCY CHECKED
- E—TRANSMITTER TUBES CHECKED
- F—ANTENNAE INSPECTED
- G—RECEIVER CHECKED
- H—RECEIVER TUBES CHECKED
- I—RECEIVER ALIGNMENT CHECKED
- J—RADIO HEADSETS INSPECTED CHECKED
- K—CONTROL BOXES, SWITCHES INSPECTED
- L—POWER UNITS CHECKED
- M—BATTERY CHECKED
- N—TIME OF AIRCRAFT IN AIR (TOTAL TO INCLUDE DATE)
- O—TECHNICIAN PERFORMING INSPECTION

NOTE:
 IN EACH COLUMN, DATE OF INSPECTION, ETC., IS ENTERED EACH TIME WORK IS CONSUMMATED ON RADIO EQUIPMENT. WHEN MAJOR REMARKS ARE NECESSARY FOR EXPLANATION OF WORK PERFORMED CHART NUMBER TWO WILL BE USED AND REFERRED TO, USING CHART NUMBER ONE AS REFERENCE.

Aircraft radio maintenance charts. Manufacturers incorporate or suggest a suitable mounting for the transmitter in their aircraft.

(Continued on page 46)

UTILITY RADIO DEVELOPMENTS

Police Radio
GENERAL ELECTRIC COMPANY has engineered a frequency modulation mobile radio transmitter and receiver operating in the 30 to 40 megacycle bands. The transmitter, of 25 watts power, is a Model 4GF4A1, while the receiver is a Model 4SF1A1. The first of these units has just been ordered by the *Indianapolis Power & Light Company*.

New RCA Field Force to Sell Police Radio

SALES engineers and service experts assigned to cover every section of the country are included in a new field force organized to merchandise *RCA* police radio and emergency communication equipment, according to Harry Mickel, in charge of *RCA* police radio sales. Heretofore,



such equipment sales have been handled by a field organization responsible for the sale of various other *RCA* products as well.

"The new representatives are associated with the District Sales Offices under the direction of Fred D. Wilson, Manager of Field Sales Activities," Mr. Mickel explained. "Their activities are coordinated with our installation and service engineers, enabling us to give the best possible on-the-spot service in every section of the country."

Aviation Radio

THE RCA AVR 15 Receiver is the result of over a year of engineering effort to design a receiver approaching the standards of airline equipment in performance yet small enough for easy installation in light aircraft.

The receiver is tunable over the radio range and weather broadcast band of 200 to 410 KCs, large specially selected knobs permitting easy



adjustment even with gloved hands. A switch is provided for instant change over to the traffic control frequency of 278 KCs.

Selectivity of the AVR 15 Receiver is of the unusually high order recommended by the *CMA* for proper reception from simultaneous radio ranges. Ample audio power, high input sensitivity, and a complete transmission line antenna system are a few of the other outstanding features of this excellent unit. Regardless of aircraft size of type of flying, the AVR 15 Receiver will prove an invaluable addition to the ship's equipment.

The electrical specifications are as follows: Circuit—Superheterodyne, with dual oscillator channel; Tubes—total 3, 2 6F7, 1 6K5; Selectivity—2.8 KC off resonance 25 DB down; Power input—with AVA 51—51A power supplies, AVA 15, 1.75 amperes at 12 volts D.C., AVR 15A, 2.5 amperes at 6 volts D.C. "B" drain approximately 25 milliamperes; Power output—better than 300 milliwatts into 600 ohm phones; Antenna Coupling—complete transmission line system for coupling to any properly constructed radio beacon antenna.

The mechanical specifications are: Construction and finish—heavy gauge aluminum case fitted with universal shock mounts. Case finished in durable grey cracked enamel. Front panel reverse etched aluminum; Approval—Approved by the Civil Aeronautics Authority for Airline Use. Price—AVR 15/15A Aircraft receiver complete with one set of tubes, one pair headphones, antenna transformer and transmission line and power supply cable for connection to A or B batteries or to AVT 15 Transmitter—\$99.50. AVA 51/51A vibrator power unit complete with vibrator and cable for connecting to AVR 15 Receiver—\$34.00.

THE RCA AVA-41 Antenna System is the result of a careful, scientific study of the many radio and aircraft operation problems involved and represents a distinct and outstanding improvement in retractable trailing antenna design.

The reel normally remains locked at all times due to a braking mechanism in the reel. Release of this brake is accomplished by a partial turn of the handle in a counter-clockwise direction. On release of the brake, while in flight, wire will be pulled from the reel by the specially constructed drag unit attached to the end of the antenna. Since a speed such as to maintain aircraft flight is necessary to furnish the required pull to unwind the reel, it is obviously impossible to foul the system by accidental release on the ground. Due to this non-fouling feature, the reel may be safely installed behind the ship's upholstery with only the counter and handle projecting within the cabin.

After the required number of turns have been released as indicated by the counter, the handle

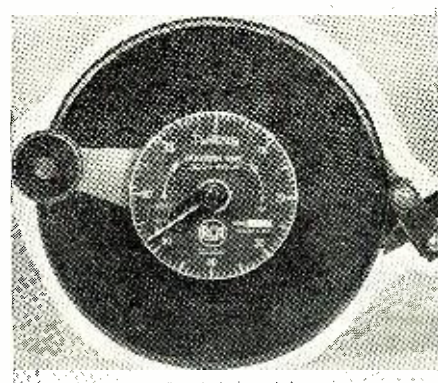

is released and returns to its original position automatically locking the reel. The wire is retracted by reeling it in, in the normal manner, the counter returning to zero as the wire is wound up on the reel.

The reel proper is 6 3/16 inches in diameter. From the rearmost face of its mounting plate to the counter face is only 2 5/16 inches. The handle protrudes 1 1/8 inches beyond the counter face and sweeps a radius of 3 3/8 inches. Loaded with the 100 feet of special phosphor bronze antenna wire which is supplied, this reel weighs only 2.5 pounds. This reel carries CAATC No. 226 permitting it to be used for scheduled airline operations.

THE RCA AVT-15 Aircraft Transmitter is capable of ample power output for any average aircraft communication requirement. The total weight of the entire installation is less than twenty-three pounds including a reel antenna system, and all accessories. The transmitter may be controlled either directly from the face of the unit or remotely by means of a small remote panel furnished at slight additional cost, thus providing extreme flexibility of installation.

Two crystals may be carried in the transmitter and the unit quickly switched and tuned to either frequency when accessible to the pilot in flight. When remotely installed, the transmitter may be tuned and locked on any one frequency between 2,500 and 6,700 kilocycles and turned off and on by means of the remote control unit. For most uses where transmission on one frequency only is necessary the AVT-15 provides

(Continued on page 50)

A S . . . SEE . . . !

by **JOHN F. RIDER**

Dean of the Servicemen

The author answers some criticism directed at signal tracing and his books.

Signal Tracing and Other Things

WE have read with mingled emotions of amusement and amazement some of the commentaries published in radio magazines concerning signal tracing. One in particular is very interesting, if we may call it that for the want of some other description. This is a letter from a serviceman in Miami, Florida, and appears on page 37 of the August issue of RADIO NEWS. The statement is made in that communication that signal tracing was brought to the attention of the radio servicing industry for the sole purpose of selling a book. The book referred to is well known, but what the correspondent apparently does not know is that the book did not make its appearance *until about 17 months after* signal tracing was first shown in a complete unit form in Chicago in June, 1938.

His analysis of the situation is somewhat erroneous in that the sale of books by publishers to the radio service industry never amounts to such proportions as to permit the formation of a complete manufacturing plant accompanied by a substantial investment approaching the upper limit of five figures and the sale of an instrument for a period of 17 months, *so as to sell a book*. That is too far-fetched for even a weak mind like ours.

Another implication made by this sagacious correspondent is that signal tracing cannot be good in view of the fact that we published in 1932 a book which explained the servicing of radio receivers by resistance measurement methods. According to him it seems inconceivable that anyone can propound an idea at one time and then seven years later come out with another which is claimed to be better than the first. He overlooks the fact that seven years ago resistance measurement as a means of locating defects was practical, as attested to by the fact that subsequent to the appearance of the book, many radio receiver manufacturers incorporated point-to-point and individual component resistance data in their service manuals.

The innuendo is made that perhaps seven years hence we might come out with some other idea or approach to the trouble localization problem. Maybe that is so, although it does not seem that way in the light of the acceptance of signal tracing, its successful application over the various frequencies up to the broadcast band and supplementary work which we have carried out at frequencies up to 70 megacycles.

But getting back to 1932, we plead guilty to one thing and that is being so stupid in 1932 as not being able to think of signal tracing. . . . Perhaps this can be excused on the grounds that being, at least we think we are, a normal human individual, we live and learn and profit by experience. But to say that the idea of resistance measurement in 1932 and the idea of signal tracing in 1938 were presented merely to sell books—really that's a little too much.

In fact this matter of being in the publishing business and also writing columns and articles for magazines has placed us on the spot more than once. We refrained from mentioning signal tracing to any extent during the time that one of our companies was producing the device which typified the system, but now that many different manufacturers are producing signal tracing apparatus and practically every issue of every magazine has something in it relating to signal tracing equipment, much of it home built, we feel more free to talk. Yet each time we start upon the subject there looms up the ogre of whether or not some people will construe such comments as being made solely to sell a book.

Is it a crime to write for magazines, express one's thoughts—convey to people making their living from radio service work, information as to what developments are in the field and still be in the publishing business? We have yet to hear that any of our jobbers or representatives approached servicemen with some lethal weapon in their hand and forced the sale of such publications. We have oftentimes made the comment that books can be obtained from any number of publishers and no matter where they were obtained, the important consideration was to get them and then study them! We make the same comment today and shall continue making those comments as long as editors of radio magazines will accept our written words and publish them. Furthermore, we shall present whatever ideas we believe to be sound and of value to the radio servicing industry and hazard the unjustified criticism that the sole purpose of the idea is to sell books. There is nothing in this world which prevents any one from writing books and most certainly nothing in this world prevented any one from writing a book on signal tracing during the 17 months that elapsed between the introduction of the idea and the appearance of that idea in the book.



John F. Rider

We can accept without any feeling and with an open mind any negative comments concerning any one idea which we may present to the servicing industry, but we reserve the right to respect such negative comments only when they come from people who say that they have tried the idea and found it lacking in capabilities—or at least have made a sound, critical scientific analysis of the idea. But to malign something which has proved itself and which, as we have stated before, will first show its tremendous advantages, by casting aspersions upon the motives behind a statement, cannot be taken with good grace. The comments referred to reflect upon the sincerity of this column and that is something which we cannot let pass unnoted.

Returning again to signal tracing, we find it necessary to pass comment upon some of the devices suggested for home construction by servicemen. This does not mean every one of the signal tracing units built by servicemen, but some which have appeared in different magazines. Apparently some of the important functions of the

(Continued on page 52)



"No, Miss Glamoure, my husband can't come. . . . But I'll send his helper!"

CAPACITY TESTER

by **R. K. WHEELER**

Indianapolis, Indiana

Although this is really an AC-DC bridge, its uses are many.

It can measure all capacities from 10 mmfd up to 100 mfd.

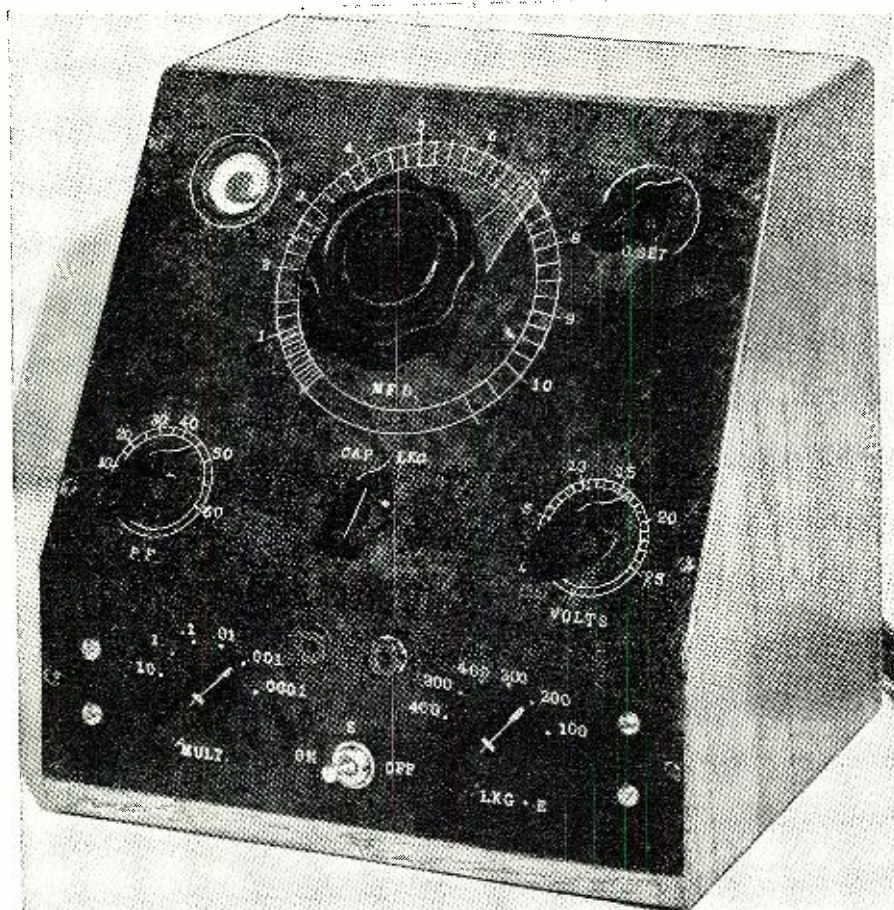

The instrument will measure capacities; test for leakage up to 200 megohms.

ALTHOUGH to many young radio men, the word Bridge has a magic sound, it is typical of many small shops that the capacity bridge is one instrument that is generally among the missing. The problem of calibration is often a strong deterrent to the experimenter and home-constructor, and since many men gain experience and pleasure from the construction of test instruments, the following article will describe the construction and simplified calibration of

a practical capacity bridge that will be suitable for general service work.

The unit presented consists of an a.c. bridge with a single linear capacity scale, that measures capacity in six ranges from 10 mmf. to 100 mfd., and includes a means of measuring the power factor of electrolytic condensers, up to 60%. Provision is also made to test paper and mica condensers at 400 and 200 volts for leakages up to 200 megohms; and electrolytic condensers at 400, 300, 200 and 100 volts,

FAMILIARITY with test instruments is a prerequisite for any serviceman, ham or engineer. One of the best ways to understand an instrument, is to build it yourself. This capacity tester—in reality an AC-DC Bridge—will not only enable you to test condensers but will also make the "bridge problem" entirely clear to you. All radiominded persons should know as much as is possible about all phases of radio. Do not neglect the test instrument. Our **National Defense Plans** will require many trained men in all angles of radio. Train yourself, and be one of those who can—if called—turn to and help. This somewhat less blatant form of patriotism might help more than all the "flag-waving" in the world.

for leakage resistance up to 2 megohms. A 6E5 tube is used as a balance indicator, and the sharpness of the null setting on all ranges is greatly increased by the use of a 6SJ7 as an amplifier before the 6E5.

The usual capacity bridge consists of two resistance arms, which are varied by different methods, and two capacity arms, one of which contains one or more fixed capacities as standards, the other arm being completed by the introduction of the condenser to be measured. In some commercial models the resistance arms are often obtained by the use of a single potentiometer, the setting of the slider determining the amount of resistance in each arm. It will be seen that as the slider is moved away from the center point of the resistance strip, the resistance added to one arm will be subtracted from the other, which results in a non-linear scale, with the settings becoming increasingly critical as the slider approaches either limit of the scale. The calibration of such a scale may be made satisfactorily in commercial laboratories, but is not attractive to the average experimenter with limited facilities.

In the instrument shown, calibration is simplified, and a linear scale produced, by the following method. The ratio arm of the bridge is composed of a number of fixed resistances, one of which is selected by switching, and the variable arm is a 10,000-ohm wire wound control. To calibrate the scale, only a reliable ohm-meter is required, the resistance being measured in 1,000-ohm steps, and the scale marked accordingly from 1 to 10. The builder should not accept the farthest rotation to the left as zero setting, as such is not likely to be the case. The first major division from 0 to 1 should be sub-divided in ten 100-ohm steps, which will facilitate closer readings in that portion of the scale. The space between the 100-ohm setting and the zero mark should be approximately the same as the spacing between the other 100-ohm divisions. When the final assembly is made the control

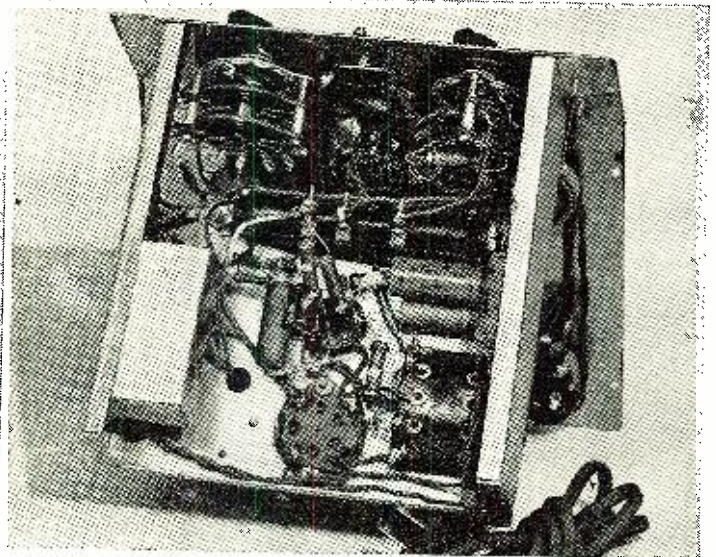
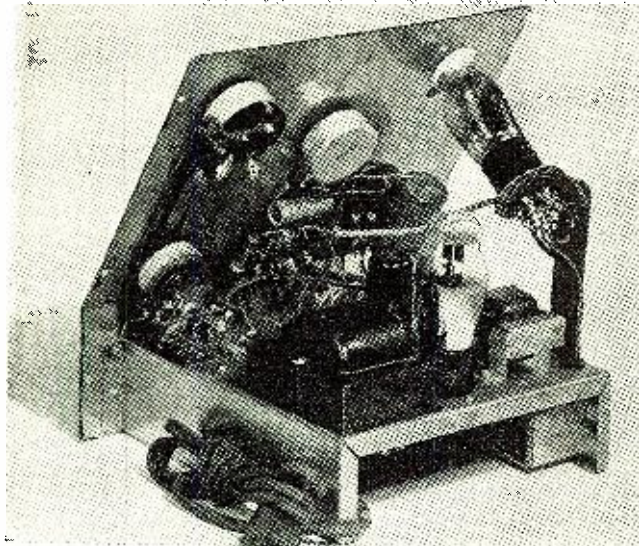

The sloping panel makes the instrument easier to read. Note compact construction.

should be set at 100 or 200 ohms by measurement, and the pointer knob fastened in line with the correct calibration point. Be sure that the multiplier is in the $\times .1$ position to avoid errors that would be present if the control was shunted by the lower resistances in the other positions.

In order to cover the wide spread required, six ranges are provided by switching, which selects the proper combination of fixed resistor and standard condenser for each range. Only two condensers (1 mf. and .001 mf.) are used as standards, and three fixed resistors (100; 1,000 and 10,000 ohms) are used in the ratio arm. This assembly forms the multiplier, and the associated dial is marked with the resulting factors. In the first three positions, the 1 mf. condenser is in the bridge circuit as a standard, and the resistors are connected in the following order: $\times 10$ —100 ohms; $\times 1$ —1,000 ohms, $\times .1$ —10,000 ohms. In the next three positions the .001 condenser is inserted in the circuit, and the resistors connected as follows: $\times .01$ —100 ohms, $\times .001$ —1,000 ohms, $\times .0001$

—10,000 ohms. When wiring this assembly the builder should keep in mind that the larger the capacity, the smaller the impedance will be.

The control for measuring power factor is a 2,000 ohm variable wirewound resistor installed in series with the standard condensers. This control is somewhat larger than necessary and tends to crowd the scale at the points of most interest—i.e. from 0 to 30%. A 1500-ohm control would be somewhat more preferable, as the scale would be spread more, and power factor would be indicated to approximately 50%. The total resistance of this control may be as low as 1,000 ohms (a stock size), which will allow measurements up to approximately

35%. To enable the constructor to calibrate the scale for any control selected for this service, the method of calculation is detailed. By definition power factor (P.F.) = R/Z , that is, the a.c. resistance divided by the condenser impedance. In an impedance triangle $R/Z = \cos \theta$. From this information the amount of resistance to be added in series with the 1 mf. standard, for any given power factor, can be determined by simple trigonometry. The relation between R and X_c , the condenser reactance, can be expressed $R/X_c = \cot \theta$; therefore, $R = \cot X_c$.

For example, P.F. 50% = $\cos 60^\circ$, and $\cot 60^\circ = .5774$. In this case assuming X_c to be 2650 ohms, the series

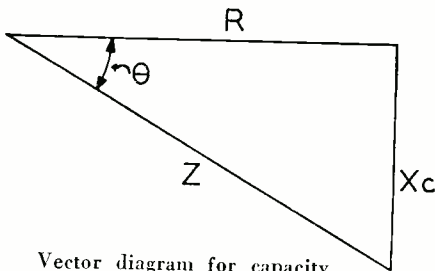

Vector diagram for capacity.

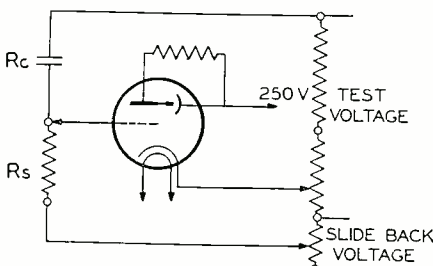

Fundamental leakage test circuit.

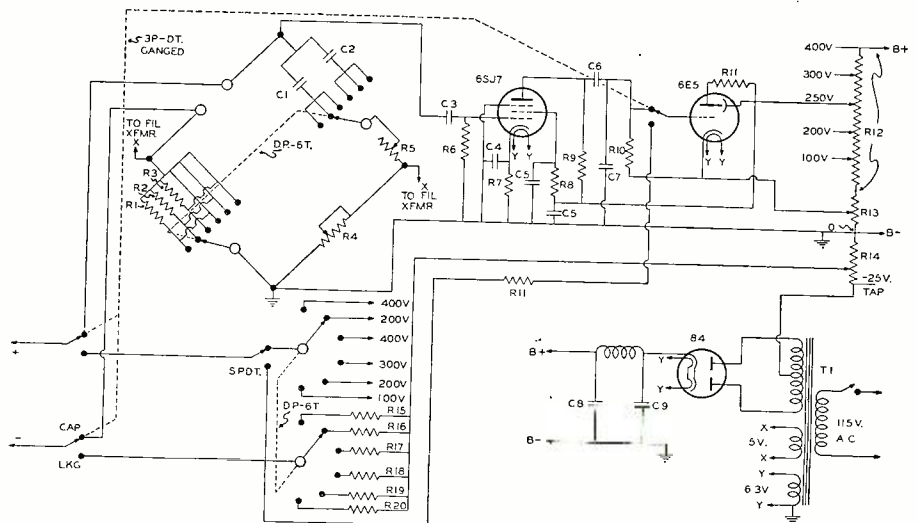

- R₁—100 ohms, 1 w. Wirt
- R₂—1,000 ohms, 1 w. Wirt
- R₃—10,000 ohms, 1 w. Wirt
- R₄—10,000 ohm pot. Mallory
- R₅—2,000 ohm pot. Mallory
- R₆—500,000 ohms, 1 w. Wirt
- R₇—1,000 ohms, 1 w. Wirt
- R₈—1 megohm, 1 w. Wirt
- R₉—250,000 ohms, 1 w. Wirt
- R₁₀—1 megohm, 1/2 w. Wirt
- R₁₁—1 megohm, 1/2 w. Wirt
- R₁₂—30,000 ohms, 10 w. with sliders. Ward-L
- R₁₃—1,000 ohm pot. Mallory
- R₁₄—2,500 ohm pot. Mallory
- R₁₅—250,000 ohms, 1 w. Wirt
- R₁₆—500,000 ohms, 1 w. Wirt
- R₁₇—2,500 ohms, 1 w. Wirt

- R₁₈—3,333 ohms, 1 w. Wirt
- R₁₉—5,000 ohms, 1 w. Wirt
- R₂₀—10,000 ohms, 1 w. Wirt
- C₁—1 mfd. 600 v. paper. Sprague
- C₂—.001 mfd. mica. Sprague
- C₃—.05 mfd. paper. Sprague
- C₄—10 mfd. 25 v. electro. Sprague
- C₅—.1 mfd. 400 v. paper. Sprague
- C₆—.05 mfd. 400 v. paper. Sprague
- C₇—.05 mfd. 400 v. paper. Sprague
- C₈—8 mfd. 450 v. electro. Sprague
- C₉—4 mfd. 600 v. electro. Sprague
- CH₁—20 hy. filter choke. Thordarson
- T₁—Pri. 115 v. 50-60 cycle. Sec. 325-0-325 v. @ 40 ma. Sec. 5.0 v. @ 3 amps. Sec. 6.3 v. @ 1 amp. Thordarson

resistance for a power factor of 50% = $2650 \times .5774 = 1529$ ohms. The values for other percentages P.F. are as follows:

P.F. (cos)	θ	cot	R
.50	60°	.5774	1529 ohms
.40	66.4°	.4369	1158
.30	72.5°	.315	835
.20	78.5°	.2035	539
.10	84.3°	.101	267
.05	87.1°	.05	133

This control is only effective on the first three ranges, that is, when the 1 mfd. condenser is used as a standard. The remaining three ranges are used for the measurement of small paper and mica capacities, whose power factor is ordinarily negligible, being considerably less than 1%.

To test condensers for capacity, the three-pole double-throw switch is turned to the "Cap" position, which connects the input jacks to the bridge, and the 6E5 tube to the output of the amplifier. The multiplier is set for the expected range, and the pointer knob of the capacity scale rotated until the target pattern of the 6E5 is at its widest opening. When electrolytic condensers are being tested the edges of the pattern will not be clear, and the P.F. control should be advanced until the opening is at its best. In the case of paper and mica condensers, the opening should be full 90°, and the edges of the illumination should be sharp and clear. If the edges of the pattern are not sharp, this indicates the presence of series resistance, generally due to faulty internal connection in the condenser. It is not possible to make a general statement regarding power factor of electrolytic condensers that will hold good in all cases. However, as a rule, the operator may expect power factors of 5 to 10% in the case of dry electrolytic condensers, and around 20 to 25% in the case of wet condensers.

The leakage tester is one that was described in detail in an earlier issue of *Radio News*. While the circuit is a d.c. bridge, in effect leakage resistance is measured by operating the 6E5 as a slide-back voltmeter, and measuring the voltage drop across a selected resistor in series with the condenser being tested.

To operate the unit shown as a leakage tester, the three-pole double-throw switch disconnects the input jacks from the bridge, connecting the positive jack to the test voltage deck of the leakage range switch, and the negative jack to the resistor deck of the same switch. The grid of the 6E5 is switched at the same time from the output of the amplifier to the common terminal of the series resistor deck. The fundamental circuit of this arrangement is shown in the accompanying diagram.

The 2500-ohm slide-back voltage control should be set at zero, and the target pattern of the 6E5 should be closed by adjusting the "0 Set" control, which is a 1,000-ohm potentiometer.

(Continued on page 59)

MIKES-HEADS-P CKUPS



Manufacturer's Specifications

Make: Audak Company, 500 Fifth Ave., New York.

Model: H-3.

Type: Magnetic.

Range: Substantially flat to about 7,500 cycles.

Stylus required: Standard short-shank steel, sapphire, or stellite.

Distortion: About 5.25% at 100 cycles and 1.95% at 1,000 cycles.

Input Level: Fully modulates groove with input of 16 db with 96 lines, and 14 db with 112 lines per inch (ref. 006W).

Impedance: Available in any impedance up to 4,000 ohms.

Drive: Magnetically powered.

Stability: Characteristics not affected by climatic changes.

Description

Models H-2, H-3, H-4 Audak cutting heads have been designed for applications that require accurate cutting of instantaneous recording discs with a minimum of distortion. They are suitable for Broadcasting Stations, Recording studios, in fact—wherever quality recording is required. Designed to fit standard mounting brackets they lend themselves admirably as replacement heads for existing equipment.

These heads will withstand greater peak voltages without distortion than previous models due to improvements in design and construction. The Model H-3 has been used in our laboratory for some time with excellent result on a *Presto 6D* transcription table. Most of the cutters used previously were not able to handle heavy audio peaks without some distortion resulting.

Magnetic cutters of the low-cost variety are subject to distortion when the normal cutting level is exceeded. The better units, due to both mechanical and electrical construction, possess the ability to handle these peaks before they reach the point of possible distortion. In other words—the more we spend for a magnetic cutting head, the greater will be the range, and the distortion percentage will be reduced accordingly.

The audio range that may be handled by the cutter depends upon the quality of material, the general design, the quality of workmanship, and the care used to adjust the cutter armature. All of these are important factors. Inasmuch as the cutter described falls into the better grade of merchandise it was reasonable to expect that the results attained would be highly satisfactory.

Test cuts were made under various conditions and with various discs. Response was

measured by the following procedure: A tone record was cut using an audio oscillator which was fed into the amplifier and cutter network at definite frequencies. These included frequencies of 40, 100, 200, 300, 400, 500, 1000, 2000, 2500, 3000, 3500, 4000, 5000, 6000, 7000, and 8000 cycles. These were chosen so that no sharp peaks would be overlooked and a false indication indicated.

A calibrated pickup amplifier, and output meter were used in conjunction with an *Audiotone 78-1 Test Record*. A curve was plotted with the above setup and this was compared with the disc cut from the audio oscillator. The difference in the response between the two represents the discrepancy of the test record and the characteristics of the *Audiotone* standard.

The amplifier used is substantially flat over the entire audio range that is commercially used. The comparative results shown by the test indicated that the cutter was very capable of full modulation up to 7500 cycles. No doubt the Model H-4 cutter would be able to increase this to its rated response to over 9000 cycles.

The cutter used has an impedance of 500 ohms which is matched to the output of the amplifier with a high-quality transformer. This transformer must be able to deliver power to the cutter without distortion if the full capabilities of the cutter are to be realized.

The discs used ranged from the most inexpensive "paper-based" variety to the finest transcription discs. The response measurements must be made with a high-grade disc such as the *Audiodisc* that is used daily in many broadcast stations. Even the very cheap discs were cut with excellent results at both standard speed of 78 rpm. and at transcription speed of 33 $\frac{1}{3}$ rpm.

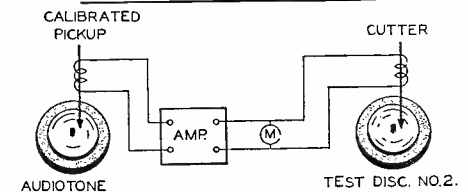
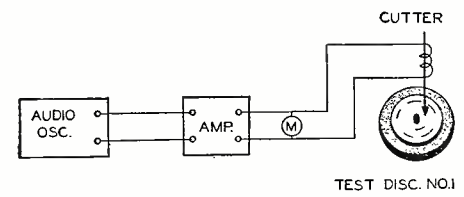

Two ways—with an oscillator, and with a disc—to cut test records.

Remarks

Most magnetic cutters used in the past few years did not have a flat response characteristic. The main fault was in the method used to damp the armature. In order to respond to a wide range of frequencies with more-or-less constant modulation it is necessary to employ means for centering the armature (damping) which will not upset the response. This is accomplished in several ways. In any case the most important factor is the care used in making these adjustments. The finest cutter or pickup can introduce serious distortion if these adjustments are not made properly. We then realize that a certain amount of care is required in making use of these instruments. For example—the cutter can be ruined by shock, or the magnet be made weak by taking the head apart and failing to employ a "keeper" across the two pole-pieces. Furthermore—the centering of the armature can be upset by hitting the side of the cutting stylus on the edge of the turnable. Intelligent use of the cutter will result in many years of satisfactory service.

Ring the Bell

How to cash in on an additional source of income from an authorized A-R agency.

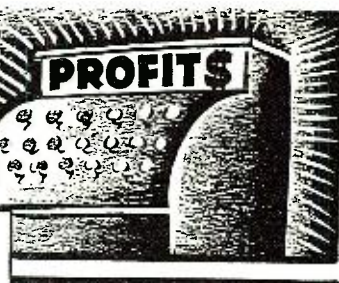

by **SAMUEL C. MILBOURNE**
Expert Serviceman, Greenwood, Miss.

▼ HERE are many service men who are missing extra dollars every month because they do not know how to get them. These extra dollars are sure-fire and payable monthly by check. Their acquisition requires no additional advertising except, possibly, an additional line in the regular ad. What is the source of this additional cash?

Manufacturer's Authorized Auto Radio Service franchises.

To those of you who have one or more of these auto radio franchises, their value as "business-getters" and "pot-boilers" is well known. To those who are not familiar with their "workings," we offer an explanation.

Manufacturers of auto radios used as standard equipment on new cars must guarantee these radios to the new car buyer. The guarantee is usually on a 90-day basis. If the radio gives trouble during this period, the car owner returns the car and set to the car dealer who refers the car owner to the nearest authorized service station for the particular make auto-radio. The authorized service station (usually an independent service man in the locality) removes the car radio, repairs it and replaces it on the car.

The usual allowable charges for such work are \$1.00 for removing and replacing the radio (to be paid by the car-radio owner), 75 cents for a minor repair, and \$1.50 or \$2.00 for a major repair (to be paid by the auto-radio manufacturer). Faulty parts are re-

turned to the nearest auto-radio distributor for replacement.

At first blush, the allowable repair charges seem too little to make a normal profit, but, in practice, they are quite ample.

For instance, if the authorized service station removes, repairs and replaces the radio, a minimum of \$1.75 and a maximum of \$3.00 is received for the service. The radios are all new and confined to a few models. Troubles are usually found easily because they are representative of each model. Broken wires, bad vibrators and defective tubes form the majority of these repairs.

Having the authorized service on one or more makes of auto-radios also opens additional fields of income for the wide-awake service man.

For instance, there is the matter of auto-radio installations. Arrangements can be made with the auto dealer to take care of his auto-radio installation work—work that probably would not be available to the service man without the authorized service hook-up. The price for such work will vary with the locality, of course, but \$3.50 to the individual with a discount to the auto dealer is being used by us with complete satisfaction. This includes removing engine noise—but all parts (such as suppressors) are billed extra, and at regular list to the individual.

Also, there is the additional field of auto-radio repairs which are outside the 90-day guarantee. Here again, much additional business is obtained through the car dealer. If a discount is given the dealer on this work, the dealer will be encouraged to act as a "salesman" for the service man.

In some cases, the car dealer takes care of his own installation work, but does not have facilities for setting up the push-buttons on the radios or for chasing down motor noise if it develops in a particular installation. This can be done also by the service man at fixed prices.

Another advantage of having an Authorized Service franchise on auto-radios of a particular make is that owners of home radios of the same make are often so persuaded to deal with you. In other words, if you are authorized to repair *Blank* auto-radios and you advertise this fact, not only will owners of *Blank* auto-radios come to you for repairs, but owners of *Blank* home radios will come also. The reason is two-fold. Those who read the advertisement carefully and understand that the authorization applies to auto-radios only, will patronize you because they feel that if the company who made their home set trusts you

enough to make you an authorized service man for the auto-radio the company makes, the home set owners can feel confident that you will treat them correctly. Those who do not see the "auto" qualification will merely assume that the authorization is for all model sets of that particular make and patronize you anyway.

You ask, "How can I obtain this additional income to *Ring the Bell*?"

Your plans should be laid carefully as on them may depend the success or failure of your efforts. Remember that what you have to put over is a *selling campaign*—first to the car dealer and, second, to the auto-radio manufacturer. To plan a successful selling campaign you must know certain facts and we will discuss these now.

Obtain a telephone book or a city directory and copy the names of all car dealers appearing in it. If the city is large, concentrate on those within a normal business radius of your shop. If the shop is located in a very small town, it may be necessary to include names of dealers in surrounding towns. A list of from six to one dozen names should suffice. Find out the make car or makes of cars each dealer sells and what make or makes of radio each uses. Also, find out the owner's or manager's name, the name of the sales manager and that of the service manager.

The next step is dependent upon local conditions. It is quite likely that you know one or more men in each dealer's organization. If so, go see them first, explain your reason for visiting them and ask their help. The first thing you must know is how the auto-radio service is being handled at

DEALERS NAME	ADD.	PHONE	CAR SOLD	MAKE RADIO	OWNER	SALES MGR.	SERV. MGR.	REMARKS

Auto radio repair chart.

ZENITH WARRANTY SERVICE REPORT No. 116317

Name of dealer: _____
 Name of owner: _____
 Make of car: _____
 Make of radio: _____
 Model of radio: _____
 Description of work done: _____
 Date of work: _____
 Name of service man: _____
 Signature: _____

A type of warranty service report.

WARRANTY REGISTRATION

6-M-390 FORD Z 000000
 AUTO RADIO

Name: _____
 Address: _____
 City: _____
 State: _____

A type of auto radio registration.

Zenith Warranty Replacement

Date: _____ Serial No. _____
 PRINT SERVICE STATION NAME _____
 ADDRESS _____
 CITY _____ STATE _____

A type of warranty replacement card.

the present time. That is, whether all service is furnished by a service man who works for the dealer or whether it is handled through some outside source. In either case it would be well to meet the manager of the auto dealer's service department, lay your cards on the table, and see what he has to say. Find out if the present service is completely satisfactory. If so, the best you can do is bow out gracefully, leaving the thought that in the event conditions change, you would be happy to serve them.

In certain cases these men whom you are to contact will be members of the same local club, church or civic organization as you. Cultivate their acquaintance and friendship. You will get a kick out of knowing them in purely a personal way, aside from any resulting business you expect to get from them.

If possible take them to your shop and show them what you have to offer. It goes without saying that you *should* have something to offer and a good local business reputation.

One cautionary point. If you haven't a reputation for *fast, accurate* radio service it might be well to save your breath until you work up a "rep." Automobile dealers expect you to give their customers the same fast, accurate service on their auto-radios as the dealer's repair shop gives on automobile repairs. They won't ordinarily take a chance on you unless they have heard some several recommendations of your service.

Having found out the possibilities of getting the authorized service business in each place, you must then sit down, pick out the two best prospects and concentrate on them—not forgetting the others. Make a bi-monthly visit to each. Sooner or later you may get the "break" you are looking for.

It may be that the dealer has no authorized service set-up on auto-radios or he may be sending it to another town. If so, your job is to convince him that it would be worth his while to have such service right in his own home town.

Next, you must write the Service Manager, Auto-Radio Department of the automobile company. If they do not handle this themselves, they will advise you the correct company to which to write. For instance, the Ford Motor Company uses both Zenith and Philco auto-radios. There is no such thing as authorized service for Ford radios, as the auto-radio manufacturers each handle their own guarantee. Thus, to obtain authorized service on *all* auto-radios in Ford cars, you must get authorized service franchises from both *Zenith and Philco*.

All automobiles (to the best of our knowledge) manufactured by United Motors use a United Motors radio, but each radio bears the name of the car for which it is intended. Also, with the exception of United Motor jobbers, no one can get a blanket auto-radio service franchise to cover all United Motor cars—each name car in this group has its own auto-radio service set-up.

Now, let us assume that you have obtained a franchise to do authorized service work on a particular make of auto-radio. Your next step is to become familiar with all the current

(Continued on page 45)

SERVICEMEN'S LEGAL ADVICE



BUSINESS is that which occupies the time, attention and labor of men for the purpose of a livelihood or profit. Generally, it may be said, there are three ways in which to conduct business, individually, as a partnership and as a corporation.

The status of an individual in business needs no elaboration upon the definition set forth above. If two or more persons associate to carry on as co-owners a business for profit, a partnership then comes into existence. The third way of doing business is under the corporate form. A corporation has been defined as an artificial person created by law as a representative of those persons who contribute to, or become holders of shares in the property entrusted to it for a common purpose.

No particular form of contract is necessary to create a partnership. The contract may be oral or written, expressed or implied. The essence of the partnership contract is the association of parties in the carrying on of trade for their common benefit and with their mutual contributions of money, property and services. The partnership business must, of course, be within legal bounds and not contrary to public policy. A partnership may be formed for a single transaction such as for the joint purchase and sale of one piece of property or of a parcel of land. As a general rule, in order to constitute a partnership, it is essential that the parties concerned have a community of interest as common owners of the business which constitutes the joint undertaking. The contribution of the partners need not necessarily be money or property, but may consist of services or skill. An agreement to share the partnership profits is an essential element of the relationship. Partners are presumed to have equal interests in the firm, but partnership contracts may be made providing for unequal interests.

All property originally brought into the partnership or subsequently acquired, by purchase or otherwise, on account of the partnership, is partnership property. Unless the contrary intention appears, property acquired with partnership funds is partnership property and any estate and real property may be acquired in the partnership name. Title so acquired can only be conveyed in the partnership name.

Every partner is an agent of the partnership for the purpose of its business and the act of every partner, including the execution of the partnership name to any instrument, binds the partnership,—unless the partner so acting has in fact no authority to act for the partnership in the particular matter, and the person with whom he is dealing has knowledge of the fact that he has no such authority. An admission or representation made by any partner concerning partnership affairs is evidence against the partnership. Where, by any wrongful act or omission of any partner acting in the ordinary course of the business of the partnership, or with the authority of his co-partners, loss or injury is caused to any person, not being a partner in the partnership, or any penalty is incurred, the partnership is liable therefor to the same extent as is the partner so acting or omitting to act.

The liability for a partnership "wrong" is joint and several in the unrestricted sense of that term, so that the person injured may proceed against such of the partners as he may desire.¹ *One partner can bind the other to the last penny of his personal fortune.* Where, for instance, one partner acting within the scope of his apparent author-

ity receives money or property of a third party and misapplies it, the partnership is bound to make good the loss. Where the partnership in the course of its business receives money or property of a third person and the money or property so received is misapplied by any partner while it is in the custody of the partnership, the partnership is also bound to make good the loss.

A partnership may be dissolved by the termination of the definite term or particular undertaking specified in the partnership agreement. It may also be dissolved by the express will of a partner when no definite term or particular undertaking is specified, or by the express will of all of the partners who have not assigned their interests or suffered them to be charged for their separate debts, either before or after the termination of any specified term or particular undertaking. The death of a partner may also dissolve a partnership, as may the bankruptcy of a partner. Also, a partnership may be dissolved by a decree of a court, such as where one partner has been declared to be of unsound mind or in any other way incapable of performing his part of the partnership contract, or where a partner has been guilty of such conduct as tends to affect prejudicially the carrying on of the business or where one partner wilfully or persistently commits a breach of the partnership agreement or otherwise so conducts himself in matters relating to the partnership business that it is not reasonably practical to carry on the business partnership with him.

From the foregoing, it has been seen, that one partner has the power to bind another partner. It has also been observed that death dissolves the partnership. These are two of the obvious disadvantages of doing business as a partnership. A corporation on the other hand may be perpetual. Some well known American corporations were formed over a century ago. Their founders having long since passed away, but the businesses as originally created by them have continued to live on. This is one advantage of doing business in the corporate form. In the event of a death of a shareholder of a corporation, the shareholder's share may be left to his widow or some other member of his family. Another advantage is the limited liability which the corporate form of doing business affords the shareholders. A shareholder is liable only to the extent of the shares which he holds in the corporation.

Usually, three or more persons may become a stock corporation for any lawful business purpose. The three or more persons desiring to form a corporation subscribe, acknowledge and file a certificate which sets forth the name of the proposed corporation, the purpose for which it is to be formed, the amount of the capital stock and the number and par value of the shares of which it is to consist. If the shares are to be classified, the number of shares to be included in each class and all of the designations, preferences, stock privileges and voting powers of the shares of each class and restrictions or qualifications are set forth in the certificate. The location of the principal office of the corporation, designating its address, is set forth in the certificate, as is the corporation's duration. The number of directors is also set forth, the minimum not usually being less than three. Also, the names and post office addresses of the directors until the first annual meeting of the stockholders is set forth in the certificate. The name and post office address of each subscriber of the certificate of incorporation is set forth in the certificate and a statement of the number of shares of stock which he agrees to take is also set forth. For instance in New York State, all

(Continued on page 64)

¹ Roberts v. Johnson 58 N.Y. 615.

² Stock Corporation Law, Sec. 5.

³ Brock v. Poor—216 N.Y. 387.

Poorman's High Fidelity Receiver

by JAMES FULLEYLOVE

Port Washington, New York

A nice high-fidelity receiver for the man who cannot afford to spend a whole lot for parts. It is easy to construct.

JUDGING by the majority of magazine articles to be read on the subject of high-fidelity broadcast receivers, one is very apt to get the impression that high fidelity and high cost go hand in hand, inseparably. Fortunately, this is not the case. If one is willing to go without the numerous gadgets usually associated with the modern hi-fi receiver but which really contribute more to ease of operation than quality of reproduction, he can build a set like the one described for as little as \$12 and still enjoy reproduction equal in quality to that of commercially built sets costing from four to eight times as much.

Upon first glance at the circuit, the reader will probably be struck most by its simplicity; for this was the theme kept in mind throughout its design. The single t.r.f. stage provides just the right amount of selectivity to separate broadcast stations 10 kc. apart and yet pass sufficient side-bands to insure good high-frequency response. There is not an over-abundance of sensitivity, but quite enough for good reception of local stations. This is not supposed to be a DX receiver.

In the interests of good bass response, it is important to use large bypass and coupling condensers in the audio section. Due to the presence of the push-pull output stage and the phase-inverter, no audio voltages are present at the cathodes of these stages, and consequently no bypass condensers are needed here. There is, however, a large audio frequency voltage built up across the detector bias resistor, and a 25 mfd. condenser is imperative for adequate bypassing at this point. As for the coupling condensers, a larger capacity than .05 mfd. does not seem to warrant itself.

The adjustment of the phase-inverter is quite simple; and while the use of a v.t. voltmeter or oscilloscope will give the most accurate results, a pair of headphones will do quite well. Simply connect whatever you have across first R12 and then R13, with some sort of steady signal applied to the amplifier input; and adjust the slider on R12 until the voltage across each resistor is the same, as indicated by the sound in the headphones, the reading of the meter, or the 'scope.

This condition indicates that the grid of the inverter section of the 53 tube is receiving the correct fractional part of the output of the amplifier section (equal to the reciprocal of the μ of the tube), so that no more amplification takes place, but only phase reversal; and the grids of the 45's receive exactly the same voltage, but in opposite phase. The signal used for this adjustment may come from any of a number of possible sources, such as a beat frequency audio oscillator, a

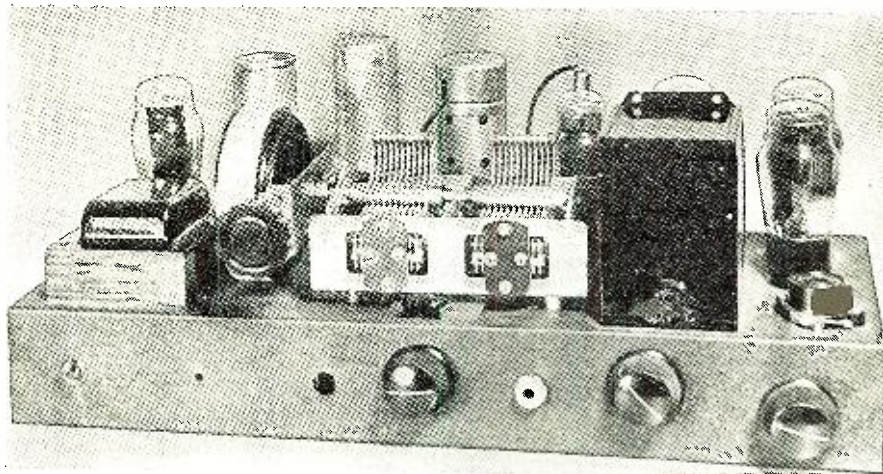

The panel is left off. The reader may use his own ideas on that.

code practice oscillator, a constant-note phonograph record, or the low voltage secondary of a transformer connected to the a.c. line; all of which should be connected in through the phonograph jack.

The loudspeaker is, without doubt, the biggest problem in an installation such as this where quality reproduction and low cost are both important factors. There is no possible substitute for a good loudspeaker; and, on the other hand, a good speaker can

very rarely, if ever, be bought cheaply. Probably the best advice one can give on this point is: "Spend the most you can afford." In this case, the cost of the receiver itself is so low that you should feel justified in spending a reasonable amount on the speaker. It will be worth it in added enjoyment.

In any case, the speaker should be a 10" or preferably 12" dynamic, and should be mounted in as large a baffle as is practical. And, incidentally, this

(Continued on page 61)

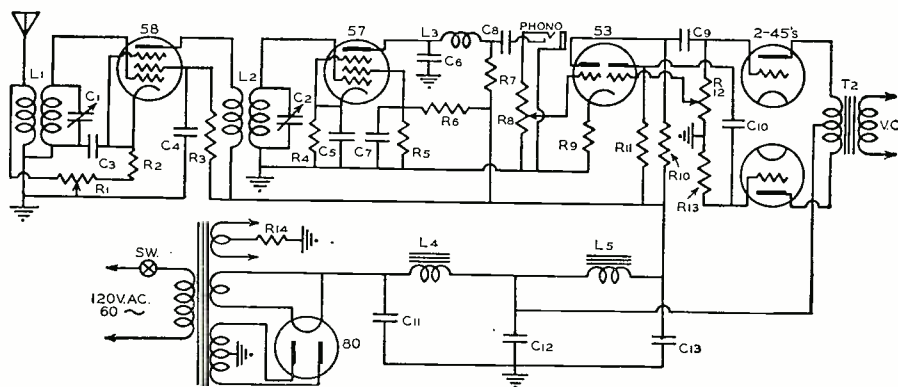

L₁, L₂—Antenna and interstage coils. Meissner.
L₃—85 mhy. rf. choke. Hammarlund
L₄, L₅—30 hy. filter choke. Kenyon
C₁, C₂—2-gang, 350 mmfd. variable. Reliance
C₃—.1 mfd. 200 v. paper. Aerovox
C₄—.01 mfd. 400 v. paper. Aerovox
C₅—25 mfd. 25 v. electro. Aerovox
C₆—.5 mfd. 200 v. paper. Aerovox.
C₇—100 nmfd. mica. Aerovox
C₈, C₉, C₁₀—.05 mfd. 600 v. paper. Aerovox
C₁₁, C₁₂, C₁₃—8 mfd. 450 v. electro. Aerovox
R₁—25,000 ohms pot. Centralab
R₂—400 ohms, 1 w. Centralab

R₃—50,000 ohms, 1 w. Centralab
R₄—10,000 ohms, 1 w. Centralab
R₅—50,000 ohms, 1 w. Centralab
R₆—100,000 ohms, 1 w. Centralab
R₇, R₈—500,000 ohms, 1 w. Centralab
R₉, R₁₀—500,000 ohms pot. Centralab
R₁₁—2,000 ohms, 1 w. Centralab
R₁₂—100,000 ohms. Centralab.
R₁₃—750 ohms, 10 w. Ohmite
T₁—Pri. 115 v. 60 cycles, Sec. 650 v. ct., 5.0 v.
2 A., 2 1/2 v. 7 A.
T₂—Output trans. on speaker
J₁—Closed-circuit jack

Serviceman's Experiences

by LEE SHELDON

Chicago, Illinois

It will pay the serviceman to figure out exactly what a repair job will cost before giving estimates.

"S it by coincidence," my partner asked one morning last week, "that the three sets you brought in yesterday each carried charges of six dollars and fifty cents?"

"Nice little clip of work," I commented, seeing danger signals ahead, and trying to switch his train of thought.

"Could be nicer!" Al snapped. "I'll bet you didn't find out what was wrong with them before you picked them up!"

"What's the difference?" I shot back. "I got the jobs, didn't I?"

"Sure," Al admitted, "but they shouldn't all go for six-fifty. The three of them—*Bosch*, *Brunswick*, and *Victor*—were the sort of old a.c. console jobs their owners always want to keep. According to my bench record, one of the jobs should have carried about five dollars; the second, about ten; and the last one could have been fixed in the house for a minimum of two-fifty."

"What's wrong with that?" I questioned. "Your total for the work is two bucks lower than mine! Besides, you know as well as I that there isn't any part in any of those three sets that costs us anything like \$6.50!"

"Even then," Al replied, "you should have examined the work thoroughly before you bid on it. If you don't the customer senses, by some mysterious power, that you don't know what's wrong with the set any more than he does. You have no more chance of concealing the fact than you have of concealing a grapefruit on a billiard table."

"I was in a hurry," I said, assuming the defensive—my usual position when my partner gets warmed up. "I just unbolted the chassis, told the customer what it would cost, and left the house. I still say it was good, fast work whether or not"

"Another thing," Al continued, as if I hadn't spoken, "a customer is always impressed when you are willing to spend time for a complete examination before you talk business. It gives him the feeling he is paying exactly what he should pay for: the particular thing that's wrong with his individual set. A thorough analysis lets him understand the seriousness of the fault,

and shows him how much skill and time you must use in getting it back to normal for him."

"Wait a minute, Al," I interrupted, "I got all three—"

"Another factor enters into a situation like that," Al went on, as if he were alone. "In cases when the customer contests your price, it is much better to know what the job will cost you. The natural tendency of most servicemen is to bid too low, thinking it is bordering on burglary to charge

assured I'll treasure them. I'd keep them over my heart—if my hip pocket was big enough!"

"Don't be flip," my partner chided. "As long as we earn our living as radio repairmen, we might as well do it properly. You especially, as outside man, should know how to handle every situation from the hello to the highball. Next time, use your head!"

I delivered all three sets the following day, and their owners were satisfied. As a result, I knew my method of quick pick-up was the right one, no matter what my pseudo-senior partner said about it.

That evening I answered a call on a *Majestic 90*. Everyone knows it's the filter block that goes west on these sets, and I made up my mind to "prove-in" my grab-and-run tactics to Al, using the *90* as a test case.

I strode into the customer's house and cut short his explanation of the set's performance.

"Mr. Spencer," I announced, pulling the cabinet from the wall, and putting one arm on top, "it will cost you exactly \$6.50 to have this set repaired, and I can deliver it Friday."

"That was quick work," he replied. Then, turning to his wife, he asked: "What do you think—should we have the work done?"

"Some other time," she replied, without looking up from her magazine. "There's no hurry."

This wasn't on the schedule. I fished around a bit, but couldn't get the job.

Later, when Al asked how I'd made out, I told him the Spencers were such tightwads there was no use bothering with them.

"You'll learn," he said.

I was still stinging under the failure when the Spencers 'phoned and told us they had thought it over, and that it was all right for us to go ahead with the work at the price we had given. Al hung up the receiver and stared at me.

"Did you quote six-fifty on that job, too?" he asked.

"Why not?" I countered gaily. "We got the job! Don't you want me to pick it up?"

"Sometimes," Al said, "I get awful lonesome, waiting for you to grow up!"

(Continued on page 63)



more than two dollars to install a 25c resistor, and believing a low price makes the deal easier for themselves, and cinches the job. This is wrong; for if you know exactly what work you have to do, and exactly how much parts will cost, you gain confidence and put yourself on firm footing during the palaver. If the going gets tough, and the commission of the contract hangs in the balance, this information is useful as ammunition for your cause: you know the customer can't take the job down the street for less money, and he knows you know."

"Wonderful words!" I remarked, letting loose a synthetic yawn. "Rest

BENCH NOTES



by **ROBERT KENDALL**
Service Manager, Indianapolis, Indiana

Lee Ward bows out, and the author takes up this column which has become a by-word among the active servicemen.

Lee Ward Leaves Us.

FELLOWS, I've got to leave you. Through a series of circumstances over which I have long since given up trying to control, I find myself in New York, working (one might say) as editor of a non-competitive magazine.

Before I turn my uniform over to the new conductor, I wish to thank my readers; first, for paying my salary (of course the checks have come from the Editor and Publisher, but they are only intermediaries); and second, for the things you've taught me. Meeting you and working with you has been an experience of great value, and I hope I have helped you, too.

Bob Kendall is taking over BENCH NOTES from now on. He is no stranger to me. Two years ago, the wife and I were passing through Indiana, on vaca-

tion. I had read some of Bob's stuff, and liked it; we stopped off in Indianapolis to tell him so.

Mrs. Ward and Mrs. Kendall went out to the front porch to while the time away with feminine nothings, while Bob and I sat in the living-room to discuss the serious matters we men of the world always keep on tap.

I soon learned of his long experience with many sorts of talkie and radio equipment; of his travels; and of his present servicing business. It was easy for me to see he was an unusually brilliant colleague, but the thing that impressed me most was his salesmanship; his practical ideas—tested and approved by trial in his own business—that set him apart from the majority.

We went over some specific cases of

customer encounter, and his judgments proved he had developed highly specialized methods of his own to complement his technical training.

Last month, when I learned of my transfer to the East, I recommended Bob Kendall for BENCH NOTES. No thanks are due me, for the choice was made by Managing Editor Kopetzky, who, incidentally, went far out of his way to make the necessary arrangements. My reason for mentioning the suggestion is simply to tell you that Bob, in my opinion, can give you more valuable servicing information per column than any other person I've ever met.

Gentlemen, meet Mr. Robert Kendall, of Indianapolis!

(Sgd) **Lee Ward**

WITH the departure of the old maestro Ward for new and perhaps greener fields, this department of necessity acquires a new pilot for better or for worse. As a practicing service man, the present writer's fingers are more calloused by the soldering iron and pliers than the typewriter keys, and the added load of a magazine column is taken on shoulders already bowed by lugging sixty-pound chassis up the stairways to the cliff-dwellers of the city.

It is, therefore, fitting perhaps that a statement of some sort be made, as to proposed policy and present intentions regarding the course to be pursued, subject to revision at a moment's notice. It is assumed that the caption *Bench Notes* implies a department for, by and with the service man, not excluding the subsidiaries of that classification, the experimenter, the home "tinker" and the beginner. While primarily it is proposed to deal with the trials and tribulations of the service man, almost any subject allied with the radio art may be discussed, the writer's opinion not being necessarily the last word on the subject. Being afflicted with that common human weakness, advice will be given freely on any and all subjects, although the writer is not so optimistic as to believe anyone will take it.

Being inclined toward indolence, our idea of the ideal column is one that is written by the readers, somewhat after the fashion of the inimitable *B.L.T.* It is likely that to many readers that *B. L. T.* was "before their time," and to those who like to read

about something occasionally besides the present state of the electron, his little book "The So-called Human Race" may provide welcome amusement after the cares of a day devoted to prowling around in the innards of midget receivers.

Thus with a touch of refinement given by the literary note, this introduction is brought to a close.

Stoodents!

MOST of us are familiar with the term "time constant" associated with A.V.C. action, and should know the simple formula by which it is obtained, that is, $RC = T$. To review the subject briefly, the action should be neither too fast nor too slow, a constant of .1 second being usually chosen. If the action is too slow, the receiver is held at low sensitivity for too long a period when turned away from a

strong signal. If too fast, the bias voltage produced by the A.V.C. may be affected by the modulation, resulting in distortion.

By inspection of the formula we see that the resistance in megohms is multiplied by microfarads, and the answer obtained, surprisingly enough, in seconds. This seems something like multiplying three apples by four pears, and getting an answer of twelve peaches. However, this formula is not an arbitrary one, but is based on fundamentals of electrical engineering, and is passed on to those with an inquiring turn of mind.

In order to avoid the possibility of bankrupting the publisher, no prizes will be offered, as no doubt a large number of men know the answer. As a clue to the student, the following helpful hint is offered—when a con-

(Please turn the page)



denser is charged the quantity is expressed $Q = CE$.

Service Benches

NO doubt many a radio man has viewed, with mingled emotions, those photos of super-de-luxe test benches, that are published from time to time in various journals. Usually they run to pastel paint jobs, chromium trim, tubular lighting, and many other of the latest gadgets of modernistic design. In the pictures they are always so spick and span, with their table tops bare of the usual clutter of tools, small parts and chassis that accumulate during the day's work, and many will wonder what they look like toward the end of a busy week. Some men sniff at what they call such "perfume counter" show places, and intimate that it is all nonsense and fol-de-rol—but no one can seriously deny that they are handsome, and attractive.

Are such dolled-up service benches a good investment—that is, do they pay? As to almost any question the answer is, it all depends. It is not improbable that a shop located in a laboring-class district might find an elaborate set-up of this kind actually keeping possible customers away, said customers associating such splendor with high prices. It is also possible that a man's shop may be located in a district, on account of a low rent, where the neighborhood drop-in trade is rather small and in the dollar class, while his profitable business lies in a choice residential district several blocks away. Customers with comfortable incomes are not prone to bring in a sackful of tubes for testing, and seldom if ever come to a service shop, preferring to order the work done by phone.

On the other hand a shop that enjoys a considerable amount of drop-in trade, would probably find such a bench a decided asset that would easily warrant the trouble and expense of its installation. Shops located in the business district of smaller towns, or the shopping centers in the suburbs of large towns should find these streamlined benches a most profitable investment in the long run. The question is not difficult for any man to decide, as it boils down to: How many people will see it, and what is their business worth?

One of our leading equipment manufacturers has prepared a booklet describing the construction of a few test benches, and a survey of shops in any city would indicate that many might profit by it. The average work bench is often a dingy, battered nondescript affair, being little more than a large table laid out with little or no planning, that sooner or later becomes the repository of all the odds and ends that the owner is too busy (or lazy) to put away properly, or has no other place for. The impression made upon any type of customer is not of the best, nor do such benches make for any kind of efficiency. It is not possible, of course, for a shop doing any business at all to maintain the extreme bareness displayed in the photographs, but it is probably safe to say that 90% of the benches would be greatly improved by a general cleaning-up. The subject is one that could stand a little
(Continued on page 42)

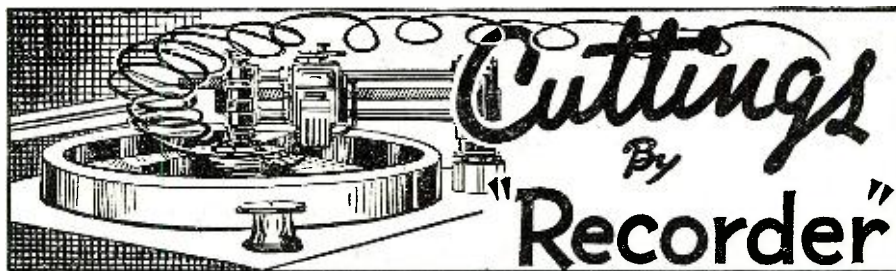

Manufacturer's Specifications

Make: Federal Recorder Company, Inc., New York City.
Model: "Little Pro 12".
Motor: Constant-Speed.
Turntable Speed: 33 $\frac{1}{3}$ and 78 rpm.
Cutting Head: Magnetic (low impedance).
Drive: From pulley on motor shaft.
Amplifier: Self-contained.
Control Panel: Includes jacks, volume controls, tone control, tuner, etc.
Feed: Overhead lead-screw carriage.
Tuner: Specially designed TRF chassis.
Table: Weighed 17 lb. steel alloy.
Speaker: 8" electro-dynamic.
Case: Reinforced case with lock-joint corners. 18x17x13 inches.
Remarks: Cuts all types of instantaneous discs up to 12" at either standard speed of 78 rpm. or at transcription speed of 33 $\frac{1}{3}$ rpm. Microphone included.

Description

The Federal "Little Pro Recorder" has been designed to offer a wide range of application to the making of instantaneous recordings of many classes. Seven features are to be found in this instrument. They are—
 Built-in radio tuner for recording off-the-air. Operation at two speeds—33 $\frac{1}{3}$ and 78 rpm.
 Built-in mixer for two microphones. Special amplifier circuit permitting off the air and microphone recording simultaneously.
 Overhead feed mechanism for positive and uniform cutting. A 17 lb. steel alloy turntable eliminating all possibilities of "wows" and wavers, and, each instrument is checked for uniform tone quality and constant speed by the Conn Chromatic Stroboscope which measures sound to 1/100th of a semitone.

Discussion

This Recorder has been provided with a self-contained radio tuner that makes it possible to record direct from radio broadcasts of favorite programs. Many recorders do not include this feature, even though there is plenty of room in the average carrying case to do so. Like their big brothers—the radio tuner is designed around special tuned-radio-frequency circuits in order that the full range of audio frequencies may be received. The tube complement is as follows: 6SK7, 6SK7, 6H6. The detector is of the Diode type to insure constant loading to the input of the amplifier at low distortion. Suitable controls are provided for proper adjustments and correct tuning. An easy-to-read aircraft dial matches the volume indicator meter and is illuminated.

The Amplifier has been designed solely for

use in this recorder. Matched to cutter and speaker for maximum efficiency. The amplifier is completely shielded, eliminating any possibility of hum due to external pickup by the microphone grids. The hum level is kept to a minimum so that it will not appear on the recordings.

The Control Panel has input packs for two microphones, together with separate controls so that they may be mixed. A separate volume control is provided for the radio tuner. Other controls include: Tone controls, Jack for a pair of earphones, Playback Volume control for playing commercial records or recordings. This panel is neatly etched to present a pleasing appearance, and is positioned at a slope where the various controls may be observed comfortably.

The Cutting Head and Carriage includes a wide-range electro-magnetic cutter. A center-drive lead screw is used for maximum rigidity and stability. Easy adjustments of the stylus angle may be made without removing the cutting head and the head may be thrown back for inserting the stylus. Noiseless adjustment of stylus pressure is also provided. This may be done during the process of recording.

The Turntable is of a heavy steel alloy and weighs 17 lbs. A felt top is provided to cushion and to protect the disc. This table is driven from a pulley on the motor shaft through an adjustable rubber roller. A change in speed from 33 $\frac{1}{3}$ to 78 rpm can be made in less than five seconds.

An 8" Electrodynamic Speaker, carefully matched to the output tubes for best tone quality is included. This is mounted on the removable cover and serves as an efficient baffle. Vibration is thus removed from the rest of the equipment and better results can be attained.

A strong carrying Case is provided to insure full protection to the recorder. Reinforced lock-joint corners are used. The covering is waterproof, soilproof canvas. The total weight of the complete recorder is 69 lbs. including microphone.

The Volume Indicator is of the meter type. The proper recording level may be observed at all times during the process of making a record and overcutting can be eliminated.

Comments

Excellent off-the-air and direct-pickup recordings were made with this recorder during our tests. Frequency response measurements were made and the amplifier found to be quite able to handle the full range of the pickup. The magnetic head responds to the high-frequencies with satisfactory efficiency. Although not capable of recording high-fidelity, the recorder is capable of turning out discs that compare favorably with commercial records. The turntable was found to be free from "wows" or rumble, due to the method of drive used. The radio tuner was able to receive all local and some distant stations with good quality. A short antenna was found to be most desirable for use with this recorder in order to eliminate inter-channel interference from strong local transmitters. In any case—the user should use as short an antenna as possible, depending upon his location. This recorder gave a good account of itself and should become one of the leaders in the portable recorder field.

The Reader Asks

What is the difference between "constant amplitude" and "constant velocity" recording?

ANSWER: The explanation, in non-tech-
(Continued on page 43)

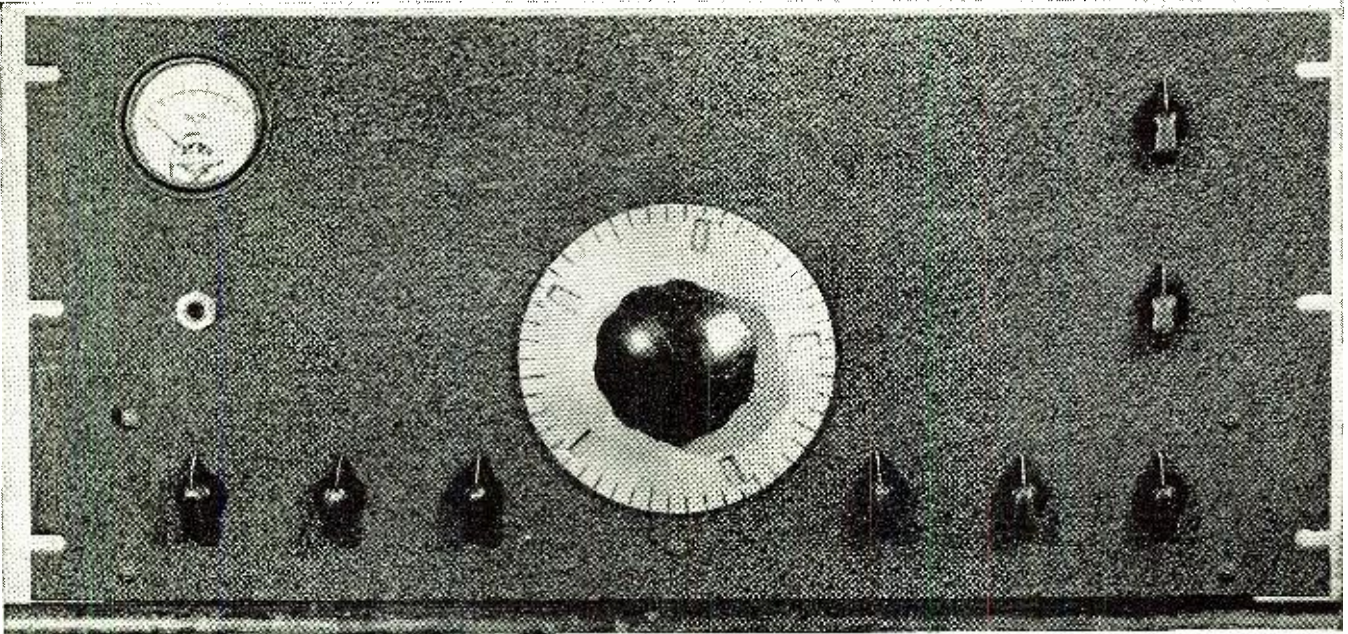

Every bit as professional-looking as a commercial set, is this home-built unit.

The Design of an **8 TUBE SUPERHERO**

by Ray E. Morrow

Seattle, Washington

A rare understanding of the problems faced by the constructor, plus good engineering technique have created this fine receiver.

WHEN building a receiver that is to be more than just another one later to be junked for parts, the builder will run up against problems that at first seem to be insurmountable. By taking each unit separately and really making it work to peak efficiency the sum of them will leave him a receiver that is close to par with the best of them. The author has been working on this design for years and at last considers it good enough to be passed on to the radio fraternity. Whether you are planning on building a new receiver or pepping up the old one, the author believes this paper will save you many hours of reading and much money. You can work any part of it into your present rig and make a good improvement.

The design is basically an 8-tube tuner and a two-stage audio channel with a voltage regulated power supply. We use two r.f. stages, a detector, oscillator, two i.f. stages, 2nd detector and beat oscillator. The two audio stages are more than sufficient and the power supply is a real improvement over the usual supply provided. A code recorder is to be mounted on the blank end of the power supply along with a speaker. The recorder is very useful for a record of stations worked and heard.

The r.f. end was built up around the

well known *National* PW4 condenser and dial assembly. Too much can not be said for this smooth acting and accurate dial. Every conceivable type of dial and condenser assembly was first tried and the PW was finally chosen. You must use one to really appreciate it.

The r.f. end is one of the most important parts of a receiver. We depend on the r.f. stages to build the signal up to the point where it will over-ride the noise generated in the mixer oscillator. We have the noise cut to a minimum, but there is still some there and this noise can kill a weak signal if it is too weak. The low priced receivers usually have no r.f. amplifier at all. We have done our best in this set to design a good r.f. end and leave nothing to chance.

We use metal tubes all the way through and the only reason is that they already have their shields on them. A shield on the oscillator can

make the dial shift its calibration if it moves while the tube stands still. The metal tube also makes for shorter grid leads in this design. The r.f. stages have 6K7's and the detector and oscillator both have 6J7's. We tried every type oscillator from a 6F6 to a 6C5 and finally end up with a 6J7. The oscillator voltage is nearly the same all across the dial and we don't have any of the usual dead spots.

The photo shows the layout of the r.f. end and the only other information necessary will be on the inside construction. The shields and bases are stock items and the only work to be done on them is to drill a 1/2" hole in the top of the can for the capacity trimmer and drill out the bottom of the base to the same size as the hole in the center of the pins. The trimmers are mounted inside the cans and just above the coils. The *inductance trimmers* are small pieces of copper the same size as a penny. They go in-

side of the coils and move up and down a brass 6/32 bolt. Each copper has a brass 6/32 nut soldered on it and we use the nut to move the copper piece up and down the threaded bolt in the coil. If we screw the copper in, the inductance is lowered and out the inductance is increased. These are very handy to have in a coil and a good design makes them absolutely necessary if the coils are to be all resonating at the same frequency at the same time, and at any dial setting. The coils are mounted on a piece of bakelite $\frac{1}{4}$ by $\frac{1}{8}$ and these in turn are mounted on the same bolts as the trimmer condensers. The unit as a whole is a neat job and the parts are all solid and no frequency drift will ever be noted. The inductance can only be changed when the coils are out of the set, but this is no problem because the trimmers are very broad in the turns it takes to change the inductance any. One turn at a time is ok when adjusting the coils.

The coil forms are all R39 and they are drillable if you have sharp drills.

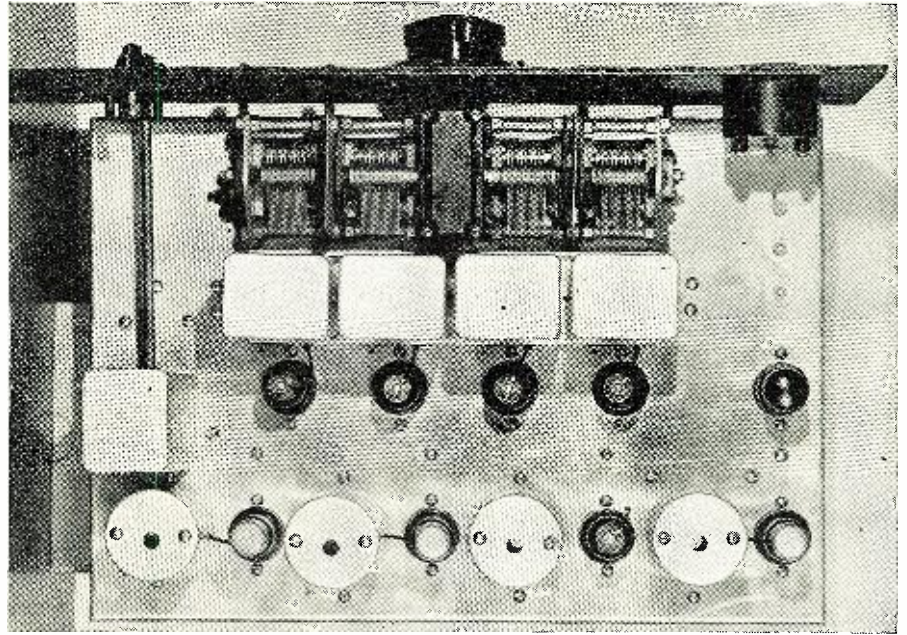

So commercial-looking, that it fooled even the technical editor!

To look at the stuff you would think they were soft, but don't let looks fool you. Have 4 or 5 drills on hand when you start the job. The simplest way to make all the coils alike is to make a paper jig for the drilling of the holes. The jig is easy to make if you use the gum paper that goes on packages that you get at the market. The coils each have two holes in them for wire.

The primary is very fine silk covered wire and the coil dope will hold it

in place. Be sure to dope the outside of the coils as soon as they are wound so they will hold their spacing. It is a little difficult to keep the wire tight, but practice makes perfect. Have the free end in a vise and wind up to it. Wind a spare wire in with the main wire for a spacer. Hook the main wire up to the form and then cut the spare off. Toothpicks make a good wire holder in the small coil form holes. Dope the winding and then put on the

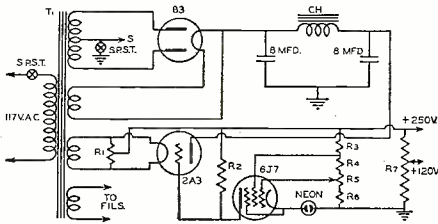

- T₁—plate and fl. trans. Pri. 117 v. 60 cycles, Sec. 475—0—475 @ 100 ma., 5.0 v. @ 3 A, 6.3 v. @ 4 A, 2.5 v. @ 3 A
- R₁—100 ohms, c.t. Ohmite
- R₂—250,000 to 500,000 ohms, $\frac{1}{2}$ w. I. R. C. .
- R₃—10,000 ohms, 1 w. I. R. C.
- R₄—25,000 ohms, 1 w. I. R. C.
- R₅—15,000 ohms, pot. Yaxley
- R₆—5,000 ohms, 1 w. I. R. C.
- R₇—25,000 ohms, 20 w. Ohmite "tap at 120 v."
- CH—20 HY 150 MA

COIL TURNS TABLE

	1st R.F.		2nd R.F.		3rd R.F.		Oscillator	Tap
Band	Grid	Plate	Grid	Plate	Grid	Plate	Grid	Ground End
10-20	6.5	6	6.5	6	6.5	6	6.5	2.5
20-40	13	32	13	32	13	32	13	4

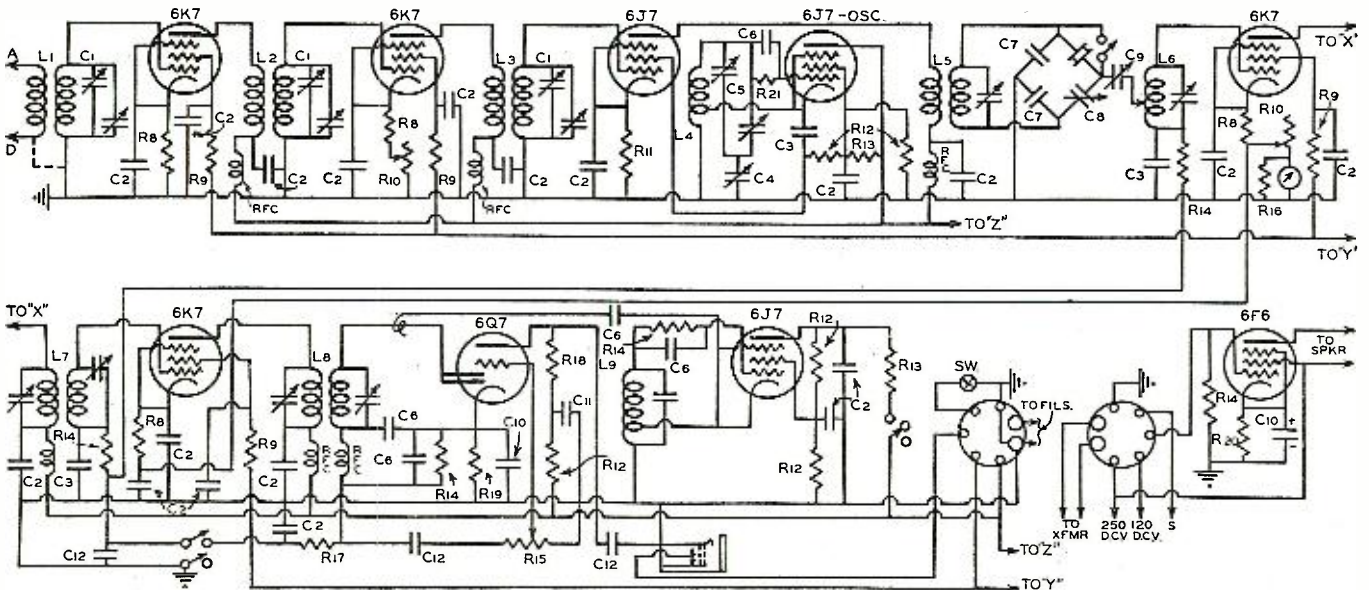

- C₁—35 mmf. per section, 3-gang
- C₂—1 mf. 400 v. paper C-D
- C₃—0.1 mf. mica C-D
- C₄—400-700 mmf. padder Hammarlund
- C₅—35 mmf. variable Hammarlund
- C₆—0.001 mf. mica C-D
- C₇—75 mmf. mica C-D
- C₈—25 mmf. variable C-D
- C₉—0—30 mmf. var. C-D

- C₁₀—10 mf. 25 v. electro. C-D
- C₁₁—5 mf. 400 v. paper C-D
- C₁₂—0.5 mf. 400 v. paper C-D
- R₁—300 ohms, 1 w. Centralab
- R₂—15,000 ohms, 1 w. Centralab
- R₃—50,000 ohms pot. Centralab
- R₄—5,000 ohms, 1 w. Centralab
- R₅—100,000 ohms 1 w. Centralab
- R₆—50,000 ohms, 1 w. Centralab

- R₇—500,000 ohms, $\frac{1}{2}$ w. Centralab
- R₈—500,000 ohms pot. Centralab
- R₉—25 ohms shunt Ohmite
- R₁₀—1 megohm, 1 w. Centralab
- R₁₁—300,000 ohms, 1 w. Centralab
- R₁₂—30,000 ohms, 1 w. Centralab
- R₁₃—450 ohms, 10 w. Ohmite
- R₁₄—250,000 ohms, $\frac{1}{2}$ w. Centralab

Coil Data—See Text

primary. The primary is larger than usual and for a reason. It resonates just below the low frequency end of the dial and this gives the coils plenty of coupling so they will be hot at the low end. The capacity in the wiring is enough to give the high end all the signal transfer necessary without adding any. When the coils are all finished and adjusted right the set is hot all the way across the dial.

The coil cans are held together with $\frac{1}{8}$ " by $\frac{1}{2}$ " aluminum bars long enough to hold all cans. The coil assembly is held to the chassis by 8 fuse clips of the small type. The coil can bolts that go through the bars have $\frac{1}{4}$ " sleeves on them and these plug into the fuse clips. We used 8 but 16 would be better. The clips, of course, are bolted to the chassis.

The coil sockets are bolted to the chassis and they have 1/16" spacers between them. The top of the socket should be flush with the top of the chassis. The grid wire goes through a hole drilled between the coil and tube socket.

Solder the wires on to the tuning condenser before you bolt it on the chassis. **DON'T TAKE THE CONDENSER APART FOR ANY REASON.** It took six hours of hard work to put ours together.

The r.f. gain control is in the second r.f. cathode. Just to be on the fussy side you could put one on the first one. We have no A.V.C. on any of the front end tubes. There does not seem to be any need for it and it simplifies grounding a great deal. We had it on and took it off. If a signal should block the detector, turn down the r.f.

Run all wires close to the chassis and in the corners. Use colored wire so you can trace them easily. There is very little wire in the set to trace, anyway. Ground all bypass condensers and ground leads to the same stage ground that they bypass. If you don't the chassis is very "hot" at some points. The ground bus on the r.f. end runs the full length of the chassis just in front of the coil sockets and is soldered to the chassis at this point only. Make a neat job because the set looks and works better. A poor job works the same way as it looks. Use ceramic washers for the antenna post insulators. They are better, neater and cheaper. All "hot" wires must be in the clear and up.

The crystal filter is the next in line. The set will work good without one, but it is very necessary in the ham bands now. You can put it in at any time so leave the spot for it open. We made ours from the start and learned something in the process. It is hard to get working, but don't give it up as hopeless. If you are none too willing to use your head you had better buy one; but if you are a fiend for work, here is the lowdown. We spent weeks on this unit and to our knowledge there has been too little written on the subject. There are a lot of articles on it, but they just leave you

(Continued on page 54)

The VIDEO Reporter

by SAMUEL KAUFMAN

THERE was a pleasing note of harmony in evidence at the first meeting of the *National Television Systems Committee* recently held in New York.

It was particularly pleasant to see television leaders who have been bitter opponents on video policies and standards gather round the conference table to work towards agreement on standards—the biggest single hurdle ahead.

Featured speaker at the first session of *NTSC* was *FCC* Chairman James L. Fly, the fellow who was severely criticized by some observers for his earlier decisions regarding television's status. But Fly's words to the nation's video brain trusters gathered around the conference table were soothing indeed. He implied that the *FCC* will be glad to work with all comers, but that real action was anticipated from those firms granted television channels. It seems that there won't be any chance for the hoarding of idle wave assignments by firms who merely intend squatting on the frequencies until the going is good. Action is anticipated from the outset.

The *FCC* chairman's remarks as well as those of the commission's chief engineer, E. K. Jett, indicate that the Administration is taking a fair stand on video problems, particularly from the angle of giving development companies the opportunity to do some developing—a logical move, indeed.

The *RMA* did a good job in getting the *NTSC* off to a smooth start. But just how smooth the going will be is tough to predict. True, the outstanding television personalities of the U.S.A. are represented on the committee. But it's a known fact that strong differences in opinion on standards have existed between some of them in the past and will take a bit of time to amicably settle.

Membership in the *NTSC* is available through appointment by the president of the *RMA*, subject to the approval of the *RMA* executive committee. But despite the *RMA* organization work, membership is not limited to manufacturers. Telecasters, laboratories and national technical organizations are qualified to participate.

The charter roster of the *NTSC* includes Adrian Murphy, *CBS*; Harry R. Luhcke, *Don Lee Broadcasting System*; Allen B. Du Mont, *Allen B. Du Mont Laboratories*; B. Ray Cummings, *Farnsworth Television and Radio Corporation*; E. F. W. Alexander, *General Electric Company*; Daniel E. Hartnett, *Hazeltine Corporation*; John V. L. Hogan; Albert I. Lodwick, *Hughes Tool Company*; Dr. A. N. Goldsmith, *Institute of Radio Engineers*; David B. Smith, *Philco Corporation*; E. W. Engstrom, *RCA*; Frederic C. Young, *Stromberg-Carlson Telephone Manufacturing Company*, and John R. Howland, *Zenith Radio Corporation*.

It is understood that the Bell Telephone Laboratories and other firms will also be represented.

Chairmanship of the committee went to G.E.'s Dr. W. R. G. Baker.

The "reason and purpose" of the *NTSC* was set forth as follows: "Because of the inadequacy of the various suggested standards for television, it is proposed to establish a committee for the purpose of developing and formulating such standards as are required for the development of a suitable national system of television broadcasting."

"This project, sponsored by the *RMA* in cooperation with the *FCC*, will be maintained independent of any other organization and will be truly representative of the majority opinion of the industry."

It all sounds well and looks well. Some persons are dubious about the assurance of harmony between all the represented firms.

But all observers seem to agree that the move is the most constructive one to date and may do more than any other single effort in hastening the arrival of commercial television on a mass scale.

THERE was a bit of irony in the fact that the very day the first meeting of the *NTSC* was held in New York, the *RCA-NBC* television station which had been maintaining an unbroken "regular" schedule for fifteen months was winding up its schedule.

NBC, incidentally is represented on the



An experiment in video-telephoning. Imagine being caught with this new set up, just emerging from your bath!

NTSC only through its parent firm, *RCA*.

Even though *NBC* is "a part of the *RCA* family"—a phrase constantly used in *Radio City*—the separate designations have come in mighty handy in ironing out delicate situations. For example, if a squawk concerning television activities is registered at *NBC*, the network lads promptly say "Don't blame us. Everything was in *RCA's* hands." And if the kick is made to *RCA*, the buck is passed to *NBC*.

But when praise for video activities comes in, both *NBC* and *RCA* are ready to take individual or collaborative bows.

IN all, it must be said that *W2XBS* did a splendid job in its fifteen-month stretch of television service. Considerable progress was noticed in program production in this short time and the staff acquired invaluable practical knowledge of what will click and what won't. Hence, even the flop shows that went on the air had some value; they provided the video program lads with formulas on how to avoid blunders.

WHEN New York's television screens went dark on July 31, there were quite

(Continued on page 58)

What's NEW in Radio

The *Thordarson Electric Mfg. Co.*, Chicago, announces a new Microphone Cable Transformer which adds greatly to the serviceability of amplifiers now having only high impedance microphone circuits. Low impedance microphones are a decided advantage when the microphone is to be used long distances away from the amplifier. The *Thordarson Cable Transformer* makes it easy for the sound man to adapt his present amplifiers to the new type microphones. With the use of this new unit, such amplifiers can be easily adapted for use with low impedance dynamic or velocity microphones.

This new Cable Transformer, which mounts directly on the amplifier, is available in two types. One is a 30 to 50 ohm unit designed for voice coil connection of dynamic or velocity microphones which have self-contained line output transformers. Hum pick-up is reduced to a minimum by the use of magnetic shielding. The transformer connects between the microphone cable and amplifier input connector, and is small and inconspicuous.

Fully described in Catalog No. 600-E, available from your dealer or by writing the *Thordarson Electric Mfg. Co.*, 500 West Huron St., Chicago, Illinois.

A power resistor decade box capable of handling real power so that it can be inserted in actual circuits to simulate working conditions, is announced by *Clavostat Mfg. Co., Inc.*, 285-7 N. 6th St., Brooklyn, N. Y.

The *Clavostat* power resistor decade box simplifies and expedites the selection of correct resistance values for any circuit or condition. It is intended primarily for laboratory use, for calibration of meters, and for development work generally. It covers a resistance range of from 1 ohm to 999.999 ohms at a maximum of 1000 volts, by means of six decade switches on the sloping front panel. Each decade will dissipate up to 225 watts, since only Greenohms (cement-coated wire-wound power resistors) are used for

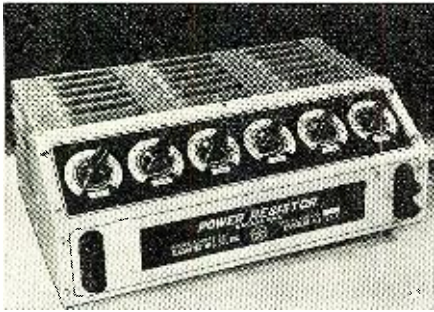

the resistance elements, together with glass-insulated wire for connections. The maximum current per decade is as follows: No. 1, 5 amp.; No. 2, 1.5 amp.; No. 3, .5 amp.; No. 4, .15 amp.; No. 5, .05 amp.; No. 6, .005 amp.

Of laboratory instrument grade throughout, this power resistor decade box will prove a worthy addition to any laboratory or engineering equipment. The metal case is handsomely finished in frosted gray with an etched black and aluminum front panel. A grille at the bottom and louvers at sides and top, provide adequate ventilation of the resistance units. A baffle plate protects the switch mechanism from the heat. The instrument measures 13" long x 8 1/2" deep x 5 3/4" high, and weighs 11 lbs.

Of particular interest in applications where size and cost are important factors is this new Midget Relay development.

Noteworthy characteristics, it is claimed, are high d.c. efficiency, "hum-free" a.c. operation, and a wide range of coil voltages.

Actual dimensions are 1 1/2" x 3/4", and mounting, on any type of panel, is permissible due to

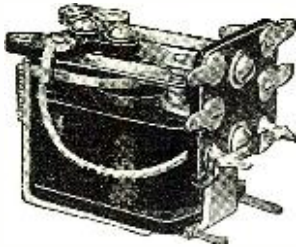

the ungrounded construction. Quick, easy installation is accomplished by a single 6/32 stud. Where some degree of sensitivity is to be desired, positive, dependable service may be attained on as little as 10 watts, with a safe continuous-duty rating of plus two watts without danger of over-heating.

Contact combinations are DP-ST or DP-DT,

employing 1/8" Silver Contacts to handle up to 200 watts on non-inductive a.c. loads.

Coil and line connections are made to adequately long, tinned solder lugs, with ample spacing and insulation between all terminals and the Relay frame.

Complete technical data and price information may be obtained by writing The *Advance Electric Company*, 1260 W. 2nd St., Los Angeles, Calif., requesting Relay Bulletin S-6.

The *Raytheon Production Corporation* announce two new *Raytheon* hearing aid tubes—types CK-505 and CK-505X, both filament type pentodes.

These tubes require less than half the filament power of our present hearing aid tubes and are a little shorter in size.

A pair of these tubes in a resistance coupled amplifier using our suggested circuit values has



a voltage gain of about 225 at 30 volts of B battery. The total B drain for both tubes is 54 microamperes and the total A drain for the two tubes in series is 30 milliamperes at 1.25 volts.

In addition to hearing aid application these tubes may be used where extremely small size and low battery drain are the primary tube requirements.

The *Turner Co.* of Cedar Rapids, Iowa, is announcing four new *Challenger* Microphones—all designed to challenge comparison in performance, appearance and price. They're styled to sell on sight, and engineered to stay sold, yet allow the jobber to make a full margin of profit.

The *Crystal Challenger*, BX, lists at only \$9.95, and comes complete with 7 ft. cable and diagrams, and is finished in attractive bronze enamel. The crystal is impregnated against moisture and changes in barometric pressure. The built-in wind-gag prevents any blast from close speaking. It has a high level of -53DB, and a frequency response of 50-5,500 cycles. This, as well as all the other *Challenger* models, fits any standard 3/4"-27 thread stand.

The *BD Dynamic Challenger* is identical in appearance with the BX, and lists at \$12.50. It is exceptionally fine for recording, ham use or P.A. jobs. BD is a rugged unit that works equally well indoors or out. The built-in transformer is free from hum pick-up, and is smooth at all frequencies. This unit has a level of -52DB, and a range of 50-5,500 cycles, and comes complete with 7 ft. cable and diagrams in 200-250 ohms, 500 ohms or high impedance.

CX Crystal Challenger is a rich brushed-chrome finished microphone that has its crystal fully protected for the ham, and is tough enough to take rough handling. It is equipped with a 7 ft. removable cable set, employing amphenol connectors. Each unit is individually tested in the *Turner Sound Pressure Room* for level and frequency response before it is shipped, assuring top performance. Its level is -52DB, and range 50-7000 cycles. The list price is \$15.

The *Turner CD Dynamic Challenger* is an exceptional value in a microphone with 7 ft. removable cable set, also utilizing amphenol connectors. It is fully protected for the ham, and rugged enough for the toughest P.A. job, and does exceptionally fine in recording. The transformer is built-in, and this model is unusually free from feedback. With removable cable set and diagrams CD is available in 200-250 ohms, 500 ohms or high impedance at only \$16.50 list.

Free Microphone Catalogs are available for all those who request them from *The Turner Co.*, 908 17th St. N.E., Cedar Rapids, Ia.

Just as the original *Bruno* single shielded conductor Cable Connectors filled an important gap, the new *Bruno "Baby"* Connectors will probably be of vital significance to the entire Public Address and allied industries.

Locking type, designed to improve the contact and minimize interrupted circuits, these new sizes have been especially designed for out-

put or loud speaker connections, and are equipped with 1/2 inch-27 thread to prevent accidental mixing of cables with microphone input. The manufacturer states that microphone,

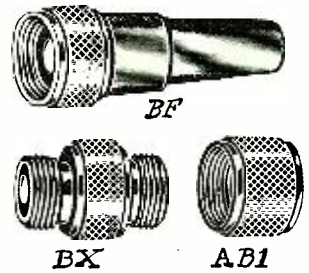

speaker and chassis connection of all types can now be made swiftly and infallibly with the help of *Bruno Baby* and the old reliable *Standard* sizes. Complete literature may be had by writing *Selectar Mfg. Corp.*, 30 West 15th St., New York City.

Announcement has just been made by the *Emerson Radio and Phonograph Corporation*, New York City, of 4 new miniature tubes for battery operation. Smaller than a human finger, these types are:

1R5 Pentagrid Converter
1S4 Power Amplifier Pentode
1S5 Diode-Pentode
1T4 Super-Control r.f. Amplifier Pentode
This complement is used in the new *Emerson* models 379 and 380 "Personal" Self-Powered Portable sets.

Small in size, their high operating efficiency has been attained by a new design which pro-



vides compactness without decreasing the size of essential electrode parts. Instead of the conventional base, a new glass button "7-pin" base sealed to the glass envelope, with the electrodes mounted directly on the glass button, makes possible the small, compact size of this series of tubes.

Shipments of these types in *Emerson* cartons are now being made.

G. V. Rockey, Vice-President and General Sales Manager of *Meissner Manufacturing Company*, has just returned from his first sales tour of the year covering Western states and the Pacific Coast.

He reports an unusually cheery outlook for 1940 among distributors and representatives whom he contacted. The generally pessimistic tone of past seasons is entirely absent and everybody seems confident that a banner year is just beginning.

Mr. Rockey found West Coast jobbers especially enthusiastic over the new *Vibrator Sales Plan* and *Counter Display* deal, just announced by *Meissner*. This plan enables the jobber to introduce the re-designed *Meissner Vibrator* in an attractive counter display carton containing six popular replacement units.

Frequency Modulation Reception is rapidly becoming available throughout the entire United States and is undoubtedly destined to be the paragon of fine radio reception in the future. In the two F-M Receivers presented herewith, *Meissner* has extended every reasonable effort to provide the finest possible reproduction of noiseless, static-free Frequency Modulation Broadcasts.

The Model 9-1037 receiver is housed in a beautiful, two-tone walnut cabinet, sturdily built, correctly designed for acoustic perfection and superbly finished. Overall height is 4 1/2 inches, width is 3 1/4 inches and depth is 15 3/4 inches. Massive—well proportioned!

The receiver chassis incorporated in this high-grade Console is the result of months of pioneer engineering in Meissner Laboratories—exhaustive field tests under actual operating conditions have developed this design to the point where it is today unexcelled, says the maker.

The circuit used in this receiver incorporates the original principles of the F-M system as developed by Major Armstrong. A high-gain r.f. stage provides efficient signal-frequency amplification; a combined mixer-oscillator tube feeds the 4.3-mc. i.f. signal into the three-stage i.f. amplifier and limiter system; a special diode

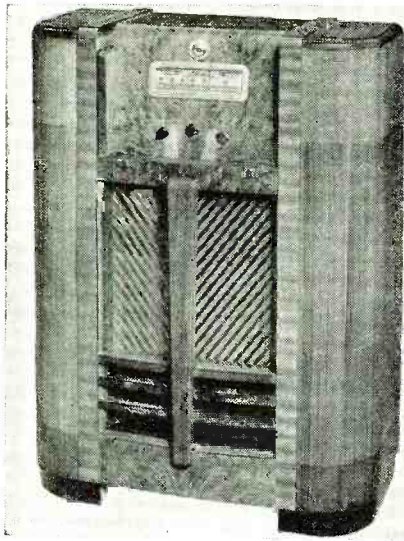

detector arrangement provides a distortion-free audio signal for the input of the two-stage high-fidelity audio amplifier. Voltage Regulation, AVC and ceramic insulation—everything to provide maximum stability and dependability!

Twelve tubes are used in this receiver: one each types 6SA7, 6HG, 6SC7, 6AD6G, 5U4G, 6CS, 6L6G, VR150 and two each types 6SK7 and 1852 (6AC7).

The frequency coverage of this receiver includes the full range of the Frequency Modulation Band as assigned by the Federal Communications Commission, 42 to 50 Megacycles.

The Table Model F-M Receiver is identical in all respects to the Console Model described above with the exception of the size and shape of the cabinet.

The two-tone walnut cabinet in which this receiver is housed is 12 1/4 inches high, 22 1/4 inches wide and 11 inches deep, gracefully proportioned and finely finished.

Either the Table Model or the Console Model F-M Receivers described here may be used as a "Converter" in connection with another receiver. Where a large, well-designed receiver with a good audio system is available, the detector output of the F-M Receiver may be fed into the "Phono" or "Television" input terminals or jack on the regular receiver. A special shielded cable is provided for this purpose.

The new Hammarlund "PA-150" power amplifier foundation unit is compact and efficient

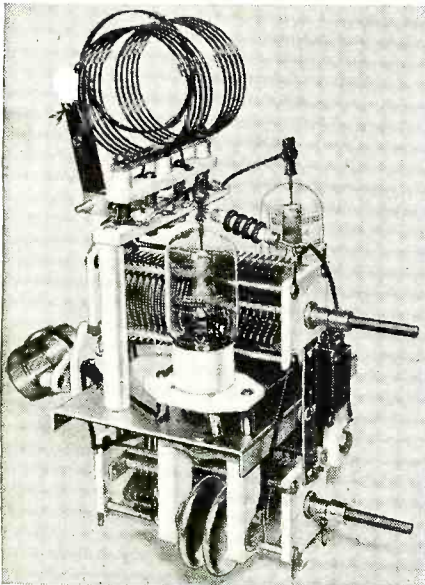

and designed to appeal to the amateur who wants to have the pleasure of building his own equipment. The "PA-150" uses small high effi-

ciency tubes and is built around a new type of variable condenser.

These condensers have completely insulated rotors. Even the control shaft is insulated. This type of condenser design permits the high voltage to be applied directly to the rotor, thus allowing increased voltage for a given plate spacing. These compact condensers in no small way contribute to the compactness of the "PA-150."

Operated under normal conditions the output of the amplifier, with type HK-24 tubes is in the neighborhood of 175 watts. That is quite a bit of power to obtain from a unit only 11 1/2" high by 8" deep and 5 1/2" wide. This amplifier may be small, but it is really potent. The variable condensers are Hammarlund type "HFBD-100-C" and will operate safely with 2,000 v. applied to the tubes for c. w. operation, or 1,000 v. 100% modulated for phone operation.

With the thought of making every phase of their sound equipment line complete, Webster-Chicago announces the enlargement of their microphone line.

Most popular among the addition is this new "Uni-Vel" microphone which incorporates such features as true cardioid characteristics, wide angle pickup in front—dead in back, full range frequency response, operates 30% closer to speakers, and unidirectional characteristics which permit favorable pickup under reverberatory conditions without background noise or



feed back thereby solving most sound pickup problems encountered in the majority of indoor installations.

The microphone is housed in a modern streamline black and chrome case giving it a strikingly attractive appearance for the first time a studio microphone offered at a price that is practical for general P.A. use. (\$49.50)

Webster-Chicago's new catalog No. 140, which completely describes and illustrates these microphones, is available upon request—Webster-Chicago, 5622 Bloomingdale Ave., Chicago, Illinois.

Something distinctly new in receiver equipment is the *Halli-crafters Model S-29 "Sky Traveler"* which combines the universal convenience features of the modern 3-in-1 portable

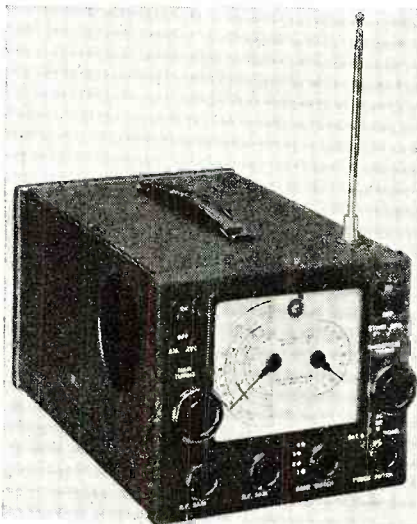

with those of a really good communications receiver. It, therefore, constitutes an ideal unit for use in ham, commercial or all-wave broadcast services—at sea, ashore or in the air.

The "Sky Traveler" is housed in a crackle-finished aluminum case with carrying handle, 7 inches high, 8 1/4 inches wide and 13 1/4 inches deep. The weight with self-contained batteries is 18 pounds. Operation is from any 110-volt a.c. or d.c. line or from the batteries. Battery life is prolonged by a built-in charging circuit with the result that one set of batteries provides approximately 100 hours' service.

Nine tubes provide one r.f. and two i.f. stages, mixer, detector and a.v.c., two audio stages, beat oscillator, automatic noise limiter, and line rectifier. The tuning range is continuous from 542 kc. to 30.5 megacycles in four steps and electrical band-spreading is provided for all parts of this range. Sensitivity averages better than 2 microvolts in all ranges.

The complete adaptability of this receiver for all types of service is indicated by the number of controls, the inclusion of both built-in speaker and headphone jack, a collapsible rod antenna socket mounted on the case plus external antenna connections for both doublet and "L" antennas. Controls include separate main and band-spread knobs and dials, r.f. gain, a.f. gain, band switch, power switch, a.v.c. off-on switch, b.f.o. off-on switch, noise limiter off-on switch, and send-receive switch.

The utility of RCA's new *Communication Receiver (Model AR-77)* for amateur radio enthusiasts and ardent radio fans of every stripe, has been heightened by the development of a new "extended range" loudspeaker designed especially for use with the receiver, according to Edward Braddock, Manager of the *RCA Amateur Radio Section*.

The new loudspeaker has an extended audio range with large power handling capabilities, giving full expression to the performance of the AR-77, Mr. Braddock said. It is available in an attractive walnut cabinet which serves as a support for the receiver, and is styled for

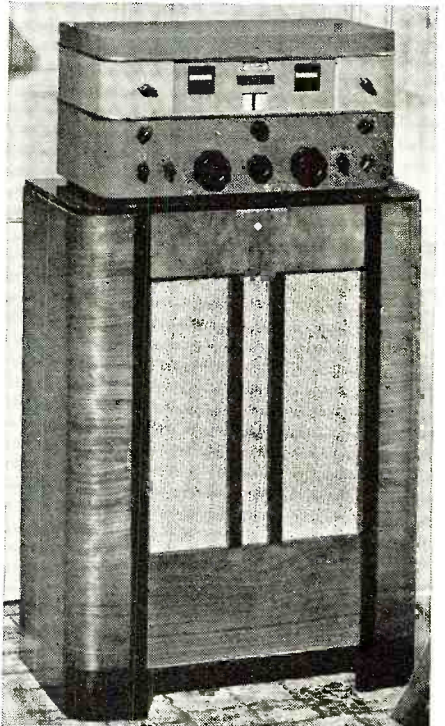

use in the living room or the short wave listener's den. The same speaker mechanism is also available in a plain, gray-finished cabinet, for use in the amateur's station.

The loudspeaker has a frequency range of from 60 to 5,000 cycles. Power handling capacity is 10 watts, and voice coil impedance is 2.3 ohms at 400 cycles. The speaker cabinet stands 32" high, 24" wide and 14 1/2" deep.

The AR-77 provides excellent amateur, foreign and broadcast band reception of unusual quality. It meets the exacting requirements for amateur and foreign reception with its high signal-to-noise ratio, unusual selectivity and remarkable stability. A higher fidelity audio system assures finer musical reproduction, while a band-spread dial makes foreign tuning easy.

Its performance as a standard broadcast receiver far surpasses the usual type of broadcast receiver. A high-gain r.f. stage reduces image response and greatly increases the signal-to-noise ratio. Two i.f. stages insure ample gain and sensitivity while negative feedback applied to the audio system greatly reduces distortion and improves fidelity.

Universal Microphone Co., Inglewood, Cal., has started to distribute its new aircraft headphone in two types. Low impedance type matches lines of 200-600 ohm impedance especially for multiple headphone connection in

plane, while the high impedance type operates from the output of tube plate.

The headband is adjustable and socket joints at the back of the case automatically fit the phones to the ears. The spring steel band is black Lastex covered. Extra sensitive earphone

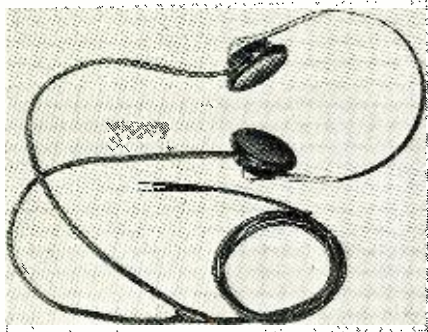

element uses Alnico magnet, high permeability iron structure, one piece coil bobbin "tropic" sealed. The assembly weighs three quarters of a pound.

A new, Model DR-125 Direction Indicator Rheostat is now offered by *Ohmite Manufacturing Company*, Chicago.

This compact, convenient device is connected to the moving part of radio rotary beam antennas, direction finding loop antennas, wind-vanes, and so forth, in order to send an indication of the position to a remote point.

It is an ideal instrument for aircraft and industrial purposes, and for amateur and commercial radio uses. Also used at an operator's desk to show the position of valves, water gates, dampers, and other apparatus.

The Model DR-125 Rheostat has a 360° con-

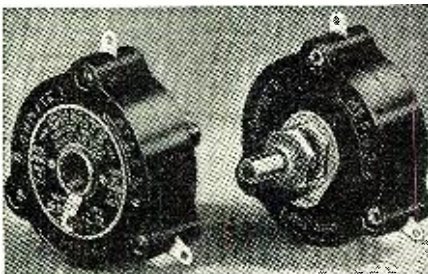

tinuous winding. It is designed for use on d.c. up to 24 volts.

Model DR-125 consists of a glazed ceramic housing which is 1 7/8" diameter and 1 3/8" deep behind panel. Mounted by a 3/8"-32 bushing and nut on any panel up to 1/4" maximum. Equipped with non-turn washer. Shaft 1/4".

Standard Ohmite Rheostats may also be used in Remote Indicating Systems. For further information, write to: *Ohmite Manufacturing Company*, 4835 Flournoy Street, Chicago, Illinois, U.S.A.

The new *Audiograph* Model AMR-25C mobile amplifier for operation from 6 v. battery and 110 v. a.c. line, just announced by *John Meck Industries*, 1313 West Randolph Street, is recom-



mended for political and advertising work. This amplifier is stated to work equally well from battery or power line, and requires no external power packs. The output is 25 watts, for either phono record reproduction or microphone operation.

There is a built-in switch that allows plate current to be shut off between announcements, thus saving up to 50% of the battery current. Since the filaments are kept burning, instant operation is secured when desired.

Complete information may be secured by writing the manufacturer, mentioning this publication.

A new Portable Radio Set Tester featuring a 40 microampere range for sensitive current measurements and a portable dry battery testing circuit is announced by *Hickok*.

(Continued on page 60)

FOR IMMEDIATE RELEASE...

Two Plead Guilty to Unlicensed Radio Operation

THE Federal Communications Commission announced today that recent investigation of unlicensed radio operation in San Francisco, resulted in the indictment of Ralph Wildt and Louis F. Books for violation of Sections 301 and 318 of the Communications Act of 1934, as amended. Both defendants pleaded guilty and will be sentenced by the United States District Court.

Peter Ruggeri, a minor, also charged with operating an unlicensed radio station will be prosecuted as a delinquent juvenile.

Hygrade Sylvania Semi-Annual Report

FOR the six months ended June 30, 1940, net income after all charges and taxes, including provision for Federal Taxes at the new and higher rates which apply to corporations, was \$416,378.54.

This is equal to \$1.68 per share earned on the common stock for this period and compares with a net income of \$343,856.66 for the first six months of 1939.

The balance sheet of June 30, 1940, showed current assets of \$6,339,263.06 which were 4.3 times current liabilities. This compares with current assets of December 31, 1939, of \$6,083,077.65 which were 4.4 times current liabilities.

FCC Chairman Places Responsibility for Commercial Utilization of Television

WITH the introductory remark that there had been enough speech-making and that now the time had arrived for real effort, James L. Fly, chairman of the *Federal Communications Commission*, told the organization meeting of the new *National Television Systems Committee*, held at the Roosevelt Hotel in New York, that the commission could not state now when television would be ready for full commercial realization because it was depending on the committee to do that job. He expressed the gratitude of the commission at the representative industry turnout, and described the committee itself as "a great body of concentrated skills."

Chairman Fly recommended a program of study, consultation, and joint research to those present at the meeting, reiterated that the television standards hitherto prevailing were inadequate for launching a uniform system, and expressed himself as highly optimistic over future prospects. He suggested that there might be a problem for the committee in obtaining transmission over several of the lower bands, and went so far as to propose that a study be undertaken of television in color, if the committee so desired, emphasizing that there were no limits to the studies on the agenda as far as the commission was concerned.

"The more station applications we have the merrier," Fly declared, "but there must be no squatting on the wavelengths, which are public domain. We will not grant an application to a station just so that it can get in and ride—it must do a substantial job."

Muldowny Re-elected National Union Prexy

REELECTION of S. W. Muldowny as President of *National Union Radio Corporation* was announced today following the organization meeting of the Board of Directors. At the same time W. R. Wilson was named Treasurer and E. O. Sandstrom, formerly acting secretary, was elected Secretary and Assistant Treasurer.

At the company's annual meeting, held in Wilmington, Del., the following persons were elected to the Board of Directors:

S. W. Muldowny, President, *National Union Radio Corporation*;
Henry L. Crowley, President, *Henry L. Crowley Manufacturing Company*;
Paul V. Galvin, President, *Galvin Manufacturing Company*, Chicago;

Penn Brook, Vice-President in charge of factories for *Sears-Roebuck and Company*, Chicago;

W. R. Wilson, Controller, *Philco Corporation*; and

Fred D. Williams, Assistant to the President, *Philco Corporation*.

Stromberg-Carlson Sales up 300% Over Last Year

SIGNED orders for new *Stromberg-Carlson* radios and radio-phonographs received after showing of the recently introduced 1941 line in major distributing centers are 300% greater than those received after initial showings last year, it was revealed by Lloyd L. Spencer, General Sales Manager of the *Stromberg-Carlson Telephone Mfg. Co.* He attributed increased orders in part to the inclusion of the staticless FM band on a number of the new models, making possible the reception of FM programs without static or interference. "Other features," he said, "that have induced much favorable comment from dealers is the wide variety of automatic radio-phonograph combinations, styling of the new cabinets and the inclusion of such patented *Stromberg-Carlson* features as the Labyrinth which improves the tonal quality of programs on any band—FM, standard, or short wave.

Latest Type Radio Communication System for Indianapolis Power & Light Company

FREQUENCY modulation radio communication will have its debut in the utility industry late this summer when the *Indianapolis Power & Light Company* plans to put into operation its new *General Electric* frequency modulation emergency communications system. Ten of *Indianapolis Power's* service cars and trucks are being equipped with G-E 25-watt FM mobile transmitters and receivers for two-way communication. Though they may be on jobs miles away, these service vehicles will be able to keep in close touch with main headquarters where a G-E 250-watt station transmitter will be in operation.

The decision of *Indianapolis Power & Light* officials to turn to the frequency modulation type of transmission in preference to amplitude modulation was made as a result of an investigation of frequency modulation transmission and its capabilities in reducing and almost completely eliminating interference of both man-made and natural origin. They were impressed with FM's ability to provide excellent reception in areas twice as far from the transmitter as could be obtained with equal-powered AM equipment.

The 25-watt FM transmitters for the *Indianapolis* system will service even a greater area than the best of previous 250-watt amplitude modulated transmitters.

Indianapolis Power officials expect the new communication system will help greatly in handling with swift dispatch any emergency that might arise on the system. In the event a line is down, a life at stake, or other emergency, headquarters will be able to have the nearest truck on the scene without delay. Once there, no longer will it be necessary to hunt for some means of communicating instructions and requests to headquarters for help in handling the emergency. Radio close at hand will do the job.

FCC Agency for National Defense Problems

CLOSE surveillance of radio operations but with a minimum of commercial disturbance or changes is contemplated by the *Federal Communications Commission* in its proposed organization of a *Defense Communications Committee*. Chairman Fly has announced that there will be no effect on broadcasting, no censorship, and that the Government has no intention of burdening or hampering normal radio operations. The

(Continued on page 62)



Hamop w9llm.



Hamop w9olm.



Hamops w9ftw, w9drt, w9ard.



Hamop w9aor.



Hamop w9ouv.



The month's prize picture: w1lbg tangles with a rat's nest rig!

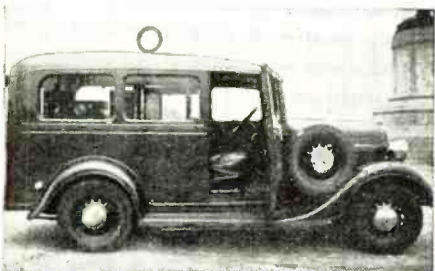

The FCC's "Bootie-chaser."

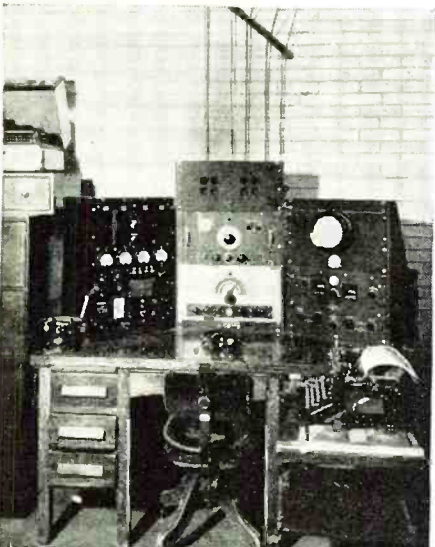

The FCC's Marine Safety Watch setup.

H A M ☆ ☆ C H A T T E R

● LE UNCA SAM has extended the time for you ops to file your finger prints until September 15th. Now there can be no excuse that you wuz on vacation, or that your "super-super-bawl-bearing 8" camera didn't work in taking your picture. Be sure to get the stuff in to the FCC by that date—the 15th—or else. . . !

HAD a guy stop us the other pee-em and ask what to do about a ham he heard calling and later working a furriner. This was after the ban on that type of QSO had been placed by the FCC. What to do, brother? That's easy! **REPORT HIM TO THE FCC!!!** There may be those who say, "I don't want to be a tattle-tale . . . I don't want to get someone into trouble . . . I don't think that it's my business to do anything about it." Man, Oh, Man! Are you wrong! Whose business is it to help keep the hams in line?? Whose business is it to see that the FCC rules are lived up to? Whose business is it to put patriotism above anything else? **NOBODY BUT YOURS!!** Why that's the very kind of thing that licked the countries that could not stand up to the Nazis! Just that sort of spirit. "Let George do it" . . . No sir! Let every ham know once and for all that we hams are treading on very, very thin ice IF we do not toe the mark! Let there be no mistake about this. **IF YOU HEAR A HAM BREAKING THE LAW IN QSO'ing A FOREIGN COUNTRY DO NOT HESITATE A MINUTE. GRAB A POST-CARD AND SEND THE INFO ALONG TO THE FCC!!** Everyone is sorry that patriotism cannot always take a popular trend . . . and reporting a ham who breaks the law is not popular . . . but it is **PATRIOTIC** and that's a whole lot more than to be unpatriotic and letting Fifth Column Activity corrupt our country into being an easy mark for the *Subversive Elements*. . . Our motto is, "Let all hams obey the law in spirit as well as in letter!" Be a Patriot—Report illegal operation which you might hear, and do it quickly—efficiently—and with deadly earnestness. Show all who might be watching that the hams **MEAN BUSINESS!**

Why Hamchatter Editors Get Grey: From the Mail Bag

Dear Hamchatter Editor:
As you are probably well aware, the majority of ECLs regard the hams as half-wits who spend the night in pointless rap-sheving or shouting "see-ew" for hours on end. This is almost entirely due to the antics of the palookas that infest the 160 meter band, to the detriment of an otherwise admirable group of men. This is not entirely my own idea, but is borne out by opinions expressed by some of the local boys who are really good.

I ran across a good example of the feather-headedness that afflicts a certain type of ham last night, that I thought might give you thought for some editorial comment on the subject.
Around 8 p.m., I came across two hams around 1980 kcs, who were shouting their heads off about an emergency Red Cross message to any

S. Carolina station. One of the hams was local and the other was located in Tell City, Indiana. After 15 minutes or so a Charleston ham called back on 1960 kcs, but met with some interference from another local ham, whose call I have forgotten.

Local boy then called Tell City asking if he could reach the Carolina ham, and Tell City said, "nope," and after about ten minutes wasted in assuring each other that Jonesy was sneering the "W's," they decided to ask Jonesy to lay off awhile. The local ham then raised Jonesy and after explaining the situation in detail turned it over to him. Jonesy bounced right back and announced a long winded discussion of the location of Tell City, it being so many miles from this and that point, and so on. After ten or fifteen minutes of this maundering, Jonesy wound up by turning it back to the local ham, saying he could then turn it over to Tell City and Tell City could turn it back to Jonesy. Nothing was said about getting off the 160. From here on the two local hams and Tell City engaged in a pointless three-way gabfest, during most of which the Charleston ham was screaming his head off for a clear channel for Red Cross traffic.

I called a ham friend of mine, who is an old-timer, and asked him if he knew these warts on the face of time, but he said no, and furthermore he didn't want to know them. He cursed the whole tribe of 160-meter phones saying that no respectable ham allowed his call to be aired there.

I don't know how it is elsewhere, but it seems to me that we have the dumbest lot of hams in the country here in (name deleted). There are probably eight or ten working on 10 and 20 that know when to know a damn thing without looking in the handbook. There is one lug here that is on the air nearly every night engaged in cross town gossip, that should take a little time off and clean up his rig. His modulation is atrocious, and half the time it sounds like he is using a.c. for plate supply.

I think this is peculiar to this town—as I met a number of hams when I was stationed in Dayton, Ohio, and most of them knew what they were doing. They did use 160 for Sunday afternoon local gossip, but seldom, if ever, engaged in the pointless drivel that marks our 160 meter band. I trust you will not take any of the foregoing as indicative of my feelings towards hams as a whole, for it is quite otherwise—but I do think there are about a dozen dubs in this city that ought to be kicked off the air.

(To which we reverently add, "Amen." Ye Hamchatter Ed.)

YLRL NEWS By W8TAY

"WYLAS" and **"WYLAC"** (Worked YL All States and Worked YL All Continents) may not prove such a "pipe dream" after all. At this writing 35 states and the District of Columbia are already represented, not mentioning Alberta, Nova Scotia, Quebec and Great Britain—plus Hawaii, Alaska and Puerto Rico. Ohio leads with 15 girls, New York is a close

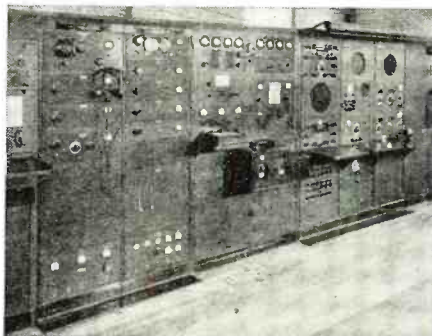

Typical FCC Monitoring Station.



Hamop w9aon and his xyl.



"She don't taste like 'Ham' to me!"

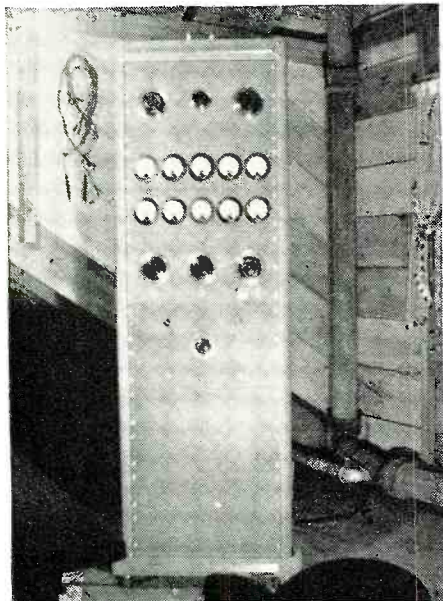

The transmitter of hamop w2cf.

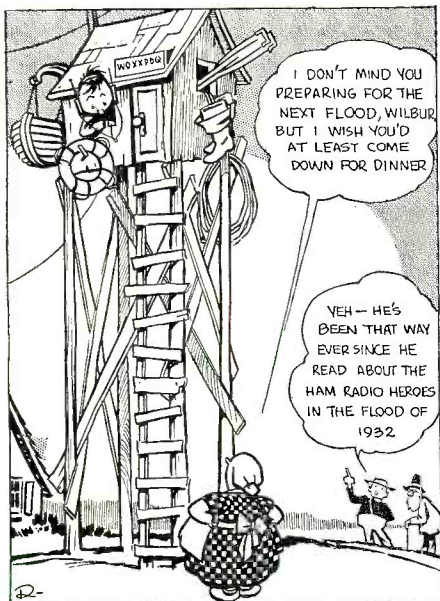

Hamop w4gff.

contender for honors with 12 YLs; Illinois, Pennsylvania and Missouri follow. The girls are optimistic enough to believe applications may be in the mails from the missing 13 states still lacking in representation. W1IOR, Lieut. C. A. Sandner, has already worked over 100 YLs. Jennie, K4FOW, and Jessie, W5HWK, both operating 10 meter phone, should be the surprised recipients by now of a recording of their voices made by W8CTI, Andy Summerville of Cleveland, who likewise presented a record of the writer's voice to her. (Frankly, I couldn't believe my ears. Who said I sounded that way?)

W3HVO was formerly 3AEC and operated from 1924 to 1928. Pauline Raser, Trenton, N. J., is active in the Delaware Valley Radio Association which has a women's auxiliary. She operates 40-80 and 160 meters.

Last month, the names of the YLRL President and Vice President were given and this month announcement is made of two recent appointments: W9NBX, Enid Carter, continues as Secretary-Treasurer of the League, while W8TAY, Anita Bien, again drew the Publicity Chairmanship post. (Thanks to the President, W7FWB, Ethel Smith, who is empowered with such authority.)

"Queens of 'Harts'" are these Leaguers: W5HWK, Jessie Hart, Eldorado, Arkansas; W7NH, Nell Hart, Twin Falls, Idaho; W9CHB, Flo Hart, Pine River, Minn. (Wonder if any is related to another?)

The Greater Cincinnati group, headed by W8TPZ, Marie, assisted by W8CKH, Gertrude of Dayton, plan a second YLRL unit patterned after the one in Cleveland. The girls just across the Kentucky line will also be invited to join. It is hoped ultimately to have localized groups all over the country and all the girls are co-operating to achieve that end. W8TLZ, Ruth, sister of W8SNV, is entertaining the Greater Cleveland group at their August meeting. As she has a beach home on the shores of Lake Erie, the girls are invited to bring bathing suits, picnic lunches, the OMs and bigger and better YL ideas. (The OMs, of course, will be excluded from the club business discussions.)

W9DXX, Alice of Homewood, Illinois, was licensed in 1930 but her newspaper work at that time prevented radio activity until several years later. Her new "shack," located 25 miles from Chicago—her old QTH—is a veritable ham-heaven. It is situated 500 feet from the highway and bounded by a large sanitarium estate as well as by the Ravisloe Country Club. She has two 60 ft. telegraph poles on her 7-acre property, as well as a 70 ft. flag-pole and a 70 ft. windmill tower but with the DX ban, she is undoubtedly wondering "What's the use?"

W7HHH, Beatrice (Bea) of Bend, Oregon, is 5th Oregon Phone Cryptographic Officer in the AARS. Operates 160-80-20 & 10 meters.

W2MWY of New York City, Ann Eleanor McGovern, is Ex-W5IRS of Kingsville, Texas.

W5IKC, Lou Lacy, Phillips, Texas, is a telephone and Teletype Op for a petroleum company and usually does her operating after 11:00 p.m.

The North Dakota girls seem to be clever at winning prizes at the fairs. W9AFK, Myrtle of Minot, who is quite clever with pencil drawings, won prizes at the State Fair while Enid, W9NBX of Bowbells, came away with a prize for her dis-

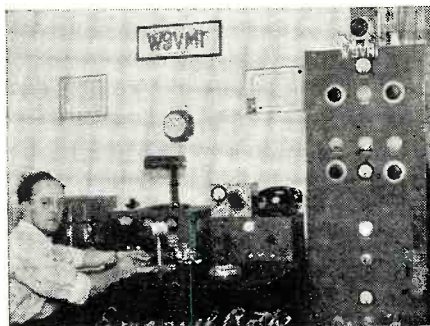

Hamop w9vmi es his hamshack!



Hamop w5iirh on Field Day.

play of QSL cards in the Hobby Dept. of the County Fair.

W9ZTU, Mickey of Fort Knox, Kentucky, has made application to join the AARS. One month recently she handled 734 messages in 24 days for the First Cavalry and the Thirteenth Cavalry. Her OM—W9ZTU—is Communications Chief in the 13th Cavalry and teaches radio in the Brigade Radio School.

W1KKG, Leora, belongs to the Nashua Mike and Key Club of New Hampshire, which state already boasts 4 YLRL'ers. She is interested in flying and is a solo pilot. Likes drills and traffic handling.

This Sixth District girl—Eva Sanderson, W6RLL of Peoria, Arizona, calls herself a "Farmerette." Not only is she interested in radio and turkeys, but lists among her accomplishments: Mandolin, Tenor Guitar and Banjo playing; singing, fishing, deer hunting, sewing and collecting picture post cards as well as housepainting and decorating. My! My! She's gone some places in her 18 years.

W7GPO, Mary of Pendleton, Oregon, received Radio and Television's Plaque Award recently for her F. B. picture of her CW & Phone Station. Mary operates 20 meters mostly.

Micky, VE4WY, as President of the Northern Alberta Radio Club helped in organizing a code class for chaps intending to join the Air Force and had about 50 members several months ago.

WSUHB's slogan "UR HAPPY BABY" identifies Adelaide's (Blondie's) station in North Braddock, Pa.

33 (Thirty Three) which has the puzzled boys' curious means, "Love sealed with friendship between one YL and another YL." This was originated by WSKYR, Clara Reger of Buffalo, N. Y., and officially adopted by the YLRL'ers. So frequently their friendship calls for more than a mere 73 in closing.

W9CHD, Lenore Kingston, changed her name recently to Conn and then changed her call to W2NAZ. Hubby is a television engineer (W2MSC) in New York City.

K4FOW was born in New Orleans.

Ada, W9RNO, Denver, Colorado, is back from a South American trip with many stories no doubt. During the course of her travels, she stopped in Port au Prince, Haiti, and visited with Mr. & Mrs. Eric Bleo.

W2USA, World's Fair Station, New York, is making a special display of all QSL cards of YLs. The League is well represented. [If there, Kay! H. C. Ed.]

An international emblem contest is in session among the members. Numerous original designs suitable for pins, letterheads, etc., have been submitted. Votes are being solicited by the Secretary on the two "finals." One design which would aptly represent the "Hair Net" Gang includes a pair of earphones, plus a hairpin, while the other more conventional drawing harmonizes with the ARRL pin but includes a fancy scroll. Other contests are being planned.

W8QHN, Virginia Sparks, is YLRL recent recruit. She is reported to be one of the first girls to take an electrical course in the history of the local High Schools. As Virginia Smith, she received her license, assisted no doubt by her father, W8PXJ.

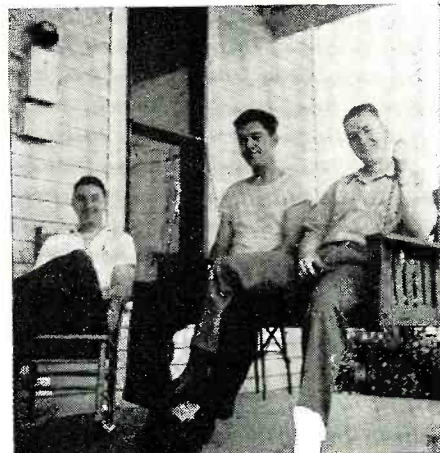

Hamops w5irh, w5drz es w5huq.

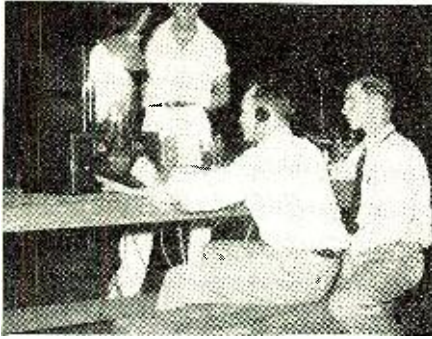

Hamop w5erv on 40 cw on Field Day.

W90UD, Letha, is as most everyone already knows, Sections Communications Manager for the ARRL in Missouri.

W2IOP wants to know if he gets new country credit for K6. The post office returned his one cent stamped card marked "insufficient postage—foreign country."

Don't do too much talking to CM7ER in English, because all he knows are the stock phrases. CR4HT is going to make everyone happy by returning to the air with 60 watts around 14400KC.

W9RPA mentioned working a fellow signing WA9A some time back. Guess the FCC didn't like the idea because no more were issued. At the present time they are re-issuing expired calls—after that we can only speculate. There doesn't seem to be any reason why WA9AA, and eventually WA9AAA can't be issued.

The VE's have many 5 letter calls, as do many DX stations and the additional — in a call wouldn't be particularly bothersome. Perhaps another solution would be complete relicensing in which the districts would be re-apportioned. Probably it would meet with too much popular disapproval to be feasible.

W3DEK the DX man is a lawyer and member of the GCAKA—

W3ANI is getting out on 20 meter fone— W3DJR is still very busy at the Phila. Navy Yard—

Crowell who was a member of 3CZN code class is now W3IOP—

SWL Brimmer is another very active beginner of 3CZN code class and is expected to meet the RI in the very near future. Good Luck John—

W3AAY and W3COD are Radio Opps at Central Airport for the TWA Lines—

The members and visitors of the Phila. Electric Co. Employees' Radio Club enjoyed a Television Broadcast and Reception put on by the Philco Television Co. W3XE. A lecture was given by one of their engineers and another gave a very interesting demonstration.

W3CNI is off the air due to much refrigeration service work—

W3CZN attended the Cumberland County Radio Club where Lieutenant B. Clifford of the 114 Inf. Regt'l HQ. Co. W3CJJ gave a very FB lecture and demonstration on "Army Communications."

The CCRA meets every 2nd and 4th Thursday of the month. If you care to meet a FB bunch of Live Wire Hams drop in and see them.

It looks like Wedding Bells after seeing 3BYK and YL at the Hamfest—

W7DX who is the RI at Seattle, Wash., also attended the Hamfest—

W3BPH and W2MFL had a J5 and Lu as visitors—

W3CZN came back from the Hamfest via Eastern Air Lines—



Hamop w5dyt displays his yll



Hamop w5cng on 75 fone on Field Day.

Mr. Pettengil and Mr. E. Braddock W3BAY of RCA Victor Co. gave an interesting lecture and demonstration on Communications for the members of the Phila. Electric Co. Employees' Radio Club. An AR77 Communications receiver was shown.

W5OHT of Wysox, Pa., is going in for Radio Service work. Lots of Luck, Harry— Several members of the GCAKA are going in for 2 1/2 meters in the near future—

NEWS from the Third District includes the announcement of the Delaware Valley Radio Association's Fourth Annual Outing and Hamfest, to be held Sunday, August 11, from 10 A.M. 'til ??? This grand jamboree will be at Trenton State Fair Grounds, Trenton, N. J., featuring free parking space, liquid refreshments, and otherwise, sports, dancing, and prizes galore. Contact 3EUH or 3CCO for reservations.

MATHIS of Georgia lets loose wid: W4FDE of Cordele, Ga., has recently purchased a new house and will be on 10 meters. He says that new BC station there will be on about July 15th.

W4AZK, Dave Traer who we listed as being at Moultrie, Ga., has accepted job with Cordele BC station and also has FB portable 20 meter rig on air there.

Jimmie Long W4KB and XYL Myrtle were host to over 100 Florida, Georgia and Alabama hams for a two-day hamfest on June 8-9th. Fishing, rag-chewing and other fun were enjoyed and all the boys report another swell time at Jimmies.

The annual Rome fest was held on June 2nd at Rome, Georgia. The Rome gang as per usual put on a swell time with prizes, speeches and plenty of eats on hand. The attendance was very good and a nice time was had by all. W4VVF and the gang certainly know how to do a ham up job of entertaining the PB crowd.

W4DPX, Montgomery, Ala., gift to ham radio has rebuilt his 160 meter rig and certainly sounds swell. We sorter hate to admit that last remark, Joe.

W4FPI at Opp, Ala., says it ain't so. The reason he hasn't been very active lately is that he has been working hard and not Y's as reported by our secret agent.

W4EQB recently visited W4GHW-W4FRF at Damascus, Georgia, and says that the boys there are mostly on ten and 160.

Note to Bud Crawford—Don't be surprised at anything you hear abt W4AUP ole Pete at Montgomery. He can QSY onto more bands than any other ham we know, and as to W4ERX at Birmingham—Boy he's got more kilowatts laying around than cats has lives II.

Dothan, Ala., club sponsored a Hamfest on June 24th which was their first. Prizes and usual eats as well as various contests were the order of the day. Attendance was very good but various calls were not obtained by this writer, due to fact that we hadda work and could not go.

PCW continues to build up swell traffic total. FNY at Brunswick has built swell new 20 meter beam that works DX nicely.

FDJ is again active on 160.

Your scribe has again been hit by hard luck in the form of lightning, which struck our house on Sunday afternoon June 9th. The flash destroyed the rig as well as the receiver and it will be sometime before we will be back on the air. The flash dazed yours truly and it was a narrow escape. Power company officials stated that it came in on their entrance and our transmitter installation was in no way to be blamed

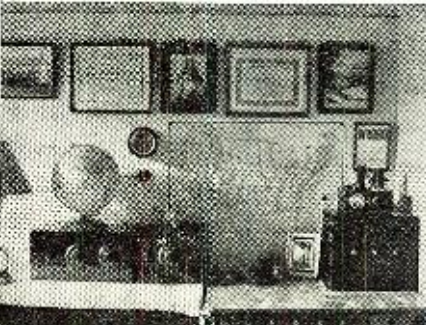

Hamstation w9dbo.



Hamop w5idk on 160 fone on F.D.

for the damage. [Ed Note: This comes as a "jolt" to us, too. Sorry!]

W4FAH is off the air at present time.

W4FPF at Brunswick must have jumped in the ocean as we haven't heard from him in a long time.

W4GHL is very active on 40.

W4EDJ has a nice sig on 40.

W4FLE is flitting around on 40 and his fist is very FB.

W4PX, the ole timer still is active on 40 and his sig is worth copying.

W4PHK is new to us on 40 and has a nice signal.

W4GTJ is very active on 40.

W4AUP is very active on 75 meter phone in case some of you W9s want to know.

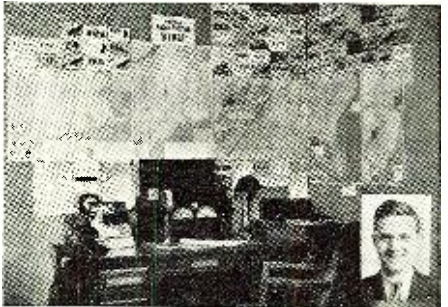

Hamop w1mgp es his vy fb rigs.

W4FID has a splendid phone xmitter on 75 and is that lovely voice your XYL om?

W4GHU, Albany, W4GFF, Cordele, and yours truly, W4ARX, have been awarded public service certificates by the Western Union Telegraph Company for work done during Feb. tornado. It's nice wallpaper and personally we thank WU for same.

NOTE to W4GFF: (Now that you have flying fever, the publishers of this magazine can supply you with Popular Aviation which same is FB). Not a paid advt.

W4BOL of Cochran tells us that his brother



"Say, Sarge, w9qxxx wants to qso us. Shall I have him call back?"

lost his plane recently when two students washed it up.

Has Tallahassee's (Florida) W4GAA lost his voice or has the XYL regained hers is what we would like to know?

Youse guys had better keep the new rules and laws regarding foreign QSOs cause we sorter like ham radio and don't want to lose same, and besides the editor of this sheet and your scribe like to eat. Hi.

W4IR has been on the sick list but is as fine as a daisy at present time getting Army Amateurs ready for winter work at Fort McPherson.

W4GPR paid a flying visit to Atlanta recently and bought out all the radio shops there hi.

W4FFI, who is on ten meters says that he has the flying fever at present time.—[Ed. Note: It's an Epidemic!]

W4GHU visited the Tallahassee, Fla., gang recently and reports a nice time.

W4CCV, Guy White of Macon was recently married at one of the largest social events of the year there. His new XYL Lydia likes ham radio though and lots of luck and happiness to you both sez us.

W4EQB says that he is being qrm'd by W4ERS on ten and that to remedy the situation he is building a new signal squirter for that band.

Has the Savannah, Ga., gang forgot your scribe?

HERE'S a little QRM from the Palmbeaches and W4DXC:

W4EZH invested in a new recvr (Sears Spl) and is getting interested in the ham biz all over ag'n.

EIA after getting knocked for the W. K. Loop



Hamrig of hamop w3bul.

by 1200 v. is rebuilding safety fashion and will be on again shortly with cathode Mod. pair of 812s in final. A boughten recvr also, tis rumored.

DXC advises he will be on the air soon. Want proof? He soldered a six-inch piece of wire to a flashlight bulb. (To save time later when he neutrs the final.) We'll believe it when we hear it, Rosey.

FNR, GFN, ACZ want to give five mtrs a fling this summer. FNR building a Lester 5, 10, Converter. (Aside to FNR—Better get some of the loose wires cleaned up in the shack, AB.

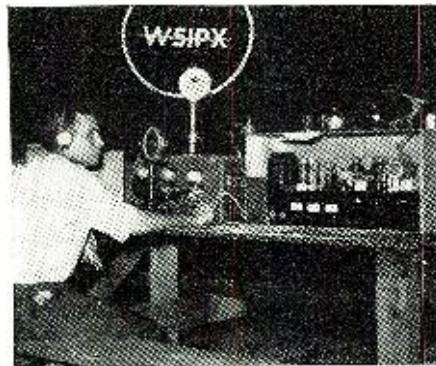

Hamop w5hos on 160 fone on F.D.

else there ain't gonna be no summer effen yu'all get across some hot stuff.)

BYD doing FB wid pair of 812s Cathode Mod.

GFN will be on 10 wid 600 watts by the time this is being read. Art wasn't satisfied getting R9 reports with the 80 watter. Betcha he doesn't get very much better Rpts wid the 600. Not on 10, that is. Arthur says he's gonna get some pix made of himself and shack one of these days. Watch for them, gang—and prepare yourselves for a big surprise. You can't always sometimes tell by the voice behind the mike.

NE of Uncle Jim's runners brought the following communication from W5IRH: Dear HAM CHATTER:

Now that summer is really here, ham radio in Little Rock is really suffering from neglect. Yours truly even attempted to revive activity by dusting off the old rig and getting back on 20 fone after about a month of inactivity, but that lasted only one day, and a local could not even be heard to call. Ham radio is bound to return, for the new cars, YLs, picnics, swimming, tennis, dancing, and laziness are surely

(Pse QSY to page 66)

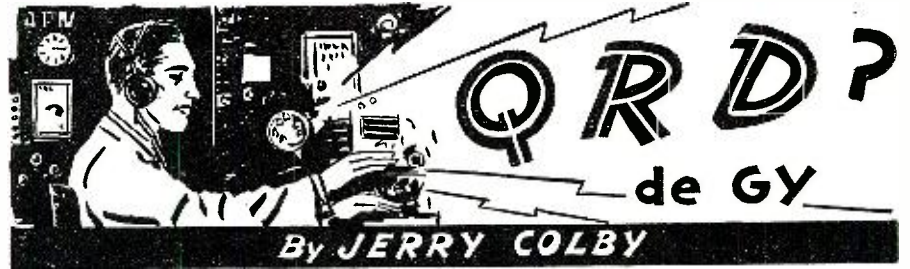

Several Hundred Radiops Needed by FCC

WE interrupt a VOX-y POP-y colyum this issue to flash: Civil Service exams are now open for radiop positions due to the present National Defense emergency of policing the wave bands. Those selected will be given temporary appointment in the field service for ninety days during which time they will be examined by the Civil Service Commission for eligibility to go on a list for further employment. \$1,800 per year for 1st Class ticketmen and \$1,620 for 2nd Class ticketmen. Several hundred inspectors and other experts will be added to the rolls to facilitate the 24 hour surveillance of all communication channels. In addition to increased monitoring duties, the FCC will be required to watch radiotelegraph and radio phone circuits; make certain of several thousand persons responsible for communications, as well as of their immediate families. There are about 100,000 licensed radiops, including "hams," a like number of cable and wire ops and other employees such as those at broadcast and other radio stations. This should be of interest to our many readers who have requested information anent jobs. Incidentally, further information about jobs and where to find 'em will be published in a following issue shortly. Watch for it!

Fred Howe Replies to "Put Up or Shut Up" Demand

IN answer to our paragraph "put up or shut up," Mr. Howe says, quote . . .

Dear Sir . . . I am wondering if you are aware that I actually did "put up" in my testimony before the Dies Committee. In reading Mr. Rathborne's reply to my charges which were, by the way, published in full in the Daily Worker issue of April 25, 1940, I observed that Mr. Rathborne did not deny any of my charges. I have read ACA News in vain to find any refutation of the long list of charges which I made before the committee.

If Mervyn Rathborne, Roy A. Pyle, Chester Jordan, T. J. VanErmen, R. H. Hansen, Joseph Selly, Michael Mignon are not Communists; if they are not members of the Communist Party; if they have not consistently followed the Communist Party Line, I suggest that each of them go before a Notary Public and make out an affidavit as follows: I, Mervyn Rathborne, President of the ACA, do hereby affirm that I am not a member of the Communist Party, that I do not support, and never have supported, Communist-Front organizations, that I have never consistently followed the Communist Party line, that I am not today following the Communist Party Line. I, Mervyn Rathborne, President of the ACA, hereby condemn the Communist Party and its members for un-American activities. I hereby condemn the Soviet Russian invasion of Finland, Poland, Lithuania, Estonia, Latvia and Roumania. I condemn Earl Browder, Roy Hudson, Sam Darcy, William Z. Foster, Jack Lawrenson, Frederick Myers, William Schneiderman and Joseph Stalin, and all communists in the ACA and the NMU for their attempts to foster upon the American people a Soviet form of government.

I, Mervyn Rathborne, President of the ACA, hereby condemn the Soviet Government of Russia for its being a dictatorship in which free speech, free press and free assemblage have been abolished. I hereby publicly condemn the principles of Communism, and those who teach them.

Mr. Colby, you appear rather childish to me when you state in your brief article: "We do not believe that President Roosevelt would appoint any man to a position of trust

like that to which Mr. Rathborne was appointed . . . the Executive Board of the NYA . . . if his background was not first investigated . . ." Besides, the National Youth Administration's Advisory Board is not in my opinion a "position of trust." It is merely "advisory." The President may or may not accept the advice of this Board. It may have been Mr. Roosevelt's intention to find out what Mr. Rathborne's views really are in respect to public questions. Therefore, the appointment—who knows? Another point is that Mr. Rathborne's position with the NYA is not one of remuneration; it is, therefore, not a position of trust.

If you are really trying to be fair you would have made a little investigation yourself. You would have read some of my testimony . . . I went to Washington for the purpose of "putting up" and this I did. I "put up" now. Now it is Mr. Rathborne's turn to "put up." It is up to him to "come clean" and make a denial which all of us can understand . . . Why did Mr. Rathborne invite Mr. S. R. Solomonik of the American League for Peace and Democracy to speak before the Third and Fourth National Conventions of the ACA? This organization "folded up" due to its exposure by the Dies Committee as being a Communist Front organization. Why did Mr. Rathborne fail to utter any protest against representatives of this league when they so frequently came to Local No. 2 to speak? Why did the Third National Convention of ACA, 1937, adjourn in a body in order to march in the parade sponsored by the American League for Peace and Democracy? Why does not the ACA and especially Mr. Rathborne, come out clean and condemn the Communist Party which he knows is bent on a political and industrial revolution in the United States? Why is Mr. Rathborne against "red-baiting"? As far as I can see "red-baiting" injures no one except the reds. Can you show me one resolution adopted by the International officials of ACA which would indicate to any one that ACA is opposed to Communism or the Communist Party?

In these days when we can so plainly see the works of the "fifth column" in various European countries, it is not enough to remain silent on this issue. It is necessary to take a firm stand, either one way or the other. "He who is not with me is against me" is as true today as it was 1900 years ago. If a man is not a Communist, he must say so in unmistakable terms. But Rathborne dodges this question. If you are trying to be fair to both unions, you will publish this letter in full in RADIO NEWS.

Sincerely, (signed) Fred M. Howe." [Ed. Note: The views expressed in the above letter are those of the author, Mr. Fred M. Howe. It is only fair of this column to publish every side of a picture that is presented for the betterment of the radiops in particular and the country in general. We will be very happy to publish Mr. Rathborne's answer to these statements.]

CB Reports fm Mid-Continent Airlines

THE teletype got us at TWA; two ops at Pittsburgh and two at Chi, also Newark Airport closed up at same time so the fellers with seniority put us young boys on the beach. But TWA did right by us; they spotted myself and one other man with this outfit and kept us on until the jobs were open here. I came off watch in Chi at 7 A.M., got the bad news and a free pass to Kansas City with the remark that Mid-Continent wanted to see me. At 4 P.M. that same day I was on the payroll for MCA. (P.S.

(Continued on page 64)

IT'S RCA FOR UNMATCHED QUALITY..UNBEATABLE LOW PRICES!

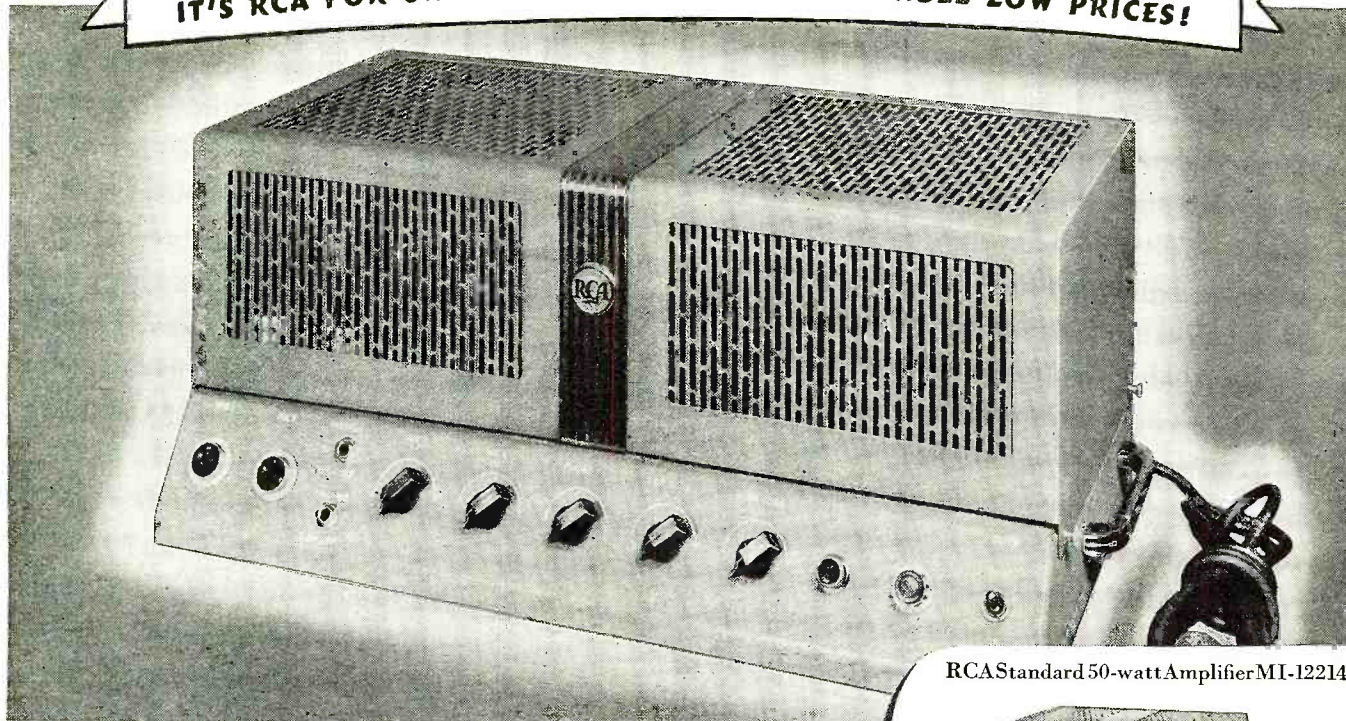

RCA Standard 50-watt Amplifier MI-12214

Economy Plus Performance

sums up the story of

New RCA Standard 50-Watt Amplifier

- 1. High Gain Single Unit
- 2. Four "High" and "Low" Inputs
- 3. Automatic Compensation for Phonograph
- 4. Bass and Treble Controls

Here's what you've wanted for a long time! This new RCA Standard 50-watt amplifier is the answer to your wish for a single unit, high power amplifier for all around use. An outstanding performer, its moderate cost stamps it a real "buy."

Look at these features! They tell the story: 50 full watts of high quality power . . . four high and low impedance input positions for microphone and phonograph . . . electric mixing . . . inverse feed-back . . . automatic phonograph (bass) compensation . . . Beam power output tubes . . . bass and treble controls . . . high gain . . . no interaction between inputs . . . full frequency response . . . pilot light . . . externally fused power transformer.

No matter what your amplifier requirement, remember—RCA can fill it with *low priced* equipment that will do a real job.

Any sound system sounds better equipped with RCA Radio Tubes



RCA 6-watt Amplifier MI-12209 operates from high impedance microphones and high or low impedance phonograph inputs. High gain—excellent frequency response. An outstanding value at a low price.

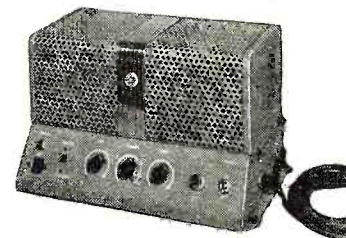

RCA 15-watt Amplifier MI-12202-B. This medium power, high gain amplifier has two individually controlled input positions for microphone and phonograph. Continuously variable tone control and other features. 15 to 20 watts output—Intra-Tube Mixing, two high impedance inputs, phonograph input jack. Excellent for moderate power installations.

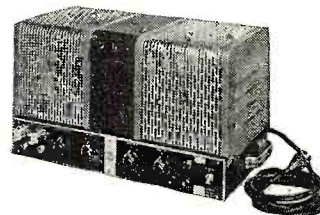

RCA 25-watt Amplifier MI-12205 has most modern circuit design, is extremely flexible, can be used for four input positions for microphone and phonographs; Remote Electric Mixing, bass and treble controls, provision for extra inputs, automatic phonograph compensation, and other features.



COMMERCIAL SOUND

RCA MANUFACTURING CO., INC., CAMDEN, N. J.
A Service of the Radio Corporation of America

TECHNICAL BOOK & BULLETIN REVIEW

RADIO OPERATORS' LICENSE GUIDE, written and published by *Wayne Miller*, suite 200, Engineering Building, Chicago, Ill. 155 pp. plus addenda. This new publication gives all of the up-to-the-minute questions and answers that are likely to be asked of the prospective radio operator during the examinations. It contains over twelve hundred and fifty acceptable answers to the six element radio operators' license examinations as embodied in the New Federal Communications Commission Study Guide. A need has arisen for an adequate, authentic and up-to-date study guide for students and others about to take the examination for radio operators' licenses.

Based on the culmination of fourteen years of extensive experience in all phases of the radio industry, the writer has endeavored to fulfill this need. Every effort has been made to present the subject in sufficient detail to fulfill ordinary requirements, and, in accordance with this aim, constructive criticism and suggestions are welcome.

The presentation of this book will appeal to those who enjoy studying material that is not "drawn-out" or too brief. The questions are right up-to-date, and the answers are carefully written with a minimum number of words so as not to confuse the student.

Many circuits are illustrated and described to aid the student in his study. Chapters include: Basic Law—Basic Theory and Practice—Radiotelephony—Advanced Radiotelephony—Radio-telegraphy—Advanced Radiotelegraphy—Appendix, which includes United States Radio Inspection Districts—FCC Rules and Regulations governing Commercial Radio Operators—Abbreviations to be used in Radio Communication—Miscellaneous abbreviations to be used in Radio Communication and International Morse Code with extracts from the list of punctuations and other signs contained in the Telegraph Regulations of the Cairo Conference of 1938.

WE PRESENT TELEVISION, edited by John Porterfield and Kay Reynolds. Published by *W. W. Norton & Co., Inc.*, New York City. 298 pp., price \$3.00. What will television mean to the American public? What is its technical background? How will television be supported? How is a television program produced? What new problems does the actor encounter? Will television take over the movies? What is the mobile unit, frequency modulation, facsimile, tele-surgery? These and a host of similar questions are answered by experts in special phases of the television field. Here are chapters by producer, program direc-

(Continued on page 59)

MANUFACTURERS' LITERATURE

THE AMPHENOL NEWS. Published by the *American Phenolic Corp.*, Chicago, Vol. 1—No. 5. This describes the new addition to the versatile line of electrical connectors by this company. These are known as the new "AN" series and have been especially designed for aircraft communication and navigation equipment, radio broadcast and police stations, public address, marine navigation, signalling and control devices, railroad safety control, communication and signal equipment, telephone, telegraph and public utilities, motion picture, theater and studio work, instrument connectors, electrical testing, industrial controls, and power and heat control. Copies of this bulletin may be obtained by writing to the *American Phenolic Corp.*, 1250 Van Buren Street, Chicago, Illinois. Free. (RADIO NEWS No. 9-107.)

RADIO SERVICE SHORT CUTS. Published by *Radio & Television Retailing*. Contains practical "bread and butter" tips for radio dealers and servicemen on how to find and repair the most common troubles peculiar to specific models of receivers plus reference charts of permanent value and use. This manual might properly be named "Money Making Short Cuts for the Radio Dealer and Serviceman." It has a wealth of new material, including all recently compiled troubles and cures, all arranged for quick reference. Price on the above bulletin may be obtained by dropping a line to the *Radio & Television Retailing*, 330 West 42nd St., New York City. (RADIO NEWS No. 10-103.)

RCA HAM GUIDE, published by the *RCA Manufacturing Co., Inc.*, *Commercial Engineering Section*, Harrison, New Jersey, price 15c. The new HAM GUIDE contains valuable information for both the amateur, who is just a beginner, and to the men who have been engaged in the design and construction of radio equipment for many years. This book features the RCA transmitting tubes which have been designed, primarily, for amateur radio applications. Each type is completely described, its ratings given and sufficient space is allocated covering the applications of each particular tube. A wide selection of high frequency triodes is presented and the advantages of each discussed. A section of the book is set aside for "Transmitting Circuit Facts," which includes general tube and transmitter data and deals with circuits in general, efficiencies, design suitability, power sensitivity, circuit flexibility, mechanical and electrical considerations, and economic stability. The subject of neutralizing is gone into in great detail and is one of the most accurate explanations that we have seen. To those amateurs lacking

knowledge of R.F. amplifier circuits, we recommend the GUIDE highly; for the advanced amateur, information pertaining to all phases of transmitter design is given. Price 15c per copy. *RCA Manufacturing Co.*, *Commercial Engineering Section*, Harrison, N. J. RADIO NEWS No. 10-104.)

LAFAYETTE 1941 MASTER CATALOG. *Lafayette Radio Corporation* (formerly Radio Wire Television, Inc.) now have their "Master" catalog for 1941, Number 82, ready for distribution. One of the biggest "books" ever issued by this concern, its 196 pages are brimming with items to meet every possible radio requirement. By far the most comprehensive radio buying guide in the world, this handsome new catalog with its four-color covers features 32 pages of the latest Lafayette radios and radio-phonograph combinations, in addition to several new types of its famous "Radiocorder" home recorder. 32 pages are devoted to Lafayette's new line of public-address equipment; 96 pages are given over to every possible type of radio equipment, parts and tools for the serviceman, experimenter and set builder. 13 pages of test instruments for all purposes are included. The "Ham," F.M. and television fan will find over 25 pages devoted to the latest equipment for short wave and u.h.f. work. 3 pages list the latest type of fluorescent lighting fixtures for home and industrial purposes.

A post-card addressed to the above company at 100 Sixth Avenue, New York City, will bring this catalog to any of our readers, without charge, or a copy may be obtained by a personal call at this or at any of the following branch stores: 265 Peachtree Street, Atlanta, Ga.; 110 Federal Street, Boston, Mass.; 901 W. Jackson Blvd., Chicago, Ill.; 542 E. Fordham Rd., Bronx, N. Y.; 90-08 166th Street, Jamaica, L. I.; and 24 Central Ave., Newark, N. J. Free. (RADIO NEWS No. 10-102.)

CUSHING PARTS CATALOG. *T. F. Cushing*, 349 Worthington Street, Springfield, Mass., distributor of radios, parts, sound and refrigeration, has issued a 250 page catalog. Contains latest listings and prices of hundreds of items. It is a comprehensive book and one which any jobber would be proud to produce. Servicemen and dealers can receive a free copy direct from Cushing. (RADIO NEWS No. 10-101.)

SUN PA CATALOG. *Sun Radio Company*, 212 Fulton Street, New York City. (Continued on page 66)

Build Your Own Oscillator

(Continued from page 14)

other is made variable between the frequency of the fixed oscillator and a value equal to that frequency plus or minus 15 or 20 kilocycles. Thus the heterodyne beat note may be varied between zero and 15,000 to 20,000 cycles per second—representing the entire useful audio spectrum. It will be seen that it is of no consequence whether the frequency of the variable oscillator is increased from the value corresponding to that of the fixed oscillator or decreased, as long as a maximum difference of 15 to 20 kc. is created. Also, it will be seen as unimportant the actual frequency upon which the fixed oscillator is operated as long as the *difference* with respect to the variable oscillator permits coverage of the entire band of audio frequencies.

For reasons of stability, however, it is the accepted practice to operate the r.f. oscillators in a beat frequency audio unit on rather low frequencies (at some selected point between 100 and 400 kc.). The two oscillators are as nearly identical in construction as it is possible to make them and they are mounted in such proximity as to experience very nearly the same temperature changes in order that both will drift in the same direction by the same number of cycles, thereby maintaining the beat note constant.

The output voltages from the fixed and variable oscillators are mixed in a suitable *demodulator* circuit (figure 4) from whence the resultant beat note is passed to a low-distortion audio amplifier, the output of this amplifier being the output of the instrument.

The dial of the variable oscillator frequency-control condenser is marked off in the frequency difference, 0-20,000 cycles per second, and a small shunt variable trimmer condenser permits setting the variable oscillator to zero beat with the fixed unit when the instrument dial is at zero cycles.

Figure 4 shows the basic principle of the instrument in functional block diagram. Numerous refinements are worked into a working version of beat frequency oscillator, however, to make the picture look not quite so simple. These refinements include any of the several devices to stabilize the self-excited oscillators, to suppress radio-frequency and audio-frequency harmonics, and to secure regulation of the power supply voltage.

The requirements that set the mark the instrument must constitute a separate discussion which follows—requirements that dictate the design and complicate the arrangement of the instrument.

Operating Requirements

A bird's-eye view of those requirements will clarify the constructional scheme underlying the development of the writer's oscillator and will at the same time summarize for the enter-

MEISSNER—and F-M

the only COMPLETE line
for Listeners and Experimenters

CONSOLE F-M RECEIVER

For highest quality, noiseless, static-free reproduction of Frequency Modulated Broadcasts, this big console receiver is the finest obtainable!

Its powerful, 13-tube chassis, with built-in super-sensitivity, together with a special high-fidelity P-M Dynamic speaker in the large bass-reflex tone chamber assure the discriminating listener of maximum satisfaction. Covers the complete F-M frequency range (42 to 50 MC) and is provided with a very flexible five-position "tone" control—exactly the right quality at your fingertips!

The large, walnut-finished cabinet is a work of art in itself—41 inches high, 30¼ inches wide and 15½ inches deep—massive, but well proportioned. The special bass-reflex tone chamber is completely enclosed at the rear for most effective baffling. Rich, two-toned veneers provide a beauty seldom seen except in the highest-priced receivers.

Model 9-1037 List \$135.00

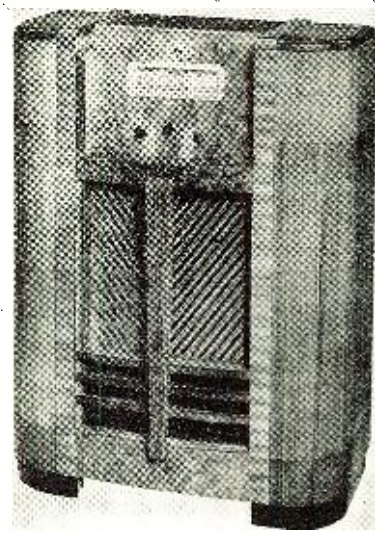
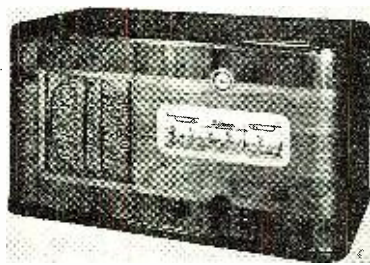

TABLE MODEL F-M RECEIVER

This model is identical in all respects to the Console Model described above except for the size and shape of the cabinet. Uses the same 13-tube chassis and same high-quality P-M speaker. Housed in a beautiful two-tone walnut cabinet, 12¼" high, 22¾" wide and 11" deep it provides a convenient economy of space but at the same time, permits a quality of reproduction impossible with an ordinary type receiver.

Model 9-1023 List \$99.25



R-F TUNING ASSEMBLY

For the experimenter who wants to build his own! Complete "front end" of the F-M receiver, wired and tested, ready to install in chassis as single unit.

01340 List \$21.50

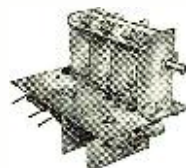

4.3 MC I-F TRANSFORMER

Special, wide-acceptance band I-F transformers designed for all stages between the mixer and limiter tubes. Double-tuned, set at 4.3 MC.

01348 List \$1.75



DISCRIMINATOR TRANSFORMER

The "heart" of the F-M receiver, this wide-band transformer is specially designed for its important position between the limiter and detector. Air-tuned.

01350 List \$6.00

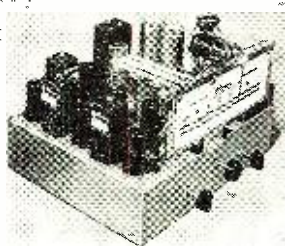

F-M CHASSIS ONLY

The same chassis used in both the above receivers—separately available for installation in your own cabinet! Complete and ready to operate, less tubes and speaker. See it at your Jobbers!

9-1041 . . . List \$68.30

Ask About the New Meissner Recorders!

ORDER THIS INSTRUCTION BOOK

See your Jobber at once or send 50c direct for your copy of the big 168-page Meissner Instruction Manual. Contains latest data on Frequency Modulation, complete circuit and pictorial diagrams on Meissner kits.

ASK FOR FREE CATALOG

Get your name in early! Brand new Meissner General Catalog will be ready soon. Lists hundreds of items of interest to the serviceman and experimenter. You can't afford to be without it. Order yours today!

ADDRESS DEPT. N-10
MT. CARMEL ILLINOIS
"A FAMOUS NAME FOR TWO DECADES"

prising experimenter the rules governing the design and construction of beat frequency oscillators of any type.

Wave Form. Since good wave form is a leading feature of any good beat frequency oscillator, every effort must be made to render the output voltage sine wave in character. The normal uses of the instrument dictate this pure-signal generation.

Sinusoidal output may be secured by employing fixed and variable oscillator circuits which are notoriously poor harmonic generators, setting the output voltages from these two oscillators to the proper level and ratio for low-distortion demodulation, preventing r.f. voltages from reaching the audio amplifier stage, and by employing push-pull circuits in the demodulator and audio amplifier stages to reduce second harmonic distortion. Adequate shielding must be provided to prevent stray coupling and radiation.

Finally, the audio amplifier plate impedance must be matched to the output transformer primary, and the output (gain) control is placed in the circuit where the least distortion will be occasioned by its adjustment.

Constancy of Output Voltage. Although the output control may be set to any desired level up to the maximum voltage delivered by the audio stage, it is desirable that the output voltage make no severe excursions as the oscillator frequency is varied.

The ideal beat frequency oscillator would deliver constant voltage at all frequencies on the dial, but this highly desirable condition is never fully obtained in practice because limitations are imposed even by the best quality components.

The voltage vs. frequency curve can be kept within reasonable earshot of a straight line, however, by using an excellent high-fidelity output transformer, allowing ample room in the layout and wiring of the demodulator and audio stages to keep stray capacitances at a minimum, and the use of resistance-coupled input in the audio amplifier.

After the voltage curve has been plotted, it may be further flattened by means of a carefully designed equalizer circuit inserted into the audio stage, provided the builder's ingenuity and abilities extend in this direction.

Tuning. In the interests of simplicity and speed in manipulating the instrument, it is desirable that the frequency control dial read directly in cycles per second. For reading ease, the audio band should cover as much of the dial circumference as possible; and since the frequency variation will not be linear, a special variable condenser is needed to give sufficient spread in the low-frequency region. This condenser's change in capacitance with rotation will be approximately log-arithmetic due to the odd shape of its rotor plates. The part is manufactured expressly for beat frequency oscillators.

Ordinary variable condenser types (straight line capacity, straight line wavelength, and straight line frequency) will not be suitable for tuning the beat frequency oscillator, as their capacitance change from either end setting is so rapid as to crowd all of the highly useful frequencies between zero and 1,000 cycles into an inch or less of dial circumference.

The special condenser requirement has heretofore often discouraged the private construction of beat frequency oscillators, since the special part could be obtained only at a very high price. Recently, however, a less expensive BFO condenser has become available and this item is indicated in the writer's instrument.

Oscillator Drift. The problem of oscillator stability is attacked both electrically and mechanically. For maximum efficiency and minimum drift, high-C tank circuits are employed and these contain low-drift condensers and coils with low distributed capacitance. Tube screens are supplied through voltage dividers and automatic voltage regulation of the plate-screen supply is recommended. Adequate by-passing and r.f. choking are employed in the usual circuit.

The oscillator coils and condensers are mounted most rigidly *below* the heavy chassis to remove them from the heated neighborhood of the tubes, and the two oscillators are placed as close together on the chassis as practicable in order that both may experience very nearly the same temperature changes.

The oscillator shield boxes are made of heavy gauge metal to prevent sagging and bending as well as to provide effective temperature baffling. Chassis and front panel are firmly braced to prevent sagging.

Very hot tubes, such as rectifiers, are mounted as far as possible from the oscillator stages, preferably along an edge of the chassis near cabinet vent holes.

Adequate provision must be made for the easy circulation of air through the case by the judicious placement of vent holes or louvres or by building the case from perforated stock.

Hum and Noise Level. Any component of the output voltage that may be due to power supply hum and tube or circuit noise must be so far below the signal output level as to have negligible effect in any application of the oscillator.

Both hum and noise are detrimental to the output wave form and at low signal levels compete seriously with the signal. A high hum component will, in addition, beat with the signal to give rise to objectionable heterodyne effects.

Hum is eliminated by the familiar methods; shortening, twisting, and by-passing tube heater wiring, grounding the electrical center of the heater supply circuit, use of a tightly assembled power transformer bolted firmly to the chassis at a good distance from the demodulator and amplifier stages, use

of better than average filtration in the power supply and a good husky filter choke, and selection of a power transformer which has plenty of iron for its ratings. The output transformer should have a heavy case for magnetic shielding and hum-bucking windings. The audio and demodulator stages must be isolated from all a.c. fields.

Tube and circuit noise is kept low through adequate shielding, operation at low levels, and use of a minimum of stages and amplification.

Spurious Signals. If harmonics of the fixed and variable oscillators are not removed, they will beat together, giving rise to "birdies," annoying whistles that are tuned in and out at certain settings of the dial.

The removal of birdies is a matter of preventing harmonic transmission, and is easily accomplished by selecting circuits for the two oscillators that are not good harmonic generators; and, in addition, installing satisfactory harmonic-attenuating devices, such as a composite low pass filter at the output of the fixed oscillator, or very loose magnetic coupling between oscillators and demodulator with electrostatic shielding to reduce capacity coupling.

How the foregoing principles were applied to the author's own version of the beat frequency oscillator, will be completely described in the concluding part of this article which will follow next month. Meanwhile, a study of the circuit diagram and the chassis layout together with the pictures would not be amiss to acquaint the reader more fully with the workings of the BFO.

Miscellaneous

- (1) Six-inch German Silver vernier dial. National NW
- (1) Output Binding Post Assembly. National FWH
- (2) 3/4-inch o. d. Victor Forms. National PRF-2
- (2) Shaft Bushings. National SB
- (2) Small Control Dials. 0-10 marked AUDIO GAIN and 5-10-0-10-5 marked CW OSC. National HRO
- (1) Flexible Shaft. National TX-11
- (8) Ceramic octal sockets. National CIR-8
- (1) 4-pin ceramic socket. National CIR-4
- (1) Flush Chassis Receptacles for A. C. Line. Amphenol 61-F10
- (1) Line Plug to match above. Amphenol 61-M10

-30-

Bench Notes

(Continued from page 28)

more thought than most of us give it.

TO the old timer the return of loop antennas and battery power supplies is strongly reminiscent of the early days. However, this is not an indication that radio is entering its second childhood as some cynics have hinted. Radio is still a husky infant, and will probably still be pulling rabbits out of hats, when most of us have no further use for Ohm's law.

Phonographs and Records

THE return of consumer interest in phonographs and records, has been an established fact for some time, as sales figures for the past two years show. The sale of radio-phonograph combinations has increased from a

comparatively negligible figure until it now represents a respectable percentage of the total sales. The sale of records has also increased by leaps and bounds as further confirmation of this pleasing condition.

These things, of course, mean added income for the service man, even though his investment in receivers for retail does not run to hundred-dollar combinations. The buyers of combinations now have two gadgets for service instead of one, and it is practically an axiom that the larger his investment in a radio, the more a customer will spend on service. Although many service men do not go in for receiver sales to any extent, there is no reason to overlook the extra profits to be had from the sale of record players to customers with older model sets. The wireless type of record player is easily demonstrated and the cost of a demonstrator is not large.

From the service angle several interesting problems will arise that require the service man's attention. Several complaints will be received that the "phonograph sounds like—" the descriptive word depending upon the speaker's state of mind and religious attitude. This trouble may be due to three things, the audio system of the receiver, the pick-up and its load, and of equal importance, the records themselves. It has often been found that the customer has several favorite records, which have been played so often that the grooves are fuzzy. It seems a simple enough matter to dismiss the subject with this statement, but it will not always be so simple to convince the customer without more concrete proof.

One way to supply this proof, and avoid a wordy explanation, is to take a few test records of your own, that are known to be good, on such calls. A little time should be spent in selecting these records as not all recordings are perfect—in fact, some of them are pretty sour. Musical selections make the best demonstrations, and a little psychology enters into the type of music to be chosen. It would obviously be poor policy to entertain the symphony lover with a swing orchestra, and the jitterbug would be exceedingly bored by a rendition of the classics. The investment in records need not be large, one record each of swing, sweet, concert and symphony recordings should meet most requirements.

If the trouble is not due to the records, the pick-up head is naturally suspected. Crystal pick-ups are commonly used in the later models of record players, and it is widely known that these crystals are adversely affected by abnormal heat, whether due to high room temperatures or careless application of a hot soldering iron. Many a crystal has been ruined by the over-long application of a cheap soldering iron that was too inefficient to do the job quickly, and the hot summer sun shining through glass on a crystal pick-up head will render it worthless in short order.

If the record player is the attachment type, connected directly to the input of the A. F. system, poor quality is often due to incorrect loading of the pick-up. The response of a crystal pick-up is considerably affected by the load, and so simple an expedient as a condenser across the circuit may be

sufficient. Values of .005 to .01 mf. are suggested. An improvement in bass response may be made by the installation of a simple equalizer consisting of a resistor of 15,000 to 20,000 ohms in series with a condenser of .01 to .05 capacity. In commercial jobs it will be noticed that two resistors are often connected across the grid circuit, with the pick-up connected to the junction of the resistors. Reference to wiring diagrams will give a clue to the resistor values to be used.

Record changers are being bought in increasing numbers, and should be approached by the service man with the respect due to an expensive piece of complicated machinery. It hardly seems necessary to advise against the use of strong arm tactics when these changers need adjustment, but two or

three cases have been encountered where the adjustment was apparently attempted by a man whose equipment consisted of a Stillson wrench and a machinist's hammer. Most of the adjustments on record changers are relatively simple, and the manufacturer's instructions are the best guide. —30—

Cuttings

(Continued from page 28)

nical terms is; All commercial records are cut at "constant velocity" and may be played with conventional record playing equipment. "Constant amplitude" records are cut with crystal cutters and the modulation of the groove is more uniform at various audio voltages coming from the amplifier.

—30—

If it's Results You Want—

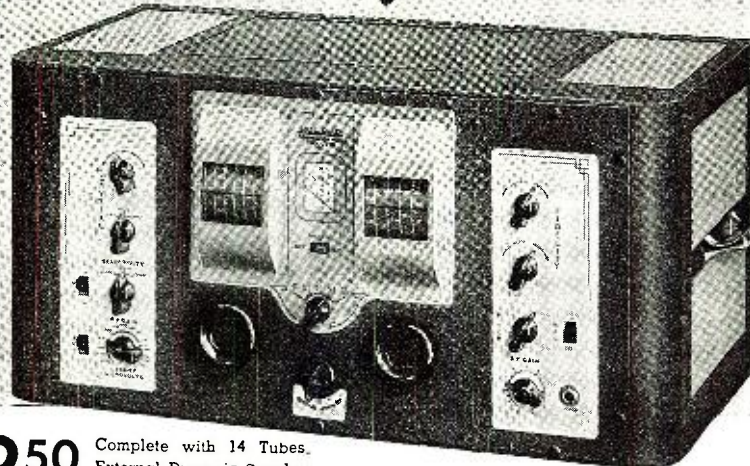

\$149⁵⁰ Complete with 14 Tubes,
External Dynamic Speaker
to Match and Crystal Filter

The New HOWARD "490" Gives You "Plus" Performance all the Way!

- 14 Tubes
- 540 KC—43 MC
- 2 Stages R.F. Preselection
- Calibrated Band Spread
- Air-Tuned I.F. Transformers
- Variable I.F. Selectivity
- Temperature Compensated Oscillator
- Split Stator Ceramic Insulated Tuning Condensers
- Variable Fidelity Audio
- 8 Watts Push Pull Output
- Automatic Noise Limiter

A Communication Receiver that could truly be termed "tops" in every respect, the HOWARD Model 490 is the result of over a year's engineering and development. New standards of performance were set and are now available for the first time outside of laboratory equipment.

You will have—sensitivity that never knows "crowding"—selectivity that may be varied from crystal CW to wide band high fidelity—an audio system with flat response of 30 to 10,000 cycles—high or low frequency cutoff of a 1600 cycle peak—and all reproduced through a dynamic speaker having the best in both high and low frequency response.

Write the factory for complete technical manual on the great 490 and see your distributor for a demonstration.

HOWARD RADIO COMPANY

1731-35 Belmont Ave., Chicago—Cable Address HOWARDCO, U.S.A.

Engineered and Built by America's Oldest Radio Manufacturer

*There's
MORE OF
Everything
in the*

New HOWARD "490"

GOOD JOBS!
for RADIO MEN in
National Defense Industries
PREPARE NOW!

NATIONAL defense orders are bringing about an employment boom in many plants—for certain types of trained personnel. Men who know Radio are in great demand! Here's your golden opportunity to get into a line that pays good money—that has plenty of future—and that offers good jobs right now!

IN ARMY AND NAVY, TOO!

In the military service too, men who know radio are needed badly. They get higher ratings and higher pay. Think that over—whether you are planning to enlist or wait for conscription. A word to the wise is sufficient!

Prepare yourself now with these books in your spare time. Right in your own home, you can

LEARN RADIO
and SERVICE WORK with
Ghirardi's **BIG 2**

RADIO PHYSICS COURSE

BASIC FUNDAMENTALS

Here's your start in Radio! If you are a beginner, this one big, all-inclusive, short-cut, self-instruction book of nearly 1,000 pages, with over 500 illustrations will give you a thorough training in the important Fundamentals of Electricity, Radio, Sound, Television, Cathode-Ray Tubes, etc.—all the essentials, all the background you need for a complete radio knowledge.

No math—no previous training necessary. It starts at the very beginning, teaching you all about Electricity first. And you can learn it all easily by yourself at home, checking your progress with the 856 self-examination Review Questions.

USED BY ARMY AND NAVY

Because Ghirardi makes everything so crystal-clear and easy to understand, this very same Radio Physics Course is used by the U. S. Army and Navy and by more radio schools and students than any other radio book!

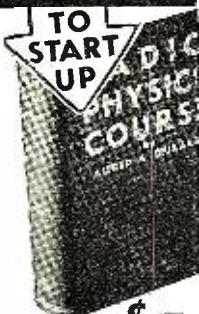

972 PAGES \$4
508 ILLUS.
856 REVIEW QUESTIONS

MODERN Radio SERVICING

LEARN HOW
with this!

This famous Ghirardi book will teach you how to test and service all types of electronic and radio equipment. It's an illustrated 1300-page "gold mine" of servicing knowledge. 420 pages explain all types of servicing test instruments—how they work, how constructed, how to build them, how to use them. Then 900 more pages give you a complete step-by-step procedure course in trouble-shooting, testing, aligning and repairing all makes of radio sets and other electronic devices. The very latest advanced, scientific Factory Methods of trouble-shooting and repairing are explained throughout. You learn service work easily at home with 720 self-examination review questions to check your progress.



1300 PAGES \$4
708 ILLUS.

MAIL COUPON TODAY!

RADIO & TECHNICAL PUBL. CO., Dept. RN-100
45 Astor Place, New York City

Send postpaid, with 5-Day Money Back Guarantee:

RADIO PHYSICS COURSE \$4. (\$4.50 foreign)

MODERN RADIO SERVICING \$4. (\$4.50 foreign)

Name

Address

City..... State.....

Please send FREE illustrated descriptive literature.

MONEY BACK IF NOT SATISFIED

SERVICEMAN'S CASE HISTORIES

Reprinted with permission, from **RADIO Trouble Shooters Handbook**, Copyright, 1939, Radio & Technical Publishing Co. Copyright in Canada and Great Britain, and all countries subscribing to the Berne Convention, by Radio & Technical Publishing Co. All rights reserved.

GENERAL ELECTRIC J-86

(Uses same chassis as RCA R-72 receiver.) See the Case Histories listed for the RCA R-72 receiver

GENERAL ELECTRIC J-87

(Uses same chassis as RCA R-75 (with 47's) receiver.) See the Case Histories listed for the RCA R-75 (with 47's) receiver

GENERAL ELECTRIC J-87-A

(Uses same chassis as RCA R-75 (with 2A5's) receiver.) See the Case Histories listed for the RCA R-75 (with 2A5's) receiver

GENERAL ELECTRIC J-88

Fading.....1) open-circuited or leaky r-f, 1st detector and i-f secondary-return by-pass condensers

Oscillation...1) corroded condenser-gang rotor contacts

Motorboating, Station hiss 2) open-circuited r-f, 1st detector and i-f secondary-return by-pass condensers

Motorboating ..1) leaky r-f, 1st detector, and i-f secondary-return by-pass condensers

GENERAL ELECTRIC J-100

(Uses same chassis as RCA R-74 receiver.) See the Case Histories listed for the RCA R-74 receiver

GENERAL ELECTRIC J-105

(Uses same chassis as RCA R-76 receiver.) See the Case Histories listed for the RCA R-76 receiver

GENERAL ELECTRIC J-107

(Uses same chassis as RCA R-77 receiver.) See the Case Histories listed for the RCA R-77 receiver

GENERAL ELECTRIC J-109

(Uses same chassis as RCA R-81 receiver.) See the Case Histories listed for the RCA R-81 receiver

GENERAL ELECTRIC J-125

(Uses same chassis as RCA R-78 receiver.) See the Case Histories listed for the RCA R-78 receiver

GENERAL ELECTRIC J-125-A

(Uses same chassis as RCA R-78(2) receiver.) See the Case Histories listed for the RCA R-78(2) receiver

GENERAL ELECTRIC JZ-835

(Uses same chassis as RCA RO-23 receiver.) See the Case Histories listed for the RCA RO-23 receiver

GENERAL ELECTRIC K-40

(Uses same chassis as RCA R-27 receiver.) See the Case Histories listed for the RCA R-27 receiver

GENERAL ELECTRIC K-40A

Weak recep-..1) high leakage or total short-circuiting of double 4-mfd. electrolytic condensers. The most troublesome unit is in the '25Z5 circuit and the

Distortion next is in the type '77 or type '78 cathode circuits

- 2) defective type '25Z5 tube. (even though it tests O.K.). Replace with new tube
- 3) inspect antenna wire at the loop on top of the tuning condenser. If this is accidentally "grounded", one terminal of the '25Z5 tube is very likely to be burned off. In this case, be sure that the trouble has been remedied before replacing the rectifier
- 4) worn insulation on antenna lead where it passes through chassis

definitely "grounded", one terminal of the '25Z5 tube is very likely to be burned off. In this case, be sure that the trouble has been remedied before replacing the rectifier

Plate currents .1) defective type '25Z5 rectifier of type '38 tubes abnormally low, (all other voltages test O.K.)

Fading1) faulty 0.01-mfd. coupling condenser between the detector plate and the grid of the output tube

RADIO PHYSICS COURSE

by Alfred A. Ghirardi

(Continued from September, 1940)

MANUFACTURE OF VACUUM TUBES

The metal parts are first assembled on the metal supports and fastened mostly by spot-welding. The entire assembly is mounted on a glass flare through which the connecting wires are sealed, and from which a hollow tube extends at the bottom. The flare is then sealed to the outer glass bulb, making an upright assembly.

The long glass tube is attached to the special high vacuum pumps which exhaust the air out. Several tubes are placed on a manifold for exhaust. They are heated by gas flames while the exhaust pumps are in operation. This quickly drives out all air and gas bubbles which may be entrapped in the pores of the walls of the bulb and all of the metal and glass parts inside of it. For a similar reason, the filament is usually kept heated by an electric current during this time. The elements are now heated to a red heat to drive out any remaining gas, by means of an external radio-frequency induction coil called a "bombarder" which drops over the glass bulb. The rapidly alternating powerful magnetic field of the coil induces powerful eddy currents in the metal parts inside, which heat them to a red heat and thereby helps to free the occluded gases which are immediately drawn off by the pumps. Of course the field has no effect on the glass bulb which is an insulator. After the tube has been evacuated as much as possible by the pumping process, it is sealed off, and the high frequency bombarder coil which is lowered over the tube heats the elements excessively to a red heat by induction. This forces out the remaining gas molecules since they expand due to the heat, and at the same time the "getter" material vaporizes and enters into vigorous chemical combination with the freed gases. Upon removal of the high-frequency coil, the vaporized "getter" condenses on the comparatively cool inner walls of the tube where it forms the familiar silver or reddish film so noticeable in vacuum tubes.

Several materials are suitable for use as getters. Among the more common are: magnesium, (same as ordinary flashlight powder), barium, aluminum, Misch-metal (a mixture composed of several rare metals of the cerium-group), calcium and cerium. Magnesium and barium are perhaps the two most widely used getters. A tiny metal cup containing the getter is usually mounted in an inverted position, usually below and to the side of the plate, so the getter is not thrown against the metal elements in the tube when it vaporizes. All of the operations of sealing the flare to the bulb, evacuating, bombarding, flashing and sealing-off are performed automatically by modern machinery.

Ringling the Bell

(Continued from page 24)

models, their method of installation, their construction, and their weaknesses. Most companies furnish their authorized service stations with full information, service procedure, manuals, parts lists, hints, etc., as well as the necessary forms which must be filled out for each authorized repair.

It is quite important that the "paper work" attendant to the obtaining of your money be handled *exactly* as the auto-radio manufacturer specifies. No "personalized" treatment is necessary. Study the various forms carefully and the instructions for their use, then *follow them to the letter*.

Let us follow out the procedure as required for Zenith authorized service. The Zenith Warranty Registration card for Ford auto-radios is illustrated. The auto dealer, upon selling the auto-radio, fills in this tag in ink and attaches it to the radio in the car. The tag must be attached to the radio in order to obtain free warranty service if required during the 90-day warranty period.

You will note that the model and serial number is printed on the face of the card and spaces are left for the owner's name, address, the purchase date, the auto dealer's name and his address.

On the reverse side the terms of the guarantee are given. In this case (*Zenith*) they are:

"IMPORTANT"

In case radio service is required during the initial 90 day warranty period, the car owner must go to his Ford dealer in order to obtain free warranty service. The dealer will make a preliminary inspection to determine whether or not the service trouble is caused by tubes or labor or fuse, and if so will correct this trouble in his own service department. If more serious trouble is experienced, the dealer will remove the radio from the car and send it to the local authorized auto radio warranty labor service station or to the nearest warranty labor distributor authorized to handle warranty parts and labor service. Transients should consult the nearest Ford dealer.

Only those distributors and service stations whose names appear in the special list furnished Ford dealers by the Ford Motor Car Company are authorized to render free warranty parts and labor service. No other service stations have been authorized to do this.

This warranty registration tag properly filled in must be sent along with the radio to the service station or distributor, otherwise they have been instructed to refuse to furnish this free service. The registration tag will be returned with the radio.

It is to the car owner's interest, and also to the car dealer's interest to see that these instructions are followed in detail.

In case the car owner elects to drive his car into an authorized auto radio service station for warranty radio service there will be a handling charge not to exceed \$1.00 for the removal and re-installation of the radio.

When a car owner or an auto dealer presents you with a set for repair, you proceed as usual. However, after the repair has been made, you must fill out a "Service Report" which is returned to the auto-radio manufacturer with your claim for a repair charge.

The *Zenith Warranty Service Report* is given here as an illustration. Note that three copies in all are made out. The white and buff copies are returned to Zenith and you keep the third, or pink, copy for your files. Note also that the information found on the *warranty registration card* is required on the *service report*. Also the repair date, a description of the trouble found and corrected, whether it was a major or minor repair and the quantity and part numbers of any parts used to effect the repair.

To obtain a warranty replacement on any part, a small pink tag is furnished. This tag, properly filled out with the date, serial number of the service report, and the service station's name and address, is attached to the warranty part and the combination is returned to the nearest *Zenith* distributor for replacement.

Actually, though the process may seem complicated, it is quite simple once a few reports have been made out. Everything has been arranged so that a minimum of paper work is necessary.

In some cases (Chevrolet for instance) it is quite important to watch the coding on all tubes and parts. Every model has a code and every tube and part used in that model is coded accordingly. Thus, if you send in a part

coded for one model and a report showing work done on another model, they cannot be honored. Tubes are likely to be shifted between two model sets previous to the time you get one of them for repair. If you aren't careful to check the code, you may buy a tube that you can't eat.

Coming back to the problem of filling out reports, I cannot stress too much the care with which you should do this. Give the auto-radio manufacturer *all* the information he asks for. After all, he's the fellow who is paying the bill and he is entitled to his money's worth.

Another point. Don't expect to grow rich on this business. Remember that it is a "pot-boiler" and a "business-getter," and that it is supposed to supplement your service work. —30—

ALLIED'S 1941 RADIO CATALOG

Shows Everything New in Radio!

FREE

212 PAGES

100% RADIO

DEPEND ON ALLIED—

THE WORLD'S LARGEST EXCLUSIVE RADIO HOUSE!





83 NEW RADIOS!

Nothing like it in all Radio!—outstanding 1941 HITS! New style plastic and wood table models—new world-wide sets—new "Camera" and 3-way Portables. Also newest 1941 low-cost Phonograph-Recorders. Combinations, Phonograph Players and Accessories, Auto Sets—all at amazingly low prices—Big special 40-page section!

NEW SOUND SYSTEMS!

1941 P.A. design—types for every Sound application. 24 new Systems—7 to 75 watts—new illuminated panels, "Safused" Speakers and other exclusive features. Lowest P.A. prices! Attractive Time Payment Plan—15 Day Trial Offer. Complete line of P.A. accessories—all in a big special 35 page P.A. Section!

NEW SERVICE SECTION!

128 value-packed pages devoted to all the new Test Equipment—new tools—new Service books—more than 1,000 quality Radio parts for every radio purpose. Radio's biggest Buying Guide—showing Everything in Radio at Lowest Prices! Also new and bigger Bargain Section—don't miss it!

AMATEURS! Don't miss the biggest Amateur Selection in all Radio! See all the new Ham Receivers, Transmitters and gear—also check the best Time Payment Plan offered anywhere. You'll see why ALLIED is famous as Amateur Headquarters!

RADIO BUILDERS! See the biggest Kit Section in Radio—dozens of brand-new Builders' Kits and diagrams—new ideas—new supplies and parts. There's nothing like this 1941 ALLIED Catalog in all Radio—get your FREE copy today!

ALLIED RADIO CORPORATION

833 W. JACKSON BOULEVARD
CHICAGO, ILLINOIS

ALLIED RADIO CORP.
833 W. Jackson Blvd., Dept. 1-K-1
Chicago, Ill.

Send me your FREE 1941 Fall Radio Catalog showing Everything in Radio.

Name

Address

City State



YOURS AT NEW LOW "Toboggan" PRICES . . . ANTENNA RELAYS By GUARDIAN

★ Modern straight-line production methods . . . and volume sales to thousands of radio amateurs . . . enable GUARDIAN to offer these precision engineered antenna relays at low prices. Buy the best . . . and save money at the same time. These relays are famous for sturdy construction and dependable operation. Easily mounted in any position. Tested under actual operating conditions, will handle any power up to 1 k.w., any frequency up to (and including) 28 MC on A.F. or R.F. circuits.



Model
A-100

Antenna Relay

Model A-100 — Double Pole—Double Throw. AlSiMag insulated. Same rating as A-100-C. For single wire fed antenna installations, two A-100-C's in place of an A-100 will avoid possible mismatch caused by distorting two-wire systems to provide for single relay installation.

LIST PRICES

Standard A-100, A-100-C, Antenna Relays AlSiMag Insulated. Operate on 110 V.—50 to 60 cycles A.C.

A-100 Double Pole—Double Throw. **\$5.95**

A-100-C Single Pole—Double Throw. **\$3.30**

**R-100 Relays AlSiMag Insulated
Same Rating as the A-100 Relays:**

R-100-C Single Pole—Double Throw. **\$3.30**

R-100 Single Pole—Single Throw. **\$2.75**

R-100-G Triple X Insulated. **\$5.00**

FREE CIRCUIT DIAGRAMS

See your jobber today or write for specifications and full details.

ASK FOR BULLETIN "N"



GUARDIAN ELECTRIC

1630 W. WALNUT ST. CHICAGO, ILL.

Aircraft and Radio

(Continued from page 18)

All radio transmitters and receivers used in aircraft are mounted on shock absorbers, or material which will lessen vibration. After installation, all shock mountings should be checked for their mobility.

The power leads to both the receiver and transmitter should be as short as possible, and filtered by installing the correct size of choke and condensers in the leads ahead of the primary source. These leads should also be bonded and shielded to the metal mass of the aircraft for receiver noise elimination.

Ignition noise is a very large problem on nearly all aircraft radio receiver installations, but by the following procedure, noise-free operation will be obtained. *Be certain*, that the engine itself is bonded to the main metal mass of the airplane structure; that all gas pipes, oil lines, magneto housings and cables are bonded to the engine properly, and that all spark plug shields are tightly fitted. That all high-tension cables are bonded to a centralized part of the metal mass.

Bonding is absolutely necessary and cannot be emphasized too highly.

Voltage regulators and current-cut-outs should be adequately by-passed with condensers having values of .5 mfd. to 1 mfd. capacity.

If noise caused by the ignition system is heard after the receiver has been installed and adjusted, and the trouble cannot be readily located in the usual manner; a probe antenna consisting of a coil of wire attached to a wooden implement about three feet long should be used. The coil is connected to a shielded lead which is grounded to the airplane near the receiver and the "independent lead" connected to the receiver itself. With the earphones on, with the engine running up to where the generators "cut-in," moving the coil near the harness (ignition) and different components of the ignition system, an increase in noise level in the telephone receivers will indicate the faulty connection or radiating member. Of course, the antenna connected to the receiver is removed, and the lead in the shield is connected to the antenna post while searching for the offending part.

The shielding of cables, etc., prevents or helps to prevent electro-static radiation; but the magnetic radiation caused by the electrical wiring system of the airplane can only be eliminated by running the supply wires, etc., parallel to each other in such a way that the fields created by the current are cancelled. Chokes mentioned above will help to eliminate a large part of the magnetic disturbances.

Defective spark plugs are the greatest source of interference and should be replaced.

Generator interference can usually be eliminated by employing condensers of about .05 mfd. capacitance shunted across the input and output of the gen-

erator. A condenser should be connected from A plus to ground, this usually eliminates generator hash.

Rain and snow static caused by the accumulation of electro-static charges on the airplane structure leaking off is minimized by employing a trailing wire, which is attached to the airplane through a fair-lead (tube) at the tail of the plane. Attached to the remote end of the wire is a resistor or "cartridge" which takes care of the accumulating charges. This device is used quite extensively by air lines and commercial aviation services today, and can be purchased at a number of aircraft radio manufacturing plants.

Power supply noise caused by faulty dynamotors, vibrator power packs, and other power supplies is quickly localized by utilizing another unit which is known to be noise free and connecting it to the receiver. However, if another unit is not available, there are two methods which may be used to determine the noise content of the power supply. The first method makes use of a pair of headphones. By connecting the output of the supply to the input terminals of a diode rectifier to which the phones are connected in series with a condenser, the intensity of noise can be determined by an aural check. The second method makes use of a sensitive indicating device calibrated in decibel units and connected to a two stage audio frequency amplifier. By noting the increase of noise level directly in decibel units, and comparing them to others plotted on the chart, the direct comparison test may be made, and used for future reference when noise again occurs. A very accurate method of noise determination makes use of the oscilloscope. This instrument will always show the relative quietness of dynamotors and other power supply devices.

Most noises caused by dynamotor operation can be traced to dirty or faulty commutators, worn brushes, or faulty brush holders; and in some cases, defective filter elements. If a vibrator power supply is used, noise can be traced to defective vibrator contacts, defective filters, or faulty rectifier tubes, such as the OZ4.

Another noise prevalent in aircraft radio receivers is tube noise. Due to excessive vibration from day to day, the internal elements of the tubes are shaken loose which results in intermittent noise according to the intensity of vibration. A tube tester employing a noise indicator is quite necessary to find the offending tubes.

If the original installation has been carefully performed, many of the undesirable noises often experienced will be eliminated.

Weight distribution is another important factor in both the installation of the receiver and the transmitter, but by consulting the manufacturer of the aircraft, this important factor can be taken care of, and it can be definitely decided where each should be located in accordance with weight dis-

tribution considerations. Sometimes a compromise must be made, but by following the manufacturer's instructions, a balanced installation will result.

The choice of a transmitter has not been considered as yet. Therefore in laying down the rules for purchasing a transmitter we must consider many things which are more or less generalized. However, the fact still remains that there are definite rules which must be followed in purchasing a transmitter if the buyer is to obtain what he is paying for.

Aircraft transmitters should be crystal controlled preferably; or they must have a means whereby frequency drift is held at a known minimum. The power output of the transmitter depends upon two factors, i.e., distance, and size. Therefore when purchasing an aircraft radio transmitter, the power output should be adequate for a distance of at least 15 miles (voice transmission). This would normally mean about eight to fifteen watts for 6210 and 3105 kcs. The transmitter itself should be compact, easily serviced, with a minimum amount of current input. The power output also being controlled by the latter.

There are a number of radio manufacturers today who build transmitters for use in aircraft whose weight is negligible, crystal controlled, with means provided for both Continuous Wave and Modulated Transmission. (Voice)

On nearly all large aircraft today used for transportation, there is usually provided an extra receiver and transmitter, entirely battery operated, which may be used in case either of the regular sets fail during flight. These sets are very compact and very efficient.

The care of aircraft storage batteries is of prime importance. They are usually manufactured in such a manner that the electrolyte cannot be spilled by maneuvering the aircraft. Those manufacturers authorized to manufacture aircraft storage batteries today make it a point to keep within the high standards set by the Aircraft Radio Industry. If an aircraft battery fails, the failure can usually be attributed to either incompetent servicing or neglect. The specific gravity (total) should never be allowed to drop below 1275, under no circumstances below 1200.

Batteries should be checked weekly and water added if necessary.

The choice of an aircraft storage battery rests upon the service required, and the size and output of the generator. It should have an overload factor of 75 to 100%. This is a high requirement, but usually can be met by battery manufacturers. The battery installed in aircraft is the life of the whole radio system, a failure here would mean the failure of the entire radio installation. Sometimes a wind-driven generator is used, however, they have been outmoded with the advent of new power supply de-

vices which occupy less space and require less maintenance.

If cables are used for connecting the different components of the installation together, along with plug connectors, they should be shielded and bonded wherever possible. If undue vibration is apparent, the cables should be taped and shellacked. The plugs should be seated firmly in their respective sockets, and the male connectors should be clean. If uncleanness is prevalent, arcing of contacts may occur which will result in receiver noise and instability.

When tuning up the transmitter after installation make certain that the proper terminal voltage is applied to the high voltage power supply and

that the rated voltage applied is constant in value.

If the set has an oscillator which is not crystal controlled, frequency changes will be noticed after the plane is in the air, and even in the case of crystal controlled transmitters, some changes in operation will be noticed if the power input voltage is not up to the manufacturer's specifications.

The terminal input voltage to nearly all aircraft radio equipment, whether a voltage regulator is used or not, is somewhat higher when the engine is operating. This is due to the added generator voltage.

It is well known that proper maintenance and repair cannot be efficiently performed if the proper testing

BUY DIRECT FROM THE MANUFACTURER AND SAVE

Announcing for the First Time — The New

DYNAROMETER

Features New Giant 8½" Double Jewelled Meter

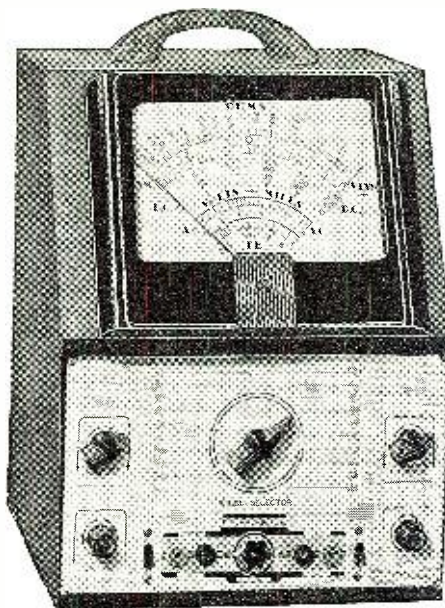

This amazing versatile instrument is our answer to the demands of radiotronics for a combination instrument which, in addition to making the usual V.O.M. measurements, will also permit DYNAMIC D.C. VOLTAGE MEASUREMENTS without interfering with or upsetting delicately balanced circuits, such as tuned circuits, electronic apparatus, control voltages, etc. Actually, as you will note from the specifications listed below, the DYNAROMETER is a combination Vacuum-Tube Voltmeter and V.O.M. besides permitting additional measurements such as Capacity, Decibels, Inductance, etc. All calibrations printed in large, easy reading type on the giant 8½" double jewelled meter. The Input Impedance for the V.T.V.M. is 11,000,000 ohms with 2,000,000 ohms per volt on the lowest range. The 4 V.T.V.M. ranges are 5, 25, 100 and 500 Volts, and because of the zero center no attention need be paid to polarity since the meter will read either in the plus or minus direction, depending on the position of the probes.

HAVE YOU EVER—

Tried to measure Control Voltages such as A.V.C., A.F.C., oscillator, etc.?
Impossible with the ordinary V.O.M. due to loading of the circuit BUT the 11-megohm input impedance of the DYNAROMETER enables measurements without molestation at any point in the receiver.

Tried to locate distortion in the audio section of a receiver?
A long tedious job with the ordinary V.O.M. but almost instantaneous with this new DYNAMIC method of testing.

Tried to isolate the cause of trouble in an intermittent job?
Not only is this possible with the DYNAROMETER, but because of the extreme sensitivity and flexibility measurements are possible at points usually impractical with a V.O.M.

SPECIFICATIONS:

- | | |
|--|--|
| 4 D.C. VOLT RANGES AT 11 MEGOHMS INPUT:
0-5/25/100/500 Volts | D.C. CURRENT MEASUREMENTS IN 4 RANGES:
0-1, 0-10/100/1 Amp./10 Amp. |
| D.C. VOLTAGE MEASUREMENTS IN 5 RANGES:
(at 1000 ohms per volt)
0-10/50/250/500/5000 Volts | 4 OUTPUT RANGES:
0-15/150/1500/3000 Volts |
| A.C. VOLTAGE MEASUREMENTS IN 4 RANGES:
(at approximately 800 ohms per volt)
0-15/150/1500/3000 Volts | 2 CAPACITY RANGES:
.0005-1 Mfd.
.05-100 Mfd. |
| RESISTANCE MEASUREMENTS IN 3 RANGES:
0-1,000 Ohms, 0-10,000 Ohms, 0-30 Megohms. | INDUCTANCE:
1 H.—70 H.
7 H.—10,000 H. |

The Dynarometer operates on 90-120 Volts 60 cycles A.C. Comes complete with test leads and all necessary instructions. Shipping weight 20 lbs. Size 13½"x10"x8¼". Our net price.....

\$18⁷⁵

SUPERIOR INSTRUMENTS CO. 136 Liberty St., Dept. RN-10
NEW YORK, N. Y.



★ "It's the best way I know to be sure of top performance!" Yes, sir—servicemen, amateurs, engineers all *know* that Ohmite Resistors work for you day in and day out—dependably! They're standard, too, with designers and manufacturers of amateur, commercial and broadcast equipment. Next time, install "Cordohms," "Dividohms," "Brown Devils," or other Ohmite Parts. Get them at your Jobber.

MAIL COUPON NOW!

OHMITE MANUFACTURING COMPANY
4883 Flournoy St., Chicago, U. S. A.
SEND FREE CATALOG 17

Name

Address

City State



OHMITE
RHEOSTATS RESISTORS TAP SWITCHES

facilities are not available.

When the manufacturer has complied with all existing regulations insofar as his radio equipment is concerned, the standard of his equipment must be upheld by the maintenance and repair personnel. In order to do this, they must have the necessary testing equipment, which will efficiently test every piece of radio equipment installed in aircraft and have on hand the necessary parts which come up to CAA specifications.

Every aircraft maintenance radio laboratory should have the following instruments for aircraft radio work: A good cathode ray oscilloscope, and accurate frequency meter (preferably crystal controlled), a capable power unit tester, a universal volt-ohmmeter with at least 5000 ohms per volt sensitivity; a tube tester of the dynamic type having an incorporated noise indicator, a probe antenna, dummy antenna with various resistive values, a calibrated test oscillator, a universal power source up to 1000 volts d.c., a calibrated vibration test stand, associated alignment tools, etc. This equipment is all shop equipment, and with the necessary parts, any aircraft radio installation may be competently taken care of.

When servicing aircraft radio equipment, it must be remembered that all component parts of the installation should *always* be kept as clean as possible. This not only includes the exterior parts, but also the interior parts of the set as well, which are liable to dust, corrosion (due to moisture, etc.), and detrimental conductive material which inevitably seeps through the ventilator openings of the receiver, transmitter, and set boxes.

In cleaning each part, care should be taken that a proper cleaning solvent is utilized. However, the type used, depends upon the part being cleaned. Carbon-tetrachloride, is generally taken to be one of the most effective cleaning solvents, and can be used with safety on nearly all component parts, both interior and exterior.

After cleaning the exterior portions of the set with carbon-tet, a light grade of machine oil (preferably typewriter oil) should be used and thoroughly wiped "dry" with a clean rag. The thin protective coating of oil applied is worth the time, because it affords added protection to corrosion, especially around humid territory. This thin protective film also acts as a polish and adds to the set's appearance.

Rotary switches (contacts), telephone plugs, commutators, etc., should be cleaned with carbon-tet. Thin sandpaper, crocus cloth, etc., should be avoided when cleaning commutators or vibrator contacts, when only a small amount of "dressing" is required.

It is of course realized that the necessary portable test equipment, etc., should also be on hand for work around the airplane itself.

The many troubles which inherently

develop in aircraft radio equipment are numerous and various.

A good rule to follow when attempting to locate trouble is: "*always look for the simplest causes of trouble first, preferable the exterior troubles.*"

A good technician is always distinguished by his manner of approach. He analyzes the symptoms first, then attempts to localize the cause. After he has found the trouble, he not only remedies it, but also examines each component part of the installation for other defects which may have occurred.

It has been often said that one test flight will equal fifty ground test operations. If this holds true, and I sincerely believe it does, there is no test which will parallel a test flight and operating the equipment under actual conditions.

A maintenance chart should be used such as the one illustrated, and used whenever maintenance work is necessary or has been performed. This chart serves as a future reference which may be consulted when troubles again prevail.

Ordinarily, the radio equipment in an aircraft should be checked thoroughly every thirty-five hours, and all antennae should be replaced every 140 hours, with a check of the transmitter frequency every five hours. If crystal controlled transmitters are used, the tuning should be checked every ten hours. Of course, a pre-flight inspection is made of all radio equipment.

Due to the vibration encountered in aircraft it is quite necessary to rigidly inspect all component parts of the installation as often as it is deemed advisable.

An inspection on the ground would consist of receiver operation, inspection for loose components, cable tightness, etc., with the engine running up and with the engine static. In this manner we have two checks.

The noise level at different operating voltages as the engine is warmed up and when the engine is not operating, gives a relative check of receiver "quietness." When testing the equipment while the engine is running, we can also observe the affects of vibration.

Distinguishing between power line interference and engine noise, along with atmospheric static, isn't really a hard job. After working around aircraft radio installations for awhile, personnel usually get onto the "knack" of distinguishing between the three types of disturbances.

Before attacking the trouble when a set is inoperative, the radio technician should consult the operator of the aircraft and ascertain as to when the set became inoperative, how long it was operated prior to inoperation, and whether or not the set exhibited any marked peculiarities just before it went out.

With the information supplied in mind, the average experienced radio technician can usually find the trouble

within a short time. However, there are times when it takes a long while before the actual trouble is located and remedied.

All sets require careful testing, and if possible, this should be done in the shop on the bench. If the pilot is in a hurry, substitute units should be provided.

It has been found that the radio sets which were carefully and properly installed and maintained at the beginning of usage, never required much actual repairing. However, there are common troubles which develop and are as follows: Defective tubes, low supply voltage, defective or discharged battery, faulty generators, defective switching relays, faulty microphones, corroded telephone jacks, defective dynamotor or vibrator supplies, faulty resistors, corroded or dirty tube socket connections, broken cords, and last but not least, defective (loose) connections caused by vibration. These were named in the order of their frequency, from experience.

Detuning of the transmitter circuits caused by vibration and detuning of the receiver circuits are also numerous.

A localizing method should be used in attacking all troubles. However, the test procedure differs according to the radio technician's experience, and due to the fact that a different method is used each time different symptoms are displayed, it would be quite useless to go into detail as to exact test procedure.

The Aircraft Radio Service Field is open to those men who are trained, and who can be depended upon. It isn't a field where the "screw-driver" mechanic of yesterday can dabble, it is a field which requires a man who keeps up on his theory and brushes up on his experiences.

A pilot's and passengers' lives may sometime depend upon how well the Aircraft Radio Technician has done his job, and for SAFETY'S SAKE, THE 50% OVERLOAD FACTOR SHOULD BE ELEVATED TO 100% WHEN WORKING WITH AIRCRAFT RADIO EQUIPMENT.

After the radio technician has finished whatever work he may have done on the equipment installed in an aircraft, and as it taxis to the runway and takes off; if that radio technician has done his job well, there can be only one thought in his mind as that plane takes off, "I HELPED TO GIVE HIM SAFETY." -30-

Blitzkrieg Radio

(Continued from page 10)

there are radio intelligence companies which are assigned the job of intercepting enemy messages, sending false messages to the enemy, locating enemy stations by radio goniometry, etc. This work is one of the most fascinating aspects of military science.

Of course, in all battle zones the enemy is seeking constantly to inter-

cept your messages. For this reason, almost everything is sent in code. But codes are not invulnerable and sooner or later, cryptographers say, any of them can be broken. Codes are changed often during battle, but you may be lucky enough to have the enemy code or he may be lucky enough to have yours. So for that reason, every effort is made to intercept.

The Russians lost the Battle of Tannenberg to the Germans, military students say, largely because Ludendorff was able to intercept their messages. The Russians sent everything "in the clear" and often, because of poor transmission between Russian stations, the Germans had the enemy battle orders before the Russians got them.

Only in extreme emergency or in a place where even if the enemy intercepted a message they couldn't do anything, does our Army permit messages to go in the clear. Even if the enemy can decode the message, the time he loses will often render the message valueless.

Anything goes in a war and this applies to radio just as it does to bombing raids. The two chief "tricks" in radio war are jamming and sending phony messages. Jamming doesn't do much good, as a rule, because it so often works out that you are jamming your own stations as well as the enemy. The Army finds it more profitable to intercept than to jam. Sending phony messages sometimes is effective.

BUY DIRECT FROM THE MANUFACTURER AND SAVE

**THE NEW MODEL 1240
TUBE TESTER**

- Instantaneous snap switches reduce actual testing time to absolute minimum.
- Tests all tubes 1.4 to 117 volts.
- Sockets for all tubes—No adapters.

Superior is proud to offer the newest and most practical tube tester ever designed. Unbelievably low in price—unbelievably high in performance.

- ★ Tests all tubes, 1.4 to 117 volts, including 4, 5, 6, 7, 7L, octals, loctals, Bauhinia Jr., Peanut, single ended, floating filament, Mercury Vapor Rectifiers, the new 8 series, in fact every tube designed to date.
- ★ Spare socket included on front panel for any future tubes.
- ★ Tests by the well-established emission method for tube quality, directly read on the GOOD ? BAD scale of the meter.
- ★ Jewel protected neon.
- ★ Tests shorts and leakages up to 2 megohms in all tubes.
- ★ Tests leakages and shorts in all elements AGAINST all elements in all tubes.
- ★ Tests BOTH plates in rectifiers.
- ★ Tests individual sections such as diodes, triodes, pentodes, etc., in multi-purpose tubes.
- ★ Latest type voltage regulator.
- ★ Features an attractive etched aluminum panel.
- ★ Works on 90 to 125 volts 60 cycles A.C.

Model 1240 comes complete with instructions and tabular data for every known type of receiving tube. Shipping weight 12 pounds. Size 6" x 7 1/2" x 10 3/4". Our Net Price.....

For a cover \$1.00 additional



\$1 85

**THE NEW MODEL 1220
POCKET LABORATORY**

- ★ WEIGHS ONLY 28 OUNCES!!
- ★ USES A 2% ACCURATE 0-200 MICROAMMETER—ENABLING MEASUREMENTS

AT

5000 OHMS PER VOLT

SPECIFICATIONS

- ★ 6 D.C. Voltage Ranges: 0-3-10-50-250-500-5,000 volts.
- ★ 3 A.C. Voltage Ranges: 0-15-150-1,500 volts.
- ★ Resistance Ranges: 0-3,000 ohms, with 15-ohm center, direct reading to 0.2 ohm; foregoing base range multiplied by 10, by 100 and by 1,000, to read up to 3 Meg. with self-contained 3 V. flashlight battery.
- ★ 4 D.C. Current Ranges: 0-200 microamperes; 0-2-20-200 Milliamperes, using wire-wound shunts.
- ★ 3 Output Meter Ranges: Same as A.C. Voltage Ranges.

- ★ 3 Decibel Ranges: From -2 to +58 D.B., based on .006 watt in 500 ohms.
- ★ Uses full-sized 3/4" square 0-200 microammeter, with 2% accuracy and finely damped movement, contained in a handsomely-designed, square molded Bakelite case.

Model 1220 comes complete with cover, self-contained battery, test leads and instructions. ONLY.....

\$10 45

**SUPERIOR INSTRUMENTS CO. 136 LIBERTY ST., Dept. RN-10
NEW YORK, N. Y.**



UTTERLY NEW!

**STRANGELY AND BEAUTIFULLY
UNLIKE ANY RADIO RECEPTION
YOU HAVE EVER HEARD**

FREQUENCY MODULATION . . . the sensational new and entirely different system of radio broadcasting and reception . . . has been approved and declared "highly perfected" by the Federal Communications Commission. It is generally predicted that some 1000 new F.M. transmitters will be installed at an early date. More than 20 are already in full operation. A completely new type of receiver is required for this amazing new Frequency Modulation reception! Always far ahead, Mr. E. H. Scott has developed a magnificent new SCOTT custom built F.M. Receiver which is causing a sensation. It creates a perfection in radio reception far above any the world has ever known!



**NO STATIC
NO INTERFERENCE
NO "NOISE"!**

Frequency Modulation reception by the remarkable new custom built SCOTT is incredibly beautiful . . . like a dream come true! NO STATIC, no interference, no "noise" can be heard within the service area of the F.M. Transmitter. In fact, the most favorable conditions for demonstrating are in the midst of a crashing electrical storm, where the ordinary radio is rendered useless! During pauses between programs or stations there is nothing but deep silence . . . only the dial lights tell you the current is on. Tone is so utterly realistic it is practically impossible to tell the difference between the original sound and SCOTT F.M. reproduction!

BE FIRST TO OWN THE F. M. SCOTT!

Don't wait. Be among the first to own this sensational new home entertainment. The custom built SCOTT is now ready to receive the new Frequency Modulation programs on the new F.M. wave band allotted by the government. ONLY the SCOTT gives a 5 year guarantee and custom builds to order, with infinite precision. The newest SCOTT offers local broadcast, short wave, and the new F.M. reception all on one chassis! Send now for amazing facts and moderate prices.

MAIL COUPON FOR MONEY SAVING OFFER!

**E. H. SCOTT RADIO
LABORATORIES, INC.**

4440 RAVENSWOOD AVE.
DEPT. 5R40
CHICAGO, ILLINOIS

Send all the facts,
analysis of SCOTT
receivers, and or-
derblank. NO obli-
gation.

Name.....

Address.....

STUDIOS: NEW YORK, CHICAGO, LOS ANGELES, DETROIT, BUFFALO



You make up a message in the enemy code, or send it in the clear, on one of his frequencies and use his station signals. This may lure an enemy unit into a trap or throw him off guard. The best way to guard against this happening to yourself is to get confirmation on questionable messages. And then, you get to know the style of your own men so well that it is hard to fool an expert.

All kinds of deceptions are possible. Sometimes, a station on one side will cut in to a net on the other side and stay for hours, sending false messages. The other side, realizing the hoax, may play along with him—giving him "innocently" all kinds of information, which will invariably prove 100 per cent false. It gets to be quite a game.

The location of enemy stations by the triangulation method may be a more effective method of disrupting his communications. When you get a big headquarters station, or even a smaller station, located, it can be put out of action by aerial bombs or artillery fire.

Because of enemy interceptors, Army units are taught to be cautious in the use of radio. A mechanized column, for instance, which is operating far from a combat zone will have a radio in the first vehicle, the last vehicle and in the commanding officers' car. These sets would be used to give orders for halting, warning that enemy aircraft had broken through, etc. But when this column is moving up into the combat area, it goes silent. This is because the enemy can tell by intercepting the column's messages just about how strong the force is, how fast it is moving and in what direction.

Similarly, in shifting troops from one position in a battle line to another, they are instructed to shut off their radio. Suppose a general wants to pull some men out of the center of his line and send them around the flank for a surprise assault. He will order the radios with that unit to be silent until the fighting begins, so that the enemy will not pick up the strange signals on their flank and prepare for defense.

Tactical radio units are also used in battle zones for obtaining and distributing weather information; time signals and news or propaganda broadcasts.

To keep these radios going in the field, the Army needs a corps of maintenance men. The simple adjustments and repairs are made by the operators in front line positions. Like hams, these boys can take a pair of pliers and a piece of wire and fix almost anything—even when the shells are popping around them.

For more serious breakdowns, each regiment has a crew of maintenance men who work back far enough so that machine gun bullets aren't always knocking the tools out of their hands. Then, removed from the battle scene, are large, well-equipped shops where

overhauling and reconstruction work can be done.

Military radio is considered one of the choice spots of the service. A man who has been trained to it in civilian life will be accepted instantly. Those who have no background in radio are now put through the Signal Corps school at Fort Monmouth, N. J., where courses are given for officers and enlisted men. There have been some 4,000 graduates of this school since 1919.

There are communications sections with almost every National Guard unit down to battalions and the Signal Corps has a reserve unit, which maintains commissioned and non-commissioned officers on its rolls. Both the Guard and the Reserve are anxious to get trained radio men these days, and this would bear consideration. It beats peeling spuds.

-30-

Utility Radio

(Continued from page 18)

the ultimate in communication simplicity and reliability—one switch to turn "on" and the microphone button to "press to talk."

The transmitter employs the use of a specially developed crystal oscillator circuit of highly efficient characteristics. Tuning is accomplished by means of variable controls and switches which are brought out through the front panel and are fitted with locks. The operating range of the transmitter is from 2,500 to 6,700 kilocycles. Output may be tuned to either crystal fundamental or second harmonic when both fall within this range. Audio characteristics are carefully designed to secure maximum response only on

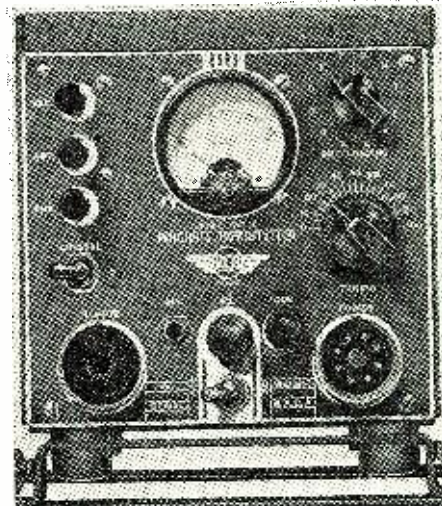

those frequencies necessary to provide maximum speech intelligibility. The audio power developed is ample to modulate the radio frequency output better than 90%.

The vibrator power unit is of the most advanced type utilizing a sealed "Powertron." Adequate filtering of the power supply results in a carrier almost entirely free from background noise. The AVT-15 draws a current with the microphone button depressed of 5.7 amperes at 12 volts and the AVT-15-A requires 10.2 amperes at 6 volts.

EAR AVIA INC., Dayton, Ohio, announce the Model ADF8 automatic direction finder. This unit is able to give reliable bearings to

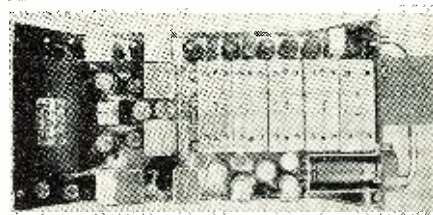

within plus or minus 1 degree on signals of 20

to 30 microvolts per meter. The loop is mechanically or motor driven and equipped with an electro-magnetic clutch so that in the event of motor failure it may be operated manually. The circuit is a superheterodyne circuit and meets all CAA requirements of construction. A shutter type dial is used, making it possible to



view only one band or the frequency being tuned. The unit has a range of 195 KCs to 6,700 KCs in six bands. A meter is provided to indicate the relative distance from the transmitter and, also, signal strength. The price of this unit can be had on application.

AIR ASSOCIATES, INC., of Garden City, L. I., N. Y., announce a new, light, portable type of interphone equipment that provides telephone communication between two or three stations in military, transport or training airplanes. Entirely self-contained; operates independently of the airplane radio equipment from dry cell batteries self-contained in the amplifier unit; readily installed in any airplane, readily moved from airplane to airplane.

Compact and light; complete two station equipment with headphones, microphones and batteries, weighs only 6 lbs. 11 oz. Has regular aviation, anti-noise "press to talk" microphones. Current is consumed only during actual commu-

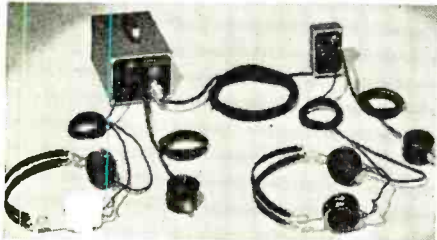

nication; microphone switch acts as "on-off" switch. Battery life over 300 "talking" hours, batteries quickly replaceable at low cost.

Individual volume adjustment at each station allows each operator to adjust the headphone volume at his station without affecting the volume at other stations—an important feature. Headphones and microphones are quickly plugged in or out at each station. The use of a newly developed, low drain beam type amplifier tube gives high amplification, permitting normal conversation in clear, understandable tones.

Model TW-52, Two-Way Interphone Equipment, Complete with Batteries, as illustrated above \$100.00. Model TW-53, Three-Way System—including all of the above equipment, plus extra Remote Station, extra Microphone and Headphones (weight 8 lbs. 10 oz.) \$141.50.

Built-in RCA Radio Is Feature of Piper Coupe

THE PIPER AIRCRAFT CORPORATION and the **RCA Manufacturing Company** have completed arrangements for the installation of two-way **RCA** radio equipment in the famed two-place Piper Coupe at the former Company's Lockhaven, Pa. factory. Transmitting and receiving equipment and a new type of antenna reel system are supplied with the fast-selling Coupes for \$466.25.

The Coupes may also be purchased with factory-installed radio receivers alone, or with a



receiver equipped with a radio range filter which enables the pilot to listen to range signals, voice broadcasts, or both together.

The complete two-way equipment includes the **RCA AVR-15A** receiver, **Model AVT-15A** 7½-watt transmitter, and **Model AVA-11** Antenna Reel System. All three units have CAA type

certification. The range is over 100 miles under ordinary conditions, satisfying CAA requirements for instrument flight.

\$50,000 Radio Equipment on SS America

RADIO equipment aboard the **SS America**, this country's new queen of the seas, is the finest and the most comprehensive ever installed on an American luxury liner.

Eight radio transmitters, nine receivers, a radio compass, a radio auto alarm, and the necessary associated equipment, give the America a never-ceasing communications link with all the important ports and cities of the world, as well as with other ships at sea. This link takes the form of telegraphic code and voice messages, the determination of the ship's exact position at any time, and the heading of alarm signals transmitted by any vessel in distress.

In charge of a complement of five radio officers, it is open 24 hours a day for telegraphic messages and from 9:00 a.m. to 12:00 midnight for radiotelephone messages. Here are located five radio transmitters and five radio receivers and the radio auto alarm. Four of the transmitters are used in radiotelegraphy and one in radiotelephony. The frequency band and the approximate power delivered into the antennae of the four radiotelegraph transmitters are: 110—

160 kilocycles, 1,000 watts; 350—500 kilocycles, 1,000 watts; 4—22 megacycles, 1,000 watts, and 375—500 kilocycles, 50 watts. The same ratings for the radiotelephone unit are 4—18 megacycles, 600 watts.

Apart from all of the main equipment in the radio room is the emergency radiotelegraph transmitting and receiving position. This is a 50-watt transmitter which can operate when all the main power generators fail. It operates on emergency generators and has in reserve two sets of storage batteries, which enable communication when all other sources of power are unavailable. Also at this position are two receivers, one of which covers the frequencies from 15 to 500 kilocycles. The other one, a type B crystal receiver, operates without batteries or tubes.

Finally, in the radio room, there is the radio auto alarm, which, so far as is known, is the first case of a passenger vessel operating a 24-hour radio watch being so equipped.

A 75-watt radiotelephone set operating on a frequency band of 2 to 3 megacycles, is installed in the ship's chart room just aft of the bridge. It is used only for shipping business, such as communicating with tug boats during docking operations and with the pier and home office while the ship is in the harbor. During

BUY DIRECT FROM THE MANUFACTURER AND SAVE

THE NEW MODEL 1280 SET-TESTER

A complete testing laboratory all in one unit. Tests all tubes, reads A.C. volts, D.C. volts, A.C. current, D.C. current, High Resistance, Low Resistance, High Capacity, Low Capacity, Decibels, Inductance, and Watts.

- ★ Instantaneous snap switches reduce actual testing time to absolute minimum.
- ★ Spare socket, and filament voltages up to 117 volts make the Model 1280 proof against obsolescence.
- ★ Latest design 4½" D'Arsonval type meter.
- ★ Comes housed in attractive, leatherette covered carrying case.
- ★ Sloping panel for rapid, precise servicing.
- ★ Works on 90-125 volts 60 cycles A.C.



The primary function of an instrument is, of course, to make measurements accurately and when designing test equipment this is our first thought. However, we also appreciate the important part the appearance of an instrument plays in the impression a serviceman makes on his customers, especially on home calls. We have, therefore, paid special attention to the outward design of all of our new instruments. For instance the panel of this Model 1280 is made of aluminum and etched by a radically new process, which results in a beautiful, confidence-inspiring appearance.

SPECIFICATIONS

- ★ Tests all tubes, 1.4 to 117 volts, including 4, 5, 6, 7, 7L, octals, loctals, filament, Peanut, single ended, floating filament, Mercury Vapor Rectifiers, the new S series, in fact every tube designed to date.
- ★ Spare socket included on front panel for any future tubes.
- ★ Tests by the well-established emission method for tube quality, directly read on the GOOD ? BAD scale of the meter.
- ★ Jewel protected neon.
- ★ Tests shorts and leakages up to 2 megohms in all tubes.
- ★ Tests leakages and shorts in all elements AGAINST all elements in all tubes.
- ★ Tests BOTH plates in rectifiers.
- ★ Tests individual sections such as diodes, triodes, pentodes, etc., in multi-purpose tubes.
- ★ Latest type voltage regulator.
- ★ Features an attractive etched aluminum panel.

- Complete A.C. and D.C. Voltage and Current Ranges.
- D.C. Voltage: 0-15, 0-150, 0-750 Volts.
- A.C. Voltage: 0-15, 0-150, 0-750 Volts.
- D.C. Current: 0-1, 0-15, 0-150, 0-750 ma.
- A.C. Current: 0-15, 0-150, 0-750 ma.
- 2 Resistance Ranges: 0-500 ohms, 500-5 megohms.
- High and Low Capacity Scales: .0005 to 1 mfd. and .05 to 50 mfd.
- 3 Decibel Ranges.
- 10 to +19,
- 10 to +38, -10 to +53.
- Inductance: 1 to 700 Henries.
- Watts: Based on 6 MW. at 0 D.B. in 500 ohms .006000 MW. to 600 watts.

Model 1280 comes complete with test leads, tabular charts, instructions, and tabular data for every known type of receiving tube and many transmitting tubes. Shipping weight 18 lbs.

PORTABLE COVER \$1.00 ADDITIONAL

ONLY
\$19.95

SUPERIOR INSTRUMENTS CO.

136 Liberty St., Dept. RN-10
NEW YORK, N. Y.

STOP FEEDBACK

Replace that Microphone with a

SHURE CARDIOID

What an amazing improvement when you plug a Shure "Uniplex" or "Unidyne" into your amplifier. These Shure Cardioids are dead at the rear! They lick feedback, cut down background noise, increase the pickup range, permit more volume. Sound Engineers everywhere are replacing ordinary mikes with these new Shure Cardioids—and installing them on new set-ups, too!

★

SHURE "UNIPLEX" CARDIOID CRYSTAL

List Price, \$32.50

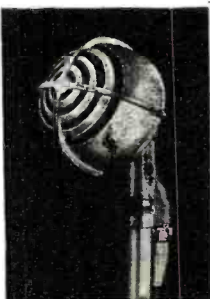

★

SHURE "UNIDYNE" CARDIOID DYNAMIC

List Price, \$42.50 and \$45.00



Shure Patents Pending, Crystal Microphones licensed under Brush patents.

MAIL COUPON NOW!

SHURE BROTHERS
225 W. Huron St., Chicago, Ill.
Send me free Bulletin 164N
entitled "Goodbye, Feedback!"

Name

Address

City.....State.....

Occupation.....



COMPACT NEUTRALIZING CONDENSERS

Where space is at a premium—use these BUD compact neutralizing condensers. Screw-type adjustment is easily locked at any setting. May be mounted in any position. Lucite insulation.

Write for your copy of the latest BUD catalog, No. 141, just off the press.



BUD RADIO, INC.
CLEVELAND, OHIO

stand-by, the receiver of this unit is tuned to the coastal harbor radiotelephone frequency. When signal is picked up it is fed into a selective signaling device which responds to certain audio frequencies. If the proper sequence is sent out by the shore station, a bell will ring aboard ship to indicate an incoming call.

Two life boats are equipped for two-way radiotelegraph communication at 500 kilocycles. Using storage batteries as sources of power, these sets will function for many hours.

Counting the two life boat antennas, the radio



compass loop antenna, the 75-watt radiotelephone antenna, the five doublet receiving antennas, the main flat-top antenna, the horizontal V and the forward inverted V antennas, there are thirteen antennas aboard the ship.

The America's radio installation called for more than 10 tons of equipment, 4½ of which were made up of special high voltage cable. The work of installation started on May 6 and was completed on June 7. At times, as many as 18 men worked on the installation.

A MARINE radio telephone of 25 watts output, has been announced by the *Western Electric Company*.

The new unit, known as the 226C, features crystal control on both receiver and transmitter, high intelligibility, and semi-automatic operation.

Installation involves connection only to antenna, ground and power supply. The compact cabinet lends itself to mounting on a bulkhead, shelf, a locker top or other convenient support. Only three control knobs appear on the panel and the transmitter goes on the air at the pressure of a finger on the handset button.

A single control is provided in the 226C for



shifting both the transmitter and receiver simultaneously to any one of four frequencies. Three of these may be utilized for ship-to-shore communication and the fourth reserved for ship-to-ship or coast guard. All controls are located on the front panel where they may easily be reached.

The radio receiver is of the superheterodyne type embodying the latest developments in circuit design.

The 226C operates from a source of 110 volts, 60 cycles, a.c. which may be supplied by a small, inexpensive rotary converter. Due to the variations in ship electric power supply systems, the converter is not included as part of the equipment. Converters are available to operate from 12, 32, or 110 volt d.c. ship power supply systems.

Marine Radio

THE HALLCRAFTERS INC., 2611 Indiana Avenue, Chicago, Illinois, have developed a Model HT-12 50 watt Marine Radiophone unit, which provides for ten crystal controlled transmitting and receiving channels. The unit operates either from 12, 32 or 110 volts d.c. or 110 volts, 60 cycles a.c. The frequency range is from 2,000 to 3,000 kcs. The transmitter uses 8 tubes in a crystal oscillator—power amplifier circuit, while the receiver uses 10 tubes in a superheterodyne circuit. The unit is mounted in a heavy metal cabinet, suitable for table or bulkhead mounting, and is corrosion protected throughout. The price varies with the power requirements from \$390.00 to \$525.00.

The Hallicrafters Inc., 2611 Indiana Avenue,



Chicago, Illinois, announce the Model S-30 Radio Compass and Direction Finder, which enables the ship's flyer to check his position against beacon, broadcast and shore radiophone stations. Sensitive headphones and tuning eye serve as indicators when taking a bearing. Cov-

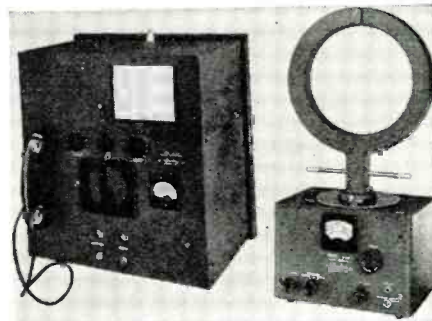

erage is from 2,000 to 3,000 kcs. It is normally used with a 6 volt battery. A 5" permanent magnet dynamic speaker is available as an accessory. Six tubes are used in the radio circuit and the radio compass loop is 12" in diameter and is mounted in an aluminum casing. The unit sells for \$99.50.

HALLCRAFTERS's has also announced a Model HT-11 12 watt Marine Radiophone Unit, containing a complete transmitter and receiver in one housing. The transmitter may be operated on any one of three frequencies in the marine band of 2,000 to 3,000 kcs. The receiver covers the standard broadcast band and, also,



marine channels. The power inputs are provided for 6 or 12 volt d.c. operation, or 110 volt a.c. operation. The transmitter consists of four tubes in the crystal oscillator-power amplifier circuit, while the receiver is a seven-tube superheterodyne. The price is \$159.50. —30—

As I See It!

(Continued from page 19)

system are not wholly understood. One of the paramount requirements of such devices, so that they live up to the universal application of the system, is that they be properly selective. The more selective the circuits intended to operate upon the r.f. and i.f. systems of a receiver, the more faithfully is it possible to employ the signal tracing idea for the localization of de-

fects. Any attempt to operate in the r.f. and i.f. systems of a radio receiver with signal tracing apparatus which is not capable of selecting between the various signal frequencies, will result in much misleading information as well as difficulty of operation.

Resistance-coupled amplifiers intended for operation upon the r.f. and i.f. sections of radio receivers are what we have in mind. Sure they will indicate signals, but not being able to differentiate between fundamental and harmonic frequencies, the test signal and the oscillator signal, the receiver oscillator and the mixer output—will tend to confuse the operation and impair the faithful application of signal tracing. Much of the success of signal tracing lies in the ability to check for signals in circuits where they do not belong and to be able to identify the signal being picked up. We bring this point to the fore because such home-made equipment can function as well as factory manufactured apparatus as long as the comparable design is used and the calibrations are correct. . . . And it is vital to every man who is building and using such signal tracing apparatus that he employ it under the proper conditions. . . . When this is done, no apology is necessary for signal tracing, for it fulfills every need found in rapid localization of defects in any radio receiver, and is capable of doing more than any other method of trouble localization which has ever been put to use.

Speaking about comparisons between signal tracing and other methods of trouble localizations, it is very simple to confuse the issue by saying that the injection of a signal from a signal generator into various points of a receiver is the same as signal tracing because both use a signal. Such is not the case because working backwards from the speaker is not tracing a signal. It is injecting a signal and basically checking the coupling unit and the tube. The weakness in this comparison will become very much more prominent as operation upon the high and ultra-high frequencies is carried out, and signal tracing will display its tremendous superiority.

Of course, there are more than two ways of killing a cat, in fact many more than two ways, just as there are many ways of transportation between any two points, and more than one way of locating some defects. But in analyzing the value of any trouble localization system we must seek for that which possesses the greatest number of applications—that which affords the fast method of progress for the greatest number of applications. In this respect signal tracing stands head over shoulders over everything else and every single, properly made test shows this to be true without qualification or reservation.

Nothing stops a man, like our Florida correspondent (page 37, RADIO NEWS, August) from working with a midget volt-ohm-milliammeter for 99

and 44/100 per cent of his service work, but maybe that accounts for his approval of the idea to return that "lily," which obviously is a receiver which he cannot service, to the set distributor. Strange as it may seem, there are no "lilies" in radio receivers. Maybe the fault is obscure because the system of trouble localization used does not show up the fault, but we doubt very much if anybody has ever worked with as many of these so-called "lilies" as we did during the first year that signal tracing was introduced. We took these volt-ohm-milliammeter "lilies" and diagnosed their faults with signal tracing, and each and every one of the faults established was of such character that it would not be dis-

FASTEST WAY TO LEARN CODE

Easy, Fascinating, LEARN by EAR To Be a GOOD OP.

The New All Electric Master Teleplex Code Teaching Machine is exactly what thousands are looking for. No experience needed. Ideal for beginners—steps up WPM for ALL Ops. There is no guess work with Master Teleplex, because it records your sending in visible dots and dashes. You SEE and HEAR exactly how you are making your signals. You learn code the way you'll be using it —by SOUND. That's why practically every school teaching code uses TELEPLEX. Complete course included at no extra charge. Used by many schools for teaching code. Low cost; easy terms. MONEY BACK GUARANTEE. Send now for booklet RN10, no obligation. Postcard will do.



TELEPLEX CO., 67-69 Park Place, New York

In Canada write: CANADIAN ELECTRONIC INST., TORONTO, ONT.

BUY DIRECT FROM THE MANUFACTURER AND SAVE



THE NEW MODEL 1230
SIGNAL GENERATOR
WITH
FIVE STEPS
OF
SINE-WAVE AUDIO

SPECIFICATIONS

RADIO FREQUENCIES from 100 K. C. to 90 Megacycles in 7 bands by front panel switch manipulation. All direct reading and accurate to within 1% on I.F. and Broadcast bands, 2% on higher frequencies. The R.F. is obtainable separately or modulated by any one of the five Audio Frequencies.
AUDIO FREQUENCIES: 5 steps of SINE-WAVE audio 200, 400, 1000, 5000 and 7500 cycles WITH OUTPUT OF OVER 1 VOLT. Any one of the above frequencies obtainable separately for servicing P.A., hard-of-hearing aids, etc.
ATTENUATOR: Late design, full-range attenuator used for controlling either the pure R.F. or modulated R.F.

CIRCUIT: The Model 1230 employs an improved electron coupled oscillator circuit for the R.F. affording positive protection against frequency drift and a Hartley oscillator circuit for the A.F. section.
DIAL MANIPULATION: Large 5 1/2" dial etched directly on front panel, using a new mechanically perfected drive for perfect vernier control.
APPEARANCE: The front panel is etched by a recently perfected process which results in a life-long attractive finish and the instrument comes housed in a streamlined shielded cabinet.
CURRENT SOURCE: The Model 1230 operates on 90 to 130 Volts A.C. or D.C. any frequency.

The Model 1230 comes complete with tubes, shielded cables, moulded carrying handle and instructions. Size 14" x 6" x 11". Shipping weight 15 pounds. ONLY

\$12⁸⁵

THE NEW CHANNEL ANALYZER

FOLLOWS THE SIGNAL FROM ANTENNA TO SPEAKER OF ANY SET

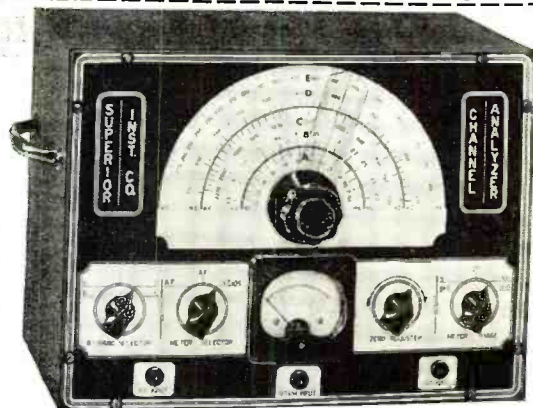

The well-established and authentic SIGNAL TRACING METHOD of locating the very circuit in which there is trouble, and the very component that causes the trouble, is now for the first time available at a price any radio serviceman can afford.

THE CHANNEL ANALYZER WILL—

- ★ Follow signal from antenna to speaker through all stages of any receiver ever made.
- ★ Instantly track down exact cause of intermittent operation.
- ★ Measure both Automatic-Volume-Control and Automatic-Frequency-Control, voltages and circuits without appreciably loading the circuit, using built-in highly sensitive Vacuum-Tube Voltmeter. Check exact gain of every individual stage in receiver.
- ★ Track down and locate cause of distortion in R.F., I.F., and A.F. amplifier.
- ★ Check exact operating voltage of each tube.
- ★ Locate leaky condensers and all high-resistance shorts, also show opens.
- ★ Measure exact frequencies, amount of drift and comparative output of oscillators in superhets.
- ★ Track down exact cause of noise.

The Superior Channel-Analyzer comes housed in shielded cabinet and features an attractive etched aluminum panel. Supplied complete with tubes, three specially engineered shielded input cables, each identified as to its purpose. Also full operating instructions. Size 13" x 10" x 6". Shipping weight 19 pounds. Only

\$19⁷⁵

SUPERIOR INSTRUMENTS CO. 136 LIBERTY ST., Dept. RN-10
NEW YORK, N. Y.



A service man has to "keep up" with the new developments these days, if he wants to hold on to his business. These books will give you an understanding of subjects vital to the success of your business . . . today! Start now! Turn your spare time into usable, money-making knowledge.

Rider's Latest Book FREQUENCY MODULATION

The most talked of subject of the moment, Rider offers this introduction to frequency modulation with special attention to F-M receivers and the problems they will present to the serviceman. Get this now—be ready. 136 illustrated pages—only \$1.00.

SERVICING BY SIGNAL TRACING

By John F. Rider

Use the system of servicing which is proved and endorsed—fastest—most modern—the system you can apply to all receivers regardless of age, type or make. Servicing by Signal Tracing operates independently of every limiting factor heretofore encountered. In this new book you learn how all receivers are brought to a common servicing level. You learn how components receive a functional check while the circuits are in an operative condition. Over 360 pages—hard covers—only \$2.00.

NEW! By John F. Rider OSCILLATOR AT WORK

Don't guess—KNOW! This new book tells all about ALL oscillators. Explains theory by means of simple illustrations, diagrams and curves. Gives you practical facts. Get your copy TODAY! 256 pages—illustrated—\$1.50.

AUTOMATIC FREQUENCY CONTROL SYSTEMS

With Automatic Frequency Control Circuits in most new higher priced models, knowledge of "AFC" means money in your pocket! Learn the practical facts, from these easy-to-understand explanations. Get your copy today. Cash-in on profitable "AFC" work. Hard covers—144 pages—\$1.00.

THE CATHODE RAY TUBE AT WORK

By John F. Rider

This is the most complete and practical book ever written on the subject—the only one prepared especially for the radio serviceman. New applications of the cathode ray tube during the past five years require that servicemen know its operation. 336 pages—over 450 illustrations—\$2.50.

AN HOUR A DAY WITH RIDER BOOKS

On Resonance and Alignment . . . On Automatic Volume Control . . . On D-C Voltage Distribution in Radio Receivers . . . On Alternating Currents in Radio Receivers. 60c each.

JOHN F. RIDER PUBLISHER, Inc.
404 Fourth Ave., New York City

Export Div.: Rucke-Int. Elec. Corp., 100 Varick St., N. Y. C. Cable: ARLAB

BANISH BEWILDERMENT—INCREASE PROFITS

Read RIDER BOOKS

EASY TO LEARN CODE

It is easy and pleasant to learn the modern way—with an **Instructograph Code Teacher**. Ideal for the beginner or advanced student. ■ Many tapes available ranging from alphabet for beginners to typical messages on all subjects. ■ Speed range 5 to 40 WPM. ■ Always ready, no QRM, beats having someone send to you.



FOR SALE OR RENT
STANDARD with 10 tapes, book of instructions, A.C. motor \$24.50 with spring-wound motor \$18.50
JUNIOR with 5 tapes and book of instructions (not rented) \$12.00
RENTAL Standard with 10 tapes and book of instructions \$3.00 first month, \$2.25 each additional month. References or \$10 deposit required. All rental payments may be applied on the purchase price should you decide to buy the equipment.
Write for details today

INSTRUCTOGRAPH COMPANY

Dept. NR, 4701 Sheridan Road, Chicago, Illinois
Representatives for Canada:
Radio College of Canada, 54 Bloor St., West, Toronto

closed by the moistened finger, the "guess" based upon fifteen years of practical service, the volt-ohm-milliammeter. Maybe it took an hour to find the fault., maybe it took two hours—but those same sets had been in service shops for weeks and were never diagnosed.

Paper is patient. Much can be written and very fabulous claims made, but sufficient time has passed since June 1938, and much has been accomplished with signal tracing since then. Some have said that signal tracing is a "trick" method of servicing. . . . Where is the trick? . . . If there is any trick in identifying what is happening to a signal as it passes through a radio receiver or a transmitter, then all radio is hocus-pocus or legerdemain. . . . If there is any trick in signal tracing, then mass hypnosis must be responsible for the acceptance of the system by some U. S. Government services; for the fact that many test equipment manufacturers, having had 12 to 18 months to break down the system, came out with signal tracing apparatus; for the fact that it has been found invaluable in the design of radio receivers as well as in the servicing of receivers; for the fact that it was received with approval in many foreign countries; for the fact that it passed the most critical of tests. . . . And we repeat—the most forceful of demonstrations is still coming—when operation will be carried out on the high and ultra-high frequencies! . . . If we have a reputation, whatever little there may be, it is staked on signal tracing!

Communication Receivers and National Defense

WITHOUT the fear of being accused of publishing a book in the future, we would like to bring to the attention of the servicing industry in line with the national defense program, the need for greater familiarity with communication receivers of all varieties, particularly those which have been advertised in various radio magazines and have been sold to the public as well as hams. Communication receivers representative of a certain design category are not very much different in basic design from the usual run of multi-waveband receivers, yet incorporate a sufficient number of variations in actual design to justify classification of the receivers in a separate category. The use of various types of band-spread arrangement, crystal filters, phasing operations of these filter circuits, noise control combinations, beat-frequency oscillators—all of these items comprise new subjects which have seldom if ever appeared in the usual run of broadcast receivers sold to the public.

As stated two months ago in this column, the serviceman who might find himself doing military duty is the most logical individual to service such receivers, for it has been his good fortune in the years past to service receivers as they come—small, big, sim-

ple and complex. This is the time to familiarize oneself with what represents the design details of such receivers. If the occasion never arises to service these receivers, all well and good, but if it does, we might just as well be familiar with what is inside.

And we go beyond receivers. Even small transmitters are of interest, at least to the extent of knowing what makes a transmitter work—the different types of oscillator circuits—modulator circuits, the process of modulation, etc. Sure, it's a big chew, but nothing can be done about it. With times as they are, one never knows what may be the next job, or the next emergency. Peace is better than war—always was and always will be, but there is no sense in being caught up the creek without a paddle.

Communication is vital in war and the proper maintenance of communication is a major necessity. No serviceman is so busy today or ever so busy that he cannot find some time to become acquainted with other things,—particularly when some of those other things may be essential to the saving of lives.

—30—

8 Tube Superhet

(Continued from page 31)

stranded on the work bench.

The first thing to get in your hair holder is that **ALL THE SIGNAL MUST GO THROUGH THE CRYSTAL AND NONE AROUND IT!!!** Why? Simple. If any goes around the crystal network, the filter doesn't filter. You saved three weeks already! The trick now is to keep all stray coupling down to the nil point. By good shielding and proper layout of the parts it can be done. The detector plate coil and the crystal input coil together with the selectivity condenser and bridge condensers must be in one can. The crystal and phasing condenser and coupling condenser go in another. The 1st i.f. grid coil and trimmer goes in still another can. Another week saved if you had worked fast. To throw more light on the subject, the selectivity condenser is the one that trims the crystal input coil. The bridge condensers are really two legs of a bridge circuit and the crystal and phase condenser are the other two. There is another method and that is to center tap the input coil and use inductive legs, but that is little different. You can see by this time that the phasing condenser is used to balance out the crystal holder capacity only. Of course, by changing the phasing condenser you unbalance the bridge and signal other than crystal frequency will go through by capacity coupling. When a crystal is working right, there is a funny ringing sound and the set is very sharp and we don't mean perhaps. You will have to learn how to tune slowly, and you must watch the meter on phone or a continuous signal. You can't understand anything on phone

when crystal is on peak and selectivity is maximum.

The detector plate coil is 4.8 mh. The crystal input is 1.2 mh. The 1st i.f. grid is 1.2 mh. We had four 1.2 mh. coils and used two as they were and put two of them together and got the 4.8 mh. coil. Have the two coils on a tube about 2" long and both windings going the same way. Then the inside of one coil and the outside of the other go together. The outside free end goes to the detector plate and the inside end goes to B supply through the r.f.c. The crystal input goes on the same tube and put it about 1" from it to start with. The outside wire of it goes to the crystal and one of the bridge leg condenser and also to the stator of the selectivity condenser. The inside goes to the only other place for it as per diagram. This whole works goes in one can under the chassis. The crystal and phasing condenser and coupling condenser go in another can on top of the chassis. The i.f. grid or the crystal output coil and trimmer go in the other can on top of the chassis. Keep all the leads short and clear of all metal. Use ceramic flexible shaft couplings and the couplings go on the condensers. The cold shafts run out of the can. These things must be done because the i.f. channel must not pick up noise of its own accord. Be sure and insulate the rotor of the selectivity condenser from ground. The crystal switch is only a piece of spring brass, soldered to the phasing condenser shaft and it shorts out the crystal when out of mesh. Look it over and you can see how to do it.

The i.f. amplifier is a straight forward affair. The straight line construction makes it very stable, with the voltages all at normal values. The bypass points and all ground points must be tied to one point. Run a bus all the way down the chassis and solder at one point only at each stage. You must bypass everything to ground through .1 mfd. condensers. An i.f. amplifier with three transformers all working to peak performance will be very unstable if all the steps are not taken to insure its stability. You may get by in the plate returns with 2000-ohm resistors in place of the chokes, but we doubt it.

The gain control is placed in the two cathode leads. Each cathode has its own limiting resistors, and by-passed at the socket to ground and also at the high side of the gain control. The low side of the gain control goes to the tuning meter. The tuning meter really works and will move on a very weak signal. An R9 signal will put it clear down on the peg. The meter is cold to ground and to the experienced that means something.

The detector is a diode. The selectivity is ample and a triode detector will complicate the a.v.c. so much, it is not worth the trouble. The a.v.c. switch and b.o. switch are combined. All switches and controls are on the shield partition. This keeps all wires to a minimum of length.

The b.o. is a simple unit and can be made up of parts on hand. The coil can be any one that will resonate at the i.f. frequency. You could make it $\frac{1}{2}$ the i.f. and use its second harmonic. The coil we used is 1.2 mh. The beat control is on the shield partition, and controlled from the front panel. The coupling to the detector is through a turn of hook-up wire.

The controls on the front panel are, left to right, b.o. pitch, a.f. gain and on off, a.v.c. on off and b.o. on off, i.f. gain, r.f. gain, selectivity control, up, crystal phase, and a dummy. The phone jack is under the tuning meter.

The phone jack is tied across the output grid. The grid line must be cut and grounded when the phones are in. The tone is terrible if the grid line is not cut when the phones are tied on.

The power cord has seven wires and they are all needed. We have one side of all filaments tied to ground, and this keeps stray coupling to a low point. **DO NOT RUN THE GROUND SIDE OF THE FILAMENT UP THE SAME WIRE AS B—**. If you do, it will hum and all the filter in the world won't stop it. What happens is this. There is a voltage drop in the filament wires and this is superimposed on the supply when they are run together. We spent one whole day trying to stop it before the light fell on us.

The power supply is not new, but the use of it on a receiver is out of the ordinary. A regulated supply is so much better than an ordinary one that there is no comparison. All the flutter on the fast fading stations will disappear, and the crystal will stay on peak when the XYL turns on the stove. With full load the voltage is 250 and with no load the voltage is about 253. A three-volt change compared to a 150-volt shift. There is absolutely no hum, due to the regulator acting both ways. The cost is a little more than the usual supply, but not much due to the lack of need for the double filter. As long as the neon bulb is lit the regulator is working. We use the neon bulb to have a fixed voltage without the use of batteries. The voltage is controlled by a sliding tap on the regulator voltage dividing net work. We also have a separate bleeder for the screen voltage to the rest of the set. The stand-by switch is on the tuner with the a.f. gain and one is also on the power pack for convenience. The stand-by switch cuts the high voltage center tap; is easy on the condensers.

The out-put stage is on the same pack as the power supply. The speaker must have a permanent field or get its field from a simple 2525 and filter net work. There is plenty of room on the chassis for it. The out-put transformer is on the chassis and wired in at all times. This stops the worry of forgetting to put the speaker on when the phones are used. Don't ground the filament of the 6F6. The 6Q7 has the first stage of a.f. and it could be left out altogether because the a.f. from the diode is very high. The power transformer must have several hun-

"HEY... DON'T FORGET THE VIBRAPACK!"



That's right, Charlie! You mustn't forget the Vibrapack,* because it provides Perfect Portable Power for radio transmitters, receivers, and P. A. systems.

Vibrapacks have *all* the desirable characteristics necessary for an ideal portable or mobile power supply—

1. Dependability—

Proved by the thousands of police radio installations where Vibrapacks operate on a 24-hour-a-day schedule to give un-failing service.

2. Efficiency—

Which means noticeably less current drain from the storage battery.

3. Compact—light in weight—

Important where space is limited, or where weight is important as in airplane installations.

4. Low first cost—

A big investment is unnecessary—you will save by using a genuine Mallory Vibrapack.

5. Low maintenance cost—less time required for servicing—

The only part of a Vibrapack which normally ever wears and requires replacement is the long-life vibrator. It requires but an instant to install a new vibrator—compare this with the elaborate overhaul required by other forms of power conversion equipment.

Ask your distributor for technical data on Vibrapacks, or write for Form E-555C.

P. R. MALLORY & CO., Inc.
INDIANAPOLIS INDIANA
Cable Address—Pelmallo

TRADE MARK REG. U. S. PAT. OFF.





**GET COMPLETE ATTENUATION
ON ALL BANDS WITH THIS
NEW MILLION MODEL SG
SIGNAL GENERATOR**

Makes the serviceman's dream come true. Blankets six bands, 50-30,000 KC—without a dead spot. Employs individually trimmed separate coils. Audio output available through regular attenuator and multiplier for testing P.A. or any audio system. Double range type resistive attenuator controls RF output with 1-100 range and multiplier steps for 1, 10, 100, 1000 times. Reads approximate microvolts. Model SG actually gives you more—yet, costs you less.

ACCURATE
DEPENDABLE
ECONOMICAL

\$34.95 NET

*If your jobber cannot supply you,
write us direct.*

MILLION RADIO AND TELEVISION
577 No. Union St. Chicago, Illinois

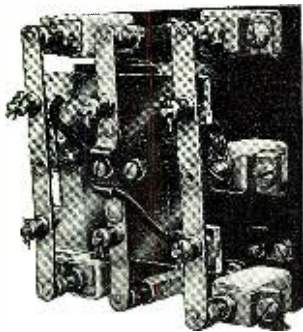

**A New
BREAK-IN RELAY
in the
HEAVY DUTY CLASS**

This relay is recommended for radio phone transmitters where push-to-talk operation is desired.

WHEN THE RELAY COIL IS ENERGIZED:

- (1) Antenna will be switched from receiver to transmitter.
- (2) Oscillator is turned "On."
- (3) Receiver plate circuit is "Open."

WARD LEONARD ELECTRIC COMPANY
47 South St., Mount Vernon, N. Y.
Please send FREE Circular 507B.

Name

Street

City and State.....

Call Signal

dred volts more than usual due to the fact that we lose about 150 to 200 volts in the regulator. The filters must be 600-volt type.

The next part is the adjustment of all the tuned circuits. This is very important and must be followed to the letter. This tune-up process will work on any set and it is well worth doing to the one you now have. The author has been in the service business for years and knows what he is talking about. After lining up several thousand sets he should.

The crystal and the i.f. amplifier must be tuned to the same frequency. The best way to do this is to use the crystal in an oscillator and use the oscillator to adjust the i.f. trimmers. Couple the crystal oscillator to the first detector grid cap, by running a wire close to it, from the oscillator tank. With crystal switch in the set shorted out adjust all the i.f. trimmers to the lowest "R" meter reading. Do this two or three times and be sure it is on the nose.

Take the crystal from the oscillator and put it back in the set.

Get an oscillator from your serviceman friend and set it to about 456 or the crystal frequency. Short the crystal out with the phasing condenser and adjust the selectivity condenser to the loudest back-ground noise. If there is no definite setting point for the selectivity control move the crystal input coil away from the detector plate coil. There will be if the adjustment is right. Of course, it is assumed the coil is ok and hooked up right.

Then leave the selectivity control alone and adjust the phasing control to the lowest noise level. Now the oscillator is coupled to the detector grid as before and tune the service oscillator to the exact crystal frequency. Watch the "R" meter and always go by it. Your ears will do you no good. Get it right on the nose. Now adjust the trimmers for all the drop in the "R" meter you can get. Do this three or four times. This is very important. The i.f. is all lined up and finished. If in doubt about the adjustment do the whole thing over. If the serviceman has a scope he will see a curve so sharp he will have a fit. Unless you know how to use a scope leave it alone. If the i.f. is oscillating start to work and stop all of it. There can be no oscillation with the crystal or it will be terrible.

Now to the r.f. end. Take the oscillator section out and put on a separate condenser. Run the dial to the high frequency end (it should be 450 on the PW4). Tune the oscillator condenser until you get a signal on the high end of the 20-meter band. Let it set and resonate the PW4 to it. If it is not at 450, set the dial there and adjust the r.f. and detector trimmers for maximum low point on the "R" meter. Of course, the signal must be a steady one.

After finding the band the service oscillator can be used for the signal with better results. Now turn the

dial to the low end and resonate the oscillator condenser to the r.f. Set the dial at about 50 and turn the oscillator condenser to the loudest point. Then turn the service oscillator to this point. It will be on another ham band. Check the trimmers and find out which ones are off and what way. Mark this down on paper. You should mark the trimmers so you will know when they are meshed. If the trimmer was ok, leave it alone and use it as a known point. If the other ones were not, ok, then you must adjust the copper disc. If the trimmer needs more capacity, screw the disc out of the coil a turn. If less, turn the disc in. The disc should be in about 1/8" to start with. Then do the high end over as above and then the low end again. Keep doing this until the trimmers are all on the nose at both ends.

After the above, the r.f. and detector are all adjusted. Leave them alone. Now hook the oscillator section back up to the PW4 and turn the dial to 450. The oscillator will have two points of resonance and we must use the one with the less capacity. Adjust the oscillator to the highest back-ground noise. There is a little pull on the high frequency bands, but that is normal. If we try to adjust from now on with a signal it will be difficult. Then go to the low end and adjust the padder to the highest back-ground noise. Be sure it is the high setting. Now back to the high end and adjust. Now turn the dial to 250 and turn the oscillator trimmer to the greatest back-ground noise and be sure it is the high frequency side. If it should be right, you are lucky; but, as a rule, it won't be. Find out whether it is high or low and if it is high, turn the disc out and if it is too low, turn the disc in. Remember if we need *more capacity*, we *turn the disc out*, and if we need less, turn the disc in. Now go back and adjust the high end and then the low end and then the center. Keep doing this until all the dial settings give the same amount of noise. Then your set is in perfect step with the oscillator and detector.

You have heard sets with a loud high end and a dead low end and the trouble is that they are out of track. If we have the set all tracked and one end is hot and one end cold, the coils are haywire or bad design.

The antenna must be on while adjusting the 1st r.f. stage. There is some detuning effect with different antennas.

The meter adjustment is under the chassis and by the i.f. gain control. To adjust it, short the antenna to ground and reset to No. 5.

The chassis is 17" x 12" x 3". It is a standard item and the shield portion is a standard 4" base cover with 1/2" cut off the side and both sides are bent over to make a 2 7/8" channel. The other shield is made of scrap aluminum.

Drill all the holes in the chassis before you mount any parts. The chassis is best marked with a soft pencil or

crayon. Drill a small hole in each center punch mark and drill from there. Solder about 6" of No. 16 wire to the condenser terminals before mounting. Clean all coil contacts with emery paper after they are finished.

The coils have turns as per the coil table.

All grid coils wound with enameled No. 19 wire wound to 1".

All primaries wound with silk No. 36 wound to 1/4".

10-20 meter coils have the primaries interwound with grid winding.

All coil forms, R 39, 1" diameter. National XR2.

All windings start 1/8 from bottom and extend 1".

The 10-20 coils have a 1/2 turn of wire looped at the top of form, and by bending one way or the other we shift the inductance to perfect tracking.

It is a very good set and is hard to make, but well worth it. Unless you are an experienced builder, don't get in a rush when it comes to putting it together. Take your time. -50-

For the Record

(Continued from page 4)

Not only is the FCC having some difficulty in finding its 500 operators which are needed to help in the monitoring stations, but the Army, Navy and other armed forces are also having their troubles in the same line. Now comes the *National Youth Administration*. It, too, is looking for operators and instructors for their program of instructing the Youth of the country in radio. Not only will the NYA training make them available after they leave the ranks as radiomen, but it will create a pool of future Army operators. Some of the factories have taken to sending out scouts into the hinterlands to "discover" radio factory talent. They are promising large pay and good working conditions to those who would up stakes and move to the factory towns. Is there a boom in radio? You can just bet there is!

MOST frequently asked question among the hams is, "Will the hams be taken off the air." We have it directly from Washington that as long as the hams behave themselves and cooperate with the Government, that they will NOT be taken off. In fact, Uncle Sam is developing new and greater numbers of hams via the NYA. The story we ran last month about the new NYA National Defense Net is good proof that the hams are to stay on the air. Add to that a letter received by Technical Editor Ollie Read from Mr. Robert R. Burton, Radio Engineer of the NYA which speaks for itself. It says in part, "In recent months added emphasis has been placed on our radio projects, since it is recognized that NYA is in a position to train thousands of operators for use in National Defense." Only one thing Mr. Burton forgets to mention, but which we know, that is that the training of the NYA group is for CW, not phone. Also he did not mention that the training was in cooperation with the Army Amateur Radio System where CW is the byword and pass-word, and phone is only used occasionally. Get hep, you

hams, and get wise we mean, CW-wise!

GOOD for a chuckle. On page 38 of last month's issue we ran a pic of a beautiful YL operator from Georgia (Joajah). We also said that we would, "furnish name on request." We didn't expect to be taken up, but we were. Several wrote in asking the lady's name. They could have investigated a wee bit more; her name appeared in the same issue on page 9, also her address! It's things like that that make small columns like this. . . . Anyway, fellows, thanks for the chuckle. We get few enough as it is these serious days, what with National Defense and such.

NEXT month we will feature, among other things, the story of radio's work for and with the U. S. Navy. You readers have no idea how hard it is to get anything through Washington. But we have hopes, a good correspondent, and a fine file of pictures. We should have a grand story. Watch for it.

FLASH! We just heard that the amateurs again were the sole means of communications during the Charleston Hurricane. While details are lacking at this moment, we are dispatching a reporter to cover the story, and to get pictures. If anything comes of it, we should be able to report back to our readers next month. We're not promising, but from what we heard in the Broadcasting Newsroom, it should be a dandy. As usual, RN is on the job at all times to bring you the very latest and hottest in radio.

HOW many of you liked the article by Staff Sgt. Schauers on aviation radio? Sometimes we think that our readers want to be informed on all phases of radio, and sometimes someone comes into the office who tries to convince us that we should stick to certain well-defined lines. How about dropping us a line? Tell us what you think. Remember, that with National Defense Plans being formulated every day, radiomen are coming more and more into the fore. It is no longer a secret that radiomen and their equipment are prime considerations of this government in its plans for the Nation's defense. We take it that there is not any definite position which will be assigned to many radiomen should they be called either in the Draft (should we have one) or in the National Guard. So best to be prepared, we thought that it was high time that the radioman learn something—no matter how little it might be—about many phases of radio. It is not necessary that he be an expert in say, for instance, aviation radio. It is only necessary that he know something about it, so that his training time in that particular field may be cut to minimum.

Later we will run articles about marine radio, police radio and any other type of communications radio that seems to fit the picture. Is this what you want? Let us know.

ELSEWHERE in this issue is the suggestion by our Washington Correspondent that you write your radio broadcast stations to ask that they open and close their broadcast day with the National Anthem. We think this an excellent suggestion. Why not do it? Surely there can be no objection; and truthfully, the other day,

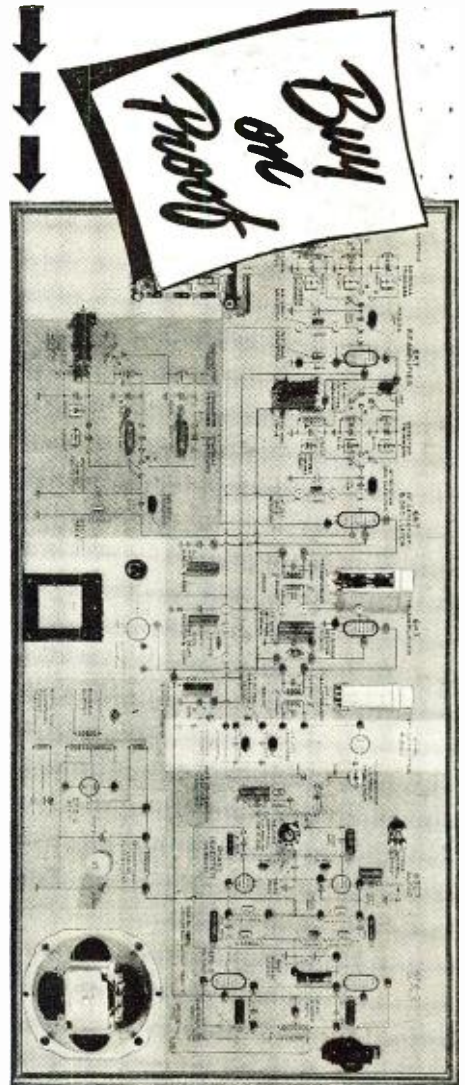

DYNAMIC DEMONSTRATOR

RCA Test Equipment Licks Service Problems Faster—More Profitably

Are you in doubt about which test equipment—and which testing methods—are best? See the RCA Dynamic Demonstrator!

It's a radio set turned "inside-out"—designed so you can readily duplicate any type of circuit defect. All the parts of a typical modern superheterodyne are shown, together with their wiring scheme.

See the Dynamic Demonstrator at your RCA Distributor's...ask for on-the-circuit *proof* of the superiority of RCA Test Equipment.



Over 335 million RCA Radio Tubes have been purchased by radio users...in tubes, as in parts and test equipment, it pays to go RCA ALL THE WAY.

Test Equipment

RCA Manufacturing Co., Inc., Camden, N. J.
A Service of the Radio Corporation of America

YEARS AHEAD
TRIPOLET
 1941 Model 1696-A
MODULATION MONITOR



You've solved your problem of getting maximum efficiency from your transmitter when you invest in a Model 1696-A Modulation Monitor. Plug it into your AC line—make simple coupling to the transmitter output and the monitor shows:

- Carrier Reference Level • Percent of Modulation • Instantaneous Neon Flasher (no inertia) indicates when per cent of modulation has exceeded your predetermined setting. Setting can be from 40 to 120 per cent. Helps comply with FCC regulations. Has two RED•DOT Lifetime Guaranteed Triplet instruments. Modernistic metal case. Model 1696-A—Amateur Net Price.....\$34.84 Also available as a rack panel mounting unit.

For More Information—Write Section 1510, Harmon Drive

THE TRIPLET ELECTRICAL INSTRUMENT CO.
 Bluffton, Ohio

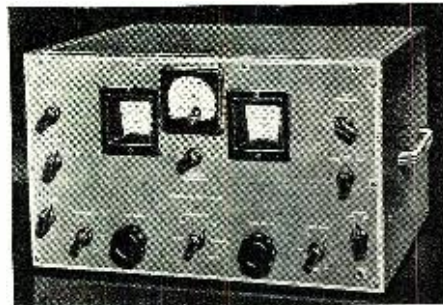

Better Results with
An HQ-120-X

THE "HQ-120-X" incorporates features which make operation on short waves a pleasure. Owners have repeatedly claimed that they can pull in stations more successfully because of the accurately calibrated dials. Also, the 6-point variable crystal selectivity control has made it possible to receive stations with practically no interference which would, normally, be completely covered with QRM. The excellent frequency stability and the calibrated amateur band spread dial have made the "HQ" a favorite with amateurs. There are other features too, such as noise limiter, voltage regulator, antenna compensator and many others which have made the "HQ" a distinctive receiver. Try it and see for yourself how really good it is.

WRITE FOR "HQ" BOOKLET!

HAMMARLUND MFG. CO., Inc. RN-10
 424 W. 33 St., N. Y. City
 Please send 16-page "HQ" booklet

Name

Address.....

City..... State.....



HAMMARLUND

Canadian Office: 41 West Av. No., Hamilton, Ont.

driving home on the Outer Drive, when we heard several cars pass us tuned to the same station and blaring forth the "Star Spangled Banner" we got a real thrill from it. It still is a grand song! . . . And a grand country.—KAK.
 * * *

Video Reporter
 (Continued from page 31)

a few disturbing consequences brewing. Several weeks before the suspension of programs from the city's lone "regular" telecasting station, W2XBS, the trade was steeling itself against the storm of protests anticipated from irate set-owners who believed that the service would never be interrupted for anything short of a state of war.

A particular headache seemed to be represented in the television sets sold on the installment plan. It was apparent that a number of purchasers—particularly those who made just a few payments—would let future payments lapse. Or, what is just as bad for the industry, some of the sets owned outright, may be sold through newspaper classified advertisements at greatly reduced prices.

Loudest squawks of all will probably come from the neighborhood bars and grills which have been counting on television sets to draw added business.

NBC explained the necessity to shut down in frequent announcements between television presentations. But despite the logic of the explanations, it's a tough job to appease the fellow who plunked down a couple of hundred bucks for a set only to discover that there are no programs available. He can't help but feel, temporarily, that he may have been better off with a ten-dollar midget receiver which, at least would bring in something out of the ether.

And worst of all is the job ahead when telecasts resume. Video equipment manufacturers will need some strong sales spiels to counteract the impression of instability prompted by the lull in programs.

THE shutdown of W2XBS was attributed to the technical changes made necessary by the FCC's recent television rulings. However, RCA was probably eager for the recess, anyway, inasmuch as it was the sole station in operation in the New York area for fifteen months and most likely felt it was doing an expensive development job for the entire industry with no immediate signs of profitable returns.

An NBC informant tells us that, although the transmitter atop the *Empire State Building* will be off the air, the recess period will be used to catalogue props and scenery, repair and paint sets and to line up suitable new program material for use when the telecasts resume. Also, engineers will be busy adapting the transmitter to new specifications. Alfred H. Morton, NBC vice-president in charge of television, made no prediction as to the date service would resume. The *Video Reporter* heard on good authority, though, that W2XBS will be back on the air in about three months and what is more the experimental "2" in the call letters may be dropped by then; there are strong rumors that the FCC will yield to commercial television before the turn of the year.

SHUTTING down W2XBS didn't affect the television tour conducted at *Radio City*. This tour, along with the NBC studio tour, is said to be a leading sightseeing attraction in New York, and the amazing part of it all is that visitors must pay to see a purely commercial setup. The television tour is physically divorced from the RCA-NBC television studio and transmitter, so the overhauling work on W2XBS in no way interfered with the guided television tours—the only phase of RCA-NBC video activity that has actually shown a profit.

TELEVISION news from London is a rarity these days. But it is encouraging to note that all video plans for the future have not been dropped due to the wartime suspension of telecasts.

Word reaches us that *Baird Television*,

one of the pioneer British names in the sight-and-sound field, is being merged with *Cinema Television*. The *Gaumont-British Picture Corporation* is identified with the financing of the reorganization, the action implying that the British movie industry isn't giving television a chance to put anything over in a big way unless the movie lads are in on the profits, too. All of which seems fair enough considering the financial backing supplied by the cinema lads.

In America, too, the trend towards a cementing of relations between television and the screen is growing stronger. And, in many instances, Hollywood backing is eagerly sought. But to have television pass into Hollywoodian control may not be too desirable.

The movie men are concerned with television progress from two distinct angles. The first is to participate in video earnings through the supplying of films to the new medium and the second is to see that home television doesn't cause a drop in theatre box-office revenue. Hence, television may stand to get a bit of kicking around under any majority Hollywood control.

However, it's a safe guess that the movie industry is already licked in any attempts to grab the television reins in this country. We predict quite a few video-movie alliances but the accent will be on the video parts of the combines.

A SAMPLE of television and movie collaboration was represented in the RCA-NBC tie-up with *RKO-Pathé Newsreel* in bringing scenes of the *Democratic Convention* in Chicago to New York look-and-listeners. The newsreel clips were flown to New York and telecast the following day. This was an interesting tie-up, but even as a pioneer experiment, it was disappointing. Getting the scenes a day late may be better than not getting them at all, but the fact remains that as long as the pictorial account was delayed, it would have been available in New York theatres anyway.

Television fans are impatient with delays. And broadcasting itself was the thing that made them that way. Look-and-listeners show a marked preference for "on-the-scene" programs. Hence, satisfactory relays between key American cities will have to be worked out.

RCA and NBC planned a stunt program from the *S.S. America* on its initial run from Newport News to New York. Television reception aboard ocean liners is not new—as we pointedly remarked in earlier columns. But the transmission of a television program from a vessel at sea would have been an eye-opener indeed. But after the engineers ironed out all technical wrinkles to make the ship-to-shore telecast possible, the plan was suddenly dropped. The only explanation forthcoming from W2XBS was that not enough accommodations were available on the vessel for the extra-large television crew essential to man the apparatus for the stunt.

NEW YORK UNIVERSITY will launch a television program course at the Fall semester under the direction of Thomas H. Hutchinson, manager of the NBC television program division. The lectures will be offered in the school's famous *Radio Workshop* which offers a full course to students desiring to major in radio. Television is already a classroom subject, at other universities and colleges, too.

STERLING FISHER, CBS director of education, recently arranged a tieup of audio and visual education facilities for the Columbia School of the Air broadcasts. But, the arrangement merely involves the use of films in classrooms as an adjunct to educational broadcasts. The need for films implies that instruction by radio needs bolstering by visual aids. Why not television instead of films? True, a well-organized plan for distributing reels to schools has been devised. But how much simpler it will be when telecasts to classrooms will eliminate the need of separate reels for each participating school!

Capacity Tester

(Continued from page 22)

eter in the voltage divider of the power supply. When a leaky condenser is connected at the input the pattern of the 6E5 will open, and the slide-back control should be advanced until the pattern is closed again. The reading of the slide-back control scale will indicate the voltage across the resistor developed by the direct current leakage through the condenser. With the constants shown, on the high range, testing paper and mica condensers, the slide-back voltage divided into 100 will give the d.c. resistance of the condenser in megohms. In the low ranges, testing electrolytics, the control setting divided into 1 megohm, will give the leakage resistance of the condenser.

These leakage ranges may be made anything the builder prefers, by varying the size of the series resistors in the circuit. Since other ranges may be desired the calculation for resistor values is given. In the high range of the circuit shown, one volt reading indicates a condenser resistance of 100 megohms. If the test voltage applied is 400 volts, the voltage ratio is 400.1, therefore the resistor ratio must be the same; i.e. $100 \text{ meg.} / 400 = .25 \text{ megohm}$. For an applied test voltage of 200 volts, the resistor would be, $100 \text{ meg.} / 200 = .5 \text{ megohm}$. Since the leakage resistance of electrolytic condensers is much lower a different set of resistors will be required for their testing. If one volt is to represent a condenser resistance of 1 megohm, and the test voltage is 400 volts, then the series resistor must be $1 \text{ megohm} / 400 = 2500 \text{ ohms}$.

At present there is no close agreement as to the normal leakage in electrolytic condensers. However, one leading condenser manufacturer has published a table which may be used as an approximate guide to leakages that may be expected in condensers of good quality.

Dry Electrolytic Condensers

Volts	D.C. Mils.
25-100	.01 ma. per mf. plus .5 ma.
150-300	.02 ma. per mf. plus .5 ma.
350-500	.03 ma. per mf. plus .5 ma.

Wet Electrolytic Condensers

Volts	D.C. Mils.
25-100	.02 ma. per mf. plus .9 ma.
150-300	.03 ma. per mf. plus 1. ma.
350-500	.05 ma. per mf. plus 1. ma.

The common power supply is built in, and should furnish up to 400 volts d.c. for leakage testing, and 20 to 25 volts for the slide-back voltage control, a total of 420-425 volts, which is just within the rating of ordinary filter condensers. If the tapped voltage divider across the power supply is large enough, around 30,000 to 40,000 ohms, to prevent excessive current drain, the average power transformer rated at 325 volts—40 ma., will fur-

nish approximately the correct voltage, when used with a type 84 rectifier, and 4 mf. condenser input. Besides supplying 6.3 volts for the tube filaments, the transformer also supplies 5 volts a.c. for the bridge, a value low enough to enable testing electrolytic condensers without damage.

There are a few other points that are worthy of special comment. The SP-DT switch inserted in the line to the common terminal of the B+ deck of the leakage range switch is for the purpose of discharging condensers before their removal from the leakage testing circuit, thus protecting the operator from a possible jolt that will cause him to regret his carelessness. The .05 condenser from the 6E5 grid to B- removes several overlapping lines from the illumination of the target, and tends to make the determination of bridge balance less critical. It is apparent that the resistors in the ratio arm should be of values close to the constants given. The builder should have little difficulty in selecting three resistors from a number of reliable make that will serve acceptably. In the absence of any better method, a number of resistors may be measured with the ohm-meter, and the best selection made. While the two condensers used as standards in the instrument shown were taken from general stock and found to be of acceptable accuracy, it is possible that the constructor may experience a little more difficulty in selecting condensers of sufficient accuracy. In that event a pair may be installed, assuming that they are reasonably accurate, and a comparison of results obtained in testing will disclose the presence of any serious inaccuracy. Some manufacturers can supply condensers with a specified low tolerance at a premium, and it may be worth while to obtain such measured capacities, if any serious difficulty is experienced along this line. It is not pretended that this unit is a precision instrument, nor can this type of construction be made so, due largely to the mechanical limitations of the wire wound controls used. However, by careful construction and intelligent selection of critical parts, it will not be at all difficult to produce an instrument with an accuracy well within the limits required by ordinary service work. In the case of the instrument shown a definite balance may be obtained with capacities as low as 5 mmf., which may be taken as an indication of the results that may be obtained from this design. —30—

Book Review

(Continued from page 40)

tor, actor, script writer, radio editor, and engineer. These men are like explorers setting off on an expedition to strange new fields; they have come from the moving picture studios, the radio, the stage, for television combines elements of all three mediums while differing in its demands from any one of them. And in this book

Frequency Modulation

EXTENDED RANGE — HIGH FIDELITY

There is now available a complete family of special Jensen products for Frequency Modulation and Television receivers as well as for monitoring and studio work. The new 15" dual-unit model in Permanent Magnet design has a built-in filter network—shows an extended high frequency response up to 14,000 cps. The 8" and 12" PM models are extended to 10,000 cycles. All three available in the standard "MT" type Bass Reflex enclosure—the two larger also available in the new Walnut "CA" type Bass Reflex enclosure. All extremely modestly priced.

Jensen Radio Mfg. Co.
6601 S. Laramie
Chicago

Jensen
Bass Reflex
REPRODUCERS

ELECTRICAL BOOKS
shipped
FREE

10
BIG BOOKS

FOR
EXAMINATION

MODERN ELECTRICITY
INCLUDING RADIO and TELEVISION

Here's great news for anybody interested in Electricity. NEW 17th edition of Applied Electricity brought right down to date with NEW Electrical subjects well covered. 10 big Volumes all shipped FREE for examination.

FOR BEGINNERS and EXPERTS

Over 3000 pages—hundreds of illustrations. Dynamos, motors, power stations, radios, television, everything electrical explained so anyone can understand it.

BIG FIELD! Big Demand! Big Pay!

Men who understand electricity are needed in thousands of industries. Autos, airplanes, machine shops—practically every industry depends on electricity and men who know this subject make big money. Pleasant, fascinating work, easy to learn and do; learn with these books. Send coupon for a set for FREE examination and see for yourself.

SEND NOW! A consulting membership in the American Technical Society now given to all buyers of this Cyclo-Pedia of Electricity.

AMERICAN TECHNICAL SOCIETY
(Publishers—Home Study Courses)

American Technical Society, Dept. E722, Drexel at 58th St., Chicago
Send for 10 days' use, NEW 10 volume set of Applied Electricity. You agree to include a membership in the American Technical Society entitling me to consulting privileges for one year. I will pay the delivery charges on the books. If I wish I may return them in 10 days and owe you nothing, but if I keep them, I will send \$2.00 after 10 days, then \$3.00 a month until the total price of only \$29.80 is paid.

NAME.....
ADDRESS.....
CITY..... STATE.....

Please attach letter stating age, occupation and name and address of employer and give at least one business man as reference.

NOW! WITH WASHINGTON COVERAGE! THE "HOTTEST" MAGAZINE IN RADIO! READ RADIO NEWS!

3 New, Low-priced SERVICE MANUALS

1. DIAGRAMS of MOST-OFTEN SERVICED RADIOS

In a single manual you have all the radio diagrams most-often-needed today. Better than 4 out of 5 sets you service are included. These important, hint-giving, trouble-shooting circuits make your job easier, permit faster and better repairs. Let this new diagram manual guide you to real time-saving and money-making radio work. No need to work blindly, get your copy of this "on-the-job" handbook of useful diagrams, service hints, alignment data, parts lists, 54 man. **\$1.95**

2. MOST POPULAR 1940 DIAGRAMS

Let this new manual give you (1) over 80% of all 1940 circuits ever needed, (2) acquaint you with recent radio developments, and (3) teach you how to service quickly and efficiently millions of sets sold last year. Includes service information on new portables, television, frequency modulation, personal tracing, amplifiers, recording, etc. Will pay for itself on the very first job. **\$1.50**

3. Motorola SERVICE MANUAL

This up-to-the-minute manual will tell you how to repair every MOTOROLA auto radio. Includes detailed schematics, service notes, alignment data, and parts lists for all of the 72 models made to date. Will repay for itself on the very first job. This large, 8 1/2 x 11 inch, 100 page manual is priced at only..... **\$1.00**

FREE EXAMINATION COUPON

SUPREME PUBLICATIONS,
3727 West 13th St., Chicago, Ill.
Rush the manuals checked below:

-1. Most-Often Serviced Radios @ \$1.95
-2. Most Popular 1940 Diagrams @ 1.50
-3. Motorola Service Manual @ 1.00

I am enclosing \$....., send postpaid.
 Ship C.O.D., I will pay postman.
 I must be satisfied, or my money will be refunded.

NAME:.....
ADDRESS:..... 144

they tell of their experiments, their discoveries, and their vision of the future, as they transmit to the reader the strangeness, the excitement of this world where new marvels are being born as pictures and sound travel through the air. Those who look forward to all its implications will eagerly welcome the invitation to come back-stage and receive the intimate and informed explanation of the subject which this book affords. —50—

What's New in Radio
(Continued from page 34)

This instrument, Model 133, has a new movement, especially designed for super sensitive radio equipment, with high torque, which assures freedom from the difficulties formerly encountered with sensitive instruments used in portable testers.

The 5" square meter has large scale opening and four color scale. Ranges are as follows: 40-500 d.c. microamperes, 5-50-500 d.c. milliamperes, 2.5-10-50-250-500-2500 volts a.c. and



d.c. 25,000 ohms per volt d.c. 1000 ohms per volt a.c. 0-30-10,000—1 meg-10 meg. resistance. Decibels. All ohmmeter ranges operate from self-contained batteries. Battery tester for testing batteries in all popular sizes up to 135 volts.

The carrying case of leatherette covered plywood has a removable cover and ample lead compartment.

For full data write the maker, The Hickok Electrical Instrument Co., 10514 Dupont Ave., Cleveland, Ohio.

Several important refinements and very obvious improvements in prong-base electrolytics are announced by *Aerovox Corporation*, New Bedford, Mass., and are made available in their Series AF units, superseding the former F series. Definite gains are scored in positive sealing of base and prongs, reduction of possible corrosion to an absolute minimum, and better mechanical construction obviating the shearing of tabs and the loosening of internal connections.

The first point of departure from the conventional is the square can shoulder in place

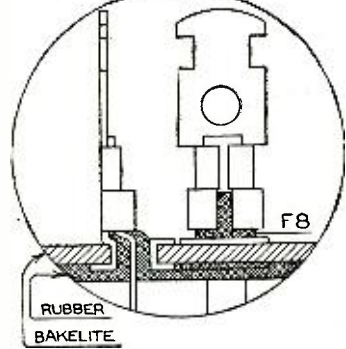

of usual sloping shoulder. This insures the solid seating of plug or disc, and eliminates any danger of shearing the cathode-tab, brought out between can side and plug.

Instead of two bakelite discs separated by a sheet of flat rubber, *Aerovox* AF construction employs a cup-shaped molded soft-rubber disc with side walls, which rests on square shoulder and against can walls. The single bakelite disc

fits within this cup-shaped rubber disc.

Also, the rubber disc has several slotted protrusions or sleeves molded in same, which slip into the slots of the bakelite disc. Through said rubber sleeves pass the anode or positive tabs which, beyond the bend within the sleeve, join the terminal lugs. This is in contrast with the straight mechanical leakage path found in conventional construction, wherein the tab passes loosely through punched holes in the bakelite, rubber and bakelite discs. AF construction provides rubber-sealed tabs.

Because the dissimilar-metal joints between tabs and lugs are sealed and protected by the soft rubber sleeves, no electrolyte can reach them to cause corrosion. Also, no electrolyte can come in contact with raw bakelite edges in the slots, to cause corrosion by impurity that may leach out of the bakelite.

Other measures are taken to insure trouble-proof operation, such as spot-welded connections, high-purity aluminum tabs, and thorough sealing against electrolyte seepage. There is a positive pin-hole vent instantly responsive to excessive gas pressures, yet normally self-sealing, in contrast to conventional practice of relying on gases oozing out through tab slots and thereby carrying along the electrolyte to cause corrosion of joints.

This new *Howard 490* communication type receiver is designed for the advanced amateur, short wave listener and commercial operator. It features fourteen tubes, coverage in six bands, from 540 kc. to 43.5 mc. (550 to 7 meters), calibrated band spread, variable select-

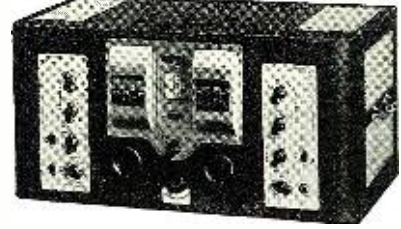

tivity i.f., variable fidelity audio system, temperature compensated oscillator, air tuned i.f. transformer and split stator ceramic insulated tuning condensers.

The *Cornell-Dubilier* Model BF-50 Capacitor Analyzer provides for the laboratory and service shop an entirely self-contained instrument which furnishes precision checks and measurements on every important characteristic of all types of capacitors. In addition it permits measurement and analysis of other circuit components such as cabled wiring, shielded leads, transformer windings and insulation, etc., all of which may have an important bearing on the operation of these circuits.

Measurements provided for include: capacity

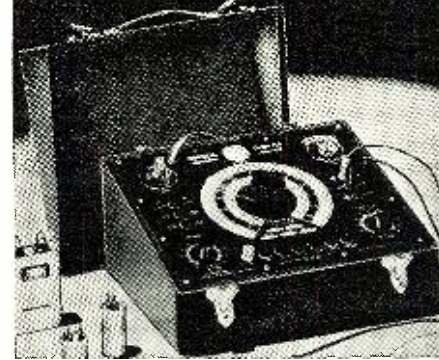

(10 mmfd. to 240 mfd.), power factor (0 to 50%), insulation resistance to 1500 megohms, leakage, shorts, open or intermittent conditions, etc.

A Wien Bridge arrangement utilizing carefully designed components insures permanent accuracy of measurements and independence of line voltage variations. Balance is indicated by a visual eye with a 12A7 amplifier built into the Analyzer for high sensitivity. Also built-in is a direct-current power supply of approximately 450 volts for use in leakage and insulation resistance measurements.

Official announcement has just been made by the Emerson Radio and Phonograph Corporation, New York City, of its entry into the radio tube replacement field.

Managing the tube division is Jack Geartner, former sales manager of Arcturus Radio Tube Co. Widely travelled in every state of the country, he is well known throughout the industry.

Mr. Geartner brings to his new connection a wealth of experience gained in the last twelve years in the industry, during which he has advertised, sold and merchandised tubes.

Commander E. F. McDonald, Jr., President of the Zenith Radio Corporation, Chicago, Illinois, has announced the appointment of Robert F. Weing as Vice President and General Manager of its subsidiary, the Wincharger Corporation in

Sioux City, Iowa. W. W. Watts who formerly held this position has resigned and is returning to the east to enter business there. Mr. Weinig who has been in charge of farm radio sales for Zenith has a wide acquaintance among distributors and dealers in the farm field and has had broad business experience as a manufacturer, distributor and sales executive. As a result of his first-hand knowledge of the needs of farm people in all sections of the country, Mr. Weinig is most enthusiastic about the tremendous farm market possibilities of Wincharger and the unlimited opportunities which exist for the creation of new uses for Winchargers in the commercial field.

V. M. Graham, Hygrade Sylvania Tube Application Chief, has been appointed Secretary of the National Television System Committee. The committee has been organized to develop and formulate standards required for the development of a suitable National Television System of broadcasting. This committee is responsible for the investigation and study of all phases of a National Television System. It aims to coordinate television engineering research and experimentation and will seek concrete data on the broad psychological and physiological aspects of a television picture reproduction.

W. A. Coogan, Foreign Sales Manager of Hygrade Sylvania, has been appointed chairman of the R.M.A. Export Committee. Mr. Coogan has served ably with R.M.A. Export members for several years and brings to the chairmanship a broad background of foreign sales activity and also a member of the Board of Directors of the gained from world wide travel. Mr. Coogan is in intimate knowledge of international markets Export Managers Club.

-30-

Sixty Simple Watts

(Continued from page 11)

discretion, but leaving them in the circuit while keying does not come under the heading of discretion.

Keying is accomplished by breaking the cathode lead, and a .01 mfd. condenser across the keying jack effectively eliminates key clicks.

The antenna tuning arrangement is suitable for tuning an end-fed Zepp with approximately quarter wave feeders. Other types of antennas will of course require different tuning setups, and reference should be made to the various handbooks on the subject for additional information. It is quite possible that with different tuning arrangements, antenna condensers of greater plate spacing would be called for, but in the circuit shown the small receiving type condensers are adequate. Small air-wound plug-in coils with link coupling are used in both the plate tank and antenna circuits, which makes band-changing an easy matter. The forty meter coils are shown in the photographs.

Power Supply

The power transformer used is a Thordarson T-6878 which has seen active duty in one capacity or another around the shack since 1935, and it still seems to be as good as new. It furnishes 7.5 rather than 6.3 volts, so a dropping resistor of 0.7 ohm is used in series with one of the heater leads to the 6L6G's. This transformer is no longer stocked by Thordarson, but a number of transformers of similar ratings are available on the market, and with 6.3 volt filament windings.

The single section filter smoothes the ripple very nicely, and all reports on the signal have been T9x. Two 8 mfd. paper condensers are connected in series to provide 4 mfd. at a working voltage of about 1000, a comfortable safety factor.

Construction

The rig is constructed on *Masonite*

which is extremely easy to work with and very inexpensive. The front panel is black crackle finished and is attached to the chassis proper with a pair of steel angle brackets (*Bud No. 1266*). All the *Masonite* used is 3/16 inches thick, both in the front panel and in the chassis itself, and has ample rigidity to support the power transformer and other parts without sagging. The chassis measures 12"x18"x1 3/4", and the front panel is 18"x8".

Referring to the front view photograph, across the bottom from left to right is the key jack, stand-by switch, and supply switch. The dial on the left is the plate tank, and the middle and right hand dials are for the antenna tuning condensers. The two toggle switches directly below the meters are for shorting the meters during keying. In the upper left hand corner is the pilot light jewel. The two small feed-through insulators are the antenna terminals.

Operation

In tuning the transmitter, the plate tank condenser should be tuned for resonance as indicated by minimum plate current and then rotated about one degree in the minimum capacity direction. If this is not done, there will be a tendency to chirp and the rig will not key properly. As the antenna is tuned to resonance, the plate current will rise to about 120 ma. In the absence of an r.f. ammeter a pair of paralleled No. 41 pilot bulbs connected in series with each feeder will be of help as an indication of antenna resonance.

Just about the biggest advantage of this little transmitter is its unusually high ratio of watts to dollars. Next in order are its ease of construction and its simplicity of operation. The word "foolproof" is very much overworked, but here is one case where it actually applies.

-30-

Poorman's Receiver

(Continued from page 25)

is one item which should not be subjected to skimping. A good baffle can be built for an almost nominal sum, and its boosting effect upon bass response is little short of amazing. *Celotex* is generally accepted as a good material for this purpose, as it is both efficient and inexpensive. Another important point to remember is that the high frequencies are projected straight forward from the speaker cone in a narrow beam; consequently the speaker should be placed in such a position as to allow the listener to sit directly in front of it if the high frequencies are to be fully appreciated.

There are only two or three points to mention in regard to the mechanical construction of this set. Mount L1 and L2 at right angles to each other and at a reasonable distance apart to avoid regeneration in the r.f. stage, this being the cause of increased selectivity and resultant side-band cutting. For the same reason, the r.f. tube should be shielded. Mount R12 in some place

More Than 25 Proved Sales Promotion Services Help You Sell



WHEN you stock Sylvania Radio Tubes, you get the most comprehensive and effective merchandising service that ever helped a dealer to bigger profits.

Look over the partial list below. Many are free. Others are available at satisfying savings. All help you sell.

Write Hygrade Sylvania Corp., Dept. RN100, Emporium, Pa., for samples of these selling aids and full information about the Sylvania way to bigger profits.

Sylvania Helps . . . That Help You Sell

- | | |
|------------------------------|--|
| 1. Big Store displays | 18. Technical manual |
| 2. Window displays | 19. Tube base charts |
| 3. Counter displays | 20. Price Cards |
| 4. Electric Clock signs | 21. Sylvania News |
| 5. Electric Window signs | 22. Characteristics Sheets |
| 6. Outdoor metal signs | 23. Interchangeable tube charts |
| 7. Window cards | 24. Tube complement books |
| 8. Counter cards | 25. Folding stock boy cabinets |
| 9. Personalized postal cards | 26. Floor model cabinet |
| 10. Imprinted match books | 27. Large and small service carrying kits |
| 11. Imprinted tube stickers | 28. Customer card index files |
| 12. Business cards | 29. Shop coats |
| 13. Door Knob Hangers | 30. 3-in-1 business forms |
| 14. Newspaper mats | 31. Job record cards (with customer receipt) |
| 15. Store Stationery | |
| 16. Bill heads | |
| 17. Service hints booklets | |

SYLVAN A

SET-TESTED RADIO TUBES

Also makers of Hygrade Lamp Bulbs and Miralume Fluorescent Light Fixtures

ASSURED STABILITY

WITH
**BLILEY
CRYSTAL
UNITS**

**10-20-40-80-160
METER BANDS**



TYPE B5 —This highly active crystal unit for the 40 meter band has less than 4 cycles/mc/°C drift. Price \$4.80.

TYPE LD2—An efficient and powerful low drift crystal unit for the 80 or 160 meter band. Price \$4.80.

TYPE HF2—Simplifies the construction of 5- 10- and 20-meter transmitters. Drift, 20 meters, 20 C/mc/°C; 10 meters, 43 C/mc/°C. Price, 10 or 20 meters, \$5.75.

TYPE BC3—A moderately priced mounted crystal with unusual activity and power output. Drift 23 C/mc/°C. Price, 40, 80 or 160 meters, \$3.35.

BLILEY ELECTRIC CO. • ERIE, PA.

RADIO OPERATORS' LICENSE GUIDE BOOK

Here's a new Guide Book that contains over 1200 questions and answers which will help you pass the new six element examinations for a commercial radio operator's license. It correctly answers all questions contained in the study guide that was recently released by the Federal Communications Commission for the use of those proposing to take its examination. It will not only see you through your examination, but will also serve as a valuable future reference book. \$3.00 postpaid. Refunded if not satisfactory. Send check or money order.



ONLY \$3.00
Postpaid

INLAND WIRELESS
SUITE 2017, FIELD BLDG., CHICAGO, ILLINOIS

NEW! 1941 MODEL Pocket NO Batteries Radio

Dual Bands-Magictenna-Microdial
Fits your pocket or purse. Wt. 6 ozs. Small as cigarette package. Receiver standard & short wave. PATENTED POWER RECTIFIER. No tubes, but series. Hi-ratio easy tuning slide "MICRODIAL". ALL OF ILL. SAYS: "MIDGET RADIO WORKS FINE!" **ONE YEAR GUARANTEE!**

Sent complete ready to listen with instructions & tiny phone for use in homes, offices, hotels, in bed, etc. **SIMPLE TO OPERATE—NO ELECTRICITY NEEDED!**

SEND NO MONEY! Pay postman only \$2.99 plus postage charges on arrival or send \$2.99 (Check, M.O., Cash) and yours will be sent postpaid. A MOST UNUSUAL VALUE! **ORDER NOW!**

FREE! PLUG IN "MAGICTENNA"—ELIMINATES OUTSIDE WIRES! MIDGET RADIO CO., Dept. HG-10, Kearney, Neb.



GOLDENTONE...50% OFF

DEAL DIRECT...FACTORY PRICES...
Over 60 models to choose from
—4 to 12 tubes. Portables
\$8.08 up. Farm sets \$8.98 up.
Car sets \$8.98 up. Foreign
band sets \$8.08 up. Samples
50% off. Quantity discounts.
counts. Free 1941 Bargain
catalog gives details of 10
day FREE trial, agent's propo-
sition, and discounts. No
obligation. Mail postcard to
GOLDENTONE RADIO CO.
Dept. R N, DEARBORN, MICH.



SOLAR RED-CAPS

Smaller Diameter Dry Electrolytics

SPEED Servicing

Write for Catalog



SOLAR MFG. CORP. Bayonne, New Jersey

PATENT and SELL your INVENTION

That clever "little idea" of yours—no matter how simple it seems—may have big money-making possibilities. Two advisory books **FREE!** tell you how to protect your ideas with a U. S. Government patent—give you six basic ways to sell your invention. Fees reasonable; terms arranged. Write for books today.

Victor J. Evans & Co.
582-L Victor Bldg., Washington, D.C. EST. 1898

WORLD'S LARGEST FIRMS OF REG. PATENT ATTS.

where it cannot easily be tampered with; because after it has once been adjusted as described previously, it should be left strictly alone.

Aside from these details, the layout of the set is not particularly important. The illustration gives an idea of how it was done by the author, using junk-box parts almost exclusively.

During the eight months in which this receiver has been in operation in the author's home, it has given numerous demonstrations of its excellent frequency response and received the compliments of all those who have heard it. However, the most positive proof of its superior characteristics and the one which will be of most interest to the reader is that which was shown in tests with a b.f. audio oscillator modulating an r.f. signal generator. The necessary apparatus was not on hand to take a genuine frequency response curve, but the results can easily be told verbally.

At the high end of the spectrum, frequencies up to 10 kc. came through with very little drop in volume; while the low notes kept coming through right down to the point where you could place your fingers on the speaker cone and count the cycles! An output meter indicated practically no drop in volume at 30 cps.

The effect of such an excellent response characteristic is instantly noticeable with even the poorest sort of program. Music of any kind takes on an entirely new air of brilliance, and instruments which you never heard before come out in their full glory. Even speech sounds clearer and more natural.

For Immediate Release (Continued from page 34)

new FCC agency will be established under an Executive Order of President Roosevelt and in cooperation with the National Defense Commission and Army and Navy authorities.

Effective policing of communications under a coordinated National Defense program is being planned and the FCC is increasing its field force by addition of many temporary inspectors. Foreign language broadcasts will be translated and scrutinized, as well as operations of amateur and other stations. All regular and also amateur operators are now being required to file statements regarding their citizenship.

FM Service Area 33 Times That of AM, Say General Electric Radio Engineers

UNDER certain conditions, the area of good broadcast service with frequency modulated (FM) transmission is 33 times greater than with amplitude, or present type, broadcasting, according to a report on tests and calculations announced recently by General Electric radio engineers.

The tests, conducted by I. R. Weir, General Electric radio engineer, involved, first, simultaneous operation of two equally powered AM transmitters and, then, of two FM transmitters. All utilized the same frequency. In each test the transmitters were located 15 miles apart with level intervening terrain. Transmitting antennas were 300 feet above the average ground level, while receiving antennas were 20 feet high.

Computations based on these tests reduced the areas involved to arbitrary unit values. These figures demonstrated that two 1000-watt AM stations have equal service areas of relatively small circular zones of 1.3 units

CAMERA FANS!

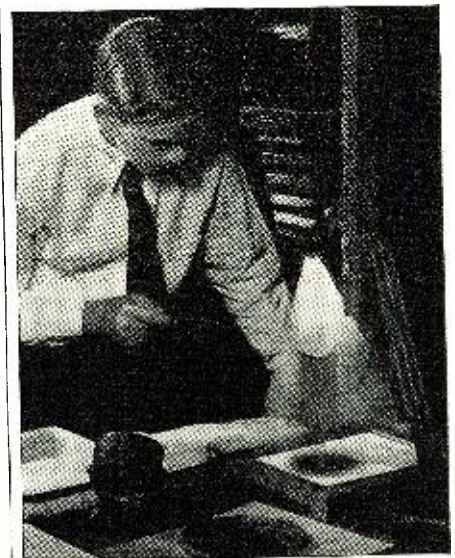

DON'T MISS THE BIG Special DARKROOM ISSUE

Here, for the first time, **POPULAR PHOTOGRAPHY** brings you a comprehensive coverage of the darkroom . . . eleven outstanding articles that will help you get the best results in developing, printing, enlarging, mounting, and retouching your pictures. Yes, every phase of darkroom work is discussed by experts . . . authoritative counsel that you will want to have at your fingertips for handy reference twelve months of the year.

READ THESE GREAT ARTICLES:

- MODEL DARKROOM AND EQUIPMENT by Haywood Parker
- DEVELOPERS AND THEIR FUNCTION by Dr. Walter Clark
- TECHNIQUE OF DEVELOPING by Hillary G. Bailey, F.R.P.S.
- INTENSIFICATION AND REDUCTION OF NEGATIVES by J. I. Crabtree
- SELECT PAPERS TO FIT YOUR SUBJECT by Peter Krause
- CONTACT PRINTING by Charles A. Savage
- ENLARGING AND PRINT CONTROL by Stephen White, A.R.P.S.
- HOW TO MAKE GOOD COPIES by Lloyd E. Varden, A.R.P.S.
- RETOUCHING FOR BETTER PORTRAITS by A. K. Wittmer
- MOUNTING YOUR PRINTS by Walter E. Burton
- MAKING PRINTS ON CLOTH, WOOD, etc., by Jacob Deschin, A.R.P.S.

ALL IN THE SPECIAL
October Issue



NOW ON SALE AT ALL NEWSSTANDS—25¢

Simplest WAY TO REPLACE BALLASTS

4 STANDARD TYPES of Amperite Regulators replace over 200 types of ACDC Ballast Tubes now in use. . . . Has patented automatic starting resistor. List \$1.00

WRITE FOR REPLACEMENT CHART "S" Amperite Co. 561 Broadway, N. Y. C.

AMPERITE

FREE CATALOG

ALL RADIO NEEDS

Here in this one big book you will find everything you need in radio . . . sets, parts and supplies . . . public address systems . . . amateur equipment . . . testers and kits . . . your nationally known favorites at lowest possible prices. Write today for this big valuable catalog and save money.

PROMPT SERVICE

BURSTEIN-APPLEBEE COMPANY
1012-14 McGEE STREET, KANSAS CITY, MISSOURI

When it's HOT NEWS . . . It's in RADIO NEWS! READ RADIO NEWS EVERY MONTH TO GET THE LATEST INFORMATION ON RADIO!

AIR POWER will dominate the Pacific . . .

by General Wm. Mitchell

Over a decade ago America's prophet of military aviation warned that our air power was the deciding factor in our defense of the Pacific, and without it, any attempt to hold our possessions or protect our country against an enemy would be fruitless. Reproduced in the October FLYING AND POPULAR AVIATION is an intensely interesting article which first appeared in POPULAR AVIATION in 1929. Read how, eleven years later, General Mitchell's statements remain thought-provoking and startling. Read all about our air power in the Pacific and what it means to us as a nation. By all means, don't miss this truly outstanding feature in the big



October Issue

FLYING AND POPULAR AVIATION

NOW ON SALE At All Newsstands

each around both stations, while two FM stations cover a service area of 43 units—33 times that of AM!

Should the power of one of the AM stations be increased from 1000 to 10,000 watts, the good reception area of the weaker, or 1000-watt station, is reduced to 0.44 units, while that of the stronger increases to 4. Of two FM stations with this 10:1 power ratio, the weaker has an area reduced from 43 units to 10, while the area covered by the stronger increases to 101 units.

If the power of one AM station is raised to 100,000 watts while the other remains at 1,000 watts, the area of the weaker is further reduced to 0.18 and that of the higher-powered AM station is increased to 12.5 units. With frequency modulation, this 100:1 power ratio results in a reduction of the lower-powered station area to only 3.7 units, while that of the stronger is increased to 190.

Even though the 1000-watt FM station is reduced to 3.7 units under such adverse conditions as a power ratio of 100:1, still the good reception area of this station is 280 per cent of that possible using AM transmitters and the most favorable power ratio of 1:1.

The tests also prove that receivers located between the service areas of two frequency modulated stations can get either station by means of a directional antenna. Thus vast AM interference areas can be converted into "discriminating" areas by the use of FM.

The General Electric tests give added proof that FM permits more stations to operate on the same channel by reducing the distance required between stations. At the same time these stations can give good reception over a much greater area than was previously possible with amplitude modulation, and can do so with lower power. —30—

Serviceman's Experiences

(Continued from page 26)

I brought the set in; Al repaired it silently; and I was very happy when I noticed both Mr. and Mrs. Spencer smiled and were especially satisfied when I delivered the set. It was a complete victory.

When I got back to the shop, I gave Al the works; told him why I was right, how I knew it, and how the *Majestic* proved it, and how we had made money, under my methods, with a minimum of wasted time and effort. Al sat quietly, without defending himself. It was a strange attitude for him—one which was possible only as a result of my utterly successful blitzkrieg.

Finally, when I had finished, he wrote two numbers on a piece of paper, and handed it to me.

"Add them!" he ordered.

The numbers were 1.88 and 3.84. After some brief finger action, I announced the total: 6.72.

"Six dollars and seventy-two cents," Al said, "is what we spent for parts on that *Majestic*: \$1.88 for the filter block, \$3.84 for the power transformer. You knew the price of the block by experience, but you were too busy wasting time to look for anything else. You would have been better off to hand 22c to the customer, bid him good day, and get along to the next job!"

"Well," I said, somewhat sheepishly, "those things happen, you know. Anyway—we still have the good will of the customer."

"Have we?" Al asked, getting up from the desk and raising his voice.

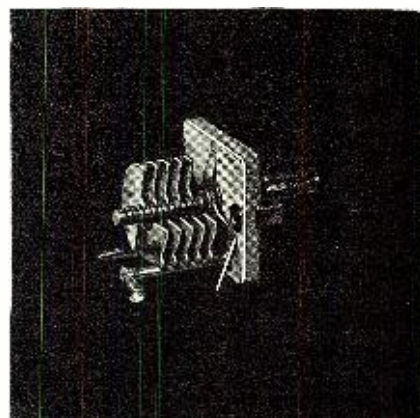

MILLEN ULTRA MIDGET CONDENSERS

are now available in double spaced models for capacities up to 35 mmfd and single spaced models up to 140 mmfd. Single and double bearing types with and without rear shaft extension. Illustrated is #20935, double spaced 35 mmfd. Net price \$9.0.

"Designed for Application"

JAMES MILLEN MFG. CO. INC.
150 EXCHANGE ST. MALDEN, MASS.



Is Radio . . . Just A Job to You?

If you can equip yourself with the necessary training . . . Radio can offer you a future few other industries can. Continuous new developments have created a need for technically trained men, who have kept their knowledge up with Radio's fast pace.

YOU CAN'T BLUFF YOUR WAY

CREI courses are planned only for serious-minded men who know that it takes Training to qualify for and to hold the big jobs and salaries that go with them. Let us suggest the course best suited for you and the easy ways of paying for it.

NEW BOOKLET . . . Just off the press!

Write for the CREI "TESTED PLAN"

An interesting booklet about Radio and the chances for your success. Please state briefly your radio experience, education and present position.

CAPITOL RADIO Engineering Institute



MAIL THIS COUPON TODAY!

CAPITOL RADIO ENGINEERING INSTITUTE
Dept. RN-10, 3224-16th St. N. W., Wash., D. C.

Please send me complete details in your free booklet. I am interested in the course checked:

Home Study Course. 1-Yr. Residence Course.

Name.....

Address.....

City..... State.....

Turner "Challenger"

Challenges Comparison in Performance, Style and Price

BX Crystal, List \$9.95

A rugged, dependable unit at a price hard to beat! Crystal impregnated against moisture and barometric pressure changes. Built-in wind-gag. Attractive bronze enamel finish. For recording, ham or P.A. work. Level -55DB. Range 50-5500 cycles. With 7 ft. cable and diagrams.



BD Dynamic, List \$12.50

Same appearance as BX. Fully protected for ham, yet rugged enough for toughest P.A. jobs. Works indoors or out; takes bad climatic conditions and rough handling. Level -53DB. Range 50-5500 cycles. 200-250, or 500 ohms, or hi-impedance. With 7 ft. cable and diagrams.

CX Crystal with Cable SET, List \$15

Rich brushed chrome finish, with removable cable set, using amphenol connectors. For ham or veteran—it's the mikes! Exceptionally free from feedback. Fully protected, well engineered. Level -55DB. Range 50-7000 cycles. With 7 ft. removable cable set and diagrams.



CD Dynamic with Cable SET, \$16.50

Same appearance as CX. Engineered to give smooth response at all frequencies. Free from hum pick-up; won't blast from close speaking. Takes rough handling. Not affected by climatic changes. Works indoors or out. 200-250 ohms, 500 ohm or hi-impedance.

Send for Full Free Information, Crystals Licensed Under Patents of The Brush Development Co.



U.S. NAVY WANTS 5400 RESERVE OPERATORS

The Communications Reserve of the United States Navy is enlisting 5400 expert radio operators!

You can qualify for your amateur or commercial license and a good rating by taking **CANDLER TRAINING** in your own home as thousands of radio operators have done in the last twenty-five years. You will get the same training McElroy and McDonald, the **WORLD'S CHAMPIONS**, received. The **NEW BOOK OF FACTS** gives you the story of the champions and inside tips that will help you. It is **FREE**. No obligation.

CANDLER SYSTEM CO.

DEPT. N-10
ASHEVILLE, NORTH CAROLINA



BROADCASTS YOUR VOICE LIKE A RADIO STATION—
to any ordinary radio within 100-150 ft. away! Between rooms, apts., houses, autos, offices—almost anywhere! No electric plug-in batteries, "Mike-Phone" tubes, and attachable "Magietenna" (eliminates aerial). Size only 3x4x1 1/2". Wt. 22 ozs. Simply connect and broadcast to nearby radios or other "Timedelayes."

ONE YEAR GUARANTEE!
Also receives many radio stations clearly—With No Changes or Extra Wires! New Model broadcasts and receives on short and standard wave! Anyone can operate it with our simple directions. A barrel of fun & amusement for everyone. Many practical uses! Finished in beautiful color crackle steel case! **Send Only \$1.00** (Check, M.O., Cash) and pay \$4.99 plus postage on arrival. **Order Now!**
WIDGET RADIO CO., Dept. THG-10 Kearney, Nebr.

With its weight in gold, huh!
Don't miss your RADIO NEWS!

"The only reason they called us back is because they got a bid from someone else after you left the first time—someone who didn't feel it was beneath his dignity to check the set properly before he committed himself. Naturally, the competitor's price was higher than ours, and Spencer called us back. All we have to show for the work now is a loss of 22c, a book loss of more than that, and a former customer who knows—because of our neglect—that we've made saps of ourselves!"

I sneaked from the store as quietly as melting ice. Since then, I've been more leisurely on all my calls.

-50-

Legal Advice

(Continued from page 24)

of the subscribers of the certificate must be of full age, at least two thirds of them citizens of the United States, and at least one of them a resident of the State of New York. And at least one of the persons named as a director is a citizen of the United States and a resident of the State of New York.² Under the *New York State Corporation Law*, no corporation shall issue either shares of stock or bonds, except for money, labor done or property actually received for the use and lawful purpose said corporation.

The corporation is an entity separate and apart from its stockholders. Even the owner of all of the capital stock of a corporation does not thereby become the legal owner of its property, but title to the corporation is vested in the corporate entity.³ While a corporation will be regarded as a legal entity, separate and apart from its stockholders, officers or directors, or from other corporations, the law will not permit this fiction to be carried to an extent so that it can be used as a cloak for fraud or illegality.

The management of the affairs of a corporation is vested in its *Board of Directors*. This authority, however, is conferred upon the directors, not in their individual capacity, but only when acting together as a Board. Whatever is done must be a deliberate act of the board of directors and not the act or acts of its individual members.

The directors of a corporation are elected by the stockholders of the corporation. The directors in turn elect the officers of the corporation. The directors of a corporation are responsible for the conduct of the corporation and the management of its business affairs. The officers have various duties which are set forth in the by-laws of the corporation. For instance, the Treasurer is responsible for the funds of the corporation, the payment of the corporate debts and the collection of the accounts receivable of the corporation.

A corporation as a separate entity may sue or be sued. In the event that the corporation is sued, and a judgment is rendered against it, the judgment becomes the liability of the corporation and not of its individual stockholder. In the partnership or individual form of doing business, a judgment against the partnership or the individual will bind either the individual or the partnership. Whereas, in the case of a corporation, a judgment against the corporation becomes the obligation of the corporation and does not personally bind the individuals who are the stockholders of the corporation.

Assuming that a group of servicemen, decide to incorporate, and one of them should die, his corporate shares may be left to his widow or to some member of his family. In this way, his widow or the members of his family continue to participate in the dividends of the corporation. The corporation will continue to live and the beneficiaries of the stockholders shares shall continue to receive the benefits of the earnings of the corporation. This is but one advantage of conducting business under the corporate form.

-50-

Q R D ?

(Continued from page 38)

TWA paid us up to the 15th, two weeks extra pay.)

The equipment is generally fair but they are putting in quite a lot of new stuff; a new 3KW rig at KC and several more slated for installation in the near future. There will probably be a few jobs opening in the next six months or year with this line as they are about ready to open up a new route thru Des Moines, Iowa. Altho at present most of the traffic is being handled by radiofone, they are increasing the size of the CW circuit by hiring combination ops (fone and CW tickets) and installing more CW xmters.

Oh, yeah, Al Segen, ex of the *Yacht Elsie Fenimore*, is now riding the *SS Gulfstar*. The *Elsie* laid up one Saturday and the following Monday morn he had a berth on the *Gulfstar*. Nize going I calls it. Congrats to the Editors on the new colyum on commersh rigs—sure glad to see it. Cul . . . 73 . . . CB.

God Bless America

WELL, me hearties, ol' Uncle Sam isn't snoozing any more, thank the Lord. He's getting wise to the fact that a lot of his guests and a few of his children are behaving in such a manner as to give rise to the suspicion that they mean harm to the venerable 'ol' gen'mun. The first thing he's doing is checking their conversation, their backgrounds and their families. The FCC is empowered to do this job, and quickly. The ol' Uncle still likes the idea of *Civil Liberties*, but he

Classified

Rate 15c per word. Minimum, 10 words.

CORRESPONDENCE COURSES

USED Correspondence Courses and Educational Books sold or rented. Inexpensive. Money-back guarantee. Write for Free Catalog listing 4000 bargains. (Courses Bought.) Lee Mountain, Pisgah, Alabama.

CORRESPONDENCE courses and educational books, slightly used. Sold. Rented. Exchanged. All subjects. Satisfaction guaranteed. Cash paid for used courses. Complete details and bargain catalog free. Send name. Nelson Company, 500 Sherman, Dept. J-237, Chicago.

PATENT ATTORNEYS

INVENTORS—Before disclosing your invention to any one send for Form "Evidence of Conception," "Schedule of Government and Attorneys' Fees" and instructions. Sent free. Lancaster, Allwine & Rommel, 414 Bowen Building, Washington, D. C.

PATENTS—Advice and booklet free. Highest references. Best results. Promptness assured. Watson E. Coleman Patent Lawyer, 724 9th Street, Washington, D. C.

RADIO ENGINEERING

RADIO Engineering, broadcasting, aviation and police radio, servicing, marine and Morse telegraphy taught thoroughly. All expenses low. Catalog free. Dodge's Institute, Elm St., Valparaiso, Ind.

RADIO

WE buy and sell used radio testing equipment. Harold Davis, Inc., Jackson, Miss.

MISCELLANEOUS

ROLLS DEVELOPED, two prints each and two free enlargement coupons, 25c. reprints, 2c each; 100 or more, 1c. Summers Studio, Unionville, Mo.

QUESTIONS and Answers Commercial Radio Operators Examinations, Two Dollars per element. G. C. Waller, 6540 E. Washington Blvd., Tulsa, Okla.

PLATER desires connection with radio concern. Can install, maintain and supervise this dept. Box A, c/o Radio News, 608 S. Dearborn, Chicago.

RADIO ENGINEERING

DEGREE IN 2 YEARS

• Complete Radio Engineering Course in 96 weeks. Bachelor of Science Degree. Radio (television, talking pictures and the vast electronic field) offers unusual opportunities for trained radio engineers. Courses also in Civil, Electrical, Mechanical, Chemical, Aeronautical Engineering; Business Administration and Accounting. Tuition, living costs low. World famous for technical two-year courses. Special preparatory department for those who lack required high school work. Students from all parts of the world. Enter January, March, June, September. 57th year. Write for catalog.

1610-D COLLEGE AVE. ANGOLA, IND.

TRI-STATE COLLEGE

RADIO ENGINEERING,

broadcasting, aviation and police radio, servicing, marine radio telegraphy and telephony, Morse telegraphy and railway accounting taught thoroughly. 48 weeks' Engineering course equivalent to 3 years of college radio work. All expenses low. Catalog free. School established 1874. Dodge's Institute, Oak St., Valparaiso, Ind.

RADIO ENGINEERING

DEGREE IN 2 YEARS

Intensive, specialized course, including strong basis in mathematics and electrical engineering, advanced Radio Theory and Design. Modern laboratory. Low tuition. Self-help opportunities. Also 2-year courses in Aeronautical, Chemical, Civil, Electrical and Mechanical Engineering. Participation in Civilian Pilot Training Program. Enter December, March, June, September. Catalog.

INDIANA TECHNICAL COLLEGE
790 E. Washington Blvd., Fort Wayne, Ind.

RADIO COURSES

Classes Start October

RADIO OPERATING—BROADCASTING
• **RADIO SERVICING**—a practical course
• **RADIO AMATEUR CODE** • **TELEVISION**
• **ELECTRONICS**—1 yr. day course, 2 yrs. eve. Day and Evening Classes. Booklet Upon Request.

New York Y. M. C. A. Schools
7 W. 63rd St. New York City

RADIO TECHNOLOGY

RCA Institutes offer an intensive course of high standard embracing all phases of Radio and Television. Practical training with modern equipment at New York and Chicago schools. Also specialized courses in Aviation Communications, Radio Servicing and Commercial Operating. Catalog Dept. RN-40.

RCA INSTITUTES, Inc.
A Radio Corporation of America Service
75 Varick St., New York 1154 Merchandise Mart, Chicago

Correspondence Courses in RADIO and ELECTRICAL ENGINEERING

ELECTRICAL ENGINEERING Get good electrical math. Prepare yourself at Low Cost, for secure future. Modern course. So simplified anyone can understand quickly.

RADIO ENGINEERING Extra fine course in radio, public address, noise-electric work. Train you to be super-service man, real vacuum-tube technician. Experimental kits furnished. Diploma on completion.

Either course, only \$25. Deferred payment plan available. Write for free copies of school catalog, student magazines, full details, SEND NOW!

LOWAS' 25
LINCOLN ENGINEERING SCHOOL, Box 931-R 22, LINCOLN, Nebr.

RADIO-TELEVISION

Oldest, largest Radio-Television school in West trains you for good pay job. Complete instruction including Radio Construction and Service, Broadcast Operating, Sound, Talking Pictures, Television, Public Address, etc. Flexible plan to meet specific needs of those with or without jobs. Transportation allowed to L. A. Earn room and board while learning. Request Free Catalog.

NATIONAL SCHOOLS

Dept. RN-10 Los Angeles

Burroughs CASH REGISTERS

LOW PRICES—EASY TERMS
COLORS TO HARMONIZE WITH SURROUNDINGS

Burroughs Adding Machine Co., Detroit, Mich.

doesn't want it abused by a lot of foreigners who have been using his Welcome mat for a soap-box. We personally feel that they might better go where their theories of government are being practiced; in Germany, Italy and Russia, where they really need people like them; where Civil Liberties is but a laughable suggestion; where even human rights have been destroyed and where a Court of Justice is a mockery of the accused. We read that Hitler's henchmen imprisoned some persons for the heinous crime of listening to an "outside" radio program. Now that even one's thoughts have been regimented and controlled, what is there left for these poor human beings to raise them above the level of the lowest animal? And these are the theories which fanatical fools would have us believe are better than our present form of government! Gentlemen, what is your choice? Ours is *God Bless America*. So with 73 . . . ge . . . GY.

Washington Communication

(Continued from page 14)

vested about \$125,000 in equipment and are converting the whole state system to FM. The FCC has allocated four channels for hams interested in FM. They are from 58,500 to 60,000; 112,000 to 116,000; 224,000 to 230,000 and 400,000 to 401,000. The engineers report considerable activity in the field. Equipment is available in the 58,500-60,000 kc channel. There isn't any store built stuff out yet, they report, but you can buy the makings. It's not very expensive and if you are going up into power, you may even find the FM transmitter cheaper. Police experimenters report that they can get more power into an antenna with less battery drain on FM than on AM. Hams have found it ideal for round-town networks and are experimenting with the equipment for disaster work. It is believed that FM will beat the interference which usually sets up in disaster stricken areas. This aspect is what chiefly interests the military. They are conducting experiments with FM, but claim that it hasn't shown much value for military operations. But they don't tell everything they know.

Odds and Ends

FINGERPRINTS are pouring in to the FCC and are being turned over to the FBI. . . . Very few hams complained. . . . The Washington Radio Club held a "proof party," with an FCC official presiding over the fingerprint outfit and made the occasion into a pleasant afternoon. . . . The monitor system made its first crack down since the hams were put under restrictions and three operators in San Francisco pleaded guilty to operating an unlicensed station. . . . Uncle Sam means business. . . . One manufacturer has had his *pre-paid* shipment of radio receivers which were originally destined for Norway, returned and it is laying up in a New York warehouse. Perhaps, Uncle Sam could seize it and make use of it. Legitimately, of course. . . . Radio Station WHIP in Indiana had been under surveillance of the FCC and the U. S. Navy Intelligence on account of it having aired so-called Bund speeches. As we go to press, the president of the station shut the so-called Bund off the air, at least from WHIP. . . . Northern Michigan lighthouses have been fenced off, and are being guarded by armed guards. . . . The Sault St. Marie locks at Sault Ste. Marie between the U.S.A. and Canada are bristling with anti-aircraft guns and armaments of all kinds. . . . At a recent ham-picnic, the Navy gave physical examinations for tyros wishing to join the Naval Communications Reserve Corps. . . . An anti-parachutist corps of ham-operators and stations is being organized in the middle-west. . . . The trade is looking for experienced radio help to get out the orders which Uncle Sam has been pouring into the field. —50—

The "Washington Communication" is the "Hottest" column in radio. Follow it every month in
RADIO NEWS

YOU CAN BECOME A MONEY-MAKING RADIO EXPERT

WITH THE **NEW SPRAYBERRY**
Personalized
HOME TRAINING in RADIO and TELEVISION

You Learn Easily in Your Spare Hours
By Doing Many Experiments with Up-To-Date Equipment

Here's a really fine, up-to-the-minute Radio and Television Training that's specially designed to give you quick results. **TRAINING PREPARES YOU FOR GOOD RADIO JOBS . . . AT EXCELLENT PAY.** My training starts right at the beginning of Radio . . . unfolds each subject in a simplified, logical, understandable style. You easily learn Television, Electronics, Facsimile Radio, Radio Set Repair and Installation Work, etc. **NO PREVIOUS EXPERIENCE NEEDED** It makes no difference what your education has been. I can fit you for a good-paying Radio job. Your success is my full responsibility.

YOU GET PROFESSIONAL TEST EQUIPMENT PLUS EXPERIMENTAL OUTFITS

. . . Includes 146 Radio Parts (to build complete Receiver), Tools, All-Wave, All-Purpose Analyzer, and Experimental Outfits for conducting actual experiments with your own hands.

I Supply

16 RADIO PARTS

RADIO TOOLS

ALL PURPOSE ANALYZER

EARN WHILE YOU LEARN
My **BUSINESS BUILDERS** show you how to put your Equipment to practical use in handling actual money-making Radio Service Jobs shortly after you begin training.

SERVICEMEN
I offer Advanced Training for those already in Radio. Get complete details in my **FREE 32-page Book**.
The Sprayberry Course is Sold Under a Money-back Agreement

RUSH COUPON for BIG FREE BOOK
SPRAYBERRY ACADEMY OF RADIO
F. L. Sprayberry, Pres.,
325-K University Place, N.W.,
Washington, D. C.

Please send me **FREE** copy of "HOW TO MAKE MONEY IN RADIO."
Name Age
Address
City State
Tear off this coupon, mail in envelope or penny postcard.
Servicemen—Check here

FREE! VERY LATEST PROFIT GUIDE
Everything in RADIO!
At the Lowest Price Ever!

Complete Selections Guaranteed Quality Replacement Parts

Everything you need in the way of exact duplicate or universal replacement or repair parts. Tubes, condensers, resistors, transformers, hardware, tools, etc. Leading brands. Every item guaranteed. Prices are low. Clean fresh stock.

Latest Radio Sets
A model for every purse and purpose. **Hi-fids, Battery Portables, Table Models, Consoles, and Phono-Radio combinations**—for operation on AC, DC, or battery power.

Public Address Equipment
A complete line of amplifiers, microphones, speaker baffles and accessories for every type of installation—permanent, portable and mobile. Amplifiers from 5 to 100 watts.

Auto Radios & Accessories
Complete auto radio section—lists the latest and finest auto radios, aerials, vibrators, custom panel controls, suppressors, padding condensers, pilot and dash lights, etc.

New Electrical Appliances
Extra profits for you! Standard Brand Electric Irons, Grills, Toasters, Percolators, Waffle Irons, Vacuum Cleaners, Clocks, Mixers, etc., at lowest prices.

SAVE MONEY AT RADOLEK

MAIL THIS COUPON TODAY
The RADOLEK CO.
601 W. Randolph St., Chicago, Dept. B-46
Send the latest Radio Profit Guide **FREE**.

Name
Address Dealer?
Experimenter? Serviceman? Amateur?



Oil

CAPACITORS

• Whether superior performance or slim pocketbook is the prime consideration in selecting high-voltage capacitors, you'll find just what you need in the Aerovox line, because of these three broad choices:

Type 09. The commercial-grade rectangular-can oil-impregnated oil-filled capacitor. Intended for heavy-duty service. Sturdy metal can with adjustable mounting bracket for upright or inverted mounting at any et for above or below chassis platform. High-tension pillar terminals. 600 to 5000 v. D.C.W. 1 to 4 mfd. in lower, 1 and 2 mfd. in higher voltages.

Type 05. The standard "ham" grade round aluminum can oil-impregnated oil-filled capacitor. Mounting ring for upright or inverted mounting, any height above or below chassis platform. High-tension pillar terminals. 600 to 3000 v. D.C.W. 1 to 4 mfd. in lower, 1 and 2 in higher voltages. An excellent capacitor for a lean pocketbook.

Type 10. The space-saver oil-impregnated oil-filled capacitor. Inverted screw mounting. Appearance and size similar to usual metal-can electrolytic. 600 to 1500 v. D.C.W. .5 to 4 mfd. depending on voltage.

Ask for CATALOG . . .

• In addition to these three "best sellers," Aerovox offers other high-voltage oil capacitors even up to 7500 v. Ask local jobber for latest catalog—or write us direct.



Hamchatter
(Continued from page 38)

not here to stay. [Ed. Note: Sez which?] Activity will probably return to normal before very long, and so until it does, I shall continue sending in what little information I can find.

W5DRZ over in North Little Rock says that he is going to wait until the European War is over before he builds the audio section of his transmitter. Bill has been spending most of his spare time on his motorcycle, fishing and swimming.

W5GGW also in North Little Rock, hasn't been heard on 20 fone for quite some while. Alex has been going fishing quite frequently in his new car.

W5HGE, formerly of Tuckerman, Arkansas, has moved to Little Rock and is employed as an operator at the CCC camp station.

W5CIU bought a new car recently, but he still has a QSO on 20 fone now and then. Uppy has been doing quite a lot of fishing and told a "whopper" of a story about the big fish that broke two cogs out of the gear on his reel. His story sounded mighty "fishy."

W5HRU also bought a new car. Nick has been having an occasional QSO on 20 fone. His new car seems to keep him quite busy, for he has waxed it several times and has fixed the broadcast radio in his car as he wants it.

W5IRH has also joined the ranks of new-car owners. Charles took a vacation trip home to Indiana in his new car a few days after he bought it. Ham radio has suffered at his station because of the new car, fishing, swimming and laziness. A new radio was installed in the new car last week with the aid of W5CIU. [Ed. Note: Jest a minut, 1RH, are you a car salesman or a Ham?]

W5DYT of Hot Springs has joined the staff of broadcast station KWFC and works a combination shift as transmitter engineer, control operator, and announcer all at once. Wayne seems to be getting time in on his ham rig on 20 fone despite the fact that summer is here and he is living on Lake Hamilton. He keeps a schedule now and then with his friend in Pennsylvania, W8MIH.

W5RWF in Little Rock and W5GUG out on Park Hill seem to be the only boys that are doing anything on 20 fone at the present.

W5DXN is Jackson, Miss., and W5DRZ of Little Rock met recently at the motorcycle races in Memphis, Tenn. They had quite a "grab-fest" since this was their first meeting in five years.

HERE is some more stuff and things about the hams in the Elesian Fields of Utopia by W5HSK, Lepanto, Ark., the Home of the Terradin Derby.

W5HHZ, Esmond Williams, formerly of Lepanto, now is working in Marked Tree at the Dehydrating Plant. We would all still like to hear him on the air.

W5GJL, Dave, of Blytheville, is experimenting with Cathode Modulation on 160 fone.

W5IQD has left Blytheville and gone back to Mich. We will still be working Dick as soon as he gets his rig set up again.

Kendal Berry, W5IRQ, Blytheville, is a new ham and has purchased a rig from W5DMR, Batesville and is heard daily on 160 fone.

W5HUX, Marshall, Blytheville recently purchased a HC9 rig, and is happy over the results. Clear sailing and dx to u Marshall.

Over 75 hams gathered at Cape Girardeau, Mo., for the semi-annual meeting of the *Motorky Club*, May 12. Roy Johnson, W5GHJ, Batesville, was toastmaster, and he, with Harry Young, W5WDE, made the day successful.

W5WRK the "keeper of the bees," Tom Story of Lepanto, will go to Memphis again June 12 to tell the members of *MARA* some more about antennas.

W5ISX, Jimmy, whose QRA is Hardy, Arkansas' play ground, is getting good results on 160 fone with the rig purchased from W9MNN, Thayer, Mo.

W5WK and W5HSK are making preparations to entertain a large number of hams at the 10th Annual Terradin Derby, Sept. 25, in Lepanto. W5GYR, Bob, Wilson, is planning to put up a vertical antenna this summer.

W"INDY" Bill blows in mid: W5HKJ is nw in the ranks of the fone men with a FB HT*9 Xmitter. Elmer has developed into a first class rag chewer. Hi Elmer.

W5FQL went dwn for his class A ticket recently and after waiting 11 weeks for the answer old Mac is really getting impatient.

W5IGQ es W5HSN are on with a couple of CM100 Xmitters in Homer, La. James es Jack get out nicely on 160.

W5HVA is knocking it out on 40. W5FHS has a husky sig on 75 fone. W5WBV really gets out with his Allan special on all bands.

W5BEV is a CW hound on 160. W5MO really has a nice sig now that he has a decent ant up.

W5OCT has a commercial fist on 40 cw. W5DAN has been run off 75 fone agn es is back on 160 his many friends? on 75 will be gld to know.

W5HMV went slumming recently es visited W5DAN in his lair in Miss. W5GXO thinks 5HMV is unfair to visiting hams he says old Windy really puts em wrk. W5IVR son of W5WN is a new ham in Port Arthur, Tex. W5GIZ es XYL are regular visitors at 5ICV old Mac will be on sn with a brand new KW rig.

W5IHH visited 5BCF es 5GHB in Port Arthur, Tex., recently.

W5IBW is now stationed in Venezuela, S. A. W5IYB is a new on in Baton Rouge, La. Jimmy got so excited on his first 40 mtr contact that he froze to the keys es had to be relieved by his old stanby 5HEZ. (sum fun eh Jeem, hi.)

W5EWW is still going strong with his cath. mod. rig on 160.

W5HRU is throwing the bull on 160 now days. W5HYI has one of the btr sigs on the 160 band.

W5HQC really puts out the watts on his xmitter in fine shape. W5GDU is vy active on 160. Louie is puttin N. O. La. on the map on 160.

W5EVE visited with his friends(?) recently at the meeting of the B.R.A.R.C. W5GAL is now on 20 mtr fone at L.S.U. University, La. hi Buddy.

RIGHT up from the C.Z., we have the following:

K5AT is abt bkng out wid rash over his new xmttr. It's 6L6 xtal, 6L6 1st dblr, 809 btr-dblr, into pr 812's wid half kw if and when wanted; really fb rig es grade dwn hr, so give wide nuf soup to make the grade dwn hr, so give him a buzz, sumtime. Incidentally, ever since Mack, the 'Lothario of the Canal Zone' has been perched on t hill at Ft. Davis he's been cussing the stone steps he had to count in the dark to get dwn fm the shack in order not to plunge the YIs into despair by bng his neck; the new shack dwn in the hollow will be easier on the nerves, but who's gonna go after the cokes now? and by the way Mack, where do you get t stuff signing urself: "The Casanova of the air-waves"?

This writer has had plenty of grief since getting dwn hr fm W1KMK; had a bunch of equipment sent dwn es then found out the outfit was kicking out of existence hr, so sent it back. Now the darn outfit is not gg to bk up so what to do? But by the jungle fuzz on my mike cord, we'll be on the air yet becuz Mack's ol rig will do nobly hr; it's being rebuilt rite now es if we can escape fm his half kw long enough we'll have the whistle on in couple of weeks.

K5AD was really fb wid his 35 watts on fone es cw until he got the bug es handles fair amt dwn; he'll be on agn sn, es he tore the thing tfc fm it air base where he is.

K5AM is off the ether, fer time being; Bray is rebuilding t old rig into new rack and panel job designed to isolate final es get rid of parasites. He's drng fb job es shud be back on the rough-house circuit an so get ur tfc ready yu moulation men es brass pounders becuz K5AM is quite a tfc hound in these parts.

Manufacturer's Literature

(Continued from page 40)

York City, has just released a lavishly illustrated 24 page public address catalog that should prove of interest to all in the sound field. Amongst the equipment described and illustrated are amplifiers and sound systems of every type and classification, including portable systems, mobile systems and complete indoor and outdoor installations suitable for the smallest auditorium or the largest arena or stadium. In addition, a number of pages are devoted to such P. A. accessories as microphones, speakers, pickups, phono motors, tuners, recorders, etc. A copy of the catalog will be gladly sent to interested persons upon request. Free. (RADIO NEWS No. 10-100.)

RADIO NEWS, Catalog Dept.
608 S. Dearborn Street, Chicago, Ill.

Please send me the literature I have checked below. If there is any charge I have enclosed the money.

- 10-100 10-102 10-104
- 10-101 10-103 10-105

Name

Address

City State

I am a Svecmn... Ham... Expermtr... This offer expires Nov. 1, 1940

**WHERE CAN YOU EQUAL
THIS 1941 RADIO FOR ONLY \$**

19.95

MIDWEST

MIDWEST

14-TUBE*
CHASSIS

COMPLETE WITH TUBES
AND SPEAKER READY
TO INSTALL IN YOUR
PRESENT CABINET



**30
DAYS
TRIAL
•
EASY
TERMS**

FACTORY-TO-YOU SAVES UP TO 50%

**FREQUENCY MODULATION
AND TELEVISION PROVISION**

Now, you can enjoy the mighty power of a 14-Tube* radio, at the amazingly low, factory-to-you price of only \$19.95.

You never heard such brilliant performance and beautiful tone for so little money! Now, tune in exciting broadcasts direct from distant overseas stations. Our famous 30-day prove-it-yourself plan, fully protects you and enables you to prove Midwest's super performance in the privacy of your own home, without obligation.

YOU BE THE JUDGE

Do like thousands have done—put this new 1941 chassis in your present cabinet. Other chassis and cabinet models are fully pictured and described in our new 1941 Factory-To-You, money-saving catalog... from 5 to 17 Tubes, and up to 5-Wave Bands... including Radio-Phonograph combinations and Home Recorders.

**AMAZING
FOREIGN RECEPTION**

Tune in broadcasts direct from the capitals of Europe. Listen direct to distant overseas stations in remotest parts of the globe. Hear history in the making before it appears in your local paper, and, before your local station announces its own version of the news!

*Fourteen tubes include Rectifiers, Control and Tuning Eye Tubes.

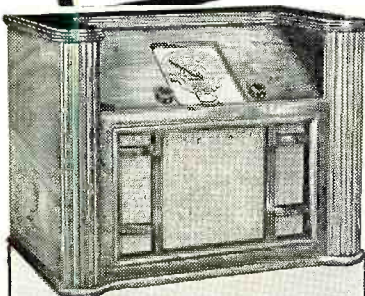

14-TUBE

**CABINET
MODEL**

\$ 29.95

COMPLETE

**FILL IN COUPON AND MAIL TODAY OR JUST
SEND YOUR NAME AND ADDRESS ON 1¢ POSTCARD**

MIDWEST *Factory-to-You* RADIOS

MANUFACTURERS OF QUALITY RADIOS SINCE 1920

Midwest Radio Corporation
Cincinnati, Ohio, U. S. A.
Dept. 11-CC

Send me your new FREE Catalog, complete details of your liberal 30-day Trial offer and factory-to-you prices.

Name.....

Address.....

Town..... State.....

User-Agents Make Easy Extra Money. Check here () for details.



**GET
MIDWEST'S
ANSWER
TO
TRADE-
INS!**

PRACTICAL TELEVISION

for the amateur
IS HERE!



"CQ-ing" the Television way

Amateur Iconoscope RCA-1847

Just announced by RCA—designed and licensed specifically for amateur and experimental use—engineered by the same men who produced the larger Iconoscopes—this "Mini-ike" paves the way for a brand new thrill for the radio pioneer. In size it is 7 $\frac{1}{2}$ " long, with a 2" face on which the images are focused. The free booklet mentioned below includes full specifications, with circuit diagrams and equipment information.

Amateur Net Price \$24.50



Think of the thrill of seeing the fellow amateur you've been talking with — of pioneering your way to new air adventures!

New Thrills, New Adventures for the Radio Pioneer

The experimental equipment pictured on this page was designed and constructed by RCA engineers to illustrate the possibilities of the new RCA-1847 Iconoscope in Amateur Television. Demonstrated in actual operation, this equipment was the hit of the Chicago Parts Show. Most amateurs already have many of the required components. And, even though you start from "scratch," it is possible to duplicate this system for no more than the cost of a medium-power transmitter!

Images are 30 frame, 120 line; require a total band width of less than 0.4 Mc, and are amazingly clear and stable. Operation is on the 2 $\frac{1}{2}$ -meter band where there is plenty of room. See articles in May and June QST for further details.

FREE! A new booklet, hot off the press, containing complete data on how to build this complete Television Rig is yours for the asking. Get one from your nearest RCA Amateur Equipment Jobber, or write to RCA Commercial Engineering Section, Harrison, N. J.



*for
Amateur*

TELEVISION

RCA MANUFACTURING COMPANY, INC., CAMDEN, N. J. • A Service of the Radio Corporation of America