

BUILD THIS ROTARY BEAM

RADIO NEWS

AND
SHORT WAVE RADIO

JANUARY

25¢

U. S. AND
CANADA



an Antenna for
AMATEURS
and
TELEVISION

See page 396

WELBY
MOORE
PICKER

Don't Miss the Short-Wave Time-Table

RECTIFIED RF SIGNAL CURRENT
HIGH-MU TRIODE PLATE VOLTAGE

AFC (AUTOMATIC FREQUENCY CONTROL)
DIODE BALANCING CIRCUITS

OSCILLATOR AND POWER
TUBE GRID CURRENTS

POWER DETECTOR BIAS

AVC DIODE CURRENTS

PHOTO-CELL CURRENTS
AND PLATE VOLTAGES

measure
them **ALL**
 WITH THE
Super-Sensitive
WESTON
Model 772
 (20,000 OHMS PER VOLT)

\$ 46⁵⁰
NET

TO DEALERS
IN U. S. A.

and remember . . .

you can buy this famous 20,000 ohms per volt analyzer, and other WESTON radio instruments, through the convenient WESTON INVESTMENT PLAN.



No instrument yet offered the serviceman has met with such overwhelming response as Model 772. The reasons are obvious. With its sensitivity of 20,000 ohms per volt, Model 772 is not only ideal for all usual testing routine . . . but it also enables you to get into and thoroughly check circuits which cannot be tested with former servicing instruments. And being built to high WESTON

standards, servicemen know that Model 772 will serve dependably for years. Before you consider the purchase of test equipment be sure to get all the facts on Model 772 and other WESTON instruments for radio servicing. Ask your jobber for full particulars or return the coupon today . . . Weston Electrical Instrument Corporation, 615 Frelinghuysen Avenue, Newark, New Jersey.

WESTON
Radio Instruments

Weston Electrical Instrument Corporation
 615 Frelinghuysen Avenue, Newark, N. J.
 Send full data on Model 772 and other WESTON Instruments.
 NAME.....
 ADDRESS.....
 CITY..... STATE.....



J. E. SMITH, President
NATIONAL RADIO INSTITUTE

The man who has directed the home study training of more men for the Radio Industry than any other man in America.

I will send you a Lesson Free to show how I train you at home in spare time for Good Jobs in Radio

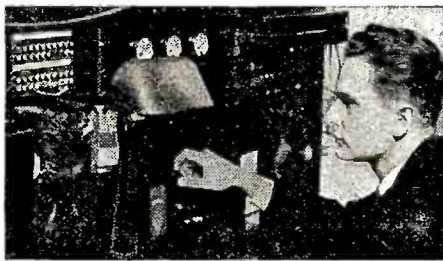

Broadcasting Stations

Employ managers, engineers, operators, installation and maintenance men for fascinating jobs and pay up to \$5,000 a year.

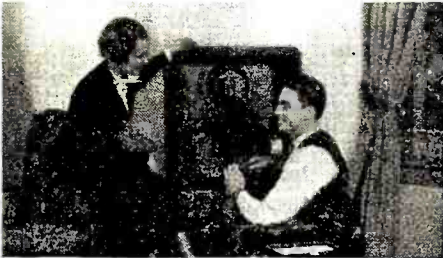

Set Servicing

Spare time set servicing pays many \$5, \$10, \$15 a week extra while learning. Full time servicing pays as much as \$30, \$50, \$75 a week.

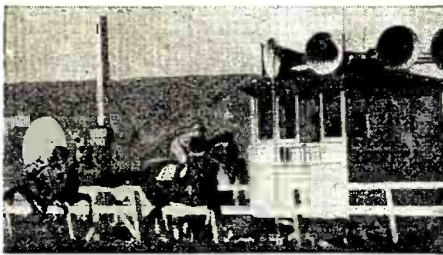

Loud Speaker Systems

Building, installing, servicing and operating public address systems is another growing field for men well trained in Radio.

Lesson on Radio Servicing Tips FREE

I'll prove that my Training gives practical, money-making information, that it is easy to understand—that it is just what you need to master Radio. My sample lesson text, "Radio Receiver Troubles—Their Cause and Remedy" covers a long list of Radio receiver troubles in A.C., D.C., battery, universal, auto, T. R. F., super-heterodyne, all-wave, and other types of sets. And a cross reference system gives you the probable cause and a quick way to locate and remedy these set troubles. A special section is devoted to receiver check-up, alignment, balancing, neutralizing and testing. Get this lesson Free. No obligation.



MAIL COUPON NOW

The Tested Way to BETTER PAY

Do you want to make more money? I'm so sure that I can train you at home in your spare time for a good Radio Job that I'll send you a lesson absolutely FREE. Examine it, read it, see for yourself how practical it is to learn Radio at home, how easy it is to understand—even if you've never had technical experience or training.

Many Radio Experts Make \$30, \$50, \$75 a Week

Radio broadcasting stations employ engineers, operators, station managers and pay up to \$5,000 a year. Spare time Radio set servicing pays as much as \$200 to \$500 a year—full time jobs with Radio jobbers, manufacturers and dealers pay as much as \$30, \$50, \$75 a week. Many Radio Experts own and operate their own full time or part time Radio sales and service businesses. Radio manufacturers and jobbers employ testers, inspectors, foremen, engineers, servicemen, paying up to \$6,000 a year. Automobile, police, aviation, commercial Radio, and loud speaker systems are newer fields offering good opportunities now and for the future. Television promises to open many good jobs soon. Men I have trained are holding good jobs in these branches of Radio. Read their statements in my 64-Page Book. Mail the coupon.

There's a Real Future in Radio for Well Trained Men

Radio already gives jobs to more than 300,000 people. In 1935 over \$300,000,000 worth of sets, tubes and parts were sold—an increase of 20% over 1934! Over 1,100,000 auto Radios were sold in 1935, 25% more than in 1934! 22,000,000 homes are today equipped with Radio, and every year millions of these sets go out of date and are replaced with newer models. Millions more need servicing, new tubes, repairs, etc. Broadcasting stations pay their employees (exclusive of artists) more than \$23,000,000 a year! And Radio is a new industry, still growing fast! A few hundred \$30, \$50, \$75-a-week jobs have grown to thousands in less than 20 years.

Many Make \$5, \$10, \$15 a Week Extra in Spare Time While Learning

Practically every neighborhood needs a good spare time serviceman. The day you enroll I start sending you Extra Money Job Sheets. They show you how to do Radio repair jobs that you can cash in on quickly. Throughout your training I send you plans and ideas that have made good spare time money—from \$200 to \$500 a year—for hundreds of fellows. My training is famous as "the Course that pays for itself."

I Send You Special Radio Equipment to Give You Practical Experience

My Course is not all book training. I send you special Radio equipment and show you how to conduct experiments and build circuits which illustrate important principles used in modern Radio receivers, broadcast stations and loud speaker installations. I show you how to build testing apparatus for use in spare time service work from this equipment. You work out with your hands many of the things you read in the lesson books. My Free Book tells you about this 50-50 method of training—how it makes learning at home interesting, fascinating, practical. Mail Coupon.

Save Money—Learn at Home Money Back Agreement Protects You

I am so sure that I can train you at home successfully that I agree in writing to refund every penny you pay me if you are not satisfied with my Lessons and Instruction Service when you finish my Course. I'll send you a copy of this agreement.

Get My Lesson and 64-Page Book Free Mail Coupon Below

In addition to my Sample Lesson, I will send you my 64-Page Book, "Rich Rewards in Radio." Both are free to any fellow over 16 years old. My book describes Radio's spare time and full time opportunities and those coming in Television; describes my Training in Radio and Television; shows you actual letters from men I have trained, telling what they are doing and earning. Find out what Radio offers YOU! MAIL THE COUPON in an envelope, or paste it on a penny post card—NOW!

J. E. Smith, President
National Radio Institute,
Dept. 7AR, Washington, D. C.

HERE'S PROOF



\$10 Week in Spare Time

"My work has consisted of Radio set servicing, with some Public Address Systems work—and in my spare time. My earnings in Radio amount to about \$10 a week."—WILLIAM MEYER, 705 Ridge Road, Hobart, Ind.



Earnings Tripled by N. R. I. Training

"I have been doing nicely, thanks to N. R. I. Training. My present earnings are about three times what they were before I took the Course. I consider N. R. I. Training the finest in the world."—BERNARD COSTA, 201 Kent St., Brooklyn, N. Y.



Good for FREE SAMPLE LESSON and BOOK on RADIO'S OPPORTUNITIES

J. E. SMITH, President
National Radio Institute, Dept. 7AR
Washington, D. C.

Dear Mr. Smith: Without obligation send me free the Sample Lesson and your 64-Page Book "Rich Rewards in Radio," telling about spare time and full time Radio opportunities, and how I can train for them at home in spare time.

(Please write plainly)

Name.....Age.....

Address.....

City.....State.....



Edited by LAURENCE MARSHAM COCKADAY

S. GORDON TAYLOR
Managing Editor

WILLIAM C. DORF
Associate Editor

JOHN M. BORST
Technical Editor

JOHN H. POTTS
Assoc. Tech. Editor

WESLEY G. HILLS
Art Editor

Vol. XVIII January, 1937

No. 7

Reading Guide to this Issue—

- AMATEURS—2, 3, 4, 7, 8, 9, 10, 11, 12, 13, 18, 21, 26, 28, 29
- BROADCAST FANS—2, 3, 4, 5, 19, 22, 23, 24, 29
- DEALERS—1, 2, 3, 4, 6, 12, 14, 15, 17, 19, 20, 22, 26, 28, 29
- DESIGNERS—2, 4, 12, 13, 20, 21, 28, 29
- DX FANS—2, 4, 5, 23, 24, 29
- ENGINEERS—2, 4, 12, 20, 21, 28, 29
- EXPERIMENTERS—2, 4, 7, 8, 9, 12, 13, 18, 20, 21, 22, 26, 27, 28, 29
- MANUFACTURERS—2, 3, 4, 6
- OPERATORS—2, 3, 4, 5, 31
- SERVICEMEN—1, 2, 3, 4, 6, 7, 14, 15, 16, 17, 18, 19, 20, 21, 26, 27, 28, 29
- SET BUILDERS—2, 4, 6, 9, 13, 20, 21, 22, 27, 28, 29
- SHORT-WAVE FANS—2, 3, 4, 5, 8, 13, 25, 26, 29
- STUDENTS—1, 2, 3, 4, 6, 7, 12, 13, 14, 16, 17, 18, 20, 21, 22, 24, 26, 27, 28, 29, 30
- TECHNICIANS—1, 2, 4, 6, 7, 8, 14, 18, 19, 20, 21, 27, 28, 29

1	Reading Guide to this Issue.....	386
2	Radio News Index (July-December 1936, Inclusive).....	423
3	Television For The British Public.... <i>The Television Reporter</i>	391
4	What's New in Radio..... <i>William C. Dorf</i>	393
5	Radio In The Spanish War..... <i>T. E. Gooteé</i>	394
6	Sound Systems Speed News Distribution.....	395
7	What You Want to Know About Microphones.... <i>John Erwood</i>	395
8	Five-Meter Rotary "Beam"..... <i>S. Perlman</i>	396
9	Pocket Size Two-Way Radio..... <i>Frederick Siemens</i>	397
10	Crystal Control for 5-10-20 Meters (Part 1)..... <i>Frank Lester</i>	398
11	The "Ham" Shack..... <i>Everett M. Walker</i>	400
12	The 807 Tube For Amateurs..... <i>B. J. Montyn</i>	401
13	Superregenerative U. H. F. Receivers..... <i>Nat Bishop</i>	402
14	The Service Bench..... <i>The Service Editor</i>	404
15	Servicemen's Prize Contest Awards..... <i>The Contest Editor</i>	405
16	The Matter of Service Charges..... <i>Zeh Bouck</i>	406
17	Call Systems as a Side Line..... <i>William C. Dorf</i>	407
18	New Unidirectional Mike..... <i>Samuel Kaufman</i>	407
19	Exposing Cut-Rate Service "Gyps" (Part 2)..... <i>John H. Potts</i>	408
20	New Circuit For Volume Expansion..... <i>J. P. Hollister</i>	409
21	Phase Inversion for Push-Pull Circuits..... <i>John M. Borst</i>	410
22	The Radio Beginner (Part 8)..... <i>The Technical Editor</i>	411
23	The DX Corner For the Broadcast Band..... <i>S. Gordon Taylor</i>	412
24	Station List (U.S. by Call Letters).....	414
25	The DX Corner for Short Waves..... <i>Laurence M. Cockaday</i>	416
26	World Short-Wave Time-Table..... <i>The S. W. DX Editor</i>	418
27	The Radio Workshop..... <i>The Associate Editor</i>	424
28	The Technical Review.....	426
29	Free Booklet Service.....	427
30	Students' Radio Physics Course..... <i>Alfred A. Ghirardi</i>	428
31	QRD?..... <i>By GY</i>	430

Newsstand Readers Attention!

If your local newsstand dealer does not carry RADIO NEWS, please write the Circulation Dept., Radio News, 461 Eighth Avenue, New York, N. Y., giving his name and address. We will see that he is supplied with copies each month.

Published Monthly by Teck Publications, Inc., Washington and South Avenues, Dunellen, N. J.

Lee Ellmaker
President and Treas.
B. Holcepl
Secretary

H. D. Crippen W. P. Jeffery
Advertising Management
Virgil Malcher
205 W. Wacker Dr., Chicago
Western Representative

EDITORIAL AND EXECUTIVE OFFICES
461 EIGHTH AVENUE, NEW YORK CITY, N. Y.

Entered as second class matter at the Post Office at Dunellen, N. J., under the act of March 3, 1879. Copyright, 1936, by Teck Publications, Inc., in U. S. and Canada. All rights reserved. Registration of title of this publication as a trade mark applied for in United States Patent Office. Printed in the United States of America. The contents of this magazine must not be reproduced without permission. We cannot be responsible for lost manuscripts, although every care is taken for their safety.

25c a copy. Subscriptions: \$2.50 a year, \$4.00 for two years; in Canada and Foreign Countries \$3.00 a year, \$5.00 for two years. Subscribers are notified that change of address must reach us five weeks in advance of the next date of issue.

SENSATIONAL *New* SCOTT "MAGIC LINK" CONQUERS "Man-Made" STATIC

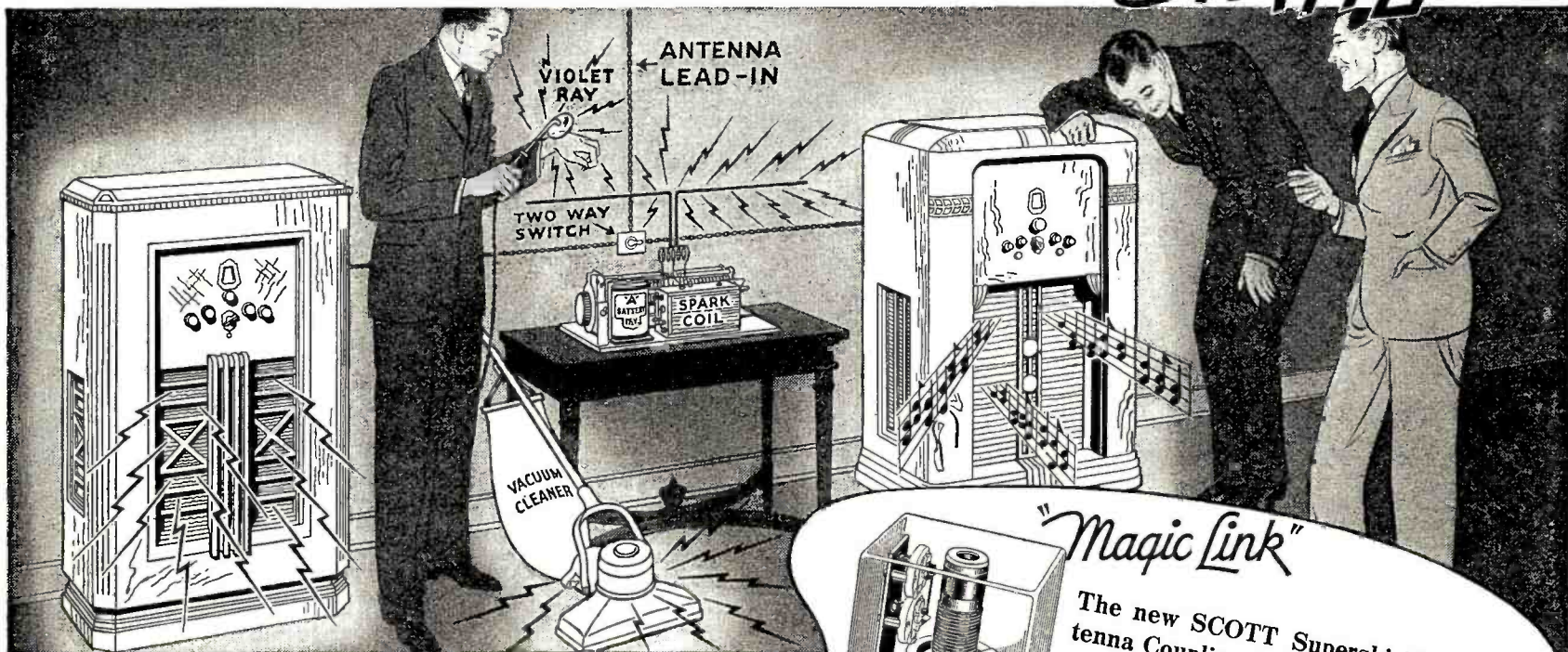

23 Tube High Fidelity SCOTT Equipped with "MAGIC LINK" IN AMAZING DEMONSTRATION PROVES QUIET FOREIGN RECEPTION NOW POSSIBLE IN BAD RECEIVING LOCATIONS

On Wednesday, October 7, 1936, at the SCOTT Radio Laboratories, a small group of radio engineers and short wave enthusiasts were shown, for the first time, the latest development of the SCOTT Research Laboratories. They intently watched two radio sets at one end of a room—both connected to the same lead-in with a two-way switch, and both tuned in to DJB, Germany, 15.20 megacycles.

GERMAN PROGRAM BLOTTED OUT BY NOISE

Suddenly, within three feet of these receivers, a terrific barrage of interference was turned on from a violet ray machine, a vacuum cleaner and an automobile ignition coil, buzzing out a stream of "man-made" static! What happened? From one receiver came a deafening roar such as you would hear in a boiler factory—and the program from Germany was completely blotted out!

CLEAR, ENJOYABLE RECEPTION WITH SCOTT "MAGIC LINK"

The two-way switch on the antenna was then thrown to the 23-tube SCOTT equipped with the sensational new "MAGIC LINK", the SCOTT Supershield Antenna Coupling System, and from Germany, over 4,000 miles away, the program came in as crystal clear, strong and enjoyable as a local station—all without the slightest trace of "man-made" static from the violet ray machine, vacuum cleaner and spark coil, each crashing and spluttering only three feet away from the antenna lead-in.

NEW DEVELOPMENT CLIMAXES YEARS OF RESEARCH

The demonstration described above, which you are now invited to witness at our Laboratories in Chicago, or our studios in New York or Los Angeles, climaxes eight years of tireless research to perfect an antenna coupling system that would reduce effects of "man-made" static picked up on lead-in, and at the same time, prevent the loss of signal strength. The new

SCOTT Supershield Antenna Coupling System now makes available to present and future SCOTT owners, enjoyable foreign reception in locations where it has been impossible to secure satisfactory, quiet reception up to this time.

WHAT THE SCOTT SUPER-SHIELD ANTENNA COUPLING SYSTEM ACCOMPLISHES

- (1) Effectively doubles the sensitivity or distance-getting ability of the antenna and receiver combination, as compared with the best results heretofore obtained with either the regular type antenna, or the best noise reducing antenna, with its associated inefficient shielded coupler.
- (2) Improves the ratio of desired signal to noise picked up on antenna lead-in by a factor of approximately 100 to 1 in the case of the best previously obtainable noise reducing antenna and shielded coupler, and by a factor of approximately 1,000 to 1 over the regular type antenna.
- (3) Entirely eliminates the necessity of switching a shielded coupler for operation on broadcast or short wave bands; this function being performed automatically with the SCOTT Supershield Antenna Coupling System.

QUIET FOREIGN RECEPTION NOW POSSIBLE IN MANY LOCATIONS FOR THE FIRST TIME

This means that residents of apartment buildings, hotels and homes with many electrical appliances, whose reception from England, Germany, Italy, France and

"Magic Link"
The new SCOTT Supershield Antenna Coupling System—100 times more effective than any other "noise reducing" system in slashing away "man-made" static from the lead-in so disturbing to enjoyable, dependable foreign reception.

COMPARE IN YOUR OWN HOME

We invite you to make a 30-day side-by-side comparison test of the SCOTT against any other receiver, regardless of price. If the SCOTT does not bring in foreign and domestic stations with more volume, greater clarity, and with finer and more natural tone then return it and we will refund your payment price without question.

It is impossible to accurately describe, by printed word, the sensational increase in *listening pleasure*, this new development now makes possible, for only by an actual listening test can you appreciate how much more enjoyably foreign short wave stations can now be received on the 23-tube SCOTT.

Send TODAY for complete proof—and full description of this remarkable new development that now makes possible in conjunction with the 23-tube FULL RANGE HIGH FIDELITY SCOTT Receiver, unparalleled tone, and distance performance in every continent of the globe. Discover this vast new world of radio entertainment you will never hear without a SCOTT. SEND COUPON NOW

FREE-SEND TODAY FOR DETAILS

E. H. Scott Radio Laboratories, Inc.
4440 Ravenswood Ave., Dept. 5A7
Chicago, Ill.

Send details of unequalled D X Tone of 23 Tube SCOTT with new "Magic Link" Antenna Coupling System.

Name.....
Address.....
City..... State.....

E. H. SCOTT RADIO LABORATORIES, INC.

4440 Ravenswood Avenue, Dept. 5A7, Chicago, Illinois

630 Fifth Avenue, New York, N. Y.

115 N. Robertson Blvd., Los Angeles, Cal.

BUILDERS OF THE WORLD'S FINEST CUSTOM-BUILT RADIOS SINCE 1924

A



BUILT ESPECIALLY
FOR *you* FOR
PEAK PERFORMANCE
IN *your* HOME
\$34.00 DOWN
\$17.08 MONTHLY

THE WORLD'S ONLY TRULY

CHALLENGE! TO THE RADIO WORLD--

We believe the MASTERPIECE V is the finest receiver that can be built today!
Let any unbiased, competent organization such as "Consumers Research Union" (to whom we have submitted a MASTERPIECE V for test and report) or any competent group of unbiased engineers, test the performance of the custom-built MASTERPIECE V side-by-side with any other receiver being made today!

Our engineers will go to the expense of building a MASTERPIECE V especially for operation in that location — just as they do when one is built individually and specifically for you.

Then we will pay the cost of this same page in RADIO NEWS and tell the world exactly what the results of this test are! Or, better still, YOU make this test in YOUR HOME! We ask only that you then purchase the receiver that you find to be the finest that can be obtained. If that receiver is the MASTERPIECE V — and we have reason to believe it will be — we will gladly arrange your purchase on Easy Monthly Terms.

Hear a MASTERPIECE V — then you will know what real custom-building means!

READ WHAT THE SHORT-WAVE EDITOR OF "RADIO NEWS" SAYS

THE fidelity of reproduction of the "Masterpiece V" receiver is so excellent that it at times seriously interfered with the conduct of the Listening Post tests of this receiver. Time and again the test periods would be devoted to listening to a program of fine music from a local broadcast station, the sheer enjoyment of which was too much to resist. Until the habit was formed of skipping the good locals when running tests, not much was accomplished either in the way of short-wave or DX listening.

Tone Fidelity

The reasons for this impressiveness was found primarily in the fact that the overall frequency response of the receiver is such that it exceeds the audio-frequency range of most broadcast stations.

In summary, it may be said that this receiver should meet the most exacting requirements of even the most critical radio listener as it combines excellent electrical design with beauty of appearance, ease of operation and all-wave coverage.

CUSTOM-BUILT RADIO

MAIL THIS COUPON!

McMURDO SILVER

MASTERPIECE

CHICAGO STUDIO—2900 SOUTH MICHIGAN BOULEVARD
NEW YORK DEMONSTRATIONS—63 CORTLAND STREET

Please send me full details on the custom-built MASTERPIECE V.

Name

Address

McMurdo Silver Corporation,
2900-A South Michigan Blvd.,
Chicago, Ill., U.S.A.



What will Mallory-Yaxley do next?

No wonder *YOU* Service Men keep asking this question.

Every time Mallory-Yaxley has done something, it has been of tremendous help to *YOU*.

Mallory-Yaxley gave *YOU* the first complete Replacement Volume Control Manual ever printed, and the first really *SILENT* Replacement Volume Control in radio history.

Mallory-Yaxley gave *YOU* sixty-nine Replacement Condensers that meet the needs of thousands and provided a Condenser Manual that saved hours of work in servicing.

Mallory-Yaxley provided a mere handful of Replacement Vibrators to render service to over three million automobile radios, and the Mallory Vibrator Manual is *YOUR* Automobile Radio Encyclopedia.

What will Mallory-Yaxley do next???

Next month, the question will be answered.

Coming!!! The "Big News" of 1937!

The biggest help you ever had.

Coming!!!

Use
P. R. MALLORY & CO. Inc.
MALLORY
 REPLACEMENT
 CONDENSERS... VIBRATORS

P. R. MALLORY & CO., Inc.
 INDIANAPOLIS INDIANA
 Cable Address—Pelmallo

Use
YAXLEY
 REPLACEMENT
 VOLUME CONTROLS

Radio News

January, 1937

Britain Inaugurates **TELEVISION** *for Public Use*

Employing a cathode-ray system, the counterpart of that already developed in America, London is now getting its television programs and television receivers are being purchased and used by the British public with exceptionally fine results. Our readers will be interested in the description of this new service. American radio enthusiasts would like a similar service here.

By the Television Reporter

ENGLAND is now firing her opening guns in the world race for television supremacy as this issue of RADIO NEWS goes to press! On a grand and stately scale, the British Broadcasting Corporation, the Government radio monopoly, with the cooperation of virtually the entire roster of Great Britain's radio manufacturers, has set the ball of public-participating television a-rolling.

Time alone will tell what country will take television leadership. There are hardly enough participating nations at this time to rate the standings of their respective television industries. The leading American television contenders, for example, claim that they are "more advanced in the laboratory" than any nation in the world. Americans are asking "Why can't our Federal Communications Commission do something to get television stations licensed and in operation here!" Our American public certainly wants television!

Rare Showmanship

With a flare of showmanship rarely displayed in conservative British industry, television was dramatically introduced to the public at the annual Radio Show at Olympia, London. Now, mind you, the British Olympia show is a solemn and sacred industrial affair. It is the property of the British Radio Manufacturers' Association, who up to this year saw to it that television

was kept a goodly distance from the exhibition hall. Without advance fanfare or ballyhoo, the 1936 show visitors were awed by sight-and-sound merchandise displayed by the nation's leading receiver manufacturers. And England is going definitely television-minded on the same great scale that America went air-minded when Lindbergh made his famous solo hop to Paris.

But the British radio industry didn't let television run wild. It is still maintaining a check-rein on its upward surge while it is feeling the pulse of the public on the situation. Dealers as well as the public are receiving gradual doses of instruction as to what it is all about. But step by step, the television *eye* is gaining on the radio *ear*!

The surprising thing (to the rest of the world) is just how refined a product the British television set really is. As expected, its cost is high. But it contains fewer tubes than the experimental laboratory models demonstrated in the U. S. A.; yields clean, sharp pictures and is an all-wave sound receiver in addition to a vision instrument.

In English Homes

Television's introduction in London is now under way. The process of acquainting the populace with the new art will reach its climax with the coronation ceremonies of King Edward VIII the coming Spring. All efforts are being made to have

LONDONERS TAKE THEIR TELEVISION SERIOUSLY
This photograph in an English home shows a typically British family enjoying a television program on one of the new sets.

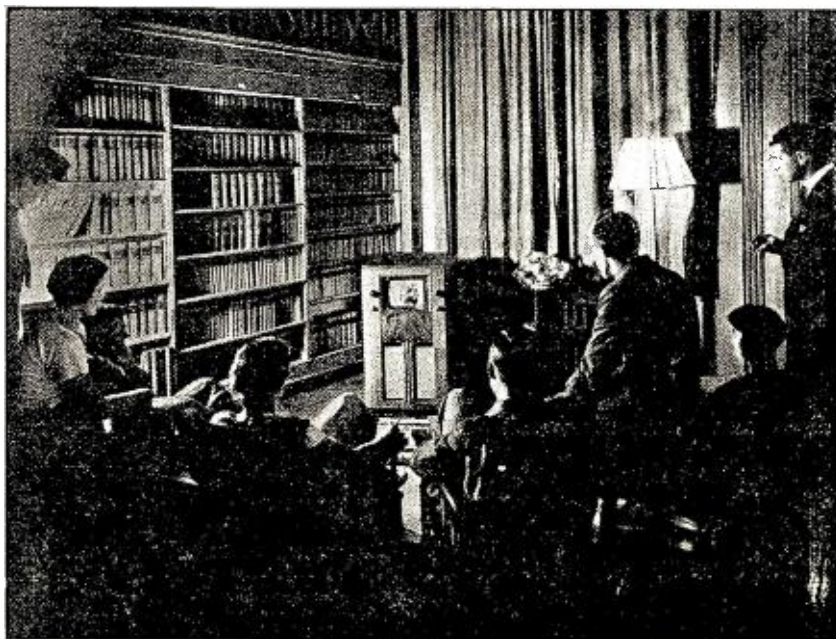

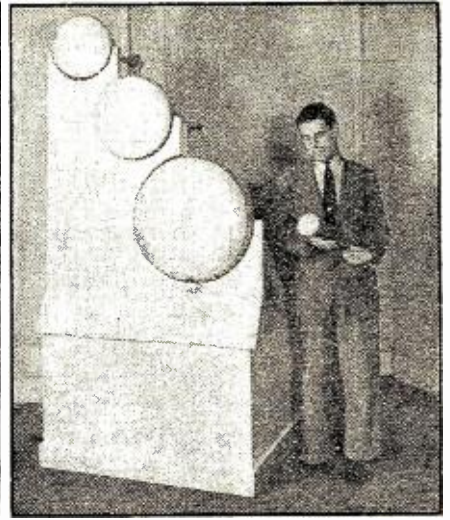
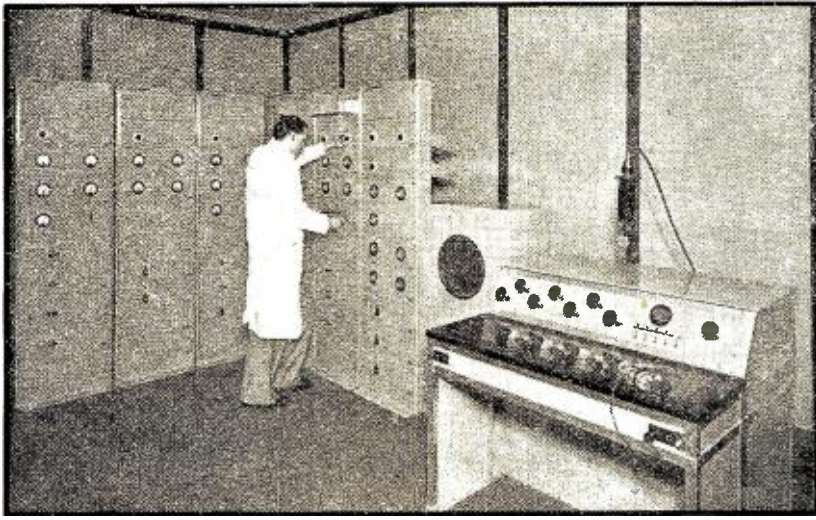
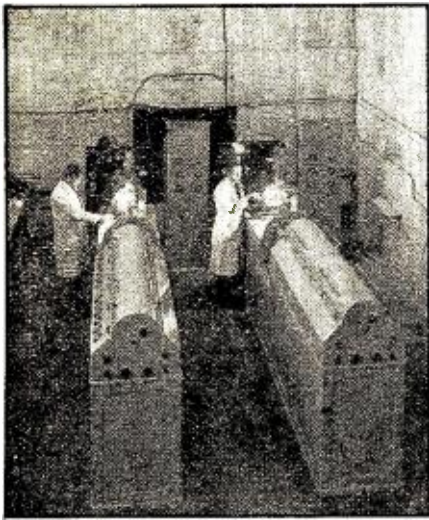

HIGHLIGHTS OF THE NEW BRITISH EQUIPMENT

The two 240-line Telecine scanner in operation for the Alexandra Palace shown at the left. Above: The Baird control desk and amplifiers used. At right: The Baird "cathovisor" cathode-ray tubes, showing the various size screens, in comparison to a small cathode-ray tube held by William Taynton, whose face was the first televised in England in 1926.

as many English homes as possible equipped with sets to see the ruler's formal acquisition of the throne. It is quite likely that that very day will mark the climax of the launching of a new visual program dynasty in the radio world.

To the date of this writing, no television studio and transmission set-up has approached in perfection of detail that of BBC in the Alexandra Palace from which transmissions are now on the air. Let's see what a tour of the Palace discloses: The television station is on a hill 306 feet above sea level. Nearly all London can be seen from the antenna site—an important point where ultra-short waves are concerned. With the combination of mast and tower height, the summit of the aerial is actually more than 600 feet above sea level. Directly below is a separate antenna for the synchronized sound signals.

Two Systems Used

There are alternate transmissions using, respectively, apparatus of the Baird Television Company and the Marconi-E.M.I. Television Company. The installations are separate. The sound transmitting equipment was supplied by Marconi's Wireless Telegraph Company according to specifications of the BBC. Such refinements as dressing rooms for artists, a restaurant, store rooms for scenery and props, and cinema projec-

tion, editing and cutting rooms are also provided.

The transmitters are all on the ground floor. This level also houses the projection theatre, restaurant and scenery productions shop. A large area has been set aside for televising such large objects as motor cars and animals which cannot be brought into the studio. Tackle and hoists for handling scenery can accommodate scenery weighing a ton.

Outdoor Pickups

The television camera can travel down a ramp to a concrete "apron" on the terrace for picking up outdoor programs. The main studios are on the upper story.

Marconi-E.M.I. pick-ups are made from a studio 30 by 70 feet in area and 25 feet high. Two stages have been built in this room with equipment for rapid interchanging. A steel lighting bridge runs across the center of the stu-

dio, providing variable illumination for both stages. Adjoining are the production and "tele-cine" rooms housing the production staff and television cameras. Incidentally, the British television cameras are built along virtually the same lines as those of RCA, Philco, Farnsworth, etc., of the U. S. A.

The Baird studio is the counterpart in size of the Marconi-E.M.I. studio. There are two stages here, too, but they are in different positions than the neighboring ones.

Five dressing rooms for men and five for women are close by, each suite having its own bath. Forty artists can be accommodated in a large chorus room. Just like the theatre, each dressing room is equipped with a call buzzer.

Many Makes Available

The Alexandra Palace Theatre has also been acquired by B.B.C., but the immediate use of the auditorium is planned for rehearsals and experiments. There is a separate band-room—the counterpart of an orchestra pit—where accompanying music will originate.

All prominent radio manufacturers of the British Isles were quick to fall in line with receivers for the public demand. As anticipated, the cost of initial equipment is high, the average model costing about \$500.

Marconiphone, Bush, Philips, Baird, H. M. V., General (Turn to page 446)

DETAILS OF A BRITISH RECEIVER

At the lower left is a front view of a television receiver made by the General Electric Company of England, with a screen and loudspeaker centered vertically and the controls for sight and sound at right and left. Below: A schematic representation of the various elements in the receiver from the aerial to the "vision" tube and the loudspeaker. The view at the lower right shows how these elements are placed.

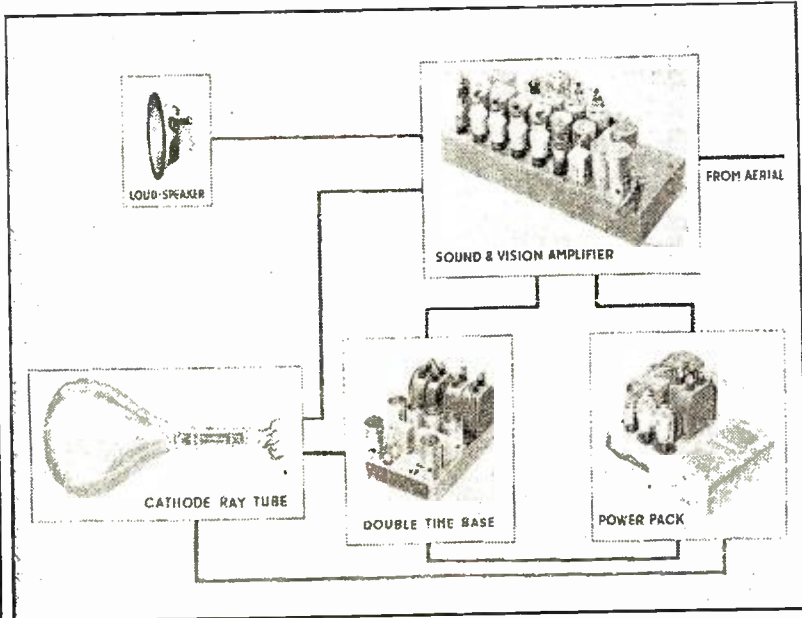
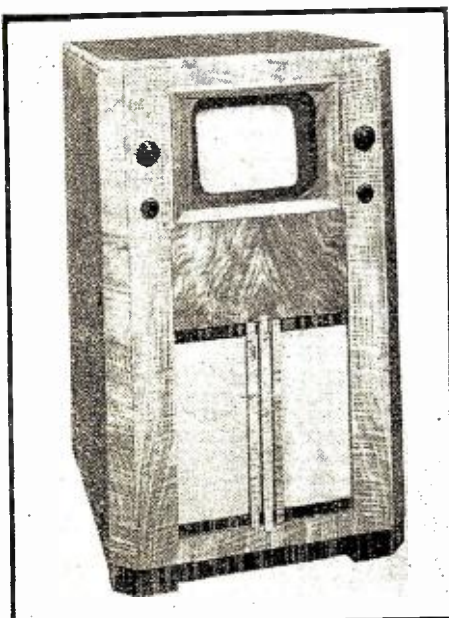

WHAT'S NEW in RADIO

By W. C. Dorf

For Instantaneous Recording

The Universal Microphone Company adds to its recording accessory line a professional steel cutting styli designed for use with their new professional recording blanks and all nitrate or acetate records. It is said to be the closest approach to a commercial sapphire cutting point. It is made of a special alloy steel and is hand finished.

Model 6-BT of Special Interest to Farmers

Here is the new RCA farm radio receiver employing 6 tubes and equipped with two tuning ranges from 530 to 1900 and 5600 to 22,000 kilocycles. This set should be of great interest to readers residing in districts without benefit of power supply. Its battery complement consists of a 2-volt storage battery or Air cell, three 45-volt "B" batteries, four built-in bias cells and a 7.5-volt "C" battery. It

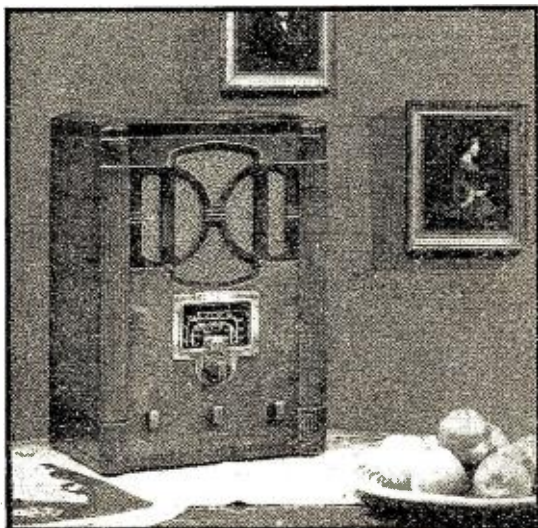

employs 2 type 49 tubes in the power stage and is equipped with an 8-inch permanent-magnet dynamic type speaker.

Aluminum Box Shields

The name of "Blan, The Radio Man," has been familiar to many experimenters

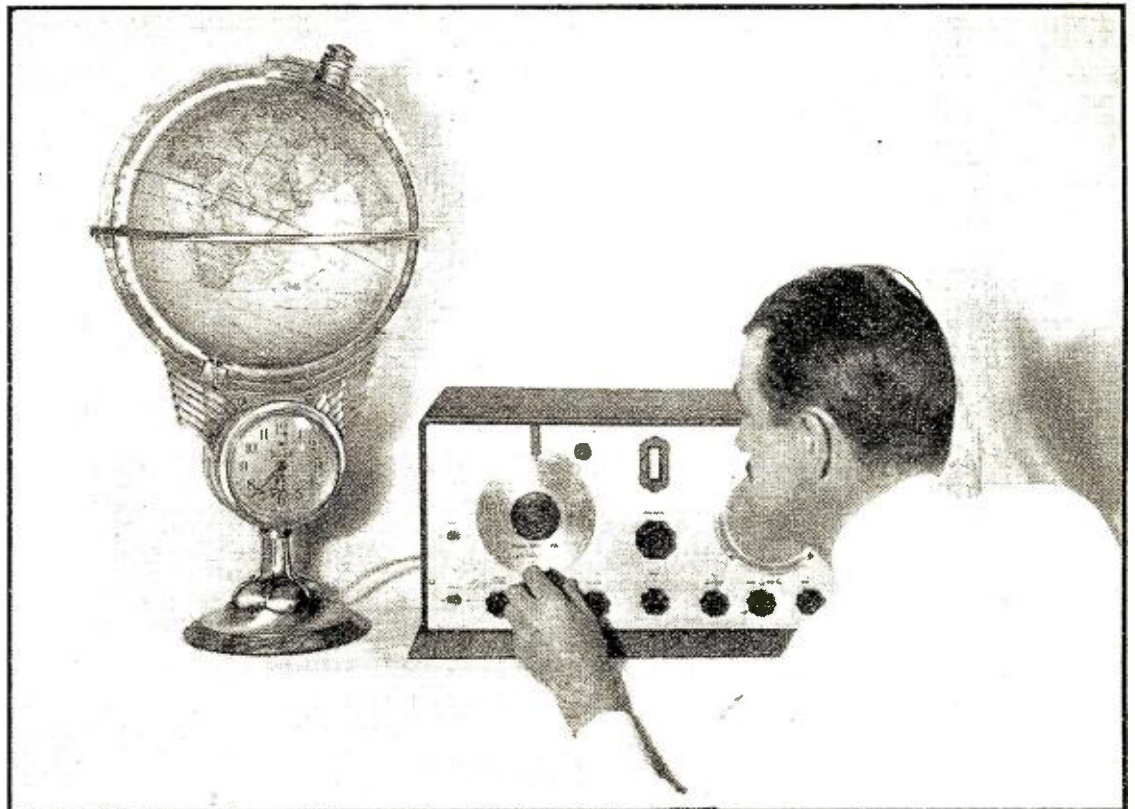
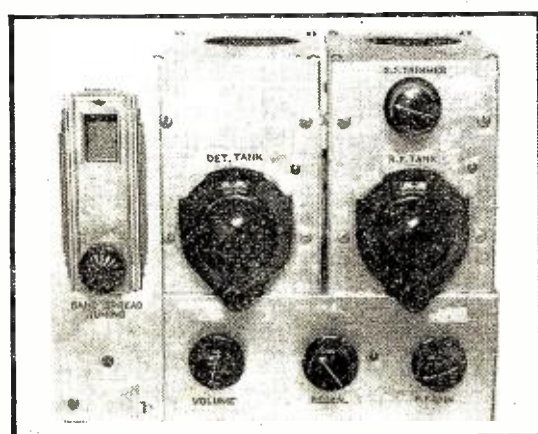

WORLD TIME-GLOBE CHECKS DX TRANSMISSION

This combination globe and clock not only gives correct time in various portions of the world, but shows daylight and darkness paths for radio signals from any point to any other point. It is entirely automatic and operated by the standard electric current.

A Complete World Time Instrument

A scientifically designed world clock which indicates the correct time in any part of the world is now available. This instrument, named the "Uniclock," also shows the hours of sunrise and sunset, daylight and darkness for any place on earth any day in the year. It consists of an

up-to-date, translucent world which globe rotates in synchronism with a Telechron clock. An internal electric light revolving once a year illuminates the daylight portion and casts a shadow over the night area of the world.

The Uniclock should prove a boon to all engineers, students, and DX fans in selecting the proper time for long distance reception.

and set builders for many years as a source of supply for aluminum panels and box shields in a large variety of stock sizes and where they can have this material cut and assembled to size to meet individual requirements. This company is a headquarters for aluminum rods and all kinds of radio set and instrument cabinets and building accessories. Typical of their work is the aluminum cabinet illustrated, made especially for the "Sky scraper" receiver described in RADIO NEWS.

A Demonstration Triode

New York, N. Y.—A new type of triode which shows visually the amount of plate current was announced by Westinghouse. The tube will be known as type WL-787. Its plate is fluorescent and the grid is so arranged that the plate current shows as luminous parallel strips which become wider when the grid voltage is made less negative. When the grid is positive the whole plate is luminous. The tube is intended for use in schools to clarify the teaching of electronics.

Power Plant Demonstrator Clinches Sales

Here is a novel and well-conceived plan for demonstrating to the rural trade the new Pioneer Gen-E-Motor portable gas-engine power plants. The large and easily accessible luggage compartments in the new cars provide the salesman with ideal mobile display facilities. The salesman can drive right into the farmer's yard, in districts without benefit of power lines, and give an effective demonstration of these new power plants. Farmers especially, will appreciate the fact that with these new power units, they can now supply their own electricity



for low-cost operation of radio receivers, washing machines, lighting systems, farm machinery, etc.

Compact Instrument with Special Appeal to Servicemen

The Ranger-Examiner model 735, combination volt-ohm-milliammeter made by the Readrite Meter Works, is a convenient pocket-size instrument for servicing calls and at the same time suitable for utility



use in the laboratory, shop or factory. It (Turn to page 440)

Radio's Role in the SPANISH WAR

An interesting report from an Official RADIO NEWS Listening Post Observer who has seen actual fighting in Spain.

By T. E. Gooteé

A WAR necessitates many radical emergency measures. These changes manifest themselves in many forms, but only recently has radio played such an important part. The present Spanish civil war has caused a complete radio metamorphosis throughout Spain.

Shortly after hostilities broke out, the Spanish rebels seized EAJ5 at Seville, and immediately began broadcasting propaganda, war news, claims of victory, and other military news meant for the public. Within three days the Loyalist forces began broadcasting Loyalist news from Madrid. Within one week every major broadcasting station in Spain was directly controlled by either the Rebels or the Loyalists solely for the dissemination of propaganda. Music and entertainment was forgotten in the effort to promulgate this propaganda. This system has continued, and has evidently proven successful to both sides.

Any afternoon or evening it is possible to tune in fifteen or twenty power-

ful stations, each equipped with several dynamic orators who delight in speaking at great length over the success of the side that they may represent. A station never uses the same wave-length twice. This is necessary in order to keep interference, from the opposing army, from rendering the transmission unintelligible. Shortly after the war broke out, opposing sides would "blanket" the other's transmission by sending out an "empty" carrier wave at the same frequency as the opposing station's transmission. The stations do not vary their frequency any great amount; a change of five or six kilocycles representing the average.

The Loyalist forces now control the majority of Spain's more powerful stations. These include all of the Madrid stations: EAQ, EAJ2, etc., as well as EAJ at Barcelona. There are now in operation in Spain fifty-three radio stations broadcasting propaganda. There are only thirty or forty communications transmitters. Most of the broadcasting stations are of such low power that their

carriers travel but a few miles. Before the present conflict, most of them were privately owned.

The Rebel army is now using a network of six portable short-wave transmitters for communication between the northern and southern armies and between Spain and Spanish Morocco, which is now held by the Rebel forces. This network operates on a frequency which is changed daily. Both code and 'phone are employed; the transmitters having an output of about 200 watts each. Four of these transmitters are of American make and are operated by Spanish army operators.

The Loyalist army does not employ radio as a direct means of communication, but depends upon the telephone and telegraph systems.

There is no amateur-radio activity in Spain for obvious reasons. Wherever possible, the Rebel forces have seized all radio apparatus of any kind suitable for transmission, and have destroyed or mutilated the equipment in many cases.

Thus radio (*Turn to page 432*)

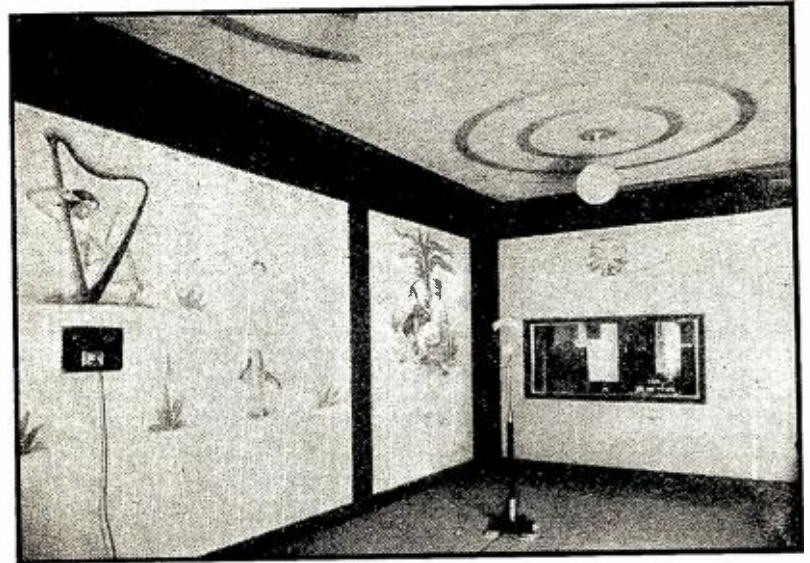

UNION-RADIO STUDIOS AT SAN SEBASTIAN
This San Sebastian station, like all other Spanish broadcast stations, is now used exclusively for the dissemination of propaganda.

MILITARY TRAINING IN RADIO

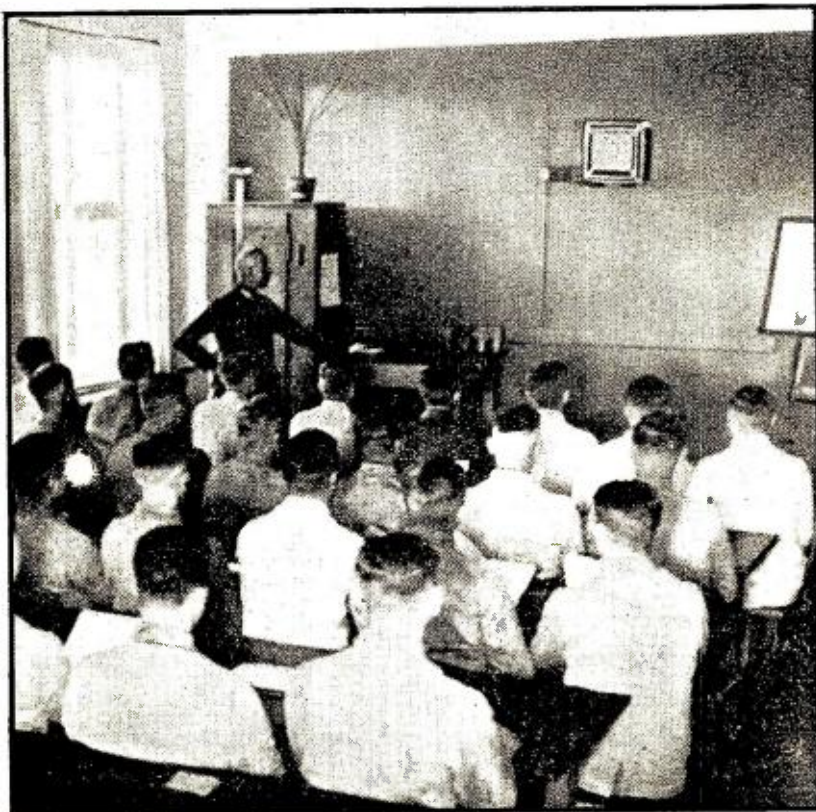

A FIELD RADIO STATION WORKING

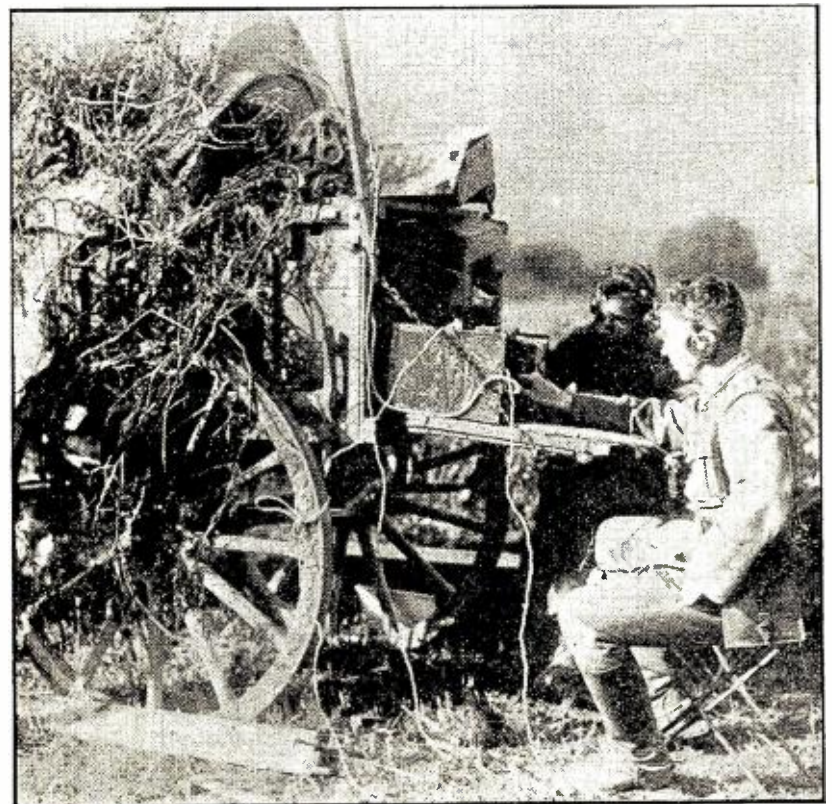

Sound Systems SPEED News Distribution

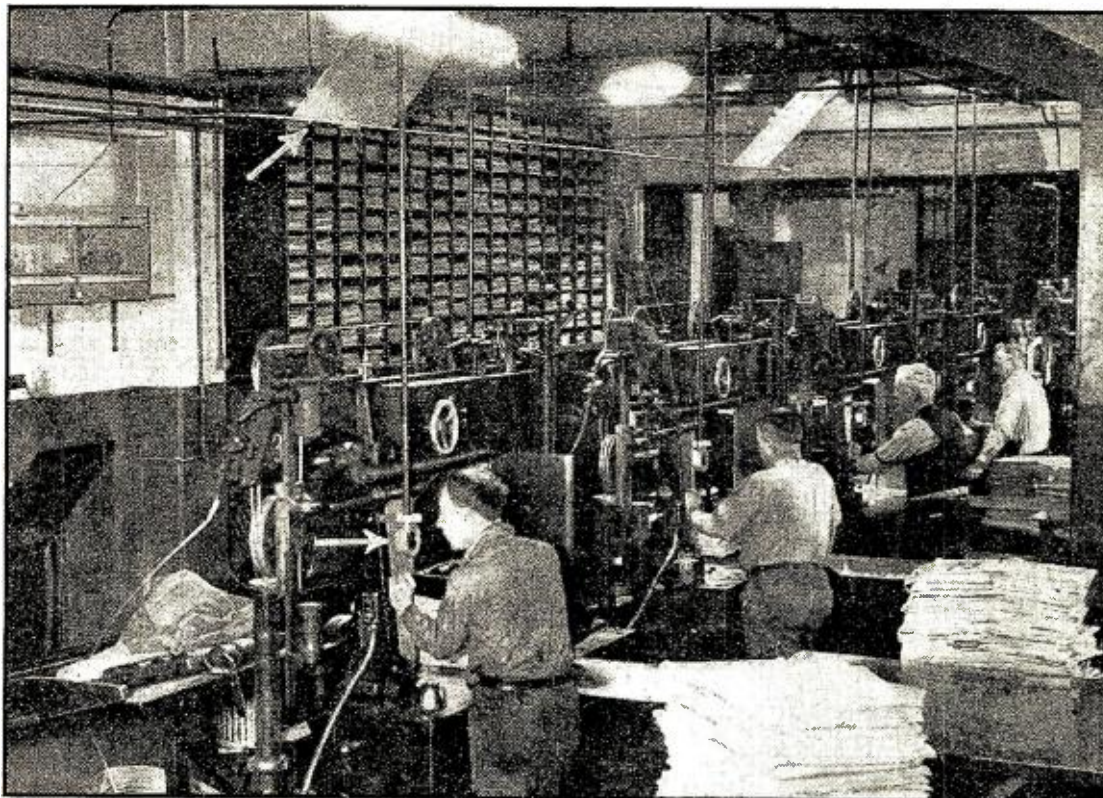

A NEW USAGE FOR P. A. SYSTEMS
The CLEVELAND PLAIN DEALER saves time and eliminates shipping-room errors by installing a sound system for communication between the news trucks and binding-room operators.

THE old speaking-tube-and-chute method formerly used in the publishing plant of the *Cleveland Plain Dealer* for conveying orders and other messages between the loading platform and binding room has been replaced by a 2-way loudspeaking sound system employing 7 crystal microphones for pick-ups. Here is a development that wide-awake service organizations may well give some thought to for application in manufacturing plants in their own local districts.

Two crystal microphones, located on the loading platform where trucks take on papers for delivery, feed through an amplifier to two speakers in the binding

room of the newspaper. In the binding room are five microphones, each attached to a baling machine, all feeding a speaker located on the loading platform outside.

With the new arrangement, trucks drive up to the loading platform and the driver calls into the microphone, "5,000 papers for Akron." His message goes to the man operating the machine which turns out the work for Akron, and the driver waits at the platform until his papers are ready. In turn, the men at

the binding machines can communicate with the drivers to clarify orders.

In spite of the fact that the noise in the binding room is tremendous, the new sound system works perfectly. Tone control is used to eliminate the high-frequency noise of the machinery.

Sound Systems, Inc., installed this communication method in the *Plain Dealer* some months ago, and its users are very well pleased with its efficiency. It has speeded up the work, made orders more accurate and eliminated confusion.

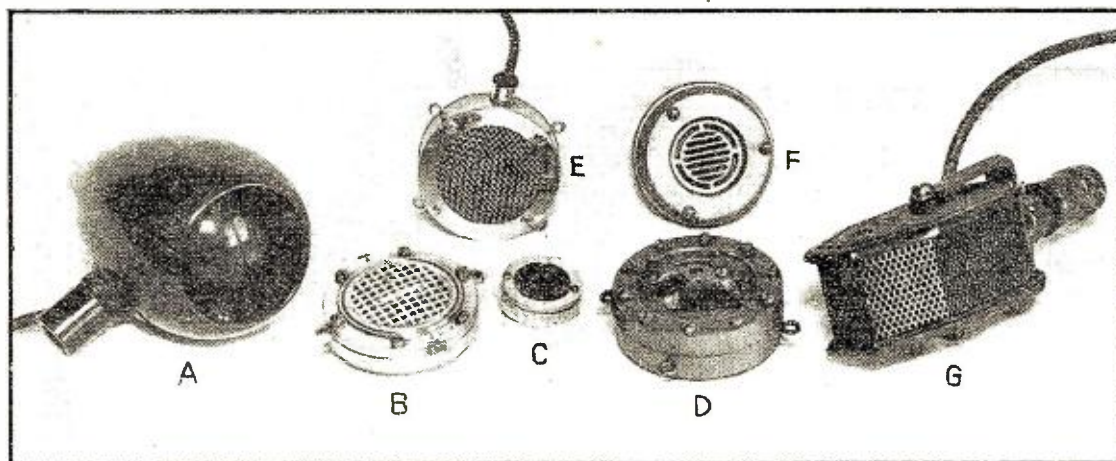

TYPICAL MICROPHONES
The various types of microphones discussed in the text are shown here: (A) Transducer "Bullet" dynamic; (B) Universal model A, single-button carbon; (C) Shure lapel type, carbon; (D) Universal Model LL double-button carbon; (E) Astatic crystal with diaphragm; (F) Bruno condenser; (G) Amperite Model RBH, velocity.

quent increase or decrease of pressure upon the carbon granules. An electric current is maintained through these granules and the effect of changing pressure of the granules is to vary the resistance of the element which causes a fluctuating current across two terminals mounted on either side of the carbon pack.

Advantages: It is low in cost, has a relatively high output and is of low impedance.

Limitations: It is limited in frequency response, its noise level is high originally and increases with years, and it requires an exciting current for operation.

Velocity or Ribbon Type Microphone

This microphone does not require a diaphragm. It has a loosely suspended ribbon maintained in an intense magnetic field. Sound pressure waves hit against the ribbon, causing it to move. This cuts the magnetic field of the magnet, producing varying potentials across the extreme terminals of the ribbon.

(Turn to page 428)

What You Want To Know About MICROPHONES

By John Erwood

The advantages and limitations of each of the five distinct types of microphones, as well as their design, are given in this informative discussion, the author of which is Vice-President of the Webster Company. Amateurs and workers in the public-address field will welcome this informative article. (Ed. Note.)

Carbon Microphone

The carbon microphone consists of a stretched diaphragm across the center of which rests a loosely packed pile of carbon granules in a carbon cup. Sound pressure waves, on striking the diaphragm, cause a lateral movement with a conse-

For Five-Meter DX ROTARY

A great increase in signal strength both obtained with a correctly designed beam not in line with the beam is automatically been designed so that it may be rotated
Twisted feeders and bad contacts

By S. Perlman

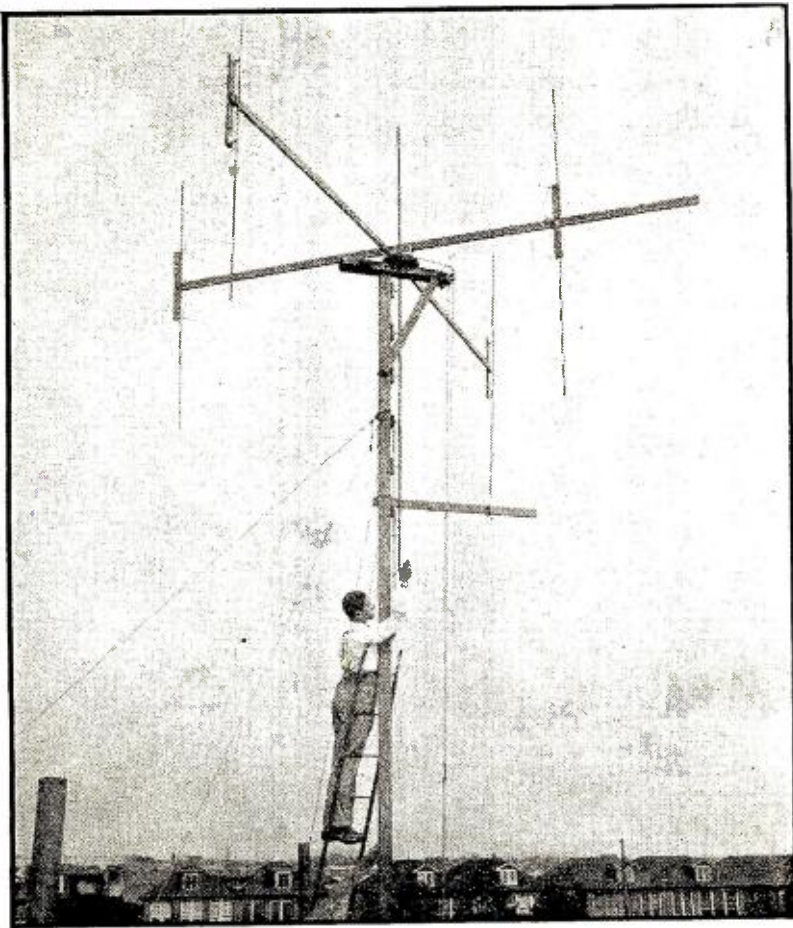

NOW and then the "Sky Wire" of an amateur radio station blossoms forth as a directive array and some of the fine DX results are obtained. Space considerations and the fixedness of directivity nullified its application more widely. Rotary beam arrays have come to my attention also from time to time, but the design features were not applicable to most conditions. Five-meter band operation, due to the reasonable dimensions of the antenna elements led to the design and construction of the array to be described.

THE fact that at a very reasonable investment in materials whose cost would not exceed by much more than that of an omnidirectional antenna, a great increase in signal strength can be accomplished in the desired direction by the use of a directive array and furthermore that the equivalent equipment to give the increase of signal radiation would by comparison cost several times more, were very strong reasons in favoring the use of a directive array. In determining what directive array should be used, simplicity of design, the use of available materials, and the flexibility of rotary operation were the guides in selecting the particular design of the beam to be described here. In looking over some of the suggested rotary arrays, one objection was to the problem arising from twisting feeders. The design finally selected as seen from the accompanying sketch is that of the Yagi beam array. This design avoids completely the twisting of the feeders. My contribution to the design is mostly in developing and constructing the Yagi beam array so that it can be used as a "rotary" beam. Basically the radiating element is the well-known "J" antenna now so popular on five meters.

While the diagram in Figure 1, showing the construction, is quite explanatory, certain details of its construction will be described to give a more complete picture of its construction and operation. The mast was a 2 inch by 4 inch joist, 20 feet long selected for its straight grain. The mast was to

be located close to the roof edge of my home. The roof is flat with a brick wall rising to a coping about two feet higher than the tarred surface. The diagonal braces joining the horizontal member to the vertical mast permitted placing the mast against the brick wall.

Guy ropes to the right and left of the mast as well as one in front of the mast keep the mast in a vertical position. The "J" antenna is mounted on bee-hive stand-off insulators which are in turn mounted on pieces of wood spacers about a foot apart. The "J" antenna consists of a half-wavelength radiator terminating in a quarter wavelength impedance matching section. The radiator and one leg of the matching section is made of $\frac{3}{4}$ inch diameter copper pipe, 12 feet long, which is extended an additional 6 inches by jamming a $\frac{5}{8}$ inch dia. piece of copper pipe into it for about two or three inches. The other leg of the quarter-wave matching section is of $\frac{1}{2}$ -inch dia. copper pipe $4\frac{1}{2}$ feet long, and it is also mounted on bee-hive stand-off insulators on the two extended wooden spacers. It is 6 inches away center to center and parallel to the $\frac{3}{4}$ inch dia. copper pipe.

The top of the radiator is 4 feet 1 inch higher than the top of the mast so that the center of the 12 inches in dia., 2 inches thick wooden pulley coincides with the center of the radiator. This was done because both the upper and lower ends of the half-wave radiator are "Hot" with radio-frequency voltage, while at the center which is a voltage node, the r.f. losses are minimized in times when the wooden pulley is wet during and after a rain. A previous antenna array was rendered useless due to r.f. leakage loss, due to contact losses at the extreme ends of the radiator.

Although the detailed drawing in Figure 2 does not show it the pulley rests on a piece of 7 inch by 10 inch bakelite, with a hole in it to clear the radiator, fastened by countersunk wood screws to the top of the two horizontal 4 foot long 2 inch by 3 inch members, bolted and braced to the top of the mast. Two galvanized 4-inch diameter wash-line pulleys with holes drilled in the cross-arms framework are mounted one on each side to change the horizontal to a vertical position of the rope for rotating the 12 inch dia., 2 inch thick wooden pulley supporting the wooden cross

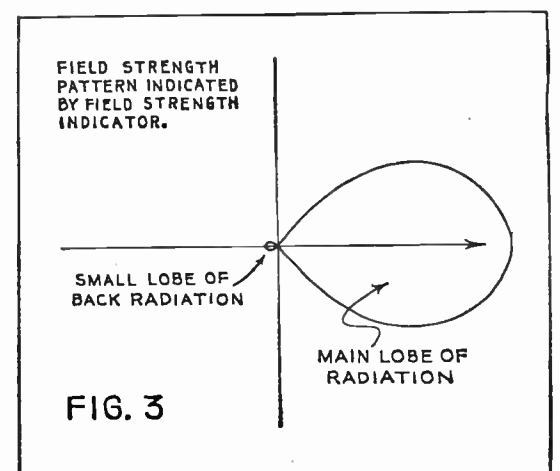
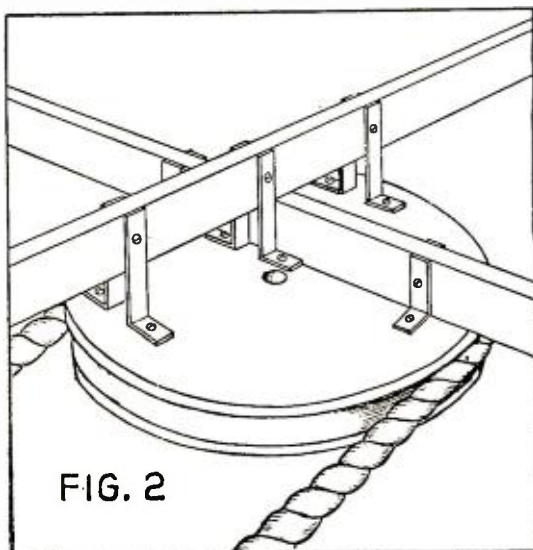

Try This Directive "BEAM"

for transmission and reception can be antenna. Also interference from stations cut out or reduced. This Yagi beam has directly at the station you wish to contact. from commutators are eliminated.

(Radio W2JCU)

straight-grained fir turned down in a wood-working lathe. Note that the assembly is in two parts. The "J" antenna (mounted on the assembled mast) represents one portion of the assembly and the three reflector elements and single director element mounted on the wooden cross members, supported on the wooden pulley as the other portion. In determining the exact placing of the reflector and director elements, the centers of their lengths are in the same horizontal plane with the center of the radiator and due allowance is made therefore, for the width of the cross arm and the thickness of the pulley. The wooden cross arms are 2 inch width fir flooring, chosen for its straight grain and mounted edgewise for stiffness. The cross members were cut from 18-foot long lengths of 2-inch fir flooring boards. The vertical cross pieces (at the locations of the reflectors and the director) have bee-hive insulators mounted at the extreme ends of their 2-foot lengths for the support of these elements. These vertical supporting pieces are of the same 2 inch width of fir flooring. Here again you will note that the elements are supported near their middle to reduce r.f. losses and permit the use of insulation which is not specifically good for high frequency use.

The rotating assembly may be assembled outdoors and close to the point where the completed antenna will be located. In assembling the pulley is placed on top of a wooden case at least 4½ to 5 feet high and each cross arm with the vertical elements mounted on it is fastened by fitted brackets of strap iron, strap brass or strap aluminum. See detail in the drawing in Figure 2. The complete assembly is then braced and strengthened with tarred mackerel fish-line to stiffen up the structure.

Note that the (Turn to page 443)

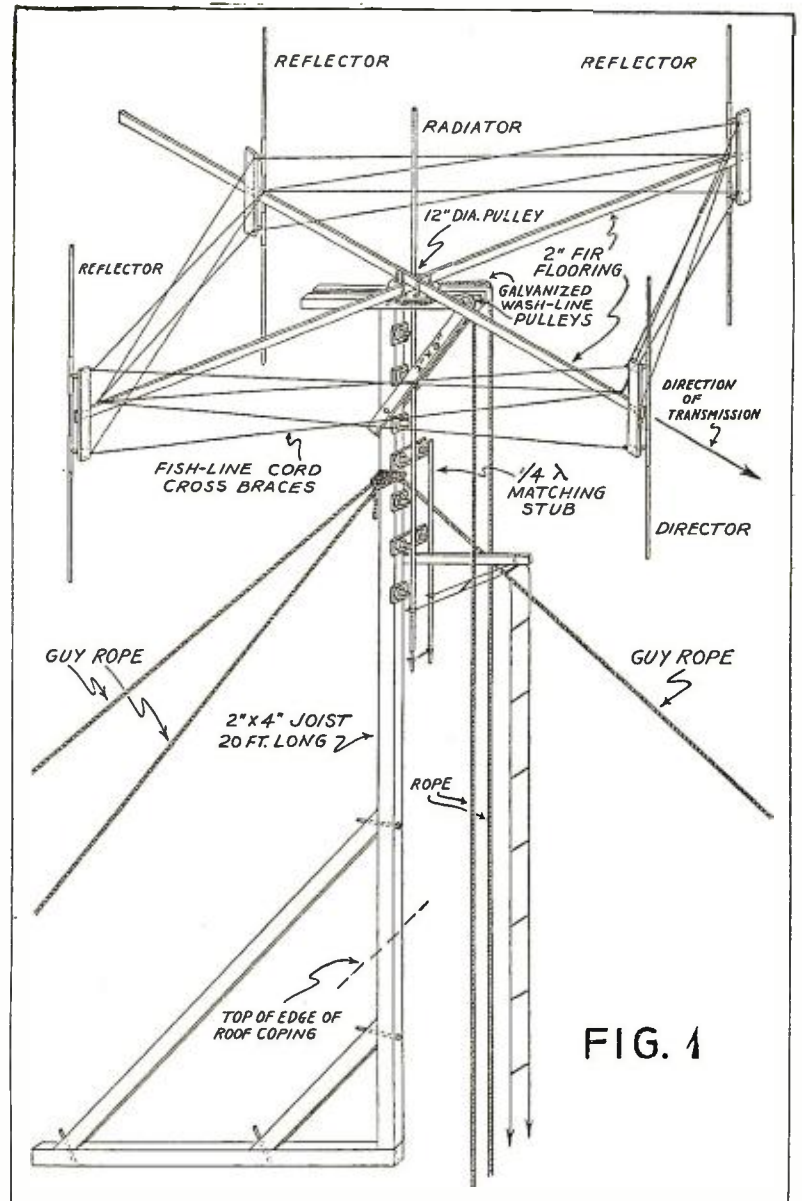

FIG. 1

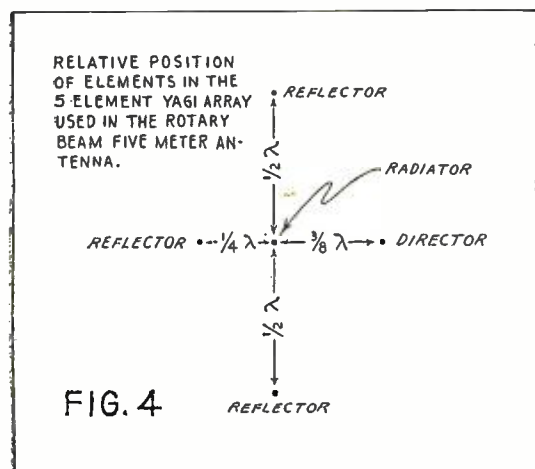

FIG. 4

Real POCKET RADIO

Midget Transceiver
Works on 3½ Meters

By Frederick Siemens

RADIO NEWS technical staff recently witnessed an interesting demonstration of a tiny 3½-meter transceiver developed by Mr. Charles Alextunias. Measuring only 1½ by 3 by 3 inches and weighing but 14 ounces, he claims it to be the smallest and lightest combination transmitter and receiver yet designed for ultra-short-wave use. With two units of similar design and construction, it was possible without any difficulty to carry on a two-way conversation between two of our offices approximately 150 feet apart. The test was made in our large steel constructed building at 461 Eighth Avenue, and there was probably considerable loss in absorption. The designer advises he has had two-way transmission over a radius of ½ mile. It employs a 955 acorn-type tube, and with 45 volts plate potential it is said

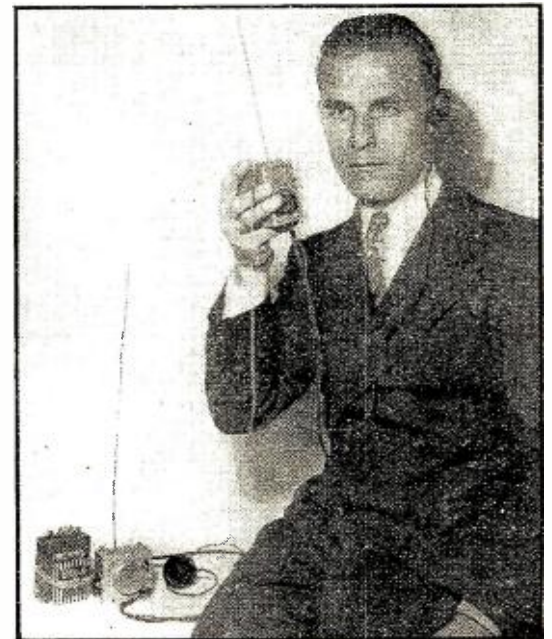

to deliver 1/10th of a watt output. By increasing the plate potential from 45 to 180 volts and with the addition of a modulating tube, the transmitter can deliver up to ½-watt output. The microphone is the single-button carbon type.

The antenna and counterpoise are made from bus bar and push-back hook-up wire cut to 1/8 wavelength. There is only one adjustable control (shown in the illustration, mounted on the side of the box), which is used for varying the tuning range from 86 to 90 megacycles. On the front of the case, just over the microphone, there is the change-over switch from transmitter to receiver or vice versa. A single lightweight Trimm headphone is employed for reception.

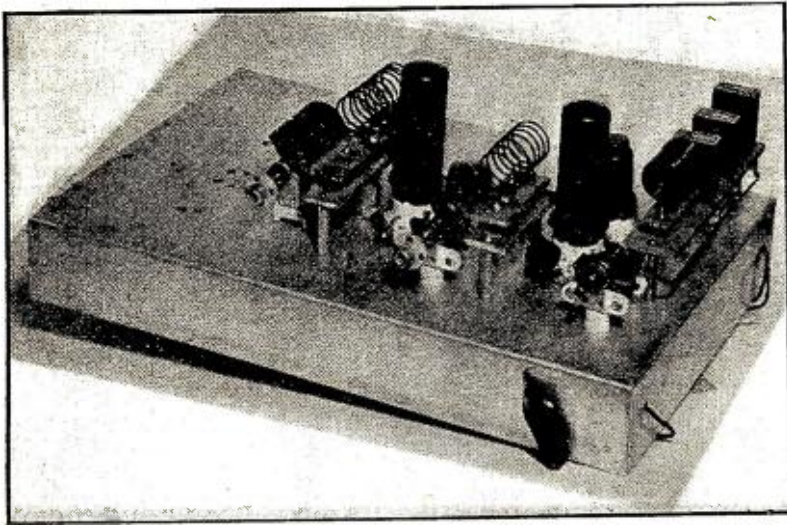

THE OSCILLATOR-DOUBLER ASSEMBLY ON A STANDARD CHASSIS

Figure 3 illustrates the parts layout, means of supporting coil plug-in assembly, of the harmonic generator and buffer-doubler driver stage.

Frank Lester Tells You How CRYSTAL Transmitter for

So many amateur experimenters trolled oscillators and doubler frequencies, with negative results, of the difficulties and outlining a done with the new 6L6 tubes is has been through all the troubles well as giving working data for

By Frank Lester
Part

IN presenting this article to the Amateur Fraternity, the author believes it advisable to give you the following summary of facts, before entering into the construction details and strange occurrences that were encountered in building this transmitter. In the first place, all of the research and design of this transmitter was conducted in such a manner as to make the results obtained easy to duplicate. The author feels quite sure that if the information given in this article is followed carefully, as well as the lay-out of parts suggested and illustrated, not only will a great deal of enjoyment be obtained in the building of this transmitter, but upon its completion, it will be found to be one of the simplest to adjust to obtain optimum performance. We might also add at this time that while the best possible performance was our aim, good appearance and simplicity was also desired without sacrifice of the primary factor, which is, of course, results.

WITH the announcement of the new 6L6 Beam-power tube designed especially for audio-frequency work, a great many experimenters immediately thought of this new tube's possibility as a radio-frequency amplifier and oscillator.

All of the popular, by this time, crystal oscillators, tri-tet circuits, etc., were first tried with these tubes in preference to the arrangement employed at present. in order to supply us with the technical and operating information that was desired.

A 6L6 tube was set up in the more or less conventional tri-tet circuit, employing a 20-meter crystal, and attempts

were made to double and quadruple in the plate circuit of this frequency multiplier, whereupon we experienced the following: In the first place, the 6L6 tube seemed to be ideal for this work, for far better than usual performance was immediately obtained on these high frequencies, with fair output and stability quite apparent. Everything looked fine until the crystal holder was touched to see if there was any crystal heating, whereupon we became quite alarmed for the 20-meter crystal was overheating in spite of the fact that only short tests were made. We then kept this circuit operating for a period of approximately one-half hour, whereupon we found that the crystal was really being overheated.

THE CIRCUIT DETAILS

Figure 1. The schematic diagram of the metal tube crystal rig for high-frequency operation.

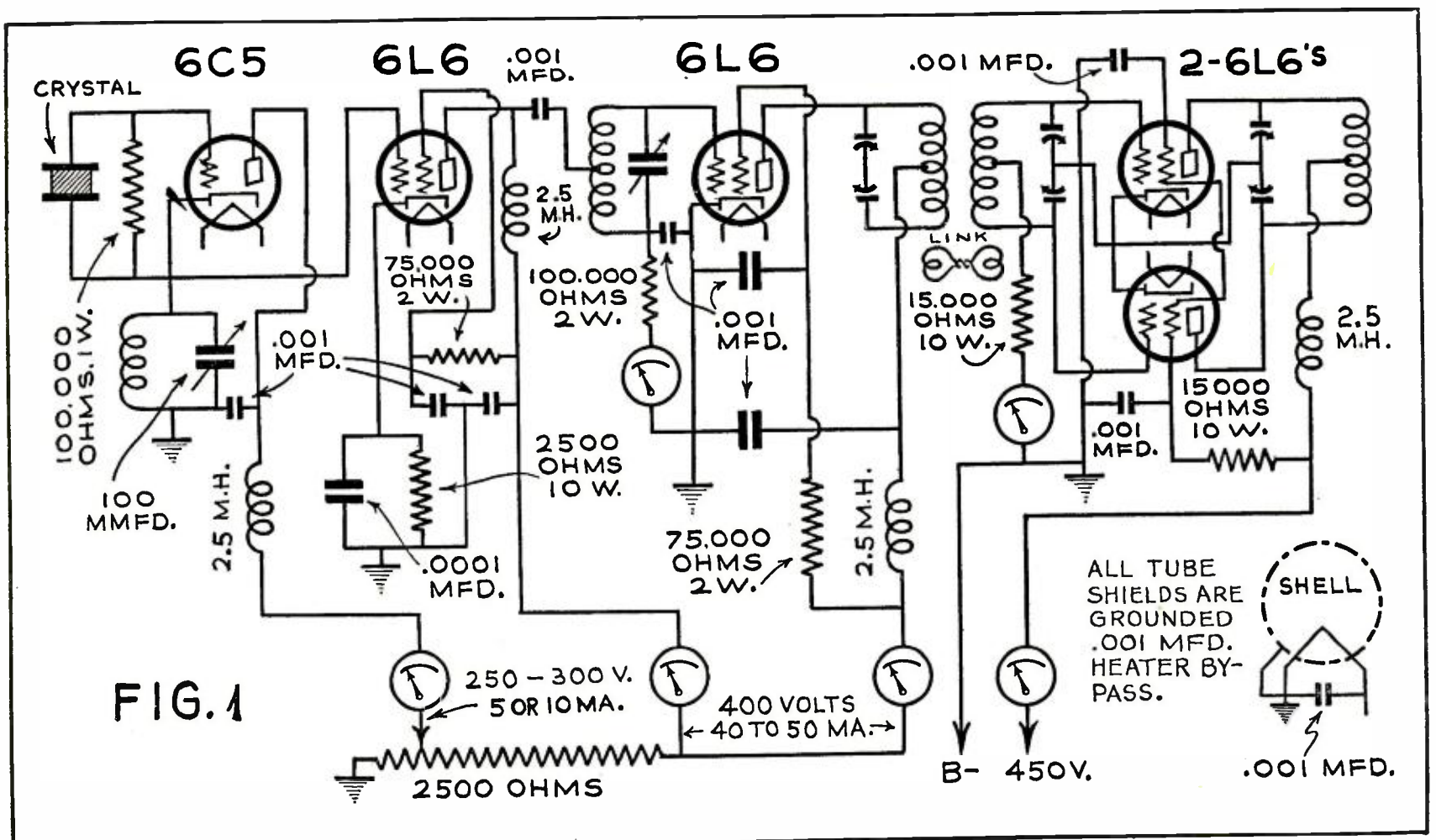

To Construct And Operate A CONTROL 5-10-20 Meters

have tried to construct crystal-con-
circuits for operation on the high
that this article telling about some
reliable method by which it can be
timely and to the point. The author
and outlines the reasons for them as
biases, excitation and circuit details.

(Radio W2AMJ)

One

which meant its possible fracture, as
well as frequency creeping, unless a low
temperature-co-efficient crystal was em-
ployed.

Lestet Circuit

We did not like this performance
and therefore set about correcting this
condition, with some improvement. We
were far from being satisfied with this
circuit, however. As it was our aim to
minimize the number of tuned circuits
and tubes employed in this transmitter,
we did not want to sacrifice the advan-
tages of the tri-tet oscillator and
therefore the author's old stand-by cir-
cuit, namely: the Les-tet oscillator, buf-
fer-doubler, immediately came to mind.
Previous experiment with this circuit
and other type tubes showed that it
had great possibilities down to 10
meters, and therefore it was imme-
diately set up. As we were already
using the new metal 6L6 tubes, it was
decided to use metal tubes throughout.
The 6C5, 6L6 combination in the Les-
tet circuit illustrated in Figure 1 clearly
indicates how the tubes are connected
to form what is, in a sense, a direct-
coupled, oscillator-doubler or multiplier
circuit. By direct coupled, we mean
that the two tubes are actually coupled
to one another in a d.c. sense, this be-
ing the connection of the cathode of
the 6C5 oscillator which is tied directly
to the control grid of the 6L6. All of
the tube shields are connected to ground,
as recommended by the manufacturer.

The same 20-meter crystal was used
in the Les-tet circuit, and it was imme-
diately apparent, in spite of the fact
that we did not add any additional
tuned circuits, or anything tricky, that
the efficiency of this combination was
quite a bit better than the aforemen-
tioned circuit. More output was ob-
tained, superior stability, and Lo! and
Behold! the 20-meter crystal remained
"ice-cold", regardless of how long this
set-up was left oscillating. This is un-
doubtedly due to the fact that only 300
volts maximum is applied to the 6C5

plate, which, when the crystal is oscil-
lating, only draws from 4 to 6 milliam-
peres. With this small amount of power
input to the oscillator, it can readily be
appreciated that the work the crystal
has to accomplish is very small, and
also that any r.f. which is developed
across the crystal holder is so low that
the thinnest of crystals could be em-
ployed without any fear of fracturing
or overheating them. This also meant
that the stability of the crystal oscillator
was all that could be desired, for due
to the low crystal current, heating, etc.,
even an X-cut crystal could be em-
ployed, without any noticeable drifting
other than that caused by the actual
changing of room temperature, which is
small. 400 to 500 volts was applied
to the plate of the 6L6 with the screen
voltage obtained via the 75,000-ohm, 2-
watt carbon or metallized resistor. The
2500-ohm, cathode-bias resistor was
chosen as the best value fixed of resis-
tance, although this could be made
variable, if one desires to experiment
and really obtain the maximum output
from the circuit when it is desirable
to drive other than a 6L6 tube. The
.0001 mfd. by-pass condenser across

this resistor was also found best for
frequency multiplication, for undoubt-
edly, a little regeneration is produced
by this r.c. circuit.

Frequency Multipliers

Frequency doubling was tried first
with fine performance, so good that we
were prompted to try quadrupling.
Much to our surprise, when the circuit
was quadrupling, the efficiency and out-
put was only slightly less than when
doubling, so we went still further and
were actually able to octuple, or in
other words, to use an 80-meter crystal
for 10-meter output. When octupling,
it was found that we could put from
1½ to 2½ mils grid current, into the
following 6L6 doubler stage, which op-
erates as a straight grid-leak bias type.
This also means that the effective grid
voltage applied to this tube would be
between 150 (for the 1½ mil grid cur-
rent) and 250 volts (for the 2½ mil
grid current). When frequency quad-
rupling, this grid current ranges from
2½ to 5 mils and when frequency dou-
bling, a little higher. We might men-
tion at this time that for best perform-
ance of the 6L6 doubler, at no time
should the grid current be more than
3 to 5 mils, for any higher value re-
sults in overdriving the 6L6, decreasing
the output of the tube. Around 2½
to 3 mils is really an ideal value to
operate it at. At this grid current and
with 450 volts on the plate, of the 6L6
doubler, with the plate circuit tuned to
5 meters, the combined plate and screen
current will be in the vicinity of 40 to
50 milliamperes loaded. This results in
producing 15 to 20 mils in the grid cir-
cuit of the push-pull 6L6's, with the
plate and screen voltages of the push-
pull, 6L6's not applied. With the 6L6's
loaded, this grid current will vary, de-
pending on the loading, and will most
likely be in the order of 10 ma., also
upon the link coupling between the 6L6
doubler plate and the push-pull 6L6
grids. We might mention, at this time,
that it was found that 6 to 8 mils grid
current with the 6L6's in push-pull,
loaded to 150 or 200 mils, was the
optimum value. (Turn to page 444)

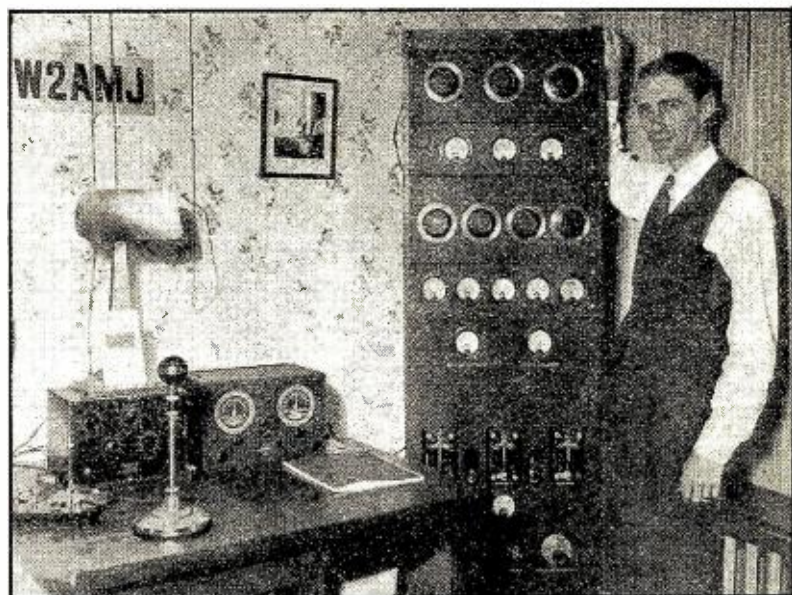

THE AUTHOR AND THE COMPLETED RIG
The two lower panels are for the high-power modulator
system. The next two panels are the oscillator and
doubler and buffer units and the two top panels are for
the high-power stage (not described here.)

Completed Data On The Transmitter

THIS is the first article of a
series of three by the same
author which will give all the con-
structional and operating details
for this very successful crystal-
controlled transmitter for opera-
tion on three bands. The next
installment will give full details
on the 6L6 push-pull stage, built
as a separate unit, and an exact
list of parts for the whole trans-
mitter. The third installment in
the following issue will give the
necessary data for constructing and
operating the final power stage, in-
cluding a diagram of the modula-
tor. The complete outfit will com-
prise a 250-350-watt transmitter
for 5-10-20 meters.

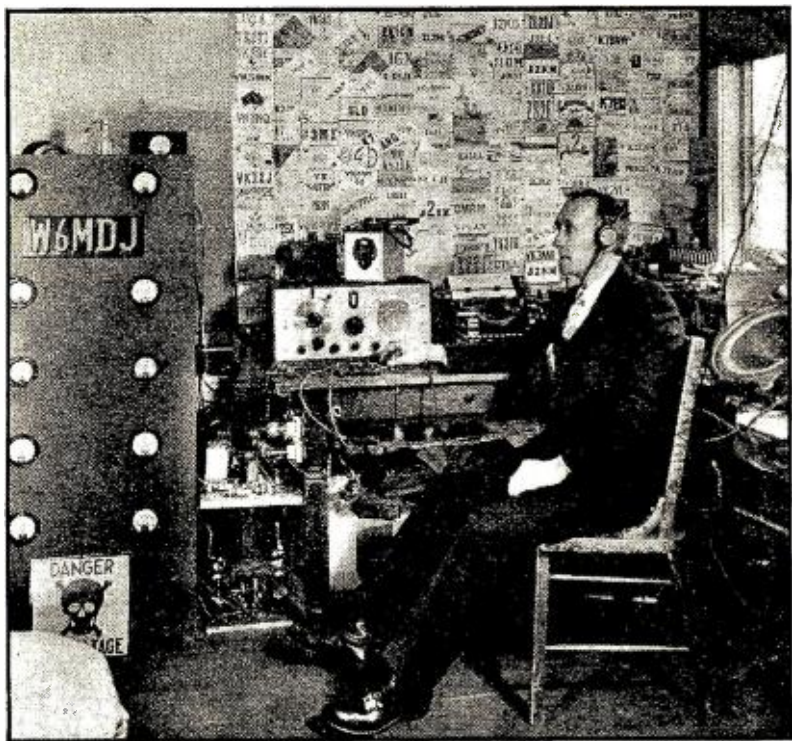

The "HAM" Shack

Conducted by
Everett M. Walker
Editor for Amateur Activities

GREAT DX'ER

The station of Norman Isherwood, W6MDJ, of Oakland California, is heard all over the world. The transmitter has 700 watts input and is home-made.

Simple CARRIER SHIFT Indicator

ALL amateur 'phone stations operating in frequencies above 30 megacycles are required by law to be equipped with a means of checking the transmitter for over-modulation. Numerous means have been devised for this purpose, among which are carrier-shift indicators and oscilloscopes. Oscilloscopes, of course, are the ideal instruments, but not all 'phone amateurs can afford them. They, therefore, must fall back on some means of showing carrier shift to indicate over-modulation.

A SIMPLE and highly sensitive carrier shift indicator and monitor can be built around the 6E5 or "electric eye" tube that is used as a tuning indicator on many modern receivers. The tube itself operates on a principle similar to the cathode-ray tube used in oscilloscopes, except on a much smaller scale. Due to its operating principle being electrical and not mechanical, it is far more sensitive to variations than the meter type of carrier indicator used by most amateurs. The meter usually used in conjunction with a diode rectifier is sluggish and frequently fails to respond to spurts of over-modulation that would be detected on the 6E5 screen. It is these spurts that occur for perhaps only a fraction of a second on certain lip and tongue sounds such as "th" and "p" that cause "buckshot" interference.

Their presence is not detectable in the quality from a transmitter. Nor is over-modulation of this kind a serious infraction on the rules of the Federal Communications Commission. As a matter of fact, it is understood the engineering division of the Commission will tolerate a little over-modulation, providing it does not exceed more than one-thousandth of a second at any interval.

Indeed, such over-modulation is not se-

rious but is difficult to control, particularly on voice transmission. The reason is obvious. There are only one or two lip sounds that cause such a condition and it is possible to have this type over-modulation with an average modulation level of less than 80 percent. But, on the other hand, on the amateur bands it becomes a serious factor because of the crowded conditions. A few of these "lipping" transmitters operating close in frequency results in an annoying interference that does not affect materially the intelligibility of a signal, but results in an annoying condition.

Without some sensitive indicator such interference passes without notice. It may be detected only with an extremely sensitive device. The mechanical meter indicators used at the majority of stations are not quick enough in action to show it up. It requires nothing less than an oscilloscope or a device that operates on the electronic principle and capable of recording fraction of a second spurts of over-modulation.

Employs 6E5 Tube

The unit employing the 6E5 and described here answers these requirements. As a matter of fact, it is just as sensitive as a cathode-ray oscilloscope. Also, it will do most of the things an oscilloscope will do except show wave form. It is mounted in a cabinet 10 by 7 by 6 inches. In addition to serving as a carrier indicator, it also may be used as a monitor for listening to the modulated signals.

It might be pointed out here that a carrier-shift meter will show over-modulation only on a stable signal of the crystal-controlled type, and, therefore, is usable only with transmitters in which there is no frequency modulation. Frequency modulation will show up on the "magic eye" just like over-modulation. This practically eliminates its usefulness on 56 megacycles or higher frequencies unless

FRONT VIEW

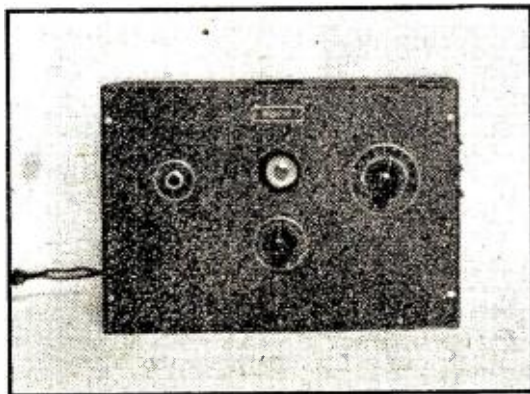

crystal control is employed. However, on 56-megacycle transmitters using crystal control, or those using electron-coupled oscillators that are isolated from the modulated amplifier by at least one buffer stage, it is possible to use a carrier-shift indicator for over-modulation observation.

The "magic eye" carrier-monitor is very reliable on stable signals. Over-modulation, of course, means modulation in excess of the carrier. If there is not sufficient carrier available to accommodate the amount of audio power used, the carrier will be compressed when the modulation exceeds 100 percent and this results in carrier shift. This condition on a carrier-shift indicator of the 6E5 type will manifest itself in the form of twitching of the screen of the tube. The action of the "magic eye," if watched carefully, will show over-modulation of less than 2 percent.

Simple Construction

Construction of the "magic eye" carrier-shift indicator-monitor is simple. The whole unit may be built for a few dollars. Essentially, it consists of a diode rectifier and amplifier using a type 85 tube, one 6E5, a tuned circuit in which plug-in coils are used for the band on which the transmitter is operated, a gain control and small power supply. The triode section of the 85 is used as a resistance-coupled amplifier to give more gain to the monitor. Ordinarily a straight diode rectifier does not give sufficient output for monitoring purposes unless a fairly large antenna is used. This arrangement gives ample output for all ordinary purposes.

The schematic circuit is self-explanatory. The carrier is picked up on a small antenna (only two or three feet of wire is necessary) and fed through the diode detector. This in turn supplies the voltage to actuate the 6E5.

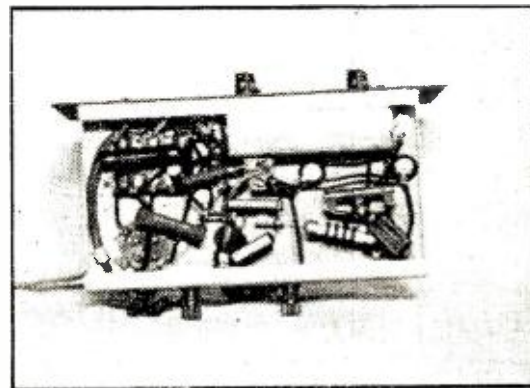

BOTTOM VIEW

The whole unit is contained in a small cabinet: power supply, the 6E5 which is mounted in the center of the front panel; the tuning control which is at the right of the 6E5; the 'phone jack which is at the left and the gain control which is mounted directly beneath the 6E5. All component parts, aside from those on the front panel, are mounted on the chassis which is 8 by 5 by 1½ inches. As may be seen from the illustrations, the 85 is mounted at the right rear of the chassis. In front of this is the plug-in coil and its tuning condenser. The

Q A Department for the amateur operator to help him keep up-to-date

plug-in coil is mounted on porcelain insulators with jacks. The coil forms are 1½ inches in diameter and equipped with banana plugs. The 6E5 socket and bracket is a standard R.C.A. adapter unit of the type sold for installation in receivers. It includes all necessary hardware, socket and leads for the tube. The rectifier tube, a type 80, is mounted at the left rear of the chassis. In front of it is the power transformer which supplies filament voltages and 300 volts r.m.s. for the plate power.

A resistance filter is used in the power supply. In addition to providing adequate smoothing, this method of filtering conserves space, a necessary precaution in constructing such a compact unit.

In constructing the unit, it was found necessary to include an audio filter in the 6E5 grid circuit due to the sensitivity of

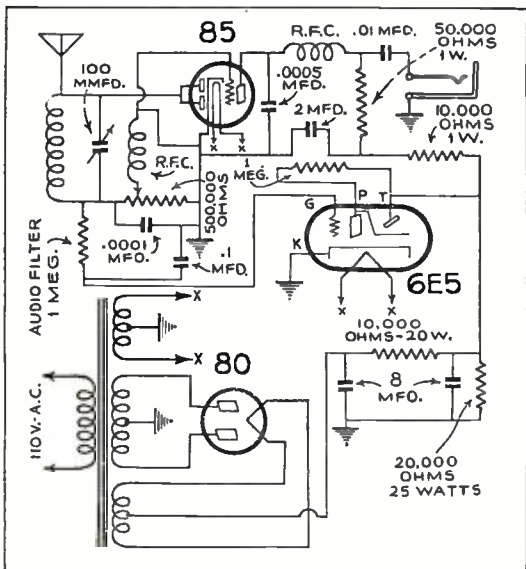

THE INDICATOR CIRCUIT

the shadow of the tube. This consists of a 1-megohm resistor and by-pass condenser. Without it the shadow on the indicating tube was inclined to be a bit fuzzy, making it difficult to detect carrier shift.

The metal cabinet is necessary, particularly when the unit is to be used in conjunction with a medium or high-powered transmitter. Without shielding the tuned coil itself will have a tendency to pick up radio frequency, and it will be impossible to adjust the screen of the 6E5 to a point where a small dark area or shadow is visible.

Sensitive in Tests

Incidentally, the carrier-shift unit was tested alongside a standard oscilloscope to determine its accuracy in detecting over-modulation. It was found that over-modulation was detectable on the "magic eye" as readily as on the sensitive screen of the oscilloscope where the entire cycle of the modulation was visible. When peak modulation was indicated on the oscilloscope, it also was shown on the carrier-shift indicator.

To use the instrument as an over-modulation indicator, it is necessary to adjust the resonant circuit to the frequency of the transmitted signal. The green screen of the 6E5 should be adjusted so that the two sides of the shadow do not quite meet. This may be done by lengthening or shortening the small antenna and adjusting the gain control. Usually two feet will provide more than enough pick-up. With

The "807" TUBE

for Amateurs

By B. J. Montyn

A NEW transmitting tube especially constructed for transmission has been announced by RCA. This tube is a beam-power amplifier, a tetrode, with characteristics similar to the 6L6, but it is a glass tube with a ceramic base and supplied with a cap connecting to the grid. It has a five-prong base, the scheme of connections is probably the same as that of the 24, 35, etc.

Although the tube is similar to the 6L6, it is not exactly the same. Apart from the mechanical differences just mentioned, it has improved internal shielding to minimize the need for neutralization.

The tube has a maximum plate dissipation of 21 watts and a very high power sensitivity; it is suitable for use as a crystal oscillator, frequency multiplier and r.f. power amplifier either modulated or unmodulated. The ratings are given below; all these values refer to a single tube or to each tube of a push-pull stage.

The Tube Characteristics

Heater voltage (a.c. or d.c.)	6.3 Volts
Heater current	0.9 Ampere
Mutual conductance, for plate cur. of 72 ma.	6000 Micromhos
Direct interelectrode capacitances:	
Grid-plate (with external shielding)	0.2 mmfd.
Input	11.6 mmfd.
Output	5.6 mmfd.
Maximum overall length	5¾ inch
Maximum diameter	2¼ inch
Bulb	ST-16
Cap	Small Metal
Base	Medium 5-Pin, Ceramic

A.F. Power Amplifier and Modulator—Class AB2

D.C. plate voltage	400 max. Volts
D.C. screen voltage	300 max. Volts
Max.-signal d.-c. plate current*	100 max. Milliamperes
Max.-signal d.-c. plate input*	40 max. Watts
Plate dissipation*	21 max. Watts
Screen dissipation*	3.5 max Watts

* Averaged over any audio-frequency cycle.

R.F. Power Amplifier—Class B Telephony

(Carrier conditions per tube for use with a max. modulation factor of 1.0)

D.-C. plate voltage	400 max. Volts
---------------------	----------------



D.-C. Screen voltage	300 max. Volts
D.-C. plate current	80 max. Milliamperes
Plate input	32 max. Watts
Plate dissipation	21 max. Watts
Screen dissipation	2 max. Watts

Plate-Modulated R.F. Power Amplifier—Class C Telephony

(Carrier conditions per tube for use with a max. modulation factor of 1.0)

D.-C. plate voltage	325 max. Volts
D.-C. screen voltage	250 max. Volts
D.-C. grid voltage	-200 max. Volts
D.-C. plate current	83 max. Milliamperes
D.-C. grid current	5 max. Milliamperes
Plate input	27 max. Watts
Plate dissipation	14 max. Watts
Screen dissipation	2 max. Watts

R.F. Power Amplifier and Oscillator—Class C Telegraphy

Key-down conditions per tube without modulation.*

D.-C. plate voltage	400 max. Volts
D.-C. screen voltage	300 max. Volts
D.-C. grid voltage	-200 max. Volts
D.-C. plate current	100 max. Milliamperes
D.-C. grid current	5 max. Milliamperes
Plate input	40 max. Watts
Plate dissipation	21 max Watts
Screen dissipation	3.5 max Watts

Typical Operation:

Heater voltage	6.3	6.3 Volts
D.-C. plate voltage	300	400 Volts
D.-C. screen voltage	250	250 Volts
D.-C. grid voltage	-50	-50 Volts
Peak r.-f. grid voltage	80	80 Volts
D.-C. plate current	95	95 Milliamperes
D.-C. screen current	10	9 Milliamperes
D.-C. grid cur. (approx.)	3	2.5 Milliamperes
Driving power (ap.)	0.2	0.2 Watts
Power output (approx.)	17.5	25 Watts

*Modulation essentially negative may be used if the positive peak of the audio-frequency envelope does not exceed 115% of the carrier conditions.

The RCA-807 may be operated at maximum ratings for frequencies as high 60 megacycles.

TOP VIEW

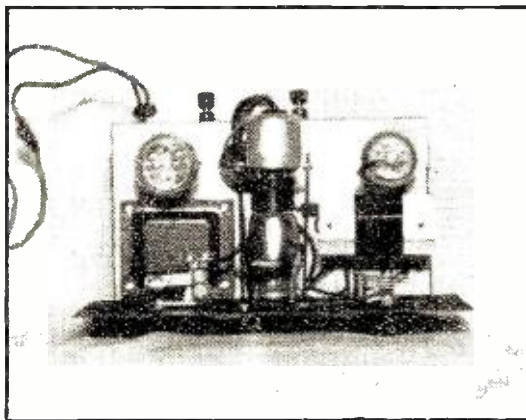

the 6E5 so adjusted, the shaded area of the "magic eye" will not change as long as modulation is less than 100 percent. But, should the modulation exceed the legal amount, the carrier will shift, and the sides of the light shaded area will flutter. They will either widen or swing closer together. If the space between the lightly shaded areas becomes wider it will indicate some degree of carrier cut-off, or over-modulation. If the shaded areas swing together, it also will indicate over-modulation, but of a different type: lopsided modulation.

In addition to serving as a modulation indicator, the unit is useful at stations where remote control is used. It, of course, (Turn to page 432)

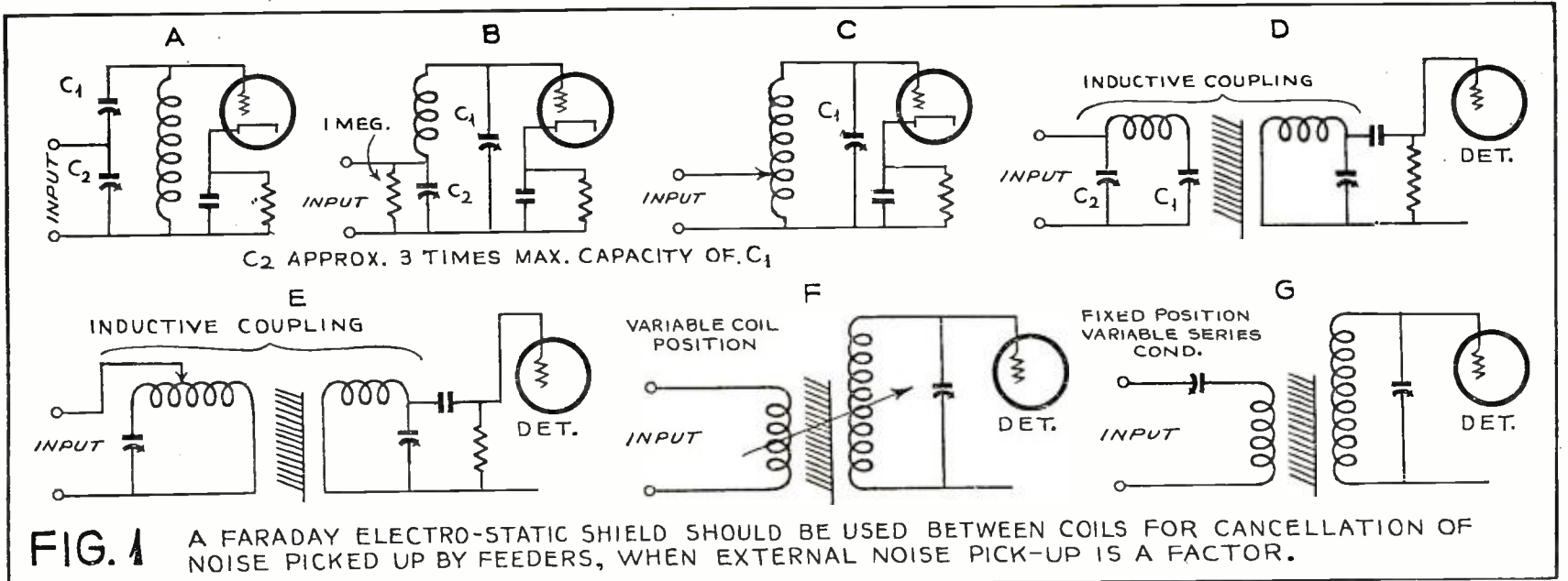

Here's The Dope You've Been Looking For On
SUPER REGENERATIVE
Receivers for the U.H.F.

This intensely practical discussion of superregenerative circuits is the result of several years of independent experiment by Mr. Bishop, culminating in a circuit widely known in New England as the "1EYM Circuit." Constructional details of a.c. and battery versions will be given next month.

THOSE of us who have worked with ultra-high frequencies have come in contact with the superregenerative receiver in one or more of its many forms. If we have experimented, we have found that some circuits give good quality and others don't; some are selective and some are broad; some radiate badly, and others don't, and so on. To anyone confronted with the problem of designing a receiver for a particular purpose, the maze of tried and true circuits which have been published is baffling, to say the least.

The purpose of these articles is not to extol the virtues of any particular circuit, but to provide the experimenter with enough facts about superregenerative receiver design to allow him to choose a circuit which will best meet his requirement. A circuit will be described in the succeeding article which has proved itself to be one effective and inexpensive answer to amateur 5-meter receiver requirements.

In order to judge the performance of any radio receiver, certain fundamental performance characteristics must be understood. In the following list are given those characteristics

By Nat Bishop (W1EYM)

which are important in judging a superregenerative receiver. I will attempt to define each one of these terms as they are apparent to the ear, rather than to a meter, and then show how circuit design affects each one.

1. Useful Sensitivity
2. Selectivity
3. Fidelity
4. Noise Reduction Ability
5. Radiation of Interference

Other factors, such as ease of tuning, cost, etc., will be discussed as they will occur under the above headings.

Useful Sensitivity

This characteristic may be broadly defined as the ability of a receiver to pull in an intelligible signal from a weak station. In some highly sensitive receivers, the set noise (or hiss) may be such as to blanket weak signals. That is why I have qualified the term with the word "useful." Here again, the ear is the judge, and the ear knows the difference between noise and speech while a meter does not.

The first and all-important fact to remember in the design of a highly sensitive receiver is that there is a level of set noise (hiss) present between the grid of the first tube and ground which must be exceeded before any signal will rise above the noise level. The logical way to attack this situation is to design the receiver input circuit so that it will extract the maximum

THE "1EYM" RECEIVER

A 4-tube receiver which operates from any 250-300-volt power supply. It gave excellent results in tests by RADIO NEWS and the circuit and constructional details will be shown next month.

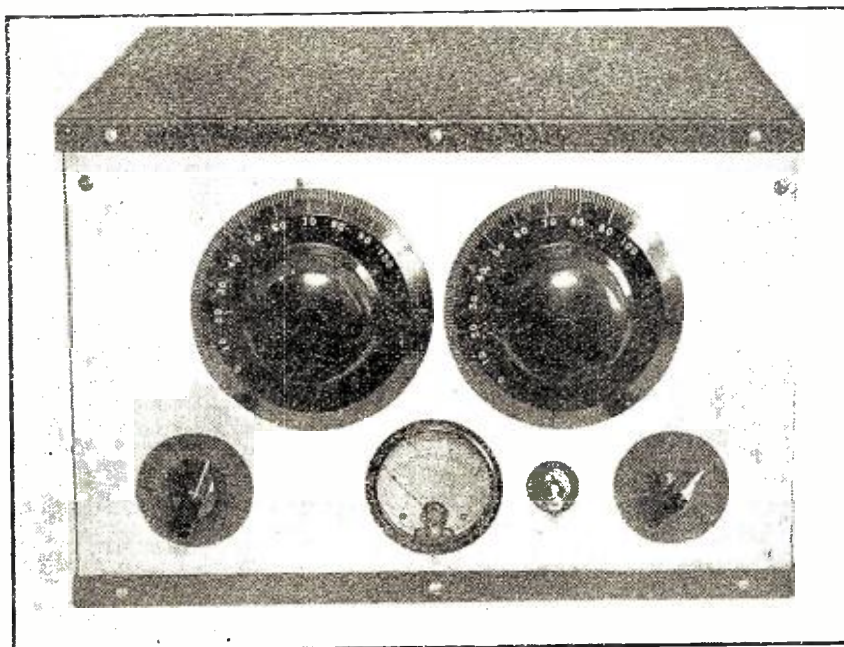

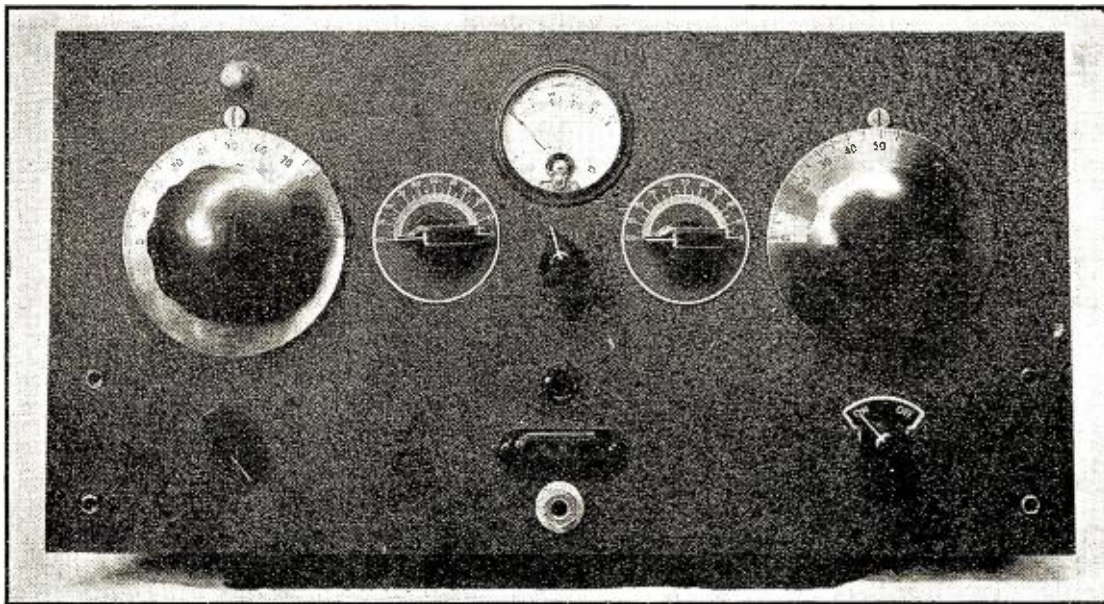

amount of signal energy from the antenna. The only condition that must be fulfilled to accomplish this is that the impedance looking into the first tuned circuit must match the source impedance.

Many antenna coupling circuits have been recommended ranging from small coils inductively coupled to the first tuned circuit, to small trimmers tied onto the high side of the first tuned circuit. Any such fixed coupling arrangement will give results if and when the source impedance is matched to the receiver input. Too many five-meter receivers vary in performance over the band because the optimum match occurs only at one part of the band. The only solution is to provide adjustable coupling which will allow the operator to get an optimum match at any frequency. Even with untuned transmission lines properly matched to an antenna, the impedance at the receiver end will vary sufficiently to make adjustable coupling worth while.

The choice of input circuits depends on several factors:

1. If an r.f. stage is ganged to the detector stage, the coupling should not be made adjustable, as it will upset the tracking of the circuits.
2. If a separately tuned r.f. stage is used ahead of the super-regenerative detector, optimum coupling may be obtained and the detector dial may be calibrated.
3. If no r.f. stage is used, adjustable coupling direct to the detector input circuit will change the calibration over wide limits.

For tuned transmission lines (Zepp feeder) or direct antenna input, Figure 1 shows a variety of circuits. A, B and C are inputs to an r.f. stage, while D and E are for inputs direct to the detector. The input impedance goes up as C_2 is decreased in capacity, or as tap is moved up. The ratio of C_1/C_2 determines the input impedance. In any case, C_1 and C_2 may be set for maximum signal at any frequency within the range, and the same applies to the tap position.

These five circuits are designed for use where the source impedance (feeder or antenna) varies over wide limits within the frequency range of the receiver. The choice depends largely on mechanical convenience because they

A PORTABLE FIVE-METER RIG

A combination transmitter and receiver (not a transceiver), the receiver portion of which utilizes a circuit based on the principles discussed in the present article. A more complete discussion of it will appear in the February issue.

will all give equal performance.

For untuned transmission lines (twisted pair, matched spaced feeders, etc.), circuits F and G are recommended, for either r.f. or detector input from the transmission line.

The importance of antenna coupling cannot be over-emphasized for u.h.f. receivers where high useful sensitivity is desired. It must be realized that optimum input coupling and maximum selectivity do not occur at the same setting of the coupling. The operator, however, can balance one factor against the other for best results on any particular signal.

Having shown what steps are necessary to get the maximum signal out of the feeders onto the first control grid,

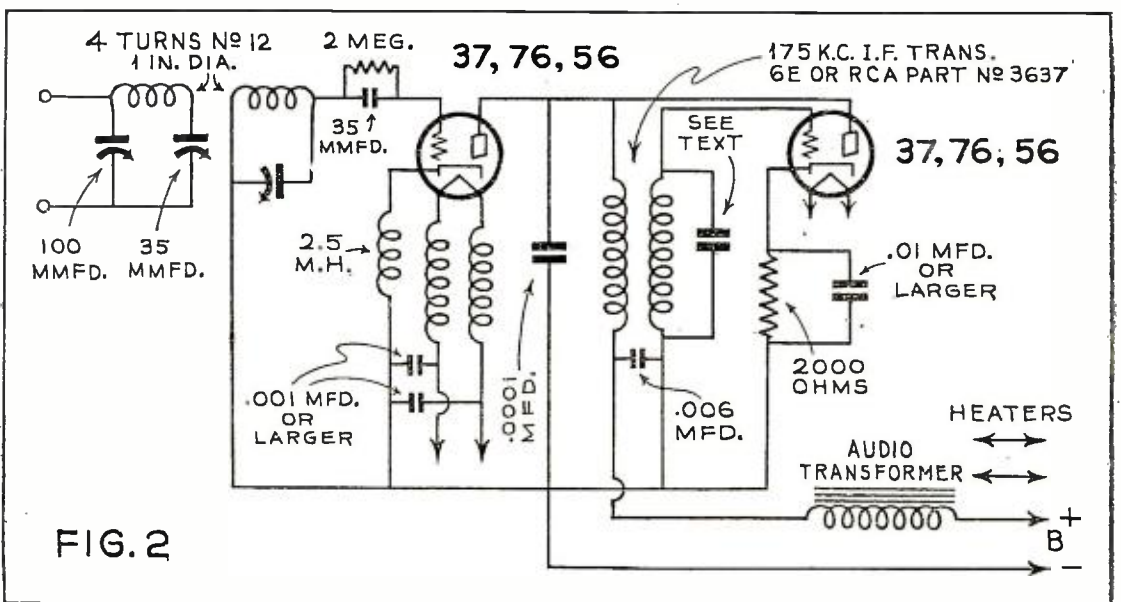
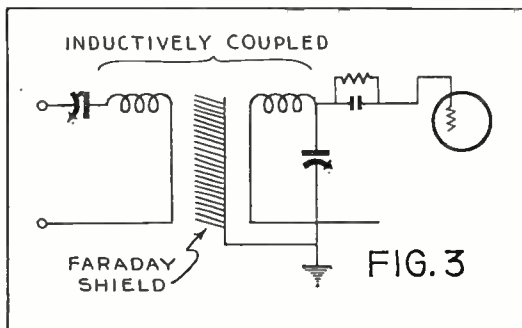

the next question is what factors give a superregenerative circuit a high useful sensitivity beyond this point. The first thing that can be done is to use as much r.f. gain ahead of the detector as possible.

At five meters and lower wavelengths, r.f. gain is expensive due to the limited production and therefore high cost of specially designed tubes such as the 954 and 956 acorn type pentodes. Standard tubes at best give very low gain at these frequencies, and it is very difficult to demonstrate any gain at all in actual practice when they are used. Economy therefore dictates that dependence must, in most cases, be placed upon the detector for sensitivity.

The detector should be capable of going in and out of the superregenerative condition smoothly and gradually. The ideal method where no r.f. stage is employed is to leave the plate voltage fixed say between 45 and 67.5 volts and control regeneration by varying the antenna coupling. The coupling circuits described allow this method of operation on a smooth receiver. Optimum coupling cannot be obtained on a self-quenched detector because it will not go smoothly from a superregenerative condition to a non-oscillating condition. It passes through an oscillating "non-supering" condition on the way which produces nothing but beat notes and poor quality. The best test to determine whether a detector circuit will give smooth operation is to pull out the quench oscillator tube and operate it as a straight regenerative detector. If any signs of self-quenched oscillations or instability are apparent, the detector will not operate smoothly when separately quenched.

Figure 2 shows a detector circuit which has proved to be very smooth in operation and which has been incorporated in several receivers with excellent results.

Selectivity

The selectivity of a superregenerative receiver is largely controlled by the value of interruption frequency chosen. The difference between the losses in an exceptionally good coil and a fair coil are negligible when the circuit is closely coupled to the antenna or transmission line. If two tuned circuits are used between the antenna (Turn to page 427)

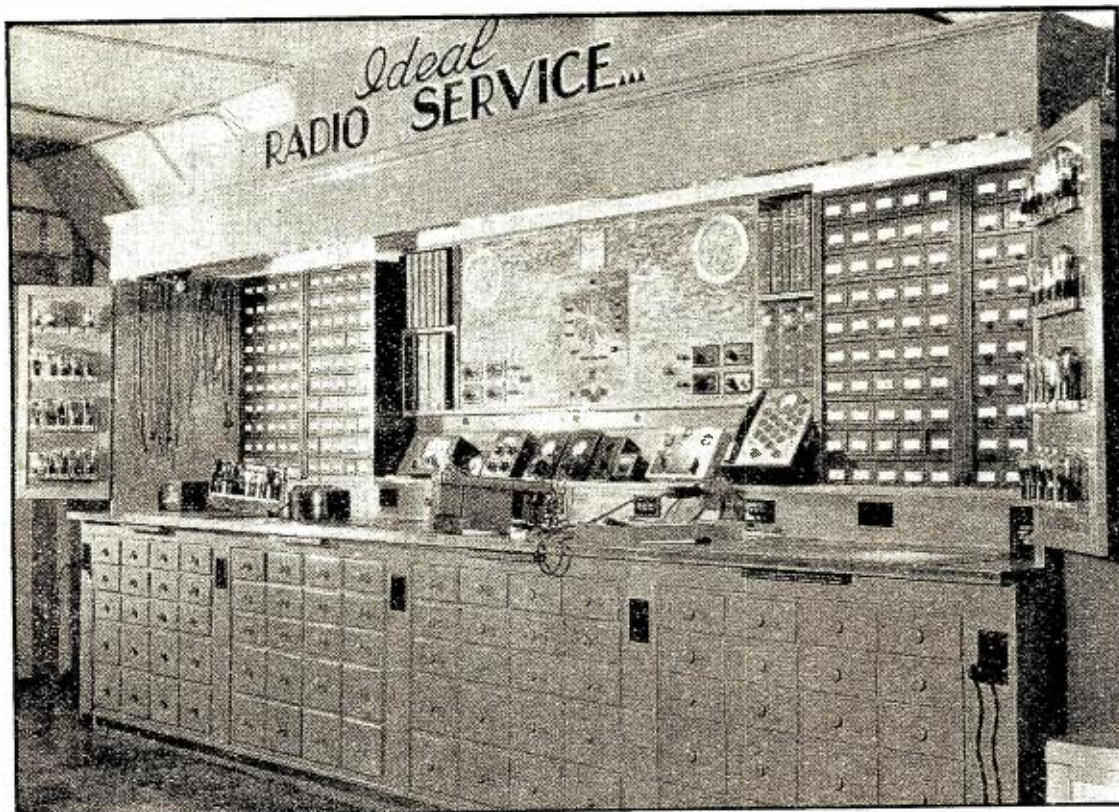

A RADIO SERVICE SHOP PAR EXCELLENCE!
Plenty of room, light, equipment—and a couple of drawers!

THE SERVICE BENCH

THE Capacity Bridge in Radio Servicing . . . An Ideal Service Shop . . . Service Sales Tip . . . Auto Radios . . . **SERVICING:** Majestic . . . Bosch . . . Philco . . . Admiral . . . Universal.

Conducted by Zeh Bouck, Service Editor

A NEW TOOL FOR THE SERVICEMAN

WITH the consistent development of receivers toward more efficient but more complicated designs, the serviceman has come to depend more and more upon the equipment of the engineer and the advanced laboratory. This was evident last year in his immediate acceptance of the cathode-ray oscilloscope. And now the a.c. capacity bridge emerges from the research laboratory to be placed upon the bench in the service shop.

There are several of these bridges on the market, and are priced at about thirty dollars or less—well within the limits of the instrument budget of the average service-

THE SOLAR CAPACITY ANALYZER

A resistance-capacity bridge, plus the conventional neon lamp analyzer.



man. They are completely self-contained, with built-in power supplies and electronic eye (6G5) null indicating tubes. They are easier to operate than most analyzers.

Originally the primary function of the capacity bridge was to measure capacity. Servicemen have, of course, been measuring capacity on different forms of capacity meters for some years, but the range of the bridge is considerably more extended than that of most meters. A good bridge will measure from 10 mmfd. (.00001 mfd.) to 100 microfarads with a high degree of accuracy. It is practicable with such a bridge to measure the minimum capacities of trimmers, the capacities of sockets, adjacent leads, grid leads, and similar capacities which may be suspected of limiting the frequency range of a receiver.

A secondary but equally important function of the capacity bridge is the direct measurement of power factor. Power factor is the only reliable index of the efficiency of a condenser, and is often high enough to be detrimental even when leakage is negligible. Condensers may test *okay* under ordinary tests and still be characterized with so high a power factor as to affect adversely the operation of a receiver. Power factors in excess of 5% should not be tolerated in paper or mica condensers, while the upper limit is 25% for electrolytics. While power factors of this magnitude may not appreciably lower the efficiency of a receiver (particularly when only a single condenser may be affected), such power factors are indicative of deterioration that is progressive and which eventually will evidence itself in complete failure.

Power factor analysis of condensers and shielded leads will often disclose the source of subtle and otherwise baffling radio difficulties. This is especially true in such instances as the gradual impairment of performance, where voltages test *okay* and

new tubes and realignment are of no avail in restoring the original pep.

As it requires only a few additional parts in the design of a capacity bridge to provide for resistance measurement, some such bridges include this feature, covering a wide range from 1 ohm to 1 megohm. The principal advantage of bridge measurement of resistance (over that employing the usual ohmmeter) is the elimination of the battery or other power source requiring a compensation adjustment on the meter. The bridge is always accurate, regardless of fluctuations in the line voltage.

The a.c. bridge being primarily designed for capacity measurement, it is logical enough to combine it with a conventional condenser tester or analyzer, with the usual neon-lamp indications for short-circuits, leakage and opens. This several manufacturers have done, and the composite instrument places at the disposal of the serviceman a most convenient and heretofore rarely available means of complete condenser analysis, plus an accurate resistance bridge.

THIS MONTH'S SERVICE SHOP

Our head photo this month shows the shop operated by George W. Leffler, Jr., as the "Ideal Radio Service," in Buffalo, N. Y. Somehow or another, Mr. Leffler manages to struggle along with one Philco shadow meter, a Weston output meter (model 571), a Weston 665 analyzer, a Weston 666 selector, one Wright-DeCoster test speaker, a Weston capacity meter, two Weston volt-ohmmeters, a Sprague condenser block, one Solar capacity analyzer, a Burton test oscillator, Ohmite Deterohm, a Philco speaker tester, one Weston tube-checker, a Model 669 Weston vacuum-tube voltmeter, an RCA cathode-ray oscilloscope, sundry volt and ammeters and power supplies, a Weston 771 Check-Master tube checker, a Remington-Rand air compressor (for cleaning chassis) and two hundred and eighty drawers!

The picture tells the story—at least part of it. Mr. Leffler describes the rest of the

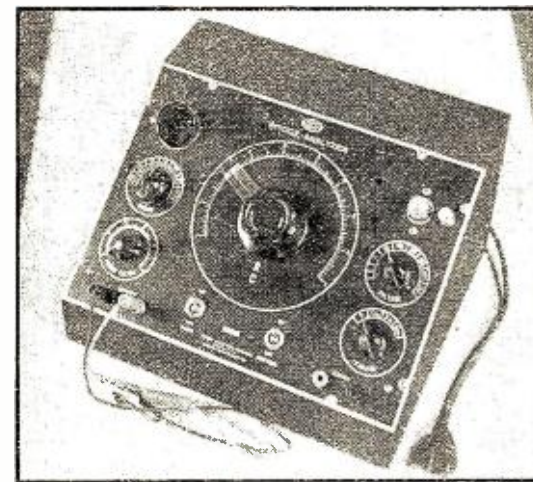

THE TOBE BRIDGE-ANALYZER

A combination designed for the serviceman. Reads power factor directly.

shop: "Beyond range of the photo, we have a roll-top desk, bookcase, typewriting table (with typewriter and adding machine), also a four-drawer steel filing cabinet. This part of the shop serves as our office, and we keep a 3 x 5 card system, listing the names of every customer, address and the date of the service call, etc. This enables us to check on our work from year to year and also provides a live mailing list. By maintaining this record, we can determine what we did to a client's radio and what we charged him—trouble and parts used. We supplement this with a weekly journal.

"We keep another card list of all tips published in the various radio magazines.

(Turn to page 422)

SERVICEMAN'S PRIZE CONTEST

Announcement of Awards

By The Contest Editor

FIRST PRIZE

An Attractive Layout

PHILIAS LEFEBVRE combines display with utility. His Service Bench is in full view to all customers entering the store. The usual equipment is built around Burton oscillators and Supreme instruments as nuclei. All instruments are portable and can be instantly removed from the panel by lifting the hinged cover. Small parts are stocked in the rack to the left—tools are kept in special drawers. (Figure 1.)

The service bench is fronted with a plywood counter, stained walnut, matching the background of the service bench itself. Mr. Lefebvre specializes in auto radios—Motorola, Bosch and Zenith. His main sideline is electric washing machines.

The display value of the service bench cannot be over-stressed. The customer is always interested in seeing where the serviceman works. A favorable impression here is one of the best sales arguments in the world. Mr. Lefebvre's bench is well worth using as a model!

SECOND PRIZE

A Horse-Shoe Bench

ASERVICE BENCH in the form of a horse-shoe is a logical and efficient design. One view of such a bench, conceived and constructed by Fred R. Wichman, is shown in Figure 2.

A SERVICE BENCH

Figure 3. Mr. Price's bench recommends itself to servicemen entering the business, where initial expense is necessarily a major consideration, but where workability must be equally considered.



One the left are boxes that pull out as drawers. Arranged in alphabetical order, they contain resistors, switches, vibrators, volume controls, etc. The shelves in the background provide room for some 40 or 50 small glass jars filled with nuts, bolts, screws, washers of all sizes—each container holding a single size. Two large windows admit plenty of daylight, and at night each side of the bench is illuminated with a 200-watt bulb supplemented with a ceiling light. The instruments are all Supreme. The floor of the shop is concrete, covered with wood.

A unique feature of this shop is the intercommunicating system between the shop itself and the front of the store. Two magnetic speakers are employed, each of which is used both as a microphone and speaker. (A few more details, Mr. Wichman?)

It would appear that Mr. Wichman is going places in the service field. He writes: "I have been servicing radios for over ten years. I never went to any school, but am thinking seriously of attending this fall if we have radio classes. I am thirty-five years young and can learn a lot more."

Most of us feel the same way about it and that is a healthy sign.

EVERYTHING ABOVE BOARD

Figure 1. Mr. Lefebvre contends that the work-bench should be just behind the counter, in full view where clients may see what is being done and how the work is conducted.



AN EFFICIENT WORKABLE JOB

Figure 2. Fred Wichman is proud of his work-room as an efficient place to do work where everything is handy and get-at-able. Nothing is dolled up, but everything is laid out for handiness in making repairs.

THIRD PRIZE

A Thought for the Newcomer in Radio Servicing

OVERHEAD is necessarily a major consideration in entering upon the service business. Fortunately, radio servicing is one of the few lines of endeavor the headquarters of which can be made the home. The attic, cellar, spare room or corner in the garage can readily be converted into an efficient service shop. (Overhead must be figured, however, (Turn to page 431))

THIS MONTH'S WINNERS

First Prize—To Philius Lefebvre, Phil's Radio Shop, 374 Main Street, Southbridge, Mass. \$10 for originality, neatness and efficiency in layout!

Second Prize—To Fred R. Wichman, Marathon Radio Service, 9426 Mack Avenue, Detroit, Mich. \$5 for arrangement!

Third Prize—To Thomas J. Price, Clarkdale, Ga. \$4 for showing the newcomer to radio how to get into the service business without an expensive overhead in the way of shop.

Congratulations and thanks from RADIO NEWS and its thousands of servicemen readers!



The Matter of SERVICE CHARGES

The radio servicing and repair business must be run on a basis that will bring a fair profit to the operators if it is to be successful. The various methods for charging for this service are therefore more important than most servicemen are apt to consider in making rates.

By Zeh Bouck

IN analyzing the possible methods of charging for radio service, it must be borne in mind that nothing arbitrary in the way of rates is feasible. They must be adapted to the community in which the serviceman functions and the clientele to which he caters. This fact holds even if the serviceman specializes in one receiver, the manufacturer of which endeavors to standardize on service costs. This can be accomplished in the automotive industry—but not in the radio field. Different makes of automobiles fall into definite price classes, and this is a factor taken into consideration in estimating standard service charges by authorized dealers. However, in radio, where one brand of receiver may cover a price range of from ten dollars to six hundred dollars, such standardization is obviously impossible.

It is largely because of these considerations that the

Flat Rate

system often fails. A flat rate of \$2.50 may be established for a service call covering the following chores: Inspection of Antenna and Ground, Test All Tubes, Realign Receiver, Tighten all Connections, Adjust Dial to Conform with kc. Readings, etc., etc. With the possible exception of the antenna and ground inspection, the labor and time involved will be considerably greater in the case of an 18-tube receiver than a simple 6-tube mantel type—even if both receivers are made by the same manufacturer.

As we see it, the principal virtue of the flat-rate idea is its sales appeal—an *advertising or publicity stunt*. As such it has its merit—its counterpart has been found profitable in the automotive field—and it may be employed occasionally. But it far from answers the problem of how to charge for service in the long run!

Parts Sold at Wholesale

Though fundamentally more sound

than the flat-rate system, the scheme of charging the customer the wholesale cost of parts used plus a labor charge, similarly finds its main justification as an *occasional advertising idea*. The heading introducing this paragraph is a good sales argument, but applied consistently, it is *poor business*. First, it can be objected to from an ethical point of view. So long as trade discounts remain a fundamental factor in our economic system, there is no reason why the layman should be able to purchase radio parts as cheaply as the trade. Also, with the profit on the sales of parts eliminated, the labor charge, if the serviceman is to make a profit, will necessarily be high, with an occasional unfavorable customer reaction. Few customers will object to paying standard list prices of parts, but some will revolt strenuously at what appears to be a *flagrant over charge for labor!*

The other extreme—

List Price for Parts

—with no labor charge, is not much better, for the simple reason that, like

HOW TO CHARGE FOR SERVICE

THE question of how to charge for radio service work is probably the most controversial problem with which the serviceman is confronted. Various methods of charge are used by servicemen throughout the country, and include: Flat Rate; Net Cost of Parts Plus Labor; List Price of Parts Without Labor Charge; List Price of Parts Plus Low Labor Charge; Contract; Free Inspection. The advocates of the various systems of pay are usually condemnatory of the others.

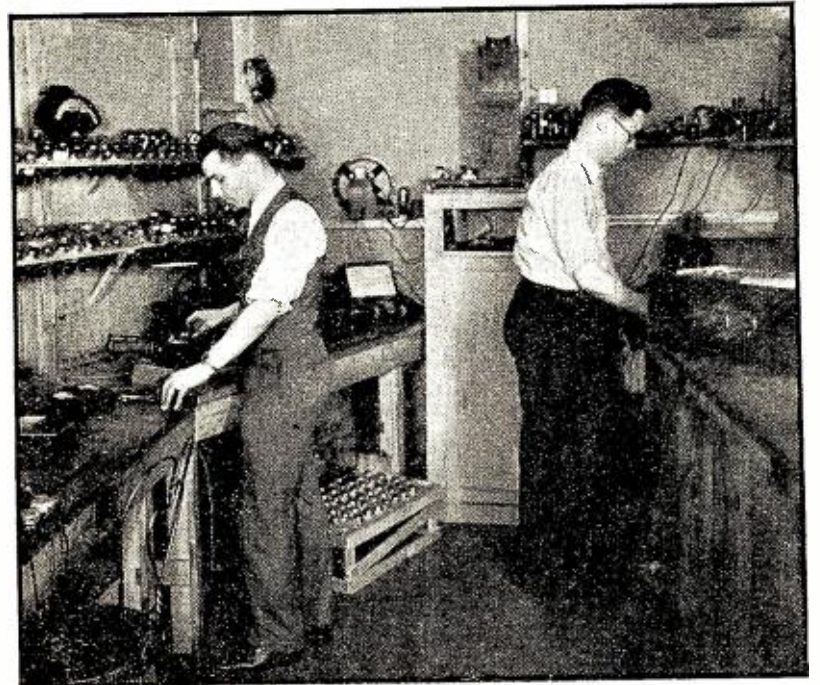

THE SERVICEMAN IS WORTHY OF HIS HIRE
The labor that the average serviceman expends on a carefully done repair job is usually the largest item in repair work. Methods of billing which purport to do this manual work for nothing usually lead to padding of costs for replacement parts.

the flat-rate arrangement, it sets up an arbitrary system of prices, permitting no elasticity for adaptation to different communities and clienteles. But once again it is a good publicity stunt, and an *occasional ballyhoo* of "No charges for labor!" may bring in some new customers.

List Price Plus Labor

It is fairly obvious that a combination of the two systems last discussed would result in a desirable compromise, i.e., list price for parts and a reasonable labor charge based upon the serviceman's standard of living and the ability of the customer to pay. Doctors charge their wealthy patients more than they do their indigent ones. In some instances—where the cost of a replacement part is high, and the labor involved relatively small—it may be desirable to give the client some discount off list price. His attention should be called to this allowance, and it will doubtless be appreciated, to your ultimate benefit. However, on every service job, your profit should represent a *combination of labor and some profit on parts*—always excepting the occasional instances when some other system of charges may be employed for advertising value.

Contract

Servicing by contract—at a flat yearly rate—is *necessarily a gamble*, whether or not parts are charged for, at list or net price, or not charged for at all. However, it has its *sales appeal*, and some servicemen find the plan highly profitable. Several such contract arrangements have been discussed in detail in *The Service Bench*.

Free Inspection

This is the "bête noire" of various service factions, many ruling out free inspection on the grounds that the laborer is worthy of his hire—that there is no reason why he should work for nothing.

However, the (Turn to page 429)



Servicemen! CALL SYSTEMS as a Sideline

By Wm. C. Dorf

THE successful serviceman and dealer is constantly on the look-out for new developments, allied to the radio field, which he can take on as a side-line and thus gain considerable additional revenue. Many an individual serviceman, operating his own business in a modest way, has been able to show black instead of red figures on his business balance sheet, principally because of the profits he has derived from radio side-lines.

THE most desirable auxiliary items for sale by radio dealers and salesmen are those that have minimum installation problems and require no special sales ability. In a new inter-office communication system, appropriately named and manufactured by the American Carrier-Call Corp., the serviceman has an instrument which meets these requirements and is ideally suited to his line of business. It is a loudspeaking "wired wireless" communicating unit for business use.

The serviceman's wide variety of calls with entry into offices, homes, restaurants, auditoriums, etc., are bound to offer excellent sales opportunities for the devices. A wide-awake serviceman can point out innumerable applications where this portable communicating system can be used to unusual advantage.

Employing two or more of these instruments as a system, it is possible to obtain instant two-way loudspeaker communication. It is easier to install than a radio set. No connecting wires are necessary between stations. To op-

USES "GUIDED" WAVE

This new telephone call system operates over the a.c.-d.c. power lines by means of guided radio waves.

erate, simply insert the line connecting cord into the nearest a.c. or d.c. 110-volt outlet and turn on the switch. The device uses an oscillatory circuit imposing a carrier frequency on the electric light lines and by this means transmits the voice frequencies between stations. It is claimed that the instrument has been so designed that it cannot radiate. It is available in different carrier frequencies so that one or more stations can operate over the same line without interfering with each other. It is obtainable in any desired combination selector switching for adaptation to special

installations. A very important factor that will recommend the instrument is its absence of line noises which are eliminated by a carefully designed filtering system.

It uses 4 tubes, comprising two type 43's, one 6C6 and one 25Z5 rectifier. The permanent-magnet, dynamic-type speaker operates as both reproducer and as a microphone. In the transmitting position (that is when the operator is talking) the reproducer operates as a dynamic-type microphone. In the receive position, the complete system operates like any other radio receiving set, with the speaker connected to the output as a regular reproducer.

The operation of the unit is simplicity itself. Looking at the control channel on the front of the cabinet, there is a switch at the top and when this is pushed all the way (*Turn to page 433*)

New "MIKE" is Unidirectional By Samuel Kaufman

AND now we come to the unidirectional mike! This latest addition to the microphone family, type 77-A, comes from the laboratories of the RCA Manufacturing Company. It is a high-fidelity instrument providing uniform wide-angle response from the front side, and negligible response at all frequencies from the back. The device is said to fill an important studio demand and will facilitate certain pick-ups made with difficulty in the past.

Construction is quite similar to that of the velocity—or "ribbon" microphone. But the ribbon in the unidirectional instrument, instead of being entirely free, is rigidly clamped down at the center and the upper half enclosed in the rear in order to obtain pressure operation. While it resembles the velocity mike somewhat in appearance and



construction, it is not strictly velocity-actuated, but rather combines velocity and pressure operation.

The manufacturers claim that this arrangement gives the mike the best features of both systems and simultaneously overcomes disadvantages inherent in both types of operation.

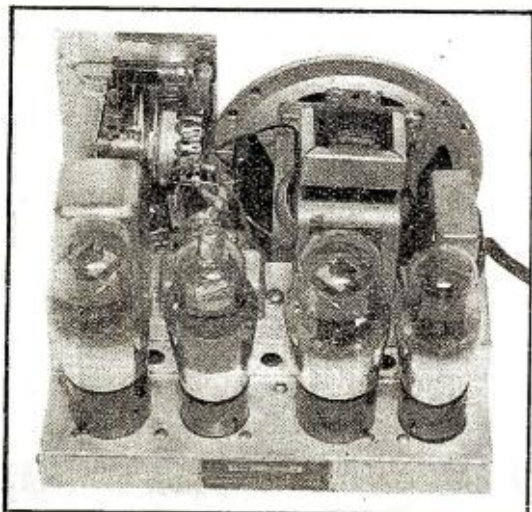

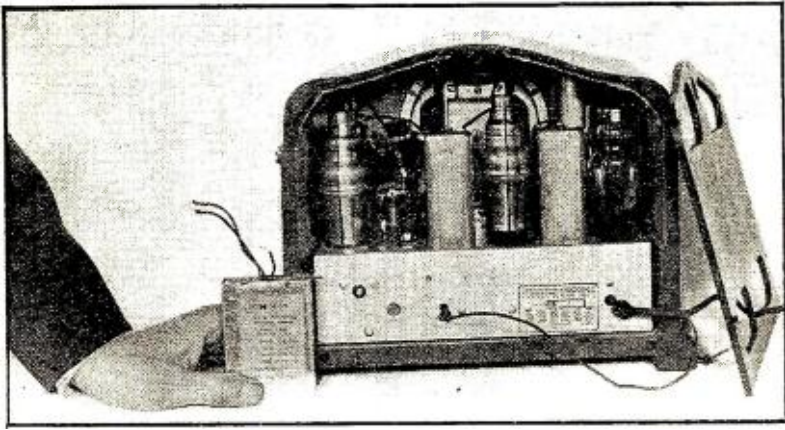

THE SET USED IN TESTS THIS MONTH

The sole trouble was a single burned-out tube. The condenser bank alongside is one which one serviceman claimed he had replaced, yet it had never been in this set and was simply a means for "building up" charges.

SURROUNDED by a close-fitting cabinet and imprisoned within metal shields closely flanked by transformers and condensers, the task of replacing tubes in modern miniature a.c.-d.c. receivers may well overawe the most daring layman owner. The difficulties encountered in profitably servicing such instruments have inspired among all legitimate servicemen a deep and consuming hatred for all cheap sets of this type. Not so the resourceful "gyp" gentry, however, who have discovered in its impenetrable fastnesses another rich field for their talents in hornswoggling the gullible public. With the familiar banner of "Tubes Tested Free," so universally shown by all good radio shops, the set owner is encouraged to tuck his tiny receiver under his arm and wend his way into the shop for a "free" test of his tubes. Will he get what is promised? Most assuredly so. Will bad tubes be replaced? Of course, but if he isn't careful, the customer may depart blithely in blissful ignorance that he has also paid for several other tubes which were not replaced.

Tube "Gyps" in Action

Since all tube filaments in such sets are in series with a resistance which is often part of the line power cord, the burn-out of even a single tube will open the circuit. No tubes will light and the power cord will no longer get warm. All of which tends to impress the owner that a dire calamity has befallen his choice possession. As might be expected, the small "gyp" minority in the service field take full advantage of the opportunity to cash in on this blessed illusion. Here are a few cases gathered during this month's RADIO NEWS racketeering investigation.

The radio shown in the photograph was prepared for the tests by giving each part an identifying mark, just as was described last month. A single 6D6 tube was then purposely burned out and put back in the set. This was the sole defect, though the chassis was left in a rather dusty condition to conform more to a normal service job. The radio was now taken to service shop No. 1 and was left with instructions to look it over, decide what had to be done to put it in first-class condition. Our investigator phoned the next day and got a

quotation of \$4.27, which was to include 3 new tubes and a \$1.00 charge for cleaning and aligning. This charge was accepted and the serviceman was asked to return the defective tubes. He returned 3 tubes, but when we checked over the set we found only one tube had been replaced. The other two did not bear our identification mark. Both were defective but had not been taken from this receiver. The set had been cleaned, however, as promised.

Hopping Up Charges

Again we put back the burned-out 6D6 and sent the radio to another shop for the same job. The diagnosis this time was a burned-out line resistor and one tube. The price quoted was \$5.95, of which \$4.95 represented the cost of replacing the line resistor. When our investigator called, however, this diagnosis had been revised. A new condenser bank, he said, had been required. Also, to improve the tone, he added a .002 condenser from plate to ground of the output tube. He also found the 43 output tube unsatisfactory and replaced it. Checking over the work, we found that, as stated, he had replaced the 6D6 and the 43, had added the .002 condenser, but not the condenser bank. As before, he was asked to return the defective parts and he did so. But the condenser bank which was supposed to have come out of the set was of a type which could not possibly have been a

WIDE VARIATIONS IN CHARGES

The prices charged in three cases where a single burned-out tube was the only trouble. The higher charges were obtained largely by misrepresentation, though some extra work was done.

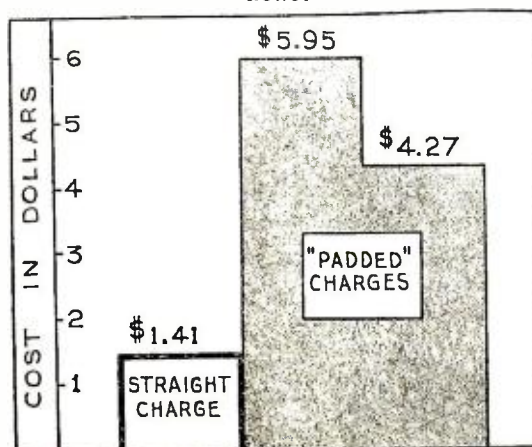

EXPOSING SERVICE

This month's check-up of cut-rate servicemen in New York City shows their actual charges to be higher than those of the best legitimate servicemen with established reputations and select clientele

part of the receiver. It was too large.

This serviceman made an earnest effort to give full value for the sum he collected. In addition to the work performed mentioned before, the set had been carefully gone over and the cabinet polished. In looking over his bill, we found that none of the operations which he did perform, also one 6D6, and one .002 condenser, had been charged for. It included only the type 43 tube, which was not needed, and the labor and materials for replacing the condenser block, which was not replaced.

The same defect was again introduced and the set was taken to a store which bore the sign "Approved Electrical Appliance Dealer." Our investigator left the receiver with instructions to estimate the cost of putting it in working order. The next day the report was received that only a single tube required replacement and that the set was in good working order. The charge was \$1.41 and was properly itemized on the bill as \$.89 for the tube, \$.50 for service and two cents sales tax. The receiver was assigned a number when left, a receipt was given the customer, and when our investigator called to pick up the set, he was required to sign a delivery receipt. A 90-day guarantee covering tubes and parts was printed on the bill and the serviceman's signature appeared on the bill. The entire transaction was handled in a thoroughly sound, honest, business-like manner. True, cut-throat competition had forced this dealer to sell the tube at a slight discount, but he had the courage and sound business sense to make a 50-cent handling charge when tubes to be tested have to be removed and replaced in the set.

Midget Sets

When a customer comes in and plunks down one of those small a.c.-d.c. sets on the counter with the request that the tubes be tested, far too many dealers and servicemen fear to make a charge for the service. This accounts for part of their antipathy toward this type of receiver. While much depends on circumstances, we do believe that a handling charge should be made in the vast majority of cases. If the total time devoted to this job were 20 minutes and the serviceman's time plus shop over-

Cut-Rate "GYPS"

Part Two
By John H. Potts

head expense were \$1.28 per hour, we find that this dealer would have covered his cost plus a few cents profit on what is usually a loss-producing service.

"Bait" Ads Hurt

There is a wide discrepancy between the price which the average set owner feels he should pay and the price that the serviceman must charge if he is to make a profit on a call. Advertising which tends to give the impression that a serviceman can call and make tests and repairs for 50 cents serves to lower the value of his services in the public mind. Often, therefore, when an honest and reasonable price is quoted it seems far too high to the customer. Others are called in to quote and the job may eventually be given to the one least competent. The entire service industry suffers from this waste and costs, already high, are further increased.

Those who do not get the job have lost their time and *time is money*. This loss must be retrieved on succeeding jobs, so prices are raised, and occasionally fraudulent practices result.

Increasing numbers of more intelligent servicemen avoid "loss leader" methods of attracting trade. They know, through bitter experience, that set owners are beginning to associate



RCA MANUFACTURING COMPANY, INC.
A RADIO CORPORATION OF AMERICA SUBSIDIARY
Camden, New Jersey

RCA VICTOR
DIVISION

October 27, 1936.

Mr. S. Gordon Taylor, Managing Editor,
Teck Publications, Inc.,
461 Eighth Ave.,
New York, N.Y.

Dear Mr. Taylor:

I have read with interest the advance proof of the article, "Exposing Cut-Rate Service 'Gyps'".

In making this investigation you have not only done a service to the public but, at the same time, you have done a real service to every honest, intelligent radio service man. There are a few unscrupulous service men and, until they are exposed and driven out of the business, radio servicing will continue to be under suspicion by the public.

In your crusade against racketeers in the radio service business you will undoubtedly have the aggressive support of manufacturers, distributors and service men.

Very sincerely yours,



T. H. Jones

TFJ:emk

bargain offers with unreliability and that successful *radio service must be based on confidence*. Manufacturers such as RCA and Philco offer their cooperation with sound plans based on a \$1.50 or \$2.00 minimum service charge. These afford progressive servicemen an opportunity to free themselves of the stigma

of most "cut-price" radio services. Many of outstanding ability have long since stepped out of the rank and file and maintain minimum charges of \$3.00 or more. It is interesting to note that the average price per job, \$3.81, of the eight test cases described this month and last (*Turn to page 446*)

New Circuit For VOLUME Expansion

By J. P. Hollister

IN phonograph recording it is necessary to keep the volume range within certain prescribed limits. If the sound to be recorded is too loud, the record groove will break down; if too weak, surface noise will mar reproduction. When the musical selection has extreme contrasts of pianissimo and fortissimo the volume range is compressed during recording with the result that some of the dramatic force is lost and the reproduction lacks some of the vitality of the original. This also occurs in symphonic and other broadcasting, often to an objectionable degree.

The purpose of the volume expander is to restore these dramatic contrasts which have been subdued in recording and broad-

casting. Early designs were rather critical in adjustment and also introduced some harmonic distortion. The new circuit, shown in Figure 1 is the latest improved type recently introduced by RCA and described and demonstrated before the Radio Club of America in October, 1936. With the expander, the record reproduction

acquired a startling orchestral brilliance which was lacking when played in the usual manner without a volume expander.

Referring to Figure 1, the signal is picked up from the volume control R4 and fed to the 6L7, thence to the remainder of the audio channel in the usual manner. (*Turn to page 444*)

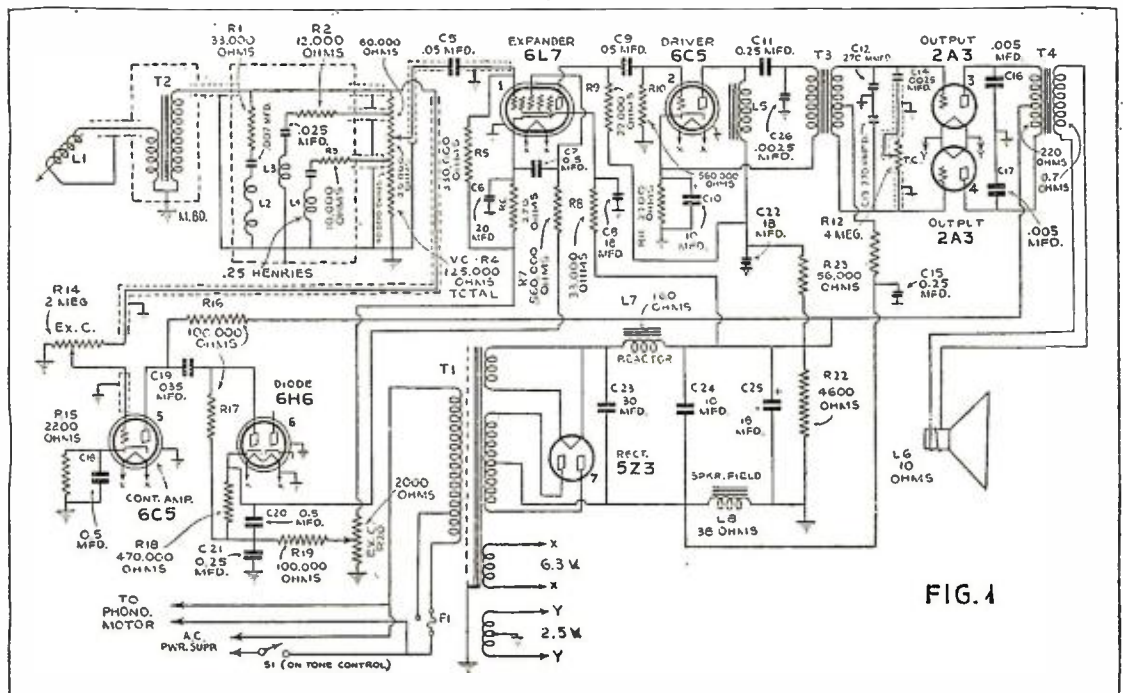

Foolproof PHASE INVERSION

for Push-Pull Circuits

By John M. Borst

THE requirements of a good phase inversion circuit are: the amplified signals must be equal in amplitude and 180 degrees out of phase at one grid with respect to the other. These requirements must be fulfilled at all frequencies.

The popular circuits may be divided into three groups each of them employing a different principle, and there are slight variations in the application of each of these types. Figure 1 shows the first type. In this case an extra tube, VT2, is employed to generate the out-of-phase signal. The signal voltage in the plate circuit of a tube is 180 degrees out of phase with the signal voltage applied to its grid. By taking a part of the signal across R1 (as at the junction of R2 and R3 of Figure 1) and amplifying it, a second signal voltage can be generated 180 degrees out of phase with

the first. Obviously, the ratio $\frac{R2 + R3}{R3}$

should be equal to the amplification in tube VT2, so as to make the voltage across R4 equal to that across R2+R3. As long as the resistance values do not change and the amplification of the tube VT2 does not change, the two voltages remain equal. It will be seen, however, that due to the presence of condenser C2, there is a small phase shift which varies with frequency. Therefore, this system would not permit perfect inversion even if working at its best. The phase shift due to condenser C2 amounts to a maximum of 6 degrees at 30 cycles when C2 is .1 mfd. and R4 is 1/2 meg.

It is possible to eliminate the error

due to phase shift by taking the grid voltage for VT2 from a voltage divider (R5-R6) in the plate circuit of VT1. The values of R5 and R6 should be high (several megohms total). The grid of VT2 will then be positive so it becomes necessary to increase the cathode resistor of VT2 in order to re-establish proper bias. This improvement was suggested and first tried by Gerard J. Kelley.

Single Tube Circuit

A second circuit which has enjoyed wide popularity, utilizes the out-of-phase voltages developed in cathode and plate circuits of an amplifier tube. If the plate load is divided equally between the plate and cathode resistor, two voltages of equal amplitude and opposite phase can be obtained. These two voltages are exactly opposite in phase and equal in amplitude, changes in the tube-characteristics will not affect this balance. There is, however, a fly in the ointment. In order to obtain the proper bias, the cathode resistor can be tapped and the grid returned to the tap. Figure 2 illustrates this method.

What Is Perfect Phase Inversion?

AN effective phase-inversion system permits the economy and excellent frequency response of resistance coupling to be applied to push-pull circuits. This article explains why some of the popular phase-inversion circuits fall short of the ideal, what can be done about it, and how to test for perfect inversion.

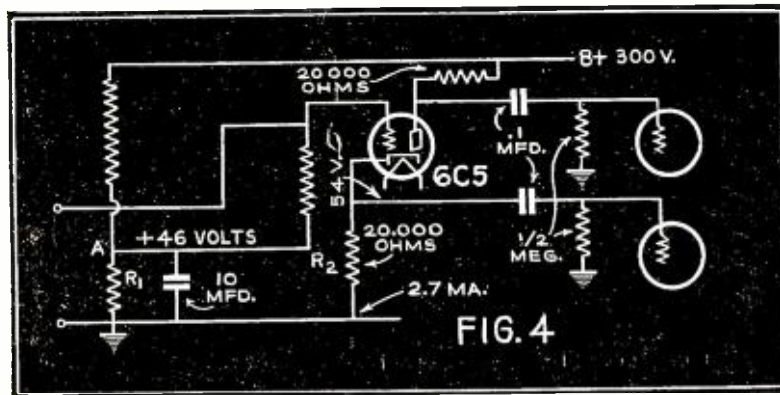

R1 and R2 should be equal and R3 should be by-passed so as to have negligible a.c. impedance. Now the input circuit must be isolated from ground and this is what causes the difficulty. Supposing the input device is a phonograph pick-up, it will have some capacity to ground (shown in dotted lines) which shifts the phase and reduces the amplitude of one side at high frequencies. Therefore, this type is more suitable for input circuits with small capacities to ground. It may best be used with a diode detector when the entire tuned circuit is isolated from ground.

An improved version of this circuit, for use with a diode detector, was supplied by RCA engineers. It is shown in Figure 3. This circuit will drive 6F6, 6L6 or 6B5 tubes in Class A and Class AB1 circuits.

In order to do away with the objection of Figure 2, several designers have found ways to return the grid circuit to ground but with a sacrifice of gain in the tube. One solution is shown in Figure 4, this circuit was suggested by Richter in Electronics, October 1935. The grid is returned to a point on a voltage divider, so as to place the correct bias on the tube. In other words, the voltage drop across R1 is equal to the drop across R2 minus the required bias. R2 is equal to R3 and the sum of the two constitutes the plate load. Now the point A can be by-passed to ground and the signal impressed between grid and ground.

Degeneration

This circuit works with degeneration, or, any signal developed across R2 is re-applied to the grid in opposite phase to the original signal (subtracting from the input signal), consequently, the output signal cannot be greater than the input signal and (Turn to page 439)

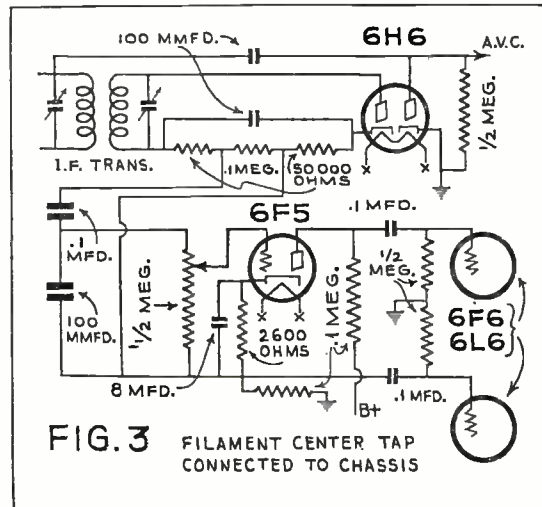
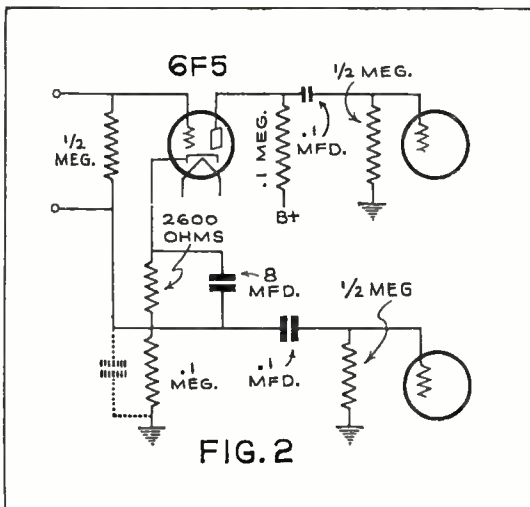
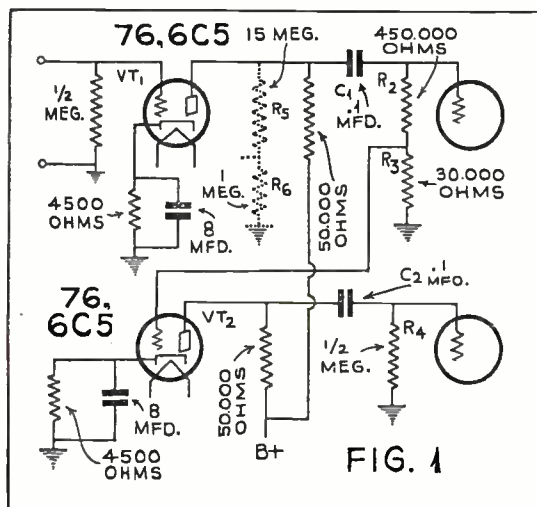

The RADIO Beginner

The earlier articles of this series acquainted the reader with the theory of operation of detectors, amplifiers and power supplies, and with the actual construction of typical equipment. We now proceed to a study of more advanced receivers and an introduction to the practical fundamentals of the tuned-radio-frequency and superheterodyne types.

Part 8—T.R.F. and Superhets By The Technical Editor

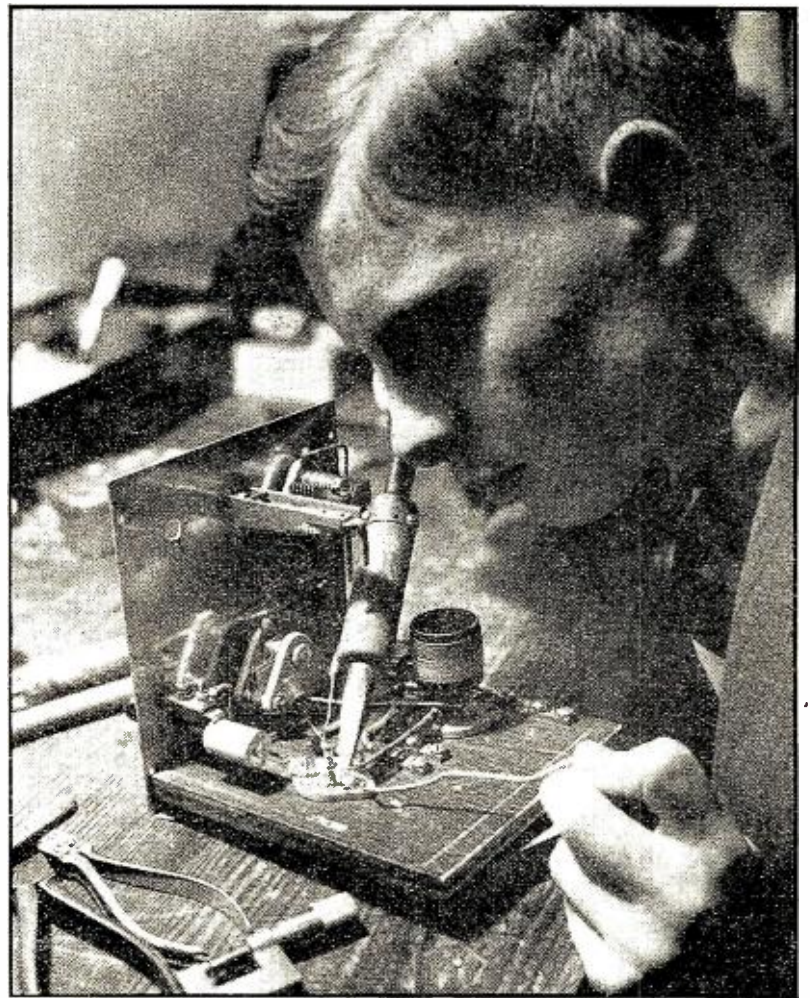

THE tuned radio-frequency receiver, also referred to as the t.r.f. type, consists of a radio-frequency amplifier, a detector and an audio amplifier. The all-wave receiver, which was described in this series for the last two issues, was a tuned radio-frequency receiver. However, modern t.r.f. receivers usually cover the broadcast band only, seldom employ regeneration, and include two or more tuned stages with all stages tuned by a single control knob. This means that all stages must be made sufficiently alike electrically so that they will be in tune with the signal and with each other at every position of the dial.

This involves some complications since it requires that the condensers, coils and capacities between wires be exactly alike. There is bound to be some difference, however, and even though there are small trimmer condensers to compensate for such differ-

ences it is usually not possible to have the set exactly in line at all frequencies throughout the range. Therefore, at points where the circuits are not in line, the selectivity and the sensitivity will suffer.

It is a characteristic of radio circuits that the selectivity varies with the resonant frequency. For instance, if a circuit has a selectivity of 10 kc. when it is tuned to 500 kc., this selectivity is likely to be 20 kc. when that same circuit is tuned to 1,000 kc. So we see that a tuned-radio-frequency receiver varies in selectivity over the band. Some form of compensation is usually employed which partially offsets these variations. Similarly, the sensitivity varies with frequency. Compensating methods are again employed but it is uneconomical to try to obtain even sensitivity and selectivity all over the range.

Another difficulty in the design of tuned-radio-frequency receivers is the avoidance of undesired oscillations. There is always some coupling between

the leads of the input and output circuits which results in a tendency toward "feedback" or regeneration. This regeneration again is a function of frequency and becomes worse at high frequencies. The tuned-radio-frequency receiver, therefore, is limited to relatively low sensitivity (unless unusual pains are taken in the design) with a proportionate increase in design and production costs.

The Superheterodyne

The superheterodyne differs from other receivers in that it changes the signal frequency to another frequency which is fixed for that particular receiver. Thereafter, the signal is amplified in an "intermediate-frequency amplifier" which is tuned to a fixed frequency and is never changed by the listener.

This process is illustrated by the block diagram in Figure 1, which is a diagram of a typical superheterodyne receiver. The signal comes in at the antenna and first (Turn to page 442)

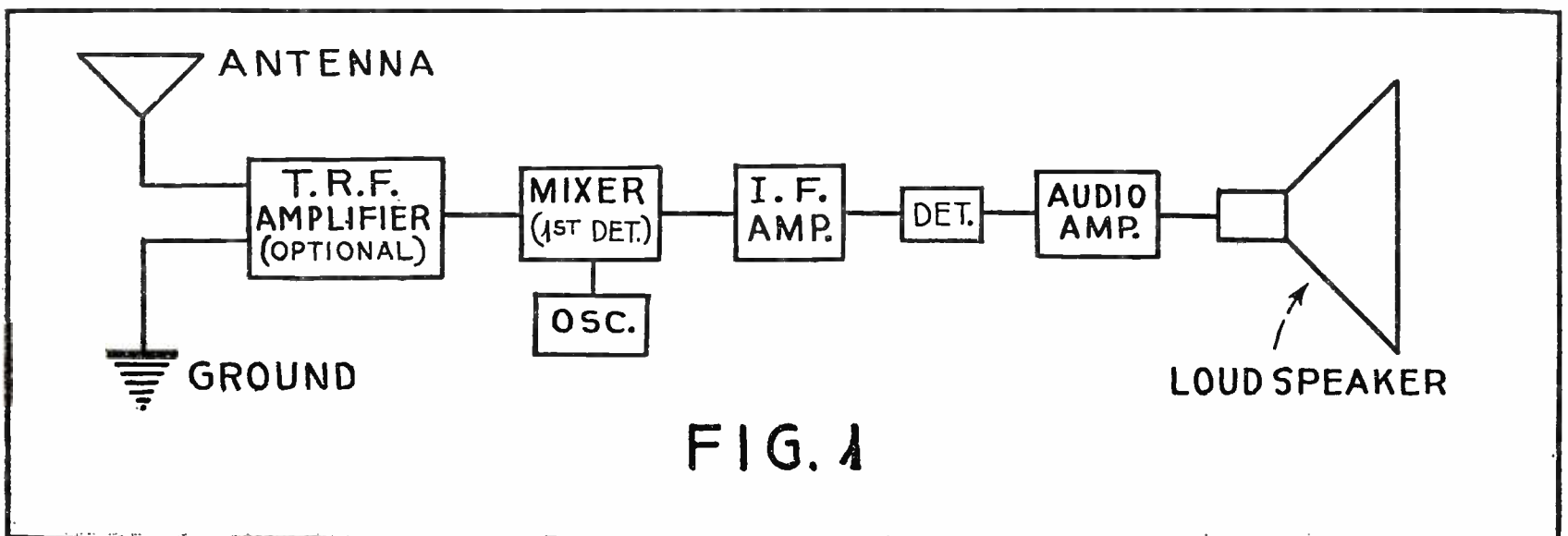

FIG. 1



THE DX CORNER

S. GORDON TAYLOR
(For Broadcast Waves)

DX Calendar

Below are given lists of special DX broadcasts which are scheduled for December and January. The initials following an item indicate the organization to which the program is dedicated and where a RADIO NEWS special has been arranged for by an Observer, his name is given in the schedule.

Don't fail to tune in the RADIO NEWS specials on this list and as many others as possible—and above all, don't fail to report to each station tuned in, giving them as much information as you can concerning their signal strength, fading, quality, etc. Where verifications are desired it is always desirable to enclose return postage.

Hours shown are Eastern Standard Time and are all a.m. unless otherwise indicated.

Day	Hour	Kc.	Call	State	Kw.	Club
DECEMBER						
2	2:30-3	1370	WHBQ	Tenn.	.1	NNRC
3	2-3	1160	CMHJ	Cuba	.2	
5	3-4	1120	KRKC	Calif.	.5	R. News
6	2-3	980	TI4NRH	Costa Rica		NNRC
7	5:30-6	1210	KFXM	Calif.	.1	NNRC
10	5:5-20	1310	WRAW	Penna.	.1	NRC
16	2:30-3	1310	WTRC	Ind.	.25	CDXR
16	5:30-6	1370	WHBQ	Tenn.	.1	NNRC
17	5-6	1350	WAWZ	N. J.	.5	NNRC
17	5-6	1160	CMHJ	Cuba	.2	
19	2:30-3:30	1360	KGER	Calif.	1	UDXC
19	3-4	570	KVI	Wash.	1	UDXC
19	3:30-4:30	1370	KVL	Wash.	.1	UDXC
19	4:30-5:30	1370	KRE	Calif.	.1	UDXC
20	1-3	1300	WHAZ	N. Y.	.5	ICCP
20	2:30-3:30	580	KMJ	Calif.	.5	UDXC
20	3-4	760	KXA	Wash.	.25	UDXC
20	3:30-4:00	1010	CKWX	B. C.	.1	UDXC
20	3:30-4:30	1410	CKMO	B. C.	.1	UDXC
20	4-5	930	KROW	Calif.	1	UDXC
20	4:30-5:30	710	KMPC	Calif.	.5	UDXC
22	1-2:30	620	CT1AA	Portugal	20	IDA
23	2:30-3	1370	WHBQ	Tenn.	.1	NNRC
26	3-4	1370	KFRO	Texas	.1	NNRC
26	6-7	1310	WTRC	Ind.	.1	NRC
27	2-5	930	CFLC	Ont.	.1	NRC
30	2:30-3	1370	WHBQ	Tenn.	.1	NNRC
30	3-4	1400	KHBC	Hawaii	.25	NNRC
JANUARY						
2	2-2:30	1370	WGL	Ind.	.1	NNRC
2	3-3:30	1370	KFRO	Texas	.1	NNRC
2	3:30-4	1370	WFOR	Miss.	.1	NNRC
2	4-4:30	1370	KTEM	Texas	.1	NNRC
2	4:30-5:30	1370	KVL	Wash.	.1	NNRC
3	2-3	980	TI4NRH	Costa Rica		NNRC
5	1-1:30	668	Jerusalem	Palestine	20	IDA
7	2-3	1160	CMHJ	Cuba	.25	
14	5-5:20	1310	WTRC	Ind.	.25	NNRC
15	1-1:30	668	Jerusalem	Palestine	20	IDA
16	2:30-3	1370	WRJN	Wisc.	.1	NNRC
16	3-4	1370	KGKL	Texas	.1	NNRC
16	4-5	1370	KFQG	Iowa		NNRC
17	3-5	1300	WHAZ	N. Y.	.5	ICCP
21	5-6	1160	CMHJ	Cuba	.2	
23	3-4	1370	KFRO	Texas	.1	NNRC
23	3:30-4	1310	WEXL	Mich.	.05	NRC
23	6-7	1310	WTRC	Ind.	.1	CDXR
27	3-4	1400	KHBC	Hawaii	.25	NNRC
31	2-5	930	CFLC	Ont.	.1	NRC

Special Frequency Checks

The Commercial Radio Equipment Company of Kansas City, Missouri, offers a special precision frequency measurement service to their broadcast station clients. Everett L. Dillard of this company has forwarded the schedule of special transmissions put on regularly each month by some of these stations. These transmissions take place when the individual channels are fairly clear and therefore provide something for the DX'er to shoot at. This schedule as given by Mr. Dillard is expected to continue in force for several months, and is as follows:

E.S.T.	Call	Location	kc.	kw.
1st Monday of each month.				
1-1:15	KTSA	San Antonio, Texas	550	1.0
1st Tuesday of each month				
1-1:15	WRR	Dallas, Texas	1280	0.5
3-3:30	KIUL	Garden City, Kansas	1210	0.1
1st Wednesday of each month				
6:30-7	KWBG	Hutchinson, Kansas	1420	0.1
1st Friday of each month				
1:45-2:15	WACO	Waco, Texas	1420	0.1
1:45-2:15	KNOW	Austin, Texas	1500	0.1
1st Saturday of each month				
3:30-3:50	KASA	Elk City, Okla.	1210	0.1
2nd Friday of each month				
1:30-2:00	WJAG	Norfolk, Nebr.	1060	1.0
2:15-2:45	KPOF	Denver, Colo.	880	0.5
3rd Tuesday of each month				
1:00-1:15	WRR	Dallas, Texas	1280	0.5
3:00-3:30	KIUL	Garden City, Kansas	1210	0.1
3rd Wednesday of each month				
6:30-7:00	KWBG	Hutchinson, Kansas	1420	0.1
4th Tuesday of each month				
3:00-3:30	KIUL	Garden City, Kansas	1210	0.1
5:30-6:00	KBIX	Muskogee, Okla.	1500	0.1
Last Wednesday of each month				
5:00-5:30	WPAD	Paducah, Ky	1420	0.1
15th and 29th of each month				
6:00-6:30	KGFW	Kearney, Nebr.	1310	0.1
25th of each month				
2:45-3:15	KADA	Ada, Okla.	1200	0.1

Consolidated Foreign "Best Bets"

Following is a list of the foreign stations being heard by Official Observers in different sections of the U. S. and Canada. Wherever either an asterisk (*) or a number appears in a column it indicates that the station has been heard in the section represented by that column. The numbers represent the approximate local time when the station is heard. Heavy numbers represent p.m. and light numbers a.m.

This list is made up from Observers' reports: Column 1 (Eastern U. S.)—Observers Tomlinson, N. Y.; Forestieri, N. Y.; Truax, Ill.; Gordon, Pa.; Goss, N. Y. Column 2 (Western U. S. and Western

DX'ER
NORMAN R. LOCKWOOD
A 1937 Zenith 5-tube and a 1935 Air-King constitute the equipment of this DX Corner in Cleveland, Ohio.

Canada)—Observers Hunt, Calif; Clancy, Alberta.

(NOTE: Official Observers and other readers are invited to send in a listing of foreign stations heard each month. In doing so it will facilitate matters if stations are reported in the same form as the list below, with the frequency, call, location, and hour [your own local time] when best heard.)

Kc.	Call	Location	1	2
565	Athlone	Irish Free State	5	..
570	2YA	Wellington, N. Zealand	5	.. 3
574	Stuttgart	Germany	1	..
580	3AR	Melbourne, Australia	5	..
583	Alpes-Grenoble	France	5	..
590	XEPN	Piedras Negras, Mexico	..	9
610	2FC	Sydney, Australia	5	..
625	TIPG	San Jose, Costa Rica	10	..
638	Prague	Czechoslovakia	5	..
640	CMBC	Havana, Cuba	8	..
640	5CK	Crystal Brook, Aust'lia	5	..
648	Lyon-PTT	Lyons, France	5	..
650	1YA	Auckland, New Zealand	5	.. 3
658	Cologne	Germany	1	..
660	XGOA	Nanking, China	..	4
668	North Regional	Moorside Edge, Eng.	5	..
670	LS4	Buenos Aires, Argentina	9	..
670	2CO	Corowa, Australia	5	..
690	JOBK1	Osaka, Japan	..	4
695	Paris-PTT	France	5	..
700	2NR	Lawrence, Australia	..	5
710	7NT	Kelso, Australia	*	..
710	JODK2	Keijo, Japan	..	5
720	3YA	Christchurch, N. Z.	5	.. 3
730	JOCK1	Nagoya, Japan	..	5
740	Munich	Germany	1	..
740	2BL	Sydney, Australia	*	..
749	Marseille-PTT	France	5	..
750	KGU	Honolulu, Hawaii	1	..
767	Scottish Regional	Westerglen, Scotland	5	..
770	3LO	Melbourne, Australia	5	..
770	JOHK	Sandai, Japan	..	3
776	Toulouse-PTT	France	6	..
780	JOPK	Shizuoka, Japan	..	5
785	Leipzig	Germany	6	..
790	4YA	Dunedin, New Zealand	5	.. 3
790	JOGK	Kumamoto, Japan	..	3
795	EAJ1	Barcelona, Spain	6	..
800	4QG	Brisbane, Australia	5	..
804	West Regional	Cardiff, Wales	6	..
810	JOIK	Sapporo, Japan	..	3
814	IMI	Milan, Italy	5	..
830	LR5	Buenos Aires, Argentina	8	..
830	3GI	Sale, Australia	5	..
830	JOJK	Hiroshima, Japan	..	3
840	VOGY	St. John's, Newf'nd'l'nd	5	..
840	XERA	Villa Acuna, Mexico	..	6
859	Radio-Strasbourg	France	2	..
860	XEMO	Tijuana, Mexico	..	7
870	LR6	Buenos Aires, Argentina	8	..
870	2GB	Sydney, Australia	5	..

THE MIGRATORY L. P. O.

The Listening Post in Kansas where Dudley Atkins III formerly carried on. He is now attending the University of California and will continue his DX activities from Los Angeles.

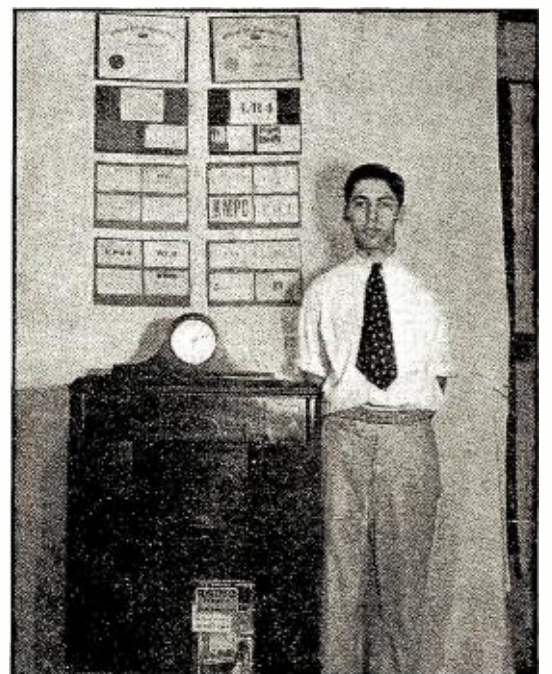

877	London Regional	Brookman's Park, Eng.	5	..
880	CMQ	Havana, Cuba	8	..
886	Linz	Austria	6	..
890	XEW	Mexico City, Mexico	8	..
904	Hamburg	Germany	6	..
910	XENT	Nuevo Laredo, Mexico	8	..
913	HHK	Port-au-Prince, Haiti	9	..
913	Radio-Toulouse	France	6	..
940	JOBK2	Osaka, Japan	3	..
950	LR3	Buenos Aires, Argentina	8	..
960	XEAW	Reynosa, Mexico	11	..
970	JODK1	Keijo, Japan	5	..
977	N.IrelandRegional	Belfast, Ireland	6	..
980	TI4NRH	Heredia, Costa Rica	8	..
980	JOXK	Tokushima, Japan	5	..
990	LR4	Buenos Aires, Argentina	8	..
990	2GZ	Orange, Australia	5	..
990	JOCK2	Negoya, Japan	3	..
995	PX1	Hilversum, Holland	6	..
1022	EAJ15	Barcelona, Spain	5	..
1040	Rennes	France	1	..
1050	CX26	Montevideo, Uruguay	7	..
1060	HJ1ABE	Bogota, Colombia	9	..
1070	LR1	Buenos Aires, Argentina	8	..
1077	Bordeaux-Lafayette	France	5	..
1095	EAJ7	Madrid, Spain	5	..
1110	XELO	Piedras Negras, Mexico	5	..
1110	2UW	Sydney, Australia	5	..
1113	Radio-Normandie	Fecamp, France	6	..
1120	4BC	Brisbane, Australia	5	..
1140	11TO	Turin, Italy	1	..
1150	LR8	Buenos Aires, Argentina	8	..
1155	Nice-Cote d'Azur	France	5	..
1190	LS2	Buenos Aires, Argentina	3	..
1195	Frankfort	Germany	5	..
1213	Lille-PTT	France	5	..
1220	4AK	Oakcy, Australia	5	..
1222	11BO	Bologna, Italy	5	..
1230	LS8	Buenos Aires, Argentina	9	..
1230	2NC	Newcastle, Australia	5	..
1240	LU7	Bahia Blanca, Argentina	9	..
1267	Nurnburg	Germany	6	..
1270	2SM	Sydney, Australia	5	..
1276	Juan-les-Pins	France	6	..
1290	4BK	Brisbane, Australia	5	..
1320	KGMB	Honolulu, Hawaii	2	..
1366	Radio-l'ile de France	Paris, France	7	..
1380	CB:38	Santiago, Chile	9	..
1380	4BH	Brisbane, Australia	5	..
1393	Radio-Lyon	France	6	..
1400	KHBC	Honolulu, Hawaii	3	..

European Operating Schedules

The following tabulation was prepared and submitted by Observer Charles E. Pellatt of England and will be of wide interest to DX'ers who try for European stations. All hours are given in Greenwich Mean Time. The a.m. hours are 0 to 12 and p.m. hours 12 to 24. Greenwich Time is 5 hours ahead of Eastern Standard Time with the result that 1:00 G.M.T. is 6:00 a.m. in Eastern Standard Time; 7:00 a.m., C.S.T.; 8 a.m., M.S.T. and 9:00 a.m., P.S.T. Hours shown in bold type indicate that they are subject to change from day to day

Observer Pellatt has obtained this data direct from the stations or other reliable

L. P. O. HARRY M. GORDON

An active DX'er of Erie, Pa., who writes: "You can quote me as saying that the Radio News 'Tena-tuner' can't be beaten for increasing signals on the broadcast band. I have built 3 of them and all of them do the job."

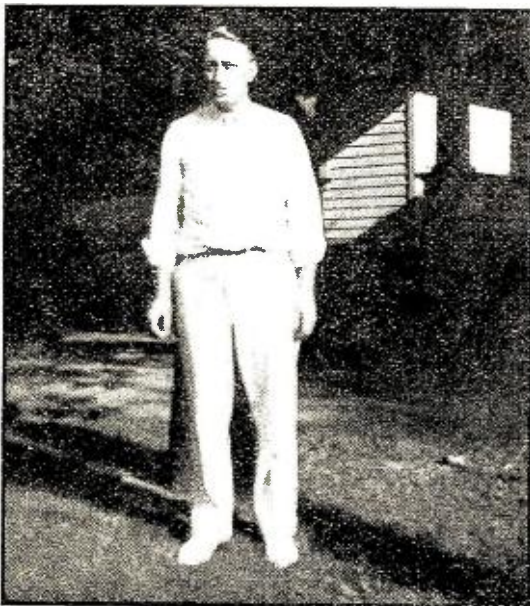

sources—a task which involved a great expenditure of time and effort on his part. The editor is taking this occasion to extend his sincere thanks and feels sure that DX readers will join him in this. If you want to write your appreciation direct, Observer Pellatt's address is 5 Brackley Street, Golden Lane, London, E.C.1., England.

Station	Kc.	Kw.	Weekdays	Sundays
Budapest 1	544	120	10.20-00.15	08.30-00.15
Beromunster	556	100	12.00-22.00 (Sat. 23.00)	09.30-23.00
Athlone	565	60	13.30-23.00	12.30-23.30
Palermo	565	3	12.15-24.00	10.00-24.00
Stuttgart	574	100	05.45-02.00	06.00-02.00
Alpes Gren.	583	15	06.50-22.45	06.50-22.45
Riga	583	15	05.55-22.10	08.00-23.00
Vienna	592	120	07.00-01.00	08.00-01.00
Sundsvall	601	10	07.45-23.00	09.30-23.00
Rabat	601	25		
Florence	610	20	07.30-23.45	08.30-23.30
Brussels 1	619	15	11.55-23.00 (Sat. 24.00)	06.37-24.00
Lisbon	629	20	12.00-24.00	12.00-24.00
T.ondelag	629	20	11.30-22.47	10.00-23.00
Prague 1	638	120	06.30-23.00	06.30-23.00
Lyons	648	100	06.50-23.00	06.50-23.00
Cologne	658	100	05.45-24.00	06.00-24.00
Sottens	677	100	12.29-23.00	09.55-22.30
Belgrade	686	2.5	12.00-23.30	09.20-23.30
Paris PTT	695	120	06.50-22.45	06.50-24.00
Stockholm	704	55	07.45-23.00	09.30-23.00
Rome	713	50	07.30-23.30	08.30-24.00
Seville	731	1.5	09.15-01.00 (Mon. 14.00-01.00)	09.30-01.00
Tallinn	731	20	06.00-22.00	07.30-22.00
Munich	740	100	06.00-24.00	06.00-24.00
Marseilles	749	1.6	07.45-22.45	07.00-01.15
Katowice	758	12	06.30-23.00	06.30-24.00
Fredriksstad	776	1	See Oslo	
Toulouse	776	1.2	06.50-00.15	06.50-24.00
Leipzig	785	120	05.50-24.00	06.00-24.00
Lwow	796	16	06.30-23.30	08.20-23.30
Barcelona	795	7.5	08.15-01.15 (Mon. fm 12.00)	08.15-01.00
Milan 1	814	50	07.30-23.45	08.30-23.30
Bucharest	823	12	05.30-24.00	06.30-23.00
Agen	832	0.5	11.55-22.00	11.55-22.00
Moscow	832	100	15.00-22.30	15.00-22.30
Berlin	841	100	06.00-24.00 (Sat. till 01.00)	6.00-01.00
Bergen	850	1	See Oslo	
Porggrund	850	1	See Oslo	
Sofia	850	1		
Valencia	850	3		
Strasbourg	859	100	06.00-?	07.00-24.00
Poznan	868	16	06.00-23.00	08.00-23.00
Graz	886	7.5	07.00-01.00	08.00-01.00
Helsinki	895	10	07.05-22.00	08.30-23.00
Linnoges	895	1	06.50-22.45	06.50-24.00
Hamburg	904	100	05.45-24.00 (Sat. 01.00)	06.00-12.00
Toulouse	913	60	08.00-00.30	11.00-00.45
Brno	922	32	06.30-23.00	06.30-23.30
Brussels 2	931	15	11.57-23.00 (Sat. 24.00)	06.37-24.00

(Pigeon racing notes from 05.00 Sats. & Suns.)

Algiers	941	12	07.00-24.00	07.00-23.00
Goteborg	941	10	See Stockholm	
Poste Parisien	959	60	07.10-23.00	07.50-23.00
Breslau	950	100	05.00-24.00	05.00-24.00
Odessa	968	10		
Genoa	986	10	07.30-23.45	08.30-23.30
Hilversum	995	60	07.40-23.30	08.10-22.40
Bratislava	1004	13	06.00-23.00	06.30-23.00
Kraecow	1022	2	06.00-23.00	08.00-23.00
Konigsberg	1031	100	05.40-24.00	06.00-24.00
Rennes	1040	40	06.50-22.45 (Fri. 00.45)	
Bari 1	1059	20	07.30-23.45	08.30-23.30
Paris	1068	?	07.00-22.00	08.30-00.30
Bordeaux-Laf.	1077	13	08.00-00.45	08.00-00.45
Zagreb	1086	0.7	11.00-22.15	10.00-22.45
Madrid	1095	3	09.00-01.00 (Mon. 14.00)	09.00-01.00
Madona	1104	50	Relays Riga 05.55-22.10	08.00-23.00
Naples	1104	1.5	07.30-23.45	08.30-23.30
Moravska Os.	1113	11	06.00-23.00	06.30-23.30
Radio Norm.	1113	15	07.00-01.00	07.00-01.00
Nyiregyhaza	1122	6.2	10.20-00.15	08.30-00.15
Hojby	1131	10	07.45-23.00	09.30-23.00
Tu. in 1	1140	10	07.30-23.45	08.30-23.30
Kosice	1158	10	06.00-23.00	06.30-23.30
Copenhagen	1176	10	07.00-24.00	08.00-24.00
Monte Ceneri	1167	15	12.00-22.30	11.00-22.30
Frankfurt	1195	25	06.00-02.00	06.00-02.00
Cassel	1195	25	06.00-02.00	06.00-02.00
Freiburg	1195	25	06.00-02.00	06.00-02.00
Coblentz	1195	25	06.00-02.00	06.00-02.00
Trier	1195	25	06.00-02.00	06.00-02.00
Prague 2	1204	5	07.30-16.00	14.30-16.30
Lille	1213	5	06.50-22.45	06.50-22.45
Gleiwitz	1231	5	05.00-24.00	05.00-24.00
Cork	1237	1	13.30-23.00	12.30-23.30
Kuldiga	1258	10	05.55-22.10	08.00-23.00
Rome	1258	1	07.30-23.45	08.30-23.30
San Sebastian	1258	1		
Nurnberg	1267	2	06.00-24.00	06.00-24.00
Christiansand	1276	0.5	11.30-22.45	10.00-23.00
Cote d'Azur	1276	0.8	12.15-?	12.15-23.00
Dresden	1285	.25	05.50-24.00	06.00-24.00
Klagenfurt	1294	5	07.00-01.00	08.00-01.00
Vorarlberg	1294	2	12.00-14.00 (Sun. & Hcl.	08.55)
Danzig	1303	0.5	05.40-24.00	06.00-24.00
Malmo	1312	2.5	07.45-23.00	09.30-23.00



L. P. O. EDWARD F. GOSS

Working under the handicap of city noise conditions, in Brooklyn, New York, he manages to pull in his share of TA's, SA's and TP's with his Scott "Imperial."

Station	Kc.	Kw.	Weekdays	Sundays
Bremen	1330	2	05.45-24.00 (Sat. 01.00)	06.00-12.00
r lensburg	1330	2	05.45-24.00 (Sat. 01.00)	06.00-12.00
Hanover	1330	2	05.45-24.00 (Sat. 01.00)	06.00-12.00
Magdeburg	1330	0.5	05.45-24.00 (Sat. 01.00)	06.00-12.00
Stettin	1330	2	05.45-24.00 (Sat. 01.00)	06.00-12.00
Montpelier	1339	5	06.50-22.45 (Relays PTT)	06.50-24.00
Dublin	1348	0.5	13.30-23.00	12.30-23.30
Rjukan	1348	.15	11.30-22.45	10.00-23.00
Salzburg	1348	2	07.00-01.00	08.00-01.00
Bari 2	1357	1	07.30-23.30	08.30-24.00
Turin 2	1357	0.2	07.30-23.30	08.30-24.00
Milan 2	1357	4	07.30-23.30	08.30-24.00
Basle	1375	0.5	12.00-22.00 (Sat. 23.00)	09.30-23.00
Berne	1375	0.5	See Basle	
Miskolc	1438	1.2	See Budapest, 550 kc.	
Eiffel Tower	1456	7	08.00-22.00	08.00-22.00

Pacific Coast DX Frolic

Word comes from the Universal DX Club of a frolic to take place the mornings of December 19th and the 20th. At the time of going to press, all arrangements were not completed, but the cooperation of at least ten stations, as listed in the DX Calendar in this department, is assured. KSFO, KGW and KEX will also definitely participate but have not as yet decided upon the time. The above information was submitted by A. J. Stansfield, president of the club.

WLAC Tips Broadcast

Cappie Hadley sends word that he has resumed the regular weekly DX news periods over WLAC, beginning Sunday morning, November 8, 12:45-1:00 a.m., and continuing each Sunday morning thereafter at the same hour. This station operates on 1470 kc. with a power of 5 kw.

Special from Radio Jerusalem

Radio Jerusalem, 668 kc., 20 kw., is dedicating two special program to the International DX'ers Alliance. These broadcasts will take place on January 5 and 15, 1:00-1:30 a.m. Observer Tomlinson, who submits this information, also states that special verification cards are being prepared for these occasions and that the first DX'er to report from each country will receive a special gift from the Palestine representative of the IDA. All reports should be addressed: Mr. Brasher, Chief Engineer (Turn to page 434)

BROADCASTING STATIONS IN THE U.S.

Alphabetically by Call Letters, Location, Frequency and Power

Compiled by John M. Borst

K.S.W.

Call	Location	Kc.	Kw.	Call	Location	Kc.	Kw.	Call	Location	Kc.	Kw.
KABC	San Antonio, Texas	1420	1-25	KGHL	*Billings, Mont. (5-day)	780	1-2.5	KROA	Santa Fe, N. Mex.	1310	.1
KABR	Aberdeen, S. Dak.	1420	.1	KGIR	Butte, Mont.	1340	1-2.5	KRRV	Sherman, Texas (C.P.)	1310	.1
KADA	Ada, Okla.	1200	.1	KGIW	Alamosa, Colo.	1420	.1	KRSC	*Seattle, Wash. (.25 kw.)	1120	.1
KALB	Alexandria, La.	1420	.1	KGKB	Tyler, Texas	1500	.1	KSAC	Manhattan, Kans.	580	.5-1
KALE	Portland, Ore.	1300	.5	KGKL	San Angelo, Texas	1370	1-25	KSCJ	Sioux City, Iowa	1330	1-2.5
KANS	Wichita, Kans.	1210	.1	KGKO	Wichita Falls, Texas	570	.25-1	KSD	St. Louis, Mo.	550	1-5
KARK	*Little Rock, Ark. (.5-1.0)	890	.25-5	KGKY	Scottsbluff, Nebr.	1500	1-25	KSEI	Pocatello, Idaho	900	.25-5
KASA	Elk City, Okla.	1210	.1	KGLO	Mason City, Iowa (C.P.)	1210	.1	KSFO	San Francisco, Calif.	560	1
KAST	Astoria, Ore.	1370	.1	KGMB	Honolulu, Hawaii	1320	.25-1	KSJS	Salina, Kans. (C.P.)	1500	.1
KBIX	Muskogee, Okla.	1500	.1	KGNC	Amarillo, Texas	1410	1-2.5	KSL	Salt Lake City, Utah	1130	50
KBPS	Portland, Ore.	1420	.1	KGNF	North Platte, Nebr.	1430	1	KSLM	Salem, Ore.	1370	.1
KBST	Big Spring, Texas (C.P.)	1500	.1	KGNO	Dodge City, Kans.	1340	.25	KSO	Des Moines, Iowa	1430	.5-1
KBTM	Jonesboro, Ark.	1200	.1	KGO	San Francisco, Calif.	790	7.5	KSOO	Sioux Falls, S. Dak.	1110	2.5
KCMC	Texarkana, Ark.	1420	.1	KGSS	Sioux Falls, S. Dak. (C.P.)	1200	.1	KSTP	St. Paul, Minn.	1460	10-25
KCMO	Kansas City, Mo.	1370	.1	KGU	Honolulu, Hawaii	750	2.5	KSNU	*Lowell, Ariz. (.25-day)	1200	.1
KCRC	Enid, Okla.	1360	.25	KGVO	Missoula, Mont.	1260	1	KTAR	Phoenix, Ariz.	620	1
KCRJ	Jerome, Ariz.	1310	.1	KGW	Portland, Ore.	620	1-5	KTAT	Fort Worth, Texas	1240	1
KDB	Santa Barbara, Calif.	1500	.1	KGW	Portland, Ore.	620	1-5	KTBS	Shreveport, La.	1450	1
KDFN	Casper, Wyo.	1440	.5	KGX	Olympia, Wash.	1210	.1	KTEM	Temple, Texas (C.P.)	1370	.1
KDKA	Pittsburgh, Pa.	980	50	KHBC	Hilo, Hawaii	1400	.25	KTFI	**Twin Falls, Idaho (1 kw.-night, Exp.)	1240	.5-1
KDLR	Devils Lake, N. Dak.	1210	.1	KHJ	Los Angeles, Calif.	900	1-5	KTHS	**Hot Springs National Park, Ark. (1060kc.-night, Exp.)	1040	10
KDNC	Lewistown, Mont. (C.P.)	1200	1-25	KHJ	Los Angeles, Calif.	900	1-5	KTRB	Modesto, Calif.	740	.25
KDON	Del Monte, Calif.	1210	.1	KHSL	*Spokane, Wash. (5-day)	590	1-2	KTRH	Houston, Texas	1290	1-5
KDYL	Salt Lake City, Utah	1290	1	KHUB	Chico, Calif.	950	.25	KTSA	San Antonio, Texas	550	1-5
KECA	Los Angeles, Calif.	1430	1-5	KICA	Watsonville, Cal. (C.P.)	1310	.25	KTSM	El Paso, Texas	1310	.1
KEHE	*Los Angeles, Calif. (1-5)	780	.5-1	KID	Clovis, N. Mex.	1370	.1	KTUL	Tulsa, Okla.	1400	.5-1
KELD	N. Eldorado, Ark.	1370	.1	KIDW	*Idaho Falls, Idaho (.5-1)	1320	.25-5	KTW	Seattle, Wash.	1220	1
KELW	Burbank, Calif.	780	.5	KIDW	Boise, Idaho	1350	1-2.5	KUJ	Walla Walla, Wash.	1370	.1
KERN	Bakersfield, Calif.	1370	.1	KIEM	Lamar, Colo.	1420	.1	KUMA	Yuma, Ariz.	1420	.1
KEUB	Price, Utah (C.P.)	1420	.1	KIEM	Eureka, Calif.	1450	.5	KUOA	*Siloam Springs, Ark. (2.5 Kw.)	1260	1
KEX	Portland, Ore.	1180	5	KIEV	Glendale, Calif.	850	1-25	KUSD	Vermillion, S. Dak.	890	.5
KFAB	Lincoln, Nebr.	770	10	KINY	Juneau, Alaska	1310	.1	KUTA	Salt Lake City, Utah (C.P.)	1500	.1
KFAC	Los Angeles, Calif.	1300	1	KIRO	**Seattle, Wash. (710 kc., 1 kw., Exp.)	650	.25	KVCV	Redding, Calif. (C.P.)	1200	.1
KFBB	Great Falls, Mont.	1280	1-2.5	KIT	Yakima, Wash.	1310	1-25	KVEC	San Luis Obispo, Calif. (C.P.)	1200	.25
KFBI	Abilene, Kans.	1050	5	KIUL	Garden City, Kans.	1210	.1	KVI	*Tacoma, Wash. (5-day)	570	1
KFBK	Sacramento, Calif.	1490	5	KIUN	Pecos, Texas	1420	.1	KVL	Seattle, Wash.	1370	.1
KFDM	Beaumont, Texas	560	.5-1	KIUP	Durango, Colo.	1370	.1	KVOA	*Tucson, Ariz. (1 kw.)	1260	.5
KFDY	Brookings, S. Dak.	780	1	KJBS	San Francisco, Calif.	1070	.5	KVOE	Denver, Colo.	920	.5
KFEL	Denver, Colo.	920	.5	KJR	Seattle, Wash.	970	5	KVOF	Santa Ana, Calif.	1500	.1
KFEQ	St. Joseph, Mo.	680	2.5	KLAH	Carsbad, N. Mex. (C.P.)	1210	.1	KVOL	Lafayette, La.	1310	.1
KFGO	Boone, Iowa	1370	.1	KLCN	Blytheville, Ark.	1290	.1	KVOR	Tulsa, Okla.	1140	25
KFHF	Wichita, Kans.	1300	1-5	KLO	Ogden, Utah	1400	.5	KVSC	Colorado Springs, Colo.	1270	1
KFII	Los Angeles, Calif.	640	50	KLPM	Minot, N. Dak.	1240	.25	KVSO	Bellingham, Wash.	1200	.1
KFIO	Spokane, Wash.	1120	.1	KLRA	Little Rock, Ark.	1390	1-2.5	KVST	San Diego, Calif.	1200	.1
KFIZ	Fond du Lac, Wisc.	1420	.1	KLS	Oakland, Calif.	1440	.25	KVSO	Ardmore, Okla.	1210	.1
KFJB	Marshalltown, Iowa	1200	1-25	KLUF	Galveston, Texas	1370	.1	KWBG	Hutchinson, Kans.	1420	.1
KFJI	Klamath Falls, Ore.	1210	.1	KLX	Oakland, Calif.	880	1	KWG	Stockton, Calif.	1200	.1
KFJM	*Grand Forks, N. Dak. (1410 kc., .5-1)	1370	.1	KLZ	Denver, Colo.	560	1-5	KWJJ	**Portland, Ore. (1040 kc.)	1060	.5
KFJR	Portland, Ore.	1300	.5	KMA	Shenandoah, Iowa	930	1-2.5	KWK	St. Louis, Mo.	1350	1-5
KFJZ	Fort Worth, Texas	1370	1-25	KMAC	San Antonio, Texas	1370	.1	KWKH	**Shreveport, La. (1100 kc., Exp.)	850	10
KFKA	Greeley, Colo.	880	.5-1	KMED	Kansas City, Mo.	950	1-5	KWLC	Decorah, Iowa	1270	.1
KFKU	Lawrence, Kans.	1220	1-5	KMFD	Medford, Ore.	1410	.25	KWSC	Pullman, Wash.	1220	1-2
KFNF	Shenandoah, Iowa	890	.5-1	KMJ	Fresno, Calif.	580	.5-1	KWTN	Watertown, S. Dak.	1210	.1
KFOR	Lincoln, Nebr.	1210	1-25	KMLB	Monroe, La.	1200	.1	KWTO	*Springfield, Mo. (5 kw.)	560	1
KFOX	Long Beach, Calif.	1250	1	KMMJ	Clay Center, Nebr.	740	1	KWYO	*Sheridan, Wyo. (.25-day)	1370	.1
KFPL	*Dublin, Texas (.25-day)	1310	.1	KMO	*Tacoma, Wash. (1 kw.)	1330	.25	KXA	Seattle, Wash.	760	.25-5
KFPW	Ft. Smith, Ark.	1210	.1	KMOX	St. Louis, Mo.	1090	50	KXL	Portland, Ore.	1420	1-25
KFPY	*Spokane, Wash. (5-day)	890	1	KMPC	Beverly Hills, Calif.	710	.5	KXO	El Centro, Calif.	1500	.1
KFQD	Anchorage, Alaska	780	.25	KMTR	Los Angeles, Calif.	570	1	KXOK	St. Louis, Mo. (C.P.)	1250	1
KFRC	San Francisco, Calif.	610	1-5	KNEL	Brady, Texas	1500	.1	KXRO	Aberdeen, Wash.	1310	.1
KFRO	*Longview, Texas (.25-day)	1370	.1	KNET	Palestine, Texas	1420	.1	KXYZ	Houston, Texas	1440	1
KFRU	Columbia, Mo.	630	.5-1	KNOW	Austin, Texas	1500	.1	KYA	*San Francisco, Calif. (5 kw.)	1230	1
KFSD	San Diego, Calif.	600	1	KNN	Los Angeles, Calif.	1050	50	KYOS	Merced, Calif. (C.P.)	1040	.25
KFSG	Los Angeles, Calif.	1120	.5-2.5	KOA	Denver, Colo.	830	50	KYV	Philadelphia, Pa.	1020	10
KFUO	Clayton, Mo.	550	.5-1	KOAC	Corvallis, Ore.	550	1	WAAB	Boston, Mass.	1410	.5
KFVD	Los Angeles, Calif.	1000	.25	KOB	Albuquerque, N. Mex.	1180	10	WAAF	Chicago, Ill.	920	1
KFVS	Cape Girardeau, Mo.	1210	1-25	KOBH	Rapid City, S. Dak. (C.P.)	1370	.1	WAAV	Jersey City, N. J.	940	.5
KFWB	*Hollywood, Calif. (5-day)	950	1-2.5	KOCH	Kilgore, Texas (C.P.)	1210	.1	WAAW	Omaha, Nebr.	660	.5
KFXD	Nampa, Idaho	1200	1-25	KOIL	Reno, Nev.	1380	.5	WABC	New York, N. Y.	860	50
KFXJ	Grand Junction, Colo.	1200	1-25	KOIN	Omaha, Nebr.	1260	1-2.5	WBOQ			
KFXM	San Bernardino, Calif.	1210	.1	KOL	Portland, Ore.	940	1-5	WABI	*Bangor, Maine (.25-day)	1200	.1
KFXR	Oklahoma City, Okla.	1310	1-25	KOMA	Seattle, Wash.	1270	1-5	WABY	Albany, N. Y.	1370	.1
KFYO	Lubbock, Texas	1310	1-25	KOMO	Oklahoma City, Okla.	1480	5	WACO	Waco, Texas	1420	.1
KFYR	Bismarck, N. Dak.	550	1-5	KONO	Seattle, Wash.	920	1-5	WADC	Tallmadge, Ohio	1320	1-5
KGA	Spokane, Wash.	1470	5	KONO	San Antonio, Texas	1370	.1	WAGF	Dothan, Ala.	1370	.25
KGAR	Tucson, Ariz.	1370	1-25	KOOS	San Antonio, Texas	1390	.25	WAGM	Presque Isle, Maine	1420	.1
KGB	*San Diego, Calif. (2.5-day)	1330	1	KORE	Marshfield, Ore.	1420	.1	WAIM	*Anderson, S. C. (630 kc.; 1)	1200	.1
KGBU	*Ketchikan, Alaska (1-5)	900	.5	KOTN	Eugene, Ore.	1420	.1	WAIR	Winston Salem, N. C. (C.P.)	1250	.25
KGBX	Springfield, Mo.	1230	.5	KOVC	Pine Bluff, Ark.	1500	.1	WALA	Mobile, Ala.	1380	.5-1
KGCA	Decorah, Iowa	1270	.1	KOY	Valley City, N. Dak. (C.P.)	1500	.1	WALR	Zanesville, Ohio	1210	.1
KGCU	Mandan, N. Dak.	1240	.25	KPAC	Phoenix, Ariz.	1390	.5-1	WAML	Laurel, Miss.	1310	.1
KGCX	*Wolf Point Mont. (1450 kc., 1 kw.)	1310	1-25	KPDN	Port Arthur, Texas	1260	.5	WAPI	Birmingham, Ala.	1140	5
KGDE	Fergus Falls, Minn.	1200	1-25	KPLC	Pampa, Texas	1310	.1	WAPU	Chattanooga, Tenn. (C.P.)	1420	.1
KGDM	Stockton, Calif.	1100	1	KPLT	Lake Charles, La.	1500	.1	WARD	Brooklyn, N. Y.	1400	.5
KGDY	Huron, S. Dak.	1340	.25	KPO	Paris, Texas (C.P.)	1500	.1	WASH	*Grand Rapids, Mich. (1-day)	1270	.5
KGEK	Sterling, Colo.	1200	.1	KPOF	San Francisco, Calif.	680	50	WATL	Atlanta, Ga.	1370	.1
KGER	Long Beach, Calif.	1360	1	KPPC	Denver, Colo.	880	.5	WATR	Waterbury, Conn.	1190	.1
KGEZ	Kalispell, Mont.	1310	.1	KPRC	Wenatchee, Wash.	1500	1-25	WAVE	Louisville, Ky.	940	1
KGFF	Shawnee, Okla.	1420	1-25	KQV	Houston, Texas	920	1-5	WAWZ	Zarephath, N. J.	1350	.5-1
KGFG	Oklahoma City, Okla.	1370	.1	KQW	Pittsburgh, Pa.	1380	.5	WAYX	Waycross, Ga. (C.P.)	1200	.1
KGFI	Corpus Christi, Texas	1500	1-25	KQW	San Jose, Calif.	1010	1	WAZL	Hazleton, Pa.	1420	.1
KGFI	Los Angeles, Calif.	1200	.1	KRE	Berkeley, Calif.	1370	1-25	WBAA	West Lafayette, Ind.	890	.5-1
KGFK	Moorhead, Minn.	1500	.1	KRBC	Abilene, Texas (C.P.)	1420	.1				
KGFL	Roswell, N. Mex.	1370	.1	KRGV	*Weslaco, Tex. (1 kw.)	1260	.5				
KGFW	Kearney, Nebr.	1310	.1	KRKD	Los Angeles, Calif.	1120	.5-2.5				
KGFX	Pierre, S. Dak.	630	.2	KRKO	Everett, Wash.	1370	.05				
KGGC	San Francisco, Calif.	1420	1	KRLC	*Lewiston, Idaho (1390 kc., .25)	1420	.1				
KGGF	Coffeyville, Kans.	1010	1	KRLD	Dallas, Texas	1040	10				
KGGM	*Albuquerque, N. Mex. (1 kw.)	1230	.25-5	KRLH	Midland, Texas	1420	.1				
KGHF	Pueblo, Colo.	1320	.5	KRMD	*Shreveport, La. (.25-day)	1310	.1				
KGHI	Little Rock, Ark.	1200	1-25	KRNR	Roseburg, Ore.	1500	.1				
				KRNT	Des Moines, Iowa	1320	.5-1				
				KROC	Rochester, Minn.	1310	.1				
				KROY	Sacramento, Cal. (C.P.)	1210	.1				
				KROW	Oakland, Calif.	930	1				

Call	Location	Kc.	Kw.	Call	Location	Kc.	Kw.	Call	Location	Kc.	Kw.
WBAL	**Baltimore, Md. (760 kc., 2.5 kw., Exp.)	1060	10	WGAL	Lancaster, Pa.	1500	.1-25	WLEU	Eric, Pa.	1420	.1-25
WBAP	Fort Worth, Texas	800	50	WGAN	Portland, Me. (C.P.)	640	.5	WLLH	Lowell, Mass.	1370	.1-25
WBAX	Wilkes-Barre, Pa.	1210	.1	WGAR	Cleveland, Ohio	1450	.5-1	WLNH	Laconia, N. H.	1310	.1
WBBC	Brooklyn, N. Y.	1400	.5	WGBB	Freeport, N. Y.	1210	.1	WLS	Chicago, Ill.	870	50
WBBL	Richmond, Va.	1210	.1	WGBF	*Evansville, Ind. (1-day)	630	.5	WLTH	Brooklyn, N. Y.	1400	.5
WBMM	Chicago, Ill.	770	50	WGCI	Scranton, Pa.	880	.5	WLVA	Lynchburg, Va.	1200	.1-25
WBRR	Brooklyn, N. Y.	1300	1	WGCM	*Mississippi City, Miss. (1120 kc., .5)	1210	.1-25	WLW	**Cincinnati, Ohio (500 kw., Exp.)	700	50
WBBZ	Ponca City, Okla.	1200	.1	WGES	Chicago, Ill.	1360	.5-1	WLWL	New York, N. Y.	1100	.5
WBCM	Bay City, Mich.	1410	.5	WGH	Newport News, Va.	1310	.1-25	WMAL	Washington, D. C.	630	.25-5
WBCN	*Buffalo, N. Y. (5-day)	900	1	WGL	Ft. Wayne, Ind.	1370	.1	WMAQ	Chicago, Ill.	670	50
WBEO	Marquette, Mich.	1310	.1	WGN	Chicago, Ill.	720	50	WMAS	Springfield, Mass.	1420	.1-25
WBIG	Greensboro, N. C.	1440	.5-1	WGN	Chester Twp., N. Y.	1210	.1	WMAZ	Macon, Ga.	1180	1
WBJW	Kinston, N. C. (C.P.)	1200	.1-25	WGN	Albany, Ga.	1420	.1	WMBD	Detroit, Mich.	1420	.1-25
WBLK	Clarksburg, W. Va. (C.P.)	1370	.1	WGR	*Buffalo, N. Y. (5-day)	550	1	WMBG	Peoria, Ill.	1440	.5-1
WBLV	Lima, Ohio (C.P.)	1210	.1	WGRC	New Albany, Ind. (C.P.)	1370	.25	WMBH	Richmond, Va.	1210	.1-25
WBNO	New Orleans, La.	1200	.1	WGST	*Atlanta, Ga. (5-day)	890	1	WMBI	Joplin, Mo.	1420	.1-25
WBNS	Columbus, Ohio	1430	.5-1	WGY	Schenectady, N. Y.	790	50	WMBQ	Chicago, Ill.	1080	5
WBNX	New York, N. Y.	1350	1	WHA	*Madison, Wisc. (5 kw.)	940	2.5	WMBR	Auburn, N. Y.	1310	.1
WBNY	Buffalo, N. Y.	1370	.1-25	WHAM	Rochester, N. Y.	1150	50	WMC	Brooklyn, N. Y.	1500	.1
WBOW	Terre Haute, Ind.	1310	.1-25	WHAS	Louisville, Ky.	820	50	WMC	Jacksonville, Fla.	1370	.1-25
WBRB	Red Bank, N. J.	1210	.1	WHAT	Philadelphia, Pa.	1310	.1	WMCA	Memphis, Tenn.	780	1-5
WBRC	Birmingham, Ala.	930	1	WHAZ	Troy, N. Y.	1300	.5	WMEX	New York, N. Y.	570	1
WBRE	Wilkes-Barre, Pa.	1310	.1	WHB	Kansas City, Mo.	860	1	WMFD	*Boston, Mass. (1470 kc., 5)	1500	.1-25
WBRT	Charlotte, N. C.	1080	50	WHBB	Selma, Ala.	1500	.1	WMFF	Wilmington, N. C.	1370	.1
WBTM	Danville, Va.	1370	.1-25	WHBC	*Canton, Ohio (.25-day)	1200	.1	WMFG	Plattsburg, N. Y.	1310	.25
WBZ	Boston, Mass.	990	50	WHBF	Rock Island, Ill.	1210	.1-25	WMFJ	Hibbing, Minn. (.25-day)	1210	.1
WBZA	Boston, Mass.	990	1	WHBI	Newark, N. J.	1250	1-2.5	WMFN	Daytona Beach, Fla.	1420	.1
WCAD	Canton, N. Y.	1220	.5	WHBL	Sheboygan, Wisc.	1300	.25	WMFN	Clarksdale, Miss.	1210	.1
WCAE	Pittsburgh, Pa.	1220	1-5	WHBO	Memphis, Tenn.	1370	.1	WMFO	Decatur, Ala.	1370	.1
WCAL	Northfield, Minn.	1250	1-2.5	WHBU	Anderson, Ind.	1210	.1-25	WMFR	High Point, N. C.	1200	.1
WCAM	Camden, N. J.	1280	.5	WHBY	Green Bay, Wisc.	1200	.1-25	WMIN	St. Paul, Minn. (C.P.)	1370	.1-25
WCAO	Baltimore, Md.	600	.5-1	WHDF	Calumet, Mich.	1370	.1-25	WMMN	Fairmont, W. Va.	890	.5-1
WCAP	Asbury Park, N. J.	1280	.5	WHDL	Olean, N. Y.	1420	.1	WMPD	Lapeer, Mich.	1200	.1-25
WCAT	Rapid City, S. Dak.	1200	.1	WHEB	Portsmouth, N. H.	740	.25	WMSD	Sheffield, Ala.	1420	.1
WCAU	Philadelphia, Pa.	1170	50	WHFC	Rochester, N. Y.	1430	.5-1	WMT	Cedar Rapids, Iowa.	600	1-5
WCAZ	Carthage, Ill.	1070	.1	WHFD	Boston, Mass.	830	1	WNB	Boston, Mass.	1230	1-5
WCBA	Allentown, Pa.	1440	.5	WHFH	Kosciusko, Miss.	1500	.1-25	WNAC	Norman, Okla.	1010	1
WCBD	Waukegan, Ill.	1080	5	WHFJ	*Cicero, Ill. (.25-day)	1420	.1	WNAD	Yankton, S. Dak.	570	1-5
WCBM	Baltimore, Md.	1370	.1-25	WHFG	Dayton, Ohio	1260	1-5	WNAX	New Britain, Conn.	1380	.25
WCBS	Springfield, Ill.	1420	.1	WHG	Hammond, Ind. (C.P.)	1480	5	WNB	Binghamton, N. Y.	1500	.1
WCCE	Minneapolis, Minn.	810	50	WHH	Bluffield, W. Va.	1410	.5-1	WNB	New Bedford, Mass.	1310	.1-25
WCFL	Chicago, Ill.	970	5	WHIA	Greensburg, Pa.	620	.25	WNBH	Memphis, Tenn.	1430	.5-1
WCHS	Charleston, W. Va.	580	.5-1	WHIB	Cleveland, Ohio	1390	1-2.5	WNB	**Springfield, Vt. (.5-1 kw., Exp.)	1260	1
WCHV	Charlottesville, Va.	1420	.1-25	WHIC	Columbus, Ohio	640	.5	WNBZ	Saranac Lake, N. Y.	1290	.1
WCKY	Covington, Ky.	1490	5	WHID	Virginia, Minn. (C.P.)	1370	.1	WNEL	*San Juan, Puerto Rico (1-2.5)	1290	.5
WCLO	*Janesville, Wisc. (.25-day)	1200	.1	WHIE	New York, N. Y.	1010	1-5	WNE	New York, N. Y.	1250	1-2.5
WCLS	Joliet, Ill.	1310	.1	WHIF	Des Moines, Iowa	1000	50	WNL	New London, Conn.	1500	.1
WCM	*Ashland, Ky. (.25-day)	1310	.1	WHIG	Jersey City, N. J.	1450	.25	WNOX	Knoxville, Tenn.	1010	1-2
WCNW	Brooklyn, N. Y.	1500	.1-25	WHIP	Harrisburg, Pa.	1430	.5-1	WNR	Newport, R. I. (C.P.)	1200	.1-25
WCOA	Pensacola, Fla.	1340	.5	WHIS	Harrisburg, Pa.	1430	.5-1	WNYC	New York, N. Y.	810	1
WCOC	Meridian, Miss.	880	.5-1	WHJB	Madison, Wisc.	1280	1-5	WOAI	San Antonio, Texas	1190	50
WCOL	Columbus, Ohio	1210	.1	WHIB	Glenside, Pa.	970	.1	WOC	Davenport, Iowa	1370	.1-25
WCOP	Boston, Mass.	1120	.5	WHIC	Jackson, Mich.	1370	.1-25	WOCL	Jamestown, N. Y.	1210	.05
WCPO	Cincinnati, Ohio	1200	.1-25	WHIB	Poyncette, Wisc.	1210	.1-25	WOI	Ames, Iowa	640	5
WCRW	Chicago, Ill.	1210	.1	WHIB	Topeka, Kans.	580	1-5	WOKO	Albany, N. Y.	1430	.5-1
WCSC	Charleston, S. C.	1360	.5-1	WHIB	Utica, N. Y.	1200	.1-3	WOL	Washington, D. C.	1310	.1
WCSS	Portland, Maine	940	1-2.5	WHIB	Bridgeport, Conn.	600	.5-1	WOMT	Manitowoc, Wisc.	1210	.1
WDAE	Tampa, Fla.	1220	1-5	WHIB	St. Louis, Mo.	1200	.1-25	WOOD	*Grand Rapids, Mich. (1-day)	1270	.5
WDAF	Kansas City, Mo.	610	1-5	WHIB	Urbana, Ill.	580	1	WOPI	Bristol, Tenn.	1500	.1
WDAH	El Paso, Texas	1310	.1	WHIB	Wilmington, Del.	1420	.1	WOR	Newark, N. J.	710	50
WDAS	Philadelphia, Pa.	1370	.1-25	WHIB	Gary, Ind.	560	1-5	WORC	Worcester Mass.	1280	.5
WDAY	Fargo, N. Dak.	940	1-5	WHIB	New York, N. Y.	1180	1	WORK	York, Pa.	1320	1
WDBJ	Roanoke, Va.	930	1-5	WHIB	Miami, Fla.	1300	1	WORL	Boston, Mass.	920	.5
WDBO	Orlando, Fla.	580	1	WHIB	Philadelphia, Pa.	610	.5-1	WOSU	Columbus, Ohio	570	.75-1
WDEL	Wilmington, Del.	1120	.25-5	WHIB	Philadelphia, Pa.	610	.5-1	WOV	New York, N. Y.	1130	1
WDEV	Waterbury, Vt.	550	.5	WHIB	Philadelphia, Pa.	610	.5-1	WOW	**Omaha, Nebr. (5 kw., night)	590	1-5
WDGY	Minneapolis, Minn.	1180	1-5	WHIB	Philadelphia, Pa.	610	.5-1	WOWO	Ft. Wayne, Ind.	1160	10
WDNC	Durham, N. C.	1500	.1	WHIB	Philadelphia, Pa.	610	.5-1	WPAD	Paducah, Ky.	1420	.1-25
WDOD	Chattanooga, Tenn.	1280	1-5	WHIB	Philadelphia, Pa.	610	.5-1	WPAP	Parkersburg, W. Va.	1420	.1
WDRB	Wausau, Wisc. (C.P.)	1370	.1	WHIB	Philadelphia, Pa.	610	.5-1	WPAX	Thomasville, Ga.	1210	.1
WDRS	Hartford, Conn.	1330	1-5	WHIB	Philadelphia, Pa.	610	.5-1	WPAY	Portsmouth, Ohio	1370	.1
WDSU	New Orleans, La.	1250	1	WHIB	Philadelphia, Pa.	610	.5-1	WPEP	Philadelphia, Pa.	920	.25-5
WDWS	Champaign, Ill. (C.P.)	1370	.1	WHIB	Philadelphia, Pa.	610	.5-1	WPG	Atlantic City, N. J.	1100	5
WDZ	Tuscola, Ill.	1020	.25	WHIB	Philadelphia, Pa.	610	.5-1	WPHR	Petersburg, Va.	880	.5
WFAF	New York, N. Y.	660	50	WHIB	Philadelphia, Pa.	610	.5-1	WPRO	Providence, R. I.	630	.25
WEAN	*Providence, R.I. (1kw.)	780	.5	WHIB	Philadelphia, Pa.	610	.5-1	WPRP	Ponce, Puerto Rico	1420	.1-25
WEAU	Eau Claire, Wisc. (C.P.)	1050	.25	WHIB	Philadelphia, Pa.	610	.5-1	WPTF	Raleigh, N. C.	680	5
WEBC	Superior, Wisc.	1290	1-5	WHIB	Philadelphia, Pa.	610	.5-1	WQAM	Miami, Fla.	560	1
WEBO	Harrisburg, Ill.	1210	.1-25	WHIB	Philadelphia, Pa.	610	.5-1	WOAN	Scranton, Pa.	880	.25
WEBR	Buffalo, N. Y.	1310	.1-25	WHIB	Philadelphia, Pa.	610	.5-1	WQBC	Vicksburg, Miss.	1360	1
WEDC	Chicago, Ill.	1210	.1	WHIB	Philadelphia, Pa.	610	.5-1	WQDM	*St. Albans, Vt. (1390 kc., 1)	1370	.1
WEED	Rocky Mount, N. C.	1420	.1-25	WHIB	Philadelphia, Pa.	610	.5-1	WRAK	Williamsport, Pa.	1370	.1-25
WEEL	*Boston, Mass. (5-day)	590	1	WHIB	Philadelphia, Pa.	610	.5-1	WRAW	Reading, Pa.	1310	.1
WEIU	Reading, Pa.	830	1	WHIB	Philadelphia, Pa.	610	.5-1	WRAN	Philadelphia, Pa.	920	.25-5
WEGL	Brooklyn, N. Y. (C.P.)	1400	.5	WHIB	Philadelphia, Pa.	610	.5-1	WRBL	Columbus, Ga.	1200	.1
WEHS	*Cicero, Ill. (.25-day)	1420	.1	WHIB	Philadelphia, Pa.	610	.5-1	WRC	Washington, D. C.	950	.5-1
WELI	New Haven, Conn.	900	.5	WHIB	Philadelphia, Pa.	610	.5-1	WRDO	Augusta, Maine	1370	.1
WELL	Battle Creek, Mich.	1420	.1	WHIB	Philadelphia, Pa.	610	.5-1	WRDW	Augusta, Ga.	1500	.1
WEMP	Milwaukee, Wisc.	1310	.1	WHIB	Philadelphia, Pa.	610	.5-1	WREC	Memphis, Tenn.	600	1-5
WENR	Chicago, Ill.	870	50	WHIB	Philadelphia, Pa.	610	.5-1	WREN	Lawrence, Kans.	1220	1-5
WEOA	*Evansville, Ind. (.25-day)	1370	.1	WHIB	Philadelphia, Pa.	610	.5-1	WRGA	Rome, Ga.	1500	.1-25
WESG	**Elmira, N. Y. (850 kc.)	1040	1	WHIB	Philadelphia, Pa.	610	.5-1	WRJN	Racine, Wisc.	1370	.1-25
WEST	Easton, Pa.	1200	.1	WHIB	Philadelphia, Pa.	610	.5-1	WROK	Rockford, Ill.	1410	.5
WEVD	New York, N. Y.	1300	1	WHIB	Philadelphia, Pa.	610	.5-1	WROL	Knoxville, Tenn.	1310	.1-25
WEW	St. Louis, Mo.	760	1	WHIB	Philadelphia, Pa.	610	.5-1	WRR	Dallas, Texas	1280	.5
WEXL	Royal Oak, Mich.	1310	.05	WHIB	Philadelphia, Pa.	610	.5-1	WRUF	Gainesville, Fla.	830	5
WFAB	Dallas, Texas	800	50	WHIB	Philadelphia, Pa.	610	.5-1	WRVA	Richmond, Va.	1110	5
WFAM	New York, N. Y.	1300	1	WHIB	Philadelphia, Pa.	610	.5-1	WSAI	Cincinnati, Ohio	1330	1-2.5
WFAS	South Bend, Ind.	1200	.1	WHIB	Philadelphia, Pa.	610	.5-1	WSAJ	Grove City, Pa.	1310	.1
WFBC	White Plains, N. Y.	1210	.1	WHIB	Philadelphia, Pa.	610	.5-1	WSAN	Allentown, Pa.	1440	.5
WFBD	Greenville, S. C.	1300	1-5	WHIB	Philadelphia, Pa.	610	.5-1	WSAR	*Fall River, Mass. (1 kw.)	1450	.25
WFBG	Altoona, Pa.	1310	.1	WHIB	Philadelphia, Pa.	610	.5-1	WSAY	Rochester, N. Y. (C.P.)	1210	.1
WFBL	Syracuse, N. Y.	1360	1-5	WHIB	Philadelphia, Pa.	610	.5-1	WSAZ	Huntington, W.		

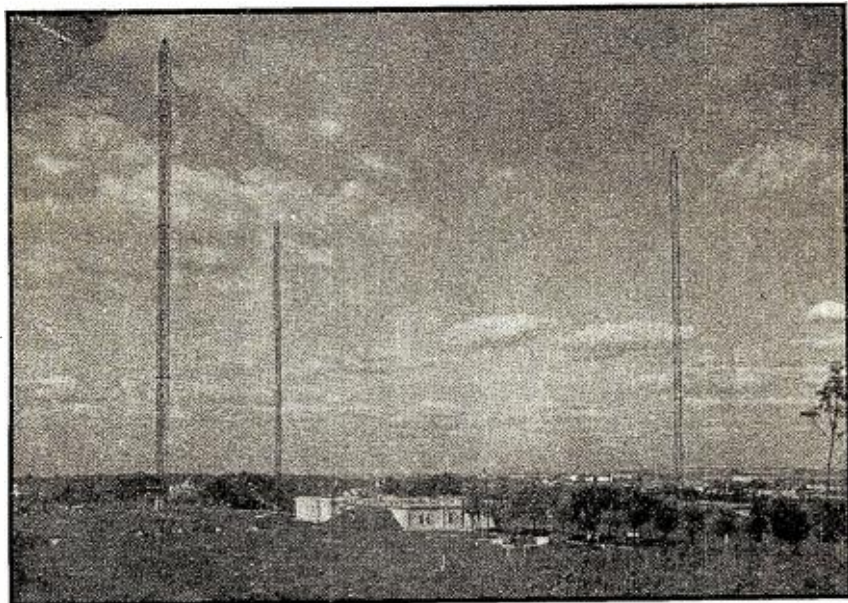

PROGRAMS FROM VIENNA
Short-wave station OER2 located
at Rosenhugel (Rosehill), Austria,
on the 49-meter band, relays Vien-
na from early morning to 5 or 6
p. m.

THE forty-sixth installment of the DX Corner for Short Waves contains the World Short-Wave Time Table for 24-hour use all over the world and Official Observers' reports of stations heard this month. Consult these two items regularly and make your all-wave set pay big dividends!

Reappointment Reminder

WE wish to remind Listening Post Observers that if they desire to be reappointed for 1937 they should send in a separate card along with their report stating that they wish reappointment. No Observers will be carried over to next year unless such a request is made, so, fellows, don't forget to apply soon.

News of Clubs

Two clubs have recently become associated with the Short-Wave DX Corner and our Editors welcome their members to the great body of DX'ers who read RADIO NEWS. These clubs are: The New Zealand DX Radio Association and the R-9 Listeners League (U. S.). Both of these associations have been doing very good work in their respective countries. The R-9 Listeners League now has 120 members and is intended primarily to serve the interests of short-wave listeners. They also desire to have radio amateurs become affiliated. Fred Webb, Vice-President of the League, writes that every effort is



made to keep the cost of membership as low as possible in conformity with reasonable service to its members. An identification pin is available to members. The League also maintains a QSL exchange bureau for members.

Any information on these two associations can be had by writing them in care of RADIO NEWS.

Another World-wide S.W. Contest

The International 6000-12,500-Mile Short-Wave Club is sponsoring a new contest for amateurs, short-wave and broadcast listeners. A large number of valuable prizes will be offered. Further details of the contest will be published in a later issue. Keep it in mind, fellows.

"Universal" Contest

The Universal DX Club now is running a contest which closes March 31st, 1937, according to A. J. Stansfield, President. Information regarding it may be obtained by writing the club in care of RADIO NEWS.

Correspondence Wanted

George C. Sholin, Official Observer for California, asks us to state that he will exchange stamps, photos, picture cards, magazines and letters with DX'ers anywhere except England, Mexico, Australia, Canada, Japan, Newfoundland, New Zealand and the United States. He will answer in either English or Esperanto, as desired.

Reports of Listening Post Observers and Other Short-Wave Readers of the DX Corner

Listed in the following columns is this month's consolidated reports of short-wave stations heard by our wide world listening posts. Each item is credited with the Observer's surname. This allows our Readers to note who obtained the information. If any of our Readers can supply Actual Time Schedules, Correct Wavelengths, Correct Frequencies and any other Important Information (in paragraphs as recommended), the DX Editor, as well as our Readers, will be grateful for the information. On the other hand, Readers seeing these reports can try their skill in pulling in the stations logged and in trying to get complete information on these transmissions. The report for this month, containing the best information available to date, follows:

GREETINGS FROM HAWAII
L. R. Giddings, DX ace of Haina,
Hawaii, officer and member of the
6000-12500 Mile Short-Wave Club,
sends greetings to SWL's the world
over.

The DX for the

Conducted by

Laurence

EUROPE

(All time is E.S.T. except where otherwise given.)

TPA2, Pontoise, France, 15244 kc., daily 6:45 a.m. (Diez, Kemp).

TPA3, Pontoise, France, as per schedule in time-table. (De Ment, Kemp).

TPA4, Pontoise, France, 25.60 meters, 10 p.m. (Coover. Slogan: Radio Colonial).

TYA2, Pontoise, France, 9020 kc., 3 a.m. (Kemp).

FNSK, S.S. Normandie, 8830 kc., heard calling Paris 1:30 to 3 a.m. (Howald). 9510 kc., R7. (Ealin). 8:30 p.m., used scrambled speech. (Ather-ton).

EAQ, Madrid, Spain, 9850 kc., daily 9 p.m. (Diez). Changed from 9870 kc. to 9840 kc. (Dressler). EA2 and FP1 also heard by Piorko, Coover, Diez. 30.4 meters. (Zarn, De Ment, Ather-ton). 9860 kc., 6-10 p.m. daily. (Partner, Markuson).

UGT, Spain, several languages used.

Affiliated DX Clubs

OUR editors hereby place a standing invitation to reliable DX clubs to become affiliated with the DX Corner, acting as advisors on short-wave activities in promoting short-wave popularity and reception efficiency. A list of associated organizations follows:

International DX'ers Alliance
Newark News Radio Club
Society of Wireless Pioneers
U. S. Radio DX Club
Radio Club Venezolano
World Wide Dial Club
International 6000-12,500 Mile Short-Wave Club
Globe Circles DX Club
Radio Fellowship
Short-Wave Club of New York
National Radio Club
Universal Radio DX Club
Chicago Short-Wave Club
Mexican League of Radio Experimenters
Monongahela Radio Club
New Zealand DX Club
New Zealand DX Radio Association
Penang Wireless Society
Radio Club of Basel
Radio Short-Wave and Television Experimenters Association
New Zealand DX Radio Association
R-9 Listeners League

DX listeners wishing to join any of these clubs and associations may write for information to the Short Wave DX Editor. Other clubs who wish to become affiliated should make application similarly. Clubs associated with the DX Corner have the privilege of sending in club notes for publication in RADIO NEWS.

Corner SHORT WAVES

M. Cockaday

(Betances). Slogan: "Union Trabajadores de Madrid."

HAS3, Budapest, Hungary, 19.52 meters, Sunday schedule changed to 9 to 10 a.m. (Atherton).

HAT, Budapest, Hungary, 13685 kc., testing evenings. (Partner).

HAT4, Budapest, Hungary, 9125 kc., Sundays 6 to 7 p.m. (Ralat, Stabler, Partner, Hartman, Kemp, Reilly, Atherton).

DJC, Zeesen, Germany, 4983 meters. (Zarn).

DZB, Zeesen, Germany, 10042 kc., Wednesdays 8:30 to 10 p.m. (Dressler, Rodriguez, Howald).

DZC, Zeesen, Germany, 10042 kc., Wednesdays 8:30 to 10 p.m. (Dressler). 29.15 meters. (Mascarenhas, Stabler).

DZE, Zeesen, Germany, 5:15 to 5:30 p.m., sent special program to Brazil. (Atherton).

DZH, Zeesen, Germany, 14460 kc. (Yoshimura). Sunday 1:30 to 4 p.m. (Horwath). 20.75 meters. (Mascarenhas).

DJA, Zeesen, Germany, 9560 kc., daily 7:20 p.m. (Diez, Kemp).

DJN, Zeesen, Germany, 9540 kc., daily 7:20 p.m. (Diez). 31.45 meters. (Zarn, Kemp).

DJO, Zeesen, Germany, 11800 kc., irregularly 7:35 p.m. (Diez, Kemp).

DJD, Zeesen, Germany, 11770 kc., daily 10:30 p.m. (Diez). 7:30 to 8 p.m. (Leutenberg, Kemp).

DJB, Zeesen, Germany, 15300 kc., daily 8:09. (Diez). 19.74 meters, 4 p.m. (Coover, Zarn). 15200 kc., 7 to 8 p.m. (Leutenberg).

DJO, Zeesen, Germany, 15280 kc., daily 8:50 p.m. (Diez).

DJL, Zeesen, Germany, 15151 kc., daily 8:50 p.m. (Diez, Kemp).

DJR, Zeesen, Germany, 1500 kc., daily 9:08 j.m. (Diez).

TFJ, Reykjavik, Iceland, 12200 kc., 1 to 2 p.m. Sundays. (Kernan). 12240 kc., Sundays 12:40 to 11:05 p.m., English program. (Fallon, Stevens). 12235 kc., 7 kw., Sundays 1:40 p.m. (Yoshimura).

SM5SX, Stockholm, Sweden, 11720

kc., 3 p.m. (Azevedo). 26.63 meters, 9 a.m. to 5 p.m. (Stevens). 11710 kc., 1:23 to 4:05 a.m. Announced in Swedish and English "Stockholm Calling." (Yoshimura). 11705 kc. by Azevedo who is not sure of call. 25.7 meters at 2:30, no English announcements. (Smith).

GSB, Daventry, England, 9510 kc. (Kempster). 12:15 to 5:45 a.m., 31.32 meters. (Zarn). 10 to 11 p.m. (Wilkinson, Leutenberg, Kemp).

GSC, Daventry, England, 9580 kc., 6 to 8 p.m., 9 to 11 p.m. (Kempster). 8 p.m. (Coover, Kemp).

GSD, Daventry, England, 11750 kc., 12:15 to 3:25 p.m., 6 to 8 p.m. (Kempster). 9 to 11 p.m. in place GSF. (Partner, Leutenberg, Kemp).

GSF, Daventry, England, 15140 kc. (Kempster). Diez reports them on 15200 kc. daily 9 to 12 a.m., 3:40 to 5:45 p.m., 9 to 11 p.m. Heard 4 p.m. by Coover, Diez, Leutenberg, Kemp.

GSH, Daventry, England, 21470 kc., 6 to 8:45 a.m. daily except Sundays, Sundays 7 to 8:45 a.m., 9 to 12 a.m., daily 3:40 to 4:45 p.m. (Kempster, Diez, Kemp).

GSH, Daventry, England, 21470 kc., daily 6 to 8:45 a.m. except Sundays. Sundays 7 to 8:45 a.m., 9 to 11:30 a.m. (Kempster). Sunday a.m. best time. (Dressler, Kemp).

GSO, Daventry, England, 15180 kc., daily 12:15 to 3:40 p.m. (Kempster, Partner).

GSP, Daventry, England, 15310 kc., 6 to 8 p.m. daily. (Kempster).

GSI, London, England, 15260 kc., special transmission 12 to 1 a.m. (Howald). 5:30 to 6 p.m. (Leutenberg). 1 p.m. on. (Stabler).

GS9UR, England, 90 meters. (Boussy).

HBO, Geneva, Switzerland, 11400 kc., nightly at 1 a.m. transmitting to 3LR in Australia. (Partner, Gallagher, Kemp).

HBL, Geneva, Switzerland, 9595 kc., 7 to 8:20 p.m. Mondays. (Dressler). 7797 kc., 8 to 8:25 p.m. (Stabler). 9580 kc. (Zarn, Flick).

HBP, Geneva, Switzerland, 7797 kc., 7 to 8:20 j.m., Mondays. (Dressler). Saturdays 5:30 to 6:15 p.m.



A "VERI" WORTH FRAMING
This verification card, which by the way measures 6¾ inches by 10 inches, is suitable for framing. It was received from XE2HF by Observer DeLaet.

(Fallon, Kemp). Slogan: "Radio Nations". Address: Information Section, League of Nations.

HBJ, Geneva, Switzerland, 14535 kc., Sundays 2 to 5 p.m. (Horwath, Edlin, Kemp).

HBF, Geneva, Switzerland, 18450 kc., heard relaying Vienna 9/20/36, 10:30 a.m. to 12 noon. (Howald, Colin, Kemp).

CSW, Lisbon, Portugal, 31.45 meters, around 6 p.m., announce in Portuguese and English. (Styles). 9870 kc., 5:15 to 5:45 p.m., Wednesdays. (Kernan, Hartman, Messer, Mascarenhas). Mondays, 4 to 6 p.m., wants reports. (Fallon, Edlin, Curtis). 9740 kc. (Azevedo). 9920 kc., heard 4 p.m. (Betances). Send reports to N.B.C., Lisbon, Portugal. (Stabler). 9930 kc. (Harris, Kernan, Messer). Have feminine announcer. (Mascarenhas, Smith, Kentzel, Dressler, Hartman, Kemp, Reilly, Goodman). Slogan: "Emisora National."

OLR, Podebrady, Radio Prague, Czechoslovakia, 49.05 meters, men and women announcers use various languages. (Kempster). 15230 kc. with American hour, Mondays, Wednesdays, Fridays, 9 to 11 p.m. (Howald). 2:48 to 4:29 p.m. (Yoshimura). Testing 2 p.m. (Ralat). 10 a.m. (Davis). For America 5 a.m., 12 noon and 3 p.m.; for Europe 10 a.m., 5 p.m. and (Turn to page 420)



TWO WELL-KNOWN OBSERVERS

At left: Thomas F. Tynan, Official Radio News Observer for Long Island and also member of the 6000-12500 Mile Club, is shown in his DX Corner. At right: Official Observer Clayton D. Sands, for Maine, shown at his Philco 5-tube receiver. Both are boosters of RADIO NEWS for listeners.



WORLD SHORT WAVE TIME-TABLE



(Continued from the Previous Page)
Hours of transmission for the World's Short Wave Broadcast Stations

FILL IN LOCAL TIME												EASTERN STANDARD TIME																																			
8	9	10	11	M	1	2	3	4	5	6	7	8	9	10	11	N	1	2	3	4	5	6	7																								
01	02	03	04	05	06	07	08	09	10	11	12	13	14	15	16	17	18	19	20	21	22	23	00																								
HOURS OF TRANSMISSION												HOURS OF TRANSMISSION																																			
Wave-length Meters												Call Letters												Frequency Kc.												City Country											
												45.38	RV72	6611	Moscow, U. S. S. R.																																
												45.80	HI4D	6550	Trujillo, D. R.																																
												46.01	YV6RV	6520	Valencia, Venezuela																																
												46.08	HIL	6510	Trujillo, D. R.																																
												46.66	HIIS	6430	Puerto Plata, D. R.																																
												46.91	HI8Q	6395	Trujillo, D. R.																																
												47.06	YV4RC	6375	Caracas, Venezuela																																
												47.24	HRPI	6350	San Pedro Sula, Honduras																																
												47.54	HIZ	6310	Trujillo, D. R.																																
												47.62	YV12RM	6300	Maracay, Venezuela																																
												47.77	HIG	6280	Trujillo, D. R.																																
												47.77	CO9WR	6280	Sancti Spiritus, Cuba																																
												48.05	HIN	6243	Trujillo, D. R.																																
												48.11	HRD	6235	La Ceiba, Hond.																																
												48.15	OAX4G	6230	Lima, Peru																																
												48.19	HJ1ABH	6225	Cienaga, Colombia																																
												48.50	HI1A	6185	Santiago, D. R.																																
												48.70	VPB	6160	Colombo, Ceylon																																
												48.70	CJRO	6160	Winnipeg, Canada																																
												48.78	VE9CL	6150	Winnipeg, Can.																																
												48.78	HJ2ABA	6150	Tunja, Colombia																																
												48.78	YV3RC	6150	Caracas, Venezuela																																
												48.78	HJ5ABC	6150	Cali, Colombia																																
												48.78	COKG	6150	Santiago, Cuba																																
												48.86	W8XX	6140	Pittsburgh, Pa.																																
												48.88	CR7AA	6137	Lourenzo Marques, A.																																
												48.94	XEXA	6130	Mexico, D. F.																																
												48.94	COCD	6130	Havana, Cuba																																
												48.96	HJ3ABX	6128	Bogota, Col.																																
												49.02	HJ1ABB	6120	Barranquilla, Col.																																
												49.02	W2XE	6120	New York, N. Y.																																
												49.10	CHNX	6110	Halifax, N. S.																																
												49.18	"Beograd"	6100	Belgrade, Yugoslavia																																
												49.18	W3XAL	6100	Bound Brook, N. J.																																
												49.18	W9XF	6100	Chicago, Ill.																																
												49.20	ZTJ (JB)	6098	Johannesburg, Africa																																
												49.22	HJ4ABE	6095	Medellin Col.																																
												49.26	CRCX	6090	Toronto, Canada																																
												49.30	HJ5ABD	6085	Cali, Col.																																
												49.31	HJ3ABF	6084	Bogota, Col.																																
												49.32	VQ7LO	6083	Nairobi, Kenya, Afr.																																
												49.34	HP5F	6080	Colon, Panama																																
												49.34	W9XAA	6080	Chicago, Ill.																																
												49.34	ZHJ	6080	Penang, S. S.																																
												49.40	OER2	6072	Vienna, Austria																																
												49.42	YV7RMO	6070	Maracaibo, Ven.																																
												49.50	W8XAL	6060	Cincinnati, Ohio																																
												49.50	W3XAU	6060	Philadelphia, Pa.																																
												49.50	OXY	6060	Skamlebaek, Denmark																																
												49.59	HJ3ABD	6050	Bogota, Col.																																
												49.59	HI9B	6050	Trujillo, D. R.																																
												49.63	HJ3ABI	6045	Bogota, Colombia																																
												49.65	HJ1ABG	6042	Barranquilla, Col.																																
												49.67	YDA	6040	Tandjong Priok, Java																																
												49.67	W1XAL	6040	Boston, Mass.																																
												49.75	HP5B	6030	Panama City, Pana.																																
												49.83	DJC	6020	Zeesen, Germany																																
												49.83	XEUW	6020	Veracruz, Mex.																																
												49.85	ZHI	6018	Singapore, Malaya																																
												49.90	HJ3ABH	6012	Bogota, Colombia																																
												49.92	COCO	6010	Havana, Cuba																																
												49.95	HJ1ABJ	6006	Santa Marta, Col.																																
												49.96	CFCX	6005	Montreal, Can.																																
												49.96	HP5K	6005	Colon, Panama																																
												49.96	VE9DN	6005	Montreal, Canada																																
												50.00	XEBT	6000	Mexico City, Mex.																																
												50.00	RV59	6000	Moscow, U. S. S. R.																																
												50.17	HIX	5980	Trujillo, D. R.																																
												50.21	XECW	5975	Xantocam, Mexico																																
												50.25	HJN	5970	Bogota, Col.																																
												50.25	XEWI	5970	Mex. D. F.																																
												50.26	HVJ	5969	Vatican City																																
												50.50	TG2X	5940	Guatemala City																																
												50.72	HH2S	5915	Port au Prince, Haiti																																
												50.76	HRN	5910	Tegucigalpa, Hond.																																
												50.85	YV8RB	5900	Barquisimeto, Ven.																																
												51.15	HI1J	5865	San Pedro, D. R.																																
												51.46	TIGPH	5830	Alma Tica, Costa Rica																																
												51.72	YV2RC	5800	Caracas, Venezuela																																
												51.90	OAX4D	5780	Lima, Peru																																
												55.45	ZBW	5410	Hong Kong, China																																
												70.21	RV15	4273	Khabarovsk, Siberia																																

List of Symbols

- | | | | |
|------------------------------------------------------------------------------------------------------------------------------------------------------------------------------------------------------------------------------------------------|----------------------------------------------------------------------------------------------------------------------------------------------------------------------------------------------------------------------|--------------------------------------------------------------------------------------------------------------------------------------------------------------------------------------------------------------------------------------------------|----------------------------------------------------------------------------------------------------------------------------------------------------------------------------------------------------------------------------------------------------|
| <p>A—Thursday, Sunday
C—Monday, Wednesday, Friday
D—Daily
E—Friday, Thursday
F—Friday
H—Sunday, Monday, Wednesday, Friday
G—Tuesday, Thursday, Saturday
I—Irrregularly
J—Tuesday, Thursday, Friday, Sunday</p> | <p>K—Monday, Friday
L—Wednesday, Saturday
M—Monday
N—Monday, Wednesday, Thursday
O—Monday, Tuesday, Wednesday, Friday
P—Except Tuesday, Wednesday
S—Sunday
T—Tuesday
Th—Thursday</p> | <p>U—Sunday, Monday, Thursday
V—Sunday, Wednesday
W—Wednesday
Z—Tuesday, Friday
AC—Monday, Thursday, Saturday
AG—Tuesday, Sunday
AH—Monday, Wednesday, Saturday
AL—Except Monday, Sunday
AM—Monday, Thursday</p> | <p>AN—Tuesday, Saturday
Sa—Saturday
XA—Except Saturday, Sunday
XB—Except Tuesday, Thursday
XC—Except Tuesday, Thursday, Sunday
XM—Except Monday
XS—Except Sunday
XY—Except Tuesday, Sunday
XSa—Except Saturday</p> |
|------------------------------------------------------------------------------------------------------------------------------------------------------------------------------------------------------------------------------------------------|----------------------------------------------------------------------------------------------------------------------------------------------------------------------------------------------------------------------|--------------------------------------------------------------------------------------------------------------------------------------------------------------------------------------------------------------------------------------------------|----------------------------------------------------------------------------------------------------------------------------------------------------------------------------------------------------------------------------------------------------|



The DX Corner (Short Waves)

(Continued from page 417)

8 p.m., Central European Time. (Westman, Fallon). Signs with tolling bells. (Stabler). Wants U. S. Reports. (Barta, De Marco). 7 to 9 a.m., 2 to 4 p.m., on either 15230 kc. or 11760 kc. (Partner, Lyons, Piorko, Lueth, Atkinson, Bower, Smith, Atherton, Dodge, Betances, Kernan). 11900 kc. (Walker). Signing at 11 p.m. (Gallagher, Miller, Stevens, Messer, Kemp, Hill). 15390 kc., 11765 kc., 4 to 11 a.m., 2 p.m. daily. (Kernan).

ORK, Ruyssede, Belgium, 10330 kc., Saturdays 1:30 to 3 p.m. (Pickering, Partner).

RNE, Moscow, U.S.S.R., 25 meters, Wednesday and Sunday at 5 p.m. (Fallon). 12000 kc. daily except Tuesday, Thursday and Saturday in English, 4 to 5 p.m. (Kemp, Stabler).

RKI, Moscow, U.S.S.R., 19.81 meters, 1:30 to 2 p.m. on Sundays. (Stevens, Kemp).

RV96, Moscow, U.S.S.R., 1:30 to 2 p.m., Sundays, 19.76 meters. (Stevens). Reported to be RAN. (Miller). 6:30 to 7:30, Sunday. (Lopez). 15180 kc., Sundays with English program, 10:30 to 11 a.m. (Croston).

RAN, Moscow, U.S.S.R., frequency announced as 12000 kc. Also heard using call RNE. Kempster believes that the time of transmission determines call used. 9600 kc. nightly from 6:30 to 7:30 p.m. instead of 9520 kc. (Dressler). Announces daily operation on 31.28 meters from 12 on. (Stabler, Tyler, Augustine). 31.24 meters. (Zarn, Azevedo). New frequency according to Inna Marr in Moscow is 9600 kc. (Partner, Stevens, Kemp).

PCJ, Eindhoven, Holland, 31.28 meters, Sundays sign off at 8 p.m. (Tyler). Heard 7 p.m. (Coover). 15220 kc. and 9590 kc., Tuesday at 4 to 6 and Wednesday 7 to 11 a.m. on 19.71 meters, Thursday from 7 to 10 a.m. on 31.28 meters. (Zarn, Westman, Smith, Betances, Kemp).

PHI, Huizen, Holland, 17775 kc. (Howald).

SPW, Poland, 22 meters, Monday, Wednesday, Friday, 11:30 a.m. to 12:30 p.m. (Stevens).

LZA, Sofia, Bulgaria, 15140 kc. Monday 6:45 a.m. (Diez). Yoshimura re-

SUGAR CANE FROM CUBA

This is the hand-drawn verification card of COCX, received by Observer Sahlbach for a report on the reception of that station.

ports them on 14970 kc., 2 kw. Sundays 12:30 a.m. to 8 a.m., 10 a.m. to 4:30 p.m. Mondays, Wednesdays, Fridays, Saturdays 5 to 7 a.m. Tuesdays, Thursdays 1 to 3 p.m. On 14915 kc. by Azevedo. 14970 kc. (Westman, Stevens). Slogan: "Radio Garato."

I2RO, Rome, Italy, 11810 kc., daily 9:30 a.m. (Howald). Change Nov. 1st, 8:15 a.m. to 12:30 p.m., 11810 kc. daily. 12:45 to 5:30 p.m., 9635 kc. daily. 6 to 7:45 p.m., 9635 kc. except Sundays. (De Marco, Lyons). 25.4 meters, 7 p.m. (Coover, Zarn). Announced that after Nov. 1st, the American hour will be on 21 meters. (Stabler, Kernan, Leutenberg, Stevens, Boussy, Kemp). Testing until 9 p.m. on 11810 kc. (Partner).

WHOSE STATION IS THIS?

The Observer who sent in this photograph to RADIO NEWS for publication neglected to write his name and address on the reverse side for identification. If he will send in another copy to match this we will print his name in the following issue.



ASIA

PVL, Bandoeng, Java, 9.42 mc., 10 a.m. (Gallagher).

PMK, Bandoeng, Java, 11.5 mc., 7 a.m. phone, (Gallagher). 11500 kc., 5 to 10:30 a.m. irregular, (Partner), formerly known as PLO.

YDC, Bandoeng, Java, 15150 kc., 5 to 10:30 a.m. irregular. (Partner, Hammersley, Kentzel). formerly known as

PLH, address—for all Java stations; Mr. J. Sanders, Engineer-in-charge, Java Wireless Stations, Bandoeng, Java.

PMH, Bandoeng, Java, 6.72 mc., daily 5:30 to 10:00 a.m., (Sholin, Gallagher).

YDA, Tandjong Priok, Java, 3.04 mc., same program as YOB, (Gallagher).

PMA, Bandoeng, Java, 19.35 mc., 10 a.m., (Gallagher).

PMN, Bandoeng, Java, 10260 kc., 4:30 to 9:30 a.m., (Davis, Diez), daily 6 p.m. (Azevedo, Dement), Sunday 2 to 4 p.m., (Smith, Gallagher, Kemp).

PLP, Bandoeng, Java, 11000 kc., 4:30 to 9:30 a.m. daily, (Davis, Azevedo), 1:30 a.m. (Kernan), daily 6 to 9 p.m., (Amas, Kernan, De Ment).

YDB, Sourabaya, Java, 9640 kc., daily 4:30 to 9:30 a.m., (Davis), relaying PLP, 9650 kc., 6 to 7 a.m., (Edlin, Gallagher).

RV15, Khabarovsk, U.S.S.R., 4275 kc. daily until 8:00 a.m., (Markuson), 1:20 a.m., (Miller).

VPB, Colombo, Ceylon, India, 49.60 meters, 10 a.m., (Stevens).

VWY2, India, 17480, (Mellanby).

JZI, Nazaki, Japan, 9545 kc., 4 to 5 p.m., every Monday and Thursday, (Bower).

JZK, Nazaki, Japan, 15160 kc., 4 to 5 p.m., Monday and Thursday, (Bower).

JVM, Nazaki, Japan, 10733 kc., 6:48 a.m. (Diez), 10740 kc., special transmission 6:30 a.m., (Davis), 2:45 p.m. twice a week, (Azevedo, Messer, Kemp, Stevens).

JVN, Nazaki, Japan, 10660 kc., Monday 6:51 a.m. (Diez, Zarn, DeMent), almost nightly 1:40 to 2:30 a.m., (Gallagher).

JVH, Tokio, Japan, 14600 kc., 12:00 to 1:00 a.m., (Howald, Zarn), 2:45 p.m., (Azevedo), "Overseas Program" 12:00 p.m., Monday and irregular, (Fallon), 12 to 1 a.m., (Amos), Thursday 3 to 4 p.m., (Mascarenhas), Sunday 5 to 6 p.m., (Gallagher, Stevens).

JYE, Nazaki, Japan, 12:00 p.m., (Gallagher).

JYU, Nazaki, Japan, 5.79 mc., 7 a.m., (Gallagher).

JVT, Nazaki, Japan, 6750 kc., daily up to 11:00 a.m., (Westman), 6800 kc., (Diez, DeMent).

HS8PJ, Bangkok, Siam, 9350 kc., Thursdays, 10955 kc. Mondays, 8 to 10 a.m., (Howald) reports this last frequency is poorer than the first, 10160 kc., 6 to 9 a.m. irregularly, (Davis), 11000 kc., Sunday 7 a.m. (Diez), 10955 kc., frequency dropped, (Partner), Thursday, 8 to 10 a.m. (Black).

HSP, Bangkok, Siam, 17.7 mc., October 14, 10 a.m., (Gallagher).

F3ICD, Saigon, Indo-China, 11700 kc., heard once on Monday, Tuesday, Wednesday, 8 to 10 a.m. but not since then, (Howald), 11730 kc., daily 7:30 to 9:30 a.m., (Partner), announce as "Radio Saigon," address—Box 295, Saigon, Indo-China.

ZBW, Hongkong, China, 9530 kc., (Turn to page 436)

The Marvel of the Radio of Industry!

Giant Magna-Span Dial affords amazing new convenience, speed and accuracy in tuning.

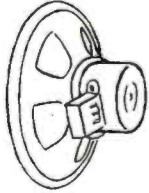
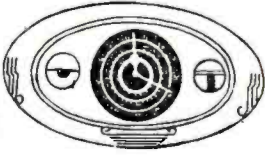

Vita-Tone Super-Dynamic Speaker brings thrilling new fidelity, vitality, realism of tone.

New Magna-Span Dial AND VITA-TONE SPEAKER
 Featured in **Knight RADIOS**
RADIO'S NEW STANDARD OF VALUES
 See the 38 Sensational Models - 5 to 19 Tubes - in Your Allied Radio Catalog

"America's most amazing radios!" 1937 Knights offer the most sensational developments in radio to double your radio enjoyment. The new Giant Magna-Span Dial which makes tuning on every wave band amazingly quick, easy and accurate; and the new Vita-Tone Dynamic Speaker which provides superb new tone quality. And besides these revolutionary improvements, the Knight brings you perfected metal tubes, the exclusive Flywheel Tuner, "Electric Eye", new Visual-Wave Band Indicator and a host of other features that again prove what tremendous values you receive by ordering from ALLIED.

Choose from 38 different models!—priced from \$8.45, complete with tubes and cabinet! All-Wave, Dual-Wave and Short-Wave—5 to 19 tubes—AC, AC-DC, 6-volt, 32-volt, battery and auto sets—new, exclusive features outstanding values in every set! See all 38 models in ALLIED's Free Catalog.

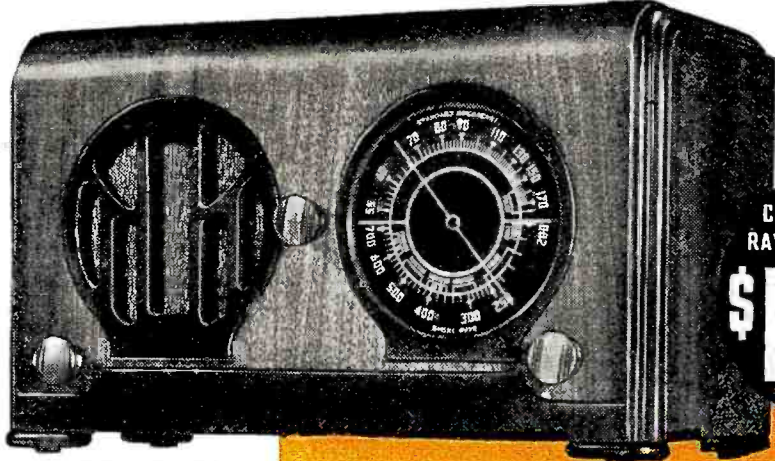

COMPLETE WITH RAYTHEON TUBES
\$13.95

11 TUBE CONSOLE

a magnificent new 11-tube All-Wave Superhet. Tunes 3 full bands—brings you the world—powerfully, dependably. Metal tube circuit—RCA and Hazeltine licensed — gives fullest sensitivity—reaches out farther—provides perfect reception—powerful performance on every band. New 12" Vita-Tone Speaker. New 11" Magna-Span Dial with every new and exclusive device for simplified tuning. Beautiful rolled-top console cabinet. See full description on pages 8-9 of ALLIED's Free Catalog.

1937'S RADIO SENSATION!
Knight **5 TUBE** A C SUPERHET

An amazing 5 Tube Dual-Wave Value—actually achieves 8-tube efficiency! Tunes 2 Full Bands from 43 to 150 meters, for Short Wave, police, aviation and amateur 'phone—also Foreign Reception on 49-meter band; Second Band covers 175 to 550 meters—upper police channel and entire range of American and Canadian standard Broadcast stations. Latest circuit—includes rubber-floated tuning condenser for greater stability; 8 tuned circuits for maximum selectivity, and Automatic Volume Control. Big 5½" Vernier dial makes tuning easy, and accurate. Full size 6" Electro-dynamic speaker reproduces with flawless fidelity at either full volume or a whisper. Beautiful "Laydown" cabinet design, as illustrated. 1937's radio sensation—see its complete features on the Back Cover of ALLIED's Free Catalog.

19 TUBE MODEL

Tunes the World! 3 full bands cover everything broadcast! Amazing new 19 tube circuit—with Dual Dreadnaught chassis (2 chassis)—Giant 30-Watt output, handled with remarkable tonal beauty by two 12" Vita-tone speakers; 11" Magna-Span Dial with five exclusive features: The "Electric Eye," Flywheel tuning, Wave Band Indicator, "Tell-Time" Scale, 340° concentric calibration. It's America's First Luxury Radio at a popular price! Read the full description of its amazing features on pages 12-13 of ALLIED's Free Catalog.



1937'S GREATEST VALUE
 SEE PAGES 8-9 and 12-13 IN YOUR ALLIED CATALOG.

1937'S WONDER RADIO

COMPLETE WITH RCA METAL TUBES
\$46.45

COMPLETE WITH RCA TUBES
\$99.50

THIS GREAT CATALOG BRINGS YOU EVERYTHING IN RADIO AT LOWEST PRICES

Parts — Kits — Test Equipment — Amateur Gear — Tools — Books, etc.

You need this Free Book, whether you sell, service or build radios, install P.A. Systems, or operate a "ham" station. ALLIED's Catalog shows everything in radio. Besides the 38 amazing new Knight Radios, its 152 pages include over 10,000 exact duplicate and replacement parts; the latest amateur transmitters, receivers and transceivers; the newest developments in test equipment; latest Public Address equipment. For Set-Builders, dozens of new kits—new metal tube DX'er, Knight Metal Tube Super-Gainer, new 6 volt all-wave set, 5-meter transceiver and many others. Also Rurlpower units and Windchargers. They're all in ALLIED's great new Catalog.

FASTER SERVICE—LOWER PRICES—HIGHER QUALITY

ALLIED's huge stocks are complete under one great roof. You get your order when you want it; our central location means faster shipping; an efficient organization gives you finest personal service. Because we are able to buy in vast quantities we get lower prices, and sell for less. Every item tested and approved by ALLIED engineers—your assurance of highest quality always! To be sure of greatest values, fastest service and lowest prices, always order from the ALLIED Catalog. If you don't have the big new 1937 Catalog, send the coupon now for your FREE copy!



Allied Radio Corp., 833 W. Jackson Blvd., Chicago, Ill., Dept. 1-A

Rush me a Free copy of your 152-page 1937 Catalog showing the 38 new Knight sets and complete Radio Supplies.

Name

Address

City State

ALLIED RADIO CORP.
 833 WEST JACKSON BLVD. CHICAGO, ILL.

ORPHANS? NO!

They bear the
RCA Trademark!

10,000 replacement parts,
available at all times,
prevent RCA Radios from
becoming orphans—re-
gardless of the set's age!



PASSING years and worn parts make no difference if the radio bears the RCA trademark. For no matter how old the set... no matter what part of its chassis needs replacement—the part is available.

There are 10,000 RCA replacement parts ready to serve owners of RCA Radios. All are of the same fine quality that was originally built into the set and sell at low prices. If your local dealer or distributor does not have the part you require on hand, he can obtain it for you quickly and easily.

RCA PARTS FOR PROFIT

RCA Manufacturing Co., Inc., Camden, N. J.
A service of the Radio Corporation of America

**HERE'S
The Key-**

SUCCESSFUL
SERVICING

-that opens
the door to
opportunity for
**PROFESSIONAL
SERVICE MEN**

Technical training is no longer a "luxury"—it is a NECESSITY! R. S. I. training was prepared, and is being constantly revised, by experienced men FOR experienced men. No waste material—but a complete home study course that starts paying for itself right from the first. Start any time—take up to 3 years to complete. Get complete details today—the sooner the better!

TERMS AS LOW AS \$5 MONTHLY



Free!

ILLUSTRATED
BOOKLET

Write today for FREE illustrated booklet: "The Key to Successful Servicing." Get all the facts now!

RADIO SERVICE INSTITUTE

SUBSIDIARY OF CREI

Dept. RN-1, 3308 14th St., N.W., Wash., D. C.

Radio News Binders
Now Available
(See Adv. on Page 443)

THE SERVICE BENCH

(Continued from page 404)

These are copied from the publications, and filed according to the name of the set manufacturer. Across from our bench we have three shelves where we keep radios that are in the shop for repairs (three shelves required!—Ed.) and on top of these shelves we have an attractive tube display."

Mr. Leffler goes in for drawers in a big way. "On the office side we have two fifty-four-drawer steel cabinets. One contains our office supplies and the magazines to which we subscribe, one year to a drawer, which keeps our literature neat and clean and efficiently filed for future reference. In the other cabinet we file data on receivers and parts—manufacturers' diagrams, vibrator guides, volume-control manuals, condenser and resistor circulars, etc.—all material that we use from day to day. This is filed alphabetically.

"Needless to say, we also have a public-address system for rent. And, by the way, we loan our customers radios while their own sets are being repaired."

We have an idea that the Ideal Radio Service has given a few of you lads something to shoot at!

THE DAY'S WORK

E. V. Roh, radio service engineer for Carl A. Anderson, Inc., Omaha, Neb., sends us the following dope on a—

Majestic 66 Auto Radio

"We were recently confronted with the problem of replacing the second i.f. coil on the model 66 Majestic auto radio. This i.f. component is of a special type with a tapped secondary, half the winding being shunted with a .0001 mfd. mica condenser. Being unable to secure these coils from our distributor, and having several of these sets in for identical servicing, we finally decided to rewire the second stage completely. After several experiments we determined to use the original volume control and the G-6C7 tube in order to provide satisfactory a.v.c. action. We removed the cathode-resistor assembly and substituted an entirely different arrangement in this particular part of the schematic.

"The revised diagram (showing the second i.f. section only) appears in Figure 1. A Bosch coil, part number IC-195, peaking at 175 kc., was substituted for the original part. We have found this arrangement to work very satisfactorily, giving maximum volume, excellent a.v.c. action and plenty of selectivity. The .1-megohm resistor coupling the diode plates in series with a .0001 mfd. condenser is not essential to good operation, but does contribute to volume."

Mr. Roh continues his contributions to servicing car radios with the following data on the—

Bosch

"A service hint in regard to all Bosch auto radios, up to and including model 79C, is a careful check-up on the continuity of the tuning condenser leads with an ohmmeter. In several instances we have run across resistances of three or four ohms—sufficient to lower the efficiency of the r.f. and oscillator stages. The trouble can be easily corrected by tightening the screws that hold the insulating bracket on the stator plates."

While on the subject of automobile radios, Henry A. Berg, Jr., of Butler, Pa., sends in the following item on the—

Philco Model CT11

"This automobile receiver has two transformer cans in the center of the chassis, held in place by means of springs which weaken with age—with resultant noise, instability, etc. The quickest remedy is to put a soldering lug under the nut on top of each can and bond them to ground with a flexible stranded wire at the same point that the variable condenser is bonded."

Admiral Auto Radio

"The complaint on this set was a bad 'clack-clack' that changed in frequency with the motion and speed of the car—a model A Ford. No mechanical defects could be found in the car. The trouble was located as a small vulcanized spot on a rear tire casing, which gave off a static discharge with every turn of the wheel! This interference was present only on paved roads."—J. O. Roberts, St. Louis, Michigan.

Universal Model 5-10

Mr. Roberts is also responsible for the following item: "This set is an a.c.-d.c. super with octal-base, glass tubes. The complaint was a bad a.c. hum—both constant and tunable. A careful check against the circuit diagram showed that a .1-mfd. condenser from the high side of the 400-ohm choke to the output of the 25A6 rectifier had been omitted in assembling this receiver. When this omission was corrected, the hum disappeared and the receiver operated perfectly."

A Live Sales Tip

At the recent IRSM convention held at the Pennsylvania Hotel, New York City, we ran across a serviceman from Flushing, L. I., who told us of a new form of circularization, which, as far as he is concerned, is original with him. While it costs

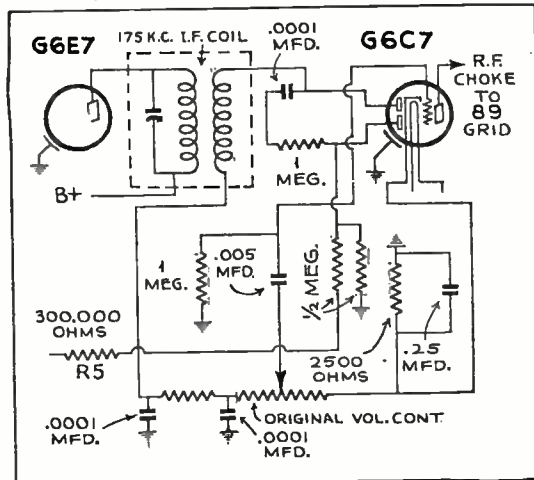

FIGURE 1

Showing the revised circuit of the second i.f. stage in the Majestic 66 auto radio.

a bit more than printed handouts, he claims (and we're inclined to believe him) that it is almost 100% effective—that is, a new customer for every "circular" mailed!

We put quotes around the word circular, for the advertising message is carried on a small recording made in his own shop. The blurb runs something like this—

"Good evening, radio listeners. This is John Doe speaking to you from the Doe Radio and Electric Shop, at 40 South Main Street. The telephone number is Main 109W. May I suggest that you file this record along with the rest of your selec-

(Turn to page 445)

RADIO NEWS INDEX

VOLUME XVIII, NUMBER 1

July, 1936 Page

January-June 1936 Index.....	4
Radio and Your Vote.....	7
What You Want to Know About Tubes.....	10
Complete Tube Chart.....	11
A Year of Metal Tubes.....	16
Data on the 6L6 Tube.....	17
Profits in Group Hearing Aids.....	17
Effective, Inexpensive Audio Oscillator.....	18
New Tuning Indicator Tube (Type 6G5).....	18
Seeing's Believing! (RCA Television Demonstration).....	19
The "Ham" Shack (Receiving Antennas).....	20
Inexpensive Field Strength Meter.....	21
New 16-Tube Superhet (Hammarlund Super-Pro).....	22
5-Meter M.O.P.A. Transmitter.....	23
Crystal Control on Five Meters.....	24
The "CQ'er" (I.C.W.-Mike Unit).....	24
Testing a 5-600 Meter Super (RCA-Mod. 175 ACR).....	25
World Short-Wave Station List.....	31
The Radio Beginner (Part 3, One Stage Audio Amplifier).....	34
The Radio Workshop.....	36
Australian DX Information.....	38
Election Profits for Servicemen.....	44
Students' Radio Physics Course (Cont'd, Resonance).....	52

VOLUME XVIII, NUMBER 2

August, 1936

Radio and Free Speech.....	69
Radio Aboard the "Hindenberg".....	72
The 5-Meter "Transceptor".....	73
Town and Country Portable Receiver.....	74
Oscillator Frequency Meter.....	77
Service Twins (Triumph Mod. 800 Oscillograph and 180 Wobbulator).....	78
Selling Service (Part 5).....	79
"Lab. Tests" of Modern Super (Hammarlund Super-Pro).....	85
The "Ham" Shack (Phone-C.W. Situation).....	86
New Amateur Transmitter (RCA Mod. ACT40 X-mitter).....	87
Doherty High Efficiency Transmitter Circuit.....	88
Installing Your Own "R" Meter.....	88
Transmitting Tube Chart.....	89
Junior Communication Receiver (Hallicrafter's Sky Buddy).....	90
Signal Seeking Circuits.....	90
Report on 5-Meter "DX".....	91
Volume Expansion and Better Quality.....	92
Vacuum-Tube Hearing Aid.....	92
Homemade Code Practice Oscillator.....	93
How to Learn the Code.....	93
Fundamentals of Electricity.....	94
The Radio Beginner (Part 4, A.F. Amplifier and Power Unit).....	96
Experimental 9.5-Meter Station.....	97
The Radio Workshop.....	98
Students' Radio Physics Course (Cont'd, Resonance).....	106

VOLUME XVIII, NUMBER 3

September, 1936

A Profitable Service Sideline (Light Meter).....	134
Radio in the Forest Service.....	137
Home-Built 5-tube Battery-Operated Super.....	140
The Improved Browning Set With Metal Tubes.....	141
Two New Ultra-H.F. Tubes (Types 316A and 304B).....	142
7-Tube Beam-Power Amplifier.....	143
The "Ham" Shack (C.W. 20-40 Meter Transmitter).....	144
New Amateur Receiver (National Mod. NC-100).....	145
Getting Started on 10 Meters.....	146
The Rig Checker.....	147
Portable 5-Meter Rig.....	148
Inexpensive "Lab" Crystal Oscillator.....	150
Matched P.A. Equipment (Webster Mod. P.A.-417 Amplifier).....	150
Serviceman's Resonance Indicator.....	151
Public-Address Replaces Fire Bells.....	153
Shielded Coil Inductance.....	153
Low-Cost B.F. Audio Oscillator.....	154

Page

Instrument Power Supply.....	155
The Radio Beginner (Part 5, A.F. Amplifier and Power Unit).....	156
C.B.S. Portable Transmitter.....	157
The Radio Workshop.....	158
Station List (U. S. Aeronautical Stations).....	160
Modern Super Tunes All Continents (Hammarlund Super-Pro).....	161
Radio Physics Course (Resonance, Cont'd).....	170

VOLUME XVIII, NUMBER 4

October, 1936

The Mad Television Scramble.....	201
Jones 5-10-20 Meter Super.....	204
5-Meter Linear Oscillator.....	207
The "Ham" Shack (5-Meter Transmitter).....	208
Ultra-H.F. Transmitter Tubes (Types T-55 and 814).....	209
Inexpensive Portable Transmitter.....	210
The Radio Beginner (Part 6, Two-Tube Regenerative Tuner).....	212
7-Tube Beam-Power Amplifier Design (Part 2).....	214
Synchronous Television Motor.....	214
Station List (Trans-Pacific Broadcast).....	215
New "Lab-Built" Super (Silver Masterpiece V).....	217
The Radio News "Tenatuner".....	218
"Wind" Radio for the Farm (Wincharger De Luxe).....	225
New B.F. Oscillator.....	225
"Selling Service" (Part 6).....	226
Serviceman's Oscillator.....	227
New P.A. System for Schools (Webster Series "S" Amplifier).....	227
Future for Trained Television Men.....	227
Inexpensive, Precision "Lab" Amplifier.....	228
Students' Radio Physics Course (Filters).....	232
The Radio Workshop.....	236

VOLUME XVIII, NUMBER 5

November, 1936

Television as Good as Home Movies (Philco Demonstration).....	265
Amateurs Can Build Television Receivers.....	267
Tunes to 4 Meters (Ultra Skyrider).....	268
20-Kilowatt Race Track P.A. System.....	269
Jones 5-10-20 Meter Super (Part 2).....	270
The "Ham" Shack (Activity on 5 and 10 Meters).....	272
An Improved Ribbon "Mike" (Bruno Velotron).....	273
Cabinets for Homemade Equipment.....	274
The Radio Beginner (Part 7, 2-Tube T.R.F. Reg.).....	276
Station List (European Broadcast).....	280
Measurements of "Lab-Built" Super (Silver Masterpiece V).....	287
Facts About Electrolytic Condensers.....	289
"Extra Service" Brings More Dollars.....	290
Dual Amplifiers Provide True Tone (Midwest Mod. 13).....	291
The "Spiderweb" Snags All Waves (RCA All-Wave Antenna).....	292
New Tubes Save Current (Types 6S7G, 6D8G, 6L5G, 6Q6G, 6N5).....	292
Students' Radio Physics Course (By-Passing).....	296

VOLUME XVIII, NUMBER 6

December, 1936

Exposing Cut-Rate Service "Gyps".....	329
Telephone Service to Harbor Craft.....	331
New Permanent-Magnet Speaker (Cinaudagraph Magic-Magnet).....	332
New A.C.-D.C. Tubes (Types 25B5, 25N6G).....	332
Home-Built, High-Fidelity Receiver.....	333
Radio Aids to Aviation.....	334
Radio News Supplementary Tube Chart.....	336
Modern Testing Equipment (Supreme Mod. 555).....	338
New Antenna Suppresses Noise (Philco All-Wave Aerial).....	338
"Movie" Dial Projects Call Letters (Montgomery Ward Receiver).....	338
U.H.F. Receiver Sets New Standards ("Ultra Skyrider").....	339
The "Ham" Shack (Curing B.C.L. Trouble).....	340
Jones 5-10-20 Meter Super (Part 3).....	342
Police Aircraft Radio.....	344
Advantages of an "R" Meter.....	344
Test Report on New Dial Disk Receiver (Midwest Mod. 18).....	345
Station List (U. S. by frequencies).....	348
Tests Prove Merits of "Lab-Built" Super (Silver Masterpiece V).....	349
Students' Radio Physics Course (Filters).....	358

Learn RADIO from REAL RADIO ENGINEERS!



HERE THEY ARE.

Kendall Clough
Chief Engineer,
Clough-Brengle
Company.

E. E. Gramer
Chief Engineer,
Standard Trans-
former Co.

Karl E. Hassel
Chief Engineer,
Zenith Radio
Corp.

F. H. Schnell
Radio Engineer
Grunow Radio

Dr. C. M.
Blackburn
Production
Department,
P. R. Mallory
and Co.

Many R-T-I Trained Men Earn up to \$75 a Week and More

These industry appointed engineers, who work for large radio manufacturers, will supervise your training at home, and get you ready for good-pay jobs in Radio Broadcasting, Installation, Servicing, Public Address System and Photo Electric Cell work. Also for coming activity in Television. Opportunities for properly trained men better than ever before. Earn while you learn. Some make \$5 and \$10 a week extra in spare time one to two weeks after starting. Many earn up to \$75 a week in full time, jobs or their own business. Some even more. No other training like mine. Get the facts if you want a better job. Write now for my free book.

50 BIG Radio Concerns Endorse R-T-I

Among them are Philco, Crosley, Grunow, Stewart, Warner and others.

RAY D. SMITH, President.

RADIO AND TELEVISION INSTITUTE

Dept. 41, 2150 Lawrence Avenue, Chicago, Ill.

MAIL COUPON FOR FREE BOOK

RAY D. SMITH, President
Radio and Television Institute (R-T-I)
2150 Lawrence Ave., Dept. 41, Chicago, Ill.

Without obligating me, send new FREE Book about spare-time and full-time Radio opportunities and how I can train for them at home.

Name

Address

City State

300% INCREASE in 2 YEARS!

RAYTHEON

TRADE MARK

MAKERS OF THE FAMOUS 4 PILLAR TUBES

This tremendous increase is the direct result of putting each tube through more than 87 rigid tests before it can bear the name RAYTHEON! No higher quality tube is possible.

THE MOST COMPLETE LINE- ALL TYPES OF GLASS, OCTAL BASE METAL AND AMATEUR TRANSMITTER TUBES

RAYTHEON PRODUCTION CORPORATION

420 Lexington Ave. New York, N. Y.
55 Chapel Street Newton, Mass.

445 Lake Shore Dr. Chicago, Ill.
555 Howard St. San Francisco, Cal.

415 Peachtree Street, N. E. Atlanta, Ga.

The RADIO WORKSHOP

Items of interest for beginners, experimenters and radio constructors.

Conducted by The Associate Editor

Instrument Amplifier

In order to obtain a more accurate balance in bridge measurement work in which a thousand cycle note was used as the voltage source, the special audio amplifier using a 6F7 tube shown in the accompanying drawing was constructed and with phones connected in the out-

of preventing the output from reaching too high a level.

After experimenting with a number of tubes, the 6F7 type was selected, because it was possible to obtain a compact two-stage amplifier of high gain with a single tube. The phones are connected in the output of the triode section of the tube.

Limiting the output was secured simply

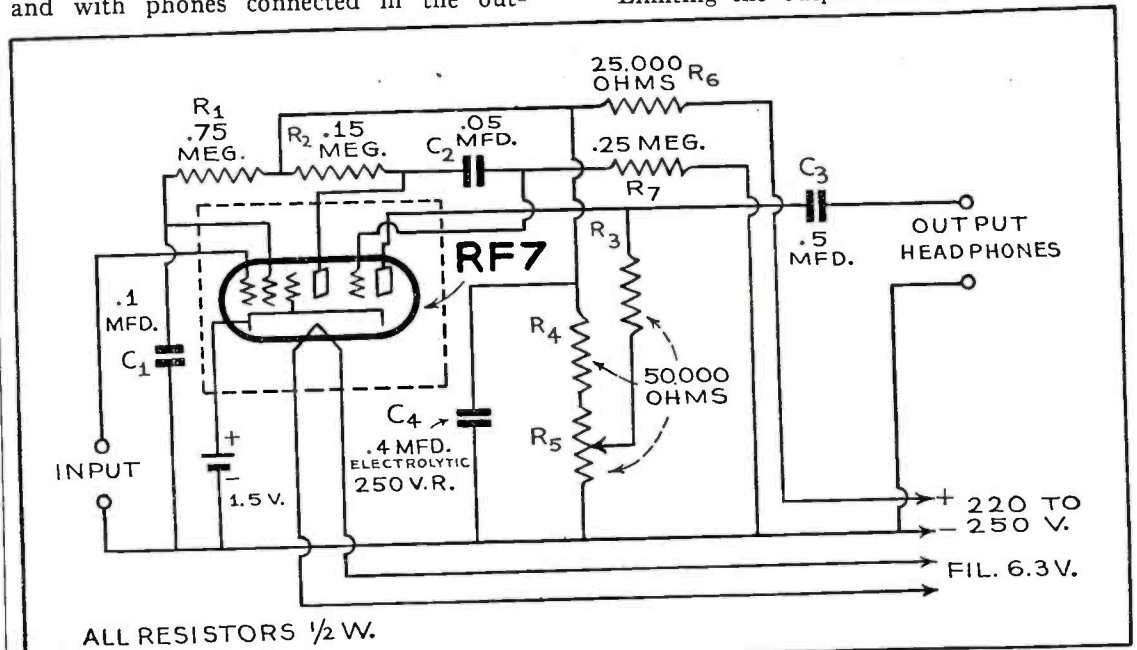

put, very satisfactory results were obtained with it as a balance indicator.

What was needed for this purpose was an amplifier of reasonably high gain with an output suitable for phones and means

by lowering the plate voltage through R4 resistor, thereby reducing the plate signal voltage swing. The high level signal was considerably distorted due to the tops of the signal being flattened out on the negative and positive peaks from overload. In order to control this action the triode plate voltage was made adjustable by means of the potentiometer R5.

The amplifier was so satisfactory that it was used as a general purpose amplifier for testing coils, as a detector-amplifier, as a preamplifier for a crystal microphone and as a means of increasing the sensitivity of an output meter.

The illustration shows the amplifier connected to the midget instrument power supply which was described in the September issue. This tiny power pack using the type 6H6 tube as a rectifier in a voltage-doubling arrangement supplies the operating voltages for the amplifier.

GERARD KELLEY,
New York, N. Y.

Make Your Own Photo-Electric Device

It is not generally known that the type 200A tube has photo-electric properties,

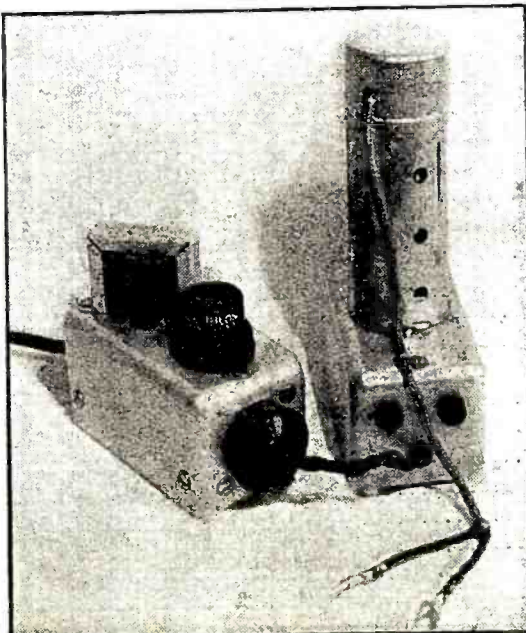

due to the caesium it contains. The accompanying diagram shows a simple oscillating circuit in which this tube is employed as a photocell. The minute amount of current developed in the 200A tube being used to operate a relay. This circuit is highly sensitive and can be used to measure very high resistances or to test insulation.

The circuit consists merely of an oscillator using a triode tube, in this case the type 30, with a variable condenser of the trimmer type, C1, used as a grid condenser and the photocell used as a grid-leak. When the condenser C1 is adjusted so that the oscillator is just on the verge

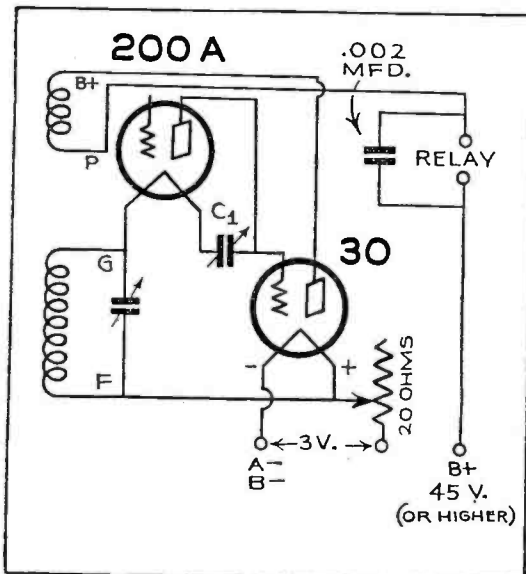

of stopping oscillation a small change in the value of the grid leak (200A) will have a large affect on the plate current. Very good insulation must be used in the grid circuit. In this application, no filament voltage is applied to the 200A tube. For the tuning inductance any oscillator coil and tuning condenser will serve, or if desired, an audio transformer can be used, in which case the B-plus terminal should be connected to the plate of the 30 tube. The B voltage can be anything between 45 and 200 volts. It should be maintained constantly as it has a large influence on the operation of the circuit at a given adjustment. Maximum sensitivity is obtained with high voltage.

In operation a sudden change in plate current starts the circuit to oscillating and thus charges the condenser C1. This charge leaks off through the 200A tube and when the charge has leaked off sufficiently the tube starts to oscillate again and the process is repeated. By correctly adjusting the condenser C1, the circuit could be so regulated to give anything from the series of clicks to a high-pitched whistle if connected to an amplifier and in the loudspeaker, or can be used like any photo-electric device to operate a relay directly to perform many functions.

The circuit is so sensitive that the light from a flashlight falling on the 200A tube several feet away will actuate a relay in the plate circuit. The 200A seems to be most sensitive in the blue end of the spectrum.

MERRITT L. PERKINS,
Three Rivers, Mich.

Helpful Information

Many of our readers will be interested in the following information on the application and use of crystal (piezo electric) headphones compiled by the Brush Development Company.

The Brush headphones are designed to have a response from 60 to 10,000 cycles, a sufficiently wide range to make them applicable to any type of electro-stethoscopic work where the higher frequencies are important. The high impedance and sensitivity enable the phones to be operated
(Continued on page 434)

A TRANSCRIPT from an AMATEUR'S LOG*

*Based on
one amateur's
actual experi-
ence with the
Ultra Sky Rider.

OK Bill, 100% that trip -- that way nearly all the time now. So you're having the same success with your Ultra that I am! Got a big kick out of five last night -- fellows from 25 to 40 miles in there like sore thumbs. Now that I can hear things I find this a darned attractive band. The expander is particularly justified on 5 as the boys do flutter around a bit but it takes care of that. The running motor on the neighbor's car doesn't even bother me, which speaks well for the noise silencer as ignition noises used to paralyze me from 40 down. Did you hear all the 10 meter stations yesterday? Seems all the 6's are on 10 nowadays. More DX there than you can shake a stick at. Now that I can hear them I've got to get the bugs out of my transmitter so that I can get down there myself.

Felt sorry for "Doc" Simpson on 20 around 3 o'clock. ON4VK had the band all sewed up on the Ultra and even tho Doc was at the mike 8CPC couldn't hear him in this country. I believe the Iron Cores are responsible for a lot of this receiver's performance. The Signal to Noise ratio is much better than we've been used to -- why, early Saturday morning -- 7:15 to be exact -- I heard four VK fones none less than 4-6 and the average 5-6-7. VK7JV and VK7CO were in especially well.

Either 20 was hot yesterday or this receiver is unusual. English fones were in from 3 o'clock on after the band lengthened out. Got SU16H, G5NI, G5ML and a flock of others.

Last night, I tried 40 and found a lot of good signals, and could separate them clearly, too. Crystal is certainly the answer on code and voice too. Much pleased with the sensitivity of the Ultra -- ZL's started coming through in great style at 10:30 o'clock,

How am I coming thru? After we get used to operating the Ultra we won't have to worry much about QRM. Even now, after only a week, I can set 'em up all by themselves and keep them that way. Darn shame more of our foreign friends aren't using the Ultra. I'd fell much surer of getting them -- sorry to be so long-winded -- guess my enthusiasm got the better of me -- Just a minute until I see if your channel is clear . . . OK, go ahead.

the ULTRA SKYRIDER



AN ENTIRELY NEW APPROACH TO ULTRA HIGH FREQUENCY RECEPTION—
3.76 to 53 meters in 4 bands. Built-in Lamb Noise Silencer. 10 All-Metal Tubes. Iron Core Expanding I.F. Transformer. Direct Reading Frequency Calibrated Micro-Vernier dial. Individual Coils for each band, and dozens of other new and exclusive features.

See it at your dealer's or write for complete information.

All Hallicrafters' Receivers now available
on Time Payments through your dealer.

the hallicrafters inc.

2603 Indiana Avenue, CHICAGO, U. S. A. — Cable Address "LIKEX" N. Y.

"MAN-MADE" STATIC

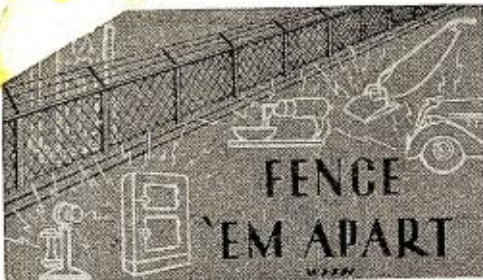

Nuisance noises caused by household appliances and motors can be completely divorced from any radio set by using a licensed A.A.&K. "NOISE-MASTER" antenna. Reception improved on both broadcast and shortwave bands. A model for every set and location.

"NOISE-MASTER" No. 14 list price
Amy, Aceves & King patented. Brings in overseas signals stronger, and eliminates "man-made" static on broadcast as well as shortwave band. For better reception in EVERY location. **\$6.75**

"NOISE-MASTER" No. 18 list price
First time at this popular price: licensed Amy, Aceves & King antenna of simple doublet type. SELF-SELECTING, recommended for clarifying shortwave reception. **\$3.40**

"NOISE-MASTER" No. 19 list price
SELF-SELECTING doublet type, Amy, Aceves and King licensed, with junction-box in the antenna line. Assures excellent all-wave reception. **\$4.30**

CORNISH WIRE CO., Inc.
30 Church Street New York City

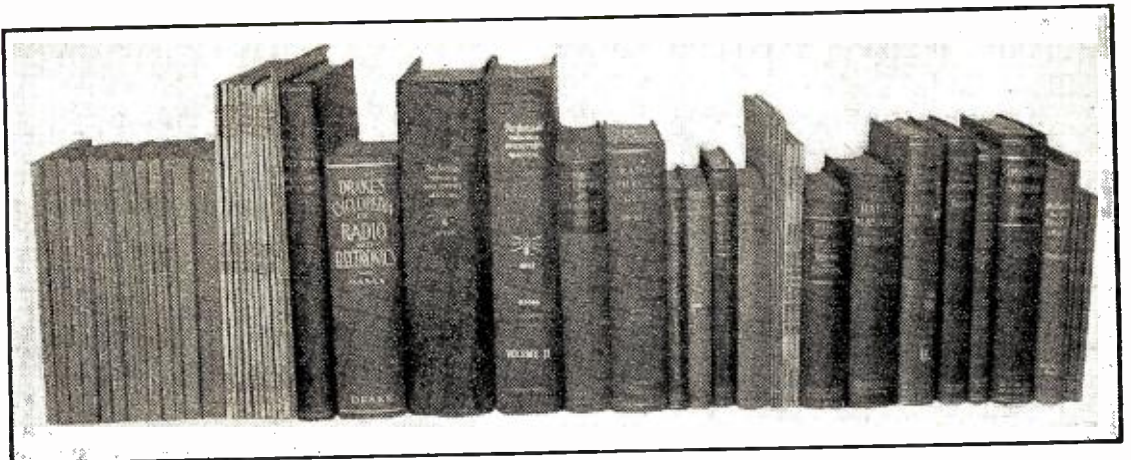

THE TECHNICAL REVIEW

CONDUCTED BY THE TECHNICAL EDITOR

Television, Volume I; published by RCA Institutes Technical Press; 1936. This is a collection of addresses and technical papers on the development of television, all the papers having been delivered by Mr. Sarnoff and engineers of RCA. Most of the technical articles have appeared in the I.R.E. proceedings but a collection of them in one volume will, no doubt, be welcome. There are a total of 25 articles; among these are four addresses by Mr. Sarnoff on the development and the future of television. One address by Dr. Jolliffe explains the required band width for television transmissions and stresses the necessity of reserving a definite range in the ultra-short-wave bands. Then there are technical articles on the propagation of ultra-short waves, the theory of the cathode-ray tube, the conoscope and the kine-scope, description of experimental receivers and transmitters and a very useful article on scanning and interlaced scanning.

Handbook of Chemistry and Physics; Twenty-first Edition; Editor-in-Chief, Charles D. Hodgman; Chemical Rubber Publishing Co.; 1936. This book supplies numerous tables, formulas and scientific data in the fields of mathematics, chemistry and physics. In its 2000 pages, one finds most of the essential information needed by engineers and experimenters.

Those who are acquainted with previous editions of this work need no further introduction. The new edition contains over 175 pages more than last year's. In the mathematical section, the logarithm tables of 4 and 5 places have been placed at the beginning. The numerical table now consists of two parts, one part giving reciprocals and circumference and areas of circles, the other, powers and roots. Additional and revised material on laboratory arts and recipes as well as on photography has been included. Other changes include a new table of the properties of plastics, a revised table of isotopes and a table for reducing gas volume to standard conditions.

The book is divided into four parts. The first part contains mathematical tables and equations. There are tables of logarithms, of trigonometric function, hyperbolic functions, compound interest tables, etc. The second and third parts contain tables of the properties of the elements, organic and inorganic compounds, oils, resins, alloys, plastics, etc.

The fourth section is devoted to physics. Here are many tables of interest to the radio engineer. There are, for instance, the table of musical scales, the table of sound absorption, tables of resistivity and dielectric constants. Among the miscellaneous tables one finds formulas of radio, a table of LC constants, wire tables, a table of tube characteristics and many others.

Automatic Volume Control, by John F. Rider; published by John F. Rider, 1936. Another volume in the series "An Hour a Day with Rider" is a complete treatise of a.v.c. systems in all its variations. The author explains the action of these circuits, beginning with the simplest and continuing with delayed a.v.c. systems, noise suppression or q.a.v.c. systems and trouble shooting.

Review of the Proceedings of the Institute of Radio Engineers for October, 1936

The Design of Doublet Antenna Systems, by H. A. Wheeler and V. E. Whitman. An article discussing the design of a double V doublet antenna for frequencies between .54 and 18 megacycles. Balanced operation is obtained above 6 mc., unbalanced operation below that frequency. A filter at the antenna end of the line performs the "switching" automatically.

Electron Beams and Their Applications in Low-Voltage Devices, by H. C. Thompson. A study of electron beams which can be produced in vacuum tubes employing no more than 300 volts anode potentials. By the use of beams, new possibilities appear in the vacuum tube technique.

The Measurement of Radio-Frequency Power, by A. Hoyt Taylor. The cathode-ray oscillograph can be employed as a wattmeter for frequencies from 25 cycles to 40 megacycles. One pair of deflecting plates is connected across a part of a high-resistance voltage divider which in turn is connected across the load. The other pair of plates connects across a condenser in series with the load. The oscillograph then traces out an ellipse, the power being proportional to the area of the ellipse, the frequency, the capacity of the condenser and a constant. Amplifiers are used to extend the sensitivity of the equipment down to .01 watt.

Review of Contemporary Literature

This department calls attention to articles appearing in recent publications. They are not included in the free booklets. The name of the publication and the date is given for each article. Addresses of publishers will be furnished on request.

Tabulation of Rectifier Tubes, Electronics, October, 1936. A table of characteristics of the vacuum, gas-filled and grid-controlled types which are intended for industrial and transmitting purposes. This table includes data on tubes from eight manufacturers.

A Method of Eliminating Cavity Resonance, Extending Low-Frequency Response and Increasing Acoustic Damping in Cabi-

TRIAD RADIO TUBE FREE!

List Value \$1.25

A DARING NEW PLAN!

Try TRIAD Tubes . . . and we know you'll be convinced of their superior quality. To induce you, we make this free offer: Send us your name and address . . . ask for your FREE TUBE CERTIFICATE and DATA CHART. Then present your certificate to your jobber when you purchase TRIAD Tubes . . . save up to \$1.25 . . . is there a serviceman or dealer who won't grab this? Write today! Address Dept. M-13.

WRITE TODAY!
SAVE \$1.25

TRIAD MANUFACTURING CO., INC. PAWTUCKET, R. I.

AIR SCOUT Jr. DOLLAR RADIO

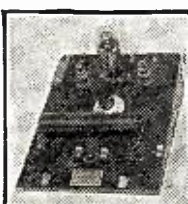

A real radio capable of keen broadcast reception. For only \$1 you get every part needed to build the powerful radio shown, including tube. Parts mount on wood panel (not in kit) which you can make yourself. Uses inexpensive dry batteries. Full-size picture diagram and detailed instructions.

\$1

FUN TO BUILD—FUN TO OWN FREE: Genuine lattice-wound Find-All coil used in Air Scout Jr. sent postpaid upon receipt of 10c to cover handling cost. For an additional 10c a picture wiring diagram with values of all parts will be included. **ALLIED ENGINEERING INSTITUTE, Dept. RN-98 Park Place, New York, N. Y.**

net Type Loudspeakers, by B. Olney; Journal of the Acoustical Society of America; October, 1936. A description of the effect of the acoustic labyrinth compared to other systems employed in radio receivers. Curves are shown of the frequency characteristics with and without labyrinth. No design data on the labyrinth are given.

A Direct-Reading Frequency Meter with Built-In Calibrator, General Radio Experimenter, September-October, 1936. Description of a new heterodyne frequency meter which uses harmonics but is direct reading and avoids any doubt as to the harmonics involved.

The All-Around Radiation Characteristics of Horizontal Antennas, by George Grammer, QST, November, 1936. An article with several curves which show the directional characteristics of a horizontal antenna.

Room Acoustics for Phone Amateurs, by G. C. Omer, Jr., Radio, November, 1936. Many amateurs never succeed in sounding "right" over the air. Too much reverberation from hard-plastered walls may be the cause. The article suggests remedies so as to reduce reverberation time, thereby making speech more understandable.

FREE BULLETINS

Just Released 1937 Catalog

Wholesale Radio Service Company has just brought out their new 1937 catalog, comprising more than 150 pages, listing all-wave and short-wave receivers, transmitters and parts, replacement units, service testing equipment, etc. For convenient reference it is divided into several sections and the receiver section is illustrated in rotogravure. Copies can be ordered free-of-charge from RADIO NEWS, 461 Eighth Avenue, New York City.



Enter Your Name for Free Booklet

The Brush Development Company, well-known manufacturer of crystal microphones and head sets, publishes an interesting little monthly magazine entitled "Brush Strokes". It contains instructive data on the application of piezo-electric products and up-to-the-minute information on new developments and products in this field. Through the courtesy of this company, RADIO NEWS readers can receive "Brush Strokes" each month, without charge. Simply send your request on your letterhead or Q. S. L. card to RADIO NEWS, 461 Eighth Avenue, New York City

RADIO NEWS Booklet Offers Repeated

For the benefit of our readers, we are repeating below a list of valuable technical booklets and manufacturers' catalog offers, which were described in detail in the July, August, September, October, November and December, 1936, issues. The majority of these booklets are still available to our readers free of cost. Simply ask for them by their code designations and send your requests to RADIO NEWS, 461 Eighth Avenue, New York, N. Y. The list follows:

- Jy1—Tube Engineering Bulletin on Harmonic Analysis of Modulation. Ken-Rad Corp. Free.
- Jy2—Free Tube Chart of the Raytheon Production Corp.
- Jy3—Public Address Catalog of Operadio Mfg. Co. Free.

- Jy4—Latest Radio Parts Bulletins Utah Radio Products Co. Free.
- At2—Modulation Booklet. United Transformer Corp. Free.
- At4—P. A. Equipment Catalog. Wholesale Radio Service Co., Inc. Free.
- At5—Amateur Radio Booklet. New York Wireless School. Free.
- S1—Catalog on Permanent Magnet Speakers Cinaudagraph Corp. Free.
- S3—Cornell-Dublier Corp. Folder on New Service Condensers. Free.
- S4—Webster Company Catalog on Sound Systems and Accessories. Free.
- S5—Transformer Replacement Catalog. United Transformer Corp. Free.
- O1—1937 Catalog of Insuline Corp. Free.
- O2—Transformer Guide, Johnson Transformer Co. Free.
- N1—Transmitting Tube Guide. Free to Amateurs and Station engineers. Taylor Tubes, Inc.
- N2—Free Tube Base Chart. Weston Electrical Instrument Corp.
- D1—Latest Radio Parts Catalog of Allied Radio Corp. Free.
- D2—Catalog on Replacement Volume Controls, Switches, Vibrators, etc. Yaxley Mfg. Company. Free to Servicemen and dealers.
- D3—Resistor Catalog, Free. Atlas Resistor Company.
- D4—Public Address Bulletin of United Sound Engineering Co. Free.

Superregenerative Receivers

(Continued from page 403)

and the detector as in Figure 1, A to E, a gain in selectivity may be obtained, especially with loose coupling. The choice of interruption frequency, however, gives the greatest amount of control over selectivity. The general rule is that the lower the interruption frequency, the greater the selectivity and, incidentally, the sensitivity. The lower limit is a frequency which is audible in the loudspeaker. Frequencies around 20 kc. appear to be the lowest practical limit without resorting to elaborate low-pass filters ahead of the audio circuits. If a switch is provided on the control panel, which cuts in and out an additional condenser in parallel with the i.f. transformer, an effective selectivity control is provided; but more about this next month. Lowered selectivity may be desirable on badly "wobulated" signals in order to get good intelligibility.

Fidelity

Distortion covers a multitude of sins, among which the most important are frequency discrimination and wave-form distortion. At the present writing, I doubt if anyone considering the design of a high-fidelity u.h.f. receiver would give superregeneration a second thought. However, for communication services and amateur work, where intelligibility is the important factor, the distortion inherent in a good superregenerative circuit is of minor importance. Frequency discrimination is largely a function of the audio circuits and loudspeaker, but wave-form distortion is produced by the detector circuit itself. The amount of this distortion is entirely within the control of the designer and the operator and may vary from complete unintelligibility to a good quality.

In explaining this point, we will assume that the incoming signal is free of frequency modulation. Now the smooth superregenerative receiver may be operated in two different manners. The first and most common way is to decouple the antenna circuit sufficiently so that a strong hissing or rushing noise is present with no signal. An incoming signal "knocks" this rush to an extent depending upon its strength. Under these conditions, the detector operates so as to give a certain amount of a.v.c. action. Unfortunately for the fidelity, this action is not confined to the carrier, and

(Turn to page 431)

SERVICE MAN MAC says:



"This ELECTRAD is the quietest control I've ever used!"

- Thousands of service men can tell you the same thing—an Electrad Carbon Volume Control is quiet when new, stays quiet in use.

- That's because of the Electrad direct friction contact construction. Just one single moving part—the contact shoe—rides over a carbon resistance element, permanently baked to a warp-and-wobble-proof Bakelite ring.

- This direct contact is self-cleaning and self-polishing, and assures perfect, stepless graduation. No gaps to cause noise or stuttering. Electrad is electrically as well as mechanically quiet.

- Try an Electrad on your next replacement job. Every Electrad control is noise tested at the factory and fully guaranteed.



New 1937 Electrad Volume Control Guide gives complete replacement data for every type of set. Most up to date and handiest manual of its kind. Every service man needs a copy. Send top of one Electrad Volume Control carton (showing Spec. No.) with business card or letterhead for yours. Address Dept. RN-1.



"RESISTOR HEADQUARTERS"

RADIO PHYSICS COURSE

ALFRED A. GHIRARDI



The RIGHT COMBINATION at your fingertips

Here's some light on that SELECTOR SWITCH PROBLEM, you Knight of the soldering iron.

If the circuit calls for more lugs than a centipede has feet—scram over to your jobber, and make up your own SELECTOR SWITCH . . . thousands of different combinations possible with a CENTRALAB Kit at his place.

Switches for

- Analyzers
- Output Meters
- R F Oscillators

- A F Oscillators
- Tube Checkers
- Decade Boxes
- Capacitance
- Resistance
- Ham Equipment
- P A Work
- Volt-Ohm-Amp Meter
- Radio Receiver Replacements



Centralab

MILWAUKEE, WIS.

British Centralab, Ltd.
Canterbury Rd., Kilburn
London N. W. 6, England

French Centralab
Co., 118 Avenue
Ledru-Rollin, Paris
XI, France

Lesson 58. Filters

If the inductance is arranged with a condenser shunting the line at each end, as shown at (A) of Figure 1, we have what is known as a π ("pi") filter section. (This name originated from the fact that the circuit diagram has the same form as the symbol π . The action of this type is somewhat similar to that explained for the T-section, excepting that now there are two condensers across the circuit. If two of these filters are connected together as shown at (B), we have at the junction a total capacitance which is equal to the sum of the two similar capacitances joined in parallel there. This circuit may be rearranged as shown at (C) where the larger single capacitance C_1 has been put in place of the two smaller ones in parallel, and is equal to two times each outside capacitance. The outside capacitances are now called $\frac{1}{2}C_1$ for convenience. At (D) a three-section filter of the "pi" type is

the inductances and capacitances required to locate this cut-off at the desired frequency. This frequency may be referred to simply as f . Usually the number of sections which the filter must have to make the cut-offs as sharp as desired must also be found.

For a low-pass filter of either the T or "pi" type, the values of capacitance in microfarads, and inductance in henries for a cut-off at f cycles per second, are given by:

$$L_1 = \frac{0.3183 Z}{f} \quad (25)$$

$$C_1 = \frac{318,300}{f Z} \quad (26)$$

$$\text{and } f = \frac{0.3183 Z}{L_1},$$

$$\text{or } f = \frac{318,300}{C_1 Z} \quad (26A)$$

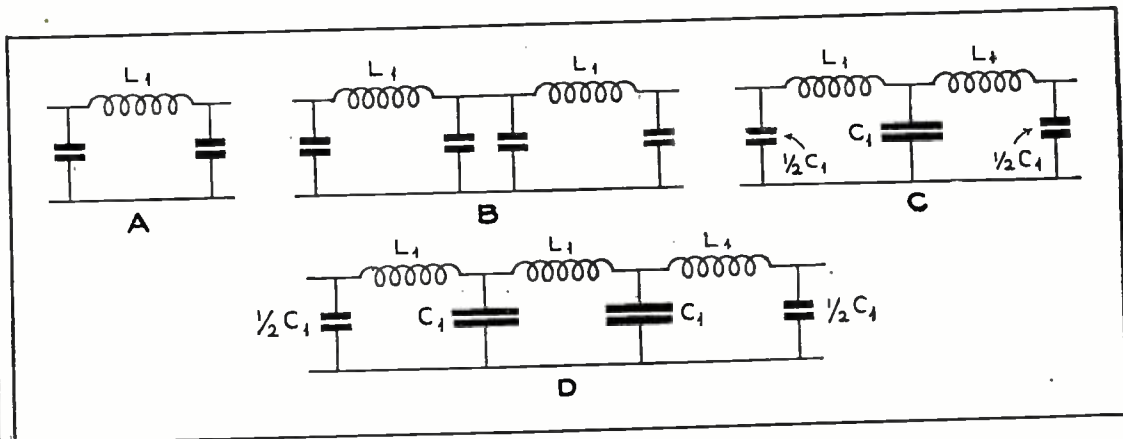

Figure 1. (A) Single section "Pi" type filter, (B) and (C) 2-section "Pi" filter. (D) 3-section "Pi" type filter.

shown. Notice that the end capacitances are $\frac{1}{2}$ the capacitances used in the repeating sections. The "pi" type filter is usually better than the T type for circuits of approximately constant current.

The point at which a low-pass filter begins to cut-off is known as the *cut-off point*, and the design consists of calculating

Notice that these formulas give the values of L_1 and C_1 as shown in Figure 1. L_1 is in henries and C_1 is in microfarads. Z is in ohms and is called the *characteristic or iterative impedance* of the circuit in which the filter is to be placed. The impedance Z is an important factor in the determination of the size of the condensers and coils.



E. H. RIETZKE

PRES. OF CREI

Is Radio . . . Just A Job to You?

If you can equip yourself with the necessary training . . . Radio can offer you an excellent future. Continuous new developments have created a need for technically trained men, who have kept their knowledge up with Radio's fast pace.

YOU CAN'T BLUFF YOUR WAY

CREI courses are planned only for serious-minded men who know that it takes Training to qualify for and to hold the big jobs and salaries that go with them. Let us suggest the course best suited for you and the easy ways of paying for it.

ILLUSTRATED CATALOG FREE

Write today for your copy. Answers your every question and shows actual equipment, as well as outline of courses.

CAPITOL RADIO ENGINEERING INSTITUTE

Dept. RN-1

Washington, D. C.—14th & Park Road
New York City—29 Broadway

Microphones

(Continued from page 395)

Advantages: It has a highly directional pick-up range which is advantageous for indoor work. Its noise level is at a minimum. Its frequency response is excellent and is largely limited by the design of its coupling transformer.

Limitations: This type of microphone is not a good device for close talking, giving bassy reproduction and is not particularly adapted to out-of-door work because of the delicately suspended ribbon.

Crystal Microphone

There are two types of crystal microphones. One employs a sound cell with a diaphragm attached to some point on the cell. In this type of crystal microphone, sound waves strike the diaphragm and vibrate the sound cell. The sound cell is so constructed that feeble currents are generated in proportion to both the level and frequency which strike it. This feeble electric current is then sent to the amplifier. In the sound cell type of crystal micro-

phone, no diaphragm is employed. This has the advantage of producing a far better frequency response than the diaphragm type as there are no limitations to the mechanical vibration which is set up in the former.

Advantages: The crystal microphone is rugged, is suitable for both indoor and outdoor work and has excellent frequency characteristics.

Limitations: Low output and high impedance.

Condenser Microphone

The condenser microphone operates upon the principle of changing capacity between two electrodes. A stretched metallic diaphragm is insulated and separated by a very small distance from a flat electrode. In this case the sound pressure waves striking the diaphragm cause it to move, thereby changing the capacity. The two electrodes and diaphragm and the stationary electrode are maintained at a potential of 90 volts or more from each other.

Advantages: Frequency response is considerably improved over the carbon microphone and the inherent noise level is low.

Limitations: Low output which requires a polarized potential for its operation. It is difficult to keep in operating condition due to the extremely small clearance between the diaphragm and the back plate. It is essentially a high impedance device and therefore is not applicable for long microphone runs.

Dynamic Microphone

The dynamic type of microphone is a complete self-contained unit that does not require field excitation. It consists of an extremely light voice coil, mounted on a diaphragm. The voice coil is maintained in an intense magnetic field which is supplied by a permanent magnet.

Advantages: The dynamic microphone has low impedance and its noise level is extremely low. It can be made with excellent frequency response.

Limitations: It is heavy and must be handled with extreme care. Also, it is non-directional.

Service Charges

(Continued from page 406)

free inspection idea, if employed in a legitimate way, is a sound bit of merchandising, mainly because in the majority of cases *something wrong will be found!* And in the rare instances where there is nothing the matter with the receiver, your frankness in admitting it will be appreciated and remembered when the set does go haywire!

The idea of free this that and the other thing has been pounded into the minds of the American buying public for several generations. It is taken for granted as a part of almost every type of service—free crank-case service, free air, free parking, etc. Ordinarily it is good sales psychology, and, if other things are done in a business-like and honest way, it may be ultimately profitable. However, it is under the banners of "Free Inspection" and "Inspection—50c" that some of the worst forms of radio racketeering are carried on, for which reason these forms of merchandising have gained a bad reputation, particularly in the larger metropolitan areas.

In summation, it would appear that the ideal system of charging for radio service would be a combination of the arrangements considered above, with the list price plus labor *predominating by far*. The criterion must be the financial status of the serviceman. If he is not making the money that will provide him with a satisfactory living, and assuming that he has sufficient business, either his expenses are *too high* or his charges *too low*. In the light of this article, the individual serviceman himself, in his own individual location, is the best judge of what revision should be made.

Radio to Unify the Nation

By J. F. Witkowski
International Correspondence Schools

No one can foretell what the future holds for radio as an educational medium. Already wonders have been accomplished in both the child and adult field; in school and in the home; in vocational and cultural lines; in religion and in politics. Radio, more than any other agent, has it in its power to unify a nation in its thoughts and aspirations—all this in the realm of sound alone. Even the most active imagination will fail in its endeavor to visualize what radio as a carrier of sound and sight—television—holds in store for the education of the world.

Free!

CLOUGH-BREngle INSTRUMENTS

New 1937 MODELS... with

NATIONAL UNION TUBES

FLASH! EXTRA!
Time Payments on Deposits!!

Service experts! Get many latest type service instruments for only a few dollars down and time payments on the initial low N.U. deposit. Remember—deposits are refunded when tube purchases are complete! Get the equipment you need, get it now, the sensational new N.U. way. See your jobber for details!



1937 Clough-Brengle Signal Generators. Model OMA operates from 110 volts, 50-60 cycle, continuously variable 100 K.C. to 30 M.C. Single and double trace selectivity. Curves for use with output meter or oscillograph; Complete with tubes and accessories. Model OC-A, 100 K.C. to 30 M.C., operates from 110 volts, 50-60 cycle. Complete with tubes and hand drawn calibration curves.

Available on N.U. tube deals with time payment plan covering deposit. Investigate.

YES—FREE—THE N. U. WAY

The National Union Way makes the purchase of National Union radio tubes doubly profitable. Besides full protection on the highest quality radio tubes, each National Union tube purchased helps to earn free equipment. But, possession of the equipment is obtained at once with just a nominal cash deposit. (Deposit is rebated when required number of tubes have been purchased.) Over 50,000 completed deals with progressive Union dealers. Don't be misled. See your National Union jobber and get all the facts.

OTHER NATIONAL UNION OFFERS

In SOUND EQUIPMENT items available include 17-watt portable system, 10-watt portable system, 6-watt portable system, phonograph pickup and turntable, etc., all manufactured by Webster-Chicago. In SHOP EQUIPMENT items available include stock cabinets, coats, display signs, etc. All items absolutely free the National Union Way. Get full details. In SERVICE EQUIPMENT items available include tube testers, analyzers, oscillographs, signal generators, modulators, meters, etc., products of such manufacturers as Supreme, Clough-Brengle, Hickok, Triplet, Readrite, Precision, Radio City, Dumont, J. F. D. and others.

ABOUT NATIONAL UNION RADIO TUBES

National Union manufactures a complete line of radio tubes in glass, metal and G-type. National Union's high quality has made them the outstanding favorite in the radio service profession. All sales policies have been formulated with the idea of making National Union radio tubes the ideal replacement tube for the radio dealer. This has been backed up with a selling program that means real support and help to the wide-awake dealer. Dealers and jobbers handling National Union radio tubes are the leaders in repair parts and services.



MODEL OMA
14¢ PER DAY \$1140 DOWN
DEPOSIT REFUNDED



MODEL OC-A
7¢ PER DAY \$540 DOWN
DEPOSIT REFUNDED

Let National Union Help You Write for Information

NATIONAL UNION RADIO CORPORATION
570 Lexington Ave., New York City

Without obligation please send me more information on RN-137

.....Free offer on Clough-Brengle Model OMA.....; Model OC-A.....

.....Free offer on

Dealer's Name

Address

City

State

Radio News Binders Prevent Loss! (See Page 443)

RADIOS **SAVE UP TO 50%**

ALL NEW 1937 MODELS!

DEAL DIRECT - FACTORY PRICES
Iron-Clad Guarantee Written

A penny post card brings you our new, full-color 16-page BARGAIN CATALOG free. Many models to choose from: 4 to 19 tubes AC-DC, All-Wave and new Farm sets that operate like city radios! Send post card or coupon below for full details of 30-day no-risk trial and Agent-User proposition. Write now!

30-DAY NO RISK TRIAL!
Enjoy it a month, then decide. Write!

MAIL COUPON *Free Catalog*

Without obligation, send me new 1937 Catalog and 30-day trial plan.
Name.....
Address.....
City.....
State.....

Goldentone Radio Co., Dept. A, Dearborn, Mich.

PREFERRED BY ALL TRIMM LEADS

with the most complete headset line in the world. Thousands of operators are using TRIMM phones because they are assured of a reliable source of supply and service.

TRIMM RADIO MFG. CO.
1770 W. Berneau Ave.
Chicago, Illinois, U.S.A.

WHY TIE UP MONEY in Tubes?

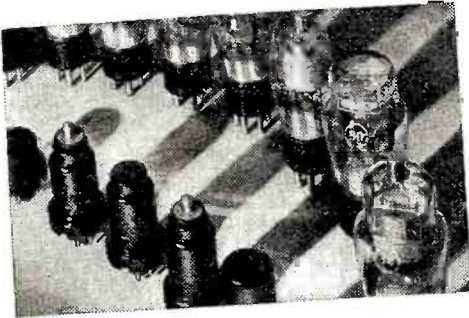

You Can Sell TUNG-SOL Tubes
Without Investing a Cent

Tung-Sol is the only line of high-quality tubes being sold nationally on a consignment plan requiring no investment by the retailer.

There are still desirable locations where independent service organizations who can meet requirements may be appointed as Tung-Sol agents. Ask for the name of your nearest Tung-Sol tube wholesaler.

TUNG-SOL

Jone-flow radio Tubes
TUNG-SOL LAMP WORKS, INC.
Radio Tube Division
NEWARK, N. J.

RIDER'S VOLUME VII

NOW AVAILABLE

AT ALL

GOOD JOBBERS

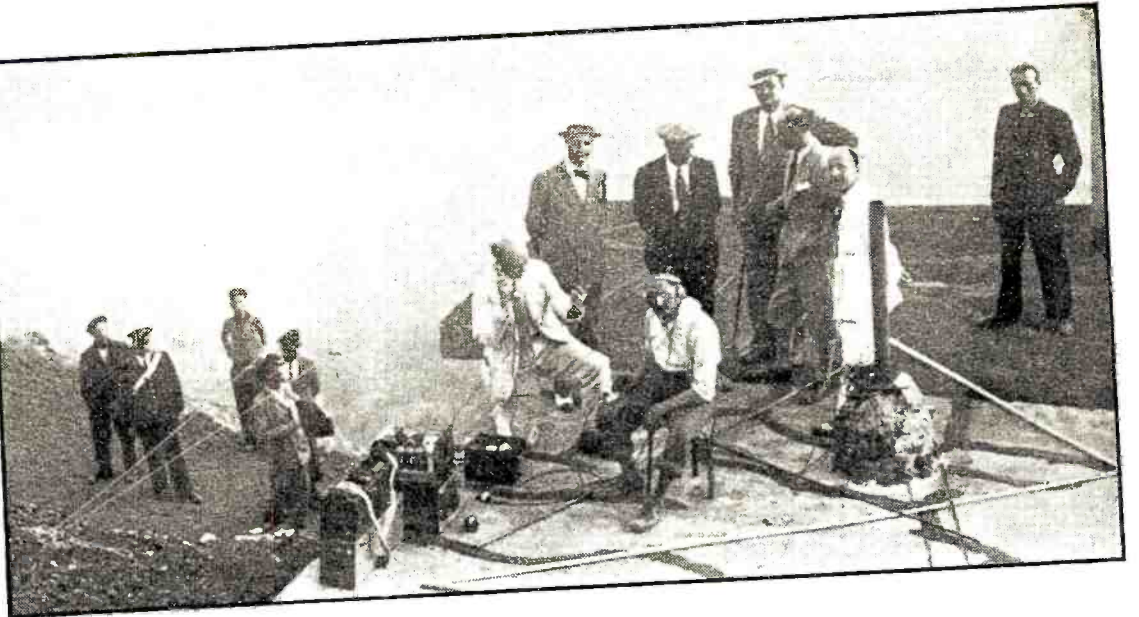

QRD? QRD? QRD?

CONDUCTED BY GY

NOW that the new ship regulations are out, the cream has been added to the frosting of the pie. Yousah, with spares for all parts being a "must," and teeth to enforce the laws laid down by the FCC, this is sure one step forward.

THERE won't be any reason now for an operator getting fired just because he wouldn't take out a boat having an antenna slowly disintegrating from old age, or lack of an extra tube, or anything else. Ships exempt from the new requirements are those which are classed as individual passenger vessels which do not go more than twenty miles from the nearest land nor more than 200 miles in the open sea between two consecutive ports, and cargo ships which do not go more than 150 miles from the nearest land. Also, the equipment must be tested twenty-four hours before a ship leaves port. Which is all sweet music to the lowly ops' ears, what ho.

To what distances operators may go to broadcast for the American public is evident from a glance at the picture in our heading, which shows NBC staff men at the crater of Mt. Vesuvius and the apparatus which transmitted the roar on the first stage of its journey to the U. S.

After hearing Dave Sarnoff of the RCA hand out his speech in reference to the advances that radio has made in the past twenty years and of its future possibilities, it gave us a thought which might also have occurred to you-all. And that is that there are thousands of small organizations conducting businesses having a foundation built around radio and its correlating industries, and it is indeed a mystery to us why so many radiomen and technicians are out of work. Let's see: there is Sound for Movies and P.A. systems, Broadcasting, Short-wave Police and Emergency Truck Units, Aviation, Telegraphy for ships and Point to Point systems, etc., and these are just a few of the many items. And still there are men out of work and we didn't even mention radio Service Work. Are we all specializing, or what?

Well, it really looks like Brother Haddock has had "enough" and is really going to step off the rostrum and retire to a nice quiet war for a rest. And after what he has gone through for the past four years, a war would just about seem rather quiet and satisfying. "Uneasy lies the head that wears a crown" is sure a good old proverb with especial emphasis on old man Hoyt. He had such competition for his job that he had to stay awake nights and watch the crown and sceptre for fear one of the boys would steal the works while he slept. It always has been that way,

even in nicer and more "genteel," refined company. If a hen didn't sit on her eggs and hatch 'em, another hen would come along and set on them, claiming the eggs for her own. Good luck, old feller, and whilst writing your Memoirs, be philosophical.

Well, fellows, in the mail this a.m. a lengthy comment was received from our esteemed friend and brother, L. W. Ward, the ubiquitous Minister of Propaganda of the ARTA. It seems as though some of our remarks anent the absence of an ARTA publication, plus the manner in which said organization is being run at the present time, were not authentic. Also, that it sounds just like company stuff, etc. . . . Ye Editor has always tried to dig up the news which he believes to be honest for the benefit of any organization that proved itself whole-heartedly for the interests of the radio operator, and after diligent search he unearthed the facts as set forth in a previous column. And the excuse that the other locals weren't paying their stipulated amount each month does not quite hit the spot, as the records show that more men are working now and a greater number of ops are receiving more wages. However, we are open-minded and reasonable and welcome further information.

Well, the second note this month was a good one. More jobs! That applies to Broadcast and Airways. Salaries remain unchanged, but there is a personnel turnover and a few more openings. This includes all states from the Pacific to the Rockies. Some jobs in the broadcast field are still combination jobs, such as announcer-operator, etc. We can count on our fingers at least eleven men who have been given broadcast berths in the past thirty days. And that isn't bad! That applies to twenty-two stations. A few stations say they have no experienced men on their available lists and that good men are hard to find. One station had to insert an ad in the paper to get a man (and that is a "Believe It or Not"). The only white spot in aviation seems to be the Pan-Am Airways, which recently hired a 15 w.p.m. operator and offered a job to a "hard-of-hearing" man. So, boys, there must be a scarcity of good ops. Dept. of Commerce is also offering jobs for their airways as airways keeper, etc., but salaries haven't risen above the usual monthly \$125. . . . A vocational study shows a tendency

to merge jobs, including operators.

A very bright suggestion cometh forth from our old side-winder Joe Dockendorf, who sez "How about Uncle Sam putting up another radio station for bearings near Virginia capes so that the large number of ships getting "QTE's" off the capes can get better service? Perhaps an auxiliary station could serve the purely c.w. stations on 750 meters while the sparks were getting their bearings on 800. It sure would relieve congestion." And those are our sentiments, too. And if any of you guzzlers and puddle-jumpers out in that wild country have any other suggestions for the easement of worries and efforts of the gang, just spill them out on paper for the perusal and benefit of all concerned.

It seems another terrific war is going to be fought on the Western Front again and the Pacific waterfront is expecting to see some tall and fancy arguing. But where the ARTA (or other radio organizations) expect to stand in this fight is not being broadcast at the present time. Whichever horse is being bet on, it seems that "discretion is the better part of valor."

And so, Boys, another bit of pensive chatter has been let loose with the hopes that you all may profit from same. It is for your benefit! You are the reason for our knocks and boosts and it is your wishes that are being publicized for discussion and criticism and approval, just as it is the public who pays the salaries of high-priced radio stars. As we turn to a station or away from it, so fluctuates the popularity of a performer. So turn on the dial and get an earful of this broadcast—Merry Christmas, Happy New Year, and all the trimmings! So with a 73, ge. . . . GY.

Super-Regenerative Receivers

(Continued from page 427)

the modulation is compressed in such a way as to distort the wave form. So fast is this a.v.c. action that on the troughs of modulation, this hiss will come up so that "whiskers" are noticed on the speech. In some circuits, particularly self-quenched circuits, a.v.c. and compression are so pronounced that satisfactory operation on strong, nearby signals is almost impossible.

If the detector is stable and smooth, a balance may be chosen between this condition of operation and a condition just below strong super-regeneration. For portable mobile work, the a.v.c. action is essential. For home station work, better quality will result when the receiver is operated so that the hiss does not come up when the incoming signal goes off the air (just below strong super-regeneration). Complete control over this function is provided by adjustable coupling. When an r.f. stage is used, adjustable feedback or plate voltage control must be used.

Noise Reduction Ability

This function may be described as the ability of the receiver to reduce the effects of impulse interference (ignition interference, etc.) picked up by the antenna, and still give intelligible reception.

The super-regenerative circuit is peculiarly suited to the reduction of ignition interference for two reasons—fast a.v.c. action and stroboscopic effect.

The speed of the a.v.c. action, which is the cause of the distortion and compression of the audio signal, gives a remarkable reduction of high-amplitude impulse noise such as produced by passing automobiles. In effect the peak value of the noise impulses is held down. At the same time,

another effect, known as stroboscopic, contributes a great deal towards a further reduction of this type of interference. This may be illustrated by the picture of a machine gun shooting through a propeller where the two are not synchronized. Only an occasional bullet will hit the propeller. The number of bullets that will hit in one minute depends on the speed of the propeller. The slower the speed, the less hits per minute. And so in a super-regenerative receiver, the lower the interruption frequency the fewer the impulses which will hit the detector at the critical instant of the i.f. cycle (just where the detector goes into oscillation). Impulses which hit at any other time have little or no effect on the average plate current and hence are not reproduced.

In order to get maximum noise reduction, therefore, two conditions must be fulfilled: the detector must be super-regenerating heavily (not too closely coupled to the antenna), and the interruption frequency must be as low as possible.

If twisted pair or transposed feeders are used, and the antenna is clear of strong noise fields, reduction of noise into the set may be had by electrostatically shielding the input coil from the first tuned coil. This may best be accomplished by a Faraday shield which is grounded and placed between the coils. This prevents the in-phase noise voltages picked up on the feeders from getting into the first tuned circuit.

Radiation

If ever the Golden Rule applied to anything, it applies to super-regenerative operation on the 5-meter band. Strong hash radiation is inexcusable even under present-day conditions. There are two general rules that should be followed by those who want to give nearby stations a break.

1. Use an r.f. stage ahead of the detector, if the pocketbook can stand the price of a 954 or 956.

2. Don't use a receiver (without an r.f. stage) which requires B voltage on the detector greater than 67.5 volts for satisfactory performance.

3. If you live in a very crowded area, use a standard tube r.f. stage even if you come out even on sensitivity.

The next article of this series will describe a circuit used in some receivers which have been built by the author with the above requirements in mind.

Prize Contest

(Continued from page 405)

even in the most modest establishment if the enterprise is to be run as it should be—on a business basis. The service shop should pay some portion of the rent, electric light and telephone bill, as a matter of principle and accounting, even though located in the home.)

Such a Service Shop is that of Thomas J. Price, Clarkdale, Ga., shown in Figure 3. The bench itself is constructed of plywood, and cost about \$3.00. The instruments are all portable—being employed both in the shop and the field—an additional factor that lowers the initial expense of getting into the radio service business. As will be observed, Mr. Price's service shop is located in a corner of his home.

Being located in a rural community, a large portion of Mr. Price's attention is devoted to battery sets. His pet sideline is selling phonograph pick-ups. He writes: "Almost every farm home has an old mechanical phonograph. This can be left as is for a temporary hook-up. Put on one of the prospect's favorite records, plug in the radio, and the rest is easy!"

GET YOUR COPY Act Now!

- 16 Page Sound Manual covering such topics in Public Address as: How to estimate installations . . . How to install . . . Hints on obtaining better performance . . . Points on Selling . . . Etc . . . Nothing else like it available . . . Be Sure to Get your Copy . . .

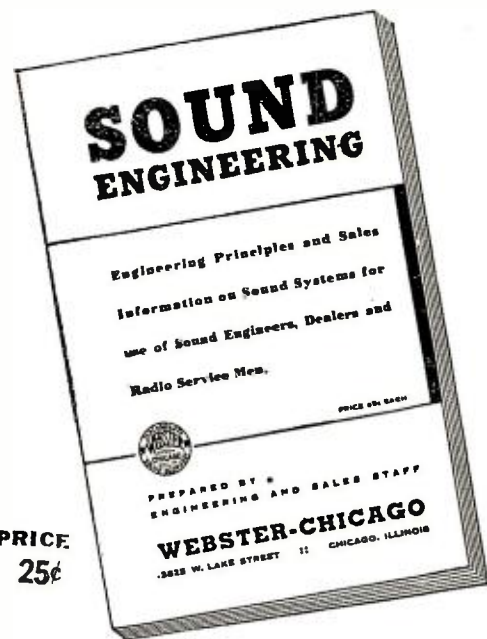

Published by

WEBSTER-CHICAGO

One of the oldest manufacturers of sound equipment in the field. Licensed under all important patents.

Products Manufactured Include:

- Portable Sound Systems, 8 to 20 Watts.
- Fixed Sound Systems, 8 to 120 Watts.
- Electric Phonograph Motors for all Cycles and Voltages.
- High Fidelity Pickups.
- Microphones: Carbon, Crystal or Ribbon.
- Speakers: Electro Dynamic or Permanent Magnet.
- Baffles and Trumpets.
- Sectionalized Sound Systems for Schools, Hotels, Department Stores, Hospitals and other institutions.
- Factory Call Systems.
- Two-Way Communication Systems.
- Custom Built Equipment of All Kinds.

NOTICE TO DEALERS

FREE COPY

Every dealer or active radio service man can obtain a copy of this Sound Engineering Manual free by signing name and address below and giving this coupon to one of our jobbers.

Name

Address

City..... State.....

Jobber..... O. K. and Send to Webster-Chicago, 3825 W. Lake St., Chicago, Ill. Section J-6.

SAVE Time! Money! Shoe Leather!

"SHOP WHOLESALE!"

Get the habit... Shop in your Slippers... it's EASIER—it's ECONOMICAL. Use the BIG FREE 1937 Radio Catalog to save Time, Money, Shoe leather, for this catalog contains the most comprehensive collection of radio values ever assembled in 156 pages of a catalog. Whatever your radio requirements, you'll find them here—member—Wholesale offers COMPLETE stocks of FRESH, STANDARD merchandise and twenty-four hour shipments.

XMAS ELECTRICAL SPECIALS

Our Special Xmas Electrical Catalog points the way to easy and economical buying of electrical gifts this Xmas. A swell collection of electrical toys, household equipment, etc. Send for this FREE catalog TODAY.

EVERYTHING YOU NEED IN RADIO

Free SEND FOR OUR CATALOGS...

WHOLESALE RADIO SERVICE CO., INC.
100 Sixth Avenue, New York, N. Y.

Rush Free Blue Ribbon Radio Catalog 65-A2..... () Check

Rush Free Xmas Electrical Catalog 67-A2..... ()

Name.....

Street.....

City..... State.....

The "Ham" Shack

(Continued from page 401)

will show when a carrier is on or off the air and at the same time permit monitoring the modulated signal. The sensitivity of the 6E5, as already pointed out, far exceeds that of the average milliammeter usually used in such circuits. Its action is not handicapped by the mechanical sluggishness of even the most sensitive meters. The screen will show up changes in a transmitter carrier as quickly as a more expensive oscilloscope, although it will not indicate the percentage of modulation.

The diode detector and the tuned circuit provide an excellent linear monitor. By plugging headphones into the jack on the front panel it is possible to get a true aural "picture" of the signal as it comes out of the other fellow's loudspeaker. The volume control facilitates adjusting the level below the distortion point of headphones.

A word of caution: never allow the headphones or loudspeaker used on the monitor to get too close to the microphone of the transmitter. Feedback that is not audible sometimes may occur which will distort the reproduced signal. Of course, if the two units get too close, they will set up a howl that will be deafening. As a monitor, the unit will show up such things as hum, distortion and other ailments encountered in 'phone transmitters.

It is not necessary to locate the instrument near a transmitter. As a matter of fact, the diode detector and audio amplifier are sensitive enough to pick up signals at distances of several hundred feet. But, as the distance increases, it will be necessary to increase the size of the antenna in order to have enough pick-up power to close the shadow of the "magic eye" tube.

Ceramic plug-in coils are used. The forms are 1½ inches in diameter and wound with No. 18 wire. For 10 meters, 3 turns are used; for 20, 12 turns; for 75 meters, 32 turns, and for 160 meters, 70 turns of No. 22 wire. It is necessary to use the smaller wire on the latter because of the limited winding space on the coil form. The size of the wire, however, is not important, the only requirement being that the circuit tune somewhat near the operating frequency.

List of Parts

- 1 cabinet 10 by 7 by 6 inches, Bud
- 1 chassis 8 by 5 by 1½ inches
- 1 100-mmf. variable condenser, National
- 1 R. C. A. 6E5 socket and bracket
- 1 four-prong socket
- 1 six-prong socket
- 1 transformer, 300-volt, 40 mil., with 6.3 v. fil., Thordarson
- 1 0 to 500,000 variable resistor
- 1 50,000-ohm, 1-watt resistor, I. C. A.
- 1 10,000-ohm, 1-watt resistor, I. C. A.
- 2 1-megohm resistors
- 1 25,000-ohm, 25-watt resistor
- 1 10,000-ohm, 20-watt resistor, I. C. A.
- 2 radio-frequency choke coils, 2½ m.h., National
- 2 .0005-mfd. condensers, Aerovox
- 1 .0001-mfd. condenser, Aerovox
- 1 2-mfd. condenser
- 1 .01-mfd. condenser
- 1 .1-mfd. condenser
- 2 8-mfd. electrolytic condensers, Aerovox
- 1 phone jack

CALLS HEARD

By N. C. Smith, 53 Birch Tree Road, Petts Wood, Orpington, England, on 20-meter c.w.:
VK3DP, VK5LB, VK5BY, VK2PX, VK3OW, VK5HG, VK4ER, VK5HW, VK3DQ, VK5JC, VK2NY, VK2HR, VK7KV, VK2JX, VK6SA, VK2TI, VK2FM, VK6FZ, VK5CM, ZL2QT, ZL4FS, ZL3JZ, ZL2FX, ZL4FO, ZL3AJ, ZL3CS, ZL4FN, ZL1HY, U9MF, U5KT, U9MI, W8NOE, W5BMD, LU7AZ, W5FMO.

On 20-meter 'phone: VK2ADU, VK2BG, HC1FG, VK2ZL, VK2QR, W5EWD, W5BEE, NY2AE, W5EE, VK2ADV.

By William Clup, 2919 F Street, Lincoln, Nebr., on 20-meter 'phone: F8DR, G5ML, G5ZJ, G5JO, G5NI, G6YU, G6VX, G6YB, HI5X, HI7G, HI4F, HH2B, HK1Z, HC2RM, K6KKP,

LU4BH, LU6KE, LU8AB, LU5AZ, NY2AE, ON4VK, PK1PU, PK1MX, PY5AQ, PY2EM, PY3AR, CE3DW, CE1AU, CE1BC, CT1BY, TI2NI, TI2LR, TI2FG, TI5JJ, VO1I, VK3WZ, VP6YP, VP7NA, VP9R, W7VA (portable Aletuan Is.), YV4AA and YV5AK.

By A. Petitjean, 212 Rue Marcadet, Paris, France, on 20-meter 'phone: W1BLO, W1FL, W1CSG, W1DIC, W1EOA, W1DET, W1ZE, W1BBA, W1UH, W1CCZ, W1HYJ, W1SZ, W1CRW, W1FNL, W1ICB, W1FLH, W1CH, W1GED, W1CTZ, W2MG, W2GMG, W2CLS, W2BYX, W2FLO, W2DH, W2BTP, W2CVI, W2CPA, W2ELO, W2HCE, W2HHT, W2APV, W2HUT, W3EOZ, W3LP, W3DY, W3BBB, W3DDO, W3CBT, W3EWW, W3EYH, W3DPC, W3FAY, W3EKH, W3EYH, W3AKE, W4DOB, W4ABY, W4TO, W4AKA, W4CRE, W4EM, W4EEW, W4FM, W4CVN, W4DLN, W4BYY, W4LL, W5INS, W5AXG, W5AHK, W5AIJ, W5FCL, W5DE, W5ACF, W5CEN, W6BYH, W6KM, W6GPW, W6AH, W6VLS, W6LFO, W6RX, W8EYK, W8DW, W8LKI, W8GLY, W8MMJ, W8IKE, W8BFG, W9FLO, W8JVF, W9BBY, W9HHQ, W9RGF, W9PIL, W9WZW, W9TB, CE3AC, CO2HY, CO8VE, HH2B, HI7G, NY2AE, VE1CR, PY2ET, PY2EJ, SU1CH, TI2FG, VE1CN, VE1BR, VE1EA, VE1CA, VE1EW, VE2WE, VE1DC, VE1IN, VE1GR, VE1AW, VE2EK, VE2HK, VE2JJ, VE2HY, VE2CA, VE3LK, VE3MB, VE3BK, VE3JV, VE3FG, VE3LK, VE5OT, VK2ABD, VK7JB, VO1J, VP3BG, VO3BK, XE1G, YV5AA, OA4AA.

By Paul C. Bird, Oak Road, RFD 4, Vine-land, N. J., on 20-meter 'phone: XE1W, XE1G, XE1AY, XE1K, XE1O, XE1CZ, XE1HH, XE1AG, XE1DD, XE1BC, XE2AH, XE2N, XE2HF, XE3D, XE3AE, XE3AG, CO2SE, CO2HY, CO2WZ, CO2LA, CO2LL, CO2WW, CO2JM, CO2RA, CO2FG, CO2KC, CO2AU, CO2AN, CO2SV, CO2XF, CO2JV, CO2CC, CO2MP, CO2QQ, CO6OM, CO7HS, CO7HF, CO7CX, CO8YB, CO8RO, HI7G, HI2K, HI2T, HI1W, HI1C, HI1F, HI5X, HI9I, HH1P, HH2W, HH2B, HH4L, HH5P, HH5PA, HK1Z, HK1ABM, HJ2LS, HJ2RS, HK3JA, HP1A, HC1FG, HC1RF, HC1RS, HC2RS, VP2CD, VP3BG, VP4TH, VP5IS, VP5AC, VP6CS, VP6YB, VP9R, VP9G, VO1I, VO1J, VO4Y, VK2ABD, YV4AC, YV4AA, YV5OM, K4SA, K4DDH, TI1AS, TI2XG, TI2RC, TI2AV, TI2EA, TI2FG, TI3AV, TI5JJ, PY2CK, PY2BA, PY2ET, NY2AE, LU4BA, LU4BH, LU5DJ, LU5AN, LU5CZ, LU6AP, LU7AZ, LU8AB, LU9PA, OA4AA, OA4R, OA4AK, CE1AR, CE1DC, CE1BC, CE3AC, YN1HS, YN1AA, YN1PR, YN1IP, TG10, CX2AJ, LA1G, SM5SX, OZ7KS, EI2J, EI8G, EI9B, G2NH, G2DC, G2TB, G2AO, G2BY, G2AA, G2MV, G2HH, G2DI, G5GO, G5VB, G5ML, G5BJ, G5NI, G5VY, G5VL, G5XA, G5WZ, G5JO, G5IS, G5TZ, G5HV, G5WA, G5YV, G5RV, G5HM, G6FS, G6XR, G6DL, G6JQ, G6GL, G6SR, G6GO, G6PY, G6QS, G6IA, G6BL, G6GS, G6LK, G6GF, G6WU, G6CW, G6GA, G6WQ, G6KL, G6JS, ON4AC, ON4FE, ON4VK, ON4BA, ON4MJ, ON4ZA, PAORP, PAOIDW, PAOSB, PAOFB, PAOV, PAOEO, F8DR, F8LZ, F8PU, F8ZN, F8II, F8XF, F8NG, F8DW, F8VP, F3JD, EA1AN, EA1AE, EA1AZ, EA2BT, EA2BH, EA3AU, EA3AV, EA3ER, EA3CY, EA3AA, EA3DQ, EA4AO, EA4AB, EA4BM, EA5BE, EA5BS, EA7AI, EA7BA, EA7BB, EASAO, EA8LW, EA8AF, CT1AY, CT1BY, CT1BK, CT1DV, CT1BG, CT1JV, CT1PV, CT2AK, HB9A, IIT, I1KG, SU1CH, SU1SG, PK1MX.

Radio's Role in the Spanish War

(Continued from page 394)

progress in Spain is in one sense definitely brought to a standstill, while at the same time radio is employed as an important medium for communications and to report progress of the war to the people.

Spanish Morocco is now in the hands of the Insurgents. All communication between this colony on the Mediterranean and Spain must be effected by means of radio. This is done by short-wave transmitters, three of which are located at strategic points on the northern coast of the colony. There are no broadcasting stations in this African colony, as the signals from some of the larger Spanish stations are sufficiently strong to keep the Moroccans informed of conditions on the mainland.

One important point has been realized by both sides. That is, that radio can always be depended upon for reliable communication when telephone and telegraph cannot.

IT'S EASY TO LEARN CODE

the CANDLER WAY!

● Listen to the fastest code operators on the air! Wouldn't you like to "pound brass" with their ease and speed? Well, you can! For most of the expert operators you hear were trained by the Candler System, the easy, scientific way of learning code.

● Candler teaches you to read code by sound like you read print by sight, the method that has proved most satisfactory of all. It's the system that has been used by the Champions in developing their amazing speed.

● The Candler System starts you out right from the beginning—you learn code as you will be using it on the air. It can help you if you are a beginner, or if you are trying to obtain your commercial license, as it has helped many who now are leaders in radio communications. Advanced Professional Training for operators trying for their commercial license.

● Write today for the Free Book of Facts that tells you all about the Candler System. Read how the world's fastest and youngest radio operators were scientifically trained and developed by the Candler System.

● Don't be satisfied with poor code. Learn all about the Candler System today.



The CANDLER SYSTEM

Dept. N-1 Asheville, N. C.

T. R. McELROY

WORLD'S CHAMPION RADIO TELEGRAPHER
23 Bayside Street, Boston, Mass.

MAC KEY @ \$7.95 a real speed key
MAC KEY DELUXE @ \$15.00
MAC CORD @ \$1.00
MAC CASE @ \$3.95
MAC OSC @ \$3.95 ac-dc oscillator, Tone control.
If u hv Mac Key wri me fo xmy ipt & dsrb iln.
All my stuff emcy gad best pduts obl. 73 Mac.

U. S. Station List

(Continued from page 415)

WSIX	Nashville, Tenn.	1210	.1
WSJS	Winston-Salem, N. C.	1310	.1
WSM	Nashville, Tenn.	650	50
WSMB	New Orleans, La.	1320	1
WSMK	Dayton, Ohio	1380	.2
WSOC	Charlotte, N. C.	1210	.1-1.25
WSPA	Spartanburg, S. C.	920	1
WSPD	Toledo, Ohio	1340	1-5
WSPR	Springfield, Mass.	1140	.5
WSUI	Iowa City, Iowa	880	.5-1
WSVA	Harrisonburg, Va.	550	.5
WSVS	Buffalo, N. Y.	1370	.05
WSYB	Rutland, Vt.	1500	.1
WSYR	*Syracuse, N. Y.	570	.25
WSYU	(1 kw.)		
WTAD	Quincy, Ill.	900	.5
WTAG	*Worcester, Mass. (1 kw.)	580	.5
WTAL	Tallahassee, Fla.	1310	.1
WTAM	Cleveland, Ohio	1070	50
WTAO	Green Bay, Wisc.	1330	1
WTAR	*Norfolk, Va. (1 kw.)	780	.5-1
WTAW	College Station, Texas	1120	.5
WTAX	Springfield, Ill.	1210	.1
WTBO	Cumberland, Md.	800	.25
WTCN	Minneapolis, Minn.	1250	1-5
WTEL	Philadelphia, Pa.	1310	.1
WTFI	Athens, Ga.	1450	.5
WTHT	Hartford, Conn.	1200	.1
WTIC	**Hartford, Conn. (1040 kc.)	1060	50
WTJS	Jackson, Tenn.	1310	.1-1.25
WTMJ	Milwaukee, Wisc.	620	1-5
WTMV	*E. St. Louis, Ill. (.25-day)	1500	.1
WTNJ	Trenton, N. J.	1280	.5
WTOC	Savannah, Ga.	1260	1
WTRC	Elkhart, Ind.	1310	.1-1.25
WVFW	Brooklyn, N. Y.	1400	.5
WWAE	Hammond, Ind.	1200	.1
WWJ	Detroit, Mich.	920	1-5
WWL	New Orleans, La.	850	10
WWNC	Asheville, N. C.	570	1
WWRL	Woodside, N. Y.	1500	.1-1.25
WWSW	Pittsburgh, Pa.	1500	.1-1.25
WWVA	Wheeling, W. Va.	1160	5
WXYZ	Detroit, Mich.	1240	1
.....	Pittsburgh, Kans. (C.P.)	790	1
.....	Watertown, N. Y. (C.P.)	1310	.1-1.25
.....	Cedar City, Utah (C.P.)	1310	.1
.....	Jefferson, Mo. (C.P.)	1310	.1
.....	Corsicana, Texas (C.P.)	1310	.1
.....	Birmingham, Ala. (C.P.)	1200	.1-1.25
WIXBS	Waterbury, Conn.	1530	1
W2XR	Long Island City, N. Y.	1550	1
W6XAI	Bakersfield, Calif.	1550	1
W9XBY	Kansas City, Mo.	1530	1

Where two powers are given, the first is used at night and the second (the larger one) in daylight—until local sunset.

C.P.—Construction permit for new station.
*Construction permit for alternate frequency or higher power or both, shown in parentheses.
**Special authorization to work on alternate frequency or power or both, shown in parentheses.

Call System

(Continued from page 407)

down, it sends out a "buzzing" call signal. The center position is to "talk" and the top is the "listening" position. At the bottom left is the combination "on-off" switch and volume control. At the bottom right is the input-output plug for connection to a special loudspeaker unit which provides increased signal for special installations.

The attractive walnut cabinet housing the entire equipment is only 9 inches long by 6 1/4 inches high by 5 3/4 inches wide. Its shipping weight is eight pounds.

The "Sterilamp"

Bloomfield, N. J.—Westinghouse Mfg. Co., has announced a type WL782 tube which is a generator of certain wavebands in the ultra-violet spectrum. Research has determined that certain parts of the ultra-violet spectrum are very efficient in destroying bacteria fungi and preventing mold. The "Sterilamp" has been especially designed for sterilizing purposes; it consists of a long glass tube containing two electrodes and a mixture of mercury vapor and other inert gases. The lamp operates from 120 volts a.c. through a special transformer.

F. L. SPRAYBERRY Broadcasting:

LET ME TELL YOU ABOUT MY
2-WAY MONEY-MAKING
RADIO TRAINING PLAN

Whether you are a young man or an older one—whether you've got a job or are looking for a really worth while future—whether or not you have ever had any previous radio experience, you owe it to yourself to investigate my unique new Radio Training method. It is a 2-Way Money-Maker. I'll teach you to make spare time profits while you learn. I'll fit you out with complete standard equipment, teach you to use it on all kinds of Radio work and teach you modern business methods, too. Investigate today! It will cost you nothing to get the facts—it may mean the turning point in your life toward the successful future of which you've dreamed!



I WILL PROVE THAT 17c A DAY

ACTUALLY SETS YOU
UP IN BUSINESS ...



THIS PROFESSIONAL EQUIPMENT IS YOURS

It can be done! I am already doing it for hundreds of ambitious fellows like you. I know I can do it for you. You'll actually be set up for a profitable business of your own—or ready for a flying start in a full or part-time job in any one of radio's fascinating branches such as aviation radio, auto radio, broadcasting, public address, etc. There is no other training like it. You learn at home in spare time—and you'll be pleasantly surprised how quickly you are ready for a real future in a rapidly growing industry that is providing fortunes for well-trained men.

REMEMBER: No matter what kind of Radio Training you take, it is ABSOLUTELY NECESSARY that you have real professional equipment such as that shown here BEFORE you are ready to start making real money. Sprayberry Training brings it to you almost at the start—teaches you how to use it under actual working conditions.

SERVICEMEN!

For those already in Radio, Sprayberry offers an **ADVANCED Training Course** that has proved invaluable to hundreds of servicemen. Saves you time—saves money—teaches you the easiest way to do the hardest jobs. Get details. Mark an X here () and we will send our **ADVANCED Radio Training Booklet** free.

SPRAYBERRY ACADEMY OF RADIO

F. L. Sprayberry, President
2546 University Place, N. W., Washington, D. C.
Without obligation on my part, please send your Free book, "YOUR FUTURE IN RADIO," and other details of famous Sprayberry Training.

Name.....

Address.....RN-1-37
PASTE COUPON ON PENNY POSTCARD AND MAIL TODAY.

1937 RADIO DATA BOOK GIVEN FREE!

(See Page 448)

HANDEE Tool of 1001 Uses

A whole shop full of tools' in one. Does away with slow hand work. Plugs in any light socket AC or DC, 110 v. 13,000 r.p.m. Uses 200 different accessories—grinds, polishes, routs, drills, cuts, carves, sands, saws, sharpens, engraves.

Get A Demonstration

at Hardware, Dept. Stores, Tool Dealers or order on 10 Day Money-Back Trial, \$10.75 and up postpaid, 3 Accessories Free. De Luxe Model \$18.50, with 6 Accessories. Catalog Free.



For Faster Better Jobs

New **CRAFTSMAN Project Book**
"Pleasure and Profit with a Handee." Easy working plans for making many interesting and unusual projects 25c, stamps or coin.

CHICAGO WHEEL & MFG. CO., 1101 W. Monroe Dept. AB, Chicago

RADIOS WHOLESALE 5 TUBE \$6.95 30 DAYS TRIAL



Tune in on politics, news, music, market and weather reports with a new ZEPHYR WORLD-WIDE RADIO. All the latest improvements. MONEY-BACK GUARANTEE, one year FREE service.

Write for
FREE
Illustrated
Catalogue

All electric, farm, battery and auto radios, buy direct and SAVE UP TO 50%. Ask about our User-Agent Plan. EARN EXTRA MONEY, be a ZEPHYR salesman.

ZEPHYR RADIO COMPANY
13137 Hamilton Ave., Detroit, Michigan

There is no other
Permanent Magnet
Speaker like the
NOKOIL



No. 1984

Cadmium plating makes all parts thoroughly rust-proof which is essential to perfect permanent performance.

A super-sensitive high power Public Address NOKOIL Reproducer at a price that is within the reach of all sound engineers.

List price **\$19.84** Dust proof
Rust proof
Weather proof

Write for catalog showing the world's most complete line of NOKOIL Reproducers and the name of our nearest distributor. Wright-DeCoster distributors are always anxious to cooperate.

WRIGHT-DECOSTER, Inc.

2255 University Ave., St. Paul, Minnesota
Export Dept.—M. Simons & Son Co., New York
Cable Address: "Simontrice"
Canadian Office
Associated Sales Co., Guelph, Ont.

1937 RADIO PARTS CATALOG

Showing The Latest
RADIO EQUIPMENT
FOR THE DEALER
THE SERVICEMAN
AND THE AMATEUR

Our new Catalog just off the Press.
Write for your free copy—Now!

CAMERADIO

601-3 GRANT ST. PITTSBURGH, PA. 30 TWELFTH ST. WHEELING, W. VA.
Established 1919

OPPORTUNITY FOR RADIO DEALERS



Provides FREE electric service to homes and farms without electricity.

AIR-ELECTRIC LIGHT and POWER PLANTS

The proven wind-driven electric plants. Nationally advertised. Furnished complete with towers and plant batteries. Sizes for all uses. Special generator built for lifetime service. Write today for literature and dealers proposition.

AIR-ELECTRIC MACHINE CO.
Dept. RN. Jewell, Iowa, U.S.A.

RADIO COURSES

RADIO OPERATING: Prepare for Gov't License Exam. ● **RADIO SERVICING:** Including Short Wave ● **AMATEUR CODE** ● **ELECTRONICS** ● **TELEVISION** ●

Day and Evening Classes—Booklet Upon Request
NEW YORK Y.M.C.A. SCHOOLS
7 W. 63rd Street, New York City



The DX Corner (Broadcast Band)

(Continued from page 413)

of Posts and Telegraphs, Jerusalem, Palestine.

Weekly Broadcast from Brazil

PRE3, 1220 kc., 10 kw., broadcasts a special program of dance music until 2:00 a.m. (Rio de Janeiro Time) each Sunday morning. Observer Tomlinson states that all reports should be addressed to: Mr. L. R. Evans, Radio Transmissora Brasileira, Caixa Postal 2726, Rio de Janeiro, Brazil.

Australian Changes

The following changes in the Australian list are reported in the October issue of "Tune In," the official organ of the New Zealand DX Radio Association: 6WB is a new station on 1070 kc., 2 kw. 4WK has shifted from 900 to 1360 kc. 2MO is now operating on 1370 kc., shifting from 1360. 3SH is moving from 1080 to 1130 kc. and 4TO from 1170 to 1080 kc. 2LV is increasing power to 1 kw. and moving from 980 to 1170 kc. 2LM has moved from 900 to 1340 kc. 2DU has been testing on 660 kc. and probably is by this time operating on a regular schedule.

CMCD, HAVANA, CUBA
The twin station CMCD (950 kc.) and COCD (6130 kc.) in their tropical surroundings

—Courtesy S. W. Observer, J. L. Lopez.

A MODERN ANTENNA SYSTEM
The broadcast antenna at LRI, Buenos Aires, is strictly "wireless". The pipe is the feeder, the tower the radiator

—Courtesy S. W. Observer, J. F. Edbrooke.

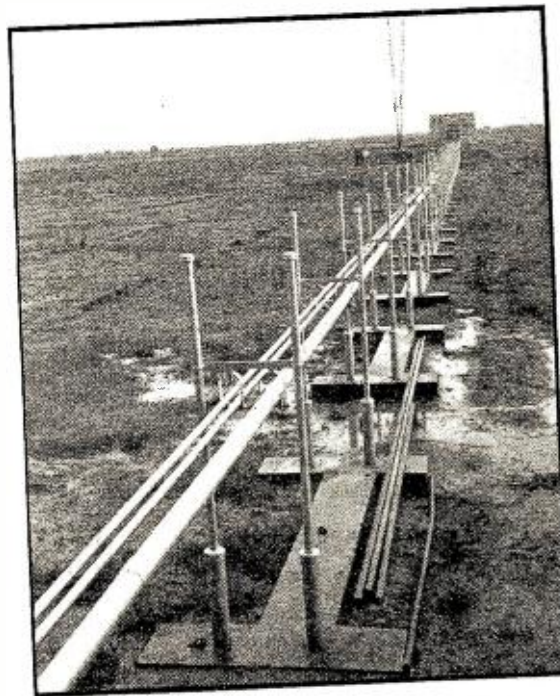

The Radio Workshop

(Continued from page 425)

from any normal source, regardless of the impedance.

These phones are best connected in parallel to gain greater advantage of the power used—rather than in series (to raise the impedance) since they already have high impedance. A blocking condenser of .02 mfd or larger, should be used in series, according to the circuit, in operating the phones in circuits where d. c. voltages are present. When the plate current in a circuit must not be interrupted, a choke or a suitable resistance should be used as shown in the accompanying circuits. Such a resistance is not critical and may have a value of from 10,000 to 100,000 ohms, depending upon the circuit requirement.

Because of the wide frequency range of the phones the noise level may be high when used for radio reception, requiring a tone control consisting of a resistance in series with the headphone, of a value to suit the individual installation. A 500,000 ohm rheostat has proven satisfactory for this purpose.

A volume control of from 50,000 to 250,000 ohms should be used with each set of phones, depending upon the circuit requirement, when there are multiple installations, for then the phones may be considered to have an impedance of over 50,000 ohms at 1,000 cycles. (Turn to page 447)

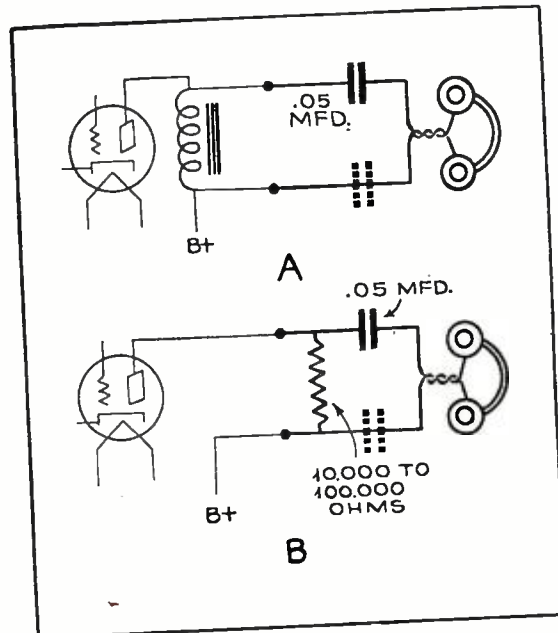

**Official RADIO NEWS
Broadcast Band
Listening Post Observers**

- Alabama: Ray Wood.
 Arkansas: James Halsey.
 California: Eugene S. Allen, Frank D. Andrews, Dudley Atkins III, Roy Covert, Bill Ellis, Henry Evansmith, Randolph Hunt, Walter B. McMenemy, Radio Fellowship, Don Ronk, George C. Sholin, Warren E. Winkley.
 Connecticut: Fred Burleigh, James A. Dunigan, Stanley Grabowski, Joseph J. Mazel, R. L. Pelkey.
 District of Columbia: George Day Cockrell, Jr.
 Illinois: Herbert H. Diedrich, H. E. Rebensdorf, D. Floyd Smith, Raymond S. Swenson, Donald C. Truax.
 Indiana: Earl R. Roberts.
 Iowa: Donald Barnes.
 Kansas: T. R. Grosvenor, Vernon Rimer.
 Louisiana: Aubrey V. Deterly, Wilbur T. Golson.
 Maine: Danford Adams, Floyd L. Hammond, Roger Williams.
 Maryland: William L. Bauer, Louis J. McVey, William Rank, Frank Zelinka.
 Massachusetts: John Collis, Frank W. Edlin, William W. Beal, Jr., Walter C. Birch, Russell Foss, Simon Geller, Warren C. Reichardt, Evan B. Roberts.
 Minnesota: F. L. Biss, Walter F. Johnson.
 Mississippi: Mrs. L. R. Ledbetter.
 Missouri: M. F. Meade, Ray W. Sahlbach.
 Montana: R. W. Schofield.
 Nebraska: Bud Crawford, John Havranek.
 New Jersey: Robert F. Gaiser, Morton Meehan.
 New York: Jacob Altner, Murray Buitekant, Paul J. Crowley, Walter J. Dustin, Jr., Carl Forestieri, Ray Geller, Edward F. Goss, Arthur B. Johnson, John C. Kalmbach, Jr., George J. Karesh, Harry E. Kentzel, Maynard J. Lonis, Harold Mendler, Robert C. Schmarder, R. H. Tomlinson, William Wheatley.
 North Carolina: E. H. Goodman.
 North Dakota: O. Ingmar Oleson.
 Ohio: Stan Elcheshen, A. J. Parfitt, Donald W. Shields.
 Oregon: David Hunter.
 Pennsylvania: Robert W. Botzum, Stanley Brus, Robert H. Cleaver, Harry M. Gordon, Jack Horner, John Kacmarcik, Edward Kocsan, J. Warren Routzahn, Francis Schmidt, Stephen G. Spicer, Joseph Stokes, Paul V. Trice.
 Rhode Island: Spencer E. Lawton.
 South Dakota: Mrs. A. C. Johnson.
 Texas: Isaac T. Davis, Thomas H. Housenfluck, E. L. Kimmons.
 Vermont: Henry T. Tyndall, Jr.
 Virginia: C. C. Wilson.
 Washington: Albert L. Bunch, W. Russell Du Cette, H. J. McClain, Jack Staley, Anthony C. Tarr.
 West Virginia: Clifford Drain.
- Foreign**
 Alaska: S. A. Tucker.
 Australia: Albert E. Faull, George F. Ingle, Aubrey R. Jurd.
 Canada: Fred W. Alfred, Bernard J. Clancy, John W. Ker, Ernest W. Law, Art Ling, Philip H. Robinson, Fred Smith.
 Cuba: Rafael Valdes Jiminez.
 England: R. T. Coales, F. R. Crowder, E. Mason Gledhill, Charles E. Pellatt, J. S. Phillips.
 Germany: Rignald Pick.
 Hawaii: L. R. Giddings.
 Japan: A. T. Yamamoto.
 New Zealand: Alexander N. Chalmers, L. W. Mathie, E. C. M. Philpott, R. H. Shepherd, Eric W. Watson.
 Switzerland: Dr. Max Hausdorff.
 Turkey: A. K. Onder.

Chain Broadcast in Australia

Sydney, Australia—On August 17, 1935 the Prime Minister of the Australian Commonwealth delivered a speech on the trade position with Japan from Canberra, which was relayed by 95 stations throughout the Commonwealth. This has been the most comprehensive broadcast made so far in Australia. The circuit required the use of 18,000 miles of trunkline, 150 highly trained specialists; it was set up on a 2 hours notice.

**Are You a Radio Connoisseur?
IF SO
"BE WISE AND KENYONIZE"**

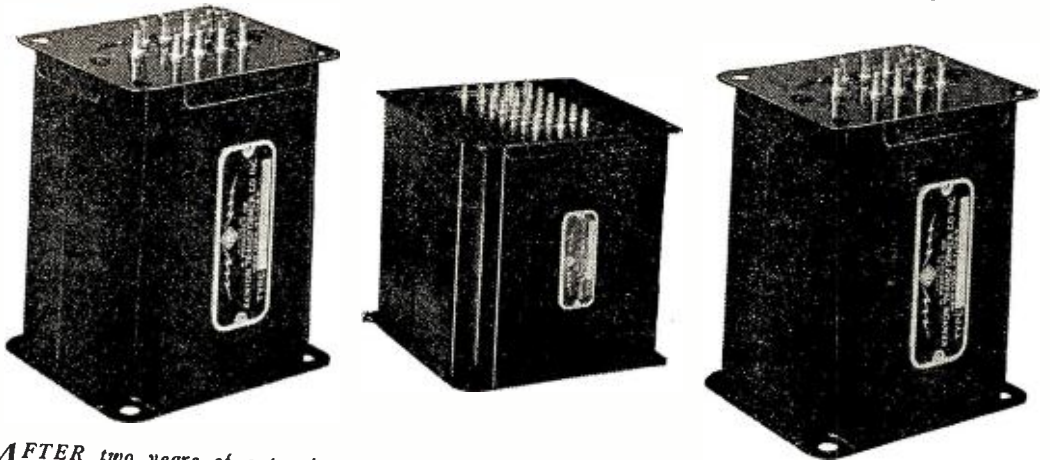

AFTER two years of extensive research we are proud to introduce our new "T" components which are the most complete and up-to-date transformers ever offered—advanced in design, economical, efficient and completely reliable. This line is designed to satisfy the demand for a quality product for P. A. work and amateur transmitter use at a new low price.

NEW EXCLUSIVE KENYON FEATURES:

Adaptability to all needs is provided by the new durable black egg-shell finish case that permits top or bottom mounting!

INPUT TRANSFORMERS

Multiple line input transformers provide perfect coupling for single and double button microphones! These transformers are provided with hum cancellation windings which permit mounting them on the chassis of high gain amplifiers!

COMBINATION PLATE AND FILAMENT TRANSFORMERS

An electrostatic shield is incorporated between the primary and secondary of plate and filament transformers for P. A. and low power transmitters.

OUTPUT TRANSFORMERS

All output transformers for P. A. applications include 500 and 200 ohm windings for matching transformers, and windings of 15, 8 and 4 ohms for speaker voice coils!

FILAMENT TRANSFORMERS

A large variety of single and multiple filament transformers provide filament supply for all types of tube combinations.

MODULATION TRANSFORMERS

Modulation output transformers for transmitters are provided with tapped secondaries which adequately carry the full Class "C" current load without saturation!

PLATE TRANSFORMERS

Kenyon plate transformers are designed to meet the rigid requirements imposed in amateur service. Many of these units incorporate the exclusive Kenyon triple and dual windings.

Ask your local dealer for a free copy of the first issue of the new 16-page monthly magazine "THE KENYON ENGINEERING NEWS." Also our new T line catalog.

Our new transmitting manual contains complete up-to-date transmitter circuits ranging in size from five watts to one kilowatt. Ten pages are entirely devoted to full page "Ken-O-Grafs" which cover most of the calculations used in radio in a modern and painless method. This book is no subterfuge for a catalog. To receive your copy send 25 cents in coin or stamps.

Address your inquiries to Chief Engineer, Sound Division

KENYON TRANSFORMER CO., INC.

840 Barry St.

New York, N. Y.

THERE'S A GOOD JOB FOR YOU IN

We Will Train You Quickly to Qualify

RADIO

The servicing of modern radio receivers requires experts—men trained for this work are needed everywhere.

RADIO OFFERS BIG OPPORTUNITIES

Your possibilities of making money are limited only by your ability and skill. There is no room for the soldering iron "guesser". But you must be trained—the sooner you begin the quicker you'll cash in.

LEARN AT HOME

We will train you at home to service and repair radio receivers of all types. Invest for future success in R.T.A. training.

NO EXPERIENCE NEEDED

You need no previous experience in Radio. We show you how to make money almost from the start. Hundreds of men are enjoying the rewards of R.T.A. training.

Full details of this great opportunity are explained in a helpful book that is **FREE**

Send for it today. It will be mailed at once.

RADIO TRAINING ASS'N. OF AMERICA
 Dept. RN71
 4525 Ravenswood Ave., Chicago



FREE

OF EXTRA COST
 This time-saving trouble-finder and circuit analyzer included.

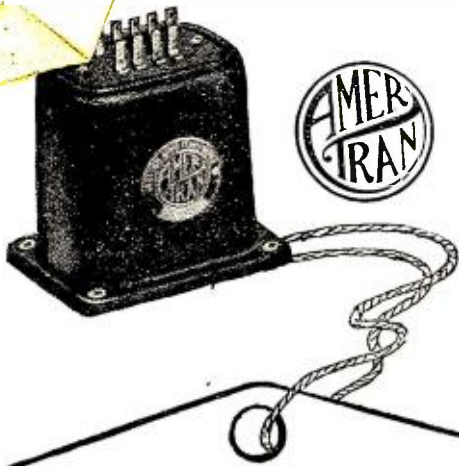

SOLD

to the Man Who knows quality construction

AmerTran Transformers are bought for their proved technical improvements, executed with skill and quality materials. Demonstrable facts about AmerTran Transformers are: Frequency characteristics are exceptionally uniform; filter types give full inductance with rated d.c. flowing; power units have better than 10% regulation. Consult our Bulletin 1002 for more details. Write:

AMERICAN TRANSFORMER CO.
178 Emmet St. Newark, N. J.

AMERTRAN
QUALITY TRANSFORMERS SINCE 1901

FASTEST WAY TO LEARN CODE
Easy, Fascinating; **LEARN by EAR**
To Be a **GOOD OP.**

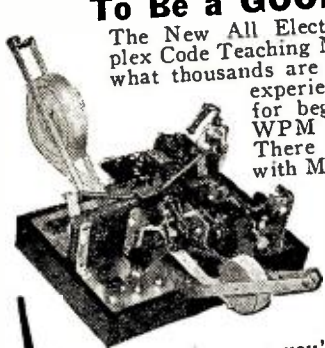

The New All Electric Master Teleplex Code Teaching Machine is exactly what thousands are looking for. No experience needed. Ideal for beginners—steps up WPM for ALL Ops. There is no guess work with Master Teleplex, because it records your sending in visible dots and dashes. You SEE and HEAR exactly how you are making your signals. You learn code the way you'll be using it—by SOUND. Complete course included at no extra charge. Used by many schools and several governments for teaching code. Low cost, easy terms. **MONEY BACK GUARANTEE.** Send now for booklet "R1," no obligation. Postcard will do.

THE "HAM" SPECIAL Standard Teleplex—A highly efficient code teacher using heavy specially prepared waxed paper tape, having two rows of perforations. Write for Free folder "R.R.1." We are the originators of this type instrument
TELEPLEX CO.
72-76 Cortlandt St. New York City
TELEPLEX—The Choice of Those Who Know

Ken-Rad
Radio Tubes

KEN-RAD TUBE & LAMP CORPORATION, INC.
Owensboro, Ky.

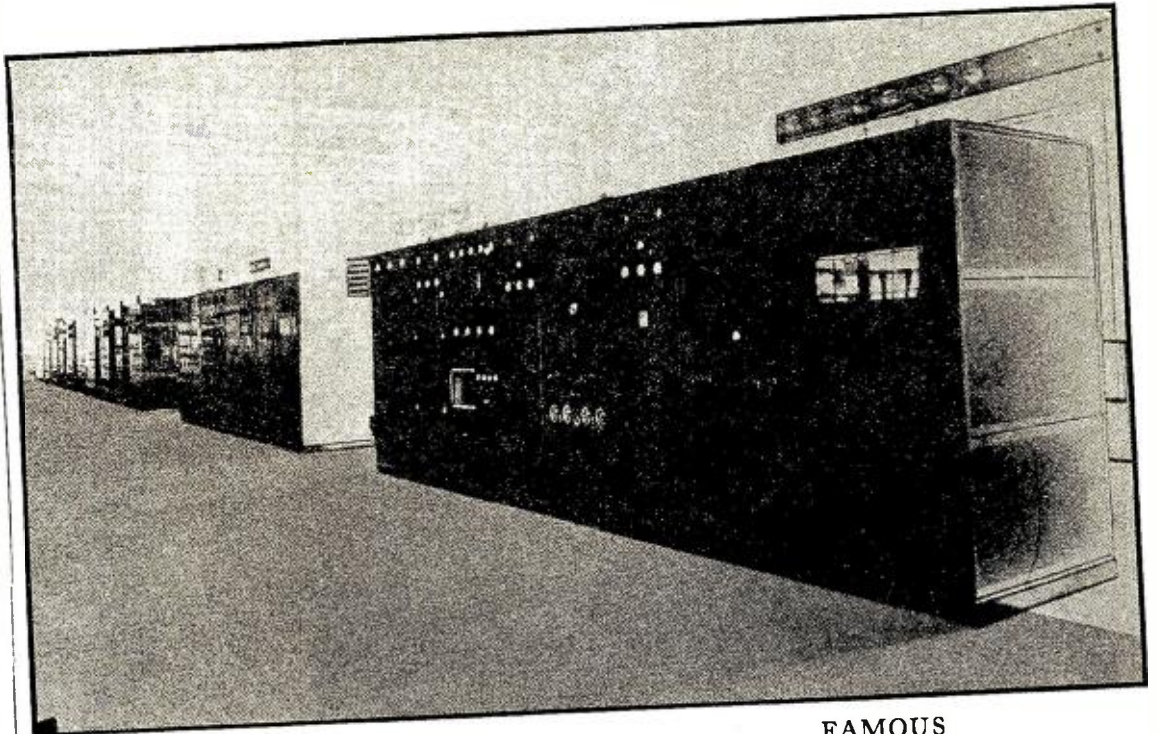

The DX Corner
(Short Waves)

(Continued from page 420)

Friday off at 10 a.m., (Howald), 9520 kc., 5:30 to 9:30 a.m. daily, (Davis), changed to 9540 kc. (Partner), (Black, Gallagher, Chiang,) 15190 kc., (Howald, Kemp, Kentzel), announce in English by man and woman, "Hongkong Calling," address—Box 200, Hong Kong, Augustine.
ZCK, Hongkong, new frequency 9480 kc., old frequency 8775 kc., until 10 a.m., (Markuson).
XGOX, Nanking, China, 6.82 mc., daily 6:30 to 8:40 a.m., Sunday, 7:30 to 9:30 a.m., (Sholin, Gallagher, DeMent), 9500 kc., 1 to 8 a.m., (Flick).
ZBX, Hongkong, China, 9.53 mc., 8.75 mc. from 4 to 10 a.m., (Sholin), louder than ZBW, R9, 7:40 to 9:00 a.m. Sunday 9520 kc., (DeMent), this station has changed to 15,190 kc.
XGOA, Nanking, China, 9460 kc., R3, (Edlin).
XGW, Shanghai, China, 10.42 mc., testing in early morning (Black) 9.51 mc., (Gallagher).
CQN, Macao, China, moved from 9553 kc. to 9680 kc. begins transmissions 5 a.m., (Croston, Edlin, Croston), 9740 kc., (Diez).
JIB, Taiwan, Formosa, 10.53 mc., 9 a.m., 10 a.m. (Gallagher), relays JFAK, 4 to 5 p.m. on second Sunday of each month (Croston).
VPB, Colombo, Ceylon, 6160 kc., (Smith), part of its transmissions are in Tornic and Sinhalese dialects, address—Chief Telecommunications Engineer, Broadcasting Office, Torrington Square, Colombo, Ceylon.
YBG, Medan, Sumatra, 28.76 meters, 11:30 a.m. to 12:30 p.m. (Smith).

AFRICA

EAJ43, Santa Cruz, Canary Islands, approximately 28.7 meters, (Styles), 2-4 p.m., 6-8 p.m. (Piorko).
EA1BC, Tenerife, Canary Islands, 7000 kc., irregular, (Rodriguez).
EA8AB, Tenerife, Canary Islands, 28 meters, 2 p.m., 6-7 p.m., (Mascarenhas).
EHZ, Tenerife, Canary Islands, 10.38 mc., 7-7:30 p.m., (Kemp). Address for verifications—Compañia Telefonica Nacional de España, South Africa, (Miller).
ZUD, Roberts Heights, South Africa, 5000 kc., irregular, (Miller). Address—Chief Operator, G.O.P., Pretoria, South Africa.
ZSS, Klipheuvell, South Africa, 15.75 meters. (Miller). Address—Overseas Communications of South Africa LTD, Box 682, Capetown, Union of South Africa.
ZTD, Durban, South Africa, 6135 kc., same

FAMOUS "JV" TRANSMITTERS
Broadcast Band Observer Yamamoto, of Japan, sends us this interesting photograph of the powerful Japanese short-wave broadcasting setup.

schedule as ZTU except at 4 a.m. Sundays, (Westman).
ZTC, Capetown, South Africa, on 500 meters, has been testing on 50 meters around 9-10 a.m., (Williams).
SUZ, Cairo, Egypt, 13.84 mc., (Kemp).
IDU, Asmara, Eritrea, 22.39 m., (Miller).
UNKNOWN SPANISH MOROCCAN, Sunday, September 27, 3:25 p.m., relaying music and speeches to Italy and Abyssinia. Believe QRA to be Melilla, (Smith).
IUG, Addis Ababa, Ethiopia, 15450 kc., announce Pronto, Pronto, Addis Ababa, daily except Sunday 9 a.m. or 9:30 a.m., (Howald, Partner).
TUNIS, Africa, 7624 kc., 7:30-9 a.m., 1-3 p.m., (Styles), 41.30 meters, (Houghton).
CR7AA, Mozambique, Africa, 6137 kc., daily 11:45 a.m.-1:15 p.m., 7:45-10:15 p.m., Sundays 3-5:30 p.m. South African Standard Time, (Yoshimura). Address—Caixa postal, 594, Lourenco Marques, Africa Oriental Portuguese.

NORTH AMERICA

CFRX, Toronto, Canada, 6070 kc., new relay of CFRB will commence early in November (Hammersley).
CFCX, Montreal, Canada, 6005 kc., formerly VE9DR, weekdays 6 p.m.-1 a.m., Sundays 10 a.m.-12:15 p.m. (Styles).
CJRJ, Winnipeg, Manitoba, Canada, 11720 kc., (Zarn), 7:30-7:45 (Leutenberg).
CJRO, Winnipeg, Manitoba, Canada, 6150 kc., (Zarn), 7:30-7:45 (Leutenberg).
CRCX, Toronto, Canada, 6090 kc., 6 p.m. (Azevedo).
W8XWJ, Detroit, Michigan, 31,600 kc., 7:30-8:30 p.m., broadcasts code practice sessions each night (Croston).
KKQ, Bolinas, California, 11950 kc., 8:30 p.m., (Edlin), 13,080 kc., (Leutenberg).
W8XAI, Rochester, New York, 41 mc., instead of 31.6 mc. (Parcells).
W3XAL, Boundbrook, New Jersey, 10.87 meters, (Williams).
W3XAU, Philadelphia, Pa., 7,700 kc., tests at 7 p.m. Mon. (Kernan). 9.59 mc., spoils broadcasts of PCJ, RAN, HBL, CB960, HB5J, and HJ2ABC (Gallagher).
W6XKG, Los Angeles, California, 31,600 kc., relays KGFJ, heard daily (Goodman). Slogan: "The Pioneer S.W. Station of the West."

RHODE ISLAND ON THE MAP
This is the DX Post of J. V. Trzuskowski, Official Observer for Rhode Island, who not only builds his apparatus but makes it work.

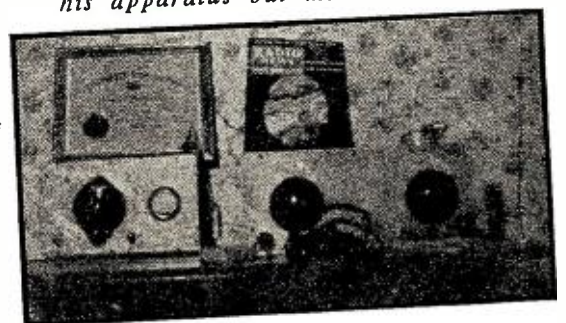

RADIO NEWS FOR JANUARY, 1937

WIXAL, Boston, Mass., 6040 kc. and 11790 kc., from a booklet; heard 10 a.m. on 15,240 kc. (Howald), 1:30-5:45 p.m. (Horwath, Leutenberg), 25.45 meters (Smith).
 W8XGI, Loraine, Ohio, 11400 kc., mornings irregularly, talking to ships, etc. (Davis).
 WIXK, Boston, Mass., 7,670 kc. and 10,700 kc. daily, (Kernan, Atherton).
 W8XK, Pittsburgh, Pa., 1187 kc., 2 p.m. (Kempster), 11,900 kc. 9 p.m. (Diez), 7-8 a.m. (Lopez).
 W2XGB, Hicksville, New York, 14,330 kc., to test with beam to Europe, 9 a.m.-3 p.m. (Styles).
 W2XAF, Schenectady, New York, 9615 kc., daily 6:50 p.m. (Dietz).
 W1XE, New Bedford, Mass., 31,600 kc., daily, 3-9 p.m., wants reports (Fallon).
 W2XE, New York, 11,830 kc., 21,500 kc., 7-12 a.m. (Lopez).
 XEUW, Veracruz, Mexico, 6060 kc., daily 8 a.m. (Diez).
 XEWI, Mexico, 11900 kc., Mon. 1:00-2:00 p.m., Tues. and Thurs., 9:15-9:45 p.m., Thurs., 6:00-7:00 p.m., address: P.O. Box 2874, Mexico, D.F. (Meehan); 11,880 kc., heard irregularly (Markuson), 11,950 kc. (Rodriguez, Atkinson, Parsons).
 XECR, Mexico City, Mexico, 40.6 meters, 7:00 p.m. (Coover), 7380 kc., every Sun. 7-8 p.m. (Augustine).
 XEXF, Board of Health, Mexico City, Mexico, 6,200 kc., asked for reports (DeMent).
 XE2HF, Tampico, Mexico, Address: Box 247, Tampico, Mexico; owned by F. H. Driscoll (DeLaet) (A very interesting "veri" card).
 XEME, Merida, Yucatan, Mexico, 9520 kc., daily 10 a.m.-3:30 p.m. and 5:30-11 p.m. (Sahlbach, Betances). Address: Radiodifusora XEME, Calle 59, Num. 517, Merida, Yucatan, Mexico.
 XEBT, Mexico City, 6036 kc., daily 7:35 p.m. (Diez).
 XEW, Mexico City, Mexico, 11,900 kc., will be on 6015 kc. (Anca).

**CENTRAL AMERICA
WEST INDIES**

ZFD, St. George, Bermuda, 10335 kc., testing 7:30-8:15 p.m. Sunday (Croston).
 CMA3, Cuba, 5 p.m., Wednes. on 15505 kc. (Edlin) 5-6 p.m. on 14.60 mc., most distinct Cuban (Beck).
 COCO, Havana, Cuba, 9750 kc., 8 a.m.-1 p.m. (Croston), 6010 kc., 8 p.m. (Azevedo), 4:00 p.m.-10:00 a.m. Sat. (Westman, Miller).
 CO5RY, Matanzas, Cuba, 6750 kc., 7-9 p.m. (Croston).
 COCX, Havana, Cuba, heard (by Davis) irregularly but often, 11,550 kc., 7 p.m. (Kentzel), news reports at 8:00 a.m., gong between reports (DeMent), heard 11420 kc. Slogan: "La Voz de Radio Philco". Address: P. O. Box 32, (Partner), train sounds and 4 chimes before station announcements. 4-12 p.m. daily, 1-3 p.m. Sunday (Horwath, Fallon, Pickering, Staley), relays CMX (Lyons, Coover, Azevedo, Walker, Hartman, Amos, Black, Smith, Wilkinson, Harris, Atkinson, Chiang, Flick, Kemp).
 COCH, Havana, Cuba, 11500 kc., approximately, daily 9 a.m.-12 m. (Howald).
 CMCX, Havana, Cuba, 11600 kc., irregularly 12-2 p.m. (Long wave CMX) (Stabler).
 CO5RY, Matanzas, Cuba, 6250 kc. (Styles). Address: Senior Berrahe, R. de la Torre Gral., Betancourt, 51, Matanzas, Cuba.
 COCO, Havana, Cuba, 9800 kc., daily 7 p.m. (Dietz), 9,750 kc. Slogan: "La Voz de RCA Victor" (Rodriguez, Williams), 10:40-11:00 p.m. (Walker), 6 p.m.-1 a.m., daily except Sunday (Partner). Slogan: "La Casa de las Medias". Address: Calle 25, No. 445, (Horwath, Fallon, Pickering, Coover, Azevedo, Markuson, Mascarenhas, Partner, Harris, Flick, Kemp, Cindel).
 COCH, Havana, Cuba, 9523 kc., daily 7 a.m., 9428 kc., daily after 7 a.m. (Stabler, Coover), 9428 kc. (Dietz, Azevedo, Kemp).
 COCD, Havana, Cuba, 6130 kc., 7-10 p.m., every evening (Cindel). Slogan: "La Voz del Aire", Sunday 4 p.m. (Stabler).
 COKD, Santiago, Cuba, 9:30 p.m. Address: P. O. Box 157; is this COKG? (Stabler).
 COCE, Cuba, 12,251 kc., 12-3 a.m. (Miller).
 HIT, Trujillo City, Dom. Rep., 6.63 mc., heard Oct. 5-6:20 p.m. (Gallagher, Kemp).
 H18A, Trujillo City, Dom. Rep., regularly evenings on 6,450 kc. (Betances).
 H14V, Trujillo City, Dom. Rep., 6477 kc., 5:9-40 p.m. (Ralat), Wednesday 9-10 p.m. (Stabler).
 H13C, La Romana, Dom. Rep. They have moved to 6730 kc. with same schedule (Harris, Ralat). Slogan: "La Voz de la Feria" (Betances).
 H13A, Trujillo, Dom Rep., moved to 6730 kc., and are heard irregularly evenings (Ralat).
 H13U, Santiago de los Caballeros, D. R., 6015 kc., 10:40 a.m.-1:40 p.m. and 4:40-9:40 p.m. from verification (Ralat).
 H15N, Santiago, Dom Rep., now on 6135 kc., 6:40-9:40 kc. from verification (Ralat).
 H1N, Trujillo City, Dom. Rep., 11280 kc., 5-6 p.m. and on 6243 kc. 12 noon-2 p.m. and 7:30-9 p.m. (Ralat, Davis, Samson, Pickering, Hartman) 11300 kc., (Fallon, Parker, Campbell). Slogan: "La Voz del Partido Politico

Dominicano" (Piorco, Coover, diez, Azevedo). Closes with Dominican anthem (Beck) 26.6 and 48.5 meters (Smith, Bower, Harris, Atherton, Stabler, Cindel, Kemp, Dressler, Boussy, Smith, Anca, Stabler, Miller).
 H18Q, Trujillo City, Dom. Rep., 6,240 kc., 7 a.m. (Azevedo) off air at present (Betances).
 H11J, San Pedro de Macoris, Dom. Rep., 5,865 kc., 7 a.m. (Azevedo).
 H11A, Santiago, Dom. Rep., 9-11 p.m., 6185 kc. irregularly (Stabler).
 HIX, Trujillo City, Dom. Rep., moved from 6,131 kc. to 6,340 kc. (Betances). From a veri: Sun. 7:40-10:40 a.m.; Tue and Fri., 12:10-1:10, 4:40-5:40 and 8:10-10:10 p.m.; rest of week 12:10-1:10 and 4:40-5:40 p.m. (Fallon) about 8540 kc. (Bower).
 H1I, Trujillo City, Dom. Rep., 20.48 meters, heard working WNC at 9:30 a.m. (Atherton).
 H13E, Puerto Plata, Dom. Rep., 6075 kc., 400 watts (Harris).
 HH2S, Port-au-Prince, Haiti, 5915 kc., (Hartman). Signs off at 9:40 p.m. (Atherton, Kemp).
 HH2W, Haiti, 48.9 meters, 7-8:30 using a new transmitter (Houghton).
 HH3W, Haiti, 21.27 meters, daily schedule is 8-10:30 p.m. and 2-3 p.m. (Houghton).
 HH2S, Port-au-Prince, Haiti, 5964 kc., 7:38 p.m. (Diez) 5915 kc., 8 a.m. (Azevedo).
 TGW, Guatemala City, Guatemala, 9540 kc., 12:30-1:08 a.m. (Leutenberg).
 TG2X, Guatemala Police, Guatemala, 5940 kc., Sat. 10-11 p.m. (Stabler).
 HRN, Tegucigalpa, Honduras, 5875 kc., 5910 kc., 7:30 p.m. (Diez). Slogan: "La Voz de Honduras."
 HRP1, San Pedro Sula, Honduras, 6315 kc., new schedule daily 8:45 p.m.-11 p.m. and 1-3 p.m. (Styles). 10 p.m. (Coover), 6235 kc., 9 p.m., (Azevedo, Kemp).
 HRD, La Ceiba, Honduras, 48.12 meters, YNLF, Managua, Nicaragua, 8-11 p.m., 9.68 mc. (Gallagher).
 TIVL, San Jose, Costa Rica, testing on 6815 kc., (Betances). Slogan: "La Voz del Morazan."
 TI8WS, Punta Arenas, Costa Rica, 39.74 mc., Sunday 5-6 p.m. (Smith).
 T1PG, San Jose, C. R., 6410 kc., Wed. and Sat. 9-10 p.m. (Fallon, Betances, Kemp).
 T14NRH, Heredia, Costa Rica, 8196, 9091, 9772 kc. (Diez). Sat. 11:30 p.m.-2 a.m. 9670 kc. (Kentzel, Pickering, Augustine, Atherton). Slogan: "La Voz de Costa Rica," irregularly.
 TIGPH, San Jose, C. R., 6710 kc., daily 7 p.m. (Diez).
 TIEP, San Jose, C. R., 6710 kc., daily 7 p.m. (Diez, Kemp).
 TIRCC, San Jose, C. R., 6575 kc., daily 10:30 p.m. (Diez).
 HP5K, Panama, 6050 kc., daily 7 a.m. (Diez).
 HP5J, Panama City, Pa., 9615 kc., daily 12-25 p.m. (Diez, Coover). Correct frequency is 9605 kc. (Augustine). "La Voz de Panama," (Immicke, Fallon), 31.28 meters, 8 p.m.

SOUTH AMERICA

HJ4ABA, Medellin, Columbia, 11810 kc., 4:30 p.m. (Horwath). Off air at present. (Betances, Leutenberg). Slogan: "Ecoo del Combeima."
 HJ4ABU, Pereira, Colombia, 6145 kc. (Rodriguez, Augustine). At 7 p.m., by Azevedo. Slogan: "La Voz de Pereira."
 HJ1ABE, Cartagena, Colombia, 9580 kc. (Pickering). Heard up to 1:30 a.m. (Williams, Pickering). 9500 kc., 6 p.m. (Azevedo, Flick). Slogan: "La Voz de los Labor Fuentes."
 HJ4ABP, Medellin, Colombia, 6035 kc., 10-11 p.m. Announces as Long-Wave HJ4ABQ. (Stabler). 30.20 meters. (Messer). 8 a.m. (Atherton).
 HJ4ABC, Medellin, Colombia, 5930 kc., 10-11 p.m. (Stabler).
 HJ1ABJ, Santa Marta, Colombia, 6025 kc., 11:30 a.m.-2 p.m., 5:30-10:30 p.m. (Croston).
 HJ3ABD, Bogota, Colombia, 6050 kc. (Markuson), 7 p.m. (Azevedo), 5925 kc., by Betances. Operates until midnight. (Miller).
 HJ4ABB, Manizales, Colombia, 6105 kc., 8 p.m. (Azevedo).
 HJ1ABK, Colombia, off air at present. (Betances).
 HJ5ABC, Cali, Colombia, 48.78 meters, 10:20 p.m. on October 9. (Atherton).
 HJ5ABD, Cali, Colombia, 6122 kc., daily 9:30 p.m. (Diez).
 HJ1ABB, Barranquilla, Colombia, 6175, 9675 kc. (Diez). Now on 6030 kc. (Walker).
 HJ1ABG, Barranquilla, Colombia, 6073 kc., 6100 kc. 9:30 p.m. (Diez). 6041 kc., 7 p.m. (Azevedo). Slogan: "La Voz del Atlantico."
 HKV, Bogota, Colombia, 8890 kc. (Diez). Monday and Thursday, 7-7:35 p.m. (Dressler). Address: Ministerio de Guerra.
 HJ4ABE, Medellin, Colombia, 6095 kc., daily 9:30 p.m. (Diez). At 6 p.m. (Azevedo).
 HJ2ABC, Cucuta, Colombia, Styles reports them now on 31.33 meters, 9575 kc. (Rodriguez, Houghton). Slogan: "La Voz de Cucuta."
 HJ1ABP, Cartagena, Colombia, 9600 kc., 8:35-9:30 a.m., irregularly. (Yoshimura). Styles reports them on 31.25; 9625 kc., by

TRIPLIET
 Pocket Volt-Ohm-
 Milliammeter
 D.C. and A.C.
 Size: 3 1/16" x 5 7/8" x 2 1/8"



MODEL 666

DEALER PRICE \$15.00

Uses large 3" Sq. Triplett Instrument
 A.C.-D.C. Voltage Scales Read: 10-50-250-500-1000 at 1000 ohms per volt.
 D.C. Milliampere Scale Reads: 1-10-50-250.
 Ohm Scale Reads: Low 1/2-300, high 250,000.

Black Molded Case and Panel.
 Low Loss Selector Switch.
 Complete with Alligator Clips, Battery and Test Leads.

Dealer Price.....\$15.00

A complete Instrument for all servicing needs. Can be used for all A.C.-D.C. voltage, current and resistance analyses.

**LEATHER CARRYING CASE
for Model 666**

Model 669, supplied extra.
 Very attractive. Of black, heavy leather with finished edges and strap.

**SEE YOUR JOBBER—
WRITE FOR CATALOGUE**



The Triplett Electrical Instrument Co.
 151 Harmon St., Bluffton, Ohio

Without obligation please send me
More information on Model 666.
I am also interested in.....
 Name
 Address
 City..... State.....



as a CUCUMBER TRANSFORMERS DO NOT OVERHEAT

There's real design in Utah Transformers, the result of fifteen years of experience in the design of radio parts. They are built with thin laminations to provide lower eddy current loss and less consequent heating. Transformer Cores, of Highest Grade Electrical Sheet Steel, are properly sized and shaped to provide the most efficient magnetic field. All Utah Transformers are completely impregnated against moisture and atmospheric conditions. Utah Transformers, like all other Utah parts are built to the highest standards of quality—the reason for their selection for over 3,000,000 Radio Receivers.

SPECIFY PARTS

- Vibrators
- Transformers
- Chokes
- Volume Controls
- Tone Controls
- Speakers
- Resistors
- Plugs
- Jacks
- Jack Switches
- Push Button Switches

UTAH RADIO PRODUCTS COMPANY

ORLEANS STREET, CHICAGO
TORONTO • ONTARIO • CANADA

Buenos Aires, South America; UCOA Radio Products Co.

15 YEARS OF LEADERSHIP



QUICK as a WINK
write for full details

SOLAR MFG. CORP.
599-601 BROADWAY NEW YORK CITY



Precision CAPACITOR ANALYZER

Capacity, power factor, leakage, resistance, directly on the panel. Highly sensitive No. 6E5 cathode ray tube used for balancing. Dials color-coded to match settings. A refined and extended Wien bridge, instantly usable in shop and afield. Two models, low priced.

Walker. Daily 6:30-11 p.m. (Dressler, Horwath, Coover). Azevedo reports them on 9615 kc. (Houghton, Kernan, Stevens). LSI, Buenos Aires, Argentina, 9830 kc., Sundays 8:30-8:45 p.m., Spanish speaking. (Dressler).

LRZ, Buenos Aires, Argentina, 15350 kc., 7 a.m. (Diez). 5 kw. Yoshimura reports them on 15280 kc. 15290 kc. at 2 p.m. by Azevedo, Croston. Slogan: "Radio el Mundo." Owned and operated by Editorial Haynes Ltd. Address: Calle Maipu 555, Buenos Aires, Argentina.

LTX, Buenos Aires, Argentina, 9708 kc., 8:45 p.m. (Diez). 9660 kc., daily, 7-9 p.m. (Rodriguez). 7-10 p.m., by Kentzel. Changed to 9640 kc. 5-11 p.m., daily (Mascarenhas). Operates only in evening. (Croston, Azevedo, Piorko, Smith).

LSN3, Buenos Aires, Argentina, 9890 kc. Announcements in English. (Croston).

LSX, Buenos Aires, Argentina, 10350 kc., daily, 2-4:30 p.m. (Westman, Dressler). 28.98 meters. (Mascarenhas). Atherton, Stevens, Messer, Kemp). 10400 kc., announces in English and Spanish. (Lopez). Slogan: "La Voz Argentina."

PRADO, Riobamba, Ecuador, 6640 kc., 9-10 p.m. Lady talking (Stabler). 45.3 meters. (Zarn).

HCJB, Quito, Ecuador, 8950 kc., heard until 10:20 p.m. (Atherton).

HC2RL, Guayaquil, Ecuador, 6668 kc., 9-11. (Mecken).

YV5MR, Maracaibo, Venezuela, 5890 kc., 4:45-9:45 p.m. (Amos).

YV2RC, Caracas, Venezuela, 5800 kc., 4-9:45 p.m. (Cindel). 7 p.m. (Azevedo).

YV9RC, Caracas, Venezuela, 6400 kc., 6 p.m. (Azevedo). 8 p.m. on. (Stabler).

RV5RMO, Maracaibo, Venezuela, 5850 kc., 8 p.m. (Azevedo, Kemp).

YV8RB, Barquisimeto, Venezuela, 5900 kc., 6 p.m. (Azevedo). 5880 kc. (Harris). Special program on October 3, 11-12 p.m. (Gallagher).

Schedule 12-1 p.m. 6-10 p.m. (Atherton).

YV7RMO, Maracaibo, Venezuela, 6070 kc., 6 p.m. (Azevedo). Off air at present. (Betances).

YV4RC, Venezuela. Off air at present. (Betances).

YV1IRB, Bolivar, Venezuela, now on air with 200 watts. (Betances). 45.8 meters. 6-9:30 p.m. (Houghton). Slogan: "Ecos del Otunoco."

YV6RV, Valencia, Venezuela, 6575 kc., (Diez). 6520 kc., 5 p.m. (Azevedo, Zarn, Kemp). Slogan: "La Voz de Carabobo."

YV12RM, Venezuela, 6340 kc., (Diez). Slogan: "Emisora 12 de Julio."

YV3RC, Caracas, Venezuela, 6150 kc., (Diez), 6160 kc., 7 p.m. (Azevedo, Kemp).

YV1ORSC, San Cristobal, Venezuela, 5720 kc., 8 a.m. (Azevedo). Slogan: "La Voz de Tochira."

YV1RH, (YV1RA, YV1RG), Maracaibo, Venezuela, 6150 kc., Mondays, 1-1:30 a.m. Same address as YV1RC. (Howald). 6350 kc., 8:30-12 p.m. (Kentzel). 1160 kc. and 6350 kc. (Beck, Miller, Chiang, Gallagher, Meade). Wants reports. (Fallon). 6350 kc., testing at 8 p.m. (Ralat). 10:40-11 p.m., Sept. 27. (Sands, Beck). 15460 kc. (Gallagher, Meade). Slogan: "Radio Valera" (Betances); "Emisora del Philco." (Atherton, Partner); "Ondas del Lago." (Betances). Address: P. O. Box 261.

YV1RC, Maracaibo, Venezuela, 6320 kc., Mondays 11 p.m.-1:30 a.m. (Howald, Gallagher, Lopez). Address: P. O. Box 261 Estado Zulia, Venezuela, 6360 kc., 12 p.m. (Lopez). Slogan: Ecos del Lago.

PRF5, Rio de Janeiro, Brazil, 4:45-5:45, daily schedule. (Stabler).

PSE, Rio de Janeiro, Brazil, 14935 kc. (Howald). 8 p.m. Wednesday. (Sholin).

CB960, Santiago, Chile, 9600 kc., signing off at 1 a.m., 9/19/36 after special program celebrating Chile's independence. (Westman).

PZ1AA, Paramaibo, Surinam, experimental on 14 meters, heard October 8, 10 p.m., calling CQ. (Atherton).

OA4R, Lima, Peru, 7140 kc., daily from 1-4 p.m. (Westman).

VP3MR, Georgetown, British Guiana, 6006 kc., Tuesdays and Thursdays. (Alfred). 6010 kc. (Azevedo, Piorko, Harris, Betances, Vassallo).



AN ACTIVE OBSERVER
Fred Atherton of Rutland, Vermont, shown at his DX Corner certainly spends a lot of time at his radio and pulls them in to break many records.

ZJV, Suva, daily except Sunday 5:30-7:30 a.m., (Sahlin, Stevens, Kemp, Atherton).

VPD, Suva, Fiji Islands, 9540 kc. increased power to 3 kw., 1:30 a.m. and on, (Styles), 5:30-7 a.m. daily, (Danis).

VK9M1, SS., M.V. Kanimbla, 11710 kc., 6010 kc. Irregular, (Chiang).

VLK, Sidney, Australia, (Kemp).

VK5DI (VK5AD), Adelaide S.W. Club, Australia, 21.42 meters, occasionally on 41.24 meters, (Smith), every Sunday morning on 21.42 meters, (Vassallo).

VK2ME, Sidney, Australia, 31.28 meters, Sundays 12:30-2:30 a.m., 4:30-8:30 a.m. Mondays 9:30-11:30 a.m., (Styles, Ealui, Ozevedo).

VK2DL, Canterbury, Australia, 7300 kc., Wednesday-Sunday from 7-9 p.m., (Fallon).

VK3LR, Lindhurst, Australia, 9580 kc., calling and testing with recordings, (Styles), Monday-Friday 3:15-8:30 a.m., from a verification, (Westman), (Croston, Ealui, Croston, Ozevedo DeMent, Gallagher, Kemp), address—Box 1686, Gen. P. O., Melbourne, (Flick).

VK3ME, Melbourne, Australia, 9150 kc., 6 a.m. (Ralat), 31.5 meters Mondays to Saturdays, 4 a.m.-7 a.m., (Styles), poor reception, (Gallagher, Stahler), reports good reception, (Kemp).

FO8AA, Papeete, Tahiti, 7100 kc., Wednesday and Saturday 12 midnight-1 a.m., (Styles), all announcements in French, Poste de Radio diffusion FOSAA Le Radio Club Oceanien Papeete, Tahiti.

Readers Who Are Awarded "Honorable Mention" for Their Work in Connection with This Month's Short-Wave Report

Raymond W. Sahlbach, Jorge Ralat, Edward L. DeLaet, Werner Howald, Harry J. Potthoff, Robert Pinkerton, A. M. Weber, Anthony C. Tarr, Thaddeus L. Grabek, George Wing Jr., Arthur B. Johnson, C. Mellanby, Bernhard Balsmo, Wilbur Croston, Oscar Taylor, Walter R. Yeary, Anton J. Cindel, E. L. Frost, Delmar H. Hertz, Matthew T. Bills, James A. Lee, C. D. Wagoner, Clayton D. Sands, Ellsworth G. Dumas, E. R. Rances, B. Kashimoto, G. L. Harris, John C. Kalmbach Jr., N. C. Smith, E. H. Goodman, Herbert Campbell, Conrad E. Perker, Arthur Immicke, Arthur B. Coover, Albert Pickering, Kenneth Dressler, Thomas Fallon, Stabler, Elee L. Tyler, L. E. Williams, John C. Lyons, P. Piorko, Caleb Wilkinson, G. C. Sholin, John J. Kernan, J. Rodriguez R., R. S. Houghton, Fred Atherton, Manuel Betances, Flavio Mascarinas, J. Wendell Partner, Louis J. Horwath, Fletcher W. Hartman, Roy E. DeMent, Albert Augustine, G. C. Gallagher, Melton Amos Hammersley, M. J. Markuson, H. Kemp, Sydney G. Millen, Edgar J. Vassallo, Harold W. Bower, H. H. Flick, R. Stevens, Harry E. Kentzel, F. W. Dodge, Peyton Black, E. P. Hill, F. T. Reilly, Lopez, Armand A. Boussy, R. C. Messer, Elmer Samson, Merton T. Meade, Grace M. Beck, August J. Walker, Morton Meehan, S. G. DeMarco, Anton C. Barta, Charles Parcels, Isaac T. Davis, L. F. Miller, Augusto Anca, Don Parsons, J. T. Atkinson, Arthur Yoshimura, H. Westman, A. J. Walker, Shokichi Yoshimura, L. C. Styles, Frank Andrews, Luis Diez, Jack Staley, Eddie C. Zarn, H. Westman Kempster, R. Muguet, Bob Creamer, Thomas P. Jordan, Norman E. McLeod, H. M. Hallman, C. H. Williams, John R. Tamm, A. Belanger, T. Burnell Unger, Charles F. Myers, Linwood R. Delano, Paul C. Bird, Norman Hendry, Elbert Gross, E. Geneve, Oliver Amlie, Robert A. Curtis, Alvaro Azevedo, Joseph V. Trzuskowski, Harry Lueth, Guy E. Hews, E. DeCottignies, Frank W. Edlin, Wm. F. Howard, Paul B. Silver, Louis C. Sciez, Howard S. Dimmick, Orville Brown, Elmer Samson, Howard Warren, Frank W. Choate, Sherry Adams, Jack Schwartz, Walter J. Starosciak, Irving Goodeve.

OCEANIA

ZLT, Wellington, New Zealand, 11000 kc., 1:30-3:00 a.m., (Howald), midnight during September and October. (Gallagher, Kemp).

KIO, Kahuku, Hawaii, 11680 kc., Monday 11:00-12:00 p.m., (Howald), 11-12 p.m., (Houghton, Gallagher).

K6XO, Kahuku, Hawaii, approximately 15700 kc., calling ships Manila and South Americans during evening hours. (Davis).

KKP, Kahuku, Hawaii, 16030 kc., Tuesday only 12:30-1 a.m., (Styles), "Hawaii Calls", 11,410 kc.-11,020 kc., 11:30-12 midnight with special program to U. S., rebroadcasts to Hawaii (Croston). Sunday 11-12 p.m., (Kernan), Saturday 11-12 p.m., (Kernan, Gallagher, Kemp).

KKH, Kahuku, Hawaii, 7520 kc., 11:30-12:00 p.m., for CBS, (Partner), HRD 10 p.m., (Gallagher).

KTR, Manila, Phillipine Islands, 10910 kc., with musical programs on Tuesday and Wednesday irregularly 9-10 a.m., (Westman).

VPD2, Suva, Fiji Islands, 9.54 mc., relays

Phase Inversion

(Continued from page 410)

the gain of the system is less than two, counting both sides of the signal.

The system should give perfect inversion, both voltages being equal as long as R2 and R3 are equal. The capacity between cathode and filament is across R2 and this would tend to unbalance the two sides, but the capacity is only a few microfarads, and the effect is therefore negligible.

Some think it a disadvantage to have the cathode "up in the air", claiming that it causes hum. For this reason it may be better to have the inverter tube immediately before the power tubes, so that any possible hum will not be amplified so much.

In order to test for equal amplitudes, some experimenters connect the two plates of the two output tubes together temporarily, so that the two signals oppose each other when flowing through one-half of the output transformer. A test signal should then be sent through the amplifier and the result should be silence or minimum sound if silence cannot be obtained. If the system of Figure 1 is used, this is also a method of finding the right ratio of the signal voltage dividers R5, R6 or R2, R3.

Using Oscilloscope

Another way of checking for equal amplitudes is by means of a cathode-ray oscillograph. Connect the vertical deflecting plates first across one side of the push-pull circuit and then across the other. The test can be made with the sweep circuit turned off, in that case the two signals will each produce a vertical line and the lines should be equally long. A precise measurement may be facilitated by marking the length of the first signal on the face of the tube. A vacuum-tube voltmeter may also be employed to measure the amplitudes and, of course, a copper-oxide rectifier and meter could be used.

Testing for correct phase relations may be made with the oscillograph. Connect the vertical plates across one side of the amplifier (across one grid leak of the first push-pull stage) and the horizontal plates across the other grid leak. The result should be a straight line. If there is any phase difference, the trace becomes an ellipse. This test should be repeated at several frequencies, because any stray capacity across one side may not show up except at high frequencies.

Very small phase or amplitude differences are perhaps not important, since the two output tubes will probably not be exactly alike. It has been explained how the amplitudes can be made equal. If phase shifts occur due to capacity across one plate load, it could be compensated by deliberately placing an equal capacity across the other plate load. This is applicable to Figures 2, 3 and 4. The result would be a slight reduction in high-frequency response on both sides of the inverter stage instead of on just one side.

Careful Wiring

The above suggests that one must be careful when wiring the circuit so as to minimize wiring capacity and to make it symmetrical. The cathode by-pass condenser in Figures 2 and 3 should be small in size and mounted away from the chassis. The volume control in Figure 3 should be close to the socket of the 6H6 and the grid lead of the 6F5 should not be shielded. The diode load resistors should also be close to the socket of the 6H6.

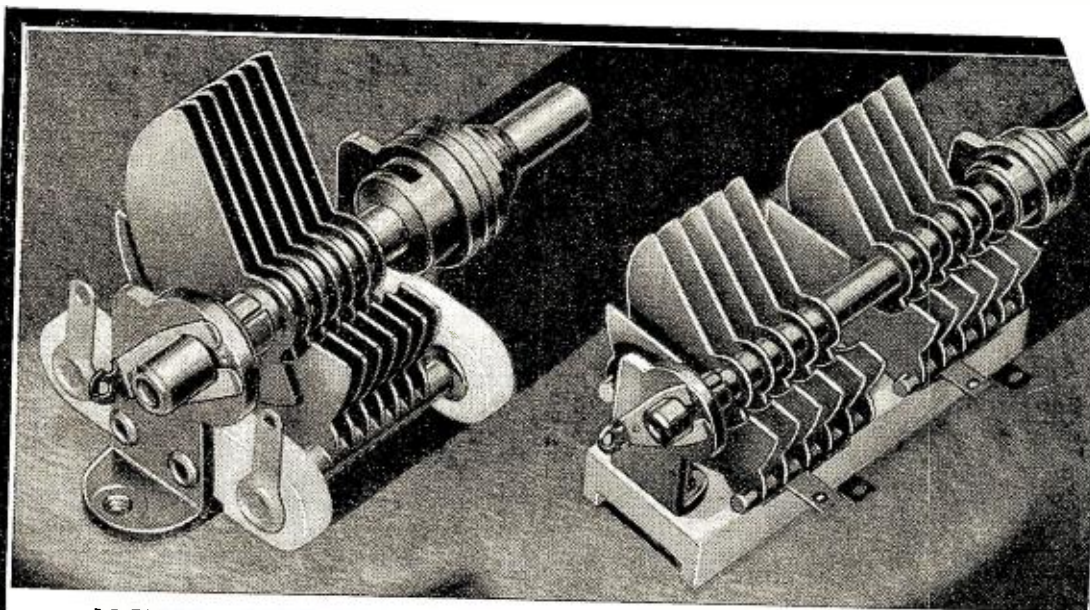

NEW "MC" MIDGET CONDENSERS!

Hammarlund proudly presents a new, complete, series of "MC" condensers. Single and split-stator types—cadmium plated soldered brass plates—Isolantite insulation—27 different sizes—20 to 325 mmf.—midline or semi-

circular plates—single hole panel and base mounting. Strictly noise-free operation, even at ultra-high frequencies with new split type rear bearing and new noiseless silver plated Beryllium wiping contact.

Write Dept. RN-1 today for "MC" booklet.

HAMMARLUND MANUFACTURING COMPANY, INC.
424-438 WEST 33RD STREET, NEW YORK CITY

HAMMARLUND'S 25TH YEAR

A Complete Line of Complete P.A. Systems

U.S.E.'s Systems are built around rugged high fidelity Amplifiers, featuring latest developments and design. Everything from 10 watts to 340 watts output. Reasonably priced.

Write for No. 106 catalog. Get the U.S.E. proposition for handling this line in your territory.

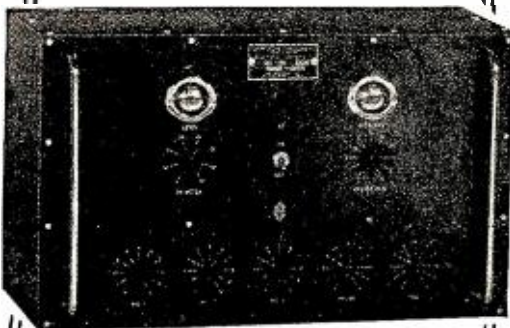

USE 60 WATTS NET AUDIO OUTPUT \$76.26

UNITED SOUND ENGINEERING CO.
2237 University Ave., St. Paul, Minn.

THE NEW "Rebroadcast" EXPLORER

Makes any Radio a Complete All-Purpose Amplifying System. Attach phonograph pick-up, microphone, or short wave set to its input—for amplification by the entire receiver and loud-speaker reproduction with tremendous volume! Also operates as beat oscillator, wave-meter, S.W. transmitter, etc. Many amazing features! Net Price \$8.95 complete less tube. Send now for FREE Literature.



RIM RADIO MFG. CO. 695 Grand St., Brooklyn, N.Y.

Train for

RADIO IN 12 WEEKS AT COYNE

The great Coyne Shops in Chicago have a world-wide reputation for training men for their start in this big-pay field in Only 12 Weeks. By their new plan YOU can take advantage of the wonderful method of learning-by-doing. Coyne training is "Learn by Doing" practical shop training. Start any time after you have enrolled. Coyne is not a home study course. You must come to the Coyne shops to get this training. No need to lose time and money while you strive and save to raise the necessary tuition.

PAY TUITION ON EASY PAYMENT PLAN

Get your training in Coyne Shops. Then start paying for your training in small monthly payments to begin 5 months from the day you start school. Then you have 18 months to complete your payments. If you will send the coupon at once I will send you complete details of this sensational new plan, together with the BIG FREE illustrated BOOK telling all about COYNE training without book study or useless theory, and how many earn while learning. I'll also tell you about the valuable instruction in Diesel engines, Electric Refrigeration and Air Conditioning, which is now included as well as details of Graduate employment help.



H. C. Lewis
President

SEND NOW FOR FULL DETAILS!

MR. H. C. LEWIS, President
500 S. Paulina St., Dept. 17-3K, Chicago, Ill.

Tell me about your Monthly Tuition Payment Plan and send me the BIG FREE Illustrated Book on RADIO.

Name

Address

City..... State.....

FREE CATALOGUE . . .

Write for attractive, free booklet describing all the latest developments in the radio testing field. Dependable instruments are products of unquestioned quality and value. Write to

RADIO CITY PRODUCTS COMPANY,
88A Park Place, New York City.

WHAT'S NEW IN RADIO

WILLIAM C. DORF

(Continued from page 393)

measures only 5/8 by 3 1/6 by 2 1/8 inches. Ohmmeter ranges from 1/2 to 1000 ohms and 0 to 100,000 ohms; voltmeter ranges 15, 150 and 750 volts and current measuring ranges of 1.5, 15 and 150 milliamperes.

Easily Mounted Window-Pole Aerial

The Tobe Deutschmann "Windo-Pole" aerial can be mounted in a few seconds. No tools are required for its installation, the clamp is slipped over the side window-casing and tightened by means of a thumb-

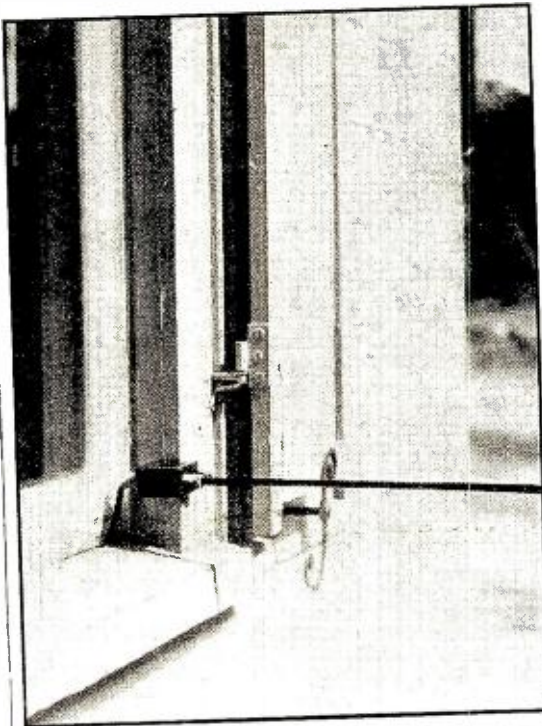

screw. It should find special favor with servicemen and salesmen for demonstration purposes. It can be mounted from a horizontal position to a 45-degree angle and when extended, its length is 8 feet.

Special Battery for Farm Use

Realizing the tremendous possibilities in new and replacement storage battery requirements for the rural trade, the Monark Battery Company has recently announced a new line of special radio batteries incorporating a number of new features in construction and electrical design that should have special appeal in this field. The outstanding features are: extra-thick plates to eliminate need for frequent recharging, one-piece rubber case, wing-nut terminals and a built-in hydrometer permitting a constant check on the condition of the battery. They are particularly applicable for gas-engine and wind-driven



farm lighting systems and as a source of power for battery-operated radio sets.

Special Coil Form for the "Ham"

The accompanying illustration shows the new Hammarlund "Giant" transmitting coil form. It is made of low-loss insulating material known as XP-53 dielectric,

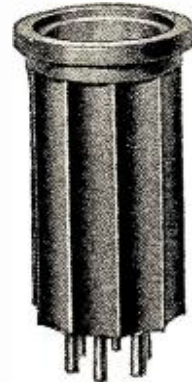

being the same substance employed in this company's popular SWF coil forms. They are grooved and ribbed, and can be mounted either by means of a special pair of brackets supplied with each form, or in the familiar plug-in coil fashion in a regulation socket. The form is 2 1/4 inches in diameter and 3 3/8 inches long exclusive of prongs.

New Instrument for the Dealer and Serviceman

The Radio City Products Co. recently introduced the model 305C combination tube checker and analyzer. It incorporates a number of new features of which the outstanding are: facilities for testing all present types of receiving tubes and spare switching arrangements for checking future tubes. It employs a 5-inch fan-type meter with English reading scale, has a sloping

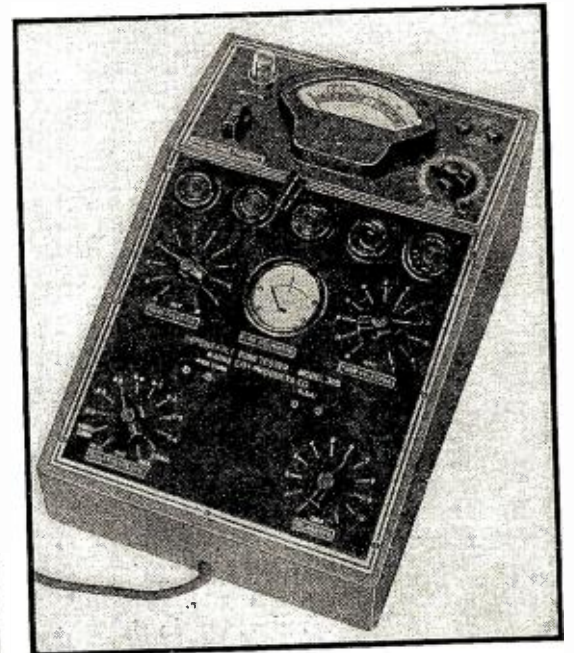

panel for easy operation, tests shorts and there is a neon light to indicate leakages above 1/2 megohm. The manufacturer calls attention to the fact that it provides individual tests on combination tubes, and in addition there is a condenser and continuity tester and resistance can be measured from 10 to 1,000,000 ohms.

Special Antenna Kit For All-Wave Receivers

The Cornish "Noise-Master" all-wave doublet antenna comes completely assembled, making for easy and quick instal-

PIONEER GAS-ELECTRIC POWER PLANTS

6, 12, 32 and 110 volts DC

PIONEER "CUB" 200 watts, 6 or 12 volts DC. Priced at only \$44.95 list, f.o.b. Chicago. Direct drive! Push-button starting! Built-in ammeter! Also "RABY JUMBO" gas-electric plants with magneto ignition: 6, 12 volts, 150 and 200 watts DC. 12, 32, 110 volts, 250 watts DC. For larger wattage requirements—"GRAND CHAMPION", 800 watts 32 volts DC. Self-excited. Push-button starting. \$149.50 list. 800 watts 110 volts DC. \$157.50 list. 1500 watts 110 volts DC, \$267.50 list.

110 Volts AC
PIONEER "Blue Diamond"

300 watts 110 volts 60 cycles AC. The lowest priced alternating current plant on the market, \$79.95 list! Ideal for PA work. Also has 50 watt DC windler for charging 6 volt batteries. Kick-pedal starting! Filter and remote control available. For larger wattage requirements—"GOLD CROWN" AC plants: 600 watts 110 volts 60 cycles AC \$165 list. 1000 watts, \$240 list. 1500 watts, \$290 list.

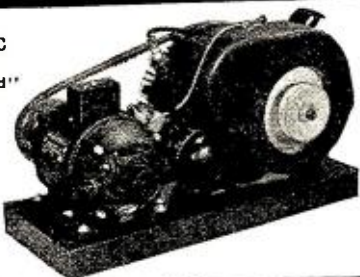

Other Pioneer Products: Wind Chargers; "Silver Band" Dynamotors; Red Seal Gen-E-Motors; Rotary Converters in various sizes and voltages.

PIONEER POWER PLANTS

Pioneer Gen-E-Motor Corporation
450-H West Superior Street, Chicago, Illinois
(Cable Address, "Simonrice" New York)
RUSH INFORMATION ON ITEMS CHECKED
 New De Luxe Air-Flo Wind Charger Converters
 Gas-Electric Power Plants Dynamotors
Name
Address State
City State

BARGAIN BULLETIN
SAVE MONEY ON EVERYTHING YOU BUY!

SPORTING GOODS
WATCHES-CLOCKS
TYPEWRITERS
OPTICAL GOODS
CAMERAS-NOVELTIES

RADIO SETS AND REPLACEMENT PARTS

NEW 100 PAGE CATALOG—JUST OUT!
SEND FOR YOUR FREE COPY TODAY!

Buy efficiently, economically, safely! Hundreds of high quality items—leading lines and standard brands—at prices amazingly low! Real bargains! Square dealing! Write today for your big, free copy of this new catalog hot off the press.

RADIO CIRCULAR CO., INC.
915 Broadway, Dept. R.N. New York, N. Y.

LEE Correspondence Courses in
RADIO and ELECTRICAL ENGINEERING

ELECTRICAL ENGINEERING Covers complete electrical field. Most modern course. So simplified anyone can grasp quickly. Prepare you for secure future. **LOW COST.**

RADIO ENGINEERING Ultra-modern course in radio, public address, photo-electric work. Trains you to be super-service man, real vacuum tube technician. Diploma given. Tuition only \$25, either course. Deferred payment plan. **FREE!** Send name quick for free copies of school catalogs, student magazines etc. **SEND NOW.**

Lincoln Engineering School, 931-7 So. 37th St., Lincoln, Nebr.

SAVE UP TO 50% RADIOS
BUY DIRECT-FACTORY PRICE
30 DAY TRIAL

\$6.95 UP

Many models to select from. Factory prices. A.C.-D.C. all wave, battery sets and new metal tube models. Farm sets that operate like city radios. Money Back Guarantee. 30-day no risk trial. Agent User Proposition. Send for New 1937 Bargain Catalog **FREE!**

Autocrat Radio Company
3855 North Hamilton Avenue
Dept. 504 Chicago, Illinois

FREE Illustrated Catalogue

lation. It is available in several models suitable for all receivers and locations.



Using one of these new antennas, the manufacturer points out the advantage of increased sensitivity on all frequency ranges.

New Switches Feature Double Contact

The heart of any switch is good contact and it is particularly important in radio circuits and meter selector switches. Noise resulting from variation in contact resistance due to corrosion has been a major

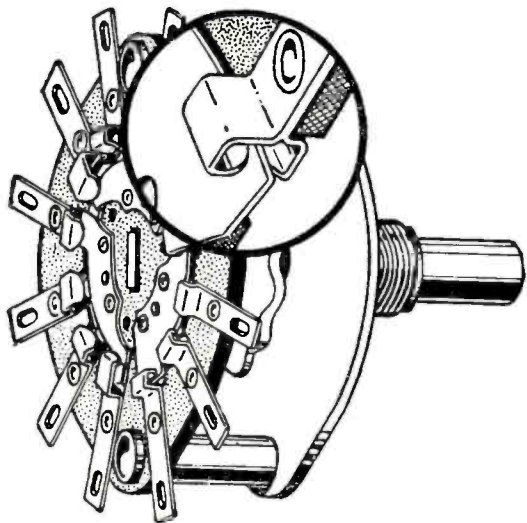

problem for switch manufacturers for all-wave receiver applications. The new line of Centralab selector switches reduces contact resistance and corrosion to a minimum as they have spring brass contact clips, heavily silver-plated, that grip the rotor points with a double jawed "bite" as shown by the magnified view in the illustration. For high frequency work the switches are available with Isolantite stators and rotors. The new line includes numerous selector switches for analyzers, oscillators, receiver replacements, P.A. work, etc.

Numerous Applications For New Power Unit

The compact device illustrated below is the new "Epcor" storage battery eliminator



introduced by the Electrical Products Company. It operates from 110 volts a.c. line supply and delivers an adjustable output of 6 volts at 10 amperes. It is designed to be extremely quiet in operation and is particularly suitable for demonstrating motor car receivers and for operating small d.c. motors, relays and solenoids. It also finds numerous other applications in the radio laboratory or experimenter's workshop and can also be used as a battery charger.

OZ4 and OZ4G

Two new full-wave gas filled rectifiers have been released by Raytheon. These are the OZ4, a metal tube, and its glass equivalent, the OZ4G. These tubes have the same type of elements and the same characteristics as the OZ3 but the OZ4 has a metal shell over the glass envelope and the OZ4G has an octal base; besides, both are very much smaller than the OZ3. Since space is at a premium in automobile receivers, the small dimensions are an important advantage. Maximum overall length of the OZ4 is 2 1/2 inches and the



maximum diameter is 1-5/16 inches. The OZ4G measures 2 3/8 inches from the tip of the keyed pin to the top of the envelope. The diameter of the glass envelope is 7/8 inch and it has a special base, 1 inch in diameter.

These tubes work as follows: when plate current less than 30 ma. is drawn, they act as cold-cathode tubes and the internal drop of the tube is 160 volts. Rectification takes place only by virtue of the difference in surface area of cathode and anodes. When more than 30 ma. is drawn, the ionic bombardment makes the cathode hot and it starts to emit electrons. The internal voltage drop is then only 24 volts. This remains the same for any drain up to the maximum rating: 75 ma. continuous and 200 ma. max. (peak). Max. d.c. output is 300 volts and it takes a minimum of 300 v. (peak) between the anodes to start the tube.

The advantages for use in a vibrator-type power supply are economy due to the absence of heater current, better regulation, and protection against high voltages when starting. This protects condensers during the heating up period. Its efficiency is equal to that of a synchronous vibrator, while using only a simple vibrator. The isolation of the cathode from the car battery circuit is of advantage, since the small capacity between cathode and filament of high vacuum tubes tends to introduce ignition noises which have to be filtered out again.

The rectifiers of the gaseous type generate r.f. noise, which has to be filtered. However, in the case of a vibrator power pack, r.f. filtering is needed anyway and this will usually be sufficient.

The OZ4 has the following base connections: 1 shell, 3 anode, 5 anode, 8 cathode.

37-Tube Receiver Employs Six Speakers

The Crosley model "DeLuxe WLW" receiver is unique from a number of angles. (Turn to page 448)

417

THINGS EVERY RADIO SERVICE MAN MUST KNOW

Ghirardi gives you all 417 in his remarkable **MODERN RADIO SERVICING** and handy **FIELD DATA** book—all clearly explained and illustrated. For instance—

How to use all kinds of test instruments. How they work. Complete construction data. Circuit diagrams. Latest models.

How to use the most successful modern methods in repairing receivers. "Case Histories" and time-saving, money-making short-cuts in service work.

How to align any make of superhet, and—

How to use the Cathode-Ray Oscilloscope method in alignment work.

How to track down and eliminate every type of noise and interference.

How to save time on all difficult troubleshooting and repair jobs. New dope on tests and remedies for hum, intermittent reception, distortion, etc.

How to install and service all makes of auto-radio receivers in all makes of cars and eliminate ignition interference.

How to master all the complexities of AVC and QAVC circuits and trouble-shoot them.

These are but a few scattered items among the 417 essentials of modern radio servicing of which these books will give you easy mastery. Your shop is only half-equipped without them. **ORDER THEM TODAY.** Money-back guarantee.

1300 PAGES 706 ILLUS.

MODERN RADIO

Servicing

\$4 *alone*

Together with 436 p

RADIO FIELD

SERVICE

DATA

\$6



To: Radio & Technical Publ. Co. Dept. RN-17 45 Astor Pl., N.Y.

Enclosed find \$6. for Combination Order, including Jan. & June '37 Supplements to FIELD DATA book. Postpaid. (Foreign \$6.50).

Enclosed find \$4 for MODERN RADIO SERVICING alone. Postpaid. (Foreign \$4.50).

Please send free circular.

MAIL TODAY!

Name

Address

Also—RADIO PHYSICS COURSE—\$4

The Radio Beginner

(Continued from page 411)

passes through the t.r.f. amplifier stage which is usually included in this type of receiver. The reason for this stage will be explained later. Then the signal is applied to the grid of a "mixer" tube. A local signal is generated by an oscillator and this signal is also applied to the same mixer tube. The process of mixing consists of the creation of new frequencies which are equal to the sums and differences of all the frequencies applied to the mixer. The result is that in the plate circuit of the mixer tube several frequencies will be present as follows: The original signal frequency, the oscillator frequency and the sum of the two and the difference of the two. Moreover, the audio-frequency signal which was already modulated on the signal frequency when it came in, has now been transferred to the sum and difference frequencies, also.

The intermediate-frequency amplifier now picks out the difference frequency and amplifies it. After the signal has been sufficiently amplified, it passes through the usual detector and audio amplifier.

The major amplification takes place in the i.f. amplifier and, because its tuning is fixed, its sensitivity and selectivity also remain fixed. Furthermore, since the intermediate frequency is generally low, the inherent selectivity is greater and it is possible to obtain more amplification without running into difficulties of oscillation; also, the selectivity can be further improved by the use of more tuned circuits, all of which can be aligned exactly in the factory.

The r.f. stage, the detector and also the oscillator must be tuned by the same control knob and they have to be so designed that the oscillator is always maintained at a fixed difference between its resonant frequency and that of the incoming frequency.

Repeat Points—Images

The superheterodyne is subject to some special troubles, however. There are what are called "repeat points" or "images". As an illustration, suppose the intermediate frequency was 175 kc. and a station operating on 1,000 kc. is tuned in. The oscillator will normally be tuned to 1175 kc. in order to receive that station. However, if the oscillator is tuned to 825 kc., it will also create a beat of 175 kc. with the incoming signal. This is known as the "image". Therefore, there are two positions of the oscillator dial which would bring in one station. It is a function of the tuned r.f. and the mixer circuits to reduce the two points to one by cutting out one of them. For instance, in the above example, the signal-frequency circuits will be tuned to 1,000 kc. when the oscillator is tuned to 1175 kc., since they are ganged on the same tuning control shaft. When adjusting the oscillator to 825 kc., however, the radio-frequency circuits will be tuned to 650 kc. Now it all depends on how selective these r.f. circuits are. If the 1,000 kc. signal is very strong and the r.f. circuits are insufficiently selective, it may be that the 1000 kc. station will pass through the r.f. amplifier. If it reaches the mixer tube, it will interfere with another station working on 650 kc. It is for this reason that a good sharp tuned-radio-frequency stage is almost essential.

There are also possibilities that harmonics of the oscillator will fall in the broadcast band or may be equal to the fundamental or harmonic of the signal frequency. In both cases, this may result in a squeal or "birdie" at a critical point of the dial. The remedy is, of course, to

shield the oscillator so well that there will be no opportunity for the oscillator frequency to enter the antenna circuit.

From the standpoint of reducing "image" effects, it is best to make the intermediate frequency fairly high. For instance, if in the above example, the intermediate frequency had not been 175 kc. but 465 kc., the 1000 kc. image would be outside of the broadcast band. The choice of a high intermediate frequency reduces the requirements for high selectivity in the r.f. circuits. In fact, in many cases, the t.r.f. stage is omitted when intermediate frequencies of 465 kc. are employed.

It was stated above, that selectivity varies with the frequency. Therefore, the lower the frequency, the better the selectivity in the intermediate-frequency amplifier. Furthermore, the selectivity of the whole receiver will be the same throughout its tuning range.

Another point to keep in mind when choosing the intermediate frequency is that it should not be within the band to be covered by the receiver and it should not be a frequency where a powerful station is working. For instance, if the intermediate frequency is 456 kc. and a local station (commercial code stations are sometimes encountered around these frequencies) were to transmit on this frequency, its signal might pass through the r.f. stages even though these were not tuned for that signal and when it reaches the mixer stage, it will keep on traveling through the intermediate-frequency amplifier, mixing with any signals present in this amplifier and causing "birdie" whistles. It is thus seen that the choice of an intermediate frequency is a compromise and there are now several standard frequencies employed which have been found to be satisfactory; 175 kc., 262 kc. and 456 kc. are some of the most popular ones.

Comparison Between the Two Types

The advantages and limitations of each type of circuit can be summed up as follows: the tuned-radio-frequency receiver is simpler in construction and therefore more economical to make than a super. On the other hand, it is limited both in sensitivity and selectivity with the result that it will generally not be a long-distance receiver. This has its advantages because sharpness of tuning is the natural enemy of good quality reception. Therefore, a broad-tuning set may deliver better quality and the tuned-radio-frequency type is an economical high-quality receiver. The sensitivity being dependent on the frequency, it generally becomes impractical to employ the t.r.f. type as an all-wave receiver especially so if a switch has to be employed for more than three circuits.

The superheterodyne can be made much more sensitive, partly due to the fact that the amplification is divided into two amplifiers at different frequencies, and partly that the intermediate frequency is low and it is easier to obtain more gain at low frequencies. The selectivity will be high even in the smaller receivers. At the present time, superheterodynes have advanced so far that they are available with variable selectivity so that high selectivity can be used for distant stations and relatively broad tuning for local high-quality reception. The same could be done with the tuned-radio-frequency receiver but it would be much more difficult. Since the intermediate-frequency amplifier provides nearly all the sensitivity and selectivity, such a receiver lends itself readily for use as an all-wave receiver.

The drawbacks of superheterodynes consist in the possibility of the presence of repeat points, and some birdies and whistles which are due to the presence of oscillator

Hand



etic events, c., from press es, the tops of , and for com- ation, police and ansmisson work. Fits the hand per- ide frequency response pical Brush sound cell ation. No button current polarizing voltage and no put transformer is required. Size only 3/4 inches x 1 1/2 x 1/2 inches. Weight 3 oz. Output level minus 66 D. B. Shipped complete with 15 feet of cable. Can be furnished on special order with locking type plug and socket for stand connection. Details—Data Sheet No. 8. Free. Send for one.

BRUSH Headphones



—meet every headphone requirement. Response 60 to 10,000 cycles. No magnets to cause diaphragm chatter. Specially designed cases minimize breakage. Light in weight—Only 6 oz. complete with headband and cords. A quality product at a low price. Details—Data Sheet No. 10. Free. Send for one.

The BRUSH DEVELOPMENT COMPANY
 1889 E. 40th St. CLEVELAND, O.
 MICROPHONES • MIKE STANDS • TWEETERS • HEAD PHONES • LOUD SPEAKERS

A NEW KIND of CATALOG
 The 1937 "RED BOOK" of **AMATEUR RADIO** from the **LARGEST EXCLUSIVE AMATEUR SUPPLY HOUSE IN THE WORLD!**
 Write for Your FREE Copy Now!
MIDWEST RADIO MART
 520 S. STATE ST. CHICAGO



Be a TELEVISION EXPERT
LEARN TELEVISION WITH RADIO NOW!
 Here's opportunity! Get ready for the best paid jobs in Radio as Television sweeps the country. Train at big-time broadcasting station. Get actual experience over our Television Station W9XAL and commercial station W9XBY. Write today for free folder and literature showing actual photos of Television broadcasting, opportunities, etc.
FIRST NATIONAL TELEVISION, INC.
 Dept. DD1 Power & Light Bldg., Kansas City, Mo.

RADIO ENGINEERING,
 broadcasting, aviation and police radio, servicing, marine radio telegraphy and telephony, Morse telegraphy and railway accounting taught thoroughly. Engineering course of nine months' duration equivalent to three years of college radio work. School established 1874. All expenses low. Catalog free.
Dodge's Institute, Oak St., Valparaiso, Indiana

LYNCH GIANT KILLER CABLE
 OF NEW AND IMPROVED DESIGN
 AVAILABLE DECEMBER 1
 An Exclusive Product of
LYNCH DIVISION
L. S. BRACH MFG. CORP.
 World's Largest Makers of
 Antenna Systems and Accessories
NEWARK, N. J. U. S. A.

Learn **SOUND RECORDING**
TALKING PICTURE PROJECTION
TELEVISION-RADIO

Master training courses qualify you for good jobs. Practical, easy to learn. Newest equipment. 30,000 graduates. Earn room and board while learning. Coach R. R. fare allowed to L. A. Write for **FREE BOOK**. Address Dept. 1-RN, 4000 S. Figueroa St.

NATIONAL SCHOOLS - Los Angeles

We've SOLVED THE PROBLEM!

THE PROBLEM: How to keep copies of RADIO NEWS in good condition and prevent important issues from getting lost. (The complaint of many of our readers.)

THE SOLUTION: Buy one of the new, sturdy RADIO NEWS Binders!



The RADIO NEWS Binder Opens Flat—Like a Book

The new RADIO NEWS Binder looks like a book and is a bound book in every respect—except that you snap the magazines in the cover, one at a time, with a little, unbreakable hooked wire. All the contents may be removed instantly and reinserted easily whenever you so desire.

Durably Bound!

It Will Last for Years!

The Binder is durably bound in tan buckram, with the name "RADIO NEWS" stamped in gold leaf on the backbone. Twelve copies of RADIO NEWS fit in each binder. You can obtain one of these new binders for only \$2, postpaid in the U. S. (Foreign prices on request.)

Money-Back Guarantee!

We are so sure that you will like this binder, that we guarantee to refund your money, upon return of the binder, within five days, if you are not entirely satisfied. Send your remittance of \$2 now and we will immediately rush your binder to you.

Mail This Coupon Now!

RADIO NEWS, DEPT. 371B
 461 Eighth Ave., N. Y. C.
 Enclosed find \$2. Please send me a RADIO NEWS Binder postpaid. (Foreign prices on request).

Name.....

Address.....

City..... State.....

harmonics and signal harmonics. Improperly designed superheterodynes also may cause interference in your neighbor's receiver. In such cases, the oscillator frequency is being radiated and may interfere with the reception of another receiver in the house which is tuned to the same frequency as that on which the oscillator is working. In general, however, none of these troubles is likely to be present in the best supers.

Important Notice for Radio Beginners

Reprints of the first five installments of this series may now be obtained in the new 1937 Radio Data Book which is given free with a subscription for 5 issues of RADIO NEWS at \$1.00 (Canada and Foreign \$1.25).

Rotary Beam

(Continued from page 397)

cross arms are displaced from the center of the pulley a suitable distance to compensate for the mounting distance of the elements due to the height of the element on the bee-hive insulator away from the cross arm. The extension behind the reflector, $\frac{1}{4}$ wavelength away from the radiator, is to compensate for the unbalanced weight by the director $\frac{3}{8}$ wavelength in front of the radiator. All the wooden pieces used were given two coats of shellac to protect from weathering. The elements were checked to see if they were vertical and square by the use of a spirit level. The bee-hive insulators were fastened to the copper pipe by drilling and tapping. Brass and copper fastenings were used wherever possible to prevent rusted fastenings from interfering with adjustments in the future.

This particular antenna was cut for use on 58.5 megacycles and the following dimensional specifications are given.

Radiator length, 8 feet-0 inch— $\frac{3}{4}$ inch dia. copper pipe. (See text.)

Reflector length, 8 feet-3 inch— $\frac{1}{2}$ inch dia. copper pipe.

Director length, 7 feet- $3\frac{1}{4}$ inch— $\frac{1}{2}$ inch dia. copper pipe.

Reflector spacing, $\frac{1}{4}$ wavelength away, 4 feet- $2\frac{1}{2}$ inches c. to c.

Director spacing, $\frac{3}{8}$ wavelength in front, 6 feet- $3\frac{3}{4}$ inches c. to c.

Side reflector spacing, $\frac{1}{2}$ wavelength away, 8 feet-5 inches c. to c.

Matching stub length, $\frac{1}{4}$ wavelength, 4 feet-6 inches maximum.

In erecting the antenna the upper end is raised about seven feet off the roof so that the pulley on the directive assembly is slid over and down on the $\frac{3}{4}$ inch copper radiator to seat it on the top of the mast. At this time the rope, preferably a $\frac{5}{6}$ inch tarred hempen rope should be threaded on the 12 inch dia. pulley and through the wash-line pulleys.

About two and one-half turns are taken around the pulley and an eyescrew is used as a stop to prevent the rope from riding off the pulley. *The latter is important!* In fact, the rotation of the pulley should be tested to avoid the unpleasant possibility of the rope coming off by checking this detail in the course of the assembly of the system. At this time the guy ropes should be fastened to the mast.

In my case a 20 foot 2 inch by 4 inch joist was rigged up as a jury mast, at the top of which a rope and pulley were
 (Turn to page 444)

You Need It. And it's FREE



The New 1936-37 Edition of Auto-Radio Installation and Servicing

One of the most expert radio engineering staffs in the world has written this book for you. And you're going to have plenty of opportunity to use it this winter.

Here are just a few of the important subjects covered in this valuable book: Elimination of motor interference for every make of 1936 car. . . . Tube compliment chart for practically all models of automobile radio sets, with I.F. peak frequencies. . . . Set and antenna installation hints, etc. These and hundreds of other problems you will meet in auto-radio installation and servicing are covered in this amazing book.

If this book were for sale you'd be willing to pay out a lot of money for it. But it isn't for sale! *It's absolutely free!* Just fill out the coupon below and send it to us.

Hygrade Sylvania Corporation, makers of Sylvania Radio Tubes and Hygrade Lamps. Factories at Emporium, Pa., Salem, Mass., and St. Mary's, Pa.

SYLVANIA

The Set-Tested Radio Tube

RN-17

HYGRADE SYLVANIA CORPORATION Emporium, Pa.

Please send without obligation your new service book, "Auto-Radio Installation and Servicing."

Experimenter Amateur Call.....
 Serviceman Employed by dealer Independent
 Member Service Organization.....

NAME.....
 ADDRESS.....
 CITY..... STATE.....
 NAME OF JOBBER.....
 ADDRESS.....

Crystal Control

(Continued from page 399)

No erratic performance or trouble of any kind was experienced up to the second 6L6 doubler stage which worked beautifully right from the start. Several experiments were, however, conducted to obtain the best possible coupling between the oscillator circuit and the 6L6 doubler grid. Inductive coupling, using both a fixed-grid coil and a tuned-grid circuit, was tried, which was abandoned, due to the additional tuned circuit required, and the possible multi-band operation of this unit. Series as well as the parallel plate feed of the first 6L6 was used, but it was found that the present circuit was superior, as well as being the simplest for multi-band operation on 5, 10 and 20 meters.

The entire part of the circuit that we have discussed so far, is so fool proof that the entire plate voltage recommended may be applied without any possible damage to the tubes or crystal. Due to the values of resistors, etc., that were finally selected, the three tubes involved will at no time draw excessive plate or screen current. As a matter of fact, any of the three tuning circuits may be varied throughout their entire range without any detrimental effects on the tubes, crystals or other parts in the circuits up to the 6L6 doubler. The 6L6 tube in the Les-tet circuit will draw only a very small amount of plate current and practically no screen current, unless the crystal and the 6C5 are oscillating. As soon as this tube starts to oscillate, the plate current of the 6L6 immediately rises due to the grid drive of the oscillator supply. If the plate circuit of the 6L6 is not tuned to resonance, due to the proper bias resistor of 2500 ohms, the maximum plate-screen current is limited to somewhere in the vicinity of 75 mils and upon tuning this circuit to resonance with any of the harmonics up to the fourth, quite a noticeable dip in plate current will be obtained.

At this point and in conclusion of this installment, we might mention that if the crystal is touched at this stage of construction or test, that the entire circuit immediately stops generating any r. f. When the crystal holder is touched with the finger, the plate current of the oscillator will go up and the plate current of the first 6L6 will go down, and the plate current of the second 6L6 doubler will go up to approximately 100 milliamperes. Immediately upon removing your finger all of the tubes will resume their former operating points and approximately 8 to 10-watts output obtained from the 6L6 doubler plate circuit (which we are describing next month) will be tuned to somewhere in the 5 meter Amateur band.

Volume Expansion

(Continued from page 409)

Also, the same signal appears across R14, the expander volume control. When R14 is advanced, the signal is amplified by the 6C5 control amplifier, rectified by the 6H6 diode and the resulting voltage across R18 is applied to G3 of the 6L7 expander. This increases the gain of this tube so that the change in volume is much larger than it would normally be. The amount of expansion varies, being less when there is little variation in the music contrast, and reaches a maximum of about 20 d.b. with extreme changes in the music volume level. R20 is used to bias G3 so distortion is

attached for the erection of the complete antenna assembly.

The antenna is now carefully raised to the vertical position, the guy ropes are tied down, and the transmission line feeders are connected on the $\frac{1}{4}$ wavelength matching section about six inches above the location of the shorting strap at the bottom of the matching section. A support for the transmission line is provided on the mast.

In order to get maximum performance from the array, a field strength indicator was used to get relative readings of field strength as changes in the frequency of the transmitter to resonate with the antenna, changes in coupling to the transmission line and the tank output circuit, changes in location of shorting strap on the matching section and changes in coupling of transmission line to matching section. Each successive change in adjustment gradually resulted in increased radiation until finally all circuit details resulted in optimum matching.

As a comparison in the direction of maximum radiation, the field-strength reading was the same at a distance of 325 feet as it was what only a "J" antenna alone read at a distance of 100 feet. The improvement resulted in a power gain in the desired direction of more than nine times or my 50-watt input to the linear oscillator employing push-pull 801's was equivalent to almost a power input of 500 watts. The increased cost of the antenna was far less than the increased cost of power supply and oscillator equipment for a 500-watt input.

The concentration of energy, as indicated by the field pattern, taken by fixing the position of the field-strength indicator at a point of 325 feet distance from the radiator and rotating the array showed that the energy was confined to an arc of 90 degrees with the greatest radiation in an arc of 60 degrees, or 30 degrees on each side of the direction of transmission.

The use of the beam has resulted in greatly improved distance and improved reports. Reports of an improvement of at least three R's in the signal-intensity scale has been a common experience as the beam was rotated through an arc of about 90 degrees.

This called for an explanation on my part to the station contacted. There is all the more reason that these results may be considered good when you learn that I am close to sea-level and the antenna is about 45 feet above street level. It also shows marked directive receiving qualities which improve in directivity close to the resonant frequency of the antenna. With its aid for receiving I heard W3AXR and W3BFB working each other. I worked W1IYX a distance of 75 miles by air, in Waterbury, Connecticut, with an R8 plus signal with its aid, and I have maintained contacts even when the QRM was bad. The improvement in my signal in spite of low height, resulted in increased DX and in the maintenance of more 100% QSO's, more than justified the experimental development from March of this year until the present time. I wonder what the results would have been if this antenna were located atop a high building in New York City or on top of one of the high hills of Northern New Jersey.

No Change in 80-Meter Band

Washington, D. C.—The Board of Directors of the A. R. R. L. have requested a cancellation of the hearing to be held before the F. C. C. on October 20, 1936. The hearing was to determine whether the 80-meter phone band would be expanded to include 3850-4000 kc.



MODEL E-155

Your whole family will always be glad you gave them a G-E! The new 1937 General Electric Automatic Focused Tone Radio brings each one of them a new world of radio enjoyment — every program they like in perfect Focused Tone.

G-E Automatic Focused Tone Radio comes in 31 handsome models—priced from \$22.50 to \$750.00 (Eastern List) — slightly higher West and South.

GENERAL ELECTRIC COMPANY
APPLIANCE AND MERCHANDISE DEPT.
BRIDGEPORT, CONNECTICUT

MILLION TUBE TESTER ANALYSER



1. All Emission
2. Shorts Hot
3. Leaks Hot
4. 0-5M Ohms
5. 0-3 Megohms
6. .01 to 3 M.F.
7. 0-10-50-500 V. D.C. 1000 ohms per volt
8. Electrolytics

MODEL TA

26.95
NET

MORE TESTS, MORE SPEED, MORE PROFITS is what service men say of MILLION test equipment. If your jobber cannot supply you—order direct—20% deposit required on C. O. D. orders. Tear out this ad and send it to us NOW for complete information on the entire MILLION line.

MILLION RADIO AND TELEVISION LABORATORIES
363 W. SUPERIOR ST., CHICAGO, ILL.

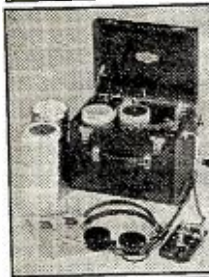

PASS CODE EXAMS

They now require 30% more speed, but you can pass easily by learning with INSTRUCTOGRAPH Code Teacher, the most practical way to learn accurately, and improve speed. Practice at your convenience, at any speed desired. Choice of two models. Buy or Rent. Send postcard for complete details now—

Instructograph Company
Dept. NR-1
912 Lakeside Pl., Chicago, Ill.
Representatives for Canada—
Radio College of Canada, Ltd.,
863 Bay St., Toronto

RADIO ENGINEERING

RCA Institutes offers an intensive course of high standard embracing all phases of Radio. Practical training with modern equipment at New York and Chicago schools. Also specialized courses and Home Study Courses under "No obligation" plan. Catalog Dept. RN-37.

RCA INSTITUTES, Inc.
75 Varick St., New York 1154 Merchandise Mart, Chicago
Recognized Standard in Radio Instruction Since 1909.

minimized. The speed with which this control action "takes hold" depends upon the time constant of the resistors and condensers in the diode voltage control circuit and is made fast enough so that sudden changes in volume are closely followed yet not so fast as to limit low frequency response.

The balance of the circuit is likewise of interest. The pickup is a special cobalt steel magnet type rated essentially flat from 50-6000 cycles with a peak of 7000 cycles. The tone arm is resonated at 40 cycles to bring up the low frequency end. The volume control has two taps to provide automatic tone compensation at different volume levels. The 6C5 driver tube is parallel-fed to push-pull 2A3's operating to give 12 watts output.

The circuit may be used for symphonic broadcast reproduction but will not give good results on speech, since the action of volume expanders tends to make speech sound jerky.

It is our belief that this new development marks a step forward in radio progress. Further improvements should be made in broadcasting and recording, through the adoption of automatic compression systems or other means, so that the full possibilities of volume expansion may be realized.

Radio Education of the Future

By William F. Aufenanger
Superintendent, RCA Institutes

A remarkable change has affected the status of radio education. A prediction based on that change indicates that radio courses, as we have known them, are to become merely preparatory studies which students, through modern channels, acquire with but small effort. The radio school is being transformed into a seat of higher learning. Such expansion in educational facilities, while following a natural trend in keeping pace with engineering developments, is in reality being brought about by a fast-increasing demand for advanced engineering instruction, which in the past year far exceeded the demand for elementary courses.

The Service Bench

(Continued from page 422)

tions? I'll admit I can hardly compete with Martinelli and Bori. But play it over some time when your radio isn't working well, and I may not sound half bad. P. S. —If yours is a radio-phonograph combination, it will be a good idea to check my name, address and telephone number off in the telephone directory. For your phonograph may go 'haywire'—with or without the radio. You may then call me, day or night, for better radio service!"

These records were mailed to a list of about fifty prospects—the list being obtained by house-to-house canvass and telephone calls. As you have nothing to sell, no one has the least objection to answering the simple question—"Do you possess a phonograph of any kind?"

Invariably the record will be played upon receipt—where a printed card or circular might find its unhonored and unread way into the waste basket. Curiosity will see to this, and the recipient of the record will inevitably be favorably impressed with the ingenuity of the idea. Often enough he will tell his friends about it—and play the record for them.

Where the recording is such that special needles are desirable, enclose two or three, pricked into a card on which is printed the request that these needles be used.

New! Announcing
the book 50,000 radio men
have been waiting for!

RADIO BUSINESS

Promotion and Management

by ALFRED A. GHIRARDI
and THEODORE S. RUGGLES

It's new! It's unique! It's sensational. A treasure chest of field-tested business methods and sales promotion ideas. Tells you how to sell. How to advertise. How to get free publicity. How to start a business. How to run a radio store. How to do more business at a better profit. Everything you need to know about the business side of radio—a complete radio business course in one big book. The same ideas given to you here have made thousands of dollars for those who used them! Hundreds of practical and successful sales and advertising suggestions ready for you to put to work making money today. Copiously illustrated. Easy to read. The only book of its kind! Soon to be released. Send the coupon today for FREE circular.



★ ADVERTISING ★

Planning your promotional program. How much to spend. Costs. How to write your advertising. Tested appeals. Getting action. Preparation and Production. Forms of advertising: —Display — Direct Mail — Newspaper — Broadcast — Phone Book — Other Media. Publicity. Merchandising. Premiums. Contests. Follow-ups, Etc.

Scores of examples of successful ads illustrated. Sales methods. Sales talks. Business Forms.

★ SELLING ★

Why people buy. Market analysis. Getting leads and prospects. Getting people into your store. Principles of selling. Store selling. Selling by phone. Outside selling—how to get by the door—following up leads. Selling talks. Sales resistances and how to break them down. Making business contacts, Etc.

Applies to radio sets, servicing, Auto Radio, P.A. work, accessories, appliances, etc.

★ BUSINESS METHODS ★

Setting up in business. Equipment. Store layout. Managing the business. Employee and customer relations. Financial data. Cost accounting. Sales and service forms and records. House policies.

CLIP AND MAIL

Today

Radio and Technical
Publ. Co., Dept. RN-17
45 Astor Pl., N. Y.

Name.....

Address.....

FOR DEALERS AND SERVICE MEN

Free Circular

Low Wholesale Prices



BIG FREE CATALOG

Over 10,000 items in this big catalog including radio receivers, nationally known radio parts and broadcasting equipment at low wholesale prices. A catalog of great value to dealers and servicemen. Write for your FREE copy today.

BURSTEIN-APPLEBEE CO.
1012-14 McGee St. Kansas City Mo.

TRI-STATE COLLEGE



Degree in 2 Years

Complete Radio Engineering course in 96 weeks. Bachelor of Science Degree. Radio (television, talking pictures and the vast electronic field) offers unusual opportunities for trained radio engineers. Courses also in Civil, Electrical, Mechanical, Chemical, Aeronautical, Engineering; Business Administration and Accounting. Low tuition, low living costs. World famous for technical two-year courses. Those who lack high school may make up work. Students from all parts of the world. Located in picturesque hill and lake region of northern Indiana. Enter January, March, June, September.

1617 COLLEGE AVE. ANGOLA, IND.



PACE-SAVER Electrolytics



Popular 1-in. dia. can job with height cut in half for given capacity. Or for same height, twice former capacity. A remarkable bulk reduction without sacrificing performance. Just ask your jobber for the AEROVOX GLS electrolytics.

Note 12 mfd. 450 v. unit above for size comparison. 250 and 450 v. working. 4 and 16 mfd. Insulated mounting. Separate leads.

1-in. dia. 2-3/16 to 4% in. high. Just the thing for better filtering in tight places.

New CATALOG: More pages. More items. More choice. Lower prices. Ask your jobber for a copy, or write us direct.



POWERTONE 5 Band 4-Tube A.C. D.C. Communications Receiver



Recognized by amateurs and short-wave experimenters as one of the year's outstanding receivers. Contains the following features—
 Bandspread tuning; New metal tubes; Airplane dial; Built-in dynamic speaker; 5-Band switch coil assembly; 15-550 meter tuning no gaps; A.C. or D.C. operation, and many others too numerous to mention. Efficient circuit employs 2-6K7's, 1-43, and 1-25Z5. Special phone jack automatically cuts out dynamic speaker for headphone reception.
 Complete Kit of Parts \$10.50

Your Cost
 Wiring and Testing Extra..... 2.50
 Matched Sylvania Tubes..... 2.25
 All Metal Crystal Cabinet..... 2.25

BUDDY 2-TUBE A.C. D.C. Receiver



Uses but two tubes but provides performance equal to that of receivers employing three. A newly designed circuit makes use of 16J7 metal tube and 1-12A7 as a combined rectifier and

pentode output tube. Coils furnished. Tune from 15 to 200 meters. Airplane dial aids materially in tuning-in stations.

Complete Kit of parts..... \$4.50
 Wiring and Testing..... 1.25
 Matched Sylvania Tubes..... 1.50
 9 1/2-15 and 200-2000 meter coils..... 1.75
 Metal Crystallized cabinet..... .95

TRY-MO RADIO CO., INC.
 85 Cortlandt St., N. Y. C.

Exposing Cut-Rate Service "Gyps"

(Continued from page 409)

month among concerns featuring cheap prices is far in excess of the highest rates commonly charged by reputable concerns for similar jobs. Thus the set owner who shops around for cut-rate service prices actually pays more in the majority of cases than does the owner who selects a dependable serviceman who makes no bid for bargain work.

A Successful Policy

It must be remembered that, in the final analysis, the best assurance of sustained success must rest on competent, conscientious workmanship at a price fair to the customer and to the worker.

Mr. Serviceman!

This and the previous article of this series constitute a powerful sales argument for the legitimate serviceman. Some servicemen have indicated a desire for reprints to distribute among their customers and prospective clients. Would you care to have reprints for this purpose if you could buy them at actual cost? If so please drop a card to the author, simply stating that you like the reprint idea and the approximate number you might need. You will not be obligated in any way. If the response to this invitation is large enough to warrant making reprints, you will be informed, a sample sent, and you can then place a definite order if you so desire.

British Television

(Continued from page 392)

Electric, Pye, Ecko and other eminent brand names appeared on the lines immediately available to the public.

An additional move of manufacturers was to include the television band (7 to 16 meters) in standard sound receivers, permitting possible future adaptation of the instruments for television reception. As in the American sets demonstrated privately to the press, most British models use the cathode-ray tube mounted vertically with the picture reflected on tilted mirror-lined lids. Receivers use an average of 25 tubes.

Scophony has supplemented cathode-ray receivers with opto-mechanical instruments projecting images of 12 by 16 inches, for home use, to 9 by 12 feet for theatres.

Virtually all models on the market function on both 240 lines, at 25 frames per second, and 405 lines, at 50 frames per

second. Initial transmissions were kept in the neighborhood of 6 to 8 meters.

Visitors returning from London have remarked how television-minded the nation has become. A new era of industry prosperity is seen ahead in the introduction of visual transmissions.

How soon will America join the world television parade? Our laboratories admittedly have everything Europe has—and more. Now is the time to come forward with public participation in the new art. America should establish the same leadership in television as it has in broadcasting!

Revision of Wire Charges

Washington, D. C.—The Long Lines Division of the A. T. & T. announced a new schedule of charges governing the furnishing of program transmission channels. The new schedule is expected to save customers \$250,000.00 a year. The adjustments, voluntarily filed by the telephone company, remedy the complaints by broadcast station licenses concerning rate practices; they do not effect a general reduction in rates, however.

INDEX TO ADVERTISERS

Aerovox Corp.	446	National Radio Institute	385
Air Electric Machine Co.	434	National Schools	446
Aladdin Radio Industries, Inc.	447	National Union Radio Corp.	429
Allied Engineering Institute	426	New York City Cancer Committee	447
Allied Radio Corp.	421	New York Y. M. C. A. Schools	434
American Transformer Co.	436		
Autocrat Radio Co.	440	Pioneer Gen-E-Motor Corp.	440
Brach Mfg. Corp., L. S.	443	RCA Institutes, Inc.	444
Brush Development Co., The	442	RCA Manufacturing Co.	422
Burstein-Applebee Co.	445	Radio Circular Co., Inc.	440
		Radio City Products Co.	439
Cameradio Co.	434	Radio Service Institute	422
Candler System Co., The	432	Radio & Technical Publishing Co.	441, 445
Capitol Radio Engineering Inst.	428	Radio & Television Institute	424
Central Radio Laboratories	428	Radio Training Ass'n of America	435
Chicago Wheel & Mfg. Co.	433	Radolek Co., The	447
Classified Advertisements	447	Raytheon Production Corp.	424
Cornish Wire Co., Inc.	426	Readrite Meter Works..... Inside Back Cover	
Coyne Electrical School	439	Rider, John F.	430
		Rim Radio Mfg. Co.	439
Dodges Institute	442		
Electrad, Inc.	427	Scott Radio Labs., Inc., E. H.	387
First National Television, Inc.	442	Silver Corp., McMurdo	388, 389
General Electric Co.	444	Solar Mfg. Corp.	438
Goldentone Radio Co.	429	Sprayberry Academy of Radio	433
Hallcrafters, Inc.	425	Sundt Engineering Co.	448
Hammarlund Mfg. Co.	439		
Hygrade Sylvania Corp.	443	Teleplex Co.	436
Instructograph Co.	444	Triad Mfg. Co., Inc.	426
International Correspondence Schools	448	Trimm Radio Mfg. Co.	429
Ken-Rad Tube & Lamp Corp., Inc.	436	Triplett Electrical Instrument Co.	437
Kenyon Transformer Co., Inc.	435	Tri-State College	445
		Try-Mo Radio Co., Inc.	446, 448
Lincoln Engineering School	440	Tung-Sol Lamp Works, Inc.	430
McElroy, T. R.	432		
Mallory & Co., Inc., P. R.	390	United Sound Engineering Co.	439
Midwest Radio Corp.	Back Cover	Utah Radio Products Co.	438
Midwest Radio Mart	442		
Million Radio & Television Lab.	444	Webster Co., The	431
		Weston Electrical Instruments Corp. Inside Front Cover	
		Wholesale Radio Service Co.	432
		Wright-DeCoster Co., Inc.	434
		Zephyr Radio Co.	433

Read Classified Advertising—It Pays

Advertisements in this section sixteen cents a word for each insertion. Name and address must be included at the above rate. Cash should accompany all classified advertisements unless placed by an accredited advertising agency. No advertisements for less than 10 words accepted. Objectionable or misleading advertisements not accepted. Advertisements for these columns should reach us not later than 3rd of 2d month preceding issue.

TECK PUBLICATIONS, INC.
461 Eighth Ave. New York, N. Y.

A.C. Auto Generators

TURN scrap into money. Autopower shows you how easily and economically auto generators can be converted into A.C. or D.C. generators and D. C. motors. 2 to 1000 volts; for sound, radio, power, light, or welding. No previous experience necessary—complete information all in new book, with simple instructions and illustrations. Endorsed by thousands. Only \$1.00 postpaid. Autopower, Inc., 410 S. Hoyne, Room A, Chicago.

Correspondence Courses

USED Correspondence Courses and Educational Books sold or rented. Inexpensive. Money-back guarantee. Write for Free Catalog listing 4000 bargains. (Courses Bought.) Lee Mountain, Pisgah, Alabama.

BIG BARGAIN Catalogue Courses 10c. Hanfling, P-799 Broadway, New York.

Patent Attorneys

PATENTS—Advice and booklet free. Highest references. Best results. Promptness assured. Watson E. Coleman, Patent Lawyer, 724 9th Street, Washington, D. C.

PATENTS. Instruction "How to Establish Your Rights" and form, "Evidence of Conception" sent Free! Lancaster, Allwine & Rommel, 414 Bowen Building, Washington, D. C.

Patents and Inventions Wanted

INVENTIONS COMMERCIALIZED. Patented or unpatented. Write Adam Fisher Company, 278 Enright, St. Louis, Missouri.

Radio

KEEP POSTED, save money with Radio Data Digest. Stamp brings sample. Kladag, Kent, Ohio.

Radio Instruction

AMATEUR RADIO licenses, complete training. Resident and correspondence courses. Every graduate a licensed operator. N. Y. Wireless School, 1123 Broadway, New York.

CANCER CAN BE CURED

when discovered in time

BUT the scourge of cancer can be lifted only if we drive home the vital importance of

Early Discovery and Prompt Treatment

Early discovery is made possible in many cases by physical examinations at regular intervals, and immediate examination on the appearance of any of the danger signals of cancer at any time.

Help us pass this message to others. Buy the Cancer Committee's labels and use them on your packages. The money you give helps maintain the work. The use of the labels on packages shows that you support the movement and brings it to the attention of others.

THE NEW YORK CITY CANCER COMMITTEE

MAIL THIS COUPON



NEW YORK CITY CANCER COMMITTEE
165 East 91st Street, New York
 For the \$1 attached, send me 10 labels and 1 year's subscription to the Committee's new publication, "The Quarterly Review."

If a resident of New York State outside the City write to:
NEW YORK STATE CANCER COMMITTEE,
Rochester, New York

If outside the State, write to:
AMERICAN SOCIETY for the CONTROL of CANCER,
New York

Name
Address

The Radio Workshop

(Continued from page 434)

Try These New Tips

During the past 15 or more years I have found many useful tips in the RADIO NEWS popular experimenter department, the "Radio Workshop". I now take pleasure in offering a few hints that have been very helpful to me on more than one occasion.

(1) For brushing out a variable condenser or around delicate parts the long feathers of the wing on tail of a chicken or other fowl will do the job better than

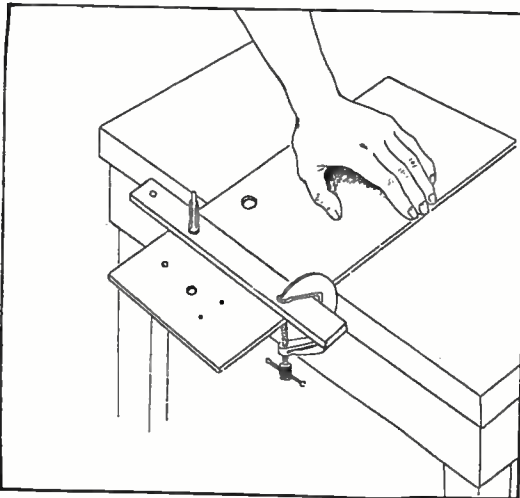

pipe cleaners so often mentioned by experimenters. The tips may be used for small touch-up paint jobs and will take the place of the camel's hair pencil.

(2) Everyone does not have a machine circular saw and to do a real straight job in sawing a panel, I find the best procedure is to lay the panel on the edge of table with a straight edge on top and clamp said straight edge along line to be sawed, using 5 and 10 cent store clamps; then saw along straight edge with fine tooth saw. In my case I used a small 14 pitch carpenter type saw. A hacksaw will not do a good straight job.

(3) Everyone does or should know a dentist. The small drills or burrs with which he raises the dickens in your tooth are like old safety razor blades to him. The drills make excellent scribes and small sized punches. The burrs come in handy for grinding into small drills or for small milling operations.

(4) How often has one needed a tap for just one job! Take a screw of the size required; file 3 indentures for cutting edges and case-harden it by heating it to a dull red. For using the tap with soft material it need not be hardened.

COL. JOHN A. HAWKINS,
Solebury, Pa.

Cash for Kinks

EVERY experimenter, from time to time, works out some simple idea or kink that could be profitably passed along to his fellow experimenters through the "Radio Workshop", a department which caters especially to the exchange of such ideas. Send your ideas to the Workshop Editor, and wherever possible include a simple but clear drawing or a photograph. All ideas published will be paid for at regular space rates.

NEXT MONTH

Complete story on N.B.C.'s television demonstration from the Empire State Building.

DX'ers Who Know Insist On Genuine ALADDIN Polyiron Air-Tuned I-f's

which give you
Greater Selectivity
Greater Sensitivity
Absolute Stability

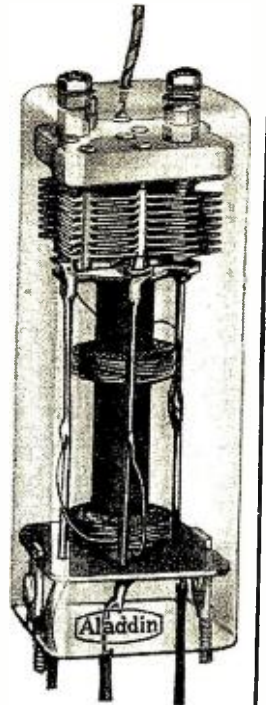

An advanced design intended for precision amateur and commercial high-frequency communication receivers. Type G transformers use air-trimmed coils on Polyiron cores.

The purpose of this design is to provide the utmost freedom from frequency drift in communication type receivers and is particularly suited to the needs of the progressive amateur and designers of special equipment, such as aircraft receivers.

Model "G" Series. In 18 Types for 175 and 465 kc.

Write for 8 page Technical Bulletin No. 536

Aladdin Radio Industries, Inc.,
466N W. Superior St., Chicago, Ill.
Licensee of Johnson Laboratories, Inc.

"The Most Complete Radio Buying Guide"

10,000 Money-Savers!

Completely revised—right up to the minute—bringing you everything in radio—at the right prices. Over 10,000 Repair Parts—a complete selection of Receivers, Amplifiers, Tubes, Tools, Books, Instruments—always in stock—ready for speedy shipment to you. You need this big Radio Parts Catalog. It's free! Send for it.



Radolek endeavors to restrict distribution of the Profit Guide to those actively and commercially engaged in the Radio Business. Please enclose your Business Card or Letterhead.

RADOLEK

601 W. Randolph St., Dept. B1, Chicago

Send the Radolek Profit Guide Free

Name.....
Address.....
Serviceman? Dealer? Experimenter?

DIO

Great rewards for trained men



The big opportunities in Radio will be enjoyed by trained men. The International Correspondence Schools Radio Course, prepared by leading authorities and constantly revised, will help make you a trained man! A fascinating book - FREE.

AVIATION ENGINEERS are leaders in modern progress



Aviation depends upon engines, and knowledge of aviation engines is a long step toward success in this rapidly growing industry. Many leading aviation engineers today took their first step by mailing a coupon to the I. C. S. at Scranton. Why don't you follow their example?

INTERNATIONAL CORRESPONDENCE SCHOOLS

Box 8284-R, Scranton, Penna.

Explain fully about your course in the subject marked X:

- | | |
|-------------------------------------------|-------------------------------------------------|
| <input type="checkbox"/> RADIO | <input type="checkbox"/> AVIATION |
| <input type="checkbox"/> Chemistry | <input type="checkbox"/> Accountancy |
| <input type="checkbox"/> Invention | <input type="checkbox"/> Advertising |
| <input type="checkbox"/> Refrigeration | <input type="checkbox"/> Electrical Engineering |
| <input type="checkbox"/> Air Conditioning | <input type="checkbox"/> Drafting |
| <input type="checkbox"/> Architecture | <input type="checkbox"/> Show Card Lettering |
| <input type="checkbox"/> Good English | |

Name.....Age.....

Address.....

New NEOBEAM OSCILLOSCOPE



- Super-Sensitivity—1 microvolt
 - 4-inch Calibrated Screen
 - Self-contained Power Supply and Sweep System
 - Simplicity of Operation
- For amplifier, microphone and speaker response. Checks modulation, locates distortion. Used in wave form study or as galvanometer and vacuum tube voltmeter. 8 3/4" x 10" x 13". Fully guaranteed.

Makes Sound Visible

Write now for details

ONLY \$40.00 COMPLETE

SUNDT ENGINEERING COMPANY

4256 Lincoln Ave. Chicago, Ill.

POWERTONE

Model 801—Pocket Volt-Ohmmeter

A sensitive compact and accurate volt-ohmmeter that will be the busiest instrument in your "lab," or out on jobs. DC voltage readings -0.5-50-500 and 1000. Resistance readings from 1/2 to 500 and 200 to 500,000 ohms. Will read from 0 to 1 Ma. Low resistance range direct reading. Meter has 1000 ohm per volt sensitivity. Battery is self contained. Panel is clearly lettered. Compensator provided for zero adjustment. Measures only 5"x3 1/4"x2 1/2". Your price complete with battery..... \$5.75

Send for illustrated circular describing Powertone test Equipment.



POWERTONE ELECTRIC CO.
179 Greenwich St., New York City
Distributor: TRY-MO RADIO CO., INC.
85 Cortlandt St., New York City

What's New in Radio

(Continued from page 441)

It utilizes 37 tubes, has six speakers (including one 18 inches in diameter), has a total weight of 475 pounds, power output from 50 to 75 watts and uses a dial 12 inches in diameter. Its coverage is con-

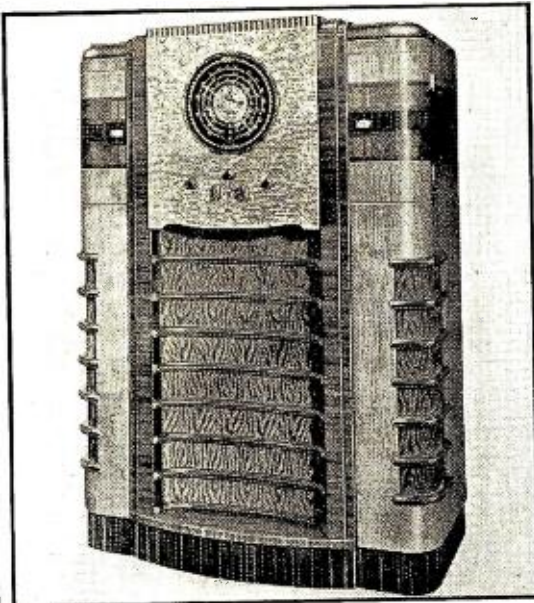

tinuous from 540 to 18,300 kilocycles, divided into three bands. All tubes are metal with the exception of one for the tuning light and the auto-expressionator circuit, and four chassis are required for the arrangement of the equipment.

Something New In Paper Condensers

The new Solar "Domino" molded bakelite paper condenser offers the important feature of greater resistance to heat and moisture and it is said that these new tiny condensers are mechanically and electrically



stronger than the older tubular paper type which they replace. They are available in capacities from .001 mfd. at 1000 working volts to .25 mfd. at 200 volts, this last size condenser measuring only 1 3/8 by 5/8 by 3/8 inches.

Proved Worth in Tropical Use

The Jefferson Electric Co. announces a new line of "Plastic-Sealed" audio transformers and chokes. The construction of the new units is similar to their standard line with machine-wound coils, vacuum-



dried and impregnated and cores of silicon steel laminations, annealed after stamping. The complete assembly, however, instead of being housed in a metal case, is enclosed in a special molded plastic of high melting point, which means protection against moisture and condensation. The manufacturer states that this new plastic jacket will not chip or crack.

Printed by Art Color Printing Company, Dunellen, New Jersey, U. S. A.

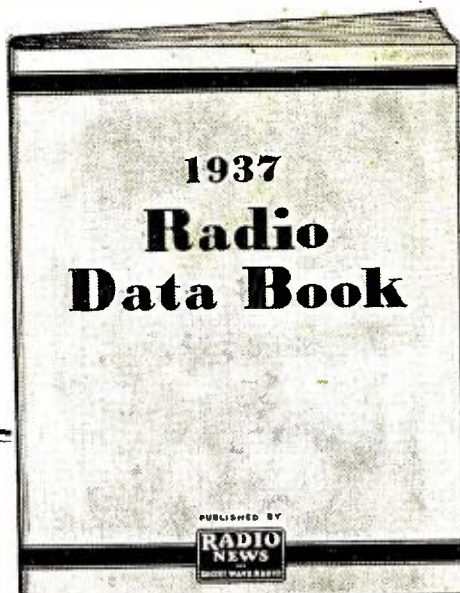

Given Free!

With A Subscription For 5 Months Radio News at \$1

Here is the book you have been waiting for! Over 75 important features of interest to every radio man! More than 160 illustrations, circuit diagrams and charts! Large 8" by 11" size! You get it FREE by placing a subscription for 5 issues of RADIO NEWS at \$1. (Canada & Foreign \$1.25)!

Partial List of Contents

The 1937 RADIO DATA BOOK has chapters on: Opportunity In Television—Characteristics of Receiving Tubes—All-Wave Reception Aids—Radio Receiver Construction — Experimental Radio Data—Amateur Radio Apparatus — Servicing and Engineering Notes — and Sound Equipment.

In addition, there is a special supplement entitled "Ten Lessons In Radio" for beginners, (a reprint of the installments of "The Radio Beginner" which appeared in the May to Sept. issues of RADIO NEWS)—and another supplement giving Up-To-Date Lists of U. S. Broadcasting Stations and the World's Leading Short-Wave Stations.

Avoid Disappointment!

Our supply of these books is necessarily limited. Avoid disappointment by sending your remittance for 5 issues of RADIO NEWS today! Present subscribers may obtain copies of this book by placing a 5-month renewal subscription at this time.

Mail This Coupon Now!

Radio News, Dept. 371
461 Eighth Avenue, N. Y. C.

Enclosed find \$1. (Canada and Foreign \$1.25). Enter my subscription for the next five issues of RADIO NEWS and send the 1937 RADIO DATA BOOK free. (If renewal, check here and present subscription will be extended.)

Name.....

Address.....

City.....State.....

(If you are a serviceman, please check here)

NOW... RADIO SERVICING IS MORE PROFITABLE... EASIER



MODEL 740
DEALER PRICE
Only \$ 18⁶⁰

VOLT-OHM-MILLIAMMETER

WITH
RANGER EXAMINER

AVAILABLE NOW IN SINGLE TESTERS. ALSO COMBINATIONS TO SUIT YOUR NEEDS

EYE APPEAL... PRECISION ACCURACY

YOU AND YOUR CUSTOMERS WILL APPRECIATE THE UTMOST IN PROFESSIONAL APPEARANCE.

Yes, Ranger-Examiner Equipment definitely means that Radio Service work can be done more profitably and easier. More profitably because considerably less money is required for precision equipment, and easier because Ranger-Examiner is a completely new line designed from scratch with all the latest improvements for quick and accurate service. Less weight too to carry around. In sturdy all-metal cases.

Ranger-Examiner testers are manufactured by the oldest company in the service equipment field whose contacts make them fully acquainted with the needs of the radio serviceman.

Model 740 Volt-Ohm-Milliammeter has a Triplett 3" square Precision Instrument. Scale readings: 10-50-250-500-1000 A.C. and D. C. Volts at 1000 Ohms per Volt (D.C. Accuracy 2%; A.C. 5%) 1-10-50-250 D.C.M.A.; 0-300 low ohms; high ohms to 250,000 at 1.5 volts. Rheostat adjustment for 13½ volts for ohm readings to 2.5 megohms. Batteries may be added permitting higher resistance readings in 250,000 ohms steps. Low Ohms to ½ Ohm—with 25 ohms in center of scale. Backup circuit. Current draw is only 1 M.A.

COMPARE FIRST... THEN BUY RANGER-EXAMINER

Be Sure to send Coupon for your FREE copy "101 Radio Troubles and Their Cures"

Get this
FREE BOOKLET
LISTING 101 MOST FREQUENT RADIO TROUBLES

★
HOW TO DETECT HOW TO CURE

★
NOTHING LIKE IT BEFORE GREATLY SIMPLIFIES EVERYDAY SERVICE

SEND COUPON NOW...



RANGER EXAMINER

READRITE METER WORKS
 115 College Dr., Bluffton, Ohio

Without obligation please send me your Free Booklet "101 Radio Troubles and their Cures," and complete Ranger-Examiner Catalog.

Name

St. Address

City..... State.....

UP TO **50% DIRECT FROM MIDWEST FACTORY!**

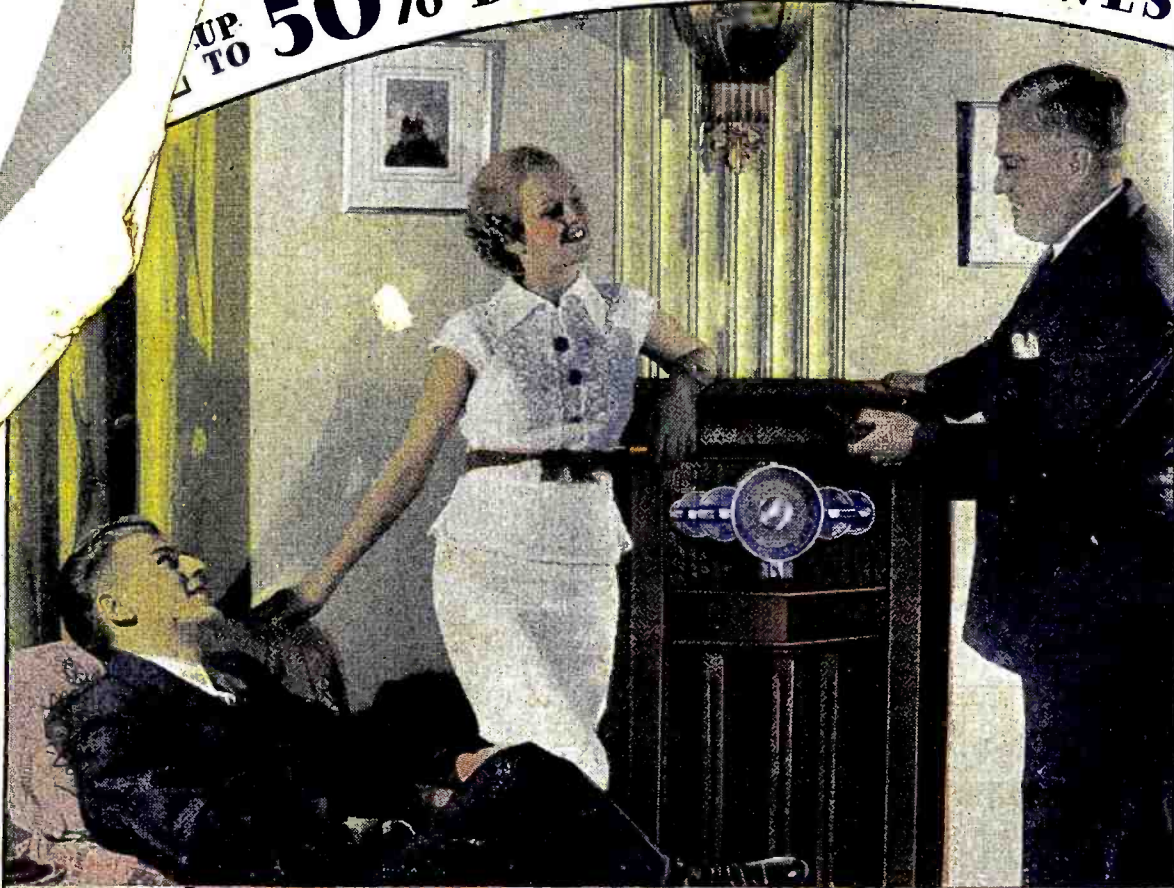

"I REMEMBER WHEN RADIO FIRST STARTED...
EVEN THEN MIDWEST WAS KNOWN FOR ITS
Power AND Beauty!"

**MAIL COUPON *Now* FOR NEW
FREE 40-PAGE CATALOG**

Mail coupon today for new, FREE 40-page catalog...and learn how you can save up to 50% by buying direct from Midwest factory. See for yourself that Midwest offers today's greatest radio values, and scores of exciting features, like Dial-A-Matic Tuning, plus Elektrik-Saver. With the sensational Dial-A-Matic Tuning feature, for example, even a child can bring in ten perfectly tuned programs in ten seconds. Zip! . . . Zip! . . . Zip! . . . stations come in instantly, automatically, perfectly . . . as fast as you can push buttons. The exclusive Midwest Elektrik-Saver cuts radio wattage consumption 50%, enables Midwest radios to use no more current than ordinary 7-tube sets.

**ONLY IN MIDWEST DO YOU GET
DIAL-A-MATIC TUNING *plus* ELEKTRIK-SAVER**



DIAL-A-MATIC TUNING

Now, even a child can bring in ten perfectly tuned programs in ten seconds! It's a big thrill to whirl the dial . . . and then hear the station you want . . . come in instantly, automatically . . . as fast as you can press buttons!



ELEKTRIK-SAVER

This exclusive Midwest feature cuts radio wattage consumption 50% . . . results in Midwest radios using no more current than ordinary 7-tube set . . . enables you to operate on voltages as low as 80 volts.



Only
\$59.50 COMPLETE
with
**GIANT
THEATRE-SONIC
SPEAKER**
(LESS TUBES)
TERMS
AS LOW AS
10¢ A DAY



**30
DAYS
FREE TRIAL**

You have a year to pay...terms as low as 10c a day...you secure privilege of 30 days' FREE trial in your own home. In addition, you are triply protected with Foreign Reception Guarantee, One-Year Warranty and Money-Back Guarantee.

**18 TUBES
SIX WAVE BANDS
4½ to 2400 METERS**

Bigger, better, more powerful, more beautiful, this super deluxe Midwest out-performs \$150 sets on a point-for-point comparison. Amazingly selective, delicately sensitive, it brings in distant foreign stations with full loud speaker volume on channels adjacent to powerful locals. You'll thrill over its marvelous super-performance...glorious crystal-clear "concert realism" . . . magnificent world-wide foreign reception. Powerful Triple-Twin tubes (two tubes in one) give 22-tube results. You can switch instantly from American programs . . . to Canadian, police, amateur, commercial, airplane, ship broadcasts . . . to the finest and most fascinating foreign programs. Never before so much radio for so little money. Why pay more? Save up to 50% by buying at wholesale . . . direct from factory...preferred by thousands of careful radio purchasers since 1920.

**MAIL COUPON TODAY FOR FREE 30-DAY
TRIAL OFFER AND 40-PAGE FOUR-COLOR FREE CATALOG**



MIDWEST RADIO CORP.

DEPT. G-11
Established 1920



CINCINNATI, OHIO, U.S.A.

Cable Address MIRACO...All Codes

MIDWEST RADIO CORPORATION
Dept. G-11

Cincinnati, Ohio
Without obligation on my part, send me your new FREE catalog and complete details of your liberal 30-day FREE trial offer. This is NOT an order.

Name _____

Address _____

Town _____ State _____

(Special offer and prices prevail only when dealing direct with factory by mail.)