

RECORDING VOICES AT HOME

RADIO NEWS

FEBRUARY

25 Cents

*and
Radio Call Book Magazine
and
Technical Review*

**How to Make
a Complete
Public Address System**



A Publication Devoted to Progress and Development in Radio

**Engineering
Service Work
Experimental Research
Industrial Application**

**Broadcasting
Short Waves
Television
Electronics**

Super Power

guarantees—

*To You Every Bit of Performance Possible
Under Prevailing Atmospheric Conditions*

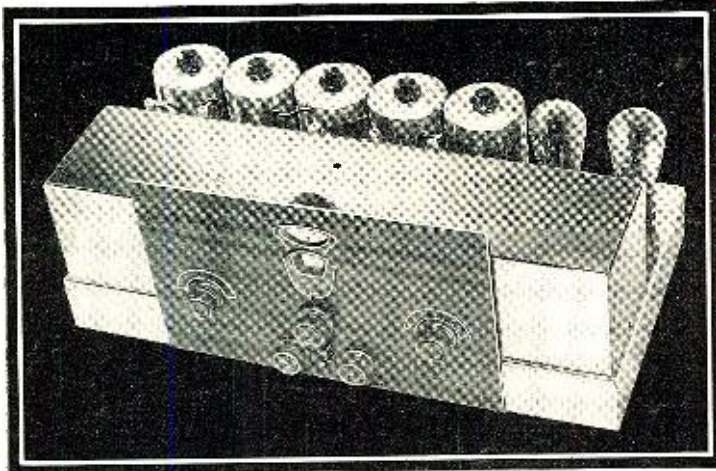

Lincoln De Luxe *All Wave Superheterodyne*

15 TO 550 METERS

With undistorted amplification made possible thru Lincoln's foresight in development of new triple push pull detector and audio system.

Automatic Volume Control
Signal Indicator

Four High Gain I. F. Stages

SUPER POWER of the New Twelve-Tube Lincoln DeLuxe SW-33, coupled with the new Lincoln developments, guarantees to you real radio reception of unlimited distance.

If you have never tuned the new Lincoln, you have missed the treat of your life.

Just tune to a European station which ordinarily fades completely out at times, and note how the Lincoln new automatic volume control holds the signal at a perfect level.

Watch the signal indicator register the weakest signal, and then tune to the exact center of the carrier wave with absolute precision.

When you wish to tune late at night, open up the sensitivity control wide, with power to reach any distance, and reduce volume control to whisper.

Throw in the 53 to 1 ratio on

the dial for ease in tuning high frequencies.

Open up the volume control to the limit and shake the floor with the tremendous amplification, without distortion.

Listen to the heavy bass vibratory notes produced by the use of the push-pull detector followed by two stages of push-pull audio and reproduced in the finest auditorium type speaker we can procure.

Note the high sensitivity provided by four tuned stages of intermediate amplification—just tune in a foreign station—you will want the volume control opened only a few degrees.

Just note what a recent Lincoln owner in Java (a country with extremely bad weather conditions, and mineral deposits, making high noise interference) says about the new Lincoln: "Foreign stations come in very loudly. Paris, Rome, Zeesen,

Konigswusterhausen, Chelmsford and a score of other European stations come in clearly; Sydney, Queensland and Melbourne from Australia can be received with great volume; JIAA from Japan is consistently heard, while Pittsburgh and Schenectady have been received. Also on the broadcast band daily reception can be had from several European stations, Japan, Manila and China. I have heard of no other set that can equal your Lincoln."

Owners of the first Lincoln models are still proud of their performance.

BATTERY RECEIVER uses ten (10) two-volt tubes, and can be used in connection with the Air Cell or storage batteries.

Mail the coupon for Laboratory information and price. New York City territory write Valentine G. Hush, Division Drive, Dobbs Ferry, N. Y.

LINCOLN RADIO CORPORATION
Dept. N-2, 329 S. Wood St., Chicago, Ill.
Please send information on A.C. D.C. receivers.

Name _____

Address _____

City _____ State _____

Print name and address plainly

LINCOLN
De Luxe Receivers

NO, YOU'RE WRONG, we're NOT advertising Movies!

Paramount Pictures merely loaned us this photo of glamorous Marlene Dietrich as "The Blonde Venus" to help us make a point about radio reception to you.

You like Marlene because of her dramatic ability, her loveliness of face and form, and the rich warmth of her throaty voice—but even more fascinating is her different, intriguing *foreignness*.

If thoughts of foreign lands and foreign tongues lure you—if you would thrill to Grand Opera direct from La Scala Theatre in Milan or a tango Orchestra direct from Madrid—if you would like to send your ears world-wide . . . you can—at the twirl of a dial.

There is no need—NOW—to be bored by the eternal sameness of your local programs—the same orchestras—the "too-well-known" features that sometimes cause you to turn off your set.

For, AT LAST, there is one radio receiver that makes your cozy home a front row seat at the whole world's daily radio performances . . . not just the portion that is broadcast here in the states, but all the fascinating radio entertainment from England, France, Germany, Italy, Spain, and even far-off Australia.

With this one set, that is not merely a promise . . . it is a GUARANTEE of daily world wide radio reception . . . for the SCOTT ALL-WAVE DELUXE alone gives such a warranty. And every part of this precision-built, custom-constructed receiver (except tubes) is guaranteed for five years, instead of the ordinary 90 day period.

The SCOTT ALL-WAVE DELUXE is a combination short wave and long wave receiver. With it you will receive U. S. broadcasts from every State in the Union with a color of tone—a new depth of resonance—that will fill your home with a soul stirring wave of tone realism such as you never before have heard in a radio receiver.

You might think so superbly performing an instrument prohibitively high priced. Not at all! Although its quality is above all other radios—its cost is but little more than that of the ordinary receiver.

The coupon at the right below is for your convenience. Use it to get the whole thrilling story of this, the world's finest radio receiver.

E. H. SCOTT RADIO LABORATORIES, INC.

4450 Ravenswood Avenue Dept. N-23 Chicago, Ill.

THE Scott ALL-WAVE Deluxe



E. H. SCOTT RADIO LABORATORIES
4450 Ravenswood Ave., Dept. N-23
Chicago, Ill.

Send me your two new brochures
and why SCOTT ALL-WAVE
Receivers out-perform
obligate me in any way.

Name

Address

City

S. GORDON TAYLOR
Technical Editor
 WILLIAM C. DORF
Associate Editor
 JOHN M. BORST
Ass't Tech. Editor



HOWARD S. PEARSE
Associate Editor
 SAMUEL KAUFMAN
Broadcast Editor
 JOS. F. ODENBACH
Art Editor

Edited by LAURENCE M. COCKADAY

VOLUME XIV

February, 1933

NUMBER 8

CONTENTS

(Cover Design by Morey)

The Eclipse and Radio By Samuel Kaufman.....	PAGE 457	Learning the Code By Walter H. Candler.....	PAGE 468
Controlling Machines by Sound By Irving J. Saxl.....	PAGE 460	A Public Address System (Part 1) By Wm. C. Dorf.....	PAGE 470
Extending Loudspeaker Range By Joseph S. Grant.....	PAGE 463	Phenomena Underlying Radio By E. B. Kirk.....	PAGE 472
A New "Super Six" Midget By C. B. Brown and K. Alexander.....	PAGE 464	Handy Microphone Substitutes By Austin Lescarbours.....	PAGE 474
Home Recording (Part 2) By Wm. H. Wcnstrom.....	PAGE 466	The Pocket Diagonometer (Part 2) By D. L. Van Leuwen.....	PAGE 475

RADIO CALL BOOK SECTION

Short-Wave, Police and Television Station Lists By the Staff.....	PAGE 477
Service Data for Servicemen By Nat Feiner.....	PAGE 479
New All-Wave Super By McMurdo Silver.....	PAGE 480
Finding Mutual Conductance By George E. Fleming.....	PAGE 482
A 15-250 Meter Super (Part 2) By S. G. Taylor and W. C. Dorf.....	PAGE 483
The Technical Review By Joe's' Calcaterra.....	PAGE 485

DEPARTMENTS

.....	PAGE 488
.....	PAGE 490
.....	PAGE 492
.....	PAGE 494
.....	PAGE 496
.....	PAGE 498
.....	PAGE 500
.....	PAGE 505

ons, Inc., Washington and South Avenues, Dunellen, N. J.

AL AND EXECUTIVE OFFICES
 h STREET, NEW YORK CITY, N. Y.

class matter at the Post Office at Dunellen,
 t of March 3, 1879. Copyright, 1933, by
 nc. All rights reserved. Title Registered
 Office. Printed in the United States of
 s of this magazine must not be reproduced
 We cannot be responsible for lost manu-
 every care is taken for their safety.

25c a Copy, \$2.50 a year,
 \$3.50 in Canada. \$3.50 in
 Foreign Countries. Sub-
 scribers are notified that
 change of address must reach
 us five weeks in advance of
 the next day of issue.

AUSTRALIA SYDNEY CLEVELAND OHIO - U.S.A. ROME ITALY

12,000 Mile Range

16 TUBES

All the New Features!

Only \$39.95

15 to 550 Meters

Completely Assembled with Large Dual Speakers

30 DAYS FREE TRIAL

Proof!

MIDWEST RADIO CORP., Cincinnati, Ohio.

Gentlemen:

"Received the 16-tube outfit. At 3:15 P.M. I started to go after Rome and in a few minutes playing with the Color-lite dial, I received this station. This afternoon, I picked up Pontoise, France (WSXK); Rome, Italy (12-RO); Mexico City (NDX); Chelmsford, England (GSSW). Have also picked up YQ, LSN, YK2ME (Sydney, Australia); Sunday morning, Sydney, Australia; Germany, Italy, France and Mexico were all coming in good."

Yours very truly,
 LOUIS CSERII,
 13605 Englesmere Ave.,
 Cleveland, Ohio, U. S. A.
 Member Int'l Short Wave Club.

NOTE: The above is just part of Mr. Cserii's interesting letter.

Don't be satisfied with less than a big, powerful, 16-tube Midwest ALL-WAVE set. A receiver covering only half the regular broadcast waves is only half a set. When you own this latest Midwest marvel, the whole world of radio is yours. With a tuning range of 15 to 550 meters, you can hear regular and short-wave broadcasts from all over the U. S. and many foreign lands. Midwest users from coast to coast report picking up England, France, Germany, Italy, Africa, South America, Hawaii, Japan, Australia, the Philippine Islands and many other far-away stations. This powerful, clear-toned, perfectly controlled set opens up new delights of radio to every listener. Such selectivity, such sensitivity, such amazingly faithful tone reproduction will delight the most critical. Don't buy any radio until you get the new 1933 Midwest catalog. Send for it today. Mail the coupon or write us a postal . . . Now!

Remember, you buy direct from the makers. No middle-men's profits to pay. You get an absolute guarantee of satisfaction or money back. You try any Midwest 30 days before you decide to keep it. Then, if you wish, you can pay in small monthly amounts that you'll scarcely miss. Mail coupon for full details, or write us a postal.



COMPLETE LINE OF NEW CONSOLES

The big new Midwest catalog shows gorgeous line of artistic consoles in the new six-leg designs. Mail the coupon now. Get all the facts. Learn how you can save 30% to 50% on a big powerful radio by ordering direct from the factory.

World-Wide Long and Short Wave Reception

The Midwest 16-tube ALL-WAVE is the last word in radio completeness and efficiency. You hear not only U. S. and foreign broadcasts, but also police calls, airplane signals, ships at sea, amateurs . . . everything that comes over the air. But it's no wonder, for this latest 1933 sensation incorporates all the worthwhile new features . . . New type tubes . . . Stat-omit tuning silencer . . . Color-Lite tuning . . . Full-floating condenser . . . 18 tuned

circuits (Super-heterodyne), 9 in cascade . . . Dual power, two separate transformers . . . Large dual speakers . . . Duplex Duo-diode detection . . . Class "B" Amplification . . . and many other sensational new refinements and improvements. You'll be amazed and delighted when you hear one of these wonderful new sets in your own home.

Deal Direct With Factory—Save UP TO 50%

TERMS as low as \$5.00 DOWN

Why buy the costly old-fashioned way and pay two or three profits? Buy direct from the Midwest factory and keep the middle-men's profits in your own pocket. Investigate! Mail the coupon. Learn how we give you a bigger, better, more powerful, clear-toned radio at a positive saving of 30% to 50% of usual retail prices. Costs only a stamp to find out. Mail the coupon or write us a postal . . . NOW!

MIDWEST RADIO CORP.
 Est. 1920
 Dept. 186 Cincinnati, Ohio

RUSH THIS COUPON FOR AMAZING FREE TRIAL OFFER AND BIG BEAUTIFUL CATALOG

Midwest Radio Corp.
 Dept. 186
 Cincinnati, Ohio.

Without obligation on my part send me your new 1933 catalog, and complete details of your liberal 30-day free trial offer. This is NOT an order.

Name
 Address
 Town State

USER AGENTS EASY EXTRA MONEY Check here for details.

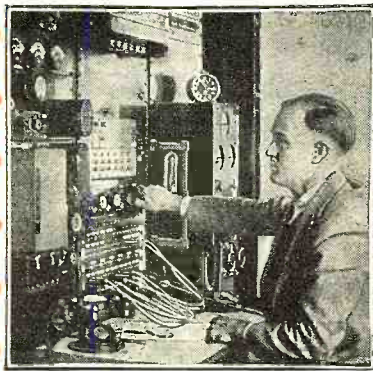

Broadcasting Stations employ trained men continually for jobs paying up to \$5,000 a year.

I WILL TRAIN YOU AT HOME

Many Make \$50 to \$100 a Week in Radio -- the Field With a Future

My book, "Rich Rewards in Radio," gives you full information on the opportunities in Radio and explains how I can train you quickly to become a Radio Expert through my practical Home Study training. It is free. Clip and mail the coupon NOW. Radio's amazing growth has made hundreds of fine jobs which pay \$50, \$60, \$75, and \$100 a week. Many of these jobs may quickly lead to salaries as high as \$125, \$150, and \$200 a week.



Police Departments are finding Radio a great aid in their work. Many good jobs have been made in this new field.

Radio—the Field With a Future

Ever so often a new business is started in this country. You have seen how the men and young men who got into the automobile, motion picture, and other industries when they were started had the first chance at the big jobs—the \$5,000, \$10,000, and \$15,000 a year jobs. Radio offers the same chance that made men rich in those businesses. It has already made many men independent and will make many more wealthy in the future. You will be kicking yourself if you pass up this once-in-a-lifetime opportunity for financial independence.

Many Radio Experts Make \$50 to \$100 a Week

In the short space of a few years 300,000 Radio jobs have been created, and thousands more will be made by its future development. Men with the right training—the kind of training I will give you in the N.R.I. Course—have stepped into Radio at 2 and 3 times their former salaries. Experienced service men as well as beginners praise N.R.I. training for what it has done for them.

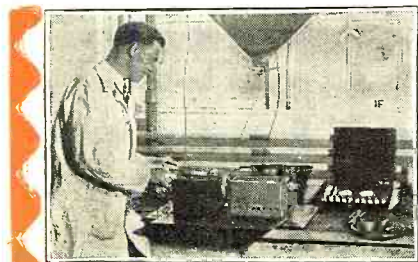

Spare time set servicing pays many N.R.I. men \$200 to \$1,000 a year. Full time men make as much as \$65, \$75, \$100 a week.

Many Make \$5, \$10, \$15 a Week Extra in Spare Time Almost At Once

My Course is world-famous as the one "that pays for itself." The day you enroll I send you instructions, which you should master quickly, for doing 28 Radio jobs common in most every neighborhood. Throughout your Course I will show you how to do other repair and service jobs on the side for extra money. I will not only show you how to do the jobs but how to get them. I'll give you the plans and ideas that have made \$200 to \$1,000 a year for N.R.I. men in their spare time. G. W. Page, 110 Raleigh Apts., Nashville, Tenn., writes: "I made \$935 in my spare time while taking your Course." My book, "Rich Rewards in Radio," gives many letters from students who earned four, five, and six times their tuition fees before they graduated.

Get Ready Now for Jobs Like These

Broadcasting stations use engineers, operators, station managers and pay up to \$5,000 a year. Radio manufacturers employ testers, inspectors, foremen, engineers, service men, buyers, and managers for jobs paying up to \$6,000 a year. Radio dealers and jobbers (there are over 35,000) employ service men, salesmen, buyers, managers and pay up to \$100 a week. Talking pictures pay as much as \$75 to \$200 a week to men with Radio training. There are hundreds of opportunities for you to have a spare time or full time Radio business of your own—to be your own boss. I'll show you how to start your own business with practically no capital—how to do it on money made in spare time while learning. My book tells you of other opportunities. Be sure to get in at once. Just clip and mail the coupon.



Talking Movies—an invention made possible by Radio—employs many well trained radio men for jobs paying \$75 to \$200 a week.

I HAVE STARTED MANY IN RADIO AT 2 AND 3 TIMES



**\$400
Each
Month**



**\$800
In Spare
Time**



**Chief Engineer
Station
WOS**



Television—the coming field of many great opportunities—is covered by my course.

"I spent fifteen years as traveling salesman and was making good money but could see the opportunities in Radio. Believe me, I am not sorry, for I have made more money than ever before. I have made more than \$400 each month and it really was your course that brought me to this. I can't say too much for N.R.I." J. G. Dahlstead, Radio Station KYA, San Francisco, Cal.

"Money could not pay for what I got out of your course. I did not know a single thing about Radio before I enrolled, but I have made \$800 in my spare time although my work keeps me away from home from 6:00 A.M. to 7:00 P.M. Every word I ever read about your course I have found true." Milton I. Leiby, Jr., Top-ton, Pa.

"I have a nice position and am getting a good salary as Chief Engineer of Radio Station WOS. Before entering Radio, my salary was barely \$1,000.00 a year. It is now \$2,400.00 a year. Before entering Radio, my work was more or less a drudgery—it is now a pleasure. All of this is the result of the N.R.I. training and study. You got me my first important position." H. H. Lance, Radio Station WOS, Jefferson City, Mo.

TO BE A RADIO EXPERT



Act Now --- Mail Coupon Below for Free Book of Facts and Proof

You Learn at Home in your Spare Time to be a Radio Expert

Hold your job. There is no need for you to leave home. I will train you quickly and inexpensively during your spare time. You don't have to be a high school or college graduate. My Course is written in a clear, interesting style that most anyone can grasp. I give you practical experience under my 50-50 method of training—one-half from lesson books and one-half from practical experiments with equipment given without extra charge. This unique and unequalled method has been called one of the greatest developments in correspondence Radio training. N.R.I. pioneered and developed it. It makes learning at home easy, fascinating, practical.

Learn the Secrets of Short Wave, Television, Talking Pictures, Set Servicing, Broadcasting, Etc.

I'll give you more training than you need to get a job—I'll give you your choice, and not charge you extra either, of my Advanced Courses on these subjects—(1) Television, (2) Set Servicing and Merchandising, (3) Sound Pictures and Public Address Systems, (4) Broadcasting, Commercial and Ship Radio Stations, (5) Aircraft Radio. Advanced specialized training like this gives you a decided advantage.

Your Money Back If You are Not Satisfied

I will give you an agreement in writing, legal and binding upon this Institute, to refund every penny of your money upon completing my Course if you are not satisfied with my Lessons and Instruction Service. The resources of the National Radio Institute, Pioneer and World's Largest Home-Study Radio School stand behind this agreement.

Find out what Radio offers. Get my Book

One copy of my valuable 64-page book, "Rich Rewards in Radio," is free to any resident of the U. S. and Canada over 15 years old. It has started hundreds of men and young men on the road to better jobs and a bright future. It has shown hundreds of men who were in blind alley jobs, how to get into easier, more fascinating, better paying work. It tells you where the good Radio jobs are, what they pay, how you can quickly and easily fit yourself to be a Radio Expert. The Coupon will bring you a copy free. Send it at once. Your request does not obligate you in any way. ACT NOW.

J. E. SMITH, President

**Dept. 3BR, National Radio Institute
WASHINGTON, D. C.**

FORMER PAY



**Experienced
Radio Man Praises
N. R. I. Course**

"Before taking your course, I had worked at Radio for over seven years, doing quite a bit of servicing, but I realized that I was in need of better training. From the first lesson on I began to understand points that had had me wondering. I would not take many times the price it has cost me, for the knowledge I have gained. In a period of nine months, I have made at least \$3,500." C. J. Stegner, 28 So. Sandusky St., Delaware, Ohio.

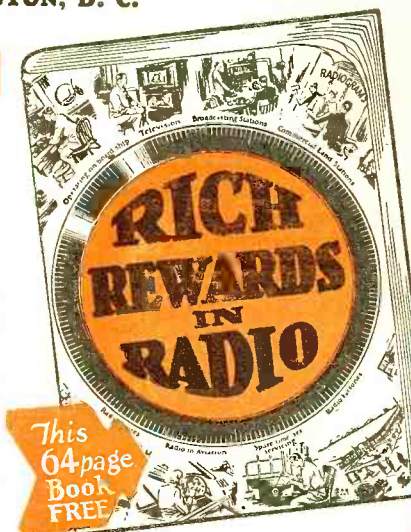

Sample Lesson Free

Act now and receive in addition to my big free book, "Rich Rewards in Radio," this Service Manual on D.C., A.C., and Battery operated sets. Only my students could have this book in the past. Now readers of this magazine who mail the coupon will receive it free. Overcoming hum, noises of all kinds, fading signals, broad tuning, howls and oscillations, poor distance reception, distorted or muffled signals, poor Audio and Radio Frequency amplification and other vital information is contained in it. Get a free copy by mailing the coupon below.

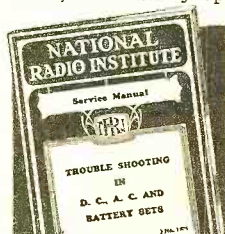

SPECIAL Radio Equipment for Broad Practical Experience Given Without Extra Charge



My Course is not all theory! I'll show you how to use my special Radio equipment for conducting experiments and building circuits which illustrate important principles used in such well-known sets as Westinghouse, General Electric, Philco, R. C. A., Victor, Majestic, and others. You work out with your own hands many of the things you read in our lesson books. This 50-50 method of training makes learning at home easy, interesting, fascinating, intensely practical. You learn how sets work, why they work, how to make them work when they are out of order. Training like this shows up in your pay envelope—when you graduate you have had training and experience—you're not simply looking for a job where you can get experience.

With N. R. I. equipment you learn to build and thoroughly understand set testing equipment—you can use N. R. I. equipment in your spare time service work for extra money.

Clip and mail NOW for FREE INFORMATION

**J. E. SMITH, President
National Radio Institute, Dept. 3BR,
Washington, D. C.**

Dear Mr. Smith: I want to take advantage of your Special Offer. Send me your Service Manual "Trouble Shooting in D.C., A.C. & Battery Sets" and your book "Rich Rewards in Radio," which explains Radio's Opportunities for bigger pay and your method of training men at home in spare time. I understand this request does not obligate me.

Name

Address

City State

"M"

The Editor—to You

WITH this issue of RADIO NEWS a new section, to be known as the Radio News Export Service, is announced. This addition to our editorial and advertising matter will be found in all copies for newsstand sale or for subscription distribution outside of the United States. It will be devoted entirely to radio information of interest to our readers in foreign lands who are servicemen, technicians, dealers, importers, scientists, experimenters and manufacturers. This new section is the result of the rapid growth of the Radio News Export Service department that has been taking care of correspondence between readers in foreign lands and American manufacturers. During the last three months this service has grown more than 100% and we feel that our readers, scattered throughout 76 countries of the world and numbering more than 15,000 outside of the United States, will welcome the addition. It will also contain descriptive data of American radio apparatus, sets, tubes and parts, for foreign distribution as well as other pertinent information regarding the export trade in general. Our Editors have noticed, during the recent year, that radio service work outside of our shores has increased in quality and, also, numerically. This service work is calling for a greatly increased variety and number of replacement parts, tubes and accessories of American make. Henceforth the Export Service coupon will be found only in this new Export Section of RADIO NEWS.

* * *

SERVICE work in the United States is also increasing, both in quality and in productivity. Our staff is continually surveying this field, amongst our own readers and through external sources. As a result of our most recent survey, which is less than one month old, we are able to state that RADIO NEWS servicemen readers buy well over \$1,000,000.00 of radio apparatus and parts from our American manufacturers each month of the year. And this is a conservative estimate, based upon questionnaire and coupon circulars sent out to our servicemen (both independent and part-time dealer servicemen as well as strictly dealer service organizations). It is also interesting to note that over 70% of the servicemen subscribing to RADIO NEWS, or buying their copies on the newsstands, are independent servicemen, running their own business. Therefore 70% of the sum mentioned above (as a potential monthly market) is reached only through the pages of RADIO NEWS.

* * *

NO OTHER general monthly radio publication or radio trade publication can compare, numerically, with the reader circulation in the trade that RADIO NEWS enjoys.

THE photograph reproduced on this page this month is that of a new bust of the great scientist, Heinrich Hertz, by the Berlin sculptor, Harold Isenstein, which was exhibited at the Berlin Radio Show. Hertz is being honored at the Berlin Exposition as one of the great pioneers of the radio world. He will be remembered for his early scientific researches with ultra-short radio waves that have since been known as "Hertzian waves." It was as a pupil of Hertz



that Senator Guglielmo Marconi first became interested in this subject and finally evolved the modern practice in wireless communication.

* * *

COMING over the Editor's desk this month are a number of letters from which a few excerpts are printed:

"As a regular reader of your valuable journal, I am writing to you in the hope that you may be able to assist me. I am desirous of corresponding with one or two Americans of about my own age (23) who are interested in radio topics generally. I am a partner in a radio service business in this town and have some experiences in this line, but I have none on the transmission side."—C. A. Hemmerdinger, Holiday and Hemmerdinger, 2, Dolefield, Bridge Street, Manchester, England.

* * *

WE trust there are some of our readers who will be interested in corresponding with Mr. Hemmerdinger.

* * *

"I HAVE just received the December copy of RADIO NEWS and note with

much interest that you have combined your magazine with the 'Radio Call Book Magazine and Technical Review.' I was a subscriber to 'Popular Radio' when you were editor of that publication, built one of your four-circuit tuners and was very pleased with it. When I began my present subscription to RADIO NEWS, I felt I had found an old friend when I noticed you were editing it. And now that you have combined with this other magazine, to which I was a subscriber, things seem to be getting under one roof, as it were. One of the most valuable sections of the 'Call Book,' particularly for servicemen, was the schematics and performance curves on receivers. I hope you will be able to continue this most excellent information, as it is about the only way to determine on paper the electrical performance of a set."—John Young, LaPlace, La.

* * *

"HERE we were all 'cocked and primed' for the second installment on the Van Leuven Pocket Diagonometer that was to have appeared in the December issue. We anxiously look forward for the second article and sincerely hope that another issue will not reach us without same."—J. C. Raynes, McPherson, Kansas.

This installment will be found in the present issue.

* * *

"I WOULD like to see more articles covering broadcast transmitters and new developments in this field, especially an article covering a frequency monitor as is required by a broadcasting station in the United States."—Leonard Smeltzer, Bellefonte, Pa.

* * *

"ONE main fault with your magazine is the lack of material devoted to the interests of those who are interested in long-distance reception."—Carleton Lord, Akron, Ohio.

* * *

WE hope the DX material in this issue will please you.

* * *

"SOME time ago I received a letter from the 'Citizens Radio Call Book' in Chicago, saying that their equipment for determining the sensitivity of radio receivers had been bought by the Teck Publications, Inc. I have been a reader of the above magazine for ten years and have also had RADIO NEWS for ten years. I must say that the schematics in the 'Call Book' were among the best in the country and I say keep up the publishing of radio schematics in the combined 'Radio News and Call Book.'"—Robert Rogers, Aundel, Quebec, Can.

Stewart M. Lockaday



SM

ANNOUNCING

THE "MASTER" OF THEM ALL

THE IMPROVED CBI

A FEW OF ITS OUTSTANDING FEATURES—

FIFTEEN TUBES

"CLASS A—PRIME" AUDIO

Using 59 tubes push-pull

AUDITORIUM DYNAMIC SPEAKER

DUAL PUSH-PULL AUDIO

55 THREE-IN-ONE TUBE

Making equivalent to 17 tube performance

AUTOMATIC VOLUME CONTROL

TONE CONTROL

NEON TUNING INDICATOR

15-550 METERS ON ONE DIAL

Without plug-in coils

ILLUMINATED WAVE-CHANGE INDICATOR

HETERODYNE OSCILLATOR FOR CODE RECEPTION

AUTOMATIC NOISE SUPPRESSOR CIRCUIT

MOISTURE-PROOFED AND NICKEL PLATED

Write for Prices and Complete Description

EXECUTIVE AND SALES OFFICES

187 West Madison Street

Chicago, U. S. A.

EXPORT DIVISION

41 Water Street

(Cables "LIKEX")

New York City, U. S. A.

SILVER-MARSHALL, Inc.



When the Queen of the Night Meets the Lord of the Day

What happens to radio signals when, during an eclipse of the sun, the sun's radiation and electronic discharge, both visible and invisible, are obscured from certain areas on the face of the earth? Do night-time conditions then prevail? Will these conditions of quickly approaching darkness affect reflection of radio waves from the upper strata of our atmosphere? Will radio reception be retarded or improved? Will all wavelengths be affected? These are questions which scientists recently set out to solve.

Radio News

VOLUME XIV

February, 1933

NUMBER 8

THE ECLIPSE AND RADIO

Some new facts concerning radio transmission are brought to light as a result of a survey RADIO NEWS has conducted among the scientists of the various organizations who sent expeditions to the area of the 1932 eclipse

THE total eclipse of the sun which was visible in the northeast of the United States and a portion of Canada on August 31, 1932, was closely observed by radio engineers and astronomers to determine the effect of the sun's influence on radio waves. Renowned scientists from all parts of the world gathered in the path of totality with special radio and recording apparatus, giant telescopes, astronomical cameras and numerous other scientific devices to participate in these tests.

Radio phenomena reported by scientific observers are termed of vast importance to radio engineering. Experts agree that much time must expire before all of the fragmentary data obtained by scientists of various countries is collected, co-ordinated and digested.

Experiments conducted in and out of the eclipse area by the National Broadcasting Company gave indications that the eclipse added distance and strength to ultra-short-wave radio transmission.

The NBC signals were transmitted from the experimental station atop the Empire State Building in New York (outside the path of totality) and were received during the eclipse at the RCA Communications station at Riverhead, Long Island, with strength increases never previously noticed. The signals were also picked up at a distant RCA station at Mount Greylock, Massachusetts. Only those receiving stations located between the Empire State

By Samuel Kaufman

Building and the path of totality were affected, according to the NBC data. Experimental stations in New Jersey—on the opposite side of the Empire State Building—reported normal reception.

Charles W. Horn, general engineer of the NBC, said that it was impossible to fully explain the condition until all the data had been studied.

"Present reports," he said, "would indicate alterations on the ultra-short waves that have never before been noted during either day or night transmission. Frankly, we are mystified, but we realize that we may be on the verge of important discoveries."

Engineers at Riverhead maintained careful checks on the ultra-short-wave signals. Before the eclipse approached totality they observed the signals gaining strength. This increase continued until about twenty minutes after the period of totality, when the signals were being received at ten times their normal strength. The signals subsequently returned to normal. The engineers at Mount Greylock, on the edge of the path of totality, reported the reception of a faint, fluttering signal along with the transmission just as the eclipse reached its climax. This was probably the most distant point of reception of an ultra-short-wave signal from the Empire State Building transmitter. Other attempts are being planned to try to pick up the station under normal conditions.

But slight variations were noticed on the broadcast and

RADIO ECLIPSE MEASUREMENTS
Dr. E. F. W. Alexanderson and his assistant using a facsimile recorder in a radio laboratory truck during the eclipse

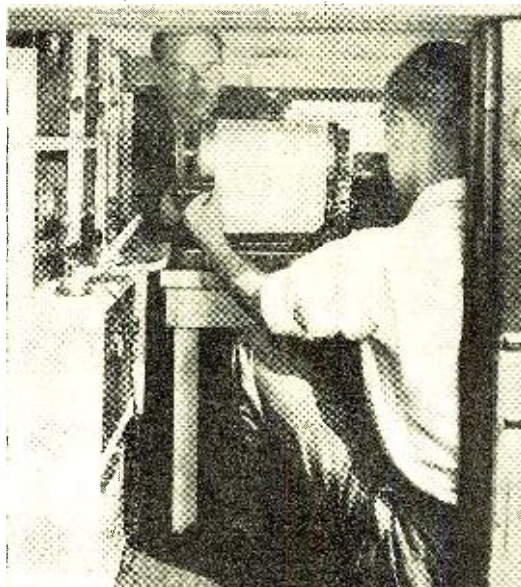



CHECKING RADIO TRANSMISSION IN A FIELD TEST

Engineers of the National Broadcasting Company with their experimental radio apparatus recording facts about radio transmission and reception in the tests on August 31, 1932

short-wave bands, according to the NBC data. Broadcast listeners reported considerable static at the time of the eclipse, but this was attributed to a tropical storm moving up the eastern coast from Florida. On short-wave circuits from Europe, RCA Communications discovered that G5FA, London; DJA, Berlin; FYA, Paris, and I2RO, Rome, were slightly stronger on daylight frequencies, prior to the eclipse, and clear in the evening after the eclipse had passed.

Dr. E. F. W. Alexanderson, radio consulting engineer of the General Electric Company, was stationed at Conway, New Hampshire, in the path of totality, and noted a complete radio eclipse of short-wave signals which preceded the optical eclipse by two hours. This phenomenon started at 1:30 in the afternoon. As the moon's shadow fell on the earth, the radio signals gradually became stronger and were back at full strength about a half hour before the totality of the optical eclipse. Dr. Alexanderson explained that this seemed to prove that fading is caused by an "electronic eclipse" rather than the approach of darkness.

An unusual occurrence was reported about one minute before totality of the optical eclipse. Signal strength increased with a sudden burst, died down just as suddenly and repeated its blast for a second time, lasting but a few seconds. Dr. Alexanderson could not explain this burst of strength in the signal. The signal was of such intensity that his assistants had to pull the headsets from their ears. One of the assistants, who was listening to a 30-meter broadcast from Nauen, Germany, had a similar experience.

Following the eclipse, Dr. Alexanderson made the following statement: "With our radio facsimile outfit we have recorded what I believe will be a most important record for scientists. We made records on Monday and Tuesday during the same period of time. By comparing these we can see just how short-wave radio was affected by both the electronic and the optical eclipse. It will take time

may have and try to carry these theories somewhat further by establishing new facts. In equipping an expedition to make radio observations on this eclipse we had in mind, particularly, to follow out a suggestion made by Dr. Irving Langmuir, who desired to obtain some more data regarding the theory that from the sun there is a corpuscular or electronic emission traveling at a rate of 1000 miles a second."

For the test, Dr. Alexanderson selected a radio-frequency transmission of 8655 kilocycles because he believed that this wave would have a skip distance not much beyond the distance at which observations were made and that the fringe effects of fading at the edge of the skip distance would be strongly pronounced. These phenomena, he said, have been apparent in television under certain unfavorable conditions where the multiple reflections, both positive and negative, which rapidly appear and vanish, suggest a dance of ghosts. Television was not used for the eclipse experiments because a permanent record was sought so that the results could be accurately compared with other results at a later date.

"Instead of attempting to transmit facsimile of writing or pictures," Dr. Alexanderson said, "we selected a type of signal with continuous-wave radiation interrupted sixty times per second, each interruption being one five-hundredth of a second. A facsimile record of this signal gave parallel black lines on a white background if the record was perfect. The signal from Schenectady, which we recorded at Conway, N. H. during normal conditions in the afternoon previous to the eclipse proved, as we expected, that we had to deal with multiple reflections. Though the signal was strong, it was of a type with rapid fadings that gives distortions of speech and music. On the record it appears like an irregular mixture of black marks on white background and white marks on black background, alternating with totally black and totally white streaks. This is the kind of signal

TEST FACSIMILE

This is a part of the record printed by Dr. Alexanderson's machine and used in interpreting the results of the investigation

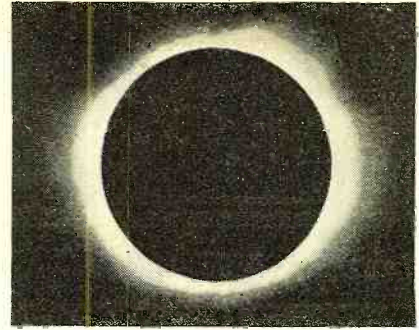
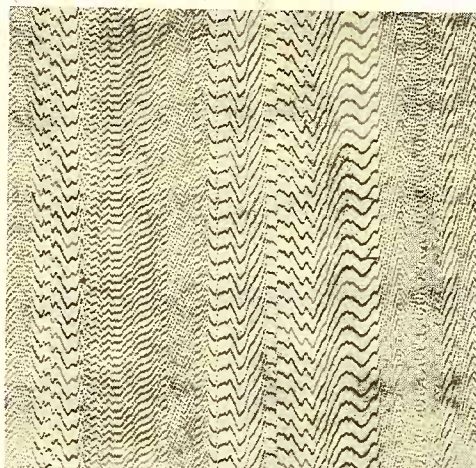

THE SUN'S CORONA

Photograph of the Corona of the sun, when totally eclipsed by the moon, taken by scientists of the Harvard College Observatory

to study these records and reach definite conclusions." The "Monday and Tuesday" referred to by Dr. Alexanderson were the two days preceding the eclipse.

At a later date Dr. Alexanderson disclosed further data on the effect of the eclipse on the propagation of radio waves.

"When," he stated, "we try to interpret something about which we really know so little as the effect of the sun's eclipse on the propagation of radio waves, the best we can do is to start with such theories as we

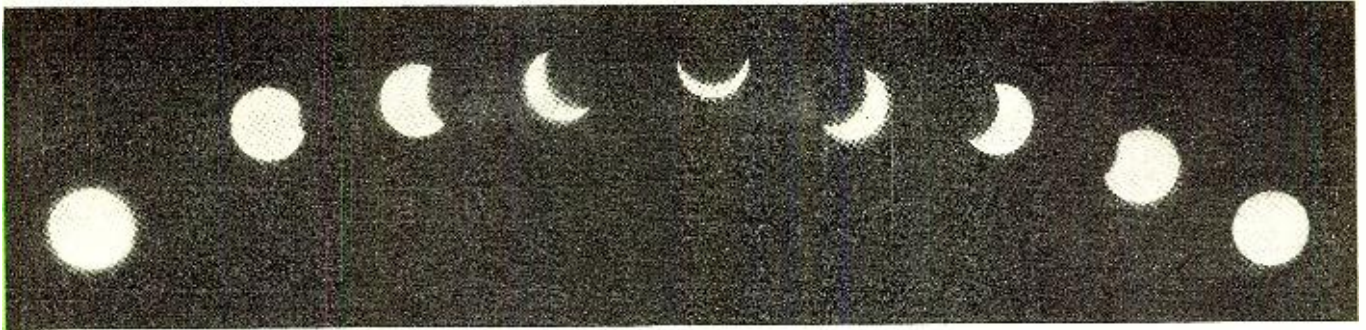

STEP-BY-STEP PHOTOGRAPHS OF THE PROGRESS OF THE AUGUST 31, 1932, ECLIPSE

This rare depiction, made at Cleveland, Ohio, where maximum of 87 percent was reached, shows the solar eclipse in its various phases. Pictures on the left are the earlier stages and the pictures on the right show the eclipse diminishing. The center picture is the eclipse at maximum

that is particularly useless for facsimile and television and was just what we wanted."

He explained that the outstanding result of the observations was that this normally strong signal almost totally disappeared during the two hours preceding the optical eclipse, which in accordance with the calculations of the astronomers would be the time during which the corpuscular or electronic eclipse would occur.

"The nearly complete disappearance of the signal," he continued, "was so striking we were worried that something might have gone wrong with our receiver, but when shortly before the optical eclipse began the signal came back first in a scattered way and then strongly and continuously, we felt that we had a complete proof of the correctness of the theory of the electronic eclipse. This record, which was taken during the whole afternoon and evening, will be preserved for those to whom it is of scientific interest."

Dr. Alexanderson pointed out that the electronic shadow, in the calculation of astronomers, falls entirely east of the path of totality where the observations were made.

He said that, in examining his record, he finds that such a graph could not have been made by a single ray.

"If the signal arrives at the receiving station after reflection," he said, "we must conclude that there are at least two such reflections; i.e., two rays arrive simultaneously, one having traveled a distance of several hundred miles more than the other. This would explain the double image on the record which occasionally gives the appearance of white lines on black background instead of black lines on white background. This theory of reflection may also explain the recent findings of Marconi that even ultra-short waves may at times reach points far beyond the horizon.

"If this theory is correct, there remains to be explained the nature of the reflecting medium which is produced by the electronic bombardment. Possibly it is one of those phenomena which has become known as the Appleton layer and which must be recognized in addition to the Kennelly-Heaviside layer to explain the phenomena of radio."

Government Observations

He said that the important point he established is that a signal of a particular wavelength and a particular distance is almost completely suppressed by the electronic eclipse "if this eclipse area lies immediately beyond the point of observation as seen from the transmitting station."

In a paper delivered before the Philosophical Society of Washington last October by T. R. Gilliland, of the Bureau of Standards of the Department of Commerce, the findings of the Government eclipse observers were disclosed.

"In view of the fact that it will be a number of years before another total eclipse will be visible in this part of the country," he said, "it was thought advisable to take this opportunity to determine, if possible, whether or not solar corpuscles are responsible for an appreciable part of the ionization. It was decided that observations should be made at a point as far to the north and east of the optical path as would be easily accessible by motor truck."

Two of the scientific trucks proceeded to Sydney, on Cape Breton Island. The type of experiment used was that originated by Breit and Tuve, he explained, for determining virtual heights of the ionized regions. The procedure consisted of the transmission of short pulses of radio-frequency energy from an antenna and the reception and oscillographic recordings at a receiving station about three miles away.

"For each pulse transmitted," Mr. Gilliland said, "energy arrives at the receiver by a path along the ground and by one or more paths through the upper atmosphere. By measuring on the oscillogram the difference in time of arrival of the ground and sky waves, the virtual height may be calculated. It has been found in general that the lower radio frequencies are returned from the lower ionized regions while the higher frequencies come from the upper region.

"If we increase our frequency to a certain point we will find that reflections from the lower region either become weak or disappear, and if we go 200 to 300 kc. above this point, strong reflections begin to appear (Continued on page 507)

THE PUBLIC LISTENS-IN ON SCIENTIFIC ACTIVITY

A special astronomical camera set-up at Conway, N. H., while Ted Husing, announcer for the Columbia Broadcasting System, stands by ready to relay a word picture of the scientific proceedings

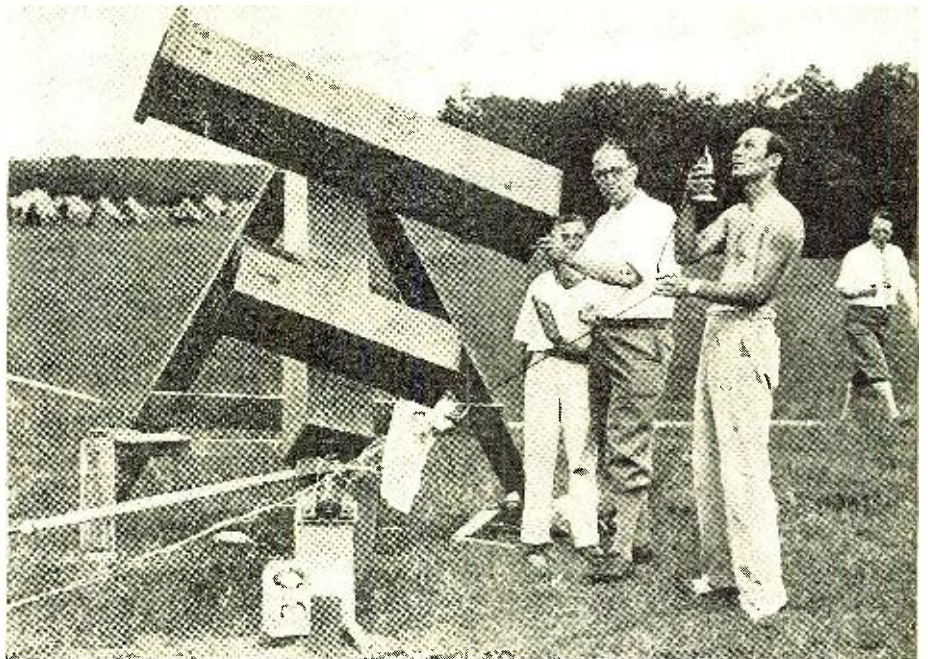

HOW SCIENTISTS ARE WORKING CONTROLLING

BY SOUND

In these methods sound waves, such as employed to actuate, through amplifiers a distance. It is expected that further may become extremely important in some manufacturing process responding machine's operator. This is not only application in some

By Irving J.

He draws in the smoke, whereupon the tip of the cigarette grows lighter, and exhales the smoke out through his nose. Apparently he is inhaling. This would settle the question, "Do you inhale?" for the world of robots also.

There are other things which he can do, if the proper words are spoken into the 'phone. He can salute, he can talk, he can blow the horn of an automobile, he can make a vacuum cleaner move over the floor, he can start a refrigerator, and many other things.

What seemed a playful demonstration—and an attractive one—makes us think deeper into the matter of radio sciences which make it possible for us humans to control nature around us.

But what is a robot, really? It is a machine, a new factor in science that makes it possible to control the vast energy sources obtained in nature. It is the spoken word, moreover, that brings out these effects, eliminating any muscular action whatsoever, even if it is as small an action as pushing a button or throwing a switch. It is a high sublimation of the fact that man, by the pure force of his brain, has been able to sustain his life in a world full of the brute powers of nature.

Man has invented machines to help him defend himself in life and to enrich it. Man has taken control over nature with the aid of these machines and with the aid of communication between men running these machines and communication between the machines and men, the control of the machine has resulted.

Now the purely spoken word, the sound as such, can control



A DOLL DANCES TO MUSIC

The illustration above shows the National dancing doll that is actuated by the sound waves coming from the Columbia receiver on which it stands. The doll is an entertaining toy that dances complicated tap steps in synchronism with musical rhythm

A GIANT robot, weighing 350 pounds and standing 6½ feet tall in spite of its tender age of 10 months, has been introduced recently into society. Its father is Radio and its mother the Electronic Sciences.

The event took place at a commercial exhibition in a well-known New York department store before an excited attendance.

Grown-ups and children alike observed with fascination the giant puppet, the action of which can be controlled by words spoken into the mouthpiece of a telephone.

Our first picture (Figure 1) shows the figure of the robot. Sitting upon a pedestal is the figure of a man built in life size of sheet metal painted white. It is sitting upon its high-legged chair, stiff and dead, and does not seem to be disturbed by the crowd gathered around it and by the excitement it arouses.

Now an engineer approaches it and connects it with its soul—vibrating electricity in the form of radio-controlling organs. In a moment the eyes of the figure flash up with a red light that oscillates—goes on and off. Now the engineer speaks into a telephone. He says "Stand up!" A few lamps flash, a motor starts to hum and slowly the giant figure rises to its feet, its eyes still flashing on and off.

The demonstrator puts a lighted cigarette in the little hole which can be recognized at the right side of the mouth of the picture in Figure 2. Some words are spoken, and the robot starts to smoke.

A TRAIN THAT OBEYS THE HUMAN VOICE

Figure 3. The young lady merely says "go ahead," "stop" and "back up" to make this GE sound-controlled toy engine go through its various movements along the track

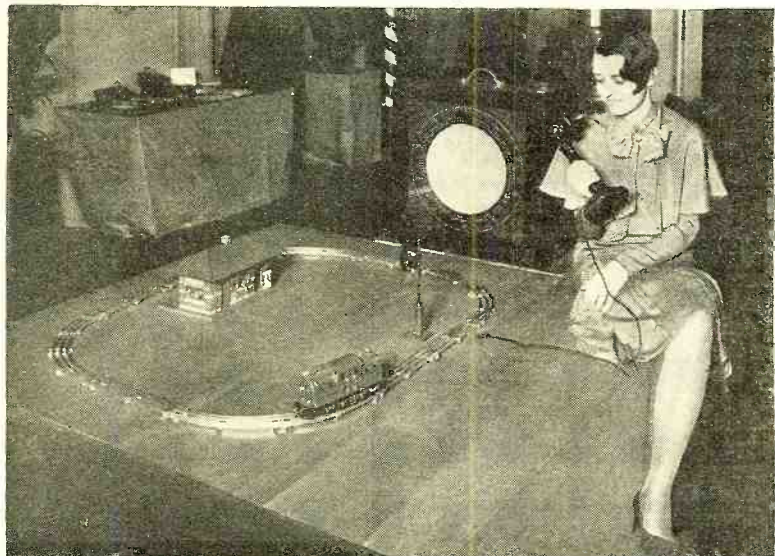

OUT NEW RADIO METHODS FOR MACHINERY

IMPULSES

ordinary speech or musical tones, are and relays, various forms of machinery at industrial applications of this principle industry—imagine a great machine in automatically to the spoken words of the feasible, but soon may be a practical of our large factories

Saxl, Ph.D.

these energy sources, can bring about action in a field where heretofore signals had to be given by mechanical

means and crude controlling equipment. The voice is now able to control powerful machines, to bring out movements and reactions which are on the borderline of the unbelievable.

But what is at the bottom of this magic? Again we have to deal with one of the beautiful side-lines which have grown from investigations in the line of radio and have culminated in the development of apparatus believed to be impossible heretofore.

But before we go into a discussion of the details of the construction of this apparatus, let us look at Figure 3, which in a varied form brings out an idea which is the fulfillment of the ambition of every youngster—to have a train that will stop and go at the command of his voice.

The toy electric locomotive shown starts forward, reverses and stops at the instant it is commanded to make any of the operations, and it never makes a mistake, provided the orders are properly directed. These orders are spoken into the mouth-piece of the telephone microphone that the young lady is holding.

It is important that single sound impulses are given very clearly. The orders are issued through an ordinary telephone transmitter of the carbon microphone type, and the action of the train is dependent upon the voice impulses of the transmitter. In the command "Go ahead, Casey," these three words make the train move ahead. Two words, for instance, "Back up," send the engine backward, and the single word "Stop" breaks the circuit and "Casey" comes to a standstill. By moving the transmitter a short distance away from the mouth, the operator may carry on considerable chatter with

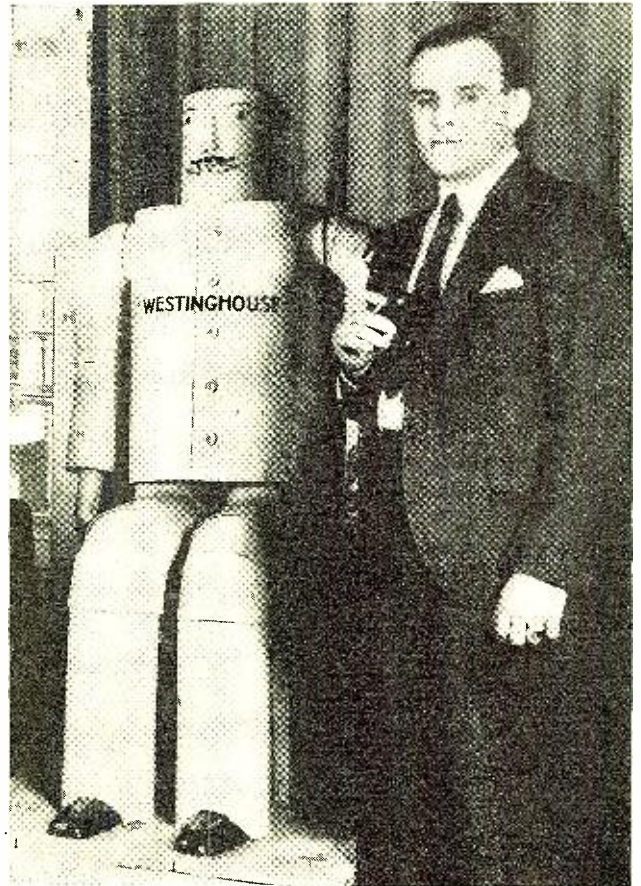

A MODERN "FRANKENSTEIN"
Figure 1. A modern mechanical man seated alongside of his human master, who merely has to speak into a microphone to make him perform; smoke a cigarette, run a vacuum cleaner and answer questions

CONTROLLING THE TOY LOCOMOTIVE

Figure 4. This is the schematic wiring diagram of the voice-controlled thyatron selected circuit used for starting, stopping and reversing the engines

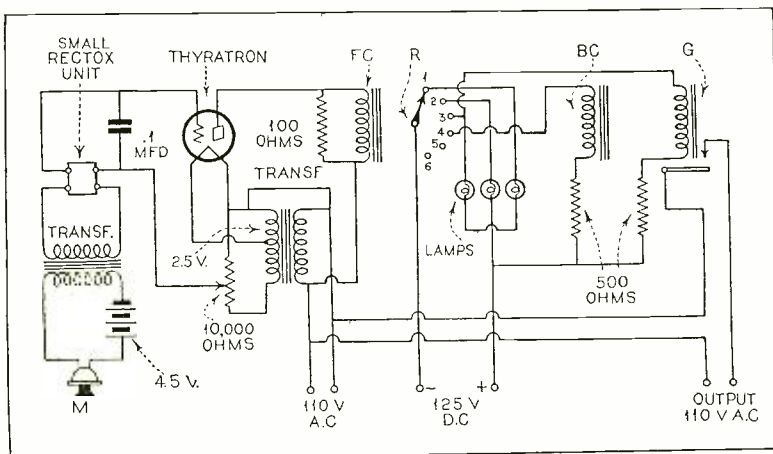

"Casey" without affecting the action of the train in the least.

The control microphone used is particularly sensitive to acoustical signals, and the operator may direct "Casey" to travel around the track and stop at a designated point. By "blowing" into the transmitter the operator is able to check the engine at any point. (The puff of wind acts the same as a spoken word.)

A little side arrangement is that the tiny locomotive with an electric headlight is made to pass a light-sensitive cell known as a photoelectric cell. Every round trip of the locomotive is recorded on the counter electrically. The equipment used for it is similar to that now used in the Hudson Tubes in New York to count automobile traffic.

In the radio robot, as well as in the toy locomotive, we find certain principal similarities. In both cases action is controlled by sound impulses. In both cases the syllable as such has been more important than the meaning of the word. Modulation and fine differentials of these impulses are of minor importance.

It is now interesting to note how these sound impulses have been translated in the case of "Casey Jones" into the control of machines.

Figure 4 shows the wiring diagram of the arrangement used in the case of the toy electric train. The power for moving the little locomotive (Casey Jones) is furnished by a little electric motor within the "engine." The direction in which this motor runs is dependent on the direction of the current passing through the motor. If

the polarity of the current is changed, the motor runs in an opposite direction and naturally, then, the locomotive runs backward. The command of the voice, "Go ahead, Casey," is converted into three electrical impulses which are carried through to the special selector which determines the polarity of the track and upon this polarity is dependent the direction in which the locomotive moves.

The wiring diagram in Figure 4 gives an approximately idea of the fundamental circuits which make this selection possible. We see on the left side the microphone, M. In series with this microphone is a battery of 4.5 volts and the primary of a transformer. Now the acoustical impulses therefore will compress the carbon in the microphone and thus reduce its resistance as long as it is compressed. In this moment the current is increased suddenly. This change of current impulse and voltage is stepped up in the transformer, the secondary of which is connected to a rectifier unit of the copper-oxide disc type.

It is readily understood that *only the change of current is transmitted*, and any amount of steady current will *not* affect the secondary, as only changes in the magnetic flux brought about by changes in the electrical current of the primary will have an effect upon the secondary.

But what can bring about this sudden change in the current? It is just an acoustic impulse as such, and we understand now why it is the same for this equipment whether we say "bang," or "go," or even "stop." It is not the meaning of the word, but the single impulse that is transmitted.

This current, which has been rectified, is now impressed upon the magic wand of the electronic scientist—a vacuum tube. In our case we have a gas-filled tube of the thyatron type FG-17.

As it needs only the minutest amounts of current to start a considerable discharge between the filament and the plate, it is possible to control a considerable quantity of electric current which can be impressed upon the relays.

The filament of the thyatron is heated by a step-down transformer which transforms the 110 volts of the line to the 2.5 volts needed. It will be noted that one side of the primary and secondary are connected so that the transformer acts as an auto-transformer.

The use of alternating current on the plate causes current to flow only when the grid maintains a certain potential that introduces the initial discharge. This is of particular importance in the use of thyatron tubes. If direct current had been used, this current between the filament and plate, once started, would

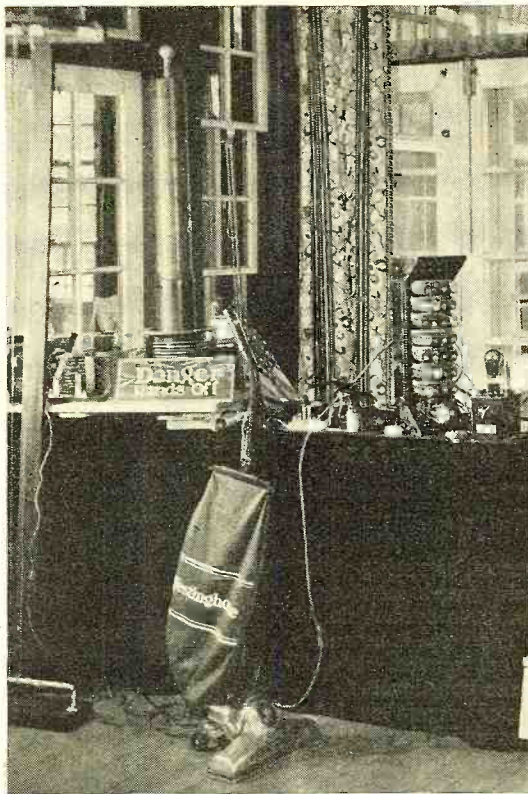

THE "ROBOT'S" CONTROL EQUIPMENT

Figure 5. On this table are shown the various external elements for controlling the Westinghouse "Frankenstein." He can fire a pistol, raise a flag, talk over a beam of light and run household machinery

upon a relay operating selective switches, it is possible to put intermediary members between the sound-sensitive organ and the operating switches.

One of these possibilities has been used in the equipment that operates the robot. This robot is called "Willie Vocalite,"

SOUND EQUIPMENT THAT ENERGIZES

Figure 2. The small table between the operator and the robot contains the sound and light beam equipment for putting thoughts into the robot's "brain" that are followed by mechanical "deeds"

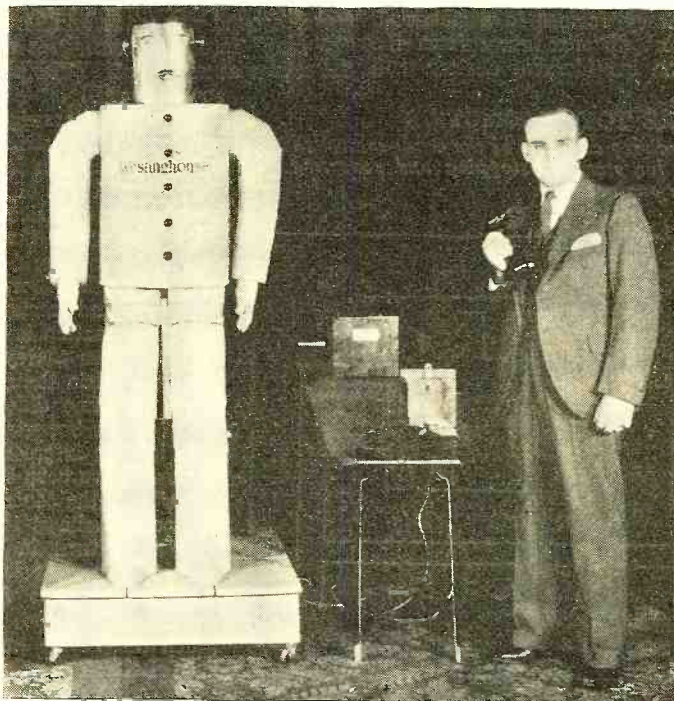

not have been interrupted as long as the plate potential was supplied.

Now by using alternating current the plate potential falls, in the negative phase, far below the value at which the continuation of the glow could be sustained. Therefore, the glow discharge takes place only for the moment that the voice impulse is impressed electrically upon the grid. After this the discharge ceases immediately and no constant current flows through the tube.

When the current flows, the tongue of the relay, R, is attracted by the soft iron of the electromagnet, FC, by a spring and ratchet drive. This movement is transferred to a number of switches. If one current impulse flows through the thyatron, the tongue of the relay is attracted once and therefore contact No. 1 is closed. If two electrical impulses flow through the relay, the tongue will move twice. If three impulses flow through the relay, switch No. 3 will be brought into action, and so on. These switches are arranged in such a way that their action causes current to be started, stopped or reversed.

The apparatus used in the voice-controlled train has many other practical applications in addition to its fascinating possibilities as a toy.

There are many ways to kill a cat, and it is possible to close or open relays by various methods. While we have, in the arrangement described above, a direct transmis-

sion selective switches, it is possible to put intermediary members between the sound-sensitive organ and the operating switches. One of these possibilities has been used in the equipment that operates the robot. This robot is called "Willie Vocalite," and, as the name implies, it is not only the *voice* but *light* that makes it operate. Of course, the initial sound-receiving part of the apparatus is similar to one mentioned before. Again the microphone is used, the resistance changes of which bring about changes in the balance of a Wheatstone bridge circuit. The detuning of this circuit operates a relay which, if closed, makes a flashlight bulb light up.

In Figure 5 we see a close-up of the controlling equipment. On the right side is a little case carrying a photo-cell and a thyatron tube. On the left side is a selective switch. Continuing in the same direction is a gun, the trigger of which can be pulled by a service motor. Also a little flag of the United States which is raised at the same moment that the gun sounds. In the foreground we see a vacuum cleaner, the wheels of which have been connected to an electric motor. If this motor is started by

(Continued on page 505)

EXTENDING LOUDSPEAKER RANGE

The author describes his experiments in increasing the frequency response in a reproducer system for any radio receiving set, thus improving to a considerable extent the quality of reception that can be obtained

By Joseph S. Grant



A UNIQUE INSTALLATION

The author uses three speakers in a special circuit design to increase both the high frequency and low frequency response, and installs them in an unused fireplace

ONE reason why the reproduction of a radio seldom sounds exactly like the original transmitted sound is due to the loss of the higher audio frequencies in the reproducing system. Although the pitch of the highest written note in music is below 5000 cycles, it is necessary to hear frequencies of at least 10,000 cycles if speech or music are to sound natural. There are many points in the radio receiver where the much-needed high frequencies may be suppressed, but the loudspeaker is usually to be blamed, and often justly, since the average cone-type speaker has a low acoustic output at frequencies above 5000 cycles.

This defect can be overcome by using two speakers, one being connected in the usual manner and the other connected so as to respond to the high frequencies only. To accomplish this, the one speaker is connected in series with a condenser, the capacity of which being such as to cause resonance at about 10,000 cycles. By connecting the speaker in this way a relatively large current will flow through the voice coil at frequencies approaching the resonant frequency of the coil and condenser combination. This will give the one speaker a rising response characteristic, being peaked at 10,000 cycles and diminishing proportionately with the frequency. When this is combined with the other speaker, a fairly uniform response can be obtained.

Since the efficiency of a loudspeaker at high frequencies is largely determined by the combined mass of the coil and cone, it is necessary to use a small speaker for this purpose. One having a 5-inch cone diameter is sufficiently large. In some cases the high-frequency response will be further improved if the small speaker is mounted in front of the baffle. Also the voice coil of the speaker must have a lower impedance than the winding to which it is connected in order to allow for the reactance of the condenser. Following is the reactance of various condensers at 10,000 cycles: .5 mfd., 32 ohms; 1 mfd., 16 ohms; 2 mfd., 8 ohms; 4 mfd., 2 ohms.

For those who do not have the necessary test equipment, the easiest way to select the proper capacity to cause resonance at 10,000 cycles is to tune the radio to a point between two stations on adjacent channels until a high-pitched whistle is heard. This whistle is a 10,000-cycle beat-note caused by the heterodyning of the two carrier waves. It is then a simple matter to obtain the right size condenser by selecting the one that allows the heterodyne whistle to be heard with the greatest intensity.

When using two loudspeakers in this manner it will be necessary to use an output transformer with a secondary winding for each speaker. Amertran makes an output transformer having three secondaries, which is excellent for this purpose. One secondary winding has an impedance of 45 ohms, the other two being 15 ohms each. Of course, the method of connecting the loudspeakers depends upon their impedance. In this original installation two Photophone speakers, which have a

voice-coil impedance of 9 ohms each, were connected in series across one of the 15-ohm secondaries, and the small loudspeaker, also having a 9-ohm voice coil, was connected to the 45-ohm secondary in series with a .5 mfd. condenser.

If possible, it will be best to connect the loudspeaker fields to a separate current supply. By doing this, the frequency response of the speaker combination can be altered by regulating the field current of each speaker individually, to suit the characteristics of the receiver to which they are connected. In other words, if the high frequencies need boosting, all one has to do is to increase the field current of the small loudspeaker or reduce the field current of the other. The
(Continued on page 511)

EXPERIMENTAL LOUDSPEAKER HOOK-UP

Shows how the loudspeakers are connected. Each field coil has a d.c. resistance of 1000 ohms and is connected to a common current supply. A series condenser is used in series with the voice coil of the small speaker to improve high-frequency response. The same scheme can be used employing only two speakers, one large and one small, providing the impedances are properly matched to the transformer

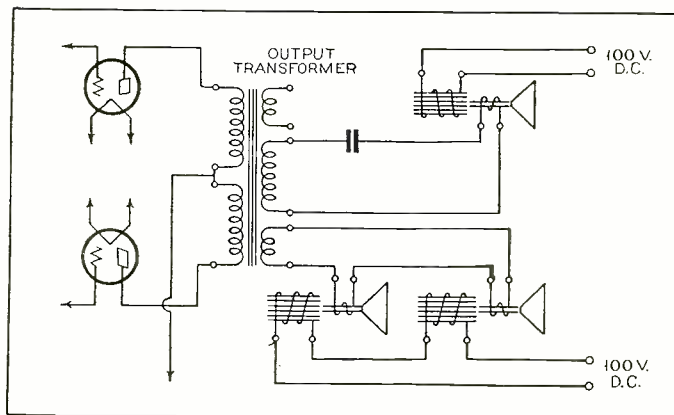

Complete Data On NEW "SUPER"

This six-tube midget superheterodyne, easy to build and inexpensive, yet

*By C. Bradner Brown**

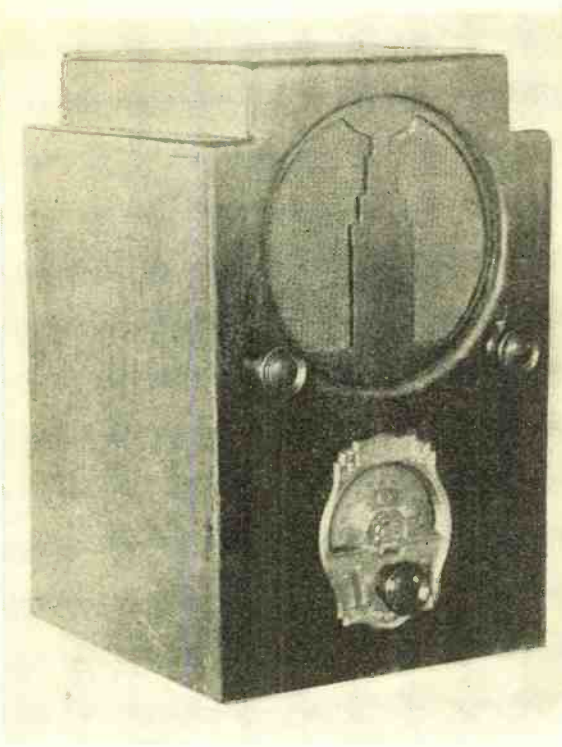

SMALL, NEAT AND EFFICIENT
Ample room is provided for the "Super-Six" Midget chassis in this home-made cabinet which measures only 7 3/4 inches by 7 3/4 inches by 11 3/4 inches outside

THE physical size and high amplification factors of the new -50 series tubes suggested the design of a real midget receiver. Heretofore most midget sets have been midget in performance as well as size. The high gain obtainable in intermediate stages with the type -58 tube, however, promised a receiver that would stand up with the larger models as to performance while still retaining the advantages of small size.

A type -58 tube is used in the first stage as a combination r.f. amplifier and frequency changer. Ordinarily, the gain in this stage is very low, but by the incorporation of a new principle the amplification is made considerable. It will be noticed that the type -56 tube used in the oscillator is coupled to the frequency-changer stage through a coil inserted in the suppressor-grid lead. Thus the r.f. from the oscillator swings this grid both positive and negative with respect to the cathode. During the positive part of the r.f. cycle a condition exists in the -58 tube much like that necessary for oscillation, and it will be remembered that in an Armstrong super-regenerative circuit a very high effective amplification is obtained by using this principle. Thus considerable extra gain is obtained over this stage by driving the suppressor grid at the oscillator rate than would have been the case had the cathode been modulated

as in the usual arrangement. The fact that this is done at an r.f. rate some 250 kilocycles above the station frequency prevents the circuit from becoming unstable, as it is a well-known fact that, as in super-regenerative action, a vacuum tube can be operated at much higher than oscillating voltages by supplying this voltage in short pulses such that the tube does not have time to go into oscillation between positive and negative pulses.

The use of a -58 in this stage also greatly reduces interference due to cross modulation by strong local stations. As would be expected, the selectivity lies almost entirely in the intermediate stages. The first r.f. stage tunes quite broadly, and for this reason little difficulty will be encountered in lining up the oscillator and r.f. stages for tracking purposes.

The volume control is a combination of antenna shunt and grid bias. A great number of systems were experimented with, but this control proved the best when it was applied to the cathode and suppressor grids of both the r.f. stage and the intermediate stage. It was found necessary to use the antenna shunt combination in order to reduce the signal strength to prevent overloading. It works very well, partially because the -58 tube is of the remote cut-off type, the mu of the tube decreasing from around 1500 to as low as 50 when the negative grid bias is increased. This reduces the amplification in the intermediate stage where it is the most effective in reducing volume.

A second type -58 is used in this stage, having both input and output tuned. Very thorough shielding is necessary if this stage is to be operated without oscillation, but with proper precautions an exceedingly high gain will be obtained. It is this amplification which accounts for the performance of the set despite the small size of the chassis.

A type -57 tube is used in a tuned input, grid-bias second detector circuit for both gain and quality of reproduction. The plate circuit is loaded with the conventional low-pass filter consisting of an r.f. choke and two by-pass condensers. This increases the gain obtainable in this stage greatly and so bet-

*Engineers, First National Television Corporation.

FIGURE 1. THE CIRCUIT DIAGRAM

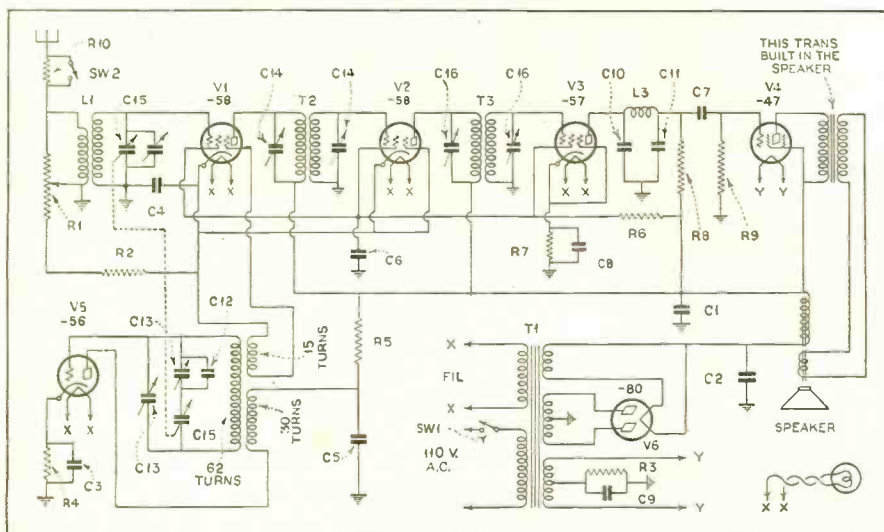

UNDER THE CHASSIS

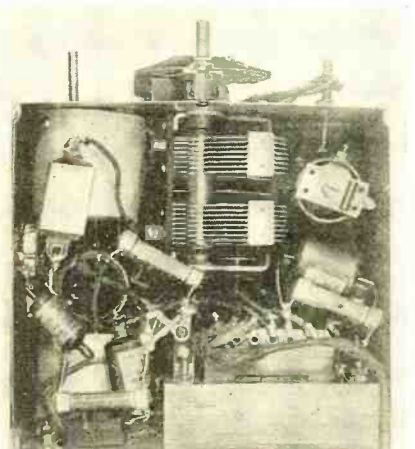

How to Build the SIX" MIDGET

using the new -50 series tubes, it offers surprisingly good performance

and Kenneth Alexander*

ters the overall performance of the receiver.

The pentode -47 stage is the usual type, feeding into an output transformer with the proper impedance to give maximum gain with best quality of reproduction. The power supply consists of a type -80 rectifier feeding a brute-force filter of 8 mfd. input and output, the field of the dynamic speaker being used as the single choke coil. This results in a considerable saving of space and is sufficient for the current requirements of the set.

The full voltage of the power supply, some 260 volts, is applied to the -58's and the pentode. The oscillator and detector are supplied through dropping resistors, while the screens also are operated at a lower potential. The by-pass condensers shown are necessary, all unnecessary parts having been eliminated in the preliminary tests, before the parts were definitely placed in the chassis.

In case the constructor wishes to make his own i.f. transformers, and the ones described are considerably smaller than the commercial models, complete details are given in Figure 2. The coils are wound on a winding form which fits the chuck of a hand drill for convenience. Two paper washers are placed in the winding form to prevent the wire from coming in contact with the wood blocks. A paper ring must then be prepared on the dowel to serve as the "core" for the coil. This is done by winding several turns of bond or writing paper and securing the end with some Duco cement. This ring should be free to slip off the winding form when completed. The coil is then scramble-wound, taking care to bring out the inside wire through a slot in the rear block before starting to wind. Every few layers, a coating of collodion should be applied to the coil. This mixture can be made by dissolving some clear celluloid in acetone. When the coil has been wound, the end block is removed and a further coating of collodion is applied to the coil. It is then allowed to dry thoroughly before using.

THE CHASSIS

The tube with shield in place is the first detector. The oscillator is concealed behind the -80 rectifier. The two i.f. tubes are at the right with shields removed

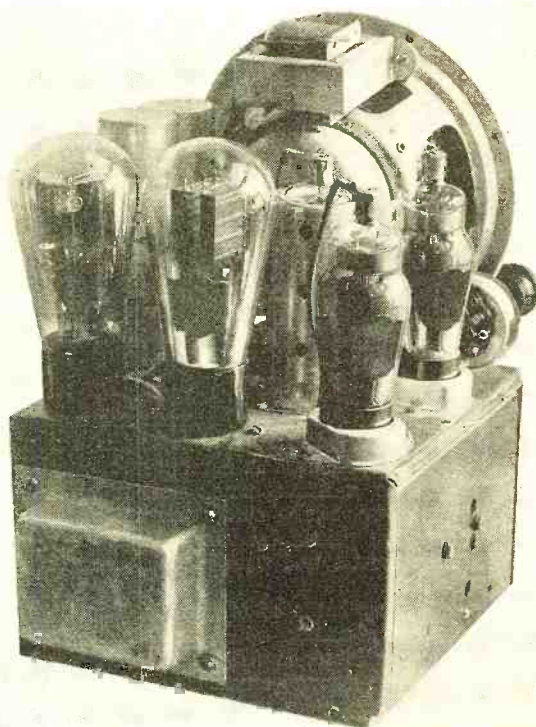

Four of these coils must be made for the two transformers. A piece of dowel is cut to length and the coils slipped over the end. When the supporting bus-bar has been driven in solidly and bent over, the unit may be fastened to the tuning condenser by soldering the bus-bar to the two opposite terminal lugs. This results in extremely strong construction with a minimum of space taken up. When all of the wires have been connected, the coils may be spaced one-half inch apart and dipped in paraffin to prevent the absorption of moisture. The shield can should then be placed over the completed transformer and cut off at the bottom so as to leave about a 1/4-inch clearance at the top of the can. This is necessary in order to allow its mounting inside the chassis. Some care should be taken that the bus-bar used for supporting the wooden dowel does not touch the shield can, and a paper lining placed inside the shield can will prevent any possibility of a short-circuit which would be disastrous to the -80 tube and filter circuit.

The antenna coil (Figure 3) consists of a 1 1/4-inch form wound with a primary and a secondary. The primary has 20 turns of No. 28 enameled wire and (Continued on page 502)

COIL AND CHASSIS CONSTRUCTION

Figure 2 (a) shows section of completed transformer, (b) form employed in preparing coils and (c) the specifications for i.f. mounting and adjustment holes to be provided in front and rear walls of chassis. Figure 3. Specifications for antenna coupling coil. Figure 4 shows details of oscillator coupler. Figure 5. From the dimensions given, readers will be able to duplicate the author's chassis

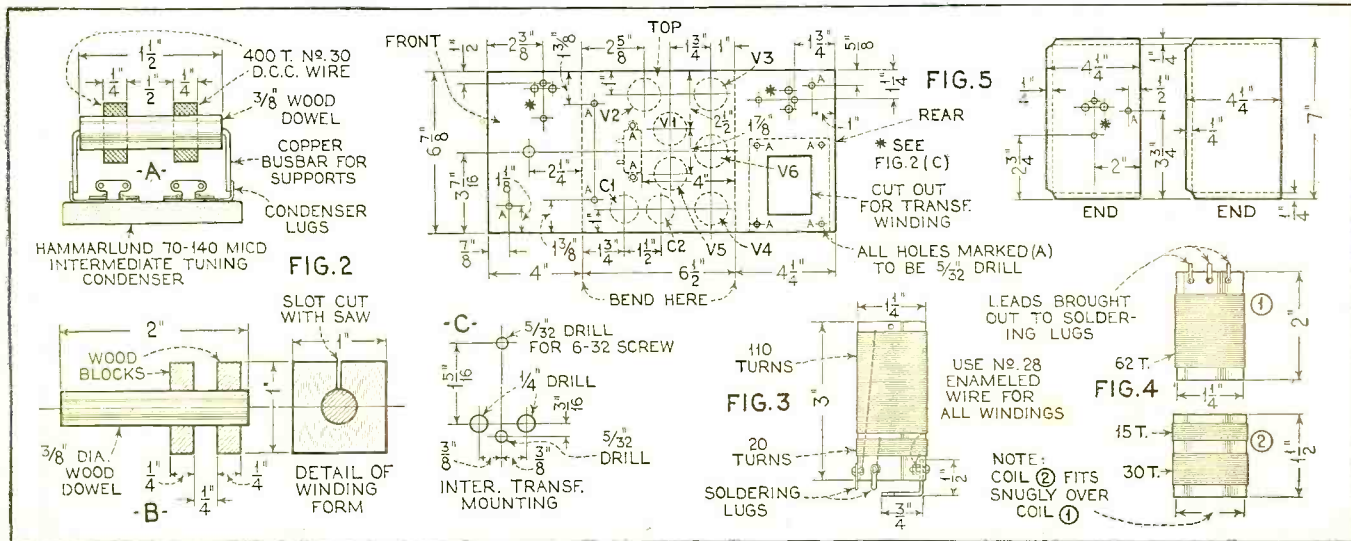

Equipment and Technique for

HOME RECORDING

Continuing his helpful and informative discussion of home recording, the author gives special attention this month to the recording process and particularly to microphones suitable for this work

LAST month we described the apparatus required for playing records. Recording is the reverse of playing. A loudspeaker can be used backwards as a microphone, feeding an amplifier, which drives the pick-up, which cuts the record. But, in general, better results are gained by using as a pick-up some device designed to convert sound waves into electric variations rather than the reverse.

There are many kinds of microphones on the market—carbon single-button, carbon double-button, condenser, dynamic. The standard condenser and dynamic microphones are far too expensive for the average amateur. However, the homemade condenser microphone described in the April and August issues of RADIO NEWS is extremely well suited to recording work, and the cost of its parts is surprisingly small. Double-button carbon microphones are intermediate in price and performance and can be obtained in a variety of models from any large radio house. The modest single-button carbon microphone, simplest and cheapest of all, is capable of satisfactory performance when well made, as evidenced by the fact that this type is part of some standard RCA-Victor home recording radio-phonographs.

Any good single-button microphone can be used. Even the transmitter of a new type telephone hand-set is fairly satisfactory. The writer uses an RCA-Victor hand microphone, shown in the illustrations, which draws a current of about 10 ma. from a 6-9 volt battery and has an average resistance of about 600 ohms, approximately matching the primary of a standard single-button microphone transformer such as the Thordarson or the Trutest. This microphone, being last year's RCA model, is offered in small lots at less than two dollars by some large radio mail-order houses. The Universal model X microphone, a relatively inexpensive double-button type, should also be satisfactory.

If the microphone is held in the hand close to the mouth, as in the RCA-Victor and other commercial systems, three stages

THE CONTROL EQUIPMENT

It is convenient to arrange the phonograph equipment in the top of the radio cabinet. This not only simplifies the recording process, but keeps the equipment out of sight when not in use



Part Two

of audio amplification, as provided by the writer's main amplifier, would be sufficient. But for reasons detailed later in this series of articles, it is preferable to suspend the microphone in front of, and not too near, the voices or instruments to be recorded. This decreased sound pick-up calls for more amplification, which is provided by an extra stage (or microphone amplifier) between the microphone and the main amplifier. With a double-button microphone or a condenser microphone, two such stages might be required.

The writer's microphone amplifier, shown in Figure 5 and one of the photographs, is simple in construction and was thrown together, board-mounted, in a few minutes. The microphone transformer is a Thordarson single-button type, its secondary being shunted by a 100,000-ohm resistor in the interests of stability and quality. The 200-ohm potentiometer acts both as an auxiliary volume control and as a microphone current control. All batteries are mounted on the board with the apparatus. In place of the UX-864 tube used by the writer, a type -30 would do very well, as the audio energy level in this stage is very small. The latter tube would, of course, require a small 3-volt A battery and a 16-ohm filament resistor.

From the microphone amplifier the voice currents enter the main amplifier through the input volume control, which is usually set somewhere below maximum to avoid feed-back resulting from too high gain. If radio music rather than local talent is being recorded, it enters the main amplifier at this point directly from the radio tuner.

Weighting the Pick-up

The phonograph pick-up, which also acts as a record cutter in recording, is plugged into the amplifier output. So that the needle may not jump out of its groove despite its rather strong vibrations, the pick-up is weighted down while recording with a yoke-shaped piece of metal weighing about two ounces. For recording, the output volume control is always set at maximum. When radio music is being recorded, it can be heard simultaneously on the loudspeaker; but when local sounds are registering, if the amplifier gain is adjusted for studio type microphone pick-up, the loudspeaker must be disconnected to avoid howling.

CIRCUIT OF "MIKE" AMPLIFIER

Figure 5. This is the circuit of the amplifier shown in the accompanying photographs

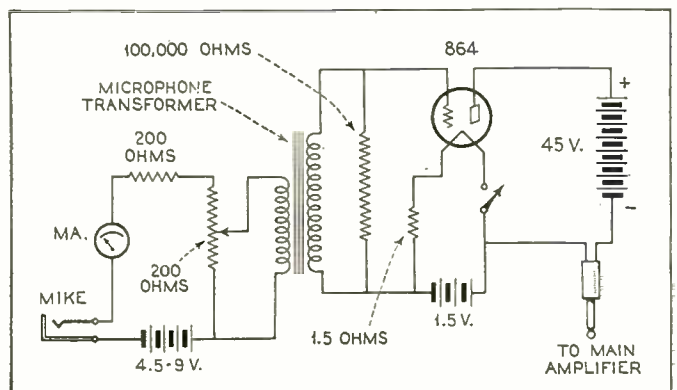

So much for the apparatus used in home recording. To record in the most elementary way it is only necessary to connect the microphone to the amplifier input and the pick-up to the amplifier output, start the weighted pick-up on the blank record and speak into the microphone. Making worthwhile records, however, demands more complicated and varied technique, which will be described in detail next month.

Microphone Technique

One of the curious things about home recording is microphone fright. From the behavior of some people, as they confront this enigmatic instrument for the simple purpose of making a record, one might think that it was connected to WEA and a national network. The fact that what the "performers" say and how they sing are going down in semi-permanent form, perhaps to posterity, seems to account for most of this trepidation. The result, however, adds to the general excitement and makes recording more fun, especially when it is being enjoyed by a sizable group of people.

As to the microphone itself, various instruments can be used in a variety of ways. The most common and elementary microphone technique is to hold a single-button carbon transmitter within one or two inches of the mouth. Most people incorrectly hold it directly in front of the mouth, where the blast of expelled air tends to rattle the diaphragm and unpleasantly accentuate high frequencies, and the moisture of the breath condenses on the diaphragm and other working parts, perhaps getting into the carbon granule chamber and causing the granules to pack solidly together. For at least two reasons, therefore, it is desirable to hold the microphone at the side of the mouth, as shown in Figure 6, if reasonably good quality is expected.

Experience in home recording, however, soon teaches that holding the microphone in the hand at all is clumsy and undesirable technique. Imagine, for example, a public speaker holding a microphone in one hand and his notes in the other, meanwhile trying to turn the pages of his manuscript with the thumb of his microphone hand! Or imagine the conductor of an orchestra rushing about with a hand microphone, trying to pick up the various instruments! If home recording is to find its widest and most enjoyable scope, the hand microphone simply will not do, for artistic reasons alone. And there are technical reasons also. In the hand, the microphone is subjected to vibration and jars which impair the quality of the record, and tipping the microphone this way or that during

THE MICROPHONE AMPLIFIER

This simple pre-amplifier provides reserve gain needed to eliminate the necessity for speaking directly into the microphone. With highly damped carbon microphones, or with condenser microphones, a two-stage pre-amplifier is desirable

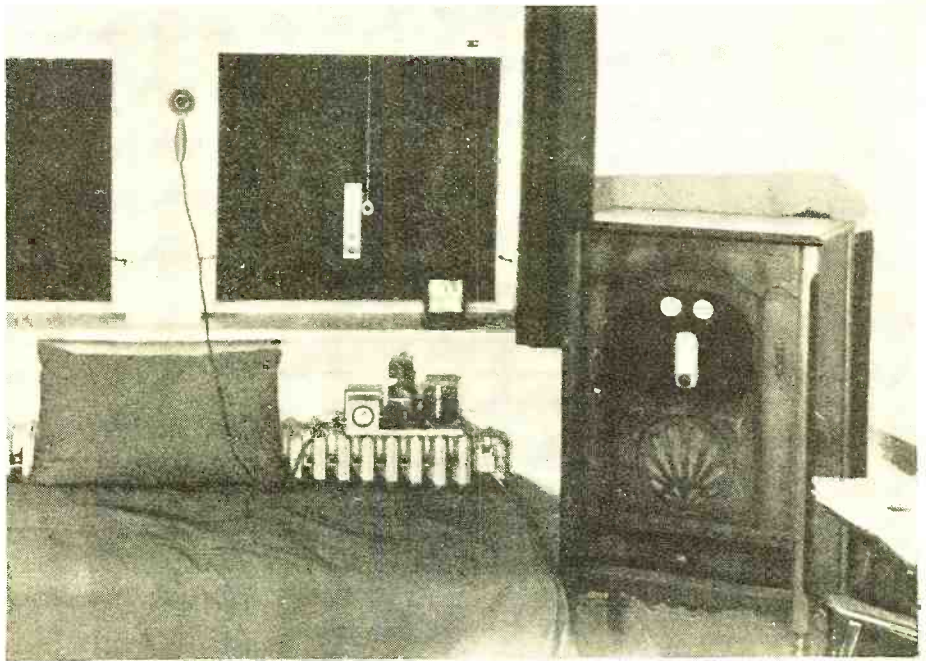
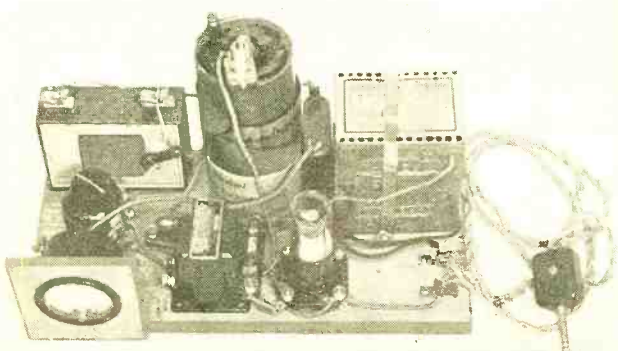

THE HOME RECORDING SET-UP

The complete equipment described is here shown as installed in a home

recording, almost impossible to avoid, varies its current and consequently its performance from moment to moment.

The alternative is to suspend the microphone in a fixed location and place the voices or instruments to be recorded where they will register best. This is the principle followed in all broadcasting studios, except that microphone stands are normally used. As two pieces of thread depending from the living room moulding, scarcely visible when they are hanging against the wall, are considerably cheaper and less obtrusive than a stand, they are used by the writer.

With the studio type of microphone (which may be simply a hand microphone suspended in the air), voices are more distant from the diaphragm, and the microphone output is less. As a result, more amplification is necessary. The writer finds it necessary to use, with the RCA-Victor microphone, one microphone stage in addition to the three-stage main amplifier, as described last month. Double-button carbon microphones or condenser microphones would require perhaps another additional stage, or four to five stages in all. In the writer's apparatus, not all the available gain is used in recording; it cannot all be used, in fact, without setting the circuit into high-frequency oscillation because of capacity feed-back. But there is sufficient gain to provide adequate recording energy when people speak or sing in ordinary tones of voice a foot or two from the microphone, (Continued on page 503)

MICROPHONE TECHNIQUE

Figure 6. Here are shown the correct and incorrect positions when using a hand microphone

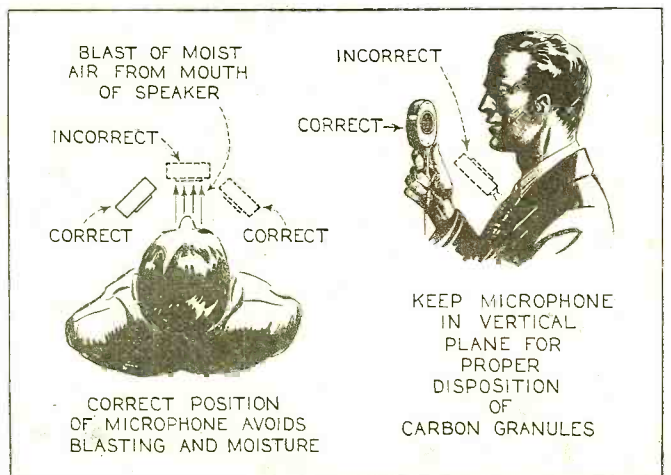

Some Important Hints In **Learning the Code**

It is important that the beginner setting up to learn the code start in the right way and the author points out several important things that should be learned in order to eliminate the possibility of starting with bad habits

OBVIOUSLY the ambition of every radio operator is the ability to copy three to six words behind the transmission, easily and accurately, with either pen or "mill." It is equally obvious that such a worthy ambition may be realized if one goes about it the right way.

The ability to copy behind is neither a trick nor a gift. No one ever became a skilled telegraph operator in a "hit-or-miss" way, any more than has any one ever become a skilled musician, surgeon, typist, tennis player, or in fact, anything that requires skill. I have heard much of "gifted" operators, but of the thousands whom I have trained and with whom I have come in personal contact, I have yet to encounter one who was actually "gifted," who became a skilled radio operator without a methodical system of training.

During the past twenty years I have been closely associated with and have trained champions and near-champions, including Theodore McElroy, whose official speed was 56½ words per minute for 5 minutes, who could easily copy plain language from 4 to 10 words behind at speeds so fast that other operators, standing by, were unable to read.

Have you ever witnessed a game of golf between professionals? Or a game of tennis. Have you had occasion to see, for instance, Bobby Jones at a tense moment of a game when all depended on a perfect putt, and nonchalantly approach his seemingly impossible task, chewing gum, while the great throngs of people crowded about him held their breath?

Before trying to define skill, let us be certain that we understand what it is not. Skill is not an accident. And skill is not a "gift." No human ever was born with skill to perform any task whatsoever. Whatever they have accomplished twenty years after their entrance to human society

is due to their training in these particular accomplishments.

Skill, then, is the result of properly directed training. Whether it is a typist whose flying fingers never strike the wrong key while her trained eye is following the copy, or a surgeon whose trained hand guides the sharp knife unerringly through a myriad of infinitesimal veins and nerves near the heart or brain, or a radio operator copying fast stuff 3 to 6 words behind, accurately and without that tense nervous and mental strain so common with the unskilled. If you learn to do a particular task correctly at the beginning, and continue doing it—over and over—without deviation, eventually you can accomplish it without having to "think" about it, consciously. You perform it semi-automatically. Your sub-conscious mind does it without the persistent direction of the conscious mind.

If you make a false start, pursue wrong methods, or undertake to teach yourself without the infallible guide of experience, you will become confused and uncertain and soon you will be wandering around in a circle like a traveler who has lost his way in a strange forest.

The chief characteristics of bad sending are lack of consistency in "timing," "spacing," "character-formation," and poor "speed."

Here is a very necessary thing to know about the dits and dahs of which Continental-Morse code consists. A dit is short—as short as you possibly can make it, whether sending 2 words per minute or 50 words per minute. It always is made the same way. There is no other way to make it. There are no slow and fast dits any more than there are long, short and medium dahs. A dah is exactly three times longer than a dit, regardless of speed.

So long as you believe there are variations in the length of

[*By Walter H. Candler**]

TO BECOME A FIRST-CLASS OPERATOR ONE MUST PRACTICE

Below are shown students receiving code signals through head sets transmitted by the instructor or by machine. Practice is important, but practice along the right lines is still more important



dahs and that dits may be made slow or fast, as the mood strikes, you will not make any progress toward becoming a skilled operator.

Examine the dit characters—e,i,s,h,5., and the dah characters—t,m,o,O. They will serve to illustrate our fundamental principle. When transmitting the word "his" at, say, 10 wpm., you make the four dits of the "h" as fast as you can, without cramping your arm or squeezing the key, uniformly, thus (...) then you allow the space of four dahs to intervene before making the "i" thus (..) and the space of four dahs before making the "s" thus (...).

When you start out to send 10 wpm speed, maintain that speed. Be consistent. If you allow the space of two dahs between two letters, three dahs between two more and four or five between two more, your speed is inconsistent and hard to copy.

Bear in mind always that your sending speed is increased and decreased by the length of your spaces, not by the speed of your individual signals. At 10 wpm., you will send the word "his" like this—"h—i—s." At 20 wpm., you will send it thus—"h-i-s." At 30 wpm., thus—"h-i-s." Beyond that speed you can soon learn to regulate your own spacing uniformly if you have patiently come up from the 5 to 8 wpm rate uniformly and developed your "timing sense" which is as necessary to code transmission as it is to music. You must practice until you can time your signals automatically—without having to "think" about it.

The first necessity is uniformity in making dits and dahs. There is only one length of dah (—) not (—) or (—). The joining of your dits or dahs in parts of a letter must be uniformly done or you make something else than what you intended. Example, the letter "v." If made thus (· · · —) it is "st." If thus A · · · —) it is "ia." If (· · · —) it is "eect." If thus (· · · —) it is "eu." So you will readily understand that "v." like all the signals of Continental code, can be transmitted but the one way, thus (· · · —).

Skill, then is the result of repetition. The man who has half a dozen or more different styles of penmanship never becomes a skilled penman, and so with any and everything, but most particularly does this apply to transmitting code.

For twenty years I have been preaching the one purposeful slogan to my students, and may I not suggest it to you? "If you are going to be a Radio operator, be a good one!"

You send and write with your hand. The motive power of your hand is supplied by the muscles of your fingers, wrist, forearm, upper arm, neck, shoulders and back. The controlling power of the muscles is supplied by the nerves, which are amenable to the brain. We learn to telegraph, hence it is an intellectual process. When we succeed, through certain procedure, in tying it up with our instincts, it becomes what we term "second nature," just as do most of our other acquirements. When, through a process of co-ordinative training, we can transmit and receive code without conscious thought as to how many dits make the letter "h" and how many dahs make the letter "o." and varying combinations for other signals, we become skilled proportionately. Lack of skill simply means we have not yet acquired the ability to co-ordinate our faculties. Trying, in a "hit-or-miss" manner to force untrained faculties to co-ordinate is like trying to force a savage chieftain to read, write and act the part of a gentleman. That is why so many ambitious code students become so nervous that in many instances, under pressure, they collapse.

The foregoing is for the purpose of conveying to you that poor concentration, lack of receiving, writing and sending ability, inability to copy a few words behind and make a clean, accurate copy, are effects, only. Trying to handle effects is

COMFORT FOR MUSCLES

In transmitting proper support for the arm muscles is a thing the experienced operator always insists on



futile. We must deal directly with fundamental causes. To overlook or ignore the functioning of the brain in telegraphing is a grave error. You telegraph with your brain. The hand that sends and writes is merely a servant of your mind—does as the mind directs.

When your hand, for any reason, cannot execute the commands of the brain, the brain frets and worries. Your hand is passive—it does not think, hence it does not worry. It can be trained to co-ordinate with the brain and carry out its commands, but until it has been so trained its capabilities are extremely limited.

Science teaches us that the muscular system is an automatic living mechanism of the most complicated and wonderful kind. To every muscle arteries carry their vital streams of food and oxygen. The muscle cells select their own diet, and the veins (not the arteries) take away the waste products. Anything that interferes with this process interferes with the co-ordinative principle of your body and throws it out of gear.

On every muscle there are the fine endings of some nerve which comes directly or indirectly from the spinal cord, and, at the proper moment, a discharge along the nerve causes the whole mass of cells or fibers in the muscle to contract simultaneously and lift the bone to which the muscle is attached. The nerve impulse is slight, merely like the match set to the great energy stored up like powder in the muscle.

Now apply this process to telegraphing—to sending, to receiving and writing with a pen or "mill". Anything that interferes with the

normal functioning of a muscle, especially in the arm of the telegrapher, throws the entire muscular and nervous system out of balance.

The transmitting key should be placed on the table far enough in from the edge so that your arm will be supported comfortably by the muscles in the forearm. The key should be held loosely, but not squeezed, in a comfortable position so that the muscles will be able to obey the commandments of the nervous system including the brain. Then start in practicing sending the code from a newspaper or from a book, keeping in mind the spacing requirements that I have previously set forth. But be sure that you make your spacings exactly correct so that your future practice will teach you to transmit the code correctly rather than incorrectly. Practice makes perfect but bad habits in sending the code are just as hard to get rid of as any bad habit.

"No one ever became a skilled telegraph operator in a 'hit-or-miss' way, any more than has any one ever become a skilled musician, surgeon, typist, tennis player, or in fact, anything that requires skill."

* The Candler System.

How to Build A RACK and PANEL PUBLIC ADDRESS SYSTEM

First of a series of articles giving full constructional details on all the essential units of equipment

By William C. Dorf

Part One



COMPLETE P.A. SYSTEM

Figure 1. A highly efficient rack and panel sound reproducing system with a Class "B" amplifier, phonograph equipment, control panel and a seven-tube super

DRILLING LAYOUT

Figure 5. Detailed dimensional drawing of the wooden baseboard for mounting the phonograph motor, turntable and pick-up

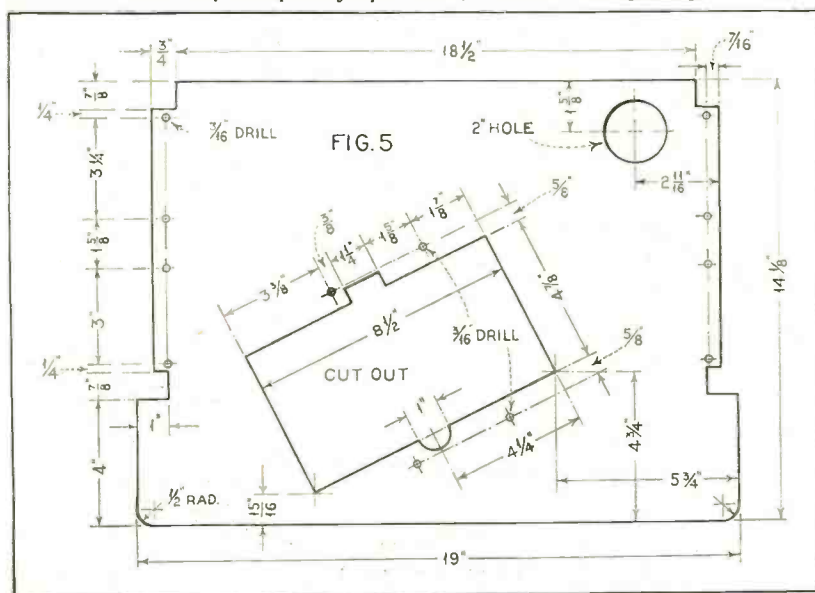

MANY an individual serviceman, operating his own business in a modest way, has felt the urgent need for a commercial type rack-and-panel public-address system—he could use it to rent out for public meetings, public-address work, community dances, etc., and thus gain a considerable revenue that he now has to miss. Also there are many experimenters who would like to own a unit of this type for their own personal use.

It is the purpose of this series of articles to give the constructor accurate details for building such a unit, containing a powerful amplifier of good tone quality, a superheterodyne tuning unit for bringing in air programs, a phonograph reproducing unit for playing records and a mixing panel that will allow of adjustment of the various units, switching, as well as provision for the use of a microphone. The series will contain individual diagrams for each section or panel and with full constructional details and operating data so that anyone having a fair knowledge of radio construction will be able to build the various units and assemble them into a complete sound system. The present article will be confined to the construction and assembly of the mounting rack, the installation of the amplifier and the construction of the mounting board for the phonograph motor, the turntable and the electrical pick-up.

The Power Amplifier

When the constructor has finished the initial assembly as described in this article, he will have a combination electric phonograph and power amplifier to which he can connect a suitable auditorium dynamic speaker or speakers, comprising a complete sound-distributing system that he can be justly proud of. The results of this work will spur him on so that he will look forward with a great deal of interest to the succeeding articles on the mixing panel and the radio tuner.

Reference to Figure 1 discloses the Class B amplifier which has already been described in detail in the article by Mr. Littman in the December, 1932, issue of RADIO NEWS. This amplifier is capable of delivering 20-26 watts of undistorted output power and uses six vacuum tubes, as follows: two type -56

tubes, three type -46 tubes and a type -83 rectifying tube. These are the tubes that make possible the enormous power output from this type of amplifier. The amplifier itself is equipped with an efficient volume and tone control and a plate-voltage delay switch. The input circuit of the amplifier can be connected direct to a radio tuner or a high impedance phonograph pick-up. A future article will describe a complete control panel for mixing and controlling several microphones and pick-up circuits.

The output circuit of the amplifier is designed for multi-speaker coupling and the power supply with the new -83 type rectifier is capable of furnishing field-excitation current for one to eight dynamic type speakers. The overall measurements of the amplifier are: 9 inches wide by 9 inches high by 17 3/4 inches long.

Phonograph Equipment

The Coast to Coast a.c.-operated phonograph motor and turntable called for in this rack and panel is a dual-speed combination designed to operate at 33 1/3 or at 78 revolutions per minute. The motor has a selection cam switch for the two speeds; it is governor-controlled and it is equipped with an automatic stop. The 12-inch turntable is covered in velveteen.

The phonograph pick-up is a General Electric feather-balance type and is rated at 200 ohms a.c. impedance. It is connected to a matching transformer the secondary of which has the proper matching value for the input circuit of the amplifier.

Besides the regular complement of tools, the builder should have an electric hand drill, a hack saw with new blades and an adjustable wrench and pliers to take the various sizes of bolts and nuts employed in the construction of the rack. The overall dimensions of the rack are: 45 inches high by 19 inches wide by 10 inches deep.

Figures 3 and 4 contain the measurements of the vertical supports and the front and side cross-pieces. When the different sections have been cut to size, spot and drill the holes as indicated. To minimize the labor in cutting and drilling, the rack supports are made from 1/8-inch thick soft steel angle stock. The necessary heavy base for the rack is made of 3/8-inch iron stock, and it may be advisable to procure the two pieces, cut to size. With a good grade of steel bit, the holes in the iron base may be drilled as indicated in the drawing shown in Figure 4. For a finished job, these holes should be countersunk for a No. 14-20 countersunk-head machine screw.

When the above work is accomplished, bolt the upright supports to the front cross-pieces (which measure 19 inches long) and also to the side cross-supports (measuring 10 inches long). The No. 14-20 square-head machine screw, 1 inch long, is used in this assembly. The next job is to prepare the base and top plates, from 3/8-inch sheet steel. The size of the base plate is 9 7/8 inches wide by 18 1/8 inches long, and it has a 1/2-inch flange, front and back, 16 3/4 inches long. The top plate measures 10 inches wide by 19 inches long.

Before installing the amplifier it will be necessary to prepare the side protection screens which are cut to size, as shown in the illustration Figure 2. These screens are fastened to the rack supports with No. 8-32 round-head machine screws 1/2 inch long. When the heavy iron base-plates have been bolted in place, the complete rack, including the protection screens, are to be given a coat of black paint.

The next job is to prepare the wooden baseboard, which measures 3/4 inch thick by 13 3/4 inches wide by 19 inches long, for mounting the phonograph motor and pick-up. All the holes and cut-outs for this baseboard are shown in Figure 5. For the correct installation of the phonograph motor and pick-up, careful attention should be paid to the dimensions shown in the drawing. Before mounting the equipment, the board is to be finished with a coat of black paint. The equipment (Continued on page 501)

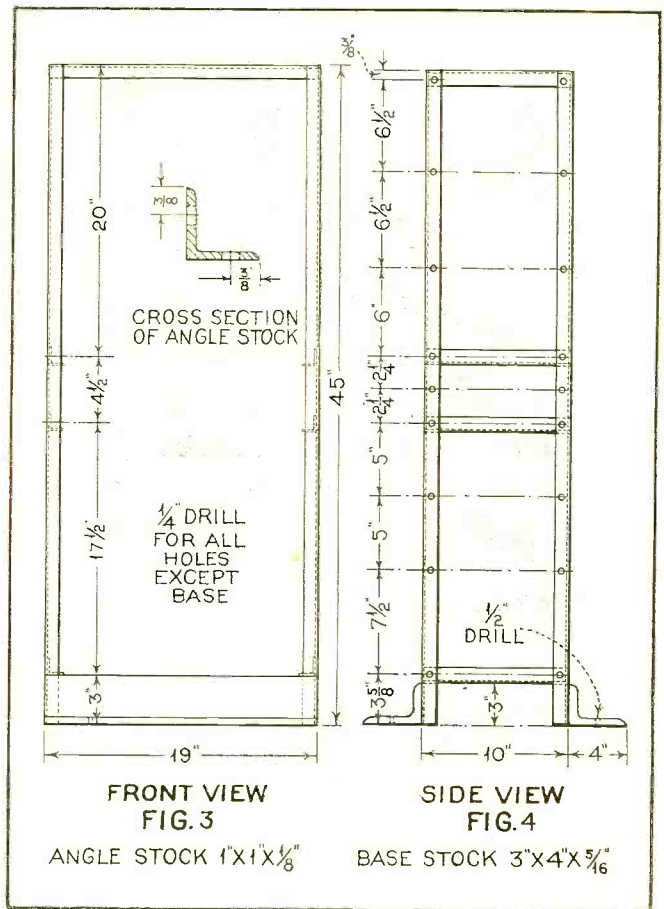

WORKING DRAWINGS OF RACK AND PANEL
 Figures 3 and 4. The dimensions and drilling specifications for the vertical supports, front and side cross pieces and base plates. Standard 1" by 1" angle stock is used for the rack assembly

INSTALLING PHONOGRAPH BASEBOARD

Figure 2. Showing the installation of the completely assembled Class "B" amplifier and phonograph motor baseboard. It further shows the side protection screens ready for fastening to sides of racks

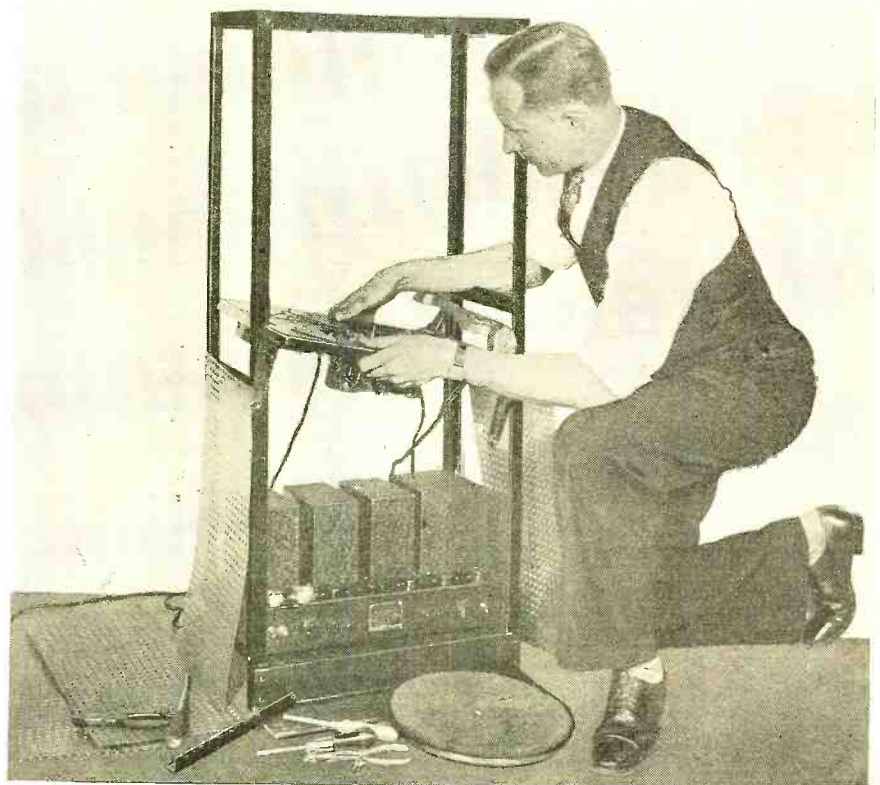

AN INTRODUCTION TO THE VARIOUS PHYSICAL Phenomena Underlying Radio

Radio apparatus of today, including television, uses practically all of the physical phenomena capable of being controlled by science. Devices which can be assembled within the space of a few cubic feet involve actions and energy transformations ranging over the whole domain of physics. Sound, heat, light, electro-static and electro-magnetic changes, as well as the dynamics of moving parts, are linked together in a chain of interactions which require study if we are to understand them

THE production of heat by friction is too common a phenomenon to arouse our curiosity and ordinarily we never think of it unless it becomes a source of trouble, as when a bearing sticks or a fuse burns out. In spite of its troublesome aspect, friction is obviously essential for without its restraining influence the mutual attraction of all matter would soon upset the world as we know it. On the other hand, we do not think of the electrical or radio phenomena which always accompanies friction, and mechanical action in general, as being of much practical importance.

For centuries friction was the only way of producing electricity, and considerable ingenuity was expended in the construction of friction machines. Volta's discovery (1800) of contact potential and chemical reactions producing electricity marked the beginning, and the discoveries of Faraday (1821) and Henry (1829) of the relations of mechanical action, magnetism and induction completed its downfall. At the present practically no attention is paid it. It is possible, though, that friction machines may come into vogue again; of course, not as they were, but in a redesigned and glorified form.

Electricity by Mechanical Action

In addition to the electric friction machine which furnished the first man-made source of electricity and served in the establishment of the groundwork of present theory (used by Hertz in his first experiments with radio waves), we have innumerable mechanical actions taking place in daily life which give rise to electricity. Of course, if all matter consists of electrical charges and nothing else, every action is electrical in nature. This is a useful way of picturing phenomena, for it gives the simplest explanations so far for what is otherwise mystifying in the behavior of matter. But putting aside for the moment any such all-inclusive point of view, we find electricity being lib-

By E. B. Kirk

Part Three

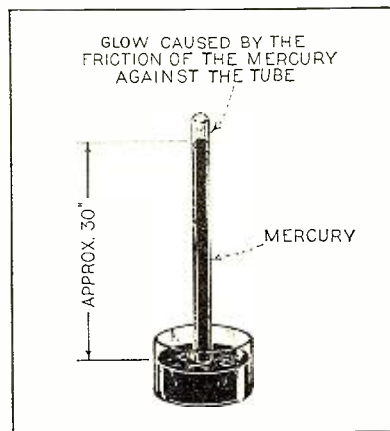

FIRST ELECTRIC LIGHT

In 1675 Picard noticed a glow above the mercury of a barometer tube he was carrying. In 1705 Hauksbee explained this action. The friction of the mercury, when agitated, against the glass produced sufficient electrical charge to cause the glow

erated in appreciable quantities around us in a number of ways. Probably most of us could not readily give more than a very vague explanation for these actions in terms of electron physics. Air currents, escaping steam, the exhaust of an automobile, or the passage of an aeroplane through the air (dry air, of course) can give rise to sufficient electrical charge to cause explosions if inflammable gases are about. Evaporization or the atomizing of liquids has been used for the production of static electricity, as in Armstrong's "hydro-electric" machine. A sand-blast striking a conducting object can set up small currents.

In many cases these charges have become a definite problem in industry. have been suspected of being the cause of mine explosions, igniting fire-damp or finely divided coal dust. High potential from rapidly moving belts have been thought to be the cause of insulation breakdowns in generators and motors. And in paper making, in printing (even on mimeograph machines), weaving and cleaning establishments, means have had to be provided for leading the charges to ground, either to prevent explosions or to allow the materials to be handled in the proper way.

Although static charges have on the whole been a nuisance outside of the laboratory, they have been put to some little use. The repulsion of similarly charged bodies has been employed for separating thin sheets of material (gold leaf, for example) or small light parts. Several attempts have been made to "make rain" by scattering highly charged sand from aeroplanes, but the results have not been definite. The use of high potential for smoke precipitation might be added, although this use is not strictly in the same category.

Simple contact of dissimilar substances, the same substances under certain circumstances, or the heating, bending or twisting of a crystal formation may cause appreciable currents to

Footnote 1. ENERGY AND WORK—For our later discussions it is essential to have certain fundamental concepts and quantitative relationships clearly in mind. To recall to mind a few important relations the following definitions and derivations are included. We know that energy is the capacity or the ability to do work, and that work is the result of a force acting through a distance (not at a distance). This is expressed—

$$\text{Work} = \text{force} \times \text{distance through which it acts} \quad (1)$$

Force, which in the final analysis comes down to electrical attraction or repulsion whether we are dealing with large masses or with atoms and electrons has never been explained. A force is measured, however, by the amount of acceleration imparted to a mass which it acts upon.

$$\text{Force} = \text{mass} \times \text{acceleration} \quad (2)$$

(for the definitions of mass and acceleration and for a complete elaboration of the meaning of energy, work and the units used for their measurement the reader is referred to a standard physics textbook).

POWER. We see that time does not enter into the equation (1) but that motion, a change of distance is the important thing. This means

that no matter the length of time required for the action to take place the work done is the same. Power, however, does involve time as it is defined as the rate of doing work.

$$\text{Power} = \frac{\text{work done}}{\text{time required}} \quad (3)$$

For example a weight may be carried to the top of a building either slowly or quickly. The work in the two cases will be the same and the energy used in raising the weight so many feet above the level of the ground goes into potential energy. It may be recovered by allowing the weight to fall back to the point from which it was raised; if the weight in its fall works levers or some kind of machine mechanical work can be obtained. If no energy was lost in friction 100% of the original work would be regained but since no machine can be 100% efficient, some energy is converted into heat. The power involved in the process depends on the speed of the change. If in one case an hour was required for the raising of the weight and in other a minute, 60 times the power would be required for the faster accomplishment.

flow. Contact potential is important in many ways and may even be the major factor in frictional electricity. It is often associated with chemical action in such an intimate manner as to mask its direct effect, but it is always a factor in batteries, electrolytic action, and in all circuits made up of a series of different conductors. We shall have reason to become better acquainted with these phenomena in later sections.

In our present discussion we shall see that friction, mechanical action in general, heat and electrical phenomena are all explainable in terms of the same basic ideas; that the atomic and electronic theories furnish us the best mechanisms—in terms of our present knowledge, at least—for explaining why these phenomena are inseparable.

The Conservation of Energy

The conservation of energy states that all forms of energy—electrical, chemical, thermal and the energy of radiation, light, heat rays, X-rays, radio waves—can be transformed and all measured in the common terms of mechanical work. The validity of this law, which we have restated, so far has not been shaken by any observation or experiment.

The law of the conservation of energy denies the possibility of perpetual motion, or the possibility of getting any work done without the expenditure of an equivalent of energy in some other form. We see all types of interchanges going on about us. Mechanical work is being transformed into heat, light, sound and electricity. Light can be changed into sound, heat, electricity and mechanical and chemical action. Chemical energy of reactions also appear in all other forms. But in every case no more energy is gotten out than is put in. Even the apparently spontaneous appearance of electrical charges requires work drawn from some source. We may rack our brains in trying to find a means or a machine for getting around this, as countless have done in the pursuit of perpetual motion, but in the final accounting what is present at the end was present at the beginning.

We shall have to assume that the reader is familiar with the fundamental ideas of elementary physics and therefore has an understanding of the terms, mass, force, energy, work, power, electrical potential and the units which are used for the measurement of these quantities.

We shall spend, however, some time on the kinetic aspect of heat, since we have under the sections of thermo and thermionic effects a number of electrical phenomena in which it is involved. Further, attempts have been made to apply the kinetic theory of gases to the free electrons in a body, and in a number of instances this method has yielded useful results, as, for example, in Richardson's basic work on the emission of electrons from hot bodies as embodied in all radio tube filaments. In many cases the electron gas theory falls down, but all theories do in one way or another. Its failures will be interesting, but primarily there is enough in its favor to make it worth considering.

Heat

A study of heat as a form of kinetic energy faces us with the problem of considering the motions and the energies of molecules, atoms and electrons. Thermodynamics lays

claim, in a broad sense, to the whole domain of energy and all of its forms of transformations, but in the ordinary and restricted sense it deals with heat energy and its interchanges. This branch of physics is inclined to deal with heat entirely by means of mathematical equations and there are some who say that energy becomes heat only when it ceases to be kinetic or radiant energy. This certainly takes away any possibility of forming a mental picture of what is taking place, and such an attitude is similar to that of the mathematical physicist who prefers to deal with the atom and the electron, purely as

a series of equations, refusing even the picture of interfering wave forms furnished by wave mechanics. For our purpose, however, it will be more useful to think in terms of the kinetic theory. That is, to consider the motions of the particles and the energies which they have by virtue of their motions, since such an approach fits in with the electron theory of electrical and radio phenomena.

Kinetic Theory

We have previously seen that, in matter, the atoms and the electrons are arranged so as to allow freedom of motion of these particles. The atoms of a gas have the greatest freedom. They are in constant motion in all directions and are colliding with one another with a frequency determined by the

constitution of the particular gas atoms, the temperature and the pressure, which control the number of atoms per unit of volume. In a gas which is left to itself so as not to gain or to lose energy (that is, insulated), the interchange of energy between the particles within the gas will come to a condition of equilibrium with a division of the total energy among the particles in proportion to their capacities for handling it. There are various ways in which the particles may move (degrees of freedom, as they are called). They may move in straight paths between collisions, rotate, or, if the atoms are joined as molecules, they may vibrate or the molecule as a whole may rotate. The heat of a gas is the total energy which it contains by virtue of the kinetic energy of the particles. Temperature, on the other hand, is an energy level and is not concerned with the total amount of energy present, but is determined by the average kinetic energy of the particles. This, it must be remembered, is a statistical affair and holds

only when there are a vast number of particles present, for in a body at high temperature there are always some particles which have low speeds and therefore low kinetic energies, and conversely, at low temperatures there are always some particles which have high speeds and proportional kinetic energy. Such extreme cases could be caused by a series of collisions of particular particles, all adding to or all subtracting from at any time the number of particles with a particular speed as a constant. A high temperature represents energy at a high level, a low temperature represents energy at a low level. A difference of temperature corresponds to a difference of energy level, and without doing work heat cannot be made to pass from one level to a higher one. (This is the second law of thermodynamics. The first law expresses the quantitative relation between heat and mechanical work, another wording for the conservation of energy.) This can be expressed as: (Continued on page 508)

Resuming This Series

THIS is the third instalment of the series, "Phenomena Underlying Radio," the last instalment of which appeared in June, 1932, issue. Mr. Kirk has been conducting a number of researches in this field collecting complete physical data on this subject that we believe will be an extremely helpful addition to the radio engineer's and experimenter's reference library. Although the material contained in this series does not always deal strictly with radio phenomena, the physical action as well as the physical laws expressed are important in radio engineering design and practice, although in many cases their true relation has been neglected.

KELVIN'S LIQUID JET GENERATOR

In this apparatus the energy of the falling drops of liquid is converted into a potential difference by acting against the attraction of an electric field. Friction, however, does not in this case play the leading rôle in generating electricity as it does in Armstrong's hydroelectric machine

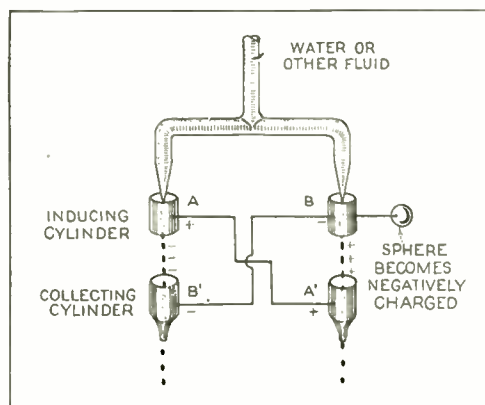

Handy Microphone Substitutes

Here are a few kinks that will help out the experimenter when there is no "mike" available

By Austin Lescarboursa

THAT impulse to try one's voice over the radio—an impulse that sooner or later must be obeyed—may be taken care of in the simplest and least expensive of ways. In fact, the average radio fan has odds and ends in his junk pile which will readily provide one or more suitable microphones if only given a chance.

It is not generally appreciated that, due to the high gain of modern power amplifiers and the amplifiers of usual broadcast receivers, radio earphones, loudspeakers and phonograph pick-ups may be pressed into service as microphones. To be sure, these devices do not possess the high sensitivity of the usual microphone, but for ordinary speech and especially for singing close up, they will render excellent service.

Headphones "Pinch-Hit" for the "Mike"

Beginning with the earphones, we have the simplest form of improvised microphone. One or two receivers may be employed. The main point is to speak right into the receiver or receivers, so as to secure the maximum vibration of the diaphragm. The old Baldwin 'phones provide the best results, since their mechanism is virtually the same as that of the electromagnetic loudspeaker. Many an old set of these headphones can be pressed into service as microphones.

The loudspeaker can also be used as a microphone. In fact, in the installation of centralized radio installations the electricians frequently make use of loudspeakers as an intercommunicating system. There is little choice between the single and the double-cone designs of electromagnetic speakers, the main thing being to direct the sound waves into the cone so as to obtain the maximum movement of the armature. A little experimenting will indicate the best angle for the sound waves to strike the diaphragm. In the case of the double-cone type, it

MAKING MUSIC

The modern version of the Hawaiian steel guitar by using a feedback effect to vary pitch



THE EARPHONE "MIKE"

Ordinary 'phones can be pressed into service as a microphone, especially for transmitting speech



THE CONE AS A MICROPHONE

With the double-cone type electromagnetic speaker best results may be had when talking into the interior of that device

appears that the loudest response is to be had when the voice is thrown into the rear opening, although a rather tubby response may result. The dynamic-type loudspeaker, provided its field coil is energized by the usual flow of current, is an excellent microphone and may be made quite sensitive. In fact, this design is the basis of studio microphones employed by some of our leading broadcasting stations today.

The electromagnetic pick-up is still another possibility as a microphone. By placing a folded piece of paper over the needle held in the pick-up, or again a paper cup, excellent response is secured. The folded paper or the cup serve to catch the sound waves and to drive the armature accordingly.

How to Connect the Substitutes

These improvised microphones may be connected with the usual power amplifier, provided, of course, the impedance values are suitably matched. In the case of the usual phonograph pick-up, it will be found to work as a microphone if connected with a radio set or power amplifier in the customary manner. In fact, this simple scheme may be employed to announce dance numbers, to simulate station announcements, and so on. The improvised microphone may also be connected with the usual radio set by means of a suitable coupling transformer in the first audio stage. Because there is such a wide variety of amplifiers and radio receivers, the exact connections are left to individual experimentation. In cases where a phonograph jack is provided, the loudspeaker or earphones will work through that jack connection.

A further bit of fun can be had by the acoustic heterodyning or feed-back effect obtained by means of two loudspeakers, one working as the microphone or pick-up and the other as the usual loudspeaker or output device. If the pick-up (Continued on page 511)

TALKING PICK-UPS

A paper drinking-cup fastened to the needle converts a pick-up into a microphone



The Pocket Diagnometer

INTRODUCING POINT-TO-POINT ANALYSIS

For general utility it would be hard to find a piece of equipment better adapted to the requirements of the serviceman than is the universal meter and set analyzer described in this and the previous article

By D. L. Van Leuven
Part Two

IN the November issue the completed universal meter and its associated controls were discussed. It was shown that the meter could be used as a multi-range d.c. voltmeter, a d.c. milliammeter, a multi-range a.c. voltmeter, an output meter or as an ohmmeter.

By the addition of a small unit containing a socket and two switches the whole can be made into a set tester. Today the old type of set tester finds its usefulness greatly curtailed. There are so many new tubes appearing that one must provide voltage tests from any socket contact to each and every other one. Further, voltage measurements alone are not sufficient. Receivers are becoming more and more complicated; with such complicated circuits resistance measurements are necessary to complete diagnosis of trouble.

The continuous development of new tubes necessitates a type of testing equipment which can easily be changed. Most of the analyzers now in use have to be submitted to major operations to be brought up to date.

The circuit selector unit here described is based on the *point-to-point* system which permits a resistance or voltage measurement between any two

points of a socket. It is believed that such a system will greatly facilitate the adaptation of the unit for tubes with more elements. This will become clear when one considers the circuit employed.

The diagram is shown in Figure 1. The terminals of the voltmeter or ohmmeter are connected to terminals T6 and T7. Tracing the circuit from T6, we find that it first goes to switch E (inside arm), and when this switch is set on any of the points marked P, SG, CG, Fil or Kat, the circuit is further traced to switch G. From here, terminal 6 can be connected to any one of the socket terminals. The other terminal, T7, can be traced to switch E and can also be connected to any one of the socket terminals. By manipulating these two switches, voltage measurement and resistance measurement from any point to any point can be made.

The remaining points of switch E are arranged for current measurement. The switch opens the circuit and inserts the milliammeter which is connected to terminals T5 and T6.

When a tube with more elements appears, all one has to do is to change the socket and to connect the additional element to one of the spare terminals on the switch G. If it is necessary to

When a tube with more elements appears, all one has to do is to change the socket and to connect the additional element to one of the spare terminals on the switch G. If it is necessary to

FIGURE 2. PANEL LAYOUT

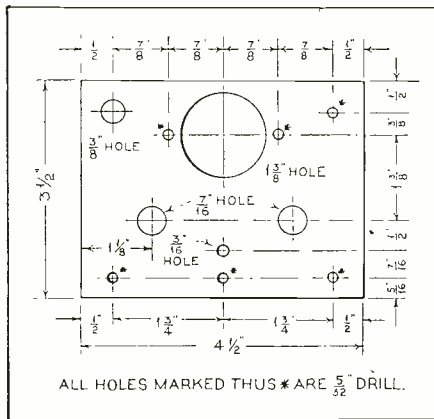

CLOSE-UP OF PANEL

Figure 3. This view shows the completed unit described in this article. The builder can purchase the panel, cut and engraved, if he so desires

UNDER SIDE OF PANEL

Figure 4. The layout and wiring are shown here; also the method of clamping the cable with a metal strap to avoid strain on the soldered connections

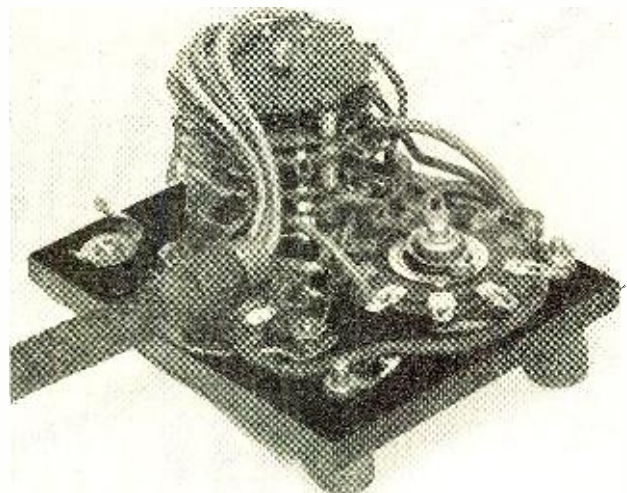
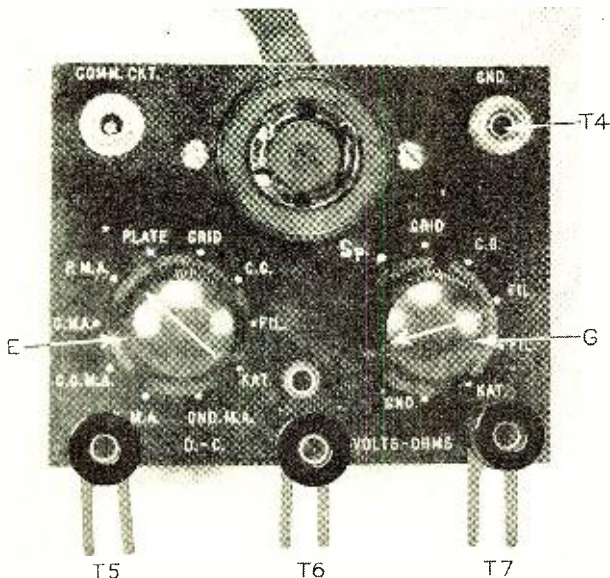

measure the current in the circuit of this new element, it can be routed to one of the spare terminals on switch E. One of these is now connected to ground; when the addition is to be made, the connection should be broken at the point indicated by the cross. The other connections are shown in dashed lines.

A spare pin-jack is also provided in the upper left-hand corner of the panel (not shown in diagram). This is for future use when an external connection might be needed.

Sometimes it is necessary to check the resistance between a socket terminal and some other point in the receiver. This is usually the ground or the filament of the rectifier tube. A special terminal on the unit is available and can be connected to the common point in question. Such an arrangement then permits the resistance measurement from this point to any socket terminal.

From the photograph it can be seen that the three terminals T5, T6 and T7 are spaced exactly like the three terminals of the unit described last month, and connections between the two can be made by means of three links. This combination is then manipulated just like a regular set analyzer.

Procure a panel according to the specifications in Figure 2. The two switches, the socket and the terminal should be mounted first. Care should be taken to mount the switches in the right position, agreeing with the markings on the panel.

Construction and Wiring

Secure the loose end of the cable with a small brass bracket to the socket-mounting screw. Insert your cable plug in a marked socket and determine the corresponding circuit of each wire by means of a continuity tester.

For convenience we shall designate the parts of switch E as follows: The section nearest the knob and panel will be known as section 3; in the diagram (Figure 1) it is shown as the inner circle. The next section is to be known as section 2 and the top arm and terminals as section 1. This switch (E) is further divided with respect to the type of circuits; one section, to be known as A, is intended for the voltage measurements, and the other section (B) has the circuit-breakers necessary for current measurement.

The easiest way of insuring correct wiring is by setting the switch E first to P.M.A. The terminals on the switch are now easily traced by following the arm. The plate connection from the cable should be run to the corresponding terminal of the circuit breaker (section B) of switch E, from there to the bottom section (3). Another piece of wire should be run from the other breaker terminal to the corresponding terminal of section 1, just below it, and from there it passes under the switch to the volt-

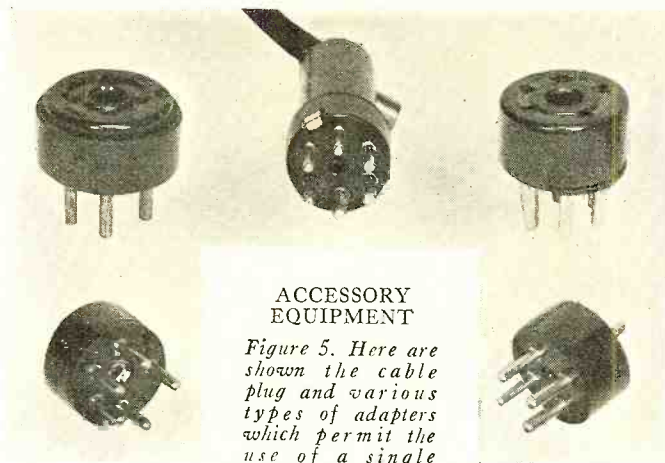

ACCESSORY EQUIPMENT

Figure 5. Here are shown the cable plug and various types of adapters which permit the use of a single socket in the instrument itself

age side of the switch, section 2. From here the wire should run to the corresponding terminal of the socket. Finally, a wire should connect the socket terminal to the corresponding point on switch G

The wires in the cable belonging to the control grid, screen grid, cathode or ground (spare) circuit should be run in a similar way. The filament wires and the suppressor grid should run to the corresponding points on the switch G and one of the filament wires to the remaining point of the voltage section of switch E.

There is an extra pin-jack, besides the one for the control grid, mounted on the panel to accommodate future tube possibilities.

The three moving arms of switch E, of sections 1, 2 and 3, lead to the terminals T5, T6 and T7.

The wiring on the switches has to be done very carefully. All lugs and wires have to be scraped or sandpapered, and a minimum of flux employed. The flux is apt to run over the contact points and cause trouble later on. Another precaution should be taken in applying the soldering iron to the wires for as short a time as possible, for too much heat may damage the switches, shunts, etc.

Operation

With both units fastened together by the links, the set is treated just like any other analyzer. Remove the tube and insert the analyzer plug in its socket. Set your voltmeter for 1000 volts d.c. Set switch E to plate and switch G to cathode. The plate voltage can now be read. If the tube is a filament type, switch G should be set to F. Similarly, one can measure the plate voltage with reference to the ground, or the grid, if desired.

After the reading of any particular voltage, the range switch should always be returned to the highest range.

When making resistance measurements, the set should be

turned off and the tubes taken out of the sockets. Set the switches of the meter unit to ohms and to the range desired. Manipulating switches E and G makes it possible to connect the ohmmeter across any two socket prongs. Moreover, a separate ground connection can be run from the extra pin-jack to the receiver chassis, which permits measurements with the ground as the common reference point. This extra pin-jack could, of course, be connected to any other point on the receiver chassis. This will enable the use of any other point as a reference point.

The rheostat of the ohmmeter is best adjusted by setting both switches E and G to the same point and varying the rheostat for full-scale deflection. A 1 megohm scale can be had by connecting a (Cont'd on page 504)

SCHEMATIC CIRCUIT DIAGRAM

Figure 1. When terminals T5, T6 and T7 are connected to terminals T1, T2 and T3 of the meter described last month, the combination becomes a complete analyzer unit

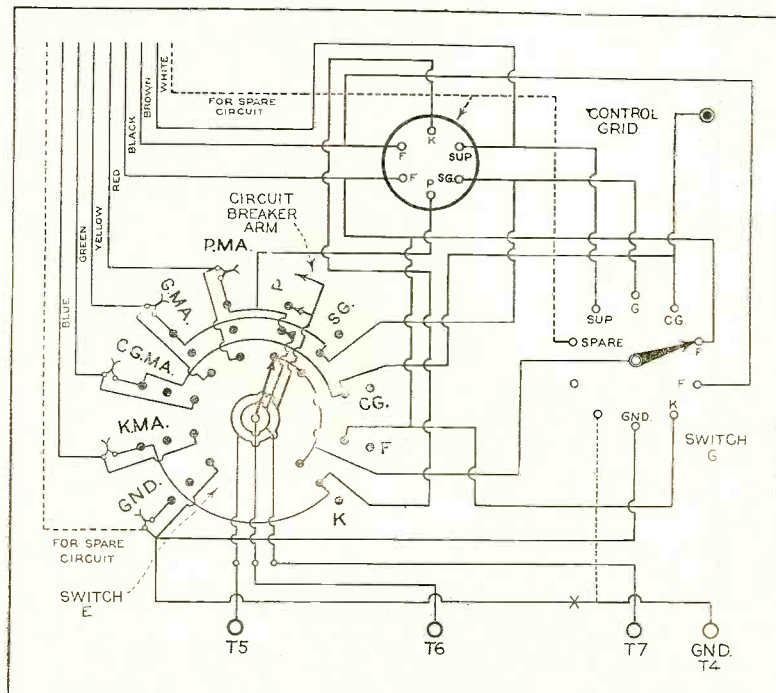

Radio Call Book Section

Conducted by S. Gordon Taylor and John M. Borst

Consolidated Short-Wave Station List

(Continued from the January issue)

By Wavelength, Frequency, Call, Location and Time

Time given is U. S. Eastern Standard Time

Wave-length Meters	Frequency Kc	Call Letters	Location	Service and Schedule	Wave-length Meters	Frequency Kc	Call Letters	Location	Service and Schedule
37.84	7,930	DOA	Doeberitz, Germany	Phone.; 1-3 P.M.	48.90	6,131	F3ICD	Saigon, French Indo-China	Broadcast: 6:30-10:30 A.M.
38.02	7,890	VPD	Suva, Fiji Islands	Phone.	48.90	6,131	HKA	Baranquilla, Colombia	Broadcast: 8-10 P.M. daily
38.02	7,890	PK2AG	Semarang, Java	Broadcast	48.94	6,130	VE9BA	Montreal, P. Q. Can.	Broadcast
38.07	7,880	J1AA	Tokio, Japan	Tests. with KEL	48.95	6,125	YV11BM	Maracaibo, Venezuela	Broadcast: 8-11 P.M.
38.31	7,830	PGA	Kootwijk, Holland	Phone. After 9 P.M.	49.01	6,125	YV11BM	Maracaibo, Venezuela	Broadcast: 8-11 P.M.
38.52	7,790	HBP	Geneva, Switzerland	Broadcast: 3-8 P. M.; irregular	49.02	6,120	W2NE	New York City	Broadcast
38.61	7,770	FTF	Paris, France	Phone.	49.02	6,120	FL	Eiffel Tower, Paris, France	Broadcast
38.89	7,715	KEE	Bolinas, Cal.	Tests; irregular	49.02	6,120	Toulouse, France	Broadcast: 2:30-4 P.M., Sun.
39.16	7,660	FTL	Paris, France	Phone.	49.10	6,110	VUB	Bombay, India	Broadcast
39.41	7,612	X26A	Nuevo Laredo, Tamps. Mex.	Broadcast: Thurs, 11-noon	49.10	6,110	VE9CG	Calgary, Alberta, Can.	Broadcast
39.42	7,610	KWX	Dixon, Cal.	Phone. to Hawaii; nights	49.18	6,100	W3XAL	Bound Brook, N. J.	Broadcast: Sat., 4 P.M. to mid-night
39.42	7,610	HKF	Bogota, Colombia	Broadcast: 7-11 P.M.	49.18	6,100	W9XF	Chicago, Ill.	Broadcast: daily 3:30 P.M.-1 A.M.
39.66	7,565	KWO	Dixon, Cal.	Phone. to Hawaii; nights	49.22	6,095	VE9GW	Bowmanville, Ont. Can.	Broadcast weekdays, 3-9 P.M., Sun. 11 A.M.-7 P.M.
39.82	7,530	Riobamba, Ecuador	Broadcast: Thurs. 9-11 P.M.	49.26	6,090	OXY	Copenhagen, Denmark	Broadcast
39.89	7,520	KDK.....	49.26	6,090	VE9BJ	St. John, N. B. Can.	Broadcast
40.00	7,500	Kauhuku, Hawaii	Phone. to KWO: 9 P.M.-2 A.M.	49.34	6,080	W9XAA	Chicago, Ill.	Broadcast: 6-7 A.M.-7-8 P.M.—9:30-10:15 P.M., 11-12 P.M., 10 P.M.-6 A.M. Sun. for ISWC
40.20	7,460	YR	France "Radio Touraine"	Broadcast: 10:30 P.M.-1:30 A.M. weekdays	49.40	6,073	ZTJ	Johannesburg, S. Africa	Broadcast weekdays, 3-9 P.M. P.M.
40.38	7,430	YR	Paris, T.S.F., France	Broadcast	49.41	6,072	UOR2	Vienna, Austria	Broadcast
40.48	7,410	Eberswalde, Germany	Broadcast: Thurs. 1-2 P.M.	49.42	6,070	VE9CS	Vancouver, B. C., Canada	Broadcast: Fri. before 1:30 A.M., Sun. 3:30-12 P.M.
40.50	7,405	HKI	Bogota, Colombia	Broadcast: 8-11 P.M. Tue., Thurs. Sat.	49.46	6,065	SASH	Motala, Sweden	Broadcast
40.54	7,400	WEM-.....	49.46	6,065	SAJ	Motala, Sweden	Broadcast: 6:30-7 A.M., 11 A.M., 4:30 P.M. weekdays
40.70	7,370	W2XBJ X26A	Rocky Point, N. Y. Nuevo Laredo, Mexico	Tests, irregular, evenings Broadcast: 9-10 A.M.-11 A.M.—noon, 1-2 P.M., 4-5 P.M., 7-8 P.M., tests after midnight; ISWC prog. 11 P.M. Wed.	49.50	6,060	CMCI	Marianao, Cuba	Broadcast
40.99	7,320	ZTJ	Johannesburg, S. Africa	Broadcast: 9:30 A.M.-2:30 P.M.	49.50	6,060	VQ7LO	Nairobi, Kenya, Africa	Broadcast: 11 A.M.-2:30 P.M. Fri. 11:30 A.M.-2:30 P.M. Mon., Wed., Thur.: 11:30 A.M.-3:30 P.M. Sat.: 11 A.M.-1:30 P.M. Sun.: 3-4 A.M. Tue., 8-9 A.M. Thu.
41.01	7,310	CM5RY	Matanzas, Cuba	Broadcast: 10:45-11:30 P.M. Sat	49.50	6,060	W3XAU	Byberry, Pa.	Relays WCAU Thu., Fri., 6:15 A.M. to midnight; other days 6:15 A.M.-3 P.M.
41.06	7,305	HSP2	Bangkok, Siam	Tests Mon. 8-11 A.M.	49.50	6,060	W8XAL	Cincinnati, O.	Relays WJW 5-9:30 A.M.-12:30-3:30 P.M., 6-12:30 P.M.
41.07	7,300	CM6DW	Cienfuegos, Cuba	Broadcast	49.50	6,060	ZL2ZX	Wellington, N. Z.	Broadcast: 2:15-6:15 A.M. Mon., Wed., Thurs., Sat.
41.47	7,230	DOA	Doeberitz, Germany	Broadcast	49.59	6,050	VE9CF	Halifax, N. S. Can.	Broadcast: Mon., Tues. 6-10 P.M. other days 6-7 P.M.
41.53	7,220	HB9XD	Zurich, Switzerland	Broadcast: 7 A.M. and 2 P.M. 1st and 3rd Sunday	49.60	6,005	VE9DR	Drummondville, Can.	Relays CTCT 7-12 P.M.
41.53	7,220	Budapest, Hungary	Broadcast: 2:30-3:10 A.M. Tu., Thurs. Sat.	49.67	6,040	Tanjong, Priok, Java	Broadcast
41.60	7,207	EAR58	Teneriffe, Canary Islands	Broadcast: 4:30-6 P.M. Sat., Sun.	49.67	6,040	PK3AN	Soerabaja, Java	Broadcast: 6-9 A.M.
41.67	7,195	V81AB	Singapore, British Malaya	Broadcast: Mon., Wed., Fri., 9:30-11 A.M.	49.75	6,030	VE9CA	Calgary, Alta, Can.	Broadcast
41.80	7,184	CM2MK	Havana, Cuba	Broadcast	49.75	6,030	VE9CA	Calgary, Alta., Can.	Broadcast
41.99	7,140	HKX	Bogota, Colombia	Broadcast	49.83	6,020	W9XF	Chicago, Ill.	Broadcast
42.00	7,139	HKT	Manizales, Colombia	Broadcast: 7-9 P.M., 11-12 P.M. Thu., Sat.	49.88	6,015	VE9CX	Wolfville, N. S., Can.	Broadcast
42.10	7,120	HKK	Cali, Colombia	Irregular	49.96	6,005	HRB	Tegucigalpa, Honduras	Broadcast
42.20	7,110	HKX	Medellin, Colombia	Broadcast: 8-10 P.M.	49.96	6,005	VE9DN	Montreal, Can.	Broadcast
42.50	7,059	Johannesburg, S. Africa	Broadcast: 5-7 P.M. Sun.	49.97	6,000	VY2BC	Caracas, Venezuela	Broadcast: 7:45-11 P.M. daily eve. Monday
42.50	7,055	V83AB	Johore Bahru, British Malaya	Broadcast: 12 midnight-2 A.M. Mon.	50.00	6,000	RW49	Moscow, U. S. S. R.	Broadcast: 4-5 P.M. Sun., Mon. Thurs., Sat., 5-6 A.M. Sun.
42.74	7,020	EAR125	Madrid, Spain	Broadcast: 6-7 P.M.	50.00	6,000	ZL3ZC	Christchurch, N. Z.	Broadcast
42.92	6,989	GBS	Rugby, England	Phone. to WND: 6 P.M. and 6 A.M.	50.00	6,000	Tananarive, Madagascar	Broadcast: 9:30-11:30 A.M. Tue., Wed., Thur., 1-3 P.M. Sat., Sun.
42.92	6,990	CT1AA	Lisbon, Portugal	Broadcast: Fri. 4-6 P.M.	50.00	6,000	Eiffel Tower, Paris, France	Broadcast: 6:30-6:45 A.M., 1:15-1:30 P.M., 5:15-5:45 P.M.
43.00	6,980	EAR110	Madrid, Spain	Broadcast: Tue., Sat. 5:30-7 P.M. Fri. 7-8 P.M.	50.00	6,000	PK2AF	Djokjakarta, Java	Broadcast: 6:40-9:40 A.M.
43.54	6,800	KEQ	Kauhuku, Hawaii	Phone. to Calif., nights	50.00	6,000	VY2BC	Caracas, Venezuela	Broadcast: 7:45-11 P.M. daily eve., Monday
43.60	6,875	F5MC	Casablanca, Morocco	Broadcast: Sun., Tues., Wed., Sat.	50.03	5,996	HKD	Barranquilla, Colombia	Broadcast: 7:45-10:39 P.M. daily, 8-10:30 P.M. Mon., Wed., 7:15, 8:30 P.M. Sun.
43.63	6,877	Rabat, Morocco	Broadcast	50.27	5,968	HVJ	Vatican City, Italy	Broadcast: 2-2:15 P.M. daily, 5-5:30 A.M. Sun.
43.73	6,860	Paris, France	Phone. 4-11 A.M., 3 P.M.	50.64	5,925	HKO	Medellin, Colombia	Broadcast: 8-10 P.M. Mon., Wed., Fri., 6-8 P.M. Tue., Thurs., Sat., Sun.
43.73	6,860	KEL	Bolinas, Cal.	Phone.	51.00	5,892	XDA	Mexico City, Mexico	Tests with XAM 10 A.M. to 8 P.M., irregular
43.74	6,840	VRV	Georgetown, British Guyana	Broadcast: 7:15-9:15 P.M., Wed. 5:45 P.M., Sun.	51.26	5,852.5	WOB	Lawrenceville, N. J.	Phone. to Bermuda, nights
44.00	6,818	XDA	Mexico City, Mexico	Broadcast	51.72	5,800	VKQ	Melbourne, Australia	Tests with XDA 10 A.M.-8 P.M. irregular
44.41	6,755	WOA	Lawrenceville, N. J.	Phone. to VRT and England nights	52.00	5,769	XAM	Merida, Yucatan	Broadcast: 7:30-10 P.M. daily except Monday
44.41	6,755	WND	Deal, N. J.	Phone.	52.00	5,769	HKN	Medellin, Colombia	Broadcast
44.41	6,755	WNB	Lawrenceville, N. J.	Phone. to Bermuda, nights	52.50	5,714	HCJB	Quito, Ecuador	Broadcast: 7:30-10 P.M. daily
44.51	6,740	WEJ-.....	52.50	5,710	VF9CL	Winnipeg, Can.	Broadcast: 1-3 P.M. Sat., Sun., 9:15-11:15 P.M. Mon., Tues. Wed., Thurs., Fri.
44.91	6,680	DGK	Nauen, Germany	Tests, irregular, evenings	54.40	5,515	SPV	Warsaw, Poland	Phone.
45.00	6,667	NFD	Mexico City, Mexico	Tests with WEJ near 9 P.M.	54.40	5,515	VPX	Penaga, Penang S. S.	Broadcast
45.00	6,666	FZI	Brazzaville, Congo	Broadcast	57.88	5,100	Bogota, Colombia	Broadcast
45.11	6,650	IAC	Coltana, Italy	Tests, irregular	58.00	5,172	OK1MPT	Prague, Czechoslovakia	Broadcast: 8:30-10:30 P.M.
45.25	6,625	HKC	Bogota, Colombia	Broadcast: 8:30-11 P.M., except Sunday	8.03	5,170	PMB	Soerabaja, Java	Broadcast
45.31	6,620	PRADO	Riobamba, Ecuador	Broadcast: 9-11 P.M., Thurs.					
45.38	6,611	RW72	Moscow, U. S. S. R.	Phone.; 2-4 P.M.					
45.98	6,525	RUI	Moscow, U. S. S. R.	Relays Moscow: 1-6 P.M.					
45.94	6,539	RUI	Moscow, U. S. S. R.	Broadcast					
46.27	6,480	TGW	Guatemala City, Guat	Broadcast: 9-11 P.M.					
46.67	6,430	VE9BY	London, Ont. Can.	Broadcast: 8:30-9:30 P.M., Wed., 7-7:55 A.M., Fri., 8-11 P.M. Sat.					
46.73	6,420	RGX	Minsk, U. S. S. R.	Broadcast, irregular					
46.94	6,425	W3XL	Bound Brook, N. J.	Relays WJZ, irregular					
47.09	6,380	HKS	Cali, Colombia	Broadcast: 8-10 P.M., Sun., Tu., Thurs.					
47.02	6,380	HCIDR	Quito, Ecuador	Broadcast: 8-11 P.M.					
48.00	6,250	CN8MC	Casablanca, Morocco	Relays Rabat: 3-4 P.M. Tu. Mon.					
48.62	6,170	HRB	Tegucigalpa, Honduras	Broadcast: 5-6 P.M., 9-12 P.M. Mon., Wed., Fri., Sat.					
48.74	6,150	VE9CL	Winnipeg, Man. Can.	Broadcast: 6-8 P.M.					
48.83	6,140	W8XK	Saxonburg, Pa.	Broadcast: 4-11 P.M. daily					

Wave-length Meters	Frequency Kc	Call Letters	Location	Service and Schedule	Wave-length Meters	Frequency Kc	Call Letters	Location	Service and Schedule
58.30	5,145	PMY	Bandong, Java	Phone. to Australia 11 A.M.	71.82	4,177	GFVV	S. S. Majestic	Phone.
59.40	5,050	VRT-ZFA	Hamilton, Bermuda	Phone. to WNB and GMBJ, nights	71.82	4,177	GLSQ	S. S. Olympic	Phone.
60.30	4,975	GBC	Rugby, England	Phone. to ships irregular	71.82	4,177	GMJQ	S. S. Belgenland	Phone.
60.30	4,975	W2XV	Long Island City, N. Y.	Broadcast; Wed., Fri. 8-10 P.M.	71.82	4,177	GDLJ	S. S. Homeric	Phone.
60.99	4,920	F8CG	Paris, France	Broadcast	71.82	4,177	WSBN	S. S. Leviathan	Phone.
62.57	4,795	VE9BY	London, Ont., Can.	Broadcast; Sun. 3-4 P.M.	71.82	4,177	GTSD	S. S. Monarch of Bermuda	Phone.
62.70	4,785	CGA	Drummondville, Can.	Phone. to ships irregular	71.82	4,177	GKPY	S. S. Minnetonka	Phone.
62.91	4,770	ZL2XX	Wellington, N. Z.	Phone.	72.87	4,116	GMBJ	S. S. Empress of Britain	Phone.
63.02	4,760	Paris, France	Phone.	72.87	4,116	WPN	Garden City, N. Y.	Phone.
63.12	4,752.5	WOO	Ocean Gate, N. J.	Phone. to ships, irregular	72.87	4,116	KTK	Mussel Rock, Cal.	Phone.
67.72	4,430	DOA	Doebritz, Germany	Broadcast; 6-7 P.M., 2-3 P.M. Mon., Wed., Fri.	74.72	4,015	NAA	Arlington, Va.	Time signal 9:55-10 P.M., 11:55 A.M.—noon
70.10	4,280	OHK2	Vienna, Austria	Broadcast Sun. first 15 minutes of hour from 1-7 P.M.	75.16	3,998	PK1AA	Batavia, Java	Broadcast
70.15	4,276	WIR	Rocky Point, N. Y.	Phone.	80.00	3,759	I2RO	Prato Smeraldo, Rome, Italy	Broadcast; 3-5 P.M.
70.21	4,273	RW15	Khabarovsk, Siberia	Broadcast; 3-9 A.M. daily	80.00	3,750	FSKR	Constantine, Tunis, Africa	Broadcast; Mon., Fri.
					82.88	3,620	DOA	Doebritz, Germany	Broadcast
					84.28	3,560	OZ7RL	Copenhagen, Denmark	Broadcast; Tu., Fri., after 6 P.M.
					95.00	3,156	PK2AG	Semarang, Java	Phone.
					99.09	3,030	Motala, Sweden	Phone. 11:30 A.M.—noon, 4-10 P.M.

Changes and Additions to the List of Broadcasting Stations in North America (Outside of the United States) as Shown in the December, 1932, Issue

CANADA

Call	Location	k.c.	watts
CFBO	St. John, N. B.	890	500
CFCA-CNR	Toronto, Ont.	1120	500
CFCO	Chatham, Ont.	1210	250
CFJC	Kamloops, B. C.	1120	100
CFLC	Prescott, Ont.	915	100
CHCH	Montreal, Que.	1200	100
CHCK	Charlottetown, P.E.I.	960	100
CHLS	Vancouver, B. C.	730	100
CHNC	Toronto, Ont.	840	5000
CHNS-CNRH	Halifax, N. S.	815	500
CJCA	Edmonton, Ont.	745	500
CJGC-CNRL	London, Ont.	595	5000
CJRM	Moose Jaw, Sask.	665	500
CKAC-CHYC-CNRM	Montreal, Que.	730	5000
CKCC	Red Deer, Alta.	840	1000
CNRD-CKCD-CHLS	Vancouver, B. C.	730	100
CKCR	Waterloo, Ont.	645	100
CJBC	Toronto, Ont.	840	5000
CKNC	Toronto, Ont.	960	500
CKOC-CKTB	Hamilton, Ont.	635	1000
CKTK	Windsor, Ont.	540	5000
CKPC	Preston, Ont.	880	100
CKWO	Windsor, Ont.	340	500
CKX	Brandon, Man.	549	500
CNRF	Halifax, N. S.	815	500
VAS	Glacc Bay	685	2000
VE-10-AB	Moose Jaw, Sask.	1200	25
VE-10-AT	Trail, B. C.	1135	125
VE-10-BP	Wingham, Ont.	1200	25
VOAS	St. Johns, N. F.	810	200
VO-SRA	St. Johns, N. F.	950	25
VOGT	Bell Island, N. F.	893	500
VOGY	St. Johns, N. F.	910	100
VONA	St. Johns, N. F.	950	500
YONF	St. Johns, N. F.	1115	500
VOWR	St. Johns, N. F.	675	500

CUBA

CMBI	Havana	1444	30
CMBL	Havana	1444	20
CMBN	Havana	1444	30
CMBS	Havana	790	150
CMBV	Havana	1140	150
CMBY	Havana	1230	350
CMCA	Havana	1135	150
CMCD	Havana	925	250
CMCJ	Havana	588	250
CMCQ	Havana	780	1000
CMCR	Havana	1325	150
CMCW	Havana	1285	150
CMCY	Havana	1365	1000
CMDB	Havana	1400	40
CMDD	Havana	588	150
CMGB	Matanzas	1205	30
CMGC	Matanzas	820	30
CMGF	Matanzas	987	50
CMHC	Tuinucu	790	250
CMHI	Santa Clara	1030	30
CMHJ	Cienfuegos	1125	40
CMJC	Camaguey	1382	150
CMJE	Camaguey	1175	30
CMJF	Camaguey	930	225
CMJG	Camaguey	1050	50
CMJH	Ciego de Avila	1017	15
CMJI	Ciego de Avila	1260	5
CMJL	Camaguey	960	50
CMQ	Havana	630	250
CMW	Matanzas	1205	30

MEXICO

XEFO	Mexico City	940	5000
------	-------------	-----	------

XEG	Mexico City	1070	250
XEJ	Ciudad Juarez, Chih.	1000	100
XEL	Saltillo, Coah.	1000	25
XER	Villa Acuna, Coah.	735	75000
XETQ	Mexico City	1230	100
XETR	Mexico City	610	2500
XETY	Mexico City	1300	2000
XEU	Vera Cruz, V. C.	1000	100
XFF	Chihuahua, Chih.	875	500
XFG	Mexico City	680	2000

Municipal Police Radio Stations in the United States

2506 kc.—115.32 meters	KGZE	San Antonio, Texas.
2470 kc.—121.4g meters.	KGOZ	Cedar Rapids, Iowa
	WPBY	Chattanooga, Tenn.
	KGPN	Davenport, Iowa
	KGZG	Des Moines, Iowa
	WPDZ	Fort Wayne, Ind.
	WPDY	Kokomo, Ind.
	WPEC	Memphis, Tenn.
	KGPI	Omaha, Neb.
	WPDY	Philadelphia, Pa.
	KGPW	Salt Lake City, Utah
	KGPD	San Francisco, Calif.
	KGPM	San Jose, Calif.
	KGPK	Sioux City, Iowa
	WRDQ	Toledo, Ohio
	WPEM	Woonsocket, R. I.
2458 kc.—122.0 meters	WPDO	Akron, Ohio
	WPDN	Auburn, N. Y.
	WPDV	Charlotte, N. C.
	WRDH	Cleveland, Ohio
	WPRR	Rochester, N. Y.
	WPEA	Syracuse, N. Y.
2450 kc.—122.45 meters	WPEF	Bronx, N. Y.
	WPEE	Brooklyn, N. Y.
	KGZF	Chanute, Kansas
	KGPO	Honolulu, Hawaii
	WPDK	Milwaukee, Wis.
	WPEG	New York, N. Y.
	KGPH	Oklahoma City, Okla.
	KGPO	Tulsa, Okla.
	KGZP	Wichita, Kansas
2442 kc.—122.85 meters	KGPK	Denver, Colo.
	WPDF	Flint, Mich.
	WPEB	Grand Rapids, Mich.
	WMDZ	Indianapolis, Ind.
	WPDL	Lansing, Mich.
	WPDE	Louisville, Ky.
	KGPP	Portland, Ore.
	WPDH	Richmond, Ind.
	WPES	Saginaw, Mich.
2430 kc.—123.45 meters	WPDY	Columbus, Ohio
	WPDY	Dayton, Ohio
	KGPB	Minneapolis, Minn.
	WPEK	New Orleans, La.
	WPDY	St. Paul, Minn.
	KGZD	San Diego, Calif.
2422 kc.—123.86 meters	KSW	Berkeley, Calif.
	WMIJ	Buffalo, N. Y.
	KGPE	Kansas City, Mo.
	KGZC	Topeka, Kansas
	KGPG	Vallejo, Calif.
	WPDW	Washington, D. C.
2414 kc.—124.27 meters	WPDJ	Passaic, N. J.
2400 kc.—125.00 meters	WPDY	Atlanta, Georgia
	KGPS	Bakersfield, Calif.
	WCK	Detroit, Mich.
	WPDY	Detroit, Mich.
	KGZA	Fresno, Calif.
	WRDR	Grosse Pointe Village, Mich.
	WAO	Highland Park, Mich.
	KGPA	Seattle, Wash.
	WPPA	Tulare, Calif.
1712 kc.—174.65 meters	WPED	Arlington, Mass.
	KGPI	Beaumont, Texas
	WPEJ	Brookline, Mass.
	WPDB	Chicago, Ill.
	WPDC	Chicago, Ill.
	WPDD	Chicago, Ill.
	WKUD	Cincinnati, Ohio
	KVP	Dallas, Texas

WPEI	East Providence, R. I.	
KGPR	Fort Worth, Texas	
KGZB	Houston, Texas	
WPET	Lexington, Ky.	
KGPL	Los Angeles, Calif.	
KGJY	Pasadena, Calif.	
WPDY	Pittsburgh, Penna.	
KGPC	St. Louis, Mo.	
WPEH	Somerville, Mass.	
WPPA	Newton, Mass.	
1570 kc.—191.08 meters	WPEQ	Baton Rouge, La.
	WPEC	Framingham, Mass.
	WPEL	Middleboro, Mass.
	WPEW	Northampton, Mass.

Television Stations in the U. S.

Call	Watts	Company and Location
1600-1700 kc.		
W1XAV	1000	Shortwave & Television Labs., Inc., Boston, Mass.
W2XR	1000	Radio Pictures, Inc., Long Island City.
2000-2100 kc.		
W9XK	100	Iowa State University, Iowa City, Ia.
W3XK	5000	Jenkins Laboratories, Wheaton, Md.
W2XCR	5000	Jenkins Television Corp., New York, N. Y.
W2XAP	250	Jenkins Television Corp., Portable.
W2XCD	5000	DeForest Radio Co., Passaic, N. J.
W9XAO	500	Western Television Research Co., Chicago, Ill.
W6XAH	1000	Pioneer Mercantile Co., Bakersfield, Calif.
W8XF	200	WJR, Goodwill Station, Pontiac, Mich.
2100-2200 kc.		
W9XAK	125	Kansas State College of Agri. & Applied Science, Manhattan, Kansas.
W3XAK	5000	National Broadcasting Co. Inc., Portable. Initial location Bound Brook, N. J.
W2XBS	5000	National Broadcasting Co., Inc., New York, N. Y.
W3XAD	2000	RCA Victor Company, Camden, N. J.
W8XAV	20000	Westinghouse Electric & Mfg. Co., E. Pittsburgh, Pa.
W6XS	1000	Don Lee, Inc., Nr. Gardena, Cal.
W9XAP	2500	National Broadcasting Co. Inc., Chicago, Ill.
2200-2300 kc.		
W9XAL	500	First National Television Corp., Kansas City, Mo.
W9XAA	500	Chicago Federation of Labor, Chicago, Ill.
W3XE	1500	Philadelphia Storage Battery Co., Philadelphia, Pa.
W9XG	1500	Purdue University, West Lafayette, Ind.
W2XAB	500	Atlantic Broadcasting Corp., New York, N. Y.
43,000-46,000 kc., 80,000 kc.	48,500-50,300 kc., and 60,000-80,000 kc.	
W10XG	500	DeForest Radio Corp., Portable
W9XD	500	The Journal Co., Milwaukee, Wis.
W3XAD	2000	RCA Victor Company, Inc., Camden, N. J.
W2XBT	750	National Broadcasting Co., Portable.
W1XG	200	Shortwave & Television Co., Portable.
W2XR	1000	Radio Pictures, Inc., Long Island City.
W2XF	5000	National Broadcasting Company, New York, N. Y.
W2XDS	2000	Jenkins Television Corp., Portable.
W6XAO	150	Don Lee, Inc., Los Angeles, Cal.
W3XC	1000	Jenkins Laboratories, Wheaton, Md.
W3XE	1500	Philadelphia Storage Battery Co., Philadelphia, Pa.
W8XL	200	WGAR Broadcasting Co. Cuyahoga Hts., Village, O.
W8XF	200	WJR, The Goodwill Station, Detroit, Mich.

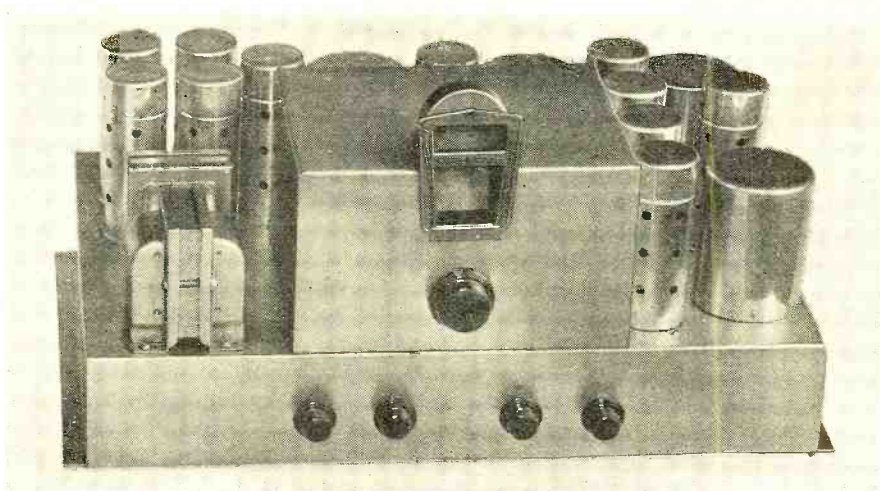

THE TUNER CHASSIS
 Finished in buffed brass and polished aluminum, the chassis presents a most attractive appearance. These sets are laboratory built, and individually checked, tested and measured before leaving the laboratory

New Fifteen Tube **ALL-WAVE DESIGN**

This new superheterodyne, covering the unusually wide range of 13 to 570 meters, includes numerous refinements such as a "squelch circuit" to eliminate between-station noise, novel tuning-meter action and provision for c.w. reception

NINETEEN THIRTY-TWO makes the writer's twentieth year in radio, during which time he has been just about everything from porter to president—amateur, set-builder, serviceman, dealer, jobber, manufacturer and engineer. During this period his principal interest has been engineering, and in consequence he has probably designed and manufactured more different radio receivers than any other living man. Recently the writer decided to devote himself to his life-long ideal, the precision engineering of the finest types of radio apparatus. The result of this decision is an all-wave superheterodyne into which has gone the experience of years of practical radio engineering—a receiver designed to satisfy the dream of the most exacting radio enthusiast. The "masterpiece" is a laboratory-built instrument throughout, hand built by the writer assisted by skilled engineers. Each set, instead of being "production checked" for performance, is individually measured on the most precise laboratory instruments for sensitivity, selectivity and fidelity, and is accompanied by its own individual performance curves, of which samples appear herewith. In addition, it is individually logged on foreign short-wave stations so that the eventual user will simply have to set the dial to a marked point to listen to Rome, London, Paris, Madrid, Australia, etc.

By McMurdo Silver*

The set uses only one accurately calibrated tuning dial to tune from 13 to 570 meters, and consists of three units—tuner, power amplifier and power supply, and giant super-efficient dynamic speaker. The tuner chassis is 19 inches long, 10½ inches deep and 8¾ inches high. The amplifier is the same length, 5 inches deep and 7½ inches high, while the giant speaker is 13¾ inches high, 8 inches deep, weighs 42 pounds and has a 12-inch cone and 2½-inch voice coil. All units are finished in buffed and lacquered brass, with the tube and i.f. transformer shields of the tuner of polished aluminum.

The receiver employs a total of fifteen tubes, which are seven -56's, one -57, three -58's, two -45's and two -80's.

The circuit is essentially a standard superheterodyne. It consists of a -58 tuned r.f. stage, -57 sensitive tuned first detector, -56 tuned oscillator, two -58 stages of dual-tuned 465 kc. intermediate-frequency amplification, a -56 used as a diode second or power detector, -56 a.v.c. tube, -56 squelch circuit or automatic noise suppressor, -56 audio beat oscillator for c.w. code reception, two -56's in a Class A Prime push-pull first audio stage, two -45's in a push-pull Class A Prime output stage, and two -80 rectifiers in parallel to supply the power for the set and speaker field.

Starting at the antenna, the r.f. stage is used to provide substantially no amplification, since this is not necessary, but

*President, McMurdo Silver, Inc.

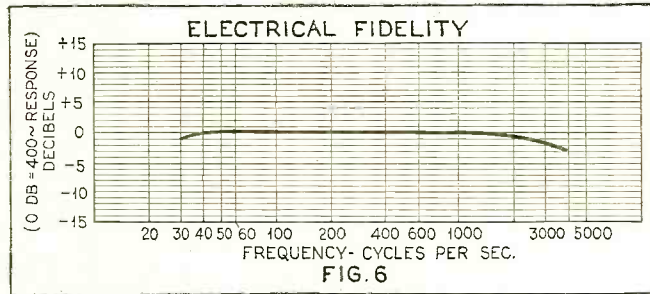
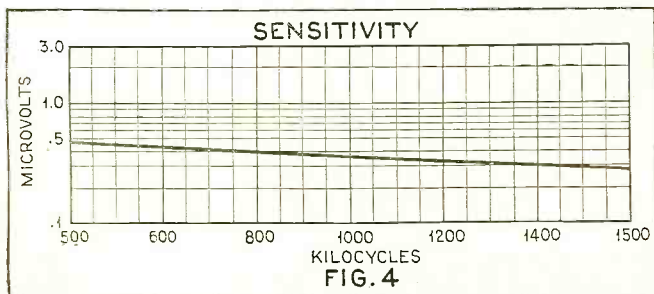

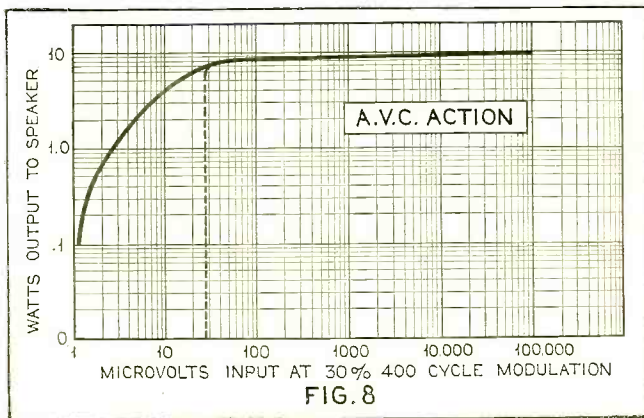
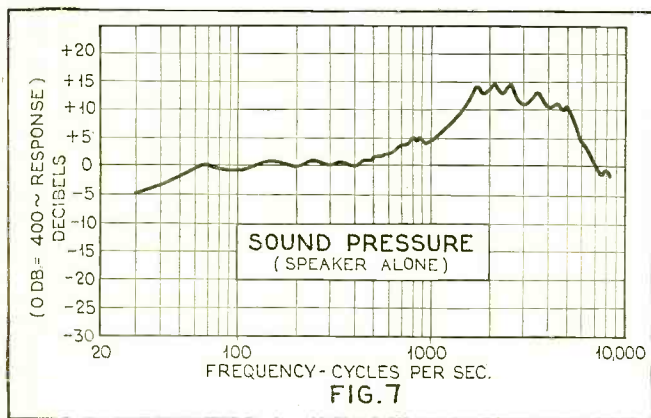

simply to provide insurance of adequate image-frequency selectivity and complete rejection of any possible code signals falling near the intermediate-amplification frequency of 465 kc.

The first detector is a -57 type tube, as this tube was found to be a much more sensitive first detector than the -58. The oscillator is conventional except for its uniform output at all frequencies and the simplicity of its band-switching system.

Wide Frequency Range

The set has four frequency or wavelength ranges, the first from 525 to 1500 kc., the second from 1500 to 4000 kc., the third from 3500 to 9300 kc., and the fourth and last from 8500 kc. to 22,600 kc. These ranges indicate adequate overlap throughout the wavelength range from 13 to 570 meters. Wave changing is done by a four-position switch which automatically changes coils in the detector and oscillator circuits and drops the r.f. stage, which is not necessary on the short waves and were it used in the customary aperiodic manner would only introduce unnecessary noise. The i.f. amplifier has three dual-tuned transformers, giving the receiver a total of nine tuned circuits. These transformers are Litz wound, and the general design is such as to provide unusual efficiency.

The second detector is a -56 type tube used as a diode—the most distortionless detector known today, it having no bends to introduce harmonic or wave-form distortion in its curve, which is the ideal straight line. Its output is more than ample to drive the audio amplifier to its full power output without overloading.

The a.v.c. tube is arranged to automatically bias the r.f. and i.f. control grids to hold the audio detector output at a practically constant level for all signals of 30 microvolts and over. It is notable for the sharp knee in its curve, indicating excellent control down into the range of weakest signals.

The squelch circuit tube is so actuated that for any signal of less than 30 microvolts it automatically biases the first audio tubes to cut off, and no noise or signal gets through—the set is silent as a tomb between stations. For signals above this level it automatically opens and allows full amplification. This cut-off level is carefully set to exclude only stations so low in strength as to be ordinarily unintelligible through the customarily prevailing residential noise level on short or broadcast

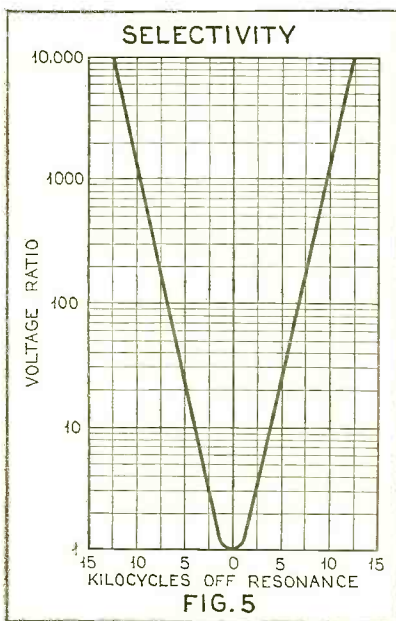

waves. Nevertheless, very weak signals can be fished for when desired, since the "squelch circuit" can be cut in or out at the throw of a switch.

Coupled to the second detector is a beat oscillator which can be adjusted to beat with the c.w. carrier either for code reception or to aid in tuning to weak phone stations. This beat-note oscillator is turned on or off by a switch.

10 Watts Output

The visual tuning meter is quite interesting and unusual. (*More will be told about this next month.*—THE EDITORS.)

The first audio stage uses a Class A Prime circuit and will in itself turn out quite considerable audio power, which can be used either for loudspeaker or headphone operation, if desired, by means of a jack on the rear of the tuner chassis. The second audio stage uses two -45's Class A Prime, operated to full capacity of 10 watts undistorted power output—and by "undistorted" is meant just that (see July, 1932, issue of RADIO NEWS for details). The power supply has one extra large power transformer, two filter chokes of unusual size and 28 microfarads of semi-self-healing dry electrolytic condensers. Two rectifiers are used, in parallel, to provide the same output as would an -83 mercury rectifier with none of its noisy performance and uncertain life characteristics.

The giant speaker deserves a story in itself. Designed by Peter L. Jensen in conjunction with the writer, it weighs over 40 pounds and has the essential requirements of an efficient unit—big field potential, field coil and voice coil. In terms of electric-to-sound conversion efficiency, it runs about 18 percent, or between three and four times as efficient as smaller speakers—as it should, since it is the biggest of the tribe. This means that, fed 10 watts by the push-pull -45 stage, it will turn out an apparent 30 to 40 watts as compared to all smaller dynamic units.

Obviously, this increased efficiency means increased effective sensitivity, so that were sensitivity measured from antenna to ear instead of antenna to speaker, the curve of Figure 4 could more properly be drawn at a level of 0.1 microvolt or less instead of .26 to .46 microvolt.

The controls of the set are five in number, being, left to right: volume control, manual tone control, single tuning knob and calibrated dial for all wavelengths, "squelch" cut-out switch and audio beat-note oscillator switch. (*Continued on page 509*)

THE POWER SUPPLY-AMPLIFIER UNIT

The Class A-prime power output stage and the power supply for the entire set are included in this separate unit. Two type -80 tubes are used in the rectifier to meet the current demands of the receiver and the field of the giant speaker

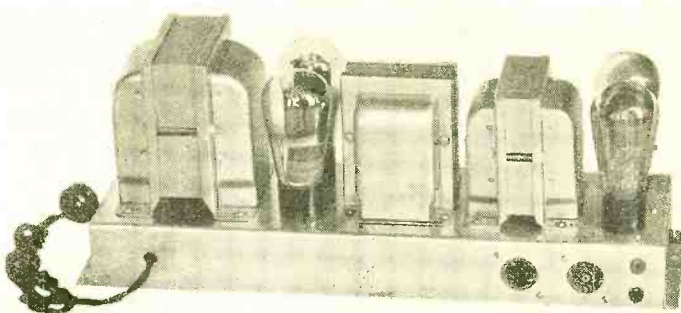

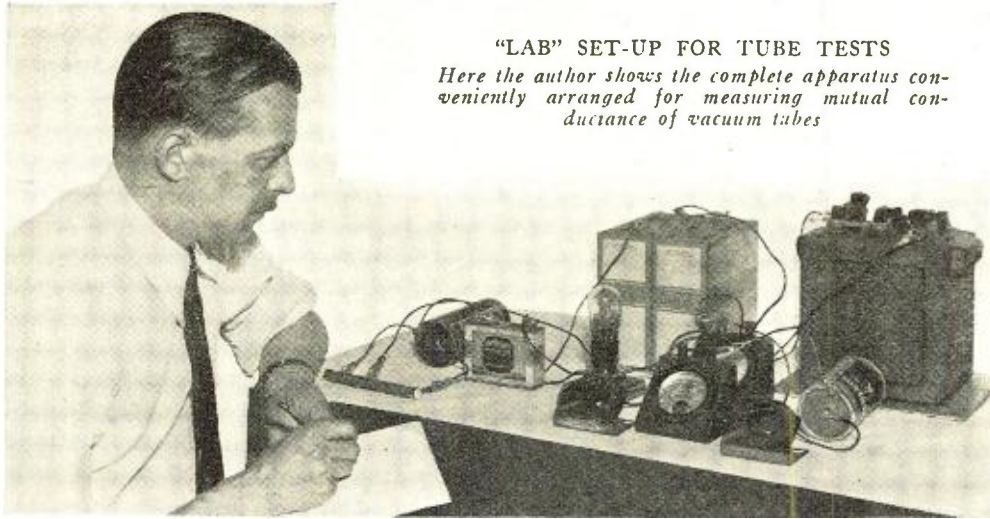

"LAB" SET-UP FOR TUBE TESTS
 Here the author shows the complete apparatus conveniently arranged for measuring mutual conductance of vacuum tubes

A SIMPLE METHOD FOR *Finding Mutual Conductance*

IN the measurement of "worth" of a vacuum tube, several factors must be taken into account, among them, electron emission, μ (amplification factor) and the internal resistance of the tube, from cathode to plate. Since the internal resistance of a tube is a function of the grid voltage, a change of grid voltage will cause a corresponding change in space current of the tube, and assuming a given voltage, the amount of change will be governed by the μ of the tube.

Hence we have one measurement that takes into account all the variable factors in electron tubes, mutual conductance, or, as it is sometimes called, transconductance. The symbol used to designate this characteristic is G_m , and the unit of measurement used is the mho. We may define mutual conductance as the ratio of change of space current to change of grid voltage, which is similar to saying if the space current of a tube changed one ampere for one volt of grid-voltage change, the G_m would equal one mho.

The mho is obviously too large a value to be used in every day practice, and the term actually employed is micromho, just as a farad is too large a measure of capacity, so we use the microfarad. A micromho is one-millionth of a mho. The G_m of modern radio tubes, with proper potentials applied to their electrodes, is almost always in the neighborhood of 1000 micromhos. This might be expressed as "one millimho," but the term is seldom or never used.

So it follows that if we wish to determine the actual worth of an electron tube, it is only necessary to have some convenient means of changing the grid voltage by a measured

amount, and an accurate method of observing the plate or space-current change. The above statement is made with the reservation that there is a small discrepancy between the "static mutual conductance" and the "dynamic mutual conductance." It is true that we will be measuring the static G_m when what we are actually interested in is the dynamic G_m , but the difference is small enough to be negligible in practical use. This is particularly true when, in all probability, the only reason we will ever have for taking this measurement is for matching tubes for push-pull circuits, where one measurement is as good as the other, or for determining whether a tube of a given type is "good, bad or indifferent." The simple set-up described here accomplishes that end perfectly.

By George E. Fleming*

As was noted, we have two factors to watch, the grid-voltage change and the plate-current change. Since 1-volt change of grid voltage is desirable, we may readily obtain that change by using a tapped resistor across a dry-cell so that changing the tap to which the grid is connected will cause just 1-volt difference in grid voltage. See Figure 1. Here R_1 is a 1500-ohm resistance accurately tapped at 1000 ohms. If one will carefully observe the potentials of the various batteries, he will note that as the switch is thrown from position 1 to position 2, 1-volt of positive bias is applied to the grid, making it 1-volt less negative than the normal C battery voltage. When this change occurs, a rise in plate current occurs simultaneously.

With only one meter in this circuit, we would have quite some difficulty in accurately observ- (Continued on page 496)

* Engineering Staff, Electrad, Inc.

CIRCUIT ARRANGEMENTS FOR THE TEST SET

Figure 1, at left, the basic circuit for the mutual conductance meter with switching arrangement for the bias at the left. Figure 2, center, the double meter arrangement which is substituted for the plate circuit in Figure 1. Figure 3, at right, then shows the final hoop-up employed with the alternate connections for screen grid or pentode type tubes

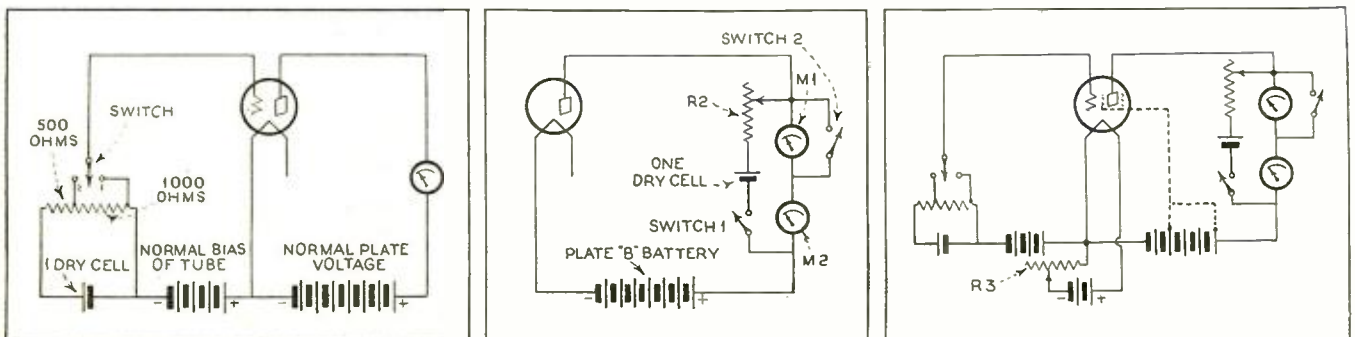

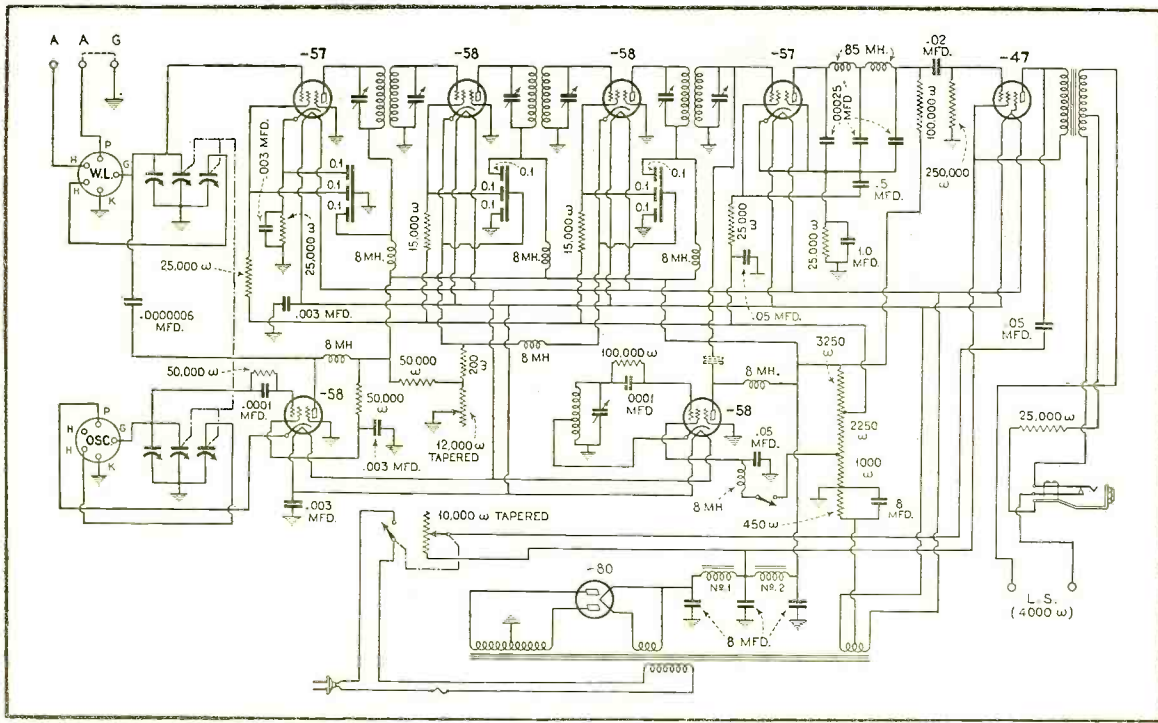

FIGURE 1. THE NEW SCHEMATIC CIRCUIT DIAGRAM

Improved 15-250 Meter Super FOR PROFESSIONAL AND "HAM" SERVICE

The universal antenna input system and new oscillator circuits are discussed, in continuing this description from last month. Reports on operating tests by typical "hams" are also quoted, showing effectiveness on amateur bands

LAST month some general information was given on the improvements recently incorporated in the Comet "Pro," including the use of the new -50 series tubes, a power output stage, more complete shielding and an interesting audio-frequency discrimination system. The present article continues this description and includes reports on actual results obtained with this receiver in operating tests.

One of the important changes in the improved model is found in the use of type -58 tubes for both the r.f. and heterodyne beat oscillators. Not just the fact that new tubes are used, but what is more important—the adoption of electron coupling. Electron-coupled oscillators have proven their outstanding utility in frequency-changing circuits of superheterodyne receivers. Their special advantage lies in their stability of oscillation at all of the usual short-wave and broadcast frequencies. Many other types of oscillators drop off materially at radio frequencies approaching 20,000 kc. (15 meters), but the oscillator circuit as employed in the receiver under discussion here functions uniformly and strongly throughout the entire range of this receiver.

Following out the circuits of the two oscillators as they appear in Figure 1, it will be noted that the oscillatory circuit (this can be most readily traced on the heterodyne beat oscillator circuit) consists of the tuned coil in the grid circuit. The cathode is connected to a tap on this coil, and the lower end of the coil is connected only to the suppressor grid of the -58 tube (this connection is made through ground), thus the control grid and suppressor grid are the two elements employed in maintaining oscillation. The plate of the tube plays no

Part Two

direct part in this process. Instead, it is used simply as a coupling element and is connected into the grid circuit of the detector tube through a tiny condenser. It is this use of an independent element for coupling purposes that aids in the unusual stability of this type of circuit.

The intermediate amplifier is the same as employed before, except that in the improved receiver tubes of the -58 type are used in the two i.f. stages. Double-tuned coupling circuits are employed, and this amplifier operates at 465 kc. as before. Sensitivity control is obtained through a 12,000-ohm tapered rheostat in the cathode circuits of these two tubes.

Another new feature of great importance is the provision for use of a transmission-line type of antenna lead-in. Such a lead-in is effective only when the two sides of the lead-in are balanced, and such a balance cannot be obtained if one end of the antenna coil is grounded. Heretofore all receivers have had one end of the antenna coil grounded,

with the result that, effectively to use a lead-in system of this type, it has been necessary to first perform a minor operation on the receiver itself, isolating this coil from the chassis and ground. In the "Pro" the two ends of the antenna coil terminate in two antenna connection posts, both insulated from the chassis and other parts of the circuit. A third post provides for grounding the chassis.

When a lead-in of the 2-wire type is employed, its two sides are connected to the antenna posts (A1 and A2, Figure 2). The "G" post can be grounded or not, as desired. To use an ordinary antenna system, the single-wire lead-in is connected to one A1 (indicated as A1 in Figure 2), the ground to the "G" post and a jumper is connected from "G" to A2 (Figure 2).

By
S. Gordon Taylor
and
William C. Dorf

In cases where a shielded lead-in system is used, including a special transformer between the lead-in and receiver, the output of this special transformer may be connected like a 2-wire transmission line, or like an ordinary antenna, depending on which method provides best results. Thus this receiver is adaptable to any type of antenna system, without alteration.

The band-spread tuning system is the same as that introduced in the original model of this receiver. Suffice it to say that this system provides unusual band-spreading advantages in any and all parts of the entire receiver range without requiring the use of special band-spread coils. Thus the receiver is equally well adapted to the amateur bands, aircraft and airport bands, short-wave broadcast ranges, police bands, etc. An example of the effectiveness of this system is found in the fact that it spreads the amateur 20-meter band over 45 degrees on the 100-degree dial, the 40-meter band over 76 degrees, the 80-meter band over 96 degrees and the 150-meter band over 100 degrees. A complete description of the band-spreading system was given in the August issue of RADIO NEWS, page 91.

Hum-free Reproduction

Before winding up the description, there is one more outstanding feature which deserves attention. This is the absolutely hum-free operation of the receiver, even when used on headphones. As will be noted in the circuit diagram, Figure 1, the power supply filter consists of two chokes and a total of 24 microfarads capacity. This provides complete filtration and is necessary inasmuch as in many types of service the "Pro" receiver is used primarily for headphone work and therefore must necessarily offer minimum hum. So successfully has this requirement been met that there is no perceptible hum in either headphone or loudspeaker operation.

In the description of the original "Pro" which appeared in RADIO NEWS a few months ago, it was featured as a short-wave receiver and was brought out by the Hammarlund Company as such. In the tests of the new model, however, a set of the broadcast-band coils designed for use with this receiver was obtained. Inasmuch as the receiver had never been featured for broadcast-band reception, it was naturally assumed that it would be much less effective on this range than on the short waves. It therefore came as a distinct surprise to find it every bit as effective on the broadcast band as on wavelengths between 15 and 200 meters. Proof of this was found in the fact that several West Coast stations were brought in with good volume when operating the receiver in New York City. KFI was so strong, indeed, that the antenna was disconnected and an 18-inch piece of wire substituted, with this station still audible. There certainly can be little wrong with the sensitivity of a receiver which will bring KFI in on a few inches of antenna. In selectivity it was found to rate just as high as in sensitivity, and the noise level was of a distinctly low order, even when not taking advantage of the noise-

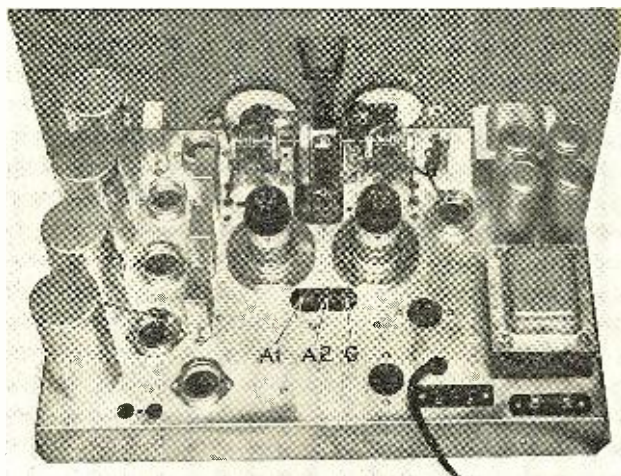

THE CHASSIS

Figure 2. The tubes and tube shields have been removed, also the shield cans inclosing the plug-in coils, to disclose details of the chassis design

cause, after all, when one gets down to a sensitivity of two microvolts or thereabouts, it is difficult to notice improvements resulting from increasing the sensitivity. Particularly is this true in locations, such as New York City, where the noise level is relatively high. In the locations in which these tests were made the noise level was considerably higher than two microvolts (on the short waves), so that at no time could the maximum sensitivity of the receiver be taken advantage of anyhow.

For these reasons the reports on operating tests as given in the September issue will be adequately representative of the most recent tests. Apparently everything receivable in any given location can be brought in on this receiver, right down to the local noise level—and many distant short-wave stations not ordinarily heard are brought in because of the low inherent noise level encountered in this set.

With the thought that amateurs would be interested in having reports on the operation of this receiver in their particular domain, RADIO NEWS made arrangements with three operators of amateur stations to try out the receiver and report their findings. The first two amateurs carried on their tests on a preliminary sample of the new model. Inasmuch as this sample was exactly duplicated when the new model was put on the market, these reports may be considered typical. The first of these tests and reports was made by Mr. Garo W. Ray, chief engineer of station WICC, Bridgeport, Connecticut. Mr. Ray, in addition to being well-known as a broadcast engineer, is also the owner and operator of an amateur station, WIANN, Bridgeport. In a letter dated August 6, 1932, he reports as follows:

UNDER THE CHASSIS

The i.f. tuning condenser adjustment screws are accessible for screw-driver adjustment. These screws are visible between the tube sockets and chokes, at the right

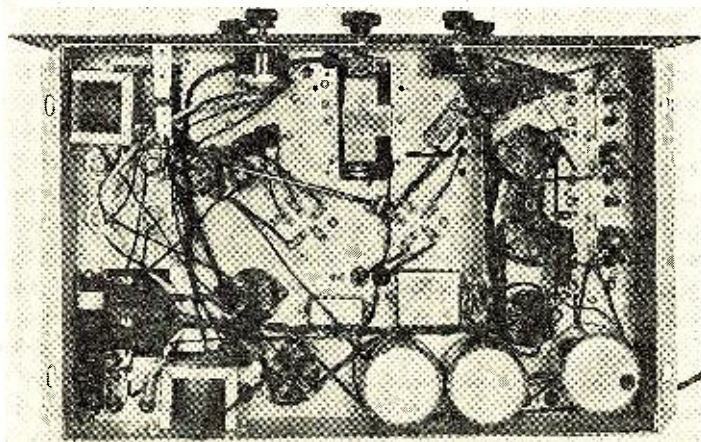

reducing characteristics of the variable tone control.

As was explained earlier, this receiver was primarily designed for airport use, and for that reason its short-wave characteristics are emphasized by the manufacturer. However, broadcast coils are available and are certainly a most valuable adjunct to amateur owners or to short-wave fans who occasionally like to swing up to the broadcast band for diversion.

Tests made with this receiver by members of the RADIO NEWS staff show it to be extremely effective. In the August issue the curves of sensitivity and selectivity were given on the original model. While both of these curves have been somewhat improved in the newer model, the differences are not particularly outstanding, be-

cause:

"I wish to thank you for the opportunity to try out the Hammarlund Comet 'Pro' at my amateur station. The performance of this receiver is excellent. The ease with which it brings in some of the real DX stations, both on 'phone and on c.w., is almost unbelievable.

"So that you may specifically know what I have heard in the few hours I managed to crowd into my already overburdened schedule, I am giving you a partial list of the farthest stations heard.

"On 'phone, the following amateurs were heard:
W6ANT, W6E00,
W6CLH, W90X, W9HCO,
(Continued on page 503)

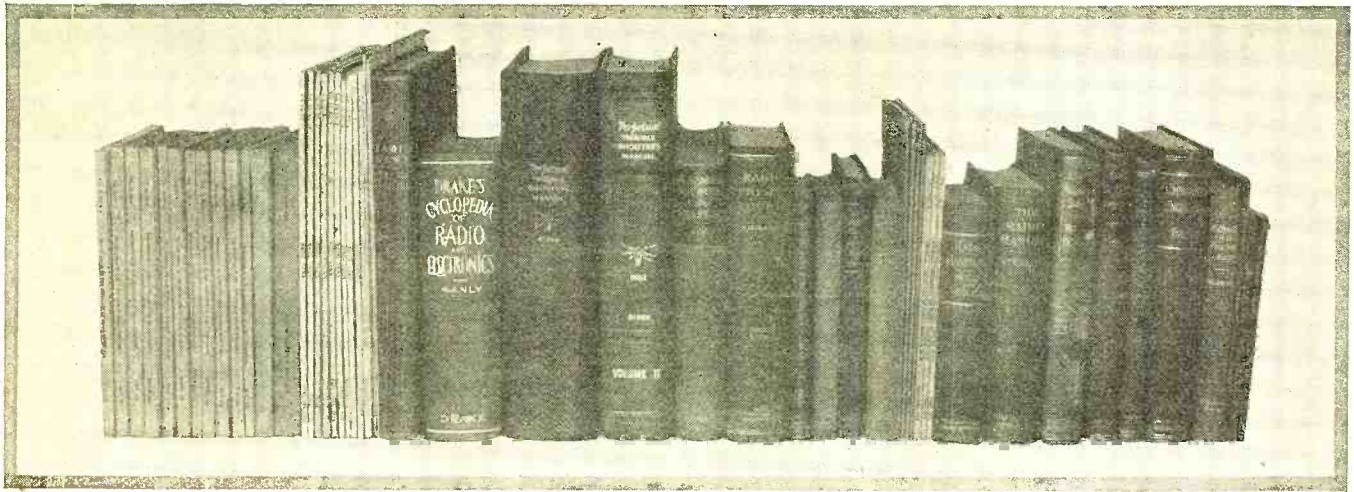

Technical Review

RADIO SCIENCE ABSTRACTS

Radio engineers, laboratory and research workers will find this department helpful in reviewing important current radio literature, books, Institute and Club proceedings and free technical booklets

Radio Operating Questions and Answers, by A. R. Nilson and J. L. Hornung; fourth edition. McGraw-Hill Book Co. 1932. The previous editions of this book have been so well known among radio operators that an introduction is hardly necessary. There have been many new types of operator's licenses available recently and so a new edition was necessary to treat these specialized subjects. This fourth edition contains questions and answers for students preparing for any license. The main body of the book has been devoted to the commercial operator on shipboard, on coast stations and on broadcast stations. Special sections follow which have been compiled for amateurs, another section for aircraft radio and police radio.

The book consists of questions with their answers, such as may occur at the license examination. These have been arranged in a logical sequence, making it almost a textbook on radio operation. However, the book is intended as a review and should be used by the student after he has already acquired a knowledge of the subject. The sections of the commercial operator have been modernized. One meets the tube transmitter in the first few pages. The spark and arc transmitter are also treated. Part IX, dealing with broadcast equipment, contains much information that is hard to get. There is, for instance, the question of pads; the answer indicates the way to calculate the resistors and there is a table of the shunt and series resistors required for a given attenuation, worked out for 200 and 500-ohm lines. Besides the technical questions, sections have been devoted to radio laws and regulations, the international abbreviations, meteorology, etc.

To show the manner wherein the questions have been answered, we quote a sample:

"Ques. 402. What are the restrictions upon methods of antenna coupling on amateur transmitters?" Ans. "Amateur stations must use circuits loosely coupled to the radiating system or devices that will produce equivalent effects to minimize keying impacts and harmonics. Conductive coupling to the antenna, even though loose, is not permitted,

Conducted by Joseph Calcaterra

but this restriction does not apply against the employment of transmission-line feeder systems to the Hertzian antennas."

Practical Mathematics for Home Study, by C. I. Palmer; second edition. McGraw-Hill Book Co. 1931. This book contains the essentials of arithmetic, geometry, algebra and trigonometry. Many readers, especially those who have difficulty with their mathematics, will appreciate this volume. It takes up arithmetic from the very beginning and explains every forward step, giving many examples and exercises. The exercises are taken from the problems presented to the author by his students. They often give much information on the practices of trades and professions. They deal with bookkeeping, mechanics, machine drawing, surveying, electricity, etc.—nearly everything under the sun.

When such an extensive territory is covered in one book, there must naturally be a selection of subjects, and the author has selected those that find most application among his students. Workers in the radio field often find their progress blocked because they cannot follow the more technical discussion of radio circuits for a lack of mathematical knowledge. To such people the careful study of this text would be a great help.

Review of Articles in the November, 1932, Issue of the Proceedings of the Institute of Radio Engineers

Crystal Control Applied to the Dynatron Oscillator, by K. A. MacKinnon. This paper describes the results of a two-year research which comprises the development of several crystal-controlled dynatron oscillators and the experimental determination of the frequency-stability curves of these circuits as well as of three Pierce crystal or magnetostriction oscillators. The new magneto-

striction-controlled oscillator circuit described has the advantages of simplicity and freedom from parasitic oscillations. The new crystal-controlled circuits have better "frequency-stability" characteristics.

A Precision Tuning-Fork Frequency Standard, by E. Norrman. This article describes the use of tuning forks as audio-frequency standards and outlines the procedures and results of a number of experiments to determine the materials, design and circuits required to provide tuning-fork standards of suitable stability.

Television Image Reception in an Airplane, by Harry R. Lubcke. This paper describes a rigorous test made on a self-synchronized, cathode-ray television system in which reception of the image was accomplished in an airplane traveling at 120 miles an hour. The results of the tests show what can be accomplished in spite of the most severe electrical and mechanical conditions.

Magneto-Static Oscillators for Generation of Ultra-Short Waves, by G. R. Kilgore. A complete description of a magneto-static electronic oscillator for generation of wavelengths of less than 50 centimeters is given, together with operating characteristics, with particular reference to obtaining maximum output and efficiency.

Radio Guidance, by J. Edward Miller. The system of radio guidance described makes use of two rotating radio beacons, transmitting simultaneously and on the same frequency. The special equipment for the output of the receiver used in the plane takes bearings from the two beacons and graphically triangulates the position of the plane on a map. The main advantage of this system is that it allows for an unlimited number of routes from a limited number of beacons.

Method for Measurement of High Resistance at High Frequency, by Paul B. Taylor. This paper gives a simple method of accurately measuring high resistances, especially

of the order of 1000 ohms to 1 megohm, at radio frequencies.

Review of Paper in the Sept.-Oct. Proceedings of the Radio Club of America

Voice Recordings for Industrial and Social Uses, by S. Young White. This paper contains information on the mechanical and electrical considerations in electrical recording, together with a discussion of the various uses to which such records and reproductions can be put in carrying on social and business contacts.

Review of Contemporary Periodical Literature

Ingenious Circuits in New Radio Receivers. Electronics, November, 1932. A description of some of the new circuits, such as quiet, automatic volume control, acoustically compensated volume control, resistance-coupled push-pull amplification, visual tuning aids, which are becoming increasingly popular in radio receivers.

Shrinkage Control in Radio-Tube Manufacture, by L. L. Shreiner. Electronics, November, 1932. An analysis of the importance of careful and continuous shrinkage control in keeping down the cost of production of radio tubes.

Photoelectric Control in the Printing Arts. Electronics, November, 1932. This article outlines the remarkable strides made recently in the application of photoelectric controls in the printing and associated industries. Their use has resulted in the production of engravings, setting of type, control of register, cutting operations, counting, matching of inks, and many other operations more satisfactorily and economically than they were done before.

Modulation and Distortion Measurements by Means of the Cathode-Ray Oscilloscope, by Samuel Bagno and Samuel S. Egert. Radio Engineering, November, 1932. This paper shows how a visual check-up on the operation of transmitters from the standpoint of percentage modulation and distortion can be made easily and with a fair degree of accuracy, by means of the cathode-oscilloscope.

Photoelectric Relays, by W. R. King. Radio Engineering, November, 1932. This article gives a brief description of the fundamental principle of operation of the photoelectric relay and points out the important considerations which must be taken into account in designing machinery and equipment for use with such relays.

Review of Technical Booklets Available

2. *1933 R.F. Parts Catalog*. An 8-page folder containing complete specifications on the entire line of Hammarlund variable and adjustable condensers, r.f. transformers, sockets, shields and miscellaneous parts for broadcast and short-wave receivers, complete short-wave receivers and transmitting variable condensers.

4. *A 15 to 200-Meter Comet "Pro" Superheterodyne*. A description of the outstanding features of the Hammarlund-Roberts high-frequency superheterodyne designed especially for commercial operators for laboratory, newspaper, police, airport and steamship use.

5. *A 1933 Volume-Control and Fixed and Variable-Resistor Catalog*. Contains new and revised specifications and list prices on the entire line of Electrad volume controls, voltage dividers, vitreous resistors, Truvolt

Turntable Design and Operation, by V. V. Gunsolley. Radio Engineering, November, 1932. This paper brings out some of the factors which affect the fidelity of reproduction of phonograph records, such as wobble, offset record centers, motor speed, vibration, needle position, tone-arm design, etc. Recommendations are made for correcting some of the faults that cause poor reproduction.

The Under \$20 Price Level. Radio Retailing, November, 1932. A frank discussion of the advantages and disadvantages of handling sets selling at very low prices.

Why Widening of the Broadcast Band Would Make Today's Sets Obsolete. Radio Retailing, November, 1932. A consideration of the effect, on existing receivers, of any possible widening or reallocation of the broadcast bands as a result of the proposals being considered at the Madrid International Conference.

High-Selectivity, Tone-Corrected Circuits. The Wireless Engineer and Experimental Wireless, November, 1932. This editorial is a summary of a report of the Radio Research Board of the Department of Scientific and Industrial Research (Great Britain), covering the questions, (1) Is the performance of

such circuits consistent with hitherto accepted theory and (2) What are the advantages and disadvantages of such receivers in relation to the practical problem of discriminating between wanted and unwanted wireless transmissions?

The Theory of Band-Pass Filters for Radio Receivers, by C. W. Oatley. The Wireless Engineer and Experimental Wireless, November, 1932. A theoretical and experimental treatment of the use of coupled circuits as a means of obtaining high selectivity without impairing fidelity of reproduction. The effects of faulty matching or ganging are discussed.

A New Type of Directive Aerial, by T. Walmsley. The Wireless Engineer and Experimental Wireless, November, 1932. This article describes a novel type of directive aerial which has no separate reflector curtain. In this type of aerial, radiating elements of various lengths are used in conjunction with each other. The non-radiating termination inserted at the end of the feeders in some types of receiving array for the purpose of matching the surge impedance of the array, is replaced by a radiating element, thus increasing the radiation efficiency of the system.

Methods of Investigating the Vibrational Frequencies of Conical Shells and Loud-speaker Diaphragms, by N. W. McLachlan. The Wireless Engineer and Experimental Wireless, November, 1932. A description of the bridge, axial air-pressure and impulse methods for determining the symmetrical vibration frequencies of conical shells in acoustic investigations.

Standard Time Throughout the World. Circular of the Bureau of Standards, No. 399. This is a revised edition of a previous bulletin, designed to give up-to-date data, maps and relative times with respect both of Greenwich Mean Time and Noon, Eastern Standard Time (United States) of the time throughout the world.

How to Get Copies of Articles Abstracted in This Department

The abstracts of articles featured in this department are intended to serve as a guide to the most interesting and instructive material appearing in contemporary magazines and reports. These publications may be consulted at most of the larger public libraries, or copies of the issues containing the articles may be ordered direct from the publishers.

RADIO NEWS cannot undertake to supply copies of these articles. They are NOT included in the RADIO NEWS Free Technical Booklet Service.

for their receivers. Also tells how to improve your customers' sets and make a profit besides.

8. *Trouble Shooting in A.C., D.C. and Battery Sets*. This is a free sample lesson of the National Radio Institute Course. It contains valuable information on how to overcome hum and noises of all kinds, fading signals, broad tuning, howls and oscillations, poor distance reception, distorted or muffled signals, etc. It is available only to RADIO NEWS readers who are over 16 years of age and who are residents of the United States and Canada.

9. *Catalog of Fixed, Metallized and Precision Resistors*. This 16-page catalog gives complete specifications of the International Resistance Co. line of metallized, wire-wound and precision wire-wound resistors, motor-radio suppressors, handy servicemen's kits, valuable technical data and list of free bulletins available on the building of servicemen's test equipment.

Free Technical Booklet Service

THROUGH the courtesy of a group of radio manufacturers, RADIO NEWS now offers to its readers this Technical Booklet Service. By means of this service readers of RADIO NEWS are able to obtain quickly and absolutely free of charge many interesting, instructive and valuable booklets and other literature which formerly required considerable time, effort and postage to collect.

To obtain any of the booklets listed in the following section, simply write the numbers of the books you desire on the coupon appearing at the end of this department. Be sure to print your name and address plainly in pencil, and mail the coupon to the Radio News Technical Booklet Service. Stocks of these booklets are kept on hand and will be sent promptly as long as the supply lasts. Do not send for any material in which you are not actually interested or of which you already have a copy, in order to avoid waste and needless postage expense.

To avoid delay, please use the coupon provided for the purpose and enclose it in an envelope by itself or paste it on the back of a penny postcard. The use of a letter asking for other information delays the filling of your request for booklets and catalogs. If possible, however, please enclose one of your blank business letterheads to establish your connection in the industry.

adjustable resistors, public-address equipment, amplifiers, replacement controls and resistors. It also includes various additions to the 1932 complete line.

6. *Line Voltage Control*. Complete characteristics and uses of a real voltage regulator and complete chart showing the correct Amperite recommended by set manufacturers

10. *Information on the Suppression of Motor-Radio Noises.* This interesting and useful folder of the International Resistance Co. gives complete information on how to overcome motor-generator, ignition coil, interrupter and spark-plug noises in automobile radio installation.

12. *Certified Tube Plan for Servicemen and Dealers.* A special plan of the Triad Mfg. Co. which makes it possible for servicemen and dealers, who maintain a service department to obtain certified Triad tubes direct from the factory, at discounts that enable them to make tube replacements at attractive profits, is described in this folder.

16. *RMA Standard Resistor Color-Code Chart.* A handy post-card size color-code chart designed by the Lynch Mfg. Co. to simplify the job of identifying the resistance values of resistors used in most of the standard receivers. It also contains a complete list of the most commonly used values of resistors with their corresponding color designations.

25. *Transposition Noise-Reducing Antenna System.* A detailed description, with technical data, on a new antenna system, perfected by the Lynch Mfg. Co., which is effective in eliminating the majority of electrical noise interference on both broadcast and short-wave reception. It is especially suited for application on all-wave receivers which sometimes give unsatisfactory results because of objectionable interference on the shorter waves. It can be applied to existing installations and offers a big field for profitable jobs for the serviceman. Its use on amateur receivers makes possible more and better QSO's.

29. *Practical Radio Engineering.* A 28-page book which gives a detailed description of the home-study course in practical radio engineering offered by the Capitol Engineering Institute. The course is divided into two main parts. The first part is intended to provide the student with the fundamental knowledge and training required to thoroughly understand the second part which is an advanced course in radio engineering. The course prepares the student for actual radio engineering work in the industry. Stress is laid on the practical application of radio principles.

30. *Shielded "Noise-Reducing" Antenna System for Broadcast Waves.* A complete description of a new Lynch low-cost, impedance-matching system of unique design—including impedance-matching transformers for the antenna and for each receiver—which now makes possible the use of a shielded transmission line of any length, without loss of signal strength. This system is designed for the elimination of "man-made" electrical interference on the broadcast frequencies, and because of its low cost, the ease with which it can be installed and the means it provides for using several receivers on a single aerial, it offers many opportunities for profitable jobs to dealers and servicemen.

31. *The Pam-O-Graph Recording Phonograph.* A descriptive folder on a high-quality instrument in three models, made by the Samson Electric Co., which makes possible faithful recording (on aluminum discs) and reproduction of lectures, musical renditions, radio programs, dictation, etc., for homes, schools, colleges, theatres, hotels, etc. It can also be used as a high-quality phonograph to reproduce standard disc records.

32. *Microphones and Accessories.* Complete descriptions and specifications of a wide variety of high-quality hand, desk and sus-
(Continued on page 505)

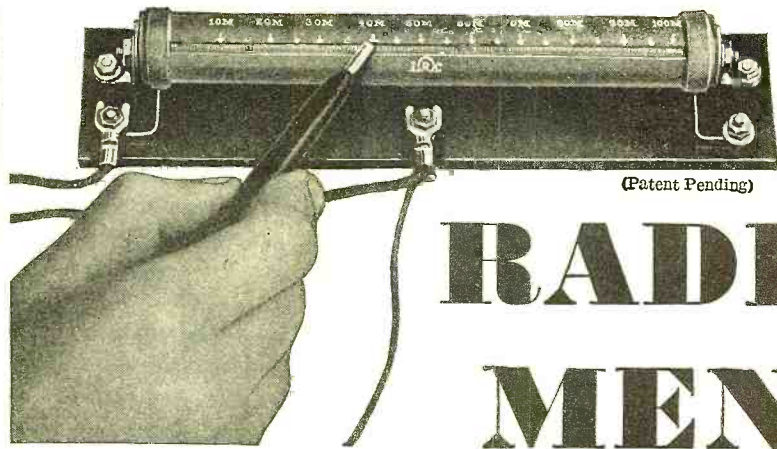

RADIO MEN!

Get This New

I.R.C. RESISTOR INDICATOR

An ingenious device which tells *instantly* the replacement value of any burned out or damaged resistor.

Small, compact, neatly boxed—slips into your vest pocket. Devised by I.R.C. engineers to be your constant companion on every repair job. Complete information on operation goes with it.

List price \$4. Sold for \$2.40
NET to Dealers and Servicemen (higher in Canada).

FREE with the

NEW I. R. C. COMBINATION KIT No. 6

This most valuable of all Kits is a permanent steel cabinet for your service bench. Contains 1/2 Watt, 1 Watt and 2 Watt Metallized Resistors and 5 Watt and 10 Watt Power Wire Wound Units—all in the most popular ranges used in all makes of radio sets. Has compartments also for screws, nuts, bolts and various service tools. An orderly method of keeping resistors and equipment. Stock card in lid acts as quick reminder for replenishing your stock. Once you see this Kit, you'll give it a hearty welcome and a permanent home on your bench.

List price of kit \$30. Sold for \$16.50 net to Dealers and Servicemen (higher in Canada) with free sales helps listed in coupon.

Contains *Metallized* and Power Wire Wound Resistors

Ask your Jobber or write us direct
INTERNATIONAL RESISTANCE CO.
Philadelphia, Pa., and Toronto, Ontario

INTERNATIONAL RESISTANCE CO., N
2006 Chestnut St., Philadelphia.

() I enclose (check) (money order) for \$16.50. Please see that I receive your Combination Kit, also your Resistor Indicator, Resistor Guide and Color Code Chart.

() I enclose (check) (money order) for \$2.40. Please forward your Resistor Indicator.

() Please send catalog, and complete data on your Service Helps.

Name.....

Address.....

City..... State.....

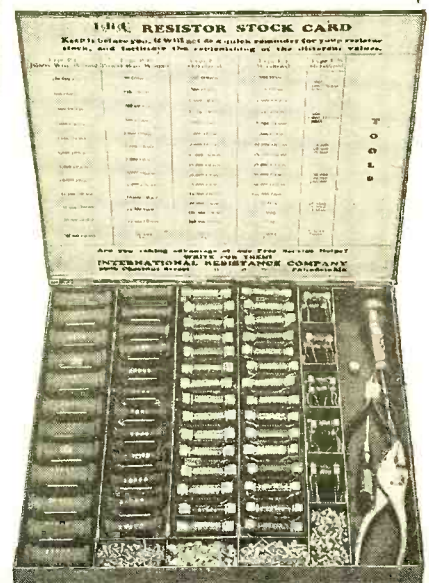



With the Experimenters

Home-made Capacity Relay, Repairing Open Circuits in Audio Transformers, Condenser Test Box, Handy Saw Tool, Unique Indoor Antenna

A Capacity Relay

The many fields opened for experimentation by the advent of the photo-electric cell, grid-glow tube and their kin are numerous and very interesting. As a source of added income to the modern radio man they offer unlimited opportunities.

The capacity relay herein pictured and described was constructed to do the work of a grid-glow tube (which could not be purchased in this city) at a cost considerably lower than that of the glow tube and its associated apparatus. Most of the material can be found around the shop of any radio addict, including the cake pan chassis.

The circuit, shown here, is primarily of the Theremin type, using three six volt tubes of the -37 type. Wired in series their filaments draw .3 ampere from the line. R3 drops the line voltage properly for the filaments. An 0-10 ma. meter is placed in the

Conducted by
S. Gordon Taylor

the rectifier circuit is the primary of any old audio transformer.

The oscillator coil is wound in two sections on a 1½ inch plug-in form. Each section consists of 30 turns and the sections are separated ¼ inch. The lower end of the bottom section goes to the plate and the top of the upper section connects to the grid. A small trimmer type of condenser (C2) is used to tune the oscillating circuit for maximum output. Any sensitive relay, such as a telephone relay, can be used, providing it will contact on not more than three milliamperes of current.

There is a decided advantage in this output over the grid-glow assembly in that it operates equally well from an alternating or direct current supply. When used in connection with window displays this is a decided advantage in some localities.

When the bias resistor is properly adjusted and the hand brought near the metal plate (A), attached by wire to the grid of the oscillator, the meter will show a reading of about 3 ma. Upon removal of the capacity the current drops to zero.

The metal plate may be glued to the inner side of a display window and a card displayed asking the passing shoppers to place their hand on the window opposite the plate. When they do so a motor starts, wheels turn, lights flash, etc. Any number of lively advertising stunts and displays can be arranged around this principle.

If the load to be handled is very large a second relay with heavy points will of course be used. However, the writer oper-

ated an eighth horse motor from the relay shown in the photo by connecting a 110 volt lamp across the contacts. When they open there is absolutely no spark and the light burns. This may be utilized also in the display. It is not advisable to use this spark elimination method with any other than an induction motor as when the relay is open the current used by the light passes through the motor. This might be injurious

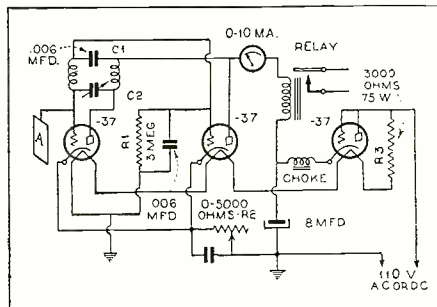

to the stationery armature of a direct current motor but does no harm to the field of an induction motor. When this system is used the light should be as large as possible without causing the motor to rotate. With this elimination of sparking a small delicate relay will handle a large load and not stick at the contacts or require setting for quite extensive periods, making it ideal for window displays and burglar alarms.

Connected to the window screens of a building the relay makes an ideal burglar alarm system, operating bells, lights, etc. If connected to many screens use a small condenser in series with the lead to the grid to cut the capacity.

E. L. DEETER,
St. Louis, Mo.

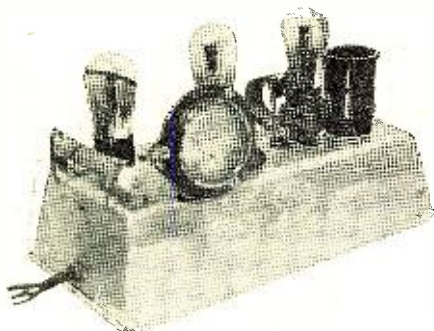

plate feed circuit to facilitate setting the relay for maximum output. The grid bias resistor, R2, is variable and is controlled from a knob on top of the chassis. The choke in

Repairing Open Circuits in Audio Transformers

The simple stunt described here is one I have used to close open primary circuits in audio transformers and open secondaries of power transformers a number of times and it has never failed me.

The only material required is a Ford, model "T" ignition coil and a transformer having a secondary voltage of 25 volts or thereabouts (I use a low voltage winding of an old transformer taken from a Philco wet type A and B eliminator), and a small push button switch.

The method of connecting these parts is shown in the accompanying diagram. The high potential output of the Ford coil is brought out at the terminals A and B. These are the terminals to which the open coil of the transformer under repair is to be connected. When everything is in readiness, the circuit is closed by means of a switch. Do not keep this switch closed for more than half a minute at a time or the coil contacts will overheat. The usual precautions should be taken in handling this equipment because of the high voltage developed in the secondary circuit of the Ford coil.

After a half minute, release the switch and test the winding for continuity. If still open, give it another half minute treatment and repeat this process until the test shows

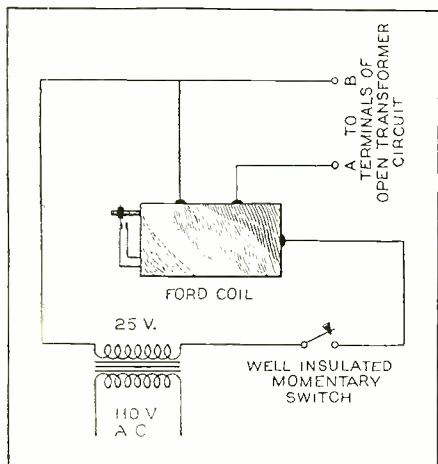

that the break in the winding has been closed.

At first sight, this method of repairing might seem like hocus-pocus. Actually there is nothing mysterious about it. When the high tension output of the Ford coil is applied to the broken primary winding the spark jumps the gap between the two severed ends of the winding. The heat of this spark causes the ends to fuse, thus repairing the break. I have tested a number of transformers repaired in this manner and have not found one in which the impedance of the repaired winding was altered by this method of repair.

In view of the fact that a recent survey of service jobs shows breakdowns in audio transformers to be the third most common cause of trouble in radio receivers, the serviceman may find it worth while to build up this transformer repair kit into a small portable case, enabling him to make transformer repairs in the customer's home.

ED. STREIB,
Baltimore, Md.

Condenser Test Box

I am an interested reader of your "With the Experimenters" column in the RADIO NEWS. I have acquired many useful ideas from its columns and wonder if an arrangement of condensers I use would be of interest to the readers.

I constructed a small box three inches

square and fitted it with a bakelite panel, on which was mounted a tap switch lever, six contact points and two binding posts. In the box I mounted six fixed condensers of the following values: .002, .006, .01, .5, 1.0, 2.0 mfd. A pair of test prods with short leads are connected to the binding posts and the condensers are hooked up so that any one value can be selected and made available at the prod tips by means of the tap switch. The values at tap points are marked on the panel.

I find this little capacity box very con-

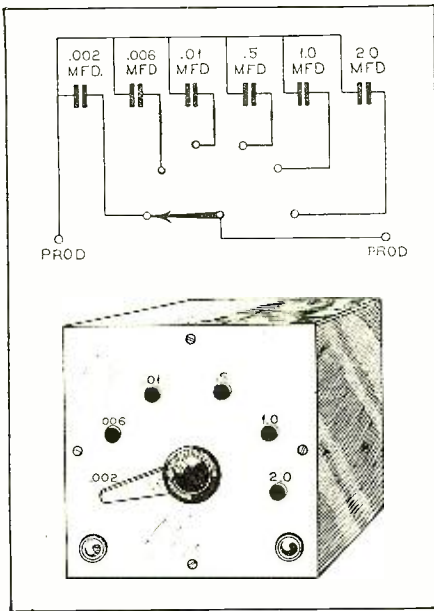

venient in locating open by-pass condensers by substitution, probing for hum reduction and especially so when the cut and try method of determining the effects of various capacity values is used.

STEVEN S. ERICKSON,
Evanston, Illinois.

Handy Saw Tool

A handy tool for kit or shop is shown above. Take some 8 or 10 inches of an old hacksaw blade. Wrap one end of it with a piece of old tire inner tube and bind this



with wire. It makes a very handy little device for small cutting in confined spaces where a regular hacksaw cannot be used.

FRANK W. BENTLEY, JR.,
Missouri Valley, Iowa.

Unique Indoor Antenna

I find that a 30-foot length of twisted pair (lamp cord), connected as shown here, makes a surprisingly effective antenna for use with a.c. receivers. As will be noted, the end of one wire is connected to a water pipe and the other end of this wire to the ground post on set. One end of the other wire is connected to the receiver antenna post and the other end left unconnected.

(Continued on page 512)

HERE'S
A TUBE
THAT MAKES
ANY SET WORK
BETTER

Blue Tubes will make more satisfied customers for you. They make any set work better. That's why more set manufacturers make them standard equipment than any other tube. More prospects for you among these thousands of set owners using Blue Tubes.

If you really want to promote your business here's your chance. Tear out the coupon below. Mail it. No obligation. We may be able to show you how to double your profits.

ARCTURUS
BLUE
TUBES



The service man who specializes on Arcturus Blues is always sure of getting FULL PRICE . . . and, therefore, FULL PROFIT . . . without argument, for quality tubes need never be cut in price.

GET THIS FREE
CHART

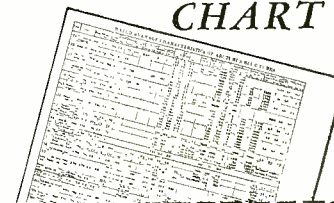

ARCTURUS RADIO TUBE CO. 2/33
720 Frelinghuysen Ave., Newark, N. J.

Name.....

Address.....



The Service Bench

Economical Noise Reduction Antennas—Transmission Line Coupling—Shielded Lead-ins—Tuned Antennas for Short-Wave Reception—Eliminating Hum in Loftin-White Amplifiers—Simple Tube "Short" Tester

THE increasing popularity of noise-reduction antennas is evident from the growing list of manufacturers now in production of relevant equipment—Lynch, Kolster, Tobe and others—and the contributions of our servicemen readers who command greater income and prestige through the installation of these modern aerials.

Noise pick-up by the lead-in is most efficaciously reduced on the conventional broadcast frequencies (200 to 600 meters) by means of a shielded lead-in or transmission system, with adequate couplers at the antenna and receiver termini. The theoretical and practical considerations involved in such arrangements have already received detailed description in the three articles by Thomas McClary in the October, 1932, by Louis Clement in the November, 1932, and by Arthur Lynch in the January, 1933, issues of *RADIO NEWS*. On the higher frequencies, notably below 100 meters, noise reduction is most efficiently attained, in amateur installations, by means of the transposition system, and, in some instances, through the use of more simple, non-grounded antennas, such as a modified Zeppelin type.

On all-wave receivers (which, by the way, represent highly profitable turn-overs for the serviceman), the transposed lead-in probably is excellent for all-around reception.

Cutting Costs on Transmission-line Installations

Mr. Robert T. Thompson, of Lansing, Mich., contributes the following data representing experiments dedicated, in keeping with the times, to the purpose of converting "Mr. Clement's data into coil sizes and number of turns with the least possible expenditure of time, material and money."

"The use of Belden transmission-line, shielded cable was the only specified item followed exactly. The search for coil cans began in the five-and-ten-cent stores and ended in the nearest kitchen with Beech-Nut coffee cans. The electrostatic shields were omitted. The junk-box was investigated for possible coils, and two of the lattice-type, from an old neutrodyne, were selected.

*Conducted by
Zeh Bouck*

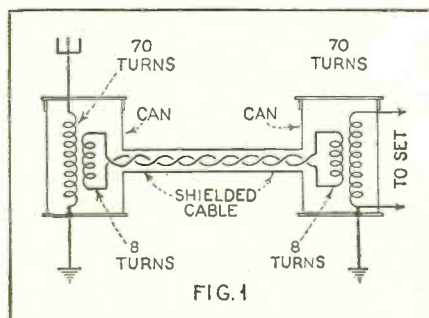

FIGURE 2

These coils have a mean diameter of 2 5/8 inches and consist of about 70 turns of wire. Eight turns were wound at the center of the coils for connection to the transmission line, 125 feet long—the circuit being shown in Figure 1. Preliminary tests were made on a midget superheterodyne receiver without the shield cans. No change in sensitivity could be detected, while the decrease in noise was very gratifying, the racket from a dial telephone being reduced from the familiar machine-gun imitation to a mere whisper.

"The coils were then mounted in the cans as shown in Figure 2, and additional tests indicated that the shielding was quite satisfactory.

"The final installation was made in the home of a friend whose reception on a Radiola 46 was considerably marred by man-made static—a complaint of every other radio owner in this apartment house. One coil was mounted just behind the chassis and connected, via the transmission line, to the other about 100 feet away on top of a low garage. Here, the can was grounded to a driven pipe and a 200-foot L-type antenna erected to extend away from the apartment and into an area remote from power lines.

"When the installation was completed, the receiver was turned on and 14 daytime stations logged—counting only those which were clear and loud enough to be really enjoyable. Heretofore, the owner had been content with only a few of the powerful locals. Having assured ourselves that we were getting adequate signal strength through the shielded cable, we began to make noises for the set to pick up. The lights were flickered, the elevator operated and the electric stove switched on and off without the least response from the set. Finally, the most dilapidated old vacuum cleaner in the building, with a reputation for forcing all neighboring sets off the air, was brought in and operated. Not a sign of the usual noise appeared!

"The fact that the combination worked satisfactorily on different antennas and various receivers—as determined in further experimentation—seems to indicate that the circuit constants are not critical for an ade-

quate reduction in noise. While the writer is aware of the limitations of his approach to the problem, it is hoped that many servicemen will be interested in the experiment and will take advantage of this economical method of greatly improving radio reception in a difficult location."

Tuned Antennas for Short-wave Converters and Receivers

In consideration of the noise problems associated with short-wave reception, Harry D. Hooten, of Beech Hill, West Va., attacks the problem from a different point of view.

"How many times have you lost a sale of a short-wave converter, or receiver, because foreign reception, around 25 meters, was impossible, due to interference from automobile ignition and power leaks? Having met with these conditions on several occasions, we began experimenting with various methods of noise reduction, with an eye for the most economical of practical systems. We found that the noise was generally worse when a ground was used—a discovery that led to the adoption of 'Zep' antenna. This reduced the noise to a surprisingly low level and actually provided a stronger signal than the grounded type of antenna system. Further experiments disclosed the fact that the flat-top, or horizontal wire, was unnecessary. A diagram of the modified aerial is shown in Figure 3 and is used where it is inconvenient to make any changes in the receiver or converter itself.

"When practical, however, it is desirable to alter the input circuit to conform with Figure 4, where C is a midget condenser having a maximum capacity of 100 mmfd. A 5-prong coil form is used (such as the National), and the antenna coil is wound on the negative filament end of the grid coil. A

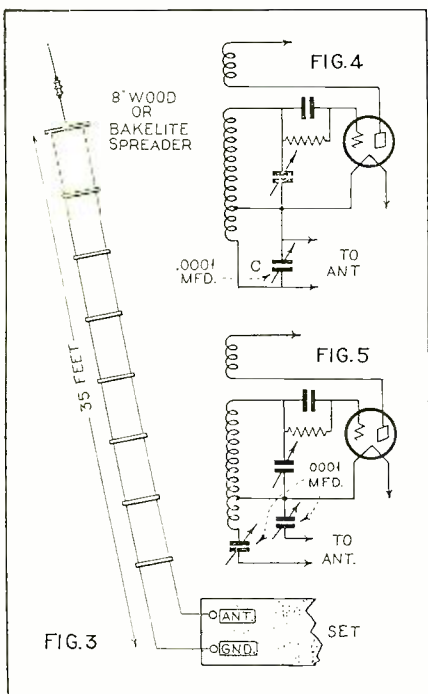

sufficient number of turns should be wound which will permit the antenna to be tuned either to the fundamental or a harmonic of the frequency being received. With this system, we have received G5SW on 25 meters, with good volume, only a few doors from a power leak that ordinarily sounds like a back-yard thunderstorm at this wavelength."

The arrangement suggested by Mr. Hooten will be effective only when the elimination of the ground connection does not upset the stability of the receiver or converter, or does not result in hum. Noise reduction will, of course, be greatest at the fundamental or

harmonic tuned frequencies of the antenna—somewhat of a disadvantage where simplicity of control is desired. However, with the resulting increased signal strength, this drawback will be largely discounted by the dyed-in-wool short-wave enthusiast. In some instances the circuit shown in Figure 5 may be preferable to the arrangement of Figure 4.

Those Humdingers Again!

R. S. Lewis, of the Modern Radio Service, Pittsfield, Ill., finds that hum in Loftin-White direct-coupled amplifiers can be eliminated by the inclusion of choke A and the

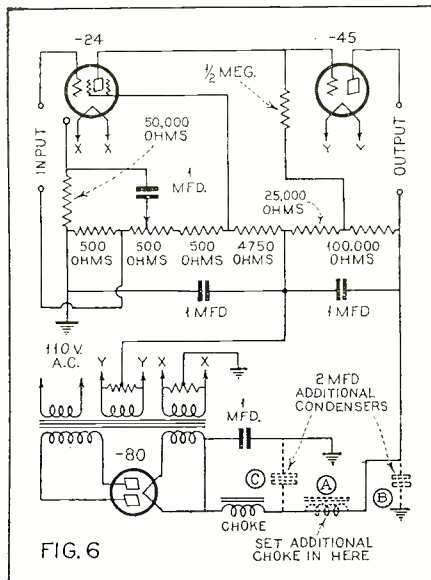

filter condensers B and C, as shown in Figure 6. The choke should have an inductance of from 20 to 30 henries at 60 ma. By slightly rearranging the 1 mfd. condenser on the back of the amplifier base, room can be made for the choke.

"The filter condensers used by the author are 2mfd. Elkon electrolytic capacitors, with 450-volt ratings. The usual precautions in reference to polarity must, of course, be observed.

"The Loftin-White amplifier should be grounded. Very often, as the amplifier is moved about, a good ground is not readily available. I have found that a condenser of from .1 to .25 mfd. capacity, connected between one side of the a.c. primary and the frame of the amplifier has practically the same effect as a direct ground. Try reversing the plug for best results."

Hum in many instances is caused by running the power transformer at too high a primary voltage. Before any drastic alterations are made on a receiver giving hum, reduction of the primary voltage should be attempted, either by changing the tap on the transformer (when such adjustments are provided for) or by the inclusion of a suitable resistance. Salzman, of Globe Radio, found this cure effective on several Fada 47's.

EQUIPMENT

A Simple Tube "Short" Tester

After all, what the serviceman really wants to find out from a tube short tester is whether or not the tube under test has a short-circuit between any of the adjacent elements. Just where the "short" is, is not important, because the chances are nothing permanent can be done about it. As Hamlet would have said if he read *The Service Bench*, "The short's the thing."

The "short" tester can therefore be simplified to the very elemental and universal device diagrammed in Figure 7. The most (Continued on page 512)



"Look to your Resistors!"
has made set owner and service-man alike OHIOHMS CONSCIOUS

1932 marked the first year that resistors were popularized, 1933 points to greater strides in this direction. The makers of OHIOHMS lead the country in aggressiveness and greater profits for its tradesmen. Keep in pace with this progress by tying up with OHIOHMS.

PROTECT-O-PACKING

has been a protection to the man selling OHIOHMS



No kinks or bent wire-leads with OHIOHMS for protect-o-packing has made installations easier and quicker—likewise adding to the attractiveness of the kit or display package.

NO Guesswork—
VALUES STAMPED ON EACH UNIT... and guaranteed CORRECT!

Each OHIOHMS has the resistance value stamped thereon. You can't go wrong with an OHIOHMS for in addition the resistance value is guaranteed to be correct within 10% tolerance.

Write for the OHIOHMS Resistor proposition and also the OHIOHMS Spark Suppressor story.

OHIOHMS

YOU CAN CASH IN ON
Cleanaire
ICE-BOX and REFRIGERATOR DEODORIZER

THE OHIO CARBON CO.
12502 BEREA ROAD CLEVELAND, OHIO
OHIOHMS are made in Canada by
C. C. Meredith & Co., Ltd., 639 Bay St., Toronto

Question Box

PHYSICS and science instructors will find these review questions and the "quiz" questions below useful as reading assignments for their classes. For other readers the questions provide an interesting pastime and permit a check on the reader's grasp of the material presented in the various articles in this issue.

The "Review Questions" cover material in this month's installment of the Radio Physics Course. The "General Quiz" questions are based on other articles in this issue as follows: Extending Loudspeaker Range, Home Recording, Learning the Code, Phenomena Underlying Radio, Handy Microphone Substitutes, All-Wave Design, Improved 15 to 250-Meter Super.

Review Questions

1. Why can the state of charge of a lead-acid storage battery be determined by a hydrometer? What should the hydrometer reading be for a fully charged cell; a discharged cell?
2. What is the objection to allowing a lead battery to stand around completely discharged?
3. How may storage batteries be charged from 110 volts alternating current electric light lines; from 110 volts direct current lines?
4. Why must the positive terminal of the charging source always be connected to the positive terminal of the battery?
5. A 6-volt lead battery is to be charged at about a 5-ampere rate from a 110-volt d.c. line with 100-watt incandescent lamps to act as current adjusters. Draw the circuit diagram of connections, showing exactly how many lamps must be used.
6. Why should the top of a storage battery be kept clean and dry and the exposed metal parts coated with vaseline?
7. What is the effect on a lead storage battery of (a) continued overcharging, (b) charging at very high rate, (c) allowing water level to get very low, (d) allowing battery to stand idle in discharged condition?

General Quiz on

This Issue

1. What changes are necessary in a standard receiver to permit the use of dual dynamic speakers in place of the usual single speaker?
2. What is the recommended position for a person when speaking into a microphone?
3. To what practical purposes have static charges of electricity been applied?
4. Name three common radio accessories which will function as emergency microphones.
5. What is the function of the "squelch" circuit?
6. Draw the circuit for an electron coupled oscillator as used in one of the modern superheterodynes.
7. What is the proper spacing between dots and dashes, between letters and between words, in transmitting code?

Student's Radio

LESSON FIFTEEN—STORAGE

This series deals with the study of the physical information of particular value to physics colleges. The Question Box aids teachers

By Alfred A.

FROM our study of the chemical reactions taking place during "charge" and "discharge" of the lead-acid storage battery, we have found that during charge, acid is returned to the electrolyte (making the electrolyte heavier or denser) and during discharge acid is taken from the electrolyte to form lead sulphate on the plates (making the electrolyte lighter in weight). The specific gravity of a material is its comparative weight with respect to an equal volume of water. For example, a cubic foot of water weighs 62.5 pounds. A material weighing twice as much (125 pounds) has a specific gravity of 2. When a lead storage battery is in a fully charged condition, the specific gravity of its electrolyte ranges from about 1.275 to 1.300. This

tube with a numbered scale at the other end. The more dense the electrolyte, the higher the bulb floats in it. If the cell is completely discharged, the hydrometer will sink almost to the bottom. The hydrometer float should not be allowed to stick to the sides of the glass tube. The scale marked on the hydrometer stem indicates the specific gravity of the solution (the decimal point is left off). If the cell is fully charged, the line marked 1280 or 1300 will be at the surface of the liquid as shown in Figure 1. When the reading drops below 1185, the battery should be recharged. If by chance a battery should become fully discharged, it should not be allowed to stand around for any length of time in that condition, for the lead sulphate on both the positive and negative plates will crystallize and harden. It is almost impossible to break this up into lead later when charging, so the battery becomes practically useless.

Charging Storage Batteries

The voltage of each cell of a fully charged storage battery on open circuit is about 2.2 volts. This voltage is approximately the same for a partly discharged cell as for one fully charged, so that the condition of charge of a battery cannot be determined accurately by an open-circuit voltage test. Since a lead cell has a very low internal resistance it will give a current of from 200 to 300 amperes on direct short-circuit. Therefore it cannot be tested with a simple pocket ammeter of the type used for testing dry cells, because this current is too large for such an instrument. Where it is suspected that acid has been added to the cells in a battery simply to bolster up the hydrometer readings to make the battery appear fully charged, it is usual to test the battery by measuring its output voltage while it is delivering current, for in this case a hydrometer test would be worthless.

All storage batteries must be charged by sending direct current through them in the direction *opposite* to their normal current flow on discharge. That is, the positive terminal of the charging source of e.m.f. must be connected to the positive terminal of the battery, and the negative terminal of the source is connected to the negative terminal of the battery.

Care should be taken in charging the battery to make certain that its positive terminal is connected to the positive terminal of the source being used for charging purposes. If the battery is charged in the opposite direction, the plates will be reversed in chemical character, and if the charging is continued for any great length of time, the battery will be destroyed. If a battery has only been charged in the wrong direction for a short length of time it can generally be brought back to normal by charging in the right direction for a very long time at a low charging rate.

Batteries are usually charged from the electric light lines. Where alternating current only is available, it must first be changed to direct current by means of a suitable rec-

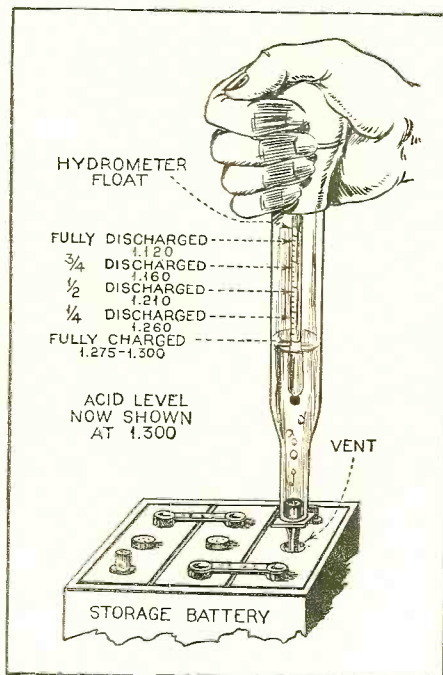

FIGURE 1

is usually read twelve seventy-five (1275) to thirteen hundred (1300). Since acid is taken from the electrolyte during discharge, the specific gravity of the electrolyte decreases. Therefore the specific gravity is a valuable indicator of the condition of charge of a battery (provided extra acid has not been purposely put into an old battery by a dishonest battery dealer simply to bolster up the specific gravity to make it appear fully charged).

To find the condition of charge of a battery by testing the electrolyte, a *hydrometer* is used. This is shown in Figure 1. It consists of a rubber bulb arranged to draw up the electrolyte from the filler cap on each battery cell, through a rubber nozzle, into a glass tube. Inside of this floats a small hydrometer consisting of a small glass tube having a hollow bulb with a weight (usually lead shot) at one end, and a thin

*Radio Technical Pub. Co. Publishers' Radio Physics Course.

Physics Course

CELLS AND CHARGING

aspects of radio phenomena. It contains teachers and students in high schools and in laying out current class assignments

Ghirardi*

tifier, since alternating current changes rapidly in direction and would discharge the battery just as much as it would charge it. Several types of rectifiers are used for battery charging, but the Tungar bulb type is perhaps the most popular.

Figure 2 shows the internal connections of a charger of this type, together with a suggested layout of charger, charging switch, and A and B batteries, for a battery-operated radio receiver installation. Chargers of this type are also adapted for charging the lead-acid type of storage B battery used in some places. The three-pole, double-throw switch in Figure 2 enables one to charge either the A battery or storage B battery at will.

Charging should be continued until the specific gravity ceases to rise any further on continual charging for an additional one-hour period. Usually the hydrometer reading will show about 1275 to 1300 at this time, but this is only true provided extra acid has not been added to the battery at some previous time.

Ventilate the battery compartment when charging, in order to dispose of gas generated by battery. Never bring a flame or spark, such as candle, lantern or lighted cigar or pipe, near the battery when charging or shortly after. This is because the explosive gas, hydrogen, is produced during charge. Keep the vent plugs in the cells. Do not remove them except to take specific

direct-current lighting circuit is at hand, no rectifier is needed and the charging of storage batteries is an easy matter. We cannot connect a 6-volt storage battery directly across a 110-volt charging source because a very large current would flow through the battery due to its very low internal resistance. This would damage the plates by overheating and buckling them and would blow the fuse in the electric light circuit. In order to limit and regulate the charging rate, a bank of

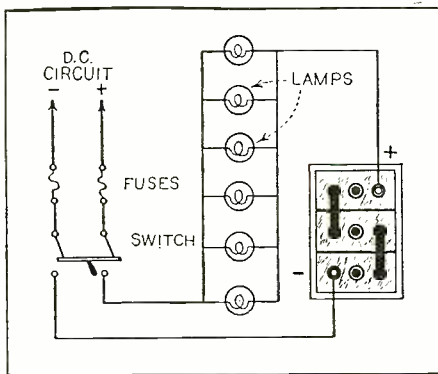

FIGURE 3

lamps or other resistance unit should be connected in series with the line, as shown in Figure 3. Ordinary 100-watt, 110-volt incandescent lamps used in homes for lighting make convenient and cheap forms of current-limiting resistances, since each lamp will pass roughly about 1 ampere through the charging circuit. If a higher charging rate than this is required, 2 or more 100-watt lamps should be connected in parallel as shown. The total charging current is then equal to one ampere multiplied by the number of 100-watt lamps connected in parallel. It is usual practice to charge radio storage A batteries at a rate of 10 amperes. Thus, to charge a simple 6-volt battery at about a 6-ampere rate, connect a parallel bank of six 100-watt 110-volt lamps in series with the battery and charging circuit as shown in Figure 3. The lamps will light up during the charging process.

Before connecting the battery to the charging circuit it is important to determine which side of the line is positive, by means of a voltmeter. If no voltmeter is available, dip the separated ends of the two line wires into a glassful of water containing a very small amount of battery electrolyte, or common table salt. A larger number of bubbles will rise from the negative wire than from the positive wire.

Where two or more batteries are all to be charged at once at the same rate from a 110-volt d.c. line, they may be connected with the positive terminal of one to the negative of the next, etc. When more than 3 or 4 batteries are thus connected the charging current passing through each 100-watt lamp is a bit less than 1 ampere, due to the counter-voltage of the batteries in series.

Care of Lead Storage Batteries

It is very important to keep the battery (Continued on page 510)

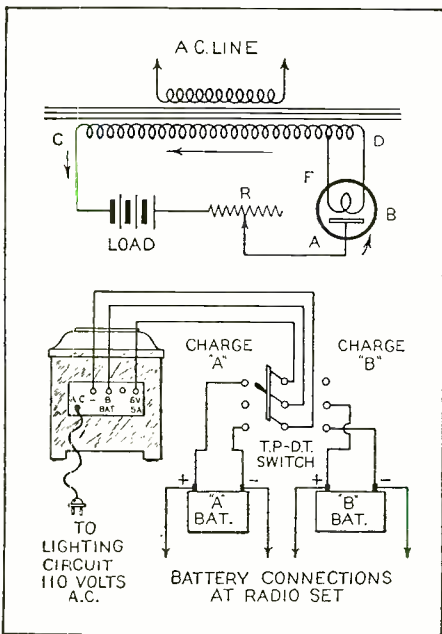

FIGURE 2

gravity or temperature readings or to add water. If the cells flood or sputter electrolyte, the liquid level is too high and should be lowered by withdrawing electrolyte.

When a direct-current charging circuit is available, as in the case where a 110-volt



No other tube manufacturer offers more to help service men and dealers Radio men everywhere are telling us what National Union means to them. And the reason why is that National Union understands and does something about the service man's problems—

1. National Union sells High Quality Tubes.
2. National Union offers FREE the finest equipment.
3. National Union gives the latest data on radio equipment.
4. National Union assures a profit . . . there is no price cutting.

Look at the valuable free equipment in this ad. Decide today to tie up with National Union for profit. Mail coupon below!

ASK YOUR JOBBER'S SALESMEN

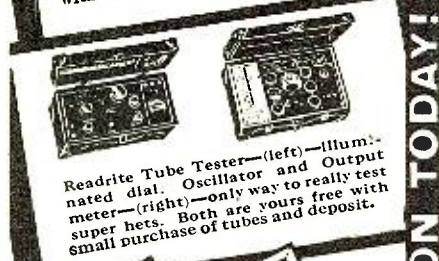
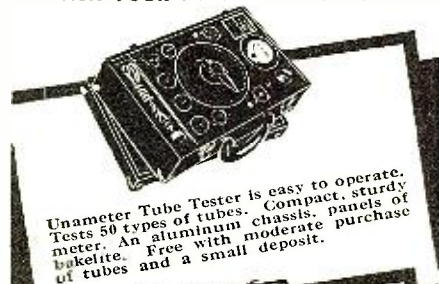

NATIONAL UNION RADIO CORP.
400 MADISON AVENUE NEW YORK

Sirs: I am interested in following equipment:
Readrite Tube Tester Oscillator & Output Meter
Readrite Resistance Tester Volume I
Unameter

NAME _____
ADDRESS _____
CITY _____ STATE _____



Yours for the Asking
SEND FOR IT NOW!

The new CENTRALAB VOLUME CONTROL GUIDE is a gold mine of information. It's a vow for replacements . . . for a fist full of Centralab Volume Controls are enough to service practically any known make. Send for the GUIDE today—sells regularly for 50c . . . it is yours for 2 three cent stamps to cover postage and mailing. Do it now.

Centralab
CENTRAL RADIO LABORATORIES
MILWAUKEE

New Way to Learn the Code At Home

Make Your Own Records

Easy to Make
Easy to Read

with

The NEW MASTER Teleplex

The only instrument ever produced that will record your own sending in visible dots and dashes and then repeat it to you audibly on headphones. Revolutionizes the teaching of code—makes learning easy, fascinating and rapid. No experience required. Designed for U. S. Signal Corps. Marvelous say radio and electrical engineers. Loaned with Complete Code Course without additional cost. Write today for folder RN-2 giving full details.

TELEPLEX CO., 76 Cortlandt Street, New York, N.Y.

FREE NEW 1933 CATALOG
JUST OFF THE PRESS—WRITE

RADIO PRODUCTS CORP. EMRO

FOR YOUR COPY NOW
Over 5,000 items at prices that enable greater profits.
145-R HUDSON ST., NEW YORK, N. Y.

Backstage in

Personal interviews with broadcast artists and executives

By
Samuel Kaufman

THE first weekly feature to go on the air from the Radio City development in the huge Rockefeller Center in New York City was appropriately directed by Roxy (S. L. Rothafel). Once again the radio veteran's presentations are billed as "Roxy and His Gang." Roxy and his group of entertainers had been absent from the microphone for more than a year. The new series, heard Sundays over the NBC, was launched in November and preceded the opening of the R-K-O Theatre in Radio City with which Roxy is associated. The famous "Gang" has been in existence for more than ten years. It was first heard on the air from the Capitol Theatre in New York and later continued at the Roxy Theatre. Roxy was born in Stillwater, Minnesota, and started his working career as a cash boy in a New York department store. He left the metropolis to manage movie theatres in the Middle West and returned East in 1913 to manage New York's Strand Theatre, which was then the largest moving picture theatre in the world. He has since been identified with the Capitol and Roxy theatres. Although his identification as a showman primarily classifies him as a theatrical man, it was his radio efforts that earned him his greatest fame and made his name a household word from coast to coast.



DAVID ROSS

DAVID ROSS, veteran announcer of the CBS, has been awarded the coveted gold medal for radio diction by the American Academy of Arts and Letters. This decision by the members of the Academy was met with warm enthusiasm in all radio circles. Ross was awarded honorable mention the previous year and his ultimate acquisition of the first place award was not at all surprising to listeners. The medal was presented to Ross last November in New York, and the NBC as well as the CBS broadcast the proceedings. The committee making the award based on diction and pronunciation on the air during a twelve-month period included: Professor George Pierce Baker, Dr. John H. Finley, Augustus Thomas, Professor Bliss Perry, Robert



ROXY (S. L. ROTHAFEL)

Underwood Johnson and Professor Irving Babbitt, Milton J. Cross, Alwyn Bach and John Holbrook—all of NBC—were the diction winners in the three previous years of the award's existence. Ross, the first CBS winner, came to the network four years ago after serving for two years on the announcing staff of old WGBS in New York. He has been continually featured on important CBS programs as well as on a presentation of his own entitled "Poet's Gold." He is a native New Yorker. His early career covered the varied duties of newsboy, agricultural student, orphan asylum supervisor, secretary, advertising writer, book reviewer and poet.

THE Lucky Strike Hour (NBC) continues its wide popular appeal by constantly featuring new talent and novel ideas. The Thursday night portrayals of Baron Munchausen by Jack Pearl are among the funniest radio skits. Pearl, a veteran stage performer, gained immediate radio popularity with his dialect performances. His programs originate in the Times Square auditorium studio of the NBC in New York, and each presentation is observed by large crowds who obtain passes from the network. The

JACK PEARL

EDDIE CANTOR



Broadcasting



EVELYN HERBERT

addition of Evelyn Herbert and Robert Halliday as vocalists on the Saturday night Lucky Strike Hour also gained favorable comment. Miss Herbert has been featured in numerous operettas and musical comedies both here and abroad.

SEVERAL months ago, when Eddie Cantor departed from the Chase & Sanborn Coffee Hour (NBC) to star in a new talkie, he left New York as one of the most popular entertainers on the air. Listeners took well to comedy and Cantor's gags, whether old or new, were oft repeated and discussed the morning following each broadcast. Upon his recent return to the program, Cantor discovered that the demand for comedy acts had increased, that there were many other noted comedians on the air, and that competition for great listener following was rather keen. There was Ed Wynn, who was proving to be one of the biggest attractions on the air; the drolleries of Jack Benny were being talked about; the silly chatter of George Burns and Gracie Allen had the nation chuckling; Jack Pearl, another stage recruit, was scoring in a big way, and countless other comedians were having their innings at the microphone. Cantor found that he had to make a fresh start upon his return. Regardless of the reputation built up a few months before, the gap of radio silence and the mounted competition made it obvious that his following was not as great as when he left. Each succeeding week is bringing him added popularity, but it

AL JOLSON



Chatty bits of news on what is happening before the microphone

all goes to prove that continuity of performance is essential for claimants to stellar titles in the broadcasting world.

SEVERAL years ago it was considered quite an event when Al Jolson, stage star, signed for a single radio appearance. The occasion was accompanied by much ballyhoo and it was a general subject of conversation. Busy with stage and talking picture engagements, Jolson had since kept away from a regular radio series, and listeners have long looked forward to the announcement that he would be heard on a weekly schedule. Thus, his recent debut as star of the Chevrolet Big Six program on NBC created much interest. Jolson, best known for his "Mammy" songs, was born in Russia as Asa Yoelson. During his childhood his parents moved to Washington, D. C., where the elder Yoelson became a cantor in

a local synagogue. Asa was trained to follow his father's footsteps. He rebelled and ran away to New York. After some wandering, he joined an army camp as mascot for a Spanish-American war regiment. He was urged to return to his parents in Washington and got a job there as a singing waiter in a café. He joined a local stage show and soon tied up with a burlesque troupe. Varied singing engagements in different parts of the country led to his joining the famous Dockstader Minstrels. In black-face make-up and with his unique style, Jolson discovered that he could make audiences laugh and cry with his songs. He was signed by the Shuberts for an appearance at the Winter Garden in New York. Since then his successes have multiplied.



LEOPOLD STOKOWSKI

THE recent return of the Philadelphia Orchestra, conducted by Leopold Stokowski, to the air was one of the most important events of the season to music-lovers throughout the nation. The programs are presented on both a sustaining and sponsored schedule over the CBS. The schedule has been so arranged that the limited Saturday night performances of the orchestra during this season are broadcast under the sponsorship of Philco. The sustaining programs are presented on Friday afternoons of all weeks excepting those during which the Philco programs are scheduled. They are omitted because the Friday afternoon and Saturday evening programs of the orchestra

Make More Money with this Better Tester!

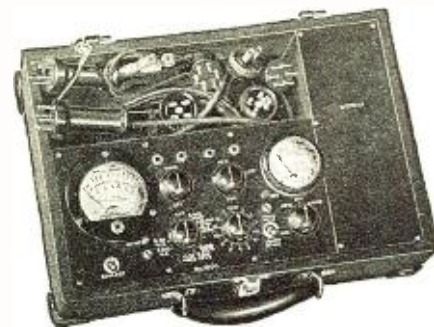

Readrite **\$33.00 NET TO DEALERS List. \$55.00**

Tester No. 1000

NOW you can test automatic volume control, diode, resistance coupling, phase shifting, automatic noise suppression, automatic tone control and the many variations of these circuits. Until this new, exclusively Readrite method appeared, it was necessary to pick your way through the circuits by the laborious and confusing prod contact method. The fact that voltage tests are inadequate and that they lead to gross errors compels testing of modern set circuits by the *resistance method*.

Mr. Dealer and Mr. Serviceman! Here is an A.C. tube tester that will fill your every requirement. Simple to use. Accurate and dependable, even at different line voltages. Only one test button for every type tube—an exclusive Readrite feature. Tests the conductance of all tubes—over the counter and out of the set. Permits accurate checking of all the old and new tubes in use today.

If your jobber cannot supply you, we will ship the No. 1000 Tester directly to you—when remittance accompanies your order at dealer's net price of \$33.00.

READRITE METER WORKS
37 College Ave., Bluffton, Ohio

MAIL COUPON NOW

Readrite Meter Works,
37 College Ave., Bluffton, Ohio.

Gentlemen:
Please send me information about Readrite No. 1000 Resistance, Continuity and Capacity Tester. Also catalog of other servicing instruments.

Name.....

Street Address.....

City..... State.....



**Dependable
Sensational
Performance!**

**5 DAYS
FREE
Trial**

**...BUD
Loud Speakers**

MR. C. M. FOX
Technical Engineer

First in the speaker field because of their **POSITIVE DEPENDABILITY** and **SENSATIONAL PERFORMANCE**. Performing efficiently with a 2-watt input, BUD has a guaranteed continuous operating capacity of 25 WATTS and a peak load of 50 WATTS! BUD assures you against embarrassing, inconvenient, costly breakdowns! For indoor and outdoor P.A. systems, BUD guarantees efficient, dependable service. Unaffected by atmospheric conditions!

BUD SPEAKERS Offered on FREE Trial Plan

Discard your obsolete, inefficient, costly, troublesome units. Standardize on BUD! It costs less to enjoy a BUD than to be annoyed with an ordinary speaker! Let BUD'S *Sensational Performance* convince you of BUD'S *Positive Dependability*. Send for details of FREE Trial Plan.

BUD SPEAKER CO.
1159 DORR ST.
TOLEDO, OHIO-U.S.A.

F. & H. CAPACITY AERIAL



Price \$1.00 Complete postpaid

Every Instrument Tested on Actual 1127 Mile Reception
A LARGE NUMBER ARE IN USE BY
GOVERNMENT, IN NAVY HOSPITAL

The F. & H. Capacity Aerial Eliminator has the capacity of the average 75-foot aerial, 50 feet high. It increases selectivity and full reception on both local and long distance stations; is absolutely guaranteed. It eliminates the outdoor aerial along with the unsightly poles, guy wires, mutilation of woodwork, lightning hazards, etc. It does not connect to the light socket and requires no current for operation. Installed by anyone in a minute's time and is fully concealed within the set. Enables the radio to be moved into different rooms, or houses, as easily as a piece of furniture. 8,000 dealers handle our line. Dealers! Over 80 leading jobbers carry our line or order sample direct. Write for proposition.

— SEND COUPON, IT PROTECTS YOU —

Name.....

Address.....

City..... State.....

Send one F. & H. Capacity Aerial with privilege of returning after 3-day trial if not satisfactory, for which enclosed find check M. O. or dollar bill, or send C. O. D. Send Literature. Dealer's proposition.

F. & H. RADIO LABORATORIES
 Fargo, N. Dak. Dept. 19

FREE

**13th ANNIVERSARY
RADIO CATALOG**

124 pages containing thousands of the greatest radio and electrical values at real bargain prices.

Send for your copy now!

AMERICAN SALES CO.
Wholesale Radio Distributors
RN-44 West 18th Street New York, N. Y.

are identical. The remaining Philco programs will be heard on March 18 and April 1, and on all other weeks of the season the orchestra will be heard Friday afternoons as a sustaining feature. CBS engineers have made extensive surveys to perfect the quality of transmission of the Stokowski concerts from the Academy of Music in Philadelphia. Both dynamic and ribbon microphones are used for the pick-up.

Mutual Conductance

(Continued from page 482)

ing this change. Hence we use two meters, as shown in Figure 2. This is done so that one meter can measure the total plate current, as will be done by M_2 , and while M_1 may be a small-range meter used only to observe the change in plate current. The method employed in their use is to set the apparatus up with switch 1 open and switch 2 closed. Unless this precaution is observed, the low-range meter will probably be burned out. With proper potentials applied to the tube from the A, B and C batteries and the grid switch in position one, the plate current will be shown on meter M_2 . Now close switch No. 1 in the plate circuit and adjust the "bucking current" by means of the potentiometer R_2 until the meter reads as close to zero as it can be observed. Now open switch No. 2, leaving switch No. 1 closed. Some current reading will probably be shown, indicating that a true zero was not reached in the first adjustment of R_2 . Readjust R_2 until M_1 reads zero. Now change the position of the grid switch to position two. A marked change of current through M_1 will be noted. If the scale of M_1 is clear and easily read, it may be interpreted directly in terms of Gm, 1 milliamperere change equalling 1000 micromhos.

Now just a word of warning. Close switch No. 2 before making any other changes in the circuit, unless you feel that you have money to throw away buying new meters!

The writer realizes that the size of meters chosen, etc., is not given in the above text, nor is any form of mounting shown. As the apparatus is always used as a laboratory set-up in our laboratory, meters are chosen according to the tube under test. If the reader intends to build this as a permanent piece of equipment, a 50-milliamperere meter would be a good choice for M_2 , while a 3-milliamperere meter is large enough for M_1 . The matter of mounting the apparatus may be left entirely to the ingenuity and taste of the builder. The complete circuit is shown in Figure 3.

Incidentally, battery operation is desirable instead of a power supply, due to perfect regulation and ease of voltage changes for various tubes. The applied voltages should always be the minimum specified by the tube manufacturers.

The following is an exact list of parts as used in our laboratory set-up.

Parts List

- M_1 Weston meters—See text.
 - M_2
 - R_1 Electrad C-20 Truvolt resistor with extra tap. Taps so adjusted to give 500 ohms and 1000 ohms.
 - R_2 Electrad RI-283 10,000 ohms, wire-wound rheostat, for low plate-current tubes.
Electrad RI-233 3,000-ohms, wire-wound rheostat for high plate-current tubes.
 - R_3 Electrad 5-ohm rheostat for high-current tubes.
Electrad RI-270 for low-current tubes.
- Sockets, wire, etc., as needed.

? Q R D ?

A column devoted to
the commercial opera-
tor and his activities
Conducted by GY

YES, gentlemen, Winter draws on, and here we are still picking turkey tidbits out of the cavities. That is the one real advantage of the handle-bar mustachios, the aftermath of a food or drink brings fond memories of bygone days (Hearts and Flowers).

The RMCA "Static Room" beckons this cold morning. "Ah, g'mornin', Joe." Static is right! . . . "What! No ice cream? What a ship. . . No, Piny, that diagram would never work. Y'see, the bottom line should go here and the grid over to there. . . Sez you, but if it wasn't for the Police Department where would you have been? Looking like a runner without a tag on your back. . . I say it'll take four months to make the trip. Ask Gately, he made the trip. . . No, Kid, it's about a seven-weeks excursion. . . Boy, that reminds me. . . So, I walks down the street—SchmeerKase or somethin'—and as pretty an eye-opener as ever stopped a freight train sez to me. . . Yes, they told me to report to work at eight, but I just couldn't see taking dictation at that price. . . So I sez to the skipper, sez I . . .

We hear from Mervyn Rathborne telling us that he did resign from the position of president of the A.R.T.A. because of other activities. He is now in the lab. of Dr. De Forest in Hollywood, which keeps him out of mischief during the daylight hours and in the evening teaches a class the "whys and wherefores" of radio. Good luck to you, Merv, OM. QSO occasionally 'cause there's a lot of the old bunch will miss hearing from you.

Life, being what it is, becomes interesting, occasionally, because of the contacts one makes in striving for knowledge. Your faithful correspondent met up with one of the real oldtimers in radio who was a figure in the then hazy industry yahs and yahs back. His electrical shop, now on Fulton Street, Brooklyn, N. Y. C., is a veritable museum of old types of receivers, coherers, spark coils, inductance coils, tank converters, etc., and etc., all covered with the dust of ages. Anthony Musorofiti, the gentleman of whom I speaketh, received his "Op" ticket 'way back when "wooden ships were manned by iron men" and crooners were told to cultivate their voices with frog candies. After much perseverance and the help of a few others, including Dr. Dan Parker, Earle Donalds, etc., the first Radio Show was put on in the Pennsylvania Hotel. He has been inventing things from time to time, and amongst them is a device, or rather method, for the raising of sunken submarines.

Being on the subject of old times, it would not be amiss to quote from a copy of RADIO NEWS of ten years vintage, "The job of Chief Radio Op on a transatlantic liner threatens to become interesting. . . At last the steamship companies are realizing the enormous possibilities of radiophone broadcasting as a means of entertaining passengers. The Mauretania has led the way by install-

ing an independent receiver in one of the salons. Its sole object is to receive the programs of broadcasting stations from either side of the water. It may be difficult to keep in constant touch, especially in midocean, but we feel confident that, in the future, certain ships will be recognized as the broadcasting stations of the sea."

TNX, Gang, for all the mail that has been flooding the old mahogany, and TNX AGN for all the kind things being said about this column. It sure is appreciated, but, like all the candidates said after they were introduced to the admiring public with one of those flowery speeches, "we don't deserve it, but keep it up," and we like it. Almost every state has been heard from, "From the rocky coast of Maine to the Gulf of California, and from the Great Lakes in the north to the Gulf of Mexico in the south," including Hawaii and, last but not least, from Shanghai, China. RADIO NEWS is broadening the scope of education on the other side of the world with the same punch-like effect as it has been doing right here. Frank Lee, an American-born Chinese, has been doing some tall poundin' and his latest stunt was keeping the air alive with MSGS and dope while the guns were booming and machine guns popping all around him. Good for you, OM; stick to the post. Another lad heard from is C. B. Trevey, Ch9pr WOD, Beaumont, Texas. Sez he gets a great kick out of seeing the names of some of his cronies and adds, "By the way, I noticed less static this summer than last and I wonder if it could be blamed on the depression?" Some politician would have blamed it on the President, what? . . .

Driving a dusty and rickety old Ford mail truck through the cactus-bedecked deserts in Texas isn't any idea of fun for "Tex" Mason (PA), whom you will remember as "Old Hell" on the Wright, Ma, etc. We thought the Injuns got him until his letter came.

Russ Ely (HG), one of the old tanker lads "from way down under" and now on the M. S. Mercury Sun, WGEP, hits the mill to enquire as to the health and whereabouts of some of his former playmates and craves an epistle or two "for the sake of Auld Lang Syne." . . . Now a chief flunky in a local department store in Indianapolis, Cliff Riggsbee, former CM of NSC in '23, '24 and '25, and plenty ham over W9AKI on 80 meters c.w., wants me to pull a Winchell and find out what happened to some of the Ops who were at that station back in those years. Give him a yell, you old cocoanut soaks! . . . Berkeley, California, is heard from through the broadcasting efforts of H. B. Murphy saying how-dee to all and requesting the info as to his exercising pulverizers from down Panama way. . . . Tsk, tsk! Such modesty on the part of Dick DeFerd (XF), polishing bright-work at WYM, Air Corps Station, at Fort Leavenworth, Kansas. Of course, and happy to QSO wid U OM. Ops is ops, like spuds is spuds, and I hope you get your hands on your copy of RADIO NEWS before the other mule-haulers do. Now that the Army and Navy have been heard from, how's to hear from the Coastguard nephews of Uncle Sammy?

Is my face pink? And to think I brung you up to be different. Oh, well, there is no accounting for what some of the lads will do when given a mill and a few sheets of bond to play with. Laying on compliments so thick—and me without the price of a new piece of headgear, but, be that as it may, you still can't borrow that fiver. Can you imagine that? Just a nize boy who thinks a tank circuit is a carnival show playing small towns. And with that, gang, Ah must needs to say "toodle-oo" and 73's until the New Year resolutions are ripped up. GY.

Standard NATIONAL High and Ultra-High Frequency MIDGET { Receiving Transmitting Neutralizing Instrument } CONDENSERS

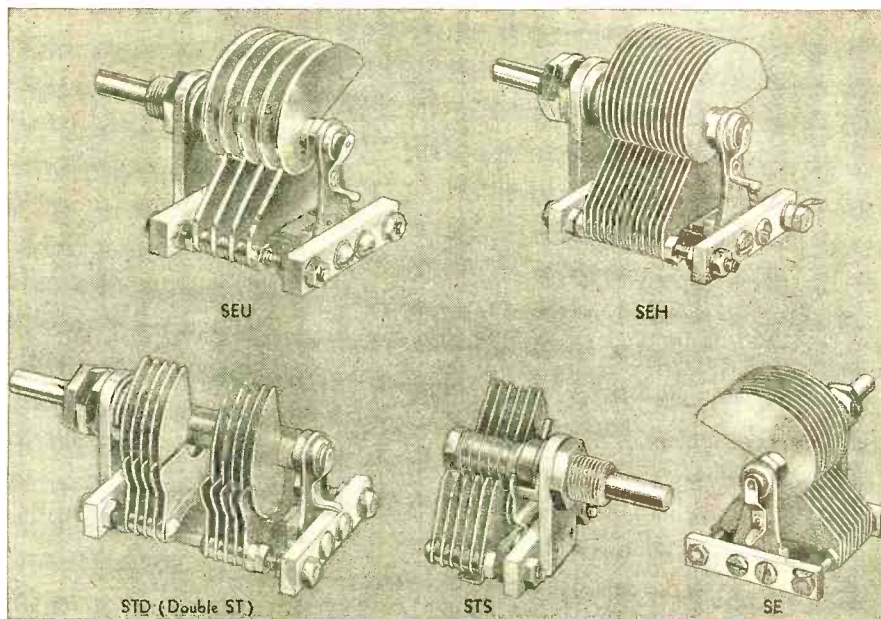

NATIONAL MIDGETS FIT YOUR EVERY REQUIREMENT

Whatever the MIDGET CONDENSER you need for high-frequency work, there is a NATIONAL MIDGET that fills the bill. We made and patented the first 270° Straight Frequency Line (Equicycle) Plate Midget in 1928. Everyone knows how much easier tuning this gives, how it spreads out the stations over 50% more dial space. This

isn't a boast—it merely indicates the experience behind the NATIONAL Line of Midget Condensers. NATIONAL Midgets are up to the minute in design and performance. As each new H.F. development or improved material has become available, it has been incorporated in NATIONAL Condensers.

NO SHORTED TURNS IN NATIONAL MIDGETS

Years ago we recognized that efficient H.F. Condensers should have no shorted turns, and years ago we began making all NATIONAL H.F. Condensers without shorted turns. In fact we had ceased even to mention this feature, but we mention it again because it is a basic feature of NATIONAL H.F. Condenser design. All two-bearing NATIONAL Midgets have the *insulated front bearings*—result—no shorted turns. Naturally the single bearing types can have no shorted turns anyway.

EXCLUSIVE CONSTANT-IMPEDANCE PIGTAIL

Constant-impedance pigtail, a patented NATIONAL feature, is only one of many advantages that make NATIONAL Midgets such consistent and invariable performers. This exclusive and electrically perfect connection to the rotor eliminates the noise, crackle, and varying impedance (A.C. inductance) of the brush type of contact.

STANDARD NATIONAL MIDGETS FOR EVERY PURPOSE AND RATING

NATIONAL Midgets are made in all capacities from 15 to 350 mmf. They are made in both single and double bearing types. Air gaps vary from .0175" to .065" with two intermediate spacings. Plate shapes include 270° straight frequency line, 180° straight wave line and 180° straight capacity line. Rotor plates vary from 6 to 22 in number with corresponding number of stator plates. As shown above, there are double section NATIONAL Midgets available. List prices vary from \$1.40 to \$5.00, dependent upon capacity, number of sections, etc.

OTHER ADVANTAGES OF NATIONAL MIDGETS

Isolantite, acknowledged high-efficiency dielectric, is used for insulating NATIONAL MIDGETS—reducing dielectric losses to a minimum; assuring uniform condenser performance at maximum level under all conditions of humidity and temperature.

Aluminum plates; thick, polished all over, with wide polished rounded edges, are used in the NATIONAL SEU Ultra-High-Frequency Midgets. Here—where rigidity and extreme stability are essential, where surface losses begin to count, we have chosen a suitable material fabricated in such a way as to give best possible performance. Equally thick plates (and thick plates are needed to give wide round edges) of any other metal, would run up cost and increase weight. In aircraft work this is most important, and there also the non-resonant characteristics of aluminum plates prevent any possibility of microphonic feedback from plate vibration.

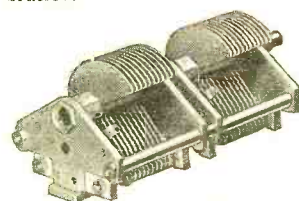

THE 2-SE MIDGET GANGED ISOLATED ROTOR

For high frequency T.R.F. and super-hetrodyne work. Rotor insulated and isolated from each other, 270° S.F.L. plates. Capacities, 50-200 mmf. each section.

Send for our Bulletin SWC-1 giving complete specifications and prices of all NATIONAL High and Ultra-High Frequency Midget Condensers.



NATIONAL CO., INC.



61 Sherman St., Malden, Mass.

What's New in Radio

A department devoted to the description of the latest developments in radio equipment. Radio servicemen, experimenters, dealers and set builders will find these items of service in conducting their work

By The Technical Staff

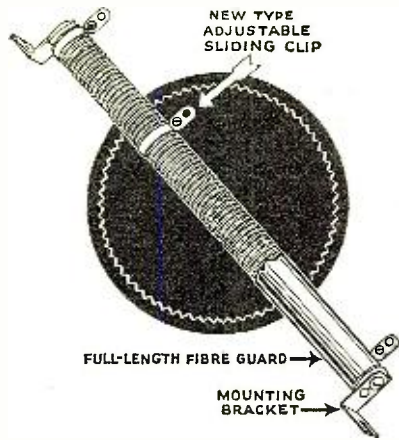

TRUVOLT the Safe RESISTOR

ONLY TRUVOLTS have these advantages:

- 1—Patented construction permits air-cooling, larger wire, greater radiation and longer life.
- 2—Spiral winding permits better electrical contact.
- 3—Sliding clips permit accurate adjustment. 1,000 volt insulation.
- 4—Full-length fibre guard prevents injury from contact with tools and hands.

Write Dept. RN-2 for Complete Catalog

175 Varick St., New York, N.Y.
ELECTRAD
INC.

TRAIN WITH R.T.A. TO BE A Professional RADIO MAN
THE TINKERER'S DAY IS DONE!

It's vital that you become a Radio technician through R. T. A. teaching NOW! New, complicated circuits . . . new tubes . . . the approach of popular television . . . all require professional service men. Their future is secure—their opportunities to make good money are unlimited. And R. T. A. can place you in their ranks quickly—easily—and surely through interesting home study that's understood by anyone who can read English.

SET ANALYZER—AT NO EXTRA COST

Included with R. T. A. Training is this excellent set analyzer and trouble shooter. After a few lessons you will know how to use it, and it becomes an immediate means of earning as you learn. Many R. T. A. students make far more than enough to pay for their training by spare time service work, using this analyzer. In addition, R. T. A. gives you life membership in a great radio service men's association with the privilege of consultation on "tough" problems at any time, and an employment service that works to keep you at work.

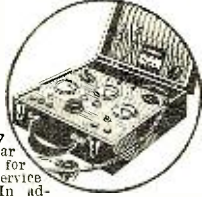

WONDERFUL OPPORTUNITIES NOW!

You don't have to wait for a dim and distant future as an R. T. A. professional Radio Technician. Even though there was never another receiver built—even though all the tremendous progress in this gigantic industry stopped—there would be enough work in conditioning and reconditioning the sets now in operation to assure you a good living. Look into this great field of professional radio service work. Learn, too, of the many other glowing opportunities open to true Radio-technicians in this field. Fill out and mail the coupon—it will bring you FACTS that will surprise you—and that may open up for you a permanent way out of depression and job-fear.

FIL N-MAIL TODAY

RADIO TRAINING ASS'N. OF AMERICA, Dept. RNA-2, 4513 Ravenswood Ave., Chicago, Ill.
Send me the FACTS about R. T. A. professional training, together with information about the opportunities in the radio service field, without obligation to me.

NAME.....
ADDRESS.....

Lightweight Headphones

Description—An inexpensive headphone receiver designed for amateur short-wave receivers and for use with crystal and portable type radio sets and to meet the many occasions where a lightweight headpiece is required. The magnets of these headphones are made from high-grade chrome steel of a



tested formula that will retain the magnetism of the phones under all reasonable conditions. The shell of this instrument is made of aluminum and explains its light weight. The headband is made of 1/2-inch steel and is adjustable to fit the head.

Maker—Acme Specialty Co., 2000 Mendell St., Chicago, Ill.

Portable Universal Receiver

Description—This compact portable receiver can operate from any 110-volt electric line supply, of either direct or alternating current (25 to 60 cycles). It should find wide application in the home where a small personal set is desired, as in the children's

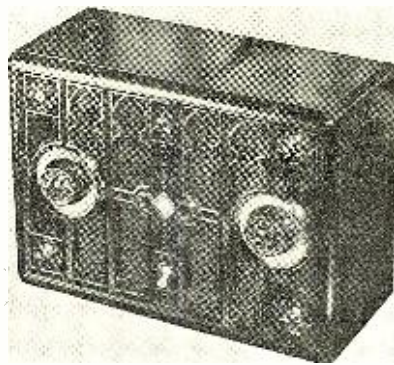

room, guest room or the study. Its small size and its universal use on d.c. and a.c. current makes this set of special interest to the traveler. The overall measurements of the set are 8 1/2 inches long by 6 1/4 inches high by 3 3/4 inches deep—it weighs approximately 5 pounds. The following type vacuum tubes are utilized: one -36, one -38, one -39 and one KR-1 mercury-vapor rectifier tube. The set and a Utah 6-inch speaker are contained in a bakelite cabinet, which is available in black, walnut and mahogany finish.

Maker—International Radio Corp., Ann Arbor, Mich.

A Convenient Mounting for Meter Fuses

Description—The above photograph illustrates the application of the new jack

type mounting for the employment of Littlefuses with multi-range meters. This type of mounting permits the user to apply the correct size of fuse for each scale reading and also allows quick and easy shifting to the different meter ranges. The bakelite barrel of the mounting enclosing the fuse is merely unscrewed to make fuse renewals. The mounting itself is secured under the meter binding post. A pin plug is made fast to the connecting lead and it is inserted into the jack to complete the circuit. Littlefuses made for the protection of delicate meters

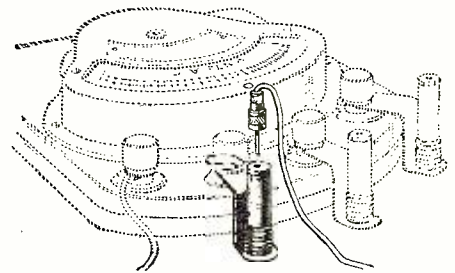

are available in 1/100, 1/2, 1/8, 1/4, 3/8, 1/2, 3/4, 1 and 2-ampere capacity.

Maker—Littlefuse Laboratories, 1772 Wilson Ave., Chicago, Ill.

Automobile "B" Battery Eliminator

Description—The "Genemotor" is a generator and motor combined in a single unit, as its name implies. The model 4680 eliminator is designed to take the place of B batteries in automobile, airplane and motorboat radio receiver installations. This company also has a model to operate a receiver from a 32-volt farm lighting plant. The different units operate from 6, 12, 32 and 110-volt input with an output voltage of 180 to 230

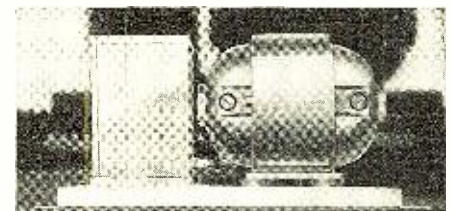

volts. The standard model No. 4680 delivers 180 volts at 30 ma. with a drain on the 6-volt storage A battery of 2.2 amperes. The overall dimensions of this unit are 6 3/4 inches by 6 inches long by 4 1/2 inches deep. The weight is 13 pounds.

Maker—Carter Genemotor Corp., 361 W. Superior St., Chicago, Ill.

Line Voltage Regulator

Description—The Amperite self-adjusting line voltage control is now available with a standard screw-type base. The manufacturer also announces an improvement in the regulating characteristics of the new control. These controls are designed to absorb 25 times as much voltage as ordinary wire. This means it can decrease voltage variations 25 times faster than an ordinary resistance. The following is a simple method for determining the correct Amperite for any set or

load. It has been found by actual test that the current consumption of standard receivers will average approximately 0.1 ampere per tube. Thus for a seven-tube set drawing 0.7 ampere, the Amperite 7-A-5 type is recommended. A 9-tube set drawing 0.9 ampere

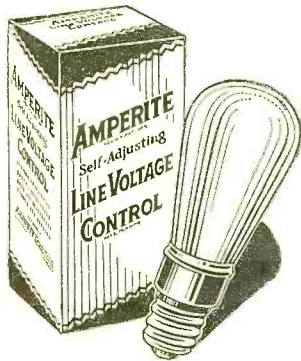

requires the Amperite 9-A-5 type control. The exceptions to this rule are receivers using the -50 type power tube. The control can be used on either 110 or 220-volt receivers. These control units are finding wide application on railroads for signal light systems, in electric companies for motor generators and in automobile concerns for use in efficiency meters.

Maker—Amperite Corp., 561 Broadway, New York City.

Microphone

Description—This inexpensive single-button microphone, known as the "Magyc-mike," is mounted with rubber suspensions, providing a floating diaphragm, and the table stand is made from cast composition metal to eliminate reverberation. The microphone is designed to simplify connections to a radio

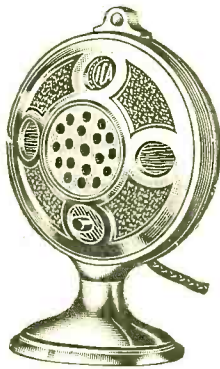

receiver for reproducing your own entertainment in the home. When the microphone is properly connected, the radio program is cut out by pressing the switch button on the microphone. You can then make any announcements. Releasing the switch button will permit the radio program to again be heard. The microphone does not need to be disconnected when not in use. The manufacturer supplies with each unit instructions for connecting the microphone to any a.c., d.c. or battery-operated receiver.

Maker—Insuline Corp. of America, 25 Park Place, New York City.

A Six-Volt Storage Battery Converter

Description—This converter, operating from a 6-volt storage battery, delivers up to 60 watts, 110-volt, 60-cycle a.c. It is especially applicable to the operation of standard midget a.c. radio receivers or small public-address systems for installations in automobile, boat or airplane. For an automobile installation the converter is mounted on the cowl under the hood and the lead wires are brought through the cowl to the

(Continued on page 500)

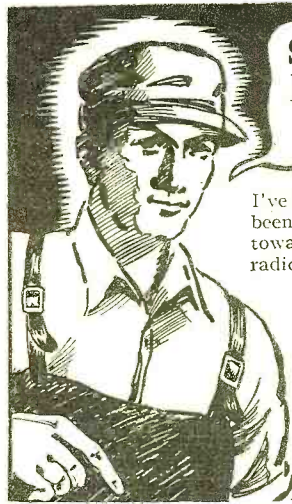

SERVICE MEN!! Here's How You Can Build This "ECONOMY EIGHT"

I've noticed that there's been a constant trend toward simplification in radio design so that it's now easier to construct an 8 tube A. C. receiver than it was formerly in the case of a 3 tube battery set.

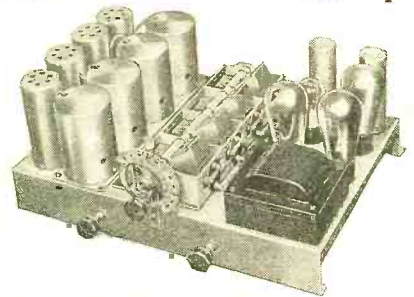

For instance, there's the ECONOMY EIGHT. You can now buy the complete kit of parts from WHOLESALE RADIO SERVICE CO. for only \$13.75! And what a radio! It has everything—great tone quality, sharp tuning and high sensitivity! Get the facts on this great Buy!

FREE 1933 Catalog

when you ask for facts about the "ECONOMY EIGHT"—be sure to ask for our new 1933 Catalog. It's FREE! Page after page of the greatest Bargains in the Radio Field.

REPLACEMENT PARTS AT LOWEST PRICES

When you want REPLACEMENT PARTS—head for WHOLESALE! We carry a tremendous stock on hand to insure fast delivery. TRUSTEST PARTS, PUBLIC ADDRESS EQUIPMENT, TUBES, KITS, etc., at LOWEST WHOLESALE PRICES. Everything is listed in our new 1933 catalog at Bargain Prices. Get your copy now from Radio Headquarters.

THIS COUPON brings THIS CATALOG

Wholesale Radio Service, Inc.
100 Sixth Avenue, New York, N. Y., Dept. N-23
Send me details of the "Economy Eight." Also your new, 1933 FREE Catalog.
Name.....
Address.....
Town..... State.....



Follow the Direct Road to Success

Do you want a better position and a larger pay envelope? Learn mathematics! Not a day passes in which you do not have to use mathematics in your work. A thorough knowledge of it makes clear so many things which are puzzling you today. You can now have a mathematics education without having to go back to school or taking an expensive correspondence course.

At Last! Mathematics Self-Taught This Simple, Easy Way!

Now you can have this easy method which has been worked out by an expert for those who do not wish to give the time and money required by other methods of mathematical study. A very simple and extremely interesting group of books has been prepared for you by a man who has devoted his life to teaching practical men the fundamentals of this important subject.

MATHEMATICS FOR SELF-STUDY

By J. E. Thompson, B.S. in E.E., A.M., Dept. of Mathematics, Pratt Institute, Brooklyn. These books start right from the beginning with a review of arithmetic that gives you all special short-cuts and trick problems that save countless hours of your time. Then they go right into higher mathematics and show you how simple it is when an expert explains it for you. In no time at all you will be tackling with ease the most difficult question on this subject.

An Expert's Simplified Methods

Mr. Thompson, the author of these books, has had many years' experience in mathematical training. He presents each practical method and problem in the clearest, simplest way. He gets right down to the kind of information that you need in your daily work.

A Complete Reference Work on Mathematics in These Four Inexpensive Books

Arithmetic for the Practical Man. Algebra for the Practical Man. Trigonometry for the Practical Man. Calculus for the Practical Man. 4 Volumes—1240 Pages—Illustrated.

Send No Money

Examine These Books for 10 Days FREE MAIL THIS COUPON

D. Van Nostrand Co., Inc. 250 Fourth Ave., New York

Send me MATHEMATICS FOR SELF-STUDY in 4 volumes. Within 10 days I will either return the books or send you \$1.65 as first payment and \$2.00 per month for 3 months—total \$7.65. (3% discount for cash.) (R.N. 2-33)

Name.....
Address.....
City and State.....
Business Connection.....
Reference.....

Look up any mathematical problem that puzzles you in these books and see how quickly you get the solution.

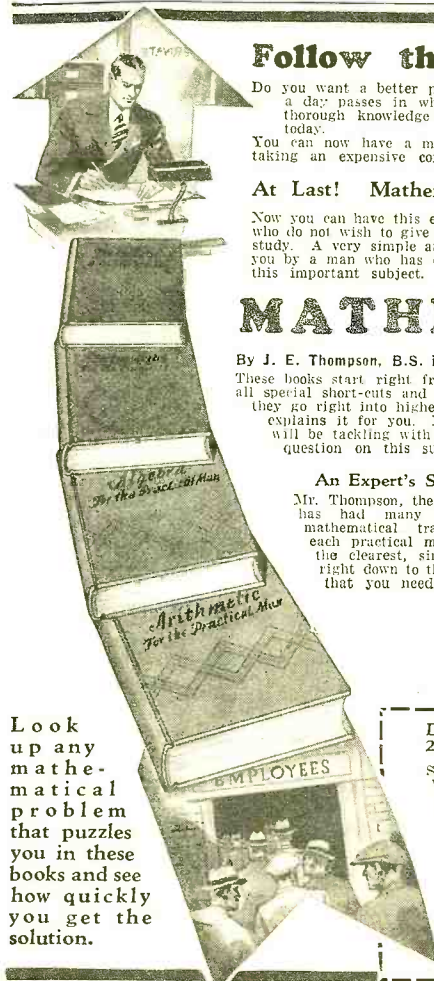

HOW TO BUILD, TEST AND REPAIR RADIO SETS



Radio Construction Library

Including Television and Short-Wave Receivers
3 Volumes, 6 x 9—993 pages, 561 illustrations.

This practical Library includes: **PRACTICAL RADIO**—The fundamental principles of radio, presented in an understandable manner. Illustrated with working diagrams. **PRACTICAL RADIO CONSTRUCTION AND REPAIR**—Methods of locating trouble and reception faults and making workmanlike repairs. Discusses modern Short Wave Receivers fully. **RADIO RECEIVING TUBES**—Principles underlying the operation of all vacuum tubes and their use in reception, remote control and precision measurements.

The Library is up-to-the-minute in every respect and is based on the very latest developments in the design and manufacture of equipment.

**10 Days' Free Examination
Easy Terms**

FREE EXAMINATION COUPON

McGraw-Hill Book Company, Inc.
330 West 42nd Street, New York

Send me the new **RADIO CONSTRUCTION LIBRARY**, three volumes, for 10 days' free examination. If satisfactory I will send \$1.50 in ten days, and \$2.00 a month until \$7.50 has been paid. If not wanted I will return the books.

Name

Home Address

City and State

Position

Name of Company.....RN-2-33

I. C. A. VARIO-DAPTER TESTS 54 TYPES OF TUBES!

No need to junk expensive equipment now that you can have this marvelous unit. Provides for all type tubes—present and **FUTURE!** Checks 5, 6 and 7 prong types including 29, 33, 34, 39, 41, 42, 43, 44, 46, 47, 51, 55 (diode) 56, 57, 58, 64, 65, 67, 69 (both plates of 80, 82, 83) 85, 89, Wunderlich, 91 (triple-twin) 93, 95. Your jobber can supply you or order direct from us using the coupon. Instruction sheet with each unit. Dealers Discount 40% off.



LIST PRICE
\$5.00

Insuline Corp. of America, 23-25 Park Place, N. Y. C. RN

Enclosed find check—money order for \$3.00. Send me a VARIO-DAPTER, postpaid.

NAME.....

Street.....

CITY.....STATE.....

PATENTS

Write for Free Information. **HOW TO OBTAIN A PATENT AND RECORD OF INVENTION**—or send drawing or model for examination.

MILLER & MILLER, Patent Attorneys
FORMER MEMBER EXAMINING CORPS U. S. PATENT OFFICE
1006 Woolworth Bldg., Dept. H, New York
206 Earle Building, Washington, D. C.

PATENTS TRADE MARKS COPYRIGHTS

"Little Ideas May Have Big Commercial Possibilities"
PROTECT THEM BY PATENTS
Send for our Free book, "HOW TO OBTAIN A PATENT" and "Record of Invention" blank.
Prompt Service—Reasonable Charges—Deferred Payments.
HIGHEST REFERENCES
VICTOR J. EVANS & CO.
Registered Patent Attorneys—Established 1898
622BB Victor Building, Washington, D. C.

Latest Radio Patents

A description of the outstanding patented inventions on radio, television, acoustics and electronics as they are granted by the United States Patent Office. This information will be found a handy radio reference for inventors, engineers, set designers and production men in establishing the dates of record, as well as describing the important radio inventions

By Ben J. Chromy*

1,863,840. **LOUDSPEAKER APPARATUS AND METHODS.** REGINALD A. FESSENDEN, Chestnut Hill, Mass., assignor to Submarine Signal Company, Portland, Me., a Corporation of Maine. Original applica-

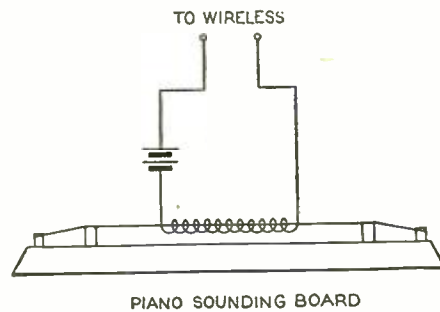

tion filed May 21, 1924, Serial No. 714,899, Patent No. 1,854,025, dated Apr. 12, 1932. Divided and this application filed Jan. 6, 1927. Serial No. 159,366. 17 Claims.

2. In the art of reproducing sounds transmitted electrically, the method of eliminating the effects of static and other disturbing electrical impulses which comprises actuating, by the received impulses, the sounding board of a piano as a loudspeaker.

8. A loudspeaker comprising a piano sound board and loudspeaker electrical mechanism attached to said sound board for actuating the same.

17. A sound producing device comprising a piano sounding board, a plurality of magnetostriction wires stretched across said board and means for energizing the same.

1,861,232. **FOUR-ELECTRODE VALVE AND THE OPERATION THEREOF.** ERNEST WALTER BRUDENELL GILL, Oxford,

* Patent Attorney, Washington, D. C.

What's New in Radio

(Continued from page 499)

switch control which mounts on the dash. The converter is sturdily constructed and its

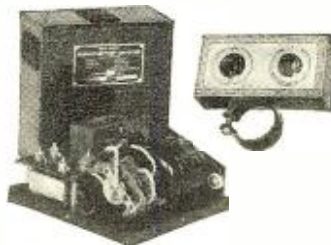

dimensions are 7¼ inches by 6¾ inches by 3½ inches. It weighs fourteen pounds.

Maker—General Talkie Equipment Co., Inc., 175 Fifth Ave., New York City.

England, assignor to Radio Corporation of America, a Corporation of Delaware. Filed Feb. 1, 1926., Serial No. 85,355, and in Great Britain Feb. 18, 1925. 11 Claims.

1. In radio apparatus the combination of a four-electrode valve having an outer grid, inner grid, anode and cathode, means for maintaining the anode potential at a positive value with respect to the cathode, means for applying to the outer grid a potential negative with respect to the cathode, and means for applying a positive potential to the inner

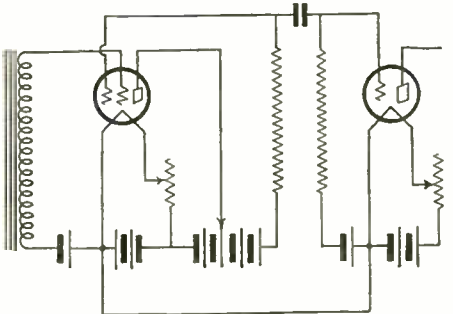

grid, the whole arrangement being such that increase in inner grid potential beyond a critical value causes a decrease in inner grid current.

1,861,739. **RADIO RECEIVER.** EARL W. DAVIDSON, Terre Hill, Pa. Filed Jan. 12, 1928. Serial No. 246,160. 5 Claims.

1. A radio receiving circuit comprising the combination with an aerial, a coupler, and an inductance, of a plurality of electron

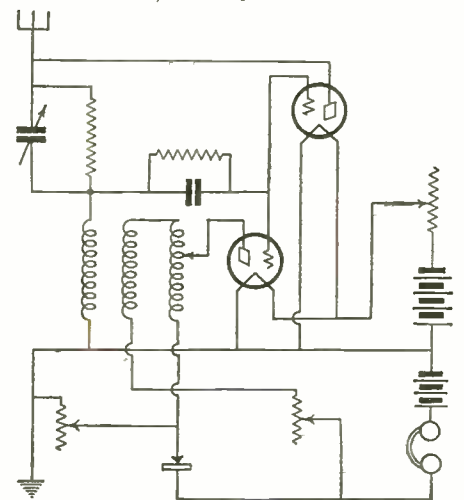

tubes having the grids thereof connected to one side of the coupler, the plate of one tube is connected to the aerial and the plate of the other tube connected to a tap in said inductance, said inductance being connected at one end to the secondary of said coupler

and at the other end to the ground and to the output.

1,868,033. MODULATING ARRANGEMENT FOR TRANSMITTER TUBES. RUDOLF URTEL, Berlin, Germany, assignor to Telefunken Gesellschaft Für Drahtlose Telegraphie m. b. H., Berlin, Germany, a Corporation of Germany. Filed Jan. 24, 1929, Serial No. 334,700, and in Germany Feb. 13, 1928. 6 Claims.

3. A thermionic discharge device comprising a cathode, an anode and a control elec-

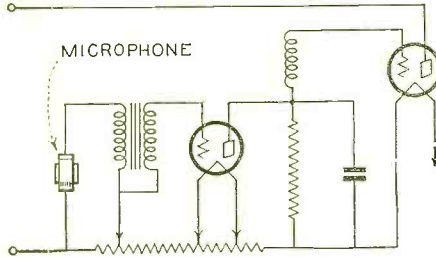

trode, a circuit connecting said anode and cathode including a source of current and a resistance in series, a second circuit connecting said control electrode and cathode, said second named circuit comprising a space current device and a portion of said resistance in series and means shunted across another portion of said resistance for controlling the value of the space current through said space current device.

Public Address

(Continued from page 471)

is now ready to be installed in the rack. First the amplifier is set on the base-plate and a No. 14-20 square-head screw, 1 inch long, is slipped through the holes in the protruded edge of the amplifier chassis, then through the base-plate and the cross-supports. When installing the phonograph motor base, tilt it slightly, as shown in the illustration in Figure 2, so that it will slip in easily and come to rest over the proper holes in the cross-supports to which it is then fastened. At this stage the constructor can mount and screw in place the 4-inch by 5-inch by 1½-inch iron angle supports to the wooden base and vertical steel uprights.

This phonograph-power amplifier combination for rack and panel design is now ready for operation, and it is only necessary to connect the output of the pick-up matching transformer to the input circuit of the amplifier and complete the connections to the speakers.

The control and mixing panel, which is to be described in the next article, will permit any desired degree of volume of music or speech to be superimposed over phonograph, microphone or radio reproduction.

The radio tuner designed for this rack-and-panel sound-reproducing system is a 7-tube superheterodyne circuit featuring push-pull detection, automatic volume control and meter tuning.

Institute Employment Service

Manufacturers who, from time to time, have occasion to employ engineers for radio work will find it advantageous to communicate with the Institute of Radio Engineers, 33 West 39th Street, New York City. The Institute has a classified list of experienced radio men seeking employment. Good men are available for practically every type of radio work. This service is rendered without cost to either the employer or employed. Any prospective employer wishing to take advantage of this service can do so by simply addressing a letter to the Institute Employment Service.

Write for this VALUABLE BOOK TO-DAY! It is FREE!

Contains thousands of listings from a log or screw to a 100 Watt Dual-Channel Rack and Panel Amplifier

1933 COAST-TO-COAST RADIO PUBLIC ADDRESS AMPLIFIERS TREATISE

FREE

We are Manufacturers of Public Address Amplifiers ranging from 4 to 100 Watts. Get our Quotations on complete Single and Dual Channel, Sound Truck and semi-Stationary P.A. Installations. **WE SAVE YOU BIG MONEY!**

Preferred in this Rack and Panel is the Four Stage Heavy Duty "26 Watt" Class B-1 Amplifier. It was described in the December, 1932 issue of *Radio News* (Consumer's Choice) and has been the most popular amplifier in the country. It is a "Push-Push" Class B-1 Amplifier with a 26 Watt output. It is a "Push-Push" Class B-1 Amplifier with a 26 Watt output. It is a "Push-Push" Class B-1 Amplifier with a 26 Watt output.

26 WATT

\$29.50 Class B-1

LOW DRAIN MICROPHONE-Phono and Radio PUBLIC ADDRESS AMPLIFIER

For Sound Trucks and all Stationary Installations.

CONSUMES ONLY 55 WATTS!

SPECIFICATIONS: GAIN: 86 DB. at 1000 cycles; INPUT To Grid of 1st Tube, through a universal volume control; THREE STAGES: 1-57 Class "A" Input RECIPIER. OUTPUT: 10,000 ohms to plates of both 59 Tubes; POWER CONSUMPTION: 85 WATTS AT FULL LOAD—55 WATTS AT NO LOAD! Plug into any 110-120-volt, 50 to 60 cycle A.C. socket; SIZE: 13 1/2 in. long, 9 1/2 in. wide, 3 1/2 in. tall. Kit of Complete Parts, with Blue Prints, etc. \$24.50. Factory Wired—Ready for Immediate Operation. \$29.50. Set of 3 RCA Tubes (1-57, 5-59, 1-59) \$4.67. Universal PHONO-MIKE Input Transformer \$5.50. Universal Output Transformer (10,000 ohms, 15, 7 1/2, 3 1/2 ohms) \$4.50.

COAST-TO-COAST-RADIO-CORP.
123 N-WEST 17TH STREET... NEW YORK, N. Y.

Get Started in RADIO



Write for free booklet telling about this growing and most promising industry. The radio operator is an officer aboard ship. His work is light, pleasant and interesting. He has many opportunities to travel to all parts of the world.

EDUCATIONAL DEPARTMENT

WEST YMCA 17 W. 63d St. New York

ADVENTURE!

DANNY DUGAN spurred his roan and galloped down into the basin... right into the discovery of a body... directly into a feud between rival ranchmen... straight into conflict with Whip Clayborn! Read "Bloody Acres."

In The February
Wild West Stories & Complete Novel Magazine
25¢ At All Newsstands

Radio Noises and Their Cure
by Tohe Deutschmann
62 ARTICLES—200 ILLUSTRATIONS
Send 50c for your copy today. (75c Canada and Foreign Countries.)
Newark Electric Co.
"A Radio Service Institution"
228 W. Madison St. Chicago, Ill.

MACY

Square Flare Trumpets

Especially designed for sound truck use! All joints are metal re-inforced. Aluminum tone arms. Aluminum finish and standard threads fully weather proof.

"STANDARDIZE ON MACY"

PRICES HAVE BEEN REDUCED

in keeping with the trend of the times, but Macy quality has been rigidly maintained.



BELL TRUMPET GIANT ELECTRO DYNAMIC UNIT FIELD EXCITER

Write for Literature and Price List on Our Latest Improvements

MACY ELECTRICAL PRODUCTS CO., INC.
1451 39th St. Brooklyn, N. Y.

WE WANT...

EXPERIENCED RADIO MEN who want MORE MONEY! Our advanced course in RADIO and TELEVISION ENGINEERING is your "short cut" to success—this course is not for beginners, we want to help you Radio men who want to get ahead.

Write today for our 28-page free booklet explaining the advanced course in Radio and Television Engineering.

CAPITOL RADIO ENGINEERING INSTITUTE
14th and Park Rd., N. W., Washington, D. C. Dept. RN-2

BURNS MONTHLY BULLETIN RADIO SERVICE PARTS

Only perpetually up-to-date complete parts catalogue available to service men and dealers. Changes every month. Keeps you up to the minute on all the latest price changes. Get these bulletins before you buy. Sent FREE to bona-fide service men and dealers. Write for the BURNS MONTHLY BULLETIN on your letter-head.

THE BURNS RADIO CO., 138 E. Third St., DAYTON, OHIO



**Unless You Have Volume II
RIDER'S
Perpetual Trouble Shooter's Manual**
You are missing wiring diagrams
and service data on
1927 1928 1929 1930 1931

receivers. These receivers shown in Volume II—do not duplicate any shown in Volume I. They are the diagrams which were not available when Volume I was printed. Now is the time to get your Volume II. More and more of these receivers are coming into your shop for service. . . . Be wise. . . . Do not wait until you are stuck on a job because you do not have the wiring diagram . . . service data. Get your copy of Volume II today. You will find that it contains the kind of service information which you will be able to use immediately. . . . The money you spend for this volume is working immediately. . . . 780 pages in Volume II. 50 pages of point to point resistance data. . . . The contents of Volume II will enable you to apply your set tester—Analyzer—diagnoser and ohmmeter to the greatest advantage.

Volume II. Price \$5.00 postpaid
FREE! Send for color code chart of resistors used in Atwater-Kent receivers.

RADIO TREATISE CO., Inc.

1440 Broadway New York City

TOMLAB
**Moving Coil
MICROPHONE
Type MC30**

The greatest advance in commercial transmitters! A moving coil, electro-dynamic, water-proof and blast proof laboratory standard instrument.

The TomLab moving coil microphone has many advantages in use. It is permanent—and stays in adjustment, regardless of weather conditions. It maintains its quality of response under wet and humid conditions, and changes in temperature up to 200° F. This microphone is ruggedly constructed to withstand ordinary rough handling. The 30 ohm twisted pair can be run 1000 feet to the speech input amplifier. The MC30 is silent, permitting unlimited amplification. The frequency response is substantially flat. It is easy to use, on TomLab attractive stands, or on its own base.

Inquiries are invited, and will have prompt and courteous attention. Catalogue on request.

THOMASTON LABORATORIES, INC.
135 Liberty St., N.Y. City

New "Super-Six" Midget

(Continued from page 465)

the secondary 110 turns of the same kind of wire. It is fitted with a bracket as shown in Figure 3. After the coil has been wound to suit, it should be dipped in paraffin or otherwise covered with a moisture-proof substance to prevent the absorption of moisture.

The oscillator coil (Figure 4) is somewhat more difficult to construct, and the directions must be adhered to if the tuning condensers are to track when completed. It consists of two coils wound separately. The inner winding is on the standard 1¼-inch form and consists of 62 turns. The outer coil is wound on a paper form which just fits around the first coil and consists of two windings, one of 30 turns and the other of 15. Number 28 enameled wire is used for all these coils. The 30-turn winding is used as the regeneration coil while the 62-turn section is the tuned portion of the oscillator circuit. The 15 turns serves as the oscillator coupling coil.

The entire coil unit is mounted on a Hammarlund screw type dual condenser, 10-70 mmfd., C13. One section of this condenser is used across the oscillator coil as a trimmer, the other section across the padding condenser as a trimmer.

A certain amount of care must be taken in assembling the parts in their proper order, as it will be noticed that much of the set is inaccessible. Hence a few suggestions will be given as to those parts which must be mounted first in order to avoid trouble. It will be found advisable to mount the power transformer temporarily and write down a list of all connections which cannot be reached when it is in place. These include the -80 socket, the pentode socket and some terminals on the -56 socket. Remove the transformer and mount the sockets and shield can bases, as these parts use the same mounting screws. Connect the grid return resistor (R9) on the -47 from grid to ground, directly under the power transformer. The filaments should be wired and leads left of sufficient length to reach the proper terminals of the power transformer.

The screen-grid by-pass condenser, the detector by-pass and cathode resistor will all mount under the first intermediate transformer which in the photographs is located next to the tuning condenser. Leads should then be soldered on all socket connections which will be covered by the power transformer, including a grid lead to the pentode. The plate of the pentode can be connected to the output transformer, as can the suppressor grid. The filter condensers can be mounted and partially wired in.

As soon as the power transformer is placed, make all of the filament connections, -80 plate leads and center-tap to ground connections. This will finish the wiring of the power transformer. The intermediate transformers can now be placed and wired as far as possible, leaving generous leads to any connection which it is not possible to make at the time. The antenna coil and tuning condenser can now be mounted, the former on one of the mounting screws for the first filter condenser and the latter by the single-hole mounting nut on the shaft. The high-voltage lead from the filter circuit is brought up to an insulated screw shown in the center of the chassis fastened onto the power transformer mounting bolt. It carries two solder lugs, and the oscillator resistor and detector plate resistor have one end each soldered directly onto these lugs. The last unit to be mounted is the oscillator coil, and all connections to it must be made with flexible leads soldered to the proper connections before placing it.

Turning the set upright, the volume control may be mounted and the resistor in the cathode circuit fastened between it and the by-pass condenser. The local-long distance switch (SW2) goes on the other side, its resistor being mounted in a vertical position directly above it. The grid clips can now be soldered on, and when the dial and dial light have been fastened in place the set is ready for adjusting.

The tuning condensers should be set to pick up some local station at the high-frequency end of the dial. The intermediate tuning condensers should then be screwed all the way in and backed off about two turns. In this way they are all set at about the same point. With the volume control at maximum, rotate the oscillator trimming condenser back and forth. This condenser screw is reached through a hole in the chassis on the left side looking from the front. If this adjustment will not give results, try rotating the tuning dial a little to either side and repeating the procedure. If none of these are effective, turn all intermediate tuning condensers in half a turn and proceed as before. Should this prove ineffective, the set will have to be serviced to determine whether all tubes have the proper voltage and current.

When a signal is located, rotate the tuning condenser for maximum volume and readjust the oscillator trimmer. The intermediate tuning condensers should now be adjusted separately for the loudest signal. Next tune down to the low-frequency end of the dial and adjust for maximum volume, using the trimmer for the padding condenser and the antenna trimmer. It may be found that the high end will then be a little off, and it may be necessary to readjust the intermediate frequency a little in order to make the set track over the entire dial.

It will be found that local stations will come through with such strength that it is not possible to control them with the volume control even in the off position. Hence, for the constructor who lives in a large city where there may be one or more powerful stations, a local-long distance switch has been added which places about 1800 ohms in the antenna. This value may be determined experimentally and depends a great deal on the location. The selectivity will be found to be comparable to that obtained from a two or three-stage t.r.f. receiver, and on locals it is usually much better. Image frequency will not give as much trouble as might be expected. Clear reception has been obtained on stations all over the United States over a period of a week. The receiver was taken to Lawrence, Kansas, and tested with an antenna strung around the moulding of a small room. A station was received on practically every point on the dial, including all of the Chicago stations, KFI, WLW and all of the more powerful long-distance stations.

List of Parts

- C1, C2—Potter dry electrolytic condensers, 8 microfarads, 450 volts
- C3—Potter Master by-pass condenser, .006 microfarad, 450 volts
- C4—Shielded by-pass condenser, .25 microfarad
- C5, C6, C7—Potter Master by-pass condenser, .1 microfarad, 450 volts
- C8—Potter Master by-pass condenser, .25 microfarad, 450 volts
- C9—Potter Master by-pass condenser, .5 microfarad, 450 volts
- C10, C11—Mica condensers, .0005 mfd.
- C12—Mica condenser, .002 mfd.

- C13—Hammarlund i.f. tuning condenser, dual type, 10-70 mmfd.
- C15—Radio Condenser Company compact double-section tuning condenser, .000375 mfd.
- C14, C16—Hammarlund intermediate tuning condenser, dual type, 70-140 mmfd.
- L1—Antenna coil (see text)
- L2—Oscillator coil (see text)
- L3—85 millihenry r.f. choke coil
- R1—Clarostat 1000-ohm potentiometer with switch
- R2—300-ohm I.R.C. resistor
- R3—500-ohm I.R.C. resistor
- R4—1000-ohm I.R.C. resistor
- R5—20,000-ohm I.R.C. resistor
- R6—75,000-ohm I.R.C. resistor
- R7—30,000-ohm I.R.C. resistor
- R8—250,000-ohm I.R.C. resistor
- R9—1-megohm I.R.C. resistor
- R10—Fixed resistor, 1800 ohms
- T1—Stancor power transformer, small type, with core dimensions 4 inches by 3 3/4 inches; windings as follows: 700-volt center-tapped, 5 volts at 2 amp.; 2.5 volts at 1.75 amp. center tapped, 2.5 volts at 4 amp.
- T2, T3—I.F. transformers (see text)
- Utah 6-inch dynamic speaker with 2500-ohm field, equipped with output transformer to match single -47 tube
- 3 Eby wafer sockets, 6 prongs
- 2 Eby wafer sockets, 5 prongs
- 1 Eby wafer socket, 4 prongs
- 3 ICA midget shields for -50 series tubes
- 2 coil shields, 2-inch diameter
- 3 grid clips
- 1 Crowe midget dial with moving spotlight
- Aluminum for chassis, wire, solder, screws, etc.

Home Recording

(Continued from page 467)

and in addition a comfortable reserve power. That is what might be called normal gain for the writer's system—an average value of 1 watt in audio energy delivered to the cutting pick-up (as shown by an average reading of .2 ma. on the volume-level indicator) for normal voices one or two feet from the microphone. However, there are many occasions when the gain must be greatly varied by means of the volume controls, in order to keep the record-cutting energy at the optimum of 1 watt level regardless of pick-up variations. If performers move too close to the microphone, the "engineer" (usually the amateur owner of the home recording apparatus) can either push them back or reduce the electrical gain. Needless to say, the latter action is simpler and less likely to ruin the record. Then, too, people's voices vary greatly in volume under the stress of emotion and excitement. They should be cautioned in advance not to talk too loud or to speak directly into the microphone, but they are likely to forget these cautions. If the engineer tells them to lower their voices while the pick-up is on the record, his request registers and spoils any performance that is really good; hence, he must use the electrical controls. The same thing is done at broadcasting studios in order to avoid overloading the transmitter on musical or vocal crescendos. There is quite a knack, incidentally, in anticipating such volume increases so as to use the volume control in time to do any good, only to be acquired by much practice. If the "engineer" is also the "announcer," he will find plenty to do during the actual recording.

In the last article of this series, Lieutenant Wenstrom will go further with his suggestions on studio technique as applied in the home.

THE EDITORS.

15 to 250-Meter Super

(Continued from page 484)

W9FDI, W9GVL, VK3ME, W5ALI, W6DCQ and a great many c.w. stations from the same districts. I am not listing all other stations heard on 'phone from each and every district in the United States. Mexican stations were also heard among those not listed.

"Not the least astonishing is my partial log of foreign broadcasting which I consider an achievement in reception in my locality, although I understand that this performance is nothing novel for the 'Pro.' On July 20th at 3:45 p.m., heard, and held during the entire performance of a minstrel troupe, the English station G5SW. Then, at 4 p.m., the Italian station 'Radio Napoli,' broadcasting the entire Beethoven Symphony, announced in Italian by a lady announcer, was received.

"On July 21st, at 6 p.m., I went back after G5SW, and there it was, broadcasting popular selections among which was the 'Lullaby of the Leaves,' which the announcer announced as 'Lullaby of the Trees.'

"At 5:50 p.m., French FYA was brought in with a program ending under the direction of Mons. Marseille Deillon. The announcer gave a résumé of the programs to follow for the week of July 22nd.

"In addition to those listed above, numerous U. S. police radio stations were heard but not logged for lack of time.

"This receiver has given me an enormous amount of enthusiasm for the high frequencies, so that I have since been spending more time at my own receiver at my amateur station in an effort to duplicate the results of the 'Pro'—but with little success."

The next report was obtained from Mr. Carlton A. Weidenhammer, owner of amateur station W1ZL, Bridgeport, and a member of the staff at station WICC. Mr. Weidenhammer reported as follows in a letter dated August 10th. By way of explanation, it might be said that Mr. Weidenhammer's report covers only reception on the 40-meter amateur band, apparently due to the fact that the receiver was equipped only with one set of coils at the time.

"My receiving location is, unfortunately, a very noisy one. It is at the intersection of two prominent traffic arteries in a rather busy section of Bridgeport. Under such unfavorable conditions, the receiver performed extremely well. It demonstrated a high degree of sensitivity and a very low noise level and was equally effective in the reception of phone and c.w. stations. Its ease of control, its band-spread and its splendid quality of output were happy features that particularly impressed me.

"The attached log is the record of an hour and sixteen minutes of listening on a poor night. Conditions were far from favorable, as local stations were coming in at an hour when skip should have made them inaudible. In spite of that, however, DX stations came through surprisingly well.

"Twelve o'clock midnight, August 5, 1932, until 1:16 a.m., August 6, 1932. All calls heard were logged on the 7-megacycle band. 12:00 midnight, CM7SH, QSA4-R7; 12:04 a.m., VP2PA, QSA4-R8; 12:14 a.m., W7BBJ, QSA3-R5; 12:15 1/2 a.m., CM5OF, QSA4-R6; 12:24 a.m., W6DZU, QSA4-R6; 12:25 a.m., CM2DO, QSA5-R6; 12:27 a.m., CM5AG, QSA3-R7-8; 12:31 a.m., W6MV, QSV3-R4; 12:39 a.m., SM5PM, QSA5-R8; 12:40 a.m., W6EEP, QSA3-R6; 12:54 a.m., W6EGH, QSA5-R7; 12:55 a.m., OA4Z, QSA3-R5; 1:16 a.m., SM2SG, QSA5-R7."

After the new "Pro" had been placed on the market, one was obtained from regular stock and was turned over to Mr. Everett M. Walker, owner of amateur station W2MW and well known in radio circles. The following is quoted from the report submitted by Mr. Walker:

NEW SENSATIONAL OFFER

Learn **RADIO**
PAY FOR TRAINING
AFTER YOU GRADUATE

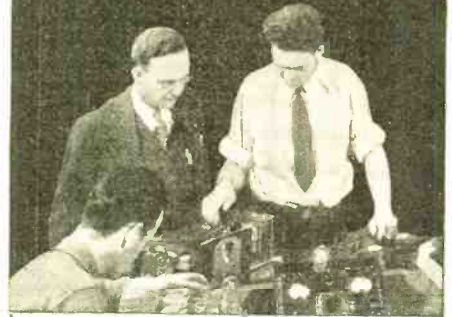

To a few honest fellows I am offering an opportunity to get a training and pay for it after they graduate in easy monthly payments. You get Free Employment Service for life. And if you need part-time work while at school to help pay expenses, we'll help you get it. Coyne is 33 years old. Coyne Training is tested—You can find out everything absolutely free. Just mail the Coupon for My Big Free Book.

Jobs Leading to Salaries of \$50 a Week and Up

Jobs as Designer, Inspector and Tester—as Radio Salesman and in Service and Installation—as Operator or Manager of a Broadcasting Station—as Wireless Operator on a Ship or Airplane, as a Talking Picture or Sound Expert—Hundreds of Opportunities for fascinating Big Pay Jobs!

10 Weeks' Shop Training AT COYNE IN CHICAGO

We don't teach you from books. We teach you by Actual Work on a great outlay of Radio, Broadcasting, Television, Talking Picture and Code equipment. And because we cut out useless theory, you get a practical training in 10 weeks.

TELEVISION Is Now Here!

And Television is already here! Soon there will be a demand for Television Experts! The man who sets in on the ground floor of Television can have dozens of opportunities in this new field! Learn Television at Coyne on the very latest Television equipment.

Talking Pictures A Big Field

Talking Pictures, and Public Address Systems offer golden opportunities to the Trained Radio Man. Learn at Coyne on actual Talking Picture and Sound Reproduction equipment.

Get the Facts

Don't spend your life slaving away in some dull, hopeless job! Don't be satisfied to Work for a mere \$20 or \$30 a week. Let me show you how to make Real Money in Radio—the fastest-growing, biggest money-making game on earth! Get my big Free book and all details of my pay after graduation offer. Mail the coupon today.

H. C. LEWIS, President
Radio Division, Coyne Electrical School
500 S. Paulina St., Dept. 23-86, Chicago, Ill.

Dear Mr. Lewis:

Send me your big Free Book; details of your Free Employment Service; and tell me all about your special offer of allowing me to pay for training on easy monthly terms after graduation.

Name

Address

City..... State.....



A NEW FEDERATED BRANCH READY TO SERVE THE WEST

Another link has been cast in the expansion plans of Federated Purchaser. With eight distributing points we are ready to cater to the entire nation with the same fast service now enjoyed by our appreciative customers. Radio men at the most remote points find that this splendid delivery service makes each Federated branch a local supplier.

RADIO DEALERS AND SERVICEMEN

4,000 radio items at real bargain prices are stocked at each branch. Radio material for Dealers, Servicemen, Experimenters, and Public Address Specialists at tremendous savings. Send your name and address to any of the branches listed below for a copy of the 108 page "RADIO BARGAIN NEWS."

BUY FROM OUR NEAREST BRANCH START SAVING ON RADIO SUPPLIES NOW.

Federated Purchaser Inc.

25 Park Place
New York City
1331 So. Michigan Ave.
Chicago, Ill.
631 Spring St. N.W.
Atlanta, Ga.
2909 N. Broad St.
Philadelphia, Pa.

169 Washington St.
New York City
9226 Merrick Rd.
Jamaica, N. Y.
273 Central Ave.
Newark, N. J.
51 East 3rd St.
Mount Vernon, N. Y.



Forty In One Tube Checker Adapter

950XYL Here's what you have been looking for—highgrade tube checking adapter—nothing like it—tests the new tubes including the 7-prong—over 40 in all. No leads, jacks, plugs or complicated directions—A typical Na-Aid product. List \$6.00, Serviceman's price postpaid \$3.75. Send for catalog—new Analyzer Plugs—Combination sockets—Coil forms—Code Sets, etc. Send 10c for 26-page adapter data sheets with 300 diagrams, new tube connections, etc.

Alden Manufacturing Company
Dept. N2 Brockton, Mass.

LYNCH ANTENNA SYSTEMS

\$5.00
LIST
COMPLETE

More Profit
Lower Price
Easier to Sell
Easier to Install
Better Results

Eliminates Man-made static and permits the use of several receivers on a single antenna.

Dealers - Servicemen

If your jobber cannot supply you, write his name and address on your letterhead and attach this ad with check for \$3.00. Kit will be sent prepaid and sale credited to your jobber.

Interesting literature describing the many other popular LYNCH products sent on request.

LYNCH MFG. CO., INC.
1775 Broadway, New York, N. Y.

"I have just passed a week in what little spare time I have in testing the new Hammarlund 'Pro' short-wave superheterodyne receiver, as you requested. Unfortunately, not having an abundance of free hours at a time best suited for distant short-wave reception, I was unable to test the set under the most desirable conditions.

"So eager were we to hear how the receiver worked, to find out whether or not it had any noticeable hum when headphones were used (almost essential to the operation of amateur station), whether the band spreading functioned to facilitate quick tuning without crowding the dial, whether or not the oscillator was stable so crystal-controlled c.w. signals would not 'wobble,' that we had the set going within a few minutes after getting it home. About thirty inches of aerial without a ground was used. After finding the 3500 kc. amateur band, by referring to the calibration charts, we hit the middle of the band when all dials were set at 50—the tank circuit, oscillator control and band-spread dials.

"Stations began to roll in with good volume. By connecting the ground, a substantial increase was marked, and a larger aerial resulted in further increase in volume, stability and sensitivity. The other two major amateur bands (7000 and 14,000 kc.) were tried. On 7000 kc. stations in all sections of the country were picked up. It being late at night, practically nothing was recorded at this sitting on 14,000 kc.

"On Sunday morning, November 13, we began to 'fish' for distance. Few broadcasting stations were on the air at this time, so we tried the 14,000 kc. amateur band. Over a period of about an hour, we logged a number of foreign and distant domestic stations. First we tuned in to CM2JT. A little later we picked up G5BY sending a 'CQ,' an English amateur who was, without doubt, the loudest station heard in the band at that time of day. We turned off the heterodyning oscillator to see what would happen. To our surprise, we were able to copy the hum of his signs QSA5-R8.

"Our prize on the 14,000 kc. band was a West Coast amateur, W6AVB, who was talking with a ninth district station in Kansas. The operator was having a 'rag chew,' talking mostly about the 'nice weather in California.' His audibility was R9, QSA4.

"Other amateur telephone stations heard on this band were CM2EA and VE3GS. C.W. stations included, among others: CM2WD, EAR10, F8EF, F8TP, G2AK, G2BY, B2HB, G5NF and G6WK.

"At about 2 p.m. on November 13th we began to tune for foreign broadcasting stations. Tuning was facilitated by using the calibration charts for the set. Our first try was on 31 meters. After tuning with the heterodyning oscillator 'on,' we brought in a strong modulated carrier. Turning the oscillator 'off,' the clear voice of a singer came from the loudspeaker. Then we sat by to await an announcement. Finally he came on. He spoke in German and finally identified the stations as 'Konigs-Wusterhausen.'

"Later we went looking for Pontoise, France. Almost immediately we picked up a carrier. A man and woman were singing a duet. Then there was a long pause. He spoke for several minutes and identified the station. The orchestra then played the French national anthem and the station went off the air. That night we also heard EAQ in Madrid.

"We then went back to the amateur bands. In thirty minutes on the 7000 kc. band we tuned in the following, among others: W9DOY, W5TR, W5TW, W8HR, W6CKQ, W4BBW, W6ALX, W7AAT and W7TS.

"On the 3500 kc. 'phone band, turning the dial over the band once, we heard W9JPK, W2BNZ, W4EB, W4TZ, W8BCH and W3GP. Of course, many others were heard,

but these were logged on one swing over the band.

"Going on to the 3500 c.w. band, we heard VE3QT, W5BOQ, W5BMI, W6CLP, W4BBO, W4ANY, W8EMT, W7OJ—and, of course, hundreds of 1's, 3's, 8's and 9's.

"The following night we tried for the famous G5SW in Chelmsford. Their signals were heard R8 QSA5. The toll of 'Big Ben' brought an end to our test with the receiver."

In quoting the foregoing reports it is not the intention to show complete records of stations received so much as to emphasize the opinions of these typical amateurs based on their experience in operating this particular receiver.

Pocket Diagonometer

(Continued from page 476)

45-volt battery in series with a variable resistance of 50,000 ohms or more and placing it between terminals T7 and T3, removing the link. Set the range switch to the 1 ma. (ohms) range and adjust the variable resistor to full-scale deflection.

Current measurements are made by setting switch E to the correct position and the range switch to the highest current range. Current measurement cannot be made in the filament circuits, and no a.c. measurements are available.

A.C. voltage measurements can be made by setting switches for the proper a.c. range. This makes it possible to measure the a.c. voltage between the two plates of a full-wave rectifier, such as the type -80, -82 or -83. The unit can be used as an output meter by connecting a 1 mfd. condenser between terminals T7 and T3 and removing the link. When the output stage of the receiver is a single tube, or two tubes in parallel, the output meter should be connected between plate and ground. This can be done by placing the tube in the analyzer and the analyzer plug in its socket. Set the switches E and G to P and Gnd respectively. It is best to start with a high a.c. voltage range as usual. When the output stage has two tubes in push-pull, the output meter has to be connected between the two plates.

The a.c. voltmeter can be used for the measurement of capacity or inductance. For this purpose, the meter is connected in series with a 100,000-ohm fixed resistor and a 30,000-ohm rheostat. It is also recommended that a Mazda lamp be placed in the line for safety. Use the lowest a.c. range and adjust your meter to full-scale deflection with the condenser or inductance shorted. Then remove the short-circuit and read the meter. The instrument can be calibrated by calculation or by measuring standard values.

The construction of this analyzer in two parts has several advantages. The selector unit can be employed with any other meters or microammeters the constructor might have, and the terminals with their links provide an opportunity for special tests. Finally, being easily dismantled, it makes for convenience and portability; the total weight is only 2 pounds and 14 ounces.

Parts List

- G—Best switch, type NS10-K
- E—Best switch, type NS10-5B (3-pole, 10-position, with 5-break section)
- T4, T5, T6, T7—International Air Research terminal posts (large)
- 1 Van engraved panel
- 2 pin-jacks
- 1 pin and grid caps
- 1 Naald 6-prong cable assembly with adapter
- 1 Naald 6-prong to 4-prong reducer adapter
- 1 Naald 6-prong to 5-prong reducer adapter
- 1 Eby 6-prong socket

Controlling Machinery

(Continued from page 462)

orders given to the mouthpiece of the telephone it makes current pass through the motor, driving the wheels. These wheels move, and accordingly the vacuum cleaner runs freely over the platform without being touched. If the motor is reversed, the vacuum cleaner runs back, exactly as the toy electric locomotive can be made to run backward by reversing the current.

More Than Toys

More than just toys, these latest applications of the radio sciences have made possible the controlling of mechanical action over distances by acoustical impulses.

By the use of equipment of this type, the householder of the future may command the furnace to open from a telephone by his bedside, doors may be opened if the right password is given, or elevators may be vocally controlled. More complicated ar-

rangements may be used in checking the doors of safes or vaults where valuables are kept by similar methods with which we can control the action of the machines, acoustically by the spoken word.

Technical Review

(Continued from page 487)

pension microphones of all types, such as carbon, condenser and dynamic, made by the Samson Electric Co. Specifications of microphone stands and cables are included.

33. Pam-110 "Class B" Amplifier and Mik-110 Combination Mixer and Input-Coupling Unit. Specifications on the characteristics of two units designed by the Samson Electric Co. to provide high gain, high quality and relatively high-power output (26 watts), with exceptional economy in both operation and maintenance. The Mik-

Radio News Technical Information Service

The Technical Information Service has been carried on for many years by the technical staff of RADIO NEWS. Its primary purpose is to give helpful information to those readers who run across technical problems in their work or hobby which they are not able to solve without assistance. The service has grown to such large proportions that it is now advisable to outline and regulate activities so that information desired may come to our readers accurately, adequately and promptly.

Long, rambling letters containing requests that are vague or on a subject that is unanswerable, take up so large a portion of the staff's working time that legitimate questions may pile up in such quantities as to cause a delay that seriously hinders the promptness of reply. To eliminate this waste of time and the period of waiting, that sometimes occurs to our readers as a consequence, the following list of simple rules *must* be observed in making requests for information. Readers will help themselves by abiding by these rules.

Preparation of Requests

1. Limit each request for information to a single subject.
2. In a request for information, include any data that will aid us in assisting in answering. If the request relates to apparatus described in RADIO NEWS, state the issue, page number, title of article and the name of the device or apparatus.
3. Write only on one side of your paper.
4. Pin the coupon to your request.

The service is directed specifically at the problems of the radio serviceman, engineer, mechanic, experimenter, set builder, student and amateur, but is open to all classes of readers as well.

All questions from subscribers to RADIO NEWS will be answered free of charge, provided they comply with the regulations here set forth. All questions will be answered by mail and not through the editorial columns of the magazine, or by telephone. When possible, requests for information will be answered by referring to articles in past issues of

the magazine that contain the desired information. For this reason it is advisable to keep RADIO NEWS as a radio reference.

Complete information about sets described in other publications cannot be given, although readers will be referred to other sources of information whenever possible. The staff cannot undertake to design special circuits, receivers, equipment or installations. The staff cannot service receivers or test any radio apparatus. Wiring diagrams of commercial receivers cannot be supplied, but where we have published them in RADIO NEWS, a reference will be given to past issues. Comparisons between various kinds of receivers or manufactured apparatus cannot be made.

Only those requests will be given consideration that are accompanied by the current month's coupon below, accurately filled out.

FEBRUARY, 1933

Technical Information Coupon
RADIO NEWS Laboratory
222 W. 39th Street
New York, N. Y.

Gentlemen:

Kindly supply me with complete information on the attached question:

- I am a regular subscriber to RADIO NEWS, and I understand this information will be sent me free of charge.
- I am not yet a subscriber to RADIO NEWS.
- I wish to become a subscriber to RADIO NEWS, and enclose \$2.50 to receive the magazine regularly for one year, and to receive this valuable technical information service free of charge.

Name.....
Address.....

LET'S LOOK AT RADIO

PAST, FUTURE, AND WHAT IT MEANS TO YOU AS A CAREER

Here you will read why many experienced radio men are adding to their general knowledge at this time . . . or are "Going back to school" to specialize in advanced subjects—and also note their recommendations to fellows ambitious to enter the radio field.

Just to illustrate the advance of radio; 23 years ago men were being instructed at America's *only* radio school in but *one* subject—The Maintenance of Marine Radio Equipment. That was all there was to teach in radio!

Today this same school—RCA Institutes—is adding new courses—and new subjects to its older courses—as the march of radio goes on—developing, possessing, advancing!

This school has always had the one major aim; to be of benefit to the radio industry. Tuition costs are kept at a minimum, with privileges of time payments—even as low as \$4 weekly. (Still less in Home Study courses, which include a post-graduate free practical training period.)

Among the thousands of graduates of RCA Institutes are many successful radio men—some high in executive or engineering posts—to whom the first principles of radio were unfolded here. They will tell you that the expert instruction and personal interest they received gave them their start and paved the way toward success.

The renowned father of radio, Marconi, has always had a strong interest in this school, in fact, for many years it bore his name as the "Marconi Institute."

Today . . . whether you are just beginning radio or have an advanced knowledge . . . RCA Institutes offers you the opportunity to cope with practical radio engineering . . . teaches you to enlarge your knowledge. We are at present presenting a new general course in radio, combining Broadcasting . . . Sound Motion Pictures . . . Aircraft Radio . . . Marine Radio . . . Radio Servicing . . . Home and Studio Recording . . . Television Fundamentals . . . Electronic Tube Applications . . . Radio Code . . . Public Address Systems . . . and other radio and allied subjects, which may be taken in whole or in units, as needed.

You may wish to specialize in a particular phase of radio or associated arts, so send for a copy of our illustrated catalog which contains all particulars about RCA Institute's various residence schools and Home Study courses.

Or visit our school in either New York or Chicago. You will find them modern, fully equipped, and ample in scope for the ever growing field of radio. But in the meantime, clip and mail the coupon below . . . it will bring you the latest details. Do it today—before you forget!



RCA Institutes, Inc.,

Dept. RN-2

New York School and Headquarters:
75 Varick Street, New York, N. Y.

Chicago School:
1154 Merchandise Mart, Chicago, Ill.

Please send with no obligation to me:

- () Full information on the New General Course in Radio. (At New York resident school only)
- () Illustrated catalog and information about specialized resident school courses in radio and allied arts.
- () Information about extension course for study at home, together with illustrated catalog.

Name.....Age.....
Address.....
City..... State.....

RADIO MEN— VALUABLE BOOKS—FREE

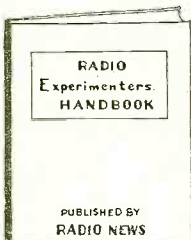

Radio Experimenters' Hand Book

This new addition to the Radio News Library is of outstanding value to every radio enthusiast.

It has chapters on: Electrical Measurements; Resistance, Inductance and Capacity Measurements; Design of Radio Components; Circuit Design; Short Wave Essentials; Photo-Electric Cell Applications; Shop Notes; Antenna Experiments; Experimental Circuits in Radio and Electronics; and Miscellaneous Radio Experiments. You need *this* book at your work-bench!

23 Lessons in Radio

This book, bound in heavy red cloth, is of tremendous value to beginners and other radio men who want *all* the dope on radio essentials.

Among the subjects covered are: Elementary Radio Theory; How the Detector Tube Works; Construction of an Audio-Frequency Amplifier; How to Build a Short-Wave Converter; Principles of Transmitting and Receiving; Standard Radio Symbols; Breaking into the Amateur Game; Building a Low-Power Transmitter; and other important articles on radio.

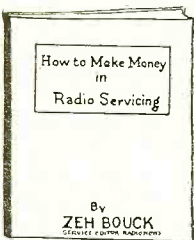
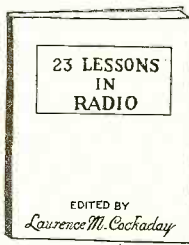

How To Make Money in Radio Servicing

What is more important in times like these than to know how to make your radio servicing business show a profit?

This book was written to enable you to do this and contains information on the following subjects: Equipment; Contacts; Advertising and Publicity; Circularization; Service Procedure; The Service Salesman; Off Season Business; Service Side Lines; The Business End of Servicing; How to Buy; and Keeping Up-To-Date. For profits—read this book!

Mathematics in Radio

In 1931 Radio News published a series of articles on "Mathematics In Radio," written by J. E. Smith, President of the National Radio Institute of Washington, D. C.

These articles are now available in a set of four booklets. The first covers the simple rules of Arithmetic; the second: Algebra; the third: Geometry; and the fourth: Trigonometry. All four leaflets are profusely illustrated with many easy-to-read diagrams and charts.

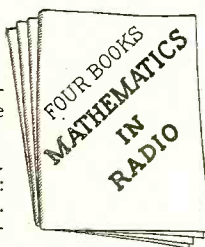

Get These Books FREE!

These books are not for sale! They are published exclusively for Radio News readers. Send in your subscription for 11 issues of Radio News at \$2 and we will send you any one of these books absolutely free!

Send Coupon Today!

Radio News Dept. 2
222 West 39th St., New York, N. Y.

Enclosed find \$2. Enter my subscription to Radio News for 11 issues and send me a copy of.....
.....If renewal, check ().

Name.....
Address.....
City..... State.....

Canada \$2.50 Foreign \$3.00

110 has three mixer positions for use with microphone, phonograph or radio, as well as quality control.

34. *Serviceman's Replacement Volume-Control Chart.* A revised list, in alphabetical order, of all old and new receivers showing model number, value of control in ohms and a recommended Electrad control for replacement purposes. Contains specifications for over 2000 different receiver models. A handy chart which should be in every serviceman's kit.

35. *Paper and Electrolytic Condenser Catalog.* A 16-page book giving specifications and prices on a very complete line of Cornell paper and electrolytic condensers for by-pass, filter, transmitting, interference filters and industrial purposes.

36. *Broadcast-Transmission, Public-Address and Manufacturers' Type Audio Components.* An exceptionally complete 16-page transformer catalog giving specifications on the Kenyon laboratory, standard and all-purpose amplifier transformer line designed to meet the exacting requirements of broadcast stations, audio research laboratories and professional public-address engineers. A special section is devoted to highly filtered rectifier systems, automatic voltage regulators and special types of test equipment. Also contains manufacturers' type audio transformers and replacement transformers with universal mounting features. Five pages are devoted to detailed schematic diagrams for preamplifiers, mixer controls, "Class A" amplifiers of from 2 to 50 watts output and "Class B" amplifiers up to 25 watts output.

37. *Servicemen's and Dealer's 1933 Testing and Trouble-Shooting Instruments.* A 16-page handbook giving complete details on diagnetometers, set analyzers, tube testers, oscillators, ohmmeters and other testing instruments and accessories made by the Supreme Instruments Corp. It also contains complete details of a series of blueprints and kits by means of which any serviceman can build any of the above instruments at a saving, and details of a self-payment plan which enables responsible servicemen to pay for these instruments while using them.

February, 1933
RADIO NEWS Free Technical
Booklet Service
222 West 39th Street
New York, N. Y.

Gentlemen: Please send me, without charge, the booklets or folders I have filled in below:

Numbers.....
.....
 Serviceman in Business for Myself
 Serviceman Employed by: Manufacturer, Jobber, Dealer. Service Organization
 Radio Engineer
 Experimenter
 Laboratory Technician
 Dealer
 Jobber
 Professional or Amateur Set Builder
 Licensed Amateur
 Station Operator

I am a subscriber newsstand reader.

I buy approximately \$..... of radio material a month.

Name.....

Address.....

City..... State.....

PLEASE USE PENCIL AND PRINT,
IN FILLING IN COUPON

BETTER CONDENSERS AT LOWER PRICES



Yes, and we can prove it! Never was such quality offered in condensers. Never such low prices. Because never were such engineering efforts, new materials, novel production methods and rigid inspection placed behind such products. Dubilier world's largest and oldest condenser specialist—offers you electrolytics, paper, mica, receiving, transmitting, industrial, laboratory and other condensers for the most reliable, longest and most economical service.

Free Catalog is yours for the asking. Just issued. Covers entire line. Write for your copy today.



DUBILIER Condenser Corp.
4377 Bronx Blvd., New York

Write CHI-RAD First!

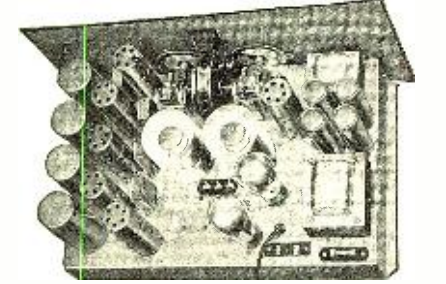

Get NEW HAMMARLUND COMET "PRO" Prices NOW
Send For Short-Wave, Replacement Parts Catalog
CHICAGO RADIO APPARATUS CO.
417 S. Dearborn St. Dept. RN-2 Chicago, Ill.

MAILING LISTS

Pave the way to more sales with actual names and addresses of Live prospects. Get them from the original compilers of basic list information—up to date—accurate—guaranteed. Tell us about your business. We'll help you find the prospects. No obligation for consultation service.

FREE 60 page Reference Book and Mailing LIST CATALOG
Gives counts and prices on 8,000 lines of business. Shows you how to get special lists by territories and line of business. Auto lists of all kinds. Shows you how to use the mails to sell your products and services. Write today.

R. L. POLK & CO.
Polk Bldg.—Detroit, Mich.
Branches in Principal Cities
World's Largest City Directory Publishers
Mailing List Compilers. Business Statistics. Producers of Direct Mail Advertising.

GENERAL MOTORS and DAY-FAN Radio Service Parts in Stock for ALL MODELS
We will solve your circuit and service problems without obligation. Mail orders promptly filled.
General Mfrs. Radio Service, 225 7th Ave., New York City

Eclipse and Radio

(Continued from page 459)

from the upper region. In this 200-kc. interval we quite often find either no reflections at all or that the reflected signal is abnormally retarded in time. The frequency at which the signals go out or where the long retardation occurs has been termed the critical frequency."

He explained that if the critical frequency should drop to a minimum during an optical eclipse then ionization in the lower region might be attributed to ultra-violet light, but if it should drop two hours before the maximum of the optical eclipse the change would be attributed to the solar corpuscles. As many direct measurements of critical frequency were made as the personnel and equipment permitted, Mr. Gilliland explained.

He summed up the Bureau of Standards findings as follows: "In conclusion, the observations here and in Nova Scotia indicate that ultra-violet light is the principal factor responsible for ionization in both the lower and upper regions. It is not claimed that the effect of solar corpuscles is not present but if the effect is present it is small compared to that of ultra-violet light."

Dr. G. W. Kenrick, Director of Research of Tufts College, made observations at Seabrook Beach, New Hampshire, on transmissions from Portsmouth Navy Yard and from the Short-Wave and Television Laboratories at Boston. He investigated effective heights of the Kennelly-Heaviside layer for frequencies of 1640, 3492.5 and 4540 kc.

"Marked layer changes associated with the eclipse were noted on all these frequencies," he said. "Observations of field intensity during the eclipse were also made on WCSH, at Portland, in the broadcast band, and on VE9GW, at Bowmanville, Ontario, operating on 6095 kc. No marked changes were noted on low-frequency signals observed from GBR at Rugby, England. A marked sky-wave was noted during the later portion of the eclipse from WCSH, however. This attained an amplitude of about twenty-five percent of the ground wave about twenty minutes after totality."

Dr. A. S. Eve, Dean of the Graduate Faculty of McGill University, Montreal, has prepared for RADIO NEWS a preliminary report of joint radio investigations in Canada during the recent eclipse.

"Special expeditions," Dr. Eve reports, "at Vankleek Hill and Corner Brook, Newfoundland, both directed by Dr. J. T. Henderson, and at Kingston, Ontario, under Dr. D. C. Rose, have furnished reports. Vankleek Hill and Kingston show distinct losses in ionization of both reflecting layers, E and F regions, during period of optical eclipse. Corner Brook gives supporting evidence. All results indicate no corpuscular eclipse."

"Northern Electric Company found no intensity change at 500 meters between Ottawa and Montreal. Canadian Marconi Company found no definite change in 22 to 37-meter transmissions received across Atlantic."

Signals received in Cleveland, Ohio, by the Case School of Applied Science from a short-wave station in the path of totality increased in intensity as the eclipse progressed, but surprised the observers by suddenly fading away completely a few minutes before the eclipse was total. More surprise was shown when the signals did not return for forty-five minutes! A report on this work was made by Professor J. R. Martin as follows:

"The tests made by Case School of Applied Science during the solar eclipse of August, 1932, were made between the eclipse observatory of the Department of Astronomy at Douglas Hill, Maine, and the Communi-

COME TO SUNNY CALIFORNIA



Learn TELEVISION-RADIO TALKING PICTURES

In just a few years, Radio has become one of the world's leading industries. Talking Pictures have brought new life and opportunity to the Movies. Now, Television is here with a promise of growth and activity so great that it cannot even be estimated. Come to Los Angeles—most active Radio center in the world—and learn these fascinating Trades. You can be one of those to reap the harvest.

BUT... YOU MUST BE TRAINED

Times are getting better. The worst of the depression is over. Thousands of new jobs will call for TRAINED MEN. Will you be ready? Regardless of the Times, the Trained man wins. He always has and he always will. Take that fact as a guide and your future is assured. Wonderful opportunities are open before you.

Get the Best Training Your Money Will Buy

Naturally, you want the best and most complete training you can secure. Analyze—Investigate. Your whole future depends upon it. For over 28 years, National has been training ambitious men by our own practical shop method. Our graduates are our best recommendation.

Life Scholarship Insures Thorough Instruction

You are not hurried through your courses at National. You are given a Life Scholarship when you enroll, which means that you can go just as fast, or take as long as you wish to complete your training. The main thing is that you master every phase of your instruction, step by step.

Actual Experience on Modern Equipment

There is no DUMMY equipment at this wonderful institution. It is all "hooked-up," ready for you to use in learning your Trade. You learn Television on actual Television Transmitting and Receiving equipment. You take part in operating our own Radio broadcasting station W6YF. In Talking Pictures, too, you learn on actual equipment, right in National's student Talkie Theatre.

EARN ROOM AND BOARD

Spare time jobs while at school. We help you get a job to pay living expenses while learning. So if you are short of money, don't let that hinder you from enrolling. 75% of our students are earning their living expenses while attending school now. We also allow your Coach Husband Fare to Los Angeles.

SPECIAL NEW COURSE Radio Broadcast Technician

Finest studio in West—sound-proof walls, broadcasting big programs—just like the most famous stations. 5 separate studios. Special course given without extra cost to students who enroll immediately. We broadcast over our own station and also by remote control. You actually learn operating the equipment, qualifying for important technical jobs.

Oldest Trade School in the West
Est. 1905. 25,000 Graduates.

ASK FOR DETAILS

Send coupon for descriptive literature. You owe it to yourself to become thoroughly acquainted with this great school. You will find the facilities here a positive revelation. Get new book, which gives you all the facts in story and pictures—SEND COUPON AT ONCE.



NATIONAL RADIO ELECTRICAL SCHOOL—Los Angeles
Dept. RN 2, 4006 So. Figueroa St.
Send Book and full details of Courses.
Name _____
Address _____
City _____ State _____

LIQUIDATION SALE

Various types of Radio Test Instruments—Radio Production Tests
R.C.A. Beat Freq. Oscillator Precision Type
Production Signal Generating System 8 Test Freq. Variable Freq. Generator for Speaker Testing
Write for Quotation on instruments needed
GENERAL MOTORS RADIO CORPORATION DAYTON, OHIO

FREE RADIO CATALOG

WRITE FOR THIS BIG FREE BOOK today. The most complete line of radio sets, service men's supplies, replacement parts, test equipment at the lowest wholesale prices.
ALLIED RADIO CORP.
831 W. Jackson Chicago

SHALLCROSS

No. 651



RADIO SET TESTER

For 4-, 5-, 6- and 7-prong tubes

This new circuit makes it possible for the service man to construct a light weight and compact, up-to-date, radio-set tester for all tubes and radio sets in general use. It uses a special set of Shallcross Super Akra-Ohm Wire-Wound Resistors.

Send 6c in stamps for Bulletin 161-D containing wiring diagram, construction details, and operating chart.

ALWAYS
Super
AKRA-OHM
 ACCURATE

Shallcross Mfg. Company
 ELECTRICAL SPECIALTIES
 700 PARKER AVENUE
 COLLINGDALE, PA.

Accurate
 NON-INDUCTIVE
 WIRE WOUND
 RESISTORS

FREE GET THIS QUICK



New and enlarged Summer edition of our Radio and Short Wave Treatise, No. 25, just off the press—100 pages check full of useful information radio items, diagrams and illustrations. Positively the greatest book in print—NOT JUST ANOTHER CATALOG. Contains a large editorial section with valuable information seldom found anywhere else. Complete space is devoted to a TREATISE ON SHORT WAVES for both beginners and regulars. For both beginners and regulars the following information listed are the following: Modernizing old radio sets—repairing speakers and headsets—making superhets out of old sets—constructing two-volt battery and automobile receivers—circuit of the famous Gernsback Megadyne One-Tube Loudspeaker Set—short wave coil winding data—discussion on S.W. adapters, converters and receivers, etc., etc. GREATEST BOOK IN PRINT

WRITE TODAY. Enclose 4 cents for postage. Treatise sent by return mail.

RADIO TRADING CO.
27 West Broadway New York City

When You Buy ALAN Short Wave Receiver, you Get

Unequaled flexibility and ease of control
Multi-Wu Sensitivity
Low Background Noise
Super-Smooth Oscillation Control



Full A.C. or D.C. Op. Absolutely Humless A.C. Operation Impedance Audio for Quality Phone Signals Micaite Insulation throughout.

Alan 2-B Battery Set requiring 1 type 32 Multi-mu tube and one 33 Pentode. Special.....	\$12.25
Build it Yourself Kit.....	10.75
Kit of 9 Tubes.....	1.55
Alan 3-B Battery Set using 2 type 34 and 1 type 33 Kit Price.....	\$15.50
Kit Price.....	13.70
Kit of Three Tubes for above.....	2.30
Alan 4-B Deluxe, using 2 type 34, one type 30 tube and one type 33.....	\$18.20
Kit Price.....	15.40
Kit of 4 Tubes.....	3.05
Alan III A. C. 4 Tube A. C. Receiver, using 2 Type 55 Tubes, 1 Type 56 and 1 Type 80. Absolutely humless, ready to plug into 110 Volt A. C. line.....	\$23.50
Kit Price (with diagram and directions).....	18.05
Kit Guaranteed Tubes.....	3.05
Alan IV A. C. 5 Tube A. C. Receiver, utilizing 2 Type 55 Tubes, one Type 56 and one Type 47 Output Power Tube and one Type 80. Ready to plug in.....	\$28.20
Set of tubes for Alan IV A. C.....	4.25

ALAN RADIO C RP. 83R Cortlandt St., New York

cations Laboratory of the Department of Electrical Engineering in Cleveland. The 75-watt transmitter was located at Douglas Hill in the path of totality, and was designed and operated by Mr. S. McCuskey of the Astronomy Department. The variations in signal intensity were recorded in Cleveland by Professor J. R. Martin of the Electrical Engineering Department who designed the receiving equipment which was connected to a Leeds and Northrup automatic recorder especially built for these tests.

"Test signals were recorded for several hours before and after the eclipse to note if any lag in the effect could be detected. Signals were transmitted at a frequency of 7125 kilocycles in the amateur 40 meter band, the transmitter using the call W1EKL.

"The tests showed a slow rise in signal intensity during the first interval of the eclipse, rising to a very high value immediately before totality. At totality the signals dropped to a very low value for some time, then again rose slowly until near the end of the eclipse, when there was a second rise in intensity to an abnormally high value. After some time the signals dropped slowly to their normal value."

Dr. Clyde Fisher, of the American Museum of Natural History and President of the Amateur Astronomical Society, informs us that the next total eclipse will take place on February 14, 1934, and will be visible in the vicinity of Borneo. The next total eclipse on the North American continent will occur on July 20, 1933. This will be visible in Alaska, Canada and Maine.

Thus, eminent scientists from many leading laboratories and universities have accumulated a mass of data which will take considerable time to work out completely. Never before have scientists been given an opportunity to gather as much radio eclipse data as during the August 31 eclipse of 1932.

Phenomena of Radio

(Continued from page 473)

Thermal energy = $k(T_1 - T_2)$, where k is a constant of proportionality. T_1 and T_2 represent absolute temperatures.

It is interesting to compare a flow of heat with a flow of electricity; the analogy is close (see footnote 1). Ohm's work leading to his famous law was guided by Fourier's study of heat conduction. He was attracted by the heat comparison, but depended on quantitative experiments for the final formulation.

Radiation by Collision

A consequence of this theory is that radiation arises as a result of the collisions in certain cases. This radiation may escape or it may be retransformed into kinetic energy within the substance. The frequency of the radiation in any case is dependent on the amount of energy involved in a collision. Radiant heat, light, X-rays can result. (The quantum theory has much to say on these points.)

We have been talking about a gas. The same general reasoning applies to liquids and to solids, although there are definite restrictions to the application of the kinetic theory of gases to these, since in a liquid, and more so in a solid, the motions of the particles are limited by closer association. In liquids the freedom is not nearly so great as in gases, but still the atoms and the free electrons have an opportunity to roam about. In solids, and particularly in crystals, the atoms are thought of as being held to movements about definite points, due to the more powerful interatomic forces. But even in solids there is a great deal of open space and the free electrons have full opportunity to move between the atoms.

Read Classified Advertising—It Pays

Advertisements in this section twenty-six cents a word for each insertion. Name and address must be included at the above rate. Cash should accompany all classified advertisements unless placed by an accredited advertising agency. No advertisements for less than 10 words accepted. Objectionable or misleading advertisements not accepted. Advertisements for these columns should reach us not later than 1st of 2nd month preceding issue.

TECH PUBLICATIONS, INC.
222 West 39th St. New York, N. Y.

Correspondence Courses

USED Correspondence Courses and Educational Books sold or rented. Inexpensive. Money-back agreement. Catalog listing 3000 bargains—FREE. (Courses bought). Lee Mountain, Pisgah, Alabama

Electrical

TRANSFORMERS rewound or built to your order. Speaker field coils. Penbleton Laboratories, 921 Parkview, Fort Wayne, Indiana.

ALL KINDS electrical motors, generators, compressors, grinders, fans. Very reasonable. Superior Electric Company, Dept. R-14, 4526 N. Leavitt Street, Chicago.

Inventions

INVENTIONS, COMMERCIALIZED. Patented or unpatented. Write, Adam Fisher Mfg. Co., 278 Enright, St. Louis, Mo.

Microphones

SENSATIONAL MICROPHONE VALUE—Universal Model T—Experimenters, single-button, watch model type, 200 ohms. Pure Gold Spot Center Diaphragm. Only \$2.00, including valuable 1933 general catalog with diagrams. Universal Microphone Co., Ltd., Inglewood, California.

Patents

PATENTS—Advice and booklet free. Highest references. Best results. Promptness assured. Watson E. Coleman, Patent Lawyer, 724 8th Street, Washington, D. C.

PATENTS, TRADE MARKS—All cases submitted given personal attention by a member of the firm. Information and booklet free. Lancaster, Alvirne & Rommel, Suite 414, 815 13th St., N. W., Washington, D. C.

PATENT Your invention now. Little ideas may have big commercial possibilities. Send for free book, "How to Obtain a Patent," and free "Record of Invention Blank." In business since 1898, specializing in patent matters, we have successfully served thousands of inventors. Delays are dangerous in patent matters—act at once and protect your idea. Reasonable fees. Deferred payments. Write us today. Victor J. Evans & Co., 649 Victor Bldg., Washington, D. C.

Pocket Radios

GUARANTEED "Pocket Radio," \$2.00. Catalogue, 10c. Neil Tasker, Shamokin, Pennsylvania.

Radio

RADIO SERVICEMEN and DEALERS: Free Subscription to PHILCO SERVICEMAN (Monthly). Radio Parts and Accessory Catalog sent free on request. Service Manuals, repair parts, etc.—write today. National Radio Parts Co., 800 So. Adams St., Peoria, Illinois.

SMALLEST RADIO IN WORLD, \$1.00 postpaid. Long Range Radio Exchange, Richland Springs, Tex.

LEARN about Radio Operating from Official Publication. 15c brings latest issue. The Commercial Radio Operators Magazine, 112 West 13th Street, New York City.

Salesmen Wanted

WANTED: Man in each county who will be satisfied with \$25 to \$35 a week earnings at the start doing service work and demonstrating new Automatic Fire Alarm in Schools, Homes, Hotels, Theatres, Public Buildings, etc. Write quick for county appointment. Fire-Cry Company, Dept. 614, Dayton, Ohio.

Unusual Astounding Fiction!

SPACE SHIPS . . . Disintegrators
. . . Death Rays . . . Interplanetary
Communication . . . Rocket Planes . . .
Time Machines . . . Fifth Dimensions
. . . Golden Treasures . . . Startling
science fiction that will hold you spell-bound and enthralled! Buy a copy of the February Amazing Stories and read stories that are different from anything you ever heard of before!

Now On Sale At All Newsstands

You will also enjoy reading Amazing Stories Quarterly. The new Spring-Summer issue is now at all newsstands—144 pages of startling fiction!

**For Thrills and Action Read
Amazing Stories
Amazing Stories
Quarterly**

All-Wave Design

(Continued from page 481)

In addition, automatic tone compensation is provided to raise bass and treble notes at low volume to take care of variations in the sensitivity of the human ear at different volume levels. The manual tone control is provided to allow for different musical tastes, and for such noise reduction as may be desired on weak signals falling below the cut-off level of the squelch circuit.

The final story of any radio receiver is told by the curves obtained in measuring its sensitivity, selectivity, fidelity, A.V.C. characteristics and speaker fidelity with precision signal generator equipment.

Figure 4 is a typical sensitivity curve such as is measured on (and furnished with) every receiver built. The sensitivity is sure to range from .5 microvolts, absolute, input for standard 50-milliwatt output at 500 kc., to .3 microvolts, absolute, at 1500 kc. This curve is flat, having a ratio of about 1.6 to 1, indicating, for all practical purposes, uniform sensitivity at all frequencies. It may well be added that without the broadcast band r.f. stage, contributing almost no gain but only image-frequency selectivity, the sensitivity from first detector on is better than 1.0 microvolts, absolute, this being effective short-wave sensitivity.

The selectivity curve of Figure 5 shows a band width of 25 kc., 10,000 times down, meaning that a signal 12.5 kc. off resonance must be 10,000 times as strong as a wanted signal to produce equal output. In practical terms of adjacent channel, or 10 kc., selectivity, Figure 5 shows that an adjacent channel signal would have to be several hundred times as strong as a wanted signal to produce equal output—a condition seldom found even in receiving a weak distant signal only 10 kc. away from a 50,000-watt local operating within a very few miles of the receiver.

The fidelity curve of Figure 6 is drawn at a level where the antenna tone compensation circuit is not in use. It is seen to be flat to 3 db. from 30 to 4000 cycles.

Figure 7 shows the response curve of the giant dynamic speaker. Integrated with Figure 6, it would give the antenna-to-ear response of the whole set. Its rise in the treble register is intentional, to give added clarity and brilliance to speech and music, but it must be remembered that the manual tone control of the set will turn this rise into a straight flat line, or a droop, at the will of the user.

Figure 8 shows the undistorted power output, A.V.C. and "squelch circuit" operation. The power output is seen to rise from 100 milliwatts at 1.0 microvolt absolute input, to 7.6 watts at 30 microvolts, absolute, input. This represents, practically, about maximum value, and it can be correctly stated that the A.V.C. systems provides practically constant volume to the ear from 30 microvolts up, the maximum power output rising to ten watts.

The vertical dotted line drawn down from 30 microvolts, absolute, shows the action of the "squelch circuit". This system entirely cuts off all amplification unless a signal of 30 microvolts, absolute, or stronger is tuned in, thus eliminating all inter-station noise and stations so weak as to be noisy themselves. Throwing the squelch cut-out switch, however, allows full use of maximum sensitivity for reception of very weak signals.

In Chicago it is no task at all to pick up Cincinnati on 700 kc. with only the exposed metal of the antenna binding post for a "signal collector"—but ground the antenna post and the set is dead. On almost any evening one hundred or more stations can be tuned in at great volume with one turn of the dial.

FILTERMATIC PRODUCTS

Help you to get the BEST possible reception from your RADIO set.

SUPER-FILTERMATIC The Modern Aerial

Thousands of satisfied users, praised by radio experts. Replaces all other aerials, reduces static and noise. Especially good on distance reception. Helps to separate stations, does not connect in light weather, therefore eliminating hum and line noise. It is very compact, measuring only 1 1/2 inches, is absolutely non-corrosive and non-reactive. Installed in one minute, no tools needed. Will never wear out. Eliminates trouble and expense of lightning-rod. Can also be used in conjunction with your present aerial.

Price only \$1.50 postpaid.

Satisfaction guaranteed or money refunded.



ALL PROGRAMS

Are Good with a FILTERMATIC. For all radios only \$1.00 postpaid.

Entirely automatic—no bothersome tuning. Improves tone, reduces static, brings in distance, increases volume, separates stations. Installed in one minute, no tools required, in series with your aerial or across your aerial and ground. Satisfaction guaranteed or money refunded.



Money back guaranteed after 5-day trial.

Service Men and Dealers Write for Particulars. Also Information about Free local newspaper advertising.

FILTERMATIC MFG. CO.

(Dept. B-10) 4458 Frankford Ave., Philadelphia, Pa.

Be a TELEVISION EXPERT

During the next few years, thousands will become rich in Television, the amazing new major industry. Will you be one of these? There is only one way for you to get into Television and that is with specialized training. Television experts are needed right now and this marvelous new business has hardly started. If you are over 17 years of age, send your name and address for full information about our plan whereby you may step out of the world's greatest Television School—occupying the three top floors of Missouri's tallest skyscraper—into a high pay position. Write Today.

Sid Noel, President
FIRST NATIONAL TELEVISION
2902 Power & Light Bldg.
Kansas City, Missouri

SERVICEMEN ATTENTION!



TRIMM FEATHERWEIGHT EARPHONES

For Hard of Hearing Installations. Write for information.
TRIMM RADIO MANUFACTURING COMPANY
1528-38 Armitage Avenue CHICAGO, ILL.

LIFE-LIKE REPRODUCTION!

Your future sound-business depends upon life-like reproduction. The microphone of your public address system is the vital link between the original and the reproduced sound. It must be good. For example, the excellence of condenser microphones, but perhaps price has been the obstacle. It needn't be. Christil-Acoustic condenser microphones contain high quality with low price. In use the world over by radio stations, sound engineers, experimenters... with thorough satisfaction.

Microphone head only \$8.00 tested, guaranteed. Kit form, if you wish, \$3.00. C. O. D. extra.
Write for circular listing condenser microphones, amplifiers, and power packs.
Christil-Acoustic Laboratories, 175 68th St., Bklyn., N.Y.

THE MOST COMPLETE LINE OF CONDENSERS AND RESISTORS FOR EVERY RADIO USE



Write for Complete Catalog free of charge

AEROVOX CORPORATION

78 Washington Street Brooklyn, N. Y.

What's Your FUTURE?



FREE HELP AND ADVICE from an ENGINEER!

What will your future be with returns at good times? Get the facts. Write me for free advice. Many men I've helped earn \$50 a week and up in drafting. I offer you the same opportunity and furnish Tools and Drafting Table when you start. Get my PAY RAISING PLAN. Write now.

ENGINEER DOBE, 1951 Lawrence Ave., Dept. 82, Chicago, Ill.

200 STUNTS

Electric Fun with 110 volts! How to make arc lights and furnaces, motors, obedient lights, alarms, and 193 other practical, mysterious and amusing devices. Book clearly explains how to do each stunt. Postpaid \$1. Experiment and inventors catalog free.



CUTTING & SONS 23 B ST., CAMPBELL, CALIF.

DEMAND FLECHTHEIM SUPERIOR DRY ELECTROLYTIC CONDENSERS

Because they are the best

A. M. FLECHTHEIM & CO. INC.
136 Liberty St. N. Y. U. S. A.

ANNOUNCEMENT

to men who want careers in RADIO



In the sign language of the Broadcasting Room this symbol means "Announcement."

INTERNATIONAL CORRESPONDENCE SCHOOLS offer a complete Radio Course designed to give thorough instruction in the whole field of radio. Study of it will give you mastery of operating and transmitting. Prepared and approved by leading radio authorities—mail this coupon for complete details today!

INTERNATIONAL CORRESPONDENCE SCHOOLS

Box 8280-M, Scranton, Penna.

Without cost or obligation, please tell me all about the NEW RADIO COURSE

Name _____ Age _____

Street Address _____

City _____ State _____

If you reside in Canada, send this coupon to the International Correspondence Schools Canadian, Ltd., Montreal, Canada

AERO INTERNATIONAL

ALL WAVE 11-TUBE SUPER-HETERODYNE DE LUXE



Completely Assembled
With 2 Matched Full
Dynamic
Speakers . . . \$29.75

At Last! World wide reception at a sane price, 15 to 550 meters. Besides the regular broadcast band it brings in foreign programs, amateurs, police calls, ships at sea and aeroplanes. One dial control. No plug in coils. Latest super-phonictubes.

AERO 4-TUBE MIDGET

\$10.95 less tubes
2.95 kit of tubes

The lowest priced quality Midget Receiver on the market today. Very selective, brings in long distance like local stations.

Aero 5-tube Midget . \$11.90
Aero 6-tube Midget . 18.50



AERO WORLD WIDE

1-Tube SHORT WAVE
SET for Headphone
\$5.95 . . . Operation

Listen in DIRECT to London, Paris, Berlin, Buenos Aires and other broadcasting stations throughout the world via short waves. Your ordinary receiver cannot tune in these low wave stations. WORLD-

WIDE RECEIVER gets 15 to 500 meters. Aero 2-Tube Short Wave Set \$8.75. The same as above set but it has 1 stage of Audio Frequency added to it. Write for complete catalogue.

CHARLES HOODWIN CO.
4240 Lincoln Ave. Dept. B-30 Chicago

2 GREAT BOOKS
THAT WILL BRING YOU MORE MONEY

RADIO PHYSICS COURSE
by A. A. Ghirardi \$3.50
Postpaid in U. S.

Here is the famous Radio Physics course lesson section you've been wanting! The in one book complete radio text for radio courses everywhere! Explains the entire field of radio! Over 500 illustrations!

RADIO SERVICING COURSE
by Bertram M. Freed \$1.50
Postpaid in U. S.

Practical! Valuable! Check technical information, hard-to-find data, and service man wants and needs in his daily work. 192 pages Over 100 illustrations!

MAIL THIS COUPON AT ONCE!

RADIO TECH. PUB. CO., Dept. R. N. 2,
80 Fifth Avenue, New York City.

Enclosed find check, cash or money order for . . . copies of Radio Physics Course at \$3.50 each, and . . . copies of the Radio Servicing Course at \$1.50 each. Check here for FREE circular describing the contents of each book in detail.

Name
Address
City State

RADIO SCHOOL
YOUNG MEN wanted to train as radio operators; we prepare for U. S. Govt. license; call or write for 40-page catalog; established 1899. Oldest, largest and best equipped school in N. E. Investigate.
MASS. RADIO SCHOOL
18 Boylston St. Boston, Mass.

Radio Physics Course

(Continued from page 493)

clean and dry, for dampness or dirt permits the electric current to leak away over the surface between the positive and negative terminals, and in time accumulates sufficiently to corrode the terminals and rot the case if it is made of wood. See that the battery, its connections and surrounding parts are kept clean, and the vent caps are in place and tight.

If corrosion has started, the only way of eliminating it is to scrape the corroded surfaces clean and then remove all traces of acid film from contact with the metal connections or terminals by the use of cloth or waste wet with ammonia or soda solution. Then (1) cover the metal surfaces which are connected together with a film of pure vaseline to keep acid from creeping in afterwards, and (2) keep the top of the battery dry and clean.

The solution (electrolyte) is a mixture of pure water and pure sulphuric acid. Ordinarily the only loss in volume of electrolyte is from the loss of its water. Some water is lost by evaporation, but most of the loss is due to the action of the charging current which decomposes the water, forming gases which are given off through the vent holes. Acid is never lost from the battery by evaporation or decomposition. It will, therefore, never be necessary to add new electrolyte unless some should get outside the cell through carelessness by leaving the vent plugs out or loose, or by bringing the level too high when adding water.

During the operation water must be added regularly to each cell. Do not allow the surface of the electrolyte to get below the top of the separators; keep it above by removing the vent plugs at intervals from all the cells and adding sufficient approved water to each cell as often as necessary. Do not fill higher than about 3/8 inch above the separators, otherwise electrolyte will be lost through the vent plugs.

Only water free from impurities such as iron, lime, etc., should be used in storage batteries, for if impurities get into the battery they will either neutralize some of the acid or else cause local action inside the battery with resultant eating away of the active material. If in doubt as to the suitability of the water, clear rain water or distilled water should be used. Distilled water is now sold in quart bottles especially for the purpose.

If a battery is to be left idle for a few weeks, it should be stored away fully charged, for if it is left uncharged, crystals of hard lead sulphate will form on the plates. These will materially reduce the output and life of the battery because they are not readily converted back into lead peroxide and spongy lead during recharging.

If a battery is not to be used for a long period of time, say a few months, it should be put into wet storage. The battery is first charged, then placed on wooden strips on a dry bench or shelf, so that air can circulate freely around it. Vaseline should be applied to all exposed metal parts. If possible, the battery should be placed on a low-rate trickle charge of about half an ampere. The level of the electrolyte should be kept above the plates by adding distilled water. If continuous trickle charging is not possible, the battery should be charged until all of the cells are gassing freely, about every month or two.

The capacity of a storage battery is rated in ampere hours; that is, amperes X hours. The capacity decreases as the discharge rate is increased, due to the increased losses caused by internal heating of the battery and the inability of the acid to properly and

INDEX TO ADVERTISERS

A	
Aerovox Corp.	509
Alan Radio Corp.	508
Alden Products Co.	504
Allied Radio Corp.	507
American Sales Co.	496
American School.	511
Arcturus Radio Tube Co.	489
B	
Baltimore Radio Corp.	511
Bud Speaker Co.	496
Burns Radio Co., The.	501
C	
Candler System Co., The.	511
Capitol Radio Engineering Inst.	501
Central Radio Labs.	494
Chicago Gear Works.	511
Chicago Radio Apparatus Co.	507
Chrisell-Acoustic Labs.	509
Clarostat Mfg. Co., Inc.	512
Coast to Coast Radio Corp.	501
Coyne Electrical School.	503
Cutting & Sons.	509
Classified	508
D	
Dobe, F. W.	509
Dubilier Condenser Corp.	507
E	
Electrad, Inc.	498
Emro Radio Products Corp.	494
Evans & Co., Victor J.	500
F	
F. & H. Radio Laboratories.	496
Federated Purchaser, Inc.	504
Filtermatic Mfg. Co.	509
First National Television.	509
Flechtheim & Co., Inc., A. M.	509
G	
General Mfrs. Radio Service.	507
General Motors Corp.	507
Grant Radio Labs.	511
H	
Hammarlund Mfg. Co.	512
Hoodwin Co., Chas.	510
I	
Insuline Corp. of America.	500
International Correspondence Schools.	509
International Resistance Co.	487
Irving-Vance Co., The.	512
L	
Lincoln Radio Corp.	Second Cover
Lynch Mfg. Co., Inc.	504
Mc	
McGraw-Hill Book Co., Inc.	500
M	
Macy Electrical Products Co., Inc.	501
Massachusetts Radio and Telegraph School.	510
Metal Cast Products Co.	512
Midwest Radio Corp.	451
Miller and Miller	500
N	
National Company, Inc.	497
National Radio Institute.	452, 453
National Radio and Electrical School.	507
National Union Radio Corp.	493
Newark Electric Co.	501
O	
Ohio Carbon Co., The.	491
P	
Polk & Co., R. L.	507
R	
RCA Institutes, Inc.	505
Radio Technical Pub. Co.	510
Radio Trading Co.	508
Radio Training Association of America.	498
Radio Treatise Co.	502
Radolek Co.	511
Readrite Meter Works.	495
Rosierian Brotherhood.	511
Ross, Malcom G.	512
S	
Scott Radio Labs., Inc., E. H.	449
Shallcross Mfg. Co.	508
Silver-Marshall, Inc.	455
Silver, Inc., McMurdo.	Fourth Cover
T	
Teleplex Co.	494
Thomaston Laboratories, Inc.	502
Trimm Radio Mfg. Co.	509
Trymo Radio Co., Inc.	512
U	
Universal Microphone Co., Ltd.	511
V	
Van Nostrand, D.	499
W	
West Side YMCA Radio Institute.	501
Wholesale Radio Service.	499

Electrical Engineering

Practical Training

New opportunities constantly opening to trained men. Practical training, largely of college standard, given by home study. Texts written by 28 authorities from General Electric, Westinghouse, Mass. Inst. of Technology, Lehigh, etc.; used by resident colleges, trade schools, U. S. Navy, etc.

School chartered 35 years ago as educational institution, not for profit, like best resident colleges. Write today for free Bulletin, list of local students and graduates.

American School, Dept. E-280
Drexel Ave. at 58th St., Chicago

THE UNIVERSITY OF THE HOME

MIND POWER

A FREE BOOK

Develop your personal, creative power! Awaken the silent sleeping forces in your own consciousness. Become Master of your own life. Push aside all obstacles with a new energy you have overlooked. The ROSICRUCIANS know how, and will help you apply the greatest of all powers in man's control. Create health and abundance for yourself. Write for FREE book, "The Wisdom of the Sages". It tells how you may receive these teachings for study and use. It means the dawn of a new day for you. Address, Scribe V. H. Z.

ROSICRUCIAN BROTHERHOOD
San Jose (AMORC) California

UNIVERSAL 3-Piece Adjustable Combination Stand

This full utility, all-purpose, adjustable banquet and floor stand out-sells any stand on the market—Three telescoping sections—Collapsible for easy transportation. Can be extended to full standing height—Honest, solid construction—Snappily finished in highly polished nickel plate—Lowest price in history. Only \$10.00 list, including 8 suspension springs.

UNIVERSAL MICROPHONE CO., Ltd.
424 Warren Lane, Inglewood, Cal., U. S. A.

Study RADIO in CANADA

A START IN RADIO GUARANTEED or your money back. Course covers Radio, Television, Sound Amplification and Telegraphy. Practical work material supplied. Preparation for Government and Service examinations. Home Study. Day or Evening Classes. Write for booklet.

RADIO COLLEGE OF CANADA, Limited
312 Yonge St. Toronto, Canada

GEARS

In stock—immediate delivery Gears, speed reducers, sprockets, thrust bearings, flexible couplings, pulleys, etc. A complete line is carried in our Chicago stock. Can also quote on special gears of any kind. Send us your blue-prints and inquiries.

Write for Catalog No. 40
CHICAGO GEAR WORKS
769-773 W. Jackson Blvd. Chicago, Ill.

SERVICEMEN-DEALERS

"Send 25c for Our Handbook and Catalog"
Complete Stock of NEW Radio Replacement Parts
Hard to Get Parts—We have them. Send us your repair work for estimate.

Grant Radio Laboratories
6521-N South Halsted St., Chicago, Ill.

quickly combine with the active material of the plates at the more rapid rate of discharge. Therefore it is usual to base the normal discharge rate for most batteries upon an 8-hour rate of discharge. For example, suppose a battery is rated at 100 ampere-hours. The normal rate of discharge is found by dividing 100 by 8, giving 12.5 amperes. This means that when the battery is fully charged, 12.5 amperes can be drawn from it for 8 hours. According to rules adapted by the National Electrical Manufacturers Association, the ampere-hour rating of a radio A battery is based on the rate (amperes) at which the battery will discharge in 100 hours down to a cut-off voltage of 1.75 volts per cell, the cell temperature being 80 degrees Fahrenheit. The rating of a storage B battery is based on the same conditions, except that the time is 200 hours. The battery must deliver current at its rated capacity until it is charged and discharged three times. As storage batteries used on automobiles are called upon to deliver heavy currents when starting the engine, the Society of Automotive Engineers' ratings for storage batteries are based on a 20-minute discharge to an end voltage of 1.5 volts per cell.

The life of a lead-storage battery varies from one or two to four or five years, depending on the charge and discharge rates and the general care accorded it. Rapid charging or discharging tends to buckle the plates and causes the active material to shed from the pockets in the plates and fall to the bottom of the jar, where it is useless. This, of course, decreases the amount of energy which the battery can store and deliver. Allowing the battery to stand idle when in a discharged condition causes the formation of hard sulphate crystals. When a battery approaches the condition where it must be replaced, it is generally unable to deliver current for anywhere near the usual length of time after being charged. This means that it must be charged very much more often than usual.

Loudspeaker Range

(Continued from page 463)

advantage of this arrangement is obvious. Since extending the frequency range will cause the slightest distortion or amplifier overloading to become easily noticeable, it is important that the loudspeakers are preceded by a high-quality detector and amplifier. Static and other noises will also be more noticeable, so it may be necessary to install a switch to disconnect the high-frequency speaker when listening to distant stations.

In the past year broadcasting companies have expended millions of dollars in extending the frequency range of their stations farther into the high end of the audio spectrum.

"Mike" Substitutes

(Continued from page 474)

loudspeaker is brought near the output loudspeaker, a howl results, the pitch of which can be varied by altering the distance between the two loudspeakers. With a little skill a quite presentable musical accomplishment is to be had—something like the Hawaiian steel guitar, with one note sliding right into the other. This acoustic effect has to be guarded against when employing the loudspeaker for speech, however. By placing the pick-up loudspeaker at right angles to the output loudspeaker, the acoustic coupling can usually be overcome, even when working relatively close together.

SERVICEMEN! DEALERS!

YOUR PROFIT GUIDE

FREE!

EVERYTHING NEW!

Servicemen—Dealers—Laboratory Heads—Manufacturers! You're missing one of the REAL ways to make your business more profitable unless you get this guide.

LOWEST WHOLESALE PRICES!

Hundreds of NEW items—all at NEW, ROCK-BOTTOM LOW PRICES that leave you a profit margin and make sales grow. All fresh, new, dependable merchandise of guaranteed quality. Send Coupon below—must be accompanied by your letterhead or business card to receive attention.

THE RADOLEK COMPANY
601 W. Randolph St., Dept. 228, Chicago, Ill.

MAIL COUPON AT ONCE!

Please send me, without obligation, the NEW Radolek Profit Guide.

Name.....

Street.....

City.....State.....

Do you do Service Work Yes No

Do you operate from Store Shop Home

(Check which, please.)

free

A Dealers' and Servicemen's Newspaper!

Contains interesting news of the radio industry, technical articles which everybody can understand, service hints, a department for "hams" and other valuable information. Issued every month. Send in your name and address promptly so that you will not miss any numbers.

BALTIMORE RADIO CORP.
N725 B'way., N. Y. C.



You Can Become a Fast, Capable RADIO OPERATOR at Home

CANDLER

Scientific System

In less than half the usual time. Amazing results. Thousands of fast Radio operators taught by CANDLER. FREE advice if you're "stuck". All questions answered personally. No obligation. If beginner, get facts on Junior Course. If Radio operator, ask about ADVANCED COURSE for SPEED and Copying Behind and "MILL" Course. FREE illustrated book will save you time and money. Write now!

CANDLER SYSTEM CO., Dept. 12
6343 So. Kedzie Ave., Chicago, Ill.

World's Only Code Specialist



E. J. Yarris, Chicago, copied 50 words in 14 hours' study. C. Lane, Portland, Ore., does 20 words on third lesson.

The World's FINEST Short-Wave RECEIVER

HAMMARLUND, for once, discards its customary modesty and asserts boldly that the new COMET "PRO" is the *World's Finest Short-Wave Receiver*.

The evidence is too overwhelming to permit anything less being said about this amazing custom-built superheterodyne.

With the whole world to choose from, the "PRO" holds honor position in the service of the U. S. and Canadian Governments, leading air-transport and steamship companies, police departments, and key stations of broadcasting networks—faithfully performing their most exacting tasks.

The "PRO" now uses four "58" tubes, two "57's," one "247" and an "80" rectifier.

It is even more *sensitive* and *selective* than before—yet surprisingly *easy to tune* with its simple band-spread system. Full loudspeaker volume. Electron coupling gives greater oscillator stability. Shielding is more effective, and the new metal cabinet prevents stray influences. Wood cabinet optional. A.C. and Battery Models.

Mail coupon for 16-page folder describing complete details of this really **GREAT** receiver.



The COMET Custom-Built "PRO" by HAMMARLUND

HAMMARLUND MANUFACTURING CO.
424-438 W. 33rd St., New York

Please send your new Catalog "33." Check here for illustrated folder describing COMET "PRO" Short-Wave Superheterodyne.

Name.....
Address.....

RN-2

ground terminal of the set.

Using this arrangement with an Atwater Kent Model 40 receiver, I find reception as strong as with a 75-foot outdoor antenna and with much less static.

Apparently this antenna system works on

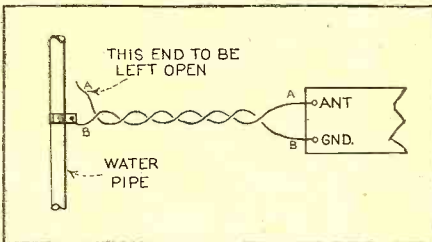

the "ground loop" principle. The water pipe, ground and the a.c. line (which is always grounded somewhere along its span) constitute three sides of a large loop. When the water pipe is connected to the ground post on the set, the loop is indirectly completed. The second wire in the twisted pair couples the loop to the antenna post of the set by virtue of the capacity between the two wires of the pair.

ARCHIE J. MAUS,
St. Louis, Mo.

The Service Bench

(Continued from page 491)

common tubes of the screen-grid variety and the -27 type are tested directly by plugging into the indicated sockets. The pilot light will flash if there is a short-circuit between

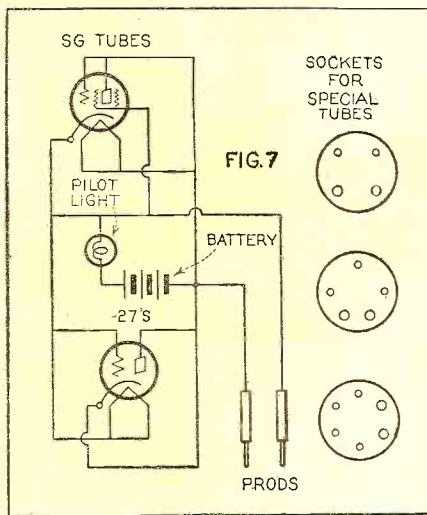

any adjacent elements. Additional 4, 5 and 6-prong sockets may be provided for testing special and less common tubes by means of test prods.

Radio Service "Lab"

The illustration shown in this month's heading is a photo of the radio service laboratory in Fenn College, Cleveland, Ohio, among the first of the higher educational institutions to recognize the vocational possibilities of technical service courses.

Common Sense to the Rescue

Hot rectifying and power tubes have the inconvenient habit of dropping even from fingers protected by a profanely requisitioned handkerchief. The simple and sensible idea of including one of last winter's gloves in the service kit is suggested by E. J. Alexander, of St. Louis, Mo., and is dedicated to the thousands of burnt fingers, sizzled atmosphere and broken tubes.

Earn Big Money

REPLACE BURNT-OUT and DEFECTIVE BALLASTS

Millions of Sets including MAJESTIC and other standard lines need ballast Replacement NOW.

JOBBERS AND SERVICE ORGANIZATIONS

Send for our plan outlining Ballast Replacement Market and Money Making Plan. Also Volume Control Replacement Data Book.

CLAROSTAT MFG. CO., INC.
285 N. 6th St. Brooklyn, N. Y.

EARN MONEY AT HOME

YOU can make \$15 to \$50 weekly in spare or full time at home coloring photographs. No experience needed. No canvassing. We instruct you by our new simple Photo-Color process and supply you with work. Write for particulars and Free Book to-day.

The IRVING-VANCE COMPANY Ltd.
265 Hart Building, Toronto, Can.

\$5,000 WILL BE PAID TO ANYONE WHO PROVES THAT THIS

is not the actual photo of myself showing my superb physique and how the Ross System has increased my own height to 6 ft. 3 3/4 inches.

Hundreds of Testimonials. Clients up to 45 years old gain from 1 to 6 inches in a few weeks!!

No Appliances—No Drugs—No Dieting **FIRST IN 1907 FIRST TO-DAY**

ROSS SYSTEM NEVER FAILS. Fee Ten Dollars Complete Convincing Testimony and Particulars 6 cents stamp.

Allow time for return mails across the Atlantic

G. MALCOLM ROSS, Height Specialist
Scarborough, England. (P. O. Box 15)

Write Us for Prices on Parts for

NEW "SUPER SIX" MIDGET

LARGEST ASSORTMENT OF RADIO PARTS IN THE COUNTRY

Send for Our 1933 Complete Catalogue

TRY-MO RADIO CORP.
85-R Cortlandt St. N. Y.

Get Into the Toy Business

As Our Manufacturer Earn Money casting our new hollow Toy Soldiers, Indians, 5 and 10c Automobiles, Ashtrays, etc., for a firm of many years standing. NO EXPERIENCE required as we furnish full instructions with moulds and buy finished goods. A rare opportunity for these times, so if you mean strictly business write at once for full details as 1933 Wholesale Season is Now Starting.

Metal Cast Products Co. Dept. 12
1696 Boston Road New York

File Your Copies of Radio News

MANY times you've probably hunted high and low for important issues of *Radio News*. And, when you finally found the copy you needed, it was torn and barely legible. Or, the copy you wanted so urgently could not be found at all!

No longer need you be inconvenienced by mislaid or torn copies of *Radio News*. No longer must you purchase duplicate copies to replace lost issues. A sturdy, convenient binder is now available to readers of *Radio News*.

In response to many urgent requests from our subscribers, we have obtained a first-class, durable binder constructed to hold twelve copies of *Radio News*, with the front cover stamped in gold.

We know this binder will render satisfactory service because we have tested it thoroughly by using it in our own office for months.

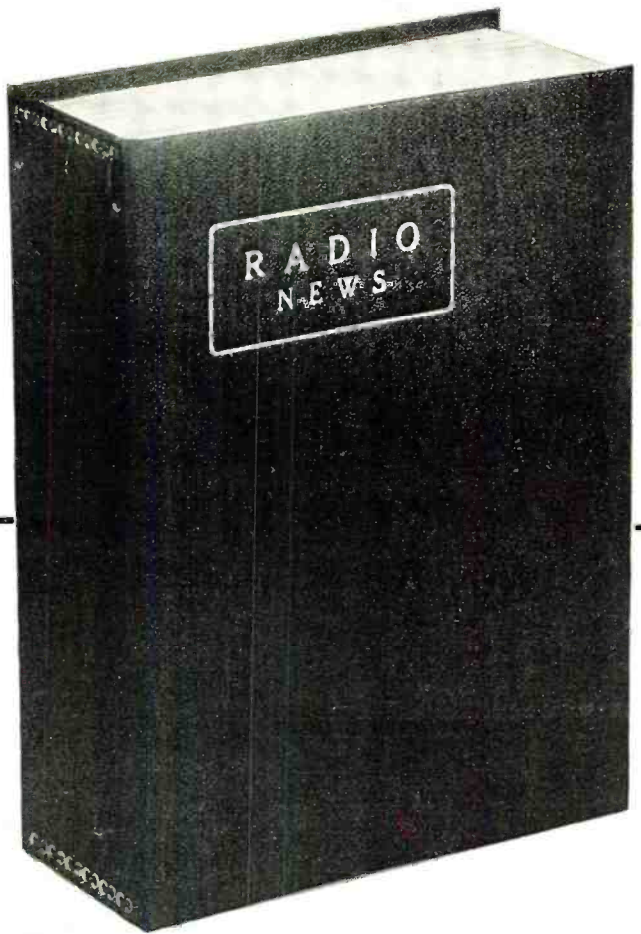

The binder we offer is covered with neat-appearing, washable, black fabrikoid. It is all in one piece—no extra parts to get lost or mislaid—heavily boarded, and easy to use. Furthermore, when opened, every page of the copies inserted is fully visible.

Here's How To Get This Binder *Free!*

Knowing that many of our readers want these binders, we are making this special offer: Subscribe to *Radio News* for 1 year at the regular price of \$2.50 or 2 years at the money-saving price of \$4 and we will send you this serviceable binder, postage prepaid, *absolutely free!* Renewal subscriptions will also be accepted!

Binders Also Available At Low Cost

If you need more than one binder—if you do not care to place a subscription at this time—you can obtain these binders at the amazingly low price of \$1—postage prepaid!

Supply Limited—Order Today

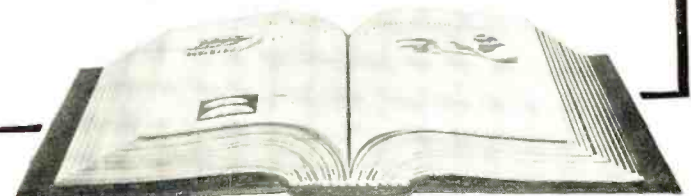

Radio News Dept. 2-B
222 W. 39th St., New York, N. Y.

Enclosed please find \$..... Enter my subscription to *Radio News* for () 1 year @ \$2.50 () 2 years @ \$4 and send me a binder free. If renewal, check (). Canada \$3 One Year; \$5 Two Years. Foreign \$3.50 One Year; \$6 Two Years.

Enclosed please find \$..... Send me binders at the special low price of \$1 each. (Foreign Price, \$1.25.)

Name

Address

City State

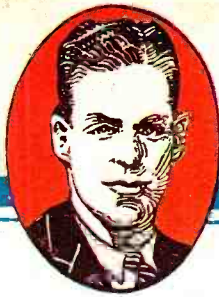

McMURDO~SILVER

The MASTERPIECE of the MASTER DESIGNER

I designed it, but I did not name it.

Impartial laboratory instruments did that.

They measured this receiver. Also the others it was designed to out-perform.

Their verdict was . . . "so far ahead of anything else that comparison is utterly impossible."

Indisputable mathematical facts, therefore designated that this receiver be known as "The Masterpiece."

You will agree that it has been correctly named . . . when you see its performance curves.

You will KNOW it is the greatest advancement in radio since the screen grid tube . . . when you make a personal test of The Masterpiece side by side with all other so called "custom-built" 15-550 meter receivers.

Now . . . with the coming of The Masterpiece you can actually "get" foreign reception with regularity and certainty—irrespective of where you live.

Now . . . you can tune from 15-550 meters without changing coils . . . without using trimmers . . . without attaching a separate antenna tuner . . . and without consulting blue prints, charts or station finders. The four wave bands are right on the Masterpiece dial and are calibrated to absolute accuracy from 15 to 550 meters.

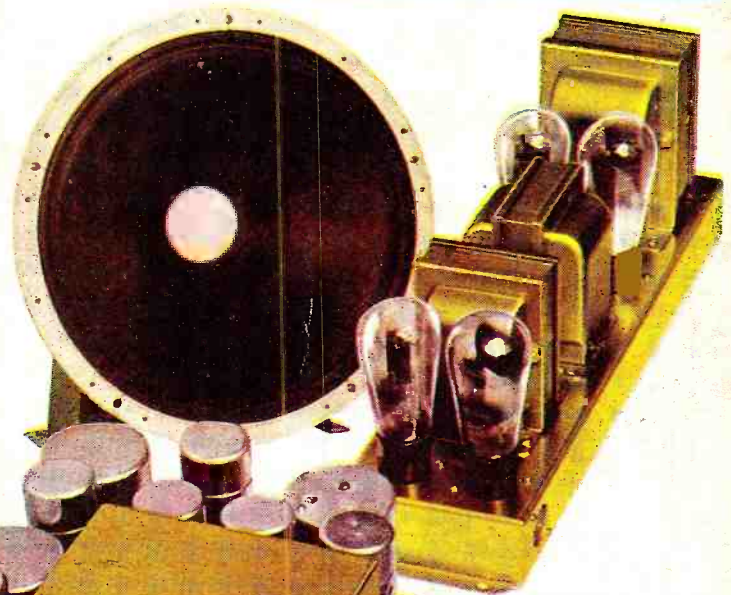

Finished in brass, buffed and lacquered just as all precision laboratory instruments are made. Trimmings in aluminum.

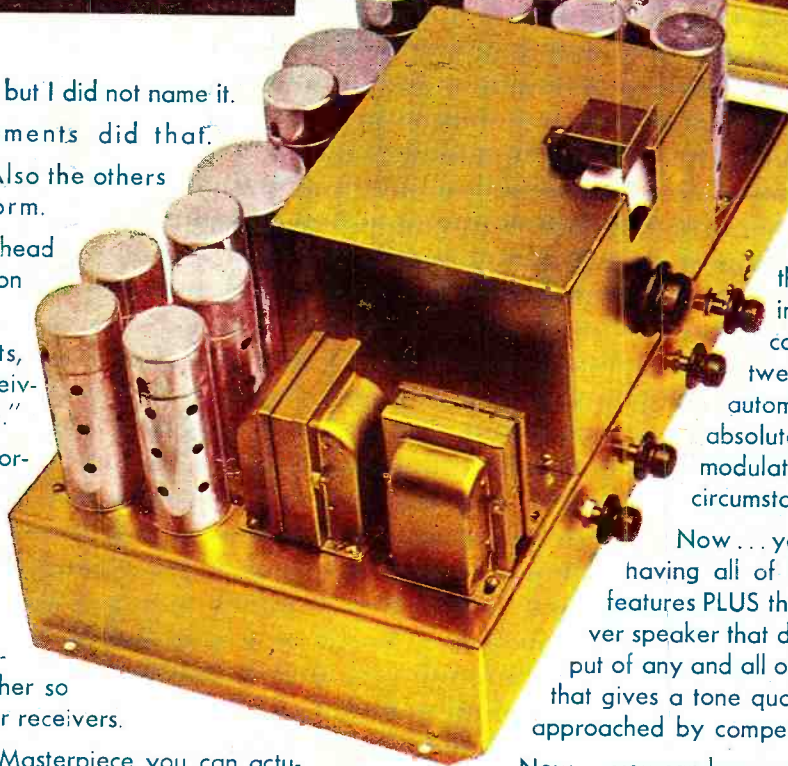

Now . . . you can have an all-wave receiver that embodies meter tuning, automatic volume control, silent tuning between stations, manual and automatic tone control and absolute freedom from cross modulation under any and all circumstances.

Now . . . you can enjoy a receiver having all of the above sensational features PLUS the 42 pound 12 inch Silver speaker that delivers 4 times the output of any and all other dynamic units, and that gives a tone quality not even remotely approached by competition.

Now . . . you can buy a receiver on which I will have personally logged three or more foreign stations outside of North America, and that is accompanied by its own specific performance curves measured on your exact set and tubes by me personally.

And last, but of no less importance, The Masterpiece comes to you for a 10 day free trial in your home . . . subject to any kind of competitive test you can think of. If you are not satisfied in every way, you may return The Masterpiece for a prompt and full cash refund.

The coupon at left and 6 cents in stamps will bring my 16 page book giving complete technical description of The Masterpiece. Clip . . . Mail the coupon now.

McMURDO SILVER, INC.
1130 WEST AUSTIN AVENUE, CHICAGO, ILLINOIS, U. S. A.

McMURDO SILVER, INC., 1130 W. Austin Ave., Chicago, U. S. A.
6c in stamps enclosed. Send technical description of The Masterpiece.

Name.....
Street.....
Town..... State.....