

RADIO GUARDS THE BABY

**RADIO
NEWS**

JULY
25 Cents



**Scientists
Hear Germs Die**

**What Television Needs
A.C. and D.C. Set Analyzers
Build an Interference Locator
Getting Down to the Ultra-Short Waves**

Televisor

Most efficient televisor produced for home use. Equipped with Duraluminum lens disc 16" diameter. Each of its 60 lenses accurately adjusted focally to produce clear, definite images on screen. Disc driven by heavy duty synchronous motor, with switch and framing device operated from front panel.

Short Wave

The Rawls Short Wave Unit in connection with the broadcast receiver has been especially designed for long distance short wave reception from 15 to 200 meters, Super Heterodyne Circuit incorporating 9 tubes in the combination. The use of the new multi mu and pentode tubes give exceptional tone and power. To switch from one short wave band to another, it is unnecessary to change coils—just the click of the panel switch and the change is made automatically.

Rawls

Broadcast

A six-tube receiver, designed to give the ultimate in tone, selectivity and power. Uses the following tubes: two 235 Multi Mu, one 224A Detector, one 227 and one 247 Pentode output with 280 rectifier. The tone quality of the set is due to the accurate matching of all parts. Its eight-inch Dynamic speaker handles, without distortion, the tremendous output of the pentode tube. Designed especially for reception of the synchronized voice with television image.

Television

The television receiver is the most important receiver of the combination. Eight tubes T.R.F. circuit, using two 235 Multi Mu in RF circuit, one 224A Detector, one 224A, one 227 and two 245's in audio circuit, also with the 280 rectifier. Very careful attention has been given the audio amplifier and its frequency response is flat from 15 to 75,000 cycles, which is necessary to give clear, definite television images. Its two 245 tubes are so connected to supply the undistorted output and current necessary for proper operation of the Rawls crater point lamp.



To give the public the very latest in television our engineers have produced the "Ultimate in Television and Radio."—Model TV85. . . .

Pioneering in the television field they were quick to grasp the need of a set capable of producing a picture large enough for a group to sit by and enjoy.

No longer is it necessary to peep into a small aperture—one person at a time. The TV85 projects a picture on a screen in the panel of set. Invite your friends—any number of people can enjoy the program.

In addition it is now possible to get the added thrill of LISTENING TO AS WELL AS SEEING your favorite artist on the screen . . . and the TV85 is not only a television receiver . . . it is also the latest in combination ALL WAVE RECEIVERS. . . . Covering bands from 15 to 550 meters.

Housed in a beautiful console cabinet that will fit the appointments of the most pretentious home. . . . TRULY the last word in TELEVISION AND RADIO. . . .

Think of the thrill of reaching out with just a turn of the dial to that unknown, unexplored region of short waves . . . just beyond the range of your present receiver. . . .

Distance means absolutely nothing . . . FOREIGN BROADCAST an exciting chase through the underworld of a distant city hot on the trail of a murderer, thief, reported clearly by the police department. You don't have to strain to listen . . . signals come in as loud and clear as your local broadcast.

Listen to AMATEUR STATIONS all over the world.

Hear the progress in the field of Aviation. Plans are timed and reported exactly the same as on the most modern railroad . . . Dallas, Texas, reports No. 622 overdue . . . quickly the entire country is on the quèvive searching for the missing plane.

It is positively thrilling . . . and don't forget all this time you are comfortably seated in your favorite chair surrounded by your family and friends . . . enjoyment for them all. . . .

Be up to date. . . order your Rawls TV85 today . . . costs no more than a good single purpose receiver, yet it provides thrills that you've never experienced.

LIST PRICE

\$ **295.00**

Dealers' franchises will be valuable. Write us of your qualifications for exclusive contract. If there is no dealer in your community handling the complete Rawls television set, write us direct.

W. C. Rawls & Company RN
Barkers Trust Building
Norfolk, Virginia

Gentlemen: Please send me complete information about your dealer's franchise.

Name.....
Address.....
City..... State.....

Yellow Base Tubes

RYB112A	Amplifier	\$1.50	RYB232	2-Volt Screen Grid	2.30
RYB120	Amplifier	3.00	RYB233	2-Volt Pentode	2.75
RYB171A	Amplifier90	RYB235	2½-Volt Multi-Mu	1.60
RYB199	Detector Amplifier	2.75	RYB236	6.3-Volt Screen Grid	2.75
RYB199	Detector Amplifier	2.50	RYB237	6.3-V. Heater Amp. & Osc'r	1.75
RYB200A	Detector	4.00	RYB238	6.3 Pentode Amp.	2.75
RYB201A	Detector Amplifier75	RYB239	6.3-V. Radio Frequency Pen.	2.75
RYB210	Power Amplifier	7.00	RYB245	Power Amplifier	1.10
RYB222	DC Four Element Tube	4.50	RYB247	2½-Volt Pentode Amplifier	1.55
RYB224A	Four Element AC Tube	1.60	RYB250	Power Amplifier	6.00
RYB226	AC Amplifier80	RYB280	Full Wave Rectifier	1.00
RYB227	AC Detector	1.00	RYB281	Half Wave Rectifier	5.00
RYB250	2-Volt General Purpose	1.60	RY1531	2½-Volt Multi-Mu	1.60
RYB281	2-Volt Output	1.60		Rawls Teletron Crater Point	10.00

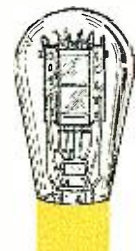

"Originators of Rawls Yellow Base Tubes"

W. C. RAWLS & COMPANY
R. N. BANKERS TRUST BUILDING . . NORFOLK, VIRGINIA

Train *with* R.T.A. *for* Radio Service Work

Important and far-reaching developments in Radio create sudden demand for specially equipped and specially trained Radio Service Men.



*This excellent
set analyzer
and trouble
shooter included
with our course
of training*

MANY skilled Radio Service Men are needed now to service all-electric sets. By becoming a certified R. T. A. Service Man, you can make big money, full time or spare time, and fit yourself for the big-pay opportunities that Radio offers.

We will quickly give you the training you need to qualify as a Radio service man . . . certify you . . . furnish you with a marvelous Radio Set Analyzer. This wonder instrument, together with our training, will enable you to compete successfully with experts who have been in the radio business for years. With its help you can quickly diagnose any ailing Radio set. The training we give you will enable you to make necessary analyses and repairs.

Serving as a "radio doctor" with this Radio Set Analyzer is but one of the many easy ways by which we help you make money out of Radio. Wiring rooms for Radio, installing and servicing sets for dealers, building and installing automobile Radio sets, constructing and installing short wave receivers . . . those are a few of the other ways in which our members are cashing in on Radio.

As a member of the Radio Training Association, you receive personal instruction from skilled Radio Engineers. Upon completion of the training, they will advise you personally on any problems which arise in your work. The Association will help you make money in your spare time, increase your pay, or start you in business. The easiest, quickest, best-paying way for you to get into Radio is by joining the Radio Training Association.

This amazing Radio Set Analyzer plus the instructions given you by the Association will transform you into an expert quickly. With it, you can locate troubles in all types of sets, test circuits, measure resistance and condenser capacities, detect defective tubes. Knowing how to make repairs is easy; knowing what the trouble is requires expert knowledge and a Radio Set Analyzer. With this Radio Set Analyzer, you will be able to give expert service and make big money. Possessing this set analyzer and knowing how to use it will be but one of the benefits that will be yours as a member of the R. T. A.

Write for No-Cost Membership Plan

We have worked out a plan whereby a membership enrollment need not cost you a cent. Our thorough training and the valuable Radio set analyzer can be yours. Write at once and find out how easily both of these can be earned.

Now is the time to prepare to be a Radio Service Man. Greater opportunities are opening up right along. For the sake of extra money in your spare time, bigger pay, a business of your own, a position with a future, get in touch with the Radio Training Association of America now.

Send for this No-Cost Membership Plan and Free Radio Handbook that will open your eyes as to what Radio has in store for the ambitious man. Don't wait. Do it now.

RADIO TRAINING ASSOCIATION OF AMERICA
Dept. RNA-7 4513 Ravenswood Ave. Chicago, Ill.

Fill Out and Mail Today!

RADIO TRAINING ASSOCIATION OF AMERICA
Dept. RNA-7, 4513 Ravenswood Ave., Chicago, Ill.
Gentlemen: Send me details of your No-Cost Membership Enrollment Plan and information on how to learn to make real money in radio quick.

Name.....

Address.....

City..... State.....

S. GORDON TAYLOR
Technical Editor
 WILLIAM C. DORF
Associate Editor
 JOHN M. BORST
Ass't Tech. Editor



HOWARD S. PEARSE
Associate Editor
 SAMUEL KAUFMAN
Broadcast Editor
 JOS. F. ODENBACH
Art Editor

Edited by LAURENCE M. COCKADAY

VOLUME XIV

July, 1932

NUMBER 1

CONTENTS

(Cover Design by Morey)

Radio News Index.....	PAGE 6	Compact D. C. Set Tester By Bernard J. Montyn.....	PAGE 24
Radio Guards the Baby By Irving J. Saxl.....	PAGE 9	Graphs and Charts By John M. Borst.....	PAGE 26
Sounds That Microbes Make By Joachim Winkelmann.....	PAGE 12	Eliminating Fringe Howl By Dale Pollack.....	PAGE 28
What Television Needs By D. E. Replogle.....	PAGE 15	An Interference Meter By Glenn H. Browning.....	PAGE 29
Below Ten Meters By James Millen.....	PAGE 16	Audio Amplifier Design By McMurdo Silver.....	PAGE 31
Five New Tubes By J. van Lienden.....	PAGE 18	A Quartz-Crystal Receiver By Zeh Bouck.....	PAGE 33
The Sprayberry Set Analyzer By Frank L. Sprayberry.....	PAGE 20	What Tube Shall I Use? By Joseph Calcaterra.....	PAGE 35
A Telephone Booster By William C. Dorf.....	PAGE 22	A Novel Wave-Changer By Gordon Fraser.....	PAGE 37
An Antenna Tuning Unit By Thos. A. Marshall.....	PAGE 23	Mathematics in Radio By J. E. Smith.....	PAGE 38

DEPARTMENTS

With the Experimenters.....	PAGE 39
The Service Bench.....	PAGE 41
Radio Physics Course.....	PAGE 46
Backstage in Broadcasting.....	PAGE 48

Published Monthly by Teck Publishing Corporation, Washington and South Avenues, Dunellen, N. J.

OFFICERS

Lee Ellmaker, *President*
 Warren P. Jeffery } *Vice Presidents*
 Huston D. Crippen }
 William Thompson, *Treasurer*
 Wesley F. Pape, *Secretary*

EDITORIAL AND EXECUTIVE OFFICES
 350 HUDSON STREET, NEW YORK CITY, N. Y.

Entered as second class matter at the Post Office at Dunellen, N. J., under the act of March 3, 1879. Copyright, 1932, by Teck Publishing Corporation. All rights reserved. Title Registered at the U. S. Patent Office. Printed in the United States of America. The contents of this magazine must not be reproduced without permission. We cannot be responsible for lost manuscripts, although every care is taken for their safety.

25c a Copy, \$2.50 a year,
 \$3.50 in Canada, \$3.50 in
 Foreign Countries. Sub-
 scribers are notified that
 change of address must reach
 us five weeks in advance of
 the next day of issue.

I will train you at home to fill a **BIG PAY** Radio Job!



Here's Proof



\$100 a week

"My earnings in Radio are many times greater than I ever expected they would be when I enrolled. They seldom fall under \$100 a week. If your course cost four or five times more I would still consider it a good investment."

E. E. WINBORNE
1267 W. 48th St.,
Norfolk, Va.



Jumped from \$35 to \$100 a week

"Before I entered Radio I was making \$35 a week. Last week I earned \$110 servicing and selling Radios. I owe my success to N. R. I. You started me off on the right foot."

J. A. VAUGHN
Grand Radio & Appliance Co.,
3107 S. Grand Boulevard,
St. Louis, Mo.



\$500 extra in 6 months

"In looking over my records I find I made \$500 from January to May in my spare time. My best week brought me \$107. I have only one regret regarding your course—I should have taken it long ago."

HOYT MOORE
R. R. 3, Box 919,
Indianapolis, Ind.,

If you are dissatisfied with your present job, if you are struggling along in a rut with little or no prospect of anything better than a skinny pay envelope—clip the coupon NOW. Get my big FREE book on the opportunities in Radio. Read how quickly you can learn at home in your spare time to be a Radio Expert—what good jobs my graduates have been getting—real jobs with real futures.

Many Radio Experts Make \$50 to \$100 a week

In about ten years the Radio Industry has grown from a \$2,000,000 to hundreds of millions of dollars. Over 300,000 jobs have been created by this growth, and thousands more will be created by its continued development. Many men and young men with the right training—the kind of training I give you in the N. R. I. course—have stepped into Radio at two and three times their former salaries.

Get Ready now for Jobs Like These

Broadcasting stations use engineers, operators, station managers, and pay up to \$5,000 a year. Manufacturers continually employ testers, inspectors, foremen, engineers, service men, buyers, for jobs paying up to \$6,000 a year. Radio Operators on ships enjoy life, see the world, with board and lodging free, and get good pay besides. Dealers and jobbers employ service men, salesmen, buyers, managers, and pay up to \$100 a week. My book tells you about these and many other kinds of interesting radio jobs.

Many N. R. I. Men Have made \$200 to \$1,000 in spare time while learning

The day you enroll I send you material which you should master quickly for doing 28 jobs, common in most every neighborhood, for spare time money. Throughout your course I send you information on servicing popular makes of sets; I give you the plans and ideas that have made \$200 to \$1,000 for N. R. I. students in their spare time while studying. My course is famous as the course that pays for itself.

Talking Movies, Television, Aircraft Radio Included

Special training in Talking Movies, Television and Home Television experiments, Radio's use in Aviation, Servicing and Merchandising Sets, Broadcasting, Commercial and Ship Stations are included. I am so sure that N. R. I. can train you satisfactorily that I will agree in writing to refund every penny of your tuition if you are not satisfied with my Lesson and Instruction Service upon completion.

64-page book of information FREE

Get your copy today. It tells you where Radio's good jobs are, what they pay, tells you about my course, what others who have taken it are doing and making. Find out what Radio offers you without the slightest obligation. ACT NOW!

J. E. SMITH, President
National Radio Institute Dept. 2GS
Washington, D. C.

Our Own Home

Pioneer and World's Largest Home-Study Radio training organization devoted entirely to training men and young men for good jobs in the Radio industry. Our growth has paralleled Radio's growth. We occupy three hundred times as much floor space now as we did when organized in 1914.

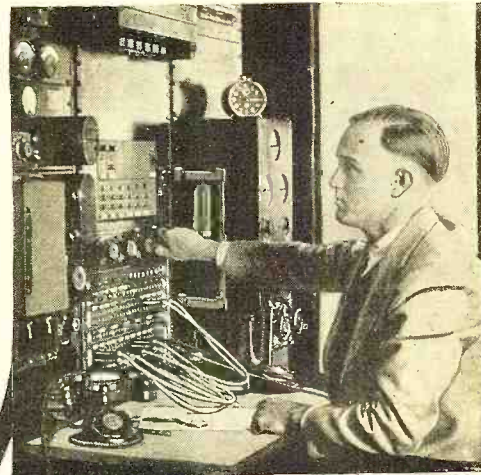

Special Free Offer!

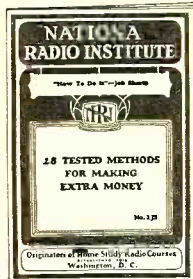

Act Quickly!

Interference are five of the subjects covered. There are 23 others. Get this valuable book by mailing the coupon.

In addition to my big free book, "Rich Rewards in Radio," I'll send you my valuable manual "28 Tested Methods for Making Extra Money." Never before available except to students. Now, for a limited time, it is free to readers of this magazine. How to make a good baffle for cone speakers, how to reduce hum in externally fed dynamic speakers, how to operate 25 cycle apparatus on 60 cycle current, how to operate 110 v. A. C. receivers on D. C., how to shield sets from local interference are five of the subjects covered. There are 23 others. Get this valuable book by mailing the coupon.

NEW Radio Equipment for Broad Practical Experience Given Without Extra Charge

With the aid of this equipment you can work out with your own hands many of the things you read in our text books. From it you get the valuable experience that tells an expert from a beginner. In a short time you have learned what it would take years to learn in the field. It's training like this that puts the extra dollars in your pay envelope. Some of the many circuits you build and experiments you perform are: Measuring the merit of a tube, building an ohmmeter, tube voltmeter, and a Grid dip meter for service work. You actually make experiments illustrating the important principles in the 25 best known sets.

I have doubled and tripled the salaries of many. Find out about this tested way to BIGGER PAY



FILL OUT AND MAIL THIS COUPON TODAY

J. E. SMITH, President
National Radio Institute, Dept. 2GS
Washington, D. C.

Dear Mr. Smith: I want to take advantage of your Special Offer. Send me your two books, "28 Tested Methods for Making Extra Money" and "Rich Rewards in Radio." I understand this does not obligate me.

Name.....
Address.....
City..... State.....

"J"

Lifetime Employment Service to all Graduates

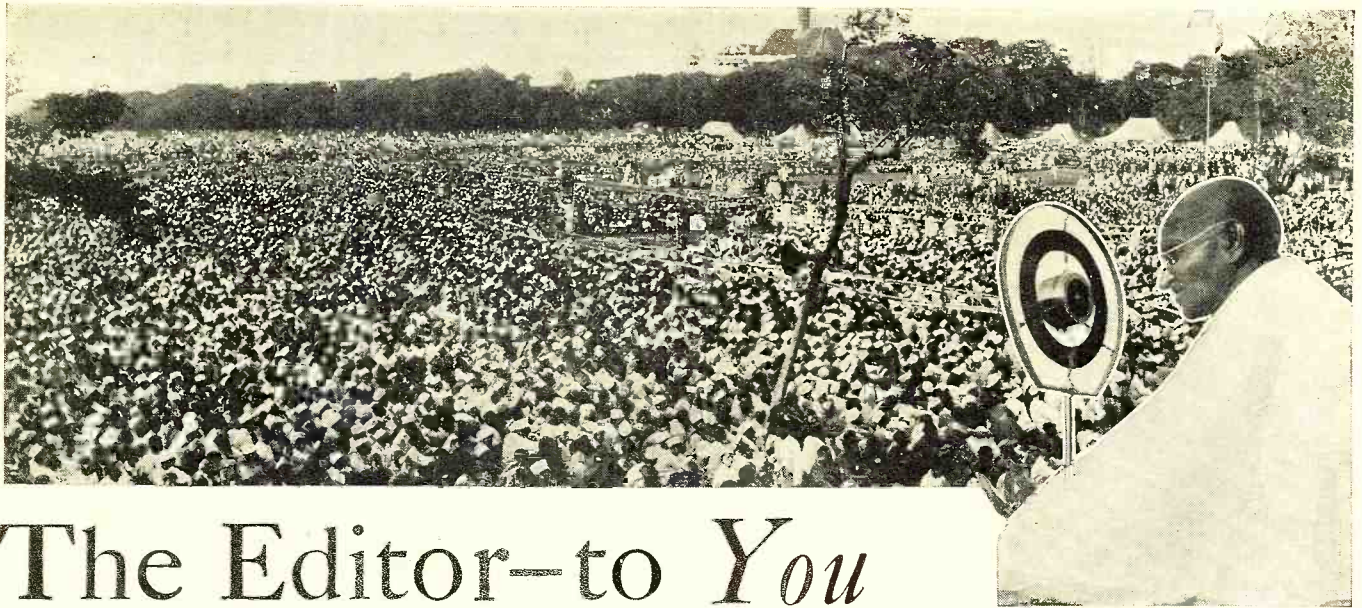

The Editor—to You

"RIGHT NOW"—two words introduced to the American radio audience by the versatile French comedian, Maurice Chevalier, are being commandeered this month as the keywords of this editorial. "Right now" is a time of critical importance to the large group of servicemen readers of **RADIO NEWS**; for this is the time when servicemen *must* plan to take full advantage of what is to be the most successful service period that radio has known for the last four years.

* * *

During the next few months we are to have events broadcast over our national networks that will, more than ever, draw the public's interest and revive enthusiasm in radio. People will insist that their radio sets are working properly. And these are the reasons: Baseball, Football, and the coming Political Campaigns.

* * *

WORLD SERIES baseball games will draw many more listeners than ever before, in these times of depression when baseball fans may save money and still follow the games, by radio, as they proceed. The same holds true of football; with the growing interest in this national *sport*, many thousands of sets will simply have to be repaired to place them in first-class working order for these events. And then comes along the most important political campaigns in history which will engross the public mind and absorb the attention of every citizen. The coming Presidential Election is more than just another election; with the Prohibition question, the charges of corrupt politics, reparations, restoration of sound economic conditions, etc. Yes, the elections this year will be taken much more seriously to heart by every voter who realizes that something must be done. And Radio will be the main channel of political contact with the population.

* * *

MR. SERVICEMAN, "Will this ready market find you prepared?" This is a

question that you, our individual readers, will have to answer yourselves. Here are some others. "Are you to 'realize' on this rush of business?" "Is your repair shop fully equipped, with all the necessary set analyzers, meters, and other apparatus to do the job quickly and thoroughly?" "Are you equipped to take advantage of this business and to make the sure profit that will be waiting for you?"

* * *

"Right now" is the time for you to be preparing yourselves. Now, in this slack season you must buy or build all of the necessary equipment that you will need. And here is where **RADIO NEWS** is ready and waiting for you. On page 20 in this issue is described the new Sprayberry a.c.-d.c. set analyzer, operating with a single meter, which gives you the very latest design. This small and compact device can be built for a relatively small cost.

* * *

ANOTHER article in this issue describes the design of an interference meter that will allow you to answer complaints and run down inductive interference—that bane of radio reception.

* * *

A THIRD article of similar importance tells you how to build a d.c. set tester of unusual simplicity and portability that is especially suitable for service work. With these articles and the timely hints appearing in the Service Bench department, we feel that this issue is of more than passing significance to *all* servicemen.

* * *

AND NOW, another interesting matter appears which leads the editor to ask, "What is wrong with American public-address equipment manufacturers?" The following letter came across the editor's desk recently, with the picture appear-

ing at the top of this page. The letter follows:

"We are forwarding to you, under separate cover, a photograph of the largest public meeting held under the Indian sky. This was held in Bombay on the 28th of December, 1931, and was addressed by Mahatma Gandhi on the day he returned to India after his participation in the deliberations of the Indian Round Table Conference in London, England. In the photograph, men and women Congress volunteers can be seen, maintaining perfect order in a mammoth gathering of over a million souls. The familiar veil of the Indian ladies and the multitudes of men wearing white Gandhi caps made of home-spun cotton can be clearly seen.

"It might interest you to know that our firm installed the public speech amplifier on the above occasion. The system installed was that of Messrs. Graham Amplion, Ltd., of London, England. The loudspeakers, of which we used eighteen for this meeting, were also of their manufacture; you can see these speakers fastened to trees and poles in the foreground. With this equipment we were able to make the voice of all the speakers distinctly audible to the vast concourse of people assembled in the spacious meeting ground.

"Here we should remark that we have hitherto failed to get a similar moderately priced and satisfactorily working speech equipment from American manufacturers of sound equipment as that of the Amplion people, in spite of the fact that we have connections with many manufacturers in the United States. We request you to mention the above fact to American manufacturers so that we may possibly come across some factory in America from whom we can import similar public-address amplifier apparatus. Yours faithfully,"

Eastern Electric and Engineering Co.,
175, Hornby Road Fort,
Post Box 459, Bombay, India.

Saurcell Lockaday

Announcing



THE *de luxe* SCOTT ALL • WAVE

15-550 METERS

no plug in coils

SINGLE DIAL

no trimmers

Proved by independent laboratory tests and by practical use to be the greatest radio achievement of all time!

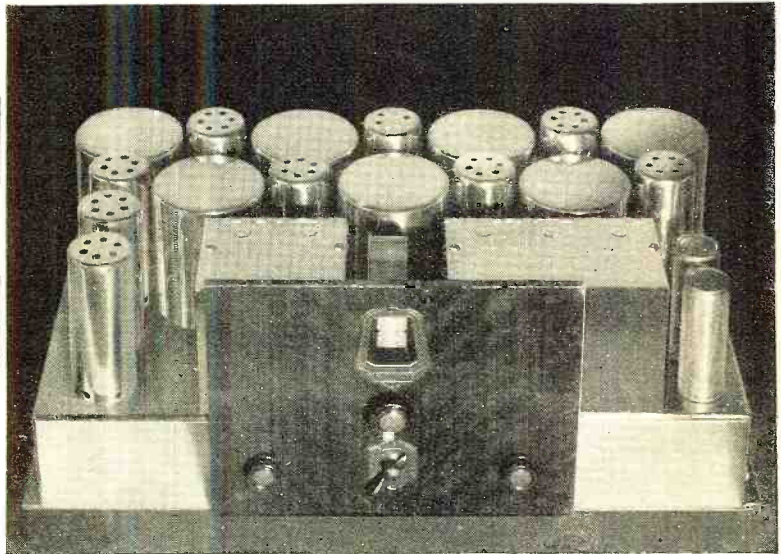

Such a receiver as the *de luxe* Scott All-Wave is still generally considered *impossible*. Yet, here it is! A 15-550 meter receiver *without* plug-in coils that tunes the whole range with absolute precision, on *ONE* dial—*without* the help of trimmers. But that's not all. The *de luxe* SCOTT ALL-WAVE incorporates far greater *sensitivity*, and obviously better *selectivity* than have ever been considered possible of attainment. And with it all, a tonal output that is guaranteed to be as perfect as the tonal input at the station!

Here IS Sensitivity - - -

*12/1000ths of a microvolt per meter at 1400 K. C. and 6/10ths of a microvolt at 600 K. C. This is an average of several thousand times more sensitivity than engineers have ever considered practical. And this sensitivity would not be practical even in the *de luxe* Scott All-Wave were it not for the unique means by which this receiver lowers the natural noise level of reception. But it IS practical in the *de luxe* SCOTT ALL-WAVE, and the 12/1000ths to 6/10ths microvolt per meter sensitivity brings in stations, *at most any distance*, with local volume. Stations that no other receiver could ever hope to get, come in on the *de luxe* Scott All-Wave, with enough volume to be heard a block away!

Entirely New Selectivity

No receiver in existence today can demonstrate such ideal selectivity as the *de luxe* SCOTT ALL-WAVE. *At 1000 K. C. it gives 4.5 K. C. separation provided the field strength of one station does not exceed the other by more than 10 times. It gives 9 K. C. separation when the field strength of one station exceeds the other 100 times. At 200 times field strength it separates by 10 K. C. At 5000 times field strength, the separation is 20 K. C., and mind you—only *ONE* dial, and without trimmers of any kind!

Absolute Reproduction!

The over-all response of the *de luxe* SCOTT ALL-WAVE, as determined by the sound pressure curve of the entire receiver

including the speaker, proves the Scott All-Wave capable of *absolute* reproduction. This curve is flat within plus or minus 2 deci bells from 30 to 3000 cycles. This means that the human ear cannot detect any difference or loss in frequencies between a selection as it is being played before the microphone and as it comes from the *de luxe* SCOTT ALL-WAVE.

*Regular 'Round the World Reception
Now Even MORE Enjoyable*

The standard Scott All-Wave of 1931 gave dependable, daily, 'round the world reception. This new *de luxe* SCOTT ALL-WAVE brings in the entire world *with perfect ease and convenience*—one dial—no trimmers—no plug-in coils. From France to Japan—from England to Australia, and from Alaska to the Argentine—they're all on the single dial of the *de luxe* SCOTT ALL-WAVE—waiting to thrill you as you've never been thrilled before. London, Paris, Berlin, Madrid, Sydney, Melbourne, Saigon, Buenos Aires, Bogota, and dozens of others are within easy, daily range of the *de luxe* Scott All-Wave 15-550 meter superheterodyne.

Send the COUPON for Curves and Proof

The story of Scott precision engineering as applied to the development and final attainment of complete perfection in the *de luxe* Scott All-Wave reveals the most outstanding radio facts of the day. The coupon will bring it to you *FREE*—also unquestionable *PROOF* that the *de luxe* SCOTT ALL-WAVE IS the *ONE* receiver that can guarantee easy, enjoyable, dependable, daily, 'round the world reception. Clip the coupon. Send it now.

**Measurements made by Radio Call Book Laboratory*

E. H. SCOTT RADIO LABORATORIES, INC.
4450 Ravenswood Ave., Dept. N-72, Chicago

THE E. H. SCOTT RADIO LABORATORIES, INC.
4450 Ravenswood Ave., Dept. N-72, Chicago, Ill.

Send me full particulars of the *de luxe* SCOTT ALL-WAVE.

Name _____
Street _____
Town _____ State _____

RADIO NEWS INDEX

VOLUME XIII

January, 1932

Thirty-seven Years of Radio Progress.....
 The Microphone—Radio's Electric Ear.....
 "Wireless" Centralized Radio.....
 Are You Responsible for Interference?.....
 The Latest Example of Tuned R.F. Design.....
 Electrical Transcription for Broadcasting.....
 The Future of Radio in Broadcasting.....
 Reducing Noise in Talking Picture Film.....
 Power Supply for the R. N. Transmitter.....
 The March of Electrons.....
 Electric Filter Design.....
 The Radio News Ear Aid.....
 A New "Super" for Circuit Experimenters.....
 How to Build a Beat Frequency Oscillator.....
 Rack-and-Panel Design for P. A. Systems.....
 Using Graphs and Charts in Modern Radio.....
 Commercial Applications of the Direct Coupled Amplifier.....
 Mathematics in Radio.....

NUMBER 7

By Senatore Guglielmo Marconi..... Page 553
 By Thomas Elway..... Page 555
 By D. E. Reptogle..... Page 558
 By Toke Deutschmann..... Page 560
 By Glenn H. Browning..... Page 562
 By Thomas Calvert McClary..... Page 564
 By Zeh Bouck..... Page 566
 By Barton Kreuzer..... Page 569
 By Nat Pomeranz..... Page 571
 By Raymond Francis Yates..... Page 573
 By C. A. Johnson..... Page 574
 By S. Gordon Taylor..... Page 576
 By Chesley H. Johnson..... Page 578
 By Donald Lewis..... Page 580
 By McMurdo Silver..... Page 583
 By John M. Borst..... Page 585
 By George E. Fleming..... Page 587
 By J. E. Smith..... Page 589

VOLUME XIII

February, 1932

Radio's Role in the Air Corps Maneuvers.....
 Television Hits Broadway.....
 Electrostatic Loudspeakers.....
 The New KFI.....
 The Radioman's Timepiece.....
 Filming Radio Programs.....
 New All-Wave Super Features High-Gain.....
 New Motor Radio Design.....
 Do Meteors Cause Static?.....
 The Radio News Telephone Booster.....
 Electric Filter Design.....
 "Super" Design Featuring 2-Volt Tubes.....
 Using Graphs and Charts in Modern Radio.....
 A New "Super" for Circuit Experimenters.....
 The Pentode Oscillator.....
 Relays for the Experimenter.....
 New Television Receiver of Novel Design.....
 CQ CQ CQ de WDDE—MacMillan Calls from Baffin Land.....
 Mathematics in Radio.....

NUMBER 8

By Lieut. Charles H. Howard..... Page 651
 By Robert Hertzberg..... Page 654
 By Hans Vogt..... Page 656
 By I. R. Baker..... Page 658
 By S. Reid Warren..... Page 660
 By Irving J. Sael..... Page 662
 By Lewis W. Martin..... Page 665
 By Justus W. Berge..... Page 667
 By John Cagy..... Page 669
 By S. Gordon Taylor..... Page 670
 By C. A. Johnson..... Page 672
 By McMurdo Silver..... Page 674
 By John M. Borst..... Page 676
 By Chesley H. Johnson..... Page 678
 By Gerard J. Kelley..... Page 680
 By C. Bradner Brown..... Page 682
 By H. G. Cisin..... Page 683
 By Ralph Brooks..... Page 685
 By J. E. Smith..... Page 687

VOLUME XIII

March, 1932

"Walking" Transmitters Link Out-of-the-Way Broadcasts.....
 The March of Television.....
 Radio Surgery.....
 Televising a Horse Race.....
 Radio's Powerful Electric Voice.....
 What Is the Triple-Twin Tube?.....
 Simple Vacuum Tube Voltmeter.....
 Opening the Church Door to the Deaf.....
 Electrostatic Loudspeakers.....
 Superheterodyne Innovations.....
 A Real Universal Meter.....
 New Motor Radio Design.....
 Using Graphs and Charts in Modern Radio Practice.....
 The "Complete" Service Unit.....
 Electric Filter Design.....
 New All-Wave "Super" Features High-Gain.....
 Mathematics in Radio.....

NUMBER 9

By Everett M. Walker..... Page 720
 By Lieut. William H. Wenstrom..... Page 752
 By Irving J. Sael..... Page 754
 By H. J. Barton Chapple..... Page 757
 By E. E. Free..... Page 758
 By John M. Borst..... Page 760
 By Ransom M. Fiske..... Page 762
 By K. P. Royce..... Page 763
 By Hans Vogt..... Page 765
 By McMurdo Silver..... Page 767
 By J. van Lienden..... Page 769
 By Justus W. Berge..... Page 770
 By W. Gerber..... Page 772
 By C. A. Johnson..... Page 774
 By Lewis W. Martin..... Page 776
 By J. E. Smith..... Page 778
 By J. E. Smith..... Page 779

VOLUME XIII

April, 1932

It's a Man's Job Behind That Microphone.....
 How to Break Into the Aviation Radio Game.....
 Radio Fever.....
 Self-Contained-Power Radio Receivers.....
 Modern Quartz-Crystal Receiver.....
 Presenting the "Twin-Grid" Tube.....
 Radical Circuit Design.....
 A Boon to the Deaf.....
 Phenomena Underlying Radio.....
 How to Make a Condenser "Mike".....
 What Tube Shall I Use?.....
 The March of Television.....
 British Radio Hoax.....
 The "Complete" Service Unit.....
 Two New Tubes.....
 Latest Short-Wave Converter.....
 Graphs and Charts.....

NUMBER 10

By Albert Pfaltz..... Page 827
 By Myron Eddy..... Page 830
 By Irving J. Sael, Ph.D..... Page 832
 By Wm. C. Dorf..... Page 835
 By Zeh Bouck..... Page 836
 By Marion W. Taylor..... Page 839
 By McMurdo Silver..... Page 841
 By S. Gordon Taylor..... Page 844
 By E. B. Kirk..... Page 846
 By George A. Argabrite..... Page 848
 By Joseph Calcatera..... Page 850
 By William H. Wenstrom..... Page 852
 By Austen Fox..... Page 854
 By W. Gerber..... Page 855
 By J. van Lienden..... Page 857
 By W. A. Smith..... Page 859
 By John M. Borst..... Page 860

VOLUME XIII

May, 1932

Experimental Research.....
 London's Radio City.....
 High-Speed Oscillations.....
 Lens Design for Scanning Discs.....
 Radio-Controlled Sailing "Yacht".....
 What Tube Shall I Use?.....
 Street Railway Interference.....
 Pentode Receiver.....
 The Radio News Multi-Ear-Aid.....
 More About the "Twin-Grid" Tube.....
 Two-Volt "Super".....
 A Modern Quartz-Crystal Receiver.....
 Complete Light Sensitive Unit.....
 A \$12.05 Short-Wave Set.....
 Graphs and Charts.....
 A Serviceman's Oscillator.....

NUMBER 11

By Laurence M. Cockaday..... Page 905
 By Samuel Kaufman..... Page 909
 By Thomas Clifton..... Page 912
 By Ralph K. Batcher..... Page 914
 By Andrew R. Boone..... Page 916
 By Joseph Calcatera..... Page 918
 By Toke Deutschmann..... Page 921
 By H. G. Cisin..... Page 923
 By S. Gordon Taylor..... Page 926
 By Marion W. Taylor..... Page 929
 By McMurdo Silver..... Page 931
 By Zeh Bouck..... Page 933
 By Bernard J. Montym..... Page 936
 By Glenn Ellsworth..... Page 938
 By John M. Borst..... Page 940
 By Mervyn R. Rathborne..... Page 942

VOLUME XIII

June, 1932

Radio Future.....
 Short-Wave Experiments.....
 \$10,000.00 a Year for Service.....
 Triple-Twin Amplifiers.....
 Radio News A.C. Multi-Ear Aid.....
 Phenomena Underlying Radio.....
 Mathematics in Radio.....
 The "Nook Midget" Chassis.....
 Grid-Glow Tube.....
 Below Ten Meters.....
 Duplex Photo-Cell.....
 Graphs and Charts.....
 Electric Filter Design.....
 The International Six.....
 What Tube Shall I Use?.....
 Quartz-Crystal Receiver.....
 Broadcast and Short-Waves.....
 Vacuum-Tube Voltmeter.....

NUMBER 12

By Irving J. Sael, Ph.D..... Page 987
 By Carlton H. Hess..... Page 994
 By Sidney Fishberg..... Page 997
 By S. Gordon Taylor..... Page 998
 By E. B. Kirk..... Page 1000
 By J. E. Smith..... Page 1002
 By Beryl B. Bryant..... Page 1004
 By M. H. Brown..... Page 1005
 By James Millen..... Page 1009
 By Mervyn R. Rathborne..... Page 1012
 By John M. Borst..... Page 1014
 By C. A. Johnson..... Page 1016
 By Allan C. Bernstein..... Page 1018
 By Joseph Calcatera..... Page 1019
 By Zeh Bouck..... Page 1021
 By McMurdo Silver..... Page 1023
 By C. Bradner Brown..... Page 1024

PROOF of MIDWEST

World-Wide Reception

CLASS OF SERVICE DESIRED		CABLE
DOMESTIC	TELEGRAM	FULL RATE
NIGHT LETTER	NIGHT MESSAGE	DEFERRED
NIGHT LETTER	NIGHT MESSAGE	NIGHT LETTER
NIGHT LETTER	NIGHT MESSAGE	WEEK END LETTER

WESTERN UNION

TIME FILED

J. C. WILLEVER, FIRST VICE PRESIDENT

NEWCOMB CARLTON, PRESIDENT

Send the following message, subject to the terms on back hereof, which are hereby agreed to

JG9 102 NL=
WINTERPARK FLO MAR 2 1932
MIDWEST RADIO CORP=
DURING LAST WEEK I LOGGED THE FOLLOWING FYA PONTOISE GBW
RUGBY HVJ VATICANCITY XDA MEXICOCITY VK2ME SYDNEY VE9GW
BOWMANVILLE 12RO ROME G5SW CHELMSFORD CGA AND VE9DR
DRUMMONDVILLE AMATEUR AND AIRPORT STATIONS FROM ALL OVER
UNITEDSTATES ALSO NUMEROUS SHIP SHORE AND TRANSATLANTIC
PHONES FROM BOTH SIDES AN HAWAIIAN TEST STATION SEVERAL
SPANISH AND GERMAN SPEAKING STATIONS HAVE ALSO BEEN RECEIVED
BUT NOT YET IDENTIFIED HAVE RECEIVED EVERY BROADCAST FROM
FYA MORNING AND AFTERNOON FOR OVER A WEEK WITH WONDERFUL
TONE AND VOLUME THE MIDWEST COMBINATION SET IS CERTAINLY
ONE TO BE PROUD OF

England, Holland,
Germany, France,
Italy, South
America,
Australia,
Hawaii, Japan

TERMS
as low as
\$5.00 DOWN

30 DAYS FREE TRIAL

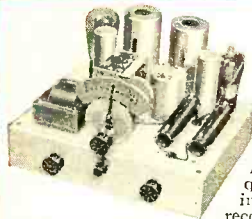

Midwest 4-Tube Short-Wave Converter

Converts any A. C. set of adequate sensitivity into a short-wave receiver for reception of foreign short-wave broadcasts, airplane conversations, ships at sea, etc. Low factory price—completely assembled—now only \$16.75. Coupon brings full details. Mail it NOW!

THESE sensational new Midwest, ALL WORLD, ALL WAVE 15 to 550 meter sets bring you the WHOLE WORLD of Radio. SHORT-WAVE and standard wave broadcasts not only from U.S. stations, coast to coast, but from many foreign countries, Canada, Mexico, Cuba, Hawaii come in like locals.



MIDWEST 11-TUBE SUPER HET.

BALANCED SUPER HETERODYNE UNIT, REAL AUTOMATIC VOLUME CONTROL, PIN-DOT SELECTIVITY, LARGE-SIZE ELECTRO-DYNAMIC SPEAKER that reproduces voice or music without distortion. All the latest features. And you buy it direct from the Midwest factory at a positive saving of 30% to 50%. 30 days' free trial—and easy payments if you wish. Coupon brings full details mail it NOW!

only
\$37.50
COMPLETELY ASSEMBLED
—WPTM—
LARGE DYNAMIC SPEAKER—

PROOF!

- Letters on file in our office prove that Midwest owners have logged these and many other foreign stations:
- FYA... Pontoise, Fr.
 - PCJ... Holland
 - GBW... Rugby, Eng.
 - G5SW... Chelmsford, England
 - HVJ... V a t i c a n City, Italy
 - 12RO... Rome, Italy
 - VK2ME... Sydney, Aus.
 - VE9DR... Drummondville, Can.
 - K6KO... Honolulu, Hawaii
 - RV15... Russia
 - F31CD... Indo-China
 - NDA... Mexico City
 - HKA... Colombia
 - OC1... Lima, Peru
 - RABAT... Morocco
 - PRADO... Ecuador

Scores of letters on file in our office show that Midwest users are regularly enjoying foreign programs from all over the world. You'll be positively amazed and delighted.

30 DAYS TRIAL: Select the Midwest you want and try it 30 days—free—in your own home. Satisfaction or no sale—that's the Midwest way.

Gets Germany, Italy, France

"March 2nd, I picked up Germany, France and Italy. On the following day, I got Rome again and heard all the music from the Royal Opera House." A. Musconi, 7122 Paschall Ave., Philadelphia, Pa.

Bermuda, Phillipines, Switzerland, Rome

"Have picked up Vancouver, B. C.; Hamilton, Bermuda; Geneva, Switzerland; also Phillipine Islands and 12-RO, Rome, Italy." Geo. Kuhr, 218 Division St., Bellevue, Ky.

Holds VK2ME Two Hours

"I heard VK2ME, Australia, this morning and held them for over two hours." E. Applebaum, 334 Johnson Ave., Newark, N. J.

BUY Direct from Factory — Save 50%

Every Midwest set is fully assembled, thoroughly tested, comes to you ready to plug in, and is backed by an absolute guarantee of satisfaction. Mail coupon now! The big new Midwest Catalog shows sensational bargains in 13- and 15-tube ALL-WORLD, ALL-WAVE Combinations, 9- and 11-tube Super Hets., 4-tube Short-Wave Converter and new AIRCELL BATTERY sets. Get all the facts before you buy a radio of any kind.

Save 30% to 50%

Sign and Mail NOW!

MIDWEST RADIO CORP., Dept. 88, Cincinnati, Ohio.

Without obligation send me your new 1932 catalog and complete details of 13- and 15-tube All-World, All-Wave Combinations, 4-tube Converter, 9- and 11-tube Super-Heterodynes, low factory prices, easy terms and liberal 30-day free trial offer.

Name.....
Address.....
Town..... State.....

MIDWEST RADIO CORP.
Dept. 88 (Est. 1920) CINCINNATI, O.



One Baby He Cannot Steal

The kidnapper entering a room equipped with the illustrated protective system could not even so much as poke a finger through the "walls" of invisible light surrounding the child's crib without setting off powerful alarm sirens located both inside and outside the house. Even if he were an expert in electrical matters, he could find no way to tamper with the apparatus that would cut it off without sounding the alarm. The devices are located on the ceiling and operate through invisible rays working through a powerful amplifier and sensitive relays

Radio News

VOLUME XIV

July, 1932

NUMBER 1

RADIO GUARDS THE BABY

Radio engineers are now developing devices using vacuum tubes, photo-electric cells and radio amplifiers for protecting precious things against the attack of criminal marauders. The author describes some of these wonderful outgrowths of radio technique and gives specific information for their construction

PANIC and alarm seized the whole country when this worst of crimes, kidnapping, did not halt even before the doors of that glorious couple, Charles A. Lindbergh, hero of a nation, and his wife, the cultured and modest daughter of the late Senator Dwight W. Morrow. A shocked and impotent world could do nothing but stand by mutely and sympathetically and pray that the twenty-one-months-old child would be returned.

A baby, preciously guarded at all times, had received its parents' goodnight kiss and was left asleep in his nursery on the second floor of a lonesome country house. Everyone knows the oft-repeated story.

Just a brief period when the ever-watchful eyes of the grown-ups were turned from the child, when it was believed to be sleeping peacefully—and stark tragedy! The baby had been stolen! In the breasts of a million parents a new fear was born. Were their babies safe? What, then, can be done to prevent a recurrence of this crime?

Even the eyes of the most reliable watchman are liable to fail, and many protective means, using strong walls, gates and other constructions, have been unable to fully prevent robbery and kidnapping. It is with a new hope that we now look towards the last and newest of all sciences, radio and its allied fields, for some protective device that will make impossible similar crimes in the future. How can radio help to protect treasures of various kinds, including the highest treasure of all: human life, health and happiness?

A conservative method which is used today in almost every safety-vault of the banks is the application of microphones through which any suspicious sound can be made perceptible in some distant room, or can be made to operate a release whereupon the door of the safe closes, alarm bells ring, etc. This device, however, is not to be relied upon for our purposes, because it can be put out of action by simply putting a box filled with cotton over it. Without underestimating the value of this device for criminal protection, it has proven valuable in a number of cases, where the parents have placed a microphone near the youngster's crib and laid a concealed wire leading from the mike to an amplified loudspeaker at some distant place—for instance, in the sleeping-room of the parents.

It is thus possible, without being personally in the room, to hear whether the child sleeps soundly or cries, makes any unusual sound, etc. But, as said before, for protection against criminals this device is not to be relied upon too much.

Scientists and amateurs now have joined forces to fully develop the wonder-tools of radio and allied sciences which have proven of more importance than was expected two decades ago.

The first inference would be to substitute the human eye with an eye that never gets tired, is always watchful and never sleeps. We have today eyes of this type with the necessary characteristics, in the form of the various light-sensitive cells and the artificial nerves, brains and muscles connected with it in the form of the various optical, electrical and mechanical devices. These devices operate, principally, by the interruption of a special beam of light, as will be described later. Secondly, newer and still more effective, perhaps, are those newest

applications of the radio sciences which record or report the approach of an object by recording and amplifying changes in the inductive and capacitive characteristics

of the surrounding medium (air). There are also a few more devices and systems which, however, have not proceeded far enough in their laboratory development to be produced on a commercial scale and which are therefore not mentioned in this connection.

Let us discuss in greater detail the actual construction of the above-mentioned devices which can be set readily into practice. The conventional light-electric device is operated by the illumination of a photocell with a beam of direct white light. A fundamental constructive diagram of this circuit is shown in Figure 1. The rays coming from the light source L are reflected in the parabolic mirror M and collected in the lens K into a parallel beam of light.

This pencil of light rays, after traveling over some distance, falls upon the photocell P, which liberates electrons within its active layer R which travel towards the positively charged anode A. This small current (produced within the photocell) is amplified in the usual way by amplifying tubes, for instance, of the -71A type. It might be mentioned that the newly developed pentode power amplifiers of the -47 type and selenium

[By Irving J. Saxl, Ph.D.]

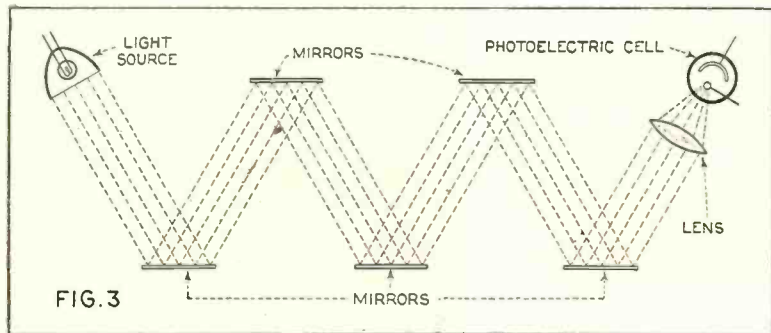
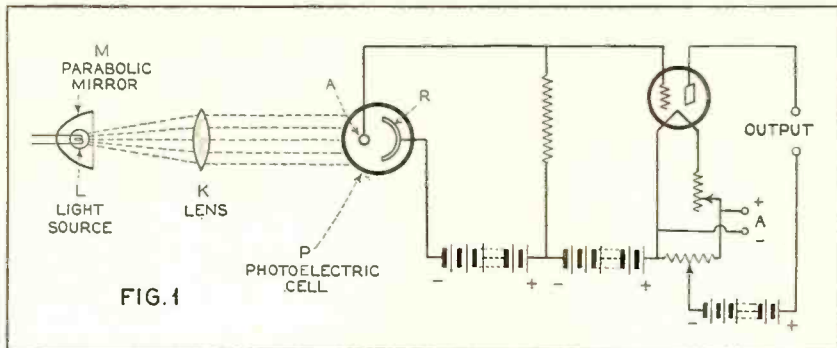
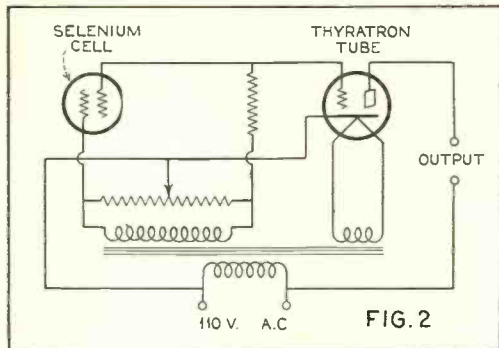

LIGHT-SENSITIVE CIRCUITS AND AMPLIFIERS

Figure 1. The light system and photo-electric cell circuit with a one-tube amplifier. Figure 2. A selenium cell used with a thyratron tube. Figure 3. The method of arranging mirrors on ceiling and floor to constitute a protective "wall" of light

cells also might be applied advantageously for this purpose. In addition, it is possible to use thyratrons as electronic relays in combination with a selenium cell, as shown in the wiring diagram in Figure 2. Furthermore, sensitive magnetic relays and highly sensitive contact galvanometers can be used if Photron cells of the type described in a previous article in RADIO NEWS are applied.

The concentrated beam of light is able to travel over a predetermined area, and any object interrupting it will cause a change in the output current which then operates a signal, for instance, a siren, bells, etc.

It is possible to handle the light rays in such a way that actually a "wall" of light is built, for instance, by multiple reflection. Figure 3 shows the way in which that can be done. A pencil of light rays is reflected back and forth, zigzag, thus covering a wide area.

Wall of Light Protects Baby

Thus it is possible to surround the place to be safeguarded—for instance, the baby's cradle—with a screen of light of any desired shape. Any objects penetrating through that light wall

would make an interruption of the light beam. This is an excellent means for controlling the field around various objects.

By using selenium cells, which are susceptible also to the infra-red invisible part of the electromagnetic spectrum, and certain light filters, it is possible to make the entire control *invisible*. No object brought into this path of the heat rays would be seen illuminated or casting a shadow. No light would irritate the object to be safeguarded—for instance, the baby; or, if this device is used for the protection of industrial apparatus, the worker who works on the machine and has his limbs exposed to a field of danger—for instance, near the piston of a punch press—is not blinded by the device. The piston would simply not go down as long as the hand is in the field of danger, but no constant discomfort from flaring light can arise.

Such light walls of *black light* can be used advantageously for protection against theft. The objects which are not supposed to be touched remain plainly visible and are still under full control. A device of this type was exhibited recently at the Colonial Exhibition in Paris. A prize was offered to anyone who could take some object out of a jewel display case without ringing an alarm. Although no visible contact was interrupted, the alarm immediately rang if the hand was brought near the objects, thus interrupting the beam of black light.

There is one more point to be taken into consideration if we look at this problem from the viewpoint of the criminal. It is possible to protect the wires and the sound horn against interruption in such a way that anybody cutting the wires or fumbling with the siren would at the same time cause the alarm to operate.

But this system may also be "fooled." This type of alarm is operated by interrupting a beam of light that falls upon a photocell. That means that as long as the photocell is illuminated, no alarm will be given. If no special precautions are taken as described hereafter, the burglar, if he were a technician, would therefore be able to place a flashlight in front of the photocell so that a continuous illumination takes place even if opaque objects are brought within the space that was filled previously with the beam of light.

Light-Chopping Device Used

How can this difficulty be overcome? By using a pulsating light current instead of direct light. If the amplifier is made for amplifying pulsations only and to sound an alarm for a *steady* flow of light, this danger can be eliminated.

It is easy to convert the output of the photocell into pulsations. Figure 4 shows a diagrammatic sketch for this purpose. For bringing about pulsations of the photo-current, the beam of light is interrupted by a rotating disc D, similar to the scanning discs used in television. This disc is driven by a small motor, M.

A LABORATORY PROTECTOR

Figure 9. Left—An engineer's model of the Thèremin device that offers a protection against burglars over many feet

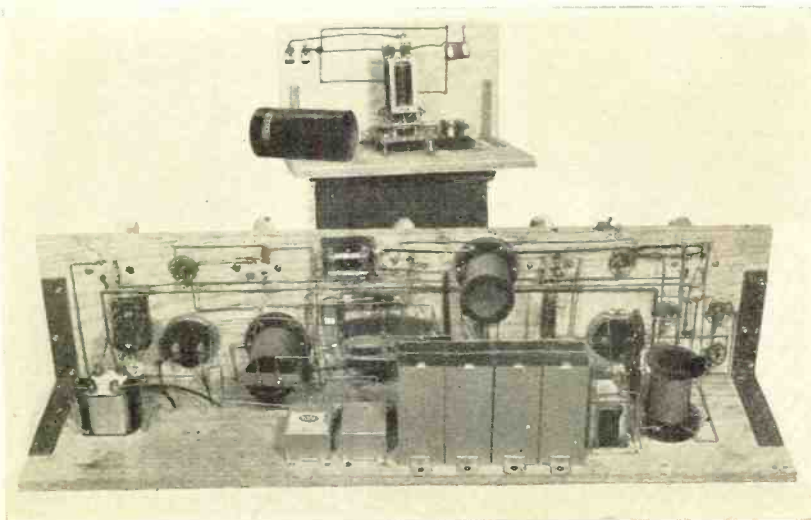

PROTECTION FOR YOUR BRIC-A-BRAC

Figure 8. Right—A burglar could not get within twenty feet of this cabinet containing rare art objects, for it is protected by the Thèremen alarm system

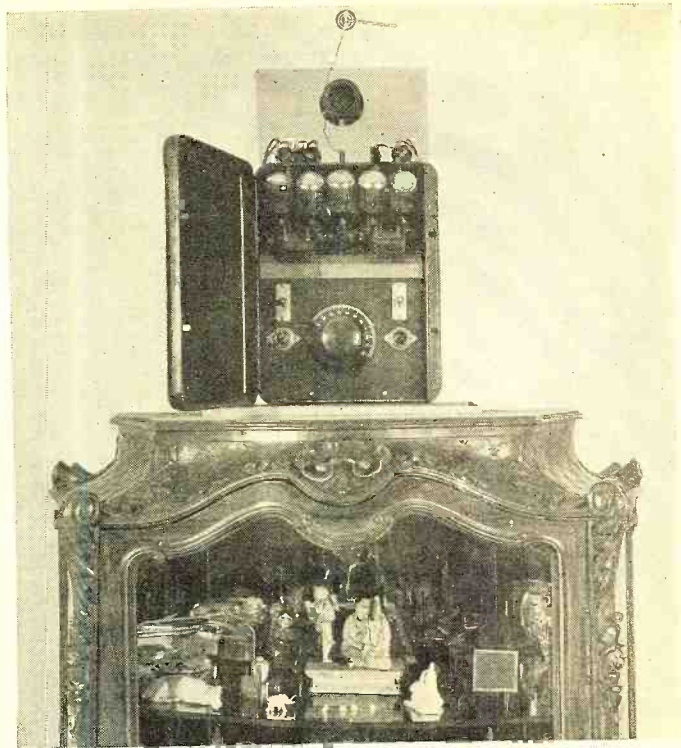

For working the relays exclusively on alternating current, the direct illumination circuit of Figure 1 has to be altered. Figure 5 shows the fundamental wiring diagram for a device which is to operate exclusively on alternating or pulsating light currents.

The pulsating impulses produced in the photocell are transferred through the condenser C to the grid of the first tube. This current is impressed upon the second tube by a transformer coupling, TR. Naturally, only alternating currents are able to flow through a condenser or can influence a transformer. In the last stage, therefore, only the alternating current impulses will be reproduced. A continuous flow of light such as from a flashlight would work like darkness; no current would be induced in the amplifier as if the light rays had been interrupted, and the alarm would operate and the burglar would be trapped.

The drawing on the frontispiece shows a safety device of this type as applied for the protection of a baby's cradle. A beam of pulsating light is produced by the reflecting and light-chopping device at the upper left side of the picture. After passing through a filter which passes only infra-red invisible light, this invisible light beam is reflected back and forth between the strip of mirror around the feet of the cradle and the mirrors at the ceiling. One specially inclined mirror reflects the rays at the corner so that a new screen of light is built which is at 90 degrees to the first one. In this particular construction only two screens are used, because the baby is placed in one corner of a room.

The light rays are collected in the box at the right upper corner of the picture. They are amplified and act upon a relay which operates a siren or a loudspeaker in the nursery or at some other place. It cannot be shut off again without turning the safety key in a steel box located conveniently. The alarm-sounding relay is likewise operated if the wire which connects the switch and the light-sensitive device is cut.

Another device makes use of changes in the electric fields surrounding the object which is to be protected against approach. Such devices go back primarily to the invention of Leo Sergejewitsch Thèremen, famous physicist, known especially for his electrical musical instruments.

Devices of the Thèremen Type

While exact data for these instruments and some other applications which derive from changes in the electrical characteristics of "space" will be discussed in detail in the later issues of RADIO NEWS, attention shall be given here to the recording and the perception of objects approaching Thèremen's sensitive devices.

If an object is brought near an oscillating circuit which is not shielded, changes occur in the tuning of this circuit. These changes, known to all radio experimenters as due to "body capacity," cause "whistling" by the approach of a body. These whistling currents can be amplified and made perceptible in such a way that they are powerful enough to move a relay that operates an alarm device or a siren, etc.

Figure 6 contains a schematic wiring diagram for such an instrument which does not produce sound as such, but is able to control the switching of any type of power device. In this way the system provides a method for generating sound or producing visual signals for alarm purposes. It embodies an

electromagnetic system of high-frequency potential operable by the approach of an object towards it, such, for example, as a person entering a room when the apparatus is applied in a burglar-alarm system. An apparatus of similar type may also be controlled by an increase of temperature when adapted in a fire-alarm system, etc. By this method it is therefore possible to protect the baby not only from approaching persons or objects but also from fire.

The movement of an object or any other variable factor in relation to the sensitive apparatus (Continued on page 44)

SOME FOOL-PROOF PROTECTIVE DEVICES

Figure 4. Sketch of a light-chopper that makes light systems fool-proof. Figure 5 shows an a.c. amplifier for the light-chopper system. Figure 6. Fundamental circuit of the Thèremen system. Additional stages may be used.

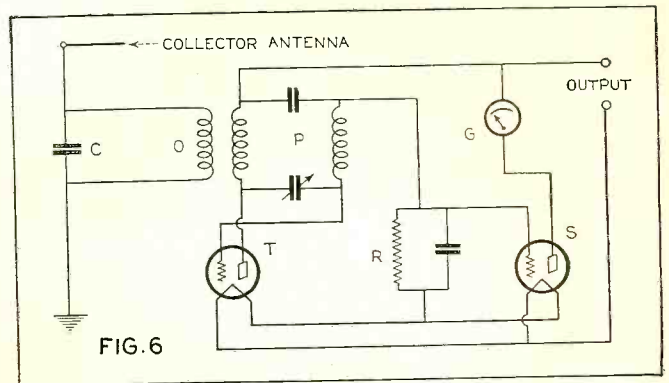

FIG. 6

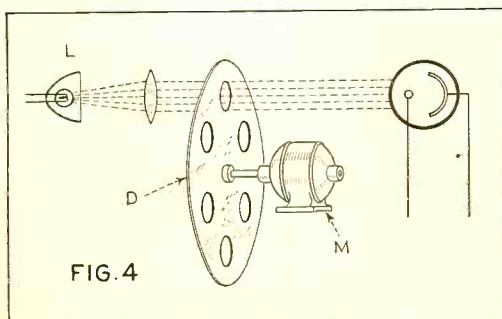

FIG. 4

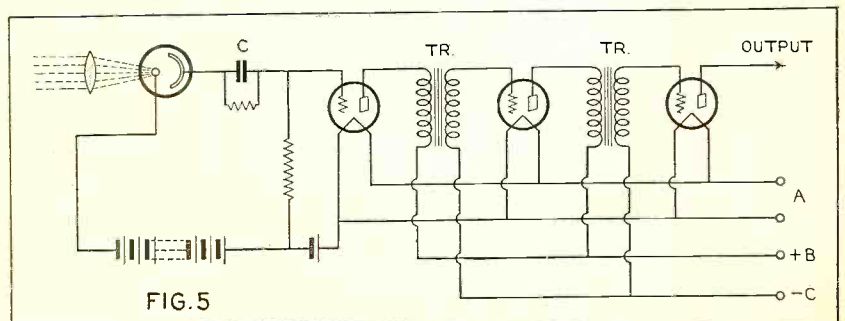
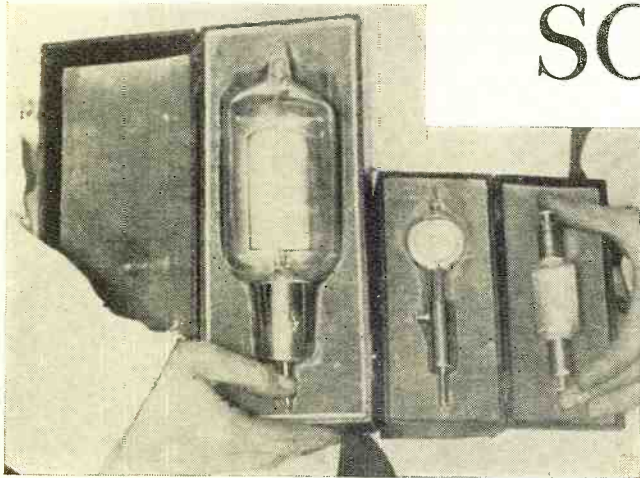

FIG. 5

HOW PHOTO CELLS AND RADIO AMPLIFIERS SOUNDS THAT



TYPES OF PHOTOCELLS
Figure 15. The three kinds of photoelectric tubes used in the apparatus described in this article

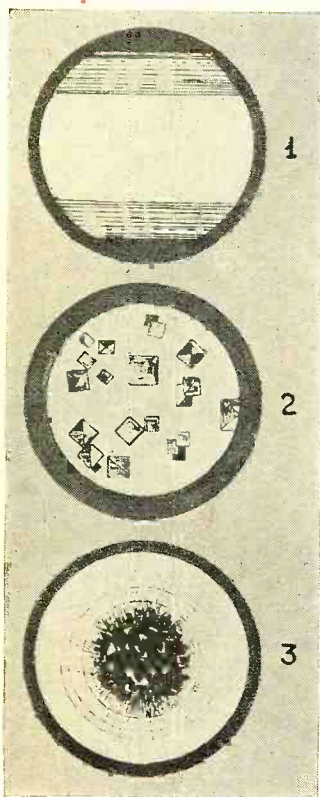

FIGURE 13A

Some new experiments recently conducted studying the microscopic world from an these new methods and points out the in accomplishing the results he has had prove interesting to experimenters and field of research

MY associates and I are probably the first human beings to listen to the death agonies of germs—and probably the first to have heard microscopic crystals grow!

By Joachim

We have been able to do this by employing photoelectric cells and powerful electronic amplifiers in studying, aurally, certain infinitesimal biological and biochemical phenomena under the microscope.

The photocell constantly finds new and unexpected applications in all branches of engineering and science. It already has enabled us to automatically turn on the lights of a city, to control electrical and steam-driven machinery, to regulate the flow of chemicals in factory processes, to produce automatically an unvarying grade of paper, to detect variations in size and material in the production of phonograph needles, to measure and sort irregular objects and materials, and many other industrial applications.

The photocell owes its usefulness in many of these new fields to its combination with the amplifying characteristics of vacuum tubes and the lack of appreciable time lag in its functioning. Without these properties, one of these large fields today—that of the sound film and television—would be equally impossible.

Since the photo-cell is sufficiently sensitive to react to variations in the illumination of very tiny objects, the idea occurred to me early in 1931 to employ it for aural studies of phenomena under the microscope.

Although certain difficulties appeared at first for such work, these were finally overcome with suitable apparatus and circuits especially worked out for this purpose. This article will describe some of the arrangements used in my laboratory. By means of this apparatus I have been able to observe some of the rhythmic sounds produced by living bacteria that have thrown new light on some of the visible phenomena partly observed before but not explained. I have been able to deal with certain problems in micro-chemical analysis of substances reacting with different reagents. I have been able to make serious studies with living micro-organisms under chemotropic or electropic excitations. I have been able to make these studies quantitatively by either listening to a loudspeaker, connected through a

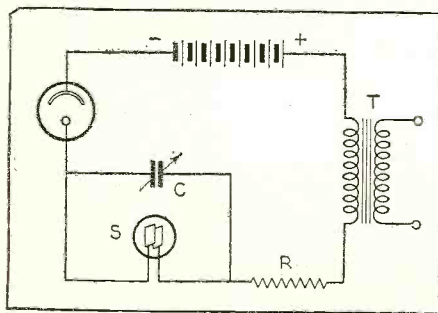

NEON PULSATOR CIRCUIT

Figure 6. Connections for neon pulsator with a light-sensitive cell

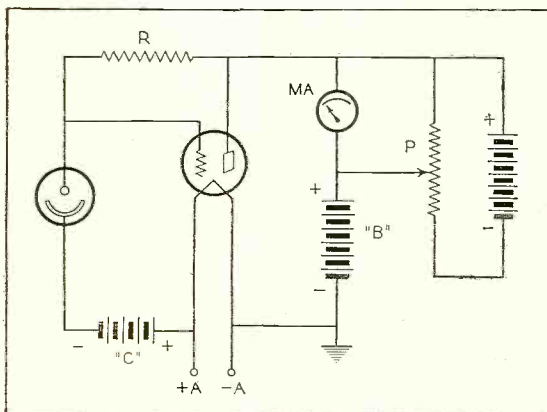

CIRCUIT AND RECORDING METER

Figure 4. The light-sensitive cell in connection with a milliammeter and biasing circuit

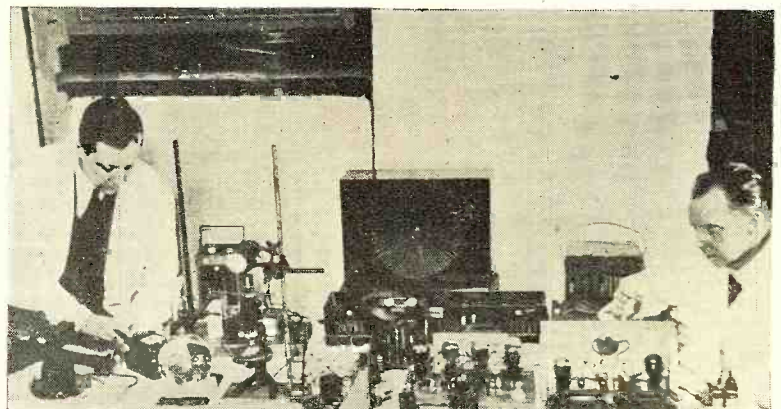

THE AUTHOR AND HIS BROTHER MAKING A READING
Figure 11. Here is shown the complete light-sensitive circuit set-up with the necessary amplifiers and recording devices

ARE ENABLING SCIENTISTS TO HEAR MICROBES MAKE

in Berlin outlining a unique method of audible viewpoint. The author describes technical details that must be considered to date. He believes that his work should that it should open up an entirely new in microscopy

Winckelmann

suitable amplifier to the photoelectric cell used or by examining a long series of impulses recorded on

a tape. I have been able to study the reaction of these microscopic creatures under anesthetics, as well as to study the cataphores of colloids, as well as a number of other little-known but scientifically promising phenomena.

The examination of microscopic preparations with the aid of photocells is possible in different ways. Therefore these methods are first briefly enumerated to be illustrated later with diagrams.

Method 1: With this method the necessary apparatus consists of the following units: (a) The microscopic arrangement including the photocell; (b) a one-tube amplifier for the photocell; (c) the measuring instrument.

Method 2: (a) The microscopic arrangement including the photocell; (b) a generator of "saw-tooth" oscillations by means of a glow tube; (c) an amplifier; (d) a loudspeaker, or (e) a rectifier with connecting Morse recorder.

The first method is, from the standpoint of equipment, simpler than the second method and gives extraordinarily accurate results with an accurate measuring instrument. Its drawback is that the measuring instrument must be read continuously, whereas, with the second method, phenomena are registered automatically. The latter method is also better suited for those experiments requiring constant observation, day and night.

The microscopic arrangement shown in Figure 1 consists of a light source of any kind, of a round-bottomed flask of about one quart, which is used as convergent lens and filter, and of the microscope. Above the latter, the photocell is placed in a light-proof tubular container in such a way that only light coming through the microscope can fall upon it. The bottle is filled with different-colored liquids according to the requirements of the experiment. These serve as a filter in order to eliminate certain bands of light, if necessary, and to manufacture a more or less monochromatic light source. It is well known that photocells vary in their efficiency with the light frequency. The response characteristic depends on the construction. The light color can

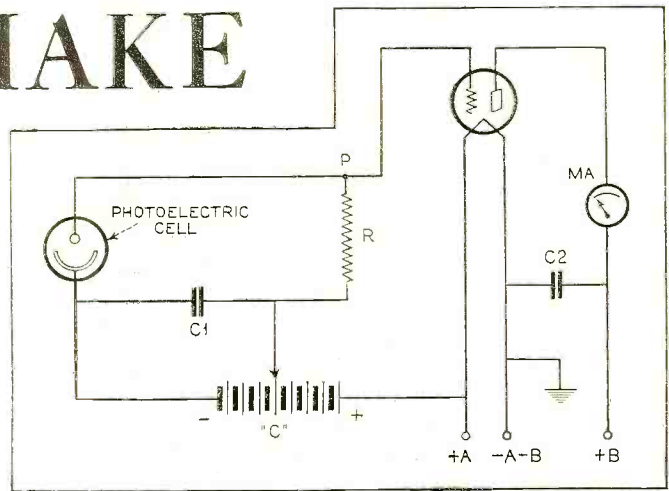

STANDARD SET-UP

Figure 2. Fundamental circuit for using a photocell with a recording meter and vacuum tube

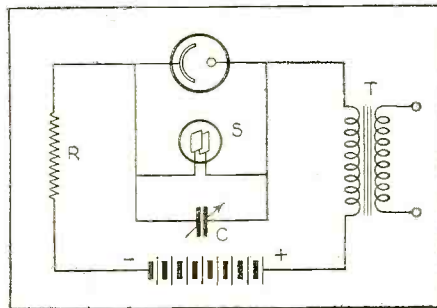

ALTERNATIVE CIRCUIT

Figure 7. Second circuit for neon pulsator with a photoelectric tube

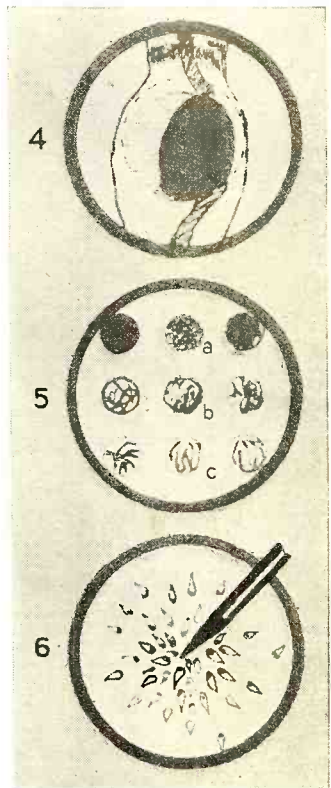
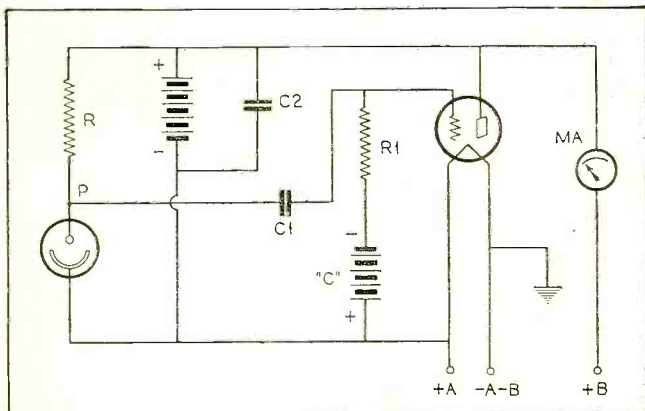
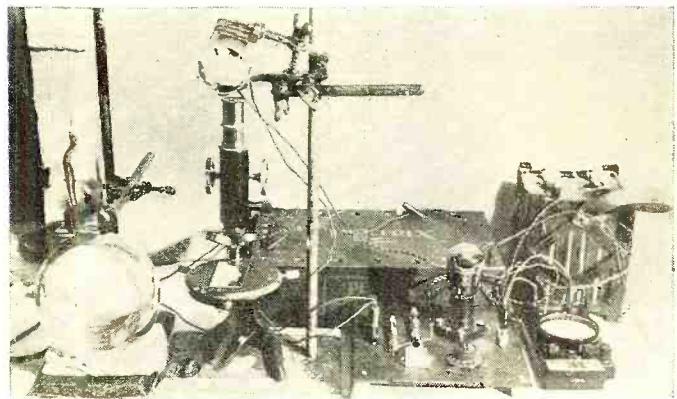

FIGURE 13B



ANOTHER METHOD OF RECORDING

Figure 3. This schematic diagram shows a variation of the schemes applied in Figures 2 and 4



METHOD OF MOUNTING PHOTOELECTRIC CELL

Figure 5. Arrangement of the apparatus, including the liquid filter, the photocell, microscope, amplifier and meter

now be matched to the cell. If it is desired to observe the experiment visually, photograph it and work with the cell at the same time, it is recommended to fill the bottle with a liquid resembling the color of daylight. Such a liquid is the diluted solution of copper salt which is formed when one adds ammonia, in drops, to a solution of copper sulphate until the first appearing precipitate is dissolved and a very light-blue solution is obtained. The light falling through this liquid greatly resembles the daylight entering the microscope from a clear sky.

The amplifier connected to the photocell can be made in different ways, according to Figures 2, 3 and 4. The photocell is coupled to the grid of the tube, either direct or through a condenser (C1). The amplification obtainable depends primarily on the μ of the tube. The bias of the tube can be arranged so that the grid is blocked. The photoelectric current relieves the blocking, and the resulting plate current is read on the milliammeter (MA). The hookup of Figure 3 has the advantage over the one in Figure 2, that the point (P) where the voltage fluctuations originate is separated from the grid by a condenser. The a.c. variations only are impressed on the grid, independent of the d.c. potential. The grid circuit is completed through the resistance (R1). The best constants for this circuit are the following:

- R—5-10 megohms
- R1—0.5-3 megohms
- C1—1000 mmfd. (if possible, air dielectric)
- C2—2 mfd.

If one wishes to work with the simplest galvanometer possible, the most suitable circuit is that of Figure 4; as low a B supply as 10-12 volts is sufficient. All other photoelectric circuits—for instance, those derived from the Wheatstone bridge or similar ones—are also suitable.

A photograph of the complete equipment is shown in Figure 5. At the left is seen the round-bottomed flask wherein the photocell is enclosed from the light and held there by a wadding of black paper and cotton.

Then follows the amplifier (which looks like a vacuum-tube voltmeter) and at the right is the measuring

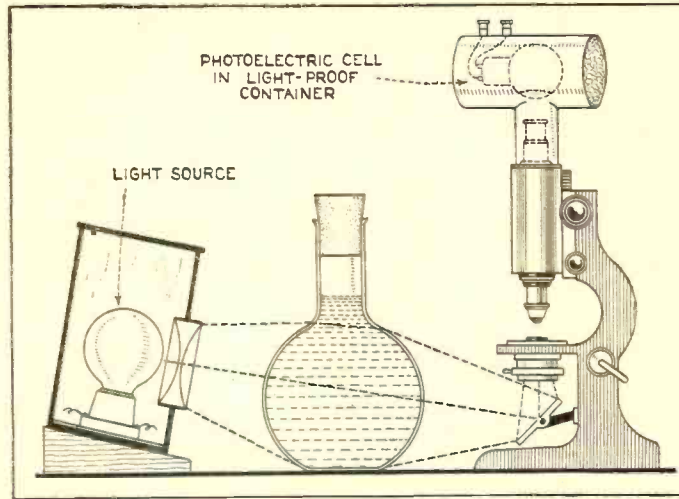

ARRANGEMENT OF APPARATUS

Figure 1. This sketch shows the method for using the water bottle as condenser and filter as well as the method for attaching the photocell to the microscope

instrument. Of course, for such exact measurements the plate and filament power is supplied by storage batteries and not by the power line. For very precise measurements the entire equipment, from microscope to milliammeter, should be enclosed in a shield (copper box), and all connections should be rigid and immovable. Then it is also necessary to supply the light source from a storage battery and not from the power line, because the latter might cause light fluctuations and accompanying serious errors.

By the second method the photocell is not coupled directly to the amplifier, but is employed to control the discharge of a condenser through a glow tube. The principles of this phenomenon are made clear to the reader in the following:

In Figure 6 a neon lamp is connected across a condenser C (1000 mmfd.) and in series with a resistor R (10,000-100,000 ohms). The photocell (Z) and the transformer (T) do not play a part in this action. The condenser (C) is charged slowly through the resistor (R) till the ionizing potential of the neon light is reached. The condenser discharges through the neon light until its potential falls below the extinguishing potential of the latter. The neon light goes out; the current is interrupted and the condenser charged again. This process is repeated and the time consumed for the discharges is proportional to the values of the resistance and capacity in the circuit. By suitable choice any desired frequency can be obtained. Not all glow lamps permit a choice of any frequency, but for these experiments frequencies from 5 to 20 cycles for registration and 50 to 1000 cycles for loudspeakers suffice.

If the photocell is connected in this circuit, the current can flow only when it is illuminated. The charges follow independent of the illumination. They occur only as long as the cell is illuminated and stop when the cell is dark. When the photocell is connected across the condenser and neon light, the opposite happens. Now the charges and discharges of the neon lamp take place as long as the cell is dark and stop when the cell is illuminated, for then the current can flow steadily through the illuminated cell. In the path of the current in (Continued on page 52)

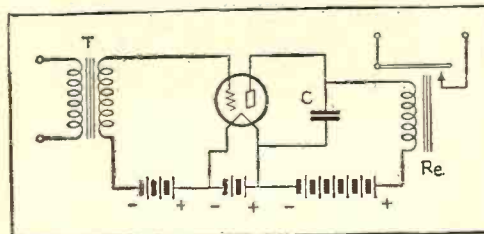

THE RELAY CONNECTIONS

Figure 9. One-tube amplifier hook-up working directly out of a coupled transformer and into a special sensitive relay

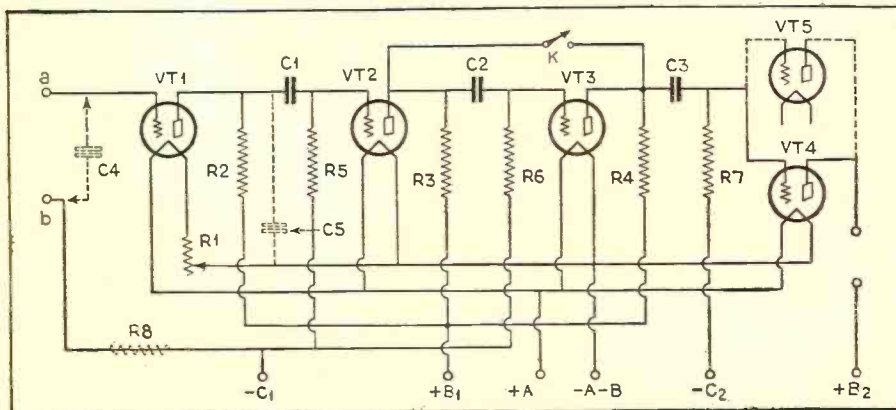

CIRCUIT OF THE RESISTANCE-COUPLED AMPLIFIER

Figure 8. Diagram showing the proper connections to be used with the amplifier for magnifying the sound frequencies produced by the movement of the microscopic bacteria, crystals or chemical reagents

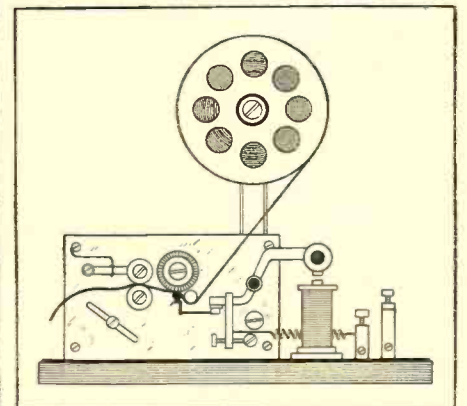

THE TAPE RECORDER

Figure 10. This is the type of tape recorder used by the author in his experiments

What Television Needs

Although television is still necessarily in the laboratory stages, the author points out the immediate needs of this new baby industry of radio and recommends improved program technique

THE television industry has come to the crossroads. For more than a decade it has existed chiefly in laboratories in this country and abroad. Research workers have been busy with television principles and their application. In many cases independence of thought has reigned, with its advantages and disadvantages. Independence of work has resulted in much duplication of effort in arriving at the same end. It has meant the lack of proper interchange of thought and ideas. But at the same time it has resulted in the growth of television along several fronts at once, each front being extended by its group as quickly as possible in the hope that its particular method would be the eventual victor in the race.

Thus we now have several organizations in this country developing television along different lines. Hollis Baird of Boston has attracted widespread attention by his attempt to merchandise television receivers in kit form through the Kresge stores, an experiment tending to lead to the development of a large television audience. This move also represents an effort tending toward the simplification and standardization of equipment.

Large-Size Images

In Chicago, U. A. Sanabria has gone in for large-size television images, even to the extent of projecting them on a 10-foot screen. And, having accomplished this feat with some measure of success, he is showing these large television pictures in motion-picture theatres around the country. While some newspaper writers, comparing television with the motion picture rather than realizing to what extent the difficult problems have been solved by Sanabria, have commented on his work with a lack of enthusiasm. Engineers and television enthusiasts, however, cognizant of the difficulties encountered, praise both his courage and his ability.

The R.C.A. engineers have confined their television to the research laboratory, from which little definite knowledge has come. The G.E. research men, under the direction of E. F. W. Alexanderson, have contributed much. The Westinghouse engineers, likewise, have developed their own type of television, utilizing the cathode-ray tube.

And Jenkins, perhaps the pioneer television worker in this country, has been striving toward perfection, sticking to the mechanical scanner, but substituting the "lens" disc for the "hole" disc and projecting the image on an enlarged screen by the use of a neon crater lamp. So television is advancing technically on many fronts.

The question now confronting television concerns the use of this knowledge and equipment in organizing the industry on a profitable basis. Television and equipment must be linked with television broadcasting. The value of television receiving equipment is predicated on the existence of television broadcast programs that will be interesting to the public, and derives its value, not of itself, but as a means of receiving these desired programs. The first interest shown in television was by the scientists, who were and are concerned primarily with the technical aspects, the methods of broadcasting pictures and receiving them. But so long as interest is confined to scientists, television as an industry cannot grow.

Public interest *must* be enlisted! Since television has been so entirely in the hands of scientists, this public interest was first aroused among scientifically minded people—young men who were radio enthusiasts, amateur operators and the like. This move was the first for two reasons: in the first place, the television engineers had a greater acquaintance with these other scientifically minded people than with any others, and secondly, because the quality of the picture received was insufficient to hold the interest of anyone not concerned with the manner of its reception rather than the picture itself.

This primary interest in the means rather than the end is definitely on the wane—which is a good sign, for taking its place is an interest in the program, an interest shared by a much larger public and opening a large market for television equipment. Already we might say that the shift toward the program is such that about as much interest is centered in the program as in the technical aspect of television. And this trend will continue as television science becomes standardized and loses its "novelty" appeal. To aid this, the television programs will improve as does the manner of their transmission and reception. The program will be important rather than the manner in which television operates, just as in motion pictures the public is interested in the picture rather than the manner in which it is filmed, projected, sound-tracked and re-produced.



By D. E. Replogle*

Entertainment Programs

Should the entertainment field take upon themselves the building and merchandising of television programs, even now before the technical end is fully per-

fected, using just the technical facilities that are at present available, the public interest in television could be tripled within a few months, in my opinion. But, unfortunately for the industry, the entertainment world is waiting until the technical end has been perfected before entering the field—quite contrary to their action with the motion picture and radio, both of which were exploited by entertainment interests with great rewards when technical development paralleled the present technical status of television.

At present television is in the hands of technicians, whose interest and ability is along technical lines. Still, these men realize that the most important step at the present time is the enlisting of the entertainment interests in television. This is a thing which the engineers are not in a position to do themselves. It is a thing which will give television its present desperately needed public interest. It will do more to advance the television industry if undertaken immediately than any technical advancement that is likely to come out of the laboratories within the next year. Moreover, it will be profitable to those who exploit this field almost from the very beginning. And since the entertainment world is in need of some exhilarating branch, television offers the ideal field for their endeavors.

On the other hand, it should not be thought that the entertainment interests can step in and immediately develop the entertainment angle of television overnight. It took many years for the motion-picture production men to arrive at a motion-picture technique that placed that industry in a unique position so far as offering a form (Continued on page 55)

*Vice-President, Jenkins Television Corp.

SOME RECEIVER AND CONVERTER DESIGNS FOR USE BELOW TEN METERS

In this second article of this series the author shows how the problems of 5-meter reception can be solved by the design of special parts and circuits. The third article will describe the complete constructional details of an ultra-short-wave superheterodyne

FEW short-wave receivers now available function below fifteen or fourteen meters. However, with the present amateur, experimental and commercial activity in the quasi-optical region below ten meters, there is a demand by the average experimenter for receivers that will perform satisfactorily at least as low as three meters.

The natural question is, how may such a receiver be constructed—what new technique and operating finesse will be required of the experimenter?

Primary among the general problems is the matter of insulation losses. The short-wave experimenter has long been familiar with the dielectric phenomena associated with high-frequency work and will readily anticipate the importance of insulation design in the quasi-optical range. In the course of laboratory experiments with a two-meter transmitter, it was possible to increase the power output 75 percent by the substitution of low-loss "R-39" insulation for bakelite in the tube base and condenser construction.

In addition to the "R-39" products, a special Isolantite has been developed for ultra-short-wave apparatus. Rigidity is another essential, and the results of these two considerations are embodied in an entirely new line of sockets, coil forms and variable condensers. These last are characterized by a minimum of high-grade insulation, thick, rugged plates

By James Millen*

with smooth rounded edges, and compact construction to facilitate the use of short low-impedance leads. (Figure 1.)

Tubes admirably suited to the requirements of reception below ten meters are now available and are represented by the -56, -57 and -58 series. These new tubes have extremely low inter-electrode capacities, high plate impedances, high amplification factors and mutual conductances, which make possible the construction of a receiver providing excellent performance on wavelengths even shorter than three meters.

The simplest type of receiver for use on this band is the straight detector circuit, backed up with a generous amount of audio-frequency amplification, made practical by the low noise level of the detector output. Such an arrangement will give good reception within 25 miles or so of the new N.B.C. Empire State Tower voice and television transmitter in New York City, and is shown diagrammatically in Figure 2. Figure 3 shows the finished receiver and Figure 4 a high-quality, high-gain audio-frequency channel. The amplifier comprises three transformer-coupled stages employing -27 tubes, completely a.c.-operated.

Super-Regenerative Receiver

Super-regenerative receivers have been particularly successful on ultra-short waves, due to the simplicity of design and the signal intensity that can be built up with a minimum of tubes. Old-timers will recall that the original Armstrong super-regenerative

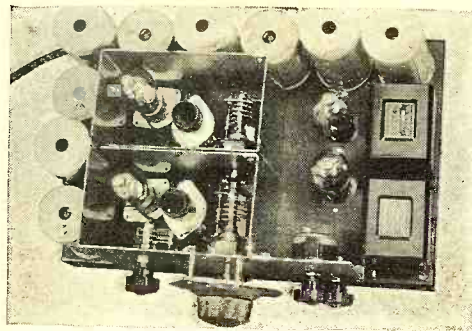

3-10 METER SUPER
Figure 6. The completed super covering 70,000 kc. between 10 and 3 meters with five sets of coils

*The National Company, Inc.

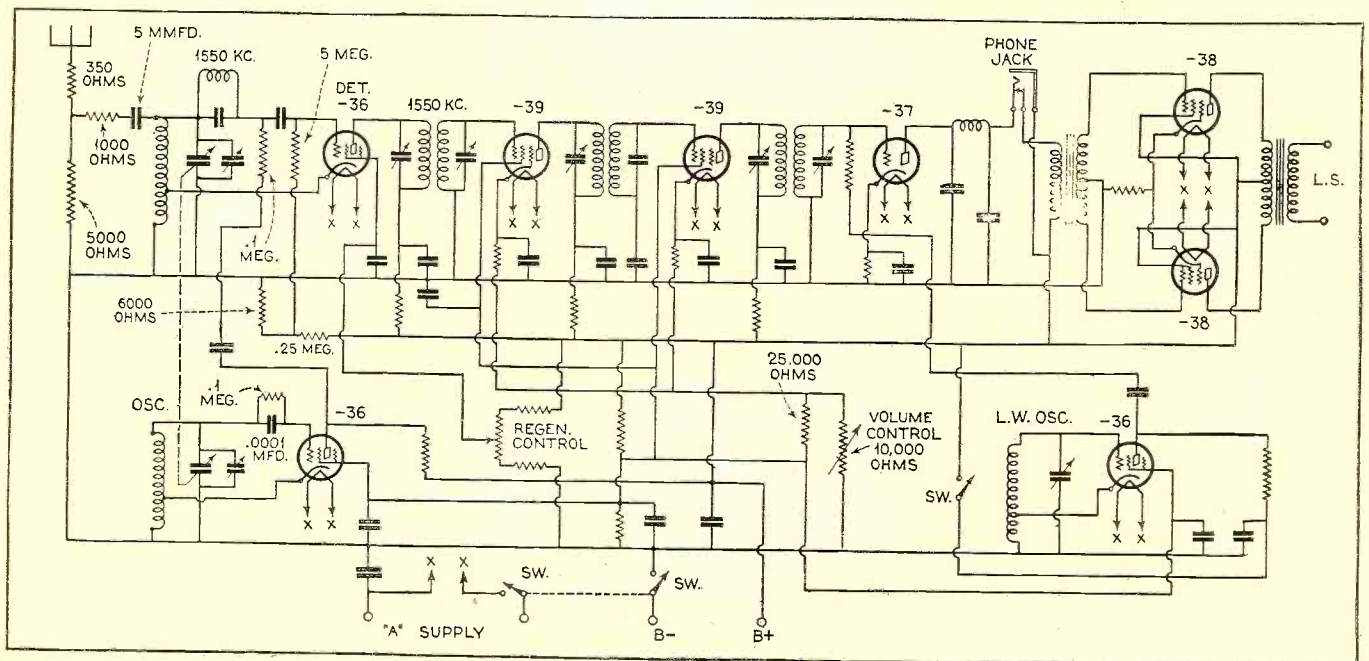

FIGURE 5. ULTRA-SHORT-WAVE SUPER CIRCUIT



TYPE -57



TYPE -56



WUNDERLICH



TYPE ER-LA



TYPE -58

CHARACTERISTICS AND CIRCUIT DATA FOR FIVE NEW TUBES

Here is the latest information on five new tubes, including the triple-grid amplifiers, the Wunderlich tube and the new automobile pentode. These characteristics should be of interest to all engineers, servicemen and experimenters

NEVER before have there been so many new tubes available and at no time has the experimenter had more opportunity for trying out or discovering new circuits and principles. It is not possible to cover, in a single article, all the information on all new tubes which are about to be released. Therefore the progress in this field will be reported from time to time in future articles in RADIO NEWS, as the tubes are made available.

The photographs on this page show five new tubes: The -56, a general-purpose triode; the -57, a triple-grid amplifier-detector; the -58, a triple-grid super-control amplifier, all three with a 2.5-volt filament; the Wunderlich tube, a special detector; and the ER-LA, an improved automobile-type pentode output tube.

The -56 tube is a general-purpose triode with an indirect

By J. van Lienden

heater and an a.c. filament. The tube is intended to replace the type -27 tube, but is superior to it in many ways. Filament current has been reduced to 1 ampere, the amplification factor has been increased to 13.5 and the size of the tube is smaller—the same size as the automobile-type tubes.

Characteristics of the -56 tube are found in the table together with the characteristics of all other tubes described in this article. These give the constants of the circuit for the use of the -56 as a transformer-coupled amplifier or a detector. If the tube is to be used in resistance-coupled amplifier stages, the plate resistor can be 50,000 to 100,000 ohms. With a plate-supply voltage of 250 volts, the necessary grid bias is -9 volts. The grid-coupling resistor should not be larger than 1 megohm.

The -56 tube can be used as a detector, either biased, grid-leak-and-condenser or diode. The bias can be obtained by

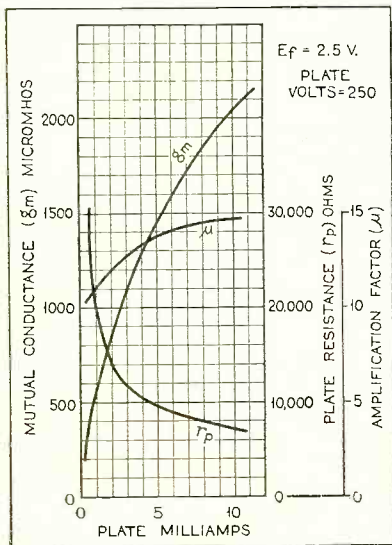

CHARACTERISTICS OF -56

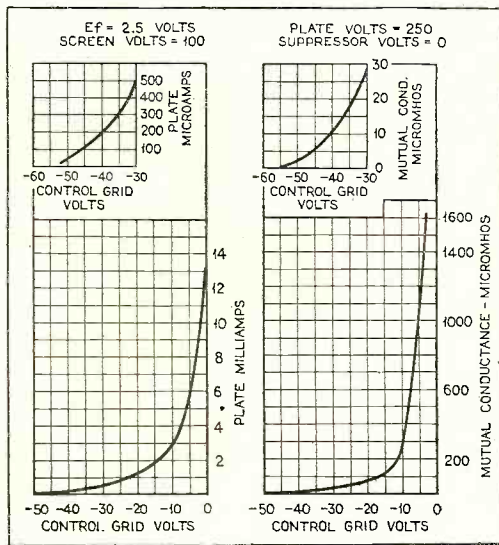

CURVES OF THE -58

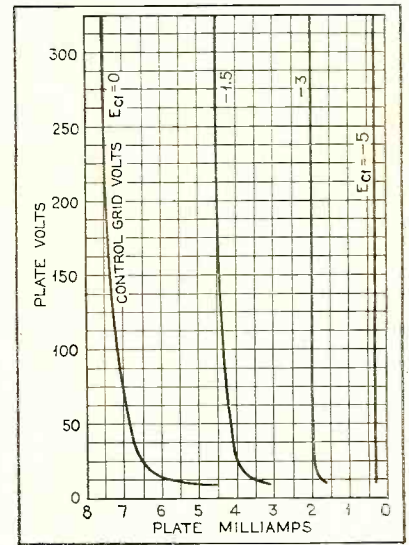

AMPLIFICATION FACTOR 1500

Figure 1. Left—These curves show how the mutual conductance, amplification factor and plate impedance vary with the plate current. Figure 2. Right—Average plate characteristics of the -57, the triple-grid amplifier-detector, for a screen potential of 100 v. and suppressor at zero bias. Figure 3. Center—These curves show how the plate current varies with the control grid voltage, and the variation of mutual conductance from 1600 to practically nothing by varying the grid bias from -3 to -50 volts

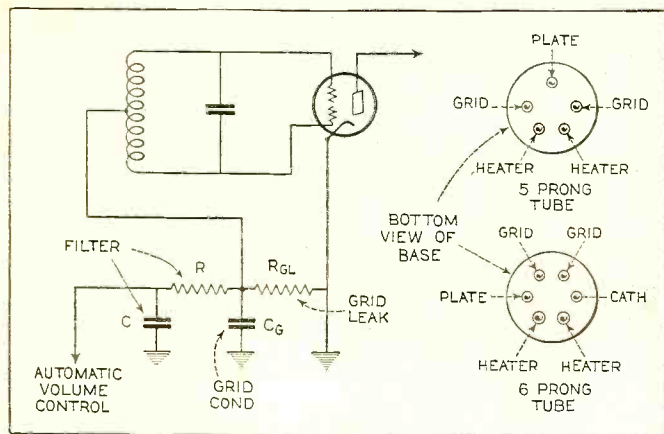

THIS DETECTOR CAN DRIVE PUSH-PULL -45s
 Figure 5. The circuit of the Wunderlich tube is simple and easy to install in existing sets. The prong connections are shown above; the cap on top of the five-prong tube is the cathode

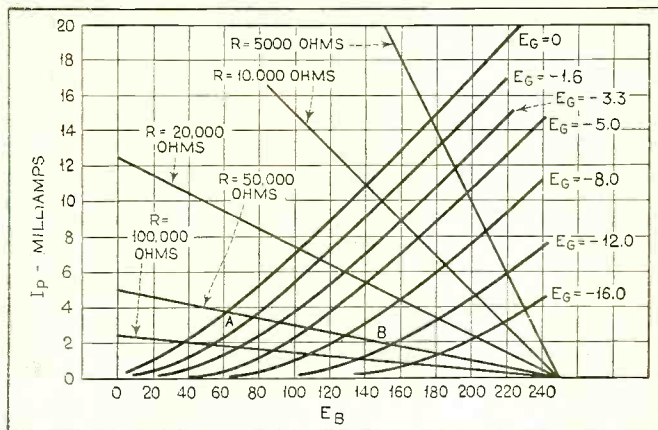

FINDING THE REQUIRED LOAD IMPEDANCE
 Figure 6. Average plate characteristics of the Wunderlich tube. The grid voltages refer to both grids connected in parallel, which is the case in its audio-amplifier action while employed as a detector

means of a resistor in the cathode lead. Its values are not critical; the manufacturers recommend 100,000-150,000 ohms. As a diode detector, it is best to connect plate and cathode together. This circuit will handle a signal of 40 volts (r.m.s.) between grid and cathode.

The cathode should not be more than 45 volts positive, with respect to the filament. The bias resistor should be adequately bypassed to prevent hum.

The Type -57 Tube

The new general-purpose pentode, called the triple-grid amplifier, includes many improvements. The tube is a very sensitive biased detector or it can be used as a screen-grid amplifier or an automatic volume-control rectifier supplying the grid bias to the r.f. or i.f. stages.

The filament current is only 1 ampere, like that of the -56 tube. In this pentode the suppressor grid has been brought outside to another prong, which makes possible many new circuit arrangements. Of course, the new base has six pins, and there is also the usual grid cap. A drawing of the six-pin base and its connections is shown in Figure 4; this data was supplied by the Hy-Grade Sylvania Company.

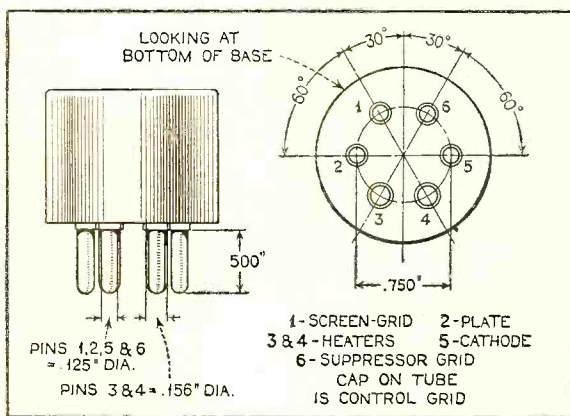

THE STANDARD 6-PIN BASE

Figure 4. Exact dimensions of the standard 6-pin base and the connections to the prongs on the -57 and -58 are shown in this drawing

A tube of such an enormous amplifying power needs perfect shielding. Therefore the inner shield that is in the top of the dome is intended to be a continuation of the outer tube shield. The dome-shaped bulb permits the collar of the outer shield to fit closely around the tube. Under these conditions the grid-to-plate capacity is as small as it is in a screen-grid tube with an outer screen section. When the tube is shielded in this way, provision should be made for ventilation, to prevent overheating of the tube.

For detection, the grid-bias method is recommended. Proper bias voltages may be obtained from the voltage divider or from a cathode resistor.

Resistance coupling is best for high-quality reception with this tube. A resistor of 1/4 megohm in the plate circuit is suitable for this purpose. When greater output is required, connect a choke across the plate resistor. A very large choke—500 henries—is necessary for good quality.

The suppressor grid can be connected directly to the cathode, and in that case it is effective in preventing the passage of secondary electrons from plate to screen grid. This makes it possible to obtain the screen (Continued on page 53)

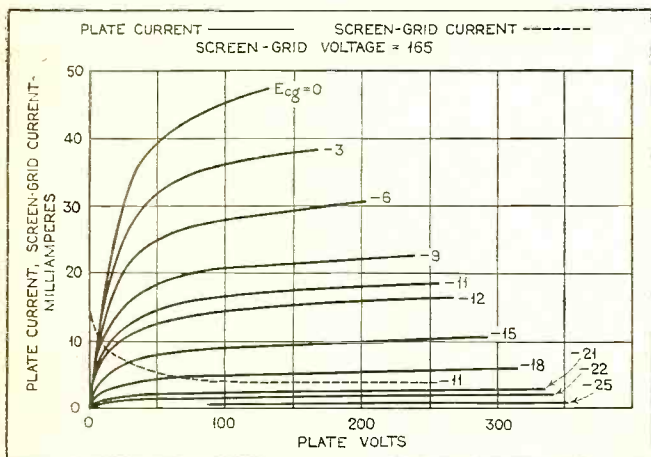

CURVES OF THE NEW PENTODE ER-LA

Figure 7. These curves show the relation between plate current and plate voltage for different control grid voltages and the screen current for the recommended grid bias of -11 volts. For automobile use

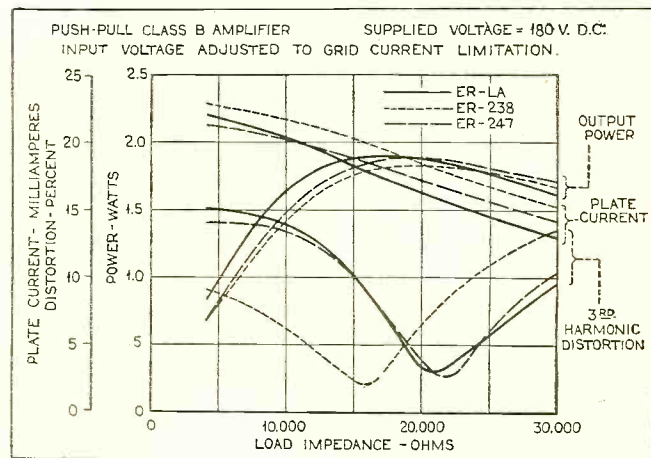

TWO ER-LA'S IN PUSH-PULL

Figure 8. When two of the new pentodes are used as class B amplifiers the harmonic distortion can be reduced. Curves show how the third harmonic is reduced by selection of the right load impedance of 20,000 ohms

The Sprayberry A.C.—D.C. Set Analyzer

Here is a set tester which will recommend itself to servicemen because of the complete variety of tests it is capable of performing, including all a.c. and d.c. measurements in all circuits of a radio set

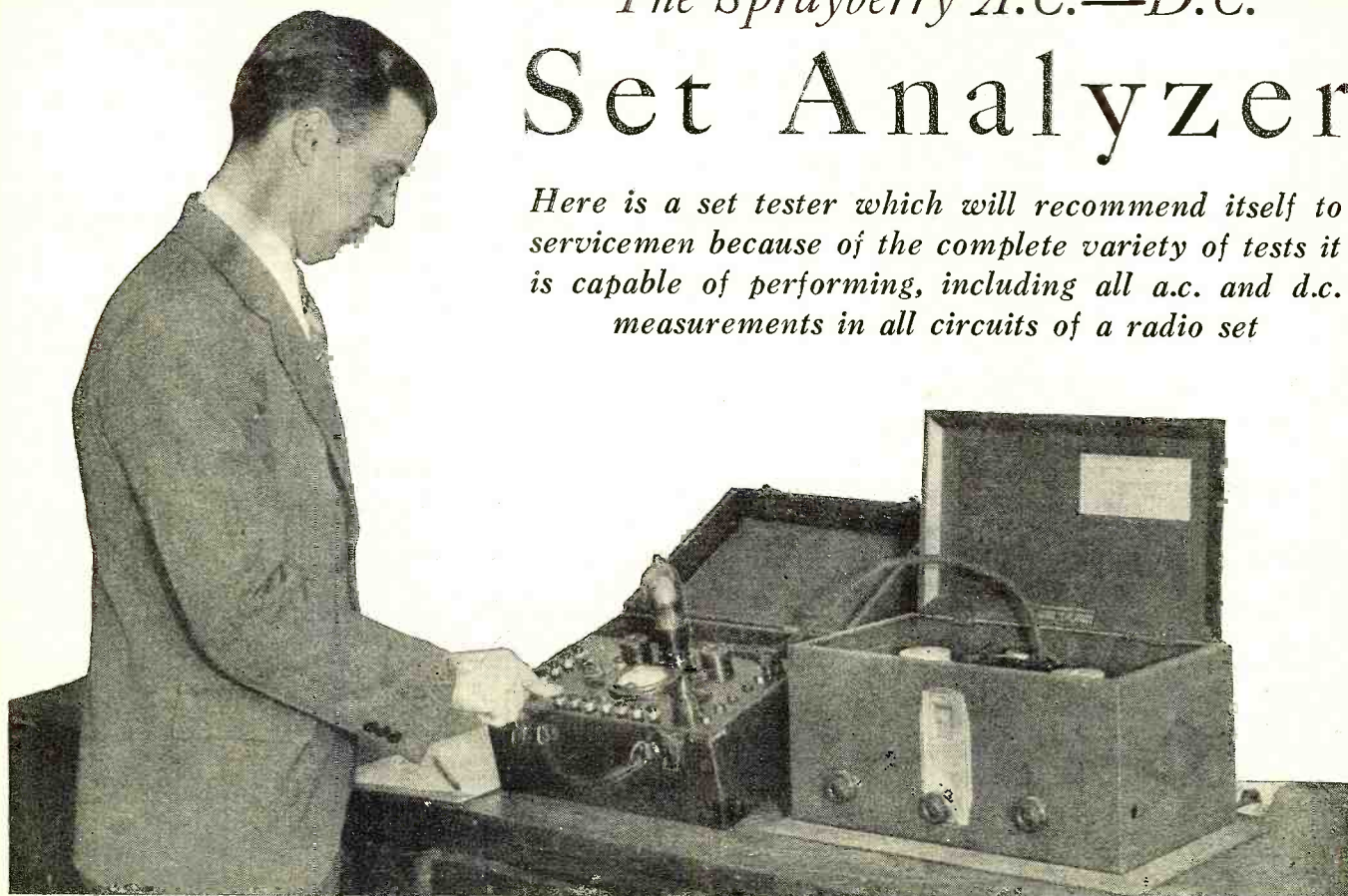

THE link between the serviceman and his job is the set analyzer. Without it he can do little towards the repair of the modern receiver. It is because of this need and the fact that many servicemen prefer to build their own analyzer units, because this enables them to thoroughly understand its use and application, that we present the design of a modern analyzer.

The analyzer about to be described was designed around the Weston rectifier type model 301 universal voltmeter. With this meter it is possible to measure both a.c. and d.c. voltage and d.c. current in several ranges, depending on the number of shunts used. The voltage range is extended by means of series multipliers. The low a.c. ranges also serve for making receiver output measurements. In fact, this one meter may be used to make all measurements on the modern receiver.

By the use of proper switches the meter is changed from circuit to circuit quickly, and within a few minutes the serviceman may determine if abnormal conditions are present in the circuits of the receiver under measurement; or in the tubes, as provision is made (S5 and S6) for testing the latter by changing the grid-bias by an amount equal to the C battery voltage.

May Be Built on Installment Plan

If for reasons of economy the constructor wishes to cut down the constructional cost for original parts, he may do so and add the other parts later. For instance, the plate current switch (S8), the plate voltage switch (S15), the grid voltage switch (S14), the filament switch (S13), one UY type socket and one UX type socket may be included. All other parts may be left out until some future time, when more money is available. However, the cost of the complete set of parts is so low (with the usual serviceman's discount), in comparison to similar manufactured testers, that the parts required are well within the reach of most servicemen.

Figure 1 shows the complete circuit in schematic form. The circuit is not at all difficult to wire after the various

parts are mounted on the panel. Any one who is able to work from a schematic diagram can do the wiring. Two UX type sockets are not at all necessary, and one may be omitted if desired. The schematic shows only two sockets, while the photo shows three, two of them being wired in parallel.

A panel may be chosen to fit available carrying cases, as no one size is essential as long as the electrical connections are correct. The writer chose a 7-inch by 12-inch panel, because that is a standard size and therefore less expensive than one of odd size. The carrying case specified in the list of parts is made to accommodate this panel, and provides a compartment for the test cable and plug.

The selection of the resistances to extend the range of the meter is of paramount importance. The accuracy of the entire tester depends on the accuracy of these resistances. Be sure, therefore, that you use precision resistors with an accuracy of at least 1 percent. The writer used I. R. C. resistors (made by the International Resistance Company) because they are easy to mount and have the proper accuracy. These are mounted on three bakelite strips, specifications for which are shown in Figure 4. The 4950, 5000, 40,000 and 50,000-ohm resistances are shorter than the others, therefore two strips are required for the under side of the mounting.

Assembly Data

The resistance units are mounted by means of eleven 6-32 machine screws, $1\frac{3}{4}$ inches long.

The supporting strip is not attached to the panel until as much wiring as possible has been done to the other units. The mounting screws should be at least 2 inches long, in order that the supporting strip will clear the switch contacts underneath the panel. Two binding posts are provided for the connection of the C battery. These are mounted in a line with the jacks at the right-hand end of the panel.

Figures 2 and 3 show the panel appearance of both top and bottom sides after all parts have been mounted.

Figure 1 should now be followed in wiring the analyzer,

By Frank L. Sprayberry*

*Instructor, National Radio Institute.

using No. 18 solid push-back wire having a good grade of insulation.

In starting the wiring it is suggested that the meter be wired first to switch S3. Then wire switches S7, S8, S9, S11, S12, S13, S14, S15, S16, S10, S5, S6 and the jacks J, J1, J2, J3 and J4 in the order named. Finish any miscellaneous wiring to the sockets and switches. Next mount the resistance support and wire the resistances to switches S1 and S4, including the 4950-ohm one between the meter and switch S3. Bore a hole between the sockets and bring out the control grid lead. Next wire the cable from test plug to the circuit. The cable has six leads; black for plus filament, blue for minus filament, brown for cathode, red for plate, yellow for grid and green for control grid.

All connections should be soldered, making sure that good contact is made at all joints.

Voltage measurements should always be made first with any set analyzer. The reason for this is there may be a short circuit in the circuit under test, causing excessive current flow. If by accident the milliammeter is connected in series with the circuit, the excessive current may damage the meter.

A fairly satisfactory way to determine if the tube has shorted elements is to make voltage measurements first, with the tube out of socket of analyzer. Next insert the tube in socket and again make a voltage measurement. If the voltage reduces to zero, or nearly so, the tube has shorted elements and another one should be used in its place.

Insert the test plug in the receiver socket. Set switch S1 to the 500-volt position and set switch S10 to the "F" or "K" position, depending on the type of tube being tested. (If the tube is of the direct heater type, such as the 26 or 45, set S10 to "F." If it is of the indirect heater type, such as the 27, 24 or 35, set S10 to "K.") Now depress the push-button of switch S15, and the plate voltage will be indicated

on the meter if the receiver is turned on. Insert tube in tester socket. If about the same reading is obtained, the tube is not shorted. However, if the tube is in a resistance-coupled circuit, the voltage reduction may be quite large, as for instance from 200 down to perhaps 50 volts. The reason for this is that the meter draws little current, so that no appreciable voltage drop develops across the plate coupling resistor. However, as soon as the tube draws current voltage will rapidly reduce, and this is entirely a normal condition.

If the 500-volt scale does not give a readable value, drop to a lower scale by turning switch S1 to the left, using the scale which just exceeds the voltage to be measured.

(When making current measurements switch S10 must be in the neutral position.)

Set the switch to the highest position, or the first one to the right, set S10 to neutral and depress the push-button of S8. Always use the highest current range to start with; you can then drop back to lower scale by turning S4 to the right. When through making current measurements, always turn S4 all the way to the right, which is the

"off" position. This will prevent any interaction between circuits should the wrong push-button be depressed at any time. The last contact to the right of S4 is the one milliamperere position. It is to be used when measuring small values of current, as for instance the current of a detector tube or the current of a screen-grid circuit. Never use this position where the current in the circuit is likely to exceed one milliamperere.

Grid voltage may be either negative or positive, with respect to the grid. A polarity reversing switch, S2, has been provided in the circuit so as to take care of this condition. This switch is normally connected so that the meter will read positive with respect to the grid. In making screen-grid voltage measurements, switch S2 is not disturbed. To make this measurement it is only necessary (Continued on page 63)

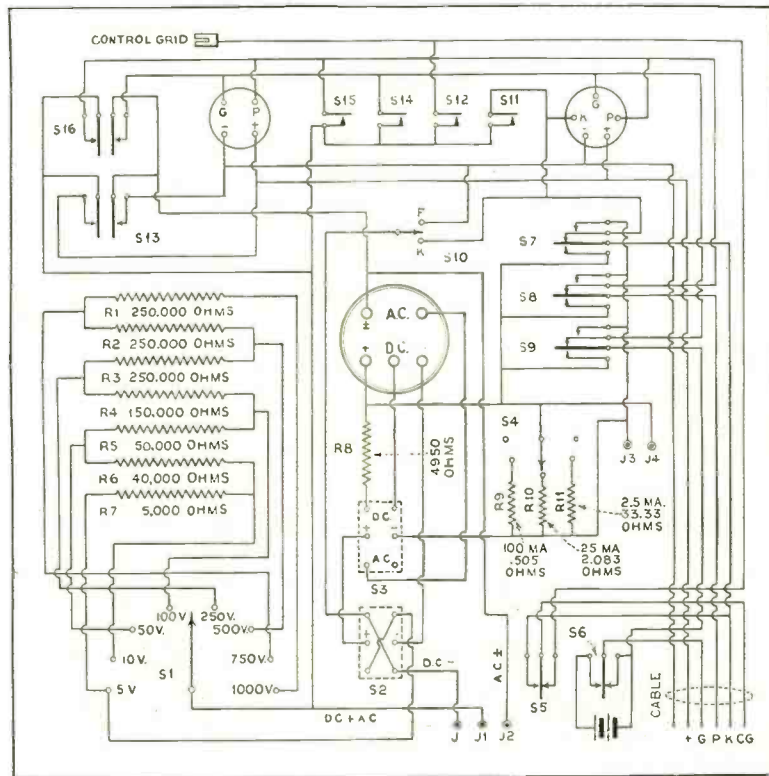

THE SCHEMATIC CIRCUIT DIAGRAM

Figure 1. All symbols used here are repeated in Figures 2 and 3, showing the location of all parts on the panel

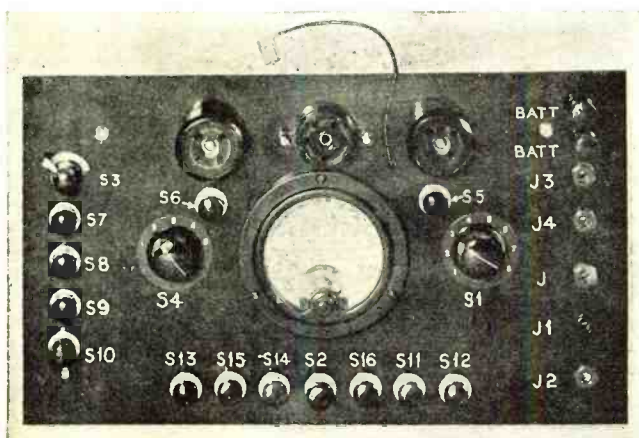

THE PANEL ARRANGEMENT

Figure 2. The neat and orderly arrangement of controls is an attractive feature of the Sprayberry tester

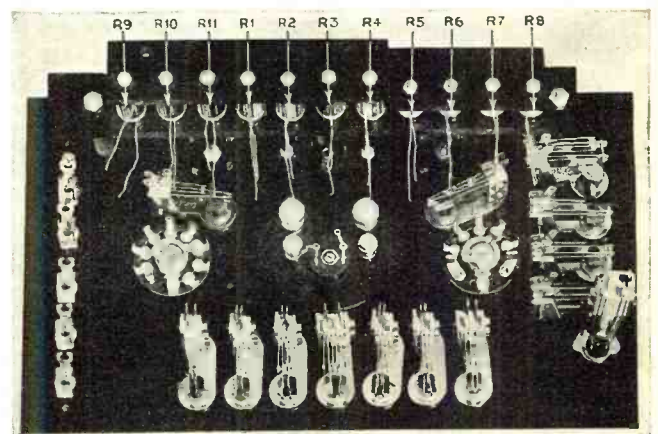

BACK OF PANEL WITH PARTS MOUNTED

Figure 3. All parts are shown in readiness for wiring and will assist constructors in assembling the unit



PORTABLE DEMONSTRATION AMPLIFIER

Before making a permanent telephone amplifier installation the telephone companies have the hard-of-hearing subscriber try out a portable model. If this proves effective, the equipment is then installed

A Telephone Booster

for the Hard-of-Hearing

Many persons who have difficulty in hearing telephone conversation are not aware that the Bell and associated telephone companies rent amplifiers, which they will install in any subscriber's home

By William C. Dorf

IT is tantalizing for a person hard of hearing to feel that a voice which may have crossed the continent is stopped just as it reaches his ear. In contrast to the task of crossing such barriers of space, entering his ear seems a small thing to ask of a voice. From an early day, therefore, the Bell System has tried to provide means for opening to the hard of hearing the field of conversation by telephone, with the great reach of contact it contains.

The effects upon hearing which different disorders produce can be grouped as those causing a general lowering of sensitivity over the entire range of audible frequencies, those causing distortion by affecting the sensitivity at certain frequencies more than at others, and those causing subjective disturbances in the ear itself which blur or obscure sounds of external origin by adding other sounds. So varied are these kinds of defective hearing that it might be supposed impracticable to design a standard telephone amplifier which would be serviceable to any great number of people. That this, fortunately, is not the case is attested by the many for whom the usefulness of their telephones is preserved by a single device.

Experience has shown that a large proportion of those who are unable to understand ordinary speech suffer from a general lowering of sensitivity without excessive distortion within the range of normal voice frequencies. For these people general amplification will restore the intel-

ligibility of speech sounds. Such is the transmission equivalent of the ordinary telephone connection that many who have difficulty in understanding speech face-to-face have no difficulty in understanding over the telephone. But there are many others who can understand speech only when its loudness is considerably greater than that of the ordinary telephone conversation. For these telephone users the present amplifying equipment has been developed.

The earliest device was a mechanical repeater, installed on the subscriber's premises, which raised the speech level to about fifty times normal. But its cost and maintenance were high, and its transmission characteristic was none too good. The advent of the vacuum tube made it possible to develop apparatus having much-improved characteristics and offering greater and adjustable amplification. Known as the No. 23-A Amplifier, it consists of a single-stage vacuum-tube amplifier, controlled by a small knob which is located conveniently near the regular telephone instrument. By turning this knob, the volume of sound may be increased, in five stages, to over 100 times its normal power. The vacuum tube and the equipment of its immediately associated circuits are mounted in a housing similar to that of a subscriber set.

The amplifier in its housing and the batteries in their battery box can be mounted anywhere in the room in which the telephone set is located, but the control equipment is mounted adjacent to the set, for ready

(Continued on page 62)



PERMANENT INSTALLATION EQUIPMENT

The small control box on the table end is the only visible addition to the standard telephone equipment. Box A is the usual bell box, Box B contains the amplifier, and Box C the battery equipment. B and C may be installed in a closet or other out-of-the-way place

PEPPING UP SHORT-WAVE RECEPTION WITH A NEW

Antenna Tuning Unit

Amateurs know the drawbacks of "dead spots" in tuning regenerative receivers. The circuit described here is designed to eliminate this trouble, at the same time increasing both the selectivity and sensitivity and reducing radiation from the antenna circuit

By Thos. A. Marshall*

THE antenna coupling unit described in this article was designed primarily to aid in reducing interference and to eliminate resonant points occurring over a wide range of frequencies. Everyone has experienced the difficulties of antenna "drags" taking place while tuning a regenerative receiver due to the effect of the antenna on the oscillating detector circuit.

Figure 1 shows a circuit which was found adaptable for reception of all short waves, with a resultant increase in selectivity and sensitivity. The trap circuit also reduces radiation or so-called "blooming."

In actual measurements made while the circuit as shown in Figure 1 was in use, it was found that the signal was increased about three times in the 15,000 kc. band, and was estimated to be as high as fifty times in the lower bands.

Most of the receivers developed at the present time are designed for coupling to the antenna through a small series capacity or through a few turns of inductance. Both these methods have a disadvantage of reducing the signal strength when the detector circuit is too strongly coupled to the antenna. There is also the disadvantage of poor selectivity. If the antenna is connected through a condenser directly across the grid coil of the detector circuit, the applied signal voltage to the detector will be equal to the resonant voltage across the coil. Under this condition, the detector will take an inappreciable current, resulting in no power. From this data the detector circuit may be considered to cause an increase in the antenna resistance by an amount R_1 . The total antenna resistance will, therefore, be equal to R plus R_1 . Thus for obtaining increased signal strength and the greatest

degree of selectivity, it is advisable to reduce the coupling below the point of strongest signal, as a marked increase in selectivity is made possible with only a slight reduction in signal intensity.

An increase in signal strength is made possible when using the circuit as shown in Figure 1, by transferring the energy at the proper point. Figure 2 shows the voltage nodes or current loops in various types of antennas. Note that it would reduce the efficiency of the antenna system as shown at a and c if the free end is grounded. However, the antenna as shown at b or d would function most efficiently if grounded at the lower end.

Figure 3 shows the voltage and current distribution in a full-wave antenna. For obtaining maximum transfer of energy to the detector circuit, the type of coupling along the antenna as shown should be used. Thus the antenna should be coupled capacitively at the voltage loops and inductively at the current loop points. If an antenna as shown at 2 (d) is employed and is tuned to resonance, the antenna turns are at the current loop point, resulting in the transfer to the detector circuit of the greatest amount of signal voltage. In an antenna operated at full wave or on its second harmonic value as shown in C,

the antenna turns are at the current node point with maximum voltage in the coil system, resulting in the transfer of energy taking place capacitively rather than inductively. The signal strength would therefore be decreased due to poor coupling. At other points along the antenna the current and voltage distribution may be such that their respective fields neutralize one another through the antenna coil system, resulting in practically zero coupling.

In the antenna system. Figure 1, the current and (Continued on page 58)

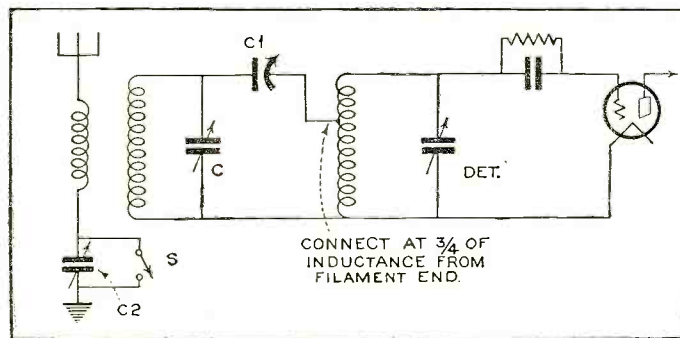

THE NEW CIRCUIT

Figure 1. Instead of coupling the antenna to the tube circuit by means of the usual inductance or capacity, both are employed, the former as a preselector circuit

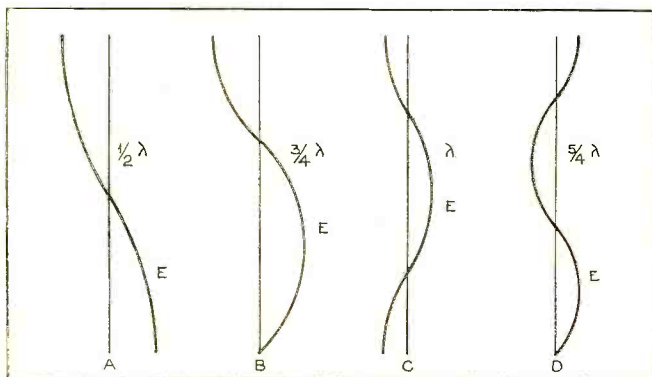

VOLTAGE DISTRIBUTION ALONG THE ANTENNA

Figure 2. Showing how the voltage loops move along the entire antenna system at different wavelengths or frequencies

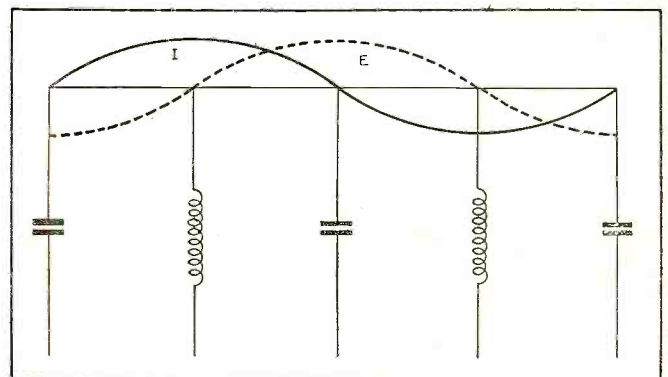

ANTENNA COUPLING METHOD

Figure 3. Whether inductive or capacitive coupling is better depends on the antenna voltage and current distribution

*Naval Communication Service.

Compact D. C. SET TESTER

This serviceman's unit meets the general demand for a small and relatively inexpensive, though highly accurate, set analyzer. It will make all d.c. voltage and current measurements on all tubes now available



By Bernard J. Montyn

LIGHT weight and compactness are two of the prime requisites for a set tester which has to be carried by the serviceman. Most jobs requiring special tools or measuring instruments are done in the shop, and many men feel that it is a waste of energy to carry equipment other than the most simple type.

The small set tester pictured in these pages contains only one relatively inexpensive meter, and the necessary switches for all d.c. current and voltage measurements on all tubes now in general use. The system has been so designed that the switching operations are very simple, and absent-mindedness is not likely to result in a damaged meter, as it sometimes does where toggle switches are employed in selecting meter ranges. Also many set testers using individual switches for each test have the drawback that damage will result to the receiver under test if two switches are thrown simultaneously. Such an accident may result, for instance, in the grid receiving the plate voltage and thus damages the tubes as well as shorting the B supply.

Normally, in the tester described here, the voltage range or current range is the highest one available, and to obtain the

lower ranges it is necessary to press the right button. Such an arrangement is an added safeguard, for in the selector switch type of tester it often happens that the operator changes from grid bias to plate voltage and forgets to change the voltmeter range switch.

Three sockets have been mounted on the panel to reduce the number of adapters required. There are still two adapters which are absolutely necessary, as will be explained below. The five-prong socket (VT3) is wired for the pentode types -47 or -33. This permits the measuring of all d.c. currents and voltages on these tubes, including the screen current.

Referring to Figure 1, if the reader wishes to trace the diagram, in order to understand it he had best begin with the external voltmeter circuit. Following the leads from the meter terminals, the plus terminal is seen to lead to a 123-ohm resistor, R1, and then to the polarity-reversing switch, S11.

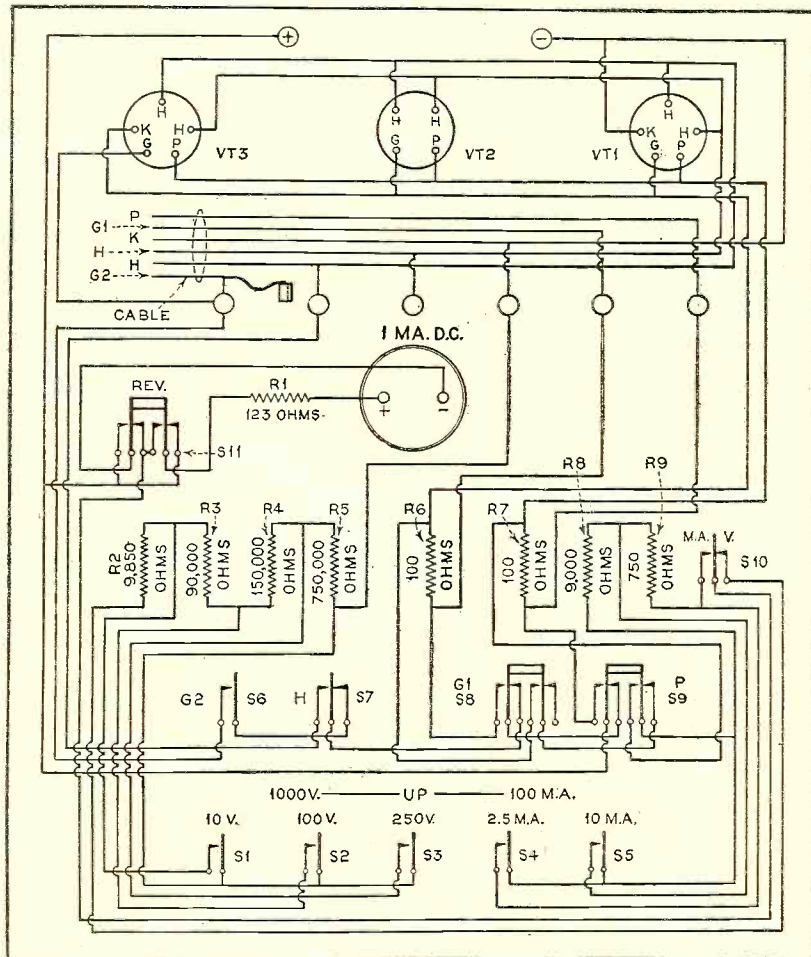

THE SCHEMATIC CIRCUIT DIAGRAM

Figure 1. The location of the various parts is shown here as they appear when looking at the panel from the under side

From there it goes to the binding post marked plus. The negative terminal is connected to the polarity-reversing switch and from there to the V-MA switch (S10), and when the latter is closed the circuit is completed through the voltmeter multipliers R2, R3, R4 and R5, which add up to 1 megohm with R1 and the meter resistance. The minus binding post connects to the far end of the multipliers.

It is seen that the voltmeter range is now 1000 volts. The switches marked 10 V, 100 V and 250 V short-circuit a part of the multiplier, reducing the total resistance in the voltmeter circuit to 10,000, 100,000 and 250,000 respectively. In the design of this instrument a meter resistance of 27 ohms was assumed.

Now follow the other connection at the plus and minus binding posts. The minus binding post is connected to the cathode in the 5-prong socket and the positive terminal is connected to one pole of the switch S9. If this switch is in the neutral position, the circuit is further completed through the left-hand blade of the switch S8 to switches S7 and S6, and there it ends. The circuit is open so long as no switches are thrown.

To measure plate voltage, turn switch P, which connects the left-hand blade to the P terminal on the sockets and disconnects all other switches from the meter circuit. To measure screen-grid voltage, throw switch G1 (S8) and have all other switches off except the V-MA switch, which should be set at V. This same setting also permits measurement of grid bias on a triode by reversing the polarity switch. The next switch, H (S7), permits the measurement of the heater-to-cathode bias in the case of indirectly heated tubes. With the employment of the special adapter provided for this purpose the d.c. heater voltage can be read with the same switch setting. This adapter is a new one, known as the Na-ald No. 955GKS. Finally, the

switch G2 (S6) is connected to the control grid of the tube under test. When more than one switch is thrown at the same time there is no damage done, but it is not advisable for it leads to confusion. For instance, throwing both G2 and P results in the plate voltage being read on the meter, and if the serviceman were expecting grid bias, he might press the 10 V button, thus overloading the meter.

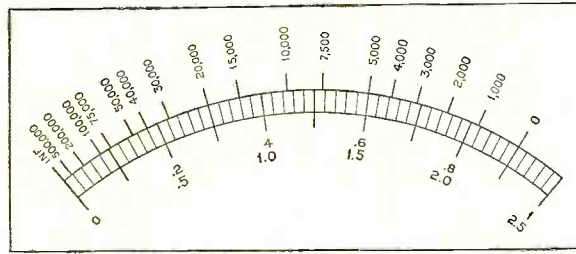

RESISTANCE MEASUREMENT SCALE

Figure 2. Resistance values can be measured by connecting the unknown resistor and a 9-volt battery in series across the analyzer binding posts. The middle scale shows the normal meter range; the lower scale is that covering the 2.5 ma. range

Current Measurements

Setting the switch S10 on the MA side connects the milliammeter in series with the resistors R1, R8 and R9, making a circuit of 9900 ohms in all. This again is connected across either R6 or R7 by the switches G1 and P. The latter resistors are permanently connected in the plate circuit and the screen-grid circuit, which makes it possible to connect the milliammeter without breaking the circuit.

When the two push-buttons marked 2.5 ma. and 10 ma. are up, the current divides through the 100-ohm resistor and the 9900-ohm circuit which are in parallel. The currents in the two branches are proportional to the conductance of each branch and inversely proportional to the resistance. Therefore the current through the 100-ohm resistor is 99 times as large as the current through the meter and the meter carries 1/100 of total current.

When the 10 ma. push-button is pressed, the resistor R8 is shorted, which makes the meter branch 900 ohms, carrying 1/9 of the current through R7 and 1/10 of the total current. This is therefore a 10 ma. range. When the 2.5 ma. push-button is pressed, the meter branch circuit has a resistance of only 150 ohms and it carries 2/3 of the current through R7 and 2/5 of the total, which makes it the 2.5 ma. range.

For the testing of four-prong tubes, use the Na-ald adapter 954DS on the end of the cable plug. (Continued on page 51)

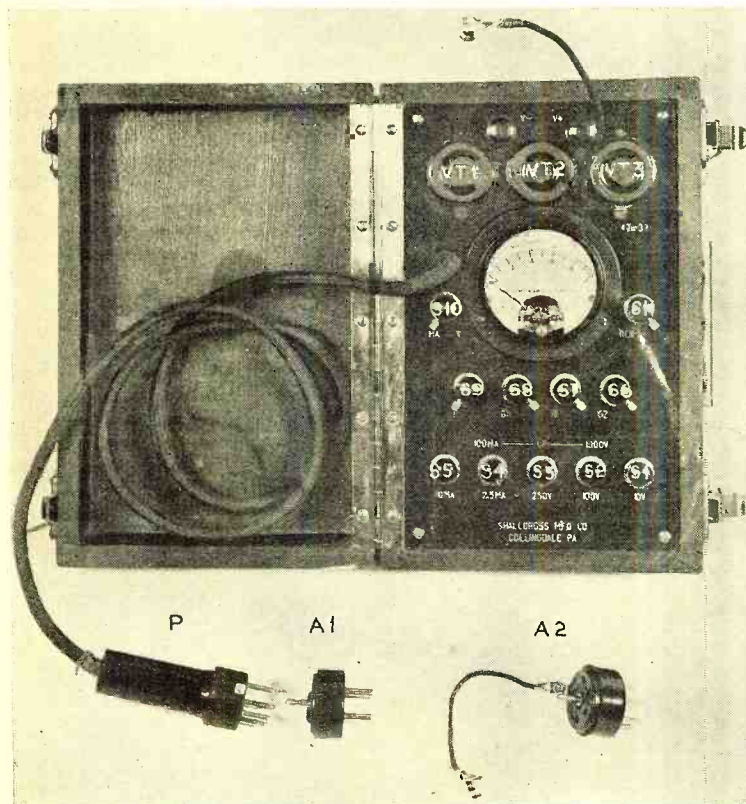

THE COMPLETE ANALYZER

The well-planned panel layout results in the utmost simplicity and speed in making tests even when used by a person who is inexperienced in this work

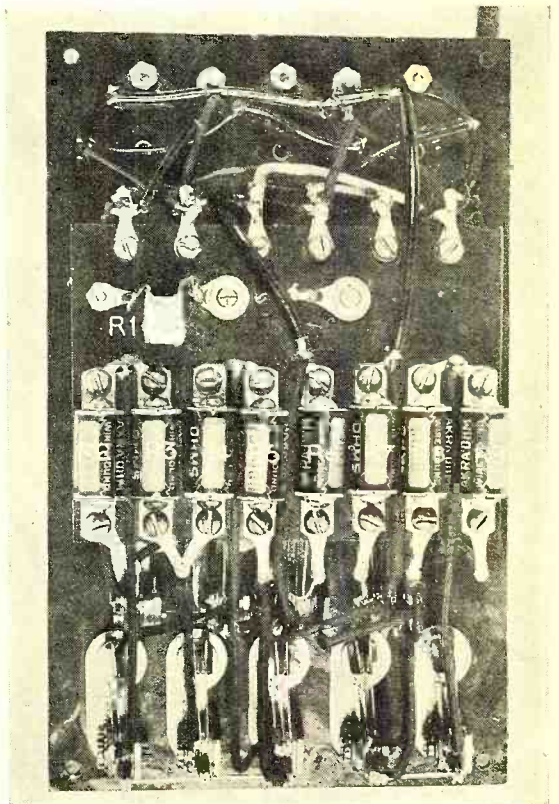

UNDER-PANEL LAYOUT

This view shows quite a contrast to the maze of wires usually found "below deck" in modern set-analyzing equipment

MODERN RADIO PRACTICE IN USING GRAPHS *and* CHARTS

Calculations in radio design work usually can be reduced to formulas represented as charts which permit the solution of mathematical problems without mental effort. This series of articles presents a number of useful charts and explains how others can be made

By John M. Borst
Part Seven

THE capacity of a home-made condenser is often more or less of a mystery. The amateur or experimenter who does not possess a bridge or capacity standard must calculate the capacity. Conversely, if a condenser of a given capacity is desired, only a calculation will eliminate guesswork.

The standard formula has been transformed into an alignment chart in Figure 1. The capacity of a condenser can be found when the area of the plates, their number, distance and the kind of dielectric are known.

The relation between centimeters and inches or mils as well as the relation between square centimeters and square inches, centimeters and microfarads is also shown in Figure 1. The "dielectric constant," also called "inductivity" or "specific inductive capacity," is incorporated on the chart, which makes the consultation of any sources superfluous.

The formula for the capacity of a condenser consisting of parallel plates is

$$C = \frac{0.0885 A (n - 1) K}{d}$$

in micro-microfarads

- where A = the area of one plate in square centimeters
- d = the distance between two plates in centimeters
- n = the number of plates
- K = the specific inductive capacity

This expression refers to a condenser with alternate plates in parallel. The formula does not take into consideration the spreading of the lines of force at the edges of the plates. This effect is negligible so long as the thickness of the dielectric is small compared to the area of the plates.

In designing this chart the prime idea has been to cover all possible cases which occur in practice. Therefore, the capacity scale ranges from 1 micro-microfarad to over 10 microfarads, and the other quantities also cover a wide range.

Examples

Two metal plates have an area of 1 square inch and are placed parallel, 1/4 inch apart, in air. What is the capacity?

Referring to the chart, draw a line from the 1-square-inch mark on the "Area" scale to 1 on the K scale. The specific inductive capacity of air is one (unity). This gives you an intersection on the turning scale No. 1. From this newly found point draw another line through the point 2 on the N scale and find a second point on the turning scale No. 2. The final line is drawn through the latter point and the 250-mils mark on the d scale. This line intersects the capacity scale at .9 mmfd.

When exactly 1 mmfd. is required, the last line should be turned around its point on the turning scale No. 2 until it intersects the capacity scale at the 1 mmfd. mark and the intersection on the d scale shows the required distance between

the plates (225 mils). The distance, however, can be left the same and the problem worked backwards, in which case an area of 1.1 square inch is found necessary.

These lines have not been added in Figure 1 because they are so close together that it might confuse the reader.

When using these charts, needless to say, one should not actually draw the lines but use a transparent ruler, a regular ruler or a tight thread.

The second example shows how to work the problem backward. Suppose a paper condenser of 1 mfd. is wanted and the dielectric available has a thickness of 2 mils. This is manilla paper, treated with paraffin. Its specific inductive capacity is 3.65 and the break-down voltage may run as high as 250 volts per mil. There is one more quantity which can be chosen and then the other one is determined. This can be either the number of plates or the size of the plates. The number of plates is the best to assume, because this has to be a whole number. Let us assume there shall be 30 plates.

For the solution of this problem, start at the 1 mfd. mark on the capacity scale. A line from this point to the 2 mil. mark on the d scale intersects the turning scale No. 2. Draw a line through the latter point and through the point representing the number of plates (30). Now note the intersection on the turning scale No. 1. Finally draw the last line from the point representing the dielectric constant, 3.65, through the point on the turning scale No. 2, which shows the necessary area of the plates as 84 square inches. As a check-up, an actual calculation gave the area as 83.7 square inches.

The experience of this second example teaches us that in certain cases the last line would intersect the area scale beyond the limits of the paper. This means that the area of the plates needed is going to be larger than 100 square inches. If the area is to be smaller than 100 square inches, either the number of plates have to be increased, the thickness of the dielectric decreased or the material exchanged for one with a greater inductivity. Then try again.

If one wishes the problem solved for values of variables outside the range of the chart, then some multiplying stunt has to be employed. For instance, suppose the paper in the above example had been dry paper with a dielectric constant of 1.8, then the last line does not intersect the area scale within the limits of the page. Therefore, multiplying 1.8 with any convenient number—say, 5—the last line is drawn from 9 through the intersection on the turning scale number one and the area scale is intersected at 34.

This result must now be multiplied by five in order to find the correct answer, which is 170 square inches.

While determining the specifications for a condenser it is important to be sure that the dielectric will stand the applied voltage. Therefore a list of the break-down voltages for different materials is found in Figure 2.

Temperature influences the ability of a dielectric to withstand electric pressure. When the (Continued on page 64)

PUNCTURING VOLTAGES (KILOVOLTS PER INCH)	
AIR	19.8
CASTOR OIL	380
EBONITE	725
FLINT GLASS	2280
GLASS, COMMON	200
" LEAD	140
GUTTA PERCHA	450
HARD RUBBER	250-950
INDIA "	160-500
MANILLA PAPER	125
MICA	430-700
OLIVE OIL	185-425
PARAFFIN	
MELTED	185
SOLID	875-1000
PARAFFINED PAPER	1250
PORCELAIN	230
SPERM OIL	200-450
TURPENTINE	280-400

DIELECTRIC STRENGTH

Figure 2. Table of break-down voltages for various types of sheet insulation

Capacity of a Condenser

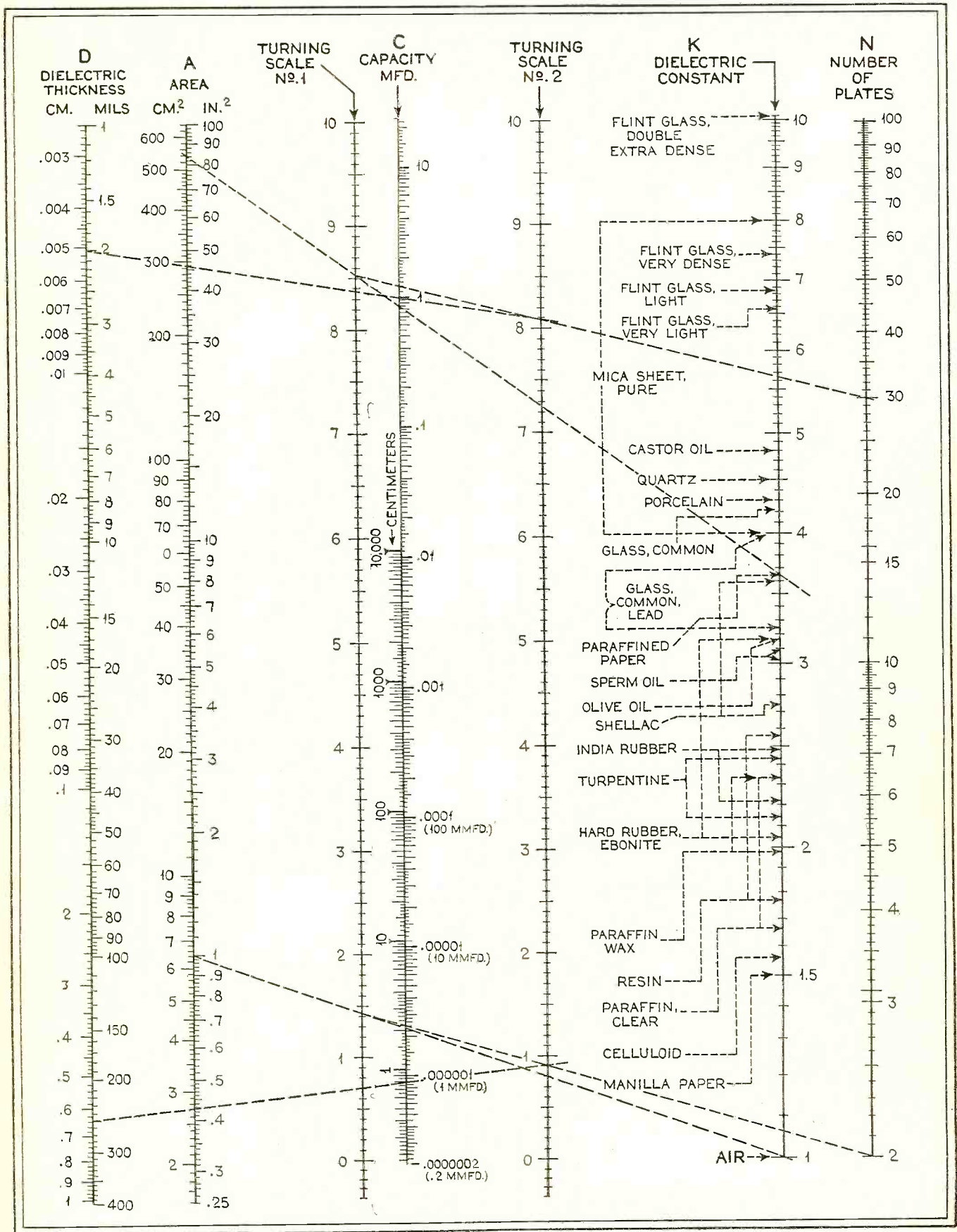

A CHART THAT WORKS FOR YOU

Figure 1—The size of condenser plates their distance apart, the number of plates, kind of dielectric or capacity can be found from this chart if the other four quantities are known. The five quantities are on three straight lines as shown in the example above.

ELIMINATING FRINGE HOWL

IN REGENERATIVE DETECTORS

The annoying howl which occurs just when a regenerative receiver is adjusted for maximum sensitivity has heretofore been accepted as a necessary evil. Now, however, the cause and remedy have been found, as explained here

By Dale Pollack

THE oscillating detector in radio receivers has rarely been used during the past few years, the tuned radio-frequency amplifier having largely supplanted it for everything except the reception of unmodulated signals. However, the impetus which is being given to high-frequency receivers at present presages the return of the regenerative detector once more. The oscillating vacuum tube introduces a number of problems into receiver design that are absent in non-oscillating circuits. One of the most pressing of these is the elimination of what is commonly termed "fringe howl." Fringe howl is an extraneous audio-frequency oscillation that occurs in a regenerative detector when it is adjusted to the critical point for maximum regeneration and is on the verge of oscillation. Unfortunately, this is a very sensitive point for the reception of signals, but reception in this condition is often impossible in short-wave receivers because of this howl which drowns out all signals and can only be eliminated by advancing the oscillation control to a less sensitive point beyond regeneration.

Fringe Howl Cause

The explanation of the cause of fringe howl which is presented here is due to L. S. B. Adler.* Apparently very little other experimental work has been done on this highly important subject and, as it has not yet been presented in this country, to the writer's knowledge, a summation of it here may prove of interest.

Consider Figure 1, the case of the oscillating grid-leak-condenser detector operating into an inductive load, usually that of a transformer. This is the circuit used in the great majority of short-wave receivers. Some type of oscillation control is being used, whether it is a variable tickler, condenser or resistance does not concern us here. As the oscillation control is advanced, the average plate current of the tube—it is a grid-leak detector—decreases. In proportion as the plate current decreases, an induced e.m.f. is built up in the plate inductance. At the same time the tube begins to oscillate. The voltage induced across the terminals of the plate inductance adds to that supplied by the plate battery and the tube oscillates more strongly than it would normally, but only for an instant, for as soon as the plate current reaches its minimum

value and the excess voltage across the inductance has spent itself through the resistance of the plate circuit, the applied plate voltage falls and the tube stops, or nearly stops, oscillating. However, the plate current drawn by the tube rises as the oscillations cease and the reactance absorbs energy from the circuit and hence reduces the effective plate voltage

to a sub-normal value. When the voltage absorbed by the reactance has been dissipated, the plate voltage attains its normal value, the plate current falls and the cycle begins again, manifesting itself in an audio-frequency oscillation called fringe howl.

A clearer picture of what occurs may perhaps be gained by examining Figure 2, which is a plate-current, oscillation-excitation curve. As the oscillation control is advanced, the excitation becomes sufficiently great at a particular point (A in Figure 2) to start regeneration, and then the plate current begins to fall. This fall in current causes the induced current to be built up across the plate inductance, which adds to the voltage supplied by the B battery. This increase in plate voltage increases the strength of oscillations and the plate current is reduced still farther. Then the plate voltage—which is merely a portion of the oscillation excitation along the abscissa of Figure 2—is reduced, and the plate current, which has been descending towards B, returns to A. The rise in plate current flowing through the plate reactance causes a concomitant absorption of voltage across the plate reactance; the excitation (in the form of plate voltage) is still farther reduced and the tube may stop oscillating entirely. When the absorption of voltage has ceased, the plate voltage rises to its normal value, the plate current falls towards A and the cycle repeats itself with a frequency determining the pitch of the fringe howl.

Inference of Plate Load

At times, however, these oscillations are highly damped and nothing more than a click results in the telephone receivers. Nevertheless, if the inductance in the plate circuit is large and the total circuit resistance, including the internal plate resistance of the tube, is low, a loud howl will occur at a certain setting of the oscillation control, the point of maximum sensitivity. This is the explanation of the usual type of fringe howl. As has been indicated, the frequency of the howl is a function of L/R , where L is the inductance of the plate reactor (Continued on page 55)

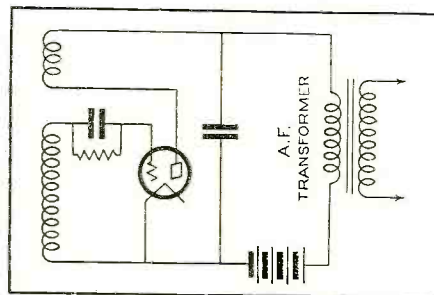

A TYPICAL CIRCUIT

Figure 1. Basic circuit of most regenerative detectors. For simplicity no regeneration control is shown

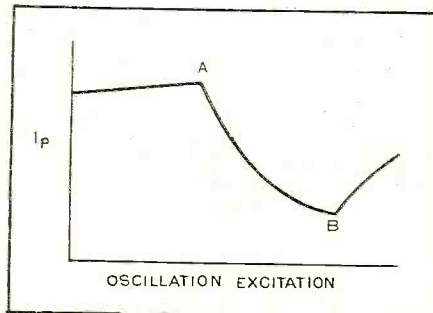
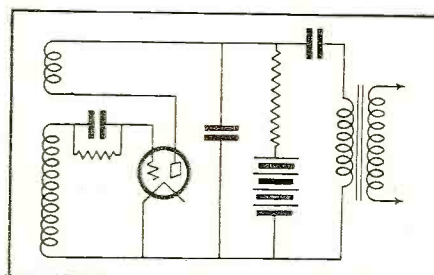

PLATE CURRENT—OSCILLATION EXCITATION CURVE

Figure 2. The variations in current are the direct cause of fringe howl, as explained in the text



ANOTHER TYPE OF REGENERATIVE DETECTOR

Figure 3. Where plate detection is employed fringe howl occurs only when resistance coupling is used

*L. S. B. Adler, "Threshold Howl in Reaction Receivers," Experimental Wireless & Wireless Engineer, p. 197, April, 1930.

DESIGN AND OPERATION OF AN Interference Meter

The prime consideration in the elimination of inductive interference from radio reception is the definite location of its origin. The author, in this article, describes the design of a new locating device that is portable and positive in action. It can be carried direct to the scene of the complaint and in short order will locate the offending electrical machinery producing the disturbance

By Glenn H. Browning

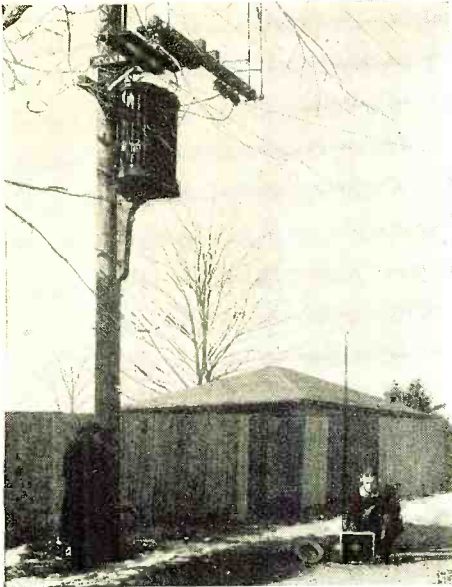

THE SLEDGE-HAMMER TEST

This test using the portable equipment and a sledge hammer determines quickly whether interference is caused by partially grounded electric light lines

FROM the very beginnings of radio broadcasting, reception has been marred by interference due to natural or man-made static. Efforts to suppress the former have in general been unsuccessful. However, the public at large is at last taking some cognizance of the fact that most interference is not due to natural causes such as thunderstorms, northern lights, heat lightning, etc., but is created by electrical equipment. As a consequence formidable plans are being laid to reduce man-made interference in thickly settled communities.

This problem is not national; it is international. At the meeting of the International Technical Consulting Committee on Radio Communication, held at Copenhagen last June, the question of radio interference from electrical apparatus was discussed at some length. Here in the United States a committee known as the "Joint Co-ordination Committee on Radio Reception" of the National Electric Light Association, National Electrical Manufacturers Association and Radio Manufacturers Association has been appointed to investigate the interference problem and take

the necessary steps toward reducing man-made static. In some cases communities have gone so far as to pass ordinances to the effect that those having electrical apparatus must comply with certain restrictions in regard to the radiation of interference from their apparatus.

In general, radio interference originating with electrical apparatus may be reduced or entirely eliminated by suitable filtering processes applied at the apparatus which in no way interfere with its operation.

So much for the general problem with which we are confronted. But how can the source of interference be traced and finally located? It has been common practice for the interference hunter to employ some type of portable radio receiver with either a loop antenna or a pole, and to make a survey of the disturbed territory. In the case of the loop antenna, some idea of the direction from which the "static" was emanating theoretically could be obtained. However, the loop antenna proved in the field to be in error in regard to the direction of the interference in a large per-

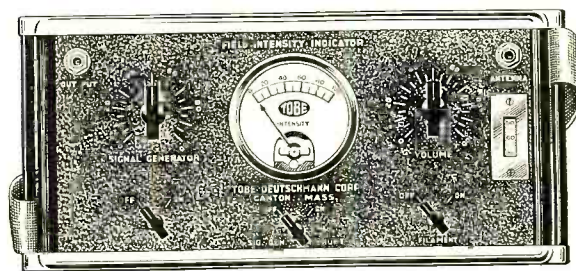

THE INSTRUMENT PANEL

The layout of the meter panel, with the various switches and other accessories

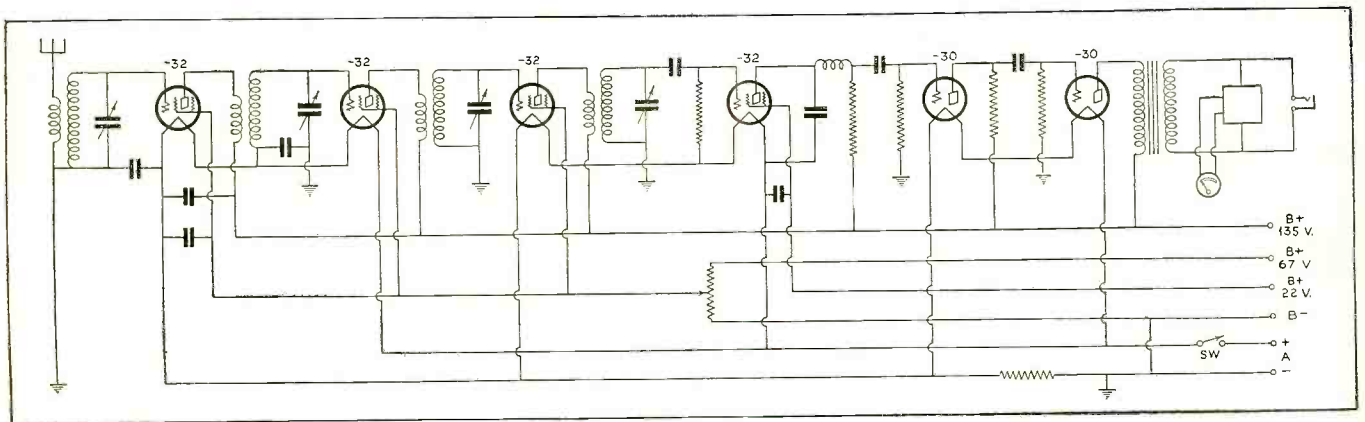

CIRCUIT FOR THE COMPLETE INTERFERENCE LOCATING METER

Figure 1. This is the schematic circuit diagram showing the hook-up for the six tubes employed for amplifying the disturbing signals and recording them on the calibrated meter shown in the upper right-hand corner. The various A and B voltages are indicated, as well as their polarities

centage of the cases, due to the fact that metallic wires conducted the signal along them and also due to reflections from metal buildings, etc. Consequently it was found that non-directional type of pick-up was preferable, for then the interference could be traced down by going towards the point of maximum signal. The amount of signal was for some time determined by ear alone, which was unsatisfactory because of its logarithmic response, and consequently meters were employed so that definite indications could be obtained.

Answering Complaints

Public Utilities find that in many cases complaints are registered where reception cannot be obtained from distant stations. The interference man answering such a complaint can, by the interference meter to be described, show that the noise only has an intensity of say 2 microvolts per meter and that in his locality that must of necessity be put up with at the present time. However, a survey made of the surroundings shows that if the complainant would erect his antenna at the side of the house or on the roof instead of in the back yard that his interference would only be 1 microvolt per meter. Thus the man sent out to investigate the complaint has been of real service and he can determine by the use of this instrument the amount of so-called permissible interference allowed in the respective district.

The preceding information gives an idea of the problems which any interference meter must be capable of answering if properly and intelligently operated.

The field intensity indicator consists essentially of a very sensitive, light, portable unit equipped with a vertical antenna of known length. The sound output, besides being audible in a pair of phones, is indicated on a meter, especially designed. A calibrated signal generator must be incorporated so that the amount of interference or the amount of signal strength from a broadcasting station may be determined in terms of microvolts per meter.

The design of such an instrument presents many interesting problems. First, the sensitivity must be extremely high, for on a short antenna 2 meters or less in height the pick-up of

the set must compare favorably with an up-to-date a.c. receiver operated on a long antenna. Then the instrument used must have the smallest possible amount of background or tube noise so that reliable signal strength data can be obtained with the volume control fully advanced. A four-stage tuned radio-frequency amplifier was adopted, using specially high-gain radio-frequency transformers working in conjunction with -32 tubes. This whole amplifier, which covers a spectrum from 530 to 1590 kc., is so designed and shielded that if the 2-meter telescopic antenna is removed the instrument may be placed in a location where the field strength is as great as 10,000 microvolts per meter without giving an appreciable indication on the meter.

The Circuit Used

The circuit of the receiver is shown in Figure 1. It will be noted that a resistance-coupled audio system is employed with a -30 tube in the last stage feeding into an output transformer. As the instrument is designed to be as light as possible, it was not found feasible to even use the -31 power tube in the last stage, as this would draw considerably more power from the small A and B batteries. Thus the interference meter is not meant to be used to feed a loudspeaker.

The output meter recording the intensity of the signals is critically damped with a half a second period. Considerable experimenting has showed that if an undamped meter is employed that the pulse type of interference such as is emitted by various devices would give a greater indication on the meter than corona, etc., which in reality is more disturbing to a broadcast program. Also, if the meter has too short a period, ordinary interference or broadcast signals will be extremely difficult to read, as the indication of the meter will follow the intensity of the signal too closely rather than indicating somewhat average values. Thus the meter employed is designed to give a fairly accurate value of the intensities of all types of interference as to their effect in disturbing broadcast programs.

A signal generator has been incorporated in the same case with the receiver so that the intensity or noise range of any signal may be measured in terms of (Continued on page 44)

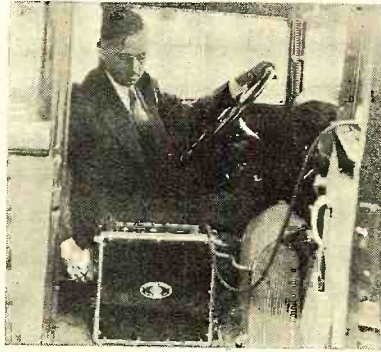

CHECKING THE NEIGHBORHOOD

By carrying the interference meter around in an automobile, an immediate check is made on interfering machines due to the increase in signal strength when passing near them

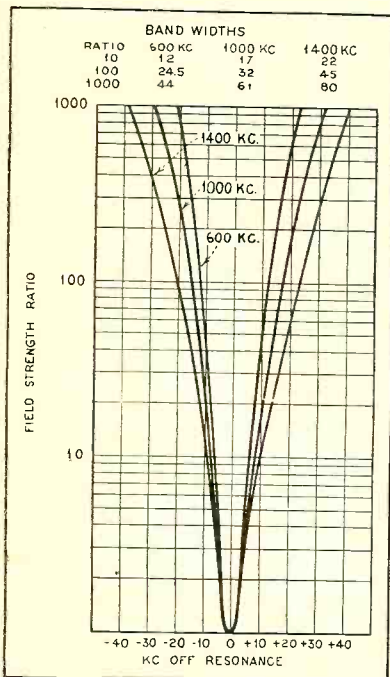

SELECTIVITY

Figure 2. Curves showing field strength ratio against kilocycles off resonance



RUNNING DOWN MAN-MADE STATIC

A serviceman has traced interference to the cellar of the complainant's home. A sparking contact in an oil burner was the cause

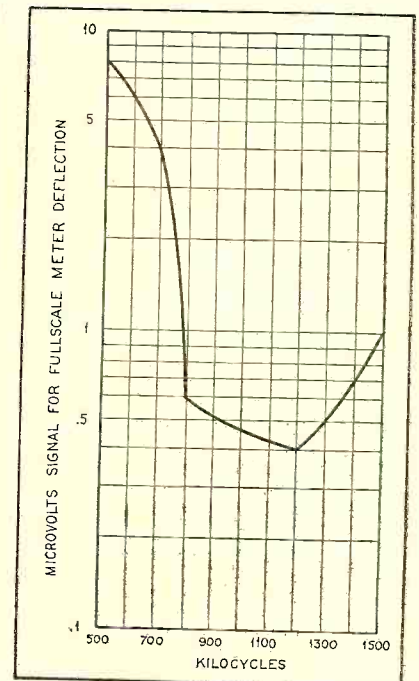

SENSITIVITY

Figure 3. Curves showing microvolts for full scale meter deflection against kilocycles

"CLASS B" TUBES—THEIR SIGNIFICANCE IN FUTURE Audio Amplifier Design

This analysis of amplifiers offers considerable food for thought to those who are interested in audio design—particularly in so far as the recently popularized "Class B" amplifier and the new type -46 tubes are concerned

By **McMurdo Silver***

IN March, 1932, several new tubes were introduced, three of them being improvements on existing -24, -27 and -35 types. The remaining two, the new -46 "Class B" output tube and the new -82 mercury vapor rectifier, tied to the -46 as the only practical means of providing good enough power supply regulation in a.c. sets, bring up a timely consideration of the design and desirability of available audio systems for home radio receivers.

Today three general types of audio power output stages are available—straight triode push-pull, pentode push-pull and class B push-pull. A consideration of the merits and possibilities of these three systems will, therefore, not be out of order.

Since we are considering high quality a.c. sets designed for home use, it is possible to classify the three available systems as: (a) -45's in push-pull (triode), (b) -47's in push-pull or parallel (pentode), (c) -46's in push-pull (class B).

In considering these three classifications, the hasty conclusion that the first classification (a) is "Class A" audio amplification, since the last (c) is "Class B," should not be arrived at, for no past set has employed what may be properly termed "Class A" amplification. For example, "Class A" audio amplification may be described as the condition where the fixed negative grid bias of a tube is so set that signal excursions vary the grid positive and negative between the limits set by the bends in the grid voltage-plate current curve. Distinguished from this "Class A" condition, where some positive grid excursion accompanied by grid current is anticipated and provided for, the type of triode audio amplification utilized in the past has been predicated upon setting the fixed grid bias at a point substantially midway between zero bias (above which grid current will be drawn) and the bend at the negative end of the Eg- I_p curve. "Class B" or "push-pull" audio amplification with previous tubes has involved setting the bias of the tubes practically at the negative cut-off point, so that as the signal excursion runs one grid so negative that it cuts off plate current, the other grid runs progressively positive. In order to utilize the full length of the straight portion of the Eg- I_p curve, the grids will of course run positive. The new -46 "Class B" tubes, however, operate at zero fixed grid bias, and as practically all of their operative excursions will, therefore, be positive, quite considerable grid current will be drawn as compared to conventional power tubes used as "Class B" amplifiers, and consequently input coupling trans-

former costs will soar if satisfactory voltage regulation is to be obtained.

To get a rough idea of the relative merits of the three systems which it is now seen can be divided into four groups, the maximum undistorted power output, the harmonic distortion percentage for generally used power output levels and power sensitivity are good guides.

Since harmonic distortion can be quite annoying, the level of 5% (I.R.E. Std.) has been arbitrarily set as the maximum allowable, and the maximum undistorted power output rating of all tubes is based on this maximum figure. Whether this rating is allowable is a debatable point, but it is a generally accepted allowable maximum. The writer has found, however, that the harmonic distortion allowable without unpleasant ear reaction will vary considerably with note pitch, note combinations and volume levels, in general it being less noticeable at high volume where it is masked by speaker distortion. He has reached the general conclusion that, at home entertainment levels, for really pleasing quality 5% is too high—1% to 1½% is about all that should be permitted.

Power sensitivity is a means of indicating the ratio of input voltage required for a given power output, and might be termed a means of expressing efficiency in terms of input voltage plotted against power output. Its greatest value is in determining the voltage required to drive the output stage and determining whether this can be provided economically and adequately by the available preceding circuit.

Comparisons

Table 1 gives a good idea of the relation of these values for the four available systems.

In terms of maximum power output, the pair of -46 tubes in push-pull (Class B) is the best, although the difference between their output of 16 watts compared to the next

best, or -45's in push-pull as "Class A" is only 3 decibels, or only a little over the minimum variation in volume perceptible to the human ear! As against this their harmonic distortion is seen to be much worse in the volume range of 200 milliwatts or armchair level, up to 2 watts, or about all that will ever be required even for bass notes in the home—except for dancing, when four to six watts may be needed.

While the -47's in push-pull (or parallel, they offering no tonal advantages in push-pull) show only 2% to 2.5% harmonic distortion in the ordinarily used power output range, they have still from four to five times as much harmonic distortion as the -45's, Class A, and one very serious disadvantage—as their output is pushed up, as it easily can and will be with any sensitive receiver today, their harmonic distortion

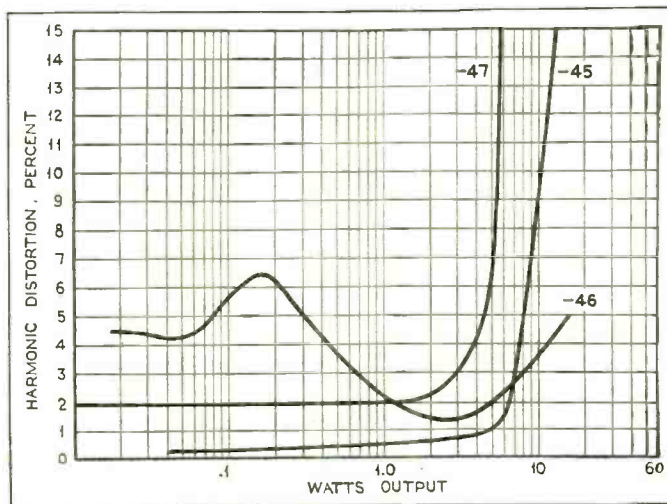

HARMONIC DISTORTION PERCENTAGES

It is the author's contention that about 1½ percent is the tolerable maximum for harmonic distortion in output tubes operating at normal living-room volume. According to these curves, the -45 tube is far better than either the -47 or the -46 in this respect

*President, Silver-Marshall, Inc.

will be very annoying indeed, rising to 20% at a little over 6 watts output as they are normally used. This explains why overloaded pentodes sound so much worse than overloaded -45's, even though the latter may only approximate Class A.

Considering power sensitivity, the -46 Class B combination is very poor—so poor, in fact, that though the figure of .118 given is the overall power sensitivity for two -46's driven by the recommended -45 driver stage, still another audio stage is really needed to drive them to full output if detector overloading is to be avoided. The pentodes are easiest to drive, and the output of a good -27 power detector will drive them quite nicely. The push-pull -45's (a) are next easiest to drive, a -27 power detector doing the job quite nicely.

Harmonic Distortion Characteristics

When -47 pentodes were first introduced in 1931, there was a story current in Chicago about the chief engineer of a well-known Chicago radio manufacturer, to whom the sales engineers of a large tube-maker were explaining the then new pentode. As the story goes, when they were all through, the set engineer picked up a sample pentode, held it up to the light, looked carefully through it, and finally, apparently deeply impressed, exclaimed, "Wonderful, absolutely wonderful—here we have 30% distortion in a bottle!" Of course, this was an exaggeration, the harmonic distortion percentage of a good pentode audio system being below the permissible 5% at home volume levels. But this engineer had sensed immediately the point made above—that in present-day radio sets it would be a certainty that though the full output of pentodes would not be utilized for home entertainment, a very unfavorable reaction would be had by users as sets were tuned by local stations where the output would momentarily rise to levels where 20% and 30% harmonic distortion would be apparent.

As an examination of Figure 1 will show, the harmonic distortion percentages are variable and too high for really good quality for -46 Class B push-pull, but not so high for pentodes as to be prohibitive, while the -45's are best by far. In stating that harmonic distortion for -46's is "too high," the writer bases this statement on a careful analysis of the reactions of a large number of people to demonstrations of the three systems simultaneously and in small groups at different times. For instance, as they listened to push-pull pentodes at 2 watts output, the quality seemed acceptable, as did that of -46 in Class B, though most remarked that it was not as "clear" or "clean" as they would really desire. But as soon as they heard the Class A push-pull -45's, they definitely condemned the pentodes and -46's! Such, then, was the reaction of a wide range of listeners to, for example, the difference between .4% to .6% harmonic distortion for the -45's as compared to only 2% to 2.5% distortion for the pentodes. It is upon these reactions that the conclusion was arrived at that over 1% to 1.5% harmonic distortion was too much for really high-quality reproduction, particularly as there appears to be a psychic reaction almost akin to pain to the listener on harmonic distortion in excess of 1% at home volumes.

Comparing Amplifier Costs

The final conclusion after one year's use and trial of pentodes, which are even better in this respect than -46 Class B amplification, was that neither of these systems could be tolerated in high-quality receivers, and that only -45's or equivalent triodes could possibly be acceptable.

Considered from a cost angle, pentodes are as cheap as -45's in terms of receiver cost, since they require the same essential equipment and power availability, whereas -46 Class B systems are far more expensive, even though they give markedly inferior results to the ear. This is because the -46's, drawing grid currents ranging up to 60 and 70 ma., must be driven by a power audio stage ahead of them, coupled through an excessively expensive coupling transformer which must have

extremely good regulation, since considerable power is required from it by the -46's. It must, therefore, have very low resistance windings and large core area, and will be quite expensive compared to the coupling transformer required for -45's or -47's. Likewise the output transformer will be excessively expensive, since it must have a high inductance compared to triode output coils. And all of this neglects the necessity of a third audio stage to precede the -45 driver stage for Class B -46's, needed because of their low power sensitivity, to prevent audio detector overloading and introducing as it does additional filtration problems and costs.

Loudspeaker Limitations

Still a further angle of the problem of amplifier overload with its consequent harmonic distortion is that dynamic loudspeaker units as used in home receivers distort rather badly at high powers, so that when more than about five watts are applied to conventional types they themselves begin to introduce harmonic distortion, and as ten to twelve watts are applied to them their quality is pretty completely shot to pieces. This is one reason why amplifier overload alone in small degrees is not in itself awfully serious in the range of say eight watts and up—at that point the speaker distortion is so bad as to mask the

amplifier distortion, and, in addition, distortion is not as immediately noticeable at high-volume levels. But from a home entertainment standpoint there is no earthly use for the sixteen watts output of -46's Class B, even if economical speakers did not go all to pieces at such levels and the amplifier cost was not excessive, exclusive of the poor low-volume quality they provide.

From this and other considerations involved, it appears that the best possible audio system for home use would employ -45's in push-pull, but would have the disadvantage of only 4 to 4.5 watts power output at 5% harmonic distortion. Investigation along this line indicated, however, that this system could be improved upon both in lowering harmonic distortion and increasing power output. Work along this line has been going on in the Silver-Marshall laboratories, and it is now possible to announce a new and economical audio amplifier using -45 tubes that will turn out eight watts at 5% harmonic distortion, and up to five watts at 1%—a Class A system that appears ideal for home reception.

The New Amplifier

The circuit of this amplifier is the conventional push-pull arrangement, the constants and not the circuit itself being the secret of its remarkable performance. It being perfectly safe to operate -45 tubes at 300 volts plate if the plate dissipation is kept down, the first step is to raise the plate voltage to 300 volts and then to bias the grids 68 volts negative. This gives a class A amplifier, which, however, will require greater grid excursion than can be supplied by a -27 power detector, particularly as, since small grid currents will be drawn at maximum output, a coupling transformer of low secondary resistance and actually a step-down ratio (1.28:1) will have to be used to feed the -45's. Consequently, one audio stage using the new -56 tube (replacing the present -27) is used between the detector and -45 output stage. This is a voltage amplifier, working, however, through a coupling transformer of step-down ratio and secondary resistance reduced to a point where a small amount of power can be drawn from it to take care of the .25 ma. average grid current drawn when the whole system is turning out eight watts.

From a cost angle there is a negligible increase for the components of the first audio stage, and as the power supply filtration of S-M receivers is excessive, anyhow, no additional cost is involved here. From a quality standpoint the system offers tone brilliance and a certain smoothness due to the elimination of the psychic annoyance of excessive harmonic distortion found in other systems. Side by side (*Continued on page 61*)

SYSTEM	MAXIMUM UNDISTORTED POWER OUTPUT	% HARMONIC DISTORTION FOR .20 WATTS OUTPUT	% HARMONIC DISTORTION FOR 2.0 WATTS OUTPUT	POWER SENSITIVITY *
(a) -45 NORMAL PUSH-PULL	3.2 WATTS	5%	1.0%	.45
(b) -47 PUSH-PULL	5 WATTS	2%	2.5%	1.55
(c) -46 CLASS B PUSH-PULL	16 WATTS	6.2%	1.3%	.118
(d) -45 CLASS A PUSH-PULL	8 WATTS	4%	6%	52

* INCLUDING SUITABLE DRIVER STAGE

TABLE I

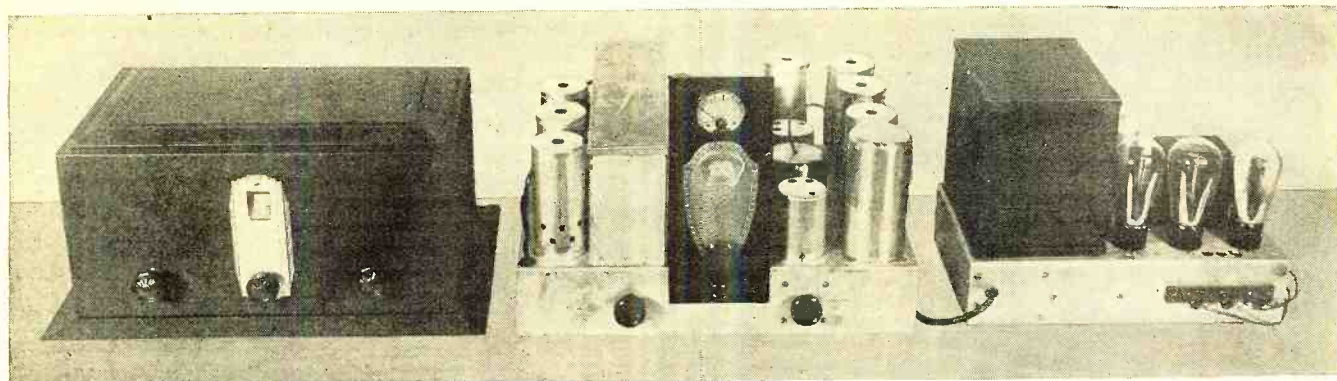

THE STENODE AND SHORT-WAVE RECEPTION
 Figure 2. The Stenode being used in conjunction with a standard converter for short-wave reception

OPERATING AND SERVICING THE STENODE Quartz-Crystal Receiver

The author concludes his series of articles with a description of some minor changes which improve reception, and suggestions for operating and servicing this modern receiver. Suggestions are also included on its application to short-wave work

OUR first obligation in this last of a series of four articles on the Stenode is to bring the circuit up to date. Aside from our own laboratory work, we have been favored with the hearty co-operation of the many amateur and professional engineers who have built these receivers, and who, in the course of their experiments, have made minor but accumulative improvements on the earlier Stenode models. Thus it is that since the description of a thoroughly modern and satisfactory receiver in RADIO NEWS for April, several slight variations have been incorporated in the recommended circuit.

Impedance-Coupled I.F. Amplification

The revised diagram is shown in Figure 1. The only variations between this circuit and that shown on page 933 of RADIO NEWS for May, 1932, are the substitution of the choke coils X1 and X2, respectively, for R11 and R13, the extra cathode by-pass condenser C17, and the addition of the resistor R18. (In order not to confuse the constructor who is familiar with the previous circuit, no R11 or R13 is shown on the present diagram, thereby making it possible to retain the original values for all other resistors.)

What was formerly a resistance-coupled stage of intermediate-frequency amplification with a decoupling resistor circuit, now becomes an impedance-coupled stage with a decoupling impedance, X2. This results in higher gain, due to the application of more advantageous voltages to the tube and to the superior characteristics of the impedance plate load. Choke coils X1 and X2 are of 10 milihenries inductance and are shielded from each other. Choke X1 is mounted in the shield can originally provided for the resistance-coupled stage. X2 is mounted under the base, directly below. With the receiver properly wired and shielded, the substitution of the impedance coupling should occasion no instability. Should a tendency to spill over and oscillate be evident, it is an indication of insufficient shielding, the remedy for which will be considered later on in this article. By-pass condenser C17 has capacity of .5 mfd. and contributes considerably to the general stability of the circuit.

The inclusion of the resistor R18 provides a bleeder circuit in the oscillator plate supply, further stabilizing the oscillator

plate voltage and reducing the tendency of the oscillator to drift. Due to the extreme sharpness of the crystal-tuned intermediate-frequency amplifier, a variation of a hundred cycles or so in the oscillator frequency will result in a definite detuning effect. Slight changes in the oscillator plate voltage are sufficient to introduce complications of this nature. By means of its voltage regulation function, R18 also simplifies Stenode tuning by reducing the plate voltage variation caused by changes in the rectifier circuit IR drop, as station resonance is approached.

The remainder of the parts are exactly as specified in the May issue of RADIO NEWS, to which the reader is referred for a complete description.

Trouble Shooting on the Stenode

The Stenode, being fundamentally a superheterodyne, is subject to the general ailments of its species. These, however, are fairly well understood, readily diagnosable, and have received considerable treatment in articles on straight supers and in John F. Rider's excellent book, "Servicing Superheterodynes." We shall therefore limit ourselves to the variations from normal operation peculiar to the Stenode.

Lack of sensitivity on all wavelengths, both as a Stenode and as an ordinary superheterodyne, may usually be attributed to lack of peaking in the tunable intermediate-frequency circuits. This is often due to an inability to reach a frequency as high as 175 kc. in the secondary circuits of L9 and L10, caused by the use of shielded wire having a high capacity. If, with the trimming condensers way out, judicious changes in the wiring mechanics fail to remedy matters, it will be necessary to remove from 50 to 75 turns from the associated coils.

Approximately a fifty percent loss in sensitivity and gain is the normal condition when switching from straight super to Stenode operation. However, any loss in excess of this—in other words, satisfactory super operation with decidedly poor Stenode response—may also be attributed to incorrect peaking. This will occur when the intermediate amplifier circuits are consistently tuned to a single frequency approximating 175 kc., but differing from the frequency to which the quartz crystal is ground. The remedy is obvious and the realignment

By Zeh Bouck
 Part Four

should be effected as directed in the third article of this series. It will occasionally happen that the receiver will be more sensitive as a Stenode than as a super. This will be probably due to accidental regeneration, and if it gives rise to no undue instability it may be tolerated or even welcomed.

Difficulty in Tuning

Due to the sharpness of the Stenode, tuning is necessarily more exacting than on other receivers. However, when using the high-ratio control on the dial, no unusual degree of skill should be required to bring in a station at its maximum resonance point. Should such difficulty exist, it points to an abnormal condition, usually an unstable oscillator tube. As the resonance point is approached, the plate current to the various tubes is changed slightly, affecting the IR drop through the rectifier and filter system, which alters the plate potential to the oscillator tube and causes it to shift frequency in a manner non-linearly related to the variation of the tuning condenser. This phenomenon has already been mentioned in reference to the utility of the resistor R18. The actual result takes the form of excessive back-lash. As the station is tuned in, the reading on the resonance meter will increase as the correct tuning point is neared. It will then fall back suddenly, and the dial will have to be reversed several degrees to attain the peak volume, to be followed immediately with another "flop," making it impossible really to tune the station to maximum response. Instability in the r.f. circuit will occasion a similar effect, and in some instances a defective quartz crystal tube will give rise to this trouble. Unless the chassis is very well mounted, the pressure of the fingers on the tuning knob may have a perceptible tuning effect. When the chassis is out of the cabinet, it is normal condition to be able completely to detune the signal merely by pressing on the top of the dial panel. The imperceptible play in the condenser shaft is responsible for this.

Signal Drift

Difficulty in tuning will generally be accompanied with signal drift, but the latter fault will often appear alone. With the Stenode operating correctly, it should not be necessary to readjust the controls, after the original tuning of the desired station, regardless of how long it is desired to listen to that station. In the majority of instances signal drift can be blamed on a poor oscillator tube. A defective or under-powered resistor at R14 or R18 will give a similar effect, and it occasionally happens that a variation in plate voltage, caused by a defective rectifier tube, is at the bottom of the phenomenon.

The contact between the cover and the coil can should also

be checked, particularly in the case of sudden drift. When this is the explanation, drift can be artificially induced by tapping the chassis. This may also be the cause of—

Microphonics

The Stenode is, of course, subject to the usual microphonic tube difficulties, and the second detector tube should be first suspected. The chassis should be carefully cushioned when operated in the same cabinet with the loudspeaker. Due to the fact that a slight variation in oscillator frequency has a far greater detuning effect than on an ordinary superheterodyne, acoustic feedback to the oscillator condenser plates is correspondingly more effective in inducing an audio howl. Where a process of elimination has definitely located this feedback as a source of trouble, a block of soap eraser rubber should be wedged tightly between the back of the oscillator stator plates and the side of the coil can. In some instances a defective stentube will give rise to microphonic conditions.

Other Crystal Tube Troubles

While the crystal tubes, readily available under the trade name of "stentubes," have an indefinite life and are remarkably uniform and free from trouble, it occasionally happens that a defective tube reaches the consumer. Several symptoms of stentube trouble have already been described. A tube with two definite peaks in the neighborhood of 175 kc. is defective—due to cracking, chipping or incorrect grinding. Two slight peaks (almost imperceptible) on each side of the 175 kc. peak, are normal. A high noise level when operated as a Stenode can generally be blamed on the crystal. However, as has been pointed out, tube noises are slightly more apparent when the receiver is operated as a Stenode, and a perceptible but not annoying increase in hiss may be accepted as normal. Exterior background noises are, of course, reduced when the receiver is operated as a Stenode.

A crystal tube that rattles when shaken is not defective. The crystal must be loose in its holder to be operative.

When the Balance Control Won't Balance

—the trouble will invariably be due to an inordinately high capacity in the wiring to either the crystal or the balancing condenser. The balance point should occur with the balancing condenser at its middle position, an adjustment which can be obtained by compensating any reasonable capacitive discrepancies by bending the stationary plates.

Instability

Instability and oscillations peculiar to the Stenode will be due to insufficient shielding around (Continued on page 60)

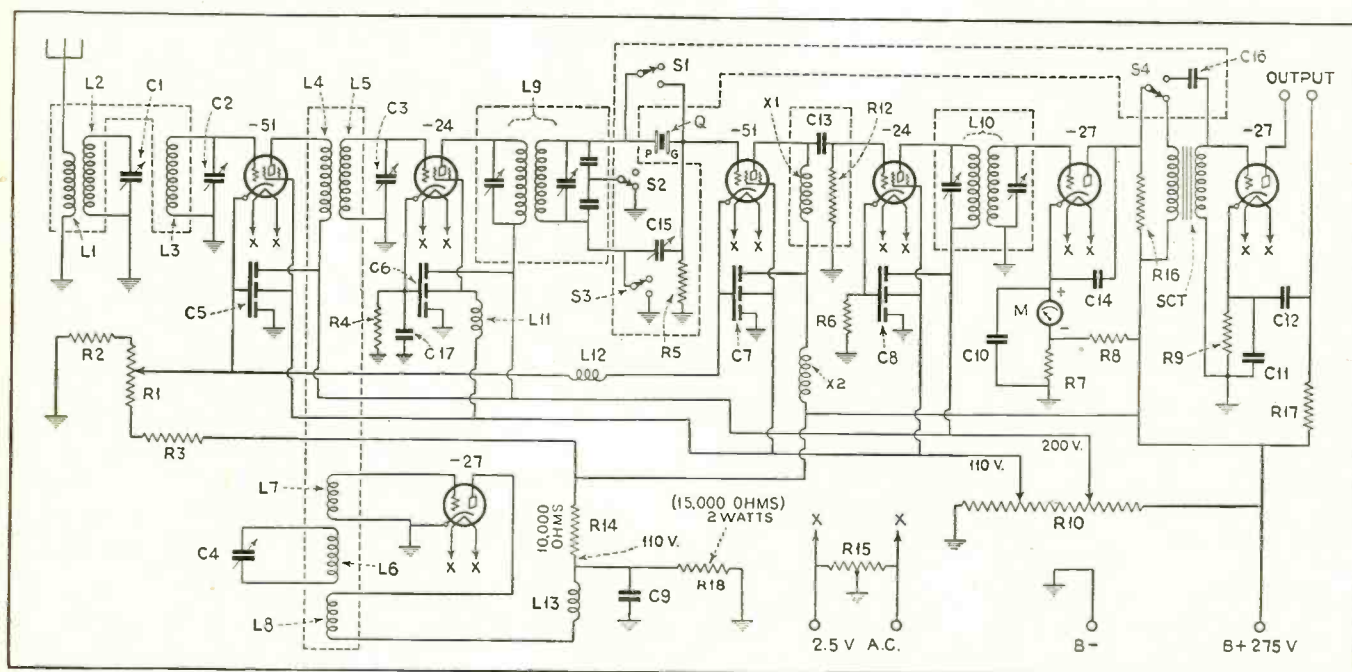

THE REVISED CIRCUIT DIAGRAM

Figure 1. This circuit incorporates improvements adopted since the description of the Stenode appearing in RADIO NEWS for May

What Tube Shall I Use?

This month the author discusses detector tubes, giving helpful pointers in the selection of the best tube and circuit for any given condition

By Joseph Calcaterra
Part Four

BEFORE delving into the advantages and disadvantages of different types of detectors, it is desirable to bear in mind the definitions which describe the different general forms of rectification (detection) ordinarily used.

The term "grid circuit rectification" or "grid condenser and grid leak rectification" refers to the detector action resulting from the curvature of the grid-voltage grid-current characteristic. The term "plate circuit rectification" or "grid bias rectification" refers to the detector action resulting from the curvature of the grid-voltage plate-current characteristic.

Explanation of Terms Used

The term "square-law detection" is used to describe that form of detection in which the audio-frequency output voltage of the detecting device is approximately proportional to the square of the radio-frequency (signal) input voltage, over the ordinarily used range of the device. The term "linear detection" is used to describe that form of detection in which the audio-frequency output voltage of the detecting device is substantially proportional to the radio-frequency carrier (signal) input voltage throughout the useful range of the detector.

The term "power detection" is technically used to describe any form of detection in which the power output of the detecting device is used to supply a substantial amount of power directly to a device such as a loudspeaker, eliminating the need for amplification or a power stage after the detector. It is common practice, however, to use the term "power detection" for detecting devices which furnish comparatively large output feeding into a single succeeding amplifier or power stage. For the purpose of this article, and to avoid confusion, we shall refer to "low output" and "high output" detectors; and to "low input" and "high input" detectors to refer to detectors capable of handling "low" or "high" input signal voltages.

Since no standard values have been determined upon to define low radio signal and high radio signal input voltages, and low audio signal and high audio signal output voltages, we shall, for the purpose of this article, consider detector input voltages of below 0.5 volt to fall in the class of low signal

input and those above that value to represent high signal input. We shall also consider detector outputs below 0.5 volts to represent low output voltages and

those above that value to represent high output voltages.

The usual grid condenser and grid leak type of detector circuit, using comparatively low plate voltages and zero grid biases, is the most common type of grid circuit detector having "square-law" characteristics. In this type of circuit, rectification or detection takes place in the grid circuit. This type of circuit can handle only comparatively low radio-frequency input voltages. Its output is limited, and usually requires two stages of audio amplification for suitable output to feed a loudspeaker.

The most important advantage of this type of detection is its high sensitivity. This advantage, however, has become a negligible factor, since the tremendous amplification which can be built up in the radio-frequency stages makes the use of a very sensitive detector unnecessary.

The grid condenser and grid leak detector also has an undesirable feature in that it produces a low value of grid-filament resistance, and this has a tendency to broaden the tuning of the detector circuit and thereby reduce the selectivity of the receiver.

Advantages of Plate Detection

The average grid condenser and grid leak detector arrangement can be made to handle higher signal inputs with more nearly linear characteristics by increasing the plate voltage applied to the tube, but there is a very definite limit to which the plate voltage, and consequently its ability to handle higher signals, can be increased. This limitation is imposed by the rapid increase in plate current which follows an increase in plate voltage.

In general, the use of the grid condenser and grid leak detection is limited to low radio-frequency signal inputs of less than one volt and where the output audio-frequency signal voltage required is of the order of not more than 1 to 2 volts.

Where higher radio-frequency signal voltage inputs must be handled, or higher audio-frequency signal voltages must be delivered, the use of plate rectification detection is recommended.

TABLE VII
TYPE NUMBERS OF SIMILAR TUBES MADE BY DIFFERENT MANUFACTURERS

RADIO NEWS TYPE NUMBERS	-00A	-01A	-12A	-22	-24	-24A	-27	-30	-32	-36	-37	-40	-99	401
ARCTURUS	—	101 A	012 A	122	—	124	127	130	132	136 A	137 A	32 *	099	—
CECO	200 A	201 A	112 A	222	224	—	227	230	232	236	237	240	199	—
CUNNINGHAM	CX-300A	CX-301A	CX-112A	CX-322	C-324	C-324A	C-327	CX-330	CX-332	C-336	C-337	CX-340	CX-299	—
DeFOREST	—	401 A	412 A	422	—	424	427	430	432	—	—	440	499	—
GOLD SEAL	GSX-200A	GSX-201A	GSX-112A	GSX-222	GSY-224	—	GSX-227	GSX-230	GSX-232	GSY-236	GSY-237	GSX-240	GSX-199	—
KELLOGG	—	—	—	—	—	—	—	—	—	—	—	—	—	401
KEN-RAD	UX-200A	UX-201A	UX-112A	UX-222	UY-224	—	UY-227	UX-230	UX-232	UY-236	UY-237	—	UX-199	—
NATIONAL UNION	—	NX-201A	NX-112A	NX-222	NY-224	—	NY-227	NX-230	NX-232	NY-64	NY-67	—	NX-199	—
PILOT	—	P-201A	P-112A	—	P-224	—	P-227	—	—	P-236	P-237	—	—	—
RAYTHEON	ER-200A	ER-201A	ER-112A	ER-222	ER-224	—	ER-227	ER-230	ER-232	ER-236	ER-237	ER-240	ERX-199	—
RCA RADIOTRON	UX-200A	UX-201A	UX-112A	UX-222	UY-224	UY-224A	UY-227	RCA-230	RCA-232	RCA-236	RCA-237	UX-240	UX-199	—
SPEED	200 AA	201 A	112 A	222	224	—	227	230	232	236	237	X-140	199	—
SYLVANIA	SX-200A	SX-201A	SX-112A	SX-222	—	SY-224	SY-227	SX-230	SX-232	SY-236	SY-237	SX-240	SX-199	—
TRIAD	—	T-01A	T-12A	T-22	T-24	T-24	T-27	T-30	T-32	T-36	T-37	—	—	—

WUNDERLICH----- THIS NEW DETECTOR TUBE IS BEING MADE BY ARCTURUS, BUT AT THIS WRITING NO TYPE NUMBER HAS BEEN ASSIGNED TO IT.

NOTE: THE ABOVE CHART SHOWS TYPE NUMBERS OF DIFFERENT MANUFACTURERS FOR SIMILAR TYPES OF TUBES. TUBES OF DIFFERENT MANUFACTURERS SOMETIMES DIFFER SOMEWHAT FROM GENERALLY ACCEPTED CHARACTERISTICS OF A GIVEN TYPE OF TUBE. FOR ACCURATE DATA ON TUBE CHARACTERISTICS OF ANY GIVEN MANUFACTURER, CONSULT HIS TUBE CHARACTERISTIC CHARTS OR BULLETINS.

NOTE *: DIFFERS CONSIDERABLY IN SOME OF ITS CHARACTERISTICS FROM TUBES OF OTHER MANUFACTURERS IN ITS CLASS.

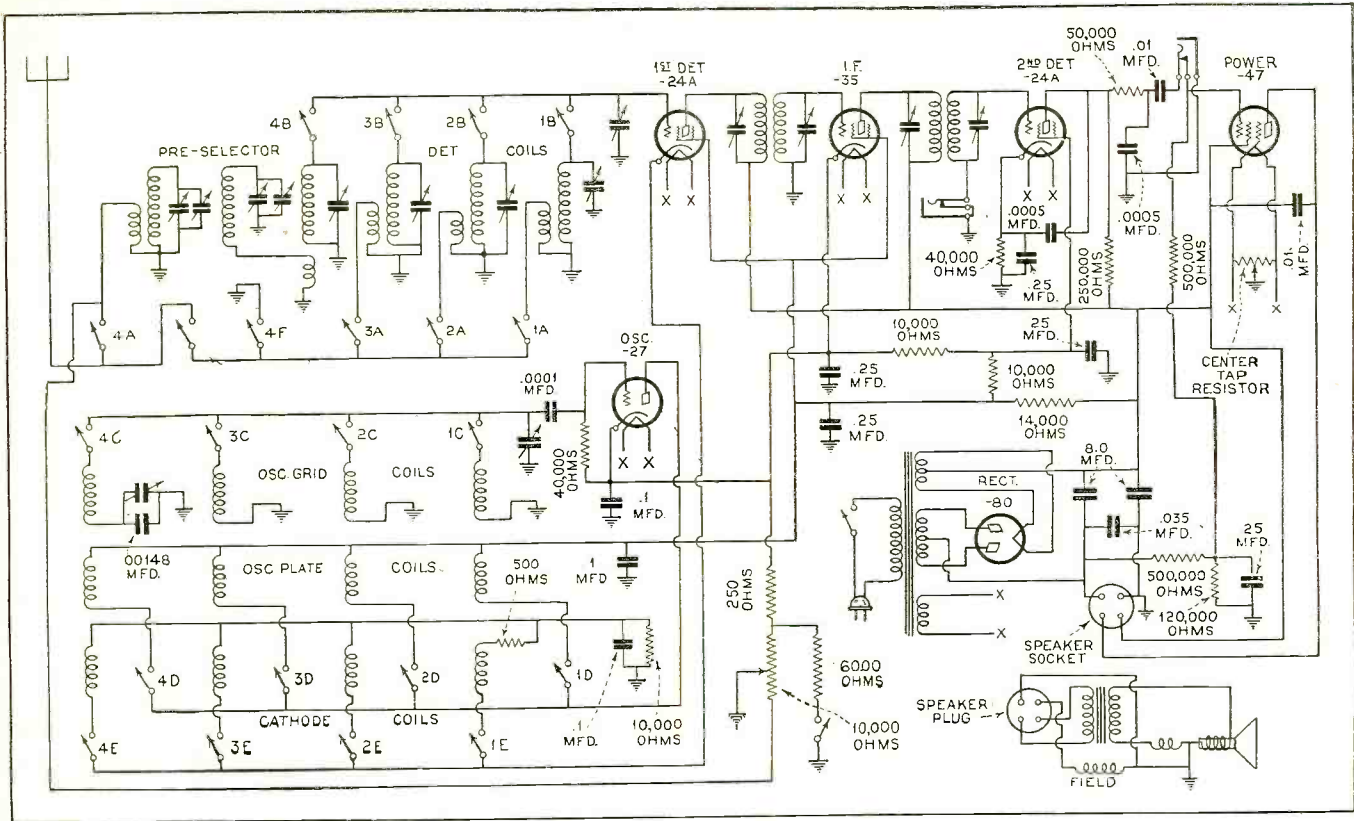

FIGURE 1. THE SCHEMATIC CIRCUIT DIAGRAM

ALL-WAVE RECEIVER DESIGN INCORPORATES NOVEL WAVE-CHANGER

The receiver design described here is one example of the efforts made by manufacturers of "all-wave" receivers to simplify operation to meet the demands of the general public for simplified operation

TO those who are interested in doing away with plug-in coils in "all-wave" receivers, one solution of the problem, as offered in one of the newest receiver designs, will provide some food for thought and consideration. This new receiver, the Pilot "Dragon," is an all-wave superheterodyne designed to cover four wavebands from 18 to 555 meters. It employs six tubes. The input is inductively coupled direct to the first detector except on the broadcast band, and in this band the pre-selector circuit is inserted ahead of the detector tube. Then comes the oscillator, one stage of intermediate-frequency amplification, the second detector and a single pentode output stage.

The Coil Assembly

The complete circuit is shown in Figure 1 and the coil assembly in Figure 2. Inasmuch as this article is primarily concerned with the coil-switching arrangement, that portion of the circuit following the first detector will not be discussed.

A study of Figure 2 will show the nine coil forms mounted on a separate chassis assembly, inside of which is the heart of the receiver—the 46-contact switch. The broadcast coils are mounted on the top of

By Gordon Fraser

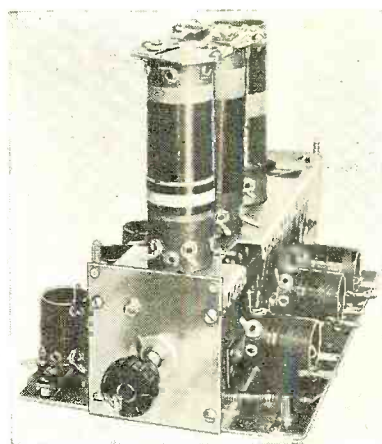

THE COIL ASSEMBLY UNIT

Figure 2. The coils are mounted on a sub-chassis which serves also as the housing for the switch assembly

this sub-chassis, and the short-wave coils are located along the sides. There are three of these broadcast-band coils, including the pre-selector coil, detector grid coil and oscillator coil. For short-wave reception there are two coils in each band, and three bands, making a total of six short-wave coils in all. The oscillator and detector tuning coils for each band are mounted on opposite sides of the chassis, the coupling between the detector and oscillator being provided by means of a coupling coil which is wound on the same form as the oscillator coils but is connected into the detector cathode circuit.

The Band Switch

There are two tuning condensers, one in the oscillator circuit and one in the first detector circuit. These two condensers serve to tune the coils in all bands, but in the broadcast-band pre-selector circuits there are two additional tuning condensers which are permanently connected across the pre-selector coils.

The 46-contact switch is especially designed for this circuit and provides light pressure but positive contacts. Set in any one of its four positions, it connects in the coils for that waveband and disconnects all (Continued on page 57)

Mathematics in Radio

Calculus and Its Application in Radio

By J. E. Smith*
Part Seventeen

IN order to apply the formulas for differentiating, the student should become familiar with the following examples with reference to the standard forms (1)-(5) inclusive (which were shown in the last lesson†).

Differentiate the following:

1. $y = x^4$

Here, formula (5) applies where $x = v$, and the exponent $4 = u$.

Solution:

$$(A) \frac{dy}{dx} = \frac{d(x^4)}{dx} = 4x^3 \frac{dx}{dx}$$

But from the formula (1), $\frac{dx}{dx} = 1$, therefore A becomes:

$$\frac{dy}{dx} = 4x^3 \text{ Ans.}$$

2. $y = x^6$
3. $y = x^2$

4. $y = x^0$
5. $y = x^5$

6. $y = ax^3 + bx^5$

Here, formulas (3) and (5) apply, where a and $b = c$ of formula (3), and the exponents 3 and 5 respectively = n .

Solution:

$$\frac{dy}{dx} = \frac{d(ax^3 + bx^5)}{dx} = \frac{d(ax^3)}{dx} + \frac{d(bx^5)}{dx} = 3ax^2 + 5bx^4 \text{ Ans.}$$

7. $y = ax^4$

9. $y = ax^7 - x^6$

8. $y = ax^6 + bx^2$

10. $y = ax^3 - bx^3$

11. $y = 5x^4 + 3x^2 - 6$

The derivative of a constant is zero; i.e., $\frac{d(c)}{dx} = 0$.

Solution:

$$\frac{dy}{dx} = \frac{d(5x^4 + 3x^2 - 6)}{dx} = \frac{d(5x^4)}{dx} + \frac{d(3x^2)}{dx} - \frac{d(6)}{dx}$$

$$= 20x^3 + 6x \text{ Ans.}$$

12. $y = 3cx^2 - 8dx + 5e$

13. $y = 2ax^2 + 4dx^2 - 5ax$

The sinusoidal functions are those expressed by the sine and cosine curves as well as those functions which are closely allied to them, which are the tangent and cotangent curves so important in geometry.

Electrical and radio theory are very often advanced by the use of calculus, which takes the liberty of performing the necessary operations on the sine and cosine functions. Let us apply the theory which was outlined above in finding the derivative of a sine function. That is, if a sine function is expressed by $y = \sin x$, it is the purpose of this analysis to determine its proper derivative.

In the previous texts it has been shown how to plot the function $y = \sin x$, and this is shown in Figure 1 for the values of x from 0-180 degrees. In order to study the derivative of this function, reference is made to Figures 2 and 3, where the values of x have been plotted from 0-90 degrees. Applying the theory which has been outlined above, we see

that when Δx approaches zero, $\frac{\Delta y}{\Delta x}$ finally approaches a limiting

value, and it is remembered that this limiting value is called the *derivative* of y with respect to x . This limit, represented

by $\frac{dy}{dx}$, has been shown above to be equal to the tangent θ .

With reference to Figure 4, it is noticed that the angle θ at the point A is somewhat larger than the values of θ for the points B and C. Finally, at the point D, the tangent line TD becomes parallel to the abscissa, and it is noticed that the angle θ has become increasingly smaller until it has approached the value of zero.

Now, the derivative of the function $y = \sin x$ at the point A is by definition equal to the tangent of θ . In like manner, the derivatives of the function at points B, C and D are again equal respectively to the tangents of the angles θ .

By close analysis of the relative sizes of these angles, we arrive at the following table: (Continued on page 50)

*President National Radio Institute.

†Note—Many of the examples have been taken from the book, "Elements of the Differential and Integral Calculus," by W. A. Granville, published by Ginn and Company, N. Y.

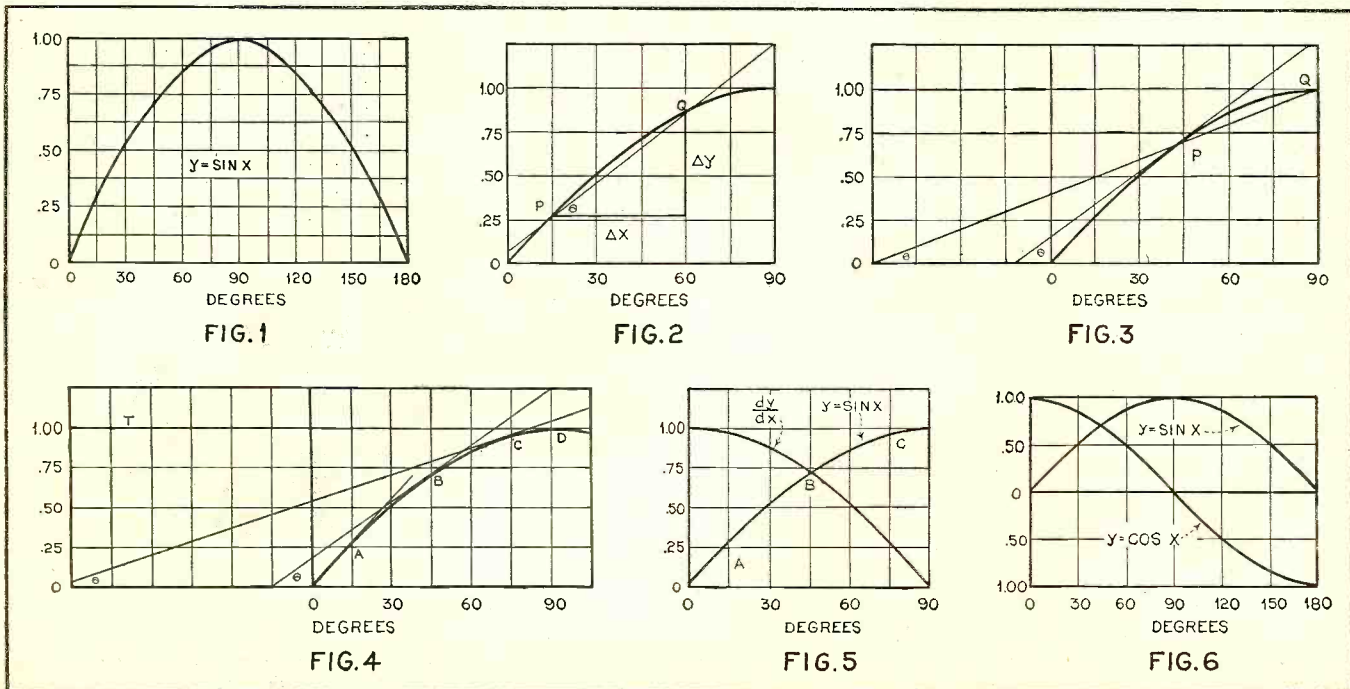

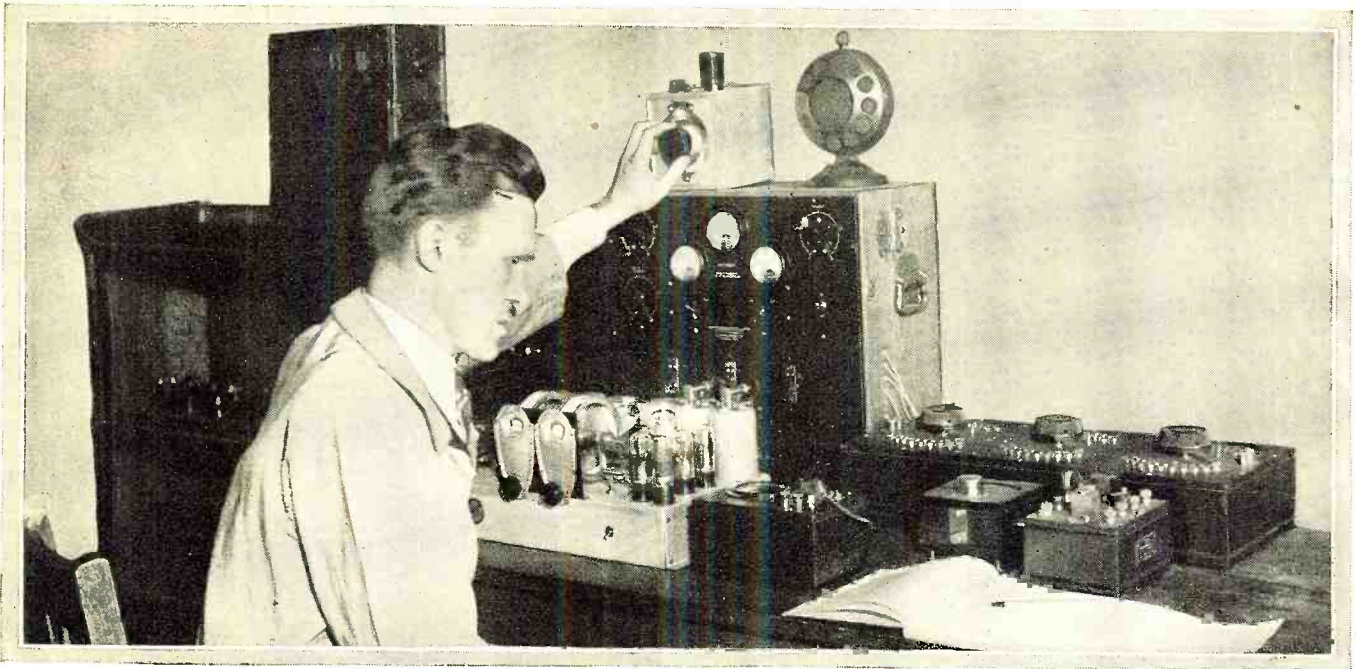

With the Experimenters

Static-Reducing Antenna, Emergency Insulator, Handy Pick-up Tool, Steadying Scanning Discs, Plate Supply Fuse, Four-Tube DX Set, Foreign Broadcast Schedules, Stand for Condenser Microphone

Antenna System for Static Reduction

IN reply to the request of the brother experimenter from Cristobal, Canal Zone, for an exchange of experiences, as published in his letter in the Experimenters Department in the January, 1932, issue, would say that I also tried grounding the free end of

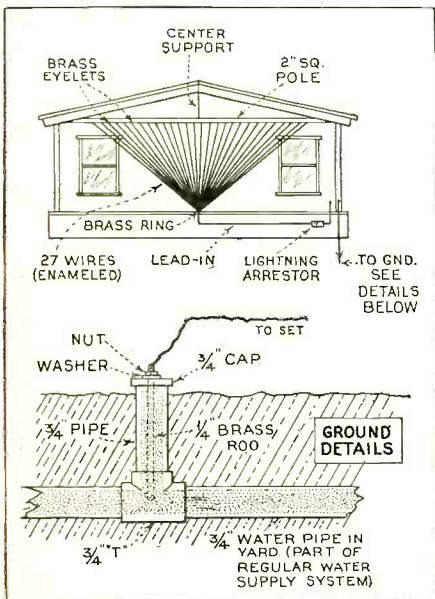

the antenna with improved results, but had my very best reception from an affair of twenty-seven wires spread fan-shaped on one end of the house wall. Tuning was fully as satisfactory and for two months in the

Conducted by S. Gordon Taylor

summertime I listened to the sweetest and smoothest reception I ever hope to get over the air, and any one living in the tropics knows what we get during the summer months. Unfortunately, however, I had to give it up, as the women folks lived in terror with the lightning playing so constantly overhead. I now use a No. 10 solid copper wire insulated in the usual way for electric lighting with good results. A lead-sheathed underground wire worked better than an exposed wire until some one actually dug it up and swiped it. He must have known it was a good thing.

I am enclosing sketches of the fan antenna and of the ground used at that time.

The antenna was the result of eight years of almost constant experimenting with overheads, undergrounds, loops, coils, inside and outside, used in every possible way, length, height, material and direction, always seeking something that would lessen the so-called "tropical crackle." Nothing, of course, will keep out the static crashes.

This big affair was tried out simply on the idea that a big man can lift a load with less effort than a child and a large amount of surface wire for pick-up meant picking up the program before reaching the noise level, and in my particular case it worked very nicely, giving me the best reception I've ever had. When an indoor antenna of twenty feet was used it was found to be impossible to listen, but switch to the big antenna and the programs came in as smooth as oil.

I found a good ground absolutely necessary and after dozens of experiments the sketch enclosed proved to be the best of all. A wave trap kept the receiver sharp enough

to separate WGN, WOR, WLW and such stations, and the whole proved very satisfactory.

WILL DAY, JR.,
Daytona Beach, Fla.

Simple Emergency Insulator

The radio experimenter often encounters the need of some kind of a ready insulator and a great many things are made use of.



The accompanying photo shows one, quickly and easily made of a snap bottle stopper. The porcelain part was removed from the wire portion and the rubber gasket placed under it, the improvised insulator being then tied in place with a bit of stout cord. The

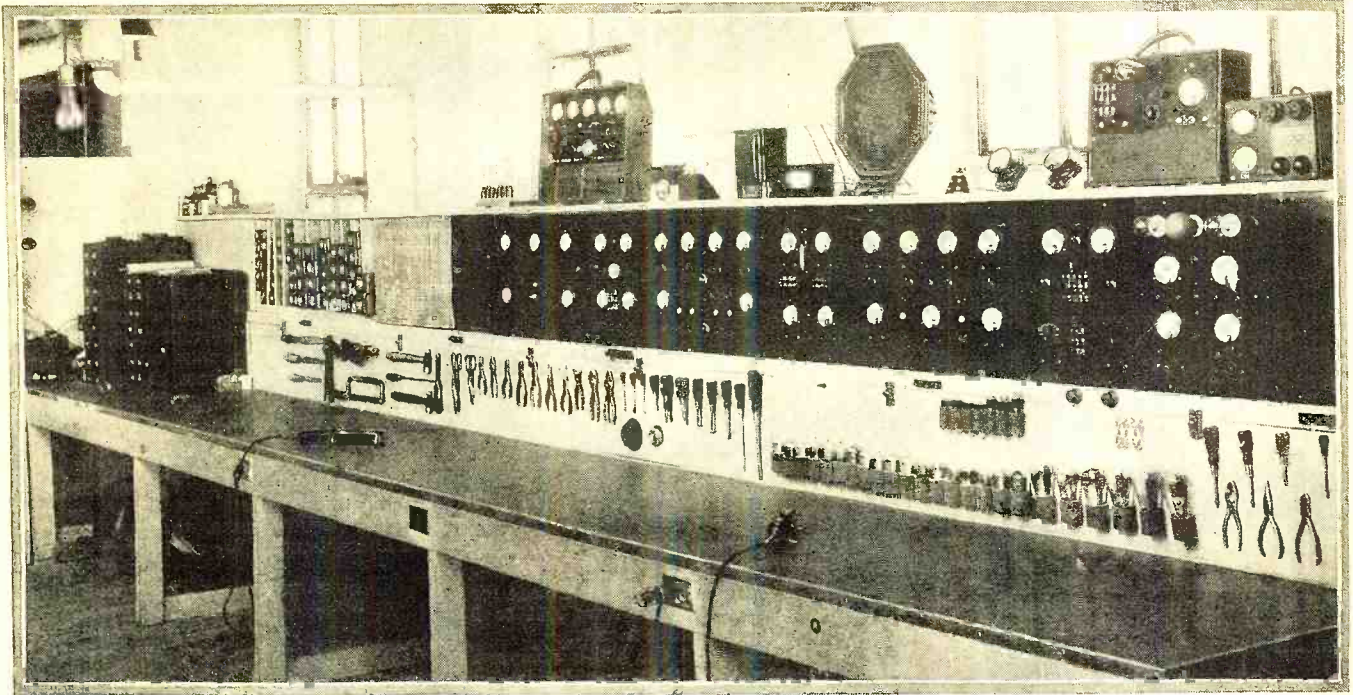

The Service Bench

Efficiency in Tube Replacement—This Month's Successful Service Shops—Handy Light for Repair Work—Other Service Equipment and Short Cuts for the Serviceman

JAMES A. ROBINSON, a consistent contributor to this department from Methuen, Mass., sends along a description of a neighboring service shop—a short "short story" that depicts not merely the possibilities of the service business, but shows how to attain them.—*The Service Editor.*

William T. Nesbitt operates a successful and efficient radio service establishment at 308 Broadway, Lawrence, Mass. Matriculating in the University of Hard Knocks in 1916, and later choosing radio as a field of operations, Mr. Nesbitt became thoroughly grounded in the radio art and science.

From a humble beginning (and supported by an almost religious adherence to a policy of square dealing, the genial proprietor of the Nesbitt shop has increased his clientele, steadily and consistently, until today his business requires the employment of three competent radio men who have received their training under the critical eye of their employer.

The equipment of the Nesbitt Radio Ser-

*Conducted by
Zeh Bouck*

vice Company is most complete. From an original and somewhat crude analyzer built many years ago, the shop now includes Hoyt tube testers, bench and portable, Jewell analyzers and oscillators for intermediate, broadcast and high-frequency adjustments. Tools include lathes and drills of every description, permitting the use of short-cut methods to modern and efficient service. A reliable supply of replacement transformers, resistors and condensers facilitates repairs.

Figures 1 and 2, respectively, show the counter with its stock of tubes and other accessories, and one of the three completely equipped service benches enclosed in sound-proof rooms of comfortable working proportions.

Among the novel features of this service establishment is the lighting arrangement,

which provides the repairman with a degree of illumination conducive to rapid and efficient work. A heavy wire is strung directly over and across the service bench. Glass insulators carry properly shaded drop-lights, which may be slid along the wire to concentrate light on any desired portion of the bench. Each bench is equipped with separate antennas, the entire shop requiring five aerials. Small parts, such as screws, nuts, bolts, lugs and washers, are segregated in handy glass jars.

Customers entering the shop are provided with comfortable chairs, a courtesy and a convenience that is appreciated.

Each tube and cartin is numbered serially, a feature that protects this wide-awake shop from the unfair tactics of unscrupulous purchasers. This system renders fraudulent replacement demands an unprofitable proposition. All tubes purchased in this shop carry the sticker shown in Figure 3.

In this way the clientele is assured of efficient service and repairs at the lowest



Figure 1. The Service Stockroom

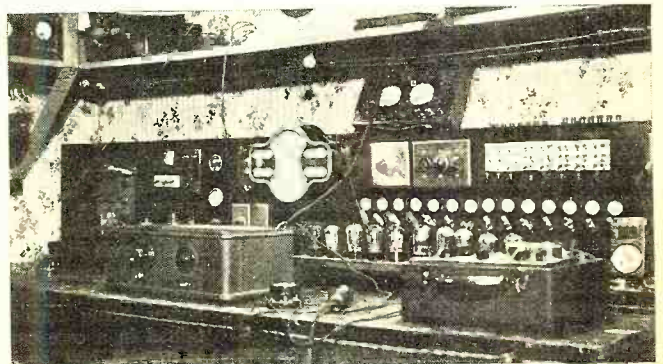

Figure 2. One of the Service benches

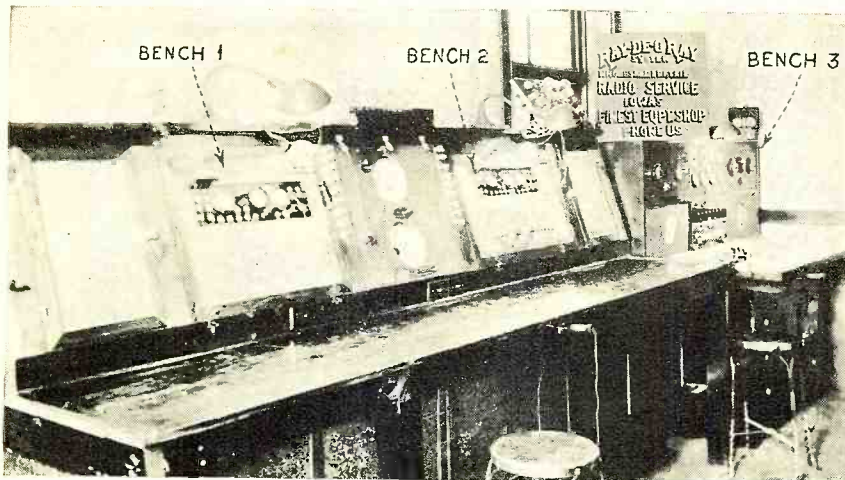

Figure 4. Service bench of the Ray-De-O-Ray system in Sioux City, Iowa

price, consistent with expert workmanship, guaranteed by thoroughly trained experts. Courtesy, conscientious effort and prompt service at a fair price are bearing fruit in an increasing number of satisfied customers, of which the proprietor is justly proud.

THIS MONTH'S SERVICE BENCHES

In addition to Mr. Nesbitt's attractive layout, we have with us this month an interesting view of the three service benches of the Ray-De-O-Ray Service System, upon the scarred surfaces of which the majority of Sioux City's radio problems are solved. The managers of this organization have already described in these columns the general methods of their contract business with local radio dealers, the volume of which has increased to the point where three fully equipped benches are required. (Figure 4.)

Test bench No. 1 is designed around Supreme Model 400-A equipment, the external terminals to the instruments being brought out with test leads and tip jacks in front of the panel.

The two speakers between benches Nos. 1

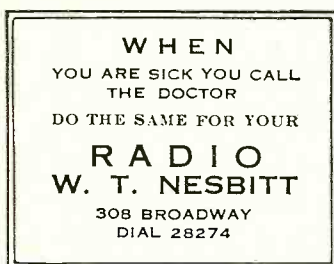

Figure 3. This reminder goes on every tube sold by a Lawrence, Mass., serviceman

and 2 provide for magnetic and dynamic outputs. Above the speakers are four signal lamps serving highly useful purposes. The first of these indicates whether or not the a.c. is turned on to test panel No. 1. The second pilot light is illuminated when the soldering iron is switched on—to our way of thinking, a utility of major importance! The third pilot light burns if the high-voltage supply is operating, and the fourth indicates current to the second test panel. The switches mounted on the small black panel just in front of the pilot lights control tube-rejuvenating circuits.

A Supreme model 400-B tester is used as the nucleus of service bench No. 2. In conjunction with special switches, every test used in service work can be effected. The

addition of a thermocouple has extended the range of the instruments to high-frequency a.c., and provision has been made for measuring condenser values from .001 to 9 mfd., as well as breakdown tests.

Both the 400-A and the 400-B analyzers are so arranged that they may be readily removed from the benches and placed in carrying cases should the need arise for extra portable equipment.

Bench No. 3 was designed and constructed in the shop and provides for practically every conceivable test, from resonance indication to battery charging current measure-

THE serviceman, like the medical practitioner, must keep up to date. At the present time tubes are the fastest changing thing in radio. The days of the simple r.f., detector and power tubes are past, and the efficient serviceman should be as familiar with the Speed Triple Twin, the Arcturus Wunderlich tube, the RCA 46, the Eveready LA and the Triad T-34 as he is with the generic type -45. Study the tube articles in RADIO NEWS and see that your name is on the mailing lists of the tube manufacturers. The 1933 sets will use these tubes, and your customers will come to you for advice concerning them long before you run up against them in service routine.

ments. This unit consists of four panels, each of which hinges forward for inspection and servicing.

In conformity with the general efficiency and neatness of the entire layout, all tools are kept in the closed racks at the ends of benches one and two.

SERVICE EQUIPMENT

An interesting bit of equipment, readily adapted to radio service uses, is what its manufacturer, the Burgess Battery Company, describes as a "focusing headlight." It is shown in the photograph, Figure 5, and consists of the business end of a flashlight, mounted on a comfortable head-strap, the power being furnished by a battery contained in a case conveniently clipped to the operator's belt or vest. The lens may be tilted, focused and the light trained di-

rectly on the work, leaving the hands free.

For dark corners we suggest the device recommended by Mr. Isadore Saltzman, serviceman with the Globe Radio Company, Jamaica, N. Y.

"An extremely handy light, which will get at places even inaccessible to a flashlight, can be made by soldering two leads to the base of a 4.5-volt lamp and connecting the free ends to the clip contacts on a C battery. One contact may of course be soldered fast. Merely suspend the bulb in the radio set—and 'let there be light!'"

Mr. Saltzman also asks a pertinent question, and answers it with a good idea:

"What does the average serviceman do with the dial knobs, nuts and bolts when he removes a chassis from the cabinet? He drops them in the cabinet, and the chances are that one or more of them is missing when he is finally ready to replace the chassis. I provide myself with a number of small paper bags, place the various parts therein, and complete my service job in a dignified posture, rather than on my hands and knees, hunting for an illusive screw."

ALL IN THE DAY'S WORK

"Did you ever waste a lot of time and profanity wading through a three-foot stack of magazines looking for information about a vaguely remembered article or service job? And after finally locating it, you decided for the nth time to index all past and future material of interest to you—but never got around to it because of the vast amount of accumulated issues?"

"Properly approached, and employing a simple but logical filing system, the task is by no means monumental. Index everything of possible interest to you in future magazines as you read them. As for past material, this may be scanned briefly for articles of major importance, or indexed only from time to time as you find it necessary to refer to them.

"The magazines should of course be arranged in chronological order. Any good size composition book, properly indexed, will serve for reference purposes. References to magazines should be made by means of abbreviations such as R.N. for RADIO NEWS, E. for *Electronics*, and so on. Ar-



Figure 5. This handy light provides a third hand to the serviceman

ticles should be indexed according to subject, and cross indexed where desirable. For instance, the article 'Getting the Professional Touch in Home Recording,' appearing in RADIO NEWS, July, 1931, on page 26, would

(Continued on page 62)

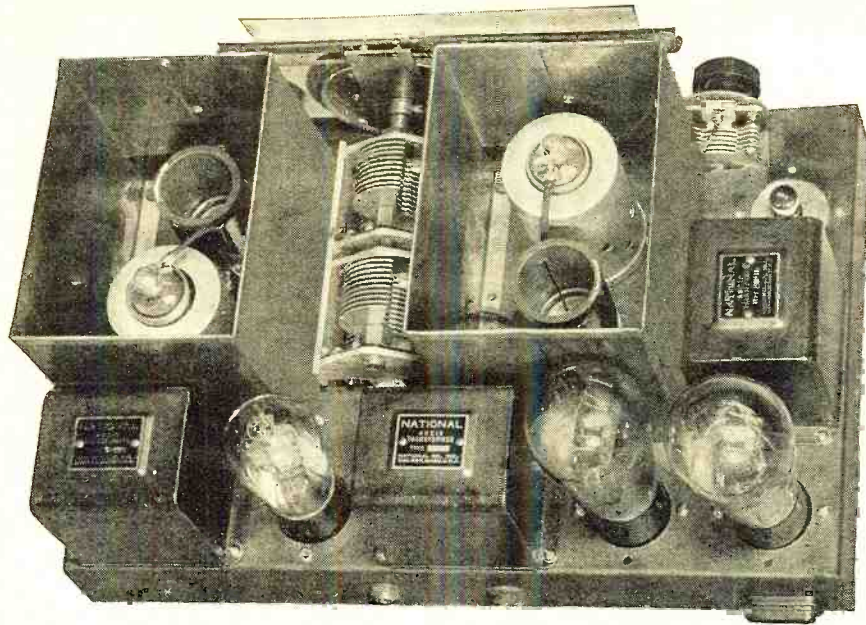

"CONTROLLED SELECTIVITY"! Plus NEW SHORT WAVE R. F. PENTODES

Result in performance surpassing even the high standards set by the NATIONAL SW-5 and SW-45 THRILL BOXES. The NEW SW-58 has an EVEN HIGHER SIGNAL-TO-NOISE-RATIO—higher than any other commercially available receiver.

IF you require **UTMOST SENSITIVITY, EXTREMELY LOW BACKGROUND NOISE** combined with **UNEQUALLED FLEXIBILITY** and **EASE OF CONTROL**, the new NATIONAL SW-58 THRILL BOX is outstandingly in a class by itself. The TRF circuit is employed because of its definitely lower background noise, long recognized by experimenters, amateurs and professionals engaged in serious communications work. But the SW-58 offers a number of improved features, never before found in a short wave TRF receiver.

GREAT R.F. GAIN REAL R.F. SELECTIVITY WITH THE NEW 58 TUBES

The high mutual conductance and low output capacity of the new SHORT WAVE R.F. PENTODE 58 tubes, employed in the NATIONAL SW-58 THRILL BOX, give great R.F. gain, even on very short waves. Selectivity in the R.F. stage, heretofore impossible of accomplishment, is secured in the SW-58 through the higher plate impedance of the new tubes.

"CONTROLLED SELECTIVITY"

An entirely new feature found only in the SW-58. This allows the receiver to be operated at the best selectivity consistent with signal strength and conditions of reception. This is possible only because of the exceptional degree of isolation between the R.F. and detector circuits, brought about through special stage and tube shielding and a new isolated rotor gang condenser described below. Thus volume can be controlled on the R.F. circuit without affecting in the least degree the sensitivity or selectivity of the tuned circuits.

NEW ISOLATED-ROTOR GANG-CONDENSER

As mentioned above, a new design of gang tuning-condenser with isolated rotors, prevents interlocking and is an essential contribution to this new order of isolation between R.F. and detector circuits. 270° plates are employed, a standard NATIONAL CO. practice, and insulation is ISOLANTITE.

IMPROVED R-39-A LOW LOSS TRANSFORMERS FOR USE WITH 58 TUBES

A special type of R-39 transformer with materially higher plate impedance to go with new 58 tubes. Fitted with a special NATIONAL 6-prong base to isolate all circuits, to eliminate detrimental effects of coupling always found when an attempt is made to employ a 5-terminal connection for the three different windings.

PLUG-IN COILS IN THE SW-58 FOR BEST PERFORMANCE

For greatest flexibility and day-in, day-out reliability, plug-in coils are best. NATIONAL CO. knows how to make efficient band-selector switches for certain types of short-wave circuits, but for a set like the SW-58, used for everyday commercial operation on leading airlines, steamship companies, and by amateurs for serious communication work, plug-in coils are definitely superior.

TYPE 100 SHORT WAVE RADIO FREQUENCY CHOKE

Another reason for the better performance of the SW-58 THRILL BOX is the new Type No. 100 Short Wave R.F. Choke. Four narrow spaced sections are universal wound on an Isolantite form. The extreme low distributed capacity of less than 1. mmf. is of vital importance in securing uniform detection over the entire SW range.

NEW TUBE-ISOLATORS AND STAGE SHIELDING

A different design of tube-isolator or shield is employed in the SW-58. This has been specially developed to take full advantage of the new screening employed in the design of the new SW RF Amplifier Tubes. The RF and Detector Circuits are completely enclosed in individual compartments which with the new tube isolators give an entirely new order of isolation between circuits.

NEW FULL-VISION VELVET-VERNIER DIAL

In keeping with the times, the SW-58 has a new Full-Vision Velvet-Vernier Dial with a linear

scale of unusual length, so that the operator may see at a glance the approximate setting in the band being used at the moment. Has all the characteristic smoothness of the Velvet Vernier Dials.

NEW NATIONAL ISOLANTITE SOCKETS

Coil and R.F. tube-sockets are the new NATIONAL design, made of Isolantite, reducing the often overlooked losses at these points. Thus in every detail, the SW-58 has been improved and corrected for those frequently ignored losses that can otherwise so easily occur at very high frequencies.

PUSH-PULL AUDIO FULL A.C. OPERATION POWER SUPPLY R.C.A. LICENSED

The SW-58 has a push-pull audio output through two 245 tubes, assuring excellent quality and ample volume for loud speaker reception of short-wave broadcasts. There is a phone-jack, of course. Operation is full AC with a special SW Power Supply, with extra shielding and filter sections for hum-less operation. R.C.A. Licensed. Also made for battery operation.

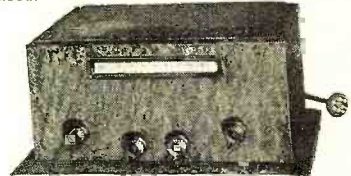

Send in this COUPON today!

NATIONAL CO., Inc.
61 Sherman Street, Malden, Massachusetts

Gentlemen: Please send me

Catalogue sheet and prices on the new AC SW-58 THRILL BOX

Volume I—NATIONAL SHORT WAVE Manual, 64 pages

Volume II—NATIONAL SHORT WAVE Manual, 64 pages

Volume III—NATIONAL "BELOW 10 METERS" Manual, 68 pages

I enclose 50c for each manual ordered, Stamps Coin Money Order

TOTAL \$
NAME.....
ADDRESS.....



A. C. SW-58 THRILL-BOX

Made by the Makers of the Famous Velvet Vernier Dials

LEARN RADIO

this easy, practical way

WRITTEN by two widely known radio engineers, these three books cover every phase of building, repairing and "trouble-shooting" on modern receiving sets.

Radio Construction Library

Including Television and Short-Wave Receivers

This practical Library includes: **PRACTICAL RADIO**—The fundamental principles of radio, presented in an understandable manner. Illustrated with working diagrams. **PRACTICAL RADIO CONSTRUCTION AND REPAIR**—Methods of locating trouble and reception faults and making workmanlike repairs. Discusses modern Short Wave Receivers fully. **RADIO RECEIVING TUBES**—Principles underlying the operation of all vacuum tubes and their use in reception, remote control and precision measurements.

The Library is up-to-the-minute in every respect and is based on the very latest developments in the design and manufacture of equipment.

Three Volumes.
6 x 9—993 pages,
561 illustrations.

See this
Library
FREE!

No
Money
Down

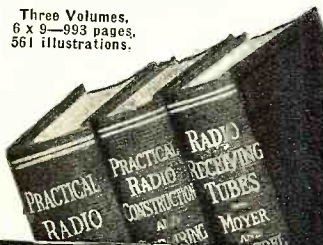

FREE EXAMINATION COUPON

McGraw-Hill Book Company, Inc.
330 West 42nd Street, New York

Send me the new **RADIO CONSTRUCTION LIBRARY**, three volumes, for 10 days' free examination. If satisfactory I will send \$1.50 in ten days, and \$2.00 a month until \$7.50 has been paid. If not wanted I will return the books.

Name

Home Address

City and State

Position

Name of Company.....RN-7-32

AERO WORLDWIDE SHORTWAVE RECEIVER \$6.45

Listen in DIRECT to London, Paris, Berlin, Buenos Aires and other broadcasting stations throughout the world via short waves. Your ordinary receiver cannot tune in these low wave stations. **WORLDWIDE RECEIVER** gets 14 to 550 meters.



AERO SHORT WAVE CONVERTERS
Convert Your Present Set into a Short Wave Super-Heterodyne
A. C. Model \$12.50—D. C. MODEL \$11.50
AT LAST: The perfect Auto Radio—ONLY \$20.00

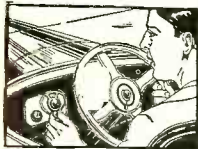

Built by pioneers in the manufacture of Auto Radio. We guarantee 1000 miles radius of reception. A masterpiece of Radio Engineering. Latest model 6 Tube Aero Pentode Auto Radio. Price of set only \$20.00. Set complete with tubes, batteries, dynamic speaker, antenna equipment and noise suppressors. \$39.50. SEND FOR COMPLETE CATALOG.

CHAS. HOODWIN CO., 4240 LINCOLN AVENUE
Dept. U-3 Chicago, Ill.

Write for booklet
"Opportunities in Radio"
Educational Dept.
West Side Y. M. C. A.
17 W. 63rd St., New York City

Make Your Own Condenser Microphone

AS DESCRIBED IN APRIL RADIO NEWS
Complete Kit Only \$3 Postpaid

The kit contains every necessary part, including the WESTERN ELECTRIC TYPE UNIT (already perfectly machined according to the article specifications) and the perforated brass back plate. Dural diaphragm, proniless tube base, protective screening and all hardware. Send money-order of \$3 for complete kit, or \$2.25 for just the perfectly machined unit (C.O.D., postage extra).

CHRISSELL-ACOUSTIC LABORATORIES
175 68th STREET BROOKLYN, N. Y.

Radio Guards The Baby

Continued from page 11)

causes a variation in the self-inductance or capacity of the oscillating system. This, in turn, brings about a variation in the frequency of oscillation of the system and that frequency variation causes operation of the sound producer or signaling apparatus. Figure 6 shows the complete system of connections in which variations of the natural period of an oscillating system O are caused by the variation of the capacity of an antenna or control conductor connected to it. The antenna comprises a wire or flexible lead which is extended around the area or district to be protected, for instance, the baby's cradle. This antenna has a definite normal capacity, and this capacity is affected when a person such as a burglar or any other object approaches it.

A radio-frequency generator tube T is inductively coupled to the oscillating circuit O. The frequency of the oscillator T is adjusted to about the resonance point of the oscillating circuit O, by proportioning the constants of the associated oscillating circuit P. When the capacity of the antenna is varied by the approach of a foreign object, a corresponding variation of the oscillations of the oscillator T takes place, resulting from and depending upon the difference between the periods of the oscillating systems O and P.

The variation of the grid current in a grid-leak resistance R causes a variation of the potential on the grid of a second tube S and the plate current of it, which may be measured with the contact galvanometer G. If the oscillating systems O and P are so tuned that a retardation of the natural frequency of the circuit O brings about a reduction of the oscillation energy of the tube T, an increase of the capacity of the antenna causes an increase of the plate current through the measuring instrument G. As long as the object to be detected is outside of the operating range of the antenna, no variation in the deflection of the instrument will take place. The plate current increases gradually in proportion to the rate at which the object approaches the antenna, until it reaches its maximum value when the object has reached the antenna. When the foreign body moves towards the antenna, the increase of the plate current of the tube S takes place gradually.

If the condenser C (see Figures 6 and 7) is constructed in such a way that its plates are attached to metallic supports which expand with heat, an increase of temperature will increase the capacity of the condenser and

the oscillating system will report "fire."

On the other hand, the method of using expanding parts gives a means for compensating slight changes which occur in the master oscillator.

Records Approach Over a Distance of 20 Feet

Such self-compensated apparatus are able to record approach of an object towards the oscillator over a distance of about 20 feet.

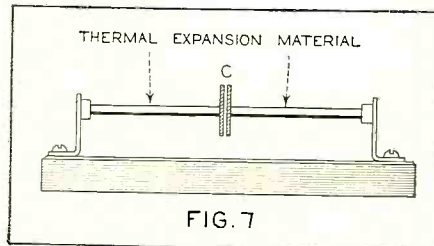

FIG. 7
PROTECTION AGAINST FIRE
Figure 7. This protective Thèremin condenser contains thermal-expansion arms which vary the capacity and give warning in case of fire

A photograph of a similar apparatus designed by Thèremin is shown in Figure 8. Figure 9 is a close-up of a laboratory-built research instrument of the same kind. In the diagram in Figure 8 only two amplifier tubes were used, giving the fundamental idea of the principle applied in these apparatus. The actual construction, embodying compensators and power amplifiers, is slightly different.

If the sensitive metallic rod, which may be hidden in the construction of the cradle, "feels" the approach of any object within a radius distance of 20 feet from any direction whatsoever, a relay will operate the sounding of a horn, a siren or a loudspeaker in any remote part of the building as a warning signal. Naturally, any other action may be initiated in the same way.

The radio sciences have thus given us ever-watchful eyes that never wink or sleep, they have given us sensitive invisible fingers that "feel" through glass and brick walls over a distance of many feet, the approach of objects which human senses might never notice. May the perfection of devices of this type add to the safety of our beloved ones.

Interference Meter

(Continued from page 30)

microvolts per meter. Adding this generator presented a number of problems. The generator had to be shielded so that signals only entered the receiver through the calibrated attenuator. Then, too, it is very desirable to have a generator which gives a "noise" similar to interference rather than a pure note, and one which did not have to be tuned to the particular frequency being received, but that gave out signals all over the 550-1500 kc. band, as static would usually do. In this design a multi-vibrator system was used and set to give out approximately a 120-cycle note. It was found to have harmonics that extended to all frequencies in the broadcast spectrum. However, the intensity of the harmonics diminishes as the frequency increases, which would mean that the input to the set would change quite radically with the frequency at which the receiver was tuned. With the present design

these characteristics can be smoothed out by filter circuits.

The resultant interference meter is shown in the photographs. The sensitivity of the instrument for a full-scale deflection on the meter employed is shown in Figure 2. The selectivity at 1400, 1000 and 600 kc. is shown in Figure 3. The instrument measures only 8 inches by 12½ inches by 14 inches, and with batteries, antenna and all equipment—even phones—its weight is slightly less than 31 pounds. Its operation is relatively simple.

Suppose that there is a complaint on interference. The trouble-shooter takes the interference meter to the home of the complainant, removes its collapsible antenna and connects to the complainant's antenna. With this arrangement he tunes in a broadcast station and sets the volume control so that the meter gives about full-scale reading. By

the turn of a switch the signal generator is started and properly connected to the interference meter; then, by turning a knob, the generated signal is brought to the same meter reading as the signal had previously given. Interpreting the setting of the generator attenuator dial by means of a curve gives the intensity of the signal in microvolts. This process is repeated for the interference, and the ratio of signal to interference can readily be calculated.

If the complainant's set is of the a.c. type, the next step is to determine how much of the noise is being transmitted over the a.c. power line. This is done by plugging a special device into the a.c. outlet and taking measurements on the interference meter. Possibly most of the noise had been transmitted into the a.c. set through the outlet. In this case, various devices may be employed to reduce the disturbance. Usually the interference is picked up over the antenna. In this case a survey of the immediate surroundings by means of the collapsible antenna and meter will show whether or not a change in direction or position, or both, of the complainant's antenna would help him. If the interference is sufficient to warrant locating its source, the trouble-shooter takes his car and makes a complete survey of the surrounding territory, taking intensity readings. After some experience it is quite easy to run down and determine where the trouble is originating.

The interference meter may also be used in determining field strengths of various stations at different times of day. For instance, one evening WEAJ in New York, on 660 kc., had a field strength of 38 microvolts per meter, while in the daytime the field was less than 3 microvolts per meter. KFI, in Los Angeles, gave a field strength one morning at 2 a.m. of 2 microvolts per meter, while KNX, Hollywood, California, put a signal into Winchester, Massachusetts, of 1½ microvolts per meter.

Thus the interference meter is not only applicable to the measurement of noise and an aid in locating the source of the man-made static, but it is capable of measuring field strength of broadcasting signals as well.

The writer feels that the use of such an instrument by the advanced type of radio service stations will open up a new field and source of income. If equipped with one of these instruments and having a reasonable knowledge of the art, a man will be capable of engaging in the work of making interference surveys for a good many cities and towns now desperately in need of such a service.

It is hoped that such an instrument will be helpful to cities now employing men to locate interference, and power companies, permitting more scientific analysis of the existing noise conditions.

Safe Operating Currents

In the May instalment of the Radio Physics Course occurred some errors in the equations under this heading. They should read as follows:

The relation between the watts rating, resistance and allowable current is

$$I = \sqrt{\frac{W}{R}}$$

Example 1: A certain 2000-ohm resistor has a rating of 80 watts. How much current will it safely carry?

Solution:

$$I = \sqrt{\frac{W}{R}} = \sqrt{\frac{80}{2000}} = .2 \text{ amp.}$$

or 200 milliamperes. Ans.

DEALERS! SERVICE MEN!
Radio Equipment
Given FREE

Stop



... National Union Radio Corp., maker of the famous National Union Radio Tubes, is offering this free equipment for a short time only. So you must act quickly.

The two service manuals shown at the left were written by John F. Rider, well-known lecturer and scientist. They should be part of every up-to-date radio man's equipment.

Volume I contains more than 2,000 diagrams on voltage, electrical values, color coding, peculiarities of receivers, amplifiers, and eliminators . . . as well as a complete discussion of trouble-shooting methods used by radio manufacturers. It is really an encyclopedia of service work.

Volume II contains more than 700 pages of the finest type of radio service material. Mr. Rider contacted the laboratories of the country's largest manufacturers . . . and now for the first time in the history of radio publications, radio receivers are broken down and point-to-point resistance data is furnished.

These volumes do not duplicate each other. Volume II picks up where Volume I leaves off. Both are different . . . both are indispensable. And you get either one or both absolutely free with the purchase of a small quantity of National Union Radio Tubes.

TUBE TESTER FREE

The Readrite Tube Tester. Compact, easily carried. It has an illuminated dial which shows the reading in even the darkest corners! Just think! This tester is yours free with the purchase of a small quantity of National Union Tubes.

OSCILLATOR AND OUTPUT METER

The Oscillator and Output Meter above is an absolute necessity for all modern service men. And you can have one free for a small purchase of National Union Tubes. Remember, you can't tune superhets without one. Be sure to send in coupon today!

NATIONAL UNION RADIO CORPORATION
400 MADISON AVENUE · NEW YORK CITY

Dear Sirs: Please tell me how I can have any one or all of the above equipment free, I am checking those in which I am interested.

VOL. I VOL. II OSCILLATOR AND OUTPUT METER TUBE TESTER

NAME _____

ADDRESS _____

CITY _____ STATE _____

Question Box

PHYSICS and science instructors will find these review questions and the "quiz" questions below useful as reading assignments for their classes. For other readers the questions provide an interesting pastime and permit a check on the reader's grasp of the material presented in the various articles in this issue.

The "Review Questions" cover material in this month's installment of the Radio Physics Course. The "General Quiz" questions are based on other articles in this issue as follows: Eliminating Fringe Howl in Regenerative Detectors; Design and Operation of an Interference Meter; Operating and Servicing the Stenode Quartz-Crystal Receiver; Radio Guards the Baby; What Television Needs; Class "B" Tubes—Their Significance in Future Audio Amplifier Design.

Review Questions

- Four vacuum-tube filaments having the following resistances are all connected in series: 20, 4, 5, 10.
 - Draw the circuit diagram showing the connection.
 - What is the total resistance of the combination?
 - How much current will flow if the entire group is connected to a source of e.m.f. of 50 volts?
- The resistances in question (1) are all connected in parallel.
 - Draw the circuit diagram for this connection.
 - What is the joint resistance of the combination?
 - What current will flow through each filament if the source of e.m.f. is 6 volts?
 - What is the total current taken from the battery?
- The filaments of two 201A vacuum tubes having a resistance of 20 ohms each are connected in parallel. In series with this group is another filament having a resistance of 10 ohms. The entire group is supplied with current from a 6-volt storage battery. What is the combined resistance of all the tube filaments, and the total current flowing.

General Quiz on This Issue

- Why do most regenerative detectors howl when feed-back is adjusted close to the point of oscillation?
- How may this condition be corrected?
- What arrangement is used in one interference locator to visibly measure interference intensity?
- How can the Stenode be used for short-wave reception?
- How is the "wall of light" used as protection against burglary?
- What is one main factor which is retarding the popularization of television?
- What is the principle of true "Class A" amplification?

Student's Radio

LESSON ELEVEN—SERIES

By Alfred A.

This series deals with the study of the physical information of particular value to physics colleges. The Question Box aids teachers

IN order to have current flowing in any conductor the circuit must form a complete conducting path from the positive terminal to the source of e.m.f. around to the negative terminal (except in the case of a circuit with a condenser). In actual electrical circuits, electrical devices are connected in either of two ways—or a combination of the two. When they are connected one after the other in such a way that all of the current flows through each of them, they are said to be in *series*. Thus, in Figure 1 the filaments of all three of the vacuum tubes shown are connected in series with each other and with the resistor R_4 , across the 110-volt electric light circuit whose e.m.f. is maintained by the electric dynamo G. In such a circuit the total resistance of the entire circuit is equal to the sum of the separate resistances. Thus in Figure 1 if the resistances of the individual parts are as marked, the total resistance is:

$$R = R_1 + R_2 + R_3 + R_4 + \text{etc.} \quad (1)$$

The total resistance is $R = 380 + 20 + 20 + 20 = 440$ ohms.

The current I flowing in the circuit is:

Another important fact regarding the se-

$$I = \frac{E}{R} = \frac{110}{440} = 0.25 \text{ amperes}$$

ries circuit is that the current is the same through every part of the circuit, since there can be no accumulation of current at any point along the circuit. If five ammeters were connected at the points marked I in Figure 1, they would all indicate the same current I , of 0.25 amperes. Also if a series circuit is opened or broken at any point the current stops flowing.

A voltage drop occurs across each of the various resistances in a series circuit, depending on its resistance. If a voltmeter were connected across the filament of tube A, it would indicate $E = I \times R_1 = 0.25 \times 20 = 5$ volts. This is the voltage drop or fall of potential across the resistance. Similarly, the voltmeter would read 5 volts if connected across the filaments of tubes B and C, since they both have resistances of 20 ohms. If it were connected across resistance R_4 it would indicate $E = I \times R = 0.25 \times 380 = 95$ volts. The sum of all these voltage drops around the circuit is equal to $5 + 5 + 5 + 95 = 110$ volts. This of course is equal to the voltage of the source of e.m.f. (G) which is causing the flow of current through the resistances. This illustrates another law of the series circuit: "The total voltage applied to the circuit is equal to the sum of the voltage drops across the individual resistances in the circuit." If any unit in a series circuit should become "short circuited," the current will increase because the total resistance of the circuit would be decreased.

Notice from Figure 1 that the voltage drop across any resistance in the circuit depends upon its resistance. Thus even though the same current flows through all parts, the voltage drop across the 380-ohm resistance is

95 volts, whereas that across each 20-ohm resistance is only 5 volts.

In radio receivers series circuits are very common in the plate circuits of vacuum tubes, as we shall see later. The adding of resistances in series is equivalent to increasing the length of the conductor, so that the total resistance is equal to the sum of the separate resistances.

Parallel Circuits

When parts of a circuit are connected in such a way that they form separate paths through which the current can divide, they are said to be connected in *parallel*, *multiple*, or *shunt*. Only a portion of the total current flowing from the source of e.m.f. flows through each path.

Figure 2 shows a parallel circuit consisting of the filaments of three dissimilar vacuum tubes supplied with current forced through the circuits by the e.m.f. of the storage battery, E. Only a portion of the total current circulating through the battery passes through each of the circuits, but of course the sum of the number of amperes of current flowing in the three circuits is equal to the number of amperes of current circulating through the battery, since all the currents combine again. The actual current in each

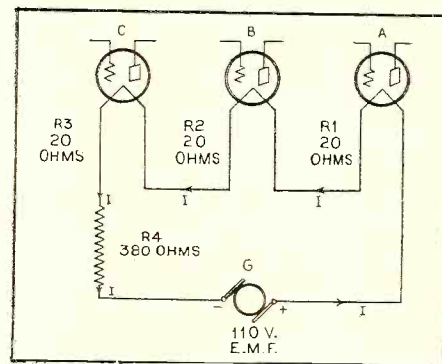

SERIES CIRCUIT

Figure 1. The same current flows through every part of the circuit

wire of the circuit is indicated on the diagram. Notice how the current coming out of the positive terminal of the battery divides to go through the tube filaments and then combines again at the negative line.

Any number of electrical devices or circuits may be connected in parallel. The current returning to the negative side of the source of e.m.f. is exactly equal to the current leaving the positive side. The current is merely circulating through the circuits. The electrical devices connected in parallel may all have the same resistance or they may all have unequal resistances. If the resistances are equal, then it is evident that the total current will divide equally among the various paths, and the combined resistance of all the paths considered together is equal to one of the resistances divided by the

Physics Course

AND PARALLEL CIRCUITS

Ghirardi*

aspects of radio phenomena. It contains teachers and students in high schools and in laying out current class assignments

number of resistances. Thus, if five resistances of 100 ohms each are connected in parallel, the combined resistance will be

$$\frac{100}{5} = 20 \text{ ohms, since five paths are being}$$

presented to the flow of current instead of only one.

When the parallel resistances are not equal, the combined resistance must be found by another method, in which the conductances of the various paths are considered. When the resistances are arranged in parallel, since several paths are being offered for the passage of the current, the effect produced is the same as if we were to increase the cross-sectional area of the original conductor. The current passing through the separate resistances is proportional to the conductivity of each path.

It was earlier stated that the *conductance*

of a circuit is equal to $\frac{1}{R}$. That is, the less

the resistance of a wire, the greater is its *conductance* or ability to conduct current. Conductance is expressed in *mhos*. Thus if

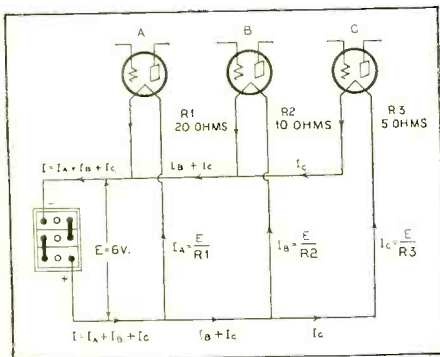

PARALLEL CIRCUIT

Figure 2. The current divides and part flows through each branch

the resistance of a conductor is 5 ohms, its

$$\text{conductance is } \frac{1}{5} = 0.2 \text{ mho.}$$

The conductance of the entire parallel circuit is equal to the sum of the conductances of its individual branches. Thus if R stands for the combined resistance of the parallel circuit, and $r_1, r_2, r_3, \text{ etc.}$, stand for the individual resistance of the parts of the parallel circuit, then

$$\frac{1}{R} = \frac{1}{r_1} + \frac{1}{r_2} + \frac{1}{r_3} + \text{etc.} \quad (2)$$

from which the combined resistance R may be calculated if the resistances of the individual branches are known. Thus in Figure

2 the combined resistance of the three filaments in parallel is:

$$\frac{1}{R} = \frac{1}{20} + \frac{1}{10} + \frac{1}{5}$$

from which $R = 2.9$ ohms. Ans.

Notice that the combined resistance is less than the resistance of any of the paths. This should be expected, of course, since even the path of the lowest resistance is having several additional conducting paths connected in parallel with it so that the resistance must be less. Additional paths increase the current-carrying ability of the circuit; that is, they decrease the resistance.

We see that two or more *equal* resistances in parallel is merely a special case of parallel circuits. Equation (2) can be used for any condition of equal or unequal resistances.

In a parallel circuit the voltage across each branch is the same as that across every other branch and is equal to that supplied by the source of e.m.f. The current which flows through each branch is simply equal to this voltage divided by the resistance of the branch. Thus in Figure 2, if the battery supplies an e.m.f. of 6 volts, the currents in the various branches are:

$$I_a = \frac{E}{r_1} = \frac{6}{20} = 0.3 \text{ amps.}$$

$$I_b = \frac{E}{r_2} = \frac{6}{10} = 0.6 \text{ amps.}$$

$$I_c = \frac{E}{r_3} = \frac{6}{5} = 1.2 \text{ amps.}$$

Therefore $I = 0.3 + 0.6 + 1.2 = 2.1$ amps. (This is the total current supplied by the battery.) As a check on this calculation we may calculate the total current directly from the value of the combined resistance of 2.9 ohms obtained above for the circuit. Thus

$$I = \frac{E}{R} = \frac{6}{2.9} = 2.1 \text{ amps (which checks}$$

with the value just calculated.)

In a parallel circuit, if any one of the branches is opened, current will continue to flow through the others. The conditions existing in parallel circuits are as follows:

1. The voltage is equal across all branches.
2. The combined resistance is less than the resistance of any branch of the circuit.
3. The total current is equal to the sum of the currents through all the branches.

Parallel circuits are very common in radio receivers. In battery-operated receivers the filaments of the various tubes are usually connected in parallel across the source of e.m.f. (battery). In a.c. electric receivers the filaments of the tubes are connected in parallel across the filament winding of the transformer. The plate circuits are connected in parallel across the B supply unit.

NEW 3

HANDY KITS

No two ranges alike

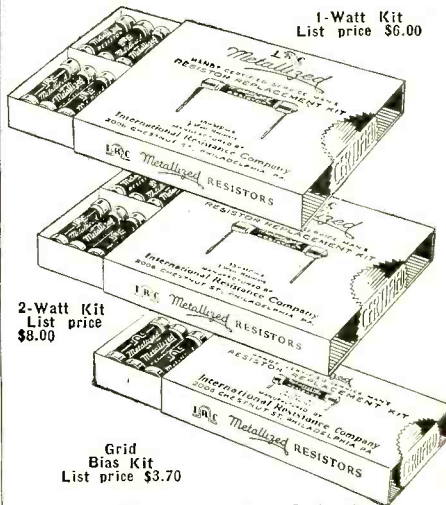

(See your prices below)

More good news! Our first Handy Certified Kit made such a hit with Servicemen that we have added two more. Three I.R.C. Kits now, supplying every possible range you need for any radio set.

The 1-Watt Kit (20 Resistors)—500 ohms to 3 megohms—gives you thousands of ranges, easily obtained from the formulas we supply.

The 2-Watt Kit (20 Resistors)—500 ohms to 500,000 ohms—provides all the needed high-wattage units.

The Grid Bias Kit (10 Resistors)—for biasing '24, '26, '27, '71-A, '10, '45, '50 and '47 tubes. Complete information on proper biasing of tubes with every kit.

Each kit is *Factory Sealed, Factory Tested, Factory Guaranteed*. With either of the 20-unit Kits, we send the famous I.R.C. Resistor Replacement Guide and Color Code Chart *Free*. See your jobber or mail the coupon.

International Resistance Co.
PHILADELPHIA TORONTO



International Resistance Co. N-7
2006 Chestnut St., Philadelphia

Gentlemen:
I enclose check (or money order) as noted, for which please see that I receive Metallized Kit.

\$3.50 for 1-Watt Kit \$4.65 for 2-Watt Kit
 \$2.15 for Grid Bias Kit (Prices higher in Canada)

Name.....
Address.....
City.....State.....

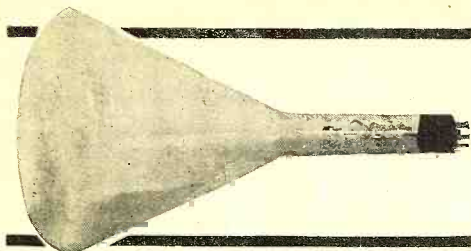

CATHODE RAY TUBES

The untold possibilities of cathode ray technique are now thrown open to you. For the first time there is offered a line of practical, efficient cathode ray tubes well within reach of any pocketbook. For example:

3" Deflecting Plate Type (above) makes available cathode ray principle at low cost. Six-prong base. Price: \$15.

S-14 Type in glass envelope similar to usual -45 power tube. Single set of deflecting plates. Useful as voltmeter, ammeter and resonance indicator or any form of wave analysis. Price: \$7.50.

Write for literature on Globe cathode ray tubes, as well as television receivers, lens discs, crater lamps, plate lamps and motors.



GLOBE TELEVISION & PHONE CORP.
185 Devonshire Street
Boston Mass.

RACON Announcing

... A radically new type Horn, having a complete circumferential coverage of 360 degrees with even intensity of distribution.



Send for Complete New Catalog on Horns and Units

NEW RADIAL HORN
Stormproof, demountable and is perfectly adapted for use on trucks, tower equipment, churches, and general public address use where a complete circumferential coverage is desired.

Again the pioneer manufacturers of acoustic sound reproducers prove their leadership with this New Radial Horn. You must also remember... there is a Racoon Horn for every purpose and nothing is finer than Racoon.

RACON HORNS AND UNITS ARE COVERED BY U. S. PATENTS NOS. 1,507,711; 1,501,032; 1,577,370; 1,521,217; 1,732,218; 1,729,448; 1,711,514; 1,781,489; 1,832,608; 1,834,327; 1,835,739.

Address Dept. R.N.-7

RACON ELECTRIC CO., Inc.
18 WASHINGTON PLACE NEW YORK
LONDON, ENGLAND TORONTO, CANADA

PATENTS

Write for Free Information, HOW TO OBTAIN A PATENT and RECORD OF INVENTION—or send drawing or model for examination.
MILLER & MILLER, Patent Attorneys
FORMER MEMBERS EXAMINING CORPS U. S. PATENT OFFICE
1006 Woolworth Bldg., Dept. H, New York
680 Earle Building, Washington, D. C.

ALUMINUM BOX SHIELDS

Genuine "ALCOA" stock, silverplated finish, 5x9x6 \$1.89
—Cabinet size \$4.65, 10x8x7 Monitor size \$3.25, 5x7x3
Coil Shield (like picture on the right) \$1.00. Any size to order.

"BUDDY" Test Prods Always sharp pointed using phonograph needles, \$1.50 pair. We can furnish all parts for the SET TESTER DELUXE described in October Radio News.

Carrying case for the Sprayberry Set Tester.....\$2.75
Instrument box for Montan's Tester..... 2.25

We specialize in parts exclusively. We can furnish everything described in this magazine. Give us a trial. Please include postage.
BLAN, the Radio Man, Inc., 89 Cortlandt St., Box N7, New York City

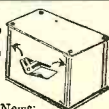

Backstage in

Chatty bits of news on what is happening before the microphone

By
Samuel Kaufman



DON CARNEY



THE ROLLICKERS

NETWORK listeners throughout the nation recently welcomed the radio-famed Rollickers Quartet back to the microphone. The four harmonizers are now heard on Mrs. Blake's Column (NBC), Tuesdays and Fridays, and on the Linit Bath Club (CBS), daily, except Saturdays and Sundays. Victor Hall, second tenor of the group, organized the Rollickers in 1926. In the brief span of a half dozen years the quartet soared to stardom on numerous network programs in addition to making talking-picture shorts and phonograph recordings. Individually and collectively, the members of the quartet have appeared on the Broadway musical comedy stage and have made personal-appearance tours of moving-picture palaces in key cities throughout the United States. Some of the past programs on which the Rollickers were regularly featured were the Camel, Maxwell House, Stromberg-Carlson, Armstrong Quakers, La Palina, Van Heusen, Quaker State Oil and Hudson-Essex hours. In addition to their numerous permanent features, the quartet made frequent guest appearances on other programs. The Rollickers consist of Clark Bremer, first tenor; Carrick Douglas, baritone; Eugene Critzer, basso, and Clifford Lang, pianist and arranger, in addition to Mr. Hall, whom we have already noted as second tenor.

Street Sketches," and clicked from the start. Since then his unique children's programs brought him new laurels. And his popularity is by no means restricted to the younger generation, many adults being on his fan roster.

B. A. ROLFE, the rotund dance-band director, whose brilliant rhythm was the highlight of the old Lucky Strike programs, is back on the NBC, being featured on the Ivory program sponsored by the Procter & Gamble Company. Rolfe now conducts a 35-piece ensemble in popular dance selections. At the age of seven, Rolfe was an accomplished cornetist. When he was eleven years old he toured Europe as a boy trumpet wonder. During his varied career he has directed orchestras for the vaudeville stage, managed moving-picture production and conducted military bands. He finally began his study of dance rhythms which led to his present radio popularity. He is fifty-one years old, and although one of the oldest, he is one of the most popular dance conductors on the air.

THE "Uncle Don" programs of Don Carney, presented daily over Station WOR, are among the most widely followed children's broadcasts in the country. Uncle Don's etiquette club has a membership of over 300,000 youngsters. His daily mail reaches tremendous proportions, and now and then he hears from some ardent listener on foreign shores. Don hails from Michigan. He picked up piano playing "by ear," and his first job was playing in a nickelodeon. Later he played in a restaurant and on the vaudeville stage. Then he turned his attention to farming and shipbuilding. He returned to the entertainment field as an extra in a D. W. Griffith film. His first radio venture was on the announcing staff of WMCA, New York. He was invited to try out for the stellar rôle in WOR's "Main

INGENIOUS and amazing feats of science were brought before CBS listeners in a series of unusual broadcasts from the laboratory lecture-room of the General Science Department in the School of Commerce of New York University. The broadcasts, Saturday evenings, under the direction of Dr. E. E. Free and his staff,



B. A. ROLFE

Broadcasting



DR. E. E. FREE

made distant listeners "witnesses" of intricate scientific experiments achieved with rare and costly apparatus. Thus the chain's listeners, in their own homes, had the advantage of benefiting by actual laboratory tests in one of the nation's great universities. Taking into consideration the limitations of the microphone, Dr. Free and his associate lecturers so reconstructed these lectures that audibility, rather than visibility, permitted "witnessing." For example, listeners to one of the broadcasts heard sounds that are not ordinarily audible to the human ear. These were made available by sensitive microphones and special laboratory apparatus. The purpose of this program was to demonstrate what science terms "capillary action." Soap bubbles were heard bursting, ginger ale was heard fizzing and soap was heard lifting particles of dirt from a human hand.



MR. AND MRS. ELY CULBERTSON

The "bombardments" and unusual effects of these sounds coming from such commonplace sources was the basis of the interesting educational program. Educational programs, when injected with the element of novelty and entertainment as in this series, draw wider audiences and are more effective than plain talks. Dr. Free's example



FLORENZ ZIEGFELD

can well be followed by other educational broadcasters.

ELY CULBERTSON, one of the world's greatest authorities on contract bridge, has joined the ranks of regularly heard broadcasts as the featured personality of an NBC series sponsored by the William Wrig-

Personal interviews with broadcast artists and executives

ley, Jr., Company. Mr. Culbertson is presented three times each week, on Mondays, Wednesdays and Saturdays. On his first two programs of each week, Mr. Culbertson analyzes a contract bridge hand for his listeners, telling how he himself would play it, and why. On Saturdays he conducts general discussions on the fine points of the game for beginners, average players and experts. Although Mr. Culbertson had previously been heard over the air, this is the first extended series in which he is presenting a detailed analysis of his system. Mr. Culbertson's recent challenge match with Sidney Lenz made him one of the most widely discussed personalities in the bridge world. His wife, who was his partner in the Lenz challenge match, joins her husband on the air from time to time.

sponsored by the Chrysler Corporation over the CBS, Sunday evenings, Mr. Ziegfeld brings to the air unusually conceived programs which are chock-full of talent. If the producer continues the high standard of guest artists he used in his first few programs, the series will undoubtedly be one of the most popular weekly features on the air. Such outstanding names as Will Rogers, Lupe Velez, Eddie Dowling, Billie Burke and Helen Morgan were included in the first few programs. Mr. Ziegfeld, it seems, decided that he would follow theatrical technique in producing his radio series. In order to rehearse the programs as long as they desire, the producer, his guest stars and musicians utilize the facilities of an outside studio in Steinway Hall, New York. The actual broadcasts also originate in this remote-control point. This identical studio was the original WABC "key" studio of the CBS before the chain moved to its own building on Madison Avenue. The studio has since been taken over by the Columbia Concerts Corporation, a CBS subsidiary specializing in concert management. New decorations have been placed in the studio, and microphone-stands and music-racks have been repaired for the occasion of the Ziegfeld series.

A CLOSER alliance between radio and the theatre was affected recently when Merlin H. Aylesworth, president of the Na-



In the Great Shops of COYNE

Pay for Your Training in Easy Payments After You Graduate

Don't spend your life slaving away in some dull, hopeless job! Don't be satisfied to work for a mere \$20 or \$30 a week. Let me show you how to make REAL MONEY in RADIO—THE FASTEST-GROWING, BIGGEST MONEY-MAKING GAME ON EARTH!

Jobs Leading to Salaries of \$50 a Week and Up

Jobs as Designer, Inspector and Tester, —as Radio Salesman and in Service and Installation— as Operator or Manager of a Broadcasting Station— as wireless Operator on a Ship or Airplane, as a Talking Picture or Sound Expert— HUNDREDS of Opportunities for fascinating Big Pay Jobs!

10 Weeks' Shop Training AT COYNE IN CHICAGO

We don't teach you from books. We teach you by ACTUAL WORK on a great outlay of Radio, Broadcasting, Television, Talking Picture and Code equipment. And because we cut out useless theory, you get a practical training in 10 weeks.

TELEVISION Is Now Here!

And TELEVISION is already here! Soon there'll be a demand for TELEVISION EXPERTS! The man who gets in on the ground floor of Television can have dozens of opportunities in this new field! Learn Television at Coyne on the very latest Television equipment.

Talking Pictures A Big Field

Talking Pictures, and Public Address Systems offer golden opportunities to the Trained Radio Man. Learn at COYNE on actual Talking Picture and Sound Reproduction equipment.

Pay After Graduation

To a few honest fellows I am offering an opportunity to get a training and pay for it after they graduate in easy monthly payments. You get Free Employment Service for life. And if you need part-time work while at school to help pay expenses, we'll help you get it. Coyne is 33 years old. Coyne Training is tested — You can find out everything absolutely free. JUST MAIL the Coupon for My BIG FREE BOOK.

H. C. LEWIS, President
Radio Division, Coyne Electrical School
500 S. Paulina St., Dept. B2-8C, Chicago, Ill.

Send me your Big Free Radio Book and all details of your Special Introductory Offer, and how I can pay for my training after I graduate.

Name.....
Address.....
City..... State.....

Write for this book
RADIO
 You cannot possibly afford to be without this valuable book! It is not just another Catalog—it is indeed a VERITABLE ENCYCLOPEDIA of the RADIO INDUSTRY
WHOLESALE PRICES

All that is new in Radio is listed in this money-saving SPRING 1932 SUPPLEMENT LATEST ISSUE JUST RELEASED! HERE ARE A FEW OF THE NEW APPLIANCES WE FULLY DESCRIBE THEREIN: Single Dial ALL-WAVE 10 to 550 Meter Super-Heterodyne Receivers; Automobile "B" Eliminator and "Auto" Motor Generators producing 110 volts, 60 cycles A.C.; Automobile Public Address Amplifiers (Ideal For Politicians); Class "B" Amplifiers; 8 tube Auto "Super-Net" Kit; Universal A.C.-D.C. Western Meters and Analyzers; "Super-Net" Short Wave Receivers; Converters, Coils, Switches; 14 tube "Super-Net" ALL-WAVE 10 to 550 Meter Single Dial Kit; "Super-Net" Essential Tuner Kit; Combination 33 1/8 and 73 R.P.M. Elec. Phono. Motors and Pick-Ups; Class "B" Amplifier R.C.A. Tubes, Transformers, Clocks, etc.; Universal Bracket Mount; 171-245-547-250 A.C. Power Replacement Transformers; Neon Flashlight Radio Set Trouble Shooter; Columbia Automatic Record Changer Phonograph and Amplifier; and thousands of other items . . . all quoted at ROCK-BOTTOM NET PRICES! We Are Specializing in AUDITORIUM SOUND TRUCK-AUTOMOBILE PUBLIC ADDRESS CLASS "A" and "B" AMPLIFIER INSTALLATIONS.

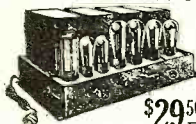

\$29.50

Investigate our 13 WATT Seven Tube THREE STAGE DUAL PUSH-PULL 250 AUDIOPHON AMPLIFIER, here-with illustrated, which we sell for only \$29.50! By all means, consult our Engineering Staff before you purchase any public address amplifier or associated equipment . . . for . . .



123 N West 17th St., New York N.Y.

AUTO-DIAL RADIO
 Quality, tone, selectivity, and power

COMPLETE \$40.00—includes set, remote control, suppressor kit, tubes and dynamic speaker. Set only \$18.00. Dealers and agents wanted. Write today.
J-M-P MANUFACTURING CO., INC.
 3427 Fond du Lac Ave., Milwaukee Wis.

FREE—FREE
WHOLESALE RADIO CATALOG
"THE BIG BOOK"
 (136 pages)
 Write now, for your free copy chock full of radio and electrical bargains.

American Sales Company
 Wholesale Radio Distributors
 44 W. 18th St. New York, N. Y.

RADIO'S REWARDS

are rich for those who are prepared. Study all branches of practical radio at RCA Institutes America's oldest radio school. Resident school in New York and Chicago. Also extension courses for home study on new "no obligation" enrollment plan. Catalog.

RCA INSTITUTES, Inc.
 Home Office, Dept. RN-7
 75 Varick St. New York

tional Broadcasting Company, was elected president of the Radio-Keith-Orpheum Corporation. Mr. Aylesworth is retaining his NBC post in addition to his new amusement assignment. Thus the two great entertainment enterprises of the Radio Corporation of America are brought under a single leadership. Of special interest is the statement of David Sarnoff, president of the R.C.A., which follows: "The activities of the National Broadcasting Company in the field of entertainment are so interrelated with the general entertainment field that it was felt the requirements of efficiency and economy would be served by the co-ordination of both entertainment interests under a single president." And, likewise, Mr. Aylesworth asserts: "The co-ordination of radio broadcasting, stage and screen entertainment, is logical and highly desirable. They are naturally associated and each will benefit the other. While the National Broadcasting and Radio-Keith-Orpheum Corporations' organizations will be entirely separate, there is a great opportunity to co-ordinate these two forces in meeting the demands of the public." Mr. Aylesworth, under his dual authority, will supervise all of the broadcasting, theatrical and motion-picture projects in New York's Radio City, which is now under construction.

PICK and Pat, of the WOR Minstrels, have been drawing a constantly growing audience for their Thursday broadcasts. Minstrel skits over the air were quite numerous in the early days of radio, but few have survived. Those that have, however, did it on exceptional program merit. Both Pick Malone and Pat Padgette were with the Merrymakers Quartet on WOR before they started the minstrel sketch. Pick was born in Dallas, Texas, but was raised in Oklahoma. He joined a stock company at

seventeen and then joined the army for two years of service. Then he opened his own show and worked with it all through the Middle West. Pat hails from Georgia. He worked on a farm until he was seventeen and then moved to Birmingham, Alabama. After singing on local amateur nights, he joined the show business and trouped for a long period. Pick and Pat met in New York and teamed up for their WOR presentations.

JOHN CARLILE, production director of the CBS, has expressed some interesting opinions of the voices of the world's great personalities who have been heard on the air. It is part of Mr. Carlile's job to select all new announcers for the CBS, and he thinks that some of our noted personalities in public life would make successful applicants for the jobs. Mr. Carlile believes that one of the finest voices on the air is that of Governor Franklin D. Roosevelt, of New York. Former Governor Alfred E. Smith's voice, the production director holds, is one entirely his own, and obviously would not do on the air for anyone other than the Governor himself. Mr. Carlile finds that President Hoover's radio voice is "typical of a kind of man who is so often inarticulate as a public speaker." But our informant hastily adds that the importance of a President's utterances will always insure a large radio audience, regardless of the quality of his radio voice. Turning towards foreigners, Mr. Carlile points out that Premier Ramsay MacDonald, allowing for his Scottish accent, has one of the richest, fullest and most flexible voices ever heard on the air. He adds that probably no voice ever heard on the air has so much character or so thoroughly paints a man's character as the voice of Premier Mussolini.

Mathematics in Radio

(Continued from page 38)

For point A, θ equals about 45°
 " " B, " " 35°
 " " C, " " 17°
 " " D, " " 0°

But the tangent of these angles is by definition equal to the derivative of the function at its respective points; thus:

$\frac{dy}{dx}$ at point A is about 1

" " B " " .70
 " " C " " .31
 " " D " " 0

Plotting these values of $\frac{dy}{dx}$ at points A, B and C, respectively, we have the graph of

Figure 5. But this $\frac{dy}{dx}$ curve is further noticed to be the same as the function $y = \cos x$, so it is apparent that:

$$\frac{d(\sin x)}{dx} = \cos x$$

or the derivative of the $\sin x$ is equal to the $\cos x$.

Figure 6 shows the functions $y = \sin x$ and $y = \cos x$ plotted together.

Formulas for Differentiating Standard Forms

The following formulas are a continuation of the ones listed above from (1-5) inclusive.

$$6. \frac{d}{dx} (\sin v) = \cos v \frac{dv}{dx}$$

The derivative of a sine function is equal to its cosine function, times the derivative of the function.

$$7. \frac{d(\cos v)}{dx} = -\sin v \frac{dv}{dx}$$

$$8. \frac{d(\tan v)}{dx} = \sec^2 v \frac{dv}{dx}$$

$$9. \frac{d(\cot v)}{dx} = -\csc^2 v \frac{dv}{dx}$$

Sec v and csc v above are the abbreviations for secant and cosecant, respectively. The application of the above differential forms to radio theory is now quite readily presented.

A Correction

At the bottom of page 1030 in the June, 1932, issue of RADIO NEWS there is an item headed "Electro-dynamic Unit," giving the maker's name as the Fox Amplifying Company, 625 Board of Trade Building, Toledo, Ohio. The illustration also contains a nameplate on which the name Fox appears. Since the magazine was printed, the company's name has been changed to the Bud Speaker Company, and in the future all of their products will carry the name of Bud.

D. C. Set Tester

(Continued from page 25)

All measurements are made in the same way as for a five-prong tube except the d.c. heater voltage, which can now be read by properly setting switches S7 and S10.

The full-wave type -80 rectifier can be tested with the same adapter. For the measurement of the d.c. voltage on the regular plate, set your switches as for plate voltage on other tubes, but reverse the polarity switch.

The second voltage on the plate can be obtained by setting switches for screen-grid voltage; that is, with switch G1 (S8), and reverse the polarity.

regular 5-prong socket. Plate voltage, plate current and grid bias are obtained as usual, but G1 now control the input plate circuit and it is with the aid of this switch that the current and voltage in this circuit are measured.

On any indirectly heated tube, the heater voltage, if d.c., can be measured with the 5-5 adapter. This same adapter makes possible the reading of control grid-to-heater voltage. Throw switch G2 for this measurement.

Resistance Measurements

The 10-volt range of the voltmeter circuit has been calibrated for resistance measurement. In Figure 2 is shown a reproduction of the meter scale with the resistance values marked on it. This scale was made with a battery of 9 volts in series with the unknown resistance. Satisfactory measurements can be made of resistors from 100 ohms to 50,000 ohms.

Constructional Details

The whole tester can be carried in a small wooden case of 9 1/8 inches by 5 3/8 inches by 2 3/4 inches deep, inside dimensions. The main panel is made of 3/16-inch bakelite and drilled according to the specifications in Figure 3. The resistors are supported on a subpanel which in turn is held in place by the terminals on the meter and straight, rigid wires. The drilling specifications of this subpanel are given in Figure 4. These two panels can be obtained drilled and engraved from the Shallcross Mfg. Co.

When wiring the tester, the constructor should be careful to connect as many wires as possible before putting the subpanel in place. The greater part of the wiring is going to be inaccessible after the mounting of the subpanel.

Parts List

- A1—Na-ald adapter, type 954DS (5 to 4 prong adapter)
- A2—Na-ald adapter, type 955GKS (5 to 5 prong adapter, pentode type)
- M—Weston model 301, flush type meter, bakelite case, 0-1 ma., d.c.
- P—Na-ald test cable plug, type 905L
- R1—Shallcross super Akra-ohm resistor, type WE-1, 123 ohms
- R2—Shallcross super Akra-ohm resistor, type 6-M, 9850 ohms
- R3—Shallcross super Akra-ohm resistor, type 6-M, 90,000 ohms
- R4—Shallcross super Akra-ohm resistor, type 6-M, 150,000 ohms
- R5—Shallcross super Akra-ohm resistor, type 6-M, 750,000 ohms
- R6, R7—Shallcross super Akra-ohm resistors, type 6-M, 100 ohms
- R8—Shallcross super Akra-ohm resistor, type 6-M, 9000 ohms
- R9—Shallcross super Akra-ohm resistor, type 6-M, 750 ohms
- S1, S2, S3, S4, S5—Yaxley push-buttons, type 2001
- S6—Yaxley single-pole, single-throw jack switch, type 720
- S7, S10—Yaxley single-pole, double-throw jack switches, type 730
- S8, S9, S11—Yaxley double-pole, double-throw jack switches, type 760
- VT1, VT3—Eby UY type sockets
- VT2—Eby UX type socket
- 2 Eby binding posts, marked + and -
- 1 conductor cable, 6-wire
- 1 screen-grid lead and clip
- 1 Shallcross type 650 radio set analyzer panel and subpanel, drilled and engraved
- 1 Blan carrying case, wood, complete with clasps and handle

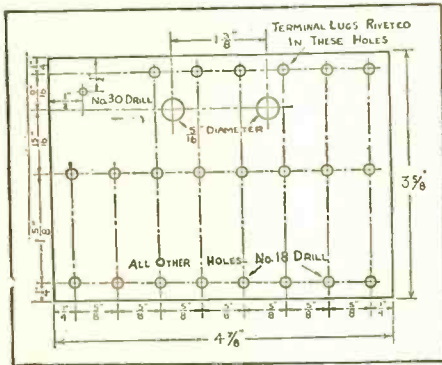
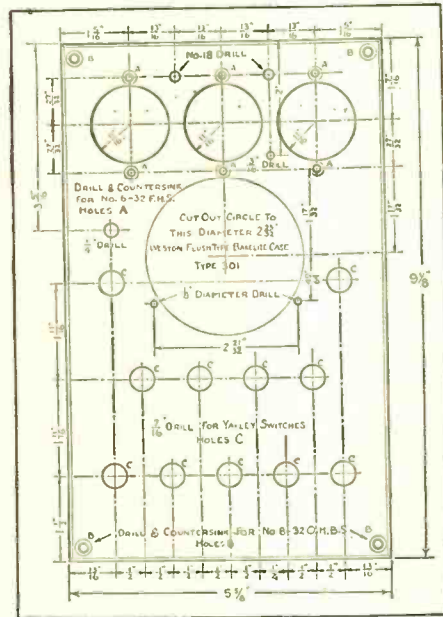

COMPLETE PANEL SPECIFICATIONS
Figure 3. (Above) The main panel.
Figure 4. (Below) The resistance-mounting sub-panel

Current in both plate circuits can be measured by setting the switches the same as for plate current and screen current, and in this case the polarity switch should remain in its normal position.

The pentode type -38 is measured in the same way as the -24, -35 and -36. Pentodes of the heater type have a different prong connection and they should be inserted in the adapter 955KS and this adapter in the special socket (VT3) marked for these tubes. The measurements are then made in the same way as for any screen-grid tube. This includes the measurement of the screen current which is obtained by setting G1. The heater voltage, if it is, d.c., can be read by setting switch H.

The Triple-Twin should be inserted in the

JUST OFF THE PRESS!

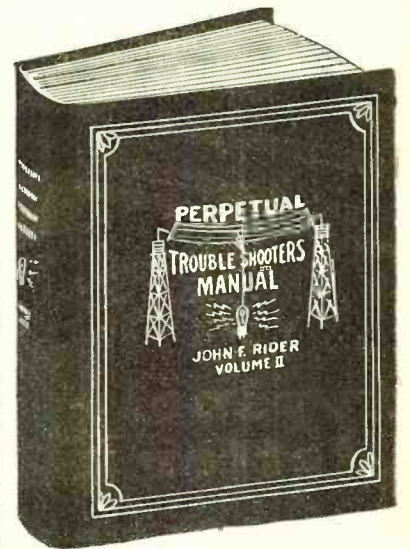

Volume No. 2 of the Perpetual Trouble Shooter's Manual

Volume No. 2 of the Perpetual Trouble Shooter's Manual picks up where Volume No. 1 left off. Absolutely no duplication of material in the two volumes. More than 700 pages of the finest type of helpful radio service material that it was humbly possible to secure.

In this manual John F. Rider fulfills every demand made by the servicing industry for service data. No other manual furnished the information contained in Volume No. 2. Rider contacted the laboratories of the radio receiver manufacturers and secured information which is not shown in their own manuals. For the first time in the annals of radio service manuals, commercial radio receivers are broken down and point-to-point resistance data is given. This is the finest type of service information and complies with the requests of service men.

Service men the country over have continually demanded electrical values of all resistances and condensers.

Volume No. 2 of the Perpetual Trouble Shooter's Manual complies with these demands by giving electrical values for every resistor and condenser contained in every receiver shown in the manual. . . . Yes sir—every resistor and condenser shown in the manual bears electrical values.

Service men the country over have continually asked for resistor and condenser values used in Atwater-Kent receivers.

Volume No. 2 of the Perpetual Trouble Shooter's Manual gives resistance and capacity values for every Atwater-Kent receiver shown in the manual. No other manual offered in the radio industry contains this type of information.

Volume No. 2 shows wiring diagrams—chassis layouts—photographic views—alignment data—location of trimmer condensers—trimmer condenser adjustment frequencies—socket layouts—voltage data—color coding—peak frequencies of super-heterodyne receivers—color coding of resistances—point-to-point resistance data—in fact EVERYTHING the service man or service shop requires to enable rapid and accurate service work.

POINT-TO-POINT DATA

Here is an example of the point-to-point resistance data. This is a partial listing of this kind of material as applied to one receiver in the manual.

From '47 Space Grid to 2nd Detector	29,454 ohms
From '47 Space Grid to IF Plate	50 ohms
From '47 Space Grid to 1st Detector	50 ohms
Plate	50 ohms
From '47 Space Grid to RF Plate	26 ohms
From '47 Space Grid to IF Screen	6,000 ohms
Grid	6,000 ohms
From '47 Space Grid to 1st Det.	6,000 ohms
Screen Grid	6,000 ohms
From '47 Space Grid to RF Screen	6,000 ohms
Grid	6,000 ohms
From '47 Space Grid to Ground	13,000 ohms
From '47 Control Grid to Ground	59,250 ohms
From IF Screen Grid to Ground	7,000 ohms
From IF Control Grid to AVC Tube	50 ohms
Plate	50 ohms

We want you to know that John F. Rider mailed several thousand questionnaires to service men at large and to owners of Volume No. 1, to determine what was wanted. The demands and requests as voted in the answers are contained in Volume No. 2. . . . We guarantee that it has no equal—and we back up this guarantee by making you the judge. If you don't like the manual—send it back and get your money. . . . This manual is as you want it to be.

Sold with a Money-Back Guarantee!

Use This Order Blank
Radio Treatise Co., Inc.
1440 Broadway, New York City

Here is \$5.00. Send me, postpaid, Rider's Volume No. 2 of the Perpetual Trouble Shooter's Manual. If I am not satisfied with its contents and return the manual in good condition within 10 days, you will refund my money.

Name.....
Address.....
City..... State.....

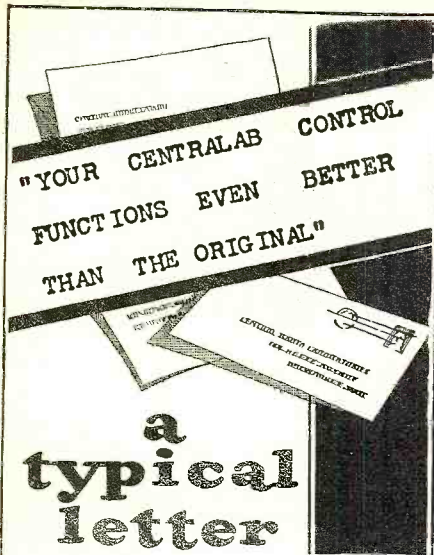

from a serviceman who has discovered the advantage of concentrating on Centralab Volume Controls.

Each and every Centralab control has been tried and approved for use in the various receivers specified in our Volume Control Guide. Even where the original control differs in appearance, or is of the wire-wound type, the Centralab unit invariably functions better.

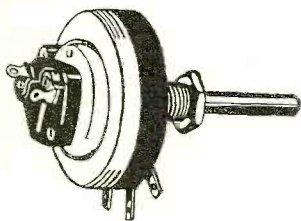

Order 5 Centralab Replacement Volume Controls and get the new 50c VOLUME CONTROL GUIDE FREE.

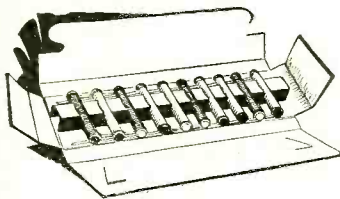

Get this service carton of 10 Centralab Fixed Resistors which list at \$3.00 for only \$1.75. FREE: the new QUICK REFERENCE WALL CHART showing resistance combinations at a glance.

Centralab

Central Radio Laboratories
Milwaukee, Wis.

Sounds That Microbes Make

(Continued from page 14)

both circuits is placed a transformer (T) which serves to transmit the frequencies to the amplifier.

The Amplifier Circuit

As soon as one deals with very accurate measurements, the construction of the amplifier plays a still greater part than for musical reproduction purposes. Only such amplifiers are suitable which are perfectly distortionless. The conventional type of resistance-coupled amplifier is best for this purpose. Figure 8 shows a circuit of such a four-stage amplifier. At a and b the "saw-tooth" oscillator, described above, can be connected. The amplifier is very simple. The coupling from tube to tube is through a condenser of 10,000 to 50,000 mmfd. and the supply to plate and grid potential takes place through high resistors in the usual manner. (R2, R3, R4 = .5 to 1 megohm; R5, R6, R7 = 1 to 2 megohms.) It is imperative that high-quality condensers and resistors are employed only. For the first three stages one utilizes hi- μ tubes and for the last one (VT4) a power tube of the necessary size. Here two tubes can be connected in parallel (as shown in dotted line).

The construction must be done very carefully. The coupling resistor should be rated

mfd. serves to by-pass undesirable frequencies. The bias of the tube is adjusted to cut off the plate current in the "rest" position. Each impulse transmitted to the grid by the transformer partly neutralizes the bias, and the resulting plate current energizes the relay. To the relay is connected the Morse recorder and the necessary battery. The complete set-up is shown in the photograph in Figure 11 and in the schematic in Figure 12.

The Possible Applications

The two circuits described here permit a recording of microscopic experiments of all kinds. Figures 13a and 13b show some illustrations. View (1) represents the microscopic image of a capillary tube through which a liquid is to flow. As soon as the color of this liquid varies in any way, we obtain by method (1) a reading of different magnitude which is directly proportion to the change in light intensity. As the coloring of the liquid depends on the quantities of coloring matter, we have here a way to measure the quantity of these substances. View (2) shows the forming of crystals. Similar studies can be made of red blood corpuscles, bacilli or other organisms. Here, too, a calibration of admitted light quantity

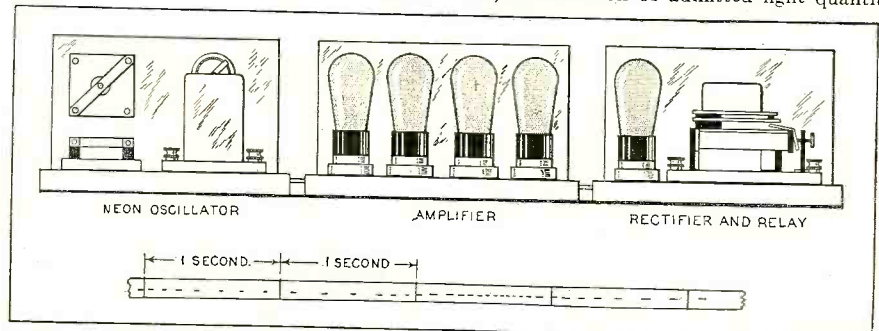

MECHANICAL LAYOUT FOR RECORDING APPARATUS

Figure 12 (Top). At the left is shown set-up for the neon oscillator; at center, the amplifier; and right, the rectifier and relay

TYPICAL RECORDING

Figure 14 (Below). This is how the records show on the tap as energized by the relay

at 2 watts. The bias for the first three tubes is very small (about -1.5 volts). For the last stage it should be about 1/10 of the plate voltage. The plate potentials can be rather high for the first three tubes, 120 to 150 volts. For the last tube use the manufacturer's specifications. If difficulty is experienced with audio feedback or high-frequency feedback, the small blocking condensers (C4, C5 = 50 to 100 mfd.) will relieve this condition. It is also recommended to place a 20-ohm resistor in series with the filament of the first tube. With many tubes the connection of a resistor (R8, .5 to 1 meg.) in the grid lead aids in quieting the circuit. Here also it is recommended to thoroughly shield the entire amplifier.

If one wishes to work with one tube less, connect the plate of the second tube to that of the third through a short-circuiting switch (K) and remove the third tube. For most purposes this three-stage amplifier suffices.

If the "saw-tooth" oscillations must be made audible, a loudspeaker can be connected to the last tube. However, if the fluctuations must be registered, this can be done with a Morse recorder.

It is only necessary to rectify the output of the amplifier. The diagram of this rectifier is simple (Figure 9). It consists of a transformer (T) which may have a rather high turns ratio and a power tube of moderate rating. The plate current energizes a relay (Re); the condenser (C) of 1 to 2

is possible, and it is clear that the growth of the crystals or the number of blood corpuscles can be measured. The number and increase of bacteria, etc., can be measured equally well.

To this purpose we can adjust the frequency of our "saw-tooth" oscillator—for a certain number per second, for instance—so that we hear 5 beats per second in the loudspeaker. When the crystal grows, the admitted light decreases more and more, and the number of beats decreases. If the bacteria multiply, the same result is obtained, but the opposite occurs when the red color of the blood corpuscles is neutralized by chemical means. View (3) shows a microscopic precipitate which is formed in gelatine and grows for a long time. Constant observation of its growth during many hours through the microscope would be impossible, but this experiment, too, can be registered on the Morse recorder, and one can determine later, without difficulty, whether the chemical reaction has been regular or irregular during this time by examining the spacing of the Morse signals. The taps is divided into equal parts by cross-lines before the experiment (Figure 14). View (5) shows a part of a micro-organism, greatly magnified. These organisms contain small bubbles (vacuoles) which contract. By careful treatment, one can color these organisms and their contents without killing them. This makes it possible to follow the contraction and ex-

pansion of such a vacuole under the microscope. The microscope must be adjusted to obtain as large a light fluctuation as possible. It is best to employ a field of the size of the dotted circle for the observations.

View (6) represents an experiment similar to that shown in View (3). It deals with the microchemical analysis of a substance by means of three different reagents—a, b and c. Three drops of each of these reagents have been placed on the substance to be examined, which has been embedded in gelatine. We see that the reaction is weakest at (a) and strongest at (c). Instead of observing all points at a time, we can measure each point photoelectrically and so obtain a clear picture of the reaction intensity.

View (7) shows an especially interesting experiment. On a glass slide are a number of micro-organisms in a thin layer of water; for this purpose lively and brightly colored organisms are preferable. In the water layer is placed a pointed instrument which either carries a trace of a chemical or brings an electric charge to the preparation. By this stimulus the organisms are either attracted or repelled from the point of excitation; they swim lively towards it or as far as possible away from it (chemotropic or electrotropic excitations).

The experiment can again be studied quantitatively, by listening to the loudspeaker or recording on the tape. The circuit of the neon lamp (Figure 7) gives a more impressive result. The beats in the speaker follow faster the more small animals are around

the stimulation point. During the experiment one still can anesthetize the animals with chloroform or apply other physiologic stimuli. So the cataphores of colloids, etc., can be studied photoelectrically. The experiments mentioned here represent, of course, only a small part of the great number of possible applications of the described methods. The writer hopes this description of his work will offer an incentive to further experimentation by others and will be glad to advise experimenters interested in these optical-aural methods for studying the microscopic.

The four photocells for these experiments were supplied to me by the firm of Otto Pressler, Leipsig. A few of the types used are shown in Figure 15. Both vacuum cells and gas-filled cells have been employed, varying from the smallest type of cell to the largest "giant" cell. During the experiments we worked with and without an eyepiece. As, however, the distance of the photocell to the eyepiece is small, it is recommended not to make the distance too small so as to illuminate the photocell in one small spot. The little photocells seem to be as useful as the larger ones, probably because the image is small. It is, of course, best to employ as strong a light source as possible, for which arc lights may be of advantage. However, these have the drawback of producing variations in the light intensity, whereas a perfectly steady light source can be had from low-voltage, high-power incandescent lamps with storage batteries.

New Tubes

(Continued from page 19)

voltage from the voltage divider or through a series resistance from the 250-volt tap. The screen current varies so little that the screen voltage remains practically constant. The latter scheme should not be used with a plate supply higher than 250 volts.

The suppressor may be given a bias with

puts. The volume can be controlled either by variation of the screen voltage or the grid bias. When the screen voltage is obtained through a series resistor, the variable grid-bias method is necessary. For larger input signals the -58 tube is better adapted; its super-control characteristic will prevent

	-56	-57	-58	ER-LA	WUNDERLICH
E _h	2.5	2.5	2.5	6.3 O.C.	2.5 6.3 D.C.
I _h	1.0	1.0	1.0	.30	1.0 .40
C _{cg-p}	3.2 MMFD.	.010 MAX.	.010 MAX.		
C _{cg-ct}	" "	5.2	5.2		
C _{p-ct}	2.2 MMFD.	6.8	6.8		
LENGTH	4 1/2"	4 19/32"	4 19/32" - 4 27/32"	4 11/16"	
DIAMETER	1 9/16"	1 9/16"	1 9/16"	1 13/16"	
BULB	S-12	ST-12 DOME	ST-12 DOME		BLUE S-12
BASE	SMALL 6 PIN	SMALL 6 PIN	SMALL 6 PIN	5 PIN	(RED) 5 OR 6 PIN
USED AS CLASS "A" AMPLIFIER					
E _p	250	250	250 MAX.	135 165	250
E _{sg}		100	100 MAX.	135 165	
E _{cg}	-13.5	-3	-3	-9 -11	
I _p	5	2.0	8.2	12 17	2-5 MA.
I _{sg}		1.0 MAX.	3.0 MAX.	2.5 3.5	
μ (AMP. FACTOR)	13.8	1500 PLUS	1280	100 100	12
R _p	9500	1.5 MEG. PLUS	800,000		12,000
G _m	1450	1225	1600	1900 2100	1200
G _m AT -40			10		
G _m AT -50			2		
E _{cg} FOR NO I _p		7 APPROX.			
POWER OUTPUT				700 MW. 1200 MW.	
LOAD IMPEDANCE				9500 8000	
USED AS PLATE CIRCUIT DETECTOR					
E _p	250 MAX.	250			
E _{sg}		100			
E _{cg}	-20 APPROX.	-6			
I _p	.2 WITH NO A.C. INPUT	.1			
USED AS GRID CIRCUIT DETECTOR					
E _p	45				250
GRID COND.	250 MMFD.				LESS THAN 100 MMFD.
GRID LEAK	1-5 MEG.				1 MEG.
USED AS FIRST DETECTOR IN SUPERS					
E _p			250		
E _{sg}			100		
E _{cg} WITH 9V. OSC. PEAK			-10 MIN.		

respect to the cathode for special purposes, such as volume control.

The -57 tube is especially adapted for radio-frequency amplification with small in-

cross-talk and distortion. It is claimed that a gain per stage of 200 is possible and practical if the plate load is a tuned circuit.

It is of the greatest importance that all

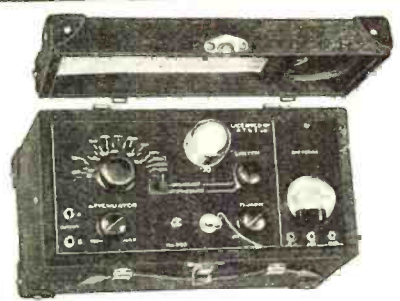

OSCILLATOR No. 550
(Licensed by A. T. & T. Co.)

Output adjustable to broadcast, low and high intermediate bands—130 to 1500 K.C. Direct reading—except for 200 to 550 K.C., which are obtained by sharp second and third harmonics.

Full instructions in cover. Heavy shielding throughout the attractive, leatherette-covered case.

Dependable. Accurate. Sturdy. No. 550—\$21.00 Net. No. 551—less output meter \$18.00 Net. Complete with batteries and tube.



RADIO INSTRUMENTS

No service man can afford to be without these dependable servicing instruments. Low in first and last cost.

Locating servicing troubles with Readrite equipment cuts your costs and makes greater profit per call.

No. 600 Set Tester makes every necessary test of radio receivers using Pentode and all types of tubes. Resistance, capacity and continuity measurement charts furnished. Simple to operate. \$18.00 Net.

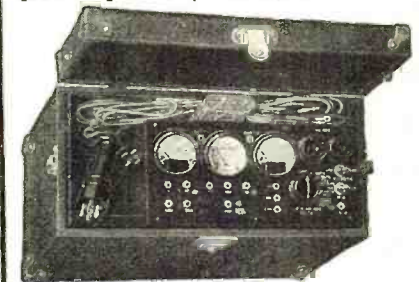

No. 600. SET TESTER

Readrite Meter Works
20 College Ave.
Bluffton, Ohio

Please send me information about Readrite Oscillator and No. 600 Set Tester. Also catalog of other servicing instruments.

Name

Address

City State

Readrite Meter Works

Established 1904

20 College Ave., Bluffton, Ohio

Experiment with PHOTO CELLS

\$50.00 KIT for \$10.00

It will open your garage doors at the flash of your headlamps—it will turn on the parking lights of your car when the sun goes down—it will detect thieves, fire or smoke in your home—it will count, match colors, operate switches, etc. The DeVry Kit comes to you complete. It uses the same genuine cesium cell that we use in talking pictures. This cell is ideal for television. You get cell, tubes, potentiometer, wire, resistances, relay, solder and complete manual with instructions showing how you can make marvelous devices in a few minutes time—all for \$10.00. Mail the coupon today.

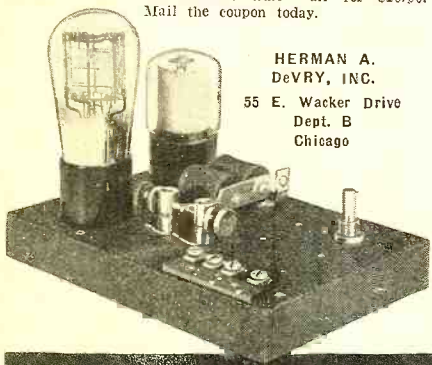

HERMAN A. DEVRV, INC.
55 E. Wacker Drive
Dept. B
Chicago

Herman A. DeVry, Inc., Dept. B, Chicago, Ill.
Enclosed is \$10.00. Send complete P. E. Cell Kit.
Name _____
Address _____
Town _____ State _____

COME TO SUNNY CALIFORNIA

and learn RADIO-TELEVISION TALKING PICTURES

Get your training in California where the great American Television Laboratories are located—where hundreds of trained sound Engineers and Mechanics are employed in the Studios of Hollywood. Scores of good jobs will be opening up—and you can prepare for them in 4 months of practical shop work in the great National School.

RAILROAD FARE ALLOWED

For a limited time we are including coach railroad fare to Los Angeles in our tuition, so the trip costs you nothing extra. Free Employment Service. Many earn while learning. Get the facts about this 25-year old Institution. Mail coupon for big Free Book.

National Television, Talking Picture and Radio School.
Dept. 711E, 4006 So. Figueroa St., Los Angeles, California.
Please send me your big Free Book on Television, Talking Pictures and Radio.
Name _____
Street No. _____
City _____ State _____

NATIONAL DISTRIBUTORS OF *Acratesl* **REPLACEMENT PARTS**
Power Transformers, Filter, and By-Pass Condensers, Volume Controls, Volume Dividers and Fixed Resistors.
Send for our free 100-Page Catalog
Federated Purchaser Inc.
25 Park Place Dept. A New York City

components of each stage are completely shielded and that all leads are by-passed in order to prevent feed-back. A double-section filter in the plate circuit may be required.

The Type -58 Tube

The triple-grid super-control amplifier tube is especially suited for radio-frequency or intermediate-frequency amplifier stages which include volume control, either manual or automatic. The mutual-conductance can be varied from maximum to about 2 microhmhos at a grid bias of 50 volts.

The appearance of the tube is similar to the -57. These tubes, types -56, -57 and -58, can be mounted vertically or horizontally. When horizontal mounting is employed, the two heater prongs should be vertically above one another.

The suppressor grid can be connected to the cathode and in that case serves to prevent secondary emission. If desired, however, it can be given an additional bias; new circuits can be designed which take advantage of the increased possibilities provided by the additional grid.

To realize the full benefit of the variable-mu properties, the grid bias should be varied while keeping the screen voltage constant. If the grid bias is obtained by means of a variable resistor in the grid circuit, the screen voltage becomes less while the bias is increased. This can be neutralized if a suitable resistor is inserted in the screen-supply lead. The varying drop across this resistor can be made to approach the change caused by the increased control-grid bias.

As a first detector in superheterodynes the -58 tube may give a gain of 1/3 of the possible gain in an intermediate-frequency stage. Moreover, the gain can be controlled by varying the control-grid bias, either manually or automatically, which is a great improvement in making a receiver that is sensitive but that can handle strong signals without blasting or overloading.

The minimum grid bias under those conditions should be 1 volt more than the oscillator peak voltage. It is reasoned that the minimum bias be used only when the input signal is very weak, so that the sum of oscillator and signal voltage is practically no more than the oscillator voltage. An interfering signal of approximately 1 volt may be present, and for that reason a bias is recommended which prevents the grid from becoming positive.

If the variable-mu feature is not employed, the grid bias should be equal to the oscillator voltage, plus the signal voltage of the strongest signal expected, plus the voltage of any possible interfering signal. Peak values of these voltages should be used for the computation.

The -58 tube is not efficient as a plate detector—grid-bias detector—because of its remote cut-off point. In order to realize any detection, the bias would have to be so large that the tube loses its efficiency.

Neither the -57 tube nor the -58 tube is recommended as a dynatron oscillator.

The Wunderlich Tube

A new push-pull detector tube has been announced by the Arcturus Radio Tube Company. This tube, which derives its name from Mr. Norman E. Wunderlich of Chicago, Illinois, employs two grids at the same distance from the filament.

The push-pull circuit of detection makes possible the combination of the superior selectivity of the grid detector with the greater power-handling abilities of the linear detector, and consequently greater output. There is no radio-frequency energy in the plate circuit, the latter being canceled out by the two grids, which are 180 degrees out of phase at the carrier frequency but in phase at the modulation frequency. The tube ad-

justs its own bias according to the amplitude of the received carrier. The varying grid bias can also be used to control the grids of other tubes without interfering in any way with the proper functioning of the detector.

Three functions are thus obtained from this one tube. It acts as a full-wave grid detector, a one-stage amplifier and as an automatic volume-control tube. The output is said to be four times the detector output of a triode. All signals, weak or strong, are handled with equal fidelity.

The circuit employed with this tube is shown in Figure 5. Let us concentrate on the detector action first. This circuit is equivalent to a regular full-wave rectifier hook-up such as is used in a B supply. When the coil of the tuned circuit is accurately center-tapped, the one grid will go as much positive as the other goes negative, and, as far as the plate circuit is concerned, there is no change. Current will flow, however, to the grids, in turn, and this current will establish a potential drop across the grid leak. As long as the radio-frequency carrier is not modulated, the voltage drop will be steady, but when modulation starts, it follows the modulation frequency, provided the capacity and resistance ratio has been properly chosen.

The audio-frequency component of the mentioned potential drop is applied to both grids in parallel, and an amplified reproduction of it is found in the plate current. Since there is no radio-frequency component in the plate circuit, no radio-frequency filter is necessary. This effect also permits the handling of larger signal voltages.

The rectified signal is applied to both grids in parallel, and for this action the principles of the tube are the same as for any triode. Its plate characteristics are shown in Figure 6. Resistance coupling is recommended for the coupling to the output tube. If transformer coupling is used, the plate current should be limited to approximately 12 ma. when no signal is being received. This can be done by a series resistor in the plate lead.

The grid condenser may vary between 50 and 100 mmfd., depending on the capacity of the leads in the circuit. Under these conditions the grid leak can be 1/4 megohm, for high quality, and from 1/2 to 1 megohm if sensitivity is of greater importance than fidelity or when compensation is to be made in the audio amplifier.

When the varying grid bias is to be used for the control of the radio-frequency amplifier, the audio-frequency component has to be filtered out. This is done by means of the resistance and condenser combination shown at R and C in Figure 5.

The condenser should be large enough to offer a practical short-to-ground for all modulation frequencies. It should have a high leakage resistance. The resistance R should be several times as large as the grid leak, so as not to spoil the detection characteristics.

Two technical bulletins on the Wunderlich tube, one written by the inventor and the other, more technical, by Professor Frederick E. Terman of Stanford University, are available to RADIO NEWS readers on request. Address your requests to RADIO NEWS, Department W, 222 West 39th Street, New York City.

The ER-LA Tube

An automobile pentode having an output power equal to the -47 tube has been announced by Raytheon Products Company. The maximum power output is 1200 milliwatts, with a signal input of 11 volts peak value.

It has been found that a filament heater allows a better mutual conductance; therefore the -LA has a filament of the oxide-coated type, similar to that of the -33 but

more rugged, to withstand rough treatment in the automobile.

The tube has been so designed that it can operate from either 135 or 180 volts B supply, getting the grid bias from the same battery.

Load impedance can be chosen for minimum second-harmonic distortion. The second harmonic is zero, for a load of 8,000 ohms, but the third harmonic is still ten percent high. More economical and distortionless amplification can be obtained by operating two tubes in push-pull as a Class B amplifier. The design of the tube permits

the C bias to be obtained through a resistance of 900 ohms, between A— and B—. The usual condenser should be connected across the bias resistor.

The even harmonics cancel out in this case, and the plate load can be chosen for lowest third-harmonic distortion. Figure 8 shows the plate current, output power and third-harmonic distortion plotted against load impedance for the LA, the -38 tube and the -47 tube. With a load impedance of 20,000 ohms, the distortion is minimum, about three percent, and the output is nearly equal to that of the -47 tube.

Fringe Howl

(Continued from page 28)

and R is the circuit resistance. Other factors also determine the presence or absence of fringe howl, the capacity of the by-pass condenser, C, for example, but in general these are so small that they may be ignored.

When use is made of plate rectification a different situation is encountered. Although this type of detector is rarely used in high-frequency receivers, a discussion of fringe howl in this circuit will serve to complete the subject. With a grid-bias detector,

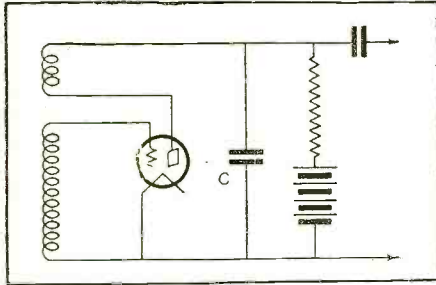

Figure 4. This shows the circuit of Figure 1, rearranged for parallel plate supply. Isolating the transformer from the d.c. plate supply solves the fringe howl problem

as opposed to the grid-leak detector, the average plate current rises when oscillation begins and hence the above discussion of fringe howl in the "leaky-grid" detector does not apply. Fringe howl will only occur in plate detection when resistance coupling is used with a comparatively large by-pass condenser connected between its plate circuit and the negative return, as in Figure 3.

Reasoning similar to that used in the grid-leak case may be applied here. In the grid-bias detector the rise in plate current with the commencement of oscillation is concurrent with an increase in the voltage drop across the plate-feeding resistor. Initially the by-pass condenser is charged to the battery potential, minus the voltage drop in the resistance caused by the normal plate current of the vacuum tube. Advancing the oscillation control, the drop across the plate resistor increases, but the charge on the condenser maintains the plate voltage applied to the tube until the charge is discharged through the tube resistance. When the charge on the condenser reaches the voltage of the battery, minus the increased drop in the resistance, the tube ceases oscillating and the plate current falls. The plate e.m.f. rises, delayed, however, by the charging of the condenser, and the cycle is repeated, resulting once more in fringe howl.

We now turn to ways and means of curing fringe howl. For a long time radio amateurs were alone in their struggle against this receiver malady. By their oftentimes unscientific, but nevertheless effective, experimenting, they found that a resistance placed in parallel with the first audio-fre-

quency transformer secondary usually eliminated the fringe howl. In the light of the preceding discussion, speaking only of grid-leak detection, it is apparent that its function is to dissipate any e.m.f. that may be developed across the transformer primary. This method is not without its disadvantages, however. In difficult cases of fringe howl the resistance value must be so low that a large portion of the signal, as well as the fringe howl, is lost. If the resistance must be much less than 50,000 ohms, it is uneconomical of signal strength to resort to this method.

Since an inductive impedance must be in the plate circuit of the grid-leak detector to make fringe howl possible, a convenient way to eliminate it is to use resistance coupling of the detector to the succeeding a.f. amplifier. Transformer coupling has its advantages and some designers might not be willing to forego the additional gain attainable with transformer coupling. The solution, then, is to use a combination of the two systems. Such a circuit is shown in Figure 4, in which the detector plate voltage is led through a resistance, but the audio-frequency component is taken off by a transformer.

At present the plate rectifier is rarely used as an oscillating detector, but it is clear that, in cases of this kind where fringes howl is encountered, it may be eliminated by either turning to transformer coupling or by reducing the size of the by-pass condenser and increasing the tickler size proportionately to compensate for the change.

What Television Needs

(Continued from page 15)

of entertainment different from anything else is concerned. The talkies likewise suffered a period of experimentation in which the motion-picture industry sought frantically to evolve a technique with which to protect its huge investment. It will be still more difficult to evolve a form of television presentation. But that work must be done. And it were far better to do it now when the investment in the television industry is relatively small than to be forced to rush about haphazardly to protect a giant.

The television technicians are more than willing to co-operate with entertainment interests in providing programs of entertainment value to the public rather than merely of scientific value to engineers. Television executives are willing to share the profits of many long years of technical research with entertainment interests who can show them how to popularize television, which must be done through the program end. The television industry, manufacturers and dealers, are prepared to produce and merchandise television transmitting and receiving equipment in accordance with the increased demand built up by programs.



June . . . the exciting nominating conventions of both political parties, and then . . . "the battle of the century" . . . marking the peak for all time in number of radio listeners per hour. No radio owner wants to miss any part of this gripping drama . . . the oratorical onslaughts . . . and the tense final hours. Time is ripe now . . . to canvas phone or write, lists of radio owners for a check-up and replacement service. And with this instrument so marvelously complete, accurate and speedy, you can make more service calls at less manpower cost and greater production profit. Designed to anticipate every possible "new" type or development in radio receivers. Say "Let's Go to Radio's Busiest Summer" by equipping with radio's most amazing service instrument—

**SUPREME
DIAGNOMETER
AAA-1 \$147.50**

5

ultra modern testing instruments in 1 for the price of

1



With only a coupon between you and increased profits, you can't afford to buy any testing instrument until you have sent the coupon below for full information on AAA-1 and the SUPREME Instruments as follows:

Model 90 Supreme Set Analyzer	\$7850
Model 60 Supreme Oscillator	\$3000
Model 70 Supreme Oscillator	\$4975
Model 40 Supreme Tube Tester	\$3000

All Prices Dealers' Net Price, F.O.B., Greenwood, Miss. Good Jobbers everywhere ready to demonstrate.

SUPREME INSTRUMENTS CORPORATION
436 Supreme Bldg., Greenwood, Miss.

Please send me full particulars on

(Here specify those interested in)

Name.....
Address.....
City.....State.....
Jobber's Name.....
City.....State.....

Build Your Own Service Equipment



TYPE 6-M

Smallcross Wire-Wound Resistors, calibrated to an accuracy of

1%, are standard equipment in the construction of the following circuits which are indispensable in laboratory and service work:

- Radio Set Analyzers
- Multi-Range Voltmeters
- Multi-Range Ammeters
- Wheatstone Bridge
- Capacity Bridge

TYPE 6-T



And other high-grade test equipment.

Send 4c in stamps for Bulletin 160-D, which fully describes a modern, convenient set analyzer which you can build yourself.

Smallcross Mfg. Company
 ALWAYS Super AKRA-OHM ACCURATE
 ELECTRICAL SPECIALTIES
 700 PARKER AVENUE
 COLLINGDALE, Pa.
 ACCURATE RESISTORS

A SHORT WAVE CHASSIS

The RELIABLE SW 2

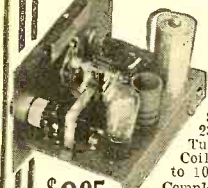

A 2-tube set—one 232 Screen Grid Detector—one 233 Pentode Audio Power Tube—3 Low-loss Plug-In Coils reaching a band from 14 to 105 meters.

\$9.95

Completely wired with a full vision open scale dial with pilot light. Panel 7 x 11. Base 6 x 10. Built with standard merchandise, including Hammarlund Isolantite Condenser. Guaranteed loud-speaker reception. Metal cabinet. Sent C.O.D. charges collect. Order today.

Radio Surplus Corp. 56 No. Vesey St. New York, N. Y.

REX RABBITS

us. We pay up to \$12 each for all you raise. Send 25c for full information and contract. Everything explained. Send at once and find out about this big proposition. Make this a profitable year.

THE EASTERN RABBITRY

Route 1, Box 236 New Freedom, Pa.

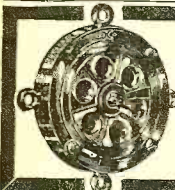

UNIVERSAL MODEL "X" 2-Button Microphone
 Advanced 1932 superiority at rock bottom prices. Pure gold contacts. Duramin diaphragm. Exceptionally rugged. Same high standard as a price that defies competition. Price \$10.00.
 Universal Microphone Co., Ltd., 424 Warren Lane, Inglewood Calif., U.S.A.

Group Hearing Aids

Selling and installing group hearing equipment for the deaf in churches, theatres, etc., opens a new field to enterprising servicemen—a field which is not highly competitive and is unusually profitable. Write for Bulletin B-3 which points out its possibilities in detail. Also Bulletin H-5 containing price lists on all parts for

The Radio News A. C. Multi-Ear Aid

and also bulletins covering all other individual and group hearing aids described in recent issues of Radio News. Complete parts in stock. Discounts to bonafide servicemen and dealers.

WILLIAM H. BRODERICK
 40 East 49th Street New York, N.Y.

Below Ten Meters

(Continued from page 17)

This may be due to one or more of several causes. The interaction of the two circuits is such in a superheterodyne that a signal variation may cause a change in the oscillator load condition, and at the same time a change in the oscillator plate voltage, either variation being sufficient to shift the oscillator frequency. A less immediate and secondary drift may be occasioned by temperature variations in the elements of the oscillator tube, due to a primary change in the load. The oscillator frequency being definitely a function of heaters and plate voltages, frequency drift will also be effected by the inevitable fluctuation in line potential.

tronic-coupled oscillator will be assimilated when it is mentioned that such oscillators operating in transmitting circuits at 24,000 kc., or 12.5 meters, have been declared the equal of crystal-controlled systems.

The completed superheterodyne is shown in the photograph in Figure 6.

An Ultra-Short-Wave Converter

A quasi-optical converter is recommended to the experimenter who does not care to inaugurate his 5-meter tests with the superheterodyne and yet desires something more sensitive than the simple detector arrangement and more flexible than the superregenerator. Such a device is highly satis-

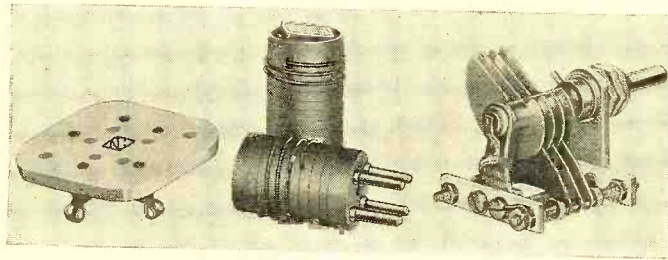

ULTRA-SHORT-WAVE PARTS

Figure 1. Socket, coils and tuning condenser specially designed for ultra-short-wave reception

These effects can be reduced to practical elimination by the use of electronic coupling between the actual oscillating circuit and the circuit supplying the oscillator frequency to the first detector or mixing tube. In Figure 5, both the screen-grid and the plate of the oscillator tube function as anodes, the screen-grid, the control grid and the cathode being the elements of a triode oscillating system. These oscillations cause a periodic or pulsating flow of plate current in an altogether independent load or work circuit. Thus there is no capacitive, inductive or any interactive coupling between the frequency-determining circuit and

factory and can be used in front of either a standard broadcast or a conventional short-wave receiver. Photographs Figures 7, 8 and 9 show the laboratory evolution of a very successful ultra-short-wave converter.

Our original converter experiments employed an odd circuit in which an effort was made to utilize a multi-element tube in a semi-autodyne arrangement. While experiments with this converter indicated several interesting possibilities, it was abandoned for the three-tube unit shown in Figure 7, employing a -36 tube as a plate-rectification first detector, a similar tube as an electronic-coupled oscillator and a -37 in an i.f. stage tuned to 1550 kc. Following painstaking experimentation, it was discovered that by the use of grid rectification, in conjunction with a suitable i.f. trap circuit, with the correct degree of oscillator coupling, the sensitivity was so increased as to eliminate the justification for the intermediate-frequency stage. (Figure 8 and 9.)

The trap circuit favors the intermediate

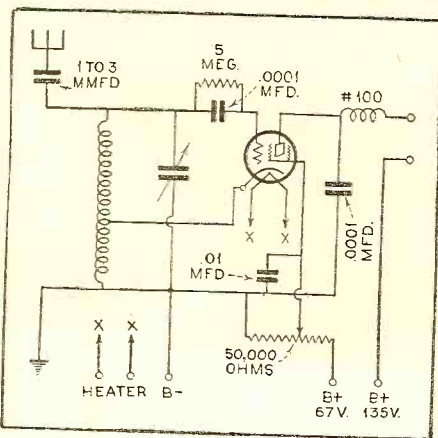

ONE-TUBE CIRCUIT

Figure 2. Circuit diagram of a simple ultra-short-wave receiver—to be followed by audio-frequency amplification

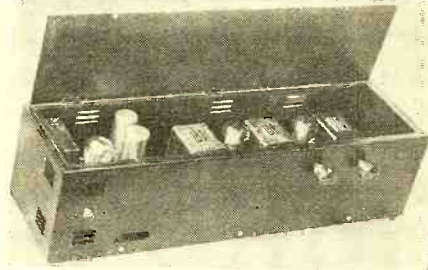

AUDIO AMPLIFIER FOR ONE-TUBE SET

Figure 4. A high-quality, high-gain audio channel for use with the single-tube ultra-short-wave receiver

the rest of the receiver. The frequency of the oscillator is also independent of any reasonable fluctuation in plate or heater voltage caused by line variations, due to the fact that such changes set up counteractive effects between the two anodes.

The general effect is comparable to the increased frequency stability secured by using a buffer stage in a master-oscillator circuit. An idea of the stability attained in an elec-

frequency, resulting in considerable amplification—the output, in effect, being impedance-coupled to the receiver. The coil and condenser must be of low-loss design, Litz wire being almost essential. The L/C ratio should be high, the condenser having a capacity in the neighborhood of 30 mmf.

(Continued on page 58)

Novel Wave-Changer

(Continued from page 37)

others. Thus when the switch is set for the broadcast band, all contacts marked with the number 4 on the diagram (Figure 4) are "made," and all contacts marked 1, 2 and 3 are left open. All unused coils are therefore electrically isolated from the used circuits, avoiding dead-end losses.

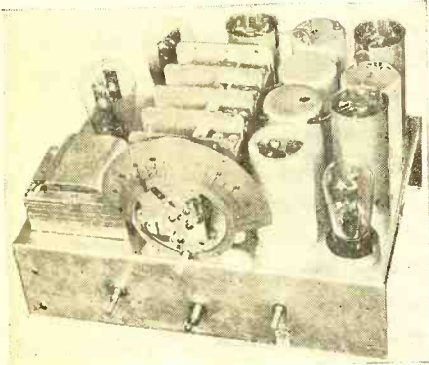

The Chassis

Many coil-switching arrangements have the disadvantage that they cause relatively high losses through absorption of the signal energy by the coils not in the circuit. These losses have been greatly reduced in the "Dragon" receiver by various means. Principal among these is the selection of coil values such that the natural periods of unused coils will not fall within the tuning range of the used coils and therefore will absorb and waste little of the signal energy. The partial shielding provided by the metal chassis itself helps further to reduce undesirable coupling which might result in absorption losses. This latter is particularly

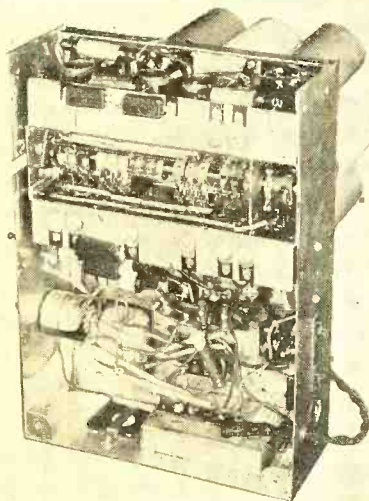

Under the Chassis

effective so far as isolating the broadcast-band coils from the short-wave coils is concerned, especially as the broadcast coils are inclosed within cans where they project above the base. Other features of the engineering design of the receiver also work toward the end of high efficiency, with absolute simplicity of operation.

From the standpoint of the user of an all-wave receiver, the elimination of plug-in coils represents a decided advance in the matter of convenience. Combine this advantage with one-dial tuning (as is done in the receiver shown here), and all-wave radio is brought down to the simplified operation demanded by the average broadcast listener.

Announcing THE GREATEST RECEIVER

in Radio History—

All the Record-Breaking Performance of Past Models, plus

14
Outstanding Features

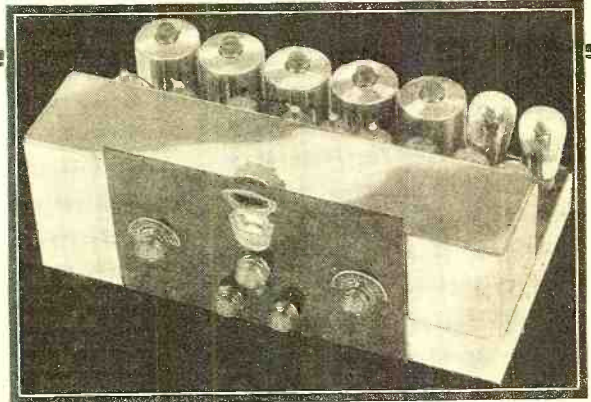

Lincoln Presents the New De Luxe 33, a Revolutionary Innovation in Design—

Records made by Lincoln Super-Powered receivers are well known the world over—records made by individual owners of Lincoln receivers *right in the home, not by the manufacturer under favorable conditions!*

NOW FOR THE FIRST TIME starting new developments have been perfected by Lincoln engineers making possible the most sensational performance which has been the dream of every radio fan.

WHEN RECEIVER IS TUNED TO RESONANCE all back ground noise is reduced to a minimum, and only the signal is heard.

YOU CAN TUNE IN A LOCAL station, reduce volume to minimum and tune every channel with equal volume without touching the volume control.

YOU CAN ENJOY PERFECT AUTOMATIC VOLUME LEVEL on short-wave signals.

YOU CAN TUNE TO PERFECT RESONANCE by meter, producing complete register of musical frequencies impossible to adjust by ear.

YOU CAN HAVE AUTOMATICALLY INCREASED SENSITIVITY on low volume for the first time eliminating static and noise.

YOU CAN HAVE AUTOMATICALLY INCREASED HANDLING POWER on strong signals.

YOU CAN HAVE FIDELITY AND MARVELOUS TONE QUALITY over a wide range of musical frequencies. You can have automatically increased bass register at low volume, just the reverse in any other receiver.

YOU CAN HAVE FINE MICRO-METER TUNING FOR SHORT-WAVE (36-1) or a normal ratio for broadcast.

YOU HAVE TREMENDOUS SUPER-POWER for any volume at any distance with high sensitivity.

Whatever you have heard or experienced in Lincoln or any other equipment, just add a few of the above revolutionary developments, and imagine what a great receiver you can own.

Write For complete information on Lincoln's new developments

LINCOLN RADIO CORPORATION

N-7, 329 S. Wood Street, Chicago, Ill.

The HAND That Encircles The WORLD

You Can Make BIG MONEY

There is romance and fortune in radio and telegraphy. Become an expert operator. Learn IN YOUR OWN HOME—easily, quickly, with TELEPLEX—the Master Teacher.

Entirely new code course in 12 rolls of tape. During last ten years TELEPLEX has trained more operators than all other methods combined.

Write for Folder "E-7"

TELEPLEX CO.
76 Cortlandt St.
New York

Teleplex



GET THIS

Free new No 23. Edition of our greatly enlarged RADIO SERVICE TREATISE. Every radio man must have it. Contains some 75 new hook-ups, circuit diagrams; over 350 illustrations. POSITIVELY THE GREATEST BOOK EVER PUT OUT BY ANYONE. Editorial contents: VACUUM TUBE TREATISE, with many illustrations; Vacuum Tube Average Characteristics Chart; How to Take Care of Your Tubes. How to Connect Phonograph Pick-ups. Improving Tone Quality of Old Sets; Connecting Additional Loud Speakers; all fully illustrated with diagrams. Other articles: Modernizing Old Radio Sets; How to Convert Battery to Power Sets; Selection of Tubes; Push-Pull Amplifiers; Replacing Audio Transformers; Photo Attachments; How to Choose Power Transformers; Voltage Dividers; Wattage of Power Transformers; Selecting and Installing Replacement Parts in Radio Sets; Filter Condensers; Repairing Eliminators, etc.

WRITE TODAY. Enclose 2 cents for postage. Treatise sent by return mail.

RADIO TRADING CO.
27 West Broadway New York City

MARQUETTE

AUTO RADIO

Sensational all Wave
9 TUBE SUPER-HET.



MARQUETTE STEERING POST MOUNTING
SNAP ON MOUNTING
NO TOOLS REQUIRED (PAT. APPL'D FOR)
REMOVABLE CONTROL (MARQUETTE PAT. APPL'D FOR) ALL WAVE
RECEPTION (151-550 METERS - PENTODE (RF AND AF)
LATEST CUNNINGHAM TUBES - ELECTRO DYNAMIC
SPEAKER - PUSH PULL PENTODE - AUTOMATIC VOL-
UME CONTROL - FULL VISION DIAL
MONEY BACK GUARANTEE. 10 DAY FREE TRIAL
PRICE COMPLETE \$49.50
WITH CUNNINGHAM TUBES AND EVERY READY BATTERIES

MARQUETTE RADIO INC.
110 West 18th St. NEW YORK
DISTRIBUTORS - DEALERS
WRITE FOR TERRITORIES NOW

HEARING AIDS!

Over 5,000,000 Deafened people in this country need hearing aids.
The DeForest Audiphone is the most efficient portable hearing device known—made in 5 sizes ranging in price from \$37.50 to \$75, it offers to the progressive radio dealer a splendid new field.

Theatre and Church Installations

Special circulars on request

Make the radio news amplifying
Hearing aid-circuits free

HEARING DEVICES COMPANY, INC.
2466 Times Bldg., Times Square, New York

TALK-SING-PLAY thru your own radio



BROADCAST your voice on programs coming through your radio set — make announcements from any part of house — inject wise cracks, josh and mystify friends. "World Mike" made especially for home use, attached in jiffy, any set. Not a Toy. Also put on own programs at home, parties, club affairs. Barrels of fun! Deluxe model "World Mike" with directions, \$1.50 postpaid. (C.O.D. 22c extra.)
DEALERS—write for our special proposition.
WORLD MICROPHONE CO.

Dept. 1049—718 Mission St., San Francisco, Cal.

Grammar at a Glance

Speak and write correctly! Win business and social success. Here is a new method for simplifying English grammar that removes the mystery and makes learning easy. Self-testing system included. See improvement immediately. Written by Columbia University teachers. Send no Money. Pay postman only \$1.25, plus postage. Refunded if not satisfied.

D. VAN NOSTRAND CO., 250-N 4th Ave., New York

SERVICE MEN

delighted with the New ELECTRAD RESISTOR REPLACEMENT HAND BOOK. Accurate guide to resistor values in all receivers. Loose leaf. Fabrikoïd cover. \$1.00 complete, including 4 supplements a year.

Write Dept. RN-7 175 Varick St., New York, N.Y.
for Details **ELECTRAD**

Antenna Tuning Unit

(Continued from page 23)

voltage nodes and loops move along the antenna as the frequency of the tuned circuit is varied. In general, the antenna circuit is tuned while the secondary circuit is also tuned and coupled to the antenna by means of mutual inductance between the coils in the primary and secondary circuits. When the antenna circuit is adjusted to the proper current loop point, a current taking place within the antenna coil will induce an e.m.f. in the secondary coil. If both circuits are properly tuned to the incoming signal, the current received from the signal will be relatively much larger than currents produced by interfering signals. Since the e.m.f. of signal frequency induced in the secondary circuit produces relatively large currents, and a larger resonant voltage across the coil system, it must be transferred capacitively to the detector circuit. Thus, it is at once understood that a condenser-coil combination as illustrated in Figure 1 will permit a variation of voltage and current distribution along the antenna to be adjusted at will, resulting in a reduction in losses of signal voltage.

The signal is fed to the detector circuit through the variable condenser C1. The correct value of this condenser is .0001 mfd., and should be set for obtaining maximum results at 80, 40, 20 and 10 meters. The readings giving maximum results for each band should be marked on the dial controlling the condenser C.

If the antenna coupling unit as described in this article is employed ahead of a radio-frequency amplifier, increased selectivity will be obtained with a moderate gain in signal strength due to very little change taking place in the effective resistance of the antenna circuit. Also, an additional gain is made possible by operating the antenna on the proper distribution point of current and voltage loops.

After the circuit has been built and connected as shown in Figure 1, it should be tuned to resonance with the detector circuit, and the capacity of the condenser C1 decreased until the detector circuit will oscillate vigorously with an increase of several divisions of the regeneration control dial. In order to obtain maximum results, the regeneration dial is increased to about six divisions higher than was required for previous operation, and the coupling capacity

both circuits to resonance without stopping the detector from oscillating.

The circuit as shown in Figure 4 gives uniform results as to signal intensity, along with any desired degree of selectivity. It must be remembered that the closer the coupling between the circuits, the larger the fraction of power which is transferred to the secondary, however, as the coupling is increased the resistance of the primary is increased. Thus the power taken by the primary circuit from the signal is reduced. In fact, the maximum power is obtained in the secondary circuit when the increase in resistance of the primary due to the coupling is equal to the resistance of the primary by itself. For this reason, there is an optimum coupling where the greatest signal strength is obtained along with increased selectivity. A further gain in selectivity is made possible by decreasing the antenna coupling. The coupling coil is made variable and is controlled by a knob from the front panel.

The condenser C2 is a .000075 mfd. type and is placed in series in the antenna circuit and reduces the total antenna capacity as the condenser capacity is reduced, hence the shorter the wavelength to which the antenna circuit is tuned. It is therefore quite evident that a considerable range in wavelengths can be covered with one plug-in coil. The switch S enables the operator to short the series condenser, leaving the antenna loaded, which will change the distribution of the node points along the antenna.

Coil-Winding Data

Band	Antenna Coil	Secondary Coil
80-meter band	7 turns	22 turns
40-meter band	5 turns	13 turns
20-meter band	4 turns	5 turns
10-meter band	3 turns	3 turns

All coils are wound on 2-inch bakelite forms with No. 22 enamel-covered wire.

The wire is wound 18 turns to the inch. The antenna coils for the circuit shown in Figure 1 are spaced 1/2 inch from the secondary coil. The variable antenna coupling coil for the circuit shown in Figure 5 is scramble wound and is made large enough in diameter to go over the secondary coils.

Below Ten Meters

(Continued from page 56)

Since the trap is connected to the high r.f. side of the signal circuit, the capacity to ground is minimized by mounting the trap close to the grid connection of the tube.

Values of grid condenser and leak are not critical, but the potential to which the grid leak is returned must be between 8 and 14 volts for highest efficiency.

As this type of detector operates with the grid slightly positive, very loose oscillator coupling is employed to reduce the possibility of overloading the grid circuit. The coupling condenser has a value of between 3 and 4 mmf. and other coupling resistor 20,000 ohms. Obviously, unless adequate shielding is used, the stray capacity between the circuits will provide sufficient but uncontrolled coupling, and if the shielding is unsatisfactory it is possible that the detector will be overloaded with no direct connection to the oscillator.

Figure 10 is the circuit of the ultimate converter, which will also receive detailed description in an early issue.

C1 decreased until it is possible to tune

A Correction

Here is the corrected diagram of the adapter A (for screen-grid tubes) shown in Figure 4 of Mr. Gerber's article on "The Complete Service Unit." This article appeared in the April issue, page 855.

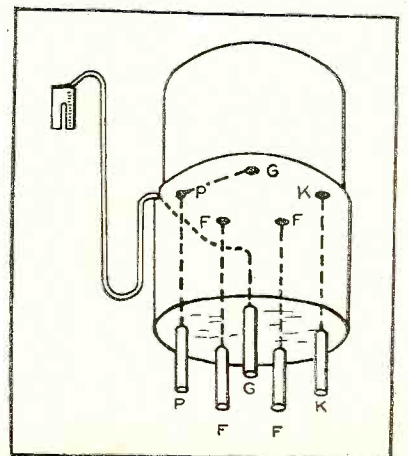

What Tube to Use?

(Continued from page 36)

tubes of the same general classifications such as 3-element and 4-element tubes can be compared using the grid-voltage-grid current curves for grid detection circuits and the grid voltage-plate current curves for plate detection circuits. In any given class, the tubes having the steepest curves will give best results, all other factors being equal. In judging the steepness of the curves it is important that the curves of different tubes be plotted on the same scales.

In general, the screen-grid tubes will be found more efficient for use either as grid circuit or plate circuit detectors. They will provide greatest sensitivity as grid circuit detectors and are capable of giving more uniform, more stable and better reproduction, though with less sensitivity, when used as plate circuit detectors. Under proper operating voltage conditions, a -24 type screen-grid tube, for instance, will handle an input of over 4 volts r.m.s. with 22 percent modulation and produce an output of over 49 r.m.s. audio voltage output, which is more than sufficient to swing a single stage -45 output tube by direct coupling, or a push-pull -45 stage by means of a low-gain transformer stage.

While the -22 and -32 type screen-grid tubes make sensitive detectors, they can be used only where the amplification following is not excessive, because with high amplification these tubes have a tendency to be microphonic, due to their light filament construction.

When screen-grid tubes are used as plate circuit detectors, it is possible to obtain about the same level of sensitivity as is obtainable with 3-element tubes operated as grid circuit detectors, but with the additional advantages of more stable and uniform performance and much better fidelity of reproduction due to the advantages of linear over square-law operation of the detector.

In choosing between the use of a screen-grid or a 3-element tube as a detector, however, one of the most important factors to take into consideration is the provision of proper load impedance.

With the 3-element tubes, the low plate resistance of the tubes makes it possible to use transformer coupling between the detector tube and the power tube or tubes, thus permitting the use of push-pull amplification in the power stage and the step-up which can be obtained by the use of a transformer. For best results the load impedance used with a 3-element tube should be at least twice the plate resistance of the tube at the lowest frequency which it is desired to reproduce.

When using screen-grid tubes, however, it is usually necessary to use resistance or impedance coupling, in order to easily and economically provide the required high impedance loads recommended in the accompanying table.

In general, screen-grid tubes, with their greater sensitivity, should be employed when they are to be used in connection with a single output stage and when cost must be kept down to an absolute minimum, whereas the 3-element power detector can be used when it is desired to use push-pull amplification in the power stage and where the voltage which must be fed into the grid circuit of the power stage (the step-up ratio of the transformer included) is not very high and does not require very high detector output. This is the case, for instance, when using pentode tubes which require comparatively low input signal to operate them at their maximum rated output.

The numerical value of the negative grid bias required when using a given 3-element tube as a plate circuit detector is approxi-



NEW as the TRIPLE GRID TUBE

Specialized training in radio and radio service, photo-electricity, sound pictures, and television.

Practical Training With Home Study
The open Road to Independence faces you. Make the first step up this road and we will help you along the rest of the way.

SEND THIS COUPON

PENNSYLVANIA RADIO AND TELEVISION INSTITUTE, INC.

1512 Walnut St., Philadelphia, Pa.

Please send me booklet, "Profitable Road To Independence".

Name

Address

City and State



DEPENDABLE—PERMANENT—EFFICIENT



Improve your present equipment with a Bud Speaker

We manufacture all types of horns that are ideal for in-and-outdoor P. A. Installation. Special throats carrying two or more BUD SPEAKERS can be supplied. Write for descriptive literature.

BUD SPEAKER COMPANY
625 Board of Trade Building
Toledo, Ohio, U. S. A.

BUD LOUD SPEAKERS eliminate such disturbances as distortion under pressure, overheating, unbalanced tone, and background noises, etc. The new and exclusive diaphragm and voice coil assembly embodies every essential for positive, permanent and dependable performance. Unaffected by temperature or humidity.

BUD ALUMINUM TRUMPET HORNS cannot be overestimated, clear, bell-like and astonishingly realistic in tone—light in weight—and free from all the dangers of exposure and atmospheric changes.

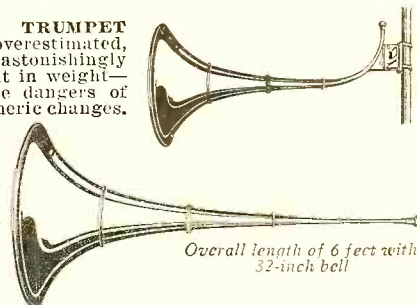

Overall length of 6 feet with 32-inch bell

ULTRA SHORT WAVE

Receiver Kit for 5 Meter Band
Transmitter Kit for 5 Meter Band
Get Our Prices

"BELOW TEN METERS"

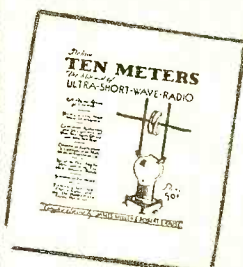

A HANDBOOK OF ULTRA SHORT-WAVE RADIO

First and only book of its kind. Compiled by James Millen and Robert S. Kraus. Full of new and highly interesting information "How to Build," etc., etc. Send stamps, coin or money order.

PRICE 50c

NATIONAL 3 TUBE TUNER ONLY \$10.88
DeForest 503A 50 Watt Tubes \$14.90 each
Antenna Wire No. 12, 100 feet, 45c
Chirad Porcelain Standoff Insulators, 10c, 90c. doz

Send 10c for 100 Page Catalog
CHICAGO RADIO APPARATUS CO.
417 S. Dearborn St. Dept. RN-7 Chicago, Ill.

F. & H. CAPACITY AERIAL



Price \$1.00 Complete postpaid
Every Instrument Tested on Actual 1127 Mile Reception
A LARGE NUMBER ARE IN USE BY GOVERNMENT, IN NAVY HOSPITAL

The F. & H. Capacity Aerial Eliminator has the capacity of the average 75-foot aerial, 50 feet high. It increases selectivity and full reception on both local and long distance stations; is absolutely guaranteed. It eliminates the outdoor aerial along with the unsightly poles, guy wires, mutilation of woodwork, lightning hazards, etc. It does not connect to the light socket and requires no current for operation. Installed by anyone in a minute's time and is fully concealed within the set. Enables the radio to be moved into different rooms, or houses, as easily as a piece of furniture. 8,000 dealers handle our line. Dealers! Over 80 leading jobbers carry our line or order sample direct. Write for proposition.

SEND COUPON, IT PROTECTS YOU

Name

Address

City

State

Send one F. & H. Capacity Aerial with privilege of returning after 3-day trial if not satisfactory, for which enclosed find check M. O. or dollar bill, or send C. O. D. Send Literature, Dealer's proposition.

F. & H. RADIO LABORATORIES
 Fargo, N. Dak. Dept. 19

BIG PA IN BROADCASTING



FLOYD GIBBONS
Famous Radio Broadcaster

IT ISN'T necessary to be a "star" to make good money in Broadcasting. There are hundreds of people in Broadcasting work who are practically unknown—yet they easily make \$3000 to \$5000 a year, while, of course, the "stars" often make \$25,000 to \$50,000 a year.

If you have talent—if you have a good speaking voice, can sing, act, write, direct or sell—then here is an amazing new method of practical training developed by Floyd Gibbons, that fits you—right in your own home in your spare time—for the job you want.

Millions of dollars paid to trained talent every year. Men and women unknown today will be the high salaried Graham MacNames, Olive Palmers and Floyd Gibbons of tomorrow. The Floyd Gibbons School will train you in the technique of Broadcasting so that you, too, may qualify for one of the big paying Broadcasting jobs open to men and women of talent and training.

Our FREE book, "How to Find Your Place in Broadcasting" gives full particulars regarding our Course. It tells you how to prepare for a good position in Broadcasting—how you can turn your hidden talents into money, without giving up your present job or making a single sacrifice of any kind. You learn at home in your spare time. Send coupon at once for free book.

Floyd Gibbons School of Broadcasting
2000 - 14th St., N.W., Dept 2G9, Washington, D. C.

Without obligation send me your free booklet "How to Find Your Place in Broadcasting" and full particulars of your home study course.

Name..... Age.....
Please Write or Print Plainly
Address.....
City..... State.....

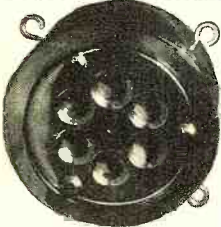

R.T.I.C. Filter-Pack Microphone

Model F: Most highly developed carbon microphone with self-contained filter pack for protection against r.f. pick-up and accidental abuse. Finest of R.T.I.C. carbon microphones—features:

Two-button design. Polished carbon buttons. Specially treated carbon granules. Case machined from solid bar stock. Statically and dynamically balanced diaphragm of gold-plated duralumin—no adjustments required. Outstanding fidelity, sensitivity, minimum hiss and long service life. Uniform response from 30 to 7000 cycles.

Write for literature describing R.T.I.C. carbon, condenser, lapel and ribbon microphones, stands, accessories, etc.

RADIO TELEVISION INDUS. CORP.

Dept. RN
130 West 42 St., New York City



THE MOST COMPLETE LINE OF CONDENSERS AND RESISTORS FOR EVERY RADIO USE



Write for Complete Catalog free of charge

AEROVOX CORPORATION

78 Washington Street Brooklyn, N. Y.

PATENTS TRADE MARKS COPYRIGHTS

"Little Ideas May Have Big Commercial Possibilities" PROTECT THEM BY PATENTS Send for our Free book, "HOW TO OBTAIN A PATENT" and "Record of Invention" Blank. Prompt Service—Reasonable Charges—Deferred Payments.

HIGHEST REFERENCES

VICTOR J. EVANS & CO.

Registered Patent Attorneys—Established 1898
622-G Victor Building, Washington, D. C.

23 Lessons in Radio FREE with Subscription for RADIO NEWS—7 ISSUES for \$1.00

Saving over Newsstand Price, \$75

This practical gift book has been compiled from the Radio Guild Lessons by the technical staff of Radio News. There are 124 pages chock-full of illustrations showing wiring diagrams of circuits, as well as actual set construction. Shows you what to do—and how to do it.

Clip this Adv. and send with \$1.00 to Radio News, Dept. 7B, 222 W. 39th St., New York N. Y. Sign name and address in margin below.

mately twice the value of grid bias required with the same plate voltage when the tube is used as an amplifier. For exact results the grid bias and plate voltages should be chosen or adjusted to give a plate current of approximately 0.1 to 0.2 milliamperes. Greatest sensitivity is obtained with the lower values of plate and grid bias voltages, but greater signal handling ability and output is obtained with higher plate and grid bias voltages.

As this article is written, technical information is being released on the Wunderlich double-grid tube designed especially for power detector use.

Among the claims made for this new tube are that it is the first tube that has been designed especially for use as a detector, whereas other tubes which are generally available are primarily amplifier tubes which have been adapted for detector use.

It is also claimed that all the advantages of high sensitivity of the grid circuit detector, the fidelity of reproduction of the linear detector, and the elimination of additional audio amplifier stages with their attendant troubles are made possible by the use of this new tube.

In addition to these advantages, it is claimed that the characteristics of this tube are such that efficient automatic volume control can be accomplished without the use of additional tubes and complicated or critical circuits.

The factors which govern the selection of tubes for use in the radio-frequency stages will be discussed in the fifth article of this series next month.

Quartz-Crystal Receiver

(Continued from page 34)

the switch controlling the audio-frequency changes when operating as a Stenode or a straight super—or in the leads connecting to this switch. Inadequate shielding at this point permits feedback from the output of the second detector to the input of the i.f. amplifier with ensuing oscillations.

The experimenter is referred to the preceding articles of this series, and to the Stenode books, for a general theoretical background to the aspects of servicing the Stenode.

The Stenode on Short Waves

The super-selectivity of the Stenode and the congested condition of the amateur radio telephone bands immediately suggests the utility of the receiver on the short waves. The elimination of the heterodyne whistles and the reduction of background noises are added arguments in its favor. As might be expected, the main problem with which the engineer has to contend is the stability of the oscillator. However, the development of electronic coupling systems and refinements in the more conventional oscillating arrangements are rapidly resulting in a thoroughly practical short-wave Stenode. The author hopes to present such a receiver to the readers of RADIO NEWS in the not distant future. In the meantime, the standard broadcast Stenode has been successfully used in conjunction with the National NC-5 converter for short-wave reception, the combination being shown in Figure 2.

The oscillator stability problem still exists, of course, but the operation of this converter is quite satisfactory, and the stability of signals received from crystal-controlled transmitters compares very favorably with the reception of broadcast signals. A marked improvement in station separation (over a straight super-converter combination) is experienced, with a distinct reduction in exterior background noises. Hetero-

Read Classified Advertising—It Pays

Advertisements in this section twenty-five cents a word for each insertion. Name and address must be included at the above rate. Cash should accompany all classified advertisements unless placed by an accredited advertising agency. No advertisements for less than 10 words accepted. Objectionable or misleading advertisements not accepted. Advertisements for these columns should reach us not later than 1st of 2nd month preceding issue.

TECK PUBLISHING CORP.

350 Hudson St. New York, N. Y.

Correspondence Courses

Used correspondence school courses and educational books sold, rented and exchanged. Money-back guarantee. Catalog free. (Courses bought) Lee Mountain, Pisgah, Alabama.

CORRESPONDENCE COURSES—Sold, Bought, Exchanged, Rented. Bargain Catalogue Free. Handling, C-799 Broadway, New York.

For Inventors

INVENTORS—Sell your inventions before patenting. Use our legal form for recording proof of invention. Write W. T. Greene, 956 Barrister Building, Washington, D. C.

Foreign Agency Wanted

WELL ESTABLISHED Norwegian Radio firm with capital desires represent leading American manufacturer of receiving sets built for European conditions. Reply Box 4102, c/o Gumaelius Annoncebureau, Oslo, Norway.

Inventions

INVENTIONS COMMERCIALIZED. Patented or unpatented. Write Adam Fisher Mfg. Co., 273 Enright, St. Louis, Mo.

Lathes

LATHES—Used and reclaimed South Bend Lathes. One 9-inch \$127; 13-inch \$276; 16-inch \$388; just a few left. Guaranteed good as new. Terms, or discount in cash. South Bend Lathe Works, 310 E. Madison, South Bend, Indiana.

Microphone Repairs

Guaranteed Microphone Repairs. Any make or Model. 24 hour service. Stretched diaphragm double-button repairs. \$7.50. Others \$3.00. Single-button repairs \$1.50. Write for 1932 catalog with diagrams. Universal Microphone Co., Ltd., Inglewood, Calif.

Pocket Radios

GUARANTEED "Pocket Radio." \$2.00. Catalogue, 10c. Neil Tasker, Shamokin, Pennsylvania.

Patent Attorneys

PATENT YOUR IDEA NOW. Send for free book, "How to Obtain a Patent," and free "Record of Invention Blank." In business since 1898, specializing in patent matters, we have successfully served thousands of inventors. Little ideas may have big commercial possibilities. Delays are dangerous in patent matters—act at once and protect your idea. Reasonable fees. Convenient terms. Write us today. Victor J. Evans & Co., 616G Victor Bldg., Washington, D. C.

PATENTS, TRADE MARKS—All cases submitted given personal attention by a member of the firm. Information and booklet free. Lancaster, Allwine & Rommel, Suite 414, 815 15th St., N. W., Washington, D. C.

PATENTS—Advice and booklet free. Highest references. Best results. Promptness assured. Watson E. Coleman, Patent Lawyer, 724 9th Street, Washington, D. C.

PATENTS secured. Low cost. Write for book "How to Get Your Patent" and "Record of Invention Certificate." Personal skillful service assured. 35 years' experience. Preliminary advice free. L. F. Randolph, 348 Victor Building, Washington, D. C.

Photography

HAVE YOU A CAMERA? Write for free sample of our big magazine showing how to make better pictures and earn money. American Photography, 3105 Camera House, Boston, Mass.

Songwriters

COMPOSERS—VERSE OR MUSIC. Brilliant opportunity. Write at once. Van Buren, 2737 McClurg Bldg., Chicago.

MATHEMATICS IN RADIO

During 1931 there has been published in Radio News a series of articles describing the use and application of mathematics in radio, written authoritatively by Mr. J. E. Smith, President of the National Radio Institute, of Washington, D. C. These articles begin with simple rules of Arithmetic, and extend through Algebra, Geometry, and Trigonometry. Each subject is treated carefully, and in simple terms, clearly illustrated with easy-to-read diagrams and charts.

We have received so many requests for reprints of these lessons from our subscribers, that we have arranged to secure a limited supply reprinted in booklet form, one booklet for each subject.

How To Get These Four Booklets—FREE

While our supply lasts, we will include a complete set of these instructive booklets with each eleven month subscription for Radio News at \$2. Sign the order from below and return to us today!

Radio News, Dept. 7, 222 W. 39th St., N. Y. C. Enclosed is \$2. Enter my subscription for eleven months of Radio News and send me without charge, the four Mathematics Booklets.

Name.....
Address.....

dyne elimination is accomplished with the same facility as on the lower frequencies, and many telephone stations can be received on the Stenode that are hopeless mush on a standard short-wave set.

The operation of Stenode plus converter is practically the same as that of any non-stenodic combination. However, due to the high impedance antenna coil in the Stenode receiver, the noise level will be "up" unless a better match is provided between the converter output and the Stenode input circuits. It is suggested that a special primary of ten turns of wire be wound over the grid coil of the first r.f. tube, one side being grounded and the other terminal connected to the antenna post on the converter.

The intermediate frequency of the converter, 575 kc., should be located on the Stenode tuning dial at about 88. The intermediate-frequency stage of the converter is tuned broadly enough to permit a reasonable amount of variation from the specified frequency. If telephonic reception is desired, a frequency free from long-wave broadcasting should be chosen. If it is desired to copy continuous-wave code signals, the i.f. should be picked close to a convenient broadcasting station (in the neighborhood of 575 kc.) which may be used to beat the signals. If the pick-up from the broadcasting station is not strong enough to provide a good signal, the lead from the Stenode coupling coil to the converter may be lengthened, or a second antenna connected to the regular Stenode antenna binding-post. Of course, a separate oscillator may be used—a desirable procedure if the broadcast carrier is powerfully modulated.

With the Stenode dial set at the correct intermediate frequency, the station should be located as carefully as possible on the converter. Unless the position of the station is known with some accuracy, it may be necessary to tune first with the receiver switched to straight super operation. The final tuning should be effected with the Stenode dial, using the 250-to-1 ratio. Should this last adjustment by any chance tune the Stenode to a broadcast carrier, the whistle can be balanced out by the balancing condenser, or both the converter and Stenode retuned—the better procedure, as it leaves the balance control free for the elimination of heterodyne interference which cannot be detuned. Shielding of the lead from the converter to the Stenode will eliminate broadcast pick-up regardless of the intermediate frequency used.

Audio Amplifier Design

(Continued from page 32)

with a push-pull or parallel pentode system, the latter, at any output from zero audibility to eight and even ten watts, suffer severely. The comparison with -46 class B is even more unfavorable. The -46 tubes will, in the author's opinion, give a black eye to class B amplification, which, sensibly utilized, has much merit, particularly for battery sets such as described in the May, 1932, issue of RADIO NEWS, where a pair of normally low power 2-volt tubes are enabled to turn out one watt of audio power at harmonic distortion rising from practically nothing to a maximum of 5% and all on so little battery power as almost to make one believe in perpetual motion.

But for a.c. sets, where power consumption at most is only a cent or two an hour, class B amplification has no place.

NEW TRIPLE-TWIN PUSH PULL AMPLIFIER

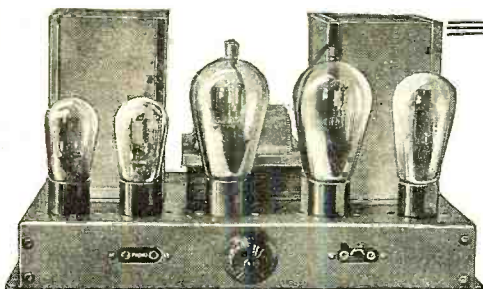

Licensed by Revelation Patent Holding Co.
Excellent fidelity of tone over the entire audio range. This STRATFORD amplifier has a 15-watt output and can cover an audience of more than 2000 people. A completely wired 3-stage amplifier suitable for use with phonograph, microphone and photoelectric cells. Dimensions over all: Length, 14½"; width, 8¾"; height, 8½". Net weight, 32 lbs. Tubes required 2-227's, 2-295's, 1-280.

Send today for special circular describing single and push-pull models.

BALTIMORE RADIO CORPORATION 725 N. Broadway
New York, N. Y.

You Can Become a Fast, Capable RADIO OPERATOR at Home

CANDLER

Scientific System

In less than half the usual time. Amazing results. Thousands of fast Radio operators taught by CANDLER. FREE advice if you're "stuck".

All questions answered personally. No obligation. If Radio operator, ask about ADVANCED COURSE for SPEED and Copying Behind and "MILL" Course. FREE BROCHURE will save you time and money. Tune in on Candler Short Wave Station!

CANDLER SYSTEM CO., Dept. RN-7
6343 So. Kedzie Ave., Chicago, Ill.

World's Only Code Specialist

E. J. Yarris, Clifton, con-
tact 1/2 year with first lesson.
C. Lane, Portland, Ore., does
20 words on third lesson.



RADIO TUBE INSURANCE THAT PAYS

Write Dept. RN-7 for easy Amperite sales plan which earns \$90 to \$110

extra each month for service men.



AMPERITE Corporation
501 BROADWAY, NEW YORK

AMPERITE
Self-Adjusting
LINE VOLTAGE CONTROL

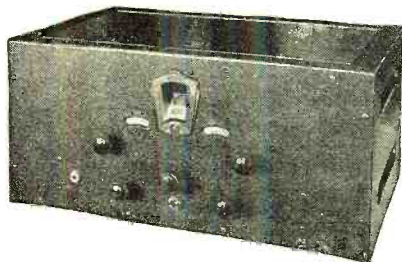

HAMMARLUND'S
New Custom-Built

COMET "PRO"

The SUPER High-Frequency "SUPER" for Professional Operators

PROFESSIONAL operators praise the COMET "PRO" Performance. They call it "the most efficient high-frequency receiver ever produced." We believe you will agree with that expert opinion. Eight-tube superheterodyne. Quiet "227" output. Extremely sensitive and selective. Easy band-spread tuning. Long-wave oscillator for clear C.W. signals. Phone and speaker connections. Connections for external power amplifier (supplied to match, if desired). Range: 14 to 200 meters.

For reception between 15 and 500 meters, the new Custom-Built COMET "All-Wave" Receiver is a sensational success.

For standard broadcast reception, the famous Hammarlund "HiQ" Custom-Built Receiver has never had a superior.

Write Dept. RN-7 for technical description of these three leading receivers.

HAMMARLUND-ROBERTS, INC.
424 West 33rd Street, New York

1
CUSTOM
BUILT

by HAMMARLUND

COMET
"All-Wave"



LYNCH

Automobile Radio Suppressors

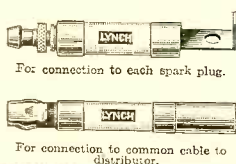

Types to fit ALL makes of cars. Based on the famous LYNCH Metalized principle which insures dependability and long life. Moisture proof, rugged and able to withstand heavy mechanical shocks, as proved by exhaustive tests. In actual use Lynch Automobile Radio Suppressors have been found to be thoroughly reliable and satisfactory.

New Low List Price of all types 50c (formerly 60c)
Service men's Cost 30c

LYNCH Automobile Suppressor Kits
 include necessary suppressors and ignition condenser.
 Type LS4 Handipak (4 cylinder) List \$3.25 Service men's Cost \$1.95
 Type LS6 Handipak (6 cylinder) List \$4.25 Service men's Cost \$2.50
 Type LS8 Handipak (8 cylinder) List \$5.25 Service men's Cost \$3.15

Write for illustrated catalog giving complete information on automobile suppressor units, and LYNCH Resistors for all radio requirements.
LYNCH MFG. CO., Inc., 1775N Broadway, New York City

Trimm 4000 Ohm Featherweight Headphone for Shortwave Operating

Its Praise Knows No Boundaries!

Invaluable for bringing in those weak signals. Lightest and most comfortable phone built. Special phones for church and theatre installations. Write for full particulars.

TRIMM RADIO MFG. CO., 1528 Armitage Ave., Chicago, Ill.

YOU CAN EARN MONEY CASTING METAL TOYS AND NOVELTIES

We have a good opening for several ambitious men to cast 5 and 10c Store Novelties, Toy Soldiers, Ashtrays, etc. needed to meet big demand. No experience or special place necessary, and we furnish moulds for casting and give full instructions. A chance of a lifetime for man with small capital, so if you mean strictly business write AT ONCE for full information.

METAL CAST PRODUCTS CO., Dept. 12
 1686 Boston Road, New York City

A New Tone Quality in Heavy Duty Units



FOX

Fox Units are guaranteed for accuracy, realism, and brilliancy—and are absolutely free from distortion under pressure. High sensitivity factor, exceptional tone balance. Unaffected by moisture or atmospheric conditions. List \$49.50.

Fox Horns—Authentic in design—superior in construction. Types for all indoor and P. A. purposes, including rams horn, exponential air column, and standard trumpet. Investigate the new 4 ft. and 6 ft. All-Aluminum Fox Trumpets, with their brilliancy and tremendous range.

Fox Units and Horns not only command attention for their output volume and tone value—they offer definite and exclusive engineering and physical features found nowhere else. The combination out-demonstrates anything on the market.

Original and exclusive manufacturers of genuine Fox Amplifying Equipment

FOX ELECTRIC & MFG. CO.
 3118 Monroe St. Toledo, O.

A Telephone Booster

(Continued from page 22)

availability. Here, by a key switch, the amplifier can be switched into or out of circuit, so that the telephone can be used by either one of impaired or one of normal hearing. Here also is the knob by which the amplification can be increased in five steps to suit the degree of the listener's deafness and the initial loudness of the speech.

When a subscriber requests this equipment from the Bell or associated telephone companies operating in his territory it is first necessary to find out whether his difficulty in hearing over the telephone is of a type that can be helped by the amplifier. Perfect assurance can be had only from a trial of the apparatus itself. The companies therefore have available a portable model for temporary use. This consists of a single carrying case containing amplifier, batteries, desk stand, and control equipment. Weighing only about thirty-two pounds, it can be conveniently brought to the subscriber's premises, made ready for use by connecting its three-conductor cord in place of the standard desk-stand cord, and left for a trial of several days, if desirable. A small hinged door in the top of the case gives the subscriber access to the control equipment without exposing the remainder of the apparatus.

If the equipment proves helpful to the subscriber, a permanent amplifier may be installed.

The Service Bench

(Continued from page 42)

be indexed under H for 'Home Recording' and under R for 'Recording,' as 'Home Recording, R.N. 7-31-26.'

"As before intimated, the labor of indexing is practically eliminated if the magazines are read with the reference book close at hand, and the notations made on the first reading. Interesting service jobs can be briefly written up—at the same time the bill is made out—filed in the convenient book-type filing case, and indexed the same as the magazine articles."

Harry Schmidt, Richmond Hill, N. Y.

A Vest Pocket Test Prod

Harry D. Hooton, of the Radio Service Company, Beech Hill, West Va., describes a continuity tester that has a distinct utility. It is satisfactory for any rough determination, and its extreme portability will make it as useful as a nail file in emergency servicing.

"Secure a flashlight of the small, fountain-pen variety, preferably with a fiber or bakelite insulating case. Substitute a small insulating disc for the lens and reflector. Clamp a threaded metal rod, about three inches long, to the disc by means of a nut on each side. The open end of the rod should be pointed, in prod fashion, and the rod itself adjusted so that the other end makes contact with the positive terminal of the flashlight battery.

"Mount a 'featherweight' telephone receiver on the other end of the holder, connecting one terminal to the negative cap on the battery and the remaining post to a short length of flexible wire ending in a small test clip.

"In servicing, the clip is connected to the chassis or ground, and the prod is used for exploring the circuit, a loud click on disconnecting indicating a closed circuit.

INDEX TO ADVERTISERS

A	Aerovox Corp. 60 American Sales Co. 50 Amperite Corp. 61
B	Baltimore Radio Corp. 61 Blan the Radio Man, Inc. 48 Broderick, Wm. H. 56 Bud Speaker Co. 59
C	Candler System Co. The 61 Capitol Radio Engineering Inst. 63 Cardwell Mfg. Corp., Allen D. 63 Central Radio Labs. 52 Chicago Radio App. Co. 59 Chrisell-Acoustic Labs. 44 Clarostat Mfg. Co., Inc. 61 Classified. 60 Coast to Coast Radio Corp. 50 Coyne Electrical School. 49
D	DeVry, Inc., Herman A. 54
E	Eastern Rabbity 56 Electrad, Inc. 58 Evans & Co., Victor J. 60
F	F. & H. Radio Laboratories 59 Federated Purchaser, Inc. 54 Fox Electric & Mfg. Co. 62
G	Gibbons School of Broadcasting, Floyd 60 Globe Television and Phone Corp. 48, 64 Grant Radio Labs. 63
H	Hammarlund-Roberts, Inc. 61 Hearing Devices Co., Inc. 58 Hoodwin Co., Chas. 44
I	International Resistance Co. 47
J	J. M. P. Mfg. Co. 50
L	Lincoln Radio Corp. 57 Lynch Mfg. Co., Inc. 62
Mc	McGraw Hill Book Co., Inc. 44
M	Marquette Radio, Inc. 58 Metal Cast Products Co. 62 Midwest Radio Corp. 7 Miller & Miller 48
N	National Co., Inc. 43 National Electrical & Automotive School 54 National Radio Institute 3 National Union Radio Corp. 45
P	Pennsylvania Radio & Television Institute 59
R	RCA Institutes, Inc. 50 Racon Electric Co., Inc. 48 Radio Supplus Corp. 56 Radio Technical Pub. Co. 64 Radio Television Industries Corp. 60 Radio Trading Co. 57 Radio Training Ass'n of America 1 Radio Treatise Co., Inc. 51 Rawls & Co., W. C. Second Cover Readrite Meter Works 53
S	Scott Radio Labs., Inc., E. H. 5 Shallcross Mfg. Co. 56 Silver-Marshall, Inc. Fourth Cover Supreme Instruments Corp. 55
T	Teleplex Co. 57 Trimm Radio Mfg. Co. 62
U	Universal Microphone Co. 56
V	Van Nostrand Co., D. 58
W	West Side Y.M.C.A. Radio Inst. 44 World Microphone Co. 58

Set Analyzer

(Continued from page 21)

to set S1 to the proper range and depress the push-button of S14.

To make a negative grid voltage measurement, set S1 properly and depress push-buttons S2 and S14 simultaneously. The

described for positive cathode voltage, with the exception that S1 is set to the 500-volt position.

Either pentode screen-grid current or regular plate-cathode current may be measured

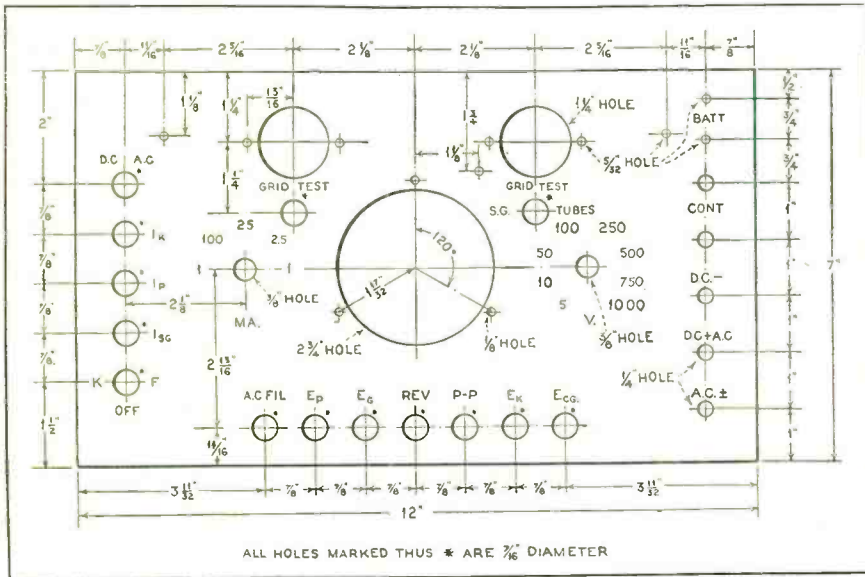

SPECIFICATIONS FOR PANELS

Figure 4. The bakelite panel and sub-panel are available in finished form, cut and completely drilled. For those who prefer to do this work themselves, the specifications are given here

regular negative grid voltage will now be indicated on the voltmeter.

Filament Voltage

To measure filament voltage, turn switch S3 to "on," set S1 to correct range, set S10 to neutral, and depress the push-button of S13.

in connection with switch S7. It is only necessary to set S4 to the proper position and S10 to neutral, then depress the push-button of S7.

Screen-grid current is measured by setting S4 properly and turning S10 to neutral, then depressing the push-button of S9. As a rule, screen-grid current will be low in compari-

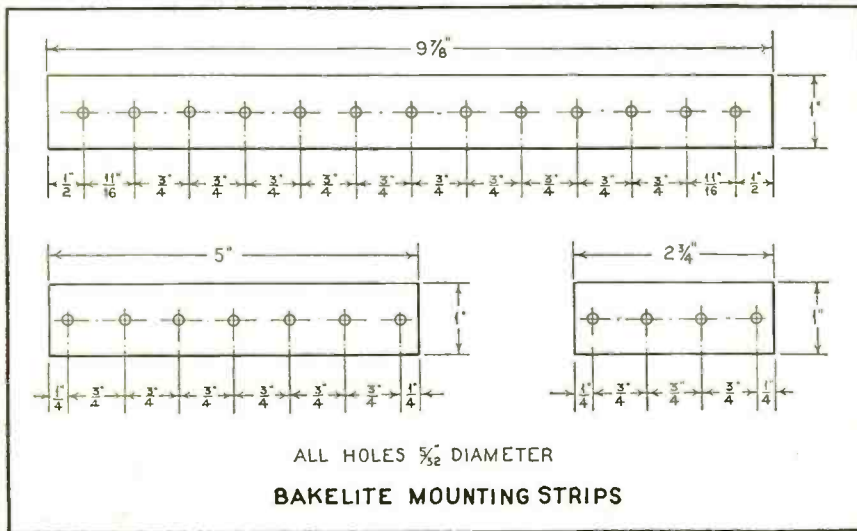

BAKELITE MOUNTING STRIPS

Control-grid voltage is always negative except in the case of a space-charge amplifier. To measure control-grid voltage, set S1 and depress S2 and S12 simultaneously. In the case of a space-charge tube, set S1 and depress S12.

Cathode voltage may be either positive or negative. In most cases it will be positive. To make this measurement, set S1 and turn S10 to F, then depress the push-button of S11. If the cathode is negative, depress S2 and S11 simultaneously.

Pentode screen-grid voltage is always positive. The measurement is made exactly as

son to other currents to be measured. However, always use a high scale first to protect the meter against shorts.

Rectifier Voltage

The voltage applied to the plates of an -80 rectifier will always be high. Therefore set S1 to the 1000-volt position. Set S10 to the neutral or off position. Set S3 to the "on" or a.c. position. Then depress the push-button of S16. The total a.c. voltage across both plates will now be indicated on the 1000-volt scale of the meter. This provides a good check on the high-voltage wind-

SPECIAL OFFER



to experienced

RADIOMEN

who want to know

"... What's

PADLOCKING

those extra dollars"

One thing is certain, when experience has carried you part of the way—higher technical knowledge is necessary for further advancement. We can help men who are in a rut—men who know enough to realize that a BETTER UNDERSTANDING of Radio and Television Engineering is the only safeguard to success.

FREE SPECIAL OFFER

CAPITOL RADIO ENGINEERING INSTITUTE
14th and Park Rd., N. W., Washington, D. C.

Please send Radio and Television Engineering examination with answers so I can test my ability and see what is covered by your advanced training.

Name.....
Address.....
City and State.....

RN-7



Know Your CONDENSERS

The CARDWELL Featherweight Midway, the big little condenser, pioneer in its class and now famous on the Airways, is made in 13 stock sizes and special to order, for both receiving and transmitting. It has many applications now being served, in many cases, by inadequate and inferior makeshifts. Get acquainted with the Midway, as different from the usual "quantity production" small-size condenser as a fine time-piece is different from a dollar watch.

Write for Literature

THE ALLEN D. CARDWELL MANUFACTURING CORP'N

89 Prospect St. Brooklyn, N. Y.

"The Standard of Comparison."

SERVICEMEN-DEALERS

Get Our Prices First
Complete Stock of NEW
Condenser Blocks
Volume Controls
Resistors

and Radio Replacement Parts

Write for our Catalogue

Hard to Get Parts—We have them. Send us your repair work for estimate.

Grant Radio Laboratories

6521-N South Halsted St., Chicago, Ill.



Living-Room Television

Hear as well as see, your radio entertainment! Entertain family and friends with movies snatched out of the air. Globe Midget Type television Receiver features:

Complete receiver and television combination. A. C. operation. No extras to buy. Costs no more than good radio set.

Simple to operate. Self-synchronized on A. C. system common with transmitter. No fussing.

Clear, brilliant images on

4 x 5 inch screen, entertaining up to a dozen persons. Flickerless.

Television includes lens disc, erater neon lamp, and silenced synchronous motor.

Eight-tube receiver designed solely for best television results. Single-control tuning.

WRITE for literature describing Globe line of television equipment for living room, experimental and laboratory uses.



GLOBE TELEVISION &
PHONE CORP.
185 Devonshire St.
Boston Mass.

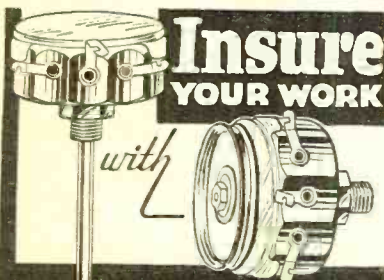

**Insure
YOUR WORK**
with
**CLAROSTAT
Replacement
VOLUME CONTROLS**

CLAROSTAT Replacement Volume Controls are "Custom-made" to exactly suit the receivers for which they are offered. Not a makeshift job lot idea.

The resistance, taper, shape and shaft are made according to the proper specifications.

There is no delay in installing them. There are no comebacks when you use CLAROSTAT products.

See the new CLAROSTAT CONTROL HANDBOOK AND CATALOG for 32 pages of dope top servicemen. Send for your FREE copy.

CLAROSTAT MFG. Co.
285-287 N. 6TH ST. BKLYN. N.Y.

**BUY THESE
Great Books!**

2 Radio Physics Course
by Alfred A. Ghirardi \$3.50
Radio Servicing Course
by Ghirardi & Freed \$1.50
Send for FREE circular at once
THE RADIO TECHNICAL PUB. CO.
80 Fifth Ave. Dept. RN-2, New York City

ing and enables you to tell if this winding is open.

Set S4 to the high position, and set S10 to neutral. Depress the push-button of S8 for one plate-current reading and the push-button of S9 for the other plate-current reading.

This measurement will indicate if both plate and grid circuits are complete. The voltage measured is the plate voltage plus the grid voltage. Set S1 properly, and turn S10 to neutral. Set S3 to the a.c. position. Depress the push-button of S16 to indicate voltage.

Mutual Conductance Tests for Tubes

After taking the plate-current reading of any tube, leave S4 set, and hold down the push-button of S8. If the tube is not of the screen-grid type, depress the push-button of S6. A plate-current change will be noticed on the milliammeter. This indicates the tube's relative condition. Usually the greater the plate-current change, the better the tube.

If testing a screen-grid tube, depress the push-button of S5 instead of S6.

Jacks J1 and J2 may be used as the connections to the a.c. voltmeter for use as an output meter. Connect these across the voice-coil leads of the speaker by means of the regular test leads. Set S3 to the "on" or a.c. position. Adjust S1 for the proper range so as to get a satisfactory reading on the meter. Make the tuning adjustments in the usual manner.

Continuity Tester Ohmmeter

Connect the test leads and the 4.5 battery in series with jacks J and J1. Set S3 to the "off" or d.c. position. Set S1 to the 5-volt position. When the two test leads are

Graphs and Charts

(Continued from page 26)

condenser heats up under a continuous load, the breakdown voltage is lowered. Therefore the tests of such condensers must be made over a considerable time at working voltage or at a much higher voltage for a short time.

Commercial paper condensers usually consist of long strips of prepared paper, with tinfoil interleaved, which is then rolled. In the case of rolling a condenser with an even number of plates, the top plate and the bottom plate form an additional section of the condenser so that in this case the rolling has the effect of adding one more plate. The reader should see whether the dielectric for this additional section has the same thickness as the other sections and make allowances for any possible difference.

When the number of plates is odd or when the paper is not rolled, the actual number of plates is used for the calculation.

The accuracy of a calculation by means of this chart will be sufficient only if the correct values for the dielectric constant and the thickness of the dielectric have been determined. This is sometimes difficult to accomplish, especially with paper as a dielectric. If the reader guesses at the constant and the actual separation of the plates, he must expect the result to be off accordingly.

A Correction

On the chart in the March issue on the design of single-layer coils, the lower section of the scale marked Form factor f (A) the numbers .09, .08, .07 should read .9, .8, .7, etc., down to 2.

touched, 4.5 volts will be indicated on the voltmeter. When there is a resistance between the two leads, less than 4.5 volts will be indicated. Thus, to test the continuity circuit, place the two leads across the circuit to be tested. If a reading is obtained, the circuit is closed. If open, there will be no reading.

If a resistance is being measured, read the scale directly in terms of current. If the scale shows .15 ma., the resistance will be

equal to $\frac{4.5}{.00015} = 500 = 15,000$ ohms.

A chart may be made which shows the current versus the resistance, so that for any value of current you may readily determine the value of the resistance by referring to your chart, thus eliminating calculations.

To determine higher ranges of resistance, use a higher battery voltage. Each time a higher voltage is used, S1 will have to be set correspondingly. It is always necessary to subtract the resistance of the test circuit from the total value so as to get the actual value of the resistance under test. If the 10-volt range is used, the test circuit resistance will be 10,000 ohms, and for the 50-volt range it will be 50,000 ohms, and so on to the highest scale of the meter, which has a resistance of 1,000,000 ohms.

The directions given may appear a bit complicated, but you will find that measurements are easily made and that the manipulation of the switches becomes natural after a few tests have been made.

The constructor will find that this analyzer can be constructed reasonably and will make measurements comparable to any type of tester in practical use by the serviceman. Below is a list of parts necessary for the construction of the analyzer.

List of Parts

- J, J1, J2, J3, J4—Yaxley insulated tip jacks, type 422
- R1, R2, R3—I.R.C. .25 meg. resistances, type WW4
- R4—I.R.C. .15 meg. resistance, type WW4
- R5—I.R.C. 50,000-ohm resistance, type WW3
- R6—I.R.C. 40,000-ohm resistance, type WW3
- R7—I.R.C. 5000-ohm resistance, type WW3
- R8—I.R.C. 4950-ohm resistance, type WW3
- R9—I.R.C. .505-ohm resistance, type WW4
- R10—I.R.C. 2.083-ohm resistance, type WW4
- R11—I.R.C. 33.33-ohm resistance, type WW4
- S1—Yaxley 8-point tap switch, type 1618
- S2—Yaxley push-button switch, type 2006
- S3—Yaxley jack switch, type 760
- S4—Yaxley 4-point tap switch, type 1515
- S5, S6—Yaxley push-button switches, type 2003
- S7, S8, S9—Yaxley push-button switches, type 2880 special
- S10—Yaxley jack switch, type 32
- S11, S12, S14, S15—Yaxley push-button switches, type 2001
- S13, S16—Yaxley push-button switches, type 2004
- 1 control-grid clip
- 1 Blan special carrying case, 12 inches by 9 inches by 5 3/4 inches, inside dimensions, covered with imitation leather
- 1 roll No. 18 push-back wire
- Blan panel kit, consisting of 7-inch by 12-inch bakelite panel and three bakelite strips for mounting resistors, all cut and drilled according to specifications in Figure 4
- 1 Weston model 301 universal meter
- 1 UX type tube socket
- 1 UY type tube socket
- 1 Alden plug and cable, type 905LC
- 1 Alden adapter, type 954DS
- 2 Eby binding posts
- Miscellaneous screws and nuts

RADIO MEN!

GET THIS
TIMELY BOOK
FREE
with
RADIO NEWS

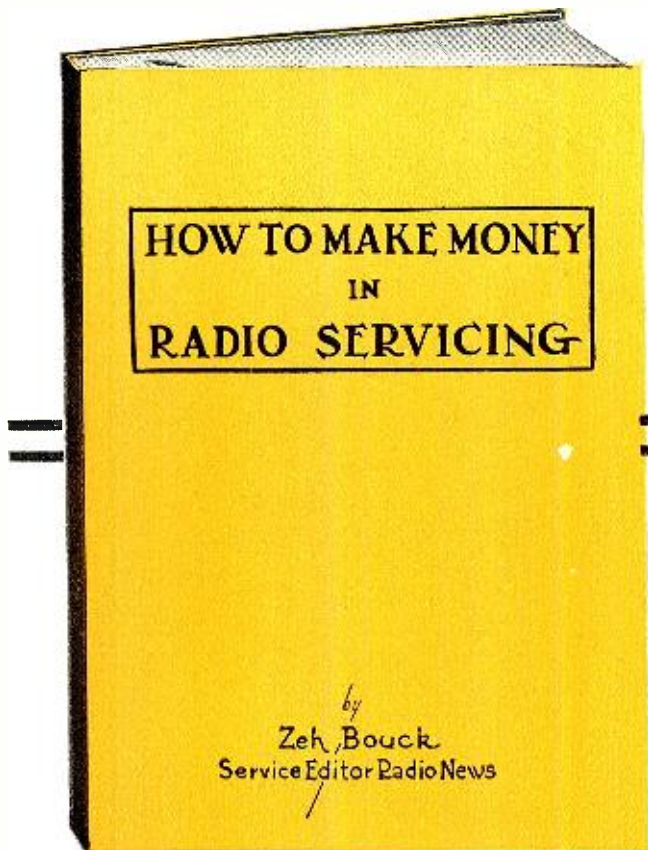

"HOW To Make Money In Radio Servicing," written by Zeh Bouck especially for Radio News, is the answer to the burning question of the hour! Prepared after months of effort and at great expense, it tells the radio service man how to make his business show a profit. And, what is more important in times such as the present?

Not only for the active service man, but also for the amateur and experimenter who desires to turn his knowledge and experience into practical money-making channels this book will prove indispensable. It tells you how, and when, and why to do things. It is *practical—up to the minute—and complete.*

For a limited time, Radio News is offering this money-making book absolutely FREE with a subscription for seven months for only \$1.00.

Save \$.75

And that is not all—in addition to securing the book FREE, you also save 75c on your subscription, as these seven issues purchased on the newsstands would cost you \$1.75.

All The Latest Developments In Every Branch of Radio

RADIO NEWS, edited by Laurence M. Cockaday, needs no introduction to radio men. From the very beginning it has led every publication in the whole field. It gives you all the radio news—while it is news. Hot from the laboratories—just out of the experimental stations—all the newest happenings in radio—direct to you in Radio News. Radio today is the fastest growing, fastest moving industry in the world. Greater expansion is just around the corner. Television—short-wave developments—electronics. Astounding new things are happening—you will want to know about them in detail. And you can—by reading Radio News.

Written By Foremost Authorities

Such outstanding authorities as Dr. Lee De Forest, Guglielmo Marconi, Laurence M. Cockaday, Dr. Irving Saxl, Ernest Lee Gahricke, Carl Dreher, McMurdo Silver, J. E. Smith, S. Gordon Taylor, Lieut. William H. Wenstrom, Dr. E. E. Free, and scores of others of equal prominence in the radio field—write regularly for Radio News. You have at your command the experience of acknowledged experts. You can use their researches—their results—to build your own future in Radio.

To make money today in radio service work, you must be well equipped. This book starts right at the very beginning, and tells you what equipment you will need to be successful. It tells you how to get customers, and how to build up a clientele by every known means of advertising and sales promotion. Numerous sample advertisements are included with instructions for their use. Full details are given regarding local contacts with dealers, as well as arrangements with manufacturers.

And remember you get seven issues of Radio News Magazine and this wonderful new book for less than thousands pay for the magazine alone.

CONTENTS OF THIS GREAT BOOK

- Introduction**—Servicing as a Profession—Business Methods and Profits—The Technical and Economic Ends of Servicing.
- Chapter One**—Equipment—The Service Shop—Fitting the Equipment to the Pocket-book—Truck Equipment.
- Chapter Two**—Contacts—Dealer Contacts and Contracts—The Local Lighting Company—Automotive Accessory Stores.
- Chapter Three**—Advertising and Publicity—Newspaper Publicity—Motion Picture Films and Slides—Billboards and Truck—The Shop Sign—Sample Publicity—Sample Advertisements.
- Chapter Four**—Circularization—A Good Letterhead—Mailing Cards—Sample Circulars—Stickers—Canvassing.
- Chapter Five**—Service Procedure—The Appearance of The Serviceman—Making the Service Call—Service "Don'ts"—Checking Over the Set—When to Take the Receiver to the Shop—Educating the Customer—Files and Records.
- Chapter Six**—The Service Salesman—Tube Sales—Set Sales—Shop and Store Displays—Impressing the Customer.
- Chapter Seven**—Off Season Business—Pepping Up Old Sets and Sales—Interference Location—Rural Possibilities—Extra Speakers—Special Baffles—Merchandising Tone Control.
- Chapter Eight**—Service Side Lines—Public Address Systems—Talking Movies—Aids for Hearing—The Telephone Booster—Picking Up Cash With Pick-ups—Electrical Side Lines.
- Chapter Nine**—The Business End of Servicing—Service Charges—Free Calls—Good Will—How to Bill and Collect—The Value of Trade-ins—Dunning Letters—Legal Points.
- Chapter Ten**—How To Buy—Where to Secure Parts—Replacement Substitutions—How to Get Best Discounts.
- Chapter Eleven**—Keeping Up To Date—How to Secure Manufacturer's Literature—Valuable Service Literature—Service Books—Technical Publications—Service Organizations.

Clip Coupons and Mail Today

RADIO NEWS, Dept. 7
222 West 39th St., New York, N. Y.

Enclosed is \$1. Please send me absolutely FREE, postage prepaid, a copy of "How To Make Money In Radio Servicing," and enter my subscription for the next 7 issues of Radio News.
(If renewal subscription check here)

Name.....

Address.....

City..... State.....

Canadian price, \$1.50, including Postage and Duty.
Foreign Postage 50c Extra.

SM

McMurdo Silver
announces

EXCLUSIVE NEW
"CLASS A-PRIME" AUDIO
IN THE
ALL-WAVE CHASSIS-728SW

ENORMOUSLY INCREASED OUTPUT
NEW TYPE TUBES
INCREASED SENSITIVITY
ONE CALIBRATED ALL-WAVE DIAL
1 OR 2 SPEAKERS
12 TUBES

A REALLY Revolutionary RECEIVER

ASK FOR ALL THE DETAILS

SILVER-MARSHALL, Inc.
6405 West 65th Street, Chicago, U. S. A.

SILVER-
MARSHALL, Inc.
6405 W. 65th St.
Chicago, U. S. A.

Please send me all the
728SW details FREE.

Name.....

Address.....