

# ★ RADIO NEWS

JANUARY

25  
CENTS

*Up and Coming*  
THE MIDGET RECEIVER



RADIO *and* MY  
FLIGHT OVER  
TWO CONTINENTS

*by* ZEH BOUCK

*What the*  
STENODE  
RADIOSTAT  
WILL DO—*By Its Inventor*  
*Dr. James Robinson*

DAVID  
HYMES

WHOLESALE PRICES

# 1931 FEATURE RADIO VALUES LOWEST WHOLESALE PRICES

## MODERN UP-TO-THE MINUTE RADIO AT TREMENDOUS PRICE REDUCTIONS

Now, as never before, are you able to buy real radio values at astoundingly low prices. Never before in our many years of experience in radio merchandising, have we been able to offer such real values—on such quality radio merchandise as you will find presented in this catalog. No matter what your radio requirements may be, you will find them offered in this large 168 page catalog in large variety. Dealers—set builders, and radio enthusiasts of every nature should have a copy of this remarkable catalog.

## BUY NOW AND SAVE—PRICES ARE DOWN

If you have planned on buying a new radio set—or if you contemplate replacing your old receiver with one of the new screen grid types, send for this catalog immediately. It will show you the way to substantial savings. Prices are down to a new all time record. In the large assortment of receivers shown, you will find just what you have been looking for—sets, accessories, kits or parts at lowest prices.

**EVERYTHING  
IN RADIO**

✓ **CHECK  
THESE RADIO  
VALUES FROM  
OUR 168 PAGE  
FREE CATALOG**

## NEW AUTO RADIO

## MIDGET RADIO



**New Midget Radio**

A modern screen grid Midget Receiver with approved five tube circuit.

Here you are offered one of the season's most popular types of receivers. Housed in a beautiful walnut midget cabinet, complete with five tube chassis and speaker, it is an outstanding value at the low price quoted.

~~\$75.00 RETAIL~~  
**YOUR PRICE  
\$34.75**

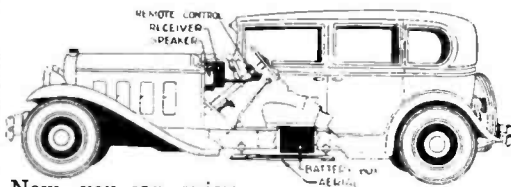

Now, you can enjoy your favorite radio programs as you drive. This new Roamer Auto radio blazes a new trail in its approach to perfection in circuit design.

**Music as You Drive**  
No need to miss your favorite program while you drive. Sporting events, news flashes, symphony, dance or opera—all are available to you with this new Roamer Auto Radio. Concealed installation with remote control. R. C. A. licensed chassis. Universal brackets simplify installation in any car. Its many special features make it an outstanding value.

~~\$100.00 RETAIL~~  
**YOUR PRICE  
\$49.45**

## THE NEW 8 TUBE SCREEN GRID SETS

Modern triple Screen Grid Receivers in beautiful consoles equipped with genuine Oxford Dynamic speakers at sensationally low prices. Values that will astound you.



~~\$110.00 RETAIL~~  
**YOUR PRICE  
\$48.25**

The receiver illustrated above is a representative value from our catalog. Beautiful walnut console, dynamic speaker with R. C. A. licensed Screen Grid eight tube chassis. A splendid value.



## 168 PAGE CATALOG FREE !

### WRITE FOR YOUR COPY TODAY

Write for your copy of this remarkable catalog today. See for yourself the unusual values that are offered. It lists over a thousand bargains, including such popular items as battery-operated receivers, super-heterodynes, remote control, electric time-switch receivers, phonograph-combinations, coin operated receivers, along with a remarkable variety of consoles, dynamic speakers, tubes, accessories, etc. No matter what your requirements may be in radio, you will find them listed in this catalog. Don't delay. Clip the coupon and send for your copy today.

WRITE TO-DAY

### EVERYTHING NEW IN RADIO

Dealers, service men, set builders and radio enthusiasts everywhere should have a copy of this catalog. It is a veritable encyclopedia of everything that's new and worthwhile in radio. Send for your copy today.

# ALLIED RADIO CORPORATION

711 W. Lake Street Dept. B-4 Chicago

### FREE CATALOG COUPON

Allied Radio Corporation,  
711 W. Lake St., Dept. B-4  
Chicago

Gentlemen, Please send me your 168-page FREE radio book of bargains. It is understood there is no obligation for sending this catalog to me, neither will I be bothered by personal calls.

Name \_\_\_\_\_  
Address \_\_\_\_\_



**We Could Have Placed 5000 More Qualified Men Last Year in Good Pay RADIO Positions**

**G**ET into the rich field of Radio via the training school that supplies big Radio employers with their new men! The Radio Training Association of America has a standing order from radio trade organizations, large manufacturers and dealers, for members qualified for full time work at splendid pay.

So great is this demand from Radio employers that positions offering good pay and real opportunity are going begging. If you want to cash in on Radio quick, earn \$3.00 an hour and up spare time, \$40 to \$100 a week full time, prepare for a \$10,000, \$15,000, \$25,000 a year Radio position, investigate the R. T. A. now.

**Special Attention to Radio Service Work**

Thousands of trained Radio Service Men are needed now to service the new all-electric sets. Pay is liberal, promotions rapid. The experience you receive fits you for the biggest jobs in Radio. The R. T. A. has arranged its course to enable you to cash in on this work within 30 days!

Would you like to work "behind the scenes" at Hollywood, or for a talking picture manufacturer? R. T. A. training qualifies you for this work. Television, too, is included in the training. When television begins to sweep over the country, R. T. A. men will be ready to cash in on the big pay jobs that will be created.

**Expert Supervision  
Lifelong Consultation Service**

As a member of the Association you will receive personal instruction from skilled Radio Engineers. Under their friendly guidance every phase of Radio will become an open book to you. And after you graduate the R. T. A. Advisory Board will give you personal advice on any problems which arise in your work. This Board is made up of big men in the industry who are helping constantly to push R. T. A. men to the top.

Because R. T. A. training is complete, up-to-date, practical, it has won the admiration of the Radio industry. That's why our members are in such demand—why you will find enrolling in R. T. A. the quickest, most profitable route to Radio.

**Mail Coupon for No-Cost Training Offer**

Memberships that need not—should not—cost you a cent are available right now. The minute it takes to fill out coupon at right for details can result in your doubling and trebling your income in a few months from now. If you are ambitious, really want to get somewhere in life, you owe it to yourself to investigate. Learn what the R. T. A. has done for thousands—and can do for you. Stop wishing and start *actually doing something* about earning more money. Fill out the coupon and mail today.

**Radio Training Association of America  
Dept. RNA-1, 4513 Ravenswood Ave., Chicago, Ill.**

**Fill Out and Mail Today!**

RADIO TRAINING ASSOCIATION OF AMERICA  
Dept. RNA-1, 4513 Ravenswood Ave., Chicago, Ill.

Gentlemen: Send me details of your No-Cost Training Offer and information on how to make real money in Radio quick.

Name \_\_\_\_\_

Address \_\_\_\_\_

City \_\_\_\_\_ State \_\_\_\_\_



Broadcasting Stations offer fascinating jobs paying from \$1,800 to \$5,000 a year.

# You're Wanted

## Take your pick of these fine **Big Pay** Radio Jobs



Operating on board ship gives you world-wide travel without expense, and a salary of \$85 to \$200 a month besides.



Spare time set servicing is paying N. R. I. men \$200 to \$1,000 a year for their spare time. Earnings begin almost at once after enrolling.



Commercial Land Stations are being opened very rapidly in our leading cities. Trans-Oceanic telephony offers many attractive jobs.



Radio factories employ thousands. Salaries for well trained men range from \$1,800 to \$5,000 a year.

**Y**OU have seen how the men and young men who got into the automobile, motion picture and other industries when they were started had the first chance at the key jobs—are now the \$5,000, \$10,000 and \$15,000 a year men. Radio offers you the same chance that made men rich in those businesses. Its growth has already made men independent and will make many more wealthy in the future. Its amazing growth can put you ahead, too. Don't pass up this opportunity for a good job and future financial independence.

### Hundreds of \$50 to \$100 a Week Jobs Opening Every Year

Radio needs more trained men badly. Why slave your life away for \$25 to \$40 a week in a no-future job when you can get ready in a short time for Radio where the good jobs pay \$50, \$60, \$75 and \$100 a week? And many of these jobs can quickly lead to \$150 to \$200 a week. Hundreds of fine jobs are opening every year for men with the right training—the kind of training I'll give you.

### I Am Doubling and Tripling Salaries

Where you find big growth you always find many big opportunities. I am doubling and tripling the salaries of many men every year. After training with me only a short time they are able to make \$1,000 to \$3,000 a year more than they were getting before. Figure out for yourself what an increase like this would mean to you—the many things that mean so much in happiness and comfort that you could buy with an additional \$1,000 to \$3,000 a year.

### Many Make \$10 to \$25 a Week Extra Almost at Once

The day you start I'll show you how to do ten jobs common in most every neighborhood that you can do in your spare time. I'll show you how to repair and service all makes of sets and do many other jobs all through my course. I'll give you the plans and ideas that are making \$200 to \$1,000 for my students while they are taking my course. G. W. Page, 107 Raleigh Apts., Nashville, Tenn., writes: "I made \$935 in my spare time while taking your course."

### You Have Many Jobs to Choose From

Broadcasting stations use engineers, operators, station managers. Radio manufacturers continually need testers, inspectors, foremen, engineers, service men, buyers and managers. Shipping companies use hundreds of operators and give them world-wide travel with practically no expense and a good salary besides. There are hundreds of opportunities for you to have a spare time or full time Radio business of your own. I'll show you how to start one with practically no capital. My book tells you of other opportunities. Be sure to get it at once.



\$400 a Month

"I spent fifteen years as traveling salesman and was making good money but could see the opportunities in Radio. Believe me I am not sorry, for I have made more money than ever before. I have made more than \$400 each month and it really was your course that brought me to this. I can't say too much for your school." **J. G. Dahlstead, 1484 South 15th St., Salt Lake City, Utah.**



\$800 in Spare Time

"Money could not pay for what I got out of your course. I did not know a single thing about Radio before I enrolled but I have made \$800 in my spare time although my work keeps me away from home from 6:00 A. M. to 7:00 P. M. Every word I ever read about your course I have found true." **Milton I. Leiby, Jr., Topton, Pennsylvania.**



Seldom Under \$100 a Week

"My earnings in Radio are many times greater than I ever expected them to be. In November I made \$577, December \$645, January \$465. My earnings seldom fall under \$100 a week. I'll say the N. R. I. course is thorough and complete. You give a man more for his money than anybody else." **E. E. Winborne, 1414 W. 48th St., Norfolk, Va.**

# for a **Big Pay** Radio Job



**I will train you AT HOME**  
**free book gives facts and proof**

**I Will Train You at Home  
 In Your Spare Time**

Hold your job. There is no need for you to leave home. I will train you quickly and inexpensively during your spare time. You don't have to be a high school graduate. My course is written in a clear, interesting style that most anyone can grasp. I'll give you practical experience under my 50-50 method of training — one-half from lesson books and one-half from practical experiments. When you graduate you won't have to take any kind of a job to get experience—you will be trained and experienced ready to take place beside men who have been in the field for years.

**Television and Talking  
 Movies Included**

My course not only gives you a thorough training in Radio—all you need to know to get and hold a good job—but also your choice, without extra charge, of any one of these special courses: Television, Aircraft Radio, Broadcasting, Commercial and Ship Radio Stations, Sound Pictures and Public Address Systems, and Advanced Radio Servicing and Merchandising. You won't be a "one job" man when you finish my course. You'll know how to handle a job in any one of Radio's 20 different branches of opportunity.

**Lifetime Employment  
 Service to All Graduates**

When you finish my course you won't be turned loose to shift for yourself. Then is when I will step in and help you find a job through my Employment Department. This Employment Service is free of extra charge both to you and the employer. My Employment Department is getting three times as many calls for graduates this year as last year.

**Your Money Back If Not  
 Satisfied**

You do not risk a penny when you enroll with me. I will give you an agreement in writing, legal and binding upon the institute, to refund every penny of your money upon completing my course if you are not satisfied with my Lessons and Instruction Service. The resources of the N. R. I., Pioneer and World Famous Largest Home-Study Radi training organization, stands back of this agreement.

**Find Out What Radio Offers  
 You—Get My Book at Once**

One copy of my valuable book, "Rich Rewards in Radio" is free to anyone interested in making more money. It tells you where the good jobs are, what they pay, how you can quickly and easily fit yourself to get one. The coupon below will bring you a copy. Send it at once. Your request does not obligate you in any way. Act NOW.

**I give You 8 Big Outfits  
 of Radio parts for a  
 home Experimental Laboratory**

You can build over 100 circuits with the outfits I give you. You learn from actual experience about A.C., Screen Grid circuits, push-pull amplification and the other features in modern sets. You work out with your hands the principles, diagrams and circuits you learn from my lesson books. You get as much practical experience under this unequalled method of home training, in a few months, as the average fellow gets in two to four years in the field.

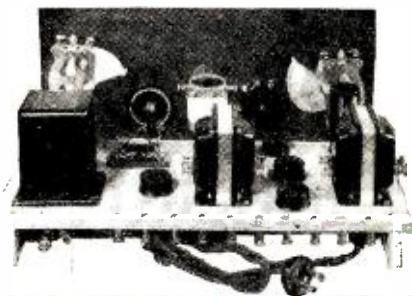

**J. E. SMITH, President**  
**NATIONAL RADIO INSTITUTE**  
 Dept. IAR WASHINGTON, D. C.



**Salary Three Times Larger**

"Before I completed your course I went to work for a Radio dealer. Now I am Assistant Service Manager of the Sparks-Withington Company. My salary is three times what it was before taking your course. I could not have obtained this position without it. I owe my success to N. R. I. training."  
 H. A. Wilmoth, Sparks-Withington Co., Jackson, Mich.

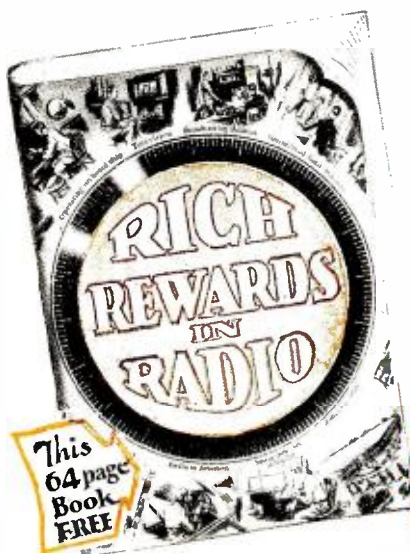

**Clip and mail NOW for  
 FREE INFORMATION**

J. E. Smith, President,  
 National Radio Institute, Dept. IAR,  
 16th and U Sts., N. W., Washington, D. C.

Dear Mr. Smith: Send me "Rich Rewards in Radio." Tell me more about Radio's opportunities for good jobs and quick promotion; also about your practical method of Home training. I understand this request does not obligate me and that no agent will call on me.

Name .....

Address .....

City ..... State .....

**S**ERVICEMEN indeed have a fortunate lot. To their already full bag of tricks, so to speak, has been added the midget or mantelpiece receiver. The fast-growing popularity of this new, miniature type of receiver is attested by the fact that, on the West Coast alone, where this new industry seems to have taken a strong foothold, there are in excess of twenty-two thriving manufacturers of these receivers and the total output runs into the thousands daily.

The live, wide-awake serviceman is finding, to his profit, that many people who now own a large console type of receiver are taking kindly to the idea of augmenting their present radio with a midget placed in the bedroom, den, and servants' quarters.

\* \* \*

**I**N this issue of RADIO NEWS is contained the first article on the Stenode Radiostat, written exclusively for RADIO NEWS readers by its inventor, Dr. James Robinson. As the title so well indicates, Dr. Robinson tells what the Stenode does and how it does it.

### Next Month

**R**ADIO NEWS will publish information of particular benefit to experimenters and servicemen on the growing demand for audio channels, pick-ups, turntables and loud speakers which are used in connection with home movie outfits to synchronize sound with film for home and demonstration use.

Also, articles by leading radio authorities, including  
James Millen  
Lieut. Wm. H. Wenstrom  
Zeh Bouck  
Beryl Bryant

AND ANOTHER ARTICLE BY  
DR. JAMES ROBINSON ON THE  
STENODE RADIOSTAT.

## TABLE OF CONTENTS

Cover—From a Painting by David Hymes	
Frontispiece: The Stenode Comes to America.....	582
Editorial— <i>Venit! Vedit! Vicit!</i> .....	584
QRD, South America.....By Zeh Bouck	586
Volume Control in Radio Receivers.....By Jesse Marsten	589
The Stenode Radiostat, What It Does and How It Does It By Its Inventor, Dr. James Robinson	590
De-Bunking Television.....By A. Dinsdale	592
Up and Coming! The Midget Receiver.....By Ralph L. Power	595
A Robot Throat for Loud Speakers.....By George E. Fleming	598
The Air Cell, a New Breathing "A" Battery.....By E. E. Horine	600
Observing the Federal Radio Licensing Requirements.....By Carl Butman	602
The new A. C. Short-Wave Supersonic Converter.....By Volney D. Hurd	604
Europe Puts the Pentode to Work.....By L. Elden Smith	606
Radio Flies the Airways.....By C. Sterling Gleason	608
Get on the Air with the Junior Transmitter.....By Don Bennett	611
The Midget Receiver and the Loftin-White Amplifier..By George E. Fleming	614
"Mikrosopes," a department devoted to radio personality sketches By Harriet Menken	615
Selectivity, Sensitivity and Fidelity Measurements of the Hammarlund Hi-Q 31.....By Donald Lewis	616
The Special Silver Superheterodyne Tuner.....By McMurdo Silver	618
Tone-Compensating Circuits for Audio Amplifiers, Part Two By Julius G. Aceves	620
A Direct-Reading Vacuum Tube Voltmeter.....By Charles Williamson	622
How to Build a Serviceman's Ohmmeter.....By Alfred E. Teachman	624
RADIO NEWS Home Laboratory Experiments.....	625
With the Manufacturers.....	627
In the RADIO NEWS Laboratory.....	628
Junior Radio Guild.....	630
RADIO NEWS Information Sheets.....	632
RADIO NEWS Manufactured Receiver Circuits.....	636
Advertising Index.....	670

25c a copy  
\$3.00 a year

Published Monthly by  
**RADIO-SCIENCE PUBLICATIONS, INC.**

\$3.50 in Canada  
\$4.00 in Foreign

183-10 Jamaica Avenue, Jamaica, N. Y.

Publishers, B. A. MACKINNON and H. K. FLY

Managing Editor, JOHN B. BRENNAN, JR.

Associate Editor, ALBERT PFALTZ

Technical Editor, GEORGE E. FLEMING

Editor, ARTHUR H. LYNCH

Entered as second class matter at the Post Office at Jamaica, N. Y., under the act of March 3, 1879.  
Copyright, 1931, by Radio-Science Publications, Inc. Editorial and Executive Offices, 381 Fourth Avenue, New York, N. Y.  
All Rights Reserved.

# BIG PAY JOBS

NOW OPEN

## FOR EVERY RADIO TRAINED MAN

Don't spend your life slaving away in some dull hopeless job! Don't be satisfied to work for a mere 25 or 30 a week. Let me show you how to quickly make BIG MONEY IN RADIO - the fastest-growing, biggest money-making game on earth.

THOUSANDS OF JOBS PAYING 600 to 2000 A WEEK

NOT A CORRESPONDENCE SCHOOL

### LEARN WITHOUT LESSONS IN 60 DAYS.

Come to Coyne and learn this fascinating big pay game - NOT BY CORRESPONDENCE but on real Radio, Television and talking picture equipment. Real modern Radio receivers, mammoth Broad-casting equipment and the very latest Television and talking picture and code practice equipment. We give you right here IN THE COYNE SHOPS the

actual experience you'll need to make you a money maker

### TELEVISION AND TALKING PICTURES

and now television is on the way. Soon there will be thousands of big pay jobs in this field. Get in on the ground floor. The fellow who learns television now can make a fortune.



### GET THE FACTS FREE

mail coupon for my big Free Book. It tells you all the facts. Tells you how you can LEARN WHILE EARNING. Free employment service for life. MAIL COUPON FOR FREE BOOK AND GET FACTS

H. C. LEWIS, President  
Radio Division, Coyne Electrical School  
500 S. Paulina St., Dept. 11-8C, Chicago, Ill.

Send me your Big Free Radio Book and all details of your Special Introductory Offer. This does not obligate me in any way.

Name .....

Address .....

City ..... State .....

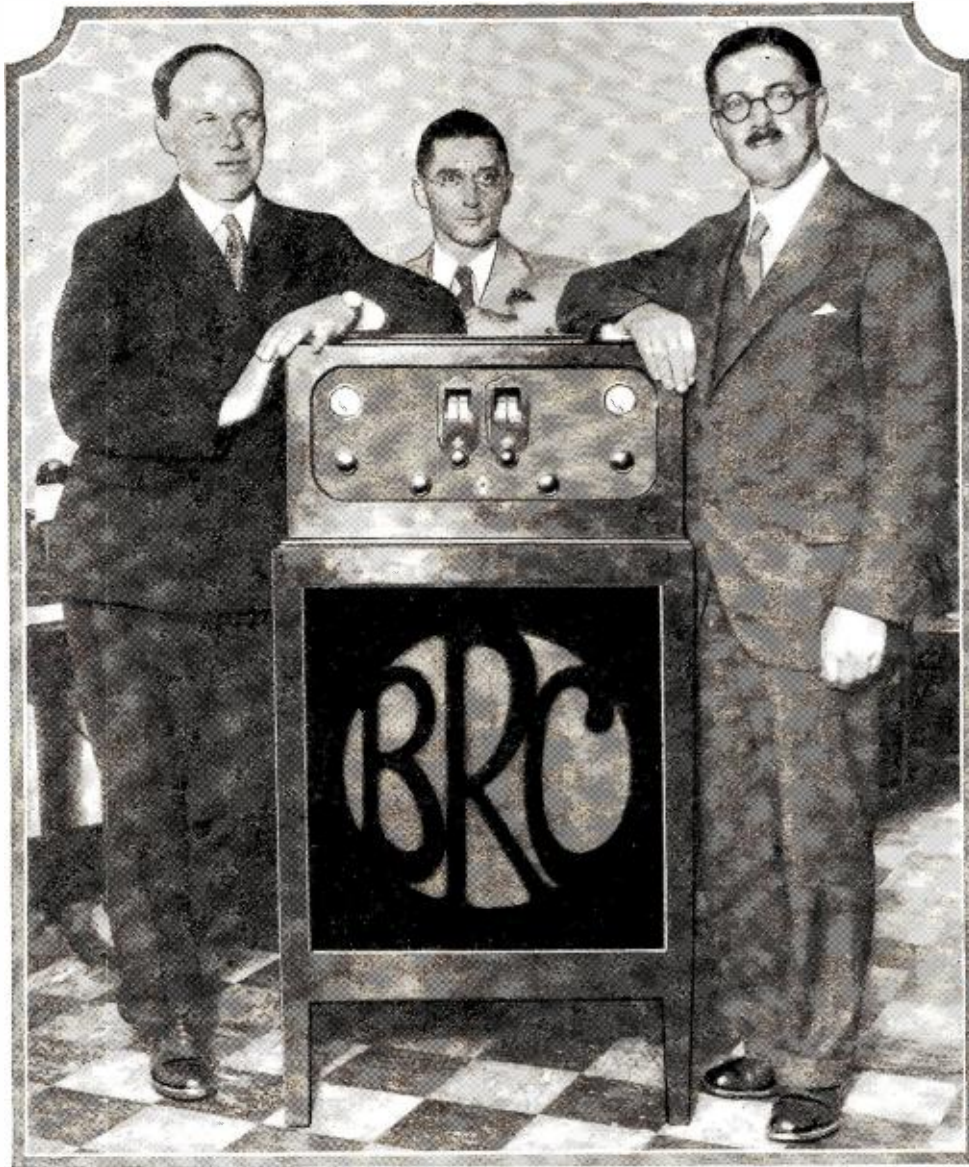

## The Stenode Comes to America

*Under the Auspices of* **RADIO NEWS**

**T**HE first demonstration and explanation of the working principle of the Stenode Radiostat, the invention of Dr. James Robinson of England, was given at Washington recently before a distinguished body of the country's leading radio engineers, including those of the Federal Radio Commission, the Army, Navy and private individuals. Above are shown, from left to right: Dr. James Robinson, inventor of the Stenode Radiostat; Arthur H. Lynch, Editor of RADIO NEWS, and Percy Harris, Chief Engineer of the British Radiostat Corporation.



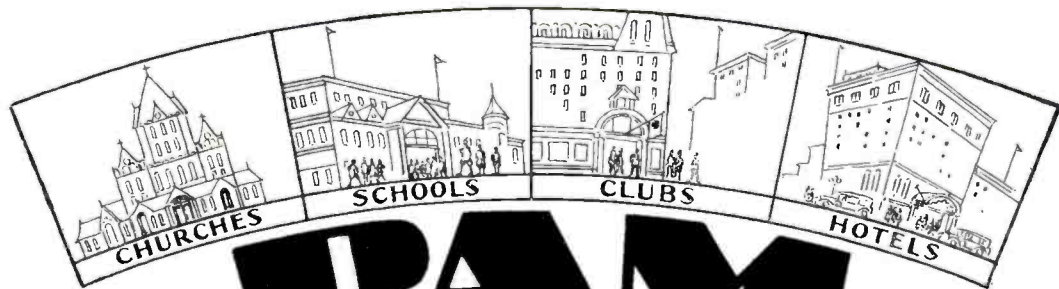
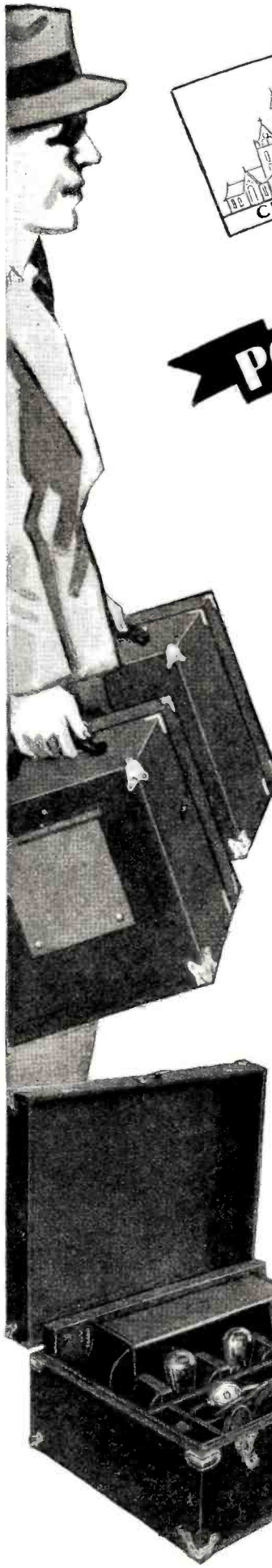

# PAM

## PORTABLE ADDRESS SYSTEM

*quickly*  
Pays for Itself

The portable PAM Address system is readily sold or rented for outdoor events or to thousands of schools, clubs, hotels, churches, and other places where up to 500 people gather.

All units are completely matched and designed to operate together as a system. Thus the dealer does not have to buy from four or five sources and then be uncertain that all units will function properly when used together.

A Portable Pam Address System consists of two units MIK-100 and PAM-100. *Total weight of both units is under 75 lbs! Five minutes is ample time for setting up and no batteries of any kind are necessary.*

Send for twin folders RN10—one descriptive of the PAM-100 and the other of the MIK-100.

Main Office:  
Canton, Mass.

**Samson Electric Co.**

Factories: Canton and  
Watertown, Mass.

MANUFACTURERS SINCE 1882



The MIK-100 two-stage microphone amplifier complete in carrying case with tubes, two-button microphone, adjustable microphone desk stand, 15 feet of microphone cord, and 25 feet of cord for connection to PAM-100, is priced at \$185.00.

The PAM 100 amplifier in carrying case complete with integral speaker and tubes for operation from phonograph pickup, radio set or microphone amplifier, priced at \$158.00.

Combined price for these two units complete with nothing else to purchase \$343.

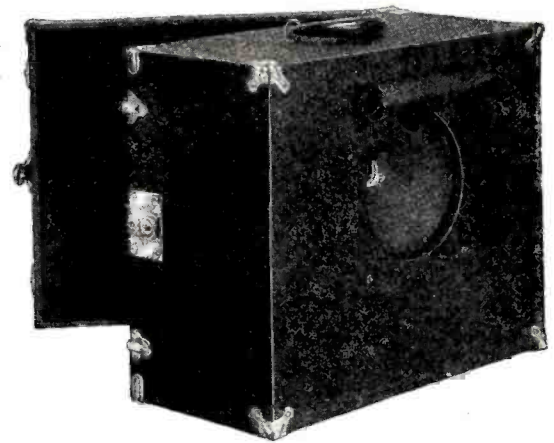
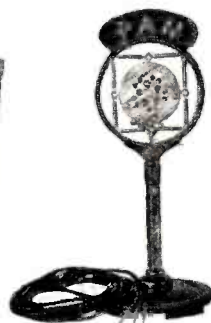
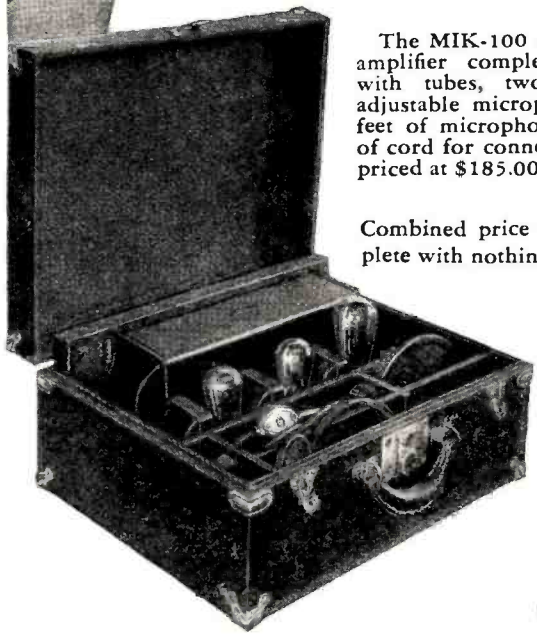



## *Venit, Vidit, Vicit!*

**D**R. JAMES ROBINSON, famous English inventor of the new system of electrical communication called the "Stenode," meaning narrow path, arrived in New York just a week before this editorial was written. He scarcely had time to visit his New York hotel before two of the Editors of RADIO NEWS whisked him and his associates away to Washington.

At Washington, the first American scientists to visit Dr. Robinson were Dr. A. Hoyt Taylor, past president of the Institute of Radio Engineers and now chief of the U. S. Naval Radio Research Laboratory; Dr. C. B. Jolliffe, chief engineer of the U. S. Federal Radio Commission, and V. Ford Graves, assistant chief engineer, and Dr. J. H. Dellinger, chief radio engineer of the U. S. Bureau of Standards. For these famous gentlemen Dr. Robinson arranged a special demonstration and he spent the whole evening in outlining, for them, the theory upon which the receiver used for his very conclusive demonstration was based. He showed two kilocycle selectivity with complete retention of tone quality.

The next day a similar demonstration and a similar outlining of his theory took place. About fifty leaders of radio thought in America attended. Among them were important engineering and financial executives of the large radio, telephone, telegraph and cable companies, the executives in charge of radio for the U. S. Army, U. S. Navy and civilian experts in these departments.

From Washington our party, with all our apparatus, made all haste, by plane and train, to fill an engagement at the Chicago Radio Show. So much interest attended our arrival and so many communication experts and financial groups wished to meet Dr. Robinson, witness the performance of his system and hear him explain it, that we could not possibly arrange a satisfactory schedule within the

three days we were there. It became necessary to arrange a single demonstration. More than one hundred leaders in all fields of electrical communication attended.

It was perfectly obvious at this extraordinary meeting, as it had been in Washington, that "many who had come to scoff remained to pray." The proof of the pudding is in the eating, and every member of our party was besieged by interested folks who wanted to know the basis on which they could manufacture under Dr. Robinson's patents.

Certainly with an invention which opens the door for television; which will enable us to reduce cable, telegraph and telephone maintenance and original installation costs to a degree heretofore considered ridiculous; which will give us many more ether channels for broadcasting, army, navy, amateur and regular commercial radio telephone and telegraph services; which, in a word, is the most important single communications invention since Morse introduced the telegraph, care must be taken to make its application serve all of us to the greatest possible degree.

Needless to say, we are very proud to have Dr. Robinson with us. He is to be in this country several months. Other demonstrations are to be conducted in key centers and, where the circumstances warrant, we have been authorized to arrange any additional private demonstrations which are considered necessary.

Dr. Robinson's first public pronouncement of any kind was made under the auspices of RADIO NEWS at the Chicago Radio Show and his own complete explanation of this new system is published in other pages of this number of RADIO NEWS.

Slightly paraphrasing Cæsar, Dr. Robinson *Venit, Vidit, Vicit*. We congratulate him and his associates most heartily.

*Arthur H. Szycho*

**R. T. I.** R. T. I. QUALIFIES YOU TO MAKE MONEY AND ITS SERVICE KEEPS YOU UP-TO-THE-MINUTE ON THE NEWEST DEVELOPMENTS IN RADIO, TELEVISION, AND TALKING PICTURES **R. T. I.**



# RADIO WANTS MEN TRAINED AS R. T. I. TRAINS THEM AT HOME FOR PRACTICAL WORK

Radio wants trained men and pays them well. This great industry would rather pay Big Money to men trained as R. T. I. trains them, than low wages to untrained "tinkers" and "guessers." Trained radio men can easily make \$40 to \$50 per week and upwards. With training and experience many make \$75 to \$100 per week and are always in demand. Get the inside facts from leading radio men in the free "R. T. I. Radio Opportunity Book."

**BETTER JOBS - BIGGER PAY**  
R. T. I. offers you the way to get into Radio right, and the definite path to the Better Jobs and Bigger Pay. You need no experience to start. You can quickly make \$10 to \$20 per week Extra Money in spare time while learning.

**APPROVED TRAINING**  
R. T. I. training is endorsed by leading Radio Concerns and Radio Trade Associations. It is prepared and supervised by well known men in different branches of radio. You will find it interesting, practical, thorough and easy to understand.

**LEARN AT HOME**  
Why? Because the fellow who trains at home the R. T. I. way learns rapidly and makes a most valuable man. R. T. I. gives you the training the radio industry wants you to have for important, well-paid work.

Make your success certain. Start R. T. I. training in radio now. Go on up in this great money-making industry that is becoming part of all our daily life. Entertainment, Education, Business, Transportation, News—all depend more and more upon radio.

**GET PAID FOR WHAT YOU KNOW**  
Be a trained man. R. T. I. gives you money-making radio training and keeps you up-to-the-minute with its service. No more worry about jobs when you complete R. T. I. training.

**TELEVISION**  
This amazing new branch of radio is part of the R. T. I. training. (No extra charge.) Be prepared for this new work—Television Service-men will soon be in demand.

**TALKING PICTURES**  
Require trained men—in the studios—the theatres—for servicing and installing the apparatus, and R. T. I. training covers this, too. Broadcasting Stations; Airplane Radio Apparatus; Sea-going Ship Radio Operating; Radio factories; Short Wave Work; Receiving Set Servicing; Selling; Repairing, etc. All these opportunities are included in R. T. I. training.

**Free Opportunity Book**  
Get the facts about the opportunities in Radio, Television and Talking Pictures in this wonderful book—it is free.

**Mail Coupon for Big FREE BOOK**



**Let F. H. SCHNELL** and the R. T. I. Advisory Board Help You  
20 years' Radio Experience. First to establish 2-way amateur communication with Europe. Former Traffic Mgr. of Am. Radio Relay League, Lieut. Com. U. S. N. R. Inventor and Designer. Cons. Radio engineer. Assisting him is the R. T. I. Advisory Board, composed of men prominent in the Radio Industry—manufacturing, broadcasting, engineering and servicing. All these men know Radio and will help you succeed in their field.

**RADIO & TELEVISION INSTITUTE**  
4806 St. Anthony Ct., Chicago, Dept. 841



**THE R. T. I. ADVISORY BOARD.** These men are executives with important concerns in the radio industry—manufacturing, sales service, broadcasting, engineering, etc., etc. They supervise R. T. I. Work Sheets, Job Tickets, and other training methods.

**R. T. I.** R. T. I. TRAINS YOU AT HOME FOR A GOOD JOB OR A PROFITABLE PART TIME OR FULL TIME BUSINESS OF YOUR OWN

**RADIO & TELEVISION INSTITUTE**  
4806 St. Anthony Court, Chicago, Dept. 841

Send me Free and prepaid your **BIG RADIO OPPORTUNITY BOOK**, "Tune In On Big Pay," and full details of your three-in-one Home Training (without obligating me in any way).

Name.....  
Address.....  
City..... State.....

With the "PILOT RADIO"  
on Its Record Breaking  
Flight Across Two Continents

# QRD

Where Are You Bound?

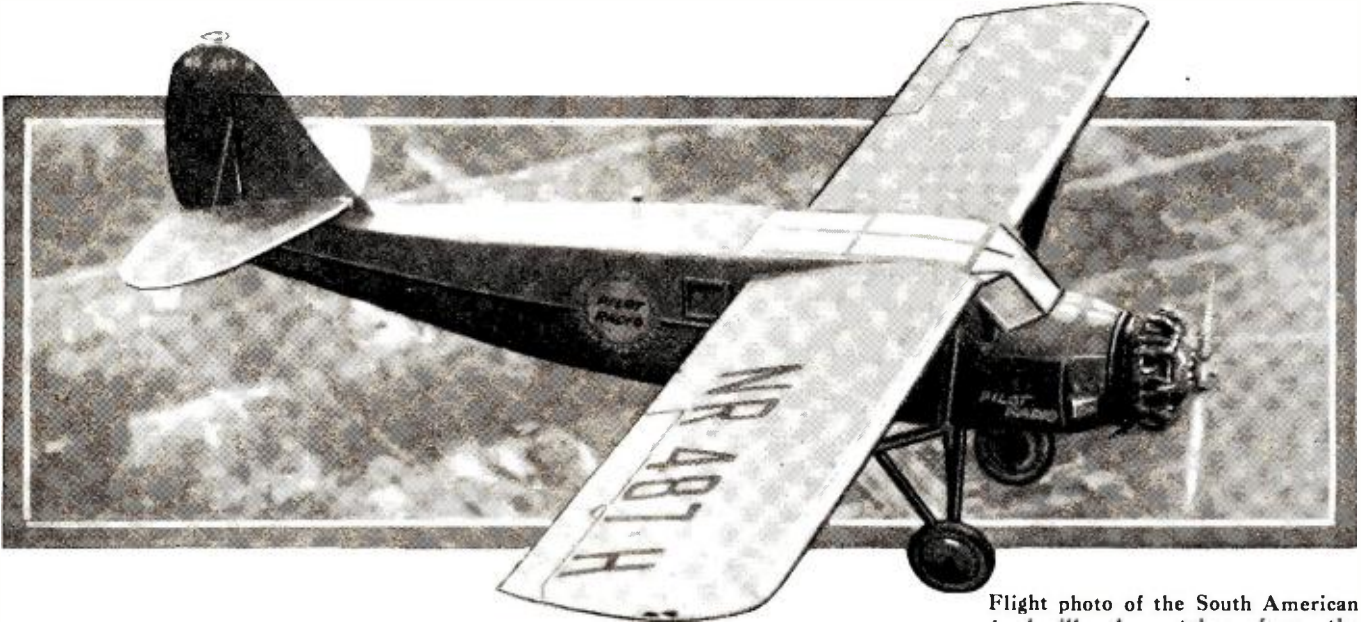

Flight photo of the South American good-will plane taken from the "Aloha" just after the start for Washington

**M**EET the crew! Captain Lewis A. Yancey, in charge of the tour—the genial navigator with Roger Q. Williams on the flight of the Pathfinder to Rome, and with W. H. ("Bill") Alexander and the writer on the first airplane to fly from the United States to Bermuda.\* Emile H. (or "Eddie," if you prefer) Burgin, our pilot—a veteran of well over three thousand hours and prominent among our transport fliers. Burgin, you may recall, came in first in the New York-Los Angeles race a few years back. As for the writer, in charge of communications, we refer the really interested reader to the police records at Santiago de Chile, in which thriving community we were unfortunate enough to become involved in the accidental killing of a native son.

The plane—may the tropic rains fall softly on her ashes—was a Stinson—the same ship we flew to Bermuda, and powered with a Wright Whirlwind, J6, 300-horsepower motor. On the Bermuda hop the plane was fitted with pontoons, and the reader may remember that we spent the night upon the ocean, tossed about by a fretful Atlantic swell. On the South American tour, wheels were substituted for the floats, converting the "Pilot Radio" into a land plane, and eventually the blue waters that had been a haven to us contributed to our ultimate disaster.

### A Midnight Radio Test

The radio apparatus carried on the South American flight was an improved modification of our Bermuda equipment. The transmitter was changed from a simple oscillator to

\*Radio News for July, 1930.

**T**HIS series of three exclusive stories by Zeh Bouck offers something new to the readers of RADIO NEWS. Against a background of engineering purpose and achievement, the author tells a story of adventure, replete with the thrills of a pioneering endeavor. Both radio and flying history were made on this 20,000-mile flight and the story is a stirring one from the take-off in New York to the first successful airplane SOS and the crack-up on Great Exuma Island.—THE EDITORS.



The fliers are shown here on the steps of the White House. Left to right—Jane Celler, Congressman Celler, Zeh Bouck, Emile H. Burgin, I. Goldberg and Lewis A. Yancey

a MOPA (master oscillator power amplifier) arrangement, with a 210 tube pushing a UX211. Sixty to seventy watts were delivered to the antenna, depending on frequency—satisfactory efficiency being secured between 25 and 60 meters, with two plug-in coils. The "Pilot Radio" carried two licenses, the U. S. experimental W2XBQ and the Argentine license LU4A.

Our primary source of power was an Exide twelve-volt aircraft storage battery. This was charged during flight by a wind-driven Esco generator with a Deslauriers constant-speed propeller. The storage battery lighted both receiving and transmitting filaments, and turned over the Esco dynamotor supplying the high potentials to the transmitting tubes. Receiving "B" voltage was obtained from a light-weight Eveready aircraft battery. The designers and manufacturers of this auxiliary equipment are to be commended on the excellence of their products and a definite contribution to the safety of air transportation.

The receiver was an a.c. Pilot Super-Wasp, reinforced mechanically to withstand the strenuousness of a twenty-two-thousand-mile air journey and electrically altered to permit the operation of a.c. tubes, in a series filament circuit, from the twelve-volt aircraft battery. A.c. tubes were desirable due to the greater sensitivity of the circuit and the reduction of microphonic or vibratory noises.

It was essential that the new transmitter be tested before actually

# South America

*More and more people are coming to realize that for safety of air travel radio is unmistakably recognized as the one big item which has made for safer flying. Radio men have not been slow to see the unlimited field for advancement in the aero-radio communications game and this article by an old-timer is only one more indication of how important a part radio has and will play in the aeronautical field*

By Zeh Bouck

PART ONE

## *New York to Panama*

taking off for South American ports. The radio installation was completed simultaneously with the final motor check-over and the adjustment of the earth inductor compass—that is, at about midnight, Tuesday, May the 13th. Our flight was scheduled to start at seven a.m. the 14th! A telephone call to the New York Times radio station, WHD, who was to contact us on the entire flight, ascertained that they were waiting for us, and we took off into a dazzling glare of flood lights. Burgin circled the field while Arthur Lynch and I completed the final adjustments on the radio apparatus. One hour later, reasonably satisfied with the transmitter and definitely sleepy, we came in low over the hangars, signaling for the flood lights, and headed into the wind. A morning mist already enveloped the field. Landing the plane, facing the blinding lights half reflected by the fog, was task for a clairvoyant. At the crucial moment someone turned off the lights! The plane landed, by virtue of natural laws, and bounced ecstatically in the air after the art and manner of an impressionistic dancer.

I motored in from Roosevelt Field to New York City to clean up a few remaining items of business, such as signing my will, and stopped at my home on the way back to pick up a toothbrush and a spare shirt. We were traveling light, and besides we had our health certificates with us in case of necessity. Out to the field

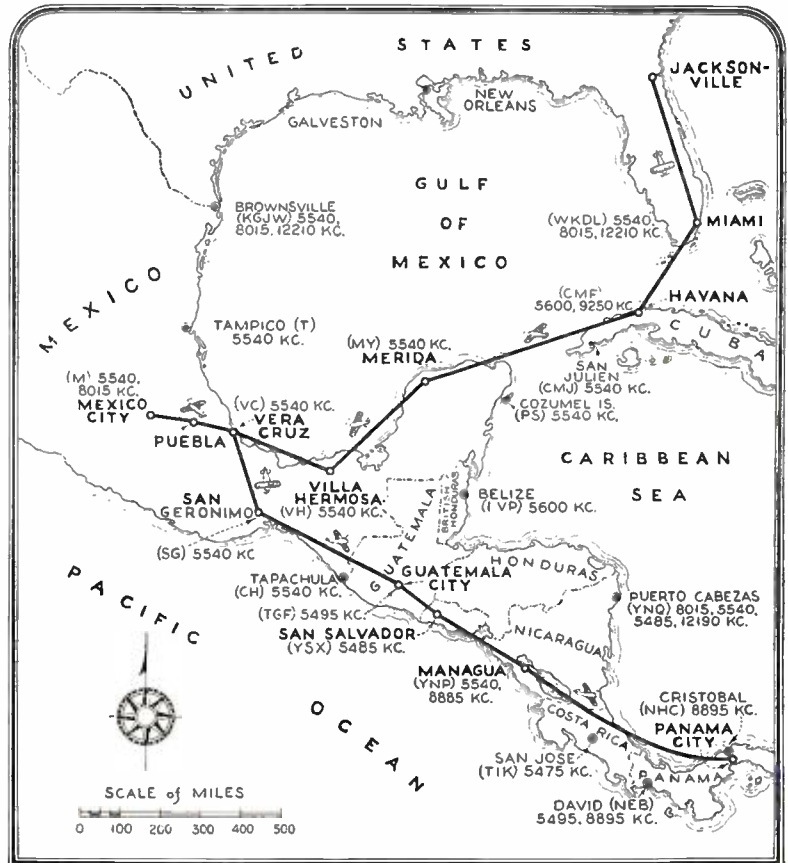

The flight of the "Pilot Radio" from Florida to Panama, showing the locations of the Pan-American radio stations

again, with the first glint of the morning sun burning off the dew haze that had almost proved disastrous the night before. Mechanics were still working on the motor, and the prop had just been turned 180 degrees in a successful effort to eliminate a last trace of roughness.

### *The Take-Off*

Our first destination was Washington, D. C. The flight was sponsored by the Pilot Radio and Tube Corporation of Lawrence, Mass., as a good-will gesture between the radio manufacturers of North America and the vast radio market of South America. And as such we were to receive the pontifical blessing of President Hoover. We were accompanied on this first leg of the tour by Mr. I. Goldberg, president of the sponsoring organization.

With our tanks half full of gas and a hard field, the take-off was a fast one. The "Aloha"—the plane which Martin Jensen flew to Hawaii in the Dole race—took off alongside of us, carrying Mrs. Yancey and Mrs. Bouck and McCory, the veteran news photographer. Flying over Long



Pan-American radio headquarters WKDL at Miami, Florida. The loop is used for bearings on the six hundred meter to eight hundred meter band

Island the two planes swayed lazily a hundred yards apart, until, with a farewell wiggle of her ailerons, the "Aloha" turned back to Roosevelt field. It was like dropping the pilot. We were off.

We lost no time in running into bad weather, hitting thick stuff just south of Philadelphia. A radio weather bulletin reported no ceiling or visibility at Baltimore, and at Wilmington we were just skimming over the Delaware River, keeping over the chimneys and masts of docked vessels well to our starboard. It looked for a time as if we would have to put her down at the Bellanca field, but a lifting ceiling invited us on, and we pushed through to Washington without further difficulty.

At the Capitol, accompanied by Congressman Emanuel Celler and his daughter, we were received by President Hoover. In the course of a conversation, Yancey asked the President if he had ever flown and if he expected to fly shortly.

"No," replied President Hoover, "I have never been up, and I certainly should like to go up. Unfortunately, there are certain inhibitions that prevent me from doing many of the things I should like to do."

The implication is that the travels of our presidents are confined to more established and "safer" modes of transportation. This is, as the President himself admits, "unfortunate." The Department of Commerce, of which Hoover was the head for some years, has been endeavoring to convince the American public—citizens of the foremost aviation country in the world—that flying is safe. Yet not one of our presidents has ever been permitted to fly, though a precedent has long been established by European royalty. The Prince of Wales is an aviator himself, and Herbert Hoover, Jr., an executive in an air transport company.

We took off the next morning for Jacksonville, battling head winds all the way down and arriving there too late to push through to Miami. We made Miami the following morning and remained over until the next day for a general check-over of radio, plane and motor. It was here that we first availed ourselves of the splendid Pan-American Airway facilities—a continued co-operation that did much to make our trip a success.

**The Pan-American Radio System**

Pan-American Airways is one of the most successful air transport companies in the world, and its present lines are conveying mail and passengers from Miami to all important points in Central and South America and the West Indies, with an additional division running from Brownsville, Texas, to Mexico City by way of Tampico. Flight schedules are maintained with railroad consistency, an achievement that is made possible only by the efficiency of their radio communication system. As a matter of fact, Pan-American pilots have told me that they would never attempt much of the bad-weather flying that is almost their daily diet without the assurance of radio communication with their immediate destinations.

At the present writing there are probably fifty Pan-American ground stations in operation, and there is no point on any of the Pan-American routes where the plane is not within reliable communication distance of at least two stations.

It is not sufficient to know the weather conditions along an air route at the start of a flight. Out-guessing rapidly changing weather has been the cause of our major air transport catastrophes. And in the tropics, weather piles up with the rapidity of an equatorial sunset. Every fifteen minutes or so

**WEATHER REPORT**

FROM Havana TIME 2 R 30 DATE May 17

To Yancey W2XBQ

General Weather Conditions Clear

GROUP 1: Horizontal Visibility unlimited

Height of Base of Lower Prevailing Clouds 4000 Feet

Amount of Sky Covered with Lower Prevailing Clouds two Tenths

GROUP 2: Total Amount of Sky Covered with Clouds four Tenths

Direction of Surface Wind South four M P U

Force of Surface Wind Ten

Weather Conditions During Preceding Hour same

GROUP 3: Barometer Reading 30.101 Thermometer Reading 80 wet 82 dry

REMARKS Field dry

Naah

Fig. 1. (Weather report blank.) A small detail in a one hundred per cent efficient organization. A Pan-American operator can copy a complete WX on this blank in a minute

**T**HE "Pilot Radio" was the first commercial plane to circumnavigate South America. From Buenos Aires—both in the air and with emergency equipment on the ground—consistent radio communication was maintained with New York City. While flying over B. A. telephone conversations were carried on with Sydney, Australia, through the intermediary of instantaneous relay transmission over an 18,000-mile circuit—probably the longest circuit ever employed for voice transmission.—THE EDITORS.

the radio operator on a Pan-Am plane hands the pilot a complete wx (weather) report telling him everything he wants to know concerning the weather before him. This information is copied by the operator on the special blank shown in Fig. 1. Only the parts in handwriting are transmitted, and the individual sections are separated by a dit-dah-dit-dah. It is therefore possible to transmit an entire wx in about one minute.

A plane leaving Tampico for Mexico City runs into thick weather with a three-thousand-foot ceiling. The pilot knows he has twelve-thousand-foot mountains in front of him. Ordinarily he would return to Tampico and await more favorable flying conditions. However, a radiogram informs him that there is an unlimited ceiling in Mexico City with scattered clouds covering about six-tenths of the sky. So he flies by instrument, coming out on top of the clouds at perhaps ten thousand feet, picks his peaks and pushes through.

The operator on the plane also transmits TR's (position reports) to the ground, and in the remote chance of a forced landing rescue planes would experience little difficulty in locating the disabled ship.

Flying a transport plane without radio may be likened to running a railroad without signal blocks.

The Pan-Am planes carry light-weight 10-watt transmitters having a reliable daylight range up to eight hundred miles. The calling and general working wavelength is 53 to 54 meters, with a shift to 47 meters in case of interference and to 32 meters on long distances such as the Havana to Panama run and from Panama to Talara, Peru.

**Au Revoir, U. S. A.**

We left Miami the morning of May the 17th, Emile making another quick take-off on the fast coral runway of the Pan-American field. Down the blue-lapped sands of Florida, out over the keys, and finally the ninety-mile water hop to Havana, Cuba. We stayed over here two days, one day for the inevitable visit to "Sloppy Joe's" and one day for recuperation. Standard Oil trucks gassed us up at the General Machado field, and Monday morning we took off for Merida, Yucatan, Mexico.

We lost sight of land north of San Julien, and a dull haze obscured the horizon. A report from PS, the island of Cozumel, showed better weather ahead, (Continued on page 640)



The fliers receiving decorations from the Mexican Government for their participation in the funeral of General Pablo Sidar. Left to right—William Olenberger, Colonel Leon, Bouck, Senior Valdez, Yancey, Burgin and Eddie Walsh

# Volume Control in Radio Receivers

*Where, in a receiver circuit, is the best place for controlling volume? This seems to be a question to which there are many divergent opinions. In this article the author presents the present-day trends and reviews information which will undoubtedly find favor with the serviceman, the one who is often called upon to repair faulty volume controls*

**T**HE problem of volume control in radio receivers, and its solution, have both gone through a series of radical changes in the past three years. These changes were a result of the transition from battery operated sets to a.c. operated sets, and in the latter the problem varied with the types of a.c. tubes used. These problems were made still more difficult with every increase in power of the broadcasting stations, because of the necessity of the volume control to handle effectively larger ranges of received signals.

Receiving sets today are being designed with sensitivities of the order of 1 micro-volt per meter. That is, when a signal voltage of 4 millionths of a volt is produced in the receiving antenna, a "normal" (mildly comfortable) loud speaker signal is produced when the volume control is set at its maximum volume position. Such an antenna signal might conceivably be produced in an antenna located several hundred miles from a powerful broadcast station. This same antenna and receiving set located in a more favorable position, say one-half mile from the broadcast station, might conceivably have induced in it as large a signal as 1 volt or more, at least 250,000 times as great a signal as in the preceding case. Obviously such a signal would cause severe overloading of all the tubes unless it were controlled. In order to obtain a "normal" signal from the loud speaker with this 1 volt input signal, an attenuation of 250,000 would have to be introduced by the volume control in one form or another. This is, with present day standards, furthermore insufficient. Consumers demand that when the volume control is set at its minimum volume position, no signal be heard. The volume control must then introduce additional attenuation to completely extinguish the "normal" signal produced after attenuating a 1 volt antenna signal 250,000 times. If we assume this additional required attenuation to be four the total attenuation required of the volume control comes to 1,000,000. In other words the volume control must be able to control effectively signals covering a range of 1,000,000 to 1 in intensity. This must fur-

By Jesse Marsten

thermore be accomplished so that no other harmful effects are introduced.

The type of control almost universally employed in battery sets has not yet been improved upon from the point of view of simplicity. As is well known, this consisted in the use of a very simple wire wound rheostat of the order of 4 to 18 ohms maximum resistance—depending upon the number of tubes and type of tube it controlled. This rheostat was placed in series with the filaments of the radio frequency tubes. By controlling the current through these tubes, the emission and amplification of the tubes was controlled. With the filament completely extinguished no signal would pass from one stage to the next except by leakage through tube and wiring capacities. By controlling a sufficient number of radio tubes excellent control of signals was obtained. Owing to the fact that some radio frequency current was always present in the battery leads, regeneration would vary with the position of the volume control and this would effect the tuning of the controlled stages to some degree. This effect, however, was not very serious.

The first commercial a.c. operated receivers employed the -26 type tube in the radio frequency stages. The filament characteristics of this tube were such as to prohibit the use of the simple filament volume control. The tube employs a fairly heavy, high current, oxide-coated filament which, because of these factors, has a high thermal inertia. As a result there is an appreciable time lag between filament current changes and temperature. As a result, with the filament type volume control finding the proper adjustment for a given signal level is reduced to a series of cut and try experiments. When the signal is too loud the volume control is reduced. Owing to thermal inertia nothing happens for a while. When the filament finally reaches its constant temperature corresponding to the changed current the signal suddenly drops and you find that it is too low. The volume control is then turned up and the same thing happens, except that now the signal may be too great or still not loud enough. After a few adjustments the proper setting is found. Obviously such a control is deficient.

The use of a C bias volume control or a plate (Continued on page 661)

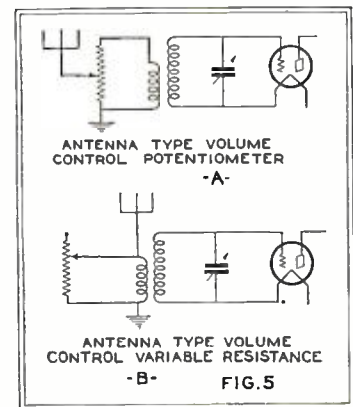
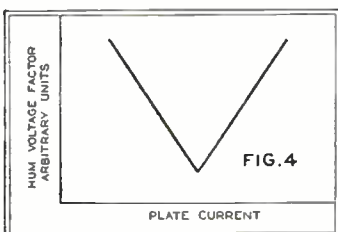
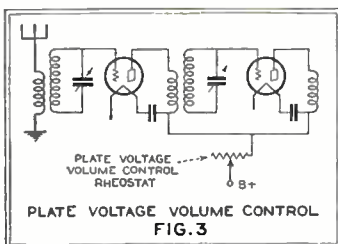
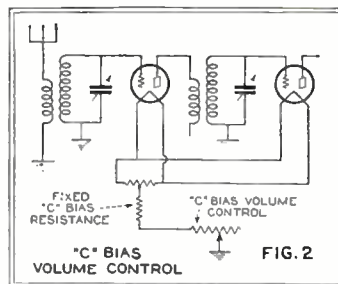
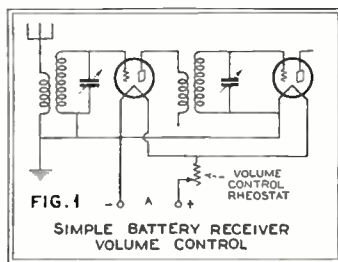

# The Stenode

## What It Does and

*In this exclusive article prepared the inventor of the Stenode Radiostat, of how the circuit works and what it American audiences composed of some Stenode Radiostat has been successfully torily separate stations which, in other*

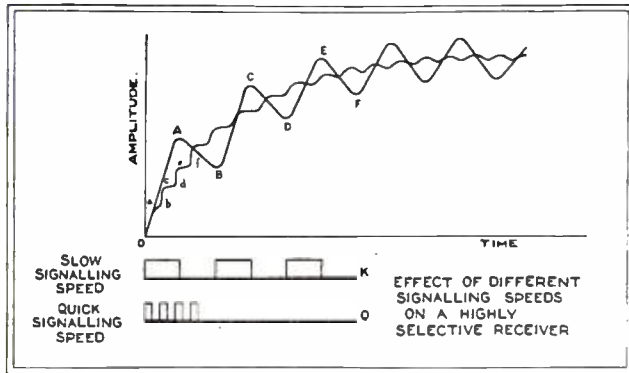

An amplitude-time curve for two signalling speeds, illustrating how in a highly selective circuit such as the Stenode Radiostat, where the damping is low, a variation in amplitude is obtained permitting passage of all modulation frequencies to the audio channel

*By Its Inventor*

**T**O a public which is primarily interested in results and secondarily in how these results are achieved the Stenode Radiostat opens up new fields of endeavor in radio, the extent of which it is difficult to comprehend.

As applied to radio, which is only one of the applications of this remarkable invention, receivers have been demonstrated here to show that without impairment of tone quality, it is possible to separate stations, which on present-day commercial receivers badly heterodyne each other; also room is made for three channels where only one existed before.

Now, as Dr. Robinson points out, it is NOT necessary to consider that the present conception of side-band transmission theory must be discarded. Rather it must be extended.

In refusing to be bound by present-day generally accepted theories on carrier modulation, Dr. Robinson has given to the scientific world new food for thought.

Suffice to say that the Stenode works—and how!

THE EDITORS.



Dr. James Robinson, inventor of the Stenode Radiostat

**P**ICTURE to yourself your personal radio receiver tuning from one end of the broadcast band to the other with every station coming in clearly with no overlapping or blanketing even when you are listening to a distant station on the next channel to a powerful local; try and imagine, also, not only what seems to you to be this ideal state of affairs, but also blank spaces between adjacent programs. This is what the Stenode Radiostat will do.

Selectivity of this order has not only been looked upon as unattainable, but scientists on both sides of the Atlantic have told us that such a state of affairs is theoretically impossible. It seemed, indeed, that progress in the development of radio, at least as far as selectivity was concerned, was stopped dead against an insurmountable wall or otherwise by the limitations impressed upon us by the general acceptance of the side band theory.

A still greater limitation, and one against which all radio engineers halted, was imposed upon television, for all progress in television seemed to be dependent upon using for this new service a wider band of frequencies than present conditions permit. I could give you many further examples of the limitations thought to be imposed upon the development of radio by this generally accepted theory, such as the restriction of amateur radio telephone experiments, beam services, trans-oceanic telephone services, and the like, but most of these will have occurred to many readers of RADIO NEWS.

Several years ago I became acutely conscious that it was vitally necessary to find some way out of the impasse. In my position as Chief of Radio Research of the British Royal Air Force, I had more than ordinary opportunities of seeing the effect of these limitations. The Army, the Navy, the Royal Air Force, big communication companies, and last, but by no means least, the amateurs, were all pressing their case for further extensions of their portions of the ether spectrum. It seemed to me absurd that a new science of such enormous potentialities should in so few years have reached what appeared to be the limit. Common sense told me there must be some way out, and I set out to explore other possible avenues along which we could find a way round the difficulties.

It has often been said that in order to solve a problem the best way is first of all to define that problem clearly. Just what did we want to do? Obviously we had to clear the ether and make room for more stations. The main reason why, for example, a minimum space of 10 kilocycles was laid down as

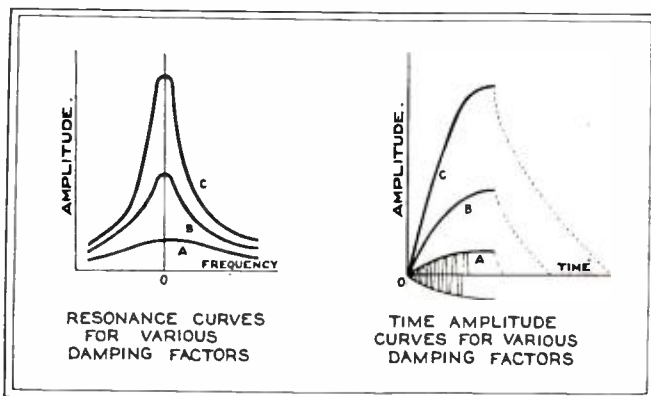

Above, at the left, are shown resonance curves for circuits where the damping varies in each case. A is a highly damped or broadly tuned circuit, while C is a low-damped or highly selective circuit. To the right the amplitude curves for these same resonance curves are shown



# Radiostat

## How It Does It

*especially for RADIO NEWS readers by the first full authoritative explanation can do is published. Before many of the leading radio authorities the demonstrated in its ability to satisfactypes of receivers, are badly heterodyned*

**Dr. James Robinson**  
M.B.E., Ph.D.

the minimum separation between broadcasting stations, was that according to the side-band theory a station modulated by frequencies up to 5000 cycles automatically produced wave lengths which had to be received up to 5000 cycles of each side band carrier. It is, of course, essential that the receiver should go as far as possible and faithfully copy all the sounds impressed upon the broadcast transmitter microphone.

In order to get any selectivity, the phenomenon of resonance or tuning had to be recognized. If we made our receivers too sharp then we received the carrier wave and practically nothing on the side waves. At the same time, the quality was thoroughly bad, high notes being cut off and music and speech made unrecognizable. It was considered necessary that the resonance curve of the receiver should be sufficiently wide to embrace all of the side-bands without appreciable loss, and receivers which we made flat enough in tuning to embrace all these side bands inevitably received some of those of the next channel. This was particularly the case when the strength of the station on the next channel was of a high order, or to put it more simply, when we wanted to receive a comparatively weak transmission through the interference of a local station but one channel away, the interference from the local station was then noticeably present.

The fact that the cutting of the side bands was accompanied by a sacrifice of quality led everyone to believe that this was a case of cause and effect, and one of my first important discoveries was that a loss of quality was due to an entirely different cause. A thorough mathematical investigation of the principles of modulation, of the form of the modulated wave transmitted and of its

The Stenode as applied to a standard type of superheterodyne. The crystal resonator circuit provides the extremely sharply tuned circuit



Percy Harris, Chief Engineer, British Radiostat Corporation, Ltd.

## Just Picture YOURSELF!

*tuning from one end of the broadcast band to the other with every station coming in clearly with no overlapping or blanketing, even when you are listening to a distant station on the next channel to a powerful local; try and imagine, also, not only what seems to you to be this ideal state of affairs, but also BLANK SPACES between adjacent programs.*

**THIS IS THE STENODE RADIOSTAT**

effect on receiving circuits of various degrees of damping, gave me my first clue to the Stenode Radiostat. I soon realized that no matter how selective the receiver may be, it can be made to reproduce faithfully all the modulation frequencies impressed upon the transmitting microphone.

The next step was to prepare in the laboratory, experimental apparatus to give a degree of sharpness of tuning hitherto considered useless. My theory, at this point, had developed far enough for me to see that we could cut off all the side bands, leaving only the carrier frequency without loss of any modulation frequencies. The quartz crystal resonator at once suggested itself as almost the ideal sharply tuned circuit, for a properly prepared quartz crystal will resonate freely at one frequency, and scarcely at all on the frequencies more than two cycles on

either side, even on such high frequencies as are used on the broadcast band. A receiver made up in this way with a quartz crystal ground accurately to the frequency of a broadcast transmission gave reproduction so bad that it was useless in any form of reception of speech or music, and the result would appear to confirm the deductions from the side band theory.

I know, however, that the reason for this bad quality was that the frequencies in the audio spectrum were being disproportionately magnified, and we could say that if all frequencies from 100 to 5000 were (Continued on page 653)

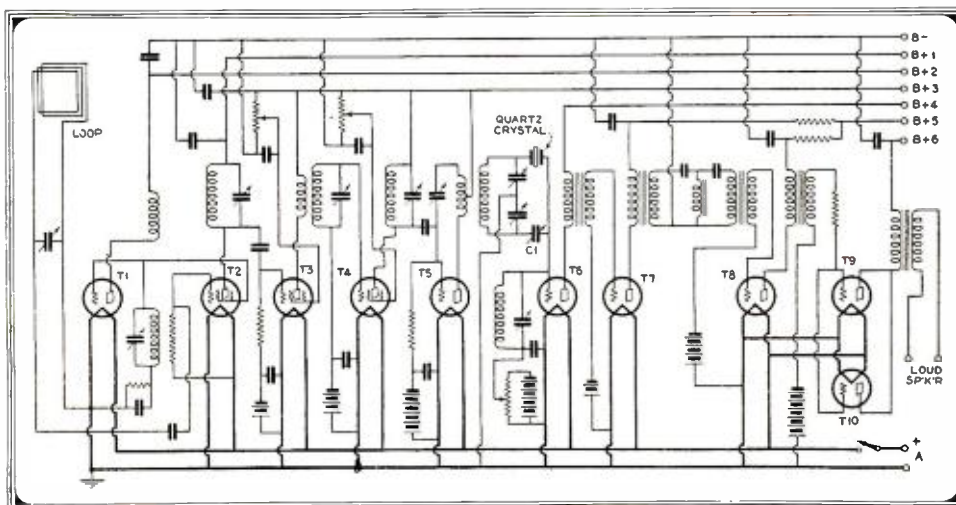



A. Dinsdale

# De-Bunking

*Many conflicting reports concerning the time have left most of us in a fog. Several fairly There are many reasons for progress in for the serious experimenter is here today. being made here and abroad we present the latest*

By A.

**I**N January, 1926, the Scottish inventor John L. Baird gave his first public demonstration of the transmission and reproduction by electrical means at a distant point of the image of a living human being. I have thus described the process, known as television, in order to differentiate it from experiments which have been made, both before and since, in the transmission of the shadowgraph images of inanimate bodies, or the reproduction by similar methods of moving picture films.

Shortly after Baird gave this now classic demonstration, the Editor of RADIO NEWS specially commissioned me to investigate and report on the Baird system, and as a result there appeared in the September, 1926, issue of this journal the first detailed account of Baird's methods to be published in the United States. That article terminated with the following words:

"Mr. Baird has definitely and indisputably given a demonstration of real television. It is the first time in history that this has been done in any part of the world."

At that time Baird unquestionably led the world, and it gave me pleasure to be able to report as quoted above. Today, four and a half years later, it is with regret that I am compelled to report that Baird has lost his leadership, and shows no signs of being able to regain it. The apparatus he uses today is identical in principle with that which he used in 1926. That this fact is not evidence of great wisdom and foresight is obvious to all who are intimately familiar with the problems of television. On the contrary, as I propose to show in this article, television cries aloud to heaven for the discovery of some entirely new principle which will free the infant art from its present limitations and permit of its normal and healthy growth.

Television, as we know it today, is capable of giving only a head-and-shoulder view of the person seated before the transmitter, and that more or less imperfectly. True, somewhat wider fields of view have been demonstrated from time to time, but with a most unsatisfactory amount of detail; the more of the individual one attempts to show, the less the detail. Television in natural colors has been demonstrated, and also television in stereoscopic relief, but any departure from the stereotyped head-and-shoulders view, in monochrome, is in the nature of a stunt designed for publicity purposes.

As to size, the received images, unmagnified, are limited to an inch or two square. It is customary to enlarge the apparent size of these tiny images by means of magnifying lenses which, besides enlarging the size of the image, also serve to show up any defects which would otherwise pass unnoticed. In many instances, also, overmagnification is resorted to, which distorts the sides of the image.

The above remarks apply to the small receiving screens of

the so-called "home televisors."

Various attempts have been made to enlarge the size of the received image so that an audience of several hundred, or several thousand people may watch it with ease.

Anyone who has followed television developments with an intelligent, but not necessarily technical interest, must have been struck by the deadly lack of originality displayed by one so-called "new" system after another, by the similarity in the size, scope and degree of perfection (or imperfection!) of the received images, and by the utter lack of any real progress towards the long-promised goal—the day when he can watch, in the comfort of his own home, the Army and Navy football Game or the World's Heavyweight Championship at Madison Square Garden.

*We are just as far from that goal today as we were from modern sound broadcasting in, say, 1902, when wireless telegraph communication was conducted clumsily and precariously by the aid of spark coils and coherers.*

I do not mean by the above statement that it will take us as long to reach our goal in television. Far from it. One has only to make a cursory examination of the record of scientific achievement to realize that as each new scientific discovery is perfected it shortens the period of incubation required by the next. Lessons learned in one science are becoming increasingly applicable to succeeding sciences, or new scientific applications.

Apart from technical difficulties, one of the troubles of television, which is doing it a great deal of harm, is that no one so far has attempted to visualize the thing in its true perspective. It is actually being handicapped by the very fact that it has made a tremendous ap-

peal to the public imagination. And this appeal is by no means of recent growth.

The history of television dates back to 1873, when an obscure telegraph operator at the transatlantic cable terminal station at Valentia, in the south of Ireland, accidentally discovered the light-sensitive properties of selenium. Contemporary scientists immediately seized upon the discovery as providing a possible means of supplying an electric eye to supplement the electric ear (telephone) then recently discovered by Bell. And from then on the story of the futuristic possibilities of television came to be built up, largely by imaginative authors.

Today, television is faced with two major problems which are classified under the heads (1) terminal equipment and (2) channels of communication. The first is essentially a problem for those engaged upon television research. The second is outside of their province, and must be solved by those skilled in electrical communication, both by wire and by radio. It is, however, desirable that both groups work in close co-opera-

**O**LDER readers of RADIO NEWS will remember Mr. Dinsdale as a frequent contributor to our columns. Until recently he has been Editor of the British monthly magazine, *Television*. In England, where he is regarded as one of the leading authorities on television and is widely known as a public lecturer, Mr. Dinsdale, now Managing Editor of our sister publication, *Science and Invention*, has been a close student of the subject for over five years. He already has two books on the subject to his credit, and is engaged upon a third, and in order to make it authentic and up-to-date he has come to the United States to investigate personally the work which is being done here. In the following closely reasoned article he presents an unbiased commonsense review of the subject.

THE EDITORS

# TELEVISION

*when we may have television in our homes satisfactory systems are in operation at present. television being comparatively slow. Television In this comprehensive review of the progress available information on this absorbing subject.*

## Dinsdale

tion, for television is but another branch of electrical communication, and must ultimately come under that general heading.

As soon as one comes to examine closely the problem of terminal equipment, one is immediately struck by the appalling lack of originality which has so far been displayed. Sooner or later every new science produces entirely new principles, technique or methods peculiar to itself. So far television has produced none of these. It relies entirely on apparatus which has long been in existence, upon principles long known to the art, and upon methods and technique which are equally old or which have been borrowed from other sciences.

Take the scanning disc, for example. Originally invented in 1884 by Nipkow, a German, it lay idle until raked out by Baird, who by combining it with modern apparatus employed in other arts, such as photoelectric cells, thermionic tube amplifiers and neon lamps, was able to demonstrate a crude form of television. Many other workers followed him, and are using the same principles and apparatus today. Lens discs and the Jenkins drum scanner are but variants of the Nipkow disc, and suffer from the same limitations. The Weiller mirror wheel, or drum, as used by Karolus, was known twenty-five years ago, and also suffers from the same limitations as the disc.

The large viewing screens demonstrated by the Bell Telephone Laboratories in 1927, and more recently by Baird and Jenkins, are strongly reminiscent of the crude suggestions made by early workers that television could be accomplished by using at the transmitter a wall built up of a large number of selenium cells, each of which would control, through a separate connecting wire, one of an equal number of small flash lamp bulbs set in a screen at the receiver. Such an



Dr. Vladimir Zworykin, of the R. C. A. Victor Company, with the new cathode ray tube which he has developed for television reception purposes

apparatus was actually built and experimented with by Rignoux and Fournier in 1906.

The underlying principle of the large screen used by Karolus in Germany, and more recently by Dr. Alexanderson in this country, is the Kerr cell (sometimes called the Karolus cell) which controls the intensity of the scanning beam at the receiver in accordance with the fluctuations of the incoming picture impulses. This cell, based on the Kerr effect, well known to physicists for many years, was originally developed by Karolus for use with his still picture transmission system, and is still being used for this purpose, with highly successful results.

In 1911 the English scientist, Campbell Swinton, declared that television would never be accomplished by mechanical methods, and described an intricate system for the achievement of television by the use of cathode ray tubes at both the transmitting and receiving ends of the system. This idea was experimented with soon afterwards by Boris Rosing in Russia and Belin in France, and is still being experimented with by several workers in this country.

This exhausts all the known apparatus which has proved capable of producing any tangible results. Let us now examine the limitations of these various devices.

Television is at present faced with two imperative demands: (1) to increase the detail of the received image, and (2) to increase the size of the image. Both of these requirements mean that the total number of picture elements must be increased and, where a scanning disc is being employed, this means increasing the number of holes in the disc. And here we encounter a vicious circle.

In order to provide increased accommodation for a larger number of holes it is necessary to increase the diameter of the disc, unless the diameter of the holes, and the circumferential distance between them is made smaller, in which case the resultant image is made smaller, not larger, as is wanted. But smaller holes, and more of them, will provide greater detail and permit of the televising of a field of view greater than the head and shoulders of a human being. The smaller the diameter of the holes, also, the more of them we can get on a disc of given diameter. Furthermore, the phenomenon known as aperture distortion becomes less apparent as the diameter of the holes is reduced.

The ideal, therefore, would appear to be the use of holes infinitely small in diameter. But, apart altogether from the impossibility of drilling an infinitely small hole, the smaller the hole the less the amount of light which will pass through

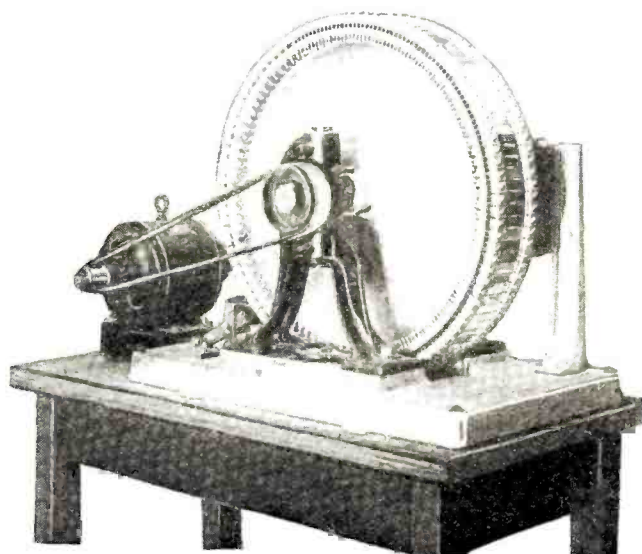

This Weiller Mirror Wheel, as used by Dr. Karolus, has 100 mirrors mounted in staggered formation around its periphery

it and light values are so small in television work already that we cannot afford to lose efficiency on this score. There is, therefore, a practical limit to the diameter of the holes, below which we cannot go. This limit must, of necessity, be a compromise wherein detail is sacrificed to satisfy the limited efficiencies of the photoelectric cells at the transmitter and the light source at the receiver.

We are therefore face to face with the necessity for increasing the diameter of the disc, and at the speed of rotation demanded (20 pictures per second, or 1200 R.P.M.), it would not be mechanically safe to build a disc more than ten feet in diameter. If such a disc were drilled with 60 holes, each 1/10" in diameter, the received image, a 60 line image, would be six inches square, unmagnified. This is a reasonable size of image for home use, but the size of the disc is most decidedly not! Also, the amount of detail in such an image would be very poor.

Alternatively, such a disc would give smaller images with better detail, down to, say, a one inch square image built up of 360 lines, or holes, each 1/360" in diameter. The detail obtainable would then be excellent, but the idea of using a ten-foot disc to obtain a one-inch picture is absurd.

It would be logical and reasonable on the part of the public if it demanded, for home use, a screen one foot square, capable of depicting any scene coverable by means of a home movie, and with as much detail. To get the detail we should have to analyze (scan) the scene into at least 100 lines per inch. To get an image measuring 12" x 12" we should therefore need 1200 holes, and each hole would require to be separated from its neighbor circumferentially by a distance of 12", so that the diameter of a disc to meet these requirements would have to be no less than 400 feet!

The crude absurdity of the disc, and the impossibility of making any further material progress with it is, I hope, now quite clear. Other mechanical methods of scanning, such as the Jenkins drum scanner and the Weiller mirror drum, do not offer any solution either; sooner or later the mechanical limitation of size will be reached.

The limitations of the Bell Telephone Laboratories' large screen obviously lie in the enormous number of picture elements which must be provided, entailing thousands of commutator segments and connecting wires. The same remarks apply to Baird's large screen. The limiting factors in the Karolus-Alexanderson large screen are (1) a scanning disc or mirror wheel is used and (2) the amount of light lost in the optical system, especially in the Kerr cell, is enormous; Alexanderson had to use a 150 ampere arc to obtain sufficient illumination for his six-foot screen.

Everything points to the conclusion that we must ultimately scrap all mechanical means of achieving television and look for some entirely new principle.

Radio communication blundered along cumbrously by brute force methods, the scope of which was decidedly limited, until the invention of the thermionic tube revolutionized the science, and permitted us to develop the intricate, all-embracing and marvelous system of radio communication which we have today. All the indications point inexorably towards the development of some means whereby we can achieve television by purely electronic methods.

The cathode ray tube appears to offer the desired solution.

Electrons are weightless, and therefore inertialess. They travel with the speed of light, and speed is the all-important factor in television, where we have to find a means of increasing the number of picture elements (representing increased detail) transmitted per second so that they run into millions. An electron stream, such as is produced by a cathode ray tube, can be moved about, or caused to scan, instantaneously by the external application of either electrostatic or electromagnetic forces.

But the disadvantages of the cathode ray tube, as at present manufactured, are that its first cost is high, its life is short, it requires expensive auxiliary equipment which involves rather heavy upkeep and running expense, it is difficult to focus the pencil or stream of rays to a sufficiently fine point, and make it "stay put" at that during scanning, and the degree of illumination produced on the fluorescent screen is low.

However, I feel confident that the ultimate solution of the television problem will be found through the medium of the cathode ray tube, but I am equally confident that by the time a complete solution is reached the cathode ray tube, as we know it today,

will have been altered out of all recognition.

So much for terminal equipment. There remains now the problem of channels of communication, and that problem resolves itself into the discovery of ways and means of transmitting the enormously high frequencies which will be involved when the problem of terminal equipment has been solved.

Take, for example, the above-defined supposititious requirement of a home image measuring a foot square, giving detail equivalent to 100 lines per linear inch. The total number of picture elements in such a picture is  $1200 \times 1200 = 1,440,000$ , and if the picture is scanned 20 times per second, the A.C. signal frequency which we must transmit will be  $1,440,000 \times 20$

$\frac{1,440,000 \times 20}{2} = 14,400,000$  cycles, or 14,400 kilocycles per second. Using present technical methods, such a frequency could not possibly be transmitted by radio except, perhaps, on a wave-length of 1 metre, or less.

However, a ray of hope has already dawned on this problem, in the form of the Stenode Radiostat invented by the British scientist, Dr. James Robinson. Briefly, this invention accom-

plishes perfect reception of broadcast stations on such razor-sharp tuning that, in the case of one receiver which I have handled myself, any interfering station tuned to within not less than 100 cycles of the assigned frequency of the desired station can be cut out completely. And Dr. Robinson's ultimate aim is to produce a receiver with an acceptance band a few cycles only in width. This will permit of the erection of hundreds more broadcasting stations without creating mutual interference, or, alternatively, a vastly wider frequency band could

be radiated by existing stations. That is the germ of the idea; it is not yet commercial as far as broadcasting is concerned.

So much for the technical problems of television. Now for a few general comments.

Nobody seems to know yet what standard of perfection will be required of television. I have talked with all the leading workers in Europe and in America, and all are at variance on this point. Baird seems to be satisfied with his present limited achievements. Karolus recognizes the (Continued on page 660)

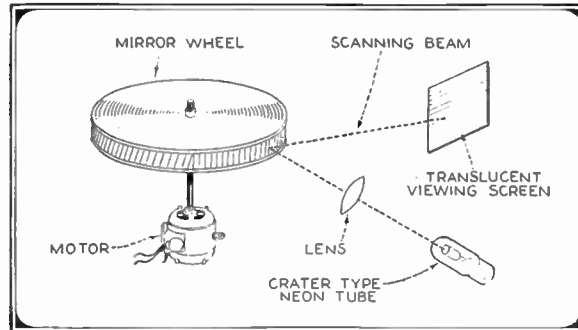

A schematic outline of the mirror wheel type television receiver developed by Dr. Karolus, by means of which he projects an image on to a ground glass screen measuring approximately four inches square

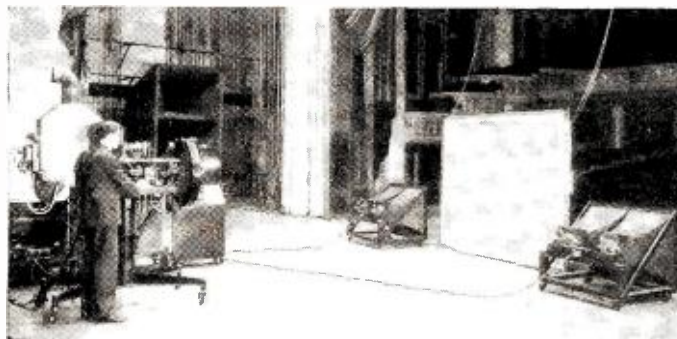

The apparatus used by Dr. E. F. W. Alexanderson, of the G. E. C. to project television images on to a six-foot screen. A 150 amp. projector lamp is used, in conjunction with an improved Karolus cell and nicol prism combination

# Up and Coming!

## The MIDGET RECEIVER

*Diamonds are not necessarily shipped in box cars, nor does a radio set have to be housed in a large cabinet to be a thoroughly good receiver. While midget receivers will never replace the console receiver as the major radio installation in the home, they find vast usefulness as an auxiliary installation in numbers of ways. Not only this, but with the mantel set the man who cannot afford a hundred or more dollars for a pretentious receiver can still have a modern receiver of modest size, with proportionate cost*

By Ralph L. Power



*Premier  
Elec. Co.*

**M**IDGET golf, midget motor cars and midget radio sets. And this doesn't necessarily mean that people are satisfied with small-sized editions of the real thing, either.

What it does mean, though, is that midget or pee-wee golf takes the place of a full grown course for those who cannot get away from the city to the country club, and it serves as a practice area for those who want to perfect certain parts of the game.

The midget or baby motor car seems to have a field as a second family car, especially valuable in city traffic.

The midget or mantel radio receiver does not at all mean merely that it is a low-priced commodity or one which competes with the more fully grown receivers.

But the mantel type set has been largely instrumental in bringing in the two-set home and providing radio entertainment, too, for those who cannot afford the higher-priced outfits.

The smaller, more compact sets have proved their worth as a portable to take away on vacation jaunts, as a set for the guest chamber, one for the nursery, servants' quarters and even in the family garden.

Starting towards the close of 1929 in Los Angeles, in an attempt to keep factories going during a depression, the



*Powel Mfg. Co.*

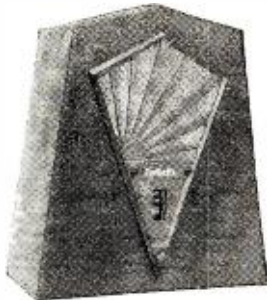

*Keller-Fuller  
Mfg. Co., Ltd.*

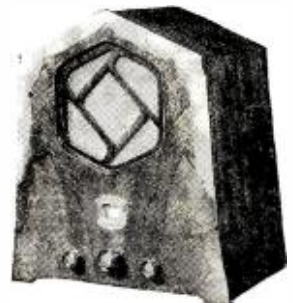

*Jewel Mfg. Co.*



*Pilot Radio  
& Tube Corp.*



*Jackson Bell  
Company*



*Keller-Fuller  
Mfg. Co., Ltd.*



*Jesse French &  
Sons Piano Co.*



*Atchison  
Radio Mfg. Co.*



*Republic Radio Co.*



*Woodstock  
Elec. Corp.*



*Woodstock  
Elec. Corp.*

*Transformer Corp. of Amer.*



*Plymouth Radio Corp.*

*Davison-Haynes  
Mfg. Co.*



*Colonial  
Radio Mfg. Co.*



*Gray-Danielson  
Mfg. Co.*



*Colin B. Kennedy Corp.*



*Zaney-Gill Corp.*



movement has gone into full swing so that there are now 37 factories in the southwest in actual production of mantel sets and at least four, if not more, nationally known radio organizations have followed suit.

Just what the ultimate result will be of the entrance of national groups into the field is, of course, problematical. Certain it is that the southwestern factories have the momentum of an early start, if that means anything, and a pretty good sized part of the research work done there is evidenced in the sets now actually on the market.

*General Design Features*

In large measure, the mantel sets are fairly similar in cabinet design, although there are outstanding features to distinguish them apart—curved peaks for some, futuristic designs in others, one or two with a clock inserted in the face of the cabinet. One shop puts out mantels in a dozen different paint jobs to match the furniture, while another has inserted a phonograph turntable in the top and thus makes a creditable miniature radio-phonograph combination set.

In the matter of the technicalities of these small sets there is not a great deal of difference, although every month or so some one manufacturer comes out with a change or two to furnish opportunity for a "new line."

Let's look at an "average" set and see what's in it. Here are the specifications and work sheet for one of the factories: D.C. voltage into filter, 300; d.c. voltage out of filter to -45 plate, 225; d.c. voltage to r.f. plate, 175; d.c. voltage to power detector plate, 50; to -45 grid, 45; to power detector screen, 22 maximum (volume control); to r.f. screen, 100; to r.f. cathodes 1 to 12 (volume control); to power detector cathodes, 1 to 10; 40-volt surge with tubes removed; a.c. voltage with side transformer secondary, 360; a.c. voltage r.f., power detector, -45 filament, 2.2; a.c. voltage -80 filament, 4.9.

The speakers, small sized, are ordinarily full dynamic, especially built to match the receiver—special field winding, 2,400-ohm, and a special voice-coil spider peaked approximately 80 cycles. Rola, Magnavox and Lansing speakers seem to predominate in the western factory make-up.

A.F. couple—resistance couple of special design (not Loftin-White), with 500 volts maximum, designed for flat curve amplification and minimum plate voltage and drain, 300 volts maximum at source.

R.F. system—two stages sharply tuned screen-grid r.f. with coils designed for maximum gain per stage without the necessity of shields, thereby preventing the losses incurred through the use of shields; three-gang condenser.

In this the gain of the r.f. channel is equal to the average receiving set which employs three stages with shields. The interstage coupling is minimized through proper coil design and proper arrangement of coils on the chassis.

Oscillation is obtainable and controllable, thus adding considerably to gain and selectivity with a fairly even distribution of stations at the lower end of the dial.

The volume control is practically perfect, without loss of tone quality at any setting, and there is no absorption or loss in gain at the maximum setting.

It controls the r.f. bias, power detector screen and



*Pierce Airo, Inc.*



*Simplex Radio Co.*



*Cardinal Radio Mfg. Co.*



*U. S. Radio & Television Corp.*

power detector simultaneously, thereby incurring no overloading of electric strain on any part of the circuit; smooth and positive in operation, not subject to excessive wear and thus necessitating frequent replacement.

In the filter system, the speaker field acts as a choke; condensers, 16 mfd. total. This is of the electro-chemical type and is not subject to corrosion or seepage. The voltage rating is conservative, self-healing in the event of punctures and perfectly sealed from moisture.

The power transformer is conservatively rated, is well insulated, designed for effective cooling. L-shaped core allowing coils to be separated and resulting in better ventilation, mounted on chassis for free air circulation.

So this five-tube set—three screen grids (one is the power detector), a -45 and a -80—can be taken as an "average" mantel type set.

*Similarity of Midgets*

I think, on the whole, that while the more than thirty factories are getting out the same number of different sets, there is no radical difference to be noted in any of them.

Some of them vary in the number of r.f. stages, some using two and others three. Some use the Loftin-White and some resistance coupling in the audio. Some use two and others three stages of screen grid. A few are using -27's instead of screen grid in the power detector circuit. Some shield while others do not.

There are, of course, various ramifications in attempts either to make the set a trifle different from other makes or in the interests of getting out something actually better.

By far the majority of the cabinets are in walnut or veneer, with a dark, hand-rubbed finish. One manufacturer has just begun to go into production for his multi-colored line in jazzy colors, while another is designing his cabinets in the form of a replica of famous California missions.

The average list price is \$59.50, although perhaps a quarter of the factories list at ten dollars higher. There is an additional charge for the carrying cases if needed.

One set is made in the form of a valise with handles on the side.

The Los Angeles factories range from small stores with perhaps ten employees and 100 sets a week, to the largest with more than 100 men and 2,000 sets every seven days.

There are, of course, a few backyard manufacturers—that is, men who do ten or a dozen sets a week in their garage at home and peddle the sets direct to the retail trade.

For sundry reasons, perhaps the difficulty and the time lost in locating miniature parts, the small establishment and the home set-builder have not done very much in this field as yet.

So the mantel type movement, starting originally to keep the men busy during dull times, has actually developed an entirely new market. Still in the embryo state, almost any day some new development may take place which might make revolutionary changes in the actual set-up of these small, low-priced receiving sets. The majority of midget set makers are licensed under RCA, Hazeltine and La Tour patents.



*Paterson Radio Corp.*



*Advance Elec. Co.*



*Flint Radio Co., Inc.*



*Automatic Radio Mfg. Co.*



*The Sterling Mfg. Co.*

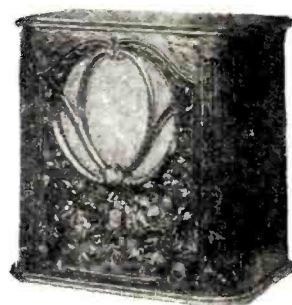

*Crosley Radio Corp.*



*Griffin-Smith Mfg. Co., Ltd.*

# A Robot Throat



Shown above are Wm. C. Eaves (sitting) and C. F. Dilks (standing), the two engineers who have perfected this system of sound production

The speaker installed at Yankee Stadium, New York, appears at the right. This new system outworked the old one outstandingly, with a fraction of the power



**N**ATURE, in the thousands of years that have gone into the evolution of man, has undoubtedly done an excellent job of engineering. It is perhaps hard to think of our bodies as purely mechanical assemblies, but if we neglect the mind, that is exactly what we are. Every known mechanical principle finds its counterpart in the human body, our bones are girders, and every stress and strain is "figured" to the final analysis. Our nerve system is a highly complex communication system, that might well be likened to the telegraph wires that span our country and carry news from point to point. The lever, perhaps the oldest known mechanical principle, used in the moving of the immense stones that went into the building of the pyramids, and even before, is utilized to good extent in our bodies. Even our digestive system may be likened to a combination of the internal and external combustion engines, whose overall efficiency any engineer might well strive to duplicate.

It is small wonder, then, that when the two young inventors, William C. Eaves and C. F. Dilks, started out to design a loud speaker, they looked to nature and modeled after her example. found in the human sound producing apparatus. Studying this system, they found certain facts in the production of sound, that they have utilized, to excellent advantage, in their speaker.

When we speak, or sing, certain mechanical functions take place in our bodies. First, the lungs are utilized to furnish a column of air. The lungs are assisted in this function by the diaphragm, whose function is to exert pressure to increase or diminish the air pressure. This air column is carried upward through the throat and mouth where it is acted upon by the larynx, the palate, the tongue, and the lips.

Quoting rather liberally from "Principles of Human Physiology" by Ernest H. Starling, M.D., we find that the larynx is made up of a number of parts, the most important being a number of vertical muscle fibers, forming the so-called "vocal cords." These cords, when stretched, are capable of vibrating,

*The Hoovenaire Air Column Loud achievements have been, a reversion of years have been spent perfecting and these two engineers have copied*

By George E.

and in so vibrating, modulate the column of air passing between them. The note emitted is determined by the number of vibrations per second of the vocal cords. The air is further modulated by the tongue, lips, etc., but this modulation is secondary. The trained voice is therefore not so much a trained "voice" as it is trained muscles. The vocal cords can be trained to function at the command of the person much as any other muscles can be trained to perform its duties by constant repetition of the action. Quoting literally, this writer also says, "In order that the vocal cords may be set into vibration, they must be put into a state of tension, and the aperture to the glottis narrowed, so as to afford resistance to the current of air. In the dead larynx it is possible to produce sounds by forcing air from bellows through the trachea, after the vocal cords have been put on the stretch by pulling the arytenoid cartilages backwards. By experimenting on patients it has been found that the pressure of air in the trachea, necessary to cause production of voice, is, for a tone of ordinary loudness and pitch, between 140 and 240 mm. of water, and with loud shouting the pressure rises to as much as 945 mm. of water. This pressure is furnished by the contraction of the expiratory muscles, *i.e.*, of the abdomen and the thorax."

So far, we have only considered the production of sound as applied to voice. As nature did not intend man to make a sound like a violin, for instance, the vocal cords are naturally not adapted to it. However, such sounds are possible, with sufficient training, as is witnessed by some of our vaudeville entertainers, who make a specialty of such imitations.

The parallel between the analysis of the human voice mech-

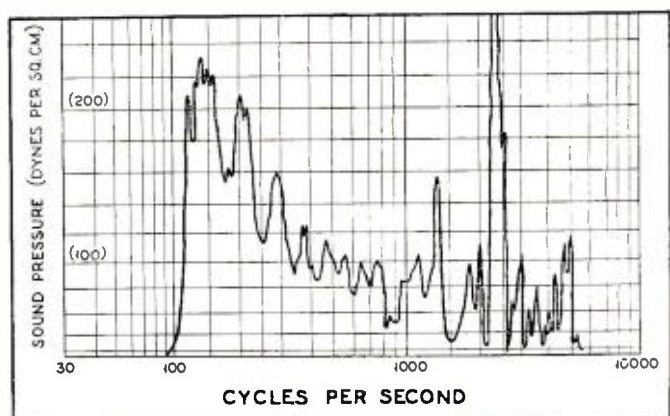

Sound pressure curves on the air column speaker. For speakers of this power, these curves are exceptionally good



# for Loud Speakers

*Speaker is, as so many engineering to the principles of nature. Thousands the human sound-producing system, mechanically this system to a detail*

## Fleming

anism and the loud speaker produced by these two young men is most marked. Corresponding to our lungs and expiratory muscles, they have an air compressor that maintains a constant pressure of 20 lbs. per square inch at eleven cubic feet per minute. This column of air is carried to the mechanical larynx through a hose, where it is modulated into sound impulses. The modulation system consists of a rigid plate, with sixteen vertical slits. Covering this, is another plate, extremely light in weight, and fastened to the rigid plate along one edge only. This plate has fifteen slits, so placed that they cover the solid portion of the rigid plate between the slits in the rigid plate.

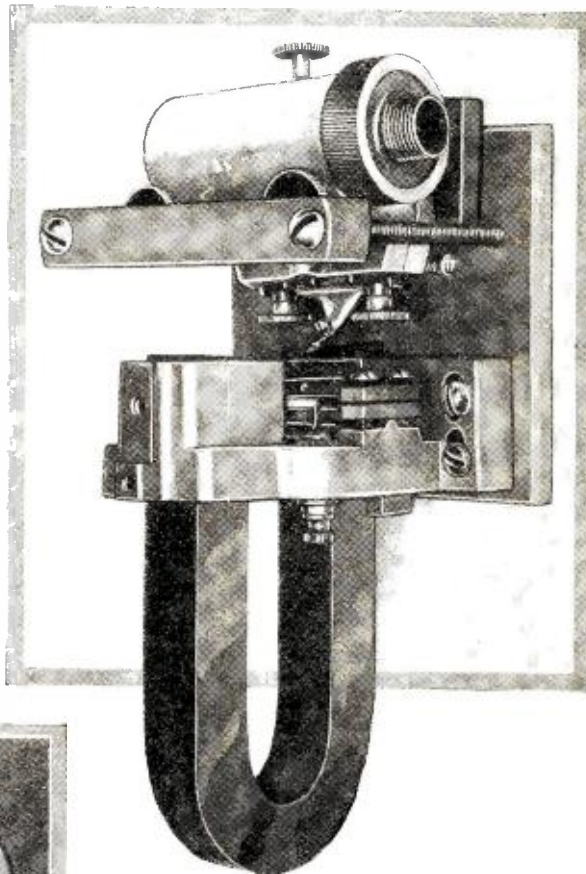

The complete sound head assembled. The motor in this instance is the familiar loud speaker unit, operating the air valve

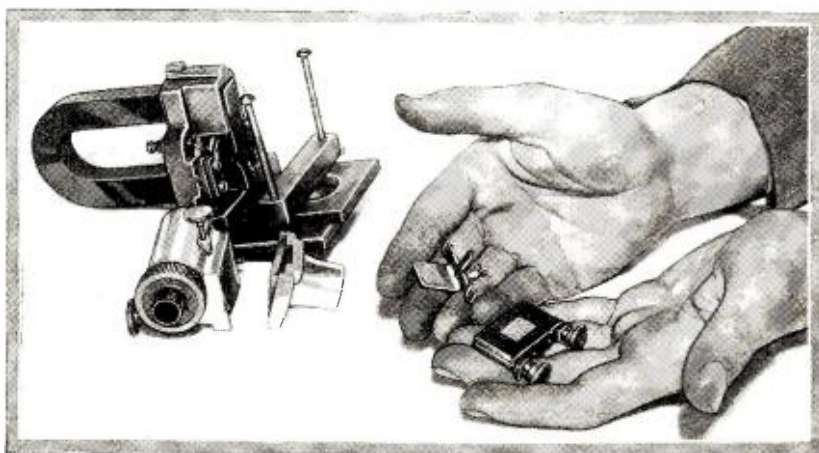

The unit disassembled. Held in the engineer's hands are the two parts of the "mechanical larynx"

Thus, when closed, we have practically an airtight joint. The lighter of the two plates is free to vibrate, being supported on one side only, the supporting medium being a light-action spring.

Now if we supply a pressure of air to the back of the rigid plate, and vibrate the movable plate, we produce a musical tone, the pitch of which is determined by the number of vibrations per second. In actual practice, this is exactly what is done, the vibrations being furnished by a familiar type of loud speaker unit.

The advantages that accrue in the use of a system such as this are numerous. To begin with, heavy moving parts with their attendant inertia are eliminated. This means high efficiency and, in practice, it is not uncommon for 60 to 70 per cent. of the electrical energy to be converted into sound energy, against some 10 to 15 per cent. as is more usual. Naturally, less amplification of the signal is

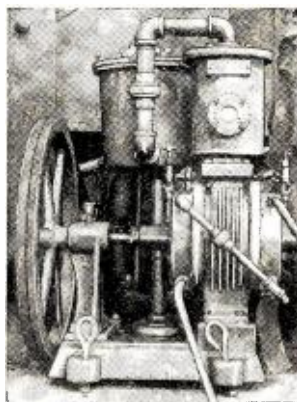

The small compressor. Future experiments will probably reduce the necessary size of the compressor materially

necessary to produce sound of a given level, and smaller power tubes, and consequently lighter amplifiers may be used.

Not only in this way is the elimination of weight an advantage. Cones and diaphragms naturally have resonant periods. This is true of any moving part. In this speaker, the moving parts are so small and light that the resonant points fall very high in the audible scale, where they are not annoying.

As to the question of the power available from a speaker of this type, we must remember that, in this instance, the signal power is only utilized to actuate the valve, and the actual power from the speaker is due to the air pressure, so the power is practically unlimited. A good comparison might be drawn here in the action of the vacuum tube, where the plate power may be likened to the air column, and the grid action to the valve. Little power is required to operate either the valve or the grid of the tube. (Continued on page 647)

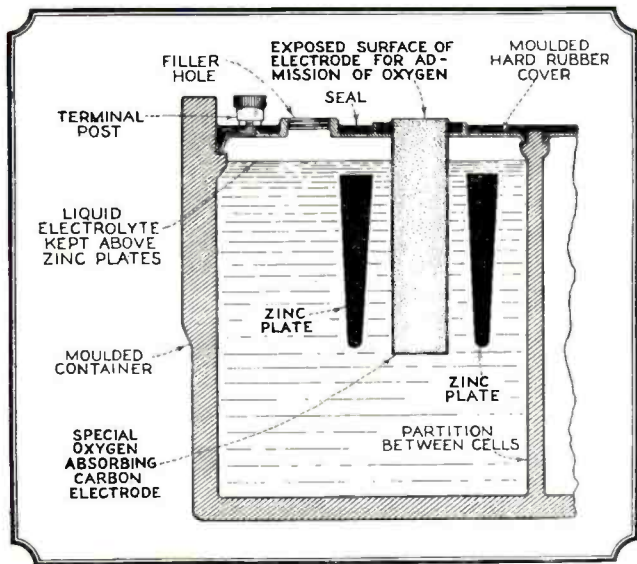

*A Cross Section of the Battery Which Uses Ordinary Drinking Water and Breathes the Same Air as the Rest of Us*

# The AIR

*A New Breathing Battery Operation" for Those*

*Many thousands of homes in the been denied the high type of radio nate city dweller because of lack of dry cell has not satisfactorily filled of storage batteries been looked upon ing practically a year's supply of with the use of the lately announced districts to enjoy to the fullest*

By E. E.

**T**HE appearance of the Air Cell receiver on the market this fall shows that the radio industry is making serious efforts to cater to that vast radio audience which lives beyond the reach of the power lines. Millions of families, so situated, heretofore have been deprived of the kind of radio reception enjoyed by their city neighbors with their a.c. sets, and, being deprived of the best, have done without.

The Air Cell receiver has changed all this. It brings radio programs into the unwired home with all the clarity of tone, freedom from annoying minor troubles and ease and simplicity of operation of the a.c. receiver. No longer need the rural dweller envy his city brother his better radio reception, because the Air Cell receiver sounds as good as an a.c. set. There are those, indeed, who claim that it sounds better, mainly because of the total absence of background power line noises, but this, being a matter of individual opinion and controversial, will not be discussed here.

The Air Cell receiver is an entirely new and different kind of radio set. Being intended for use in unwired homes, it naturally is powered by batteries. But how different from the battery sets of the past! No storage batteries; no dry cell "A" batteries to buy frequently and to hook up in complicated series-multiple connections every two or three months; no filament rheostats to be carefully and accurately adjusted to compensate for varying "A" battery voltage, or to burn out tubes through accidental misadjustment; instead, just a simple off-on switch, exactly like an a.c. receiver.

Sounds like an a.c. set, doesn't it? As a matter of fact, the Air Cell receiver is more modern than the a.c. set. It is not a made-over a.c. model, adapted for battery operation, but is designed from the ground up around new and recently perfected battery and tube discoveries especially and solely to meet the special and somewhat unusual requirements of those who live in homes not served with central station power. It looks like an a.c. set, it is as simple to operate as an a.c. set, it

is as dependable as an a.c. set and, best of all perhaps, it performs like an a.c. set.

This advancement in the art of making battery-operated receivers is the result of two important radio items which have come out of the research laboratory of the National Carbon Company and which have been produced in an attempt to furnish the radio industry the means whereby it can make the kind of receiver required and demanded by those living in unwired homes.

These two developments which make the Air Cell receiver possible are the new Eveready Air Cell "A" battery and the new 2-volt tubes.

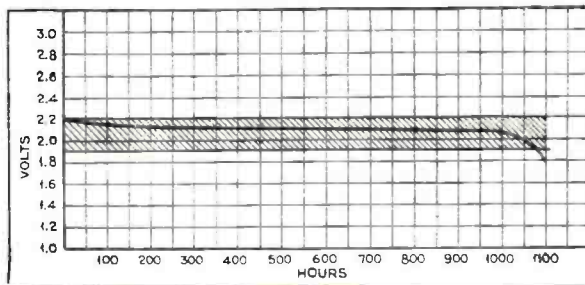

A two-volt tube air cell voltage curve. The shaded area shows the permissible leeway between top safe voltage and bottom operating voltage

It should be emphasized that the means of making the kind of receiver needed by those living in unwired homes is provided by the battery and the tube; not by the battery alone or by the tube

(Below) A few of the commercial console model receivers especially designed for use with two-volt tubes and the "air cell" battery

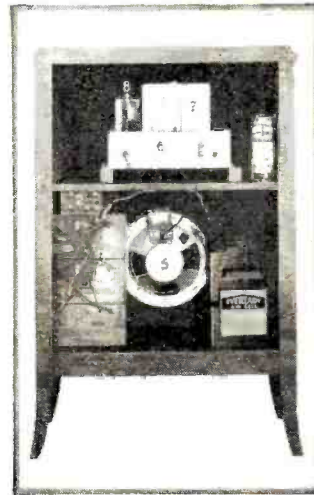

\*National Carbon Company.

# CELL

*Providing "Light-Socket"  
Beyond the Power Lines*

*farm districts of this country have reception enjoyed by the more fortunate power source. The common the bill nor has frequent recharging with favor. This new air cell, offering uninterrupted service, when coupled 2-volt tube, bids fair to enable rural the benefits of modern radio*

## Horine\*

alone, but by both in combination. Each depends on the other for success, and either alone will fall short of complete success.

Most of us are familiar with the old dry-battery sets of the past, built around the -99 and other types of dry-cell tubes, and many of us are acquired with the trouble and the grief these sets caused and which eventually resulted in their withdrawal from the market. The blame for the widespread trouble with dry-battery sets has generally been laid at the door of the dry-cell tube. It has the reputation of being delicate, fragile, short-lived and generally unsuited for home radio receivers. A study of the underlying causes of dry-cell tube failures reveals that this reputation is undeserved. It gave trouble because it was mated with the dry cell, and we now know that nature never intended the dry cell to serve as an "A" battery for radio receivers. Every time a union between a

The air cell receivers illustrated below look much like the best of console a.c.-operated receivers and furnish satisfactory operation over long periods of use

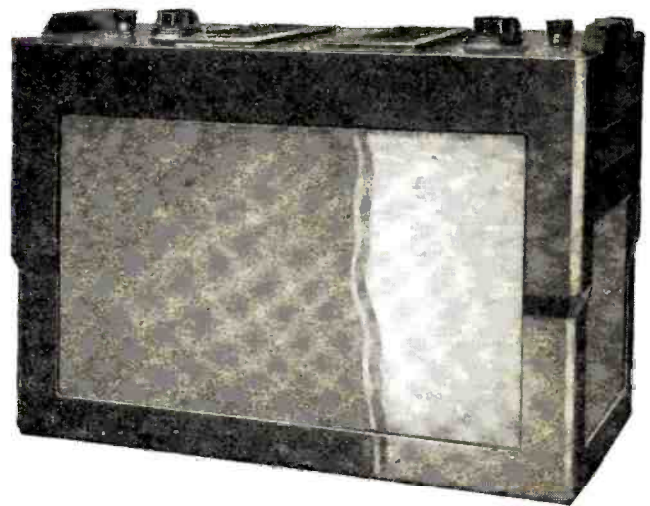

*This Is NOT a Storage Battery  
But When Used With the New  
2-Volt Tubes Will Light Seven  
Tubes for ONE YEAR*

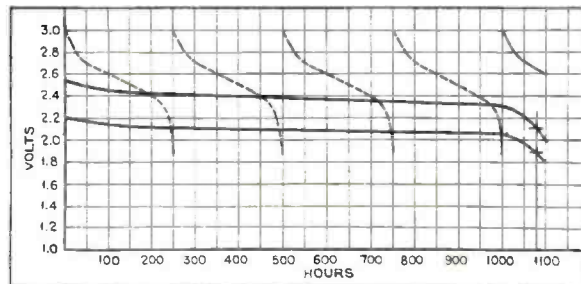

mismatched pair is consummated trouble follows, and the dry-cell-vacuum tube alliance was no exception to the rule.

This is because of an inherent difference in the electrical characteristics of the vacuum tube and of the dry cell. The tube demands, and must have, its filament current delivered to it at practically constant voltage. It is well known that if the filament voltage is raised to a point slightly above the tube's rated value, the tube loses emission, or actually burns out; if reduced to a point slightly below rating, the tube ceases to function satisfactorily. The leeway between the upper safe limit, above which burn-out occurs, and the lower satisfactory operating limit, below which the tube ceases to function, is quite narrow, being about 5 per cent. of the tube's rated voltage in most cases.

The dry cell is incapable of meeting this exacting demand for constant voltage, being inherently a variable-voltage device. The voltage of a new dry-cell "A" battery is 50 per cent. higher than the tube's rated voltage, and therein lies practically all the cause of trouble with so-called dry-cell tubes. The filament rheostat, with or without the indicating filament voltmeter, intended to absorb the excess battery voltage and to compensate for the falling voltage of the battery as it became exhausted, has demonstrated itself to be ineffective in preventing premature tube burn-out when manipulated by non-

technical radio users, and most radio users are non-technical.

The dry cell is perfectly satisfactory when called upon to deliver current to devices not demanding constant voltage and is daily demonstrating its usefulness in a host of such applications, including the "B" circuit of radio receivers. The vacuum tube also is perfectly satisfactory when supplied with filament current at constant voltage, but the differences in the two cannot be reconciled; at least, no one has succeeded in reconciling them as yet.

What is needed is an "A" battery and a tube in which these essential electrical characteristics (Continued on page 644)

# Observing *the*

*MR. BUTMAN, formerly Secretary of the Federal Radio Commission, confines himself in this article to an explanation concerning the issuance of all types of licenses by the Federal Government and points out how, by international agreement, the various nations have set up radio laws, rules and regulations with which to orderly conduct radio communication.*

*The next article in this series will take up the subject of fixed services, their channels and power, point-to-point communication by radio, emergency and agricultural services. It will also discuss the item of special applications and how they are treated.*

By Carl Butman\*

PART TWO

**H**OW the Federal Radio Commission manages to license and supervise approximately 23,000 radio transmitting stations of all types, is a mystery to many people. Further, it is amazing how few radio experts, engineers, operators and even station owners know why and how radio transmitters are supervised or the proper procedure for securing a construction permit or a license, modification or renewal. The writer has no intention of writing a legal treatise on the subject of the radio laws and regulations—that duty devolves upon the legal profession—or trying to prepare a monograph on the technical angles of radio. However, there seems to be a crying need for at least an outline and analysis of Federal radio procedure. The mass of daily inquiries at the Federal headquarters in Washington, showing the lack of understanding on the part of many owners and operators of stations, is ample evidence of such need. Some station owners seem to be in perpetual “hot water” because of the unfamiliarity of their staffs with both the law and the regulations for its enforcement.

This article will undertake at least to list the essential points and indicate how and where one can find out what isn't known regarding the regulations and special requirements covering the securing of a license for and the operation of the several types of radio transmitting stations; there are no Federal requirements covering the operation of receiving sets. Already members of the Commission staff and some of the field men have expressed interest and requested copies of this article.

Perhaps it is not entirely the fault of the individual seeking knowledge on radio regulations that he doesn't know where to find it—whether to continue to write his Congressman, hire a lawyer or make a special trip to Washington—to many the source of all general information—because, “strange as it seems,” the Government has no comprehensive book of radio regulations. The last edition of such a pamphlet, based upon the Act to Regulate Radio Communication passed in 1912, became obsolete with the passage of the Radio Act of 1927. The Federal Radio Commission, created by that act, was urged by the writer to have a new set of radio regulations prepared when he became Secretary of that body in November, 1927, but it was then thought that act itself and the Commission's General Orders, would adequately cover all inquiries.

To date, these Commission General Orders total ninety-nine. They are so numerous and voluminous, and so many of them are obsolete, that it is exceedingly difficult for one, not familiar, to dig out the essential ones. There is no official or published index nor are they classified in any way except by date of issuance. To be sure, these orders are mailed upon issuance to each licensee, and, upon request, interested parties are supplied with a complete set. However, few licensees or owners seem to have complete sets, or if they do, no one is capable of finding a particular order, nor can anyone

recall what is required or forbidden in connection with a certain practice or operation. It is with this situation in mind, that the writer will endeavor to outline the important points of the radio law and its regulation.

The Commission and its legal staff are being congratulated by licensees, applicants and lawyers upon its recent publication of General Order 93, “Practice and Procedure before the Federal Radio Commission,” effective September 1, 1930; congratulations are in order, for now questions of legal procedure and practice are definitely answered therein. Incidentally, those who have hearings scheduled should see that their attorneys have copies and that the new requirements are followed explicitly. Make no mistake, the Commission is adhering to these requirements.

## *Why Licenses Are Required*

The Federal Government licenses and regulates all radio transmitters and supervises all forms of wireless communication activities for two main reasons; first because it is necessary that these services be regulated to prevent interference and insure efficient operation and service to the public, and also because the U. S. Government adheres to the International Radio Convention, a treaty signed by seventy-four governments in November, 1927, and now ratified and proclaimed by most of these home governments. Its effective date was January 1, 1929. This world treaty provides among many other things that each signatory undertake to apply its provisions to his own country, especially with regard to international communication and designates the bands of frequencies set aside for use by the several services.<sup>1</sup> Owners and operators of ship, coastal and trans-oceanic public service stations should possess and comprehend this treaty and follow the regulations set forth in its appendix.

It is perhaps unnecessary and undesirable to recount in this article a list of the various assignments or the rules and regulations established by this treaty, since the chief regulations pertinent to the United States are recounted in the Radio Act of 1927,<sup>2</sup> which places the authority in the hands of the Federal Radio Commission. It is most essential that every licensee, and anyone connected or closely associated with the design, operation or ownership of a radio transmitting station should secure and read this act together with its amendments, especially the so-called Davis amendment affecting broadcast station allocations.<sup>3</sup> This act covers all radio activities in the United States except in the Philippines and the Canal Zone.

<sup>1</sup> Copies available Superintendent of Documents, Government Printing Office, Wash., D. C. Treaty Series No. 767, at a cost of 30 cents.

<sup>2</sup> Radio Act of 1927, Public No. 632, 69th Congress, and amendments, available as above. 5 cents.

<sup>3</sup> Public No. 195, 70th Congress.

☞ The Federal Government licenses and regulates all radio transmitters and supervises all forms of wireless communication activities.

☞ Before any radio transmitting license may be secured, or the station erected, a construction permit must be applied for and granted.

\* is Consultant and Former Secretary Federal Radio Commission.

# Federal Radio *Licensing Requirements*

*Ever since the Federal authorities found it necessary to regulate radio in all its varied fields there has been a virtual flood of laws, rules and regulations, but a woeful lack of simple, concise information available for those whose every-day life depends on the intelligent understanding and obedience to these regulations. In this article, which is the second in a series of five, the author sets down in plain language some helpful advice on How to Obtain a Station License, Observance of the General Orders, Classification of Services and other pertinent points of information*

## *How to Secure a License*

Before any radio transmitting license may be secured or the station erected, a construction permit must be applied for and granted, except for governmental, amateur, ship, and aircraft stations, for which types of stations licenses are applied for directly, no construction permits being required. Construction permits are issued only to citizens of the United States; aliens and alien organizations and even alien directors are barred. All application forms, and there are many of them, each for a specific purpose, may be secured from Mr. James W. Baldwin, Secretary of the Federal Radio Commission, Washington, D. C., or from the nine Supervisors of Radio whose main offices are located respectively in Boston, New York, Baltimore, Atlanta, New Orleans, San Francisco, Seattle, Detroit and Chicago. These officials represent for public convenience, the Secretary of Commerce, who under the present law is authorized to accept all radio station applications, although they cooperate closely with the Radio Commission. Eventually it is expected that the whole Radio Division of the Department of Commerce, which handled all radio matters before the creation of the Commission in 1927, will become a division of the Commission, but at present it is a separate entity. All applications, therefore, may be secured from and must be filed through the office of the Supervisor in whose district the station or proposed station lies. These supervisors act as field representatives of the Commission but have many other duties including all ship and land station inspection and testing, examining and licensing all operators, including amateurs. The Division Chief, W. D. Terrell, at Washington also supervises the issuance of all call letters and handles commercial radio accounts with foreign stations and organizations.

The erection of a transmitter must not be begun until a construction permit is granted and issued through the supervisor. After construction is completed, an application for a license to operate the transmitter must be filed similarly as indicated above. When that is issued and delivered to the applicant he

may go on the air. Recently prospective licensees are authorized to test temporarily, upon completion of construction, provided the supervisor and Commission are notified two days in advance.

When finally licensed, a station is authorized to operate only as specified for a period of three months if a broadcasting station, otherwise a year. It is then that a study of the General Orders becomes essential, for the Radio Act provides severe penalties for breaches of the law and imposes fines for infractions of the regulations. All stations must file renewal applications a month prior to the expiration date of their licenses.

Both the international and the Federal radio laws require that stations must be operated only by licensed operators, making it necessary for the owners to engage qualified operators licensed by the Radio Division of the Department of Commerce, which licenses all operators, commercial and amateur. Several classes of operators' licenses are provided for, as will be recounted later under the specific services. Suffice it to say now that an amateur may not operate any station except an amateur station, one authorized to communicate only with another of the same class for personal reasons and without pecuniary interest—amateurs, it is seen, may not encroach upon the commercial field.

Transmitters may not be replaced, remodelled or moved without the authority of the Commission, nor may frequencies or power be changed except as directed by the licensing authority after proper application therefor has been made in accordance with the frequency and power requirements established for the particular services.

While the ether is free to a certain extent, there being no censorship or charge for licenses—transmitting or operators—commercial and private messages must be held confidential. Then, too, obscene, indecent and profane language is taboo. Furthermore, each applicant for a license and communicating channel signs a waiver, disclaiming any priority rights he might otherwise claim with regard to the use of the ether or any particular frequency.

## *The Essential General Orders*

Those interested will find that the following list of forty-two General Orders of the Commission cover practical routine matters. Many orders have been omitted from the complete list of ninety-seven, since they have become obsolete, having served merely to extend license periods in the early days of the Commission when it was impossible to issue renewal licenses to individual stations, or were issued for specific purposes but have no significance now. *(Continued on page 646)*

☐ All applications may be secured from and must be filed through the office of the Supervisor in whose district the station or proposed station lies.

☐ Both the international and Federal radio laws require that stations must be operated only by licensed operators.

# How to Make Your Broadcast Receiver a Short-Wave Superheterodyne by Using the

## New A. C. Short-Wave Supersonic Converter

*Following the presentation of the design details of the battery-operated "Supersonic" in the June, July and August issues of this magazine, the designer and author, Manson E. Wood and Volney Hurd, were veritably besieged with requests for details on an a.c.-operated "Supersonic." Their latest job, described here fully, can readily be added to the regular broadcast receiver, thus making up the whole installation a fine short-wave superheterodyne receiver*

By Volney D. Hurd\*

**S**HORT waves and short-wave reception is in the public eye. People who a year ago were just about considering the purchase of a broadcast receiver for the living-room now have their seven-, eight- and nine-tube super-bloodydyne receiver and in the everlasting endeavor to keep up with the times are inquiring about a short-wave receiver with which to tune in those seemingly elusive foreign stations.

The experimenter, the custom set-builder and in general the man who has been identified with the progress made in the receiver field during the past few years knows about and undoubtedly has had working a short-wave receiver which suits his purposes. But the man who is just beginning to make inquiries into this amazing field is confronted with many difficulties. Usually he does one of two things. Either he makes a wild stab at the construction of some type of short-wave receiver or else he consults his local radio serviceman or dealer in the hope of obtaining advice. Usually, too, he has a limited amount of money to spend on the purchase of his new pet and, correctly so, wonders whether he can make use of any part of his present broadcast receiver.

Wide-awake servicemen have not been slow to recognize this new field which in a surprisingly short time has sprung up and in consequence have enriched themselves to the tune of many dollars for service well rendered. In this article we will attempt to show how observing servicemen may extend their scope of activities; experimenters may really provide themselves with a short-wave receiver of the most modern type without seriously affecting the installation or operation of the regular

broadcast receiver in use in the home. Reception of signals on short waves has confined itself mainly to the use of one or the other of two systems which are now in vogue. Either a complete receiver for short-wave reception is built, incorporating in it not only the tuner section but also the audio channel, or an adaptor is constructed consisting of only the short-wave tuning section for plugging into the detector socket of the regular broadcast receiver so as to make use of the existing audio channel in that receiver. In the first instance the duplication of receivers presents a serious item of cost, while in the second there is the inconvenience which is necessitated by the removal of the broadcast receiver's detector tube and the insertion in that socket of the short-wave set's adaptor.

But now a new system of reception presents itself which has none of the so-called drawbacks of the other two mentioned systems. This is the employment of the superheterodyne method of reception wherein the regular broadcast receiver is used as the intermediate amplifier, tuned to 550 meters, a separate unit called a converter placed before the receiver as a frequency changer.

In the June, July and August, 1930, issues of RADIO NEWS, Mr. Manson E. Wood and I described a home-built type of supersonic converter and since then the National Company has improved upon the original version of this device. A description of it is presented here.

As may be seen by studying the accompanying diagram, Fig. 1, the circuit is not a radical departure, although it has some interesting features. For instance, experience gained in broadcast receiver design in circuit isolation



Looking at the adaptor from above. This view shows the simplicity and neatness of the layout

\*Radio Editor, *Christian Science Monitor*.

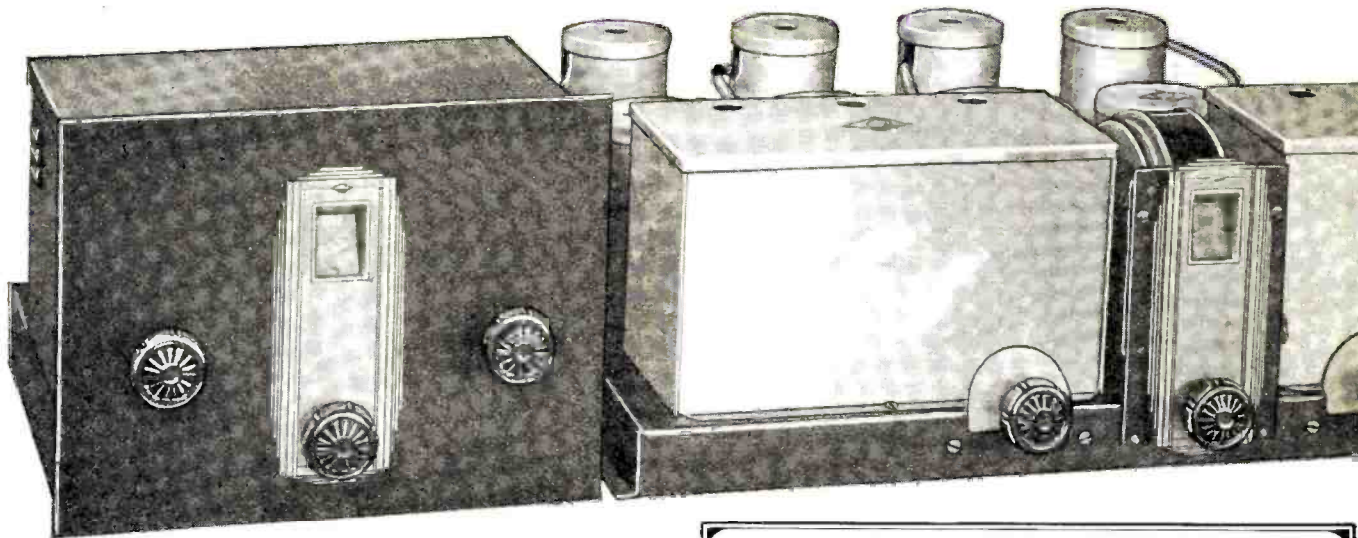

Above—The adaptor in use with the National MB-30 receiver. Right—The wiring diagram of the “Supersonic.” Note the 50,000 ohm regeneration control

has been carefully applied in the design of this unit; complete by-passing is a feature, and correct voltages for plate potential and biasing are accomplished within the unit through a resistance network properly by-passed.

Of particular interest is the solution of the coupling of the oscillator and input or first detector circuits. In short-wave superheterodyne design these two circuits offer a problem due to the fact that tuning one tends to react upon the other. At short waves, where tuning is sharp, this is a decided disadvantage. In the Wood Supersonic the coupling of plate circuits was used. In this receiver one of the earliest of radio ideas, the link circuit, was resurrected, and it fits perfectly into the 1930 radio picture. This method of coupling eliminates the disadvantage of one circuit reacting on the other and, at the same time, proves to be efficient for the transfer of energy in all the wavelength bands used—an important point in short-wave work where really great spaces in the radio spectrum must be covered by a single instrument.

In its physical design this receiver is interesting. As may be seen from the photographs, it is a compact unit in an all-metal case, but it avoids one of the common causes for complaint in short-wave sets—the necessity for lifting the cover and reaching into an awkward space to change coils. The coils for this job are on the outside, which permits their change with ease.

The coil forms themselves are made of R-39, a new type of molding material developed especially for high-frequency insulation purposes by the Radio Frequency Laboratories at Boonton and made available commercially in the shape of forms for plug-in inductances by the National Company. This new low-loss material is made of pure bakelite resin and ground mica. This differs from ordinary molded bakelite in that the latter is comprised largely of wood “flour” and bakelite resin. This wood “flour” is highly hygroscopic and contains a considerable percentage of moisture, which results in the losses encountered when using conventional molded bakelite forms for short-wave work.

One of the handicaps to the use of this new material, however, is its extreme hardness and abrasive nature which make it extremely difficult to thread. In fact, the carbide threading tool, the hardest tool known to science, will lose its edge and have to be resharpened after threading as few as 50 coil forms. The efficiency of this material is clearly shown by an incident that occurred during the development of the coils for this converter. The first experimental set of coils had been wound on a good grade of the usual coil form material, while awaiting the samples of

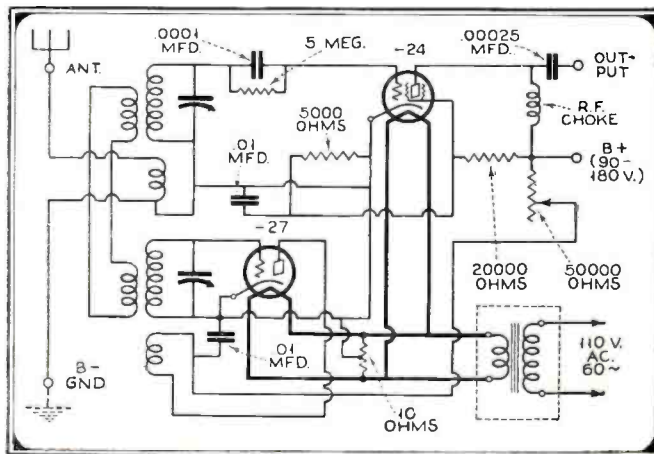

the R-39 forms from the molder. When the R-39 forms arrived they were wound in accordance with the specifications worked up in connection with the experimental bakelite forms, but it was found that, due to the lower losses of the new material, the number of turns on the tickler winding had to be cut almost in half in order for the circuit to function in the same manner, so much less energy needing to be fed back with such efficient material for the forms.

- The coils cover the following bands:
- “Black” No. 11 Range 14.5 to 25 meters
  - “Red” No. 12 Range 23 to 41 meters
  - “White” No. 13 Range 40 to 70 meters

Another interesting feature in the new converter is the specially designed short-wave tuning condensers with straight frequency line 270° rotation plates. These condensers were described in detail in connection with the story on the SW5 Thrill Box short-wave receiver by James Millen and Robert Kruse, which appeared in the June issue of RADIO NEWS, for which receiver they were originally designed.

In adapting this unit for a.c. it was found best to put a filament transformer right in the unit so that it could be plugged into a light socket separately; other units trying a system of running wires over to the broadcast set ended up in difficulties. Voltage dropping and awkward connections to the existing tube arrangements were the outstanding problems, but supplying the filaments separately from within the unit eliminates these troubles.

This leaves the only connection, other than the ordinary connecting wires for operating the unit, a single “B” lead. With the complete by-passing employed in this unit, the “B” lead can be attached any place in the set where one may get (Continued on page 669)

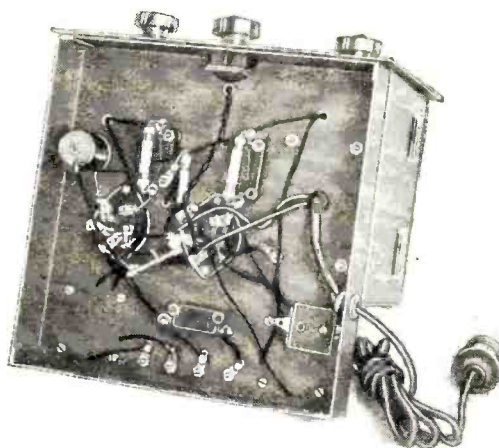

All the wiring is done underneath the deck, in the “point to point” fashion

# EUROPE Puts the

*To Americans the pentode is practically ingly has not as yet found favor with Europe has been successfully using this of the latest European receiver designs The author also reviews the television new German tube which is*

**By L. Elden**

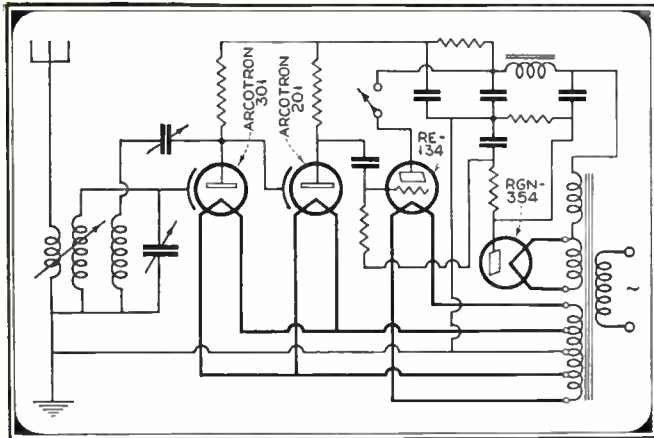

A typical German receiver circuit—the Telefunken—Hab—Aristron. This receiver employs the Arcotron tubes in the first and second sockets

Below, the Germans' "S2" five-tube neutralized receiver with single dial illuminated tuning control

**I**N spite of our conviction of superiority in things of the technical world, we in America can frequently learn much from the work and experience of our European cousins. This is undoubtedly true in the field of radio. And particularly is this true of vacuum tube development. More than one of the tubes which we use as everyday equipment found its first commercial application on the other side of the Atlantic. In view of this situation, it should profit us well to observe present-day tendencies in the European radio field. Perhaps in this manner we can gain some insight into what our future holds in the way of new developments.

At the moment, the pentode tube is the largest question mark on the radio horizon, and anything regarding it that we may learn from the experience of others is of particular value. It is the latest addition to the already large family of types and designs of vacuum tubes that we have at our disposal. While it has developed out of the experience gained from the use of the screen-grid tube, it is something more than an improvement on this design. The addition of the third or earthing grid, preventing re-radiation from the plate, a phenomenon which has limited the amplifying ability of the common forms of audio-frequency amplifier tubes heretofore, has made possible an audio-frequency amplifier of hitherto unheard of possibilities. The audio-frequency portion of the average receiver today constitutes one of the more important elements in its cost. The potential simplification and cheapening in cost of audio amplification that the pentode holds forth have made it a popular topic of discussion and speculation among radio men since its first announcement.

The pentode tube first appeared on the American market in the season of 1929-1930, when a few of the smaller tube manufacturers announced various models. In Europe,



A combination German phonograph, radio receiver and power supply

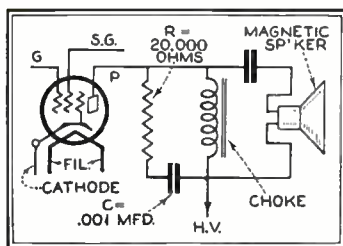

An inside view of a German version of the midset receiver

This circuit is recommended by pentode tube manufacturers to reduce overemphasis of the high audio frequencies in the magnetic speaker type

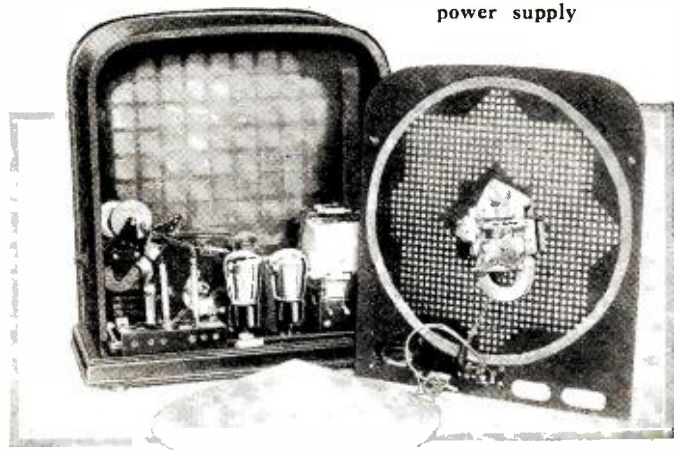



# PENTODE *to* Work

*a new kind of tube—and one which seem-receiver designers. On the other hand, tube for more than a year and some incorporate this tube in their make-up. trend abroad and gives the details of a evidently finding wide use*

## Smith

Another popular type of German broadcast receiver, the Seimens "31"

ticularly is this true of Germany, where manufacturers are just this season announcing d.c. filament models of the tube. However, it should be pointed out that these tube manufacturers, such as Telefunken, have given the tube extensive tests in their laboratories and as a result of their co-operative agreements with their many licensed receiver manufacturers, the latter have developed and are announcing pentode-equipped receivers at the Berlin Radio Show.

Up until the present time almost no European manufacturers have produced receivers using the pentode. The use of the tube has been confined to the amateur, the experimenter and the research laboratory. But in this respect one must remember that the broadcast fan who "builds his own" is not yet a thing of the past in Europe, as he seems to be becoming in America, and that this field of use is still of considerable importance. Magazines devoted to the interests of this group are more numerous than in the United States. These publications have frequently carried excellent

To the right, a new Telefunken screen-grid tube with glass bulb removed

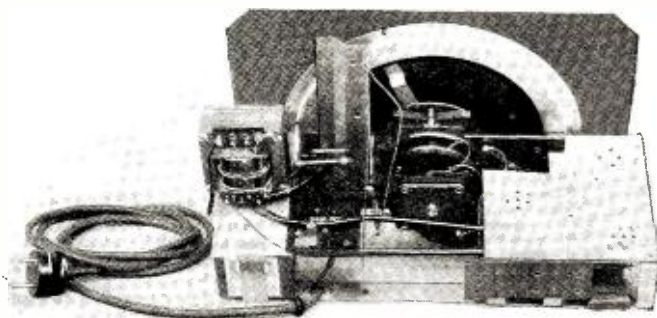
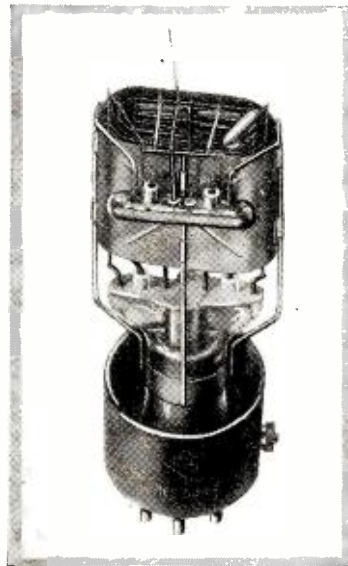
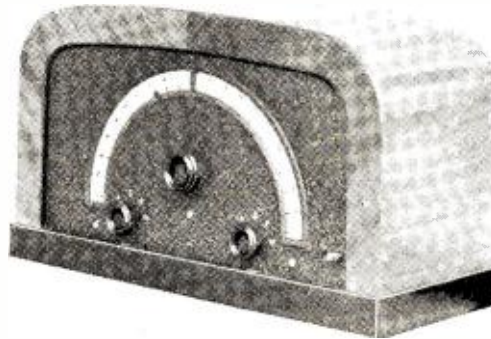

CHARACTERISTICS OF A FEW TYPICAL EUROPEAN PENTODES									
COMPANY	TYPE	FILAMENT	FIL. VOLTS	FIL. AMPS.	MAX. PLATE VOLTS	MAX. S-G VOLTS	MUTUAL A.C. CONDUCTANCE MA/V	AVERAGE PLATE CURRENT	MAX. INPUT
• MAZDA	P-230	D.C.	2	0.3	150	125	1.5	—	—
"	P-425	D.C.	4	0.25	150	150	2.0	—	—
"	A.C. PEN	A.C.	4	1.0	250	200	2.2	—	—
TELE-FUNKEN	RES-664	D.C.	4	0.6	400	—	3.5	30 MA.	30 WATTS

\* EDISON SWAN ELEC. CO  
 † AMPLIFICATION CONSTANT = 1.2  
 INTERNAL RESISTANCE = 25,000 OHMS

articles dealing with the use of the pentode and anyone who wishes to take the trouble can find a number of such articles in current English magazines.

However, this experimental stage is considered as past by the leading receiver manufacturers. At the August and September radio shows in Germany and England an appreciable number of pentode-equipped receivers were announced. Almost all of these, both in England and Germany, conform to one general type. They are of the small, low-priced class, intended for sale to the

man of limited means. The pentode is not being used in Europe in the higher quality, more expensive receivers. The small receivers take a number of forms, utilizing their two or three tubes in various ways. The most common arrangement utilizes two tubes—a power detector with one stage of pentode audio-frequency amplification. It is interesting to note at this point that the Edison-Swan Company states that "a very efficient two-valve circuit may be built which will give loud-speaker quality and volume satisfying most domestic requirements" by using a pentode as a cumulative grid detector, preceded by one screened-grid high-frequency amplifier. Three-tube receivers are using the pentode as the output tube in every case and have either one stage of radio-frequency amplification or an additional stage of audio frequency between the detector and the pentode. The Germans favor the three-tube receivers, as in either case the input to the pentode is greater than in the two-tube arrangement and greater utilization of the principle of the pentode is attained. They do not believe the tube gives anywhere near its theoretical amplification when used with very small inputs. Sets of two and three tubes seem almost amusing to the American (Continued on page 654)

A rear view of the Seimens "31" showing the extremely large tuning scale

The Ip-Ep curves for the English Mazda a.c. pentode tubes

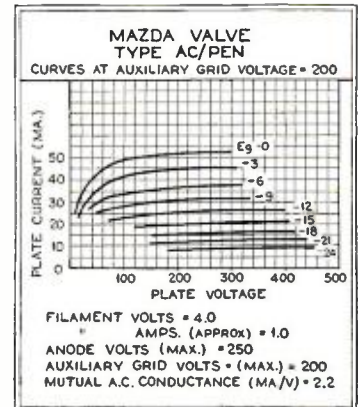

Frank M. Kennedy (below) radio engineer of TAT-Maddux lines, is shown testing the long-range portable radio telephone instruments used in their planes. The set weighs 131 pounds and has established a 1200 mile record for commercial aviation. At the bottom is a radio house and towers at Waynoka, Okla.

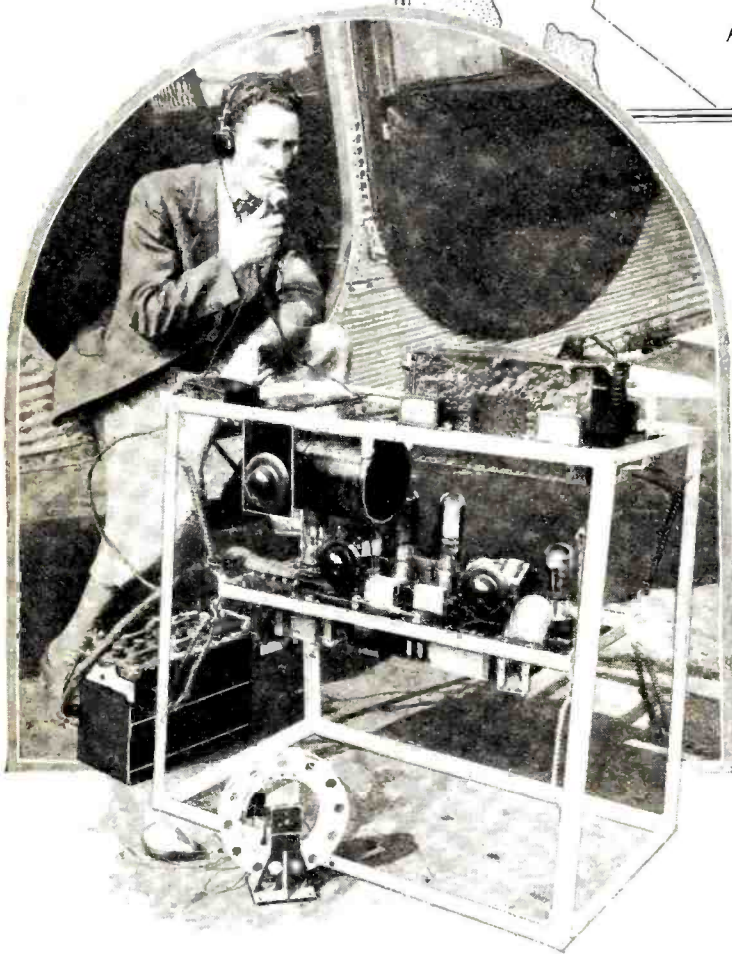
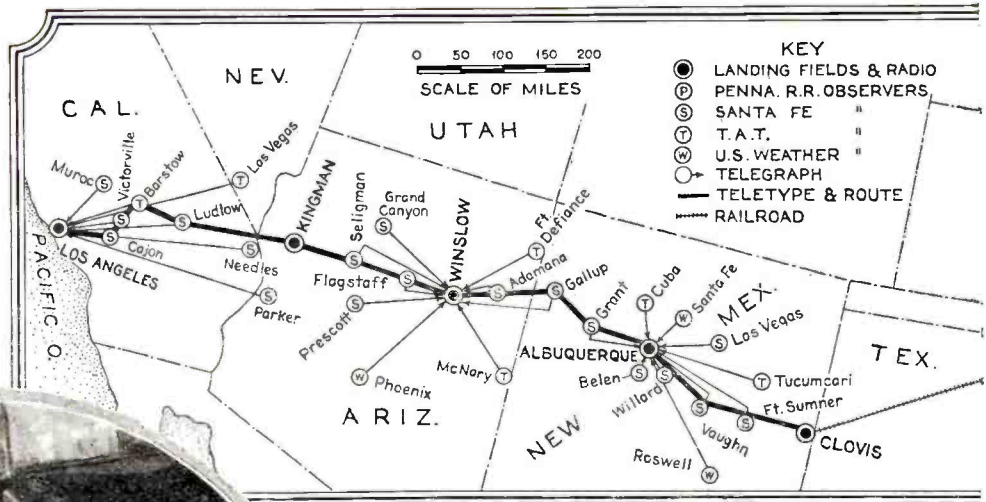

# RADIO

## *The Air-*

*The fact that radio, as applied to paying investment is attested by the TAT-Maddux lines involving two-plane and a chain of 2000*

**By Sterling**

**I**S airplane radio, as applied to commercial air transportation, a paying investment?

"Yes!" say the operators of two of the largest air transport lines in the United States, and they are backing their judgment with the expenditure of hundreds of thousands of dollars for radio equipment.

TAT-Maddux Air Lines, which operate a coast-to-coast transport service in conjunction with the Santa Fé and the Pennsylvania railroads, have undertaken the installation of complete, two-way radio telephone equipment on every ship of their lines. Installation is progressing at a rapid rate, and will probably be completed before this article sees print. The project involves the construction of fifteen aircraft short-wave transmitters and receivers, and the erection of from seven to eleven 2-kw. ground stations, at an estimated cost of approximately \$300,000.

Close upon the heels of this announcement comes word that Western Air Express has placed an order with the Western Elec-

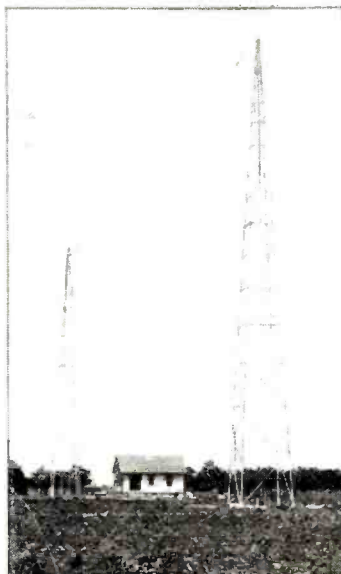

tric Company for \$200,000 worth of radio equipment, which is being installed as fast as delivery can be made.

These projects definitely place the seal of approval of big business men upon airplane radio. Practical experience in the every-day operation of their lines has demonstrated to these executives that radio is quite as necessary to the captain of the air lines as it is to the skipper of an ocean-going ship.

Airplane radio has drawn the teeth of the greatest peril of air transportation. It has made the lost ship virtually a thing of the past. Just as the train dispatcher knows at every instant the exact position of every train in his section, so the ground force of the aerial transportation company keeps minute check on the movements of each ship in its division. Every pilot must report to the nearest ground station at least once in each fifteen minutes. Detailed logs are kept

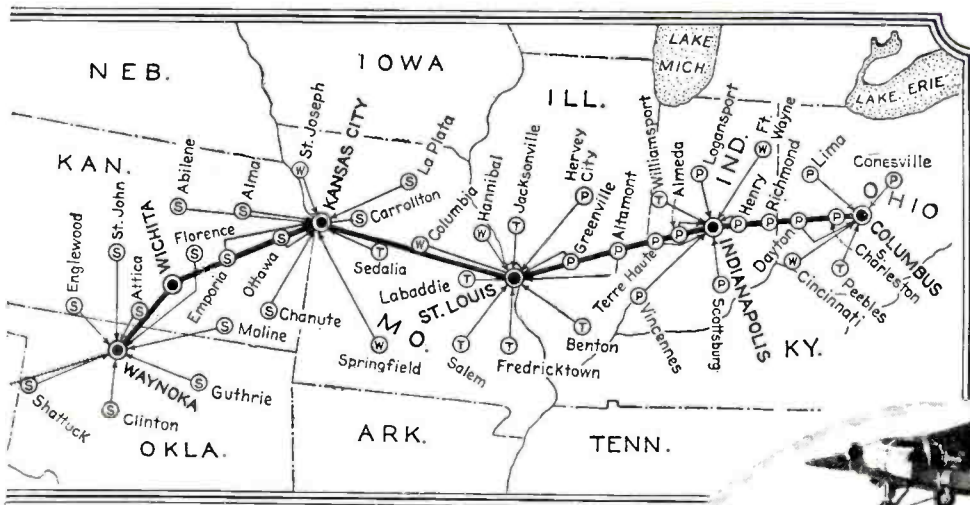

At the left is a map giving a clear picture of the elaborate communications system which safeguards commercial fliers. Immediately below is one of the Maddux planes flying over a Western mountain range

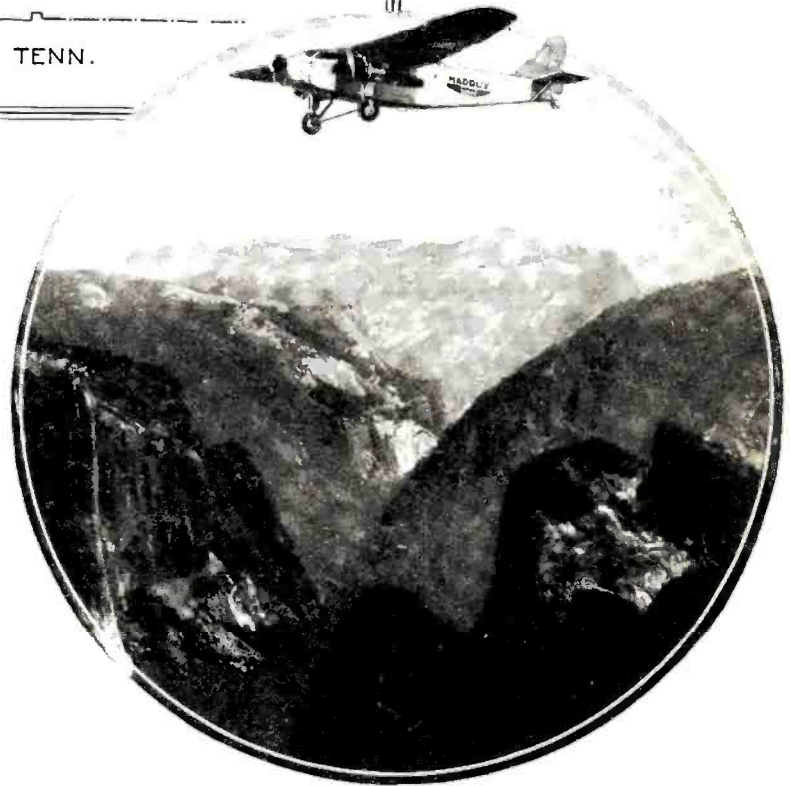

# FLIES *Ways*

*commercial air transportation, is a elaborate coast-to-coast network of way telephone equipment in every watt ground stations*

Shown below is a radio transmitter unit developed by E. W. Proctor, radio engineer of TAT-Maddux. Its complete weight is 87 pounds and it can be installed in a new plane in five minutes

## Gleason

by all operators. In case of a sudden forced landing, officials of the company know the location of the missing ship to within fifteen minutes' flying distance.

Even a forced landing has lost its terror for the pilot. The short-wave transmitter now in use can be used when the ship is on the ground. An emergency antenna strung up to the nearest tree or fence post, and the pilot is in touch with headquarters. No need to walk many miles to summon aid—five minutes after the ship is down, help can be on the way.

While radio telegraph has been used to a varying extent by a number of commercial companies, TAT-Maddux has gone a step further, not only by making the installation apply to every ship in the line, but also by equipping each transmitter for radio telephone, which is used almost exclusively for communication with the ground.

Aside from the obvious gain in flexibility afforded by the

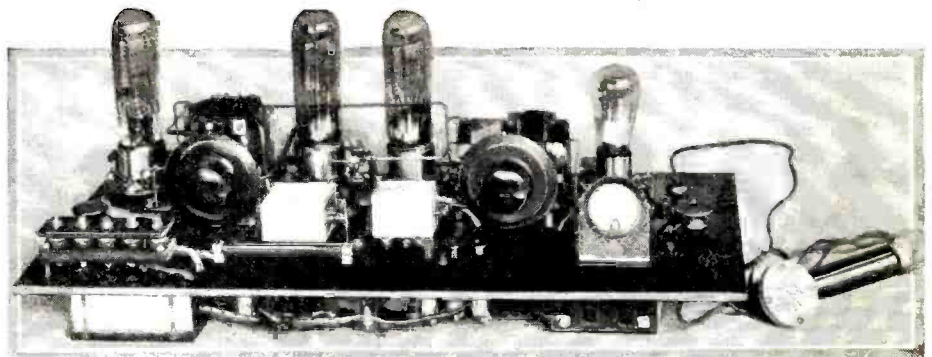

use of voice instead of code, an additional advantage is the fact that first or second-class commercial operators' licenses are not required for the operation of these sets, the radiophone grade being sufficient. Instead of including one or two radio operators for each ship, the whole flying personnel may be trained to operate the transmitters, thus relieving the radio operator from much of his responsibility. Every pilot and mate in the service holds a license of radio-telephone grade. A radio training school is maintained at the Grand Central Air

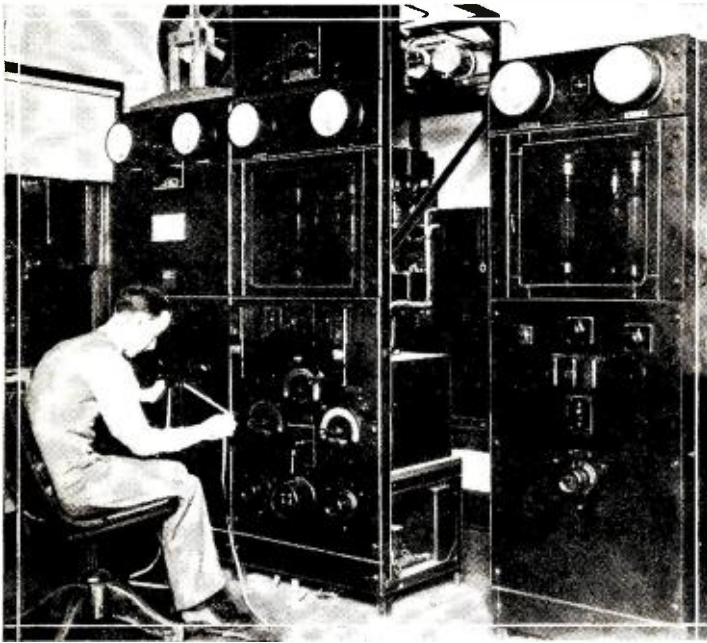

Above is the interior of a TAT-Maddux radio house. Each house is connected with the field office by the teletype system. The man shown here is reading a teletype tape. At the right is the TAT-Maddux radio station at Albuquerque, New Mexico



Los Angeles—have central weather bureaus equipped with regulation weather bureau instruments. In addition to certain standard equipment, there are automatic graphing instruments for recording temperature, barometric pressure, and wind velocities. In order to obtain information as to ceiling height, as well as to wind direction and velocity in the upper strata of the atmosphere, balloons are released at certain times of the day, and their course observed through theodolites. Each field has its own meteorologist, whose office joins that of the field manager, and who has a direct wire to the radio station.

Twice daily, two hundred U. S. Weather Bureau reports are received here, recorded upon weather maps and analyzed. At midday, localized reports are received from all TAT-Maddux weather observers, supplementing the general data of the government bulletins.

The work of these key observers is supplemented by additional observation stations located along the line of flight, at intervals of fifty miles. In addition, off-line observers are stationed at distances of seventy-five miles or more from the course, and about one hundred miles apart. Most of the operators at these points are the railroad operators at Santa Fé or Pennsylvania railway stations, except in sections where neither railroad operates. Each station operator is furnished with over \$1,000 worth of meteorological equipment, and is specially trained in this work. In other districts, the reports are furnished either by the U. S. Weather Bureau stations or else by observers employed by TAT-Maddux. All told, there are seventy-two subsidiary observation points besides the ten central stations.

The off-line observations are valuable because they inform the pilot if bad weather is going to cross his path, or if better flying conditions can be found by deviating from the direct course.

The locations for these off-line observation points were chosen so as to enable the pilot to reach either his destination or else an emergency landing field before being overtaken by a moving storm centre. Consideration was given to the fact that a storm centre rarely travels faster than thirty miles an hour.

From each observing station to the nearest collecting centre goes a code message covering the observed weather conditions. Some idea of the compactness attained in these reports may be gained from the following five-word message sent over the teletype to the chief meteorologist: (Continued on page 652)

Terminal at Glendale, California, under the direction of Frank M. Kennedy, radio engineer in full charge of the western division. Instruction given there enables the flyers to pass the U. S. Department of Commerce test for operator's licenses.

Realizing that even the radio beam and beacon have definite limitations, especially when it comes to changing the flying course to avoid storms or deviating from a bee-line course to make necessary passenger connections, TAT-Maddux engineers have installed direction finding equipment in all ground stations. Any pilot may ascertain his exact position by calling up two near-by stations and getting his radio compass bearings. Plotting these readings upon the map, he obtains a point of intersection which unmistakably indicates his location.

The busiest part of a busy organization is the TAT-Maddux communications network, paralleling the path of the plane's flight from coast to coast. The central strand of the network is the chain of 2,000-watt ground transmitters, which not only work with one another, but are the means of contact between the plane and earth. Linking these stations is a system of teletype lines, which form a fast channel for routine message traffic, and also act as a "broadcast" system for weather reports. Tributary to these are the telegraph lines, which relay messages from off-line observation points established to compile periodic weather reports.

Naturally a great many of the messages have to do with the weather, for wind, fog, cloud and storm are always a matter of concern to flyers. Given an accurate knowledge of what is ahead of him, the pilot can shape his course so as to avoid danger and get through with the minimum of delay. This knowledge is placed before the pilot constantly by the TAT-Maddux weather service, an institution half the size of the United States Weather Bureau.

Ten of the main landing fields—Columbus, Indianapolis, Kansas City, Waynoka, Albuquerque, Winslow, Kingman and



The above view is typical of the interior of the ground radio stations in the coast-to-coast communications network of the TAT-Maddux lines

Below is a front view showing the simplicity of the Junior Transmitter

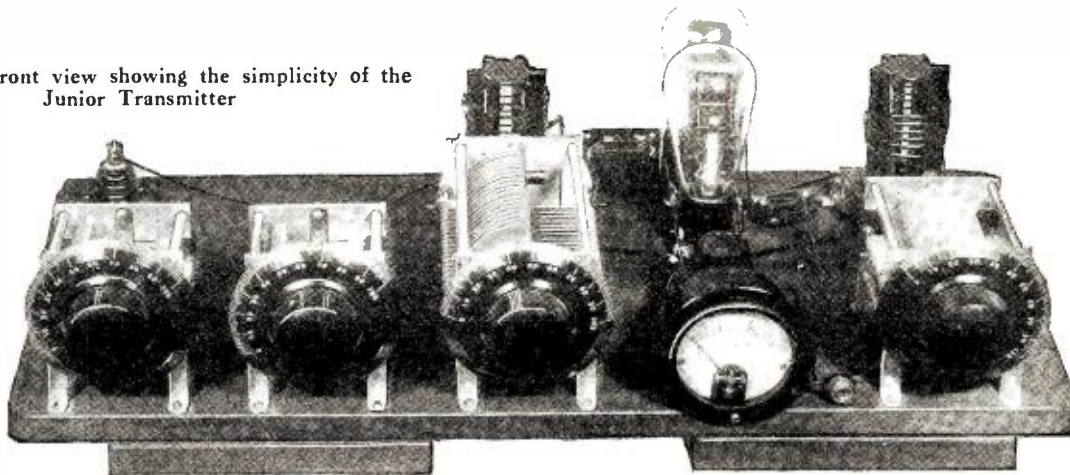

# Get On the Air

with the *Junior Transmitter*

*Instructions for the beginner on how to build a low-cost, low-power transmitter for amateur use. In the "breadboard" transmitter described here, the author uses only the best of parts in a layout which is remarkably simple, and easy of duplication. Succeeding articles will describe power supply, tuning and will also show how alterations can be made to increase its output*

By Don Bennett

"NOW listen, Don. You've been talking for years about getting on the air. When are you really going to start?"

"Aw, Gus, you know that just as soon as I get a little time and some money I'll get some junk together and—"

"You're going to do it right now! You've put it off long enough. Sit down and we'll work up a list of parts."

"Oh, all right. What shall I get?"

"We'd better pick out a circuit first, then get the parts for it."

"What circuit had I better use? Hartley?"

"No, I don't think so. The Hartley is O.K., but for a beginner I think a tuned-plate, tuned-grid is better."

"Why?"

"Well, in the first place, it is easier to adjust. All tuning is done by condensers alone, whereas in the Hartley you have to adjust clips as well as tune with the condensers. You eliminate the clips of the Hartley and the flexible leads that go with them. A Hartley is not easy to adjust if you are not experienced. Maladjustment is easy, and it means very

---

*MR. BENNETT, the author of the article presented here, is active in ham work in the Second District. For the benefit of newcomers into the amateur fraternity he has written this article as though he himself were confronted with the problems which besiege such newcomers in their initial effort at transmitter construction.*

*This is only the first of a long series of such articles which Mr. Bennett has been commissioned to write for RADIO NEWS readers. Our present schedules call for an article a month for the next eight months. These articles will deal with such subjects as power supply design; adjusting the transmitter; frequency measurements; antenna design; improvements in the transmitter; applying modulation for phone work; and other kindred subjects.*

THE EDITORS.

---

much reduced efficiency, lowered output and general dissatisfaction. With the tuned-grid, tuned-plate circuit you can adjust quicker, easier and more surely for a beginner. In fact, I think you had better make your transmitter a push-pull job."

"Push-pull? Gee, that's a lot of work, isn't it?"

"Just as easy as making a single-tube job, and you not only retain the straightforward wiring of the tuned-grid, tuned-plate, the simpler layout and the highly desired condition of widely separating the grid and plate tuning circuits, but you get greater stability in the push-pull, almost entire elimination of frequency shift and greater output because your push-pull transmitter works on alternate half-cycles of the radio-frequency wave just as in a broadcast receiver the push-pull amplifier works on alternate half-cycles of the audio-frequency wave.

"Push-pull has the advantage over a single tube in stability because one of the causes of shift or creepage of frequency in a single-tube circuit is caused by the change in capacity between the tube

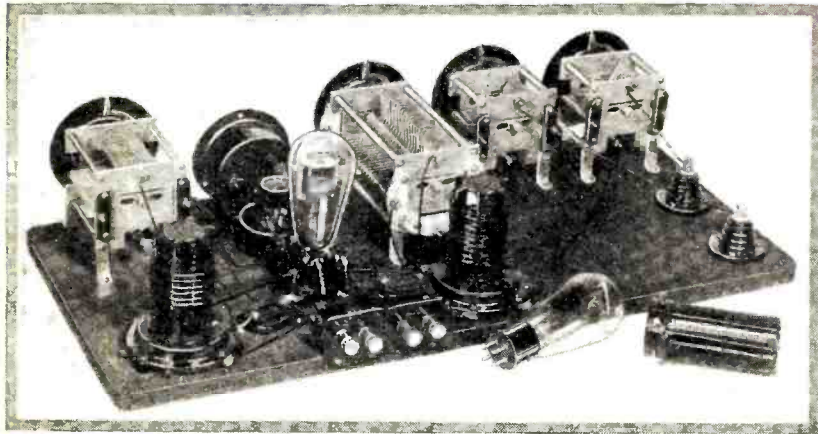

Back view of the transmitter. All the parts will fit on the baseboard easily, if this layout is followed

elements as the tube changes temperature. You can see that a variation in the filament voltage will cause a frequency shift as will an overloaded plate which heats the tube up. This intra-element capacity must be considered as being a part of the tuned circuit. In push-pull we at least halve this capacity because the elements of the two tubes are in series with each other across the tuned circuit, whereas the single tube has its full capacity across the circuit.

"This reduced effective capacity across the tuned circuit also permits less radio-frequency current to flow in the tubes and this reduces heating, because the less capacity the less current flow. The reduced radio-frequency current in the tube itself will increase the tube's efficiency because it reduces the overloading possibilities. In the case of a tube with a thorium-coated filament, overloading will tend to de-activate the filament and for that reason, if I were you, I wouldn't use any tubes but those with oxide-coated filaments."

"Gee, Gus, what a lot to know about a circuit. I thought it was just a bunch of lines on a piece of paper. You may be just a ham, but you certainly know *why* to do things. The next thing is to show me *how* to do them. What parts shall I get?"

"Before you spend any money we had better draw out the circuit and make a list of parts (Fig. 1). This same circuit, incidentally, can be used for any size tube merely by changing the constants to fit the power that must be handled."

"How about the power supply?"

"One thing at a time, young fellow. We'll build the transmitter first and then the power supply."

**Parts Needed**

"You should know by this time that there are always parts needed for any kind of a set that don't appear on the circuit drawing. We'll tackle the parts shown first and then get the others so that there won't be any extra trips to the store. Let's see now; first we have our inductances, L1, L2, L3. They, of course, need wire and something to wind it on. Standard amateur practice usually specifies 1/4-inch copper tubing that is self-supporting, but for this low-power rig we're building we can use something that will enable you to shift bands more quickly and also make a neater appearance in the set. Outside of the wire, which we'll dope out later, we need two of the coil forms made by Radio Engineering Laboratories for each

As we're going to work in all three bands, we will need ms in all. Then we'll need two coil bases to fit, one for te tank and one for the grid tank. Tanks, you know,

are the tuning circuit, consisting of an inductance and a capacity.

"For capacity to tune the tank, we need variable condensers. The plate tank condenser must be able to withstand high voltages and high radio-frequency current, so we'll get a regular transmitting condenser. This condenser, C1, has a capacity of 350 mmfd. (.00035 mfd.) and we'll use a National. The grid tank condenser, C2, can be a receiving type condenser but must be well insulated. We'll use a National here, too, one with a capacity of 1,000 mmfd. (.001 mfd.). The antenna tuning condensers should be well insulated but need not be double-spaced. National receiving type condensers will do here because of our low power, but if you ever rebuild to a higher power you will have to put transmitting condensers in. C3 condensers have a capacity of 500 mmfd. each (.0005 mfd.)."

"You forgot to mention these L3 coils. What are they?"

**Antenna Tuning Coils**

"They are the antenna tuning or coupling coils. I didn't mention them because they are wound on the same form as the tank coil. Next we need two sockets to hold our tubes V1 and V2. Guess we'll use GR sockets here, regular UX base with heavy spring contacts.

"C4 is the plate by-pass condenser that serves to by-pass any stray radio frequency (r.f.) that might try to creep into the power pack and back into the 110-volt mains. You'll notice that we are using series feed for our plate supply and we do that because it practically eliminates radio-frequency current in the power lead. However, we'll put the by-pass condenser in to take care of the stray r.f. If, later on, when we are tuning it up, we find that we do get r.f. back in the high-voltage leads, we can put a radio-frequency choke in the positive high-voltage lead. Incidentally, the by-pass condenser should be capable of withstanding the peak voltage on surges which

would be 1.4 times the d.c. voltage. As we are going to use 600 volts on the plate, our condensers should be rated at 1,000 volts. A Sangamo will do this nicely. C4 has a capacity of 200 mmfd. (.002 mfd.), as has C6, the grid condenser. The filament by-pass condensers are 600 mmfd. (.006 mfd.). These by-pass condensers are really not needed if your transmitter is truly 1931 style.

However, we'll put them in and after we tune up we'll try and take them out. If the transmitter is functioning properly there should be no r.f. in the filament circuit and therefore there is nothing to by-pass.

"The grid leak R1 is 10,000 ohms and I

Enlarged diagram of the filament circuit, showing the jack for keying. If properly balanced, the two .006 condensers will be unnecessary

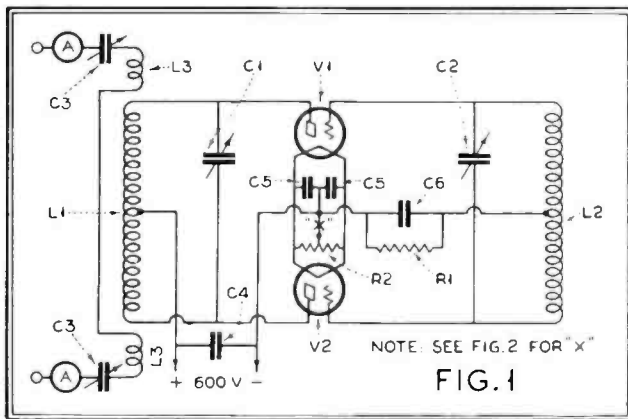

In this wiring diagram two ammeters are shown, although not absolutely necessary. Their use is advisable, however, to balance the circuit

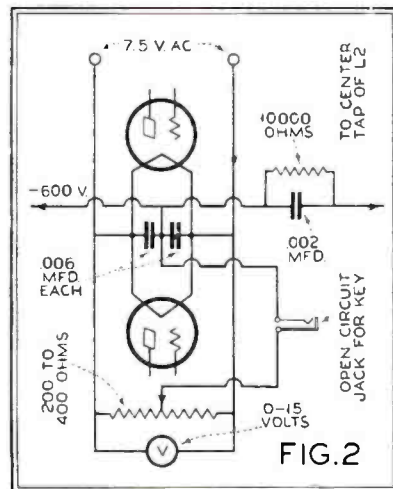

think we will use these new non-inductive resistors made by S. S. White. One nice thing about them is that if you want to increase the resistance, you take a nail file and file away some of the material and presto, up goes the resistance. They're compact, too, which makes it nice. R2, which we use for a center tap on the filaments, is 200 to 400 ohms. The reason we use the resistor rather than the center tap of the transformer is so that we can get the exact electrical center of the filament circuit for our negative return. Occasionally in commercial transformers the center tap is not in the true electrical center and this will cause a 60-cycle hum to modulate our emitted wave and destroy the clean note we want to get from this transmitter. We'll use a General Radio potentiometer here. It will easily carry the current and the amount of wire in this instrument will enable us to get as close to the exact center as is possible with a commercial product outside of the laboratory.

"We'll also need a filament voltmeter to measure the voltage at the filament. Then we'll need two antenna ammeters. One will do in a pinch, but if you have two you can balance the antenna circuit and get more efficiency from the transmitter. These are rated at 0-2½ amperes of radio-frequency current and should be of the thermo-couple type. The filament voltmeter should read 0-15 volts a.c. We'll also need four GR138Y binding posts.

"To connect to the antenna we will need two General Radio stand-off insulators. We will also need a baseboard, a piece of wood 12"x28"x1" thick. This should be very dry and should be stained before the equipment is put on it.

"For keying we need either binding posts or a jack. Let's use a jack, it's so much easier to hook into when operating. An open circuit jack will do nicely and it is hooked up as shown in the circuit drawing. Incidentally, let's make a larger scale drawing of the filament arrangement so that it is perfectly clear. (Fig. 2.)

**Tubes**

"Now we come to the most important thing you have to buy, outside of the ½ and ¾ inch wood screws for mounting the parts, and that is the tubes. The tubes are the heart of the whole transmitter and if we watch anything, the tubes are "it." I am partial to the deForest type 510. This is a special oscillator tube similar to the 210 so much used by hams but it has extra rigid construction that prevents vibration in the tube that would cause the emitted signal to "wobble." Larger elements that are stronger electrically so that they will stand the excessive overloading that every ham treats his transmitter tubes to and has the much desired oxide-coated filament that

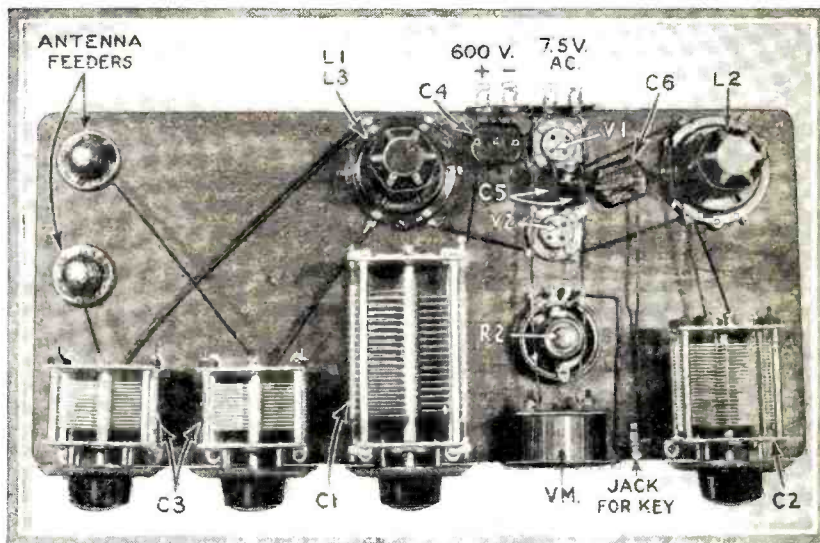

Above is a top view of the transmitter. The lettering of the various parts corresponds to the lettering used in the text

I mentioned before. The ordinary 210 is rated at 7½ watts but the 510, with only slightly higher voltage and current requirements, gives twice the output, being rated at 15 watts.

"Say, Gus, do you mean to tell me we can get all those parts on a 12"x28" baseboard? It sounds to me as if I had better get another room to hold it all."

"You get it and I'll show you how to get it all on there with plenty of room to spare."

**The Layout**

Several days elapse while Don gets together his parts and then he and Gus go into conference on the actual building.

"Here it is Gus, do your stuff. I've tried a million ways to get this stuff on the board and I can't make it look right."

"A little simple juggling and presto! there you are, m'lud." (See Fig. 3.)

"Gee, that's easy now. What do we wire it with?"

"This No. 12 enameled wire that you got for winding your coils. Run all leads in as direct a line as possible and if you must make bends, don't make them sharp, but have a slight radius to the bend. If the bends are sharp there is a good possibility of having eddy currents at the bends, and that is not efficient."

**Winding the Coils**

"We wind the coils with different sizes of wire (see chart Fig. 4.) In every case the antenna coils are of the heavy No. 12. The best way to wind them is to start one side of the winding by forming the wire around the column on the R.E.L. coil form and soldering it to the lug inside the form. Then wind, spacing the turns so that there are two empty notches between every turn (on the 20 and 40 meter coils, and wind the wire in every notch on the 80 meter coil). Plan your lug arrangement so that it is symmetrical. (See Fig. 5.) One nice thing about using these coil forms is that you don't have to worry about the center tap clip, as the center tap is soldered in place. Be sure when winding the coils that you wind the wire in the same direction always. This is especially important in the antenna coils.

"Go ahead, big boy. Wire it up and then I'll come around and show you how to build the power supply. After that we'll tune her up and get on the air. O.K.?"

"O.K."

(Continued on page 665)

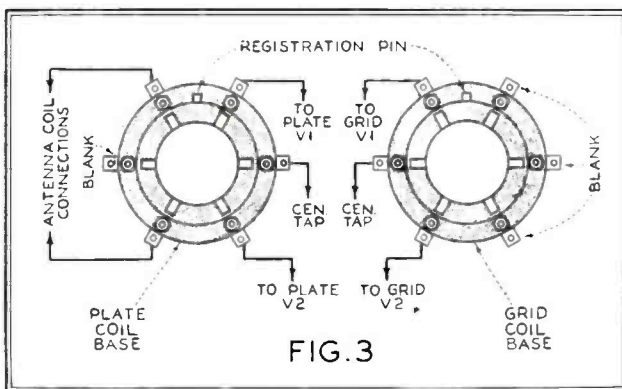

How to wire to the coil bases. This should be carefully noted, for a mistake here will prevent the transmitter from "perking"

WINDING CHART FOR COILS - FIG. 4						
BAND	L1	SIZE	L2	SIZE	L3	SIZE
20 METER	4 T	Nº 12	4 T	Nº 12	4 T	Nº 12
40 METER	6 T	Nº 12	6 T	Nº 12	4 T	Nº 12
80 METER	20 T	Nº 18	8 T	Nº 18	6 T	Nº 12

NOTE: ALL WIRE ON COILS ENAMELED

Antenna coils are wound in two sections, half the winding on each side of the plate coil and on the same form. Pass the connecting link (without cutting wire) through the inside of the form in making the two halves of the antenna coil. These tunes are not exact. Exact windings are governed by accuracy of spacing, etc. No spacing between turns on the plate winding of the 80-meter coil. Two notches between the antenna coil turns in every case

# The Midget Receiver

## and the Loftin-White Amplifier



Photos courtesy The Sterling Co.

The midget receiver—simplicity itself

*Because of the compactness in construction which it affords, the Loftin-White audio amplifier lends itself quite nicely to midget receiver construction. The receiver described here is an excellent example of how the L-W amplifier has been applied to this type of receiver construction. Servicemen particularly will find it to their advantage to keep abreast of the times, of which the midget, or mantel receiver, is an outstanding instance*

By George E. Fleming

HERE has grown up, almost overnight, an entirely new phase of the radio industry, the building of the midget receiver. Engineers who had been accustomed to the use of parts in the design of their receivers with no thought of weight nor size were faced with a new problem. Every individual component now had to be of the least weight possible and the smallest size that could be designed. Cabinets had dropped from 27 to 30 cubic feet to 1 cubic foot. And yet no sacrifice could be made of tone quality or sensitivity. For this type of receiver could not be a makeshift, as its mission in life was to supplement the large receiver rather than replace it, and to give to the man with limited means the same type of radio reception enjoyed by his more fortunate friends. What could have been more natural than to turn to the Loftin-White system as a logical aid in obtaining that end?

The success that one of the leading manufacturers has had with the Loftin-White system is remarkable, having built into a cabinet of the mantel type, 13" high by 11" wide, a little receiver of two radio-frequency stages, using screen-grid tubes, feeding into the L.-W. detector-amplifier system. This little midget does everything that could reasonably be expected of its larger brothers, both as regards sensitivity, selectivity and tone quality.

Several unusual features have found their way into its design. In the radio-frequency end of the receiver the primary coupling is "close" without loss of selectivity. That end has been gained by placing one turn of the primary very close to the grid end of

the secondary winding and the remainder of the primary at the low-potential end of the secondary winding. Liberal bypassing is used to assure stability at the high gain that is realized.

The volume control, too, is worthy of note, being a tandem control device that simultaneously acts on the antenna coil and the screen-grid voltage of the radio-frequency tubes. If either system were used alone, unsatisfactory operation might result. On the antenna coil, while the signal would be reduced, the background noise of the receiver would not. If the screen-grid voltage alone controlled the volume, detection in the radio-frequency tubes would result. However, using both systems simultaneously combined the advantages of both, without their disadvantages. This phase of the (Continued on page 667)

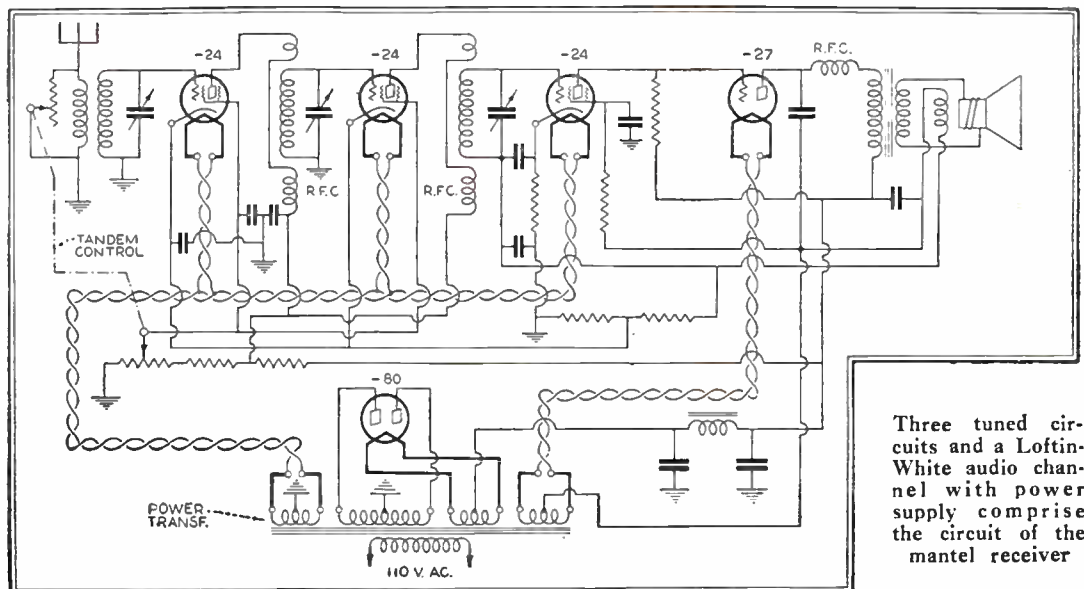

Three tuned circuits and a Loftin-White audio channel with power supply comprise the circuit of the mantel receiver



# Mike- roscopes

By Harriet Menken



**JESSICA DRAGONETTE**, who comes to you each Friday night via NBC, tells me that to her radio spells romance. Each time you turn your dial to Jessica, and you usually do, you may be sure that she is feeling as though she were bound on a thrilling, romantic adventure. Jessica has a slender figure, limpid eyes, and red-gold hair, and dresses exquisitely. She is always in love, and frankly prefers men to women. Her life has been an adventure.

Born in the Orient, she was brought up in a convent and then turned loose on Broadway. Jessica tells me that her fans are ever sending her mementoes. Is that you? She says she adores garnets, men, and happy dispositions, writes her own continuities and hopes we won't have television. She believes that the charm of radio lies in the fact that you may draw your heroines with your own imagination, your own dreams and visions of beauty. Jessica believes that most people are essentially romantic, and sh—! don't tell anyone, but underneath those dreamy eyes, that ethereal voice, we suspect Jessica knows how to cash in on her opinions!



**I WATCHED** an audition for announcers one day at the Columbia studios held by Jack Ricker, production chief over there. There were seventy-three men tried out and I noticed that the greatest number of applicants for the position of announcer were actors and salesmen. There were also violinists, advertising men, journalists, school boys, singers, accountants, reporters, musicians and three radio announcers. Their average age was twenty, although the ages ranged from 19 to 51. Most of them had no previous experience on the air.

Each applicant was given a sheet of paper to read, including many names of composers and musical terms. If they got through to Mr. Ricker's satisfaction, the would-be announcers were handed another sheet of what might be called "commercial copy." The third test was to have been ad lib. Mr. Ricker meant to ask the man at the "mike" to look around the room and describe what he saw, but none of the airy contestants even got that far.

To me the outstanding impression of the entire morning was my surprise at the lack of ability among the applicants. I shared an impression, which I think prevails, that there are thousands of mama's boys lying around the hearth fires who could be good announcers if they were only given a chance. This time at least, results proved to the contrary. Out of 73, Mr. Ricker did not find one satisfactory announcer.



**HAVE** you ever tried to picture the boys at NBC who won the Announcers' Gold Medal last year and this annum? If you want to envisage the first winner of the gold medal, the picture is heavy, about 250 pounds heavy, and that's Milt Cross. This gentleman hasn't that dapper, alert mark of theater, radio and automobile salesman (don't throw it, I had eggs for breakfast!) he is an easy going soul, without that dramatic flair, and I can best picture him in a nice rocking chair on a wide porch with his collar open and feet up on the railing.

Milton Cross met his wife at church where she was assistant to the minister and she accompanied him in both senses of the word on his airy debut eight years ago over the Westinghouse plant in Newark, the original WJZ station. The station has moved but Mr. Cross has been with it ever since. He tells me that he thinks he is the second oldest man in service on the air and that he has a little girl of four and a half—Lillian—as he said this Mr. Cross smiled, and that's how I visualize him, comfortably smiling.



The announcer who won this year's gold medal is a different breed of broadcaster. Alwyn Bach looks like one of those deep, dark men who have a mysterious past, an exciting future and a very busy present.

Mr. Bach says that the idea that he's an enthusiastic golfer is just one more illusion! Golf is not to his liking at all. "a little mild tennis will do."

When I asked Mr. Bach, the man from Worcester, how he got himself in  
(Continued on page 638)

*A VOICE floats out to you over the air. What is the rest of the picture? Are they dark or fair, young or old, these people whom you meet only through the microphone? What do they eat for breakfast, what's their matrimonial status, their favorite restaurant, their home town, their present eccentricity? The answer to all this is what this department is attempting. It will be conducted by Harriet Menken, who has become known as an expert in this line through her radio column in the New York World entitled "Behind the Microphone."*



*Miss Menken spends each day in New York's large studios, the National Broadcasting Company and the Columbia Broadcasting System, and is in constant contact with "airy" folk, news and gossip.*

*Miss Menken also writes radio articles in each Sunday's "World," signed "Dorothy Sinton." She conducts a weekly theater column on the air over station WOR on Wednesdays at 12.15. Recently she played the lead in a radio drama over a hook-up of fifty-one stations on the Columbia chain and has broadcast over WOR, WABC, WJCA, W'PCH and WOY, among other stations.*

*Ere radio, Miss Menken was engaged with the theater and motion pictures. She sold her play "Romantic" for Broadway production, she was stage manager of the Theater Guild School, an organ of the Theater Guild, and was dramatic critic of the "Long Beach Life" and affiliated papers. Among her theatrical activities Miss Menken has been affiliated with several motion picture organizations in a literary capacity, notably the Motion Picture Commission of the State of New York. Miss Menken threw aside all her interests to enter radio and has rapidly become one of its best known writers.*



# SELECTIVITY, SENSITIVITY

By Donald Lewis\*

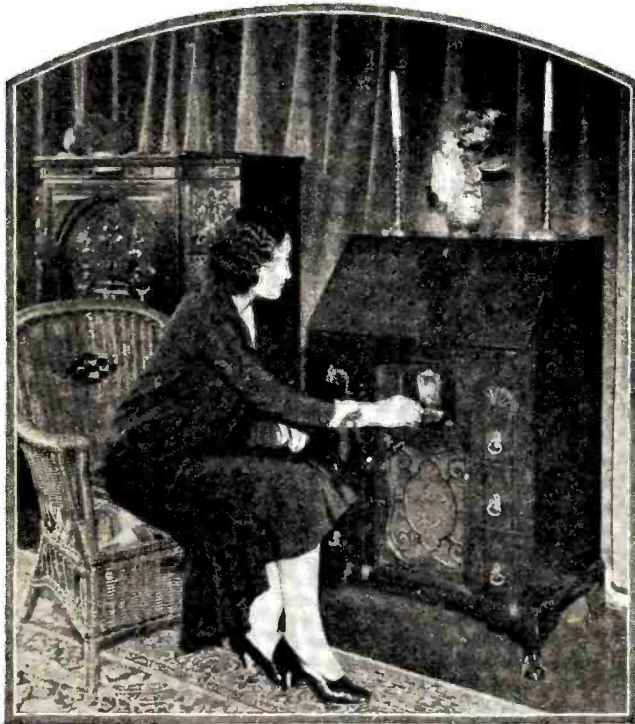

The Hammarlund Hi-Q 31 in a cabinet

*This is the third and final installment of for RADIO NEWS readers, describing the receiver. The serviceman and custom portant fact that kit-built receivers are as to ultimate satisfactory performance A knowledge of how the receiver has future work the serviceman*

could be obtained in any other way.

The overall measurements described in this article were made by a prominent radio engineering laboratory on a Hi-Q 31 receiver borrowed from one of the district offices of the Hammarlund Manufacturing Company. In no sense, therefore, was the receiver a special laboratory job, but represented the average performance of a receiver wired and tested under ordinary factory routine. We publish these curves rather than those made in the laboratory of the Hammarlund Manufacturing Company since they represent tests by an outside engineering organization on a standard model of the Hi-Q 31.

Regarding the equipment used and the conditions under which the tests were made let us quote from the report of the laboratory:

*Equipment Used*—General Radio Type 377-B Low Frequency Oscillator. General Radio Type 403-C Standard Signal Generator.

*Conditions of Measurement*—All measurements were made in the manner suggested and outlined by the Institute of Radio Engineers Standardization Committee and published in detail

**I**N the two preceding issues of RADIO NEWS we have described in some detail various features of the Hammarlund Hi-Q 31. We have shown why this receiver uses a three stage band-pass pre-selector and why the circuits in this pre-selector were coupled by both capacity and inductance. It is only when such a combined coupling is used that uniform band width over the entire broadcast spectrum can be realized. To obtain high and uniform sensitivity at all points on the dial the Hi-Q 31 utilizes an especially designed radio-frequency coupling transformer with a high inductance primary and capacity coupling between primary and secondary. Other features described in the preceding articles were the linear high-voltage screen-grid detector, the combination resistance and transformer-coupled audio amplifier, the complete filtering circuits and the special loud speaker with two field windings. In this article we present some overall selectivity, sensitivity and fidelity measurements which will serve to give positive proof of the excellent characteristics of the Hi-Q 31. Obviously, careful engineering of the various parts of the receiver is of little use unless they are combined together in such a manner as to produce a complete set having the ability to tune in a very weak station, the ability to always separate the desired station from all other stations, and the ability to reproduce the program from the desired station with excellent quality. But overall measurements, especially if they are made in accordance with the recommendations of the Institute of Radio Engineers, serve to give the prospective purchaser more absolute proof of the performance of a receiver than

Hammarlund Mfg. Co.

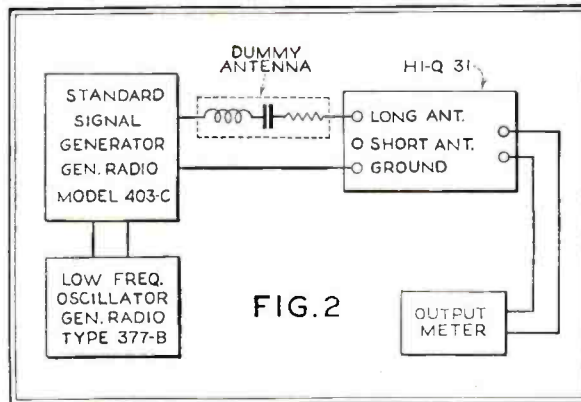

Fig. 2. Laboratory set-up for making overall measurements. The standard signal generator supplies a small known modulated r. f. voltage to the antenna system, the r. f. oscillation being modulated by a voltage from the low frequency oscillator. The power output, measured by the output meter, is maintained constant at 50 milliwatts

Fig. 1. Overall sensitivity characteristic. The average sensitivity is approximately one micro-volt per meter

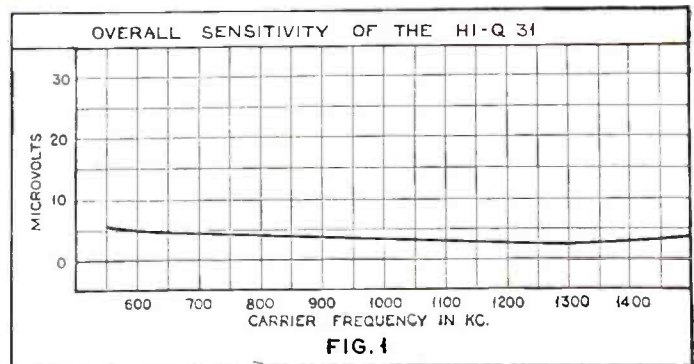

FIG. 1

# and FIDELITY Measurements of the Hammarlund Hi-Q 31

*a series of articles, prepared exclusively design and circuit details of a unit-built set-builder should not overlook the im- now given the same serious consideration as a completely manufactured receiver. been designed is of inestimable aid in may be called upon to do*

in the 1929 year book of that organization.

In Fig. 1 is shown the overall sensitivity of the Hi-Q 31 for all carrier frequencies from 550 kc. up to 1500 kc., the ordinates indicating the total radio-frequency input voltage to the antenna system. A general idea of the circuit arrangement used for this test can be obtained from Fig. 2. The "dummy antenna" can be considered to have an effective height of 4 meters and therefore to obtain the sensitivity of the receiver in microvolts-per-meter the ordinates should be divided by four. For example, at 600 kc. the curve shows the total microvolts input to be five. Therefore, at this point the receiver has a sensitivity of five divided by four or 1.25 microvolts-per-meter. We described in a preceding article the uniform gain r.f. transformers and the fact that these transformers are actually effective in making the set uniformly sensitive over the entire broadcast band is shown by Fig. 1. It will be noted that the sensitivity varies only in a ratio of approximately 2:1 and this degree of uniformity is unusually good.

The fact that the sensitivity of the receiver is never less than approximately 1.4 microvolts-per-meter means that plenty of volume can be obtained from exceedingly weak stations. The relation between the field strengths in microvolts-per-meter required for ordinary reception and the sensitivity in microvolts-per-meter of the Hi-Q 31 may be appreciated from the fact that excellent service from a local station usually means that the field strength from the station is in the order of 10,000 microvolts-per-meter or more.

The sensitivity of the Hi-Q 31 is such (and the curve of Fig. 1 proves this) that it is possible to receive any station whose field strength is above the noise level. Although there will be occasions when many users will not have to utilize the full sensitivity of the receiver, the extreme sensitivity will prove necessary when the listener desires to hear a particular program from a distant station. The high sensitivity will also be appreciated in those parts of the country where many of the best stations are located several hundred miles away—this is not an uncommon condition in many of the centrally located states. In any event we cannot see why one should take the trouble to build a set with a comparatively poor sensitivity when a sensitivity in the order of 1 microvolt-per-meter is available as in

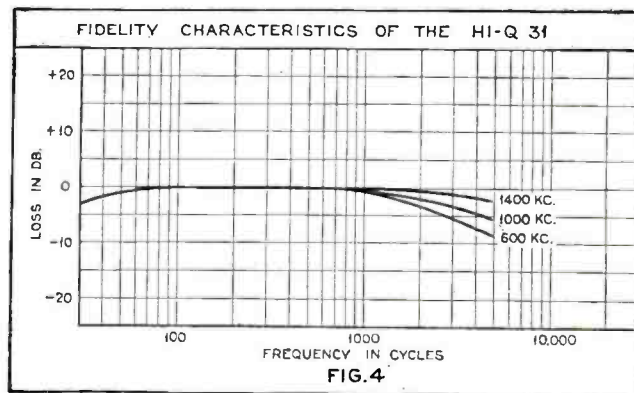

Fig. 4. Overall fidelity characteristics. The modern broadcast station transmits all audio frequencies from about 30 cycles up to about 5,000 cycles. This figure indicates that the Hi-Q 31 gives essentially uniform amplification to all these

the Hi-Q 31. We would not make this statement if the high sensitivity of the Hi-Q 31 had been obtained at a sacrifice of selectivity or quality of reproduction, but as the following curves will show, the receiver also has extremely good selectivity and fidelity.

Overall sensitivity measurements on a receiver are made by impressing a small modulated radio-frequency voltage, in series with a dummy antenna, across the input terminals of the receiver and adjusting the r.f. voltage (maintaining the percentage modulation constant at 30 per cent.) until 50 milliwatts of audio-frequency power are obtained across a resistance connected in the output circuit of the receiver. Selectivity measurements are made in much the same fashion except that the frequency of the modulated r.f. input voltage is varied in small steps to the extent of some 30 kilocycles either side of the frequency to which the set is tuned. Selectivity measurements are made at the three standard frequencies of 600, 1,000 and 1,400 kc. As the frequency of the modulated r.f. input is varied its voltage is adjusted to maintain the audio-frequency output power constant at 50 milliwatts. Curves are then plotted showing the ratio of the r.f. input voltage required at some particular frequency off resonance to the r.f. input voltage at resonance to maintain standard output. A group of such curves on the Hi-Q 31 are shown in Fig. 3. Their interpretation should not be difficult if the above explanation is carefully read. For example, the 600 kc. curve shows that when the r.f. input voltage was adjusted to minus 10 kc. (590 kc. in this case) the field strength ratio was found to be 270. In other words, at 590 kc. 270 times as much input voltage was required to produce standard output as was required when the input frequency was adjusted to 600 kc. Other points can be similarly interpreted.

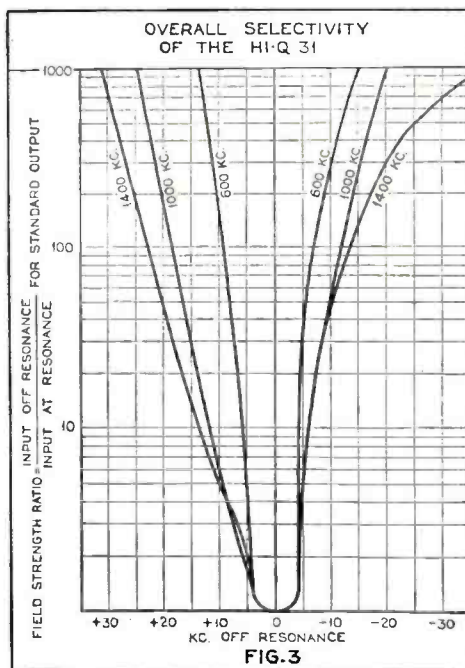

Fig. 3. Overall selectivity curves. These curves indicate the uniform band-pass characteristics of the Hi-Q 31

(Continued on page 650)

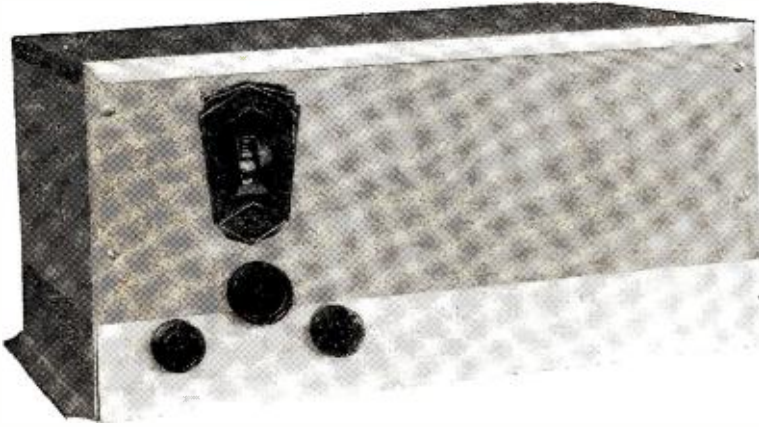

Fig. 1. A front view of the S-M. 714, a highly selective tuner employing the superheterodyne principle

*SERVICEMEN will find this article of particular interest, as undoubtedly the superheterodyne is the outstanding receiver for 1931. Thoroughly mastering the principles of this modern design will materially assist in the servicing of any receiver of this general nature.*

# The "Special" Silver Super-

IN the preceding three articles of this series we have considered the problems of the design of superheterodyne receivers capable of satisfactory performance under present broadcasting conditions, and two specific modern superheterodynes have been described. In this, the fourth and final article, a very special type of superheterodyne tuner will be described, one that has been especially designed for a degree of selectivity that, even as little as a year ago, would have been considered utterly unattainable.

To readers of the previous articles, describing the Silver-Marshall Model 724 and Model 36 superheterodynes, there will probably appear little need for greater selectivity than either of these designs provide, and for home use their almost absolute 10 kilocycle or adjacent channel selectivity leaves nothing to be desired. But for use in broadcasting stations, or in locations possibly only a small fraction of a mile away from some powerful broadcaster, a higher degree of adjacent channel and image frequency selectivity can be used with benefit, and it is for just such exacting and ordinarily discouraging problems that the Model 714 superheterodyne tuner illustrated in Figs. 1, 2 and 3 has been developed. In its design not only have the latest developments in superheterodyne construction been utilized, but, in addition, the latest developments in straight t.r.f. design.

Essentially, as shown in Fig. 4, the 714 consists of one screen-grid r.f. stage, a screen-grid first detector, an oscillator, two screen-grid i.f. stages and a -27 type of second or power detector, in order that the output impedance may match such standard two or three-stage audio amplifiers as it may be used with. In this essential description it is substantially the same as the two broadcast receivers previously described, but from this point on the design is much different.

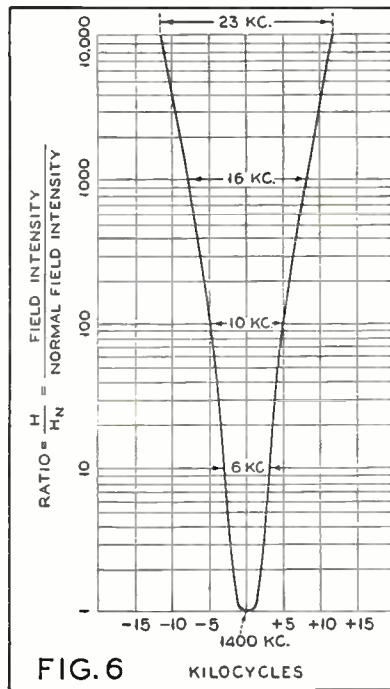

FIG. 6 Kilocycles

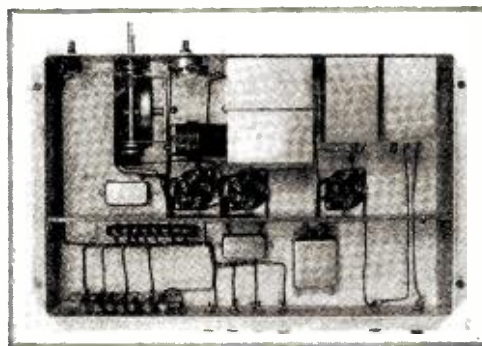

Fig. 6. (Above) The selectivity curve of the receiver. Fig. 2. (Below) Looking at the underside of the superhet chassis. Fig. 5 (Right) The uniform response over the broadcast is shown in this graph

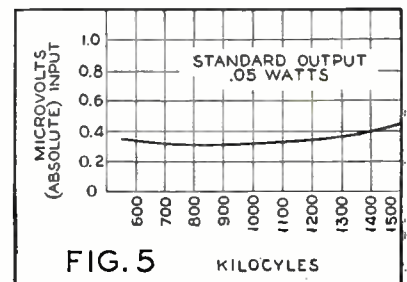
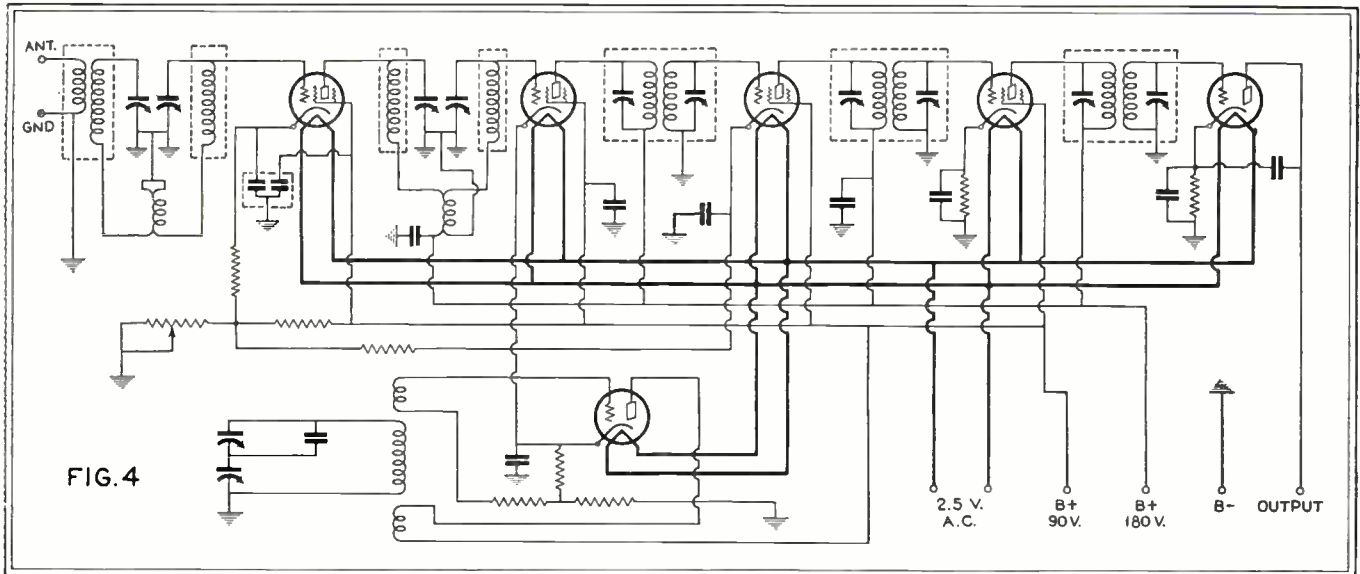

FIG. 5 Kilocycles

Preceding the r.f. amplifier tube is a dual pre-selector circuit consisting of two coils and two sections of a five-gang condenser. These two circuits assure not only a very high degree of adjacent channel selectivity, but also a high degree of image-frequency selectivity, as well as freedom from crosstalk, or cross modulation, of distant stations by powerful near-by stations. For reasons which were pointed out in the last article the energy transfer of this dual circuit is less efficient than that of a single tuned circuit, but, on the other hand, for the specific purposes for which this design was developed the selectivity gain more than offsets the slight limitation on the tuner's extreme sensitivity. The screen-grid r.f. tube is followed by a second dual selector circuit, likewise consisting of two coils and two sections of the gang condenser. So used, it is possible to maintain a good voltage transfer from r.f. to first detector tube without quite the same disadvantage encountered in the antenna selector,

the voltage gain of the r.f. tube and second selector being around 30 times, or the same as that obtained from the single tuner circuit r.f. stage of the two previously described receivers. The coils for these circuits are individually shielded in rectangular aluminum cans, and the selector circuit coils are coupled by means of small bifilar-wound coupling coils to a value



The schematic circuit of the S.-M. 714 superheterodyne tuner

# Heterodyne Tuner

*This tuner has been designed especially for use in places where an exceptionally high order of selectivity is required to tune through powerful local stations. In this article, the fourth of a series on present-day trends in superheterodyne design and construction, the author explains the receiver's properties in the matter of sensitivity and selectivity and tells how these measurements were made*

By McMurdo Silver\*

just below critical coupling, to insure the highest possible order of adjacent channel selectivity. The reason for individual rather than chassis and partition shielding is, again, the type of operation for which the circuit was designed—in or close to a powerful transmitter, where the pick-up on exposed coils might mitigate against effective selection by the selector circuits. The overall selectivity of these four tuned circuits is in excess of that of extremely good four-tuned-circuit t.r.f. sets, because all four circuits in this design are used in the two selector circuits, making for a much steeper resonance curve than would the use of the same four circuits in cascade, or even with two in one selector and the other two in cascade.

The oscillator, with its primary circuit and isolated tuning or "tank" circuit, is similar to that of the two supers previously described, but is coupled to the first detector grid coil by a small coupling coil. The oscillator tank circuit is tuned by the fifth section of the five-gang condenser, which is provided with special ratchet-type trimmers which, once set, will permanently retain their setting, this being very important, as is also the alignment of the whole circuit, since the extreme selectivity of the selector circuits is such that if the oscillator were to fall out of

alignment a serious loss of both gain and selectivity would result. This was not so true of the first receiver described, the 724 model, since the r.f. circuits in that receiver are provided not so much for adjacent channel selectivity as for image frequency and cross-talk suppression, and a slight misalignment would not seriously affect overall performance.

The 175 kc. intermediate-frequency amplifier is assembled as one unit, being essentially similar to that used in the 724 model, except for the second detector, which is a -27, rather than the more efficient -24 detector of the 724's i.f. amplifier. The second detector is made a -27 tube in order that its output impedance may be low enough to match standard audio amplifiers, which are not adapted to work out of a high-impedance detector such as a -24. Although the -27 detector is distinctly less efficient in terms of input to output ratio than the -24, this factor has been overcome by raising the i.f. gain sufficiently to compensate for this, and additionally by the fact that the tuner will almost always be used with at least a two-stage audio amplifier, as against the one-stage audio amplifier of the receivers described in former articles.

All parts are mounted upon a formed and pierced steel chassis 16½ inches long and 10½ inches deep, which is housed in a steel shielding cabinet with removable cover 8½ inches high. (Continued on page 656)

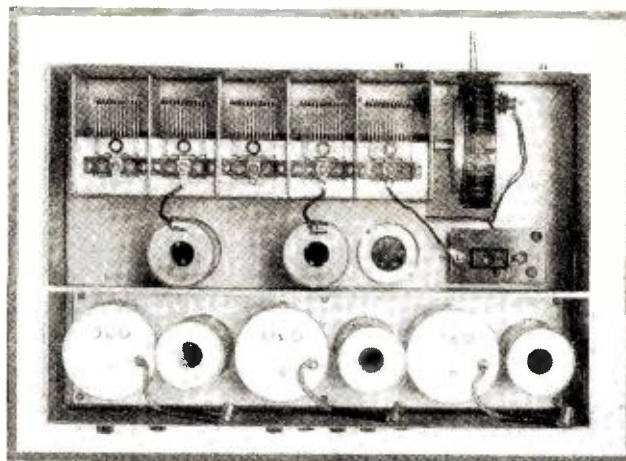

Fig. 3. Top view of the chassis. Note the simplicity of layout in spite of the multiplicity of tuned circuits

\*Silver-Marshall, Inc.

# Tone-Compensating Circuits for Audio Amplifiers

## PART TWO

IT will be noted that the rate of change of amplitude with frequency is not sufficiently steep to accomplish the desired results. To make it steeper, an inductance introduced in series with R and C as in Fig. 7 will change the shape of curve A, Fig. 6, and will be represented by curve B, Fig. 6. There is no need of a physically separate coil; the leakage reactance of the transformer when properly chosen may accomplish similar results in practice. The control of the extent to which the treble tones are thus magnified is effected by providing the resistance R with a sliding arm like a potentiometer and connecting the transformer as in Fig. 7.

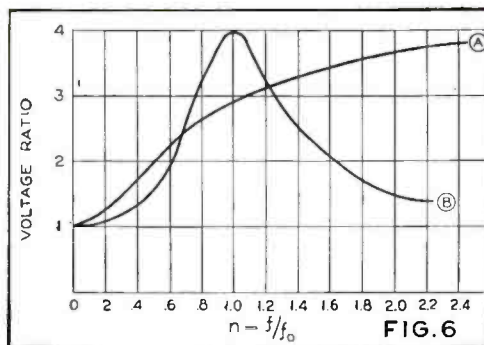

Fig. 6. The effect of adding the inductance "L" in Fig. 7. Curve "A" was taken without, and curve "B" with the inductance added

### 3—Elimination of Surface Noise:

The elimination of surface noises is a rather difficult problem because they consist mostly of excitation, impressing sharp mechanical shocks to the moving element in the pick-up. Hence, any mechanical or electrical system in the whole chain which is not periodic will oscillate and that will result in surface noises. There are some other noises which come from forced vibrations due to inherent irregularities in the "grain" of the disc. These are almost impossible to eliminate unless a good portion of the upper register is sacrificed, and we have to look for further improvements in the process of manufacture of discs and in the chemistry of the substances used. The natural oscillations occur at frequencies in the neighborhood of 3,700 cycles in most cases. There seem to be several bands of frequencies, but it has been found by trials that if the group around the first named figure is suppressed, over one-half of the total volume of surface noise is eliminated. For this reason a tuned shunt that will reduce considerably 3,700 cycles plus or minus six per cent. in each side will eliminate a lot of surface noise without wiping off the entire octave from about 2,500 to 5,000 c.p.s. as often happens with condensers shunting the grid or plate circuits of the amplifier tubes or the output to the dynamic speaker. The elimination of only three notes is hardly noticeable because these high frequencies occur practically in all instances as overtones and very rarely as solo tones. Therefore the color of the tone of a few notes will suffer to some extent, while the neighboring notes contain all their overtones, and it will be quite difficult even to a trained musician to distinguish when these three frequencies are present or when they are suppressed in a rendition even of the best of the classics.

The elimination of single frequencies, or narrow bands, can be accomplished as well by series tuned traps, Figs. 9-10, or by combinations of series and shunt circuits forming T sections. The calculations for a series rejector are too well known to insist upon them, but unless such circuits are used

where current is drawn and not merely potential, as when used between tubes, they will accomplish very little or nothing. The best place for series traps is either between the pick-up and input network or between the output of the amplifier and the speaker. If the inductor is provided with taps, the effect may be increased or diminished by changing the tap without affecting the tuning, as shown in Fig. 10.

### 4—Elimination of Natural Periods:

The suppression of resonating frequencies, whether due mostly to defects in the speaker or to poor acoustic conditions, presents a very similar problem to that of the elimination of surface noises. In the case of the scratch noise, the frequencies should be practically wiped out, whereas in the case of the resonance problem they should only be reduced in magnitude to such an extent that they will come at the same level as the neighboring frequencies. In shape, the acoustic resonance graph is similar to the tuning characteristics of radio sets, and although not so sharp as the combined effect of several r.f. stages, it may be sharper than a single stage of tuned r.f.

The calculations for the design of a tuned shunt are exactly the same as in the case of the scratch elimination shunts; the proper proportions of a q and Q should be chosen. However, for a given shunt which may take care of the most severe cases (and by severe is meant sharp resonance), the effect can be at the same time subdued as well as broadened by the insertion of series resistance. It will be noted that the magnitude and the sharpness go hand in hand in the case of the acoustic resonance, for the sharper the resonance of the mechanical

system, whether coming from the properties of the loud speaker alone or from resonating spaces near it or in the room itself, the greater the maximum amplitude or resonance will be. So it is with the tuned shunt; the smaller the resistance

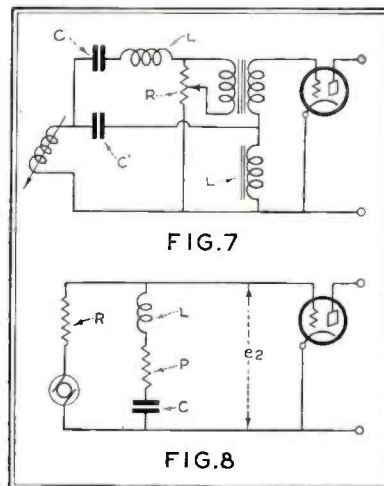

Fig. 7. Compensated input circuit, for correcting pick-up deficiencies, and the equivalent electrical circuit is shown in Fig. 8

\*Chief Engineer, Amy, Aceves & King, Inc.

*In this, the second part of this paper, Mr. Aceves gives practical data for compensating an amplifier to make up for deficiencies in associated apparatus. Using this data, the experimenter may alter his own amplifier to duplicate the results obtained by the author*

**By Julius G. Aceves\***

within the shunt, the greater the short-circuiting effect that it will possess for the selected frequency, and the smaller the effect (relatively speaking) on the neighboring frequencies.

Up to the present we have seen how an existing amplifier may be given the desired characteristics to compensate for the deficiencies in the processes of recording and reproducing. It is well to show how easy it is to build an amplifier containing all the features that we have described, and which will have sufficient gain for ordinary purposes. Fig. 11 represents an amplifier designed to operate from a phonograph pick-up to an output of about 15 watts. The phonograph pick-up P delivers its voltage to a constant impedance "fader" made of three resistances,  $r$ ,  $r'$  and  $r''$ , and immediately a scratch shunt C1 follows. The first stage contains a transformer with series condenser C1 and shunt resistance R1 for the purpose of controlling the base reinforcement and regulating the amount of this gain. The dotted lines in the secondary circuit represent the leakage inductance and the distributed capacity of the secondary, which by suitable transformer design may be made to reinforce the upper register. To control the gain in this part of the scale, a resistance R1 with a condenser C1 in series with it may shunt the secondary.

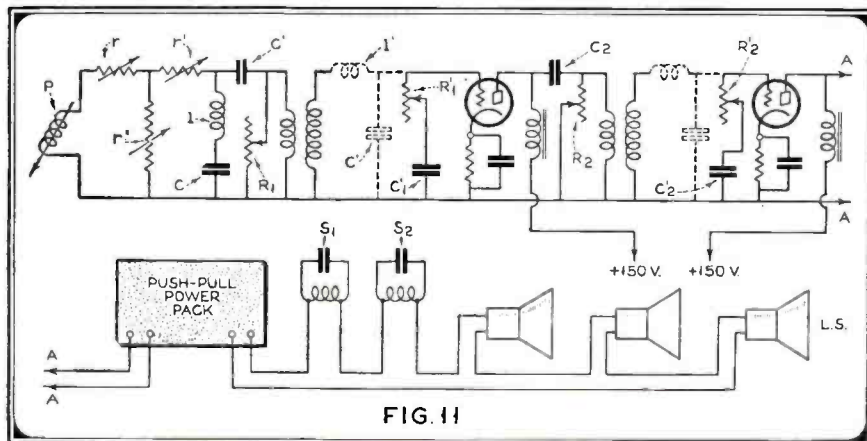
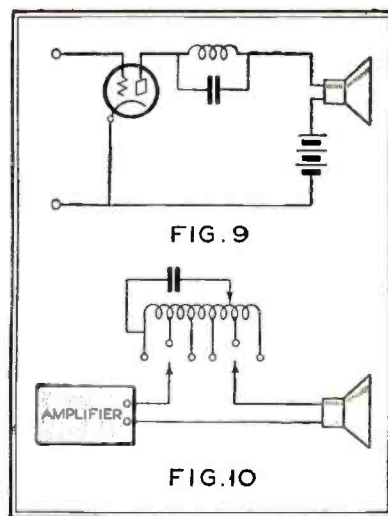

Fig. 11. A complete tone compensated amplifier built according to the information given in this series of articles. The compensation used in the various circuits is clearly shown. Properly constructed, an amplifier of this nature will give "flat line" results from pick-up to loud speaker

The second stage contains substantially the same apparatus, but the frequencies to which the capacities and inductances are adjusted should be about 10 to 15 per cent. different from the values used in the first stage for reasons discussed in Sec. 1. The push-pull stage contains only a series condenser which will reinforce the bass. It is left without control because all records are deficient in bass and therefore there is no need of reducing the little gain which it brings in.

The resonance of the natural periods of the speakers or of the auditorium are corrected by means of shunt traps S1-S2 in the output circuit of the amplifier where they belong. since these natural periods vary in different localities and they may be totally absent, at least appreciably, in many places. It will be noted that they can be adjusted in frequency by varying the number of turns included in the condenser circuit. and in attenuation factor by varying the number of turns included in the connection to the line. The tubes are of the separately

Tuned trap circuit in the output, to correct speaker deficiencies. Fig. 9 shows a single stage filter, with fixed tuning, and Fig. 10 is a variable tuning circuit



heated cathode, the heater circuits of which are not shown. The four-section electrolytic condenser with two 8 and two 18 microfarad sections is of standard make and will take care of the low-tension filtering and by-passing. The chokes and resistances will act as sufficient filtering series elements, even in the case of high-gain 60-cycle amplification. Care must be exercised to avoid magnetic interlinkage between interstage transformers and the power transformer and choke, as a very small amount of induction will be greatly magnified. The performance of an amplifier such as has been described and illustrated is similar in nature whether the audio frequencies come from a pick-up, a photo-cell or the detector tube of a radio set. In commercial applications, the chokes used to feed the plates of the amplifiers may be substituted by resistances, so long as a high-voltage source is available, which is the most general case even when -45 type tubes are placed in the power stage. By suitable selection of thickness of laminations and arrangement of the windings of the interstage transformers, the controlling resistances R, R<sup>1</sup>, R2, R<sup>2</sup> may be eliminated, but the performance of the amplifier will be fixed and not adjustable, which, by taking average conditions, may be acceptable in less expensive amplifiers.

**Emphasis of Bass Notes**

In actual radio sets there is a tendency to emphasize so-called bass notes, occurring at about 100 to 150 cycles. This is a rather sad state of affairs because the bass tones in music have much lower fundamentals as a rule, and the effect obtained from such sets is well characterized as "boomy."

Here the resonance suppressors of Fig. 10 will do a lot to remove this objectionable feature, while the parallel feed of the audio-frequency plate circuits, as shown in the amplifier of Fig. 11 with

suitable values of coupling condensers will bring out the bass fundamentals below 100 that give such rich and full sonority to good music.

It will be noted that when space is not available for the chokes required for the parallel feed, they may be replaced by resistances, having a value equal to—or nearly so—the a.c. plate resistance of the tubes used. The small loss of overall gain will be more than compensated by the superior tone quality. The elimination of d.c. flow through the primaries of the audio transformers will not only increase their inductance, but will prevent distortion due to iron saturation.

In conclusion, it may be noted that there are but few extra compensated amplifiers, with respect to what would be absolutely needed in standard amplifiers, but the extra parts which are required for an amplifying system such as that described here will make an enormous difference in the tone quality to the fastidious listener.

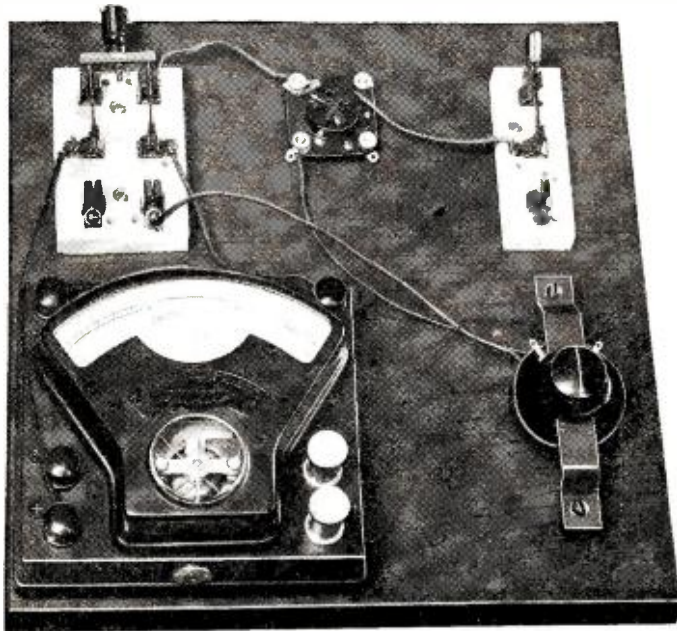

This direct reading vacuum tube voltmeter does not require the usual calibration or specially drawn meter scale

# How to Measure with a Direct Reading

By Chas. Williamson

**E**XPERIMENTERS who are working with Loftin-White or similar direct-coupled amplifiers soon discover that no intelligent progress can be made until they have means of measuring grid biases and plate potentials which will not disturb the voltage distribution that they are trying to measure. A recent article in another publication has suggested that the only device available for such use is the tube voltmeter. But in its usual form, this instrument requires either a calibration curve or a specially drawn meter scale. A tube voltmeter which largely overcomes this limitation will be described in the course of this article. First, however, let us refer to two other devices which may be equally convenient for some workers.

Those who have access to large and well-equipped laboratories may use electrostatic voltmeters for potentials above 50 volts, and standard potentiometer circuits for those below 5. Between 5 and 50 volts, however, a special circuit is needed if no current is to be drawn from the device being tested.

Such a circuit is shown in Fig. 1. Suppose that we wish to measure the potential drop in the coupling resistor R1. We may select for V any voltmeter of suitable range. G is a portable galvanometer or a zero-center micro-ammeter. R2 is a protective resistance, its value depending on the characteristics of the galvanometer. It should be as high as possible without reducing the sensitivity of the circuit. With a Leeds-Northrup pointer galvanometer, 50,000 ohms has proved suitable. R3 is a potentiometer resistance, the value of which depends on the source of power being used. If this is a d.c. lighting line, R3 may be a 16-inch tubular rheostat of 200 to 1000 ohms. If batteries or an eliminator be used, R3 may be 5000 ohms, but should carry 30 milliamperes.

All that the observer has to do is to move the sliding contact P to a point where the galvanometer G indicates no current. The reading of the voltmeter V is then exactly equal to the desired potential drop in the resistor R1.

It will be observed that the above is a way of using an ordinary voltmeter to measure the unknown potential, and gives results of the same order of accuracy as that of the meter itself. It has the disadvantage that a control must be manipulated before the result can be observed at all; but after this is done, the result is read directly. The voltage range within which this method may be used is limited only by the meters and power sources available.

A more familiar device for making such measurements as those under discussion is the tube voltmeter. Inasmuch as any ordinary voltmeter may be used as a milliammeter to measure the plate current of a receiving tube, the question arises, why may not such a meter be made direct-reading? An extended series of experiments has shown that this is quite feasible over the greater part of the range. Fig. 2 gives the circuit. C is a negative grid biasing battery, R is a variable resistor, and V is the voltmeter. Battery supply is shown, for constancy of calibration is thus better assured.

The procedure for direct calibration is as follows. Suppose we wish to measure d.c. potential on a meter reading to 15 volts. We connect a minus 9 volt C battery as shown, and then a few blocks of B battery in the usual way, using at first the 90 volt tap. The tube may be any general purpose type, such as the -01A, -12A, -26, or -27.

Two known voltages must now be applied across the input. A good way to do this is suggested in Fig. 3. With these connections, the same meter determines the known input voltages and serves as plate milliammeter for the tube. A double-pole double-throw switch and a small input battery giving 9 and 15 volts are the added pieces of apparatus. Note the polarity!

In order to avoid overloading the meter, we shall begin by using too much resistance at R, say 2000 ohms. We adjust the input battery tap to 15 volts, the B battery to 90 volts, and then throw the double-pole switch each way in turn. In general, the posi-

TABLE I

TUBE	Eb	Ec	Rm	R	CALIBRATION			
					15	10	5	0
-01-A	120	-9	3000	1400	15	10	5.3	1.5
-12-A	105	-9	3000	1700	15	10	5.3	1.6
-26	99	-9	3000	1540	15	10	5.35	1.65
-27	101	-9	3000	1680	15	10	5.35	1.4

TABLE 5

TUBE	Eb	Ec	Rm	R	CALIBRATION			
					15	10	5	0
-45	166	-41	1500	11000	150	100	52	7
-45	112	-29	1500	4900	75	50	25.5	6
-45	69	-15	1500	1560	30	20	10.6	2.6
-45	56	-12	1500	360	15	10	5.5	1.9

TABLE 2

TUBE	Eb	Ec	Rm	R	CALIBRATION			
					15	10	5	0
-01-A	81	-6	3000	1260	15	10	5.1	1.3
-12-A	54	-4½	3000	1590	15	10	5.1	1.1
-26	75	-6	3000	1560	15	10	5.35	1.4
-27	75	-7½	3000	1700	15	10	5.3	1.3



# Potential Drop in High Resistances

## Vacuum Tube Voltmeter

*In measuring grid biases and plate voltages in direct-coupled amplifier work the voltage distribution must not be disturbed. A direct reading vacuum tube voltmeter, which does not require the usual calibration or specially drawn meter scale, is described in this article*

tion nearer to the operator will give a lower deflection than 15 volts to the meter. We next reduce the variable resistance R until the voltmeter reads alike in each position of the switch. As soon as success is attained, the input battery is to be changed to 9 volts, and the switch thrown back and forth as before. In general, the reading obtained on the tube voltmeter will be too low. In this event, we must change the input battery back to 15 volts, increase the B potential somewhat, and repeat the whole operation, first readjusting the resistance R to give 15 volts for each position of the double-throw switch, and then testing at 9 volts as before. A few small dry cells may be added to the B battery to give the exact B potential needed. When the circuit is properly adjusted, the meter will show 15 volts for both positions of the double-throw switch, and also 9 volts for both positions. For all combinations of tube, fixed bias, and meter that the writer has tried, there is some particular pair of values of B potential and biasing resistance that will give the direct calibration exactly.

The next thing the experimenter will want to do is to test the direct-reading tube voltmeter over the whole range. This will show that the calibration is quite precise between 9 and 15 volts, and still good enough for

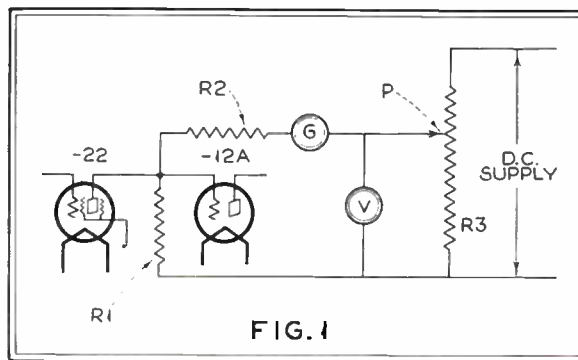

Fig. 1. A special circuit for measurements between 5 and 50 volts, when no current is to be drawn from the device being tested

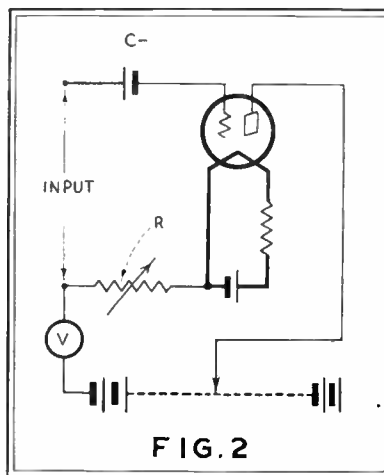

Fig. 2. Above is the circuit for using a direct reading tube voltmeter. C is the negative grid biasing battery, R the variable, and V the voltmeter

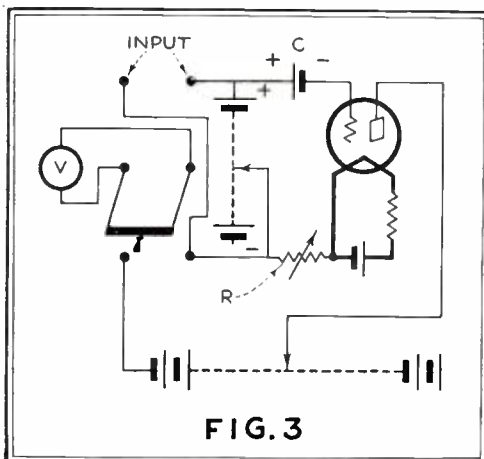

Fig. 3. A method of applying two known voltages across the input to obtain direct calibration is shown at the left

many purposes as low as 5 volts, the error being on the order of 5 per cent. too high. Below this point the error becomes considerable, due to the curvature of the tube characteristic; but this is not of much consequence, inasmuch as a lower-range meter should be used for such voltages. The best range of any meter is the upper two-thirds of the scale. Within these limits the direct-reading tube voltmeter is gratifyingly accurate. The input battery must be removed or disconnected before the tube voltmeter is put into service.

Table 1 gives a list of constants that have been found to work with a 15-volt meter having a resistance of 3000 ohms, and drawing a full-deflection current of 5 milliamperes. It will be noted that at no time is the grid of the tube allowed to go positive, for the total bias, composed of the IR drop in the resistor added to the fixed value of the C battery, is in excess of the maximum meter reading in volts. The full advantage of the tube voltmeter as a non-current-drawing instrument is thus preserved.

In this and in all of the succeeding tables, RM stands for the resistance of the meter in the plate circuit, and R for the biasing resistor.

In seeking to make further adjustments tending toward improvement of this device, the reader will find the following principles useful.

1. A decrease in the value of the biasing resistor increases the slope of the calibration curve.

2. A decrease in the grid battery potential may be compensated by a decrease in the plate battery potential, so as to leave the maximum tube voltmeter reading unchanged.

3. The grid must not be allowed to go appreciably positive.

Table 2 shows the constants found appropriate when the lowest possible grid bias was used for each tube listed. It has the double  
(Continued on page 662)

## Would You Like to Have A GOOD OHMMETER?

- That has a uniform linear scale.*
- That is self-calibrated and direct reading.*
- That has a range from 50 to 100,000 ohms.*
- That is simple and speedy to operate.*
- That can be made at a low cost.*
- That is accurate within 1%.*

If you would, then read how this serviceman made one

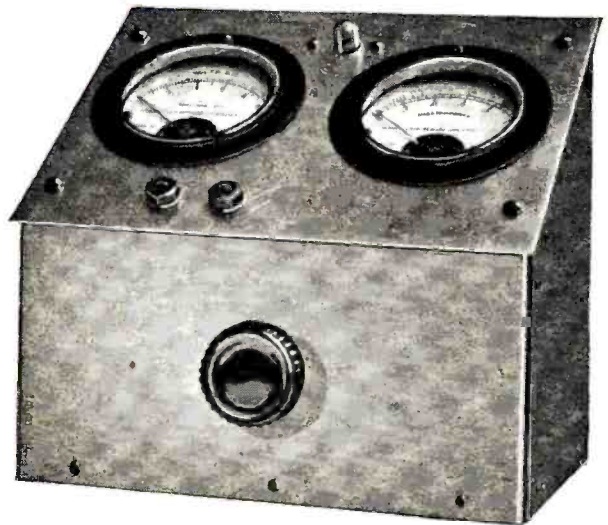

An ohmmeter built from the description below

# How to Build A Serviceman's Ohmmeter

By Alfred E. Teachman

**A** FEW years ago when resistances were rheostats and ohms were something we weren't on speaking terms with, it didn't make much difference if one possessed an ohmmeter or not. Today some questionable manufacturers seem to have come to the conclusion that to produce a good healthy receiver it is necessary to put in, for good luck, about two handfuls of resistors with values from a few ohms up to as high as sales resistance. In their ardor to do the cheapest thing at no expense some of them have overlooked the possibilities of slipping in a little break-down resistance and, as a consequence, it becomes necessary, now and then, for the serviceman to make a check-up to find out why "we can't get all the stations we used to get." Oftentimes it is found that these plucky little guardians of the current will change ohms rather than suffer the disaster of getting burned out. It is almost as common to find a resistance that has lost some of its value as it is to find one that has increased.

With resistances ranging commonly between 50 and 100,000 ohms it becomes quite a problem to the serviceman to check up on them even if we quite forget speed and accuracy. In service stations where ohmmeters are found they are usually of the continuity test type and cover only four or five thousand ohms. They cost twenty to thirty dollars and then aren't big enough for the job.

It is clear, then, that the serviceman's needs call for an ohmmeter of

very wide range. It should be fairly accurate, fast in operation, small in size and of low cost, especially the latter.

I knew that I needed such an instrument, but like many servicemen I lacked the buying power. I figured that if I was going to have anything I would have to make it myself. Right away I got the blues when I thought of having to make a calibration curve to go with my home-made substitute. It wouldn't have been so bad if I could have made a chart with a straight line calibration, but then I had never heard of an ohmmeter with a uniform scale.

After much figuring and dopping I came to the conclusion that the only way I could make a sufficiently wide range of resistance measurements with the apparatus available was by using the voltmeter and ammeter method. By this method (Fig. 1) you can find the value of an unknown resistor by dividing the applied voltage by the observed current. This is simply an application of Ohm's law;  $R = E/I$ . I had made a temporary set-up as in Fig. 1 and had made a number of measurements when it occurred to me that it would be kind of nice to have a smooth variable source of applied voltage, so that

the voltage could be adjusted until the current was an easy decimal quantity. For instance: we take an unknown resistance and connect it in position as in Fig. 2. By means of the variable voltage divider we adjust the voltage until the milliammeter reads .001 amperes. Now we ob-

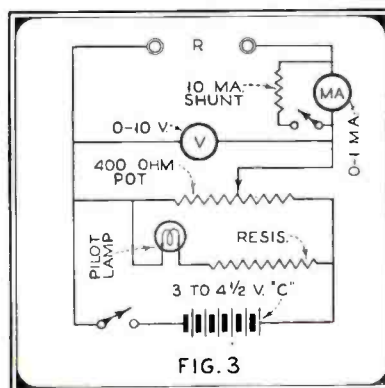

FIG. 3

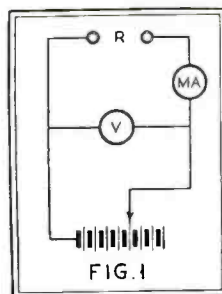

FIG. 1

Figs. 1 and 2 show various methods of obtaining variations in voltage. Fig. 3 above shows the complete circuit of the serviceman's ohmmeter as described in the text. A type of construction is suggested by the illustration in the upper right-hand corner of the page

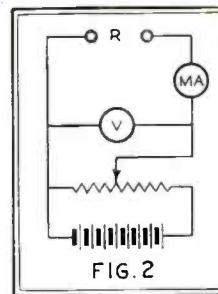

FIG. 2

~RADIO NEWS HOME LABORATORY EXPERIMENTS~

# The Vacuum Tube Voltmeter

## What It Is and How It Is Used

**I**N the study of audio and radio-frequency circuits it is in many cases impossible to use the same sort of instrument that one might use to measure the voltage of a battery or the d.c. current through the circuit or the voltage at the light socket. It is a simple matter, comparatively, to build a meter that will cover a considerable range when one works with d.c. currents or voltages, or when one works with 60 cycles. But when the exper-

imeter attempts to measure current of a million cycles and a few microamperes the problem is increased in difficulty many fold.

The vacuum tube has made possible tremendous progress in the realm of audio- and radio-frequency measurements. The tube is a simple and effective source of radio-frequency

meter across it would overload the generator! In vacuum tube circuits we frequently deal with thousandths of a watt (milliwatts) or millionths of a watt (microwatts), and obviously we cannot use ordinary instruments for measuring purposes since the power required by the instrument is large in comparison with the power we have to work with. We must therefore use a measuring instrument which consumes a negligible amount of power. Since the vacuum tube voltmeter possesses this characteristic it forms an indispensable part of every laboratory's equipment.

There are various kinds of vacuum tube voltmeters. We can build them using grid leak and condensers. Others use plate circuit detection. Some are known as amplifier-voltmeters and others as reflex vacuum

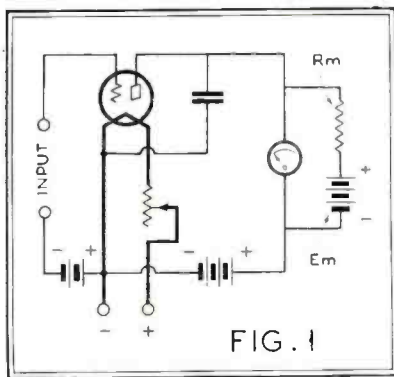

FIG. 1

and audio-frequency voltages and a similar tube used in somewhat different fashion provides a very effective means of accurately measuring these voltages. The latter tube, usually known as a vacuum tube voltmeter, is one of the laboratory's most versatile and useful instruments. It can be used to measure voltages and currents of any usual amplitude and frequency, to measure the voltage or power amplification of audio- or radio-frequency amplifiers, to measure the r.f. resistance of a coil or condenser, and for many other purposes.

The advantage of the vacuum tube voltmeter is that it has a negligible effect on the circuit to which it is connected due to the fact that it requires an insignificantly small amount of power for its operation. The importance of this characteristic can be appreciated from the following example. Suppose we wanted to measure the voltage of a generator used to supply current for lighting in a building. The generator might turn out 110 volts and perhaps 1,000 amperes. The power output of the generator would therefore be  $110 \times 1,000$  or 110,000 watts, which is the same as 110 kilowatts. We might measure the voltage with a voltmeter having a resistance of say 10,000 ohms. The power consumed by the voltmeter would then be

$$P = \frac{E^2}{R} = \frac{110^2}{10,000} = 1.21 \text{ watts}$$

Since the generator is rated at 110,000 watts and the voltmeter only consumes 1.21 watts, connecting the voltmeter across the generator will have a negligible effect. Suppose, however, that the generator only had a power output of 1 watt. Then connecting the volt-

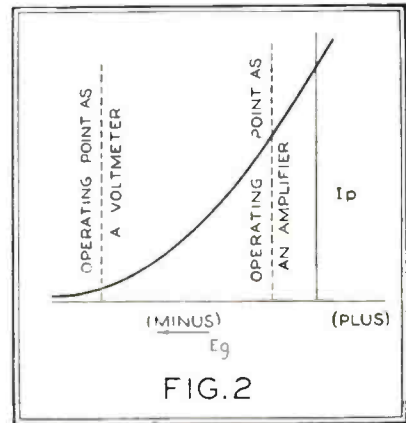

FIG. 2

In the following discussion we wish to point out the essential differences between the various types of vacuum tube voltmeters and their fields of usefulness in the hope that it may aid the experimenter to understand how they work and how they should be used.

The vacuum voltmeter using a grid leak and condenser does not find wide use in the laboratory since it does take a slight amount of power from the device to which it is connected. Although the power it consumes is much less than that taken by an ordinary d.c. voltmeter, for example, it is sufficient to effect the characteristics of many circuits. Since it has this disadvantage and is also rather unstable in operation, we will not discuss it in any further detail. We would not recommend that this type of vacuum tube voltmeter be used by the experimenter.

The vacuum tube voltmeter which finds most general use in the laboratory is indicated schematically in Fig. 1. It consists essentially of a tube supplied with grid and plate voltages, a d.c. meter in the plate circuit and a by-pass condenser between plate and filament. The a.c. voltage to be measured is placed across the input terminals and the magnitude of the voltage is determined from the reading of the d.c. meter in the plate circuit of the tube.

Obviously, if the readings of the meter in the plate circuit are to serve as indication of the a.c. input voltage to the voltmeter, it is necessary that the d.c. plate current change if an a.c. voltage is placed on the grid of the tube. If a tube is operated at its rated grid and plate voltages, no change in plate current will take place unless the tube is overloaded; it is for this

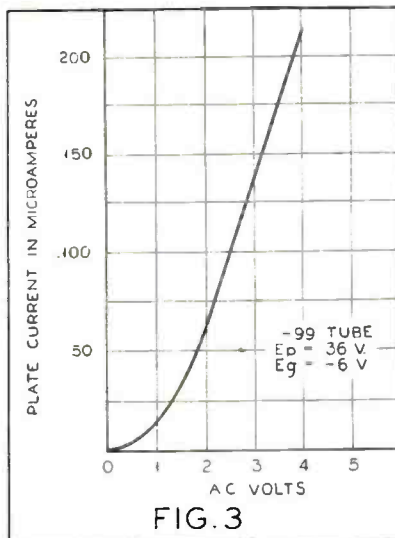

FIG. 3

reason that the fluctuations of a millimeter in the plate circuit of a power tube can be used to indicate whether or not the tube is overloaded. So long as the current remains constant the tube is not producing distortion, but if the meter fluctuates then the tube is being overloaded. In the vacuum tube voltmeter it is necessary that we so adjust the grid and plate voltages that an a.c. voltage on the grid will always produce a change in plate current. We do this by so choosing values of plate and grid voltages that the tube is operated on the lower bend of its characteristic, Fig. 2. When the tube is operated under these conditions the increase in plate current during one-half of a cycle is greater than the decrease in plate current during the other half. As a result the average plate current increases. The instrument can then be calibrated by applying various known a.c. voltages to the grid and noting the plate current reading; thereafter we can always determine the value of an unknown voltage by noting the plate current reading; thereafter we can always determine the value of an unknown reading and then referring to our calibration data to determine what input voltage would produce this value of plate current.

The calibration of the vacuum tube voltmeter has probably proven a stumbling block to many experimenters with the result that they have used the voltmeter simply to indicate comparative voltages without having any means of knowing the actual a.c. voltages applied to the grid. A calibration can be made by applying known voltages to the grid, as indicated previously, but this necessitates that instruments be available for measuring a.c. voltages of from about 0.5 up to about 3 volts, the usual range of the ordinary vacuum tube voltmeter. For this reason the following data on the method of calibrating a vacuum tube voltmeter by simply noting plate current readings will prove useful. The method was suggested by W. B. Medlam and U. A. Oswald in the November, 1926, *Experimental Wireless and Wireless Engineer* (England). Let us explain this method by using a specific example. Suppose a tube were to be used with a negative bias of minus 3 volts and a plate voltage such that the normal d.c. plate current is 10 microamperes. We want to know what the plate meter would read if an a.c. voltage of 1 volt peak (0.7 volt r.m.s.) were applied to the grid of the tube. To determine what the plate current would be we should determine the d.c. plate current when the bias is equal to the normal value minus the peak value of the a.c. voltage and the plate current for a bias equal to the steady bias plus the peak value of the a.c. voltage. Since in this case the normal bias was 3 volts we must determine the plate current for a bias of 3 minus 1 or 2 volts and for a bias of 3 plus

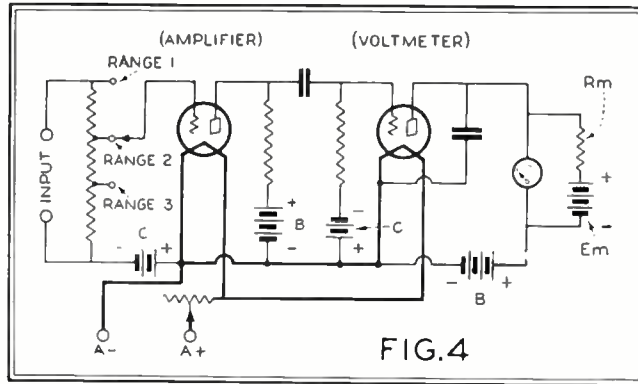

FIG. 4

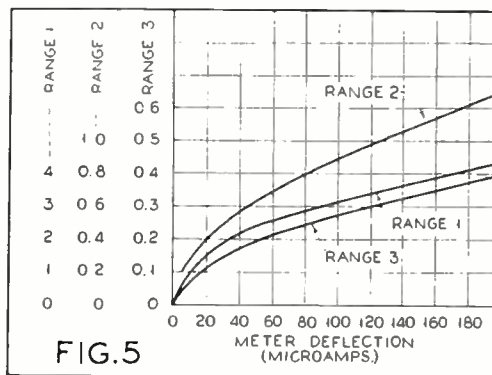

FIG. 5

1 or 4 volts. If these were measured we might find the following values:

$I_p$  for a bias of 4 volts equals 1.7 microamperes.

$I_p$  for the normal bias of 3 volts equals 10 microamperes.

$I_p$  for a bias of 2 volts equals 34.1 microamperes. The general formula for determining the plate current at any assumed value of peak a.c. input voltage is given below:

$$I_m = \frac{I_c}{4} + \frac{I_f + I_l}{4}$$

where—

$I_m$ —reading of the plate meter

$I_c$ —plate current corresponding to the steady bias on the grid

$I_f$ —plate current corresponding to the steady bias plus the peak value of the a.c. voltage

$I_l$ —plate current corresponding to the steady bias minus the peak value of the a.c. voltage

Substituting the preceding values in the general formula, we have:

$$I_m = \frac{10}{2} + \frac{34.1 + 1.7}{4} = 13.95 \text{ microamperes.}$$

By actually applying an a.c. voltage having a peak value of 1 volt to this tube it was found that the plate meter read 14 microamperes, which is in very close agreement with the calculated value. Therefore by using this comparatively simple method it is possible for the experimenter to calculate the calibration curve of a vacuum tube voltmeter of the type shown in Fig. 1 simply through the use of the d.c. voltmeters and milliammeters which he probably has available. These calculations should be made for a number of assumed values of peak a.c. voltage after which a curve can be plotted showing the plate current for various a.c. voltages. The general form of the calibration will be the same as is indicated in Fig. 3, which is the calibration curve for a type 199 tube with a plate voltage of 36 volts and a steady d.c. negative bias of 6 volts.

The ordinary vacuum tube voltmeter such as is indicated in Fig. 1 cannot be used with accuracy for the measurement of voltages less than about 0.5 volt. Of course the lowest voltage which can be accurately measured depends upon the sensitivity of the meter in the plate circuit, but even with a meter having a range of 200 microamperes the curve of Fig. 3 shows that but slight deflections are obtained with input voltages in the order of 0.5 volt. To obtain greater sensitivity, i.e., to be able to accurately read voltages below about 0.5, a (Continued on page 649)

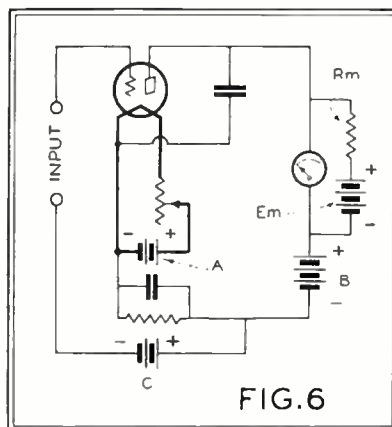

FIG. 6

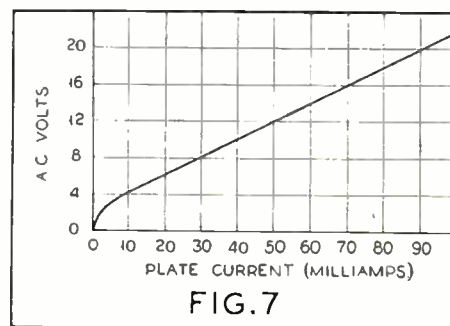

FIG. 7

# NEWS from the MANUFACTURERS

## Short-Wave Adapter

The J-M-P Manufacturing Company, Milwaukee, Wis., has brought out a short wave adapter known as the "Submariner" which may be used attached to any receiver by inserting its plug in place of one of the tubes. A tube is put in the



socket at the top of the adapter and the aerial is removed from the set and attached to its antenna post. The "Submariner" is designed to operate with an aerial because loops cannot tune below 200 meters.

This adapter is made in several models, making it available for use with any type of radio, a.c. or d.c. The instrument is 5½ inches wide by 6½ inches deep at the base, by 7 inches high. A slow motion tuning dial has a ratio of 64 to 1.

## Walker Super-Converter

The Workrite Radio Corporation, 1812 East 30th St., Cleveland, O., announces the George W. Walker Super-Converter (Model No. 4), an adapter for converting a radio receiver into a short wave superheterodyne.

With this converter it is only necessary



to plug into the electric light socket, disconnect the antenna from the a.c. or battery r.f. receiver, and attach same to the converter. A wire connection is then made from the converter to the antenna post of the receiver. This is a four-tube converter requiring a stage of screen-grid radio frequency ahead of the detector. The tubes needed are one No. -24, two No. -27 and one No. -80. Both tuning

and oscillator condensers are ganged and controlled by a vernier dial insuring simplicity and ease of operation.

The converter is especially designed to cover a wave band of 15 to above 200 meters. One of the coils furnished with it covers the wave band of 15 to 50 meters. The converter measures 7 inches, by 7 inches by 12 inches long.

## Polyphase Electric Pick-up with Tone Control

The Audak Company of New York announces a new polyphase electric pick-up with tone control. The entire line of pick-ups made by this company can be obtained, if desired, with new tone control as an integral part of the unit. Tone control, which has been based on pick-up has three settings—permitting the emphasis of the low, middle or the upper



ranges. By merely shifting contacts it is possible to vary and control tone of the electrically reproduced record to the exact taste of the listener. Control is accomplished by building up the registers desired at their source of energy and the other registers retain their full value and are not muted.

## Grooming Television for the Living Room

Although only recently emerged from the secrecy of the research laboratory, radio television or radiovision now frankly bids for a place in the living room, alongside the usual sound broadcast set. Utmost simplicity of operation, self-contained equipment, compact dimensions, and socket-power operation, make for the attractiveness of radiovision, now that regular programs are on the air in many localities.

Studying the problems of radiovision reception in the home, the engineers of the Jenkins Television Corporation of Jersey City, N. J., have endeavored to provide equipment for the lay operator. Therefore, automatic synchronizing means have been introduced, so that the scanning mechanism of the receiver remains in automatic step with that of the transmitter. Instead of depending on an a.c. power system common to both receiver and transmitter, which would greatly limit the area served by any television station, the engineers have developed a synchro-

nizing method based on the signals themselves. Again, instead of a tricky short-wave regenerative receiver, which not only introduces distortion but curtails detail to a marked extent, the engineers have developed a simple non-regenerative receiver, especially designed for radiovision work, operated on the usual a.c. supply.

The latest Jenkins radiovisor, known as Model 300, is contained in an attractive cabinet. The front carries a large and specially corrected magnifying lens, which, in combination with another lens inside the deep shadowbox, permits of showing the pictures to several persons at a time. Below the lens is the switch panel, with one switch to start and stop the motor, and the other to switch from pictures to loud speaker in following the radiovision program. To the right is the speed adjustment for bringing the scanning disc in perfect step with the transmitter, after which the automatic synchronizer maintains correct speed. On the right-hand side are the framing devices.

A 60-cycle eddy current motor supplies



most of the power to drive the radiovisor scanning disc. The synchronizer is used to keep the disc in perfect step with the distant transmitter, applying the slight acceleration or braking, as the case may be. This device is a phonic motor, operating on the strong 720-cycle (48 x 15) scanning frequency present in the usual 48-line, 15-pictures-per-second radio vision signal. It comprises a toothed rotor on the drive shaft of the radiovisor, together with an electromagnet or field coil furnished with 720-cycle energy by means of an extra amplifier in the radiovision receiver. This signal component is filtered out, amplified and fed to the phonic motor field.

A notable improvement has also been scored in the special neon or television lamp employed. Instead of a large plate lamp, as in previous models, the new Jenkins radiovisor employs a lamp with a small plate, which permits of consider-

(Continued on page 638)



*A department devoted to the presentation of technical information, experimental data, kinks and short-cuts of interest to the experimenter, serviceman and short-wave enthusiast*

*Conducted by George E. Fleming*

**W**E wonder just how many of you readers are following the "dope" on the Stenode Radiostat that has been appearing in RADIO NEWS. If you haven't, we would certainly suggest that you dig up the last two or three issues and look it over, because you are being let in "on the ground floor" of something good. Here in the laboratory we are accustomed to seeing unusual things accomplished by our contemporaries, but frankly we were just a little dubious of anything that sounded as good as the advance information did. However, the Stenode has arrived in America, and the visiting engineers are making themselves at home in our laboratory. The other afternoon they asked us to lend them a typical American receiver that was what we call selective, and a radio-frequency oscillator. We complied with both requests and stood around to see what was going to happen.

First they hooked up the receiver and tuned in a signal from one of our medium-powered broadcast receivers, and then turned on the oscillator and adjusted the output from the oscillator until it was equal in intensity to the signal from the transmitting station. Then we were asked to give them, on a loudspeaker, a signal of

### *A New Laboratory Service for You*

*IN keeping with our policy of serving our readers, we announce that a recent acquisition of additional precision laboratory apparatus makes it possible for us to undertake practically any type of experimentation, research or quantitative measurement work that might be required by any of our readers in the development of their ideas.*

*To custom set builders and to small manufacturers we can supply curves or take any quantitative measurements on apparatus submitted, at very reasonable prices.*

*It is our firm belief that the future of radio lies as much in the hands of the experimenter and the short-wave fan as it does in the laboratories regularly engaged in development work. We wish to be as helpful as possible to the man who is without the facilities of a large laboratory but who has real ideas, and as we have expressed it before, we want you to feel that the RADIO NEWS Laboratory is your laboratory.*

EDITOR.

two signals as cleanly as you please, with no trace of the interfering signal. The proof of the pudding, in this instance, was certainly in the listening, and we must say that we predict a tremendous success for the Stenode.

### *The Automatic Volume Control*

You were asked last month to tell us about any interesting experiments that you might have performed on automatic volume controls. At the time of this writing, which is before the December issue is out, we naturally have gotten no response to this request. However, our experiments have gone forward along certain lines, and we think that we have such a device that will do just about everything that can be expected from an automatic control. There are some wrinkles to be ironed out, but we hope by next month to be able to give you all the data on it.

However, don't let that stop you from sending in your ideas on the subject. It will make for interesting discussion, and there is every possibility that your ideas are better than ours. In the meanwhile, we do want to present a very interesting type of bridge circuit that makes one of the smoothest manual controls we have ever seen. Looking at Fig. 1 we see a

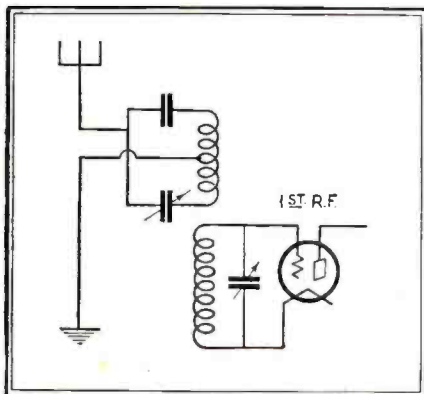

Fig. 1

150 cycles from our audio oscillator. This we did, and they calmly proceeded to adjust the radio-frequency oscillator until the output from the receiver was a beat note of the two signals of 150 cycles, and the audio oscillator was turned off. Now we had, in effect, two transmitters 150 cycles apart.

The first intimation that we had that they were amusing themselves at our expense came when we were asked to try to separate the two signals by tuning the receiver. Being accustomed to "10 kilocycle separation," we naturally replied that it was impossible. "Not at all," we were told; "listen." Turning to the Stenode, they proceeded to separate the

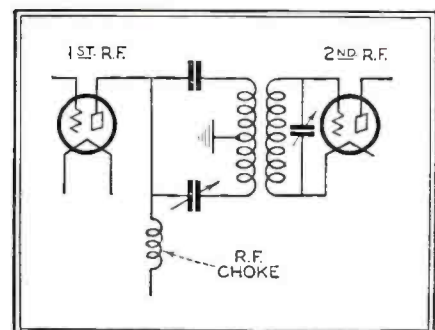

Fig. 2

simple Wheatstone bridge circuit, in which two of the branches are inductances and two are capacities. When this circuit is in balance, no voltage is developed across the coil, so no signal is passed along to the tuned circuit coupled to it. If this circuit is used in the antenna circuit, the coils should be about ten turns each. To get the proper polarization, they may be one continuous coil, center tapped. The condensers may be 150 to 220 mmfd., one fixed and the other variable. The variable may be of midget size. If the two condensers are identical, maximum volume will be obtained at the minimum setting of the variable condenser. If the two are not matched, minimum volume may be had at some other point other than at maximum setting of the variable, so it is obviously advantageous to have them matched. Fig. 2 shows the same system used interstage.

**Distributed Capacity in Coils**

Not infrequently we find that upon completion of a radio receiver the tuning circuits do not cover nearly so much of the spectrum as we had figured they would. This comes from the fact that the coils have various capacities shunting them that had not entered into our figures, such as capacity between leads, minimum capacity in tuning condensers, and distributed capacity in coils.

We may easily find out from the manufacturer just what the minimum capacity of a tuning condenser happens to be, and take that into our calculation, and we can reduce the capacity between leads to a very small amount by proper placement, so we have left only the distributed capacity of the coil.

This distributed capacity may easily be figured, however, if we use a simple method that we have used for a long time in the laboratory. The only apparatus necessary is a carefully calibrated condenser and a calibrated oscillator. Referring to Fig. 3, we see that the coil is actually shunted by a small capacity, due to the distributed capacity. The condenser in heavy lines is the calibrated condenser. What we want to measure is this small capacity, Xc.

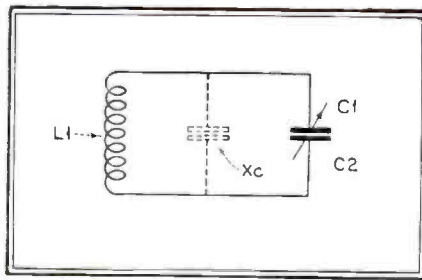

Fig. 3

Set the oscillator at a low wavelength, say 300 meters, and tune the coil with the calibrated condenser to resonance. If the oscillator is of the grid dip type this will be easy. Carefully note the capacity necessary to accomplish this tuning, and call it C1. Now set the oscillator at 600 meters, and again tune the coil to resonance at that wavelength, and call this capacity C2. Solving this equation, Xc

***I**n asking questions of our Technical Information Department two types of questions are considered. Our method of charging for this service is as follows:*

*No charge for any question regarding the list parts to be used in any unit actually described in RADIO NEWS, or where they may be procured.*

*No charge for any subscriber's question except where the answer requires more than an ordinary amount of research and in such cases we will advise you what the charge is to be before going ahead with your reply.*

*A charge of \$1.00 for all technical questions regarding hook-ups, service, etc., received from non-subscribers with the same exception in connection with questions entailing more than ordinary research.*

$$\text{equals } \frac{C2 - 4C1}{3} \text{ and we find the distributed capacity.}$$

It is easy to see why this formula holds when we consider the fact that when we tune a coil by a condenser to two wavelengths, one being twice the other, four times the capacity is necessary. However, due to the distributed capacity, in tuning a coil we have two capacities, one of which remains fixed. So to tune the coil we must use four times as much capacity on the tuning condenser plus three times the distributed capacity, to obtain resonance at double wavelength.

**Short-Wave Antenna System**

We are indebted to Mr. C. M. Luchessa, of Modesto, California, for the following short-wave antenna scheme that ought to prove a boon to our city-dwelling hams.

The majority of amateurs live in the city, where the backyard space available permits the erection of only one suitable antenna. Many of these amateurs desire to operate on more than one frequency, consequently one antenna must function properly on every allotted frequency band.

The arrangement illustrated by the diagram, Fig. 4, has been in use at the writer's station for over a year, and it has worked remarkably well.

The antenna is a 40-meter half-wave radiator of the Zeppelin type, with feeders 33 feet long and a flat-top radiating portion of 66 feet. The feeders are tuned by .0005 condensers and a system of switches provides either a series or a parallel tuning arrangement.

When a series connection of the condensers is desired SW1 is opened, putting C1 in series with the feeder. SW2 is thrown to B, connecting C2 in series with the other feeder. When the condensers are to be connected in parallel with the inductance, SW1 is closed, shorting out C1, and SW2 is thrown to A, which switches C2 across the inductance.

The following table gives the arrangement for different bands:

Band	Condenser Arrangement
10	Series
20	Parallel
40	Series
80	Parallel

**The All-Purpose Clicker**

An instrument of inestimable value for use by the radio serviceman, the research man, the electrician, the automobile mechanic—in fact, by anyone dealing with electrical circuits—is the all-purpose clicker to be described in this article. It will measure the continuity and, with reasonable accuracy, show the resistance of the circuit whether it be one ohm or five hundred thousand ohms—without the use of complicated switching arrangements and with only a 4½-volt "C" battery as a power supply. It requires no standard resistances or instruments for calibration purposes—the instrument can be constructed and calibrated entirely from the following information.

- The parts required are as follows:
- 1 d.c. milliammeter, 0 to 1 ma. (Weston model 301 or equivalent).
  - 3 jacks—which close a circuit when the plug is entered.
  - 1 plug.
  - 1 carbon or other resistance—5,000 ohms.
  - 1 carbon or other resistance—1,000 ohms.
  - 1 4½-volt "C" battery (new).
  - 1 panel and case.
- (Continued on page 657)

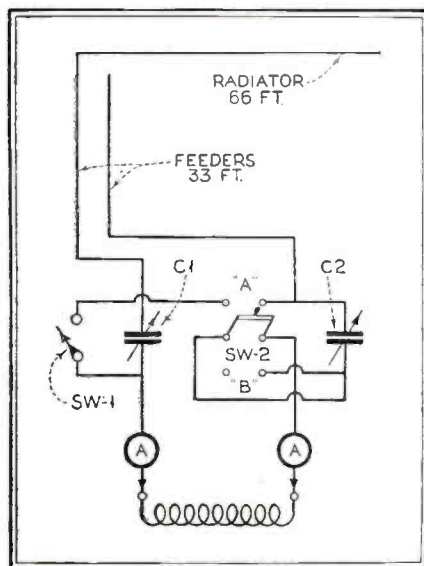

Fig. 4

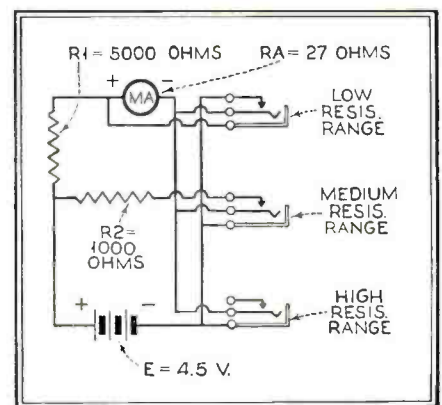

Fig. 5



# The Junior Radio Guild



LESSON NUMBER SIXTEEN

## Using Mathematics in Radio

PART TWO

**T**HE multiplication of simple numbers in the order of 13 x 6, or 25 x 14 and similar products is well taken care of by the straight long band method, but it is easily appreciated that when numbers are involved which include two or more places beyond the decimal that considerable time may be involved to obtain the corresponding answer.

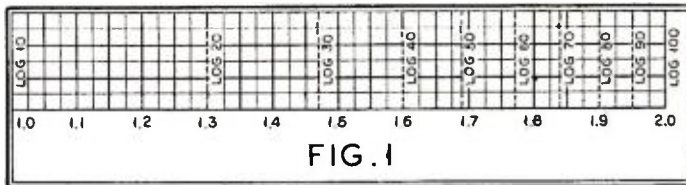

FIG. 1

### The Slide Rule

The slide rule is a labor-saving device and there are numerous occasions where we shall be considering the various constants of the elements in a radio system, and their relationships involving multiplication and division. The use of a slide rule will materially decrease the time required for solving the problems.

It is the purpose of this text to bring out forcibly the understanding of the necessary mathematics as used in radio in order to appreciate a little more clearly the fundamental designs, construction and operation of radio receivers. For, after all, in the final analysis, the student desires to be acquainted with a sufficient amount of information along electrical and mechanical designs to warrant him to form his own judgment as to the soundness of certain developments. In the text will doubtless be encountered new expressions and new ideas to the student which may at first have a foreign meaning, but all of these will have some direct bearing on radio, and will be brought forward to show their importance.

As a means of introducing the principle of the slide rule, let us operate in the common number 10. It is well to keep in mind always that mathematics is primarily one of operating in certain functions, changing their relations so that new ideas can be formulated. We have:

- (A)  $10 \times 1 = 10$
- (B)  $10 \times 10 = 100$
- (C)  $10 \times 10 \times 10 = 1,000$
- (D)  $10 \times 10 \times 10 \times 10 = 10,000$

We may express (B) as:  
 $10 \times 10 = 10^2$   
 which is equal to the square of 10.

Similarly, (C) as:  
 $10 \times 10 \times 10 = 10^3$   
 which is equal to the cube or third power of 10. And (D) as:

$$10 \times 10 \times 10 \times 10 = 10^4$$

which is equal to the fourth power of 10.

Now we can introduce the proper name into mathematics, that of "logarithms," which simply means that "a logarithm is an exponent." Thus:

- for  $10^2$ , 2 is the exponent
- $10^3$ , 3 is the exponent
- $10^4$ , 4 is the exponent

Then we can say:

- from (B) the logarithm of 100 = 2
- (C) the logarithm of 1,000 = 3
- (D) the logarithm of 10,000 = 4

Therefore, from (A) the logarithm of 10 = 1.

Now it is interesting to note that for numbers between 10 and 100 that the logarithm must necessarily be some value between 1 and 2, and will probably take some values, such that if:

- $\log 10 = 1$
- $\log 30$  might be 1.47
- $\log 60$  might be 1.77
- $\log 90$  might be 1.95

Since mathematics is such an old art, and the theory of logarithms has been in use for so many decades, certain mathematical tables have been prepared for the use of students in order to save time and shorten the labor involved. Referring to such a logarithmic table, it will be of interest to show graphically the divisions taken for the logarithms from 10 to 100. Referring to Fig. 1, we have seen that  $\log 10$  (read as the logarithm of 10) = 1 and the  $\log 100 = 2$ . Drawing vertical lines to indicate this, we will expect that the logs of 20, 30, etc., will take some values between 1 and 2. Let us refer to a logarithm table, and we find the following values:

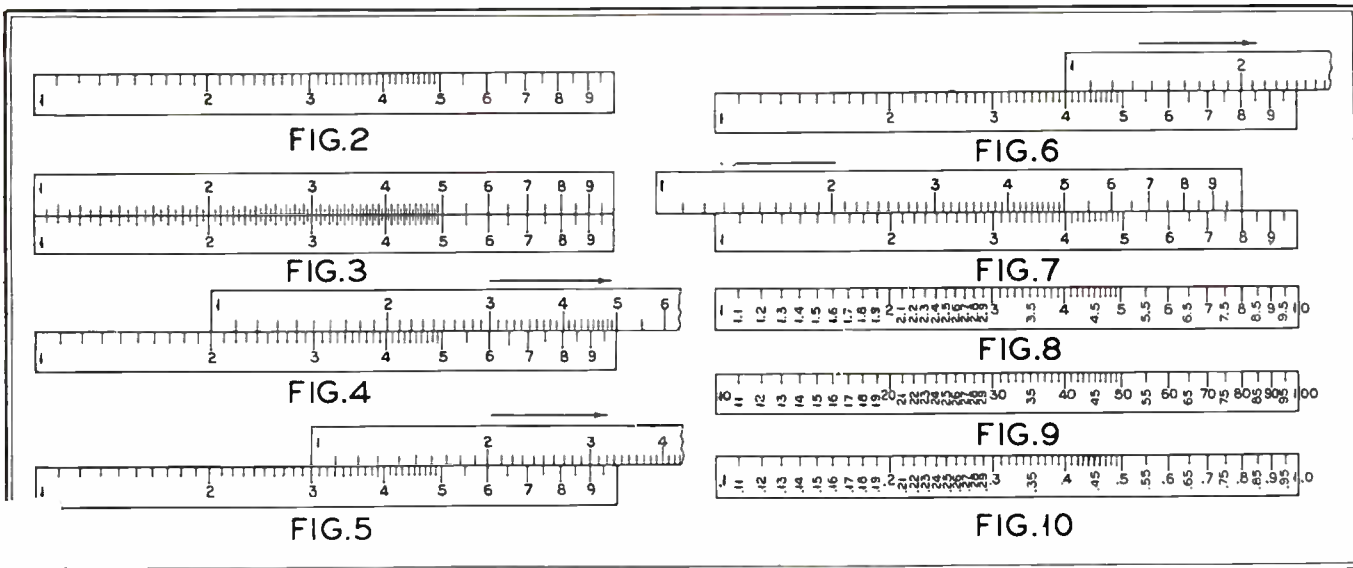



- log 10 = 1.00
- log 20 = 1.30
- log 30 = 1.47
- log 40 = 1.60
- log 50 = 1.69
- log 60 = 1.77
- log 70 = 1.84
- log 80 = 1.9
- log 90 = 1.95
- log 100 = 2.00

The dotted vertical lines show graphically this relationship. The purpose of showing such a graph is to point out that instead of using a uniform scale it is sometimes very advantageous to refer to a logarithmic scale and such a scale is shown in Fig. 1. Let us refer to a similar scale shown in Fig. 2 and divide each main part into 10 equal parts. We now have the working principle of a slide rule.

By placing two such scales, one above the other, as shown in Fig. 3, so that the top scale can be moved either to the right or left, we will find which can be performed. Let us move the top scale to the right so that the left-hand index comes directly over the 2 of the lower scale, as shown in Fig. 4. It is important to note that directly under the following numbers, 2, 3 and 4 on the movable scale, appear the numbers 4, 6 and 8, respectively, on the lower scale. In other words, since the movable scale is set on 2, we can find that the product of  $2 \times 2$  is found by referring to the 2 on the movable scale and noting the result directly below. Thus,  $2 \times 3 = 6$  and  $2 \times 4 = 8$  is found readily by just one setting of the slide rule.

Again, if it is desired to multiply  $3 \times 2$  or  $3 \times 3$  it is seen that by one setting of the slide rule, as shown in Fig. 5, the results are easily obtained. Likewise, in order to find the product of  $4 \times 2$ , further adjustment of the movable scale as indicated in Fig. 6 is necessary.

Now it is evident that it may be necessary to place the movable scale of the rule to the left as well as to the right and we find that this is so when we attempt to multiply  $8 \times 5$ , as indicated in Fig. 7. By placing the right-hand index of the movable scale so that it comes directly over the 8 of the lower scale, we note that directly under 5 is the numeral 4, and therefore the product is 40.

This brings us to the point that we may consider the scale of Fig. 2 in such a manner that the main divisions can be assigned any number of arbitrary values.

1. It can be considered in units as 1, 2, 3, etc.
2. It can be considered in tens as 10, 20, 30, etc.
3. It can be considered in hundreds as 100, 200, 300, etc.
4. It can be considered in thousands as 1,000, 2,000, 3,000,

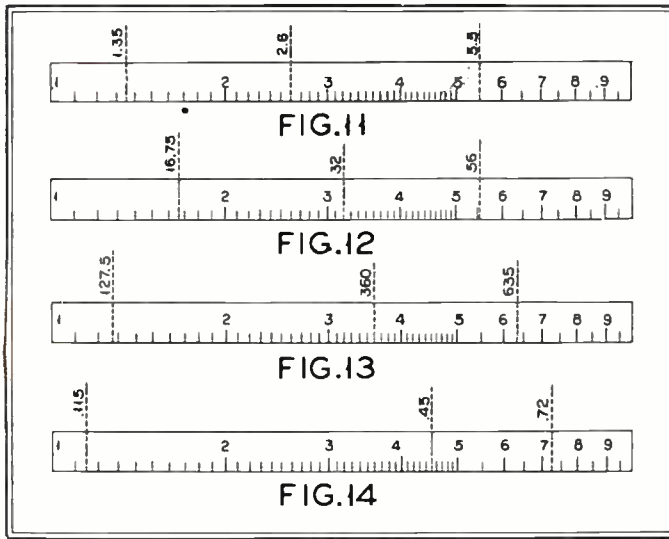

- etc., or corresponding higher values, and
5. It can be considered in decimals as .1, .2, .3, etc.
6. It can be considered in hundredths as .01, .02, .03, etc.
7. It can be considered in thousandths as .001, .002, .003, etc., or any corresponding lower values.

In addition, each main division may be divided into equal parts, and these integral parts subdivided so that any degree of accuracy can be obtained.

Thus the scale of Fig. 8 can be read as 1, 2, 3, etc., in which case the subdivisions will take the values 1.1, 1.2, 1.3—2.1, 2.2, 2.3—3.1, 3.2, 3.3 and similarly throughout the rest of the scale.

Likewise, the scale of Fig. 9 can be read as 10, 20, 30, etc., in which case the subdivisions will take the values 11, 12, 13—21, 22, 23—31, 32, 33, etc. Again, the scale can be read as .1, .2, .3, etc., in which case the subdivisions will take the values .11, .12, .13—21, .22, .23—31, .32, .33, etc., as indicated in Fig. 10.

**Division by Slide Rule**

We have seen that numbers can be readily multiplied by the slide rule and this will be more appreciated when we shall find it necessary to multiply such numbers as  $3.1416 \times 800$  and similar products. Division of numbers can be as readily applied to the slide rule, for division may be considered as simply a reverse operation of multiplication. Referring to Fig. 4, let us desire to divide 6 by 3 and we see that if we place the 3 of the movable scale over the 6 on the stationary scale that we obtain the answer under the left-hand index of

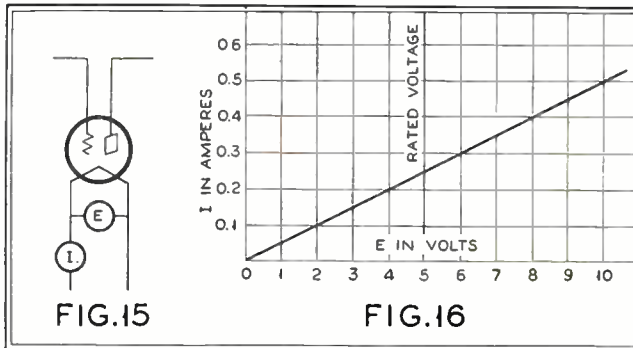

the movable scale as 2. Likewise, by referring to Fig. 5, let us divide 9 by 3, and we see that the answer is obtained under the left-hand index as 3. Again, by referring to Fig. 7, in order to divide 40 by 5, we find the answer in this case to be under the right-hand index of the movable scale as 8.

There are two rules in the operation of the slide rule which determine the position of the decimal place and these are stated as follows:

a. For multiplying:

1. When the slide is to the left, the number of significant figures or digits in the answer is equal to the sum of the number of digits of the two numbers. (Continued on page 660)

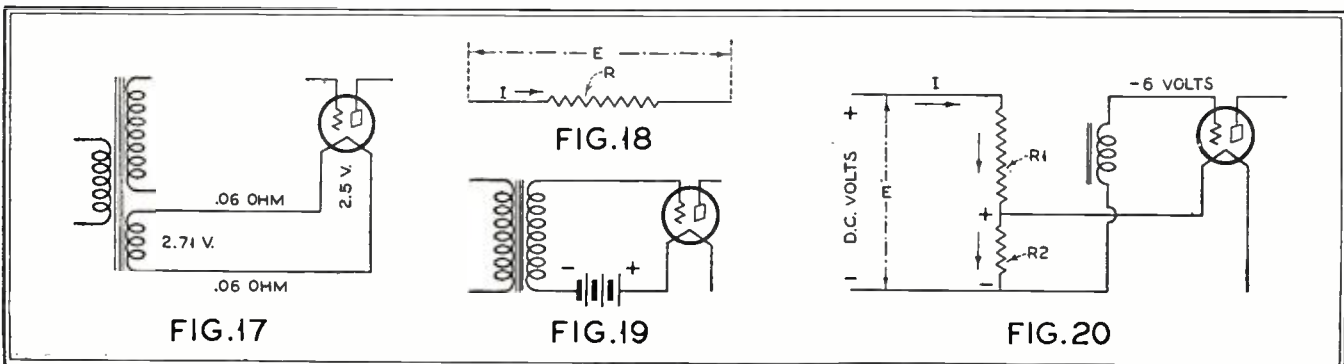

# RADIO NEWS INFORMATION SHEETS

## Figuring Voltage Divider Resistors

**F**IGURING the proper resistors to use to get various voltages is one of the simplest and yet most confusing problems met by the experimenter. However, it is merely an application of Ohm's law and really should cause us no trouble.

To begin with, we must decide just what amount of bleeder current we desire to use. It is always advisable to use a certain amount of this current, although it is energy wasted, for tubes will vary slightly, and it is this apparently wasted current that keeps our voltages constant. Ten milliamperes is usually a good value to use.

Let us take a specific problem to solve, and remember that all other instances will be the same, except for different values of current, and consequently different values of resistance. Suppose we have, for instance, a source of voltage of 300 volts, as we will have in most -45 power packs, and we wish to get 135 volts for three radio-frequency tubes and a power detector, and also  $67\frac{1}{2}$  volts for the screen-grid voltage of the radio-frequency tubes, and we have decided to use 10 milliamperes as the bleeder current. Now the first thing to do is to ascertain the current drain at each position. Data sheets furnished us by tube manufacturers indicate that at this voltage screen-grid tubes will draw about three milliamperes on the plate

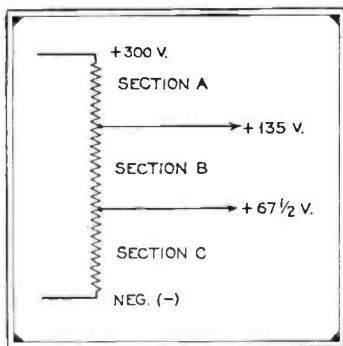

and about 1 milliampere of screen current per tube. The power detector will take about 1 milliampere plate current.

Section A of our resistance bank will carry all of this current, 9 ma. plate, 3 ma. screen, 1 ma. detector and 10 ma. bleeder, or a total of 23 ma. current. Three hundred minus 135 gives us the voltage drop desired, or 165 volts drop. Ohms law tells us that R is equal to E (volts) divided by I (current). To avoid using decimal fractions when dealing with milliamperes, multiply the volts by 1,000 and use milliamperes as a whole number instead of a decimal frac-

tion. So our solution is R is equal to 165,000 divided by 23, or 7,174 ohms. Now for section B. Here we have the difference between 135 volts and  $67\frac{1}{2}$  volts to drop, or a desired drop of  $67\frac{1}{2}$  volts. We no longer have the 9 ma. plate current of the radio-frequency tubes, nor the 1 ma. detector current, as that has been disposed of, so we have left 13 ma. current. R in this case equals  $67,500$  divided by 13, or 5,192 ohms. Section C is only carrying the bleeder current of 10 ma., and the drop across it is again  $67\frac{1}{2}$  volts. So R equals  $67,500$  divided by 10, or 6,750 ohms for section C.

By following this general method, proper resistors may be figured for any voltage and current. As stated above, ten milliamperes will usually keep the voltage constant.

# RADIO NEWS INFORMATION SHEETS

## By-passing (Part I)

**N**O item in the design of a receiver is more important than the use of proper values of by-pass condensers. Economy dictates that by-pass condensers be as small as possible, while electrical consideration says otherwise. At some place must a compromise be struck, so it has become practice among engineers to use a condenser whose reactance is one-tenth that of the resistance or reactance that it may be used to by-pass. Repeated experiments have shown that this is a perfectly good compromise, and efficient by-passing will be accomplished when such values are used.

Taking four typical examples, let us consider the requisite size of condenser to be used in each case. Fig. 1 shows resistance to be by-passed, so let us give it a value of 10,000 ohms, for instance. As the reactance of a condenser increases with frequency, we must take the lowest frequency to be by-passed and predicate our results on this frequency. Suppose we say 120 cycles as the frequency, as this is a common value found in power packs.

The formula for finding the reactance of a condenser is

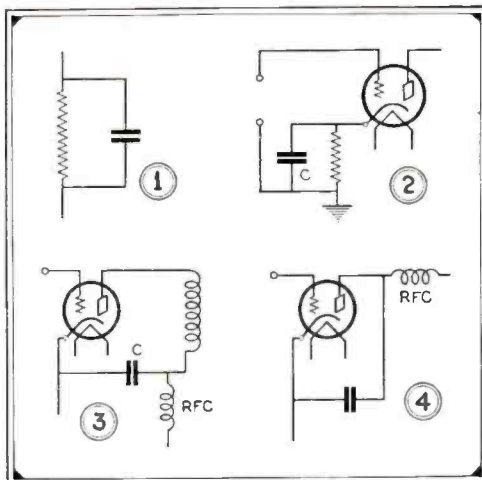

$$\frac{1,000,000}{2\pi F C}$$
 where the size of the condenser is expressed in microfarads, F is the frequency and pi is 3.14. Now if the resistance to be by-passed is 10,000 ohms, the reactance of the condenser must be 1,000 ohms to satisfy our original premises, so the formula becomes C equals  $\frac{1,000,000}{2\pi F X_c}$  when

$X_c$  is the capacitive reactance. Solving the equation, after substituting the known values, we get C equals 1.46 microfarads.

Fig. 2 is a bias resistance in the cathode circuit of a tube, and the solution is exactly as before, except that the frequency is different.

If this tube happens to be in one of the audio stages of a receiver, we will have to estimate the lowest frequency passes by the amplifier. Thirty cycles is a safe choice. However, if this tube happens to be in the radio-frequency end of the receiver, 500,000 cycles will be the figure. A little figuring will show that at radio frequency the by-pass may be very much smaller than at audio frequency. Part II will appear next month.



# WHY NOT GRASP SUCCESS?

## Study radio in your spare time at home

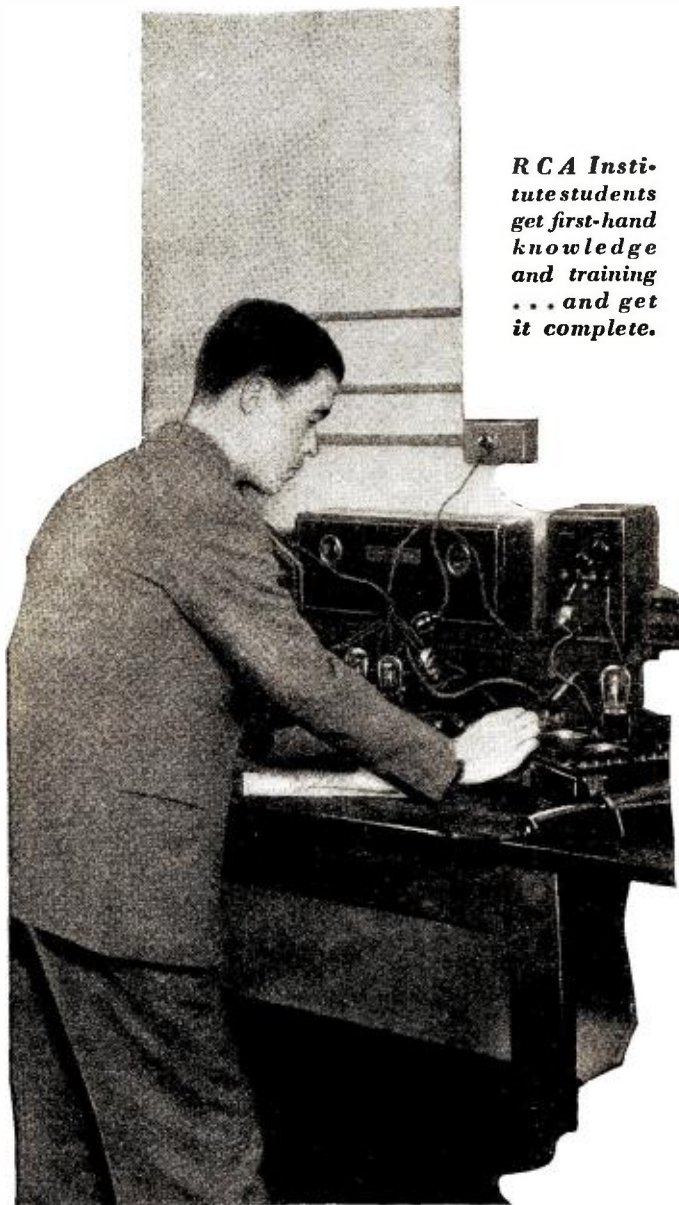

**RCA Institute students get first-hand knowledge and training . . . and get it complete.**

**A**RE you satisfied with the position you now hold? Do you feel that you're worth more money? Are you pleased with yourself, your work, your associates . . . and your future? What does next year hold for you . . . and the year after that?

Are you content to merely plod along through the best years of your life . . . or do you want to get into far pleasanter work . . . meet more interesting people . . . and hold a well paid position?

The ambitious man ties his future to an industry that's developing rapidly . . . that's going *up and up!* Your life lies before you . . . will it be a losing game or a profitable adventure? . . . Will you **GROW** with a **GROWING BUSINESS** or will you waste your life and opportunities in an industry that is already fighting a losing battle?

If you are looking for a **REAL** opportunity . . . if you want to make the most of your life . . . to grasp the success that should be yours, *then we say to you, "Study Radio."*

Everyone knows that Radio is the fastest growing industry in the world today . . . countless opportunities are waiting for men who have the training and ability to grasp them. Where have you heard of any business that has developed as fast as this? Radio needs *trained* men and needs them **NOW!** *Think of the future Radio offers you!*

You can easily obtain the training you need under the direction of RCA Institutes, a division of Radio Corporation of America, which thoroughly trains men in every branch of radio and also assists them in obtaining employment. You learn radio by actual experience on the very latest types of radio equipment. You study under the direction of nationally known experts. You can learn all about radio servicing and selling, ship operating, shore station operating, radio telephony and telegraphy, and airplane radio equipment . . . also instruction in sound motion picture installation, maintenance and repair!

### **Study at Home in Your Spare Time**

The RCA Institutes complete Home Laboratory Training Course gives you all you need to know about radio. The lessons are of absorbing interest . . . easy to learn. You rapidly progress, step by step . . . and you receive absolutely free the complete RCA Institutes Laboratory Equipment, a modern outlay of apparatus furnished to every student . . . enabling you to easily solve radio problems. This is the way for you to acquire, in your spare time, the commercial knowledge and ability that command good pay.

### **Home Training Course By America's oldest and foremost Radio training organization**

This home training course and free laboratory equipment are backed by more than 20 years' experience. A signed agreement by RCA Institutes assures you of absolute satisfaction . . . furthermore, if after taking this course you are not satisfied in every way, your money will promptly be returned to you.

### **Read this free book**

Everything you want to know about Radio . . . Describes in detail the home training that has placed thousands of men in good paying positions. Forty fascinating pages of pictures and text all about radio.

RCA INSTITUTES, Inc.  
Dept. EX-1  
75 Varick St., New York, N. Y.

Gentlemen: Please send me your big FREE 40-page book which tells about the many opportunities in Radio and about your famous laboratory method of radio instruction at home.



**Mail this coupon NOW . . . start on the road to success in radio TODAY!**

Name .....

Address .....

Occupation .....

# READ HOW YOU CAN DO IT

## Study radio in the finest equipped schools in America

In order to make it easy for you to study radio, RCA Institutes has opened six completely equipped schools throughout the country . . . at New York, Chicago, Boston, Baltimore, Philadelphia and Newark, N. J. Each of these six schools has the very last word in radio equipment. They all offer exactly the same training in day or evening classes . . . you study under the personal direction of RCA experts. In this way you learn at the very heart of radio itself, because you study under the direction of RCA . . . the great corporation that sets the standards for the entire radio industry. The very progress of radio is measured by the achievements of the famous engineers in the great research laboratories of the Radio Corporation of America.



*You get commercial training that prepares you for success in radio.*

### Only training course

sponsored by Radio Corporation of America

Graduates of these schools are thoroughly posted in all the very latest developments, the newest inventions and greatest discoveries in radio, because they study in the finest equipped schools in America.

That's what RCA Institutes does for you . . . that's the kind of training you want . . . the practical, thorough knowledge that you need for success in radio.

### Opportunities for Trained Men

Graduates frequently obtain positions shortly after graduation. Every graduate receives the thorough training that gives him the knowledge and the confidence to hold a good paying position.

### Come in today . . . See for yourself!

Step into the nearest school and then you will know why it is that thousands of men have acquired the training that has enabled them to occupy well paid positions in radio. Meet the instructors, talk to the students, examine the equipment . . . convince yourself . . . See what radio can offer you, and what RCA Institutes can DO for you. We will be glad to meet you . . . glad to explain everything . . . to show you everything . . . without the slightest obligation on your part! Come in today and get a copy of our free book, or send for it by mail. See what our course has done for others and what it can do for you!

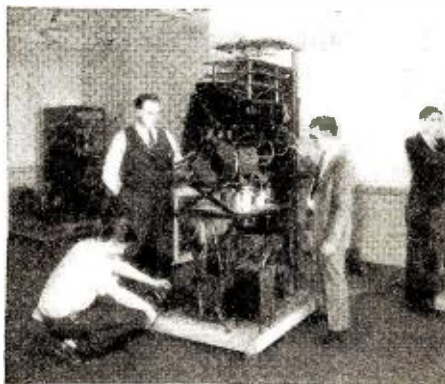

#### BOARD OF MANAGERS OF RCA INSTITUTES, Inc.

The names of these men are known throughout the world as the greatest names in radio. Their experience will guide you in your training

Chairman of the Board  
**GENERAL JAMES G. HARBORD**  
Chairman of the Board  
Radio Corporation of America

President  
**RUDOLPH L. DUNCAN**

Vice-President  
**F. R. BRISTOW**

**WILLIAM BROWN**  
Vice-President and General Counsel  
Radio Corporation of America

**W. A. WINTERBOTTOM**  
Vice-President  
RCA Communications, Inc.

**CHARLES J. PANNILL**  
Vice-President  
Radiomarine Corporation of America

**GEORGE S. DE SOUSA**  
Treasurer, Radio Corporation of America

**E. A. NICHOLAS**  
President, E. A. NICHOLAS, Inc.

**A. E. REOGH**  
Vice-President, RCA Photophone, Inc.

**CHARLES HORN**  
General Engineer  
National Broadcasting Company

Send this coupon to the school most convenient for you to attend.

## RCA INSTITUTES, INC.

A division of Radio Corporation of America

RCA Institutes, Inc., operates resident schools, giving day and evening classroom instruction in the following cities. Mail the coupon to or call at the institute most convenient to you.

- 222 North Bank Drive, Chicago
- 75 Varick Street, New York
- 899 Boylston Street, Boston
- 1211 Chestnut Street, Philadelphia
- 560 Broad Street, Newark, N. J.
- 1215 N. Charles Street, Baltimore

RCA INSTITUTES, Inc.  
Dept. EX-1

Please send me catalog describing your resident school (classroom) instruction.

Name.....

Address.....

Occupation.....



## Radio News Manufactured Receiver Circuits

### AMRAD BELL CANTO SERIES

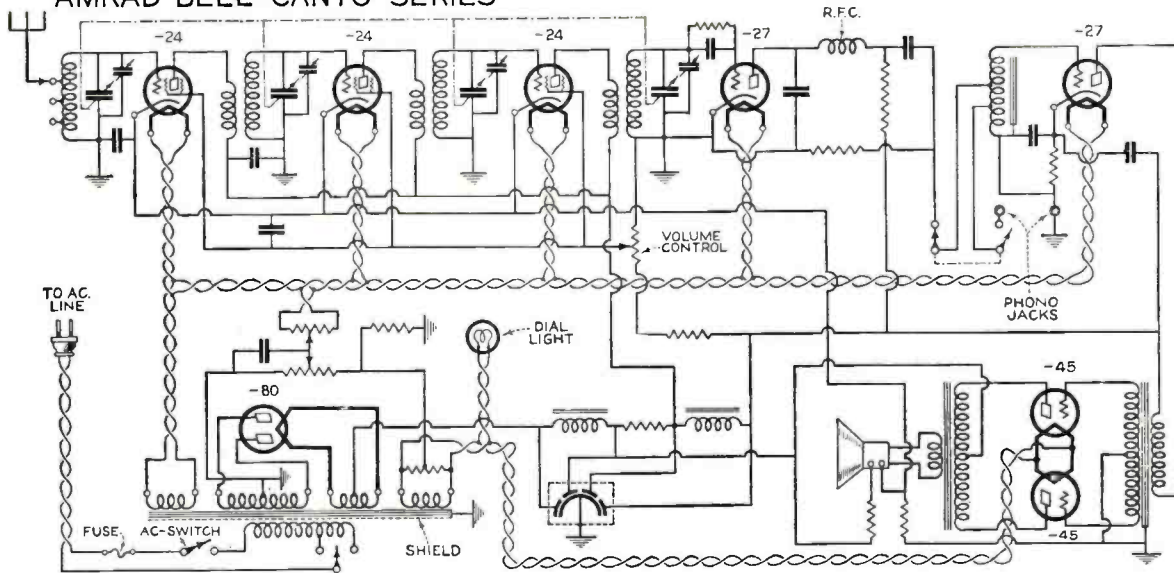

THE Amrad Bell Canto Receiver is a seven-tube receiver with several unusual features. Type -24 tubes are used in the three radio frequency stages, -27s in the detector and first audio stage, while -45 tubes are used in a push-pull power output stage. The antenna stage has a tapped inductance instead of the more familiar antenna coupling coil, and appropriate taps are available for an antenna of any length. Trim-

mer condensers are used across all of the main tuning condensers to accurately match the tuning of the individual stages.

The first stage of audio has, instead of the usual transformer, a resistance and impedance combination. The impedance is tapped to obtain a step up ratio through an auto transformer action. An electrolytic condenser is utilized in the filter section of the power pack.

## Radio News Manufactured Receiver Circuits

### CROSLY MODEL 609-610 A.C.

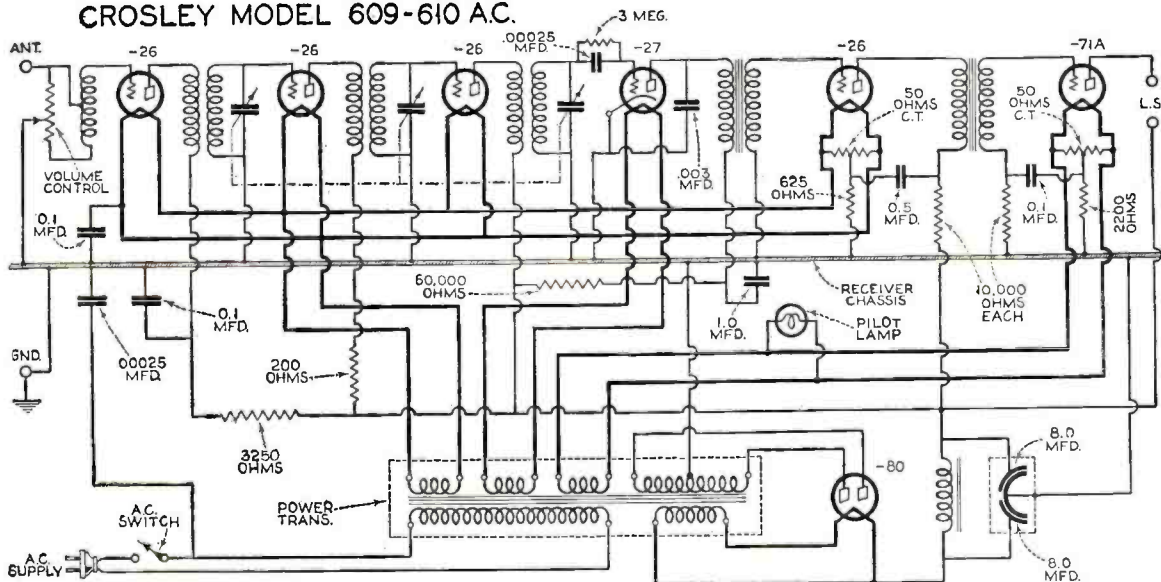

THE Crosley Model 609-610 a.c. model used -26 tubes in the three radio frequency stages, and in the first audio stage. A -27 tube is used as a detector, with a grid condenser and leak connection, while a single -71 tube is used in the power output stage. The audio amplifier is transformer coupled in

the conventional manner. The volume control of this receiver is a potentiometer across the antenna coil, the antenna proper being connected to a midtap connection of this coil.

The power supply makes use of an -80 type tube as a rectifier, and a two section electrolytic condenser is used.

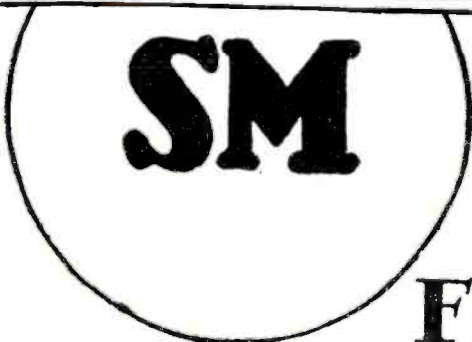

# A Short-Wave Range of Five Thousand Miles

The S-M 738 is a self-contained converter that makes a powerful short-wave superheterodyne when attached to any broadcast set.

There is nothing that the finest commercial short-wave receiver (costing three times as much) will do, that the 738 will not duplicate and beat if your broadcast receiver has any punch at all. Under favorable weather and local receiving conditions, it will give you every American short-wave broadcaster and the principal foreign stations—for to every bit of the sensitivity and selectivity of your broadcast set is added the additional power of a 224, and a 227 tube!

The 738 Converter is built in a beautiful black crystalline case with a hammered silver dial escutcheon—a credit to any living-room.

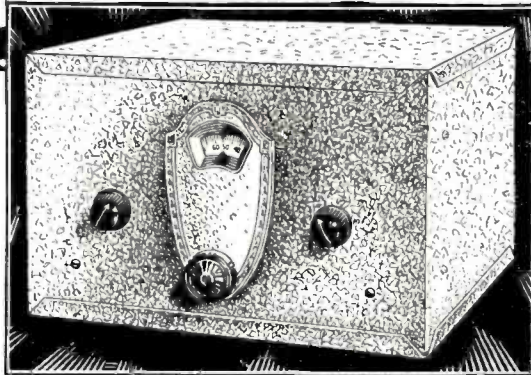

The wired model can be hooked up in three minutes—you merely remove the antenna lead from the broadcast receiver and connect it to the antenna post of the converter; then run two leads from the 738 to the antenna and ground posts of the broadcast set. That's all.

It tunes by a single dial, (which tunes the oscillator circuit) and an auxiliary

midget condenser.

It will give, in addition to short-wave broadcasting, phone and i.c.w. where there is any carrier modulation at all.

Included in the list price are eight coils (four pairs) which cover the wave length range of from 18 to 206 meters. Tubes required: 1-'24, 1-'26, 1-'27.

Price, completely factory-wired, tested and RCA licensed, less only tubes ..... \$69.50 List  
Component parts total ..... \$59.50 List

## S-M 737 Bearcat

The Bearcat is a self-contained, a. c., short-wave receiver that is a bearcat. Operated with an S-M 850, 870 or any other above-average speaker, it will give loud-speaker code and short-wave broadcast programs ranging up to 5,000 or even 10,000 miles, depending on weather and local receiving conditions.

The Bearcat consists of one stage of tuned a. c. screen-grid r. f. amplification using a '24 tube followed by a '27 detector of the regenerative type. The detector is resistance-coupled to a '24 screen-grid first audio tube which in turn feeds through a stage of resistance to a '45 power output tube. The power supply, operating from any 105-120 volt, 50-60

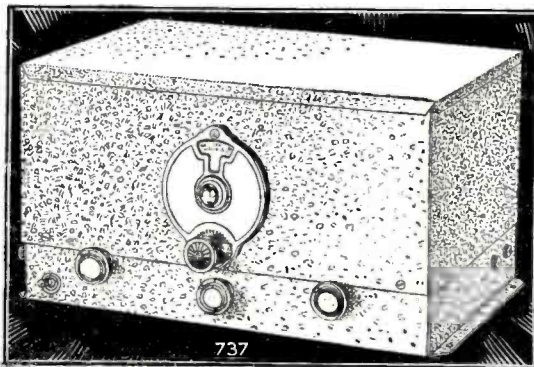

## 5,000 to 10,000 Miles

cycle alternating current lighting circuit, uses an '80 rectifier and provides all A, B and C power for the receiver.

One of the 737's outstanding points of superiority is the built-in midget condenser that allows spreading of the amateur bands over 180 degrees by a turn of the wrist. In addition, it gives very satisfactory vernier control on short-wave broad-

casting—particularly foreign stations that are so difficult to tune in on the average short-wave receiver.

Price, completely factory-wired, tested and RCA licensed, less tubes and speaker ..... \$139.60 List  
Component parts total ..... \$119.50 List

## And Superheterodyne Broadcast Receivers

Ask your nearest jobber about the two finest broadcast receivers ever built—the *nine-tuned-circuit* 724 superheterodyne and the *eleven-tuned-circuit* 714 superheterodyne tuner—or write for your copy of the new SILVER-MARSHALL GENERAL PARTS CATALOG.

The Radiobuilder, Silver-Marshall's official publication, tells the latest news of the great S-M laboratories. Fill in the coupon for a sample copy. If you are a custom-builder or a radio dealer you should be an authorized S-M Service Station. It costs you nothing and is invaluable to you.

**SILVER-MARSHALL, Inc.**  
6405 West 65th Street • Chicago, U. S. A.

Silver-Marshall, Inc., 6405 W. 65th St., Chicago, U. S. A.  
Send your NEW 1931 CATALOG with sample copy of the RADIOBUILDER. Also Data Sheets as follows (Enclose 2c for each Data Sheet desired.)

- ..... No. 21. 737 Short-Wave Bearcat.
- ..... No. 23. 738 Short-Wave Superhet Converter.
- ..... No. 24. 724 Screen-Grid Superhet Receiver.
- ..... No. 25. 714 Screen-Grid Superhet Tuner.

Name .....

Address .....

## Mike-roscopes

(Continued from page 615)

the mood for announcing (he was to go on the air in a moment) he merely mused, "I wonder if I am."

Some of the New York papers criticized the choice of Alwyn Bach as medal winner this year, because they felt he deliberately copied Milt Cross. Although David Ross of Columbia would have been high in my list for the medal, I think the accusation against Alwyn unfair. He has far too much personal magnetism to have to copy anyone.

SOMETIMES I think if I hear another jazz orchestra I'll go mad—why when the so-called best minds in radio get together to work far into the night and cook up a program for the client, do they come out with just another jazz band? Do you really like them as much as all that? Write me, will you?

But I'd be satisfied if we only had a few, and I'd pick as one of the survival of the fittest, B. A. Rolfe's Lucky Strike Orchestra. I like Mr. Rolfe because there is so much of him to like, because he's had such a colorful vaudeville-movie career, because when he broadcasts he visualizes his far away audience and romances about them, and because, unlike other orchestra leaders I've seen, Mr. Rolfe, while conducting, does not look haggard and wild eyed, jump about as though he'd been educated to be a contortionist at a circus, or emote as though at any minute he might end it all. Mr.



Rolfe told me: that the lowest salary of any of his musicians is \$40, a broadcast while the highest paid gets as much as \$150 each time they go on the air; that he wants the Lucky Strike Orchestra to be a mixture of delicacy and dynamic; that one of the musicians who is netting approximately \$700, weekly was playing for pennies on a Staten Island ferryboat two years ago; and that when television comes, every musician will have to be an actor. If only some actors were musicians!



marcel wave, as one of our radio artists says. "Merlin," this 20th century magician, who makes sounds come out of the air, relates an amusing incident. It seems he visited a friend's home, and was introduced to another guest with the remark, "Mr. Aylesworth is President of the National Broadcasting Company you know." "You are?" was the excited rejoinder. "Do you actually know Graham McNamee?" "Yes". "Amos and Andy?" "Yes". "Gee, I wish they'd drop in here some time!"

I HAVEN'T talked to you much about beautiful women in radio, and most of you men like nothing else but. Well, here's one for you, Virginia Gardener of NBC. She's your friend of the old Empire Builders' program, Mystery House, Cockoo, the Moxie Hostess, and more recently, Borax. Virginia looks like a Follies girl with a soul. She's tall, slender and is the only girl with regular features and thin eyebrows I've ever seen who can still look soulful. She was born in New York, went to Newport and Bar Harbor, and can forget it—No, she's not married, beat again, heart—Let me present, Miss Gardener.



feller project, which, though it is only in a sense a castle in the air at the moment, may soon emerge as an actuality.

(Continued on page 669)

## News from Manufacturers

(Continued from page 627)

able enlargement of images without loss of brilliancy or contrast.

The companion self-synchronizing receiver for the radiovisor just described is a special form of short-wave radio receiver, designed to meet the peculiar and exacting requirements of radiovision reception in the simplest and most efficient manner. This design eliminates the main causes of poor radiovision reception usually traceable to an inadequately designed receiver and amplifier. While some results may be obtained with the average short-wave radio set, good half-tone pictures are generally impossible. The special radiovision receiver, however, in combination with a satisfactory radiovisor, provides good radiovision results in the home where sufficient signal strength exists.

In keeping with standard receiver practice, the radiovision receiver is of the complete a.c. type and is entirely self-contained with power amplifier and power pack. There is a single tuning control as well as volume and coupling controls. The tuning range is from 95 to 180 meters, covering the radiovision wave length band without requiring several sets of interchangeable coils. Three stages of tuned screen-grid radio-frequency amplification replace the usual regenerative circuit. A band-pass filter serves to pass the full radiovision signal without stripping the side bands so essential to pictorial detail. This is followed by a non-regenerative linear power detector (regeneration definitely ruins picture reception) which feeds into a two-stage resistance-coupled audio amplifier employing -24 type screen-grid tubes. The final or power stage is of the -50 type. The amplifier employs a special resistance network which amplifies uniformly over a range of from 15 to 30,000 cycles as compared with the better broadcast receivers covering from 60 to 5000 cycles. The chassis construction is of the totally shielded type which eliminates the greatest part of local interference and backdoor reception, and is responsible for the exceedingly stable operation of this receiver. The chassis, which, in appearance, is practically identical with present-day screen-grid broadcast receivers, slides into a neat walnut table of the right size and height to carry the radiovisor.

### Control Amplifier

Gates Radio and Supply Company, Quincy, Illinois, announces their model 1020 control amplifier for use in broadcast stations. This amplifier is the company's latest development for either remote control or station amplifier work having all modern requirements for unrepulsive operation.

The amplifier uses a three-stage combination impedance capacity and transformer-coupled circuit, a pair of -71A tubes being used in the final audio stage in a push-pull circuit giving a possible undistorted output of 1.4 watts with a gain of 80 TU over all.

(Continued on page 651)



# World Famous Radio Receivers



## Console Quality

in a Midget Broadcast Receiver  
You Can Place Anywhere

### PILOT MIDGET

This attractive two-tone walnut miniature A. C. receiver has proved the equal of high priced consoles in many locations throughout the country. Because—it embodies console features; 2-224 Screen Grid stages, 1-224 Screen Grid Power detector, 1-227 Audio stage, 1-245 Power Audio output stage and specially designed electro dynamic speaker. A super powered 280 voltage supply gives trouble-free operation from any 110-20 volt house current line.

Pilotron tubes are standard equipment because Pilot retailers know none are more reliable.

**PRICE**  
Complete in  
Modernistic  
Cabinet **\$59.50**  
less tubes

## For World-Wide Radio Reception

Short and Long Waves, 14 to 500 Meters

### PILOT Super-Wasp

*Rev. J. W. Nilsen, Bolonque, Congo-Belge Africa says: "Here in the heart of Africa I have received 9LO, JB, 2BL, 5SW, AFK, PCJ, WGY (W2XAF), WRNY (W2XAL) and more stations on loud speaker with my Pilot Super-Wasp."*

*David W. J. Jones, Brisbane, Australia says: "I have received on my Super-Wasp all the test transmissions between W2XAF (Schenectady, U. S. A.) and VK2ME (Sydney NSW), Aero, ICT Holland, GSSW England and Sydney—London phone service."*

*Austin R. Baldwin, St. Raphael (Var.) France, says: "I heard from KDKA 25.4 meters. 'We will now rebroadcast a concert from London.' Shortly after the music from London came in clearly, having twice crossed the Atlantic."*

**Pilot Super-Wasp Comes in KIT FORM  
which can be assembled in a few hours**

BATTERY SET KIT

**\$29.50**

Kit K-110: The battery-operated Super-Wasp. Batteries and Tubes extra.

A. C. SET KIT

**\$34.50**

Kit K-115: The A.C. Super-Wasp. Use your own ABC pack or Pilot K-111, specially designed for the Super-Wasp. Power Pack and Tubes extra.

**PILOTRON  
RADIO  
TUBES**

ENDORSED BY  
PROFESSIONALS



# PILOT RADIO



LICENSED UNDER  
RCA PATENTS

At Dealers Everywhere or Write to

**PILOT RADIO & TUBE CORPORATION**  
LAWRENCE, MASS.

Chicago Office:  
234 S. Wells Street

New York Office: 525 Broadway  
OFFICES IN PRINCIPAL COUNTRIES OF THE WORLD

San Francisco Office:  
1278 Mission Street

**Bargains for Servicemen,  
Experimenters and  
Amateurs**

**TRANSFORMERS**

THORDARSON 175 watt—1150 volts center tapped, two 7.5 and one 3 v. windings	\$4.25
THORDARSON 250 watt—1200 volts center tapped, two 7.5 and one 3 v. windings	\$5.75
THORDARSON 100 watt—700 volts center tapped, one 5 and one 2.5 v. windings	\$3.75
THORDARSON 100 watt—same as above but for use with 25 cycle A.C. current	\$4.25
AMERICAN FILAMENT TRANSFORMER—110-120 V. primary—secondary—two windings—2.5 volts at 11 amps., and 2.5 volts at 3 amps. Mounted and cased	\$3.75
THORDARSON Push Pull output transformer	\$2.75
AMERICAN center tapped 4000 volts tapped at 3000 with filament windings of 2.5 volts at 10 amperes and 7.5 volts at 3.75 amperes	\$16.50
AMERICAN center tapped 3000 volts tapped at 2000 with filament windings same as above	\$13.00

**CHOKES**

THORDARSON Filter Choke, 30 henri—150 mils. 3000 volts insulation test	\$3.25
THORDARSON Double Filter Choke, contains two 18 henri—250 mil. chokes	\$6.25
R.C.A. Double Filter Choke, contains two 30 henri—100 mil. chokes	\$1.75
AMERICAN 30 henri at 300 mils. with 4000 volt insulation	\$9.75

**CONDENSERS**

FLECHTHEIM HIGH TENSION Filter Condensers, with porcelain insulators, guaranteed.	
1500 volts—1 mfd.	\$2.70
2 mfd.	5.10
4 mfd.	8.70
2000 volts—1 mfd.	6.00
2 mfd.	9.00
4 mfd.	15.60

Write for special prices on 3000 volt condensers and type HS & HV.  
 DUBILIER Filter Condenser, 1.75 mfd., 1000 working voltage D.C. \$1.35  
 DUBILIER 11.75 mfd. condenser, 3 mfd. at 1000, 4 mfd. at 600 and 4.5 and .25 mfd. at 160 working voltage D.C. \$3.75  
 DUBILIER Plate Stopping Condenser, .000125 mfd. at 1000 volts \$3.35  
 DUBILIER 10 1/4 mfd. condenser, 3 mfd. at 800, 3 at 600, 3/4 at 400 and 1 mfd. at 200 working volts \$4.50

**TUBES**

GENUINE R.C.A. 216-B Rectifying Tubes, 7.5 volt filament, 550 plate volts	\$2.35
KENOTRON Rectifying Tubes, filament voltage 8 to 10, plate 550 volts	\$
GENUINE DE FOREST Transmitting Tubes shipped you direct from factory	
503-A, \$30.00; 511, \$30.00; 545, \$33.75 (50 watt oscillators, modulators, etc.)	
552, \$24.25 (75 watt oscillator and R.F. amplifier, low internal capacity.)	
566, \$9.00 (half wave mercury arc rectifier, filament 2.5—plate 7500 volts.)	

**SPECIALS**

AMERICAN DOUBLE BUTTON, will respond to frequencies from 30 to 7000 cycles, low carbon bias, 100 ohms per button	\$31.50
BRADLEYSTAT, type E210, current capacity 10 amperes, for transmitters	\$ 95
WARD LEONARD—12500 ohm, heavy-duty resistor tapped at 6000, 6000 and 1600	\$1.50
R.C.A. Power Rheostats (heavy duty) will carry 15 amps. for large tubes	\$3.00
CENTRALAB Gain Controls for four transmitters, 0-2500000 ohms	\$ 75
AMERICAN 50 watt transmitting sockets, made from heavy bakelite	\$2.45
AMERICAN 250 watt transmitting sockets, two ends	\$2.55
PILOT SUPER-WASP, D.C. kit, all parts complete for excellent receiver	\$29.50
PILOT SUPER-WASP, A.C. kit, practically humless, for short waves	\$34.50
PILOT Short Wave Plug In coils, set of five for all bands	\$4.95

**AMERICAN SALES COMPANY**  
 N 21 Warren St., New York City

**Wireless (Radio)**

and Morse telegraphy taught thoroughly. School, oldest and largest; endorsed by Telegraph, Radio, Railway and Government officials. Unusual opportunities. Expenses low—can earn part. Catalog free.  
**DODGE INSTITUTE, Oak St., Valparaiso, Indiana.**

**PHOTOELECTRIC CELLS**  
 By Dr. Norman R. Campbell and Dorothy Ritchie  
 Research Staff, General Electric Co., Wembley, England. A complete, practical treatise. Illustrated. \$4.50

**TELEVISION** Foreword by John L. Baird  
 By Sydney A. Moseley and H. J. Barton Chapple  
 History, latest theories and developments. Illustrated. \$2.50  
**ISAAC PITMAN & SONS, 2 W. 45th St., New York**

**QRD—South America**

(Continued from page 588)

and MY, Merida, reported conditions excellent. The weather cleared as we sighted the coast of Yucatan, and the flat, scrubby prairie sent back the heat of the sun in waves that bumped the plane unmercifully.

Merida is the capital of Yucatan, an arid eastern peninsula of Mexico, where the inhabitants worry as much about getting water to drink as we do about having to drink it. In Merida, hundreds of windmills burrow into subterranean rivers. The ancient Mayan tongue survives in the interior, the sole living thing of all the ancient American civilizations. The Indians speak the language intoned by the priests when, each year, Mayab, the sacred virgin, was sacrificed to an insatiable god beneath the Pool of Death.

From Merida to Vera Cruz we again ran into thick weather, and were tempted to put the plane down at Villa Hermosa, where the operator radioed us a report of good landing conditions. However, a subsequent message from VC, Vera Cruz, informed us of excellent visibility

of seventeen summers and with a predilection for a generalship in the next revolutionary army. He has already killed one person with this improvised locomotive, and lopped the hands off a peon woman. He drives the device playfully at eighty kilometers an hour over a rickety roadbed, and one steps out at the Tejeria end relieved at the prospect of a safe airplane journey ahead.

Vera Cruz is perhaps the hottest and dustiest seaport in the world. It is noted for possessing one hotel with an elevator (the Imperial, by the way) and its red light district. The elevator is a relief and should be taken advantage of. Vera Cruz is also known as the City of the Three B's—bells, bats and buzzards. The bells clang interminably from a city full of clocks in disagreement as to the hour. The bats flit about of an evening, along with the fire eaters and other mendicants among the tables of the sidewalk restaurants. The buzzards are the scavengers, and are partly if not wholly responsible for the degree of sanitation of which Vera

The Mayab—the funeral plane carrying the ashes of Pablo Sidar—just before the take-off from Tejeria with the "Pilot Radio" as American escort

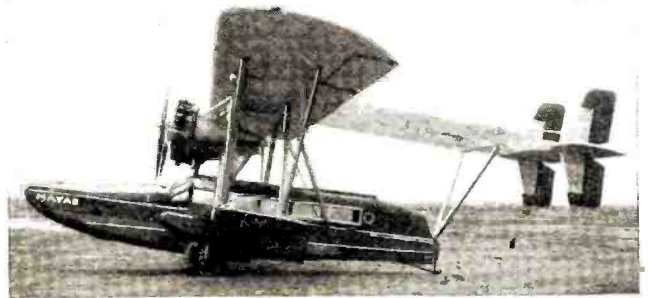

at that point and we pushed on to clearing weather and a lifting ceiling. We had hoped to get through to Mexico City that afternoon, but the clouds were heavy and low over the mountains. We learned here that the Mayab—the funeral plane carrying the ashes of General Pablo Sidar, who was killed in an attempted non-stop flight from Mexico to Rio de Janeiro—had taken off for Puebla. She returned shortly, confirming our estimation of the difficulties in getting through that day.

The Mayab is a Sikorsky, owned by the Governor of Yucatan. At the time of our flight she was piloted by an old friend, Erret Williams. The Mayab carries gas for twelve hours, and it is more than rumored that his excellency, the Governor, will take advantage of this at the next revolution.

**Bats, Bells and Buzzards**

The Vera Cruz airport is located at Tejeria, about twenty miles west of the city. There are no roads through the swampy territory intervening, the only available transportation being a section of the railroad connecting Mexico City with its seaport. Trains pass through Tejeria once a day in each direction. However, Pan-American provides a Ford car equipped with flanged wheels that ride the rails. It is piloted by a Mexican youth

Cruz may brag.

The next morning I rode out to Tejeria on the Ford, following the Mexico City express which leaves the yards at six-forty. A cow got in the way of the express, and when we passed by five minutes later the argument was over and the major portion of the animal was deposited along the embankment. Two buzzards were already at work. When we returned that evening, weather making it impossible to push through to Puebla, bones as white and dry as those of Tutankhamen were all that remained of the cow.

While we were unable to clear the mountains that day we made a genuine attempt at it, along with the Mayab and three escorting Mexican Army planes under the command of General Azcarate. We had been requested to accompany the aerial funeral as an official American escort, and to keep Mexico City informed of the progress of the funeral by radio. We had been flying two and a half hours in an endeavor to climb over the clouds to locate the pass on either side of Orizaba, when radio word was received that the Mayab had returned to Tejeria. With something akin to relief, we cut the gun and began to kill our fourteen-thousand-foot altitude. When we arrived at the field we found that one of the escort planes was still missing, and it turned

(Continued on page 642)

# A Million Dollar GUARANTEE

THE pledge of perfect performance that goes with every CHAMPION Tube is backed with the entire resources of this million dollar organization.

When service adjustments are due. (they rarely are) Champion dealers never hem-and-haw over technicalities. Full, fair and complete satisfaction is the unqualified rule of every sale!

*For complete radio satisfaction install*



*Dated Ribbon Labels*

take the "cuss" out of customer. Date of sale filled in by dealer establishes a definite service check... the fairest possible to everybody!



*The Giant with the Velvet Voice*

# Champion RADIO TUBES

Champion Radio Works, Inc. 1192 PINE STREET, DANVERS, MASS.

## A SENSATION!

Because it has definitely set up extraordinary new standards of superlative performance, this amazing receiver has enjoyed a sensational reception this year. With 10-kilocycle or better station separation and a superb tone that beggars description, it brings new thrills to the man who knows radio.

It is entirely new—new in principle—new in operation. It employs the newly perfected Hopkins Band Rejector System. By this method, clipping stations apart on a hair-line turn of the dial is accomplished without sacrifice of perfect tonal reproduction. The moment you tune and hear it, you sense the revolutionary difference between it and the fine radio of the open market. It is the set for those who are satisfied only with the best!

## HFL MASTERTONE 10

## A POWERFUL SUPER-HETERODYNE WITH THE HOPKINS BAND REJECTOR SYSTEM

Not just another super-heterodyne, but one wholly different. Aside from the exclusive use of the Hopkins circuit, it operates at a new frequency. Employs a new pre-selection system. New kind of R. F. amplification. With greatly improved sensitivity, providing an unhampered flow of every signal entirely through the circuit, the reception range is really astounding. Far away stations come in like locals! A clarity of reproduction that holds you spellbound!

### Try It and See for Yourself

Bounding power that places at your whim the world of broadcast! Tone that in its sheer realism is awe-inspiring. Magic-like in its stark naturalness! Quick as a flash in tuning, it accepts

the chosen station to the exclusion of everything else in the air. You have never tuned a radio set like this before. You have missed something in radio in not doing so. Try it in your own home entirely at our risk. Give HFL the chance to prove these unusual claims without risk of a penny to yourself.

### This Book Will Tell You

The coupon brings to you without cost a little Brochure describing in detail this wonder receiver. It tells its price. It tells you why this set performs so amazingly. It points to an easy way of its purchase. Mail the coupon today and soon begin to enjoy radio as you have never been able to do so before.

10-KILOCYCLE STATION SEPARATION



DEALERS: Write for special HFL Franchise.

### High Frequency Laboratories

Dept. A131, 3900 N. Claremont Ave., Chicago

HIGH FREQUENCY LABORATORIES, Dept. A131, 3900 Claremont Ave., Chicago.

Without cost or obligation, please send me a copy of your new Brochure describing the new 1931 H. F. L. Mastertone 10 and your liberal selling policy.

Name \_\_\_\_\_  
 Address \_\_\_\_\_  
 City \_\_\_\_\_ State \_\_\_\_\_



## RADIO NEEDS YOU

*Learn at home!*

THOUSANDS of positions are opening up in the field of radio. It seems certain that for the next five years there will be more jobs than there are trained men to fill them.

This is your opportunity! Study radio now, at home. Train yourself for a position as radio operator on a ship or in one of the many new land communication stations. Get the knowledge you need to become a radio expert on installations or service.

Radio has only begun to grow. Get in now, and rise with this fascinating business.

You don't have to give up your present job, or spend your savings on tuition. The International Correspondence Schools plan lets you learn while you earn—at home, in spare time.

Famous radio authorities have prepared the great I. C. S. Radio Course. It is complete—up to the minute. Even the latest developments, such as television, are covered. Many graduates of this course are already earning big salaries in the various branches of radio.

Find out *today* just how the I. C. S. can train you for a radio position. There is no obligation in asking. Just mark and mail the coupon.

INTERNATIONAL CORRESPONDENCE SCHOOLS  
Box 8280-K, Scranton, Penna.

Without cost or obligation, please tell me all about the  
NEW RADIO COURSE

Name \_\_\_\_\_

Street Address \_\_\_\_\_

City \_\_\_\_\_ State \_\_\_\_\_

If you reside in Canada, send this coupon to the  
International Correspondence Schools of Canada, Ltd.,  
Montreal



**Dealers and Servicemen!**

Write for Your Free Copy of  
**Radio Bargain News**  
Issued Monthly by

**Federated Purchaser**

20 Hudson St.

New York, N. Y.

## QRD—South America

(Continued from page 640)

out subsequently that he had pushed on through to Puebla. The pilot told a story that while the weather had been rather thick, and that even though he himself had hit the railroad tracks twice while flying through the pass, the hop was really nothing to bother a good flier. The Commandant of Balbuena Field, who was flying one of the other escort ships, appreciated his comments and with Mexican gratitude promoted the pilot to official fog flier, with standing orders to fly from Mexico City to Vera Cruz, via Puebla, every day the weather is thick.

The following day was ideal—unlimited visibility and a ceiling dotted high with a few cirrus clouds. We made altitude almost by the time we reached the pass, and pushed through with the white cone of Orizaba above us, glistening in the sun. The planes of the funeral cortege rose and fell languidly. Colonel Leon leading in a Douglas, then the Ma-

"aterrasaqui suavi," the equivalent of our "happy landings," and much flying was done at the Bar of the Regis Hotel.

We were seated there one evening with Señor Modesto Huete, Consul General of Costa Rica to Mexico. At another table were the son of the lately assassinated President Obregon, a girl, and our old friend Colonel Leon. In struts a Mexican appeared according to the best Hollywood tradition, leather trousers and jacket, spangles, lace and filigree, a gold and silver holster, cartridge belt studded like the harness of a pet pony, and all of this glittering caballero topped with a sombrero of indescribable gorgeousness. He lurched to the bar with a natural swagger accentuated by a recent over-indulgence in native whiskey, and ordered four "sententa cinco." He drank these with a generalissimo gesture, then cast his eye belligerently over the cantina. The Mexican started as he saw young Obre-

The hottest place on earth — Managua. We wore coats because our shirts were dirty



yab, two more Mexican planes, Cloyd Clevenger in a Spartan, and the "Pilot Radio." The Mayab was the first to land at Puebla—our ship last. The field at Puebla is well over seven thousand feet above sea level, the air thin and we came in fast. It was here that Pablo Sidar was given his third funeral, the field named in his honor, and we started our series of hair-trigger take-offs.

We were first off the following morning. The prop seemed reluctant to grab the light air, and the plane gathered speed like a penguin. We were half-way across the field before the tail was up, and a hundred feet from the boundary flags before she took the air. Burgin held her down for speed, and a wheel clipped a flag before he zoomed her over the plateau. Slipping aft, into the shack, we called M. Mexico City, and sent a message to Secretary of War Amara, telling him that the funeral was on its way.

### *We Miss a Revolution*

The shadow of our plane brushed the side of Mount Popocatepetl, known familiarly as "Popo." A half hour later we passed Ixtacchuatl (known familiarly as "that mountain near Mexico"), and shortly after, the ashes of Pablo Sidar were landed at Balbuena Field for his last funeral.

We laid over in Mexico City six days for a motor check-over, during which time we demonstrated the radio equipment to the Mexican government. The three of us were decorated for our participation in the Sidar swan-flight. The Mexicans are most hospitable. They have a toast,

gon, stumbled over to the table and began to pull an ornately engraved revolver from his holster. He was watching Obregon's face, not his hand, and his befogged eyes failed to read the fact that Obregon had drawn an automatic from a shoulder strap, and had it pressed against his lace-covered belly. In a flash, Leon reached across the table, forced the revolver back into the holster and the Mexican from the table. As Leon led the incipient revolutionist from the cantina, Obregon slipped his own pistol under his armpit, lit a cigarette and ordered another drink.

Señor Huete turned to me regretfully. "Leon is a fool," he said. "He should not have interfered. Obregon would have killed him in another moment. Now he may go out and get himself into trouble. Things are not as they used to be—." The voice of the Vice-Consul was sorrowful. "In the past year there have been only five—no, not even five, only four—people shot here in this bar."

### *A Tight Squeeze*

A wet field and a difficult approach added zest to our take-off from Mexico City, which is even at a slightly higher altitude than Puebla. We skimmed over the trees with something less than inches to spare and headed south for Puebla. A lowered ceiling, with the mountains shrouded in clouds, balked us just before the entrance into the valley, and we turned back in an effort to make the northern pass. As we flew over the flying field we had left an hour before, we were

(Continued on page 643)

## QRD—South America

(Continued from page 642)

joined by Colonel Leon in a Douglas, who, so we later learned, had set out to find us on the theory that we had cracked up immediately following our take-off. Aviators' funerals had become a habit with him.

The north pass was clear, and we were just pushing through, when the oil pressure dropped, necessitating a second return to Mexico City. On the way back we radioed M to locate Eddie Walsh, the Wright mechanic, at either Saborn's or the Regis, and he arrived at the field just five minutes after the plane. A bit of dirt removed from the check valve, and we were off again, a half hour later, with another hair-graying attack on the shrubbery at the far end of the field. The delay had given the clouds just time enough to build up in the northern pass, and, as we poked our nose into the mountains, they closed in behind and above us. We were imprisoned in a series of wind- and rain-swept valleys eight thousand feet above the sea. Radio communication with Vera Cruz informed us that weather was clear on the coast, and our only chance was to feel our way, under a fifty-foot ceiling, down the narrow valleys. They tried to flag us down at an emergency field, the one and only flat spot in the mountains, but we were past, a roaring shadow in the mist and rain, almost before we saw it; and the valley was too narrow for even the tightest sort of a vertical turn.

The sea and a broken sky above were welcome sights.

Another night in the town of the three B's and we took off for Guatemala City, stopping en route at San Geronimo for gas. The early part of the day was perfect, and Orizaba could be seen glistening to the northwest for an hour and a half after the take-off. As we came in for a landing at San Geronimo, the starter waved us off with a red flag. Burgin gunned the motor, and as we zoomed over the runway a peon languidly arose from the grass where he had been indulging in a morning siesta. A checkered flag then indicated that the field had been cleared of obstructions.

We were accompanied by one of the Pan-American Fords, a companionship that was gratefully acknowledged when the weather thickened a hundred miles north of Guatemala City. Guatemala City is situated on a plateau five thousand feet above sea level and can be approached either over the eight-thousand-foot mountains surrounding or through one narrow pass. A wx report informed us that while there was a two-thousand-foot ceiling at Guatemala City, the sky was completely covered, leaving the pass, rapidly filling with clouds, as the only possibility. The Ford pilot knew his way, and we followed close behind him until actually in the pass, when he radioed us to keep a mile between the two planes in case the pass closed, forcing him into a tight turn. The ceiling dropped just as our wheels touched the airport at Guatemala City.

The next morning a heavy load of gas  
(Continued on page 645)

# QUALITY

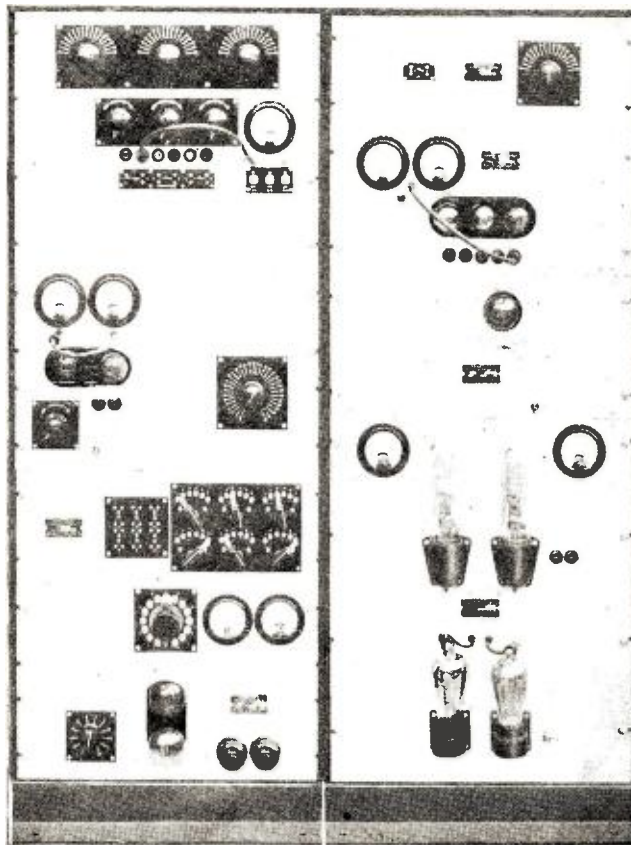

## AMERTRAN

AmerTran products have been recognized since 1922 as the best available equipment for every conceivable application in the field of sound reproduction. Complete 50-watt systems of the type illustrated are specified where flawless reproduction is required in large volume. Also, radio experimenters who desire the same high-quality music in their homes may use AmerTran parts in their home-made or custom-built radio receivers. These are of the same high quality as those used in the manufacture of our precision amplifying equipment and represent the closest possible approach to the ideal that engineering genius can provide. They are the "Standard of Excellence for Sound Reproduction".

**Audio-Frequency  
Transformers  
Transmitting  
Equipment  
Power Amplifiers  
Filter Chokes**



**Power-Supply  
Transformers  
Parallel-Feed  
Chokes  
Sound Systems  
Power Blocks**

**American Transformer Company  
178 Emmet Street  
Newark, N. J.**

American Transformer Company  
178 Emmet Street, Newark, N. J.

RN-2-31

Please send me your general catalog describing AmerTran audio parts and power amplifiers.

Name.....

Street & No..... Town..... State.....

# MEN WANTED

20 to 35 years old

# RADIO

First Lesson Free!

Broadcasting  
Television  
"Talkies"  
Manufacturing  
Service  
Sales  
Auto-Radio  
Aviation

## See how easy to learn

See how quickly you can get ready for well-paid positions in fastest growing, most prosperous industry.

Big demand right now

from employers for broadcast operators, testers, inspectors, service-men, designers, installers, and "trouble-shooters".

## \$40 to \$75 a week — and more!

With free radio lesson we'll send you our amazing combined training and employment agreement—good for help in securing a beginner's job when you're only half way through. Guarantees you help in finding a position, satisfactory in salary, after you finish, or money refunded.

## A World of Opportunities to Choose From

Rockefeller is building a \$500,000,000.00 "radio center" in New York. 20,000 movie theaters have gone "talkie". Auto-radio is selling like wild-fire. Midget sets are selling at rate of 10,000 a day! Aviation, television, servicing, sales—all these mean highly paid jobs and plenty of them. All you need to get one is the kind of training we give you, backed by a real placement service.



### RADIO TESTER GIVEN

\$20.00 set analyzer and trouble-shooting job-tickets a part of this training without extra charge.

## Lesson FREE!

### Mail Coupon

for free radio lesson and book of thrilling facts about this wonder-industry and how to "break in."

### American School

Dept. R-180, Drexel Ave. & 58th St., Chicago

THE AMERICAN SCHOOL  
Dept. R-180, Drexel Ave. & 58th St., Chicago

Please send without cost or obligation, free radio lesson and job ticket and radio bulletin.

Name..... Age.....

St. No. ....

City..... State.....

**The CROSLEY**

# ROAMIO

**AUTOMOBILE RADIO RECEIVING SET**

**EXPLORE THE SHORT WAVES**

*with the*  
**EXPLORER PLUGLESS CONVERTER**

Covers 15-200 Meters without Plug-in Coils  
Price only \$14.50

**WRITE FOR FREE DESCRIPTIVE LITERATURE**

**RIM RADIO MFG. CO.**  
695 Grand Street Brooklyn, N. Y.

# The Air Cell

(Continued from page 601)

harmonize, rather than oppose each other, and that is just what the Eveready Air Cell "A" battery-two-volt tube combination is.

The Air Cell "A" battery is a constant-voltage battery; its voltage remains at practically full initial strength throughout its remarkably long life without recharging. Consequently there is no need for a filament rheostat or other device intended to compensate for varying battery voltage.

The 2-volt tube is unusually sparing in its consumption of both "A" and "B" current. This conserves the power of the Air Cell "A" battery and makes the "B" battery last much longer than has been the case with many battery-operated receivers of the past.

The small filament which makes the 2-volt tube so sparing in its use of "A" battery current also makes it as susceptible to burn-out, when over-voltaged, as the 199, if not actually more so. Therefore these new tubes should not be considered dry-cell tubes in any sense of the word, for unless they are supplied with constant voltage from the Air Cell "A" battery they will be subject to the same troubles experienced in the past when attempts to use dry cells as the "A" battery were made. If powered with dry cells their life is usually short, erratic and generally unsatisfactory. If supplied with filament current at constant voltage they will last as long and perform as well in proportion to their capabilities as any filament type tube similarly supplied.

The all-important constant-voltage feature of the Air Cell battery is made possible by a remarkable form of carbon, used as the positive electrode, which has the property of extracting the essential depolarizing oxygen directly from the air and making it available where needed within the battery, as required.

Heretofore the only way of introducing oxygen into batteries has been to employ some chemical or mineral rich in oxygen, built into the cell. The oxygen carrier in the dry cell, for example, is manganese dioxide, a natural mineral occurring at widely separated points in the earth's crust. The characteristic decline in voltage of the dry cell is due in large part to the gradual exhaustion of the limited oxygen supply originally sealed up in the battery.

In the Air Cell battery the oxygen carrier is the air we breathe. This fact gives it its name. With an unlimited supply of oxygen always available, the voltage-reducing hydrogen cannot accumulate within the battery, but is converted into harmless water as fast as it forms. Consequently the working voltage remains at practically full initial strength until the active ingredients have been consumed.

The Air Cell "A" battery has a capacity of 600 ampere-hours. Most of the Air Cell receivers now on the market employ seven 2-volt tubes, two of them being power output tubes. This places a load of approximately .55 ampere on the "A" battery. With 600 ampere-hours available, the corresponding life is well over 1,000 hours, or on the basis of 3

hours daily use of the receiver, a whole year.

Compare this with a dry-cell "A" battery. Not that dry cells are practical for use with these receivers, because they are not, but a comparison will serve to illustrate the immense improvement of the Air Cell receiver over the dry-battery set.

The most economical dry-cell "A" battery for a 7-tube, 2-volt set would consist of eight-dry cells, in two groups of four cells each, the cells in each group being connected in multiple and the two groups connected in series. For the uninitiated this is a most difficult connection to make correctly, but, assuming that the set owner succeeds in making it, which is assuming a lot, and further assuming that the filament rheostat is always accurately and precisely adjusted, and in all ways giving the dry-cell "A" battery all the breaks, it will last about 80 days if used 3 hours daily. In the course of a year, four and one-half such battery installations will be consumed, each with its complicated series-multiple connection to be made, totalling 36 dry cells, costing \$18.00.

Under the same condition of 3 hours daily use one Air Cell "A" battery is a whole year's supply of filament power, and it costs less than half what a year's supply of dry cells would cost. Furthermore, it has only two terminals and therefore is easily connected to the receiver. No chance of burning out tubes or short circuiting the battery through wrongly made connections. Then, too, there is no possibility of the owner of an Air Cell receiver burning out his tubes through accidental misadjustment of the filament rheostat, because the Air Cell receiver has no filament rheostat.

The Air Cell battery uses a liquid electrolyte, but until placed in service it is dry. In the dry state it is inert; no depreciation occurs. It therefore may be placed in service at the end of any elapsed time after manufacture and still deliver its full quota of ampere-hours.

To energize the battery for service it is only necessary to fill it up with water. It takes about 6 quarts. Distilled water is not necessary. Any water suitable for drinking purposes will do.

The battery consists of two cells, assembled in a molded container and permanently connected in series. The nominal voltage of the battery is 2.5 volts. While the voltage is not absolutely constant in the strictest sense of the word, the decline in voltage from beginning to end of life is only a fraction of the decline in the dry cell and is well within the leeway of permissible voltage range of the 2-volt tube filament.

In the Air Cell receiver the conventional filament rheostat is replaced by a simple, inexpensive fixed resistor of correct value to reduce the battery voltage to the tube voltage. All such a receiver needs in the way of filament control is a simple off-on switch, just like an a.c. set. With an Air Cell receiver the power can be switched on without danger of dam-

(Continued on page 647)

### QRD—South America

(Continued from page 643)

and another high-altitude flying field broke the monotony of things and almost our necks. Again a wet field slowed up the take-off, and had the ancient Indian viaduct, just off the far end of the field, been two inches higher, archeology would have lost one of its finest relics.

After an hour's futile flying, in an endeavor to get over the mountains or through the pass, we were forced to return to the field, where Emile made a perfect landing with the heavy ship—a landing that was only duplicated in skill by his take-off the next morning.

#### *We Clear the Mountains*

The wind had changed and this day we took off with the viaduct on our tail. Once again the plane lurched sluggishly ahead, tail-heavy and reluctant to move. The air speed needle seemed to creep along the dial like the hour hand on a watch. Barely off the ground at the far end of the field, it became painfully evident that two trees towered far above the limits of any possible zoom. With perfect finesse Burgin dropped the right wing under the branches of one tree, raising the port wing above the branches of the left tree, at the same time giving just enough rudder to prevent a slip.

This time we succeeded in pushing over the mountains, and we radioed back a report of clear weather on the coast to the Pan-American plane taking off for Vera Cruz. Seven hours later we landed in Managua, Nicaragua, a section of Central America just slightly hotter than hell.

It was our pleasure in Managua to meet Lieutenant Fike and Sergeant Martin of the marine radio station NN1NIC, and, at the key, to work Rosenthal's station, W2QU, in New Rochelle, New York.

We took off the next morning for Panama, again heavily laden with gasoline, and again we celebrated by flying through the fence on the east end of the marine field.

#### *Our First Radio Record*

We stopped over at France Field. Colon, five days for alterations adapting the oil cooling system to tropical flying. It was here that we established our first long-distance contact with WHD in New York. With a prearranged schedule for three o'clock in the afternoon, we arrived at the field to find the motor cutting on one magneto. Flight out of the question. We ran an emergency antenna from the fairlead at the bottom of the plane to the top of an automobile seventy-five feet away. WHD came back at our first call, and we arranged for a flying schedule the following day, at which time, four thousand feet over the Panama Canal, we sent through fourteen messages, including one eight-hundred-word press dispatch.

Next month Zeh Bouck continues with the story of the "Pilot Radio" flight from Panama to Buenos Ayres, Argentina.—THE EDITORS.

# Now FREE to All Servicemen and Dealers—this New Condenser Guide

IN this day, with power-converters being universally used, it is vitally important that men in the radio business know how they are made—how they can be improved—how they can be repaired. Not the least important part of a power-converter or power-pack is the filter condenser, and the New Mershon booklet on Filter Condensers is the most complete, helpful booklet on this phase of radio ever written.

In successive chapters this booklet deals with the various condenser problems and their solutions. Voltage surge effects, condenser life limits, moisture, safety-valve action, cost and size, are all carefully and completely analyzed so that the average man can easily understand which filter condensers are the best to use and why.

The booklet is replete with diagrams and photographs illustrating all the important points. It also contains a complete description of the Mershon Puncture-Proof Filter Condenser and shows why it ranks first in this all-important field of radio equipment. Although the regular price of the booklet is 10 cents, we offer it FREE to RADIO NEWS readers. Send for your copy today.

### 30 Prominent Manufacturers Use Mershon Condensers in their Receivers

Zenith, Sparton, Crosley, Colonial, Kennedy, Howard, Amrad and DeForest-Crosley of Canada are among the numerous manufacturers using Mershons. Rigid tests in their own laboratories have proved that Mershons provide better filtering, greater reliability, almost unlimited life—all at lower cost.

#### How You Can Use Mershons

If the receiver you handle, or the ones you repair, give you filter condenser trouble, Mershons will eliminate it for you. Use them for replacements.

If you build power-amplifiers or transmitters, Mershons in the power-packs will assure you of freedom from condenser replacements.

This new booklet shows you how to use them. A FREE COPY will be sent you for the asking.

#### Costs No More Than Other Condensers

Mershon Puncture Proof Condensers cost no more than other condensers, yet their first cost is their last.

Once you have them installed you can forget about condenser troubles. That is why thousands of service men are using Mershons to replace burned-out condensers in their daily work.

Because of their larger capacity, Mershons improve the filtering of the power-pack with the result of considerably reduced hum.

Twice As Many In October!

In October, servicemen and dealers used more than twice as many Mershon Puncture-Proof Condensers as in any other month in Mershon history!

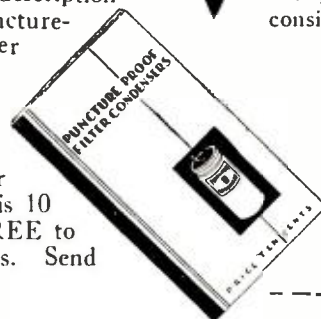

## Now FREE Mail Coupon Today!

The Amrad Corporation  
409 College Ave.  
Medford Hillside, Mass.

Gentlemen:

Please send me a copy of your new booklet, entitled "Puncture Proof Filter Condensers," regularly priced at 10 cents a copy, but FREE to me.

Name .....

Address .....

## REESONATOR

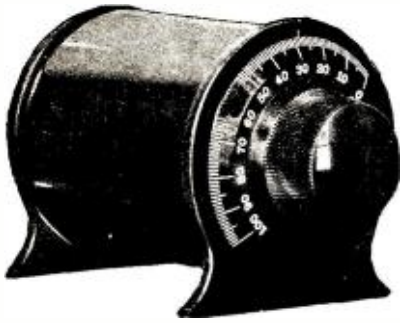

**For distance and sharp tuning. Over 40,000 satisfied customers. Now only \$3.95.**

The Reesonator will increase the volume, distance, power and selectivity of your radio set to the equivalent of the addition of two extra tubes. It will enable you to play with dance volume stations which were barely audible without it. Attaches across aerial and ground leads without tools by anyone in less than a minute. It is especially recommended for all sets having an untuned antenna or floating tube such as: Radiola 16, 17, 18, 33, and 333; Atwater Kent models 30, 32, 35, 37, 38, 48 and 49, certain models of Victor, Temple, Silver-Marshall, Knight, Apex, Dayfan, Crosley Bandbox and Jewellbox, and many others. Saves 25% on A and B batteries on battery sets. Return in three days for refund if not satisfied.

### F. & H. AERIAL ELIMINATOR



Price \$1.25 Complete

Every Instrument Tested on Actual 1000 Mile Reception  
The F. & H. Capacity Aerial has the capacity of the average 75 foot aerial 50 feet high. It increases selectivity and full reception on both local and long distance stations and is absolutely guaranteed. It eliminates unsightly poles, guy wires, mutilation of woodwork, etc. It does not connect to the light socket and requires no current for operation. Enables set to be moved into different rooms with practically no inconvenience. We predict this type of aerial will be used practically entirely in the future. Installed in a minute's time by anyone. Return in three days if not satisfied.

#### ALL ITEMS SHIPPED POSTPAID

Send C. O. D. or  Enclosed please find check or M. O. for \$..... and for which please send me the items checked on a three-day money-back guarantee basis.

Reesonator  
 F. & H. Capacity Aerial Eliminator  
 Literature  Dealers' Proposition

**F. & H. RADIO LABORATORIES**

Fargo, N. Dak. Dept. N

**Announcing**

**ELLIS MODEL 10**  
for Small  
**Public Address Systems**

The Ellis Model 10N Microphone at \$25.00 list is something entirely new in microphones at this price. By means of a special gold plated corrugated metal diaphragm developed at our laboratory we have attained many of the advantages of the stretched metal diaphragm. Your jobber can secure this for you if he does not have it in stock. Write for details of mechanical and electrical characteristics.

**ELLIS ELECTRICAL LABORATORY**  
Sole Corporation

337 W. MADISON ST. Chicago, Illinois

Dealers and Service Men Send for the Latest Issue of

NUBOR  
FLASHES

It contains hundreds of Radio and Electrical bargains  
Have You Received Your Copy?

NUBOR RADIO CO., 14R Warren Street, New York City

## Observing the Federal Licensing Requirements

(Continued from page 603)

### Essential General Orders of the Federal Radio Commission

(Prepared by Carl H. Butman)

4. Broadcast frequency band defined as between 550 and 1500 kilocycles.
7. Maximum deviation from broadcast frequencies established as one-half kilocycle; violations considered as cause for revocation of license. Opening and closing announcements of frequency required.
8. Broadcast stations required to announce call letters and location once each fifteen minutes. Violations considered cause for citations to appear before Commission.
9. Permission to assign or transfer all licenses necessary. Applications for voluntary and involuntary assignments available.
15. Affidavits regarding broadcast interference; how filed.
23. Modification application necessary for permission to move main studio, especially out of state. (All contemplated studio removals should be reported.)
30. Portable broadcasting stations abolished.
31. Compliance. Section 18, Radio Act, 1927, required, wherein candidates for public office are extended equal opportunities to broadcast.
40. Assignment of broadcast frequencies in U. S. and Canada; designation of clear, regional and local channels, and power limitations thereon.
41. Definition of daytime broadcasting stations, limiting operation to local sunset. (See also No. 48.)
42. Limitation of maximum broadcast power to 25 kilowatts and 25 kilowatts experimentally, and limitation of number of channels per zone such use. (Amends No. 40.)
48. Definition of limited-time broadcast stations. (Amending No. 41.)
50. Picture and television broadcasting. (See No. 56.)
51. Regulations on use of damped waves, or spark apparatus. (See Nos. 70 and 82.)
53. Use of excess day power broadcasting stations.
56. Pictures and television broadcasting. (Amending No. 50.)
61. Daylight-saving time regulations for broadcasting stations.
64. Regulations for experimental stations, including relay, visual, etc. (See No. 68.)
66. Broadcasting stations required to guard marine distress channels.
68. Regulations for relay broadcasting. (See No. 64.)
70. Use of damped waves by ships, amending No. 51. (See No. 82.)
74. Allocation of channels to services other than broadcasting.
75. Answers to reports of violations by supervisors required in three days.
77. Applications covering installation of automatic frequency control in broadcasting stations.
78. Announcement by broadcasting stations of all records and mechanical re-

production required preceding broadcasting; exclusive transcriptions must also be announced following reproduction.

79. Regulations covering Alaska.
82. Requirements for use of damped waves or spark sets. (See Nos. 51 and 79.)
83. Alaskan licenses extended to January 25, 1931. (See 79.)
84. Amateur radio regulations.
85. Emergency police service. (Amending No. 74.)
86. Emergency power-company service. (Amending No. 74.)
87. (Reallocation of certain broadcast frequencies.) Not effective; held up pending court action.
88. Covering required separation between frequencies above 1500 kilocycles, and channel widths.
89. Applications for renewals of all licenses must be filed with Supervisor thirty days prior to expiration date.
90. Posting of station and operator's licenses in transmitter room required.
91. Maximum allowable carrier power and relation between licensed and rated power defined for broadcast transmitters.
92. Assignment of unit values to broadcasting stations for determining quotas by zones and states. (See also Explanation thereof, containing revised quotas.)
93. Practice and procedure before the Federal Radio Commission. (Mainly concerning legal matters.)
94. Regulations and requirements for aeronautical stations.
95. General order 95 issued by the Commission on September 29th has to do with Section 12 of the Radio Act of 1927, as amended. The gist of the order covers procedure when applications for consent to assignment of a construction permit or license are filed. In the event voluntary assignment is sought, assignor and assignee both sign applications. When involuntary assignment is sought the application is signed by the assignee and must set forth nature of such involuntary assignment and must have attached thereto a certified copy of the court order or legal instrument, by which assignee obtains such license. The Commission now holds that insolvency of a licensee shall be considered as grounds for revocation of station license and/or refusal of the renewal thereof.
- Violations of general order 95 are deemed grounds for revocation of a station license under section 14, of the Radio Act of 1927, as amended, or for denial of renewal licenses (this general order repeals general order 9).
96. Auxiliary broadcasting transmitters.
97. Percentage of modulation.

### Three Main Service Groups

The special regulations covering the licensing and operation of broadcasting stations were covered in detail in my article published in RADIO NEWS for December, 1930, "Explaining the Radio Laws," so will not be repeated here although they are covered pretty well in the 39 general orders just cited. There are today over

(Continued on page 648)



## The Air Cell

(Continued from page 644)

aging the tubes when the battery is new and with full working filament voltage available until the battery has delivered practically all of its theoretically calculated capacity.

The Air Cell battery is not a storage battery. There is no gassing or bubbling of the electrolyte under any condition of service. Consequently no fumes, corrosive or otherwise, are emitted from the battery. It delivers its long life without recharging and with no attention other than to add a little water at infrequent intervals to replace that which is lost through evaporation.

The maximum current which the battery can deliver is determined by the maximum rate at which the special carbon electrode can extract oxygen from the air. This corresponds to .75 ampere, and since this is nearly 50 per cent. more current than most Air Cell receivers will need, there is little likelihood of the battery being overloaded when used for its intended purpose.

A number of receiver manufacturers already are producing Air Cell receivers, and as their superior qualities become more widely known and their popularity increases as a consequence, it is fairly certain that before long the dweller in the unwired home will be able to buy an Air Cell receiver of almost any make he may choose.



## Robot Throat

(Continued from page 599)

It is also interesting in closing to know how this system works out in practice. Some time back, one of these speakers was used in New York City to talk to a group of people across the Hudson River in New Jersey, six miles away. The electrical power utilized in this test was furnished by an amplifier utilizing two -50 type tubes, or about as much power as some people use in their radio sets in an ordinary sized living room! The people on the Jersey side heard every syllable perfectly.

In a recent test at the Yankee Stadium, one of the speakers, also using a push-pull -50 amplifier, was used in comparison with a battery of ordinary public address speakers actuated by a push-pull 50-watt amplifier. Above the noise of the crowd the ordinary speakers could not be understood, but with the air column speaker, every word was perfectly distinct.

We are told by the inventors that experiments are under way to reduce the pressure necessary for operation, and if successful, the compressor can be made so small and light that it may easily be carried in one hand. They are also experimenting with a system for use in airplanes that utilizes the head wind as a source of air pressure, entirely eliminating the necessity of a mechanical compressor.



## FRESH EGGS -- FRESH TUBES

**Y**OU know the fine points of fresh eggs. But how about fresh tubes—tubes produced during the past month or two, rather than tubes produced a year or two ago and taken from a huge inventory?

Fresh tubes are more important than fresh eggs. There is no style about eggs: they all look alike and taste alike except for the degree of freshness. But with tubes there are definite styles, trends and improvements constantly being introduced—not particularly visible, to be sure, but certainly audible in the performance.

Insist on fresh tubes—tubes produced during the past month or two—tubes that do not represent the liquidation of vast inventories.

DeForest Audions, made on rigidly controlled production schedules, are fresh tubes. They are shipped as rapidly as they are produced. The DeForest Audions you receive today from DeForest distributors or dealers were produced within the past two or three months. That is why they incorporate the latest and best features known to the radio tube art.

*Let us tell you more about fresh DeForest Audions and what they mean to you in increased sales and greater net profits. Better still, let DeForest Audions speak for themselves.*

DE FOREST RADIO COMPANY : : PASSAIC, N. J.

**DeForest** RECEIVING AND TRANSMITTING **TUBES**  
(AUDIONS)

**CODE AT HOME RADIO AND TELEGRAPHY**  
Has Helped Thousands NOW! On Land, Ships, and Air—Your Career  
To Better Positions Future is Secure. Know Code. The Auto-Omnig-  
U. S. Govt. Depts., Colleges, graph teaches you easily and quickly. Learn by  
Scientists, and Schools use it Listening. Models \$15-\$40. Catalog Free.  
THE OMNIGRAPH MFG. CO., 810 E. 39th St., N-8, Brooklyn, N. Y.



### JOHN F. RIDER

Is Now Conducting  
An

**ADVANCED RADIO and ELECTRONIC COURSE**  
for serious minded

**RADIO SERVICEMEN · EXPERIMENTERS**  
**PROFESSIONAL SET BUILDERS**

who wish to study at home, in order to increase their earning power and prepare for the future.

JOHN F. RIDER, Steneck Trust Bldg., Hoboken, N. J. RN-2  
Dear Mr. Rider: Please send me all details about your SPECIAL HOME STUDY COURSE. This does not obligate me in any way.

Name .....  
Address .....  
City ..... State .....

## Observing the Federal Licensing Requirements

(Continued from page 646)

**Amazing Reception!**  
**RED ARROW ANTENNA**  
 (Sponsored by Yahr-Lange of SUPERBALL fame)

A new "all directional" aerial which in addition to giving marvelous reception has the added advantage of being a handsome weather vane.

Does away with unsightly wire aeri-als and makes a real ornament for any home. Easily brings in distant stations with amazing clearness, due to patented condenser which neutralizes entire system.

Write for more complete description.



**\$6.50**  
 Complete with Installation Kit

**SUPERBALL ANTENNA**  
 Over 1,000,000 in Use

Join the million satisfied owners of the famous SUPERBALL ANTENNA.

Enjoy greater selectivity, volume and distance with the SUPERBALL ANTENNA, which brings out the hidden powers of any radio set.

Buy a SUPERBALL ANTENNA today and really begin to enjoy radio reception.

Get one TODAY at your RADIO DEALERS.



**\$8.25**  
 Complete with Installation Kit

**YAHR-LANGE, INC.**  
 205 E. Water St. Milwaukee, Wis.

600 broadcasting stations in operation, many other station applications are pending. The existing stations vary in power from 50 to 50,000 watts; they are distributed fairly generally over the whole country. This distribution may readily be observed by consulting the Commission's latest State list and General Order 92, as well as its explanation covering the present quota assignments by zones and states. As is pretty well known these broadcasting stations operate only on the frequencies between 550 and 1500 kilocycles, actually a very small part of the frequency spectrum running from 10 to 30,000 kc., and containing 1825 possible channels, dependent of course upon the established separation.

### The Radio Spectrum

In general the radio communication spectrum is divided into five groups reaching from the long-wave or low-frequency channels to the very short-wave and very-high-frequency channels. The first band, described as the low and intermediate frequency group, or frequencies between 10 and 550 kilocycles, contains 465 separate channels assigned for the use of ship, coastal, point-to-point, radio compass and radio-beacon stations.

The second group of channels is, in this country, assigned only to radio-phone broadcasting stations; it lies between 550 and 1500 kc. and provides 96 channels, six of which are assigned exclusively to Canadian broadcast stations.

Medium high frequencies, between 1500 and 6000 kc. come next, and provide some 639 channels which are designated as the continental band and are assigned to stations in this country and others with the understanding that other stations be not interfered with. In this group lie the police, geophysical, fire, maritime, aviation, point-to-point, public service, visual broadcasting, emergency power company, experimental and some of the amateur channels.

The next group comprises what is called the trans-oceanic channels, or high frequency band, used internationally for long-distance communication; they lie between 6,000 and 23,000 kc. and there are 624 of them in use by the several nations operating such type stations. Conditions for such use require that interference with stations in their countries be avoided. The long-range trans-oceanic stations, some amateur and several special services, including relay-broadcasting, operate in this band.

Finally, there is the very-high frequency band wherein operate experimental stations and recently a few commercial stations in Hawaii. There is some question as to just how many channels lie in this part of the spectrum, which literally reaches from 23,000 kc. to infinity, as spacing channels are not definitely established.

The total available channels with the present channel separation for practical purposes is the sum of those listed above, or 1324.

Perhaps the most important and economic group is the fixed service since it includes all point-to-point stations carrying on international communication via radio in opposition to the cable services, including public point-to-point circuits which transmit and receive messages to and from foreign stations on what are termed the international channels. Of this type station there are now licensed 229, including similar public stations authorized to communicate only with other U. S. stations on the domestic circuits, paralleling the telegraph and telephone land lines.

Other services in this same class include emergency stations erected by certain electric power companies all operating on a single channel and only in use when other means of communication fail; agricultural stations operated for the benefit of farming and marketing interest and of course the public! the general and special press telegraph circuits exclusively maintained for the convenience of newspapers and news services, and the special services authorized in Alaska until January 25, 1931, for interior communication only. They tie in with the Signal Corps' Alaskan Cable circuit to the States, and are all under the local supervision of the Signal Corps of the Army.

The great group of mobile stations comes next. Chief in importance are some 2,200 ships which fly the American flag, and other land and air portable stations, such as automobile and aircraft stations. Some 200 airplanes are today equipped for communication with special aeronautical ground stations. There are also included some 90 coastal stations licensed to communicate with ships by both radio telegraph and telephone systems. The press is also accorded the use of certain mobile channels for press broadcasts to ships.

The third and last general group, termed the special services, covers the great army of 19,000 amateur stations, a large number of Governmental stations comprising the U. S. Army and Naval stations ashore and afloat; there are also Coast Guard, radio companies, airways and lighthouse and other services all of which stations operate on special channels assigned by executive order of the President. In this class also are the fire and police services which operate in especially designated bands and the diversified experimental services covering geographical, relay and visual broadcasting and other special circuits authorized for experimental use only.

Each service has its own frequency assignments and special operating regulations, as may be observed by those interested by examining the following general orders the titles of which indicate the services covered; Nos. 50, 51, 56, 64, 68, 70, 74, 79, 82, 83, 84, 85, 86, 88, and 94.

Future articles of this series, however, will deal with the regulations concerning the licensing and operation of the three main types of service; namely, Fixed, Mobile and Special.

(Continued on page 650)

**1931 Radio Catalog**  
**RADIO BARGAINS**  
**WHOLESALE DISCOUNTS**  
**LOWEST PRICES**

**RADIO CATALOG 1931**  
**WHOLESALE**

**REGULAR WHOLESALE TRADE DISCOUNTS!**

Nationally-advertised, guaranteed radio merchandise, including the sensational bonded LAFAYETTE ALL ELECTRIC RADIO RECEIVER, with tone control. Write at once for FREE 1931 Radio Bargain Catalog, showing complete selection. Don't buy until you see this wonder catalog!

**WHOLESALE RADIO SERVICE CO.**  
 Dept. A-12; 38 Vesey St., New York

**FREE!**

**Radio's Biggest Values**

Up-to-the-minute offerings at lowest wholesale prices. Includes newest Tone Control, Screen Grid Superheterodyne, Radio-Phonograph combinations, short wave receivers, automobile radios. Public address, attractive walnut consoles and latest accessories, parts and kits. Don't buy until you see our big catalog.

**Send for FREE Complete Catalog**

**Western Radio Mfg. Co.**  
 128 W. Lake St. CHICAGO

## Home Lab. Experiments

(Continued from page 626)

screen-grid tube may be used or an "amplifier-voltmeter" may be constructed. The amplifier-voltmeter can be designed for use only over a certain range in frequency. For measurements at audio frequencies the circuit takes the general form shown in Fig. 4, and Fig. 5 shows sample calibration curves for such a circuit. The stage of amplification increases the gain by a factor of about 7 and we are therefore able to accurately measure voltages down to about 0.1 volts and by means of multipliers the range can be extended up to about 4 volts.

Where the ability to measure small voltages is not essential but it is necessary that the voltmeter be capable of measuring a large range in voltage a reflex voltmeter should be used. The ordinary single-tube voltmeter has an effective range of about 4:1; by the use of a reflex circuit the range from minimum to maximum voltage may be made 10:1 or greater. The circuit arrangement of a reflex voltmeter is shown in Fig. 6 and a sample calibration curve in Fig. 7. If the circuit of the voltmeter is examined it will be found that the plate current must pass through the resistance R to reach the filament and the voltage drop across this resistance produces a voltage drop which increases the negative bias on the tube; therefore the greater the plate current the greater the negative bias on the grid. As a result the plate current increases less for a given a.c. voltage than it would were the resistance R not in the circuit, and in this manner the range in voltage over which the instrument is useful can be increased.

In the circuits of the various types of voltmeters will be found a resistance R and a battery Em connected directly across the meter in the plate circuit. This combination of resistance and battery is used to force a current through the meter in the opposite direction to the current due to the electron flow through the tube. This opposing current is generally necessary because under conditions of no a.c. input a certain amount of current flows in the plate circuit and produces a deflection on the plate meter. For example, a 200-microampere plate meter might be used, but if the normal plate current with no a.c. input was 100 microamperes, then only half of the scale of the instrument could be used. If, however, a current of 100 microamperes is passed through the meter in the opposite direction its deflection will become zero and the entire scale of the instrument then becomes available to indicate a.c. voltages. The resistance R should be much larger than the resistance of the meter. If we had to balance out a steady plate current of 100 microamperes and the battery Em had a voltage of 6 volts, then the resistance R must be

$$R = \frac{6}{100 \times 10^{-6}} = 60,000 \text{ ohms}$$

These various types of vacuum tube voltmeters can be set up in the experi-

(Continued on page 651)

**Small in  
SIZE**



**Super-TONATROL**

**Large in  
PERFORMANCE**

Licensed under U. S. Pats. 1,773,105 and Pats. Pend. and Canadian Pats. 281,172 and 286,778.

# SILENT — DURABLE

## The BETTER Volume Control FOR ALL RADIO PURPOSES

For quiet, smooth control of radio volume, experts agree that there is no substitute for the super-TONATROL.

Dissipates a full 5-watts. And tests prove it will outlast the useful life of any radio set. New type resistance element permanently fused to vitreous enameled steel plate. Pure Silver floating contact. Stepless variation. Metal cover aids rapid heat dissipation. 7 types for all usual radio requirements. Write for special folder describing types and recommend uses.

### Better Resistors and Voltage Controls For Every Radio Requirement

Electrad manufactures a complete line of resistors and voltage controls for every radio and power supply requirement, including television. Correct engineering principles and rigid supervision of manufacturing stand behind each Electrad product—your assurance of highest quality. Choose Electrad and be certain of PERFORMANCE.

Specialists in Loftin-White Direct Coupled Amplifiers. Three models, with '45, '50 and '50 push pull output. Mail coupon for data.

175 Varick St., New York, N.Y.

**ELECTRAD**  
INC.

ELECTRAD, INC., Dept. RN-1  
175 Varick St., New York

Please send Super-TONATROL Folder.  Check here for circular covering all Electrad Products.  
 Check here for Loftin-White Data.

Name .....

Address .....

**WHAT A THRILL!**

All the locals and the world at your finger tips!!!

**PILOT SUPER D.C. \$29.50  
WASP A.C. \$34.50**

For short wave and regular broadcast reception nothing equals this set that has made history in "round-the-world" communication. Shipped in kit form with full set of tubes and simple instructions for easy assembly. A. C. model, \$34.50. Battery model, \$29.50. Power Pack for A. C. set, \$18.40, including Rectifier Tube. Other A. C. tubes, \$9.90. Tubes for D. C. set, \$8.25. Typical 20th Century values—where you get everything in radio at lowest prices. Send 25% deposit, balance C. O. D. plus transportation. Speaker extra. Power Pack extra.

SEND FOR CATALOG and FREE RADIO GIFT

**20th CENTURY MAIL ORDER CORP.**  
200 West Jackson, Chicago, Ill.

**HOTEL WASHINGTON**

Opposite the United States Treasury  
PENNSYLVANIA AVENUE  
AT 15TH & F STREETS  
400 ROOMS—400 BATHS

Floor clerks on each floor. Desks open from 7.30 A.M. until midnight. A service particularly attractive to ladies traveling alone.

Easy of access yet located at the very center of life in the Capital City.

RATES NO HIGHER THAN ANY OTHER FIRST CLASS HOTEL

Booklet sent upon request  
S. E. BONNEVILLE  
Managing Director  
WASHINGTON, D. C.

# EXCELLO RADIO



Excello Radio  
Phonograph  
Combination  
Model R-369

New 1931 "Excello" Screen  
Grid Superheterodyne,  
9-Tube Radio

The combination Radio and Electric Phonograph shown above is completely equipped with radio, phonograph equipment and super dynamic speaker. This beautiful Excello Radio assures excellent reproduction—perfect in tone quality.

Complete catalog free on request

**EXCELLO**  
PRODUCTS CORPORATION  
4832 West 16th St. Cicero, Illinois

Write for Free Instructions



**"HOW TO SOLDER PERFECTLY"**

VULCAN ELECTRIC HEATER CORP.  
Dept. M, 225 Variek St., New York City  
Makers of Vulcan Electric SOLDERING TOOLS. Ask your dealer about them.

**FREE!**

**RADIO DEALERS SET BUILDERS AGENTS SERVICEMEN OUR BARGAIN BULLETIN IS WAITING FOR YOU**

**This COUPON means MONEY for YOU**

Baltimore Radio Corp.  
47 Murray St., N. Y. C.

Gentlemen: Kindly send me your latest Radio Bargain Bulletin. Print name and address clearly.

Name .....  
Address .....  
City ..... State ..... "N"

## Selectivity, Sensitivity and Fidelity Measurements of the Hammarlund Hi-Q 31

(Continued from page 617)

These selectivity curves indicate some very important characteristics of the Hi-Q 31 receiver. In the first place, one should notice the band-pass characteristics of the several curves with the result that side-band suppression is negligible. Also it will be noticed that the lower part of each of the three curves coincide, indicating that the receiver has uniform band-pass characteristics at all broadcast frequencies. Were it not for the fact that the band-pass circuits of the Hi-Q 31 used combined capacitative and inductive coupling the lower parts of the various curves would not coincide and as a result the receiver would not give essentially uniform fidelity over the entire broadcast band. The straight sides of the various curves are responsible for the fact that the receiver is capable of eliminating all stations except the one to which the set is tuned. For example, the 600 kc. curve shows a band width of only 28 kc. at a field strength ratio of 1,000. In many receivers a band width of 80 kc. is not uncommon. In the same manner the 1,400 kc. curve shows a band width of about 70 kc. in comparison with band widths of over 100 kc. in many other sets. The excellent band width characteristics of the Hi-Q 31 are due to the fact that the set uses six accurately matched tuned circuits.

Before discussing the fidelity characteristics we might make a few remarks concerning the "bumps" in the 1,000 and 1,400 kc. selectivity curves. It is difficult to understand what they are due to, although any serious concern about them is perhaps largely academic since they do not affect the quality or the selectivity to any marked extent. Inaccurate alignment of the tuning condensers would not produce such a characteristic. The peculiar shape of these two curves may possibly be due to some slight pick-up between the signal generator and the set in addition to the direct pick-up between the set and the output terminals of the signal generator. It is probable that the right-hand portion of the 1,000 and 1,400 kc. selectivity curves are a more accurate representation of what the left half of these curves should look like.

The overall fidelity of the receiver from antenna terminal to power output tube is shown in Fig. 4. These fidelity curves are made by tuning the set to 600 kc., adjusting the r.f. input frequency to 600 kc. and then varying the audio modulation frequency from 30 up to 5,000 cycles, maintaining the percentage modulation constant at 30 per cent. If as the audio modulating frequency is varied the audio power output varies from the standard of 50 milliwatts, the r.f. input voltage is increased sufficiently to maintain constant audio-frequency power output. The ratio of the r.f. input at 400 cycle modulation to the r.f. input at some other modulating frequency is converted into decibels and curves are then plotted showing the variation with audio-frequency modulation. Three sets of fidelity curves, one at

600, another at 1,000 and another at 1,400 indicate how the fidelity of the receiver differs at various points in the broadcast band. The variation in fidelity at various broadcast frequencies is due largely to the change in side-band suppression in the radio-frequency amplifier. At 600 kc. the side-band cutting is most severe and therefore we find the greatest falling off in output at high audio frequencies. At 1,400 kc. the side-band cutting is very slight and as a result the quality is somewhat improved. But the curves of Fig. 4 show that in the Hi-Q 31 side-band suppression has been reduced to a very low value over the entire broadcast band. The loss of 8 db. at 5,000 cycles for the 600 kc. condition is unusually small; many sets not using band-pass circuits show a loss of 20 to 30 db. at 5,000 cycles. The fidelity curves also show excellent response at low frequencies down to 30 cycles. The loss of 3 db. at 30 cycles shown by the curve is too slight to be noticed by even the most sensitive ear.

We must conclude from these overall response characteristics of the Hi-Q 31 that the care used in designing each component of this receiver has certainly been justified. The overall response characteristics are essentially what one would expect to find from a careful analysis of the individual parts of the set. We are sure that the excellent characteristics of the receiver will be appreciated by all of those custom set builders and experimenters who construct the Hi-Q 31.

## Observing the Federal Licensing Requirements

(Continued from page 648)

A communication has just been received from Mr. Butman stating that two more general orders have been passed by the Federal Radio Commission.

*General order 98 amends old general order 28 but not in any material way except to define what a main studio is, and reiterate the fact that it must not be moved out of the district, state or territory, in which it is located without permission.*

*The second of these new general orders is 99 and amends the Commission's aeronautical allocations covered in general order 94.*

THE EDITORS

## CORRECTION

Through an error in the press, the price of the Superball Antenna in the Yahr-Lange advertisement on page 575 in the December issue of RADIO NEWS was given as \$3.25 instead of \$8.25.

## News from Manufacturers

(Continued from page 638)

A microphone mixer is incorporated which has the ability to mix three carbon or condenser microphones. Each microphone circuit is controlled by a cam type anti-capacity switch. Signal lights illuminate, designating what circuits are in operation. The mixer is featured with



noiseless mixing and current controls and is designed for unrepulsive operation.

A volume indicator is part equipment with separate indicator and monitor tubes.

## Wellston Gold Test Aerial and Tone Control

Wellston Radio Corporation of St. Louis, Mo., reports that they are introducing a new filtered type aerial known as the Wellston Gold Test Aerial. This device measures only 2½ by 5 inches inside and contains an equivalent of 54 feet of aerial, 50 feet above ground. It is non-directional and non-corrosive and is designed to take the place of all present types of indoor and out-



door antennas. The aerial is an improvement of a similar product previously made by this company.

The Wellston Radio Corporation is also marketing a new tone control, which, like the aerial, is small in size and is easily connected to the set. An illustration of the tone control is shown here.

## Home Lab. Experiments

(Continued from page 649)

menter's laboratory with but little difficulty. Much information concerning their characteristics can be obtained in this way. The experimenter and serviceman will find many uses to which they can be put, but their maximum usefulness will only be appreciated if one is willing to take the trouble to thoroughly understand their operating characteristics—but no amount of ordinary reading will give this knowledge. To obtain it, it is necessary to roll up one's sleeves, go into the "lab" and get to work.

# HUMBLESS A. C. Operation

on the Short Waves

with the New A. C. THRILL BOX

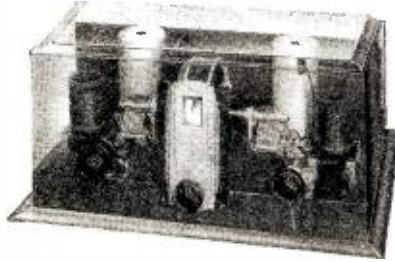

COMBINES every requirement of the expert Short-Wave Experimenter and Amateur, and the Radio Enthusiast who wants good loud speaker reception of SW broadcasts from all over the world. Not a compromise between a Short-Wave and Broadcast circuit. A.C. Model gives FULL A.C. OPERATION. No hum, even with head phones. DOUBLE SCREEN-GRID with grid-leak detection. Special New R-39 Type R.F. Coupling Transformers. No special tubes required. Uses standard heater tubes throughout. Single dial operation, easy to operate and log. Uses New NATIONAL Projector Dial. No grunting or backlash, no hand capacity; Loud Speaker operation from Foreign Stations; push-pull audio with special phone-jack after first stage.

Thoroughly shielded chassis. Easy to assemble and wire. Ideally suited not only for Short-Wave Broadcast reception, but for all S. W. amateur and communication uses. Easily adapted for still wider spread of amateur bands, if desired. Perfect performance down to 9 meters, using NATIONAL R.F. Transformers No. 10.

Also available in new battery model, using the new UX 230, 231 and 232 tubes.

# NATIONAL

PRECISION SHORT-WAVE  
RADIO PRODUCTS



## RADIO OPERATORS WANTED



Radio operators are officers aboard ships. Well paid, pleasant work, travel. You can qualify in a short time in our well-equipped school under expert instructors.

Write now for free booklet on "Opportunities in Radio."

West Side YMCA  
Radio Institute

113 West 64th St., New York, N. Y.

The New NATIONAL A. C. SW-5 THRILL BOX is easily assembled by anyone with genuine NATIONAL Radio Parts. Some of the more outstanding of these are described below.

### R. F. Transformers



Standard set of four pairs covering from 21.2 to 2.61 m.c. Special coils can be supplied for the 33—21.2 m.c. and the 2.61—1.5 m.c. ranges. Forms are moulded R-39, the new low loss coil material, developed by Radio Frequency Laboratories. Blank forms also available for winding experimental coils.

### The Condensers

The type S-100, specially designed for short-wave work, not a cut-down broadcast condenser. Insulated main bearing and constant impedance pigtail. 270 degrees straight frequency line plates.



### The Dial



The NATIONAL Projector Type Drum Dial, standard equipment on the A. C. Thrill Box has the same easy control that is characteristic of the National Velvet-Vernier Dials. Equipped with non-metallic drive, avoiding clicking and de-tuning. The dial scale is projected in magnified form on to a ground glass screen which reads the same from any position, without parallax. The escutcheon, of beautiful modern design, is finished in brush silver.

### The Power Unit

A separate unit, with handy cable and soft rubber-covered connecting plug. Designed for humless operation, incorporating special R. F. filter in addition to double section hum-filter. Employs UX-280 Rectifier tube and licensed under R. C. A. Patents.



----- COUPON -----

NATIONAL CO., INC.  
Sherman, Abbott and Jackson Sts.  
Malden, Mass.

Gentlemen:

Please send me, free, Short Wave Bulletin No. 141.

Enclosed, please find 50c (stamps or coin) for your new NATIONAL SHORT WAVE HANDBOOK, describing all the new Short Wave Circuits (just off the press).

Name .....

Address .....

RN-1

KEEP POSTED ON RADIO PROGRESS

JOIN THE RADIO INTERNATIONAL GUILD

—now has 60,000 members—who exchange information and tips of value to experimenters, set builders, service men. Also personal news and short wave gossip—membership fifty cents for a year, including subscription to official organ RADIO DESIGN—well known contributors make this quarterly livest of Radio publications. Send 50¢ today and receive current issue together with membership button, identification card and R. I. G. certificate.

Radio International Guild, RN-131, Lawrence, Mass. Enclosed find 50c. Enroll me as a member of the R. I. G. Send button and Radio Design for one year.

Name .....

Address .....

## BUILD YOUR OWN CAPACITY BRIDGE

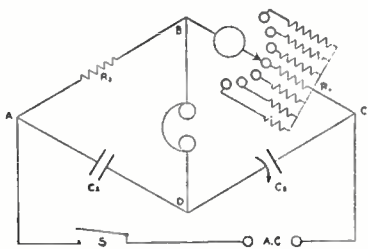

Super Akra-Ohm wire-wound resistors were recommended for the construction of an inexpensive capacity bridge in September QST. The following Super Akra-Ohm Resistors, Type GM, were used:

Each	Each
1— 100 Ohm.....\$1.25	1— 10,000 Ohm....\$1.50
1— 300 Ohm..... 1.25	1— 30,000 Ohm.... 1.50
1— 1,000 Ohm..... 1.25	1—100,000 Ohm.... 2.00
1—3,000 Ohm..... 1.25	



We manufacture wire-wound resistors of any value from 0.01 to 10,000,000 ohms having negligible inductance and distributed capacity and calibrated to an accuracy of 1%. Their use is highly recommended for Laboratory Standards, High Voltage Regulators, Telephone Equipment, Television Amplifiers, Grid and Plate Resistors, Electrical Apparatus, and Test Equipment, etc.

Prices range from \$1.25 for 100 ohms to \$4.00 for 500,000 ohms.

Send us your dealer's or jobber's name and we will send you a copy of the article reprinted from September QST, telling how to build a capacity bridge. Address Dept. D.

**Shalross Mfg. Company**  
 ELECTRICAL SPECIALTIES  
 700 PARKER AVENUE  
 COLLINGDALE, PA.

## Radio Flies the Air-Ways

(Continued from page 610)

"BHDOF DHOEH DFOOB EFFOF FBOG."

Decoded, the message yields the following information:

"A light breeze is blowing from the Northwest. The sky is partly cloudy.

"Horizontal visibility is six miles. Barometric pressure 30.02 inches.

"Temperature is 48.4 degrees above zero. Wet bulb depression is 5.8 inches (Humidity is calculated from this reading.)

"Six-tenths of the sky is obscured by alto-stratus cloud formations at an altitude of 6,000 feet.

"Two-tenths of the sky is obscured at an altitude of 2,000 feet."

The meteorological division includes the

the plates. Filaments are fed from a 12-volt storage battery.

Existing commercial equipment having proved too heavy and cumbersome for practical use, a model light enough to be mounted in the tail of the ship was made the goal of research. Thus was developed the present transmitter, which weighs only 37 pounds, including all controls, tubes, antenna and microphone. The transmitter panel alone tips the scales at only 30 pounds. Former equipment used weighed 185 pounds and had to be carried in the passenger cabin.

The receiver is a six-tube modified superheterodyne, using three screen-grid tubes and affording an overall gain of between three and seven million. It operates from a separate five-foot vertical antenna. For transmitting, a trailing aerial wire is used. All controls are located in the forward cockpit of the ship and are connected to the apparatus by a thirty-foot length of flexible dental cable. All connections may be changed and the receiver and transmitter replaced in five minutes, a plug-in terminal arrangement simplifying the connections to a few simple motions.



E. W. Proctor, TAT-Maddux radio engineer who designed their new transmitter

### Shielding Harness

To prevent interference from the ignition system, TAT-Maddux has developed its own shielding harness, which wholly eliminates local disturbances. The entire ship is shielded, wing to wing, nose to tail.

Operating waves of the transmitter are 457 kc. on the transcontinental run, and 333 kc. on the Pacific Coast route, which parallels the coast and extends from San Francisco as far south as Agua Caliente, Lower California. Ten channels are held by TAT-Maddux, encompassing frequencies ranging from 333 to 3106 kc. The design of the transmitter makes it readily adjustable to any of these frequencies.

Although the equipment was designed to cover a range of 200 to 250 miles, conversations are held regularly over distances of 400 to 600 miles. The record so far was established when the ground operator at Kingman, Arizona, heard an Eastern division airplane report its position as 20 miles east of Columbia, Missouri—an airline distance of over 1,300 miles.

### 98 Per Cent. Efficiency

The TAT-Maddux installation is not an experimental set-up, for it has proved itself over many thousands of miles of flight. It flies 5,000 miles daily, with the 20 tri-motored Ford planes in use on the eastern and western divisions. No failure of the equipment has yet been reported. Every fifteen minutes each pilot tests it by actual communication with the ground—and a recent check over the files of nine months' operation revealed an efficiency of better than 98 per cent!

**WELLSTON GOLD TEST AERIAL** Gets Greater Distance



Reduces Static & Hum  
 The World's Smallest Aerial 2 1/2 by 5 inches in Size  
**IMPROVES RADIO RECEPTION**

### EASY TO INSTALL

It is a simple matter to install the WELLSTON GOLD TEST AERIAL—even a child can do it in a few minutes time. No extra tools are needed. Place it anywhere—inside on the back of the radio cabinet. Once installed no further attention is required.

### IT WILL NEVER WEAR OUT

Made of emerald green genuine solid (condensite with binding posts to match, this NEW AND IMPROVED WELLSTON GOLD TEST AERIAL is of the filtered type endorsed by radio engineers. Although small enough to fit the palm of your hand, it has a capacity equivalent to 34 ft. of best grade aerial wire strung 50 ft. high in the air.

IF YOUR DEALER CAN'T SUPPLY, ORDER DIRECT  
**Price \$2.50**  
**WELLSTON RADIO CORP.**  
 Dept. 104 St. Louis, Mo.

chief meteorologist, at St. Louis, an associate meteorologist, at Columbus, responsible for the Eastern division; an associate meteorologist at Los Angeles, supervising the Western division; and junior meteorologists at nine landing fields, each responsible for eight or ten observers in his particular territory.

### Mass of Information

The mass of detailed information gathered by this widespread network is sifted and analyzed by the experts at the central meteorological stations. Bulletins are relayed to the pilots as they fly. If an emergency arises the pilot calls headquarters and is given advice by the division superintendent. The pilot is thus relieved from the responsibility of making important decisions himself, and is given the benefit of the complete knowledge of the central bureau.

Much of the success of the TAT-Maddux radio system may be credited to the transmitter developed by E. W. Proctor and Daniel Givens, company communication engineers. The set is mounted upon a single bakelite panel bread-board style, and comprises three fifty-watt tubes—oscillator, power amplifier, and modulator—fed by a 7 1/2-watt speech amplifier tube. A double-voltage, engine-driven generator supplies 1,000 volts to

## The Stenode Radiostat

(Continued from page 591)

impressed at equal strength upon the transmitting microphone, the output from our highly selective receiver would be expressed as inversely proportional to frequency.

Thus notes of 100 cycle frequency were twice as strong as those of 200 cycles, those in turn being twice as strong as notes of 400 cycles and so on. It then remained to design a special audio frequency amplifier having a characteristic curve directly proportional to frequency, notes at 200 cycles being magnified twice as much as those of 100, and so on. In this way the overall response curve of the receiver could be made substantially uniform over the whole scale, giving first-class quality without sacrifice of the abnormal selectivity which characterized the radio frequency portion.

I am not attempting to give the order in which this work was done, but merely trying to give you a picture of the development of the apparatus in the form which has already been demonstrated in this country. For example, prior to evolving the apparatus just described, I had proved my principles in quite another way by means of what is called my phase reversal system. But I cannot describe this to you without first giving a little more time to the reason why in a highly selective circuit the audio frequencies are disproportionately reproduced.

Early in the article I indicated that according to the theoretical views held by practically all scientists, the resonance curve of a receiver must embrace all of the side-band frequencies if proper quality is to be obtained, also indicating that my own theory had shown this reasoning to be fallacious. Let us now consider for a moment exactly what happens in a circuit of a very low impedance, one that is tuned so sharply that hitherto it has been considered useless for radio telephone communication.

Let us imagine, for example, that a pure note of 1000 cycles is played in front of a broadcast station microphone. This note causes a rising and falling in amplitude of the carrier wave 1000 times a second, and we say that the carrier is modulated at this frequency. When the signal is picked up in a receiver tuned to the particular transmission, a resonance effect takes place and we have, roughly speaking (considering a carrier frequency of a million) 1000 radio waves to each rise and fall. If we impress upon the microphone a note of 2000, then we have only 500 waves for each rise and fall, similarly a note of 4000 will have 250 waves and so on.

Now the intensity of current which the signal will build up in a sharply resonant circuit is a function of the number of waves impressed upon the receiver. You will see that in each pulsation note of 1000 you have twice as many waves for resonance purposes as you have in the note of 2000, therefore, the built-up signal will be roughly twice as strong. Carry this reasoning through all the frequencies in the audio spectrum and you will see

very easily that the reproduction of frequencies in a very sharply tuned circuit is, as I have pointed out early in this article, inversely proportional to frequency.

So far, of course, we have not found the ideal sharply tuned circuit, which would be a circuit that would respond easily to one frequency to the total exclusion of all others. Even the quartz crystal falls considerably short of this ideal. At the same time the commercial application of such a circuit would be impractical because we would pass through the station so easily when tuning as to miss it altogether. The present Stenode circuits have been worked out to be a practical compromise between infinite selectivity and easy handling. The tuning is broad enough to be easy to handle while being at least twice as sharp as the most difficult modulated conditions require; and when turning the dial we find a station, pass through it, find silence, and then, sure enough, the next station will come up clearly and distinctly without a trace of interference so soon as we reach the correct degree on the dial. The fact that there are blank sections between transmissions will show you that you have there space for a large number of new transmissions in the ether when this form of receiver is used.

### Phase Reversal

I have already mentioned the phase reversal method of receiving which forms the basis of one of my Stenode receivers. In this the effects of persistence in giving a disproportionate building up of different frequencies are counteracted in the high frequency part of the circuit without in any way sacrificing selectivity, the audio frequency amplifier being of a normal type. The particular circuit used for this is one of great potentialities and has already given admirable results, but at the moment is not quite so simple as that used in the Stenode Radiostat receiver which I have brought to this country.

The circuit diagram reproduced on page 591 will enable you to see how the Stenode is worked out in practice. The high selectivity which is the great feature of the receiver is obtained by sending the incoming signal through a quartz resonance circuit, and in order that one quartz circuit can be made to function for all frequencies in the broadcast band, we utilize the superheterodyne principle, converting the incoming waves from their normal frequency to that of the quartz crystal circuit.

We thus have a loop receiving circuit, or tuned circuit connected to an antenna if necessary, an oscillator circuit for beating the local oscillations with the incoming oscillations, so as to produce the intermediate frequency, screen grid intermediate circuits, a highly selective quartz circuit (or the "Gate" as we sometimes call it), the second detector and a specially designed audio frequency amplifier to cor-

(Continued on page 658)



Prominent Radio Retailers and Jobbers acclaim ARCTURUS

**LIFE-LIKE TONE**

Just two months ago we emphasized a distinctive Arcturus feature—*Life-like Tone*. Radio dealers everywhere were interested. They were convinced that *Life-like Tone* would create a new demand for Arcturus Tubes.

Newspaper Advertising on *Life-like Tone* first appeared on September 4th. Public response was immediate. The telegrams above show what the radio trade thinks of Arcturus *Life-like Tone*. The quick 7-second action of Arcturus Tubes and their *Life-like Tone* are bringing better business and increased profits to radio dealers from coast to coast.

You, too, can benefit by this Arcturus feature. Ask your jobber for all the facts about Arcturus Blue Tubes.

ARCTURUS RADIO TUBE CO., Newark, N. J.

**ARCTURUS TUBES**

The TUBE with the LIFE-LIKE TONE

# CHIRAD

APPROVES  
NEW NATIONAL  
SHORT-WAVE

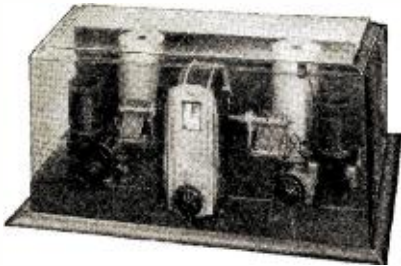

## A. C. THRILL BOX

A new humless A. C. operated short-wave receiver. Wave length range of 15 to 550 meters. Loud speaker reception frequently occurs on foreign broadcasts. No back lash or hand capacity. Completely shielded. Uses standard heater tubes. Unquestionably the finest short-wave receiver on the market today. Complete receiver or in kit form. Also available for D.C. or Battery operation. Write for details.

### 1931 CATALOG FREE

Write for your copy. Complete line of transmitting and receiving short-wave supplies.

**CHICAGO RADIO  
APPARATUS CO.**

415 S. Dearborn St., Dept RN-1, Chicago, Ill.



### Searching the Infinite

Out across space new suns are being mapped by giant telescopes.

In millions of radio receivers CENTRALAB volume controls are helping to reach out across space to bring in noiseless, sputterless reception.



### Dealers and Servicemen

Service all old and new sets with a handful of CENTRALAB volume controls. Send 25c for VOLUME CONTROL GUIDE showing circuits for old and new sets.

SEND THIS COUPON

# Centralab

CENTRAL RADIO LABORATORIES  
Dept. 225G, 22 Keefe Ave., Milwaukee, Wis.  
Enclosed find 25c for VOLUME CONTROL GUIDE.

Name .....

Address .....

City ..... State .....

## Europe Puts the Pentode to Work

(Continued from page 607)

radio user who is accustomed to at least five or more in the average receiver. But in Europe economy is of great importance, and lack of standardized mass production makes even the small receiver more expensive than it would be in America. Furthermore, almost every large city in Europe has its high-power broadcasting station whose power may go as high as twenty to fifty kilowatts. With such powers, and with no need for such great selectivity as is necessary in the United States, smaller receivers are much more feasible. All of these pentode-equipped sets will be marketed for prices ranging from fifty to seventy-five dollars with tubes but without loud speakers.

The design of the equipment is significant and points out a number of the advantages and disadvantages of the pentode in its present form when used with present-day loud speakers. Against the one great advantage that the tube offers—simplified, economical audio-frequency amplification—there arise a number of limiting factors: (1) The high resistance of the tube serves to increase the speaker's response to the higher audio frequencies, particularly when used in conjunction with the magnetic type of reproducer, thus introducing a serious problem of distortion; (2) this factor of distortion confines the present use of the tube to the small and lower-priced receiver; (3) while the tube gives best results when used with the moving coil type of speaker, unfortunately such speakers do not operate well on low power inputs and, regardless, would cost as much as the small receivers themselves. As a result of this situation, the first pentode receivers will be used with the magnetic speaker. Overemphasis of the higher frequencies is to some extent eliminated by

fiers used in Germany. This fact has consequently limited its use to the small receiver where economy is paramount.

Speaking in general, it is the opinion of the tube and receiver manufacturers in Europe that the pentode is to be an important factor in radio during the 1930-1931 season. Particularly is this true in England, where development has reached



Receiver for pictures and sound with window

its highest stage. Some doubt is expressed in Germany as to the response of the German people to the new receivers, due to the slight impairment of quality just discussed. The German has a not entirely unfounded belief that his people are better educated musically than other nationalities and are more likely to be critical of imperfect reproduction. But the American who has observed German crowds at the talkies, listened to radio and phonograph music in their homes, and particularly observed the crowds that gather on the sidewalk to listen to the latest phonograph record that is being reproduced in the most atrocious form, is inclined to doubt the importance of this factor.

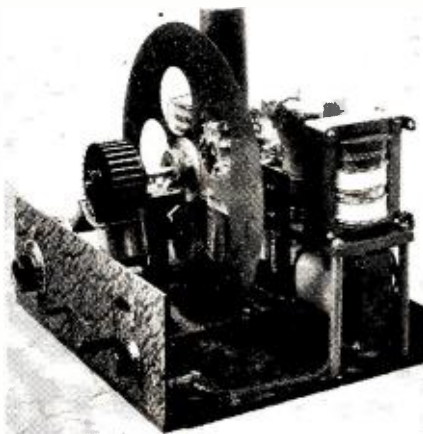

New Fernsch Universal receiver with picture transmitter

Considerable interest is being shown on the part of the European manufacturers in some of the very low-priced broadcast receivers that have been rather successfully marketed by certain of the smaller American manufacturers during the past year. They feel that they can only increase their volume of sales in the future through appealing to the wider market found in the lower price brackets. The new pentode receivers being introduced this season are intended for this market. In view of the serious embarrassment which the American radio industry passed through during the past year and its inability as yet to increase sales to a unit volume equalling that of even the automobile industry, which is older and selling a much more expensive product, it would appear that American radio manufacturers might find it very advantageous to take steps in the same direction. It is undeniable that the pentode tube offers a technical aid to anyone who takes the step in this direction.

While dealing with the subject of European tube developments, mention must

(Continued on page 655)

the use of a by-pass circuit such as shown in the accompanying diagram. But the fact remains that the pentode does not produce as high a quality of reproduction as is obtained from the push-pull amplifiers of the better British receivers and from the resistance-coupled ampli-



# Europe Puts the Pentode to Work

(Continued from page 654)

be made of the new Telefunken Arcotron 301 which will be announced at the Berlin Radio Show this year. Nothing like this has ever appeared on the market in the United States. This tube, developed by the Telefunken Company in Germany, differs from the familiar vacuum tube principally in its mechanical construction. Briefly, the plate and filament are placed side by side, approximately three-eighths of an inch apart, and sealed in the usual fashion into a flat-shaped glass bulb which carries a special design of base for mounting purposes. The plate is of approximately the diameter of that used in the familiar UX199 but has perhaps twice its length. The filament is of the ordinary tungsten variety, operating from a one-volt supply. The interesting and surprising feature of this tube is the grid. Instead of placing a wire mesh in the area between the filament and plate in order to control the space charge and thus the plate current, the grid takes the

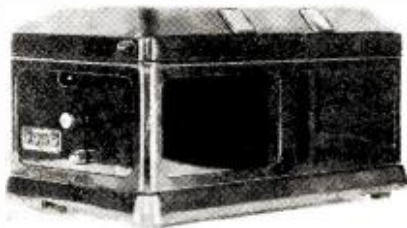

Completely shielded and screened Lorenz 3-circuit, 4-tube receiver with A.C. operation, utilizing screen grid hook-up

form of a metal coating on the outside of the glass bulb, and thus completely surrounds the filament and plate, except for the small area at the base where the leads are taken out. Old-timers and students of tube development may remember of experiments by Weigant back in 1912 in which he attempted to control the filament-plate flow by external grids of various types, without appreciable success. Telefunken engineers, working with a similar idea but with greatly improved mechanical facilities, have now developed a satisfactory tube of this design. While the first models of the tube are small and capable of handling but very small plate currents, they have been very satisfactory in small audio-frequency amplifiers using resistance coupling. The tube has an amplification constant of thirty-three.

Even more surprising and of much greater significance is a second form of this tube which can be operated as a detector, directly from an alternating current filament supply, without the use of the conventional a.c. heater type of filament. This is accomplished by introducing mercury vapor into the same type of tube as described above. The tube, thus formed, has the interesting property of detecting and passing on the signal in its audio frequency form, without introducing the alternating current modulation that inevitably occurs when a.c. is applied to the ordinary tungsten filament tube. However, this tube can only be used as

a detector. It does not possess amplifier characteristics. The high vacuum type can be used in any of the conventional ways when it is operated from a d.c. filament supply. As an audio-frequency amplifier it is satisfactorily used on a.c. when the filament returns are carried to center-tapped resistors.

At the Berlin Radio Show this year receivers using these tubes are to be introduced. They will contain the mercury vapor a.c.-operated detector, one stage of audio-frequency amplification using the high vacuum Arcotron and a conventional power tube in the output stage. While at the present time it does not appear that receivers of this design hold a great advantage over the ordinary variety, the possibilities inherent in the new idea bear watching.

### Television in Europe

A few words concerning the status of television development in Europe are not out of order. It sometimes seems that the Europeans have surpassed us in television development. However, this is decidedly a misconception. Methods in use are very much the same in America, England and Germany and progress appears to be at a comparable rate.

In Great Britain, the Baird Company is marketing a complete television receiver in both assembled and knocked-down form. The equipment, with the exception of a few artistic embellishments that have been added for sales purposes, is very similar to that which has been available to the American experimenter for the past two years. Baird uses the standard scanning-disk, photo-electric cell method in his transmissions which are made daily by the BBC in London. The vision broadcast on 356 meters is accompanied by a sound broadcast on 261 meters. The programs are given on Tuesdays and Fridays at 12 to 12:30 a.m. and on other week days from 11 to 11:30 a.m. The receiver, consisting of neon tube, motor with synchronizing device, voltage regulator, scanning-disk, magnifying lens, mountings and cabinet, assembled for use on the output of the typical broadcast receiver of five or more tubes, can be purchased in London for approximately \$125. The results attained seem to be very much the same as those of American experimenters where good broadcasts are available.

Television development in Germany has been carried on largely by the Telefunken Company. Visitors to that country can see a daily demonstration of the Telefunken system at the Deutsches Museum in Munich. While the principle of scanning is still adhered to, it is accomplished in a slightly different manner. Instead of using the familiar disk, scanning is obtained by means of a rotating wheel, approximately eight inches in diameter, on the circumference of which small rectangular mirrors are mounted with their planes parallel to the shaft on which the wheel rotates. By using a large number of these mirrors, each mounted at a

(Continued on page 659)



## Amazingly Easy Way to Get Into ELECTRICITY

Don't spend your life waiting for \$5 raises in a dull, hopeless job. Now... and forever... say good-bye to 25 and 35 dollars a week. Let me teach you how to prepare for positions that lead to \$50, \$60, and on up to \$200 a week in Electricity—NOT by correspondence, but by an amazing way to teach right here in the great Coyne Shops that makes you a practical expert in 90 days! Getting into electricity is far easier than you imagine!

### Learn Without Books

#### In 90 Days—in Coyne Shops

Lack of experience—age, or advanced education bars no one. I don't care if you don't know an armature from an air brake—I don't expect you to! It makes no difference! Don't let lack of money stop you. Most of the men at Coyne have no more money than you have. That's why I have worked out my astonishing offers

### Earn While You Learn

If you need part-time work to help pay your living expenses I'll help you get it and when you graduate I'll give you lifetime employment service. Then in 12 brief weeks, in the great roaring shops of Coyne, I train you as you never dreamed you could be trained... on one of the greatest outlays of electrical apparatus ever assembled... real dynamos, engines, power plants, autos, switchboards, transmitting stations... everything from door bells to farm power and lighting... full sized... in full operation every day!

### No Books--No Lessons

No dull books, no baffling charts, no classes, you get individual training... all real actual work... building real batteries... winding real armatures, operating real motors, dynamos and generators, wiring houses, etc.

## GET THE FACTS

Coyne is your one great chance to get into electricity. Every obstacle is removed. This school is 90 years old—Coyne training is tested—proven beyond all doubt—and endorsed by many large electrical concerns. You can find out everything absolutely free. Simply mail the coupon and let me send you the big free Coyne book of 150 photographs... facts... jobs... salaries... opportunities. Tells you how many earn expenses while training and how we assist our graduates in the field. This does not obligate you. So act at once. Just mail the coupon.

### BIG BOOK FREE!

Send for my big book containing 150 photographs telling complete story—absolutely FREE

COYNE ELECTRICAL SCHOOL, H. C. LEWIS, President  
500 S. Paulina St., Dept. 11-77, Chicago

Mr. H. C. LEWIS, Pres.  
COYNE ELECTRICAL SCHOOL, Dept. 11-77  
500 S. Paulina St., Chicago, Ill.

Dear Mr. Lewis: Without obligation send me your big, free catalog and all details of Free Employment Service, Radio, Aeroplane, and Automotive Electrical Courses, and how I may "earn while learning."

Name.....

Address.....

City..... State.....

**Official  
RADIO SERVICE MANUAL**

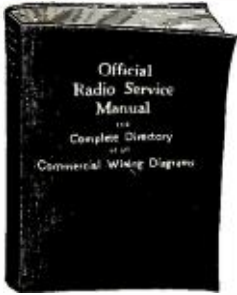

and  
**Complete Directory  
of all  
Commercial  
Wiring Diagrams**

**IN LOOSELEAF  
FLEXIBLE  
LEATHERETTE  
BINDER**

Over 1,000 Diagrams  
and Illustrations, etc.  
352 Pages 9 in. by 12 in.  
Weight, 3 lbs.

**\$3.50 Per Copy**

Never in the history of radio has there ever been published a service manual, so complete, as this new OFFICIAL RADIO SERVICE MANUAL. It is a veritable encyclopedia of service information—worth several times its price. Its educational value is of great importance, not only to service men, but to everyone interested in radio.

Hundreds of wiring diagrams, as well as important data, of commercial receivers since 1927, and some many years earlier, have been collected and placed at the disposal of radio service men. Additional service data for new receivers as they appear on the market will be supplied at trifling cost.

The OFFICIAL RADIO SERVICE MANUAL contains a most comprehensive instruction course for servicing any manufactured radio set, also many important articles on Amplifiers, Automotive Radio, Antennas, Condensers, Detectors, Meters, etc.

Send cash, checks or money order today for this important radio work.

**GERNSBACK PUBLICATIONS, INC.**  
Dept. 200, 98 Park Place, New York, N. Y.

As per your offer, I enclose, herewith, \$3.50, for which you are to send me, postpaid, one copy of the OFFICIAL RADIO SERVICE MANUAL.

Name .....

Address .....

City ..... State .....

**Home-Study  
Business Training**

Your opportunity will never be bigger than your preparation. Prepare now and reap the rewards of early success. Free 64-Page Books Tell How. Write NOW for book you want, or mail coupon with your name, present position and address in margin today.

- Higher Accountancy
- Mod. Salesmanship
- Traffic Management
- Rail. Station Mgm't
- Law: Degree of LL.B.
- Commercial Law
- Industrial Mgm't
- Banking and Finance
- Telegraphy
- Business Mgm't
- Railway Accounting
- Paper Salesman's Training
- Business Corres.
- Credit and Collection
- Correspondence
- Modern Foremanship
- Personnel Mgm't
- Expert Bookkeeping
- C. P. A. Coaching
- Business English
- Commercial Spanish
- Effective Speaking
- Stenotypy—Stenogry

LaSalle Extension University, Dept 194-R, Chicago

**WANTED MEN**

To Manufacture Metal Toys and Novelties



Big demand for Toy Soldiers, Animals, 5 and 10c Store Novelties, Ashtrays, etc. We cooperate in selling goods you make also buy them from you. Small investment needed to start and we help you build up. WE FURNISH COMPLETE OUTFITS and start you in well paying business. Absolutely NO EXPERIENCE and no special place needed. A chance of a lifetime for man with small capital.

CHRISTMAS RUSH is now starting, so if you mean strictly business and want to handle wholesale orders now being placed, write AT ONCE for full information. METAL CAST PRODUCTS COMPANY, Dept. 12, 1696 Boston Road, New York City

We carry a full line of Replacement Parts for

**Earl-Freed-Freshman and  
Freed-Eisemann Receivers**

Write for service parts bulletin  
FREED SALES SERVICE CO.  
16 Hudson St. New York City

**Superheterodyne Tuner**

(Continued from page 619)

In this, as in the previous designs, actual isolation apparatus is quite simple, due to the differing frequencies at which amplification takes place, but great care has been taken to use no common ground returns through the chassis, and to keep all r.f. currents out of the chassis to prevent coupling between circuits which would result in instability. Binding posts for antenna and ground, second detector plate (output) and for "A" and "B" power are located on the back of the chassis. The controls upon the front of the cabinet are the tuning knob for the vernier drum dial, calibrated in kilocycles, the volume control, and the on-off switch, which is not actually connected to anything in the receiver but is provided for connection in the power supply lead to the audio amplifier or power pack, with which the tuner may be used.

The tuner may be operated with no other cabinet than the shielding cabinet in

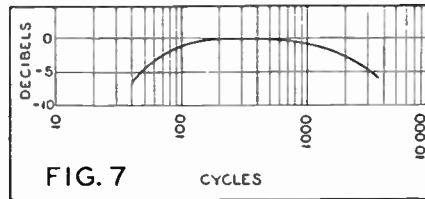

**FIG. 7**  
Audio response between 50 and 3500 cycles

which it is contained, or it may be placed in a standard console type cabinet, if desired. In any event, it must be cushioned by sponge rubber strips if it is placed in the same cabinet or on a table adjacent to the loud speaker with which it is operated as, due to the great selectivity, vibration from the loud speaker would conceivably cause vibration on the gang condenser plates to a degree which would seriously impair the tone quality, if such vibrations were allowed to be transmitted to the gang condenser through solid mounting of both chassis and speaker.

The matter of alignment of the r.f. and oscillator circuits of the tuner is somewhat more intricate than is the alignment process for the 724, due to the extreme selectivity preceding the first detector. In practice, since the oscillator is so designed as to track with the selector circuits throughout the middle of its range and to deviate only at the extreme ends of the range, the alignment process is carried out at two frequencies—1400 kc. and 600 kc. The alignment process, after the receiver is set up and in operation, is, first, to make absolutely sure that, with the mechanical staff upon the dial shaft loosened so as to be inoperative, when the gang condensers are fully enmeshed and against their own stops, the point marked "Stop" on the dial scale reads directly against the escutcheon or window pointers. This done, a 1400 kc. test signal is then tuned in and the dial shifted to read exactly 1400 kc. against its pointer. The left hand, or center trimmer, or the gang condenser trimmer

trimming the oscillator circuit is then adjusted to bring the signal back in, if it has faded out when dial was set at exactly 1400 kc., or to bring the signal to maximum intensity. This done, the oscillator is in line, and the remaining four trimmers on the gang condenser which trim the two selectors are adjusted in the ordinary manner as on a t.r.f. set for maximum response. All of these adjustments are then gone over to make sure that the very best possible alignment has been obtained.

The lead from the upper stator or trimmer lug of the extreme left-hand section of the gang condenser running down to the fixed condenser on the low frequency trimmer bakelite micarta panel is then unsoldered and the external variable condenser with maximum capacity of 400 to 500 mmfd. is connected between the chassis and the lead to the trimmer condenser on the micarta sub-panel, but not to the gang condenser section. This done, a 600 kc. signal is tuned in by rotating the receiver dial which then controls only the selector circuits and external oscillator condenser. If the alignment at 1400 kc. has been correctly made, the 600 kc. test signal should be received at exactly 600 kc. on the dial, or within a fraction of that point. When this has been done, the external oscillator condenser is disconnected and the lead between the low frequency trimmer and the stator of the left section of the gang condenser is reconnected, when the signal probably will not be heard. Without touching the dial, which remains set properly to tune the selector circuits to the 600 kc. signal, the oscillator is brought into line by adjusting the trimmer screws on the micarta sub-panel of the low frequency trimmer. This must be done without touching the trimmers on the five-gang condenser or shifting the setting of the condenser. The alignment of the receiver should then be checked at all frequencies throughout the broadcast band and checked again at 1400 kc. No further trimmer adjustment should be necessary to bring the receiver into line at any other frequency in the broadcast band, and will not be necessary if the two steps of alignment described above have been properly executed.

The measured characteristics are shown in Figs. 5, 6, and 7. The absolute sensitivity is seen to range from .35 microvolts per meter at 550 kc. to .32 at 900 kc., and .44 at 1500 kc., giving a gain ratio of less than 1½ to 1 over the entire frequency range. This sensitivity is unquestionably excessive for any known location on the American continent, and simply means that in almost any location it will be possible to receive any signal intelligible above the prevailing noise level, and, as a matter of fact, where signals are below the noise level, to bring in a considerable volume of noise. Since, however, the sensitivity is easily con-

(Continued on page 659)

# In the Radio News Laboratory

(Continued from page 629)

The parts are assembled on the panel according to the sketch (Fig. 5) and accompanying photographs. The apparatus is wired as in the circuit diagram, Fig. 6. Care should be taken to get the polarity of the meter and battery as illustrated. All connections must be well soldered according to instructions given in past issues of this magazine. After the clicker has been completely wired and a new battery attached, the plug should be entered into the high-resistance range jack and the two test leads short circuited. The 5,000-ohm resistance should then be adjusted so that the milliammeter reads 0.9 ma. If the milliammeter reads more than 0.9, add some resistance in series with the 5,000-ohm unit. If a carbon resistance has been used, scraping it a bit will raise its resistance. If the milliammeter reads less than 0.9 ma., lower the resistance. This can best be done by shunting it with a high resistance, such as a grid leak. The total resistance will then be

$$5,000 \times \text{grid leak resistance}$$

$$5,000 + \text{grid leak resistance}$$

In other words, if 1/2 megohm is shunted across the 5,000-ohm resistance it will lower the effective value by 50 ohms, 1/10 megohm will lower it by 250 ohms, etc. This adjustment, once set, need never be changed. When the battery dies down (after about 3 or 4 months) so that the reading becomes less than 0.86 ma., the battery should be replaced.

Figs. 6, 7 and 8 show the actual circuit connections obtained when the plug is inserted respectively in the low, medium, and high-resistance jacks. Below each circuit is the exact equation for calibration computations, and below that is the equation simplified; i.e., with the values

as previously described substituted in.

These equations show that the range of this instrument can easily be changed to suit the individual constructor's requirements. The medium scale can be shortened and the high scale can be lengthened to include resistances as high as several

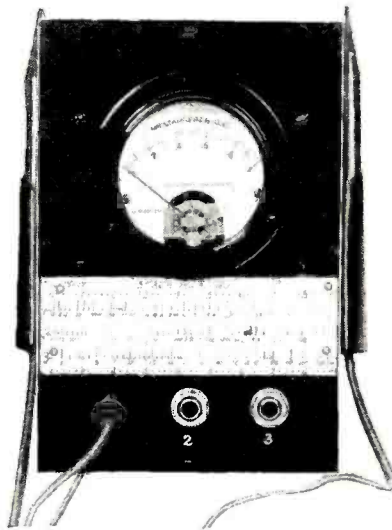

The all-purpose clicker

megohms. For example, if in equation (8) we substitute  $E = 22\frac{1}{2}$  V, and  $R_1 = 25,000$  ohms (to make the milliammeter read 0.9 ma. when the test leads are shorted, as  $E = IR_1$ ,  $R_1 = \frac{E}{I} =$

$$\frac{22.5}{.009} = 25,000$$

then for  $R_0 = 1$  meg-

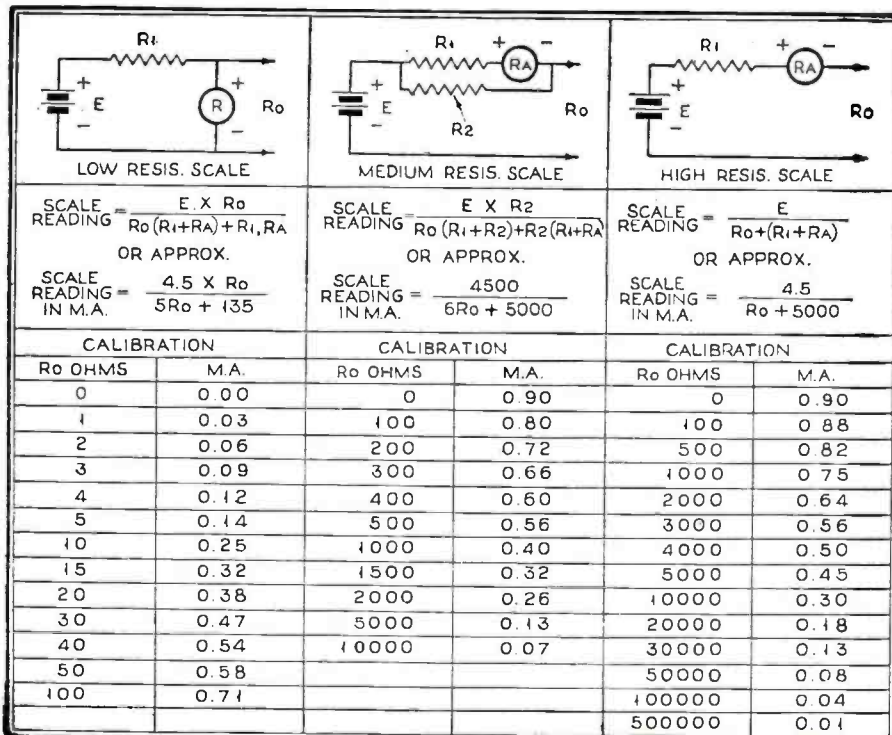

Fig. 6

Fig. 7

Fig. 8



**Manufacturers of  
The Most Complete  
CONDENSER and  
RESISTOR Line  
in Radio**

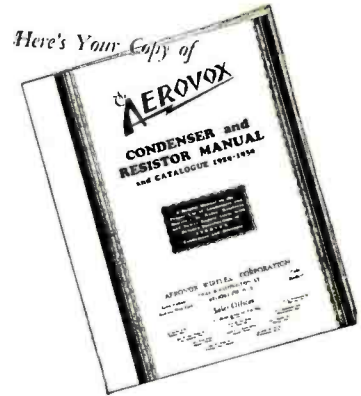

**Sent Free on Request**

This interesting and helpful Manual and Catalogue containing a wealth of information on condensers and resistors and complete electrical and mechanical data on the complete line of Aerovox condensers and resistors will be mailed free of charge on receipt of the coupon below.



The Aerovox Research Worker is a free monthly publication issued to keep radio engineers, experimenters and servicemen abreast of the latest developments in receiver and power supply design, and especially with the proper use of condensers and resistors. A request on the coupon below will place your name on the mailing list.

**Check and Mail This Coupon**

AEROVOX WIRELESS CORP.  
78 Washington St.  
Brooklyn, N. Y.

Gentlemen:  
Please send me without charge or obligation:

- ( ) Your 32-page Condenser and Resistor Manual and Catalogue.
- ( ) The Research Worker.

Name .....  
Street .....  
City ..... State .....



Yes! It's a new **RADIO!** Try any outfit—**30 days Free** BEFORE YOU BUY



**Factory to you**  
**SAVE to 50%**  
**SUPER Screen Grid**  
**Push-Pull Latest**  
**Electric Radios**

Enjoy a powerful new 1931 Miraco outfit for 30 days—no risk, no obligation to buy. Get Send-No-Money, Amazing Special Factory-to-You Offer

11th Successful Year

**MIRACO**

Compare with Costliest Sets! America's big, old, reliable Radio Factory springs its 11th anniversary sensations! Latest SUPER

**SUPER Screen Grid**  
**49.88**  
COMPLETE  
less tubes

Screen Grid, perfected Push-Pull, Super-Dynamic Electric AC sets of finest construction with costliest features—Varitone and automatic sensitivity control and no hum—at astounding low factory prices. Clever new cabinets—big variety—exclusive designs. Compare with costliest radios—unparalleled with Miraco's sharp selectivity, RICHER, CLEARER TONE and DISTANCE-GETTING, don't buy! Delighted thousands report programs from Coast to Coast with tone and power of expensive outfits. Full year's guarantee. Play safe, insure satisfaction, save lots of money—deal direct with big, old factory—pioneers in fine set making—11th successful year. Write and be convinced!



Send postal or coupon. Amazing 'Send No Money' Offer. No Obligation.

**USER-AGENTS!**  
Exclusive Territory.  
Big Money. No Risk.

**MIDWEST RADIO CORPORATION**  
Pioneer Builders of Sets—11th Year  
804-CJ Miraco Bldg., Cincinnati, Ohio  
Send Amazing Special Factory Offer.  
 Interested in Agents' Proposition

**Free**  
NAME \_\_\_\_\_  
ADDRESS \_\_\_\_\_



**AMAZING NEW INVENTION**  
**MAKES OUTSIDE AERIALS OBSOLETE**

Nothing to wear out, burn out or corrode. Guaranteed satisfactory results under normal conditions.

Radiodyne "Grountenna" pulls signals from the ground—the most remarkable invention since the vacuum tube. Eliminates common danger of outside aerial coming in contact with electric power lines, lightning hazard, or damage by sleet and storm. Saves its cost in a single year—can be moved with the set at will. Ideal for apartments to avoid outside aerial congestion and interference.

**DISTANCE** Brines in long-distance stations with surprising ease and unusual clearness. Can be used with any type set—non-directional.

**SELECTIVITY** Reduces interference to a minimum and assures uniform reception at ALL points of the dial.

**EASILY INSTALLED** Install a Radiodyne "Grountenna" on your own set in 5 minutes. Merely hook up wires to aerial and ground post of "Grountenna." If your radio dealer does not yet have Radiodyne "Grountenna," we will supply you direct.

Price **\$6.00** Postpaid.

**WESTERN COIL & ELEC. CO.** Dept. N., Racine, Wis.  
Designers and Builders of Radio Equipment since 1915

**ALL PROGRAMS**

Are Good With a

**FILTERMATIC**

Entirely Automatic  
No Bothersome Tuning  
Improves Tone—Reduces Static  
Brings in Distance  
Increases Volume  
Prolongs Life of Tubes  
Separates Stations

**FOR ALL RADIOS**

ONLY **\$1.00** POST PAID

Send Cash or P. O. Money Order  
Satisfaction Guaranteed or Money Refunded

**SERVICE** Men & Dealers Write for Our Attractive offer

FILTERMATIC MFG. CO., Dept. B-10  
4458 Frankford Ave. Philadelphia, Pa.



**The Stenode Radiostat**

(Continued from page 653)

rect the effects of persistence. For fixed wave-length working, such as amateur radio telephone, for example, or for transoceanic telephone communication, it is unnecessary to utilize the supersonic superheterodyne principles, for the special quartz tuned circuit can be tuned directly to the transmission frequency and considerable simplification effected in this way.

*Numerous Problems*

I have not, of course, much space to deal with the thousand and one problems and difficulties which have had to be overcome in developing the Stenode receiver in its present form. The quartz crystal, for example, which is mounted in a vacuum, had to be very carefully investigated, and the best form of mounting found; the superheterodyne receiver had to be restudied from the very beginning, for it was found that in the forms most generally used the superheterodyne suffered from a number of defects which prevented me from obtaining really high grade quality. Special precautions had to be taken in the design of apparatus to tune sharply enough for the Stenode. Thus, by many months of intensive work, with a laboratory staff held keenly interested in the development of something essentially new, all of the difficulties were overcome and I was able to accept the kind invitation of the Editor of RADIO NEWS to avail myself of the facilities of the RADIO NEWS laboratory to demonstrate my apparatus to scientists and radio engineers in this country.

*Basis of Operation*

Finally, I would like to point out that the whole of the work on the Stenode has been based on well-known mathematical and physical principles and the fact that the apparatus works in a way which has hitherto been held impossible according to the side-band theory does not worry me in the slightest. A number of scientists of international repute are now working on the theoretical basis of the Stenode, and it has already been indicated to me that at least two of them have found what may be termed the missing link in the side band theory which will enable it to accommodate the Stenode facts and also the basic theory of side bands.

*What of the Future?*

The ultimate theory may be a year or two in appearing, but meanwhile the practical work and application of the new facts go on. In this connection I would point out that there is no general agreement on the theory of the crystal detector which was rendered obsolete by the valve, and even Marconi's coherer is not properly understood! Probably the Stenode Radiostat will be in universal use long before scientists agree on the theory, but what does that matter so long as we have cleared the ether?



*Tallest Hotel in the World*

*46 Stories High*

Chicago's  
**MORRISON HOTEL**

Corner Madison and Clark Sts.

The Morrison Hotel is closest in the city to stores, offices, theatres and railroad stations. All rooms are outside with bath, running ice water, bed-head lamp and Servidor.

**1,950 Rooms—\$2.50 Up**

*Write or Wire for Reservations*

**In Science and Invention**  
for January

Your Last Chance to Enter Our \$3,250.00 Ideal Tool Shop Contest—It's easy as can be to win model equipment!

**"There She Blows!"**—William M. Roddy presents a thrilling tale of whale harpooning, and explains the processes through which Mr. Whale goes before he appears in perfumes, soaps, fertilizers, corset stays, umbrellas, cattle feed, meat for man, and various other useful articles.

**Glowworms Light These Caves**—An authentic account of the luminous, spiderlike creature, the glowworm that provides illumination for the Glowworm Grotto of the Waitoma Caves, New Zealand.

**The Backwoods of Modern Russia**—Priests who sacrifice horses to spirits; animals and human beings living in the same huts; these are among the customs prevailing in the year 1930.

**Harnessing Ocean Temperatures**—A full explanation of Drs. Georges Claude and P. Boucherot's experiments to derive unlimited power from the ocean depths.

**Mechanical Ears**—Weird contrivances to warn anti-craft defence units of approaching airplanes.

**How to Make and Throw Boomerangs**—William H. Van Shrum, an expert in making and throwing these spinning wings, tells you all about them.

**How and Why Automobile Tires Wear Out; New Ideas for the Owner and Driver.**

**Amazing Partnerships of Nature**—Gaylord Johnson's "Believe It or Not's" for ants and aphides, fish and shark, hermit crab and sea anemone.

**Unscrambling the Ether**—The latest radio wonder, a superselective receiver, the Stenode Radiostat, fully discussed; What's New in Radio, and Television in Germany Today, to interest our radio and television fans.

A great number of How-To-Make-Its, including: A Revolving Book Table from an Old Plano Stool; A Guillotine Cigarette Cutter; A Band Saw; A Sun Lamp; A Compact Oak Bedroom Suite; Synthetic Dyes.

# Europe Puts the Pentode to Work

(Continued from page 655)

slightly different angle, the rotating series can be caused to reflect a beam of light in such a manner as to scan an object just as is done with the standard scanning-disk. The reflected light is picked up in the ordinary fashion by photo-electric cells and amplified and transmitted. In the receiver, a beam of light from a small arc is controlled by a Karolus cell, which incidentally was well described in the September issue of RADIO NEWS. The cell, connected to the output of the receiving set, controls the beam of light in sympathy with the received modulations. This modulated light beam is in turn thrown upon another rotating series of mirrors, identical with those at the transmitting end and revolving in synchronization. The beam reflected from the mirrors will form a picture of fair detail one foot square. This system, in the demonstration at Munich, produces a picture approaching but not equalling in quality that obtained by the Bell Telephone Laboratories in the demonstration given at their offices in New York City.

Television has passed through stages in

Germany very analogous to those that have been witnessed in the United States. A year or so ago there was much public interest, but as it developed that television in the home was still a thing of the future, this interest waned and the situation today is very much like that in America.

It is significant that in both England and Germany television enthusiasts now feel that the greatest possibilities, at least for the immediate future, lie in the adaptation of the art to the theatre and public gathering place, rather than in general home use by the layman. As a matter of record, the Baird company has given a number of demonstrations in London this past summer. As a reproducing screen they have been using a board approximately six feet square, on which are mounted a great number of small flashlight bulbs. These are separately connected to contacts on a rotating commutator and are illuminated in such order as to form a picture to the eye. It is not known whether this system is considered successful or not.

# Superheterodyne Tuner

(Continued from page 656)

microvolt sensitivity per meter, the tuner runs from about .08 to .11, which is probably the highest order of sensitivity ever found in any commercial receiver or tuner ever before offered on the American or on any foreign market. The sensitivity measurements were made with the tuner connected to an S-M 677B amplifier, a two stage, resistance coupled, audio amplifier of quite low gain, inasmuch as only a -27 tube is used in the first audio stage. The sensitivity would, of course, be higher with a higher gain two or three-stage amplifier, but such additional gain would be unusable and the only reason for the use of a higher gain audio amplifier would be the fact that such amplifiers are usually provided with higher orders of power output, such as might be required for public address work.

The selectivity curve shows a band width of 6 kc. ten times down from resonance, 10 kc. one hundred times down from resonance, 16 kc. one thousand times down from resonance, and 23 kc. ten thousand times down from resonance which, like the sensitivity of this tuner, is unquestionably the highest order of selectivity ever found in any commercial receiver offered upon the American, or on any foreign market. There is really little more to be said, for it is obvious that selectivity of this order insures, in 999 out of every thousand cases, absolute 10 kc. selectivity against almost any powerful local station. Due to the somewhat flat-topped effect of the r.f.

selector circuits of the 714, as well as the similar effect in the i.f. amplifier, the fidelity is extremely good, being, as can be seen from Fig. 7, only 6 db. down at 40 cycles, and a similar amount down at 3500 cycles from the peak response at 400 cycles. The cut-off above 4000 cycles is extremely sharp, due to steep aided resonance curves of both r.f. and i.f. circuits.

## In the R. N. Lab.

(Continued from page 657)

ohm (1,000,000 ohms) we have scale reading =  $\frac{E}{R_u + (R_1 + R_a)}$  (neglecting

$R_a$ , which is very small) or scale reading =  $\frac{E}{1,000,000 + 25,000}$  = 0.00022 or

.22 ma. This, then, has multiplied the scale five times. The same reasoning can be applied to equation (7). Equation (6), however, does not lend itself very easily to change. This is the only circuit that requires the use of the d.c. resistance of the milliammeter. This can be obtained very easily from the manufacturer. Twenty-seven ohms for the Weston model 301 and 30 ohms for the Jewel model 88 are reasonable values to use.

R. M. SOMERS, East Orange, N. J.

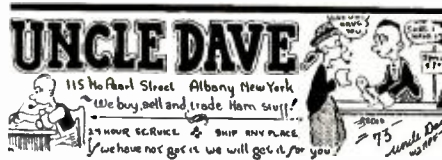

### Special for This Month

- Broadcasting Station Crystals, 500 cycles plus or minus, including calibration, guaranteed. \$ 30.00
- 200 cycles plus or minus, including calibration. 45.00
- Manhattan full wave high voltage rectifier tube, 90 mills at 470 volts. No filament type. Ideal for 210 supply. List at \$12.00 Special \$1.50
- Double button Microphone cord, 10 ft. three-wire, unshielded. .75
- Manhattan telegraph keys with board. .85
- Manhattan telegraph keys with circuit board. 1.25
- Tested and functioning, not guaranteed U.X. 210 and U.X. 250. .95
- Used Wheatstone bridges. \$25.00 and \$40.00
- Du-wire A. C. cable with Jones plug and receptacle 6 ft. 1.00
- General Radio 1000 cycle audio oscillator. 20.00
- Good sub panel four and five prong sockets 10c each. Dozen. 1.00
- 85 mill R. F. chokes, unmounted. Each. .25
- Victor 30 Henry 150 mill chokes. 1.35
- U.X. or U.3. sockets. .12
- Power crystals, specify anywhere in the 3500 K.C. band. Guaranteed. 5.25
- Dustproof bakelite crystal holders. 1.50
- Crystal blanks, unfinished. 1.75
- Finished oscillating crystal blanks. 2.75
- Calibrated Monitors, built for three uses: Oscillator, Monitor and Frequency meter. These are individually calibrated and are checked against Piezo oscillators. With batteries and three coils for 20, 40 and 80 meters. Not. 9.35
- Wave Meter for 20, 40 and 80 meter band with individual charts, complete indicator and coils. 6.25
- Donnan power transformers, 300 watt 1000 volts each side of center and with the following voltages: 3 C.T., 10 C.T. and one 10 and one 20 not C.T. Fully mounted. Wgt. 14 lbs. 5.95
- Ward-Leonard 10,000 ohm, 50 watt trans. leaks 5000 ohm leaks. .50
- 39
- New Universal double button microphones, model BB, net. 16.50
- Model KN, net. 32.50
- Model LL, net. 48.50
- Microphone cases, special. 2.25
- New Sprague 8 mfd 430 volt electrolytic condensers. 1.25
- New Morahan 18 mfd, electrolytic condensers. 2.00
- Flechtheim 2 mfd 1500 volt Porc. ins. condensers. 4.50
- Flechtheim 4 mfd 1500 volt Porc. ins. condensers. 7.75
- Rectobull mercury vapor R-81 type, just out, new, list at \$7.00. Net price. 4.40
- Rectobull mercury vapor R-3 type, net, postpaid. 10.00
- Slightly used Western Electric 212A and D tubes, guaranteed. 35.00
- Slightly used R. C. A. U.V. 211 or 203A tubes, guaranteed. 17.00
- Slightly used Western Electric 50 watters, guaranteed. 15.00
- R. C. A. U.V. 240 111 Mu tubes. 1.00
- Slightly used R. C. A. U.V. 851 1000 watters, guaranteed. 175.00
- New Allen-Bradley 500 watt radiostat. 5.50
- National var. condensers .00045, 3000 volt with velvet vernier dials. 9.50
- New Ceco 230 2-volt 180 type. Non Mic. 1.25
- New Ceco 231 2-volt 120 type. Non Mic. 1.25
- New Ceco 232 2-volt screen grid, D. C. 1.50
- New Thordarson 30 h. 250 mill. choke, Special Sanguano .00025, .0005, .002, .001 500 volt condensers. 3.75
- 1.20
- Used U. X. 852 tubes, guaranteed. 20.00
- R. F. chokes for receiver and transmitter. .50
- Solid Enamelled No. 12 aerial wire. 100 feet. 1.25
- Two hundred feet coils. 1.65
- Weston Galvanometers, new unboxed model 375 7.00
- Weston model 425. Thermo milliammeter, 0-125 or 0-250 milla. 7.00
- Weston current shared thermo galvanometer, 0-100 model 425. 7.50
- Microphone stands, adjustable floor model, brass parts adjustable to 78 inches. Statuary bronze finish. 9.25
- Microphone stands, table model, brass construction, bronze finish. 4.25
- 50 watt sockets. 95
- 250 watt sockets for 212D tubes. 3.50
- 204-A—250 watt sockets, set. 1.95
- U. X. 281 tested and functioning. .85
- Latest Amateur Call Book. .85
- Western Electric 2051D tubes, new original cartons. 3.50
- Variable condensers, all sizes. 75c to 1.00
- Double Closed Circuit jacks. 1.14
- Dubilier .00025, .0005, .0001, .002 mfd fixed condensers. Each. .20
- 30 Henry 150 mill Victor chokes, tapped. 1.65
- Victor A. B. C. transformers for 245 tubes. 2.45
- All types, tested audio transformers. .59
- 201A, 190, 112A, 171A, W. D. 12, 226, 227, 245, 280's. Each tested and functioning. .50
- Not guaranteed. .50
- Stand-off Insulators, similar to General Radio Each 10c. Dozen. 1.00
- Tobe six-volt, 2 1/2 amps. dry A. eliminator. 12.50
- Phileo type four-volt replacement jars. Each. 1.75
- Phileo type six-volt replacement jars. Each. 2.35
- Signal Corps key buzzer blinker practise set. 1.75

We carry the most complete line of transmitting equipment as well as receiving apparatus. We are short wave Specialists. Broadcast transmitting stations built to specifications. Write for free Ham sheet. Include postage with all orders and 20% deposit against C.A.D. shipments.

Visit our radio shack when in town  
What have you for sale or trade?

We carry everything for the Ham  
MORE FOREIGN TRADE SOLICITED  
Write for free Ham sheet

**UNCLE DAVE'S RADIO SHACK**  
115 North Pearl Street, Albany, New York  
Phone 45746

# Easy to Install AMPERITE In Any Electric Radio

JUST insert AMPERITE. Instantly controls fluctuating line voltages up or down between 100 and 140 volts, to exact requirements. Installed in 5 minutes. No chassis changes.

Only the bulb type AMPERITE can give your set delicate voltage regulation. Saves tubes and upkeep cost; protects power equipment, improves tone quality.

A type for every electric radio, including yours. Ask your dealer or write us giving your set name and model. Address Dept. RN-1

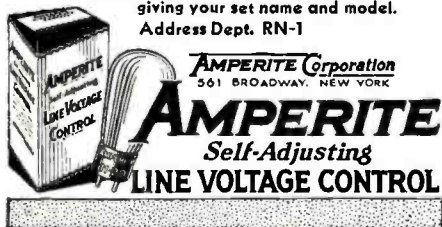

## Popularity

comes quickly when you learn to play a band instrument. For quick advancement and greater musical success start on an easy-playing Conn. The choice of Sousa and the world's greatest artists. Many exclusive improvements at no added cost!

**FREE TRIAL, EASY PAYMENTS**  
Write for details and free book. Mention instrument. C. G. CONN, Ltd. 111 Conn Building, Elkhart, Indiana

**FREE TRIAL**

**\$3.75** **RCA SPEAKER CHASSIS** **FREE**

Identical chassis as used in R. C. A. Model 100B and 103 magnetic speakers. Note built-in output transformer—huge magnet—self baffling metal housing. Delivers great volume without rattling or distortion! 3" diameter—4 1/2" deep.

**SEND FOR THIS BOOK** **JUST ISSUED**

**SET ANALYZER—TUBE TESTER**  
Resembles in appearance and construction most expensive and most elaborate testers. Tests (push-button principle) 0-7, 0-150v. A.C.; 0-20, 0-100 D.C. mills.; 0-10, 0-50, 0-500, D.C. Volts. Tests all type tubes. Complete with continuity test cables, other test leads, clips, leatherette case 7 1/4" x 9" x 3".

**RADIO SURPLUS CORP.**  
56 N. Vesey St. New York

Your Price **\$13.95**

**MASON, FENWICK & LAWRENCE**  
**PATENT LAWYERS**  
600 F St., N. W., Washington, D. C.  
Estb. over sixty years. Send sketches. Electrical, Aeronautical and Chemical Inventions carefully handled. Practice before the U. S. Courts and the Patent Office. Prompt and careful service. Write us. Protect your inventions.  
**TRADE MARKS REGISTERED**

# De-Bunking Television

(Continued from page 594)

need for vast improvement. Dr. Alexander thinks that a limited form (not necessarily the present limited form) of television will do, while Dr. Ives agrees with me that television will eventually have to be capable of doing all that the home movie can do, both as to scope or field of view, size of image, and comfort in viewing in the image. That we shall ultimately get the latter is certain, but I refuse to attempt to prophesy when.

Many people express doubt as to whether the public wants television in the home at all. At present the radio is left on and each member of the family continues to occupy himself or herself by talking, reading, sewing, etc. The music is there simply as a background; nobody gives his full attention to it except when something highly interesting or important is on. Now, if you add television, i.e., sight, to the present sound, it means that those who want to participate in the entertainment must cease all other occupations and concentrate with both eyes and ears. I can't see that state of suspended animation lasting long in the average home.

There is, of course, a definite field for television, projected on to a full size motion picture screen, in the movie theatre, where it could portray spot news events and thus supplant the present news reel. Or the physical distribution of copies of films could be eliminated by running off a film at a central transmitting station and feeding subscribing theatres by television methods.

I am continually being asked when all these things are going to be possible, or even when a real start will be made to give some form of television to the public. Here is my answer.

Looking at the thing in its true perspective we must regard present achievements in television, and the methods by which they are achieved, as merely a preliminary, and very elementary examination of the subject, and of the problems involved. Call them crude laboratory experiments if you like. They have served their purpose. Unfortunately too much publicity has been given to them, and the public has been misled into believing that the ultimate aim has been achieved, and

that apparatus for the home can be supplied now.

The next phase is exemplified by the fact that the entire television staffs of the General Electric and Westinghouse companies have been transferred to the R.C.A. Victor plant at Camden, N. J., where they are busily and silently engaged behind locked doors. That there is some significance in this move may be adduced from the confident statements made by R.C.A. executives of late, and by the strong emphasis on television in connection with the new \$250,000,000 radio city which is being planned by the R.C.A., N.B.C. and Rockefeller interests. Merlin Hall Aylesworth, president of the N.B.C., tells me that the project is being built round television.

We are told that this gigantic new radio city will be ready in three or four years' time, so we may logically assume that by that time television will have been so far advanced by those now working on it that it will be ready for the public. Even then it is not likely to be ready in the perfect form which I have outlined in this article, but at least it will have gone a long way towards it, and it will be presentable in some form acceptable to the public.

That television in its present crude and limited form is not acceptable to the general public is evidenced by the fact that attempts which have been made, both in this country and in England, to sell commercial televisions have failed ignominiously. The reason is not far to seek. There is definitely no entertainment value in the present image. For the experimenter the story is a different one. He requires no entertainment value and is quite content to experiment with terminal equipment.

But the day will come when televisions will be as popular in our homes as radio sets are today. A television industry will grow to the proportions of the present radio industry. Meantime, with the aid of a little more moderation in television publicity, we may be enabled to possess ourselves in patience, secure in the knowledge that pioneer work is being done, and that we shall ultimately get what we have been promised.

# The Junior Radio Guild

(Continued from page 631)

Thus, in multiplying  $95.5 \times 3.63$  we find that the slide is to the left; the number of digits in the two numbers are respectively 2 and 1; their sum being 3, we have the answer in three places as 346.

2. When the slide is to the right, the number of digits in the answer is one less than the sum of the number of digits of the two numbers. Thus,  $255 \times 315 = 80,000$ .

b. For division:

1. When the slide is to the left, the number of digits in the answer is the

difference of the number of digits of the two numbers. Thus, in dividing 35.5 by 7.3, the slide is to the left; the difference of the number of digits of the two numbers is 1, we have the answer 4.88.

2. When the slide is to the right, the number of digits in the answer is the difference of the number of digits of the two numbers, plus one. Thus, in dividing 65 by 4.35, the slide is to the right; the difference of the number of digits of the two numbers is 5 plus 1 gives the answer as 15.

(Continued on page 662)

## Volume Control in Radio Receivers

(Continued from page 589)

of hum. The -26 type tube hum voltage factor in the set is variable and dependent upon the operating voltages. It is a minimum for definite values of plate and grid voltages. Any change in either of these factors results in a rise in hum, Fig. 4. Either of these means of control was therefore unsatisfactory.

Control of any of the tube constants was out of the question. The problem of controlling volume was reduced to one of introducing sufficient attenuation between circuit elements, such as, for example, between antenna and first tuned circuit.

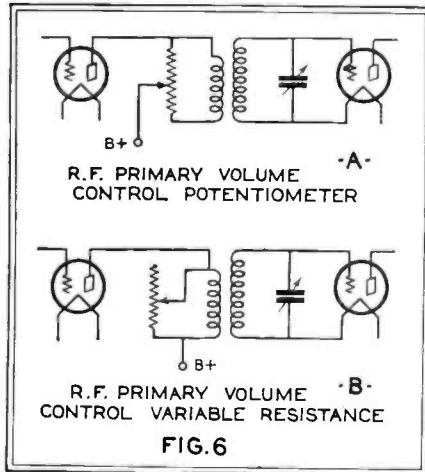

or between tuned circuit and tubes. This took the form of a simple potentiometer or variable resistance located across one of the circuit elements. Either one of these units could be used in numerous positions in the receiver, the principal ones being in the antenna input circuit, Fig. 5; across the primary of one of the radio frequency transformers, Fig. 6; across one of the tuned circuits in the radio frequency stages or detector stage, Fig. 7.

The use of a volume control across one of the tuning elements in the receiver introduced additional loading in the tuned circuit which was detrimental to both the sensitivity and selectivity of the set. To reduce this effect as much as possible it was necessary to use high resistance volume controls, having maximum resistances of the order of  $\frac{1}{4}$  to 1 megohm. Even such high resistances reduced to some extent the sensitivity and selectivity of the circuit across which they were located, but production and performance limitations prohibited the use of higher values. The need for such high variable resistances which had to be noiseless—as far as possible—and which had to vary non-uniformly with respect to angular rotation, prohibited the use of wire wound resistances, and led to the almost universal use of the graphited paper type of unit.

Where a volume control resistance is used across a tuned circuit or its equivalent, the condition should be met that the loading introduced across the tuned circuit should be independent of the setting of the volume control. This condition

(Continued on page 663)

## World-Wide Reception With the NEW Short-Wave Norden-Hauck SUPER DX-5

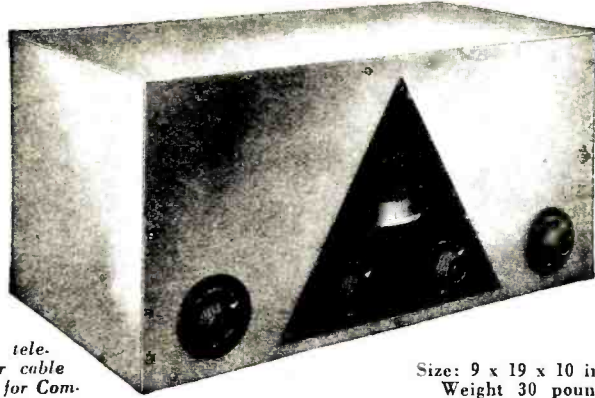

Write, tele-  
phone or cable  
TODAY for Com-  
plete Information

Size: 9 x 19 x 10 inches  
Weight 30 pounds

Entirely New Advanced Design      New Pentode Tube  
Sensational Distance      Range 20-200 Meters  
Reliable Performance

Adaptable for Long Waves and down to about 10 meters  
for Experimental Reception  
A-C and D-C Models

**NORDEN-HAUCK, Inc.**

**Engineers**

South St. and Delaware Ave.

Philadelphia, Pa., U. S. A.

Cables: "Norhauck"

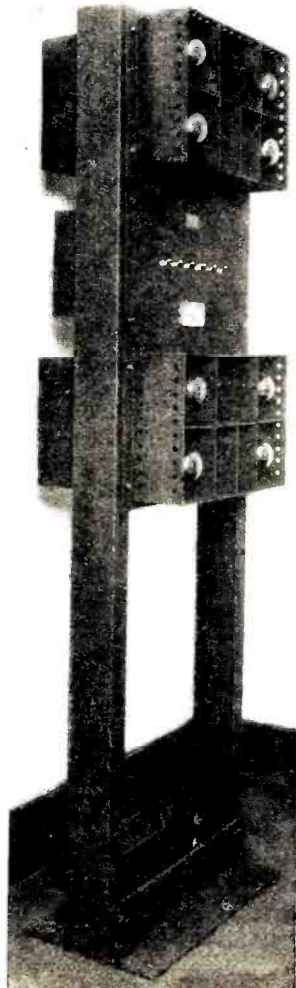

## RACK and PANEL AMPLIFYING EQUIPMENT

Ferranti D3 rack type amplifiers are ideal for experimental and educational purposes and for the distribution of sound and music. Ferranti audio and special matching transformers have flat curves suitable for precision requirements.

Write for prices, recommendations and other details.

**FERRANTI, INC.**  
130 West 42nd Street  
NEW YORK, N. Y.

# S. W. and Superhet Kits

We have on hand—ready for immediate shipment—

### AT WHOLESALE PRICES

- SILVER MARSHALL 738 S. W. Superhet converter, completely wired ..... \$40.87
- In kit form, not wired ..... 34.99
- SILVER MARSHALL 724 AC Broadcast Superhet, completely wired ..... 58.51
- In kit form, not wired ..... 51.45
- SILVER MARSHALL 714 AC Broadcast high-gain tuner, completely wired ..... 51.45
- In kit form, not wired ..... 48.51
- SILVER MARSHALL 677B High Quality Push-Pull Amplifier, completely wired ..... 48.51
- In kit form, not wired ..... 40.28
- NATIONAL SW5 Receiver, completely wired, with power pack ..... 72.91

DeForest transmitting tubes, and Thordarson Power Equipment at Substantial savings. Particular attention given to EXPORT ORDERS.

### H. JAPPE CO.

New England's Largest Radio Jobbers  
46 Cornhill, Boston, Mass.

## ✓FREE BOOKS of BUSINESS HELPS

We publish over 200 Home Study Books, each a complete treatise of its subject. We have one or more for you. Books on

- Commercial Art
- Lettering
- Advertising
- Sign Making
- Radio
- Aviation
- Painting
- Silk Screen Process
- Decoration
- Automobiles
- Battery Work
- Electricity
- Carpentry
- Building
- Contracting
- Sheet Metal Work

and many other subjects. All fully described in our FREE CATALOG. Check the subjects in which you are interested and write today.

**FREDERICK J. DRAKE & CO., Publishers**

Room 510—179 No. Michigan Blvd., Chicago

Drake books are for sale in all book stores

ACCOUNTING LESSON  
FREE

New Revised Course  
Now Ready!

Find out about it by  
trying it free

Send for our new book,  
"The Accountant—Who he  
is, What he does, How to  
become one," and the first  
lesson free of charge.

In reply please state age and position  
**INTERNATIONAL ACCOUNTANTS SOCIETY, INC.**  
A Division of the  
**ALEXANDER HAMILTON INSTITUTE**  
Dept. 166, 3411 So. Michigan Ave., Chicago

SOUND

By

Amplex

LICENSED BY LOFTIN-WHITE

Offer an Interesting and Profitable

proposition for responsible experienced Installation Engineers, Custom Builders, Service Men, Dealers, Contractors. AMPLEX will help you sell and install super-AMPLEX L.W. sound systems for parks, airports, schools, hotels, theaters, etc. . . . You can bid lower, make more sales and profits, and get better results than with any other known system. Protected territories. Write in detail to our General Manager.

AMPLEX INST. LABS.  
132-M West 21 St. New York City

# The Junior Radio Guild

(Continued from page 660)

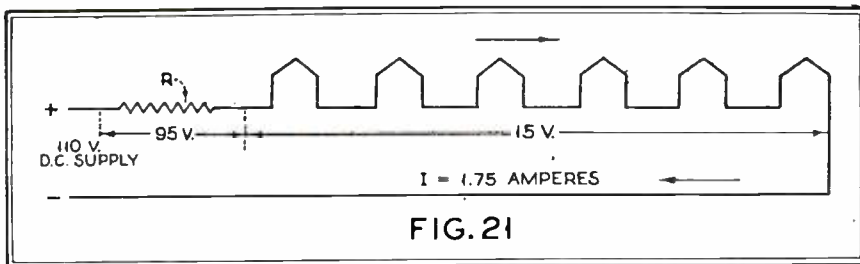

### Examples for the Slide Rule

Show by marking the scale of Fig. 11 the proper position of the following numbers. The first three examples are indicated.

- 4.9
- 1.55
- 8.8
- 4.3
- 3.95
- 1.05
- 2.25
- 4.1
- 1.175
- 2.07
- 3.6
- 1.9
- 7.1
- 2.4
- 8
- 3

Show by the marking scale of Fig. 12 the proper position of the following numbers:

- 5.5
- 2.6
- 1.35
- 3.4
- 1.8
- 2.25
- 9.6
- 7.3

(Continued on page 666)

## Vacuum Tube Voltmeter

(Continued from page 623)

advantage of permitting a lower plate voltage and of diminishing the error in the lower part of the scale.

Table 3 shows the changes necessary when meters of differing resistances are used.

Power tubes are of course required when higher ranges are attempted. Table

resistance are used. Table 6 gives two sets of values. Work is being undertaken to determine what may be done with eliminator-type instruments. A. C. calibrations are also being attempted. One that has already been found is listed in Table 7.

In conclusion, it should be pointed

TUBE	Eb	Ec	Rm	R	CALIBRATION			
					15	10	5	0
-45	56	-12	1500	360	15	10	5.5	1.9
-45	32	-6	3000	1650	15	10	5.3	1.4

Table 3. The changes necessary when meters of differing resistance are used

TUBE	Eb	Ec	Rm	R	CALIBRATION			
					150	100	50	0
-45	356	-90	15000	7500	150	100	52	15
-71-A	276	-90	15000	6130	150	100	53	15

Table 4. Data for use with a 150-volt meter having a resistance of 15,000 ohms

TUBE	Eb	Ec	Rm	R	CALIBRATION			
					6	4	2	0
-12-A	49	-3	600	300	6	4	2.2	0.9
-27	47	-4 1/2	600	170	6	4	2.1	0.8

Table 6. Two sets of values for low-range work

TUBE	Eb	Ec	Rm	R	CALIBRATION RMS. 60 CYCLES			
					15	10	5	0
-71-A	109	-9	3000	440	15	10	5.45	3.2

Table 7. A listing of a.c. calibrations

4 gives the data for use with a 150-volt meter having a resistance of 15000 ohms.

It is interesting to note that the higher ranges may also be reached by retaining one of the 15-volt meters previously used, and suitably changing the constants of the circuit. Table 5 shows how this may be done. Attention is called to the lower operating voltages then required for the high ranges.

Low ranges are possible only to a limited extent when meters of ordinary

out that the data in all of the above tables hold good only for the individual tubes that were used by the writer. While tubes of reliable manufacture do not differ greatly among themselves, each set-up should be calibrated by the experimenter as outlined in the ninth paragraph of this article. The procedure is simple and the device once adjusted will hold its calibration for a long time, provided the sources of power are reliable.



## Volume Control in Radio Receivers

(Continued from page 661)

obviously precluded the use of a straight variable resistance across a tuned circuit, as in Fig. 7a, for as the volume is gradually reduced a smaller and smaller resistance shunts the tuned circuit, with consequent elimination of the selective and gain properties of the circuit. With the volume control in this position of the circuit, it was therefore essential that a potentiometer type of control be used. Fig. 7b, which imposes a fixed resistance load across the tuned circuit. Volume control is secured by tapping off a variable signal voltage to be applied to the grid of the radio frequency tube which the circuit feeds.

The same remarks apply in the case

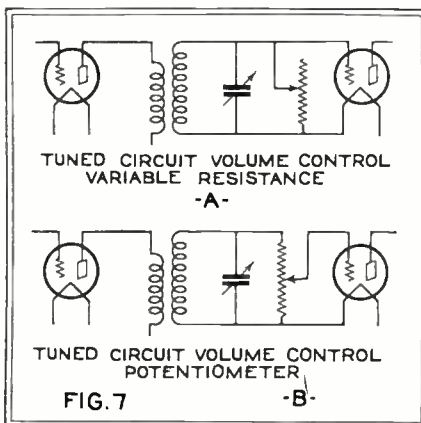

where the volume control is used across the primary of a radio frequency transformer. Here, of course, owing to the lower impedance of the primary, a lower resistance volume control may be used, and in general practice this value is of the order of the plate resistance of the radio frequency amplifier tube, about 10,000 ohms maximum. This load in parallel with the tube plate resistance is reflected into the tuned secondary circuit to a degree depending upon the effective turns ratio of the radio frequency transformer. If a straight variable resistance volume control is used, this reflected load will vary with the setting of the volume control, and at very low volumes where the resistance is very small the reflected load across the tuned circuit will be great, with the same harmful results that a small resistance across the tuned circuit would produce. So that here, too, the potentiometer type of control was found more suitable.

In receivers employing an antenna coupling tube with an untuned antenna system it made very little difference which type of control was used in the antenna circuit, there being no tuned circuit to influence. The maximum value of the unit was much lower than in either of the preceding cases, 1000 ohms being an order of magnitude figure. Where a tuned antenna system was employed the same considerations are applicable as outlined above.

One feature of interest in connection with the above is that of the three pos-

(Continued on page 664)

## IF YOU DEMAND THE BEST IN SERVICE EQUIPMENT—

**B**E sure to investigate carefully the merits of the new General Radio TYPE 404 Test-Signal Generator. Today a high-grade test oscillator is a useful piece of equipment for the service laboratory. Tomorrow it will be an essential. Equip your shop with modern instruments.

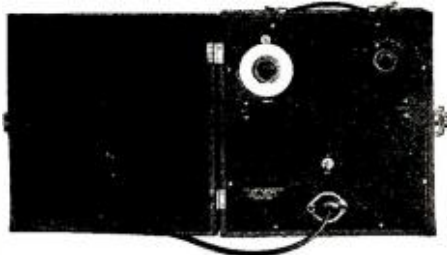

TYPE 404 Test-Signal Generator  
Price \$95.00

We shall be glad to send you a complete description of the test-signal generator if you will request it on your business letterhead.

ASK FOR BULLETIN 932-R

GENERAL RADIO COMPANY

OFFICES, LABORATORIES, FACTORY—CAMBRIDGE A, MASSACHUSETTS

Pacific Coast Warehouse: 274 Brannan Street, San Francisco

**Byrd's Antarctic Radio Equipment**  
Receivers, transmitters, and latest navigation aids used on this epochal flight fully described.

**Television**  
Mr. C. F. Jenkins, father of television and radio movies, gives you in his own words complete directions for building practical television equipment.

**Interference Elimination**  
New methods systematically outlined by W. F. Fleming, radio engineer.

**Radio Auto Alarm**  
Description of new device for ships which keeps the SOS watch while operator is off duty.

**Short-Wave Apparatus**  
Commercial and amateur, described and illustrated.

**New Broadcasting Equipment**  
Temperature-controlled Piezo crystal oscillator; 100% modulation panel and other new apparatus. —and these are only a few of the new subjects added to the most complete radio handbook ever published.

## The Latest Data!

Complete and up-to-date information covering the entire field of radio—all arranged for ready reference in this one big guide book.

## THE RADIO MANUAL

A Handbook for Students, Amateurs, Operators, and Inspectors

Here's the answer to every question about the principles, operation, and maintenance of apparatus for radio transmitting and receiving. Important new chapters have been added to bring it right up to the minute. Many new photographs and diagrams have been included. It is now more than ever the one complete handbook covering the entire radio field.

A Complete Course in Radio Operation in ONE VOLUME

Prepares for Government License

26 big chapters cover: Elementary Electricity and Magnetism; Motors and Generators; Storage Batteries and Charging Circuits; The Vacuum Tube; Circuits Employed in Vacuum Tube Transmitters; Modulating Systems and 100% Modulation; Wavemeters; Piezo-Electric Oscillators; Wave Trans; Marine Vacuum Tube Transmitters; Radio Broadcasting Equipment; Arc Transmitters; Spark Transmitters; Commercial Radio Receivers; Marconi Auto-Alarm; Radio Beacons and Direction Finders; Aircraft Radio Equipment; Practical Television and Radio Movies; Eliminating Radio Interference; Radio Laws and Regulations; Handling and Abstracting Traffic.

Prepared by Official Examining Officer

The author, G. E. Sterling, is Radio Inspector and Examining Officer, Radio Division, U. S. Dept. of Commerce. The book has been edited in detail by Robert S. Kruse, for five years Technical Editor of QST, the Magazine of the American Radio Relay League, now Radio Consultant. Many other experts assisted them.

Examine It FREE!

The revised edition of "The Radio Manual" is now ready. Nearly 800 pages; 269 illustrations. Bound in flexible Fabrikoid. The coupon brings the volume for free examination. Within 10 days you may return the volume or send the price of \$6.00.

MAIL THIS COUPON

D. VAN NOSTRAND CO., Inc.  
250 Fourth Ave., New York

Send me the Revised edition of THE RADIO MANUAL for examination. Within ten days after receipt I will either return the volume or send you \$6.00, the price in full. (R. N. 1-31)

Name .....

St. and No. ....

City and State .....

Business Connection .....

# WORLD-WIDE SHORT WAVE RECEIVER

ONLY \$6.45

Span the World with this Set!

A new radio thrill for you! Listen in DIRECT to London, Paris, Berlin, Buenos Aires and other broadcasting stations throughout the world via short waves. Enjoy unique foreign programs from strange lands. Your ordinary receiver cannot tune in these low wave stations. WORLD-WIDE RECEIVER gets 14 to 550 meter stations with surprising clarity. **SEND NO MONEY!** Just write your name and address on a postcard and ask us to send you this wonderful guaranteed short wave set. Pay postman \$6.45 plus a small delivery charge. All orders West of Rockies must be accompanied by \$1.00 deposit. Foreign countries must remit in full. Order today!

## NEW RADIO BARGAINS

- Low Power Transmitter adaptable for phone or code. With plug-in coils ..... \$14.75
- Auto Radio—Uses 3—224, 2—227 tubes and 1—245 power tube, single dial, tremendous volume. Compact. Fits any car. We guarantee this set to perform better than sets selling up to \$150. . . . 20.00
- B Eliminator, Bone Dry, with 280 tube, 180 volts, will operate up to ten tube set, fully guaranteed. . . . 6.75
- AC—A B C power packs ..... 8.75
- Tubes: UX type, 30-day replacement guarantee, No. 210, \$2.25; No. 250, \$2.35; No. 281, \$1.85; No. 245, \$1.25; No. 224, \$1.25; No. 227, 75c; No. 226, 65c; No. 171, 75c.
- International Microphone, two-button, for public address systems and transmitters, speech or music ..... \$9.75

WRITE FOR BARGAIN CATALOG  
CHAS. HOODWIN CO.  
4240 Lincoln Ave., Dept. A-3, CHICAGO

## LEARN RADIO TELEGRAPHY



Walter H. Candler, known the world over for his success in developing thousands of Radio and Morse operators.

Uncrowded field. Unlimited opportunities. Good pay. You can quickly qualify at home with the aid of The Candler System. Our methods eliminate all hit-or-miss procedure. Endorsed by leading authorities for 19 years. Necessary instruments furnished. For best results put yourself under the direction of this recognized authority. Write today for FREE particulars.

THE CANDLER SYSTEM CO.  
Dept. RN Chicago, Ill.  
6343 So. Kedzie Ave.

## ACME WIRE PRODUCTS

Parvolt Filter and By-Pass Condensers, Magnet Wire-All Insulations, Varnished Insulations, Coils.

THE ACME WIRE CO.  
NEW HAVEN, CONN.

## U. S. NAVY SURPLUS

- General Electric 24/750-volt 150-watt Dynamotors ..... \$27.50
- General Electric 24/1500-volt 350-watt Dynamotors ..... 37.50
- 500-watt 500-cycle generators with exciters ..... 7.50
- Westinghouse 6-15 V 500-watt ..... 15.00
- Westinghouse 27.5/350-volt 90 mills ..... 7.50
- Twins for double voltage or current ..... 15.00

Shafts for external drive \$3.00 additional.  
HARRY KIENZLE, 501 E. 84th Street, N. Y.  
Pioneer Distributor of Government Surplus  
Complete list on request

Dealers and Service Men Standardize

## METALLIZED RESISTORS

For Permanent Replacement—Accurate Guaranteed

Write for descriptive catalogue "N"  
LYNCH MFG. CO., INC., 1775 B'way, N. Y.

# Volume Control in Radio Receivers

(Continued from page 663)

sible positions for the volume control given above, the antenna position is the poorest from the point of view of noise level. This is most noticeable when receiving very powerful signals requiring that the volume control be turned down for a comfortable loud speaker signal. On such a test it will be found that the ratio of noise to signal is greatest when the volume control is located in the antenna stage. The reason for this will be evident from the following considerations. Noise which appears in the output of a receiver is the result of noise picked up outside the receiver and noise which originates in the receiver proper. The former is independent of the circuit position of the volume control, while the latter is not. Receiver noise, apart from hum, is a combination of tube noise and

volume control set at its minimum volume position. In some instances it was not possible to reduce the signal to a comfortable level. This condition gave rise, in some of the earlier a.c. receivers, to the use of the so-called "local-distance switch." This was an additional switch, located somewhere on the panel or cabinet of the receiver, which in effect cut out one radio frequency stage of amplification or otherwise reduced the gain of the receiver. With this reduced radio gain a powerful signal could be controlled. This had a number of disadvantages. In the first place it added an additional control to the set. In the second place for some signals the switch did not act according to Hoyle. It was possible to receive signals which, although not capable of being completely controlled with the

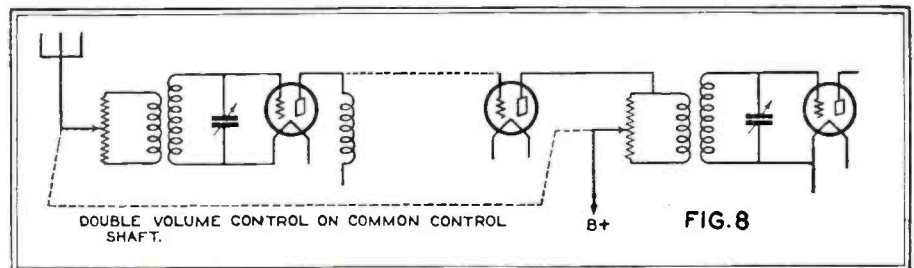

circuit element noise, and is more or less a fixed quantity for any given receiver. These noises modulate the carrier wave which is present in the receiver, which noises therefore show up in the loud speaker output. When volume is adjusted by an antenna control only, the signal amplitude fed into the input of the receiver is reduced, whereas the receiver noise amplitude originating after the antenna is at its full value (since receiver amplification is maintained at its maximum value) and we have a high degree of noise modulation. If, however, the signal fed into the input of the receiver is greater, and the volume is adjusted by a control located in the radio frequency amplifier beyond the antenna, the relative degree of noise modulation is smaller (since the noise is the same but the signal amplitude is greater); and secondly, the volume adjustment reduces the noise and the signal together, so that the ratio of noise to signal is reduced. It should be noted that the volume control is effective in reducing the noise-signal ratio to the extent that it is removed from the antenna stage, since it is effective in reducing noise (for a given output) originating ahead of it but not behind. Hence the nearer it is located to the detector circuit the less will be the noise present.

A single volume control employed in any of the positions enumerated above was found to be deficient and commercially unsatisfactory because of its inability to completely control powerful signals such as might be received in the vicinity of a broadcaster. In such a case, depending upon the sensitivity of the receiver and the field strength at the receiving antenna, a loud speaker signal of high level could be received with the

switch in the "distance" position, did not give sufficiently loud signals with the switch in the "local" position and the volume control on full. This gave rise to the use of the double volume control which controlled volume in two positions in the circuit, Fig. 8. This consisted either of two separate volume control units, each connected to its own circuit, mounted on one shaft and controlled by one known, or of two resistance strips mounted in one container, each resistance strip having its own electrical terminals. By thus controlling two circuits in the receiver, any signal ordinarily encountered in practice could be adjusted to any desired level.

Improvement of the life factor of the -27 tube led to the adoption of this tube for use throughout the receiver. This led to a simplification of the volume control problem. In this case as with the -26 type tube it was not possible to use a filament or heater control owing to the high thermal inertia of the heater. The hum voltage factor is practically independent of plate current variations, and this tube therefore lends itself admirably to the "c" bias type of volume control. By increasing the "c" bias of the radio frequency tubes the mutual conductance and therefore amplification of these tubes is reduced and in this way volume may be controlled. By using this control on a sufficient number of radio stages complete control of any signal encountered in practice is obtained. A single volume control unit, having a maximum resistance of the order of 50,000 ohms is suitable for this purpose, the unit being designed as a two-terminal variable resistance.

(Continued on page 665)

## Junior Transmitter

(Continued from page 613)

### Key to Circuit Drawings

- L1, L2, L3—See text.
- C1—350 mmfd. National transmitting condenser.
- C2—1,000 mmfd. National receiving condenser.
- C3—500 mmfd. National receiving condensers.
- C4—2,000 mmfd. Sangamo fixed condenser (1,000-volt rating).
- C5—6,000 mmfd. Sangamo fixed condenser.
- C6—Same as C4.
- R1—10,000-ohm S. S. White resistor.
- R2—400-ohm General Radio type 214-A potentiometer.
- V1, V2—DeForest type 510 oscillator tubes.
- A—Jewell 0-2½ thermocouple ammeters.
- V—Jewell 0-15 a.c. voltmeter.

### Parts Required, Not Shown in Circuit

- 6 R.E.L. coil forms for tuning coils.
  - 2 R.E.L. coil bases for forms.
  - 2 GR 349 sockets.
  - 2 GR 260 stand-off insulators.
  - 4 GR 138Y binding posts.
  - 1 open circuit jack.
  - 1 piece bakelite 4½"x3"x¼" (for mounting binding posts).
  - 4 National velvet vernier tuning dials.
  - 1 baseboard 12"x28"x1" thick.
  - 2 dozen ½" round head wood screws.
  - 2 dozen ¾" round head wood screws.
- (Get these small enough in diameter to pass through the smallest hole in any piece of the apparatus.)  
Soldering lugs, solder, wire.

## Volume Control in Radio Receivers

(Continued from page 664)

The adoption of the a.c. screen grid tube for use in the radio frequency stages introduced another problem in volume control. Volume can be controlled in this tube as in the -27 type tube, namely, by varying the "C" bias of the tube. It can also be controlled by varying the screen grid voltage. Either of these methods gives satisfactory control, provided the signal input to the first tube is not too great. For loud signals, such as are produced in the vicinity of local broadcasters, either of these methods is unsatisfactory, not because they do not give complete control, but because distortion is introduced. As the volume is reduced by either of the above methods a point is reached at low output, where the loud speaker signals come through in spurts with severe distortion. This can be corrected only by reducing the input signal to the first screen grid by means of an antenna volume control, which must necessarily be used in conjunction with a "C" bias or screen voltage adjustment in order that complete control of loud signals may be secured. This requires a double volume control similar to that previously described.

H  
A  
M  
M  
A  
R  
L  
U  
N  
D

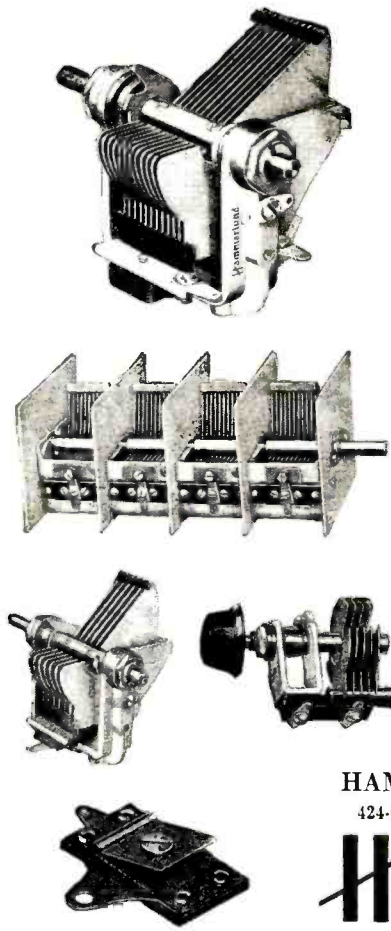

## For Every Purpose

SINCE Radio began, Hammarlund has been condenser headquarters.

Not by chance has Hammarlund leadership been consistently maintained—but simply by the art of better engineering, better manufacturing and better values.

Whether it is for tuning a single broadcast circuit—multiple circuits from two to four—short-wave work—balancing or trimming—Hammarlund supplies precisely the condenser needed.

And you can rely on that full measure of superiority which has always made Hammarlund the preferred condenser by radio experts throughout the world.

Write Dept. RN-1 for literature on condensers and other Hammarlund Precision Products.

HAMMARLUND MFG. CO.

424-438 W. 33rd Street, New York

For Better Radio  
**Hammarlund**  
PRECISION  
PRODUCTS

C  
O  
N  
D  
E  
N  
S  
E  
R  
S

Newest  
THING IN RADIO

\$295

Vari-Tone

MAKES A 1931 MODEL OF YOUR PRESENT RADIO

Gives you **TONE CONTROL!**

Connects in One Minute to any Electric or Battery Radio

**TRY IT A WEEK At Our Risk!**

Makes your set sound like a latest 1931 "tone control" model. **SATISFACTION or money back!** Vary tone and pitch to suit yourself. No need to buy a new \$200 radio. Send \$2.95 or order C. O. D. Free literature. Radio agents wanted..

**VARI-TONE LAB. Dept. 117**  
P. O. Box 700, Cincinnati, O.



## ALUMINUM BOX SHIELDS

Genuine "ALCOA" stock aluminum finish. 6.95. \$1.80—Connet size \$4.65. 10x12" Monitor size \$1.25. 4x4x5 Coil Shield (like picture on left) \$1.00.

### ANY SIZE TO ORDER.

Coil Shields, Coil Hole Covers, Shielded Wire, Service Men's Test Leads 65c, 75c and \$1.00 pr. Drum Dial cable by foot or mile. B. B. L. Units, \$2.75. 24- or 6-volt Pilot Lamp 10c. Pilot Lamp Sockets 10c. \$1.00 dozen. Resistance wire for Shunts, R. E. L. Coil Forms. Please include postage.

**BLAN, the Radio Man, Inc.**  
89 Cortlandt Street, Box 2, New York City



## GEARS

In stock—immediate delivery Gears, speed reducers, sprockets, thrust bearings, flexible couplings, pulleys, etc. A complete line is carried in our Chicago stock. Can also quote on special gears of any kind. Send us your blue-prints and inquiries.

Write for Catalog No. 40  
**CHICAGO GEAR WORKS**  
769-773 W. Jackson Blvd., Chicago, Ill.

**SHORT WAVE  
WITH YOUR PRESENT RADIO**



**“THE SUBMARINER”**

Short wave reception from all parts of the world is enjoyed by many users of “Submariners.” No need to buy a special short wave receiver, as the “Submariner,” attached to your receiver in a few seconds, will bring in reception for only a fraction of the cost.

“Submariners” are available designed for operation with each type of receiver. They are priced from \$17.50 to \$27.50, with fixed wave band of 19-50 meters, or interchangeable coils of 13-145 meters. The “J” feature, an exclusive “Submariner” achievement, enables you to get superior results with all of the newest receivers. The models JATV, 19-50 meters, at \$22.50, or the JATV, 13-145 meters, at \$27.50, have a tremendous wallop when attached to the

**NEW SCREEN GRID SUPER-HETERODYNE  
receivers.**

**ORDER TO-DAY**

*Sent postpaid upon receipt of price, or C. O. D. if \$1.00 accompanied order. Foreign—Cash with order.*

**J-M-P MANUFACTURING CO., INC.**  
3417 Fond du Lac Ave. Milwaukee, Wis., U.S.A.

**The HAND  
That  
Encircles  
The WORLD**

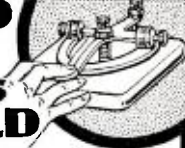

**There's ROMANCE IN  
TELEGRAPHY.**

The man who knows the code is in touch with the world. Become an expert operator. Make big money. Learn IN YOUR OWN HOME—easily, quickly with TELEPLEX—the Master Teacher.

**GUARANTEED To Teach You.**  
Write for Folder “E-1”



**TELEPLEX CO.**  
76 Cortlandt St.  
New York

**teleplex**

Something Entirely  
New!!

**HAMMOND  
ELECTRIC  
CALENDAR  
CLOCK**



Perfect Time from AC Socket. No Winding—No Oiling—No Regulating.  
Shows Day of Month and Date  
Changes Automatically Every 24 Hours.  
Polished Black Bakelite Modernistic Cases. Silver Dial with Raised Figures, Green Second Hand and Minute Marks.

**\$12.50 Complete**

Unconditional One-Year Guarantee—An Ideal Gift!  
**NELSON ELECTRIC COMPANY**  
508 S. Dearborn Street, Chicago, Illinois

**Massachusetts Radio and  
Telegraph School**

18 Boylston Street, Boston

Send for Catalogue

Tel. Hancock 8184 *Established 1905*

SEND FOR **FREE CATALOG**

**AMALGAMATED  
PURCHASERS, INC.**

OFFICIAL HEADQUARTERS  
ALL RADIO REPLACEMENT PARTS

142 N LIBERTY ST., NEW YORK CITY

# The Junior Radio Guild

(Continued from page 662)

56 32 16.75 88 53 12 46.5 87  
10.5 28.5 66 13.75 21.5 68 20.5 38

Show by marking the scale of Fig. 13 the proper position of the following numbers:

360 635 127.5 910 215 105 910  
265 550 135 455 290 195 800

Show by marking the scale of Fig. 14 the proper position of the following numbers:

.45 .72 .115 .96 .335 .53  
.105 .88 .2075 .77 .385 .156

## Applications of Arithmetic in Radio

In any radio receiver, whether it is an a.c. receiver, battery or d.c. receiver, vacuum tubes are used as either radio-frequency amplifiers, detectors, audio-frequency amplifiers or power tubes. We know that these tubes require a certain current at a specified voltage to light the filaments in order that they will function properly. The current (I) taken by the tube is determined from Ohm's law:

$$I = \frac{E}{R}$$

where E is the voltage across the tube and R is the resistance of the filament. If, as indicated in Fig. 15, the resistance of the filament is 20 ohms, let us investigate the value of I for various voltages E.

If E is 0 I equals 0

1	.05
2	.1
3	.15
4	.2
5	.25
6	.3
7	.35
8	.4
9	.45
10	.5

This is plotted in Fig. 16, and we see that for the rated voltage of the tube at 5 volts the current is .25 amperes. The life of the tube is dependent upon the current taken by the filament, which we see is dependent upon the voltage. An excess voltage will burn out the tubes and a lack of voltage will give decreased performance. Very often tubes are rated at a nominal voltage and given a plus or minus 5 per cent. tolerance. Thus, if a tube is rated at 5 volts, and remembering that 5 per cent. simply means 5/100, which is the same as .05, we have:

a. The maximum rating of the tube is  $.05 \times 5$ , which is plus .25 or 5.25 volts.

b. The minimum rating of the tube is  $.05 \times 5$ , which is minus .25 or 4.75 volts. Thus, if the tube operates between 4.75 to 5.25 volts it will be satisfactory.

Let us investigate the condition of voltage distribution in an a.c. receiver where the filament voltages are supplied from a winding in the power transformer as shown in Fig. 17. If the tube is one rated at 2.5 volts at 1.75 amperes, which is a usual rating for the filaments of screen-grid radio-frequency tubes, or the heater type detector and audio-frequency tubes, it will be found in practice that the wiring from the transformer winding to the tube will have appreciable resistance.

If the resistance of these leads is a total of .12 ohms we find that the voltage lost in the wiring is:

$$E = IR = 1.75 \times .12 = .21 \text{ volt}$$

Therefore, in order that the tube obtain the proper voltage of 2.5, a supply voltage of 2.71 will be necessary.

We have seen that if a current flows through a resistor R, as shown in Fig. 18, that a voltage E will be developed across the resistance which is determined by the formula:

$$E = IR$$

This property of developing a voltage across a resistance is used extensively in all d.c. and a.c. receivers to provide the necessary “B” and “C” voltages for the grids and plates of the various tubes in a radio receiver. We know that tubes in a radio receiver require a “C” battery for proper operation, as shown in Fig. 19, where the grid must be at some negative voltage in respect to the filament. Now if a d.c. voltage is available, as indicated in Fig. 20, we find that current will flow from plus to negative through resistors R1 and R2. Current flowing through R2 will develop a voltage across it such that the plus potential can be applied to the filament and the negative end to the grid of the tube through the secondary of the audio-frequency transformer. Thus, if the desired grid voltage is 6 and the value of the current through the resistor R2 is .125

$$\text{amperes, we see that } R = \frac{E}{I} = \frac{6}{.125}$$

48 ohms is the amount of resistance necessary to develop 6 volts across R2.

Whenever current flows through any resistor we have all experienced that heat is developed from it and we express this resistor as using so much power in watts. Thus, flat irons, electric heaters, toasters and soldering irons all have resistor elements and produce heat at a certain watt rating. This is expressed as

$$P = I^2R$$

Every consumer of electricity is naturally interested in the amount of watts the radio receiver will take, as it is this which directly affects the cost of electrical maintenance.

Let us suppose we have 6 tubes of a radio set which require 2.5 volts each at a current of 1.75 amperes which will obtain their supply from a d.c. source of 110 volts, as indicated in Fig. 21. The total voltage across the bank of tubes will be  $2.5 \times 6 = 15$  volts, leaving 95 volts which must be dissipated in the resistor R.

$$R = \frac{E}{I} = \frac{95}{1.75} = 54.25 \text{ ohms}$$

The power dissipated in the resistor is:  
 $P = I^2R = 1.75 \times 1.75 \times 54.25 = 166.25$  watts.

It is of interest to show that since the voltage and current of the resistor R are respectively 95 volts and 1.75 amperes we find that multiplying these:

$$E \times I = 95 \times 1.75 = 166.25$$

which is the same value obtained for the watts above, therefore the watts can also be expressed as:

$$P = IE \text{ as well as } P = I^2R$$

## The Midget Receiver

(Continued from page 614)

design is dwelt on as being indicative of the care that has gone into the entire design of this receiver.

### The Loftin-White Amplifier

It is in the amplifier proper, however, that we find the greatest engineering advances. The advantages of the Loftin-White system are too well known to require lengthy comment, among them being very excellent detector action, with high audio gain. Also the ability to use very little filter in the power pack, due

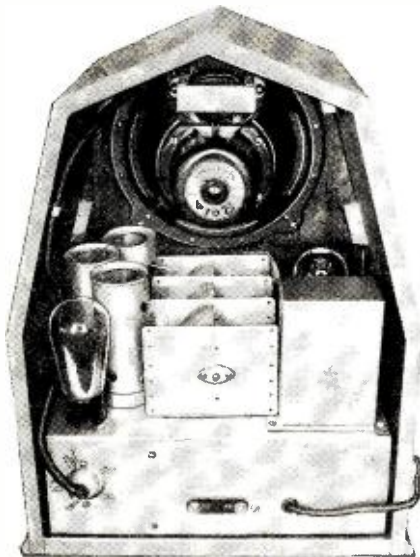

This back view shows how every available inch is utilized. The cans at the left cover the screen-grid tubes, with a power tube in the foreground. The rectifier is at the right behind the transformer housing

to the hum-bucking feature found in this type of amplifier. This last feature is particularly advantageous, due to reduction in both weight and cost, features that are very necessary in midget receivers. Close observation of the wiring diagram will show many of the changes that have been made in the conventional circuit. To begin with, the hum-bucking is fixed, instead of being variable. This has the obvious advantage of convenience, as well as reducing the possibility of trouble that is always present in any variable control. A point has been picked that is average for all tubes, and upon actual test it was found that with tubes of wide variation the hum is inaudible, except in very extreme cases.

### Speaker Excitation

The field of the dynamic speaker is excited by using it as a portion of the C arm of the power tube, and 32 milliamperes flow through it. Its resistance is 4,700 ohms, so the wattage is 3.8, which is sufficient to fully excite the field. By using in this manner, excitation is accomplished without potential loss, as it simply replaces a resistance in the conventional circuit.

# RESISTORS

## GET THIS GUIDE TODAY

If you have not received one of our new Resistor Replacement Guides, be sure to send in for it now. Service men and amateur operators agree it is the most helpful radio book ever offered. This handy little Guide shows clearly and concisely not only how to locate cause of trouble in radio sets, but it also shows the proper types and values of resistors to use in the various types of radio receivers. Fill out the coupon and mail it today.



International Resistance Co.  
2006 Chestnut Street  
Philadelphia, Pa.  
Kindly send me one of your Guides. List price, 50c. Free with the purchase of six resistors. RN 1-31  
Name.....  
Address.....

International Resistance Company  
2006 Chestnut Street Philadelphia, Pa.

## SERVICEMEN!

Clarostat Offers Two Good Money-Makers for You

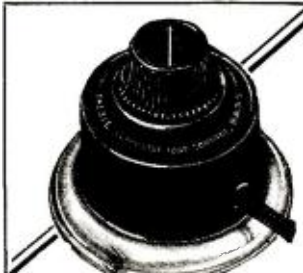

Clarostat's latest achievement is the tone control. It can be easily installed in any receiver, bringing it up to date. The Clarostat Tone Control modifies the tone gradually to suit individual musical taste. It is easy to install. List Price \$2.35

Also made in panel mounting type. List Price \$1.80

The Clarostat Automatic Line Voltage Regulator regulates the line voltage on all makes of electric sets. It insures a steady flow of current. It reduces noises. It saves tubes from excessive voltages. Made in 2 types—"A" for sets consuming less than 100 watts—"B" for sets consuming 100-150 watts. List Price \$1.75

Send for latest literature or better still order samples now from your Jobber or direct from us.

Clarostat Mfg. Co., 285 N. 6th St., Brooklyn, N. Y.

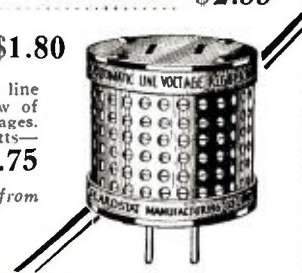

# RIGHT NOW!

Send for Our

## NEWEST CATALOG

Largest Assortment and Biggest Bargains in

Hammarlund, National, Amertran, Aerovox, Yaxley, Samson, Sylvania, Arcturus, de Forest, RCA Tubes, Public Address Amplifiers, Weston, Jewell Meters, Jensen, Rola, Best Speakers, Universal Microphones, etc.

ALL MERCHANDISE AT WHOLESALE

S. HAMMER RADIO CO.

142 Liberty Street, New York  
Tel. Hitchcock 1152—Dept. N

### Read Classified Advertising—It Pays!!!

Advertisements in this section twenty-six cents a word for each insertion. Name and address must be included at the above rate. Cash should accompany all classified advertisements unless placed by an accredited advertising agency. No advertisements for less than 10 words accepted. Objectionable or misleading advertisements not accepted. Advertisements for these columns should reach us not later than 1st of 2nd month preceding issue.

#### Agents Wanted

Guaranteed Genuine Gold Leaf Letters anyone can put on store windows. Large profits, enormous demand. Free samples. Metallic Letter Co., 422 N. Clark, Chicago.

#### Automobile Accessories

Automobile Carburetor Booster. Saves Gasoline; adds Power. Mailed, \$1. Give make and year. John Hanley, 816 Ford Bldg., Detroit, Mich.

#### Business Opportunities

FREE BOOK. Start little Mail Order Business. Radwll, 38-A, 74 Cortlandt Street, New York.

#### Correspondence Courses

Used correspondence school courses sold on repurchase basis. Also rented and exchanged. Money-back guarantee. Catalog free. (Courses bought.) Lee Mountain, 1156th, Alabama.

CORRESPONDENCE COURSES—Sole. Bought, Exchanged, Rented. Barkain Catalogue Free. Hunting, C-799 Broadway, New York.

#### Correspondence Schools

STUDY RADIO IN CANADA—in Canada's pioneer college endorsed by leading radio manufacturers. Day, evening, home study and special trade courses with free scholarships and trip to Toronto (all expenses paid). Write today for free booklet. Radio College of Canada, Limited, 310 Yonge Street, Toronto, Canada.

#### Detectives

DETECTIVES. Work home or travel. Experience unnecessary. Particulars free. Write George Wagoner, 2190-X Broadway, N. Y.

#### Equipment

BATTERY CHARGERS for Service Stations. Prices lowered. Direct from factory. Write for bulletin 19. Adams-Barre, Columbus, Ohio.

#### For Inventors

INVENTIONS COMMERCIALIZED. Patented or unpatented. Write Adam Fisher Mfg. Co., 278 Enright, St. Louis, Mo.

#### Help Wanted—Instruction

Detectives Earn Big Money. Experience unnecessary. Write American Detective System, 2190-K Broadway, N. Y.

#### Miscellaneous

HAVE YOU A CAMERA? Write for free samples of our big magazine showing how to make better pictures and earn money. American Photography, 3105 Camera House, Boston, Mass.

Power Supply Transformer, \$1.55. Power Amplifier, employing 227, 280, Two 247's \$31.50. Barreto Electric Manufacturing Co., 334 Pearl, New York.

AMATEUR TRANSMITTERS, \$15.00 up. Free list. Neal Brown, Richland Springs, Tex.

## In the January Issue of Amazing Stories

THE PRINCE OF SPACE, by Jack Williamson. In the days of uncharted seas and sailing vessels, even piracy, now impossible, occasionally showed a benevolent streak. What such a career might prove to be in the air in future times, when more or less successful traffic between planets is established, we cannot foretell. But there are always two sides to every question—as our well-known writer proves in this beautifully written interplanetary novellette, complete in this issue.

VIA THE TIME ACCELERATOR, by Frank J. Bridge. While followers of Professor Goddard's theories and hopes are studying ways and means for the realization of rocket space travel, those scientists who believe with Einstein that time is a dimension are probably trying to find some manner of travel in time. If history and biography of past days contain so much that is fascinating, how much more absorbing would items of the future be? What our author dreams of for our earth a million years from now makes thrilling reading.

TANKS UNDER THE SEA, by Harl Vincent. Here is another Vincent story, done in his best manner. It might be worth while to think seriously about some of the theories propounded here in regard to such important items as atomic motors, radium, the miracle element, and the many kinds of rays, for our author is not only a writer of note—he knows his science, too.

THE DRUMS OF TAPAJOS, by Capt. S. P. Meek, U. S. A. (A Serial in three parts.) Part III. There seems no end to the amazing developments to be found in this wonderful tropical hidden city, and there certainly is no let-up in the excitement and thrill contained in this concluding instalment.

And other scientific fiction

#### Patent Attorneys

PATENTS—Write for Free Information, HOW TO OBTAIN A PATENT and RECORD OF INVENTION—or send Drawing or Model for Examination. Miller & Miller, Patent Attorney (former Patent Office Examiners), 1096 Woolworth Building, New York; 262 McGill Building, Washington, D. C.

PATENTS—Advice and booklet free. Highest references. Best results. Promptness assured. Watson E. Coleman, Patent Lawyer, 724 9th Street, Washington, D. C.

PATENTS, TIME COUNTS In applying for patents. Send sketch or model for instructions or write for free book, "How to Obtain a Patent" and "Record of Invention" form. No charge for information on how to proceed. Clarence A. O'Brien, Registered Patent Attorney, 309-A Security Savings and Commercial Bank Bldg., Washington, D. C.

PATENTS, TRADE MARKS—All cases submitted given personal attention by a member of the firm. Information and booklet free. Lancaster, Allwine & Rommel, 269 Ouray Building, Washington, D. C.

Inventors—Should write for our Guide Book, "How to Obtain a Patent," and Record of Invention Blank, sent Free. Send model or sketch of inventions for our inspection and instructions free. Radio, Electrical, Chemical, Mechanical and Trademark Experts. Terms Reasonable. Victor J. Evans & Co., 922 Ninth, Washington, D. C.

#### Personal

TALKIE AND MOVIE PRODUCERS are clamoring for new short story ideas, plots, etc. Perhaps you can write one that we can shape and sell for you. One writer (V. M.) received \$3,000. New York best market. Write for full particulars. Daniel O'Malley Company, Suite B, 1776 Broadway, New York.

#### Radio

"WORLD" RECEIVER, \$1.25. Illustrated Barkain Catalogue 10c. Nell Tasker, Shamokin, Penna.

Wanted—Men to work with National Radio Service organization. No selling scheme. Radio Doctors, Inc., Dept. N, Essex St., Salem, Mass.

#### Song Poem Writers

SONG POEM WRITERS—"REAL" proposition. Hibbler, D-191, 2104 Keystone, Chicago, Ill.

COMPOSERS—VERSE OR MUSIC. Brilliant opportunity. Write at once. Van Buren, 2291 McClurg Bldg., Chicago.

SONGWRITERS! Advance royalty payments, new talking picture song requirements, etc., fully explained in our free instructive booklet. Write today. Song poems examined free. Newcomer Associates, 1674-VV Broadway, New York.

#### Wireless

LEARN WIRELESS (Radio) and Morse Telegraphy. School, oldest and largest; endorsed by Telegraph, Radio, Railway and Government officials. Expenses low—can earn part. Catalog free. Dodge's Institute, Cour St., Valparaiso, Ind.

## See the Craters in the MOON!

**Astronomical and Terrestrial TELESCOPE**

Magnifies 30 Times

Own a genuine Astronomical Telescope. See thousands of miles away. Make Sun, Moon Flashes, Stars your next door neighbors. Moon Craters, Sun Spots, Eclipses enlarged 30 times. Strange Thrills!

Hours of fun looking at scenery, games, bathing beaches. Great for trips and voyages. Made like telescopes used in observatories. Cording wools. Moon seemed 10 yards away.

See Landscapes, Games, Ocean Scenes, Enlarged 30 Times!

Diameter 2 inches. Special friction adjustment for focusing. Adjustable bracket and clamp can be fastened to chair, fence, branch, etc. Finest materials. Will last a lifetime.

**Five Days' Free Trial**

Rush only \$1.00 now. Pay balance \$2.95 plus postage, when postman delivers. Keep 5 days. If not delighted, return telescope and money will be refunded.

**EARN \$10 A DAY**  
Charge 25c to look at the moon

ROLL-O SPECIALTY CO., Dept. S-335  
220 E. 3rd St., Cincinnati, O.

### QUIT TOBACCO

Don't try to banish unaided the hold tobacco has upon you. Thousands of inveterate tobacco users have, with the aid of the Keeley Treatment, found it easy to quit.

### KEELEY TREATMENT FOR TOBACCO HABIT

Quickly banishes craving for tobacco. Successful for over 50 years. Write today for FREE BOOK and particulars of our MONEY-BACK GUARANTEE.

THE KEELEY INSTITUTE, Dept. L-611, Dwight, Ill.  
Home of the famous Keeley Treatment for Liquor and Drugs. Booklet Sent on Request. Correspondence Strictly Confidential.



## TYPEWRITER 1/2 Price

Save over 1/2-Rock Bottom Price on all standard office models—Underwood, Remington, Royal, etc.—Easiest terms ever offered. Also Portables at reduced prices.

**SEND NO MONEY**

All late models completely refinished. See brand new. Fully Guaranteed. Sent on 10 days' trial. Send No Money. Big Free Catalog shows actual machines in full colors. Greatest bargains ever offered. Send at once.

10-day Trial

231 W. Monroe St.  
International Typewriter Exch., Dept. 193, Chicago

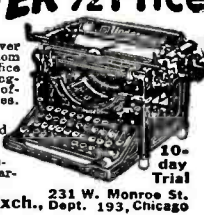

## News from Manufacturers

(Continued from page 651)

### The Crosley Pal

The Crosley Radio Corporation of Cincinnati, Ohio, announces a new cabinet receiver known as the Crosley Pal, measuring 25 inches high by 21 wide and 10 1/2 deep.



The Crosley Pal uses two screen-grid type -24 tubes in radio-frequency stages, one screen-grid tube type -24 in the detector stage, one -45 tube in the power output stage and one type -80 tube as a rectifier.

## Book Reviews

*Tin Pan Alley*, by Isaac Goldberg. Published by the John Day Company, New York. 227 pages.

As the title implies, this book gives an interesting historic sketch of the past forty years, during which time a multitude of popular songs, tunes and lyrics have poured forth from that narrow street in the Roaring Forties. Adding to the interest of this work is a short preface by George Gershwin.

The range of Dr. Goldberg's book includes everything from the very earliest attempts of American song writers to an analysis of the present-day theme song as exemplified by the talkies and the influence of radio and the talkies on music publishing.

*Tin Pan Alley* will provide interesting reading to anyone engaged in radio broadcasting. It will be obvious to the student of modern American music that the American public is becoming better trained in appreciating the technique of popular songs. This fact can profitably be kept in mind by radio broadcasters, program creators, writers and production men and all those who contemplate going into the broadcast field.

*New Empires*, by Karl A. Bickel, president United Press Association; published by J. B. Lippincott Company, Philadelphia, Pa. 112 pages. \$1.50.

The first part of this book is a concise account of a newspaper man's job, his duties and what it is essential for him to know.

In the second part Mr. Bickel goes on to discuss radio and the effect it is likely to have on both the advertising and news sections of the papers. How effective is radio as a news agency? How has radio advertising affected newspapers?

## Mike-roscopes

(Continued from page 638)

Roxy was born 48 years ago in Stillwater, Mass. He tells me that when he was seven years old he first attended theatre at the opera house in Stillwater; that they played an operetta which even then entranced him; that the first theatre he ever had of his own was in a miners' town in Pennsylvania, behind a barroom. Roxy told me that there are only two things in which he has never been disappointed—the Grand Canyon of Arizona and his first glimpse of the tropical sea.

Roxy jumped aboard the ether band wagon with his Monday nights Roxy Gang over NBC and more recently with his Roxy Sunday afternoon concerts. You see, he saw the "airwriting on the wall". When I asked Roxy what he considered the ideal qualities for a producer

of radio, he said he must be a psychologist, he must be human, have vision, courage, tolerance, be a good executive and somewhat of a damn fool!

HAVE you ever felt the refrigerated air or whatever it is, at some of our elaborate Metropolitan studios? I'd feel better if they'd have it all over the place or not at all. As it is, I am always alternately wishing for a fur coat and an electric fan. And I wish you technical men would tell me how to open a door in the studios without feeling as though you were going to be killed on the spot! I don't need electricity in the air, not that kind, thank you. Please consider this pathetic query under the head of "Help Wanted".

## Short-Wave Supersonic Converter

(Continued from page 605)

around 90 volts. It can even be attached to the speaker, for the voltage is not at all critical.

In tuning, the oscillator is the sharp control, the antenna circuit being quite broad. For this reason the tuning dial is attached to the oscillator condenser and just a plain knob attached to the antenna tuning condenser, which latter device is then used in much the same fashion as the "trimmer" on the broadcast receivers of a year or so ago. By such a procedure this new converter is, to all intents and purposes, of the single control type.

Due to the tremendous difference in frequency to which the intermediate frequency is tuned from that of the incoming signal, a very novel type of vernier tuning control is obtained by using the broadcast receiver (intermediate-frequency amplifier) tuning dial as a vernier tuning control. Such an arrangement is particularly nice in connection with amateur reception, as it gives a "band spread" effect at any desired frequency. When using such a combination for amateur communication work, where it is neces-

sary to receive cw signals, the need for an additional heterodyne oscillator is eliminated by employing one of the local broadcast stations for this purpose. All that is necessary is to add a very short length of antenna, say 12 inches or so, to the antenna post of the broadcast receiver and then tune the receiver so that it is just off resonance with this local broadcaster. The amateur cw signal will then be found to beat against the carrier of the broadcast station, resulting in very nice cw reception.

The last and most important point of all, and this cannot be emphasized enough, is the need for a very sensitive broadcast receiver for use with this job. The converter is contributing no gain in itself, and all the amplification must come from the broadcast receiver. This receiver should also be a band-pass affair to get the best tone quality. We have been using the converter with the new National MB-30, a perfectly band-passed affair with super sensitivity and selectivity, using six tuned circuits. This, or a similar unit, should be used.

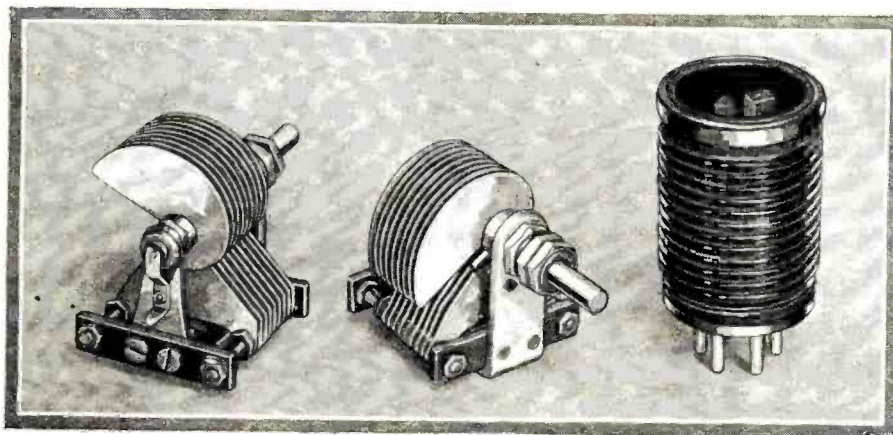

A front and rear view of condenser and the new S.-W. coil form

Meeting  
the demand  
for **BETTER**  
radio tubes



» » the new  
improved

**TRIAD**  
**T-224**



The improved construction of TRIAD T-224 now makes possible finer tube performance than you've ever known before! Its new design practically eliminates microphonics and burnouts and assures a quality of tone reproduction that is startling in its reality. Yet this is only one of the many remarkable improvements car-

ried out thru the entire TRIAD Line. TRIAD engineers have worked ceaselessly toward a greater perfection in tube manufacture—and have achieved it! Give your set the added advantage of TRIAD equipment—it will bring you far greater radio enjoyment!

**TRIAD**  
**RADIO TUBES**

TRIADS are now manufactured under R. C. A., G. E. and Westinghouse patents.

TRIAD MFG. CO., Inc.  
Pawtucket, R. I.

More Radio Men Than Ever  
NOW USE

# FLECHTHEIM

## SUPERIOR CONDENSERS

—The reason is plain—

Finest,  
Least  
Expensive  
Condensers  
Having  
The  
Highest  
Efficiency,  
Improved  
Materials

Complete  
range, from  
250 V. D.C.  
to  
5000 V. D.C.  
  
ONE  
of our leaders is  
Type UF, un-  
cased, dipped-  
in-pitch filter  
condensers, rated  
at 450 V. D.C.,  
330 rms. RAC.  
Priced most rea-  
sonably.

"Our Transmitting Condensers Are  
Used by Over 50% of the Broad-  
casting Stations."

Catalog No. 22 on Request

A. M. Flechthheim & Co., Inc.  
138 Liberty St., New York City, N. Y.

## LEARN RADIO

this easy, practical way

WRITTEN by two widely known radio engineers,  
these three books cover every phase of building,  
repairing and "trouble-shooting" on modern receiving  
sets.

### Radio Construction Library

This practical Library includes: PRACTICAL RADIO—The fundamental principles of radio, presented in an understandable manner. Illustrated with working diagrams. PRACTICAL RADIO CONSTRUCTION AND REPAIR—Methods of locating trouble and reception faults and making workmanlike repairs. Discusses modern Short Wave Receivers fully. RADIO RECEIVING TUBES—Principles underlying the operation of all vacuum tubes and their use in reception, remote control and precision measurements.

The Library is up-to-the-minute in every respect and is based on the very latest developments in the design and manufacture of equipment.

Three Volumes,  
6 x 9—993 pages,  
561 Illustrations.

See this  
Library  
FREE!

No  
Money  
Down



## FREE EXAMINATION COUPON

McGraw-Hill Book Company, Inc.  
370 Seventh Avenue, New York

Send me the new RADIO CONSTRUCTION LIBRARY, three volumes, for 10 days free examination. If satisfactory I will send \$1.50 in ten days, and \$2.00 a month until \$7.50 has been paid. If not wanted I will return the books.

Name .....

Home Address .....

City and State .....

Position .....

Name of Company.....RN-1-31

### INDEX TO ADVERTISERS

<b>A</b>	
Acme Wire Company	664
Aeronox Wireless Corp.	657
Alexander Hamilton Institute	662
Allied Radio Corp.	Inside Front Cover
Amalgamated Purchaser, Inc.	666
American Sales Co.	640
American School, The	644
American Transformer	643
Amperite Corp.	660
Amplex Instrument Laboratories	662
Amrad Corp., The	645
Arcturus Radio Tube Co.	653
Automatic Radio Mfg. Co., Inc.	Inside Back Cover
<b>B</b>	
Baltimore Radio Company	650
Blan, the Radio Man	665
<b>C</b>	
Candler System, The	664
Central Radio Laboratories	654
Champion Radio Works, Inc.	641
Chicago Gear Works	665
Chicago Radio Apparatus Co.	654
Chicago Salvage Stock Store	672
Clarostat Mfg. Co.	667
Classified Advertising	668
Conn. Ltd., C. G.	660
Coyne Electrical School	581-655
Crosley Radio Corp.	644
<b>D</b>	
DeForest Radio Co.	647
Dodge Institute	640
Drake, Frederick J., & Co.	662
<b>E</b>	
Electrad, Inc.	649
Ellis Electrical Laboratory	646
Excello Products Corp.	650
<b>F</b>	
Federated Purchaser	642
Ferranti, Inc.	661
F & H Radio Laboratories	646
Filtermatic Mfg. Co.	658
Flechthheim & Co., Inc.	670
Freed Radio Sales and Service Co.	656
<b>G</b>	
General Radio Co.	663
Gernsback Publications, Inc.	656
<b>H</b>	
Hammarlund Mfg. Co.	665
Hammer, Radio Co., S.	667
High Frequency Labs.	641
Hoodwin Co., Chas.	664
<b>I</b>	
International Correspondence Schools	642
International Resistance Company	667
International Typewriter Exchange	668
<b>J</b>	
Jappe Co., H.	662
J M P Mfg. Co., Inc.	666
<b>K</b>	
Keeley Institute	668
Kienzle, Harry	664
<b>L</b>	
La Salle Extension University	656
Ludy Hotel	670
Lynch Mfg. Co., Inc.	664
<b>M</b>	
Mason, Fenwick & Lawrence	660
Massachusetts Radio & Telegraph School	666
McGraw-Hill Book Co., Inc.	670
Metal Cast Products	656
Midwest Radio Corp.	658
Morrison Hotel	658
<b>N</b>	
National Carbon Co., Inc.	642
National Co., Inc.	Back Cover and 651
National Radio Institute	578-579
Nelson Electric Co.	666
Norden-Hauck, Inc.	661
Nubor Radio Co.	646
<b>O</b>	
Omnigraph Mfg. Co.	647
<b>P</b>	
Pilot Radio & Tube Corp.	639
Pitman, Isaac, & Sons	640
<b>R</b>	
R C A Institutes, Inc.	634-635
Radio International Guild	651
Radio Surplus Corp.	660
Radio & Television Institute	585
Radio Training Association of America	577
Rider, John F.	647
Rim Radio Mfg. Co.	644
Roll-O Specialty Company	668
<b>S</b>	
Samson Electric	583
Sedgefield Inn	670
Shallcross Mfg. Co.	652
Silver-Marshall, Inc.	637
<b>T</b>	
Teleplex Company	666
Triad Mfg. Co., Inc.	669
Twentieth Century Mail Order	649
<b>U</b>	
Uncle Dave's Radio Shack	659
<b>V</b>	
Van Nostrand Co., Inc.	663
Vari-tone Lab.	665
Vulcan Electric Heater Corp.	650
<b>W</b>	
Washington Hotel	649
Wellston Radio Corp.	652
Western Coil & Electric Co.	658
Western Radio Mfg. Co.	648
Weston Electrical Instrument Corp.	671
West Side Y. M. C. A. Radio Inst.	651
Wholesale Radio Service	648
<b>Y</b>	
Yahr-Lange, Inc.	648

**Green Grass Greens**

Down from the rigor of cold winds and snow, to the temperate sunshine of Piedmont Carolina and Sedgefield Estate, where the gold greens are green and bridle trails wind for 50 miles thrashably every year. Sedgefield Inn awaits you with the hospitable air of an English manor house. Overnight from New York.

MAIN LINE SOUTHERN R. R.  
U. S. ROUTE 70  
N. C. ROUTE 10

**SEDFIELD INN**  
SEDFIELD GREENSBORO, NORTH CAROLINA  
JOHN C. WALLER, MGR.

**HOTEL LUDY**

SOUTH CAROLINA AVE. AT THE BOARDWALK

**ATLANTIC CITY'S**

NEWEST CENTRALLY LOCATED FIREPROOF HOTEL

**\$6.00**

DAILY AND UP

AMERICAN PLAN

WIRE PHONE OR WRITE R. B. LUDY M.D.

## Build Your Receiver With the Aid of Blueprints!

A limited supply of blueprints still available on the following receivers:

- The Junk Box Short Wave Receiver .....25c
- A Two-Tube Reflex Receiver.25c
- How to Construct the Pre-Selector .....25c
- A Bloopless One-Dial Two-Tube Set .....25c

Write to Radio News, BLUEPRINT DEPARTMENT, 381 Fourth Avenue, New York City.



# A Serviceman's Ohmmeter

(Continued from page 624)

serve on the voltmeter what voltage is required to pass .001 amperes through the resistance. In this case, we'll say, it is 2 volts,

$$R = \frac{E}{I} \text{ or } 2 \div .001 = 2 \text{ ohms.}$$

Easy? You don't have to do it on paper, just simply read the voltage and then in your mind point off three places. To divide by .001 is the same as multiplying by 1000 and to multiply by 1000 point off three places to the right.

Gee boy, we got something now! All we got to do is connect in the unknown

internal resistance) to read the voltage impressed on the unknown resistor. It seems that our range in measuring ohms will be limited to 10,000. Not so, however, because there is another way out. Simply this: instead of adjusting the voltage until your milliammeter reads .001 amp., adjust it to one-tenth of the scale or .0001 amp., then multiply the reading of the voltmeter scale by 10,000 instead of 1000. This means that if .0001 amp. is flowing under a voltage of 10 then the resistance in circuit is 100,000 ohm.

$$\left( R = \frac{E}{I} \right)$$

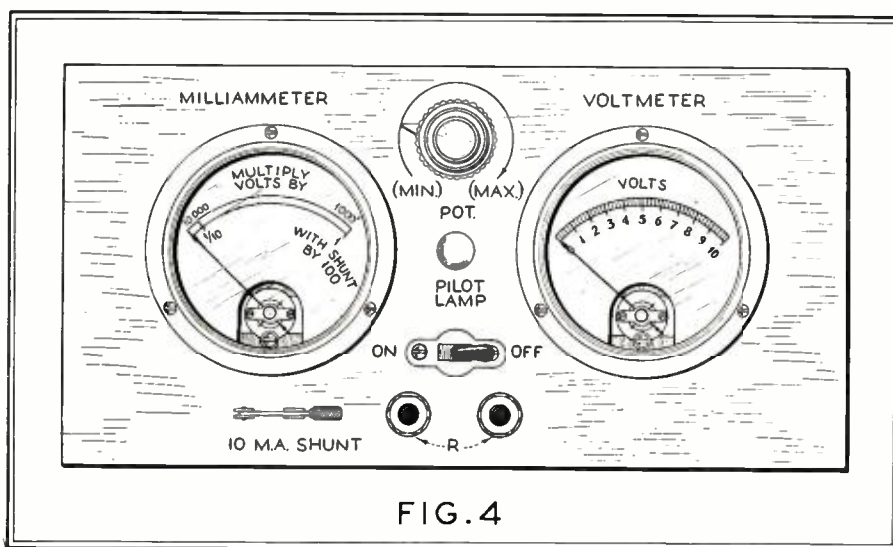

FIG. 4  
A front view suggesting a panel layout of the ohmmeter

resistance and adjust the voltage until the current passing is .001 amp., then read the volts and multiply by 1000 and there is your answer in ohms.

Now think a minute—if we are going to keep our current at .001 amp. when making a measurement then it is going to take 1 volt to push it through 1000 ohms, 2 volts for 2000 ohms, 3 volts for 3000 ohms and so on up the scale. Well now if that is the case you are getting your ohm readings direct from the scale of the voltmeter (times 1000) and that is a straight line or uniform characteristic scale!—something out of the ordinary for ohmmeters.

Well, so far we have been doing pretty nicely and we have about decided that the ammeter in this arrangement will have a full scale value of 1 milliampere. If it takes one volt per thousand ohms to operate the meter then it will require 100 volts to reach our high ideal of 100,000 ohms. That is too much bulk and weight. Let's decide that three of the regular type four and a half volt C batteries are all that we can carry or conveniently put in the case. That will give us a maximum of 13½ volts and if we allow for wear we should always be able to obtain 10 volts from them. We'll use a voltmeter with a range of 10 volts (any

Perhaps you are beginning to see now that the ammeter serves principally as a multiplying indicator telling you how much to multiply the "volt" scale by in order to read directly the ohms in circuit.

We have found now how to get two ranges with the instrument, 0 to 10,000 by using a multiplying factor of 1000 and 0 to 100,000 by using a multiplying factor of 10,000. We can extend this multiplying scheme a little more and get an advantage in widening the range between 0 and 1000 ohms so as to make it more readable. This is done by placing a multiplying shunt on the milliammeter so as to give it a range of 10 ma. or .01 amp. With the shunt switched in we adjust the multiplying indicator to full scale and multiply the reading on the "volt" scale by 100. We will thus be able to read clearly from 50 to 1000 ohms.

A diagram of the completed instrument is given in Fig. 3. A switch is provided to cut off the voltage divider so that it will not bleed the batteries when not in use. The pilot bulb is a further precaution against leaving the switch in the "on" position when the instrument is not in use.

The better the meters used, of course, the greater will be the accuracy.



**NEW**  
**Weston**  
MODEL  
**566**

*Low price test set for  
radio servicing*

THIS new Weston test set is designed for radio service men and dealers who specialize in servicing radio receiving sets in the home.

These men will find this new two meter test set ideally suited for their requirements because it combines the highly desired Weston dependability of operation with low cost.

### Servicing Scope

Weston Model 566 checks all type tubes under the same conditions as exists when in their sockets, giving readings quickly, conveniently, and accurately. Model 566 furnishes adequate measurements for testing all models of receiving sets:—checking power transformers; line voltage; heater voltage, and plate current and voltage at power pack; battery voltages, resistance and continuity of circuits, condensers and speaker coil currents.

### Equipment

Model 566 contains two 3¼ inch standard high quality Weston meters with scales specially calibrated for convenience and ease in reading. The meter on the left is a nine range A.C. Model 476 for 1,000, 200, 16, 8, 4 volts, 8, 4 amperes, and 100, 20 milliamperes. The meter on the right is a 10-range D.C. Model 301 for 1,000, 250, 100, 25, 10 volts, 0-100,000, 0-10,000 ohms and 100, 25, 2.5 milliamperes. The various ranges of the D.C. Volt-ohm-milliammeter are controlled by a 23 point Bi-polar switch. The ranges of the A.C. meter are controlled by a dial switch. A polarity reversing switch is provided; also binding posts, leads and tester plug for use in taking external readings.

For more complete information, write for Circular HH.

**Weston Electrical  
Instrument Corp.**

615 Frelinghuysen Avenue,  
Newark, N. J.



# OUR NEW 1931 CATALOG—JUST OUT!

# RADIO BARGAIN FLASHES

# FROM THE WORLD'S LARGEST RADIO STORE

**New** A-C SCREEN GRID & D-C BATTERY RECEIVERS  
 PHONO COMBINATIONS  
 DYNAMIC SPEAKERS  
 TUBES PARTS  
 SUPER HETERODYNES  
 AUTO-MANTEL AND ELECTRIC CLOCK SETS

Buy Now and Save

Prices offered in this catalog are so remarkably low that it will pay you to buy now even for future needs.



## Modern UP-TO-THE-MINUTE Radio! at Lowest Wholesale Prices...

All the very latest improvements in radio equipment. Large assortment of Screen Grid Sets, DC Battery Sets, Phono-Combinations, Dynamic Speakers, New Mantel Sets, Beautiful Consoles, Slot Machine Sets, Electric Clock Sets, Superheterodynes, New Accessories, Tubes—Parts.

**Radio prices have hit bottom—Get your share of the bargains**

### Never Before Such Values—

**Send for Catalog—It's FREE**

You will find in this book just what you are looking for and all at prices that will greatly astonish you. Because we are the world's largest radio store, we are able to buy and sell in such large quantities that we can make marvelous savings.

**WE HANDLE EVERYTHING IN RADIO**

Our immense stock is complete with practically everything of the latest in radio. Quick deliveries and real cooperation are assured you on all of your orders.

**Fill Out Coupon and Mail Today**

**CHICAGO SALVAGE STOCK STORE**  
 509 So. State St.  
 CHICAGO, ILL. Dept. 512

The Place to Save Money On RADIO



Buy Now Prices Are Down

**DON'T DELAY**

Get your copy of this catalog containing new rock-bottom prices on latest sets, kits, parts and accessories.

**FREE CATALOG COUPON**  
 Chicago Salvage Stock Store  
 509 So. State St., Dept. 512  
 Chicago, Illinois  
 Kindly send me, free of charge, your new radio catalog.

Name \_\_\_\_\_  
 Address \_\_\_\_\_

The  
LITTLE BEAUTY  
with the  
BIG VOICE



\$79.50

Complete  
with tubes

## The TOM THUMB Console As New As Tomorrow Morning

**I**N response to the increasing demand for radio receivers smaller in size, but having all the power, selectivity and tone that the public requires in radio, the engineers of the Automatic Radio Mfg. Co., after months of experimenting, have produced the Tom Thumb Console. This receiver, only 30 inches high and 17 inches wide, has selectivity, sensitivity and tone quality heretofore associated only with higher priced large receivers.

Artistically, the beautiful Tom Thumb Console cabinet adapts itself to any surroundings. It is particularly fitting for the hotel room, or small apartment. For that son or daughter in college it will make an ideal Christmas gift.

The Tom Thumb Console is a six-tube receiver, employing four screen-grid tubes, a -45 in the output

stage, and an -80 rectifier. The speaker is the latest type, full dynamic, and the chassis is completely shielded.

Complete with tubes, the price is only \$79.50.

### The TOM THUMB Midget

The little brother to the Console. It contains the same powerful, selective receiver as the larger model, yet it is only 16 inches high and 12½ inches wide. Price, complete with tubes, only \$69.50. See your distributor today. If he cannot supply you, write us direct.



Small in  
size, but  
a giant  
for  
reception

\$69.50  
complete  
with  
tubes

### Dealers and Jobbers

Cash in on the popularity of the New TOM THUMB Receivers. Write or wire us today!

Both Receivers also Available in D. C. 110-Volt Models.  
Complete With Tubes. Priced \$10 Higher.

Write Us Today for Full Particulars

**AUTOMATIC RADIO MFG. CO. INC.**  
DEPT. D, 112-118 CANAL ST. BOSTON, MASS.

# NATIONAL MB-30



AND SPEAKER-AMPLIFIER UNIT

Setting New Standards of Performance and Tone Quality  
Based on the New Vreeland Band - Selector Principles



**A NEW RADIO PRINCIPLE** makes possible the NATIONAL MB-30, with entirely new standards of performance and tone quality. The advanced Band-Selector Patents of Dr. Frederick K. Vreeland, combined with the basic work of Glenn H. Browning and James Millen on the MB-29, have produced a new and finer instrument in the MB-30—with performance second to none. Dr. Vreeland has been in the forefront of radio developments ever since his early work on the Superheterodyne.

**HERE IS A TUNER** with uniform sensitivity over the entire band of the order of one microvolt per meter, or better, very high selectivity without loss of tone quality, no cross-talk, no oscillation at any frequency.

**AN IDEAL RADIO PICK-UP** for existing amplifiers and easily adapted for rack panel mounting.

**CIRCUIT DETAILS.** Double pre-selector stage, six (6) Tuned Circuits, 4 Screen-Grid R. F. Stages, low impedance output 227 Power-Detector, making possible operation with any standard audio amplifier. Chassis is thoroughly shielded and mechanically rugged.

**KIT OR WIRED.** Either completely wired and laboratory tested and adjusted (Licensed under Vreeland Patents), or as assembled unwired parts for those who prefer to do their own wiring. For special amplifier-speaker unit and consoles designed expressly for use with the MB-30, see descriptions at right.

Write us today! Use Coupon.

**NATIONAL**  
Precision-Built  
RADIO PARTS



## Amplifier Speaker-Unit



Specially designed for easy installation with the MB-30. Provides proper operating voltages. A new Jensen Speaker comes as part of equipment. This is quickly and easily mounted on amplifier chassis and a special cord and plug connects it instantly. Output is Push-Pull through 245 tubes.  
*Licensed under R.C.A. Patents*

## Beautiful Consoles



National Company has available beautiful consoles for housing the MB-30 and National Amplifier-Speaker. These consoles are built to our standards of heavy, honest construction, and are of restrained and beautiful design which will harmonize with the finest surroundings.

## Simple Installation

Installation of the MB-30 and Amplifier-Speaker is exceedingly easy. The Amplifier-Speaker is simply inserted in the upper section of the cabinet,



the Tuner in the lower section. Everything is arranged and ready. There is no difficult or fussy fitting or planning.

**Send Coupon Today  
for Free Book**

### COUPON

NATIONAL CO., INC.  
Sherman, Abbott & Jackson Sts., Malden, Mass.  
Gentlemen:

- Please send me new free bulletin describing the new MB-30 Tuner.  
 Enclosed please find 10c (stamp or coin) for your MB-30 HANDBOOK.

Name.....  
Address.....