

**SPECIAL SUPERHETERODYNE NUMBER**

# **RADIO NEWS**

30  
**NOVEMBER  
25 CENTS**

**Carl Dreher  
on Fidelity of Sound in  
Talkie Recording**

**The R C A-Victor  
Silver and Hatry-Young  
Superheterodynes**

**Operating Notes  
on the Radio News  
Short-Wave  
Superheterodyne**



**The How and Why of Superheterodynes**

by **JAMES  
MARTIN**

# FREE RADIO CATALOG

EVERYTHING NEW IN RADIO

BETTER RADIO  
LOWEST WHOLESALE PRICES!



\$110 VALUE-YOUR PRICE  
**48**<sup>25</sup>

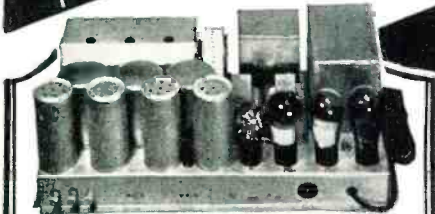

### The New Knight Screen Grid Chassis

The circuit of the New Knight 8 Screen Grid is the heir of years of experience in radio manufacture. Just as it is rich in years of development, so is it replete with an amazing array of advanced features representing the peak achievement in all-electric radio.

### 8 Tubes—Three Screen Grid

Knight 8 excellence is partially explained by its ingenious circuit which employs three powerful screen grid tubes with an unequalled sensitivity. Two tremendous "245" tubes in push-pull audio arrangement make possible remarkable tone and volume.

### New Filtered Tone

Pronounced clarity of tone is the outstanding characteristic of the advanced Knight 8. True life-tone, vibrant and vivid so that you can identify every instrument and every voice, proves that the 1931 Knight loses nothing in reproduction.

### Dynamic Speaker Equipped

The powered dynamic reproducer is especially designed to match the impedance of the receiver perfectly. It reproduces beautiful tone at any volume, unmarred by any trace of hum or distortion.



## Send For This Catalog Today

OUR NEW "1931" catalog is just off the press—168 pages full of the latest in radio attractions—over 500 illustrations—showing the newest improvements in radio. Prices are lower than ever before. Hundreds of specials are offered at really astounding prices.

### Wholesale Prices

Everything in this book is offered at the lowest wholesale prices, which means a tremendous saving to you for anything you want to buy—whether in complete sets—accessories, parts or kits.

### All The New Accessories

New 1931 Screen Grid, Tone Control, A. C. Humless All-Electric Sets, Public Address, Phono-Combinations, Dynamic Speakers, Beautiful Consoles. Also battery operated sets.

### Wonderful Values

You will be surprised at the remarkable values offered in this book of radio bargains. All the latest features priced to give you remarkable savings.

### Tremendous Stocks

The resources of this \$3,000,000 company make it possible for us to buy in large quantities at great savings, and to carry a complete stock of every possible kind of accessory—no matter what you want in radio, we have it.

## Use Coupon Below For Free Catalog

Simply sign your name and address to the coupon given below, and mail to us, so as to get this new "1931" book of radio bargains. It is absolutely FREE and we will be glad to send it to you. The prices in it sell themselves.

### Slot Machine Sets

Here is the latest machine for bringing in the money automatically for stores, hotels, depots and other public places. A nickel will play it for six minutes.

### Phono-Combinations

Screen Grid Radio receiver operates in conjunction with the finest phonograph equipment. A flip of a switch and the radio broadcasts come in through your radio receiver; another flip and the phonograph records may be reproduced electrically.

### Electric Clock Sets

Automatic time switch turns radio on and off. Just set for the time your favorite program comes on the air. The set will do the rest.

**ALLIED RADIO CORPORATION**  
711 W. Lake Street Dept. B-2 Chicago

## FREE CATALOG COUPON

Allied Radio Corporation,  
711 W. Lake St., Dept. B-2  
Chicago

Gentlemen,

Please send me your 168-page FREE radio book of bargains. It is understood there is no obligation for sending this catalog to me, neither will I be bothered by personal calls.

Name \_\_\_\_\_

Address \_\_\_\_\_



**We Could Have Placed 5000 More Qualified Men Last Year in Good Pay RADIO Positions**

**G**ET into the rich field of Radio via the training school that supplies big Radio employers with their new men! The Radio Training Association of America has a standing order from radio trade organizations, large manufacturers and dealers, for members qualified for full time work at splendid pay.

So great is this demand from Radio employers that positions offering good pay and real opportunity are going begging. If you want to cash in on Radio quick, earn \$3.00 an hour and up spare time, \$40 to \$100 a week full time, prepare for a \$10,000, \$15,000, \$25,000 a year Radio position, investigate the R. T. A. now.

**Special Attention to Radio Service Work**

Thousands of trained Radio Service Men are needed now to service the new all-electric sets. Pay is liberal, promotions rapid. The experience you receive fits you for the biggest jobs in Radio. The R. T. A. has arranged its course to enable you to cash in on this work within 30 days!

Would you like to work "behind the scenes" at Hollywood, or for a talking picture manufacturer? R. T. A. training qualifies you for this work. Television, too, is included in the training. When television begins to sweep over the country, R. T. A. men will be ready to cash in on the big pay jobs that will be created.

**Expert Supervision  
Lifelong Consultation Service**

As a member of the Association you will receive personal instruction from skilled Radio Engineers. Under their friendly guidance every phase of Radio will become an open book to you. And after you graduate the R. T. A. Advisory Board will give you personal advice on any problems which arise in your work. This Board is made up of big men in the industry who are helping constantly to push R. T. A. men to the top.

Because R. T. A. training is complete, up-to-date, practical, it has won the admiration of the Radio industry. That's why our members are in such demand—why you will find enrolling in R. T. A. the quickest, most profitable route to Radio.

**Mail Coupon for No-Cost Training Offer**

Memberships that need not—should not—cost you a cent are available for a limited time. The minute it takes to fill out coupon at right for details can result in your doubling and trebling your income in a few months from now. If you are ambitious, really want to get somewhere in life, you owe it to yourself to investigate. Learn what the R. T. A. has done for thousands—and can do for you. Stop wishing and start *actually doing something* about earning more money. Fill out the coupon and mail today.

**Radio Training Association of America  
Dept. RNA-11 4513 Ravenswood Ave., Chicago, Ill.**

**Fill Out and Mail Today!**

**RADIO TRAINING ASSOCIATION OF AMERICA  
Dept. RNA-11, 4513 Ravenswood Ave., Chicago, Ill.**

Gentlemen: Send me details of your No-Cost Training Offer and information on how to make real money in Radio quick.

Name \_\_\_\_\_

Address \_\_\_\_\_

City \_\_\_\_\_ State \_\_\_\_\_

*Superhets!*

**I**N this issue of RADIO NEWS we have attempted to publish as much authoritative up-to-the-minute information about superheterodynes as it was possible to obtain.

McMurdo Silver, a pioneer in superheterodyne design, will be remembered as the assistant of A. J. Haynes, who, back in 1924, produced the Haynes' Superheterodyne. Since that time the radio world is greatly indebted to "Mac" Silver for the many fine "super" designs he developed.

Since all this very recent activity in superheterodynes was started by the decision of RCA to allow its licensees to manufacture this type of receiver, it is only natural to expect that the "super" receiver offered this season by RCA Victor will come in for its generous share of scrutiny. We are happy to present in this issue the story of the engineering which characterizes this receiver.

Superheterodyne articles on theory, short-wave super converters and others complete an already complete line-up.

**RADIO NEWS for  
December**

**N**EXT month we devote the pages of RADIO NEWS especially to articles which will find favor with the serviceman. Custom-built receivers, laboratory and shop test apparatus, a two-page display of exceedingly interesting serviceman's test benches and work shops will be only a few of the features of this issue.

**TABLE OF CONTENTS**

Cover—From a Painting by David Hymes

Frontispiece: Superheterodynes by the Thousands..... 388

Editorial ..... 390

More About the Stenode Radiostat.....By *A. Dinsdale* 392

The "How and Why" of Superhet Circuits.....By *James Martin* 395

The Engineering Behind the RCA-Radiola Superheterodyne  
By *W. L. Carlson, R. S. Holmes and N. E. Wunderlich* 398

Making "110 Volts" Mean What It Says.....By *John J. Mucher* 401

How to Build a Good "Local" Receiver.....By *E. S. Wright* 402

Some Observations on Skip Distance and Ultra-High Frequencies  
By *Thomas A. Marshall* 406

Selectivity + Fidelity + High Gain = Superheterodynes..By *McMurdo Silver* 408

Getting the "Low-Down" on Short Waves.....By *Fred H. Schnell* 411

Judgment of Sound Quality in Motion Picture Recording....By *Carl Dreher* 414

Television Now Taught in Technical Schools..... 417

Health Cures by Means of Sound Amplifiers..... 417

Back Talk on Wenstrom's Radio-Sunspot Articles  
By *Lieut. Wm. H. Wenstrom* 418

A Six-Tube Short-Wave Super.....By *L. W. Hatry* 420

Adapting Your Broadcast Receiver to Short-Wave Reception  
By *George W. Walker* 422

Controlling Army Pursuit Planes by Radio.....By *Lieut. Charles Howard* 424

Bringing the I. R. E. Convention to RADIO NEWS Readers..... 427

The Unit-Built Receiver.....By *Donald Lewis* 428

The Radio Forum, for Experimenter, Serviceman and S-W Fan..... 430

RADIO NEWS Information Sheets..... 433

Junior Radio Guild..... 436

News from the Manufacturers..... 440

RADIO NEWS Home Laboratory Experiments..... 442

RADIO NEWS Manufactured Receiver Circuits..... 446

Underwriters' Radio Regulations.....By *N. Pomeranz* 448

Index to Advertisers..... 478

25c a copy  
\$3.00 a year

Published Monthly by

\$3.50 in Canada  
\$4.00 in Foreign

**RADIO-SCIENCE PUBLICATIONS, INC.**

183-10 Jamaica Avenue, Jamaica, N. Y.

Publishers, **B. A. MACKINNON** and **H. K. FLY**

Managing Editor, **JOHN B. BRENNAN, JR.**

Technical Editor, **GEORGE E. FLEMING**

Associate Editor, **ALBERT PFALTZ**

Editor, **ARTHUR H. LYNCH**

Entered as second class matter at the Post Office at Jamaica, N. Y., under the act of March 3, 1879.  
Copyright, 1930, by Radio-Science Publications, Inc. Editorial and Executive Offices, 381 Fourth Avenue, New York, N. Y.  
All Rights Reserved.



There's  
Something  
**BETTER**  
in a  
Winner!

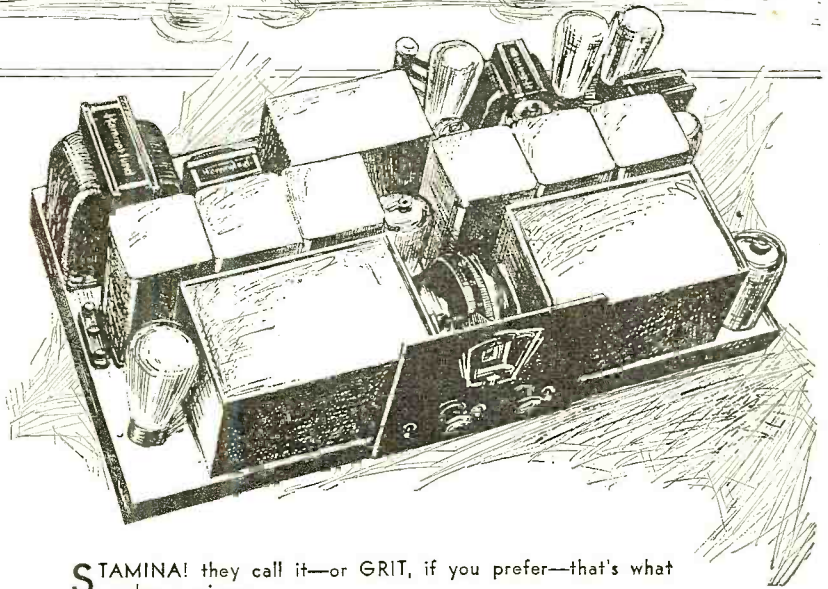

Choice of ten charming  
consoles, including three  
radio-phonograph combi-  
nations.



**S**TAMINA! they call it—or GRIT, if you prefer—that's what makes a winner.

Motor or radio—it's got to be BETTER or fall out.

Six years of glorious success are back of Hammarlund-Roberts Custom-Built Radio—six years of persistent pioneering—six years of leading the procession.

With such a record you can expect the new HiQ-31 to be exactly what it is—a PERFECTED radio, cleverly engineered, superbly designed and built to out-perform the field.

Name your ideal features and check against these HiQ-31 highlights:—

Hair-splitting selectivity through a three-stage tuned band-filter and three-stage screen-grid radio frequency amplifier—both brand new; new linear power detector using a shielded screen-grid tube; new resistance coupled first audio stage feeding direct into push-pull '45's; amazing sensitivity; four times that of standard receivers; dazzling brilliance of tone; new automatic phonograph connection; new oversize power plant; new local and distance volume control; new high-frequency noise filter and tone regulator; six tuned circuits; nine tubes, including automatic line voltage control and full-wave rectifier; a wide choice of beautiful cabinets.

And the best of all—you can easily assemble it yourself from factory-wired units, or for a small fee, delegate the work to your local custom-builder.

Mail coupon for the 48-page illustrated HiQ-31 Manual.  
It contains a wealth of valuable radio data.

HAMMARLUND-ROBERTS, INC.  
Dept. RN 11, 424-438 W. 33rd Street  
NEW YORK, N. Y.

**HiQ-31**

*Custom-Built Radio*  
by **HAMMARLUND**

HAMMARLUND-ROBERTS, INC.  
Dept. RN 11, 424-438 W. 33rd St.,  
New York, N. Y.  
Enclosed 25c (stamps or coin) for which please send  
copy of the HiQ-31 Manual.  
Name.....  
Address.....

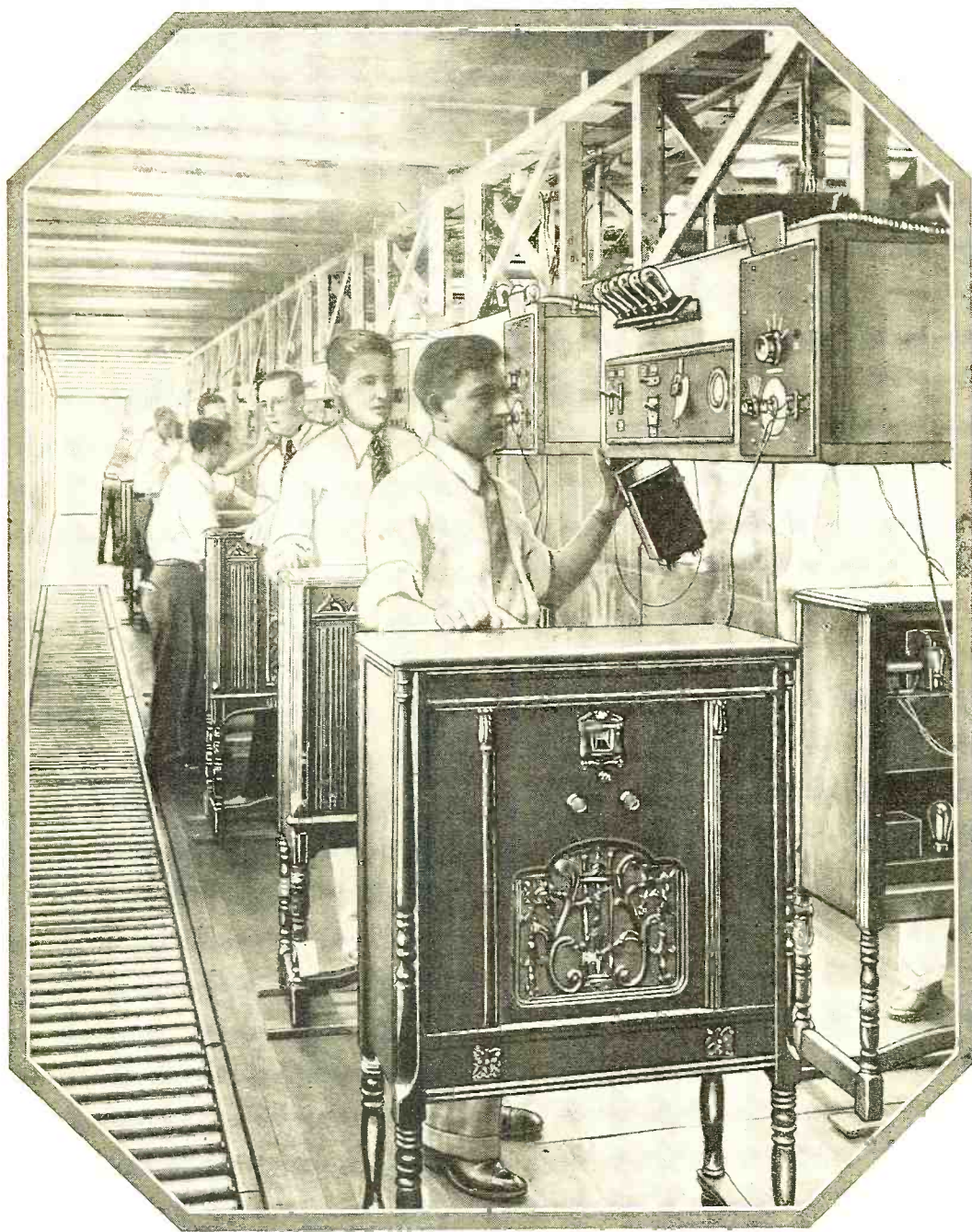

## Superheterodynes by the Thousands

**H**ERE is the advance guard of the parade of the superhets which we may expect to see featured as the most efficient type of radio receiver it is possible to design and build. This picture was taken in the plant of RCA-Victor, Incorporated, at Camden, New Jersey, and shows a line of superheterodynes in console cabinets undergoing final test on the production line. The dramatic engineering story behind this new and interesting receiver is told in this number.

# a Big Job Open for Every Radio Trained Man

# 5000

## Service Men Needed

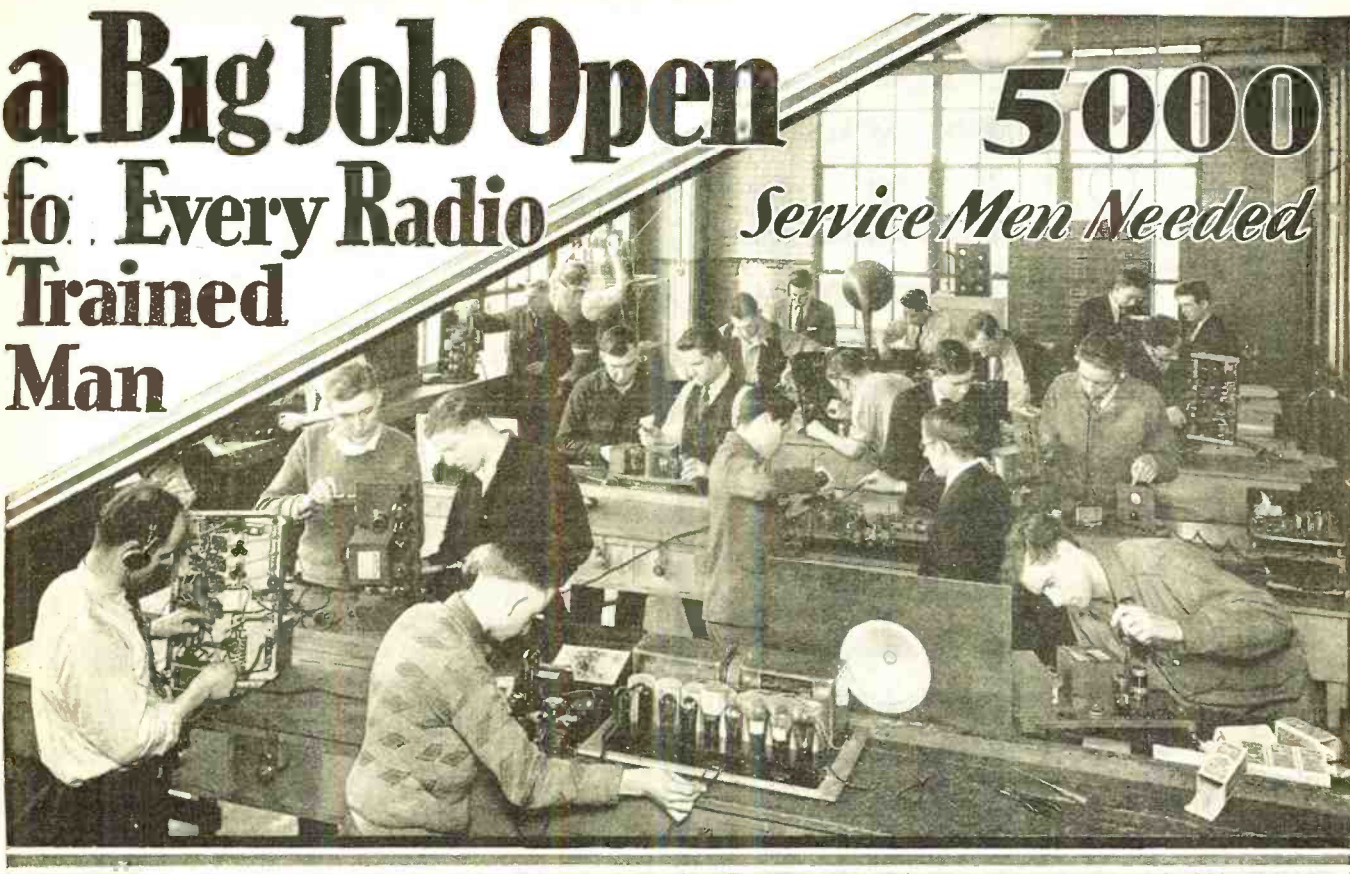

ACTUAL PHOTOGRAPH OF STUDENTS WORKING IN SERVICE DEPT. OF COYNE RADIO SHOPS

# EARN RADIO-TELEVISION TALKING PICTURES in 8 WEEKS By Actual Work ~~~ In the Great Shops of Coyne

Don't spend your life slaving away in some dull, hopeless job! Don't be satisfied to work for a mere \$20 or \$30 a week. Let me show you how to make REAL MONEY in RADIO—THE FASTEST-GROWING, BIGGEST MONEY-MAKING GAME ON EARTH!

**THOUSANDS OF JOBS OPEN**  
Paying \$60, \$70 to \$200 a Week

Jobs as Designer, Inspector and Tester, paying \$3,000 to \$10,000 a year—as Radio Salesman and in Service and Installation Work, at \$45 to \$100 a week—as Operator or Manager of a Broadcasting Station, at \$1,800 to \$5,000 a year—as Wireless Operator on a Ship or Airplane, as a Talking Picture or Sound Expert—THOUSANDS OF JOBS PAYING \$60, \$70 and on UP TO \$200 A WEEK.

**No Books - No Lessons**  
**All Practical Work**

Coyne is NOT a Correspondence School. We don't attempt to teach you from books or lessons. We train you on the finest outlay of Radio, Television and Sound equipment in any school—on scores of modern Radio Receivers, huge Broadcasting apparatus, Talking Picture and Sound Reproduction equipment, Code Practice equipment, etc. You don't need advanced education or previous experience. We give

you—right here in the Coyne Shops—the actual practice and experience you'll need. And because we cut out all useless theory, you graduate as a Practical Radio Expert in 8 weeks' time.

## TELEVISION Is on the Way!

And now Television is on the way! Soon there'll be a demand for THOUSANDS of TELEVISION EXPERTS! The man who learns Television NOW can make a FORTUNE in this great new field. Get in on the ground-floor of this amazing new Radio development! Come to COYNE and learn Television on the very latest, newest Television equipment.

## Talking Pictures A Great Field

Talking Pictures and Public Address Systems offer thousands of golden opportunities to the Trained Radio Man. Here is a great new field of Radio work that has just started to grow! Prepare NOW for these mar-

velous opportunities! Learn Radio Sound work at Coyne on actual Talking Picture and Sound Reproduction equipment.

## EARN AS YOU LEARN

Don't worry about a job! Coyne Training settles the job question for life. We often have more calls for Coyne graduates than we can supply. YOU GET FREE EMPLOYMENT SERVICE FOR LIFE. And don't let lack of money stop you. If you need part-time work while at school to help pay living expenses, we will gladly help you get it. Many of our students pay nearly all of their expenses that way.

## COYNE IS 31 YEARS OLD

Coyne Training is tested, proven beyond all doubt. You can find out everything absolutely free. How you can get a good Radio job or how you can go into business for yourself and earn from \$3,000 to \$15,000 a year. It costs NOTHING to investigate! Just MAIL THE COUPON for YOUR COPY OF MY BIG FREE BOOK!

H. C. Lewis, Pres. **Radio Division** Founded 1899  
**COYNE ELECTRICAL SCHOOL**  
500 S. Paulina Street Dept. 80-5B Chicago, Illinois

H. C. LEWIS, President  
Radio Division, Coyne Electrical School  
500 S. Paulina St., Dept. 80-5B, Chicago, Ill.  
Send me your Big Free Radio Book and all details of your Special Introductory Offer. This does not obligate me in any way.

Name.....  
Address.....  
City.....State.....

## A Million Dollar Idea

AS this editorial is being written, engineering representatives of an English inventor, whose new system for radio transmission and reception may upset and greatly improve our present method, are preparing to leave London for New York. They are bringing models of receivers which they claim will enable us to operate three times the present number of broadcasting stations, without interference, on the present broadcast band. These new receivers are neither expensive nor difficult to build.

As we write we form a mental picture of the derisive nodding of Solonic heads and the desperate raising of hands in the air by the receiver manufacturers and broadcast station owners. We hear the sepulchral echo of the voice of the ultra-conservatives and engineering die-hards who say "The system is fundamentally unsound and it will not work. This newly touted but very laughable invention is nothing but the peg on which a lot of pseudo-scientific charlatans can hang a lot of questionable publicity for the purpose of exploiting the public through the sale of stock. It is merely the annual bid for the publicity which is necessary for any of the hair-brained schemes used for the periodical 'revolutionizing' of the radio business. We had hoped there would be no such revolution this year, but here is the old bugaboo larger and livelier than ever."

We must admit having been mildly impressed in much the same way when the first newspaper announcements of the Stenode Radiostat appeared about a year ago. The claims made for it were so broad that we took them with a grain of salt. We noted that they were being made in the name of a group of estimable English scientists and decided that it might be well to investigate, even though the claims made in the newspaper articles could not be reconciled with current engineering practice.

A few years ago, when we organized the International Radio Broadcast tests, we were fortunate in having the hearty cooperation of Mr. Hugh S. Pocock, Editor of the *Wireless World* and *Radio Review*, in London. Through our correspondence we came to know him well and to hold his judgment in high regard. We cabled for a report from him. It was not very encouraging. Nearly six months later the subject came up at one of our editorial meetings and we decided upon further investigation. The reports were extremely interesting.

We found that Mr. Percy Harris, formerly Technical Editor of Mr. Pocock's publication, had resigned to become Chief Engineer of the British Radiostat Corporation, Ltd. He spent some time traveling this country a few years ago and we came to know him quite well. We wrote him and received a much more complete picture of the myriad applications which may be made of what is apparently the most startling invention of this decade.

We invited Mr. Harris and his associates to utilize the facilities of RADIO NEWS Laboratory on their contemplated visit to this country and are happy to announce their acceptance. Within a few weeks we expect to be able to demon-

strate some of the simpler applications of Dr. James Robinson's extremely interesting invention.

Incidentally, many demonstrations have been made before the leading European scientific bodies and many governments are now investigating its operation. Among other things, The London Daily Mail, which publishes in Manchester and in London, simultaneously, is now using the Stenode principle on a wire telegraph line between the two cities with the result that the communication capacity of the lines has been increased many times.

So much has been said and so much purposely left unsaid about television that any reference to it usually compels attention. Perhaps it is well, then, to say that in the opinion of the inventor, the Stenode Radiostat is the key to the broadcast television problem because it will permit, within the limiting factors which other portions of the television problem bring about, the establishing of many television broadcast channels without in any way limiting present broadcasting facilities.

Not the least interesting is the possible application of the Stenode application to amateur or "ham" activities. It is common knowledge that there is not sufficient room for these ardent investigators in the portions of the frequency spectrum assigned them by international agreement, through our own Department of Commerce. The section now allotted to the amateurs for radio telephone communication is particularly narrow and radio telephones require a wider band for each station than is necessary for radio telegraphy. Without in any way altering international agreements on frequency allocation the Stenode, it is claimed, will allow the amateurs to increase the number of existing stations and enable them to improve the character of transmission and reception as well.

The Stenode applied to telephone and telegraph lines will, by increasing the number of conversations possible over each line, result in tremendous saving in equipment and a great increase in telephone and telegraph facilities along with great reduction in the cost of these rapidly expanding services.

Last month we published an introductory article on this very important subject by W. T. Cocking and in this number we have the extremely interesting article by A. Dinsdale, for three years editor of *Television Magazine*, London, and now Managing Editor of our sister publication, *Science and Invention*. Mr. Dinsdale has just come from London. He is a personal friend of Dr. Robinson. He has witnessed numerous demonstrations of this new and revolutionary invention, and has handled a Stenode receiver himself.

We have called the Stenode a "Million Dollar Idea." After learning of its multiplicity of applications we feel sure that our estimate is conservative in the extreme. Perhaps we would be nearer the correct figure if we made it a billion. In any event it is with keen gratification that RADIO NEWS will place all the authorized information by the inventor of the Stenode Radiostat at the disposal of the communications services of the world each month.

Arthur H. Lynch



**R. T. I.** R. T. I. QUALIFIES YOU TO MAKE MONEY AND ITS SERVICE KEEPS YOU UP-TO-THE-MINUTE ON THE NEWEST DEVELOPMENTS IN RADIO, TELEVISION, AND TALKING PICTURES **R. T. I.**



# RADIO WANTS MEN TRAINED AS R. T. I. TRAINS THEM AT HOME FOR PRACTICAL WORK

Radio wants trained men and pays them well. This great industry would rather pay Big Money to men trained as R. T. I. trains them, than low wages to untrained "inkers," and "guessers." Trained radio men can easily make \$40 to \$50 per week and upwards. With training and experience many make \$75 to \$100 per week and are always in demand. Get the inside facts from leading radio men in the free "R. T. I. Radio Opportunity Book."

**BETTER JOBS—BIGGER PAY**  
R. T. I. offers you the way to get into Radio right and the definite path to the Better Jobs and Bigger Pay. You need no experience to start. You can quickly make \$10 to \$20 per week Extra Money in spare time while learning.

**APPROVED TRAINING**  
R. T. I. training is endorsed by leading Radio Concerns and Radio Trade Associations. It is prepared and supervised by well known men in different branches of radio. You will find it interesting, practical, thorough and easy to understand.

**LEARN AT HOME**  
Why? Because the fellow who trains at home the R. T. I. way learns rapidly and makes a most valuable man. R. T. I. Gives you the training the radio industry wants you to have for important work.

Make your success certain. Start R. T. I. training in radio now. Go on up in this great money-making industry that is becoming part of all our daily life. Entertainment, Education, Business, Transportation, News—all depend more and more upon radio.

**GET PAID FOR WHAT YOU KNOW**  
Be a trained man. R. T. I. gives you money-making radio training and keeps you up-to-the-minute with its service. No more worry about jobs when you complete R. T. I. training.

**TELEVISION**  
This amazing new branch of radio is part of the R. T. I. training. (No extra charge.) Be prepared for this new work—Television Service-men will soon be in demand.

**TALKING PICTURES**  
Require trained men—in the studios—the theatres—for servicing and installing the apparatus, and R. T. I. training covers this, too. Broadcasting Stations, Airplane Radio Apparatus, Sea-going Ship Radio Operating, Radio Factories, Short Wave Work, Receiving Set Servicing, Selling, Repairing, etc. All these opportunities are included in R. T. I. training.

**Free Opportunity Book**  
Get the facts about the opportunities in Radio, Television and Talking Pictures in this wonderful book—it is free.



**Let F. H. Schnell**  
and the R. T. I. Advisory Board Help You  
20 years' Radio Experience. First to establish 2-way amateur communication with Europe. Former Traffic Mgr. of Am. Radio Relay League, Lieut. Com. U. S. N. R. Inventor and Designer. Cons. Radio engineer. Assisting him is the R. T. I. Advisory Board, composed of men prominent in the Radio Industry—manufacturing, broadcasting, engineering and servicing. All these men know Radio and will help you succeed in their field.

**RADIO & TELEVISION INSTITUTE**  
4806 St. Anthony Ct., Chicago, Dept. 848

**Mail Coupon for Big FREE BOOK**

Name.....  
Address.....  
City..... State.....



**THE R. T. I. ADVISORY BOARD.** These men are executives with important concerns in the radio industry—manufacturing, sales service, broadcasting, engineering, etc., etc. They supervise R. T. I. Work Sheets, Job Tickets, and other training methods.

**R. T. I.** R. T. I. TRAINS YOU AT HOME FOR A GOOD JOB OR A PROFITABLE PART TIME OR FULL TIME BUSINESS OF YOUR OWN



Dr. James Robinson  
M.B.E., D.Sc., M.I.E.E., F.Inst.P.

**D**R. ROBINSON, the inventor of the Stenode Radiostat, is one of Britain's leading scientists in the realm of electrical communication. He was formerly head of the Department of Radio Research and Photography of the British Air Ministry, and a member of the Radio Research Board, the advisory body to the British Government which deals with all questions of technical policy in connection with all forms of radio communication, civil and military. As an inventor he is perhaps best known as the creator of the Robinson Wireless Direction-Finding System, which he perfected during the war for use on aeroplanes, but which has since been used with equal success on board ship. He also has many other important inventions to his credit.

We are indebted for this information to Dr. Robinson's personal friend, Mr. A. Dinsdale, who is now the managing editor of our sister publication, *Science and Invention*, and the author of the accompanying article.—EDITOR.

**S**T. GEORGES, Hanover Square, is frequently one of the focal points of London's social world, for it is a favorite church for fashionable weddings. Very interesting, no doubt, but what has that to do with the subject of this article? you may ask. Just this. Right beside this famous old church, which dates back to the seventeenth century, is the headquarters of the British Radiostat Corporation, a five-million-dollar corporation formed (and registered in Canada) for the purpose of developing and exploiting the Stenode Radiostat receiver. The modest but well-appointed offices and laboratory of this corporation are at the present moment the focal point of interest to radio men the world over.

Dr. James Robinson, the inventor of the Stenode, is a British scientist of high repute in radio circles. Formerly head of the wireless research department of the Royal Air Force, he already has many important inventions to his credit, the best known of which is the system of radio direction-finding which bears his name.

The Stenode Radiostat was first demonstrated last fall, and very sensational claims were made for it, but at that time it was not possible to publish any technical details concerning it. Through the courtesy of Dr. Robinson I am now able to reveal for the first time to American readers the details of the system.

When the invention of the Stenode was first announced the

## More About the

*In the following article, the author, formerly editor of Television Magazine of London, a member of the Council and Executive Committee of the British Television Society, and now managing editor of Science and Invention, describes in detail the principles and working of Dr. J. Robinson's recently invented Stenode Radiostat, a superselective receiver which, it is claimed, will make it possible to put thousands of new broadcast stations on the air without creating new interference. The new receiver also opens up boundless possibilities for the future development of television, by permitting the broadcasting of very much wider frequency bands than are possible at present. The first article on the Stenode Radiostat was published in the October RADIO NEWS.*

*Others will follow*

sensational statement was made that sidebands, as we know them, do not in fact exist in ether space. This claim gave rise to considerable discussion in England, principally in the pages of *Nature*, where Sir Ambrose Fleming, F.R.S. (the inventor of the Fleming valve, the forerunner of the modern thermionic tube) sought to show that sidebands do not, in fact, exist, but are merely a convenient mathematical fiction, designed to explain observed phenomena. In a further article, designed to wind up the discussion, and which was published in the April, 1930, issue of the *Television Magazine*, Sir Ambrose further suggested that sidebands do not exist in ether space, but are the creation of our only means of exploring that space (from a wireless point of view), i.e., our present radio receivers.

That sidebands do appear to exist, with present technical methods and apparatus, there can be no question; every broadcast fan knows that to his cost. Let us, for a moment, examine them and probe the real meaning of this obstacle to further progress.

In Fig. 1 is shown the resonance curve of a sharply tuned unmodulated carrier wave. Such a curve, with well-designed apparatus, is very sharp. That is to say, the bulk of the radiated energy (amplitude) is concentrated on a single frequency; on either side of the frequency to which the apparatus is tuned the amplitude falls off so rapidly as to be practically negligible within a few hundred cycles of the fundamental frequency.

As soon as the carrier wave is modulated, however, the superimposed audio frequencies increase the "spread" of the resonance curve to an extent dependent on the maximum value of the audio frequencies. In ordinary broadcasting, this maximum value is 5,000 cycles, so that the total spread of the resonance curve is the fundamental frequency plus or minus 5,000 cycles. In other words, the total space in the ether, or waveband, occupied by the modulated wave is 10,000 cycles, or 10 kc., wide. The appearance of the resonance curve is now as shown in Fig. 2.

Resonance curves are obtained by allowing continuous waves of different frequencies to arrive at a receiver and by noting the current which is obtained for each frequency. The frequency which gives the maximum response (peak of the curve) is the fundamental frequency, or the frequency to which the receiver is tuned. The resonance curve therefore means that when a receiver is tuned to a certain frequency it responds best to waves which possess that frequency; but it also responds to

# Stenode Radiostat

By A. Dinsdale



A view of the Hanover Square laboratory of the British Radiostat Corporation, where the Stenode Radiostat was invented by Dr. Robinson



Mr. Percy Harris, well-known British receiver designer, operating the main tuning control of the laboratory model Stenode Radiostat

waves of a different frequency, the amount of response diminishing as the frequency of the incoming signals recedes from that to which the receiver is tuned.

In the case shown in Fig. 2, the receiver is tuned to frequency  $N_0$  and the incoming signals are of the same frequency, but are modulated. The sideband theory, by employing Fourier's theorem for the analysis of complicated wave forms, asserts that the modulated waves of frequency  $N_0$  can be looked upon as a series of waves of different frequency, but each of constant amplitude. However, the reality is that the waves which are arriving are of one frequency but of variable amplitude. Until the arrival of the Stenode it was becoming usual for radio engineers to consider the reality to be that modulated waves actually do consist of a series of waves of different frequency, but each of constant amplitude. The new facts, however, have made engineers look upon the sideband theory in its correct light, which is that modulated waves may be regarded as a series of independent waves, although they are not necessarily so.

On the basis that modulated waves consist of a series of different waves which are all transmitted simultaneously, it is necessary to provide a radio receiver having a resonance curve wide enough to receive the whole of these frequencies. Thus, for telephony, the resonance curve should be (in Europe) 9 kc. in width, and, in fact, it should be more than this, because the resonance curve should be almost horizontal over the 9,000 cycles in order that all frequencies may be received equally.

Fig. 1. Resonance curve of a sharply tuned unmodulated carrier wave. Fig. 2. Resonance curve of a modulated carrier wave. Fig. 3. Curve "a" resonance curve of an ordinary broadcast receiver; curve "b" resonance curve of a much more sharply tuned receiver

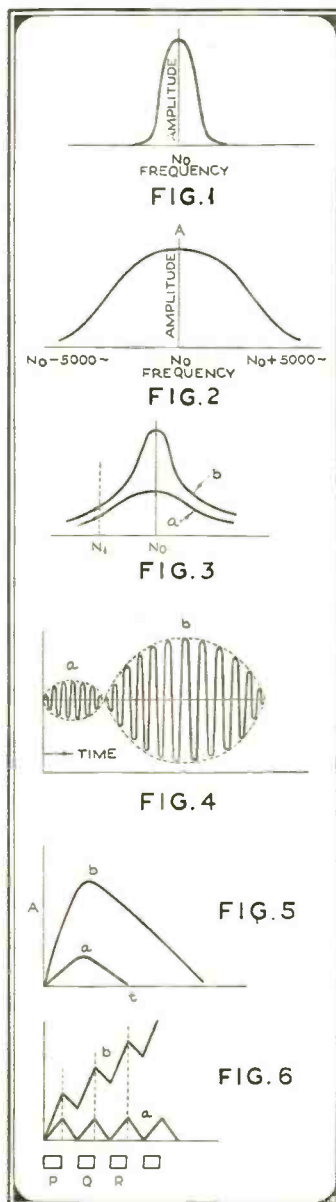

This implies that the resonance curve of normal type should actually be 20,000 cycles or more in width in order to receive one telephony (broadcast) station without distortion. Thus, the sideband theory places a definite limit on selectivity and indicates that for telephony we must have a receiver with a resonance curve at least 9 kc. in width, and for television a still wider resonance curve. It follows, therefore, that the frequency (wavelength) assignments of broadcasting stations must not be less than 9 kc. apart; otherwise interference will result in all receivers within range. All broadcast fans are only too familiar with this result.

Such a wide separation between stations naturally places a definite limit upon the number which can operate within a prescribed area. As a matter of fact, on the broadcast waveband between 250 and 550 meters there is room for only 72 broadcasting stations to operate (on a 9 kc. separation) without causing mutual interference, unless they are so widely separated geographically as to be out of range of one another, or share a wavelength with a distant station. If we could somehow impress on a carrier wave all the intelligence we wanted to, either aural or visual, without causing a frequency spread of more than, say, 1,000 cycles, we could build nine stations for every one in existence today. Alternatively, we could achieve this desirable result if, somehow, we could extract the necessary intelligence from an ordinary carrier wave with a radio receiver having a resonance curve only 1,000 cycles wide.

The situation is even more serious than

Fig. 4. Built-up curves corresponding to "a" and "b" of Fig. 3. Fig. 5. Actual envelope of the r.f. oscillations shown in Fig. 4. Fig. 6. Effect of signalling speed on circuits having different resonance curves

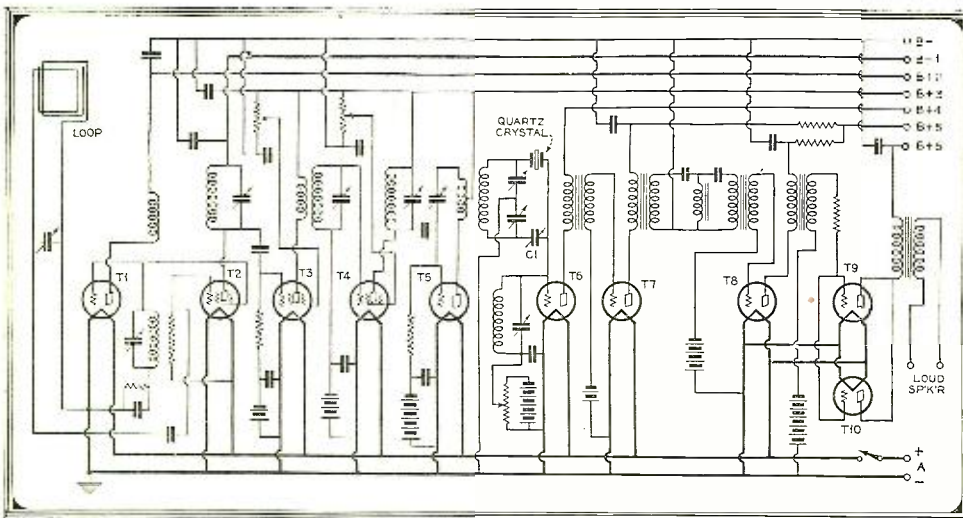

Fig. 9. The complete circuit diagram of the circuit developed by Dr. Robinson

coil and condenser, we speak of it as an oscillatory circuit. If current is made to flow in such a circuit, it would continue to flow forever were it not for electrical losses in the circuit. The effect of these electrical losses is spoken of as the damping in the circuit. A good analogy can be found in a mechanical device that, set in motion, continues until the inertia is overcome by friction. In this case, the friction is the damping of the device.

Oscillation due to feedback is usually termed "self oscillation," and will be so designated

this. Broadcasting is only one of the uses to which radio is put for communication purposes, and the broadcast waveband is only a small part of the entire spectrum of wavelengths. Between 15 and 26,000 meters thousands of radio stations are packed like sardines in a tin, all engaged on some important communication service or other, such as telephony, telegraphy, facsimile (photo-telegraphy) transmission, military and naval services, broadcasting and experimental work. There is no room for any more stations on any wavelength, for any purpose, under existing technical methods.

But have we reached finality in radio technique? The answer is that there is no finality in scientific matters. In any desperate circumstances, the hour of greatest need produces the man who is capable of dealing with the situation. The latest child of science, radio, has in a scant thirty years so outgrown its pants that it is in danger of dying of suffocation before it is anything like full grown. A man with a pair of scissors is desperately wanted to cut the pants adrift, and the urgent call is being met by Dr. Robinson. Radio communication is about to be freed and given liberty to expand and grow one hundred-fold.

Dr. Robinson proceeded to examine what would happen if we employed a receiver with a resonance curve much narrower than that which was apparently demanded by the sideband theory. Ordinarily, of course, such a procedure would result in cutting off some of the sidebands, thus producing distortion.

In Fig. 3 are shown two resonance curves *a* and *b*, *a* being of the normal type for telephony, and *b* much more selective. The frequency for correct tuning is shown as N0 and a frequency N1 is shown which differs from N0 by, say, 5,000 cycles, so that curve *a* is suitable for telephony reception, as all frequencies which are supposed to take part in the carrying of telephony are more or less equally received. On the face of it, curve *b* would appear to give a larger amount of distortion, and it was common to state that a circuit with a resonance curve of this type cuts off the upper sidebands.

Before going into the effects of damping in circuits, we wish to draw a distinction here between an oscillatory circuit as opposed to the oscillation in a receiver due to feedback. When we have an electrical circuit in which current can freely flow, particularly if this circuit has a timing factor, such as a

in the following paragraphs:

Let us examine, however, what happens when signals arrive at any receiver. In this case it is useful to observe how an incoming signal makes the receiver oscillate. The signals make the receiver oscillate at first with a low amplitude, which amplitude increases to a definite maximum. When the signal ceases, the receiver oscillations do not die down to rest instantly, but continue for a time.

There are great differences in this response between circuits of high and low damping. In Fig. 4 are shown the build-up curves corresponding to the resonance curves *a* and *b* of Fig. 3. In Fig. 4 actual high-frequency oscillations are shown, but the feature which is of most importance is the actual envelope of these high-frequency oscillations, and these are shown in Fig. 5.

From these curves we learn certain general principles; firstly, that the maximum amplitude which is attained increases as the resonance curve gets sharper; secondly, a definite period of time is required for the receiver to build up oscillations to their maximum value, and this build-up time is greater the sharper the resonance curve.

These three principles can easily be demonstrated by the reader himself, provided that he is a sufficiently experienced radio experimenter. Take a single-tube regenerative receiver and tune in telegraph signals. Now adjust the tickler coil until the threshold point of self-oscillation is almost reached, and it will be observed that each signal takes an appreciable time to build up to full strength, and a slightly longer time to die out. Each signal tends to set up a ringing sound.

Better and more easily observable results will be obtained on wavelengths over 10,000 meters, using an independent heterodyne (local oscillator) to produce a beat

note with the incoming c.w. signals.

The relation between this experiment and the argument at present being advanced is, of course, that the nearer the tickler coil is adjusted to self-oscillation point, the sharper the resonance curve of the receiver is being made. As all radio fans know, a receiver in this condition is hopeless for receiving broadcasting; the resonance curve is so sharp that the most appalling distortion results.

It is very interesting to observe the effect of signalling speeds on circuits with different (Continued on page 472)

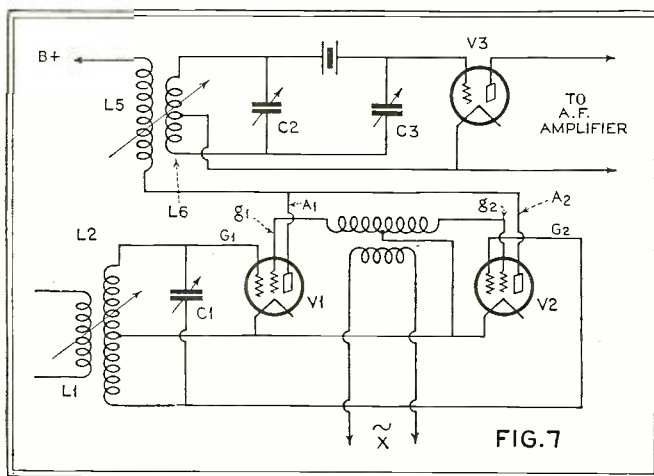

Fig. 7. A circuit illustrating the principle of the Stenode Radiostat. L1—feeding coil from aerial or from r.f. amplifier; L2, C1—circuit tuned to incoming waves. Coil L2 is center-tapped, its ends being joined to grids G1 and G2 of tubes V1 and V2; G1, G2—second grids with coil L3 between them, its center being grounded; L4—coil in circuit of generator X for comparatively low frequencies, i.e., frequency of reversal. L3 and L4 are coupled; A1, A2—plates connected together and fed by "B" voltage through primary coil L5, which is coupled to coil L6; L6, C2—circuit tuned to incoming signals; Q—quartz crystal; C3—balancing condenser; V3—detector tube. The a.f. amplifier is of ordinary type

# The "How and Why" of "SUPERHET" Circuits

*Dividing the super circuit into three principal fundamental units—the frequency mixer, intermediate amplifier and audio amplifier—makes it much easier to comprehend. Mr. Martin, whose writings on fundamental radio engineering and design have won him a large following among RADIO NEWS readers, has done a remarkable piece of work in this informative article which certainly removes the clouds from the superheterodyne sky and converts an apparently complicated mechanism into one which is easy to understand*

By James Martin

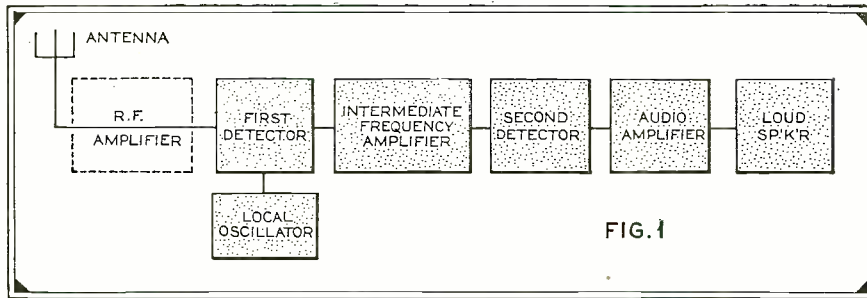

FIG. 1

Fig. 1. The various sections of the superheterodyne receiver are illustrated in this figure. Compare the various sections with the standard type of tuned r.f. receiver shown in Fig. 2

adjacent channel, the sensitivity determines the ability of the receiver to pick up distant stations or to operate with a very small antenna and still obtain sufficient volume, and the fidelity indicates the quality of the speech and music reproduced by the loud speaker. Selectivity and fidelity are closely tied together

It is a characteristic of many devices that a knowledge of their fundamental mode of operation is much more easily understood than is the design and operation of individual parts of the apparatus. In a few words we can sketch how a sound is produced by a violin, for example, but an exact knowledge of how the vibrations of the string are communicated to the bridge, nut and tail-piece, through belly, ribs and back, to the atmosphere and hence to the ear is a knowledge possessed only by the experienced instrument maker. In the same manner it is not difficult to understand the fundamental

The superheterodyne, because of band-pass characteristics that can be closely approximated, is ideally suited to short-wave and television reception.

in the manner indicated below. In analyzing the superheterodyne receiver we will therefore consider how these three factors of selectivity, sensitivity and fidelity influence its design.

Every superheterodyne consists of six essential parts as indi-

Accurate alignment of all tuning condensers to obtain maximum performance is easily accomplished in the superheterodyne because the intermediate frequency amplifier always operates on the same frequency.

Fig. 4. This diagram shows the changes in frequency produced when a carrier wave is modulated. Before modulation only a single frequency is present; after modulation "side-bands" are produced extending about 5,000 cycles either side of the carrier frequency

factors that form the basis for the operation of the superheterodyne type of receiver, although a knowledge of the considerations that effect of design of the various parts of a superheterodyne involves a thorough understanding of all phases of radio engineering. Our purpose in this article is to explain the underlying theory of the superheterodyne, with the idea not only of showing how the receiver works, but what its distinguishing features are, and how they make it possible to build a receiver which is, in many ways, almost ideal.

In the design of any radio receiver the three most important factors are the selectivity, sensitivity and fidelity. A high order of selectivity makes it possible to tune in one station without interference from another station operating on an ad-

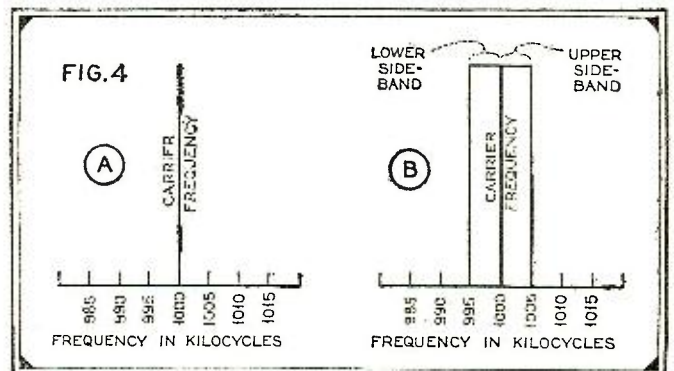

cated in Fig. 1. In some cases, for reasons to be explained later, an r.f. amplifier may be placed ahead of the first detector, but this unit is not essential to the operation of this type of receiver. The signal is picked up by the antenna, passed through the r.f. amplifier (if one is used), thence to the first detector, where it is combined with a signal from the local oscillator. It then passes into the intermediate-frequency amplifier, the second detector, then the audio amplifier and

**⌈ The heart of the superheterodyne is the intermediate frequency amplifier. Upon its characteristics largely depends the overall performance of the receiver. ⌋**

finally reaches the loud speaker, where the electrical signal is converted into sound.

In Fig. 2 are shown the essential parts of an ordinary tuned radio-frequency receiver. By comparison with Fig. 1 it will be seen that the superheterodyne is different in that it contains two detectors, an oscillator and an intermediate amplifier. In the ordinary set, indicated in Fig. 2, the signal is picked up by the antenna, is then amplified by the r.f. amplifier, detected (changed from radio frequency to audio frequency), then amplified at audio frequency, the output from the audio amplifier supplying the loud speaker. This, essentially, is all that takes place as the signal passes through a tuned r.f. receiver. Now let us examine in some detail what happens to the signal in a superheterodyne receiver.

In order to understand the statements that are to follow, we must know just what sort of radio wave is transmitted by a broadcasting station. The fact that a broadcasting station actually transmits a carrier frequency and two sidebands has been mentioned many times, but a brief discussion of this point is given below since it affords an important reason for the use of the superheterodyne.

When a broadcasting transmitter is on the air, but is not sending out a program, it emits a signal frequency, which is that frequency assigned to it by the Federal Radio Commission. As soon as any sounds are impressed on the transmitter they cause changes to take place in the signal transmitted by the station, which result in the production of currents having frequencies somewhat greater and somewhat less than the carrier frequency. Before modulation the signal from the broadcasting station looks like A of Fig. 3; after modulation—that is, after voice or music is impressed on the carrier—the signal looks like B of Fig. 3. This figure does show how the carrier varies in amplitude with the signal, but it does not show the introduction of new frequencies.

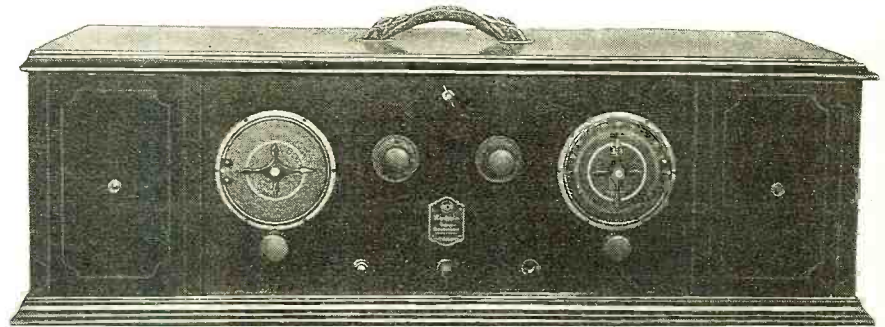

One of the first commercial types of superheterodyne available for general public use

frequency, without having to worry about its operation over a broad band of frequencies extending from 550 to 1,500 kc. Or it would be very nice if we could build a set to work at

**⌈ Practically uniform sensitivity, selectivity and fidelity over the entire broadcast band is possible in the superheterodyne. ⌋**

some fixed frequency and then place some device in front of the set that would change the frequency of any signal picked up by the antenna to that frequency for which we had designed our receiver. Such a device has been invented, it is usually known as a frequency-changer, and it forms an essential part of every superheterodyne receiver. Let us see how this can be accomplished.

**“Beat” Frequencies**

Whenever two radio-frequency currents are combined in a detector circuit two “beat” frequencies are produced, equal to the sum and to the difference of the two currents. For example, if we combine 1,100 kc. with 1,000 kc. we obtain two new currents one of which has a frequency of 1,100 plus 1,000 or 2,100 kc. and another which has a frequency of 1,100 minus 1,000 or 100 kc. Now it is comparatively difficult to build good amplifiers to work at very high frequencies, but not difficult to build good amplifiers to work at low radio frequencies. In the above example we would therefore build an r.f. amplifier to amplify the 100 kc. beat note. If our

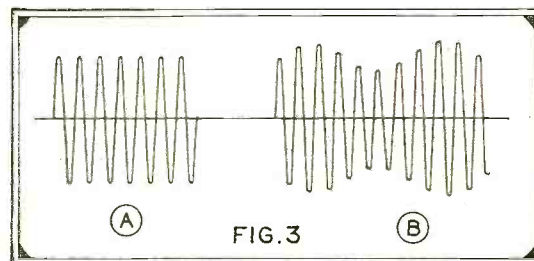

Fig. 3. How the current in the antenna of a broadcasting station looks before and after modulation. Modulation causes the current to vary in amplitude about a mean value

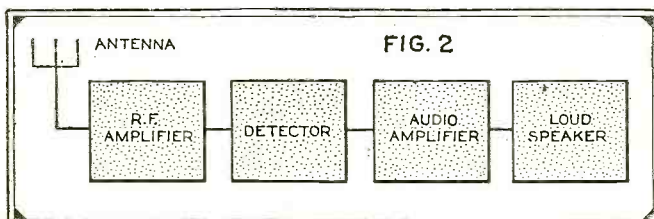

Fig. 2. The tuned radio-frequency receiver consists of only four essential parts. It is therefore a much simpler type of circuit to understand than is the superheterodyne

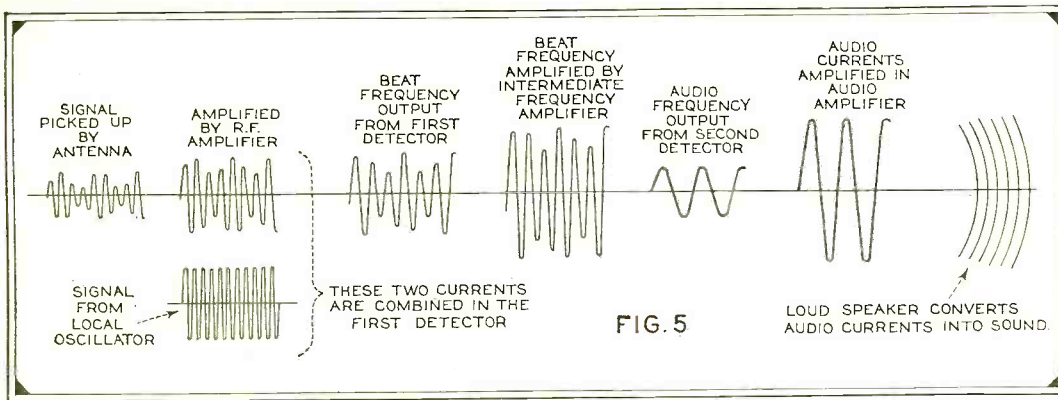

Fig. 5. Here's what happens to the signal as it passes through the various circuits of a superheterodyne receiver. The small voltage picked up by the antenna is amplified, combined with the output from a local oscillator, amplified again, detected, amplified for a third time and then it reaches the loud speaker, where it is converted into sound

amplifier was designed for this frequency we would therefore have to change every signal to 100 kc. Since the broadcast band extends from 550 to 1,500 kc. this could be accomplished by combining these currents with another current which could be made to have any frequency from 450 to 1,400 kc. or 650 to 1,600 kc., since either of these combinations would make it possible to obtain a 100 kc. beat frequency.

In practice the two radio-frequency currents are combined in the first detector of the superheterodyne. One of the currents is the signal picked up by the antenna and the other current is obtained from the local oscillator (see Fig. 1). These two currents produce in the output of the first detector a current whose frequency is equal to the difference between the two currents which were combined; this difference frequency is then passed on to the intermediate-frequency amplifier. The second detector is connected to the output of the intermediate-frequency amplifier and the currents are reduced to audio frequencies by this second detector. After that they are amplified by an audio amplifier in the usual manner and then serve to supply power to the loud speaker. Fig. 5 graphically indicates these points.

In summary of the above discussion we can say that the superheterodyne circuit makes it possible to construct an efficient receiver to work at a fixed frequency, the frequency of all incoming signals being changed to this predetermined fixed frequency by means of a local oscillator coupled to the first detector circuit.

In the intermediate-frequency amplifier excellent selectivity and a high order of amplification are readily obtained, due largely to the fact that the radio frequency at which the amplifier works is quite low. At these low radio frequencies high gain per stage is possible and circuits having band-pass characteristics can be closely approximated. On the other hand, uniformly high gain and band-pass characteristics are difficult to obtain at broadcast frequencies. The fact that in the superheterodyne amplification takes place at a low radio frequency is one of the major advantages of this type of receiver.

Not only is it possible to build intermediate-frequency amplifiers to have better inherent selectivity than r.f. amplifiers operated at broadcast frequencies, but the fact that a difference frequency is used, contributes to the selectivity of a superheterodyne. Broadcast stations are separated by 10 kc. and at 1,000 kc., for example, this represents a frequency separation of one per cent.  $(\frac{10}{1,000} \times 100)$ .

Consider what happens when we make use of beat frequencies, assuming that the intermediate frequency was 100 kc. If we were receiving a station transmitting on 1,000 kc. then the local oscillator frequency would be 1,100 kc. to give a difference of 100 kc. Stations on adjacent channels of 990 kc. or 1,010 kc. would then produce beat frequencies of 110 and 90 kc. respectively. This represents a frequency separation of 10 per cent.  $(\frac{110 - 90}{100} \times 100)$ .

By using an intermediate frequency we have therefore caused two stations to be separated by 10 per cent. in frequency, although their actual separation in the broadcast band is only 1 per cent.

But there are other factors that influence the choice of the intermediate frequency. Let us consider especially the case of the modern superheterodyne broadcast

receiver which is generally designed with an r.f. amplifier (shown in dotted lines in Fig. 1) ahead of the first detector. Here we find, as is the case with any r.f. amplifier, that the interference from a given station becomes less as its frequency becomes farther away from the station we desire to hear. That is, if we are listening to a station on 600 kc. much less interference would be obtained from a station on 1,000 kc. than would be obtained from a station on 700 kc. Now suppose we had the intermediate-frequency amplifier operating at 50 kc., then to tune in a broadcast station operating on 600 kc. would adjust the oscillator to 650 kc. But the correct intermediate frequency could also be obtained from a station operating on 700 kc. since  $700 - 650$  gives 50 kc. If the intermediate frequency was 180 kc. then we would have to tune our oscillator to 780 kc. and then we might get interference from a station on 960 kc. Arranging these figures in table form, we have:

Intermediate Frequency	Desired Station	Oscillator Frequency	Interference from Station on	Frequency Separation between desired and interfering stations
50	600	650	700	100
180	600	780	960	360

The important fact to notice is that as the intermediate frequency is increased, the frequency separation between the desired station and the interfering station increases, being 100 kc. with a 50 kc. amplifier and 360 with a 180 kc. amplifier. The tuned circuits of the r.f. amplifier preceding the first detector will of course be much more effective in eliminating the signals from the interfering station in the latter case. As the intermediate frequency is raised the possibility of interference from harmonics in the oscillator is also lessened. The actual choice of the intermediate frequency therefore becomes a compromise between a number of factors including amplification, stability, selectivity, interference, etc.

In all of the preceding discussion we have indicated, indirectly, the advantages of the superheterodyne. From the standpoint of selectivity it has the advantage that the intermediate frequency amplifier, which is where most of the selecting occurs, can be made to have a very (Continued on page 448)

A rear view of the chassis of the RCA portable "super." This receiver employed a built-in loop and operated on 3-volt tubes from dry cells, contained within the carrying case

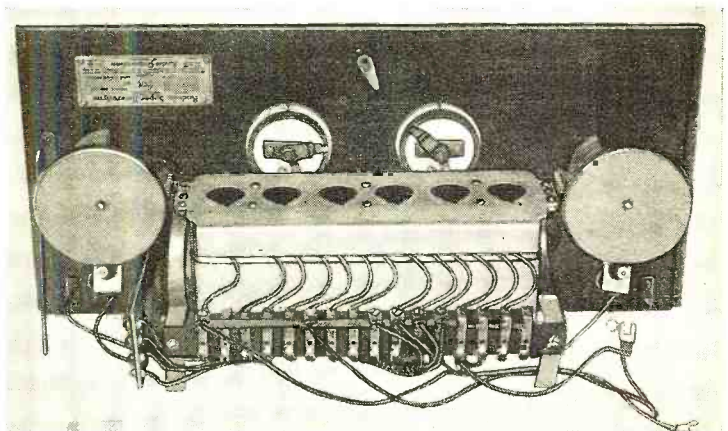

The  
Engineering  
Behind

the **R.C.A. RADIOLA**

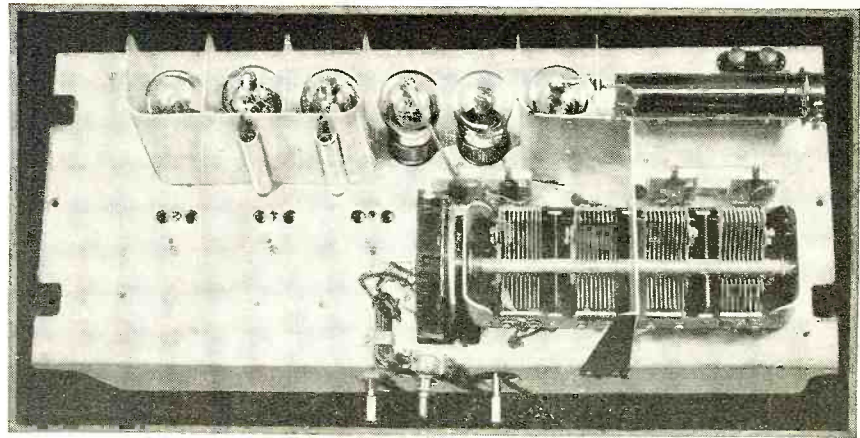

**I**N order to give the excellent reception to which the present day broadcast listener is entitled, a receiver must give much better performance than would have been considered satisfactory a few years ago. It must be able to bring in the distant stations without interference from powerful local stations, and at the same time give high quality reproduction of programs coming from nearby stations.

The superheterodyne circuit is particularly adapted to meet these difficult requirements. Instead of relying on selecting and amplifying the signal at the incoming broadcast frequency, by means of circuits which must be adjusted to that frequency, the superheterodyne changes the broadcast frequency to a lower, fixed frequency where it can be amplified and unwanted frequencies eliminated much more efficiently.

By  
W. L. Carlson

R. S. Holmes and  
N. E. Wunderlich

*the designers of this receiver*

This fixed frequency is usually called the intermediate frequency.

The ease of obtaining high amplification and selectivity in an intermediate frequency amplifier is chiefly due to the relatively low frequency used and to the fact that the characteristics of such an amplifier are independent of the broadcast frequency to which the set is tuned. In the 1930 RCA Radiola superheterodyne an intermediate frequency of 175 kilocycles has been chosen as the best compromise between amplification, stability, selectivity and undesired responses.

Roughly the selectivity of a receiver is determined by the number of selective circuits it has. Thus, ordinary radio-frequency receivers have three or four tuned circuits. The better ones have five. The 1930 RCA Radiola superheterodyne has nine selective circuits, three at radio frequency and six at in-

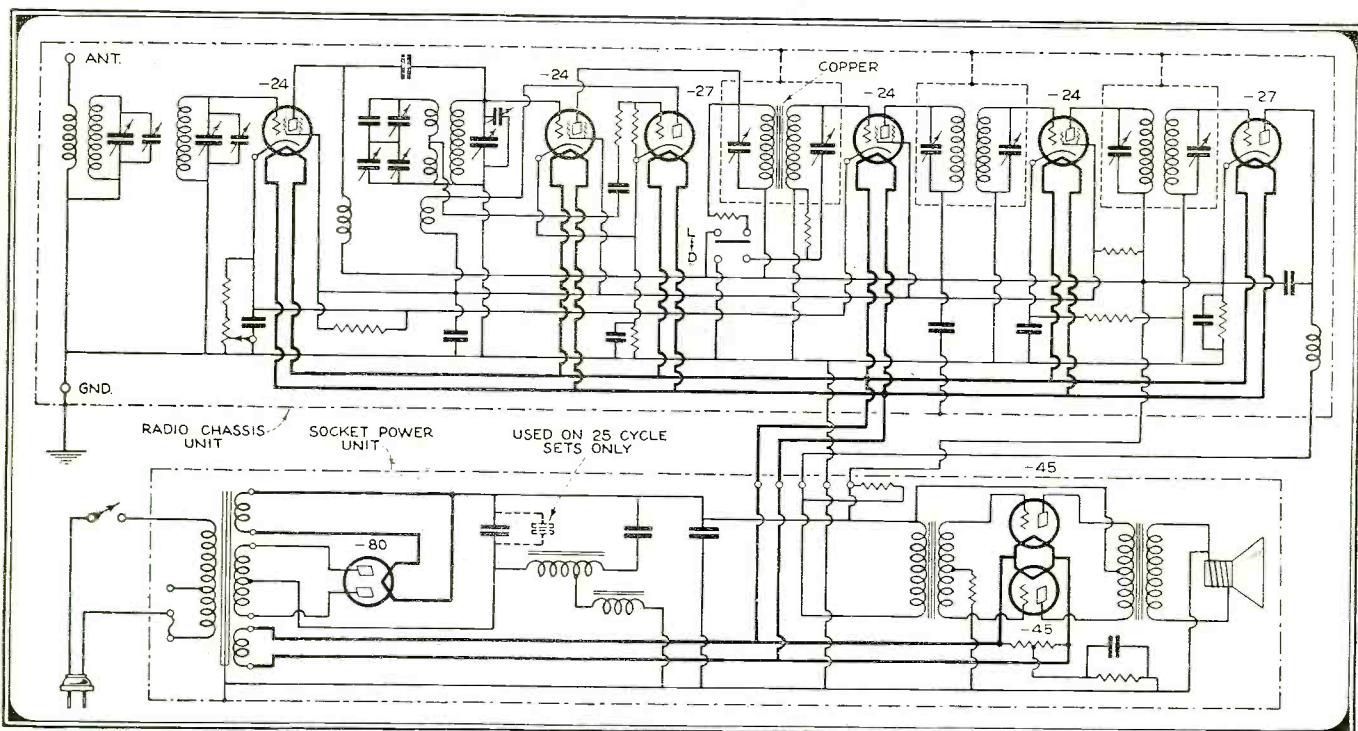

Schematic wiring diagram of the RCA-Victor superheterodyne. Full details of the various units comprising the circuit are contained in the text. The dotted line indicates the tuner section, which is separate from the power supply-audio channel



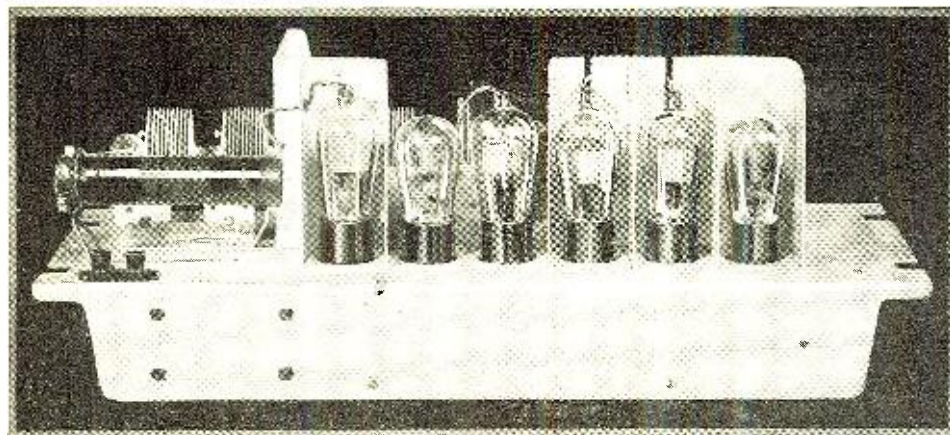

Looking from the back of the radio-frequency portion of the receiver. The selector circuit ahead of the first detector is seen on the left. This portion of the receiver comprises the radio-frequency amplifier, the first detector, the intermediate amplifier, and the second detector

Top view (on opposite page). The order of the tubes is from right to left. r.f. amplifier, oscillator, first detector, two intermediate amplifier tubes, and second detector. The unit control condenser gang is "trimmed" by the porcelain base trimmer condensers in the rear of the main gang

# SUPERHETERODYNE

*The superheterodyne situation has a new face. RCA licensees are no longer restrained from making and merchandising what is generally considered the peer of all receivers. In this informative article the authors give us the fundamentals on which the RCA itself bids for supremacy against the new field of competitors it has seen fit to recognize. It will be interesting to compare the engineering, which, incidentally, is made public for the first time here, with the engineering behind competing designs which shall be described in a steady procession in forthcoming issues of RADIO NEWS.*

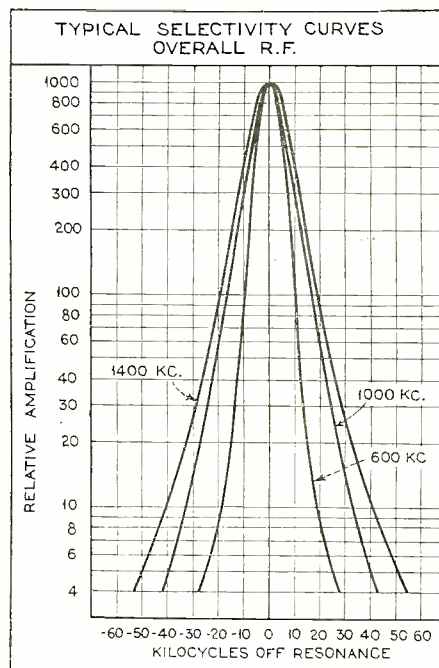

intermediate frequency. The fidelity of a receiver is usually considered to be a function of the audio frequency system and the loudspeaker. This assumption is true in regard to the lower acoustic frequencies, but at higher acoustic frequencies the high frequency amplifiers, in which the intermediate frequency amplifiers are included, play a large part. Thus, if the intermediate frequency characteristic of the receiver is such that it will attenuate the higher frequency side bands of the broadcast signal, the high acoustic frequencies will be lacking in the reproduction.

For good fidelity of reproduction, therefore, the resonance characteristic of the receiver should be broad enough to prevent attenuation of the high-frequency side bands. This characteristic in the 1930 RCA superheterodyne is obtained by the use of coupled circuits.

### *Pre-selection and the Radio-Frequency Amplifier*

In order to eliminate extra responses in a superheterodyne, pre-selection at the incoming broadcast frequency is required. In any type of receiver it is desirable to have some selectivity before the first tube in order to eliminate interference, such as secondary modulation. It is also desirable in a superheterodyne to have a relatively high signal level at the grid of the first detector (or frequency changer) tube.

Thus in the 1930 superheterodyne there are two tuned circuits ahead of the first tube. These two circuits are so coupled as to give high attenuation to frequencies outside the desired band.



The typical selectivity curve reveals that the receiver is super selective, and yet not guilty of appreciable side-band cutting. Whatever high frequencies are lost in the circuit does not materially affect the overall response

The amplifier and power supply unit. This unit is composed of the power supply for the entire receiver, the push-pull output stage of audio-frequency amplification, and the loud speaker

Following the radio-frequency tube is a capacity coupled radio-frequency transformer, which, with the tube, gives a uniform amplification of about thirty over the broadcast band.

### *Oscillator and First Detector*

The oscillator circuit is a conventional one for use with a three-element tube. It consists of a tuned grid circuit with a plate feed-back coil coupled to it. The grid of the tube is connected to the mid-tap of the tuned grid circuit to minimize

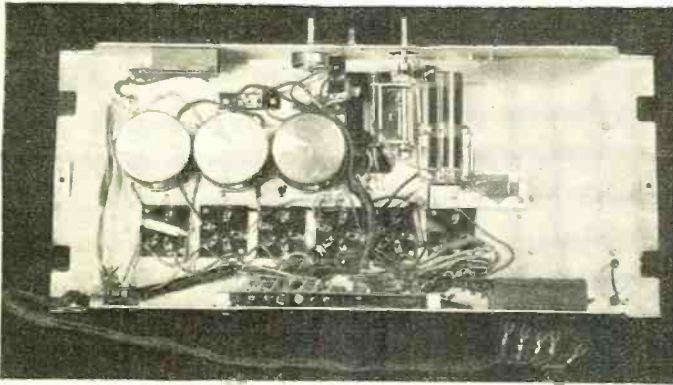

The three intermediate transformers are housed in individual metal shields. One wiring cable takes care of practically all of the wiring necessary on this unit.

The overall fidelity of the audio response is shown in per cent. of amplification at 400 cycles. This curve is quite unusual in a superheterodyne, for the selectivity of the system tends toward the suppression of the higher frequencies

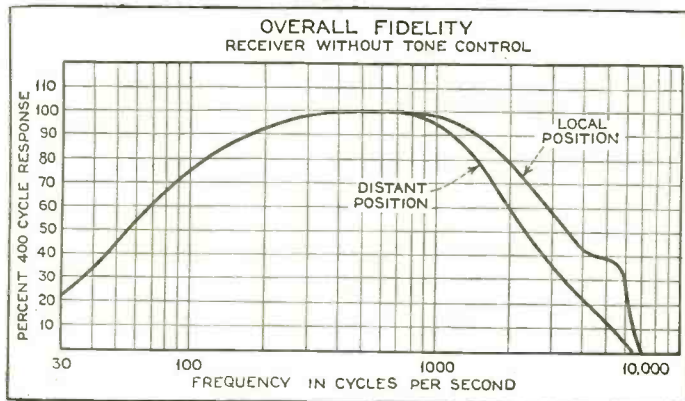

change in oscillator frequency with tubes. The oscillator is self biased by means of a grid leak and blocking condenser.

The tuning elements of the oscillator circuit are so designed that the oscillator frequency is always approximately 175 k.c. higher than the frequency to which the radio-frequency system is tuned.

The oscillator tuned circuit is coupled to the secondary of the radio-frequency transformer which is in the grid circuit of the first detector. The coupling is so arranged that the magnitude of the oscillator voltage on the first detector grid is correct for the most efficient rectification. In the case of the -24, used in this receiver, the peak value of oscillator voltage on the first detector grid is seven or eight volts.

### Intermediate-Frequency Amplifier

The function of the intermediate-frequency amplifier is to furnish the major portion of the amplification and selectivity of the receiver. It consists of three transformers and two amplifier tubes.

The first intermediate-frequency transformer is connected to the "local-distant" switch so that in the "local" position the selectivity is impaired slightly in order to prevent side-band attenuation. In the "distant" position the transformer is extremely sharp and offers greater attenuation to frequencies outside the desired band.

The transformer consists of a tuned primary connected in the plate circuit of the first detector and a tuned secondary connected in the grid circuit of the first intermediate amplifier tube. The secondary is partially shielded from the primary to loosen the coupling and improve the selectivity. The transformer is mounted in a copper can to keep the losses at a minimum, while at the same time shielding the transformer windings from other parts of the circuit. When the "local-distant" switch is thrown to the "local" position a resistor is thrown across the primary and another in series with the secondary to broaden the resonance of the transformer and reduce its amplification.

The second and third intermediate-frequency transformers

are both alike, and consist of tuned primary and tuned secondary coupled tightly enough to give a broad top resonance characteristic with high attenuation to frequencies outside the desired band. These transformers are mounted in iron cans to shield them from other parts of the circuit and to add sufficient loss to prevent double peaks in the resonance characteristic.

All three transformers have adjustable capacitors across both primary and secondary for accurate tuning.

### Audio-Frequency System

Plate circuit rectification and a single stage of audio amplification are used in this receiver. This system eliminates the grid leak detector and two audio stages commonly used in the past. Plate circuit rectification eliminates the loss of high acoustic frequencies due to the time constant of the grid leak and condenser. The low audio gain causes a correspondingly low a.c. hum and decreases the tendency for microphonic howl.

The blasting and breaking up of the sound output, when tuning through a local station, is ordinarily due to overloading of the output tubes. This disturbance is reduced to a minimum in this receiver by designing the audio system so the detector overloads at about the same time as the audio tubes.

The two -45 tubes in push-pull are used in this receiver, thus providing a large output without distortion.

### Loud Speaker and Cabinet Acoustics

The loud speaker used in this receiver is an improved electro-dynamic instrument especially designed to give excellent quality and high output without distortion.

Very great care has been taken in designing the cabinet for this receiver in order that the reproduction may be brilliant and faithful. Holes have been bored in the cabinet under the loud speaker to prevent cabinet resonance, and the dimensions of the cabinet are correct for the loud speaker used.

### Function of the "Local-Distant" Switch

The adjacent channel selectivity and the fidelity of broadcast receivers are so related that it is impossible to emphasize either of these characteristics without a corresponding sacrifice in the other. In general, the characteristic most desired in a receiver, when receiving distant stations, is good selectivity, so that the station may be satisfactorily received without interference from adjacent channels. In receiving local (Continued on page 464)

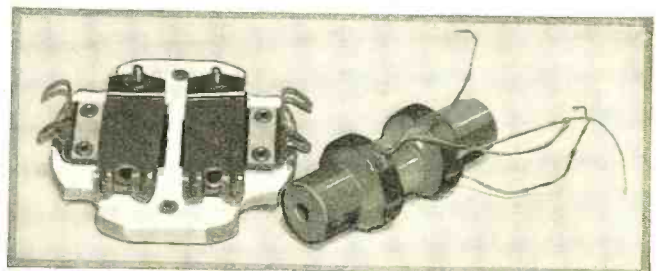

The coils and tuning condensers of the intermediate frequency tuning units. The coil is mounted vertically on the porcelain base above the tuning condensers and the whole is enclosed in a metal shield

*THE editor was so impressed with the testing methods used by the engineers in charge of production of this receiver at the RCA-Victor plant, in Camden, that he requested permission to make a separate story on that phase alone. Permission was granted, and it will be our privilege in a coming issue to give our readers a look in on some of the most remarkable testing apparatus it has been our good fortune to see.*

# Making "110 Volts" Mean What It Says

*In discussing line operated radio receivers we usually assume the existence of a line voltage of 110 volts. But, what with varying loads placed on the generating plants, in a great many sections of the country, the line voltage is either abnormally high in the daytime or subnormally low in the nighttime. Simple line voltage regulators rectify this condition so that practically a 110 volt supply to the radio receiver is maintained at all times*

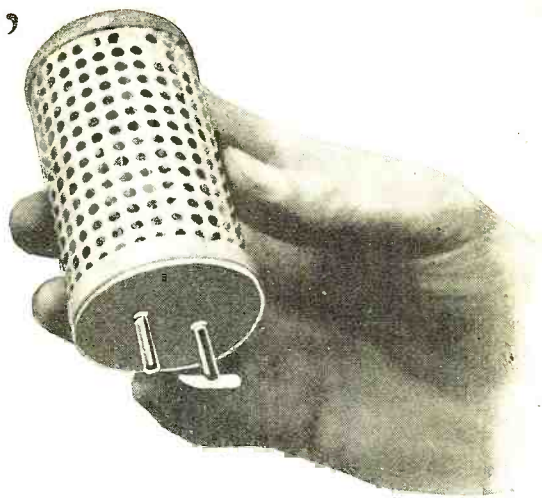

By John J. Mucher\*

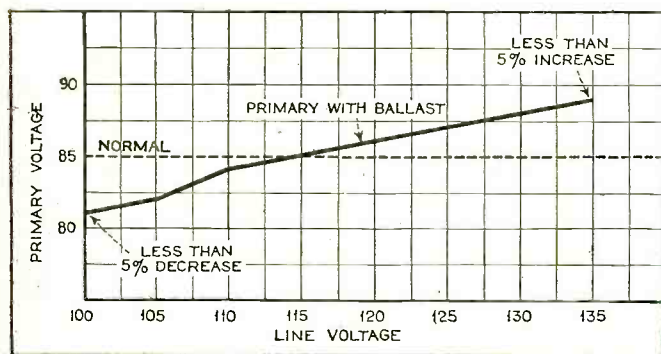

**W**HAT'S in a name? Well might that question be asked regarding the so-called 110-volt current supply, especially after measuring the actual voltage. Better still might it be asked after viewing recording voltmeter charts made in various parts of the country, or after talking with many dealers regarding the loss of set sales in sub-normal voltage areas or again the excessive servicing in abnormal voltage areas, or finally after visiting manufacturers who have been busily engaged in replacing broken-down power packs.

Despite all that has been said and written by power companies and their associations, a positive 110-volt supply is a rare phenomenon these days. There are too many factors, many of them beyond the control of the power companies, to assure a 110-volt supply at all times. Such problems as sufficient power plant capacity, ample transmission lines, distance between consumer and power house or stepdown transformer, transformer capacity, varying load placed on the transmission line, and even the wiring of the home itself, play a part in running the line voltages up and down the scale. A study of recording voltmeter charts made in various parts of the country indicates a range of from 85 to 140 volts as by



A plug-in type of line voltage regulator. It is merely necessary to plug in the plug from the cord on the receiver and then plug in the regulator to a convenient wall socket to put it into service

no means uncommon for the so-called 110-volt power supply.

So far, so good. But what of it, so far as the usual socket-power radio set is concerned? And that is precisely the main question with which we are concerned—the effect of abnormal and subnormal line voltages on radio set operation.

To begin with, let us consider abnormal or high line voltage. When the line voltage is excessive, the radio set starts out with abnormal primary voltage, which in turn is transformed into excessive voltages in the filter circuits, plate circuits, and filament or cathode circuits. The first indication of excessive line voltage is a noticeable increase in the volume and sometimes in the sensitivity of the radio set. The tubes also glow brighter, but in the absence of a basis for comparison this may not be noticed. In short order, the radio tubes wear out, due to excessive operating temperature. A slight increase in voltage reduces the tube life by one-half or less. It is by no means uncommon to have the normal 1000-hour life of a typical tube reduced to 100 or even to 50 hours, on over-voltage operation. More serious still is the strain placed on the power transformer and filter condensers. Certain manufacturers have been known to have tens of thousands of power packs returned to them because of excessive applied voltages. Their sets have been criticized because of this commonly known fact. And yet, truth to tell, their sets are as well designed and built as any other set without line voltage protection. It is simply because such manufacturers enjoy a nation-wide distribution, reaching out to

abnormal and subnormal voltage areas throughout the country, that they have suffered the full consequence of fluctuating line voltage.

Then there is subnormal line voltage. Most radio enthusiasts give little thought to this phase of line voltage fluctuation. They believe that excessive line voltage is to be guarded against, while insufficient line voltage causes no harm whatsoever. They are wrong—very wrong, indeed. First of all, insufficient line voltage greatly hampers the performance of the set. Tubes cannot operate at sufficient temperature for the necessary electronic emission; there is insufficient plate voltage for the desired sensitivity; there is a noticeable falling off in volume;

(Continued on page 452)

\*Clarostat Mfg. Co.

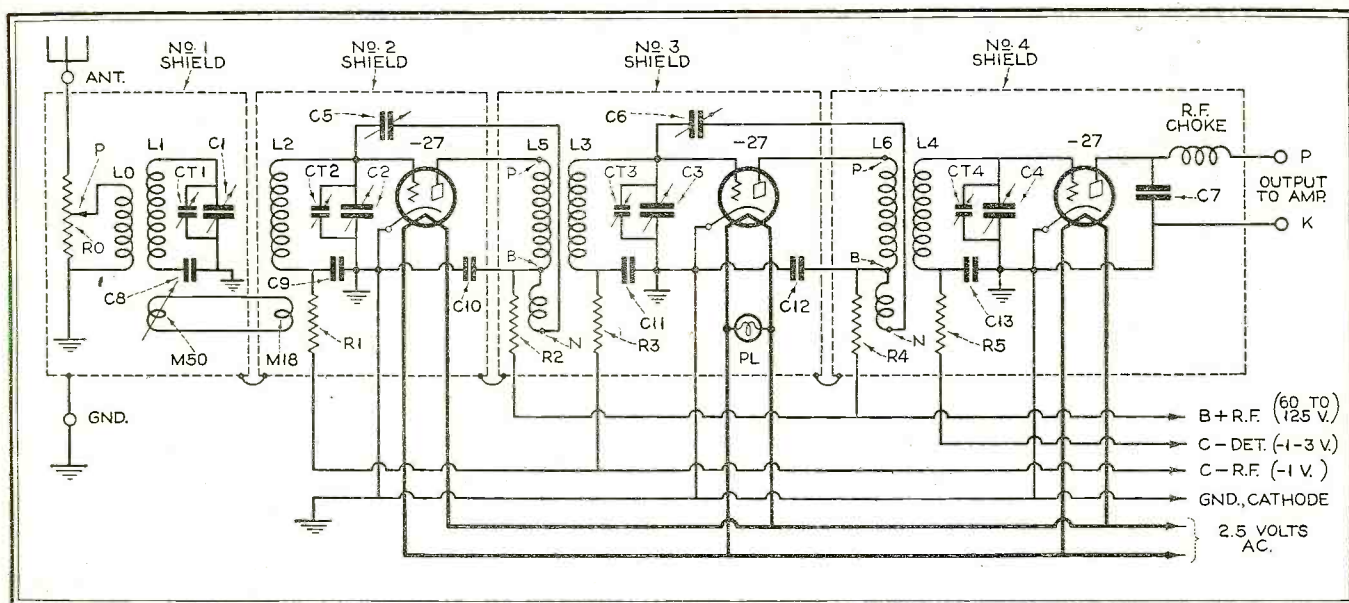
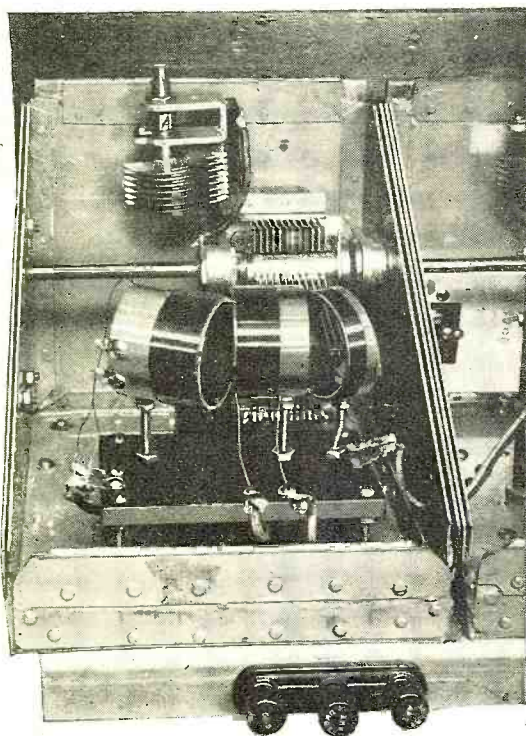

Fig. 1. The circuit employed by Mr. Wright in his tuner. In shield can No. 1 is the pre-selector or band-pass tuner circuit while in cans Nos. 2 and 3 are the tuned r.f. amplifiers. No. 4 contains the non-regenerative detector circuit. The lettered parts may be identified in the parts list

# How to Build A Good



A rear view of the pre-selector stage. The trimmer condenser CT1 is shown mounted above the regular tuning condenser. A double can thickness insures a perfect contact between the top and bottom section of the shield cans

The four shield cans are separated by the drum dial, as shown. This view also indicates the layout of parts in the 2nd r.f. and detector stages

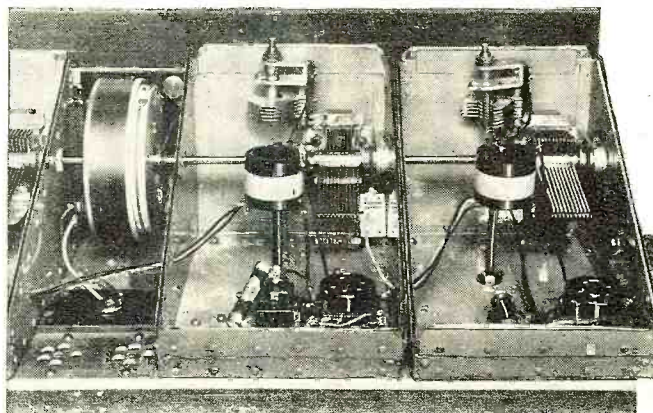

**W**HAT is a good receiver? There are so many considerations which enter into the intelligent answering of this question that there are bound to exist differences of opinion on so controversial a subject. Largely the answer depends upon the viewpoint of the one asking the question. Does he go out for DX or is he content to listen to local reception to the exclusion of broadcasts from distant stations? For the DX enthusiast there are the multi-stage screen-grid r.f. tuners, or the superheterodynes. This article describes a tuner which when used with a high-grade audio amplifier and proper speaker will give very fine reproduction, especially on local reception. A number of these tuners have been built, tested, changed and the optimum values selected. Over a period of years this particular design seems to give about all that is required for high-grade reception, ease of handling and general good performance. It is easy to build and requires no special parts.

In order that a tuner may deliver a faithful signal to the amplifier it must not cut sidebands, undesired oscillations or regeneration must not exist, the radio-frequency currents must be confined by chokes and condensers to their proper paths, and a method of volume control must be used which does not alter the voltages on the tubes.

This tuner consists of a totally shielded two-stage single-control neutrodyne, having an unusual tuning system preceding the first r.f. tube.

Referring to Fig. 1, L0 is an antenna coil which, in conjunction with the antenna capacity across this coil, forms a circuit resonant at about 500 meters. This circuit is not sharply resonant, having losses in it, and therefore the effect is to make the tuner more sensitive at and around 500 meters than would normally be the case. Since otherwise the tuner would be more sensitive around the 200-meter vicinity, the net result is toward a constant gain receiver. This coil is primarily used as a source of r.f. energy which is controlled by the position of P on R0. R0

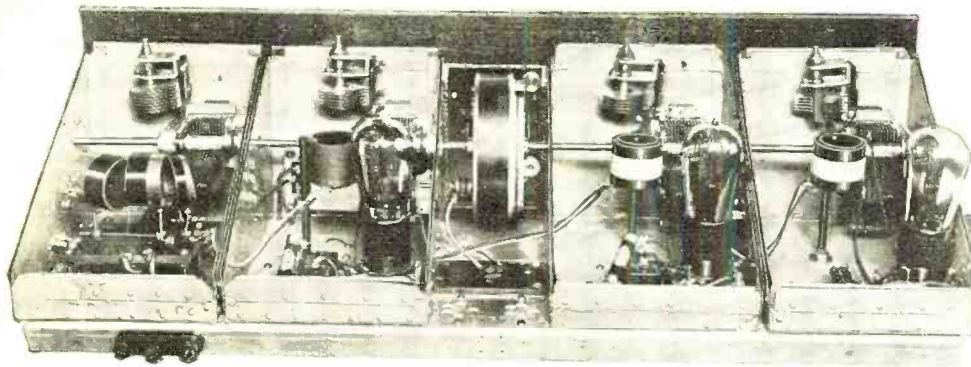

Below: The "Local Tuner" presents a simplicity of appearance and its one dial makes it easy to tune

Here's a complete rear view of the Wright "Local Tuner." The one dial controls all four tuning condensers. Each stage is completely isolated from the others by means of copper shield cans



# "LOCAL" RECEIVER

*"Quality, not quantity," might be used to describe the Wright local receiver. Sufficient selectivity to separate all the local stations, but not so selective as to cut the side bands that carry the audio modulation. This receiver is indicative of the present design toward the best quality possible*

therefore becomes the volume control for the tuner. Radio-frequency energy is fed into coil L1 from L0 and sets the circuit L1, C1 into oscillation. This circuit, L1, C1, is coupled loosely to L2, C2 by the loop circuit M, really a low-impedance line, providing a known inductive coupling minus any undesired and unknown capacitive coupling.

By coupling L1, C1 and L2, C2 we form a band filter, which can be set to give the well-known and desirable flat-top tuning curve. This band filter also prevents cross-talk when receiving a weak station near a strong local. The rest of the tuner is a two-stage neutrodyne with certain refinements. Each tube is biased, taking its bias from a 1000-ohm variable resistor in the power supply. Condensers and resistors are inserted as shown to form filters and thus keep the r.f. currents where they belong. The detector is of the "C" bias type, and best results are gotten with a long detector plate voltage, about 22 volts. This must be variable while in operation. Quite a difference in tone quality and hum will be noted when varying this voltage.

The r.f. tubes are not critical and may have a plate voltage of 60 to 125 volts, C bias, 1 to 2 volts gotten from the same resistor which gives "C" bias for the detector tube.

Condensers C1, C2, C3 and C4 are .0005 mfd. straight-line frequency type and all on one shaft. No other type will line up as well at all frequencies. When once the condensers are lined up at one frequency, no change is necessary at any other frequency in its range. Condensers C5 and C6 are 35 mmfd., very small. C8, C9, C11 and C13 are .25 mfd. (200-

By E. S. Wright, M.E.

volt) such as Aerovox and C10 and C12 .25 mfd. 400-volt Aerovox or similar.

R1, R3 and R5 are 50,000-ohm resistors of say 1 watt size or less, such as Elmenco or Aerovox. R2 and R4 are 10,000-ohm Aerovox, Elmenco or similar, to carry 4 mils at 100 volts. The choke coil in the plate circuit of the detector is 85 millihenries, and in some cases is better omitted. Try both ways and let the ear decide.

Coils L1, L2, L3 and L4 are all alike and consist of bakelite for 1 1/2" diameter, 1 1/2" long, with the winding at one end. L5 and L6 are alike and each contains the primary and neutralizing windings of one stage. They are wound on bakelite tubes 1 1/4" diameter, 1 1/2" long and placed L5 inside of L3 and L6 inside of L4. These coils are wound as described.

Each coil consists of an 18-turn primary and an 18-turn neutralizing winding, both wound together, with No. 36 d.s.c. wire. The neutralizing winding, Fig. 1, is electrically reversed. Make two holes, N and B, about 1/4" from end of tube as shown at A in Fig. 1, fasten a No. 36 wire in each hole and, taking the

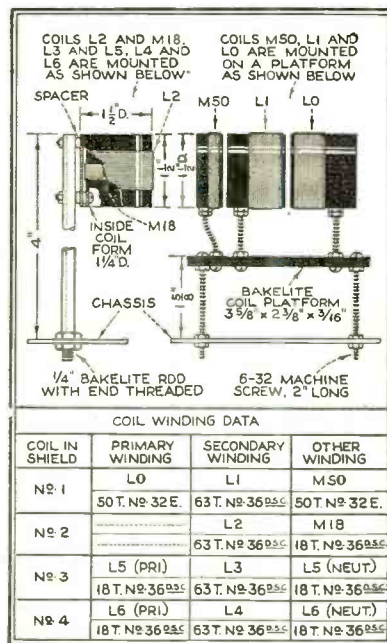
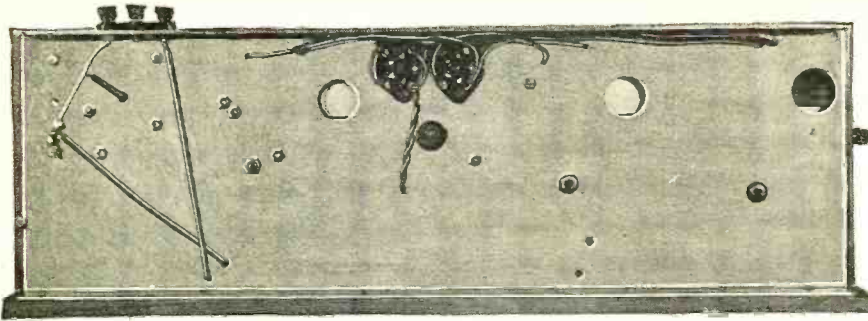

Fig. 2. The details of coil winding and the specification for all coils used are given above. These directions should be followed closely if results similar to Mr. Wright's are to be expected



Underneath view: Most of the wiring is carried from shield to shield "above deck." Only the wiring to the antenna posts, and to the power supply is shown here

two wires in hand, wind them together as shown, N on top of B, until 18 of these double turns have been completed. Then stop, make a hole and bring down the lower of the two wires to a terminal and call it P. Then bring down the other or upper wire and fasten it to B. Thus B becomes the common junction of the two windings, on the primary, and the other the neutralizing winding, now reversed electrically. P goes to the plate of a tube, N to the neutralizing condenser and B to the condenser which leads to the cathode of the tube. The sketch at A in Fig. 1 shows the construction of this coil except that for simplicity it is drawn as though there was only one turn instead of 18.

Referring to coils M50 and M18, M50 is 50 turns of No. 32 enamel on a 1 1/2" diameter form 1 1/2" long, the winding being at one end of the form. M18 is 18 turns of No. 36 d.s.c. on a 1 1/4" diameter coil 1 1/4" long, placed inside of L2 at lower end of L2.

This tuner uses three tubes of the three-element heater type, -27 type. Screen-grid tubes can and have been used, but for the purpose for which this tuner was designed they offer no advantage. However, this tuner with a 75 ft. antenna will get down to the noise level promptly, and beyond that no tuner can go.

As to the shielding for this tuner, it is not desired to set down exact measurements since these may be varied, within reasonable limits, to suit the constructor's needs. Many shaped shields have been tried and all found workable, some better than others. Use copper, .030" thick for shield and base. Aluminum will do, but copper is better. Have all joints wiping joints, or close fitting. Four cans or shields are required, all alike, or else one can divided into four. A base is required of size to hold the cans. The condensers are mounted on the base. The coils are mounted on 1/4" bakelite rod uprights on the base, the axis of the coil vertical. The tubes are mounted as shown and the by-pass condensers and chokes at the base of the tubes and on top of the base, not under it. The coils should be placed so as to be in the center of the space available after the condensers and tubes are in place. Place each coil in the same position in cans 2, 3 and 4 to insure the same losses and the same inductance per coil. This is important.

**How to Wire the Tuner**

All wiring must be soldered, using only rosin as a flux. A pair of wires connect M50 and M18, which are in separate shields. From No. 2 to No. 3 shields run three wires carrying r.f. currents, namely, those running to P, N and B of coil L5.

Run these three wires cabled together as far as possible and through the same hole.

These same instructions apply to the next stage also; that is, the three wires running to P, N and B of coil L6 in can No. 4.

The P and cathode or K wires from the detector tube may be led out under the base to binding posts placed on one edge of base and insulated. Where these wires continue on to the amplifier use a lead-covered pair and ground the lead sheathing to prevent hum pick-up.

When installing R0 do not allow more than 1 1/2" of antenna wire inside of No. 1 can. R0 is a 25,000-ohm potentiometer with a special taper and the only one the writer knows to be satisfactory is the Electrad Supertonatrol No. 1. This has the required taper and is not wire-wound.

The wiring so far described carries a.c. currents capable of producing inductive results on other wires. The rest of the wiring, the supply wiring carries no r.f. currents and no a.c. except the low voltage 2 1/2 a.c. filament supply. These 2 1/2-volt pairs may be twisted together, or lead-covered cable used. The supply wiring should avoid all a.c. wiring and should be cabled together, coming into the tuner near the detector tube end and branching off as required, like the branches of a tree trunk, until it comes to an end at the antenna end of the tuner. The cable should run under the base in the corner formed by the top and side of the base, and the length of the tuner, under the row of tubes.

All condensers, resistors, chokes, etc., are inside the shields on top of the base and all supply wiring under the base. Tube sockets are on top of the base, not protruding through it. When wiring the filaments of the tubes use No. 18 twisted pairs, one pair direct to each tube.

Place M50 in about the angularity shown on sketch No. 3, and L0 about as shown. Mount M50 and L0 on 6/32 machine screws 2" long as indicated by dots on sketch No. 3. M50 and L0 must be arranged so that their axes can be made parallel to axis of L1 or at right angles thereto.

Assuming that you have constructed the tuner, follow this procedure before setting in operation.

1. Check the tuner over to see that it is correctly wired. Use a continuity tester if you have one. As each wire is seen to be correctly placed, mark it in red on the diagram. When done the diagram should be all red.
2. Insert tubes, attach amplifier and power supply, and speaker and proceed to measure all voltages, plate and "C" bias.

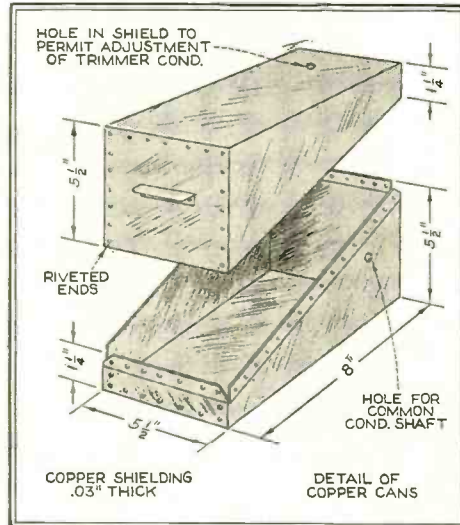

The details of the individual copper shield cans. The joints between the upper and lower can are double to insure contact, and complete shielding, between units

Any conventional audio might be used, but the prescribed units are recommended, so that the advantages gained in the radio frequency end will not be lost in the audio end of the receiver

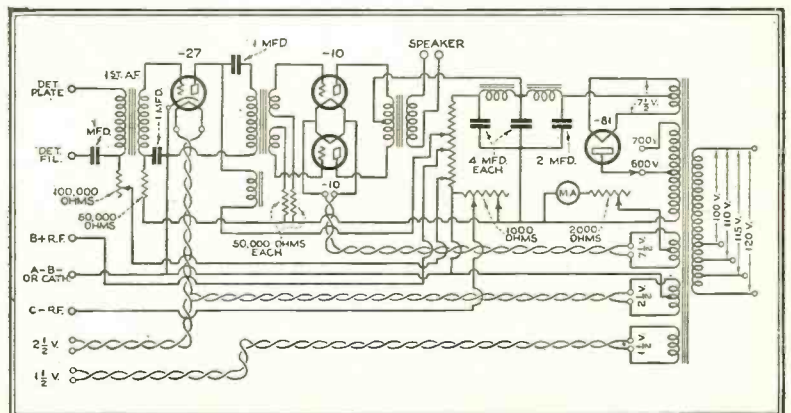

3. Set dial to 100 and see that all condensers are fully and evenly meshed.
4. Advance volume control and tune in any signal.
5. Remove shields and, while in operation, re-align each condenser.
6. Replace shields and now adjust trimmer condenser through small hole in shield. These trimmer condensers, 50 mmfd. Hammarlund, have been set at 1/2 fully meshed before adjusting them and while adjusting the main condensers.
7. Neutralize r.f. tubes. Remove shield. Remove filament wire from one leg of filament on No. 1 r.f. tube. Leave tube in socket. Tune in a strong local. Adjust C5 for minimum signal and then replace filament wire. This neutralizes No. 1 stage. Repeat for No. 2 stage. Very little capacity of C5 and C6 will be required.
8. Now adjust "C" bias detector, in the power supply while in operation, for best results as judged by ear.
9. Adjust "C" bias r.f. for best result.
10. Adjust M50. Start with M50 closely coupled to L1, *i.e.*, axes parallel, and turn M50 away from L1 until signal suddenly diminishes. Stop here and go back 1/5 of the distance and leave M50 there.
11. Adjust L0 same way. Looser coupling gives better selectivity and less power, and vice versa.

Now then, as a final step, when the tuner is operating well and all condensers lined up, you may add a trifle of capacity to C1 and subtract the same amount from C2 by means of the trimmers on C1 and C2. This will give the proper band-pass effect. Also vary the coupling between M50 and L1. By experimenting, the tuner may be set to have a 20 kc. flat-top tuning curve, or narrower if desired. At high frequencies it will tend to broaden out slightly, not seriously, and this again may be counteracted by the relative coupling M50 to L1.

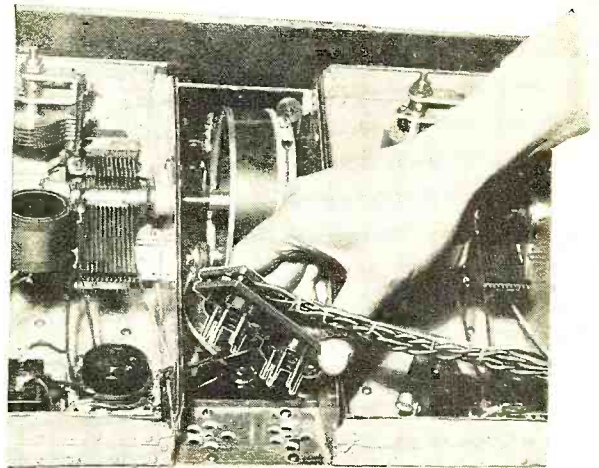

Contact to the audio unit—power supply is made through cables, ending in socket contacts. The operator is shown inserting the male plugs in the female sockets

The trimmer condensers are mounted directly on the main tuning capacities. The mounting furnishes the common ground contact

When all is right the tuner will have a 20 kc. flat-top tuning curve (sharper, if desired) and may be called complete.

Use a two-stage push-pull audio, 210 or 245 tubes, and use good transformers and a dynamic speaker, otherwise your work is for nothing.

PARTS LIST

One panel, 26 1/2"x8"x1 1/2"; 1 aluminum base, 25 1/2"x8 1/4"x1 1/8"; 4 hermetic seals, 5 1/2"x6"x6"; copper as described in article; 1 National drum dial; binding posts; 1 antenna-ground combination; 1 output pair; 4 Hammarlund .0005 S.L.F. condenser; 4 Hammarlund 50 mmf. trimmers; 2 Hammarlund neutralized condenser 35 mmf.; 7 by-pass Aerovox cord 1/4 mid. inserted as directed; 1 Aerovox .0005 plate by-pass condenser; 1 No. 1 Supertonacrol volume control; 3 Aero 50,000 ohms with mounts; 2 Aero 10,000 ohms with mounts; 3 five-prong standard sockets; 3 227 or 327 tubes; 1 shaft 1/4"—23"; 1 r.f. choke 85 mil. inserted in plate circuit of detector; coils as in article.

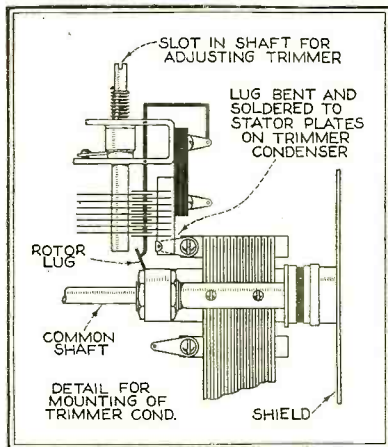

At left. Winding the coils L5 and L6. Shown below are the various stages laid out in logical manner, each stage resembling another, except the antenna stage. The relative positions of the parts are shown here clearly

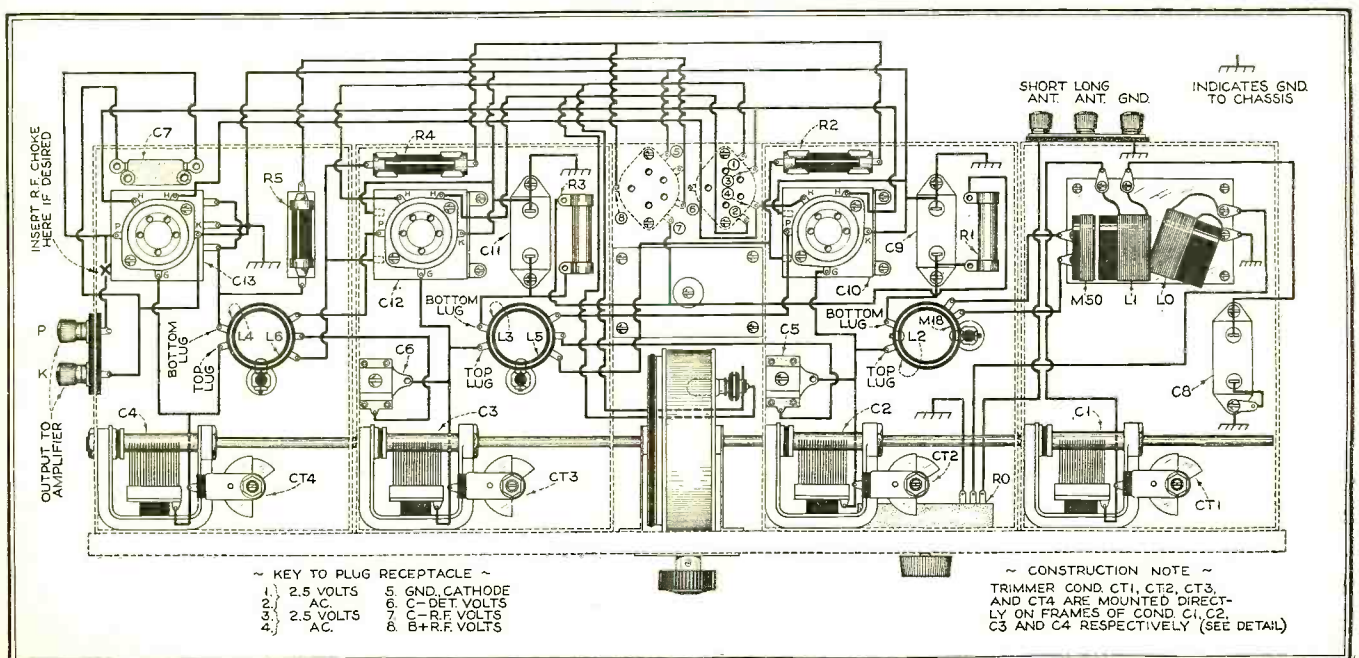
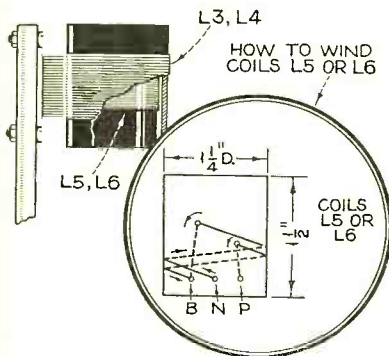

# Some Observations on Skip Distance

and

By

Thomas A. Marshall

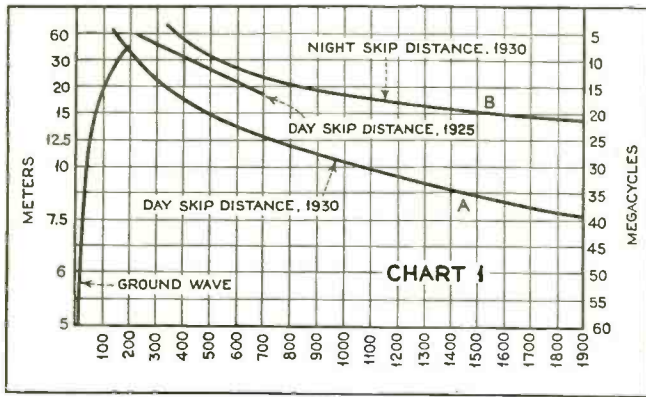

**T**HE discovery of skip distance, and that waves were propagated by refraction in the layer and reflection at the ground, has enabled scientists to determine the height of the Kennelly-Heaviside layer to be approximately 150 miles. Certain data have been published from time to time that the skip distance is proportional to the layer height. By means of mathematical treatment, they have published certain data that waves below 11 meters could not be used efficiently, as the bulge of the earth would prevent reception at distant points. The actual measurements made by the writer do not coincide with the theoretical data as given heretofore. In actual practice, shorter waves than 11 meters have been found to be efficient. Hence, the existing theory must be modified to agree with actual conditions.

It is quite apparent that data for determining skip distance theory was taken from observations made with receivers which employed non-sensitive tubes, and ordinary conventional circuits. Another reason for the inaccuracy of skip distance theory obtaining during 1925 lies directly towards results accomplished by low-powered transmitters. An example of this condition could be understood by referring to results obtained on 8310 kc. as shown in Chart 4. The ground wave for this frequency overlaps the sky wave component, making it possible to receive a signal from zero miles to several hundred miles. There is a zone of weak signals, but they are strong enough to carry on reliable communications. This condition

is made possible by an increase in the distance of the ground wave and by increase in the sky wave component. Both increases in distances are due to higher-powered sets and to more sensitive receivers being developed. The sky wave component enables signals to be received toward the ending of the ground wave component, and increases in strength until the main sky wave is received. Chart 4 shows this condition for 8310 kc.

Reception of short waves is not based on

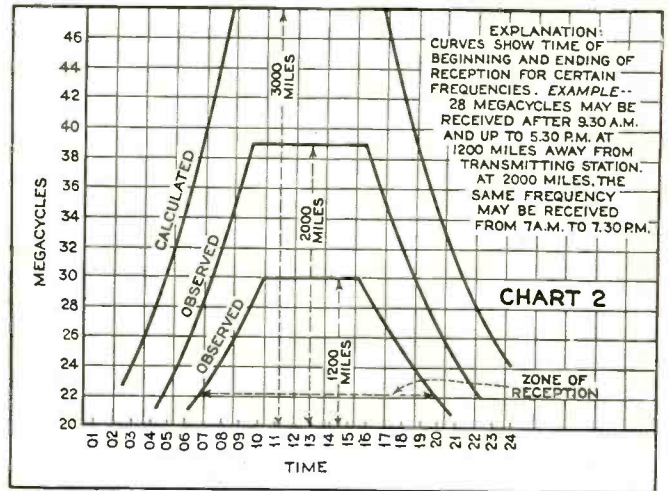

certain freak conditions, since daily observations on reception of frequencies from 20,000 to 40,000 kc. have been made continuously over a period of two and a half years. The writer has continued observations while cruising in the Pacific Ocean, at Panama, and along points in the Lesser Antilles, to New York.

In actual practice, it has been found that the skipped distance at night is approximately four times the day skip. Therefore, the layer at night is proportionately higher than during the day. The layer begins to rise at any particular point on the earth at about 4 p.m., local time, and rises very rapidly up to 9 p.m., where its movements are somewhat decreased as shown by the graphs in Chart 2, curve B. It was also found that the layer travels pretty well on schedule; in fact, its schedules are much more nearly accurate than a great many railway trains. During the month of April the greatest variation was found to be 3 minutes. WQL on 21,220 kc. was taken as a standard frequency for making these observations. The signal always starts on a downward value in strength about 5 minutes before the last signal is heard. The decrease is gradual until a value of 1 to 2 in audibility is reached. At this point, the signal suffers from violent fading for a short period, finally fading out. As the data for making the charts shown in No. 2 were taken during the month of March and for a southerly direction, it should be realized that at times the ranges during other months will be greater or less than those shown.

Successful radio communications to distant points as great as half-way around the earth with wavelengths below 50 meters clearly proves that the attenuation is small. The reader should contrast these results with data given in chart No. 3, which shows the pronounced earth's absorption on the ground wave component of the radiated energy from the antenna. It will be noted by the reader that any station will be heard with

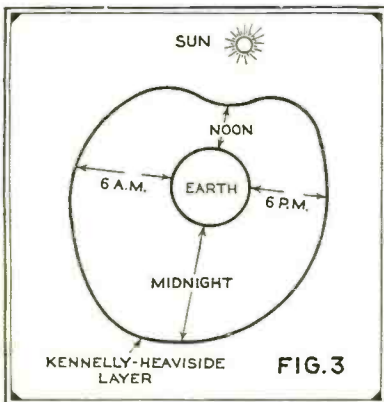

Fig. 3. Showing how the earth is enveloped with the layer, which has a cardiac shape, and moves with the earth



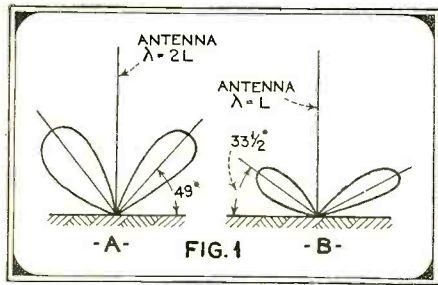

Fig. 1. In viewing A and B, the sky component leaving the antenna depends on the wave length and type of antenna employed

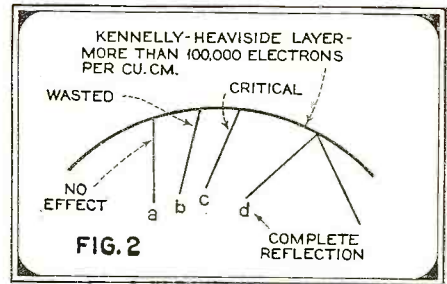

Fig. 2. This shows the effect of the Kennelly-Heaviside layer on the sky bound component of the emitted wave from a given station

# Ultra-high Frequencies

*Must the existing theory of skip distance be modified to agree with the author's measurements of waves below eleven meters? Contrary to opinion, he finds that they are efficient and that the skip distance is proportional to the height of the Kennelly-Heaviside layer. The skip distance at night is approximately four times the daytime skip*

maximum signal strength after the primary skip zone has been passed. The signal will decrease in strength as the distance is increased. This phenomena, combined with the earth's absorption, leads forcibly to the conclusion that short waves must travel in the upper atmosphere, and that absorption in these regions is comparatively slight.

Results accomplished in practice as shown in Charts 1 and 3 clearly prove predictions previously given that a transmitted wave consists of two main components, one of which clings to the earth and suffers rapid absorption, while the other compo-

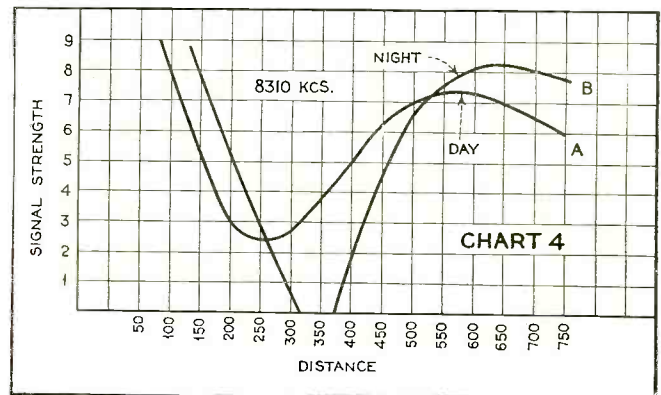
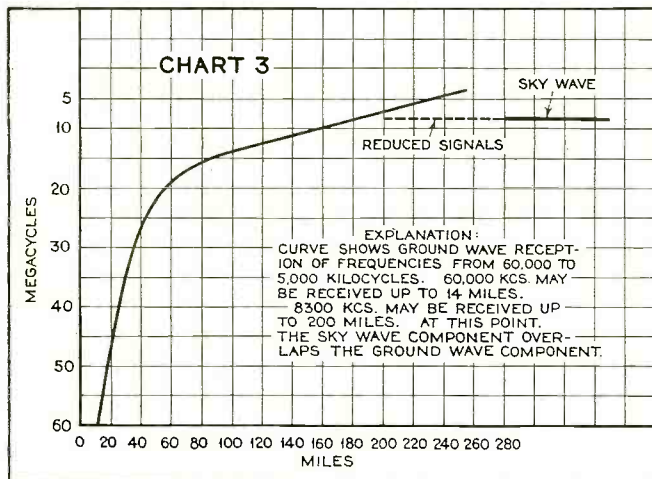

a given station. In viewing these angles, it is at once seen that all of the energy radiated from the transmitter does not return to the earth. Fig. 3 shows how the earth is enveloped with the layer, which has a cardiac shape, and moves with the earth.

During experimental work it was found that some unusual conditions exist at night at certain distances from a given transmitting station. Signals on 8310 kc. were about strength 3 at 200 miles away during daytime, while at night signals from the same station were clearly heard. According to results of experiments conducted by Austin and Cohen, they found that the energy density fell off as the sixth power of the distance. B in Chart 4 shows strength of signals from a certain station during nighttime, while A shows results for day work. From these data it is quite apparent that the signal during night suffers less absorption. Hence the increased distance of transmission via the ground wave component. The absorption effect can be taken into account by multiplying the received current by the attenuation factor.

$$E = \frac{4.75 \cdot 10^{-5} d}{\sqrt{A}}$$

Where d is the distance in meters,  
 A is the wavelength in meters, and  
 E is equal to 2.718, base of Naperian logs.

The application of this formula may be understood by referring to Table 12, Robison's.

The application of the attenuation factor is for daytime transmission over the sea. For transmission over land, the factor is somewhat modified, depending on the soil. Since A appears in the denominator, the (Continued on page 451)

nent, sometimes called sky wave, returns to the earth after refraction from the Kennelly-Heaviside layer. The point of return to the earth depends entirely on the time of the day and on the frequency employed as shown in Chart 2. Different frequencies radiated from a certain antenna are reflected at different angles from others. This is because the bending depends in part upon the frequency. In actual practice, the sky component of energy radiated from a vertical antenna is at angles varying according to the relation of antenna length employed. A and B in Fig. 1 show the relation of the radiated angle to the wavelength.

In viewing A and B in Fig. 1, the sky component leaving the antenna depends on the wavelength and type of antenna employed, while Fig. 2 shows the effect of the Kennelly-Heaviside layer on the sky-bound component of the emitted wave from

# SELECTIVITY + FIDELITY

*In this, the second of a series of three articles, the author points out the advantages of the superheterodyne principle as being chiefly due to the fact that amplification is accomplished at a single frequency. This means that highly efficient circuits may be designed to work at this frequency, as they only have the one band to amplify instead of a multiplicity of bands that must be compromised with in other systems*

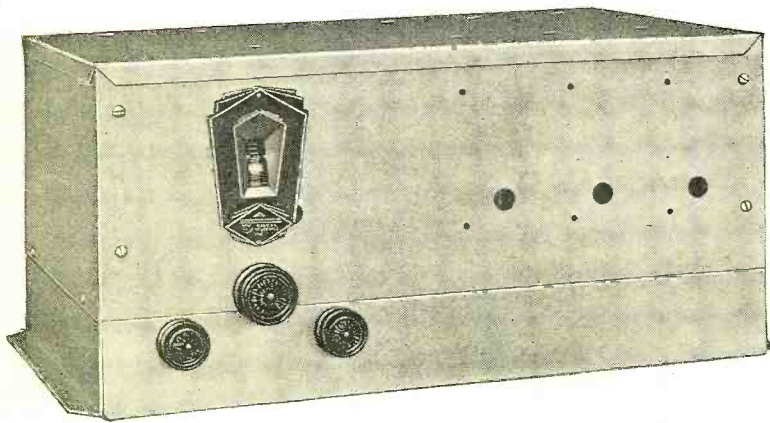

Fig. 3 (above). A superheterodyne tuner, for use with standard a.c. audio amplifiers, to be described in next month's RADIO NEWS. It employs a double dual pre-selector using a five-gang condenser to tune the four selector and one oscillator circuits and one r.f. stage, a first detector, two i.f. stages and second detector, all using -24 tubes

Fig. 1. The selectivity curves for a typical t.r.f. receiver, which may be compared with those for a superheterodyne, shown in Fig. 2

IN the first article upon present-day superheterodynes, appearing in the October, 1930, issue of RADIO NEWS, the writer treated rather briefly the general problems of modern superheterodyne design and gave specific data upon a particular receiver. This second article will deal more specifically with some of the more important problems and requirements involved and a short-wave superheterodyne converter, while the third article will treat of the mechanical and electrical characteristics of a superheterodyne tuner, employing four tuned circuits preceding the first detector, and illustrated herewith.

Within the past fifteen to eighteen months radio receivers have been built showing orders of sensitivity of as low as zero microvolts per meter at 1,400 kc.—this, however, an extreme and rather absurd case in which, with absolutely no input signal applied to the receiver at 1,400 kc., the sensitivity was such as to deliver a 50-milliwatt signal at the output. The explanation for this condition is circuit and tube noise, the amplification following the first tuned circuits being sufficient to produce a standard 50-milliwatt output simply as a result of the minute tube noises and noises caused by thermal agitation in the first

circuits of the receiver. While this extreme case is rather absurd, the point to be made is that there is a limit to the sensitivity of a radio receiver which may be practically utilized, even under the best of conditions, and that sensitivity has already been attained in commercial receivers on the market, both t.r.f. and superheterodyne designs. Therefore, the principal advantage of the superheterodyne design today is the extremely high order of adjacent channel sensitivity which the well-designed superheterodyne can provide, rather than high sensitivity, although it is only fair to mention that it is relatively easier to obtain the maximum desirable order of sensitivity

from the superheterodyne than from the t.r.f. receiver, due to the greater simplicity of obtaining high intermediate-frequency amplification. Just what is the maximum sensitivity that a radio receiver should possess is still a somewhat debated question, though it is rather generally admitted that sensitivity on the order of one to two microvolts per meter is excessive for 70 to 80 per cent. of the average home locations, and is even more than satisfactory for even the small minority of users so located as to be favored by extremely low noise and interference levels. This, incidentally, seems to be the opinion of the majority of engineers, though there are many who will still maintain that sensitivities of from 5 to even as low as 20 microvolts per meter are adequate for satisfactory radio entertainment for receivers to be installed in the larger cities of the country. There is every reason to believe that they are correct. One commercial receiver now upon the market is held, in production, to a sensitivity ranging from  $1\frac{1}{2}$  to 3 microvolts at the worst, and from approximately  $\frac{1}{8}$  to  $\frac{4}{10}$  of a microvolt at the best. Unquestionably, this "best" condition provides a degree of sensitivity well in excess of what may be used, even under the most favorable conditions found on the North American continent; and the "worst" condition may be taken as providing more than ample sensitivity for 90 per cent. of all home conditions in this country. In fact, a receiver showing  $1\frac{1}{2}$  to 3 microvolts per meter sensitivity will, if tuned over the broadcast range when set at maximum gain, show an excessively high noise level between all stations which may be heard—a condition distinctly unpleasant to the radio layman. As has been stated, such sensitivity may be obtained from a good t.r.f. receiver as well as from a superheterodyne and, therefore, the factor making for the superiority of the superheterodyne today is not so much sensitivity as selectivity.

In Fig. 1 appears the selectivity curves of the best t.r.f. four-gang receiver which was measured up, out of the large

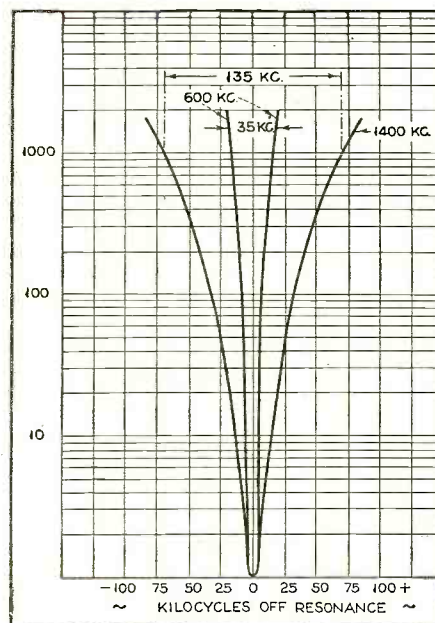

\*Silver-Marshall, Inc.

# + HIGH GAIN = Superheterodynes

By McMurdo Silver\*

number of commercial sets available to a well-known laboratory, in recent months. At a thousand times down, or at a condition where an interfering signal would have to be one thousand times as strong as a wanted signal to produce equal volume, it is seen that at 600 kc. the curve is approximately 30 kc. broad; whereas, at 14 kc. the curve is nearly four times as broad, or 135 kc. wide. As stated, this represents the selectivity of the best commercial four-gang receiver upon the market at the time these tests were made—within the last few months. And it may be stated with certainty that side-band cutting, or suppression of the higher audio tones, is very noticeable on the lower broadcast frequencies, though, despite the appearance of the curves, it is less noticeable and, in fact, might be considered as not disadvantageous to good tone, at the higher broadcast frequencies. Supposing, for the sake of argument, that the designer of this receiver attempted to compensate for side-band cutting to produce good fidelity of reproduction at 600 kc. This would involve, in all probability, compensation in the audio amplifier; that is, provision of the audio amplifier with gain curve sloping in exactly the opposite direction to that of the r.f. selectivity curve, or probably showing the higher audio tones around 3,000 to 4,000 cycles boosted from five to seven times in the audio end to compensate for a suppression of five to seven times by the r.f. amplifier. At 600 kc. such a receiver would have very close to perfect tone, but at 1,400 kc. the highs would be boosted out of all proportion to the bass and lower middle register, and unless a manual tone control were provided the reproduction would be extremely unpleasant. Even were a manual control provided the setting for a given tone would vary so greatly from one end of the broadcast band to the other that it would make the general reception obtained by the average listener unpleasant at best.

In addition to this, the selectivity of the receiver does not approach what could be desired, particularly at the higher broadcast frequencies, where the selectivity is such that separation of reasonably strong stations on adjacent channels is a practical impossibility—say, from 1,000 kc. up. No matter what methods might be employed, it would be impossible in a t.r.f. receiver to appreciably improve this selectivity ratio of approximately 4 to 1 throughout the broadcast band, and it can be definitely stated, therefore, that the high frequency of the selectivity of the receiver would be woefully lacking, as any listener who has operated any commercial t.r.f. receiver on the higher broadcast frequencies can realize only too well. Comparing this selectivity, however, with that shown in Fig. 1 of the October article (Fig. 2 herewith), a very marked difference is noticed. At one thousand times down, the selectivity curve of a good superheterodyne is seen to be only about 22 kc. wide, or nearly twice the best selectivity obtainable from the t.r.f. receiver whose curve is shown in Fig. 1 herewith. An



Fig. 4. A front view of a short-wave superheterodyne converter, attachable to any standard broadcast receiver

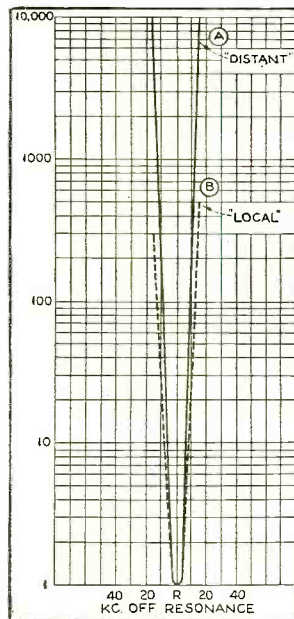

Fig. 2. The selectivity curve for a "super," showing response obtained with switch thrown to both "local" and "distant" reception

additional beauty of the superheterodyne is that, as the adjacent channel selectivity is determined almost entirely by the intermediate-frequency amplifier, this selectivity is so close to constant over the entire broadcast band of 550 to 1,500 kc. that the receiver may be definitely termed to have uniform selectivity at all broadcast frequencies. Comparing the curve of Fig. 2 with the 1,400 kc. curve of Fig. 1, it is seen that the superheterodyne selectivity curve, being only approximately 22 kc. wide at one thousand times down, is over six times better than that of the t.r.f. receiver, which shows a band width of 135 kc. one thousand

times down at 1,400 kc.

Considering the matter of fidelity, the selectivity of the i.f. amplifier is such as to appreciably suppress the higher audio tones in the range of 2,500 to 4,000 cycles, but in the uniform selectivity of the superheterodyne over the entire broadcast band lies its particular advantage—the fact that it is a simple matter to uniformly compensate in the a.f. amplifier for side-band cutting of the i.f. amplifier. While it is difficult to determine from Fig. 2 exactly how far down a 4,000-cycle note would be, because of the extreme selectivity of the superheterodyne, it can be stated, from an actual laboratory analysis of the fidelity curves, that a 4,000-cycle note is approximately seven times down, as against the bass register. As this

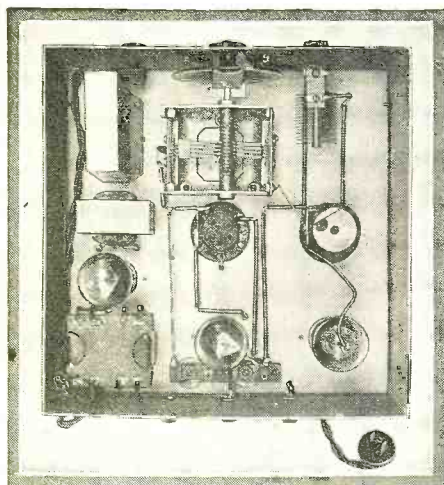

Fig. 5. The top view of the short-wave superheterodyne converter. In addition to the requisite tuning circuits, this unit also houses its own individual power supply

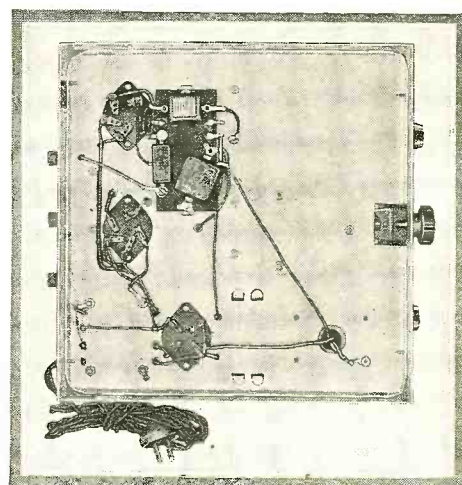

Fig. 6. Below the base of the chassis for the short-wave "super" converter is located much of the wiring, together with by-pass condensers and sockets

suppression is practically uniform over the entire broadcast band, it can be seen that if the audio amplifier is compensated to an exactly opposite extent—that is, if 4,000 cycles is arranged to be seven times up, as compared to the bass register of the audio amplifier, the overall fidelity curve would appear as practically a straight line from 40 to 4,000 cycles, and this is exactly the case in the receiver described in the October issue. Above 4,000 cycles, because of the extreme selectivity of the i.f. amplifier, the cut-off is extremely sharp, and from an examination of Fig. 2 it is seen that stations upon adjacent channels to the wanted signals would have to be 1,000 times as strong as the wanted signal to provide equal output.

In this connection, it is interesting to consider the extreme to which an English designer has gone in the construction of an i.f. amplifier. In an English superheterodyne design one of the i.f. stages employs a quartz crystal rather than a tuned r.f. transformer, since the quartz crystal provides much lower damping than can be had in a tuned circuit. The order of sensitivity is so high that the normal "wobble" of a broadcast station will sometimes cause it to fade in or fade out.

At first glance, it would appear that in the receiver employing the circuit illustrated in the October article it would be vitally necessary that the alignment between r.f. detector and oscillator stages should be extremely exact, and this is certainly desirable. At the same time, however, analysis of the conditions involved will indicate that as the first r.f. and first detector circuits are employed to provide image frequency selectivity rather than adjacent channel selectivity and as their adjacent channel selectivity in itself is not very great, a slight deviation in alignment between oscillator and first detector and r.f. circuits will not be particularly serious. This is distinctly advantageous, as at best it is a very difficult engineering matter to develop an oscillator which will track exactly 175 kc. away from a first detector and r.f. amplifier circuit. At first thought it would appear feasible, by means of a small midget condenser in the oscillator circuit, to trim the oscillator into exact alignment with the first detector and r.f. circuits, but actually this is not practical, as the determining selectivity of the receiver is that of the i.f. amplifier, which is translated into oscillator dial settings. In any event, such trimming is not necessary, since, as stated, the purpose of the first detector and r.f. tuned circuit is to provide off-channel or image-frequency selectivity rather than adjacent-channel selectivity, so that misalignment between the first three cir-

cuits, even to the extent of 10 kc., is practically unnoticeable in terms of final results. Nevertheless, in the oscillator diagrammed in the October issue the circuits have been so thoroughly worked out that with the i.f. amplifier set at exactly 175 kc., as it is before leaving the factory, the first three circuits will align within 3 kc. over the entire broadcast band without difficulty but, as stated, even should they be out of alignment within 10 kc., no appreciable disadvantage will result.

For short-wave reception, the superheterodyne system, though sometimes regarded as complicated, unquestionably provides the best and most satisfactory type of short-wave set, for it is the only system permitting any high order of amplification, due to the practically insurmountable problems involved in the design of a short-wave r.f. amplifier, in which it is almost impossible to obtain any fair order of amplification, practically satisfactory stability, or reasonable commercial simplicity. With the superheterodyne, on the other hand, almost any desired order of amplification can be obtained on short waves, and a high order of simplicity attained, since where it is required to cover a wide frequency band only two coils need be changed for each band and there is no difficulty of circuit ganging involved.

In Figs. 4, 5, 6 and 7 is illustrated and diagrammed a short-wave converter, consisting of an oscillator and first detector which, when placed before an ordinary broadcast receiver, employs the r.f. amplifier of the latter as an intermediate-frequency amplifier and turns the whole combination into a superheterodyne. This converter is in distinct contrast to previous short-wave converters, usually consisting of only a regenerative short-wave detector designed to be plugged into the detector socket of a t.r.f. or other set, and to utilize only the audio amplifier of the latter. In the case of this converter, all of the amplification of the t.r.f. receiver with which it is used is utilized and slightly augmented by the gain resulting from the frequency conversion.

The converter consists of a -24 first detector with plug-in coils which are tuned by a .00014 mfd. vernier or midget type of condenser, as it was not thought desirable to bring the condenser control out to a vernier dial, since it is not particularly critical in setting and tuning may be more easily mastered when the first detector tuning is regarded as a vernier or trimmer adjustment rather than as a regular tuning control. The oscillator, however, is extremely sharp and, employing a somewhat similar coil to that of the (Continued on page 460)

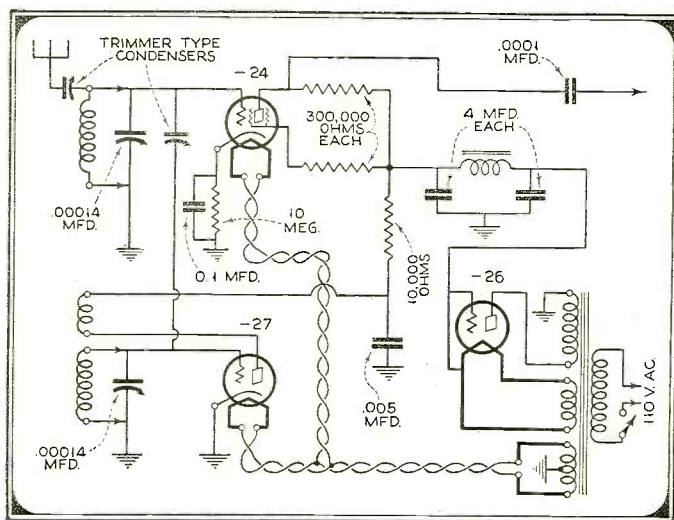
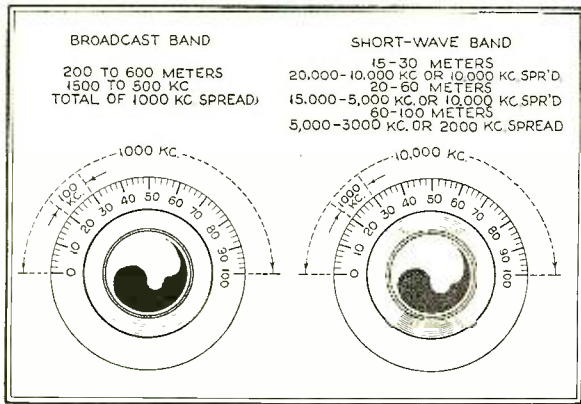

Fig. 7. This diagram gives the wiring details of the short-wave superheterodyne. Note that it possesses its own filament, grid and plate power supply



These two dials demonstrate graphically why the short-wave receiver is so much sharper than the broadcast receiver. The band covered by the short-wave receiver is ten times as great as the band covered by the broadcast receiver

# Getting the "Low-Down" on Short-Waves

*In the August, September and October issues of RADIO NEWS the author described the theory, operation, design and construction of the RADIO NEWS Short-Wave Superheterodyne. In this article he points out the practical difficulties which confront the short-wave receiver operator and warns him against a too literal acceptance of "all over the world" reception on short waves. The facts set down here are applicable not only to the operation of the RADIO NEWS Short-Wave Superheterodyne, but to other short-wave receivers as well, and for this reason short-wave fans will find it educating and instructive*

By Fred. H. Schnell\*

W9UZ

WITH poor tools, a skillful workman can do good work —with good tools a skillful workman can do excellent work and with good tools a good workman can do good work. So it is with radio receivers, and especially short-wave receivers, few of which can be classed above fair. With a fair short-wave receiver a skillful operator can obtain satisfactory reception, but not so the unskillful operator who runs into some little difficulty in tuning his broadcast receiver. Much depends upon the design and construction of the receiver, but more depends upon the operation of the receiver, if the best results are to be obtained.

There is but little doubt that the short-wave receiver has had proper attention, from the manufacturing standpoint. Until recently a short-wave receiver was a poor sales item—it was something that required too much sales talk and advertising per sale. Gradually this is changing, because the manufacturer now realizes that he must put into his short-wave receiver the same quality of material and the same class of merchandise that he puts into his broadcast receiver. He also realizes that the short-wave receiver must require no additional skill on the part of the operator to obtain satisfactory reception (conditions permitting) from the short-wave receiver as that which he obtains from his broadcast receiver. Things which are beyond the control of the manufacturer are weather and atmospheric conditions, fading and hours of operation, particularly short-wave broadcasting. With regular hours of broadcasting, national and international, and with a good short-wave receiver, one who can tune a broadcast receiver to his own satisfaction can sit down and enjoy a number of short-wave programs during the week. Of course, there will be days when fading is so bad as to make reception rather annoying. Seldom is this true with every broadcasting

\*Chief of Staff, Radio & Television Institute.

station. At other times reception is remarkably good. Reception results are different in every part of the world and results differ during the seasons and during the hours of the day. However, there is no reason why a certain amount of pleasure and enjoyment should be denied those who are interested in short-wave reception, but it is advisable to have a fundamental understanding of what is what and why.

On and on and on will go the pro and con argument of what is a good short-wave receiver. It may be settled some day in the far distant future, much too far to be of any benefit to the prospective short-wave listener of today who is waiting for that day. Too much waiting has been done already. Let the prospective buyer of a short-wave receiver make a decision of his own. Let him decide whether or not a particular type or make of short-wave receiver will fit his demands. He now has a choice of a number of them—probably he can find just what he wants—if not, he ought to make it himself or have it made for him.

A very important consideration in any short wave receiver is the tuning speed—that is, how fast it covers the frequency range and what is the frequency range for each plug-in coil if it is that type of receiver. Some short-wave receivers have a tuning capacity of 135 to 150 micro-microfarads, and three or four plug-in coils to cover the wavelength band from 15 to 150 meters. The thinking short-wave prospective buyer will make a few mental notes and then start with a pencil and some paper to do a little figuring.

When he starts to compare the speed of the frequency tuning with that of the broadcast receiver he will find a thing or two of interest. He will find that the average broadcast receiver (assuming that it covers the 200 to 600-meter range) covers a frequency range of 1,000 kilocycles, 500 to 1,500 kilocycles. The broadcast receiver usually has a dial of 100 divisions to cover (Continued on page 468)

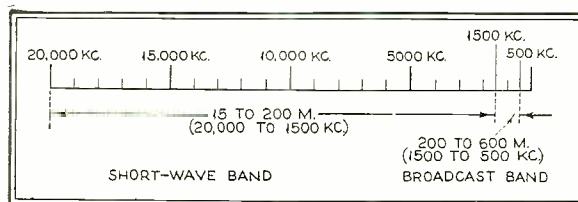

Note the small percentage of the frequency spectrum utilized by the broadcast band in comparison with the short-wave band

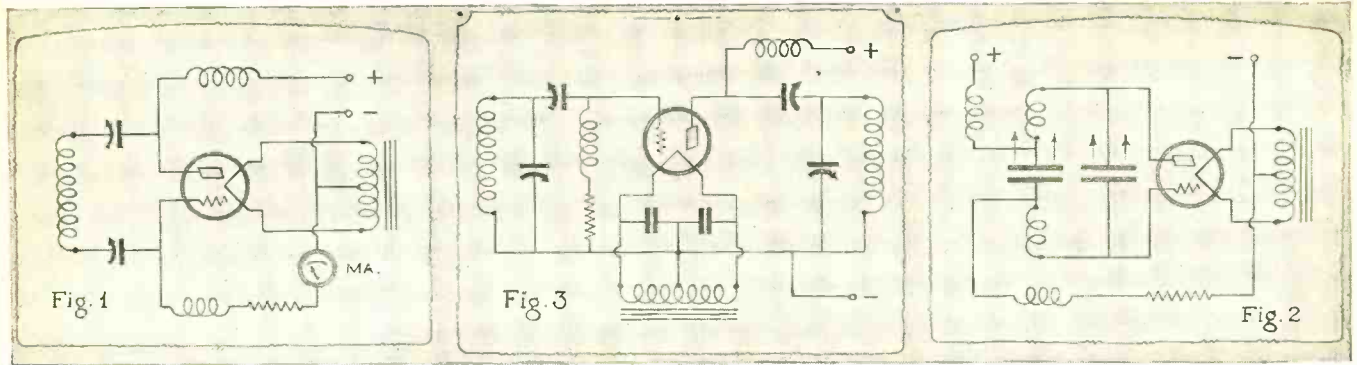

Fig. 1. A Hartley circuit without filament clip. This circuit produces relatively high grid current, eliminating the necessity for a low range and naturally expensive meter

Fig. 2. Another circuit arrangement which works well. Tubes having relatively large internal capacities will operate better with small blocking condensers, as indicated in Fig. 1

Fig. 3. A tuned plate-tuned grid circuit. Care is necessary in a transmitter employing this circuit, since a small difference in construction may unbalance the tuned circuits

# Practical 5 and 10 Meter Transmitters for Short-Wave Exploration

*Not content with the laurels won after dint of hard work in the more commonly known 20-40-80 meter amateur bands, short-wave experimenters are finding a new and interesting field for conquest in the extremely high-frequency bands. Be assured, you will become acquainted with many intriguing and startling effects in this new and as yet unexplored realm*

ONE has to admit that, no matter how good the DX or how high the traffic total, there are times when one prefers experimental work. If experimentation is to be done the 5- and 10-meter bands offer exceptional possibilities for the study of effects which, under the exaggerated conditions at the ultra-radio frequencies, become readily investigated with apparatus of simple construction and low cost. Anyone may have theoretical ideas (which seldom work out) about these frequencies, but few have actually done work which is practical. For this reason, instructions are given below for the practical construction of several types of transmitters. The transmitter is the first step in experimental work of this nature; wavemeter calibration can then easily be done with the aid of the oscillator. (See the writer's article in April RADIO NEWS.) Wavemeters for use below 5 meters are discussed here, as well as a method which can be used in the  $\frac{3}{4}$ -meter band.

For Fig. 1, the inductance at 60 mc. (5 meters) consists of about 5 2-inch spaced turns of No. 14 wire. The condensers are 30-mmfd. "midgets." A grid leak of 10,000 ohms is about right for any of the circuits described. Both grid and plate chokes should be carefully constructed. Although choke operation depends to some extent upon the position in the circuit in which it is used, one consisting of three small windings

By A. Binneweg, Jr.

of 50, 100, and 50 turns of No. 36 wire, connected in series, on a  $\frac{1}{4}$ -inch form, has given good results. The values of

parts used will depend upon the tube, lengths of lead and other factors of construction. Values given above for Fig. 1 will serve as suggestions for any of the circuits to follow.

The circuit of Fig. 1 has many advantages for general use. The "blocking" condensers are in series with the tube capacity, giving a low resultant capacity with any of the usual tubes.

Due to the relatively high L/C ratio, the r.f. voltage is high, the efficiency is quite high and oscillations are readily produced. Ordinary midget condensers can be used in a low-power set, as the two are in series with the plate voltage. If one condenser were used, double plate spacing is usually necessary.

Fig. 1 is the Hartley circuit without a filament clip. Usually the use of a filament clip will give less output. A choke or a condenser in series with the filament clip improves matters. The voltage distributions at these frequencies are often not the same as at lower frequencies, due to the exaggerated effects of small values. When the clip is connected, the effects are changed. In general, the simplest possible arrangements with the shortest leads, consistent with other requirements, will give

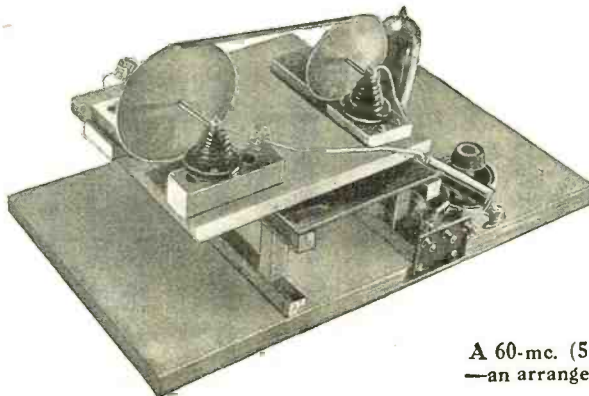

A 60-mc. (5-meter) oscillator with disc condensers —an arrangement used by the author in his 5-meter experiments

the best results.

Fig. 1 gives relatively high grid currents so a low range instrument is not necessary. A grid-meter is quite convenient, as it gives a sensitive indication of resonance or oscillations. In experimental work, one of the necessities at these frequencies is a reliable resonance indicator and test for oscillations. Certain adjustments may change the frequency beyond the wavemeter range, but under normal conditions a grid current is a rapid check. A plate meter is not always satisfactory, since under circuit conditions the change in deflection is small at resonance or when oscillations start. For tubes of 5 or 7½ watts with usual voltages, a 0-25 d.c. milliammeter will serve for the grid meter. For lower voltages, a smaller size instrument is necessary. The grid current value will depend upon the circuit used, its constants, and to some extent upon the frequency. In one 3-meter oscillator a 112 tube with 180 volts of "B" battery on the plate gave one milliampere of grid current.

Fig. 2 is another arrangement which works well. The chokes in this circuit are not so important and can often be omitted. Both condensers in the oscillating circuit are of the parallel-plate type, as shown in the illustration. The plates are about 4 inches in diameter and are soldered to pieces of copper tubing at the center; holes in the ends of the tubing fit over screws in a pair of wall insulators. A scale at the side can be calibrated to read in mmfds. The condenser nearest the tube in Fig. 2 should be large compared to the tube capacity and the leads to the tube should be short. One plate in each condenser is fixed, and the other movable for adjustment. Tubes having relatively large internal capacities will operate better with small blocking condensers as used in Fig. 1.

The condensers must withstand the plate voltage used. The leads between the condensers, which comprise the inductances, may be of copper strip. A grid-meter of handy size can also be used with this circuit. Circuits having no grid condenser will usually give larger grid currents. Usually a circuit having lower losses will operate on lower plate voltages.

In some arrangements, the filament circuit is found above ground potential and subject to hand effects. In this case if a.c. is used it is likely that connection with the lighting circuits will cause trouble. Filament chokes will help. In some layouts filament chokes are not necessary. Results are often better when battery supply is used for both plate and filament. Plate and grid chokes should be connected when possible at positions of low potential.

Fig. 3 is a tuned plate-tuned grid circuit. Small difference in construction may throw off the range of one tuned circuit, so care is necessary. The condensers in the tuned circuits should be very small for best results. Somewhat more adjusting is required than in circuits requiring but one tuned circuit, but this is worth while. A tube of low internal capacity, such as the H-tube or UX-852 gives very good results. In one experimental set, capacities of about 10 mmfd. served for the blocking condensers while about 15 mmfd. was used for the tuning

Fig. 4. A simple circuit which will operate well with any of the normal run of tubes. For frequency adjustment it is merely necessary to slide the condenser leads along the turns

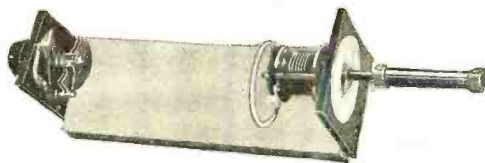
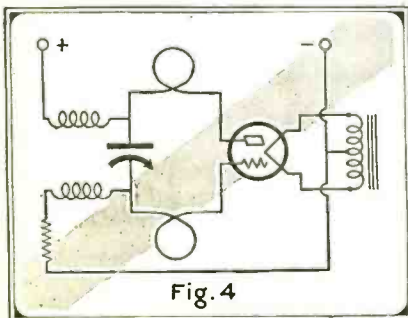

This illustration gives you some idea of the construction of a wavemeter for use in the 5-meter band (and below)

what beyond the minimum values. Although the distributed capacity is often sufficient, filament by-pass condensers will help. They should be mounted very close to filament at the tube. The blocking condensers are very small, and a tube of low internal capacity should be used, otherwise excessive r.f. current may deactivate the filament in some tubes. Filament chokes may be necessary.

Fig. 4 shows a circuit which will operate well with any of the usual tubes. The chokes are not important and can often be omitted. The condenser can be variable or fixed. A small mica condenser, which will stand the plate voltage, of about 100 or 250 mmfd. can be used. Good practice requires a rating of about twice normal plate voltage. The frequency is changed by sliding the condenser along the turns and resoldering at the position corresponding to the desired value.

The capacity is not critical as long as it is above a certain minimum. This condenser is in series with the tube capacity so that its capacity has relatively little effect on the frequency; the inductance is varied for large frequency changes; it affects the frequency to a maximum degree when its capacity is comparable with the tube capacity.

By shortening the leads to the tube, and using a small fixed condenser, this circuit will oscillate as low as 1½ or at 2¼ meters. By amplifying the second harmonic of a 1½-meter oscillator, a master oscillator-power amplifier set for experimental work in the amateur band at ¾ meters will result. The third harmonic of a 2¼-meter oscillator can also be amplified for this work.

The simplest arrangement is to extend the grid and plate leads, connecting the grid and plate chokes at the end of the wires. A minimum of apparatus is necessary but the LC relation is not such as to give the best efficiency, but this may not be necessary. This circuit can be improved by connecting a condenser of at least 100 mmfd. at the end of the wires. An interesting modification is shown in Fig. 5. Two pancake coils are mounted for variable coupling, the capacity between the two windings serving as the condenser. The capacity between the windings is not far from that furnished by a pair of parallel plates of the same diameter, if the turns are close.

The base of the tube should be removed for frequencies below 5 meters. A convenient plug-in-tube scheme can be arranged so that the frequency can be easily changed. Each tube is provided with its simple oscillating circuit, gridleak and chokes and is mounted on a UX socket. When plugged in, the oscillator operates immediately and at good efficiency since the constants for each tube are adjusted beforehand. The four connections to the UX base consist of (Continued on page 450)

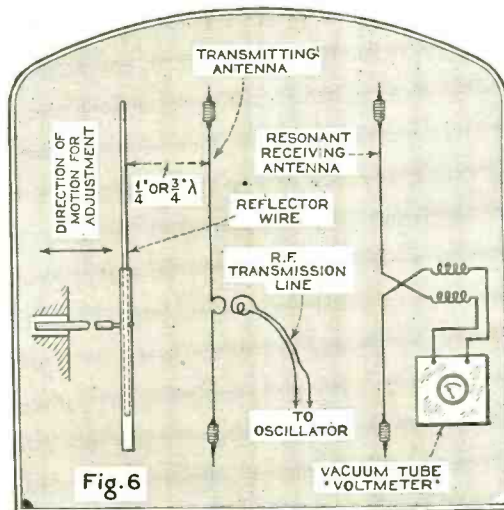

Fig. 6. Depicting the method employed for measuring waves in space. The arrangement consists of three antennas, i.e., a reflector, a transmitting antenna and a receiving antenna

condensers, with good operation. A small midget condenser can be used for the grid tuning condenser, but the plate condenser should have copper foil separated by a piece of mica will serve for the plate-blocking condenser. One of the copper pieces is movable to vary the capacity. Both blocking condensers are reduced in value until oscillations cease, and are operated some-

what beyond the minimum values. Although the distributed capacity is often sufficient, filament by-pass condensers will help. They should be mounted very close to filament at the tube. The blocking condensers are very small, and a tube of low internal capacity should be used, otherwise excessive r.f. current may deactivate the filament in some tubes. Filament chokes may be necessary.

Fig. 4 shows a circuit which will operate well with any of the usual tubes. The chokes are not important and can often be omitted. The condenser can be variable or fixed. A small mica condenser, which will stand the plate voltage, of about 100 or 250 mmfd. can be used. Good practice requires a rating of about twice normal plate voltage. The frequency is changed by sliding the condenser along the turns and resoldering at the position corresponding to the desired value.

The capacity is not critical as long as it is above a certain minimum. This condenser is in series with the tube capacity so that its capacity has relatively little effect on the frequency; the inductance is varied for large frequency changes; it affects the frequency to a maximum degree when its capacity is comparable with the tube capacity.

By shortening the leads to the tube, and using a small fixed condenser, this circuit will oscillate as low as 1½ or at 2¼ meters. By amplifying the second harmonic of a 1½-meter oscillator, a master oscillator-power amplifier set for experimental work in the amateur band at ¾ meters will result. The third harmonic of a 2¼-meter oscillator can also be amplified for this work.

The simplest arrangement is to extend the grid and plate leads, connecting the grid and plate chokes at the end of the wires. A minimum of apparatus is necessary but the LC relation is not such as to give the best efficiency, but this may not be necessary. This circuit can be improved by connecting a condenser of at least 100 mmfd. at the end of the wires. An interesting modification is shown in Fig. 5. Two pancake coils are mounted for variable coupling, the capacity between the two windings serving as the condenser. The capacity between the windings is not far from that furnished by a pair of parallel plates of the same diameter, if the turns are close.

The base of the tube should be removed for frequencies below 5 meters. A convenient plug-in-tube scheme can be arranged so that the frequency can be easily changed. Each tube is provided with its simple oscillating circuit, gridleak and chokes and is mounted on a UX socket. When plugged in, the oscillator operates immediately and at good efficiency since the constants for each tube are adjusted beforehand. The four connections to the UX base consist of (Continued on page 450)

Fig. 5. An interesting modification of the circuit shown in Fig. 4. Capacity coupling between the two coils takes the place of the variable condenser

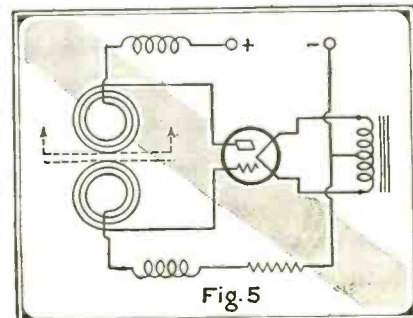

# Judgment of Sound Quality in Motion Picture RECORDING

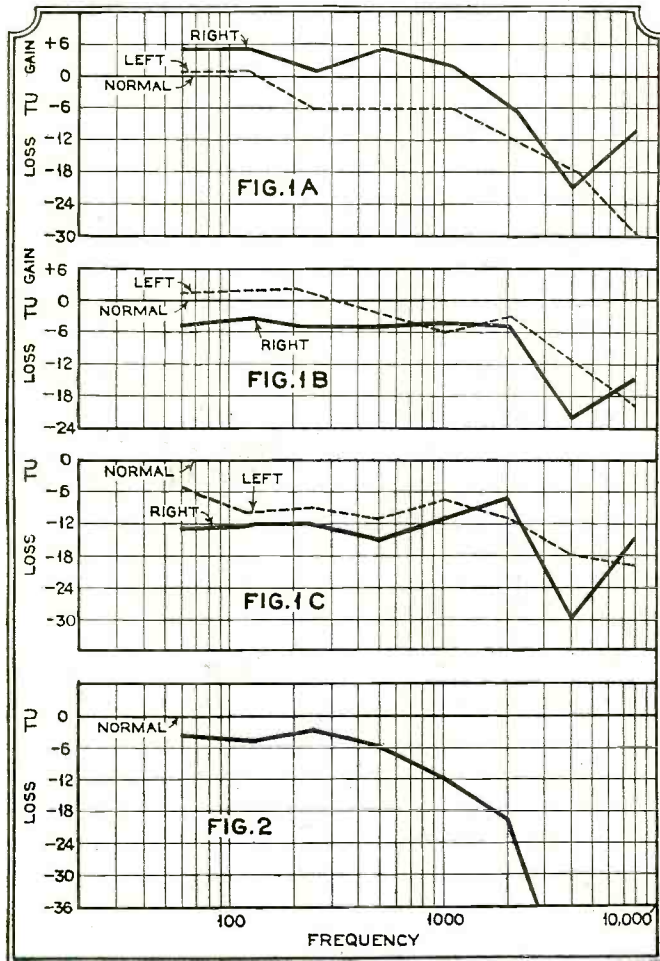

Fig. 1. (A, B and C) are typical audition curves. An ear corresponding to the curve in Fig. 2 could not judge high frequency output correctly

**A**FTER a scene has been "shot" on a talking movie stage, the assistant director looks up inquiringly at the stage recordist who has been engaged in operating the microphone boom and who is in touch with the first recordist or "mixer" in his booth. The stage man gets words from this not quite omnipotent technician and roars out the verdict: "O. K. for sound!" Of course it is not always O. K. for sound the first time, but in the end a result is usually achieved which the sound expert considers satisfactory. This is the beginning of a process which contains many uncertainties.

What has actually happened? On a set with fairly well-known acoustic qualities actors have been speaking in various voices, while moving about; one or more pick-up men have been trying to follow them with microphones suspended above the heads of the actors; another technician in a remote booth has been listening to the results and perhaps changing levels to suit himself. His listening may be done in a small enclosure with a loud speaker a few feet from his head, or in a somewhat larger room imperfectly simulating a theatre.

The film exposed by this procedure is then developed in a laboratory, printed and synchronized with the picture. In a studio projection room which has about one-twentieth the volume of a theatre, the director of the picture, the producer, cameramen, cutter, etc., then review each day's results. These are known as the "dailies" or "rushes." The head of the sound department may also be present at these showings; at any rate, he is called in if there is a dispute regarding the quality of the sound. Finally the film is edited, most of the previously viewed material being dropped out, and previewed at a local theatre. Further cuts and adjustments are made on the basis of the audience's reaction, and the final product is run in various parts of the country on all kinds of projection equipment for the pleasure or edification of the public.

In the daily ritual of listening to the rushes, in order to judge sound, the following factors play a part:

1. The character of the sound as recorded on the film;
2. The reproducing equipment on which the sound print is run, and the acoustic characteristics of the room;
3. The physical characteristics of the ears of the various observers;
4. The psychological auditory characteristics of the listeners, including their individual taste in listening to reproduced music, dialogue and noise.

It should be noted at this point that the judgment of the recording engineer nominally in charge of sound on the picture is not the final voice in the matter. He must satisfy his superiors, particularly the director of the picture, and above all the producer. His actual influence varies in different studios, and in any given studio it depends on the man himself. At best he has not over fifty per cent. of the power to decide what

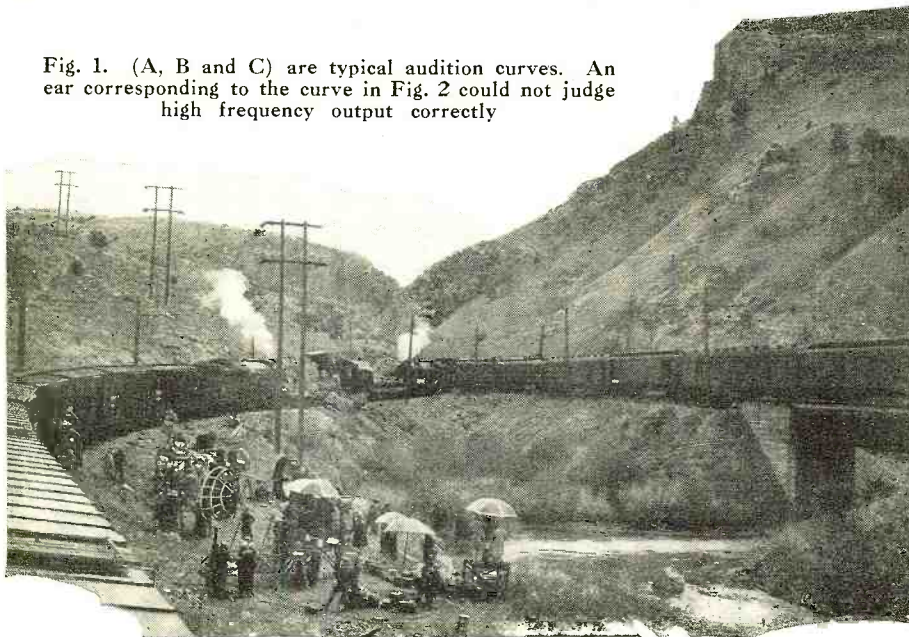

Preparing for a scene in "The Record Run," a Radio picture. Note the large sound reflectors in the left foreground



*The analysis of sound reproduction is highly complicated because it is based on the known limitations of apparatus, the acoustical properties of rooms and the varying psychological and physiological differences in individuals*

**By Carl Dreher**

the recording shall be like. At worst he is a mere automaton trying to do the bidding of his organizational superiors. Hence, in your judgment of what you hear in the theatre, don't lay all the blame on the sound man whose name sometimes appears on the screen, nor, if the result is good, ascribe it entirely to his skill. The personnel situation is much more complicated than that.

Let us now consider the steps which are taken in any properly operated studio to keep the above four factors under control as much as possible.

As far as the original recording goes, daily frequency runs are made on the equipment, so that its characteristics are well known. The acoustic properties of sets have been extensively studied and usually a fair engineering estimate of the behavior of any given set may be made. A skilful recordist becomes so accustomed to his control devices, such as the loud speaker in his booth, volume indicators, etc., that he can allow for the difference between his listening conditions and those encountered in the fictitious "average" theatre. Again, he and his colleagues in the sound department should have some idea of how the acoustic characteristics of the projection-room in



The unusual sound stage photo shown above reveals a shadow-like figure of an electrician preparing the lights for a love scene. At the left is another scene from the Radio picture "Inside the Lines." The man with the tape is getting focus measurements. Microphones in both views appear within the circles

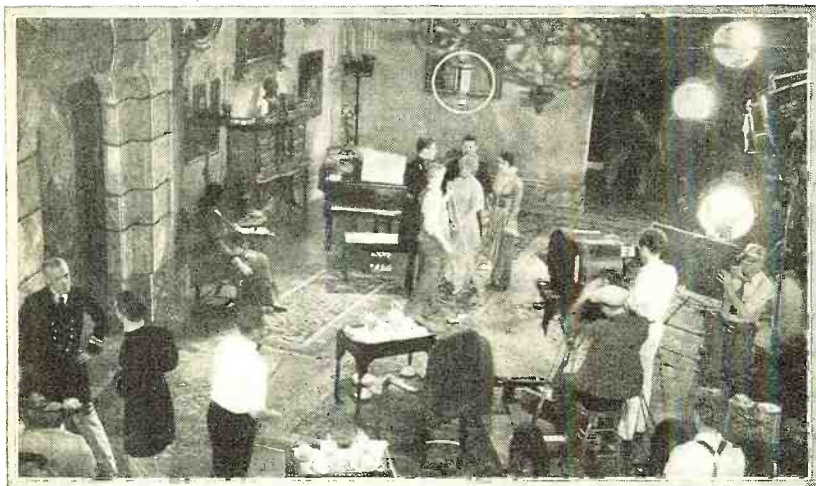

better with his right ear, which is somewhat normally sensitive, particularly in the low and middle range. It drops off above 1,500 cycles, but begins to rise again at 4,000. Subject B has the reverse condition, the left ear being more sensitive than the right, with, however, less difference between the two ears. The right ear is remarkably flat between 60 and 2,000 cycles, then it drops off. Subject C, while well within the range of good hearing, is definitely less sensitive in both ears. We would expect subject C to require a louder level in reproduction than, say, subject A, since there is a difference of some 12 TU between their average sensitivities in the middle range. This, indeed, turns out

to be the case; Mr. A likes his sound medium, while Mr. C wants it loud. But Mr. B, whose ears are almost as good as Mr. A's, is just as eager for loud sound as Mr. C. In other words, not only do we have to take psychological factors into account, but there is an element of individual taste involved. Apparently Mr. B, while equipped with a pair of very good ears, wants more sound than he actually needs. *De gustibus non est disputandum*—there is no use disputing about tastes. It might take a psychoanalysis to establish the reason for Mr. B's idiosyncrasy.

Added to the difficulty of arriving at the proper levels is judgment of frequency and admixture of overtones. Such an ear as that shown in the curve of Fig. 2 could obviously not judge the proper proportion of high-frequency output correctly. But even where only normal hearing is involved there is room for dispute. During the past few months most of the Hollywood stu-

For one thing, even among normal individuals, ears differ widely. The three parts of Fig. 1 show some more or less typical audition curves. These were made on three different individuals with a Western Electric audiometer. In each case zero level is the norm. Subject A, we note, hears a good deal

to be the case; Mr. A likes his sound medium, while Mr. C wants it loud. But Mr. B, whose ears are almost as good as Mr. A's, is just as eager for loud sound as Mr. C. In other words, not only do we have to take psychological factors into account, but there is an element of individual taste involved. Apparently Mr. B, while equipped with a pair of very good ears, wants more sound than he actually needs. *De gustibus non est disputandum*—there is no use disputing about tastes. It might take a psychoanalysis to establish the reason for Mr. B's idiosyncrasy.

dios have been in pursuit of what is known as "sound perspective." Briefly, the theory of sound perspective is that the sound should match the picture, close sound corresponding to a close-up picture, medium sound to a medium camera shot, etc. When a character is in close-up and facing the audience, his speech should be correspondingly loud and highly intelligible, since he is directing the beam of high frequencies directly at the listeners. If he turns around, there should be a drop in his high-frequency output in reproduction, since the beam is now directed away from the audience and they would in the natural situation lose a good deal of the high tones. If the character walks away from the microphone, the sound should decrease further in intensity, as well as in proportion of high frequencies. The object is to make the reproduced material sound as it would were the audience present at the original performance. For a more extensive discussion of the principles involved, the reader is referred to the paper by J. P. Maxfield on "Technique of Recording Control for Sound Pictures" in the *Technical Digest* of the Academy of Motion

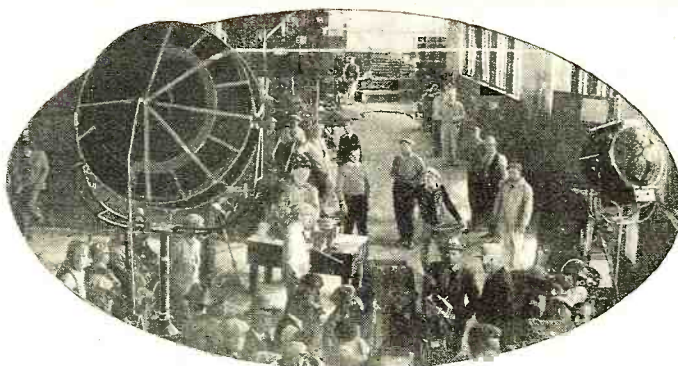

A railroad shop scene about to be recorded. A prominent place is accorded the large sound reflector

picture producer is usually a man who made silent pictures for twenty years and opposed the introducing of sound *in toto*. The sound engineer has been in the picture business for two years and lives by sound alone. Nevertheless, the sound engineer is in the position of advocating some sacrifice of sound quality, for which he is confident the picture itself will compensate. The producer is in the position of wishing to rely entirely on the technical merits of the sound, with apparently no desire to have the picture dominate in the ensemble. Arguments in projection-rooms must sometimes make the ironic gods lean down from Olympus and laugh.

Many directors and producers, on the other hand, understand the principles of sound perspective perfectly and co-operate with the sound department to the fullest extent. They realize that the idea entails some complications, but they believe that the result is worth a little added trouble and cost. It is true that recording with sound perspective requires close coordination between the director, the cutter and the sound man.



At the left is an aerial view of the home of Radio Pictures. The other picture shows final construction of the world's largest sound stage—500 by 150 feet and five stories high. Note the pile of wool quilts used for sound absorption

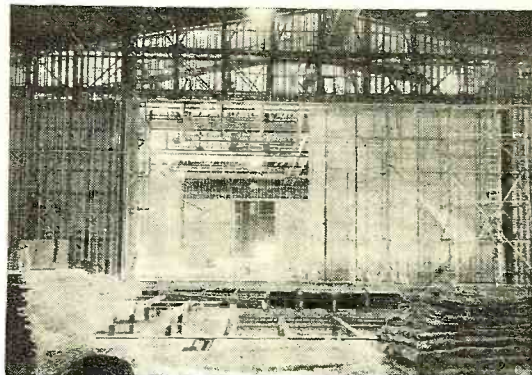

Picture Arts and Sciences. Maxfield points out, incidentally, that the proper utilization of sound perspective generally involves setting only one microphone for pick-up and suppressing most of the knob-turning proclivities of the mixers.

It would seem self-evident that sound perspective is a valuable means of enhancing the illusion in sound picture production, with merely the reservation that at times there may have to be a compromise between intelligibility and realism. That is, the sound must not be allowed to become actually unintelligible for any length of time, even where it might be so under natural conditions. With this concession, it would appear that everyone concerned should agree on the advisability of utilizing sound perspective. But this is not the case. I have heard producers denounce the whole principle and declare that they wanted all sound in their pictures uniformly loud and clear. I believe their position to be untenable, but it will take time to prove this. In the meantime the producer is financing the picture, and by a well recognized principle of equity, is entitled to get what he wants for his money.

There is a comical aspect to this complication. A motion

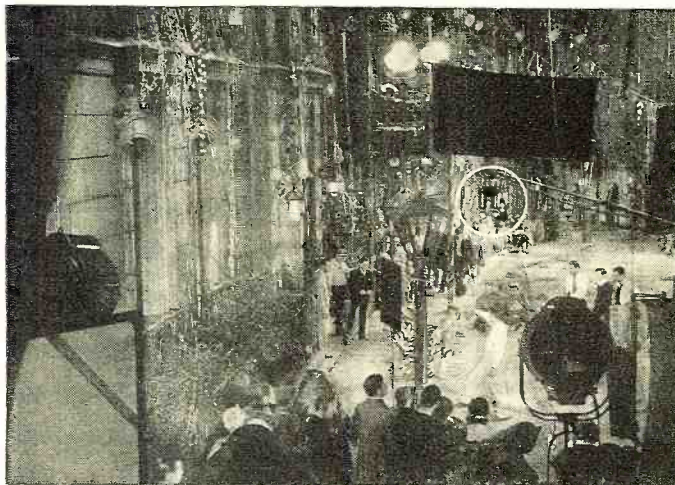

Looking at a film scene from the sound booth. The microphones are within the white circle

If, for example, the cutter mixes up sound and picture takes, matching close-up sound with a medium or long camera shot, the result is chaotic. Again, the stage man may spoil the effect by injudicious manipulation of his microphone boom. If, when a character turns away from the audience, he swings the microphone so that the actor continues to talk into it, the result will be that the sound remains the same as when the actor turns away. This is unnatural and constitutes a defect of the same kind as that often seen in the early talking pictures, where shouts through a door, for example, were as clear as the same sounds within the

room—because they were not picked up through the door.

An inherent difficulty of judging rushes in the projection-room is that scenes are not taken in sequence, so that the picture as it is actually shot may begin with a scene in the middle of the shift, proceed to the end, and finish up with the beginning. Moreover, what with all the various camera angles which are shot and the fact that in all cases a great deal more footage is run through the recorders and cameras than will appear in the final cut picture, the stuff which takes thirty minutes to run in rush form may be reduced to (Continued on page 459)

# Television Now Taught in Technical Schools

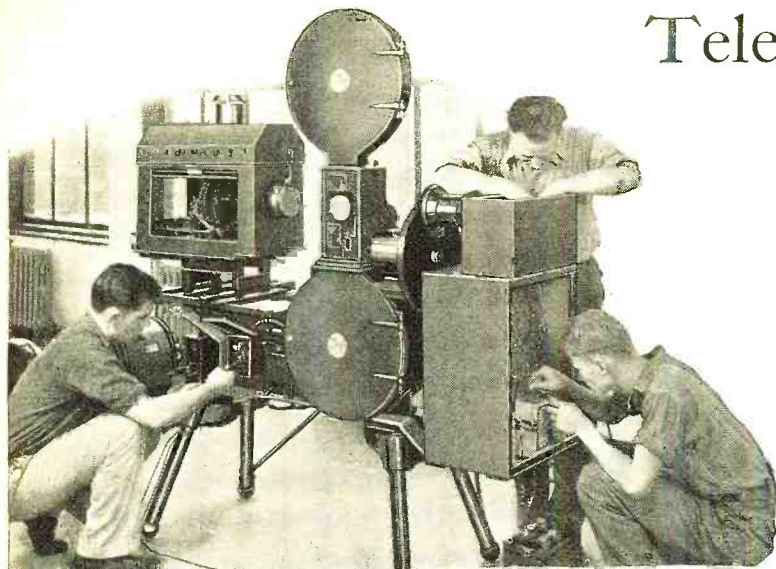

Students of the Coyne Electrical School are shown in these two photographs "learning by doing." The apparatus shown here is the very latest type of television equipment, the upper photo being the television camera and the lower a scanning device for living subjects

**A**NTICIPATING future demands for competent skilled technicians in the installment and operation of television equipment, one of the leading electrical schools of the country has recently added a course in television technique, installation, servicing and operation to the already rather complete radio course now being offered by that institution.

In its entirety the radio division of this school offers instruction in radio, television and sound reproduction by actual shop work.

A great amount of modern radio equipment, including radio receivers of many kinds and types, a complete commercial broadcasting transmitter, the very latest Jenkins television transmitting and receiving apparatus, speech amplifier racks, and code practice equipment, has been installed and officers of the school feel that it is the most modern of its kind now in existence.



# Health Cures *by* Means of Sound Amplifiers

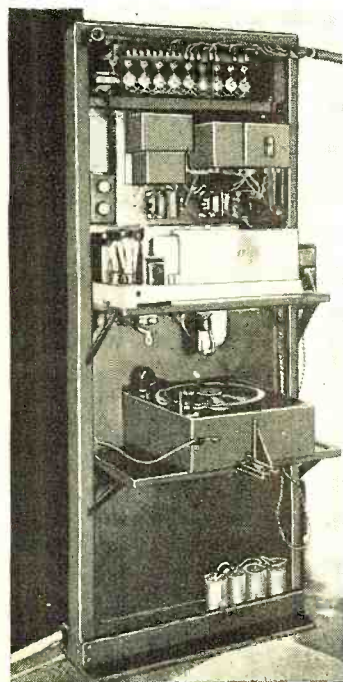

**N**O longer will patients at Muirdale Sanatorium, one of the leading tuberculosis sanatoriums in the country, located at Wauwatosa, Milwaukee County, Wis., disturb fellow patients with untimely radio programs. Nor will patients without means—Muirdale is a county institution—have to do without radio. Nor will Dr. Bellis, director of the institution, have to make general announcements hereafter by means of mimeographed memos.

For a combined public address, phonograph and radio reproduction system has been installed in the institution by means of which records and broadcast programs may be heard through earphones at every bed. And Dr. Bellis can order all to bed through the system or give his patients a health lecture at any time. Both hospital authorities and patients are highly enthusiastic.

"Such a system is a decided improvement," comments Dr. Bellis. "Before its installation we had become a roadhouse rather than an institution, the principal purpose of which was to effect cures through rest and quiet."

The equipment consists of a rack and panel assembly with a Philco 96 chassis as the basis, an output system consisting of a stage of 250 push-pull power amplification coupled to the distribution equipment, standard microphone and amplifier, and a slide-in phonograph with electric pick-up, together with necessary controls. (Continued on page 463)

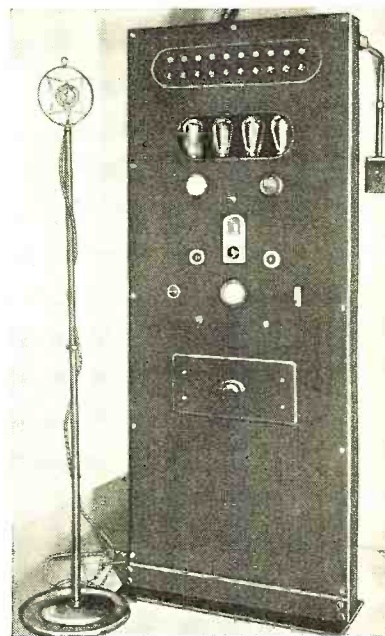

## Mr. Lott says - - -

¶ Reception always improves in the direction of a high and always falls off in the general direction of the low.

¶ I do not believe that temperature has any effect on either transmission or reception. The apparent effect noticed is probably purely local and will not hold good in any other location.

¶ During my investigation covering a period of seven years, I have not yet found any correlation between wet ground and reception.

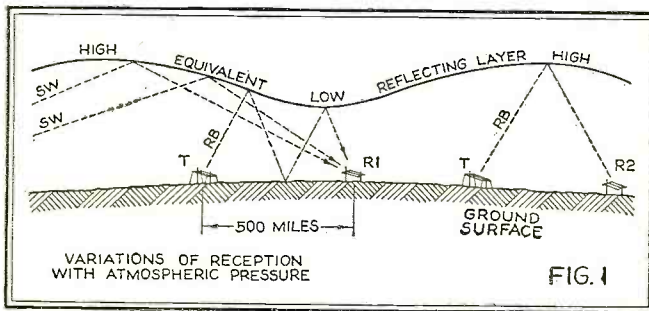

Receiver R1 in "low" receives stronger distant short-wave signals due to focusing; and weaker near-by broadcast signals due to low layer and many reflections  
Receiver R2 in "high" receives stronger near-by broadcast signals due to high layer and few reflections

**A**MONG the letters from readers evoked by our two recent articles in RADIO NEWS—"More Light on Short-Wave Transmission" in the February issue and "Sunspots, Weather and Radio" in the April issue—are three communications of real scientific interest. Two are from widely separated points in the United States; the third comes from half-way round the world.

An interesting and important letter comes from A. V. Lott of Sellersburg, Indiana. Mr. Lott writes in part:

"I was much interested in your article in RADIO NEWS on the subject of sunspots, weather and radio. My interest was due chiefly to the fact that the findings reported were so different from my own findings on the same subject. After reading your article I cannot help but think that we are all more or less like the blind men who examined the elephant. We are handicapped by being forced to make our investigations from a single location. If we could make our investigations from widely separated points we would get a better idea of the whole situation.

"Here in the Central States we have broadcasting stations all around us, and we also have lows and highs on all sides of us, so we get a broader view of the matter. We know beyond question that reception from the west increases as lows pass while reception from the east decreases as lows pass. Also, reception from the west decreases as highs pass and reception from the east increases as highs pass. Reception always improves in the direction of a high and always falls off in the general direction of the low. Your explanation of this phenomenon is plausible, but, unfortunately, it does not satisfy conditions as we find them here. Sometimes highs are of great extent. Sometimes they hang over us with very little move-

# BACK

on the recent  
on "Sunspots,  
by Lieut. William

ment for a week or ten days at a time. During this period reception remains good.

Evidently the improvement is not due to reflection from the ionized layer of the pressure slope, as you suggested, but to some other cause not yet known.

"I do not believe that temperature has any effect on either transmission or reception. The apparent effect noticed is probably purely local and will not hold good in other locations. Here in the Central States we have noticed that warmer weather comes along with low pressure, and it is accompanied by a falling off in reception. Reception will not improve until the pressure increases, and when the pressure is high, reception will be equally good regardless of temperature, even though the temperature may vary from—20 to 100 degrees in the shade.

"During my investigations covering a period of seven years

I have not yet found any correlation between wet ground and reception. Lows often pass over this location without rain. Sometimes they pass even without clouds. We have experienced periods of eight to ten weeks with scarcely a trace of rainfall. Lows would pass over regularly and reception improved even though the ground was bone dry. During dry weather the air becomes filled with smoke, dust and haze. These fine particles may, under certain conditions, become highly charged with electricity. When thus charged radio transmission may be affected. A good rain will wash all of this electrified dust and haze out of the air and reception will improve. However, the improvement will be due to a cleansing of the air rather than to the wet ground.

"My investigations lead me to believe that fading is due to an atmospheric slope crossing the line of reception. When the pressure is steady throughout the line of reception there will be no fading. When the pressure is falling slowly or rising slowly the fluctuation in signal strength will be hardly noticeable. With slowly falling pressure we can expect increasing cloudiness. With slowly rising pressure we can expect the clouds to continue another day. The more rapid the increase in pressure the more pronounced will be the fading, and the more rapidly the clouds will clear away."

Mr. Lott's main finding, that reception is best in and towards "highs" and worst in and towards "lows," is just the opposite of our short-wave results mentioned in the article. While we are not ready to accept absolutely Mr. Lott's finding or to reject our own, we have an open mind towards both views for several reasons. For one thing, short-wave results are very uncertain, and the broadcast signals observed by Mr. Lott are probably a better guide. Also the short-wave signals, having covered thousands of miles, have crossed many "lows" and "highs," and are less subject to local conditions. We could undoubtedly weigh Mr. Lott's results more heavily if they were based on quantitative measurements rather than qualitative estimation. Pickard found by such quantitative measure-

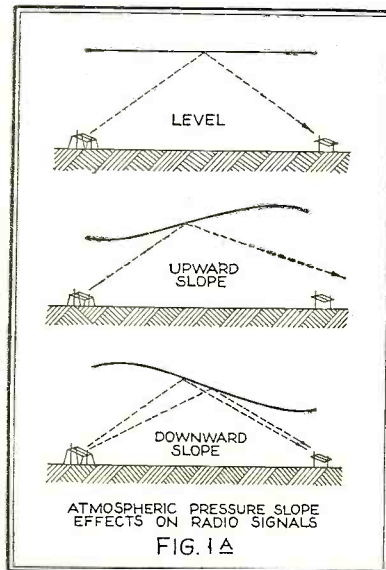

An upward slope in the equivalent reflecting (or refracting) layer tends to scatter divergent signal rays, while a downward slope in the layer tends to concentrate them on the receiver

# PICKARD

## series of articles Weather and Radio" H. Wenstrom



ments that reception increases "as lows pass" and in the article we interpreted this to mean that "lows" favor reception. But actually, as a "low" passes Pickard's receiver near Boston a "high" is probably between Boston and the Chicago transmitter. In other words, the pressure gradients of the atmosphere are like hills and valleys in topography; where a "low" ends, a "high" begins. Therefore we might say that Pickard's results show reception to be best through "highs," and are in agreement with those of Mr. Lott. As shown in Fig. 1, it is possible to have better short-wave reception and poorer broadcast reception in a "low." The distant short-wave signal is focused on the receiver by the slope of the low as explained in the April article. The near-by broadcast signal, however, is differently affected. In covering the same distance along the ground, it must go through more reflections under the lowered ionized layer of a "low," attenuating the signal. In a "high," on the other hand, it will suffer fewer reflections, reaching the receiver with greater strength. Thus both Mr. Lott's results and our own can be explained by the same general theory.

During March and April we made daily quantitative measurements of various broadcast and short-wave signals, as well as morning and evening observations of atmospheric pressure, temperature, relative humidity, etc. The correlations are very slight, but there is some tendency towards a high night signal from WLW at Cincinnati when pressure is increasing at West Point—in other words, when a high is between the receiver and transmitter. This is in fair agreement with Mr. Lott's views. However, a careful examination of the weather maps for the same period indicates that we cannot say at all positively that reception is always better in "highs"; relations are more complicated than they appear on the surface. The main difficulty is that solar activity affects the signal much more than atmospheric pressure; further, the solar effects are so complicated and obscure that it is difficult to eliminate them from the picture. For this reason a better time to study the effects of atmospheric pressure on reception will be during the sunspot minimum of 1934-35. From a superficial examination of the other curves we are inclined to agree with Mr. Lott that pressure is certainly the chief meteorological element—possibly the only one—affecting radio reception. There has not been time so far, nor is space available here, to analyze the curves by mathematical and statistical methods. It is of course a well known meteorological fact that temperatures rise with the approach of "lows" and fall with the coming

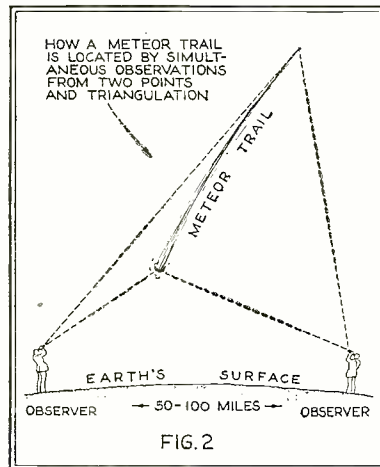

Two pages of one of the articles especially prepared for RADIO NEWS by Lieut. Wenstrom on the subject of sunspots, weather and radio. These articles have commanded wide attention and not a little of constructive criticism

of "highs." Mr. Lott writes also: "I would like to advance the suggestion that radio waves are more or less earthbound. They probably travel in the atmosphere until they reach a stratum where the density is such that they are automatically turned back to earth. Signals transmitted on the lower frequencies apparently are unable to penetrate a vacuum or even a light atmosphere. When we transmit on higher and higher frequencies we find the signals more and more able to penetrate an atmosphere of less and less density until the waves become like light waves in that they are able to penetrate a vacuum. The extremely high frequencies are of no value for communicating between points on the earth, but may be very valuable when we learn how to communicate with other planets." Here Mr. Lott's idea is essentially in agreement with the commonly accepted beliefs of scientists about radio wave propagation, at least for the short waves. This general theory was quite thoroughly discussed in our February article. Mr. Lott continues:

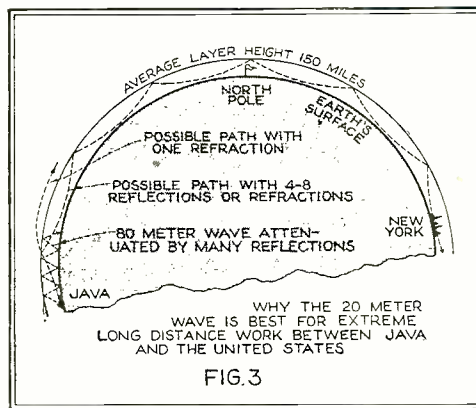

"We can readily see that any agency that causes the critical density of the atmosphere to rise will enable the signals to reach higher levels and thus reach greater distances. High pressure brings improved reception because the critical strata are then much higher than they are during periods of low pressure. Darkness brings improved reception for the same reason, the atmosphere being much deeper at night than it is during the day." This idea is a particular application of our general theory that atmospheric pressure governs ionized layer height to a certain extent, as indicated in the April article. Mr. Lott applies the general theory in the reverse direction—to "highs" instead of "lows." In Fig. 2 of the April article, which shows a "low" over the receiving station, the incoming radio rays are actually traversing a "high" which, due to the hill and valley pressure gradients mentioned above, begins of necessity where the low ends. The layer will of course be higher in a "high," and a high layer favors reception. There will also be a "dome" in the layer with possible focusing effects (Continued on page 453)

# A Six-Tube Short-Wave

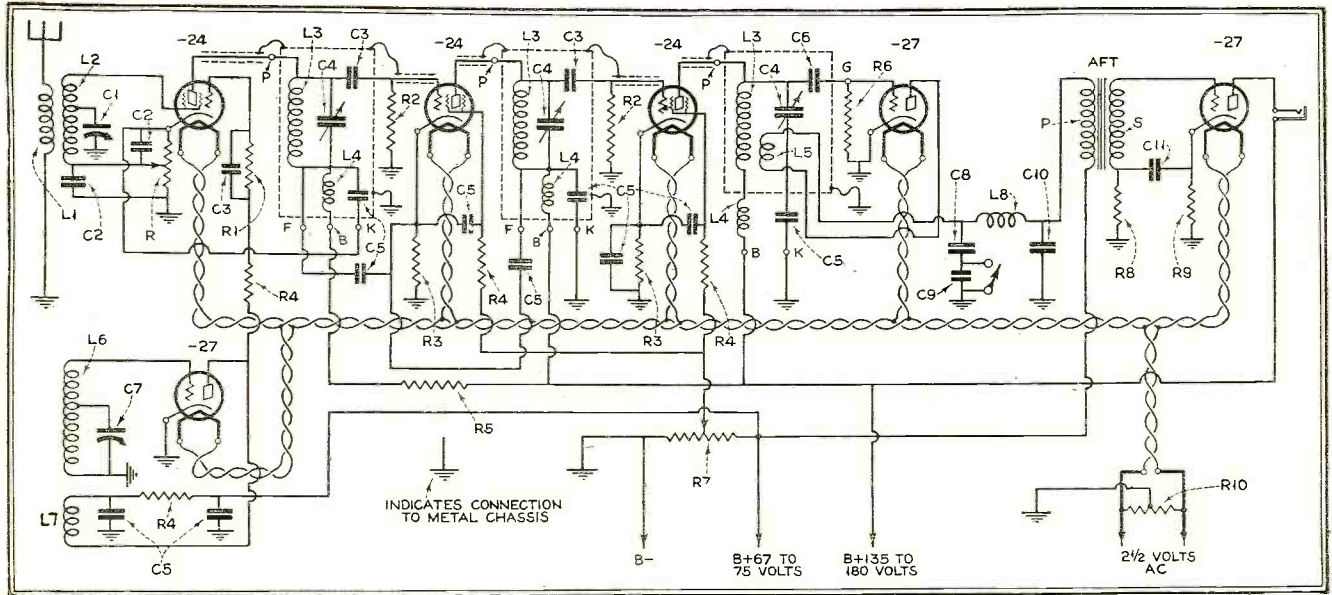

Schematic diagram of the S-W super. The shielding of inter-stage leads, as shown here, is of highest importance to obtain stability in the intermediate amplifier

**W**HEN the designer considers the superheterodyne in its pure form, which is when it is made up solely of first detector, intermediate r.f. amplifier, second detector and audio amplifier, and momentarily ignores the variation possibility in its components he has but one constant which can be varied with important effect upon the selectivity and sensitivity of the resulting set; this is the intermediate frequency.

He can, of course, depart from the pure form and make the outfit a hybrid including tuned r.f. amplification, but we are primarily concerned with the superheterodyne on short waves and there, if he is to minimize complication, he is forced to omit r.f. amplification at signal frequency.

For the superheterodyne is fundamentally a dual- or single-tuning-control receiver, whereas unless expense is added it cannot easily contain ganged tuning in the signal-frequency amplifier. Which is the not very difficult problem of the manufacturer and the expense for the ordinary buyer. But with plug-in coils the ordinary buyer is up against the final and most considerable complication of having to keep track of a multitude of coils and to plug in three of them for each tuning range when one r.f. stage is used, worse and worse with more. So much for a start.

The intermediate frequency can affect both selectivity and sensitivity. The latter is affected by the tubes and frequency chosen. Ordinary triodes, the -27, -01A, -99, etc., amplify effectively with most economy for triodes at the relatively low frequencies from 300 kc. down, and the quadtodes, the screen-grid tubes, -22, -24, etc., from 1,500 kc. down, which adds about five octaves to this economically effective range above which any type of tube causes increased cost to maintain, or get less amplification. In extenso, to avoid misunderstanding, the screen-grid tube is of course superior to the triode at any of the frequencies mentioned and therefore the most economical type of the two.

The screen-grid tube, of course, being available, is the one to be used.

The intermediate frequency affects both amplification and selectivity, and as seems usually to be true, the change beneficial to the latter is harmful to the former. Good design requires aiding one and minimizing harm to the other in order to satisfy the requirements of a useful compromise.

If the frequency chosen is too high, amplification can become poor; whereas if the frequency is too low, selectivity will suffer a subtraction.

The choice of frequency affects the selectivity in this manner. Remember that if only a detector precedes the i.f. amplifier this detector is protected by only one tuned circuit, which, as usual, is small buffer against the world. That is why all pure-form superheterodynes in the broadcast range have such low large-signal selectivity, although, due to the intermediates' cascade of tuned circuits, they always have great medium- and small-signal selectivity; whatever the detector will accept the i.f. amplifier has to use. An intermediate frequency of 300 kc. is got from a signal of 5,000 kc. (60 meters) by beating the signal frequency with a heterodyne frequency of 5,300 or 4,700. The oscillator, in other words, has two tuning points, a useful one and a needless one. The latter is what upsets the selectivity of the set, for if we are tuning to the example frequency the oscillator will have a second tuning point 600 kc. up or down from its tuning point. If its tuning point is 5,300, the parasite will be at 4,700 or 5,900 and a strong station on either of those frequencies,

which one depends on the oscillator tuning range, will only be detuned from the detector by approximately 10 per cent. and the strong near-by station can force through easily.

However, if the intermediate frequency were increased to 1500 kc. the detuning would be 50 per cent., far better, and the chances of keeping out the near-by station tremendously increased.

Nor is adding to selectivity the only advantage of increas-

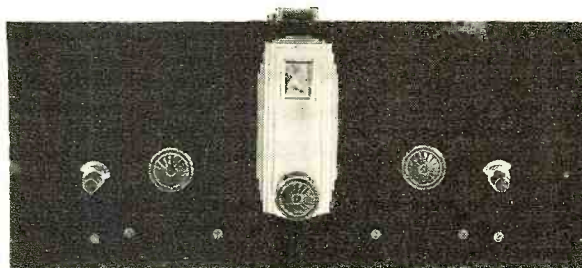

The business-like appearance of the front panel is in keeping with the efficient circuit design

\* Hatry and Young, Inc.

# SUPER

*Careful choice of the intermediate frequency of this short-wave superheterodyne permits high gain, excellent selectivity and an absence of repeat points*

By L. W. Hatry\*

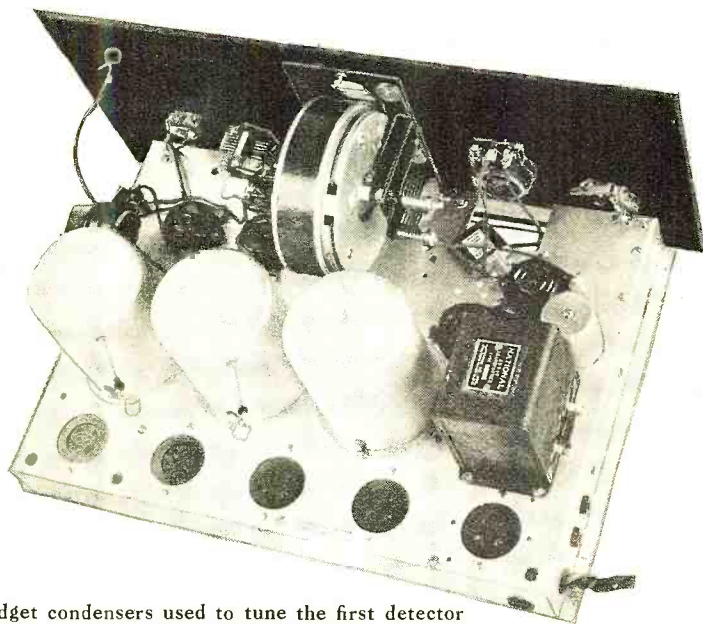

The midget condensers used to tune the first detector and oscillator stages are shown here. The oscillator is actuated by the calibrated dial, while the first detector condenser is operated by a knob in the front panel

ing the i.f. It has the additional advantage of forcing the oscillator's second tuning point off the dial and thus out of reach, if the oscillator tuning is so arranged. For instance, if the i.f. is 1,500 the two oscillator tuning points are 3,000 kc. apart, double the intermediate frequency. And if the oscillator tunes only over 3,000 kc. every frequency in its range except the beginning and ending ones, these having repeats only at the extremes of the dial, will have no repeats. We gain here a minimum of confusion.

Which ends up simply at a choice of frequency which must be made to avoid throwing away too much amplification. Fortunately we know from the frequently described experiences of the manufacturers of broadcast receivers that the screen-grid tube reaches 1,500 kc. comfortably and begins noticeably to decrease amplification above that until at 20,000 kc. it is giving little if any. Fifteen hundred kc., by permitting good amplification, good selectivity and a tuning range of at least 3,000 kc. without important repeats, is completely satisfactory if it also is outside the set's signal-frequency range. Fortunately it is since short waves of importance have frequencies from 3,000 kc. up and thus we cannot in our signal-tuning equipment run into the i.f. and bog in a complete mix-up.

Of course we will want to choose an i.f. outside the regular broadcast band in order to avoid picking up unwanted stations.

But that is easy; 1,550 kc. is generally sufficient when the local broadcaster possesses not more kilowatts than program.

Whence we come to other things, such as the tuning ranges, first detector, oscillator, intermediate amplifier transformers, second detector and audio amplifier.

A method of winding the plug-in coils. Taps are made by looping the wire through a hole in the form and soldering to appropriate lugs. All coils should be wound in the same direction

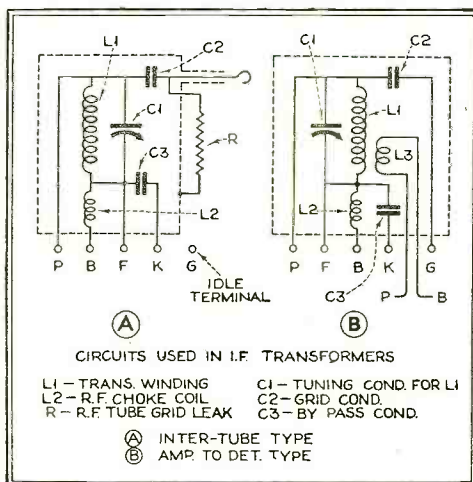
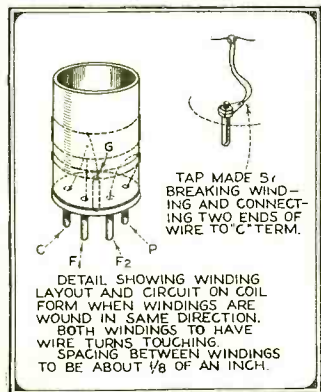

The i.f. transformers—A, the inter-tube type at the left is slightly different from the detector coil because of the regeneration introduced in the detector stage

The tuning ranges we can limit by tapping the coils so that the tuning capacity is effective across only part of them. This method has simplicity and effectiveness to recommend it. Thus we can restrict ourselves to 3,000 kc. or less per range and fit in with the allowance made by the i.f. The oscillator coils, because of the oscillator's second tuning point, will tune not one but two frequency ranges, wherein a usual disadvantage is turned to good use, allowing half as many coils as ranges.

The first detector tube will be a screen-grid tube for two reasons: its amplifying ability adds to sensitivity and in being like the rest of the tubes it needs a first i.f.t. like the others, which means minimization of complication and hence expense, an item the buyer can appreciate. But—

This screen-grid tube will not be used in the screened manner. It will be used as a space-charge device. This because as an amplifier its impedance is high and difficult enough to match, 800,000 ohms for the -22 or -32, 300,000 ohms for the -24. As a bias detector, in which form it must be used for efficient 1,500 kc. output, its impedance is way up to—um, blank and gone and so inefficiently matchable that transferring any power through it to the load becomes nearly impossible. As a space-charge detector, however, the impedance is more reasonable and the results consequently more satisfactory.

Now the detector and oscillator work together as a converter of the signal frequency to the amplifying or intermediate frequency. This conversion is accomplished by heterodyning on the part of the oscillator and rectifying, theory says, on the part of the detector. The heterodyning will occur if the oscillator and signal frequencies both impress themselves on or mix themselves in the detector plate current. The signal is impressed on the plate current by being placed on an active grid of the quatriode detector, thus modulating the plate current. The method I have found most satisfactory for mixing in the oscillator current is to place it on the other, and in this case space-charge grid, by means of which it too modulates the detector plate current. Probably the original of this system is the Ultradyne scheme first published in RADIO NEWS and devised by R. E. Lacault, although (Continued on page 462)

# Adapting to

By  
George W. Walker \*

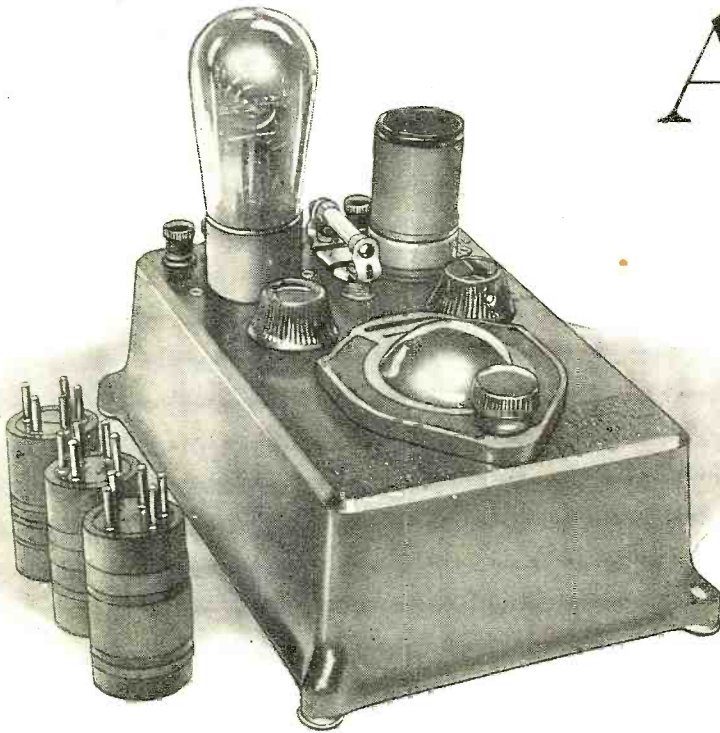

Four coils of the plug-in type covering a wavelength range of from 15 to 550 meters are used with the single-tube short-wave adapter unit illustrated above. Servicemen are finding it to their advantage to recommend the practice of units like this to augment the regular broadcast reception

Simplicity itself. The layout of the tuning condensers and other components of the adapter below the metal chassis is shown to the right

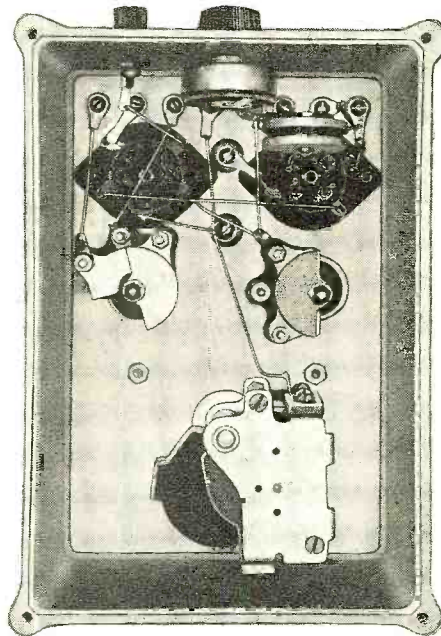

**T**HE reception and transmission of short-wave broadcasting is not at all new, even though it is now the common topic of all conversation among the élite of radiodom. For many years broadcasting on the peculiar but penetrating short waves has been carried on by those who really looked toward the future. Experiments were not only supported by the recognized radio wizards and engineers but much credit must be given to the amateur, who, true to his convictions, prophesied the wonders we now discuss in a casual manner.

It is the belief of the writer that the average radio fan is not so much interested in knowing how the transmission of short-wave signals is accomplished as in how he may benefit from the research and experiments conducted successfully over a number of years. You hear daily of foreign reception by the fortunate fan who possesses a short-wave tuner. You may be amazed to know that so simple a radio device as an inexpensive short-wave adapter, which can be quickly attached to your present receiver, is capable of receiving short-wave transmissions from England, Holland, Germany, Australia, South America—in fact, all parts of the world.

A short-wave adapter is not a magic box, even though it is looked upon with amazement. The only difference between an adapter and a complete short-wave receiver is that the required tuning circuit, or otherwise the heart of the receiver, is assembled in a separate compartment or unit. As the audio circuit in all types of receiver is more or less of standard design, and as the same type speaker and tubes used with the regular broadcast receiver may be utilized, there is no need of any

great additional expense to enjoy short-wave reception with your present receiver. The mere attaching of the adapter to your receiver provides for a change in the tuning band so that the short-wave stations may be heard. Your receiver is not disturbed other than the connection of the antenna wire to the adapter and the removal of a tube for insertion of the plug attached to the adapter. An adapter plug for quick and immediate connection of the unit to your receiver is available in either a.c. or battery type. No other accessories are required.

While the tuning of most short-wave adapters is quite similar, there is a great difference in the results, and it is results that the radio fan expects and demands. The most common circuit used for short-wave reception employs a regenerative detector. This circuit has stood the test of time and the older radio fans will recall what had been accomplished in the past with the single-tube regenerative tuner. Today, it is even more useful. Today there are a number of short-wave kits and adapters on the market to meet the increasing demand for receiving equipment suitable for the reception of short-wave broadcast programs. One such outstanding unit, a unique, yet most practical, radio device called the Flexi-Unit, has been introduced recently. Many years of research and experiment are represented in its development. The performance of this neat and attractive flexible unit has been proved, and because of its

wide applicability to laboratory and experimental work an explanation of its many uses will meet undoubtedly with the approval of the considerate radio fan. Especially will those who take their short-wave tuning seriously confirm this description of an ideal adapter.

Lack of oscillation, excessive oscillation, dead spots, poor regeneration control, body and hand capacity, faulty material and crude assembly are to be avoided in the design of any receiver. This is quite a large order, but it is not impossible. The Flexi-Unit described here is designed to overcome these objections. A brief examination of the unit is sufficient to impress the most critical fan as to the workmanship of assembly and the quality of the material used. Our laboratory experiments satisfy us that the use of a mere sheet-iron shield is hardly better than no shield at all. The result was the selection of an aluminum casting, specially designed for the purpose, with a panel of  $\frac{3}{8}$  inch thickness. Surely a positive prevention of body and hand capacity and insuring complete circuit isolation.

A glance at the circuit charts, showing antenna connection,

\*The Workrite Radio Corp.



# Your Broadcast Receiver Short-Wave Reception

For the beginner just breaking into the short-wave game an elaborate outlay of special short-wave receiving apparatus is not entirely necessary. Adapter units comprising a s-w tuner and detector may be used with existing broadcast receivers of either a.c. or battery-operated type. This article describes the outstanding features of one such unit and, in addition, shows how the experimenter may employ it in other rôles for experimental purposes

readily indicates the variability of oscillation. Note that the antenna can be connected directly to the primary, directly to the grid, through the midget condenser to the primary, or through the midget condenser to the grid. Each of these connections affects the oscillation quality of the circuit. A particular connection is decided upon after you have tried them all and select the one meeting the conditions under which you will operate the unit.

Due to the flexibility of the circuit the unit may be operated with either battery or a.c. receiver, or as an individual single-tube receiver. By removing the grid leak mounted on the top of the panel and shorting the grid condenser with a link furnished for this purpose the unit is ready for use as an extra stage of tuned radio-frequency amplification employing regeneration and possessing the selectivity and volume equal to two or three stages of ordinary tuned radio-frequency amplification.

When connections are made so as to make the unit serve as an r.f. oscillator many valuable uses for the unit will be found; for instance, in checking and calibrating your receiver, or transmitting a signal to determine the sensitivity of the circuit. The radio serviceman and experimenter can rearrange the circuit to meet any of their requirements or new idea. With a calibrated short-wave oscillator it is very simple to chart or log new receivers to determine the exact setting of the dials for wanted stations without the need of "fishing" for them. Also the use of the Flexi-Unit as a short-wave pre-amplifier will prove interesting.

### Plug-in Coils Facilitate Wave-Band Change

To avoid unnecessary losses and insure good electrical contact the plug-in type coil has been selected after considerable tests with various means of changing the coils mechanically. Four plug-in coils wound with silk-covered wire on bakelite forms and designed to cover a waveband of 15 to 500 meters are furnished with each unit. (Continued on page 460)

As an r.f. oscillator the circuit for the adapter unit is arranged as shown directly to the right. At the far right is shown a circuit arrangement employing the adapter as an r.f. amplifier, while above it is shown the circuit of the adapter using it as a straight short-wave detector unit

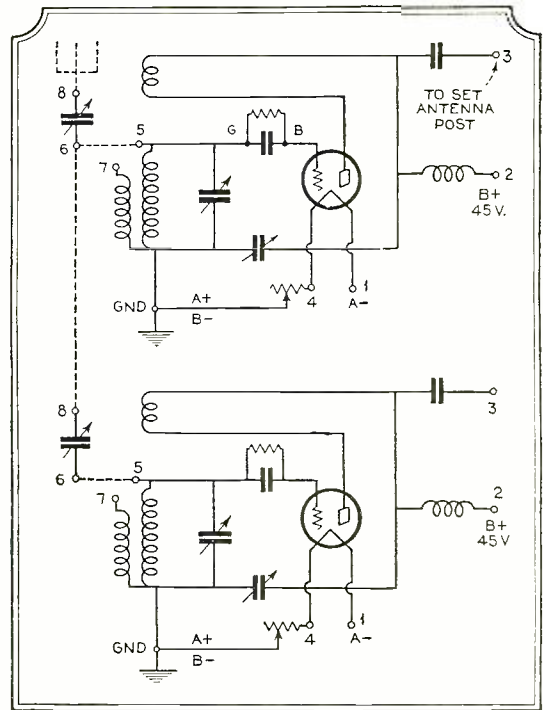

By using two adapter units in the manner shown in the circuit above, a detector-oscillator arrangement is provided, permitting the use of the regular broadcast receiver as an intermediate frequency amplifier for superheterodyne use

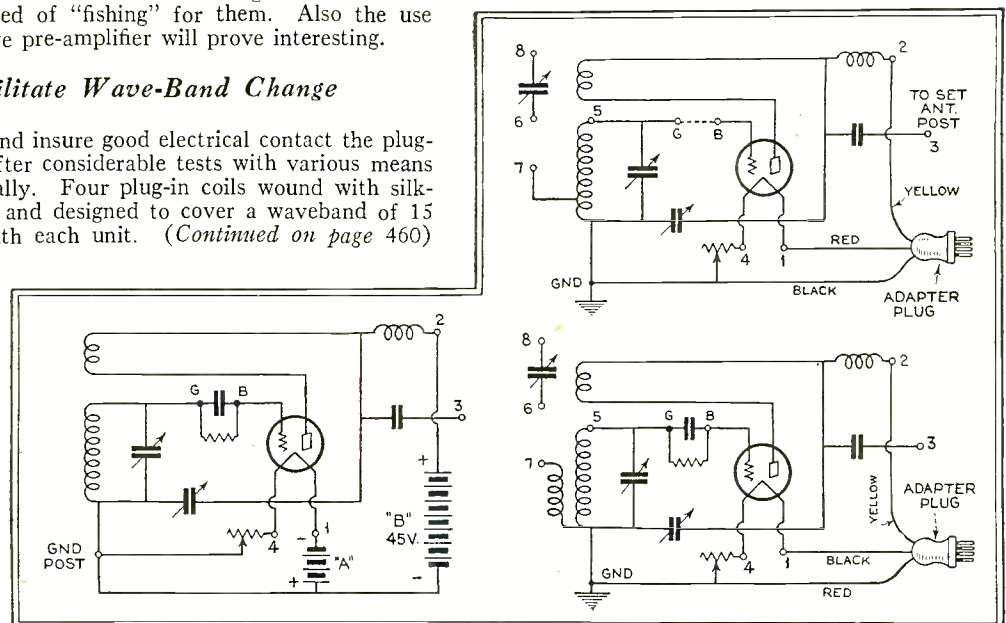

# Controlling Army Pursuit Planes

*The use of radio in airplanes is not new. During the war many observation planes were radio equipped to communicate with ground stations behind the lines in the direction of artillery fire. Commercial planes for safety's sake carry a most elaborate yet compact radio installation. It has not been until recently, however, that the Army Air Corps has employed radio as a means for directing and controlling the movements of a squadron of planes while in flight. The question might well be asked, "Will radio change aerial warfare"? Lieutenant Howard explains how his squadron installed a radio communication system in their planes and describes briefly some of the equipment*

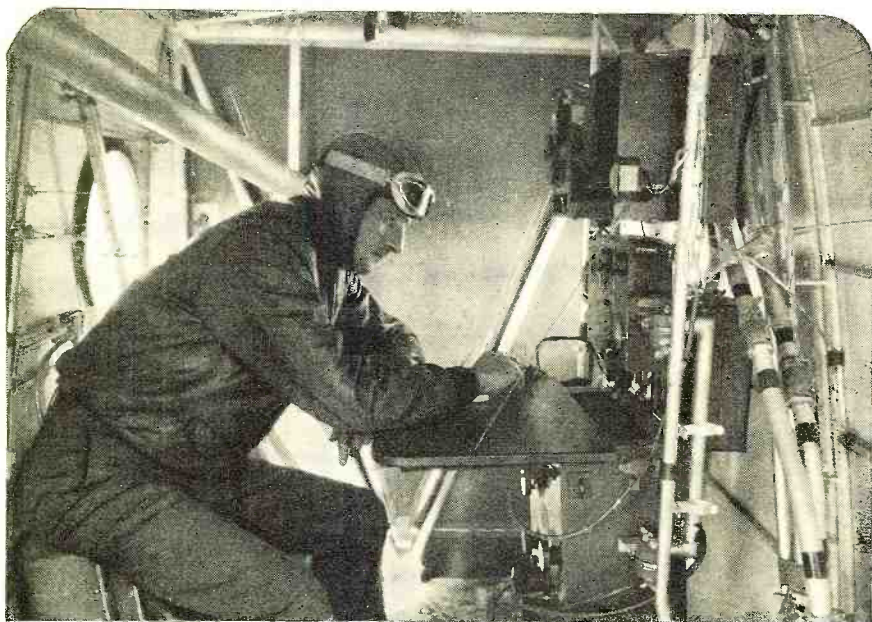

Major Carl S. Spatz, under whose direction the planes of the 95th Pursuit Squadron at Rockwell Field, San Diego, Calif., were equipped with radio. The illustration above shows Major Spatz at the key of one of the transmitters

**W**ILL radio change the modern pursuit pilot from the dashing, daring free-lance of the World War to a soldier of the air, flying, shooting, fighting under a leader who directs his almost every move from a vantage point where he can dispose air forces with the certainty of a commander accustomed to dispose fighting men on the surface of the earth? Will radio lose to us the Guynemeres, Lukes, Bishops and Rickenbackers?

Free of all restraint from the "higher command," those men sought their quarry and earned their glory where they found it.

On the tales of these heroes much of the glamour of the pursuit pilot with his little plane, almost small enough to be part of him and doing his bidding at the slightest movement of the controls, is based.

Radio may change free-lance fighting in the air. With recently developed two-way radio communication the pilot may travel far from his base, but every minute a small voice follows him telling him where to rendezvous, perhaps warning him of an unseen enemy. At times this may be irksome to a pilot, but often a great comfort.

In the World War, when an enemy was sighted and the battle started, soon every man fought for himself. Frequently a pursuit pilot found himself surrounded by enemy planes and entirely separated from his comrades. Now that lack of co-ordination is changed.

Under the direction of Major Carl S. Spatz, commanding

officer of the 7th Bombardment Group, which includes the 95th Pursuit Squadron at Rockwell Field, San Diego, California, steps were taken recently to equip as many as possible of the little Boeing pursuit planes with radio. The command plane of the 95th was provided with a transmitter and receiver and each flight leader with a receiving set only.

Obstacles immediately presented themselves. Not the least of these was the fact that the average pursuit pilot preferred not to be bothered with radio helmets.

Mechanically, the change meant added weight, the addition of trailing wire antenna to the planes, other electrical equipment, vacuum tubes and "gadgets" with which pursuit pilots generally have little patience.

Soon after the war the Signal Corps of the army developed for the air corps a pursuit set known as the SCR 133. This was a voice transmitter using three 5-watt tubes; a master oscillator, a power amplifier and voice modulating tube, operated

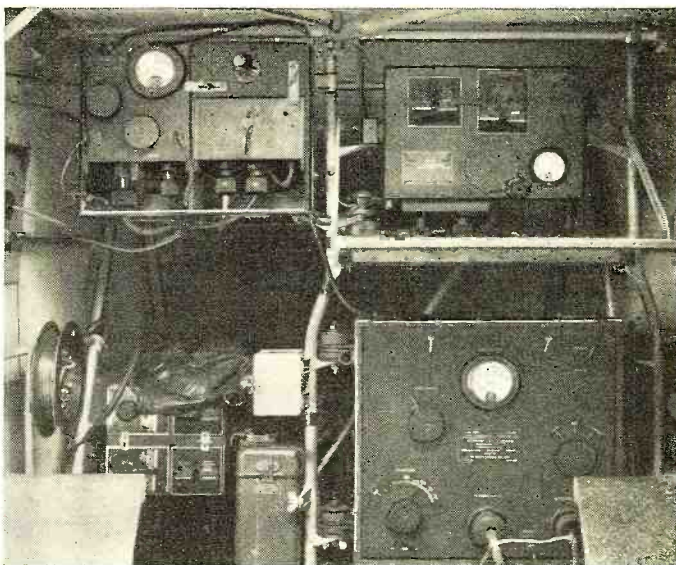

This photograph shows the placement of the various parts which go to make up the complete airplane transmitter and receiver. Note that all of the units are suspended in a frame on shock-absorbing clamps so as to minimize vibration effects which are set up by the planes. Note, too, the antenna reel mounted on one of the metal pieces of the frame of the airplane

# by RADIO

By Lieut. Charles Howard

*11th Bombardment Squadron, Air Corps, U. S. Army*



Lieut. Charles Howard

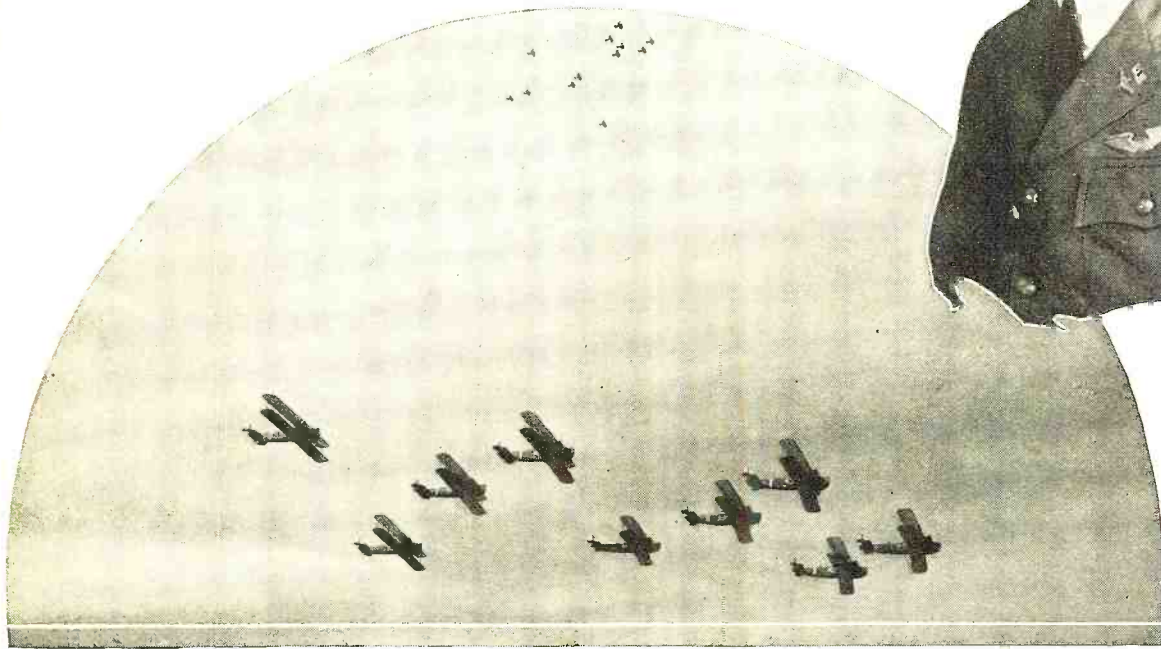

In the foreground is shown a flock of army bombers, while high above for protection is a flock of radio-equipped army pursuit planes

with a plate voltage of 350 furnished by a dynamotor running from a 12-volt storage battery. To keep the battery charged an engine-driven generator with its regulator devices was necessary. All these things made extra weight and were objectionable from that standpoint.

Pursuit pilots for some time on the basis of these objections succeeded in keeping radio out of their planes. This left the subject of the practicability of radio control still a debated question. So without regard to tactical consideration, the SCR 133 was installed in a Boeing pursuit plane. The wavelength range of the set as now installed covers from 200 to 350 meters. For this reason it was not considered advisable to attempt to get enough power into a short fixed antenna to cover the distance range required; therefore a conventional reel and trailing wire antenna were installed on the outside of the fuselage. One hundred twenty-five feet of wire were used for the antenna. In properly disposing of the weight many mechanical and electrical devices had to be created to get the various components of the weight into the small allowable space. When it was finally accomplished it looked like the inside of a "ham's" radio shack, and "ham" like, it worked. And, when one listened on the ground set or broadcast receiver to the pilot flying several thousand feet above, the speech was of excellent quality. When sitting in the cockpit of another plane, however, the wind and ignition noises made all but a few words unintelligible.

### *Only Short Ranges Possible*

Due to low power, it was necessary to run the receiver close to the oscillating point and at this point it was found that the spark-plug interference increased faster than signal strength, therefore only short ranges were possible.

Being something of a ham and consequently a believer in the efficacy of code in putting traffic through and having read signals through this noise in observation planes, it was decided to key the carrier wave, thus transmitting pure CW, i.e., continuous wave. With the key in the transmitter circuit and the

oscillating receiver it was found possible to work much greater distances, and thus, for pilots familiar with the chirp of the CW signal good communication was possible. On the other hand, the very sharpness of the set made it easy to lose the signal due to a small frequency change or a directional change on either transmitting or receiving plane.

### *Buzzer Provides Tone*

For that reason it was decided to broaden the wave by some form of buzzer modulation. The idea of trying out the small tone alternator used on ICW transmission with the observation plane set occurred to us. How to get it into the circuit without too many circuit changes was solved by putting its output leads on a microphone plug and plugging in where the voice "mike" usually went. This gave a beautiful tone readily received and not given to fading on small frequency changes. From this time on, all missions were worked through the use of radio with increasing success.

This small success created added interest on the part of the pilots. Some elementary movements of formation were being handled. To keep pace with the possibilities of radio control a system of abbreviations and code signals for maneuvering was developed under direction of Capt. H. M. Elmendorf, commanding officer of the 95th Pursuit Squadron. This code system reached a high state of evolution and during the Air Corps maneuvers in California during April the radio-equipped pursuit squadron was able to acquit itself to great advantage and to earn the plaudits of both their brother pursuit squadron and the staff.

Not only was contact in the squadron maintained, but also with bombing and attack units over a distance, in one case, of 70 miles.

A word concerning the receiving set used may not be amiss. It is known to the Air Corps as the BC 152 and is a five-tube circuit using a resistance-coupled antenna blocking tube, a tuned radio frequency, oscillating detector and two audio, all in a box



Here are a few of the men under the direct supervision of Lieut. Charles Howard, the author of this article, who were intimately connected with the experimental and installation work of equipping army bombers and pursuit planes with radio. From left to right they are: Lieut. Charles Howard, Commanding Officer of the 11th Bombardment Squadron; Lieut. Ivan Farman, Squadron Communication Officer; Privates Cooper, Berger and Westerman, operators

about two inches by ten inches by fourteen inches in size and with a single tuning control, a regeneration control and a rheostat for the filaments. The set is sharply tuned, especially when near oscillation.

Three sets of plug-in coils enable it to cover a frequency band of 200-1500 kcs. Although formerly used with the trailing wire antenna this has been supplanted for pursuit work by a fixed antenna. A wire was strung from the lead-in on the side of the fuselage to the rear wing strut, to the rudder post and the wing strut on the other side. Not much of an antenna as far as effective height is concerned, but it picks up very well enough signals to cover the required distance ranges, especially where the receiver is used in an oscillating condition. Further equipment no doubt will result in improvements.

The mast type antenna familiar on modern passenger planes will not be possible until the sensitivity of the present receiver is improved. No doubt a new receiver design will enable a very small collector to be used. This of course will necessitate a shielded ignition system.

In this connection it will be remembered that up to date the pursuit airplane receivers have been used with no ignition shielding at all. One need listen only once to realize what a barrage the eighteen spark plugs in a nine-cylinder engine can set up in his ears.

It seems likely the limitation of antenna size may establish the wavelength of pursuit radio, and much work is being done on the higher frequencies and consequently small antenna systems.

While pursuit pilots can receive voice and telegraph, as I explained, the engine noises drown out voice to the point where it generally is unintelligible. Telegraph signals come in clearly to pursuit pilots flying as far distant as 20 miles from the sending set in a bombardment plane. The bombers carry transmitters using 50 watts power. Only the leading plane of the 95th Pursuit Squadron has to date been equipped with a transmitter, a 5-watt instrument.

Our experiments to date indicate the possibilities for more extended use of radio. We have carried on two-way communication between bombers up to date to a distance of 50 miles. Between bombardment planes and the low-power ground station at Rockwell Field two-way communication has been established up to 85 miles. This limiting range has been fixed by the

ground station's low power output. On the other hand, a plane reporting in on prearranged schedule has been heard at Rockwell Field from a point 150 miles distant. While the pursuit sets were designed for only five-mile intercommunication, on several occasions they have given good results up to 10 miles. Los Angeles weather stations have been heard by planes over San Diego, 110 miles distant, and hourly broadcasts of weather reports have been received by army planes at all points on the 500-mile run between San Diego and San Francisco.

Development of the use of radio in combat aviation will advance as rapidly as equipment is perfected. Radio will make possible accurate control of units in flight, between unit and higher commanders also in flight. It will make possible control of units from the ground and of course will be a valuable adjunct in the receipt and transmission of weather and other information while in flight.

In applying radio to pursuit in reality we have adapted existing apparatus which was already well developed, leaving the real difficulty one of added weight, which, to a pursuit plane designed to operate at high altitudes, is of prime importance. It is hoped that with development work now going on we can eliminate much of this weight by using a generator that will supply both high and low voltage, possibly even eliminating the heavy battery. This will do away with apparatus which now constitutes a major portion of the weight charged to the radio installation.

Having installed the set, we found that the antenna problem offered some complications. While I have already mentioned this, possibly brief elaboration will be of interest. Due to the fairly long wavelength—from 200 to 350 meters—it was necessary to have a fairly long antenna, a condition met only by use of a trailing wire. The trailing wire made it necessary to install a reel. Again space was at a premium and the ordinary installation within the cockpit was out of the question. For that reason a bracket was made and the reel fastened outside the cockpit but easily within reach of the pilot's right hand. To make contact from the antenna to the set an insulated fair lead was installed on the trailing edge of the lower wing.

During early tests the pursuit sets operated well, but new problems constantly were encountered. At the outset the tubes

lasted only a short time. We determined the cause to be one of original design in which a voltage of 12 was used in the radio design, while the low-voltage generator was supplying 15. This soon was solved by constructing a resistance to interpose between the generator and battery lines and the dynamotor, thus cutting the voltage at this machine to approximately 12, but still allowing sufficient on the battery line.



Here is one of the army bombers, typical of the class that was equipped with radio

One of our most important problems has been suppression of the ignition noises. Until means of preventing ignition interference are applied it is probable that only dot-and-dash code can be used successfully. It has been found that ignition noises can be suppressed effectively by enclosing every wire carrying high or low tension current in a metallic sheath and connecting this sheath to metal parts of the plane or engine every few inches. This is accomplished by using braided flexible metal mesh. Of course, this is objectionable in that oil and water soak through and sooner or later may cause the spark plugs to miss fire. What is needed is a conduit that in addition to being an ignition shield actually will increase the reliability of the electrical system by keeping out water and oil, thus prolonging the life of cables and making a real saving in maintenance. We are making progress in this direction.

No matter what perfections the future may bring, it should continue to be a source of satisfaction to the 7th Bombardment Group and the 95th Pursuit Squadron to know that it was with service equipment and a will to do, that they developed the possibilities of radio in pursuit, using it so successfully that they out-performed other squadrons and stirred an interest that will have a far-reaching effect in air corps tactics.

# Bringing the I. R. E. Convention to RADIO NEWS Readers

*When some six hundred of the country's most prominent radio engineers gather, as occurred at the recent Institute of Radio Engineers' Convention at Toronto, Ontario, Canada, you may be sure that the technical papers presented represent the cream of current highly technical literature. Realizing that the majority of our readers were not able to attend, yet are interested in a summarization of the technical proceedings, we take this means of presenting a summarized version of each paper delivered*

**S**OME Developments in Broadcast Transmitters, by I. J. Kaar (General Electric Co.) and C. J. Burnside (Westinghouse Electric & Mfg. Co.). This paper described the advances that have been made in transmitter design during the past few years. Besides explaining quite completely the technical characteristics of various transmitters from 100 watts up to 50 kilowatts, the paper showed several curves indicating audio frequency characteristics flat within 2 db. from about 30 cycles up to 10,000 cycles—this means that the fidelity of the modern transmitter is much better than that of any existing radio receiver. To make most efficient use of the power available in the transmitter high modulation must be used and hence we find these modern installations all designed for 100 per cent. (i.e. complete) modulation. Crystal control is almost universally employed and modulation usually takes place in the amplifier tubes preceding the antenna stage. This makes it possible to obtain 100 per cent. modulation without requiring as much power in the modulator bank as would be necessary if the final, or antenna stage were to be modulated.

\* \* \*

*The Rôle of Radio in Growth of International Communication*, by H. H. Buttner (International Tel. & Tel. Co.). A brief summary of the growth of international communication. In 1926 the telephone systems of the United States, Canada and Cuba, representing 64 per cent. of all the telephones in the world, were interconnected. By 1930 transoceanic radio-telephone circuits had increased this total to 84 per cent.—in other words, 84 per cent. of all the telephones are connected with each other by means of wire or radio. This is certainly a record to be proud of.

\* \* \*

*Selectivity, a Simplified Mathematical Treatment with Oscillographic Demonstration*, by B. Def. Bayly (University of Toronto). The paper presented a mathematical treatment of r.f. voltage gain in terms of resonant curves. It discussed the conditions for maximum gain, suggested a new expression, that of rating selectivity in decibels, and described an apparatus by which the selectivity of a receiver may be shown on an oscillograph.

---

**F**ROM August 18th to August 21st the Institute of Radio Engineers held at Toronto, Canada, what proved to be one of their most successful Annual Conventions. This was the fifth yearly meeting and first international gathering of the members of the Institute and it was attended by some 600 prominent radio engineers, a number of whom delivered papers during the technical sessions held in the Crystal Ballroom of the King Edward Hotel.

The technical papers delivered during the various technical meetings covered the entire field of radio communication. All of these meetings were attended by members of the staff of RADIO NEWS and in the following paragraphs we have briefly summarized for our readers some of the important facts brought out at these sessions. Our summary is based largely on the data contained in the papers, copies of which were distributed at the technical sessions. Unfortunately copies of all papers were not available and for this reason a few papers are not described.

---

*Theory and Operation of Tuned Radio-Frequency Coupling Systems*, by H. A. Wheeler and W. A. McDonald (both of the Hazeltine Corporation). An excellent paper, and a noteworthy contribution to the subject of radio-frequency amplifier design. Mathematical expressions and experimental curves applying to a number of different coil designs and coupling systems are given. They show methods of obtaining uniform radio-frequency amplification or means whereby the amplification may be made to vary over the broadcast band in any pre-desired manner. Considerable attention is given to the design of the antenna stage of the broadcast receiver.

\* \* \*

*The RCA Photophone System of Sound Recording and Reproduction for Sound Motion Pictures*, by Alfred N. Goldsmith and M. C. Bat-

sel (vice-president RCA; chief engineer, RCA Photophone, Inc.). Besides discussing the general considerations governing the selection of sound-on-film recording and reproducing apparatus the paper gives a rather detailed description of various parts of such systems. A representative curve of an RCA Photophone amplifier shows a characteristic essentially flat from about 50 cycles up to 6,000 cycles. A curve of a dynamic loud speaker shows it to be down about 10 db. at 100 cycles, up about 10 db. at 2,000 cycles and down about 6 db. at 5,000 cycles—400 cycles being the reference point. The power output of the large amplifiers, used in big theatres, is 200 watts.

\* \* \*

*Low-Frequency Radio Transmission*, by P. A. DeMars, G. W. Kenrick (Tufts College) and G. W. Pickard (RCA-Victor Co.). The paper deals with field intensity measurements at 17.8 kilocycles from the RCA station, WCI, located at Tuckerton, N. J. Curves show the effect on field strength of day and night, magnetic disturbances, magnetic storms, and polarization. Description is given of the apparatus used in making these measurements.

\* \* \*

*The RCA World-Wide Radio Network*, by Arthur A. Isbell (RCA Communications, Inc.). A historical sketch of the growth of the RCA communication system from its birth in 1919 up to the present. The paper (*Continued on page 466*)

# A New Idea in The

By  
Donald Lewis\*

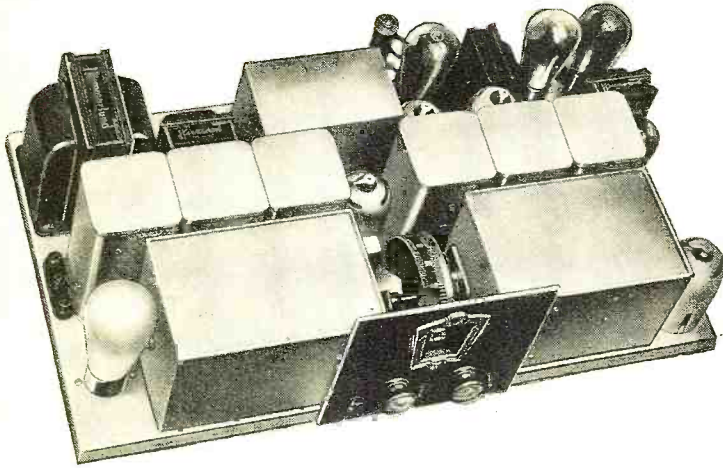

The striking feature of this particular broadcast receiver is the completeness of shielding which is applied to the entire r.f. portion of the circuit. The shielding is extended even to the vacuum tubes, each tube having its own individual shield

Some general idea of the placement of the parts employed in the assembly of the Hi-Q-31 may be gained from the two illustrations shown above and to the right

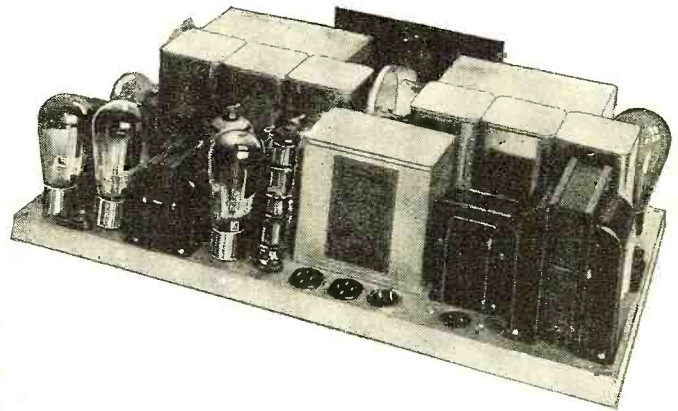

SO far as the radio listener is concerned a receiver is considered good when it is capable of receiving with excellent quality the program from any station to which he desires to listen without interference from other stations. But this means that the receiver must be sensitive enough to go down to the "noise level." The radio-frequency amplifier must be perfectly stable. The set must be easy to tune. The volume must be readily adjustable over the range from maximum to minimum and this adjustment must not be tricky, but must work smoothly and without sudden changes in volume. One station must not be able to "ride in" on the carrier of another station, which in engineering terms means that there must be no cross talk. The set must be selective enough to tune in only the desired station, but this selectivity must *not* be obtained by cutting sidebands which results in the loss of high frequencies that gives the crispness and sparkle so essential if reproduction is to sound natural. The set must be able to produce comparatively large amounts of volume without overloading. There should be no audible hum in the loud speaker and the entire receiver must, of course, be entirely a.c. operated. Such are some of the essential characteristics which a really first-class receiver must have, and these characteristics must be attained over the entire broadcast band. The building of these characteristics into a set is not by any means a simple task. In the following paragraphs we wish to point out how these characteristics have been obtained in the new Hammarlund H-Q 31 receiver, this year's model of a series of receivers which for several years past have been built with much satisfaction by thousands of experimenters and custom set builders.

First let us consider the problems of selectivity and quality, since in certain ways these two characteristics go hand in hand. For as many moons as we can remember engineers have realized that it is difficult to obtain selectivity and good fidelity at the same time. On the one hand we have receivers which may reproduce all the audio-frequency notes in their proper proportion, but which, so far as selectivity is concerned, are as broad as the proverbial barn door. On the other hand, we have receivers which, as the advertisers say, are as sharp as a knife blade, but these receivers, unfortunately, do not re-

produce any of the high frequencies since they are all lost through side-band cutting in the r.f. amplifier.

Modern broadcasting conditions require the use of at least four tuned circuits for selectivity and many of the older receivers using type -27 tubes in the r.f. amplifier contain four tuning condensers. But when the screen-grid tube is used as an r.f. amplifier, we find, even though laboratory tests show good selectivity characteristics, that when placed on the air the set will produce cross talk. This cross talk is due to non-linearity and overloading in the first r.f. amplifier, the screen-grid tube being one which is quite easily overloaded. To prevent cross talk some device must be placed ahead of the screen-grid tube to pass the signal we desire to hear but which will largely suppress all undesired signals so that the r.f. voltages finally reaching the grid of the first tube will not be sufficient to overload it. But if ordinary tuned circuits were to be used for this purpose, side-band cutting resulting in the loss of the essential high frequencies would become serious. For this reason we find that in the Hi-Q 31 that the pre-selector placed ahead of the first r.f. amplifier is a band-pass filter. The band-pass characteristic makes it possible to pass the desired signal and its side bands and at the same time to suppress undesired signals. The band-pass filter therefore eliminates all cross talk in the Hi-Q 31 without introducing the serious disadvantage

of side-band cutting. The circuit indicates the band-pass filter to be of the simple inductively coupled type. Experiment and theory indicate that such filters pass a band at 1,500 kc. which is three times as broad as at 500 kc. Filters coupled capacitively have exactly the opposite characteristics. Actually the filter in the Hi-Q 31 contains combined capacitive and inductive coupling, the capacitive coupling consisting of two small fixed condensers not shown in the circuit diagram. The combination of these two types of coupling in the unit makes it possible to obtain

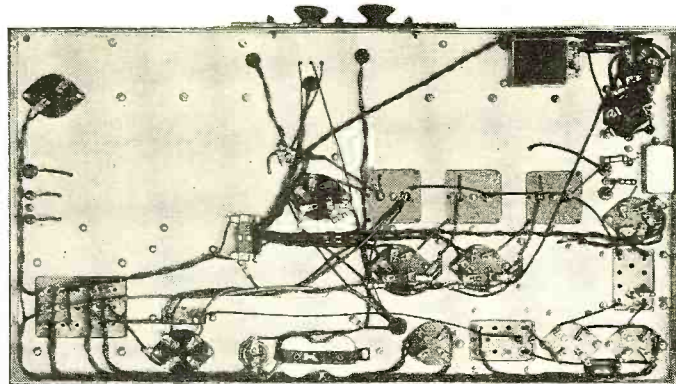

All of the wiring with the exception of the leads from the caps of the screen-grid tubes is accomplished underneath the chassis. Point-to-point wiring is employed, as shown above

\*Hammarlund Mfg. Co.

# Receiver Construction

## Unit-Built Receiver

*This article is the first of a series of three describing the design and constructional details of the 1931 Hi-Q receiver. It consists essentially of a three-circuit pre-selector or band-pass tuner, a three-stage high-gain tuned r.f. amplifier using a.c. screen-grid tubes, a power detector and two stages of audio-frequency amplification. In the audio amplifier resistance coupling is employed in the first stage, while push-pull transformer coupling is used in the final stage. Because of the unit assembly and wiring of this receiver, custom set-builders and servicemen will find the construction and servicing of it quite simple*

essentially uniform band width over the entire broadcast spectrum.

The above discussion serves to indicate why this new receiver has such excellent selectivity. Actually before reaching the detector the signal passes through six tuned circuits, three of them located between the r.f. amplifier tubes and three of them located in the band-pass filter. At the same time side-band cutting in these circuits has been held to a low value.

All of this care to prevent excessive side-band cutting was taken to eliminate the loss of the essential high audio frequencies. It is in this way that the problems of selectivity and quality are tied together. In the remainder of the receiver are to be found special circuits designed to amplify and pass on to the loud speaker all of the audio frequencies from 30 cycles up to a frequency well above the highest note on a piano. In this connection let us analyze the characteristic of the detector and audio amplifier. The first thing to note is the fact that a screen-grid detector is used (because it is about ten times as sensitive as a -27) and the high plate impedance of the screen-grid detector tube necessitates the use of resistance coupling to the following circuits. Reference to the (Continued on page 456)

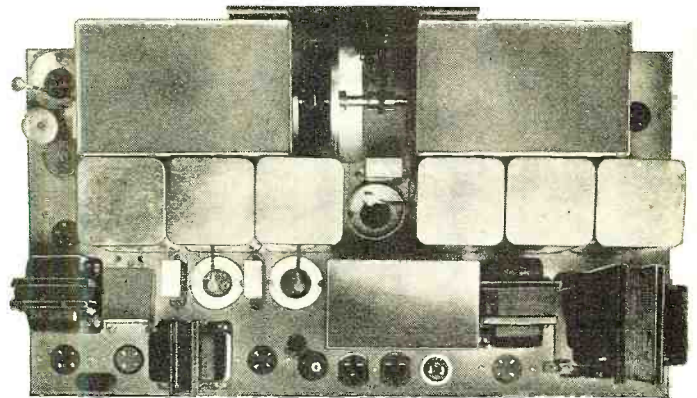

In the two large shield cans at the top are the triple section tuning condenser units. Both units are controlled by a single tuning dial

The circuit employed in the 1931 version of the popular HiQ line of receivers. A three-section pre-selector is followed by a three-stage r.f. amplifier, non-regenerative detector and two-stage audio amplifier with power supply

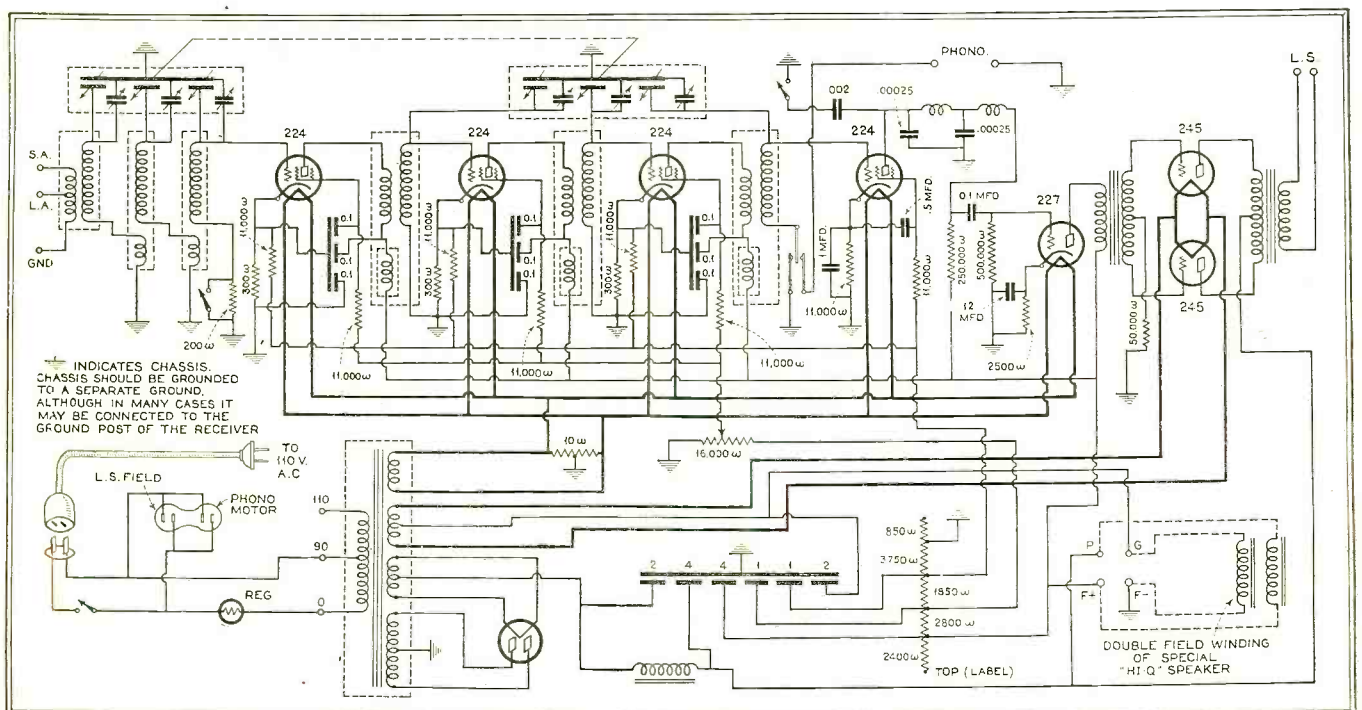

# The Radio Forum

*A Meeting Place for Experimenter, Serviceman  
and Short-Wave Enthusiast*

## The Experimenter

### Adding Filament Secondaries to Power Transformers

I have hit upon a plan to save buying extra transformers for a.c. filament supply. For with the advent of the new a.c. screen-grid tubes, most transformers supplying filament voltage are inadequate to

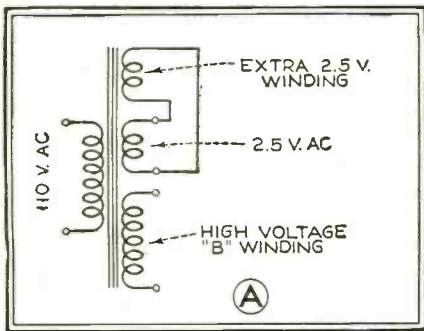

supply the extra number of 2.5 volt tubes. I remedied my case by removing the power transformer from my 5.m.675 power supply and winding five turns of No. 14 d.c.c. wire over the other turns. By connecting the ends in parallel with the usual 2½ volt winding, I found the amperage sufficient for four 2½ volt

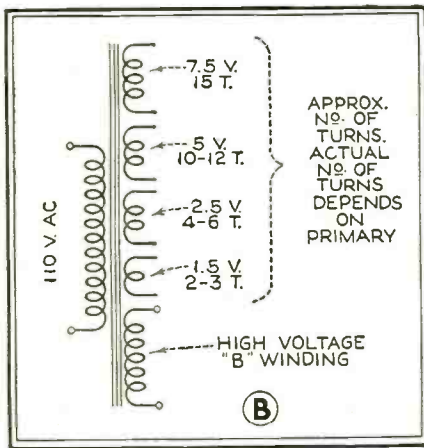

tubes. For six tubes, two windings may be added and connected in parallel like dry cells. Of course, the number of turns to be wound depends on the number in the primary and can be determined only by experiment. Likewise by varying the number of turns any filament voltage can be obtained from transformers supplying

"B" voltages only. Smaller wire may be used for higher voltages.

PHILIP G. HUGHES,  
Birmingham, Ala.

### A Dynamic Speaker (Baffle-Board)

The principle illustrated in the drawing is that of the individual vibration of the separate sections of a one-piece, ¼ inch clear white pine board, to produce in an entirely new way the baffling arrangement of a dynamic speaker. Regardless of the power that the speaker is able to produce this method is superior to any that the writer has ever used. No measurements in inches are given as to the size of the board, etc., for this, as well as the distance from the centre hole of 2

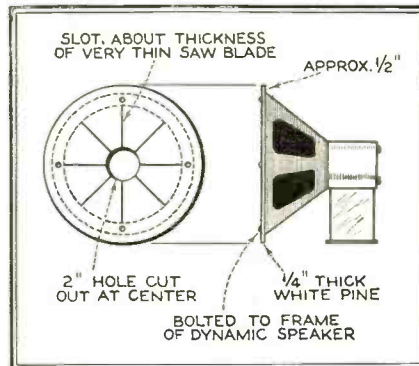

inches diameter to the inside edge of the speaker frame, will depend upon the kind and size of dynamic speaker that it is used upon.

G. A. PICKUP,  
Nashville, Tenn.

### A Coil Winding Device

Here is a handy device for winding coils which can be made with practically no cash outlay.

Make three blocks—soft wood will do—from 1" or ¾" board. Two of the blocks are 1½" high and 4" wide; cut out a semi-circle at top to hold spindle or coil holder, wire this spindle down to blocks by passing wire over spindle and down through base-board. Saw or file grooves in spindle for the wire, this helps to keep spindle in place and acts as a top bearing for spindle. Wire spindle down on the outside of each block, this stops end play.

The third block is about 2½" high, bore a hole for a ¼ bolt in line with centre of spindle and make a short wooden block 1¼" long to fit coil-form. You

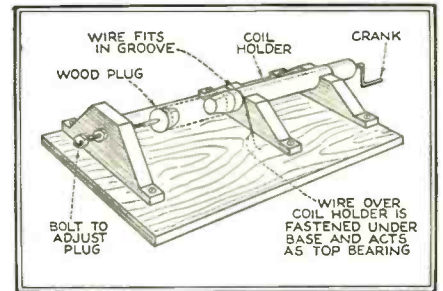

now can slip coil form over spindle and push block in the other end and tighten up bolt. You can wind as fast as you care to turn. Be sure and fasten the blocks down firmly to baseboard.

JOHN F. SPARROW,  
Ashley, Saskatchewan, Canada.

### Duo Volume Control Finds Many Applications

In keeping with present-day practice of utmost simplicity of operation, radio experimenters are finding many uses for the duo volume control clarostat or two variable resistance units in tandem, operated by a single control. Heretofore, such devices have been limited to set manufacturers, but now they are being made available to radio experimenters and home set builders.

Any desired combination of resistance values from 100 ohms to 50,000 ohms may be obtained in the duo volume control, for controlling various circuits simultaneously. One resistance may be decreased while another is increased, or the two resistances may be increased or decreased together.

Among the uses for the duo volume control are such combined functions as antenna and C-bias control; microphone mixer control; varying the screen-grid potential and C-bias; shunting the antenna-ground circuit and varying screen-grid potential; shunting the antenna-ground circuit and varying C-bias; shunting antenna-ground circuit and shunting the secondary of the first audio transformer; maintaining constant impedance in multiple speaker circuits; and series resistance to match speaker impedance.

CHARLES GOLENPAUL,  
Brooklyn, N. Y.



# The Serviceman

## Connection of Loud Speakers

The accompanying sketch shows how two burnt-out tube bases (UX) and a socket to correspond may be used to change the connection of two speakers from series to parallel, and vice versa.

The upper sketch shows the speaker connections to the socket—AA from one speaker and BB from the other. The only alteration necessary in the socket is a slight enlargement of the holes so that the larger (filament) plug of the tube base can easily slip through to the contact spring. Lower left (1) shows the arrangement of the plug connections; any two adjacent pins are shorted and the two wires from the output slipped in and soldered to one of the "shorted" pins

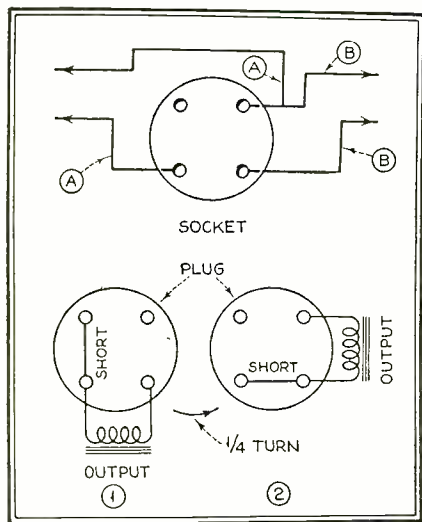

and to the next following. This arrangement may be made a permanent connection or the two wires left free to connect the output leads by clips. When the plug is inserted into the socket in position (1) the speakers are connected in series. Now remove the plug and give a quarter turn and reinsert. The connection is now parallel.

The two speakers in use are situated in different rooms, one about ten feet from the set, the other about forty feet (actual length of wires) away in another cabinet. For individual control each speaker is by-passed with a high resistance. When the two are in parallel, of course, either resistance controls both. No ill affects are apparent from the by-passing of higher frequencies—in fact, there is just sufficient in the case in point to improve the effect of the more distant speaker.

The socket will be mounted to suit the convenience and desires of the individual.

Speakers should be of equal or nearly equal impedances for this arrangement. I find little or no difference in quality when the change over is made. The parallel connection with one speaker shorted is best to give full volume when reception is weak.

A quarter turn to the left from the first position will put one of the speakers in circuit (A in the diagram) but this is not important, as either may be shorted out by the resistance when reception is not desired by the occupants of the room in question.

D. HOYLE,  
Coleman, Alberta, Canada.

## Adding "Pep" to Commercial Receivers

I live in a section of the country where we have no local stations, and where the powerful stations from all sections come in with about equal strength, so you see that I am confronted with two problems; one, that of little daylight reception, and the other interference between eastern and western stations transmitting on the same frequency at night. The latter, I am afraid, there is no satisfactory remedy for, but I have been able to improve daylight reception to some extent.

Many, or practically all, of our present day sets are of the single dial type. Ordinarily there is one stage of untuned radio frequency ahead of the tuned stages. I reasoned that if this untuned stage could be kept in phase at all times with the tuned stages, the efficiency of the set could be considerably increased, and daylight reception improved, as well as increasing the selectivity at night. Of course, in order to do this you have to make a two-control receiver out of it, but not many people will object to that if it gives them the desired results.

The most satisfactory way I have found to tune this stage is by means of a variable condenser of suitable size connected across the aerial and ground, or in series with either of them. The most satisfactory method can be determined by trial. I have found that by this means I can tune in daylight stations that otherwise could not be reached. The style of mounting this extra tuner can be varied to suit the conditions and the set for which it is designed. It will probably be easier to sell this device to your customer if it is put up in a neat little box as small as can be reasonably used and mounted on a panel. Some of the wooden cabinets will lend themselves to mounting on the lid or the end of the cabinet. In some cases room can be found on the panel to mount it.

GORDON E. LOCKERD,  
Portales, New Mexico.

## A Green Eye Shade for Escutcheon Plate

Having mounted two Hammarlund drum dials in an a.c. superheterodyne it was found that due to the near white color of the translucent scale and the brightness of the a.c. dial lamps, gazing at the scale when tuning the set was hard on the eyes.

This was very nicely remedied by glueing a piece of green celluloid to the back of the escutcheon plate and over the opening through which the scale is viewed when tuning. The celluloid should be of a light green color about half as deep as the celluloid used in eye shades and may be purchased at any store selling engineers' and artists' supplies.

The celluloid is secured with glue (I used John Collins' transparent glue, which may be purchased in small tubes at the stationery counter in the five and ten cent store), which is applied around the opening and in the center of the adjacent flat surface. Cut celluloid somewhat oversize and lay on top of glue, gently stretching it to prevent wrinkles. When

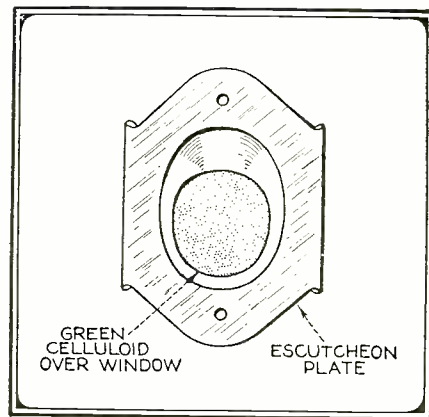

glue has dried trim off excess celluloid with a razor blade. Do not place glue too near edge of opening, as it will squeeze out when stretching the celluloid and show in opening.

In addition to making tuning more comfortable the green color blends well with the cabinet and one will be surprised how much dust it will keep from the face of the drum.

GEORGE F. SCHREIBER,  
Pittsburgh, Pa.

## Special Tool Makes Neutralizing Easy

I have been called upon to neutralize many receivers having neutralizing condensers which have an adjustment which consists of a threaded stud with a threaded sleeve screwed on it. This sleeve has a slot in the top, but as the threaded stud comes above the sleeve, in most cases, it cannot be adjusted with an ordinary screw-driver.

I made a simple instrument to adjust these condensers by filing a slot in the blade of a screw-driver. The screw-driver should be one having a blade about 3/8" wide and should have a large wooden handle to insulate the hand from the condenser being adjusted. The slot should be about 1/8" wide and about 1" deep.

RALPH MELLON,  
Pottstown, Pa.

# With the Short-Wave Fans

## Improving the Short-Wave Receiver

By Berthold Sheffield

**M**ANY experiments have shown that for good all around S-W reception (15-100) meters, a single wire, 60 foot long, antenna gives excellent results. Shorter lengths down to 20 feet, strung up in a room or outside, gave astoundingly strong signals. Stranded enameled copper wire is preferable from plain copper wire. The soot and dirt which collect on an average city antenna act as high resistance paths for the feeble currents in the antenna, and

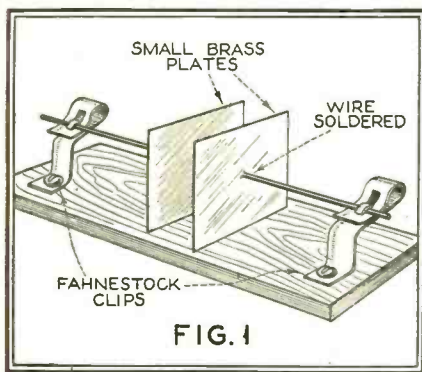

per (penny) or brass plates, about 1/2 inch square, can be utilized as antenna condensers, by providing a suitable mounting for their separation (Fig. 1). The condenser is connected as in Fig. 2. If a variable midget is employed, be sure to connect the stator side to the antenna. Otherwise you will experience considerable body capacity while adjusting.

There are at present many good coils on the market. Also RADIO NEWS has given many coil specifications for the home builder in earlier issues. Still, I might say that coils, whose diameter to length ratio is about as 1 is to 2 1/2, are very efficient for S-W reception. Tube bases also make satisfactory coil forms. Dope is often employed successfully, but more often "doped" coils show high losses. Very rigid inductances can be constructed by heating the copper wire so that it can be wound on rigidly without burning one's paws! The contracting wire, if properly

consequently cut down the signal strength considerably. The enamel, however, protects the wire from the elements, tho it does not hinder the passage of r.f. current. One good glass insulator at each end of the antenna is sufficient.

The lead-in should be taken from one end of the antenna. It is important that both antenna and lead-in are well separated from all obstructions, either by proper spacing or else by insulators.

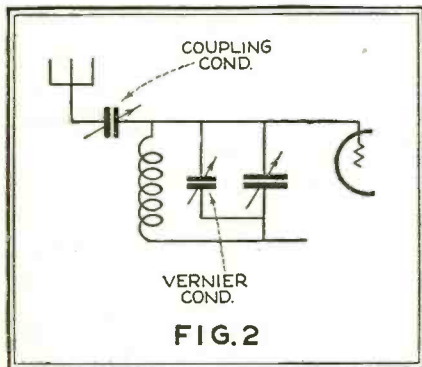

A ground is not always necessary in S-W work. If it is found, however, that body-capacity is overcome by its use, it may take the conventional form of an electrically and mechanically solid ground connection to a waterpipe, or equivalent.

Although it has not been definitely proven advantageous, capacitive coupling (electrostatic) to the secondary circuits has been found to give stronger signals than magnetic coupling. A small variable midget condenser of anywhere from 5 to 15 mmfds. will do the trick. Two cop-

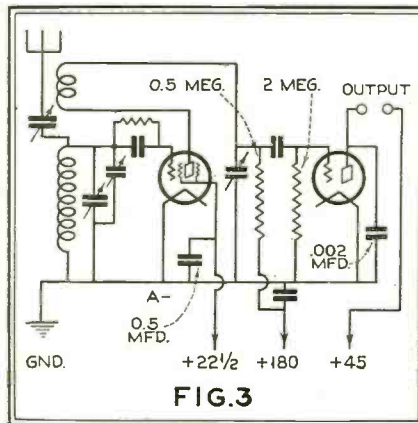

fastened at both ends of the form, will tighten and remain so, unless the coil is subject to excessively high temperatures. The coils should be convenient to handle, so as to facilitate changing from one band to the other.

The grid condenser may be .0001 or .00025 mfd. Its value materially influences the "suddenness" of regeneration. If your receiver goes into oscillation with too sudden a "plop," outside of experimenting with the size of your tickler coil, increase the value of your grid condenser. Although grid-leaks as high as nine megohms are very satisfactory for long DX code reception, for S-W broadcast 4 or 5 megs give good results, with less of that sudden "plop" tendency of going into oscillation.

The choice of a good tuning condenser (about 140 mmfds.) for short waves is a very much overlooked factor. The plates of the condenser should be rugged and well spaced. One manufacturer has especially good condensers with double spaced plates and a rotating radius of 270° instead of the usual 180°.

The vernier dial must have a very

smooth mechanism. A noisy dial with backlash is taboo on short waves. The turning ratio should be at least 6 to 1, and preferably higher. There are dials available whose transformation ratio is very easily changed from 6 to 1 to any ratio up to and including 20 to 1. Such dials are highly desirable for the DX fisher, at the same time making the receiver attractive in appearance.

A variable midget condenser (3-5 plates) shunted across the large main tuning condenser, by connecting stators and rotors of these two elements together, and fitted with a good vernier dial is very effective, especially when listening to a

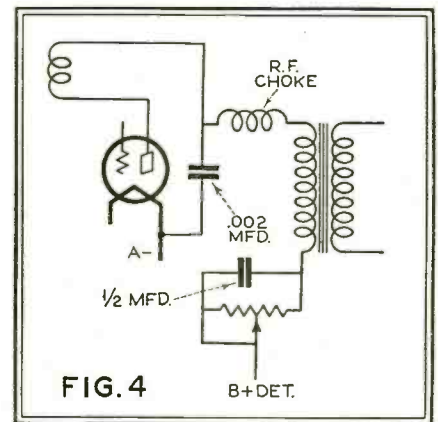

particularly weak broadcast signal, where sharpness of tuning is essential. Care must be taken to keep all wiring as short as possible. (This applies to all r.f. and detector wiring.) The ENTIRE grid lead should be no longer than 4 inches. The grid condenser should be mounted as near and as rigidly as possible to the detector tube socket.

The -01A type and -12A type of tubes

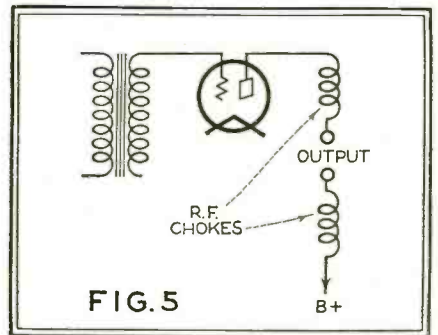

are very good and quiet detectors. The -22 and -24 are excellent as such, though it takes quite some time to get onto their individual tricks. If the screen grid variety of detector is used, the following a.f. stage must be resistance coupled, to match the high plate output impedance. Fig. 3 shows a tried and good hook-up for the -22 (or -24) as detector. The screen-grid voltage should be about one third of the plate voltage.

Both the -27 and the -24 type of a.c. tubes have been satisfactorily used with  
(Continued on page 453)

# RADIO NEWS INFORMATION SHEETS

By Elmore B. Lyford

## The Neon Tube Oscillator

Index No. R-351

**V**ERY few experimenters are familiar with the fact that an audio oscillator which is perfectly good for many testing purposes may be built at a cost of less than a dollar, and made without the use of a vacuum tube at all. It is the purpose of this Information Sheet to describe such an oscillator, which is very handy for many tests of loud speakers, audio amplifiers, etc.

As may be seen from the accompanying diagram, the oscillator consists of nothing but a neon "glow lamp," a variable high resistance, a condenser, an old audio transformer and some B batteries. The neon glow lamp should be one of the small round type, mounted on an electric lamp screw base, and procurable in almost any radio store for about fifty cents.

The action of the oscillator is as follows: the battery slowly charges the condenser C, its current flow limited by the resistance R, until the voltage across the condenser becomes higher than the breakdown voltage of the neon lamp. When this occurs, there will be a glow discharge within the lamp which discharges the condenser, and the cycle starts over again. The sudden pulse of current of the condenser discharge passes through the primary T, and causes a similar pulse in the secondary.

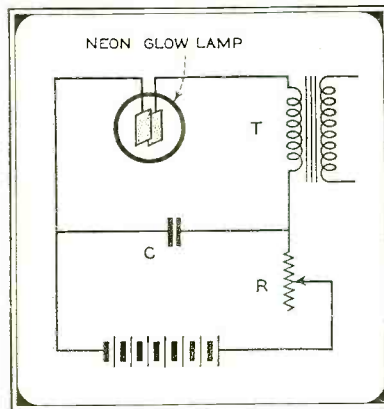

The frequency with which these pulses occur—the frequency of the oscillator—is determined by the size of the condenser and by the resistance. The larger either of them is, the more slowly will the oscillations occur.

The battery voltage used must be a few volts higher than the voltage rating of the neon lamp, which will generally be around 125 volts. If the battery voltage is too high, the lamp will glow continuously, and if it is too low the lamp will be inoperative. This voltage is quite critical, and needs adjustment to within two or three volts.

The resistance should be high—from 100,000 ohms to one megohm, and should be continuously variable. The condenser may be any size at all, from one microfarad for very slow oscillations down to almost nothing for high audio frequencies.

Another place in which an oscillator of this nature is of value is in oscilloscope work, for the wave form is practically triangular in shape. That is to say, that the current rises abruptly to maximum, and falls as abruptly to minimum, so that the peaks are sharply angular instead of the rounded hump found at the peak of the wave form of other oscillating circuits using inductance and capacity as the timing factors.

# RADIO NEWS INFORMATION SHEETS

By Elmore B. Lyford

## Piezo-Electric Crystals—(Part I.)

Index No. 537.65

**P**IEZO-ELECTRICITY is the name given to the electric field which is generated in some natural crystals when they are deformed or compressed in certain directions. Slabs cut from these crystals, when compressed, show a measurable difference of potential between their two sides. The crystals which are most active in this respect are those of Rochelle salt, tourmaline, and quartz.

The reverse effect also holds true with these crystals—when they are placed in an electric field they expand in one direction and contract in the other. This *converse* effect, as it is called, is the one which finds such great application in the field of radio transmission.

Quartz is much less active piezo-electrically than are many other crystals, but because of its unrivaled mechanical properties, it is the crystal which is almost universally used. When such a crystal is placed in an alternating electric field, it alternately expands and contracts, following the changes of the impressed field. If the alternations occur at the frequency which is the natural period of the crystal, these expansions and contractions become very strong—often great enough to crack or break the quartz plate, unless the power is carefully limited.

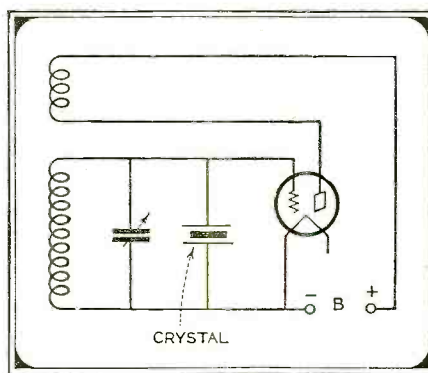

The crystal naturally wishes to vibrate at its natural period or at some harmonic of it, and if coupled to a tuned circuit, tries to keep the tuned circuit at this frequency. By selecting a crystal plate of the right characteristics, and coupling it to a similarly tuned circuit of a tube, as shown in the diagram, the oscillations generated by the tube may be kept constant to within a small fraction of a kilocycle—often to within one one-hundredth of one per cent.

This is much closer than is possible to hold the frequency of an oscillating circuit by any other means. Since the crystal is the controlling

factor and its frequency is determined by size, the frequency cannot vary.

Since the elasticity of quartz is practically constant, the natural period of any vibrating plate is roughly proportioned to its thickness—the greater this is, the lower will be the frequency at which the crystal will resonate. For vibrations in this "longitudinal mode" as it is called, the natural period of quartz plates is very close to 110 meters per millimeter of thickness. The plates used for frequency control in broadcast stations, therefore, range from about 2.0 to 5.0 millimeters in thickness, and are generally about an inch square in their other two dimensions.

# RADIO NEWS INFORMATION SHEETS

By Elmore B. Lyford

## Band Pass Circuits

Index No. R-141.2

**T**HE wave sent out by a broadcast transmitting station consists of a radio frequency "carrier wave," modulated by an audio frequency wave which represents the voice or music being transmitted. The carrier wave is of a single frequency only, but when modulated it consists of this frequency and many others nearly the same, both above and below the carrier frequency. These modulated waves are the ones we desire to receive.

In general they are thought of as occupying a band of about five thousand cycles each side of the carrier frequency, or a total band of ten kilocycles. We wish to receive all of this band equally well, but nothing outside, for if we go outside we may get into the band of the station on the next channel, and experience interference.

The solid line of Fig. 1 shows the tuning curve of an average good tuned circuit, and the dotted line shows the shape we should like it to have in order to receive the whole band equally well. It may be easily seen that there is quite a difference in shape between the real and the ideal curves.

Fig. 2 shows how the "band pass" idea may be applied

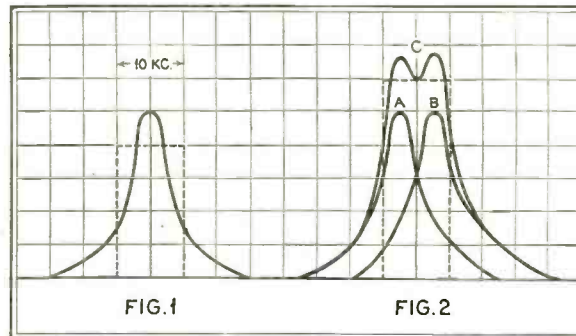

to overcome this difficulty. Here we have two tuned circuits, A and B, each one having by itself a curve similar in shape to the curve of the tuned circuit of Fig. 1. These two circuits are not, however, tuned to exactly the same frequency, nor is either of them tuned exactly to the frequency which it is desired to receive. One circuit is tuned a few kilocycles higher and the other a corresponding amount below, so that the difference between them is about five kilocycles.

With an arrangement like this, the signal band which finally passes through the combination may be determined by adding curves A and B, and is represented by curve C. Comparison with the ideal curve, represented by the dotted line, shows that the combination is practically perfect.

These desirable features can be realized in practice by individually tuning two circuits, one to a point slightly above the resonance point of the frequency to be received, and the other to a point slightly below. The two circuits may then be coupled together by placing them in proximity to each other, the coupling being accomplished by their mutual inductance.

# RADIO NEWS INFORMATION SHEETS

By Elmore B. Lyford

## Condenser Microphones

Index No. R-385.5

**T**HE condenser microphone operates on an entirely different principle than does the carbon microphone, described in these Information Sheets last month. The condenser microphone is a much more recent invention than its carbon relative, and possesses certain advantages which have caused it to supersede the older type in nearly all broadcasting use.

A condenser microphone consists in its essentials of nothing but two metal plates. One is a flat brass disc, called the "back plate," and the other is an extremely thin, tightly stretched circular sheet of duraluminum, called the diaphragm. This diaphragm is spaced .001 to .002 inches from the back plate, and well insulated from it.

These two plates together form a small condenser, from which the microphone derives its name. Sound waves striking the diaphragm cause it to move slightly toward or from the back plate, and thus vary slightly the capacity of this condenser. All the other parts of the completed microphone are either for insulation, support or protection of these two condenser plates.

In use, the condenser microphone is normally "polarized" by having 180 volts connected across it. See accom-

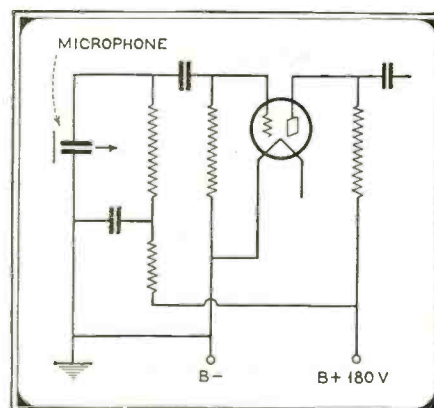

panying diagram. Any change in capacity, caused by sound waves, means a tiny flow of changing current into and out of the condenser. This current must flow through the resistance R, thus setting up a voltage across it. This voltage, which represents the sound, is applied to the grid of the first amplifying tube the same as in any other resistance-coupled amplifier.

Since the capacity of the condenser transmitter is very small, the capacity between the leads from it to the grid of the first amplifying tube must also be kept very small. It is general practice, therefore, to build the transmitter and the first stage or two of amplification as a unit. Western Electric builds one stage only into its "microphone amplifier"—the R. C. A. builds two, the second one being push-pull.

The signal available from the condenser microphone is very small, so little, in fact, that two stages of amplification are usually required to bring the signal level up to that of a carbon grain microphone. However, absence of the usual hiss that is so objectional in the carbon type of microphone, much better frequency characteristics, and ruggedness make the condenser "mike" the preferable of the two types.

# RADIO NEEDS YOU!

## ...and YOU Need Radio!

Many opportunities for service men, mechanics, radio operators for ship, shore and broadcast stations

**M**ANUFACTURERS and broadcast-  
ing stations are seeking trained  
RCA Institutes men. Millions of sets  
need servicing... thousands of ships  
require experienced operators...  
Never before was there an opportunity  
like this.

### The Only Radio Course Sponsored by Radio Corporation of America

RCA Institutes (A Division of Radio  
Corporation of America) conducts  
courses in every branch of Radio and  
assists graduates in obtaining employ-  
ment. Why wait another day... See for  
yourself what Radio will do for you...

Study Radio under the direction of RCA  
... the organization that sets the stand-  
ards for the entire radio industry...  
Study under the direction of RCA ex-  
perts... Learn the "why" as well as  
the "how" of radio problems... by act-  
ual experience with the remarkable  
outlay of apparatus given to every  
student.

### Graduates of RCA Institutes Find It Easier to Get Good Jobs

Students of RCA Institutes get first-  
hand knowledge, get it quickly and



Radio Inspectors  
\$2000 to \$4500  
a Year

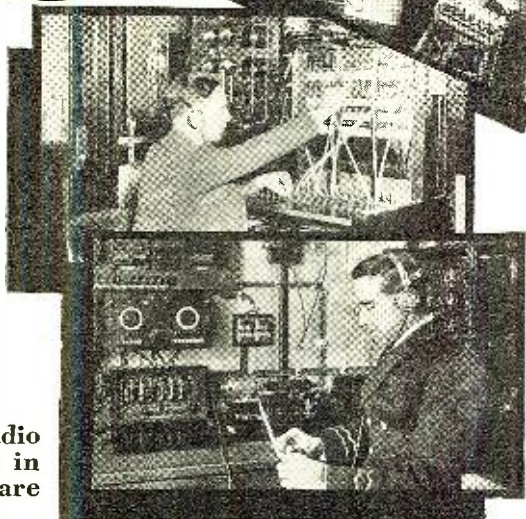

Radio Broadcast  
Mechanics  
\$1800 to \$4800  
a Year

Radio  
Operators  
\$90 to \$200  
a Month  
(Board Free)

### Study Radio at Home in your Spare Time

Increase your earning capac-  
ity by learning Radio under  
the direction of RCA experts.

Ask about amazing outfit of  
special radio equipment sup-  
plied to every student of the  
RCA Home Laboratory Training  
Course.

See for yourself how you too  
can tune-in on success by  
studying Radio in your spare  
time.

### Study Radio

by taking Radio Study Course  
at any of these RCA Institutes  
resident schools (classroom  
instructions)... RCA ex-  
perts instruct you in every  
phase of radio... The man  
who trains TODAY will hold  
down the big-money job of  
the future.

RCA Institute resident  
schools that give classroom  
instructions are located in  
the following cities:

- New York  
75 Varick Street
- Boston, Mass.  
899 Boylston Street
- Philadelphia, Pa.  
1211 Chestnut Street
- Baltimore, Md.  
1215 N. Charles Street
- Newark, N. J.  
560 Broad Street
- Chicago, Ill.  
222 North Bank Drive

get it complete. Success in Radio de-  
pends upon training and that's the  
training you get with RCA Institutes.  
That's why every graduate of RCA  
Institutes who desired a position has  
been able to get one... usually in  
from three to ten days after gradu-  
ation. That's why trained graduates  
are always in demand!

### Send for

### FREE BOOK

...Or step in at any of our resident  
schools and see for yourself how you  
too can quickly place yourself upon the  
road to success in Radio... how you can  
speed up your earning capacity...  
earn more money than you have ever  
earned before. Come in and get our  
FREE BOOK or send for it by mail.  
Everything you want to know about  
Radio. 40 fascinating pages packed  
with pictures and descriptions of the  
many opportunities in this fastest  
growing industry of today.

**Send for Free Book Today!**

# RCA INSTITUTES INC.

A Division of Radio Corporation of America

RCA INSTITUTES, Inc.  
Dept, Exp 11, 75 Varick Street, New York

Gentlemen: Please send me your FREE 40-page book  
which illustrates the opportunities in Radio and de-  
scribes your home laboratory methods of instruction.

Name.....

Address.....

Occupation.....



# The Junior RADIO Guild



## LESSON NUMBER FOURTEEN

### Analyzing Receiver Circuits

**W**HILE outdated and outmoded at the present time, some the various tuning circuits that have enjoyed popularity in the past are still of interest to the experimenter of today. Principles do not change in scientific fields, and the very complicated receivers of today are logical outgrowths of the less complicated systems the old-timers used yesterday. If we are to grasp the full details of the tuning systems used, we must go back to the basic.

Fig. 1 shows the simplest form of tuning device, a "one slide tuner." This was a coil of wire, sometimes hundreds of turns, wound on a form in a continuous coil. Along one side of the coil the insulation was removed from the wire to make a path half an inch or so wide. A slider was arranged to slide along this path, making contact with each turn of wire. Thus we had a variable inductance. This was not purely "inductive tuning," for the coil had the capacity of the antenna in shunt with it, as well as its own distributed capacity. When the capacitive reactance of the circuit equalled the inductive reactance, at a given frequency, the circuit "peaked" at that frequency. In other words, the overall reactance was very high at the frequency to which the circuit was tuned, and comparatively low at other frequencies. As a matter of fact, in explaining the tuning action of this simple circuit, we have given you the

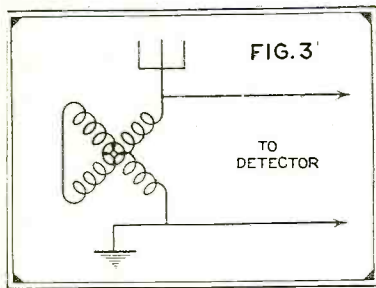

basic law governing all tuning circuits. Not always was the wire wound on a "rolling pin." The coil took as many different characters as Lon Chaney at his best. One other form was the "spider web" coil where the wire was wound on a form not unlike the spokes of a wheel, and tapped at, say, every ten turns, the tap being brought to a switch. Another switch would, perhaps, make connection with each turn for ten turns, so that proper manipulation of the two switches would enable the operator to select any number of turns.

We also had two and three slide tuners, but they were simply complications of the one slide variety.

Then the loose coupler made its advent (Fig. 2). Every fan of that day had one, or more of these, and some of them were wonderful to behold. We worried little about efficiency in those days, and the writer had a loose coupler with the larger coil 18 inches in diameter, wound with about three thousand turns of wire! The idea was to cover all the bands with one tuning unit. It did, and then some.

The loose coupler, mechanically, consisted of two coils, so arranged that one could slide back and forth

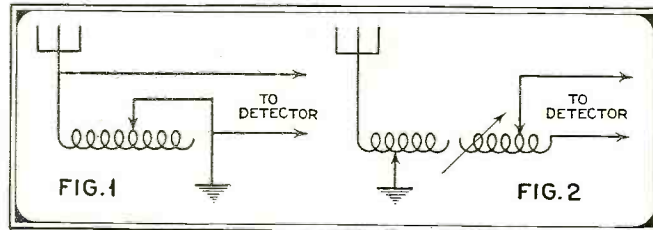

inside the other coil, and thus vary the coupling. Each coil had a slider or taps, so that it could be individually tuned, thus giving two tuned circuits, which was quite a help in obtaining the selectivity needed to separate the two spark transmitters in a radius of a hundred miles or so that might be in operation

simultaneously. The variometer (Fig. 3), operated in a similar manner to the one slide tuner, in that it was a variable inductance. Two coils of wire were so arranged that one might revolve inside the other. If the rotor coil was so tuned that the windings bucked each other, the inductance of the unit was small. Reversing the rotor would so place the coils that they assisted each other, in which case the inductance was large. Any point between the two extremes adjusted the inductance in proportion. Along with the incidental capacity in the circuit, tuning was accomplished. This device, too, had its variations such as the "D" coils, etc.

Aperiodic coupling to the antenna was the next step. Here we see in Fig. 4, the antenna circuit is not tuned, but is a simple coil in inductive relation to a secondary coil that is tuned by a variable condenser. Here we have two departures. In the secondary we have fixed inductance and variable capacity, which is just the reverse of the systems previously discussed.

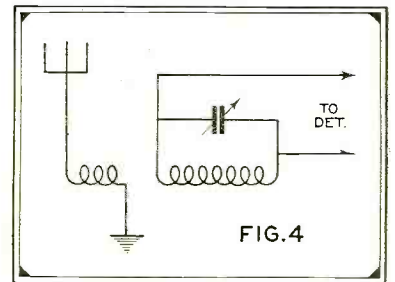

The discovery of regenerative circuits was undoubtedly one of the greatest steps forward in the march of progress. Almost overnight, reception ranges jumped from a hundred miles or so to a couple of thousand miles. However, the system had drawbacks that eventually spelled its doom. When regeneration was carried too far, the tube "spilled over," and the system became the nicest little transmitter one could wish. The air was filled with squeals and howls until one thought that one had at last tuned in Hades and was listening to the wails of the lost souls. Nevertheless, we would never have known radio as it is today without this step.

By studying the circuit (Fig. 5), we see a coil in the plate circuit of the tube coupled back to the grid circuit. In detecting the signal, a tube does not suppress all of the radio frequency, and there is an appreciable amount of radio frequency present in the plate circuit. If this is fed back to the grid circuit in proper phase relation, the two become additive, and the r.f. is again applied to the grid of the tube for further amplification. If this is carried too far, the tube will "oscillate," with the results outlined above.

This circuit literally had thousands of variations, (Cont'd on page 438)

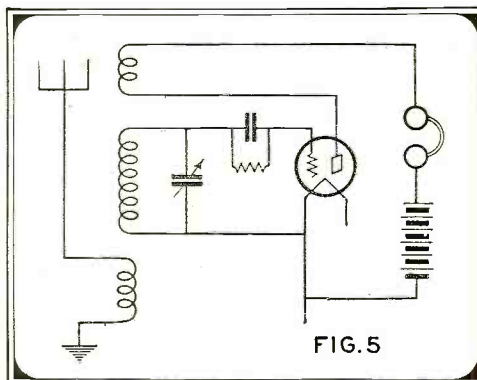

# » TUBES HAVE A DIRECT BEARING ON RADIO SERVICE AND COSTS

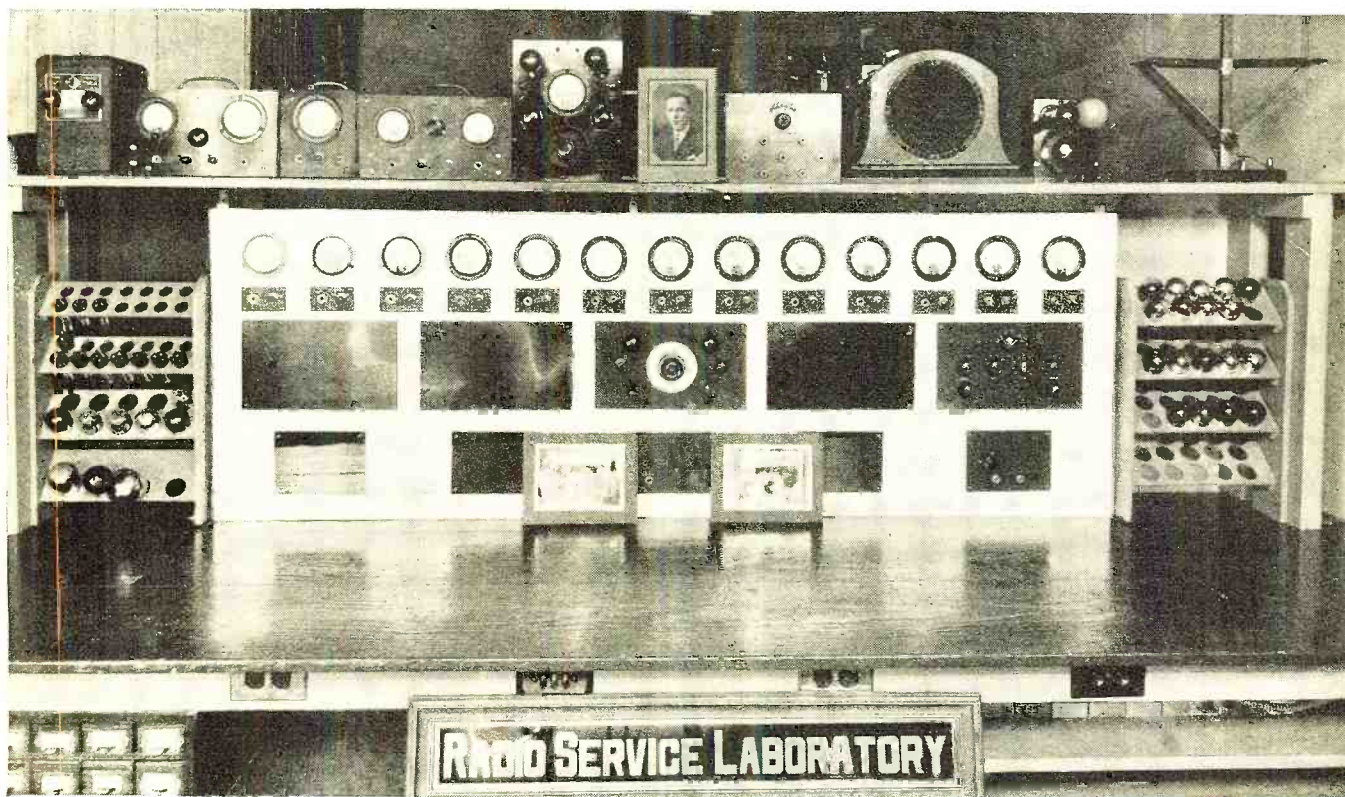

Here is a letter from the Cargile Radio Company of Tulsa, Oklahoma, giving some important facts about radio service, and a recommendation for Eveready Raytheon 4-Pillar Tubes:

"We have watched with great interest the development of your Eveready Raytheon Tubes, as we believe that good radio tubes have a more direct bearing on radio service, and service costs, than is ordinarily recognized. After making extensive tests on your Eveready Raytheon Tubes we are pleased to recommend them and take this opportunity to express to you our appreciation of the many fine qualities of these tubes.

"Our tests showed these tubes to be very efficient and to have unusually uniform characteristics, which we attribute largely to your 4-Pillar type of construction. We have also

found these tubes to have exceedingly good lasting qualities under the varying conditions imposed upon them in actual use in various machines operated at different line voltages."

Information and sales-helms, designed for servicemen's use, will gladly be sent to you free. Among them is a blueprint, giving engineering data on Eveready Raytheon 4-Pillar Tubes. Thousands of service-men are using this material to advantage. Write our nearest branch.

\* \* \*

*The Eveready Hour, radio's oldest commercial feature, is broadcast every Tuesday evening at nine (New York time) over WEAJ over a nation-wide N.B.C. network of 31 stations.*



Trade-Marks

**NATIONAL CARBON CO., INC.**  
General Offices: New York, N. Y.  
Branches:

Chicago                      Kansas City  
New York                  San Francisco  
Unit of                      and Carbon  
Union Carbide              Corporation



far too many to even begin to recount them. However, they all worked on the feed-back principle.

Cascaded radio frequency amplifier tubes are comparatively recent in their inception. Fig. 6 shows such a circuit. The input to the first tube is tuned by a coil and condenser combination. The tube works on the straight portion of its curve, as an amplifier. The plate circuit is coupled to the input circuit of the succeeding tube by inserting a coil in series with the plate, and inductively coupling the coil to the input coils of the next tube. Thus a signal could be built up to quite respectable amplitude before detection.

This system had certain drawbacks, in that if the amplification was carried to any extent, the signal fed back through the interelectrode capacity of the tube, and the tube will oscillate.

Various methods of correcting this condition were advocated, the most popular of which was the "neutrodyne" circuit (Fig. 7). This system did not try to correct the condition at its source, as we do today by the use of screen grid tubes, but rather deliberately fed back a portion of the signal to the grid through a condenser that was of the same capacity as the internal capacity of the tube, so that the two balanced out.

This expedient removed the feed-back from this source, but there was also feed-back from other sources, such as stray coupling between wiring in the circuit, and common power supply. This led us into extensive shielding, and isolation of circuits by chokes and bypass condensers.

All of which brings us up to the present day receivers. No matter what individual characteristics a particular receiver may have, its selective tuning rests upon the basis of one or more of the circuits we have discussed. If we understand the traits of the various systems used in the past, we should have no difficulty comprehending just how any receiver works, even though at first glance it appears complicated. Analyzed, it is bound to fall into some of the foregoing classifications.

One exception to the foregoing paragraph is found in the superheterodyne circuit. In almost all of its various circuits, it does fall into our generalizations, but in others it differs widely. A whole book could easily be written on supers, but space forbids that we give them more than just a thought.

In a super, the signal is picked up at the frequency of the transmitting station, and sometimes amplified at that frequency. In this respect, it resembles an ordinary tuned radio frequency receiver. However, after detection, the transmitted frequency is mixed with a locally produced frequency from an oscillating, and a third frequency is formed. This is further amplified in a so-called intermediate frequency amplifier, which is nothing more or less than another radio frequency amplifier whose constants are so chosen that it amplifies at the frequency known as the intermediate frequency. The advantage thus gained is that a multiplicity of stages can be used here without tuning difficulties, as once tuned the amplifier remains tuned to one frequency. It is only necessary to tune the input to the first detector to the frequency of the wanted station, and then tune the oscillator so that the beat frequency between the two is the frequency to which the intermediate amplifier is tuned.

### Receiver Circuit Modifications

We have said that all modern receiving circuits depend upon one or more of the foregoing principles for their action. This is true, but modifications may make the fact obscure. For instance, take the band pass circuit. This type of circuit invariably takes the form of two (sometimes more) tuned

circuits, each of the circuits similar to the tuned coil in Fig. 4. The two circuits are tuned to two slightly different frequencies, and coupled together so that the overall tuning of the combination has a double peak which approximates a resonance curve with a flat top.

### Tuned Circuits

The method of coupling the two tuned circuits varies in practice, but the end accomplished is the same. Occasionally we see these coils wound on one piece of tubing, with a small separation between them. In this case the coupling is the mutual inductance between the two coils. Again we see them

coupled in another way, that is the low potential ends of the coils are returned to ground through a small capacity that is common to both circuits. Here the reactance of the condenser, being common to both circuits, forms a coupling medium between them. Frequently this condenser will be shunted with a high resistance. This is simply so that the succeeding tube in the cascade system may be

biased. As there is no current flowing in the grid circuit, this resistance may be in the order of megohms, in fact it usually is in this order.

### Screen Grid Circuit

Then again, the interstage coupling between the screen-grid tubes in a system utilizing these tubes is considerably different from the method used with three element tubes, although fundamentally the same. Here we have a new problem, that is not present when three element tubes are used. The plate impedance of screen grid tubes is very high. We know that if one wishes to develop any appreciable voltage across the load in the plate circuit of the tube, we must get the load very high, somewhere in the order of the plate impedance of the tube, if possible. This fact has given rise to various types of coils to accomplish the end in view. Most often, a very large number of turns of wire are used in the primary circuit of the coil, closely coupled to the secondary. In this case, the load of the tuned secondary is reflected back into the primary. The coupling to the secondary is accomplished in

various ways, sometimes the primary is bunch wound and inserted into the secondary, and again, some circuits have been developed where the coils were wound by using two wires wound together on the tube so that in the completed coil, one would be the secondary and the other the primary. In any case, the circuit shown in Fig. 6 is unchanged in principle.

### Band Pass Circuit

The band pass circuit described before is utilized by some designers to good advantage. In this instance, one of the tuned circuits is placed in the plate circuit of the screen grid tube, and the other in the grid circuit of the succeeding tube. This is an almost ideal arrangement, for by using one of the tuned circuits in the plate circuit of the tube, very high impedance may be developed here where it is needed, and at the same time, band pass tuning may be had.

So we see, that no matter what modifications expediency demands, any circuit is simple if dissolved into its fundamentals. No matter how far his children have strayed, the old one slide tuner still remains the daddy of them all.

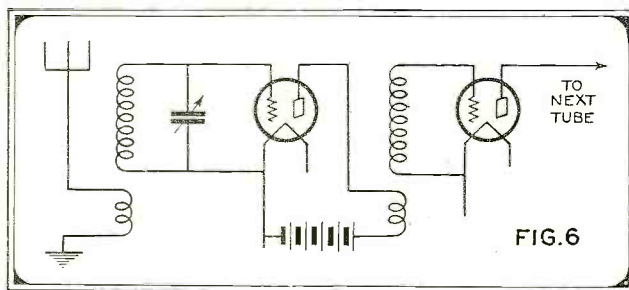

FIG. 6

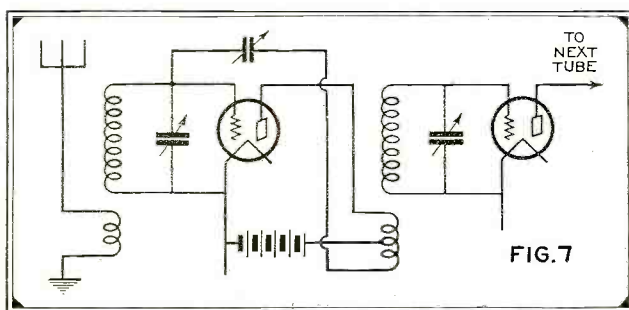

FIG. 7

Next month and for several months thereafter the Junior Radio Guild will present a simple course in Radio mathematics.



**SM**

# Make a Short-Wave SUPERHETERODYNE Out of Any Broadcast Receiver

## New S-M 738 Short-Wave Converter

Here is the newest and one of the most interesting of radio sensations—a self-contained, all a.c. operated converter that makes a powerful short-wave superhet of any broadcast receiver. Tuning control is by a single dial which tunes the oscillator circuit and an auxiliary midget condenser. All the sensitivity and selectivity possessed by the broadcast receiver contributes to the short-wave performance, giving results never before achieved. Included in the list price are eight coils (four pairs) covering wave lengths of from 18 to 206 meters. Tubes: 1-24, 1-26, 1-27.

S-M 738 Superhet Converter, factory-wired and licensed, \$69.50 List. Parts total \$59.50.

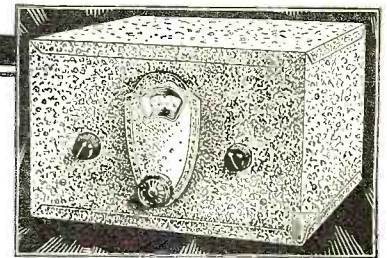

S-M 738 Superhet Converter

## And a Real t. r. f. Short-Wave Set

The 737 Bearcat is the latest thing in short-wave receivers. It has everything: built-in power supply, one-dial tuning, a real gang condenser, a screen-grid circuit with two s.g. tubes, and you can spread the ham bands by a twist of the wrist!

And there's nothing on the Bearcat just because it's pretty. Perfect battleship shielding, two double-shielded tuned circuits, a regenerative non-radiating detector, and a powerful '45 second audio stage. Eight specially designed plug-in coils (included in list price) cover a wave-length range of from 16.6 to 200 meters—all foreign and American short-wave broadcasting as well as the ham bands. Four extra coils (\$5.50 List) cover the American broadcast bands.

Tubes required: 2-24, 1-27, 1-45, 1-80.

S-M 737 Short-Wave Bearcat, completely factory-wired and licensed, \$139.60 List. Component parts total \$119.50 List.

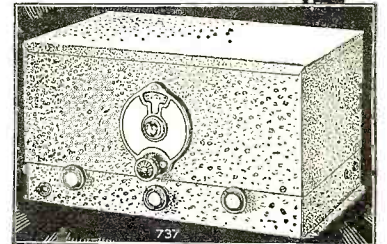

S-M 737 Short-Wave Bearcat

## New S-M 714 Dual Pre-Selector Superhet Tuner

The 714 Tuner—successor to the famous Sargent-Rayment 710 and the 712—accomplishes a perfection of design never before attempted: the building of a double pre-selector tuned-radio-frequency circuit into a single-dial screen-grid superheterodyne for all a.c. operation. Amazing sharpness of tuning is achieved through the use of eleven tuned circuits. The dual pre-selector circuits absolutely prevent the cross-modulation usually encountered in ultra-sensitive superhets, and insure complete suppression of the second resonance "spot." The 714 is unhesitatingly recommended as a tuner for use with the very best amplifiers in any installation or where interference is worst.

Tubes required: 4-24, 2-27.

S-M 714 Superhet Tuner (only), completely factory-wired, tested and RCA licensed, \$87.50 List. Component parts total \$76.50 List.

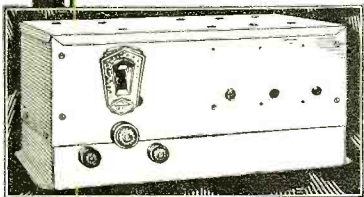

S-M 714 Superhet Tuner

## New S-M 724AC and DC Screen-Grid Superhets

The 724 is a superheterodyne custom-built receiver that will make a DX bug of the most hardened experimenter. It has nine tuned circuits—six (three dual pre-selector) circuits in the i.f. amplifier, preceded by two tuned r.f. circuits, plus the oscillator circuit. It has uniform selectivity and sensitivity over the entire broadcast band, with no trace of second "spot" or repeat points.

Tubes required (in the AC model): 5-24, 1-27, 2-45, 1-80.

Tubes required (in the DC battery model): 5-32, 1-30, 2-31.

S-M 724AC Superhet receiver, completely factory-wired and RCA licensed, \$99.50 List. Parts total \$87.50 List.

S-M 724DC (for batteries) factory-wired, tested and licensed, \$82.50 List. Component parts total \$68.50 List.

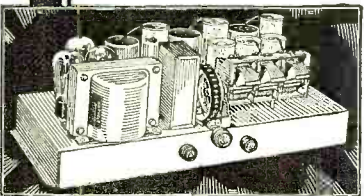

S-M 724 Superhet Receiver

Write for your copy of the Silver-Marshall 1931 General Parts Catalog. The Radio-builder, Silver-Marshall's official publication, tells the latest news of the great S-M laboratories. Fill in the coupon for a sample copy.

**SILVER-MARSHALL, Inc.**  
6405 West 65th Street • Chicago, U. S. A.

- Silver-Marshall, Inc., 6405 W. 65th St., Chicago, U. S. A.  
... Send your 1931 catalog with sample copy of the RADIOBUILDER. Also Data Sheets as follows: (Enclose 2c for each Data Sheet desired.)
- .... No. 21. 737 Short-Wave Bearcat.
  - .... No. 22. 770 Auto-Set.
  - .... No. 23. 738 Short-Wave Superhet Converter.
  - .... No. 24. 724 Screen-Grid Superhet Receiver.
  - .... No. 25. 714 Superhet Tuner.

Name .....

Address .....

# NEWS from the MANUFACTURERS

## Two New Models Announced for Philco Line

Two new models have been added to the line of Philco radio receivers, it was recently announced by the Philadelphia Storage Battery Company, makers of Philco radios. Both ends of the scale in size are represented by the new models, which are respectively the largest and the smallest sets Philco has ever manufactured.

The large model will be known as the Philco Concert Grand. It is a combination phonograph and radio, and will occupy the same relative position to the rest of the line that the concert grand piano does to the upright and the apartment grand piano.

The phonograph mechanism boasts the improved electro-magnetic pick-up, the inertia-weighted pick-up arm, the new motor, and the other improvements of the Philco combination radio and phonograph model. The radio receiver utilizes the model 96 screen-grid plus chassis, a nine-tube a.c. set with tone control and automatic volume control, and the new Philco electro-dynamic speaker. The tone control knob regulates not only the radio reception but also the phonograph recording.

The outstanding feature of the Concert Grand is a new baffle board to be

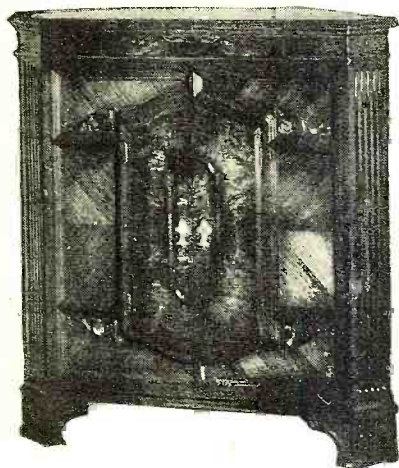
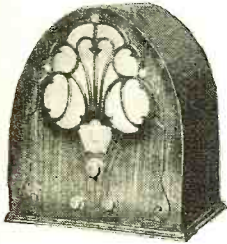

found on this model only. It is twelve square feet in size.

The small model will be known as the Philco Baby Grand. The cabinet is only 16 inches wide and 17½ inches high, and is Gothic in design, built of genuine walnut. It houses a full-performing seven-tube screen-grid Philco receiver and a built-in electro-dynamic speaker. The set is all-electric and plugs into any a.c. light socket.

## Short Wave Receiver Kit

Insuline Corporation of America, 70 Cortlandt Street, New York City, has brought out a new custom-built a.c. short-wave receiver kit called the I. C. A. Conqueror.

The Conqueror kit consists of several laboratory-built units, each of which comes to the constructor already assembled, wired, tested and adjusted. These units are mounted by the builder on a drilled metal chassis and interconnected by means of marked, measured leads, which are secured to their respective terminals. No soldering is necessary and the entire job can be completed with a screw-driver. Instructions, diagrams,



photographs and working drawings are furnished with each kit.

By interchanging coils it is possible to cover wavelengths of from 14 to 600 meters.

The Conqueror is a five-tube receiver with an r.f. tube of the -24 type screen grid, the detector a -27 a.c. tube, the first two audio tubes are also the -27 type, while the output tube is a standard -45 power tube.

## Standard Transformer Corp. Organized in Chicago

The Standard Transformer Corporation, with offices and factory at 852 Blackhawk Street, Chicago, has been organized by Jerome J. Kahn and C. R. Bluzat, formerly sales manager and sales engineer respectively with the Transformer Corporation of America.

The plant is now completely equipped and is in production on a complete line of power transformers, audio transformers and chokes.

## Clarion Junior Receiver

To supply the demand for a mantel type radio, the Transformer Corporation of America, Chicago, Ill., announces the addition of Clarion Junior to their regular line.

This model is engineered along the same lines as the larger sets, having among other outstanding features triple screen-grid radio frequency amplification, tone-control, full electro-dynamic speaker, screen-grid power detector, local distance switch and illuminated dial. The sturdy all-steel chassis—cadmium plated—is enclosed in a heavy walnut cabinet.

## Radio Control Clock

Dumont Electric Corporation, 40 West 17th Street, New York City, announces a radio-controlled clock that will automatically turn a radio receiver on or off at any prearranged time. This clock will function on any house current. In addition

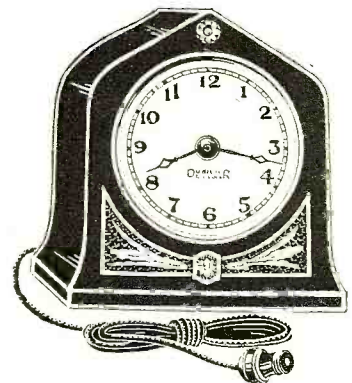

to automatically controlling radio receivers it can also be used for other similar purposes. It is six inches high, five and a half inches wide, two and a half inches deep and is furnished with an eight-foot length of cord.

## High-Voltage Rectifier

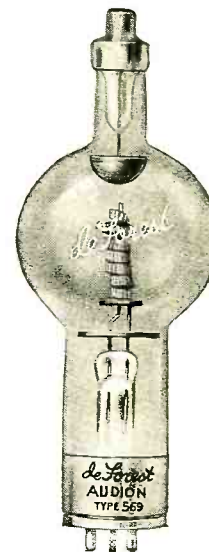

A new high-voltage rectifier of high efficiency is announced by the De Forest Radio Company of Passaic, New Jersey, as still another addition to its large line of transmitting audions.

The De Forest audio 569 is a large-sized mercury-vapor, hot-cathode rectifier rated at 20,000 maximum peak inverse volts, and 5 maximum peak amperes.

It is ideally suited for high-voltage d.c. plate supply for transmitting and similar purposes. Standard 504A mountings are employed, and the tube operates in a vertical position. It is interchangeable with UX869. The cathode is in the form of a heavy alloy ribbon arranged in helical form, and mounted about a heat deflector disc, while the anode is a carbon button directly above the cathode. The efficiency of this rectifier is several times that of the corresponding thermionic or vacuum type rectifier, or above 99 per cent.

# HUMLESS A. C. Operation

*on the Short Waves*  
with the New A. C. THRILL BOX

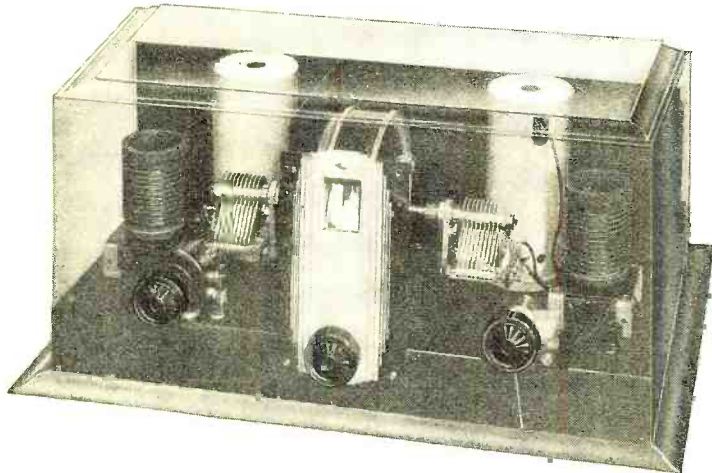

**C**OMBINES every requirement of the expert Short-Wave Experimenter and Amateur, and the Radio Enthusiast who wants good loudspeaker reception of SW broadcasts from all over the world. Not a compromise between a Short Wave and Broadcast circuit. A. C. Model gives FULL A.C. OPERATION. No hum, even with head phones. DOUBLE SCREEN-GRID with grid-leak detection. Special New R-39 Type R.F. Coupling Transformers. No special tubes required. Uses standard heater tubes throughout. Single dial operation, easy to operate and log. Uses New NATIONAL Projector Dial. No grunting or backlash, no hand capacity; Loud Speaker operation from Foreign Stations; push-pull audio with special phone-jack after first stage.

Thoroughly shielded chassis. Easy to assemble and wire. Ideally suited not only for Short Wave Broadcast reception, but for all S. W. amateur and communication uses. Easily adapted for still wider spread of amateur bands, if desired.

Also available in new battery model, using the new UX 230, 231 and 232 tubes.

*Write Us Today! Use Coupon*

**NATIONAL  
PRECISION SHORT-WAVE  
RADIO PRODUCTS**



The New NATIONAL A. C. SW-5 THRILL BOX is easily assembled by anyone with genuine NATIONAL Radio Parts. Some of the more outstanding of these are described below.

### R. F. Transformers



Standard set of four pairs covering from 21.2 to 2.61 m.c. Special coils can be supplied for the 33—21.2 m.c. and the 2.61—1.5 m.c. ranges. Forms are moulded R-39, the new low loss coil material, developed by Radio Frequency Laboratories. Blank forms also available for winding experimental coils.

### The Condensers

The type S-100, specially designed for short-wave work, not a cut-down broadcast condenser. Insulated main bearing and constant impedance pigtail. 270 degrees straight frequency line plates.



### The Dial



The NATIONAL Projector Type Drum Dial, standard equipment on the A. C. Thrill Box, has the same easy control that is characteristic of the National Velvet-Vernier Dials. Equipped with non-metallic drive, avoiding clicking and detuning. The dial scale is projected in magnified form on to a ground glass screen which reads the same from any position, without parallax. The escutcheon, of beautiful modern design, is finished in brush silver.

### The Power Unit



A separate unit, with handy cable and soft rubber covered connecting plug. Designed for humless operation, incorporating special R. F. filter in addition to double section hum-filter. Employs UX-280 Rectifier tube and licensed under R. C. A. Patents.

**Send Today!**

### COUPON

NATIONAL COMPANY, INC.  
Sherman, Abbot and Jackson Sts., Malden, Mass.

Gentlemen: Please send me complete information on the NEW National S. W. 5 THRILL BOX. ( ) A.C. ( ) Battery Operated.

I am interested in S. W. Apparatus for Experimental and amateur use (check here) ( )

Name .....

Address .....

RN-11-30

# ~RADIO NEWS HOME LABORATORY EXPERIMENTS~

## The Power Tube PART TWO

**I**N the last issue of RADIO NEWS we discussed in this department some of the factors influencing the operation of power tubes. We showed by means of a simple d.c. circuit how the power output depends on the load resistance. We found also that by means of a transformer we can have the tube work into a very low resistance provided the transformer has the proper turns ratio to step up this low resistance to a value equal to twice the plate resistance of the tube. Space was not available last month to sketch all the factors upon which the operation of the power tube depends and for this reason the discussion is continued in this month's Experiment Sheet.

Many facts regarding the operation of a power tube in a circuit can be obtained with the aid of a group of curves showing the relation between the plate voltage and the plate current for various values of grid bias, and from a group of curves showing the relation between plate current and grid voltage for various values of load resistance. The latter group of curves is more readily understood, although the former are generally used by engineers.

Let us therefore go into the "lab" and obtain data with which we can plot a group of curves showing the relation between plate current and grid voltage with various values of load resistance. These curves would be known as dynamic  $I_p$ - $E_g$  curves,  $I_p$  meaning plate current and  $E_g$  meaning grid voltage. The circuit to use is shown in Fig. 1. When we performed this test we used a -71A tube and if you use the same type tube the test should be performed as follows:

First determine the proper operating voltages. In the case of the -71A we should use 180 volts on the plate and 40 volts on the grid. The normal plate current is 20 milliamperes. We should remember that we must have 180 volts on the plate, and since there will be a loss in voltage, due to the plate current flowing through the load resistance  $R$ , the battery voltage  $E_b$  will have to be greater than 180 volts.  $R$  should have various values from zero up to about four times the a.c. plate resistance of the tube. Let us use values of  $R$  of zero, 1,000, 2,000,

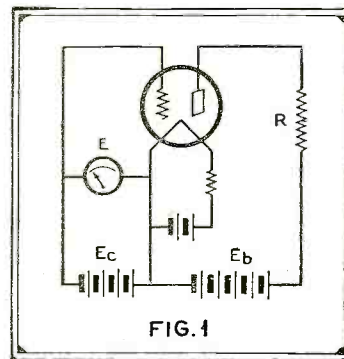
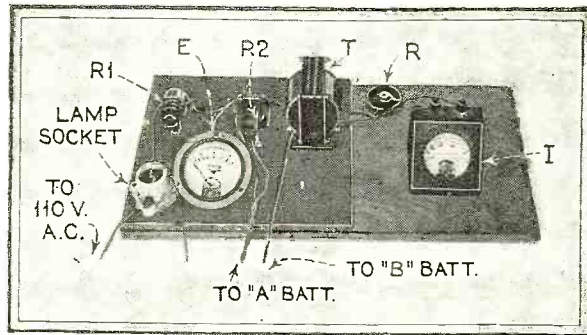

FIG. 1

4,000 and 8,000. If these values are used, then the battery voltages shown in column 4 of Table 1 are required. To perform the experiment we must connect to the plate circuit the proper value of battery voltage,  $E_b$ , Fig. 1, for the load resistance and then measure the plate current as we vary the value of the grid voltage. You will then obtain a group of data as indicated in Table 2. From this data a group of curves should be plotted as shown in Fig. 2.

These curves show clearly how the distortion produced by a power tube depends upon the load resistance. We have all read many times that if a tube is not to produce distortion it must have a straight characteristic. Keeping this point in mind, examine the curves of Fig. 2, and what do you find? Simply that the characteristic of the tube is very curved with low values of load resistance, but becomes straighter and straighter as the load resistance is increased.

Since the plate resistance of a -71A tube is about 2,000 ohms, the load resistance ought to be 4,000 ohms (see last month's Experiment Sheet) and these curves show that the 4,000-ohm characteristic is quite straight over practically its entire length. The 8,000-ohm curve is much straighter and this load resistance would produce even less distortion, but we would then obtain much less power output from the tube. We must therefore compromise between distortion and power output and engineers have decided that the amount of distortion produced when the load resistance is twice the tube's plate resistance is sufficiently small as not to be noticeable to the ear. This group of curves also indicates why the plate milliammeter can be used to indicate distortion. If such is the case the plate meter fluctuations ought to be much greater with low values of load resistance than with high values. A few examples will indicate that this is true.

All the curves cross at a grid voltage of 38 volts and this voltage point should therefore be taken as a reference point. Suppose that a signal with a peak value of 20 volts is placed on the grid. Then the grid voltage will swing from 38 - 20 or 18 volts down to 38 + 20 or 58 volts. Therefore the maxi-

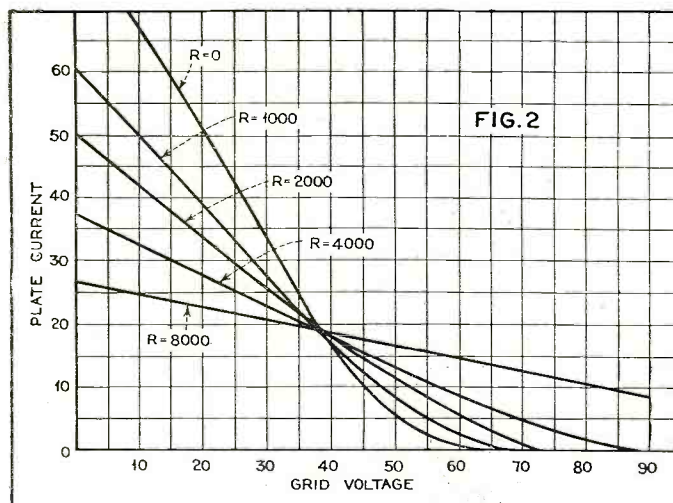

FIG. 2

FACTORY TO YOU—SAVE to 50%—COMPARE WITH COSTLIEST OUTFITS BEFORE YOU BUY

# Enjoy a powerful new Miraco 30 DAYS FREE

Latest 1931 SUPER Screen Grid Outfit (No obligation to buy)



**NEWEST IN RADIO!** 1931 Miraco "Easy Chair" model with magazine racks, each end. Place it anywhere in any room. Easily moved about. Contains a complete full-size radio and Super-Dynamic speaker! No outside aerial or ground required. Many other new, clever models, obtainable nowhere else, shown in free literature.

**Get Our "SEND NO MONEY" 11th Anniversary Offer!**

Latest 1931 **SUPER Screen Grid** FULL YEAR'S GUAR.  
lighted 1 dial steel chassis  
Vari-Tone and Automatic Sensitivity Control  
Also latest PUSH-PULL Amplification

Built like—looks like—performs like newest radios in many outfits much more costly. Latest, finest, heavy duty construction. Skillfully engineered to super-utilize a battery of "224" SCREEN GRID tubes—in addition to "245" PUSH-PULL POWER, "224" HUM-FREE long-lived POWER DETECTOR and AMPLIFIER and "280" A-C TUBES. Vari-tone feature gives any tone-pitch your ears prefer. Automatic Sensitivity Control reduces "fading," protects tubes. Phonograph pick-up connection. Built-in house wiring aerial and ground. Built-in plug for electric clock, lighter, lamp, etc. Super-sturdy power section. Razor-edge selectivity; Super-Dynamic Cathedral tone quality; marvelous distance-getter. Solid one-year guarantee if you buy! Wide choice of cabinets.

**Easy Chair Model**  
(as illustrated less tubes)

Only **\$49.88**  
COMPLETELY ASSEMBLED

Values possible because you deal direct with big factory

# MIRACO

TRADE MARK REGISTERED

**CATHEDRAL TONED, SUPER SELECTIVE, POWERFUL DISTANCE GETTERS**

You need not send us a cent! For its 11th successful year, America's big, old, reliable Radio Factory again sets the pace in high-grade, latest guaranteed radios *direct to you*. And now—at history's greatest savings. With this newest perfected SUPER SCREEN GRID, push-pull, super-powered and humless electric AC set in clever, beautiful new Miraco-Master-crest consoles obtainable nowhere else—you are guaranteed satisfaction, values and savings unsurpassed. *Get Amazing Special Offer!*

**Don't Confuse with Cheap Radios**

With Miraco's rich, clear Cathedral Tone, quiet operation, razor-sharp separation of nearby stations, tremendous "kick" on distant stations, Vari-Tone and automatic sensitivity control, and other latest features—be the envy of many who pay 2 or 3 times as much!

**EASY TERMS to reliable persons only**

**USER-AGENTS WANTED**

**Exclusive Territory—Try it at Our Risk!**

Spare or full time. No contract, no experience required. Big money! Send coupon now!

Send for proof that delighted thousands of Miraco users cut through locals, get coast to coast, with tone and power of costly sets.

Miraco's are built of finest parts—approved by Radio's highest authorities. Our 11th successful year!

**Deal Direct with Big Factory**

Miraco outfits arrive splendidly packed, rigidly tested, to plug in like a lamp and enjoy at once. No experience needed. Entertain yourself 30 days—then decide. Liberal year's guarantee if you buy. Play safe, save lots of money, insure satisfaction—deal direct with Radio's big, reliable, pioneer builders of fine sets—successful since 1920. SEND POSTAL OR COUPON NOW for Amazing Offer!



At our risk, compare a Miraco outfit with highest priced radios 30 days and nights. Surprise, entertain your friends—get their opinions. Unless 100% delighted, don't buy! Your decision is final—no argument!

Only marvelously fine radios, of latest perfected type, at rock-bottom prices, can back up such a guarantee. Send postal or coupon for *Amazing Special Factory Offer!*

**MIDWEST RADIO CORP., 804-AN Miraco Dept., Cincinnati, Ohio**

**BEAUTIFULLY ILLUSTRATED LITERATURE, TESTIMONY OF NEARBY USERS, PROOF OF OUR RELIABILITY—**

All the proof you want—of our honesty, fairness, size, financial integrity, radio experience and the performance of our sets—including Amazing Factory Offer—sent without obligation!

**Free!**

**MIDWEST RADIO CORPORATION**  
Pioneer Builders of Sets—11th Successful Year  
804-AN Miraco Dept., Cincinnati, Ohio

**THIS COUPON IS NOT AN ORDER**

WITHOUT OBLIGATION, send latest literature, Amazing Special Free Trial Send-No-Money Offer, testimony of nearby users and all Proof.  User.  Agent.  Dealer  
 Check here if interested in an EXCLUSIVE TERRITORY PROPOSITION  
NAME..... ADDRESS.....

**NEW LOW FACTORY PRICES**  
**SAVE to 50%**  
Similar Low Prices on Beautiful Variety of Latest Fine Consoles  
Send Coupon!  
**30 DAYS' FREE TRIAL**



Full-size wall console with latest 1931 features. Beautiful design and woods. Priced very low, factory to you.

Popular "Lo-Boy". Takes very little space. Stores haven't anything as classy at \$50.00 more.

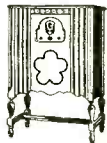

Medium-size "Hi-Boy". Sliding doors. Rich design, fine woods, fine finish. Astonishingly low factory price to you.

These Consoles are Equipped with **SUPER DYNAMIC CATHEDRAL TONE REPRODUCERS**

Also built-in aerial and ground and built-in extra light socket!

Magnificent new creation. Super Screen Grid Radio. Phonograph under same lid. Greatly under priced. Send coupon for low factory to you prices.



mum and minimum plate currents will be as shown in Table 3.

Note the conditions with zero load resistance. In this case the plate current increases 35 ma. above the normal current of 19 ma. but only decreases 18 ma. The result is that the average current is increased and consequently the reading of the plate meter increases—and in this manner indicates that the tube is producing distortion. With 4,000 or 8,000 ohms load resistance the increase and decrease in current are equal and the plate meter reading would not change, indicating no distortion. Actually the increase and decrease would not be *exactly* the same even under these conditions, but the meters and curves cannot be read accurately enough to indicate very slight differences. Nevertheless we have proven the point that the plate meter fluctuations do indicate distortion and the figures in the preceding tabulation show why and how.

With the aid of a few common meters it is possible to make a number of very interesting measurements on power tubes. Of particular interest is the actual measurement of the power output with various voltages on the grid. The circuit of Fig. 3 shows how this can be done using the 60-cycle lighting circuit as the source of a.c. voltage. The picture on this page shows a convenient arrangement of the parts indicated schematically in Fig. 3. The 25-watt lamp serves simply to protect the apparatus in case of an accidental short circuit—which should of course be carefully guarded against. The voltage on the grid of the tube is measured by the meter E, which should be able to read up to about 50 volts. A low-range a.c. voltmeter can of course be used with a multiplier to increase its range. The meter "I" reads the a.c. plate current developed across the secondary of the output transformer T. We used a Ferranti output transformer with a turns ratio of 25. The resistance R is part of the load, the remainder of the load being the resistance of the meter I. As indicated in last month's sheet, the load resistance is stepped up by the square of the turns ratio of the transformer. In this case the square of 25 being 625, every ohm of load resistance looks like 625 ohms to the tube. Therefore if we want to test the tube with 4,000 ohms in the plate circuit the actual resistance required is 4,000 divided by 625 or 6.4 ohms. We used for I a Weston 500 ma. thermo-milliammeter, model 425, which has a resistance of 1.2 ohms. Therefore R should have a resistance of 6.4 — 1.2 or 5.2 ohms. An ordinary rheostat is a convenient type of resistor to use for R since it can then be readily varied to obtain different values of load resistance. The resistance R1 connected in series with the a.c. line should have a value such that the voltmeter E may be varied from practically zero up to about 50 volts. The picture has been marked in the same manner as Fig. 3 so experimenters should have little difficulty in setting up the circuit.

The procedure is to vary the voltage E impressed on the tube and note the reading of the meter I. Knowing the resistance of the meter and the value of R,

LOAD RESISTANCE R	PLATE CURRENT Ip	IP R DROP IN LOAD RES.	BATTERY VOLTAGE REQUIRED (180+IpR)
0	20	0	180
1000	20	20	200
2000	20	40	220
4000	20	80	260
8000	20	160	340

TABLE 1

GRID VOLTAGE	PLATE CURRENT WITH LOAD RES. OF				
	0 OHMS	1000 OHMS	2000 OHMS	4000 OHMS	8000 OHMS
90	0	0	0	0	9
80	0	0	0	2	11
70	0	0	1	5	13
60	1	3	6	9	15
50	6	9	12	14	17
40	17	17	18	18	19
30	34	28	26	23	21
20	51	39	34	28	23
10	-	49	42	33	25
0	-	61	50	38	27

TABLE 2

multiplied by the square of the transformer ratio to obtain the actual resistance into which the tube is working.

Curves for any load resistance showing the relation between power output and input voltage will indicate that the power output is proportional to the square of the input voltage. This means that if a certain output is obtained with a certain input voltage, then four times the output will be obtained if the input voltage is doubled. Four times the input voltage gives sixteen times as much output. The relation will hold true until the peak value of the input voltage (1.4 times the voltmeter reading) is equal to the d.c. bias on the grid of the tube. If this value is exceeded the grid begins to draw current and the tube is overloaded. The output power will continue to increase but will no longer be proportional to input voltage squared.

When the tests are made a d.c. milliammeter should be placed in the plate circuit of the power tubes and notes made of the changes that take place in plate current as the input voltage is varied. It will usually be found that the plate current will increase as the tube begins to overload and the voltage at which this begins will be found to occur at approximately the same input voltage at which the square law relation ceases to exist.

The preceding notes on the factors affecting a power tube's operation in an actual circuit, which can be experimentally determined in the manner described, will serve to indicate, we hope, the usefulness of these simple tests in giving the experimenter a knowledge of tube circuits.

If these experiments are carefully made the experimenter will understand why distortion is produced if a tube is worked into a low load resistance and how the distortion progressively decreases as the load resistance is increased. From the latter series of tests described in this Experiment Sheet the experimenter will have learned the relation between the power output from a tube and the a.c. input voltage on the grid, and how this relation changes as soon as the tube begins to overload. There is no better way to learn something about tubes and radio circuits than by having a small "lab" of one's own and actually performing various simple experiments.

LOAD RESISTANCE	MAX. Ip	MIN. Ip	INCREASE Ip MAX-19	DECREASE 19-IP MIN.
0	54	1	35	18
1000	41	3	22	16
2000	37	7	18	12
4000	29	9	10	10
8000	23	15	4	4

TABLE 3

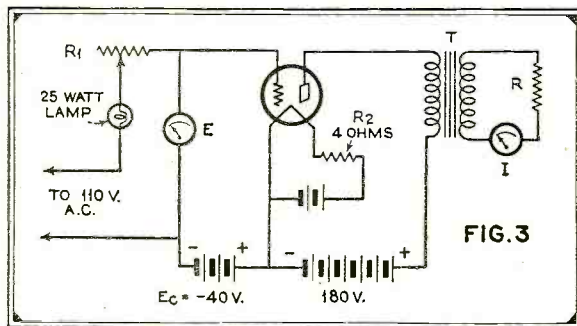
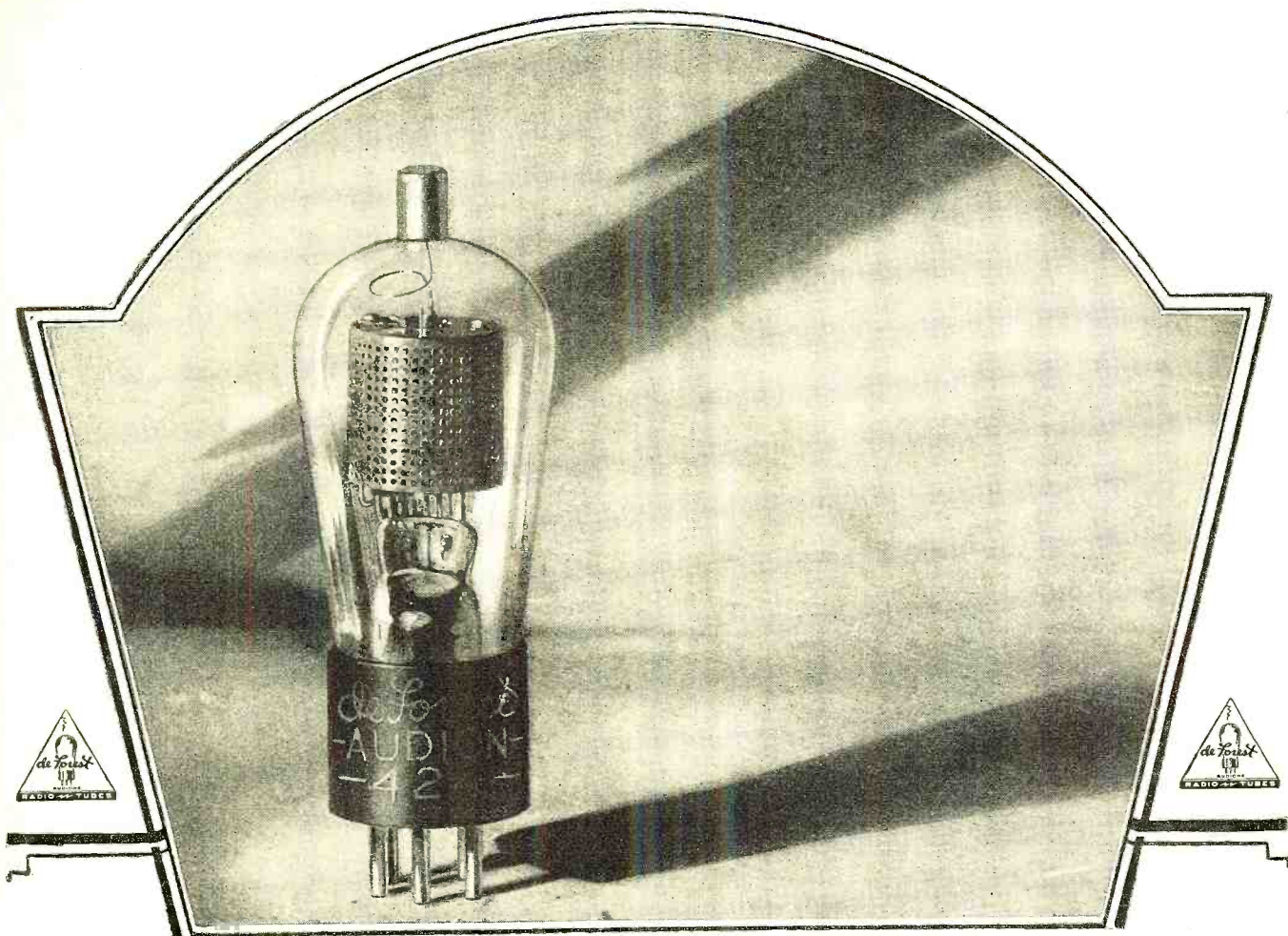

FIG. 3



## Pioneering - Continued

**E**VERYONE knows that Lee de Forest invented the Audion or three-element vacuum tube. But everyone does not know that de Forest pioneering continues. After a quarter century, DeForest still leads in research, invention and engineering development, as reflected in de Forest Audions.

With the advent of A.C. radio sets de Forest pioneering capacity was challenged once again. Of ordinary A.C. tubes there were certain to be plenty. Was it possible, however, to produce A.C. tubes that would equal, in performance, reliability and long life, the filament tubes developed over two leisurely decades?

The challenge has been answered. The 427 A.C. Detector-Amplifier Audion and again the 424 A.C. Screen-Grid Audion are the contributions by de Forest research workers and engineers to

the new A.C. radio art.

Sturdy mechanical details; accurately spaced elements permanently positioned; definite characteristics that insure matched tubes; ample and uniform emission throughout long service; minimum of hum and crackling noises; highest attainable evacuation in regular production; absolute stability and positive reliability—these de Forest characteristics constitute the better half of the story. The remaining half is *price*. de Forest engineers, through the development of unique high-speed, automatic production equipment, have made laboratory quality available at an every-day price.

The steady, untiring, far-seeing pioneering of yesterday, today and tomorrow insures for de Forest Audions the latest and best that the vacuum tube art has to offer.

• DE FOREST RADIO COMPANY • PASSAIC, N. J. •

*Branch Offices Located in*

Boston • New York • Philadelphia • Atlanta • Chicago  
 Pittsburgh • Minneapolis • St. Louis • Kansas City • Los Angeles • Denver • Seattle • Detroit • Dallas • Cleveland  
 Export Department : 304 East 45th Street, New York City

**de Forest**  
 AUDIONS

**RADIO TUBES**

# Radio News Manufactured Receiver Circuits

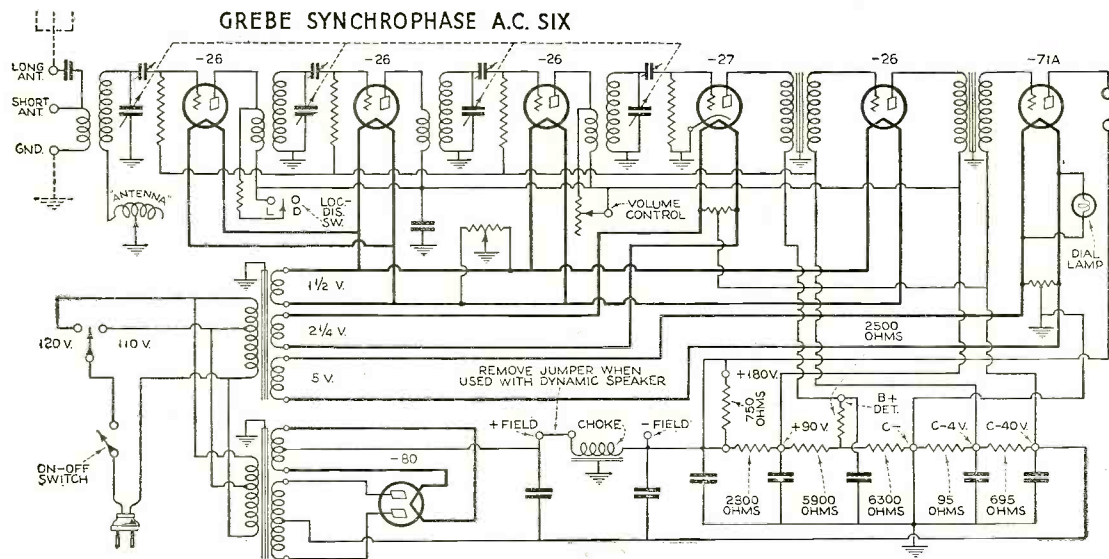

**T**HE Grebe Synchronphase A.C. Six is a six-tube receiver of the tuned radio-frequency type. The tubes employed are four -26's, one -27 and one -71A. The -26's are in the radio-frequency stages, and the first audio stage, the -27 in the detector and the -71 as a power output tube. Provision is made to use either a short or a long antenna by appro-

appropriate taps on the antenna coil. The power supply, which employs an -80 type tube, furnishes all necessary voltages for the operation of the receiver. Provision is also made to operate the receiver from line voltages of 105 to 125 volts by taps on the power transformer. Provision is also made to excite a dynamic speaker field if desired.

# Radio News Manufactured Receiver Circuits

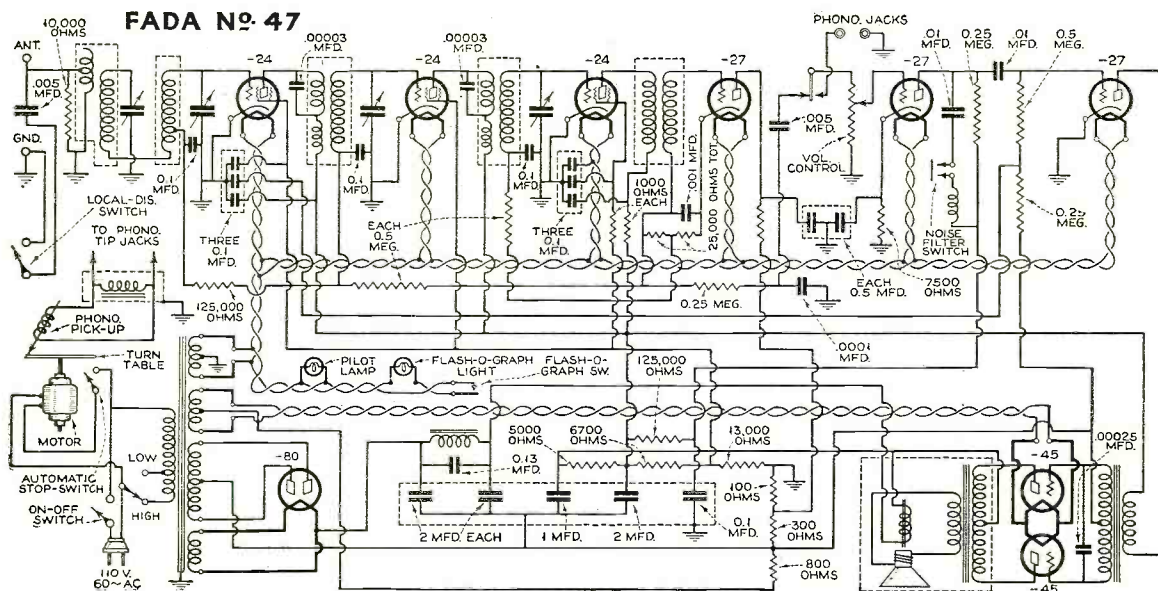

**T**HE Fada No. 47 receiver has numerous new features. The receiver is an eight-tube job, utilizing -27 tubes in the detector and first audio stages, -24's in the radio-frequency stages, and -45's in the push-pull power output. The power supply uses an -80 type tube. A band selector circuit is used ahead of the first radio-frequency tube to prevent cross modulation of stations, and a local-distance switch is placed

in the antenna circuit. The "Flash-O-Graph" is an automatic light that flashes as a station is tuned in on the receiver. A phonograph pick-up is included in the assembly, along with turntable and motor, equipped with automatic stop switch. Provision is made for operation on low or high line voltage by appropriate taps on the power transformer. A "local-distance" switch is also provided.





WHOLLY  
NEW

1931  
MODEL

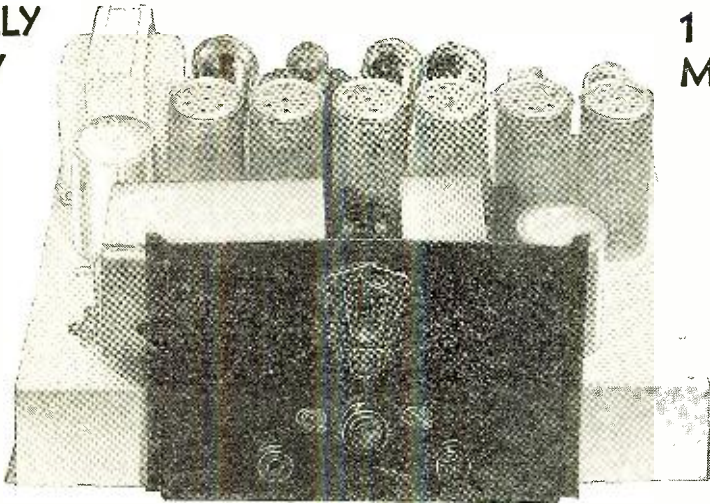

10 TUBES  
« « «  
EMPLOYS  
HOPKINS  
BAND-REJECTOR SYSTEM

10 KILOCYCLE  
STATION  
SEPARATION  
« « «  
WORLD-WIDE  
RECEPTION!

# WHEN RADIO'S HISTORY IS FINALLY WRITTEN THIS AMAZING SUPER WILL BE SET DOWN AS THE FIRST « « « REALLY GREAT RECEIVER

In the development of all arts and devices, there stand out epochal, basic achievements toward perfection. Motor car men know exactly the feat that marked the turning point to today's unflinching reliability of the automobile. The aviation expert knows what plane established the pattern of design and construction to insure safe travel through the air.

And, we know enough of radio now to make this bold claim that this wonder 1931 H. F. L. Mastertone 10 marks entry to an entirely new era in this new art.

### The Super's the Thing!

Long known to be the ideal circuit for receiver use, it remained for H. F. L. to adapt the super-heterodyne to practical home reception. True to its name, the super has been the superior set in power, in selectivity, in pure tonal quality. Yet to combine these qualities with the demanded simplicity of control and ease of operation was a task that baffled radio's best engineers for years.

Now we have all these features in a history-making receiver and at a price that bespeaks the genius and

cleverness of today's engineering skill and manufacturing ingenuity.

### Awe-Inspiring in Action!

This receiver is actually, definitely revolutionary. It sets up entirely new standards of design, building and performance. Operation of silky smoothness that thrills you to new heights of radio enjoyment. Sharpness of selectivity that is truly breath-taking in its surprising precision. A sweet, full tone quality that is inspiring in its sheer naturalness! Power and reach that awes even the hardened, experienced DX explorer!

### Why It is Different

H. F. L. exclusively uses the newly perfected Hopkins Band Rejector System, a circuit of which you will hear much from now on in radio. By this method, the width of the band may be adjusted to **absolute precision, without impairment of the audio.** Tune the entire scale in steps of 10 kilocycles, just as surely as you set the clock! Distant stations reproduced with

the same clarity and definiteness as locals!

### Try It at Home

Surging power that lays the world of broadcast at your finger tips! Tone that lifts you to the realm of illusion with the artists before you—reproduction that elevates you to hitherto unscaled heights of musical enjoyment.

Give H. F. L. the chance to prove all these unusual claims. Test the giant power of the Mastertone in your own home. Experience its uncanny separation of stations. Thrill at its amazing reach into the far corners of the world. Do this all at our risk.

### Book Tells All

Details of this history-making receiver and our new policy of distribution, placing this wonder set within the reach of all, are set out in a new Brochure. Send for and get this book without cost or obligation. No salesman will call on you—you will not be importuned to buy. Write now. You owe it to yourself to know all about the H. F. L. Mastertone 10 before purchase of any new set.

**HIGH FREQUENCY LABORATORIES**  
DEPT. E-930, 3900 CLAREMONT AVENUE  
CHICAGO, ILLINOIS

**AMERICA'S LOWEST PRICED FINE RADIO!**

# H « F » L

**MASTERTONE  
SUPER 10**

HIGH FREQUENCY LABORATORIES, Dept. E-930  
3900 Claremont Ave., Chicago.

Without cost or obligation, please send me a copy of your new Brochure describing the new 1931 H. F. L. Mastertone 10 and your liberal selling policy.

Name \_\_\_\_\_

Address \_\_\_\_\_

City \_\_\_\_\_ State \_\_\_\_\_



# Radio and the Underwriters Regulations

**G**ETTING an Underwriters' certificate for apparatus installed by the radio amateur or experimenter has always seemed such a supposedly futile job that the average radio man usually neglects the thing entirely. The 1930 "National Electrical Code" issued by the National Board of Fire Underwriters for electric wiring and apparatus as recommended by the National Fire Protection Association and approved by the American Standards Association (effective January 1st, 1930) really looks complicated, but a careful perusal of the requirements brings the job down to a minimum of changes.

There isn't an installation, unless approved by the Board of Underwriters, that hasn't a violation of some sort which makes the insurance policies void in case of fire near the apparatus concerned or in the same house. The result of this is that premiums are paid to insurance companies on policies that would pay no money in case of fires.

Insurance companies take the stand that all radio equipment, whether receiving or transmitting, must be declared on all policies to make those policies valid. Using the latest type electric receiver as an appliance is not passed by the insurance people unless OK'd by the Underwriters' Bureau and declared on the policies.

Equipment declared to the insurance companies and not passed upon by the Board of Underwriters either brings an increase in rate of over 100 per cent or a complete cancellation.

Two specific instances of this occurred when two stations in Brooklyn were struck by fire. The first, one of Brooklyn's best known operators, suffered when lightning struck his transmitting antenna during the height of a mid-summer electrical storm. From there, it jumped into the house wiring circuits and scorched the walls around the antenna lead-in. The transmitter was reduced to a molten mass of metal and glass. Since the station was not passed upon by the Board of Fire Underwriters and was not declared on the fire policies, no insurance money was forthcoming. The damage to the house was little but the amateur would have been in the same circumstances had the whole house burned to the ground.

In the second case, the fire started in the house wiring of the A.C. lines and burned through the ceiling of the cellar. The insurance company took the stand that radio frequency from the transmitting antenna had entered the house wiring and had caused them to burst into flames. The amateur, realizing the futility of following the company up on the insurance money because of his lack of an Underwriters' OK on the station, lost that much money through his negligence.

The thing simmers down to just this: equipment must be passed by the Board of Underwriters and declared on policies or money is needlessly wasted in paying premiums on policies that would not do a bit of good were a fire to start.

Here follows a digest of the "National

By N. Pomeranz  
W2WK—W2APD

Electrical Code" in simplified form dealing only with amateur and experimental radio installations as well as those required on ordinary receiving sets.

The requirements here are the simplest of the lot. Antenna wires must be kept well away from power wires carrying more than 600 volts and from railway, trolley or feeder wires, so as to avoid the possibility of contact. An approved lightning arrester or switch must be used between the antenna and ground. No extension cords carrying current from an outlet to the receiver must be more than seven feet long. Splices in such extensions must be properly soldered and taped and must be done in the approved electrical fashion.

Here, the same requirements as for broadcast receivers must be observed and in addition, transformers used for B plate supply larger than the average sized receiver transformers and over 500 volts (secondary) must be installed as those in transmitting stations. High voltage carrying leads must also be installed as explained further under "Transmitters."

In addition, storage-battery leads shall consist of conductors having approved rubber insulation. The circuit from a filament, "A", storage battery of more than 20 ampere-hours capacity shall be properly protected by a fuse at not more than 15 amperes. The circuit from a plate, "B", storage-battery shall be properly protected by a fuse at not more than 1 ampere in the negative lead. Fuses shall be located not more than 18 inches along the wire from a battery terminal.

Care must be taken by the experimenter not to use flexible electric wire or "hook-up" wire in carrying voltage to and from his power supply to his equipment. This is a point that is particularly looked for by Underwriter inspectors.

The antenna offers the largest stumbling block of an amateur installation. Size or wire used in both the antenna proper, lead-in and counterpoise (if any) must be strictly adhered to. Insulation is a sore spot.

The antenna and counterpoise conductor sizes shall be not less than No. 14 if of copper or No. 17 if of bronze or copper-clad steel. Single strand copper is desirable. Antenna and counterpoise conductors outside buildings must be placed so that they do not swing closer to open supply conductors more than two feet if the supply wires carry less than 600 volts or more than ten feet if more than 600 volts. Where all conductors involved are supported so as to insure a permanent separation and the supply wires do not exceed 150 volts to ground, the clearance may be reduced to not less than four inches. Lead-in conductors on the outside of buildings must not come nearer than the distances specified unless separated by a continuous and firmly fixed non-conductor which will maintain permanent separation. The non-conductor shall be in addition to

any insulating covering on the wire.

The size of wire to be used in both the antenna, and counterpoise where stations to which power supplied is less than 100 watts and where voltage of power is less than 400 volts must be No. 14. Where stations to which power supplied is more than 400 volts and more than 100 watts, No. 7 soft copper, No. 8 medium-drawn copper, No. 10 hard-drawn copper or No. 12 bronze or copper-clad steel must be used. Lead-in conductors must be no smaller than No. 14 wire. Splices and joints in the antenna span shall be soldered unless made with approved splicing devices. (For best operating and the least amount of wobbling, all joints should be soldered).

Each lead-in conductor shall enter the building through a non-combustible, non-absorptive, insulating bushing slanting upward toward the inside or by means of an approved device designed to give adequate insulation and protection. The lead-in conductor from the building entrance to the set shall have rubber insulation approved for voltages up to 600.

Each lead-in conductor shall be pro-

(Continued on page 477)

## Superheterodyne Circuits

(Continued from page 397)

close approach to band-pass characteristics, since it always works at the same frequency and it is not necessary therefore to design it to have such characteristics over a broad band of frequencies. From the standpoint of sensitivity the arrangement is almost unlimited, since high gain is readily obtained by adding stages to the intermediate-frequency amplifier—again the comparatively low frequency at which this amplifier works is the important point for the difficulties involved in the design of high gain amplifiers rapidly decrease as the frequency at which they must work is lowered. From the standpoint of fidelity, the band-pass characteristics which can be obtained make it possible to obtain a high order of selectivity without losing the sidebands which are absolutely essential if good quality is to be a characteristic of the reproduction.

It is these characteristics which make a good superheterodyne such an excellent broadcast receiver. It is these characteristics that cause the engineers of the Bell Telephone Laboratories to use this type of receiver in the transoceanic telephone system, and to use it when receiving television signals. It is these characteristics that make it such an excellent circuit for use on short waves.

The superheterodyne involves so many beautiful principles of engineering that it would appear questionable whether, for a long time at least, any other circuit will be invented that will prove more advantageous. There is no question but that it has intrigued the experimenter ever since it was invented. Probably many circuits will come and go before the experimenter will cease trying his hand at "another super."

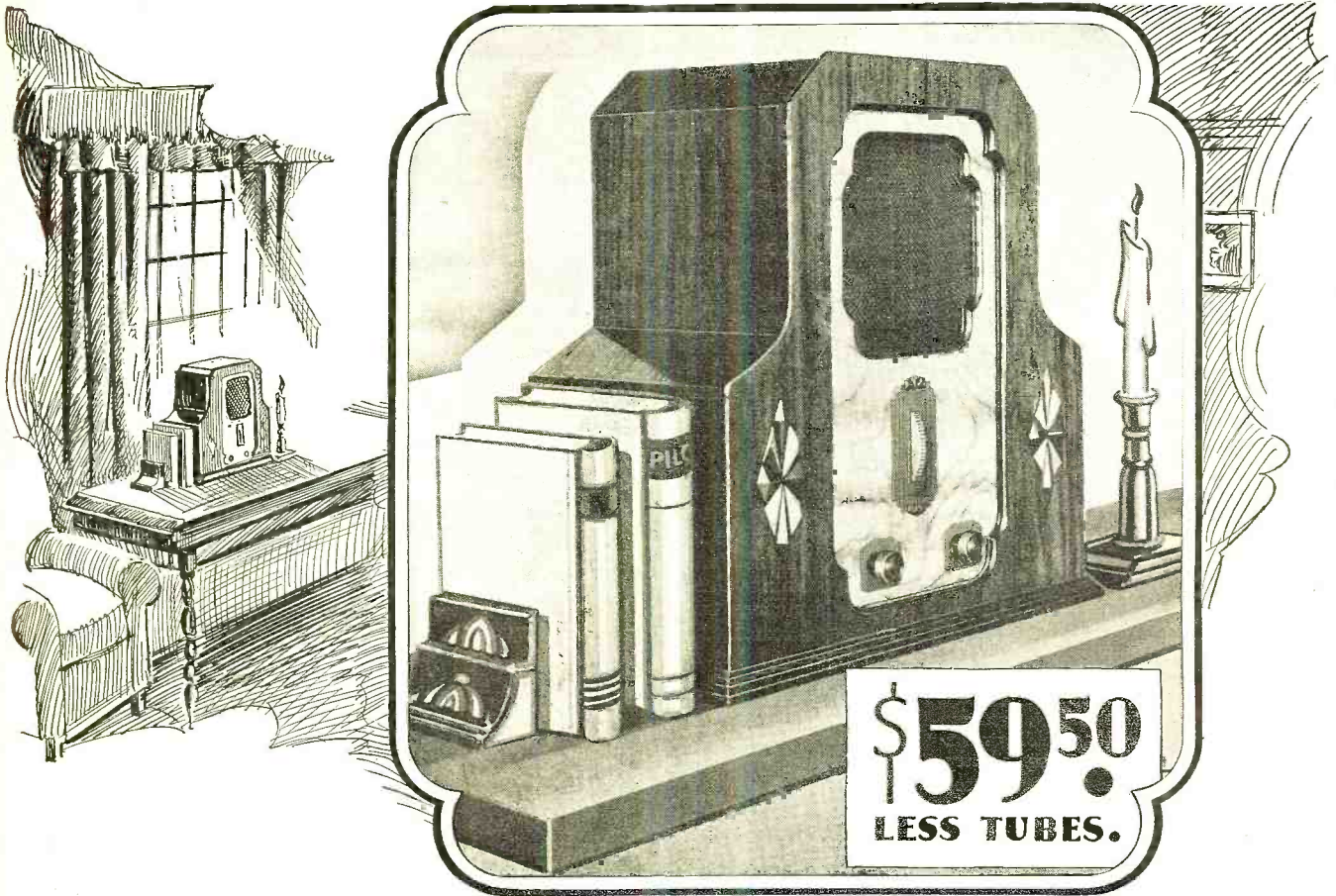

**Your Pilot Retailer  
Is Part of Pilot's Plant**

He is no mere middleman dealing through other middlemen. He is a representative of the factory chosen for his ability to cooperate with Pilot's laboratory engineers in seeing that you enjoy all the abundant satisfaction built into every Pilot product whether it be kit, set, tube, or accessory.

This compact A. C. Midget Receiver in its beautiful two-tone walnut cabinet gives radio performance of console quality. Its modest price is only possible because every part, including tubes, was designed by the same engineers, and made by the same skilled workers—all under one roof—that of the Pilot Radio Plant, the largest factory owned and operated by a radio manufacturer. It is the outstanding miniature receiver in selectivity and sensitivity because of two screen grid stages; in undistorted tone, because of Screen Grid Power Detection; in volume and depth of tone, because of 1-227 audio stage and 1-245 power audio stage. Full Shielding. Its special electro dynamic speaker of Pilot design, is the last touch necessary for complete superiority. Pilotron Tubes are furnished with every Pilot Midget because Pilot retailers know none are more reliable, and that unreliable tubes cause 80 per cent of their service troubles.

**PILOT RADIO & TUBE CORP.**

Chicago Office:  
234 S. Wells Street

LAWRENCE, MASS.

San Francisco Office:  
1278 Mission Street.

**PILOT**

**MIDGET**

L I C E N S E D      U N D E R      R C A      P A T E N T S

## KEEP STEP WITH RADIO PROGRESS!



RADIO is one of the real marvels of this modern age. The demand is for technically trained men—men who keep pace with the unfolding revelations of this mighty and promising industry.

The International Correspondence Schools Course in Radio, prepared and constantly supplemented by outstanding authorities in the field, is specifically designed to meet the requirements of the radio industry for technically trained radio men.

Authorities responsible for the preparation of the I.C.S. Radio Course include: H. H. Beverage, Radio Corporation of America; George C. Crom, American Transformer Company; Keith Henney, author of "Principles of Radio"; Malcom E. Gager, instructor at the Massachusetts Institute of Technology; E. V. Amy, consulting radio engineer, formerly with R.C.A.; H. F. Dart, authority on radio tubes; Julius C. Aceves, consulting radio engineer, formerly of Columbia University, and others.

The I.C.S. Radio Course is complete, from the foundational principles of radio to the most advanced stages. It also outlines the principles and possibilities of television.

Mark and mail the coupon. We will send you all details. This act may be the real beginning of your career in radio!

INTERNATIONAL CORRESPONDENCE SCHOOLS  
Box 8283-J, Scranton, Pa.  
Without cost or obligation, please tell me all about the  
NEW RADIO COURSE

Name \_\_\_\_\_  
Street Address \_\_\_\_\_  
City \_\_\_\_\_ State \_\_\_\_\_  
If you reside in Canada, send this coupon to the International  
Correspondence Schools Canadian, Ltd., Montreal, Canada

## 5 and 10 Meter Transmitters

(Continued from page 413)

two for the filament, one for the plate and the gridleak connection to filament center-tap. The master-oscillator is preferably inductively coupled to the amplifier, conductive coupling loads the oscillator, the constants of which are already small.

A good tube goes a long way toward successful operation at these frequencies. The small tubes will appeal to the average experimenter because of low cost. The UV-202 is adapted to this work if not over about 300 volts is used on the plate. If higher voltages are used, the dielectric loss in the stem soon heats the glass which then becomes conducting. The tubes can be tested for oscillator use if a grid meter is used. When the power is first turned on, the grid current will be a certain value. As the tube heats the grid current usually decreases due to increased losses. If the plate voltage is too high and the leads are close in the stem, a small arc forms at the end of about 3 minutes developing a flashover. A tube should be tested for at least 5 minutes at the plate voltage to be used. In one 202 tube the grid current decreased from 5 to 4 milliamperes and others gave similar changes. In one type of CG-1162, the average decrease was about 4%; the plate current increases. Of the CG-1162 there are two types available of which the one with the "200-type," side, plate supports seems to be the best. It has only one grid lead brought out, while the other usually has two. If more than one tube is to be used in an oscillator set up, each tube should be tested separately first.

A grid-meter can also be used to test the choke coils used in the oscillator. In a low-power oscillator, the finger can be touched to the filament-end as a test; a large change in grid current or a grid-meter which is "alive" denotes a poor choke. Small chokes wound on match sticks are good for the grid. About a 5% change in grid current is allowable.

A home-made frequency meter and a method for calibration are essential for work below 5 meters. Calibration down to about 1 meter is conveniently done with a pair of lecher wires spaced close together, and a shorting link for locating the half-wave positions for measurement. A pair of wires on a portable support on which is mounted a meter stick can also be used for the higher frequencies. The oscillator coupled to the end of the shorted wires is provided with a grid meter for indicating half-wave positions.

The wavemeters shown in the illustration consist of a copper loop of wire and midget condensers. If mounted on the same baseboard, they should be well separated. Extension handles or slotted knobs for these are necessary. Near 300 mc., the condensers should be very small allowing more inductance to couple the oscillator to. The wavelength is first measured on the wires, and this value marked on the paper wavemeter scale when the wavemeter is tuned into resonance with the oscillator.

Since at 5 meters reflectors are quite

small and give large increases in signal strength in a definite direction, at small cost, they will be used extensively. The parabolic reflector is best. It differs from the usual directive systems employing the broadside-on or end-on schemes of transmission in that the reflector wires all derive their power from the main antenna. The phase relation of the currents in the reflector wires with respect to the antenna, depends directly upon the distance apart. When the phase relation is known, the reflector wire can be considered as an independent radiator and the combination of its field with that of the antenna studied. The strength of the reflector's field will depend upon the strength of the main antenna's field, upon the distance between the two, and upon how closely the reflector wire is tuned to the oscillator frequency.

The reflector wires should be carefully tuned. The best method is to set a field-strength measuring apparatus (described later) at a convenient place in the direction of transmission and then to adjust the wire lengths until a maximum deflection is obtained. If several wires are used as a reflector, it may be possible to tune the transmitter for best operating frequency. Each wire added changes the capacity between wires and to earth.

The radiated field from the main antenna induces a current in the reflector wire such that the secondary radiation opposes the main antenna field at the reflector wire, and is similar to that which would be emitted by the antenna 180 degrees earlier or later. The time required for the field to travel the distance between wires must also be considered since the oscillating current changes to another part of its cycle during this time. With the reflector wire at a quarter wavelength behind the antenna, a 90-degree phase change takes place at the antenna when the field travels the quarter wavelength to the reflector. The reflector wire, however, radiates a field 180 degrees out of phase which takes 90 degrees to reach the main antenna so that the two fields are in phase at the start of another cycle. Maximum strength in the direction of transmission is also obtained when the reflector is placed  $\frac{3}{4}$  wave in back of the antenna, but the maximum will be smaller, since less power is absorbed by the reflector wire at the greater distance. Behind the reflector, the fields are 180 degrees out of phase and cancel for the odd multiples of  $\frac{1}{4}$ -wave distance between the two wires, but the field from the reflector is weaker, so there is some "leakage."

In Fig. 6 is shown a method for measuring waves in space which can be used for wavemeter calibration. The three antennas are arranged horizontally. The oscillator is inductively coupled to the half-wave antenna as shown. The reflector wire consists of a length of telescoping tubing insulated from a movable support by which its distance from the transmitting antenna can be varied. The length of the reflector will be longer as it is un-

(Continued on page 451)

**Newest  
THING IN RADIO**

**\$2.95**

**Vari-Tone**  
MAKES A 1931 MODEL OF  
YOUR PRESENT RADIO

**Gives you TONE CONTROL!**  
Connects in One Minute to any  
Electric or Battery Radio

**TRY IT A WEEK At Our  
Risk!**

Makes your set sound like a latest 1931  
"tone control" model. **SATISFACTION  
or money back!** Vary tone and pitch to  
suit yourself. No need to buy a new  
\$200 radio. Send \$2.95 or order C. O. D.  
Free literature. Radio agents wanted.

**VARI-TONE LAB. Dept. 107**  
P. O. Box 700, Cincinnati, O.



## 5 and 10 Meter Transmitters

(Continued from page 450)

loaded. The receiving system can consist of a crystal detector and a 1 milliamperere d.c. meter. A more powerful oscillator such as the UX-852 or H tube should be used in this case. A thermocoupler can be used, its output being connected between grid and filament of a receiving tube which is adjusted to give maximum plate current change when the transmitter is operated. This arrangement works well with a 310 tube oscillator. The reflector is placed at either  $\frac{1}{4}$  or  $\frac{3}{4}$  wave from the transmitting antenna and adjusted until maximum response is obtained in the receiver. A minimum is obtained at a distance of  $\frac{1}{2}$  wave. The distance between the reflector and transmitting antenna can then be measured. The reflector will probably give best results slightly closer than  $\frac{1}{4}$  wave, probably due to the fact that the greater energy pick-up offsets any slight phase difference at the receiver.

If the wires are arranged vertically, the approach of a human body to the transmitting antenna will cause an increased deflection at the receiver due to reflection. Many interesting experiments are possible with this arrangement.

## Skip Distances

(Continued from page 407)

absorption is increased as the wavelength is decreased.

From observing the results of reception for various frequencies over certain distances and from a study of the limits of reception due to the angle of radiation leaving the antenna, it should be possible to increase the period of reception at a given point by controlling the angle of radiation. It should also be possible to vary the radiation angle for ultra-high frequencies, thus enabling reception at certain distances. The radiation angle control system could be arranged by employing a plane horizontal antenna and a horizontal reflector system arranged so as to be rotated beneath the antenna. By this arrangement any radiation angle could be produced.

Chart 1 shows that we can receive at short distances on very high frequencies and can increase the distance by decreasing the frequency. Frequencies down to approximately 8,400 kc. can be received up to several hundred miles without interruption from the skip-distance effect. Above this value the skip distance is increased rapidly.

In Chart 2 the writer has calculated the possible use of frequencies up to 49,000 kc. It is to be noted that this condition exists theoretically, and shows that the zone of reception increases in time as the distance is increased. Reception of higher frequencies should also be made.

In conclusion we might predict that employment of 50,000 to 60,000 kc. will be made possible from New York to Rio de Janeiro or still farther distances.

# Experience Proves TRUVOLTS are BETTER

For Eliminators and Power Packs

U. S. Pat. 1676869 and Pats. Pend.

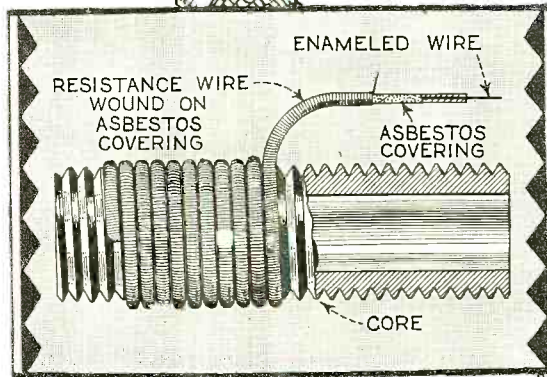

TRUVOLT RESISTORS are "double-wound." The resistance wire is first wound around an asbestos-covered enameled copper core. This is then wound around a grooved fire-clay base. Only with this distinctive winding, patented by Electrad, can there be secured the greater air-cooling which has made TRUVOLT world-famous as the Perfect Performing Resistor.

TRUVOLT Resistors have long been the first choice of experienced radio men for eliminators and power packs, because their experience proves that, for this purpose, only the best is good enough. The open air-cooled winding (see illustration) insures lower operating temperature, more accurate values and longer life in battery eliminators and power packs. Fixed TRUVOLT Models (illustrated above) have a convenient sliding clip for exact adjustment of resistance value. This feature, found only on Electrad TRUVOLT Resistors, greatly simplifies service, installation and experimental work. It also cuts down the number of replacement units necessary.

Made in all usual sizes and wattage ratings. Also TRUVOLT Resistor Banks for Standard Circuits.

ELECTRAD manufactures a complete line of resistors and voltage controls for every radio and power supply requirement, including TELEVISION.

Intelligently standardized production and mass purchasing of raw materials effect large savings in Electrad's original manufacturing costs—savings which are passed on to consumers in Electrad's moderate prices for exceptionally high-grade products.

## Super-TONATROL Heavy Duty Radio Voltage Control

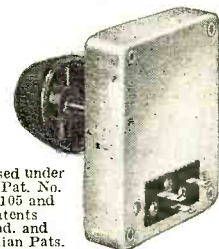

Licensed under U. S. Pat. No. 1773195 and Patents Pend. and Canadian Pats. 281172-286778

Built for long life with heavy currents. Resistance element permanently fused to enameled metal plate. Easily dissipates 5 watts. Pure silver multiple contact provides smooth stepless variation. Metal cover, firmly riveted for strength.

7 types to meet most volume control needs.

\$2.40 to \$3.50.

175 Varick St., New York, N.Y.

# ELECTRAD INC.

MAIL COUPON FOR ELECTRAD DATA  
 ELECTRAD, INC., Dept. RM11, 175 Varick Street, New York, N. Y.  
 Please send circular describing TRUVOLT RESISTORS and SUPER-TONATROL Products.  
 Check here for literature covering all Electrad products.  
 Name .....  
 Address .....

**BRAND NEW**  
**GENUINE Model 3**  
**CORONA**  
**LOWEST PRICE EVER OFFERED**



**\$2.00 DOWN**  
**BALANCE EASY TERMS**

**HERE'S your chance to own that brand new Genuine Model 3 Corona you've wanted—on the easiest terms ever offered—at LOWEST PRICE ever offered! Complete in every detail; back spacer, etc., MANUFACTURER'S GUARANTEE. Recognized the world over as the finest, strongest, sturdiest, portable built. Try this wonderful portable typewriter—the same machine that has satisfied 500,000 users.**

**Yours for 10 Days FREE—Send No Money**

Experience the joy this personal writing portable typewriter can give you! Use it 10 days free! See how easy it is to run and the splendidly typed letters it turns out. Ideal for the office desk, home, traveling. Small, compact, light, convenient. Don't send out letters, reports, bills in poor handwriting when you can have this Corona at such a low price or on such easy terms. Remember these are brand new machines right out of the Corona factory.

**Carrying Case Included—If You Act Now**

Leatheroid carrying case, oiler, instructions free on this offer. Send no money—just the coupon. Without delay or red tape we will send you the Corona. Try it 10 days. If you decide to keep it, send us only \$2—then \$3 a month until our special price of \$39.90 is paid. Now is the time to buy. Mail coupon today!

**MONEY SAVED**  
**By Using This Coupon**

**Smith Typewriter Sales Corp.**  
 (Corona Division)  
 469 E. Ohio St., Chicago, Dept. B-91

Ship me the Corona, F. O. B. Chicago. On arrival I'll deposit \$2 with express agent. If I keep machine, I'll send you \$3 a month until the \$37.90 balance of \$39.90 price is paid; the title to remain with you until then. I can have 10 days to try the typewriter. If I decide not to keep it, I will repack and return to express agent, and get my money back. You are to give your standard guarantee.

Name \_\_\_\_\_  
 Address \_\_\_\_\_  
 Employed by \_\_\_\_\_

**YAXLEY** Push Button Switches

In a wide range of multi-spring combinations. Yaxley construction throughout. Now, in the following numbers:

No. 2001—Make Contact	.....\$1.00
No. 2002—Break Contact	..... 1.00
No. 2003—Single Pole, Double Throw	..... 1.15
No. 2004—Two Make Contacts	..... 1.30
No. 2005—Two Break Contacts	..... 1.30
No. 2006—Double Pole, Double Throw	..... 1.60

**YAXLEY MFG. CO.**  
 Dept. N 1528 W. Adams St. Chicago

Making "110 Volts" Mean What It Says

(Continued from page 401)

the tone quality is decidedly off standard. It might be consolation to some uninformed set owners to feel that, in compensating for the off-standard performance, the tubes should last much longer. And even here, there is no consolation for subnormal line voltage, when the true facts are known. Subnormal line voltage places a serious strain on certain tubes. Power tubes and rectifier tubes, when supplied with insufficient filament voltage, have been known to arc seriously, and are thereby ruined in short order. Some tube manufacturers have experienced trouble in this direction, especially since they are unable to convince the average set owner that his trouble is with subnormal line voltage. To make matters worse, some set owners employ fixed resistance as a so-called line voltage control. Such fixed resistance, while offering protection against abnormal line voltages, actually works greater damage on tubes than when nothing is used, because, when the line voltage drops down to normal, the fixed resistor brings down the applied voltage far below safe limits.

Set designers are well aware of the line voltage problem. Many sets today are provided with "high" and "low" taps on the power transformer, with a suitable switch, fuse or other arrangement whereby the set may be operated for say 110-115 volts or 115-130 volts. While better than nothing, the tapped primary idea is by no means a true solution of the line voltage fluctuation problem. It so happens that few power systems are permanently high or low. Most of them fluctuate during the hours of the day, and even from minute to minute, due to generating conditions and varying loads on the line. What is necessary, therefore, is some compensating means at any given moment for the actual line voltage.

For some years there have been on the market various forms of plug-in devices, fitting between the set's attachment cord and the usual socket or outlet, and intended for the protection of electric radio sets against excessive line voltages. These devices serve their purpose well just so long as the line voltage remains abnormally high. However, when the line voltage drops to normal, these fixed series resistors do more harm than good. This fact is immediately apparent; since the resistance value is fixed, such devices always reduce the line voltage by approximately the same voltage drop. For instance, when the line voltage is at the normal of 110 volts, the fixed resistor plug cuts the voltage down to 100 or less, which, of course, causes the set to perform poorly, while introducing danger of damage to power tubes and rectifier tubes due to insufficient filament temperature. The cure is to remove the plug every time the line voltage drops and to replace it in circuit just as soon as the line voltage rises again. How this is to be done is left to the reader's imagination and ingenuity. Obviously, a good voltmeter is necessary to check the line voltage at all times, together with a watchful eye and willing hand. Fortunately, how-

ever, there are other and better ways of achieving safe operating voltage for the electric radio set.

It becomes obvious, then, that line voltages fluctuate over considerable limits, above and below the 110 volts for which the usual set is designed. What is necessary, therefore, is a resistor in series with the primary of the power transformer, always adjusted for the necessary resistance value to cause a greater or less drop in voltage, so as to strike the mean voltage for which the set is designed.

An automatically compensated resistor for controlling applied voltage is known as a ballast. Even in the young radio art the ballast is by no means new. Some of the earliest battery sets had ballasts to safeguard delicate tubes. The first a.c. radio sets of 1925 were provided with ballast tubes with iron wire in a hydrogen atmosphere. These tubes were placed within a metal housing or "smokestack" for the dual purpose of providing sufficient ventilation and for protecting the radio set and operator against possible explosion, should there be a leak in the tube so that air could become mixed with the hydrogen gas.

Recent research and development efforts have served to make available entirely new forms of line ballasts, which get away from iron wire and hydrogen gas. Instead of a glass bulb device, the latest line ballasts are in the form of a perforated metal case, providing free air circulation for the enclosed winding. The casing is so designed as to take in cool air at the bottom and to distribute the heated air through the top. Such free circulation makes for a remarkably prompt response to the slightest increase in line voltage, as compared with the relatively sluggish response of most ballasts of the enclosed type, let alone the non-breakable feature.

The metal cartridge or clorostat ballast is available in two forms, namely, the built-in ballast, designed and matched for a specific transformer and load, which compensates for subnormal quite as well as abnormal line voltages, and the accessory ballast, which may be used with any standard electric set, and which compensates for abnormal line voltages and normal voltages, but cannot compensate for subnormal line voltages.

The built-in ballast is part and parcel of the radio chassis. It is designed for a definite transformer primary and secondary load. The primary is generally wound for say 85 volts, with the ballast representing the necessary voltage drop between that voltage and the full line voltage. The resistance of the ballast automatically rises or falls, so that the applied voltage is always approximately the same. The chassis of a set calling for the line ballast includes a standard electric receptacle or a two-hole socket, into which fit the flat prongs or round prongs of the ballast. Unfortunately, some owners of a set designed for a line ballast do not take advantage of this added feature. Since the line ballast is

(Continued on page 454)

## Back Talk

(Continued from page 419)

analogous to those within the reflector of an auto headlight, particularly along the steep slopes between highs and lows. Thus while at first sight Mr. Lott's views seem the opposite of our general theory, they actually confirm it in a particular case.

In another letter Mr. Lott adds that he has found the pressure slope between the transmitter and receiver has a considerable effect on signal strength. Reception is good with the signal coming down a pressure slope towards his receiver (from a "high" towards a "low"), and poor with a signal coming up a pressure slope towards the receiver. This observation can be explained by focusing effects as illustrated in Figure 1A, and might be called a further proof of our concave-convex mirror theory.

### Effect of Pressure Changes

Mr. Lott's location in the mid-west, with powerful broadcasters in all directions, is (as he points out) very favorable for the study of radio variations with pressure changes. It is to be hoped that he will continue the work, if possible with quantitative methods, and that other radio enthusiasts near the geographical center of the United States will become interested in the problem. In important work of this kind the value of quantitative data cannot be overstressed. Various methods of making such measurements on radio signals were described in the June RADIO NEWS—"A Research Opportunity for the Radio Amateur."

Another very interesting letter comes from Gilbert Brown of Los Angeles, California. Mr. Brown writes:

"Back quite a few years ago—ten or twelve, I believe it was—I was in a small town just fifteen miles south of York, Pennsylvania. About dusk (it was in the summertime) I happened to be looking just a few degrees above the horizon toward the west, and suddenly I saw what appeared to be a small ball of fire start a zig-zag course through the heavens. It did not follow any definite course and several times recrossed its own path; it left behind it a very well-defined wake, not unlike a mark left on a blackboard by drawing over it with the flat side of a piece of white chalk. This well-defined trail remained in the heavens and, if I remember correctly, it both faded and drifted; the latter statement I am not quite sure of. As I was about 10 years of age at the time I do not remember accurately whether it was accompanied with any sound or not, but I do definitely remember that there was no storm anywhere west of us in this country at the time. Several papers wrote as many varied accounts of the phenomena."

There are only two possible explanations of this apparition; it was either ball lightning or a meteor. Many people pooh-pooh ball lightning and attribute the effect to optical illusion, but in "Physics of the Air," an excellent advanced meteorology text, W. J. Humphreys very rea-

(Continued on page 455)

# The One Sure Way to BIG PAY in RADIO



Send for my Free Book  
See how Quickly I Train You at Home  
to Fill a Big-Pay Radio Job

**YOU must have NRI training to be a CERTIFIED RADIO-TRICIAN**



Television—the coming field of many great opportunities—is covered by my course.



Broadcasting stations offer fascinating jobs, paying from \$1,800 to \$5,000 a year.



Operating on ships gives world-wide travel and \$65 to \$200 a month besides.

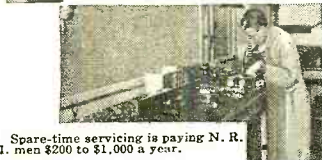

Spare-time servicing is paying N. R. I. men \$200 to \$1,000 a year.



**Seldom Under \$100 a Week**  
"Dear Mr. Smith: For the month of November I made \$577 and for December over \$645 and January, \$465. My earnings seldom fall under \$100 a week."  
E. E. Wisborne, 1414 W.43th St., Norfolk Va.

**FREE 64 page BOOK**



In Radio more than in any other field, the surest, quickest way to get ahead is through *training!* For Radio is in crying need of more well-trained men. Competition is keen among the untrained fellows but the way is wide open for men who *know* Radio! Moreover, there are plenty of opportunities to earn while you learn—many of my students make \$200 to \$1000 in their spare time while learning. That is why I urge you to mail the coupon below for my free book. It tells about the great money-making opportunities that Radio offers trained men—and how you learn at home to become a Radio Expert.

### Many Earn \$50 to \$100 a Week

Many of my graduates are earning \$50 to \$100 a week. After completing my training you, too, should earn as good or even better pay. Hundreds of fine jobs are opening every year. Broadcasting Stations pay \$1,800 to \$5,000 a year to Radio engineers, operators, and station managers. Radio manufacturers continually need testers, inspectors, foremen, engineers, service men, buyers, for jobs paying up to \$15,000 a year. Shipping companies use hundreds of operators, giving them good pay plus expenses. Radio dealers and jobbers pay \$50 to \$100 a week to trained service men, salesmen, buyers, managers. Talking Movies pay as much as \$75 to \$200 a week to men with Radio training. Another way to make big money is to open a spare time or full time Radio sales and service business of your own. And any day now Television may open the way to a new world of opportunities to men who *know* Radio.

### My Free Book Tells All

Get the whole story. Send for my 64-page book of facts on the many opportunities for trained men in Radio today. It has put hundreds of fellows on the road to bigger pay and success. It also contains full information on the "Eighteen Star Features" of my home-study training, including Lifetime Employment Service to graduates. I back my course with a signed agreement to refund every penny of your money if, after completion, you are not satisfied with the Lessons and Instruction Service I give you. † Don't let lack of complete training keep you down. Fill in and mail the coupon NOW!

**J. E. SMITH, President**  
National Radio Institute, Dept. OMSS  
Washington, D. C.

## Mail Coupon Today

J. E. SMITH, President  
National Radio Institute, Dept. OMSS  
Washington, D. C.

Dear Mr. Smith: Send me your free book. I want to know exactly what Radio offers trained men—and what you offer in home-study Radio training. I understand this places me under no obligation and that no salesman will call.

Name .....

Address .....

City ..... State .....

# Making "110 Volts" Mean What It Says

(Continued from page 452)



## A NEW SUPER-HET BY LAFAYETTE

It's here at Wholesale! The new Lafayette Super-Heterodyne. Super-selectivity—and then some. Intermediate-frequency amplification that puts a new thrill in radio reception. The sharpest radio frequency circuits ever produced. A custom built "Super" that is breath-taking in its newness. The new A C operated Lafayette Super (R. C. A. licensed) is a nine-circuit, screen-grid receiver. Amazing low price. Write for particulars.

## LAFAYETTE WIDE WORLD SHORT WAVE RECEIVER

Enjoy the thrill of perfect short-wave reception with the new LAFAYETTE WIDE WORLD SHORT WAVE RECEIVER. A C operated. Push-pull amplification. Double Screen Grid. Operates on a wave length of 9 to 550 meters. Pulls in stations all over the world—Java, Australia, Holland, England, etc. Priced sensationally low.



## RUSH THIS COUPON at once!

Wholesale Radio Service Company  
38 Vesey Street  
Dept. L-12, New York

Send me a copy of your 1931 radio catalog ABSOLUTELY FREE. I am particularly interested in

New Lafayette Super-Box Heterodyne  
 New Lafayette Wide World Short Wave Receiver.

Name .....  
Address .....  
Town .....  
State .....

**FREE**  
RADIO CATALOG  
New 1931 Wholesale Radio Catalog. Coupon brings yours free.

**WHOLESALE RADIO SERVICE CO.**  
38 VESEY ST. Dept. L-12 NEW YORK

## "Dependable 'B' Battery Power"

For long and short wave receivers. Prices reasonable. Also "B" batteries operating from 32 to 110 volt D. C. farm lighting systems.

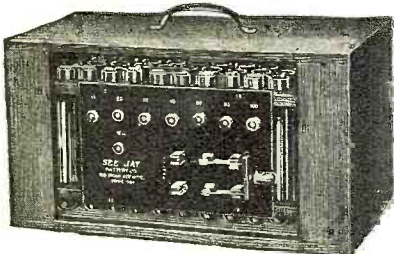

Write for our free interesting booklet. See Jay Battery Co., 911 Brook Ave., N. Y. C.

## Massachusetts Radio and Telegraph School

18 Boylston Street, Boston

Send for Catalogue

Tel. Hancock 8184 Established 1905

usually not included in the original shipment, but, like tubes, must be bought and inserted, the owners frequently short circuit the ballast receptacle and operate the set without. In so doing they may eliminate the very essential series resistance, thereby placing a grave strain on the set and tubes, or, at best, they are receiving no protection for their tubes.

Of more general interest is the accessory form of clarostat regulator, since it is applicable to any electric set. When the line voltage is normal or low, the voltage drop in this device is so low as to be negligible. As the line voltage increases, the resistance of the plug-in device increases so that at all times the receiver gets an applied voltage within normal limits. As an example, with a line voltage of 115, the set should get 110 volts, while with 140 volts on the line only 120 volts will reach the set, which is entirely safe and within the usual limits of 110 to 120 volts specified by set and tube manufacturers. Two types of accessory clarostat regulators are made, namely, Type A for sets consuming up to 100 watts, and Type B for those requiring between 100 and 150 watts. To determine the wattage of a set, the wattage of each tube is determined and then totaled, as per the following table:

TABLE FOR DETERMINING WATTAGE OF SETS

Type of Tube	Wattage
250	45
281	15
210	17
280	15
245	18
224	7
227	7
226	5
171	10
112	10

The automatic ballast should not be confused with the usual so-called line voltage regulator with fixed resistance. The latter has no real compensating feature. It reduces applied voltage at all times, due to voltage drop caused by series resistance. A comparison of a typical fixed resistor "line voltage regulator" and the automatic accessory form of clarostat ballast may be of interest in illustrating the fundamental difference between such devices. The following charts show actual readings taken during the tests on two devices. It should be noted that the units were tested by passing through them the average current required by various sets at low, normal and high line voltages. The voltage drop at each current was measured with a high-resistance Weston a.c. meter, and the resistance was calculated from these figures.

### CLAROSTAT TYPE A REGULATOR

Amperage	Voltage Drop	Resistance
.80	7	8.75
1.00	12	12.00
1.20	20	16.66

### CLAROSTAT TYPE B REGULATOR

1.1	6	5.45
1.3	10	7.69
1.6	18	11.25

### SO-CALLED LINE VOLTAGE REGULATOR (Fixed Resistor)

#### LIGHT DUTY (Cold 16.2 ohms)

.60	9.6	16.00
.80	13.0	16.25
1.00	16.0	16.00
1.20	20.0	16.66

#### HEAVY DUTY (Cold 11 ohms)

1.0	11.0	11.00
1.1	12.5	11.36
1.3	15.0	11.53
1.6	19.0	11.87

#### EXTRA HEAVY (Cold 6.5 ohms)

1.3	8.0	6.15
1.5	9.5	6.33
1.7	11.0	6.47
1.9	12.0	6.81

It will be noted from the above that while the truly automatic type or ballast line voltage regulator changes its resistance to compensate for changes in voltage, the fixed resistor type in common use does not do so. Therefore, the latter offers no real measure of protection to fluctuating line voltages, although it may be of some use where the line voltage remains abnormally high.

One important consideration in line ballasts is that of quick heating and prompt response. Due to the free air circulation, the clarostat type radiates the generated heat at the proper rate to maintain the necessary working temperature without lag. When the current is first turned on cold tubes and ballasts there is a slight surge until the ballast warms up, which may be from 25 to 30 seconds. During this time the tubes require more current, because their filaments, acting as ballasts, have comparatively low resistance when cold. After this short period any additional voltage would be likely to injure the tube filaments or heaters. Ballasts having restricted ventilation take from four to seven minutes to heat up, and therefore overload the entire set during this period.

From the strictly engineering standpoint, the radio chassis, if it is to be used in many and scattered localities, positively requires a line voltage regulating device. The usual tapped primary transformer is no solution, first, because it requires manual setting, which is generally neglected; secondly, because a voltmeter is required to ascertain proper tap to use; thirdly, there is no provision for rapid changes to meet rapid line voltage fluctuations.

From the servicing standpoint, the ballast is essential. It reduces service calls, tube replacement claims and power pack troubles, representing a marked saving to all concerned in money and in good will alike.

From the merchandising standpoint, the chassis provided with the ballast may be sold anywhere and everywhere. It performs uniformly well. It stays sold.

From the set owner's standpoint, the chassis with automatic line voltage regulation or ballast performs uniformly and satisfactorily at all times, and insures maximum life from the tubes, not to mention costly power pack replacements.



## Back Talk

(Continued from page 453)

sonably deduces that this peculiar effect is simply a stalled thunderbolt, lacking sufficient voltage to break down (or ionize) the last part of its path. The fact that Mr. Brown noticed no clouds in the vicinity makes the ball lightning idea very improbable but not impossible, for we have personally seen lightning strike from the blue sky in Arizona.

### Meteors

The chances are, then, that what Mr. Brown saw was a fireball, or meteor large enough to reach the lower atmosphere. Most meteors, smaller than grains of sand, burn up completely in the upper atmosphere and appear as streaks of light or "shooting stars" in the clear night sky; but occasionally a big one reaches the earth—a meteorite as big as an ocean steamer struck Siberia several years ago, blasting the forest and killing every animal within a radius of fifty miles. May such a one never strike one of our large cities! Meteorites are visible in daylight; they make a tremendous noise; and they usually leave a whitish trail which drifts with the wind. The only confusing element is that Mr. Brown's fireball pursued a zig-zag course; this is hard to understand, as they usually travel in approximately straight lines. Because meteors tell us much about the upper atmosphere they are of interest in studies of radio reception; they are best seen during the early morning hours. Their courses are usually determined by triangulation as shown in Fig. 2. Anyone who observes a large fireball is fortunate (provided it is not making straight for him), and may notice facts of scientific value.

### A Letter from Java

From far Java, land of the Balinese dancers, comes another interesting letter. W. L. Hasselbach of Kediri writes primarily for permission to translate the February article into Dutch for colonial short-wave hams. But he also states that many amateur transmitters are on the air in Java, chiefly in the 20-meter band, using both code and phone. His own call is PK2AL.

The reason for using the 20-meter band is quite apparent. The path between Java and the United States is so long, and so placed on the earth's surface, that part of it is always in sunlight. Sunlight lowers the ionized layer, and the low layer necessitates a very short wavelength. Ten meters is a little too short for average conditions. Ordinarily 20 meters show large skip distances, but at a distance of 12,000 miles the signal zones have begun to overlap. Finally, the 20-meter signal half-circles the earth with few reflections, as shown in Fig. 3. Java and western Australia are nearly antipodal to the eastern United States—the maximum dx available on this finite earth! In addition, Java-America tests might be important in solar correlation work because the signals must cross the region of the north magnetic pole.

# BUILD AND REPAIR POWER PACKS WITH PUNCTURE-PROOF FILTER CONDENSERS

BETTER THE FILTERING AND ELIMINATE, ONCE FOR ALL TIME, THE DANGER OF HIGH VOLTAGE BREAKDOWN

Zenith, Sparton, Crosley, Colonial, Kennedy, Howard, Amrad, DeForest-Crosley or Canada and a long list of other prominent radio manufacturers have used Mershon (Puncture Proof) Electrolytic Condensers in their receivers for years,—for these units provide better filtering, greater reliability and almost unlimited life, at lower cost.

In building or repairing power-packs for receivers, transmitters or power-amplifiers, Mershon Condensers are equally of value to you.

### —FEATURES—

- THEIR FIRST COST IS LOW.
- THEY ARE SELF-HEALING. Voltage surges that can ruin ordinary filter condensers have no effect on them.
- THEY ADD PROTECTION TO THE POWER PACK, by absorbing voltage surges.
- THEY INCREASE THE FILTERING OF THE POWER PACK, because of their larger capacity.
- THE MORE THEY ARE USED, THE BETTER THEY BECOME. Their active life is almost unlimited.

### HOW TO USE MERSHONS

Mershon Condensers are manufactured in several different capacities and two different mounting styles. Single Unit Mershons have the positive terminal at the top or bottom, as desired, with capacities of 8 or 18 Mfd.

Multiple Unit Mershons have positive terminals at top, and may be obtained in either Double Unit or Triple Unit styles.

These latter are the most economical filter condensers available. They cost less per Mfd. than even the Single Unit Mershons, and are equivalent in filtering action.

An unusually effective filter circuit for power-packs using the type —80 rectifier tube (very popular with receiver manufacturers) is shown in the diagram.

One Mershon Condenser, Type Triple-S, with two chokes, supplies complete filtering. The only additional condensers required are the usual small ones across the low voltage detector plate tap and bias resistors.

The first choke can be of low inductance (about 5 Henries) and high current carrying capacity. The second choke can be of high inductance (20 Henries or more) and low current carrying capacity. It need carry only the plate currents of the detector, first audio and R. F. tubes.

The New Mershon Booklet "Puncture Proof Filter Condensers" contains other effective filter circuits and much interesting information about Mershon Condensers and their uses. Send for a Free Copy.

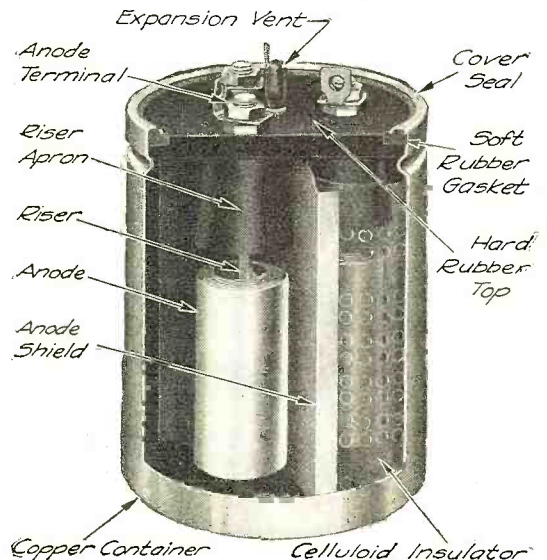
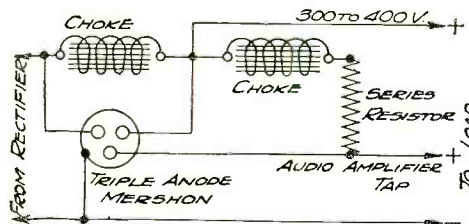

Cut-away view of the New Style Multiple Anode type Mershon Condenser, showing latest patented construction.

### WHAT USERS SAY

NDR, Augusta, Maine, says "Having great success with Mershons. Using a bank of Mershons Sunday, put new NDR on the air and got Xtal report first QSO." "Our only worry is that someone will buy them right out of our filter system." WIBES says, "I successfully blew a 4,000 volt bank of — condensers before acquiring the Mershons, but have had no trouble whatsoever since." WICCP says, "Had 'RAC' reports on my transmitter before, but now am getting 'DC' and 'pure DC.'"

From a radio distributor, "Zenith has been using your condensers for more than two years, and we as jobbers have found them to be all that is claimed for them." From a dealer, "Have sold Crosley and Amrad for three years, and have yet to have a Mershon go bad." A service manager, "Have not known of one going bad in a receiver yet."

The success of Mershon Condensers is based upon years of development and actual experience in service. It is the only electrolytic condenser with such a background.

Forty of the Leading Parts Distributors stock the New Mershon Condensers. If yours cannot supply you with the ones you want, write us for prompt action.

# Electrolytic MERSHON Condenser

Manufactured Exclusively by  
THE AMRAD CORPORATION  
365 College Avenue  
Medford Hillside, Mass.

The Amrad Corporation 365 College Avenue Medford Hillside, Mass.		NAME .....
Please send me prices and booklet on the New Mershon Condensers. <input type="checkbox"/>		STREET .....
I am a Parts Jobber. Send me your new Jobbers' Proposition. <input type="checkbox"/>		CITY .....
		STATE .....

## Learn to Be a Well-Paid AVIATION Mechanic

The Aviation industry pays its mechanics more than any other line. It is an uncrowded field that needs good men. Every plane that flies must be carefully and constantly cared for by ground men. There is a big opportunity for you in this work.



"Red" Jackson—  
Twice holder of the  
World's Endurance  
Record—a Von Hoff-  
mann graduate.

### Proper Training Can Be Had in from 6 to 12 Weeks

Compared with any other business, Aviation training takes but a very short time. In the Von Hoffmann School the training you get exceeds government requirements. It is thorough and practical. This School is a leader. Late types of planes and modern and complete ground equipment only are used. Because of the reputation of the School, Von Hoffmann graduates find ready employment.

If you prefer to pilot, ask for information about the courses approved by the U. S. Dept. of Commerce for Transport, Limited Commercial and Private—Ground and Flying courses.

Located on the famous \$2,000,000 Lambert-St. Louis Airport.

### Write for Our Illustrated Catalog

It gives detailed information about the opportunities in Aviation—about the school—about the courses—about the low cost—and it tells you how to make your start in this great business. No obligation involved. Use the coupon below for convenience.

A practical method of easy payments is available for those who desire it.

## Von Hoffmann Aircraft School

2335 Lambert-St. Louis Flying Field, St. Louis, Mo.

VON HOFFMANN AIRCRAFT SCHOOL  
2335 Lambert-St. Louis Flying Field  
St. Louis, Missouri. MAIL TODAY

Name.....  
Address.....  
City..... State.....  
Age..... I am interested in  
( ) FLYING COURSE ( ) MECHANICS COURSE  
( ) WELDING COURSE ( ) HOME STUDY

## RADIO OPERATORS WANTED



Radio operators are officers aboard ships. Well paid, pleasant work, travel. You can qualify in a short time in our well-equipped school under expert instructors.

Write now for free booklet on "Opportunities in Radio."

### West Side YMCA Radio Institute

113 West 64th St., New York, N. Y.

## LEARN BY LISTENING Telegraphy

Morse or Continental

Step into this interesting—uncrowded—HIGHLY PAID Profession. Become a trained operator in Morse or Radio

Code, easily, quickly, at home, with TELEPLEX, the Master Teacher. Used by the U. S. Government and leading schools.

Write for Folder E-11

TELEPLEX CO.

76 Cortlandt St., New York, N. Y.

Learn AT HOME With

eleplex



## The Unit-Built Receiver

(Continued from page 429)

diagram will show the use of a 250,000-ohm plate resistor coupled to the grid circuit of the following -27 by a 0.1 mfd. condenser, the resistance in the -27 grid circuit being 500,000 ohms. It is only by the use of resistance coupling in the output of the screen-grid detector that uniform amplification at all audio frequencies can be obtained. Of considerable importance is the double section r.f. filter in the plate circuit of the detector. This filter consists of two r.f. choke coils in combination with two 0.00025 mfd. condensers. This double-section filter is used to prevent any possibility of r.f. feedback from the plate circuit of the detector to the antenna, for if this occurred the receiver would oscillate. The -27 first audio amplifier tube is coupled to the primary of the input push-pull

gang condenser section, the individual tube shields, and the individual coil shields. The circuit diagram shows each screen circuit of the r.f. amplifier tube to be filtered by means of a 0.1 mfd. condenser and an 11,000-ohm resistor. Each plate circuit is filtered by means of another 0.1 mfd. condenser and an r.f. choke coil contained inside the coil shield, these choke coils being individually shielded from the r.f. transformer. The grid circuits of the screen-grid tube are bypassed by a third 0.1 mfd. condenser. The 11,000-ohm detector grid biasing resistor is shunted with a 1 mfd. condenser and the screen circuit of the tube is by-passed with a 0.5 mfd. condenser, the voltage supply being filtered by an 11,000-ohm resistor. Many tests on audio amplifiers have indicated that the low-frequency response depends largely upon the by-passing of the grid resistor of the first audio amplifier tube. In the Hi-Q 31 we find the 2,500-ohm biasing resistor shunted by a 12 mfd. condenser. This unusually large capacity completely prevents any common coupling effects in the bias resistor. The use of individual "C" bias resistors for each tube together with individual filter circuits serves to indicate the care that has been taken in the Hi-Q 31 receiver to eliminate common coupling between various circuits.

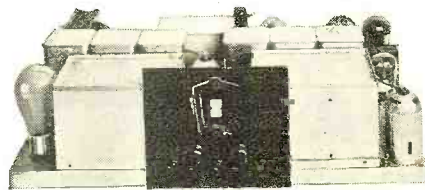

A front view of the new 1931 Hi-Q receiver. The general layout is quite similar to the 1930 model

Volume is controlled by means of a 16,000-ohm resistor which serves to vary the voltage applied to the screen grids of the r.f. amplifier tubes. The receiver is also equipped with a local-distance switch which when thrown to the local position cuts a 200-ohm resistor directly in the tuned circuit feeding the grid of the first r.f. amplifier tube. This serves therefore to cut down the voltage of all signals impressed on the grid of the first tube. This is a much better arrangement than permitting full voltages to be applied to the first grid and then trying to reduce them in the following stages. By means of the variable volume control and the local-distance switch excellent control of volume can be had on all stations, local or distant.

transformer, which has a ratio of 1:1. This low ratio may seem rather surprising, but it is possible to build low-ratio audio transformers to have much better frequency response characteristics than high-ratio transformers, and this is why a 1:1 ratio is used. The input push-pull transformer feeds two type -45 tubes arranged in push-pull and the output transformer feeds the loud speaker. From these two tubes in push-pull it will be found possible to obtain almost 5 watts of undistorted power, and this is more than sufficient for all ordinary uses.

Besides the on-off and the local-distance switch there will be found a third switch on the panel which is the tone control. When closed it connects a .002 mfd. condenser across the plate circuit of the detector tube. As a result the reproduction is given a mellow quality which many people seem to like. This control will also be found useful in eliminating interference frequently experienced when listening to distant stations.

The sensitivity of the receiver is sufficient to make it possible to go down to the noise level in any locality. The fact that the receiver has such high sensitivity is of course due largely to the use of three screen-grid tubes in the r.f. amplifier. It is also due to the use of a screen-grid detector, which, as stated previously, is some ten times as good as three-element detectors. Special insulation is also to be found in the coils and tuning condensers to give these two important units low-loss characteristics. The primaries and secondaries of the r.f. transformers have also been designed to give high uniform gain over the entire broadcast band. Each section of the gang condensers is equipped with a small compensating condenser so that every circuit can be brought into exact resonance to obtain maximum gain and selectivity.

The Hammarlund dynamic loud speaker recommended for use with this receiver is rather unusual in design. Its field winding contains two separate coils, one of 850 ohms and the other of 3,000 ohms. The 3,000-ohm coil is used as the second filter choke in the plate supply unit and the 850-ohm coil is placed in the filament circuit of the -45 tubes to supply the necessary bias for these tubes. In other receivers bias for the -45 tubes is obtained from a simple resistor and the power consumed

The complete shielding and filtering incorporated in the receiver can be judged by reference to the photographs and circuit diagram. The photographs indicate the complete shielding over each

(Continued on page 458)



# Champion

Ribbon Labels for Dating

Give Everybody "a better break"!

*the Set User:*

buys definite and honest service . . . date of purchase stamped on ribbon label eliminates arguments and misunderstandings.

*the Dealer and Jobber:*

finds unreasonable claims ended, and replacement losses negligible. The dated ribbon label measures honest service with yardstick accuracy!

. . . and Everybody's Better Satisfied!

CHAMPION RADIO WORKS

DanVers, Mass.



Illustrated with 40 dripping scenes from the good old days, by the famous Bob Dean.



"ONE ON THE HOUSE"!

Only 50c. While They Last!

## THE HOME BARTENDER'S GUIDE AND SONG BOOK

CONTAINS 200 authentic recipes which will make you smack your lips and long to live over again the days of your youth. You wish you could try them all immediately, just as the authors once did. If the good old days ever do come back, we recommend that you pause awhile after each and before the next.

contains dozens of famous old songs that you will want to get right up and sing loud and long—especially loud and long if you have tried a few of the recipes. Here you will find "Father, Dear Father. Come Home with Me Now," the original "Frankie and Johnnie" song, and many others.

**Precise Recipes**

are given explaining exactly how bartenders of old concocted practically every drink known to mankind. Many forgotten gems of purest translucent color are here restored to the human race. Perhaps they may yet spread their sunshine on these dark days when the mixing of a good drink is almost a lost art. And what drinks they are!! Here are just a few:

- Kiddie Kar Cocktail
- Manhattan
- Tom Collins
- Golden Fizz
- Bacardi Rickey
- Hello, Montreal
- Harvard Cocktail
- Careless Love
- Widow's Kiss
- Horse's Neck

**And What Illustrations!**

Profusely—lavishly they crowd the pages. "Everybody Works But Father"—"Don't Hit Your Mother, It's Mean"—"Down Where the Wurzburger Flows," and scores of others. Truly these rare portrayals of scenes from bygone days are the work of a genius. So vividly will they stir your memories, they will bring tears to your eyes. They alone are worth a hundred times the modest price of this complete "HOME BARTENDER'S GUIDE."



**Buy It at Your Newsdealer's or Rush this Coupon Back AT ONCE!**

Radio-Science Publications, Inc.  
 Dept. 2411  
 381 Fourth Avenue, New York, N. Y.

Gentlemen: Ship me immediately . . . . . copies of "THE HOME BARTENDER'S GUIDE & SONG BOOK." I enclose 50c for each copy ordered.

Name . . . . .

Address . . . . .

City and State . . . . .

# The Unit-Built Receiver

(Continued from page 456)

in this circuit is just wasted. In the Hi-Q 31 the additional field coil supplies the bias and the current flowing through this coil supplies additional field excitation for the loud speaker. In this way we therefore obtain an additional 3.5 watts of field power without placing any additional load on the rectifier. For those who already have a satisfactory loud speaker it is simply necessary to place into the circuit an additional resistor and choke coil, both of which are arranged for easy connection in the circuit.

Provision is made for a phonograph pick-up, the phonograph-radio switch serving to connect the pick-up to the grid of the detector tube. The phonograph jack is automatically connected in the circuit when the tuning dial is turned to its lowest setting. Power for the electric turntable is obtained by connecting the lead from the motor into one of the two convenience outlets placed near the back edge of the chassis. The other outlet can be used to supply power to an electro-dynamic loud speaker.

Line voltage fluctuations are taken care

of by means of a voltage regulator placed in the 90-volt primary of the power transformer.

The Hi-Q 31 is built on a strong metal chassis measuring 12 $\frac{3}{4}$ " by 23 $\frac{3}{8}$ ". All wiring is done under the subpanel. The fact that each unit of the receiver is supplied completely wired and tested makes the assembly and adjustment of the receiver a simple task practically devoid of possible trouble.

In this article we have endeavored to bring out the highlights of the new Hi-Q 31. Future articles will discuss in detail the construction and operation of the receiver and definite data on the characteristics of various parts of the set will form an important part of these discussions.

We feel that this new receiver is really outstanding in its overall performance. Engineers and others who have had the opportunity to test preliminary laboratory models have been enthusiastic about the high quality of the reproduction and the receiver's ability to pick up distant stations without interference.



## Smooth Sailing DEMANDS Control

Regattas are won when Control is at the Helm. Every care-free gust of wind must be controlled, every sail bellying properly, working the sloop smoothly, surely around the final buoy and down the last leg, the winner. In millions of homes radio skippers are cruising around the dials with CENTRALAB Controls at the helmsman's hand.

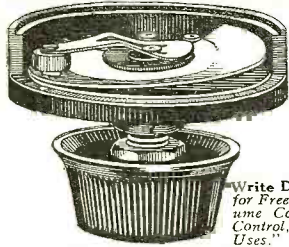

With Centralab Control at the helm, there is always a smooth, noiseless reception. Be sure it's a CENTRALAB Control.

Write Dept. 225-G for Free Booklet "Volume Control, Voltage Control, and Their Uses."



CENTRAL RADIO LABORATORIES  
Dept. 225-G 22 Keefe Ave. Milwaukee, Wis.

Latest data on radio receivers for Dealers, Servicemen and Amateurs

## The Radio Construction Library

WRITTEN by two widely known radio engineers, these three books cover every phase of building, repairing and "trouble-shooting" on modern receiving sets. This practical Library includes: PRACTICAL RADIO—The fundamental principles of radio, presented in an understandable manner. Illustrated with working diagrams. PRACTICAL RADIO CONSTRUCTION AND REPAIR—Methods of locating trouble and reception faults, and making workmanlike repairs. Discusses modern Short Wave Receivers fully. RADIO RECEIVING TUBES—Principles underlying the operation of all vacuum tubes and their use in reception, amplification, remote control and precision measurements.

Three Volumes, 6 x 9—993 pages, 561 illustrations.

See this Library FREE!

No Money Down

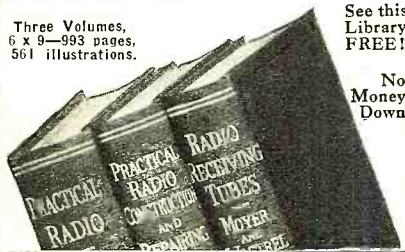

McGraw-Hill

FREE EXAMINATION COUPON

McGraw-Hill Book Company, Inc.  
370 Seventh Avenue, New York

Send me the new RADIO CONSTRUCTION LIBRARY, three volumes, for 10 days' free examination. If satisfactory I will send \$1.50 in ten days, and \$2.00 a month until \$7.50 has been paid. If not wanted I will return the books postpaid.

Name .....

Home Address .....

City and State .....

Position .....

Name of Company .....RN-11-30

a.c. on their filaments, and if such simple precautions are taken, as proper by-passing, grid return to cathode and twisted filament wires kept away from the wiring, efficient results will be had.

Usually regeneration is controlled by a throttle condenser. This is by no means the most satisfactory method. There is a decided detuning effect in capacitive control, which is reduced to an astounding minimum when resistance control of regeneration is employed. (Fig. 4.) The variable resistor may be anything between 50,000 and 200,000 ohms. A wire-wound resistor is not quite stepless, and therefore not as satisfactory as a coated strip resistor, although the wire wound affair lasts much longer than any other. A  $\frac{1}{2}$  mfd. bi-pass condenser will smooth out the noises created by the moving contactor on the resistor strip. A good vernier dial on the throttle control is not essential. However, when tuning in weak signals, it is a great asset.

So far I have neglected r.f. amplification. We cannot condemn the good natured efforts of various manufacturers to improve S-W receivers by using tuned screen grid radio frequency amplifiers on short waves. We have found in actual practice that a tuned screen amplifier on S-W is no more effective than untuned r.f. There is no amplification apparent, though the use of the tube has some advantages. It smoothes regeneration by removing the antenna from the tuned circuits, thus avoiding dead spots, and almost any length antenna may be employed without considerable change in signal.

The home builder must let his pocket book decide what kind of audio amplifi-

cation is advisable. There are many makes of good and comparatively cheap transformers on the market, suitable for both phone and code reception. For code reception alone high ratio transformers (10-1 if available) will emphasize the higher notes more, and give greater signal strength. For combined code and phone reception, or the latter alone, two stages of 3 to 1 transformer coupling are sufficient. A power tube in the last stage is hardly necessary.

All signals should be tuned in carefully with the head-phones, and then they may put on the loud speaker. It is generally rather difficult to tune in the signals directly on the loud speaker.

Occasionally it is found that signals will vary in strength on touching metal parts of headphones or loudspeaker. This can easily be eliminated by the insertion of small r.f. chokes in the out-put leads. (Fig. 5.)

A metal panel is not necessary, nor is a rubber panel essential, though desirable in moist regions. Good veneer  $\frac{1}{4}$ -inch wood makes an efficient and pleasant-looking, strong panel.

Do not use shock-absorbing sockets in your receiver. If any of the tubes should vibrate near an r.f. circuit, it would mar the reception, by periodically changing the constants of your receiver automatically.

Yes, a good "B" eliminator may be used on S-W receivers. Be sure, however, that it is good, and that it has an efficient filtering system. There is absolutely no reason for any disturbance from a good "B" substitute, except a slight residual and non-disturbing a.c. hum.

## With the Short-Wave Fans

(Continued from page 432)

# Sound Quality in Motion Picture Recording

(Continued from page 416)

one minute on the screen after cutting. This sometimes gives rise to an exaggeration of defects in the minds of the studio listeners, while in other cases the critics tend to become used to distortion, so that after they have memorized a speech it appears quite intelligible and normal to them. In short, for effective viewing of rushes from all angles, one must not only possess critical judgment in listening, but it is necessary to acquire the knack of cutting the picture mentally and listening to the projected material on any given day in the light of what it is probably going to sound like when the public sees it. This is not easy, but it can be done to some extent by a skilled director, and when a producing group is got together, the members of which are able to do this more or less consistently, the nearest approach to the movie millennium is achieved.

## The Entire Problem

A sense of proportion and the knack of looking at problems from the standpoint of the picture as a whole are indispensable to the recordist on all jobs above the routine level. With all the contributions which broadcasting has made to the technique and personnel of talking pictures, many broadcasting operators do not realize the complications of picking up sound accompanying a picture, instead of under the made-to-order conditions of broadcast transmission. Take, for example, the dilemma of the recordist on a location job with an expensive company. It is late in the afternoon and the light is rapidly disappearing. The director wants to make a shot. He says, "The light's going; never mind the sound." If the recordist holds up the scene, he may seriously antagonize the director. If, on the other hand, he yields too easily, he may get poor sound and be blamed for it later in the projection-room, where things look a great deal different than on location. He may conclude that he has a chance of getting good or passable sound, and on that basis decide to take a chance in the interest of the picture as a whole. It is the intelligent acceptance of such hazards and the most effective utilization of the pick-up possibilities which remain that differentiate the successful recordist from the one who is eliminated as unfit. A recordist who never takes a chance, but always insists on perfect conditions for sound, will not remain long in the business. One who never gets up on his hind legs will not remain in it either.

## Compromises

Other compromises which must be made are at times when an actor's voice happens to be bad because of a cold or other difficulty, and, nevertheless, it is necessary to shoot because his contract calls for only a limited appearance, or because of some other limitation on time. Again, even an actor with a chronically poor voice may present other advantages from the box-office angle which make it necessary to tolerate this deficiency.

Re-recording offers some degree of relief from a number of the vexing problems entailed in judging sound quality in the movies. With a good re-recording channel the recordist is in a position to raise or lower levels through a considerable range when the first result is not entirely satisfactory. By means of suitable filters, modification of frequency content in re-recording is possible, so that the effect of distance may be simulated. Of course this should not obviate efforts to get the best possible sound in the beginning. The capable recordist tries to get it right the first time and utilizes every device toward that end. For example, when he is asked to pick up on a stage some sound, such as the shouting of a newsboy ostensibly coming from outdoors, he will not, as a rule, attempt to use an indoor pick-up, but will place a microphone outside the stage and get his effect in that way.

## New Problems

As the art progresses, new problems arise to complicate judgment of sound. For example, if microphone reflectors should come into extensive use, it would be possible to get close-up acoustic pick-up at a considerable distance. This would entail numerous economic and dramatic advantages, but it would also involve a tendency to sacrifice sound perspective. The problem will then be to get good perspective under the new conditions, just as new problems in pick-up arose when microphone booms were introduced. The sound technician who is entitled to his place on the pay-roll has already solved so many of these problems that he is not daunted by the ones looming up in the future. He realizes that while the recording and judgment of high-grade sound is difficult, it is nevertheless possible, and as the art progresses, equipment, technique and conventions will be gradually adapted to its needs.

## Antenna Tuning Devices

In some types of receivers, especially those employing an aperiodic primary or antenna coil reception can be improved materially by the insertion in the antenna



circuit of an external loading or tuning device. To satisfy the demand for such a device the Essenbee Radio Devices Company of Chicago has recently placed on the market their product, the Claratone.

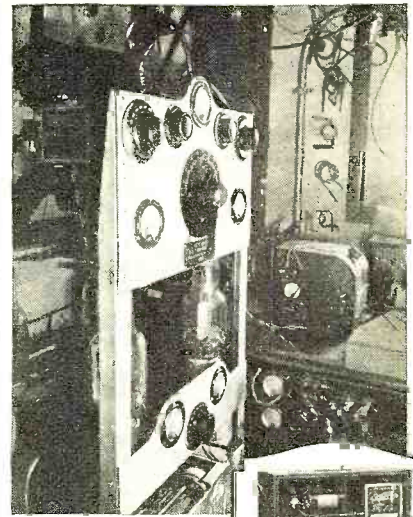

Showing eight of the many Weston Instruments used in the radio cabin on the "City of New York."



Three Weston Instruments were used on this portable radio transmitting and receiving set.

in "Westons,"  
Byrd  
found the

## DEPENDABILITY he needed

WHEN Commander Byrd formulated plans for the long stay in the Antarctic, a very important task was the selection of equipment that would give service under the most adverse conditions.

There were no service organizations, factory representatives, nor extensive repair facilities in Little America; but a group of men, thousands of miles from civilization, whose lives and hopes depended upon the reliability of their equipment.

Only Radio could penetrate their isolation. It was radio that carried daily messages to the waiting world, that kept exploring parties in touch with Little America, and with Commander Byrd in his flight over the South Pole. And Weston points with pride to this important and

unfailing radio service which was controlled with Weston instruments— instruments not made especially for the expedition, but taken directly from our standard stock. Again Weston has kept faith.

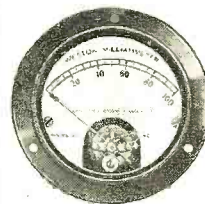

The 2" and 3/4" Weston D.C. and Thermocouple Models were used by the Byrd Expedition.

WESTON ELECTRICAL  
INSTRUMENT CORPORATION

615 Frelinghuysen Ave. Newark, N. J.



## Better radio reception..with a CLAR-A-TONE

only  
**\$1.95**  
post-paid

Special Introductory Price

**MONEY-BACK GUARANTEE**



Pure, clear tone—greater volume—interference cut out instantly! Attach Clar-A-Tone to your set and enjoy tone you never thought your radio could produce.

Thousands of owners say Clar-A-Tone is amazingly ingenious. And radio engineers will tell you what a fine technical accomplishment it is.

Regular price, \$2.50—but now as special introductory offer, we will ship you a Clar-A-Tone direct for only \$1.95. Mail the coupon below with check or money-order, or currency. *No C.O.D.'s.* Money back any time within 10 days if you're not satisfied. Simple installation instructions complete on box.

**EARN GOOD MONEY AT HOME BY SELLING CLAR-A-TONES**

ESSENBEER RADIO DEVICES CO.  
732 Mather Street, Chicago, Illinois

Enclosed find my payment of \$1.95 for Clar-A-Tone, sent postpaid. And send me details on money-making plan for agents.

Name .....

Address .....

City ..... State .....

**JOBBERS, DEALERS: WRITE FOR OUR INTERESTING PROPOSITION**

## PHOTOELECTRIC CELLS

By DR. NORMAN R. CAMPBELL and DOROTHY RITCHIE, Research Staff, General Electric Co., Wembley, England. Illustrated, \$4.50.

The first thorough presentation of practical application of photoelectric cells in television, sound projection, etc. Also discusses theory and uses. "Particularly timely... well worth its addition to one's library."—*Electronics.* Send for Technical Book List.

---

## TELEVISION

By SYDNEY A. MOSELEY and H. J. BARTON CHAPPLE. Illus., \$2.50

Foreword by John L. Baird

The development of television, early experiments and its present and probable commercial use, is told as a fascinating story of scientific triumph. Well illustrated. It shows a number of hitherto unpublished photographs and diagrams.

Write for Technical Book List

ISAAC PITMAN & SONS, 2 W. 45th St., N. Y.

## ACME WIRE PRODUCTS

Parvolt Filter and By-Pass Condensers, Magnet Wire-All Insulations, Varnished Insulations, Coils.

**THE ACME WIRE CO.**  
NEW HAVEN, CONN.

## Selectivity+Fidelity+High Gain=Superheterodynes

(Continued from page 410)

first detector, it is tuned by a .00014 mfd. condenser controlled by a vernier dial. A -27 tube is the oscillator, and power supply for both tubes of the converter is obtained from a small, self-contained power unit. While it might be feasible to obtain all power for the converter directly from the receiver by which it is employed, this would involve pulling leads out of the set and would complicate the connection of the converter to it; it has been felt, therefore, that it is wiser to incorporate a complete power supply unit directly in the converter for simplicity and, particularly, in view of its low cost. A -26 tube is used as rectifier, being fed by a small transformer which also supplies filament current for the -24 detector and -27 oscillator. Filtration is provided by one high inductance choke and two 4 mmfd. dry electrolytic, semi-self-healing condensers. The whole construction and design of the converter is so ridiculously simple that there is little explanation necessary, the circuit diagram being self-explanatory, as are the photographs. The antenna is coupled to the first detector through a small trimmer type condenser which, upon installation, is initially set to provide the most satisfactory results, as is also the similar small trimmer condenser used to couple the oscillator to first detector grid circuit. The first detector is coupled to the antenna binding post of the broadcast receiver through a 300,000-ohm resistance and a .0001 mfd. fixed condenser. To install the converter it is only necessary to insert its power supply plug into a 110-volt, 50 or 60 cycle light socket, remove the antenna lead from the receiver and connect it to the antenna post of the converter and then connect the two posts on the converter to antenna and ground posts of the receiver. To omit the converter it is simply necessary to shift the antenna lead from the converter back to the receiver antenna post. In operation, the volume is controlled entirely by the receiver volume control, it being contemplated that the converter will be placed on top of, or beside, the regular broadcast receiver which, in turn, is tuned to some low frequency around 600 kc., on which normally no station can be heard. If, when the converter is used, the receiver tuning dial is always set at exactly the same position, the oscillator dial on the converter may be logged definitely, which is, of course, a great convenience.

In actual operation it has been found that the results obtained from this converter, in conjunction with a good broadcast receiver, were distinctly superior to those obtained from any short-wave receiver which it has been the writer's privilege to play with, including a number of short-wave superheterodynes. The selectivity is extremely satisfactory, indeed, and the problem of image-frequency selectivity is not troublesome, due, first, to the use of very high intermediate frequencies—that to which the broadcast receiver is tuned, which generally places the image frequency 1,000 kc. or further away from the wanted station, coupled

with the fact that the short-wave channels upon which the converter will be operated are not as crowded as are the American broadcast channels; consequently the possibility of image-frequency interference is much less than on a superheterodyne operating in the broadcast band. This short-wave converter may be employed with a broadcast band superheterodyne receiver, in which case the resultant combination might be termed "double-super," due to the fact that two intermediate frequencies would be employed—one in the broadcast band, that to which the superheterodyne broadcast receiver would be initially tuned, and the other the superheterodyne i.f.

### Further Adaptation

When the converter is adjusted in conjunction with the broadcast receiver for reception of short-wave telephone or broadcast signals it does not permit of reception of short-wave c.w. signals. It is a very simple matter, however, to adapt it to c.w. telegraph reception by the simple process of so tuning the broadcast receiver with which the converter is used that it is set very close to a local broadcast station, which is then used as a local oscillator to heterodyne the short-wave telegraph signals. It is assumed, however, that the broadcast receiver is sufficiently sensitive to pick up at least one high-wave local station either directly upon its coils or on the small length of connecting wire between its antenna post and the converter. Of course, if preferred, a separate local oscillator, set to beat with the intermediate frequency or the wave to which the broadcast receiver is tuned, may be used for short-wave reception and, since this will be unmodulated, it is somewhat preferable to the use of a local broadcast signal as heterodyne.

## Adapting Your Receiver to Short-Wave Reception

(Continued from page 423)

Each coil is numbered and readily distinguished from the others. One of the coils covers the broadcast band of 200 to 550 meters, another the band of 100 to 200 meters, and the two smaller coils cover together the popular 15- to 100-meter band. There is sufficient overlap on each coil so that the entire band of 15 to 550 meters is easily covered.

The parts and materials used in the construction of the unit are: 1 .0003 tuning condenser; 1 .000045 antenna midget condenser; 1 .0001 regeneration "Vol" midget condenser; 1 bakelite vernier tuning dial, 1 30-ohm rheostat; 1 4-prong tube socket; 1 5-prong coil socket; 1 by-pass condenser; 1 r.f. choke coil; 1 grid leak; 1 .00015 grid condenser; 1 cast aluminum shield; 4 plug-in coils; 8 binding posts.

**HOTEL LUDY**  
SOUTH CAROLINA AVE. AT THE BOARDWALK  
**ATLANTIC CITY'S**  
NEWEST CENTRALLY LOCATED FIREPROOF HOTEL  
**\$6.00**  
DAILY AND UP  
AMERICAN PLAN  
WIRE PHONE OR WRITE R. B. LUDY M.D.

## Home-Study Business Training

Your opportunity will never be bigger than your preparation. Prepare now and reap the rewards of early success. Free 64-Page Books Tell How. Write NOW for book you want, or mail coupon with your name, present position and address in margin today.

- |  |  |
|--|--|
| <input type="checkbox"/> Higher Accountancy        | <input type="checkbox"/> Business Corres.      |
| <input type="checkbox"/> Mod. Salesmanship         | <input type="checkbox"/> Credit and Collection |
| <input type="checkbox"/> Traffic Management        | <input type="checkbox"/> Correspondence        |
| <input type="checkbox"/> Rail. Station Mgm't       | <input type="checkbox"/> Modern Foremanship    |
| <input type="checkbox"/> Law: Degree of LL.B.      | <input type="checkbox"/> Personnel Mgm't       |
| <input type="checkbox"/> Commercial Law            | <input type="checkbox"/> Expert Bookkeeping    |
| <input type="checkbox"/> Industrial Mgm't          | <input type="checkbox"/> C. P. A. Coaching     |
| <input type="checkbox"/> Banking and Finance       | <input type="checkbox"/> Business English      |
| <input type="checkbox"/> Telegraphy                | <input type="checkbox"/> Commercial Spanish    |
| <input type="checkbox"/> Business Mgm't            | <input type="checkbox"/> Effective Speaking    |
| <input type="checkbox"/> Railway Accounting        | <input type="checkbox"/> Stenotypy—Stenog'y    |
| <input type="checkbox"/> Paper Salesman's Training |  |

LaSalle Extension University, Dept 1194-R, Chicago

## TYPEWRITER 1/2 Price

Save over 1/2-Rock Bottom Price on all standard office models—Underwood, Remington, Royal, etc.—Easiest terms ever offered. Also Portables at reduced prices.

**SEND NO MONEY**  
All the models completely refinished like brand new. Fully Guaranteed. Sent on 10 days' trial. Send No Money. Big Free Catalog shows actual machines in full colors. Greatest bargains ever offered. Send at once!

231 W. Monroe St.  
International Typewriter Exch., Dept. 1193 Chicago

**RADIO TUBES**  
Cunningham—Arcturus—Radiotron—Eveready—Raytheon  
Dealers' & Service Men's Test Kits a Specialty  
Write for Special Prices  
**NELSON ELECTRIC COMPANY**  
Wholesale Radio Apparatus  
508 South Dearborn Street, Chicago, Illinois  
Wholesale Radio Catalog Sent Free Upon Request

**EXPLORE THE SHORT WAVES**  
with the  
**EXPLORER PLUGLESS CONVERTER**  
Range 15-200 Meters—Price Only \$14.50  
**WRITE FOR FREE LITERATURE**  
RIM RADIO MFG. CO.  
695 Grand Street Brooklyn, N. Y.

**GEARS**  
In stock—immediate delivery  
Gears, speed reducers, sprockets, thrust bearings, flexible couplings, pulleys, etc. A complete line is carried in our Chicago stock. Can also quote on special gears of any kind. Send us your blue-prints and inquiries.  
Write for Catalog No. 40  
**CHICAGO GEAR WORKS**  
769-773 W. Jackson Blvd., Chicago, Ill.

## Course in Radio Broadcasting

THE first college course in the business of radio broadcasting is being offered this year by the College of the City of New York. Frank A. Arnold, director of development of the National Broadcasting Company, has been engaged to deliver a series of lectures on Radio Broadcast Advertising and the course, which will be open to both men and women, was inaugurated Monday night, September 29.

The lectures will be given every subsequent Monday night from 8:00 to 10:00 o'clock at the School of Business and Civic Administration, Lexington Avenue at Twenty-third Street.

Mr. Arnold, who has been active in broadcasting and has been an authority on broadcast advertising since its very beginning, plans to cover every phase of the alliance between business and radio. Author of several books on the subject of radio advertising, he has traveled more than 100,000 miles studying listener reaction and the dozens of problems connected with broadcast advertising.

The announcement of the radio course is seen as a milestone in the recognition and development of radio, according to radio executives. It marks the first time an American college has included lectures on radio advertising in its curriculum.

The course will include lectures on the technique of broadcasting and will illustrate methods used in preparing both sponsored and sustaining programs. The historical background of present day broadcasting will be the basis of the initial lecture, and this will be followed by a discussion of the development of broadcasting to its present status.

How the air audience is obtained, the technique of making an advertising program fit the product, the value of goodwill in broadcasting and other phases of the business will be discussed and analyzed.

A part of each lecture period will be devoted to the answering of questions and an informal discussion of various features of broadcasting.

Enrollment in the city college will not be necessary for persons wishing to take the course, it was explained.

Mr. Arnold is well known in the advertising world as well as in the radio studios. For twelve years he was president and general manager of the magazine "Suburban Life," and for nine years was an officer and director of the Frank Seaman Advertising Agency. He was named Director of Development for NBC when the broadcasting company was organized in 1926.

### Hearst Proposes Fifth Long-Wave Station

In addition to the long-wave stations authorized for construction at New Rochelle, N. Y., Chicago, Atlanta and San Francisco, the American Radio News Corporation, a Hearst subsidiary, now asks the Federal Radio Commission to authorize the building of a new 10-kilowatt station of the same type at Denver.

## AEROVOX

BUILT BETTER  
CONDENSERS AND RESISTORS

Without a Doubt  
The Most Complete  
**CONDENSER and RESISTOR Line**  
in Radio

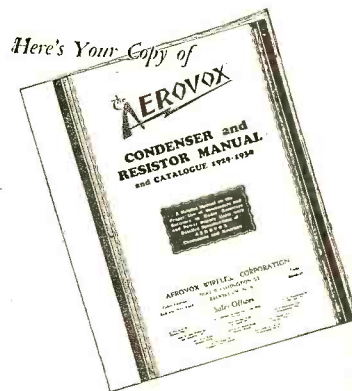

Sent Free on Request

This interesting and helpful Manual and Catalogue containing a wealth of information on condensers and resistors and complete electrical and mechanical data on the complete line of Aerovox condensers and resistors will be mailed free of charge on receipt of the coupon below.



The Aerovox Research Worker is a free monthly publication issued to keep radio engineers, experimenters and servicemen abreast of the latest developments in receiver and power supply design, and especially with the proper use of condensers and resistors. A request on the coupon below will place your name on the mailing list.

Check and Mail This Coupon

AEROVOX WIRELESS CORP.  
78 Washington St.  
Brooklyn, N. Y.

Gentlemen:

Please send me without charge or obligation:

- ( ) Your 32-page Condenser and Resistor Manual and Catalogue.  
( ) The Research Worker.

Name .....  
Street .....  
City ..... State .....

**AEROVOX WIRELESS CORP.**  
78 Washington St. Bklyn, N. Y.  
PRODUCTS THAT ENDURE



## Give Your Radio Set A Fair Chance

**Equip It With the  
Best Aerial Material**

The best radio set made is handicapped by poor aerial equipment. See that your dealer supplies you with the best by insisting upon a Corwico Aerial Kit, which includes a Corwico Vulcan Lightning Arrestor with a \$100 guarantee. All materials are of the highest grade and assure perfect broadcast reception.



PRICE

\$2.50

Complete

At Your Dealers  
or Direct Upon Receipt of Price

CORNISH WIRE CO.

24 Church St. New York City

MAKERS OF THE FAMOUS



BRAIDITE HOOK-UP WIRE

## ★ LATEST SUPERHETS and S.W. Kits

We have in stock and ready for immediate delivery the complete parts for Silver-Marshall, National, Hatry & Young, and the Radio News S. W. Superhet Receivers. All for sale at

**WHOLESALE PRICES**

SILVER MARSHALL 738 S. W. Superhet converter, completely wired.....	\$41.70
In kit form, not wired.....	\$35.70
SILVER MARSHALL 724 AC Broadcast Superhet, completely wired.....	\$59.70
In kit form, not wired.....	\$52.50
NATIONAL S. W. 5 Receiver, completely wired, with power-pack.....	\$74.40

Particular attention given to all EXPORT ORDERS.

### H. JAPPE CO.

New England's Largest Radio Jobbers  
46 Cornhill, Boston, Mass.

### ALUMINUM BOX SHIELDS

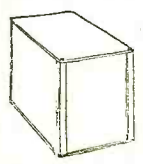

Genuine "ALCOA" stock, silverdip finish, 52x26, \$1.89—Corner size \$1.65.

ANY SIZE TO ORDER.

Coil Shields, Coil Hole Covers, Shielded Wire, Dubilier Duratrons, Neon Test Lamp, \$1.00, Midcot 3-Plate Condenser, 50c, Sprague 25 Condensers, 50c, 001 Variable Condensers, \$1.25, Bakelite Tubing Magnet Wire, 65-ohm Resistors for 2-Volt Tubes on 6 Volts, 30c, Soft Rubber Grommets, 3 for 5c, Osc. Coils, Pilot Coils, Kits and Parts. Please include postage.

BLAN, the Radio Man, Inc.  
89 Corlandt Street, Box 1, New York City

# A Six-Tube Short-Wave Super

(Continued from page 421)

he made the oscillator r.f. current the detector plate supply, which is similar in essence. Robert S. Kruse, however, well-known short-wave radio engineer of West Hartford, was exciting the screen grid of a quatrode from the oscillator as long as two years ago, which is the first I heard of this specific method. However, until contradicted I claim to be the first intentionally to have raised the intermediate frequency in a short-wave superheterodyne up to about where it belongs. However—

The intermediate-amplifier transformers are impedance- or auto-coupling devices, which is to say they employ a

condenser of .0002 mfd. and leaks as high as 7 megohms, the maximum being best for sensitivity. For a.c. the -27 is sufficiently similar and takes a lower leak. Thusly we handle No. 1.

Nos. 2 and 3 for d.c. operation get the -40 followed by a high-grade a.f. transformer. The high- $\mu$  tube and the good transformer give medium to poor tone, good intelligibility of speech and high sensitivity, a most desirable combination for either telegraphic or telephonic communication. For a.c. operation the -27, of course, and with a high leak.

Regeneration can be fixed in a set of this type, which, due to the r.f. amplifier, is nearly always working the detector at maximum signal. Extreme regeneration by fine control would not be particularly effective and is hence unnecessary. Consequently the regeneration is got from a tickler and set by a fixed throttle condenser composed of two capacities in series. Shorting out one of these capacities makes the larger effective and throws the second detector into oscillation for the beatnote reception of carriers or c.w. telegraphy.

Such a second detector worked at fairly low plate voltages is only good for comparatively small undistorted output voltages. Consequently at least two a.f. stages should be employed. Through two 3-1 a.f. transformers and a first a.f. tube the maximum undistorted voltage available for the power tube is just sufficient to overload a -71A run at 135 of "B" and normal bias. More a.f. voltage gain must be had if greater output power than that from a couple of -71A's in push-pull is desired. This is true according to experimental data. Actually, apparently satisfactory tone is got with only the gain of two stages, the last being push-pull -45 tubes. But the *best* requires at least 200 voltage gain from the input of the a.f. to the grid of the power-amplifier tube.

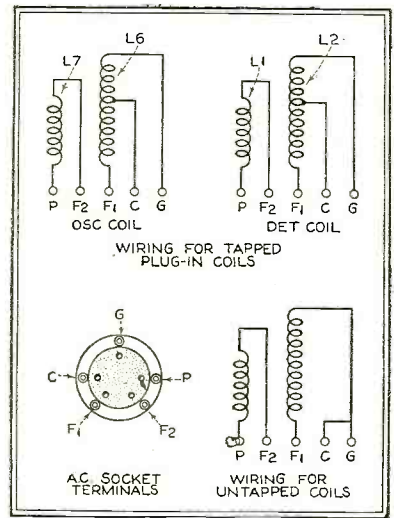

The electrical circuit of the various coils employed in the six-tube S-W Super

common primary-secondary winding. Thus all the impedance of the tuned circuit is effective to the tube. A stopping condenser isolates the tube coupled to from the high voltage and a grid-leak type resistance of two megohms completes its grid d.c. circuit. The couplers themselves may be seen in the photographs of the HY-7 set. The unit i.f. transformer also contains the "B" circuit r.f. choke and by-pass condenser.

The second detector must be considered from two viewpoints: that of the broadcast or music listener and that of the short-wave radio-telegrapher or telephoner. The first wants distortion at a minimum, the second wants it at a maximum and the last can permit quite a lot if intelligibility remains. Fortunately we can compromise on the permissible for the last and please both him and number 2, partly because they are of the same tribe; but number 1 is pleased only somewhat short of tone perfection—he insists.

Regeneration in the second detector is desirable since it adds to the i.f. selectivity and amplification. A good second detector for the d.c. set is the -12A, since it fits in well with audio transformers of high grade due to its low impedance and good tone characteristics as a grid detector. It is satisfactory with a grid

### Coil Table

Oscillator Coils				
	L5	Tap	L6	Freq. Range
01—	7	4	5	13,000-15,000 kc.
	Use 01 with A2 also			10,000-12,000 kc.
02—	18	no tap	10	6,000-7,800 kc.
	Use 02 with A4 also			3,000-4,800 kc.
03—	31		14	4,700-6,000 kc.
	Use 03 with A6 also			1,700-3,000 kc.

Antenna Coils			
	L2	Tap	L1
A1—	8	4	NON-INDUCTIVE
A2—	11	5	
A3—	13	..	
A4—	33	..	
A5—	18	..	
A6—	50	..	

ON ALL COILS (except A6) L5 and L2 are wound with 22 D.S.C. wire. On A6 L2 is wound with 30 D.S.C. All L6 and L1 windings are No. 30.

The spacing between L5-L6 or L2-L1 is always about 1/8 inch. Closer spacing will do little but much greater spacing on 0 coils will alter frequency ranges slightly. In any case only tuning ranges and not performance will be altered. Turns of wire are wound touching, and windings are kept as near the bottom of the coil form as possible.

(Continued on page 463)



# EXCELLO NEW 1931 RADIO



Model R-279  
Phono-Radio  
Combination

Excello Radio, 3 screen-grid radio tubes with dynamic speaker. Furnished complete with phonograph equipment. Meets perfectly the highest standards of program re-creation. Excello Radio means excellent reproduction. Free catalog of Radio, Radio-Phonograph Combinations and Consoles. Write today.

**EXCELLO**  
PRODUCTS CORPORATION  
4832 West 16th St. Cicero, Illinois

## ✓ FREE BOOKS of BUSINESS HELPS

We publish over 200 Home Study Books, each a complete treatise of its subject. We have one or more for you. Books on

- |  |   |
|--|---|
| <input type="checkbox"/> Commercial Art      | <input type="checkbox"/> Decoration       |
| <input type="checkbox"/> Lettering           | <input type="checkbox"/> Automobiles      |
| <input type="checkbox"/> Advertising         | <input type="checkbox"/> Battery Work     |
| <input type="checkbox"/> Sign Making         | <input type="checkbox"/> Electricity      |
| <input type="checkbox"/> Radio               | <input type="checkbox"/> Carpentry        |
| <input type="checkbox"/> Aviation            | <input type="checkbox"/> Building         |
| <input type="checkbox"/> Painting            | <input type="checkbox"/> Contracting      |
| <input type="checkbox"/> Silk Screen Process | <input type="checkbox"/> Sheet Metal Work |

and many other subjects. All fully described in our FREE CATALOG. Check the subjects in which you are interested and write today.

**FREDERICK J. DRAKE & CO., Publishers**  
Room 510—179 No. Michigan Blvd., Chicago  
Drake books are for sale in all book stores

**MASON, FENWICK & LAWRENCE**  
**PATENT LAWYERS**  
600 F St., N. W., Washington, D. C.  
*Estb. over sixty years. Send sketches.*  
Electrical, Aeronautical and Chemical Inventions carefully handled. Practice before the U. S. Courts and the Patent Office. Prompt and careful service. Write us. Protect your inventions.  
**TRADE MARKS REGISTERED**

**STUYVESANT ELECTRIC CO.**  
53 Walker St. New York  
Write for  
**FREE CATALOGUE**  
ON LATEST RADIO BUYS

## A Six-Tube Short-Wave Super

(Continued from page 462)

### Complete Circuit of A.C. HY-7 Six-Tube Superheterodyne

- L1—Antenna winding of detector plug-in coil.
- L2—Secondary winding of detector plug-in coil.
- L3—I.F.T. winding, 150 turns No. 30 d.s.c., 1" diameter tubing.
- L4—R.F. choke built in i.f.t. can.
- L5—Tickler of 8 turns on top of L3 at "B" end.
- L6—Grid winding of oscillator coil.
- L7—Plate winding of oscillator coil.
- L8—Hammarlund shielded r.f. choke.
- 1 indicates connection to metal chassis.
- C1—50 mmfd. midget pilot.
- C2—.01 mfd. Sangamo fixed condenser.
- C3—.0005 mfd. Sangamo fixed condenser.
- C4—100 mmfd. Hammarlund equalizer, range with L3 about 1650-1475 kc.
- C5—.25 mfd. Sprague midget fixed condenser.
- C6—.0002 mfd. Sangamo fixed condenser.
- C7—Same as C1.
- C8—.00015 Sangamo.
- C9—.00005 mfd. Sangamo.
- C10—.001 mfd. Sangamo.
- C11—1 mfd. Flechtheim.
- R—5,000-ohm Electrad royalty potentiometer.
- R1—100,000-ohm Durham metallic leak.
- R2—2-megohm Durham metallic leak.
- R3—400-ohm Electrad suppressor resistance.
- R4—2,000-ohm Electrad suppressor resistance.
- R5—25,000-ohm Durham metallic.
- R6—3-megohm Durham metallic.
- R7—25,000-ohm Electrad royalty potentiometer.
- R8—50,000-ohm Durham metallic.
- R9—2,250-ohm Durham metallic.
- R10—10-ohm centre-tapped Yaxley.



## Cures by Sound Amplifiers

(Continued from page 417)

By turning a knob the whole is put in operation, and the flip of a switch makes either the radio, phonograph or microphone ready for use. Reproduction is transmitted uniformly throughout the institution over 10,000 feet of wire, supplying 372 headphones through jacks at each bedside.

There are ten circuits in the output system with four volume levels to permit variations in any one of the circuits, to compensate for heavy loads or long distance. The switches are so arranged that with five positions any one or any group of circuits may be connected, disconnected, or operated at any volume. When the circuits are disconnected no sound can be heard in any head-set connected in that circuit. Although No. 19 twisted wire inside telephone wire without lead shield or metal braid of any kind is used throughout this installation, there is no cross talk.

*Every One Of  
Your Customers*

**WILL BE INTERESTED IN  
THIS ARCTURUS FEATURE  
LIFE-LIKE  
TONE**

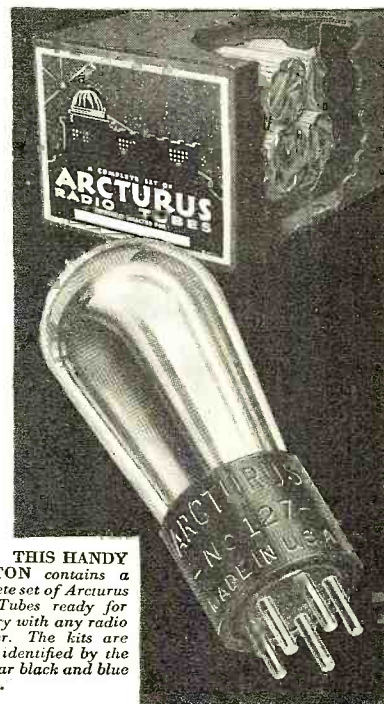

THIS HANDY CARTON contains a complete set of Arcturus Blue Tubes ready for delivery with any radio receiver. The kits are easily identified by the familiar black and blue design.

**N****NATURAL**, Life-Like reproduction! That's the feature you emphasize when you're showing a set; that's the kind of reception every buyer expects.

Now Arcturus gives you, in the new air-cushioned package, a set of Arcturus Blue Tubes especially selected for the designated receiver. With a complete set of Arcturus Tubes in a radio, you know you'll get unusually clear, brilliant programs, and you know that they will keep the set sold.

The advanced design of Arcturus Tubes eliminates mechanical background noises—every note, every word, comes in with a vivid Life-Like Tone. In addition you get the 7-second action that has made Arcturus Blue Tubes famous.

Get the details from your jobber today. Arcturus Radio Tube Company, Newark, N. J.

**ARCTURUS  
TUBES**  
*The TUBE with the LIFE-LIKE TONE*

## BUILD YOUR OWN CAPACITY BRIDGE

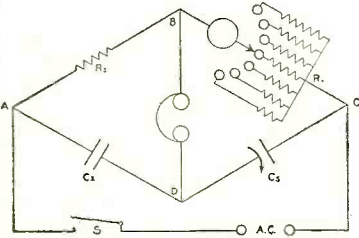

Super Akra-Ohm wire-wound Resistors are recommended for the construction of an inexpensive capacity bridge in September QST. The following Super Akra-Ohm Resistors, Type 61, were used:

Each	
1— 100 Ohm.....	\$1.25
1— 300 Ohm.....	1.25
2— 1,000 Ohm.....	1.25
1— 3,000 Ohm.....	1.25
1— 10,000 Ohm....	\$1.50
1— 30,000 Ohm....	1.50
1— 100,000 Ohm....	2.00



We manufacture wire-wound resistors of any value from 0.01 to 10,000,000 ohms having negligible inductance and distributed capacity and calibrated to an accuracy of 1%. Their use is highly recommended for Laboratory Standards, High Voltage Regulators, Telephone Equipment, Television Amplifiers, Grid and Plate Resistors, Electrical Apparatus, and Test Equipment, etc.

Prices range from \$1.25 for 100 ohms to \$4.00 for 500,000 ohms.

Send us your dealer's or jobber's name and we will send you a copy of an article reprinted from September QST, telling how to build a capacity bridge. Address Dept. D.



## The CROSLLEY ROAMIO AUTOMOBILE RADIO RECEIVING SET

FOUNDED 1899

IN 12 WEEKS

# LEARN ELECTRICITY

EARN \$60 to \$200 a Week!

Get in the field that offers you BIG PAY— Be an Electrical Expert. Coyne is not a correspondence school. Everything practical. No books or useless theory. You do actual work on huge outlay of electrical equipment. You don't need education or experience. Earn while you learn. Free courses in Radio, Aviation Electricity and Auto Electricity right now. Also special offer.

WRITE FOR FREE BOOK and details of special offer and Life Scholarship. Mail coupon.

**COYNE Electrical School**  
H. C. Lewis, Pres. Founded 1899  
500 S. Paulina St. Dept. 80-77, Chicago, Ill.

H. C. LEWIS, Pres.  
COYNE ELECTRICAL SCHOOL, Dept. 80-77  
500 S. Paulina Street, Chicago, Ill.  
Please send me FREE your big catalog and your special offer of free railroad fare.

Name.....  
Address.....  
City..... State.....

# The Engineering Behind the RCA-Victor Radiola Superheterodyne

(Continued from page 400)

or powerful distant stations, where interference is usually less, the most desirable characteristic is good quality.

The "local-distant" switch in this receiver is arranged to perform this function.

### "Local" Position

At the "local" position the receiver is still very sensitive, but its selectivity is impaired slightly in order to get better tone quality. The receiver should normally be operated with this switch in the "local" position. In the "distant" position better sensitivity and selectivity are obtained, and throwing the switch to this position will give better volume on extremely weak signals and on all signals the frequency of which is but slightly different from powerful local stations. The difference in tone quality of the two positions of the switch, while noticeably better at the "local" position is still very good at either position. At times when the noise level is high, throwing the switch to the "distant position," even when receiving a local station, may give better results because of the greater selectivity of the receiver in this position.

### Volume Control

Volume control is accomplished by varying the control grid bias on the radio-frequency and first intermediate-frequency amplifier. This gives a balanced reduction in amplification at both radio and intermediate frequency when the volume control is reduced.

### Shielding

The amount of shielding required in an ordinary receiver is determined, to a large extent, by its amplification or sensitivity. The purpose of the shielding is to eliminate feed-back which would cause instability or oscillation. In general, the higher the frequency to which an amplifier is resonant the more likely it is to be unstable. In a superheterodyne most of the amplification takes place at the low intermediate frequency, so that much less shielding is necessary than would be required at broadcast frequencies for the same sensitivity.

### Power Supply

In the power supply a -80 rectifier tube is used. The filter system is especially designed to eliminate a.c. hum from the loud speaker. The loud speaker field is used as one of the inductive elements of the filter, so the total rectified current flows through its winding, providing a powerful magnetic field.

In order to eliminate resistance coupling through the power supply leads, the voltage divider resistors for the radio amplifier tubes are located on the chassis. All grid returns are grounded and most of the tubes are self-biased by their plate current flowing through resistors in their

cathode circuits, further reducing any chance of coupling through common resistance.

### Dial Indicator

The dial indicator is of the projection type and is calibrated directly in kilocycles so that the receiver can be turned directly to a station once its frequency is known.

### Testing the Receiver

In the construction of any receiver, the methods of testing the various components determine in a large measure the ultimate results to be obtained from that receiver. The Radiola superheterodyne is indicative of the truth of this statement.

Before assembly in the chassis, each component is tested in almost every conceivable way. Selectivity curves are run on radio-frequency transformers in such a manner that each transformer is individually tested before inserting it into its shield, and again after the shield is put on. The assembly is again tested after the coils are mounted on the chassis and wired up.

No laboratory could be more exact in their measurement work than the operators of these testing machines. The machines themselves are marvels of engineering ingenuity, and a description of them makes a separate story in itself. In a coming issue we hope to give our readers that story, with a full description of the testing apparatus used.

## Radio for N. Y. Air Police

(From RADIO NEWS Bureau)

**S**LOWER than many other major cities in getting its police radio system under way, New York City nevertheless is making ambitious plans for the use of radio in crime detection and pursuit. Not only does the New York Police Department propose to transmit instructions to squad cars via radio, which is the chief use of radio in police work today, but it intends to employ its system to broadcast instructions to New York's recently established unit of sky police.

Instructions to aviators by radio is nothing new, but the use of radio by flying policemen has not been undertaken elsewhere for the simple reason that few, if any, other cities have police aviation units. The scheme is perfectly feasible and will undoubtedly be sanctioned by the Federal Radio Commission when requests are made for special wavelengths for the purpose.

Systems have been established or are being established in such cities as Chicago, Detroit, St. Louis, Cleveland, Washington, San Francisco, Seattle, Minneapolis, St. Paul, Indianapolis, Louisville, Columbus and Miami.

## Monster Tubes for New 400,000-Watt KDKA

(From RADIO NEWS Bureau)

TWO giant tubes, each standing six feet high and requiring the passage of five tons of cool water through their water jackets every hour, are the "nerve centers" of the new KDKA which has practically been completed by the Westinghouse Company at Saxonburg, near Pittsburgh. Rated at 200,000 watts each, the tubes are 200 times as powerful as those in use in the average broadcasting station and more than 50,000 times as powerful as those used in average electric radio receiving sets.

### Gradual Increase

Instead of stepping up its power to 400,000 watts immediately, the operators of KDKA propose to go gradually to 50,000 watts, the maximum power now allowed by the Federal Radio Commission. And instead of making a sudden transition to the new transmitter, they have asked the Commission to authorize the use of the old KDKA at East Pittsburgh simultaneously with the new for a period of three weeks during which the old transmitter's output will be decreased gradually and the new one's increased.

### Synchronization

The old and new stations will operate in synchronization with one another during the transition period. Thus the station's listeners will not suffer the inconvenience of adjusting their receiving sets to the new volume expected from the new station. The Westinghouse Company has asked the Commission for authority to operate experimentally after midnight this fall and winter with its maximum power of 400,000 watts, the highest power any station in the world has ever undertaken to use. For normal operations, the power will be held to 50,000 watts, as required by the Commission, in spite of the eight-fold greater capacity of the station.

## New Class of Radio Operator's License

(From RADIO NEWS Bureau)

A NEW class of radio operator's license, to be known as commercial third-class and authorizing its holders to operate radiotelegraph or radiotelephone installations on aircraft and other stations which may be designated by the Federal Radio Commission, has been established by the Radio Division of the Department of Commerce. Applicants for this class of license must pass code tests in transmission and reception at a speed of fifteen words per minute in Continental Morse code. There is also a practical and theoretical examination consisting of comprehensive questions covering the care and operation of vacuum tube apparatus and radio communications laws and regulations. The tests are given by district radio supervisors.

## World-Wide Reception With the NEW Short-Wave Norden-Hauck SUPER DX-5

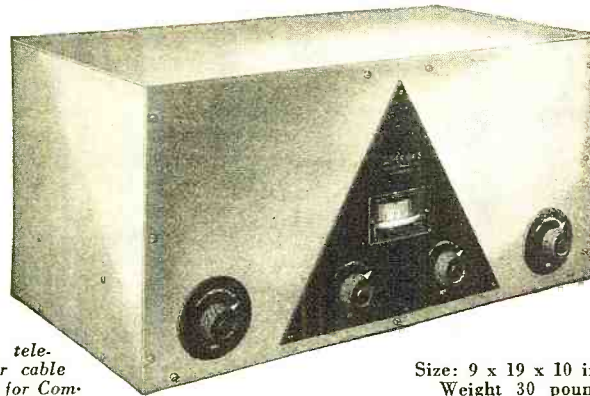

Write, telephone or cable TODAY for Complete Information

Size: 9 x 19 x 10 inches  
Weight 30 pounds

Entirely New Advanced Design      New Pentode Tube  
Sensational Distance      Range 20-200 Meters  
Reliable Performance  
Adaptable for Long Waves and down to about 10 meters  
for Experimental Reception  
A-C and D-C Models

We have an attractive proposition for the progressive dealer and professional service man.

**NORDEN-HAUCK, Inc.**  
South St. and Delaware Ave.

**Engineers**  
Philadelphia, Pa., U. S. A.

Cables: "Norhauck"

## TOM THUMB MIDGET RADIO

FOR smaller homes, for hotels, for schools, for apartments, Tom Thumb Midget Radio is the incomparable giant of performance. It incorporates in its circuits features which reproduce every tone rich, pure and colorful:—six tubes, three screen-grid tubes, one 227 tube, one 45-power tube and a full dynamic speaker, completely shielded and mounted in a beautiful two-tone walnut Gothic cabinet, measuring 16" x 12½" x 8".

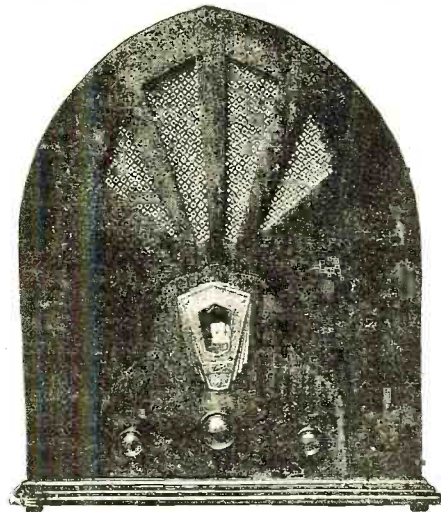

SERVICE men and dealers everywhere! Turn your time into additional money. Once a prospect sees and hears the Tom Thumb Midget, he wants it. It is easy to sell. Orders coming in from all over the country indicate that the public mind is turning toward the midget type of set. Tom Thumb gives the best profits and makes them quickly. Get in touch with your jobber today or wire us for information. Address, Dept. M.

NEW  
TOM THUMB  
MIDGET RADIO

Only  
\$69<sup>50</sup>

Tubes Included

**AUTOMATIC RADIO MANUFACTURING CO.**

112-118 Canal Street

Boston, Mass.

## The I. R. E. Convention

(Continued from page 427)

### FLECHTHEIM SUPERIOR CONDENSERS MEASURE UP TO THE FINEST STANDARDS

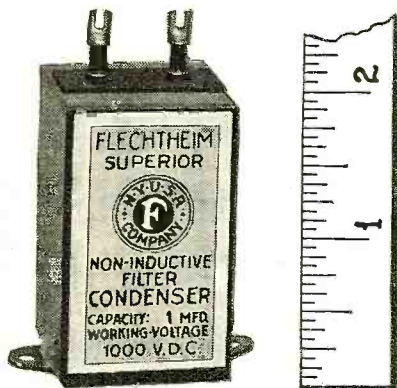

Smallest Physical Size  
Highest Electrical Characteristics  
Most Conservative Rating  
Most Reasonable Price

—DEPENDABLE—

"In use by over 50% of the broadcast stations in the U. S. A."

Catalog No. 22—free

A. M. FLECHTHEIM & CO., INC.

138 Liberty St., New York City, N. Y.

### Enjoy SHORT WAVE reception on your radio.

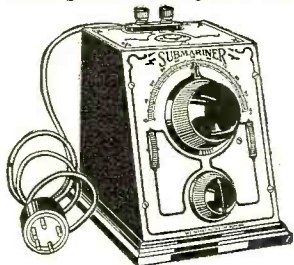

#### "THE SUBMARINER"

Short wave reception from all parts of the world is now possible with the SUBMARINER. No need to buy a special short wave receiver when the SUBMARINER will bring in reception at a fraction of the cost. Plugs in on your present broadcast receiver. Versor tuning device with a ratio of 64 to 1 makes tuning exceptionally easy, thus enabling you to pick up stations otherwise impossible to get. The SUBMARINER, made since 1926 is completely shielded—a quality product throughout.

Prices: Regular model AC or DC, fixed wave band, 19-50 meters, \$17.50. Interchangeable coil, 13-145 meters, \$22.50. The "J" feature, an exclusive "Submariner" achievement, gives five times the volume of any other adapter. AC or DC, prices as follows: Fixed wave band, 19-50 meters, \$22.50. Interchangeable coil, 13-145 meters, \$27.50. In ordering give model of set and numbers on tubes in it. Five-prong tube for AC receivers recommended for short waves, \$2.50.

Will be sent prepaid on receipt of price, or C.O.D. if \$1.00 accompanies order. Foreign orders, add 50c postage, no C.O.D.

J-M-P MANUFACTURING CO., INC.

3416 Fond du Lac Ave. Milwaukee, Wis., U.S.A.

### WANTED MEN

To Manufacture Metal Toys and Novelties



Big demand for Toy Soldiers, Animals, 5 and 10c Store Novelties, Ashtrays, etc. We cooperate in selling goods you make also buy them from you. Small investment needed to start and we help you build up. WE FURNISH COMPLETE OUTFITS and start you in well paying business. Absolutely NO EXPERIENCE and no special place needed. A chance of a life time for man with small capital. CHRISTMAS RUSH is now starting, so if you mean strictly business and want to handle wholesale orders now being placed, write AT ONCE for full information. METAL CAST PRODUCTS COMPANY Dept. 12 1696 Boston Road New York City

describes, non-technically, some of the apparatus used in receiving and sending.

*The Van Der Pol Four-Electrode Tube Relaxation Oscillation Circuit*, by R. M. Page and W. F. Curtis (Naval Research Laboratory). Most tube oscillators are designed to produce pure alternating currents. This paper describes a circuit which produces oscillations consisting of pulses occurring in regular order—its output is therefore far from sinusoidal. Its output can be controlled by a higher frequency of extremely small amplitude and this gives great promise that the circuit can be used in frequency division.

*Polyphase Rectification Special Connections*, by R. W. Armstrong (Westinghouse Electric and Mfg. Co.). A very complete and important contribution to the subject of voltage rectification, the characteristics of various circuits and factors governing their selection.

*Certain Factors Affecting the Gain of Directive Antennas*, by G. C. Southworth (American Tel. & Tel. Co.). Directive antennas have always been widely used to increase the efficiency of transmission and reception. This paper discusses a number of different combinations and indicates their gain and directive properties.

*Aviation Communication*, by J. Stuart Richardson (Northern Electric Co.). The author points out that an important factor in the growth of aviation is the problem of safety—and radio will, in fact already is, playing an important part. The requirements of aviation radio equipment are dependability, simple to operate, sensitive, light in weight, and compact. It is pointed out that Major Kingsford-Smith in his transoceanic flight in the "Southern Cross" made use of radio and it is extremely doubtful whether the flight would have terminated successfully had the radio not been available to obtain bearings.

*A New Frequency-Stabilized Oscillator System*, by Ross Gunn (Naval Research Laboratory). The very interesting oscillator circuit described by the author has a frequency stability comparable to that of temperature crystal controlled oscillators. To obtain such stability without the use of a crystal is a remarkable feat. The oscillator has found wide use in commercial and naval aircraft radio communication problems. It is, of course, much more flexible than the crystal controlled oscillators.

*Variation of the Inductance of Coils Due to the Magnetic Shielding Effect of Eddy Currents in the Cores*, by K. L. Scott (Western Electric Co.). The paper analyzes the shielding effect on eddy currents in the interior of cores. Expressions are obtained showing the variations of inductance with frequency. Experimental results show that the actual inductance of coils is actually less than predicted values. The paper contains considerable experimental data.

*Radio Electric Clock System*, by H. C. Roters and H. L. Pauling (Stevens Institute of Technology). This paper describes a clock system which employs time signals from a government station to automatically correct an electric clock. A radio receiver is used to amplify the time signals from NAA and detect them to produce d.c. pulses of current. These d.c. pulses are used to operate a magnetic selector. The system is turned on automatically a few moments before NAA begins to send the signals.

*Power Equipment for Aircraft Radio Transmitters*, by J. D. Miner (Westinghouse Elec. & Mfg. Co.). All systems of power supply for aircraft transmitters are briefly described by the author. These include the wind-driven generator, the dynamotor, the main engine-driven generator, the auxiliary engine generator set, a combination wind-driven generator and dynamotor and a constant speed main engine-driven alternator. The author reaches the conclusion that no available type of power equipment can be regarded as entirely satisfactory.

*Overseas Radio Extensions to Wire Telephone Networks*, by Lloyd Espenschied (American Tel. & Tel. Co.) and William Wilson (Bell Telephone Laboratories). Widely separated wire telephone networks are now being connected together by means of overseas radio-telephone links. The authors review the progress that has taken place, discussing some of the problems and technique and factors affecting service.

*Advances in Transoceanic Technique*, by Hobart Mason (Western Union Telegraph Co.). Progress in the construction of transatlantic cables is described from the earliest laid in 1858 up to the most recent type, which operates at 1,400 letters per minute. A table shows that in July of 1866 the rate between New York and London was \$100 for 10 words or less. In April, 1923, the rate was only \$0.20 per word!

*The Radio Communication Services of the British Post Office*, by A. G. Lee (Engineering Department, General Post Office, London). The principal services operated by the British Post Office are: Ship-to-shore radio telegraphy, long-distance telegraph, point-to-point radio-telegraphy in several European countries, point-to-point radio-telephony, radio telephony to ships. In addition the Post Office has a close interest in broadcasting. The extent of these services and some of the equipment used is described in this paper.

### Other Papers

*A Unique Aircraft Transmitter*, by M. H. Schrenk (Naval Research Laboratory).

*The Practical and Commercial Aspects of Sensitivity and Selectivity of Radio*  
(Continued on page 467)

## The I. R. E. Convention

(Continued from page 466)

Receivers, by W. D. Loughlin (Radio Frequency Laboratories).

Efficiency of Loud Speakers, by A. Ringle (RCA-Victor Co.).

Functional and Structural Evolution of the Vacuum Tube, by Keith Henney (McGraw-Hill Publishing Co.).

## Canada-U. S. Agree on Aviation Radio

(From RADIO NEWS Bureau)

AS in the case of last year's division of the continental short waves, entire agreement now prevails between the United States and Canada with respect to the allocation of both short and long waves for aeronautical radio services. This country's fast expanding aviation radio services and Canada's now have at their command a sizable block of low frequencies as well as high frequencies for broadcasting weather information and instructions to and from planes, for radio-beacon guidance of aircraft in flight and for inter-airport communications.

Under a newly adopted scheme for coordinating the airways communications and radio aids to navigation in Canada and the United States, it has been decided that the international calling frequency of 333 kilocycles be kept free from assignments to craft or stations other than those engaged in communications for international flights. In addition, American and Canadian radio-beacons operating on the same frequency must be situated at least 750 miles apart.

Various technical details are involved in the division of wavelengths between the two countries and in the joint of some of the wave lengths in both countries. In the high frequency range, the United States will continue to use 3106 kilocycles as the national calling frequency and Canada will use 5630 for the same purpose. The frequencies 3492 and 5630 have been reserved for Canadian stations on the Canadian Transcontinental Airways from Halifax to Vancouver.

Officials of the two countries have yet to work out with aviation companies operating between Chicago and the Twin Cities a change of frequencies from those now specified in the American aviation radio plan so that Canadian planes flying from Winnipeg to Minneapolis and St. Paul will be able to work their radios in closer coordination with the American lines. A conference on the subject is expected to be called this autumn.

### Xavier de Nice Heads Electrad Export Department

Xavier de Nice, widely known expert in export matters has been appointed export manager for Electrad, Inc. Mr. de Nice was formerly merchandising counsel for the American Exporter and for ten years was export manager for the American Chain Company and associated companies.

# SOUND SYSTEMS

for

## ALL PURPOSES By AMPLEX + LOFTIN-WHITE

HERE is one of the many specially designed rack and panel models by AMPLEX plus Loftin-White—meeting those exacting requirements of Quality, Power and Simplicity, yet at Low Cost. One complete foundation unit, flexibly and efficiently arranged—a sound system capable of furnishing programs from radio, phonograph or microphones from one or more locations, to a selective system of one to twenty, or one to forty speakers, including monitor speaker. Quality—well, it's all Loftin-White by AMPLEX plus complete matching of all units, resulting in a practically flat fidelity curve. Volume—all and more than ever required. Distortionless and humless. Efficiently arranged for ease of installation. Simplicity of design and ease of operation. Flexibility and interchangeability of panels, so that equipment may be enlarged as requirements demand, without obsoleting any parts. Built with the usual AMPLEX high safety factor, insuring a minimum of servicing, plus longevity. Lower in cost—and markedly superior. ENGINEERING COUNSEL—as recognized amplification authorities, further enhanced by exhaustive laboratory and field study of the sound systems requirements of educational institutions, hotels, air-ports, stadiums, parks and large and small auditoriums, AMPLEX offers a complete engineering counsel service, WITHOUT CHARGE. Send sketch and details of your proposed installation—we will give you expert counsel and quotations—FREE.

A booklet describing AMPLEX L-W Amplifiers and Sound Systems—nine standard table models from single '45 to push pull '50's—fourteen standard rack and panel models for educational institutions, hotels, etc.—and two real three-stage 50-watt models for the largest of indoor and outdoor installations—now available.

# Amplex

INSTRUMENT LABORATORIES

132H West 21st Street  
New York, N. Y.

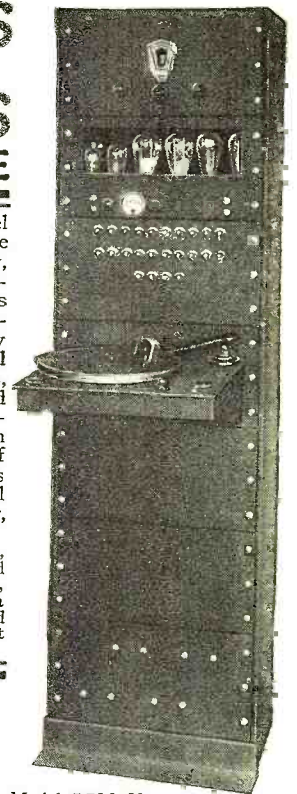

Model RPM 20  
Licensed under Loftin-White patents pending.

An Interesting and Profitable proposition for responsible, experienced Installation Engineers, Custom Builders, Service Men, Dealers, Contractors. More sound systems sales, bigger profits and better results. Protected territories. Write in detail to our General Manager.

*Metallized* RESISTORS make satisfied customers...



Service counts in radio more than anything else. Standardize on Metallized Resistors (more are used by service men than any other make).

### REMARKABLE BOOKLET

Write for it

Our new Resistor Replacement Guide eliminates any loss of time on a job, which means a greater profit for you. Write today.



MADE BY THE MAKERS OF

INTERNATIONAL RESISTANCE CO.  
2006 CHESTNUT STREET PHILADELPHIA, PA.

HERE ARE SOME TYPICAL VALUES WHICH ARE CONTAINED IN OUR

**RADIO BARGAIN BULLETIN No. 31**

HAVE YOU A COPY?

- DURILLER 114 Mid. High Voltage Filter Condenser Block. D. C. Working Voltages 1,000, 600 and 400. . . . . \$3.75
- VICTOR REPLACEMENT FILTER CONDENSER BLOCK. 104 Mid. D. C. Working Voltage 600 and 400 v. . . . . \$3.25
- POTTER 13 Mid. High Voltage Filter Condenser Block. D. C. Working Voltage 600. . . . . \$4.25
- DURILLER 4 Mid. High Voltage Filter Condenser Block. D. C. Working Voltage 600. . . . . \$1.80
- ABROVOX 7 Mid. High Voltage Filter Condenser Block. D. C. Working Voltages 1,000, 800 and 400. . . . . \$3.75
- THORDARSON HIGH-VOLTAGE POWER TRANSFORMER—250 Watts—for 2-UX-250's or 210's, and 2-UX-281 Tubes. . . . . \$5.75
- THORDARSON HIGH-VOLTAGE POWER TRANSFORMER—175 Watts—for 1-UX-250 or 210 and 2-UX-281 Tubes. . . . . \$4.25
- RCA POWER TRANSFORMER for UY-224 Screen Grid and UX-245 Power Tubes. Type 380. . . . . \$3.75
- THORDARSON PUSH-FULL INTERSTAGE TRANSFORMER. . . . . \$3.95
- RCA POWER TRANSFORMER No. 8335 For Radiolas 33, 18 and 17. Supplies Plate Filament Voltages for four 226's one 227, and one 171-A and 280 Tubes. . . . . \$3.75
- JEFFERSON STEP-DOWN TRANSFORMER, 110 V. to 14 V. at 2-1/2 Amps. . . . . \$ .95
- THORDARSON SONORA POWER TRANSFORMER. Supplies plate and filament voltages to four 224's, one 227, two 245's and one 280 Tubes. For B, 31, 33 and 35 Receivers. . . . . \$3.75
- THORDARSON—30 Henry—150 Mill Choke, Model T-2030A. . . . . \$3.25
- THORDARSON DOUBLE FILTER CHOKE, Model T-2458, contains two 15 Henry 250 Mill Chokes. . . . . \$6.25
- RCA DOUBLE CHOKE COIL No. 8336. Contains two 30 Henry 100 Mill Chokes. . . . . \$2.50
- FILTER CHOKE—30 Henries—120 Mills. . . . . \$2.00
- SAMSON "PAM" No. 16. TWO-STAGE POWER AMPLIFIER (less tubes). . . . . \$38.50
- KOLSTER R-5—ELECTRO-DYNAMIC SPEAKER, complete with 210 or 250 Power Amplifier and "B" Supply Unit in Cabinet. List \$175.00 (less tubes). . . . . \$26.50
- The New GOULD KATHANODE UNIPOWER 6-VOLT Automatic Radio. "A" Power from light socket. . . . . \$9.75
- RCA TWO-STAGE AUDIO TRANSFORMER PACK Part No. 5067. For Radiolas 33, 18 and 17. Ratio of each Transformer 3-1. . . . . \$1.90

AMERICAN SALES CO.

Dept. N., 21 Warren St., N. Y. C.

**HY-7 SHORT WAVE SET**

6 tube A. C. or D. C. Comes already assembled, but unwired. NOW \$58.<sup>50</sup> Price . . . . . ONLY NET

**NATIONAL A.C. SW-5**

The best short wave set of its type. Tuned R. F. regenerative detector, push-pull audio. Complete with tubes and power-pack, wired and ready NOW \$81.<sup>80</sup> to use. . . . . ONLY COMPLETE

**HATRY and YOUNG, Inc.**

119 Ann St., Hartford, Conn.

**Most Amazing Book of its Kind ever Published!**

Brings new Radio thrill. Shows you where to dial for every station in the U. S., Canada, Mexico and Cuba. Lists all chain programs. Provides ideal method of logging. Many other features.

**Doubles Your Radio Pleasure**

A radio becomes intensely fascinating—with Radiex. See for yourself. Your news-dealer, radio store or Kroger's can supply you—or send a quarter direct for your copy.

Radex Press, 1305 E. Sixth, Cleveland, O.



**Radios Biggest Values**

Up-to-the-minute offerings at lowest wholesale prices. Includes nearest Tone Control, Screen Grid Superheterodyne, Radio-Phonograph combinations, short wave receivers, automobile radios. Public address, attractive walnut consoles and latest accessories, parts and kits. Don't buy until you see our big catalog.

**Send for FREE Complete Catalog**

**Western Radio Mfg. Co.**  
128 W. Lake St. CHICAGO

Getting the "Low-Down" on Short Waves

(Continued from page 411)

the 180-degree movement of the tuning condenser and that the dial has some sort of vernier with a ratio of 3 to 1 or thereabouts. If the tuning dial moves through 100 dial divisions and if the condenser and coil arrangement is such as to give absolute straight frequency tuning over the entire dial, then it would be possible to tune in 100 different broadcasting stations, each with a separation of 10 kilocycles, providing the receiver was selective to 10 kilocycles. Unfortunately, this isn't true because some broadcasting stations are so close to the receiver that they actually use more than 10 kilocycles.

Now when the prospective short-wave buyer examines the tuning range of the short-wave receiver, he selects one of the plug-in coils and finds that it has a tuning range of 15 to 30 meters. He can easily make a mistake in thinking the short-wave receiver doesn't cover as wide a band as the broadcast receiver. Fifteen to 30 meters indicates a 2-to-1 wavelength range while the 200- to 600-meter broadcast receiver indicates a 3-to-1 range. But it is not the wavelength range that he must consider—it is the frequency range in kilocycles. The broadcast receiver covers a range of 1,000 kilocycles and the short-wave receiver which has a plug-in coil that tunes from 15 to 30 meters covers ten times the frequency range of the broadcast receiver—10,000 kilocycles. The frequency for 15 meters is 20,000 kilocycles; for 30 meters it is 10,000 kilocycles. Then he will find that on the same basis of station separation (10 kilocycles per station) that he will have a frequency range sufficient for 1,000 stations but that he must crowd ten stations on one dial division. Imagine trying to separate the ten stations on one dial division! Even if the short-wave receiver had the same proportion vernier ratio—it would have to be a 30 to 1 (a nice mechanical contrivance)—it would require mighty careful operation. Yes, it could be done, but how!

Suppose the receiver had a 20- to 60-meter range plug-in coil. That is the same wavelength ratio (3 to 1) as the broadcast receiver. That ratio looks more appealing to the prospective buyer, yet close examination only reveals the fact that the tuning frequency range is still 10,000 kilocycles, 20 meters being 15,000 kilocycles and 60 meters being 5,000 kilocycles. No sane or experienced amateur would think of using this sort of receiver without a subsidiary condenser control across his main tuning condenser and then only with a well-chosen vernier dial. On top of all this, there is still another unfortunate thing—no tuning condenser will give exactly the same frequency range for all of the plug-in coils, because each coil has a different value of inductance and distributed capacity. Either they tune slowly at the low end (highest frequency) or the other.

The only tuning unit that does cover the entire frequency range from 3,000 kilocycles to 20,000 kilocycles (15 to 100 meters) without plug-in coils is the Aero Automatic Short-Wave Tuner. Not only

does this tuner cover the mentioned frequency range but it covers it smoothly and at the rate of about 1,300 kilocycles per each 100 dial divisions of tuning and the frequency is straight-line from one end to the other. The capacity and inductance are varied simultaneously. Using a National type "A" dial, the ease of tuning is comparable to that of the broadcast receiver.

Another point which the prospective short-wave buyer will discover, if he hasn't already discovered it, is that he has been led to believe that he can tune in short-wave broadcasting stations from all over the world any time he wants to. Surely, not intentional misleading advertising on the part of the advertising manufacturer, yet, truthfully it must be said that the average prospect has that impression. His first night with the short-wave receiver is a most disappointing one, nine times out of ten. Foreign short-wave broadcasting stations broadcast at irregular periods and at times they are shut down for several days. Again, they may test for a period of several hours every day for weeks. Some of the U. S. stations are on the air fairly consistently and at fairly regular hours. One must learn these hours by persistent listening and watch for the announcements of schedules as they are broadcast.

I have camped for hours and hours on the carrier frequency of a broadcasting station (foreign) without hearing a single word spoken. Having a calibrated receiver and frequency meter, I know just about where to find each station on my receiver dials. Some days they are good and others they are pretty bad. During the early hours of the morning when Sydney, Australia (VK2ME), is broadcasting on a frequency of about 10,400 kilocycles (28.8 meters) I have had signals of such volume that the volume or gain control had to be turned down close to minimum. Then again, VK2ME will be weak—sometimes for several days. G5SW, located at Chelmsford, England (11,750 kilocycles, 25.53 meters), is seldom good enough for clear reception at my Chicago location. PCJ, Eindhoven, Holland (9,590 kilocycles, 31.26 meters), is very good at times, usually more consistent than G5SW. There are many other foreign short-wave broadcasting stations and a good many in the United States, but no one of them can be counted on for 100% reception every day in the week, week in and week out. The same is true for the trans-Atlantic radiophone stations. Their carriers can be heard for hours and hours before they start using voice. This may go on for several days, yet some other frequency, either higher or lower, may be good enough for commercial communication.

The Lindbergh aviation address, scheduled for world-wide reception, failed to reach many parts of Europe because conditions between here and there were very unfavorable. Fading was bad and atmospheric conditions were very bad. Yet, with all these things, there have been

(Continued on page 469)

## “Low Down” on Short Waves

(Continued from page 468)

many, many short-wave programs received in America and then put out over the regular chain of broadcasting stations. And there are many more to come.

Once these things are explained by the advertising manufacturer and once they are understood by the short-wave enthusiast there will be an increasing interest in short-wave reception and, correspondingly, an increase in the demand and sale of short-wave receivers. Until then the whole short-wave broadcasting field is apt to remain stagnant just because of a misunderstanding which has no plausible reason for existing.

### Operating Notes on the RADIO NEWS Short-Wave Super

A few words here on the operation of the RADIO NEWS Short-Wave Superheterodyne will not be amiss, in as much as doubtless a good many of RADIO NEWS readers will by this time have completed the receiver.

To obtain the best from any receiver circuit, each unit must be operating at its peak efficiency, so this suggests that we test each unit separately. Place a pair of phones in the plate lead of the first detector tube, with the oscillator tube removed from the receiver. Signals from a near-by transmitter operating on phone should come in loud and clear. If they do not, trace this circuit carefully, checking voltages, etc., until they do come in clearly. Replace the oscillator tube.

You should now be able to tune in signals. If you cannot, place the phones in series with the plate circuit of the oscillator tube, and touch the grid connection to the tube with the tip of the moistened finger. If the tube is oscillating properly, a distinct “plop” should be heard. If this plop is not heard, try a different tube, and careful adjustment of the battery voltages. As a last resort, reverse the feedback coil connections, for if these are connected wrong the tube will not oscillate.

Next, try tuning the receiver with the oscillator tube out. If signals are heard, it is an indication that one or more of the intermediate-frequency tubes are oscillating. To correct this condition, if it prevails, try shifting tubes, adjusting voltages, especially the screen-grid voltage on the tubes, and look for high-potential leads placed too close together so that feedback occurs due to the capacity between them.

Occasionally an audio amplifier will develop a singing noise due to audio oscillation. This is more common now than before, due to the fact that we have better audio transformers available. If this occurs, try reversing the secondary connections to one of the transformers. This will cure the trouble, with little loss in volume.

Now with everything all set to work, try tuning in phone stations. The oscillator dial will tune very sharply, and unless one is careful, a station may be

(Continued on page 471)

# GEORGE W. WALKER FLEXI-UNIT

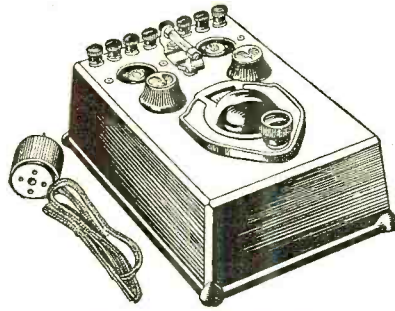

Showing No. '01 Adapter Plug

## FLEXI-UNIT

### Exclusive Features

(Possessed by No Other Device on the Market)  
Efficient reception of the entire wave band of 15 to 550 meters with four silk insulated plug-in coils.

An attractive Aluminum Cast Shield of 1/8" thickness to insure against body or hand capacity.

Unit may be used with either A. C. or Battery receivers, or as an individual single tube receiver for short or long waves.

Unique antenna connection arrangement insures freedom of oscillation at all frequencies without dead spots.

Serves many purposes. Indestructible! Simple to operate—and inexpensive.

Write for Free Literature

One of America's Pioneer Radio Manufacturers

**THE WORKRITE RADIO CORP.** 1815 E. 30th St. Cleveland, Ohio

*A Flexible Radio Device of Unlimited Application*

Short-Wave Receiver  
Short-Wave Adapter

Regular Broadcast Tuner  
R.F. Pre-Amplifier (Booster)

Radio “Experimental” Unit  
Oscillator—Wavetrap

USE THIS UNIT AHEAD OF YOUR SHORT-WAVE TUNER AS A R.F. BOOSTER

Should your dealer List Price be unable to serve you promptly—Mail **\$16.00** your order direct to factory. Including Coils

No. '01 Adapter Plug (Battery) . \$2.00  
No. '27 Detector Plug (A.C. Set) . 2.50  
No. '27 R.F. Adapter Plug (A.C. Set) ..... 3.00

## NO SLUMP IN ADAPTATIONS!

NEW adaptations of long known fundamentals continually reveal some necessity for condensers different in form from the usual standard types heretofore found inadequate.

With the ever-increasing traffic on the shortwave channels—selectivity and sensitivity become of paramount importance in the modern radio receiver. Many operators acclaim the merits of the push-pull system, using double section variable condensers in the tuning circuits. To meet this demand our 202-E has been developed, giving a total capacity of .00075 mmfds. with 2 sections in series. With interchangeable coils a tuning range of 5 to 80 meters can be covered readily. Write for literature.

THE ALLEN D. CARDWELL MANUFACTURING CORPORATION  
81 Prospect Street, Brooklyn, N. Y.

## SERVICEMEN

Are you one of the many servicemen who have been cashing in on this?

*Underwrite* Line Voltage Regulator  
**CLAROSTAT**

It regulates the line voltage on all makes of electric sets. It insures a steady flow of current. It reduces noises. It saves tubes from excessive voltages. Build up good will and keep your new customers by recommending and installing the clarostat. Write for discounts. List Price **\$1.75**

Type A—for sets consuming less than 100 watts.

Type B—for sets consuming 100-150 watts.

**CLAROSTAT MANUFACTURING CO.**

285 North 6th St.

Brooklyn, N. Y.



## DEALERS AND SERVICEMEN



Write for Your FREE Copy of this BIG Catalog 40 PAGES OVER 1,000 ITEMS OF REPLACEMENT PARTS FOR ALL STANDARD SETS

Free Write

FEDERATED PURCHASER  
20 HUDSON STREET, N. Y. C.



**PILOT MIDGET**  
\$59.50

This compact A. C. receiver in beautiful two-tone walnut cabinet gives radio performance of console quality. Produced in the internationally famous Pilot Radio plant. Full screen grid and electro dynamic speaker give the MIDGET outstanding selectivity and sensitivity. A typical 20th Century value—where you can get everything in radio, short wave kits, parts, tubes, accessories at lowest prices. The MIDGET, \$59.50, tubes \$16 extra, sent postpaid on receipt of \$18.75, balance C.O.D. plus transportation charges.

SEND FOR CATALOG and FREE RADIO GIFT

20th CENTURY MAIL ORDER CORP.  
200 W. Jackson, Chicago, ILL.



**WORLD-WIDE SHORT WAVE RECEIVER**  
ONLY \$64.50

Span the World with this Set!

A new radio thrill for you! Listen in DIRECT to London, Paris, Berlin, Buenos Aires and other broadcasting stations throughout the world via short waves. Enjoy unique foreign programs from strange lands. Your ordinary receiver cannot tune in these low wave stations. WORLD-WIDE RECEIVER gets 14 to 550 meter stations with surprising clarity. SEND NO MONEY! Just write your name and address on a postcard and ask us to send you this wonderful guaranteed short wave set. Pay postman \$0.45 plus a small delivery charge. All orders West of Rockies must be accompanied by \$1.00 deposit. Foreign countries must remit in full. Write today!

CHAS. HOODWIN CO.  
4240 Lincoln Ave., Dept. L-30, CHICAGO

Send For Our  
**BARGAIN BULLETIN**  
It Will Save You Money!

**Harrison Radio Co.**  
35 Ft. Washington Ave. Dept. N. New York City

## Trend Abroad Also to Higher Powers

(From RADIO NEWS Bureau)

A COUNTERPART of the rush of America's leading broadcasting stations for high power is evident in the obvious trend toward higher powers in other countries. The American problem has crystallized in demands from twenty-six stations for the present maximum allowable power of 50,000 watts, demands which will be the subject of five continuous weeks of hearings before the Federal Radio Commission starting September 15.

No foreign broadcasting administration has ever attempted such superpower as 400,000 watts which the Federal Radio Commission has authorized KDKA of Pittsburgh to employ experimentally. Nor has any foreign radio station ever gone as high as the 200,000 watts used by WGY of Schenectady last year in past-midnight tests which revealed the tremendous listening ranges that can be achieved with the higher powers.

However, the highest powered broadcasting stations in regular operation in the world today are in Europe. They are the Soviet Comintern station near Moscow and Radio Roma near Rome, both of which have a capacity of 100,000 watts, though they are officially rated with the International Broadcasting Union at Geneva at 75,000 and 60,000, respectively. Then there is the new station at Prague, unrated in the International Union's listing, but reported at the time of its building to have 120,000 watts.

Power is an important factor in European broadcasting because power increases almost inevitably mean the overreaching of programs into contiguous countries. Accordingly, when the technicians of the European broadcasting administrations met at Prague in April, 1929, an effort was made to limit powers to 60,000 watts. Some countries, notably Russia and Switzerland, balked at formal agreement to such a limitation, so that to all intents and purposes no real agreement exists.

Both Moscow's Comintern and Radio Roma are believed to be operating at their maximum powers. At Leningrad there is a 40,000-watt broadcaster and at Moscow there is another station of 20,000 watts. From France comes a report that Radio Toulouse, probably the most popular station in that country, is about to be enlarged at a new site with a power increase to 60,000 watts. France's highest powered at present is at Strasbourg, which uses 12,000 to 20,000 watts, while Radio Paris has 16,000.

It is interesting to note that Europe's 263 broadcasting stations are better known by their locations than by call letters. Germany's highest powered is Zeesen, with 37,000 watts. England's is Brookmans Park, with 50,000, with Daventry using 25,000 both on its intermediate and long wave channels. England also has London 1 and London 2, both using 30,000 watts.

On the continent there are, besides the Russian and Italian stations, Radio Oslo with 60,000 watts, Lahti of Finland with 40,000, Motala of Sweden with 30,000, Vienna Rosenhugel with 18,500, Lakihegy

of Budapest with 15,000 to 20,000, and Warsaw, Riga and Bucharest with 12,000 each. In Athens, an American concessionaire has contracted to build a new 25,000-watt. In Nanking, the Chinese have contracted with the German Telefunken for a broadcasting station which is described as "one of the most powerful in the world."

Coming closer home, the proposal to build a new 50,000-watt station in Havana is significant, especially so since American interests are back of it. Then there is the proposal to erect seven 50,000-watt stations, or one in each province, as the mainstay of Canada's broadcasting structure if and when the recommendations of the Royal Commission which investigated radio last year are adopted.

## Amateurs Arrange Standard Signals

(From RADIO NEWS Bureau)

CROWDING of the amateur radio bands and the necessity of maintaining their wavelengths to utmost precision to prevent interference have led to an arrangement whereby the American Radio Relay League, official organization of the amateurs of the United States and Canada, will permit outsiders to utilize "ham" radio channels for the first time in amateur history.

Station W1XP of Massachusetts Institute of Technology at Boston, W9XA1 of the Elgin Watch Company at Elgin, Ill., and a Pacific Coast station yet to be selected next fall will begin to transmit standard frequency signals in the amateur bands to enable the amateurs and all other users of high frequency transmitters to calibrate their apparatus to know precisely whether they are on frequency.

One or the other of these stations will be on the air every evening, making it possible for the 17,000 amateurs of the United States, the 2,000 of Canada and others who want to avail themselves of the service to check their apparatus. At present, only WWV of the Bureau of Standards at Washington furnishes such a service, but only on a once-a-month basis. The signals that will emanate from the stations cooperating with the amateur organization will be of sufficient power to be received regularly all over North America and with a fair degree of consistency all over the world.

## Resistor Replacement Guide

UNDER the title of "Resistor Replacement Guide," the Service Department of International Resistance Company, 2006 Chestnut Street, Philadelphia, Pa., has prepared a piece of practical radio literature for the radio serviceman. In loose-leaf form, so as to be kept constantly up to date by inserting new sheets issued from time to time, there is now available a vast fund of data dealing with resistance fundamentals, formulas, and requirements of standard radio sets for several years past.



# NEW YORK'S NEW HOTEL LINCOLN



Where modern scientific planning and management make possible rates surprisingly moderate. 1400 Rooms, each with bath and shower.

\$3-5 For One \$4-7 For Two

Telephone Lackawanna 1400

Eighth Ave., 44th, 45th Sts. Times Square · NEW YORK

**NEW ELECTRIC RADIO**

**\$27.50**

**6 Tubes—Screen Grid**

Amazing new long distance 6-tube A. C. screen grid radio at a price anybody can pay. Marvelous tone. Plenty of volume for dynamic speaker. Absolutely free from A. C. hum. The very latest A. C. radio using three screen grid tubes and the price is only \$27.50. All ready to plug in the electric light socket and operate. This is the most startling radio bargain offer in history.

**AGENTS MAKE FORTUNES**

Live agents everywhere are making big money selling the new set. Demonstration always means a sale. Add SIXTY DOLLARS A WEEK PROFIT to your present income in spare time evenings. This ultra-modern all-electric set replaces battery radios everywhere. Exclusive territory franchise worth fortune to right men but act quick as choice territory is going fast, and my company has asked me to place good men in all open territory QUICK. Write or wire immediately and be sure to give me the name of your county.

P. H. WILCOX, Secretary, 4910 N. Crawford Ave., Chicago, Ill.

**LAW STUDY AT HOME**

Become a lawyer. Legally trained men win high positions and big success in business and public life. Be independent. Greater opportunities now than ever before. Big corporations are headed by men with legal training. Law-trained men earn \$5,000 to \$10,000 Annually

We guide you step by step. You can train at home during spare time. Degree of LL. B. conferred. Successful graduates in every section of U. S. We furnish all text material, including fourteen-volume Law Library. Low cost easy terms. Get our valuable 64-page "Law Guide" and "Evidence" books FREE. Send for them NOW.

LaSalle Extension University, Dept. 1194-L, Chicago  
The World's Largest Business Training Institution

**See the Craters in the MOON!**

Astronomical and Terrestrial TELESCOPE

Own a genuine Astronomer's Telescope. See thousands of miles away. Make Sun, Moon Planets, Stars your next door neighbors. Moon, Spots, Craters, Sun, Spots, Edipses, enlarged times. Strange Eclipses

Hours of fun looking at scenery, games, bathing, holidays. Great for trips and voyages. Made like telescopes used in observatories. Gerding wrote, "Moon seemed 10 yards away."

Price Only \$3.95

See Landscapes, Games, Ocean Scenes, Enlarged 30 Times!

Diameter 2 inches. Special friction adjustment for focusing. Adjustable bracket and clamp can be fastened to chair, fence, branch, etc. Finest materials. Will last a lifetime.

Five Days' Free Trial

Rush only \$1.00 now. Pay balance \$2.95 plus postage, when postman delivers. Keep 5 days. If not delighted, return telescope and money will be refunded.

**EARN \$10 A DAY**  
Charge 25c to look at the moon

ROLL-O SPECIALTY CO., Dept. M-335  
220 E. 3rd St., Cincinnati, O.

## Invents Multiplex Television System

(From RADIO NEWS Bureau)

A television receiver that can be attached to an ordinary radio set like a loudspeaker, reproducing moving images from electrical impulses transmitted along a wave length employed for the simultaneous broadcasting of speech and music, has just been patented by Chester Leslie Davis, 27-year-old Washington inventor. With the issuance of the patent by the United States Patent Office, announcement was made that it has been assigned to Wired Radio, Inc.

The youthful inventor's multiplex system of television and broadcasting eliminates the scanning disc and all movable parts at the receiver, thereby simplifying greatly the present methods of reproducing television images. The receiver is a large glass screen which, when not lighted, looks like a framed windowpane into which longitudinally parallel wires have been imposed. The images move along the wires, which are surrounded by gas that causes them to glow when in operation.

Described by the Patent Office simply as a "signaling system" this method of television employs the principle of establishing voltage nodes and anti-nodes along conductors encased in gaseous chambers. Extreme economy in the use of wave bands is claimed for this system for, besides occupying the same frequency employed for the accompanying speech or music, the television signals will not vary more than 500 cycles from that frequency, according to the inventor.

Young Davis, a native of Missouri, came into prominence in the radio world when he was barely 16. Operating an amateur radio station at his home in Perry, Mo., he discovered that the Aurora Borealis produces an alternating current of extremely low frequency, causing periodic fading of the received radio signal. Considerable discussion was aroused in scientific journals at the time the young "ham" announced his discovery.

Born in Revere, Mo., Davis studied electrical engineering at Iowa State College, University of Detroit and George Washington University. While in military service from 1923 to 1925, he erected the Army Signal Corps' 10-kilowatt station at Fort Leavenworth, Kan. Later he built several broadcasting stations in Detroit. Until recently, he was engineering assistant to John B. Brady, Washington patent attorney. Lately he has been working on radio and talking motion picture inventions at his laboratory in Santa Barbara, Calif.

## "Low-Down on Short Waves

(Continued from page 469)

passed over without hearing it at all. The first detector dial will be comparatively broad of tuning. Practice will be the best teacher in the art of tuning the short-wave receiver. As suggested last month, the oscillator dial may be calibrated by tuning in the standard frequency signals from designated transmitters.

## LATEST MARVEL OF RADIO

Make Your Old Set a 1931 Model for \$5.75 Complete



Tune Your Tone as You Do Your Radio for Any Set

The F & H Tone Control and Noise Eliminator will vary the tone so as to conform with the personal musical taste of any individual, brilliant, treble, or that deep mellow bass found only in the high priced modern tone controlled sets. AS A NOISE ELIMINATOR 50% to 95% of the high pitched static and line noises can be eliminated. Finished in beautiful crystalized finish and comes complete with adapters and twelve foot silk cord for convenient remote control. Connected by anyone in a minute's time. Three-day trial money-back guarantee of satisfaction.

## REESONATOR

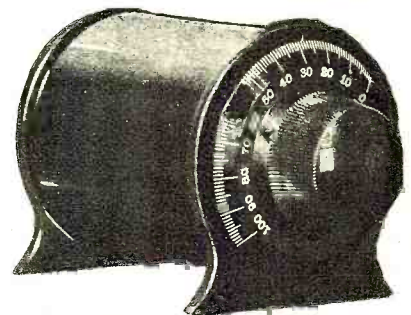

For distance and sharp tuning. Over 40,000 satisfied customers. Now only \$3.95.

The Reesonator will increase the volume, distance, power and selectivity of your radio set to the equivalent of the addition of two extra tubes. It will enable you to play with dance volume stations which were barely audible without it. Attaches across aerial and ground leads without tools by anyone in less than a minute. It is especially recommended for all sets having an untuned antenna or floating tube such as: Radiola 16, 17, 18, 33, and 333; Atwater Kent models 30, 32, 35, 37, 38, 48 and 49. Certain models of Victor, Temple, Silver-Marshall, Knight, Apex, Daylan, Crosley Bandbox and Jewelbox. Saves 25% on A and B batteries on battery sets. Return in three days for refund if not satisfied.

## F. & H. AERIAL ELIMINATOR



The F & H Capacity Aerial has the capacity of the average 75 foot aerial 50 feet high. It increases selectivity and full reception on both local and long distance stations and is absolutely guaranteed. It eliminates unsightly poles, guy wires, mutilation of woodwork, etc. It does not connect to the light socket and requires no current for operation. Enables set to be moved into different rooms with practically no inconvenience. Installed in a minute's time by anyone. Price complete, only \$1.25.

### ALL ITEMS SHIPPED POSTPAID

- Send C. O. D. or  Enclosed please find check or M. O. for \$..... and for which please send me the items checked on a three-day money-back guarantee basis.
- Tone Control  Reesonator
- F & H Capacity Aerial Eliminator
- Literature  Dealers' Proposition

F & H RADIO LABORATORIES  
 Fargo, N. Dak. Dept. 233

# SMOOTHES OUT RADIO VOLTAGE "BUMPS" Automatically!

The new AMPERITE for electric radio automatically prevents fluctuating line voltage which interferes with radio reception. Delivers to your radio exactly the voltage required for efficient operation. Greatly improves tone and sensitivity. Saves tubes. Insist on AMPERITE in the electric radio you buy or build. No radio can be modern without it.

Install AMPERITE in the electric radio you now have.

Ask your dealer or write Dept. RN-11, giving name and model number of your set.



## NEW NATIONAL SHORT-WAVE

A new powerful AC or DC operated receiver. Tunes in foreign stations with remarkable regularity on wavelength range of 15 to 550 meters. Complete Receiver, or in Kit form.

### AUTO-RADIO

*Kits, Sets and Accessories*  
**1930 CATALOG FREE**

Set Builders! Write for your copy. Complete line of short-wave supplies, standard parts and accessories.

### CHICAGO RADIO APPARATUS CO.

415 S. Dearborn St., Dept. RN, Chicago, Ill.

## ELLIS MICROPHONES

Models 29N and 30N, \$75.00 list. Approved by every high grade Amplifier Manufacturer in the country. Used by Broadcast Stations and Public Address Systems everywhere. Complete line of stands, cords, etc. Write for descriptive literature and name of nearest jobber.

**ELLIS ELECTRICAL LABORATORY**  
337 W. Madison St. Chicago, Illinois

**\$375** **FREE**

Identical chassis as used in R. C. A. Model 100B and 103 magnetic speakers. Note built-in output transformer—huge magnet—self baffling metal housing. Delivers great volume without rattling or distortion! 9" diameter—1 1/2" deep.

**SEND FOR THIS BOOK** **JUST ISSUED**

**RADIO BARGAINS**

**SET ANALYZER—TUBE TESTER**  
Resembles in appearance and construction most expensive and most elaborate testers. Tests (push-button principle) 0-7, 0-150v. A.C.; 0-20, 0-100 D.C. mills.; 0-10, 0-50, 0-500, D.C. Volts. Tests all type tubes. Complete with continuity test cables, other test leads, clips, leatherette case 7 1/4" x 9" x 3".

**RADIO SURPLUS CORP.**  
56 N. Vesey St. New York

## More about the Stenode Radiostat

(Continued from page 394)

resonance curves, and in Fig. 6 the effect is shown for telegraphic dots, the dots being shown at P, Q, R, etc. It is obvious that for curve *a*, Fig. 3, each dot allows the receiver to build up to its maximum and die down to zero, and thus we get a separate response for each dot, as shown by curve *a*, Fig. 6. In curve *b*, however, at the end of the first dot the receiver has not time to cease oscillating before the second dot arrives, so that we have the response curve, due to the dots, of a very complicated shape, and the receiver is tending to build up to an indeterminate value. This effect can also be demonstrated by the experiment quoted above. A point of tickler coil adjustment can be found, when no signals are arriving, when the arrival of two or three weak signals, or one strong one, such as a loud crash of static, will set the receiver off into continuous self-oscillation.

Here we have a very important fact in electrical communication, which is to the effect that in order to obtain faithful reproduction a suitable amount of damping in an ordinary receiving circuit is re-

done so, we obtain the result that we can get faithfulness of reproduction of signals (telegraphic, telephonic, etc.) in conjunction with the fact that the receiver still has a very sharp resonance curve, so that it can only be excited appreciably by signals over a comparatively narrow band of frequencies. The Stenode Radiostat has provided solutions to these problems.

One method by which this has been achieved is to cause signals to act on a very selective receiver, first of all to build up the receiver oscillations to a certain value, which is not necessarily their maximum value, and then to cause the same signal to bring the receiver to rest again. It is necessary to make this occur at a frequency which is higher than any frequency which takes part in the actual modulation.

Thus, if we are concerned with telephony, the receiver must be excited and brought to rest more than 5,000 times per second. This effect is achieved by causing incoming signals to act on a receiver, first of all in one phase and then for a similar period in the reverse phase.

A circuit for achieving this result is shown in Fig. 7, where incoming signals are applied in opposite radio-frequency phase to the grids of two tubes. There is one other grid in each tube, and when these two grids are of the same potential, no radio-frequency signals can pass through the combination, as we have a state of balance. However, a low-frequency oscillation is applied to the extra grids in such a way that these two grids are always at opposite potentials; and the frequency of this oscillation would be of the order of 10,000 cycles per second in the case of telephony. From the parallel-connected anodes of this combination signals are fed to the selective receiving circuit.

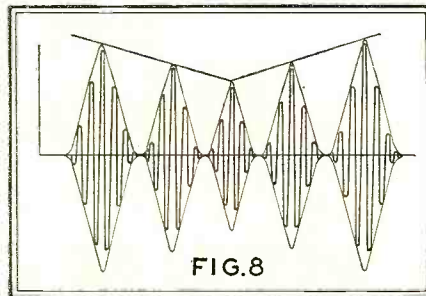

Fig. 8. Showing the response obtained from the circuit illustrated in Fig. 7

quired. However, in view of the seriousness of the present situation in the realm of radio communication, it is essential to make an attempt to obtain this faithfulness of reception even when we have a very selective receiver, which receiver is made selective by removing the damping. It is of importance to note also that the deliberate introduction of damping makes a receiver less sensitive.

In order to obtain selectivity (and increase sensitivity) we remove the damping, and once the receiver is excited by an incoming signal it takes a very long time to die down to rest or, in other words, its oscillations are very persistent, and they must be stopped or quenched before the receiver is fit to respond to another signal. Old-time radio men who remember the old quenched spark discharger will understand what is required; the function of the quenched spark discharger was to quench oscillations in the primary circuit of the transmitter, so as to leave the aerial circuit free to oscillate at its own frequency, free of interference.

It is therefore necessary to try to find some means for overcoming this persistence of very selective receivers, some quenching device; and when we have

The result obtained from such a combination is shown in Fig. 8, from which it is seen that we obtain pulses of high (radio) frequency, the number of pulses being the same as the low frequency which is fed to the second grids of the tubes in Fig. 7. The amplitude of these separate pulses in Fig. 8 obviously depends on the instantaneous amplitude value of the incoming signals, so that if these signals are varying in amplitude we find that we obtain an envelope of response which, after rectification, corresponds to the original signals which were transmitted.

It is obvious that this Stenode receiver can only be excited by signals which are within the narrow resonance curve which is employed, so that if we use a receiver with a resonance curve less than 100 cycles in width we have a highly selective receiver, and we can still obtain perfect reproduction of modulated signals. Actually, the selective arrangement which is employed is a piezo-electric device, and its resonance curve is well below 100 cycles in width.

I have just had an opportunity of attending a demonstration of a laboratory

(Continued on page 473)

## Stenode Radiostat

(Continued from page 472)

model of the Stenode, during the course of which I was allowed to handle the receiver myself. Stations all over Europe, Russia and Northern Africa were tuned in during the course of the evening without the slightest difficulty from interference. Two ordinary receivers, both very selective, of well-known British makes, were available for comparison purposes. Stations which on these receivers were entirely blanketed by the two London transmitters at Brookmans Park, or were hopelessly heterodyned by stations on practically the same wavelength, were received on the Stenode perfectly clearly and with ease. Either one of the two heterodyning stations could be tuned in by an adjustment of the main tuning control.

As a supreme test the 1½ kw. station at Leipzig, about 800 or 900 miles distant, which operates on a wavelength

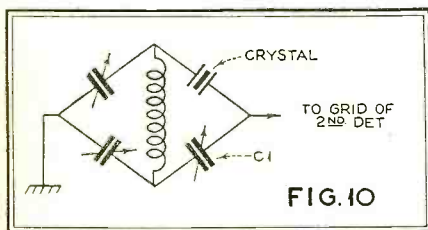

Fig. 10. The quartz crystal "bridge" circuit drawn so as to show its similarity to the Wheatstone bridge

only 9 kc. below that of the 30 kw. London National Program transmitter (which transmits on 261 meters) was tuned in perfectly without the slightest sign of interference from the London transmitter, which was less than 10 miles away. It has been estimated that London's field strength is no less than 32,000 times as great as that of Leipzig. No ordinary receiver, including a well-known and very selective American receiver with four stages of r.f. amplification, can perform this feat anywhere round London.

The tuning of the Stenode is so fine that it is practically impossible to pick up a station by means of a 50-1 slow-motion tuning dial. The main tuning condenser is therefore shunted by a single plate variable condenser having a capacity of 3 micro-microfarads. One complete turn of the knob controlling this gives a variation of 1 micro-microfarad. Either of the near-by London transmitters can be entirely tuned in or out by one-tenth of a revolution of this knob!

As a further test, a local oscillator located within a few feet of the Stenode was switched on, but unless adjusted to within a very few cycles of the frequency to which the Stenode was tuned it caused no interference.

The particular model of the receiver which was being demonstrated was comprised of three units: (1) a sensitive superheterodyne, (2) a Stenode quartz crystal bridge, and (3) an equalizer and ordinary a.f. amplifier. The complete circuit diagram is given in Fig. 9, from (Continued on page 475)

# BUILT TO GIVE PERFORMANCE-PLUS!

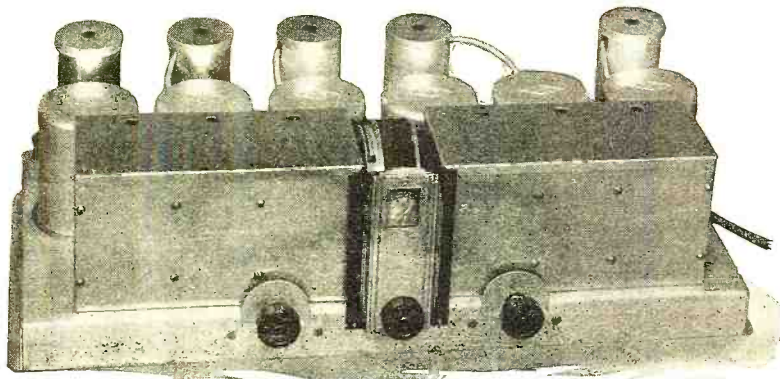

An entirely new and further improved design of the well-known MB-29 Tuner

Made with genuine NATIONAL Radio Parts

Higher selectivity—no tendency to cross-talk. Distance to limit of noise level. Absolute freedom from oscillation. Elimination of tube-hiss and other background noises. Exceptionally rigid

construction, thoroughly shielded. Especially suitable as radio pick-up for existing amplifiers—may be built on rack panel, if desired. Assembling and connections very simple, easily understood by anyone.

NATIONAL CO., Inc., Malden, Mass.

Est. 1914

## NATIONAL SCREEN-GRID—MB-30

# RIGHT NOW!

Send for Our

## NEWEST CATALOG

Largest Assortment and Biggest Bargains in

## RADIO SETS and PARTS

ALL MERCHANDISE AT WHOLESALE

S. HAMMER RADIO CO.

142 Liberty Street, New York  
Tel. Hitchcock 1152—Dept. N



**CODE AT HOME RADIO AND TELEGRAPHY**  
 LEARN WITH AUTOMATIC ROMNIGRAPH Has Helped Thousands To Better Positions U. S. Govt. Depts., Colleges, Scientists, and Schools use it NOW! On Land, Ships, and Air—Your Career Future is Secure. The Auto-Omnigraph teaches you easily and quickly. Learn by Listening. Models \$15-\$40. Catalog Free.  
 THE OMNIGRAPH MFG. CO., 810 E. 39th St., N-6, Brooklyn, N. Y.

## JOHN F. RIDER

announces

A personally written and personally conducted  
**ADVANCED HOME STUDY COURSE**  
 for serious minded

**RADIO SERVICEMEN EXPERIMENTERS**  
**PROFESSIONAL SET BUILDERS**

who wish to increase their earning power, prepare themselves for future radio developments and better their financial condition.

JOHN F. RIDER, Stenec Trust Bldg., Hoboken, N. J. RN-1  
 Dear Mr. Rider: Please send me all details about your SPECIAL HOME STUDY COURSE. This does not obligate me in any way.

Name .....  
 Address .....  
 City ..... State .....

# NEW BOOKS at Magazine Prices!

Each of the following 50c books is of the large size, 8½ x 11½ inches, containing 96 profusely illustrated pages, bound in beautiful colored covers. The contents of any one of them is equivalent to the average 300-page volume, and in ordinary book form would probably cost you from \$2.00 to \$10.00. Get these exceptional bargains TODAY, while we still have them in stock!

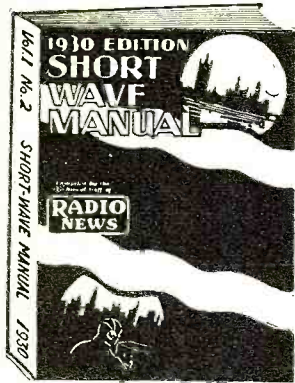

## NEW RADIO TROUBLE FINDER & SERVICE MANUAL

Ever have your radio reception fail or become distorted just when a big program was on and you wanted to hear every delicate inflection of tone distinctly? That's when this big book is worth its weight in gold. In simple words and easy to understand charts and pictures, it shows you how to find and correct any radio trouble quickly. It's just the book you need for improving the reception of your set, repairing sets for friends, and for starting a profitable repair business of your own. Shipped, prepaid, to your home for only **50c**

## HOW TO WIN AT BRIDGE

by Wilbur C. Whitehead

The world-famous Bridge authority's newest book. His easy picture method shows how to play both Auction and Contract Bridge TO WIN! Complete rules of play and methods of scoring for both Auction and Contract Bridge. Contains 500 hands to bid and play, with complete solutions and analyses in back of book. The biggest 50c worth ever offered to Bridge fans. Printed in 2 colors. Hearts and diamonds shown in red throughout. 96 pages. Large 8½ x 11½-inch size. Beautiful colored cover. Price postpaid, only... **50c**

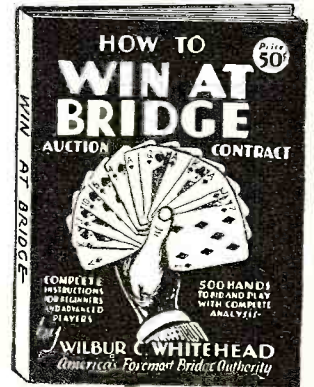

## LUCKY BREAKS

Read about the \$315,000 fortune waiting for some Lucky person! Read what Belasco, Copeland, Untermeyer, Taft and others think of Luck. Read about Luck in the movies, in athletics, above the clouds! Read about the Luck of the real person who actually did break the bank at Monte Carlo. Read about the Luck of Columbus, Napoleon, Lafayette. The Luck that made Presidents. Read these true stories of amazing Lucky Breaks and be prepared when yours comes along. Price, prepaid, only... **50c**

## FLYING FOR EVERYBODY

19 Chapters—More than 120 Photographs, Maps and Diagrams. This book is the one complete Aviation Manual which covers every phase of flying from the ground up. Condensed in its pages is the essence of years of experiences of Aviation's foremost authorities. No air-minded person should be without it. Price, prepaid, only... **50c**

## POPULAR MAGIC AND CARD TRICKS

Mystify your friends; charm the ladies; be the life of any party. Make glass bowls vanish, cards fly, coins disappear. Do hundreds of other magic tricks and games as easily as a professional. Over 200 described and illustrated in this big book on magic. Prepaid, only... **50c**

## NEW SHORT WAVE MANUAL

Experience the thrills of the Short Waves of hearing Europe, Africa or Australia direct as clearly as native stations. This big book, replete with illustrations and How-to-Build diagrams and plans, crowded with 28 chapters by Lieut. Wenstrom, Marshall, Spangenberg and other foremost S-W authorities, represents the last word in authentic S-W data. The most complete up-to-the-minute short wave manual ever published. Brings you more information than books selling at ten times its price. Shipped, prepaid to your home for only... **50c**

## RADIO AMATEURS' HANDIBOOK

Sometimes called the Radio Amateurs' Bible. 30 profusely illustrated chapters bring you 10 How-to-Build articles, with complete instructions and diagrams; new radio wrinkles, DX hints, data on the new tubes, answers to AC problems, and helpful, money-saving ideas for the radio service man. 96 illustrated pages. Large 8½ x 11½-inch size. Beautiful colored cover. Shipped, prepaid, to your home for only... **50c**

## 1001 RADIO QUESTIONS AND ANSWERS

If you own a radio, you need this book. Everything you want to know about radio is in it, from "How to Kill Outside Radio Noises," to a clear description of the newest tubes and how to use them. If you have a question on radio, here is your answer and a thousand more. 96 illustrated pages. Large 8½ x 11½-inch size. Beautiful colored cover. Shipped, prepaid to your home for only... **50c**

## ANATOMICAL MANIKINS MALE & FEMALE

By Dr. David H. Keller  
Book measures 6 x 14 inches. Contains 12 large plates of the human body, male and female, with complete descriptions of every muscle, nerve, gland, bone, organ, etc., including reproductive organs of male and female. Books of this kind ordinarily cost from \$10 to \$25 when bought through medical supply establishments. Price, complete and prepaid, only. **\$1**

## Also the Following at Only 25c Each

- How to Make It (working in wood, metal, cement, paint, etc.)
- How to Electrify Your Radio Set
- What Radio Set Shall I Buy
- How to Build the Famous One Knob Set
- 101 Radio Hook-Ups
- The Neutrodyne and All About It
- Cookoo Nuts (A game in book form for parties)
- S'matter Pop (the famous comics in book form)

## MAIL TODAY

RADIO-SCIENCE PUBLICATIONS, Inc.  
Dept. 2411, 381 Fourth Ave., New York, N. Y.

Gentlemen: Please ship me, prepaid, the books whose titles I have listed below. Remittance is enclosed.

.....  
 Name.....  
 Address.....  
 City.....  
 State.....

Buy Them at Your Newsdealer  
or Mail Coupon AT ONCE! ➡

# More About the Stenode Radiostat

(Continued from page 473)

which it will be seen that ten tubes are employed. It was explained, however, that the great sensitivity of the receiver was in no way due to the inclusion of the Stenode principle. The receiver was standard as far as the number of tubes was concerned, the only addition being tube T7, which was made necessary by the inclusion of the Stenode bridge, but did not add to the sensitivity of the receiver. Its range, therefore, was no greater than that of a superheterodyne of similar characteristics. But its selectivity was enormously greater.

Reception was carried out on a loop antenna, but in order to meet objections that this might contribute to the selectivity, the loop was grounded, thus ensuring all-round reception, no matter in what direction the loop was facing.

Referring to Fig. 9, the first tube, T1, is the oscillator, T2 the first detector, T3, T4 and T5 the intermediate-frequency amplifier tubes, T6 the second detector, T7 coupling tube to the equalizer circuit, and T8, T9 and T10 the a.f. amplifier tubes, the last two being connected in parallel.

Up to T5 the circuit is that of a normal superheterodyne employing screen-grid tubes in the i.f. stages, but coupling T5 to T6 is a special "gate" or "bridge" circuit containing a quartz crystal of the flat-plate type. This is arranged in a special holder so that its plane of oscillation is parallel to the mounting plates. The i.f. and bridge circuits are both tuned to the same frequency, in this case 107 kc. The bridge circuit is shown by itself in Fig. 10, which has been drawn so as to show its resemblance to a Wheatstone bridge. Unless condenser C1 is carefully adjusted to balance the capacity of the crystal holder, signals will leak through the latter, and the effect of the crystal itself will be nullified. In practice, in searching for stations, the bridge circuit is deliberately unbalanced by detuning C1, whereupon the receiver functions in the normal manner. Once the desired station has been picked up, or "scented" through interference, C1 is readjusted to the correct balancing value, and a slight readjustment of the main tuning control brings in the desired station clearly.

The function of the bridge circuit depends upon its leading characteristic, which is that it will only allow to pass through it signals the frequency of which is within a few cycles of the frequency of the crystal itself. Obviously, the crystal can have only one frequency of oscillation. As it is naturally desired to receive signals of different frequencies, a frequency changer is necessary ahead of the crystal, and this is the function of the superheterodyne, which is used to change the frequency of all incoming signals to that of the crystal, 107 kc.

After passing through the bridge circuit the signal is impressed on the grid of the second detector, which has to be heavily negative biased to bring the modulation on to the rectifying part of the tube curve, because the low-damped crystal circuit produces a signal with a

large c.w. component and relatively small modulation.

As a result of this low damping, however, low notes build up to a much greater extent than high ones, the ratio being about 60-1. If the signal were a.f. amplified immediately, therefore, terrific distortion would result, so the output of the second detector is first fed through T7 and the equalizing or filter circuit shown between T7 and T8. In the receiver which I handled this equalizing circuit was adjustable so that any ratio of high to low notes could be obtained to suit the individual. The net result was that reproduction was perfect and, with the volume control full on, overpowering in volume even on very distant stations. A dynamic speaker was used.

Although, according to Fig. 9, there appear to be a large number of controls, most of them are ganged, so that the actual number is quite reasonable, as can be seen from the accompanying photographs. Once the main controls have been set, tuning from station to station can easily be effected by unbalancing the bridge (one control), adjusting the main tuning control (one control), rebalancing and slight returning.

During the course of the evening I noticed a very curious and interesting fact. Stations which I knew to be crystal-controlled came in with unvarying strength. Other stations varied in strength considerably. When I remarked about this fading I was told that the stations concerned were wandering from their assigned frequencies. I proved this by following them on the main tuning control of the Stenode. On an ordinary receiver these stations were apparently dead steady!

Another curious thing, also illustrative of the extraordinary selectivity of the Stenode, was the fact that a certain Continental station, comprehensibly receivable on an ordinary receiver, was utterly unintelligible on the Stenode. This, I was told, was due to the fact that the Stenode is designed expressly to receive amplitude modulation only. The station in question is made up of oddments of old equipment and thinks it is transmitting frequency modulation. There is therefore no one steady frequency available to pass through the Stenode bridge.

Although Dr. Robinson does not claim that the Stenode will eliminate static, man-made or natural, it certainly minimizes both sorts very considerably. Hanover Square is one of the worst parts of London for radio reception, for it is within a quarter of a mile or so of Piccadilly Circus and Leicester Square, London's theatreland, where thousands of flashing signs were causing pandemonium in the ordinary receivers. There was also, on the occasion of my visit, a fair amount of natural static, but on the Stenode all that could be heard was an occasional very brief click.

With such a receiver available which has a resonance curve less than 100 cycles wide and can yet receive broadcasting perfectly, it is clear that of the 9,000

(Continued on page 476)

## DEALERS and SERVICE MEN:

### WE SPECIALIZE IN REPLACEMENT PARTS

**BAL-RAD**  
REPLACEMENT BLOCK  
For Atwater Kent No. 37  
This unit contains the proper chokes and high voltage condensers. All flexible wire colored leads identical to the original. **\$4.95**  
Fully guaranteed **\$4 each**

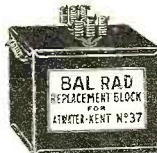

**BAL-RAD**  
Replacement Block for Majestic "B" Eliminator  
The condensers in this block are composed of high voltage condensers. Guaranteed for 1 year. **\$2.95 each**



**VICTOR CONDENSER BLOCKS**  
Replacement in All Victor Sets  
Contains 10% mfd. Our price **\$3.25**



**EARL & FREED**  
Power Transformers  
For models 95, 78 and 79, using 5-227, 1-280, 2-245 tubes.  
60 cycle ..... **\$4.50**  
25 cycle ..... **4.75**  
Model 22, using 3-226, 2-171A, 1-280, 2-227 tubes.  
60 cycle ..... **\$3.50**  
25 cycle ..... **3.75**



**R.C.A. REPLACEMENT 600V CONDENSER BLOCK**  
For Radiolas Nos. 18, 33 and 51.  
Part No. 8333. Special. **\$1.50**  
Each



**THORDARSON Power TRANSFORMERS**  
For Replacement in Zenith Sets  
Models ZE 10-33-33X-34. This transformer can also be used for circuits employing the following type tubes: 5-227-1-171A-1-280.  
Our price ..... **\$3.50**



**VICTOR PUSH-PULL TRANSFORMER—Input and Output**  
Can be used with 171A-245 or 250 type tubes. Output matches moving coil on all dynamic speakers.  
With Metal Jacket **\$2.50** | Without Metal Jacket **\$1.50**



**BAL-RAD HY VOLTAGE Surge-proof Condensers**  
For General Repair and Power-Pack Work  
We guarantee these condensers for 100 per cent. free replacement. Repairmen should carry a few dozen in stock.

	MFD.	Working Volts	Each
One	600	"	30c
Two	600	"	40c
Four	600	"	60c
One	800	"	50c
One-half	300	"	25c



**R.C.A. BY-PASS CONDENSER**  
Part No. 5996  
Comprising one 1/2 and three .1 mfd. condensers.  
List **\$3.00** **35 cents each**



**R.C.A. DOUBLE FILTER CHOKES**  
Part No. 8336  
R. C. A. Replacement Part No. 8336 contains two 30 henry 80 ml chokes. Each choke **95c**  
insulated for 1,000 volts



**PIGTAIL CARBON RESISTANCES**

500 ohm	15000 ohm	10000 ohm	} <b>\$1.25</b> Per doz.
1000 ohm	25000 ohm	20000 ohm	
4700 ohm	2 megohm	75000 ohm	

**TERMS** 20% with order, balance C. O. D. 2% discount allowed for full remittance with order only.  
No Orders Accepted for Less Than **\$2.50**  
**BALTIMORE RADIO CO.**  
47-N MURRAY ST., N. Y. C.  
Send for Our Latest Bargain Bulletin

HIGH VOLTAGE..SELF-HEALING..MOUNT IN ANY POSITION



Dealers, Set Builders and Service Men, Write or Wire for Descriptive Literature, Prices, Samples.

## DRY Electrolytic Condensers

TRY CONCOURSE'S new high voltage Electrolytics! Designed for peak voltage of 500 or even higher . . . with a better power factor efficiency than the usual type condenser. Light in weight, long-lived on the shelf . . . not affected by extreme heat or cold . . . a model of efficiency and economy. From less than 1 to 200 or more microfarads . . . in various types, round or square housing . . . and we can make them to your own specifications.

## NEW....

FOR the modern radio set! A better Electrolytic, mountable in any position, that will not damage the set by leaking . . . and is self-healing. Forms on applied current to proper rated capacity in a few minutes. Lower cost per mfd. Better in every way . . . and cheaper in the end!



**CONCOURSE**  
ELECTRIC COMPANY, Inc.  
296 East 137th Street  
New York City

## Read Classified Advertising—It Pays!!!

Advertisements in this section twenty-six cents a word for each insertion. Name and address must be included at the above rate. Cash should accompany all classified advertisements unless placed by an accredited advertising agency. No advertisements for less than 10 words accepted. Objectionable or misleading advertisements not accepted. Advertisements for these columns should reach us not later than 1st of 2nd month preceding issue.

### Agents Wanted

**A SPLendid SIDE LINE**—We sell pass books, check covers, coin bags, etc., mainly to banks. They are centrally located and do business quickly. Little time is lost. Our samples are light, compact, easily carried. Sales run into money, items repeat well, commission is liberal, and all of advertising novelties for merchants. Our quality is good, the variety extensive, the styles interesting. Line is big enough to devote your whole time if you wish. We are manufacturers, own our build-ings, been in business sixteen years, ship to every State. Eighteen thousand banks have bought from us. You could work wherever you happen to be. Correspondence invited. Continental Bank-Supply Co., Mexico, Mo.

Guaranteed Genuine Gold Leaf Letters anyone can put on store windows. Large profits, enormous demand. Free samples. Metallic Letter Co., 422 N. Clark, Chicago.

### Correspondence Courses

Used correspondence school courses sold on repurchase basis. Also rented and exchanged. Money-back guarantee. Catalog free. (Courses bought.) Lee Mountain, Pisgah, Alabama.

**CORRESPONDENCE COURSES**—Sold, Bought, Exchanged, Rented. Bargain Catalogue Free. Hanfling, 1-799 Broadway, New York

### Detectives

**DETECTIVES.** Work home or travel. Experience unnecessary. Particulars free. Write George Wagoner, 2190-X Broadway, N. Y.

### Help Wanted and Instruction

Detectives Earn Big Money. Experience unnecessary. Write American Detective System, 2190-K Broadway, N. Y.

### Inventions

**INVENTIONS WANTED**—Patented, Unpatented. If you have an idea for sale write, Hartley, Box 928, Bangor, Maine.

### Male Help Wanted

**GET outdoor government jobs;** \$135-\$200 month; vacation. Patrol forests and parks; protect game. Details free. Write **DELMAR INSTITUTE**, B-31, Denver, Colo.

### Miscellaneous

Radio-frequency chokes 20 cents. E. Anander, Route 5, Jamestown, N. Y.

**HAVE YOU A CAMERA?** Write for free sample of our big magazine showing how to make better pictures and earn money. American Photographs, 3105 Camera House, Boston, Mass.

### Model Aeroplanes

"CITY OF CHICAGO" WORLD'S DURATION "PLANE 30" Plan, 20c. Model Aviator, Dept. E. G., 601 Washington, Chicago.

### Patent Attorneys

**PATENTS**—Write for Free Booklet, HOW TO OBTAIN A PATENT and RECORD OF INVENTION—or send Drawing or Model for Examination. Miller & Miller, Patent Attorneys (former Patent Office Examiners), 282 McGill Building, Washington, D. C.

**PATENTS, TRADE MARKS**—All cases submitted given personal attention by a member of the firm. Information and booklet free. Lancaster, Allwine & Rommel, 269 Ouray Building, Washington, D. C.

**Inventors**—Should write for our Guide Book, "How to Obtain a Patent," and Record of Invention Blank, sent Free. Send model or sketch of inventions for our inspection and instructions free. Radio, Electrical, Chemical, Mechanical and Trademark Experts. Terms Reasonable. Victor J. Evans & Co., 922 Ninth, Washington, D. C.

**PATENTS**—Advice and booklet free. Highest references. Best results. Promptness assured. Watson E. Coleman, Patent Lawyer, 724 9th Street, Washington, D. C.

### Radio

**Wanted**—Men to work with National Radio Service organization. No selling scheme. Radio Doctors, Inc., Dept. N, Essex St., Salem, Mass.

### Song Poem Writers

**COMPOSERS—VERSE OR MUSIC.** Brilliant opportunity. Write at once. Van Buren, 2171 McClurg Bldg., Chicago.

**SONG POEM WRITERS**—"REAL" proposition. Hibler, D-191, 2104 Keystone, Chicago, Ill.

**SONG WRITERS' POEMS—MELODIES**—Opportunity—Tommy Malie, RN4215 North Ave., Chicago.

### Wireless

**LEARN WIRELESS** (Radio) and Morse Telegraphy. School, oldest and largest; endorsed by Telegraph, Radio, Railway and Government officials. Expenses low—can earn part. Catalog free. Dodge's Institute, Cour St., Valparaiso, Ind.

**QUIT TOBACCO**

Don't try to banish unaided the hold tobacco has upon you. Thousands of inveterate tobacco users have, with the aid of the Keeley Treatment, found it easy to quit.

**KEELEY TREATMENT FOR TOBACCO HABIT** Quickly banishes craving for tobacco. Successful for over 50 years. Write today for FREE BOOK and particulars of our MONEY-BACK GUARANTEE.

**THE KEELEY INSTITUTE, Dept. L-609, Dwight, Ill.**  
Home of the famous Keeley Treatment for Liquor and Drugs. Booklet Sent on Request. Correspondence Strictly Confidential.



## Stenode Radiostat

(Continued from page 475)

cycles separation which we allow between broadcasting stations, 8,900 cycles is just so much waste space in the broadcast waveband. In other words, where one broadcast station now operates there is room for a total of *ninety* stations, provided everybody uses one of the new receivers. Or, alternatively, the modulation frequency of a transmitter could be increased very considerably for television broadcasting purposes. All are agreed that before television can become a really big popular success a much larger field of vision will have to be transmitted. This means broadcasting frequencies far in excess of 9 kc. Perhaps the Stenode Radiostat will provide a way out.

### Marketing

There is no hope of the Stenode coming on to the market for broadcasting purposes in the immediate future, however. Radio broadcasting is only one of the many uses to which the ether is put; the entire field of radio communication is very much broader, and to begin with Dr. Robinson is concentrating on the adaptation of his receiver for commercial point-to-point services in order to speed up communication. The British Radiostat Corporation does not intend to manufacture or sell apparatus itself, but will license others to do so. Meanwhile, research work is being continued with a view to simplifying the receiver.

### Commission Adds to Staff

Latest additions to the staff of the Federal Radio Commission are John A. Willoughby, of Florence, N. C., who comes to the Commission from Aladdin Industries, Chicago, as a senior radio engineer, and Hobart Newman, of Washington, formerly assistant federal attorney for the District of Columbia, who has joined the legal department.

### Amateur Standard Stations

Station KHJ, Los Angeles, has been chosen by the American Radio Relay League as the third station to transmit standard frequency signals in the amateur bands in order to enable the "hams" and all other short wave users to calibrate their apparatus so as to maintain stability on their wave lengths. The other two stations will be W9XAM of the Elgin Watch Co., Elgin, Ill., and W1XP of the Massachusetts Institute of Technology, Boston.

### Radio Center of World

"Radio Center of the World" is the title now claimed by Camden, N. J., as a result of the consolidation of all RCA-Victor production in that city. September 19 was set aside as a holiday for the formal dedication of Camden as a radio center where, it is estimated, some 20,000 workers will be employed in radio production.

# The RADIO NEWS Radio Association

AS this issue of RADIO NEWS goes to print the Radio News Radio Association, the newly formed organization for the stimulation and advancement of short-wave radio, performs its first useful service. Members of the Association, under the direction of the Technical Staff of RADIO NEWS were assigned duties at the Short-Wave Headquarters of the Radio World's Fair held in Madison Square Garden from September 22nd to 27th.

On top of the "Garden" in the radio shack of WMSG a very sensitive short-wave superheterodyne, in fact the RADIO NEWS Short-Wave superheterodyne, described in the August, September, and October issues of RADIO NEWS by Fred H. Schnell, was installed for the purpose of receiving twice daily foreign broadcasts on short-waves. A pair of special lines connected the station to the Headquarters booth in the Exposition Hall when provision had been made to allow the public in groups of thirty to listen in on headphones to the short-wave broadcast programs being picked up above. So much for that.

Since the first announcement of the Radio News Radio Association was made in the August issue of RADIO NEWS, hundreds of applications for membership have been received and each mail brings in a flock more.

If your application for membership has not as yet been acknowledged don't be-

come alarmed. The veritable flood of applications has temporarily swamped our clerical facilities and it may be a while yet before you receive notice of the receipt and acceptance of your application for membership in the R. N. R. A.

Of course, in a new organization such as ours things move a bit slowly, but nevertheless the work of the organization is progressing and a definite schedule of technical talks, meetings on the air, etc., will be published in an early issue of RADIO NEWS.

Remember, it costs you absolutely nothing to join this organization. Simply make use of the coupon below, fill it out, and mail it to Short-Wave Headquarters. RADIO NEWS, 381 Fourth Avenue, New York City.

To join the RADIO NEWS Radio Association fill out this information slip and return it to the address indicated. Print the information required in ink.

Name .....

Address..... City.....

Do you own a short-wave receiver?...

What make?.....

Are you a transmitting amateur?...

What's your call?.....

What kind of a transmitter is used? .....

## Underwriters Radio Regulations

(Continued from page 448)

vided with an approved protective device (lightning arrester) which will operate at a voltage of 500 either inside the building at some point between the entrance and the set which is convenient to a ground, or outside the building as near as practicable to the point of entrance. The protector shall not be placed in the immediate vicinity of easily ignitable stuff or where exposed to inflammable gases or dust or flying of combustible materials.

The ground wire running to the lightning arrester must be of copper, bronze or approved copper-clad steel and shall not be smaller than No. 14 copper wire nor smaller than No. 17 if of bronze or copper-clad steel. The protective grounding conductor shall be run in as straight a line as possible from the arrester to a good permanent ground. The ground connections shall be made to a cold-water pipe where such a pipe is available and is in service and connected to the street mains. An outlet pipe from a water tank fed from a street main or a well may be used, provided such outlet pipe is adequately bonded to the inlet pipe connected to the street water main or well. If water pipes are not available, ground connections may be made to a grounded steel frame of a building or to an artificial ground such as a galvanized iron pipe or a rod driven into permanently damp earth or a metal plate

buried similarly. Gas piping must not be used for the ground. The protective grounding conductor shall be guarded where exposed to mechanical injury. An approved ground clamp shall be used where the protective grounding conductor is connected to pipes. Ground wires may be run inside buildings if securely fastened in a workmanlike manner but must not be nearer than two inches to any electric light or power wires not in conduit.

Antenna and counterpoise wires must be securely mounted on insulators at least five inches clear of buildings, said insulators having not less than five inches creepage and air-gap distance to inflammable or conducting material, except that the creepage and air-gap distance for CW sets of less than one kilowatt power input shall not be less than three inches.

The antenna must be grounded at all times when the transmitter is not in use. For this purpose, a heavy clip at the end of a heavily insulated wire can be used to short the antenna to the ground. The flexible lead must be securely mounted at least five inches from the wall on approved insulators. This clamp arrangement can take the place of a lightning arrester if desired, although the ground requirements still hold true. It is advisable to make the flexible lead at least eight inches in length to insure

(Continued on page 479)

## New Developments!

**Complete Instructions and Data on All Recent Radio Inventions Now Yours for Ready Reference in This One Big Guide Book of Radio.**

**BYRD'S Antarctic Radio Equipment**—Receivers, transmitters, and latest navigation aids used on this epochal flight fully described.

**TELEVISION**—Mr. C. F. Jenkins, father of television and radio movies, gives you in his own words complete directions for building practical television equipment.

**INTERFERENCE ELIMINATION**—New methods systematically outlined by W. F. Fleming, radio engineer.

**RADIO AUTO ALARM**—Description of new device for ships which keeps the SOS watch while operator is off duty.

**SHORT WAVE APPARATUS**—commercial and amateur, described and illustrated.

**NEW BROADCASTING EQUIPMENT**—Temperature-controlled Piezo crystal oscillator; 100% modulation panel and other new apparatus.

—and these are only a few of the new subjects added to the most complete radio handbook ever published.

# THE RADIO MANUAL

*A Handbook for Students, Amateurs, Operators, and Inspectors*



Here's the answer to every question about the principles, operation, and maintenance of apparatus for radio transmitting and receiving. Important new chapters have been added to bring it right up to the minute. Many new photographs and diagrams have been included. It is now more than ever the one complete handbook covering the entire radio field.

**A Complete Course in Radio Operation in ONE VOLUME**

**Prepares for Government License**

20 big chapters cover: Elementary Electricity and Magnetism; Motors and Generators; Storage Batteries and Charging Circuits; The Vacuum Tube; Circuits Employed in Vacuum Tube Transmitters; Modulating Systems and 100% Modulation; Wavemeters; Piezo-Electric Oscillators; Wave Trap; Marine Vacuum Tube Transmitters; Radio Broadcasting Equipment; Arc Transmitters; Spark Transmitters; Commercial Radio Receivers; Marconi Auto-Alarm; Radio Beacons and Direction Finders; Aircraft Radio Equipment; Practical Television and Radio Movies; Eliminating Radio Interference; Radio Laws and Regulations; Handling and Abstracting Traffic.

**Prepared by Official Examining Officer**

The author, C. E. Sterling, is Radio Inspector and Examining Officer, Radio Division, U. S. Dept. of Commerce. The book has been edited in detail by Robert S. Kruse, for five years Technical Editor of QST, the Magazine of the American Radio Relay League, now Radio Consultant. Many other experts assisted them.

**Examine It FREE!**

The revised edition of "The Radio Manual" is now ready. Nearly 800 pages; 369 illustrations. Bound in flexible Fabrikoid. The coupon brings the volume for free examination. Within 10 days you may return the volume or send the price of \$6.00.

**MAIL THIS COUPON**

**D. Van Nostrand Co., Inc.**  
250 Fourth Ave., New York

Send me the Revised edition of THE RADIO MANUAL for examination. Within ten days after receipt I will either return the volume or send you \$6.00, the price in full.

(R. N. 11-30)

Name .....

St. and No. ....

City and State .....

Business Connection .....

**NEW IMPROVED**  
the  
**TRIAD**  
**T-224 TUBE**



This newly designed T-224 tube now makes possible a finer performance for your radio—and far greater enjoyment for YOU. Its durable construction

practically eliminates microphonics and burnouts—and assures a longer life of perfect service. Constant research and the best of engineering skill have been combined to make this tube perfection available to you. Your nearest TRIAD dealer will gladly demonstrate the superior reproducing powers of TRIAD T-224. Why not speak to him about it—today?

TRIADS are now manufactured under R. C. A., G. E. and Westinghouse patents.

TRIAD MFG. CO., INC.  
Pawtucket, R. I.

**TRIAD**  
**RADIO TUBES**

**INDEX TO ADVERTISERS**

<b>A</b>	
Acme Wire Company	460
Aerovox Wireless Corp.	461
Allied Radio Corp.	Inside Front Cover
American Sales Co.	468
American Transformer	Inside Back Cover
Anperite Corp.	472
Amplex Instrument Laboratories	467
Amrad Corp., The	455
Arcturus Tubes	463
Automatic Radio Mfg. Co., Inc.	465
<b>B</b>	
Baltimore Radio Company	475
Blan the Radio Man	462
<b>C</b>	
Cardwell Mfg. Corp., The Allen D.	469
Central Radio Laboratories	458
Champion Radio Works	457
Chicago Gear Works	461
Chicago Radio Apparatus Co.	472
Chicago Salvage Stock Store	480
Clarostat Mfg. Co.	469
Classified Advertising	476
Concourse Electric Co.	476
Cornish Wire Co.	462
Coyne Electrical School	389-464
Crosley Radio Corp.	464
<b>D</b>	
DeForest Radio Co.	445
Drake, Frederick J., & Co.	463
<b>E</b>	
Electrad, Inc.	451
Ellis Electrical Laboratory	472
Essenbee Radio Service Co.	460
Excello Products Corp.	463
<b>F</b>	
Federated Purchaser	470
Flechthelm & Co., Inc.	466
F & H Radio Laboratories	471
<b>H</b>	
Hammarlund Mfg. Co.	479
Hanmarlund-Roberts, Inc.	387
Hammer Radio Co., S.	473
Harrison Radio Co.	470
Hatry & Young, Inc.	468
High Frequency Labs.	447
Hoodwin Co., Chas.	470-478
<b>I</b>	
International Correspondence Schools	450
International Resistance Co.	467
International Typewriter Exchange	461
<b>J</b>	
Jappe, Co., H.	462
J M P Mfg. Co., Inc.	466
<b>K</b>	
Keeley Institute	476
<b>L</b>	
LaSalle Extension University	461-471
Lincoln Hotel	471
Ludy Hotel	461
<b>M</b>	
Mason, Fenwick & Lawrence	463
Massachusetts Radio & Telegraph School	454
McGraw-Hill Book Co., Inc.	458
Metal Cast Products	466
Midwest Radio Corp.	443
<b>N</b>	
National Carbon Co., Inc.	437
National Co., Inc.	441-473
National Radio Institute	Back Cover and 453
Nelson Electric Co.	461
Norden-Hauck, Inc.	465
<b>O</b>	
Omnigraph Mfg. Co.	473
<b>P</b>	
Pilot Radio & Tube Corp.	449
Pitman Isaac, & Sons	460
<b>R</b>	
R C A Institutes, Inc.	435
Radex Press	468
Radio Surplus Corp.	472
Radio & Television Institute	391
Radio Training Association of America	385
Rider, John F.	473
Rim Radio Mfg. Co.	461
Roll-O Specialty Company	471
<b>S</b>	
See Jay Battery Co.	454
Shallcross Mfg. Co.	464
Silver-Marshall, Inc.	439
Smith Typewriter Sales Corp.	452
Stuyvesant Electric Co.	463
<b>T</b>	
Teleplex Company	456
Thorndike Co.	478
Triad Mfg. Co., Inc.	478
Twentieth Century Mail Order	470
<b>V</b>	
Van Nostrand Co., Inc. D.	477
Vari-Tone Lab.	450
Von Hoffmann Aircraft School	456
<b>W</b>	
Washington Hotel	478
Western Radio Mfg. Co.	468
Weston Electrical Instrument Corp.	459
West Side Y. M. C. A. Radio Inst.	456
Wholesale Radio Service	454
Wilcox, P. H.	471
Workrite Radio Corp., The	469
<b>Y</b>	
Yaxley Mfg. Company	452

**A Bargain Sale of**  
*Wonderful*  
**Factory Sites and Structures**

**ELEVEN** factories in the heart of the New England industrial district are for sale at prices that will permit a reduction of 50% or more in your operating overhead. On the main line of the Boston & Albany. Also on main Boston Post Road affording excellent truckage facilities to important markets. Labor and housing conditions excellent. Cheap hydro-electric power will be available from nearby central station. Plants adapted to production of textiles, radios, automobiles, hardware, chemicals, printing or any commodity requiring heavy machinery. Factories will be sold separately or as unit. Write for descriptive folder.

Write for complete description

**Thorndike Co.**  
West Warren, Mass.

**RADIO BARGAINS**

Low Power Transmitter adaptable for phone or code. With plug-in coils \$14.75  
Auto Radio—Uses 3—224, 2—227 tubes and 1—245 power tube, single dial, tremendous volume. Compact. Fits any car. We guarantee this set to perform better than sets selling up to \$150. 20.00  
B Eliminator, Bone Dry with 280 tube, 180 volts, will operate up to ten tube set, fully guaranteed. 6.75  
AC—A B C power packs 8.75  
Tubes: UX type, 30-day replacement guarantee. No. 219, \$2.25; No. 250, \$2.35; No. 281, \$1.85; No. 245, \$1.25; No. 224, \$1.25; No. 227, 75c; No. 228, 65c; No. 171, 75c.  
CHAS. HOODWIN CO. 4240 Lincoln Ave. Dept. L-3, Chicago

**HOTEL WASHINGTON**

PENNA. AVE. 15th & F STREETS N.W.  
WASHINGTON, D. C.

400 ROOMS — 400 BATHS

Opposite the United States Treasury and the new \$17,000,000.00 Department of Commerce Building

*Easy of access yet located at the very center of life in the Capital City*  
Rates no higher than any other first class hotel

BOOKLET SENT UPON REQUEST  
S. E. BONNEVILLE, Managing Director

**SCIENCE AND INVENTION FOR NOVEMBER**

Are You Entering Our \$3,250.00 Tool Shop Contest? Get Your Share of Ideal Home Workshop Equipment Free!  
"Making Modern Suspension Bridges Safe"—Don Charles tells just how it is possible to build bridges twice as long as the one under construction across the Hudson.  
"On the Shoulders of the Wasps"—The entire fig industry rests on the shoulders of the wasp, according to George A. Pettit.  
"Will the Rocket Replace Artillery?"—Gawain Edwards describes the potential horrors of the rocket.  
"A Visual Attack on the Fog Problem"—Lieutenant W. H. Wenstrom explains just what to do to combat fog in flying.  
"Why Not Light Up Those Dark Corners?"—Unique lighting effects you can assemble.  
"Checking Up on Your Receiver Parts," "What's New in Radio," for the radio fans.  
A great number of *How to Make Its*, including: *Modernistic Bookshelves, A Pirate's Chest, Your Own Castings, A Sun Lamp, A Plate Rack, A Jig Saw.*



# Underwriters Radio Regulations

(Continued from page 477)

full input to the antenna from the transmitter and cause any current to be lost through the proximity of a ground.

## Cable Requirements

Where high voltage transformers of more than 500 volts and more than 200 watts are used, BX cables must be run directly to the meters and must not be less than No. 14 if the transformer is under 500 watts nor less than No. 10 if over 500 watts. Suitable fuses must be used and all switches must not be less than ten ampere rating. The easiest way to install transformers is to make outlets off the BX cable and run the transformers from these as appliances. Duracord or some like approved commercial electric cord must be used as conductors of current from the outlets to the transformers.

Since the work must be done by or under the supervision of a licensed electrician, all the minor details about BX cable installation are known to him. This also applies to motor-generator outfits.

Packard cable or a like commercial product must be used in carrying the high voltage from the power supply unit to the transmitter proper.

The rectifier and filter can be built on a board but must be mounted on a slate slab and must be clear of power-carrying wires except those concerned in the rectifier or filter.

## A. R. R. L. Handbook

The Board of Fire Underwriters is not concerned with the wiring done in the transmitter itself or the rectifier and filter. Any size or wire may be used here, but it is advisable to follow the instructions set forth in the Amateur's Handbook published by the American Radio Relay League. For best efficiency, the largest wire should be used in every place possible. This ensures stability in the transmitter.

At W2WK, a pull-chain, ten ampere switch is being used to throw the 110 line voltage off and on, with the pull-

cord close at hand, but the switch and outlets at a distance from the receiver. It is found that the hum created in the receiver is reduced to a minimum when the line voltage leads are kept as far away from the receiver as possible.

Amateurs and experimenters are cautioned against the use of electric extensions of over seven feet in length even for lighting purposes. This is a direct violation and even though not concerned in certificates issued for amateur stations, it is liable to void policies.

In conclusion, it is advisable to get in touch with your local Underwriter's office and iron out any difficult points that may arise before you start your installation. This procedure will save a re-installation.

## New Vacuum Tube

A NEW type of vacuum tube, so sensitive that it will measure a hundredth of a millionth of a billionth of an ampere, has been developed by the General Electric Company.

The electron flow in this new four-element tube is such that a current expressed as 0.0000000000000001 ampere, compares with the electron flow through the usual 50-watt incandescent lamp as do two drops of water with the enormous volume of water spilled over Niagara Falls in a year. Something like three quintillion electrons per second (3,000,000,000,000,000,000) flow through the ordinary 50-watt incandescent lamp; the new vacuum tube is able to measure accurately a flow of about 63 electrons per second.

## Extreme Sensitivity

The new tube is so sensitive to infinitesimal flows of current that astronomers can use it with photoelectric tubes in determining the amount of heat radiated by stars countless miles away. The current is measured in fractions of quadrillionths an ampere—the stellar distances in multiples of quadrillions of miles.

## Automobile Ignition Eliminators

WITH the increasing popularity of automobile radio has come a development of devices suitable for eliminating the troublesome noises from the receiver which are generated by the discharge action of the spark plugs. This form of interference, if not completely eliminated, all but ruins satisfactory radio reception in an automobile in motion, and for the purpose of elimination of such types of interference the Tilton Manufacturing Company of New York has devel-

oped a kit of special spark plug resistors and bypass condensers. The kit is illustrated here.

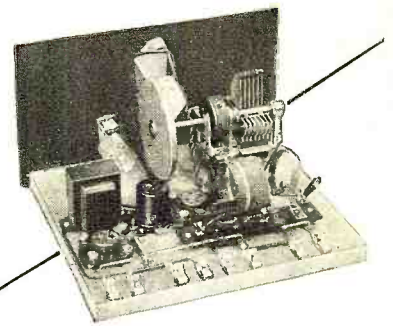
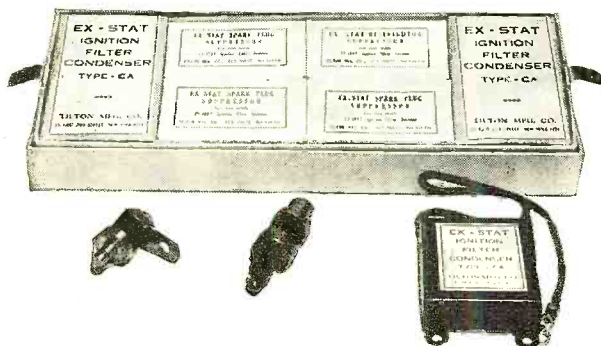

## A SHORT-WAVE SET YOU'LL BEAG ABOUT—

Boy, it *does* bring 'em in! Two tubes—regenerative detector and one audio stage. Easily constructed from the Hammarlund kit, containing all parts, as illustrated.

It includes the famous Hammarlund Drum Dial, the new Hammarlund wide-space short-wave "Midline" Condenser and the improved Hammarlund Space-Wound Plug-in Coils. Covers the range of 15 to 105 meters. Extra coils available for higher wave bands.

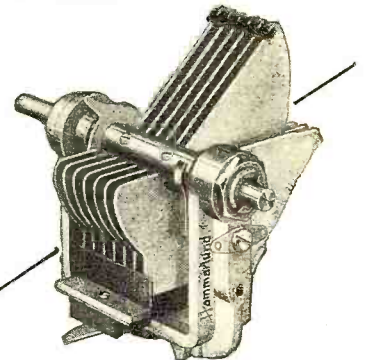

## The New HAMMARLUND Wide-Spaced SHORT-WAVE Condenser

Heavy, widely-spaced plates for strength. Less chance for accumulation of dust causing capacity changes in close tuning.

"Parmica" insulation, which closely matches the ideal dielectric efficiency of dry air. Current loss greatly reduced; sensitivity and selectivity much improved.

Double cone, smooth-operating bearings—easily adjusted for wear, non-corrosive brass plates with tie-bars. Strong aluminum alloy frame.

A real short-wave condenser in the three most desirable sizes: 150, 125 and 100 mmf.

Write Dept. RN11 for Details of Hammarlund Short-Wave Equipment.

HAMMARLUND MFG. CO.

424-438 W. 33rd Street, New York

For Better Radio  
**Hammarlund**  
PRECISION  
PRODUCTS

*Lowest Wholesale Prices* **SUPER RADIO VALUES**  
**FREE RADIO CATALOG**

- Screen Grid Sets
- D C Battery Sets
- Phono-Combinations
- Dynamic Speakers
- New Mantel Sets
- Slot Machine Sets
- Electric Clock Sets
- Super-Heterodynes
- New Accessories
- Tubes—Parts

**H**ERE'S our new catalog chock full of all the latest radio features at lowest wholesale prices. Because we are the world's largest radio store, we are able to buy and sell in such large quantities that we can make marvelous savings for you.

You will find in this book the new, Humless, Screen Grid A. C. all-electric and battery operated sets; a wide range of beautiful consoles, from the small mantel model types to the most ornate and artistic of radio furniture; dynamic speakers of tremendous volume and richest tone; accessories, parts and kits in wide variety—in fact, everything that is standard, as well as everything that is new, in Radio. Get this book today.

We have everything in radio. Our immense stock is complete with practically everything new in radio. Quick deliveries and genuine cooperation are assured on all orders. Send for your copy of this new catalog and find out the remarkable savings that we are passing on to you.

**FREE CATALOG  
 ROCK-BOTTOM  
 PRICES ON  
 LATEST SETS  
 KITS PARTS &  
 ACCESSORIES**

*Write for Catalog to-day!*

**CHICAGO SALVAGE STOCK STORE**  
*World's Largest Radio Store*  
 509 So. State St., Dept. 511, Chicago, Ill.

**FREE CATALOG COUPON**

Chicago Salvage Stock Store  
 509 So. State St., Dept. 511  
 Chicago, Illinois

Kindly send me, free of charge, your new radio catalog.

Name .....

Address .....

# AMERTRAN

announces

2

NEW ADDITIONS

to a

famous line

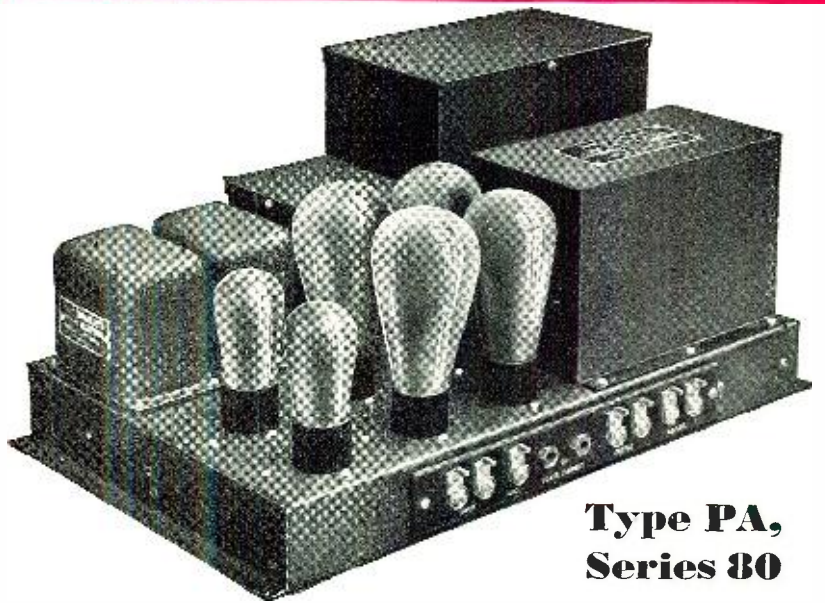

**Type PA,  
Series 80**



## AMERTRAN AUDIO TRANSFORMERS

In announcing the new and improved Amertran DeLuxe Audio Transformers, it is again shown that Amertran sets the "Standard of Excellence".

Redesigned for even greater protection from moisture—constructed to live a still longer, more useful and trouble-free life, with perfect fidelity of tone—Amertran DeLuxe Audio Transformers are always demanded when the best is required.

For perfect satisfaction—for long-lived economy—Amertran equipment is everywhere recognized as the wisest choice.

## AMERTRAN POWER AMPLIFIERS

An economical means of obtaining flawless reproduction of sound in large volume is available in a new series of Amertran Power Amplifiers, the result of months of laboratory experimentation and exhaustive field tests.

There are four sizes in the new Series 80, one to fill every requirement. The big Type PA-86, shown in the illustration will flood an auditorium with a full volume of music or speech without distortion. Smaller models are made for installations in restaurants, clubs, dance halls, schools and homes—wherever exceptional fidelity of reproduction at high volume is desired.

The mounting and construction is such that they are installed easily, with no bothersome wiring and connections, and are proof against tampering or damage. Simple controls and easy portability are added features that contribute to the popularity of Amertran Power Amplifiers whose record of performance has won the distinction of being considered the "Standard of Excellence" for Audio Reproduction.

*Licensed under patents of R.C.A. and Associated Companies*

## AMERICAN TRANSFORMER COMPANY

178 EMMET STREET  
NEWARK, N. J.



**For Complete Details Write for Following Bulletins:**

No. 1000—The complete Amertran line—prices and specifications.

No. 1050—Amertran Audio Transformers. Describing 34 designs.

No. 1077—Amertran Concert Hall Amplifiers—Type 25-A.

No. 1079—Amertran Power Amplifiers—Type PA, Series 80.

No. 1088—Amertran Power Transformers and Blocks—Type 245.

No. 1060—Amer-Chokes—audio, filter and modulation chokes.

No. 1066—Amertran Rectifying Equipment for Radio Transmission.

R. N. 11-30

Please send following bulletins—check (✓) those you want.  
Bulletin 1000 ( ) ; 1050 ( ) ; 1060 ( ) ; 1066 ( ) ; 1077 ( ) ;  
1079 ( ) ; 1088 ( ) .

Name.....

Street & No.....

Town..... State.....



# MEN!

Get Your Copy of **My New Book**

*It shows you*

## How to get a good job in the Radio Industry

**Hundreds of Jobs paying \$50, \$60, \$75, \$100 a week are opening in Radio every year.**

**J. E. SMITH, Pres**  
NATIONAL RADIO INSTITUTE

I showed these men how to get **Big Pay** jobs like these



### Seldom Under \$100 a Week

"My earnings in Radio are many times bigger than I ever expected they would be when I enrolled. In November I made \$577, December \$645, January \$465. My earnings seldom fall under \$100 a week. I merely mention this to give you some idea of what a Radio man can do who has the training."

E. E. WINBORNE,  
1414 W. 48th St., Norfolk, Va.



### \$3000 a Year in Own Business

"I cannot give N. R. I. too much credit for what I have been able to do in Radio. I can safely say that I averaged \$3000 a year for the past three years. I am in the Radio business here. Any man who really wants to advance cannot go wrong in Radio. There is certainly a lack of trained men."

FRED A. NICHOLS,  
P. O. Box 207, Eaton, Colo.

If you are earning a penny less than \$50 a week, send for my book of information on opportunities in Radio. It is free. Radio's amazing growth is making hundreds of fine jobs every year. My book shows you where these jobs are, what they pay, how I can train you at home in your spare time to be a Radio Expert.

### You have many Jobs to choose from

Broadcasting stations use engineers, operators, station managers and pay \$1,800 to \$5,000 a year. Manufacturers continually need testers, inspectors, foremen, engineers, service men, buyers for jobs paying up to \$15,000 a year. Shipping companies use hundreds of operators, give them world-wide travel with practically no expense and \$85 to \$200 a month besides. Dealers and jobbers (there are over 35,000) are always on the lookout for good service men, salesmen, buyers, managers and pay \$30 to \$100 a week for good men. Talking Movies pay as much as \$75 to \$200 a week to men with Radio training. There are openings almost everywhere to have a spare time or full time Radio business of your own—to be your own boss. Radio offers many other opportunities. My book tells you about them. Be sure to get it at once.

### My New 8 Outfits of Parts give you extensive Practical Radio Experience

With me you not only get the theory of Radio—you also get practical Radio experience while learning. You can build over 100 circuits—build and experiment with the circuits used in Atwater-Kent, Majestic, Crosley, Eveready, Stewart-Warner, Philco, and many other sets. These experiments include A. C. and screen grid sets, push pull amplification and other late features. When you finish my course you won't need to take "any old job" just to get experience—you will be trained and experienced ready to take your place alongside men who have been in the field for years.

Back view of 5-tube A. C. screen grid tuned Radio frequency set—only one of many circuits you can build with the parts I give without extra charge.

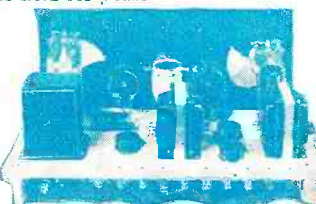

### I Will Train You at Home in Your Spare Time

Hold your job until you are ready for another. No need to leave home. All I ask is part of your spare time. I have doubled and tripled the salaries of hundreds through my practical home-study training. You don't have to be a high school or college graduate. My course is written in easy, simple terms that most anyone can understand.

### My course includes Talking Movies, Wired Radio, Television

My course is up-to-date with Radio's latest uses and improvements. It includes Radio's application to Talking Movies, Television and home Television experiments, Wired Radio, Radio's use in Aviation, in addition to fitting you for many other lines. When you finish you won't be a "one job" man. You will be trained for many jobs.

### Money Back If Not Satisfied

I will agree in writing to refund every penny of your tuition if you are not satisfied with my Lesson Texts and Instruction Service when you have finished my course. This agreement is backed by the Pioneer and World's Largest organization devoted entirely to training men and young men for good jobs in the Radio industry, by correspondence.

### Find out what Radio offers you Get My Book

This book gives you the facts on Radio's opportunities and the many features and services of N.R.I. training. It gives you 100 letters from actual students who have proved that my methods are successful. Get your copy today. There is no obligation.

**J. E. SMITH, President,**  
National Radio Institute, Dept. OMS  
Washington, D. C.

**THIS COUPON IS GOOD FOR ONE FREE COPY OF MY NEW BOOK**

**mail it NOW**

J. E. SMITH, President  
National Radio Institute, Dept. OMS  
Washington, D. C.

DEAR MR. SMITH:—Send me your book. I want to see what Radio offers and what you offer in Radio training. This request does not obligate me in any way.

Name.....

Address.....

City..... State.....

**Lifetime Employment Service to all Graduates**