

RADIO NEWS

REG. U.S. PAT. OFF.

OCTOBER
25 Cents

Over 200
Illustrations



Edited by HUGO GERNSBACH

THE MAGIC LOUD SPEAKER
See Page 328

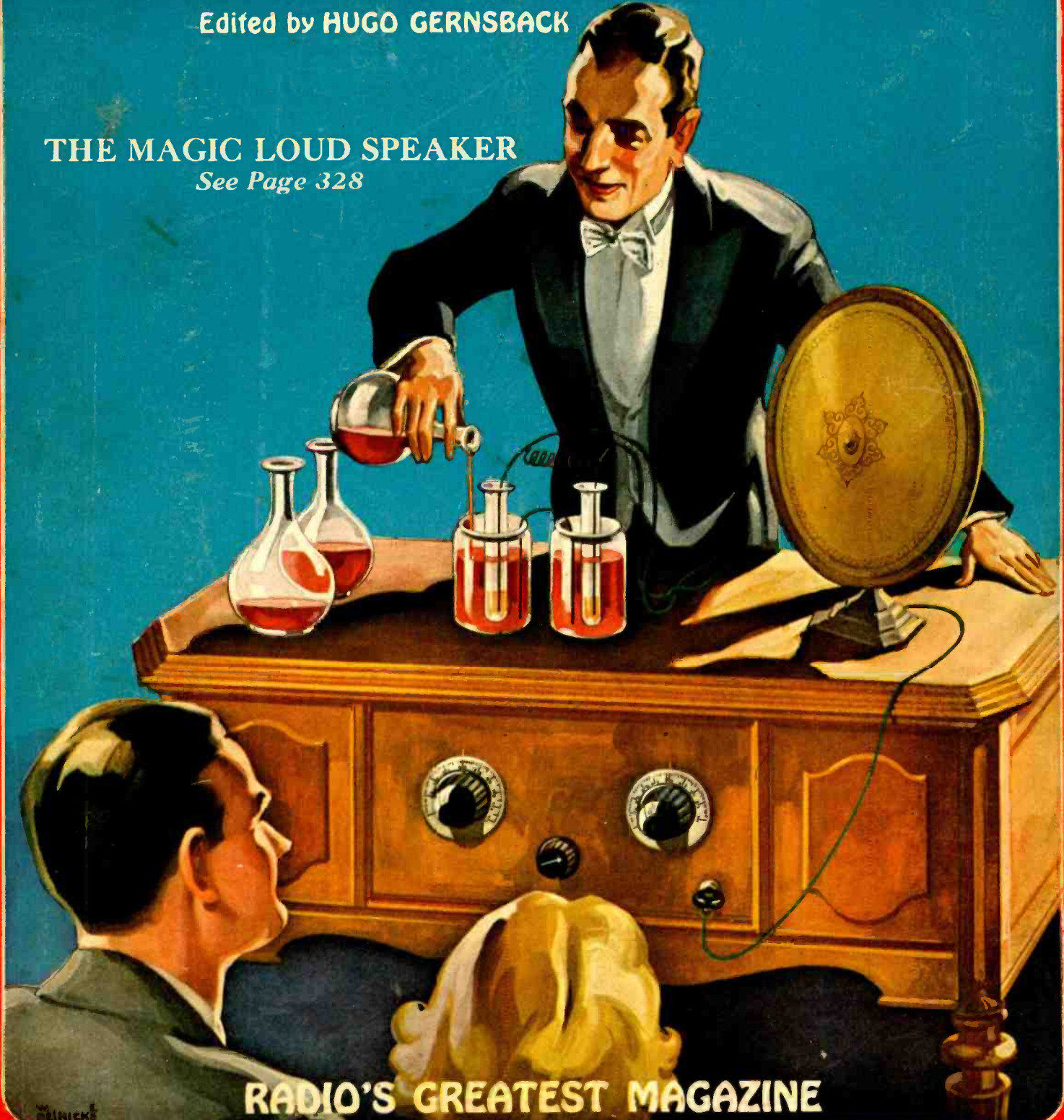

RADIO'S GREATEST MAGAZINE

EXPERIMENTER PUBLISHING COMPANY, NEW YORK, PUBLISHERS OF
SCIENCE & INVENTION - RADIO LISTENERS' GUIDE - SPARE-TIME MONEY MAKING - FRENCH HUMOR - AMAZING STORIES



Cunningham RADIO TUBES

The Advance Guard of Radio

Ever alert, always on duty, these delicate instruments of infinite precision and accuracy are the sentinels that guard and protect the nerve center of your radio set through which every radio impulse is transformed and magnified into audible sound.

To equip your set throughout with new Cunningham Radio Tubes is to experience the very utmost that your set is capable of giving.

Consult your dealer today. See that he gives you the correct types of Cunningham Radio Tubes for which your set is designed.

*Twenty types—all in the
orange and blue cartons.*

E. T. CUNNINGHAM, Inc.
NEW YORK CHICAGO SAN FRANCISCO

Krauss



Tower Adventurer

\$9.50

\$10.50
WEST OF
DES MOINES,
IOWA

YO, HO, HO! headin' for buried treasure unknown lands the Tower Adventurer exemplifies a genuine sailing ship of early days that will at once appeal to lovers of ship models. The full-rigged galleon in natural colorings is cast integral with the protecting ornamental frame. The large 17" free-edge cone is driven by the identical armature-type unit as the higher priced models with a tone quality and volume as delightful as exceptional.

Ask Your Dealer or Write for Illustrated Circular

TOWER MFG. CORP. 124 Brookline Ave., Boston, Mass.

MORE THAN TWO MILLION TOWER PRODUCTS NOW IN USE

*PRICES ON
CASTLE CONE
AND
PIRATE SHIP
SLIGHTLY HIGHER
WEST OF
DES MOINES, IA.

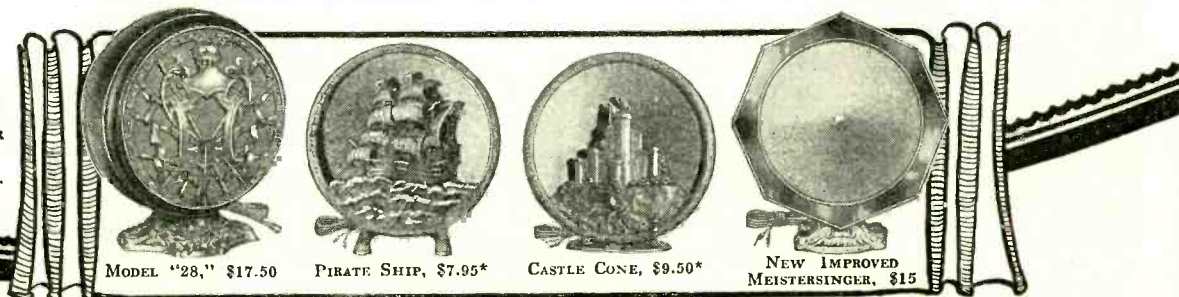

MODEL "28," \$17.50

PIRATE SHIP, \$7.95*

CASTLE CONE, \$9.50*

NEW IMPROVED MEISTERSINGER, \$15

RADIO NEWS

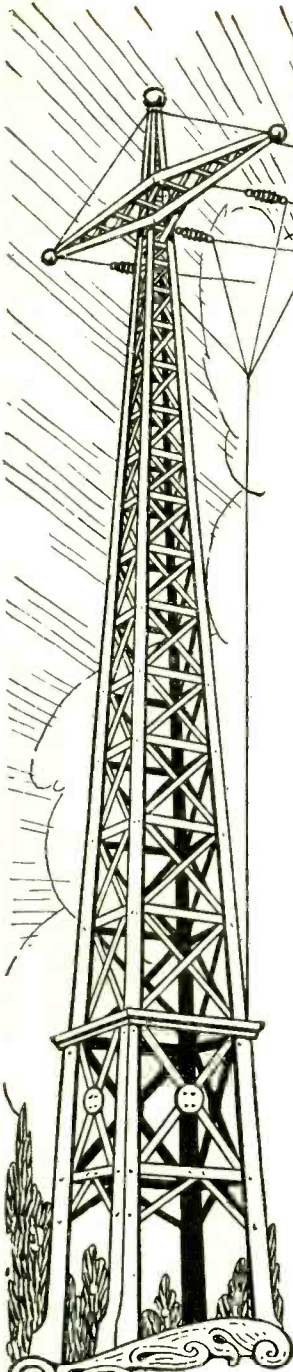

Published by EXPERIMENTER PUBLISHING COMPANY, Inc., Publishers of "Radio News," "Science and
"Invention," "Radio Listeners' Guide," "Spare-Time Money Making,"
"Amazing Stories," and "French Humor."

H. GERNSBACK, President. S. GERNSBACK, Treasurer. R. W. DEMOTT, Secretary.
Member: Audit Bureau of Circulations Radio Magazine Publishers Association

Editorial and General Offices: 230 Fifth Avenue, New York City

VOLUME 9

OCTOBER, 1927

NUMBER 4

Contents of This Issue:

Radio Enters Into a New Phase, By Hugo Gernsback	321	Building a Six-Foot Exponential Horn, By T. H. Millar	347
A Set for Each Member of the Family, By Armstrong Perry	322	The RADIO NEWS Special Short-Wave Broadcast Receiver, By Kendall Clough	348
The Radio Beam Method of Transmission, By Lieut. H. F. Breckel	324	The Knickerbocker Four, By Robert Hertzberg	352
Radio in Transoceanic Flight, "This is Station WOODS," By L. A. Collins	326	The Qualitone Six, By Robert F. Goodwin	355
Progress in the Radio Drama, By Charles Magee Adams	327	Biasing the Grid Without "C" Batteries, By Sylvan Harris	358
The Magic Loud Speaker, By A. Binneweg, Jr.	328	Ultra-High-Frequency Experiments, By John L. Reinartz	360
Radio News of the Month, New Experimental 100-Kilowatt Trans- mitter at Schenectady, "Listen, My Children," By Robert Francis Smith	329 331 332	Correspondence from Readers, Letters from Home Radio Set Construct- tors,	362 363
What's New in Radio, The Evolution of the "A" Socket-Power Unit, By O. T. McIlvane	334 337	Progress in Radio, Radiotics,	364 365
List of Broadcast Stations in the United States, The Radio Beginner—How to Build Radio Sets, By Clyde A. Randon	338 339	RADIO NEWS LABORATORIES, Radio Wrinkles, I Want to Know, Radio Technique in Germany, A Combined Horn-and-Cone Loud Speak- er, By Robert N. Auble	366 368 369 407 409
Buried Aerial Reduces Static, By H. Winfield Secor	340	The Capacity and Wavelength of Your Aerial, By Sydney P. O'Rourke	411
Low Loss, By E. H. Rietzke and S. K. McDonald, Jr.	342	Eliminating the Detector Tap, By M. R. McCabe	416
How the Strobodyne Works, By R. E. Lacault	344	"Radio Love," Giant Loud Speaker Heard Six Miles Over Lake,	417 420
Recent Developments in "B" Power-Unit Design, By James Millen	346	Radio Jingles, Radio Bugs, Book Review,	423 425 429

In Forthcoming Issues:

**NEW APPLICATIONS OF THE CAR-
BORUNDUM CRYSTAL DETECTOR**
By E. STUART CAPRON

Describing a new unit, which can be plugged
in the detector socket of a receiver.

**CHANGES IN FREQUENCY DUE TO
SHIELDING**
By HAROLD A. ZAHL

The author continues the exposition of his
original researches into the effects of shielding
on coils.

THE PERIDYNE FIVE
By HUGO GERNSBACK
This receiver incorporates a novel system of
compensation for single-control receivers, which
will be of interest to all constructors. The
article will be complete with all constructional
data.

RADIO NEWS is published on the 10th of each preceding month. There are 12
numbers per year. Subscription price is \$2.50 a year in U. S. and possessions.
Canada and foreign countries, \$3.00 per year. U. S. Coin as well as U. S. Stamps
accepted (no foreign coins or stamps). Single copies, 25 cents each. Checks and
money orders should be drawn to order of EXPERIMENTER PUBLISHING
CO., INC.

All communications and contributions to this journal should be addressed to
Editor, RADIO NEWS, 230 Fifth Ave., New York, N. Y. Unaccepted contributions
cannot be returned unless full postage has been included. All accepted contributions
are paid for on publication. A special rate is paid for novel experiments; good
photographs accompanying them are highly desirable.

RADIO NEWS, Monthly. Entered as second-class matter, July 12, 1924, at the
Post Office at New York, N. Y., under the Act of March 3, 1879. Additional entry
at Long Island City, N. Y., and San Francisco, Calif. Title registered U. S.
Patent Office. Copyright, 1927, by The Experimenter Publishing Co., Inc., 230
Fifth Ave., New York. The Contents of this magazine are copyrighted and must
not be reproduced in the United States without giving full credit to the publica-
tion. Translation into foreign languages must not be made unless permission
is obtained from the publishers. Copyrighted in Germany. Reproduction of
articles in Germany is reserved for Radio, Berlin 42.

RADIO NEWS is for sale at all newsstands in the United States and Canada,
and at Brentano's, Ave. de L'Opera, Paris, France. European agents: S. J. Wise
Et Cie, 40 Place Verte, Antwerp, Belgium.

HOW TO SUBSCRIBE FOR RADIO NEWS. Send your name, address and re-
mittance to Experimenter Publishing Co., 230 Fifth Ave., New York. Mention the
name of the magazine you are ordering. We also publish SCIENCE AND INVEN-
TION, RADIO LISTENERS' GUIDE, SPARE TIME MONEY MAKING,
AMAZING STORIES and FRENCH HUMOR. Write clearly.

RATES AND TERMS. The subscription rate for RADIO NEWS is \$2.50 per
year. (12 numbers). When remitting do so by check, money order, or registered
letter if cash is enclosed. Avoid sending cash through the mail if possible. Sub-
scriptions for less than one year are not accepted. Subscription may be made in
combination with SCIENCE & INVENTION, RADIO LISTENERS' GUIDE,
SPARE TIME MONEY MAKING, AMAZING STORIES and FRENCH
HUMOR.

POSTAGE. We prepay postage in all parts of the United States, Mexico and
island possessions. For foreign or Canadian subscriptions we require 50 cents in
addition to the subscription price for additional postage charge.

CHANGE OF ADDRESS. Notify us as far in advance as possible. It requires
several weeks to make an address change on our records. Always write clearly.

General Advertising Dept., 230 Fifth Avenue, New York City

ADVERTISING REPRESENTATIVES

L. F. McCLURE, 720 Cass Street, Chicago, Ill.
DAVIES, DILON & KELLY, 15 West 10th St., Kansas City, Mo.
T. F. MAGRANE, Park Square Bldg., Boston, Mass.

HARRY E. HYDE, 518 Drexel Building, Philadelphia, Pa.
A. J. NORRIS HILL CO., 5 Third St., San Francisco, Calif.
412 West Street, Los Angeles, Calif.
Leary Building, Seattle, Wash.

-when the crown stands or falls....

"- You're there with a Crosley .."

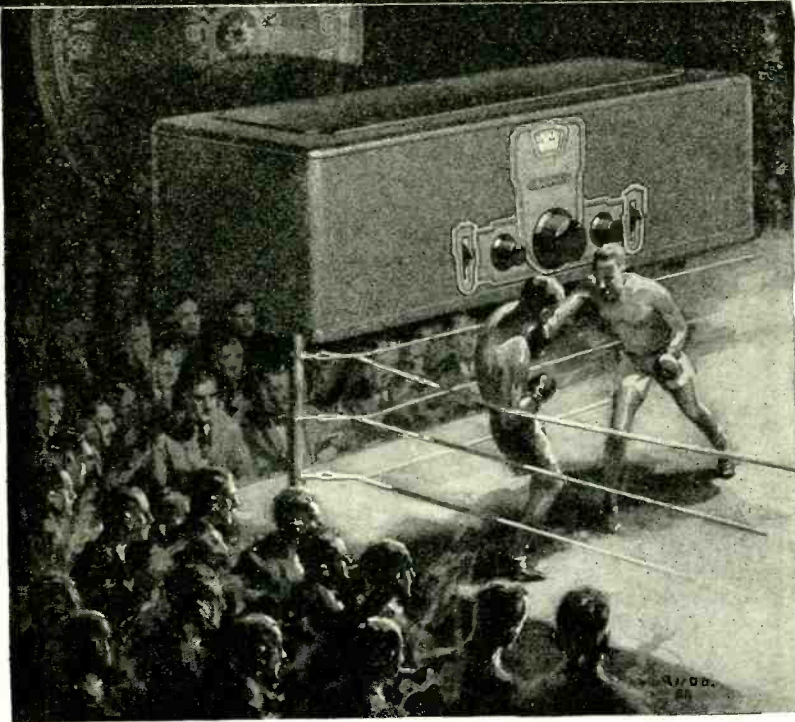

The Crosley Radio Corp.: Why don't you radio manufacturers stop talking like a lot of doctors and tell us what it's all about in one cylinder words? What's this "shielding" business anyway? Yours truly, Buford Bros., Nashville, Tenn.

Shielding is necessary in a modern radio receiver. The more sensitive the set is, the more you need it. Some sets

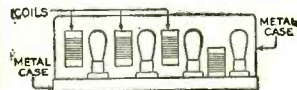

are merely housed in a metal case. This helps to keep strong local signals from breaking through, but it is even more important to keep them where they belong after you get them the proper way from the antenna.

A set has tubes, condensers and coils. Here is a coil. The lines around it are the magnetic field. You know the earth's magnetic field will work a compass down in a mine, or up in a plane (it certainly worked for Lindbergh) and the fields around unshielded coils get all mixed up and the set howls and squeals and has to be choked off by turning down the filaments in the tubes.

Now if the coils are housed in copper shields the fields can't mess each other up, and the tubes can do a real job of amplifying. The coils in Crosley sets have these copper shields, and there isn't anything better.

Then there are the condensers, and if it wasn't for the shield around them, the fields would act like those in the coils, and the results would be just as bad, or worse.

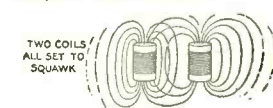

It isn't enough to shield the coils and the condensers, because even the wiring of the set has fields around it. This too is shielded, as it is in all really high grade sets.

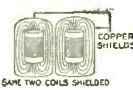

can be as good as the best without costing half as much.

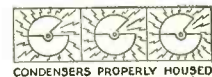

APPROVED CONSOLES
Selected by Powell Crosley, Jr., as ideal, acoustically and mechanically, for the installation of the Crosley "Bandbox" Genuine Musicone built in. Crosley dealers secure them from their jobbers through H. T. ROBERTS CO. 914 S. Michigan Ave., Chicago, Ill. Sales Agents for Approved Console Factories Showers Brothers Company The Wolf Mfg. Industries



The BANDBOX

A 6 Tube Receiver of unmatched quality at \$55

Many features of this set have been found heretofore only in the most expensive radio. Since Crosley is licensed to manufacture under nearly all important radio patents, this combination with Crosley leadership and experience, naturally produced an amazing radio, the remarkable value of which can be judged by the following features incorporated and by seeing it and hearing it at your dealers.

1. Completely shielded coils, condensers and wiring.
2. Acuminators for sharper tuning.
3. Completely balanced genuine neutrodyne.
4. Volume control.
5. Single tuning knob.
6. Illuminated dial.
7. Single cable outside connections.
8. Designed for easy installation in consoles.
9. Beautiful frosted brown crystalline finished cabinet.

AC model using new R.C.A. AC tubes and working directly from electric light socket through Crosley Power Converter is \$65. Power Converter \$60 extra.

Hear this wonderful new contribution to the enjoyment of radio. If you cannot find one of the 16,000 Crosley dealers near you, write Dept. 22 for his name and literature.

Crosley is licensed to manufacture under patents of the Radio Corporation of America and associated companies, also the Hazeltine Corporation and La Tour Corporation.



IMPROVED MUSICONES

Musicones improve the reception of any radio set. They are perfect affiliates in beauty and reproductive effectiveness for Crosley Radios. Adjustable model with brown mahogany finish, stands 36 inches high, \$27.50 — 16-inch Super-Musicone as pictured above with "Bandbox", \$12.75 — 12-inch Ultra-Musicone, \$9.75.

CROSLEY RADIO

The Crosley Radio Corporation, Powell Crosley, Jr., Pres. Cincinnati, Ohio.

Crosley Radio is licensed only for Radio Amateur, Experimental and Broadcast Reception.

Prices slightly higher west of the Rocky Mountains

INDEX TO ADVERTISERS

	Page		Page
A		K	
Abox Co., The	403	Karas Electric Co.	394-417
Acme Apparatus Co.	315	Kodel Radio Corp.	313
Acme Electric & Mfg. Co., The	401	L	
Acme Wire Co.	384	Lacault Radio Elec. Labs., R. E.	306-394
Aero Products, Inc.	382	Lacey & Lacey	417
Aerovox Wireless Corp....	404	Langbein-Kaufman Radio Co., The	407
Airgap Products Co.	423	Leutz, Inc., C. R.	308
Alden Mfg. Co., The.....	376	Lucas & Sons, John	411
Algonquin Electric Co., Inc.	384	M	
All-American Radio Corp..	371	M & H Sporting Goods Co.	420
All Radio Co.	376	Magnavox Co., The	386
Allen-Bradley, Inc.	372	Massachusetts Radio and Telegraph School	409
Alter Co., The Harry 386-398-426		Metro Electric Co.....	301-401- 412-421
American Auto & Radio Mfg. Co....	384-397-400-440- 408-420-426-428	Micarta Fabricators	306
American Battery Co.....	407	Midwest Radio Corp. Inside Back Cover	
American Bosch Magneto Corp.	305	Miller-Welles Co.	413
American Hard Rubber Co.	390	Miniature Ship Models, Inc.	420
Amplion Corp. of America	416	Muter Co., Leslie F....	413-419
B		N	
Balsa Wood Reproducer Co.	412	Nassau Hotel, The	388
Barawik Co., The 407-409-418-423-425-427		National Carbon Co., Inc.	310
Belden Mfg. Co.	306	National Company, Inc..	306-382
Benjamin Elec. Mfg. Co. 306-380-417		National Radio Institute..	309
Bogue, B. N.	420	New York Storage Battery Co.	405
Boudette Mfg. Co.	379	Niagara Metal Stamping Co.	388
Brady, John B.	386	Norden-Hauck, Inc.	395
C		O	
C. E. Mfg. Co., Inc.	306	Omnigraph Mfg. Co., The.	403
	Back Cover	P	
Cable Supply Co., Inc.	400	Parker, C. L.	411
Carborundum Co., The ..	389	Pathfinder, The	424
Cardwell Mfg. Corp., Allen D.	306	Polymet Mfg. Corp.	376
Carter Radio Co.	306-380	Press Guild, Inc., The ...	374
Central Radio Labs.	386	Q	
Chemical Institute of N. Y., Inc.	387	Q. R. S. Music Co., The..	416
Chicago Radio Apparatus Co.	395	R	
Cloverleaf Mfg. Co....	375-432	Radiall Co.	306-380
Consrad Co., Inc. 382-399-406-422-425-430.		Radiart Laboratories Co..	394
Copper & Brass Research Ass'n.	421	Radio Association of Amer.	304
Cornish Wire Co.	389	Radio Equipment Co.	425
Coyne Electrical School... 320		Radio Institute of America	394
Craftsman Radio Products.	426	Radio Manufacturers Show Ass'n.	427
Cresradio Corp.	397	Radio Service Co.	418
D		S	
Crosley Radio Corp., The.	299	Radio Specialty Co.	385
Cunningham, Inc., E. T. Inside Front Cover		Rajah Co., The	420
E		Randolph Radio Corp.	319
Daven Radio Corp.	374-424	Raytheon Mfg. Co.	311
Deutschmann Co., Tobe..	428	Rowan Battery Supply Co., Walter	376
Dubilier Condenser Corp..	306	T	
Duro Metal Products Co..	408	Samson Electric Co. ...	306-416
F		Sangamo Electric Co.	418
Eby Mfg. Co., Inc., The H. H.	404	Shure Radio Co.	425
Electrad, Inc. ...	306-378-398-426	Silver-Marshall, Inc.	388
Electric Specialty Co.	429	Smith, B. Hawley	400
Elliott Radio Corp.	381	Southern Toy Co.	418
Engineers' Service Co....	307	Sovereign Elec. & Mfg. Co.	428
Erie Fixture Supply Co. ..	397	Sprague Specialties Co..	420
G		Starrett Mfg. Co.	397
F & H Radio Labs.	414	Steinite Radio Co.	423
Fansteel Products Co., Inc.	373	Sterling Mfg. Co.	398
Fast Co., John E.	411	Straus & Schram	303
Ferbend Electric Co.	408	Strobodyne	306
Ferranti, Inc.	409	U	
Formica Insulation Co., The	409	V	
Freshman Co., Inc., Chas.	312	Valley Electric Co.	400
Fritts & Co., D. H.	306	Van Ashe Radio Co.	388
Frost, Inc., Herbert H. ...	428	Van Horne Co., Inc., The	316
H		Vitalitone Radio Corp. ...	424
Gearhart-Schlueter	390	W	
General Electric Co.	405	Walker Co., The Geo. W.	423
General Industries Co., The	426	Ward Leonard Electric Co.	390
General Radio Co.	427	Warren Electric Co.	378
Gold Seal	404	Webster Co., The	413
Goodrich Rubber Co., The B. F.	400	Western Radio Mfg. Co..	378
Gould Storage Battery Co., Inc.	397	Westingale Electric Co. ...	317
Graymore Radio Corp. ...	407	Westinghouse Elec. & Mfg. Co.	377
I		Windsor Furniture Co. ...	416
Independent Electric Wks.	395	World Battery Co.	424
International Resistance Co.	409	World Radio Corp.	418
Interstate Sales Co.	306	X	
J		X-L Radio Labs.	306-382
J-M-P Mfg. Co.	424	Y	
Jewell Electrical Inst. Co..	411	Yaxley Mfg. Co.	384-418
Jewell Labs.	415		

**30
DAYS
FREE
TRIAL**

7 Tube Set Single Dial Radio

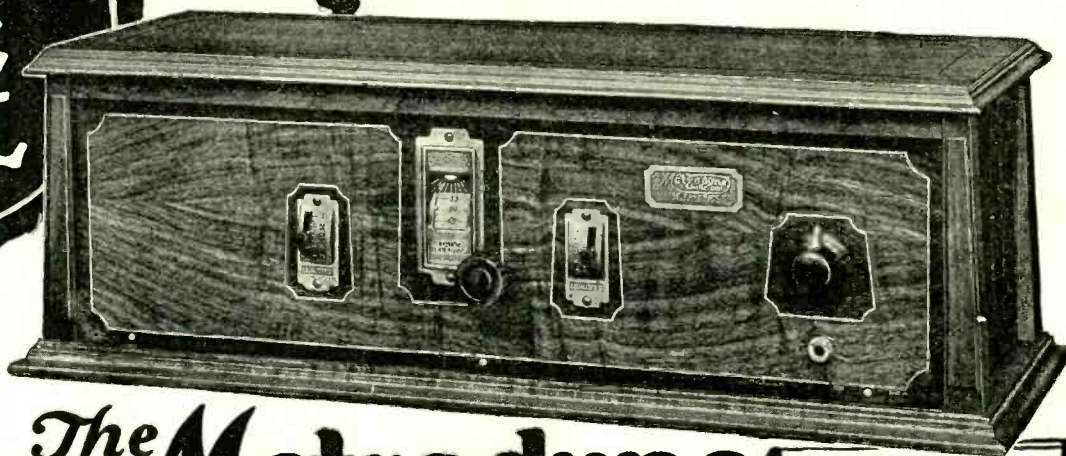

**Metrodyne
Radio Sets**
Are Equipped
For
**BATTERY or
ELECTRIC
operation**

The Metrodyne

ONLY ONE DIAL TO TUNE

RETAIL PRICE
\$75⁰⁰
Completely Assembled
Big Discounts to
Agents and Dealers

Wonderful offer direct from the factory! The world's greatest radio! A perfect working, single dial control, 7 tube receiver! And just to prove our claims, we will ship it to your home for 30 days' free trial. Test it under all conditions. Test it for distance, volume and tonal quality—and if you are not convinced that it is the best single dial set you ever heard, return it to the factory. We don't want your money unless you are completely satisfied.

Three Year Guarantee

**BIG PROFITS
TO AGENTS AND DEALERS**
Our Agents and Dealers make big money selling Metrodyne Sets. You can work all or part time. Demonstrate the superiority of Metrodynes right in your home. Metrodyne Radios have no competition. Lowest wholesale prices. Demonstrating set on 30 days' free trial. Greatest money-making opportunity. Send coupon, a letter or a postal for our agent's proposition.

Metrodyne Super-Seven Radio

A single dial control, 7 tube, tuned radio frequency set. Tested and approved by Popular Science Institute of Standards, Popular Radio Laboratory, Radio News Laboratory and by America's leading Radio Engineers. Designed and built by radio experts. Only the highest quality low loss parts are used. Magnificent, two-tone walnut cabinet with beautiful, gilt metal trimmings. Very newest 1928 model, embodying all the latest refinements.

Easiest set to operate. Only one small knob tunes in all stations. The dial is electrically lighted so that you can log stations in the dark. The volume control regulates the reception from a faint whisper to thunderous volume, 1,000 to 3,000 miles on loud speaker! The Metrodyne Super-Seven is a beautiful and efficient receiver, and we are so sure that you will be delighted with it, that we make this liberal 30 days' free trial offer. You to be the judge.

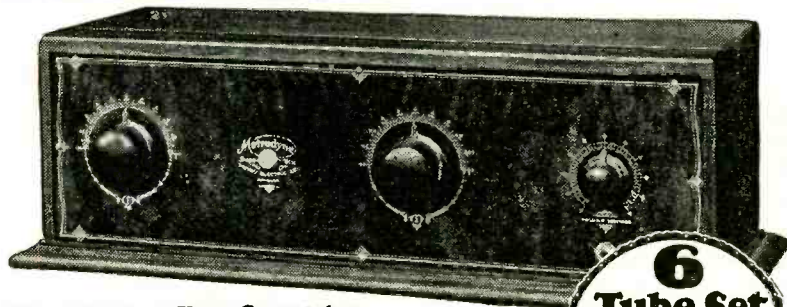

**6
Tube Set**
\$48⁵⁰
RETAIL PRICE
Completely
Assembled

30 Days' Free Trial—3 Year Guarantee

Metrodyne Super-Six

Another triumph in radio. Here's the new 1928 model Metrodyne 6 tube, two dial, long distance tuned radio frequency receiving set. Approved by leading radio engineers of America. Highest grade low loss parts, completely assembled in a beautiful walnut cabinet. Easy to operate. Dials easily logged. Tune in your favorite station on same dial readings every time — no guessing.

Mr. Howard, of Chicago, said: "While five Chicago broadcasting stations were on the air I tuned in seventeen out-of-town stations, including New York and San Francisco, on my loud speaker horn, very loud and clear, as though they were all in Chicago."

We are one of the pioneers of radio. The success of Metrodyne sets is due to our liberal 30 days' free trial offer, which gives you the opportunity of trying before buying. Thousands of Metrodynes have been bought on our liberal free trial basis.

MAIL THIS COUPON
or send a postal or letter. Get our proposition before buying a radio. Deal direct with manufacturer — **SAVE MONEY — WRITE NOW!**

MAIL COUPON BELOW

Let us send you proof of Metrodyne quality—our 30 days' free trial offer and 3 year guarantee

Mrs. Wm. Leffingwell, Westfield, N. J., writes: "The Metrodyne Radio I bought of you is a wow! This is as good as any \$225 machine I have ever seen."

N. M. Greene, Maywood, Ill., writes: "My time is up and the Metrodyne works fine. I got Havana, Cuba, Oakland, Calif., Denver, Colo., Toronto, Canada, all on the loud speaker."

J. W. Woods, Leadville, Colo., writes: "Received the 7-tube Metrodyne in fine condition. Had it up and working same day received. Was soon listening to Los Angeles, San Diego, Oakland and other California points; also St. Louis, Kansas City and other east and south stations—all coming in fine. Am more than pleased. Sure enjoying it."

We will send you hundreds of similar letters from owners who acclaim the Metrodyne as the greatest radio set in the world. A postal, letter or the coupon brings complete information, testimonials, wholesale prices, and our liberal 30 days' free trial offer.

METRO ELECTRIC COMPANY
2161-71 N. California Ave., Dept. 2
Chicago, Illinois

Gentlemen:

Send me full particulars about Metrodyne 6 tube and 7 tube sets and your 30 days' free trial offer.

Name.....

Address.....

If you are interested in AGENT'S proposition, place an "X" in the square

METRO ELECTRIC COMPANY
2161-71 N. California Ave. • Dept. 2 • Chicago, Illinois

New

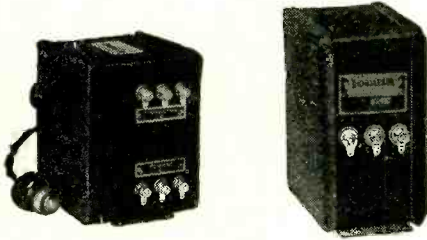

130 M. A. FULL WAVE RECTIFIER

Here is a power unit that will satisfy the ever increasing demand for improved quality of reception. A split secondary 550 volts either side of center, makes possible full wave rectification, using two 216-B or two 281 tubes. Current capacity, 130 milli-amperes. The low voltage secondary, 7½ volts, will supply two UX-210 power tubes, enabling the use of push-pull amplification in last audio stage. The Double Choke Unit 2099 is designed for this power unit. Contains two individual chokes of 30 henries, 130 milli-amperes capacity each.

T-2098 Transformer, 4½" x 5¼" x 5¾"
List Price, \$20.00

T-2099, Choke Unit
3¼" x 4¾" x 5¾"
high

List Price
\$14.00

Realistic tone quality, that elusive but much talked of characteristic of radio reception— can be obtained only through the use of apparatus of the finest materials and workmanship. For years Thordarson transformers have been the choice of many discriminating manufacturers of quality receiving sets. Follow the lead of the leaders. If you enjoy good music specify Thordarson transformers

THORDARSON ELECTRIC MANUFACTURING CO.
Transformer Specialists Since 1895
WORLD'S OLDEST AND LARGEST EXCLUSIVE TRANSFORMER MAKERS
Huron and Kingsbury Streets — Chicago, Ill. U.S.A.

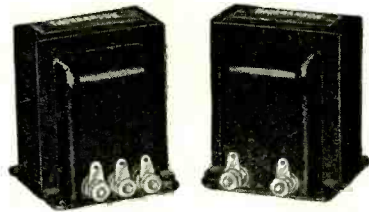

POWER PUSH-PULL TRANSFORMER and CHOKE

Quality reproduction that cannot be obtained with straight audio amplification, is made possible through the Thordarson power push-pull combination. This arrangement is designed for use with power tubes only and has sufficient capacity for all tubes up to and including the UX-210. Makes an ideal power amplifier when used with power supply unit T-2098.

Input transformer couples stage of straight audio to stage of push-pull. Output choke is center-tapped with 30 henries on either side of center tap. Dimensions of both transformer and choke, 2½" x 2½" x 3" high.

Input Transformer T-2408

List Price, \$8.00

Output Choke T-2420

List Price
\$8.00



A. C. TUBE FILAMENT SUPPLY

The new R. C. A. and Cunningham A. C. filament tubes will be very popular with the home constructor this season. The Thordarson Transformer T-2445 is designed especially for these tubes. Three separate filament windings are provided.

Sec. No. 1, 1½ volts, will supply six UX-226 amplifier tubes.

Sec. No. 2, 2½ volts, will supply two UX-227 detector tubes.

Sec. No. 3, 5 volts, will supply two 5 volt power tubes.

In addition to the above, this transformer is equipped with a receptacle for the B-supply input plug. Supplied with six-foot cord and separable plug for attachment to the light circuit. Transformer in compound filled, crackle-finished case. Dimensions — 2¾" x 5¾" x 4¾".

A. C. Tube Supply, T-2445

List Price, \$10.00

THORDARSON ELECTRIC MFG. CO. L
500 W. Huron St., Chicago, Ill.

Gentlemen:
Please send me your booklets describing your new power supply transformers.

Name.....

Address.....

City..... State.....

(3562)

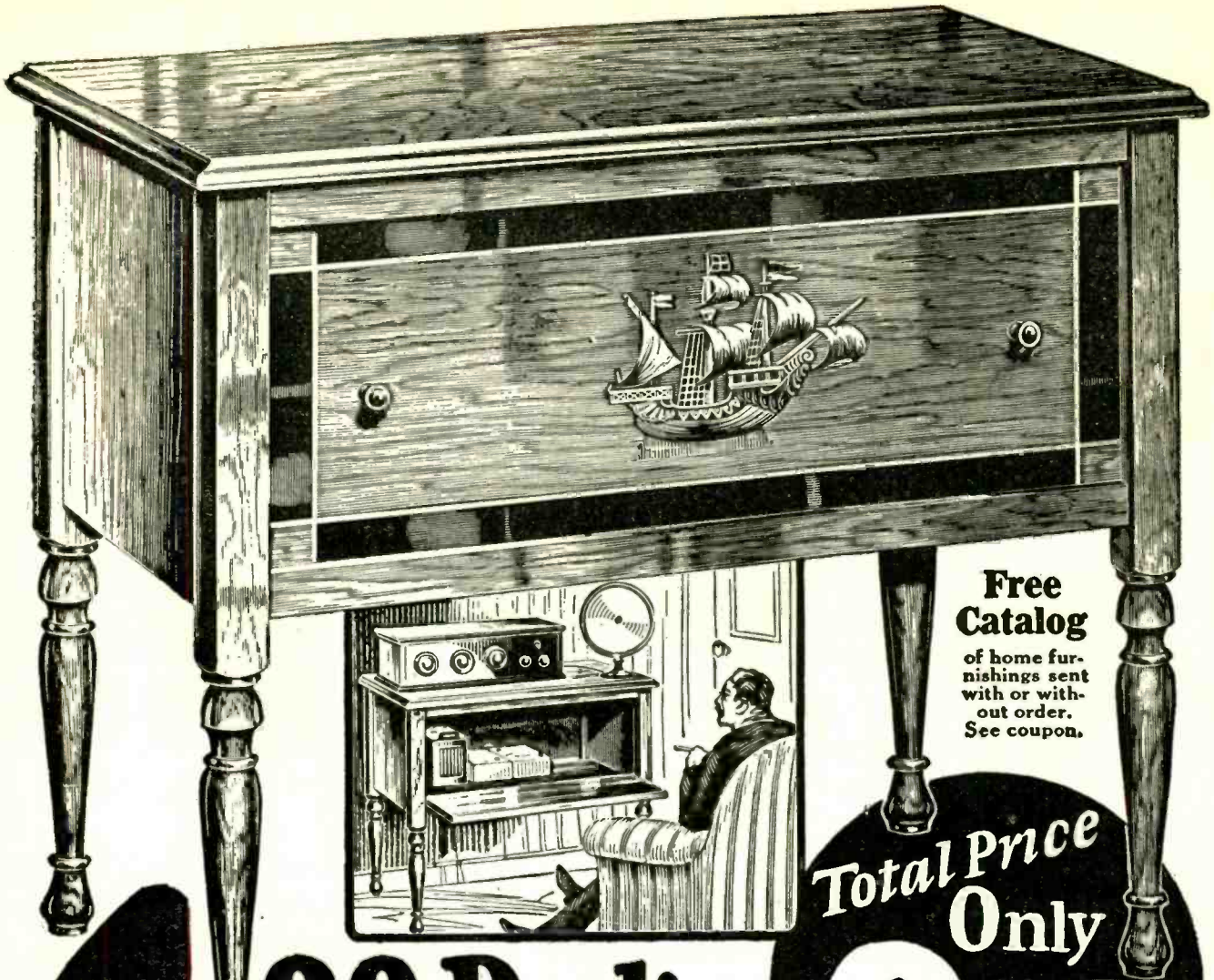

Free Catalog
of home furnishings sent with or without order. See coupon.

Total Price Only

\$1.00 down brings this **Radio Cabinet** **\$9.90**

Free Trial Yes, only \$1.00 with coupon brings this stupendous cut price bargain to your home on 30 days' trial. A handsome radio cabinet with ample room inside for all batteries, charger and eliminators. All unsightly accessories out of sight in a splendid piece of furniture. Made of beautifully grained, thoroughly seasoned selected hard wood. **Elegant Walnut Finish** Will not warp. Highly polished outside surfaces; front panel in popular two-tone effect, ornamented with Galleon Ship in full colors, giving hand-painted effect. Rich gold border countersunk on front panel, will not wear off. Neatly turned legs and beaded edges. Strongly built; all joints reinforced. Top 30 3/4 inches x 16 1/4 inches, ample for any radio and loud speaker. Height 30 3/4 inches.

\$1.00 a Month After 30 days' trial, if not satisfied, send it back at our expense and we'll refund your \$1.00 plus all transportation charges you paid. Or keep it and pay only \$1.00 a month till you've paid our smashed cut price for this sale—only \$9.90. Our credit price beats cash prices anywhere. Order by No. B9859A. Shpg. wgt. about 60 lbs.

Send Coupon NOW!

STRAUS & SCHRAM Dept. R 3577 **Chicago**

Enclosed find \$1.00. Ship Walnut Finish Radio Cabinet. I am to have 30 days free trial. If I keep the cabinet I will pay you \$1.00 monthly. If not satisfied, I am to return the cabinet at your expense and you are to refund my money and any freight or express charges I paid.

Walnut Finish Radio Cabinet, No. B9859A, \$9.90

Name -----

Street, R.F.D. -----

or Box No. -----

Shipping Point -----

Post Office ----- State -----

Married or Single ----- Nationality or Color -----

If you want **ONLY** our free catalog of home furnishings mark X here

CASH IN ON RADIO Now

EARN \$75.00 a Week in your spare time

ACT AS A RADIO DOCTOR

HELP YOUR DEALER

BUILD SETS FOR YOUR NEIGHBORS

Follow the Example of Thousands—Join the Radio Association—Learn Radio—Take Advantage of its Big-Pay Opportunities

THE RADIO ASSOCIATION OF AMERICA will help you make money in Radio, full or part-time. It will teach you how to build and repair sets; start you in business, if you wish.

Earned \$500 in Spare Hours

Hundreds of members earn \$3 an hour serving their communities as "radio doctors." * Member Lyle Follick, Lansing, Mich., has already made \$500 in his spare time. Member Werner Eichler, Rochester, N. Y., is earning \$50 a week. Member F. J. Buckley, Sedalia, Mo., is earning as much money in his spare time as he receives from his employer.

The Association will train you to be a "radio doctor" and to build sets "tailored" to your neighborhood needs, that you can sell for less than the "ready-made" sets offered by your local dealers.

We Will Start You in Business

If you prefer a business of your own to becoming a Radio Engineer, our co-operative plan will start you in a business of your own without capital.

This plan gives the ambitious man his opportunity to establish himself in his community.

Many have followed this plan and established radio stores.

Doubled His Income in Two Months

Member W. E. Thon, Chicago, was a clerk in a hardware store when he joined the Association. The training we gave him enabled him to secure the managship of the Radio Department of a large store at a 220% increased salary.

"I attribute my success entirely to the Radio Association," he writes. "Your method of instruction is wonderful." Membership in the Association has increased the salaries of innumerable men. Some turned their extra hours into cash being "radio doctors" for their neighbors; others by accepting employment with neighborhood radio dealers. Scores of our members are now connected with big radio organizations in different capacities. Others are proprietors of prosperous stores.

From Clerk to Owner

"In 1922 I was a clerk," writes Member K. O. Benzing, McGregor, Ia., "when I enrolled. Since then I have built hundreds of sets—from 1-tube Regenerative to Superheterodynes.

"I am now operating my own store and my income is 400% greater than when I joined the Association. My entire success is due to the splendid help you have given me."

Membership Privileges

If interested in Radio as a profession or a profitable hobby, join the Association. You will receive a comprehensive and practical training in Radio that will fit you for Radio's big-pay opportunities.

You will have the benefit of proven business-building plans. Our Employment Service will be at your disposal. You will have the privilege of buying radio parts at wholesale. You will have the Association behind you in carrying out your ambitions.

ACT NOW—If You Want the No-Cost Membership Plan

Now is the time for you to join. The success of the Association was so tremendous during 1926 that we are still able to offer a limited number of Memberships that may not—need not—cost you a cent. To secure one of them, write today without fail. We will send you details and also our book, "Your Opportunity in the Radio Industry," that will open your eyes to the possibilities in Radio for you. Let us hear from you at once.

RADIO ASSOCIATION OF AMERICA
4513 Ravenswood Avenue
Chicago, Ill. Dept. RN-10

Gentlemen:

Please send me by return mail full details of your Special Membership Plan and also a copy of your book, "Your Opportunity in the Radio Industry."

Name

Address

City State

BOSCH RADIO

ARMORED



What impressed me more than anything else was the fact that the tones were so perfect as to give the impression that I was in the same room with the artist instead of miles away. The Bosch Radio also has an advantage in that there is an utter absence of unharmonious sounds.

SIGNED BY

Ethel Barrymore



Model 57—Seven tubes, has Bosch RFL circuit, efficient built-in loop, built-in 18-in. reproducer, walnut cabinet with selected pattern woods, spacious power unit compartment. Single station selector, electrically lighted dial, Bosch Line O'Lite tuning, armored and shielded, wired for battery or socket power operation and operates on loop or wire antenna from two to two hundred feet. Price with built-in reproducer \$340.00



Model 76—Six tubes, Bosch RFL circuit—Single station selector Bosch Line O'Lite tuning, wired for battery or socket power operation, armored and shielded, spacious power unit compartment, solid walnut cabinet beautifully finished with and without built-in reproducer.

With built-in reproducer, \$195.00

Without built-in reproducer \$175.00

How fitting that Ethel Barrymore should recognize instantly the dramatic effect of the life-like tone of Bosch Radio.

Deliveries can be made to purchasers with the original factory settings. These armored and shielded receivers are wired for battery or socket power operation.

It is the technical excellence of Bosch which gives every model in the line keenness of tuning, clearness, perfect melody, natural tone without distortion or other annoyances.

All Bosch Models have an electrically lighted Single Station Selector. Some of the handsome new cabinets have built-in loops and built-in speakers, with spacious room for power equipment—meeting the demand of the day for perfect radio and fine furniture. See and hear Bosch Radio before you buy any radio—and dealers who are in business to stay are urged to write for the Bosch plans. Write today.

Just the radio reception radio dealers and radio purchasers have been waiting for. Bosch Radio is outstanding in construction—built on a steel chassis, short solid connections, minimized solder operations, a rigidity never before obtained in radio construction.

AMERICAN BOSCH MAGNETO CORPORATION - - Springfield, Mass.
BRANCHES: NEW YORK CHICAGO DETROIT SAN FRANCISCO

All these Bosch Radio Models are ready for socket power operation with the famous Bosch Socket Power Units which successfully meet your demand for the elimination of batteries. The total cost of the Bosch Nobattery "A" and the Nobattery "B" is... \$100.00

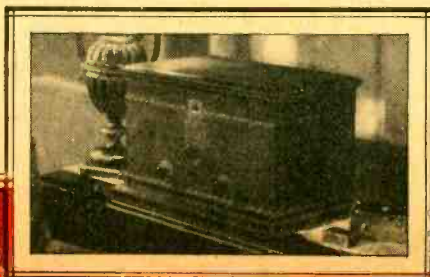

Bosch Radio Receivers are licensed only for Radio Amateur, Experimental and Broadcast Reception. They are manufactured under patent applications of American Bosch Magneto Corp. and are licensed under patent applications and patents of Radio Corp. of America and under applications of Radio Frequency Laboratories, Inc.

Model 66—Six tubes Bosch RFL circuit, single station selector.

wired for battery or socket power operation, \$99.50.



*Build
The*

STROBODYNE

acclaimed by set builders—

RADIO'S GREATEST CIRCUIT

THERE are few instances in Radio where popularity has been so swiftly and easily gained for a circuit than in the case of the "STROBODYNE."

The first Set Builders to grasp the marvelous basic principle of the "STROBODYNE" system and immediately assembled the receiver praise the circuit without reservation.

A few of the many letters we have received are printed on the right.

The following are but a few of the features which have been developed to an unusual degree in "The Strobodyne":

- (1) Extreme selectivity enabling you to tune out interference.
- (2) The ability to receive distant stations as a matter of course, rather than as an event.
- (3) Unusual tone quality due to the precision and quality of the apparatus used.
- (4) All the volume you want—undistorted.
- (5) Extreme simplicity of tuning and adjustment.
- (6) Easy to build and every product fully guaranteed.

The products of the well-known manufacturers below have been combined to make the STROBODYNE a circuit of sensational performance.



Fill out and mail this coupon NOW!

- 3 Hammarlund Variable midline condensers .00035 mf.
- 1 Set Hammarlund Strobodyne coils
- 3 Hammarlund Shields
- 2 Hammarlund Equalizing Condensers
- 1 Hammarlund Brass Shaft 10 1/4" long
- 2 Samson Symphonic Transformers
- 1 Samson No. 85 Choke
- 4 Radio Electric R.F. Units Type F
- 5 Radio Electric Fixed Matched Condensers
- 1 Mearns Fabricator Panel 8" x 24" x 3/16"
- 1 Mearns Fabricator Sub Panel 12" x 25 1/4" x 1/4"
- 1 Interstate Sales Output Filter
- 3 Carter No. M-20 Midget Rheostats 20 ohm
- 1 Carter No. M-400 Midget Potentiometer 400 ohm
- 1 Carter No. 1 Short Jack Open Circuit

- 1 Carter No. 2A Short Jack Closed Circuit
- 1 Carter Imp. Battery Switch
- 1 Cardwell Balanced Tyle 618A
- 4 Dubilier By-Pass Condensers .5 mf. Type 907
- 1 Dubilier Fixed Condenser .002 mf. Type 601
- 8 Benjamin Sockets UX Type 9040
- 12 X-L Binding Posts
- 2 National Co. Dials
- 4 Amperites Type 1A
- 1 Amperite Type 112
- 1 Electrad Royalty Variable Resistance Type B
- 2 25 ft. coils Belden Colorubber
- 7 CeCo Vacuum Tubes Type 201A
- 1 CeCo Vacuum Tube Type 112
- 1 Fritts Cabinet for Panel 8" x 24" x 1 1/2"

Address all inquiries to "STROBODYNE," 230 Fifth Ave., New York

What Some STROBODYNE Builders Say

"I've built myself a set along the lines of STROBODYNE, but using parts I had and some specified parts. Using an antenna about 150 feet long and 20 feet high I picked up KFI, Los Angeles at 12 midnite each nite for 9 days. Not bad for summer. WJZ and WGY come in with terrific loudspeaker volume on one audio stage. I'm going to build a friend a set using specified parts. I guess he'll get the South Pole, as he has an aerial 50 feet high. I've built every set known, but the STROBODYNE is the best every way and has about twice as much volume."

W. G. COREY,
7312 Bennett St.,
Pittsburgh, Pa.

"I have constructed the STROBODYNE and I want to let you know of the results I have had with it. I have used it for only 3 nights and last night I brought in WDAF, Kansas City, with tremendous volume on the speaker. All speech could be easily understandable at 150 feet away from the speaker. This same station (WDAF), when brought in on a set using three stages of tuned R.F. det. and two audio and working properly, was barely audible on headphones using all six tubes.

"I have constructed several supers and I can easily say that the STROBODYNE is the greatest circuit without question. My aerial is a single wire 65 feet long and 3 stories high at the near end and one story at the far end. It is almost entirely killed by 3-story brick buildings on all four sides, but I got WDAF, WGY, both with the same volume and excellent tone through five local stations with no interference at all."

CHESTER KELLEY,
1231 No. LaSalle St.,
Chicago, Ill.

"Have just completed the STROBODYNE receiver; it is working fine. The volume is great and it is very powerful."

H. LEONARD WILSON,
239 Gradman,
Cincinnati, Ohio.

"STROBODYNE"
230 Fifth Ave., New York

I enclose 50c. for one copy of the official construction book, giving all data on the STROBODYNE, and all supplementary information.

Name

Address

City

State

Build the "ENSCO" 3 Ft. Cone

"The World's Finest Loud Speaker"

In Less Than An Hour

Standard Kit

\$10.00

Wall Kit

With Hardwood Frame

\$11.00

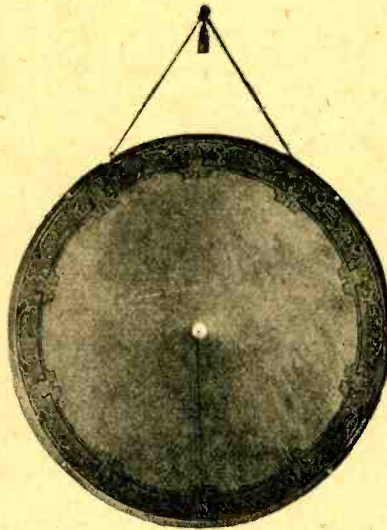

Visit Our Booth

at the

New York, Chicago

and Boston

Radio Shows

ANYONE who can handle a pair of scissors, a screw driver and a pair of pliers can assemble this remarkable speaker. Endorsed by the leading radio engineers of America and described in practically every radio publication. *Described by Clyde J. Fitch in Radio News.*

COMPLETE KIT

Kit contains the famous "Enesco" Direct-drive unit (fully covered by patents), the only successful direct-drive unit operating a 3 foot Cone, Alhambra FON-O-TEX Cone Material; Metal Apexes; Extension Pin and 12 page illustrated Book of Instructions, for easy assembly of any of six styles of Cone, Roll, Wall, Pedestal or Console speaker, sizes 24, 30 or 36 inches.

Send This Coupon

If your dealer hasn't been supplied with the "Enesco" Kit, send us the coupon with your remittance and we will send it to you. Shipping charges prepaid.

Dealers and Jobbers

Write for the "Enesco" profit making proposition. The finest cone speaker at a price everyone can afford.

ENGINEERS' SERVICE CO.

25 Church St., New York 73 Cornhill, Boston
 28 E. Jackson Boulevard, Chicago
 331 Bay Street, Toronto, Ontario

ABSOLUTELY GUARANTEED

We guarantee the "Enesco" to be the equal of any manufactured speaker, regardless of price. The "Enesco" produces the truest tones you have ever heard. After you hear your set with the "Enesco" Cone, you will wonder how you were ever satisfied with your former speaker.

GO TO YOUR DEALER

Thousands of progressive dealers all over the country have the "Enesco" on demonstration. Go to your dealer and hear the "Enesco"—compare it with any speaker in his store, regardless of price, then buy the "Enesco"—assemble it in less than an hour and enjoy radio reception, the like of which you never thought possible.

Engineers' Service Company

25 Church Street, New York 331 Bay St., Toronto, Ontario
 28 E. Jackson Blvd., Chicago 73 Cornhill, Boston

(Send to nearest office)

Send me a:

Standard Kit - \$10.00

Wall Kit - \$11.00

(Check which you want)

In Canada prices are \$11.50 and \$12.50

I am enclosing:

Check

Money Order

Cash (be sure to register letter)

Send C. O. D.

Name.....

Address.....

City.....

State.....

LEUTZ

UNIVERSAL TRANSOCEANIC

9 TUBES

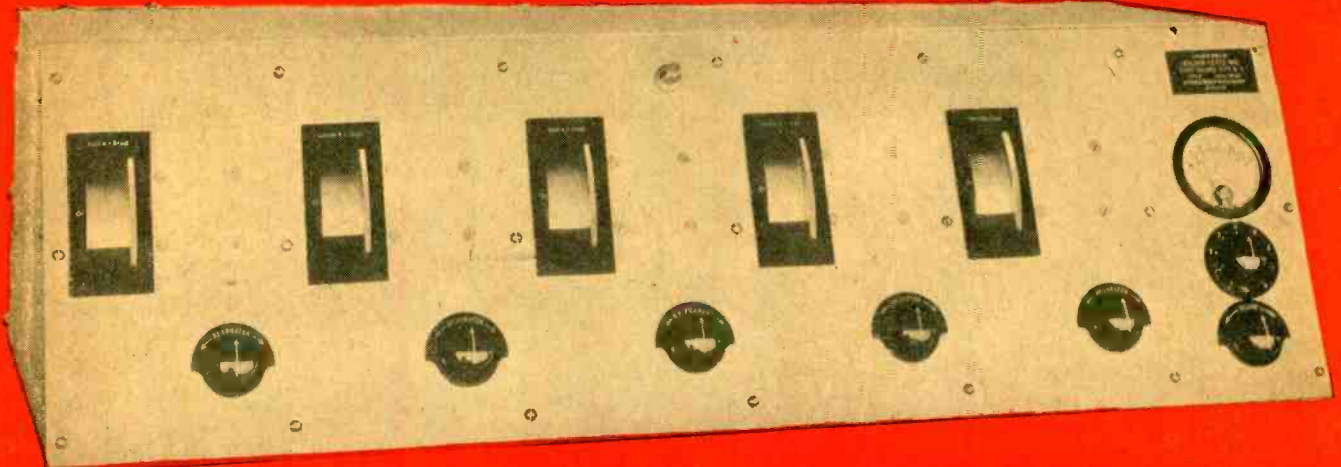

TRUE SELECTIVE POWERFUL

NEVER before has any radio ever provided at so low a price, so many QUALITIES and exclusive features. Modern to the minute in design, offering True distinction in appearance, built of fine materials, master workmanship, — the "UNIVERSAL TRANSOCEANIC" is the outstanding triumph of the most favorably known builders of powerful radio receivers.

Write For Our New Literature Today.

C. R. LEUTZ, Inc.

Sixth and Washington Aves., Long Island City, N. Y.

NOW

\$150

DIRECT

FROM OUR FACTORY

TO YOU

QUALITY AT LOW COST



IF you're making a penny less than \$50 a week, clip coupon now for **FREE BOOK** that tells you about big money opportunities in **RADIO**. Better conditions **NOW** than ever before, in this wonderful new industry! The reason is: television accomplished, trans-Atlantic Radio telephony now in use, many other wonderful advances and inventions constantly widening the field of Radio opportunity. Radio needs trained men **NOW!** And you can get the necessary training easily and quickly—**AT HOME**—through new, practical, tested methods that already have helped hundreds gain success in the Radio field. Yes, right at home in your spare hours, you can get all the knowledge you need for success in Radio—**Big Free Book** contains all the proof—send for it today!

Extra Dollars For You Almost At Once

Think of earning \$15, \$20, \$30 extra "on the side" every week without interfering with your regular job, beginning only a few weeks after you start this training! You can—my Radio training course is world-famous as the "Training That Pays For Itself." My thorough, practical usable training methods show you how to pick up this extra cash in your spare hours, while all the time you're preparing for the bigger Radio job ahead. In this way, you can pay for your course and put money in the bank, all through profits I teach you to make right after you start with me. And then, after only a few months of spare time training, you're ready to take the bigger Radio positions!

Send Today For 64-Page FREE BOOK—Mail Coupon

Send the coupon below, and I'll send you my 64-page book—it's free. Hundreds of pictures and facts about the opportunities for big money in the Radio field, how I help you take advantage of them, the 6 outfits of practice material I send you that you can build into 100 Radio circuits, and the other pay-raising facts you want to read. No previous Radio experience needed to take advantage of this offer, and no special schooling is necessary. Find out all the facts for yourself—mail coupon today.

Address J. E. SMITH, President NATIONAL RADIO INSTITUTE Dept. MB-9, Washington, D. C.



J. E. Smith, President, National Radio Institute, is one of the leading Radio educators of the world. He has helped hundreds of men to success in the Radio Profession.

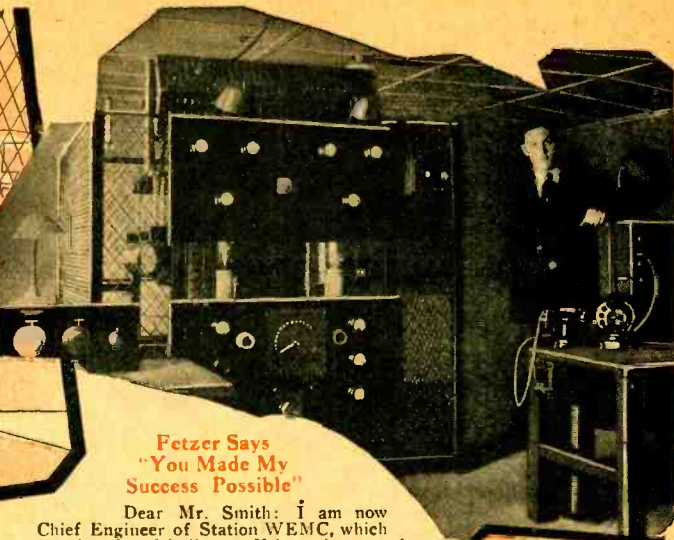

Fetzer Says "You Made My Success Possible"

Dear Mr. Smith: I am now Chief Engineer of Station WEMC, which I designed and built myself from the ground up. Six months were required for the work, and the equipment was designed for 5,000 watts. Previous to building this station I had designed and built two others, one a 500-watt station. I visited all the important Radio stations of Europe and the eastern half of the United States before designing WEMC, in order to get all the latest ideas. I am very happy in my work, feel that I have "arrived" in the Radio profession, and I give your thorough training the credit.

Cordially yours,
John E. Fetzer,
Station WEMC, Berrien Springs, Mich.

Builds \$100,000 Broadcast Station

Find Out FREE How Fetzer, Chambers and Hundreds of Others Have Gained Success in

RADIO

Mail Coupon Below For Free Book

"My Salary Three Times What It Was, Thanks To You" Says Chambers

Dear Mr. Smith: Herewith a photograph of myself in my Radio laboratory here at Detroit. I am making almost three times what I made before taking your course, and will receive another substantial increase very soon. As you know, in the capacity of Radio Engineer here I am in full charge of Radio activities apart from the sales department. So far I have met with steady advancement, and I expect more for the future. The knowledge I got from you enabled me to get where I am today, and believe me, I shall always be a booster for your fine school.

Sincerely,
E. L. Chambers,
6050 Cass Ave., Detroit, Mich.

Chief Engr. At Stewart Warner Branch



Here's the coupon that Fetzer and Chambers clipped

COUPON

J. E. SMITH, President, National Radio Institute, Dept. MB-9, Washington, D. C.

Dear Mr. Smith: Please send me your free 64-page book with all the facts about learning Radio for bigger pay. I understand this places me under no obligation.

Name.....

Address.....

Town..... State.....

Restored Enchantment



This is the Eveready Layerbilt that gives you Battery Power for the longest time and the least money.

THERE is no doubt of it—radio is better with Battery Power. And never was radio so worthy of the perfection of reception that batteries, and batteries alone, make possible. Today more than ever you need what batteries give—pure DC, Direct Current, electricity that flows smoothly, quietly, noiselessly. When such is the current that operates your receiver, you are unconscious of its mechanism, for you do not hear it humming, buzzing, crackling. The enchantment of the program is complete.

Batteries themselves have improved, as has radio. Today they are so perfect, and so long-lasting, as to be equal to the demands of the modern receiver. Power your set with the Eveready Layerbilt "B" Battery No. 486. This is the battery whose unique, exclusive construction makes it last longer than any other Eveready. Could more be said? In most homes a set of Layerbilts lasts an entire season. This is the battery that brings you Battery Power with all its advantages, conferring benefits and enjoyments that are really tremendous when compared with the small cost and effort involved in replacements at long intervals. For the best in radio, use the Eveready Layerbilt.

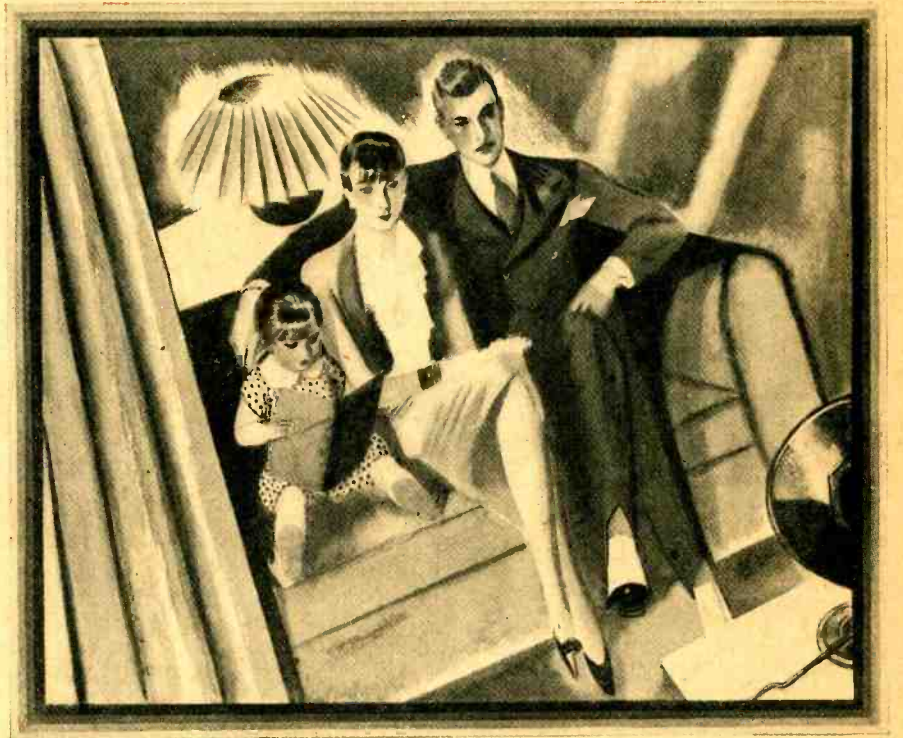

Radio is better with Battery Power

At a turn of the dial a radio program comes to you. It is clear. It is true. It is natural. You thank the powers of nature that have once more brought quiet to the distant reaches of the radio-swept air. You are grateful to the broadcasters whose programs were never so enjoyable, so enchanting. You call down blessings upon the authority that has allotted to each station its proper place. And, if you are radio-wise, you will be thankful that you bought a new set of "B" batteries to make the most out of radio's newest and most glorious season.

NATIONAL CARBON CO., INC.  New York—San Francisco

Unit of Union Carbide and Carbon Corporation

Tuesday night is Eveready Hour Night—8 P. M., Eastern Standard Time

WEAF—New York	WGR—Buffalo	WGN—Chicago	WRC—Washington
WJAR—Providence	WCAE—Pittsburgh	WOC—Davenport	WGY—Schenectady
WEEL—Boston	WSAI—Cincinnati	WCCO { Minneapolis	WHAS—Louisville
WDAF—Kansas City	WTAM—Cleveland	{ St. Paul	WSB—Atlanta
WFI—Philadelphia	WWJ—Detroit	KSD—St. Louis	WSM—Nashville
		WMC—Memphis	

Pacific Coast Stations—9 P. M., Pacific Standard Time

KPO—KGO—San Francisco	KFI—Los Angeles
KFOA—KOMO—Seattle	KGW—Portland

Have you heard the new Victor record by the Eveready Hour Group—orchestra and singers—in Middleton's Down South Overture and Dvořák's Goin' Home?

EVEREADY
Radio Batteries
—they last longer

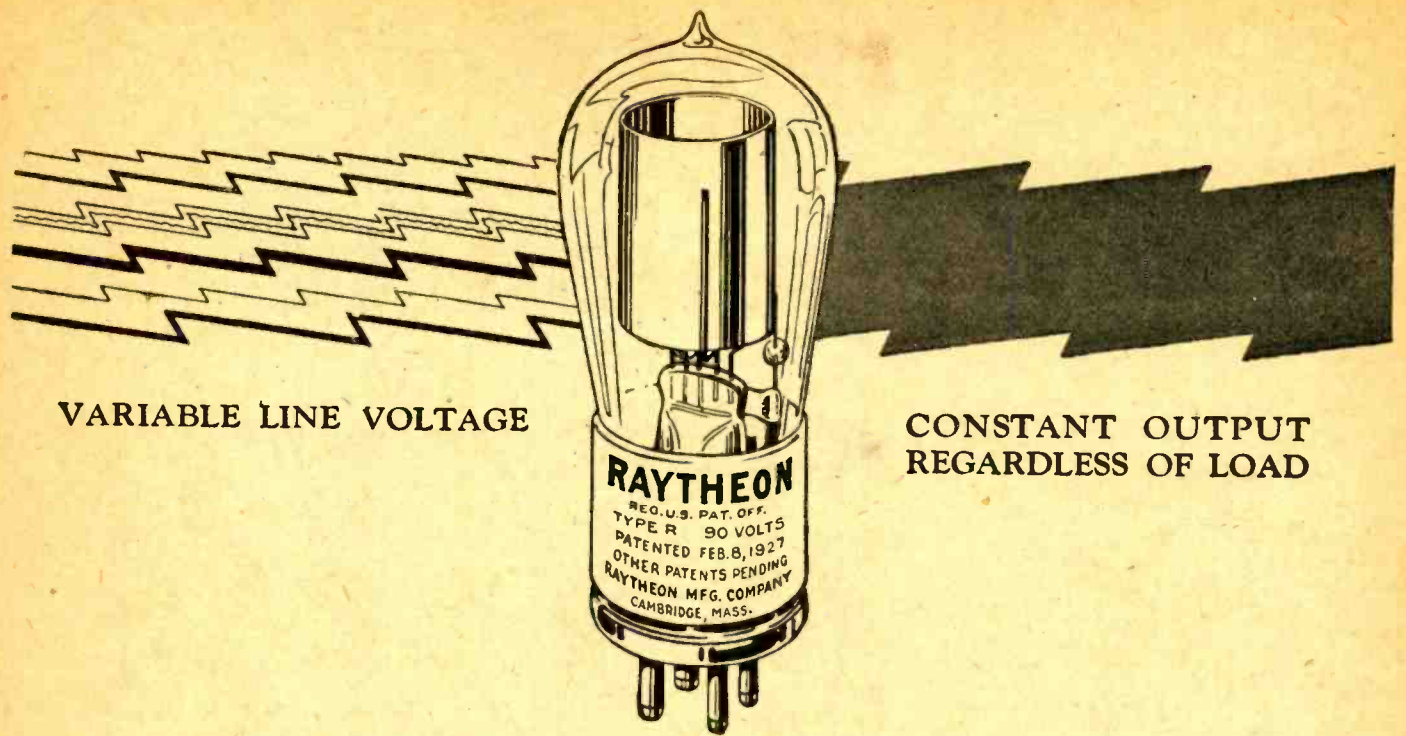

VARIABLE LINE VOLTAGE

CONSTANT OUTPUT
REGARDLESS OF LOAD

Raytheon Voltage Regulator Tube

EXPERIENCE gained in seven years of exhaustive research, experiments and tests, have enabled the Raytheon Research Laboratories to produce a new and fundamentally improved Voltage Regulator Tube of marked characteristics.

Raytheon—Type R, when incorporated in the proper B Power circuits, maintains constant voltage on the 90 and lower voltage taps and greatly improves the voltage regulation on the 180 and 135 volt taps, *regardless of variations in either the line voltage or load current.* The variable voltage controls can be thus eliminated and the construction of the unit simplified.

Furthermore, this new tube has a very pro-

nounced effect in eliminating the last vestige of ripple from the output, and when connected to an amplifier will completely eliminate "motor-boating".

A new feature—the *starting anode*—incorporated in type R, maintains constantly a state of ionization in the tube to prevent any "going out" regardless of the load fluctuation.

Raytheon—Type R, can be used in any power unit circuit now on the market employing a glow tube with greatly improved results. Diagrams of an approved Type R tube installation, in connection with the heavy duty Raytheon BH tube, can be had from the Raytheon Research Laboratories upon request.



Raytheon BH—a 125 milliamperere rectifying tube, because of its constant heavy duty output, is especially designed for use in conjunction with the Raytheon Type R Regulator Tube in light socket power units.

Raytheon, Type R, 90 volts, 60 milliamperes—Price \$4.00



Raytheon A—the compact efficient rectifier, new in principle and construction. For A battery chargers and A battery eliminator units.

Raytheon BA—a 350 milliamperere rectifying tube for complete battery elimination. Watch for the new ABC power units employing this rectifier.



RAYTHEON MANUFACTURING COMPANY
CAMBRIDGE, MASS.

Raytheon

THE HEART OF RELIABLE RADIO POWER

a New development!

Freshman EQUAPHASE

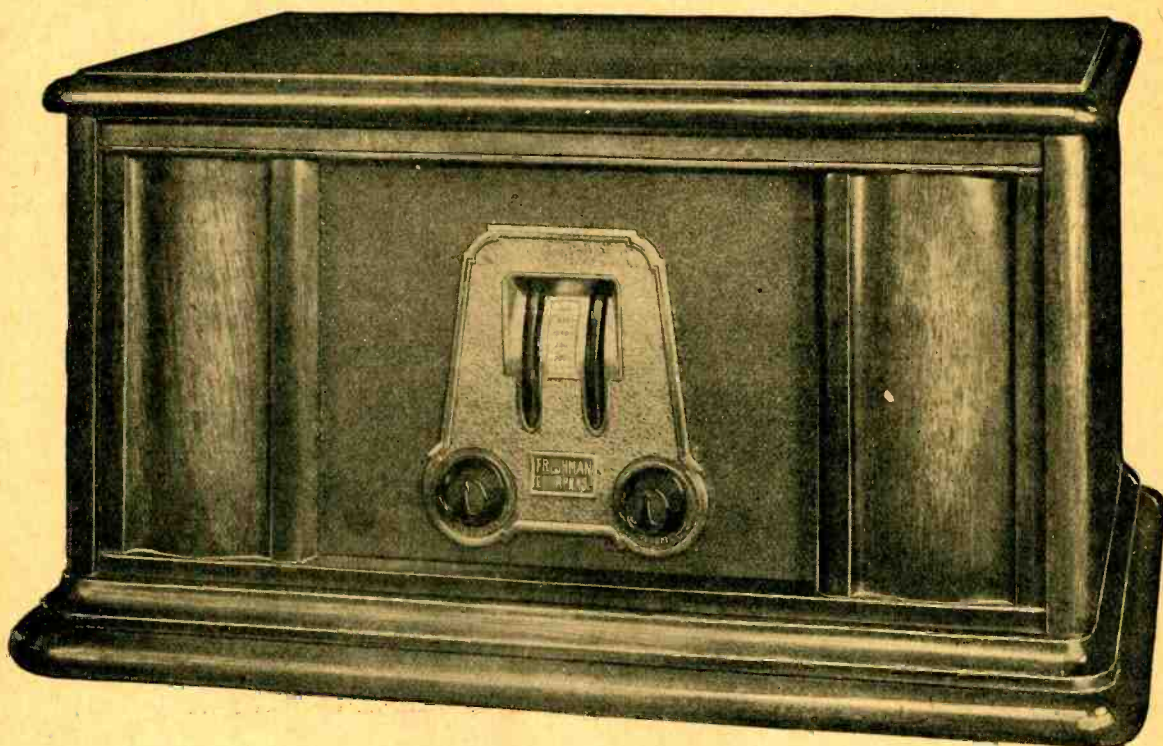

An entirely new principle of stabilization and these features:

- 1: Four tuned circuits
- 2: Single drive—one control
- 3: Full floating tube shelf
- 4: Drum type illuminated dial — calibrated in wavelengths
- 5: Solid Mahogany cabinet — artistically high-lighted

\$70

A Freshman development—licensed under patents: R C A — General Electric Co. — Westinghouse Electric & Mfg. Co. and American Tel. & Tel. Co.

Write for complete literature

CHAS. FRESHMAN CO., INC. Freshman Building, New York

New Metal Solves Radio Socket Power

FIRM in their conviction that direct light socket radio power was possible, scientists experimenting with molten elements in temperatures well beyond those previously achieved, have triumphed in the discovery and perfection of a new metal that solves this problem for all time.

Throughout the entire radio industry this new element, Kuprox, is heralded as the final link necessary to make radio reception in the home as carefree and simple as the operation of an electric iron, sweeper or toaster.

Today, radio fans everywhere recognize that in Kuprox, the elimination of radio batteries has been made a certainty. At last, direct light socket radio power, without acids, liquids or charging bulbs has been perfected through the discovery of this revolutionary new element.



The Replacement Unit, a series of simple Kuprox metal discs, riveted together.

Kuprox was discovered by scientists directed by Professor S. J. M. Allen, Ph.D., of the Post Graduate College of Engineering, University of Cincinnati, who succeeded in rearranging the entire atomic structure of copper, through a secret process, thus converting the most common metal used in electrical work, into a new element that permits the passing or rectifying of current only in one direction.

Kuprox lasts indefinitely. Once connected with the electric light socket Kuprox Radio Power Devices may be forgotten for they require no attention, no adjustments, no replacements. Thus, in one stroke, the bothersome electrolytic trickle chargers with the fumes and acids have been eliminated.

In addition to its use in complete A, B, and C electric radio power devices, Kuprox is also being manufactured in an ingenious device that brings to an end all the bother and trouble experienced heretofore with all electrolytic trickle chargers.

With this device, known as the Kuprox Replacement Unit, and retailing for only \$4.50, it is possible to convert any standard wet trickle charger or power unit into a dry rectifier that requires no attention. It is easy to attach. Simply disconnect the present jar of acid and throw it away. Install the Replacement Unit in its place by two simple binding post connections. Besides eliminating all the watering and attention, the new replacement delivers about twice the former charging rate, resulting in much higher efficiency of the battery to which it is attached.

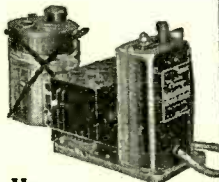

How the Kuprox Replacement Unit replaces the acid jar on trickle chargers.

Now—Electric Radio Power—without acids, liquids or charging bulbs

Dry, permanent power that requires no attention!

The most startling development of the radio season!

NOW, for the first time, radio is really and truly electric. No more of the bother and worry... none of the troublesome watering and attention that until now all socket powers required. KUPROX has eliminated all this. It has brought absolute freedom from radio cares. It makes your set entirely electric.

KUPROX is all-metal...it is dry...it needs no watching or watering...it cannot wear out. You install KUPROX Devices on your set and forget them. A variety of models, from Trickle Chargers to Combination Models which supply all radio power from a single compact unit. See the complete KUPROX line at your dealer's.

KUPROX

RADIO POWER DEVICES



KUPROX "A" TRANSIFIERS—Batteryless, noiseless, electric "A" power. Dry, dependable, needs no attention. Operates any receiver. 4-volt or 6-volt, \$28.50 and up.

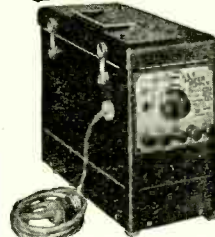

KUPROX A & B TRANSIFIERS—All radio power from a single unit. Controlled from set switch. Absolutely dry, requires no attention. \$57.50 and up.



KUPROX "B" TRANSIFIERS—Dry, permanent, free of hum. Models for all sets and circuits, \$14.50 and up.



KUPROX Replacement Unit—For replacing acid jar on all standard trickle chargers and power units. \$4.50

KUPROX Trickle Chargers—1-amp. rate. Large model gives 2½-amp. booster charge. \$10.50 and \$18.50.

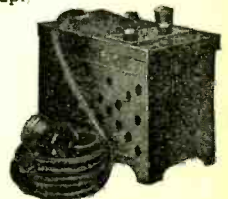

WRITE FOR FREE BOOKLET—"The Secret of Successful Battery Elimination" describing KUPROX Radio Power Devices.

THE KODEL RADIO CORPORATION, 501 E. Pearl St., CINCINNATI, O.

© 1927 K. R. Corp.

TELEVISION - is here -

Radio Fans! Mechanics! Scientific men! Everybody! Build a TELEVISION SET--The greatest and most amazing development of the 20th Century

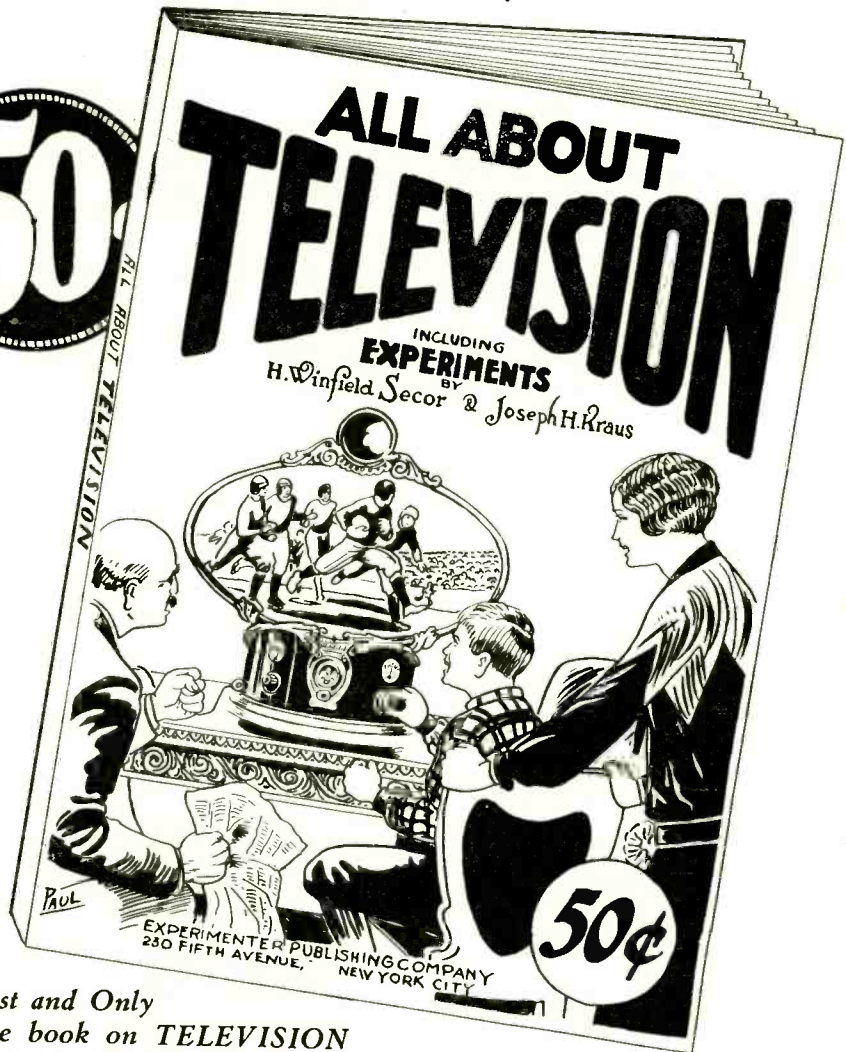
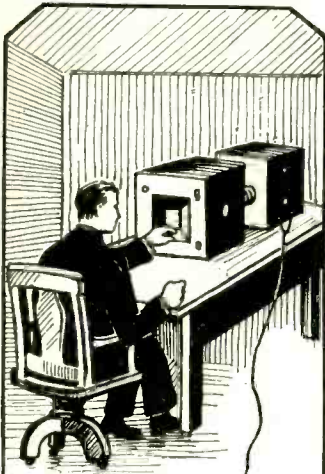

The First and Only complete book on TELEVISION

HERE, friends, is the first book to be published giving you the history of TELEVISION, from the first crude experiments at the beginning of the 20th Century—to the comparatively perfect machines just put into daily operation.

From this book you can build your own, workable television set that will serve as a fundamental apparatus for hundreds of tremendously interesting and amazing experiments.

Get in now on this new development. You may be fortunate enough to discover some improvement to Television that will be worth many thousands of dollars.

Start with a copy of this new book today.

116 Pages—Size 9x12 inches, Illustrated.

50 CENTS THE COPY—*Everywhere*

or clip this coupon and send it to

EXPERIMENTER PUB. CO., Inc.
230 Fifth Ave., New York, N. Y.

EXPERIMENTER PUBLISHING CO., Inc.
230 Fifth Avenue, New York, N. Y.

Gentlemen:—I enclose 50c for one copy of the new book "TELEVISION."
Name.....
Address.....
City.....
State.....

No Matter What Set You Have ACME Apparatus will make it better

THESE are the days of quality reception and that's where Acme comes in, Acme for Amplification. During all these years of Radio Broadcasting, Acme has had this thought in mind, "After all how well you can hear is the thing that counts."

There's the Acme double free-edge cone speaker—thousands in use, thousands of satisfied listeners. It took five years and 320 experimental models to make this speaker.

There's the Acme B Power Supply with Raytheon tube, the first on the market. Three years of experience in making and selling these eliminators has earned the reputation of making the B Power Supply that stands up and works.

People tell us, "I have one of your

first eliminators and it's still going strong."

Acme now offers a single stage power amplifier to add to any set. All you have to do is connect your set, your B supply and your speaker to the amplifier, put in a power tube, plug into the lamp socket and your radio enjoyment will increase a hundred fold. No additional A battery current and no C battery to add, both of these supplies are included in the unit.

Acme has two booklets, (Amplification without Distortion) telling how to improve any radio set and (Power Supply for Radio Sets) telling the story of Lamp Socket operation.

Fill in the coupon below for the one you want.

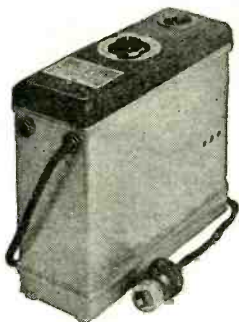

ACME E-4 B-Supply
\$35.00

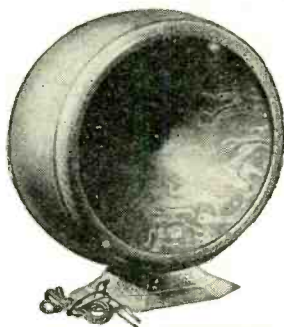

ACME K-1 SPEAKER
\$25.00



ACME PA-1 Power Amplifier
\$12.50



ACME

for amplification

ACME APPARATUS CO.
Dept. R N-1 Cambridge, Mass.

Gentlemen: Please send me a copy of the booklet checked below. I enclose 10 cents for each copy.

Amplification without distortion

Power Supply for Radio Sets

Name _____

Street _____

City _____ State _____



VAN HORNE TUBES
ARE BEST
and
COVER ALL TYPES
including
LATEST A. C.-POWER
and
RECTIFIER TUBES



30 Days FREE TRIAL

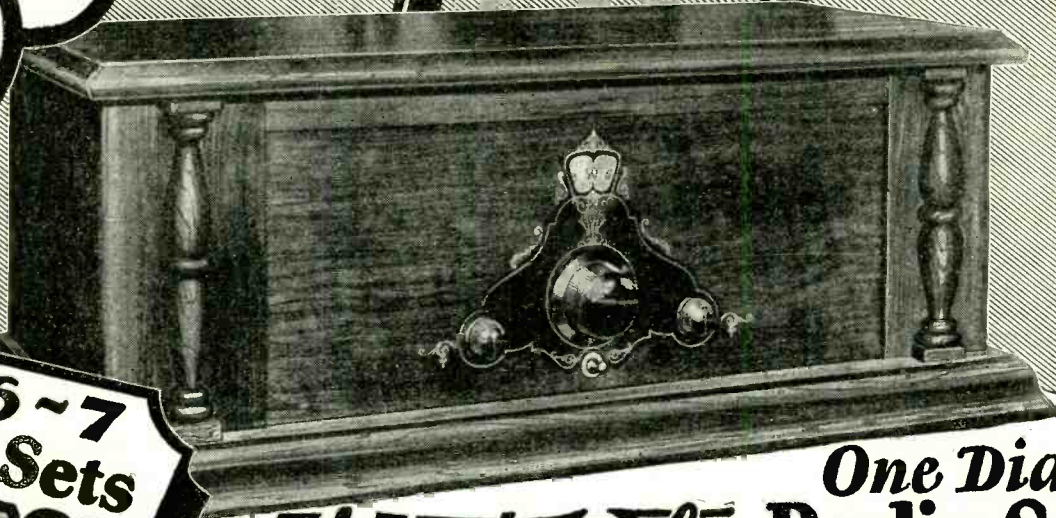

**5-6-7
Tube Sets
\$47.00
to
\$72.00
RETAIL PRICES**

One Dial Westgale Radio Sets

NOW!—the new 1928 WESTGALE line of Radio Models are ready for you to try. And we stand ready to put any one of our 24 new styles in your home and let you use it to your heart's content on 30 DAYS' TRIAL. Entertain your family and friends. Listen to programs from all over the country. Note the distance, selectivity, and volume. But most of all, hear their amazing, deep, mellow, tone,—then if you are not convinced that WESTGALE gives you more for your money than you can get elsewhere,—YOU DON'T HAVE TO KEEP IT.

*The Last Word in
Quaranteed
Radio
Sets
and
the
Biggest
Values
Ever
Offered*

Why Not Be Our Agent?

Buy at cost. We want Agents and Dealers in every locality to demonstrate and take orders for these amazing new 1928 Westgale Models. This is your chance to get a Westgale Radio at a big discount and make it pay you big money. Millions of radios will be sold this season. Get a Westgale set on 30 Days' Trial—demonstrate to your neighbors and friends and get your share of these big radio profits.

Your Own RADIO Free

Our new Catalog also explains a plan whereby you can put a Westgale Radio in your home on 30 Days' Trial—demonstrate it to your neighbors and friends in your spare time and get your own set without cost before the trial period is up.

Thousands of Westgale Sets have been sold on this 30-Day Trial Plan. For years we have maintained the reputation of being first with the latest in Radio. These new 1928 models are no exception,—they are the last word in Radio and priced at just about half the usual cost. Why not have the newest Radio? Why pay high prices? Why take chances, when you can test out any Westgale model in your own home on 30 Days' Trial.

24 Models to Choose from Table Styles--Consoles--De Luxe Cabinets

This season Westgale offers you 5 tube—6 tube—and 7 tube models in your choice of a beautiful array of table styles, consoles and period type walnut cabinets. Don't buy any radio until you send the coupon for our new catalog which pictures and describes our complete line in almost any size or style you could wish for. Don't wait,—a special introductory discount from retail prices for those who write quick. Mail the coupon today—get posted before you buy.

Special Discounts to Agents

To quickly introduce these wonderful new 1928 models we are offering for a limited time a big reduction, 'way below retail prices, on the FIRST Westgale set placed in each community. So get busy now! Be first in your locality to mail the coupon for our FREE catalog and get full particulars of this special discount offer.



Only
\$85.00

Retail Price
Including Speaker

Westgale Electric Company
(Formerly Westingale Electric Co.)
Dept. 1810
1751 Belmont Ave., CHICAGO, Ill.

Mail Today—Don't Delay

WESTGALE ELECTRIC CO.,
Dept. 1810, 1751 Belmont Ave.,
CHICAGO, ILL.

Please send me your FREE catalog on the new 1928 Westgale Radio Sets. Also full particulars of your Special Discount Offer on the first outfit placed in each community.

Name.....

Address.....

America's First Three Home Entertainers!!!

The incomparable book of
MYSTERY and
AMAZING FICTION

The First **AMAZING STORIES** "ANNUAL"

featuring--- The Master Mind of Mars
by **EDGAR RICE BURROUGHS**

also stories by such famous Authors as H. G. Wells, A. Merrill,
Murray Leinster, A. Hyatt Verrill and Austin Hall

Where can you duplicate the galaxy of Amazing, Scientific fiction writers listed above? Where in America or elsewhere can you match the fiction stories of these master writers?

The feature of this new 116 page volume, **AMAZING STORIES ANNUAL**, which includes the very choicest selections of these writers is a special attraction, the story "The Master Mind of Mars," by no less a leading writer of America **EDGAR RICE BURROUGHS**.

This story appears in print for the first time in **AMAZING STORIES ANNUAL**.

If you want a copy of the greatest book of Amazing Fiction.—If you want a book that will give you thrills and chills galore—then buy a copy today of the first **AMAZING STORIES ANNUAL**.

50c THE COPY

Sold on all Newsstands or order direct

EXPERIMENTER PUB. CO., Inc.
230 Fifth Ave. New York, N. Y.

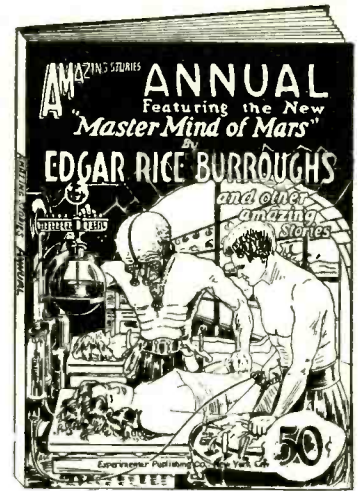

A whole book of
TRICKS

1000 HOURS of FUN With **SAM LOYD**

THERE are more than one thousand hours of truly amazing fun and frolic—in Sam Loyd's "Tricks and Puzzles." There is only one Sam Loyd, the Puzzle King, the incomparable, a true master mind, and he has crowded in this new volume, "Tricks and Puzzles," the best work of his lifetime. In this book are thousands of puzzles of every conceivable nature, games, tricks, conundrums. Hundreds of illustrations. Scores of real brain-teasing puzzle stories, dozens of humorous anecdotes.

With this inexhaustible gold mine of lively entertainment at hand you need never be at loss for an evening's party program or a rainy day's delight.

It's a book for young and old folks alike—Riddles for the youngsters—Brain teasers for the grown-ups.

The kind of a book every home should have in its book-rack. 116 pages, 100 or more illustrations, large size, 9 x 12 inches, with beautiful 2-color cover.

50c THE COPY—ON ALL NEWSSTANDS

If your dealer cannot supply you write direct

EXPERIMENTER PUB. CO., 230 5th Ave., New York

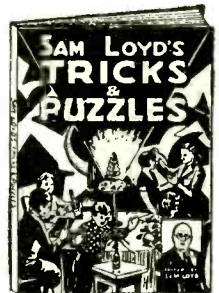

Learn the
SECRETS

SECRETS of YOUR HANDS!

96 Page Book. The Revelation of Character, etc., in Hands

FINGERPRINTS are used throughout the world as a means of apprehending criminals—but fingerprints are but a small portion of the secrets of your character that your fingers, your palm, even your handshake reveals.

Every inch of your hand has been charted by the experts of this highly developed science, and so simply and accurately that anyone can learn the telltale signs by heart.

Here is a brand new book with all the latest information—written in such a way that you can quickly master "Palmistry."

Typical hands of lawyers, doctors, people of strong characteristics are shown in large drawings on many pages.

Everything is simplified, easy to understand. The book contains 96 pages, hundreds of illustrations and is the large book size, 9 by 12 inches.

50c THE COPY—ON ALL NEWSSTANDS

If your dealer cannot supply you write direct

EXPERIMENTER PUB. CO., 230 5th Ave., New York

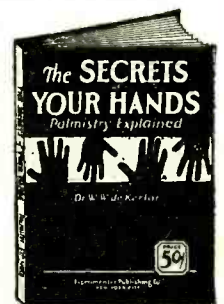

30 Days FREE TRIAL

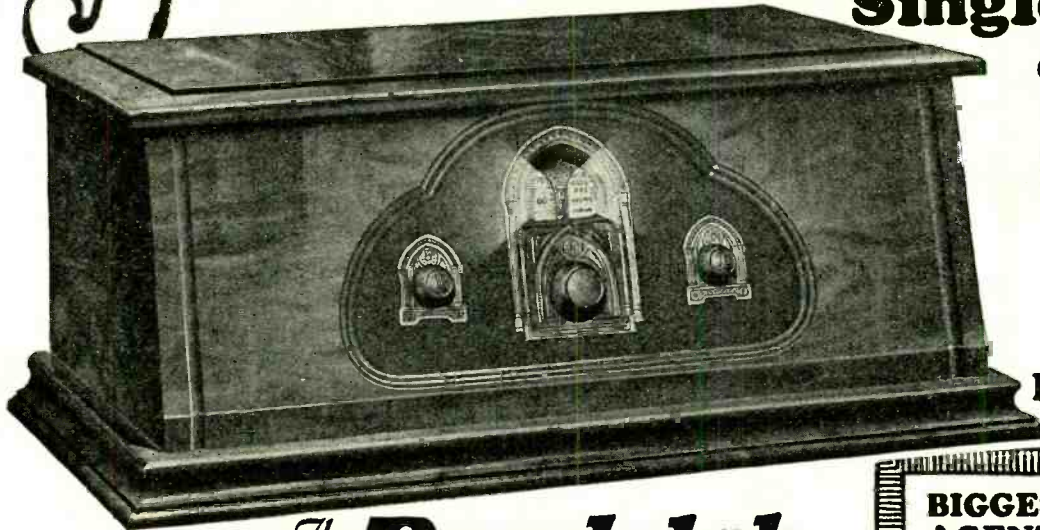

Single Control

7-Tube

\$ 77

RETAIL PRICE
Completely Assembled

The **Randolph**

SINGLE CONTROL - ILLUMINATED DRUM

POWERFUL seven-tube radio at factory price. Test it without spending a cent. We claim the Randolph Seven will out-perform any radio and we want you to satisfy yourself that it will. To do this, we will send you this powerful radio to try for 30 days. Test it for distance, clearness, ease of operation, tone and every other way you can. Unless it more than satisfies you, return it to us. **Every Randolph set must make good before it is sold.**

Battery **ALL ELECTRIC OPERATION**

The Randolph Seven is sold for use with batteries or connected for operation direct to electric light socket—absolutely batteryless—no chargers or batteries—just plug in socket and tune in. 100% efficient either way. Its construction and performance have been tested and approved by leading radio engineers and authorities and leading radio and scientific publications.

Single Control—Illuminated Drum

One drum dial operated by one simple vernier control tunes in all stations with easy selectivity to tremendous volume. No overlapping of stations. Illuminated drum permits operation in the dark. Volume control for finer volume modulation. This is a 7-tube tuned radio frequency receiver with power transformers and power amplification. Space wound solenoid coils. Full and completely shielded. A real receiver of the highest quality. Tremendous distance, wonderful tone quality, simple to operate.

The Randolph cabinets are in themselves beautiful pieces of furniture made of carefully selected solid burl walnut. Bas-relief bronze escutcheon plates are mounted on the dial panel. In design and appearance it is a cabinet worthy of the high-quality radio it contains. Solid walnut beautifully shaped surrounds the soft verdi-green panel. Nothing has been spared to make the Randolph Seven the leading radio receiver. We are so sure that it will surpass even your best hopes that we know how safe we are in making the **30 day free trial offer.**

Read What Owners Say

I have logged more than 50 stations from coast to coast.—Lloyd Davenport, Littlefield, Texas. I have logged 52 stations from Cuba to Seattle—the set is a world beater.—J. Tamplinson, Detroit, Mich. Your set is a revelation—has all others tied to the post for distance and selectivity.—Waldo Powers, Vergennes, Vermont. On strength of its performance sold two more sets this week. T. Scanlow, Orlando, Florida.

Beautiful Amphiphonic Console Set

Made of the finest carefully selected solid walnut. Two-tone shaded finish. Has built-in cone loudspeaker that compares with any on the market and accurately reproduces high and low notes. Send for the folder today that shows this beautiful console in full colors and gives complete details. **Compares with most table sets in price.** For battery or all-electric operation ready to plug in and tune in. Write for complete descriptions.

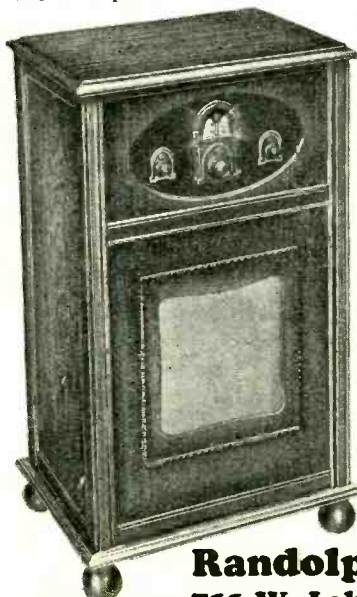

Randolph Radio Corporation
711 W. Lake St. Dept. 122, Chicago, Ill.

BIGGEST DISCOUNTS to AGENTS and DEALERS

WORK either full or part time and make big money. Tremendous advertising campaign helps you sell. Regardless of whether you have ever sold before, be sure to get our proposition. The Randolph sells on first demonstration. Men and women both can make money this easy way. Get your demonstration set for thirty days **FREE TRIAL.**

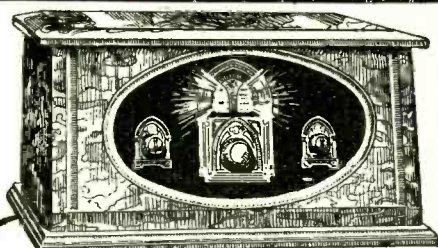

6-Tube

\$ 55

Retail Price
SINGLE CONTROL

The **Randolph**

Now you can have a new, modern, single-control, six-tube radio. Do not compare this set with old style 2-dial 6-tube sets selling for about the same price. The Randolph 1927 Senior Six has also been tested and approved by the leading radio engineers. Comes in a beautiful solid walnut cabinet of hand-rubbed finish. Single control. Illuminated Drum with space for logging. Absolutely dependable and very selective. Sent for 30 Days Free Trial. You test it before you buy.

Mail Coupon Now

The Randolph Radio Corporation are pioneers in the manufacture of radios. All of its vast and unlimited resources have been used in making and perfecting of the Randolph Receivers. Because of our long and successful experience in the radio business, we are perfectly confident in sending out a Randolph Radio on trial. We know what it will do. Mail us the coupon now for the greatest radio offer ever made.

USE THIS COUPON TODAY!

Randolph Radio Corporation,
711 West Lake Street, Dept. 122
Chicago, Illinois.
Send me full particulars about the **RANDOLPH Six** and **Seven-Tube Table and Console Sets** with details of your **30 Day FREE Trial Offer.**

Name.....
Address.....
City..... State.....
Mark here () if interested in Agent's proposition.

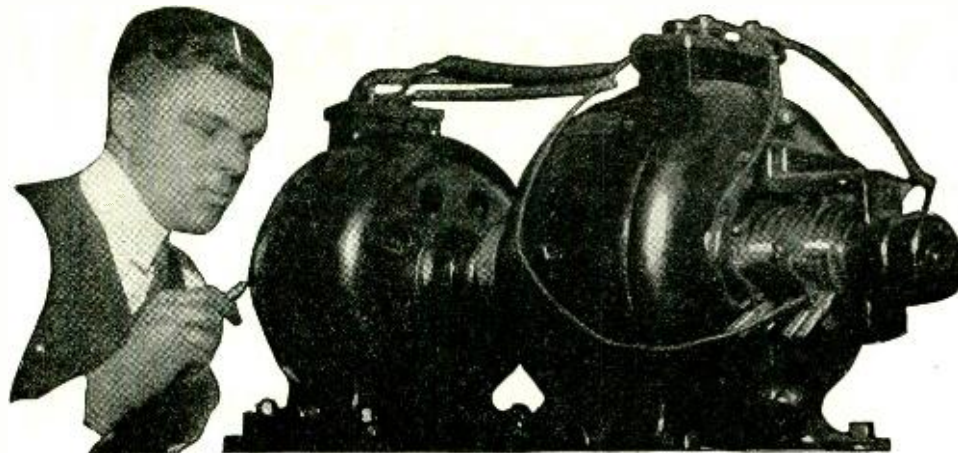

Amazingly Easy Way to get into ELECTRICITY

Don't spend your life waiting for \$5 raises in a dull, hopeless job. Now . . . and forever . . . say good-bye to 25 and 35 dollars a week. Let me show you how to qualify for jobs leading to salaries of \$50, \$60 and up, a week, in Electricity—NOT by correspondence, but by an amazing way to teach, that makes you an electrical expert in 90 days! Getting into Electricity is far easier than you imagine!

Learn Without Lessons in 90 DAYS

LACK of experience—age, or advanced education bars no one. I don't care if you don't know an armature from an air brake—I don't expect you to! I don't care if you're 16 years old or 48—it makes no difference! Don't let lack of money stop you. Most of the men at Coyne have no more money than you have.

Railroad Fare Allowed

I will allow your railroad fare to Chicago, and if you should need part-time work I'll assist you to it. Then, in 12 brief weeks, in the great roaring shops of Coyne, I train you as you never dreamed you could be trained . . . on the greatest outlay of electrical apparatus ever assembled . . . costing hundreds of thousands of dollars . . . real dynamos, engines, power plants, autos, switchboards, transmitting stations . . . everything from doorbells to farm power and lighting . . . full-sized . . . in full operation every day!

No Books—No Printed Lessons

No books, no baffling charts . . . all



Prepare For Jobs Like These

Here are a few of hundreds of positions open to Coyne-trained men. Our free employment bureau gives you lifetime employment service.

Armature Expert	\$100 a Week
Substation Operator	\$65 a Week
Auto Electrician	\$110 a Week
Inventor	Unlimited
Maintenance Engineer	\$150 a Week
Service Station Owner	\$200 a Week
Radio Expert	\$100 a Week

Now In Our New Home

This is our new, fireproof, modern home where in is installed thousands of dollars, worth of the newest and most modern Electrical Equipment of all kinds. We now have the largest amount of floor space devoted to the exclusive teaching of practical electricity in the world. Every comfort and convenience has been arranged to make you happy and contented during your training.

real actual work . . . building real batteries . . . winding real armatures, operating real motors, dynamos and generators, wiring houses, etc., etc. That's a glimpse of how we make you a master practical electrician in 90 days, teaching you far more than the average ordinary electrician ever knows and fitting you to step into jobs leading to big pay immediately after graduation. Here, in this world-famous *Parent school*—and nowhere else in the world—can you get such training!

Jobs, Pay, Future

Don't worry about a job, Coyne training settles the job question for life. Demand for Coyne men often

exceeds the supply. Our employment bureau gives you lifetime service. Two weeks after graduation, Clyde F. Hart got a position as electrician with the Great Western Railroad at over \$100 a week. That's not unusual. We can point to Coyne men making up to \$600 a month. \$60 a week is only the beginning of your opportunity. You can go into radio, battery or automotive electrical business for yourself and make up to \$15,000 a year.

Get the Facts

Coyne is your one great chance to get into electricity. Every obstacle is removed. This school is 28 years old—Coyne training is tested—proven beyond all doubt—endorsed by many large electrical concerns. You can find out everything absolutely free. Simply mail the coupon and let me send you the big, free Coyne book of 150 photographs . . . facts . . . jobs . . . salaries . . . opportunities. Tells you how many earn expenses while training and how we assist our graduates in the field. This does not obligate you. So act at once. Just mail coupon.

Get this FREE Book

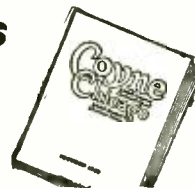

Mr. H. C. Lewis, Pres. COYNE ELECTRICAL SCHOOL, Dept. 77-77 500 S. Paulina St., Chicago, Ill.

Dear Mr. Lewis: Without obligation send me your big free catalog and all details of Railroad Fare to Chicago, Free Employment Service, Radio and Automotive Courses, and how I can "earn while learning." I understand I will not be bothered by any salesman.

Name
 Address
 City State

COYNE ELECTRICAL SCHOOL
 H. C. LEWIS, President, Dept. 77-77
 500 S. Paulina St., Chicago Established 1899

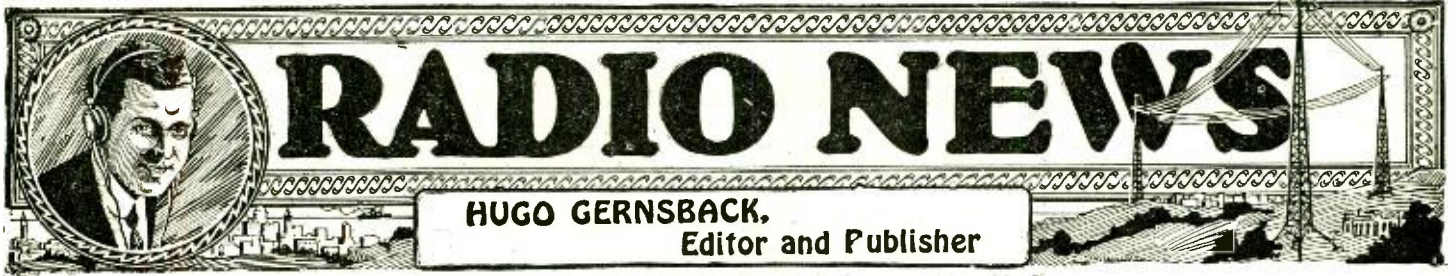

RADIO NEWS

HUGO GERNSBACK,
Editor and Publisher

Editorial and General Offices, 230 Fifth Avenue, New York

Vol. 9

OCTOBER, 1927

No. 4

RADIO ENTERS INTO A NEW PHASE

By HUGO GERNSBACK

THE great revolutions are those that are silent, and almost invisible. Usually, the greatest revolutions are economic in their nature, and therefore not seen immediately, but they are prolonged over a considerable time.

The radio industry is now in the midst of one of these major revolutions, which may change its entire aspect during the next few years.

Let me review what happened in radio, even before broadcasting began. Originally, back in 1910, the radio industry, just coming into life, was content to build and manufacture parts which were sold to the radio amateur. The amateur of that day bought the various parts and promptly screwed them down to an old table. This was his radio set, with which he received "wireless" code from other amateurs, from commercial stations and ships.

About 1916, the manufacture of the first complete sets began. They were more or less self-contained, but necessarily rather crude, to our present way of thinking. But still separate parts, in value, formed the greatest proportion of sales by the radio industry.

When broadcasting started, in 1921, the sale of parts to the public immediately jumped to a tremendous figure; and it was some time before the sale of completely-manufactured sets took the lead and exceeded that of parts. Then gradually the ready-made factory-built set came into the ascendancy and greatly eclipsed the sale of separate parts. That is the situation which we have at present. Though in 1922 and 1923 every radio dealer stocked an immense number of parts and but few sets, the situation in this country has been reversed since then, and there are now comparatively few dealers who stock parts. Most of them nowadays stock a complete line of sets and accessories.

There is, of course, a great difference between *parts* and *accessories*: parts being usually taken to mean those items that go into the manufacture or construction of a radio set, whereas accessories are the articles that are necessary for the operation of the complete set. Under accessories are listed such articles as tubes, batteries and socket-power units, loud speakers, headphones, etc.

But it is believed that we are now facing a silent revolution and that the order of things is to be changed once more. The reason is purely economic, and found primarily in the patent situation.

The Radio Corporation of America, and its allied interests, who always have been in the lead, as far as radio patents are concerned, have during the course of years acquired practically all of the important radio patents in this country; and they are therefore in a position to impose terms on all who have infringed their patents. Of course the cry of "Monopoly!" will, as usual, go up; but the point remains that, after all, every patent is a *monopoly*, and that any one to whom is issued a patent must protect his rights—otherwise he stands to lose them. In upholding the rights to its patents, the Radio Corporation, after all, is within its rights, and will now reap the benefits from the patent situation.

As generally known, practically every one of the large radio manufacturers is now paying a royalty of 7½ per cent to the Radio Corporation, with a clause of \$100,000 per annum minimum royalty. This, of course, means but one thing, and that is, the price of radio sets must go up. Furthermore, the small set manufacturers will no doubt go back into the parts business; as the Radio Corporation will probably license only those who are financially responsible (and it may be presumed that most of the smaller ones probably are

not in a position to guarantee a minimum royalty of \$100,000 per year).

What has been predicted for a number of years has thus come to pass. The radio set business will be in the hands of a few strong corporations, which will control the legitimate set business in the United States on a highly competitive basis. All other reports to the contrary, this certainly is not a general monopoly of the set business; and we believe that, in time to come, it will work out to the advantage of the public.

But what about the parts business? It is believed in many quarters that, because of the conditions just mentioned, the general parts business will come back with a grand rush. Parts manufacturers, of course, sell their merchandise to set manufacturers; and this outlet, frequently, is their largest source of income. But outside of this, they sell their merchandise to radio dealers and to professional set builders. From present indications, there will be a great and immediate demand for parts; because the small set manufacturer, being put out of the way, will leave the road clear for the professional set builder to come into his own.

The man who builds a set now and then, in his attic, is not likely to be worried by any patent situation, nor will the radio interests be much concerned about professional set builders. Quite the contrary, the Radio Corporation has always maintained that it encourages the amateur and constructor. More than ever, no doubt, the big interests now feel that they have little to lose on account of the set builders. Nevertheless, during the next year, a vast quantity of radio sets and power packs will be manufactured and made by these professional set builders, who do a very sizable business in these transactions. It is a peculiar situation, but one very well understood by radio economists, that there is always a healthy demand for the home-made set. It works out somewhat along these lines:

A set builder or an amateur sees a new circuit described in *RADIO NEWS*, or elsewhere. He promptly builds it and finds that it works well. A few of his friends or acquaintances see and hear the set and are impressed by it; because, as is usual in such cases, it is the *latest* thing. They immediately wish to get one like it; and, right away, the set builder is busy making two or three sets for his friends at a nice profit to himself.

The set builder naturally is well able to compete with the manufacturer, for two reasons. First, his time costs him little, and in price, therefore, he can compete easily with the factory-made set. Secondly, he has the jump on the manufactured set for the simple reason that, as like as not, his circuit is the latest out, and, therefore, will have improvements that the manufactured set can not boast for some months to come.

The large set manufacturers, as a rule, change models only once a year, and, therefore, at some time during the year the radio art will have advanced somewhat beyond their facility to follow. Of this situation the professional set builder takes advantage by incorporating the latest advances in his set.

There are always several hundred thousand people in this country who build sets either for themselves or for friends; and this number is likely to increase materially in the immediate future, because of the economic reasons just explained.

Summing up, therefore, these facts, it is reasonable to predict that the radio parts business during the next few years will show a very large and healthy growth.

... In which the Editor reviews three eras of economic change, which the development of radio art has brought about in this industry... and heralds the expected arrival of a fourth, due to the concentration, in the hands of a few large concerns, of the manufacture of receivers... why this must result in the division of radio set production between "the great industry" and the building at home, for personal use or on a custom basis, by constructors... how conditions will favor the professional set constructors in obtaining a good volume of business... and therefore continue to encourage the manufacture of component parts.

Mr. Hugo Gernsback speaks every Tuesday night at 9.30 P. M. from station WRNY on various radio and scientific subjects.

A Set for Each Member of the Family

In Which Are Set Forth Excellent Reasons Why More Than One Set Is Necessary in the Home

ALUMP of sugar, hung from the ceiling by a string and swung from mouth to mouth around the table, was considered the height of elegance at dinner parties in the good old days of colonial history. Primitive people in the tropics still squat in groups around a pot of "poi" and dip their fingers in the common dish. But the general tendency of civilization is toward individuality and exclusiveness. "The old family tooth brush," if it ever existed except in ribald song, has gone to the dump.

The family bicycle of the early nineties led quickly to fleets of "bikes" of graduated sizes to fit parents and children of different stature. The automobile, to which the greater part of the population merely aspired for many years, because its cost seemed prohibitive, is now owned by one person in seven; families that enjoy a fair degree of prosperity have from two to five or more.

Radio is the lowest-priced of all the modern inventions that have started as luxuries and so quickly developed into necessities. It is time to abandon the obsolete idea, that one receiver is enough for a family.

The members of every family, even if there are but two persons in the household, have individual tastes. The newspaper publishers, whose rapid rise to wealth and power has been one of the marvels of this age of publicity, turned their financial corner when they realized this and began to provide women's pages for the feminine readers, sporting pages for athletic youths, and comics for the "kids" in addition to the news pages that sold the papers to the heads of families. There are hardly two persons in a family who would be equally interested in the same program at the same time; except when a Lindbergh or some other hero rouses the enthusiasm of the entire nation and attracts our attention from our ordinary trains of thought.

By ARMSTRONG PERRY

BOYS SHOULD HAVE THEIR OWN SETS

A few weeks ago a boy of ten asked me if I could tell him where to buy a radio receiver cheap. I directed him to a shop where two-tube sets, listed a few months ago at \$35, were selling at \$3.95. There is nothing against these bargain sets that manufacturers have sacrificed because of overproduction or to clear the way for new and better models. They are just as good as they

own room. He has more fun with it than he does with the 5-tube set in the living room; where somebody always insists on hearing a concert all through, instead of twirling the dials to see how many funny combinations can be made out of bits of programs. The rest of the family have more fun with the 5-tube set than they would if he did not have a separate outfit with which to try his experiments, too, so everybody is happy. He even carries his outfit to school for the science class to use.

One of the tragedies of childhood is



If the boy be given his own set to play with, the rest of the family will have more enjoyment from the large receiver. And the boy will be out of mischief and acquiring a useful part of his education

were when they were sealed in their cartons. This boy cheerfully spent \$11 of Dad's money for tubes, batteries and accessories so that he could have a receiver right in his

"Don't!" It is that, more often than the home itself, that boys run away from. They want to have their own things and use them in their own way. A few dollars invested in parts for a one-tube set, plus the wisdom to keep still until a youngster asks for advice, will hold a family together more effectually than the sternest hand that ever administered correction.

If the boy is a Scout—and he is likely to be because there are more than a million of them now—he certainly should have a portable receiver for picking up code signals. The sending and receiving of Morse code is a part of the routine work of every Scout. A single-circuit regenerative receiver is not particularly vicious in field work far from the congested sections; and it is possible to combine a receiver and a low-power transmitter in a light and inexpensive set operated with power from dry batteries.

RECEIVERS FOR TOTS

Even the smallest tots like to operate receivers adapted to their years. A crystal set, such as some savings banks provide free of charge for depositors, is almost indestructible and will answer the purpose. Some are sold as low as a dollar.

If the home is so far from a broadcast station that only a tube set will bring in any program, one can be made from a coil, condenser, rheostat, socket, tube, grid leak and condenser, batteries and phones. These parts can be mounted on a board in half an hour by anyone who can turn a thumbscrew

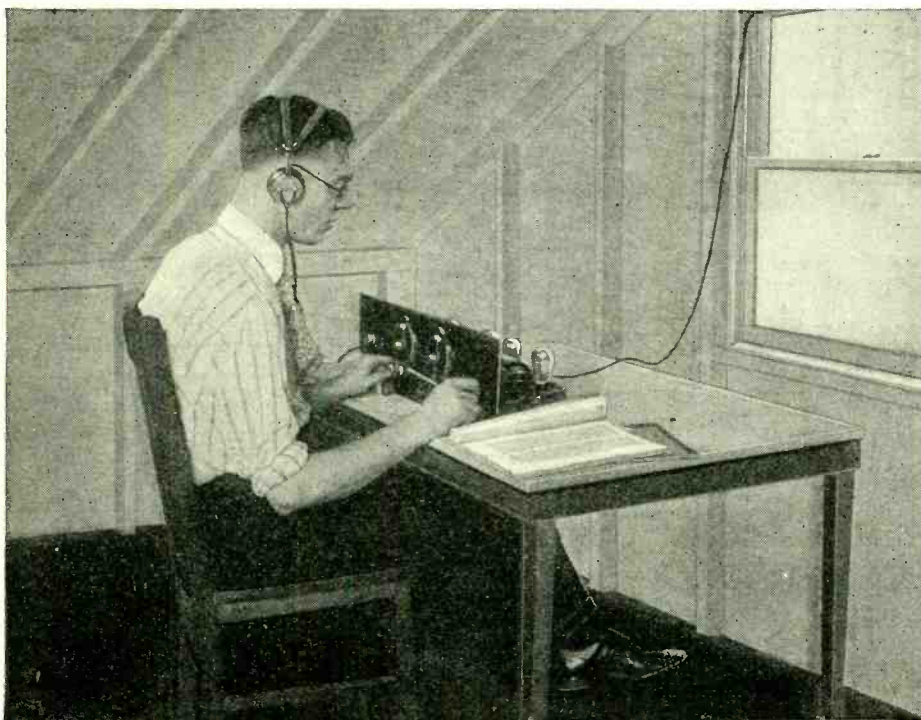

The more sedate son goes in for the newest circuits and tries for DX stations. His set would not be tolerated in the living room; but up in the attic he can enjoy himself to his heart's content.

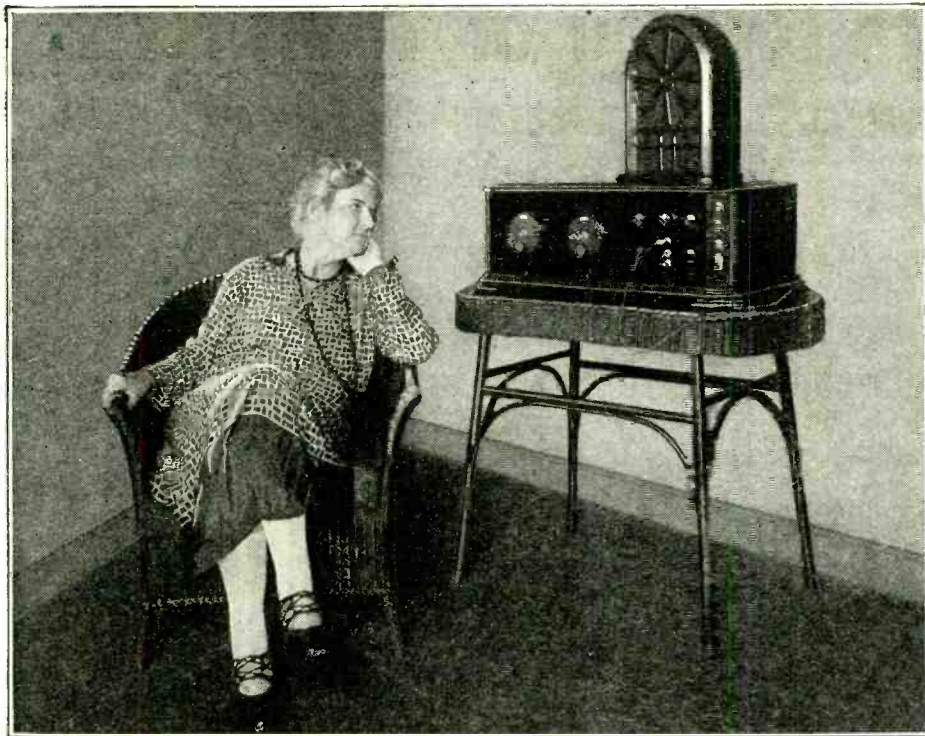

Older people sometimes prefer listening to sermons and songs of the past, instead of jazz and the snappy songs of the day.

and a screw driver. The set may become the center of attraction at parties where little Mary learns the gentle art of being a hostess.

No parent who ever witnessed the pride and joy developed by such a possession ever would let a child feel again the lack of confidence implied when Daddy locks the family set so the children cannot operate it. Daddy can lock his set without creating bitterness when the children have the same privilege with their own sets.

GRANDPA AND GRANDMA, TOO

Old people in the home often suffer more from sensitiveness than children. They too like to have their own radio receivers and use them without interfering with others or being interfered with. Of course, old folks are not what they used to be when we were young. At sixty many of them still are going strong, dancing, golfing, motoring, and enjoying life to the full. But "three score and ten" comes on apace, old friends drop out, physical weakness and loneliness oppress. The loud speaker, bellowing jazz by the hour to liven the feet of seventeen, often drives seventy to distraction.

Old folks sometimes like to get away where it is quiet and listen in for the old songs and the serious-minded lecturers. They like sermons better than young people do, because much to which they look ahead lies in that realm of mystery which only religion attempts to explain. No high-power horn or cone is needed to satisfy their longings. If their hearing is dulled, a pair of light phones that do not press too heavily upon the head may be better than a more expensive device. One to three tubes, one dial, a place and a set to call their own is what many of them want.

RADIO IS A GOOD NURSE

It is hardly necessary to suggest that shut-ins of any age should have radio receivers of their own. Radio has proven itself to be, not only a source of entertainment to persons confined to their beds, but also a potent therapeutic agent, keeping the mind in condition to speed recovery.

It is not enough to have another person bring in a program and let it run. What a sick person needs is the knowledge that there is at least one thing that he can do for himself. There is scarcely any exertion in operating a radio receiver. Even a very weak invalid can turn the dials for himself if they are placed in a convenient position, for example on a swinging table overhanging a bed.

An active man, temporarily laid up by a broken leg or some other disabling accident that does not deprive him of the use of

his hands, can ask for no better fun than to assemble a radio set. Many men dream of some far-off, elusive day when they can sit down with no immediate, pressing responsibilities and make radio receivers just as they want them. With such a task to take his attention, many a man would actually enjoy a period of confinement to his home; it would be almost as good as a vacation. Incidentally, it might make things very much easier for the rest of the family, if the things are true that the women tell about the tempers of men who have to stay at home a while.

RADIO FOIBLES FOR FLAPPERS

The debutante and the "sub-deb" have ideas of their own about radio. Usually they know little about it, technically, and care less; but a radio set is an article of furniture and, as such, is capable of artistic treatment as a chair or a dressing table.

In the primrose days of pulchritude the young lady seems to prefer furniture that is pink, blue, yellow or cerise, or whatever matches her complexion, eyes, hair, or clothes. A studious and constructive young man, who is outside the family looking in, might make a hit by presenting his lady love with a hand-made radio set with its cabinet unadorned. Together they might decorate it to suit her taste; and after a while redecorate it to match another gown or a new shade of complexion. As many and as attractive sketches, silhouettes and other decorations can be applied to radio cabinets as there are on lamp shades. Individuality can be expressed *ad lib*.

About the only kind of radio receiver that can keep up with some of the young folks who flit hither and yon, in an effort to be in several places at once and not miss anything, is a portable set. The young man of the family should be encouraged to build one, for there is so much more variety in radio programs than there is in a ukulele or a saxophone.

GUESTS APPRECIATE RADIO

Every guest room ought to have its own receiver. There are many folks who find it difficult to sleep in a new place for the first

(Continued on page 395)

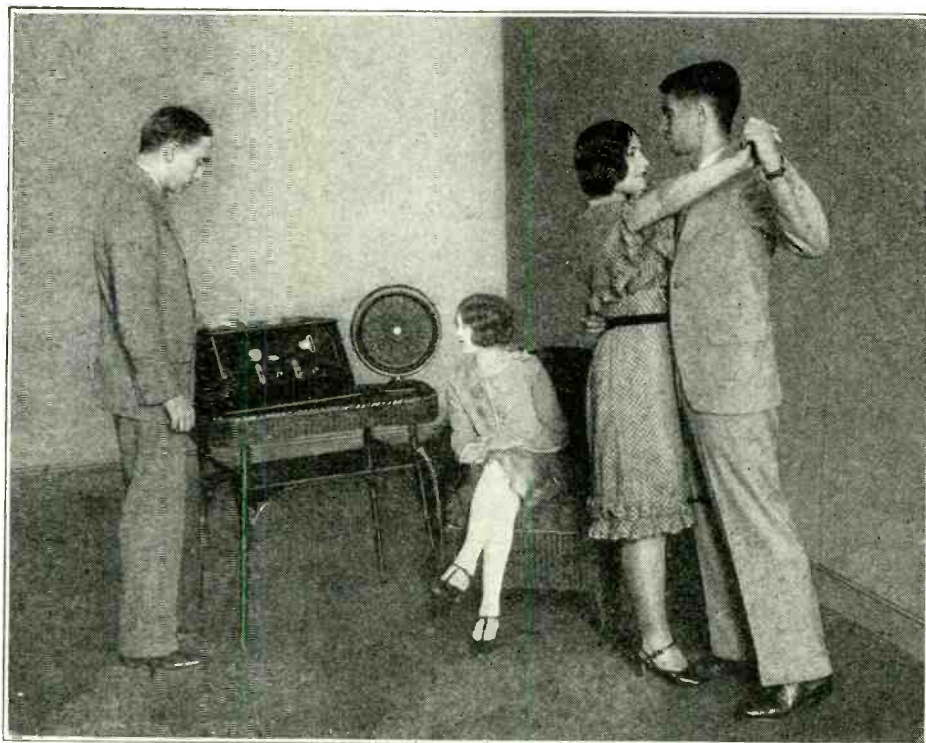

Often Father wants to listen-in when Miss Flapper wants to dance; and, if there is not more than one set, someone must be disappointed.

The Radio Beam Method of Transmission

THE history of the so-called "Radio Beam" system, now being employed by the British station located in southwest Cornwall for directional communication with Canada, dates back almost to the very inception of the art of wireless telegraphy. In fact, the modern application of this directive method of radio transmission may be quite properly termed a reappearance of an early-discovered phenomenon; which was never applied commercially, because of the lack of efficient equipment, or other practical drawbacks.

EARLY RESEARCHES

It is a matter of record that the German professor, Rudolf Heinrich Hertz, employed the beam or directive system of radio transmission as early as 1888; when he utilized a system of parabolic reflectors (see Fig. 3) which concentrated, into a narrow directional beam, waves in the order of only thirty centimeters in length.

It is also recorded in the British patent application of Guglielmo Marconi (dated June 2, 1896) that he utilized a wavelength of only ten inches in experiments incidental to the development of the beam system of radio transmission. It is also recorded in the same patent, with specific relation to the beam system, that: "When it is desired that the signal should only be sent in one direction, the oscillation producer is placed in the focus or focal line of a reflector, comprising a metallic sheet of brass or copper shaped to a parabolic form. (See Fig. 3.) This reflector is then directed towards the receiving station, which comprises a concave reflector with the receiver proper mounted in such position as to intercept the reflected ring of radiations which exists behind or before the focus of the reflector; and the receiver ought to be preferably tuned with the length of wave of the oscillation transmitted."

PERIOD OF DEVELOPMENT

Thus we see that the basic principles of the so-called modern radio beam method, as well as the now generally-used short waves, are old; both having been utilized by the earliest proponents of the art of radio. However, it is only proper to state that the development, leading eventually to commercial use of the combination of the two basic ideas, progressed steadily, if slowly, over the years intervening. The recorded achievements of Marconi, as well as the con-



This picture shows a very early model transmitter, invented by Marconi for short-wave beam-radio work.

© Herbert Photos, Inc.

By **LIEUT. H. F. BRECKEL**

ceptions of other noted radio inventors, in the field of directional radio transmission (among them being DeForest, Brown, Franklin, Braun and others) serve to exemplify the important benefits they believed would result from the commercial or military application of such a system.

Judging from results obtained and from records available, Marconi pursued his search for perfection and practical application aggressively and, ultimately, was successful. It is reported that he was successful, as early as 1907, in carrying out radio beam transmission between his station in Cornwall, England, and a squadron of naval vessels at anchor off Gibraltar in the Mediterranean; communication with one of the vessels being carried on without her consorts

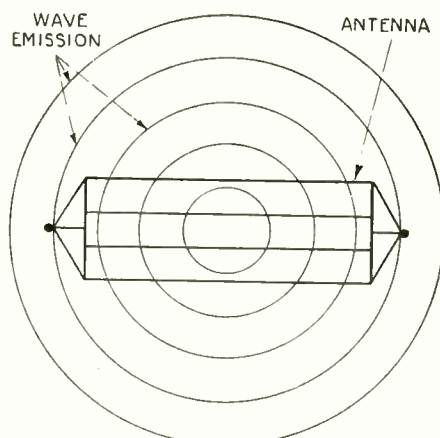

FIG. 1

The wave emission from an ordinary flat-top transmitting antenna. It spreads out in all directions, almost equally.

(although close at hand) being aware of it, the signals from Cornwall being focused in a narrow beam over the intervening miles upon the vessel's receptor device.

This feature would seem to possess certain strategical advantages to a naval force in the way of promoting secrecy and minimizing interference to its communications under certain conditions; such as attempted "jamming" on the part of an enemy force.

In the year 1923 Marconi predicted that "the radio beam system would bring about a somewhat revolutionary change from ordinary long-wave methods hitherto employed for radio communication between distant countries," this prediction being based apparently, on the practical advantages afforded through the utilization of such a system. Briefly considered these are:

HIGHER EFFICIENCY

- (1) The reduction of interference, whether direct or set up by harmonics, between stations; thus making it possible to operate in a given band of frequencies a greater number of stations. This is accomplished through propagation of the wave forces to their destination in a narrow beam rather than allowing them to spread out in all directions as with the ordinary method of radio transmission.
- (2) Greater economy in power consumption for a given distance, due to more effective utilization of the oscillatory energy, through the method of focus-

ing the major portion of it in the desired direction.

- (3) Due to the comparatively narrow zone traversed by the signals, the reception thereof is limited to such receptor stations as are located immediately in the plane of the propagation; thus affording an element of secrecy and privacy to the communicated intelligence. This is further augmented by the extremely high speed of transmission; which, being in the neighborhood of 200 words or more per minute, makes it practically impossible to copy the communicated intelligence except through the medium of elaborate, automatic recording apparatus.
- (4) Owing to the use of short waves by the system, it possesses the additional advantages of higher possible speed of transmission and reception, as compared to the ordinary methods employed for long-distance communication; as well as higher audibility of signal values at the receptor end for a given power input. Further, due to the greater volume of signal strength and the minimized interference due to atmospheric or static, communication can be maintained virtually without interruption. Traffic is thus speeded up, there being no reason for "repeats" or ceasing communication entirely until the atmosphere clears, so frequently the case where the ordinary systems are employed.

COMPARISON WITH BROADCAST METHODS

In effecting an elementary comparison of the broadcast system of radio transmission to the beam system, the former may be best illustrated by the ripples or waves formed on the surface of a pool of water when a stone is thrown into it. These travel over the entire area of a circle. In the case of a radio transmitter, the original energy contained in the antenna system is widely disseminated throughout space, only a very minor portion reaching any one particular reception point. The efficiency factor of such a system is very low, especially when it is desired to effect communication with only one point; whereas energy is propagated in all directions. This objection does not, of course, apply to broadcast stations or others desiring to reach the greatest number of receiving points for a given transmission.



Marconi's early model receiver for focusing the signals from beam transmission, designed by him in 1895.

© Herbert Photos, Inc.

In the radio beam system, however, the principle of propagation is different, in that the energy generated in the antenna system is concentrated and focused into a beam. This can be likened to the ray of a searchlight which concentrates all of the light emanating from a given source and propagates it in a given direction only. This focusing of the radio energy into a narrow beam of some 15° width results in an intensive propagation directly toward the receiving station with which it is desired to communicate, little or none taking place in other directions.

The efficiency factor of such a system is at once apparent and it is only necessary to mention that the strength of signals received from a beam transmitter is computed

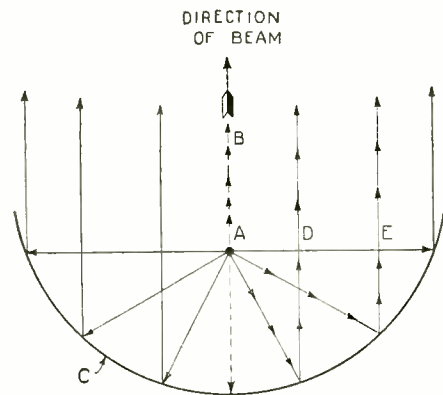

FIG 3
A is the focus of the reflector, C. The waves starting at A are reflected parallel to A-B, as indicated at D and E, thus being concentrated into a narrow beam.

to be some 24 times greater than that from the ordinary type of radio transmitter utilizing the same power input and wavelength and operating under the same atmospheric conditions.

TYPES OF ANTENNA

The essential difference between the broadcast and the radio beam methods lies merely in the antenna systems employed. The ordinary type of antenna normally employed is shown in Fig. 1; and functions, generally speaking, as set forth in the "stone and water" analogy.

The radio beam antenna system is shown in Fig. 2, and differs essentially from the ordinary type, as can be at once perceived. It comprises two distinct networks of vertically-suspended wires; one possessing the larger number of vertical units and being termed technically the "reflector," while the other has half as many vertical wires and is called the "radiator" or aerial.

The two units comprising the whole antenna system are spaced a quarter-wave-

length apart, by the horizontal cross-arms of the T-type masts employed for suspending them. Both the radiator and reflector wires are hung vertically from insulated horizontal wires, being sustained at even tension against swaying, etc., by means of a system of weights and balances. In the particular system employed by the British station at Bodmin (Cornwall) and the Canadian station at Yamachiche, it is recorded that some 32 wires are used for the radiating section of the transmitting antenna; each of these being divided into four half-wave sections connected through special inductances.

The reflector section is suspended in the rear of the radiating section, opposite to the desired direction of propagation, as also shown in Fig. 2. Each of the four tuned radiating sections comprising the unit is energized by means of feeders, of such inductive and capacitive values as to provide the proper degree of resonance between the various sections comprising the whole. The source of energy is in the form of a conventional vacuum-tube transmitter of the master oscillator-power amplifier type, of some twenty thousand watts power.

In regard to the functioning of the antenna system, it may be stated that the wave emission proceeds forward in the normal direction to be expected where a vertical antenna is utilized, as well as in the opposite direction. However, this rearward component of the emitted wave, instead of being allowed to dissipate itself by radiation to all points of the compass, is restrained or blocked from so doing by the network of reflector wires suspended in the rear of the radiating wires. The rearward component of the wave emission, upon encountering this reflector system, is deflected or re-radiated forward, opposite to its original direction, in the desired direction of propagation; thus re-enforcing the forward component of the wave emitted by the radiating system proper. This action is also depicted in Fig. 2.

RECEIVING REFLECTORS

For the reception of the transmitted radio beam, an antenna system of practically similar design is employed as the collector for the receiving apparatus. It is so located that the wires which correspond to the "radiating" section of the transmitter, and now become the "collector section" for actuating the receiver, face the plane of propagation of the beam emanating from the transmitter. In the rear of this collector section is suspended the reflector section, identical in construction to that employed for the transmitting antenna. The latter acts in much the same manner on the received energy; i.e., it intercepts an additional amount of energy from the propagated wave-front, reflecting it forward to the main collector sec-

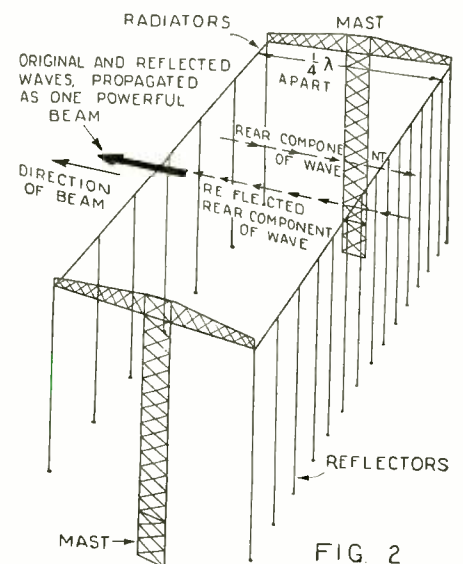

FIG 2
How the antenna system of a beam transmitter functions may be seen above.

tion, where it greatly augments the signal strength.

It has been stated that the energy collected at the receptor, by such an antenna system, is theoretically more than 100 times greater than that picked up by the conventional style of aerial, operating under identical conditions. There would seem to be no question of the numerous advantages accruing through the general use of the radio beam method of transmission on the part of military, naval and commercial radio telegraph systems; as well as in transoceanic and point-to-point radiotelephony systems where the elements of secrecy and consistent covering of distance without interference are even more important.

As applied to the art of radio broadcasting, the only real advantage of the radio beam system would be in the transmission of programs from a central source to distant points; say, for example, from one country to another, for re-broadcasting by the station through which the greatest number of listeners could be reached. In fact, the utilization of any other type of transmission than that radiating in all directions would defeat the purpose of the broadcasters, whose aim is to cover as much territory and distance as possible with a given power.

The development of the radio beam method of transmission, to the point where it is practically useful, constitutes one of the major contributions to the radio art in several years. Yet the art may be considered to be still in its infancy; for there is much that we do not understand of its puzzling phenomena, the solution of which will result in even greater progress.

Radio in Transoceanic Flight

THE recent flights of Commander Byrd across the Atlantic, and of Lieutenants Maitland and Hegeberger over the North Pacific from Oakland to Hawaii, have marked an epoch in the practical application of radio to aerial navigation. The very deficiencies in the working of the apparatus, reported at length in the press, though at the time they caused apprehension to the flyers and the multitudes on land who waited for news of their success, have been invaluable in their demonstration of the correctness of the principles involved, and the necessity for better facilities to make long-distance aviation as much a matter of routine as steamship travel is today.

A BLAZED AIRWAY

The radio-beacon system, developed by the U. S. Army and now under the special care

of the Bureau of Standards, has proved its absolute certainty over the distances covered along routes in the Eastern United States. As explained in the July, 1926, issue of RADIO NEWS, it comprises two stations, one at each end of the flyers' route. At each of these there are two automatic transmitters with aerial systems at right angles to each other; one sending continuously the Morse letter N (dash-dot) the other the letter A (dot-dash). So long as the plane's directional receiver is pointed directly at both, the two signals blend and form a continuous succession of letter Ts (plain dashes). But, should it swing from this course, immediately one letter or the other predominates; and the change of sound advises the pilot to correct his course.

This signal was lost by the flyers a short distance out of San Francisco by a temporary

trouble with their receiver; but that at the Hawaiian end was picked up nine hundred miles from the islands, where it indicated correctly a track but three miles wide and was followed to the landing place. Higher power and perhaps reserve receivers will make this system a successful one for long-distance flights between two airports. A refinement of it consists in substituting a visible signal—pilot lights of three colors—for the audible one. A model of this system is one of the sights on exhibition to visitors at the Bureau of Standards in Washington.

The Byrd plane, "America," was equipped with an automatic sending unit flashing continuously its call letters, WTW. This was operated by a small wind-driven turbine on the fuselage. In addition to this, there was the regular manual method of operating the
(Continued on page 421)



"This is Station WOODS"

How Various Forest Noises Can be Heard Through an A. F. Amplifier

By L. A. COLLINS



YOU have doubtless more than once taken a walk through a forest and listened in its comparative quiet to the characteristic sounds, such as the singing and scolding of birds, the myriad chirpings and hummings made by insects, the rustling of branches and the crackle of leaves. To those who are familiar with the causes and individualities of these forest noises, all this is perhaps an old story; but it seems possible that many more people do not realize the many wonders of wild life and that, if these were brought to their attention, the study would be an interesting one.

Annually the song of the nightingale is broadcast from a garden in Oxted, England, through one of the British radio stations, and eagerly awaited by thousands. When a program like this is put on the air there are countless difficulties to be overcome and no definite hour and date can be set, as the birds may not keep their appointment. Very few transmissions of this nature have been tried in the United States; but, if the experimenter wishes to branch out in a field of new endeavor, he should try the ideas outlined below.

It has been mentioned many times that, if the output of a microphone is connected to the input of the audio-frequency amplifier of an ordinary radio receiver of good quality

the sounds made in front of the microphone will be reproduced with great volume and fidelity through the loud speaker. The problem then resolves itself into preparing a microphone for outdoor use.

PREPARING THE STUDIO

It is unnecessary to have a special microphone but, of course, the more sensitive the instrument is, the better. An ordinary microphone, like that employed in the house telephone, can be used; such an instrument can be procured at a very small cost at any radio store. We will assume that the experimenter has a microphone of this type available. It is first necessary that the instrument be made weather proof. It

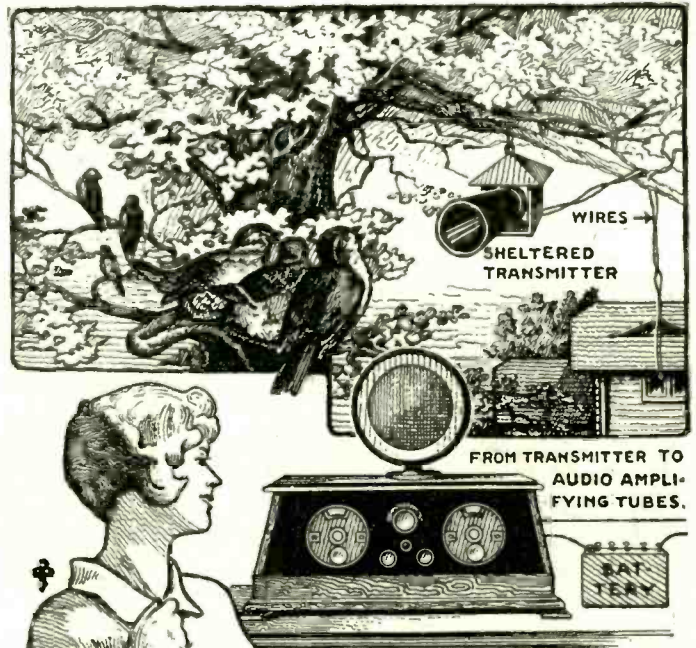

The transmitter in its shelter can be suspended from a limb of a tree, and the wires from it connected to the set.

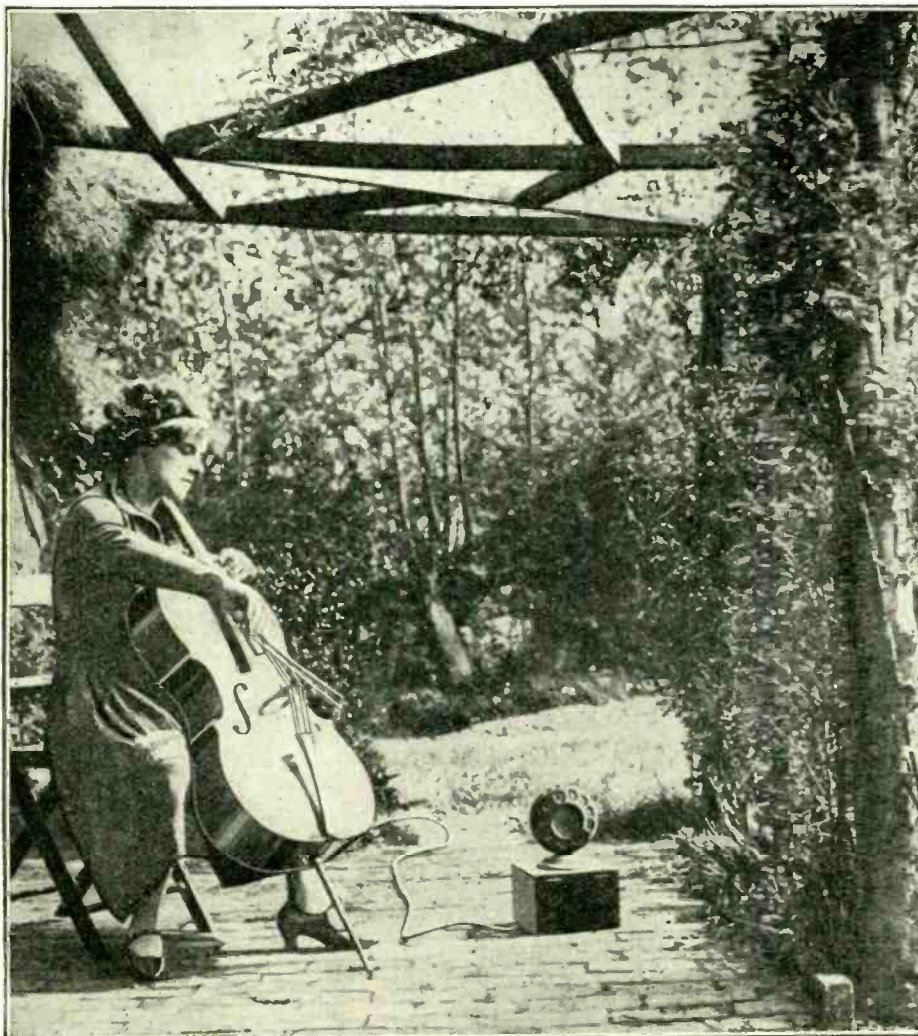

Enticing the nightingale to broadcast its song in an old English garden.

© Wide World.

might be said, in passing, that if the experimenter can get the use of such a microphone as is used in a broadcast-station studio, the results will be much improved; for this type is much more sensitive than the ordinary telephone transmitter.

A small wooden shelter can easily be constructed to fit around the microphone, as pictured in the accompanying sketch. Into the opening in one side of this shelter is fitted a small cardboard cone, behind which is the microphone. This cone acts as a collector for the various sounds which it is desired to reproduce, and greatly aids the effectiveness of the whole equipment. The wooden shelter should be painted, so that it will be watertight in case a sudden shower should occur before the apparatus can be removed from the open. The leads from the microphone should be run in as direct a line as possible to the receiving set, so that the losses will be as small as possible.

The question now arises, "Where shall the microphone be suspended or placed?" This of course will depend upon local conditions. However, if the experimenter is active, he can suspend the sheltered microphone in a tree wherein birds are wont to congregate. Or it might be the case that a vine clinging to a house nearby is the meeting place of feathered folk. Placing the instrument there is a simple matter. Again, if the experimenter lives in the country, he doubtless knows places frequented by pheasants, quails or partridges. Although these birds are far from being song birds, it is interesting to hear the noises they make.

PAYING THE ARTISTS

In order to get birds to perform, it may sometimes be necessary to give them some compensation; for birds in this respect are not unlike human beings. The microphone may be placed near a bird-house in a garden, or fastened securely in a fork of a tree,

(Continued on page 382)



Progress in the Radio Drama



The Audience as Well as the Actors Has Become More Experienced

ONE of the most striking evidences of the rapidity with which radio has developed can be found in the fact that, though broadcasting is little more than six years old, the listener seldom thinks of programs as still in the experimental stage. The adaptation of material and technique to the peculiar conditions of air presentation—a problem which might well have daunted the best talent—has proceeded so swiftly and smoothly that today what is, in many particulars, a new art stands established as regards accepted prac-

By CHARLES MAGEE
ADAMS

the part heard that the illusion created by simply hearing proves unconvincing; as, conversely, in the case of a first experience with the movies. But as more plays are heard, gradually, through the operation of natural psychological laws, the absence of the part seen becomes less and less of a

Next, there has been a marked improvement in transmission and reception during the last two or three years. This has, of course, proved an advantage to musical programs as well, by providing increased fidelity of reproduction. But the drama has benefited more peculiarly and to even a greater degree.

It stood in need of better technical facilities more than did the musical program; because, with transmitters and receivers of the type in use two or three years ago, the shortcomings of voice reproduction were more obvious, at least to the untrained ear. It is necessary to add that much is still to be desired in this condition, particularly with many popular-priced receivers and inferior transmitters.

A PSYCHOLOGICAL TASK

Further, to be successful, the drama must do more than reproduce, even faithfully, a series of notes and harmonics. It must create an illusion—a task considerably greater than that confronting the musician. So, every improvement in the transmission and reception making for distortionless reproduction of fine voice-shadings and the reduction of extraneous noise has made this goal easier of attainment.

This naturally suggests what has proved to be the most conspicuous technical fact that listener-experience with the drama has demonstrated—namely, that dramatic transmission and reception are most satisfactory over comparatively short distances.

On the face of things, given the same atmospheric conditions and excellence of equipment, drama should be as effective from a distant station as from one close by, just as in the case of music. But the purpose of drama, as against music, is to tell a story—weave a spell. Accordingly, any interruption such as static or fading, which would be insignificant to music, can well be fatal to drama by breaking the story's thread and destroying the illusion.

This would seem to indicate that the audience for drama is much more limited by distance than that for music; a contention which may or may not be supported by the

(Continued on page 376)

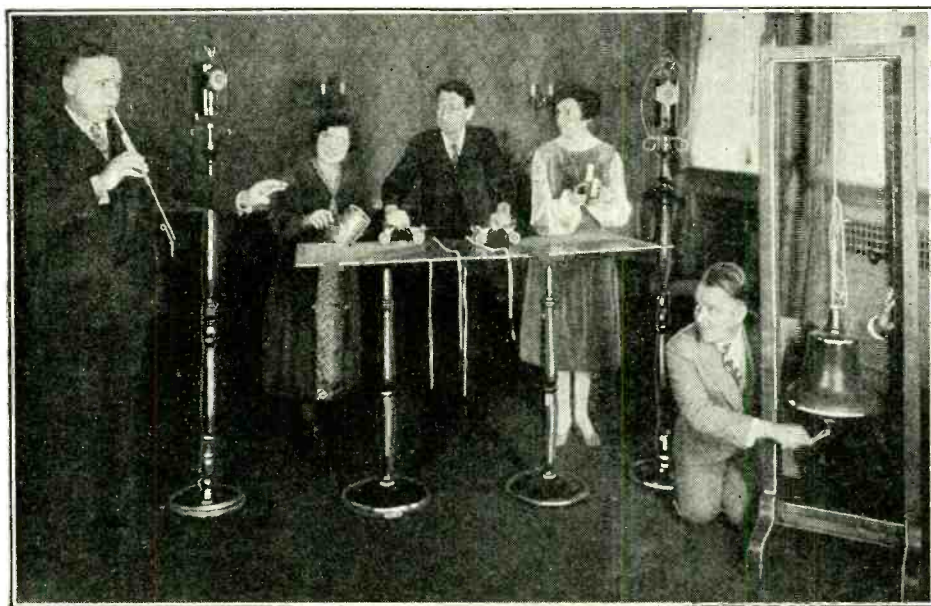

When it is necessary for the hero to save the beautiful maiden from the onrushing train, these people produce the train's noises.

tices and precedents; with one conspicuous exception—the radio drama.

Compared with other types of broadcast offerings, there can be no question that this is still in the experimental stage. Not only is its value disputed, between one school which sees in it a potential rival to the stage itself, and another which dismisses it as inconsequential; but practices and precedents are almost as varied as the stations and companies engaged in its presentation. Yet, in spite of all this, it is clear to any observant listener that the radio drama has made sufficient progress, particularly during the last two or three years, to justify further intensive effort and study on the part of those sponsoring it.

It seems to the writer that this progress has been due to two causes, other than technical and artistic improvement in the radio drama itself—of which more presently—and the first is the fact that the audience has become more accustomed to listening.

CULTIVATING THE IMAGINATION

This would seem to have scant bearing on the success of the broadcast drama; but examination proves that a fundamental, if somewhat subtle, bit of psychology is involved. Unlike a concert, which can be enjoyed as well with eyes closed, the audience both hears and sees a play in the theater, and sees far more of it than is generally realized. In fact, just how much of a play is seen cannot be appreciated till it becomes necessary to merely hear it, as in the case of the radio drama. Then the absence of the part seen at first throws such a heavy burden on

handicap and the part heard steadily more important; till simply hearing the play produces an illusion whose convincingness compares quite favorably with that of both seeing and hearing. This is the change which has been taking place in the audience, unconsciously, through the continued broadcasting of radio dramas.



The man at the right calls for help into the fiber waste basket, for he is drowning; and the rest of the people make noises like a gang-fight in a water-front shed.

Photos by courtesy of General Electric Co.



The Magic Loud Speaker

Some Mystifying Tricks With a Radio Set and How to Do Them



THEY darkened the room and turned on one bright light directly over the magician and the large, mahogany table. We sat in the shadows wondering what the glasses, that tricky-looking loudspeaker and the radio set would do next. Finally, the tall gentleman with the gleaming shirt and butterfly tie arranged several minor details on the table, clinked some glasses against one another, and ran a long wire across the top of the table and into his radio set. Then he spoke.

"Ladies and gentlemen," he began; his dark eyes sparkled and his stiff shirt showed to better advantage; "I have recently discovered some of the long-lost secrets of nature which have been bottled-up for centuries and which had never been brought to light. For instance, certain chemicals, when dissolved in water, have the peculiar property of absorbing energy from passing waves radiated from broadcast transmitters. It is unbelievable that this phenomenon has so long lain dormant; think of the tremendous possibilities that await the experimenter in these liquids!

"I have succeeded, with a certain rare salt for example, in storing-up a complete broadcast program and later, sometimes as much as a year later, actually reproducing the entire program by incorporating a vessel containing this salt in an ordinary radio-reception apparatus. These salts offer such astonishing possibilities and reproduce such beautiful programs, (of course, free from all traces of distortion) that I have arrived at the conclusion it would be a real treat, for those assembled here, to witness a demonstration of these properties."

THE MYSTIC BOTTLES

He leaned over the glasses and we all watched. His hair was parted in the exact center and glistened, as now he adjusted this thing and then he adjusted that. A bottle was noisily uncorked and a reddish liquid found its way into some of the glasses. He held up one of these in his hand.

"Gentlemen," he continued, "I have always been a total abstainer, but the color of this liquid is suggestive of better days. However, the chemical contained herein has the peculiar property of which I spoke.

"Here before me I have a deep vessel containing an ordinary salt solution. . . . Say, you little fellow, here, in front here, come taste. . . . Not too much; it is a rather concentrated solution. . . . Pretty salty, eh?

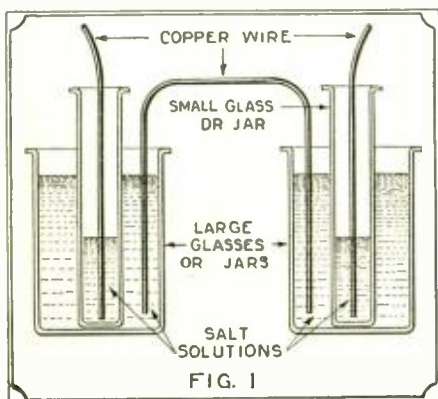

The arrangement of the jars forming the condensers, in series with each other, and in parallel with the main tuning condenser of the set.

By A. BINNEWEG, Jr.

"Into this vessel I shall place these two glasses, both containing some of the mysterious chemical. An ordinary copper wire dips into both glasses, and other leads are connected to the loud speaker. There is another secret connected with these fluids which I discovered. Of course, one must construct the apparatus so that only one frequency is absorbed; otherwise there would be non-selective absorption and all music programs would be absorbed and only a jumble of unintelligible sounds could be drawn from the



"Nothing mysterious about this arrangement, you see; only glasses, salt solution and a length of wire."

solutions. By placing this coil of wire across the two leads from the vessels, only the desired station is selected, as you shall see.

"Nothing mysterious about this arrangement, you see; only glasses, salt solution and a length of wire. Of course, the chemicals are peculiar, but they are easily handled. I shall give you a demonstration of these wonderful properties."

SELECTING A PROGRAM

He placed a dangling wire into the salt solution and the loudest and clearest program we had ever heard rendered over KZOO, issued from the nearby loudspeaker. The peculiar method he employed astonished us.

"By using vari-colored chemicals and selecting the desired amounts, I can bring in other stations."

This time he poured blue liquid into one glass and put yellow into the other. The proportions were evidently critical for he used a small measuring-glass to secure the right amounts.

"Now we shall bring in WREK in New York."

Several wires were adjusted and the same wire was again dipped into the vessel containing the salt solution, this time on the opposite side. Station WREK was broadcasting boxing returns from the ringside.

Some little fellow in front asked our entertainer to hold the program as he wanted

the results. His request was complied with.

"The different combinations of these solutions that are possible are almost limitless, and any program broadcast may be selected. The apparatus is really simple, too; would members of the audience care to inspect it?"

HOW IT WAS DONE

I knew Tom wanted to see the stuff, as he was habitually curious and always sat in front. He told me afterwards that as far as he could see, the magician was right; only a few wires, some colored solutions and thick drinking-glasses had comprised his equipment. We were curious but it didn't do us any good.

A close friend of the magician, some time later, however, did tell us how the tricks were performed and we were surprised at the really simple principles involved. Anyone can easily do these tricks.

The glasses and associated equipment formed a condenser. The coil was but a few turns of insulated wire. It was not actually connected electrically to the condensers, its insulated ends being merely wrapped around the wires in the jar. It lends a mystifying air to the apparatus, but otherwise performs no electrical function. The salt solution, which is conducting, acted as one of the condenser "plates" and the solution in the glasses served as the other. The walls of the glasses served as the dielectric and each vessel, with its glass, was thus a condenser. Because of the comparatively high capacity caused by the glass insulation, two of these "condensers" were connected in series. (See Fig. 1.)

Fig. 2 shows how the jars are connected in a set using one condenser for tuning. It will be seen that the condensers formed by the jars act as a "vernier" in shunt with the regular variable condenser employed in the radio receiver itself. Simply run two flexible wires (separate wires, not double-twisted lamp cord) to the terminals of the condenser, and then set the latter about ten degrees lower than usual for any particular station. By pouring salt solution into the inner glasses, you can then determine just how much liquid is necessary to produce the additional capacity effect to tune the receiver circuit to resonance for that station.

Obviously, this scheme can be applied with greatest effectiveness to a receiver using only a single variable condenser for tuning. If the set employs two or three tuned stages, it will be necessary, of course, to use a jar (or a pair) for each of the two or three condensers, respectively. This means but little extra work, and the trick becomes even more interesting than before.

(Continued on page 393)

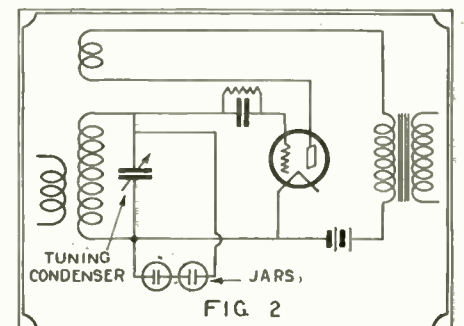

The circuit diagram, showing how the jar condensers are connected to the set. As their capacity is increased by pouring in liquid, the wavelength to which the receiver is tuned increases.



Radio News of the Month



THE PERILS OF HAMMING

"HAMS," the amateurs who embody radio enthusiasm to the nth degree, have occasionally complained of the lack of friendliness on the part of their neighbors and of the regulatory authorities in America; but the American "ham" has a bed of spineless roses, compared with his brethren elsewhere, as shown by the pages of *QST*. It is announced that a Japanese amateur has been licensed; but four more were fined 50 yen each for working without a license which could not be obtained. In China, as in Estonia, amateur radio is prohibited: there are amateurs, but confrères in foreign countries who hear their "sigs" must send acknowledgments under sealed covers, through third parties, to prevent the authorities from detecting them. Needless to say, the amateur who would look with disapproval on evaders of the laws where they are reasonable, sympathizes with pluckers of forbidden fruit. So the magazine dismisses a message from "A Dutch station, who, in giving his reply message in the recent international (amateur) test, said, 'Here no transmitter. Dutch amateurs not being licensed,'" with the simple comment, "Suppose it must have been two other fellows."

RADIO DURING THE ECLIPSE

OBSERVERS during the English total eclipse in June noted, as was the case in America two years ago, that signals received became stronger just before totality, and lessened with the return of light. With short waves, however, marked fading in reception of the 30-meter station PCJJ in Holland was observed; this phenomenon is attributed to the effect of the shadow of the moon on the Heavside layer altering suddenly the angle of reflection of these short waves, and thereby changing their skip-distance. With directional loops, a marked sudden change in the apparent bearing of stations being received was noted; an effect similar to a much slower one noticed during normal twilight.

THE SWIMMER'S COMPANION

OFTEN, in the past year or so of swimming contests, music has been used to sustain the human fish in their trials of endurance. The German champion, Otto Kaemmerich, recently acquired a swimming cap equipped with headphones, which was tested successfully in the North Sea on a program from Hamburg, over a hundred miles away.

RADIO IN BULGARIA

SOFIA, the capital of Bulgaria, is to be equipped with two radio stations, one to reach as far as London, (1350 miles), by code; and one for phone transmission as far as Vienna (600 miles). In addition to this, it is stated that the government is about to license the use of private receiving sets, hitherto forbidden; so that another market for apparatus is opened.

SOCKET COLOR SCHEME

A SUGGESTED standard for future design covering the color of vacuum-tube sockets, which has been adopted by the Radio Division of the National Electrical Manufacturers' Association reads: "The colors for vacuum-tube sockets in receiving sets shall be as follows: For general-purpose tubes—dark red; for special detector tubes—green; for audio power tubes—orange." This proposal is to enable rapid identification of sockets in all sets.

RADIO AND LIGHTNING

DURING a recent thunderstorm in Middlesbrough (England) four houses were struck by lightning and badly damaged. When the matter was reported to the Middlesbrough housing committee it was stated that the houses were situated in an area thick with wireless aerials and were about the only four not equipped.—*Amateur Wireless*.

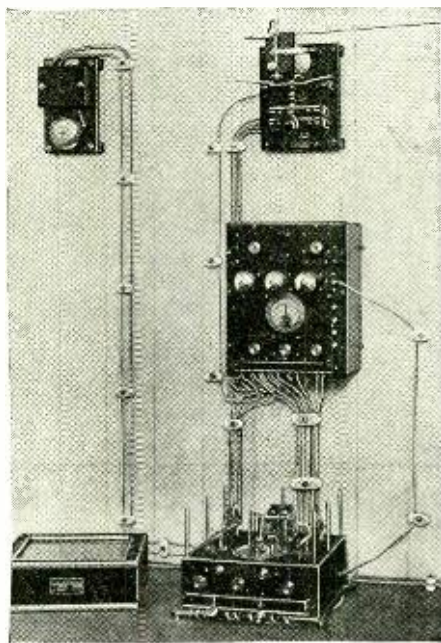

This radio receiver automatically sets off the alarm gong whenever an "SOS" on 600 meters is received, thus making it unnecessary to keep an operator listening in. This type is being installed on many British ships.

© Herbert Photos

A ROYAL "MIKE"

WHEN King George V of Great Britain broadcasts, a special microphone is brought out. This instrument, reserved for the royal use, is covered with silver wire and bears the Lion and the Unicorn in gold. Intrinsically, it is said to be the most valuable in the world.

LENGTHENING RADIO CHAINS

THE vogue of network broadcasting is shown by the fact that nearly every event of nation-wide interest brings a new record. The Lindbergh reception at Washington sent out by 50 transmitters, and the Dempsey-Sharkey match with 51 are to be eclipsed, it is predicted, at the fourth annual dinner of the Radio Industries in New York on Sept. 21. On this occasion perhaps a hundred stations will transmit the program of the evening.

A RADIO HUNTING PARTY

A BRITISH radio club, the Golders Green and Hendon Radio Society, recently conducted a very successful hide-and-seek competition for its members. The club's short-wave transmitter was operated on 150 meters in a concealed location; and ten parties of members, each in a motor car with a loop receiver, a map and compass, started from as many points a few miles apart and endeavored to find the transmitter. Only one was successful; though a second came very close.

RADIO ADVERTISING REGULATION

WHILE there is a demand, in some quarters, for less censorship of political speeches over the radio, there is an increasing demand in others for more of it, applied to advertising. The federal radio commission has refused to take the position that it should ban direct advertising from the air, as some interests ask; but the federal trade commission, which is authorized to inquire into "unfair trade practices," has challenged one radio advertiser to prove the truth of his statements—just as it might do if they were made by mail, or through word of mouth by his salesmen. The criticism in this case does not apply to the medium. The advertising club of Des Moines, Iowa, has memorialized the radio commission, also, to rule that all advertising messages must be reduced to writing, before delivery into the microphone, in the exact form in which they are to be given. Generally speaking, it may be said that broadcasters, like publishers, will find it necessary for their own interests to insist upon "truth in advertising" through their medium, if it is to maintain its investment value.

"RADIO TREATMENTS"

A RADIO inspector was recently called upon to investigate reports of "broadcasting electromagnetic radio treatment waves" at Roanoke, Va. The doctor, a devotee of the electronic school, explained the theory that his apparatus "cut up the waves in sufficient lengths to kill diseases" and disseminated them among the population; and claimed that, with a sufficiently powerful apparatus, he could treat the whole state. The inspector found only a "haywire" broadcast receiver, the "transmission" being apparently from an X-ray machine which was causing some local interference. When the proposition that radio waves are either helpful or injurious to the human organism is advanced, it is only necessary to remember that no sensations or effects of either kind are felt by those who are constantly employed around the most powerful transmitters, where the magnetic fields are very intense.

BOMBS BROADCAST POORLY

RECENTLY, before broadcasting the play "R. U. R.," in which a violent explosion figures, the London station 2LO tested its apparatus. The noisemaker caused real "blasting," for the current demand was too great and the safety-fuse of the transmitter operated. So this radio-dramatic effect had to be toned down for presentation.

ANESTHETIC RADIO

IN the Alfred Hospital, Melbourne (Australia) an elaborate installation of individual radio equipment is used by the medical staff as an important adjunct of their work. Beside each bed is a wall plug and headphones; patients are encouraged to go to sleep with the phones on their heads, and after they have fallen asleep, nurses remove the headpieces. Especial care is taken to insure that patients on the eve of an operation are thus lulled to sleep, in order that they may gather strength; and the anesthetizing and operating rooms are similarly equipped. This installation was largely contributed by the public and the radio industry, the postal electricians' union performing the wiring gratis.

(Continued on page 374)

Radio News of the Month Illustrated

By GEORGE WALL

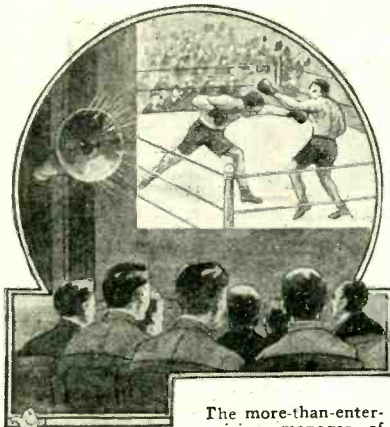

The more-than-enterprising manager of a movie theatre "up York State" advertised that pictures of the Dempsey-Sharkey fight would be received by radio. The broadcast of the fight was received in the usual manner; but, in lieu of television apparatus, the wily manager showed bits of old films of the Dempsey-Gibbons encounter. It does not appear from the report how many of the audience detected the trick.



From time immemorial, the story-teller of the East has been a picturesque feature in public places, entertaining an audience who had no books or newspapers. Now, with the introduction of broadcasting in Turkey, shops and baths have installed radio sets; and the aggrieved story-tellers have appealed to the government for protection against this competition.

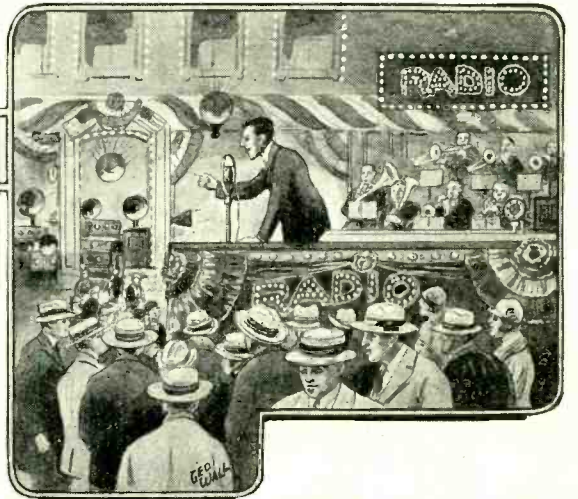

Cortlandt Street, in Downtown New York, is "Radio Row." Around its intersection with Greenwich Street, for blocks, radio stores are gathered thickly, and their speakers assail the air. The week before the Radio World's Fair in this city, the dealers of this neighborhood will hold a "block party." Special displays, the presence of radio stars in person, a beauty contest, and many other attractions will be offered to entertain the public and stimulate interest in radio's latest developments.

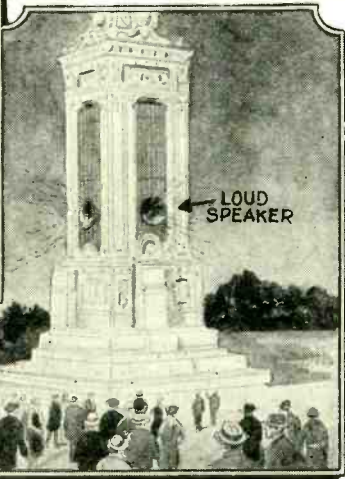

Above is a 225-foot loud-speaker cabinet. At any rate, the Tower of Jewels at the recent Ohio-Cleveland industrial exposition was used for the purpose, as shown. This handsome structure, illuminated day and night by concealed reflectors, was the central unit of the exposition grounds.

Below are indicated the arrangements of a real "radio hook-up." A young couple in a small town in Virginia were married to the strains of music whose performers were on the Gay White Way of New York. The program was relayed through Washington, which is the newly-weds' local broadcast centre.

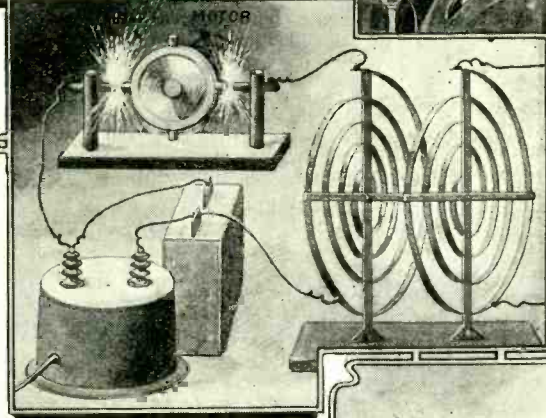
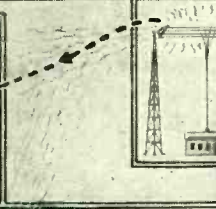

A prominent California promoter owns his own broadcast station. As a result of disagreement between himself and former associates over a deal, he determined to take his case to the public via radio, and announced a series of talks explaining his position. As soon as he started, it is reported, simultaneous interference began from an unknown source. The listeners heard only noise, from possibly some such outfit as this. Causing wilful interference with radio is an offense which renders the perpetrator liable to imprisonment and \$5,000 fine.

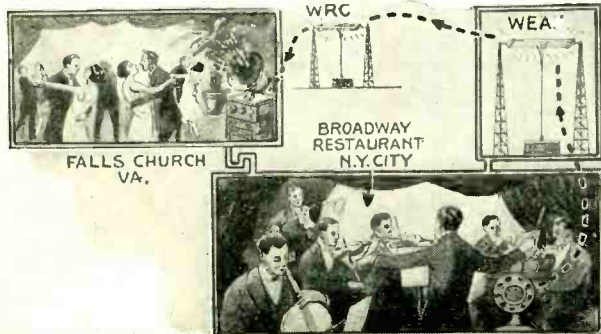
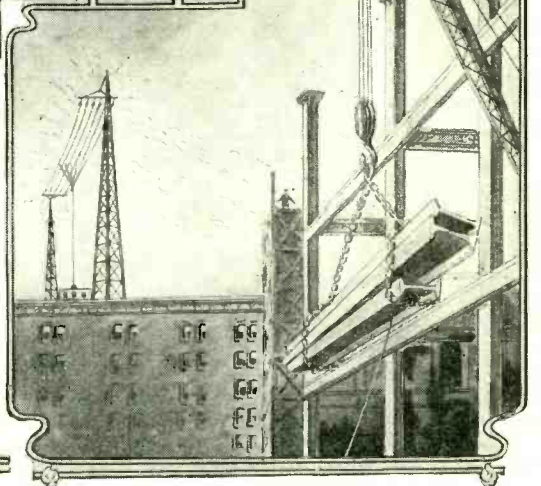

One of the greatest technical problems now confronting the broadcasters of the country is that of regulating their carrier-wave to the required frequency. As the emitted wave is governed by the inductance and the capacity in the antenna circuit, anything which affects the capacity of the aerial to ground affects the emission. For instance, as illustrated above, a large steel building was being erected near a Pittsburgh station. Every time a load of steel beams went up—thus affecting the aerial's capacity—a listener-in with a sensitive test could observe a fading effect and change of wave-length. Another broadcaster, whose transmitter is on the sea shore, informed the radio commission that he had traced a change of wave-length to the fact that the rise and fall of the tide altered the effective height of his aerial. Even standard-frequency stations, by whose transmissions a home-made wavemeter may be calibrated, have shown variations exceeding the regulation half-kilocycle allowed by the radio commission, according to measurements by inspectors. The problem is being solved by the use of automatic "piezo-electric" regulators, built around pieces of quartz ground to a size which permits them to vibrate only at the fundamental frequency of the transmitter.

New Experimental 100-Kilowatt Transmitter at Schenectady

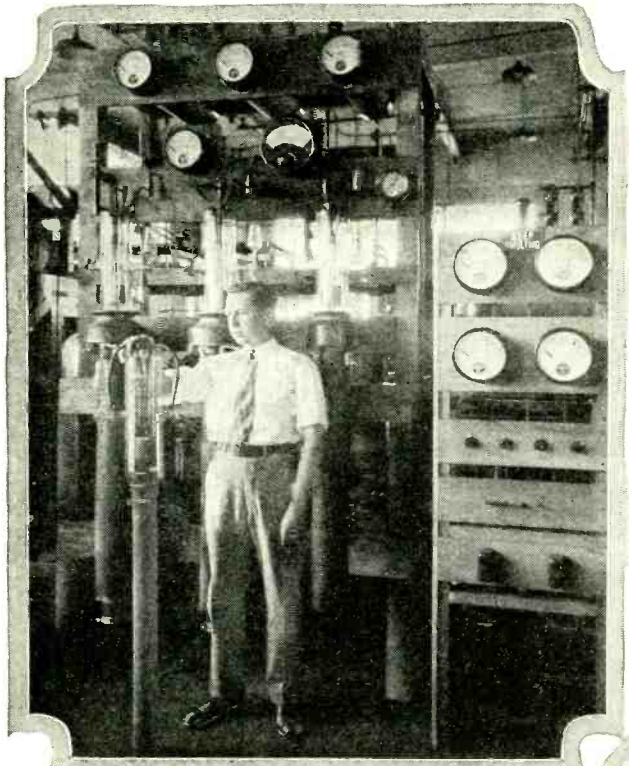

Above is shown one of the operators holding a 100 kw. transmitting tube, which has been removed from its water-cooling jacket. The anode (plate) of these tubes is of copper and approximately three feet long by $3\frac{3}{4}$ inches in diameter. For filament heating the tube needs 210 amperes at 33 volts, two of these tubes being normally operated in parallel. They work into a "tank" circuit, which is inductively coupled to the antenna by means of coupling coils and a transmission line.

Photos by courtesy of General Electric Co.

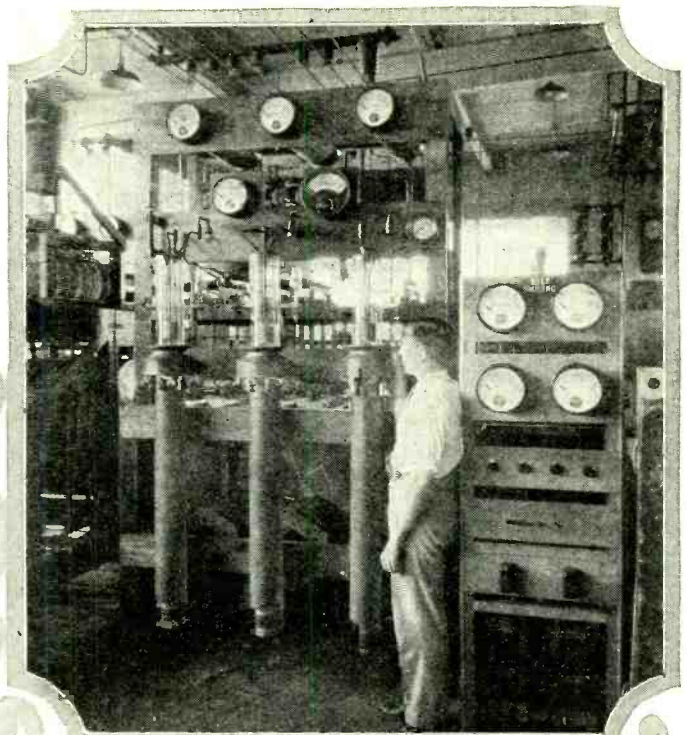

For the first time in the history of radio broadcasting a power of 100 kw. was modulated and put into the antenna, at midnight on August 4 in the transmitting laboratories of the General Electric Company at South Schenectady, N. Y. Five of the 100-kw. transmitting tubes, described in the June, 1927, issue of RADIO NEWS, are used in this powerful transmitter, which occupies less than half the space needed for the 50-kw. set. Two of these giant tubes are used in the amplifier and three are required for the modulator. The former two, with a "spare" beside them, are shown above.

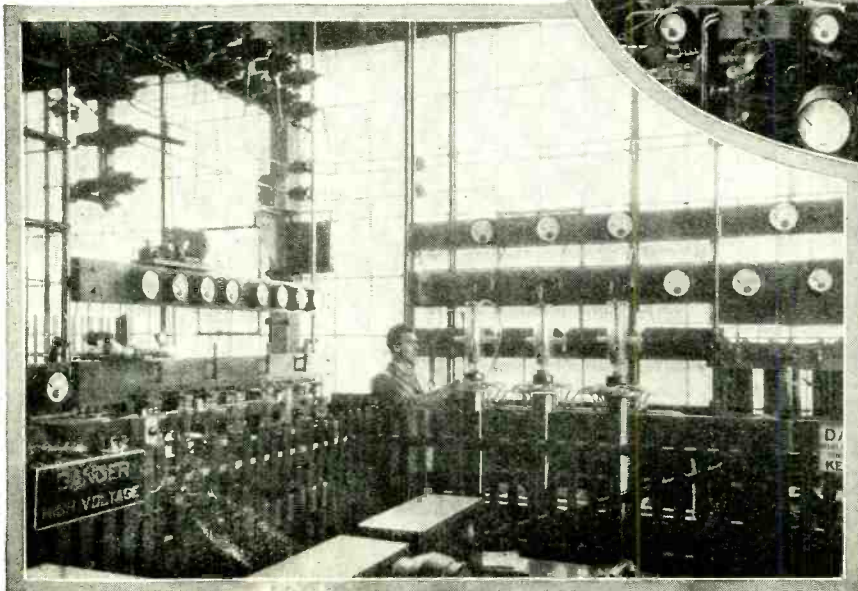
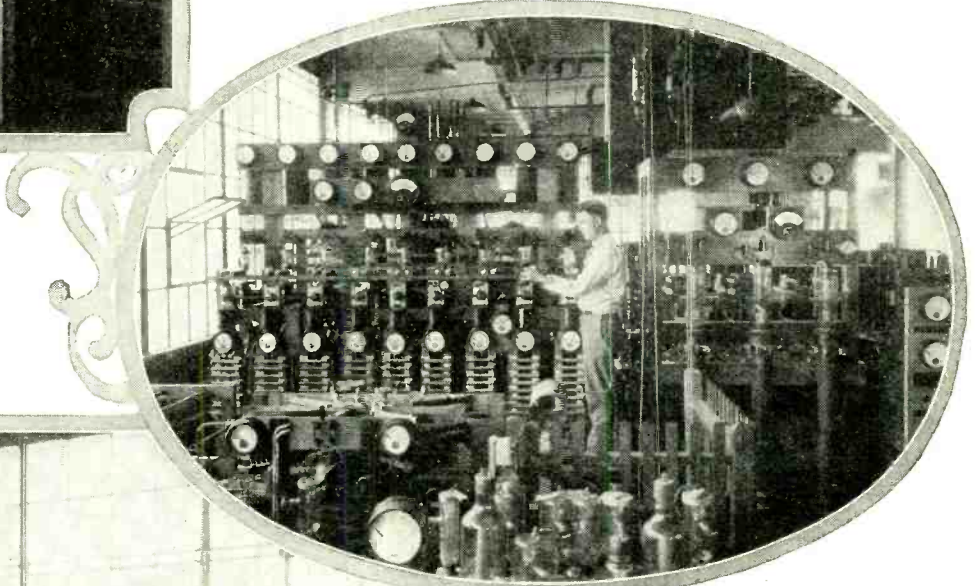

Above at the left is shown the 50-kilowatt transmitter of WGY. and at the right may be seen the new 100-kw. set. The 50-kw. set, which up to the present has been operating on 30 kw. in accordance with the ruling of the Radio Commission, has nine 20-kw. tubes, two of them "spares." A cage antenna two feet in diameter and 240 feet high, and a radial-wire counterpoise, 240 feet in diameter, are used. The 100-kw. experimental transmitter operates on exactly the same frequency, 790 kilocycles, and a quartz crystal is used to maintain this uniform. In the illustration at the left may be seen a section of the 50-kw. modulator unit and, at its right, the 100-kw. tubes used in the super-power transmitter. Because of the great amount of power employed, safety devices of all kinds are installed, so that the operators are perfectly protected at all times. Protective devices shut off the power in case a tube fails and the operator is automatically warned if the cooling water fails. Reports show that high quality was maintained, indicating remarkable control of the enormous power used.



Listen, My Children—By ROBERT FRANCIS SMITH



Shakey Helps the Master Do His Stuff

APRIL showers bring May flowers—also wet feet, sticky clothes, colds, and radio reception that kids you into believing a station in the next block is Shanghai. It's one of those humid afternoons, about five-thirty, and I'm trying to get at least Chicago, and can't even raise WRNY, right here at Brightmere-on-the-Deep, Long Island. However, I does raise KAIN, to such a vocal extent that the connubial anchor peeks in from the kitchen and capitalizes on my temper.

"Is muzzer's boy angry?" she coos, like a blues singer minus static: "Is hims cross?"

For my part, I can stand baby talk from babies—infantile ones—and that ends it. I slam down the cans and emanate a few watts towards the pots-and-pans deadfall.

"Virtue ain't even its own reward," I yelp: "Cross, my eye! Why shouldn't I be cross? I've behaved myself all day, and nobody's got any reason to wanta ground my aerial, yet, with a prize supper program from Chi due on at five, all I can corral is a lousy ten-watt plaything across the Island that's giving a lecture on how to swim the English Channel, by the Mother's League? I'm asking you?"

Doris pokes her bob back into view. "Well you needn't broadcast all over the scale," she snaps, her natural, good-hearted self. "Can I help it if it's raining? Why don't you try something easy—like stopping an express train with a lath fence?"

Small solace here, so I gets up, weary. It's Sunday, and we've guests invited to dinner, which means I've gotta put on my tie and coat. It's supposed to be our day of rest—we being Joe Hammerstein and Doris Darling, deft artists with the pedal digits, now playing in the *Inanities*, on Broadway, the street of wise guys and shell games. But all the rest I get is when I can dodge some trick labor Doris' got laid out for me and skip over to The Master's.

Our millionaire neighbor, Gerard Lawson—The Master to us—is a scientist, no fooling. He lays particular stress on radio, and what it don't lay onto him at times is a caution. Jerry's young, brunette, as determined as a congressional candidate on his first baby-kissing tour, and our devoted pal. Today I can't alibi over to his joint, because

he's coming to the feed, along with others of our intimate gang.

About six The Master shows up, and shortly in comes Mrs. Maxwell, with Doc, her hubby, dutifully in tow. Doc Maxwell is our local pill-prescribing genius, also a radio hound, and not so dumb, either. Soon the bunch from town heaves in—Tap Jones and his bride, Mildred LeRoy, of the *Inanities*, with a surprise for us all in the form of Jim and Mabel McKenna, with the one and only Shakey.

For the benefit of the newcomers, the last-mentioned individual is an English crow, billed as Shakespeare, the Bird of Avon. Shakey has a split tongue and a startling ability at mimicry—he can repeat anything anybody in the audience calls out. That's his theatrical specialty, but in private the bird also has a double-entendre line that's usually fresh and always fast. Once, a couple years ago, Shakey accidentally put one over on The Master, and Jerry's never fully forgiven the bird for it, although it wasn't the fault of anyone in particular.

Shakey's been away over a year, touring Australia, South Africa and Europe, but he remembers us right away.

"Hello, Joe!" he caws. "How's the ankles?"

"Loose, old timer," I replies, grinning.

The bird was once booked on the same vaudeville bills with us for thirty-four weeks, so he oughta know us; but he's only seen The Master once or twice, and I'm surprised that the crow remembers Jerry's ventriloquial fiasco.

"Well, well!" chirps Shakey, eyeing Jerry closely. "The voice! The voice! Listen, my children—"

The Master colors, but grins feebly. "How do you do, Shakey?" he greets.

So we dine—Doris having been able to brush up on the culinary art since we've been near enough to a stove to describe one—and everybody fills up, congenial. The small talk continues until I've helped clear the table, when we all flop into the front room to argue.

It's radio from then on, since Tap and Mildred have a set, and Jim finally succumbed to a portable in Sydney and hasn't been the same since he heard Frisco from

Singapore, so static flies fast. All are in things except Jerry, who seldom busts into our bush-league DX affairs except to correct misinformation or render a solution. But after an hour or so, during which Jim explains the marvels he worked with his suitcase outfit, Doc throws the red flag to Jerry.

"Well, what's new tonight, Jerry?" he inquires. This is the regular opening speech, and presages something to think about.

The Master don't speak for a moment. Then he shakes his head, slow and uncertain.

"With my work? Oh, nothing material. Several theories—my weather control is progressing—but beyond that, no tangible gains."

He lapses back into silence, but we see that something is worrying him. Shortly, I come out cold turkey.

"You seem troubled, Jerry. What's the matter—somebody short-circuit your new tubes?"

"No, no," mutters Jerry. Then he sits up and looks at us direct: "It's not radio, Joe," he states. "As a matter of fact, I'm afraid it isn't even scientific, but it bothers me."

"New heavy underwear?" inquires Jim, sympathetic.

"No," replies Jerry, not getting the point—personally, I don't think he heard it. The Master's sense of humor is small, but there are limits, still—"but it comes largely under the heading of show business, and I thought you'd be interested."

"Yea, bo!" puts in Jim.

"I'll probably make myself appear idiotic if I speak of it, but I can't get it off my mind."

"Details, please," I request. The others nod, their curiosity aroused. The Master's ideas may not always navigate properly, but they invariably cut a lot of foam while they float.

"It happened last night," begins The Master: "I was over in Newark, visiting a friend in a hospital, and as I was coming home my attention was drawn to a theatre sign. I decided to pass the remainder of the evening there. Perhaps I didn't exhibit much discretion in my choice of quality entertainment—you call it 'small-time' vaudeville, I think—but I went in, for a particular reason."

We nod, all ears.

"This reason was due to the billing of a certain performer. His name was Gourdin—know of him?"

He's a stranger to us. "Small-time, all right," says I: "Go on."

"Gourdin, it stated, was a mind reader. Not a fortune teller, nor a magician, but a pure telepathist. Naturally, I am skeptical. I don't think I've ever told you before, but magic is a hobby of mine, in all its phases, particularly those in which abnormal mentality is stressed. I didn't expect to see anything unusual, but I did."

"Yes?"

Jerry continues: "Indeed, yes. To begin with, the man worked with but one assistant. Gourdin seemed to be an Oriental of some kind, to judge by outward appearances—The Master has been wised up a lot since he took to running backstage at the *Inanities*—and the girl, he said, was his daughter.

"Immediately upon making his entrance, Gourdin requested a committee to come up and blindfold him thoroughly, using bandage rolls and adhesive tape. I volunteered as one of the committee, and I am positive that after we had finished Gourdin could not see.

"While blindfolding him, I took close note

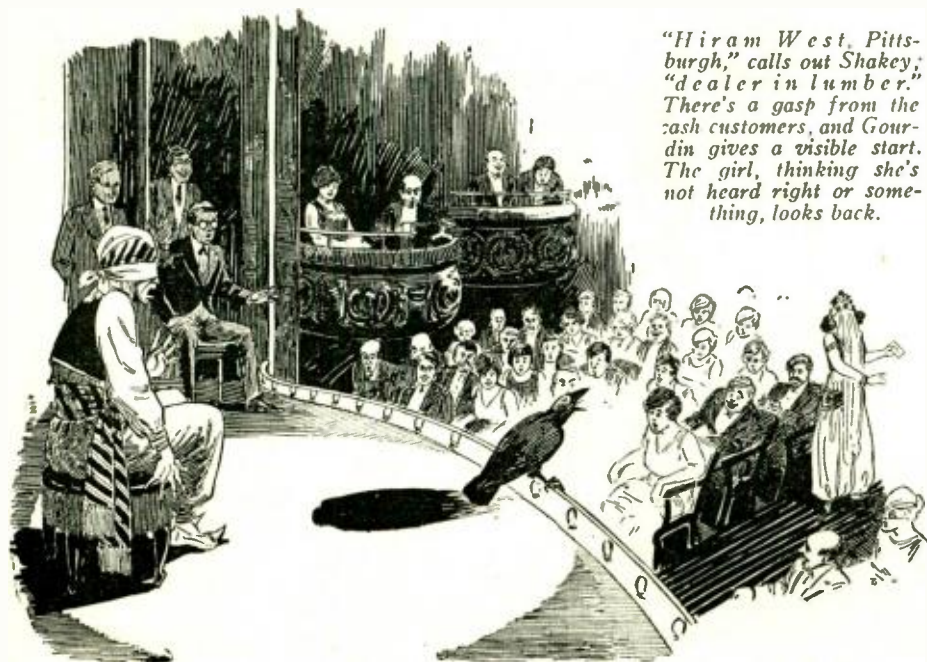

"Hiram West, Pittsburgh," calls out Shakey; dealer in lumber." There's a gasp from the cash customers, and Gourdin gives a visible start. The girl, thinking she's not heard right or something, looks back.

of the floor to preclude any electrical contacts with the chair. To make sure, I moved the chair several inches from where it had been left by the stage hands. Also, though I fear I offended Gourdin slightly, I insisted upon feeling about his person to ascertain the presence of any material radio equipment in his clothing. I am fairly satisfied that there was none. Then the act commenced, with one committee member on the stage to apprehend any information that might be whispered from behind the drop. I was that member."

"I'm pained that I missed seeing The Master on the rostrum, because he has an ideal stage presence. A coupla seasons ago Jerry teased himself into doing a scientific act in vaudeville, and went over so big The Master thought he was being kidded and quit cold.

"Gourdin's act," continues Jerry, "was one of the most remarkable telepathic demonstrations I have ever seen. Professing to be Turkish, Gourdin had his daughter dressed in harem fashion, with long heavy garments and a thick veil over the lower half of her face.

"In operation, Gourdin sat, almost rigid, in his chair on the stage. The girl went up the aisles, viewed objects presented by the audience, and Gourdin did his stuff. The girl did not speak a word at any time, nor make any significant gestures—though the latter would have been useless, in consideration of Gourdin's being blindfolded—and yet, with uncanny accuracy, he described each article shown to the girl. These objects covered a wide range, numbering one or two which would never be counted on as being in the normal possession of anyone in a vaudeville theatre. One man, evidently a physician, opened his case and asked the telepathist to describe the paraphernalia. Doctor Maxwell can vouch for the mass of heterogeneous medical equipment such kits usually afford, yet the man read off the entire contents, including inscriptions on bottles and the names of most of the instruments.

"We have all seen trick acts where the signals were given by subtle arrangements of words. 'What's this?' meant pencil; 'What is this?' signified a fountain pen; 'What have

I here?' indicated a watch, and so on. The system in cases like that is highly elaborate, even if only the most common objects are covered, let alone having codes for things like a stethoscope.

"I cannot but be convinced that there was some clever trickery connected with the demonstration, yet in his claims Gourdin was most conservative. He explained that he could not read anybody's mind, but only that of his daughter. At the outset of the performance, seasoned vaudeville goers probably would anticipate another 'code' act; those at the Newark theatre were surprised greatly when it became apparent that the girl was not to speak. Telepathy, of course, is possible—it often occurs inadvertently—but a definite system of mind reading, even between two individuals, is open to high criticism."

We're silent for a spell. Then Doc Maxwell speaks.

"I'd like to see that act," he says, slowly.

I hop up and grab a copy of the *Billboard*. "Lessee," say I, hunting up a column: "Gourdin—um—oh, yes—first half of this week, Paterson, last half Jersey City."

Personally, I'm more interested in the thing than I care to admit, since anything that can fool The Master has gotta be good. The others seems sorta wondering, too.

"I shall be occupied until Wednesday or so," states The Master: "But would any of you care to come with me—say, on Friday?"

"Make it the matinee, and yes," I agree: "I've gotta be behind the footlights myself at eight, and so do Doris and Tap and Mildred."

"Count me in," says Doc Maxwell. "Me too," carols Jim. "I gotta open week and a free mind."

Shakey, who's been feigning boredom, pulls his head from his wings and eyes us sleepily.

"What about the meal-ticket?" he caws. "Don't I get a swipe at this bozo?"

"Shakespeare!" reprimands Mabel.

"Remember your grammar!"

"Sorry," says Shakey. "Hi, ho, the merrie-o."

That fowl's perception, audible and optical, is a marvel. I puts in a word for him.

"Aw, Jim, take Shakey along," I pleads. "He's been in worse dumps."

"Bright boy," grunts Jim. "How'm I gonna get this baby into the audience—ask me, willya?"

I grins. "Why confuse yourself in an audience?" I demands. "Go where you'll feel homey—backstage with Pop Logan, the manager, and chin with the gang. You can take it all in from the wings."

It ain't been so many years since Jim and Mabel were tickled cerise to play these honky-tonks; so they both agree to pile over to Jersey City with us Friday afternoon. Tap and Mildred are in it, too, and we all promises to dig up crazy things to try to stump Gourdin with.

Friday rolls in, and the bunch meets in Jersey City and goes to the show shop *en masse*. Jim and Shakey slip backstage, and the rest of us get seats in a row, with The Master on the aisle and me next to him.

The feature picture is on at the moment, and we watch with trepidation the hero rescue the heroine from the burning building. The news reel is next, and the parade of the Elks' Lodge in Bushwa, Kansas, is a striking bit of master photography. Then the show proper sets in.

Time-tried acrobats open, not so rotten, nor so wonderful. In the deuce comes a song-and-dance team, mixed, worrying along with a coupla old pop numbers and steps that were antique when I began my original milk diet. The third spot draws a sketch, very sketchy. And fourth on a six-act bill is Gourdin.

I look him over careful but, if I've ever lamped him before, I ain't hep to where, when nor why. He's a small, swarthy gink, with a permanent smile and very white teeth. At the call for a committee Jerry

(Continued on page 390)

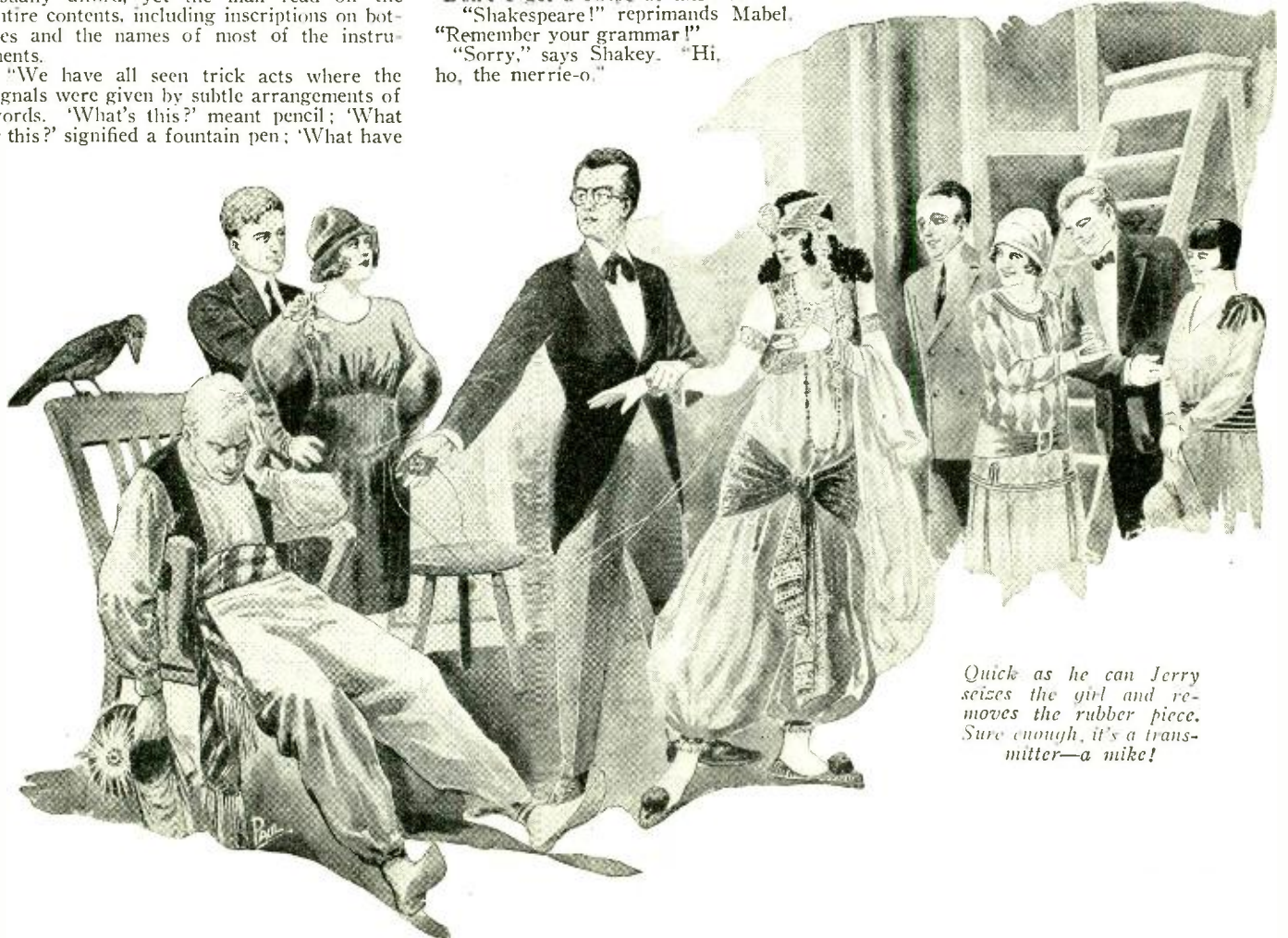

Quick as he can Jerry seizes the girl and removes the rubber piece. Sure enough, it's a transmitter—a mike!

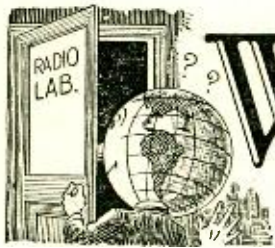

What's New in Radio



NINE-TUBE "SUPER" USES FOUR I. F. AMPLIFIER STAGES

THE numerous refinements, which have been made in the physical conceptions of the justly famous superheterodyne circuit, are well exemplified in the "Nine in Line" receiver, which is illustrated on this page. This set employs the "super" hook-up in more or less fundamental form, but the design of the individual parts and the nature of the mechanical layout attract attention because of their unusual features.

The receiver shown herewith is not a factory product, but was assembled from parts which are available in convenient prepared

vide unprecedented sensitivity. Two of these are sharply tuned, to provide a degree of selectivity even greater than that of the average good superheterodyne.

The intermediate-frequency amplifier consists of an untuned input transformer (T1), followed by another untuned transformer (T2) in the second stage. Next is a tuned transformer (T3), then one untuned (T4) in the fourth stage; this is followed by another, tuned (T5). Each of the untuned transformers passes a wide band of frequencies, their function being to provide coupling which will result in a high degree of amplification. However, selectivity cannot be neglected, and it is for this purpose that the

amplification, and followed this with a second tuned stage, for greater selectivity.

Another feature which tends to increase sensitivity is the inclusion of regeneration in the circuit of the first detector (VT1). It is a known fact that regeneration, at broadcast frequencies, is approximately the equivalent of a stage of tuned-radio-frequency amplification. Therefore, by including regeneration in the circuit of the first detector, the effect of an additional amplifier stage is obtained.

The input and frequency-changer circuits are not unusual. The broadcast-signal energy picked up by the loop antenna is applied to the grid of the first detector tube, VT1. The regeneration in this circuit is provided by the center-tapped loop and controlled by the midget variable condenser, C3. In the lead from the loop to the grid of the first detector, a small coil is inserted; and this coil is coupled to the tuned circuit of the oscillator, VT2. Through this coupling medium a locally-generated frequency is also impressed on the first detector. This latter frequency is, of course, that to which the oscillator circuit is tuned. The output of the detector tube is therefore a composite of the two impressed frequencies. An incoming signal of any frequency can be changed to any other predetermined frequency by simply varying the frequency of the local oscillator. In this particular case it is desired to have the detector output correspond in frequency to that to which the intermediate amplifier is tuned. This is accomplished by tuning the detector input circuit, by means of the condenser C1, to the wavelength of the broadcast station to which it is desired to listen, and then adjusting the oscillator tuning condenser to a frequency which will combine with the incoming signal frequency to form a third, equal to that to which the intermediate amplifier is tuned.

The two variable condensers C1 and C2 are therefore the only tuning controls for the entire receiver. The principle of frequency changing as described may sound complicated, but in tuning this principle may be forgotten and tuning accomplished in the same manner as with any two-control re-

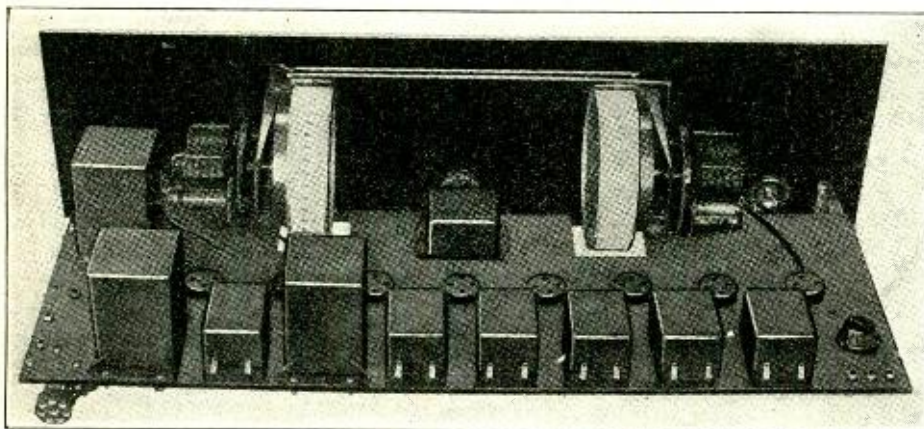

Rear view of the nine-tube superheterodyne. The various radio and audio-frequency transformers and oscillator coils are aligned evenly along the back edge of the sub-panel. The two white cylinders are the indicating scales of the condenser-control drums.
Illustrations courtesy High Frequency Laboratories

form. Any radio fan desirous of making a set like it can do so at home with ordinary hand tools. If he follows the complete plans and instructions that accompany the parts, he will have an instrument second to none in the requirements of general selectivity, sensitivity and quality.

An unusual feature of this receiver is the fact that it makes use of four stages of intermediate-frequency amplification to pro-

tuned transformers are included. The broad band of frequencies passed by the untuned transformers is applied to the stage which contains the first tuned transformer. Because of the effect of this sharply-tuned transformer, the output of this stage is in the form of a narrow frequency band. Wishing to go even further than this, the designers of this receiver added another untuned intermediate stage for the sake of additional

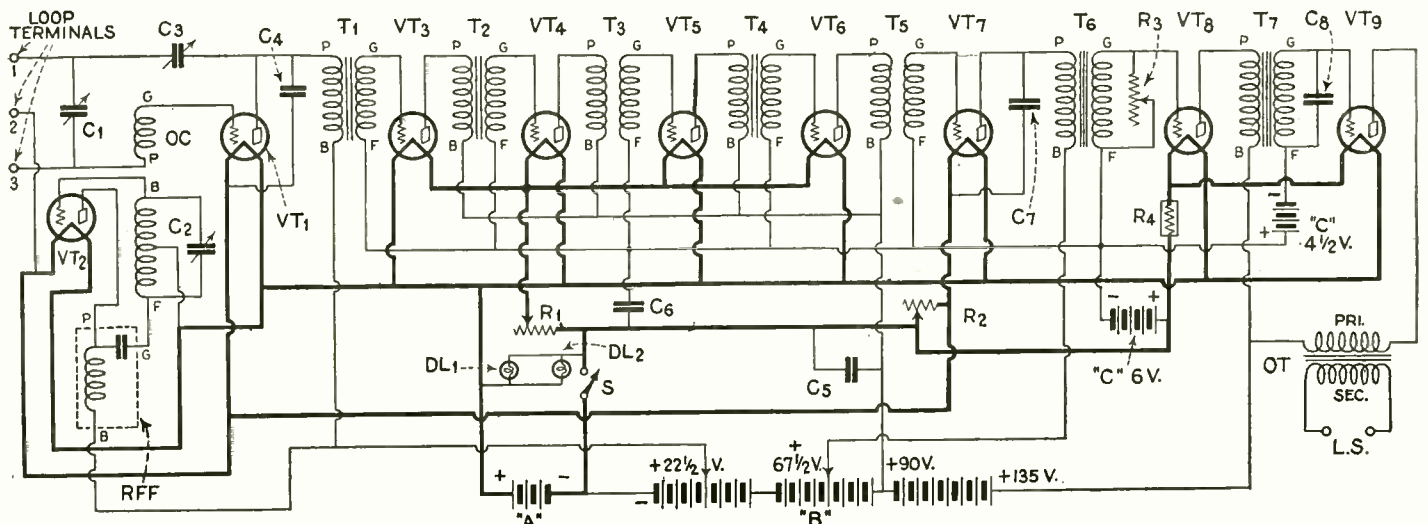

Complete schematic hook-up of the 9-in-line "super". C1, main tuning condenser; C2, oscillator condenser; C3, regeneration control; VT1, first detector; VT2, oscillator; OC, oscillator coupler; RFF, R.F.

choke unit; T1 to T5, intermediate-frequency transformers; VT3 to VT6, I.F. amplifier tubes; VT7, second detector; T6, T7, A.F. transformers; VT8, VT9, A.F. amplifier tubes; OT, output transformer; DL1, DL2 dial lights; R3, volume control.



Panel view of the nine-tube superheterodyne, showing the simple but pleasing appearance of the receiver.

ceiver. For all ordinary reception the regeneration control condenser C3 may be set at zero and left that way. The only time it is used is when it is desired to tune in some very distant station; in which case it can be moved up until the detector circuit is just below the oscillating point.

After the signal passes through the intermediate amplifier it is impressed on the grid of the second detector, VT7, and then passes on through the two-stage audio-frequency amplifier.

The "Nine in Line" receiver employs eight tubes of the 201A type and either a 112- or a 171-type in the last audio stage.

The entire receiver, in spite of its nine tubes, requires less connection wire than many three-tube receivers. The grid and plate leads are all short and direct and there is little chance for the constructor to make serious errors.

ATTRACTIVE CONE SPEAKER

IN the description of a cone speaker using a rigid metal framework, printed on page 221 of the September number of RADIO NEWS, the back of the instrument was incorrectly designated as the front, and the front as the back. Another illustration, showing the true front of the speaker with its covering of wine-colored silk, is printed herewith so that readers may recognize the reproducer as it appears ready for service. In the illustration previously shown the silk covering was not visible, having been removed (before the photograph was taken) to expose the actual working unit ordinarily concealed by it.

Just below the center of the speaker, and protruding through the silk cover, is a small adjusting rod, marked S in the illustration, by means of which the speaker is adjusted for best results. Once the proper setting has been found, this rod is left untouched.

This new cone speaker, which stands approximately 15 inches high and is 13 inches in diameter, is the junior model of a line of four speakers noted for their excellence of reproduction. All the models employ a balanced-armature actuating unit, which is ruggedly constructed and utilizes four powerful permanent magnets capable of lifting a ten-pound weight. These magnets are angu-



This is the actual front of the cone speaker. The letter S indicates the adjusting screw.

Illustration courtesy Bondette Mfg. Co.

larly spaced and carefully balanced with a minimum of air gap. Exceptional volume, with a wholly natural tone, is the result.

The other three speakers manufactured by the same firm are the senior model, which is 18 inches high, 16 in diameter and octagonal in shape; the wall model, which is equipped with a heavy suspension cord and decorative tassel and otherwise is identical with the senior model; and the floor-standard design, which is mounted on an upright base similar to a piano or floor lamp. The supporting frame of each model is finished in semi-gloss mahogany, with base to match, and is practically unbreakable. The base is provided with heavy felt pads, so that it cannot mar the surface of furniture, while the back of the cone itself is protected by metal arms integral with the frame.

"A-B" SOCKET-POWER UNIT IS NEAT AND COMPACT

A COMPLETE "A" and "B" socket-power unit, capable of operating practically any radio receiver of from one to ten tubes, directly from an alternating-current lamp socket, has been brought out by a Wisconsin manufacturer. The device is exceptionally neat and compact, occupying little more room than is required by many storage batteries alone. The steel containing case is finished in an unobtrusive brown color, and over all is twelve inches long, eight wide and ten high. To install the instrument the radio set owner need only screw the attachment plug with which it is supplied into the nearest lamp socket or base receptacle, and then connect the "A" and "B" wires of his set to the binding posts provided for them on the terminal board inside the case.

This power-supply device, on the "A" side (which supplies the current that lights the filaments of the radio tubes), employs a glass-jar storage battery which is charged during periods of radio-set idleness by an automatically-controlled, integral charging unit. Power is supplied to the radio receiver from the battery only; the A.C. house line is automatically shut off from the filament circuit during operation of the set.

The charger incorporated in the unit is not of the "trickle" type, but of considerably heavier current capacity. It is automatically turned on when the radio set is turned off; and the charging continues until the battery has been fully replenished. When the cells attain a condition of full charge the charger is automatically cut out of the circuit. A high initial charging rate is used, with a gradual tapering off in value as the battery voltage is built up. This arrangement is consistent with good battery practice.

The glass jar of the "A" battery being fully transparent, the user is able to observe the condition of the cells at all times; convenient observation windows for the purpose are cut in the side of the steel containing cabinet. Two colored balls which float in the electrolyte act as a form of hydrometer indicator, and simplify the checking of the battery's condition of charge or discharge.

A new feature introduced in this combination "A" and "B" unit is a special emergency switch, used only for reconditioning the battery after the latter has stood idle for a considerable length of time. Under normal operation conditions, a double-acting automatic relay switch operates the charger, this switch being actuated in its first stages of operation by the voltage of the battery lead to the tube filaments. However, if the bat-



The "A-B" power unit with the top removed. A is the rectifier for the battery charger; B, the six-volt storage battery; BU, the "B" supply section; I, glass side of the battery jar through which the indicator balls may be viewed.

tery is left standing idle over a period of months, with resultant weakening of the cells, the automatic relay is supplemented by the manual emergency switch. If this switch is turned on, the battery will be soon recharged and the former automatic operation then continues.

The "B" section of the combination power unit is of more or less familiar appearance, involving the use of the usual step-up transformer, gaseous-tube rectifier, filter condensers and choke coils. Among its distinctive features is a hook-up which prevents the common "motor-boating" trouble.

NEW STABILIZING SCHEME IN SIX-TUBE RECEIVER

A NEW six-tube receiver, embodying a number of interesting features in its electrical design and mechanical construction, has been brought out by one of the largest radio firms in the United States. Its circuit diagram and several illustrations showing its general appearance are given on the next page.

The set is supplied in two types, one for operation with battery tubes of the 201A type, and the other for use with the new alternating-current bulbs. With the first model, the owner may use a storage "A" battery and dry or storage "B" batteries, or the same "A" battery and a "B" socket-power unit, or any of the numerous and convenient "A-B" socket-power units now on the market. With the second model, the "A" power is supplied by the house-lighting current, which is stepped down to the proper voltage by a small and simple transformer; a "B" supply unit of some kind is also necessary for the plate circuits.

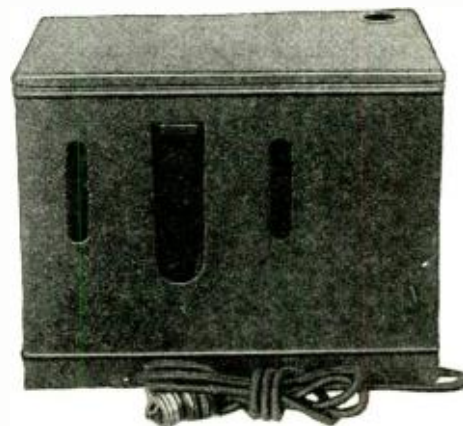

The complete socket-power unit as it appears ready for service. The level of the electrolyte in the cells may be observed through the slots in the metal case.

Illustrations courtesy Briggs & Stratton Corp.

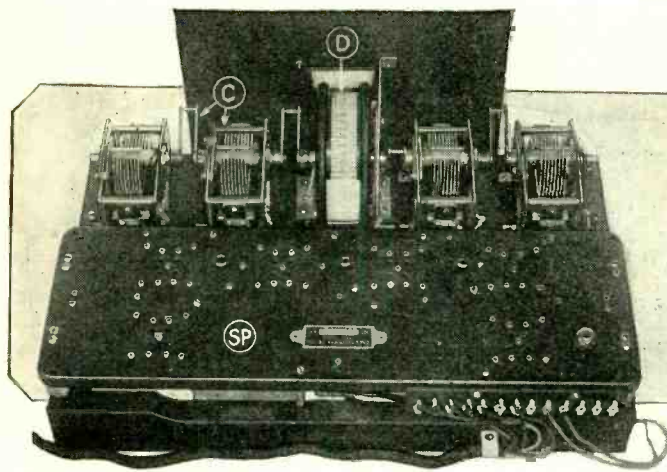

Rear view of the receiver chassis: D, scale of the drum control; C, four-gang condenser controlled by the drum; SP, the metal sub-panel on which the tubes are mounted.

Illustrations courtesy Chas. Freshman, Inc.

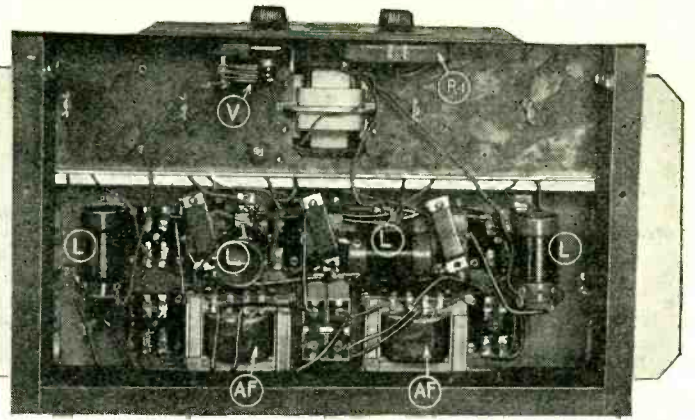

Under side of the chassis, showing the arrangement of the various R.F. and A.F. components: V, "vernier" condenser; R1, rheostat for the R.F. tubes; L, R.F. transformers; AF, A.F. transformers.

The use of these new A.C. tubes does not obviate the need for a separate "B" unit of some kind, as some readers might think. The tubes use alternating-current only for heating their filaments, thus doing away with an "A" supply; but they require pure direct current ("B" supply) for their plates, just as do all other three-element receiving tubes.

As will be evident from the circuit diagram, this new six-tube set uses three stages of tuned radio-frequency amplification, a non-regenerative detector, and two stages of straight transformer-coupled audio amplification. A rather unusual stabilizing arrangement, involving a small variable condenser and a tapped resistor connected in the primary circuits of each R.F. transformer, insures the receiver against oscillation in the R.F. circuits, which is fatal to good quality of reception and ease of control. The adjustment for stabilization is made on the small condensers.

The four R.F. transformers, designated as L in the illustrations, are simple solenoids, wound on insulating tubing of small diameter and length. They are mounted on the under side of the metal sub-panel (SP) in such a manner that the magnetic field of each is at right angles to those of its immediate neighbors. This arrangement reduces inter-stage magnetic coupling to a minimum, no shields between the inductors being used.

The four variable condensers (C), which tune the R.F. stages, are coupled together to turn as one instrument, being controlled by a drum which protrudes edgewise through the front panel, which is made of metal. This drum carries a translucent scale, graduated in meters, which is illuminated by a small flashlight bulb when the set is turned on by means of the rheostat, R1. In the rear view of the set this drum unit is marked D; in the front general view of the receiver its knurled edge, which the operator manipulates with his fingers, is marked C.

The drum control operates directly on the

condenser shafts, no gears or other reducing apparatus being employed. The manufacturers claim this feature eliminates a great source of service trouble, since no adjustment of the operating mechanism is ever required.

To compensate for the different electrical characteristics of different aeri-als, a separate "vernier" condenser (V) of small size is provided. It is connected across the secondary of the antenna coupler, and is mounted on the front panel beneath and to the left of the drum control. Its small knob, with that of the rheostat, R1, balances the appearance of the panel in a simple but effective fashion.

The rheostat, R1, controls the current to the filaments of the three R.F. amplifier tubes, thus serving as a volume control. It acts also as a switch for the entire receiver; for when its contact-arm is run off the end of the resistance winding, the entire filament circuit is opened. A separate fixed resistor, R2, keeps the current to the detector and the audio amplifier tubes at the proper value.

The audio amplifier uses two heavy transformers of excellent characteristics, and reproduces voice and music with strength and clarity. A power tube, of either the 112 or 171 type, is used in the second stage.

A metal sub-panel (SP) holds the tube receptacles, the R.F. transformers and the components of the stabilizing units, the by-pass condensers (BP), and the audio transformers (AF). This entire panel rests on springs, the tubes being therefore protected against shocks, such as are caused by the slamming of nearby doors or by a strong wave of sound often produced by the loud speaker if it is kept near the set. The instruments suspended from the sub-panel (particularly the heavy audio transformers) act as damping weights and quickly quiet down the tubes if the panel is jarred violently.

Connections to the "A," "B" and "C" bat-

teries or socket-power units are made by a long flexible cable which extends through a hole in the back of the set cabinet. The loud-speaker cord and the aerial and ground wires are likewise passed through holes in the cabinet to their respective connection points.

Mechanically, the receiver is strong and well built. The small front panel, whose crystalline brown finish is finger-mark proof, serves merely as a decorative front for the working instruments, all of which are supported by a rigid chassis made of copper and wood. The chassis itself is bolted securely to the cabinet in a manner to defy considerable rough handling.

The particular set illustrated in this department is the table model. The cabinet is of genuine mahogany, and is 22 inches long, 11 high and 14 deep. The same electrical unit is also built into more elaborate console and cabinet models; one of these includes a phonograph which works electrically through the amplifier portion of the radio receiver and the loud speaker.

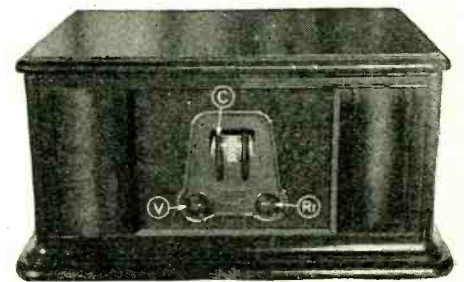

General view of the complete receiver in its cabinet. C, control drum; V, "vernier" condenser; R1, combined volume control and set switch.

DRUM DIAL FOR CONDENSERS IS WELL CONSTRUCTED

WHEN mechanical and electrical efficiency are combined with neatness and beauty, the result is an instrument or piece of apparatus which is difficult to improve in any way. Such an object of merit is the control-drum for variable condensers which is pictured in the accompanying illustrations.

The first requisite of any type of dial is that it operate smoothly and, if it is of the vernier type, that no back-lash or slipping of gears shall be possible. From the sketch may be seen the manner in which the condenser is attached to the drum mechanism. The mounting plate is screwed to the front panel and on this is mounted the variable condenser, with its shaft parallel to the panel. On the large graduated drum, embedded in the bakelite of which it is made, is a brass bearing through which the condenser shaft is run. This shaft is held in position and is

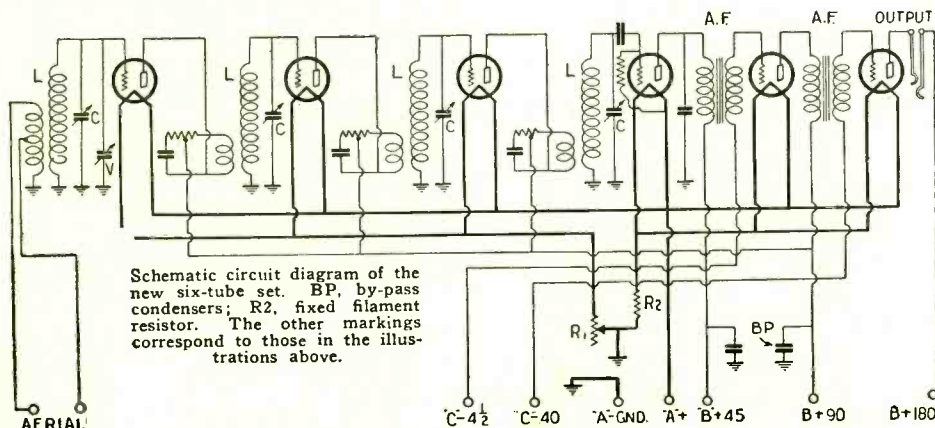

Schematic circuit diagram of the new six-tube set. BP, by-pass condensers; R2, fixed filament resistor. The other markings correspond to those in the illustrations above.

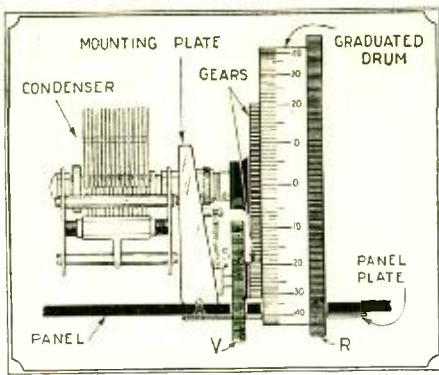

Left: How the drum control looks from the top of the panel; V, vernier-adjustment wheel; R, knurled rim of drum, permitting quick adjustment to approximate position; S, spring, holding gears tightly in mesh.

Right: The cone speaker partially disassembled: SU, speaker unit; OU, output filter; B, mounting brackets; L, lips, which fit against them.

Illustration of speaker courtesy All-American Radio Corp.

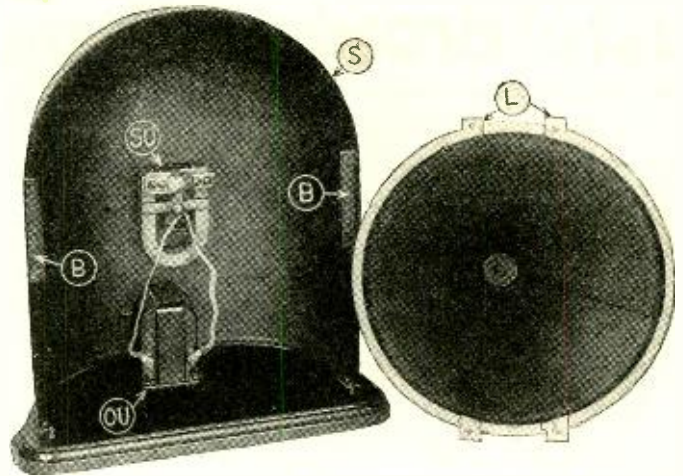

prevented from slipping by means of a brass chuck, which fits into the bearing. The right-hand edge of the drum is knurled so that rough adjustments can be made easily.

In order to obtain a vernier action, a bakelite gear is moulded as an integral part of the drum itself. The smaller gear is moulded in one piece with the vernier drum, shown at V in the sketch. A brass shaft is embedded

desired to have more than one control, two of these drums can be mounted as shown. The two knurled edges, coming together, make it possible to vary all the condensers

NEW CONE SPEAKER PROVIDED WITH PROTECTIVE FILTER

THE loud speaker shown in the accompanying illustrations has a cone diaphragm which is incased in a metal cabinet. On the wooden baseboard within the cabinet is an output filter, OU, the input side of which is connected to the loud-speaker terminals of the radio receiving set. On the rear wall of the rounded metal case S is mounted the speaker unit, SU. Attached to the cone are four lips, L, which are fastened to the metal rim of the cone, and also screwed to the brackets, B, at each side of the metal cabinet.

The metal cabinet is finished in bronze, it is fifteen inches high and eleven and a half inches in width. The mechanism is concealed from view by a gold-cloth screen behind the front grill-work of the speaker.

The inclusion of the output filter in the same cabinet with the loud speaker makes an excellent combination for present-day radio service. The increased use of power tubes, especially in newer radio receiver models, has brought about a need for improved loud-speaker design, such as that incorporated in (Continued on page 419)

A double-drum unit shown as it would be used with one single and one double variable condenser. The front-panel plate is beautifully engraved, and gives the radio set on which it is used a very handsome appearance.

Illustrations of drum courtesy Tyrman Electric Co.

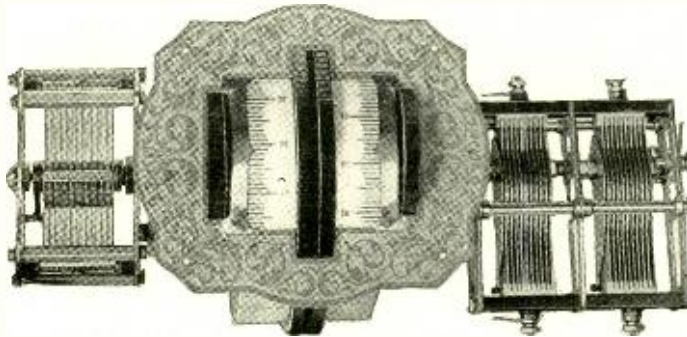

in this drum, which rotates in a socket, S. This socket has attached to it a spring which pulls the small gear against the larger one, thus insuring perfect meshing.

Almost any make of condenser can be used with this control, as several holes and slots are drilled in the mounting plate. If it is

at the same time; hairline adjustment can be had by varying the verniers at the sides.

The 0-100 scale on the periphery of the drum is of silvered metal with black figures and divisions. The plate fastened on the front of the panel is of copper, handsomely etched.

The Evolution of the "A" Socket-Power Unit

By O. T. McILVANE*

THE evolution of the "A" socket-power unit is rather unusual in several ways. At this time it has reached a comparatively high degree of development and perfection, but to the radio public it is a new device just making its appearance; though, as a matter of fact, it has been evolving for the past three or four years. A brief account of the successive stages of evolution of the "A" power device that have come to the writer's personal attention, may be of interest.

Even before the advent of radio broadcasting to the public, engineers were working on the problem of battery elimination. Batteries were expensive and, in the case of the storage type, mussy and troublesome. The problem of replacing the plate battery or "B" battery for the radio set was not difficult, because of the very small amount of current involved, so it was first successfully solved. "B" power units are well known today to the layman and have been a common radio commodity for the past two seasons. The "A" battery current, however, being many times greater than that used for the plates of the radio tubes, offered a much more difficult problem to the engineer. While for a "B" unit condensers of 10 to 15 microfarads are sufficient and are convenient in size, for the "A" device capacities as high as 15,000 to 20,000 microfarads are necessary to filter the current properly. This was the

first big stumbling block in the construction of an "A" socket-supply unit, for condensers, as known then, of so high a capacity would be as large as a good-sized office desk, and would cost several thousand dollars.

USE OF "FLOATING" BATTERIES

Other devices were then sought for use as filter capacities. The first scheme that the author found satisfactory was developed in the latter part of 1924. It consisted of two dry "C" batteries and a choke coil,

connected as shown in Fig. 1. This system was cheap and satisfactory and would operate sets of five tubes or less without any hum in the receiver. For sets of more tubes than five tubes, the resistance of the dry batteries was too high, allowing the voltage to fluctuate. The operation of this system depends on the fact that, at voltages equal to the cell voltages, the resistance across the cell banks is very high; so that practically none of the current flows through them, but it continues to flow on out through the filter (Continued on page 418)

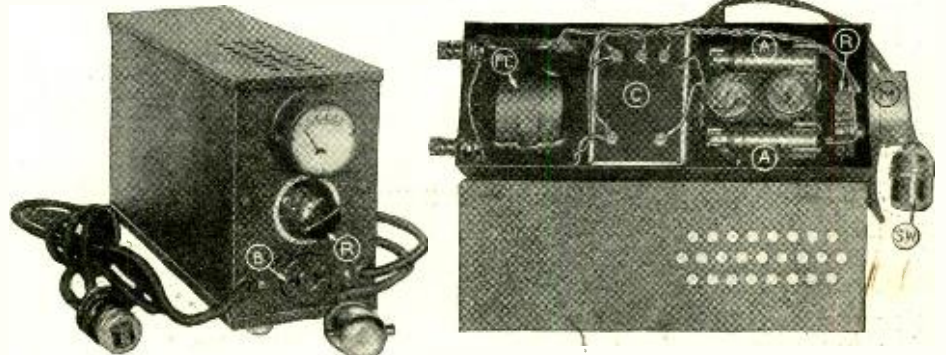

FIG. 2

Left: The "A" power unit ready for use. R, adjusting rheostat; B, receptacle for plug of "B" supply unit. Right: The inside of the "A" unit. FC, filter choke coils; C, the 20,000-mf. filter condenser; AA, rectifier cartridges; R, rheostat; M, voltmeter; SW, control switch.

*Research Laboratory, The Sterling Mfg. Co.

List of Broadcast Stations in the United States

Radio Call Letter	BROADCAST STA. Location	Wave (Meters)	Power (Watts)	Radio Call Letter	BROADCAST STA. Location	Wave (Meters)	Power (Watts)	Radio Call Letter	BROADCAST STA. Location	Wave (Meters)	Power (Watts)	Radio Call Letter	BROADCAST STA. Location	Wave (Meters)	Power (Watts)
KDKA	East Pittsburgh, Pa.	316	30000	KGES	Central City, Neb.	204	10	KWVG	Brownsville, Texas	278	500	WOOD	Chattanooga, Tenn.	246	500
(Also *63.6 meters and other short-wave transmissions on varying power.)				KGEU	Lower Lake, Calif.	227	50	WXLL	Portland, Ore.	270	50	WDRG	New Haven, Conn.	283	500
KDLR	Devils Lake, N. D.	231	15	KGFW	Fort Morgan, Colo.	219	10	KXRO	Aberdeen, Wash.	271	50	WDWF	Cranshaw, N. J.	361	300
KDLI	Salt Lake City, Utah	258	100	KGEY	Denver, Colo.	201	15	KYA	San Francisco, Calif.	309	500	WDMW	Asbury Park, N. J.	375	500
KDLB	Irbank, Calif.	229	250	KGKZ	Kalispell, Montana	205	100	KYW	Chicago, Ill.	526	2500	WDTZ	Tuscola, Ill. (daytime)	278	100
KEX	Portland, Ore.	240	2500	KGFB	Iowa City, Iowa	224	10	KZM	Oakland, Calif.	246	100	WEAF	†New York, N. Y.	*492, 50,000	
KFAB	Lincoln, Neb.	309	*2000	KGFF	Alva, Oklahoma	216	50	WAAD	Arlington, Virginia	*434	1000	WEAL	Ithaca, N. Y.	481	250
KFAD	Phoenix, Ariz.	273	500	KGFG	Oklahoma City, Okla.	205	25	WAAG	Cincinnati, O.	268	25	WEAM	North Plainfield, N. J.	240	250
KFAU	Boise, Idaho	285	*2000	KGFH	La Crescenta, Calif.	224	250	WAAM	Newark, N. J.	389	500	WEAO	Providence, R. I.	319	500
KFBB	Havre, Mont.	275	50	KGFI	San Angelo, Texas	220	15	WAAT	Jersey City, N. J.	246	300	WEAR	Cleveland, Ohio	400	1000
KFBC	San Diego, Calif.	535	100	KGFJ	Los Angeles, Calif.	208	100	WAAW	Omaha, Neb. (daytime)	319	500	WEBC	Superior, Wis.	242	250
KFBD	Sacramento, Calif.	535	100	KGFK	Hancock, Minn.	224	50	WABC	Richmond Hill, N. Y.	326	2500	WEBE	Cambridge, Ohio	248	10
KFBL	Everett, Wash.	224	100	KGFH	Raton, N. M.	222	50	(Also 64.0 meters, 500 watts)			WEBH	Chicago, Ill.	366	2000	
KFBU	Laramie, Wyo.	428	500	KGFJ	Yuba City, Calif.	211	15	WABF	Pringleboro, Pa.	205	250	WEBJ	New York, N. Y.	256	500
KFCB	Phoenix, Ariz.	244	125	KGFN	Aneta, Ne. Dak.	200	15	WABQ	Philadelphia, Pa.	237	500	WEBR	Buffalo, N. Y.	224	15
KFCR	Santa Barbara, Calif.	211	50	KGFO	Los Angeles, Cal. (port.)	204	100	WABR	Toledo, Ohio	280	50	WEBW	Beloit, Wis.	358	500
KFDM	Beaumont, Texas	375	500	KGFP	Mitchell, So. Dak.	213	10	WABW	Wooster, Ohio	248	50	WECC	Chicago, Ill.	242	500
KFDS	Shreveport, La.	236	250	KGFW	Ravenna, Neb.	300	10	WABY	Philadelphia, Pa.	248	50	WEEL	Boston, Mass.	447	500
KFDY	Brookings, S. D.	230	250	KGFX	Pierre, S. D. (day)	254	200	WABZ	New Orleans, La.	248	50	WEHS	Evanston, Ill.	216	100
KFDZ	Minneapolis, Minn.	216	10	KGGH	Deer Oola, La.	207	100	WAGC	Akron, Ohio	297	500	WEMC	Berrien Springs, Mich.	484	1000
KFEC	Portland, Ore.	214	50	KGGI	Waller, La.	213	50	WAGD	Detroit, Mich.	311	100	WEMF	Chicago, Ill.	288	500
KFEL	Denver, Colo.	248	2500	KGGJ	San Antonio, Texas	220	50	WAGF	Brooklyn, N. Y.	229	500	WEPS	Gloucester, N. Y.	291	100
KFEQ	St. Joseph, Mo.	231	1000	KGGK	Amarillo, Texas	244	150	WAGS	Lexington, Mass.	216	5	WEVD	Woodhaven, N. Y.	246	500
KFEY	Kellogg, Idaho	232	10	KGGT	San Francisco, Calif.	270	50	WAGT	Taunton, Mass.	214	10	WEW	St. Louis, Mo.	353	1000
KFGG	Boonville, Iowa	230	10	KGGU	Honolulu, Hawaii	207	600	WAIU	†Columbus, Ohio	283	5000	WFAA	Dallas, Texas	500	500
KFH	Wichita, Kan.	246	500	KGGV	Portland, Oregon	492	1000	WALK	Willow Grove, Pa.	201	50	WFAM	St. Cloud, Minn.	252	10
KFHA	Gunnison, Colo.	254	50	KGGW	Longview, Wash.	244	100	WALM	†Minneapolis, Minn.	225	500	WFBC	Knoxville, Tenn.	231	50
KFHL	Oskaloosa, Iowa	213	10	KGGX	Oakland, Calif.	384	5000	WAMD	Auburn Ala. (daytime)	326	1000	WFBD	Cincinnati, Ohio	246	550
KFI	Los Angeles, Calif.	468	5000	KGGY	Los Angeles, Calif.	405	500	WAMN	Chicago, Ill. (portable)	326	500	WFBG	Altoona, Pa.	280	100
KFII	Portland, Ore.	214	50	KHMC	Harlingen, Tex.	236	100	WASH	Grand Rapids, Mich.	256	250	WFBJ	Collegeville, Minn.	273	100
KFIO	Spokane, Wash.	246	100	KHMK	Spokane, Wash.	370	1000	WATT	Boston, Mass. (portable)	201	100	WFBM	Syracuse, N. Y.	258	750
KFIP	Yakima, Wash.	248	100	KHML	Anita, Iowa	461	100	WBAA	West Lafayette, Ind.	*273	500	WFBP	Indianapolis, Ind.	225	250
KFIU	Juneau, Alaska	225	10	KHNS	San Francisco, Calif.	220	50	WBAB	Harrisburg, Pa.	300	500	WFBR	Baltimore, Md.	225	100
KFIZ	Fond du Lac, Wis.	268	100	KHNT	Seattle, Wash.	349	2500	WBAL	†Baltimore, Md.	285	5000	WFBZ	Galesburg, Ill.	248	50
KFJB	Marshalltown, Iowa	248	100	KHOB	Blytheville, Ark. (day)	285	15	WBAP	Fort Worth, Texas	500	1500	WFBI	Philadelphia, Pa.	405	500
KFJC	Oklahoma City, Okla.	273	*750	KHOC	Independence, Mo.	270	1500	WBAX	Nashville, Tenn.	218	100	WFII	Hopkinsville, Ken.	280	*500
KFJJ	Astoria, Ore.	250	15	KHOD	Portland, Ore.	207	10	WBBC	Wilkes Barre, Pa.	250	100	WFKB	Chicago, Ill.	224	500
KFJM	Grand Forks, N. D.	333	100	KHOU	Portland, Ore.	270	10	WBBD	Brooklyn, New York	227	500	WFKD	Philadelphia, Pa.	205	50
KFJN	Portland, Ore.	248	100	KHVA	Oakland, Calif.	246	250	WBLA	Clearwater, Fla.	366	500	WFLA	Clearwater, Fla.	366	500
KFJY	Fort Dodge, Iowa	441	100	KHVB	Oakland, Calif.	508	500	WGB	Lancaster, Pa.	252	50	WGBB	Freeport, N. Y.	246	400
KFJZ	Fort Worth, Texas	350	50	KHVC	Denver, Colo.	268	250	WGBE	Memphis, Tenn.	278	15	WGBF	Evansville, Ind.	236	250
KFKA	Greeley, Colo.	400	200	KHVD	Shenandoah, Iowa	396	1000	WGBI	Scranton, Pa.	231	250	WGBH	Scranton, Pa.	231	250
KFKB	Milford, Kansas	242	*1500	KHVE	Medford, Oregon	250	50	WGBL	New York, N. Y.	319	500	WGBI	New York, N. Y.	319	500
KFKU	Lawrence, Kansas	251	500	KHVF	Ingleswood, Calif.	224	250	WGBM	Chicago, Ill.	242	500	WGBM	Chicago, Ill.	242	500
KFKV	Chicago, Ill.	526	2500	KHVG	Fresno, Calif.	366	50	WGBN	Chicago, Ill.	207	100	WGBM	Chicago, Ill.	207	100
KFKW	Chicago, Ill.	225	5	KHVI	Clay Center, Neb.	380	500	WGBS	Takoma Park, Md.	207	50	WGBM	Chicago, Ill.	207	100
KFLV	Rickford, Ill.	268	100	KHVN	Tacoma, Wash.	254	250	WGBT	Boston, Mass.	288	500	WGBM	Chicago, Ill.	207	100
KFLX	Galveston, Texas	270	100	KHVO	Fst. Louis, Mo.	300	5000	WBUS	Boston, Mass. (daytime)	303	100	WGBM	Chicago, Ill.	207	100
KFMR	Sioux City, Iowa	441	100	KHVP	Los Angeles, Calif.	524	500	WBKN	Brooklyn, N. Y.	268	100	WGBM	Chicago, Ill.	207	100
KFNH	Northfield, Minn.	236	500	KHVR	Los Angeles, Calif.	524	500	WBMD	Detroit, Mich.	211	100	WGBM	Chicago, Ill.	207	100
KFNW	Shenandoah, Iowa (day)	461	500	KHVS	Santa Monica, Calif.	375	500	WBND	Buffalo, N. Y.	288	100	WGBM	Chicago, Ill.	207	100
KFOA	Seattle, Wash.	447	1000	KHVT	Los Angeles, Calif.	337	500	WBNG	New York, N. Y.	268	100	WGBM	Chicago, Ill.	207	100
KFON	Long Beach, Calif.	242	500	KHVA	Denver, Colo.	326	*5000	WBQ	Richmond Hill, N. Y.	326	500	WGBM	Chicago, Ill.	207	100
KFOR	Lincoln, Neb.	217	100	KHVB	Corvallis, Oregon	270	500	WBRC	Birmingham, Ala.	244	250	WGBM	Chicago, Ill.	207	100
KFOX	Omaha, Neb.	258	100	KHVC	State College, New Mex.	395	5000	WBRE	Wilkes Barre, Pa.	250	100	WGBM	Chicago, Ill.	207	100
KFOI	St. Paul, Minn.	283	250	KHVD	Omaha, Neb.	258	500	WBRL	Tilton, N. H.	232	500	WGBM	Chicago, Ill.	207	100
KFOJ	St. Paul, Minn.	283	250	KHVE	Los Angeles, Calif.	524	500	WBRS	Brooklyn, N. Y.	211	100	WGBM	Chicago, Ill.	207	100
KFOL	Dublin, Texas	271	15	KHVF	Chicago, Wash.	300	500	WBST	Wellesley Hills, Mass.	384	100	WGBM	Chicago, Ill.	207	100
KFPM	Greenville, Texas	271	15	KHVG	Chicago, Wash.	300	500	WBTC	Charlotte, N. C.	258	500	WGBM	Chicago, Ill.	207	100
KFPR	Los Angeles, Calif.	232	250	KHVI	Council Bluffs, Iowa	278	*2000	WBZ	†Springfield, Mass.	433	15000	WGBM	Chicago, Ill.	207	100
KFPV	Cartersville, Mo.	263	50	KHVA	Portland, Oregon	319	1000	WBZA	Boston, Mass.	333	500	WGBM	Chicago, Ill.	207	100
KFPY	Spokane, Wash.	246	250	KHVB	Durango, Colo.	200	5	WCAC	Mansfield, Conn.	275	500	WGBM	Chicago, Ill.	207	100
KFQ	St. Louis, Mo.	322	50	KHVC	Seattle, Wash.	476	250	WCAD	Canton, N. Y.	366	500	WGBM	Chicago, Ill.	207	100
KFQB	Fort Worth, Texas	300	100	KHVD	Denver, Colo.	306	1000	WCAG	Fittsburgh, Pa.	517	500	WGBM	Chicago, Ill.	207	100
KFQD	Anchorage, Alaska	315	100	KHVE	Chicago, Wash.	300	500	WCAL	Columbus, Ohio	535	250	WGBM	Chicago, Ill.	207	100
KFQU	Holy City, Calif.	250	100	KHVF	Chicago, Wash.	300	500	WCAN	Lincoln, Neb.	380	500	WGBM	Chicago, Ill.	207	100
KFQW	Wenatchee, Wash.	217	100	KHVG	Chicago, Wash.	300	500	WCAM	Camden, N. J.	224	500	WGBM	Chicago, Ill.	207	100
KFQZ	Hollywood, Calif.	232	100	KHVI	Chicago, Wash.	300	500	WCAN	Baltimore, Md.	384	250	WGBM	Chicago, Ill.	207	100
KFRG	San Francisco, Calif.	454	1000	KHVA	Chicago, Wash.	300	500	WCAT	Rapid City, S. Dakota	248	100	WGBM	Chicago, Ill.	207	100
KFRH	Columbia, Miss.	250	500	KHVB	Chicago, Wash.	300	500	WCBA	Philadelphia, Pa.	337	500	WGBM	Chicago, Ill.	207	100
KFRS	San Diego, Calif.	500	500	KHVC	Chicago, Wash.	300	500	WCBB	Portland, Vermont	254	100	WGBM	Chicago, Ill.	207	100
KFSG	Los Angeles, Calif.	275	500	KHVD	Chicago, Wash.	300	500	WCBC	Carthage, Ill.	341	500	WGBM	Chicago, Ill.	207	100
KFUL	Galveston, Texas	258	500	KHVE	Chicago, Wash.	300	500	WCBD	Allentown, Pa.	292	100	WGBM	Chicago, Ill.	207	100
KFUM	Colorado Springs, Colo.	236	100	KHVF	Chicago, Wash.	300	500	WCBE	Zion, Ill.	345	5000	WGBM	Chicago, Ill.	207	100
KFUS	St. Louis, Mo.	545	500	KHVG	Chicago, Wash.	300	500	WCBF	New Orleans, La.	227	5	WGBM	Chicago, Ill.	207	100
KFVP	Denver, Colo.	237	100	KHVI	Chicago, Wash.	300	500	WCBG	Oxford, Miss.	242	100	WGBM	Chicago, Ill.	207	100
KFV	Ord, Mo.	243	100	KHVA	Chicago, Wash.	300	500	WCBH	Baltimore, Md.	384	100	WGBM	Chicago, Ill.	207	100
KFVS	Oakland, Calif.	256	50	KHVB	Chicago, Wash.	300	500	WCBM	Providence, R. I. (port.)	201	100	WGBM	Chicago, Ill.	207	100
KFUT	Salt Lake City, Utah	500	50	KHVC	Chicago, Wash.	300	500	WCBN	Springfield, Ill. (port.)	210	100	WGBM	Chicago, Ill.	207	100

The Radio Beginner

How to Build Radio Sets

The Correct Procedure in Wiring and Building Receivers

THERE are innumerable kinks, learned by practical experience, that will give the best results and save the radio set builder time and sometimes expense. The proper procedure in laying out panels and baseboards, wiring a set, and finally, doing good soldering, will be described here. The beginner, as well as the more advanced set-builder, may learn some things that have not come to his attention before.

DRILLING PANELS

The best way to drill panels is to lay them on a piece of paper, on a smooth surface, so that the expensive material will not be scratched. Drill the holes from the rear of

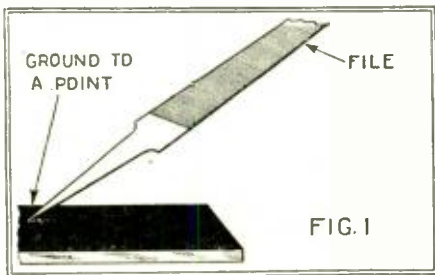

A scribe for marking the position of holes on a panel can be made by grinding the end of a file to a point.

the panel, because the opposite side usually chips and the dials will cover this over; the inside of the cabinet is the most important to the home-builder, simply because the interior is so often inspected by curious friends. After the proper positions for the various parts have been determined, the templates for the various instruments are placed in exact position by inserting pins through them and into the punch-marks previously placed in the correct positions on the panel. Two or three drops of glue at various places on the template will hold it well in place.

With a punch (or the end of a file which has been ground to a point; see Fig. 1), mark the positions of the holes on the panel. Remove the template and wipe the glue from the panel with a moist rag, then dent the panel with a center-punch, so that the drill

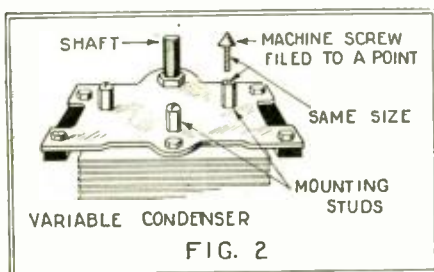

By using a machine-screw with a pointed head, the mounting holes can be easily located on a panel.

By CLYDE A. RANDON

used will be given a correct start. Drill the holes, using drills of the proper sizes, usually indicated on the template. However, exactness in the size of drills is usually unnecessary; in fact, it is often desirable to use a somewhat larger size than recommended; as any small discrepancies in alignment then make little difference.

If a template is not available (which is often the case when the instrument has been removed from another set) the panel may be marked quite easily by means of a machine-screw, which fits into the holes for the regular mounting screws. It should have the same thread as the mounting screws to be used, and its head should be filed to a fine point at the exact center, as shown in Fig. 2. Bore in the panel a hole the size of the condenser shaft, insert the shaft in this hole and press the machine-screw with the pointed head firmly against the panel, thus marking the latter. This operation can be repeated for the rest of the screw-holes, and the panel is thus easily and accurately marked. After the holes are countersunk, and the instrument fitted properly, the hole for the shaft should be enlarged with a larger drill or with the countersink.

THE BASEBOARD

Hook-ups are usually drawn in such a manner that one can follow them in laying out the equipment on the baseboard. The blueprints furnished by RADIO NEWS for the sets described in its columns are a great aid in this work. One must be careful to keep clear of the board all apparatus composing the radio-frequency parts of the circuits. All coils should be as far away from surrounding panels, wiring and transformers as possible, and should preferably be supported above the baseboard. The battery leads, especially those to the filament, may be run directly on the baseboard in ordinary heavy insulated wire. It is sometimes convenient to mount the baseboard on two sub-panel brackets, which are available in a number of styles; part of the equipment may then be mounted on the under side of the board.

WIRING THE SET

There is perhaps no merit, other than rigidity, in using heavy-gauge wire in connecting a radio set. All wires carrying plate and filament currents should be kept well apart and should be well insulated. "Spaghetti" insulation is good and often saves tubes from burning out as a result of an accidental short circuit.

Neat, right-angle bends greatly enhance the appearance of a completed receiver; these are easily made even with comparatively-heavy wire if a pair of round-nose pliers is used. The wire is held in its approximate location and is bent while in position, thus saving much time.

Binding-post strips can be supported above

the panel by means of small brass angles; binding posts and tap-switches should not be mounted on the panel, usually. The binding posts can be placed somewhere along the baseboard; and there is usually no excuse for tap-switches in modern receivers employing variable condensers as the tuning elements. If the post-strips are mounted at the rear of the set, the connections can be made through small holes in the back of the cabinet.

SOLDERING PROCEDURE

Soldering causes more difficulties than anything else connected with set construction. The first requisite is a good soldering iron, preferably an electrically-operated one, al-

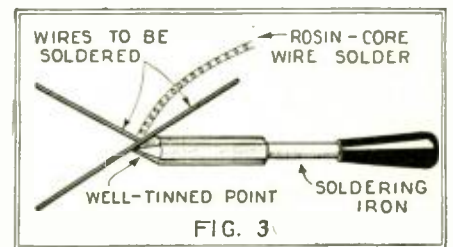
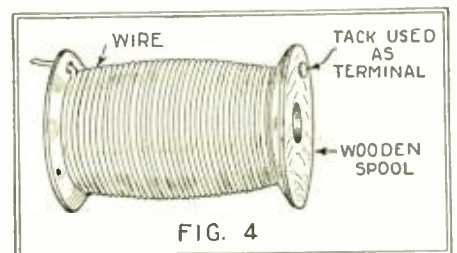

Fig. 3 shows the correct position of a soldering iron and solder, in relation to the wires being soldered.

though any iron which can be "tinned" properly is all right. The iron should not be made too hot, otherwise it will be difficult to "tin" it. "Tinning" consists simply of obtaining a thin layer of solder on the iron in a metal-to-metal contact with the tip of the tool. If the iron is not tinned properly, difficulty will be experienced in soldering, as it is this thin layer of molten solder on the iron which successfully carries the heat to the joint. One can scarcely melt solder with a hot iron which is not tinned, as a film of oxide forms on the iron and prevents the heat from reaching its objective. Tinning is important. With an old file, clean the end of the iron and, before oxide has a chance to form, brush a little flux over the spot and quickly apply the solder. There should be a good coating of the solder on the end of the tool.

(Continued on page 394)



An easy method for making R. F. choke coils is to bunch-wind No. 36 wire on an ordinary spool.



Buried Aerial Reduces Static

Effectiveness of Underground Antenna in Clarifying Radio Reception

By H. WINFIELD SECOR

THE static bugaboo has not troubled radio listeners so much as usual this summer, especially because the weather has been very cool, but there has been enough static to let us know that it was in the air. Static, as popularly understood, is an atmospheric electrical disturbance which makes itself known in radio reception by the short crashes we hear on the loud speaker. Sometimes these crashes are of a weak nature, and more or less straggling or spasmodic. At other times the crashes are quite regular and strong, which generally indicates that a thunderstorm is but a few miles away and liable to pass overhead before a great while.

Recently there has been brought to the attention of the radio public a new means of helping to overcome the annoyance of static. We are glad to say that it is not one of those tin cans into which you pour a little water every night before retiring. (Probably you have seen some of these green or red cans about the size of a tomato tin, many hundreds of which were sold at one dollar apiece right on Broadway, New York City, a short time ago.) Of course these "gimmicks" are of just about as much use as a straw hat is to an Eskimo.

The new means of overcoming static to which we refer is nothing more or less than an adaptation of our old friend, the Rogers underground antenna. It might seem, from some of the remarks we have heard concerning this new static-free aerial, that it is something brand new and quite untried; but nothing is farther from the truth. After the War it was the writer's good fortune to have access to some of the official files containing naval engineers' tests on the Rogers underground and underwater aeri-als; and all that need be said concerning these official tests is that they show a marked reduction in the intensity of static when compared with that of the incoming signal ("static-signal ratio.") Underground aeri-als" were used extensively by government operators to listen in frequently while thunder storms were directly overhead.

The writer also had the pleasure of visiting the laboratory of Dr. James Harris Rogers at one time; and demonstration showed that the underground, as well as the undersea antenna, represents a fine piece of scientific work. The only thing that has up until recently deterred the average radio listener from the adoption of the Rogers underground antenna, is the fact that the average man (like the writer) does not have any great appetite for shoveling dirt and digging a two-foot ditch one hundred feet long.

COMPACT BURIED ANTENNA

Several designs for the underground antenna have been worked out; and the writer

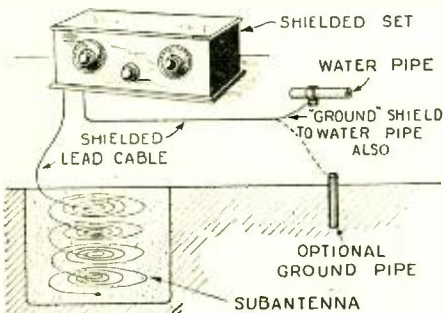

FIG. 4

The method of connecting the set to ground, as well as "aerial," for best results, is indicated above. Both aerial and ground leads should be lead-sheathed.

recently tried one of the simplest forms, which is that of the multiple spiral, shown in one of the accompanying diagrams, Fig. 2. This multiple spiral, comprising four to six "pancakes" or "pies," wound with lead-sheathed, insulated copper wire, is buried in a hole which you may easily dig in your cellar, or back yard, the hole being about four feet deep and three to four feet in diameter.

In passing, it is interesting to note (as shown in Fig. 1) how it is that an insulated wire, preferably sheathed in lead, and buried in the ground, say two feet deep, can pick up the radio waves. As pointed out in articles by the writer several years ago, these underground and undersea "aerials" pick up radio signals because they are traversed or cut by the grounded section of the radio waves, as these glide along over the surface of the earth or water. There are several ways in which buried antennas may be connected to a receiving set (the set of course should be of the fully shielded type in order to realize the full results accruing

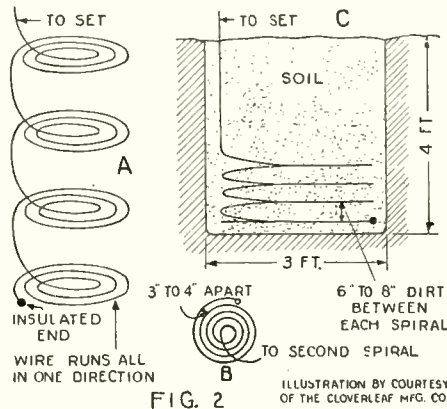

FIG. 2

ILLUSTRATION BY COURTESY OF THE CLOVERLEAF MFG. CO.

The method of laying the underground aerial wire in the most convenient and compact form is illustrated above, as explained in the text. B is a top view of one "pancake."

from the use of a buried aerial) and several of these schemes are shown herewith.

Fig. 2 shows, at A, how four spirals or pancakes of lead-sheathed, rubber-covered wire are arranged in a hole covered with earth, as shown at C. A hole about four feet deep, and three to four feet in diameter, is dug; and at the bottom the first spiral is laid in by hand, the free end of the wire being insulated with tar, as shown. After winding several turns, spacing the turns three to four inches apart, until the center turn is about six inches in diameter, this pancake is covered with six to eight inches of earth, the wire is led to the side of the hole, and the second spiral started. This is repeated until four to six spirals have been placed in the hole, depending upon the length of the lead-sheathed wire available. Seventy-five to one hundred feet of the wire is usually incorporated in spirals thus buried. As the dirt is placed over the last spiral, it is well to pour several pailfuls of water on the dirt in the hole; and, if the soil is very dry in the location where the hole is dug, some water should be poured on the soil each day.

The diagram, Fig. 3, shows the manner in which the writer installed one of these sheathed underground "aerials." An important thing, in connection with this method for overcoming interference and static, is to see that the lead-covered cable extends

right up to the set; secondly, that the set used is shielded by a grounded metal case; and thirdly, the ground wire should consist

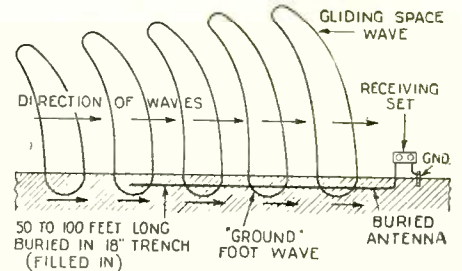

FIG. 1

Ordinary radio waves are "grounded," as shown, and therefore are readily picked up by the buried aerial wire. A large proportion of static impulses are not grounded, and therefore do not come in with the "signal."

of a piece of lead-sheathed wire running to the water pipe, or to a piece of pipe driven into the ground, the sheath on the ground wire being also grounded. (See Fig. 4).

DIRECTIONAL EFFECTS

Probably the most efficient form of buried aerial is that in which the sheathed wire is run straight in a trench about 18 to 24 inches deep, as shown in Fig. 1. These underground or underwater "aerials" (they have been successfully used in U. S. Navy tests by simply dropping the wires in the water, or on a beach, or in a lake—see Fig. 9) are directional in the sense that the ordinary elevated aeri-als are; and Fig. 6 gives a rough idea of the field of maximum response, or at least its direction. In the case of Fig. 5 we have the result of two buried aeri-als, which is one of the forms devised by Dr. Rogers originally, and shown in his patents. The usual form of buried antenna, which most people will probably prefer, and which involves the utilization of but one buried "aerial" proper, together with an ordinary ground, as shown in Fig. 6, will give a maximum response in the direction shown.

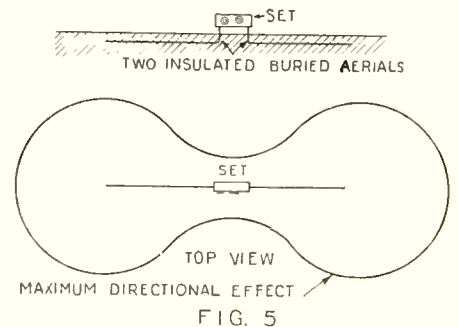

FIG. 5

The inverted-"T" antenna above gives more even reception all around.

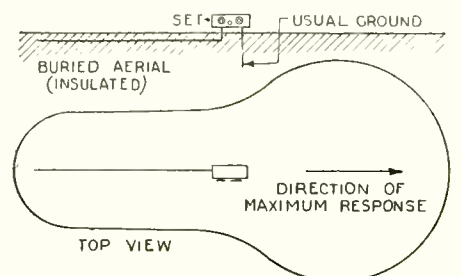
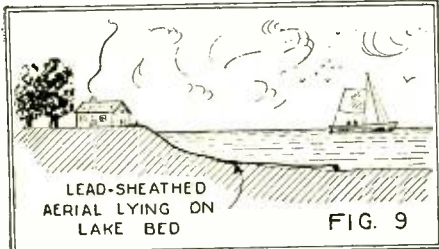

FIG. 6

The "L" antenna receives the signal most strongly in the direction to which it points. It is easier to install.

The ideal way to arrange an underground antenna is in the manner shown in Fig. 7, and here the listening is done on successive sets, using a pair of buried aeri-als which are in line with the station desired, such as AA, BB, etc. In this case it should be noted that the maximum response is in the direction corresponding to the axis of the aeri-als, i.e., in the same direction that they point.



Naval tests have shown the efficiency of an aerial submerged in the water, as shown. The end, of course, is insulated.

In some of the experiments made by Dr. Rogers and others with underground aeri-als, an ordinary loop was placed in a well, or simply in a hole dug in the earth. An improvement is suggested by the writer in Fig. 8, where a loop is wound with lead-sheathed, insulated copper wire, the sheathed leads running up to the set, which is of the shielded type. It is presumed that a super-heterodyne is to be used in this case; and of course it should be placed as close as may be convenient to the earth, in order to make the loop leads as short as possible. It is interesting to note also that fairly good results have been obtained by placing the sheathed aerial wire on top of the ground, but, for maximum static elimination, the wire should be buried.

TESTS AND RESULTS

During an actual test, conducted by the author with a "subantenna" buried in the ground in the fashion illustrated by Fig. 3, and using a fully-shielded receiving set of the superheterodyne type, the following stations were logged during the last two weeks in June and the first week in July. During this time there was a considerable amount of static in the atmosphere, as was made

manifest by listening to reception on an ordinary unshielded set which was connected to a regular outdoor antenna and also at times to a loop. The set used for these comparative tests was a superheterodyne without shields.

Using the shielded set with the buried subantenna in the form of several spirals, in a hole in the ground as previously described, the stations listed below were picked up; and no noticeable static was heard over periods extending from one-half hour to two hours. At the same time, static "splashes" were heard when using the unshielded set, connected with the outside antenna and loop alternately.

Here is a partial list of stations heard on the subantenna: WNYC, WEAf, WJZ, WOR, WHN, KDKA, WPG, WPCH, WAAM, WGY, WABQ, WGR, WMCA.

The author's tests were conducted at his home, located 26 miles northwest of New York City. It would seem that, with the subantenna simply buried in a hole, as illustrated by Fig. 3, this gives about the same range as the average outdoor antenna or loop for summer reception. It has been the writer's experience, in his location at the base of the Ramapo Mountains, that 350 miles (which includes KDKA, Pittsburgh and WGR, Buffalo, with Philadelphia to the south), represents the average summer range, no matter which set is used.

Many people have asked whether an ordinary three-tube regenerative set would give any worth-while results on the subantenna of the type illustrated by Fig. 3; and strange as it might seem, the answer is in the affirmative. The signals seemed to be as loud, with a three-tube regenerative set connected to the subantenna, as they were when the set was connected to the usual outside aerial and ground. Of course, the sheathed-ground connection was used in connection with the subantenna. It should also be borne in mind, of course, as mentioned in the first part of this article, that, whether a three-tube set or any other kind is used, proper shielding must be employed in all cases; the shielding being grounded or connected to the earth, i.e., to the ground wire of the set.

These underground antennas for the elimination of static and interference from power lines, etc., can now be purchased in several

sizes, with full instructions for their installation, at a reasonable price. Truth, it is said, is even stranger than fiction, and so it would seem in the case of this new system for the elimination of static. Though all sorts of complicated hookups have been suggested from time to time, together with tremendously elaborate loop-antenna systems, not forgetting the tomato-can eliminators which many fakers have foisted on a long-suffering public at prices ranging from \$1.00 up to \$10.00 or more, the cost of the underground antenna is far less in proportion, if we consider the gains in efficiency and static elimination, than that of any of the systems or "gimmicks" proposed heretofore.

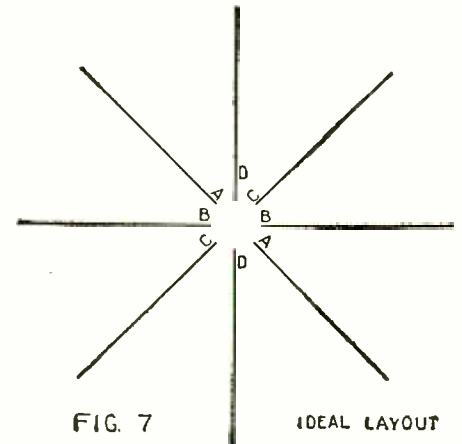

The ideal system of reception, though difficult to install, would afford choice of four pairs of directional leads; those being selected which would bring in most strongly any desired station.

UNDERGROUND TRANSMISSION

The buried or underground aerial presents an excellent medium for investigation by radio amateurs and experimenters everywhere. One of the unusual angles of this underground-aerial idea lies in its use for transmission of radio signals. Dr. James Harris Rogers, conducted a number of tests in radio transmission with an underground aerial several years ago; and he received responses from radio listeners in practically every state in the union.

Those radio experimenters who attempt transmission experiments with a buried aerial should bear in mind that the wire will have to be very heavily insulated, in order to prevent undue leakage and loss of energy. One of the schemes tried out with a buried transmitting antenna was to support the copper aerial wire suitably in the center of a tile pipe, the tile having a diameter of about six inches. For short-wave experiments, of course, the aerial has to be of only short length. In transmitting, the buried aerial will show the same directional characteristics as when it is used for reception.

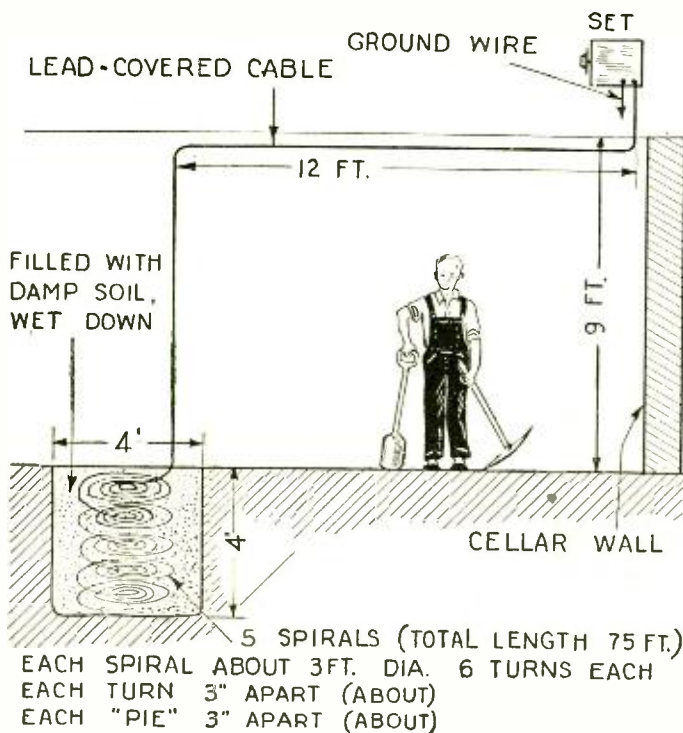

5 SPIRALS (TOTAL LENGTH 75 FT.) EACH SPIRAL ABOUT 3FT. DIA. 6 TURNS EACH EACH TURN 3" APART (ABOUT) EACH "PIE" 3" APART (ABOUT)

FIG. 3

At the left we have the convenient way of installing a sub-antenna in the cellar, as adopted by the writer. The ground connections are shown in Fig. 4. At the right are diagrammed the arrangements necessary to use an underground loop, buried in a suitable box, and rotatable by the hand-wheel above ground.

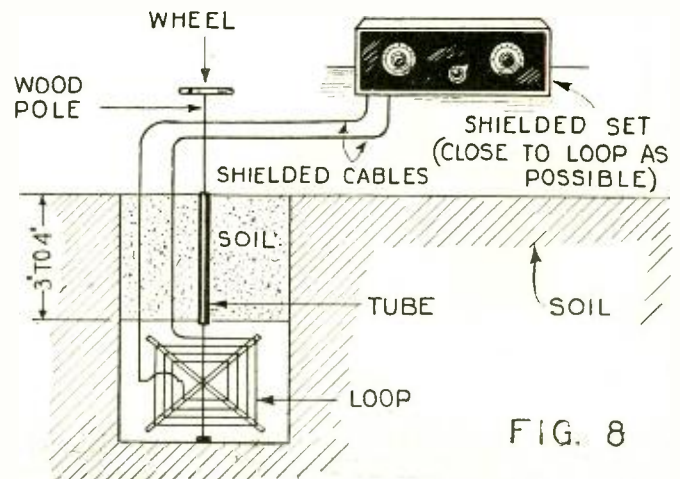
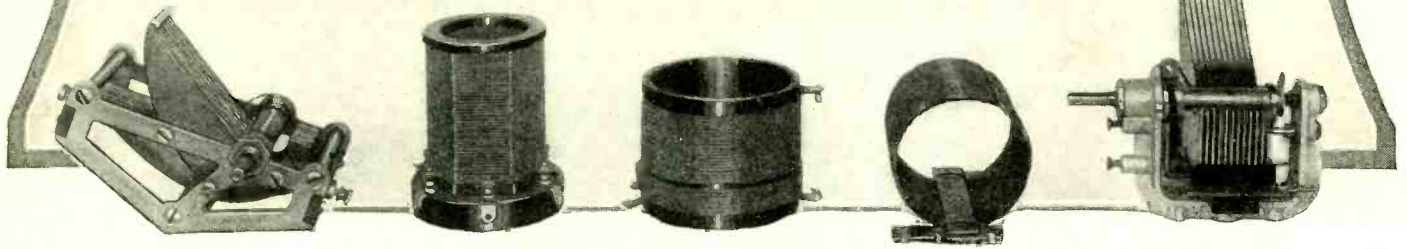

FIG. 8

LOW LOSS



By E. H. RIETZKE and S. K. MACDONALD, Jr.

LOW LOSS" is one of the most overworked and misused expressions heard whenever a group of fans who build their own sets get together. And yet low loss is one of the most important considerations in the construction of a radio receiver, if selectivity and distance are to be obtained. Likewise, in the construction of a transmitter all possible losses must be eliminated if high efficiency is desired.

In many types of receivers losses are deliberately introduced in order to prevent circuit oscillation or to make several circuits tune broadly enough to allow them to be controlled by a single dial. These circuits, however, are never efficient; and, though by using more tubes fair results may be obtained, many six- and seven-tube receivers in the low- and medium-price class are easily outworked by efficient, well-designed and more expensive five-tube sets.

This same statement applies to home-built sets. Many good four-tube sets, using efficient circuits, will outwork some of the more expensive five- and six-tube sets which depend on deliberately-introduced losses for their stable operation.

In order to know how to make a circuit "low loss," and in order to be able to buy really low-loss apparatus we must first understand what "low loss" means and what causes losses in a circuit.

THE ELECTRON THEORY

The only loss in any electrical circuit is due to the expenditure in heat of power or energy. According to the electron theory, which is now accepted by the world of science, all matter is made up of atoms (each the smallest subdivision of an element which

retains all the *chemical* properties of that element). The atom in turn is composed of a *nucleus* (consisting of a number of large positive charges) surrounded by an *equal* number of electrons; each electron having a negative electrical charge exactly equal to the electrical value of one of the positive charges in the nucleus.

The electron is sometimes considered as being merely a charge of negative electricity and as having no mass. This conception of the electron is, however, erroneous. The electron has a mass approximately equal to 1/1875 of the mass of one of the positive charges in the nucleus of the atom.

The mass of the nucleus, however, consisting as it does of a group of the larger positive charges, is so large (compared to the electron) that, for the purpose of computing the mass of any given substance, the mass of the electrons may be neglected.

In any substance, except at a temperature of absolute zero (-273° C., the temperature of interplanetary space), the atoms of the substance are continually moving around in haphazard directions, the velocity of atomic movement depending upon the temperature. Around each atom the electrons revolve, each in its own orbit; and the velocity of the electron, due to its small mass, is much greater than that of the atom. The velocity of the electron varies with temperature and with the construction of the atom, but is usually from a few miles to around thirty miles, a second.

The electrons of all substances are alike. So also are the positive charges that make up the nuclei of all substances, the only difference between different substances being in the arrangement and number of positive

charges and electrons in the various materials.

CONDUCTORS AND INSULATORS

Now in some substances, such as copper, the orbits of the electrons, as the latter revolve around the nuclei of the atoms, are such that it is easy for an electron to break away temporarily from its nucleus and, for an instant, be free in the space between the atoms. If, at this instant, a strong positive charge were placed close to this electron, the electron, being a negative charge, would move towards this positive charge. If the substance were such that there were at every instant many of these free electrons, then many of these electrons would move toward the positive charge. This movement of electrons constitutes a current flow; and this substance would be called a *conductor*.

In other substances, such as glass or bakelite, the arrangement of the electrons around the nucleus of the atom is such that it is very difficult to cause an electron to leave its atom. If the large positive charge is applied to these electrons, the great number of electrons are not at liberty to rush towards this positive charge. In order to cause an appreciable movement of electrons toward the positive charge, this charge must be high enough to actually overcome the attraction of the nucleus for its electrons and to tear these electrons loose. This substance would be called an *insulator*.

How good an insulator it is depends upon how high the applied voltage must be before the electron is caused to leave the nucleus of its atom. However, if this voltage is applied across the insulator there is a *tendency* for these electrons to move toward the positive charge and away from the negative charge; and, while they do not actually leave their respective nuclei, there will be a certain displacement of electrons, or a distortion of their orbits, such that the electrons are farther away from the nuclei on the side of the positive charge than on the side of the negative charge. Occasionally also an electron breaks loose and travels in the direction of the positive charge, thereby producing a small flow of current.

It will be seen that no *substance* is a perfect insulator; the only perfect insulator being a perfect vacuum in which there are no electrons.

HEAT LOSSES

Now, in the conductor, as the electrons move toward the positive charge they do not have a free uninterrupted path. They are continually colliding with the other atoms and, at each collision, heat is produced, due to the mass of the electron striking the mass of the atom. This heat does no useful work and is therefore a loss in the circuit. Also, if the conductor is such that there are not so

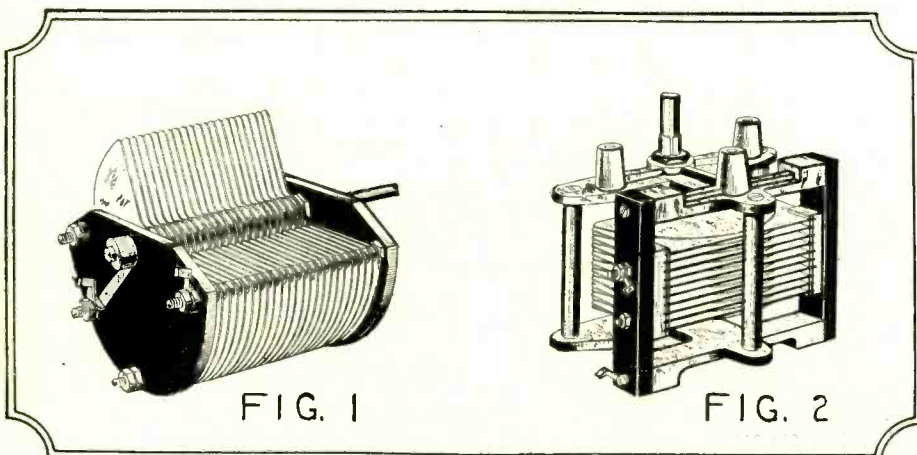
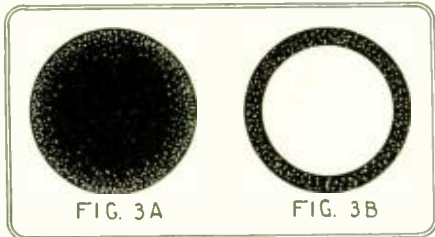

Fig. 1. An old-style variable condenser with the rotor and stator insulated from each other by large end-plates of non-conducting material.

Fig. 2. A modern "low-loss" condenser, with grounded rotor and with a minimum of insulation at the point of weakest electrostatic field.

many free electrons available (as in a conductor of very small diameter, or in a poorer type of conductor such as iron), more power is required to cause a movement of electrons equivalent to that in the better conductor. The greater the power required to produce a given current flow in a conductor,



High-frequency current travels mostly on the surface of a conductor, as shown in Fig. 3A. Therefore, hollow tubing, as in Fig. 3B, is as good a high-frequency conductor as solid wire.

the greater the loss in this conductor must be.

In the insulator there are also power losses. It has been shown that, whenever we apply a difference of potential across an insulator, a displacement of the electrons in the insulator takes place. Now, in order to cause this displacement of electrons, power must be expended in heat. For example, if we had a large crowd of people packed tightly together in a room, and suddenly created a disturbance on one side of the room, most of the people would turn to look. Even though each person held his place on the floor the sudden turn in one direction of the crowd would expend power in heat. If these people were to turn rapidly from one side to another, time after time, a great amount of heat would be generated.

CONDENSER LOSSES

In a radio-frequency circuit the current and voltage reverse several million times per second and, if we have in this circuit a condenser with insulation between the plates, the rapid reversals of voltage across this insulation cause equally rapid displacements of the electrons throughout this insulation, expending considerable power in heat. In some types of transmitting condensers, using wax for insulation, this heat produced when the condenser is overloaded will melt the wax. In a condenser the power loss in the conducting surfaces is very small, even though extremely low-resistance conducting material may not be used, on account of the comparatively large surface of the conductor.

The power loss in a condenser is in the insulating medium between the plates. This loss is called the *dielectric loss* and is very small in dry air. In any of the common insulating materials, i.e., glass, rubber, bakelite, mica, etc., the dielectric loss is great compared to that of air. The best insulator then, from the standpoint of low loss, would be air. The best condenser would be one employing in its construction the minimum amount of insulating material. A good condenser should be one of sturdy construction, with not more than two insulating supports between the rotor- and stator-plate forms; and this insulation should be as small as practicable and should be so arranged that it does not come between the plates themselves. See Figs. 1 and 2.

LOSSES IN R. F. CIRCUITS

Losses in the coils and wiring are the principal losses in radio-frequency circuits. At high radio frequencies the current travels only on the surface of the conductor, the penetration into the center of the conductor becoming less as the frequency is increased. We have seen that the resistance, and therefore the power loss, depends upon the cross-sectional area of the conducting surface. Now a conductor of a size that had a certain resistance to direct current would have a

higher radio-frequency resistance due to this so-called skin effect; that is, as the current travels only on the surface of the conductor, the portion of the conductor actually carrying current would have a smaller cross-sectional area than the entire conductor. As the frequency increases, this effect becomes more pronounced. The best conductor for a radio-frequency circuit then would be one of large surface area. However, the rapidly expanding and collapsing magnetic field around the conductor, cutting the center of the latter, induces eddy currents inside the conductor that produces considerable loss in its center.

To get away from this eddy-current loss and still have a large surface area, it has long been the custom in transmitting circuits to use thin copper tubing of considerable diameter. In this way the conductor has the surface of both the inside and outside of the tubing. (See Figs. 3A and 3B.)

LITZENDRAHT WIRE

In receiver design the use of large copper tubing is not practical. A good substitute, however, is found in Litzendraht wire. This is a conductor formed of many strands of very small wire, each insulated from the others by a coat of enamel. (See Fig. 4.) This is braided in the form of a cable and

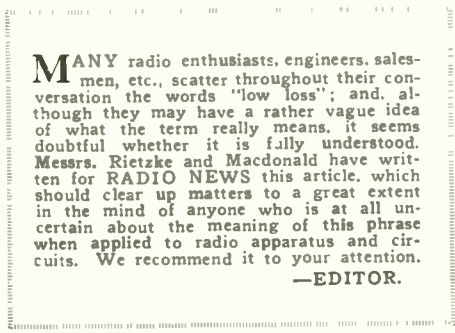

MANY radio enthusiasts, engineers, salesmen, etc., scatter throughout their conversation the words "low loss"; and, although they may have a rather vague idea of what the term really means, it seems doubtful whether it is fully understood. Messrs. Rietzke and Macdonald have written for RADIO NEWS this article, which should clear up matters to a great extent in the mind of anyone who is at all uncertain about the meaning of this phrase when applied to radio apparatus and circuits. We recommend it to your attention.

—EDITOR.

the entire cable insulated with a silk covering. A very efficient and popular size of Litz wire for receiver work is size 20-36; that is, a conductor made up of twenty strands of No. 36 enameled wire. This wire is so small that the radio-frequency current penetrates almost the entire cross-section of the conductor. By using twenty strands a comparatively large surface area is obtained. In the broadcast band a noticeable increase in selectivity and signal strength will usually be obtained if the solid wire on the coils is replaced with a good grade of Litz wire. This material, unfortunately, is rather expensive and is difficult to solder properly.

If, however, we go to the higher frequencies, around several thousand kilocycles, another effect makes itself known. Since these different strands are insulated from each other they act as plates of a condenser, causing considerable capacity effect between strands; the enamel acts as the dielectric of the condenser. Therefore, at high frequencies, while by using Litz we undoubtedly have less loss due to the skin effect, the dielectric loss in the enamel between strands becomes so high as to more than counteract the other increase in efficiency and we actually lose efficiency. For very high-frequency work it is better to use a fairly large size of solid conductor, number 16 or 18, for receiver coils. Still larger wire could be advantageously used at the extremely high frequencies, that is from ten to sixty thousand kilocycles (30 down to 5 meters).

COILS AND CONNECTIONS

The shape of the coil has also considerable to do with the losses. For a long time, due to the low distributed capacity and therefore the wide tuning range available with a given condenser, basket-weave coils were very popular. However, due to the number of sharp bends in this type of coil, the radio-frequency resistance is high. For selectivity and good

signal strength the solenoid type of winding is preferable, even at a slight sacrifice of tuning range.

Another place in receivers where care must be taken is in the connections. While, for the sake of solid connections, solder is usually advisable, the solder should not be used to make the connection. A good electrical connection should be made before soldering and the solder used only to strengthen the connection mechanically. A good grade of soldering flux should be used, with particular care paid to its non-corrosive qualities.

A flux that is not non-corrosive will in time form a corroded coating between the connected conducting surfaces, introducing additional resistance and making the connection mechanically weak. A good grade of rosin-core solder is excellent, but care must be taken not to get too much rosin at the connection. Connections are sometimes found that are held together by the rosin alone. These connections, of course, offer a high resistance.

LOSSES IN SHIELDING

Another common source of loss in some types of receivers is in the interstage shielding. If the shields around the various circuits are not properly designed and of very low-loss construction, they may ruin the set for reception of distant stations. The magnetic field around the coil, expanding and contracting, cuts the shielding of the circuit, inducing eddy currents in the shield. If this shielding is of very low-loss material (a good conductor), these eddy currents will expend very little power in the shield, most of the energy being retransferred back into the tuned circuit. However, if the connections between the various parts of the shield are dirty or loose, power will be expended in the resistance introduced into the paths of the eddy currents by the poor connections. In a transmitting circuit, particularly one employing high power at high frequencies, sparking will sometimes take place at these points of poor contact.

The power in an R. F. circuit receiving energy from a distant station directly from the antenna is extremely small and, if any appreciable amount is lost, the more distant stations will not be heard.

RECAPITULATION

To summarize the points of particular importance:

1. The actual insulating material used in the condensers should be kept at the minimum, and should not be directly in the electrostatic field.
2. A solenoid type of winding using Litz wire will probably give the best all-around results in the broadcast band. At the extremely high frequencies a large size of solid conductor will give the best results.
3. Care should be taken to make all connections *electrically* as well as *mechanically* strong.
4. Shielding should be used with discretion; and care should be used in keeping the resistance of the shields themselves low.

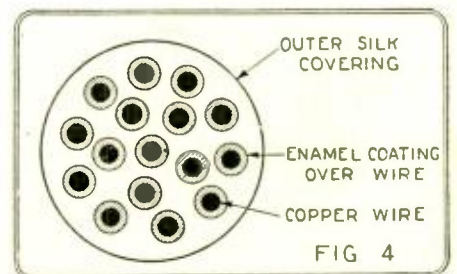

An enlarged cross-section view of Litzendraht wire. The outer silk covering holds the thin wires together, so that they may be handled as a single cable.



How the Strobodyne Works

A Detailed Explanation of the Electrical Actions Within This Circuit



By R. E. LACAULT

SINCE the appearance of the first American articles on the remarkable new Strobodyne receiver, the Editor has received from readers a great many inquiries for a more detailed explanation of its electrical action, and how it differs from that of the more usual superheterodyne and other frequency-changing receivers with which they are familiar.

Mr. Lacault, who is one of the best-known authorities on superheterodynes, having invented the famous Ultradyne system, translated the Strobodyne articles from the original French and worked out the design of the receiver with American components. He has prepared this article for RADIO NEWS to answer these inquiries; it is followed by a couple of the more outstanding letters, to which a specific reply is made, at the end of the article.—EDITOR.

A QUESTION asked by a great many readers is: "Exactly how does the Strobodyne oscillator work?" In order to answer this question, we shall first recall a few facts about vacuum-tube operation which will make the explanation clearer.

The vacuum tube acts as a relay which controls a fairly large amount of current when the voltage on the grid is varied only slightly. When a vacuum tube is connected as shown in Fig. 1, the current of the "B" battery flows through the tube between the filament and the plate; because the electrons emitted by the filament form an invisible conducting path between the two electrodes. The relay action takes place in the following manner:

If we connect a "C" battery as shown in the diagram, with the "-" lead running to the grid, the current furnished by the "B" battery, which flows through the tube, is made

less than before. If the voltage of the "C" battery is increased, the current in the plate circuit decreases further until when the voltage of the "C" battery is high enough, no current at all will flow through the tube. If we reverse the "C" battery, connecting the "+" lead to the grid, we find that the current in the plate circuit increases. The higher the voltage of the "C" battery, the more current flows through the tube; until a certain value is reached; after which the plate current does not increase any more.

When the grid is negative the current through the tube decreases, because the negative charge repels the electrons (which are also negative) and thereby weakens the invisible conducting path formed by the electrons flowing from the filament to the plate. On the contrary, when the grid is made positive, it attracts electrons, just as the plate does, and their flow being increased, a greater current passes through the tube. We now come to another point which is very important in amplifier operation.

When the grid is positive it operates like a small plate, as mentioned, and the "C" battery like a small "B" battery; and, since the electrode attracts electrons, a small current flows through the grid circuit. As the voltage of the "C" battery is increased this current increases also.

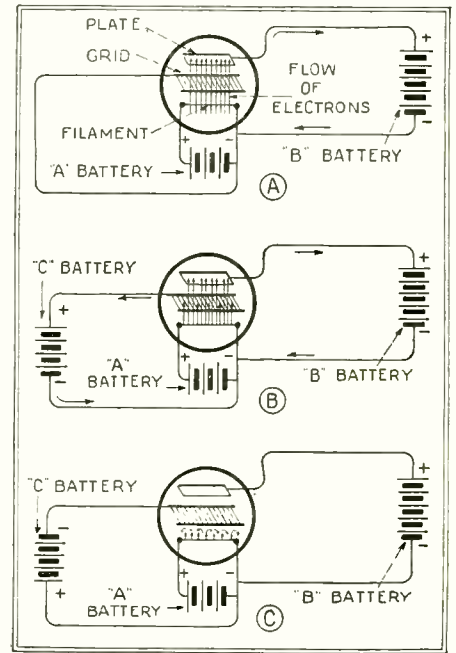

Fig. 1. At A we have the filament-plate flow of electrons in a vacuum tube. When the grid is made positive (B), more current flows between the filament and the plate; while less or even none can pass through the tube as the grid is made negative (C).

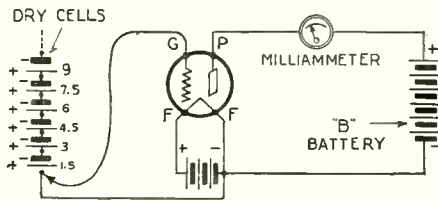

Fig. 2. The circuit that is employed for ascertaining the "characteristic curve" of a vacuum tube, such as shown in Fig. 3.

PLOTTING THE CURVE OF THE TUBE

To make matters clearer and to illustrate the variations of current, we may draw the "characteristic curve" of a typical vacuum tube, say one of the 201A type. You can do this easily if you have a D.C. milliammeter. The circuit is shown in Fig. 2. Procure a piece of paper with vertical and horizontal lines, as shown in Fig. 3, and lay off on the sides the value of plate current as shown, and at the bottom the voltages of the "C" battery which will be used. Light the filament of the tube and read the milliammeter. Then, on the vertical line at the zero mark (which means that no plus or minus voltage is applied to the grid) mark a dot where it crosses the horizontal line extending from the value of current shown by the meter. In a typical case this current is 3 milliamperes (a milliamper is one thousandth of an ampere). Next connect the wire from the grid to "-3" volts in the "C" battery and read the current on the meter again. You will notice that it is less than before. Going up the vertical line above "-3," mark another dot where it crosses the horizontal line starting at the value of current shown by the meter, written on the right; in this case 2 milliamperes.

Then connect the grid wire to "-6" volts and, above this value, mark a dot on the line crossing the value of current shown by the meter. Repeat this for each new dry cell added in the grid circuit, until the meter reads zero. Then draw a line passing through

all the dots, and a curve will be obtained, as illustrated at the left of Fig. 3. This shows clearly how the current in the plate circuit is reduced when the grid is negative.

Now if the whole "C" battery is reversed, a new series of dots may be put down above each value of "C" battery at the right of the zero vertical line. In this case, however, the current will increase as the grid is made more positive, as shown by the curve obtained by joining the new series of dots. The complete curve will look like the one shown in Fig. 3. The "bend" at the upper right shows that, after a certain value of the "+" grid voltage is reached, the plate current does not increase any more; because the plate

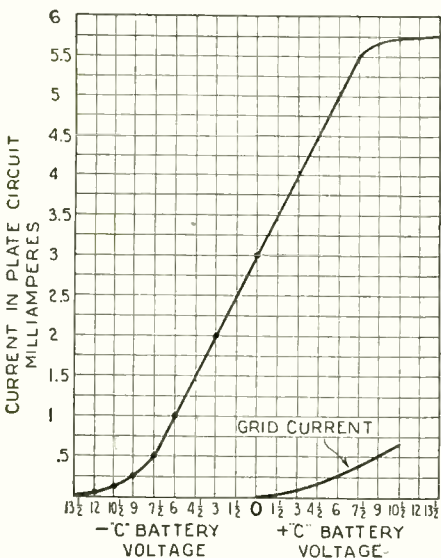

Fig. 3. A typical "characteristic curve" of a vacuum tube, made by using the hook-up in Fig. 2.

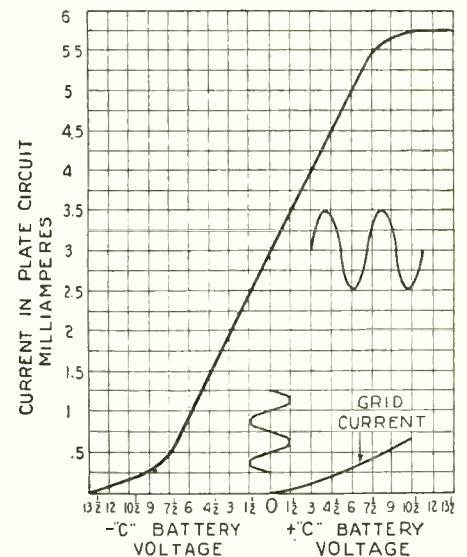

Fig. 4 shows how a signal applied to the grid of a tube varies its voltage, thereby increasing and decreasing the "B" current flowing in the tube.

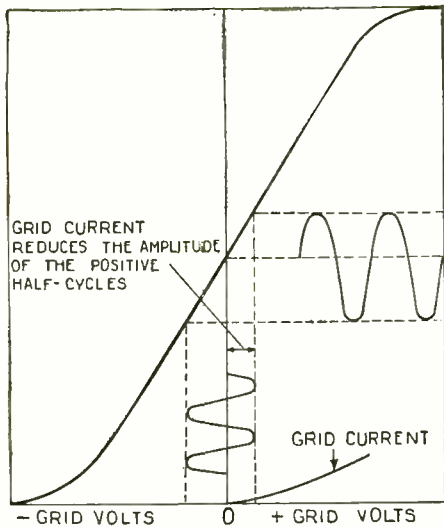

Fig. 5A. Showing how the upper halves of the cycles are smaller in amplitude than the lower halves; this is due to the grid current's damping half of the signals applied to the grid.

becomes saturated; that is, it is unable to attract any more electrons unless the "B" battery voltage is increased. If a higher voltage "B" battery is used, the curve plotted may appear to be shifted to the zero line; so that a high negative voltage from the "C" battery will be required to bring the plate current to zero, and but a very small positive "C" voltage will cause the plate current to reach the saturation point.

THE "GRID SWING"

Looking again at the curve, we can see how a signal is amplified by the tube. When a receiving circuit is connected to the grid and the filament of an amplifier tube, an alternating current is impressed upon the grid; so that it becomes alternately plus and minus when a signal is received. We can draw the line showing this alternating current on the zero line of the curve (Fig. 4), if no "C" battery is used. Supposing that the current received is very strong, it will make the grid successively plus 1½ volts, then 0, then minus 1½ volts, then 0, etc., during each cycle. By following up the vertical lines above "+1½" and "-1½," we can see that the current in the plate circuit will vary from 3 milliamperes up to 3.5, then down to 2.5, then up again and so forth; and we have graphically represented the variations of plate current. It is an enlarged or amplified variation of the alternating current, which was applied to the grid.

If, while the curve of the tube was being plotted, a sensitive meter had been connected in the grid circuit, we could have observed that, as soon as the grid was made positive, a small current started to flow in the grid circuit. This current, plotted on the same paper as the plate current, has the values in-

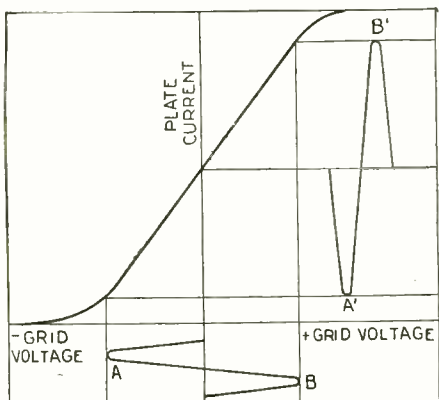

Fig. 6. Curves showing the variations of grid voltage and the corresponding plate current in a vacuum-tube oscillator.

dicated by the curve designated "grid current" in Fig. 3. If we refer again to Fig. 4, we can now see why the grid current causes distortion. When the half-cycles of the amplified signal make the grid positive, the grid current flows through the secondary of the transformer which is connected in the circuit; and this current opposes and reduces the signal applied to the grid. This results in a reduction of the plate current; and, since this does not take place during the other half-cycles which make the grid negative, the result is a deformed plate-current variation, as shown in Fig. 5A.

If the grid were made positive by means of a "C" battery, the distortion would not occur; because the grid current would flow through the circuit all the time and both half-cycles would be damped equally (as shown in Fig. 5B), but the total amplification would be less. This arrangement is used in some forms of radio-frequency amplifier to prevent them from oscillating. With a potentiometer, the grid voltage (and thereby the grid current) may be regulated; and use is made of its damping effect in the circuit to control the amplifying action of the tube.

THE OSCILLATOR

When a vacuum tube is made to oscillate by applying the amplified variations of plate current back upon the grid through a transformer, the grid voltage swings through a wide range; and this, in turn, increases and

FREE
To Strobodine Builders

WE have issued a beautiful decalcomania nameplate to be affixed on the panel of every Strobodine, as illustrated here. This is a neat design, measuring about one inch in diameter, and executed in gold and colors.



All set builders constructing the Strobodine are entitled to this decalcomania. When it is affixed to the panel it appears as if the latter had been engraved with this design. Do not fail to send for it. A postal with your name and address will bring it to you.

decreases the plate current, as explained previously. Fig. 6 shows how this takes place. When the grid is made very negative, as shown at point A, the plate current decreases down to the value at point A'. When the grid goes positive, as at point B, the plate current reaches the value shown at point B'. This happens at the frequency to which the oscillating circuit is tuned.

THE STROBODYNE

In the Strobodine, use is made both of the amplifying action of the tube when the grid is negative, and of the damping effect of the grid current when it is positive. Fig. 7 shows how this is obtained. The circuit L1-C1 is the tuned circuit of the oscillator, and L2 is the plate coil, which transfers the variations of plate current back into the grid circuit to keep the tube oscillating. L3 is the coil through which the signal is applied to the grid. During the operation of the circuit, the following takes place:

If a signal is applied to the grid through coil L3 in phase (in the same direction) with the variation of grid voltage, the two add to each other and the grid is more negative than without the signal voltage, as shown in Fig. 8A. The result is that the plate current decreases further. When the grid becomes positive, however, the grid current flowing through coil L3 is so strong that it chokes the signal voltage; which in this case does not increase the positive voltage on the grid, and thereby the plate current. If the signal voltage across coil L3 is out of phase (in the opposite direction) with the grid voltage,

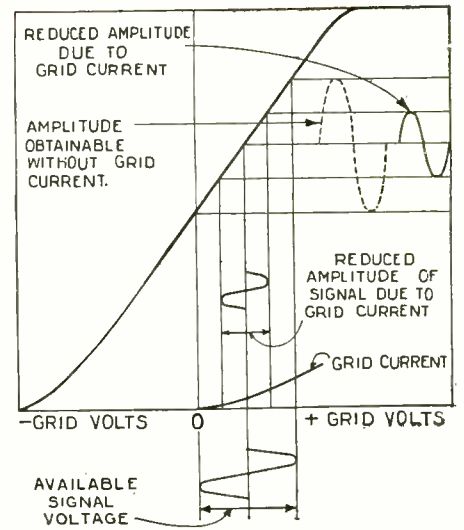

Fig. 5B. This diagram illustrates how a tube amplifies less when the grid is positive, because of the grid current.

it will tend to make the grid positive whenever it is negative. The net result of this opposing effect is that the grid does not become as negative as it would if the signal was not applied. In this case the plate current does not decrease as much as shown in Fig. 8B.

Since the oscillations and the signals are not of the same frequency, this variation in the decrease of plate current takes place at a different rate from either, which is the beat-note frequency that is amplified and detected, through the other tubes. Fig. 8C shows how this takes place during a number of cycles.

WHY THE STROBODYNE IS MORE SENSITIVE

In the usual type of superheterodyne, a first detector is used to rectify the mixed frequencies of the signal and local oscillator. Since the output of a detector is about equivalent to the square of the applied voltage, it follows that for very weak signals there is comparatively little response. For instance, if the input is, say, 1 the output is only 1, because the square of 1 is 1; while if the input is 2, the output is 4. Similarly, for an input of 4, the output is 16. Therefore, the weaker the input voltage, as when distant stations are being received, the weaker the response—other things being equal.

In the Strobodine system, since there is no detector, this effect does not take place and, no matter how weak the received signal, a response is produced in the output circuit. The effect is further magnified by proper regulation of the strength of the local oscillations (by means of the rheostat and the variation of coupling in the tapped coupler), and by the regenerative effect in the Strobodine tube. If you refer to Fig. 7 you will notice that the coil L2 is in the plate circuit of the tube, like the

(Continued on page 401)

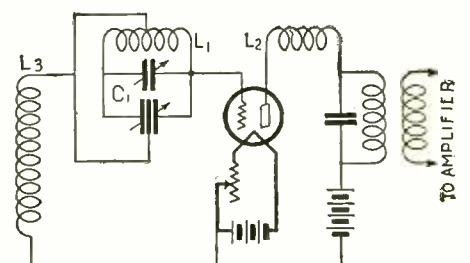

Fig. 7. The Strobodine circuit, which is the heart of the Strobodine receiver.

Recent Developments In "B"-Power-Unit Design

The New Raytheon "R" Tube and Its Use

By JAMES MILLEN

THE strides made during the past two years in the development of "B"-power-supply units have been quite rapid. The first of such devices to be described in any of the radio magazines were assembled mainly from amateur transmitting equipment. In the light of present-day engineering and standards of performance, those pioneer instruments now seem rather crude, costly, and cumbersome pieces of apparatus. Nevertheless, they worked.

During the past few years, since the design of this forerunner of the modern plate-supply device, a great deal of important research work has been done, by both independent engineers and those of many of the more progressive radio corporations, toward the bringing of the "B"-supply unit to its present high state of development.

One of the first and most important steps along this line was the development of the present-day filamentless full-wave rectifier tube—the original commercial form of which, the "S" tube, was used in some of the first amateur socket-power units.

Then came really fine filter circuits, which actually did remove all the "hum" and thus made possible the first "B"-power units suitable for satisfactory operation with receivers having high-quality audio channels and loud speakers of the better grade.

RESULTS OF HIGH VOLTAGE

Perhaps the chief objection to a device of this type was the method employed in obtaining the various "B"-voltage taps. The variable resistors used could be so adjusted as to apply anywhere from zero to several hundred volts to the plate of any one tube. Thus, by careless or ignorant adjustment, the user frequently damaged a detector or other low-voltage tube.

Then again, should the "A"-battery switch be turned off while the "B"-power was kept on at any time, the voltage output of the unit at some of the taps became several times the normal value. This occasionally resulted in damage to the receiver itself—the puncturing of low-voltage by-pass condensers in particular.

As time went on, the rectifier tubes were still further improved; so that they could handle currents much in excess of those required by the average receiver. Thus it became possible to use a combination of pseudo-load and tapped-potentiometer resistors in the design of "B" units with fixed voltage taps which would provide just about the right voltages for the average set. Such

a system is used in many of the high-grade "B"-socket-power devices now on the market.

This method of minimizing voltage variations with changes in external load depends on the shunt, parasitic-resistor load, drawing less current as the useful load is increased. Thus the change in total current drain or load on the rectifier and filter is but a fraction of the change in useful load.

It should be borne in mind that a voltage regulation system of this type, while perhaps less expensive, and certainly worthwhile improvement over its predecessors, has not all of the advantages of a unit employing the new voltage-regulator tube described in this article.

VOLTAGE REGULATOR TUBES

About the same time the first commercial use of the tapped-potentiometer resistors was made, another method of constructing a fixed-voltage "B"-socket-power device made its appearance. This method made use of an additional tube, known as a voltage regulator or "glow tube."

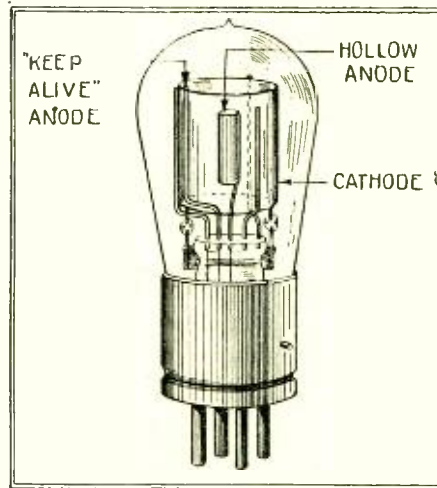

Fig. 3. A phantom view of the new tube, showing the respective positions of the three elements.

supply unit, will hold the voltages obtainable from the various taps to values quite nearly constant, regardless of the variations

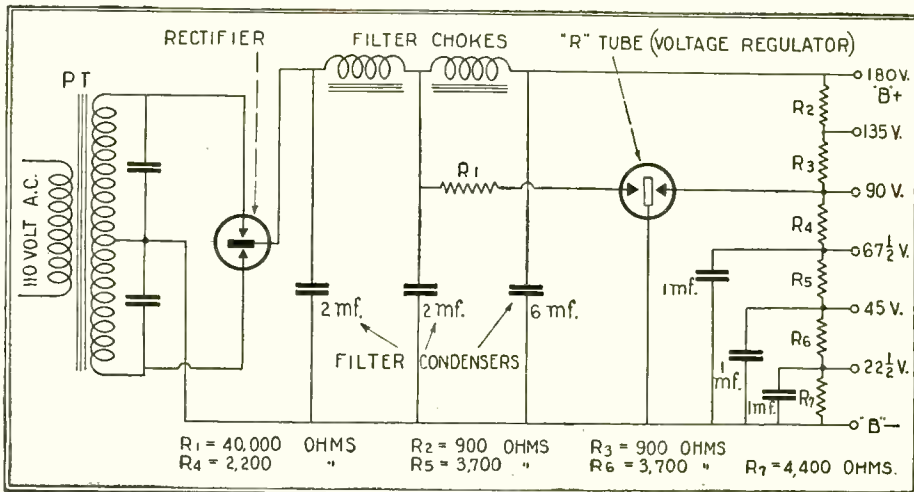

Fig. 4. The circuit diagram of a "B" power unit which uses a double-wave rectifier and a voltage regulator.

The glow tube is a unique device which, when connected in series with a suitable resistor across the output of a "B"-power-

in load that are likely to be encountered in actual practice.

For some time past, the UX-874 (or CX-374) voltage-regulator tube has been available. (Continued on page 386)

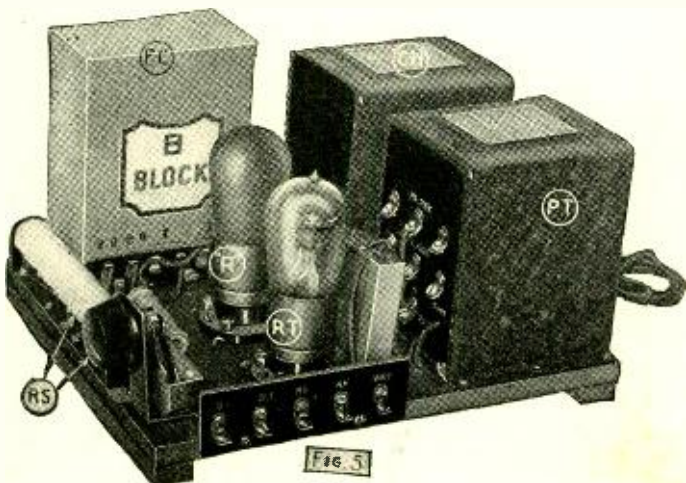

Fig. 5

At the right is a "curve" (Fig. 1), illustrating the operation of a glow-tube of the two-element type. The new "R" tube can be utilized to better advantage than the one whose curve is here shown.

At the left, Fig. 5 shows a home-constructed "B" power unit in which are incorporated the latest principles of design. RT is the rectifier tube and R, the voltage-regulator tube, which has a third element; FC are filter condensers; CH, the filter chokes; PT, the power transformer and RS, the resistors indicated in Fig. 4 above.

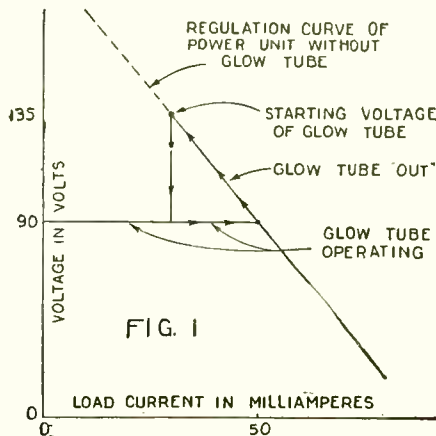

FIG. 1



An Exponential Horn of Square Cross-Section



How to Construct a Substantial Six-Foot Horn Which Will Give Remarkable Low-Note Reproduction

By T. H. MILLAR, Jr.

THIS article will be found an interesting supplement to two which appeared in the August issue of RADIO NEWS; the first, by Mr. Hanna, describing the theory and design of the exponential horn; the second, by Mr. Baumgartner, the construction of such a horn from wrapping paper. Mr. Millar here gives equally simple directions for constructing a somewhat more substantial horn, of square cross-section. These articles should stimulate, as suggested here, further development work on the part of enterprising experimenters.

—EDITOR.

VERY interesting field for experiment was opened to the writer, and several of his friends, by Major J. S. Hatcher's article, "The Passing of Canned Music," in RADIO NEWS for April, 1926. Data very kindly furnished by Major Hatcher have recently been utilized in the construction of a number of exponential horns, and the results have been found most satisfactory. This article will explain the constructional methods adopted.

The horn described is six feet long, and straight. While several of us have been trying to shape it into more compact form, yet preserving its characteristics, such a construction is exceedingly difficult with ordinary facilities. On the other hand, the horn shown here can be made with ordinary mechanical ability and easily-procured materials, and it has such superior tonal qualities that an agreeable surprise is waiting for anyone with the inclination to build one. It will reproduce broadcast programs with a fidelity attained only by the best of speakers.

Major Hatcher's article described and illustrated round horns; but with ordinary tools it has been found much easier to construct a square one and the shape of the cross-section does not appear to be a critical factor, as the square horns have given excel-

lent results. The particular one here described was, with other speakers, tested on a bench regularly equipped with the usual switches for testing speakers alone or in combination. This home-made horn was found to be perceptibly better in tone quality than several standard speakers of good quality.

COMPOSITION BOARD USED

The six-foot length was chosen, on Major Hatcher's recommendation; and the inside dimensions, from the $\frac{5}{8}$ -inch throat to the 20-inch mouth of the bell, are shown in Fig. 1. Dimensions are given for every six inches up to four feet from the throat; and for every three inches thereafter, because of the more rapid increase of the curve. After the points have been laid off, they may be joined by freely-drawn lines, if no suitable curve is at hand. If you have not a straight-edge sufficiently long, a chalk-line may be used for the center.

A single sheet of beaver or wall board contains enough material to make one horn; it is eight feet long, four feet wide, and $\frac{3}{16}$ -inch thick. It is divided into four pieces, as shown in Fig. 2, as a preliminary step. The pattern, laid out as shown in Fig. 1, is then applied to each piece in succession; a strip equal to the thickness of the material being added to one side, on each strip. All four pieces may then be cut out; they are exactly alike.

MOUNTING THE SIDES

The next move is to shellac each piece on the face which will be inside. They are then put together, as shown in Fig. 3, overlapping on successive sides. All are fastened partly by small brads. (It is well to drill the wall board for the brads, as otherwise they are apt to split it.) In this operation, two pairs of hands, though not absolutely necessary, are better than one.

The wall board is sufficiently flexible to accommodate itself to the curve desired,

under pressure; and the outside edges are fastened with gummed mending tape, $\frac{1}{4}$ inches wide. This tape should be creased down the center before it is applied. A ten-yard box, costing fifty cents or less, is ample for one horn.

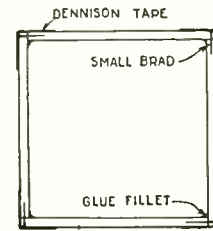

FIG. 3

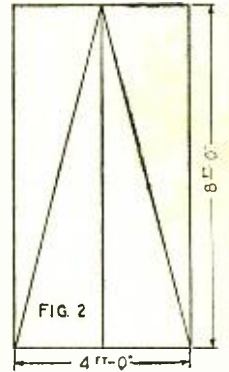
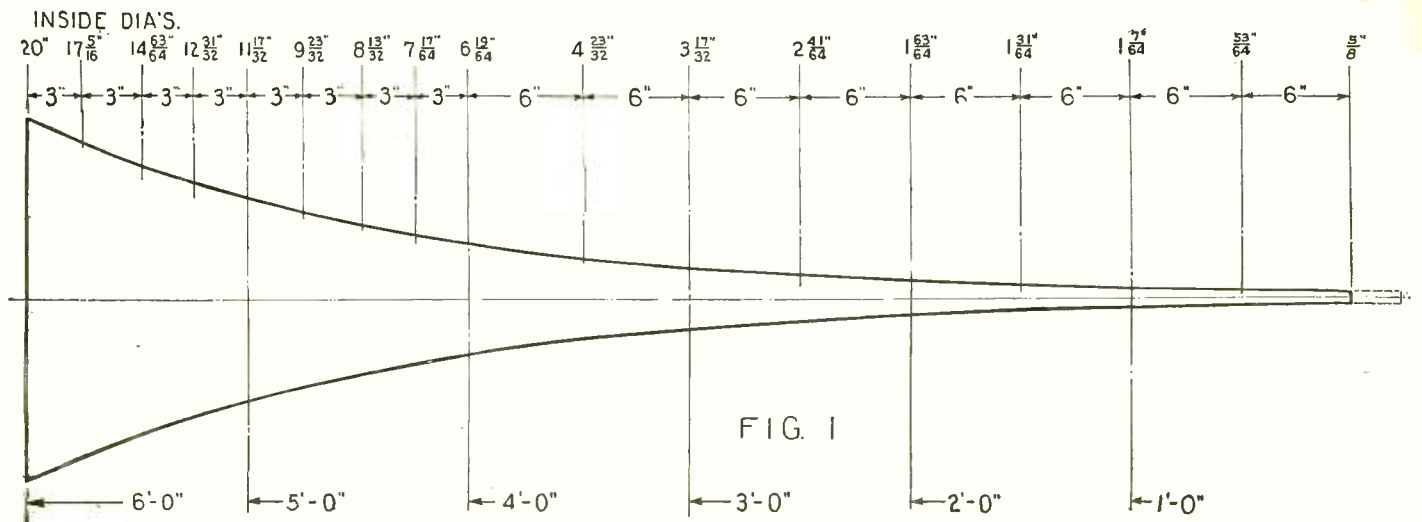

Fig. 2 shows how the wall board is cut, the four pieces necessary being taken from the same sheet. Fig. 3 illustrates the method of making the corners of the square horn airtight.

When everything is in place and dry, a very neat fillet can be made in the inside corners, by carefully running a good glue down each in turn, catching the excess at the bottom. One corner, of course, must dry before work is undertaken on the next. This will prevent pin-hole leaks at the corners.

Before finishing the horn on the outside, try it with your set at full volume. If the bell develops a vibration, due to the thinness of the material, reinforce it with paneling of the same material. After that, the horn may be decorated to suit your fancy.

Although this horn is large, it is easy to handle if it is mounted on a suitable base. The results are so satisfying as to encourage experiment to find a more compact form, which can be mounted in a cabinet, with no sacrifice of efficiency. It is well worth trying, and the writer is still working on this problem with his colleagues.



Above are shown the widths of the six-foot exponential loud-speaker horn at suitable short intervals along its length. The material necessary for making one of these horns can be obtained from a single sheet of wall board. The pattern, which is shown in Fig. 1, is prepared and laid upon the wall board; and the latter is cut along the lines indicated, allowing on one side an extra lap equal to the thickness.



The Radio News Special Shortwave Broadcast Receiver*



Constructional Details of a Set Operating From 15 to 550 Meters

By KENDALL CLOUGH †

IN the September issue of RADIO NEWS the theoretical phases of this receiver were discussed. The main feature of this set is that it is designed primarily for high quality of reproduction, an unusual characteristic for this type of receiver. In a test conducted in the heart of New York City, short-wave signals from stations KDKA, WLW, WGY (2XAF and 2XAD) and others were heard with excellent volume and quality of reproduction. In the near future it is to be expected that more and more stations will drop down into the short-wave region; so it will be well worth the constructor's time to familiarize himself with this type of apparatus.

For the purpose of contributing to the experimental development of short-wave broadcast work, the RADIO NEWS station, WRNY, New York, has been equipped with a new short-wave transmitter, which will be in operation when this issue is read, on 30.91 meters—ten times the frequency of its longer-wave transmissions. Its hours of operation will be, normally, from 10:30 a. m. to 1:00 p. m. on all week days; from 2:30 p. m. to 5:15 p. m. on Mondays, Wednesdays and Fridays, and to 3:00 p. m. only on Tuesdays and Thursdays; from 7:00 p. m. to midnight on Tuesdays and Fridays, from 9:00 p. m. to midnight on Wednesdays, and from 7:00 p. m. to 9:00 p. m. on Saturdays; from 11:00 a. m. to 1:00 p. m. and from 2:00 p. m. to 7:00 p. m. on Sundays. These hours are Eastern Standard Time (Daylight Saving Time, one hour faster, only until the last Sunday in September) which is five hours slower than Greenwich Mean Time and six hours slower than Western European Summer Time.

While these transmissions may be impossible to receive in a zone of "skip distance," a few hundred miles around New York, they will undoubtedly be received easily in the southern and western United States, and in most other countries, where suitable receivers are tuned to this wavelength. The experimental tests, conducted on one-tenth the power, have already been heard across the Atlantic; and, with the full power, these short waves will undoubtedly be receivable frequently, if not consistently, throughout the Antipodes. We shall welcome reports on the reception of this station, by amateurs and others with short-wave receivers; as well as the experiences of those who have been working with the short-wave receiver described in this article.—EDITOR.

THE average radio broadcast enthusiast in the United States does not give much thought to the wavelengths upon which the concerts he listens to are transmitted. That is to say, as long as he gets a station's programs with a minimum of interference and in most cases a maximum of volume, he is perfectly satisfied. But a large group of people in far-off lands are not thinking a great deal about this sub-

ject, for which Mr. Average Fan in America cares so little.

ODDITIES OF SHORT WAVES

The very short wavelengths—and by this we mean those under 100 meters—have been found to be much more satisfactory for transmitting over long distances than those between 200 and 550 meters. The group of shorter waves has characteristics all its own, and is in some respects the antithesis of the waves in the broadcast band. For example, take an ordinary 1-kilowatt transmitter operating on a wavelength of 350 meters. It is a well-known fact that, the nearer a receiver is to the transmitter's antenna, the stronger will be the signals picked up. In the case of a wavelength under 50 meters

for their daily information as well as entertainment. This receiver is simple of construction and can be depended upon to give excellent service in all respects. Static for some reason or other does not affect the short-wave signals as much as it does those transmitted above 200 meters. This receiver should be, therefore, especially of interest to those living near the Equator; for there static is at its worst almost constantly.

Elsewhere in this article will be found a list of the stations throughout the world which transmit programs on wavelengths under 100 meters.

THE SHORT-WAVE CIRCUIT

Heretofore the majority of short-wave receivers have been designed with audio amplifiers to amplify only a narrow band of A. F. frequencies, in the vicinity of 800 or 1000 cycles, as they were constructed with "code,"

The panel view of the RADIO NEWS Special Short Wave Broadcast Receiver. The dials marked C1 and C2 control the two variable condensers, used for tuning; R1 controls the filament rheostat and S indicates the filament switch.

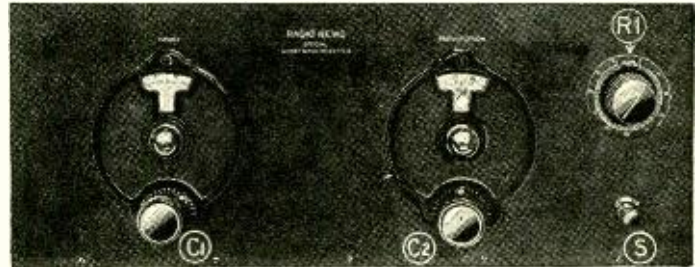

the contrary is the case; so much so that, outside the station's immediate field, the signals are not heard with sufficient strength to operate a loud speaker unless the receiver is as much as 1000 miles from the transmitting antenna. This zone of silence is measured by what is termed the "skip distance."

Skip distances vary with the wavelength of the carrier wave employed. It is believed by many experimenters that waves under 8 or 10 meters have a skip distance so great that, once released, they never return to earth. Also the atmospheric conditions, as well as the time of day and season of the year, play important roles in the satisfactory reception of short-wave signals. There is still much opportunity for research along these lines.

The set described in this article is one that will be welcomed by those persons who are living in out-of-the-way regions, far from the broadcast centres, yet depend on radio

or telegraph reception primarily in mind. Naturally, when phone transmission was picked up with a receiver so designed, the reproduction left much to be desired. However, the Radio News Special Short-Wave Receiver has been so designed that it will be first and foremost a set to please the broadcast fan.

As explained in the September issue of Radio News, the commonly-used grid condenser and grid leak are not satisfactory for a set of this type. Such a combination has low impedance for radio-frequency currents and a high impedance for audio-frequency and direct currents. The impedance employed should, on the contrary, have a low impedance for radio-frequency currents and a high impedance for audio-frequency, yet a low resistance for direct current. The best impedance that will satisfy these terms is an iron-cored inductor shunted by a small fixed condenser. In the receiver herein described the secondary of a 2:1 audio-frequency transformer is shunted by a .0001-mf. condenser, this combination replacing the conventional grid leak and condenser. (See circuit diagram.)

INTERCHANGEABLE COILS

In order to cover the desired wavelengths, special plug-in coils are used, these being shown in an accompanying illustration. The wavelength ranges for these coils, as given by the manufacturers, are as follows:

No. 1 (3 turns) 15-35 meters; No. 2 (8 turns) 32-68 meters; No. 3 (19 turns) 57-133 meters.

Larger coils may be had that will cover the 125-250- and 235-550-meter bands, thus making possible reception on the broadcast band without difficulty.

These ranges will vary somewhat with different condensers and different detector tubes, but the designations given will aid to some extent when tuning in. As may be seen in the top view of the set, the inductances are so mounted that they can be plugged into the base marked L, thus altering the wavelength range of the receiver.

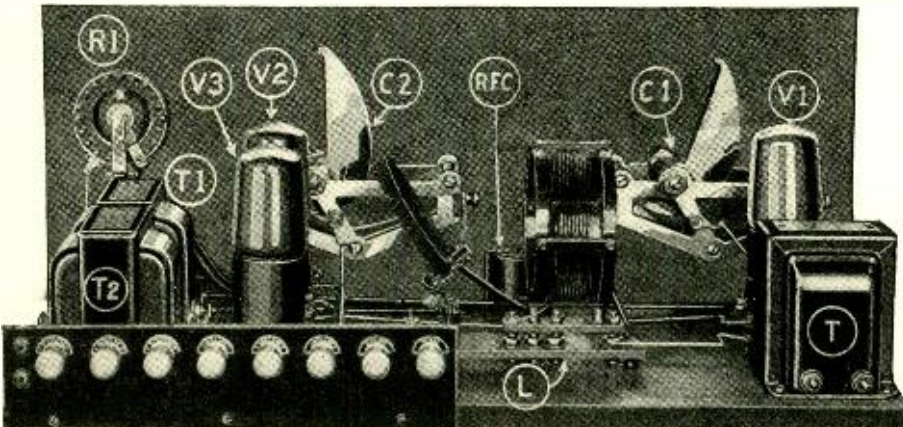

One of the plug-in inductances is here shown placed in its mounting. The various parts are marked with the same symbols as they bear in the wiring diagram.

* RADIO NEWS Blueprint Article No. 31. † Director, Research Laboratories of Chicago.

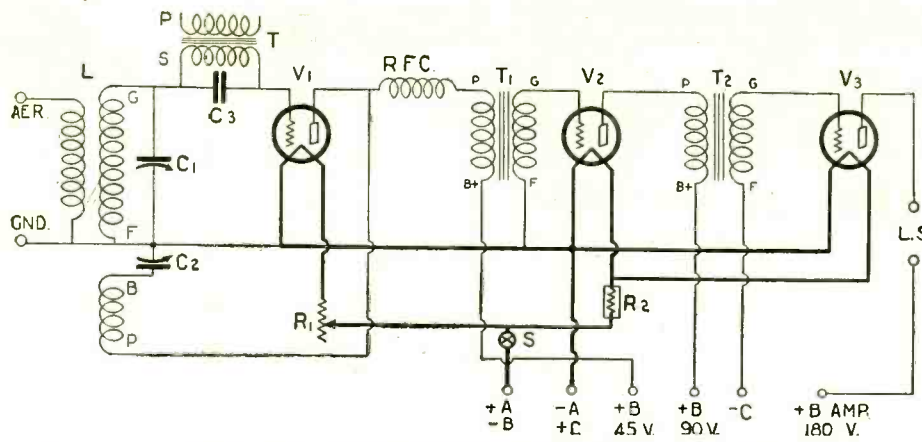

The schematic diagram of the RADIO NEWS Short-Wave Receiver. This set has a regenerative detector and two stages of transformer-coupled A.F. amplification.

The secondary of the tuner, L, is shunted by a S. L. F. variable condenser, C1, having a capacity of 140 mmf. In series with this

parallel arrangement is a 250-mmf. condenser, C2, which is also in series with the tickler coil, BP. This tickler coil being

fixed, regeneration is controlled by the condenser, C2. The aerial and ground are connected permanently in the set to the primary coil, which is so hinged that its coupling to the secondary can be varied.

HIGH-FREQUENCY CAPACITY EFFECTS

A special choke coil, RFC, is connected between the plate of the detector tube, V1, and the primary of the first audio-frequency transformer. This choke is employed, so that the self-capacity of the primary of this transformer will not short-circuit the radio-frequency currents in the plate circuit of the detector tube. Many of the choke coils that were tried in this circuit had to be discarded because of the "holes" in the tuning range; i.e., points at which the set refused to oscillate, regardless of the amount of capacity used in the 250-mmf. regeneration condenser. The choke used in the circuit is one which has a uniform effect over the entire wavelength range of the set.

The audio-frequency amplifier is composed of two stages of transformer-coupled amplification. Either a 112- or a 171-type

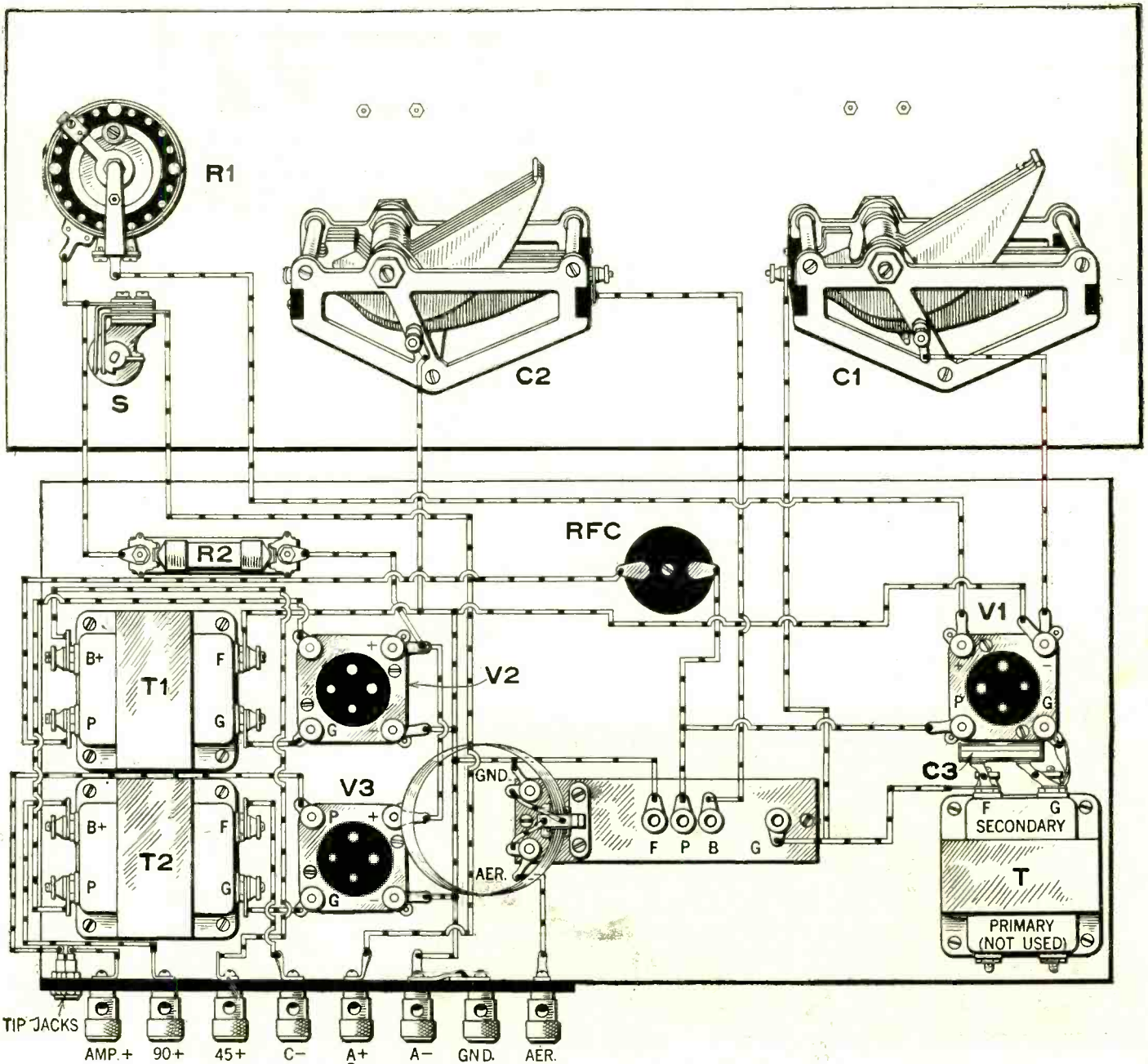

The wiring diagram shows exactly how each connection should be made. This is most important in a short-wave set; as frequencies much higher than those in the broadcast band are encountered.

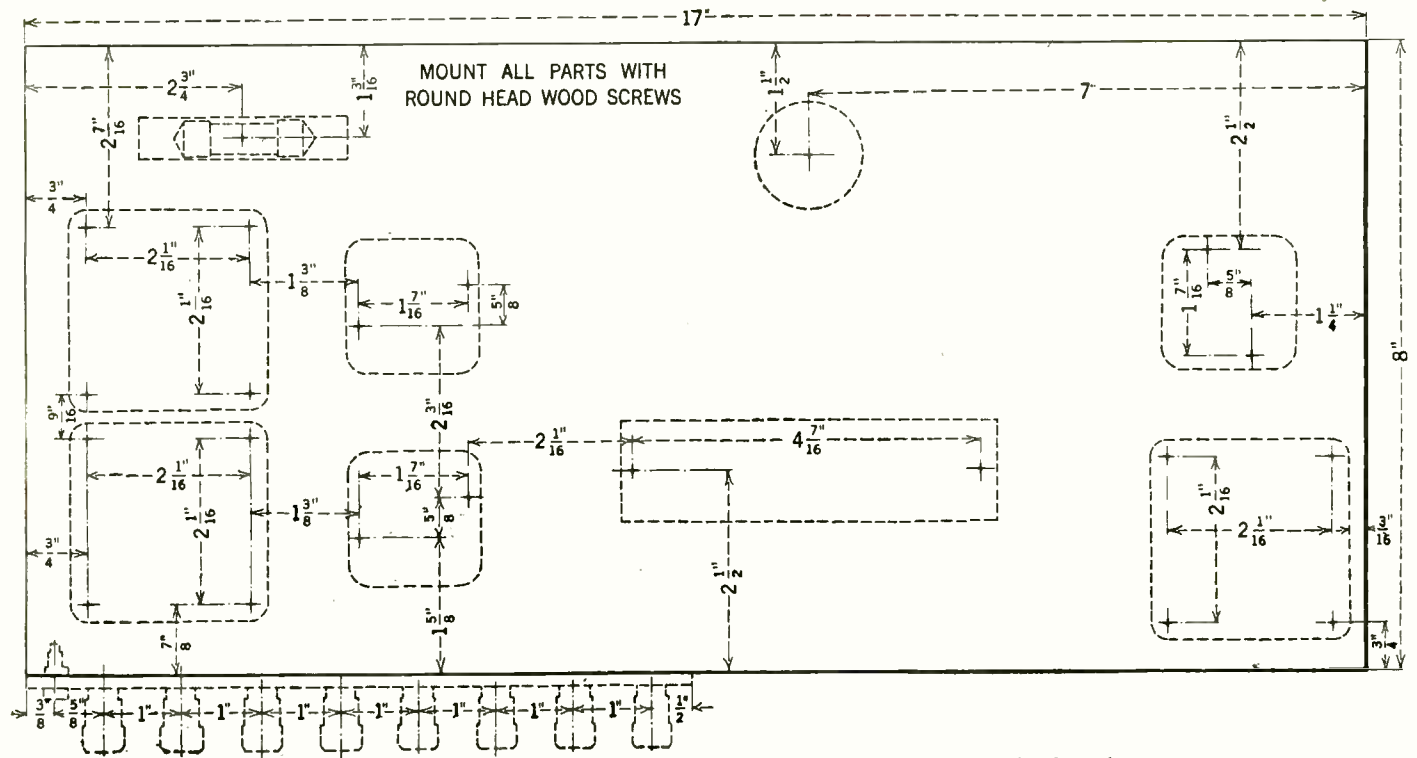

This diagram shows the location of the instruments on the baseboard, which is of wood.

power tube can be used in the last stage with the appropriate negative grid bias at the "C" terminal. A voltage of 180 is indicated on the schematic diagram, but the value at this point will depend upon the type of power tube employed.

ASSEMBLY SUGGESTIONS

As may be seen from the accompanying sketches, the construction of the RADIO NEWS Special Short-Wave Receiver is very simple. A wooden baseboard is used, with a panel of such length that when the apparatus is placed in its proper position crowding will not result. It must be remembered that in a short-wave receiver many precautions must be taken that would not be necessary in a receiver working on waves of only one tenth the frequency.

The transformer, T, the secondary of which is used for the impedance leak in the grid circuit of the detector tube, is located at the rear of the baseboard in order that there may be no chance for hand-capacity effects in the tuning of the set. Immediately in front of this transformer is placed the detector tube socket, thus making the leads in this portion of the circuit as short as possible.

The two variable condensers are mounted on either side of the center of the panel. At the right side of this panel are mounted the rheostat, R1, and the filament switch, S. The

two audio-frequency transformers, T1 and T2, are placed side by side along the right-hand edge of the baseboard, thus leaving sufficient space for their accompanying vacuum tubes. The inductor mounting is located in the middle of the baseboard. The radio-frequency choke coil, RFC, is placed near the front panel between the two condensers.

ADJUSTMENTS AND TESTS

Since this receiver is intended primarily for the reception of short-wave broadcast

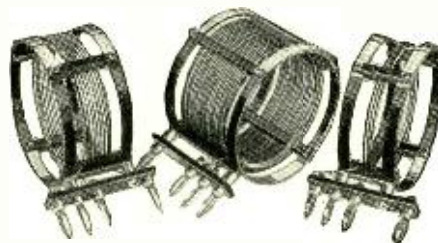

The three plug-in coils which are employed to make the receiver cover a wavelength range from 15 meters up to 130.

stations, it was decided to alter the three standard short-wave plug-in coils in order to make them cover the broadcast transmitters in the most satisfactory fashion. The many

hundreds of short-wave amateur stations, using code, fall in or near the broadcast bands; so that the experimenter who knows the Continental code will have little difficulty in picking up "ham" transmitters all over the world.

Starting with the large 19-turn coil, it was found that with the condenser used it did not tune down to 57 meters, as the manufacturer specified. Its lowest range was about 65 meters, and therefore it could not receive either WLW on 52 meters or KDKA on 62. It was cut down to 12 turns, and then easily brought in WLW at 10 on the dial and KDKA at 45. The wave-length range of this coil is now 46-85 meters, which also takes in the American amateur phone band.

The eight-turn coil was next tried. This also failed to tune down as low as specified—32 meters. It would go down only to 39 meters, thus skipping WGY (2XAF) on 32.77 meters, and PCJJ, Eindhoven, Holland, on 30.2 meters. Two turns were removed from this coil, leaving six. It then covered the band from 27 to 46 meters, taking in thereby the most important DX bands used by transmitting amateurs all over the world. Using this receiver, the operator of station 2CRB, in Brooklyn (New York City), communicated with stations in France, Germany, Australia and New Zealand.

With the three-turn coil, it was found impossible to make the receiver oscillate until the transformer secondary was replaced by a regular grid leak of five megohms value. The set then worked remarkably well, bringing in WGY (2XAF), several Australian and British transmitters, and numerous European amateurs.

LOCAL CONDITIONS

In the experiments undertaken in New York City several aerials were tried and very little was found to choose between them, in either signal strength or selectivity. It was also found that the set is remarkably easy to tune, as there is very little trouble from body capacity.

In experimenting with the set it may be found that its operation does not come up to expectation. This may be because of the locality of the antenna or some other factor over which the operator has no control. In some cases the introduction of a 2-megohm grid leak in series with the impedance in the grid circuit of the detector tube has been found to improve matters considerably. A

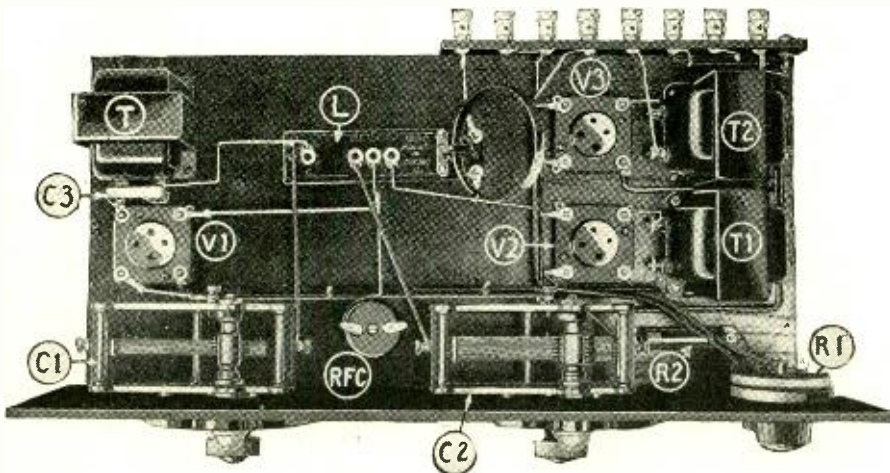

Top view of the RADIO NEWS Special Short-Wave Receiver. C1, tuning condenser; C2, regeneration control; L, plug-in coil base; T, grid choke; C3, grid condenser; R.F.C., R.F. choke; T1, T2, A.F. transformers; R1, R2, filament resistors; V1, V2, V3, tube sockets.

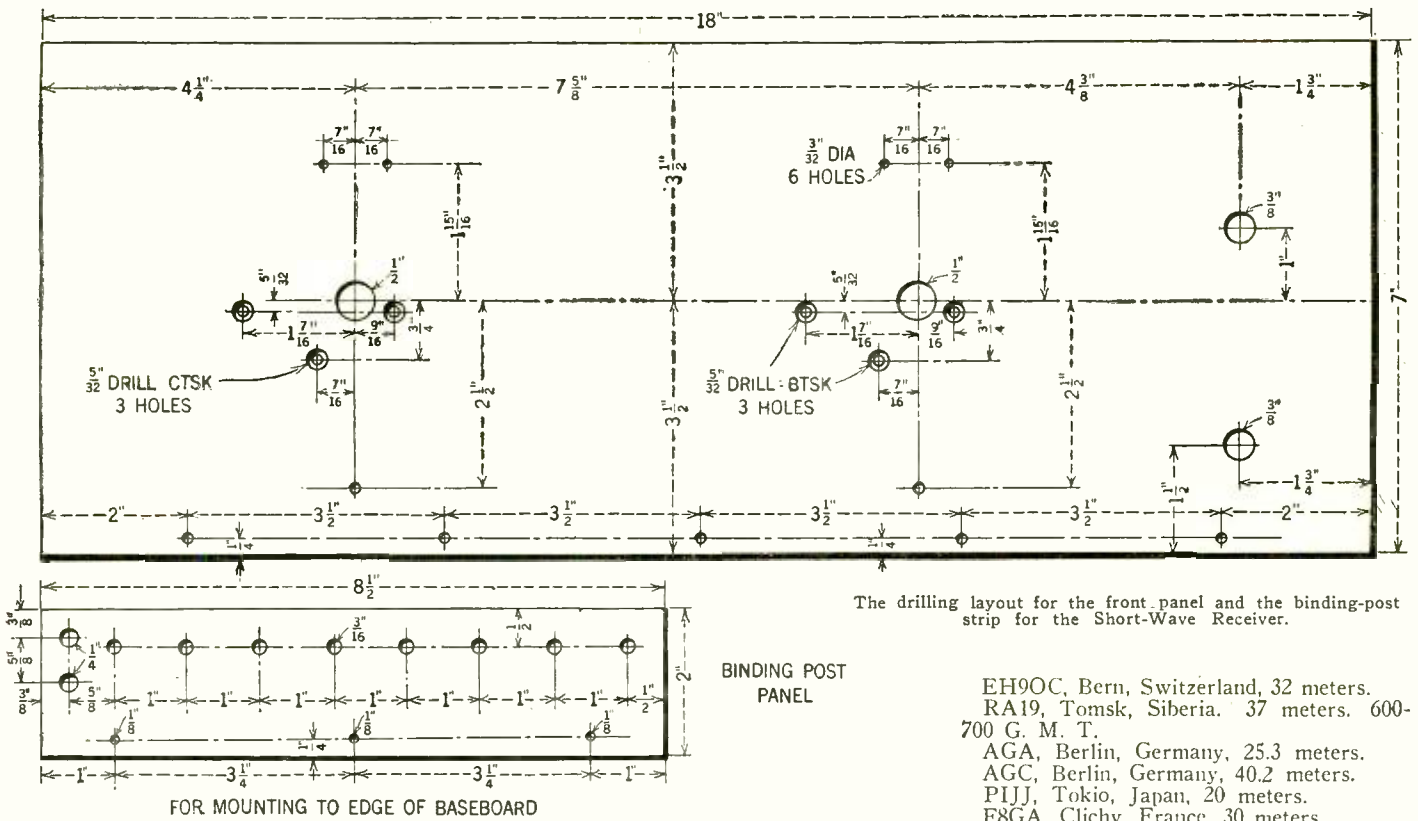

The drilling layout for the front panel and the binding-post strip for the Short-Wave Receiver.

double-circuit jack in the output of the first stage of the audio-frequency amplifier may come in useful for headphone reception, in case there is too much of a background noise when both stages are used. This could be mounted on the binding-post strip at the rear of the baseboard.

An output filter device has not been shown but may be inserted ahead of the loud speaker, in the customary manner, when the higher voltages are used. The seeker after short-wave DX will use the phones, with lower voltages, considerably in his journeying among the numerous messengers of the short waves.

An excellent quality of reproduction, however, has been obtained from the program broadcasts of the larger stations; on the wavelengths most suitable to their distance from the receiver, and also at the time of day best suited to those wavelengths. Extreme distance reception, though better when unbroken darkness lies between transmitter and receiver, is possible in broad daylight on the shortest waves, especially below 30 meters.

SHORT-WAVE BROADCAST STATIONS

As yet but a very small number of regular broadcast stations in the United States have installed short-wave transmitters upon which are sent out anything but experimental programs. However, it will be of interest to the short-wave fan to know where to hunt for stations in this region of the radio "spectrum"; so below will be found a list showing the wavelength used and the time of transmissions, whenever possible; though the latter, especially, are subject to change on brief notice.

KDKA, Pittsburgh, Pa., 14 and 62 meters. Expects to change soon to 26 and 52. Transmissions almost nightly.

WGY, Schenectady, N. Y. 2XAF, 32.77 meters. Transmissions on Tuesday, Thursday and Saturday nights from 6:30 to 12, E. S. T. 2XAD, 22.02 meters, on Monday, Wednesday, Friday and Sunday nights.

WLW, Cincinnati, O. 52.02 meters. Transmissions nightly.

WABC, New York. 64 meters. No definite schedules, experimental.

WRNY, New York. 30.91 meters. Experimental.

2LO, London, England, rebroadcast on 23 and 33 meters by G2NB, Caterham, Surrey, England, between 4 and 5 p. m., E. S. T. (2100 to 2200 GMT).

PCJJ, Philips Laboratories, Eindhoven, Holland, 30.2 meters. Usually transmits Tuesday and Thursday, 1820 and 2020 G.M.T.

CF, Canadian Marconi Co., Drummondville, Quebec. 32.0 meters. Experimental.

PKXX, Malabar, Java. 17.4 meters. Monday, Wednesday and Friday, 2:20-7:20 P. M. Tuesday, Thursday and Saturday, 7:20 P. M.-12:20 A. M. (Java is 12 hours and 20 minutes ahead of E. S. T.). This station, almost half round the world, represents the greatest distance to be obtained on short-wave broadcasts.

- EH90C, Bern, Switzerland, 32 meters.
- RA19, Tomsk, Siberia. 37 meters. 600-700 G. M. T.
- AGA, Berlin, Germany, 25.3 meters.
- AGC, Berlin, Germany, 40.2 meters.
- PIJJ, Tokio, Japan, 20 meters.
- F8GA, Clichy, France, 30 meters.
- JIPP, Tokio, Japan, 35 meters.
- JB, Johannesburg, South Africa, experimental. Reported on 20 to 25 meters and around 60.

These stations have phone transmission; but it should be remembered that, scattered all over the world, are hundreds of amateurs who not only transmit in code but use phone also, as well as an increasing number of point-to-point short-wave phone stations.

The transoceanic short-wave beam transmitters can also be heard with this receiver, if the location of the set is in approximately a direct line with the transmitter and receiver. The beam of waves spreads about 15 degrees in 3,000 miles or over a width of 700 miles; and if the receiver is in this area there is comparative certainty that the signals can be picked up.

SYMBOL	Quantity	NAME OF PART	REMARKS	MANUFACTURER ★
L	3	Set Of Coils	Plug-In Type	1
C1	1	Variable Condenser	.00014 mf. S.L.F. type	2 4, 8, 10, 13, 14, 15, 20
C2	1	Variable Condenser	.00025 mf. S.L.F. type	2 4, 8, 10, 13, 14, 15, 16, 20
C3	1	Grid Condenser	.0001 mf.	3 10, 15, 17, 18, 19, 21, 22
	3	Sockete	UX Type	4 14, 15, 16, 24, 25, 30
R1	1	Rheostat	20 ohms	5 12, 15, 16, 19, 21, 25, 26, 27
R2	1	Amperite	Automatic Filament Rheostat 3 A-type	6
PFC	1	R.F. Choke		1 14, 23
T1 T2	3	A.F. Transformers	2-1 Ratio	7 2, 12, 14, 16, 28, 29, 30, 31
S	1	Filament switch		5 4, 15, 19, 21, 25, 32
	2	Dials	Vernier type	8 2, 12, 14, 15, 16, 30
	2	Binding Posts		9 5, 10, 15, 16, 32
	2	Tip Jacks		10 5, 22, 25
	1	Base Board	8" x 17" x 1/2" wood	
	1	Panel	7" x 18" x 3/16"	11 33, 34
	1	Binding Post Strip	8 1/2" x 2" x 3/16"	11 33, 34

NUMBERS IN LAST COLUMN REFER TO CODE NUMBERS BELOW.

1 Aero Products, Inc.	2 Karas Electric Co.	3 Polymet Mfg. Corp.
4 Benjamin Electric Mfg. Co.	5 Yaxley Mfg. Co.	6 Radiall Co.
7 Thorngren Electric Mfg. Co.	8 National Co.	9 R.F. Radio Laboratories
10 Ameco Products, Inc.	11 Wharton Fabricators, Inc.	12 All-American Radio Corp.
13 General Radio Co.	14 Silver Marshall, Inc.	15 Pilot Electric Mfg. Co.
14 General Radio Co.	17 Aerovox Wireless Corp.	16 Bakelite Condenser Corp.
15 Electro, Inc.	20 United Scientific, Lab. (U.S.L.)	21 Central Radio Co.
16 Leslie F. Mather Co.	21 Woke Engineering Lab. (WEL)	24 Allerton Electric, Inc.
17 Herbert H. Pratt, Inc.	26 Allen Bradley Co.	27 American Mech. Lab. (Cincinnati)
18 Dongan Electric Co.	29 Samsom Electric Co.	30 Emerson Tully Mfg. Co.
19 American Transformer Co.	32 C.P. Lutz, Inc.	33 American Wire Rubber Co. (Patton)
34 Laclede Corp.	35	34

★ THE FIGURES IN THE FIRST COLUMN OF MANUFACTURERS INDICATE THE MAKERS OF THE PARTS USED IN THE ORIGINAL EQUIPMENT DESCRIBED HERE.

If you use alternate parts instead of those listed in the first column of manufacturers, be careful to allow for any possible difference in size from those originally used in laying out and drilling the panel and sub-base.

From copyright, 1927, by Pub. Co.



The Knickerbocker Four*

A Set in Which an Automatic Regeneration Control Eliminates One Knob



By ROBERT HERTZBERG

FOR simplicity of construction, ease of operation and general effectiveness, the inexpensive little four-tube set described in this article is in a class by itself. It incorporates all the well-known electrical advantages of sets of the one-stage R.F., regenerative-detector type, along with the additional feature of automatic regeneration control. The ingenious combination of the tickler coil with the condenser of the detector tuning circuit eliminates what was previously a critical adjustment, and reduces the number of continuously-variable tuning controls from three to two—one for each hand.—EDITOR.

THE basic circuit which has enjoyed probably the greatest popularity among home builders of radio receivers is that incorporating a single stage of tuned radio-frequency amplification, a regenerative detector, and two stages of transformer-coupled audio amplification. This fundamental arrangement is the basis of scores of sets, which have been presented under a variety of names by radio publications and radio manufacturers; and the wide favor and application it has been accorded is indication enough of its general efficacy. The Browning-Drake and the Hammarlund-Roberts are two outstanding exemplifications of this highly successful hook-up.

The methods, however, employed for stabilizing the R.F. circuit and for controlling the regenerative action of the detector tube of the circuit, vary considerably. In practically all the variations of the hook-up that have appeared so far, the adjustment for neutralization of the R.F. tube is left undisturbed when once made; but in all the sets, (without exception, it can safely be stated), the regeneration control is a manual one, which requires manipulation whenever the tuning dials are turned. Of course, it is possible to leave this regeneration knob (whether it represents a tickler coil, a feedback condenser, or a variable resistor) at a low setting, tune in a station to maximum strength, and then raise the knob until the signals are boosted to the desired volume.

Or, if we prefer, this control may be turned on full, the set tuned, and the knob setting then reduced until the heterodyne whistle disappears.

A little reflection will show that neither of these two methods is a particularly good one. If the first is used, the receiver is not operated at its maximum sensitiveness when the operator is "fishing" for stations at the

for a set of this kind is one in which the regeneration control is combined with one of the tuning condensers, in such a manner that the regenerative action is automatically regulated by the dial attached to the condenser shaft, and thus maintained at its peak value (just below the point where the tube "plops" into oscillation) at all settings of this dial. If such an arrangement can be effected, the receiver will be really a "two-handed" one; it will work at maximum efficiency at all times (regardless of the skill of the operator); and it will not squeal or radiate.

At the right is shown the front panel view of the 4-tube Knickerbocker receiver. The dials, C1 and C2, control the variable condensers having similar designations; R1 and R2, filament rheostat controls; SW, filament switch; and TJ, tip jacks for loud speaker.



very time when the unequalled advantages of regeneration are most desired; if the second is used, the tuning will be critical and the set will squeal horribly every time it is tuned to the carrier-wave of a broadcast station. It will also radiate an irregular wave of its own which will raise havoc in neighboring receivers, and it will make its operator the most despicable radio character in his community—a "blooper."

The necessity for handling the regeneration control simultaneously with the tuning knobs, in order to maintain the receiver in a sensitive condition, is soon realized by the owner of any of these combination R.F.-regenerative-detector outfits. The regeneration knob assumes an importance equal to that of the tuning dials, and must be considered as a third major control, not merely as an auxiliary. Thus, any of these receivers is actually a three-dial instrument and not one of two dials. Its operator cannot hope to obtain the results of which the receiver is truly capable until he has developed a rather unusual dexterity in one of his hands.

It is obvious that the ideal arrangement

SOLUTION OF THE PROBLEM

A simple, inexpensive, easily-constructed four-tube set embracing these very features has actually been constructed, and RADIO NEWS takes great pleasure in presenting the complete description to its readers. This receiver has been designed by Mr. Louis G. King, inventor of the well-known Equamatic system, and incorporates some of the Equamatic principles and apparatus. It is called the "Knickerbocker Four," and may be highly recommended as a dependable little outfit, possessing all the cardinal radio-receiver virtues of selectivity, sensitivity, volume, clarity and ease of control. It uses relatively few parts, and can be assembled between supper and bedtime by any person capable of handling such simple tools as a screwdriver, a pair of pliers and a soldering iron.

The front panel may be obtained already drilled and appropriately engraved; so that the constructor, by purchasing this, can save himself at a trifling cost the most difficult part of the entire assembly operation. Any radio fan who has marked out and patiently drilled a tough piece of insulating composition knows how delightfully convenient these prepared panels are.

CIRCUIT DETAILS

In actual electrical design, there is nothing radical or even "different" about the Knickerbocker Four; the circuit being the familiar one aforementioned, comprising one stage of tuned-R.F., regenerative detector, and two stages of transformer-coupled A.F. The all-around effectiveness of this arrangement having been well and often demonstrated, no attempt has been made to change it in any essential details, and the reader will recognize the hook-up readily. The superiority of the receiver lies in its mechanical arrangement, which greatly enhances the electrical operation.

The antenna coupler L1, is an Equamatic two-circuit coupler, which is integral with a .00037-mf. variable condenser, C1. The primary of this coupler is attached to the extension shaft of the condenser, and is so

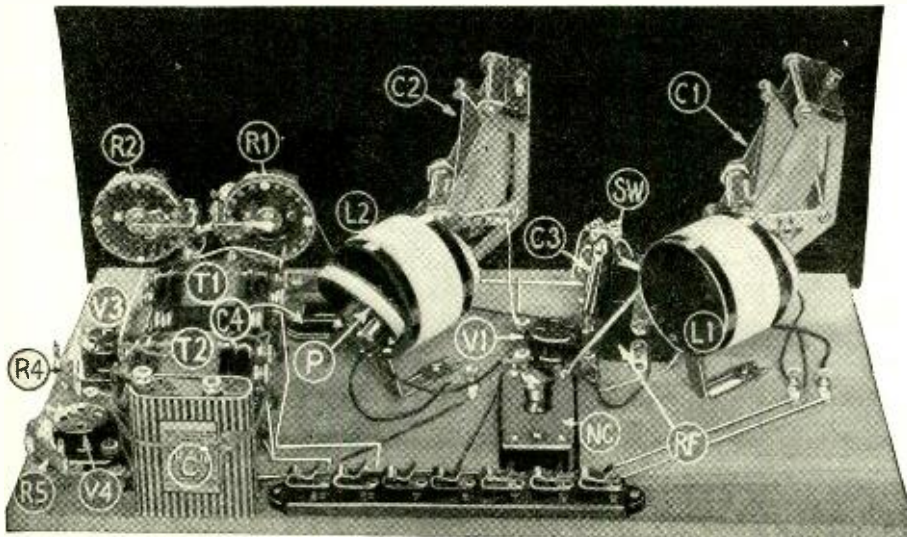

C1, C2, variable condensers; R1, R2, rheostats; L1, antenna coupler; L2, 3-circuit coil; C3, fixed condenser; C4, grid condenser; RF, R.F. choke coil; T1, T2, A.F. transformers; R4, R5, 4-ohm resistors; N.C., neutralizing condenser.

*RADIO NEWS Blueprint Article No. 32.

constructed that its coupling in relation to the secondary increases as the condenser capacity increases. The secondary coil is fitted to a slotted, L-shaped mounting bracket, which can be slid along the wooden base-board; and the primary coil is on a swivel joint, so that any degree of coupling can be obtained at will. The adjustment is very flexible, so that it is possible to secure tight coupling at the low wavelengths and loose coupling at the longer, or *vice versa*; or to make intermediate adjustments, to suit any local aerial conditions. The automatic variation of the coupling insures good transfer of energy at all wavelengths, a virtue not possessed by couplers having fixed primaries of a few turns.

The interstage R.F. transformer L2, is a special three-circuit Equamatic coupler, similar in construction to the antenna coupler. In this unit, the variable coil turned by the condenser shaft is the tickler; the primary coil P, which is wound on a separate little piece of tubing, is hinged at the outer end

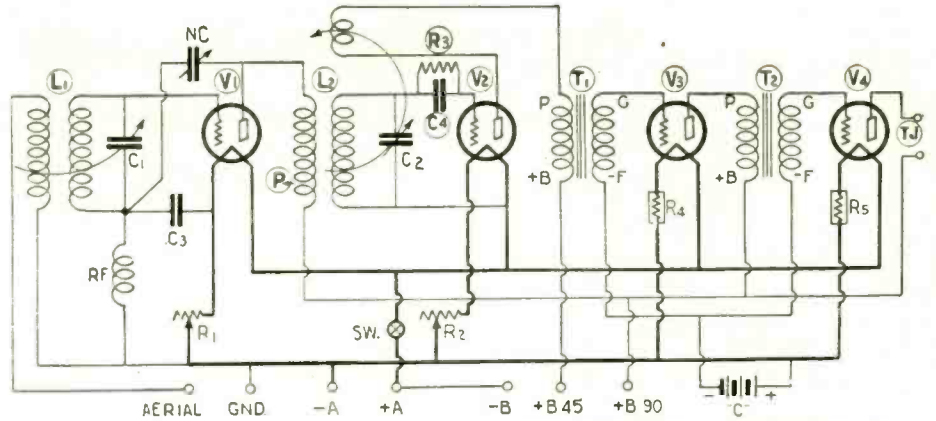

The parts in the above schematic diagram of the Knickerbocker Four are numbered, as are those in the other illustrations.

of the secondary. The latter coil is fitted with an L-shaped slotted bracket, so that it too can be moved back and forth, or turned in relation to the tickler.

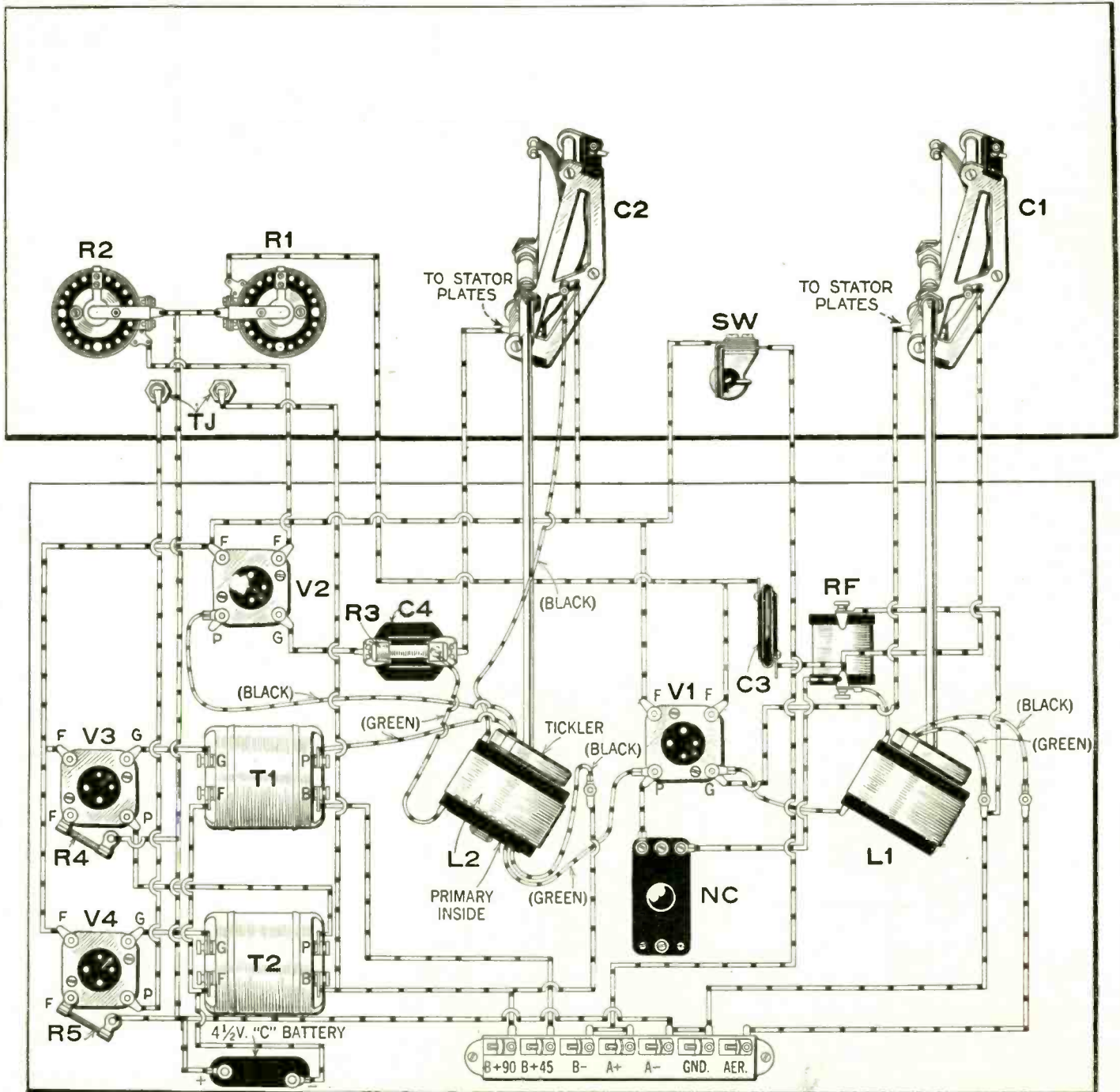

The wiring diagram of the Knickerbocker Four receiver. The diagram can be easily followed if each connection in the illustration is blacked out with a pencil after the corresponding wire has been soldered in the set. This corresponds in all details with the schematic diagram above, with which it may be compared.



The Qualitone Six*



Aperiodic-Detection System Feature of This Excellent Set

By
ROBERT F. GOODWIN

THE Qualitone Six embodies three stages of radio-frequency amplification (two tuned and one "aperiodic") and all controlled by two dials on the front panel. The aperiodic circuit, which precedes the detector, makes use of two midjet variable condensers, one variable and one fixed resistor. The set has been designed with the best of parts, and the results which it has produced are entirely in keeping with the high quality of the components. It has been thoroughly tested in the RADIO NEWS Laboratories, where it operated in most satisfactory fashion. It is recommended, without reservation, as a desirable broadcast receiver for the home.—EDITOR.

It is simple to construct and to manipulate, producing results that will satisfy the most critical listener.

We advise the constructor to follow the following directions closely. He will then be sure of obtaining the efficiency the writer has striven to give. The parts used in the set illustrated herewith are among the best obtainable. In the event that the builder makes any substitutions for the makes specified, care and discretion should be used; otherwise the desired final results will not be obtained.

to the first-stage audio transformer, now goes to the condensers and variable resistor designated as C4, C5 and R1 in the schematic diagram. An additional tube is added, this now being the detector tube; its plate will, of course, go to the first transformer of the A.F. amplifier.

ELIMINATION OF UNDESIRABLE COUPLING

This will give us three stages of R.F. amplification (with only three tuned circuits instead of four), in combination with the

CONSTRUCTION

Glancing at the circuit, you will notice that there are three tuned stages, an aperiodic detector and two stages of transformer-

THE receiver described in this article incorporates a method of detection called the "Aperiodic Detector." It was evolved by the author some years ago, when he was looking for a system that would have a flat amplification-characteristic over the entire broadcast band. Research work resulted in the discovery of a network of resistance and capacity; and the combination proved to be simple and very efficient. In reality, it is a slight modification of the resistance-coupling idea but, actually, it serves a better purpose.

Some radio technicians may claim that this system or network is not efficient in comparison to the rated capabilities of tuned transformers, but it possesses a number of interesting features.

Assume we have a five-tube set with two tuned R.F. stages and a tuned detector circuit; it may be improved by the addition of the aperiodic detector system. This is accomplished by merely removing the grid leak and condenser from the detector circuit and bringing the wire from the R.F. transformer secondary (which previously went to the grid condenser) to the grid of the third tube. The plate of this tube, previously connected

Panel view of the Qualitone Six. C1 and C2 are tuning condensers; R3 and R4, volume controls; C3 is the compensating condenser. See diagram on the following page.

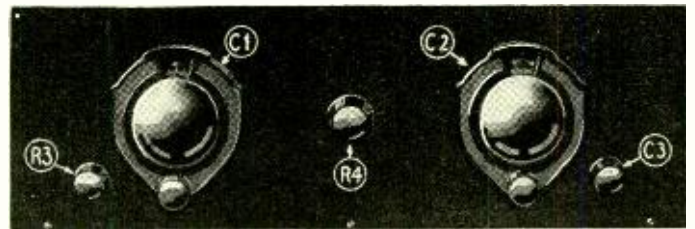

aperiodic detector, without adding additional controls. If we were to add an additional tuned stage instead of the aperiodic detector, we would experience much trouble trying to control the oscillations caused by inter-stage coupling and other factors. With the aperiodic detector system, no troublesome inductive effects are introduced; because of the fact that resistance and capacity are used in place of a tuned circuit.

This system may also be applied with advantage to a set now using one stage of tuned R.F. amplification. The new receiver would then have two stages of R.F., with two tuned and one aperiodic circuits, with the same number of tuning controls as before.

The Qualitone Six, incorporating the aperiodic detector idea, was designed to meet all the existing conditions of broadcasting.

coupled audio-frequency amplification, including an output transformer to prevent the D.C. of the plate supply from damaging the speaker windings. The amplifier is designed to amplify faithfully all the notes of the musical scale, as they are transmitted by a high-quality broadcast station.

The set is built into a standard 7x21x14 inch cabinet. All the parts are mounted and wired above the baseboard; this feature greatly simplifies the construction. The exact positions of the parts are shown in the various accompanying illustrations.

BALANCING THE R.F. AND DETECTOR

After the receiver is completely wired, first check all leads so as to be sure that proper voltages are being applied to their respective portions of the circuit. Then all the tubes may be inserted.

First adjust the phasatrol and the resistor, R1, entirely to the right. Turn the resistor, R3, completely to the right, being positive that the condensers, C4 and C5, are at full capacity. The latter adjustment may be made by turning the screws of the condensers all the way to the right. Then tune in a strong, high-wave signal, being sure that tuned circuits are in resonance by adjusting the compensating condenser, C3. Should regeneration be present turn the phasatrol to the left (with R3 three-fourths of the way to the right) until oscillation is diminished. Then tune in a low-wave signal, say about 280 meters, and repeat by turning the resistor, R3, three-fourths of the way to the left and then adjusting the phasatrol to the left until oscillation has again diminished. Repeat this operation at several wavelengths until oscillation is controlled solely by the variable resistor, R3. At all times make sure that the last two tuned circuits are in resonance.

Make sure that the "C" bias on the first and second audio stages is correct. The proper voltages are stated on the tube wrappers, the values depending on the voltage applied to the plates. Should distortion be present in the set, turn the resistor, R1, slightly to the right. This will clear the

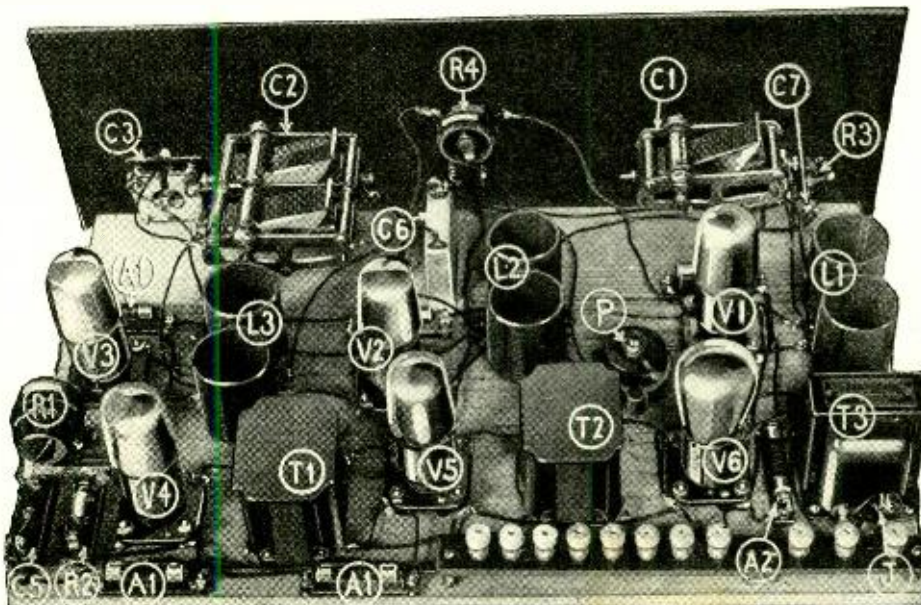

The midjet condenser C5 is out of the view in this illustration, being behind the resistor R1. That lettered C5 is really C4, as the diagram will show. The two condensers are alike. The second binding post from the right is not used, and is not shown in the working drawing.

*RADIO NEWS Blueprint Article No. 33.

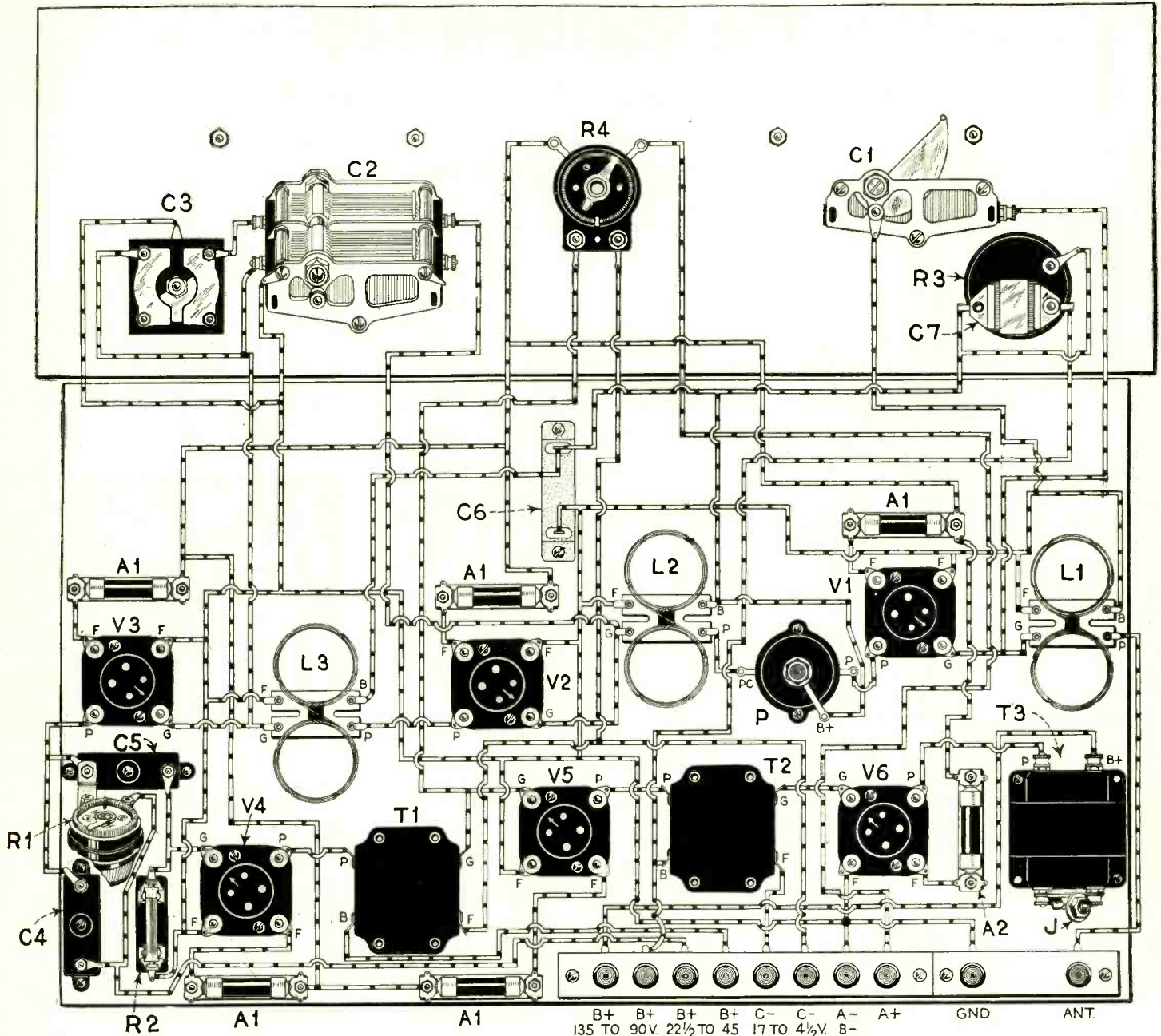

Every connection of the Qualitone Six is shown here very plainly. The terminals of the filament switch are the two lugs which protrude from the top of the resistor R4. Condenser C7 is fastened directly beneath one binding post of the resistor R3.

signal, providing the tubes and batteries are good. When "B" batteries are used for plate supply, the voltage applied to the variable resistor, R1, is from 45 to 90 volts; with a "B" socket-power unit it may be

varied from 22 to 90 volts, to prevent "motor boating."

Following the above system, it should not take the fan more than twenty minutes to have the receiver perfectly balanced. Then

it will be noticed that the operation of the set is very simple. The control of oscillation will be the variable resistor, R3. The writer has found that stations 1,000 to 2,000 miles away come in with plenty of volume;

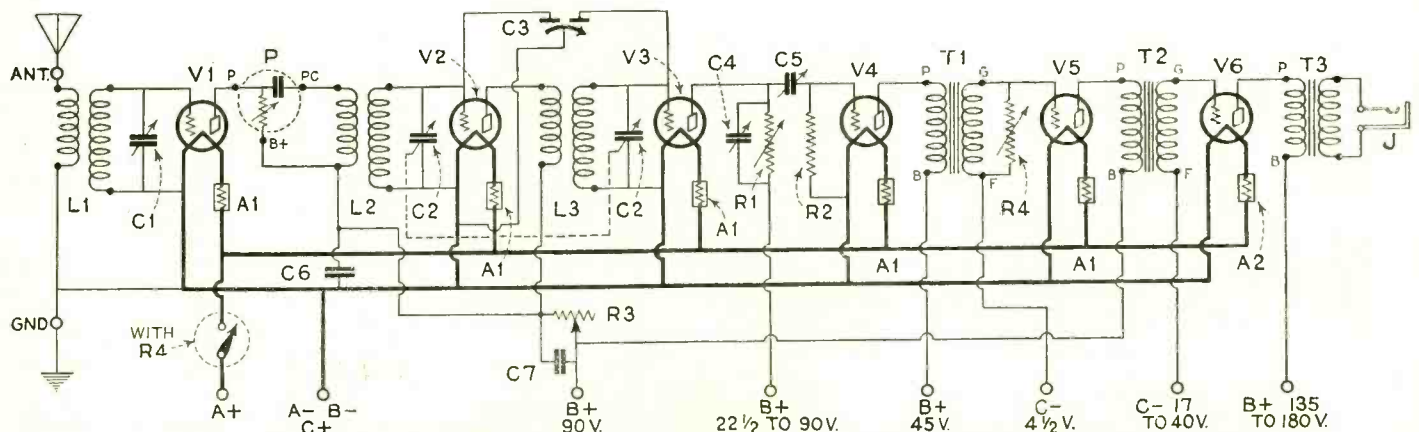

The schematic hook-up of the Qualitone Six. This corresponds exactly to the pictorial hook-up at the top of the page.

Biassing the Grid Without "C" Batteries

How the Drop in Resistors or Tube Filaments Can be Utilized to Good Advantage

By SYLVAN HARRIS

As everybody, who knows anything about radio at all, appreciates by this time, the radio receivers of the future, and many of this coming season, are to be completely operated from a single source of power; as for instance, a lamp socket connected into the house wiring. The obvious idea of this is to eliminate all local sources of electric power, such as batteries, which fail after a limited period of use and must be renewed or recharged. The public utilities can nowadays be trusted to furnish power without interruption; so that once the "electric set," as it is called, has been satisfactorily developed, the operator will have no further concern about his power supply, and will be able to give his entire attention to the tuning.

As we have said, the source of power in these "electric sets" is to be the lamp socket; in nearly all cases this furnishes alternating current, which must be rectified. We will not concern ourselves here with this problem, because enough has been said along these lines by other writers. The same is true of the filtering methods, used with the rectifiers, for ironing out the "ripples" which exist after the alternating current is rectified. For the purposes of this article we will start with the voltage at the output of the filter, that is, after the A. C. has been rectified and filtered.

The problem which remains is to obtain various different voltages from the one supply, and to utilize these voltages in several ways—to supply voltage to the plates of the tubes, to supply the biasing voltages for the grids of the tubes, and to supply the voltage for lighting the filaments of the tubes. In other words, we have to obtain a different voltage for each element or electrode in each tube. And, although the title of this article indicates that we will deal mainly with the biasing voltages, it will be necessary to say a few things with regard to other voltages as well.

VOLTAGE DIVISION

We begin with a few words about the general process involved in obtaining the different voltages; once we clearly understand this, there will be no difficulty in understanding the rest. Suppose we have a source of direct voltage (indicated by V in Fig. 1) such as we obtain at the output of the filter in our "B" socket-power unit. This supplies current to a resistor, tapped at various points. Suppose we connect a voltmeter across the points *a* and *d*; it will measure the complete voltage of the source, *V*. Suppose we connect the voltmeter across the points *a* and *b*, including one-quarter of the resistance; it will then indicate one-quarter of the voltage, $\frac{V}{4}$. In other words, the resistor is connected as a "voltage divider," or potentiometer, as it is more commonly called.

The operation of the voltage divider depends upon Ohm's Law. There is a certain current, which we will call *I*, flowing through the resistance. Let us call the resistance between the points *c* and *d*, *R*. Then there will be a voltage drop between these two points equal to *I* times *R*.

Now let us see how we can begin to apply these principles to obtaining a grid bias in a vacuum-tube circuit. Fig. 2 shows part of

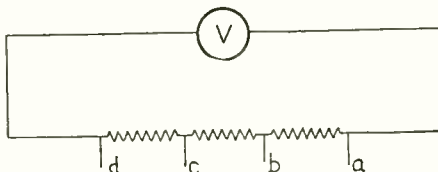

FIG. 1

If *V* is a source of direct current, various voltages can be measured across the different resistances, according to the *IR* drop in each.

the circuit of an audio-amplifier stage, the tube being connected to the secondary *S* of an A. F. transformer. The lower end of the secondary is supposed to be connected to the filament of the tube; that is, *a* is to be connected to *b*; and, if we want a grid bias on the tube, this bias is introduced between *a* and *b*.

It would be a simple matter to connect a "C" battery between *a* and *b*, but we are trying to avoid batteries. So we must use some arrangement such as we were discussing before. In other words, suppose we insert a resistor between the points *a* and *b* (Fig. 2) and then pass a current through this resistor. We will then have in this resistor a voltage drop which acts as a biasing voltage. It is easy enough to insert the resistor in the circuit, but where are we going to get the current to send through it? The answer is easy enough. Why not use the plate current of the tube, or the current which comes out of the "B" supply, in this case, from the "B" socket-power device?

GRID-BIASING RESISTANCE

This is exactly what we can do, and Fig. 3 shows how. You will note that there are two by-pass condensers included in this circuit in order to clear the paths which the alternating audio frequencies follow. The condenser *C*₁ prevents the alternating signal currents from passing through the resistor *R*, which we have inserted, and out into the "B—" lead. The condenser *C*₂ by-passes the "B+" lead also in a similar manner. Although the final wiring diagram of an am-

plifier may not appear exactly like this, the circuits are the same; for these by-pass condensers are always included in the circuit, or at least should be.

Now it is clear how we get the voltage drop between the points *a* and *b* in Fig. 3. The current from the "B" socket-power unit flows from "B+", up through the primary of the transformer *T*₁, then passes from the plate to the filament, then through the resistor *R*, and thence back to the "B—" of the power unit. It is also clear that the point *b* is more positive than the point *a* by an amount equal to the voltage drop in the resistor *R*; and this amount is equal to the resistance multiplied by the plate current *I*_p, which passes through it. The arrows show the path which this plate current follows.

As a concrete example, suppose that we want a "C" bias of 9 volts, and the plate current of the tube is 10 milliamperes. The resistance which we require in *R* is then 9 divided by .010, or 900 ohms. Or, suppose we want a biasing voltage of 4.5 volts and have a plate current of 5 milliamperes. Then *R* will have to be, again, 900 ohms. In other words, simply divide the required voltage by the current which passes through the resistance, and we obtain the value required in this resistance.

ACCUMULATED VOLTAGE DROPS

Fig. 4 shows the circuit of a detector followed by a three-stage amplifier using double-impedance coupling. If you follow the path of the "B" current, starting from the "B—" terminal, you will be able to see how the various biasing voltages add up as we pass from one stage to another. For instance, let us start out at the "B—" terminal. Then following the path through *R*₃, then *R*₂ and then *R*₁, and we arrive at the filament lead, or "A—." The top ends of the resistances are therefore more negative than the lower ends. Suppose we have a drop of 3 volts in *R*₁. Then it is clear that the grid of the amplifier-tube *V*₁ is 3 volts negative with respect to the filament of *V*₁.

Suppose again that the drop in *R*₂ is 4.5 volts. Then, if we pass from the grid of *V*₂ to the filament circuit, we first have to pass through *R*₂ with its 4.5-volt drop, and then through *R*₁ with its 3-volt drop, before we reach the filament; so that the second tube has a grid bias of 4.5 plus 3, or 7.5 volts. And likewise the third tube (assuming a drop of 25 volts in *R*₃) has a grid bias of 25 plus 4.5 plus 3, or 32.5 volts.

In order to make the tracing of the circuits a simple matter the filament lead ("A—") and the grid-biasing circuits have been drawn in heavy lines in Fig. 4. In audio amplifiers it is good practice to join the negative terminal of the "B" supply with the negative terminal of the "A" supply; but you will notice here that there is a difference of

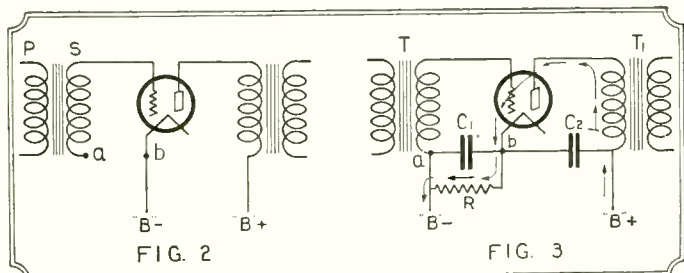

FIG. 2

FIG. 3

If a resistor is connected between *a* and *b* in Fig. 2, a negative bias will be applied to the grid of the tube, as shown in Fig. 3.

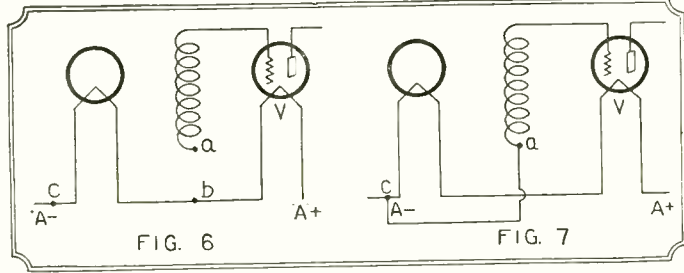

FIG. 6

FIG. 7

If the grid return *a* is connected to *C*, instead of to *b*, then there will be a negative bias of 5 volts on *V*, equal to the drop in the filament of the tube. This is shown in Fig. 7.

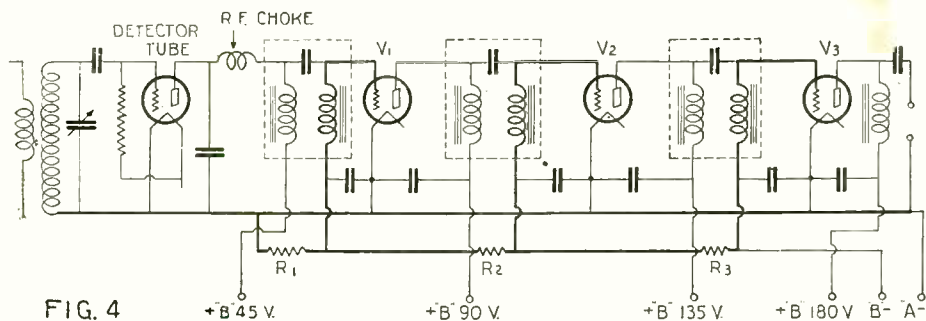

FIG. 4 When resistances, such as R1, R2 and R3, are introduced into an amplifier circuit, negative grid voltages of different values may be easily obtained.

voltage between the "A—" and the "B—" equal to the sum of all the grid-biasing voltages. In the case described above, and as marked on Fig. 4, the "A—" lead is 32.5 volts positive with respect to the "B—" lead.

(In order to keep the diagram simple in appearance, the filament wiring has not been shown complete; the filament circuits are connected in the usual manner, with all the filaments in parallel and operated by a 6-volt supply. Six by-pass condensers are included in the diagram; these are preferably 1 microfarad each.)

The method described above for determining the values of the resistors, R1, R2 and R3, is approximate, although it gives values sufficiently accurate for many purposes. The error lies in neglecting the change in the plate current when the resistance is inserted in the circuit. If accurate biasing voltages are required corrections will have to be made; the accurate value of the resistor being slightly greater than the approximate value here obtained.

WITH THE DETECTOR TUBE

If it is desired to use a detector which rectifies by virtue of the curvature of the "plate characteristic" (that is, the commonly known "C"-battery detector), the same method may be used for obtaining the required grid bias. The arrangement of the circuit is shown in Fig. 5. It will be noted that a by-pass condenser and an R. F. choke coil are included in the plate circuit of the detector; this represents good practice. The value of the condenser is about 0.001-microfarad.

It is obvious that this method of obtaining the grid-biasing voltages may be used with any type of audio amplifier except the resistance-coupled.

TUBE-FILAMENT RESISTANCES

There is another scheme for obtaining the grid-biasing voltages, which applies to receivers or amplifiers in which the filaments of the electron tubes are connected in series; as where the 300- or 400-milliamper cold-cathode rectifier tubes are used to supply both "A" and "B" voltages. The circuit arrangement is quite different, however, and is worthy of study. For in such circuits, the filaments being in series, we have already in the circuit resistances from which we can obtain the biasing voltages, in the shape of the filaments themselves. A glance at Fig. 6 will illustrate what is meant.

Here we have shown, in skeleton form, an electron-tube circuit with the filament of the tube connected in series with the filament of the tube preceding. The grid-return of the tube V is at a; which would be connected to the point b (that is, to the filament of the tube) if we did not require a grid bias. Or, if we wanted to use a "C" battery, we might connect it between a and b, including of course, a suitable by-pass condenser.

However, if the filament circuit goes to the "A+" on the right, and to the "A—" on the left, it is clear that any point in the filament circuit is negative with respect to any other point on the right of it. For instance, in Fig. 6, the point c is five volts

negative with respect to the point b, if we are using a 201A tube, because this is the voltage drop in the filament of the tube. So it is clear that, if we connect the grid return a (Fig. 6) to the point c instead of to the point b, the grid of the tube V will be at a potential which is 5 volts negative with respect to its own filament. Or, going a step

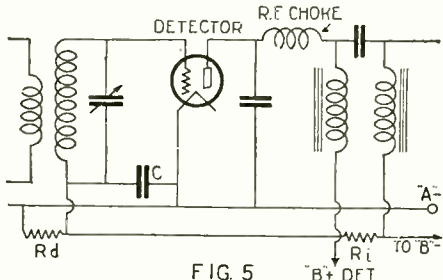

FIG. 5 In the above schematic diagram is shown a method whereby a negative grid bias can be put on the detector tube.

farther, if we wanted a higher grid bias, we might carry the connection from a beyond two or three filaments, each filament adding another 5 to the biasing voltage. Fig. 7 indicates the grid-return connection for a bias of five volts.

SERIES-FILAMENT CIRCUITS

Fig. 8 shows how the method is applied to a complete circuit. We have here two stages of R. F. amplification using a bridge circuit, a detector, and two stages of A. F. amplification, with all the filaments connected in series. Suppose we require a bias on the grid of the first A. F. amplifier, V1. The grid return of that tube, the point a, can be connected ahead of the detector filament, to the point b, placing a biasing voltage of 5 volts on its grid. Thus, in order to travel from the grid of V1 to the filament of this same tube, we have to pass through the filament of the detector tube, giving us the 5 volts. Having obtained the bias in this manner, the proper plate voltage to use can be determined from a knowledge of the characteristics of the tube.

Now how about obtaining the bias for the last tube, V2? Suppose we want a 30-volt bias on this grid. There are only four fila-

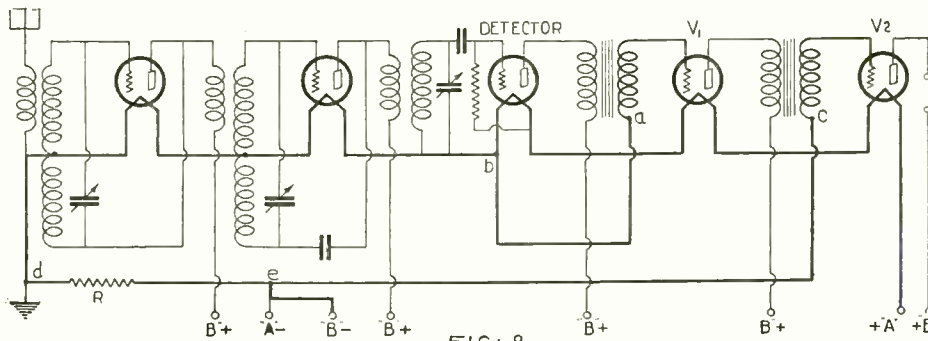

FIG. 8 When a receiver has tubes whose filaments are connected in series, negative grid voltages can be obtained easily by taking advantage of the IR drop in the filaments of the tubes, as shown above.

ments preceding it, so that the most we could get by utilizing the voltage drops in the filaments would be 20 volts. We require 10 volts additional. If we were content to use only 20 volts we could connect the grid return c to the point d; but, since we require 10 volts more, we have to insert in the negative filament lead a resistor R, of sufficient value to give us the 10 volt drop. Then we connect the grid return c to the point c, and we have our 30-volt bias.

The next question to answer is: What is the value of this resistor, R? The answer is simple enough. We have flowing through it a current of 1/4 ampere, for this is what we require to light the tubes. We require a 10-volt drop in it. Therefore the resistance must be 10 divided by .25, or 40 ohms. And the next question to be answered is, what must the "A" voltage be? Of course, this must be taken care of in the power supply, but we must know what voltages we require of the power pack. This answer is likewise very simple. We have five filaments in series, each filament requiring 5 volts, and in addition we have the 10-volt drop also in series. The "A" voltage required of the socket-power unit is therefore 5 x 5, plus 10, or 35 volts.

It is clear that the principles attached to the design of circuits in connection with eliminating the various batteries are simple enough, once they are known; but the main difficulty in building such circuits is to provide suitable resistors. Those chosen must be capable of carrying the current without excessive heating. For instance, in the circuit of Fig. 4, the resistors R1, R2 and R3 must be capable of carrying the total current from the "B" supply; which may be as high as 50 or 60 milliamperes, depending upon the tubes and the plate voltages used.

But this is not so serious a problem as selecting the resistor R in Fig. 8, which must carry a current of 250 milliamperes (1/4 ampere), or, more correctly, about 300 milliamperes, since the filament circuit also carries the various plate currents.

The reader of this article may be tempted to criticize it on account of its incompleteness, but it must not be forgotten that its subject is closely connected with the design of the power pack itself. The receiver and the power pack must be designed together, and it must not be thought that a power pack designed for one receiver can be used successfully with another. So you see the problem is a great one. The purpose of this article is to discuss only one or two of the problems of power-operated receivers, in such a manner that the novice as well as the expert can clearly classify the information in his mind, and connect it properly with the rest of his radio knowledge; instead of having to assimilate a number of disconnected facts from a dozen or more articles on electric receivers.

(Those experimenters who are working with receivers requiring negative "C" bias for the grids of either the detector or the amplifying tubes will do well if they try the methods that have been outlined in the above article.—EDITOR.)

Ultra-High-Frequency Experiments

Description of Measurements and Transmitting Equipment for Work on Five Meters

By JOHN L. REINARTZ

THIS article is the sixth and final one of the series that Mr. Reinartz has written this year for RADIO NEWS. It deals with ultra-high frequencies and describes the construction of a transmitter and receiver operating in the neighborhood of five meters.

This is very interesting place in the wavelength scale for experimentation. Although many workers have been experimenting in this region for quite a while, very little real progress has been made. It is strongly recommended that more work be done with these high frequencies; for who knows, as Mr. Reinartz says, "it may be here that the remedy may be found for all the ills to which radio is heir."—Editor.

ONE of the most interesting phases of amateur radio lies in the realm of wavelengths under 15 meters, which is about the shortest wave upon which reliable transmission has been effected. Most of the work that has been done up to this time under this wavelength has been on 5 meters. This ultra-short wave has not yet proved very satisfactory for the transmission of signals; but it offers a field of investigation that holds unlimited possibilities for the experimenter.

It should be remembered that the ultra-high frequencies encountered in the neighborhood of 5 meters behave very differently from the ordinary signals to which the "ham" is accustomed. While it is true that

the length of connections, for instance, in sets for use in the 40-80 meter band is very important, it is far more so around 5 meters. This can be easily seen when the fact is taken into consideration that the inductances used in the set described in this article each consist of a *single turn of wire approximately one inch in diameter*. It might be better to say instead that in ultra-short wave sets connections are *eliminated*, as far as possible.

ACTUAL WAVE MEASUREMENTS

Before describing the 5-meter set it might be well to consider a method of measuring the lengths of radio waves. This method of measurement is not new by any means; but it has been found by the writer to come in so handy, in so many instances, that he wishes to present it to those fans who are unacquainted with it.

It is known as measurement by the Lecher wires and the apparatus needed should be in every reader's work-bench.

Let us assume that it is desired to measure accurately the wavelength of a transmitter operating around 16 meters. A bare copper wire about 32 feet long is connected to the transmitter's condensers, as indicated in Fig. 1A. This wire is then stretched across the room and at the closed end so separated that the two lengths are about three inches apart. This separation, in the writer's work, is done by means of a glass insulator.

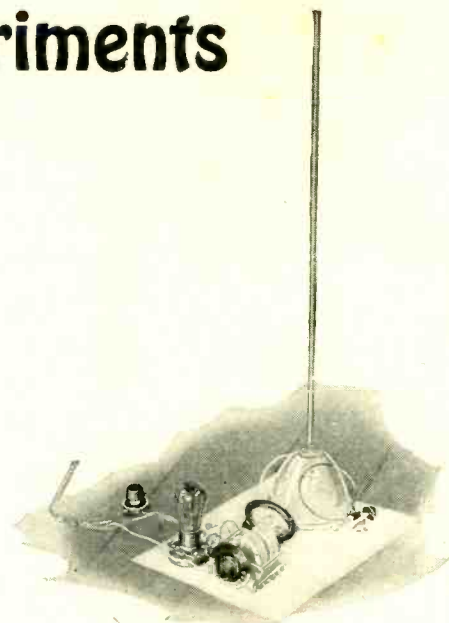

The 5-meter set, using a double condenser. (For diagram see Fig. 3.) A 5-meter wave-meter may be seen, leaning against the glass insulator.

We have now one continuous wire, about 32 feet long, folded in half, making two parallel strands 16 feet long. When the output of the transmitter is connected as shown, there will be established in this wire "standing waves" which can be easily and very accurately measured. It will be seen in Fig. 1A that a wave of 16 meters is set up with the voltage node at the exact center of the wire. This is true, no matter though the wave has a length longer than the total length of the wire; the point of minimum voltage will be at the middle of the portion connecting the two parallel strands. This being true, it is a simple matter to find the approximate position of the voltage crest of the wave, by means of a neon exploring lamp, which will glow brightest at the point of maximum voltage.

Using a neon lamp, however, is far from being an accurate method; as the lamp will glow brightly for a space of several inches along the wire. Instead, use is made of the fact that at the *point of maximum voltage occurs the point of minimum current*; which is indicated at the point where the dotted sine wave crosses the upper wire in Fig. 1A.

We will assume that the point of maximum voltage has been approximately found by means of the neon lamp. To the terminals of a high-frequency ammeter with a range of 0-5 amperes are connected two fairly heavy bare copper wires, just long enough to touch each of the Lecher wires, which are strung about 3 inches apart. When the meter is placed at different portions of the wires, different readings will result. At the point where the current node occurs the reading will be lowest; whether it drops to zero or not depending upon the amount of power being used in the transmitter. When this point has been found, the distance from it to the center of the connecting wire will be exactly *one quarter of the wavelength* upon which the transmitter is operating.

If insufficient power is being generated it may be found that the ammeter will read zero over perhaps an inch or so of the wire. If it is possible to increase the power so that the meter will not drop to zero, this is done. The lowest reading shows where the exact point is located. If it is impossible to raise the power, then carefully note the point at which the meter first reads zero. Then slide the meter along the wires until the first upward movement of the needle is seen. Half the distance between these two points is the current minimum.

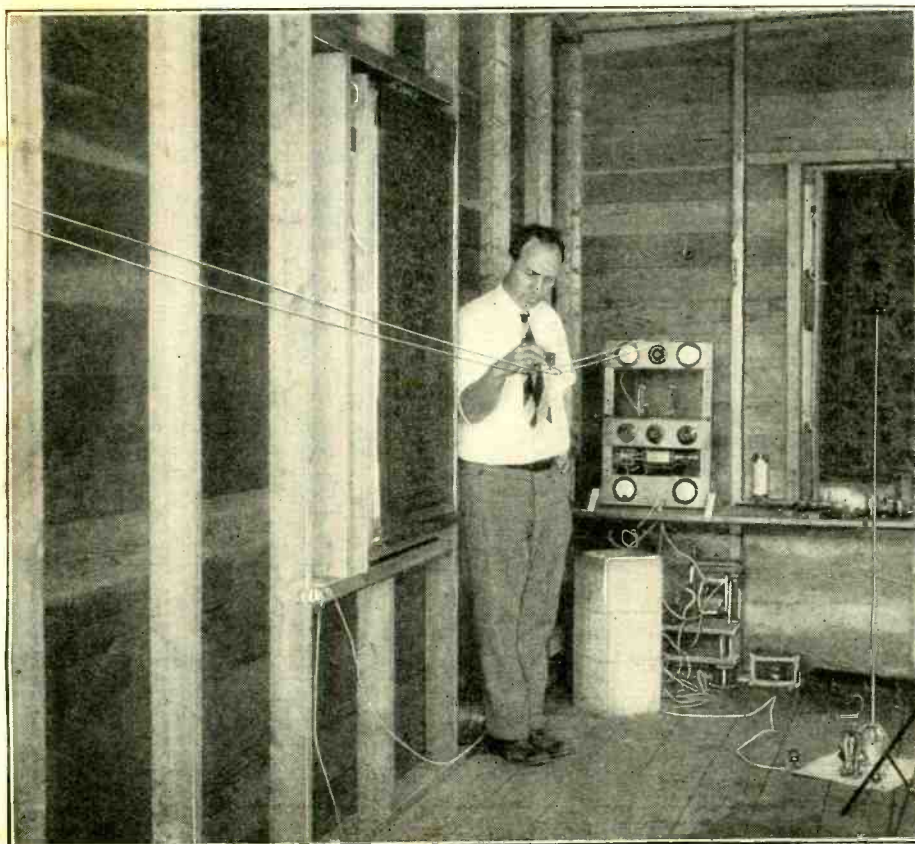

The author demonstrating the method of determining the wavelength, on which a transmitter is operating, by means of the Lecher wires and an ammeter. The transmitter and power equipment may be seen in the background.

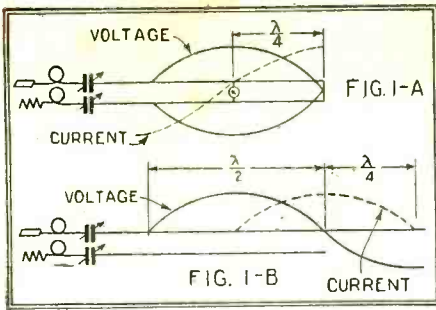

How the standing waves take their positions on Lecher wires; showing the voltage and current crests and nodes.

A COMBINATION 5-METER SET

Figs. 2 and 3 are schematic diagrams of a combined receiving and transmitting circuit for work on 5 meters; the only difference between them being in the type of variable condenser and antenna employed.

Fig. 2 shows two condensers, C and C1, in the plate and grid circuits, these condensers being of the midget type. The antenna is a copper rod or tube of a length equal to exactly one fourth of the wavelength—in this case 1.25 meters, assuming that the set is to operate on exactly 5 meters. The wire connecting this antenna to C must be at least twice the length of the antenna or half the wavelength.

In Fig. 3 a double-section variable condenser (each half having a capacity of 125 mmf.) is used. The antenna is inductively coupled by means of the inductance, L2, to the plate and grid coils, L and L1. These three "coils" have but one turn each, which is the case also with the inductances, L and L1, in Fig. 2. The wire used in these is No. 12 bare copper wire and the diameter of the turn is 1 inch. As may be seen in the accompanying illustration, the single-turn loops are placed as close as possible to the condenser terminals.

The resistance R, the grid leak, must be ten times as large as it would be ordinarily; in this case it is 100,000 ohms. The rheostat, R1, of course depends upon the size of the tube employed. When the set is used as a receiver R1 is used to control regeneration. It is best to use a vacuum tube having a plain non-thoriated filament; i.e. of tungsten.

In the case of the double condenser in Fig. 3 the rotary plates may be touched without any change occurring in the wavelength. This is because the voltage at this point is zero; and to make doubly sure of this fact the rotary plates of the condenser can be grounded, as is indicated by the dotted connection.

No choke coils are required in either of these circuits, because there is infinite reactance at the condenser connections of the plate and grid coils. For reception a pair of phones is introduced at X (in both Figs. 2 and 3).

One of the most important parts of the entire installation for ultra-short waves is the antenna system. The system of measurement of radio waves by the Lecher wires and ammeter is here brought again into use; for it is extremely necessary to have the lengths of the wires connecting the vertical antenna to the set, as well as the antenna itself, as near the correct dimensions as possible.

It will be seen in Fig. 2 that the wire connecting the rod acting as the antenna to the condenser, C, is equal to half the wavelength, the antenna being half as long. Another wire of equal length is attached to the condenser, C1, but this is connected to C1 only, the other end being unconnected.

ADJUSTMENT

After the set has been assembled and is operating, it is not known upon exactly what

wavelength it is working. A very slight change in any dimension will mean a change in wavelength; and therefore it will be necessary to determine the frequency at which the set is operating with the condensers set, we will say, half-way in. The two condensers are connected to a pair of Lecher wires (as shown in Fig. 1A) and the position of the current node is determined as previously explained. We will assume that we have been very fortunate and that this node is located 1.25 meters (4.1 feet) from the center of the wire connecting the two Lecher wires together. This wire is then cut in the center, one end connected to a rod 1.25 meters long, and the other end left open. Another important thing is that the wire connecting the antenna to C and the open wire must be equal in length to at least one half the wavelength being used, in this case 8.2 feet or 2.5 meters. This is shown in Fig. 1B. The length of the connecting wires makes no particular difference, as long as they equal one half the wavelength.

The same method of determining the wave length of the set shown in Fig. 3 can be employed, each of the Lecher wires being connected to the stationary plates of the

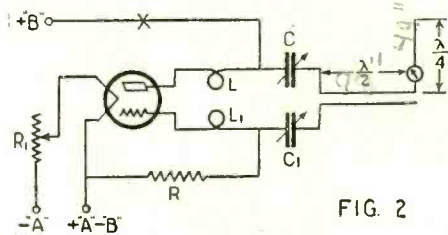

FIG. 2

If two midget condensers are used in the circuit the apparatus is connected as shown above.

condenser. The connection between the antenna and the coupling coil, L2, should be as short as possible.

BEAM TRANSMISSION EXPERIMENTS

As mentioned previously, the only apparatus use for waves of these short lengths is in laboratory testing and experiment. However, if the amateur wishes something new with which to play, the short waves around 5 meters hold unlimited possibilities. It is quite possible that from down in these ultra-low regions may come the great solution for all the ills to which radio is heir. It might be possible to utilize a beam system, such as one the writer experimented with several years ago.

In the illustration at the right may be seen the five-meter transmitter, which has two midget condensers in the plate and grid circuits (the circuit diagram being given in Fig. 2). The length of the antenna equals one quarter of a wavelength; it consists of a copper rod or tube, about one quarter of an inch in diameter. This is fastened at the apex of a glass insulator, as may be seen, and is connected to the transmitter by a pair of wires equal in length to at least one-half wavelength. In the background may be seen the author's transmitter, with his power equipment under the shelf. These have been described in previous articles of this series.

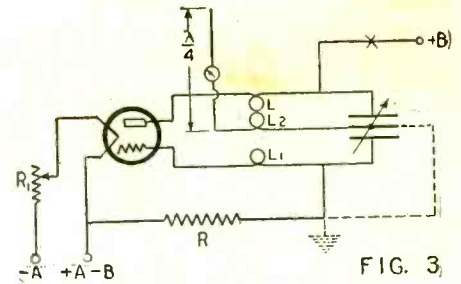
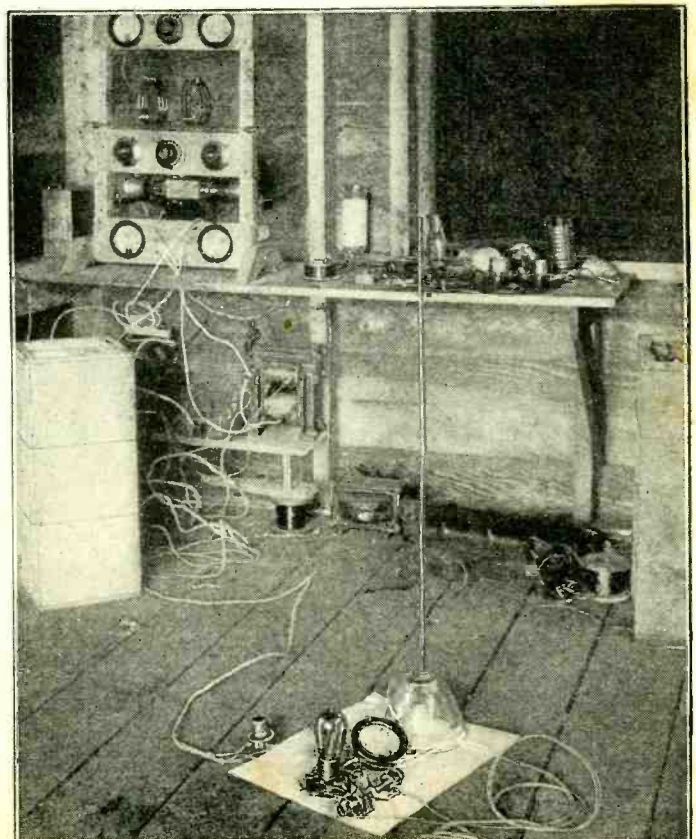

FIG. 3

When a double condenser is employed a single-turn coil, L2, must be introduced in the antenna circuit.

A parabolic reflector was made, using for a frame a bicycle wheel rim to which the wires were attached. From every spoke a relatively heavy wire was bent in the shape of a parabola. In the center of the rim, and at the focal point of the reflector, was placed the copper rod which was to be the antenna. By locating the rod at the focus of the parabola, all the waves generated were caused to strike the reflector at such an angle that they were projected forwards in a single parallel beam. In this manner the beam's direction could be varied and aimed at the receiver. Messages were sent, by using this system of transmission, over a distance of two city blocks; but this seems to be hardly worth mentioning, when waves a few meters longer can be sent over distances measured in thousands of miles.

Readers of this series of articles may run into some troubles which the writer can perhaps assist them to remedy. If they will write him in care of RADIO NEWS, (enclosing a self-addressed stamped envelope) he will be glad to help them out of their difficulties, to the best of his ability. It will aid him considerably, also, if such communications are so planned that he can answer them on the same paper upon which they were written.



Correspondence from Readers

RADIO GRAMMAR

Editor, RADIO NEWS:

I would like to call attention to a very grave error in grammar committed by numerous readers of your magazine, or writers, from time to time in the use of the word "broadcasted." *There is no such word.* Many people do not understand that the word "broadcast" is complete in itself, and does not require the *ed*, or sign of the past tense, affixed to it.

Publication of this might call attention to those who use the word that does not exist.

W. J. MURROW,

108 Latta Pl., Macon, Ga.

("The English language," as a colored philosopher observed, "am berry unregular." In many cases it offers alternative forms, and authorities differ as to which should be preferred; "practise" or "practice," for instance. At one time the past tense of "cast" was "casted"; and, while this is now quite obsolete, the Standard Dictionary shows "broadcasted" as correct, though not preferred. It is the belief of RADIO NEWS that, as a general proposition, the shorter form is to be preferred; as this is in harmony with the genius of the English language, which is discarding as fast as possible all signs of inflection. For that reason also, though many cling to the expression, "broadcasting station," we believe that "broadcast station" is simpler and conveys the idea accurately.)

A MESSAGE FROM THE ALPS

Editor, RADIO NEWS:

Referring to Mr. F. C. Staves' letter in the July edition of Radio News, we beg to inform you that, understanding his challenge is to the whole world, we take great pleasure in answering him.

We have never tried to get heaven or the other place; but we have brought in stations from all parts of the world with our Norden-Hauck Super-10 Admiralty Model. If Mr. Staves wants a receiver to outperform his present one in distance, volume, selectivity and quality, the only one we believe can meet these requirements satisfactorily is the Super-10. It has proven this over here; we are working on wavelengths from 35 to 3600 meters.

Our antenna is a multi-wire "L," 30 meters long, height 28 meters; the ground is a copper plate, 2 meters square, buried 4 meters deep in the earth in a sort of well. We say well; for every two days about ten gallons of water are thrown in from a workshop. In this manner the ground is kept moist.

An important fact is the following: We are situated 1000 meters above sea level in the heart of our industries; electric motors in almost every house, having two ourselves. Next door's a printing office with eight motors; 50 meters away the lighting power house with four large dynamos working day and night. For all that, inductance, noises, and industrial static are completely eliminated; meaning that our reception is not troubled with these unpleasant noises which are the plague of other receivers.

Presuming that our installation may interest you, we have enclosed photographs of our radio reception salon and office. The batteries in cabinet are charged by throwing switches to the right and without removal from their place. Hoping to hear from you and Mr. Staves.

ED. E. J. DE LOPEZ-GIRARD,

La Chaux-de-Fonds, Switzerland.

A "RADIO ROOM" IN THE HOME

Editor, RADIO NEWS:

Radio would be looked upon with more appreciation by the public in general if the manufacturers would have first in mind tone quality. It costs money, but the results are worth it. When I can sit and listen in contentment to tone that compares favorably with the original in the studios, it makes me wonder.

Beginning where the music and voice is originated, the studio is constructed along the best acoustical lines; the ceiling and walls are covered with draperies, the microphones and musicians are scientifically arranged. In short, everything is done to prevent anything but pure tones from striking the microphone. Therefore, pure music is transmitted.

Now go to the receiving end. In my estimation, a good radio, using a faithful speaker, is more pleasing to the ear than an orchestra out in the open air, or in any room other than the studio; because in the open

tones are lost, and in a building echoes and impure tones enter.

How would it then be to have a special room in your house, similar to a studio, for your radio? Would this not be as it should be? I think that we could thus obtain a replica of the original, or at least 99% of it. I believe I can understand voice better over a good radio than listening to the speaker in his presence.

JOE F. BENNETT,

527 No. Lincoln St., Bloomington, Ind.

(Mr. Bennett's suggestion may seem ambitious to the average radio set owner, particularly the occupant of a kitchenette apartment in a large city; but it points to an ideal. In the meantime, the set owner who is not fortunate enough to possess a suitable music room may often improve results by an intelligent disposition of his receiver and speaker.)

HOW ENGLAND HEARS AMERICA

Editor, RADIO NEWS:

Do American radio fans realize, I wonder, how extremely well broadcasting from the United States is heard in England? Probably it will come as a surprise to most of them when I say that, at my house, some thirty miles northwest of London, I can obtain full loud-speaker reproduction of the broadcast programs on almost any night from year's end to year's end.

During the winter months, WGY, WJZ, WBZ, KDKA, and several others are frequently heard on the normal broadcast wavelengths; but in summer time nothing is as a rule receivable from them. It is the short-wave relays that are so remarkable for their reliability, for their signal strength and for the amazing quality of reproduction that is obtainable. It is largely due to this short-wave broadcasting by the American stations that reception on the higher frequencies is becoming one of the most popular diversions of radio enthusiasts on this side of the Atlantic. The usual outfit consists of a Reinartz tuner, with special low-loss coils and condensers, followed by two audio-frequency stages so arranged that either or both of them can be used at will. For reception on telephones one audio stage is

(Continued on page 395)

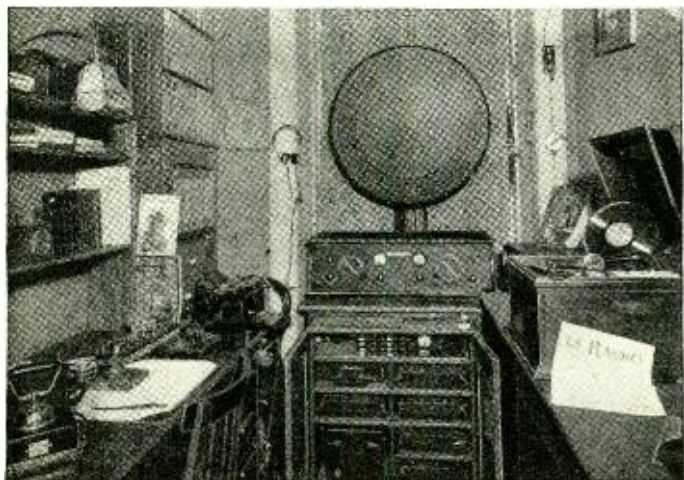

At the left is shown the office of M. Lopez-Girard, with the radio receiver and its current-supply equipment, phonograph and adapter. (The firm deals in records of Afro-American music, jazz, spirituals,



etc., which are in high demand in Europe.) At the extreme left is a telephone of the European type. The illustration at the right shows the demonstration parlor, with its cone connected to the receiver.

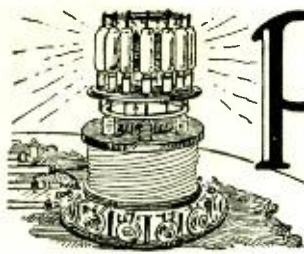

Progress in Radio



REDUCING SPACE-CHARGE EFFECT IN TUBES

THIS invention which has recently become the subject matter of a British patent No. 269,032, has been communicated by "Die Radio-Rohren-Laboratorium Dr. Gerd Nickel G.m.b.H." of Berlin. In accordance with the present invention, the control of the electron stream is effected by means of ionized atoms which are produced within the tube at a pressure between .0001 and .0001-mm. of mercury, this pressure being maintained by emission from a positive ion source. Referring to Fig. A, B is the bulb, A the anode or plate, and C the cathode. Near to the cathode C is placed a positive ion-emitter P in the form of a second filament coated with barium sulphate, caesium chloride, or barium iodide, capable of emitting positive ionized atoms, and arranged so as to receive the incoming signals. The connections are shown in the diagram, those for the resistances, batteries and telephones being as usual.

The emitted electrons, which form groups around the cathode in the form of a space-charge cloud, have such low velocities that they can be affected in respect of their velocity and direction of motion by the smallest electrical influences. Such influences are provided by the positive ionized atoms which pass into the space charge. The rate at

Although this electrode E has the appearance of an ordinary grid, its function is not that of a grid; inasmuch as its essential operation is that of completing the circuit with the cathode.

The action of this type of tube is probably as follows: During the phase in which the cathode is at negative potential and is therefore filled with electrons, the positive ionized atoms present in the discharging space are conducted to the cathode and are therefore carried into the middle of the space charge of the electrons surrounding the cathode. As the ionized atoms come close to the electrons the effective force is very great. The anode voltage will result in an attraction of the liberated electrons. It is probable that such ionized atoms will assist a very much larger quantity of electrons to separate from the space charge than would otherwise be the case.—*The Wireless Trader*, London.

when applied to radio-frequency coupling; although with the use of more than one R. F. stage the problem of neutralizing

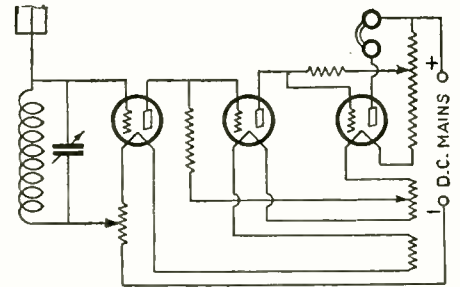

The same system using a socket-power D. C. unit. The simplicity is apparent.

would at once enter. A high-voltage "B" battery is required, owing to the number of taps; but the author claims especially merit for the system in balancing out the commutator ripple when a socket-power unit is used. In this case, it is represented, the fluctuations of the lighting current affect the three elements of each tube simultaneously and thus cancel out. A diagram of a similar unit, with a D. C. power supply (this is very generally available in England) is shown to illustrate this idea. The filaments, it will be noted, are in series.

DIRECT INTERTUBE COUPLING

WHILE the advantages of different types of coupling are being debated, an English experimenter, J. F. Johnston, is developing a circuit whereby the plate of each tube is connected to the grid of the next solely by a short piece of wire—this being practically a no-loss arrangement. In *Wireless Magazine* and *Modern Wireless* he explains his circuit as one "in theory giving better reproduction than a set using any other known circuits and results in practice as good as any likely ever to be obtained with the present type of tubes."

The circuit which evokes from its designer this enthusiasm is shown in the diagram: it contains, as its pictures show in the original articles, a minimum of apparatus and a few short, direct leads. In a three-tube set—detector and two A. F. stages—besides the aerial coil and tuning condenser, the tubes and sockets, two plate resistors and binding posts are the only parts. However, it is necessary to supply "A" current from a separate source to each tube. (The English 2-volt tube operates from a single cell.)

The reason for this is that the biasing of the successive grids is obtained by tapping the "A" batteries in at different points along the "B" battery; a determination of values which must be found by experiment. Each grid is at exactly the same potential as the preceding plate, as is evident; regulated by the tapping of the "B" battery and the value of the interposed resistor.

Equal value is claimed for the system

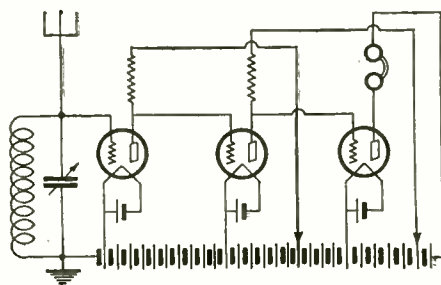

A unique system of coupling, wherein the plate of each tube and the grid of the next are at the same potential.

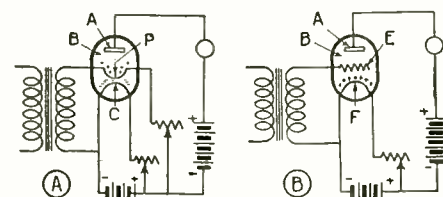

Fig. A., at the left, shows the two-filament tube; to one, the filament P, is made the usual input connection. Fig. B shows a filament having a positive and negative emitting surface.

which the ionized atoms are produced depends upon the anode voltage, the area of the surface of the emitter, the materials with which it is coated, and the degree to which it is energized. This rate of emission is thus obviously subject to control. It must be such as to maintain the pressure within the bulb at the order given above. When the valve is first used it already contains hydrogen gas given off from that occluded by the electrodes at the low pressure above stated. The required pressure is subsequently maintained by the emitted ions. The temperature of the emitter should be 600 to 700 degrees, which can be controlled by means of a filament rheostat. When the tube is functioning correctly a blue fluorescence appears therein.

Referring now to Fig. B, it will be seen that instead of two separate filaments, C and P, only one filament F is provided, this being coated partly with the same substance as the positive ion emitter P and partly with the same coating as the cathode C, so that some portions of it will discharge the electrons and inter-spaced portions will discharge the positive ionized atoms. The circuit is shown in the figure. The electrode E has as large a surface as possible in the vicinity of the cathode, and does not require heating.

A PORTABLE CABINET

The invention consists of a cabinet containing the components of a radio receiving set, having a lid in which the aerial is in-

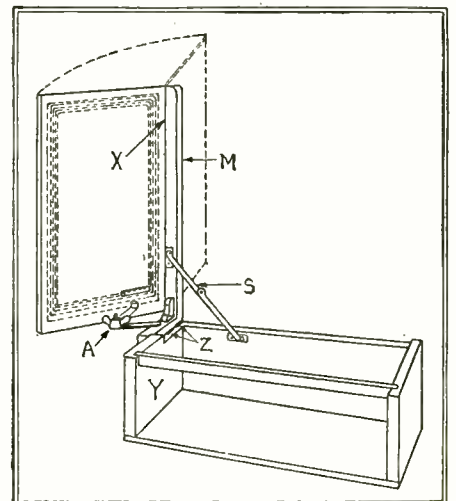

The loop which fits in the cabinet's lid may be rotated without moving the cabinet, making it ideal for portable sets.

corporated; the lid being hinged along one edge to a part frame (loop) member, which in turn is hinged to a wall of the cabinet about an axis transverse with the lid hinge. British patent No. 269,349 has been issued to its inventor, James Wesley Galloway, of Ayrshire, Scotland.

In the drawing the lid is hinged at X to a member M complementary to the rear wall (Continued on page 399)

Radiotics

BANG! BANG! ALSO BOOM!!

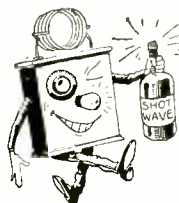

Echoes of the disturbance of 1917 in the *Newark, N. J. Star-Eagle*, of June 21st: "A special SHOT wave transmitting set was installed in the plane. . . . Evidently one of the surplus sets that have been on sale at some of these army and navy stores; we would like to know whether it was shot with a bullet or hootch.

Contributed by Stan Worris

LATEST IN MOTOR DESIGN

In describing a new car the *Detroit News* of June 26, states: "it was able to employ a higher compression RADIO." Whether the compression is in the tubes or in the manner in which the set is put together, the *News* fails to say; but we suppose portability is highly increased.

Contributed by W. J. Weipert, Jr.



SABOTAGE?

In the *Boston Globe* of June 22nd, under "Questions and Answers," we note the following: "In the case of WBET there has been reported that this station has not been as well received since it was transferred to a new WAGE." Is WBET acting sulky because of its reduced wage?

Contributed by Mrs. M. D. Bridge.

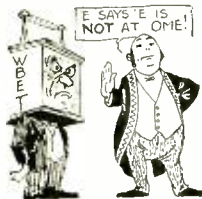

NEW STYLE CONNECTORS

Wood will be used in place of copper for wiring, if the *Pittsburgh Press* of July 3 has the right dope: "It is essential that all of the JOISTS be securely soldered if a receiver is to operate efficiently." It looks as though soldering will now be done with a hammer and nails.

Contributed by Frank M. Walling.



SOME TANKS!

Interest in the latest invention exhibited by the *Dallas News* of June 18: "Gasoline tanks holding fuel sufficient for 70 hours AND A LONG WAVE RADIO SENDING AND RECEIVING SET." We think that tubes, condensers, etc. would clog up a gasoline feed-line; but apparently the plane flies O.K.

Contributed by Comperc Basoni.



NICE AND TIGHT?

New type of socket announced by the *Rochester, N. Y. Times-Union* of June 13: "The tubes are LACED in the socket of the new set." Mike of the Investigation Department reports that this wobble-proof socket is for use in portable sets for contenters of the 18th Amendment.

Contributed by Anonymous.

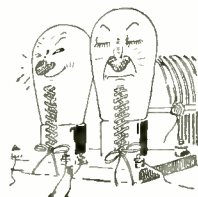

TRY THIS IN YOUR GARDEN



Advice to gardeners from *QST Magazine* for May, 1927: "In the class of unsatisfactory apparatus we must first think of our HOME-GROWN Wavemeters." We wonder, if you catch some radio waves and plant them, is the result a crop of wavemeters?

Contributed by Louis Learch.

INSIDE STUFF

Startling exposure by the *New York Journal* of June 14, on the subject of a radio address on "Lindy's Voyage in a NUTSHELL." Evidently in this broadcast the famous "WE" was not the Spirit of St. Louis, as given out through the general press. We want to know, how come?

Contributed by Harold Dibblec.



IF you happen to see any humorous misprints in the press we shall be glad to have you clip them out and send to us. No RADIOTIC will be accepted unless the printed original giving the name of the newspaper or magazine is submitted with date and page on which it appeared. We will pay \$1.00 for each RADIOTIC accepted and printed here. A few humorous lines from each correspondent should accompany each RADIOTIC. The most humorous ones will be printed. Address all RADIOTICS to Editor RADIOTIC DEPARTMENT, c/o Radio News.

MORE LITIGATION

This jam from the "What Do You Know About Radio" column in the *Rochester, N. Y., Democrat and Chronicle* of June 20: "Why are WJZ's UNSUED towers maintained on the top of the Aeolian Building?" This looks as if WJZ's towers are about the only ones that aren't mixed up in some lawsuit.

Contributed by John C. Heberger.



NAUGHTY! NAUGHTY!

That radio is indeed a member of the Generation of Flaming Youth is evidenced by this advertisement, found in the *Minneapolis Journal* of June 26: "Five-tube radio \$25.00, complete LAMPS SPEAKER." Can you imagine a five-tube receiver strutting up and down the avenue, ogling the good-looking girls as they pass?

Contributed by E. W. Topel.



POILS WITT DIEMENTS

Advertisement from the *Philadelphia Evening Bulletin* of June 22: "'B' Battery Eliminator, 2 or 3 VALUABLE plus controls." We wonder how much these controls are worth and whether they are set with diamonds or some other precious stones? We thought radio had graduated from the class of luxuries into necessities.

Contributed by Edith Schert.

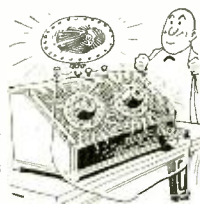

WE NEED 'EM IN NEW YORK



Assertion from the *Queries and Answers* department of the *Boston Globe* of June 24: "It is a TUNNEL radio frequency outfit with three controlling knobs." Evidently this set will dig tunnels while furnishing music to the hard working excavators.

Contributed by P. F. Flynn.

ANOTHER LIGHT BRIGADIER

New wrinkle about the well-known Strobodine receiver divulged by the *New York Sun* on July 9, with an illustration of "The fundamental circuit of the frequency CHARGER." No wonder that this hook-up shows some speed; but those interested in the upkeep may want to know how often it is necessary to charge the frequency?

Contributed by F. R. M. Evans.



PAGE THE GERRY SOCIETY!

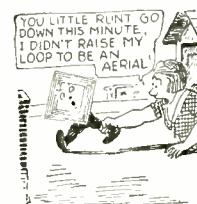

Cruelty to receiving apparatus threatened by the adoption of advice found in the *New York Telegram* of July 26: "RUNT the aerial, if possible, between the two highest objects on the roof." But how do we stunt the youthful aerial's growth? Or can we expect late hours and jazz company to bring about this seemingly undesirable condition?

Contributed by K. E. Crilly.

FOR THE BABY BATTERY

Advice to the owners of infant batteries, from the *Rochester, N. Y., Democrat and Chronicle* of June 26: "Says RUBBERBIBS end many battery troubles." We suppose that with the rubberbib there is not so much chance of the acid getting around where it should not be. Why did no one think of this idea before?

Contributed by A. H. Murray.

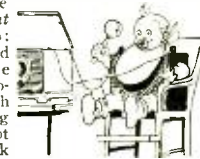

WE WANT ONE

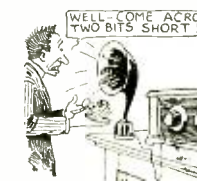

Competition with Uncle Sam's Mint announced in the advertising columns of *RADIO News Magazine* for July: "A three-unit device . . . that utilizes any style phonograph and reproduces through a wave receiver and loud speaker \$20.00." If you tuned in a short-wave station, would you be short-changed?

Contributed by Frank Isom.

UPON THE WAVES!

Trend towards lowering the high cost of living indicated in the *Cincinnati, O., Enquirer* of July 17: "And so . . . lies the way of the local BREAD-CASTER." Now, boys and girls, we are seriously thinking of throwing up the old job and getting a receiving set that will gather in the grub. What's the use of working now, when we can just tune in?

Contributed by R. L. Odell.





Radio News Laboratories



RADIO manufacturers are invited to send to RADIO NEWS LABORATORIES samples of their products for test. It does not matter whether or not they advertise in RADIO NEWS, the RADIO NEWS LABORATORIES being an independent organization, with the improvement of radio apparatus as its aim. If, after being tested, the instruments submitted prove to be built according to modern radio engineering practice, they will each be awarded a certificate of merit; and a "write-up," such as those given below, will appear in this department of RADIO NEWS. If the apparatus does not pass the Laboratory tests, it will be returned to the manufacturer with suggestions for improvements. No "write-ups" sent by manufacturers are pub-

lished in these pages, and only apparatus which has been tested by the Laboratories and found of good mechanical and electrical construction is described. As the service of the RADIO NEWS LABORATORIES is free to all manufacturers, whether they are advertisers or not, it is necessary that all goods to be tested be forwarded prepaid, otherwise they cannot be accepted. Apparatus ready for, or already on, the market will be tested for manufacturers free of charge. Apparatus in process of development will be tested at a charge of \$2.00 per hour required to do the work. Address all communications and all parcels to RADIO NEWS LABORATORIES, 230 Fifth Avenue, New York City.

T.R.F. RADIO RECEIVER

The "Herbert Lectro" shown, submitted by Harold Herbert, Inc., 40th Avenue and 23rd St., Long Island City, N. Y., is a three-dial, five-tube radio receiver which incorporates two tuned-radio-frequency stages, a tuned detector, and two stages of audio frequency. The two radio-frequency stages, detector and the first audio use UX-199-type tubes; while a UX-171 is used in the last audio stage. The interesting feature about this receiver is that it works directly from the 60-cycle A.C. line. A built-in power



AWARDED THE RADIO NEWS LABORATORIES CERTIFICATE OF MERIT NO. 2092.

BINDING POST

The binding post shown, submitted by John Lucas and Sons Co., Chicago, Illinois, is of the spring-pressure type and made of nickel-plated brass. This binding post is compact and sturdy, and provides a good contact with the connecting



wires. A 3/8-inch screw is used for its attachment in the panel. AWARD THE RADIO NEWS LABORATORIES CERTIFICATE OF MERIT NO. 2093.

TUNED-R.F. RECEIVERS

The radio receiver shown (Model 80), submitted for test by King-Buffalo, Inc., Rano Street, Buffalo, N. Y., is a single-control, six-tube set and embodies two stages of tuned radio, one tuned detector, and three audio-frequency stages. The three rotors of the tuning condensers are controlled from the same illuminated dial, which is calibrated in wavelengths. The stator of the condenser tuning the antenna coil can be swung slightly upon the condenser shaft, a feature which allows changing the capacity without interfering with the rotor. A finer



adjustment in tuning is thus obtained. The entire sub-panel is elastically attached to the frame of the receiver in order to protect the tubes from outside mechanical vibrations and to prevent microphonic noises. This receiver tunes sharply, is sensitive, and permits very fine reception.

AWARDED THE RADIO NEWS LABORATORIES CERTIFICATE OF MERIT NO. 2097.

This radio receiver (Model 81), submitted by the same company, is also of the single-control type. It is a six-tube set and incorporates two tuned radio-frequency stages, one tuned detector and three stages of audio frequency. The tuning of the condensers is effected in the same manner as in the type 80 receiver. The three coils used are completely shielded in copper cans. The bakelite panel, carrying the tube sockets of the two radio stages and the detector, is elastically suspended from the metallic frame of the set in order to prevent micro-telephone noises. This receiver is enclosed in a very neat cabinet. It is very sharp in tuning, sensitive, and affords very good reception of music



and speech with regard to quality and volume. AWARD THE RADIO NEWS LABORATORIES CERTIFICATE OF MERIT NO. 2098.

TERMINALS

The spring connectors shown submitted by A. W. Herbert, Pragerstrasse, 15, Berlin W., 50, Germany, are of the spring-pressure type and have their tips either threaded or split and, therefore, can be used



either as binding posts or as plug-in tips in connection with tip jacks. AWARD THE RADIO NEWS LABORATORIES CERTIFICATE OF MERIT NO. 2099.

LOUD SPEAKER

The loud speaker (type "Mozart" shown) submitted by the Mikro-Lautsprecher G.m.b.H., den Lutzow-Strasse 96, Berlin W. 35, Germany, is of the horn type. The air chamber is formed by a cavity inside the cast block of a special metallic



composition which carries the reproducing unit. The reproducing unit is adjustable and well designed. This loud speaker affords very good reproduction of music and speech, although at very high audio frequencies a peak has been noticed. AWARD THE RADIO NEWS LABORATORIES CERTIFICATE OF MERIT NO. 2100.

VACUUM TUBE

The "Z-P" 201A-type tube shown, submitted by the Zetka Laboratories, 67-73 Winthrop St., Newark, N. J., has an "M" shaped oxide-coated filament, and is designed for use as an audio- or radio-frequency amplifier. The filament voltage of this tube is from three to six volts and the current from .22 to .26 amperes. The amplification constant of this tube is approximately 8.5 and its plate impedance 7700 ohms (at 90 volts). The tube is of very rugged construction and uses a brown-bakelite base of the UX type. AWARD THE RADIO NEWS



LABORATORIES CERTIFICATE OF MERIT NO. 2102.

LEAD-IN CONNECTOR

The radio lead-in connector shown, submitted by the Ajax Electric Specialty Co., Radio Bldg., St. Louis, Mo., permits easy connection of the lead-in to the aerial and ensures a perfect contact between them. The two small coupler plates forming this unit are identical, each being provided with two "V" shaped grooves. The aerial wire and the lead-in are clamped between the plates when the screw in the center



is tightened, and are prevented from slipping out by the sharp edges of the grooves.

AWARD THE RADIO NEWS LABORATORIES CERTIFICATE OF MERIT NO. 2104.

AUDIO COUPLING UNIT

The tuned double impedance shown, submitted by the Leslie F. Muter Co., 76th and Greenwood Avenue, Chicago, Ill., is an audio-amplifier coupling unit and consists of two tuned impedances, inductively coupled by their common iron core, which are tuned to a very low frequency by means of a fixed con-



unit, using a QRS full-wave rectifying tube, supplies the necessary "B" voltages and the filament current for the UX-199 tubes, which are all in series. A.C. is used for heating the filament of the UX-171 tube. This receiver is neatly built and its operation is very satisfactory with regard to sensitivity and quality of reception.

AWARDED THE RADIO NEWS LABORATORIES CERTIFICATE OF MERIT NO. 2009.

RECTIFIER TUBE

The "Kelvin" rectifier tube shown, submitted by the Eureka Tube Mfg. Co., 42 Walnut St., Newark, N. J., is of the full-wave gas-filled type and designed to be used in "B"



power-supply units, using rectifiers of 85-milliampere current capacity. Tested in connection with several standard "B" power units, this tube has been found to operate very satisfactorily.

AWARDED THE RADIO NEWS LABORATORIES CERTIFICATE OF MERIT NO. 2091.

VACUUM TUBE

The "Supertron" tube shown, submitted by the Supertron Mfg. Co., Inc., Hoboken, N. J., is of the 201A type and has a UX base made of isolantite. The amplification constant of this tube is 10 and its plate impedance is approximately 12600 ohms (at 90 volts). Its static characteristics are almost identical to those of the standard 201A tube. In order to prevent microphonic noises, the elements of the tube are mounted between two isolantite plates. This tube operates very satisfactorily as amplifier or detector.

denser, which is in the same container. The object of tuning is to exaggerate the amplification of the low frequencies and thus compensate, to a certain extent, the inefficiency



of most loud speakers at those frequencies. This impedance unit is intended to be used in a three-stage audio-frequency amplifier; and employs in each stage a different coupling-capacity value. An amplifier built with those impedances gave excellent results.

AWARDED THE RADIO NEWS LABORATORIES CERTIFICATE OF MERIT NO. 2106.

FIXED RESISTOR

The metallized resistor shown, submitted by the Polymet Mfg. Corp., 599 Broadway, New York City, has for its resistance element a small glass rod which is covered



with a thin metallic deposit. A light coat of paraffin protects the element against moisture. It is available in different resistance values and can be successfully used as a grid leak or as a resistance element, in connection with resistance-coupled amplifiers.

AWARDED THE RADIO NEWS LABORATORIES CERTIFICATE OF MERIT NO. 2107.

VACUUM TUBES

The special tubes (TC-200A and TC-200B types), submitted by the

Televocal Corporation, 588 12th St., West New York, N. J., are efficient detectors. The amplification constants and the plate impedances are, respectively, 20.6 and 33,000 ohms for TC-200A, and 15.5 and 23,000 ohms for TC-200B. These tubes use a UX base.

AWARDED THE RADIO NEWS LABORATORIES CERTIFICATE OF MERIT NO. 2109.

The tube shown (TC-201A type), submitted by the same company, is of the UX-201A type and similar in construction to the tubes mentioned above. The amplification constant of this tube is 8.9 and its plate impedance at 90 volts is



11,500 ohms. This tube can be used conveniently either as an audio or a radio amplifier, or as a detector.

AWARDED THE RADIO NEWS LABORATORIES CERTIFICATE OF MERIT NO. 2110.

The power tube (TC-112 type), submitted by the same company, is of the UX-112 type and designed to be used in the last audio stage. Its filament-heating current is half an ampere and a plate voltage up to 157½ can be used, provided the proper negative grid bias is applied. The amplification constant of this tube is 7.3 and its plate voltage impedance at 90 volts is 5500 ohms.

AWARDED THE RADIO NEWS LABORATORIES CERTIFICATE OF MERIT NO. 2111.

TEST LAMP

The "Radio Trouble Lamp" shown, submitted by the Ajax Electric Specialty Co., Radio Bldg., 1926 Chestnut St., St. Louis, Mo., is of considerable aid in locating troubles in radio receivers. It allows the



user often to ascertain whether a circuit is broken or not. A 4½-volt flashlight lamp is used, which can be conveniently operated from the "A" battery.

AWARDED THE RADIO NEWS LABORATORIES CERTIFICATE OF MERIT NO. 2113.

RECTIFIER TUBE

The "Gold Seal" rectifier tube (type GSX-213 shown), submitted by the Gold Seal Electrical Co., 250 Park Ave., New York City, is of the full-wave rectifier type. The normal filament current is 2 amperes at 5 volts and the tube is rated to deliver a maximum of 65 milliamperes direct current at the maximum plate voltage of 220 volts.



AWARDED THE RADIO NEWS LABORATORIES CERTIFICATE OF MERIT NO. 2116.

FIXED RESISTORS

The "Pyrohm" resistor shown, submitted by the Aerovox Wireless Corp., 70 Washington St., Brooklyn, N. Y., is designed for use in radio "A" and "B" power-supply units and is capable of carrying relatively heavy loads. This unit is of the wire-wound type and covered with vitreous enamel to protect the fine resistance wire against mechan-

ical injury and corrosion. Taps are provided for the corresponding resistance values. These units are



made in different resistance values to carry 20, 40, 100 and 200 watts load.

AWARDED THE RADIO NEWS LABORATORIES CERTIFICATE OF MERIT NO. 2118.

The "Metalohm" shown, submitted by the same company, uses as a resistance element a glass rod covered with a metallic conductive sub-



stance. The resistance value of these units is permanent and does not change with use. Available in all standard resistance values.

AWARDED THE RADIO NEWS LABORATORIES CERTIFICATE OF MERIT NO. 2119.

ALTERNATING CURRENT TUBE

The "Van Horne" A.C. tube shown, submitted by the Van Horne Co., Franklin, Ohio, is designed to eliminate the necessity of having a D.C. source for heating the fila-



ment. In this tube the filament is heated by the light-line alternating current, which is stepped down to 1.1 volts. The filament current is 2 amperes. The amplification constant of this tube is 9 and its plate impedance at 90 volts is approximately 5000 ohms.

AWARDED THE RADIO NEWS LABORATORIES CERTIFICATE OF MERIT NO. 2120.

Letters from Set Constructors

(Continued from page 363)

cast reception was almost taboo. As a rule the aerial is superfluous.

J. H. VAN KOOLBERGEN,
P. O. Box 338, Chicoutimi, P. Q., Canada.

A JAPANESE CIRCUIT

Editor, RADIO NEWS:

I have been a reader since April, 1926, and am interested in your novelty, and especially about DX reception. I am a member of the Pittsburgh Post's Home Radio Club, and also a "DX Club" member of Radio Doings (Red Book.)

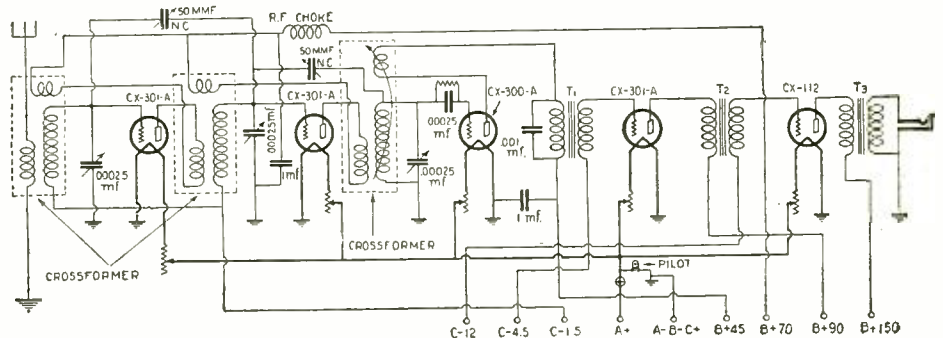

Above, a Japanese circuit, the "Crossdyne." No data have been received regarding the R. F. transformer units from which it derives its name. The triple-regeneration feature would seem quite ticklish.

At the left, above, Mr. Lindner's R. F. and detector, which are not unusual; and below, his A. F. amplifier, using high-μ tubes. Much experiment may be necessary to secure the exact adjustment required for good work.

All the Australian stations come in very loud, so that one can hear it a quarter-mile away.

My aerial is of the cage type; its length is 50 feet, 30 feet high. It consists of six strings of 7 strands each, of No. 23 S.W.G.; and five hoops per thirteen feet. The lead-in and ground wire are 7-stranded No. 18 S. W. G.

I think the name "Crossdyne" must be a stranger to you. This system of radio-frequency amplification was invented by a Japanese engineer two years ago. It has a wonderful sensibility. The circuit diagram accompanying is that of my receiver.

I shall gladly reply to any inquiries about the Japanese radio broadcast stations from any radio fan in the United States and other countries.

MINORU NAKAMURA,
c/o Nakamura Besso, Yamate,
Osio, Kanagawa Ken., Japan.

A LOW-VOLTAGE A.F. AMPLIFIER

Editor, RADIO NEWS:

The accompanying schematic diagram is a hook-up of my present set, the audio end of which I consider unique as well as powerful. The reproduction obtained is really remarkable. I am a set builder and experimented quite a while before I arrived at this combination. The "B" supply is All-American, shunted by a Mershon condenser; the speaker an Acme-K1. I have tried this same hook-up using 301A tubes in the first and second A.F., but find them unable to carry the power.

(Continued on page 427)

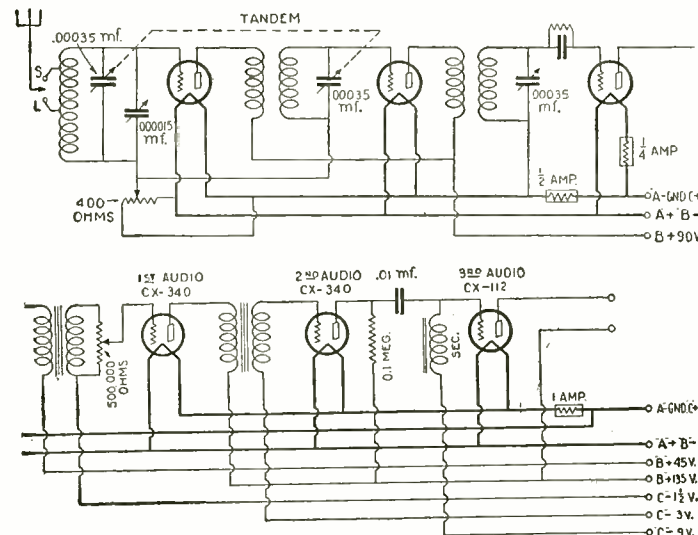

Radio Wrinkles

AN EASILY-MADE LOOP

A LOOP for a receiving set is readily made by using a phonograph record as material for the spacers at the ends. A 10-inch disc is cut in quarters with a hack saw; and then a half-square, measuring 2½ inches from the outer edge on each side, is cut from each segment.

The center line of each segment is then located and two holes are drilled, ⅝-inch apart, the first being ½-inch from the bottom. Then, after measuring 1 inch from the center line each way on the outer edge, 6 slots are filed or sawed on each side, ½-inch apart; making 12 in all in each quarter of the circumference.

The arms and standard of the loop are 1x2-inch material, cut and slotted as shown. Glue and two screws are used to fasten the quarter discs in each slot. The arms, slotted at the other ends, are fastened with glue and two screws each to the standard.

A piece of formica or other insulating composition, 6x1-inch, is drilled in four places; ¼-inch from each end and ¾-inch away from the center. Three holes are also drilled for binding posts; the center post being insulated from the standard by inserting a piece of mica between them.

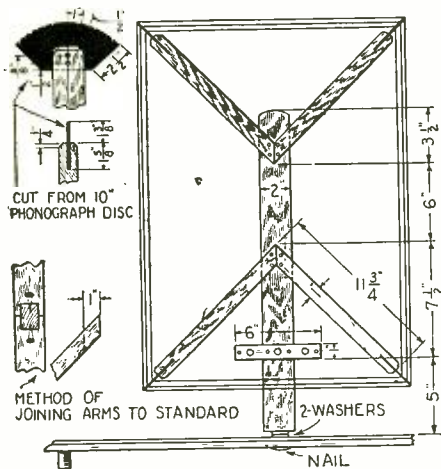

The spreaders of this loop are parts of an old phonograph record.

The bottom is drilled and bushed with a small piece of copper tubing. A nail through a large board on the cabinet top is used as a pivot on which the loop is turned.

The completed frame is wound with No. 22 wire (special loop wire may be used to advantage) starting at the left binding post, thence through the wire hole at the left, the forward slot on the lower left arm, and then clockwise to its full length. The center is tapped to the center binding post; and the other end finally passed through the last hole in the strip to the right binding post. For the center tap, the wire is scraped and soldered to a tap or clip fastened to the center post. If the frame is turned over, for winding past the center, the turns should then be made counter-clockwise, in order that the complete loop shall be wound in one direction.

When complete, the loop measures over all 17¼ inches horizontally, and 25¼ inches

vertically. The curve of the discs causes the outside turns to be a little smaller than this.

Contributed by E. A. Hill.

TUBE SILENCER

TO stop that microphonic ring, the following device has been found very satisfactory: from a sheet of lead cut a cross five inches square outside. Cover this with friction tape and then bend the

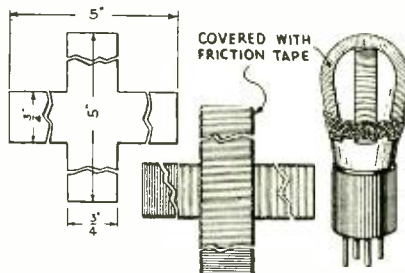

A piece of sheet lead fastened to a vacuum tube as shown will reduce microphonic noises.

four arms down firmly on the offending tube and fasten them firmly with three turns of tape around their ends.

Contributed by R. H. Huxford.

HOME-MADE MICROPHONE

A VERY satisfactory microphone may be constructed from an old phonograph reproducer unit and an ordinary transmitter button. The reproducer unit is mounted on the back of an upright piece of wood, which is screwed to a baseboard of the same material. Care should be taken that the needle holder points down, in such a position that when a needle is inserted in the holder it will bear lightly against the front of the button. A hole may be bored into the wooden upright directly in front of the reproducer diaphragm and a metal or cardboard mouthpiece inserted. This makes a

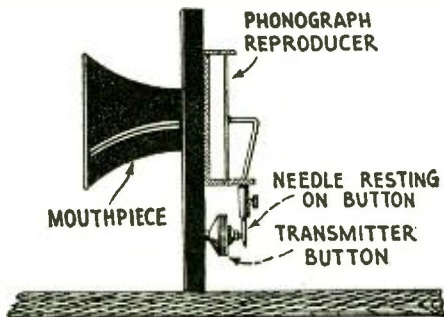

A sensitive microphone can be easily made by mounting a "Skinderviken" button as shown.

simple, inexpensive microphone that will answer all ordinary requirements.

Contributed by Sterling C. Spielman.

SPRING-HELD PULLER

A SMALL tool, especially desirable for handling parts in locations too confined for use of the fingers or even the

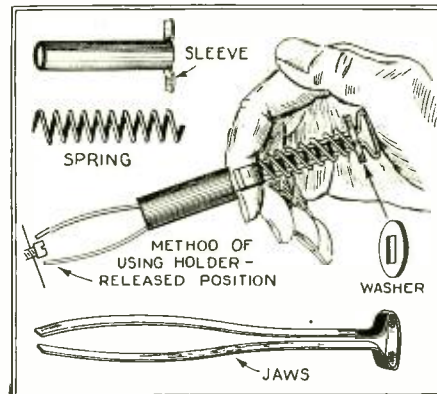

A convenient holder for small objects can be very easily made as shown above.

pliers, is shown in the sketch. It will handle small screws, nuts, pins, wire, connectors and, in fact, any of the small parts; removing them or putting them in place and adjusting them for soldering. It consists of a pair of tweezer-like jaws made up of a piece of spring steel, which slides in a tubular sleeve. At the handle end is a washer, which seats a spring and brings spring pressure to bear against the sleeve.

In operation, the tool is gripped in the hand, the fingers sliding the sleeve to the rear and permitting the jaws to open. When the sleeve is released, it slides forward and closes the jaws.

Material to make this tool is usually available in any tool box or spare parts box. The sleeve is about ¼ inch in diameter, and three inches long. The spring may be of 1/16-inch steel wire.

Contributed by G. A. Luers.

ONE-HOLE SWITCH MOUNTING

THIS device makes it possible to use a regular switch lever and several points in a hook-up, without marring the panel for future use. Only one hole is required, as will be seen. A small piece of insulating panel and two sheet iron brackets are required. It will be necessary to remove the knob from the switch and add an extension to the usual shaft, to come through the main panel, in which only one hole is required, as will be seen.

Contributed by Willis Barlow.

(Continued on page 399)

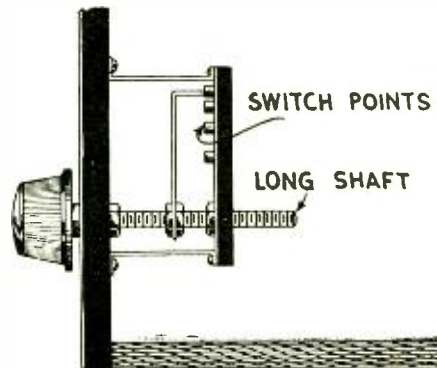

By mounting inductance taps as shown in the sketch the appearance of the panel is bettered.



THIS Department is conducted for the benefit of our Radio Experimenters. We shall be glad to answer here questions for the benefit of all, but we can publish only such matter as is of sufficient interest to all.

1. This Department cannot answer more than three questions for each correspondent. Please make these questions brief.
2. Only one side of the sheet should be written upon; all matter should be typewritten or else written in ink. No attention paid to penciled matter.
3. Sketches, diagrams, etc., must be on separate sheets. This Department does not answer questions by mail free of charge.
4. Our Editors will be glad to answer any letter, at the rate of 25c. for each question. If, however, questions entail considerable research work, intricate calculations, patent research, etc., a special charge will be made. Before we answer such questions, correspondents will be informed as to the price charge.

VOLUME CONTROL FOR RESISTANCE-COUPLED AMPLIFIERS.

(Q. 2335.) Mr. J. Norton, Linden, N. J., writes: Q. My present receiver consists of a regenerative detector with a three-stage resistance-coupled amplifier. This set delivers ample volume, but at certain times I desire to decrease the output. I have tried a modulator plug across the loud speaker, but this resulted in distortion. Can you suggest any better form of volume control?

A. Now that power tubes are in universal use with "B" units furnishing both "B" and "C"

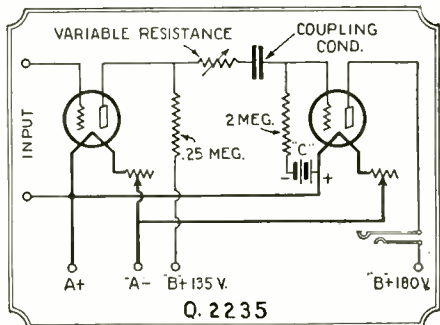

A variable resistor, of 0-500,000 ohms, in series with the coupling condenser and plate, makes a good volume control.

supply, it is becoming more and more usual to dispense with jacks or switches for amplification stages. Generally speaking, this tends toward simplicity and freedom from stray couplings, and is therefore a step in the right direction.

When a radio-frequency amplifier is used, volume may be sufficiently reduced by simply turning down the rheostat of the R.F. stages; but when no R.F. amplification is used the problem becomes a difficult one, and in most cases leads to distortion. Reducing regeneration control is fairly satisfactory in the hands of an expert, but is not to be recommended for sets of the family type. One drawback of reducing regeneration control is that it broadens tuning.

Perhaps the worst method is (though advised by some manufacturers) to include a variable resistance across the loud speaker. It is certainly very effective for controlling the amount of noise produced, but cannot possibly prevent distortion due to tube overloading. In fact, as far as this trouble is concerned, the method amounts merely to shutting the stable door after the horse has escaped.

A circuit which has given very satisfactory service is shown in the accompanying diagram. This volume control consists of an ordinary variable high resistor having a range from zero to approximately 500,000 ohms.

A TWO-TUBE PORTABLE RECEIVER

(Q. 2236.) Mr. Thomas Robinson, Seattle, Washington, writes:

Q. Kindly publish the schematic wiring diagram of a simple portable receiver using two tubes. I desire to operate this set from a loop so that it can be used when it is impossible to erect a temporary aerial.

A. As a rule, portable receivers consist of several stages of radio-frequency amplification with a detector and the usual audio amplifier. However, considerable care must be taken in the design and construction of receivers of this type. A circuit which will give good results with a regular antenna will often be unstable when operated in conjunction with a loop. This is due, in part, to interaction between the loop and the radio-frequency transformers, which can be prevented only by very

complete shielding. Again, where compactness is of prime importance, which is usually the case in a portable receiver, there is always a tendency to crowd the parts; thus again setting up unnecessary oscillation. The best course for the average radio fan might be to adopt a circuit without any form of radio-frequency amplification other than that obtained from the use of regeneration.

Providing that accurate control of regeneration is possible, the sensitivity of a combination as shown in Fig. Q. 2236 is surprising; even when it is operated with a loop aerial small enough to be accommodated in a case of medium size. The arrangement is a modification of the well known Hartley circuit, using a center-tap loop. Unless the control of regeneration is really smooth, results will be disappointing from the point of view of range; and to attain this end, every effort should be made to operate the detector tube to the best advantage. A potentiometer is included in order that the grid circuit may be adjusted to a point giving a compromise between best detection and smoothest regeneration. In a set of this kind, where light weight and compactness are important, the voltage of the "B" battery may be low; 45 volts is sufficient. The range of the receiver is, of course, increased enormously by the connection of an aerial and ground, as a loop is at best only a feeble collector of energy. In order to provide for this addition, aerial and ground terminals may be attached; the former being joined to a point on the loop which is found by experiment to give best results (generally to the second or third turn on the grid side of the center tap), and the latter to the negative side of the "A" battery.

The apparatus needed for the building of this receiver is as follows: One center-tap loop; one .0005-mf. variable condenser; one .00025-mf. fixed condenser; one 2-megohm grid leak; one .00005-mf. condenser for regeneration control; one 400-ohm potentiometer; one R.F. choke coil; one audio transformer, ratio 5:1; one fixed condenser, .002-mf.; one rheostat; two sockets; tubes, batteries, wire, etc.

REMEDIES FOR MOTOR BOATING

(Q. 2237.) Mr. J. Shea, Sandusky, Ohio, writes: Q. I am using a six-tube receiver, which includes a three-stage resistance-coupled amplifier. This set works very well when using dry "B" batteries; but, since I substituted a "B" power unit, I have been experiencing a great deal of "motor boating." Can you suggest any means of eliminating this nuisance?

A. Various recommendations have been made to remove the disturbance which you complain of, namely "motor boating." The usual procedure usually consists of placing an audio-frequency choke

in the detector "B" lead and then connecting a 4-mf. condenser from the receiver side of this choke to the negative leg ("A") of the detector tube filament. This by-passes the detector plate current with its audio- and radio-frequency current components around the resistor of the first audio stage, thus preventing coupling with the audio stage which also passes through this resistor. The primary winding of any audio transformer makes an excellent audio-frequency choke, although standard chokes are to be preferred. If the above does not effect any improvement, the following changes in the values of plate and grid resistors will perhaps alleviate the trouble.

If the amplifier is the standard three-stage unit, it will incorporate 0.1-megohm plate resistors in the first, second and third stages, and grid resistors of 1-megohm, 0.5-megohm, and 0.25-megohm values respectively in the first, second and third stages. The changes recommended are as follows: The plate resistor for the first audio stage should be changed to a 1-megohm or a 0.5-megohm unit, and the grid resistor for this stage to a 0.25-megohm unit. The second plate resistor should be a 0.25-megohm unit and the second grid resistor an 0.1-megohm unit. For the third stage, an 0.25-megohm should be used in the plate circuit and an 0.1-megohm in the grid circuit.

In view of the higher plate resistances, a higher value of plate voltage should be applied to the detector stage in order to obtain the correct effective voltage. It would also be well to try different values of the coupling condensers. Values from .006 mf. to .05 mf. should be experimented with until best results are obtained.

INTERFERENCE FROM ELECTRIC CARS

(Q. 2238.) Mr. S. Woolley, Indianapolis, Ind., asks:

Q. 1. How can I minimize the interference caused by the passage of trolley cars which go directly in front of my house? Every time a car passes, terrific noises which completely obliterate reception are heard in my loud speaker.

A. 1. This kind of interference is sometimes very difficult to overcome, especially since you are located so near the trolley line. Much depends upon the kind of set you are using, and it would be better to use as little audio-frequency amplification as possible, since a disturbance of this type is usually amplified more than the incoming signals. The use of a counterpoise in place of the ground will greatly help by getting rid of any interference due to earth currents; but, if the trouble is very persistent it may be necessary to resort to the use of a loop aerial, with a resulting decrease in signal strength. It may even be necessary to shield the entire receiver to completely remove the annoyance.

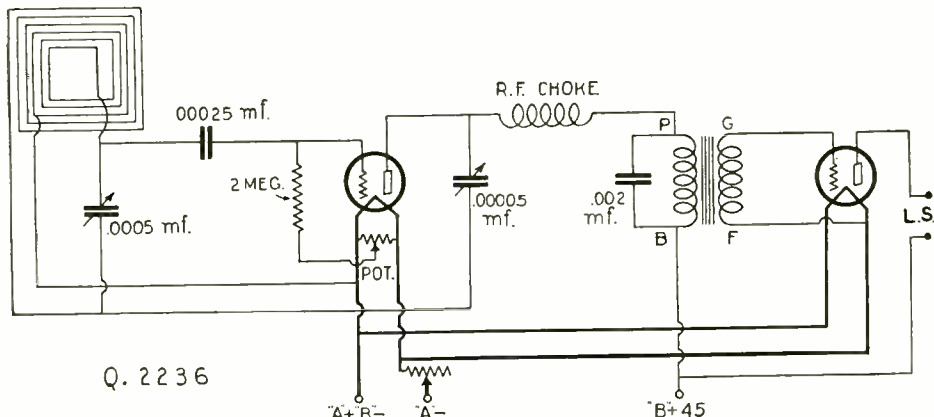

The schematic diagram of a two-tube portable receiver, which may be operated from a loop antenna, is shown above and should give satisfactory reception.

Q. 2. In my study of the different diagrams of radio receivers, I have noticed that the grid leak has sometimes been placed between the grid and filament of the detector tube. I had always understood that the grid leak should always be connected directly across the grid condenser. Is there any advantage in either way?

A. 2. It will be found in most cases that very little difference is noticeable whether the grid leak is connected directly across the grid condenser or from the grid to the filament. In certain receivers, however, it has been found that slightly better results are obtained by using the grid-to-filament connection. In this case, the end of the grid leak farther from the grid of the tube should go to the "A+," in order to give the grid the positive bias necessary for grid-leak detection with special tubes.

If the detector is the first tube of the set and the grid return is connected to the positive side of the filament circuit, the leak may be used directly across the grid condenser, since the grid will obtain its positive bias through the tuning coil. The same applies when the detector tube follows a stage of radio-frequency amplification, if the grid return of the R.F. transformer goes to the "A+." Since this is the usual connection of the grid return in most receivers, the placing of the grid leak across the grid condenser will probably prove most satisfactory.

LOOP AERIAL'S DIRECTIONAL PROPERTIES

(Q. 2239). Mr. H. Valentine, Teaneck, N. J., asks:

Q. 1. Why is a loop aerial directional?
A. 1. If the plane of the loop is at right angles to the direction of the transmitter, the waves from the transmitting station will reach both sides of the loop simultaneously. The currents, induced in every part of the winding under these conditions, will cancel out exactly and no difference of potential will set up across the ends of the winding. If the plane of the loop is not at right angles to the direction of the transmitting station, the waves will reach one side of the frame before the other. The currents produced in each side of the loop will then be out of phase with each other, and therefore, cannot cancel out. The more nearly the plane of the loop winding is made to coincide with the direction of the transmitting station, the greater the phase difference and, of course, the greater the potential differences set up across the ends of the winding.

Q. 2. For what purpose are grid leaks used in resistance-coupled amplifiers? I understand the function of a grid leak when used in conjunction with a detector tube, but when rectification is not required, I do not see what purpose the grid leak serves.

A. 2. A grid leak, whether used for the detector tube or in a resistance-coupled amplifier, fulfills one important function—that of allowing the grid of the tube to which it is connected to retain its mean potential at a suitable value. If the leak were not present, electrons reaching the grid from the filament through the space in the tube would, by accumulating there, give the grid of the tube such a high negative potential that the tube would be unable to operate efficiently.

Q. 3. Can two 75-turn honeycomb coils connected in series be used instead of a single 150-turn coil? Will the tuning range be the same?

A. 3. If the two 75-turn coils are connected in series and are coupled together very closely, in such a way that the fields of the coils reinforce each other, the inductance of the combination will be nearly equal to that of a 150-turn coil of the same type. This means that both coils must be placed next to each other, in such a way that the direction of the windings is the same.

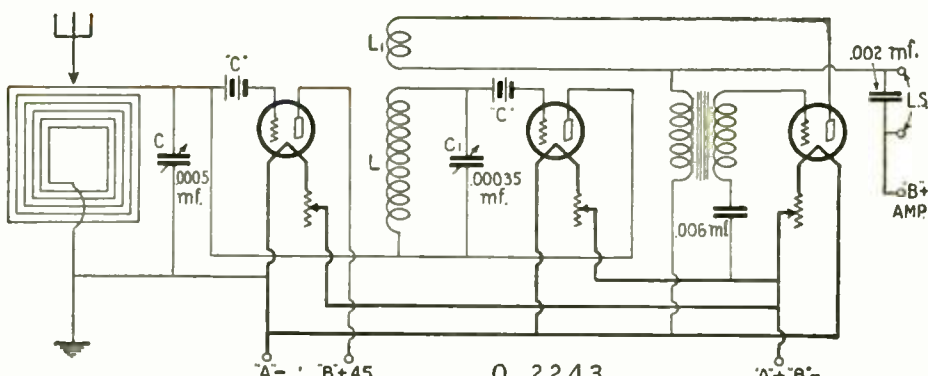

The schematic diagram of the Retrosomic three-tube receiver, with which a loop in combination with an aerial is employed.

LOUD-SPEAKER CONNECTIONS

(Q. 2240). Mr. S. Gilbert, Washington, D. C., writes:

Q. 1. As the terminals on my loud speaker are marked positive and negative, I should like to know which is the correct way to connect the speaker to the set, and whether it really matters which way the loud speaker is connected.

A. 1. There are a right and a wrong way of connecting up a loud speaker; the former is usually determined by changing the connections of the loud-speaker cord. As a rule, reception will be somewhat better when the correct polarity is determined. However, although sometimes no difference in results will be noticed at first, there is danger of the magnetism of the permanent magnet being destroyed by the action of the magnetic field set up by the plate current. The correct way is to join the positive terminal on the loud speaker to that terminal on the set which is internally connected to the "B+," and the negative terminal of the loud speaker to the loud-speaker terminal on the set which connects to the plate of the last tube. If this is done, the magnetic field set up by the plate current will serve to strengthen the magnetism of the permanent magnet.

Q. 2. What is a "solenoid" coil?
A. 2. This is merely another name for a single-layer coil wound on any circular form.

"B" BATTERY QUERY

(Q. 2241). Mr. J. Sharkey, Jersey City, N. J., writes:

Q. I always make a practice of disconnecting the "B" batteries from my receiver after shutting off the set each night, and I notice that on reconnecting the leads a small spark is visible. Does this indicate that current is drawn from the batteries, even when the set is not in use?

A. On the assumption that you are using by-pass condensers across some part of the "B" supply (as most sets do), we think that in all probability the spark is caused by the sudden flow of charging current into these condensers, and if so, the effect is quite normal. The charging current is so small that it is practically negligible and does not decrease the life of the battery to any extent whatsoever. There is no real need of disconnecting the "B" batteries each night, as the flow of current from them should cease as soon as the two filaments are extinguished.

CONVERTING A D.C. POWER UNIT

(Q. 2242). Mr. A. Murphy, Buchanan, Sask. (Canada), writes:

Q. My present house-lighting system is 110 volts D.C. I am using it in conjunction with a D.C. power unit to furnish the plate voltage for my receiver. However, I have been informed that the power company will shortly turn over to A. C., thus making my present outfit useless. Not wishing to incur unnecessary expense of purchasing a new A.C. power unit, I desire to connect my present unit into one capable of being operated from A.C. I will be greatly obliged if you could supply me with a circuit showing the necessary alterations.

A. It will not be a difficult matter to convert your D.C. power unit for use on an A.C. supply. Actually this can be accomplished by the construction of an additional unit which can be attached to your present one. You will require a special rectifying tube and a transformer having a high-voltage secondary delivering about 200 volts on each side of the center tap. The construction of this transformer is not recommended unless the reader is experienced in the making of such apparatus. It would be preferable to purchase one ready-made. A tube of the Raytheon type is very convenient; but a rectifier such as the 213 will be satisfactory, although it requires a separate filament winding. In any event, the connections are shown in the accompanying diagram. The fuses shown in the supply leads to the primary winding are not essential, but are nevertheless advisable; as they will blow if an excessive load is imposed on the circuit, due to a short circuit in the secondary windings or a breakdown of the filter condensers. Unless a safety device of this nature is incorporated, damage may result in the primary or excessive heat be generated, which will burn the insulation of the coils. This will bring about short-circuited turns, and possible burn-out of the transformer.

THE RETROSONIC RECEIVER

(Q. 2243). Mr. M. Perran, Niagara Falls, New York, writes:

Q. I have noticed in your magazine references to the Retrosomic receiver, which I understand is quite popular in European countries. I have seen several diagrams of this receiver, but unfortunately the constants of the different parts were not given. Can you supply me with a schematic diagram of this set giving the values of the different components?

A. In these columns will be found the diagram of this receiver. The following are the parts used in its construction: One standard loop aerial; one .0005-mf. variable condenser; one .00035-mf. variable condenser; two cardboard tubes, each 3 1/2 inches in diameter and 3 inches long; four ounces No. 24 D.S.C. wire, for coil L; two ounces of No. 28 D.S.C. wire, for coil L1; two "C" batteries (tapped); one audio transformer, 5:1 ratio; one .006-mf. condenser; one .002-mf. condenser; three sockets; three rheostats; one panel, 7x20 inches; binding posts, bus bar, etc.

The windings of coils L and L1 are absolutely elementary. L consists of 64 turns of No. 24 wire and L1 consists of 89 turns of No. 28 wire. Both coils are wound in single-layer style, and separated by approximately 4 inches; although the exact distance must be found by experiment. Two 4 1/2-volt "C" batteries, tapped at 1 1/2 and 3 volts, will be quite satisfactory. The best position of the aerial connection on the loop must be found by means of a clip. With the clip temporarily connected to the terminal of the loop which goes to the first "C" battery, tune in some local station by means of the two variable condensers. Adjust all three rheostats for best volume, that is, for the time being, disregarding the degree of selectivity, try changing the position of coil L1 with respect to L, remembering that for each such adjustment condenser C1 should be readjusted. Now turn your attention to the aerial, trying different taps on the loop until the greatest volume is had. For local stations, change-

(Continued on page 384)

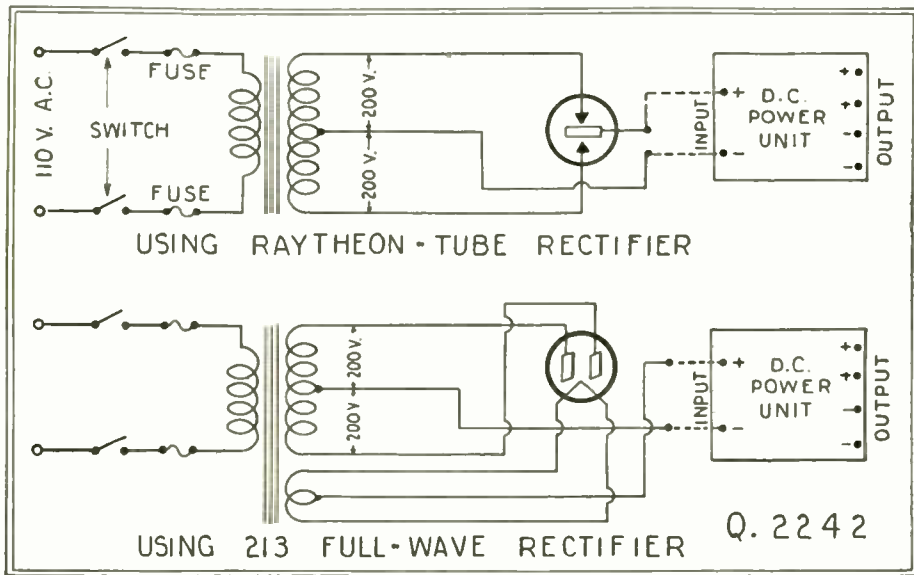

Schematic diagrams of a "B" socket-power unit, for use on 110-volt A. C., and made to utilize apparatus in a D. C. unit.

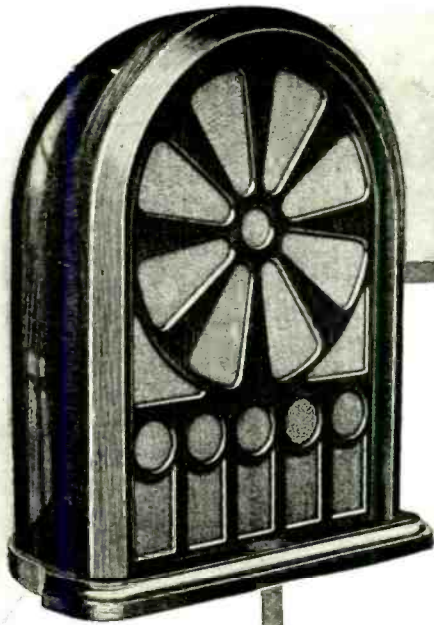

"Perfect!"
say experts



ALL-AMERICAN
TRADE MARK
REPRODUCER

MANY radio experts, hearing the All-American Reproducer for the first time, have exclaimed, "Here at last is a reproducer worthy of a fine receiver."

This splendid unit will give you greater enjoyment of radio; because it reproduces with faithful accuracy. There's no shrill harshness of the treble; no exaggeration of bass tones.

Throughout the entire amplification range—in full volume or turned down to a whisper—all the tones come rich and full.

Make this test yourself—compare the All-American Reproducer with any other, at any price. You'll learn instantly why the All-American is the ideal unit for getting the greatest possible enjoyment of radio. Ask your dealer about it.

ALL-AMERICAN RADIO CORPORATION
4209 Belmont Avenue
CHICAGO, ILLINOIS



ALL-AMERICAN
TRADE MARK
"B" Power
Socket

This is a compact, efficient and low priced unit. It embodies every feature of bulky and higher priced power units. Small enough to fit in any radio battery compartment. Has two controls and will deliver 29 to 180 volts. Price \$27.50

(Raytheon tube extra)





Bradleyunit-A PERFECT FIXED RESISTOR

Unaffected by temperature, moisture or atmospheric changes. Does not age or change in resistance.



A solid-molded fixed resistor, baked under high pressure, and accurately calibrated. Can be soldered without affecting accuracy.

Two Remarkable Radio Resistors

Bradleyunit-A is an outstanding success! It is a fixed resistor for radio circuits of all kinds, and has a capacity of 2 watts. It is rugged and can be soldered easily, without affecting the rating of the unit.

Bradleyohm-E is widely used by manufacturers of B-Eliminators for plate voltage control. Its remarkably wide, noiseless range, accomplished with two columns of graphite discs, accounts for its tremendous popularity.

Use Allen-Bradley resistors in your own hook-ups for superlative results. Follow the example of prominent radio manufacturers. They know!



Bradleyohm-E is available in several ranges and ratings. Sold in distinctive checkered cartons. Ask your dealer for Bradleyohm-E

Allen-Bradley Co.

ELECTRIC CONTROLLING APPARATUS

287 Greenfield Ave.  Milwaukee, Wis.



The Knickerbocker Four

(Continued from page 354)

the right edge of the board, while the binding-post strip is placed along the back edge. In following out these directions, with regard to determining the relative positions, the constructor should hold the baseboard with the panel edge nearest him.

As all the parts of the Knickerbocker Four are in open view, and all wires are run above the baseboard, little difficulty should be experienced in the wiring of the receiver. All connections are made with flexible insulated wire, the ends being either soldered in place or tightened under the heads of the binding posts, on the instruments which are provided with the latter. The pictorial wiring layout and the schematic diagram show everything plainly. If the constructor carefully follows the connections as shown, the set will work as soon as it is connected to its "A" and "B" current-supply units, the aerial and the ground.

As each wire is fastened in place, the constructor should run a pencil mark along the corresponding line on the pictorial diagram (page 353); so that he will know definitely that, when all the lines have been blacked out, the set is finished.

In this diagram, for clearness, the length of the extension shafts on the variable condensers has been exaggerated, and some of the lines representing wires are out of proportion to the lengths of the wires themselves. However, with the actual apparatus in front of him, the constructor should have no trouble in making the proper connections.

The coils L1 and L2 are supplied with lengths of colored flexible wires. These wires are appropriately labelled in the pictorial wiring diagram.

A small 4½-volt "C" battery is tied to the rearmost audio transformer by means of a piece of string. In this position its connecting wires are very short and it is out of the way.

ADJUSTMENTS

After the set has been completely wired, the necessary "A" and "B" batteries, or

socket-power units, should be connected to the binding posts on the strip, and four tubes inserted in the sockets. The aerial and ground are also connected. It is necessary to neutralize the set for the particular tubes used, this operation being performed in the following manner:

Start with the knob of the neutralizing condenser turned completely out. Then tune in a low-wave broadcast station and turn the radio-frequency rheostat R1 as high as it will go. The set will now oscillate. Turn the neutralizing condenser in slowly until oscillation ceases, and then rock the condenser dials, back and forth, at the point the station was received. If the set is stable and does not produce a whistle with this movement, it is perfectly neutralized. If it still oscillates, turn the neutralizing condenser knob in or out to a slight degree, until this action stops.

The primary coil P of the coil L2, which is hinged on the rear end of the secondary, should be varied, if a satisfactory adjustment cannot be made on the neutralizing condenser alone. A few minutes of patient experiment will yield an effective setting.

If it is found that the regeneration, as produced by the tickler coil on the end of the condenser, C2, is not in perfect step with the tuning condensers, a slight variation of the tickler and the secondary from the specified 58-degree angle will overcome the trouble. These adjustments are extremely important, and should not be done hurriedly or impatiently. If the operator "nurses" the detector tube up to the point just preceding oscillation he will have a tremendously sensitive set.

If difficulty is encountered in making the detector regenerate at all, a .001-mf. fixed condenser should be bridged between the "P" post of the first audio transformer T1 and either the positive or the negative side of the filament circuit. This is a certain remedy.

SYMBOL	Quantity	NAME OF PART	REMARKS	MANUFACTURER *
L1	1	Antenna Coupler	SPECIAL- Fits on condenser C1	1
L2	1	A. Circuit Coil	SPECIAL- Fits on condenser C2	1
T1, T2	2	A.F. Transformers	.00037 mf. EXTENDED SHAFT TYPE	1 3, 8, 9, 10
C1, C2	2	Variable Condenser	.00037 mf. EXTENDED SHAFT TYPE	1
R1, R2	2	Rheostats	20 ohms	2 6, 7, 11, 12, 14
SW	1	Filament Switch		2 12, 13, 14
TJ	2	Pin Jacks		2 6, 14, 16
RF	1	R.F. Choke	85 Millihenries	3 10, 17, 18
NO	1	Neutralizing Cond.	.00003 mf. to .0003 mf.	3 9, 16, 19, 20
	4	Sockets	UX type	4 10, 12, 14, 21, 22
C3	1	Fixed Condenser	.0001 mf.	5 6, 12, 23, 24, 13, 26
C4	1	Grid Condenser	.00025 mf. With Clips	5 6, 12, 23, 24, 13, 26
R3	1	Grid Leak	2 Megohms	6 6, 11, 12, 13, 26, 27, 25
R4, R5	2	Fixed Resistors	4 ohm	2 15
	2	Dials	Vanier Type 4" diameter	1 9, 10, 12, 13, 26, 29, 30, 35
	1	Panel	7" x 18" x 3/16"	7 31, 32, 33, 34
	1	Baseboard	9 3/4" x 17 1/2" x 1/2" Wood	
	1	Binding-Post Strip	7 Posts 7" x 1" x 1/2" Hard Rubber	
	7	Binding Posts	Spring-Clip Type	36
V1-4	4	Tubes	20L-A type	37 38, 39

NUMBERS IN LAST COLUMN REFER TO CODE NUMBERS BELOW.

1 Karas Electric Co.	2 Tuxley Mfg. Co.	3 Samson Electric Co.
4 Benjamin Electric Mfg. Co.	5 Samsco Electric Co.	6 Anso Products, Inc.
7 Higneta Fabricators, Inc.	8 All-American Radio Corp.	9 Pacent Electric Co.
10 Silver-Marshall, Inc.	11 Allen-Bradley Co.	12 Pilot Electric Mfg. Co.
13 Polymet Mfg. Co.	14 Herbert H. Frost, Inc.	15 Radiall Co. (Asperite)
16 Leslie F. Water Co.	17 Acme Products, Inc.	18 Radio Engineering Labs. (REL)
19 E. T. Radio Laboratories	20 Bremer-Tully Mfg. Co.	21 General Radio Co.
22 Airgap Products, Inc.	23 Electrode, Inc.	24 Aerovox Wireless Corp.
25 International Resistance Co. (Durham)	26 Dabiller Condenser Corp.	27 Tube Deutschemann Co.
28 National Company	29 General Radio Co.	30 Alden Mfg. Co.
31 Amer. Hard Rubber Co. (Radion)	32 Farnica Insulation Co.	33 Lihnole Corp.
34 Insulating Company of America	35 Martin Copeland Co. (Marso)	36 Pahnstach Electric Co.
37 C. E. Mfg. Co.	38 Radio Corporation of America	39 E. T. Cunningham, Inc.
40	41	42

* THE FIGURES IN THE FIRST COLUMN OF MANUFACTURERS INDICATE THE MAKERS OF THE PARTS USED IN THE ORIGINAL EQUIPMENT DESCRIBED HERE.

If you use alternate parts instead of those listed in the first column of manufacturers, be careful to allow for any possible difference in size from those originally used in laying out and drilling the panel and sub-base.

Balkite has pioneered— but not at public expense



Balkite "A" Contains no battery. The same as Balkite "AB" below, but for the "A" circuit only. Not a battery and charger but a perfected light socket "A" power supply. One of the most remarkable developments in the entire radio field. Price \$32.50.



Balkite "B" Has the longest life in radio. The accepted tried and proved light socket "B" power supply. 300,000 units in use show that it lasts longer than any device in radio. Three models: "B"-W, 67-90 volts, \$22.50; "B"-135,* 135 volts, \$32.50; "B"-180, 180 volts, \$39.50. Balkite now costs no more than the ordinary "B" eliminator.



Balkite Chargers

Standard for "A" batteries. Noiseless. Can be used during reception. Prices drastically reduced. Model "J,"* rates 2.5 and .5 amperes, for both rapid and trickle charging, \$17.50. Model "N"* Trickle Charger, rate .5 and .8 amperes, \$9.50. Model "K" Trickle Charger, \$7.50.

*Special models for 25-40 cycles at slightly higher prices.

Prices are slightly higher West of the Rockies and in Canada.

The great improvements in radio power have been made by Balkite.

First noiseless battery charging. Then successful light socket "B" power. Then trickle charging. And today, most important of all, Balkite "AB," a complete unit containing no battery in any form, supplying both "A" and "B" power directly from the light socket, and operating only while set is in use.

This pioneering has been important yet alone it would never have made Balkite one of the best known names in radio. Balkite is today the established leader because of Balkite performance in the hands of its owners. Because with 2,000,000* units in the field Balkite has a record of long life and freedom

from trouble seldom equalled in any industry. Because the first Balkite "B," purchased 5 years ago, is still in use and will be for years to come. Because to your radio dealer Balkite is a synonym for quality. Because the electrolytic rectification developed and used by Balkite is so reliable that today it is standard on the signal systems of most American as well as European and Oriental railroads. Because Balkite is permanent equipment. Balkite has pioneered — but not at the expense of the public.

Today, whatever type of set you own, whatever type of power equipment you want, whatever you want to pay for it, Balkite

has it. And production is so enormous that prices are astonishingly low.

Your dealer will recommend the Balkite equipment you need for your set.

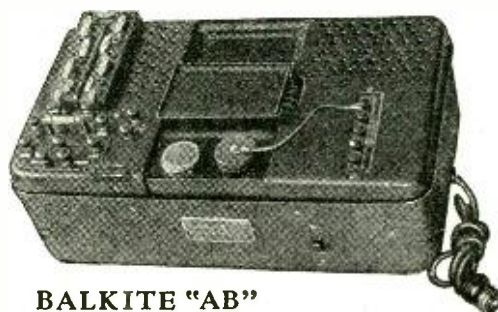

BALKITE "AB"

Contains no battery. A complete unit, replacing both "A" and "B" batteries and supplying "A" and "B" current directly from the light socket. Contains no battery in any form. Operates only while the set is in use. Two models: "AB" 6-135,* 135 volts "B" current, \$59.50; "AB" 6-180, 180 volts, \$67.50.

FANSTEEL PRODUCTS COMPANY, Inc.

North Chicago, Illinois

FANSTEEL

Balkite



Radio Power Units

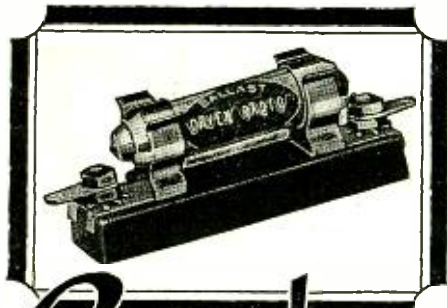

Good for LIFE!

THE DAVEN BALLAST

You never need to worry about your automatic filament controls again—no danger of burning out—no possibility of changing characteristics, after you have changed to the Daven Ballast.

Make your last change now—or better yet put Daven Ballasts in the new set you are building, with the positive knowledge that they will still be as good as new after the set has been discarded.

Made in 1/4, 1/2, 3/4, 1 and 1 1/4 amperes and supplied either with or without the special mounting illustrated.

GLASTOR

THE TRANSPARENT RESISTOR

- Permanent
- Accurate
- Noiseless

as long as the glass remains unbroken.



The Daven Glastor is unlike any other resistor made, *the resistance material is part of the glass itself*, its value cannot change, it cannot become noisy and its resistance is always what the label says it is.

Make your last change now, replace your old type resistors and grid leaks with the new permanent Daven Glastors and forget them. Made in all sizes and sold by good dealers everywhere.

Free Catalog

The new Daven Catalog is ready for distribution. Your copy will be sent you free upon request.

"The Size of Most"
DAVEN RADIO CORPORATION
 Resistor Specialists

140 Summit Street Newark, N. J.

Radio News of the Month

(Continued from page 329)

RADIO BURGLAR ALARM

AN English firm has just introduced commercially a radio burglar alarm, which adds new terrors to Bill Sikes' profession. When the alarm is set off, a small, battery-operated transmitter commences to send out a signal on between 600 and 800 meters; and this automatically brings a warning buzz from the loud speaker of a six-tube receiving set, which may be 50 miles away, if so desired.

LITHUANIA'S RADIO TAX

"IN Lithuania the radio tariff is to be 10 pence (20 cents), and 2 shillings and a penny (50 cents), for crystal and tube sets respectively in towns, and 5 pence (10 cents), and one shilling and three pence (31 cents), in villages. As a result of this law," says *Popular Wireless*, "I have no doubt that the dividing line between a town and a village will come to be perfectly defined. I think that the criterion will be the size of the mayor's whiskers! If such a tariff existed in Scotland the 'back to the land' problem would solve itself in approximately twenty-four hours. (I shall hear about this, mark my words!)"

RADIO SCHOOLING IN RUSSIA

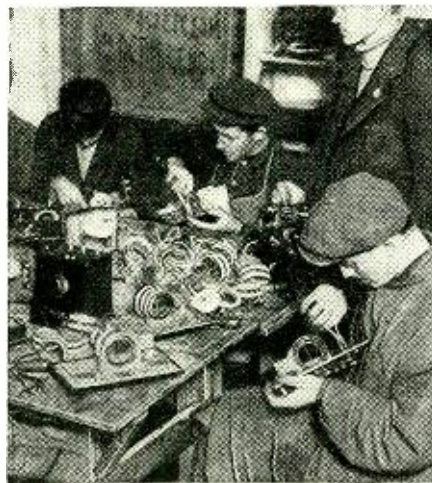

Russia's soviet government, possibly the greatest radio propagandist, institutes radio classes in its schools. Here is a radio "first-grade" class in Moscow, building simple crystal sets. © Herbert Photos.

DIAMONDS IN RADIO

EVERY now and then some of our readers send in a "Radiotic" about a "valuable resistor," or other piece of radio apparatus; "variable" being meant, of course. However, a radio set may be built around a diamond ring, which will take the part of the more humble crystal detector and its cup. The diamond, unlike other forms of carbon, is practically an insulator, and the detecting action is attributed to minute impurities; so that gems of grades below the "first water" are best. The possible rectifying powers of sapphires, rubies, opals, and a host of other gems can be investigated, suggests the veteran experimenter, J. F. Corrigan.

Incidentally, the hardness of the crystal is not decisive. A recent British patent has been published, in which detection is accomplished between a block of alum connected to a "B" battery and a block of nitre (salt-petre) connected across an "A" battery. The alum is connected in series with the aerial and with the phones, through the "B" battery, and then to the "A" circuit and to ground.

Enjoy LOUD SPEAKER OPERATION from a CRYSTAL

NO "TUBES" - NO "B" BATTERIES - NO COSTLY "ELIMINATORS"

THE SKINDERVIKEN TRANSMITTER BUTTON

Simple microphone button provides a most effective and inexpensive way to satisfactory speaker operation. Easy to build and operate circuit.

FOR several years our English cousins have been able to purchase on the open market a radio amplifier of the microphonic type, which enables one to operate a loud speaker from a crystal detector, thus obviating the use of vacuum tubes, "B" batteries, etc.

Everybody can do this now with a Skinderviken Button.

The Skinderviken Button is fastened to the diaphragm of the speaker unit. It will act as a "microphonic relay." Every time an incoming signal actuates the diaphragm, the electrical resistance of the microphone button will be varied correspondingly and the current from the battery, in series with the button and the loud speaker, will fluctuate accordingly.

Thus the problem of securing sufficient power to actuate the Loud Speaker is simply and adequately solved.

The results from this very novel and simple unit will astound you.

The expense of this hookup is trifling compared to elaborate tube circuits that give no greater actuation of the speaker.

Besides this there are many other valuable uses in Radio Circuits for this marvelous little button. Every builder of Radio sets should have a few on hand.

LISTENING THROUGH WALLS

This Unit makes a highly sensitive telephone, the real thing—you listen through walls with ease. Plenty of fun and real detective work too.

CONDUCTING SOUND THROUGH WATER

Make yourself a miniature submarine signaling apparatus like those used during the war. Simple circuit with this microphone unit gives splendid results.



95¢ EACH
TWO FOR \$1.75

FREE 8-page circular fully explaining these and many other uses for these units sent with each order.

PRESS GUILD,
 16R E. 30th St., New York, N. Y.

Enclosed find \$.....for.....Microphone Units as advertised above.

Name

Address

City-State

are roof and loop aerials doomed?

Why, when modern radio sets are built to reproduce music in all its original beauty, should you tolerate static and other foreign noises with which the air is filled? That's why we ask, "Are roof and loop aerials doomed?" Because you no longer need to put up with noisy reception from the air. Clear, loud, static-free, noise-free reception from the GROUND is now possible with your present set. All you need is a Subantenna.

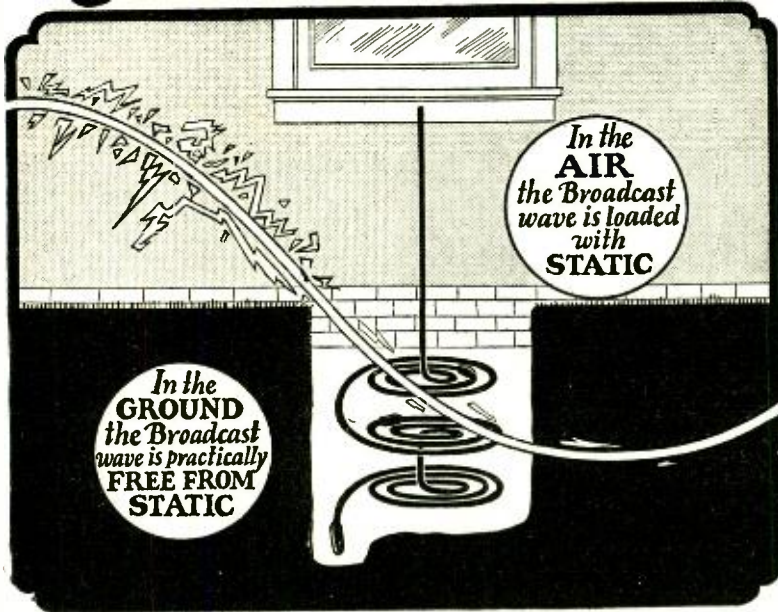

SUBANTENNA

- does away with **STATIC** nuisance
- gives crystal **CLARITY**
Summer and Winter
- increases **DISTANCE**
- improves **SELECTIVITY**

Testing laboratories find, and users testify that SUBANTENNA is, beyond all doubt, the greatest means of improving radio reception yet placed within the reach of listeners. Freedom from static nuisance in all seasons and weathers—greater distance—better selectivity—all are made possible by this great, new underground antenna.

Thousands know the joy of Radio with Subantenna

"I get plenty of stations with my Subantenna on the loud speaker, that I have never been able to reach with my outside aerial. It absolutely cuts down interference to the minimum,

cuts static out too—not just partly out—but ALL out!"

H. S. M., North Carolina

Results—Almost Unbelievable!

"After 4 years of testing aerials I at last found the master in the Subantenna. The first night I used it was a very hot summer night. Static was very bad on my outdoor aerial. I connected my Subantenna and one could hardly believe the results. It was wonderful."—F. L. C., Mass.

Better Than Music from the Air

"We have the Subantenna installed and it is all you claim it to be. It works fine, we enjoy it very much. We would not want to go back on the high-in-the-air aerial again as we get so much better reception on Subantenna."—A. J. L., Maine.

Surprised and Satisfied!

"I received the Subantenna and installed it the same night and believe me I was surprised with the result for I was quite suspicious about it. I am well satisfied."—R. E. G., Canada.

Uses Static-Free Ground Waves

The same radio wave you have always taken out of the air, also travels thru the ground. Only, in the ground, the wave is practically static-free! Subantenna intercepts the broadcast wave while it is in the ground, and brings it to your set unadulterated as when broadcasted. Think what this means to you! Loud, clear distance summer and winter, regardless of how much static or noise there is in the air. No wonder thousands of fans have taken advantage of our FREE TRIAL OFFER, then permanently changed to Subantenna.

Does Away with the Unsightly Cluttering-Up of Roof Tops

The same device which will make radio a thousand-fold greater pleasure for you, will also alleviate the need for cluttering up your roof top with a tangle of wires, posts and cross sticks. Only a short lead-in comes out of the ground from Subantenna up to your set—a wire so small it cannot be noticed. Quite a contrast to the long, dangling lead-in the roof-type aerial requires—and what a joy to be rid of the sprawling, ungainly looking loop. If Subantenna did nothing more than merely do away with the roof and loop types of aerials it would be worth its price many times over.

Very Easy to Install.

No climbing around on slippery roofs to install Subantenna. No frames to build—no insulators to fool with. Just dig a 3 foot hole in your basement or outside your house, bury Subantenna, connect it to your set, and the job is done. Anyone can do it, with assurance of the same kind of perfect results fans are

constantly writing us about. And, when once installed, Subantenna

Never Needs Attention

Day in, day out, year after year Subantenna provides the same loud, clear reception. Never needs cleaning or repairing like an aerial does, and of course, it can't blow down. In fact, Subantenna improves with time. The harder the earth becomes packed around it, the louder it brings the stations in.

TRY IT ON FREE YOUR SET FREE

Install Subantenna. Leave your old aerial up. Select a bad night when DX is almost impossible with the ordinary aerial. Make a comparison station for station, connecting first your aerial, then Subantenna. If, from stations that are just a mess of jumbled noise with the old aerial, you don't get reception that rivals local in sweetness and clarity the instant you switch to Subantenna, this test won't cost you even a single penny. Obtain a Subantenna from your dealer or send coupon at once for scientific explanation of Subantenna and for particulars of GUARANTEE and FREE TRIAL OFFER. SEND COUPON NOW!

SUBANTENNA

THE NEW UNDERGROUND ANTENNA



CLOVERLEAF MANUFACTURING CO.

2713-B CANAL STREET

CHICAGO, ILLINOIS

CLIP AND MAIL AT ONCE

CLOVERLEAF MFG. CO.
2713-B Canal Street, Chicago, Illinois

Tell me all about SUBANTENNA, your unequalled, unconditional guarantee and your FREE TRIAL OFFER.

Name.....

Address.....

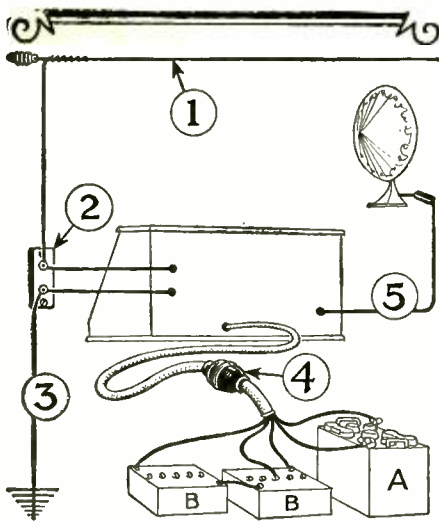

5 Important Accessories for Your Radio Set

1—Beldenamel Aerial Wire

Each strand protected by several coats of baked Beldenamel. Cannot corrode, even after long use. Maintains high set efficiency for range and volume.



2—Belden Lightning Arrester



A safeguard that is essential with every outdoor aerial. A high quality lightning arrester, approved by Fire Underwriters.

3—Belden Ground Wire

A special rubber-covered flexible conductor for lead-in and ground wires.



4—Belden Battery Cords

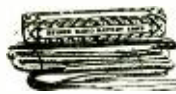

Furnished with or without A & B-battery fuses. Protects tubes and batteries. Improves appearance of set.

5—Belden Extension Cord

25-ft. extension cord for loudspeakers. Provided with connector. No tools required. Conductors are rubber-covered.



Belden Manufacturing Co.
2314A South Western Ave., Chicago, Ill.

Specify
Belden
Radio Accessories

Progress In Radio Drama

(Continued from page 327)

experience of stations, but which has been amply borne out by listener-experience. If true, it is another justification for the recent trend toward local, as against distant broadcasting, and for the chain method.

INCREASING THE CAST

As to the technique of presentation, perhaps the most important progress the radio drama has made of late is that toward larger casts. Two years, and even a year ago, six or seven was the maximum number of characters it was considered feasible to use successfully in a single scene; and some directors limited the number to as few as four or five. This, of course, often meant the sacrificing of important dramatic effects; but it was contended that the audience could not differentiate more characters satisfactorily. However, most notably in the case of a syndicated serial, "The Step On The Stairs," it has been demonstrated that as many as ten or fifteen characters can be used in a single scene with complete success.

The dramatic superiority of this larger cast is obvious; and it is interesting to note that success has been achieved by the differentiation of characters as against mere voices, coupled with the more frequent use of characters' names. By these means the audience has been enabled to distinguish between the various actors without confusion; and on the basis of this result it is reasonable to expect a material enlargement of casts by those directors who have insisted on a small number. The one mechanical difficulty disclosed by the experiment has been that of keeping all actors within proper speaking distance of the microphone. But this can be easily overcome by the use of several microphones, with suitable control arrangements.

THE AUDIBLE "SCENE"

The effectiveness of the musical "background" is a technical detail about which radio drama directors have waged many lengthy discussions; some using it liberally, others banning it altogether. From the listener's viewpoint, it seems its use is justifiable in many instances, provided it is actually a background. The moment it intrudes itself into the foreground and particularly when, as often, it blots out the lines, it becomes a liability rather than an asset; and much the same holds in the case of "noise effects".

In spite of liberal exploitation, it has been my experience that the value of these adjuncts to broadcast plays has been much over-rated in many quarters. Dramatically, they can be compared with the pistol shots, horse's hoofs, and locomotive bell, which the trap-drummer used to inject into the early movies by way of lending verisimilitude—now happily abandoned.

In the last analysis, the burden of creating the desired illusion in the radio drama, as in the movies, rests squarely, if not entirely, on the actor. Under certain conditions a limited amount of noise effects serves a genuine dramatic purpose. But the noticeable trend away from their profuse use toward the absolute minimum necessary for added realism represents distinct progress; particularly when introduced in a manner that will not interfere with the lines, as they too often did previously.

It is gratifying too, to note that such noise effects as are being used are now judged at the receiving end and not in the studio, as formerly. Just how ludicrous a change can sometimes be wrought in the step from microphone to loud speaker is demonstrated by the experience of a friend who took effects incidental to one of the early radio dramas

Use Polymet Products



Type F1001—Small Buffer Condenser for the output of the transformer. Tapped .1-c-1 Mfd.



Type F1002-F1003—The entire condenser requirements for Filter section. Two units tapped at 4-4-c Mfd. and 8-1-1-1-c-1-c Mfd.

for Raytheon "ABC" Eliminators

For efficiency and permanent satisfaction you can't beat Polymet Products. More and more Radio Engineers are every day specifying Polymet Products because they know by experiment that they are the leaders. To insure lasting satisfactory results for Battery Eliminators, Power-Packs and Electric Sets, buy only Polymet "better made Radio Essentials." They are the best.

Send for our latest booklet showing some of the most popular circuits and the complete line of Polymet Products.

Polymet
Manufacturing Corporation
599 Broadway, N.Y.

POLYMET PRODUCTS

FREE

THE RADIO MAN'S BUYERS GUIDE
WALTER ROWAN
BATTERY SUPPLY CO.

FREE

To Set Builders and Dealers

Write today for this big new Catalog. It's yours for the asking without obligation. Contains everything worth while in Radio, including all popular kits described in this and other leading publications. We carry in stock a complete line of parts, accessories, consoles and cabinets.

Buy Direct

from the largest Jobbing house in the middle west and save money on all radio equipment. Try us for quick, accurate service. No delays, no substitutions.

WALTER ROWAN
BATTERY SUPPLY CO.

227 N. Peoria St. Chicago, Ill.

NA-ALD

ALDEN MANUFACTURING CO.

Dept. K-33 Springfield, Mass.

EVERYTHING IN RADIO

AT ATTRACTIVE PRICES. SETS OR PARTS.
Orders shipped exactly as ordered. Prompt Service.
Write for Prices. Mail Order Only. Send Your Address.
ALL RADIO COMPANY, 417 North Clark St., Chicago

Trickle charge or
full-rate charge—
*You get either or both
with*

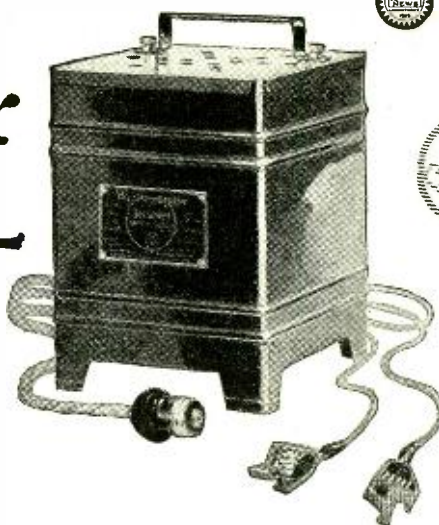

Westinghouse Rectigon Battery Charger

YOUR battery needs two kinds of charging!

Under ordinary conditions, a low-rate charge, "trickled in" during the hours that the set is idle, will keep the battery full of pep. Then, for occasions when prolonged use of the set drains more power than trickle chargers can replace, you need a high-rate charge. The Westinghouse Rectigon gives you *both kinds of charging*. Rectigon charges at a high rate and at a low rate—and it charges wet "B" as well as automobile batteries.

~~\$18.00~~
Now
\$14.00

Rectigon is a Westinghouse product—and you know Westinghouse knows radio. Back in 1920, the first program ever broadcast came from radio station KDKA. Rectigon is safe—uses no acids or chemicals. Long-lived, with no moving parts to break or wear out. Does no harm if you tune in while charging, nor if the light

company turns off the power while Rectigon is in the circuit. Get away from charging station expense with Rectigon Home Charger. At your dealer's, now \$14.00.

WESTINGHOUSE ELECTRIC & MANUFACTURING COMPANY, EAST PITTSBURGH, PA.
Offices in All Principal Cities • Representatives Everywhere
Tune in with KDKA—KYW—WBZ

For trickle charging only—the long-lived little Rectox. No guesswork, no acids or chemicals, no trouble. Leave Rectox permanently on charge and replace during "silent hours" the power used during average "operating hours." Two rates of charge— $\frac{1}{2}$ ampere and $\frac{3}{4}$ ampere. At most dealers', \$11.50.



See the Westinghouse exhibit of Rectigons, Radio Instruments, and Micarta Radio Panels at the Sixth Annual Radio Show, Coliseum, Chicago, October 10th to 16th, inclusive: Booth 1, Section AA.



WARREN

"B" Supply

(MODEL "T" TUBE UNIT)

Only \$31.50 Complete



\$31.50
including
tube

Here's what it's
Guaranteed to deliver

260	Volts	at	25	Mills
235	"	"	35	"
210	"	"	45	"
185	"	"	55	"
162	"	"	65	"
140	"	"	75	"

from 110 V. 60 Cycle
A.C. Current

Here it is—an absolutely new "B" supply (tube unit) that gives you even more power than you'll ever need. Whether you have a one or a dozen tube set the Warren delivers the voltage and current even above its rated capacity. It comes to you complete, including 85M. tube for \$31.50. (West of Rockies \$33.00.)

Unapproached in reproducing the most delicate sounds in their natural tones; unparalleled in delivering constant "B" power without objectionable hum. Unsurpassed for quality material, workmanship and appearance.

The Warren has three voltage controls. A turn of a knob provides any voltage you may require on the detector, intermediate or the amplifier. Also has direct power tap for high power tubes. Measures 5½" x 6½" x 9½". Steel case finished in old gold.

The same house that makes the famous "Warren" electrolytic (chemical) unit—approved by RADIO NEWS—that is giving complete satisfaction in every state in the Union is now placing on the market this new Model "T" tube unit. Acclaimed by engineers, experts and radio laboratories as equaling and in fact surpassing units of double the price. Send in your order direct if your dealer does not yet have the new Warren. Sold on a money-back guarantee.

Dealers: Write for proposition quick!

Warren Electric Co.

Dept. RN Peoria, Ill.

Ship at once Warren "T" (tube unit) @ \$31.50. Complete. (West of Rockies \$33.)

Ship at once Warren "C" (Chemical unit) @ \$29.75. Complete (West of Rockies \$31.25.)

Send Free Literature on Tube Unit Chemical Unit .

Use this coupon—write name and address plainly on margin below.

for noise in his receiver; and spent some time in diligent search for the supposed trouble before he discovered his mistake.

EXIT THE "DESCRIPTIONIST"

Another phase of progress in the technique of presentation which has proved particularly welcome is the discarding of the "descriptionist," and the substitution of lines adapted to show what action is taking place, even the setting.

The descriptionist (unfortunately still extant at some stations) was an announcer or member of the company who interspersed the lines of the original stage version with descriptions of the action and setting. For example, a scene would be held up several minutes while someone read—not always well—a description of a sunrise which was to affect the characters; or, worse than that, a gripping climax might be followed by the prosaic voice of an announcer explaining "She fell dead."

Dramatically the result was, of course, as hopeless as the intrusion of the editor or the printer, not to mention the author, into a novel. The illusion simply could not survive the shock; and only the novelty of its being broadcast made the whole endurable at all.

Now lines are carefully adapted to indicate action as it takes place and all lengthy description of setting is given in advance, sympathetically. The result is, that once the play is started, the illusion has no such insurmountable handicaps to overcome; and the contribution of this one improvement to the success of the radio drama is difficult to over-estimate, though, as has been suggested, some directors still employ the descriptionist.

THE INVISIBLE ACTORS

As to personnel, the one outstanding fact which has emerged as a result of the listener's experience with the radio drama is that stage success carries no assurance of an actor's qualifications for broadcasting.

This was aptly demonstrated by the leading woman in a company presenting a widely advertised prize play. She had achieved justifiable prominence on the stage, and from this it was assumed that in undertaking a role on the air her success would be as conspicuous. But before the microphone her work proved to be unconvincing; apparently because she unconsciously depended on facial expression and gestures, as she did on the stage, when obviously voice was the only means she could use.

That is why all the leading stations and companies are now choosing actors, not on the basis of stage experience, but on voice qualifications alone. It is reasonable to expect a new type of actor, skilled in portrayal of character by voice only, to be developed as the radio drama develops; just as, conversely, the movies have developed another type adapted to their peculiar requirements.

LENGTHENING THE PLAY

On the value of the broadcast play itself, there has been considerable vigorous debate among directors regarding the respective merits of the full-length as against the single-act play; proponents of the latter contending that the attention of the radio audience cannot be held satisfactorily by the longer type through the medium of hearing alone. Speaking as a listener, it seems to me this group has somewhat the better of the argument, but not because of the attention-factor.

It has been demonstrated conclusively that, given proper presentation, the radio audience can be held as satisfactorily by a three- or four-act play as can the audience in the theater. But the radio audience differs from a theater audience in one important particular. In the theater, the audience is assembled when the play starts, and can be expected to remain till it is finished. But,

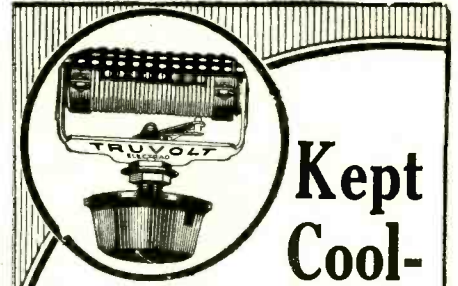

Kept Cool-

Like the best Air-plane Motors

TRUVOLT

A Correct Wire Variable Voltage Control

Here is the finest voltage control you can possibly buy for your power devices! Its special mechanical construction gives greater radiation area and keeps it cool like an air-cooled engine. This prevents deterioration and assures permanent accuracy with long life.

Resistance made entirely of nichrome wire with very low temperature coefficient and exposed directly to air—heat not held in by enamel coverings as in other resistances. Permits potentiometer control and gives positive metallic contact at all times with 30 exact readings of resistance.

Type	Ohms Resistance	Milliamperes Current
T- 5	0 to 500	224
T- 10	0 to 1,000	158
T- 20	0 to 2,000	112
T- 50	0 to 5,000	71
T-100	0 to 10,000	50
T-200	0 to 20,000	35
T-250	0 to 25,000	32
T-500	0 to 50,000	22.5

Eight stock types with resistances up to 50,000 ohms. All rated at 25 watts. List \$3.50 each.

Also full line of fixed wire resistances. Write for free resistance booklet.

Dept. 12A, 175 Varick Street
New York City

"This is an Eliminator Year"

ELECTRAD

BIG RADIO CATALOG

From the "Big, Friendly Radio House"

NEW 1928 Book offers finest, newest well-known sets; parts, eliminators, accessories at lowest prices. Set-builders, dealers, agents—WRITE for this CATALOG!

Western Radio Mfg. Co.

126 West Lake St., Dept. 17, CHICAGO

Insure your copy reaching you each month. Subscribe to RADIO NEWS—\$2.50 a year. Experimenter Publishing Co., 230-5th Ave., N. Y. C.

Why I Selected the Sonochorde



Read What She Says —

MY husband and I are "radio bugs." Our radio is going almost constantly. He knows several radio dealers and has been continually bringing home radio sets and loudspeakers to try out. Of them all we found SONOCHORDE to be by far the best because it gives us the most delicate reproduction with full clear volume. We like the silk front and protected back. Then, too, the metal frame which is finished in Mahogany harmonizes beautifully with any room. Everyone who hears our speaker says its the very finest they have ever heard.

—MRS. A. L. McLAUGHLIN, Lynn, Mass.

SONOCHORDE Cone Speakers are on sale at most good stores. If you are unable to secure yours, write us direct and we will send you your nearest dealer's name.

The SONOCHORDE Cones

Senior Model

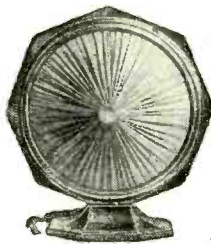

\$25

Junior Model



\$15

The large SONOCHORDE Speakers are made in Wall Models—Floor Standard Models and regular Table Models.

The SONOCHORDE Junior is made only in the Table Model style. Write for illustrated circular today!

Dept. A
BOUDETTE MFG. CO.
Chelsea, Mass.

BENJAMIN

Cle-Ra-Tone Sockets

are specified for the 8-Tube Stroboddyne Circuit



Spring Supported Shock Absorbing

Tube holding element "floats," independently of the base, on four perfectly balanced springs. Positive tube to terminal connections. Shock absorbing feature is not affected by stiff bus wiring.

Non-Microphonic. The greatest aid to the non-noisy operation of the set. Gives longer life to the tubes.

The choice of experts and amateurs for practically every prominent and successful circuit for several years.

Among the most recent circuits, in addition to the 8-Tube Stroboddyne, for which it has been specified are:

Magnaformer 9-8, Camfield Super-Selective 9, Lynch Suppressor Circuit, H.F.L. Nine in Line, World's Record Super 10, Melo-Heald Fourteen, St. James Super, Two-Dial Equamatic, Knickerbocker 4.

Push Type, on Mounting Base: Benjamin Cle-Ra-Tone Sockets, 75c each Without Mounting Base 50c each

New Y Type Socket

Specially designed, for use with 5-pronged A. C. Radio Detector Tubes: For direct attachment to panel . . . 90c each For mounting on top of panel . . . \$1.20 each

At all Radio Jobbers and Dealers

Made by

Benjamin Electric Mfg. Co.
120-128 S. Sangamon St., Chicago

247 W. 17th St. New York 448 Bryant St. San Francisco

Manufactured in Canada by the Benjamin Electric Mfg. Co., Canada, Ltd., Toronto, Ontario

in the case of the radio drama, the entire audience is rarely tuned in at the outset. Instead, the number of listeners at any given moment varies widely, according to the whims and desires of those at the receivers.

Under these conditions a listener who tunes in on a station and encounters the second or third act of a three- or four-act play is likely to tune out again; knowing that, as he has missed what went before, his chances of enjoying what remains of the program are remote. But if he encounters instead a one-act play, he is likely to wait through the remainder of it, assured of being able to enjoy the program to follow, even though he came in late.

This, however, is not so much an argument against the long play as a reason why stations presenting this type should advertise their programs with even more care than in the case of musical offerings. Personally, I have missed several excellent full-length dramas through not having announcements of them in advance, when, properly informed, it would have been possible for me to tune in on them at the outset instead of cruising about the dials as usual.

A MEDIUM OF INSTRUCTION

Perhaps the most important development in broadcast material during the last two or three years is the commercial program; and, in the light of the popularity this type of offering has achieved, it is remarkable that no large-scale attempt has been made to adapt the radio drama to its purposes.

The possibilities are obvious. The romance of industry has always been a fruitful field for the dramatist and it should be possible to prepare a play which, while providing good entertainment, would at the same time "sell" the radio audience a favorable impression of the sponsor's business. The New York Edison Company, over station WRNY, has made a beginning in this direction with plays designed to bring out the usefulness of electricity in modern life; and, following this example, other organizations should be able to utilize the same method of approach, as easily as with the musical program. Any such play should, of course, be entertainment first and publicity second. Otherwise, from the sponsor's viewpoint, its commercial value would be nil.

It is clear from all the foregoing that the radio drama has not only established itself as a permanent feature of broadcast programs, but, through steady improvement in its character and methods, has won a firmer place in the esteem of the audience during the last two or three years. Whether or not television reaches the stage of practicability and becomes an active ally, it is certain that, on the basis of the gratifying and very real progress which has been made, there is ample justification for those sponsoring the broadcast play to give further effort and study to the problems which remain still to be solved.

GETTING A KICK OUT OF RADIO



CARTER

New and Complete Line Fixed Condensers

Molded Mica Condensers



New method of predetermining capacity before molding insures extreme accuracy. Carter condensers are guaranteed within 10% of rated capacity.

By-Pass and Filter Condensers



By-Pass

These condensers are guaranteed to stand up and maintain their capacity. Carter methods of construction have many points of originality, which make possible the guaranteeing of these condensers to within 10% of their rated capacity.



These condensers are impregnated under conditions and by methods that insure that they will not only be accurate when made but will continuously stay accurate. They are not affected by climatic conditions. Furnished in all standard capacities.

Any dealer can supply

In Canada: Carter Radio Co., Ltd., Toronto

Offices in principal cities of the world.

Carter Radio Co.
CHICAGO

MEMBER BMA

Standard

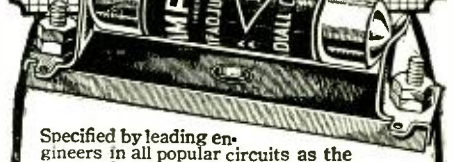

Specified by leading engineers in all popular circuits as the one perfect form of tube filament control. Insist on Amperite—the only automatic variable filament resistance. Beware of substitutes and imitations. There is only one Amperite and nothing else will do. Eliminates hand rheostats. Simplifies wiring. Types for all tubes. Price \$1.10 mounted (in U.S.A.). At all dealers. Write for Free Hook-Ups and construction data to Opt. RN 10

Radiall Company

60 FRANKLIN ST., NEW YORK

AMPERITE

The "SELF-ADJUSTING" Rheostat

Insure your copy reaching you each month. Subscribe to RADIO NEWS—\$2.50 a year. Experimenter Publishing Co., 230 Fifth Ave., N. Y. C.

\$ Only 1 Down Brings You Either of These Guaranteed Eliminators

Super-Power "A" Eliminator

Here is a constant, unvarying, smooth, humless current at 6 volts for any radio receiver using 201-A and power tubes. **Uncertain storage batteries** with their changing power, **chargers** and other bothers are **done away with**. This eliminator completely replaces "A" batteries. In addition your set gets perfect current at all times—it is always ready to do its best. Stations come in easily and quickly.

Not a Battery-Charger Combination

This Super-power "A" Eliminator consists of a large capacity rectifier which changes the alternating house-lighting current into direct current. Then a highly efficient heavy duty filter system of extremely high capacity changes the pulsating direct current from the rectifier into smooth, even current for lighting the filaments in the radio tubes. Anyone can install this Super-power "A" Eliminator in a few minutes. Just attach it to your set and plug it into an electric light socket. Your set is instantly supplied with the correct amount of hum-free current, used only when set is in use. You are assured of good current whenever you want it. This "A" Eliminator works perfectly whether used once or thousands of times a year. It has no moving parts to wear out. Operates from light socket 110-120 volts, 50-60 cycle A.C., output 6 volts direct current for all sets up to 12 tubes with power tubes. **There are no batteries to be charged.** It is fool-proof in operation. Once attached it is permanent—you can forget you ever heard about "A" batteries.

Test It for 30 Days Before You Buy

Just fill out the coupon below and mail it to us with a dollar bill. We will send you this "A" Eliminator to test. It must deliver satisfaction before you buy. After 30 days trial pay only \$5.00 a month until you have paid \$31.50. Only our great buying power enables us to make this liberal offer and to also sell this Super-power "A" Eliminator for easily 1/4 less than is ordinarily asked. Take advantage of this offer today.

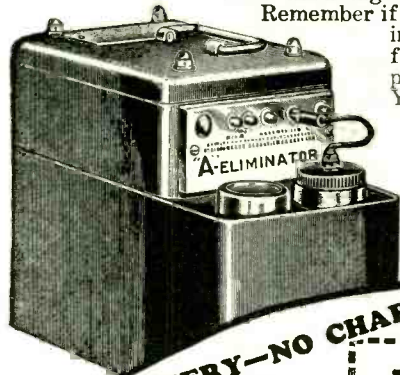

NO BATTERY—NO CHARGER
NO BULBS
NO HUM
NOTHING TO WEAR OUT OR REPLACE

ELECTRIFY ANY RADIO

Super-Power "B" Eliminator

Do away with "B" batteries—their annoyance—and the constant expense of always getting new ones. The great "B" Eliminator offered here replaces them permanently. Just attach this eliminator to your set—plug it into an electric light socket—and a steady flow of power is delivered to your set. Hum, noise, distortion and all other disturbances are gone. Built with heavy duty chokes, transformers and the finest of condensers in the filter system, it is 100% efficient at all times—the most modern and flexible "B" Eliminator in the world. **Used with any good "A" Eliminator it completely electrifies your set.**

Complete With Raytheon Tube

This Super-power "B" Eliminator can be used with any set up to 12 tubes. It comes complete with full wave rectifying 85 mil. Raytheon tube, making possible the delivery of great current at a high voltage. This Raytheon tube has indefinite life as it has no filament to burn out. Delivers up to 180 volts.

The case is beautifully finished in olive green Duco with black panel etched in gold. Equipped with rubber-covered cord and socket plug. High voltage taps and variable adjustments enable the use of new power tubes. Operates from 110-120 A. C., 50-60 cycle current. Has tap for intermediate voltage on which 67½ to 90 volts may be obtained. The detector tap will supply 22½ to 67½ volts. Variable adjuster will deliver any desired detector voltage. On and off switch and high and low voltage switch are integral parts of the eliminator. No additional switches or cords are necessary.

Only \$1.00

We make the same liberal offer on both the "B" and the "A" Eliminator. Fill out the coupon and mail it to us with a dollar indicating which eliminator you wish. If both are desired send \$2.00. Each eliminator must then make good while you test it for 30 days before you pay another cent. After test the balance is due in easy installments. This "B" Eliminator ordinarily sells for as high as the cash price of \$42.50. This

is your opportunity to get it for only \$29.50 payable in easy installments.

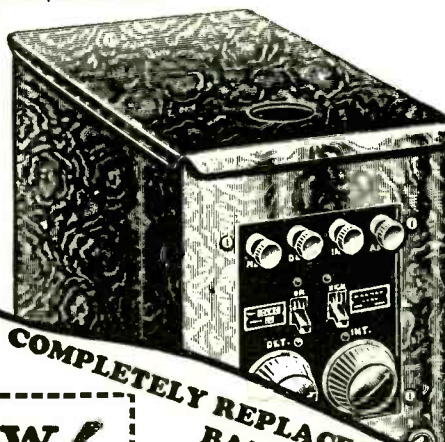

Complete instructions with each unit for wiring to set.

AT REDUCED PRICES

COMPLETELY REPLACES "B" BATTERIES
EASY TO ATTACH
Plug Into Electric Light Socket

Mail This Coupon NOW!

ELLIOTT RADIO CORPORATION, DEPT. 173
 709 West Lake Street, Chicago, Illinois

Attached find \$1.00 for which you agree to send me () "A" Eliminator at \$31.50, () "B" Eliminator at \$29.50. (Send \$2.00 if both are desired, as described in your ad.) Full particulars will be sent me by return mail and my money refunded if I do not accept your offer.

Name _____
 Address _____
 City _____ State _____

The Famous AERO SHORT WAVE KIT

Used in Important New Circuit!

Be sure to read all about the new RADIO NEWS SHORT WAVE RECEIVER circuit constructed around these improved coils described in detail in RADIO NEWS.

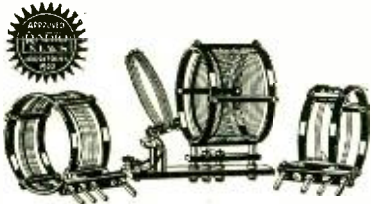

AERO LOW WAVE TUNER KIT
Code No. L. W. T. 125 . . Price \$12.50

Always the prime favorite of all experts and amateurs insistent upon the very best in short wave reception, the AERO Low Wave Tuner Kit for this season has been made even better than ever!

As used in the new short wave circuit described in this issue of RADIO NEWS, these improved coils are certain to produce performance beyond compare. Even greater volume, selectivity, tone quality and flexibility is definitely assured.

Range 13 to 725 meters

The AERO Low Wave Tuner Kit illustrated above is completely interchangeable. The kit itself includes 3 coils and base mounting covering U. S. bands 20, 40 and 80 meters. You can increase the range of this kit to 725 meters by use of AERO interchangeable coils No. 4 and 5 (Price \$4.00 each) or you can decrease the range to go as low as 13 meters by use of AERO interchangeable coil No. 0 (Price \$4.00).

By all means build this new RADIO NEWS Short Wave Set. The AERO coils used in its construction can be procured from your dealer or direct from our factory. We have also arranged to furnish the Westinghouse Micarta drilled and engraved panel for this receiver direct from our factory. Write us at once for full information.

AERO Unit Used in Super-Regenerative Set

This excellent wave trap is unusually efficient because of its low distributive capacity and low high frequency resistance. Eliminates bothersome interference. Wonderful for crystal sets.



Code No. WT-40 . . Price \$4.00
A New AERO Choke Coil

Modern circuits of high sensitivity demand the use of radio frequency chokes in certain parts of the circuit. The AERO Noskip No. 60 Choke Coil is designed to have a uniform choking action over a wide range of wave lengths, including Broadcast bands and Amateur short wave bands as well. Many chokes employed for this service have an unpleasant characteristic of showing so-called "holes" in the tuning range; that is, points on the tuning dial where the receiver cannot be made to oscillate. These conditions are completely corrected with the new AERO Noskip No. 60 Choke Coil. Price \$1.50 each, at your dealer's or direct.



AERO PRODUCTS, INC.
Dept. 105
1772 Wilson Ave. Chicago, Ill.

"This is Station WOODS"

(Continued from page 326)

next to a branch on which some "bait" has been placed. Bread-crumbs, bits of crackers and corn, suet, etc., if placed in a shallow dish, will attract the singers; and they will almost always reward your trouble with songs or at least chirpings.

If the experimenter lives in a section of the country where various wild animals abound, it is a simple matter to do some "acoustical hunting." If a clump of woods is convenient to the house, bait of different kinds can be scattered in front of the microphone; or the latter might be placed at the animals' watering place.

It has been mentioned previously that the insect world offers a vast range of possibilities for experiment. Sometimes we are only too well acquainted with the noises of various insects; but hundreds exist that are not commonly known and it is for these that the experimenter wishes to try. For flying insects dampened sugar, or perhaps some meat that has begun to spoil, will prove to be a lure. Of course, it should be remembered that many insects make no noises at all, or at least, their stridulations are of a pitch too high to be audible by human ears. (See "Nature's Radio," RADIO NEWS, May, 1926.)

If it is possible for the experimenter to procure an ultra-sensitive microphone, he will receive many noises from the woods that he could not hear otherwise. Even with the regular microphone, there is no doubt that many most interesting experiments can be performed and a great deal of knowledge gained.

CAUTIOUS BRITONS

"TO avert the possibility of disaster during last week's thunderstorm, the 2LO aerial was momentarily 'earthed' (grounded) seventeen times. This was carried out by an engineer stationed to watch for each flash," says *Wireless World* (London), prefacing the query: "B. B. C. Quicker Than Lightning?"



Pep up Your Set!

Quick, easy tuning—more volume, clearness, stability, with an X-L VARIO-DENSER in your circuit.

Model "N"—Micrometer adjustment easily made assures exact oscillation control in all tuned radio frequency circuits. Neutrodyne, Roberts 2-tube, Browning-Drake, Silver's Knockout. Capacity range 1.8 to 20 mfd. Price \$1.00.

Model "G"—Obtains the proper grid capacity on Cockaday circuits, filter and intermediate frequency tuning in super-heterodyne and positive grid bias in all sets. Capacity range, Model G-1 .0002 to .0001 Mfd. Model G-5 .0001 to .0005 Mfd. Model G-10 .0005 to .001 Mfd. Price each with grid clips, \$1.50.

X-L PUSH POST—Push it down with your thumb, insert wire, remove pressure, wire is firmly held. Vibrations will not loosen, releases instantly. Price each 15c. Also in strips of 7 on black panel marked in white. Price \$1.50.



FREE big, new 16-page book of wiring diagrams showing use of X-L units in the new LOFTIN-WHITE constant coupled radio frequency circuit, and many other popular hook-ups. Send for yours today.
X-L RADIO LABORATORIES
2426 Lincoln Ave., Chicago, Ill.

R. E. Lacault

has written the most practical and comprehensive book ever conceived for builders or owners of Super-Heterodynes.

SUPER-HETERODYNE

Theory and Construction

By

R. E. LACAULT

PRICE \$1.97

CONSRAD CO., 230 5th Ave., New York

Improves Tone



Protects Speaker

This is a power tube output device for preventing the flow of direct current in the winding of the loudspeaker, thereby protecting it from burning out and improving the quality of its tone. A device of this kind is specified by R. C. A. and all other power tube manufacturers.

Price, NATIONAL Tone Filter with 5-foot phone-cord for instant attachment to any existing set.....\$7.00
Price, without cord.....\$6.50

Send for Bulletin N-10

NATIONAL

tone filter

NATIONAL · CO · INC · W · A · READY · PRES · MALDEN · MASS ·

Try This New Way-Buy Magazines at Wholesale

THIS is News! Big news for magazine readers of all classes! By special arrangement with a number of publications, we are able to offer you **wholesale** prices on the best of the standard magazines. Buy your magazines **now** under this great offer and you will save half or more than half the price at the single copy or newsstand rate. And you will save almost half in nearly every instance over the regular yearly subscription rates. Furthermore, we will send each magazine to a different address if you direct, or all to one, as you wish.

Never before have magazine clubs been offered in this way. Always heretofore all magazines in the club had to be sent to one person. We have changed all that! You can now have all the magazines sent to yourself, or only one or two to yourself and the other ones to different persons.

Show this offer to your friends, relatives or neighbors. Give them the advantage of wholesale price on their favorite magazine! For instance, you'd like "Radio News," one friend wants to renew his subscription for six months to "Review of Reviews," and another one would like "Illustrated Monthly." Separately the price would be \$6.00; but you can buy

them now for only \$2.99! Less than half!

What would please friends and relatives more—What would remind them of your thoughtfulness so many times during the year, as a subscription to a nice magazine! What three presents could you buy for so little money that would look so big? A dollar or so apiece wouldn't buy much of a gift, but think what it buys here. If you can mark "Xmas" on the Coupon Order we will send the first copy of each magazine to reach the name given just before Christmas and will also send a beautifully engraved Christmas Card announcing it as your gift.

Before the name of each magazine is a number. Order by number only. If you want "Radio News," "Illustrated Monthly" and "Success" sent to you, order numbers 1, 2 and 29. If you want "French Humor" (26 issues) and "Illustrated Monthly" and "Success" order 5, 2 and 29. If you want these three sent to three addresses, indicate by number which magazine is to be sent to the respective name. Be sure to send order coupon properly filled out and don't fail to enclose remittance—your check will be acceptable.

You get the pair of magazines listed in each column heading plus any one magazine below. Order by reference number shown in brackets in front of each magazine.	(1) RADIO NEWS (2) Illustrated Monthly and any magazine below.		(3) AMAZING STORIES (2) Illustrated Monthly and any magazine below.		(4) SCIENCE & INVENTION (2) Illustrated Monthly and any magazine below.		(5) FRENCH HUMOR-6 mo. (2) Illustrated Monthly and any magazine below.	
	REGULAR	OUR PRICE	REGULAR	OUR PRICE	REGULAR	OUR PRICE	REGULAR	OUR PRICE
(6) American Boy	\$6.00	\$3.99	\$6.00	\$3.99	\$6.00	\$3.99	\$5.50	\$3.69
(7) American Magazine	6.50	5.01	6.50	5.01	6.50	5.01	6.00	4.51
(8) Better Homes & Gardens	4.60	2.79	4.60	2.79	4.60	2.79	4.10	2.49
(9) Boy's Life	6.00	3.76	6.00	3.76	6.00	3.76	5.50	3.39
(10) College Humor	7.00	4.16	7.00	4.16	7.00	4.16	6.50	3.89
(11) Collier's Weekly	6.00	4.66	6.00	4.66	6.00	4.66	5.50	4.39
(12) Cosmopolitan	7.00	5.01	7.00	5.01	7.00	5.01	6.50	4.69
(14) Delineator	7.00	4.98	7.00	4.98	7.00	4.98	6.50	4.69
(15) Etude	6.00	4.01	6.00	4.01	6.00	4.01	5.50	3.66
(16) Everybody's Magazine	6.50	4.28	6.50	4.28	6.50	4.28	6.00	4.09
(17) Golden Book	7.00	4.01	7.00	4.01	7.00	4.01	6.50	3.69
(18) Good Housekeeping	7.00	5.01	7.00	5.01	7.00	5.01	6.50	4.73
(19) Hunting & Fishing	4.50	2.98	4.50	2.98	4.50	2.98	4.00	2.62
(20) McCall's Magazine	5.00	3.14	5.00	3.14	5.00	3.14	4.50	2.86
(21) Modern Priscilla	6.00	3.56	6.00	3.56	6.00	3.56	5.50	3.29
(22) Motion Picture Magazine	6.50	4.48	6.50	4.48	6.50	4.48	6.00	4.19
(23) Open Road for Boys	5.00	2.69	5.00	2.69	5.00	2.69	4.50	2.46
(24) People's Home Journal	4.50	2.71	4.50	2.71	4.50	2.71	4.00	2.48
(25) Pictorial Review	5.50	3.75	5.50	3.75	5.50	3.75	5.00	3.54
(26) Review of Reviews	8.00	4.98	8.00	4.98	8.00	4.98	7.50	4.76
(27) Rev. of Reviews (6 mo.)	6.00	2.99	6.00	2.99	6.00	2.99	5.50	2.74
(28) Screenland	6.50	3.48	6.50	3.48	6.50	3.48	6.00	3.29
(29) Success Magazine	6.50	3.79	6.50	3.79	6.50	3.79	6.00	3.58
(30) Woman's Home Comp'n.	5.00	3.49	5.00	3.49	5.00	3.49	4.50	3.31
(31) Youth's Companion	6.00	3.69	6.00	3.69	6.00	3.69	5.50	3.47

Special Combinations

Or you can have either of the four pairs of magazines given in column headings plus these:	REGULAR	OUR PRICE
(29) Success and (12) Cosmopolitan	9.50	6.01
(23) Open Road for Boys, (19) Hunting and Fishing, (8) Better Homes and Gardens	6.60	3.65
(20) McCall's, (8) Better Homes and Gardens, and (24) People's Home Journal	6.10	3.49
(28) Screenland, (10) College Humor, and (20) McCall's	10.50	5.99
(32) Popular Science and (33) Scientific American	10.00	7.49
(34) Woman's World, (8) Better Homes and Gardens, (24) People's Home Journal and (35) Needlecraft	6.10	3.69

Please be careful to mention numbers. We positively will not break combinations. These offers not good in Canada or elsewhere outside the U. S.

SPECIAL OFFER COUPON!

Please Cut Out Along Broken Lines and Mail This Coupon with Remittance.

CONSRAD CO., Dept. R, 230 Fifth Ave., New York City.

I enclose \$..... for following subscriptions:

Send Magazine No..... to Send Magazine No..... to

Send Magazine No..... to Send Magazine No..... to

Send me Magazine No..... } My Name

 } Address

The publisher of Radio News guarantees the reliability of this and all other advertisers.



ACME Celatsite Wire

Tinned copper bus bar hook-up wire with non-inflammable Celatsite insulation, in 9 beautiful colors. Strips easily, solders readily, won't crack at bends. Sizes 14, 16, 18, 19; 30 inch lengths.

Flexible Celatsite for sub-panel wiring

A cable of fine, tinned copper wires with non-inflammable Celatsite insulation. Ideal for sub-panel or point-to-point wiring. Strips easily, solders readily. Nine beautiful colors; sold only in 25 ft. coils, in cartons colored to match contents.

Spaghetti Tubing

Oil, moisture, acid proof; highly dielectric — used by leading engineers. Nine colors, for wire sizes 12 to 18; 30 inch lengths. (We also make tinned bus bar, round and square, in 2 and 2½ ft. lengths.)

Stranded Enameled Antenna

Best outdoor antenna you can buy. Seven strands of enameled copper wire. Presents maximum surface for reception, resists corrosion; this greatly improves the signal. Outside diameters equal to sizes 14 and 16. (We also offer solid and stranded bare, and stranded tinned antenna.)

Loop Antenna Wire

Sixty strands of No. 38 bare copper wire for flexibility, 5 strands of No. 36 phosphor bronze to prevent stretching. Green or brown silk covering; best loop wire possible to make.

Battery Cable

A rayon-covered cable of 5, 6, 7, 8 or 9 vari-colored Flexible Celatsite wires for connecting batteries or eliminator to set. Plainly tabbed; easy to connect. Gives set an orderly appearance.

Send for folder
THE ACME WIRE CO., Dept. D
New Haven, Conn.

ACME WIRE
MAKES BETTER RADIO

I Want to Know

(Continued from page 370)

ing the clip on the loop will not apparently make any difference, but for distant stations it should be adjusted carefully.

When tuning for distant stations always remember to point the edge of the loop in the direction from which the transmission is expected. By this means you will get fair volume; but the maximum signal strength will be had only when the correct position of the aerial has been determined. This tapping of the loop is the key to the set's ultimate efficiency and, so, too much care cannot be expended upon it. As each station comes in note the particular portion of the loop which gave the best results. However, before the set can be considered finished, the coupling between the two coils should be adjusted on a distant program and a trial should be made of reversing the connection to the primary of the audio transformer.

PROPER CONNECTION FOR POWER UNITS

(Q. 2244). Mr. H. Ogden, New Haven, Conn., writes:

Q. I am using a five-tube receiver of the tuned-radio-frequency type. Lately I installed a trickle charger, but no sooner had I done so than two of the tubes burned out. Can you tell me the cause of this, or any precautions to take when using a trickle charger or other power unit?

A. The trouble which you describe has become quite prevalent recently, because of the increasing number of receivers which are operated from socket-power units. An incorrect connection, if it does not immediately cause damage to the receiver, may not be apparent at first; but trouble may develop in a short time.

In some trickle chargers, the transformer that supplies the alternating current to the rectifier is of the auto-transformer type, instead of having the usual separate primary and secondary windings with insulation between them. In many places, in fact in most localities, one side of the A.C. supply line is grounded, as required by law, and then of course the receiver itself is grounded. The result of all this is that it is possible to apply the full 110 volts directly across certain portions of the receiver, resulting in their being burnt out, and the set rendered useless.

A perfect remedy for this possible source of trouble and one which is simply applied, is to connect a fixed condenser, of about one microfarad capacity, in the ground lead of the receiver, thus preventing any short-circuiting of the 110-volt supply. In addition, it may also be well to have a similar condenser in the antenna lead; for the simple reason that the minute gap in the lightning arrester may act as a path for the line current to get to the ground, and again cause some trouble. The only precaution we must take is to be sure that the condensers employed are tested to withstand at least 110 volts A.C. and not D.C., since A.C. has a greater tendency to break down condensers. Ordinary condensers, such as are used in "B" power units, will be quite satisfactory.

BRITISH AERIAL REGULATIONS

SET owners in Great Britain must not only pay for the privilege of hearing radio programs, but they are subject to other governmental regulations. A "P. M. G. aerial" is the title bestowed on a hundred-foot aerial and lead-in, this being the maximum allowed by the regulations of the postmaster-general who rules the radio waves for Britannia. In New Zealand, a superheterodyne may not be connected to an aerial, but must be used with a loop.

COSTLY SOUND-POWER

SAYS Capt. H. J. Round, well-known British radio engineer: "I have calculated out that the sound-power that we get in the air from a loud speaker costs us, from dry batteries, about \$50,000 a kilowatt-hour. For some time to come we shall have to dodge the issue; because, so far, a much more efficient loud speaker does not seem to be in sight."

RADIO TERM ILLUSTRATED



"A Fan with His Head 'Set' On."

YAXLEY

Automatic Power Control



Here is just another reason why Yaxley Approved Radio Products are so popular with the radio fans. A new and better Automatic Power Control that does all the extra switching for you in a sure and positive way. Cuts in the B eliminator and cuts out the trickle charger when the set is turned on; cuts in the trickle charger and cuts out the B eliminator when the set is turned off.

No. 444-Series Type. Now furnished with new construction, exclusively Yaxley that keeps the voltage drop less than two-tenths (2/10) volts when used with sets having a current draw equivalent to four 199-type of tubes up to eleven 201 type of tubes. \$5.00

Cable Connector Plug



Preserve the neat appearance of your set by centering all battery wires in one neat compact cable. The Yaxley Cable Connector Plug does this in a simple and efficient way. Plug is of Bakelite construction with contact springs of phosphor bronze—a positive contact assured at all times.

No. 660—Cable Connector Plug, Complete \$3.00

No. 670—Cable Connector Plug, for Binding Post Connections, Complete \$3.50

At your Dealer's. If he cannot supply you send his name with your order to

YAXLEY MFG. CO.
Dept. N, 9 So. Clinton St.
CHICAGO, ILL.

AT LAST! Control of Radio Reception from Your Easy Chair

Turn set on and off—get station after station—swiftly—surely—DX—without leaving your easy chair.



The NEW Thermodyne

REMOTE CONTROL RADIO TUNING UNIT

No other tuning unit in the world like it. Tune your set from any room of your home. Attached to any single

receiver with removable dial in a few minutes by removing old dial and attaching adapter plate with Remote Control Unit.
Mechanical Model...\$18
Electrical Model...\$60
West of Rockies, add 10%

Write today for circular describing radio's newest and most revolutionary development.

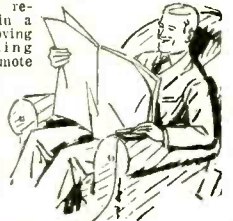

ALGONQUIN ELECTRIC COMPANY, Inc.
Leo Potter, President
245 Fifth Avenue, New York City

5 TUBE RADIO

At Low Factory Prices

It's a wonder for power and selectivity. Famous ARL circuit. Coast to coast reception! Finely built of selected, tested parts. Thousands now in use.

FREE Log and Call Book and New 132-p. Catalog with thousands of nationally advertised bargains. Latest in radio at big savings. Write for Free copy.
AMERICAN AUTO & RADIO MFG. CO.
BARRY SCHWARTZBERG, PRES.
Dept. 101, American Radio Bldg., Kansas City, Mo.



WHOLESALE PRICES

--- for Dealers, Community Set Builders, General Repairmen and Agents ---

Be sure to get this great 100-page book with net prices to the radio trade.

Radio Specialty Company is radio's oldest radio parts mail order house in the country, and the new confidential prices on standard radio merchandise are the lowest of any radio house.

We are ready now to appoint additional agents in all parts of the country. If you care contemplating making big money in radio merchandise, be sure to get in touch with us at once.

WHEN WRITING
TO US,
USE YOUR
LETTERHEAD

1927
Edition
No. 17
500
Illustrations
NEW
Enlarged
Edition



**THIS
100 PAGE
RADIO
CATALOGUE
FREE**
75 HOOKUPS

BUY!!
from Radio's Oldest
Mail Order House

We are the oldest established, exclusive radio mail order house in the country. Our motto is "Quick Shipment." All orders are shipped within 24 hours. Quick, prompt, courteous service. We carry a larger variety of radio parts and findings than any other radio house in the country.

"RASCO HAS IT"

If you are in need of certain small radio parts that other radio and mail order houses do not bother to carry, get the Rasco parts catalog and you will find them there, anything from a screw to copper ribbon and telephone diaphragms, as well as thousands of other small radio findings. Just to mention a few:

Lugs, nuts, dials, vernier dials, jacks, plugs, every kind of knob, cords, panels, screws, sliders, washers, selenium, tinfoil, switches, crystals, cap nuts, Litz wire, cord tips, brass rods, resistances, name plates, spring binding posts, switch parts, metal ribbon, carbon balls, binding posts, all types, switch points, switch levers, lock washers, carbon grains, ground clamps, metal pointers, insulated tubing, low melting metal, antenna connectors, bus bar wire, as well as thousands of other articles.

We carry the Largest Variety of Small Radio Parts in the World. BUT We also carry ALL standard radio merchandise. ANYTHING IN RADIO



RADIO SPECIALTY CO.

**98W PARK PLACE
NEW YORK CITY, N. Y.**

LOBOY MODEL
\$160 (without tubes)



MAGNAVOX
Power Cone Speaker
(Dynamic)

Now—a speaker to match the finest set

Improved quality of reception is the keynote of the new sets and tubes. Magnavox matches the finest with its new power speaker. Built on electro-dynamic principles under patents controlled exclusively and made famous by Magnavox.

All the music in ALL its natural beauty is possible only with this type speaker. Even extreme upper and lower register fundamental notes can come through with complete fidelity. Volume ranges from pianissimo to fortissimo without the slightest distortion.

Uses one 216B and one 210 type tube. For connection with alternating house current, doing away with B batteries and B eliminators. Works directly from light socket.

Magnavox Electro-dynamic speaker unit only, type R4, for 6 volts 1/2 ampere field winding \$45.00.

Type R5, unit only, for use in Electric phonograph 100 volt 40 milliamperes field winding \$45.00.

Type R50, unit only, as used in Loby Speaker complete with amplifier and eliminator \$110.00.

Warwick Model Cone

Permanent magnet type handles power tube volume without distortion \$27.50.

Type M7 Self contained, complete permanent magnet cone, unit only, 8 3/8" diameter \$12.50. If you don't know a Magnavox dealer, write us.



THE MAGNAVOX CO.

Oakland, California
1315 So. Michigan Ave. Chicago

Recent Developments In "B" Power-Unit Design

(Continued from page 346)

able to manufacturers and home constructors, but has never been given very much attention by either group. Perhaps one reason for the limited use of this tube is the general lack of information on just how and why to use it. Perhaps another is in the tube itself. Like the first of anything to be put on the market, it has its shortcomings.

Just what is this voltage-regulator tube, how is it used, and why?

A simple form of glow or voltage-regulator tube might consist of a bulb in which are located, in a rarefied atmosphere of certain inert gases, two electrodes; one of large area, such as a cylinder, and the other of relatively small area, such as the end of a wire.

If properly designed and connected, in series with a resistor of the correct size, to a suitable D.C. voltage supply, the tube will glow, much like a neon-tube sign. Furthermore, the supply voltage may be raised or lowered at will, within limits set by the design of the particular tube, without altering the voltage across the terminals of the tube. Now this is just the action that takes place in a radio plate-supply device.

As the load placed upon a "B"-power unit by different types of sets, or different adjustments of the same set, causes the maximum voltage output of the power unit to tend to vary, the glow or voltage-regulator tube varies the load it imposes upon the unit in just the reverse manner. It thus maintains a constant load on the latter and therefore a constant voltage across the terminals of the regulator tube, regardless of the load drawn by the radio set.

NO ADDITIONAL COST

The action of the tube in holding the voltage of the output circuit constant serves also to eliminate the small ripple due to incomplete filtering, and thus makes possible a reduction in the capacity of the final filter condenser. The saving effected by this reduction in the number of costly filter condensers is just about equivalent to the cost of the tube itself; so that the parts for a power unit with a regulator tube need cost no more than the parts for one of the conventional type.

In fact, a properly-designed voltage-regulator tube, when in operation, has also several other properties in common with a large fixed condenser. One of these is extremely low A.C. impedance which, when combined with its instantaneous response as a voltage regulator, entirely eliminates the annoying "motor-boating" effect; which so often re-

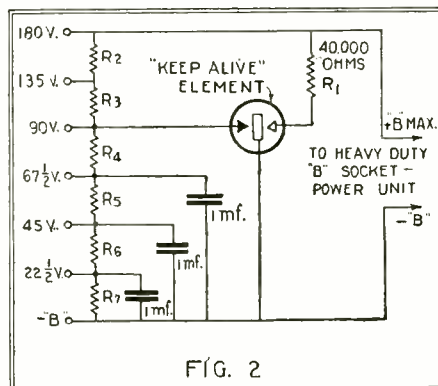

FIG. 2
Schematic diagram showing how the tube is connected in a socket-power-unit circuit. See Fig. 4 (page 346) for values of the resistors required.

Smooth Control for POWER CIRCUITS

Centralab 4th Terminal Potentiometer

is new, heat-proof, warp-proof—has an added semi-variable contact arm which is adjustable behind panel to any resistance value. 175 ohm unit gives 2 variable voltages in ABC power circuits. 250 ohms is used with the new Raytheon ABC power circuit. 2,000 ohms is for "C" bias in such circuits as Amertran Power Pack.



Two 6,000 ohm units in series across output of a "B" filter gives best possible voltage regulation. Continuous operation at temperatures of 482° F. and beyond is permitted. A metal core, asbestos insulated, expands with the resistance wire windings, and narrow resistance strips give small resistance jumps per turn, giving double insurance of smooth action and even regulation under all conditions. 175, 250 ohms, \$2; 2,000, 3,000, 6,000, \$2.25.

Wire - Wound Centralab Fixed Resistor



Built for the heavy current of A and B power circuits. The wire is wound over asbestos, fixed with heat-proof cement. Ample area. Being flat and thin makes them very easy to mount. Resistance values for all ABC Power Circuits.

At your dealer's or C. O. D. Send for the new Centralab A and B power circuit literature.

CENTRAL RADIO LABORATORIES
19 Keefe Ave. Milwaukee, Wis.



FOR RADIO DEALERS ONLY
ROCK BOTTOM PRICES
on everything in Radio

Only the newest and latest (1927-1928) radio goods; no obsolete products; no "seconds" or sub-standards. All goods of tested and proved quality and established reputation—absolutely guaranteed.

Get This Wonderful New Price Guide

Compare its money-saving values. Test our "Minute-Man" shipping service with a trial Rush order. Write NOW for your copy of Harry Alter's new "Radio Book."

The Harry Alter Co.

1770 Michigan Avenue Chicago

Special Library of Information on RADIO PATENTS and TRADE MARKS

JOHN B. BRADY

Patent Lawyer

Ouray Building Washington, D. C.

Cable address: RADIOPAT

Telephone: Main 4806

Insure your copy reaching you each month. Subscribe to RADIO NEWS—\$2.50 a year. Experimenter Publishing Co., 230 5th Ave., N.Y.C.

SUCCESS

from

CHEMICAL INSTITUTE OF NEW YORK
16 East 30th Street, New York City.

Mountoursville, Pa.

Gentlemen: I must tell you the success I have had since taking your chemistry course. My salary has been increased several times, and different industrial plants are coming to me for a little advice on different things, netting me a fair side income.

I am only sorry that I did not make my whole life study of the wonderful science.

(signed) *M. E. Van Sickle.*

CHEMISTRY

NOW
is the Time to Study
Chemistry

Not only are there boundless opportunities for amassing wealth in Chemistry, but the profession affords congenial employment at good salaries to hundreds of thousands who merely follow out its present applications. These applications are innumerable, touching intimately every business and every product in the world. The work of the chemist can hardly be called work at all. It is the keenest and most enjoyable kind of pleasure. The days in chemical laboratory are filled with thrilling and delightful experimentation, with the alluring prospect of a discovery that may spell fortune always at hand to spur your enthusiasm.

Easy Monthly Payments

You don't have to have even the small price of the course to start. You can pay for it in small monthly amounts—so small that you won't feel them. The cost of our course is very low, and includes everything, even the chemistry outfit—there are no extras to buy with our course. Our plan of monthly payments places a chemical education within the reach of everyone. Write us and let us explain our plan in full—give us the opportunity of showing you how you can qualify for a highly trained technical position without even giving up your present employment.

CHEMISTRY has no equal as a profession in the modern world. There is mystery, romance and fortune awaiting the man in the laboratory.

Millions have been made by the discoverers of the chemical formula of dynamite, bakelite and many other world known chemical products.

Opportunities in the chemical profession abound on every hand—and as modern business and competition progresses the chemist will play an important part.

Profit by the experience of Mr. Van Sickle and many others, resolve to study chemistry NOW.

YOU CAN LEARN AT HOME

To qualify for this remarkable calling requires elaborate specialized training. Formerly it was necessary to attend a university for several years to acquire that training, but thanks to our highly perfected and thorough system of instruction, you can now stay at home, keep your position, and let us educate you in Chemistry during your spare time. Even with only common schooling you can take our course and equip yourself for immediate practical work in a chemical laboratory. Dr. Sloane gives every one of his students the same careful, personal supervision that made him celebrated throughout his long career as a college professor. Your instruction from the very beginning is made interesting and practical, and we supply you with apparatus and chemicals for performing the fascinating analyses and experimental work that plays such a large part in our method of teaching, and you are awarded the Institute's official diploma after you have satisfactorily completed the course.

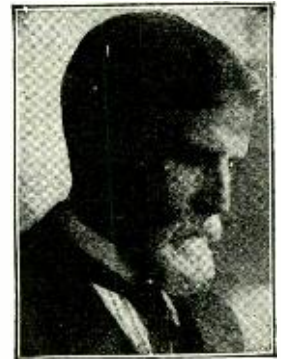

T. O'CONOR SLOANE,
A.B., A.M., LL.D., Ph.D.

Noted Instructor, Lecturer and Author. Formerly Treasurer American Chemical Society and a Practical chemist with many well known achievements to his credit. Not only has Dr. Sloane taught chemistry for years but he was for many years engaged in commercial chemistry work.

Special 30 Day Offer

Besides furnishing the student with his Experimental Equipment, we are making an additional special offer for a short while only. You owe it to yourself to find out about it. Write today for full information and free book "Opportunities for Chemists." Send the coupon right now while it is fresh in your mind. Or just write your name and address on a postal and mail it to us. But whatever you do, act today before this offer is withdrawn.

DON'T WAIT—MAIL COUPON NOW!



EXPERIMENTAL EQUIPMENT FURNISHED TO EVERY STUDENT

We give to every student without additional charge this chemical equipment, including forty-nine pieces of laboratory apparatus and supplies, and forty different chemicals and reagents. These comprise the apparatus and chemicals used for the experimental work of the course. The fitted heavy wooden box serves not only as a case for the outfit but also as a useful laboratory accessory for performing countless experiments.

Chemical Institute of New York

Home Extension Division 10

16-R- East 30th St.
New York, N. Y.

CHEMICAL INSTITUTE OF NEW YORK
Home Extension, Division 10
16-R—East 30th Street, New York City.

Please send me at once, without any obligation on my part, your free Book "Opportunities for Chemists," and full particulars about the Experimental Equipment given to every student. Also please tell me about your plan of payment and your special 30 day offer.

NAME

ADDRESS

CITY STATE.....

R.N. Oct., '27.

SM

Realism In Reproduction



REALISTIC reproduction—that is what Silver-Marshall unconditionally guarantees for the famous 220 audio and 221 output transformers. No matter what type of audio amplification you are using in your present set, or the set you're going to build, S-M promises that if you use 220 audio and 221 output transformers you'll get more realistic quality of reproduction than by any other method. And S-M backs this promise by a money-back guarantee—either S-M transformers are better than anything you've ever heard, or your money will be cheerfully refunded.

S-M has backed every transformer sold with this guarantee. In the last year more 220's have been used than any other high grade transformer—why? Simply because laboratory and ear tests have shown them to be absolutely unbeatable. That's why they are chosen for the new Infradyne, the Laboratory Super, the Aero "4," "5" and "6," the Shielded Six, the Unipacs, etc. Over half the popular circuits soon to be released depend on them.

This year S-M is given the sincerest form of flattery—practically every other manufacturer is striving to copy 220 characteristics. But imitations never equal originals—S-M audios remain supreme. 220 audio transformer is priced at \$8.00, 221 output transformer \$7.50.

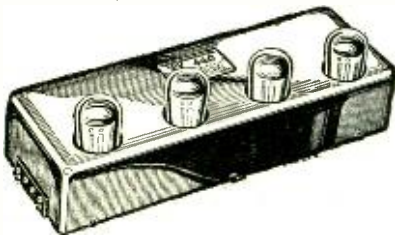

440 Jewelers' Time Signal Amplifier

The S-M 440 Amplifier is a three-stage tuned R. F. amplifier and detector completely wired and sealed in a copper and brass catacomb and tuned exactly to 112 K.C., the 2677 meter wavelength of the U. S. Naval Observatory Station at Arlington (NAA).

Each of the four circuits of the amplifier is sectionally shielded. The selectivity is so great that interference from other wavelengths is impossible, while with large low resistance tuned air core transformers, hermetically sealed, the amplification is tremendous—higher than that of any 3-stage long wave amplifier that can be constructed from standard parts today. The 440 simplifies receiver construction and eliminates all guess-work in transformer matching. Price \$35.00.

SILVER-MARSHALL, INC.

848 West Jackson Blvd. Chicago, U. S. A.

Please send me complete laboratory data on audio amplification and new S-M developments.

Name

Address

City

sults when an attempt is made to use one of the ordinary run of "B"-power units with a resistance-, impedance- or dual-impedance-coupled amplifier, and is a defect of the majority of amplifiers capable of good low-note amplification.

CHARACTERISTICS OF FIRST TUBES

The first type of voltage-regulator tube to appear on the market was of the two-element type and, like the first of almost any developments had disadvantages. Different tubes varied considerably in characteristics; some having a working voltage of as low as 70, while that of others was over 100. Then the voltage across individual tubes would vary quite a bit between the conditions of "no load" and "full load." Still another fault was that, should the power unit be heavily loaded for any reason, the tube would go out and, before it again became operative, the voltage across it would have to rise to a rather high value; which frequently resulted in damage to low-voltage by-pass condensers, either in the power unit or the radio set.

This high starting-voltage requirement is well illustrated by the regulation curve made for the 90-volt tap of a B-power unit employing a voltage-regulator tube of the two-element type. (Fig. 1.) The curve is quite flat until the point is reached where it would intersect the normal regulation-curve of the power unit when no voltage-regulator tube is employed (dash line). Then it follows this normal curve. In returning the normal curve is followed, with the voltage increasing as the current decreases, past the 90-volt point, until a sufficiently high voltage is reached to ionize the the gas in the regulator tube and cause the voltage drop across its terminals to return to 90 or thereabouts.

Perhaps the most serious objection to the older voltage-regulator tubes was their tendency to oscillate and introduce noise into the output circuit of the power-supply device. The use of a power unit equipped with such a tube would occasionally introduce sufficient noise into the loud-speaker output to interfere seriously with satisfactory reception. But now, as a result of considerable research work, the new Raytheon "R" tube, with its third element, has been perfected.

NEW THREE-ELEMENT TUBE

Its small size and low cost permit its ready use in many cases where the older form of tube is out of the question. Its non-oscillating operation, long life, close control of voltage, (a variation of only 3 volts between the conditions of "no load" and "full load" being the maximum allowed by the designers) and its third or "keep-alive" element, are all features which help to make this voltage-regulator tube one of the most outstanding recent developments in the "B"-power supply field.

By means of the third element, the high-voltage peak of the curve in Fig. 1 is eliminated. The tube will never "go out," regardless of how low the voltage across its control electrodes may drop.

The base-contact connections of the tube are so arranged as to permit the direct use of the tube without adapters or any changes in wiring in "B"-power units and combination amplifier-power units originally designed for use with the two-element tubes. When it is so used, of course, only two of the elements in the "R" tube function, but, while the advantage of the third element and its "keep-alive" circuit is lost, still many of the other merits, such as close voltage regulation and non-oscillating operation, are retained.

If so desired, the new tube may be readily enough added to many of the standard commercial "B" units to provide fixed voltage taps and eliminate trouble with "motor-boating." Fig. 2 shows how the connections



THE Premax tubular steel aerial mast gives you that wider range, finer reception and more varied programs which every radio fan wants, at less than the cost of a good wooden pole.

Light but strong — Rustproof and durable — Fits any roof. Two lengths — 7 and 10 ft. — both adjustable and telescoping into a 4 ft. section for easier erection.

Attractively finished in olive drab enamel. \$2 and \$3 for the 7 and 10 ft. masts, respectively. Complete with guy wire, pulley and roof anchors. Get them from your dealer, or by parcel post prepaid direct from

Niagara Metal Stamping Corp.
Dept. RN-2 Niagara Falls, N. Y.

PREMAX Parkerized Rustproof
Metal Specialties



Dan-Ashe Radio Co.

210 North 10th St. ST. LOUIS, MO.

Come Now to The NASSAU at Long Beach, L. I.

Just 40 minutes from New York by train

*The Boardwalk is Glorious
The Air is Laden with Health
The Hotel is a Pleasant Treat*

**Sea Baths, Music, Dancing
Festive Week-Ends**

Room Plus Food—Only \$8 per Day

Open All Year

Telephone: Long Beach 100

HENRY H. GERARD, *Managing Director*

Insure your copy reaching you each month. Subscribe to RADIO NEWS—\$2.50 a year. Experimenter Publishing Co., 230 Fifth Ave., N. Y. C.

are made. The only limitations to such an arrangement are that the "B" unit be of a heavy-duty type; that is, have choke coils capable of handling 80 milliampères or so without core saturation.

The illustration (Fig. 3) shows the general appearance and the internal construction of the "R" tube. It will be seen that the device greatly resembles externally the ordinary two- or three-element vacuum tubes, being fitted with a standard four-prong base.

DESIGN OF UNIT FOR "R" TUBE

Figs. 4 and 5 show a home-constructed "B"-power unit incorporating the latest principles of design. As will be seen from the circuit diagram (Fig. 4), the device differs from the majority of the high-grade units described during the past year in various radio periodicals only in that it employs the additional voltage-regulator tube, fixed voltage taps and fewer condensers.

A MUTUAL MISUNDERSTANDING

*The tomcat heard the birdies chirp
In the speaker, loud and clear.
He went outside, the antenna eyed
And said: "They ain't out here!"*

*"Them dad-binged bloopers are at it again,"
Raved the radio bug to his wife;
And the tomcat sat on the backyard fence
And mused "Wotta life! Wotta life!"
—Helen Peters.*

THE JUNIOR FAN'S DREAM

*I wish that I had a lot of KOIN:
I'd wait till late to get up in the "moin";
I'd seek KOLOrado and camp in the
WOOD,
And get a big KICK out of life while I
could.
—Clarence Thompson.*



Complete Antenna Kits

Simplify Set Hook-ups and Aerial Installations



SPECIAL KIT No. 2—Price \$3.50
Contains the following:
100 Ft. Coil 7/22 Copper Aerial Wire in a carton
40 Ft. Rubber Covered Weather Proof Lead-in Wire
1 Braided Storm King Lightning Arrestor
2 Glass Insulators
1 Window Lead-in Strip
1 Quick Adjusting Ground Clamp
3 Porcelain Nail Knobs
2 Galvanized Screw Eyes
25 Ft. No. 18 Flexible Rubber Covered Hook-up Wire
1 Instruction Sheet

CORWICO RADIO WIRES
"Best from the Ground Up"

Antenna Wire (Solid, Stranded and Braided)	Hook-up Wire
Complete Aerial Kits	Lead-in Wire
Magnet Wire	Annunciator Wire
Battery Cable	Loop Aerial Wire
Bus Bar Wire	Litz Wire
	Flexible Wire

CORNISH WIRE COMPANY
30 CHURCH ST., NEW YORK CITY

Other Corwico Kits can be had at from \$1.75 to \$1.50. Write for complete Corwico Wire Circular.



It isn't a Question of DX-ing any more— Quality of tone is the thing

MOST listeners-in want crystal clear, undistorted tones more than distance.

They seem to want to set their dials for a desired program and get it right—to get it full, strong and free from the annoyance of blurring and what might be termed "warped" tones.

The one big thing that Carborundum Stabilizing Detector Unit does in any set is to improve the tone quality. Besides you will find that it increases the volume and gives you greater distance—if you want it.



\$3.50
IN U.S.A.
WITHOUT DRY CELL

The Carborundum Stabilizing Detector Unit

Reg. U.S. Pat. Off. CLARIFIES RECEPTION

So will Carborundum Grid Leaks and Resistors

Send for Hook-Up Book D-1

THE CARBORUNDUM COMPANY, NIAGARA FALLS, N. Y.
SALES OFFICES AND WAREHOUSES IN New York, Chicago, Boston, Philadelphia, Cleveland, Detroit, Cincinnati
Pittsburgh, Milwaukee, Grand Rapids
The Carborundum Company, Ltd., Manchester, Eng.

The Carborundum Company
Niagara Falls, N.Y.
Please send free Hook-Up Book D-1

Name _____
Street _____
City _____
State _____

There is a Vitrohm Radio Resistor for EVERY power unit

More than 90 standard Vitrohm Resistors and Rheostats cover the resistance need of every socket power circuit now on the market.

Resistance is the heart of power circuits. Make sure of quiet, permanent, and unfailing service by insisting on Vitrohms for radio.

Vitrohm Resistors and Rheostats are guaranteed unconditionally for continuous-duty in any circuit where they operate within their watts dissipation rating, and Vitrohm Resistors have the highest continuous-duty rating without resistance change of any resistor.

New Vitrohms

The list below of new resistors and rheostats is partial. A full description of new Vitrohms for Radio is available without charge. Send for it.

RAYTHEON 350 M. A. UNITS

Vitrohm Resistor 507-70.....\$7.50
Vitrohm Rheostat 507-59..... 5.50

QRS 400 M. A. CIRCUITS

Vitrohm Resistor 507-62.....\$7.50
Vitrohm Rheostat 507-59 5.50

SILVER-MARSHALL UNITS

Vitrohm Resistor S-M 653.....\$2.50
Vitrohm Resistor S-M 655..... 2.50
Vitrohm Resistor S-M 657..... 5.00

THORDARSON POWER PACKS

Vitrohm Resistor for R-171.....\$2.15
Vitrohm Resistor for R-210..... 2.65
Vitrohm Resistor for R-210..... 4.90
with UX874 Regulator Tube

The Adjustat

A new Vitrohm Rheostat, dissipating 20 watts, having 15 steps of resistance. The Adjustat is priced at \$3.00. 11 types are available in the following resistances and current capacities:
507-79, 1-ohm, 4 amp.—507-71, 2 ohms, 3 amp.—507-72, 6 ohms, 1.5 amp.—507-73, 20 ohms, 1.0 amp.—507-74, 30 ohms, 0.75 amp.—507-80, 50 ohms, 650 m.a.—507-81, 600 ohms, 180 m.a.—507-75, 1000 ohms, 125 m.a.—507-76, 2250 ohms, 90 m.a.—507-77, 10,000 ohms, 40 m.a.—507-78, 25,000 ohms, 10 m.a.

WARD LEONARD
ELECTRIC CO.
MOUNT VERNON, N. Y.

Listen, My Children

(Continued from page 333)

and I goes up. Gourdin recognizes The Master right away.

"You are still unconvinced, M'sieu?" he inquires, very Frenchly.

"Yes," says Jerry, shortly: "I want to see your act again."

Then Gourdin does a neryv thing. He steps to the front and tells the audience who The Master is.

"M'sieu Lawson is a skeptic," he states—how he found Jerry's name we couldn't learn, though The Master is well enough known in scientific circles—"and is interested in proving that I am not what I claim to be. We will both appreciate it very much if all of you will please try to confuse me as much as you can."

"Brave lad," I admit to myself, but Gourdin continues: "I do not say that I can read anyone's mind," he explains. "That I cannot do. But I can receive telepathic messages from the mind of my daughter, whose mental plane is even with mine. She will come among you, speaking not a word, and if you will exhibit articles in plain view, she will flash their descriptions to me. If she does not know the name of the object, she will describe it mentally, and transmit the thought to my mind. I thank you."

The Master and me blindfold Gourdin, and does a sweet job of it, too. I glance in at the wings, but I don't see Jim any place—probably shooting craps with somebody—so both The Master and I sits down and watch.

The girl goes down in the audience, and begins picking up proffered objects. If I do say so myself, this act has the others skinned galley-west. She scarcely misses a cue, nor does Gourdin, even when Doc Maxwell holds up a sphygmomanometer, which he has labeled with a tag. The girl looks at it, then Gourdin says: "A blood-test apparatus, the name of which I frankly cannot pronounce—it is—concentrate, my dear—it is s-p-h-y-g—one moment, please—sphygmo-man-o-meter, that is correct?"

You've gotta slip him the olive branch, he's clever. I'm on the *qui vive* for signals, and so is The Master, but nary a one do we get. I'm just about convinced that Gourdin's straight, when I happen to glance sideways and observe Jim and Shakey in the wings.

Jim's wearing the most puzzled expression I ever saw on his funny mug, except the time he got booked into the Palace by mistake and made a hit, and I don't savvy the whyfore, when Shakey suddenly flies off Jim's shoulder and alights on the edge of the foot-light trough, in plain view of everybody. A murmur arises, but the girl's back is turned, and she don't see the bird. A man hands her his business card.

"Hiram West, Pittsburgh," calls out Shakey: "Dealer in lumber."

There's a gasp from the cash customers, and Gourdin gives a visible start. The girl, thinking she's not heard right or something, looks back, as she does so taking a watch from somebody.

"Serial Number 55673, gold plated, seventeen jewels," caws Shakey. Then he mentions the make. Gourdin stands up, and makes a frenzied attempt to loosen his headgear. The Master quiets him with a low spoken word. The girl, with remarkable presence of mind, stays silent, but continues the act to its normal closing point. The audience ain't quite hep, but sense an Ethiopian in the log pile. Gourdin's explanation that he was merely adding a thrill by ventriloquial means, was offered by The Master, since Gourdin was too weak to talk. But the bunch is none too well convinced, and comments and applause are about equal

No matter whether you want to improve a set you now have or build a new one—get this book first. Tells how to build the latest one, two and three dial receivers—5 to 7 tubes.

10¢ PREPAID

GEARHART-SCHLUETER, Fresno, Cal.

Build Any Set but use ACE Hard Rubber PANELS

Their high insulating values insure the utmost protection against leaks and losses which often cause poor reception.

Made with Crackle or plain Polished Surface in all regular sizes:

7 x 10, 7 x 12, 7 x 14
7 x 18, 7 x 21, 7 x 24
7 x 26, 7 x 30 inches.

Low prices at all dealers or write to

AMERICAN HARD RUBBER CO.
11 MERCER STREET
NEW YORK, N. Y.

Makers of famous RADION PANELS

Insure your copy reaching you each month. Subscribe to RADIO NEWS—\$2.50 a year. Experimenter Publishing Co., 230 Fifth Ave., N. Y. C.

when the act leaves the stage. Jerry and me are in close tow, also Jim and Shakey. Gourdin, his blindfold removed, flops onto a chair in his dressing room.

"But how did you know?" wails Gourdin, wringing his hands. "My act! It's ruined!"

"Not necessarily," says The Master. "You sha'n't be exposed, as long as you do not claim any supernatural powers."

"But the bird—the bird—" chokes Gourdin. The girl, weeping, then removes her veil.

Across her mouth is a tight-fitting hard rubber mask, about four inches long by two high, and an inch deep. This is so snug that she can whisper inside of it without anyone's hearing her.

Quick as he can Jerry seizes the girl, and removes the rubber piece. Sure enough, it's a transmitter—a mike!

"Chase me!" I yelp.
 "A small, compact, high-wave transmitter," states The Master, after revealing the rest of the girl's outfit, concealed in her harem dress. Then Jerry makes another dash, this time to Gourdin's ears. Pulling a hand magnifying glass from his pocket, he examines the auditory cavities. Gourdin, unprotesting, sits dumb in his chair. Soon Jerry's produced something, a small pink object.

"I might have known!" he exclaims.
 "What?" I demands.
 "A cleverly contrived super-cardrum!" he declares. "This drum, fitting outside the natural drum, gave to Gourdin's ears a range of sound far beyond any ordinary mortal's. Gentlemen, Gourdin could hear radio messages direct!"

"You mean—"
 "All Miss Gourdin had to do was to speak into the transmitter. At the short range required in a theatre auditorium, her apparatus was able to produce a distinct impression on this special drum. Just how well Gourdin could hear ordinary radio broadcasting is up to question."

Gourdin shakes his head. "I could not," he says, "unless the station was within a few hundred feet of me. But explain, please—the bird!"

Jerry smiles his faint smile. "Shakespeare, here, gave me my first clue," he states. "Are you not aware, Mr. Gourdin, that animals, birds and insects have audible receptivities far greater than those of human beings? That birds, for example, can hear sounds that we cannot?"

"Meaning that Shakey heard the girl's voice?" I ask.

The Master nods. "Precisely," he replies. "Since it happens to be a part of Shakey's act to repeat that which is called out, he naturally seized upon circumstances and did his bit. Being back stage quite likely heightened the atmosphere, and he flew on when he heard things being yelled—as they doubtless sounded to him."

A pause. Then Jim butts in: "But tell me, Jerry, how come the bird can't hear regular broadcasting? He ain't never mentioned it."

"I don't know," admits The Master, frank and earnest. "Probably the same reason Gourdin gave—the waves become distinctly audible only when within very close range of the station. Then again, maybe Shakey has been hearing radio all these years. It's entirely possible that birds and insects can hear radio communication without apparatus. But if they can, we have never had an inkling of it, until now. But it is a wonderful field for investigation—I shall begin proceedings forthwith."

Jim grunts. "Maybe this explains how the bird's been getting those stale jokes he's been slipping. By radio—can you tie it?"

The Master's starting for the door. "Have no fear, Gourdin, you shall not be exposed," he states. "But I must get busy on this new theory. The possibilities are unlimited. I shall begin tests immediately."



The Temple of Heaven, Peking, China
 Originally built in 1420 A.D., this magnificent edifice is believed by the Chinese to cover the exact center of the earth.

FOR MEN AND YOUNG MEN World Travel With All Expenses Paid!

How often you've longed to see for yourself the awe of Egypt's pyramids—the beauties of the gorgeous Mediterranean sunset—the squalor of China's ancient cities! Now you can do it—travel the whole world at will, all your expenses paid. Every one of your expenses of travel will be paid for you—you won't be out a cent of your own. And you can draw a good salary besides!

There is a big demand for men to handle the Radio operating on board the ships of the world. Practically every vessel must carry one man—many of them two or three or more. Radio operating is easily and quickly learned—and the work is very interesting and pleasant. There is no other work like it for the man who wants the experiences and pleasures of world-travel.

Radio operators aboard ocean liners live luxuriously—they rank as officers of the ship. Meals, a private cabin, all other living needs are furnished free, and besides the operators draw a good salary. You don't have to sign up for a long term—you can change ships as often as you like, so as to go to any part of the world you prefer on each voyage.

Book with Full Information Sent Free

My free 64-page book gives all information about this field of work, and the opportunities for travel, fascinating work and advancement. Send for it today—get all the facts. You can learn in your spare minutes at home to qualify for a Radio Operator's position. Just a few months of my practical training in your spare time at home and you'll be prepared to start on your travels.

My methods of training are recognized by the U. S. Government. My graduates are all over the world. My Employment Department, which keeps in touch with employers and supplies them with Radio Operators, is at your service without charge when you complete your training.

No special education is necessary—lots of men I've trained didn't even finish the grades. Read about it for yourself in my big free book—learn how I'll prepare you quickly and easily at home for these big opportunities. Send the coupon TODAY! Address: J. E. SMITH, President, National Radio Institute, Washington, D. C.

 **The "Sailaway" Coupon—Mail it now!** 

J. E. SMITH, President,
 National Radio Institute,
 Dept. MM-19, Washington, D. C.

Dear Mr. Smith: Please send me your free 64-page book, with all information about learning Radio for bigger pay, and as a means to world-travel at will, all expenses paid. I understand this places me under no obligation.

Name

Address

Town..... State.....

Six Big October Specials!

A new Aeroplane
Catapult and
Reversible Propellers

New and effective
Fog Beacons

Houses built
of Newspaper



Does Coffee
Poison the Heart?

Expose of Another
Quack Medical Cure-all

"The Sun-Eaters"
A Big Story by Ray Cummings

Also

a hundred or more articles equally as important

25¢
ON ALL
NEWSSTANDS

OCTOBER SCIENCE AND INVENTION presents a superlative issue. No less than six of the hundreds of articles in this wonderful issue are each, in themselves, a feature worth the price of the issue. If it's a development of Science—it appears in SCIENCE AND INVENTION magazine—and in such a manner as to be understandable by anyone. Hun-

dreds of pictures and illustrations by special artists help to make the most complicated inventions clear. SCIENCE AND INVENTION brings to you monthly over 100 pages of marvels—things that affect your everyday life. You owe it to yourself to keep pace with Science. GET THE OCTOBER ISSUE AT ANY NEWSSTAND.

EXPERIMENTER PUBLISHING CO., 230 5th Ave., New York, N. Y.

THE
WINGED
DOOM
by
Kenneth Gilbert

AROUND
THE UNIVERSE
by
Ray Cummings

TREASURES
OF TANTALUS
by
Garret Smith

AEPYORNIS
ISLAND
by
H. G. Wells

THE
PARADISE
OF THE ICE
WILDERNESS
by
Jul Rejis

ALL IN

FIVE amazing master stories in the great October Number. Stories the like of which you have never read before. A combination of thrilling fiction and the marvel, mystery and action of Science.

25¢ THE COPY

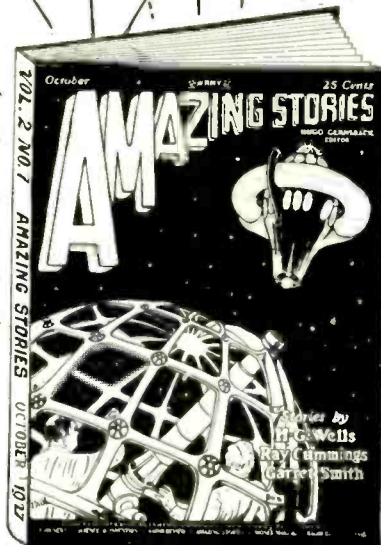

EXPERIMENTER PUBLISHING CO.
230 Fifth Avenue New York City

OCTOBER

AMAZING STORIES publishes the works of such famous authors as H. G. Wells, Jules Verne, Garret Serviss, Ray Cummings, Edgar Allan Poe and many others. There's a big pleasant surprise, packed with thrills, in the October Issue of AMAZING STORIES. Ask your dealer for a copy today.

ON ALL NEWSSTANDS

As he's about to leave, The Master spies Shakey, on the back of a chair. He eyes the bird a moment, then walks over and extends his hand.

"Well, Shakespeare, we're even," he says. "Shake!"

The fowl balances himself, and lifts a wing. "There are more things in heaven and earth, Horatio," he caws, abrupt. Shakey's quotations aren't always finished, but the spirit's there.

The Master wipes his eyes. "Shakey, you said a bill-full," he grins.

Copyright 1927 by Robert Francis Smith

The Magic Loud Speaker

(Continued from page 328)

The presence on the table of the fairly long wires from the sensitive grid circuits of the set will make the whole set-up somewhat sensitive to body-capacity effects. Because of this, it should be easy for the "magician" to make the music from the loud speaker fade in and out; merely by changing his position slightly in relation to the apparatus on the table.

Just as certain dial settings, or values of capacity, bring in certain stations, so does the quantity of solution in the glasses affect the capacity, and thus tune in the stations. The area of the surfaces opposed to each other is varied by pouring more or less solution into the glasses. The more solution, the higher the received wavelength. As the two glasses are in series, the total capacity is smaller than if only one glass were used. This is necessary, as most glasses are too thin; and quite convenient, for different combinations and colors of solutions are possible.

The color of the solution has nothing to do with the operation. All the liquids are simply plain salt solution into which different coloring ingredients have been added. One determines exactly how much solution is necessary in each glass to bring-in a particular station, and these values are tabulated. A small rule is used to measure the depth of the solution, or a measuring-glass to measure the contents; one can prepare the solutions beforehand. It is then only necessary to pour a predetermined amount into each glass, whereupon the station will be heard.

Thick glasses should be used; as their capacities, when used in this arrangement, are about right. A little experiment with different glasses will aid one in securing the best results.

The surfaces of the glasses not exposed to the liquid should be kept dry and clean and the two containers should be separated somewhat; otherwise the tuning will be very broad, due to leakage effects. Long, thick-walled glasses are the best to use. Any good conducting liquid can be used in place of salt solution; the lower the resistance, the sharper the tuning.

The equipment necessary is so easily obtained, and the trick can be made so effective that it is an after-dinner stunt which usually "goes over big."

SOURCE OF INTERFERENCE

AFTER hearing the Dempsey-Sharkey fight in New York over 2XAF (the short-wave relay of WGY) the critic of *Amateur Wireless*, London, observed that "the broadcast showed conclusively that the commentaries here would be improved if they followed the American method of only employing one announcer instead of two, as then there is no chance of the broadcast being spoilt, as has been the case on several occasions here by the announcers during particularly exciting moments both speaking at once."



when all you need is this ~?

The trouble and expense of erecting an outdoor antenna are now absolutely unnecessary. The *Dubilier Light Socket Aerial* has taken the place of loose wires, crazy poles, lightning arresters and all the other accessories of an old-fashioned antenna. Full volume is guaranteed. So is clarity and distance. You'll find, too, that this remarkable device greatly reduces both static and interference. Convince yourself without risk—all dealers sell the *Dubilier Light Socket Aerial* on a 5-day money-back basis. Price \$1.50.



Dubilier Approved Blocks for Power Units

If you're building an A-B-C eliminator, insist on the high factor of safety found only in the approved Dubilier condenser blocks. Raytheon and all standard circuits provided for.



The Accurate Dubilier Metaleak

Don't underestimate the importance of accurate and quiet tubular leaks in the performance of your receiver. Metaleak is smaller than most but interchangeable on any standard mounting. All resistances—40c to 65c.

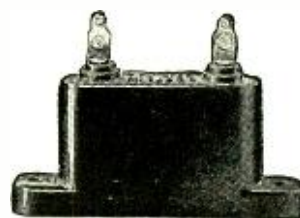

You'll Like the New Dubilier Micadon

A new shape and moulded Bakelite case have made the "Standard Fixed Condenser of Radio" a better and better-looking Micadon. Fully protected from injury and outside capacity. Terminals adapted to screwed or soldered connections.

Prices 45c to \$1.50

Dubilier Condenser Corporation
4377 Bronx Blvd., New York

Dubilier Condensers



Learn Radio and command a worth while salary

If you are earning the average young man's pay you can more than double your salary by taking the Radio Institute of America's course in radio operating. The demand for men is large. And advancement is rapid.

Study at home

Radio Institute of America has for the last eighteen years offered the finest radio instruction obtainable—qualifies you to pass the U. S. Government Commercial or Amateur License Examination. The low cost of the course makes it a real investment that pays dividends in higher wages. Study at home! Send the coupon now for full information.

RADIO INSTITUTE OF AMERICA

324 Broadway, New York City

Send this in



RADIO INSTITUTE OF AMERICA
324 Broadway, New York City

Please send me full information about your Home Study Course of code and technical radio instruction which qualifies for the U. S. Government Commercial or Amateur Radio License.

Please send me full information on your technical course for radio dealers, jobbers and salesmen.

Name

Address

How to Build Radio Sets

(Continued from page 339)

When soldering a joint, hold the tinned part of the hot iron against the wires to be fastened, and then apply a little of the solder to the wire, as shown in Fig. 3. The solder will flow over the wire and, if the iron is then removed, the excess will be removed by the iron.

Use the convenient wire-solder which has a rosin core. This rosin core first flows over the joint to be soldered and removes the oxide; the solder then flows upon the clean wire. If ordinary wire solder is employed, a little flux must first be applied to the joint, and after this the solder. Rosin flux should be used because it is non-acid and does not continue to act on the wire after the soldering process is completed. Acid flux sometimes leaves green deposits on the wire, and often is responsible for "noisy joints." The rosin flux takes a little time to do its work and the iron should be held on the joint until the solder "flows" on the wire. When the iron is removed, the joint is not completed until the solder visibly sets or "freezes." The process is really easy after one tries it a few times.

GENERAL HINTS

The use of separate "B" batteries with the radio-frequency amplifying stages often eliminates troublesome feed-back, so sets which "howl" badly with batteries common to all stages may show marked improvement with separate sources of plate current. The tubes used in modern sets are usually not critical as to filament voltage; so that fixed or automatic filament resistors are often very convenient.

The trend in modern set construction is toward one or two-control sets, with as few as possible of the parts mounted on the panel. The days of long, multi-control receivers, with plenty of knobs and dials on the panel, is gone.

One can often build a very fine receiver on a bread-board for testing purposes, and a panel and cabinet may be used later when the outfit is beyond the experimental stage.

Single-circuit sets are out of date and, although they may give good results in outlying places, their characteristics are such as to give broad tuning. There is nothing to be gained in experimenting with these sets; they create local interference, too.

Most sets should be equipped with a switch for turning the tube filaments on and off, all other battery connections remaining as they are. A phone jack should also be used, as this greatly facilitates the connection of phones or loud speaker at will. If a phone jack is used, this may be placed at one end of the panel and a small panel-mounting filament switch at the other. On the finished sets the vernier dials available on the market should be used almost exclusively as they give close-tuning and look considerably better than plain ones.

For experimental purposes, one can often purchase cheaply 43-plate condensers, which are too large for ordinary work, but which may be cut down easily to the desired size by removing plates. For small chokes to keep radio-frequency current confined to the proper channels, an ordinary wooden spool, if wound with about 300 or 400 turns of small wire (No. 36) in "bunch-wound" fashion, serves very well. This method of construction is shown in Fig. 4.

THE NEEDS OF TODAY

What the world wants is a radio receiving set that can be carried around by the caddy on Sunday mornings.

—David Ferris Kirby.

Do You Contemplate Building A New Set?

R. E. LACAULT
Nationally known radio engineer and originator of the—
ULTRADYNE

and who also constructed and tested the Radio News Laboratory model of the

Strobodyne
Will Advise
-YOU-

Complete information and list of standard parts sent upon request.



New 1927-1928 Radio Handbook of 48 pages sent free on request.

R. E. LACAULT
RADIO ELECTRIC LABORATORIES

116 West 65th St., New York City
Only firm having exclusive services of Mr. R. E. Lacaull, E.E.

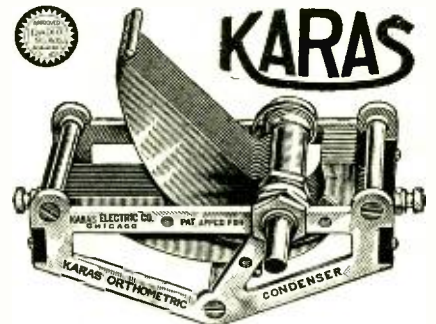

They must be KARAS

YOU must use Karas S. F. L. Variable Condensers in your Radio News Short Wave Receiver to obtain the results described in the article in Radio News, which specifies Karas Orthometrics. You will need a Karas .00014 mfd. and a Karas .00025 mfd. Condenser for this short wave set. Your nearest dealer can supply you with both of these at \$6.50 each. You can expect wonderful results when Karas Condensers are used.

Write us today for latest information about the NEW Karas 2-Dial Equamatic.

KARAS ELECTRIC CO.

4038-J North Rockwell Street
CHICAGO

Set Builders!

Be first to build the new Magnaformer 9-8 Circuit—Commander-in-Chief of the Air—featured by Radio Authority G. M. Best in Sept. and Oct. Radio. Read his articles. See also Sept. and Oct. Popular Radio and C. R. Call Book. Two years ahead of the field. Outstanding feature is its marvelous Tone-Quality. Women, musicians and experts especially are enthusiastic in their praise of its amazing fidelity of tone. The NEW scientifically designed and precisely matched Magnaformer Intermediate Long Wave R. F. Transformers are the cause. Everyone who hears or tunes a Magnaformer 9-8 decides to own one immediately. Beautiful in appearance. Changes from 9 to 8 or 8 to 9 tubes instantly. Great distance getter—super-selective—a world of volume—quiet operating—easy to tune—easy to build. Any one can do it. All standard parts. NO AFTER-SERVICE. The Ideal set to build for others. Send NOW for free descriptive literature.

RADIART LABORATORIES COMPANY
19 S. La Salle Street Dept. 17 Chicago

A Set for Each Member of the Family

(Continued from page 323)

night or two. A pair of phones, attached to a small receiver, shut out strange, disturbing sounds and bring in soothing, slumber-wooding melodies.

The servant in the house needs a radio set also. It is both generous and wise to provide one. There is something basic in human nature that compels us, when we work, to keep time with music if any is audible. There is monotony enough in housework under even the best conditions, and those who follow it as a profession are very likely to tune in some quick and cheery music. The lively rhythm speeds up the work.

AN IDEAL TO WORK FOR

The building of radio sets in the home has been an avocation, mainly. Although some constructors have gone into building sets for money, there are others who do not care to do so. They prefer to bestow their handiwork as gifts where they will do the most good. A completely equipped home, with a radio receiver for every member of the family, guests and employees, is a worthy ideal toward which to work.

The erection of aerials, the wiring of the house for radio, the question of power supply, and other problems, provide mental and physical exercise for men of constructive type.

From the simple crystal detector that boys delight to experiment with, right up to the superheterodyne, there is a place for every kind of set in any home. There is good fun in building them and the recreation leads to profitable vocations, if pursued long enough and in the right direction. In the lives of a considerable number of men whose names now are household words, it has led to fame and fortune.

Correspondence From Readers

(Continued from page 362)

generally sufficient; the second is used when the signal is good enough to be put on the loudspeaker.

The most reliable of the short-wave stations, on the whole, are 2XAD and 2XAF, the relays of WGY. The former broadcasts on Sundays, Mondays, Wednesdays, and Fridays, using a wavelength of 22.02 meters; the latter on Tuesdays, Thursdays, and Saturdays with a wavelength of 32.77 meters. So completely certain is one of being able to receive them that I have never the slightest hesitation about saying to a friend who is spending the evening with me, "Would you like to hear some music from America?" This is tempting Providence with a vengeance but so far I have never yet been let down once.

The shorter-wave station 2XAD is as a rule good as soon as he comes on the air, which he does at 10 p. m. with us, for our time is five hours ahead of Eastern Standard Time. In summer time the strength of this station is apt to decline as it grows darker in Schenectady; but an increase occurs as soon as the dawn begins to break over here. The other relay of WGY, 2XAF, behaves in just the opposite way, being as a rule at its best when darkness prevails over the whole path traversed by the waves. During the twenty-four-hour tests carried out by these two stations last June we found over here that 2XAD was the better transmission during daytime and 2XAF at night.

A HIGH-POWERED 10-TUBE MODEL FOR 1928

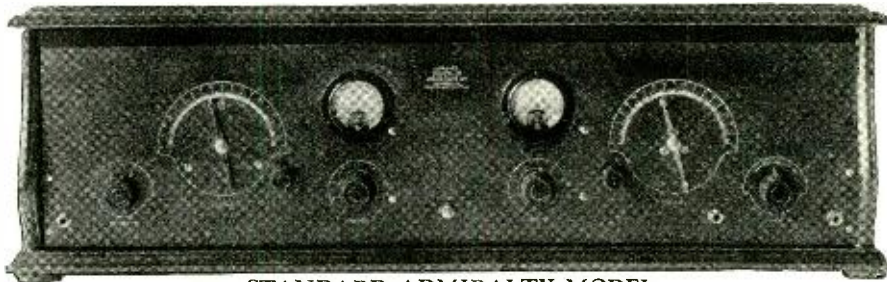

STANDARD ADMIRALTY MODEL

NORDEN-HAUCK IMPROVED SUPER-10

LICENSED UNDER HOGAN PATENT 1,014,002

"Highest Class Receiver in the World"

This new and advanced design brings to you all the luxury and performance you could possibly desire in a radio receiver. Absolutely nothing has been omitted to provide supreme reception—a new standard previously unknown.

The up-to-the-minute engineering principles found exclusively in the improved Super-10 are comparable to the high compression head and super charger in an automobile engine.

In the Norden-Hauck Improved Super-10 you have

- Wonderful Selectivity
- Faithful Reproduction with any Degree of Volume
- Signals received at only one point
- Two major tuning controls for all wave lengths
- Wave band 200/550 meters (adaptable down to 18 and as high as 6000 meters with removable coils)

Material and workmanship conform to U. S. Navy specifications.

The improved Super-10 is sold complete as a manufactured receiver, or we are glad to furnish blue prints and all engineering data for home construction.

Upon request, new attractive illustrated literature will be promptly mailed to you without cost or obligation on your part.

Tear off and mail today—

Your correspondence or inquiry for further information is cordially invited

Write direct to

NORDEN-HAUCK, INC.
ENGINEERS

"Builders of the Highest Class Radio Apparatus in the World"

MARINE BLDG., PHILA., PA., U. S. A

Cable: Norhauck

NORDEN-HAUCK, INC.,
MARINE BLDG., PHILA., PA.

Gentlemen:

- Without obligation on my part send me complete literature on the new improved Super-10.
- I enclose \$2.00, for which send me, postpaid, complete Blue Prints and operating instructions for the new improved Super-10.
- I enclose \$1.00, for which send me Blue Prints of the Model 500 B. C. Power Unit.

Name.....

Address.....

\$75 to \$125 Weekly
Charging Batteries Starts You



Let me show you how to make big money right from the start. I've prepared a FREE book explaining all details. First week's profit pays for all equipment. You can get all the battery charging business in your community with my Service Station Charger—it's years ahead of ordinary chargers—handles 50% to 70% more batteries. I explain everything—start you in a business of your own and put you on the way to big money. Write for FREE BOOK.

C. F. HOLMES, Chief Engineer, Dept. R.N.
Independent Electric Works
5116 Ravenswood Ave. Chicago, Ill.

FREE BOOK Just Out



TRANSMITTING APPARATUS

A Complete Stock at "Chi-Rad"

In addition to our regular broadcast apparatus we carry a very good stock of transformers, chokes, grid leaks, high test condensers, etc., for transmitting purposes.

NEW SHORT-WAVE COILS

Specially built by "Chi-Rad." Write for descriptive bulletin and catalog. Dealers and set-builders please use business letterhead when writing for discounts.

Chicago Radio Apparatus Co.
415 S. Dearborn St., Dept. RN, Chicago

FRENCH HUMOR



120

FRENCH HUMOR

MODESTY

—C'est un homme bien peu recommandable, je l'ai souvent rencontré dans certains endroits où j'aurais voulu d'être vue moi-même.

"He's a man I wouldn't recommend very highly. I've often seen him where I would have blushed to be seen myself."

FRANCE sends its matchless wit and humor to every American Home

FRANCE, the magic land of humor, wit, and keen, knife-edged "parlay," now offers humor-loving Americans its choicest, finest humor through the new weekly magazine, "FRENCH HUMOR."

Americans (who have never been in France) invariably hold the opinion that anything French in humor or jokes must be smut with a Capital S. This is, of course, all tommyrot. The average far-famed Gallic wit is no more smutty than the average Chicago citizen is a Gun-man.

This new magazine will show America what makes the Frenchman laugh—also that humor is international. It will

foster a better understanding between Americans and Frenchmen as a whole. Illustrated jokes in "FRENCH HUMOR" are printed first in French—and then in the English translation—this will be of great interest and help to those who are studying or who have a smattering of this important world language.

The first copy of "FRENCH HUMOR" will prove what we say—it's the funniest, wittiest and most entertaining magazine you have ever read.

Copies are sold on all newsstands, large size magazines 9x12 inches, profusely illustrated with genuine French illustrations.

10¢ WEEKLY
ON ALL NEWSSTANDS

EXPERIMENTER PUB. CO., INC.
230 Fifth Ave. New York, N. Y.

KDKA'S nightly transmission on a wavelength of 62 meters is generally very well heard; though during the past summer signal strength was often rather poor until 1 a. m. (8 p. m. E. S. T.). Curiously enough the harmonic on 20.6 meters often comes in better than the fundamental. WLW on 52.02 meters is also quite easy to pick up on favourable nights, and WIZ on approximately 40 meters is often well heard.

The two great enemies of long-distance broadcast reception on the short waves are static and fading. Though static has been terribly bad with us this summer on the broadcast band and above, it has seldom been so troublesome as to interfere seriously with reception of the short-wave stations. If it is bad early in the evening it often clears off shortly after midnight, returning again a little before daylight. Fading varies a great deal both in character and in intensity. Speaking generally, stations transmitting on wavelengths above 50 meters are much more seriously affected by it than those below. The typical fading is of a rather rapid kind, loud and soft periods alternating at intervals of a second or two.

Sometimes, however, as happened on the night of July 4, fading of an extremely quick type occurs, making singers sound as though they were indulging all the time in tremolo effects. On this particular night there were actually two different kinds of fading occurring at the same time, during one period on wavelengths between 50 and 65 meters. Very rapid fading was superimposed, so to speak, upon quite slow fading. In addition to the tremolo effect there was a slow rhythmic rise to maximum signal strength and a decline again to minimum, the full cycle occupying about five seconds.

This, however, was an exceptional night and, as a rule, the American short-wave stations are so well heard that one can listen with genuine pleasure to the various numbers broadcast. What is particularly interesting is that, if the result of some important event is too late for inclusion in one's evening paper or for the news bulletin broadcast at nine o'clock by our own stations, one can often obtain the news by listening to the bulletins from WGY via 2XAD or 2XAF.

In Europe we have at present only one short-wave broadcasting station regularly at work. This is PCJJ, the installation at Eindhoven in Holland, which broadcasts on Tuesdays, Thursdays and occasional Saturdays between 5 p. m. and 8 p. m. G. M. T., or between noon and 3 o'clock Eastern Standard Time. Germany has, however, two short-wave stations, one at Königswusterhausen with a wavelength of 58 meters and another at Berlin which generally uses a wavelength of about 42 meters. Neither of these works regularly and I heard the other day officially that they had not conducted any transmissions for some little time.

I not infrequently pick up an Italian station, 1SX, whose wavelength seems to vary between 40 and 45 meters. So far I have been quite unable to obtain any information about this station, though when announcing himself he says "Uno ess ix, Roma." On one occasion I picked up another Italian transmission, 1AX, which appeared to hail from Turin. I cannot of course be absolutely certain that I did not hear 1AX's or 1SX's harmonic. Some of these are exceedingly strong over here: I have in fact tuned in several of the British, German and Swedish stations on certain evenings on their fourth or fifth harmonics.

We have at present no official short-wave station in this country; though it is stated in our papers that an amateur, Mr. Gerald Marcuse, has applied for permission to conduct short-wave broadcasting to the Empire at his own expense for twelve months. It seems likely that he may obtain this per-

THE IMPROVED UNIPOWER

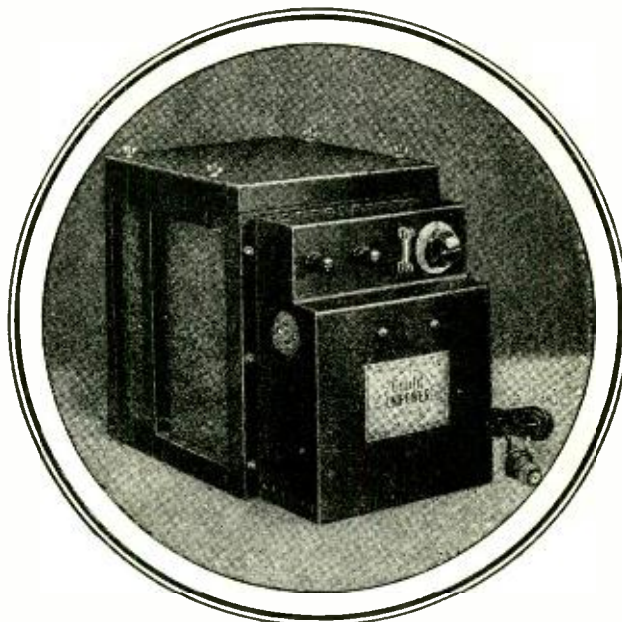

Time-tested design with an added feature

— the new KATHANODE
Submarine type battery element

The new improved Gould
Unipower embodies the same fea-
tures of design that have built
its reputation for reliable service
from the start.

But in the hidden battery ele-

ment a new rugged submarine
type of battery construction is
now employed for the first time
in radio history. It means still
longer life — with less attention
— and it practically ends all
service expense.

Gould Storage Battery Co., Inc.,
250 Park Ave., New York City

Ask to see the finest
Unipower Gould ever built

The new
IMPROVED
Kathanode

Unipower

A GOULD PRODUCT

Laboratory Product

**CRESCENT
LAVITE
RESISTANCES**

For Distortionless Amplification
Used in 75 big broadcasting stations.
12,000, 48,000, 50,000 and 100,000 ohms.
\$1.50 each. Other special resistances made
to order at \$2.50 each. We can supply resist-
ances from 3,000 ohms to 10 megohms.

Cresradio Corp., 166-32 Jamaica Ave., Jamaica, N. Y.

LIGHTING FIXTURES
Ready to Hang
Direct from the manufacturer.
Completely wired, including
glassware. Send for new
catalogue No. 28. Just Re-
duced Prices.

Special Proposition To Dealers.
Erie Fixture Supply Co., Inc.,
Station R. Erie, Pa.

RADIO PANELS
OF GENUINE BAKELITE

Cut, drilled and engraved to order. Send rough
sketch for estimate. Our Complete Catalog on
Panels, Tubes and Rods—all of genuine Bake-
lite—mailed on request.

STARRETT MFG. CO.
520 S. GREEN ST. CHICAGO

Radio on Terms
Play While You Pay! **\$985**

A marvelous set for distance, tone,
selectivity, 6 tube—1 dial (illuminated).
Beautiful cabinet. Easy monthly pay-
ments while you enjoy nation-wide pro-
grams. FREE Log and Call Book and
Big Catalog containing thousands of
Radio Bargains. Write today for copy.
AMERICAN AUTO & RADIO MFG. CO.
HARRY SCHWARTZBERG, PRES.
Dept. 107 American Radio Bldg., Kansas City, Mo.

Insure your copy reaching you each month. Subscribe to Radio News—\$2.50 a year.
Experimenter Publishing Co., 230 Fifth Avenue, N. Y. C.

**More
for your
money in this
\$28.50
Sterling
"B" Power Unit**



\$28.50 is an amazingly low price for this "B" Power Unit. Yet, in spite of price, Sterling quality is maintained throughout.

For efficiency, long life, in fact for permanent operation, only the genuine Raytheon BH rectifier is used. For convenience there's an "on" and "off" switch.

Current regulation? It's perfect! Amplifier and detector voltages are variable. An additional primary control regulates all voltages to suit large or small sets.

No wonder the Sterling R-81 is found today on thousands of 3 to 8 tube sets, giving constant, dependable light socket service. Ask your dealer for a demonstration of the Sterling R-81.

THE STERLING MFG. CO.
2831-53 Prospect Ave. • Cleveland, Ohio



The Sterling Mfg. Co.'s 21-year reputation stands behind every dealer who sells the Sterling line.

**Perfect current
Regulation
for your
set**

**Genuine
Raytheon
BH
Equipped**

mission, though the matter is still under consideration.

I notice, by the way, that there seems to be an idea prevalent in the United States that broadcasting in this country is in a perfectly hopeless mess. This is very far from being actually the case—you probably do not realize what a nation of grumblers we are! As a matter of fact the number of broadcast licenses is steadily increasing, the programs are on the whole pretty good, and there is no widespread discontent.

RALPH W. HALLOWS, M.A.,
226 High Street, Berkhamsted,
Hertfordshire, England.

DOUBLE-GRID TUBES

Editor, RADIO NEWS:

I read with great interest your admirable introduction to the current (August) issue of RADIO NEWS, "Radio on the Upswing," especially the paragraph dealing with the double-grid tube. I have noted that all of our radio magazines have been singularly silent about this tube; and I have often wondered why American radio publications have taken such little interest in this fairly new radio development. This tube is being used in a great many circuits in France, and I would like to see some articles appearing about it in America. Strange to say, very little attention is being paid to it in England.

There seem to be some very definite advantages in connection with it that should make a very strong appeal to the American radio "fan," who is interested, generally, in anything that is new. It seems to offer great advantages for experimentation in the radio amplification field; and I, personally, would welcome seeing some articles on circuits employing this tube appearing in English.

G. HAMILTON COLKET,
c/o Bankers Trust Co.,
5, Place Vendome, Paris, France.

GERMAN RADIO HOUR

Editor, RADIO NEWS:

The writer has just finished reading Mr. Adams' most interesting article in the September issue, entitled "Radio and Our Spoken Language."

He is certainly to be complimented on this article; but, at the same time, I feel it is my duty to let you know that in the paragraph entitled: "No Foreign Language Programs," I believe he has been misinformed, or his search failed to disclose the correct information.

I wish to advise you that the "Chicagoer Herold," with the American admirers of German art in the city of Chicago, broadcasts regularly over Station WIBO, every Sunday between 2:30 and 3:30 P. M. This hour is known as the German Radio Hour and affords real German entertainment by German artists. In the city of Chicago we have a German population of 500,000 and upwards.

I am very pleased to state that, from the volume of letters, telegrams and phone calls of appreciation we have received, we are convinced all nations are appreciative of a broadcast station in their mother tongue, and I venture to say that within a short period of time all nations will be represented by a broadcast station.

JULIUS KLEIN,
Managing Editor "Chicagoer Herold,"
20 E. Jackson Blvd., Chicago, Ill.

SPANISH CHAIN BROADCASTS

In place of the former independent programs, since July 17, Spain's six leading stations, Madrid, Seville, Salamanca, Bilbao, San Sebastian and Barcelona, are now giving a single one, by the aid of land lines, which link them all in a national network.

RADIO IN CHINA

The official ban on radio in China appears to have been lifted, at least in the North, according to an announcement that licenses may be obtained in Peking and Tientsin.



Listed by Underwriters Laboratories

**Keep Off
the Roof**

**ELECTRAD
Lamp Socket Antenna**

\$1.00

Why risk your neck erecting aerials? Use this lamp socket antenna which makes an aerial of every electrical outlet.

Neat in appearance, takes no current, absolutely safe. A distance getter. Tested at 2500 volts A.C.

At your dealer's or write

Dept. 51, 175 Varick Street,
New York, N. Y.

ELECTRAD

**ALL THAT'S
NEWEST
IN RADIO
GOODS**



with better service, quicker shipments and lower prices that give you, as a retailer, tremendous advantages over your competitors. Write at once for the

**Greatest Catalog
of Radio Goods, Sets, Kits and Parts—
GET YOURS!**

No order too small—none too large to receive painstaking attention. Check the prices in this wonderful book with invoices you are paying. Note: We sell only to radio retailers. Write today!

The Harry Alter Co.

1772 Michigan Avenue CHICAGO

For Your
Convenience and Safety
subscribe to

Radio News

Through Our
Authorized
Agent

Times Sales Co.,
431 S. Dearborn St.
Chicago, Ill.



This company has representatives throughout the U. S. who are authorized to accept subscriptions to RADIO NEWS at the regular prices and terms as printed on their order forms.

RADIO NEWS can recommend the TIMES SALES COMPANY for prompt, accurate and courteous service to subscribers.

RADIO NEWS - 230 Fifth Ave., N. Y.

Progress in Radio

(Continued from page 364)

and end wall Y of the cabinet. M is hinged in turn at Z to the end wall Y. With this arrangement the lid may be first swung backwards to the ordinary "open" position about the hinge X and then into an erect position. A hinged strut S is provided for holding the member M—and with it the lid—in erect position, and a loop is provided as shown, the necessary directional effect of which is obtained by the angular adjustment of the lid about its vertical axis. The aerial may be locked in any desired angular setting by a locking arm A.—*The Wireless Trader*, London.

British Radio Work

BRITAIN'S beam system is now practically complete with the successful operation of the stations which link England to India and South Africa. The wavelengths used in the latter communication are around 16 and 34 meters.

At the same time that the Indian beam system was opened, operation of the Bombay and Calcutta broadcast stations in that country began. Both are 3-kw.; the former, 7BY, is on 357 meters, the latter, 7CA, on 370. Receiving sets in India are subject to a license fee of 10 rupees (\$3.65) of which 80% goes to the broadcaster, the Indian Radio Co., Ltd. This company also receives 10% of the value of all radio apparatus imported into India.

The Malayan Broadcasting Service may do well; it is to receive \$18 of each \$20 yearly license in Malaya; and to be allowed to sell six minutes' advertising in each hour.

Radio Wrinkles

(Continued from page 368)

SOCKET-POWER RELAY CONTROL

WHEN batteries are used exclusively for the operation of a receiving set, a single switch mounted on the panel controls the flow of current.

Now that "B" power units have become a popular accessory to a receiving set, the use of an additional switch may be obviated by the use of a control relay, the design and construction of which is illustrated.

The purpose of the spring shown in the sketch is to open the contacts when the coil is de-energized, thus discontinuing operation of the eliminator. The spring effect is obtained by coiling the lead to the movable contact; or a separate steel spring, fastened to some other part of the armature, may be used.

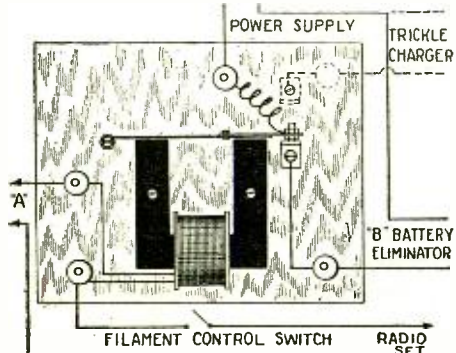

Circuit diagram of socket-power relay control.

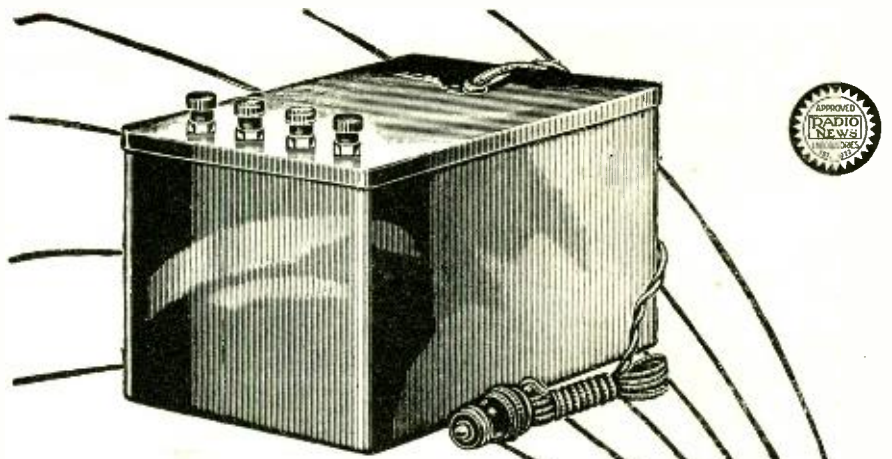

it's the Value behind the price that counts!

Because every part in the Townsend "B" Socket Power Unit is made and assembled in our own factory we can give you a high grade instrument at a surprisingly low price. Now everyone can enjoy wonderfully improved reception, uninterrupted by screeches of fading batteries.

Reports from hundreds of satisfied users prove that the Townsend "B" Socket Power is the most remarkable value in Radio today.

Money Back If Not Delighted

Sold on real guarantee of money refunded if not satisfied. Delivers up to 100 volts on any set, on D. C. or A. C.—any cycle. Full tone, clarity and volume.

Approved and passed by the rigid laboratory tests of Radio News and Popular Radio

SEND ORDER TODAY

Simply fill out the coupon and slip it into an envelope with only \$1.00 and mail at once. Your Townsend "B" Socket Power Unit will be sent promptly. Deposit only \$5.85 plus postage with the postman. Try out for 10 days—then if not amazed and delighted with improvement in reception, return it to us and purchase price will be refunded.

HERE'S YOUR PROOF

Your Eliminator is doing just fine; worth five times the price. H. R. Boyd, Urbana, Ohio.

Your Eliminator works very well. I get distant stations very strong and clear on my Browning Drake. Geo. Bigras, Montreal, Canada.

I cannot praise your Eliminator too much. Better than many I have seen at many times the price. D. W. Beard, Los Angeles, Calif.

Have been using your Eliminator for several months and am well pleased with its reliability and economy. R. Bond, San Antonio, Texas.

Your Eliminator on my "ROBERTS" is fine and clear; best I ever heard and no trouble at all. A. Saille, Passaic, N. J.

Reception with your Eliminator is so good and clear, it seems the artists themselves are in the room. Floyd Fry, Oakland, Calif.

More than pleased with your Eliminator. Bringing in stations that I never heard before. Levi O. Gabowry, Worcester, Mass.

complete
\$6.85
\$1.00 Down
Balance C.O.D.

Townsend "B" Socket Power

TOWNSEND LABORATORIES
713 Townsend St. Dept. 25
CHICAGO, ILL.



TOWNSEND LABORATORIES,
713 Townsend St., Dept. 25
Chicago, Ill.
Gentlemen: Attached find \$1.00.
Kindly send at once Townsend "B"
Socket Power Unit, C. O. D. for
\$5.85, plus postage, on guaranteed
10-day free trial.
Name State
Address
City

Attach Only \$1.00 to this Coupon

LEARN RADIO — at Home

"Radio Educator Course" gives complete schooling in Radio—complete in 5 volumes

Want to learn the Theory, Design, Construction, Operation and Maintenance of Radio? These five component parts of a complete Radio Instruction Course are outlined in five volumes that contain not merely the essentials as so many books do, but more; they contain all that any modern up-to-the-minute textbook on

any subject would cover. They are in themselves a COMPLETE radio education teaching every possible portion of Radio science. Size of each book 6 by 9 inches, handsomely bound and illustrated with charts, diagrams, descriptions of equipment, etc. Each volume 52 pages.

SEND NO MONEY

for these books. Just forward your name and address. We send you the books at once. On receipt of same you pay the postman \$1.97 plus a few cents postage and then they are yours.

Published and Distributed by

THE CONSRAD CO., INC., 230 Fifth Ave., NEW YORK



Everywhere
Under
The Sun

Speed
SUPER
EMISSION
**Radio
Tubes**

A Tube for
Every Radio Need



EXHIBITING AT THE
FOURTH ANNUAL RADIO SHOW
NEW MADISON SQUARE GARDEN
SEPTEMBER 19th-24th



CABLE SUPPLY CO.
MANUFACTURERS
EXECUTIVE OFFICES
31 Union Square, New York

If a trickle-battery charger for the "A" battery is used, an additional feature may be incorporated in this apparatus. It acts as follows: when the radio set is shut off, the relay is de-energized and the armature is returned, by the spring, to its normal position. However, when it returns to this normal position the charger circuit is closed through the movable contact and another fixed contact. In this manner, the filament switch controls everything—plate voltage supply when the filaments are lit and battery charging when they are out.

A small three-sided steel core, either solid or laminated, measuring about 2 inches on a side and approximately 1/2 x 1/2 inch in cross section, will be required. Wind approximately 200 turns of No. D.C.C. copper wire on the center leg. In cases where the power supply is alternating current, if any abnormal hum develops in radio reception, after introducing the relay in the circuit, this winding may be divided, half being placed on each outside leg of the core and connected with additive polarity; i.e., so that the magnetic fluxes set up by each half will work together and not oppose. In the latter case there would be no mechanical force exerted on the armature.

A thin strip of iron or steel lamination may be used for the armature and should be long enough to cover both pole faces of the magnet. A strip of fibre should be fastened to one end. In the other end of the fibre strip, at a sufficient distance to insulate the power supply circuit from the armature, is placed the contact, consisting of a threaded bolt with the head cut off and a nut holding it on either side of the fibre strip. The pivot is a threaded bolt with the armature strip curved around it.

Contributed by George T. Trainer.

EASILY-MADE INSULATOR

A HANDY insulator for temporary use may be quickly made. First, paste into the shape of a tube a piece of card-

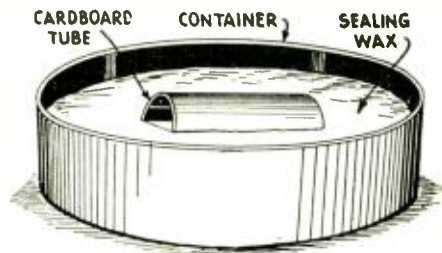

By immersing a cardboard tube in melted sealing wax an excellent insulator is made.

board 1 1/2 x 4 inches. Dip this into sealing wax and let the latter harden. This will serve the purpose till a more substantial one may be obtained.

—Contributed by Francis Hile.

RADIO PARTS CONTRABAND

IN its campaign against "pirates," or listeners who do not pay a license fee, the administration of the Union of South Africa has introduced a bill containing this measure into parliament:

"Any person who sells, gives or in any manner whatever supplies any valve (tube), loud speaker, or telephone receiver for radio to any person who is not a licensed listener under this act shall, within seven days after such supply, notify the postmaster-general thereof by written notice setting out the name and address of the person so supplied. Failure to comply with the provisions of this sub-section shall constitute an offence."

After this clandestine sale of tubes in South Africa will be real "bootlegging."

**90 Volt Power
Unit :: \$12.75**

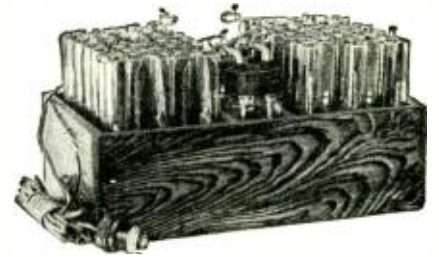

Hums, line noises, etc., positively impossible with this new advanced unit. Plug in and forget Non-acid and noiseless. All detector and intermediate voltages plainly marked. Simpler to hook up than dry cells. Operates any type set 1 to 12 tubes. Greater volume and clearness guaranteed. If not thoroughly satisfied return after using 30 days for complete refund. Guaranteed further 2 years. For 110-120 volts A.C. 25 to 60 cycle current. 90 volts, \$12.75; 112 1/2, \$15.25; 135, \$17.50; 157 1/2, \$19.50; 180, \$24.00; 202 1/2, \$26.00. Also built for D.C. current 110 and 32 volts at only \$3.00 additional, any size above. Ample stocks—same day shipments. Simply say—ship C.O.D. or write for my interesting literature, testimonials, etc.

B. HAWLEY SMITH

334 Washington Ave.,

Danbury, Conn., U. S. A.

Goodrich



Radio Panels

Black, Mahogany and Walnut.
Standard thickness 3-16" and 1/4".
High softening point prevents warping.

Low free sulphur content prevents discoloration.

Machine easier and are better electrically than any other material in common use.

Your radio dealer has them or will get them for you—if not, write to us and we will see that you are supplied.

Also hard rubber for coils, spaghetti tubing and miscellaneous rubber items for Radio Manufacturers.

Radio Sales Division

The B. F. Goodrich Rubber Company
Established 1870 • Akron, Ohio

RADIO AGENTS
Make Big Money
EASY to sell American Radios and Supplies. Nationally advertised, high quality merchandise at wholesale. Big profit on every sale. No capital to invest. No stock to carry. Order direct from my huge warehouse as you sell.
Get My Liberal Offer and also Big New 122-page Catalog and Guide—"How to Sell Radios"—free. Full of bargains—all latest in Radio. Write today.
AMERICAN AUTO & RADIO MFG. CO.
HARRY SCHWARTZ, Pres.
Dept. 105 American Bldg., Kansas City, Mo.

**Valley
Chargers**
Manufactured by
VALLEY ELECTRIC CO.
ST. LOUIS, MO.

How the Stroboddyne Works

(Continued from page 345)

primary of a radio-frequency transformer in a regular tuned-R.F. stage.

Now, in an R.F. stage, a large primary in the plate circuit causes the tube to oscillate easily, without the aid of deliberate coupling between the plate and grid circuits; this is due to the *capacity* effect between

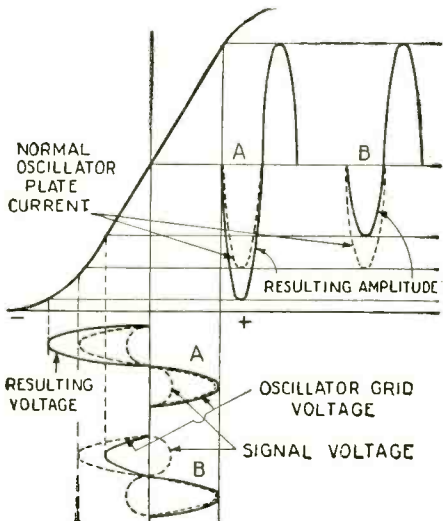

Fig. 8. The diagram shows how the received signal varies the amplitude of the oscillator current, in one way only.

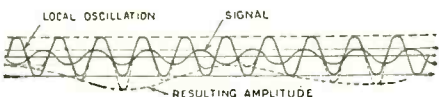

Fig. 8C shows the wave formation through a number of cycles.

the grid and the plate of this tube. To prevent these oscillations, some controlling device must be used, or the circuit neutralized in some way. In the Stroboddyne, the plate coil L3 is large enough to cause the tube to oscillate at the frequency of the incoming signal, and during the half cycles when the grid of the tube is negative the incoming signal is *amplified by regeneration*. This is what makes the system so sensitive. The regenerative effect is not only automatic (because it stops as soon as the grid becomes positive), but its *efficiency* increases as the signal strength decreases. This makes the Stroboddyne arrangement extremely sensitive.

STROBODDYNE OR SUPERHETERODYNE?

One of our readers, after reading the articles in the July and August issues, presents the following propositions:

"It seems to me that there is a much simpler and more profitable way of considering the theory of the circuit from its relation to that of the superheterodyne. When you realize that the essential elements of the new circuit and the general electrical relationship of the elements are in every respect identical with those of the superheterodyne — so that, in fact, two circuits presumedly working on the two theories could be distinguished only by an expert in the theory of each, or by their name plates—it seems only right to point out just wherein the difference lies.

"Consider first the superheterodyne. The radio-frequency energy picked up by the loop varies the potential of the already negative grid of the mixer tube over very small

POWER UNITS THAT MEAN GOOD Reception POPULAR IN PRICE & USE

Reception

Acme Universal "B" Power Supply

BE-40 \$34.50
BE-60 \$39.00



Acme Trickle Charger and Control Switch \$17.50 Complete



Acme Automatic Control Switch ACS-1 \$3.75



"A" Power Unit APU-6 Complete \$35.00

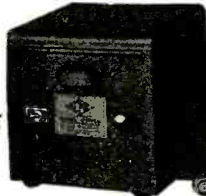

Matchless Service

Dependable Quiet

"ACME A & B" SOCKET POWER UNIT

gives your radio a strong flow of constant, dependable A and B power. One switch control. Quiet—attractive—efficient—big value.

Type AB-2-R—60 \$72.50 Complete ready mills, at 180 volts to operate

All prices quoted are List, East of the Rockies. Sold through leading Jobbers and Dealers everywhere.

Members of Radio Manufacturers Association

ESTABLISHED 1917.

Factory Representatives in leading cities

Clip this Coupon & Mail Today

Name _____
Street _____
City _____
State _____

Our Latest Literature will be sent you

THE ACME ELECTRIC and MANUFACTURING COMPANY.
1412 Hamilton Avenue Cleveland, Ohio

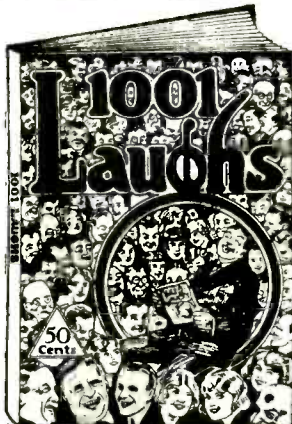

LAUGH—an hour a day for the rest of your life! 1001 LAUGHS

Did you ever pick up a French, German or Spanish joke magazine and wonder what their specially good jokes were?—Here's a brand new laugh book with hundreds of the best Foreign jokes and illustrations translated into English for you, together with plenty of good American humor and cartoons.

Altogether this is the greatest, funniest, most uproarious book of jokes and funny illustrations ever presented to Americans. Each leaf of this book is one merry round of pleasure. Every joke is a winner.

Relax from your daily grind, spend an hour a day in good old-fashioned laughter. It's a healthy recreation. "1001 Laughs" is an extra-large size book, 9 x 12 inches, with over 300 illustrations.

50c EVERYWHERE — OR ORDER DIRECT
EXPERIMENTER PUB. CO., 230-5th Ave., N.Y.

BOOK BARGAINS



You can save 25% to 60% on every book you buy!

CONSRAD BOOK HEADQUARTERS

BULLETIN NUMBER 5

Keep your library up-to-date at half the cost
Latest editions of Fiction, Science and all other subjects

AVIATION

601. **Our Air Force.** By William Mitchell. 232 pages. Bound in stiff cloth, 9 by 6 inches. A discussion of the place the air corps should take in our national defense forces, by the famous former air Chief. Amply illustrated. Regular Price \$5.00
Our Price \$3.13

602. **Aeroplane Performance Calculations.** By Harris Booth. 216 pages. Bound in stiff cloth, 9 by 6 inches. A collection of the mathematical calculations required by plane designers and aero engineers. Illustrated with drawings, graphs and charts. Regular Price \$8.00
Our Price \$4.37

BIOGRAPHY

686. **Twenty Years on Broadway.** By George M. Cohan. 272 pages. Bound in stiff cloth, 9 by 6 inches. The great "Song and Dance Man" tells about his life on the White Way, and of the years it took to get there. Regular Price \$3.00
Our Price \$1.97

FICTION

780. **Hilda Ware.** By L. Allen Barker. 328 pages. Bound in stiff cloth, 8 by 6 inches. For a man to fall in love with his secretary is not uncommon, but it is uncommon the way the resulting situation is developed in this novel. Regular Price \$2.00
Our Price \$1.49

822. **Return of the Prodigal.** By May Sinclair. 376 pages. Bound in stiff cloth, 8 by 6 inches. A prodigious novel by a woman writer whose reputation is world wide. Regular Price \$2.50
Our Price \$1.29

807. **Terrible Island.** By Beatrice Grimshaw. 296 pages. Bound in stiff cloth, 8 by 6 inches. Love and romance in the glamorous South Sea Islands. Regular Price \$2.00
Our Price \$1.37

778. **Princess of Paradise Island.** By Kerson Gamber. 312 pages. Bound in stiff cloth, 8 by 6 inches. Charlie Bonsal was blue and broke. Then his uncle died and left him owner of an island in the Bahamas. But Charlie found a Princess also in possession—and from there on we have an amazing love story, mystery and adventure. Regular Price \$2.00
Our Price \$1.37

749. **Centerville, U.S.A.** By Charles Mery. 288 pages. Bound in stiff cloth, 8 by 6 inches. A series of short stories and sketches of American actualities. Small towns presented by a man who can see and who can write. Regular Price \$2.00
Our Price \$1.49

743. **Unravelled Knots.** By Baroness Orczy. 408 pages. Bound in stiff cloth, 8 by 6 inches. A collection of thrilling and swiftly moving mystery stories by the far-famed authoress of "The Scarlet Pimpernel," with an extraordinary eccentric as the central figure. Regular Price \$2.00
Our Price \$1.49

823. **Dr. Morel.** By Karen Bramson. 216 pages. Bound in stiff cloth, 8 by 6 inches. The strange story of a man whom all women loved and no woman understood. Tensely written, and much psychological subtlety. Regular Price \$2.00
Our Price \$1.09

771. **Lucky Prisoner, The.** By Count Gobineau. 296 pages. Bound in stiff cloth, 8 by 6 inches. A tale of love and fighting in the most romantic period of French history—told with all the dash of a Dumas novel. Regular Price \$2.00
Our Price \$1.49

734. **Education of Sallie May.** By Fanny Kilbourne. 168 pages. Bound in stiff cloth, 8 by 6 inches. A "hit" with men, but unable to "get by" with her own sex, Sallie May, a successful screen actress, sets out to "get educated"—with unexpected romantic results. Regular Price \$1.50
Our Price \$.89

801. **Veneerings, The.** By Harry Johnston. 448 pages. Bound in stiff cloth, 8 by 6 inches. A widely known English writer takes up the threads of the lives of Hamilton Veneering and his children, who lived in the pages of Dickens' "Our Mutual Friend," and presents them as chief actors in a story of shady and legitimate finance. Regular Price \$2.00
Our Price \$1.37

678. **Dr. Jekyll and Mr. Hyde.** By Robert Louis Stevenson. 96 pages. Stiff paper bound, 7 by 5 inches. The well known Stevenson story of a man who led a double life. In a popular edition. Regular Price \$.25
Our Price \$.19

803. **Wednesday Wife, The.** By Juliette Gordon Smith. 232 pages. Bound in stiff cloth, 8 by 6 inches. A love story of the East, of harems, and Sultans, and dancing women. Regular Price \$2.00
Our Price \$.97

805. **Turtles of Tasman, The.** By Jack London. 280 pages. Bound in stiff cloth, 8 by 6 inches. It is as a writer of short stories that the late Jack London is renowned, and this collection explains why. Regular Price \$1.25
Our Price \$.79

796. **What I Remember.** By Millicent Garrett Fawcett. 280 pages. Bound in stiff cloth, 9 by 6 inches. Record of the long and interesting life of a woman identified with the many reform movements in English politics—and the great and small people she met in that work. Illustrated. Regular Price \$4.50
Our Price \$2.25

789. **Flying Emerald.** By Ethelreda Lewis. 304 pages. Bound in stiff cloth, 8 by 6 inches. An adventurous mystery story of a green diamond and of Northern people among the gray sand dunes of Southwest Africa. Regular Price \$2.00
Our Price \$1.49

791. **There Is A Tide.** By J. C. Snaith. 384 pages. Bound in stiff cloth, 8 by 6 inches. In a deft and scintillating comedy the author tells of Maime Derrante, from Cowbarn, Iowa, and her adventures in the smartest English society circles. Regular Price \$2.00
Our Price \$1.37

773. **Mr. Bottleby Ooes Something.** By E. Temple Thurston. 360 pages. Bound in stiff cloth, 8 by 6 inches. Gentle, fumbling, woman-hating Mr. Bottleby finds love in his life, and the result is an entertaining, amusing and romantic bit of fiction. Regular Price \$2.00
Our Price \$1.37

787. **Wounded Souls.** By Sir Philip Gibbs. 328 pages. Bound in stiff cloth, 8 by 6 inches. A truth telling novel by a distinguished writer. A vision of the new order; the triumph of the heart and spirit over the brute forces of matter. Regular Price \$2.00
Our Price \$1.57

774. **Mr. Moffatt.** By Chester Francis Cobb. 320 pages. Bound in stiff cloth, 8 by 6 inches. An intensely human story of a humble man who is struck down by Fate—and his fight to live. Regular Price \$2.50
Our Price \$1.65

800. **Back Stage.** By Roland Oliver. 296 pages. Bound in stiff cloth, 8 by 6 inches. The hopes, disappointments, loves and surprises of life "back stage" are in this rapidly moving novel of Peter Millard, the playwright, and the people with whom he worked and played. Regular Price \$2.00
Our Price \$1.29

SCIENCE

617. **Britain's Heritage Of Science.** By A. Schuster and A. E. Shipley. 336 pages. Bound in stiff cloth, 8 by 6 inches. A diverting history of science and the great scientific men of Great Britain. Illustrated with Plates. Regular Price \$5.00
Our Price \$3.05

663. **Clouds.** By Geo. Aubourne Clarke. 136 pages. Bound in stiff cloth, 9 by 6 inches. A descriptive illustrated guide-book to the observation and classification of clouds. Beautifully illustrated with plates, some in colors. Regular Price \$8.00
Our Price \$3.98

610. **Volumetric Analysis, Notes On.** By J. B. Russell and A. H. Bell. 104 pages. Bound in stiff cloth, 8 by 6 inches. A scientific book of laboratory instructions for students attending college or technical schools. Regular Price \$.90
Our Price \$.59

SPORTS

794. **Roughing It Smoothly.** By Elton Jessup. 256 pages. Bound in stiff cloth, 8 by 6 inches. An unusual book for the vacation camper in which an editor, wise from long experience, shows the easiest path to out-of-doors comfort, and ways to avoid discomfort. Illustrated. Regular Price \$2.50
Our Price \$1.29

665. **Cross-Country Skiing.** By Arnold Lunn. 128 pages. Bound in stiff cloth, 7 by 5 inches. A handbook for the novice in ski-ing, with much of interest for the experienced runner, by an expert in this sport. Diagrams and illustrations. Regular Price \$2.00
Our Price \$1.03

667. **Alpine Skiing At All Heights And Seasons.** By Arnold Lunn. 120 pages. Bound in stiff cloth, 7 by 5 inches. In this informative and practical volume the author seeks to convert mountaineers and plain ski-runners into ski-runners of the mountains. Illustrated. Regular Price \$2.00
Our Price \$1.19

STAGE AND ACTING

628. **Practical Hints On Acting For The Cinema.** By Agnes Platt. 160 pages. Bound in stiff cloth, 8 by 6 inches. A simple, helpful manual of vital value to anyone who intends to take up screen work. All important items are included. Regular Price \$2.00
Our Price \$1.07

627. **Practical Hints On Training For The Stage.** By Agnes Platt. 184 pages. Bound in stiff cloth, 8 by 6 inches. A stimulating and useful collection of intimate talks on the art and business of becoming an actor or actress. Regular Price \$2.00
Our Price \$1.06

These are only a few samples of the hundreds of latest books

SEND FOR COMPLETE BULLETIN No. 5

Use this coupon—order now, as some editions are limited—mention book numbers

THE CONSRAD COMPANY, INC., 230 Fifth Ave., New York, N. Y.

Gentlemen: I enclose \$..... for books number.....

Send me complete

Name

bulletin number 5

Address

limits. This grid is likewise supplied with locally generated energy, which also varies its potential slightly. If we add these two potential conditions, we can represent the result at the grid as in Fig. 9a.

"It will be noticed that, in spite of the variations, the grid is always at a negative potential; and this is the condition for proper operation. This condition is assured by the application of a permanent bias and only a very minute supply of energy from the local source.

"Now, when these resulting potential variations on the mixer grid are translated by the tube into variations in plate current (amplified) due to the curvature of the tube characteristic, we get detection in the well-known manner, resulting in plate-current variations of the following type (Fig. 9b).

"These plate-current variations are easily seen to be made up in first approximation of the addition of a normal high-frequency component and a low difference-frequency component, the latter being passed through the intermediate amplifier.

"Let us now consider the theory of the Strobodine circuit. In this case, as before, we impress the signal energy upon the grid of a tube; thus producing similar variations in its potential. But in this circuit the normal bias of the grid is rather less than in the average superheterodyne. Considering

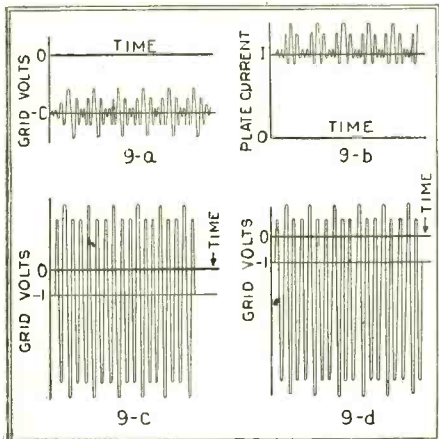

These four sets of waves illustrate the theory of the Strobodine, in its relation to the superheterodyne.

the position of the rheostat and the filament drop, somewhat more than one volt negative would doubtless cover it, as against four or five volts for the superheterodyne. But, in any case, the signal potential variation would be quite negligible, compared with even as little as one volt; so that, in order to throw the grid positive during one half of each cycle, we must impress a rather high intensity, relatively, from the local oscillator. If we add, therefore, as before the potential variations due to the signal to those resulting from the oscillator, we get as follows (Fig. 9c). This will represent the true state of affairs if the filament of the mixer is not lit (and, of course, if a separate oscillator is used.) It will be noticed, however, that during that portion of the cycle above the zero line the grid will normally draw electrons from the filament. This process will require power; so that the positive grid potential will be actually much less than shown. The actual potential is more like that shown in the following diagram (Fig. 9d).

"The effect of this eccentric grid potential upon the plate current is the next thing to consider. It is easy to see that the effect of the curvature of the tube characteristic is to counteract the influence of this eccentricity in grid potential upon the plate current. In other words, the "superheterodyne action" in the circuit is exactly opposed to the "Strobodine action." We could easily

The Best and Cheapest "A" Power

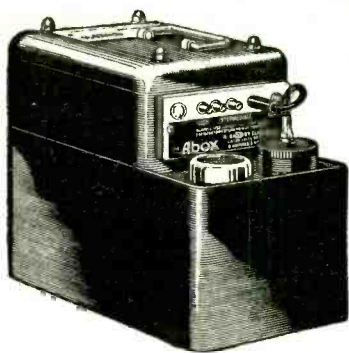

Abox

Complete "A" BATTERY ELIMINATOR

Licensed by the Andrews-Hammond Corporation under Andrews' condenser and other Andrews and Hammond patents and patent applications.

32.50

Complete
Slightly higher west of Rockies.

Contains no battery and operates direct from the light socket

NO CHANGES IN SET NECESSARY

The Abox "A" Eliminator is a rectifier and the Abox Filter circuit built into one compact unit. It changes the alternating current from the light socket to 6-volt hum-free current. It is always ready at the touch of the switch to deliver the correct current so essential for maximum reception.

The Abox contains no battery in any form. It is never charged or discharged. It is fool proof in operation. It regulates against line voltage fluctuations and, regardless of line surges, no damage can be done to tubes. This is accomplished without automatic cut-outs or troublesome relays.

Fully guaranteed for one year.

Ask your dealer for ABOX—the best and cheapest "A" Power.

Send for free circulars.

Dealers—Write for name of nearest jobber.

The Abox Company

215 No. Michigan Avenue Chicago, Ill.

LEARN THE CODE AT HOME

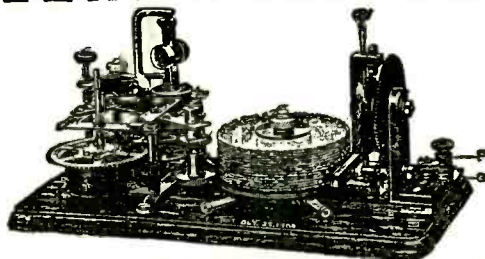

WITH THE OMNIGRAPH

THE OMNIGRAPH Automatic Transmitter will teach you both the Wireless and Morse Codes—right in your own home—quickly, easily and inexpensively. Connected with Buzzer, Buzzer and Phone or to Sounder, it will send you unlimited messages at any speed, from 5 to 50 words a minute.

THE OMNIGRAPH is not an experiment. For more than 15 years, it has been sold all over the world with a money back guarantee. The OMNIGRAPH is used by several Depts. of the U.S. Govt.—in fact, the Dept. of Commerce uses the OMNIGRAPH to test all applicants applying for a Radio license. The OMNIGRAPH has been successfully adopted by the leading Universities, Colleges and Radio Schools.

Send 6c for Catalog
THE OMNIGRAPH MFG. CO.

DO IT TODAY.
15 HUDSON STREET, NEW YORK CITY

If you own a Radio Phone set and don't know the code—you are missing most of the fun

Insure your copy reaching you each month. Subscribe to Radio News—\$2.50 a year.
Experimenter Publishing Co., 230 Fifth Avenue, N. Y. C.



**Best tubes—
Best reception**

New broadcast developments make it necessary to have the latest types of tubes for fullest enjoyment of your receiving set.

Bring it up to date with a complete installation of the new Gold Seal radio tubes—specially developed for modern reception. You will be delighted with the improvement.

You can make the changes yourself—no trouble. Our new booklet tells you all about it. Send today for your copy—it is free. Use coupon below.

All Standard Types

**Gold Seal Electrical Co.
250 Park Ave., New York**

Send me copy of the new booklet.

Name _____

Address _____

**Gold Seal
Radio Tubes**

imagine conditions such that these actions would practically neutralize each other and there would be thus no intermediate frequency due to either effect. This phenomenon should be noticed in either circuit through a suitable adjustment of the oscillator energy and the "C" voltage of the mixer; for it is only in the relative values of these two qualities that these circuits differ materially. But, due to the opposition of these two effects in the Strobodyne, the Strobodyne effect must be sufficient in intensity to neutralize completely the superheterodyne action before it can be itself a factor.

"I mention these considerations as of importance in determining whether a signal is Strobodyned or superheterodyned; as it is apparently a matter of choice with a given circuit. The relative merits of either system with regard to selectivity and sensitivity, when we are certain with which we are dealing, can best be decided by experiment.

E. H. KURTH, Sc. D.,
Palmdale, California."

DISTINCT CHARACTER OF THE STROBODYNE

Dr. Kurth's explanation of the superheterodyne operation is correct; but a signal is not "Strobodyned" unless applied to the grid of the oscillator in the manner shown in the circuit. The reason for this is that the characteristic curve of a tube which is oscillating is different from its curve in the non-oscillating state. The slope of the curve is not so steep when the tube oscillates; and it extends more toward the left of the "0" grid-bias line.

In this case the signal is amplified while the grid swings negative; and is damped when the grid swings positive, because of the grid current as already explained. This effect produces rectification. The amplifying action is magnified by the regenerative effect of the oscillator tube during the negative half-cycles, and this is what makes the Strobodyne system sensitive.

It works along the line of super-regeneration, in which both the negative and positive resistances are varied, except that, due to the phase relation between the incoming and local oscillations, a beat-note is produced.

ANOTHER LETTER

Another reader challenges the novelty of the Strobodyne more bluntly. He says:

"Being a regular reader of RADIO NEWS, I of course have read your articles on the Strobodyne circuit, and I am surprised at your attempt to foist this on the radio public as a new circuit. I do not wonder that the originator of the circuit expects some difficulty in convincing the public that he really has a new circuit, or rather a new principle—the only new feature about it being his new and rather clever illustration of the principle.

"Illustrate it in whatever way you wish, by the stroboscope, by two men walking at different rates of speed, by two clocks ticking at unequal rates, and call it whatever you wish, hereto, ultra, strobo, or tropa, the result remains the same; the beat from the oscillator is superimposed upon the beat of the input system, resulting in a heterodyne action. The Strobodyne system possibly might be arranged with such variation between the input and the oscillator, as not to give a true harmonic, in which case it would be practically regeneration; but, when you have your inductances and capacities arranged so that the output is at the same wavelength as that of the superheterodyne, it is operating on the harmonic principle, and the action would be the same under any other name.

"It's merely the Tropadyne with a stage of radio frequency preceding, and with a bridge system very slightly different from that of the Pressley, which in turn was but

New!



No More Socket Trouble

A socket's only job is to provide a perfect contact. The New Eby Socket has a 3 point wiping spring contact the full length of the prong, the most scientifically perfect type known. The prongs are completely enclosed and fit snugly against the phenolic walls of the socket—they can't spread.

With the New Eby Socket your socket troubles are gone. Easy to mount above or below Bakelite, Wood or Metal.

Specified in most of the leading popular circuits.

List Price 40c.

THE H. H. EBY MFG. CO.
INCORPORATED
4710 Stenton Ave.
Phila., Pa.

Makers of Eby Binding Posts



In Trouble??

Has a moisture permeated bypass condenser ruined your receiver or amplifier? A defective bypass condenser or coupling condenser in a receiver or amplifier mars reception—causes distortion.

Insure against such troubles—use the latest AEROVOX development—an AEROVOX bypass condenser sealed in a Bakelite case—non-inductively wound—impervious to moisture—its electrical condition is as good after a year as the day it was installed.

Made in all capacities up to 1 mfd and rated at 200 volts D C working voltage.

AEROVOX
"Built Better"
70 Washington St., Brooklyn, N. Y.

a slight alteration of the Tropadyne; and the man who can devise some new and different illustration of the principles of this circuit, can equally well introduce it as something new.

C. S. CULP,
Alliance, Ohio.

DIFFERENCE BETWEEN STROBODYNE AND TROPADYNE

The writer replied as follows to Mr. Culp's letter:

"The Strobodyne circuit is different from the Tropadyne in the following points:

"In the Tropadyne a grid condenser and grid leak are used to get a detector action, and at the same time to form a bridge which prevents the tuning circuit from reacting on the oscillator and varying its frequency while the tuning condenser is rotated.

"In the Strobodyne the pick-up coil, through which the signal voltage is applied on the oscillator, is in series in the grid circuit and the circuit is damped by the grid current during each half-cycle, when the grid is positive. During the other half-cycle, when the grid is negative, the signal is applied on the grid of the oscillator tube, which acts during this time as an amplifying tube.

"Furthermore, regeneration takes place, due to the plate coil, and the whole system acts as a super-regenerative circuit; the only difference being that the variation frequency is high, and, since it is different from the incoming signal by a few kilocycles, a beat note is produced.

"Rectification takes place in the system because half of the signal voltage is cut out by the damping effect of the grid current. Experiments prove that the sensitiveness of this arrangement is greater than that of other bridge systems used in the supers you mention.

"This circuit was published by RADIO NEWS because, after testing and measurements, it proved better and therefore of interest to the experimenters who desire a sensitive receiver.

"We hope you will be able from this short explanation to see the difference between the Strobodyne and the other supers, and we assure you that we shall be glad to furnish you with any other information you may desire."

(The same assurance is extended to any other readers of RADIO NEWS who may be interested in the theory or construction of the Strobodyne; as many, it seems, already are. We shall be glad to hear results, and aid in solving difficulties, if any arise, from building and operating this remarkable receiver.—EDITOR.)

ANTENNAS NOT LIGHTNING MENACE

DURING the summer, storms have caused some apprehension on the part of radio listeners who fear outside antennas may be lightning conductors; RADIO NEWS has received several inquiries on this subject.

"Radio antennas are not to be regarded as effective protection against lightning," lightning experts at the Bureau of Standards inform us, "but on the other hand, their limited extent prevents them from becoming a menace. They need not be considered as potential inviters of lightning strokes, being in a class with other metal objects normally found about buildings, such as metal gutters, downspouts, and wire clothes-lines." A good lightning arrester makes the radio lead-in safer than these reputedly harmless building accessories. It should be needless to say, of course, that the electrical nature of a radio set is no more attractive to lightning than that of an electric light or a flatiron.

Incidentally, so far as known, there is no case on record where lightning has been attracted by an inside antenna.

**More than 1,000,000 owners of
General Electric
Battery Chargers
now have peppy radio batteries - always**



5-Ampere Tungar



\$10 \$14
\$24



G-E Trickle Charger

Keep your radio set ready—at all times—for all the good things that come over.

Just turn on Tungar (the name of the General Electric battery charger) at night, leave it as you would the light in the hall . . . in the morning your storage batteries are pepped up and ready for active duty.

More than 1,000,000 G-E Tungars are in use today. For the Tungar long ago established its reputation for dependable, trouble-free, economical service.

Your dealer can help you. Ask him to show you the popular 2-ampere Tungar that gives both trickle and boost charging rates. It charges "A" and "B" radio batteries and auto batteries, too.

Tungar causes no radio interference. It cannot blow out tubes.

An overnight charge costs a dime.

It is a G-E product developed in the Research Laboratories of General Electric.

The 2- or 5-ampere Tungars charge 2-, 4-, and 6-volt "A" batteries, 24- to 96-volt "B" batteries in series; and auto batteries, too. No extra attachments needed.



Tungar—a registered trademark—is found only on the genuine. Look for it on the name plate.

**New Low Prices
(East of the Rockies)**

2-ampere Tungar, now \$14
5-ampere Tungar, now \$24
G-E Trickle Charger, now \$10

Merchandise Department
General Electric Company
Bridgeport, Connecticut

GENERAL ELECTRIC



100 AMP. RADIO BATTERY

6 Volts \$8.95 Rubber Case

Guaranteed TWO Years. Shipped direct from factory to you. No middlemen's Profits—no delays—no grief. For clear reception no better power than battery power.

SEND NO MONEY

This is a real 100 Amp. Radio Storage Battery—honestly built of best materials by pioneer battery builders. Solid rubber case—not wood—(nonleakable). Will operate the average 5-tube set from 3 to 4 hours daily for a month to six weeks. Other sizes carried in stock for immediate shipment. Auto Batteries in solid rubber cases. Guaranteed 1 year, but will last 3 years if properly taken care of.

6 volt 60 amp.....	\$6.95	6 volt 11 plate.....	\$9.95
6 volt 80 amp.....	7.95	6 volt 13 plate.....	11.95
6 volt 120 amp.....	9.95	12 volt 7 plate, Dodge	13.95

All other sizes of Radio and Auto Batteries upon application.

NO DEPOSIT OR ADVANCE PAYMENT REQUIRED

Simply order—and we will ship by express at once and you can examine battery at your express office to your heart's content. If you agree with us that it's the biggest offer ever made—pay the expressman the cost of the battery plus express charges and the battery is yours.

IF YOU PREFER TO REMIT WITH ORDER—DEDUCT 50c
You run no risk as we replace any defective battery during the life of the guarantee. APPROVED by Radio News Laboratory.
NEW YORK STORAGE BATTERY CO., Inc., 633 West 47th Street, New York, N. Y.

Insure your copy reaching you each month. Subscribe to RADIO NEWS—\$2.50 a year. Experimenter Publishing Co., 230 Fifth Avenue, New York City.

The Companion- of every RADIO SET

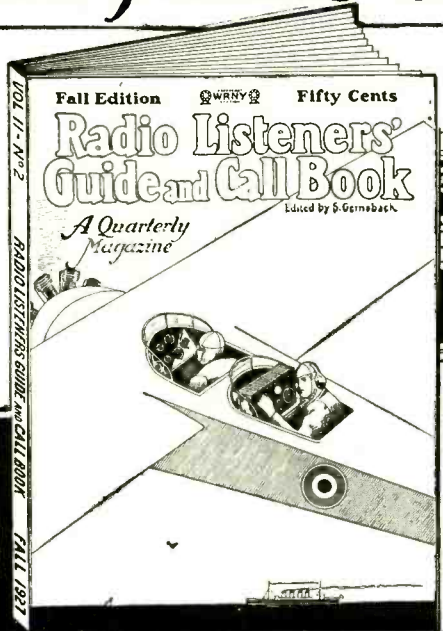

the first - and most important book - for every Radio Set owner or builder.

Like a Tourist Guide—a Railroad Time Table—an Instruction Book—and a Construction Manual all in one—that is what the new "Fall Edition" of RADIO LISTENERS' GUIDE and CALL BOOK is to a Radio Listener.

It guides you in touring the Air—with its most complete, up-to-date and comprehensive list of Broadcast Stations the World over.

It gives you the power, the Wavelength and the Ownership of all stations.

It contains a number of pages devoted exclusively to hints and practical suggestions on keeping a set in good order.

—and it publishes a wide selection of the very latest and finest Radio Circuits with complete building instructions.

In this issue is complete information on the renowned "STROBODYNE," the amazing circuit from France.

176 pages in all. Hundreds of illustrations. Size 9 x 12 inches.

Get your copy today—Keep it by your set—You'll find it helpful every day of the week.

**176 Pages of Radio
PRICE 50c**

If your newsdealer cannot supply you
USE THIS COUPON

CONSRAD COMPANY, Inc.,
230 Fifth Ave., New York.

Enclosed find 50c for one copy of the fall edition of RADIO LISTENERS' GUIDE and CALL BOOK.

Name
Address
City-State

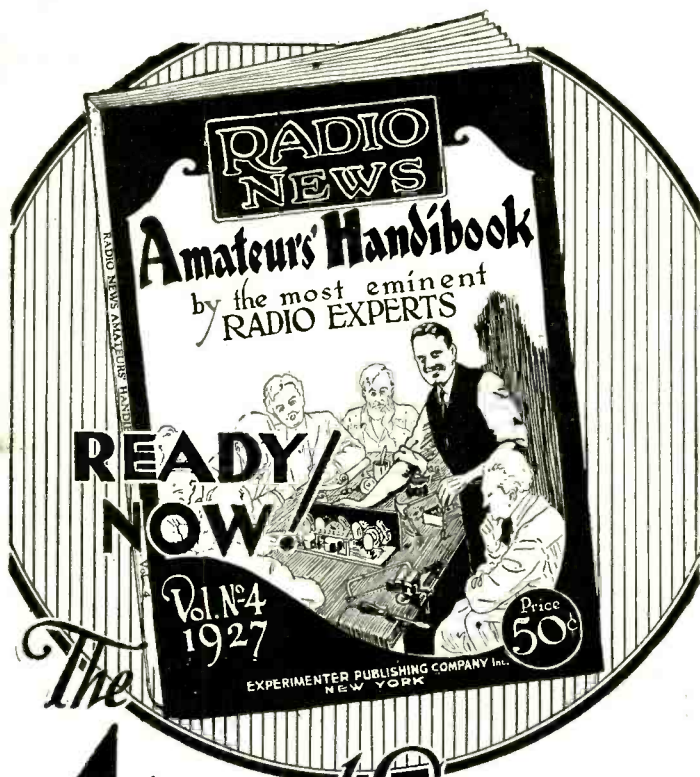

The **4th** and Greatest edition of =



AMATEURS' HANDBOOK

HERE is the greatest Radio Handibook ever published! Right up to date—a brand new edition of the very finest selected articles that have appeared in RADIO NEWS, Radio's Greatest Magazine, this year.

All new Radio—Plenty of latest model circuits with blueprint diagrams, ready for building. This is the most popular Radio Book ever printed. The past three editions were completely sold out.

—And you we offer the biggest and best edition of them all—116 pages of 1927 Radio complete with elaborate circuit diagrams and illustrations and parts. Size 9x12 inches.

Copies are going fast, get your order in now— or see any newsdealer. Only 50c.

50c the Copy

AT ALL NEWSDEALERS

or direct from

**EXPERIMENTER PUBLISHING CO., Inc.,
230 Fifth Ave. New York**

Radio Technique in Germany

URING a recent visit to the United States, Baron Manfred von Ardenne, the young German radio engineer who is co-inventor of the Loewe multiple tube, thus summarized the difference in broadcast methods in an interview to the press:

"Organization of broadcasting in Germany is such that most listeners have not the choice of different programs offered in the United States. That condition is to be remedied in the near future by the erection of a station, at Zeesen, near Berlin, with 100 kilowatts of power in the antenna, using a wave-length of 1250 meters. This station will commence working at the beginning of next year and ought to be picked up across the Atlantic. It will relay every night the best program running in Germany, from whichever city it is being given, and will thus be the first station of its kind in the world.

"In a country where the same program is broadcast through the networks by many stations, all on different wavelengths, it may be of interest to hear that in Germany successful experiments have been carried out between Berlin and Stettin with a new arrangement which may be of great importance in the future of European broadcasting. By means of quartz wavemeters two or more broadcasting stations are tuned to exactly the same wavelength and broadcast the same program without the slightest mutual interference. (*This principle has been employed during the past year by two American stations, WBZ and WBZA.—EDITOR*). Thus only the number of programs, but not that of stations, is limited; a fact of the greatest importance in Germany, where every larger town desires its own station, in order to make strong reception possible with the simplest of receivers. The crystal receiver is still very widely used over there.

"Interference from coastal stations and ships is not serious in Germany because most of them transmit with plain continuous waves on longer wavelengths.

"As regards the technical quality of broadcast transmission, I have the impression that the microphones in use in Germany, especially the well known Reisz microphone, are very good in the transmission of the violin, the soprano and the distinctive instruments of large orchestras. The main reason for this is that the German stations transmit the high frequencies faithfully. The American stations, however, seem to me to reproduce the lower notes extremely well.

"Another remarkable fact is that, in spite of the far greater distances here in America, the land-line relays are better than those in Germany. This is probably due to better land-line equalising, which cannot be carried out in Germany to the same extent for lack of sufficient means; although the theory of these equalisers is very well known over there.

HIGH MUSICAL QUALITY

"Programs, on the whole, are on a rather high level in Germany, because, thanks to the licensing of broadcasting listeners, relatively large sums are placed at the disposal of the program committees of the broadcast stations. These committees are composed of leading educators, civic workers and artists.

"The educational value of broadcasting in Germany is very great, since the less prosperous and educated part of the people constitute by far the greatest number of regular listeners; while in the homes of the more

Silver Beauty

POWER

For Your Present Set or the Set you eventually buy

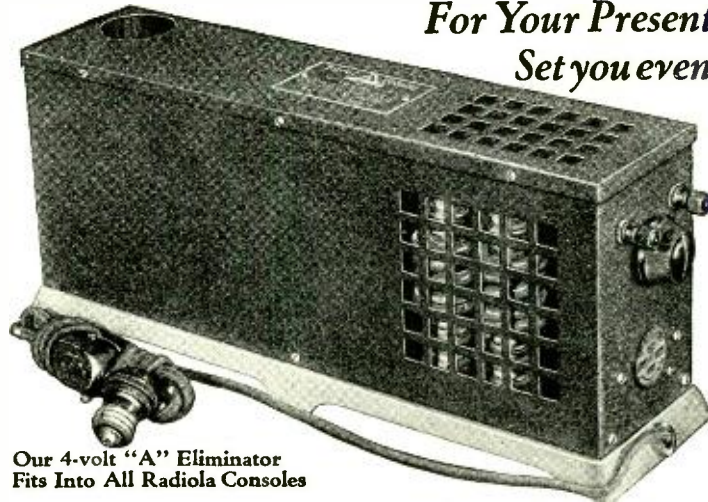

Our 4-volt "A" Eliminator Fits Into All Radiola Consoles

\$39⁵⁰

6-volt—2 amp.

\$43⁵⁰

6-volt—3 amp.

\$39⁵⁰

4-volt—1/2 amp.

\$2 Higher West of Rockies

Finally—the Perfect "A" Eliminator

Perfect, because its principle is simple and correct!

THE 110 volts Alternating Current is scientifically reduced with the famous "Silver Beauty" transformer coil to deliver the proper voltage to an especially developed dry, noiseless rectifier, which transforms the electricity to direct current. This current of exact voltage, is then transmitted through a patented special filter which clarifies the current, eliminating

all foreign noises caused by rectifier or generator.

The result! A smooth, noiseless, constant "A" current supply, that makes radio reception the pleasure it is intended to be.

"Silver Beauty" is the outstanding "A" eliminator today. Nothing equals it. Endorsed by prominent radio engineers—adopted by leading distributors and dealers—approved by thousands of users. These are sufficient reasons for making "Silver Beauty" your final choice.

Silver Beauty POWER

- Replaces "A" storage battery and charger.
- Has full wave "dry" rectification.
- Maintains required voltage in uniform, constant flow.
- Operates automatically by moving a switch.
- Economical—uses minimum amount of current [about 1-10 cost of using electric iron].
- Has rheostat control for additional refinement in voltage and reception.
- Gives maximum power to radio tubes and lengthens their life.
- No acids to test or spill.

Satisfactory Results Guaranteed

Silver Beauty

"B-C" UNIT

Does away with "B" and "C" batteries

Embodies every up-to-date refinement and principle, insuring smooth, unflinching reception. As beautiful as it is efficient.

Silver Beauty CHARGERS

Employing an entirely new method of rectification. Two models—with or without bulbs.



180 Volts—40 Milliamperes \$45⁰⁰

Individual adjustment adapted to all sets



Triple-A-Specialty Company

Manufacturers of the famous Silver Beauty Chargers
312-316 SOUTH HAMILTON AVE.
Chicago, Illinois



A GOOD TRICKLE CHARGER \$5⁰⁰
AMERICAN BATTERY CO.
2051 N. Racine Ave. Chicago
Established 1889

"Strobodine" Circuit
We carry a complete stock of the specified parts for the new Strobodine circuit, as specified in RADIO NEWS.
Send for free literature and our beautiful 48-page catalogue.
GRAYMORE RADIO CORP.
142 Liberty St., New York City

ELKAY EQUALIZORS
specified as "ballast" for the Super Regenerative Set are made by The Langbein-Kaufman Radio Co. (Dept. N), 62 Franklin St., New Haven, Conn. Write for prices and tables of values.

FREE RADIO GUIDE
BIG NEW 1928 CATALOG—4000 ITEMS Shows the latest circuits, the newest developments in radio at startlingly low prices. Get the parts you want here and save money. The best in parts, kits, complete factory-built sets and supplies. Orders filled same day received. Write for free copy NOW. Standard discounts to dealers, set builders, agents. BARAWIK CO., 540-559 Monroe St., Chicago, U. S. A.

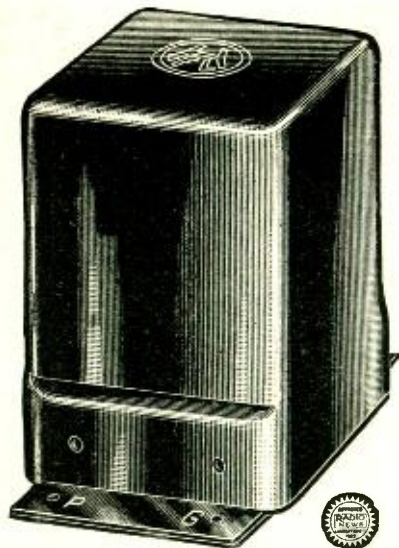

H.F.L. Transformers

H.F.L. C-16 Audio Transformers and C-25 Output Transformer—New Companions of a Great Circuit

H.F.L. C-16 is the most efficient Audio Transformer built. It carries signals at highest volume and lowest amplitude without blasting or developing harmonics. Operates with all power tubes as well as standard tubes.

H.F.L. C-25 Output Transformer handles the voltage output of power amplifying tubes, at the same time matches the impedance of the average speaker to the tubes. Protects loud speaker unit without reducing plate voltage.

Mechanical features of these two transformers are: A coil designed and treated to exclude moisture and withstand heavy electrical surges without breaking down—complete magnetic shielding to avoid interstage coupling—terminals brought out so as to insure short leads.

Endorsed by America's Leading Engineers—Guaranteed by the Manufacturers

The new C-16 and C-25 Transformers will work in any circuit and will improve any Radio Set.

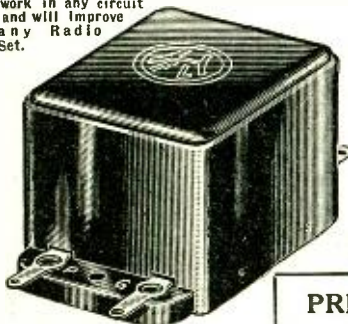

Set Builders and Dealers

If your jobber cannot supply you with H. F. L. Transformers, write us for name of nearest jobber.

High Frequency Laboratories

131-D NORTH WELLS STREET CHICAGO, ILL.



wealthy and highly-educated there is a surprising lack of radio equipment. Germany being the land of Wagner and Beethoven, these people expect too much of radio in the line of classical music to be much interested. But, with the advent of new devices now being developed which will make reproduction practically perfect, radio is sure to gain ground in these circles as well.

"The technical development of broadcasting in Germany practically always moves along theoretical lines, and the theory of radio and kindred subjects is very far advanced over there; while in the United States I have found the practical side extremely well developed. A union of the two would be sure to bring about a great advance in the science of broadcasting."

HEAT EFFECTS IN CONDENSERS

Too little thought is given to the matter of temperature in the handling of condensers, according to Harry F. Houck, well-known radio engineer. This authority on condensers warns us that, when placed in radio power units, they should not be exposed to a high temperature due to the radiated heat of tubes or resistors in the immediate vicinity. The condensers should be protected from heat by partitions, if possible; and the tubes and resistors should be provided with proper ventilation. At any rate, paper condensers should not be heated beyond 110° F. The leakage mounts rapidly with increase in temperature; and the leakage, in turn, reduces the resistance and therefore passes more current through the condenser.

Recent tests serve to throw considerable light on this matter of heat in the performance of condensers. In a direct comparison between condensers heated to normal room temperature, and condensers heated to 125° F. (over a period of eighteen hours to make certain that the condensers were heated throughout their mass and not just externally) the condensers heated to the higher temperature withstood a 20% higher breakdown voltage.

This might seem contrary to expectations and would indicate, on its face, that condensers were benefited by heating. However, such performance is no indication of life, and subsequent life-tests have shown that a condenser heated above room temperature has its life shortened materially. Hence it is recommended that condensers be operated at the lowest possible temperatures; especially since the impregnating compound usually melts around 135° F.

40 Non-Technical Radio Articles

every month for the beginner, the layman and those who like radio from the non-technical side.

SCIENCE & INVENTION, which can be bought at any newsstand, contains the largest and most interesting section of radio articles of any non-radio magazine in existence.

Plenty of "How To Make It" radio articles and plenty of simplified hook-ups for the layman and experimenter. The radio section of SCIENCE & INVENTION is so good that many RADIO NEWS readers buy it solely for this feature.

Radio Articles Appearing in October Science & Invention

- The 4-Tube "Cash-Box" Set, By Wendell Buck
- Underground Antenna Reduces Static, By H. Winfield Secor
- Radio "Ears" Guide Balloons.
- Radio Oracle—Questions and Answers.
- Latest Patents.

10 Days Trial





Forget "B" Battery Nuisance

FERBEND

"B" Socket Power Unit

Within Reach of All

Original cost less than half of any equipment of similar quality; lowest maintenance cost. Equal to any, not only in operation, but in workmanship, quality, durability and appearance. Sooner or later you will change to "B" Socket Power. Why pay more?

Model III, for 90 volts . . . **\$12.50**
all sets using 90 volts . . .

Model IV, for extremely large sets and sets using power tubes; delivers up to 180 volts, \$17.50.

ORDER NOW

Shipment made direct upon receipt of price or C. O. D., if preferred. Use for 10 days; if not satisfied, write us within that time and purchase price will be refunded. Send today.

FERBEND ELECTRIC CO.
425 W. Superior St., Chicago

Tested and Approved by the Rigid Laboratory Tests of Radio News and Popular Radio

ENDORSEMENT
Hartford, Conn.
Enclosed find \$17.50 for which please ship me one of your high voltage Eliminators as advertised. At the present time I am using your 90 volt model I bought from you some time ago, but having built a new set which requires more "B" voltage, the larger Eliminator is necessary. I am having no trouble disposing of the smaller Eliminator to one of my friends. It certainly does all you claim for it, and I will gladly recommend your products to anyone.
Herbert G. Bissell

QUALI-TONE DELUXE

Specified for use with the Super Regenerative Set described in Radio News ALSO



Magnaformer 9-8 circuit, World's Record Super receiver, 9 in Line, Niblo Heald, Victor, St. James, Popular Mechanics Economy Nine, and all other receivers using .0005 condensers.

Holds World's Records

The Quali-Tone holds two world's records—brought in stations 8,000 miles distant and most consistent reception of far-distant stations. Compare Quali-Tone construction, design and performance with any loop and you will find that it excels in every particular. It incorporates every loop improvement and is flawless throughout. The Quali-Tone within a radius of 7 1/2 inches. Try the Quali-Tone or Quali-Tone for the finest reception.

THE DELUXE \$12.50
THE QUALI-TONE 10.00

JOBBERs write for circulars DEALERs

DURO METAL PRODUCTS CO.
2651 N. Kildare Ave. Chicago, Ill.

RADIO AT WHOLESALE



Write for my Big 1928 Radio Catalog—just off the press. Thousands of marvelous bargains in nationally advertised goods. All the LATEST IN RADIOS and equipment. Lowest wholesale sale prices. Agents Wanted.

FREE Log and Call Book and Catalog. Get your copy today. Send postcard now!

American Auto & Radio Mfg. Co.
HARRY SCHWARTZBERG, PRES.
Dept. 103 American Radio Bldg., Kansas City, Mo. 3

DEALERS NEW 1928 CATALOG

A Combined Horn-and-Cone Loud-Speaker

By ROBERT N. AUBLE

WHILE most of the loud speakers of the horn type now on the market are satisfactory devices for the amplification of the upper range of audio frequencies, very few of them will respond to the lower frequencies. The cone type of speaker, on the contrary, handles the lower tones quite satisfactorily, but does not always reproduce the upper frequencies. It becomes desirable, therefore, that a radio receiver should be equipped with both types of speakers in order that speech and music may be truly reproduced. The two types of speaker may be operated from the same unit by means of the scheme outlined in the accompanying sketch, with but slight sacrifice of the efficiency of the unit for the purpose for which it was designed.

The common design of loud-speaker unit is shown in cross-section in the diagram: A-A is the diaphragm; B-B the electromagnets in the plate-"B"-battery circuit, and C is the opening for the attachment of the horn. To operate a cone from this unit, solder a threaded drive-rod to the lower side of the diaphragm at its center. This drive-rod

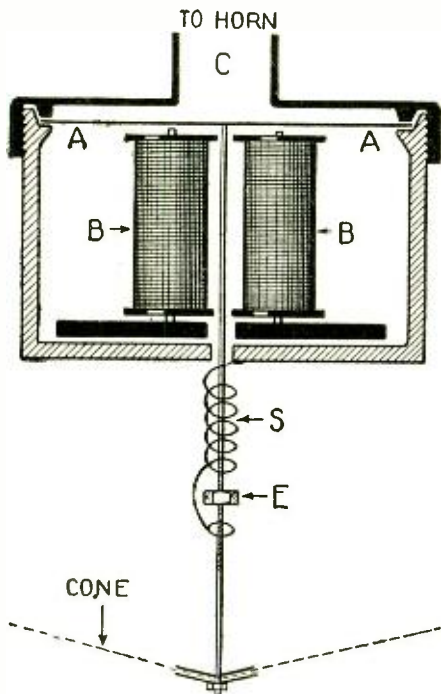

The author's ingenious plan for operating both cone and horn from one unit. The cone drive-rod must be balanced by a spring to compensate for the whole weight upon it.

may be any stiff rod of brass or copper, of suitable size to pass between the electromagnets. It is then passed through a hole bored in the case and the lower end of it is fastened to the cone. The making of various types of cones has been described in recent issues of RADIO NEWS.

SUPPORT FOR THE ROD

The weight of the cone is likely to cause a distortion of the diaphragm such that it will strike the pole pieces and produce "blasting" in the horn. To prevent this, a light coil-spring S is attached to the drive-rod and to the case, its tension being adjusted to such a degree as to carry all the weight of the cone. This adjustment may be made easily while the speaker is in operation by means of the knurled nut (shown at E) placed under the last turn of the coil spring.

New Formica Kit Panels!

Drilled and decorated front and sub panels for the leading kits of the new season can be had in Formica.

Dealers and jobbers can supply you with Magnaformer Front Panels 7" x 26" x 3/16" Black, decorated in Gold, drilled and Magnaformer Sub Panels 9" x 25" x 3/16" Black, Drilled.

Tyrman Superheterodyne front panel 7" x 24" x 3/16" decorated and drilled and sub panel 9" x 23" x 3/16" drilled.

World's Record Super 10 front panel 7" x 26" x 3/16" decorated and drilled and sub panel 10" x 25" x 3/16" Black Polished, Drilled.

Camfield Nine front panel 7" x 30" x 3/16" Black, decorated and drilled, sub panel 10" x 29" x 3/16" Black Polished, Drilled.

In addition there are panels for the Melo-Heald Superheterodyne; Madison Moore One Spot; World's Record Super Nine; Victoreen one and two dial; H. F. L. Nine-In-Line; Infradyne and others.

These panels are sold by jobbers and dealers everywhere.

THE FORMICA INSULATION COMPANY

4618 Spring Grove Avenue

Cincinnati, Ohio

FORMICA
PANELS Are
Sold by Dealers
Everywhere!



FORMICA

Made from Anhydrous Bakelite Resins
SHEETS TUBES RODS

Formica has a
Complete Service on
Insulating Material for
Radio Manufacturers

For Perfect Amplification—

FERRANTI



Audio Frequency Transformers
Amplify faithfully every note in
the scale—each transformer tested
ten times—your set needs one for
perfect reproduction. Model A.F. 3
—\$12.00. Model A.F. 4—\$8.50.
FERRANTI, INC.
130 West 42nd St., New York, N.Y.



RADIO SCHOOL

Send for Catalogue
MASSACHUSETTS RADIO and
TELEGRAPH SCHOOL

NEW TERM SEPT. 12
18 Boylston St. Boston, Mass.

FREE RADIO GUIDE

Big New 1928 Catalog—4,000 Items
Gives special hook-ups with illustrations.
Shows big savings on standard radio parts,
complete sets, kits. Be sure to get this
thrifty book before you buy. Write letter or postal NOW.
Standard discounts to dealers, set builders, agents.
BARAWIK CO., 129-132 N. Jefferson, CHICAGO, U.S.A.

Insure your copy reaching you each month. Subscribe to Radio News—\$2.50 a year.
Experimenter Publishing Co., 230 Fifth Avenue, N. Y. C.

The whole
COUNTRY
is
praising
AMERICA'S
FIRST
RADIO
ENCYCLO-
PEDIA



\$2

A place in every
home, every library,
every laboratory

S. GERNSBACK'S RADIO EN-
CYCLOPEDIA is the only
standard work ever published in
America attempting to classify al-
phabetically the countless words
used in the highly specialized science
of RADIO. The ENCYCLOPE-
DIA is written in plain English so
that everybody can understand the
definitions and descriptions.

No expense has been spared, cov-
ering over two years in compilation,
to make it worthy a place in your
library.

It is published in one volume—
168 pages—size 9x12 inches, nearly
an inch thick and nicely accom-
modates the beautiful illustrations and
the large, easy to read type.

Every page is replete with illus-
trations—to make the text easily
understandable.

REMEMBER THIS IS A
REAL ENCYCLOPEDIA—NOT
A DICTIONARY.

The book contains as a supple-
ment a classified cross-index de-
signed to bring together radio refer-
ences under one heading having re-
lations in common.

All circuits new and old are de-
scribed by word and picture.

The work contains 1,930 defini-
tions, 549 photographs, drawings
and diagrams.

SEND NO MONEY—Just for-
ward your name and address. We
will send you the Book at once.
You pay postman \$2, plus postage
on delivery.

Order Direct from
S. GERNSBACK
230 Fifth Ave., New York

NEW YORK, N. Y. . . . It is the best work of the kind we have ever seen and shows considerable painstaking and laborious effort.—*Telegram*.

NEW YORK, N. Y. . . . The volume amounts to practically a compact review of all that has been done in radio up to this date.—*Radio*.

NEW YORK, N. Y. . . . Many radio fans will be interested in the new Radio Encyclopedia by Sidney Gernsback.—*Sunday Post*.

NEW YORK, N. Y. . . . It will be of great value to the engineer.—*Radio*.

NEW YORK, N. Y. . . . The encyclopedia is also a valuable reference work.—*Radio*.

NEW YORK, N. Y. . . . It is a complete clas- sification of the latest authoritative data in radio.—*Evening Star*.

NEW YORK, N. Y. . . . A book that will be of value to all that are in- terested in practical radio work.—*Examiner*.

PITTSBURGH, PA. . . . Many radio fans will be interested in the new Radio Encyclopedia by Sidney Gernsback.—*Sunday Post*.

PITTSBURGH, PA. . . . It will be of great value to the engineer.—*Radio*.

PITTSBURGH, PA. . . . The encyclopedia is also a valuable reference work.—*Radio*.

PITTSBURGH, PA. . . . It is a complete clas- sification of the latest authoritative data in radio.—*Evening Star*.

PITTSBURGH, PA. . . . A book that will be of value to all that are in- terested in practical radio work.—*Examiner*.

PITTSBURGH, PA. . . . Many radio fans will be interested in the new Radio Encyclopedia by Sidney Gernsback.—*Sunday Post*.

PITTSBURGH, PA. . . . It will be of great value to the engineer.—*Radio*.

PITTSBURGH, PA. . . . The encyclopedia is also a valuable reference work.—*Radio*.

PITTSBURGH, PA. . . . It is a complete clas- sification of the latest authoritative data in radio.—*Evening Star*.

PITTSBURGH, PA. . . . A book that will be of value to all that are in- terested in practical radio work.—*Examiner*.

PITTSBURGH, PA. . . . Many radio fans will be interested in the new Radio Encyclopedia by Sidney Gernsback.—*Sunday Post*.

PITTSBURGH, PA. . . . It will be of great value to the engineer.—*Radio*.

PITTSBURGH, PA. . . . The encyclopedia is also a valuable reference work.—*Radio*.

PITTSBURGH, PA. . . . It is a complete clas- sification of the latest authoritative data in radio.—*Evening Star*.

WASHINGTON, D. C. . . . It presents a com- plete classification of the latest authoritative data in radio.—*Evening Star*.

SAN FRANCISCO, CAL. . . . A book that will be of value to all that are in- terested in practical radio work.—*Examiner*.

SAN FRANCISCO, CAL. . . . Many radio fans will be interested in the new Radio Encyclopedia by Sidney Gernsback.—*Sunday Post*.

SAN FRANCISCO, CAL. . . . It will be of great value to the engineer.—*Radio*.

SAN FRANCISCO, CAL. . . . The encyclopedia is also a valuable reference work.—*Radio*.

SAN FRANCISCO, CAL. . . . It is a complete clas- sification of the latest authoritative data in radio.—*Evening Star*.

SAN FRANCISCO, CAL. . . . A book that will be of value to all that are in- terested in practical radio work.—*Examiner*.

PITTSBURGH, PA. . . . Many radio fans will be interested in the new Radio Encyclopedia by Sidney Gernsback.—*Sunday Post*.

PITTSBURGH, PA. . . . It will be of great value to the engineer.—*Radio*.

PITTSBURGH, PA. . . . The encyclopedia is also a valuable reference work.—*Radio*.

PITTSBURGH, PA. . . . It is a complete clas- sification of the latest authoritative data in radio.—*Evening Star*.

PITTSBURGH, PA. . . . A book that will be of value to all that are in- terested in practical radio work.—*Examiner*.

PITTSBURGH, PA. . . . Many radio fans will be interested in the new Radio Encyclopedia by Sidney Gernsback.—*Sunday Post*.

PITTSBURGH, PA. . . . It will be of great value to the engineer.—*Radio*.

PITTSBURGH, PA. . . . The encyclopedia is also a valuable reference work.—*Radio*.

PITTSBURGH, PA. . . . It is a complete clas- sification of the latest authoritative data in radio.—*Evening Star*.

PITTSBURGH, PA. . . . A book that will be of value to all that are in- terested in practical radio work.—*Examiner*.

PITTSBURGH, PA. . . . Many radio fans will be interested in the new Radio Encyclopedia by Sidney Gernsback.—*Sunday Post*.

PITTSBURGH, PA. . . . It will be of great value to the engineer.—*Radio*.

PITTSBURGH, PA. . . . The encyclopedia is also a valuable reference work.—*Radio*.

PITTSBURGH, PA. . . . It is a complete clas- sification of the latest authoritative data in radio.—*Evening Star*.

The fact that the diaphragm type of loud- speaker unit has not heretofore proved very satisfactory for the operation of a cone, is due, in the writer's belief, solely to the fact that none of the adaptations has provided adequate means of relieving the diaphragm of strain due to the weight of the cone and drive-rod.

If the diaphragm of a loud-speaker unit is loaded by any weight at its center there is a tendency to make that point a nodal point, as may be easily demonstrated by sprinkling lycopodium powder or sun-flower pith on a diaphragm so loaded. If the unit is con- nected in the plate circuit of an oscillating vacuum tube modulated at an audible fre- quency, a satisfactory test may be had. When a pure low-pitch tone is produced the powder will be heaped up at the nodal points. It will be observed that the central point is not vibrating. If the central point is a node, it will obviously not operate a cone; and the note produced by the diaphragm itself will be distorted, because the pull on the dia- phragm by the electromagnets is not dis- tributed symmetrically about the center.

If the drive-rod be fixed to the upper surface, and care be taken to support its weight by a flexible spring, of low natural period, it is possible to secure such an ad- justment that the drive-rod and the attached cone are semi-floating. In such case the mass of the cone will act only as though the diaphragm tension were increased and the center point will vibrate. There will be a slight loss of efficiency, due to the inertia of the cone, unless the ampere-turn strength of the electromagnets is correspondingly in- creased.

OVERCOMING DIFFICULTIES

The note produced by this arrangement will be disagreeable, however, because it is impossible to suppress the sound produced by the diaphragm independently of its action on the cone.

If the drive-rod for the cone is attached to the lower surface of the diaphragm, and its weight be compensated by a suitable spring, as described herein, it is possible to make use of the vibrating diaphragm to operate a horn, and at the same time the additional benefits to be derived from the cone may be had. Though such an arrange- ment, so far as the cone is concerned, is not so satisfactory as the balanced-armature type of unit, the addition of the horn is adequate compensation for this loss; because the range of response of a good horn is such that only a small additional amplification of the lower audible frequencies is necessary to render the reproduction faithful to the original sound. If the lower tones are unduly ampli- fied, the average ear, being more or less insensible to these frequencies, will receive an impression of distortion from the unusual prominence of the tones not ordinarily heard.

Station
WRNY
NEW YORK
309.1 Meters—970 Kilocycles
is owned and operated by the
publishers of this magazine
Our Editors will talk to you
several times every week—
See your Newspaper
for details
TUNE IN ON
WRNY

S. GERNSBACK 230 FIFTH AVE., N. Y.
Send me 1 copy of your Radio Encyclopedia. I will pay postman \$2 plus postage on delivery.

Name

Address

City

State

The Capacity and Wavelength of Your Aerial

By SYDNEY P. O'ROURKE

IT is very interesting, when carrying out experiments with various sets and circuits, to know the capacity of your aerial to ground. There are various complicated formulas by which the capacity and inductance may be calculated fairly accurately; but these involve accurate measurements of the length and height of the aerial which are not very practicable for the average experimenter.

A much simpler method, and one which gives very accurate results, if conducted properly, is to tune in your local station, with the aerial and ground connected in the usual way and the aerial tuning condenser in parallel with the coil.

For instance, supposing WGY is tuned in at 30 degrees; now disconnect the aerial and again tune in the same station. It should appear now at about 120 degrees; in the phones, of course.

There is, therefore, a difference of 90 degrees between the two readings, which in the case of a .0005-mf. condenser, corresponds to .00025-mf. Thus .00025-mf. is the capacity of the aerial to ground. It is essential, of course, to use an old-type variable condenser with semi-circular plates; as this is the only type which gives a straight-line-capacity reading from 0° to 180°.

Most experimenters, however, will have hidden away in their junk box one of these ancient variables, which may be connected up temporarily for the above calculations. It is a big point in short-wave work to keep the aerial capacity as low as possible, and the above method may serve as a measurement of any aerial-ground improvements that may be effected.

YOUR AERIAL'S WAVELENGTH

The usual method of determining the natural wavelength of the aerial system is by the well known formula: Wavelength equals 1885 times the square root of the microfarads multiplied by the microhenries.

Another method is described below which, in the writer's opinion, is very much more practical. It should appeal to the non-mathematical reader, since it involves no algebraical calculations or formulas.

Disconnect the aerial from the set and tune in your local station with the ground connected to its usual terminal. You should receive it at fairly good strength with an ordinarily efficient set. Take note of the aerial-tuning condenser's dial reading. Let us suppose in a particular case that this is 130°. Now connect the aerial lead and tune in any station you can, nearest to 130° on this dial. Supposing in the first instance WGY is received; now, when you have connected up the aerial, WEA F tunes in at 130° or thereabouts. Subtracting WGY's official wavelength from that of WEA F, we have, $491.5 \text{ less } 379.5 = 112.0$ meters. 112.0 meters then is the natural wavelength of the aerial in question.

Finally, a word about the receiving set. In order to find the wavelength accurately it is absolutely necessary to have a method of regeneration which, when varied, will produce no change in the wave to which the set is tuned; since less regeneration will be required when the aerial is disconnected. A receiver of the Hartley or Reinartz type is most suitable.

VOLTA'S CENTENARY

DURING the recent observance of the centenary of Alessandro Volta (in honor of whose invention of the battery the "volt" is named) a 5-kw. special broadcast transmitter was operated from his birthplace, Como, Italy.

A "Million-Dollar" Front For Your Receiver

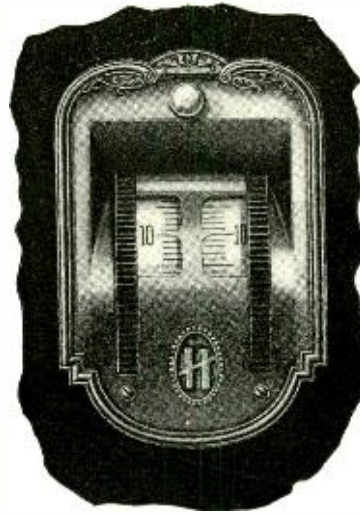

FRONT VIEW

HAMMARLUND waited to produce a drum dial that would make the single-control of tuning condensers really practicable.

Local stations can now be tuned in over the entire wave band by the simple movement of two fingers. Distant stations, requiring a finer adjustment, are brought in by a slight realignment of the individual halves of the dial.

Viewed from the front, the new Hammarlund Drum Dial gives to any receiver a delightful, professional finish. The bronze escutcheon plate, richly embossed and oxidized, endows the panel with a classic beauty.

The New HAMMARLUND Illuminated Drum Dial

An up-to-the-minute tuning improvement every set-builder will want to install.

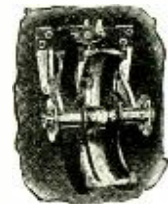

BACK VIEW

Mechanical Features

Over-size die-cast frame; Bakelite drums, with knurled edges; translucent celluloid wavelength scales, illuminated by a small electric light, with handy switch, connecting with the "A" Battery circuit. Adaptable to all standard panel proportions.



HAMMARLUND MANUFACTURING COMPANY

424-438 W. 33rd Street, New York

Already many leading radio designers have officially specified Hammarlund Precision Products for their latest circuits.

For Better Radio
Hammarlund
PRECISION PRODUCTS

Dealer inquiries invited concerning several other new and appealing Hammarlund developments, having a wide sales appeal.

C. L. PARKER

Ex-Examiner U. S. Patent Office

Attorney-at-Law and Solicitor of Patents
McGill Building, Washington, D. C.

Patent, Trade Mark and Copyright Law



LUCAS SPRING BINDING POST

A Spring Binding Post unequalled for service and simplicity, requiring but a press of the finger to make necessary connections giving you satisfaction unexcelled. Seven posts to a slab. Marked or plain. Single 10c. Double 15c. Manufacturers, Dealers and jobbers write for prices.

JOHN LUCAS & SONS
654 N. Talman Ave., Chicago, Ill.

JEWELL WRITE
For Our 32 Page
Radio Instrument Catalog
No. 15-C
JEWELL ELECTRICAL INSTRUMENT CO.
1650 Walnut St. Chicago



Raytheon or Q. R. S. A-B-C Unit Condenser Packs

Illustration shows condenser pack used in Q. R. S. or Raytheon A-B-C unit. Fast extra capacity Hi-Test condensers fit all units, whether specified or not. Free condenser booklet brings the facts. Dealers and jobbers, send for price list.

JOHN E. FAST & CO.
3982 Barry Ave., Dept. C. Chicago, U. S. A.

Artistically Correct

The Balsa Speaker lends itself to any scheme of decoration, Chintzes, cretonnes, tapestries, even wall papers may be used.

It is artistically correct in every respect even to the specially designed Lata Balsa Reproducer Unit which is recommended for use with these speakers.

Lata Balsa Speakers may be purchased either in kit form or completely assembled. Send for prices.

BALSA WOOD REPRODUCER COMPANY
331 Madison Ave., New York City



See the complete line at Booths CC-2, FF-7, Radio World's Fair

THE BRITISH VERSION OF RESISTANCE COUPLING

BECAUSE of its low first cost, economical operation and unexcelled tone quality with ample volume, resistance-coupled amplification has long been a favorite in Great Britain, as well as in this country. If anything, our British friends have developed this method much further than we have, because of greater concentration in that direction. Therefore, the accompanying comments by Philip R. Coursey, chief engineer of the Dubilier Condenser Company of England are of practical interest:

"We note," states Mr. Coursey, in his comment on our typical American resistance-coupled layout, "that the maximum value for the plate resistance in a resistance-capacity coupling unit is 0.1 megohm and that the maximum value of the grid leak is given as 1 megohm. We notice also that the capacity for the coupling condenser is suggested as 0.1-mf., or even as large as 0.5-mf."

"In our research laboratory we have been carrying out a number of tests occupying a considerable period of time, to determine the best values of the components of such a coupling arrangement; and we find that a capacity even of the order of 0.01 mf. is rather large for such a unit, as it results in an uneven amplification over a large frequency band. The usual value which we employ is of the order of 0.005-mfd."

"We also observe that you state a value of 30 for the mu of the tube used is exceedingly high, whereas we are, at present, using a tube with a mu of the value of 50. However, we would point out that, even using a tube which has a mu of only 30, we have found a considerable increase of amplification per stage may be obtained by using a much higher plate resistance than you suggest, and a much higher value grid leak. In our standard coupling unit, we use a plate resistance of 1 megohm, and a grid leak of 3 megohms; and although this reduces the plate current to a very small value, usually 40 or 50 microamperes, on careful test we have found that it is not necessary to use an extremely high plate voltage to obtain good operation. In fact, in the case of the detector tube, by means of a resistance-capacity coupling, plate voltages of the order of 50 to 60 volts are ample, the plate current being of the order of only 40 or 50 microamperes."

"We think that these figures may be of interest to you, as indicating the values that are used at the present time in this country and indicating the results that we have obtained so far with this excellent method of audio-frequency coupling."

RADIO TERM ILLUSTRATED



A Grounded Receiver

Don't Hire An Expert!

Repair Your Radio Yourself With

The Radio Trouble Finder

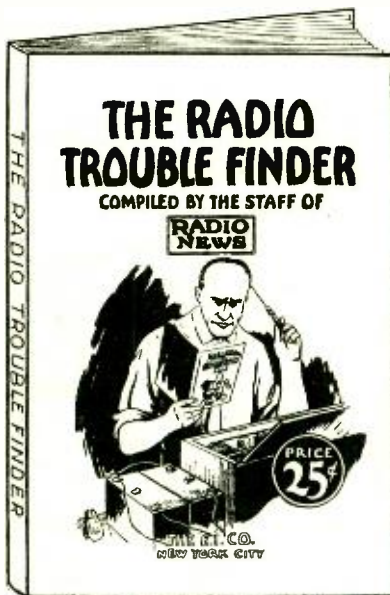

Book Contains 64 Pages
Size 6 x 9, Illustrated, Handsome 2 Color Cover

No matter how much or how little you know of your radio receiver, this new "Radio Trouble Finder" book is going to be a big help.

It explains the common and special faults of all the standard receivers of today; tells how to recognize instantly, by various methods, where the trouble lies and also gives special simple tests by which you can determine what is wrong with your receiver. Then for each particular fault there is explained the proper procedure for correcting it.

25c the Copy

ON ALL NEWSSTANDS

or direct from

CONSRAD CO., INC. . . . 230 Fifth Ave., N. Y.

DUTIES OF CONDENSERS IN POWER-SUPPLY EQUIPMENT

THE filter condensers used in "B" socket-power units should have sufficient dielectric to withstand the full voltage of the device over many years of service, and also to withstand the occasional peaks or surges which may run two or three times the maximum output voltage. It is wise practice, says Harry Houck, eminent radio engineer, to employ filter condensers rated at twice the output voltage; in other words, for a 200-volt maximum output "B" device, the filter condensers should be of 400-volt working voltage rating, and so on. The condenser nearest the rectifier is subjected to the greatest electrical strain, since the current at this point is not entirely straightened out and therefore has decided peaks in voltage. It therefore follows that the first condenser in any "B"-unit should have ample dielectric strength. If condensers of different dielectric strength or voltage rating are employed, then the first filter condenser should rate highest, as a measure of protection.

There are three filter condensers in the usual two-section filter system. The first condenser (that nearest the rectifier) does not have much influence on the hum or smoothing of the output current. It is intended rather to maintain the output at a fairly fixed voltage, despite the fluctuating current drain. It serves for the regulation of the rectifier.

The second condenser controls the degree of hum, and any increase in the capacity of this condenser, within reasonable limits, reduces the hum in conjunction with the proper choke coils.

The third condenser controls the tone quality at full volume, because it acts as the virtual electrical flywheel of the "B" unit. It provides an ample reserve of energy to meet the unusual drains, particularly those caused by the deep, bass notes, placed on the "B" supply. This condenser should be as large as possible, say even up to 8 mf. capacity. The usual manufactured "B" socket-power unit can be materially improved by placing additional condensers, say 4 to 6 mf. in capacity, across the "B—" and highest "B+" terminals; thus building up the last condenser in the filter system for the best system for the best tone quality.



Recognized Dependability of MUTER Products Makes This

Standard "B" Power Unit Your Best Buy

\$24.50

Until we could produce one standardized, dependable "B" Power Unit for all sets we stayed out of this field.

NOW we have ready for you the best possible "B" Power Unit at one standard popular price. Parts are made and assembled in the Muter factory under a high degree of workmanship fully assuring exactness in every stage of manufacture.

Outstanding Characteristics Uniform—Constant—Power

Fixed Controls used with separate fixed voltage taps, giving ample range and definite knowledge of voltage gotten.

Capacity ten tubes, or seven with a power tube.

Rating 40 mills at 150 volts. Will deliver 180 volts for new type 171 power tube.

Condensers, Muter filter condensers of ample capacity and acknowledged quality ensure long life and uniform output.

Uses Standard Cunningham or Radio Corp. Full Wave Vacuum Rectifying Tube because of long life and stability. Used on 110 to 120 volt, 60 cycle A. C. current only.

No Noise—No Vibration



Dependable Products

The Complete Quality Popular Priced Line Send for comprehensive catalog

Ask Your Dealer—or Send Coupon

Prompt shipment will be made upon receipt of price, and we will pay postage—or C. O. D. plus postage, if you prefer. You will find the Muter "B" Power Unit supremely satisfactory in every way, so see your dealer or mail coupon for yours today.

LESLIE F. MUTER CO.

76th and Greenwood Ave. Dept. 827-NX CHICAGO, ILL.



LESLIE F. MUTER CO., Dept. 827-NX
76th and Greenwood Ave., Chicago, Ill.

I enclose \$24.50 — you pay postage.
 Send C. O. D. — I will pay postage.

Send complete Muter Catalog.

Name

Address

City

State

My Dealers Name



IN OUR OCTOBER ISSUE

AROUND THE UNIVERSE, by Ray Cummings. If you love interplanetary stories—and who doesn't?—here is one that will do your heart good. Incidentally,

the astronomy contained therein is most excellent as well as correct, and gives you an insight into the wonders of the universe.

TREASURES OF TANTALUS, by Garret Smith, Part I. One of the most daring and exciting stories we have ever read. The idea of the author's *telephonoscope* is of tremendous interest. How one man succeeded in practically controlling the entire world thereby, is told in inimitable style by this famous author.

THE WINGED DOOM, by Kenneth Gilbert. Now that aviation has come to the fore again, this story gives you a peep into the future, and you see what may happen when a powerful nation is about to invade this country.

ÆPYORNIS ISLAND, by H. G. Wells. Written in a lighter vein, the story tells in an exceedingly interesting manner, some things about the huge extinct bird, the Æpyornis, whose habitat was Madagascar.

WEBSTER

"Bone-Dri" A Socket Power and Battery Chargers
Equal to Webster "B's"—Raytheon equipped.

Enough said! Before you miss an important program from run down batteries, equip your set with Webster "A," "B," and "C" socket power. Operate from electric light socket.

Send for free booklet "How to eliminate your batteries"

THE WEBSTER CO.,
866 Blackhawk, Chicago

Send for this New Book free

Everything in Radio

Miller-Welles

Every new radio development is shown in this big catalog, including such hook-ups as the Tyrman Ten, 9 In. Line, Camfield, Silver-Marshall, Karas, Carter, Aero Coil and numerous others. All nationally advertised radio parts and accessories are listed and described. Everything worth while in Radio now in stock and ready for shipment. Orders filled and shipped same day they are received. Lowest prices given to Set Builders and Dealers. Write today for this catalog.

Miller-Welles Co., 18-M W. Kinzie St., Chicago, Ill.

Insure your copy reaching you each month. Subscribe to Radio News—\$2.50 a year. Experimenter Publishing Co., 230 Fifth Ave., N. Y. C.

TELEVISION -is here!!!

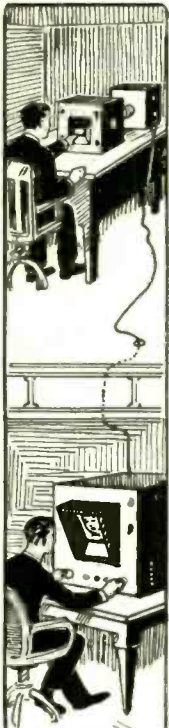

Radio Fans! Mechanics! Scientific Men! -Everybody! -Build a TELEVISION SET. The greatest and most amazing development of the 20th Century

50 CENTS

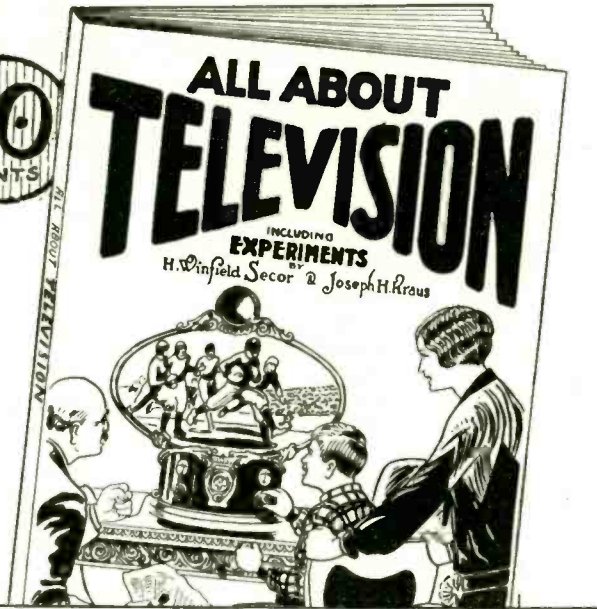

HERE, friends, is the first book to be published giving you the history of TELEVISION, from the first crude experiments at the beginning of the 20th Century—to the comparatively, perfect machines just put into daily operation. From this book you can build your own, workable television set that will serve as a fundamental apparatus for hundreds of tremendously interesting and amazing experiments.

Get in now on this new development. You may be fortunate enough to discover some improvement to Television that will be worth many thousands of dollars.

Start with a copy of this new book today. 116 Pages, 9 x 12 inches, illustrated.

50c EVERYWHERE or write direct
EXPERIMENTER PUB. CO., Inc.
230 Fifth Ave., New York

EXPERIMENTER PUB. CO., Inc.
230 Fifth Ave., New York, N. Y.
Gentlemen: Enclose 50c. for one copy of "ALL ABOUT TELEVISION."

Name.....
Address.....
City.....
State.....

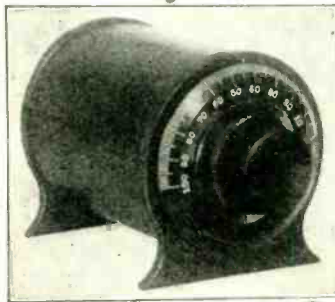

Pat. Pending
IMPROVED MODEL
\$4.75

References: First National Bank, Dunn's or Bradstreet's.

"When a station is hard to get, and it is a distant hit, Use a RESONATOR"

Introducing the latest addition to a radio set. The Resonator is guaranteed to bring in distant stations that were infinitely out of your reach before and bring them in loud and clear so that they will fill the whole house with perfect rendition of speech and music. Through actual tests we have found that it will increase the power and volume of your radio from five to twelve times. Equivalent to two extra tubes.

Especially adapted for Alwater Kent and similar single-dial machines. Can also be used to great advantage on two- or three-dial T. R. F. receivers. It is not a wave-trap, but will eliminate or reduce to an absolute minimum all interfering stations. Dealers' inquiries solicited.

DON'T TAKE OUR WORD FOR IT. WE GUARANTEE SATISFACTION.

Can be installed by anyone in less than a minute. Try one for three days, if not thoroughly satisfied we expect you to return it and your money will be cheerfully refunded. Sent post-paid on receipt of \$4.75 or remit \$1.00 with order and pay balance to postman on delivery.

F & H RADIO LABORATORIES

Fargo

North Dakota

SELECTIVITY IS RADIO'S GREATEST NEED TODAY

"IN this country," said Admiral W. H. G. Bullard, chairman of the Federal Radio Commission, addressing the industry, "there seems to be a demand today for the more sensitive and selective radio receivers; and, by that, I mean more sensitive means should be developed for tuning purposes, for the manipulation of dials to a finer degree of movement. The number of broadcast transmitting bands, I am sure, can be very much increased and the channels can be brought closer together. But the receiver of today, as a rule, cannot be manipulated to take care of the fine adjustments necessary to cut out one or two stations that may be operating simultaneously with very close frequencies. Physical tests have shown that, with due care, bands of frequencies can be used within a very small percentage difference by the use of properly-arranged crystal control; but this is hardly to be deemed worth while if the receivers cannot be finely adjusted to receive them.

RELIEF FOR CONGESTION

"This seems to be a matter which should engage the attention of radio manufacturers, and the general thought is that not sufficient attention has been given to the receiving end. If all the broadcast stations could be fitted with the latest properly-designed crystal control to assure their being kept on their assigned frequencies, and receivers were similarly designed to receive those frequencies, the number of stations that could find place in the air would be very materially increased, and the work of the Federal Radio Commission might be very much reduced."

ENGLISH SHORT-WAVE PLANS

THE recent highly-successful broadcasts by the Dutch short-wave station, PCJJ, which have been heard throughout the world, like those of the leading American stations, have roused the spirit of emulation in the bosom of the British lion.

Says *Wireless World*, of London, on the subject: "Matters in connection with Empire broadcasting have proceeded apace. The B. B. C. have made an announcement to the effect that they are immediately undertaking the erection of a short-wave station at Daventry. Capt. Eckersley has stated that it will be some six months before the station is completed, and a very long time before Empire broadcasting can be inaugurated. It seems to us that there is no justification for such a delay.

"It appeals to us as almost pathetic that, on the occasion of our recent celebration of Empire Day, a request should have been addressed to the Dutch station authorities at Eindhoven for the program to be broadcast through that station. The request was turned down, and with good reason, we consider; for what possible excuse have we for asking a foreign broadcast station to distribute a program of that character to our Empire, when it is merely lack of enterprise on our part which has prevented us from being able to carry out such a transmission for ourselves?"

During the recent celebration of Canadian Dominion Day, the Marconi short-wave beam system was used to transmit the program across the Atlantic.

RADIO IN ISLAM

CALCUTTA'S newest mosque is to be equipped, among other innovations, with a loud-speaker system. Mohammedans use no bells to summon the faithful, but only the human voice. This, however, may evidently be piously aided by radio.

THE FILAMENTS OF YOUR VACUUM TUBES

THREE types of substances are used as the source of electrons in present-day vacuum tubes. These are the oxides of certain metals, such as calcium, barium, strontium, etc.; the pure metals themselves, such as tungsten or molybdenum; and these pure metals mixed with a small amount of thoria (oxide of thorium) to produce the so-called thoriated or X-L filament.

The oxides are coated on a wire of platinum or nickel, and give off their electrons at temperatures below the melting points of these metals. The pure tungsten filaments are operated at about 2400° or 2500° C., while those containing thoria are operated around 2000°. Operating at the same temperature, the emission from the thoriated tungsten filament is about five thousand times greater than from tungsten. A pure thorium filament, however, vaporizes and melts at too low a temperature to obtain sufficient emission from it to make a successful tube. It, however, evaporates much slower in the form of a thin film on a tungsten base, and so it is used in this condition.

The popular 201A, as well as the 199 type of tube, has a thoriated filament, with a tungsten base containing one or two per cent. of thoria. This thoria, at the proper operating temperature, slowly diffuses to the surface of the filament as thorium metal. The large emission of the thorium is thus secured at the high operating temperature of the tungsten filament. Some idea of the quantity of electrons given off from the hot filament is gained from the fact that 6,280,000,000,000,000 electrons per second escape from the surface when the emission current is one milliamper.

OSCILLATION CONTROL FOR R. F. STAGES

TO control oscillation in R. F. amplifiers, there have been suggested innumerable intricate methods, ranging from delicate balancing and neutralizing systems to the use of crude "lossers" in the forms of non-inductive resistors in the grid-return leads and the well-known potentiometer stabilizer. The use of variable plate voltage has also been suggested. A great number of these methods are either beyond the ability of the average radio layman to struggle with, or of such inefficiency as to be out of tune with engineering methods of today.

One of the simplest and most effective methods of controlling oscillation in R. F. circuits seems to be that of using, in series, across grid and plate of the R. F. tube, a midget variable condenser and a variable high resistor with a range from practically zero to several megohms if possible, and relatively fine adjustment.

An ideal arrangement comprises a .00025-mf. mica condenser, together with a universal range resistor, wired in series and connected to the grid and plate terminals of the tube socket. The resistor should be mounted alongside the tube, together with the mica condenser, to keep the R. F. wiring as short as possible. With several turns of the knob to cover a range of 200 to 5,000,000 ohms, this arrangement permits fine regulation of the R.F. stage.

WOODEN RADIO MASTS

STATION WLBW, Oil City, Pa., utilizes no iron in its aerial supports. The towers are built like the familiar type of oil derrick; and guyed by wooden supports—hickory "sucker rods" formerly used in pumping crude petroleum from the wells, and thoroughly saturated with the insulating fluid. It is believed that this construction eliminates many of the troubles caused by changing aerial capacity.—Clarence Thompson.

Tone reproduction

That no one even thought was possible~

New delights—beyond your fondest dreams—are realities in this new speaker—the sensation of the radio world. Now for the first time in your life hear radio as you never heard it before! No harsh notes—no grating—no slurring at the bottom of the scale. The marvelous tone quality of the Temple Drum Speaker is finer than anyone thought was possible.

Not a Cone

—but a long compensated exponential air column type matched with a new Temple Unit.

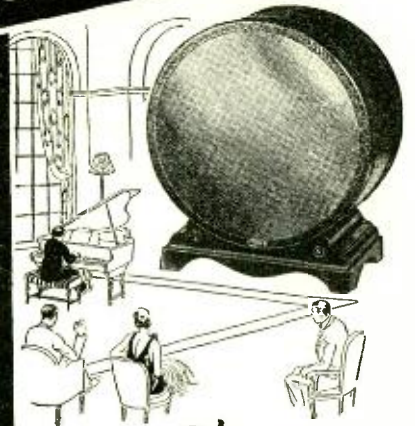

The
TEMPLE DRUM SPEAKER
has given the world a new appreciation of Radio



Console Model No. 65, containing the same tone chamber as drum type model No. 18. Beautifully finished in walnut Spanish design.

YOU will never tire of Radio if you use a TEMPLE SPEAKER. It will triple the value of your set—give added pleasure indefinitely—and justify all you have invested in radio equipment. A development of the long compensated exponential air column principle.

Any Temple dealer will be pleased to give you a complete demonstration with a Temple comparator.

Console Cabinet Model No. 65—priced at \$65.00; west of Rockies, \$75.00
Drum Type Model No. 13, 13 inch—priced at \$29.00; west of Rockies, \$32.00
Drum Type Model No. 18, 18 inch—priced at \$48.50; west of Rockies, \$55.00

If your dealer cannot supply you write us for complete information and name of nearest Temple Dealer.

TEMPLE, INC.

213 South Peoria Street, Chicago

LEADERS IN SPEAKER DESIGN

AT LAST! the Ideal Radio Receiving Set Kit on 30 DAYS FREE TRIAL

1. Automatic electrical controlled regeneration—giving maximum sensitivity and selectivity over entire broadcast band.
2. Unequalled quality of reproduction with all the volume that could be desired.
3. Complete kit of parts for the Jewell 6-Tube, Hilograd, Dual Impedance Radio Receiver **\$72.50** (this includes everything) with working diagrams of layout and wiring.....
4. Essential Kit for Jewell Hilograd Radio Frequency Circuit, with blueprints..... **\$17.50**
5. Essential Kit for Jewell Dual Impedance, Audio Amplifier, with blueprints..... **\$27.50**

GUARANTEE—We are so confident that the results obtained with this receiver will be so satisfactory to the most critical radio fan that we will refund in full if returned for any reason within 30 days.

PARCEL POST PREPAID ON RECEIPT OF REMITTANCE

JEWELL LABORATORIES - 126 W. 73rd St., New York City

The New Symphonic Push Pull



Push Pull Input Transformer



gives great power with quality

YOU who love rich bass notes and tonal brilliancy will find this beautiful pair of Samson brush-copper-finished audio units—Push Pull Input Transformer and Push Pull Output Impedance have brought back into its own the push pull circuit, which eliminates tube harmonics.

With two type 171-power tubes having but 180 volts on their plates as much undistorted volume can be obtained as with a type 210 tube having 400 volts on its plate in an ordinary amplifying circuit—and two type 210 tubes can be used with these units for dance-hall volume.

The Samson Symphonic Push Pull Input Transformer will satisfactorily work into tubes up to 50 watts capacity. Unfiltered AC current may be used on the filament in push pull circuits without hum in either first and second stages, or both stages. The Push Pull Output Impedance eliminates the distortion always found in any transformer—no matter how well it is made. Price per pair—\$19.50.

For those desiring to use more than one stage of push pull the new Symphonic Interstage Push Pull Transformer, Type Y is now available. Price . . \$14.00.

This is the first announcement of the availability of these units for public use.

Send for free reprint article on a complete audio amplifier.

SAMSON ELECTRIC COMPANY



Main Office: Canton, Mass.

Manufacturers since 1882

Factories at Canton and Watertown, Mass.

Eliminating the Detector Tap

By M. R. McCABE

IT has long been a mystery to the writer. Why radio designers and constructors continue to design and build radio sets employing a tapped "B" current supply with a reduced voltage for the detector tube. It is apparent that this practice puts an additional load on one section of the battery and causes it to run down more quickly than would be the case if the load were distributed over the whole battery. Possibly the first user of a multi-tube set used a tapped "B" battery, and the rest followed suit until it became a habit. Needless to say, this can be remedied in a very simple manner and expense reduced at the same time.

On the other hand, assume the use of a "B" socket-power device. The early forms of these devices were often troublesome, for want of a reliable device to control the detector-tube plate voltage. An adjustable resistor was employed for the purpose, and added to the difficulty of operation because the detector voltage had to be adjusted every time the filament control on the set was altered. The perfecting of more efficient power units remedied this condition, because of their flatter load-voltage characteristics; and the use of fixed resistors became practical.

Assuming a third case, where the set builder constructs his "B" power supply apparatus. By proper design of the set in the first place, the necessity for a detector-

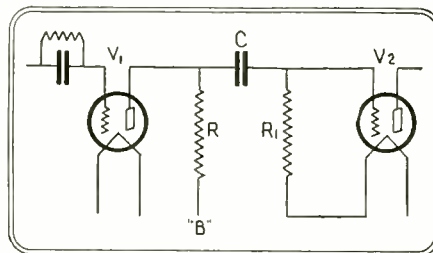

By the use of a suitable resistor in the detector plate lead, the drain on the battery is made uniform and its life thus prolonged.

plate tap is done away; and this results in an appreciable saving in the cost of the equipment.

To obtain these advantages it is necessary only to employ resistance coupling between the detector and the first audio stage of the receiver. The various applications of resistance coupling have been covered in detail in RADIO NEWS, and little need be said of the application of the system to any particular circuit.

USE OF HIGH RESISTANCES

It might be well, in passing, to mention that experiment with the value of the coupling resistor is advisable. It has been stated repeatedly that values in the neighborhood of 100,000 ohms function best; whereas the writer has on many occasions employed resistances as high as 3 megohms with superior results. The lower values did not seem to give as high amplification. It is interesting to note in this connection that Dr. A. Hund, of the Bureau of Standards, recommends plate-resistance values between 2 and 10 megohms with a circuit on which he has experimented. These high values will work in regular resistance-coupled circuits and save considerable on the "B" battery current. The blocking or coupling condenser between the plate and grid should be higher than usually employed; one-half microfarad is recommended in order to pass the lower

For Your "B" Battery Eliminator Ask Your Dealer for Guaranteed



Q·R·S
Trade Mark Registered

Gaseous Rectifier Tubes

Are Better

60 MILLIAMPERES

\$450

85 MILLIAMPERES

\$450

400 MILLIAMPERES

With Ionizer 300 Volts
for A, B and C Eliminators
with Charts and Diagrams

\$700

Manufactured by **The Q·R·S Company** CHICAGO

Established 1900. References: Dun, Bradstreet or any bank anywhere.

WINDSOR HORN and CONE Loudspeakers
and Loudspeaker Consoles
WINDSOR FURNITURE COMPANY

1410 Carroll Avenue, Chicago, Illinois
Los Angeles Branch, 917 Maple Ave.



Insure your copy reaching you each month. Subscribe to Radio News—\$2.50 a year.
Experimenter Publishing Co., 230 Fifth Avenue, N. Y. C.

audio-frequency tones. The grid leak on the first audio tube should be as high as possible without blocking or loading of the grid, which will be evidenced by distortion or periodical shutting-off of the music.

The volume resulting from this change is as great as if transformer coupling had been employed throughout the receiver. The reproduction is of course improved if there is any change; this depending upon the quality of the transformer that otherwise would be used. The detector-plate current is drawn equally from the entire "B" battery and is less with high coupling resistors than when a transformer is used. The amount of wiring has also been reduced and a home-made "B" supply device is simplified and cheapened. All these benefits are self-evident and proven practical; so let us put the tapped "B" battery with the slide-tuner and forget them.

"RADIO LOVE"

*Your voice comes vibrant, low and sweet
O'er miles of pulsing air,
And floods my quiet, lamplit room
With music, rich and rare.*

*Through each soft note emotion thrills,
My heart leaps to its power,
And fancy lifts its radiant wings
And soars one golden hour.*

*I know not whether you be fair,
With witching eyes and glinting hair;
But this I know, my senses leap,
And to your music cadence keep.*

*So close and intimate you seem
In my still room, each mellow note
Trembles in ecstasy and flies
In golden glory from your throat.*

*I hardly breathe, I close my eyes,
And every sense half swoons in sound,
For while you sing, all yours am I,
A prisoner by your music bound.*

*I know not whether you be fair,
Or old or young, beyond compare,
Or common clay, but this is clear,
Full once a week, I love you, dear.*

OREOLA HASKELL

RADIO TERM ILLUSTRATED



"Body Capacity."

—The Listener-In, Melbourne (Australia).

KARAS Parts Enable the NEW
"KNICKERBOCKER 4"
To Deliver Truly Amazing Results

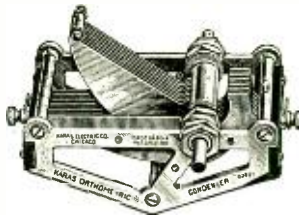

2 Karas Orthometric Extended Shaft .00037 mfd. Variable Condensers are used in the KNICKERBOCKER 4. Price, each, \$6.75.



2 Karas Harmonik Audio Transformers give the KNICKERBOCKER 4 its tremendous volume and purity of tone. Price, each, \$5.



1 Karas 3-Circuit Inductance, price \$5.50 (this 3-Circuit Inductance is the heart of the KNICKERBOCKER 4), and 1 Karas Equamatic Inductance Coil, price \$4.00.



THERE is no question about results when you build the KNICKERBOCKER 4 described and illustrated in detail in RADIO NEWS. It surely steps out and delivers! This marvelous new 4-tube receiver has all the volume ordinarily expected from a 5- or 6-tube set. Its tone is rich, powerful, sonorous and clear as a bell. As a distance getter it is a wonder. In selectivity it equals the finest super. And for ease of tuning and simplicity of operation you can't beat the KNICKERBOCKER 4; it is in a class all by itself.

Why is the KNICKERBOCKER 4 so much better?

The circuit used in the KNICKERBOCKER 4 is new—different—better than any other 4-tube circuit ever designed. And simpler. Instead of having to make adjustments in the detector circuit with an extra control, this is automatically accomplished with the dial of the tuning condenser in this circuit. The turning of this dial gives absolutely hair line adjustment of the Karas 3-Circuit Inductance and Karas Condenser both at one time. There never was such a circuit for simplicity of operation—ease of tuning—satisfactory results.

Karas Parts are Vital to Its Success

The KNICKERBOCKER 4 was built around Karas Parts and no others will give you the same results, so be sure to use the following Karas Parts when you build this set:

- 2 Karas Orthometric S.F.L. Extended Shaft .00037 mfd. Variable Condensers
- 2 Karas Harmonik Audio Transformers
- 1 Karas Equamatic Inductance Coil
- 1 Karas 3-Circuit Inductance
- 2 Karas Micrometric Vernier Dials



Your dealer can supply you with these Karas parts and the other standard parts you will need to build this receiver. Begin to build it today. You know the quality and straight frequency line characteristics of Karas Orthometric Condensers—the splendid volume and purity of tone provided by Karas Harmonik Transformers—the reliability of Karas Inductance Coils and 3-Circuit Inductances—and the 1-1000th of an inch control furnished by Karas Micrometric Vernier Dials. So be sure to order these Karas parts, so as to make sure of 100 per cent performance of your KNICKERBOCKER 4.

Write for complete, detailed information about the KNICKERBOCKER 4—wiring instructions—everything you need in the way of information. Mailed free on request. Address

KARAS ELECTRIC CO.
4038-J North Rockwell Street, Chicago

ALL ABOUT
TELEVISION

Complete 116 page book gives history of this subject with complete instructions for building a home apparatus.

PRICE 50c

EXPERIMENTER PUB. CO., INC.
230 Fifth Avenue - New York

BENJAMIN
Cle-Ra-Tone Sockets

Shock Absorbing, Spring Suspended. Anti-Microphonic. Specified for the

Knickerbocker 4

At all Radio Dealers—75c each

BENJAMIN ELECTRIC MFG. CO.
New York Chicago San Francisco

INVENTORS who derive largest profits know and heed certain simple but vital facts before applying for Patents. Our book Patent-Sense gives those facts; sent free. Write **LACEY & LACEY**, 631 F St., Washington, D. C. Established 1869.

WORLD RADIO CORP., BOSTON, MASS.

"World" Radio Sets



5-Tube Tuned Radio Frequency

\$24.50

for set alone

Our World famous Payment Plan is at your disposal. You may purchase this set by paying only

1.00 weekly until completely paid for. No interest charges or any extra charges whatsoever.

Famous 1927 Model—type D-5—WORLD 5-tube Receiver. Excellent tone quality. Hairline selectivity—Brings in station after station with slight turn of dials. Marvelous reproduction from shrillest cry of clarinet to the deepest tone of the bass viola. Hundreds of unsolicited testimonials from enthusiastic owners. Because we manufacture our own sets, our price—\$24.50—represents big saving. Every set fully guaranteed. Instruction book included.

OUR SPECIAL OFFER!
Famous Magnavox Loud Speaker
FORMERLY NAT. ADV. \$30

OUR PRICE **\$7.85**
50c Weekly
W. R. C. Tubes 201-A \$1.50

PAY NO MONEY DOWN!

Pay NOTHING on Delivery! Simply Send Coupon!

WORLD RADIO CORP.

349 WASHINGTON ST., BOSTON, MASS.

Manufacturers and International distributors of the famous "World" radio sets and radio products

Gentlemen: Upon receipt of this order ship me the \$24.50. World 5-tube Radio Receiver. I will pay \$1.00 weekly as advertised.

MAGNAVOX (check here)

NAME

ADDRESS

Clip and mail this coupon now. Please tell us something about yourself to help establish your credit. Thank you! (Radio News 10-27)

"A" Socket-Power Unit

(Continued from page 337)

circuit to the output. However, for all current whose voltage is higher or lower than the operating voltages, the resistance of the cell banks is very low, and these currents are by-passed. For this reason the voltage remains constant and a smooth current is delivered from the rectifier tube.

The next step was to substitute wet cells for the dry "C" batteries, as the former have a very much lower internal resistance. In order to eliminate the wet feature of this type of cell, a "jelly" electrolyte was used. This is made by using the proper proportions of sodium silicate and sulphuric acid. This solution jells after it has been added to the cell and forms a mass which will not run out, yet furnishes sufficient sulphuric acid for the proper operation of the battery. An "A" power unit of this type operates satisfactorily and requires very little attention. A small amount of water added a few times a year, to keep the paste from hardening, is all that is necessary in the way of attention.

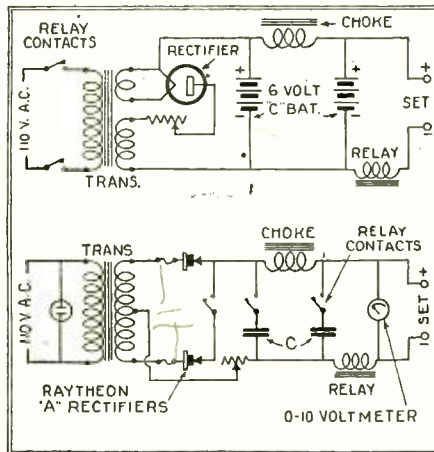

Fig. 1 (top): An early type of "A" power supply, using two batteries floating across a rectifier line. Fig. 3 (bottom) hook-up of the new "A" unit described in the accompanying article.

While this unit operates without hum, it was not the ultimate answer of the engineer. With the elimination of the wet cell in mind, a novel filter condenser was developed by the author in conjunction with the engineering staff of a Cleveland manufacturing company. This consisted of two lead sheets rolled into a small roll with a layer of wood-pulp paper as a separator. This paper was saturated with sulphuric acid. A cell of this type has a very low internal resistance, due to its large surface area. It also has the advantage that it can be sealed in a paraffin-coated box, being practically dry and containing no liquid to spill. The gassing of a cell of this kind is negligible, also because of its large plate area.

While this type of filter is also satisfactory in operation and very cheap to manufacture, costing only a few cents per cell, it was likewise not considered the ultimate; and development work went on, to perfect a true electrostatic condenser which was small and of a very high capacity.

From the formula for determining condenser capacity, it is readily seen that the capacity varies inversely as the thickness of the dielectric and directly as the area of the condenser plates. As the plate area could not be increased beyond a certain amount, because of size and cost, the only thing that could be done was to decrease the thickness of dielectric. Due to the

IN R.F. by-pass circuits



SANGAMO MICA CONDENSERS

A HIGH self inductance in condensers used in R. F. by-pass circuits means a loss in capacity at the lower wave lengths.

In many by-pass condensers the inductive reactance below 300 meters is appreciable. They become choke coils.

Use the larger capacities of Sangamo Mica Condensers in all R. F. circuits. Self inductance is negligible and direct current resistance more than 35,000-megohms! Sangamo Mica Condensers are all capacity.



SANGAMO ELECTRIC COMPANY
6336-2 SPRINGFIELD, ILLINOIS

\$5.50 buys this famous cabinet



Our dealing direct brings this cabinet to you at half the usual retail price. Made either from selected hardwood, with Mahogany finish or from solid Walnut, rubbed to a beautiful piano lustrous, the Iveyline Cabinet makes a fitting climax to your set-building efforts. It has full length, nickeled piano hinge, nickeled lid support, rubber feet to prevent vibration and lid splined to avoid warping. Fully illustrated catalogue available. Just write. If you send us your order today, the cabinet will be on its way within 12 hours from receipt of order. Select your size and finish and mail your order today. Cash with order or if C.O.D. half price with order.

"The Iveyline"

	Mahogany Finish	Solid Walnut
7x18x10.....	\$5.50	\$6.50
7x21x10.....	6.00	7.00
7x24x10.....	6.25	7.50
7x26x10.....	6.75	8.00
7x28x10.....	7.00	8.50
7x30x10.....	7.25	8.75
7x18x12.....	7.00	8.00
7x21x12.....	7.50	8.50
7x24x12.....	7.75	9.00
7x26x12.....	8.25	9.50
7x28x12.....	8.50	10.00
7x30x12.....	8.75	10.25

All prices f.o.b. Hickory

12 hour service factory to you

Southern Toy Co. Inc.
Manufacturers Hickory N.C.

Send for Latest RADIO CATALOG and GUIDE

Big New 1928 Catalog—4,000 Items Standard discounts to dealers, set builders, agents. Write for free copy. The Barawik Co., 540-559 Monroe St., Chicago.



YAXLEY

Selected for the

Knickerbocker 4

- 2 No. 120 K Rheostats..Each, \$1.35
- 1 No. 10 Midget Battery Switch Each, .50
- 2 No. 416 Pup Jacks, Per Pair, .25
- 2 No. 2L Resistance Units..Ea. .15

Yaxley Cable Connector Plug

is recommended for the neat, compact and accurate battery connections of this set.

No. 669 Cable Connector Plug with two extra contacts, which may be used for aerial and ground connections, loud speaker connections or in a variety of ways to meet practically any requirement.....\$3.25

At your dealer's

YAXLEY MFG. CO.

9 So. Clinton St. Chicago, Ill.

IRELAN WONDER STATION FINDER

More distance—Volume—More Selectivity—Tone Quality. Save tubes and batteries. Improves any set.

No extra wiring.....\$1.25
If your dealer cannot supply you write to us direct.

RADIO SERVICE COMPANY
603 West Erie Avenue
PHILADELPHIA, PENNA.



enormous capacity necessary, the dielectric had to be extraordinarily thin. The only way to obtain this easily was to resort to very thin gas films on the surface of the condenser plates. If films of one molecule or so in thickness could be produced, then the capacity would be sufficiently high for the filtering of "A" currents. As the breakdown voltage of a condenser for this purpose did not have to be very high (only sufficient to insure safe operation at 6 volts), it seemed possible that films of this nature and having these properties could be produced. As it is well known that aluminum forms a film of such properties, when used in any one of several different solutions, this was the natural material to use for the purpose. The condenser, as finally evolved, is made by rolling up two sheets of aluminum, separated by a sheet of very thin paper, which is treated with a proper compound to produce the desired film. It has been estimated that the capacity of one of these condensers is about 10,000 microfarads. Two of them are enclosed in a compact can, only six inches high, for use in a new "A" socket-power unit, recently placed on the market.

The complete unit, as it appears in commercial form, is shown at the bottom of page 337. Two binding posts at the rear of the case are marked "A+" and "A-;" to them are connected the wires that formerly went to the storage "A" battery.

The device is turned on and off by a switch in an extension cord. This controls directly the 110-volt current to both the "A" and "B" units, a receptacle being provided for the "B" plug. However, an automatic switch may be used to operate the power unit from the set, if so desired. A circuit diagram of the instrument is shown in Fig. 3.

The whole "A" unit is only twelve inches long, seven inches high and four wide. The containing case is of steel, neatly finished in a crystalline brown effect. On the front end are mounted a voltmeter and a rheostat, by means of which the correct operating voltage may be maintained.

What's New in Radio

(Continued from page 337)

this instrument, to handle the heavy radio currents without permitting distortion or endangering the unit windings. With the more recent receivers, a loud speaker which served admirably a year or two ago might become a rasping affair due to the much heavier currents passed through it.



Front view of the cone speaker. The cone itself is protected by the front metal grillwork, behind which is a screen of gold cloth, harmonizing with the cabinet.



Do You Know How to Stop That Rasping Cackle In Your Loud Speaker



Protect It From

Paralyzing "B" Current with The New Muter Clarifier

[OUTPUT TRANSFORMER]

Haven't you often wondered just why it's so difficult to get clear, natural, enjoyable reception? Haven't you many times felt like throttling that scratching, squawking, inhuman voice? Thousands of set owners are surprised to learn that their speakers are being throttled—constantly—by paralyzing high "B" voltage current. That's exactly what ails them.

The Muter Clarifier is especially designed to prevent this; it diligently protects the Speaker and coils, assuring vast improvement in tone, quality and volume. Nothing else serves the same purpose. This compact, attractive little instrument is easily attached in a few moments

without disturbing set. Try out to your own pleasure on our liberal guarantee—you won't recognize your set.

See Your Dealer—or Send Direct

Dealers can quickly secure Muter Products for you from leading jobbers. However, should you have any difficulty obtaining them from your dealer, mail coupon direct to us. Prompt shipment of Clarifier, complete with phone cords attached, will be made upon receipt of price or C. O. D. if you wish. Give your speaker a chance to show what good reception means. MAIL COUPON TODAY!

LESLIE F. MUTER CO., 76th & Greenwood Av., Dept. 827N, Chicago, Ill.

Use This Coupon!

LESLIE F. MUTER CO.,
76th & Greenwood Ave., Dept. 827N Chicago, Ill.

Send Muter Clarifier at once, postage prepaid. \$5.00 is enclosed.

Send C. O. D.

Send complete Muter catalog.

Name.....

Address.....

City.....State.....



DEPENDABLE PRODUCTS

The Complete Quality Popular Priced Line. Send for comprehensive catalog.



Save 25% to 60% on Every Book You Buy

FREE

Book Bargain Bulletin Number 25

Hundreds of Bargains

CONSRAD CO., INC.

230 Fifth Avenue New York

New 1928 Wholesale Radio Catalog

FREE to Dealers—

136 pages of the greatest values ever offered. Beautiful color illustrations showing electric and non-electric sets. High quality "A" and "B" Eliminators at new low prices. Astonishing low prices on nationally advertised parts, kits, loud speakers, chargers, cabinets, consoles and other radio accessories. Write for this book on your letterhead today.

HAMILTON-CARR RADIO CORP.
711 W. Lake St. Dept. 174 Chicago

Insure your copy reaching you each month. Subscribe to Radio News—\$2.50 a year. Experimenter Publishing Co., 230 Fifth Ave., N. Y. C.

RADIO'S Greatest Triumph

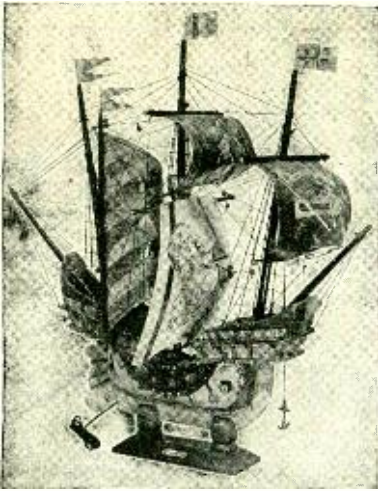

THE MELODY SHIP

Size: 26" high, 12" wide, 27" long (overall)

You can put these ship model loud speakers together in a few hours of pleasant pastime

You need not know anything about ship building or loud speakers to assemble one of these models. As a matter of fact, if you have never seen a ship you can put the ship model loud speaker together in a few hours by following our diagrams and instruction sheet, which is so written that a school boy can understand it. All you need is a small hammer. The parts are numbered on the diagram to make the process even more simple. As long as you can understand such instructions as these (actually taken from assembling chart that is included with every model) you cannot fail: "Take No. 57, place it in front end of No. 56 and tap lightly with hammer. Next take No. 58 and place it up against No. 57 and tap with hammer to bring it into place."

Easy? Nothing simpler. The instructions are just like that from the beginning to end. Do this and that—and before you realize it a beautiful model has grown before your eyes.

The MELODY SHIP is made entirely of wood. A positive free edge cone speaker with a unit of the electro magnet type, powerful enough to operate a 72-inch cone, is attached to the main-mast. This insures splendid service and ample volume with no distortion.

The loud speaker is made in the shape of a sail and does not alter or change the appearance of the ship in any way. The sails are artistically painted with the various designs and figures of the period represented by the models. The tone of this loud speaker is far superior to any cone of its size on the market today. This is made possible by our patented melody sail.

Write for our beautiful illustrated catalog. Fill in the coupon below and we will act upon it immediately.

Miniature Ship Models, Inc.
3818-20-22-24 Baring Street
Philadelphia, Pa.

MINIATURE SHIP MODELS, Inc., DEPT. X
3818-20-22-24 Baring St., Phila., Pa.

Please send me the complete parts for the loud speaker ship model cut to fit, and ready to assemble for the La Pinta as shown above. I will pay postman \$12.50 plus postage (a few cents).

PLEASE PRINT NAME AND ADDRESS PLAINLY

Name

Street or R. F. D.

City

State

6 TUBE RADIO

One Dial Latest advanced circuit. All steel chassis totally shielded. Balanced parts of best quality. Marvelous power and selectivity. Gets the long range stations as clear as a bell. One dial single control. An unsurpassed value—just one of our many mighty bargains. **FREE Log and Call Book** and Big New Catalog—just off the press. Full of Radio Bargains. Send for your free copy now!
American Auto & Radio Mfg. Co.
Harry Schwartzberg, Pres.
Dept. 102 American Radio Bldg.,
Kansas City, Mo.



You can be quickly cured if you STAMMER

Send 10 cents for 288-page book on Stammering and Stuttering "Its Cause and Cure." It tells how I cured myself after stammering 20 yrs. B. N. BOGUE, 6972, Bogue Bldg., 1147 N. 111 St., Indianapolis.

Giant Speaker Heard Six Miles Over Lake

ON a clear summer evening a few weeks ago, six miles out on Lake Michigan, with the lights of Chicago twinkling over the smooth waters, was a yacht on which a dozen or so men were listening to "magic" music. This adjective seems appropriate, because, in the darkness, it was impossible to see from whence the music was coming, yet it was loud and clear though radio receiver and phonograph on the boat were silent.

One of the men spoke and a sailor ran up the ladder to the bridge. Soon a searchlight blazed forth from the yacht in a series of short and long flashes. The character of the music changed from a jazz band to the rich full tones of a baritone. The group of men listened for a few minutes and then wrote their impressions of the music on

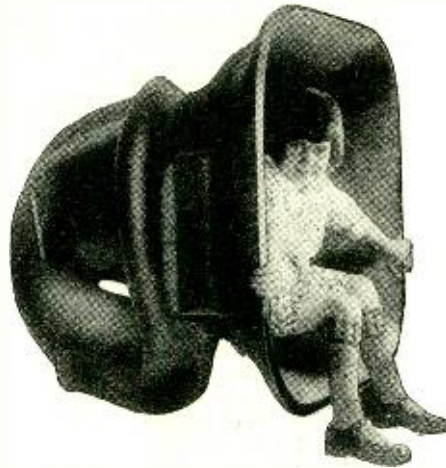

This is one of the giant loud speakers used in the six-mile demonstration. Compare its size with that of the child sitting in its bell.

Illustration courtesy Temple, Inc.

papers that each held. Again an order was given; once more the searchlight's beam stuttered, and then a man's voice was heard telling about the manner of loud-speaker horn to which the men on the yacht were listening.

On the lake shore, at the Chicago Yacht Club, was located this wonderful loud speaker; which was one of the type illustrated herewith. As may be seen, the bell of the horn is approximately three feet across and the air column about ten feet long; the latter being actuated by a specially-designed unit. Different selections of music were played and speeches were made into an amplifier connected to the horn and the sounds were heard far out on Lake Michigan.

The yacht, "Perry Kay II," was stopped every half mile and the music was judged at the several points. Even at six miles, speech could be distinguished and the different musical selections easily recognized. In order to have a double check of the performance, a similar horn was installed on the boat and the same tests conducted in a reverse manner, with the same very satisfactory results. It is reported that, even with the tremendous volume possible with a horn of this nature, the quality of reproduction is very good and that the output of the horn can be tuned down to a soft, mellow tone.

TRUTH IN BROADCASTING

PHONOGRAPH reproduction over the radio is legitimate, but must not be passed off on the audience as the presentation of the artists in person, says the federal radio commission, ordering that all mechanically-reproduced music must be announced in advance as such by broadcast stations.

Tested 1500 Volts

Every Sprague Condenser is factory tested at 1500 volts and capacities are kept constant by a special waterproof asphalt wrapper and a new process of triple impregnation.

Capacities from .00007 to .1 MFD.

The new .1 MFD, no larger than ordinary condensers of smaller capacities, is truly a condenser revelation. Order from your dealer or send one dollar for sample, complete with mounting bushings.

SPRAGUE SPECIALTIES COMPANY
Dept. N Quincy, Massachusetts

RAJAH SOLDERLESS SNAP TERMINALS

Instantaneous in Operation—Positive Contact. For Panel, Ground and Battery Connections.



Patented—Sept. 23rd, 1924

The base stud is tapped and furnished with 8-32 screw and washer. This fits all "B" Batteries with screw posts.

As used on

TUNGAR—RECTIGON—PHILCO—EXIDE
B ELIMINATORS

Terminal, complete... 15c. Extra base studs... 5c
Furnished with

BAKELITE FERRULES

in three colors—BLACK, RED, GREEN



List Price — 25 cents each

From your dealer or direct from the factory postpaid

THE RAJAH CO. - Bloomfield, N. J.

M&H

Radio's largest
kit supply house

ESTABLISHED 30 YEARS

Genuine

STROBODYNE

KITS—Ready for delivery
Complete outfit as selected by
designer for Radio's most
amazing circuit

We have complete kits for all
constructional articles appearing
in this Magazine.

M & H SPORTING GOODS CO.
512 Market St., Philadelphia, Pa.

Insure your copy reaching you each month. Subscribe to RADIO NEWS—\$2.50 a year. Experimenter Publishing Co., 230 Fifth Ave., N. Y. C.

Radio in Flight
(Continued from page 325)

transmitter, working on ship wavelengths, and a receiver. The operation of this equipment was successful, far exceeding the estimated range, and it was heard by both ship and shore stations.

FOG THE WORST ENEMY

When the "America" reached Europe, an unusual contingency was met. The signals from the plane were heard on land; and the plane received messages from below. It was, however, impossible to establish the plane's location accurately enough to allow of landing in the impenetrable fog which hid the powerful signal lights, for lack of any known points of reference to its position; and descent was finally made in the waters of the English Channel.

Immediately, however, the remedy was obvious; aerial "radiophares" or beacons, equipped with loop receivers capable of taking bearings on a plane from the ground, as a radio-compass station does with a ship; or even better, probably, a radio compass for the plane which would lead it directly to the radio beacons at the flying fields.

Another remedy has been suggested by the distinguished radio engineer, John Hays Hammond Jr.—that of land lines beneath radio air lanes. These lines would carry radio-frequency current, automatically interrupted by distinctive signals. These could be picked up by planes flying over them, in any weather, and followed to their center. At the fields a short-wave transmitter would send up a vertical beam, as a final guide to landing.

Another proposal is made by C. Francis Jenkins, the inventor of the radio-map transmitter. Mr. Jenkins suggests a series of low-power short-wave stations with beam reflectors, at intervals of any 25 miles, along an airplane. Each will have a range, of say 40 miles, in the line of travel. Their radiations will overlap; and thus provide a continuous channel of signal reception for the air pilot. The latter will have a little lamp before him, indicating by its brilliance the accuracy with which he is keeping the course. The cost of such transmitters is estimated as low as \$250 each.

These facilities, however, though valuable for the thickly-populated regions over which important airways lead, would be difficult to maintain in the desert, and impossible on the ocean. The navy, therefore, will doubtless devote the major portion of its research to the improvement of radio-compass equipment for airplanes.

The British admiralty has just issued an official order to all the direction-finder (radio-compass) stations along the English coast that, in case of "a distress call being received from an aircraft in distress over the English Channel, the position of the aircraft will be fixed by directional wireless (radio) from the appropriate direction-finder stations and an SOS warning will then be broadcast to shipping by North Foreland wireless station, giving the necessary particulars."

While this might result in the rescue of an airplane's crew, it would not facilitate safe landing, which was the recent problem which confronted Commander Byrd. The U. S. Navy is endeavoring to promote a more extensive use of radio apparatus capable of communication with shipping; and is working on radio-compass equipment. That at present used is mounted outside the fuselage of the plane; and is fixed, so that it is necessary to turn the plane itself to take a bearing. This, however, is deemed more positive and reliable than a revolving loop on aircraft.

The problems of radio navigation have been solved; it only remains to supply the needed apparatus in sufficient amounts to control, guide and insure safety to the navigation of the air.

Plug In—and Tune In

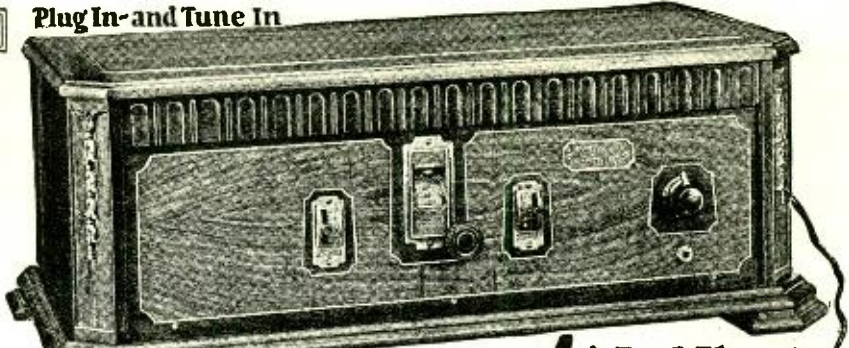

30 Days Free Trial

Agents! Dealers! Big Profits!

Make big money taking orders for Metrodynes. All or part time. Metrodyne All-Electric Radios are in a class by themselves. Unequaled for quality, performance and price. Demonstrate at home and take orders. Lowest wholesale prices. Your demonstrating set on 30 days' free trial. Write today for further details.

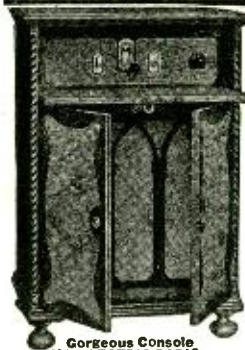

Gorgeous Console ALL-ELECTRIC RADIO
Genuine walnut cabinet, in beautiful, two-tone finish. Built-in genuine Metro Cone large size speaker. Brings in programs with great volume, reproducing the entire range from the lowest to the highest notes with remarkable clearness and distinction. All metal parts finished in old gold. Wonderful electric radio, in a cabinet that will beautify the appearance of any home.

Now! A Real Electric Radio Set

Three Year Guarantee

Shipped direct from our factory at

ROCK BOTTOM PRICES

Cost Less Than Most Battery Sets

No Batteries, Chargers or Eliminators No Acids; No Liquids—Plug In—Press Button—Tune In

Metrodyne
ALL ELECTRIC RADIO

7 Tubes — Single Dial Set

At last! The radio you've dreamed about! If you have electricity in your home you can now enjoy coast-to-coast reception without the care, bother and muss of batteries, chargers, eliminators, etc., with this genuine batteryless radio set. Simply insert the plug in socket, press switch button and "tune in." You could not buy a better radio set than the Metrodyne All Electric, at any price.

Beauty—Efficiency—Dependability

100% Electric Radio. Only the highest quality low loss parts are used throughout. Solid walnut cabinet, beautiful two-tone effect, with handsome gilt metal trimmings. Has electrically lighted dial. Log stations in the dark. Only one dial to tune in all stations. Excellent tone qualities—wonderful volume—very selective. Size of cabinet, 28 x 13 x 10.

Costs Less Than Most Battery Sets

Do not confuse the Metrodyne electric radio with ordinary light socket sets, because the Metrodyne is truly an All Electric Radio—consumes less than 2c worth of power a day. Comes to you direct from the factory. Its low cost brings it down to the price of an ordinary battery set.

Write Today! We are so confident that you will be delighted with this wonderful, easy-to-operate Batteryless Radio that we offer to ship it to your home for **THIRTY DAYS' FREE TRIAL**—you to be the judge. A postal or letter brings complete information. **WRITE TODAY!**

METRO ELECTRIC COMPANY
2165 N. California Ave. Dept. 603 Chicago, Illinois

Write today for your copy of

"Copper Shielding for Radio"

This new book shows how to improve the reception of your set. There is no charge.

Copper shielding means greater selectivity and sensitivity.

COPPER & BRASS
RESEARCH ASSOCIATION
25 Broadway, New York

Use Any Circle Size of Half Dollar

WIN \$500!

How Many Times Can You Write the Letter A in the Circle

Try it! See how easy it is to win! Takes little time—no work—just play—and it may win you a fortune! No red tape! No complicated rules! Neatness and fine handwriting do NOT count!

NO SUBSCRIPTIONS TO SELL! NO SECOND PUZZLE TO WORK!

You will not be required nor asked to get any subscriptions! No other puzzle to solve! Qualify yourself! Put in the A's and send in your circle! If you can't use this paper draw a circle the size of a silver half-dollar on any kind of cardboard or paper. Use only capital A's. Use pen or pencil. Don't let any A touch another. That is all the rules to remember. And if you put in more than anyone else you get the \$500.00 in cash right away after Dec. 30th, 1927 which is the closing date for this contest.

200 OTHER \$2.50 PRIZES! 1000 MORE 50c PRIZES!

If you don't win the first prize you can surely win one of the 1,200 other prizes! And there is no catch or trick to this. We make this wonderful offer as a means of advertising the Inkograph, the amazing new writing instrument. Everybody who uses it is amazed at the ease with which it writes. Read about the amazing Inkograph elsewhere in this ad! Then mail in your circle and the coupon below and you are qualified to win. In the event of a tie each contestant will be awarded the full amount of the prize tied for.

SEND NO MONEY! MAIL THIS COUPON

Conrad Co., Dept. R.
230 Fifth Ave., New York City

I hope to win \$500.00. I have put A in the circle this many times.....as per my solution attached. Please send me one Inkograph on 10 days free trial for which I will pay the postman the regular price of \$1.50, plus the few cents postage charges. You are to refund my money if I don't like the pen.

NAME

STREET

P. O.



This Amazing New Pen

This amazing new kind of fountain pen writes on any kind of paper—on cheap news-paper or wrapping paper as easily and smoothly as on the finest bond, without scratching, clogging, blotting, leaking or soiling hands. Never misses, skips or blurs. Answers as both pen and pencil. Makes 3 or 4 carbon copies! Bear down as hard as necessary! You won't bend, break or spread its 14-K. solid gold point! Salesmen, business men, and farmers use it to keep carbon copies of letters, orders, sales bills, etc. Holds enough ink for 20,000 words! Refills itself in 2 seconds! Uses any ink! Get one! Try it 10 days and if you are willing to part with it just send it back and we will refund your money! We make this offer because we know you wouldn't take \$10 for it if you couldn't get another!

READ WHAT USERS SAY!

"I am a teacher. The Inkograph is better than any \$7 fountain pen."—John R. Atwell, Chadwick, N. C.
"I wouldn't take \$5 for this Inkograph. I mean every word."—R. H. Wilson, Beckley, W. Va.
"The Inkograph makes two carbon copies of my requisitions twice as well as the best indelible pencil."—Wm. L. Partney, Placerville, Ia.
"It sure has improved my handwriting."—M. F. Johnson, Medina, Wis.

KEEP CONDENSERS COOL

IT is good practice to mount the filter condensers of a "B" socket-power unit in an upright position, although this is not imperative. However, the ventilation of condensers is an essential too often overlooked, even by some manufacturers of such units. Condensers should not be subjected to the heat from the rectifier tube or the resistors; although it is not uncommon to find filter condensers exposed to a heat of 130 degrees Fahrenheit. Paper condensers, with the impregnating compound necessarily of low melting point, cannot stand up under continuous heat. They should be protected from any heat in the radio power unit by sufficient spacing, by partitions, or by ample ventilation, if safe and long operation is sought.

NEW QRAs

5ABO, A. L. Eakin, Tonkawa, Okla. 50 watts, on 80 and 170 meters, phone only. Asks reports.
5AET, (portable, 7½watts, 20-40 meters), 5AYL, (75 watts, 40 meters), J. W. Hudgins, 104 Oakwood Ave., Huntsville, Alabama.

THE HEIGHTH OF NERVE

RADIO listeners may have wondered why the Sydney broadcast station 2BL, which has been so very successful in re-broadcasting the programmes of oversea radio stations, was so slow in re-broadcasting the American station WGY last week, says *The Listener-In*, of Melbourne, Australia. Listeners to 2FC, the other Sydney station which also re-broadcast WGY, heard the whole thing splendidly. The voices of the Australians speaking in Schenectady were so clear that every word could have been written down. 2BL, however, was late in coming on the air with the American re-broadcast. Though the chief engineer of that station had his receiving set in excellent condition and was all ready for the performance, WGY refused persistently to be tuned in. The engineer looked over his set again. Everything was perfect. Still no appearance of WGY. Again he overhauled the set, but all to no purpose. In desperation the engineer rushed outside to look at his aerial, and there to his indescribable disgust he found a couple of lead-in wires fixed to the aerial and connecting with an adjoining flat. A couple of radio enthusiasts had taken a loan of the 2BL aerial for their own reception, while half the listeners in New South Wales were waiting to hear the American station re-broadcast. By the time the 2BL engineer had said all he had to say on the subject and had cleared the offending leads-in from his aerial, WGY had been going for nearly an hour. The engineer is still going.

A FRENCH RADIO PROGRAM

BEZIERS, France, has a low-power broadcast station on 158 meters. It is fortunate that few listeners, if any, in the United States can tune it in; for a correspondent of *Wireless Magazine*, London, did so—and this is what he heard:

"A talk on how to drink brandy.
"A description of a brandy distillery.
"The market quotations of the best brandy brands for the week.
"Two songs magnifying the value of Beziers brandy.
"A statement in a natural-history talk that the River Orb is lower than it was at the beginning of this century."

A SIGN FOR TELEGRAPHERS

LONDON boasts of a huge radio-battery sign, of the flashing electric-lamp type, facing the Nelson monument in Trafalgar Square. Only radio and other code operators, however, will notice that the sign is flashing out the company's name in the dots and dashes so mysterious to the public.

IT'S HERE!

You Will Like It—and Profit!

THE WORLD'S GREATEST

RADIO CATALOG

New kits featured include: Aero—Bodine—Camfield—Citizens—H-F-L—Infradyne—Karas—Melo—Heald—Scott's—Silver Marshall—St. James—Tyrman—etc.

Complete stock carried. Prompt, efficient, dependable service, always.

Established 1918

Now Free—Send for your copy today!

The best in Radio—at a big saving—all under one roof. You don't need to look elsewhere. Contains all the information you need.











TELEPHONE MAINTENANCE CO.
123-H South Wells Street Chicago, Illinois

CHICAGO'S OLDEST RADIO HOUSE

WHOLESALE ONLY



RADIO JINGLES

A LABOR OF LOVE

Old Barney Google was forced to 
 The saucers and  to support
 Spark 
 The waiter's  that reached his
 pockets 
 Oft made his eyes bulge in their 
 Spark's bill was high, but what was sweeter
 Than to earn enough  with which
 to 

—Oscar M. Hawkins

DÉCLASSÉ

Said the  to the A. C.
 "I don't blame you for acting blue;
 When you hooked up with that 
 'Twas a real step-down for you."
 —Helen Peters

OHM'S LAW DEBATED

"Will you come and take me home?"
 Said the Ampere to the Ω :
 "No! For you I've no assistance;
 If you'll get a little volt
 To come and 'take a holt'
 Then perhaps you'll get by my 
 M. S. Andelin.



RESOURCEFUL!

Said a battery charger, named Peter
 "My girl's coming today; I should treat her,
 But she comes on a boat
 And a loan I can't float—
 So I guess I will let a 
 —Ashley N. Chandler



Q S V

"Oh, by head," sniffed Johnny O'Rhode,
 "Feels as dough it is godda explode!
 If you'd do't co'prehend
 What I'b sayig, by frie'd,
 It's because ob by terrible 
 —William Lemkin.

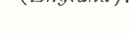
ELEGY TO A PARROT

Polly's left this mortal 
 Removed by unseen 
 To think of poor old 
 O'ercomes me with re 
 —S. Baymar (England).

BASEBALL STUFF—(THIS IS DEEP)

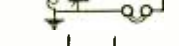
Haines and O'Farrell were 
 mates,
 In that fatal seventh 
 When Hornsby slammed a 
 drive,
 Clean out of the 
 he did whack it!
 —Oscar M. Hawkins.

Victoreen

**Dependable Standardized Super Parts Accepted
 as the Best in Radio**

If you want the ultimate in radio reception—if you are one of those who demand range, clarity, volume and selectivity, then you will appreciate Victoreen supremacy in the super field! Victoreen has gained the confidence of those whose radio experience is based on scientific knowledge. They accept the new products of Victoreen, knowing that a progressive step has been made in Radio—one that has passed the experimental stage and arrived at the point of the utmost in satisfactory results.



**Victoreen Radio
 Frequency Transformers**
 No. 170—For Storage Battery
 Tubes
 No. 171—For Dry Battery
 Tubes

The very heart of the Super Circuit! These units are instruments of great precision, being matched and tuned to within one-third of one per cent and eliminating the necessity of tube matching. Due to their peculiar construction, stray fields are eliminated, enabling the Transformers to be placed in close relation to each other. Interstage oscillation is prevented in this efficient instrument.

Price \$7.00

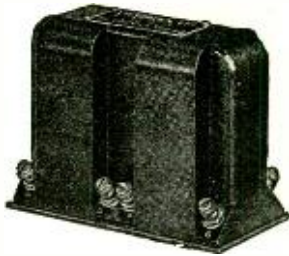

**Victoreen 112
 Audio Transformer Unit**

This unit is worthy of its place in the Victoreen Circuit and renders a marvelous offering in tonal quality—presenting all the intimate naturalness of the original program. Designed to handle up to 400 volts of B battery supply, this unit is especially adapted to the Western Electric cone speaker or similar types. The transformer consists of two stages of Audio amplification in one case and is designed for use with two 112 power tubes.

Price \$22.00



Makers also of the famous Victoreen Long Wave Super Coils, Master Control Units, Rheostats and Audio Control Units

The GEORGE W. WALKER Co.
 MERCHANDISERS OF VICTOREEN RADIO PRODUCTS
 2825 CHESTER AVENUE CLEVELAND OHIO



Steinite RADIO ELECTRIC-NO-BATTERY

**ONE COMPLETE SYNCHRONIZED UNIT
 No Chemical Rectifiers, Acids or Liquids of Any Kind**

Licensed under Radio Corporation of America Patents for Radio Amateur, Experimental and Broadcast Reception

Dealers are Interested

Production must be limited to 100,000 sets—76,000 are already contracted for.

Jobbers Write
 Today for terms and territory and complete description of the

**STEINITE
 MODELS**
 that have won such wide popularity

WRITE OR WIRE

GENERAL SALES OFFICE **CHICAGO, ILL.**
 506 So. Wabash Ave.

Steinite Radio Co. Atchison, Kans.

Manufacturers Famous Steinite Laboratory Products

Largest Exclusive Radio Factory in the West

The AIRGAP SOCKET
"It gets that last mile"

LOWEST CAPACITY FOR SHORT WAVE SET
 At all dealers or direct postpaid 60c each.
 AIRGAP PRODUCTS CO., Mfr.
 56 Clinton Street Newark, N. J.

**Send for Latest
 RADIO CATALOG
 and GUIDE**

Big New 1928 Catalog—4,000 Items
 Standard discounts to dealers, set builders, agents. Write for free copy. The Barwik Co., 540-559 Monroe St., Chicago.

HOQUIAM (WAJH) U.S.A.
6503 MILES
 on loud speaker with the new **DAVEN BASS NOTE RECEIVER**

Although the New Daven Bass Note Receiver brings in enough distance to satisfy any DX hound we have not talked about it before. Here is but one record: 6503 miles on Loud Speaker. G. A. Johnson of 249 Eklund Avenue, Hoquiam, Wash., using the new Daven Bass Note hook-up got 4QG, Brisbane, Australia, and of course, had it authenticated.

The New Daven Bass Note Kit, a duplicate of the one used by Mr. Johnson is now ready. Every part, every wire, even the screws are supplied, drilled and engraved panel, drilled base board, battery cable, etc., but without cabinet, tubes or batteries.

Complete Kit \$68.50

Quality Reception is synonymous with Daven but with the Daven Receiver embodying the new coils, you will get greater distance, sensitivity, selectivity and volume than you ever thought possible.

Get the complete kit in its own box to avoid substitutions. If your dealer can't supply you, write us.

DAVEN RADIO CORP.
 140 Summit St., Newark, N. J.

BRISBANE (4QG) AUSTRALIA

Changes Your Set Into a Short Wave Receiver

Sent postpaid anywhere in U. S. upon receipt of \$15.00 H. O. or C. O. D. plus postage upon receipt of \$1.00 to guarantee carrying charges. When ordering state kind of set so that detailed directions for use may be given if necessary. Also state type of tubes, such as UX199, UV199, WD111 or 201A.



The SUBMARINER

Regardless of the kind of set you have, this device will permit you to listen to short wave stations between 30 and 75 meters. Operates with sets such as T R F, Neutrodyne, Super-Heterodyne, regenerative sets and all other types. No additional tubes or batteries required. No changes to the wiring of the set. A short aerial and ground is connected to the "Submariner," and a cable and plug attaches it to the set. Requires less than a minute to attach or detach. Operates as a wave changer with Super-Heterodynes, and as a detector unit with others.

SHORT WAVE RECEPTION

is practical because they penetrate better, and there is less static. There are several powerful stations using the wave band covered by the "Submariner" for broadcasting programs. You may also learn code by listening to amateurs from all parts of the world. Get a thrill by tuning in a station your friends cannot get. You will have a highly efficient short wave receiver when the "Submariner" is attached to your set. Nothing else like it on the market. Take a trip in the low waves on board the "Submariner."

ORDER TODAY

We guarantee to refund if the "Submariner" fails to operate.

J-M-P MANUFACTURING CO.

Dept. 119 Milwaukee, Wis.

10 BIG WEEKLY MAGAZINES 10¢

Most unusual offer! Ten weekly issues of America's liveliest illustrated magazine for 10¢. Highest quality fiction; unusual articles; sparkling wit and humor; special departments for every member of the family. Send your name, address and 10 cents without delay. The Pathfinder, Dept. C-88, Washington, D.C.

MOVIE STUFF

There once was a rascally rajah,
 Who wanted his harem much larger;
 So from each desert sheik,
 Some fair one he'd take,
 And carry her off on his



—Eileen Doyle.

SHOCKING!

There's a guy who is known to enthuse
 Over anything tasting like booze;
 You should hear his lips smack
 At a drink of shellac.
 And bay rum he will never re



—William Lemkin.

UP IN THE AIR

The bold flyer sent chills through the group
 That stood watching him nose-dive and swoop,
 He would tail-spin and glide,
 Then swing on his side,
 And astound them by



ing the



—William Lemkin.

IMPROVING THAT SET

While many like sports, others drive a sedan
 And some have a love for the arts,
 It can't be denied that the Radio Fan
 Is also a man of

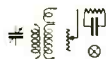

—J. J. O'Connell.

A RADIO GRAFTER

A TRUE (?) story is told in *Wireless Magazine* of a young lady who was asked by a friend how her new radio receiver suited her. She replied: "The set is going splendidly. The only thing I have to complain of is the way they cheat me at the charging station. I have taken my battery there each week, and when I have brought it away there has been exactly the same amount of juice in it as when I took it. I know, because I made a pencil mark on the outside of the battery to show the level of the juice."

ANOTHER EXPLANATION

Bert: "What's the idea of these kilocycles instead of meters in the wave-length?"
 Bill: "Dunno. Unless it means the number of times you twiddle the knobs round to tune in."—*News of the World*, London.



A HEAVY DROP IN VOLTAGE

World "A-B" Socket Power Unit
World Prices
Save 50%
 \$14.75 complete
 \$37.50 complete
"A" POWER UNIT
 For economy—service—lasting satisfaction—there are no finer Power Units made, even at twice the price. Thousands of satisfied users back this statement. See for yourself. "A-B" Unit has variable control with 40 milliamperes capacity at 135 volts. "A" Unit has Westinghouse electrical equipment. Both operate on 50 or 60 cycles at 110 volts A. C.
Send No Money Just state Unit wanted and we will ship day order is received, by express C. O. D. subject to examination on arrival. 5% discount if cash is sent with order. Modernize your set at 60% saving. Send today.
WORLD BATTERY COMPANY
 1219 So. Wabash Ave., Dept. 50, CHICAGO, ILL.
 Station WSBG owned and operated by World Battery Company

\$15.00
NEW VITALITONE SHIP MODEL
 Even more striking than the preceding models. A real model of the famous Santa Maria. Beautifully finished in color. Antique Polychrome. With the famous Vitalitone Unit.
VITALITONE RADIO CORP.
 88 University Place New York City
 Sold at all reliable dealers everywhere.

FREE WHOLESALE RADIO CATALOGUE
The Book they are all talking about
WHOLESALE RADIO CATALOG
 Listing thousands of items in standard radio parts, Kits, Accessories, Complete Sets, Furniture, etc. Every Set Builder and dealer should have a copy. Real wholesale prices. Send for your copy today.
THE HARCO COMPANY
 1259 So. Wabash Ave. Chicago, Ill.
 The HARCO CO. 1259 So. Wabash Ave. Chicago

Insure your copy reaching you each month. Subscribe to RADIO NEWS—\$2.50 a year. Experimenter Publishing Co., 230 Fifth Ave., N. Y. C.

RADIO "BUGS"

MANY of our readers have already responded to the suggestion that they endeavor to put life into the conventional symbols of radio. The vivid action of the little scene below speaks for itself.

Its delineator, F. W. Cerny, of Mesa, Arizona, pictures "The Trans Brothers, Radio and Audio," in that moment of surprise when they have come unexpectedly upon "Toroidus Inductus, the most deadly coil in Radio Land."

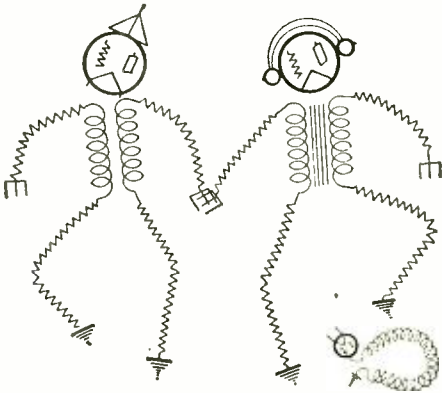

John R. Sargent, of Philadelphia, whose name seems to recall memories of an artistic nature—or is it Landseer of whom we are thinking?—delineates the friend of man in an inquisitive moment. He comments on this "Battery Hound": "Although he doesn't bark or bite, at times he's very shocking."

"How about 'hot dogs' of this kind? You might be 'charged' for them but they certainly would be full of 'juice.'" Ow-oo!

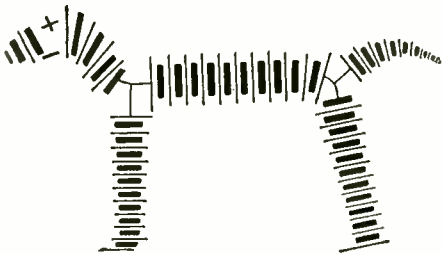

We have been trying to identify the pedigree of this canine. He is beyond doubt a Bat Terrier.

For the two best-drawn contributions yet received, we are indebted to that famous author, Mr. Anonymous. At least the covering letter, bearing a Brooklyn address, was unsigned. The grim-looking Melanesian and

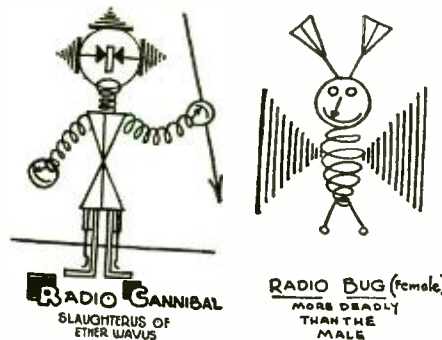

RADIO GANNIBAL
SLAUGHTERER OF
ETHER WAVES

RADIO BUG (female)
MORE DEADLY
THAN THE
MALE

the airy, delicate ladybug are equally well executed. The artist is invited to communicate his—or her—real name to the Jingle Editor.

But we implore our readers not to trifle

FREE The Greatest RADIO CATALOG

Every community set builder and agent needs this book. Every live dealer in radio sets, parts, accessories, supplies, etc., should have a copy of this bargain wholesale catalog. You will be amazed at the thousands of money saving radio items illustrated and listed in this storehouse of everything you could possibly need in radio.

Radio's Newest Products

The book contains all the latest and most popular kits—all the famous, nationally known radio parts, accessories and supplies—the very newest types and designs of table cabinets and consoles—everything at prices that mean bigger profits for you.

Radio Kits

We can supply complete kits for any of the popular circuits described in the national Radio magazines; such as, The Strobodine, Silver-Marshall Laboratory Model Super, Nine-in-Line, Tyrman 10, Remler Infradyne, Karas, Aero, and many others. In fact our special Radio Kit Book which is combined with our Vest Pocket Edition contains the largest selection of radio kits offered by any wholesale house in the country.

Short Wave Section

Our catalog contains a section devoted to a showing of the highest grade short wave receiving and transmitting apparatus. Also the finest electrical appliances for use in the home.

Large Stocks—24 Hour Service

Dealers! Make More Money

Tie up with a house that carries large, complete stocks—that gives you the highest quality radio parts—that insures speedy shipments and 100% satisfactory service. Tie up with Shure. Our wholesale vest pocket price list and discount sheet, together with the 1928 bargain catalog will be sent to you on request. Write on your business stationery—but write quickly.

1928 WHOLESALE CATALOG
of
RADIO Sets, Kits and Everything in Radio

Real Bargains to Dealers

SHURE RADIO COMPANY

337-C Madison Street Chicago, Ill.

TELEVISION!

The Newest and Greatest Development of the 20th Century

Complete 116-page book gives all information on this marvelous science akin to Radio—Tells how to build your own apparatus.

SEE PAGE 314

Money from LIMERICKS!

EARN big cash prize money writing interesting, fascinating Limericks. Anyone can learn. New book, written by noted Limerick authority, tells you in detail how to compose winning lines, also gives valuable rhyming dictionary of words especially suitable for Limericks.

Hundreds of dollars being offered monthly by many magazines and newspapers. An easy, pleasant way for you to increase your income in Sparetime.

Get your copy of this Book NOW!
"Limerick Writing For Profit"

50c the Copy

CONSRAD COMPANY, INC.
230 Fifth Ave. New York, N. Y.

Big FREE RADIO

PARTS, HOOK-UPS, SETS and Catalog & Guide

BIG NEW 1928 CATALOG—4,000 ITEMS. Standard discounts to dealers, set builders, agents. Write for free copy.

Barawik Co., 540-559 Monroe St., Chicago

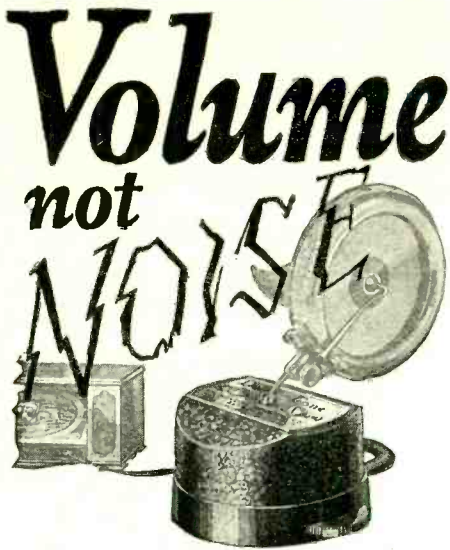

WITH Dulce-Tone—the perfected radio-talking-machine-speaker—you utilize all the time-tested and scientifically developed sound reproduction elements of your phonograph. Your radio reception will have full, undistorted volume, and the same clear, mellow tone you get in playing a fine record.

Far better reception; does away with the unsightly horn; as easy to use as playing a record. Complete satisfaction fully guaranteed. \$10 at your dealer's or by mail from

The General Industries Co.
Formerly named The General Phonograph Mfg. Co.
22 Taylor St., Elyria, Ohio

Dulce-Tone

Write quick FOR HARRY ALTER'S
New Wholesale RADIO BOOK

"Minute-Man" shipping service means quicker turnover for radio dealers—bigger business and more profits without increasing your capital investment.

Everything in RADIO at **BED-ROCK PRICES**

made possible by cash buying and cash selling. If it is used in radio and is a reputable product, we have it. Send now for catalog.

Note: We sell radio retailers only

The Harry Alter Co.
1768 Michigan Avenue CHICAGO

\$1.00 WILL SAVE YOUR SPEAKER

The Craftsman Dollar Speaker Filter is Guaranteed to relieve your speaker of the DC plate current (up to 250 volts). It gives speaker a chance to operate at its best. Attached in a second. Send dollar bill NOW!

CRAFTSMAN RADIO PRODUCTS
9 Orchard St. Newark, N. J.

further with the Latin grammar in seeking titles for their "bugs." Otherwise we shall have all the philologists and entomologists in the city making hostile demonstrations outside the office. Stick to the English, Manhattanese, or Bronx languages as sources of nomenclature.

Our Western friends seem to be used to reptilian encounters. Will A. Ellington of Plainview, Texas, thus conceives the "rattler" and warns: "Watch the ground for a signal, and if you meet up with one of the

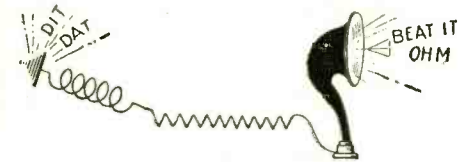

resistance-coupled super-rattler sets, be prepared for DX reception." We think we would prefer DX transmission.

Several other "bugs" are in the editorial drawer, awaiting publication, and the competition is still open. Sketches should be made in ink, on good white paper or cards. It is not necessary that they be finished drawings—our art department can prepare them for reproduction—but they must contain that element of *personality* which the above drawings so amusingly illustrate. For each one accepted and printed, \$1.00 will be paid. Address the Jingle Editor, RADIO NEWS, 230 Fifth Avenue, New York City.

CORRECTION NOTICE

THE diagram of a hand-pass filter, printed on page 26 of the July, 1927 number of RADIO NEWS to illustrate the article entitled "Some Aspects of High-Quality Reproduction," by Paul Traugott,

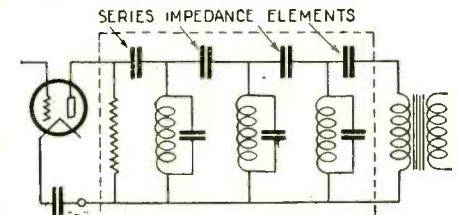

Schematic diagram of an I.F. band-pass filter, preceding the second detector of a super-heterodyne.

was incomplete in that four series impedance elements, in the form of fixed condensers, were omitted. The corrected diagram is given herewith; the other should be disregarded.

THERMOCOUPLE FILAMENT SUPPLY

THE attempt to use the property, by which two dissimilar metals generate an electric current when heated at their point of contact, as a source of radio "A" power, is still continuing. A device of this type is being commercially manufactured in Germany, for the low-consumption tubes available in Europe. Eight tubes drawing 600 milliamperes at 4 volts, about equivalent to as many of our 199-type tubes, may be supplied by a device with 120 elements; and two-volt tubes by one of 60 elements. The current thus generated is pure D. C., without hum from the A. C. heater; but, as 150 watts is drawn from the lighting mains, the efficiency is only about 1.6%.

NEW GERMAN LOUD SPEAKER

SIMPLE construction, it is reported, marks the "Jiroka" speaker, lately developed in Germany. It is double, consisting of two lens-shaped wooden discs which are the sounding elements; in the inside of each is a small recess containing a very short soft-iron bar, with a 2,000-ohm winding. These are placed almost in contact, end to end, and their windings connected in series. The signal currents of audio frequency cause the two magnets to vibrate, each being the armature of the other, and thus communicate their motion directly to the discs. It is claimed that this speaker requires less energy than the ordinary headphones.

A MEDIUM OF INDIVIDUALITY

"GOOD will is the strongest asset of any business. I have found radio to be the strongest factor in building good will for my organization."
—S. L. Rothafel ("Roxy.")

Exclusively Licensed by Technidyne Corporation Under U. S. Patent No. 1593658, July 27, 1926.

Startling!

"TONATROL"

A True Tone and Volume Control

This new and highly perfected Electrad device is amazing users with its smoothness and efficiency in controlling volume. It permits reception of soft music or the most powerful tones with remarkable clarity.

Sturdy Bakelite construction. Very simple to install in any receiver.

Tonatrol—Standard Volume Control... \$1.50
Tonatrol—Type W.S. (with filament switch) ... \$2.00

Write for installation booklet for the proper way to control volume.
Dept. 49C, 175 Varick Street, New York, N. Y.

ELECTRAD

Great Sensitivity

Made with our exclusive superior feature—the TELEVOCAL SUPPORT—Televoctal Quality Tubes won't short and are non-microphonic. Manufactured, tested and balanced by technical experts, they combine sensitivity with high amplification. Insist on Televoctal—the quality tube that's guaranteed.

If your dealer cannot supply you, write us giving his name. Televoctal Tubes are made in all Standard Types.

TELEVOCAL CORP'N
Televoctal Bldg.
Dept. A2, 588-12th St.
West New York, N. J.

TELEVOCAL QUALITY TUBES

RADIO ACCESSORIES at WHOLESALE

Radio Sets, "B" Eliminators, Chargers, Tubes, Kits, Parts—everything new in Radio at lowest wholesale prices. Thousands of nationally advertised bargains. All listed and illustrated in my Big New Catalog and FREE Call Book. 132 Pages of valuable Radio in: FREE formation—trouble finding, set building—Radio knowledge of all kinds. Write today. HARRY SCHWARTZBERG PRES.

AMERICAN AUTO & RADIO MFG. CO.
Dept. 104 American Radio Bldg.
Kansas City, Missouri

BIG BARGAIN CATALOG

Letters From Constructors

(Continued from page 367)

When the set is first turned on, for about 15 seconds it will motorboat, and then quiet down absolutely. The 500,000-ohm potentiometer controls modulation very nicely. The transformers are two Silver-Marshall 220s, the secondary of a third being used as the grid impedance in the final A. F. stage.

The radio end is a common T.R.F. using Camfield Duoformers; oscillation being controlled by a 400-ohm potentiometer, and the filaments by Daven 1/2- and 1/4-ampere ballasts. The Daven Leak-condenser is used. The set is mounted in a 7x26 cabinet, 9 inches deep, on a wooden baseboard.

If some of RADIO NEWS' readers want a "he-man's" amplifier without high voltages and large cost, here is one that is really a dandy. Men who have seen and heard it, and know quite a bit about radio, have shaken their heads and wonder why it does work, especially with high-mu tubes.

MELVIN E. LINDNER,
928 Ambia Street, Toledo, Ohio.

(Mr. Lindner has undoubtedly been fortunate—or painstaking—in matching this amplifier so that it will work well. The object of using high voltage on the grids of the large power tubes is to prevent its being overcome by the positive swing of the highly-amplified signal. The "motorboating" is undoubtedly due to the changing impedance of the tubes while they are warming up.—EDITOR.)

THREE-FOOT CONE SPEAKER

Editor, RADIO NEWS:

I have just completed a 36-inch cone speaker, as described by Mr. Mithoff in the May issue of RADIO NEWS. I want to say it more than comes up to expectations; it is wonderful. I was very much surprised when it was connected to a four-tube set (one R. F., regenerative detector and two audio stages). The tone beats anything I ever heard; a piano sounds just like one, every instrument of a band comes in, and an organ is great. The article was very much appreciated—not mentioning others; in RADIO NEWS they are all good. I have not missed an issue since the first one came out.

GEO. A. JOHNSON,
612 East Walnut St., Bloomington, Ill.

TRANSPACIFIC RECEPTION

Editor, RADIO NEWS:

I have been a subscriber to RADIO NEWS for about two years, and am particularly interested in the Home Set Constructors' department. I built the Regenerative *Interflex* last fall. Not having a carborundum detector, I substituted a grid condenser and grid leak. With this set I received programs from JOAK (Tokio, Japan) and 2BL (Sydney, Australia). I have letters of verification from these two stations, and have heard, to my own satisfaction, programs from JOBK and JOCK; but, owing to the nature of their programs, in Japanese speech, did not try to verify. To prove that this DX is not freakish, my verifications cover a period from October, 1926, to March, 1927. As for U. S. stations, this set has more volume, more selectivity, and more everything than any five- or six-tube set I have seen. I am going to build another this year, using one transformer-coupled stage and three resistance-coupled in the A. F. amplifier.

GILBERT HALE,
Box 687, Douglas, Ariz.

UNDERGROUND ANTENNAS

Editor, RADIO NEWS:

Having read about wells and underground antennas, and living last March where we had a 50-foot dug well, drilled to 128 feet (water standing 30 feet in dug portion) I lowered an ordinary antenna, enameled wire down the dug portion until it rested on the bottom. For a weight I used 5 feet of 1/2-inch copper tubing, coiled in a 3-inch circle; 10 feet from the top of the well, or 10 feet from the top of the water as the water was standing 20 feet from the top. I soldered on my usual, insulated lead-in wire. As it was wet around the well, I threaded the lead-in wire through a 30-foot, 3/4 inch rubber hose, until 10 feet above the ground where it entered the house.

The set was a Radiola 26, with the "Home Battery Box" attached to the portable part.

As a ground I used a counterpoise hung in the cellar, 15 feet from the set.

Result, clear loud-speaker reception bringing in WHO rebroadcasting dance music from the Montmartre Cafe, Detroit.

After 10 minutes' reception, I disconnected ground antenna; switching to outdoor aerial (30 feet from ground, using counterpoise) and also my usual ground (which is 10 feet of 2-inch black pipe driven straight down and filled with water) and could receive WHO only on the earphones.

From the underground antenna I had absolutely no interference; but from the outdoor antenna I had transformer noise due to a leakage in the neighborhood, also noises that I term static. KGO and KPO, the two large San Francisco broadcast stations, were going full blast 50 miles away and KPO could be heard slightly in the background when the outdoor aerial was connected.

When using the aerial and ground on the Home Battery Box on the Radiola 26, the loop is taken

U. J. HERRMAN
MANAGING DIRECTOR

G. CLAYTON IRWIN, Jr.
GENERAL MANAGER

RADIO MANUFACTURERS SHOW ASSOCIATION

Presents

FOURTH ANNUAL

RADIO WORLDS FAIR

MADISON SQUARE GARDEN
NEW YORK CITY

SEPT. 19-24
INCL.



OFFICIAL SHOW

SIXTH ANNUAL

CHICAGO RADIO SHOW

COLISEUM
CHICAGO

OCT. 10-16
INCL.

The exhibits of new inventions and developments in radio receivers, parts and accessories will be of great interest to all amateurs, professionals and radio fans. You will also meet radio's most popular entertainers and announcers. Among the many new innovations will be "The Theatre of Wonders," a storehouse of magical and practical inventions you can't afford to miss.

Special business sessions for the trade.

Radio shows open daily from 1:00 P. M. until 11:00 P. M., Monday to Saturday inclusive.

NATIONAL RADIO DAY SEPTEMBER 21



4 Adjustable "B" Voltages in Any Combination

from 0 to 180

Also Adjustable "C" Voltage from 0 to 50

Type 445 Plate Supply, Price \$55

The New

GENERAL RADIO PLATE SUPPLY

Embodying new and distinctive features in plate supply design

- Adjustable wire wound resistance with sliding taps which control voltages so that any combination of voltages from 0 to 180 may be taken from the four positive "B" terminals. This method of voltage control is superior to the use of several resistances with exterior knob controls. It has the advantage that once the sliding taps are adjusted to the proper operating voltages of the tubes, they are tightened in place by thumb screws and voltages will remain constant, but are immediately available for readjustment whenever the unit is used with a different set.
- Adjustable "C" voltage for power tube.
- High voltage test condensers in filter circuit.
- Uses UX-280 or CX-380 rectifier tube which has maximum output of 100 milliamperes, thereby providing sufficient current for sets of the multi-tube type.
- Automatic cut-out switch breaks the 110 volt A. C. circuit when cover is removed for adjusting voltages or connecting wires to taps, thereby making unit absolutely safe even in the hands of persons not familiar with electrical apparatus.
- Designed to meet the specifications adopted by the National Board of Fire Underwriters.
- Absolutely guaranteed against mechanical and electrical defect upon leaving the General Radio factory. Cost, which has been a secondary consideration to over-all efficiency, has been kept as low as peak performance and production economies permit.

Price from your dealer or direct from the factory if your dealer cannot supply you:

Type 445 Plate Supply Unit.....\$55.00

Type UX-280 or CX-380 Rectifier Tube for above.....\$5.00

Licensed by the Radio Corporation of America only for Radio Amateur, Experimental and Broadcast Reception. Under terms of R.C.A. license unit may only be sold with tube.

GENERAL RADIO CO.

Cambridge, Mass.

SAVE 25% TO 60%
on every book you buy.

Write for

BOOK BULLETIN No. 5

CONSRAD CO., 230 Fifth Avenue, New York

FREE RADIO GUIDE

BIG NEW 1928 CATALOG—4000 ITEMS Shows the latest circuits, the newest developments in radio at startlingly low prices. Get the parts you want here and save money. The best in parts, kits, complete factory-built sets and supplies. Orders filled same day received. Write for free copy NOW. Standard discounts to dealers, set builders, agents. BARAWIK CO., 540-559 Monroe St., Chicago, U. S. A.



**Write to us
and then
right to you**



will come this new
**FREE
CATALOG**
of unusual radio bargains

EVERYONE interested in radio—dealers, set-builders and fans—are finding in this new 1927-28 "Book of a Thousand Radio Bargains" values which are marking Hampton-Wright as outstanding in the radio field. The latest and best merchandise in radio parts and accessories, made by the world's best known manufacturers, here are offered as surprising values. Mail this coupon today—and take advantage of Hampton-Wright's greatest year!

✚ Mail This Coupon TODAY! ✚

HAMPTON-WRIGHT
128 Darmody Bldg., Indianapolis, Ind.

Dear Sirs: I want this new Hampton-Wright "Book of a Thousand Radio Bargains." Please mail one today to:

Name _____ Address _____

City _____ State _____

HAMPTON-WRIGHT
RADIO PARTS AND ACCESSORIES
DARMODY BUILDING + + + INDIANAPOLIS

FROST-RADIO
De Luxe Apparatus
Now At Your Local Dealer's

You will want to inspect and order the new Frost De Luxe Apparatus at your dealer's. It's not only NEW, but it is wonderfully finer than any other line on the market.

You can secure these new parts in the following Series: Series 1700, Metal Frame Rheostats and Potentiometers; Series 1800, Bakelite Rheostats and Potentiometer (also made with filament switch at slightly higher cost); Series 1880 (2-terminal) and 1890 (3-terminal) Variable High Resistances (also with switch, if desired).

You will find in Frost De Luxe parts the quality and finish that you have always sought, plus absolute dependability under all conditions of operation.

HERBERT H. FROST, INC.
Main Offices and Factory: Elkhart, Ind.

off the front of the set and attached to the back. Now the pump is driven by a 15-hp electric motor, starting and stopping on air pressure and, when I have the outdoor aerial connected and the pump starts, there is a crashing noise picked up. When I first connected up the set to the underground aerial, I shut off the main switch so that the pump could not start. When I connected the underground aerial the second time I purposely exhausted the air, so that the pump would start, and the crash aforementioned was decreased at least 75 per cent with the underground aerial.

Many thanks for your very interesting magazine. I do not understand the very technical parts but, in my opinion, it is the easiest to understand for a layman.

ALBERT DE LA MARE,
37 Crystal Springs Road,
San Mateo, Calif.

IN THE JUNGLE

(This letter from Mr. Tasker is forwarded to RADIO NEWS by a friend. His transmitter is SH-1JT.)

"Recently I was ordered up country to take charge of a radio station on the borders of Brazil. I am about 200 miles from Georgetown and about 100 miles from Boa Vista in the midst of the South American jungle. I have had no chance before to answer your letter so I now take the opportunity to do so.

"As soon as I got my orders to leave town I built myself a short-wave transmitter and receiver for experimental research work. My transmitter is a 5-watter. My receiver was a Schnell but, after reading the article in RADIO NEWS with a description of the 'Pilotone' short-wave set, I changed my set and built the latter. I am using Pilot variable condensers in each set. (See RADIO NEWS for February, 1927, page 972.)

"The results have been simply astounding. I used a 30-foot aerial and 30-foot counterpoise for transmitter, and a 40-foot single-strand aerial for reception. All were about 5 feet above ground with the jungle all around.

"I have heard nearly every country in the world at good loud-speaker volume (detector and two audio) and listen in regularly to WGY, KDKA, and the new Dutch station at Eindhoven, Holland. All broadcasting is heard on a loud speaker and this in the midst of the virgin forests."

JOSEPH T. TASKER, A.M.I.R.E.,
61 Hadfield Street, Georgetown,
Demerara, British Guiana.

AERIAL PLUS LOOP

Editor, RADIO NEWS:

Since you published, in the August issue of RADIO NEWS, my letter regarding the Dyadyne circuit, I have received about a dozen letters, some from Canada, asking me for help in making the circuit. I have advised them all to send for the RADIO NEWS Amateurs' Handbook, Vol. 3, in order to build the set properly. Now it is up to them; I have done my share.

I have discovered something very useful to help bring in distant stations, especially in the summer. You can try it and will be surprised in the difference in volume. When nights are bad I use my seventy-foot outside aerial in series with a loop antenna—the aerial first, followed by the loop, then to the set—and the difference is really remarkable. As practically all the stations are east and west from my location I do not have to change the direction of the loop very often.

VICTOR LA SALLE,
3702 Pine Grove Ave., Chicago, Ill.

STRANGE-SOUNDING CALL LETTERS

RADIO has created an "ideographic" language—or, shall we say, "ideophonic" in which letters and sounds stand for abstract ideas. Such, for instance, as the three-dot, three-dash, three-dot, combination (popularly, and inexactly, called "SOS") which means peril and emergency. Such are the numerous combinations of letters which the radio operators use, with conventional meanings, from QRA ("What station is that?") "This is—" to QTF ("Where am I?") "You are in latitude—and longitude—". The "hams" have filled the ether with peculiar signals, such as OM ("Old Man"—a term of comradeship) and CUL ("See you later") which have become international without reference to their original derivation from the English.

The call letters of the broadcast stations present no problem to the listeners, so long as they are confined to the borders of their own countries; but international radiophone broadcasting meets the fact that, while the American and Western European countries use the same alphabet (the "Roman"), they do not pronounce the letters or their names alike. In Europe this problem is met by polyglot announcing. Here, however, is the way in which *Radiofonía*, of Rome, tells short-wave listeners to identify Schenectady, one of the few American stations to be heard in Europe: "The 'speaker' announces 'WGY calling,' which in Italian sounds thus—*Dubleiu ge nai coling.*"

Generally, in most European languages except the English, A is "ah," E is "A," I is "E," and U and Y are represented by sounds to which there is not always a corresponding pronunciation in English. Z is "zed" outside of the United States; and W (originally UU or VV) is a stranger to most Continental alphabets. The average American would find trouble in guessing that Y is represented by the French "igrec."

Trade Mark Reg'd U. S. Pat. Office
CONDENSERS
"Superior to all others tested!"

Recognized Radio engineers have for a long time known the excellence of TOBE Condensers. They have the quality of continuing to function perfectly over long periods of time.

Now the TOBE No. 662 high voltage condenser block has been selected exclusively by McMurdo Silver for use with the new Silver Marshall UNIPAC and Mr. Silver has written us:

"It is indeed a pleasure to inform you that on completion of our test we find that the condenser blocks that you have submitted have proven exceptionally satisfactory and, insofar as we can determine, superior to all other condenser banks which we have tested."

Send for price list N-10

Tobe Deutschmann Co.
Engineers and Manufacturers of
Technical Apparatus
CAMBRIDGE, MASS.

SOVEREIGN

A-C TUBES and KITS
MODERNIZE YOUR RADIO!

Build your own Battery-less receiver or convert your present set with SOVEREIGN equipment.

NO MORE
Hum — Microphonic noises
"A" Battery — Charging —
"A" Battery Eliminator.

BUT INSTEAD
Clear — Clean Cut — Truthful
Reproduction.

If your dealer cannot supply you, we will ship C. O. D. direct to you.

We have prepared a comprehensive NON-TECHNICAL pamphlet on A.C. tubes and receivers—Write for your copy today.

SOVEREIGN ELEC. & MFG. CO.
123 N. Sangamon St. - - - Chicago

BARGAINS IN BOOKS!

Write for FREE Bulletin No. 25 containing hundreds of big discounts in popular books.

CONSRAD COMPANY, INC.
230 Fifth Ave. New York, N. Y.

Book Review

THE LAW OF RADIO COMMUNICATION, by Stephen F. Davis. Published by McGraw-Hill Book Co., Inc., New York. 6 x 9 1/4 inches, 216 pages. Price \$3.00.

In this work Judge Davis (who has been solicitor of the Department of Commerce during a considerable period when the administration of radio affairs in the United States was lodged in its hands) has accomplished the double task of producing a book which the lawyer may read for advice on radio, or the radio expert for advice on law. To the fullest extent possible, the technicalities of both sciences have been couched in simple language, which the layman may readily understand.

To add to the task, the author was confronted with the problem of picturing a lofty edifice not as yet reared, and for which no architect's plans are available. It is a principle of our law that, while courts will follow where possible the reasoning employed in previous decisions, they will not bind themselves for the future, nor give a statement as to what their action in a hypothetical case would be. For that reason, when the progress of modern science and business makes necessary a new branch of law to meet novel conditions, the results of legislation and executive regulation must be worked over, through the process of many trials and judgments, to make a code which shall be consistent with itself and with the great body of the common law. In this book, the author undertakes, not to prophecy, but to compare the problems caused by radio with those produced by other revolutionary discoveries, and show the reasoning which has decided previous actions before the courts.

The rights of the government as against the individual, and vice versa; the claims of that nebulous entity known as the public; the rights of the owners of radio apparatus as against each other, and as against interference from other sources; the laws of copyright, of slander, and of program ownership, are illuminatingly discussed. Whatever the evolution of the law in its dealing with this subject, this book will always have the honors of a pioneer; and, for the present, will be of the highest value to those who are concerned with a defence of valuable rights in radio operation.

SALES—AT WHAT COST? Published by the Zinke Company, Chicago, Illinois. 8 1/2 x 11 inches, 16 pages, illustrated folder. For free trade distribution.

This folder, issued by the founders of the Zinke Sales Plan, who are nationally-known sales engineers, offers a comprehensive study of the radio field of the United States as a wholesale and retail market. The statistical charts and figures, wherein it emphasizes the overlooked value of the "immense small-town market," should prove of vital interest to all radio manufacturers and distributors.

RADIO ANNUARIO ITALIANO, 1927. Published by Radio Novita, Rome, Italy. 6 x 8 1/4 inches, 575 pages, illustrated, paper. 35 lire (\$2.30).

GUIA RADIO, (No. 3) 1927. Published by Revista Telegraphica, Buenos Aires, Argentina. 5 1/2 x 7 3/4 inches, 112 pages, paper. 50 cents (22 cents U. S.).

The first of these, in English the *Italian Wireless Directory and Year Book*, is the second number issued. With characteristic thoroughness, it is indexed in five languages, Italian, English, French, Spanish and German. It is both a technical and a trade publication; its first section reviews the development of radio throughout the world, with data on the European stations, their administration, and full particulars as to Italy's radio services of all kinds, regulations, customs information; in addition to general information which may be expected from a book of radio reference. Its second part includes a gazetteer of the Italian radio trade and manufacturing industry. Its advertising shows the apparatus, both domestic and imported, available in Italy, in wide variety. The work will be of special value to exporters, as well as to those desiring to keep in touch with developments, business and scientific, of radio abroad.

Guia Radio ("Radio Guide") is especially for the South American amateur, containing lists of radio stations (broadcast, commercial, amateur and experimental), and official regulations in Argentina (which has by far the largest number) Brazil, Chile, Uruguay, Peru, Cuba and Spain. Information on code and signals is included, with a Spanish-English radio vocabulary. The advertisements of American and European apparatus, as well as Argentinian, and a directory of the growing radio industry in this progressive country, appear in its pages.

ALL MODERN CONVENIENCES

AN enterprising real-estate developer in Inver, Buckinghamshire (England) sells houses complete with fittings, including a two-tube radio receiver, with loud speaker and other accessories, and an aerial built into the roof.

TYRMAN VERNIER DRUM

For all fine receivers this Vernier Drum is a precision tuning device assuring efficiency—accuracy and simplicity for all double and single control receivers.

A high grade bronze or-

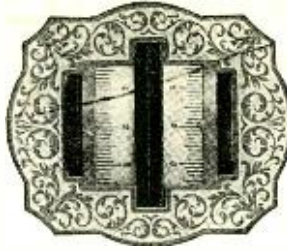

namental escutcheon encloses the drums and vernier—A Tyrman unit of unequalled beauty. The center knurl enables fast tuning while the vernier provides hair line adjustment.

7 Outstanding Features of the Tyrman Vernier Drum

1. Distinct visibility of graduations; they are silver etched with raised lines and figures.
2. Accuracy of moulding; the 5 1/2-inch Drums and Verniers are acknowledged Masterpieces of bakelite moulding.
3. New clutch arrangement assures perfect concentricity of drums and condenser shafts.
4. Flexible spring balanced bearing holds the vernier in steady contact with the drum.
5. Absence of "backlash" combined with smoothest action ever obtained in tuning devices.
6. Universal mounting makes it adaptable for all popular condensers.
7. Unequaled beauty of appearance.

DOUBLE CONTROL

\$10.00
For All Popular
Condensers

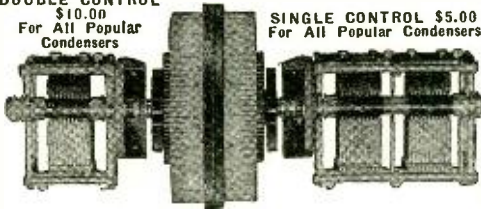

SINGLE CONTROL \$5.00
For All Popular
Condensers

All Reliable Dealers and Jobbers carry Tyrman Products in stock

Literature sent upon request.

TYRMAN ELEC. CORP.

143 W. Austin Avenue
Chicago

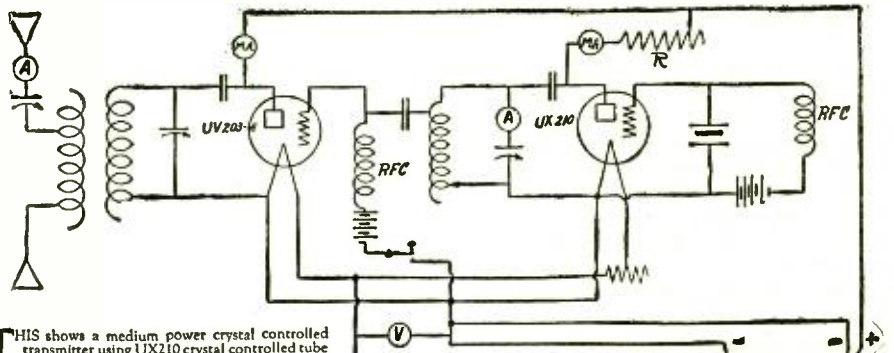

THIS shows a medium power crystal controlled transmitter using UX210 crystal controlled tube feeding a UV203-A power amplifier. Filament and plate voltages are to be obtained from Item 34, operating from either DC or AC house mains. The voltage to the filament of the tubes is variable, either by the field rheostat in the filament generator circuit (not shown) or by the resistance in the filament circuit of the UX210 tube. Keying is done in the bias circuit of the 203-A power amplifier. As the amplifier is NOT neutralized, the power amplifier must work on some harmonic of the crystal tube (preferably the second), for all operations in the 20, 40 or 80 meter bands. A crystal having a fundamental of 160 meters will allow operation in all bands with best output in the 80 meter one. An 80 meter crystal is best for 40 meter operation and in like manner the 40 meter crystal would be best for 20 meter operation. Forty meter crystals are hard to get and blow up easily, so for 20 meters the 80 meter crystal is used again. Both tubes obtain plate supply from the plate end of Item 34, the UX210 being supplied with not over 350 volts through resistance R, and the 203-A taking the full 1000 volts.

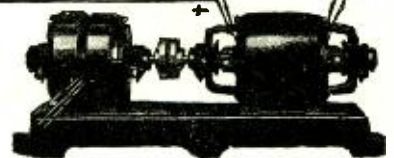

ELECTRIC SPECIALTY COMPANY

211 South Street

TRADE "ESCO" MARK

Stamford, Conn., U.S.A.

Manufacturers of Motors, Generators, Motor-Generators, Dynamotors and Rotary Converters for Radio and other purposes



OCTOBER BLUEPRINTS

You can obtain a complete set of Blueprints for these receivers direct from RADIO NEWS.

- THE RADIO NEWS SPECIAL SHORT-WAVE BROADCAST RECEIVER
Radio News Blueprint Article No. 31 \$1.00
- THE KNICKERBOCKER FOUR
Radio News Blueprint Article No. 32 \$1.00
- THE QUALITONE SIX
Radio News Blueprint Article No. 33 \$1.00

Order Direct from RADIO NEWS

230 FIFTH AVENUE, NEW YORK, N. Y.

MENTION NAME OF RECEIVER AND ARTICLE NUMBER

OPPORTUNITY AD-LETS

Follow these advertisements every month. Reliable advertisers from all over the country offer their most attractive specials in these columns.

Classified advertising rate twenty-two cents a word for each insertion. Ten per cent discount for 6 issues, 20 per cent discount for 12 issues. Names and addresses must be included at the above rate. Cash should accompany all classified advertisements unless placed by an accredited advertising agency. No advertisements for less than 10 words accepted.

Objectionable or misleading advertisements not accepted. Advertisements for the December issue must reach us not later than October 1st.

CIRCULATION LARGER THAN THAT OF ANY OTHER RADIO PUBLICATION

EXPERIMENTER PUBLISHING CO., INC., 230 Fifth Avenue, New York, N. Y.

Agents Wanted

Big Money and fast sales. Every owner buys gold initials for his auto. You charge \$1.50; make \$1.35. Ten orders daily easy. Write for particulars and free samples. American Monogram Co., Dept. 133, East Orange, N. J.

Guaranteed Genuine Gold Leaf Letters anyone can put on store windows. Large profits, enormous demand. Free samples. Metallic Letter Co., 422 N. Clark, Chicago.

Radio Agents—Make Big Money. Easy! selling Marvellous New Sets and accessories. Buy from factory at lowest prices. Get Big New Catalog with thousands of nationally advertised bargains. FREE Call Book. Write today. American Auto and Radio Co., Dept. 108, Radio Bldg., Kansas City, Mo.

Sell subscriptions to magazines known the world over. Steady monthly income with absolutely no investment required. Hundreds of selling arguments every month. Start now. Full information sent free, no obligation. Agency Division, Experimenter Publishing Co., 230 Fifth Avenue, New York.

Business Opportunities

Free Book. Start little Mail Order Business. Pier Company, 72AF Cortland Street, N. Y.

Inventions Commercialized. Patented or Unpatented. Write Adam Fisher Mfg. Co., 278 Enright, St. Louis, Mo.

Co-operative membership in EIA RADIO is establishing one honest, industrious man of each locality in his own successful radio industry. Young married men preferred. Write, naming your county. Equitable Industries Association, Radio Division, 350-R Broadway, New York.

67 Ways to Increase Income. 96-page book "Spare-time Money Handbook" contains 67 practical and complete plans to operate sparetime business. For everyone who wants more money. Price only 50c. Conrad Company, Inc., 230 Fifth Avenue, New York.

Chemistry

Learn Chemistry at Home. Dr. T. O'Connor Sloane, noted educator and scientific authority, will teach you. Our home study correspondence course fits you to take a position as chemist. See our full page ad on page 387 of this issue. Chemical Institute of New York, 16 E. 30th Street, New York City.

Correspondence Courses

Used correspondence school courses sold on repurchase basis. Also rented and exchanged. Money-back guarantee. Catalog free. (Courses bought). Lee Mountain, Pisgah, Alabama.

For Inventors

Inventions Commercialized. Patented or Unpatented. Write Adam Fisher Mfg. Co., 278 Enright, St. Louis, Mo.

I am in touch with hundreds of moneyed men and manufacturers who wish to buy good inventions. Hartley, 38 Court St., Bangor, Maine.

Television Offers Opportunities. Learn all about Television. It is now in the first stages of practical development. Inventors must improve apparatus. Complete history of Television and all plans for building experimental apparatus in 116-page book. Price 50c. Experimenter Pub. Co., 230 Fifth Avenue, New York.

Games and Toys

Boys! Boys! Look! Big illustrated catalogue of Tricks, Puzzles, Novelties, Jewelry. Send 10c for your copy today. Sincere Studios, 24 E. 21st St., New York, Dept. 14.

Help Wanted

Earn \$25 weekly, spare time, writing for newspapers, magazines. Experience unnecessary. Details FREE. Press Syndicate, 973, St. Louis, Mo.

Detectives Needed Everywhere. Travel. Experience unnecessary. Particulars free. Write, American Detective System, 2190 Broadway, N. Y.

Government Forest Rangers, Chauffeur-Carriers, Patrol Guards, Mail Clerks, Special Agents (Investigators) needed often, \$125-\$250 month. "How to Qualify" mailed Free. Write, Ozment, 251, St. Louis, Mo.

Let me add \$30 a week to your pay without interfering with your present occupation. Interesting, pleasant work. Particulars free. Albert Mills, 9371 Monmouth, Cincinnati, Ohio.

National Publisher, needs agents, boys and shops to help sell great national magazines. No investment required. Big profits, sparetime work very successful. Write Agency Division, Experimenter Pub. Co., Inc., 230 Fifth Avenue, New York.

Instruction

Learn Chemistry at Home. Dr. T. O'Connor Sloane, noted educator and scientific authority, will teach you. Our home study correspondence course fits you to take a position as chemist. See our full page ad on page 387 of this issue. Chemical Institute of New York, 16 E. 30th Street, New York City.

Double Entry Bookkeeping mastered in 60 hours with 8 Keys guaranteed; diplomas. International Bookkeeping Institute, Dept. 28, Springfield, Mo.

Miscellaneous

Inventions Commercialized. Patented or Unpatented. Write Adam Fisher Mfg. Co., 278 Enright, St. Louis, Mo.

Thousands of Radio Bargains. Write. Oman, 156 Concord, St. Paul, Minn.

Save Money at Home. You can build many home necessities yourself, such as furniture, kitchen utensils, decorative material, etc., thus saving many dollars. All constructional information on hundreds of things given in 116-page book "How to Make It." Price 50c. Experimenter Publishing Co., Inc., 230 Fifth Avenue, New York.

Multigraph typewritten letters sell anything. Two dollars thousand. Meyer Rey Corporation, Monmouth, Illinois.

Forms to Cast Lead Soldiers, Indians, Marines, Trappers, Animals, 151 kinds. Send 10c for illustrated Catalogue. H. C. Schlercke, 1034 72nd St., Brooklyn, N. Y.

Old Money Wanted

\$2 to \$500 each paid for hundreds of Old or Odd Coins. Keep all old money, it may be very valuable. Send 10c for New Illustrated Coin Value Book, 4x6. Guaranteed prices. Get posted. We pay Cash. Clarke Coin Company, 14 Street, LeRoy, N. Y.

Patent Attorneys

Patents—Send for form "Evidence of Conception" to be signed and witnessed. Form, fee schedule, information free. Lancaster and Allwine, Registered Patent Attorneys in United States and Canada, 269 Ouray Bldg., Washington, D. C.

Patents. Send drawing or model of your invention for examination and instructions. Advice and booklet free. Highest references. Best results. Promptness assured. Watson E. Coleman, Patent Lawyer, 724 9th Street, N.W., Washington, D. C.

Inventors—Should write for our Guide Book, "How to Obtain a Patent" and Record of Invention Blank, sent free. Send model or sketch of inventions for our Inspection and Instructions Free. Radio, Electrical, Chemical, Mechanical and Trademark Experts. Terms Reasonable. Victor J. Evans & Co., 922 Ninth, Washington, D. C.

Patent applications filed for inventors. New financial plan. Inventors' Service Bureau, Box 1648, Washington, D. C.

Patent Sense—Valuable book free. See Lacey's ad page 417. Lacey & Lacey, 631 F. St., Washington, D. C. Established 1869.

Patents

Inventions Commercialized. Patented or unpatented. Write Adam Fisher Mfg. Co., 278 Enright, St. Louis, Mo.

Postage Stamps

Stamp Collectors—Phillips Monthly Bulletin (illustrated) offers over 2,000 special bargains, sets, packets, single stamps, etc., each issue. Free. Phillips, Box 1012, Hartford, Conn.

Printing Outfits and Supplies

Print your own cards, stationery, circulars, paper, etc. Complete outfits \$8.85; Job Presses \$11. \$29; Rotary \$149. Print for others, big profit. All easy, rules sent. Write for catalog presses, type, paper, etc. Kelsey Company, F-13, Meriden, Conn.

Radio

Boys! Don't Overlook This. The "Rasco" Baby Detector, Greatest detector ever brought out with moulded base. Fully adjustable. See former advertisements in this publication, or our catalog. Detector with Galena Crystal, complete 50c, the same detector with Radioite Crystal, 75c prepaid. Send for yours today. Radio Specialty Company, 96-98 Park Place, New York City.

Attention!—50 vacuum tube book-ups. The greatest collection of vacuum tube circuits ever brought under two covers at such insignificant cost. These diagrams will be found in the great "Rasco" catalog, which contains raw materials and parts in a greater profusion than any other catalog. Send for free catalog. Radio Specialty Co., 96-98 Park Place, New York.

Radio (continued)

Fifty or More Radio Books, want to know anything about Radio sets, constructions, or theoretical data, broadcasting or Amateur information—write for Free catalogue of books. Experimenter Pub. Co., 230 Fifth Avenue, New York.

Tubes, sets, parts. Bargain prices. Literature free. Radio. N427 East 16th, New York.

Transmitters built for any Wavelength. Short Wave TUNERS, Wavemeters and parts for all sets. Immediate delivery. Lowest figures on everything. Write S & S Radio Company, 31 N. Warren St., Trenton, N. J.

100 H. 125 MA, High grade chokes \$5.75. Write for quotations and lists. Radio Parts Sales Co., Orange, N. J.

Lowest prices on parts, kits and sets. Write for list. Rissi Radio, 4827 Springle, Detroit, Mich.

Wanted—Men to work with National Radio Service Organization. No selling scheme. Co-Operative Radio Doctors, Dept. A, 131 Essex St., Salem, Mass.

Salesmen Wanted

66 Miles on 1 Gallon—Amazing new moisture gas saver. All autos. 1 Free. Critchlow, E-88, Wheaton, Ill.

Scenery to Rent

World's Most Beautiful settings for operas, plays, minirets. Amelia Grain, Philadelphia.

Song Poems

Song Poem Writers—Address Hibbeler, D7X, 2104 N. Keystone Ave., Chicago.

Song Writers

Song-Poem writers. Address Monarch, 236 W. 55th St., Dept. 122, New York.

Stamps and Coins

100 Different Stamps FREE to Approval Buyers. Postage 3c. Write NOW. Wineholt Stamp Co., Woodbine, 15, Penna.

Telegraphy

Telegraphy—Both Morse and Wireless taught thoroughly. Big salaries. Wonderful opportunities. Expenses low, chance to earn part. School established fifty years. Catalog free. Dodge's Institute, Cour St., Valparaiso, Ind.

Wanted to Buy

Full Value Paid for Old Gold, Jewelry, Watches, Diamonds, crowns, bridges, dental gold, silver, platinum, gold or silver ore; magneto points, old false teeth. Packages returned if our offer is not satisfactory. United States Smelting Works (The Old Reliable), 39 So. State St., Dept. 16, Chicago, Ill.

BOOK BARGAINS

You can save 25% to 60% on every book you buy through our wonderful bargain offer. Latest editions of Fiction, Scientific Books, Biographies, etc. More than 200 selected titles by the best authors.

Bulletin No. 25 lists all books.

FREE
BULLETIN NUMBER 25

THE CONRAD COMPANY

230 Fifth Avenue - - New York



Plug In and Tune In

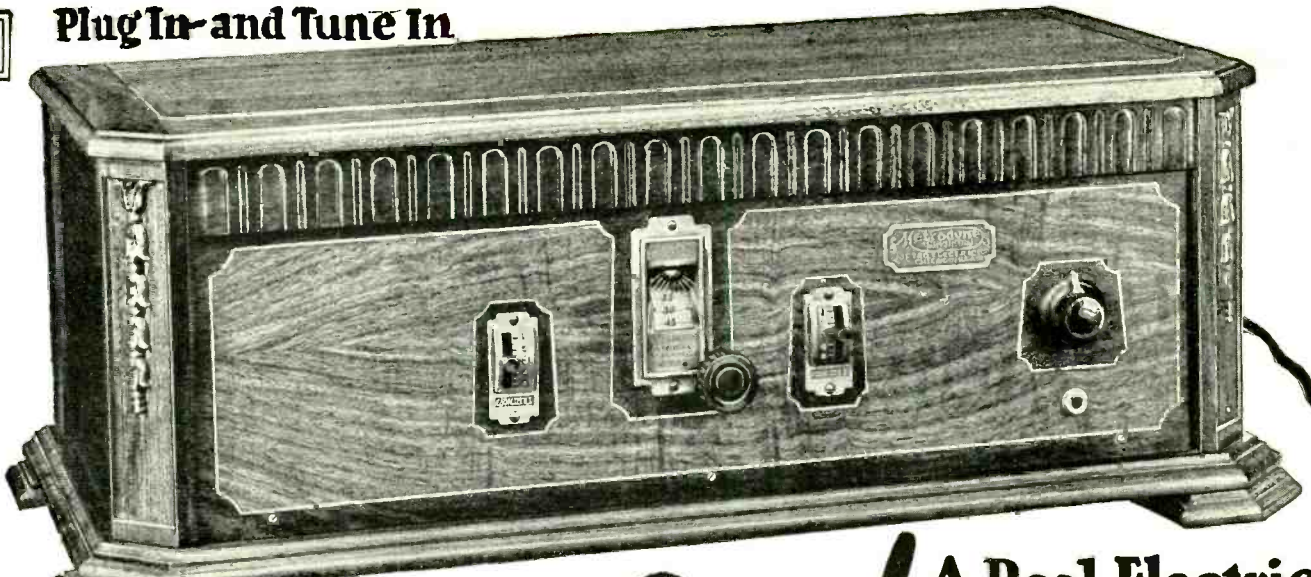

30 Days Free Trial

Now! A Real Electric Radio Set

Three Year Guarantee
 Shipped direct from our factory at rock bottom prices—cost less than most battery sets

No Batteries, Chargers or Eliminators
 No Acids; No Liquids—Plug In—Press Button—“Tune In”

Metrodyne
ALL ELECTRIC RADIO

AGENTS! DEALERS! BIG PROFITS!

Make big money taking orders for Metrodynes. All of part time. Metrodyne All Electric Radios are in a class by themselves. Unequaled for quality, performance and price. Demonstrates at home and takes orders. Lowest wholesale prices. Your demonstrating set on 30 days' free trial. Mail coupon below for details.

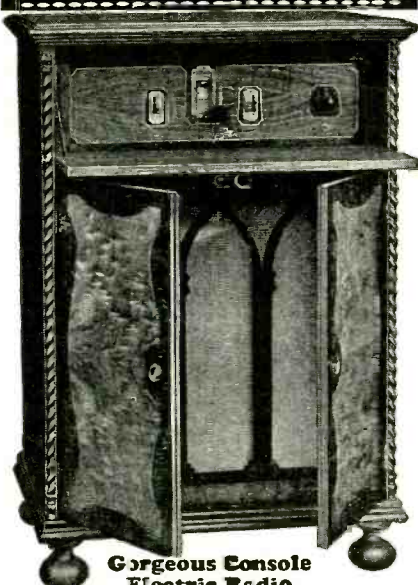

Gorgeous Console Electric Radio

Here is the Metrodyne All Electric Console Radio—a gorgeous, genuine walnut cabinet, in a beautiful two-tone finish. Has a built-in genuine Metro-Core large size speaker. Brings in programs with great volume, reproducing the entire range from the lowest to the highest notes with remarkable clearness and distinction. All metal parts are finished in old gold. Wonderful electric radio in a cabinet that will beautify the appearance of any home.

7 Tubes—Single Dial Set

100% Electric Radio

BEAUTY—EFFICIENCY DEPENDABILITY

At last! The radio you've dreamed about! If you have electricity in your home you can now really enjoy coast to coast radio reception without the care, bother and muss of batteries, chargers, eliminators, etc. The Metrodyne All Electric is a real, genuine batteryless radio set. Simply insert the plug in the socket, press the switch button and “tune in.” You could not possibly buy a better radio set than the Metrodyne All Electric, no matter what price you paid.

The Metrodyne All Electric Radio is a 7 tube, single dial set. Only the highest quality low loss parts are used throughout. Solid walnut cabinet, beautiful two-tone effect, with handsome gilt metal trimmings. Size of cabinet, 28 inches long, 13 inches deep, 10 inches high. Has electrically lighted dial so that you can log stations in the dark. Only one dial to tune in all stations. Excellent tone qualities—wonderful volume—very selective.

Costs Less Than Most Battery Sets

Do not confuse the Metrodyne electric radio with ordinary light socket sets, because the Metrodyne is truly an all electric radio—consumes less than 2c worth of power a day. Comes to you direct from the factory. Its low cost brings it down to the price of an ordinary battery set. We are so confident that you will be delighted with this wonderful, easy-to-operate batteryless radio that we offer to ship it to your home for thirty days' free trial—you to be the judge.

Mail This Coupon

We are one of the pioneers of radio. The success of Metrodyne sets is due to our liberal 30 days' free trial offer, which gives you the opportunity of trying before buying. Thousands of Metrodynes have been bought on our liberal free trial basis—**WRITE TODAY!**

METRO ELECTRIC COMPANY
 2165 N. California Ave. Dept. 602 Chicago, Illinois

METRO ELECTRIC COMPANY
 2165 N. California Ave., Dept. 602
 Chicago, Illinois

Gentlemen:
 Send me full particulars about Metrodyne All Electric Radio and your **thirty days' free trial offer.**

Name _____
 Address _____
 If you are interested in AGENT'S proposition place an "X" in the square

MAIL COUPON NOW!

new·different·better!

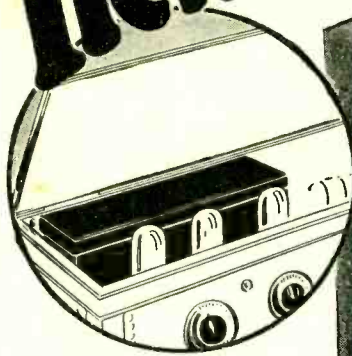

Small, thin, and compact. Fits inside of most any table-type cabinet, or slides in between books on book shelves.

The knob on the end panel operates the variable resistance (wire-wound everlasting type) which is placed in the 110 volt a.c. primary circuit. This affords you absolute mastery over line voltage fluctuations.



For
110 Volt
60 Cycle
Alternating
Current

No exposed binding posts to short or shock. Wires to the set pass thru slots in the back of the case.



2 Year
Guarantee

180 Volt TUBE TYPE "B" Eliminator
(Q.R.S. or Raytheon)

Price no longer stands in the way of enjoying a high powered, long life, thoroughly dependable "B" eliminator. For the Cloverleaf "B" is now ready for delivery—a "B" built to the highest standards of electrical practice—a "B" that supplies every voltage (up to 180 volts at 85 milliamperes) needed by the modern multi-tube radio set—a "B" eliminator that will operate a Super Heterodyne receiver and resistance coupled audio amplifiers without a trace of "motor-boating"—a "B" not affected by line voltage fluctuation and possessing a dozen other outstanding features—at a price just half what others ask! Try it FREE. Prove its superiority, before you buy.

Operates "171" Power Tube

Never before has there been a "B" eliminator at the price of the Cloverleaf which supplied enough current to operate the new high voltage power tubes. The Cloverleaf DOES. It supplies the 22-45-90-135 volt outputs for the radio frequency, detector and ordinary audio requirements of any set—then it provides 180 volts for the operation of the power tube. No buzz—no hum—no odor—no acids or liquids.

Small and Compact—Fits Inside Most Any Table-Type Set

The Cloverleaf "B" is only 3 inches wide, only 5 3/4 inches tall and only 9 inches long. Its "thin model" construction enables it to be placed inside most any radio cabinet. Or—if it must be out in full view, its handsome crystal maroon finished metal case presents a neat appearance.

THE TRUE LIFE-TIME

"B" ELIMINATOR—Finest Quality

Don't confuse the Cloverleaf "B" with cheap electrolytic or chemical "B" eliminators. The Cloverleaf is the standard gas-tube rectifier type which uses either the Raytheon or QRS tubes. Moreover, the Cloverleaf "B" is not to be classed with similar type eliminators which use only one choke coil in the filter circuit, and which use short-lived single-paper filter condensers. The Cloverleaf has two oversize chokes, has the very finest high voltage, heavy duty filter condensers that money can buy, and the best grade of wire wound resistances that can be made. A better "B" cannot be built—and no "B" eliminator offers you so many advantages as the Cloverleaf—and think! Its better quality and better construction acclaim it the true "lifetime" eliminator.

1/2 the price of others

Why pay twice the price of the Cloverleaf "B" when you can't possibly get more in performance and long life? Remember—You Take No Risk. Try it FREE. READ OUR OFFER.

TRIAL FREE!

We want you to try the Cloverleaf; to put it to any test you can. Hook it on to 8 or 10 tubes. Make it drive a power tube. Compare it with any other "B" eliminator at any price. Compare its performance—compare its many detailed advantages such as the absence of exposed binding posts and many other important refinements. Make this test at our risk under our FREE TRIAL GUARANTEE OFFER. Then decide why, if at all, you should pay more for a "B" eliminator than the ridiculously low price at which the Cloverleaf Lifetime "B" is sold. Mail coupon at once for full particulars of this great new "B," and for details of our FREE TRIAL GUARANTEE OFFER and 2 Year Guarantee.

Made by the makers of Subantenna the underground antenna whose remarkable performance has placed the Cloverleaf Mfg. Company in the enviable position of being known as makers of reliable radio apparatus

lifetime Cloverleaf "B" ELIMINATOR

Made by **CLOVERLEAF MANUFACTURING CO.**
2712-B CANAL STREET CHICAGO, ILLINOIS

CLIP AND MAIL AT ONCE

CLOVERLEAF MFG. CO.
2712-B Canal St., Chicago, Ill.

Tell me more about the Cloverleaf "B" Eliminator and particulars of your FREE TRIAL OFFER.

Name

Town

State

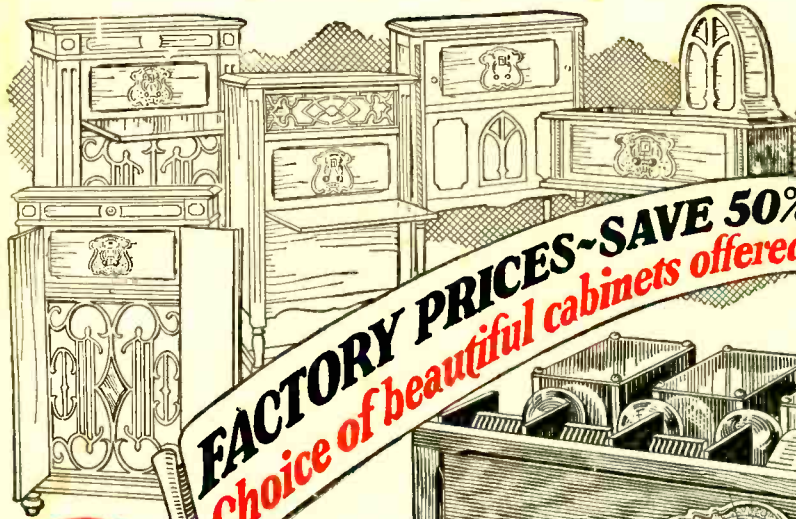

FACTORY PRICES - SAVE 50%
Choice of beautiful cabinets offered

TRY IT 30 DAYS FREE
BEFORE YOU BUY

ALL METAL SHIELDED CHASSIS

8 tube - one dial
MIRACO
TRADE MARK REGISTERED

Only \$69⁷⁵
Retail List Completely Assembled

MAGNIFICENT TONE - SUPER SELECTIVE - POWERFUL DISTANCE GETTER

All Electric or Battery Set!

America's big, old, reliable Radio Corporation* (8th successful year) *guarantees* its big, powerful, latest 6, 7 and 8 tube Miraco sets to give "the finest, most enjoyable performance obtainable in high grade radios." Unless 30 days' use in your home fully satisfies you and everybody who hears it that a Miraco is unbeatable at any price for beautiful, clear cathedral tone, razor-edge selectivity, powerful distance reception, easy operation, etc. — *don't buy it! Your verdict final!* — absolutely no strings to this. Save or make lots of money on sets and equipment by writing for testimony of nearby users and *Amazing Special Factory Offer.*

choice. Many thousands of Miraco users — who bought after thorough comparisons — testify they enjoy programs Coast to Coast, Canada to Mexico, loud and clear — with the magnificent cathedral tone quality of costliest sets. Don't confuse Miraco's with cheap, "squawky" radios. Miraco's have finest parts, latest approved shielding, metal chassis, etc. — as used in \$200 sets.

Big Discounts to User-Agents

7 tube one dial METAL SHIELDED CHASSIS
\$49⁷⁵
RETAIL LIST

MIRACO "Powerplus" sets — both in 8 and 7 tube models — have magnificently beautiful, clear cathedral tone quality. Turn one dial for stations everywhere. Ultra-selective. Miraco multi-stage distance amplification gives "power-plus" on far-off stations. Latest all-metal shielded chassis. Illuminated dial. Fully guaranteed. *Try one free for 30 days!* Choice of beautiful cabinets.

Run from Light Socket or Batteries
Miraco's work equally fine on electric house Dealers Write! current or with batteries. Take your

Deal Direct with Big Reliable Makers
 Your Miraco reaches you completely assembled, rigidly tested, fully guaranteed. Easy to connect and operate. *30 days free trial.* 1 year guarantee if you buy. Choice of beautiful consoles [with latest built-in orthophonic type speakers having 8 feet of tone travel] and table cabinets, also offered. You take no risk, you insure satisfaction, you enjoy *rock-bottom money-saving prices* by dealing direct with one of radio's oldest, most successful builders of fine sets.



USER-AGENTS! Make big profits showing your Miraco set to friends
 *MIDWEST RADIO CORPORATION, Cincinnati, O.

Free!

BEAUTIFULLY ILLUSTRATED CATALOG AND AMAZING SPECIAL OFFER

SEND NO MONEY. — 30 DAYS' TRIAL
 Special Wholesale Price Offer to User-Agents, Bank References and testimony of nearby Miraco users — sent with catalog.

Electrify Any Radio
 with **MIDWEST NO-BATTERY "A-C" Light Socket Power Units**



"A", "B" and "C" power, direct from light socket, without batteries! Write for Midwest prices and discounts. Midwest Units are highest grade — lastingly dependable, quiet in operation, fully guaranteed.

Amazing value as 30 Days' Trial Will Prove

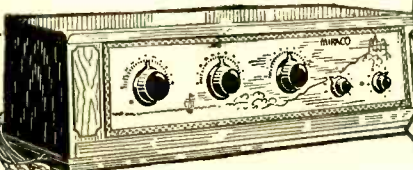

6 tube Super \$36⁷⁵ RETAIL LIST

Mail Coupon Right Now

MIDWEST RADIO CORPORATION
Pioneer Builders of Sets
 404-A Miraco Building, Cincinnati, Ohio.

THIS COUPON IS NOT AN ORDER

Without obligation, send free catalog, **AMAZING SPECIAL OFFER**, testimony of nearby Miraco users.

NAME

ADDRESS



Unseen Precision

YOU cannot measure CeCo Tube performance and quality with a micrometer. Only the "yard stick" of experience, scientific skill and experimentation can determine the super-value of CeCo Tubes in steadiness, clarity, volume, longer life. If your technical skill and equipment qualify you to make an engineering test of CeCo Tubes, we invite you to do so. If not, we direct your attention to the recommendations of authorities (whose opinions are of unquestioned weight in the world of radio), including Browning, Lynch, Cockaday, Harkness, Hurd, Best, Bernard, Henney and others. All have used and recommended CeCo—The Tube of Longer Life.

*Ask Your Radio Dealer for
Complete Data Sheet or write direct to*

C. E. MFG. CO., Inc. Providence, R. I., U. S. A.

Largest exclusive Tube Manufacturers in the World.

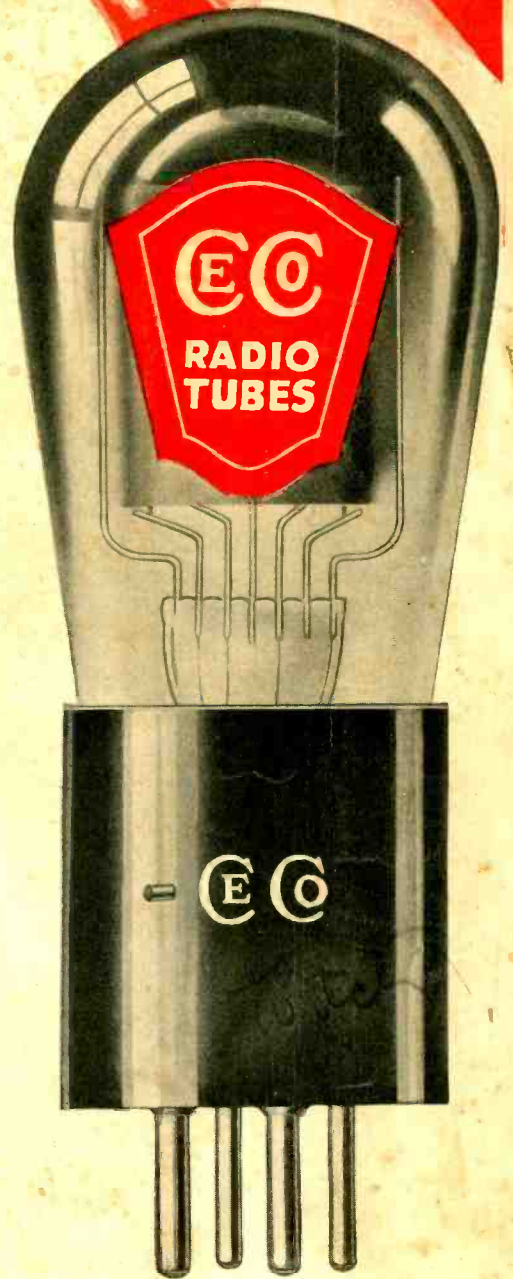

**There's a CeCo Tube
for Every Radio Need—**

- General Purpose Tubes
- Special Purpose Tubes
- Power Tubes
- Filament Type Rectifiers
- Gas Filled Rectifiers
- A. C. Tubes