

RADIO NEWS

REG. U.S. PAT. OFF.

25 Cents

April-May

1922

Over 125 Illustrations

Edited by H. GERNSBACK

HOW TO MAKE THE
RADIO CONCERTA
SEE PAGE 930

OVER
40 SPECIAL
RADIO
ARTICLES
FOR THE
BEGINNER



CIRCULATION LARGER THAN ALL OTHER RADIO MAGAZINES COMBINED

CUNNINGHAM VACUUM TUBES

CUNNINGHAM
C-300
GAS CONTENT
DETECTOR

\$ 5⁰⁰



For
**HOME
RECEIVING
SETS**

*Amplifies
as it
Detects*



The trade mark GE is the guarantee of these quality tubes. Each tube is built to most rigid specifications.

THROUGHOUT the entire country today Cunningham Type C-300 Gas Content Detector Tube is recognized as the ideal tube for use in Home Receiving Sets.

For clear reception of Concerts, Market Reports, Stock Quotations, etc., sent out by radio, this tube cannot be excelled.

The one tube which gives the best results used with any type receiving set applicable to wave lengths of 100 and 3000 meters for both spark and C. W. Telegraph and Telephone, this Cunningham Detector Tube is being purchased everywhere by those operating Home Receiving Sets.

In addition to its remarkable detector properties, low B. battery, quietness in operation, it is a free and persistent oscillator for regenerative amplification and C. W. reception and functions without distortion of the received signals.

Many wonderful tributes have been paid this tube by those who have achieved the remarkable results that it always gives.

Your nearest dealer will gladly give you full information about this tube or write direct to us.

E. J. Cunningham

Trading as

AUDIOTRON MFG. COMPANY

248 First Street
San Francisco, Calif.

154 West Lake Street
Chicago, Illinois

LEARN ELECTRICITY

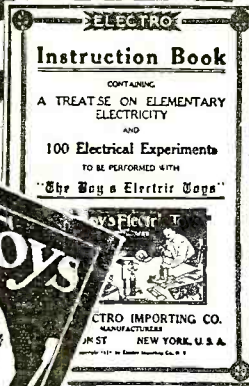
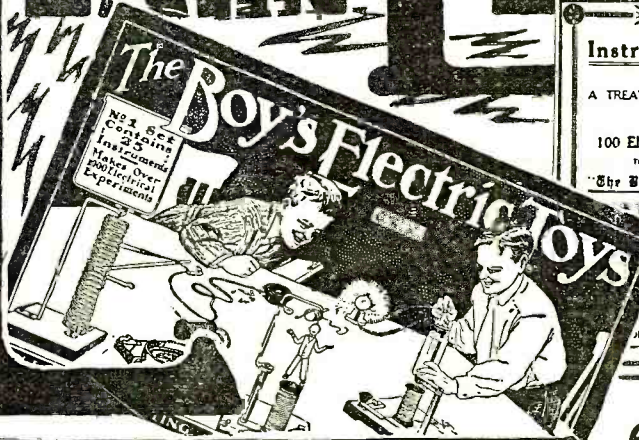

The BOY'S ELECTRIC TOYS

As Shown
\$7.50
Complete

Teaches you all the principles of electricity by the "Learn by Doing" Method. Entertaining, Instructive, More Fascinating than any game. The most complete electrical experimenters' outfit that has ever been put on the market.

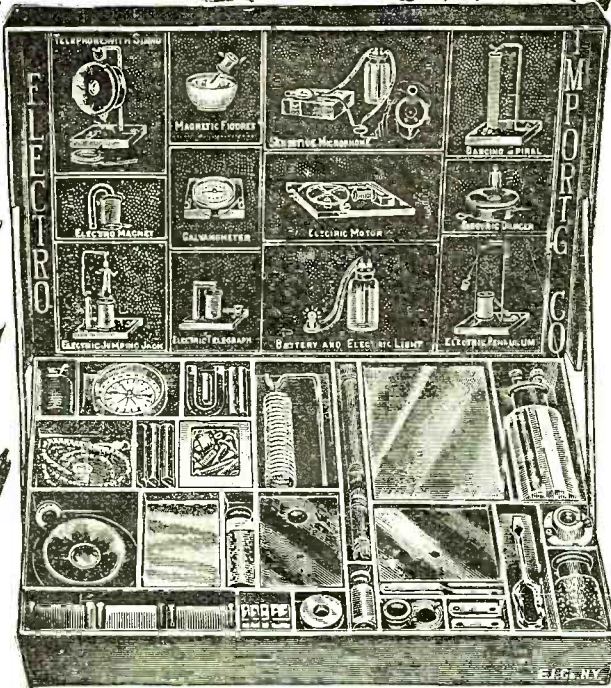

Valuable Electrical Instruction Book With Each Outfit

With each outfit we furnish free a very comprehensive book of electrical instruction. All the fundamentals of this fascinating science are clearly explained so even a layman can understand every word. Profusely illustrated. The instructions for building the apparatus are given in such a simple and easily grasped manner that anyone can make them without the least trouble. Over a hundred experiments that can be performed with the outfit are listed in the instruction book, nearly all of them illustrated with superb drawings.

A Sample of What You Can Do With This Outfit

This illustration, made from an actual photograph, shows only a very few of the many instruments that can be made with the Boy's Electric Toys: Electric Pendulum, Electric Telegraph, Current Generator, Dancing Spiral, Galvanometer.

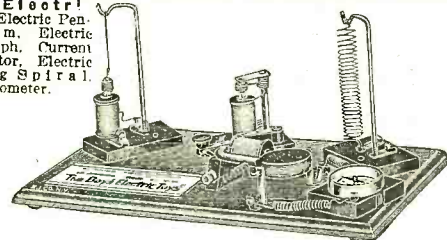

The outfit contains 114 separate pieces of material and 24 pieces of finished articles ready to use at once. Among the finished material are included: Chromic salts, lamp socket, mercury, core wire, iron filings, three spools of wire, carbons, machine screws, flexible cord, wood bases, glass plate, paraffine paper, binding posts, screw-driver, etc. etc.

Teaches You How To Build Electrical Apparatus

THE BOY'S ELECTRIC TOYS contains enough material to make and complete over twenty-five different electrical apparatus without any other tools, except a screwdriver furnished with the outfit. The box contains the following complete instruments and apparatus which are already assembled:

Student's chromic plunge battery, compass-galvanometer, solenoid, telephone receiver, electric lamp. Enough various parts, wire, etc. are furnished to make the following apparatus:

Electromagnet, electric cannon, magnetic pictures, dancing spiral, electric hammer, galvanometer, voltmeter, hook for telephone receiver, condenser, sensitive microphone, short distance wireless telephone, test storage battery, shocking coil, complete telegraph set, electric riveting machine, electric buzzer, dancing fishes, singing telephone, mysterious dancing man, electric jumping jack, magnetic geometric figures, rheostat, erratic pendulum, electric butterfly, thermo electric motor, visual telegraph, etc., etc.

Shipment guaranteed within 24 hours.

SEND NO MONEY

We have so much confidence in this set that we desire to ship it to you C. O. D. with the privilege of inspection. It does not cost you one cent to take a good look at the outfit, and see if it comes up to your expectations. If it does, pay the postman \$7.50, plus shipping charges. If it does not, you need not accept it, and we will pay the return charges as well.

THE ELECTRO IMPORTING CO.
231 Fulton St., N. Y. City

ELECTRO IMPORTING CO.
231 Fulton St., N. Y.

As per your advertisement, ship to me at once, C.O.D., the Boy's Electric Toys with privilege of inspection. It is understood that if I do not like the outfit I can refuse it.

Name

Address

City State

(RN 4-22)

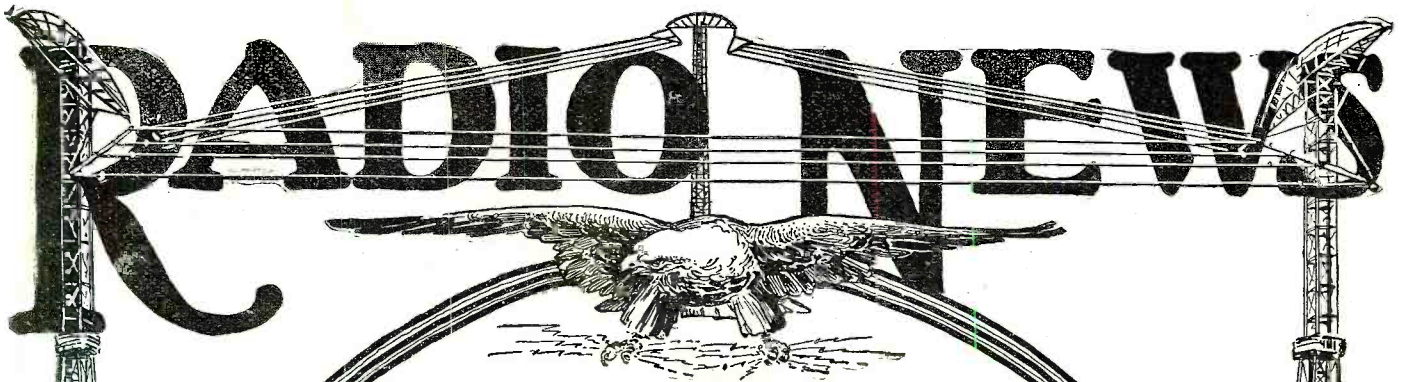

CONTENTS

VOL. 3

FOR APRIL-MAY

No. 10-11

	PAGE
Editorial. By H. Gernsback.....	921
Improved Land and Marine Pattern Wire- less Direction Finding Cabinets, By Maurice E. Pelgrims	922
The Super-Phone	924
A Compact Portable Loop Aerial Receiver By S. R. Winters	924
Portable Radio Telegraph-Telephone Set, By Maurice E. Pelgrims	925
The New York Radio Show.....	926
The Operating Principles of a Radio Com- pass.....By Paul G. Watson	928
Audio Frequency Transmission, By E. H. Hansen	929
Aerials. By Fred A. Burgess.....	929
How to Make a Radio Concerta, By Robert E. Lacault	930
A Study of the Antenna System, By C. M. Grabson	931
The Station Annunciator, By John F. Bront	931
Resistance in High Frequency Work, By Louis Frank	932
A Capacity Increase Method of Reception, By Victor H. Laughter	933
Design of Radio Receiving Loop Antenna, By R. R. Batcher	933
A Practical Loading Coil Unit, By D. R. Clemons	934
Multiple Coil Tuner, By E. F. Batcheller	934
The Construction of an Experimental Radio Set.....By John R. Meagher	935
A Five and Ten Watt C.W. and Radioph- one Transmitter...By Florian J. Fox	936
How to Make Regenerative Receiver and Single Stage Amplifier.....	938
A Super-Selective Receiver, By Samuel Kopelson	938

	PAGE
A Practical 50-5000 Meter Wavemeter, By D. R. Clemons	939
Useful Hints for the Amateur, By John Brennan	939
Radio Telephony, By Louis Gerard Pacent	940
The New Radio Legislation, By H. Gernsback	944
The New Radio Broadcasting Station WGY	945
Methods of Transmission Used in Broad- casting Stations	946
Fort Wood Broadcasting Station WVP.	947
Washington Notables Listen In.....	948
Radiophone for Trains.....	949
Talking from Office to Ship at Sea.....	949
Freak Receiving Sets.....	950
A Portable Regenerative Receiver.....	951
The Crystal....By Bernard Greensfelder	956
A Discussion of the Relative Merits of Different Forms of Receiving Apparatus for Use in Broadcasting Work, By Arthur H. Lynch	957
Some Useful Ideas.....	959
An Easily Constructed 180-800 Meter Re- generative Receiver, By John R. Meagher	960
An Efficient Crystal Detector, By Leigh E. Charwick	961
The "Two in One" for Radio Amateurs, By Roy Anderson	961
Two-Step Amplifier for Twenty-Five Dollars.....By Victor Andrews	962
An Original Type of Tuner-Coupler Coil, By F. W. Draper	962
Sensitive Crysta Receiving Set, By Harry L. Gray	963
A 30-Volt "B" Battery for One Dollar, By Edwin W. Wilson	964
Radio Digest	967
Who's Who in Radio—John V. L. Hogan	968

RADIO NEWS is published on the 25th of each month at 233 Fulton Street, New York. There are 12 numbers per year. Subscription price is \$2.50 a year in U. S. and possessions. Canada and foreign countries, \$2.75 a year. U. S. coin as well as U. S. Stamps accepted (no foreign coins or stamps). Single copies, 25 cents each. A sample copy will be sent gratis on request. Checks and money orders should be drawn to order of EXPERIMENTER PUBLISHING CO., INC. If you should change your address notify us promptly, in order that copies be not mis-carried or lost. No copies sent after expiration. All communications and contributions to this journal should be addressed to Editor, RADIO NEWS, 233 Fulton Street, New York. Unaccepted contributions cannot be returned unless full postage has been

included. All accepted contributions are paid for on publication. A special rate is paid for novel experiments; good photographs accompanying them are highly desirable.

RADIO NEWS, Monthly. Entered as second-class matter June 8th, 1919, at the Post Office at New York, N. Y., under the Act of March 3, 1897, Title registered U. S. Patent Office. Copyright, 1921, by E. P. Co., Inc., New York. The Experimenter Publishing Co., 233 Fulton Street, N. Y., N. Y. The Contents of this magazine are copyrighted and must not be reproduced without giving full credit to the publication.

RADIO NEWS is for sale at all newsstands in the United States and Canada; also at Brentano's, 37 Avenue de l'Opera, Paris.

Published by EXPERIMENTER PUBLISHING CO., INC., 233 Fulton Street, New York City
Publishers of Radio News and Science and Invention

H. GERNSBACK, President S. GERNSBACK, Treasurer R. W. DEMOTT, Secretary

GREBE RADIO

“He who wishes to know the road through the mountains must ask the experienced traveler.”

In seeking the right path in Radio, let GREBE be your guide.

Doctor Mu

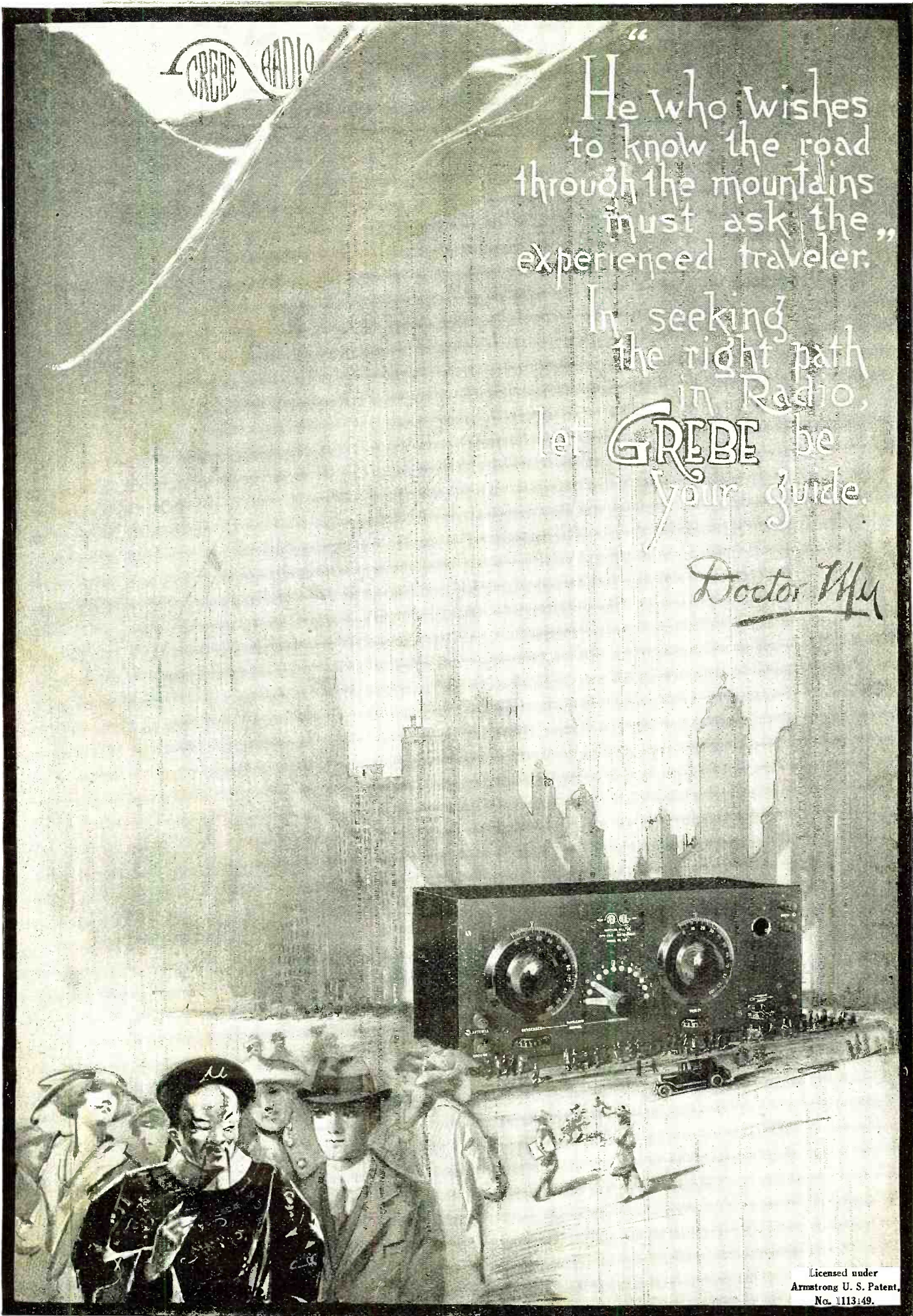

Licensed under
Armstrong U. S. Patent,
No. 111349.

Frost-Radio

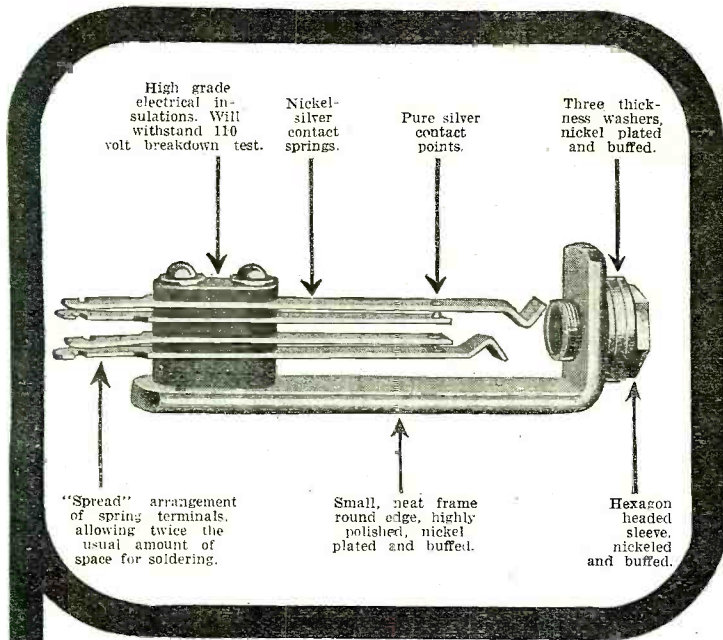

Improved JACKS and PLUG

Specially Designed for Radio Panel Work

INTERCHANGEABLE WITH OTHER STANDARD MAKES

Cuts are actual size

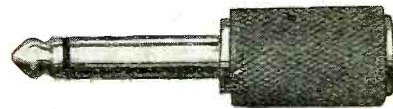

No. 132. Plug only, \$1.00

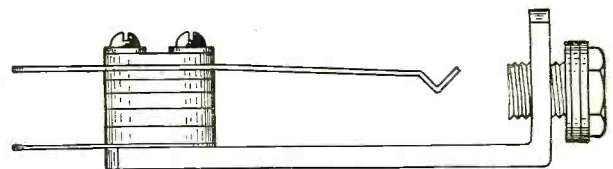

No. 133. Jack only, \$.65

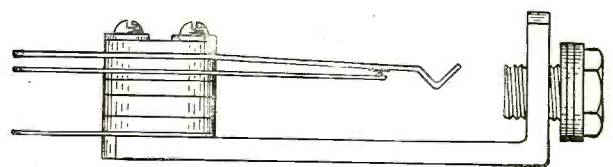

No. 134. Jack only, \$.75

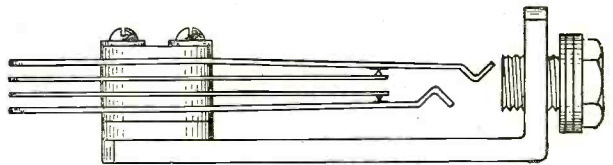

No. 131. Jack only, \$.90

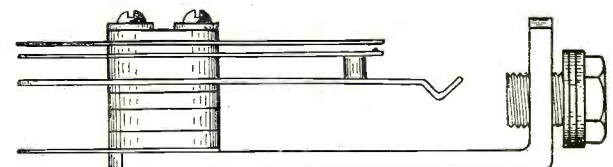

No. 135. Jack only, \$1.00

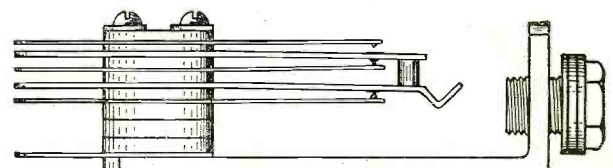

No. 136. Jack only, \$1.25

The smallest, neatest, most perfectly finished jacks and plugs that have ever been offered to the Radio trade. They have been specially designed for panel work and are of standardized construction so as to be interchangeable with other standard makes.

A particularly desirable and exclusive feature of the FROST-RADIO Jack is the "spread" arrangement of the spring terminals which allows twice the usual amount of space for soldering to the wiring. These terminals are heavily tinned.

Another striking feature is the nickel plated and highly buffed finish used throughout.

Sturdy construction, perfect spring adjustment, gripping contact of springs on tip and sleeve of plug.

Packed in individual containers.

Two-color wall posters now ready for Dealer distribution.

WE ARE NOW IN QUANTITY PRODUCTION AND ARE MAKING IMMEDIATE DELIVERIES.

Attractive Discounts to Distributors and Dealers. Write or wire for proposition and samples.

HERBERT H. FROST

154 W. Lake Street
Chicago, Ill.

THE CORRECT ANSWER To the "B" BATTERY PROBLEM

\$14.00

50 VOLTS
2 VOLT
STEPS

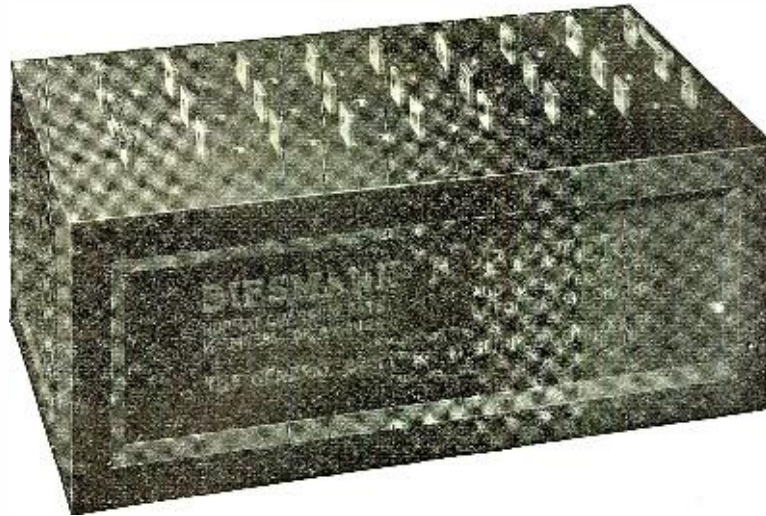

\$14.00

EASILY
CHARGED
LONG LIFE



THE BIESMANN "B"

FULLY GUARANTEED



COMBINATION DETECTOR *and* AMPLIFIER BATTERY

24 cells, individually tapped, permitting use of any voltage from 2 to 50 volts in steps of two volts each. Provides a noiseless circuit for the receivers. The electrolyte is a semi-solid; cannot spill or leak. One piece cast "Rub-Tex" Indestructo case, of which the individual cells are a part. Highly polished and neat in appearance. Pasted type plates especially developed for Radio service. Can be re-charged at any Battery Service Station, or on any type of vibrating rectifier by using the circuit provided with the battery. Complete instructions with each battery. Contacts between cells easily accessible. Over-all dimensions; 9 inches long, 4½ inches wide, 4½ inches high.

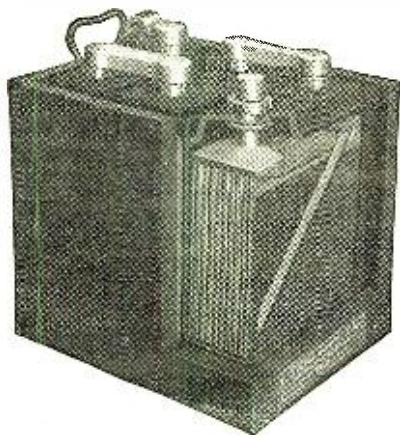

The "BIG SIX" A-BATTERY

A FEW FACTS BRIEFLY STATED

Semi-solid electrolyte which cannot spill—No injurious sulphation—Plates will not buckle—Highest electrical efficiency and voltage maintenance—Quickly and easily recharged—Can stand idle indefinitely without injury—Superior physical properties—Hard wood case.

THE "BIG SIX" IS FULLY GUARANTEED AS TO LIFE, CAPACITY, ELECTRICAL EFFICIENCY, DESIGN AND WORKMANSHIP

6 volts— 40 Ampere Hours	\$20.00
6 volts— 60 Ampere Hours	22.00
6 volts— 80 Ampere Hours	25.00
6 volts—100 Ampere Hours	28.00

Furnished in one piece cast "Rub-Tex" Indestructo case at an additional charge of \$2.00 on each battery.

MANUFACTURED BY
General Battery and Supply Co.,
CHICAGO, ILLINOIS

JOBBERS
Write For Our Interesting Sales Proposition

SOLE DISTRIBUTOR

HERBERT H. FROST, 154 West Lake St., CHICAGO, ILLINOIS

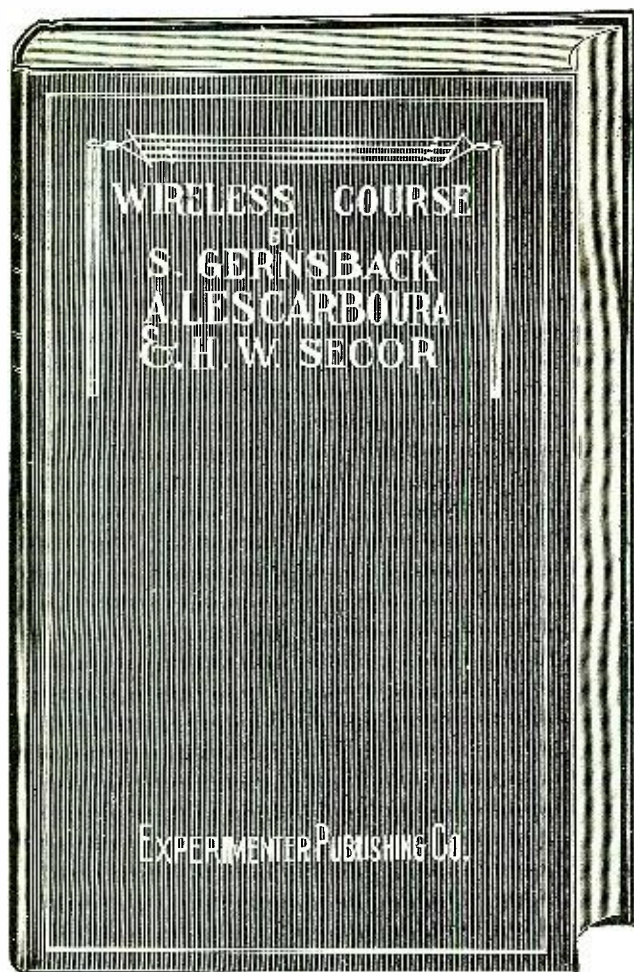

WIRELESS COURSE

in 20 Lessons

By

**S. GERNSBACK, H. W. SECOR,
A. LESCARBOURA**

Beautifully Stiff Bound
in Red Cloth
Gold Stamped
Size 7 x 10 inches
160 Pages
20 Lessons
360 Illustrations
30 Tables
Price \$1.75 Prepaid



Exactly the Same Books
But Soft Bound,
and not Gold Stamped
Price \$1.25, Prepaid

THIS Course has been considerably revised in order that it meet some of the many important changes which have occurred in Radio Telegraphy and Telephony within recent years. Much valuable data and illustrations concerning the Vacuum Tube has been added. This comprises the theory of the Tube as a detector and as an amplifier, and in addition has been included modern amplification circuits of practical worth. Incidentally, space has also been devoted to the development of the Radio Compass as operated and controlled by the United States Navy with its consequent great aid to present-day navigation.

The beginner and general student of radio will find this Course of great value in securing the necessary fundamentals of a most fascinating and instructive vocation, or avocation—as the case may be. Radio holds out considerable inducements as a career.

The Publishers

**The Experimenter
Publishing Co., Inc.**
236 FULTON STREET
NEW YORK, N. Y.

The Experimenter Publishing Co., Inc.
236 Fulton Street, New York, N. Y.

Enclosed find \$1.75 for which send me one copy of
 stiff
 soft bound WIRELESS COURSE. Postpaid.

Name

Town

Address

State

Learn Radio Free At Sweeney Auto School

Radio 'Phones from Sweeney School Talk to You Anywhere in U. S. Sweeney's Great Sending Station Carries Concerts, Auto News and Live Information From The Million Dollar Trade School

Free to Auto Students Receive messages — learn to build your own set—get familiar with radio work—all this in-struction now part of the regular eight weeks' Mechanics' and Electricians' course without a cent extra charge. The world is radio mad. The "voices in the air" seem to be the most wonderful development of years. Every mechanic should know something about this work. He is the right man to sell and install radio sets. I am not offering a course to make commercial operators. I am simply giving free some intensely interesting experience. When you come to the Sweeney School you come to learn by practical experience, motor mechanics and allied subjects with the intention of fitting yourself for a real job and good pay. But will it not interest you to pick up messages from all over the world; to hear concerts; to hear San Francisco and New York talking to you? Will it not interest you to learn to make your own radio receiving set so that when you go back home you can listen in any time on the Sweeney service? The Sweeney School is always the leader. That's why I am erecting one of the world's largest sending stations. That is why I am offering you young men mechanically inclined this FREE opportunity to learn something about radio telephony.

FREE I will gladly send my 72-page illustrated catalog FREE. Also a copy of the "Sweeney School News," a most interesting monthly school paper published here. You will enjoy them. Read the worthwhile stories of men like yourself who came to Sweeney's and found success. Read how Frank Powell and Harry Wilson built up a \$20,000 business in about two years after graduating. \$20,000 built up a \$25,000 yearly garage business at Clearmont, Mo. These stories and others are told by the Sweeney students. Also I want you to learn how my students enjoy themselves after work in the swimming pool, club and reading rooms, etc. No colored students accepted. GET THE FREE RADIO COURSE NOW.

EMORY J. SWEENEY, President

Send the Coupon Right Now

LEARN A TRADE
Sweeney
SCHOOL OF AUTO-TRACTOR-AVIATION
1007 SWEENEY BLDG. KANSAS CITY, MO

Learn a Trade and Get a Good Job I know that there is a great future for you as a trained motor mechanic. The only question is, Are you Mechanically Inclined? If you are, then TODAY IS YOUR OPPORTUNITY. No matter what you are doing—what you have been doing—I am sure that the automotive business offers you bigger—better—more prosperous future.

Begin Right That's what I want to impress upon every man who sees the great future in the automotive business. COME TO SWEENEY'S, the School of Practical Experience. Sweeney graduates are in every part of the United States and in foreign countries—over 46,000 of them—and they are loyal Sweeney boosters. They are proud of THEIR SCHOOL—their success in business is creating demand for these men. Hundreds of letters come to my desk—these boys of mine write me personally—they want SWEENEY GRADUATES—every day—every week brings new openings. Again I say, START RIGHT—come direct to the SWEENEY SCHOOL—and in eight short weeks you will have a Sweeney Diploma—it commands recognition for you. Don't delay—send for my BIG FREE BOOK today—I want to tell you of my Big New Wireless Telephone Offer—this is in addition to my regular—it's the greatest offer that I have ever made.

Good Jobs for You With your radio experience here you can go back home and install receiving sets or sell them. You can make sets for yourself. You can run a garage. You learn how to weld a broken crank case. You learn how to make a real 4,000-mile tire from old casing and rubber. You can be a chauffeur or truck driver. You can be an auto mechanic—a repair man in a shop or factory. Learn about stationary engines. Learn tractor work. Be a demonstrator or salesman. Hundreds of good jobs open to Sweeney trained men. Even before he finished his course Runsey was grabbed by the American Radiator Co. at \$150 a month as an expert welder.

WHO IS THE RIGHT MAN?

to have the agency for or make radio receiving sets? To install sets? The garage man or auto mechanic? At the Sweeney School learn how to handle radio work. Get an agency for a \$25 receiving set. The first week you are home you can EARN the whole cost of your school tuition.

For Big Free Catalog Mail This Coupon Today!

EMORY J. SWEENEY, President
Dept. 1007 Sweeney Bldg., Kansas City, Mo.
Send me free without any obligation your 72-page catalog and your Sweeney School News. Tell me of the opportunities in the Auto and Tractor Business.
Name
P. O. State.....

**Ready
April 20th**

**A New Radiophone
Easily Operated By A Child**

Will receive broadcast
radio entertainments
within a radius of fifty
miles—*clear as a bell*

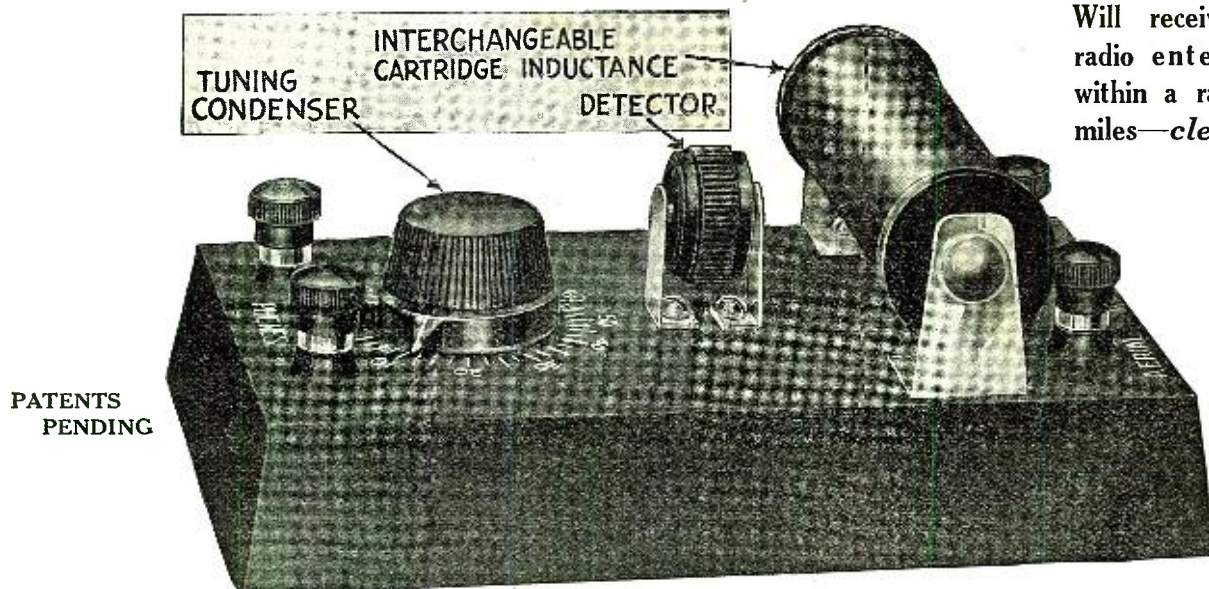

Price \$12.50

(Without Phones)

NATIONAL AIRPHONE

(MODEL G)

This set has been perfected by experts in the design of Radio Receiving Apparatus—to meet the very exacting requirements that the most recent developments in the Radio Art have made necessary.

Outstanding Points of Superiority:

1. Ultra-sensitive Foolproof Detector; entirely enclosed in composition case. Air and dust proof, no fussy minerals, no Catwhisker, no balls nor spring. To adjust for maximum sensitivity simply rotate the black disk slowly.
2. Most Compact Radiophone Receiving Set Made: $6\frac{1}{2}$ " long, $4\frac{1}{4}$ " wide, $2\frac{3}{4}$ " high,—small enough to put in coat pocket or desk drawer.
3. Entire casing constructed of hard rubber composition. No wood, no warping, no losses through leakage.
4. Rugged construction throughout, nothing to get out of order, insuring long life in service.
5. Elimination of all switches, current taps and switchpoints prevent loss of electrical energy.
6. Use of interchangeable cartridge coils gives wide range over which radiophone broadcast or radio telegraph signals can be heard. 25 miles or over for radiophone concerts; up to 1000 miles for telegraph signals depending upon coils used.
7. Two Cartridge tuners, wave length 150 to 400 meters supplied with each outfit, one takes in general broadcasting stations (360 meters), the other from 500 to 1000 meters.
8. Anyone without previous experience can operate a NATIONAL AIRPHONE, no delicate adjustments necessary, no fussing.
9. Variable Mica Condenser used is acme of simplicity—high capacity, impossible to short-circuit.

We are now ready to assign territory to Jobbers and Dealers who will appreciate the advantages of a well designed serviceable and efficient outfit.

TRADE MARK **NATIONAL AIRPHONE CORPORATION** REG. U.S. PAT. OFF.
20-22 Hudson St. **New York City**



RADIO NEWS

H. GERNSBACK—Editor
ROBERT E. LACAULT—Associate Editor

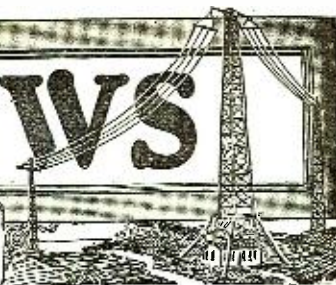

Vol. 3

APRIL-MAY, 1922

No. 10-11

Is Radio a Fad?

WE are often wont to hear at the present time the remark made that Radio is nothing but a fad, and that while the public at large has gone wild about everything connected with Radio, it will soon wear off, like all other fads. That Radio is not a fad, but on the contrary that it is here to stay permanently, and grow into undreamt of proportions can be easily proven in dozens of different ways.

In the first place, a Radio entertainment, broadcasted as it is, by our various stations now, is life itself. When you go to a moving picture show, or when you listen to a phonograph concert, you are always conscious of the fact that neither is alive. Radio, on the contrary, is pulsing life itself. Why do more people use the telephone than the telegraph? One reason is that the telephone is a live instrument, while the telegraph is not. You can converse with your friend by telephone, you can hear his voice, and you can talk with him almost in the same way as if you were face to face. You cannot do this over the telegraph. This is one of the reasons the Radio telephone will never be a fad, but it will become dearer and closer to us as the years go by.

One of the greatest attractions of the radio broadcast to-day is that it is not only absolutely free without any cost whatsoever to the listener, but the entertainment is convenient as well, for the reason that we do not have to transport our bodies in order to listen to the entertainment, as we must do when we go to the theatre or concert.

In these days, of hectic rush, when our lives are so complex, people prefer to stay at home evenings and listen to the entertainments there, and that is precisely why Radio has taken such a tremendous hold upon the popular imagination. That Radio is taking on undreamed of proportions might perhaps best be shown in a rather unexpected way.

In one of the dramatic periodicals of the month we find the amazing statement that the managers of two of the best known theatrical chains will dismiss any and all singers, actors, or actresses who give Radio entertainments over the broadcasting stations! In other words, our vaudeville and moving picture houses are afraid of Radio to such an extent that they already see ruin staring them in the face because the managers think that everybody will stay at home instead of frequenting their theatres. Of course, this is all pure nonsense and the theatrical managers should be the first ones to realize it. It was proven, for instance, recently when one of the Broadway musical comedies was broadcasted by Radio, that the attendance the week after was greater than ever, thousands of people being turned away because they could not buy tickets.

Why? Exactly for the same reason that when Douglas

Fairbanks and Mary Pickford stay at a hotel no matter in what town, there will be a rush to see them in the flesh. It is exactly so with the radiophone. When they hear an actor's or an actress' voice over the radiophone, it certainly creates a desire among a great majority of the people to hear the performer in person. The radio broadcasting stations, therefore, do more to successfully advertise the performance than all the handbills and all the newspaper advertisements combined.

Another novel point in the trend of the times was recently shown when certain music publishers banded themselves together and declared that the radiophone broadcasting stations, when sending out copyrighted music, were violating the copyright! We would not be surprised soon to have special copyright notices printed on all new musical selections somewhat as follows: "This selection must not be used over the radiophone without special permission of the owners." We can see where the composers will derive the same swollen incomes from the radiophone as they derive from the phonograph records.

A recent newspaper clipping from Philadelphia reports the fact that many new houses are now being equipped with aerials, one for each tenant. We wager that within five years houses will give a free antenna with every apartment. This will be a big factor to rent houses more quickly, once the shortage has been corrected.

In the New York *Times* of Sunday, March 19th, we read where the Alexandria Hotel Co. has called for bids on radio equipment for its new hotel at Long Beach, L. I. This hotel will have 600 rooms and there will be 600 radio receiving sets, one for each room! It is claimed that it will cost \$150,000 to put the plan into effect, and of course in a case of this kind, it would not do to string 600 separate aerials on the roof, unless we design a new architecture for radio hotels, to which, however, we have not come as yet. So the Alexandria will probably have loops in every room, with which the guests can play to their hearts content. We wager right now that the hotel will be a "howling" success, especially if the amplifiers get out of tune and howl as they sometimes are wont to do.

We have stated before in these columns that Radio is here to stay. With all the millions of dollars of capital being poured into the new industry, it will be readily understood why radio will never be a fad. We are now in exactly the same position as the automobile was when it first made its debut. The Radiophone is in practically the same position to-day as was the automobile when people said that it was only a fad, as the bicycle was, and would die out sooner or later. The Radio industry soon will rival the automobile industry and this is only a modest prediction.

H. GERNSBACK.

Notice

Due to the fact that we are now printing an edition which is almost five times as large as that printed four months ago, we have fallen behind in our schedule and for this reason the present issue is the April-May number, we having combined two issues together. *The next number*

will, therefore, be the June number.

In order that no one will be the loser, we have advanced all subscriptions on record for one extra month to take care of the change.

THE PUBLISHERS.

Improved Land and Marine Pattern Wireless Direction Finding Cabinets

By MAURICE E. PELGRIMS



Fig. 1. Direction Finding Set for Use on Board Ship. Only One Adjustment is Required to Tune This Compact and Durable Outfit.

THE wireless direction finding apparatus has developed during the past two years to such a point as to become a practically indispensable aid to navigation. The British Marconi Company recently adopted two new pattern D.F. receivers, which have the advantage of being very compact, the complete apparatus being combined in one cabinet, thus reducing the amount of space occupied to a strict minimum, while maintaining the highest factor of efficiency obtainable.

The Marine type, Fig. 1, has been especially designed for use aboard ship. It is particularly easy to operate, as there are no complex tuning adjustments, all that is necessary in this direction being effected by turning one handle; at the same time the sharpness of tuning is satisfactorily maintained, and owing to the incorporation of an amplifying detector of the most recent type, the receiving range is very considerably augmented. A simplified diagram of connections of this receiver is given in Fig. 2. With the exception of the two batteries and the operator's phones, the whole apparatus is contained in one small compactly designed unit, the general appearance of which is illustrated in Fig. 1.

In the strong teak case forming this unit are four metal-lined electrically shielded compartments for the four component pieces of apparatus, the direction finder, the transformer, the tuning condenser and the amplifying detector. Each component is built up on an ebonite panel corresponding in size to the front of its compartment, and is held in position by ebonite capped brass holding down screws, which also serve as electrical connections. This type of construction permits of any component being easily and rapidly removed for inspection and cleaning without in any way disturbing the remainder of the gear and without the necessity of breaking any soldered joints. It also facilitates the adaptation of the standard receiver to the special requirements of any unusual service, and in case of accidental damage permits of any component being replaced on the spot, thus avoiding the necessity of returning the complete unit for repair.

The direction finder component may be described as a "tightly coupled" high-frequency transformer having two independent primaries or field coils at right angles, embracing a rotatable secondary coil as indicated diagrammatically in Fig. 3. Each of the field coils has its center point earthed and is in circuit with one aerial (Fig. 4), and the search coil is connected to the detector through the special transformer described below. The function of the direction finder is to combine the signals received on the two aerials in such a manner that the movable search coil is influenced by them when it lies in a plane corresponding to the direction from which they are received, and is unaffected when it lies in a plane at right angles. The search coil is most strongly influenced when it embraces as much as possible of the field due to the fixed coils, and each aerial receives best from a transmitting station in its own plane. Thus, if the sending station lies in the plane of the aerial A, the aerial B will receive nothing, and the search coil must line in the plane of the fixed coil a in order to embrace as much as possible of the field and receive

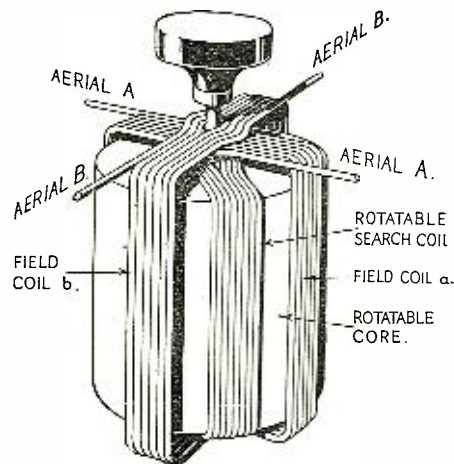

Fig. 3. Diagram of the Direction Finding Unit Showing the Method of Winding. Each of the Field Coils is Fixed and Connected to One of the Two Antennae Required in This System.

sending station lies in a direction which is not directly in the plane of either aerial, both receive signals, and the strength in each is proportional to the cosine of the angle between the direction of the sending station and the plane of the aerial. It follows that when this occurs the two fixed coils set up a resultant field equivalent to that which would be created by an imaginary fixed coil in a position intermediate between a and b and corresponding to the direction from which the signals are received. In other words, the two fixed aerials A and B, with their corresponding fixed coils a and b, are equivalent to an imaginary movable system, consisting of one field coil and one aerial, which automatically adjusts itself to lie in the plane of the incoming signals. The direction of the sending station can be ascertained, therefore, by rotating the search coil until the signals are of maximum or minimum strength and noting its position. In practice the minimum is used, since it is more sharply defined. The field coils are carried on an insulated cylindrical framework within which is a rotatable cylindrical core carrying the search coil. The connection with the latter is made at each end of the central spindle through the medium of a pair of wires of non-corrodible metal running in an annular groove and maintained in contact by a spiral spring under tension. The upper end of the central spindle terminates in a circular ebonite handle, to which is attached the indicating pointer. The handle and pointer, together with the circular scale, are to be seen on the left hand side of Fig. 1. The O point on this scale is the minimum point for stations in a line directly ahead and astern.

The transformer component, which is illustrated in Fig. 5, consists of three highly

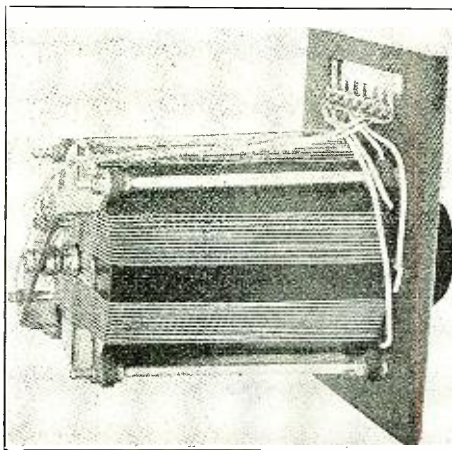

Fig. 6. Actual View of the Direction Finding Unit Showing the Two Stationary Field Coils and the Rotating Search Coil, by Means of Which the Direction of Transmitting Station is Obtained.

signals of maximum strength. If, under these conditions, the search coil lies in the plane of the fixed coil b, it will embrace no field and receive no signals. If the sending station is in the plane of the aerial B, the conditions will be reversed. When the

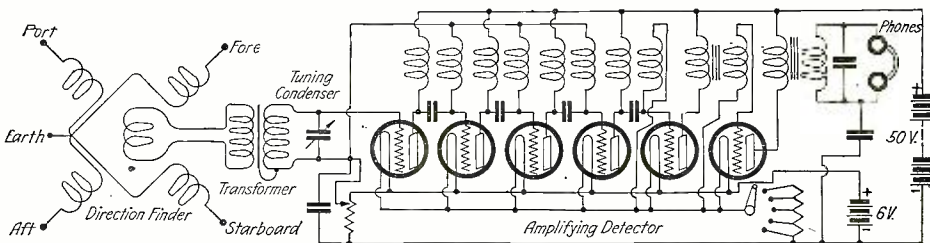

Fig. 2. Complete Wiring Diagram of the Direction Finding Set Illustrated in Fig. 1. This Set is Designed for Use on Board Ship.

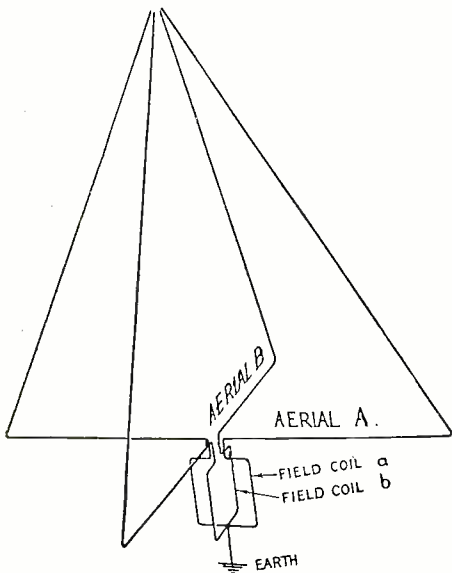

Fig. 4. This Diagram Shows the Manner in Which the Two Field Coils of the Direction Finding Unit Are Connected to the Two Antennae. The Center Point of Each is Connected to Earth.

insulated air-cored transformer elements, together with a range-changing switch of sound mechanical construction and correspondingly high insulation. The windings are designed for wave-lengths of 300 to 800, 750 to 2,000, and 1,900 to 4,800 meters, but the exact ranges obtained will depend upon the size of the aerial. Between the primary and the secondary windings of each transformer element is a shield, consisting of a copper sheath. The function being influenced by the aerial system in any of this shield is to prevent the detector from other way than that necessary for direction finding.

The condenser component consists of a specially designed variable air-condenser, permitting the tuning over the whole range corresponding to any setting of the switch. Rotation of the circular ebonite handle on the face of the panel carrying this component alters the relative position of the two sets of capacity vanes, and so brings about the smooth and continuous variations in capacity necessary for rapid and accurate tuning.

Referring to Fig. 1, it will be noted that there are six valves. The function of the four on the right-hand side is to amplify, in four stages the high frequency currents from the transformer. The fifth valve acts as a rectifier, and the sixth performs the function of a "note magnifier" i.e., it amplifies the rectified signals. On the left of the panel is a six-point rheostat and switch for controlling the filament currents, and above this is a circular ebonite handle, the rotation of which operates the potentiometer and so regulates the potential on the grids of

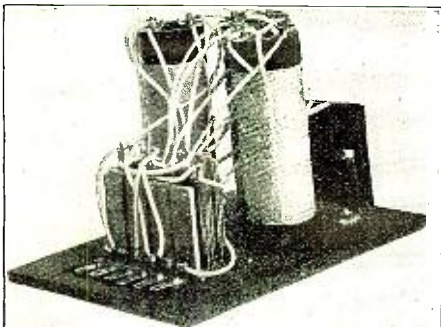

Fig. 9. The Oscillation Transformer Unit of the Land Pattern Set. The Three Way Switch Provides a Position for Stand-by and Direction Finding, and the Third to Determine in Which of the Two Possible Bearings the Transmitter is Located.

the first three valves.

In the Marconi system of direction finding, no movement of the aerials is required, hence they may be of such a size as to ensure good, highly directional reception and conform to standard requirements in regard to insulation and mechanical strength. Two independent aerials are used. They are in the form of closed loops, rectangular or triangular in shape, erected with their center lines on the same vertical axis and with their planes at right angles, as is indicated diagrammatically in Fig. 4. In ship installations, the aerials usually take the form of triangles suspended by their top corners

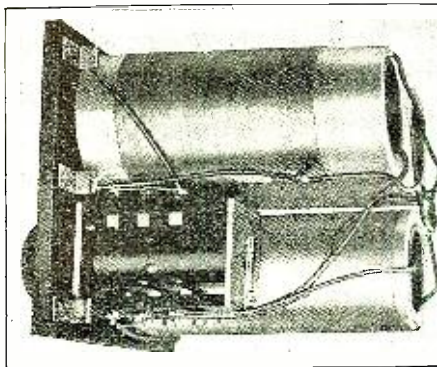

Fig. 5. The Oscillation Transformer (Unit Here Illustrated is Adapted for Three Ranges of Wave Lengths by Means of the Switch Shown in the Foreground.

through insulators from a triatic or other fore and aft stay, or from a sprit gaff or bracket on one of the masts. Their horizontal base wires ordinarily lie in directions fore and aft and athwart ships, crossing each other at right angles, the two bottom corners of each triangle being made fast through insulators to suitably disposed anchoring points. The average range obtained with the above described set in actual practice, and working with the ordinary coast or ship station, is of the order 300 to 400 miles, an ample margin being thus provided over normal requirements.

Fig. 6 illustrates the special land pattern set, especially designed for use on land in connection with the navigation of ships and aircraft. It is somewhat larger than the above described Marine pattern, and differs from that instrument in several respects. The circuit is of an improved type, in which patented aperiodic aerial sys-

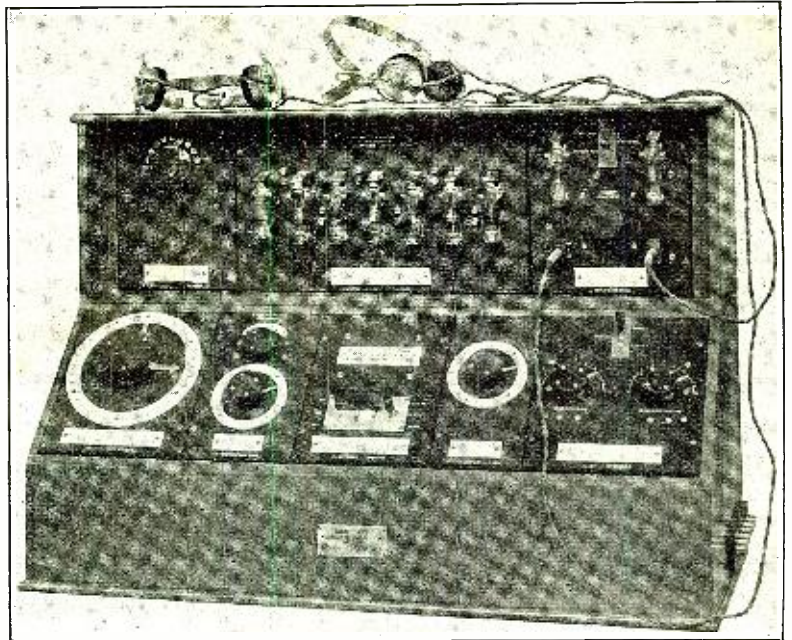

Fig. 6. Direction Finding Set for Use on Land in Connection with the Navigation of Ships and Aircraft. It is Larger Than the Marine Type of Set and Has Many Additional Features.

tem and tight coupled search coil is combined with an additional refinement in the shape of a loose coupled jigger. A higher degree of radio frequency amplification is provided also, and a two-stage audio frequency amplifier or "note magnifier" replaces the single stage of the marine type. The circuits are equally suitable for the reception of spark, tonic train, telephony or continuous-wave signals, but in the latter case a local oscillation generator is included in the installation. Fig. 6 shows the complete direction finder. It consists of a strong teak case, containing eight components in separate compartments, each of which is copper lined and thus electrically screened from its neighbors. The eight components comprise—the direction finder, the aerial tuning condenser, the transformer panel, the jigger condenser, the jigger panel, the control panel, the amplifier unit, and the double note magnifier. Electrical connection to each component is secured by a row of small screw terminals covered by an ivory plate. This type of construction permits any component to be easily removed for inspection, etc., without disturbing the remainder. By operating the wave-changing switches mounted on the instrument, the following alternative ranges can be obtained: Range 1, 300 to 750 meters; Range 2, 700 to 2,000 meters; Range

(Continued on page 1014)



Fig. 7. Sketch Showing the Actual Appearance of the Antenna System Required to be Used With the Direction Finding Sets Described in This Article.

The Super-Phone

By S. R. WINTERS

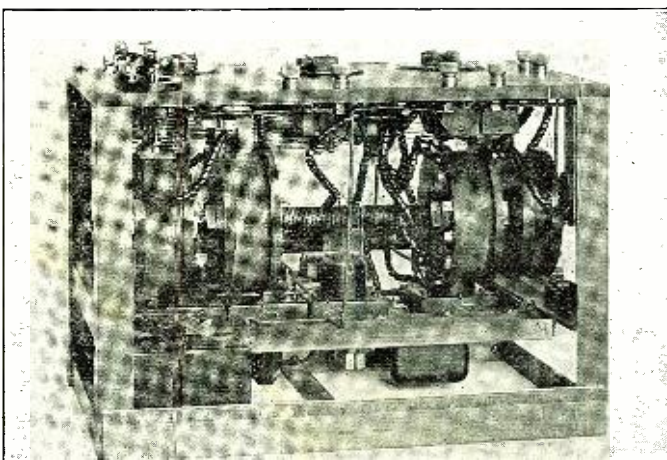
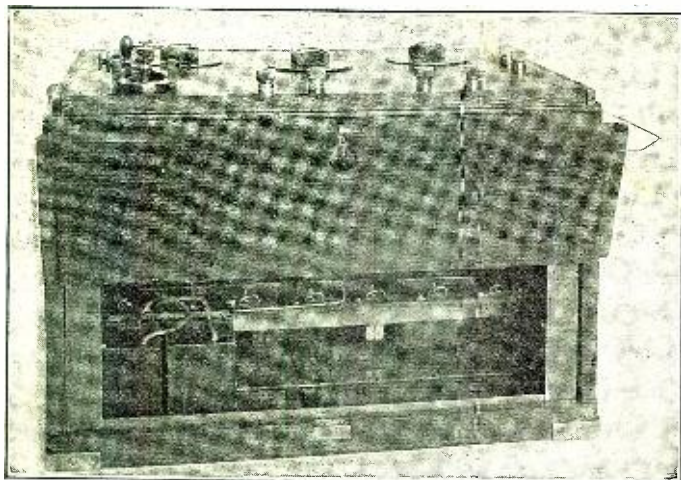

With This Instrument it is Possible to Insure the Secrecy of a Conversation Carried on Over an Ordinary Telephone Line. The Current Traveling, Being of High Frequency, Cannot Operate the Ordinary Receiver.

OFFICES, banks, brokerages, diplomatic circles, and military headquarters, are the variable agencies which may draft upon the services of an invention developed by R. D. Duncan, Jr., chief engineer of the research laboratory of the Signal Corps, United States Army. Described as a "super-phone," the device aims to insure secrecy for communications, a condition not heretofore guaranteed, by conventional telephone and telegraph systems.

Portable, weighing barely 40 pounds, this invention employs existing telephone or telegraph lines for conveying messages, cloaked in privacy, for distances ranging from one to ten miles. It is an offspring of "wired wireless" or "line radio," a system of radio-telephony and radio-teleggraphy discovered by Major-General George O. Squier, Chief Signal Officer of the United States Army. And, to briefly recite its principle of operation, radio signals are conveyed along or in close proximity to a wire instead of traveling unguided through ether or space.

The "super-phone" is a complete transmitting and receiving outfit, and as an attachment to an existing telephone line, the operator is not bothered with the details of its mechanism. The physical circuit between two subscribers is established by simply connecting the accessory unit to the common telephone system. By the mere pressing of an electric button a switch, which is closed automatically, throws the normal telephone into the circuit of the "super-phone." A communication may then be transmitted in secrecy. The conversation having been completed, the receiver is placed on the hook and normal conditions are restored. The shifting from the transmission to the receiving of messages is negotiated with ease and rapidity, somewhat contrary to the procedure involved in the use of the common radio-telephone. Hence the label on the new invention, "Line-Radio Duplex Transmitter and Receiver." The compact outfit readily lends itself to use in both radio-telephony and radio-teleggraphy.

The high-frequency generator employed in-

cludes three electron vacuum tubes, supplemented with amplifying and rectifying units. The vacuum tubes are standard equipment of the Signal Corps. Opportunities are afforded for operating the "super-phone" from both filaments and plates from 110 volts of direct current. The source of plate voltage is encased in a wooden box when rugged service in the field is anticipated. Similarly, the major mechanism is ruggedly constructed in contemplation of its application afield, in the event of future wars, when military manoeuvres are to be surrounded with utmost secrecy.

High-frequency alternating currents, the supporting vehicle for "line radio" or "wired wireless," is employed in the operation of this telephone or telegraph attachment. These currents are modulated at the transmitting end by speaking into a microphone, the former being detected at the other end by conventional wireless receiving apparatus. The communication is finally conveyed to an ordinary telephone receiver.

(Continued on page 1035)

A Compact Portable Loop Aerial Receiver

By S. R. WINTERS

THE carpenter and his kit of tools are proverbial. The chemist and his laboratory instruments form an inseparable bond of association. The housewife and her sewing bag are identified with respect to the handiness of the needle, thread and scissors. Similarly, the astounding development of radio-telephony and radio-teleggraphy invites the use of an arrangement whereby compactness and convenience are combined to render easily available radio appliances in the home, office, or afield.

An invention of Brent Daniel, of Washington, D. C., supplies this need in the form of a versatile radio-receiving set, recently built. Like the two-way street, its advantages are two-fold. Divided into two compartments, this semi-portable wireless outfit is readily detachable. The upper half of the trunk-like apparatus is a complete radio receiving

unit. The lower compartment is a receptacle for storage batteries, a battery charger,

and a meter for indicating the strength of the current being charged. Likewise, space is ample for accommodating a magnavox, head telephones, and spare vacuum tubes.

The amplifier is comprised of three stages—radio frequency, two of audio, and a detector. Incorporated in this compartment with the amplifier is also a tuner, which is so versatile in adaptation as to permit of the use of either a coil aerial or conventional antenna. An ammeter indicates a correct filament temperature. Glancing at the photograph herewith reproduced, at the right of the upper compartment of the outfit are seen three knobs for controlling the filament temperature. The fourth knob of the series in view, located near the center of the receiving apparatus proper, controls the grid potential. This stabilizer

(Continued on page 1025)

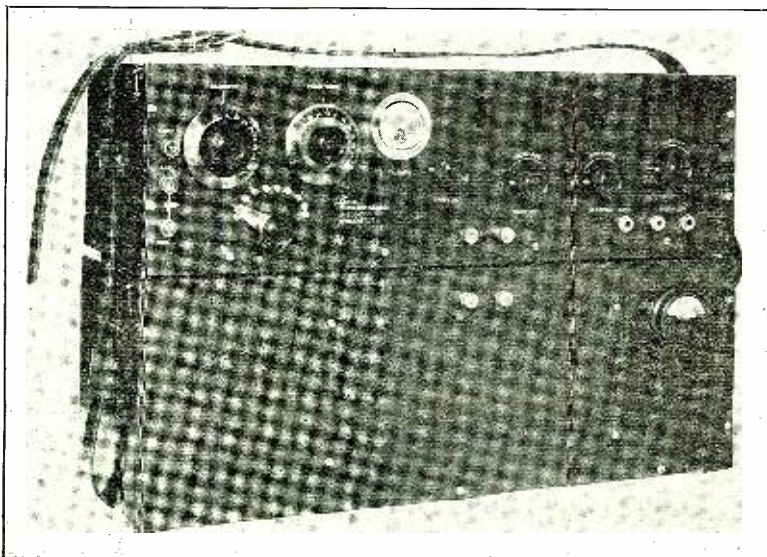

In the Upper Part of This Compact Receiver Are Mounted the Tuner and Amplifiers. In the Lower Part Are the Loud Talker, Batteries and Loop Aerial, Which May be Folded.

Portable Radio Telegraph-Telephone Set

By MAURICE E. PELGRIMS

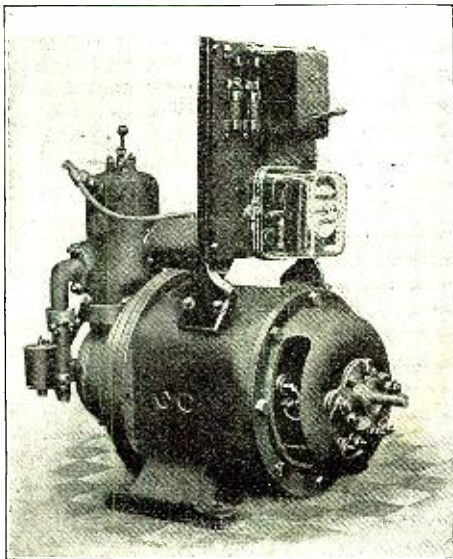

Above is an Unusually Compact Gasoline Engine-Generator Used to Charge the Batteries and Supply the Current to the Set in Fixed Stations. On the Right is the Well-Designed Transmitter and Receiver, Highly Portable and Efficient.

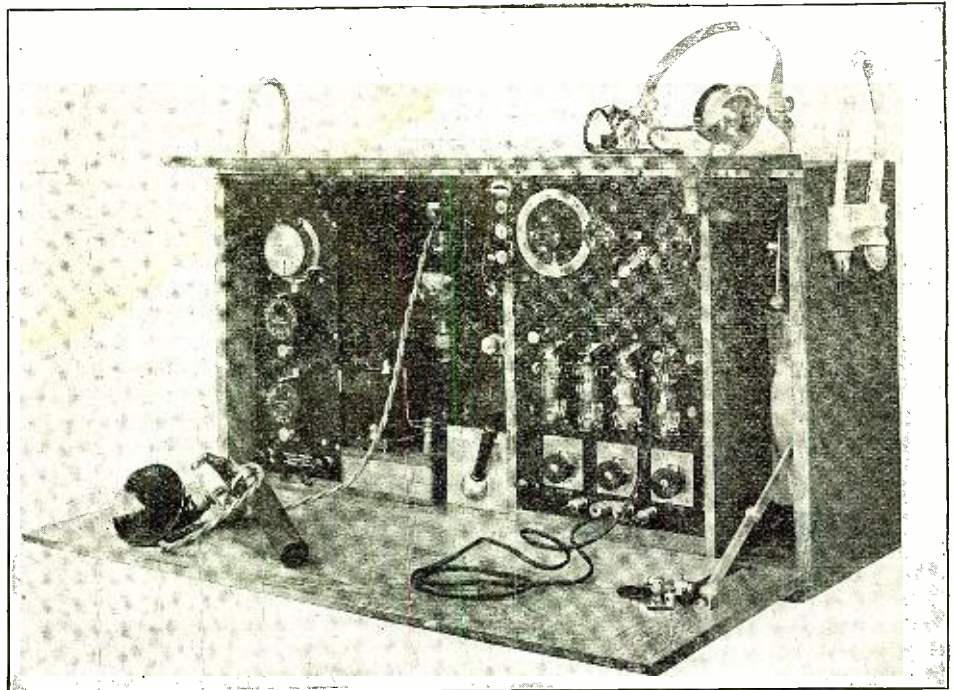

RECENT improvements in the transmission and reception of speech by wireless have opened up a new and vast field for the use of radio communication which was hitherto restricted by the necessity of would-be users of this means of communication having to learn the Morse code. Wireless telephony not only enables conversation to be carried on by persons having no knowledge of the dots and dashes, but it also saves valuable time, inasmuch as messages can be exchanged at something like ten times the speed possible by the ordinary method of spelling out every word in the Morse alphabet.

The illustration (Fig. 1) shows one of the very latest types of combined wireless telegraph and telephone sets, designed and constructed by the British Marconi Company, for use in such countries, where centers of production, such as farms, ranches, mines, etc., are dotted about at wide intervals with open country between them and the railroads or shipping centers to which their products must be sent. It has thus been designed not only from a perfectly efficacious point of view as a reliable and cheap means of communication over long stretches of territory, but also in such a manner as to make its operation of the utmost simplicity, permitting even the non-technical minded to be able to make adequate use of it, with

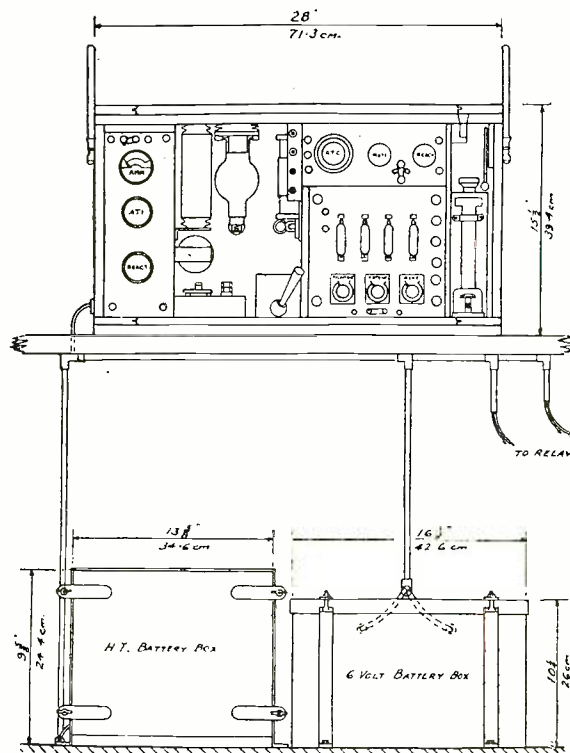

This Drawing Shows the Dimensions of the Compact Outfit. On the Left is a View of the Small Portable Generator.

and on the other hand to transmit C.W. signals.

The complete installation is made up in three different forms: (a) the "Mobile" equipment, which is provided with a petrol (gasolene) engine for driving the generator, the latter having two different windings, one supplying high tension current at 1,500 volts to the transmitter, and the other low tension current at 12 volts for charging the filament batteries. This type is particularly suitable for installation on automobiles or horse-drawn vehicles, and is also adaptable for pack transport. (b) The stationary equipment No. 1, which is provided with a motor for driving the generator, the motor being wound to suit the local supply. It is suitable for installation in buildings where a source of electric power is available. (c) Also a stationary equipment, but not provided with a motor for driving the generator. In this case the generator is used as a rotary transformer, a 24-volt battery supplying current to the low tension windings of the generator. This set is especially suitable for use where no source of electrical power is available.

In all three sets the wireless apparatus, including the generator, is identical, the chief difference being in the prime mover and in the connectors.

The transmitter has a wave range of about 10 per cent. on either side of any optional middle wave from 300 meters to 900 meters. The middle wave adopted on the standard sets is 425 meters, thus giving it wave range of 380 meters to 470 meters.

The receiver and amplifier have two wave ranges, one from 300 meters to 600 meters, and the other optional, but unless otherwise called for, from 550 meters to 1,100 meters.

The cabinet containing the transmitter and receiver is extremely compact and the instrument is eminently an efficient commercial set. Of particular interest may be cited the neat manner in which scales have

(Continued on page 1014)

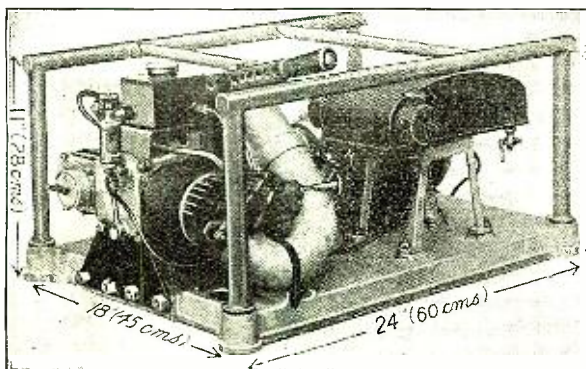

a minimum of preliminary instruction. Three standard types have been adopted, one of 500 watts having a range of 70 to 140 miles, one of 100 watts having a range of 30 to 50 miles and one of 20 watts having a range of 10 to 20 miles. The illustration shows the second one of these three types.

A simple jack switch with two possible positions is embodied in the transmitter enabling the operator on the one hand to transmit speech or tonic train Morse signals,

The New York Radio Show

THE second annual convention and exhibition of the Second Radio District Council, held at the Hotel Pennsylvania, March 7 to 11, was undoubtedly a signal success. In many respects it was the greatest radio show in history.

On the day of its opening a crowd of 10,000 persons stormed the doors endeavoring to gain admission, but the space was so limited that more than half of them were turned away. These conditions persisted throughout the four days of the exhibition. The freight elevators of the hotel were used to carry the enormous crowds up to the top floor, where the exhibition was held.

The crowd itself was interesting. There were many more of the uninitiated public present than the actual amateurs themselves.

During the last few months radio has been prominently before the public and those who knew little or nothing of its very existence have had radio forced upon their attention through the daily press. Each day some new achievement in radio has been announced or some old ones re-hashed for the benefit of those who previously took little interest in the art. People have been buying radio sets like "hot cakes" and anything that looks like a piece of wire-less apparatus has found a ready sale. Radio begins to match up with Prohibition as a topic of conversation at the Clubs and the afternoon teas. It has been headlined and cartooned until the general public has, of one accord, stood up to remark that there must be something in it.

The Radio show was probably given more free advertising than any similar event and, when it opened, a large proportion of New York City's population, swelled by delegations from all over the country, decided to attend. The amateurs, of course, were there in solid formation. They intended to get in, even if they had to take rooms at the Pennsylvania over night and sneak in before the crowd came in the morning. Those who came late, if they succeeded in gaining entrance, were entertained by an excellent and uncomfortably close view of the backs of other people's necks. Some of the amateurs who attended the show would probably find it difficult to give a description of any of the apparatus exhibited, but could undoubtedly give a very vivid and possibly venomous dissertation on the distracting dissimilarity of human necks when viewed from the rear.

On one occasion when we visited the show, the crowd was so dense that, although we adopted subway tactics, we only succeeded in reaching about the sixth row from the booths. Being rather inclined to lengthiness, however, we succeeded in viewing the exhibits over the heads of the crowd and were satisfied. As the crowd moved, perforce we moved with it. After a little, we became conscious of someone pulling our coat tails and turned to hear the plaintive voice of a small and youthful friend, who was also an ardent "Ham," complaining that, although he had attended the show three times, he had so far only been successful in becoming wedged in the center of the crowd. We took him in hand and later provided him with a front row view.

Many of the public who went to the show probably left their homes with skeptical minds. They had read of music and speeches being broadcasted by radio, but regarded it all with a certain amount of disbelief. At the Exhibition the doubts of such were more than dispelled. When WJZ started up, the sixty-two antennae on the roof of the hotel connected to as many receivers, ranging from crystal sets to power amplifiers, produced in the show rooms a fair reproduction of a political meeting at election time in full swing. The familiar tones of the announcer at the broadcasting station were repeated by the sixty-three receivers in mild or stentorian tones, according to the power of the amplifiers. The acrials and receivers were so close together that occasionally one would affect another, and the terrific howls from both loud speakers led one to suppose that an animated dog and cat fight was in progress in that section.

Each day, Mr. E. D. Glavin exhibited his radio-controlled baby automobile which emerged, followed its mysterious circuit of the space cleared on the floor and returned to its garage with a precision that was almost uncanny.

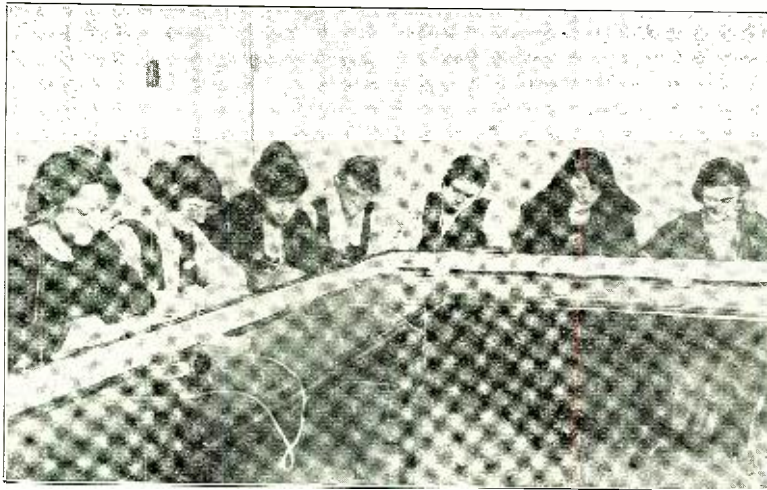

Competitors for the First Women's Amateur Speed Contest Prize offered at the Radio Exhibition. Miss Ruby Yelland Was the Winner. Copying 30½ Words per Minute and No Errors. She is the Fourth From the Left in the Photo.

The strongest impression gained from a visit to all the booths and the various apparatus on exhibit was the tendency amongst the manufacturers to simplicity of control and handsome appearance of the receivers. The object of some seemed to be to eliminate entirely all sign of wires, tubes, dials or other controls commonly associated with receivers, and to enclose all apparatus in beautifully-carved cabinets giving somewhat the appearance of the more expensive variety of Victrola and which could be placed in the drawin-room without damaging the scenery. A comparison with some of our own home-made apparatus strewn over the table in a haphazard manner provides rather an alarming contrast. The actual results produced may not be dissimilar, but the appearance most assuredly is. A glance into the interior of some of these cabinets revealed the conventional assembly of regenerative tuners with two or three stages of amplification and loud speaker or, in some cases, additional steps of radio frequency amplification before the detector. Storage battery, plate batteries and everything necessary to the reproduction of signals were contained in the cabinet and the controls were simplified as much as possible. Some also included a phonograph in the same

cabinet, using the same loud speaker for both radio and phonograph music.

In one of these was embodied a rather unusual feature. In connection with the loud speaker an electric blower caused a forced draught of air to be blown out of the horn. This greatly increased the audibility and carrying distance of the sound waves.

One receiver exhibited had, contained in one small cabinet with the usual panel and controls in view, a single circuit tuner, detector and two-step amplifier, with loud speaker. With this type of receiver it was only necessary to light the filaments of the tubes, all further adjustment being made by varying the condenser and inductance in series with the antenna. This should appeal particularly to those who have no knowledge of radio and merely wish to hear the program of the local broadcasting station.

Two new types of storage plate batteries were on exhibit. The jars of one were made in the shape of flash-light dry cells and lay side by side, resulting in a very compact unit. The 12 jars of the other were circular with rubber tops, arranged in groups of three abreast and about six inches high. Each type provided two volts and their capacity was about three ampere hours each. They were designed for a low discharging rate. The advantage of this type of plate battery is obvious and the makers claim that they will work noiselessly.

A vacuum tube receiving set in very compact form and employing some entirely new features was exhibited by another manufacturer. The tube itself is of a recent design and quite different to the usual type of V.T. It is cylindrical in shape and possesses only two elements. The tube is mounted on the face of the panel and is clipped on in much the same way as a fuse is clipped into a fuse block. The exclusive principle of this type of tube is the fixed magnet, which acts upon the flow of electrons in the tube and, by its relationship, aids detection. No plate battery is required with the tube and it uses only .5 ampere filament current. It is not suitable for C.W. reception, since there is no heterodyne or regenerative action, but the makers claim it is very sensitive as a detector of spark and radiophone. The variometer in the receiver is of unusual design and consists of four flat coils with zigzag winding, two stationary and two movable. In addition to its advantage in compactness, the close proximity of the windings of this variometer is supposed to provide a very large ratio of maximum to minimum inductance and consequently a wide range of wave-lengths.

The same firm exhibited a crystal detector enclosed in a glass tube which had been exhausted of air, thus protecting the crystal from oxidation and dust.

In panels there were some new and very useful ideas. One was manufactured with a copper mesh shielding underneath the back surface. This type of panel should prove exceedingly useful for sets where it is desirable to shield the instruments or to prevent detuning of circuits by body capacity. Another kind was made to meet the demand

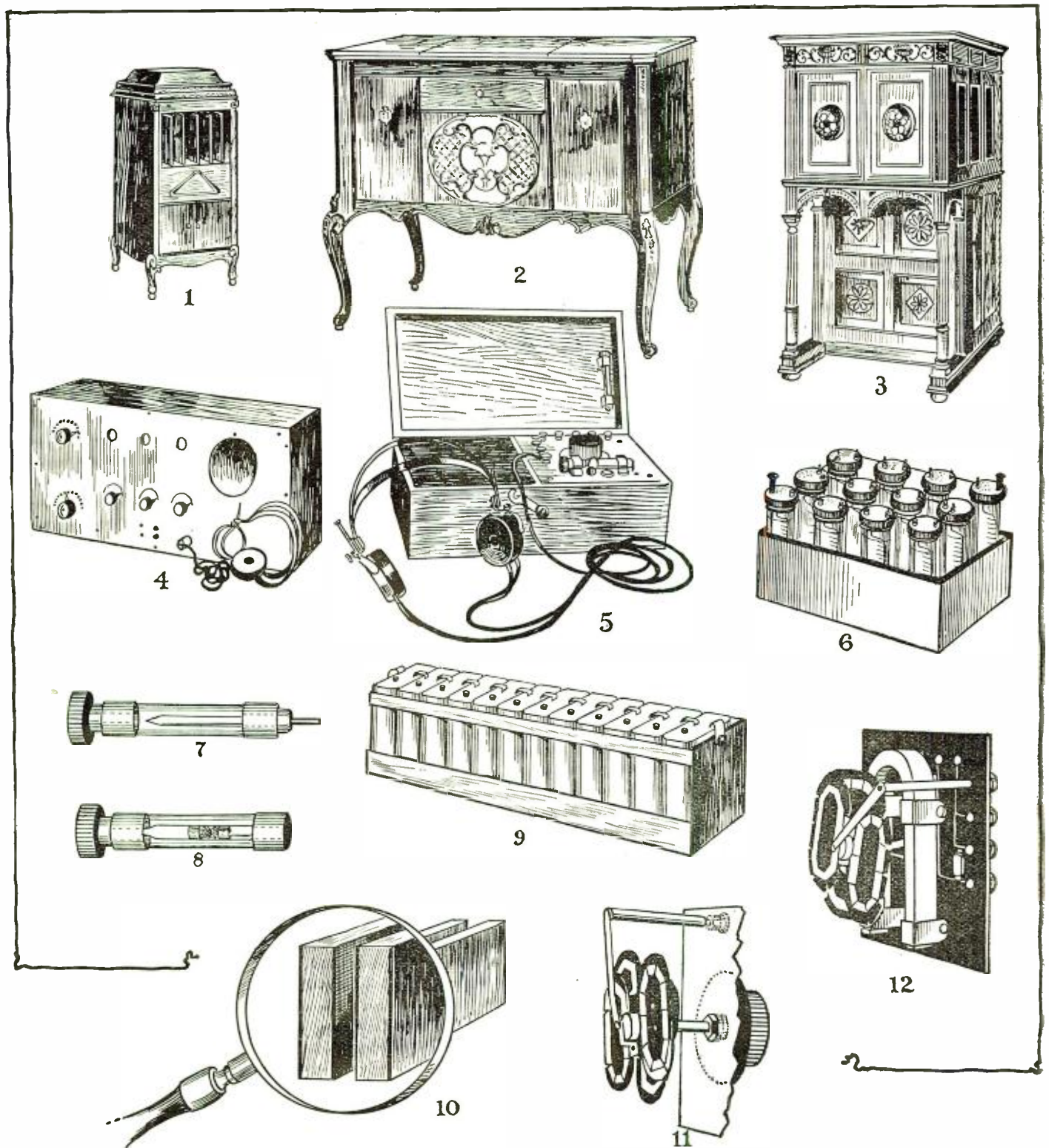

Figs. 1, 2 and 3 illustrate new types of receiving cabinets exhibited to the public for the first time at the Radio Show. Everything necessary for the reception and reproduction in loud tones of radiophone transmission is included in the handsome cabinet. Controls are greatly simplified. Figs. 2 and 3 also include a phonograph using the same loud speaker as the radio receiver, and Fig. 3 employs an electric blower to increase the sound. Fig. 4 is a simple and complete receiving set intended for the novice in radio. There are only two controls in addition to the filament rheostats. Loud speaker is built in the same cabinet. Fig. 5 is a complete and very compact receiver employing vacuum tube of recent design which requires no plate battery. Everything except the antenna is included in this small cabinet for the reception of the signals, and wave lengths ranging from 100 to 1,000 meters are obtained by single control. Fig. 7 is the vacuum tube used in this receiver and Fig. 12 is a back view of the same receiver removed from the cabinet. The fixed magnet seen in Fig. 12 acts upon the flow of electrons in the tube and aids detection. The variometer, which is clearly shown in Fig. 11, is of unusual design and very compact. Figs. 6 and 9 illustrate two new types of storage plate batteries. These may be recharged. Fig. 8 is a crystal detector enclosed in a vacuum to prevent oxidation. Fig. 10 shows two kinds of panels, one with copper shielding inside the panel for prevention of body capacity effects and the other is made of fibre with bakelite veneer to reduce the cost.

for a more economical panel than has hitherto been made and which may be used with apparatus in which a very high value of insulation is unnecessary. It is made of hard vulcanized fibre, veneered on both sides with thin sheets of condensite celeron. It has the same appearance as the more expensive make of solid panel.

In the exhibition rooms there was a government booth where Federal inspectors examined amateurs for transmitting licenses and another where the Signal Corps exhibited some of its apparatus. There were speed contests for both men and women, and each evening in the ball room on the first floor lectures were deliv-

ered to those fortunate enough to gain entrance. Moving pictures showing the action of a Vacuum Tube were thrown on the screen. One of the most interesting lectures was that delivered by Mr. Paul F. Godley, describing his experiments in reception of U. S. amateurs' signals in Scotland. (Continued on page 1034)

The Operating Principles of a Radio Compass

By PAUL G. WATSON, I. R. E.

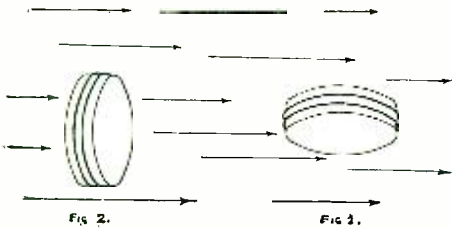

FIG. 2. A Current is Induced in Coil Fig. 2 for the Lines of Force Pass Through it, While No Current Flows in the Other as it is Parallel With the Field.

THE present form of radio compass was developed by Dr. F. A. Kolster, of the Bureau of Standards, in 1915, and was later modified and improved by several Naval radio experts.

The fundamental purpose of the radio compass is to determine the bearing, and if possible, the direction of an unknown transmitting station. A second use, somewhat minor, in its present application, but not in principle, is its use as a directional receiver, to eliminate interference in congested districts.

As a start in explaining a radio compass, it is necessary to understand the electrical and magnetic field in which it will act. Let us consider the transmitter in Fig. 4, which, to make it simple, we will assume is a single vertical wire. This type of transmitter is non-directional in radiation. The oscillations radiating from this antenna are closed rings, as shown in Fig. 4, and extend

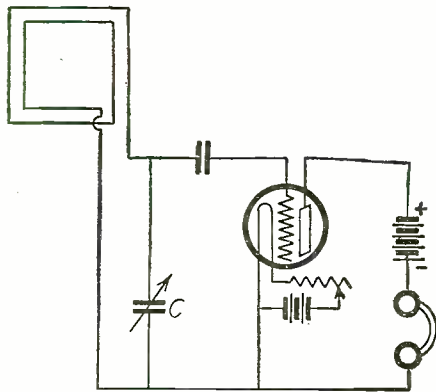

FIG. 3

Hook-up of a Loop Aerial Used for Direction Finding Work.

for an indefinite distance, including the radio compass station at "C." For clearness, it can be assumed that "T" is a ship, and that "C" is on the coast, trying to locate "T."

Elementary electrical theory teaches that a coil of wire placed in a varying magnetic field will have an E.M.F. induced in it, the magnitude of which depends upon the variation and strength of the magnetic field. If the coil is placed with the windings and lines of force parallel, Fig. 1, little or no current will be induced in the coil. If the coil is revolved 90 degrees and placed so the lines of force are at right-angles to the wires, Fig. 2, a maximum current will be induced as the magnetic field varies.

Now to combine the action of this simple coil in a magnetic field with that of a radio compass, which in fact is that very thing with additions for tuning, etc. Arrangements for tuning the radio compass are shown in Fig. 3. This is only a fundamen-

tal diagram and contains none of the refinements applied to the modern radio compass. The similarity to a wavemeter can be noticed. When the coil is placed in the field of the transmitter "T," Fig. 4, the lines of force acting in circles as shown in the figure; the coil in position "B," Fig. 4, will have practically no current induced in it, since the conductors and lines of force are parallel. If an arrangement is made for revolving the coil to position "A," Fig. 4, it can be readily seen that the lines of force from "T" will have their maximum effect on the coil in this position, perpendicular to the lines of force. It should be evident to

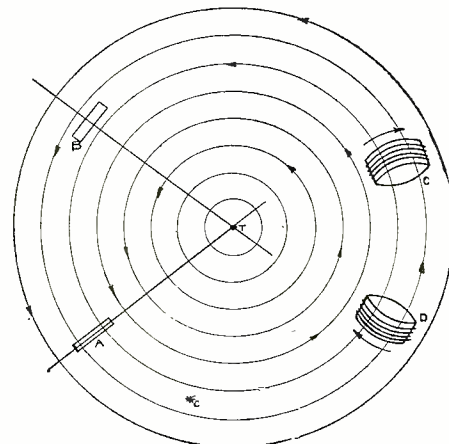
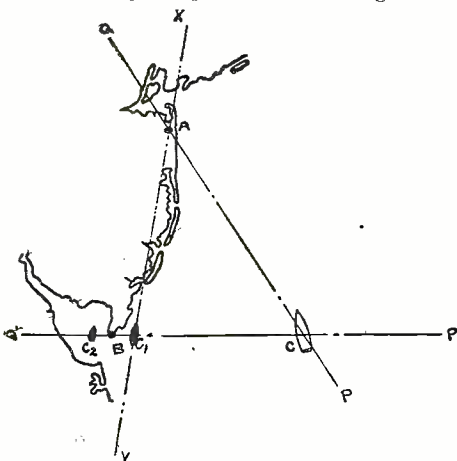

Fig. 4. The Coil in Position A Pointing at Transmitter T Has a Maximum Current Induced in it While the Coil in Position B Will Have Practically No Current Induced in it. Coils C and D, When Revolved, Will Show Two Maxima and Two Minima of Current. If Revolved 180 Degrees the Direction of Current is Reversed.

the radio man that the efficiency, of the coil, is very low, and before its signals can be compared with signals received in the regular way, they must pass through several steps of amplification. To get a maximum current in the coil, it is brought to resonance with the transmitter, by the condenser "C," Fig. 3. The connection between the simple coil and the compass coil can be seen readily in this paragraph.

In Fig. 4 with the coil in position "A," it can be seen that the plane of the coil winding points directly to "T," while also, in this position the current reaches a maximum amplitude. Also in Fig. 4, it can be noticed that a change of position of 180 degrees in



Practical Illustration of Compass Work at Sea. Position of Ship C is Easily Located From Compass Stations A and B, But With the Bilateral System an Error of 5 Degrees by A Throws Ship C Off True Position.

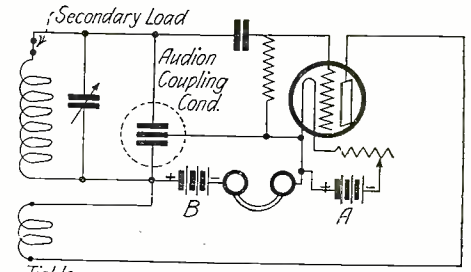

FIG. 7

© RADIO NEWS 1922

The Capacity Coupled Audion Circuit.

either "A" or "B" makes no difference in the amplitude of the E.M.F. This gives in one revolution of the coil, two maxims and two minims, in the E.M.F. amplitude of the coil. It need not be said that the position "B," Fig. 4, is the minima adjustment, as this is self-evident. Converting these terms into those of signal intensity, the position of coil "A," pointing to the transmitter, gives the intense signal, while position "B," Fig. 4, gives a weak signal, or possibly no signal at all.

It is brought out by the fact that there are two maxims and two minims, that only a bearing, and not a direction can be obtained from a compass using the coil alone as an antenna. No distinction could be made between the true direction and a direction 180 degrees from it. This type of compass is the most easily understood, and is known as the "Bilateral" radio compass.

The "Bilateral" compass can be greatly

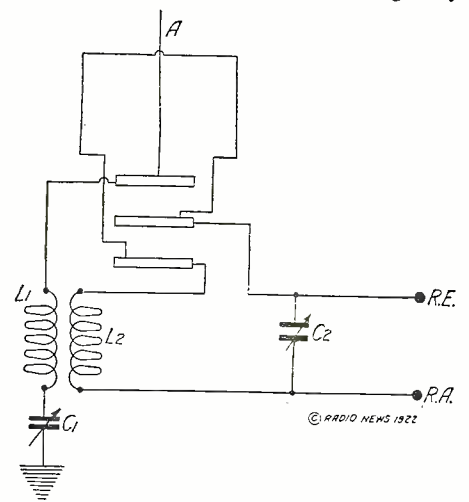

Fig. 6. Method of Introducing Current From the Non-Directional Antenna Into the Compass Circuits. The Antenna Circuit is Coupled to the Coil Circuit Through L₁ and L₂.

improved by having one of its maxims increased and the other maxima decreased, or by having the minims in a similar relation. By making this addition to a "Bilateral" compass it becomes possible to determine direction as well as bearing. This new type, or modified radio compass, is called the "Unilateral" radio compass, since the direction, as well as the bearing, is now known.

As has been previously explained in using the "Bilateral" compass, two maxims and two minims were found, either of which could be used to indicate the bearing of the transmitter. For reasons which will clear themselves later on, let us use the maxima indication, which is position "A" in Fig. 4. With the coil in position "C" fix an arrow to the coil, pointing to the transmitter. Revolve the coil 180 degrees and note that

(Continued on page 1018)

Audio Frequency Transmission

By E. H. HANSEN

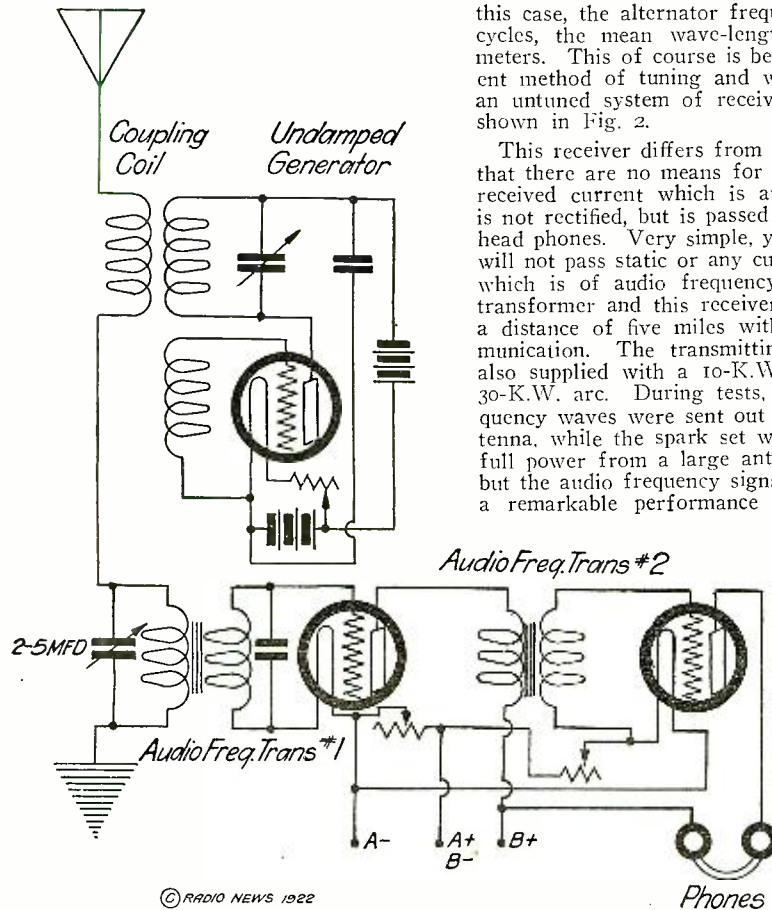

© RADIO NEWS 1922

this case, the alternator frequency being 60 cycles, the mean wave-length is 5,000,000 meters. This of course is beyond any present method of tuning and we must devise an untuned system of receiving such as is shown in Fig. 2.

This receiver differs from the ordinary in that there are no means for tuning and the received current which is audio frequency is not rectified, but is passed directly to the head phones. Very simple, yet this receiver will not pass static or any current save that which is of audio frequency. A ½-K.W. transformer and this receiver were used at a distance of five miles with perfect communication. The transmitting station was also supplied with a 10-K.W. spark and a 30-K.W. arc. During tests, the audio frequency waves were sent out on a small antenna, while the spark set was operated on full power from a large antenna. Nothing but the audio frequency signals were heard, a remarkable performance when the dis-

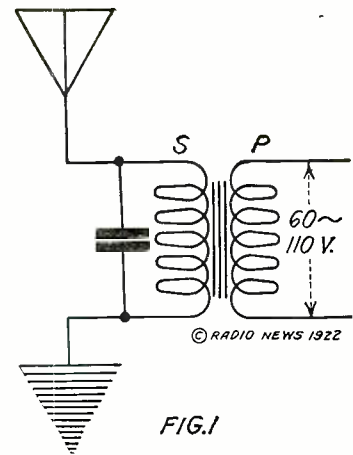

FIG. 1

Step-up Transformer With Secondary Connected Directly to Antenna and Ground Radiating Waves of 5,000,000 Meters.

fore long to lay before the readers of RADIO NEWS full details.

Experiments have also been carried out using the receiver shown in the diagram with a heterodyne or undamped generator. Signals from radio frequency stations are received by this method, but are transformed, before passing into the receiver, into audio frequency, thereby eliminating any form of rectification and permitting reception from a single station. Static is entirely eliminated as well. Tuning is wholly dependent upon the beat wave between the heterodyne and the incoming signal.

As these tests were carried out in Europe, the following results may be interesting: Lafayette radio, a distance of 700 kilometers radiating 475 amps. into the antenna, gave an audibility of 200. Stavenger, Norway, LCM, a distance of 900 kilometers, radiation uncertain but from unofficial information 190 amps., audibility 150. The only American station heard with this set was WSO with an audibility of 50. These audibilities are low compared with other receivers; yet, being free from all interference and static are strong enough for reliable reception.

Much remains for development along these lines and it is hoped that American experimenters will reproduce and enlarge on the tests shown herein.

HAVE you ever thought what a wonderful radio set would be one that was free from static and all interference? This, many will say, is the millenium in radio, yet experiments have proven that it is highly feasible. Audio frequency transmission and reception is the answer to this problem

In diagram No. 1 we have a step-up transformer with the secondary taps directly connected to antenna and ground. When the key is depressed, waves of the order of $f/300,000,000$ are propagated into space. In

tance of five miles and the power of 10-K.W. are considered.

A range of five miles is far from adequate, however, and experiments have been under way for some time to extend this distance. Owing to the inability to build a transmitting antenna within a resonant frequency of the transformer, (the efficiency of the ½-K.W. transformer used being less than .006), other methods have been used successfully. Owing to patents being obtained on this system, only an outline can be shown in this article and it is hoped be-

Fig. 2. Method of receiving audio frequency waves. The received current is passed directly to the phones. With the external heterodyne radio frequency signals are also received.

Aerials

By FRED A. BURGESS

IN constructing a wireless set, far too little consideration is given to the efficient design of the aerial. During a good many years in the wireless game it has been our experience that the erection of an aerial is largely a hit or miss proposition with the average amateur. He puts up the biggest aerial that local conditions will permit, and then tries to design his set so that it will give maximum efficiency with his aerial instead of designing his aerial to work in harness with his set.

It is, therefore, the purpose of this article to put the amateur straight on a few points pertaining to the construction of aerials, and to show him just how he may obtain maximum transmitting efficiency on any desired wave-length.

Experience has proven that an aerial which is short enough to transmit on 200 meters is too short to give the best results for receiving. Therefore, it is advisable, and even imperative where real DX work is required, that the up-to-date amateur should possess two aerials, a short multi-

wire one for sending, and a long single wire one for receiving.

In erecting any aerial it should be kept as far away as possible from power lines, telephone lines, trees, tall buildings, etc., as such objects have considerable effect on both the transmitting and receiving effi-

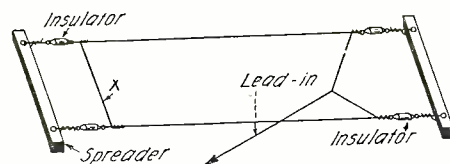

When a Short Aerial is Used for Transmitting Better Results Are Obtained by Connecting the Free Ends of the Wire Together.

ciency. Where it is absolutely necessary to erect it in the immediate vicinity of power lines or telephone lines it should be installed at right angles to such lines. Also where two aerials are erected they should be at right angles to each other in order to minimize their mutual effect. The height of

the aerial will be governed largely by local conditions, but the higher you can get it the better.

The aerial wire should be stranded, or at least No. 1 solid, wire. The stranded wire is preferable since it presents a larger surface and, therefore, offers less resistance per unit of length, but No. 12 or No. 14 soft copper wire will give excellent results. Phosphor bronze wire is even better than copper, due to its greatest tensile strength.

For all round amateur work the inverted L aerial is as good as any. There are two methods of connecting this type of aerial. One is known as the "loop" (see diagram) and the other as the "straightaway." In the loop system the ends of the aerial wires farthest from the lead-in are connected together as shown at X, whereas in the straightaway this connecting wire is omitted and the aerial wires are left unconnected. Where great height and length cannot be obtained the loop has proven superior to

(Continued on page 1033)

How to Make a Radio Concerta

By ROBERT E. LACAULT

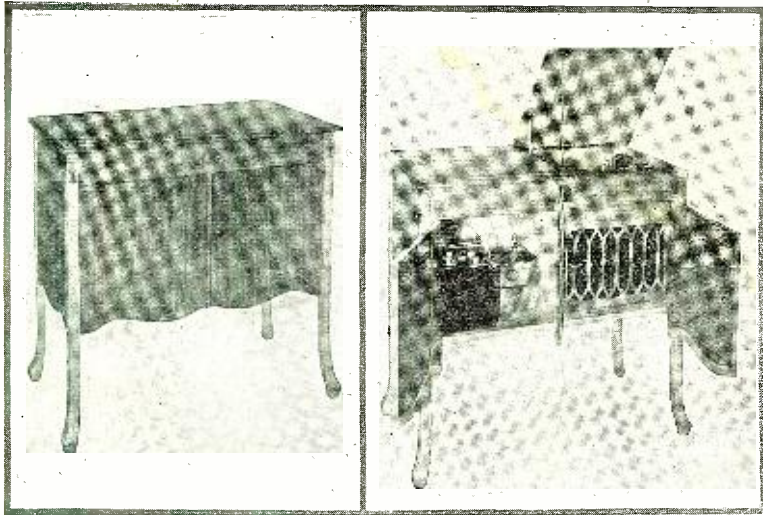

In this stylish cabinet is installed a complete receiver, with loud-talker and batteries. A loop aerial is used in conjunction and may be mounted on a screen, as shown on the front cover of this magazine. There is only one adjustment to be made to tune the set so that even an inexperienced person can operate it.

SINCE radio has been popularized by the wide publicity given to the radio telephone broadcasts, the public has become interested, and today radio receivers begin to replace the phonographs in the homes. Several types of phonograph cabinets transformed into radiophone receivers could be seen at the radio show, recently held in New York City, some of them being of good styles, but reaching such prices as to prohibit their use by the average public. Furthermore, all of these apparatus make use of outdoor aerials and ground connections which necessitate some installation, sometimes difficult or impossible, in apartment houses of the cities. In designing such a receiver, in order to make it really practicable, a loop aerial should be used, so that no installation whatsoever is required.

The "Radio Concerta" described in this article may easily be built with standard parts and apparatus obtainable in radio shops. With it, a loop aerial is used, thus doing away entirely with outside wires, ground connection, etc. If the sight of the loop is objectionable, it may be hidden under a curtain, a table, or mounted on a fire screen as shown on the front cover of this magazine, illustrating the complete outfit in operation.

Phonograph cabinets without the mechanism or accessories may now be obtained. One of them, shown in the photograph, was used to serve the purpose and was equipped

with the wooden sound box, movable top, and the board supporting the mechanism of the phonograph, upon which were mounted the instruments composing the whole outfit. There is only one adjustment to tune the set to the proper wave-length; this is accom-

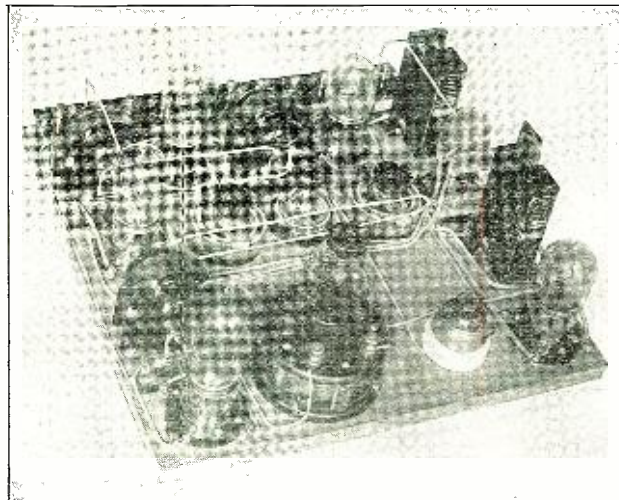

Here is the Amplifier With the Tuning Condenser and Main Switch Mounted on a Board, Which May Easily be Removed From the Cabinet.

plished by means of a variable condenser connected across the loop aerial, and giving a variation sufficient to tune in most of the radiophone broadcasting stations that may be heard. An ordinary switch controls the current of all the filaments of the vacuum

tubes used in the amplifier, as well as in the field of the loud talker, which is of the Magnavox type. Consequently, once the condenser has been adjusted so as to receive the transmission from a radio broadcasting station with maximum intensity, it is merely necessary to turn on the switch when the station is transmitting, to bring in the music and speech that are being transmitted. This feature makes of the Radio Concerta an ideal instrument, for it may be operated by anyone, once it is installed.

In the amplifier are incorporated two stages of radio frequency amplification, a detector, and three stages of audio frequency amplification, the last stage of which may be used as power amplifier so as to operate the loud talker with maximum efficiency. The diagram is shown at the bottom of the page, with the indication of each instrument. In this diagram J1 represents a single circuit jack, for the connection of the loop aerial to the set, which is made by means of a plug. J2 is a double circuit jack, to cut in the second step of audio frequency amplification if it is desired to use a pair of telephone receivers for long distance reception. K2 is a variable condenser shunting the loop aerial for the purpose of tuning the circuit to the proper wave-length, while L is the grid leak and K1 the grid condenser the capacity of which depends upon the type of vacuum tube detector used; it is generally between .00025 and .0005 microfarad.

T1 represents the radio frequency transformers, and T2 the audio frequency transformers, which should have a ratio of turns of about 8 or 9 to 1, so as to obtain maximum amplification. The letters P and S indicate the primary and secondary windings of each transformer. V1 represents the vacuum tubes of the radio frequency amplifier, which should preferably be AP amplifying tubes. V2 is the detector tube. V3 the amplifying tubes of any make, and V4 the 5-watt power tube upon the plate of which a very high voltage may be applied. R1 and R3 are respectively the rheostats of the radio and audio amplifier tubes which should be of sufficient size so as to carry about three or four amperes. R2 is an ordinary 6-ohm rheostat.

On the right of the diagram, A represents the six-volt battery, which should be of sufficient size to supply all the tubes and the field of the loud talker, for a sufficient length of time without recharging. C and C1 are the grid batteries which are used only if a rather high

(Continued on page 1036)

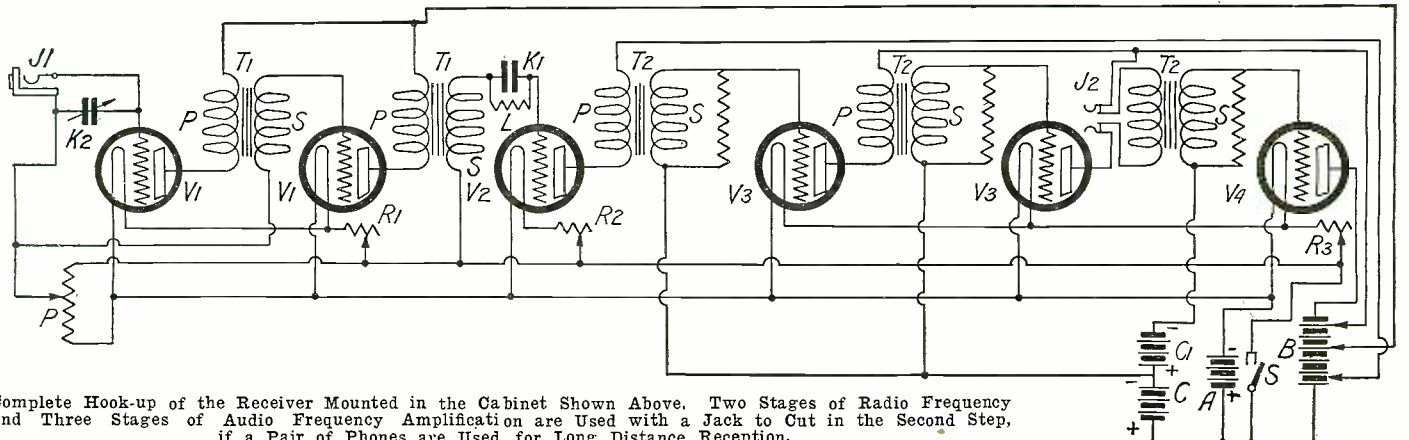

Complete Hook-up of the Receiver Mounted in the Cabinet Shown Above. Two Stages of Radio Frequency and Three Stages of Audio Frequency Amplification are Used with a Jack to Cut in the Second Step, if a Pair of Phones are Used for Long Distance Reception.

A Study of the Antenna System

PART III

By C. M. GRABSON

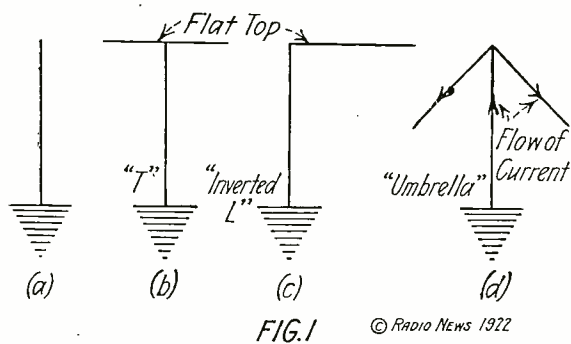

FIG. 1 © RADIO NEWS 1922

Various Types of Aerial Used in Amateur Stations.

THE first two parts of this study were concerned with a theoretical consideration of the constants of the antenna, the effect of inductive and capacitive loading on these constants and the practical measurements of them. This part of the study will take up a comparison of different types of antennae as used in commercial practice, and ground systems.

The range and efficiency of a radio transmitter depend, of course, upon a large number of factors, to wit: Type of transmitter employed, antenna input, nature of country traversed by the waves, current in the receiving antenna, type of receiver used, types of transmitting and receiving antennae. All these and other factors, too, enter into consideration. But assuming all other conditions to be the same, the range will depend upon the types of antennae employed. Thus 1 kw. in a straight wire antenna will produce entirely different results from 1 kw. in an umbrella antenna. The importance, therefore, of understanding antenna structures will be evident. For the effect of an otherwise perfect transmitter can be almost completely nullified by an improper antenna struc-

ture and ground system.

In taking up the comparison it will only be necessary to consider three typical forms of antennae as used in most stations: The simple vertical antenna, the flat top antenna, inverted L or T shape, and the umbrella antenna with counterpoise ground.

Simple diagrammatic representations of these antennae are shown in Fig. 1. Corresponding to each of these antennae there is a current distribution curve as shown in the same figure. These distribution curves will be seen to be very important in comparing these forms of antennae.

Of the three types of antennae under discussion the straight vertical wire is the simplest. It has the smallest surface area and consequently its capacity is smaller than either the flat top or the umbrella antenna, assuming the same height. The umbrella antenna has the maximum capacity of the three, for the end of the antenna where the maximum potential exists is nearest the

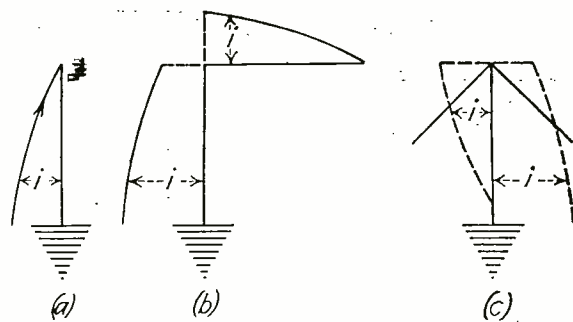

FIG. 2 © RADIO NEWS 1922

The Current Distribution Along the Wires in Various Forms of Antennae.

ground. It follows that the fundamental of the umbrella antenna will be higher than that of the other two, which explains why that type is more suitable for long wave work.

A comparison of these three types of antenna from the point of view of radiation is best accomplished with the aid of the current distribution curves of Fig. 2. Fig. 2a shows the current distribution curve of the straight vertical wire antenna and it will be seen that the current amplitude is non-uniform along the length of the antenna. Now it is an established principle in the theory of radiation that the radiation of an antenna is directly proportional to the current in the antenna, assuming uniform current distribution. It is evident therefore that a vertical wire antenna with its non-uniform current distribution will not radiate as well as another antenna having the same current uniformly distributed along the vertical portion.

By glancing at the current distribution curves of the flat top antenna and umbrella antenna we see at once their superiority over the vertical wire antenna. The current is almost uniform along the length of the ver-

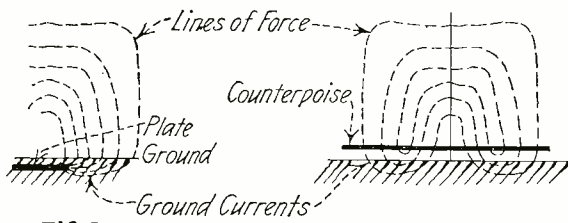

FIG. 3 © RADIO NEWS 1922

FIG. 4 © RADIO NEWS 1922

These Sketches Show the Proportion of Lines of Force Passing Through the Ground When a Counterpoise or a Ground Plate Are Used.

The Station Annunciator

By JOHN F. BRONT

PRACTICAL apparatus for the summoning of operatives at radio stations, has been long sought. It might be pointed out that apparatus of this type would be particularly useful on shipboard and at isolated points of communication on land. When one station at a distance from the other, may summon operatives to the apparatus, it is obvious that there will be required no steady attendance of personnel at the receiving apparatus. The operators, probably employed at other tasks, may be summoned to the receiver without maintaining a steady

watch, and their time occupied at such times as there is desired communication by a corresponding station.

A whimsical prophecy might be safely made that in future radiophone practice, there will be in vogue an automatic switching device which will function in the same manner as the modern automatic wire telephone central stations, which eliminate the necessity for the maintenance of a large number of highly specialized employees as

required on the manually operated switchboard, and which latter has been a stumbling block for the wire phone companies since the evolution of the wire systems to their present stage of efficiency. With the automatic device, there are required practically no employees except those actually occupied in the maintenance of the plant.

Automatic signalling apparatus for radio stations will be peculiarly applicable to shipboard stations and those stations on

land where the traffic handled is both light and intermittent. On ships, personnel will be called to the apparatus only at such times as correspondence is de-

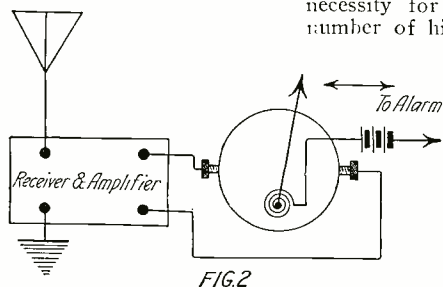

FIG. 2

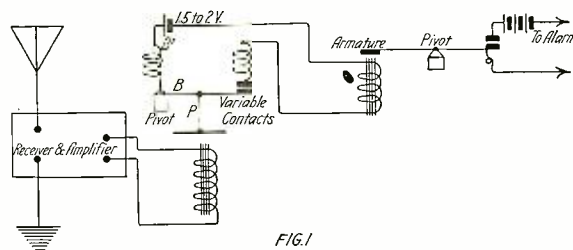

FIG. 1

These Arrangements of Relays May be Used to Ring a Bell When a Station is Calling on a Certain Wave-length, Thus Preventing the Operator From Keeping a Constant Watch.

Resistance of High Frequency Work

By LOUIS FRANK

HIGH frequency currents differ so markedly in their properties from direct currents or low frequency currents that it would be expected that other electrical properties, such as resistance, are also different. Resistance is such an important property of radio circuits that it is well to take up a detailed analysis of the part resistance plays in radio.

In the first place, let us note one very important distinction between the resistance of a direct current circuit and that of a radio

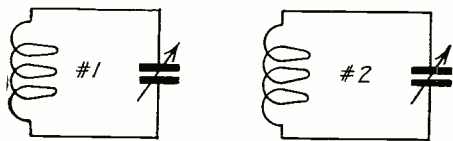

FIG. 5
© RADIO NEWS 1922

If Circuit No. 2 is Brought Near Circuit No. 1 in Which High Frequency Current Flows, the Resistance of the Latter Will Increase on Account of the Energy Induced in the Other Circuit.

circuit. The energy which is dissipated in a D.C. circuit is proportional to the resistance of the circuit. This energy is always dissipated in the form of heat, and the resistance of a D.C. circuit is always practically constant (except, of course, for negligible rises, due to small rises in temperature), and proportional to the geometric dimensions of the conductor, and the material of the conductor. In a radio circuit, on the other hand, heat is only one of many ways in which energy is dissipated. Energy may be transferred to other neighboring circuits by induction, energy may be radiated into space, energy may be dissipated by brush discharges, losses in dielectric of condensers, etc. Thus we see that apart from energy dissipation in the form of heat due to wire resistance, in a radio circuit energy is dissipated in many more ways. Hence since the resistance of circuit is measured by the amount of energy dissipation we see that the resistance of a radio circuit is bound to be very high.

We will take up one by one the various factors which affect the resistance of the radio circuit. The first important question is the ohmic resistance of the circuit, and how it varies with the frequency. When a direct current flows through a wire, the current distributes itself uniformly over the cross-section of the wire, i.e., the current density at every point of the wire is the same. On the other hand, when an oscillatory current flows through a wire, the current distribution is not uniform, i.e., the current density is not the same at every point of the wire. Now the resistance of a wire to a current of non-uniform distribution is greater than the resistance of the wire to current of uniform distribution. The reason for this will be clear from these considerations. Suppose a given wire has a total current of i amperes flowing through it, and that the wire is divided into n equal unit sections. Then, assuming uniform current distribution, each unit section will carry the same current, Fig. 1. The same amount of heat will be generated in each unit section which results in a definite total amount of heat dissipation, and therefore a definite resistance of the wire. Suppose now, the same current of i amperes flows in the outer half area of the wire as shown in Fig. 2 by the shaded area. This is equivalent to non-uniform distribution of cur-

rent, since the inner half area of the wire carries no current. The total current i amperes flows through half the number of wire sections, it follows that each section now carrying current, carries twice what it did for uniform distribution. Since the heat generated in each section is proportional to the square of the current in it, it is seen that the heat generated in each section is now four times that generated for uniform distribution. But since there are only one-half the number of sections carrying current, the total heat generated in the wire is one-half of four, or two times that generated for uniform distribution. Therefore, the resistance of the wire to currents of non-uniform distribution is greater than that to currents of uniform distribution.

Since oscillatory currents produce non-uniform distribution of currents, it follows from the above that the resistance of wire to oscillatory currents must be greater than the resistance to direct currents. Now the greater the non-uniformity of the current distribution the greater does this resistance become. The current distribution becomes more irregular and non-uniform, the greater the frequency of the current, and it is for this reason that the resistance of wire to high frequencies increases with the frequency.

The effect of high frequency on the distribution of the current in a wire is to crowd the current to the outside of the conductor. This effect is so great that when we come to radio frequencies the current travels only on the outer layer or surface of the conductor, and hardly penetrates at all to the inside. It is for this reason that this phenomenon is called "skin effect."

What is the reason for this skin effect? A detailed explanation of this phenomenon would involve a complicated mathematical analysis. However, a simple explanation can be made along the following lines: When a current flows through a wire, a magnetic field is set up around the wire and magnetic lines of force circle the wire as in Fig. 3. These lines of force not only exist outside the wire, but also penetrate inside the wire as shown. When the current stops flowing these lines of force collapse or disappear. When high frequency

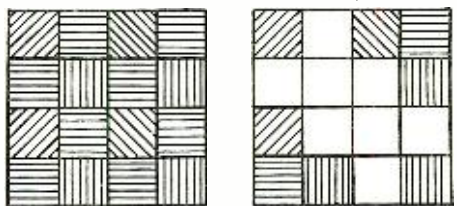

FIG. 1 © RADIO NEWS 1922 FIG. 2

These Diagrams Show the Proportional Area of Wire Carrying the Same Intensity of Direct and High Frequency Alternating Current.

current flows through the wire, the current alternates in direction and passes through zero value. Thus the magnetic lines of force will form in one direction around the wire, disappear, and form in the other direction around the wire. However, it takes an appreciable amount of time for the lines of force to penetrate into the interior of the wire, due to the very rapid fluctuations of the current. Hence the lines of force are mostly outside the wire, with some concentrated near the surface of the wire on the inside, as in Fig. 4. Now consider the wire to be made up of a num-

ber of filaments. The inductance of each of these filaments depends upon the number of lines of force surrounding it, the greater the number the higher the inductance. Since the filaments inside the wire have circling them the lines of force inside and outside the wire, while those on the surface of the wire have only the lines outside the wire circling them, it follows that the further toward the center of the wire the filaments are, the higher will be their inductance. Hence those filaments

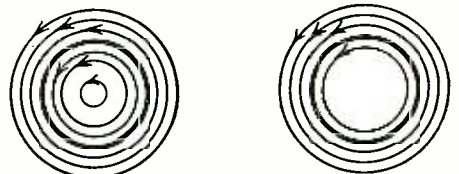

FIG. 3 © RADIO NEWS 1922 FIG. 4

In These Sectional Views of a Conductor May be Seen How Currents Travel in Wires. The Wire, Fig. 3, Carries D.C. and Fig. 4, High Frequency A.C. Note the "Skin Effect".

inside the wire have the greatest reactance, while those nearer the surface, the least, and consequently the current tends to travel mostly in those filaments near the surface since they have the least reactance. This is the explanation for the crowding of the current on the surface and the skin effect.

As these high frequencies employed in radio the current travels only in the outer layer or skin of the wire, it appears that thick solid wires are useless because the inner portions of the wire remain unused. There is thus a loss in efficiency and economy by employing solid wire for high frequencies. To overcome this, copper tubing hollow on the inside, or copper strip, is employed. The copper strip, it is seen, approaches a skin, and so does the hollow copper tubing. In both these cases there is a minimum of wasteful material. It will also be clear that the thinner the round wire is the less will be the skin effect, since there will be very little depth to the wire. Consequently there will be a smaller discrepancy between the D.C. resistance of a wire and the high frequency resistance as the wire diameter is decreased. Consequently resistance wire used as a standard is largely made of high resistance wire of extremely small cross-section. In winding coils another expedient is used to reduce the skin effect, namely, the use of so-called "Litzendraht." As stated above, the thinner the wire the less will be the skin effect. But where currents of any magnitude are to be carried, the thin wire will not have sufficient surface to carry the current without undue heating. If, however, a large number of these thin strands are so interwoven or braided together as to make each strand appear on the outer surface of the completed cable, an equal number of times along the same length, its skin effect will be reduced to a minimum. For not only is the complete wire composed of highly thin strands, which is advantageous, but since each strand is as much outside and inside the cable as any other, the number of lines of force around each strand is the same, and hence the skin effect is a minimum. These are some of the practical applications in radio of understanding the phenomenon of skin effect and high frequency resistance.

In discussing the resistance of coils in (Continued on page 993)

A Capacity Increase Method of Reception

By VICTOR H. LAUGHTER

WHEN the Standard Armstrong regenerative circuit is employed for reception of wave-lengths from 100 to 200 meters, it becomes very difficult to maintain a stable adjustment. Consider that we are operating on a wave-length of 100 meters, one frequency will be 3,000,000 and as the best beat note is from 800 to 1,000, our adjustment will have to be held above or below this difference to get the proper tone. Due to the fact that a minute change in capacity will cause a corresponding large change in the frequency of the operating set, we have the familiar hissing noise occasioned by the approach of the hand or body near the controls. The more sensitive the operating point, the more marked the instability. In the method described herein the writer has made the attempt to utilize the fact that all short-wave length circuits are extremely sensible to a minute capacity change, and apply in such a manner that it becomes an advantage.

The circuit is shown in detail in Fig. 1. Here we have the usual aerial connected to the inductance L_1 . The L_1 circuit consists of the variable capacity C and the added inductance L_2 . V_1 represents the vacuum tube detector arrangement. In this particular case it is considered that L_1 is tuned to 100 meters wave-length equivalent to a frequency of 3,000,000; V_2 - V_3 is a standard two-step radio frequency amplifier.

At H is shown an oscillating circuit made up of a vacuum tube, inductance L_3 , capacity C_1 and C_2 . At M is indicated a magnet which acts upon the diaphragm D , which is part of the capacity C_2 . R indicates a crystal or other rectifier. The capacity C_2 may consist of a metal disc B , about $1/8$ " thick, drilled with $1/64$ " holes, and with the diaphragm D mounted in a telephone receiver, the two being separated by means of a thin paper washer. The diaphragm is placed next to the magnet pole pieces, which in this case can be a standard telephone receiver with 1,500-ohm windings. Suitable leads are provided from B and D . C_1 is a variable with a small zero capacity. The telephone receivers are connected as indicated.

The first adjustment is that of the H circuit. Start the circuit oscillating and tune to the point where the frequency is approxi-

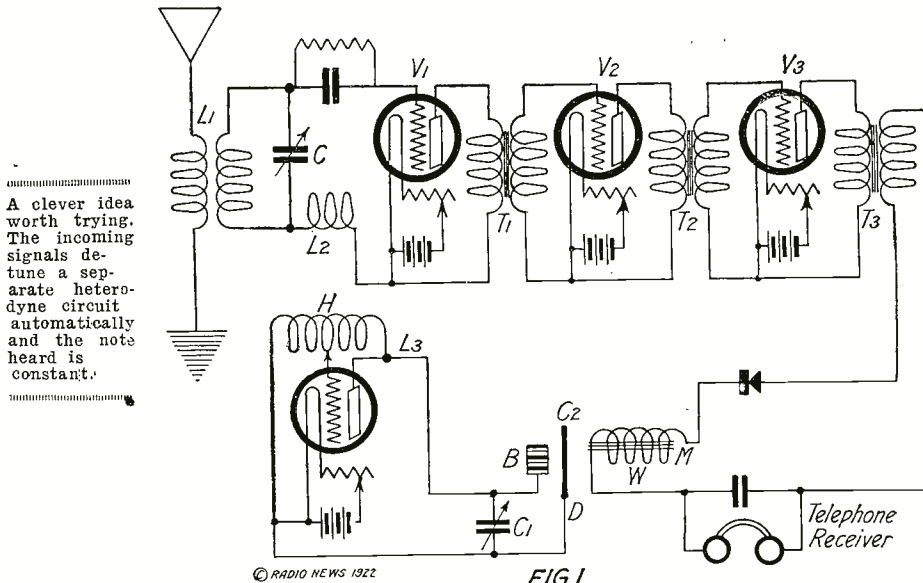

A clever idea worth trying. The incoming signals detune a separate heterodyne circuit automatically and the note heard is constant.

mately 2,900,000 or 100,000 out of resonance with the L_1 circuit. Consider that we have an incoming wave of 100-meters length, the incoming frequency of 3,000,000 will intermingle with that of the induced H circuit, 2,900,000, and a radio frequency current of 100,000 will be the result.

This current will be detected and amplified through V_1 - V_2 - V_3 . The secondary of T_3 is connected to the magnet windings of M through the rectifier R . We will assume that the flow of the current, after rectification is such that it will increase the magnetic strength of the pole pieces. The increased magnetic pull of the pole pieces on the diaphragm D will increase the distance between D and B . As D and B are the respective plates of a condenser, this increase will reduce the capacity of the H circuit, thereby causing a corresponding raise in the frequency of the oscillations it is generating. The two circuits were originally 100,000 frequency out of resonance. At this point it should be noted that the increase in frequency of H will have cumulative effect, that is, the nearer resonance the two circuits approach, the greater becomes the tendency to bring resonance about. With resonance plotted against current, we get a characteristic similar to that

of the crystal detector. With the rise in the frequency of the H circuit we finally reach the point where an audible note will be heard in the receivers. At certain moments during the operation the currents will be of equal value and amplitude, and if in phase, an increased current will flow to the grid of V_1 . Likewise, the frequencies will reach the moment when 180 degrees is out of phase, in which case the current of the grid of V_1 will momentarily be reduced to zero. This current reduction will extend back to the magnet M and allow the diaphragm to return to its original position. During this operation two points of audibility have been passed, one on the rise and one on the decline. The incoming wave, however, will cause this action to again occur just as long as it affects the grid of V_1 . This action is similar to that of an interrupter. The note in every case will be that of the natural period of the diaphragm D . The adjustment of the H circuit should be such that no tone is heard in the receivers until affected by the incoming signal current. To get a greater condenser action, so as to maintain a wider value between the frequencies, it is only necessary to increase the steps of amplification.

Design of Radio Receiving Loop Antenna

By R. R. BATCHER

ONE of the greatest advantages of a loop antenna, in these days when landlords are so busy figuring rent raises that they have no time to grant permission to radio enthusiasts to erect antennae on their apartment houses, is that one can be built to fit the smallest available space within the radio room. It is not affected by snow, winds or sleet, nor by loose and swinging guy wires and clotheslines such as are usually found on the roof of an apartment house. The lightning protection equipment which often becomes an expensive necessity with an overhead antenna, moreover, is no longer required since a loop may be mounted in a room and is thus no more of a hazard than a bed spring, or a dishpan.

Several articles have appeared during the last couple of years, giving designs of loop antennae, but the general design of a

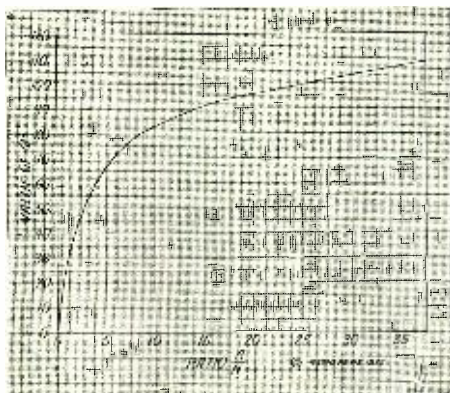

Factor Q in the Formulae Given is Determined With This Curve.

loop that will fit the space that is to be had, will not be out of place. It has been estimated by a New York daily paper that there are about 200,000 amateurs at the present time within the metropolitan area of that city. It is possible that the majority of these are interested only in the reception of the radiophone broadcasts, and for these the loop will serve the purpose admirably.

The loop should be at least 2' square and larger if possible. In most cases, within limits, the larger the loop the greater its efficiency, although this is not always strictly true. The larger the loop, the less turns will be necessary to give the required inductance, and hence the less distributed capacity is introduced. On the other hand, the larger the loop the less efficient the coil is as an inductance, on the basis that the inductance is proportional to some power (Continued on page 1007)

A Practical Loading Coil Unit

By D. R. CLEMONS*

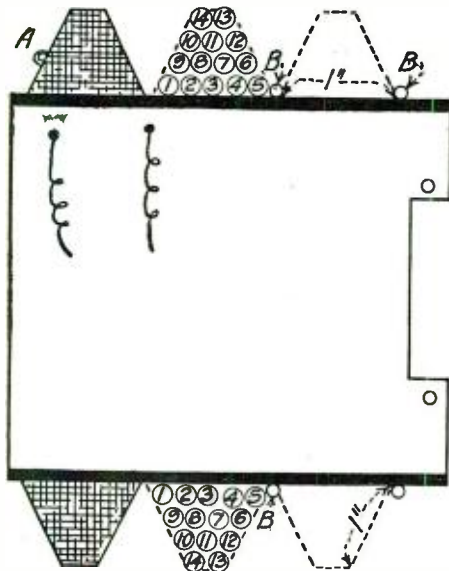

FIG. 1. © RADIO NEWS 1922

The Method of Winding the Wire in Layers is Here Shown.

HOW may I increase my wavelength so that high power, long-wave stations may be received? This question pops up in every one's mind at least once during his experience. Like other problems, it is inconvenient to answer directly until the remaining constants of the circuit are known.

Assume that we now possess a receiving set consisting of a loose coupler, receiving variable condenser and accessories. If a coupled circuit is also desired on long wavelengths, we might increase the inductance of each circuit until it is large enough to tune over the longer wave-lengths now used by many stations here and abroad. In this connection, the same circuit and accessories could be used as with the lower wave-lengths; both the primary and secondary circuits having been loaded sufficiently.

How large, and how many turns, then, will be required for such inductances for loading my set? The maximum wave-

*Instructor in Radio, Dodge's Radio Inst.

length now used is about 18,000 meters. The LC constant to extend through is 90, which value requires 90,000 micro-henries inductance with the average condenser of 0.001 mfd. It is desirable to sub-divide such a large unit into sections so that progressive values may be included in the circuit. In the average station, about 75,000 micro-henries will suffice.

What kind of coil should be used? A very large number are now on the market. However, many would like to build their own. These may be wound up in various ways: Long solenoids, bank wound, spider-web, or merely into a form of square cross section. Experiences with bank windings and staggered patterns are often discouraging. The simplest type of winding that I can recommend will now be described. The illustration included here shows an inductance of 45 milli-henries used for extending a receiver over 18,000 meters. Any one with moderate ability can employ this method.

The unit is sub-divided into three sections of 11 milli-henries each. A sketch of the cross section shows the method of winding. The unit was made as follows: A bakelite tube 5" in diameter was cut to a length of 5". The first section was started by tying two cords (B in Fig. 1) 1" apart. The wire used was No. 22 gauge triple cotton covered. The end was passed through a small hole in the tube and the space between cords filled with the first layer. The second layer was wound back over the first, as shown by the numbers in the sketch.

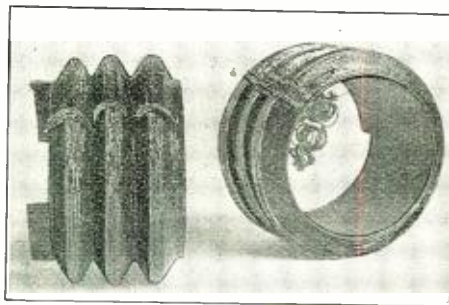

Side and End Views of the Completed Loading Unit.

Multiple Coil Tuner

By E. F. BACHELLER

The coils cannot be made more loosely than as shown by C and F, but as that is

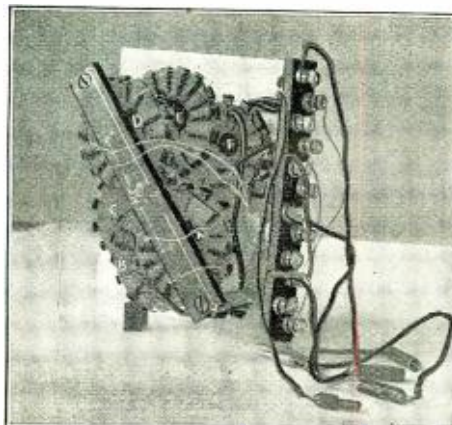

A Pancake Variometer That Has Been Found to be More Selective Than the Ordinary Ball and Cup Type.

CREDIT for the idea and construction details of this tuner were given to B. A. Engholm in RADIO NEWS of July, 1921.

The coil is made to plug into a regular "DeForest Coil Mount and coils are connected at both ends to binding posts 1 to 12.

Coil A to 12 and 11, coil D to 10 and 9, coil B to 8 and 7, coil E to 6 and 5, coil C to 4 and 3, and coil F to 2 and 1, this was done to facilitate the trying of various hook-ups.

The combination that seems to have the most unusual results is as follows: Coils A and C are connected as a variometer; 12 connects with 4, and 11 and 3 plug into primary of triple coil mount; 10 connects with 2, and 9 and 1 plug into tickler of mount; 8 connects with 6, and 7 and 5 plug into secondary of mount.

Coils A and D are stationary, B and E mounted to revolve together, with C and F mounted as the second revolving unit, both with dial or pointer on front of cabinet.

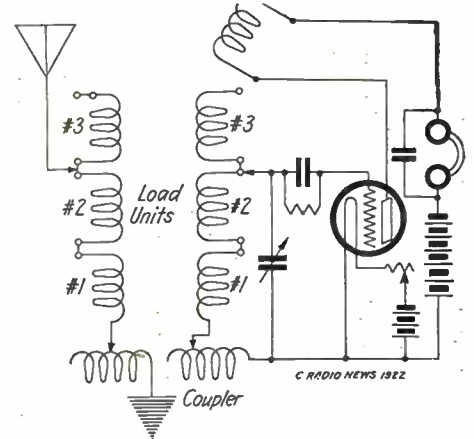

How the Loading Coil May be Connected in a Receiving Circuit.

Each successive layer should be one turn less than a layer beneath it, so the winding becomes of triangular cross section as the winding continues. When six turns per layer were last wound, holes were drilled close to the coil on either side and cord passed around, binding the last turn in tightly after which a piece several inches long is bent downward into the inside of the tube. Very heavy shellac was applied at points on each layer to tack the turns, thus keeping them in place until finished. Heavy shellac was applied to each section as finished. All sections should be wound in the same direction, or else connected so that all values add mutually.

Most builders cannot employ triple covered cotton; so it may be convenient to use double or single cotton covered No. 24 gauge. If No. 24 double cotton is used, I suggest that each coil be wound with a width of 3/4" between cords on the first layer. Smaller gauges may be used; also enameled wire if economic conditions forbid the more expensive variety. About five sections will be required for No. 22 cotton, with the average set; four sections for No. 24 cotton, and two sections for No. 24 enameled, which must be tapped frequently.

Each section may be tapped by bending
(Continued on page 1028)

all the circuit will stand, it was not necessary to make the cabinet larger.

With these coils and hook-up, I have heard KDKA on one step and the sparks are more selective than any coils I have ever tried.

This seemed the remarkable part of the hook-up to me, as we are in a nest of broad sparks here.

The signals do not seem to be as loud as with other different hook-ups, but more selective, especially on spark, and the phones have less howl to tune out.

These were wound with a variety of wire, single, double and triple covered and no doubt can be much improved by rewinding properly.

The C-F coils are No. 24 single silk, B-E coils are triple covered gas fixture wire, No. 24, and A-D are No. 24 double cotton.

Coils are 2 7/8" in diameter and the cabinet is 7" x 6" x 3 3/8".

The illustration shows a four-coil pancake variometer.

\$350 Detector Amplifier Prize Contest

IF Radio is to be the great thing we all expect it to be some day, it will be necessary for the public to become more and more interested in its wonders. The public at large is still somewhat skeptical and while thousands of laymen are becoming converted to Radio each and every day, we are still far from our goal. As long as there is not a Radio outfit in EVERY house in the United States, we have not fulfilled our mission. Now, it is a fact that not everyone cares to invest a great deal in Radio, but wishes at first to become convinced. Not everyone can visit a friend and hear the wonders of the Radio broadcast and if he does, nine times out of ten, he finds that the outfit which his friend has, costs anywhere from \$75 to \$200 and as a beginner, he does not care to invest so much money.

So he goes and buys a cheap crystal set, costing anywhere from \$5 up. He takes it home, and makes it work after a fashion, but he is not satisfied. His friends are likely to sniff at such an outfit because a head set is necessary for the music cannot be heard in the whole room with a crystal outfit.

What is desired and needed most today to convert the public at large to the Radio art is a simple outfit that will give music loudly. At the present time, we appreciate, this cannot be done. Frankly we have ourselves, not often seen a crystal outfit that brought the music in loudly, and many experts will probably deride us by claiming that we are stepping backwards instead of forwards in attempting to make a crystal talk loud. We are not at all deterred by that, for we firmly believe that in the multitude of amateurs, there are a few who will be able to turn the trick.

We know that it can be done. Some years ago, there were sold outfits that worked on a microphonic principle that stepped up the small energy, from the vibrating telephone diaphragm. These loud talkers were none too good and not a huge success; still thousands of them were sold.

Our aim is to pay the prizes as shown here for the best detector amplifier that will bring in the music loud, so that it can be heard in a fair-sized room. Here are the conditions. With an ordinary detector set, it should be possible to hear music as broadcasted from one of our broadcasting stations so that the sound can be heard by everyone in a fair sized room. When we speak of a detector, we mean one that is not a vacuum tube. Any other detector may be used. It may be a Gaylena, a Perikon, or Silicon type. It may be a magnetic or an electrolytic one.

1st Prize	\$150.	in Gold
2nd	75.	" "
3rd	50.	" "
4th	35.	" "
5th	25.	" "
6th	15.	" "
	350.	

It makes no difference. Or it may be an entirely new kind of detector, of which we know nothing today. The only exclusion is the vacuum tube detector as that term is understood today.

In order to win a prize such an amplifier must bring in the music audibly within a radius of 50 miles from the station, on a 4-wire aerial, not longer than 35 feet. If a loop can be used, so much the better. The amplifier may be of the microphonic type, or any other type that can be constructed by

the average experimenter. It should not be a contrivance that is very difficult to adjust and which does not "stay put."

The amplified music may be received on any contrivance that brings in the volume of the sound loudly such as a horn, bowl, etc. If more than one detector is necessary there will be no objection to that.

In connection with this contest, it would seem to be physically impossible to award a prize unless the Editors have fully satisfied themselves that the device works. For that reason one of the requirements is that a model must be submitted with every entry. This model is to remain the property of the builder. It will also be understood that the patent rights, if any, will revert to the builder, and such rights will not go over to the publisher in this contest. The only rights that the publisher reserves are the right to publish the article or articles on such amplifiers, and also the right for all manuscripts submitted which may be published at his option in future issues, such manuscripts to be paid for at regular space rates. In all events a complete sketch must be furnished by the contestant.

No manuscripts entered in this contest can be returned. We reserve ourselves the right to publish all worthy ideas, which did not win a prize by paying regular space rates. Use only one side of the paper for writing and keep sketches on a separate sheet. No penciled matter can be considered. More than one idea may be entered by contestants. The contest is open to everyone, radio clubs included, except manufacturers of wireless apparatus. All prizes will be paid upon publication.

Should two contestants submit the same idea, the same prize will be paid to both.

This contest closes on May 15th at twelve o'clock, noon, at New York, by which time all entries must be received.

Address all manuscripts and models to Editor, *Radio Amplifier*, care of this publication.

The Construction of an Experimental Radio Set

By JOHN R. MEAGHER

THERE are three chief requisites in the construction of any radio set; they are, good performance, neat appearance and total cost.

Once upon a time, in the days of crystals and sparks, a good receiver could be built for about \$15 or less, aerial, phones and lightning switch included. Nowadays, although the performance of the tube receivers is ten times over all better, the cost including batteries, phone, aerial, light switch and bulb of a short-wave set mounts up to the interesting sum of \$50. This is a very low estimate. Now, price is a paramount consideration to thousands of amateurs who depend upon their earnings after school, or upon the generosity of the "OM." So when a radio set is contemplated, it is generally home-made, the purchase of a complete set being out of the question. To buy the parts and assemble them is the general procedure. The average experimenter, however, overlooks many things that are essential to the good operation of any set.

To take the first requisite, good performance, we must be able to change the circuit connections of the set to make experiments, otherwise it may not function to the best of its ability. *There are no sets, ready made, on the market where this is absolutely possible.* The only method now is to spread the component instruments on a table and hook them up with short, direct leads. Spreading the instru-

ments all over the table, however, does away with the second requisite, neat appearance; besides a great deal of dust is collected.

The following description of a unit panel set and cabinet that allows for unlimited

Terminating Posts

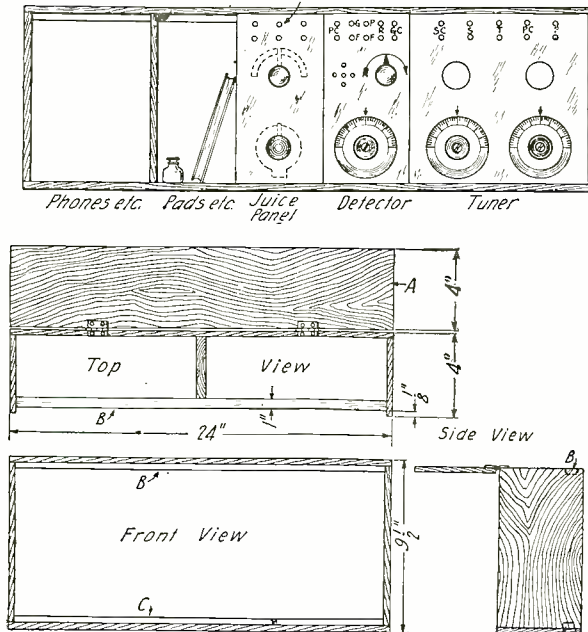

By Using This Type of Cabinet, Panels May be Added or Easily Changed When Desired.

expansion should prove of interest to the experimenter.

Fig. 1 shows the construction of the cabinet. Following the Wireless Specialty Apparatus construction, the panels are flush with the front of the cabinet, contrary to the Westinghouse method. The size shown is for panels 9" high. This height will be found best for the hands and is adapted to almost any type of panel. De Forest panels will fit. The length of the cabinet is optional and is governed by the table space available and the total number of panels that will eventually be constructed. The cover is hinged for the removal of the tubes. The woodwork on this cabinet can all be done with a saw, sandpaper and an ordinary supply of patience. To construct the cabinet shown, purchase about 12' of white wood from your local carpenter. The width is 4", and the wood should be 1/4" thick. Have the carpenter plane down the edges if they are not already smooth, and after cutting the pieces to size, fasten together with small brads and flat headed small brass wood screws. The finish is optional. Two small brass hinges are needed for the cover, and any means may be provided for holding the cover down. The panels are all drilled in the corners for small brass wood screws to secure them to the cabinet. The holes may all be placed about 1/2" from the sides and 1/16" from the top or bottom,

(Continued on page 1037)

A Five to Ten Watt C. W. and Radiophone Transmitter

By FLORIAN J. FOX

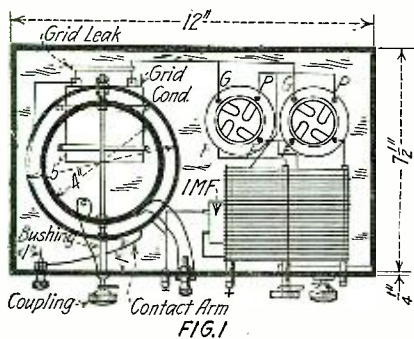

FIG. 1
Plan of the Completed Set Looking From Above. This Plan Indicates the Positions and Measurements of the Various Pieces of Apparatus Behind the Panel.

I HAVE received quite a number of letters requesting further particulars concerning the C.W. set which was mentioned as being used with the transformer and rectifier described in the December issue of the RADIO NEWS. For this reason I shall describe the set as well as I can, partly for the benefit of those whom I could not satisfy by letter, and partly for those who may be interested in the construction of an extremely simple, compact and yet very efficient C.W. and Radiophone set. At the time of the last writing I mentioned a radiation of over one ampere, but nothing about results, as I did not have a chance to "try her out." Since then I have been able to work quite a number of stations within a range of 300 miles or so, 8ANW, 8AQV and 8TB being the records up to date. That is for C.W. The phone has been picked up in neighboring towns and 2BML reported having received it with phones on the table using two stages of amplification. He is about 25 miles from my station, but the set should do even better.

For simplicity the set will be described just as it was made here, allowing the experimenter to change parts, dimensions or lay-out, as he wishes. However, considerable thought and care were exercised in the designing of it and the builder will make no mistake in following the dimensions given.

The set is so designed that if the maker wishes, he can build a cabinet into which the panel will fit, and it will be found that the set will slide right into the cabinet.

The base may be made of any kind of wood. The finished size is 7 1/2" wide, 12" long and 3/4" thick.

The panel is 1/4" phenol fibre or formica, and the dimensions are 8" x 12" as shown in the accompanying drawings, which also show location of parts with necessary dimensions for drilling holes. All the dimensions for the holes in the variable condenser and the switch are not given. These will depend upon what kind of condenser and switch, respectively, the amateur will use.

The primary tube is of formica, 6" long and 5" in diameter. A straight line is drawn along the length of the tube parallel to the axis. Along this line holes are drilled as follows: one-quarter inch from

top, one inch from top, one-half inch from bottom (or 5 1/2" from top), near the bottom hole, and the second hole from top a few small holes are also drilled, by means of which both the wire and the string can be fastened to the form before winding. Diametrically opposite the second hole from the top another hole is drilled. The brass rod supporting the secondary coil will be passed through these holes, so care should be taken to line them up right.

A good way to wind the coil is to cut off about 56' of the wire (No. 16 bare) and an equal amount of string, and lay them out straight side by side. (You will probably have to do this out in the yard.) Now fasten one end of both the wire and string to something firm and fasten the other two ends to the coil, taking care to have about as much tension in the wire as in the string.

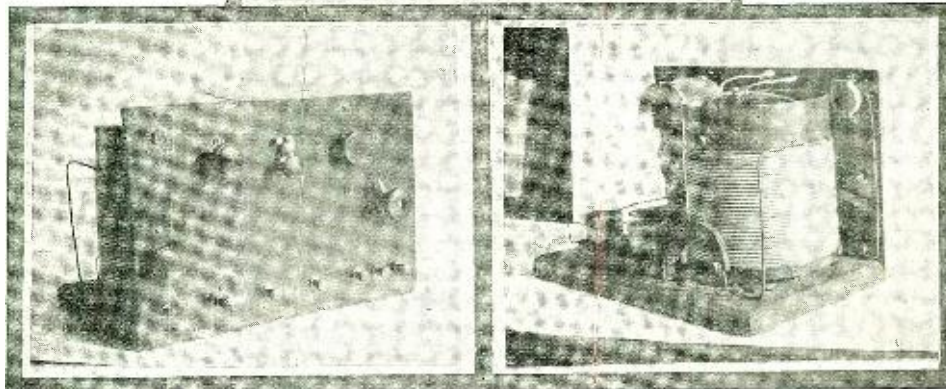
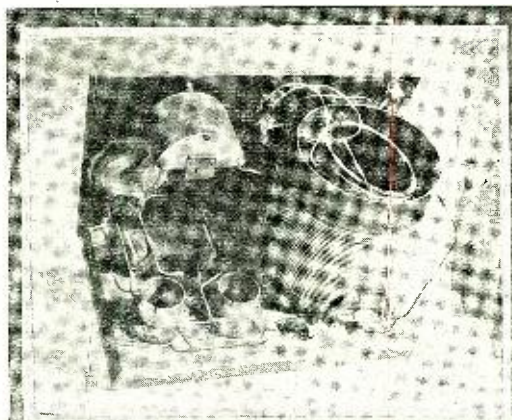

Three Views of the C.W. and Radiophone Transmitter. Full Instructions, With Dimensions, Are Given in This Article, Making it Possible for Anyone to Construct This Set.

This is done by simply changing the length of either the string or copper a very slight amount. Now wind the coil by turning it in your hands, advancing slowly as the winding progresses. You can easily regulate the tightness of the winding in this way. If the wire and string are spaced about an

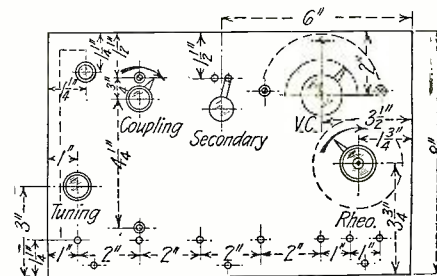

FIG. 2

Plan of the Front Panel Indicating the Exact Positions of All Holes to be Drilled. This Plan Should be Drawn Full Size by the Builders and the Holes Punched Through it.

inch apart where they are fastened, it will be found that they fall into place by themselves practically as the winding progresses.

Before beginning to wind, consult the photographs thoroughly, otherwise you will be tempted to cover the whole tube with wire. It will be found that about 30 to 35 turns will have been wound on. The coil may be left as it is, or else treated with shellac. Some may prefer to remove the string afterwards, in which case the wire must be "stuck" to the tube with shellac or liquid bakelite in order that the turns may not become displaced and touch each other.

The secondary was made as follows: Holes are first drilled through the center, as shown in the illustrations, for fastening to the brass rod. Small holes are drilled on the edges, and the ends of the wire may

be anchored to these. Wind on about 16 turns of No. 16 D.C.C. (stranded if you can get it) copper wire. Take a tap at the tenth turn. Make all leads from the coil of flexible copper wire, any reasonable size. After the eighth turn, a space of about 1/4" is left. In other words, when you come to the holes in the middle of the tube leave a clearance of about 1/4" for the brass rod and lock nuts.

The brass rod used for supporting the secondary and varying its coupling, is 7/8" long and is threaded with an 8/32 die throughout its entire length. Threading the whole rod facilitates the assembly. The assembly of the different lock nuts, guide nuts, etc., may be seen in Fig. 1. The accompanying illustrations also bring out the general lay-out of the set as a whole rather clearly.

The holes at the top and bottom of the tube are used for fastening the coil to the panel. Machine screws about 1 1/2" long are used for this purpose. Bushings each 1" long are cut from heavy brass tubing and are used to space the coil with respect to the panel. See Fig. 1. In this drawing is also seen the sliding contact. This works something like a switch arm and resembles the type of sliders which are often seen on loose couplers and tuning coils. The photograph depicting the side view shows this slider and also the method used for making a contact to same. The screw to which the

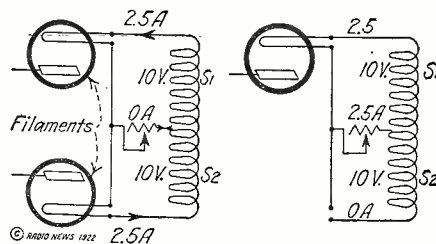

The Method of Connecting the Filament Rheostat is Here Shown. On the Left the Two Tubes Are in Parallel. If it is Desired to Use Only One Tube, the Other is Cut Out by a Switch, as Shown on the Right.

How to Make a Regenerative Receiver and Single Stage Amplifier

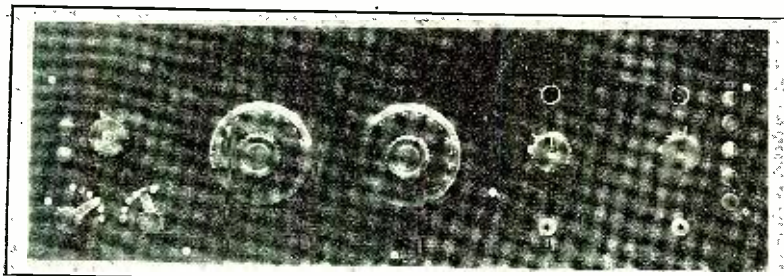

These show the front and top views of the short-wave regenerative set with one-stage amplifier. The cover of the cabinet is removed to show arrangement of the apparatus.

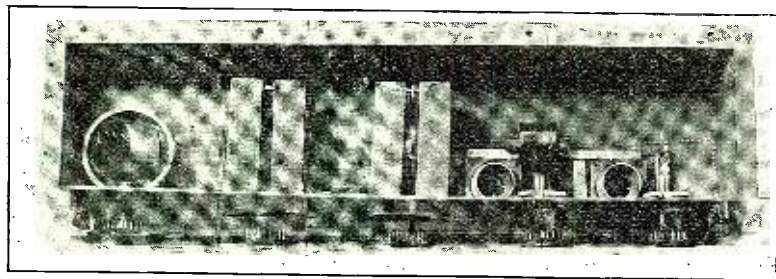

THERE is a great demand today for regenerative receivers and some difficulty is being experienced in purchasing them. It is one of the simplest and yet most efficient types of receivers. It will receive spark signals, radiophone speech and music and continuous wave signals. Furthermore, it will amplify spark and radiophone signals more than one hundred times.

Some of those new to radio have probably imagined that a great deal of skill and knowledge would be required to build such a receiver, but we will demonstrate how simple it is. It is only necessary to purchase standard parts, which may be obtained at any radio dealer's, and assemble the receiver according to the instructions given below.

The following is a list of parts required for the receiver illustrated on this page:

- Vario-coupler, with switches and switch-points for same.
- 2 variometers.
- 2 tube sockets.

- 2 Filament rheostats.
- 1 Audio Frequency Amplifying Transformer.
- 1 Double-circuit phone jack.
- 1 open-circuit phone jack.

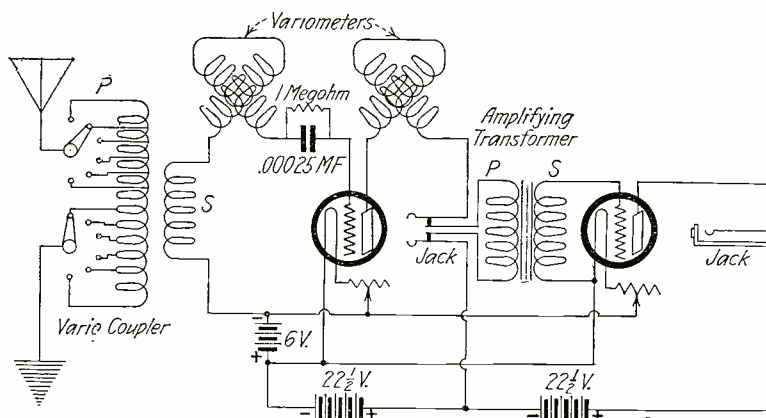

Wiring Diagram of the Regenerative Receiver and Amplifier. The Names of the Parts Are Indicated.

- 7 binding posts.
- 1 grid condenser and grid leak.
- 1 Bakelite panel and cabinet.
- 2 plate batteries—22½ volts each.

The total cost of these parts should not exceed \$40.00 and the only additional equipment required is the antenna, filament storage battery and pair of telephone receivers.

In the receiver we illustrate there is contained, in one cabinet, the regenerative tuner, consisting of vario-coupler and two variometers, with detector tube, and a second tube coupled to the output of the first tube through an audio-frequency amplifying transformer. Fairly loud signals will be obtained with this receiver, and, if desired, more steps of amplification may be added in the same manner as the single step shown.

The front panel is of bakelite and measures about 24 inches by 6½ inches. Referring to the photographs, the two binding posts on the left are connected to the antenna and ground. The switches and switch points vary the primary inductance of the vario-coupler, and the handle above is connected to the rotor of the vario-coupler. The two large dials are on the center-shafts of the two variometers. On the right are seen the two telephone jacks with the filament rheostats directly above them, and at the top there are two holes in the panel to permit inspection of the vacuum tubes. Of the five binding posts at the right, the two lower ones are for the positive and negative leads of the filament storage battery. The three top ones are for the plate batteries.

The two plate batteries are connected in series with the positive end on one binding post and the negative on another. The third binding post is connected to a tap in the plate battery at a suitable voltage for the detector tube. At the back of the panel the wiring connects the negative of the plate battery to the positive of the filament battery.

In assembling this set the vario-coupler, two variometers, two tube sockets and transformer are arranged as shown in the photograph and screwed down to the base of the cabinet. Holes should be drilled in the front panel to permit the center-shafts of the variometers and vario-coupler to pass through to the front of the panel and turn easily. Holes for the rheo-

(Continued on page 1031)

A Super-Selective Receiver

By SAMUEL KOPELSON

IT would seem that the short-wave tuners using variometers for tuning and inductive coupling are the sharpest tuning sets that are made to-day, but this is not so. Many types of receivers have been devised to improve the tuning, but there is one type of tuner that still is peer of them all. This is the Capacitively-Coupled Tuner. It seems strange, but up to the present writing I have never seen one set of this type constructed for short-wave work. Probably the chief idea that the capacitively-coupled tuner is not popular in amateur work is that the amateur has been given the very wrong impression that this type of set is very difficult to tune and on the whole is not as efficient as the inductive-coupled type. I determined to experiment with this neglected type of tuner and after constructing

several different sets I can say without hesitation that there is absolutely no other receiver for amateur work that can compare with the capacitively-coupled tuner, as far as tuning is concerned. As for signal strength, there was no difference than when using a standard short-wave set. The last set that I made is the best of them all. It is so simple to make that the set can be constructed and connected in a half hour. Three variable condensers and one variometer are required. The condensers should have a capacity of .0005 mfd. each. The 23-plate Murdock condensers are fine for this purpose. If larger ones are on hand they can be used. The circuit is shown in Fig. 1. The primary consists of 30 turns of cotton covered magnet wire wound on a

(Continued on page 1031)

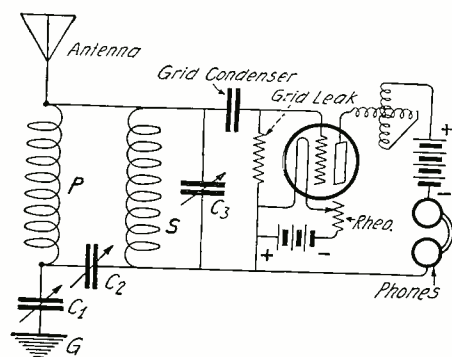

Great Selectivity is Obtained With This Four-Circuit Regenerative Set.

A Practical 50-5000 Meter Wavemeter

By D. R. CLEMONS*

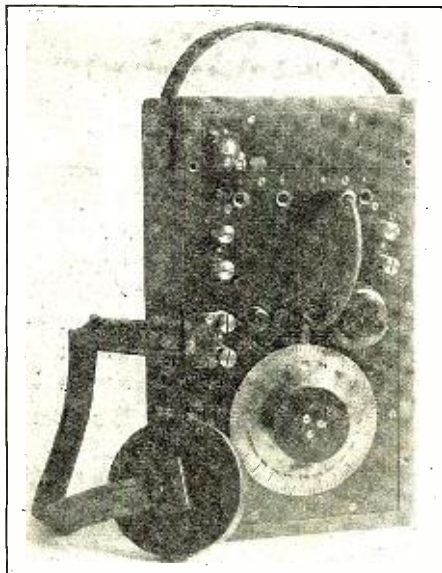

With This Wave Meter a Wave Length Range of 50 to 5,000 Meters is Obtained by the Plug and Jack System. No Extra Coils Are Needed.

THE wavemeter illustrated was constructed for the measurement of wave-lengths of 50 to 5,000 meters. In this class of instrument the essential parts consist of an inductance and capacity, either or both of which may be varied for adjustment of the circuit. It is most convenient to employ a variable condenser and an inductance variable stepwise.

If the inductance is a single large unit, tapped at intervals, it will possess distributed capacity which permits a fundamental upon a moderate wave-length when another portion of the circuit is tuned. Of course, using a small portion of the induc-

tance for lower wave-lengths may cause the entire inductance to respond and cause absorption and inaccuracy of readings. To prevent this, wavemeters are commonly provided with several fixed inductances for the different bands of its range.

This instrument was constructed to cover a considerable range of wave-lengths and yet have no assortment of coils employed. The schematic diagram is given. Coil A is a small spiral inductance of 25 microhenries attached to the instrument through flexible leads contained within a canvas sheath. This inductance is used singly alone on short waves and also serves as the "finder" or "pick-up" coil on all others. Coils B, C and D are sections of a three-layer bank wound solenoid within the cabinet. These sections are of progressive values to provide overlaps. A flexible plug is used to include inductance through the jacks shown.

By plugging into jack No. 1 the ball tip connects coil A in the electric circuit and isolates B, C, and D, at which the wave-length is 50 to 300 meters. In jack No. 2 section B of 75 microhenries is added to A and provides a range of 270 to 600 meters. Now, the fundamental of D (which is now in the field) is 320 meters at which resonance and distortion should occur. By short circuiting this large section D, when it is not used, its capacitive value is destroyed by the negligible drop across it. In this state, at the lowest frequency effecting it, the reactance is several thousand ohms, so that a very small loss is present in it, and its effect on the circuit negligible. By plugging into jack No. 3, coils A, B, and C are in circuit and the wave-length is then 500 to 2,000 meters—a very useful band. By inserting plug into jack No. 4, the short circuit is removed, and B, C, and D are mutually added to A which carries readings from 1,200 to 5,000 meters.

A pull push switch connects in a buzzer

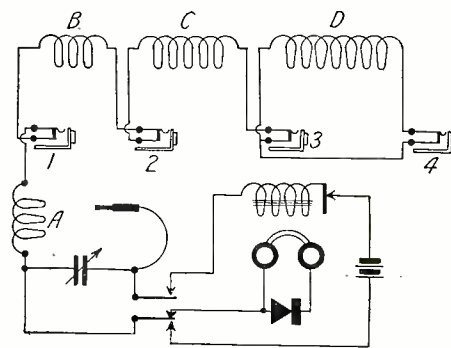

Schematic Diagram of the Connections of the Wave Meter Described in This Article.

and battery for driving, or a detector for reception. All accessories are mounted upon a Fibroc panel. The dial is turned from brass and stamped by hand. The lower half is directly calibrated in micro-microfarads so it may be used as a standard Calibrations were made by comparison and bridge method.

The variable condenser is known as the CotoCo with a capacity of 0.001 mfd. maximum. The finder is of 25 micro-hys consisting of a small flat spiral carried within two walnut discs. The unit B, C, and D, was computed for overlapping bands by plotting the usual curve and selecting points for separation into sections. Overlaps were provided for by assuming condenser values of 0.00075 mfd. maximum and 0.0002 minimum. Section B is of 75 mhys; B and C is 1,200 mhys; B, C, and D is 6,000 mhys.

An attempt was made to provide a small portable meter of considerable range. Numerous coils were eliminated by this principle. Such an instrument we have found very useful in our work where much data is collected in the field. It may appeal to others also.

Useful Hints for the Amateur

By JOHN BRENNAN

WITH the recent advent of the radio telephone broadcasting have come many styles and types of receiving apparatus advertised as being specially designed and fitted for this new and enterprising branch of radio. Foremost among this list are the regenerative tuners, multi-stage amplifiers and loud talkers with their special vernier controls, rear battery connections, filament controls and other unique constructional features.

Noticeable, also, are the patterns published by a well known radio firm. The pattern set for the regenerative tuner of this series of publications has been constructed and the results that were obtained compare favorably with any of the high priced sets now on the market.

The demand for these patterns has been great, mainly because of the simplicity of construction and the detailed information supplied with each pattern.

The need for such plans is quite evident when it is considered that every day there are many joining the radio ranks with no mechanical experience or proper knowledge of the purely mechanical side of radio.

The amateur should first formulate definite plans before constructing a set. By properly laying out the work on paper

with the necessary dimensions, data on coils, placement of the various units, and wiring diagram, much will be accomplished and the actual assembling made much easier.

PANELS

Most panels used are of bakelite, formica, or hard rubber. Hard wood makes a pretty good substitute.

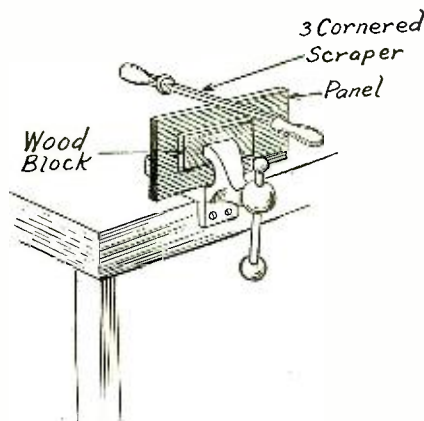

This Sketch Shows the Method by Which a Three-Cornered Scraper May be Used to Smooth Off Panel Edges.

In laying out the markings for the holes to be drilled in the panel, a center punch, scriber, and light hammer are necessary. A hard pencil will serve in place of the scriber. If two adjoining edges of the panel are true they may be used as a straight edge on which to base the other measurements. Or center lines may be drawn across the length and width of the panel and these used in place of the straight edge, all holes being laid off from the center point.

If a scriber is used, scratch the panel very lightly with it so that the markings may be removed later, when finishing off the surface. If a pencil is used it is quite easy to rub off the markings after all holes have been laid out.

It is absolutely necessary that these pencil lines be entirely erased. A high resistance leak will be formed if a pencil line remains drawn between the various elements on the panel.

When drilling the panel, it is best to place underneath it a block of wood so that the drill does not break through and chip the edges of the hole.

Difficulty is very often encountered in cutting panels of various sizes. A very easy method is that of using a hack saw with a

(Continued on page 1026)

Radio Telephony

By LOUIS GERARD PACENT*

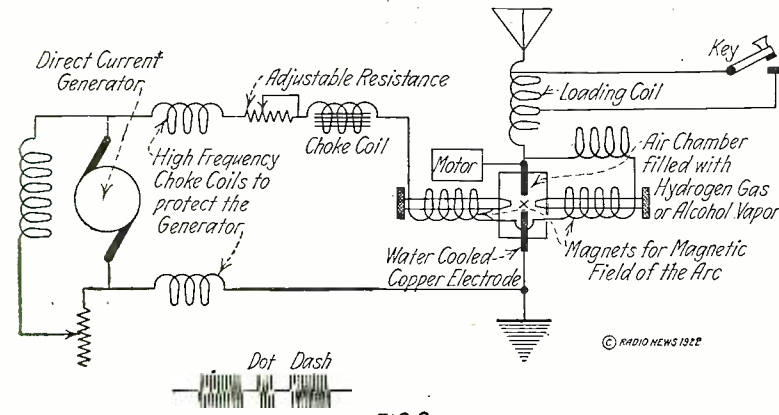

FIG.2

JUST after the experiments of Marconi in 1898-1900 in radio telegraphy, a few successful experiments were made in which the voice was transmitted by electric waves over distances of several miles. Up to about 1915, however, no commercial or practical use had been made of radio telephony, due to the lack of a means of producing enough modulated power to satisfactorily transmit over any great distance.

In the latter part of 1915, the A. T. & T. Co. performed their classic experiment and transmitted speech from their audion transmitting station, at the Naval Station at Arlington, Va., to observers at Honolulu, Colon, Panama, Paris and Mare Island, California.

The wireless telephone was used to a very large extent during the war for short distance communication between submarine chasers, transports and battleships at sea, for training purposes between aircraft, between aircraft and ground, and between ground stations. The success of these installations was due to the vacuum tube and a knowledge of its use in the production and modulation of high frequency currents. In order to understand wireless communication, let us look into the theory connected with the subject by means of analogies which are familiar to us all.

WATER WAVES, AIR WAVES, ETHER WAVES

If a pebble is thrown into the water, a splash takes place and water waves are set up which travel in all directions in expanding circles with the speed of only a few inches per second. Sound waves are set up by a disturbance of the air and travel in all directions with a speed of nearly 1,200 feet per second. The human ear recognizes as sound, vibrations of the air between 50 and 15,000 per second.

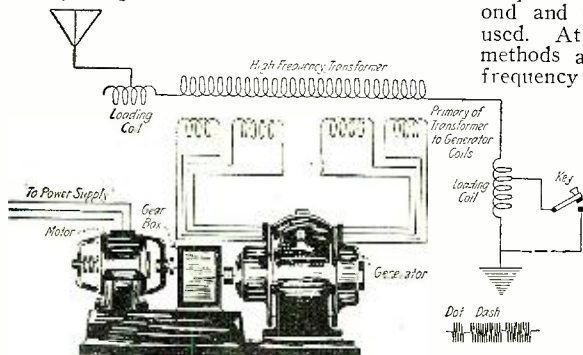

FIG.3

This is the Circuit of a High Frequency Alternator as Used in All Big Stations. The Undamped Waves Produced Are Similar to Those Emitted by the Arc Transmitter.

*President Pacent Electric Co., Inc.

Fig. 1, on the right, shows a spark transmitter and the damped oscillations produced in the circuit, by the successive discharges of the condenser, while on the left is the circuit of an arc transmitter producing undamped waves. Compare the signals of constant amplitude emitted by this set with those of Fig. 1 produced by the spark transmitter.

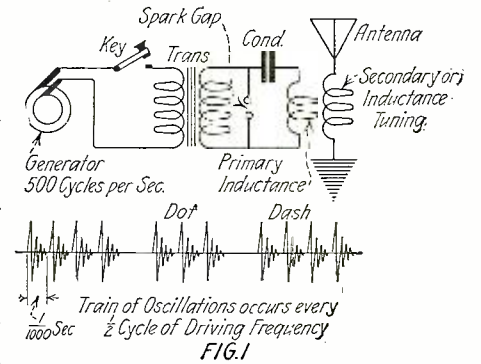

FIG.1

system is in general used for some Naval and ship to shore communication. This source of high frequency, due to the fact that the oscillations are damped (fall off rapidly) and not continuous, is not suitable to radio telephony, see Fig. 1.

ARC METHOD OF GENERATION OF CONTINUOUS WAVES

Duddell in England, Poulsen in Denmark, and others, studied the electric arc and found that it could be used to generate high frequency continuous oscillations. (Oscillations which are of equal amplitude and do not fall off.)

The Poulsen Arc makes use of a magnetic field and a hydrogen vapor around the arc as aids in its operation. The Arc is primarily used for long distance radio telegraph stations, although of late years 2-K.W. arcs have been installed on ship stations and have proved to be very satisfactory. The arc is limited in its usefulness to the extent that 1,000 meters is about the shortest wavelength that it is practical to operate on at the present time. The largest arc station in existence is installed at Bordeaux, France, and is rated at 1,000 K.W. This station can be heard in almost any part of the world. A typical arc circuit is shown in Fig. 2.

THE HIGH FREQUENCY ALTERNATOR

Fessenden in the old days recognized the advantage of a machine-made radio frequency source of power and had a number of small machines (2-K.W.) built. They operated at extremely high speeds (20-30,000 R.P.M.) and for that reason were not very practical. Goldschmidt of Germany, Jolly, Bethenod and Latour of France, and others have produced high frequency generators with varying degrees of success. Alexander-son, who built some of the first gen-

Ether pervades all space and is supposed to be a perfectly elastic medium. By disturbing the ether electrically, ether or electro-magnetic waves are set up, which travel in all directions unless otherwise directed,

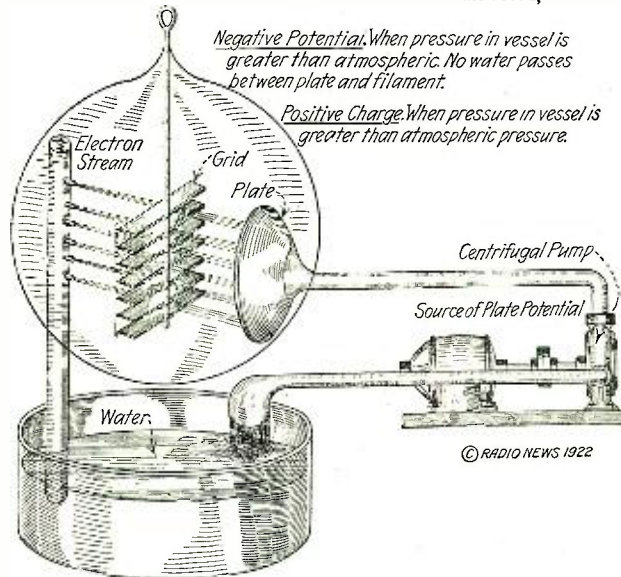

FIG.4A

This Analogy Clearly Shows the Functioning of a Vacuum Tube Detector. The Shutter in the Center Represents the Grid, and May be Opened or Closed by the Handle, Producing Upon the Water Stream the Same Effect as the Variation of Potential of the Grid Upon the Electrons.

with a speed of 186,000 miles per second. It is easier to grasp the meaning of this when we express the speed of ether waves in this way. The speed is equivalent to traveling 7½ times around the earth, at its equator, in one second.

The ether waves set up an electric and magnetic field which, when they cut the receiving antenna, set up in it an electric pressure exactly similar to that in the transmitting antenna. In radio communication, frequencies between 10,000 cycles per second and 60,000,000 cycles per second are used. At present there are a number of methods available for producing the radio frequency power necessary for radio communication; of these, the four most common means will be discussed briefly.

THE SPARK RADIO TELEGRAPH SYSTEM

When Hertz demonstrated that electro magnetic waves, predicted by Maxwell's mathematics, really existed, he produced them by making use of the oscillatory discharge of a condenser through an inductance. This same type of high frequency was used by Marconi and in all of the spark transmitters in use today. The spark

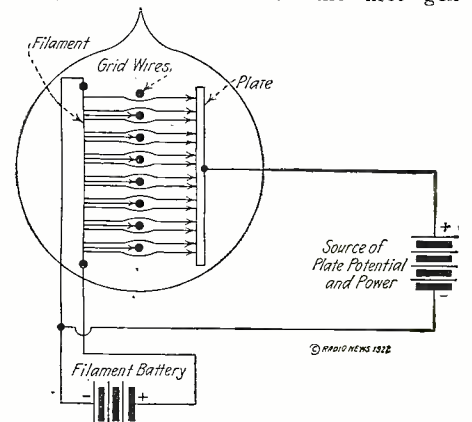

FIG.4B

Here is the Circuit of a Vacuum Tube Corresponding to the Analogy of Fig. 4A. When the Grid is Positive, the Electrons Can Flow From the Filament Toward the Plate, Which, Being Positive, Attracts Them.

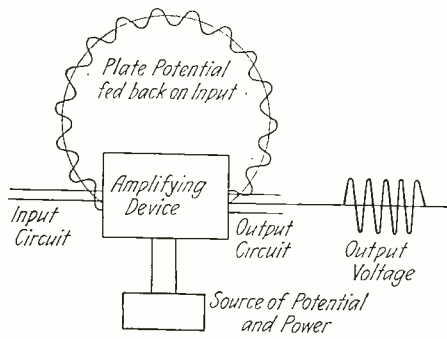

FIG. 6A

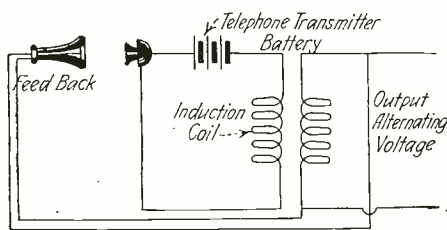

FIG. 6B

Fig. 6A is a diagrammatical representation of the feed back effect, while Fig. 6B illustrates it by a practical analogy. On the right, Fig. 7G shows how the output of an oscillator may be modulated by means of a microphone and modulator tube.

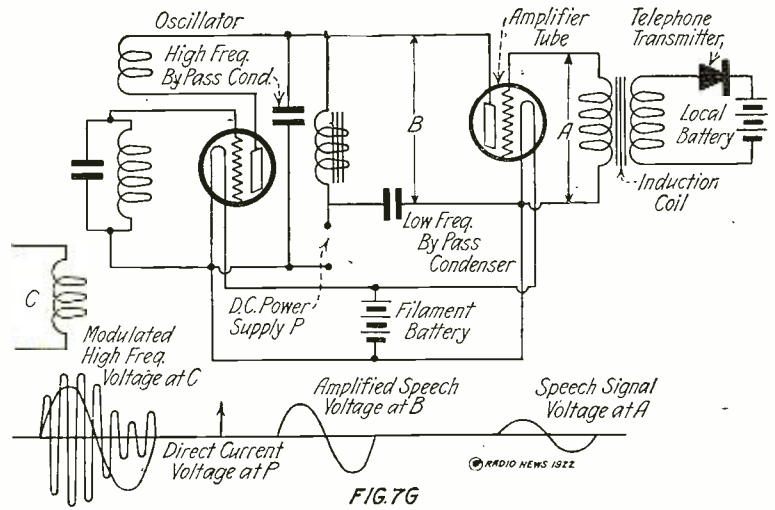

FIG. 7G

erators for Fessenden, designed the alternator which is being used by many of the high power telegraph stations of the world. Most of these generators are of about 200 K.W. capacity and have a range in frequency of approximately 15-30,000 cycles per second (Fig. 3).

The alternator at New Brunswick, N. J., was modulated by the use of a magnetic amplifier and was used to carry on successful radio telephone tests with the S. S. George Washington, when President Wilson returned from France a few years ago. The telephone signals from this station were heard in various parts of the country, in Europe and other parts of the world.

THE AUDION. ITS PART IN RADIO COMMUNICATION

Radio Telephony would not be in its present state of development were it not for the vacuum tube. The V.T., with proper associated apparatus, is the most satisfactory type of generator of high frequency oscillations we know, because it can be made to generate, at will, any frequency from, say, one cycle per week to several score million cycles per second. The V.T., too, performs all of the functions necessary in radio telephony, namely:

Generation of electrical oscillations of high frequency and modulation of these oscillations with the speech signal at the transmitting station and the detection of the oscillations and amplification of the received signal at the receiver.

ing station. In order to get a better understanding of the audion and how it performs these functions, the following paragraphs are written.

The V.T. is an evacuated vessel, (Fig. 4B), containing any incandescent filament, which is a source of negative electrons, a plate and a grid which controls the flow of

analogous to the action of the audion. The electrons emitted (Fig 4B) from the filament are attracted by the plate and flow to it when it is charged positively, but no electrons flow to it when the plate is negatively charged. Thus the plate filament circuit of an audion is a rectifier, in that current flows only when the plate is positively charged.

The grid when uncharged, does not appreciably affect the flow of electrons, but when negatively charged repels electrons and causes fewer of them to reach the plate, thus reducing the plate current. The electron stream and hence the current can be reduced to zero by the application of a sufficiently large negative charge to the grid. A positive charge on the grid causes more electrons to reach the plate and, therefore, increases the plate current.

THE AUDION AS AN AMPLIFIER

Referring to Fig. 5A, suppose the vacuum pump is operating and there is a stream of water flowing through the shutter to the plate. The control of the grid, electrically, is a pressure control and can be represented by the mechanical control, as shown. Suppose the pressure varying in Fig. 5A, with time similar to that shown at A, is applied to the grid through the pressure pump X. The shutter will cause similar undulations of the water (electron) stream which will produce similar large variations of the flow of water of the plate pipe, as shown.

This is analogous to the action of the

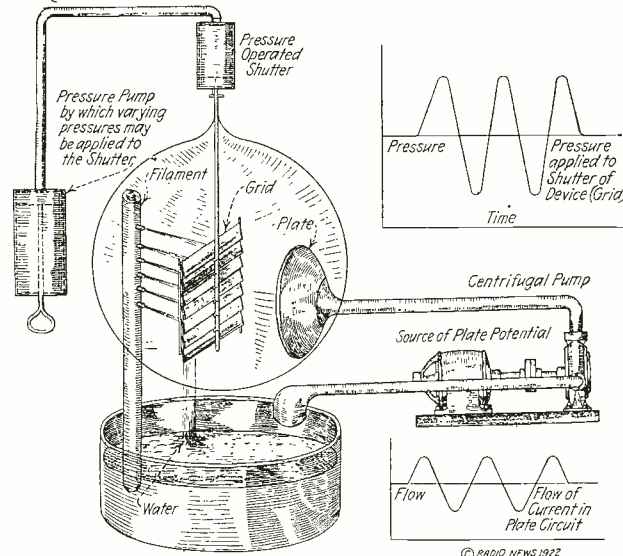

FIG. 5A

In This Analogy, Similar to the One on the Opposite Page, the Piston When Moved, Causes the Shutter, by Variations of Pressure, to Periodically Stop the Stream of Water; These Variations May be Compared to the Oscillations Received Which Change, the Polarity of the Grid.

electrons from filament to plate. The filament when heated emits negatively charged particles or electrons which fall back on the filament, unless attracted to the plate by a positive charge.

Let us look at Fig. 4A. The filament is represented by a tube in a glass bulb. The water acts in a way like the electrons. The plate is represented by a funnel shaped form. The hand operated shutter between the filament and the plate illustrates the action of the grid. When the vacuum cleaner P is operated to produce less pressure in the bulb than in the surrounding air, it represents the condition of the positively charged plate, and the water streams flow through the shutter to the funnel. The shutter can control a large flow of water with but little effort. If, however, the pump were operated in such a way as to increase the pressure in the bulb, no water electrons will flow between filament and plate. This is, in a way,

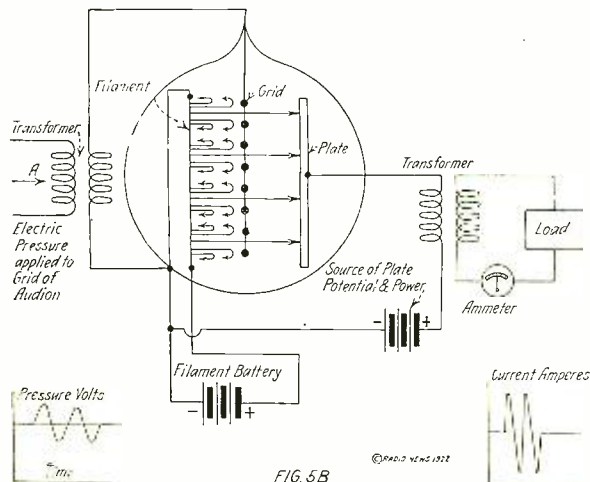

FIG. 5B

When the Grid Becomes Charged Negatively it Repulses the Electrons Which are Themselves Charged With Negative Electricity and Prevent the Current From the Plate to Flow, as the Conductor Formed by the Electron Flow is Broken.

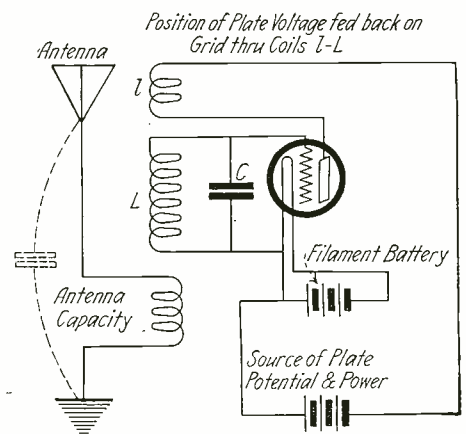

FIG. 6C

This Diagram Shows the Actual Electric Feed-Back Circuit Represented in Fig. 6A.

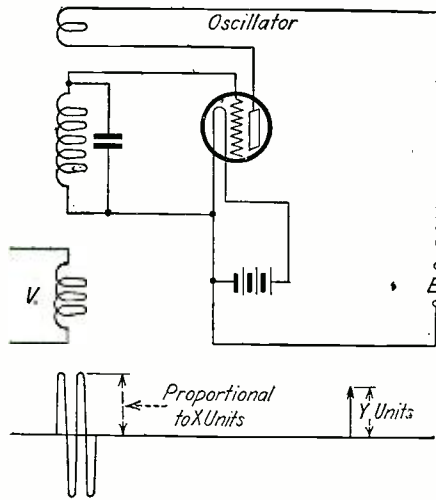

Fig. 7D

Showing How a Speech Current, Applied on the Oscillating Circuit, Modulates the Oscillations by Varying Their Amplitude.

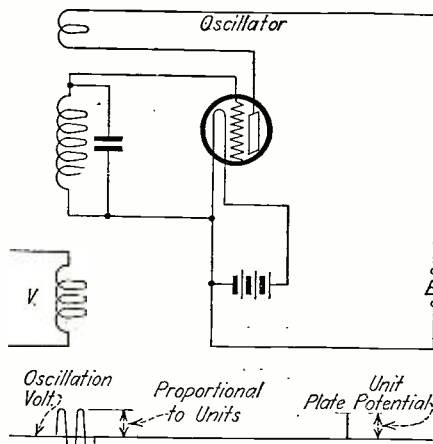

Fig. 7C

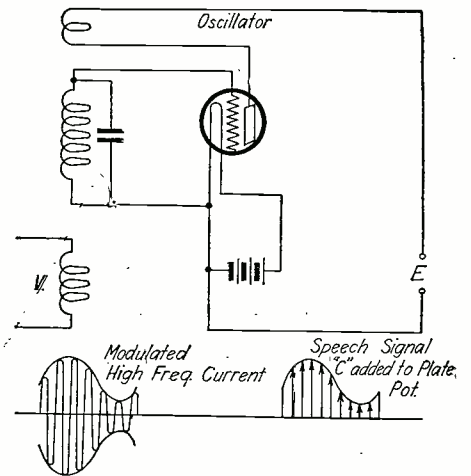

Fig. 7E

audion (Fig. 5B). A small voltage (electrical pressure) applied to the grid at A causes similar variations in the electron stream by the action already described, which is another way of saying that the current in the plate circuit is varied in proportion to the grid voltage. The plate current in turn sets up a much larger voltage across the terminals of the transformer in the plate circuit. The transformer is used to suit the tube circuit to the load circuit.

It should be noted in the audion circuits that the power in the output or load circuit comes from the source of potential; the vacuum pump in the case of the analogy, the plate battery in the case of the audion.

THE AUDION AS AN OSCILLATOR

If we apply a small alternating voltage source to the input of an amplifier, and use its amplified output, the device becomes practically a separately excited oscillator. If, now, instead of having a separate small generator produce the input voltage, which is just like the output voltage, a portion of the output voltage is fed into the input circuit, the circuit will continue to oscillate. The frequency will be determined by the constants of the circuit (Fig. 6A). This action is just the same as that which takes place when the telephone receiver is held close to and in front of the transmitter (Fig. 6B). The receiver feeds into the transmitter the amplified sound produced in the receiver. The frequency of the howl produced is determined by the natural periods of the diaphragm and other parts of the circuit (Fig. 6B).

Pictorially, Fig. 6A represents the oscillator as an amplifying device which receives its power from a source of a constant potential. The output voltage is shown and

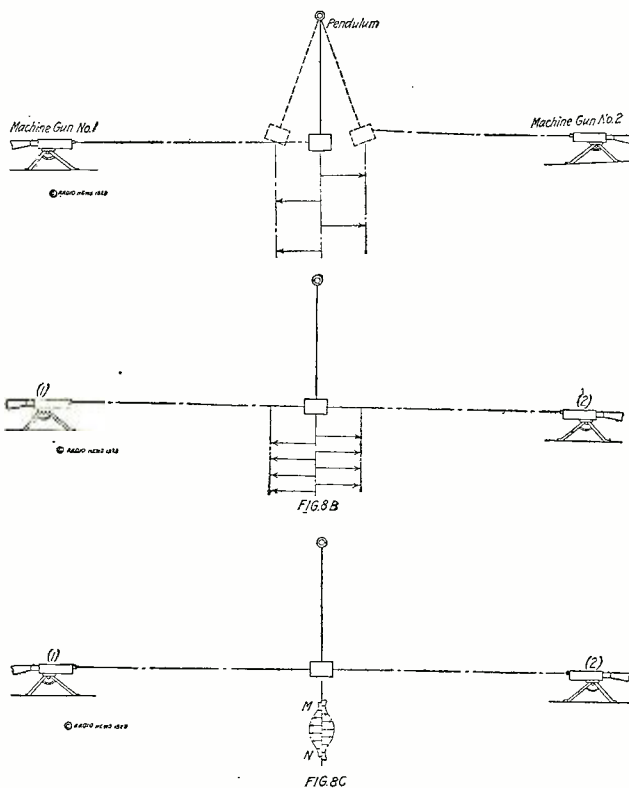

This Analogy Explains Clearly the Detection or Rectification of the Continuous Waves Into Audible Sounds.

that portion of it which is fed back into the input circuit is represented graphically.

Fig. 6C shows schematically an oscillator circuit. The tuned circuit LC determines the frequency and the output voltage is fed into the input through the coupling between coils I and L.

In directly connected sets the

antenna can be substituted for condenser C. The circuit as shown is the antenna circuit coupled to the oscillator. In this case the antenna circuit must be tuned to the same frequency as that produced by the oscillator.

MODULATION

In a simple telephone circuit, a transmitter is connected in series with a source of constant potential, usually a dry battery, a line and telephone receiver (Fig. 7A). When we speak into the transmitter, the diaphragm shakes up the carbon grains and changes the resistance of the circuit, which causes a current varying with these voice undulations to flow in the line.

Before speaking there is a constant current flowing in the circuit, but no sound is produced in the telephone receiver. Upon speaking, this voice current, as it is called, is added to the constant current and causes the diaphragm to move in the same way as that of the transmitter and reproduce those sounds which are spoken into the transmitter. The speech currents are said to modulate the constant line current.

In radio telephony, the high frequency current which produces the electro-magnetic waves corresponds to the constant current of the telephone line, while the modulated high frequency current corresponds to the modulated line current (Fig.

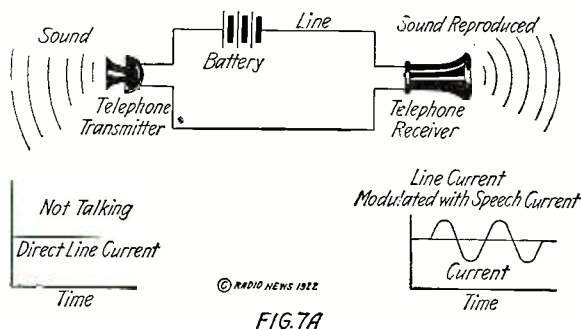

FIG. 7A

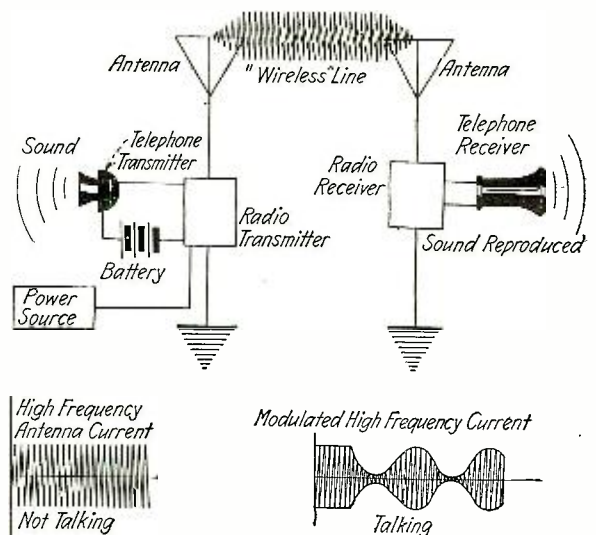

FIG. 7B

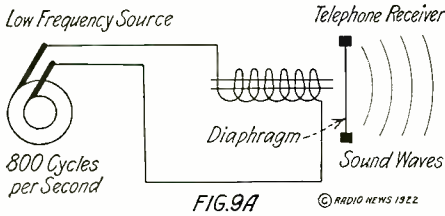

FIG. 9A © RADIO NEWS 1922

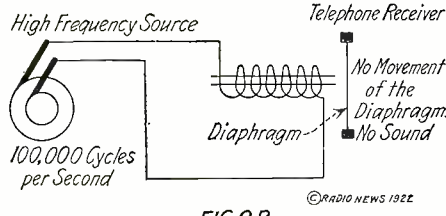

FIG. 9B © RADIO NEWS 1922

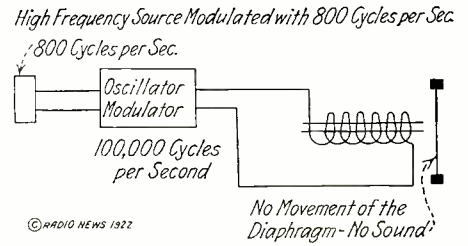

FIG. 9C © RADIO NEWS 1922

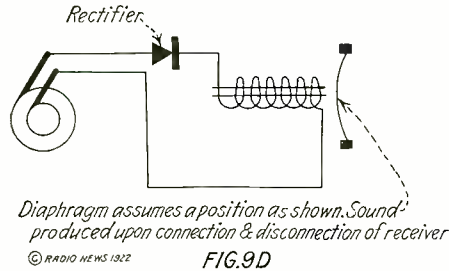

FIG. 9D © RADIO NEWS 1922

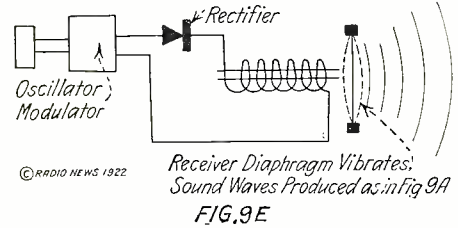

FIG. 9E © RADIO NEWS 1922

In These Diagrams Are Illustrated the Conditions Required to Translate the High Frequency Oscillations Received Into Sounds.

will of course move away from it as the result of the impact of the projectile; if Gun 2 is fired, it will be driven in the opposite direction. The pendulum will swing back and forth, providing the shots are not fired very rapidly. This corresponds to the case Fig. 9A in which the telephone receiver is connected to an 800-cycle generator. The diaphragm will move back and forth in accordance with the driving voltage and produce sound waves.

Now suppose the guns are fired alternately so rapidly that before the pendulum, due to its inertia, has been, started it receives

In Fig. 9C, no motion of the telephone receiver diaphragm results when it is connected to a source of modulated high frequency currents.

If the gun No. 2 in Fig. 8B ceases firing, the pendulum will move as indicated in Fig. 8D. Similarly the receiver diaphragm, Fig. 9D, due to the action of the rectifier, would assume the position indicated as long as the high frequency is applied to it.

In the case of Fig. 8C, if the gun No. 2 ceases firing, the pendulum will move back and forth between a and b. The telephone receiver similarly, due to the action of the rectifier, would move back and forth in accordance with the modulation frequency (800 cycles) and produce the sound produced by the 800-cycle current in Fig. 9A.

The audion can be made to act as an apparent rectifier by the proper adjustments and circuit arrangements. In Fig. 9F, the audion is shown arranged so that variations of grid potential, positive or negative, can be applied and their effect on the plate current noted. The graphs show the plate current variation for different values of grid voltage for a well evacuated audion. This graph is called the characteristic curve of the audion.

Fig. 10B is the characteristic curve of the audion connected as shown in Fig. 10A.

7B). In the modulated current the amplitudes vary in accordance with the modulating speech signal. (Speech current.)

In other words, in order to modulate a high frequency current with a speech wave, it is necessary to cause its amplitude to vary in accordance with the speech current. The following explains one method of accomplishing this.

Suppose power at unit potential is applied to the oscillator at E, and that unit voltage will be produced across V (Fig. 7C). If now Y units are applied to the oscillator the output high frequency will be Y times the output under conditions of Fig. 7C, see Fig. 7D. If voltages of amplitudes, the envelope of which represents the speech signal, are applied successively, Fig. 7E, the amplitude of the output voltage or current will vary in accordance with the speech signal "C." Electrically we can modulate the output of the oscillator by adding to the direct current supply speech currents as indicated in Fig. 7F.

Fig. 7G is a schematic diagram showing one of the possible ways in which an oscillator output can be modulated by a speech signal. The speech signal voltage is produced by talking into the telephone transmitter. This produces the signal voltage across "A" as indicated in the Fig. 7G. This

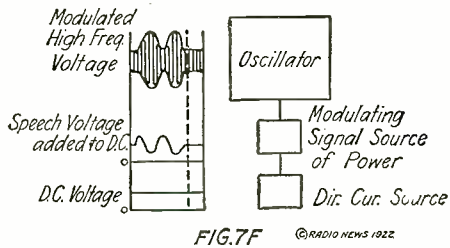

FIG. 7F © RADIO NEWS 1922

Showing the Production of Modulated Waves Step by Step.

is amplified by the audion amplifier and applied across the terminals of choke coil at "B." The voltage has the same form as that across "A," but is greatly amplified. This voltage is added to the D.C. voltage from the power supply and produces the modulated high frequency voltages across C, the envelope of which is the speech signal.

DETECTION

Now that we have seen how speech currents can be produced, and how high frequency currents can be modulated, let us see how the modulated waves so produced at the transmitting station are received and translated back into sound similar to that spoken into the transmitter.

Detection probably can be best understood by a consideration of the following analogies and examples. Fig. 8A shows a pendulum and two machine guns, one on either side. If Gun 1 is fired, the pendulum

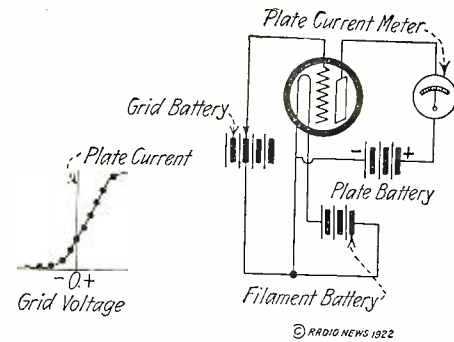

The Characteristic Curve of a Vacuum Tube and the Hook-up Used to Determine It. © RADIO NEWS 1922

an impact from the opposite direction. Obviously the result is no motion. Fig. 9B is the corresponding case in which the telephone receiver is connected to a high frequency source. Since the frequency is high with respect to the natural frequency of the telephone receiver diaphragm, no motion and, therefore, no sound results.

Fig. 8 illustrates the case of modulated high frequency impacts of projectiles on the pendulum which is produced by firing the projectiles at different velocities from the guns No. 1 and No. 2 alternately.

Since the sum of the impacts during the time MN in one direction are equal to those in the other direction, no motion results.

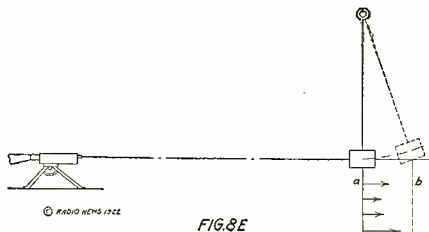

FIG. 8E © RADIO NEWS 1922

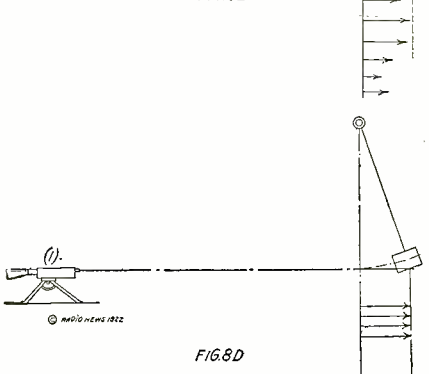

FIG. 8D © RADIO NEWS 1922

Analogy of the Rectification of the Oscillation.

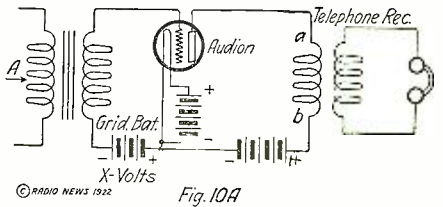

Fig. 10A © RADIO NEWS 1922

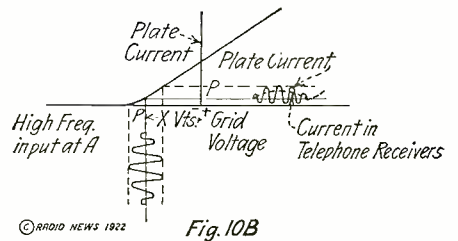

Fig. 10B © RADIO NEWS 1922

Diagram of Connections and Curve of a Vacuum Tube.

By the application of a grid battery of x volts to the tube, the plate current is reduced to P milliamperes and any signal voltage will be applied at A. will be applied to the bent part of the characteristic curve. The high frequency voltage will produce the heavy line plate current as indicated in Fig. 10B. This pulsating current will produce the current shown in dotted lines in the telephone, which will reproduce the sound spoken into the radio transmitter.

(Continued on page 1050)

The New Radio Legislation

By H. Gernsback

WE print, herewith, the full official text from the Washington Radio Telephone Conference, which took place in Washington during the week of Feb. 27th. As we mentioned in our last issue, there was no cause for anxiety by the amateurs. The government has always fully realized the value of the radio amateur and the experimenter; we also predicted our belief that nothing would be done that would curb our activities.

The draft, which we present, herewith, is, of course, only the recommendation of the Technical Committee, appointed by Mr. Hoover, but we feel safe in saying, that generally speaking, this draft will probably become law in one way or another with very few changes, if any.

We believe that the amateur has reason to feel very happy about the new changes which practically leave his status as it was before. It may also be seen that his wave length has been increased somewhat and he now has a larger wave band than he had before. We believe that the amateur will be satisfied with the outcome of the conference, particularly as the new wave length, that is 150 to 275 meters, will allow enough latitude for all experimentation.

It will also be noticed that the recommendation is that amateurs police themselves in the future, which is as it should be. The amateur has done so with more or less success in the past, and we believe that in the future he will do even better.

Speaking of the new recommendations in general, we believe that the entire Radio Fraternity, be they commercial, amateur, or otherwise, will have no reason for complaint, as all interests seem to have been taken care of, as well as it is humanly possible to do without encroaching upon any one's rights and at the same time leave the road open to the expansion and development of the new art.

We all realize that the radio telephone has brought a revolutionary change not only in radio itself but in our private lives as well. We believe we are not wrong in stating that the radio telephone will change our future habits as much as the telephone did when the public adopted it.

Regulation we all know was needed; as long as the regulations are fair to all concerned, radio will now surely come into its own, and it seems as if the radio millennium were soon to be at hand.

Our readers will be informed of all new developments pertaining to new legislation in future issues of this publication.

SUMMARY OF PRELIMINARY REPORT OF THE TECHNICAL COMMITTEE OF THE RADIO TELEPHONE CONFERENCE

The Radio Telephone Conference was divided some days ago into committees, of which one of the most important is the Technical Committee under the chairmanship of Dr. Stratton.

This committee has now issued tentative recommendations as to methods and policies for radio telephone control. The committee puts its recommendations forward for consideration and constructive criticism by interested organizations with a view to reassembling again in two or three weeks to reconsider such criticism.

The recommendations are of great length and detail. They first point out the necessity for Government control of Radio telephones as the only solution to the present chaos of interference: that unless there is definite regulation of all telephone transmitting stations the whole system will be destroyed by interferences.

In order to accomplish this the committee recommends that the existing powers of the Department of Commerce should be extended to complete control of transmitting stations. It does not recommend any control of receiving stations. The committee recommends that wave lengths below 6,000 meters should in a general way be reserved for radio telephone service but that those wave lengths which have become fixed in service for telegraph service within this range, such as SOS signals, shall be retained. But it is the hope and expectation that the radio telephone may ultimately keep the whole range from zero to 6,000 meters.

The committee considers that the present development of the art warrants the separation of twenty different wave bands within this range, of which seventeen lie between zero and 2,000 meters. In the assignment of these wave bands the committee recommends that priority first be given to broadcasting service and that secondarily, broadcasting service itself should be divided into priorities in the following rotation, first Government broadcasting; second, educational and public broadcasting; third, private broadcasting, including entertainment, news, etc., and fourth, toll broadcasting.

Reservation of wave lengths between 150 and 275 is made for amateurs and some opportunity in experimental wave lengths would be assigned to them in addition. The committee recommends that amateurs shall police themselves as to division of their wave bands between different varieties of amateur work. The committee recommends in addition to the establishment of wave bands for different services in various priorities that it is also necessary to limit the amount of power used in transmitting stations, thus limiting each of them to some special zone in order to further limit interferences and enable a wider variety of wave lengths to be assigned to different localities. The committee also recommends that the time of day occupied by different transmitting stations for different services should be placed in control.

The conference strongly recommends the extension of authority of the Government into thorough control of transmitting stations and that the radio telephone may be considered a public utility.

The tentative recommendations follow:

TENTATIVE REPORT OF DEPARTMENT OF COMMERCE CONFERENCE ON RADIO TELEPHONY

Resolved, That the Conference on Radio Telephony recommend that the radio laws be amended so as to give to the Secretary of Commerce adequate legal authority for the effective control of the establishment of all radio transmitting stations except amateur, experimental and Government stations and of the operation of non-governmental radio transmitting stations.

Resolved, That it is the sense of the Conference that radio communication is a public utility and as such should be regulated and controlled by the Federal Government in the public interest.

Resolved, That the types of radio apparatus most effective in reducing interference should be made freely available to the public without restriction.

I. ALLOCATION OF WAVES

A. It is recommended that waves for radio telephony be allocated in bands according to the class of service as follows:

RECOMMENDED WAVE ALLOCATION

	Wave Length, Meters	Frequency Kilocycles per Second
(1) Transoceanic radio telephone experiments, non-exclusive..	6,000	50
(2) Fixed service radio telephony, non-exclusive.....	5,000	60
(3) Mobile service radio telephony non-exclusive	3,800	90.9
(4) Government broadcasting, non-exclusive	2,850	105.2
(5) Fixed station radio telephony, non-exclusive.....	2,650	113.2
(6) Aircraft radio telephony, non-exclusive.....	2,500	120
(7) Government and public broadcasting	2,050	146
(8) Radio beacons, exclusive..	1,850	162
(9) Aircraft radio telephony and telegraphy, exclusive...	1,650	181.8
(10) Radio compass, exclusive..	1,550	193.5
(11) Government and public broadcasting, 700 miles inland	1,500	200
(12) Mobile radio telephony, non-exclusive	1,500	200
(13) Mobile radio telegraphy, exclusive	1,050	285.7
(14) Aircraft radio telephony and telegraphy, exclusive	1,050	285.7
(15) Private and toll broadcasting, exclusive	950	316
(16) Restricted special amateur radio telegraphy, non-exclusive	950	316
(17) City and state public safety broadcasting, exclusive	850	353
(18) Technical and training schools (shared with amateur	850	353
(19) Amateur (exclusive, 150 to 200 meters) (shared with technical and training schools, 200 to 275 meters)	750	400
(20) Reserved	700	428
	750	400
	700	428
	750	400
	650	462
	650	462
	525	572
	525	572
	500	600
	435	690
	310	968
	310	968
	285	1,052
	275	1,091
	275	1,091
	200	1,500
	275	1,091
	150	2,000
	below 150	above 2,000

Note 1. The terms used in the above schedule are defined as follows: "Broadcasting" signifies transmission to an unlimited number of receiving stations without charge at the receiving end. It includes:

(1) *Government broadcasting* signifying broadcasting by departments of the Federal Government;

(2) *Public broadcasting* signifying broadcasting from public institutions, including state governments, political subdivisions thereof, and universities and such others as may be licensed for the purpose of disseminating informational and educational service;

(3) *Private broadcasting* signifying broadcasting by the owner of a station, as a communication company, a store, a newspaper, or such other private or public organization or person as may be licensed for the purpose of disseminating news, entertainment and other service; and

(4) *Toll broadcasting* signifying broadcasting by a public service radio telephone company as a paid service.

(Other definitions to be added.)

Note 2. A station carrying on two or more of the broadcasting services specified in classes 2, 3 and 4 must be licensed for each class of service.

Note 3. Public broadcasting may temporarily be permitted to be done at the wave bands assigned to private and toll broadcasting, with a change to the assigned longer waves at a later date.

Note 4. Municipal and state radio telephone service for public safety should in small cities be conducted by interrupting the broadcast service of classes 2, 3 or 4 in case of emergency. In large cities this service will ordinarily have its own station and will use the wave band, 275 to 285 meters, assigned to such service.

Note 5. Private detective agencies desir-

(Continued on page 984)

The New Radio Broadcasting Station WGY

A RADIO broadcasting station, more powerful than any now sending out programs, has been installed by the General Electric Company at its plant in Schenectady, N. Y.

From the roof of a five-story factory building, two towers 183' high and spaced 350' apart, support an antenna at such height as to give the wireless waves unobstructed freedom to travel equally well at a speed of 186,000' per second in all directions.

This station has not been regularly operated, nor has an advance announcement been made of the impromptu or test programs sent out, which would cause amateurs to be listening, yet, letters have been received from such distant points as Cedar Rapids, Iowa, Minneapolis, Minn., and Santa Clara, Cuba, the last place being 1450 miles distant, announcing that the programs have been heard. These reports come from operators who, in an evening's experimentation with their receiving sets, have accidentally come upon the waves from Schenectady and are no indication of the distance this station may be heard.

Broadcasting stations, with but a fraction of the power of this station, have been heard at distances of 2,000 miles or more, under favorable atmospheric conditions.

The General Electric station has been licensed to operate on a 360-meter wavelength under the call letters of WGY. It is equipped with the most modern of radio apparatus, including the multiple tuned antenna which, because of its many advantages, has been installed in Radio Central, the world's most powerful commercial station at Rocky Point, L. I., and other Trans-oceanic stations of the Radio Corporation of America.

A three-room studio, where the programs are produced, is located in a company office building, 3,000' from the transmitting station. One room is used as a reception room for the artists, where they may sit and chat until their time on the program arrives, without danger of interfering with what is going on in the studio. The second room is the studio, where a concert grand piano, a victrola, an organ and other equipment for the artists are to be found. Here a number of portable microphones which are commonly known as pick-up devices can be shifted about to locations best suited for the reception of announcements, musical numbers, or whatever may be sent out. In the room on the opposite side of the studio is apparatus for amplifying the sound waves before they are transmitted by wire to the broadcasting station.

A switchboard in the studio, which lights a red light when the station is in operation, thus warning persons in the room that whatever they may say will be sent out to thousands of ears of an invisible audience,

is within reach of the studio director at all times. Not until he throws a switch can anything reach the antenna. A telephone attached keeps him constantly informed just how the program is going out and allows

there is nothing in this room to indicate it as different from any musical studio.

In the apparatus room, the sound waves are put through a number of steps of amplification by means of vacuum tubes which increases their volume thousands of times. The amplified sounds are then put into a wire and sent to the broadcasting station, where they enter another bank of vacuum tubes, known as modulators or molders of the electric waves.

Direct current at a high voltage is necessary for the operation of a transmitting station. To obtain this, a 220-volt alternating current line, which is but little higher than the voltage used for lighting purposes in the home, is boosted to 30,000 volts by means of a transformer. This voltage is then applied to a number of vacuum tubes, acting as rectifiers, which change the voltage to direct current. Placed between the rectifier and the modulator or molding tubes, is

a high power oscillator tube. The electric power entering this tube sets the ether into vibration and upon these vibrations the electric waves, molded into shape in the modulator tubes, are sent to the antenna to go out into space.

BROADCASTING OF SONGS BRINGS NEW PROBLEMS.

The musical activities of the various radio broadcasting stations have not only been looked upon with interest by publishers and allied lines, but the rapid developments, scope and power of this new device have features which many in the music publishing field believe will result in time to their disadvantage.

As the publishers see it, there are many good features attached to the broadcasting of songs and before any action is taken regarding such activities, which might be considered premature, the publishers seem willing to await developments. They feel that from several directions, in case the future development of the radio in its present use becomes disadvantageous to their interest, they have the power to curtail such activities, at least, under the present method of programing and with the song material involved.

Where the wireless program is received in an opera house, hall, or public auditorium, etc., the publishers, particularly of popular music, see no evil, but much good. It is the amateur receiving stations and the future development of such that bring up questions that may develop into problems.

Conclusions can hardly be reached at this time, however, and the trend of development of wireless telephony seemingly takes many angles. It is thought in some circles that wireless will replace theatre orchestras, at least in motion picture houses, and this is quite possible.

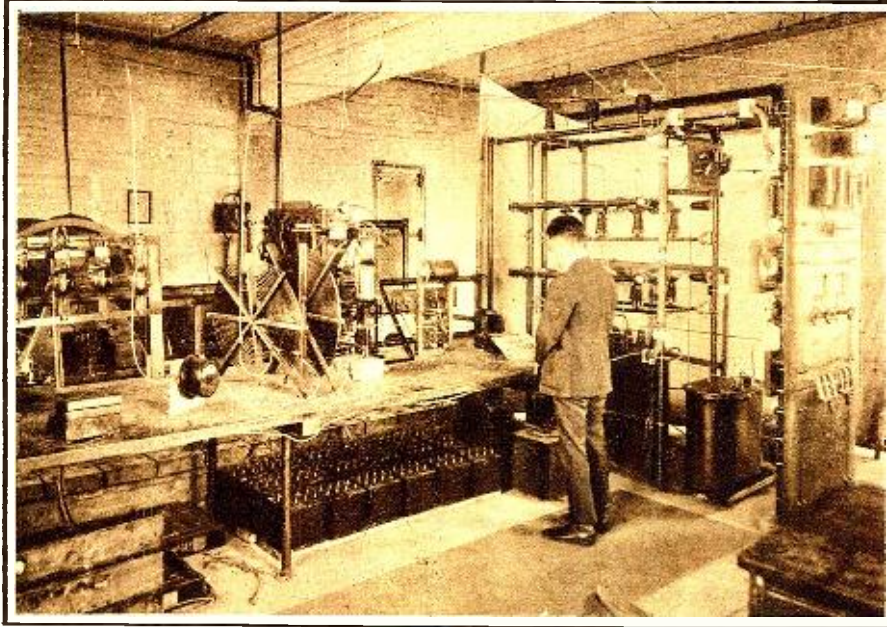

Interior of Transmitting Room in WGY, General Electric Co.'s Radio Broadcasting Station, Schenectady, N. Y. This is the Most Powerful Radio Broadcasting Station in the Country. The Picture Shows Tube Sets, Control Board and Other Apparatus. The Programs Are Sent Out From Another Building Nearby.

Photograph by courtesy of General Electric Co.

him to change position of the artists or microphone, if such is necessary to improve the tone quality of the entertainment.

With the exception of the small pick-up devices or microphones and the switchboard,



One of the 183-Foot Towers Supporting the Antenna of the General Electric Co.'s Radio Broadcasting Station, Erected on the Building Where the Powerful Transmitting Apparatus is Located.

Photo by courtesy of General Electric Co.

Methods of Transmission Used in Broadcasting Stations



This Operator is Holding the Microphone Near the Victrola Horn and Transmitting the Record by Radio.



Transmitting Musical Notes Produced on Wine Glasses, by an Artist, at One of the Broadcasting Station Studios.

MUSIC and speech is today being broadcasted by scores of stations throughout the United States on regular schedule. With suitable receiving apparatus it is possible for people living in almost every section of the country to listen each hour of the day to programs of various descriptions, providing them with education and entertainment. Seldom is a station unable to keep to its schedule by reason of breakdown. Their programs are published in the daily newspapers. Most of them commence broadcasting at 11:00 A. M., play one or two selections on the Victrola, and possibly give a weather forecast. At noon the time signals from the Navy Station at Arlington are received and relayed by some

of the radiophone stations the microphone is supported on a stand, and attached to it is either an ordinary large megaphone or one of special design which is best able to collect the sound waves of the singer's voice and convey them to the microphone. It is supported at a level with the head of the singer. Sometimes another microphone with megaphone attachment is held near the piano. With one or two large and suitably designed horns, it is possible for an entire orchestra to play in the studio and their music be conveyed by the microphones to the transmitting apparatus. It is manifest that one of the most important features of music and speech transmissions is the microphone. The method at present used has been adopted as the result of years of experience to find the best method of modulation. Radio telephony is obtained by the variation in audio frequency of the amplitude of radio frequency waves. It is essential that the radio frequency

sent out. In the evening speeches by well-known men and women are made on various topics, and musical concerts of one or two hours duration broadcasted. The music is provided by artists of the opera and stage. Vocal and instrumental music is enjoyed nightly by thousands. In transmitting this music, various methods are used. In connection with the station there is a studio in which the artists sing or play. There is little or no sign of radio apparatus. The transmitter is in another room and the only connections between the two rooms are the wires leading to the microphone. One microphone is very often all that is necessary. If an artist is singing to piano accompaniment,



Reading the Weather Report to the Thousands of Radio Audiences in Their Homes.

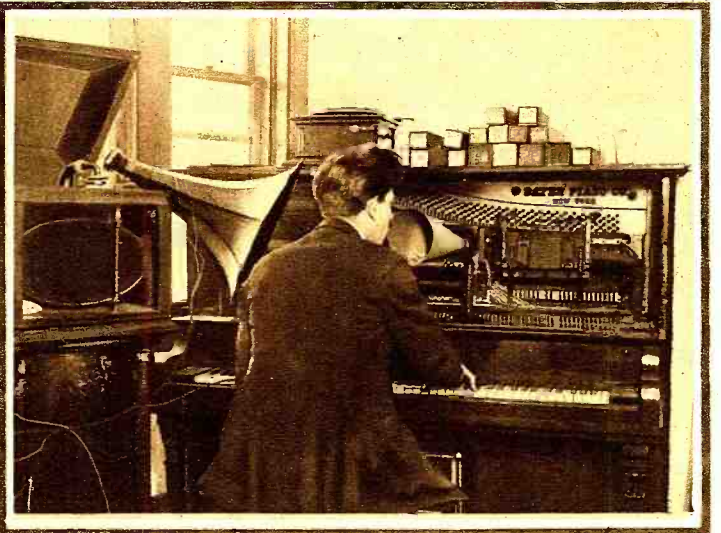

An Artist Singing into the Microphone at One of the Broadcasting Stations and Playing His Own Accompaniment on the Piano. Note the Two Horns, One Being Used to Pick Up the Voice, the Other the Music.

Fort Wood Broadcasting Station WUP

WYCB, at Fort Wood, New York Harbor, is one of the most recent of the radio telephone broadcasting stations and is, in many ways, unique.

The station has been placed at the disposal of the Amateur Radio Reserve, 2nd Corps area, by the Signal Corps and is broadcasting entertainments each night from 9 to 9:55 p.m., on a wavelength of 1260 meters.

Many features incorporated or proposed for incorporation in the broadcast programs of the Amateur Radio Reserve, in most cases, be original and of vital interest. They will include educational and amusement details that will appeal to all interested radio men.

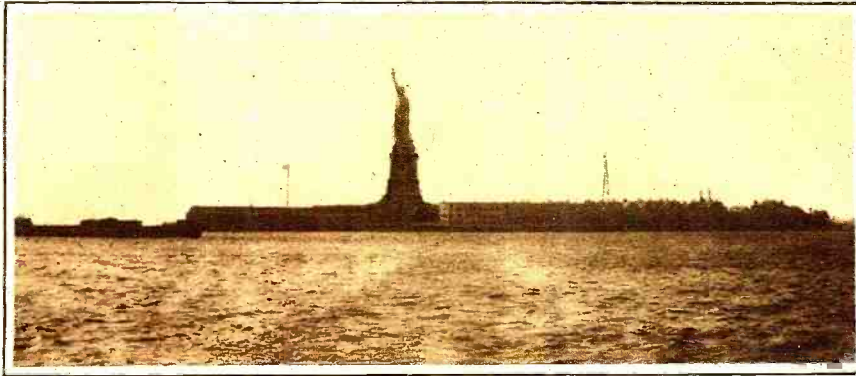

Fort Wood From the Hudson River. Note Antenna Tower on the Right.

of the military service. However, due to the close cooperation and contact maintained with the Signal Corps of the Army, the organization represents probably the closest association amateurs have ever enjoyed with official recognition of their services to radio.

Great care is exercised by the Executive Committee to assure themselves that the amateur stations designated as relay points are of the highest type and efficiency, both as regards the equipment and the operators. To

rying on official traffic, and in addition, prepared to carry on the radio communication of the government when called upon by any governmental department.

The amateur radio reserve, 2nd Corps, Area, U. S. A., is strictly a civilian organization, not obligated in any way to either military service or military training, other than obtaining for the benefit of the amateur the full benefits extended by the Signal Corps to all amateurs in a broader manner than might be obtained by

such stations as meet the requirements of the Executive Committee, a station certificate is allotted, designating the station as thoroughly qualified to maintain reliable service in carrying on official traffic. The

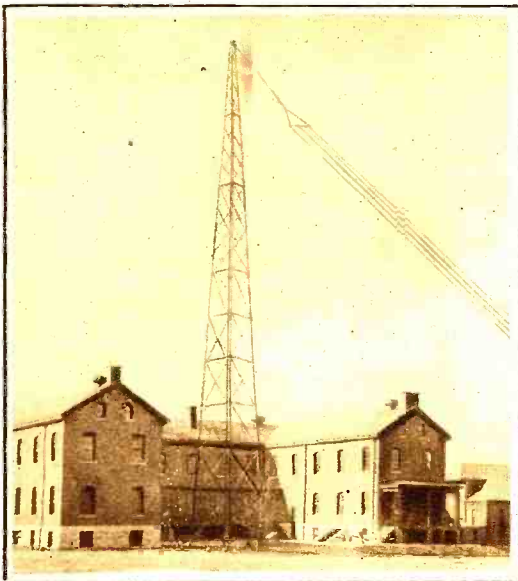

On the Left is Shown One of the Towers at WYCB and on the Right the exterior of the Operating Room. Note the Lead-in to the Roof. Below is Shown a View of the Interior of the Station. In the Center May be Seen the 3 K.W. Transmitter. The Operator on the Left is Broadcasting a Gramophone Record.

the individual. The organization functions under its Executive Committee, which is composed of men of the highest standing in the commercial, educational and amateur radio fields, and includes no members



The amateur radio reserve, 2nd Corps Area, U. S. A., is an organization of high-class radio men with which the Signal Corps of the Army is cooperating to the greatest extent in transmitting educational information and assisting the amateur as far as possible. This organization is developing a amateur station relay routes from the Fort Wood Station to all stations of the Army for the purpose of forming a reliable and efficient net work of amateur stations, capable of and actually carrying

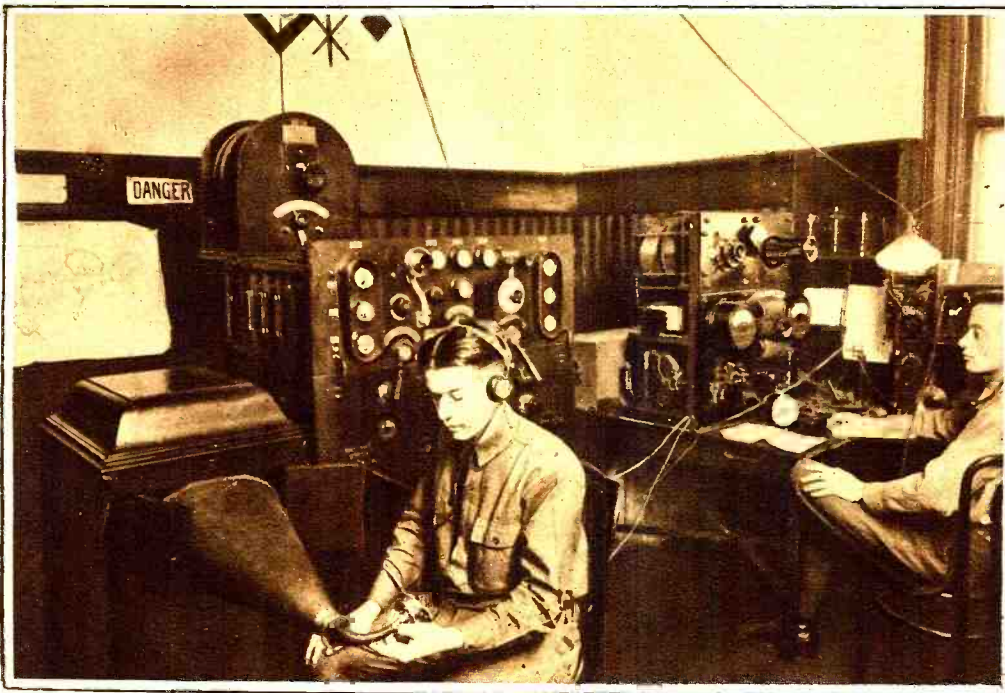

Committee reserves the right to recall the certificate in the event of dismantlement of the station or for other cause.

Although all amateur stations are not permitted to act as relay points in the net work and receive certificates, there are many other features dear to the hearts of all amateurs which the Amateur Radio Reserve, in cooperation with Army authorities, has placed at the disposal of its members, among which are Free calibration of wave meters; (Continued on page 908)

Washington Notables Listen In



© By Underwood & Underwood.



© By Underwood & Underwood.

SO much interest has been aroused in Washington by the phenomenal development of radio telephony during the last few months, that many well-known government officials have expressed an eagerness to hear what it is all about and whether it is really true that one can hear music and speeches by radio.

Secretary of Commerce Hoover, after so much discussion on radio at the conference called by him lately at Washington, is seen at his office in the Department of Commerce, listening in on the amateurs at first hand. Secretary of the Navy Denby and General Pershing are listening to one of the broadcasts of the government station at Anacostia. Other government officials have had receivers installed in their homes or offices and are enthusiastic in their praise of the radiophone.

President Harding led the way by ordering the installation of receiving apparatus at the White House. The familiar sound of "NON transmitting," followed by a few broadcasted selections on the Victrola, or a speech on some subject of popular interest, are now being heard on the President's loud-speaker. Intermingled with it, possibly, is the crackling of static or the whistle of the carrying wave as the Chief Executive sits in front of the bakelite turning the dial. Not many of us expected so soon to have the President of the United States listening in with us and experiencing the same subtle joy that is ours when we succeed in tuning in a distant station. It demonstrates as nothing else could the great advancement that has been made in amateur and commercial radio. Radio has at last actually invaded the sanctity of the offices of the President and he is enjoying it. Others have followed his lead and the highest of the land are now members of the great fraternity of Radio.

When it became known that the President was anxious to hear some of this "wireless music," about which the whole country seemed to be rapidly growing crazy, there was keen competition as to who should obtain the order for its installation. Manufacturers of different makes of apparatus offered their services. President Harding patronized local trade, however, and gave



© By Underwood & Underwood.

Some of the Washington Officials Who Have Taken up Radio. Secretary Hoover, After the Radio Conference, is Listening in on the Amateurs at His Office in the Department of Commerce, While Secretary of the Navy Denby and General Pershing Are Hearing the Broadcast of the Anacostia Station.

the order to the Navy Department. The Navy Department had everything in readiness and the receiver was installed. It was set up on two of the shelves in the bookcase beside the President's desk. At first the loop aerial was used, but the President seemed to have contracted the radio bug in infection and immediately wanted to hear some more distant stations than the loop provided. An outdoor antenna was therefore erected and now, when he has a few moments to spare, Mr. Harding tunes up and listens in to stations located all over the United States. His receiving apparatus is also adapted for receiving on the longer wave-lengths, and, if he learns the code, the President will soon be receiving his European news direct from POZ. The receiver consists of short and long wave regenerative tuner with two steps of amplification. Signals loud enough to be heard at a distance are obtained with a loud speaker.

The first music to be received with the President's wireless outfit was a concert played by the Government station at Anacostia, which is less than three miles from the White House. The station broadcasts special programs from 7:30 p. m. to 9:30

p. m. on Wednesday and Friday nights. The first hour is usually devoted to speeches on various topics while during the last hour music is sent out. The President had invited a few friends to hear the music and he, himself, seemed greatly pleased with the results.

The next day he told inquiring correspondents that he had heard a band concert by wireless telephone the previous night. The correspondents immediately had visions of the President hearing music at least from Europe and seemed distinctly disappointed when Mr. Harding told them that the transmitting station was only a few miles away. But, newspaper correspondents to the contrary, receiving apparatus which is made for the President is as limited as that made for any ordinary mortal.

The possibilities of this manifestation of official interest in amateur radio are boundless. Receivers have been installed in thousands of homes throughout the country and continue to be installed daily. When the occasion warrants, it will be possible for the President to speak directly from the White House to thousands of the citizens of the Republic with an ease and rapidity and a personal appeal which would be impossible by any other method.

At election time candidates will be able to speak personally to the constituents and possibly swell the number of votes cast for them by a personal explanation of the details of their campaign.

News of an official character may be conveyed to the people directly from its source and without the medium of newspapers.

The House of Representatives has recently passed a resolution authorizing the installation of a radio telephone transmitting apparatus in the Capitol Building, by means of which the debates of the Senate and House of Representatives will be broadcasted to all. This resolution is of such importance, and will prove so interesting to the amateur radio man that we quote it in full.

67TH CONGRESS—2ND SESSION
H. J. RES. 278.
IN THE HOUSE OF REPRESENTATIVES
February 27, 1922.

(Continued on page 1024)

Radiophone for Trains

THE installation of Radio stations on moving trains is not new. The Marconi company, a long time ago, installed on the New Jersey line some spark sets which were used to communicate with the stations installed at various points, so that the trains could keep in constant touch with any of these. Later, some Radiophone sets were tried, but did not give all the results expected. These were of the DeForest type, using a tungsten arc and later, vacuum tubes. More recently, extensive experiments along this line have been carried out in Europe and have proved a very practical means of communication for the passengers on trains of the Berlin-Hamburg line, on which the first sets were installed there. The illustrations on this



Photo, Underwood & Underwood

Above is a View of a German Train Equipped With a Radio Phone Station, Below May be Seen the Aerial on One of the Cars. Note the Arrangement of the Wire.

page show two cars equipped with aeri- als, which may be used either connected in paral- lel, or one acting as an aerial and the other as a counterpoise. In other types of sets, one aerial is used for transmitting and the other for receiving.

In France, experiments have been carried out since 1919 and have proved so successful that Radiophone sets have been adopted by two companies, to be installed on trains; these function on the principle of guided wave Radio telephony. Since the beginning of the experiments, the engineers who designed the sets thought of using the telegraph wires, which run along the tracks, as a means of guiding the Radio waves, and this

scheme, thanks to the vacuum tube trans- mitters, proved very efficient.

200', and during all the trip communication was excellent and modulation reported perfect.

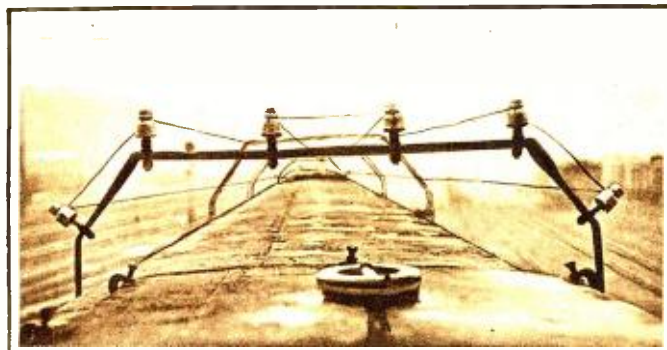

The Aerial Seen From One End.

It appeared, during the tests, that the intensity of the received signals was not influenced by the distance between the train and the station, which leads to the hope that considerable distances will be covered, without increasing the power of the sending set. The energy received at the station is such that a relay may easily be operated to close the circuit of a bell, or other signalling device, to call the operator, when it is desired to communicate with him.

Thanks to the duplex system, it is possible to use this Radiophone (Continued on page 956)

Talking from Office to Ship at Sea

THOMAS H. ROSSBOTTOM, General Manager of the United States Lines, is the recipient of hundreds of telegrams and letters of congratulation on account of his pioneer work in using the wireless telephone in communicating with the big liner "America" a short time ago.

Maritime history was made by Mr. Rossbottom in his use of the wireless telephone in receiving the report of his Captain and in transmitting orders to the ship. This is the first time in history that the commander of a merchant vessel has made his report to the operator by wireless telephone, and that orders from the operator were transmitted to the ship by the same medium. The occasion for this was the arrival of the steamship "America" on March 6.

While the "America" was still a considerable distance from Ambrose Channel Lightship, Mr. Rossbottom was connected up through the powerful station at Deal Beach, N. J. Within ten minutes after the call was made Captain William Rind, of the "America," was on the telephone. After an exchange of greetings Captain Rind told Mr. Rossbottom the speed he was making, and the time he expected to reach Quarantine.

Mr. Rossbottom in reply gave his instructions to Captain Rind concerning the special arrangements which had been made with the Public Health officials at the Quarantine station for the passing of the

vessel beyond the sunset hour.

Mr. Rossbottom and Captain Rind conversed for several minutes. Mr. Rossbottom talked over the telephone at his desk, the one that is normally used in his daily business, and without any special appliances. Conversation was successfully exchanged with the vessel at a distance of 370 miles and was achieved as the result of a long series of tests which have been conducted by the American Telephone and Telegraph Co. in co-operation with the Radio Corporation of America. The apparatus on the S.S. "America" was installed by the Radio Corporation of America and Mr. J. F. Farrington, of the Western Electric Co., was in charge of the station in so far as the telephony tests were concerned. On shore, special apparatus was installed by the telephone company at Deal Beach, N. J., for transmission purposes, while Elberon, N. J., acted as the receiving station. Many amateurs have heard these tests in operation and "2 X J calling KDOW" has become quite a familiar sound to them. Subsequent to the initial conversation between Mr. Rossbottom and Captain Rind, President H. B. (Continued on page 956)



Mr. Thomas H. Rossbottom, General Manager of the United Water Lines, Speaking From His Office to the S.S. America at Sea by Radiophone.

Freak Receiving Sets



A Close-up of the Radio Garter in Action, Showing One of the Snap-Chains Being Held to Ground.

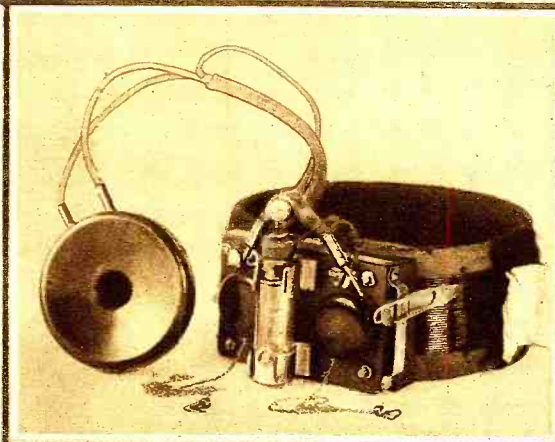

The Radio Garter, Invented by Walter P. Miller, Staff Photographer of the Post-Intelligencer. One of the Eye-Glass Snap Chains is Connected to the Antenna and the Other to the Ground.



This Girl Reporter is Seen Wearing the Radio Garter in Her Office, and is Showing the Method of Receiving.

POCKET wireless sets have been for some years an accomplished fact, but it remained to the present boom time in radio to develop the spectacular in small receivers. Pocket wireless sets are, in fact, no longer restricted to the pocket. They appear today in the form of rings, garters, books and in other weird and wonderful designs. Some of these are illustrated on this page. They are all products of the wide interest in radio which has developed recently. They serve their purpose in drawing the attention of the public to radio in a striking manner.

On of the girl reporters on the "Post

Intelligencer" was so fascinated by her new hobby that she decided she simply must have some convenient method of carrying it around with her; so her mechanically inclined friend, Mr. Walter P. Miller, staff photographer of the Post Intelligencer, invented a complete receiving set for her in the shape of a garter. Wire is wound round a piece of stiff cardboard and covered with silk to give the appearance of a lady's garter. Attached to this are two ordinary eye glass snap chains, one of which is held under the foot to make a ground, and the other connected to a coil of wire in the wearer's hat, forming the antenna. The crystal detector is in a glass tube attached to the garter and there are two little binding posts for the telephones.

Mr. R. G. Rinehart of Elizabeth, New Jersey, has invented a receiver made in the form of a ring. This little set measures one inch in length, five-eighths of an inch

wide and seven-sixteenths of an inch in thickness. It is believed to be one of the smallest sets in existence. An umbrella is used as an antenna.

The other young lady illustrated who looks as though she was reading a book, is really correcting her watch by the radio time-tick. The receiving set is made in the form of a book, with two pancake-wound coils, the inductance being varied on the variometer principle. The crystal detector is mounted in the binding of the book, and resembles a fountain pen. The cap is removed to adjust the "cat-whisker" handle.

There have been many other such inventions of a similar nature. One warm day next summer we fully expect to be

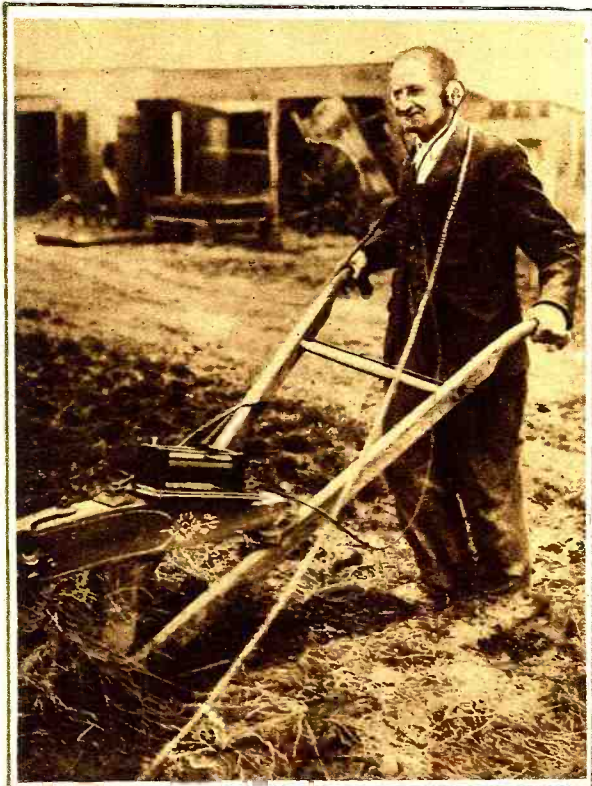

On the right is a young lady correcting her watch with a radio receiver in the shape of a book. The farmer on the left is warned of approaching meal-time by his son's radiophone.

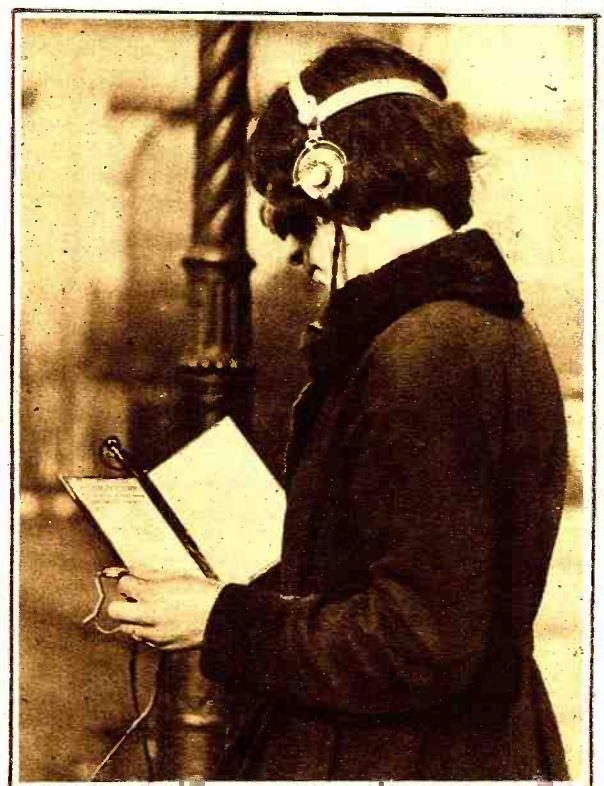



The Radio Ring in Operation. This Set is Most Efficient in Wet Weather, as a Good Ground Can be Obtained. The Umbrella Antenna is Useful in More Ways Than One.

ture dials will be concealed inside his plug hat.

The photograph of the old farmer with the two-slide tuner balanced on his plough is interesting. Until this new-fangled wireless business came into his home the old farmer had been able to pretty accurately judge meal-time by the normal state of his appetite. Evidently, however, he had misjudged once or twice and his son, who had installed a radiophone on the old farm, fitted his father's plough up with a receiving set. Now, when meal time approaches, the old farmer is given ample warning by his son. An occasional piece of jazz also helps the old man to keep happy while he is working.

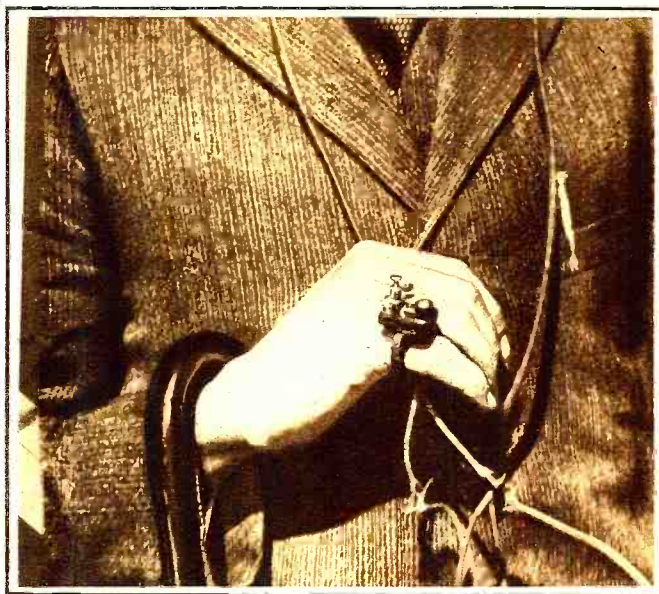

One of the Smallest Radio Sets in Existence Made Into the Form of a Ring.

confronted by the alarming spectacle of an elderly gentleman standing in the middle of Times Square, holding aloft a large umbrella and making strange adjustments with his plug hat. When the crowd has subsided and the traffic resumed he will explain that he was merely correcting his watch by the time tick from Washington and that the best ground he could find was a manhole in the middle of Times Square. His wireless receiver with minia-

SCHEDULE FOR RADIO PHONES REVISED.

A revision of the radio telephone broadcasting schedules has been made at a meeting of the various representatives of the operating stations in San Francisco. The meeting, held under the direction of the

Pacific Radio Trade Association, was presided over by the president, A. H. Halloran, editor of "Radio."

The schedules follow:
Telephone Schedule — Northern California "Inland Stations."

Every Afternoon except Sunday—
4:00 to 5:00 p. m.—Oard Laboratories, Stockton. Press.
5:30 to 6:30 p. m.—Hobrecht, Sacramento. Press and concert.

SUNDAY—
2:00 to 3:00 p. m.—Oard Laboratories, Stockton. Concert.

(Continued on page 1012)

A Portable Regenerative Receiver

THE receiver shown in the illustration is probably one of the most compact regenerative receivers ever made. It was designed and made by Mr. J. McLaughlin of New York.

The inductances are basket-wound coils arranged on mountings in the same manner as fuses in fuse blocks. The distance between the coils may be varied by turning them outward or inward. When these coils are removed, and laid side by side in the rack provided for them, the box in which the receiver is built may be closed, with only the binding posts showing on the outside. The size of the closed receiver is only three inches by four-and-a-half inches by one inch. An RAC-3 type of audion is used as a detector. The condensers each consist of two aluminum plates separated by a mica disc. By changing the distance between the two plates, the capacity of the condenser is varied. A small D. P. D. T. switch for changing the primary condenser from a series to a shunt position is provided. The knob of the filament rheostat is seen in the illustration on the right, while the V. T. may be seen on the left. The circuit used is a regenerative one with primary and secondary condensers.

coils or honeycomb coils may be used to receive at longer wave lengths. The binding posts on the outside are connected to the filament battery, plate battery and telephones. As the make of tube used operates on four volts for the filament, it is possible to use three dry batteries for this purpose. The only additional equipment necessary

for a complete receiving outfit would be a small plate battery, a pair of telephone receivers and a coil of aerial wire. The whole outfit may be carried in a case measuring five cubic inches. This is about the size of a Graflex camera case.

YOSEMITE LINKED TO WORLD BY RADIO.

Because Yosemite Valley is literally a "hole in the ground" some wireless experts declared local conditions were entirely against successful operation of a wireless station there. Yosemite's granite cliffs rise straight into the air for 3,400, 4,000 and occasionally 5,000 feet. Nevertheless valley folk recently have been getting news reports, weather predictions, market quotations and lots of good music right out of the air, with no other aerial than wires strung between two of the giant trees with which the valley floor is forested.

Edwin J. Symmes of Alameda put in the first wireless set for his own amusement and has received messages from several score damped and undamped wave stations, including Honolulu and Catalina Island. Government authorities also have put in a station, which will be used to keep in touch with the outside world.

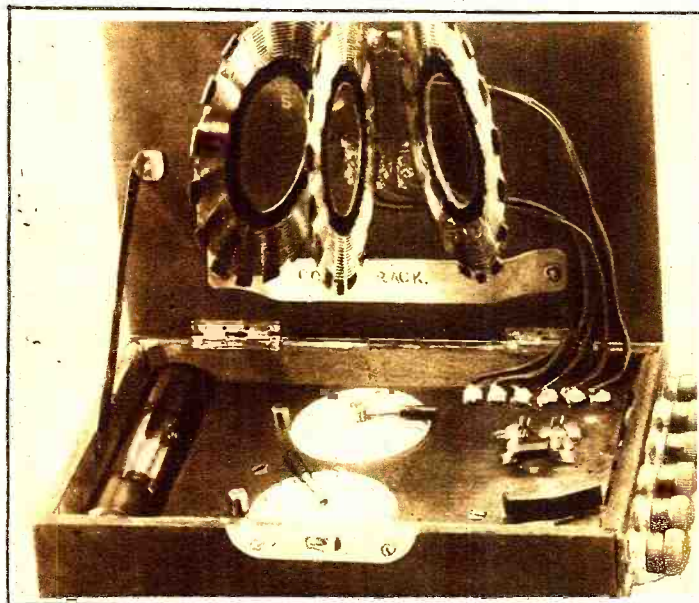

This Receiver When Closed Measures Only 3 x 4½ x 1 inch and Yet is Just As Efficient as Most Regenerative Receivers of Larger Size.



THIS Department is open to all readers. It matters not whether subscribers or not. All photos are judged for best arrangement and efficiency of the apparatus, neatness of connections and general appearance. In order to increase the interest in this department, we make it a rule not to publish photographs of stations unaccompanied by a picture of the owner. We prefer dark photos to light ones. The prize winning pictures must be on prints not smaller than 5 x 7". We cannot reproduce pictures smaller than 3½ x 3½". All pictures must bear name and address written in ink on the back. A letter of not less than 100 words giving full description of the station, aerial equipment, etc., must accompany the pictures.

PRIZES: One first monthly prize of \$5.00. All other pictures published will be paid for at the rate of \$2.00.

Station 9HY of Chicago, Ill.

This Month's Prize Winner

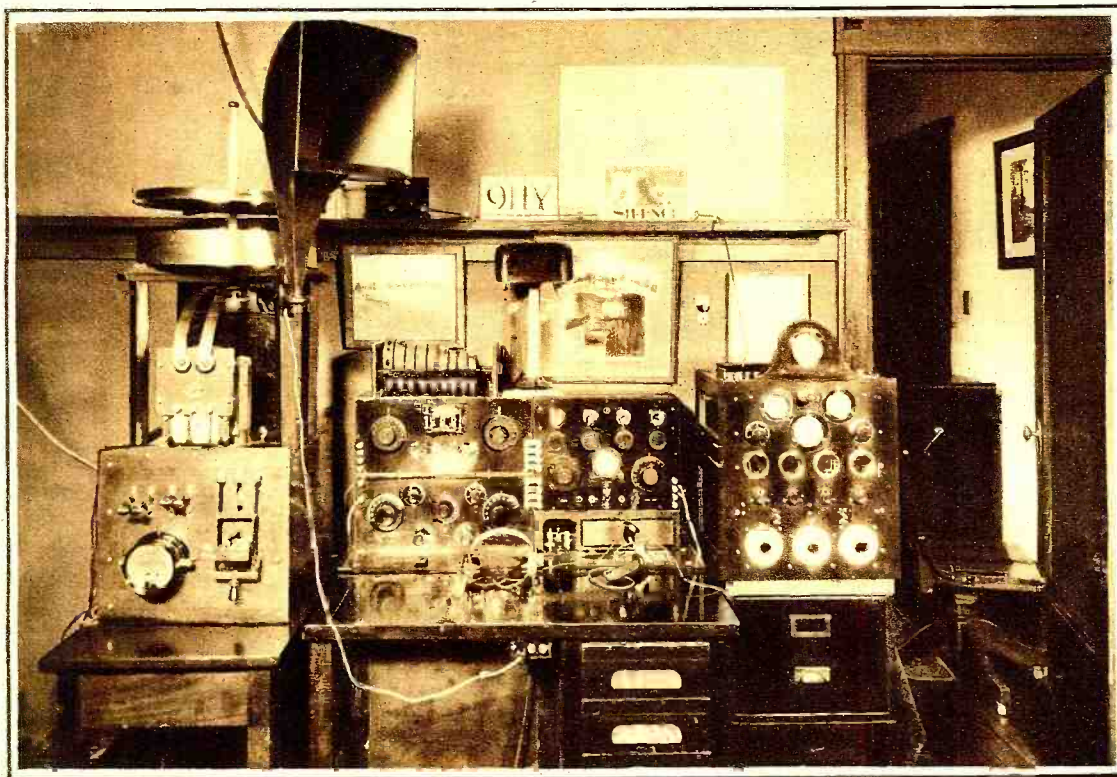

variometers are used in series with the large variometers, which gives an adjustment much finer than a mechanical vernier. In tuning in C.W., a complete throw of the vernier variometer dial is equal to but three white lines on the large variometer dials. The tuner is completely

This Well-Designed Set Was Built Entirely by the Owners, J. H. Jay and C. W. Clark. Note the Excellent Workmanship of the C.W. Transmitter Shown Below.

shielded with grounded copper plates. The long- and short-wave tuners are in identical mahogany cabinets and form a symmetrical lay-out with one above the other.

The detector and three-stage amplifier unit is mounted in a large mahogany cabinet. A grid variable condenser and a 43-plate variable phone condenser are included in this unit, as is a 0 to 50 volt meter for giving detector "B" battery readings. A three way cam switch gives an off, "A" battery, and "A" with "B" battery positions. When set upon a low cabinet the above unit forms a complete symmetrical receiving unit with connections made by short nickel plated bars. There is no howling on three stages, as the amplifying transformers are spaced very far apart, the same being true of the tubes.

A small cabinet with one stage of radio frequency forms an intermediate unit between the short-wave regenerator and the detector and three-stage audio frequency amplifier unit. The plate variometer of the regenerator acts as the radio frequency air core transformer. In this same cabinet is also contained an "A" battery potentiometer.

As the complete receiving set occupies the entire length of the
(Continued on page 974)

STATION 9HY is located at 6027 Kimbark Avenue, Chicago, Ill. and was completely designed and built by J. H. Jay and C. W. Clark.

A C.W. set using C.W., I.C.W. and M.C.W. is the principal transmitting unit, while a one-half K.W. spark set forms a secondary transmitting unit. Either may be used by throwing a switch.

The receiving set comprises a long-wave tuner employing dual-lateral coils, a short-wave regenerative tuner, and a detector and three-stage amplifier. Either the long- or the short-wave tuners may be used by throwing a four-pole double-throw switch. Wavelengths of from 150 meters to 20,000 meters can be covered. The long-wave tuner is made up of a triple coil geared mounting with two 43-plate variable condensers, the latter being a series parallel condenser. The short-wave regenerative tuner is made up of the usual plate and grid variometers with double tap coupler. Vernier

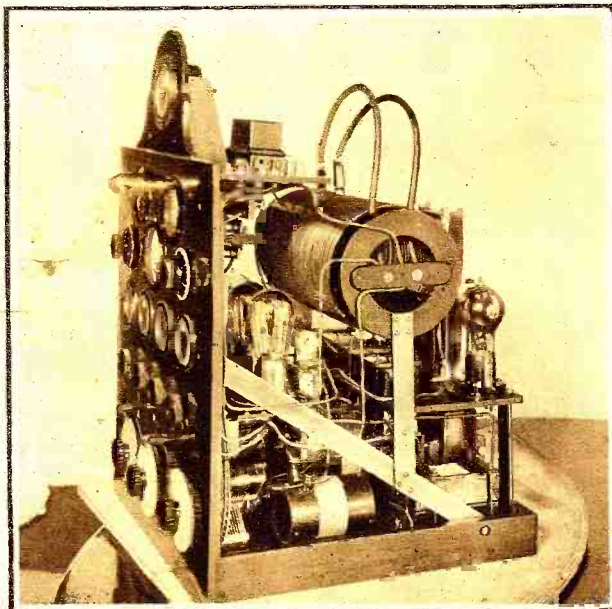

Station 7XG at Portland, Oregon

Owned by Willard P. Hawley, Jr.

THE transmitting set, which was designed and built by Mr. Chas. Austin, President of the Northwestern Radio Manufacturing Co., whose manufacturing plant and experimental station (Call 7XF) is located at 1556 East Taylor Street, Portland, Oregon, consists of four 50-watt Radiotron power tubes, two being used as oscillators and two as modulators, the Colpitt oscillatory circuit and the Heising modulation circuit being used.

To supply the filament current, an Acme transformer is used, giving 9.75 volts A.C. on the filament. The plate current is supplied by a Robbins and Myers motor generator set, the motor being a 3/4 H.P., single phase, 110-volt A.C. direct connected to a special double-wound generator with a 72-bar commutator at each end, each generator being 1/4-KW., and giving far in excess of the 500 volts required. By connecting the two generator output leads in series, a voltage up to 1,500 volts direct current is easily obtained. A voltage regulation from 300 to 1,500 volts is obtained by a 10,000-ohm Ward Leonard rheostat.

At the lower left-hand corner of the transmitting panel is a drum switch control which is marked "Voice," "Receiving," "Off," "C.W." and "Chopper." When turned to "Voice," the transmitting panel is ready for the transmission of speech or music for through the ingenious arrangement of the drum switch the filaments are lighted, the motor generator is started, furnishing current to the plates and the set is in full working order. The same holds true when control is turned to "C.W." or "Chopper." When finished with transmitting, the drum switch is always turned to receiving position, and the apparatus is then ready for receiving. To the right of the drum switch control, first, is the wave-length control; second, the coupling control, and third, the condenser control.

The Weston meters on the panel, starting from left to right, are as follows: First, oscillator plate current milliammeter; second, oscillator grid current milliammeter; third, radiation thermo-ammeter; fourth, modulator plate milliammeter; fifth, volt meter for plate current.

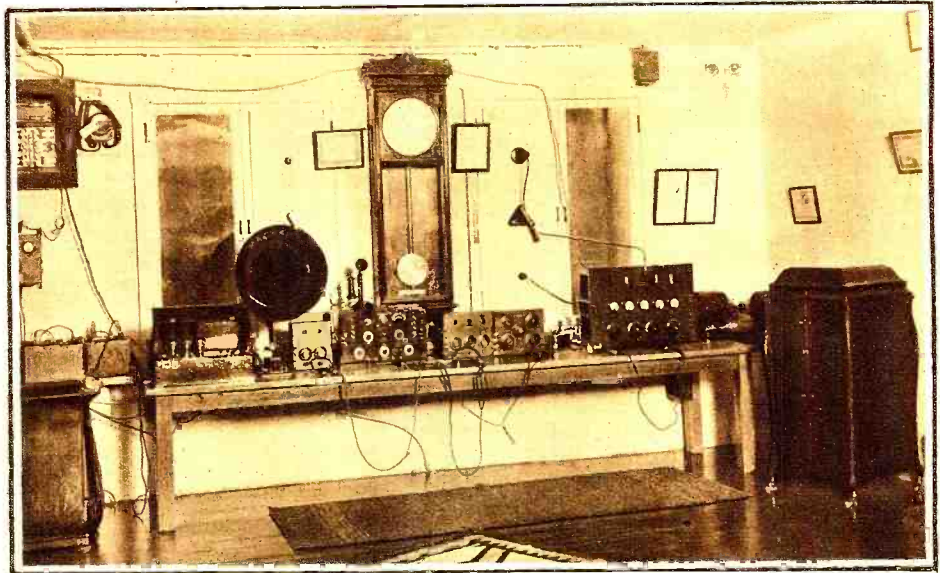

This Radiophone Station Uses Four 50-Watt Tubes With Two as Oscillators and Two as Modulators. By Means of One Switch it is Possible to Use Straight C.W., Chopper or Phone.

A chopper motor, 1/20 H.P. Westinghouse, with 900-cycle note, is used for I.C.W.

The receiving apparatus was designed and built by the Northwestern Radio Manufacturing Co., being a short-wave receiver, which consists of a plate variometer, grid variometer, variocoupler, primary inductance and primary condenser.

This handles wave-lengths from 160 to 450 meters. The 450 to 900-meter range is obtained by shunting a fixed condenser in the secondary circuit. Connected to the short-wave set is a detector and two-step amplifier of the same make.

For long waves from 600 to 20,000 meters, a Colin B. Kennedy long-wave receiver is used. Control of the wave-length of this receiver is obtained by switches cutting in and out, wound banks of inductances; connected to this receiver is a Northwestern Radio Manufacturing Co.

two-step amplifier. For use with either the short- or long-wave receivers, is a large Magnavox, and a three-stage power amplifier, which consists of three stages of 5-watt Cunningham transmitting tubes, each stage having two tubes in parallel. An 8-volt, 80 amp. hour Exide storage battery is used to energize the field of the Magnavox and furnish current to light the filaments of the power tubes. For the plate of the power tubes three banks of Eveready dry batteries are used, each bank being 108 volts connected in series.

A 6-volt, 100-amp. hour Exide storage battery furnishes current to the filaments of the Cunningham detector and ordinary amplifier tubes, and two 43-volt Eveready "B" batteries furnish current to the plates of the detector and ordinary amplifier tubes. I speak of ordinary audio frequency amplifiers to distinguish them from the larger

(Continued on page 980)

R. A. Bircher's Station at Rochester, N. Y.

HAVING read many RADIO NEWS magazines, I have not yet seen a Rochester station, so I am enclosing a photo of mine.

My receiving set consists of the following: one Clapp - Eastham coupler which is just the thing for amateurs starting in the radio game, also a pair of Brandies phones, and the audion control on the upper right-hand corner. This cabinet I made myself. I use a Moorhead valve and the blank space on the left is reserved for a single-stage amplifier and a murdock 43-plate condenser.

In my transmitting apparatus I employ a one-half kilowatt Packard transformer, murdock rotary, murdock O. T., Boston key, and a one-K.W. Thordarson condenser. The last-named

is, I believe, better than a moulded condenser.

My antenna is of one wire about 150'

long and 50' high. Later I will make a four wire aerial.

IT KEEPS THEM HOT ALRIGHT.

Si Jones for the first time on board a ship of the Navy is being shown around by an officer friend of his. Upon entering the Radio Room he is being told of the wonders performed by wireless.

Si—"Gosh dang, but this is a wonderful arrangement." (Then turning to operator, who is busy copying a message), "Why do you wear those funny things on your ears for?"

Radio Op who is tired of listening to his foolish questions—"You see I am receiving a message from Alaska and as it is very cold up there I am wearing these to keep my ears from freezing."

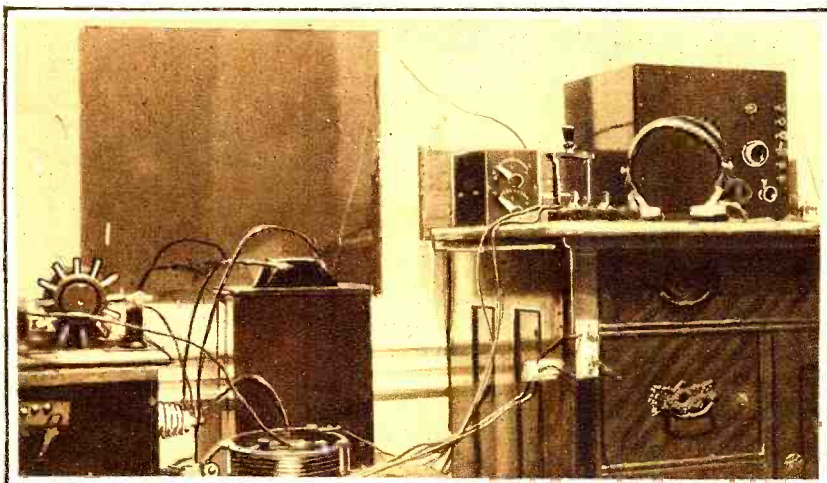

This Set is One of Simple Design and Consists of Rotary Spark Transmitter and Loose Coupler With V.T. Detector. Mr. Bircher is Gradually Adding to His Set.

P. J. Faulkner's Station 2BFH

At Paterson, N. J.

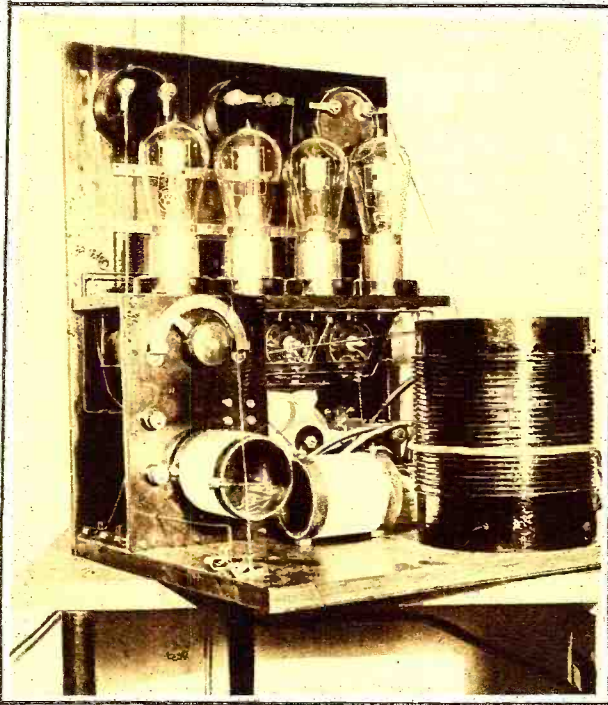

Back View of the Radiophone Transmitter Showing Clearly its Neat and Efficient Design. Note Around the Inductance, the Turn of Heavy Cable Connected to the Microphone.

pleted two weeks ago and we have not had a good chance to try it out on long distance work, two of our tubes being burned out and the other two not much good. We radiate 1.1 amperes on exactly 200 meters.

The receiving set consists of a triple-coil mounting, two condensers and a series-parallel switch mounted in a cabinet with a hard rubber panel. Single layer coils, shown in the picture, are used for all waves up to 900 meters, and honeycomb coils for longer waves. A loud speaker was made by cementing a 36" phonograph horn to a single 1,500-ohm receiver, and with the detector and two-stage signals are heard all over our apartment. To the extreme right may be seen the 68-volt Edison "B" battery, and directly under it the lamp bank used in charging our 6-volt "A" battery from the 110-volt D. C. electric light mains. The "B" battery is charged the same way, substituting a single lamp in series for the lamp bank.

We have copied signals from Rome, Italy, on the east; Pearl Harbor, Hawaii, on the west, and Balboa, C. Z., on the south. Our aerial consists of a 4-wire "T" 100'

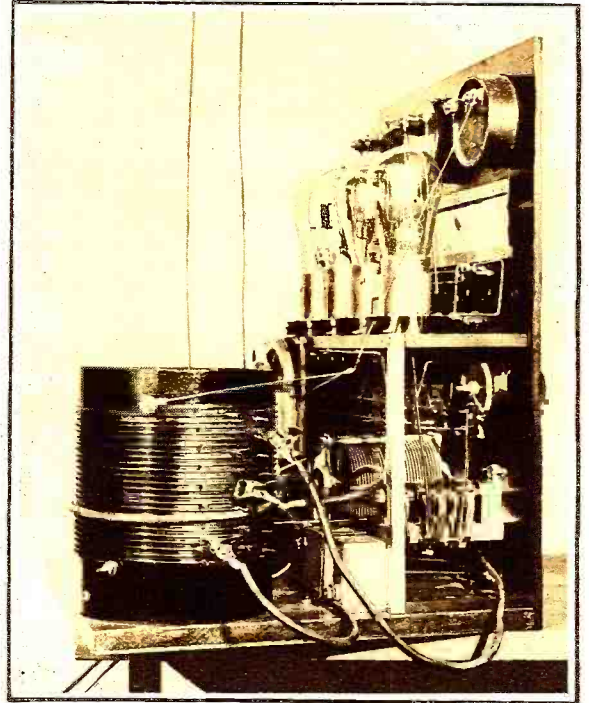

This Radiophone Employs Four 5-Watt Tubes; Modulation is Obtained by the Absorption Loop Method.

THE accompanying photographs are of my wireless station 2BFH. They are doubly interesting in view of the fact that they were taken by myself by electric light, using two 200-watt lamps, and exposed 40 seconds at stop F16 for the pictures of the transmitting set, and 2 minutes 25 seconds at F22 for the complete transmitting and receiving set.

The transmitter consists of four 5-watt tubes, mounted on a panel in the conventional manner, with the necessary rheostats, meters, buzzer, drum-switch, etc. The power is supplied by a 400-volt generator, which also supplies 10 volts for the filament, and is run by a 1/4-H.P. D. C. motor, the power plant being mounted on a shelf and suspended on four coiled springs to absorb noise and vibration. The tone wheel is mounted on a 6-volt, high-speed motor, also suspended to deaden the noise and vibration. The small panel under the main panel contains a 500-volt V. M. for the generator, and on the back of it is mounted the filter system, consisting of the regulation choke coils and condensers. Voice modulation is obtained by the absorption loop method, and is said by listeners to be perfect. The set was com-

long in the flat top, located on 15' masts on top of a four-story building, with a 47' lead in to the second floor.

P. J. FAULKNER,
2BFH.

JERSEY AMATEURS WANT 270-METER WAVE.

Technical experts of nine radio clubs of New Jersey in Plainfield recently adopted resolutions recommending that the radio amateur be allowed to use wave-lengths up to 270 meters in the transmission of continuous wave signals and that spark transmitting be restricted to wave-lengths under 200 meters.

The resolutions will be sent to United States Senator Frelinghuysen, who had notified the Plainfield Radio Association that the present prohibition on amateur broadcasting is soon to be rescinded and has asked for suggestions from amateurs concerning new regulations. Copies of the resolutions were also sent to Congressman Ackerman and radio officials.

They also resolved that clubs should see that oscillation transformers be used by spark coil transmitters.

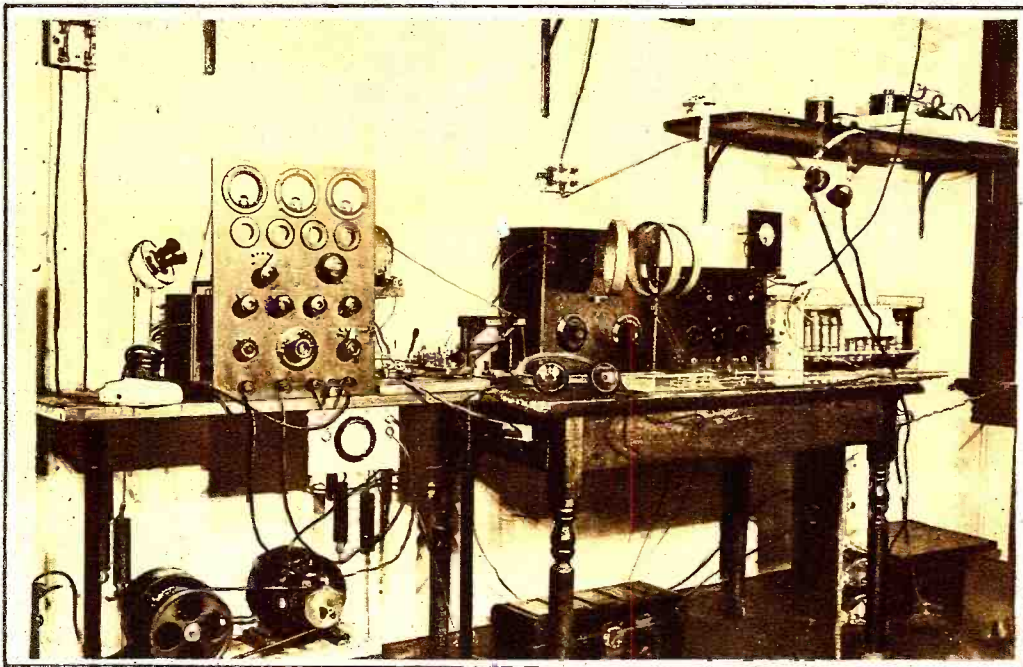

View of the Complete Station Showing Radiophone Transmitter and Regenerative Receiver. The Motor Generator is Suspended on Springs to Absorb Vibrations.

Ralph P. Bucher's Station 3PG

At Philadelphia, Pa.

THE accompanying photograph is of my station, 3PG. I have made some changes in my transmitting apparatus, which have worked out more than satisfactorily. I reduced the primary of the O.T. to one turn, inserting the condenser in the bottom of the turn and inserting the rotary in top of the turn, thus doing away with all leads. The efficiency has been almost doubled and I have been able to communicate with more distant stations than before. However, it requires a larger value of capacity, so I built up a glass plate oil condenser until my closed circuit was tuned to 200 meters.

My receiver consists of a short-wave regenerative set (shown on the right), a two-step amplifier, and honeycomb set which is used for long waves. I change from one set to the other by a small master switch. I have copied hundreds of long distance spark and C.W. signals with this receiver, some of them coming in so loudly that I can barely stand the phones on my ears. I use Western Electric phones and a small loud speaker, which has proven very efficient. I have constructed all my apparatus only buying parts for same, and am getting wonderful results with my set. Several people have told me that they never re-

Very good results have been obtained at this station in both transmitting and receiving. Note the single turn of the primary of the oscillation transformer.

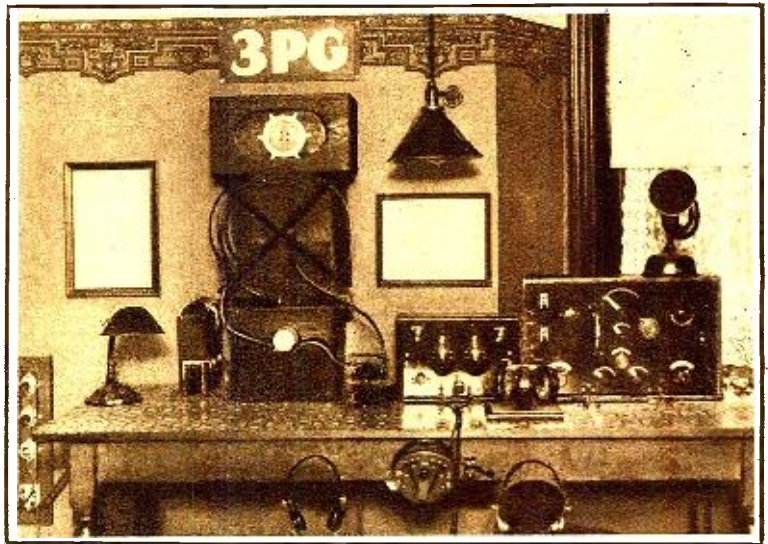

ceived signals of such intensity as those received at my station. On an average night, KDKA can be heard 75' away from my receiving table.

I will be glad to receive cards from distant stations hearing my signals, as my range has been much increased by the improvement of the O.T.

The Milwaukee Amateurs' Radio Club

THE Milwaukee Amateurs' Radio Club was founded in January, 1917, by L. S. Baird, A. C. Kletsch, Jr., J. B. Hitz, and Alonzo Pawling.

In the spring of 1919 and shortly after the Government ban on amateur radio activities was removed, a meeting of the Club was held and plans were made for the coming Club season of 1919-1920. A careful survey of the city was made and a list of all amateurs was compiled. This list was the nucleus of the complete record of all amateurs in the city that the Club now keeps. The Trustees' Room of the Milwaukee Public Museum, which has a seating capacity of about one hundred, was secured as a hall for the Club to convene in.

At the first meetings in the fall of 1919, a new constitution was adopted and officers were elected.

The Club became affiliated with the American Radio Relay League, Inc., and L. A. Degner, a member, was appointed City Manager. Many other events, both business and social, took place this year.

During the season of 1920-1921 meetings were held in a lecture room in the Old Insurance Building. The Milwaukee membership of the now defunct Wisconsin Radio League was absorbed by the Club and the Club became affiliated with the Chicago Executive Council (Radio),

Through the efforts of the leaders of the Club, the Milwaukee Radio Executive Council was formed. This Club and several others are represented in the Council. The season was closed by a successful social and dance held in the dining room of the St. James Episcopal Church.

This season the Club meets weekly at 8:00 p. m. on Monday evenings, except the third Monday of each month, in the Trustees' Room of the Milwaukee Public Museum. Visitors and prospective members

it. Members are encouraged to present before meetings both radio traffic and technical problems. It is the hope of the directors of the Club that in the near future a plan will be inaugurated whereby a certain period of the meetings will be devoted to giving instruction in elementary electricity and radio communication.

This year the Club has embarked on an extensive lecture program. An attempt has been made to secure from the ranks of employees of Milwaukee's electrical industries

a number of men who could lecture on some subject that has points in common with radio communication. Some of the lectures that have been given are: December 8, 1921, "The National Electric Code and Its Application to Radio Signaling Apparatus," by A. C. Schultz, Electrical Inspector, Wisconsin Inspection Bureau; January 23, 1922, "Serving the Radio Amateur," by W. S. Wilder, Sc.B., E.E., Electrical Testing Division, The Milwaukee Electric Railway and Light Co.; February 13, 1922, "The Theory of the Electron Tube," by R. C. Siegel, Sc.B., The University of Wisconsin, 1921; February 27, 1922, "Some Possibilities in the Development of Electron Discharge Apparatus," by Arthur Simon, member I. R. E., Electrical Engineer, Cutler
(Continued on page 1039)



This is a Photograph of the Members of the Milwaukee Amateurs' Radio Club at One of Their Recent Meetings. In the Front Row From Left to Right May be Seen E. J. Seifert, L. S. Baird, E. W. Ruppenthal, H. F. Wareing, L. W. Klingbiel, A. J. Simandel, C. M. Crapo and I. H. Strassman, Officers and Directors of the Association.

are welcome at all meetings. At meetings when outside speakers are not present, members present papers, and informal discussions take place. Previous to the hour of opening the meeting, half an hour is devoted to code practice for those who desire

are welcome at all meetings. At meetings when outside speakers are not present, members present papers, and informal discussions take place. Previous to the hour of opening the meeting, half an hour is devoted to code practice for those who desire

The Crystal

By BERNARD GREENSFELDER

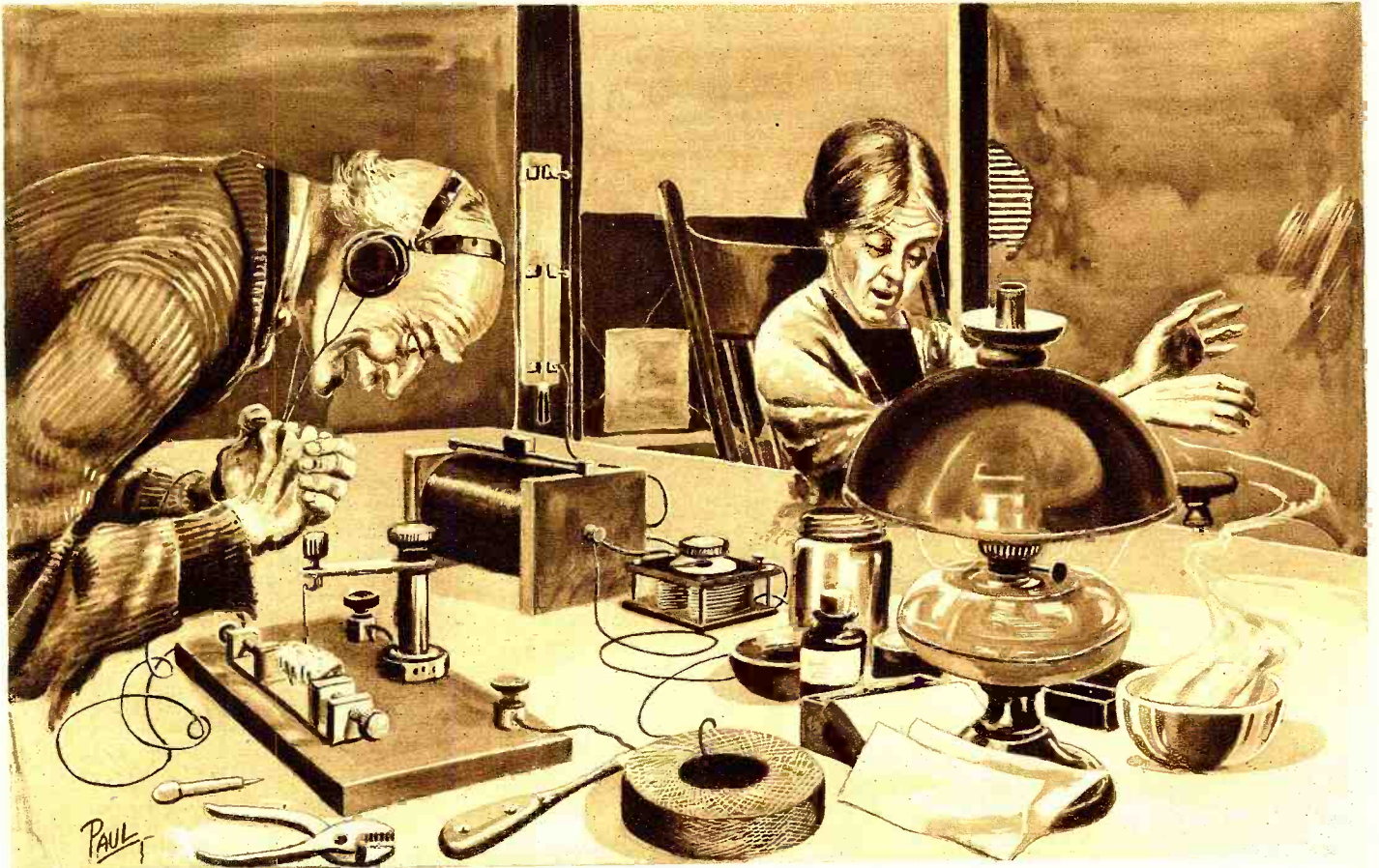

FOR fourteen long years John Foster had pursued a phantom—a super-sensitive rectifying mineral, which when used in a universal radio-receiving hook-up, might receive any signal by the mere turning of a single control. This chimera had he sought, since the day he first read of Marconi's achievements. He was a machinist, and therefore was able to soon have his wireless set constructed and in operation. From then on he became a confirmed enthusiast and experimenter.

He kept pace with the steady march of improvements, up to the advent of the audion; this last was too much for his uneducated mind, for an unembellished grammar-school education is not conducive to a clear comprehension of the intricacies of the theory of thermionic valves. Besides this, Foster had a childish reluctance to desert his protracted search and start anew in bewildering fields.

At various times he had visited the galena deposits in Colorado, carefully testing hundreds of galena crystals, and other minerals. He always returned to his home in San Francisco with some remarkably sensitive specimens, but they were hopelessly short of his desires and dreams. He never tried to dispose of them, lest some curious rogue should become suspicious and apprehend his secret endeavors. Foster entirely failed to realize that the infinitesimal radio pulsations coming from some far-distant transmitter must be amplified if they are to actuate the phone diaphragms.

Slowly and gradually he increased his receiving radius. He could vividly remember that first night five years before, when after an exhausting search among the hills for his "Golden Crystal"—he called it that—the plaintive note of the 300 K.W. spark at Koko Head, Hawaii, came to his straining ears. Then, shortly after, in the dim hours of the early morning, how he had trembled

when he heard the powerful transmitter at Choshi, Japan, calling, "KIE de JCS—." Across the Pacific on his mineral detector! And yet, although this mineral was by no means considered by Foster as his "Golden Crystal," he imagined he was well on the way to his ultimate goal.

Not content with his never-ending mineralogical investigations in search of a new and wonderful rectifying mineral, he set up a crude chemical laboratory with the aid of his only brother, Benjamin, and there they painstakingly treated glistening bits of jagged rock with chemicals—complex compounds and mixtures, made by the indiscriminate mingling of all the available chemicals that they were able to procure. An observer would have been strongly reminded of the witches' cauldron consulted by Macbeth, if he could have seen the machinist bending over noxious liquids, dipping in and out crystals of molybdenite, silicon, potassium ferrocyanide, and what-not.

So, through the years, this monomaniacal obsession grew on the man. It was fortunate he had no children to be raised and educated. His partially deaf wife bore her husband's eccentricities with resignation, on the theory that it was better to have a scientific crank than a poolroom-loafer, such as the majority of the housewives in the near vicinity were afflicted with.

At the shop they were not so patient. In slack times, old "Dippy" John, as the men dubbed him, was always among the first to be laid off, for machinists at the age of sixty-five are liable to make many errors in their difficult work.

The experiments Foster performed were not without cost. The neighbors gossiped about the mortgages on Foster's house and its growing dilapidation. In fact, the Fosters had always served as an interesting topic of conversation to the idle neighbors.

They had not yet forgotten the excitement caused by Benjamin Foster, the younger brother, when he embezzled 5,000 from a local trust company. He had disappeared, never to be seen again. It had been hinted that John Foster knew too much to be good for him.

For two months old "Dippy" had not been seen at his bench. Business was bad, and despite the old man's piteous plea, the boss replied, "No, John, we will probably not want you until next April."

Foster stumbled homeward, counting his money; thirteen dollars and sixty-eight cents!

Somehow he had weathered November and December; the prospect of three bleak months on thirteen dollars and sixty-eight cents made the machinist shudder. He could already see where he was headed, after his visionary pursuit of wealth in the shape of royalties from patents on hypersensitive mineral cubes.

Friends? He had none who could truly answer to that appellation. In his zeal to protect and seclude his activities he had shunned all the usual reciprocal visits between radio amateurs. His former "friends" were antagonized by his continued unwillingness to "let them in" on his scientific adventures and discoveries. So old John had the delightful prospect of spending his sixty-fifth Christmas in cold and hunger.

Two months later, Foster got up from the little apparatus left to him. He had sold most of his much-used and badly-worn factory-made instruments.

To the avaricious eye of the pawnbroker and second-hand man, his complex home-made apparatus, although well turned out, was devoid of potential profit. Moreover, old John's self-made paraphernalia was dearer to him than life.

His wife called up to him, "Hurry, John."
(Continued on page 978)

THE BEGINNER

A Discussion of the Relative Merits of Different Forms of Receiving Apparatus for Use in Broadcasting Work

By ARTHUR H. LYNCH

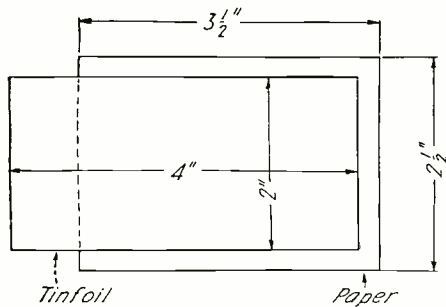

Fig. 1

The Size of the Tinfoil and Paper Sheets in the Condenser is Shown Here.

LAST month we considered the simplest form of receiving outfit, comprising a single wire or double wire, antenna, a crystal detector, a single slide tuning coil and telephone receiver. Mention was made of the fact that a single slide tuning coil was not the best form of apparatus for use in tuning to the desired station while reducing interference from undesired stations. For this reason we will take up now devices which are simple to make, yet very much more effective in their operation than the single slide tuner.

As mentioned in the previous discussion, it is recommended that the experimenter procure a crystal detector from a reliable dealer rather than attempt to make this unit himself. There are two reasons for this. First—A good crystal detector may only be made where it is possible to have access to lathe or other metal turning machine. Second—The retail price of a good crystal detector is so low, that the time spent in making one warrants its purchase.

In connection with receiving circuits more suitable operation is obtained when a fixed condenser is used. The action of a fixed condenser is as follows: The incoming signals striking the antenna are of an alternating character. Their alternations occur so rapidly as to make them inaudible, and it is doubtful that any mechanical device could be made flexible enough to vibrate in synchronism with these very rapidly alternating pulsations or oscillations, as they are called in radio. In order to make these oscillations audible they are broken up by various means into groups. Each group is, therefore, a composite of a number of rapidly moving oscillations. The method used for obtaining these groups is a combination of the condenser and the detector.

In the circuit described last month, there was no condenser shown; however, there actually was a condenser employed because the antenna wires and the earth beneath them formed two opposing elements of the condenser, having an air dielectric between them. The action of this form of condenser is to be taken up shortly. For the time

being let us concern ourselves with the action of another condenser which may be made very easily.

MAKING THE FIXED CONDENSER

In order to make a fixed condenser, it is necessary to employ some form of sheet conductors so arranged that there will be two series of conductors separated from

\$50. In Prizes

With this month, we are inaugurating a special prize contest for radio amateurs and beginners. There will be three monthly prizes as follows:

- First Prize \$25.00 in gold
- Second Prize \$15.00 in gold
- Third Prize \$10.00 in gold

Total \$50.00 in gold

What we desire is simple ideas exclusively for the beginner and the novice, the simpler the radio idea, the better the chance to win the prize.

There are lots of valuable little stunts that you amateurs run across every month, and we mean to publish these for the benefit of the entire Radio fraternity.

If possible, a clear photograph should be sent with the idea, but if that is not possible, a good sketch will do.

This prize contest is open to everyone. All prizes will be paid upon publication. If two contestants submit the same idea, both will receive the same prize. Address all manuscripts, photos, and models, to *Editor Radio Wrinkle Contest*, care of this publication.

each other by some form of non-conductor. Where low power is employed, such as is the case in simple receiving outfits, the ma-



Fig. 2

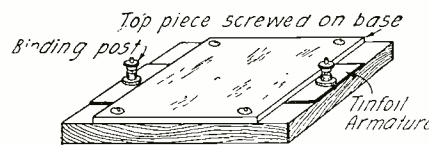

Fig. 3

Fig. 2 Shows How the Tinfoil Sheets Composing the Armatures are Interlaved With the Dielectric. Below is a View of the Complete Condenser.

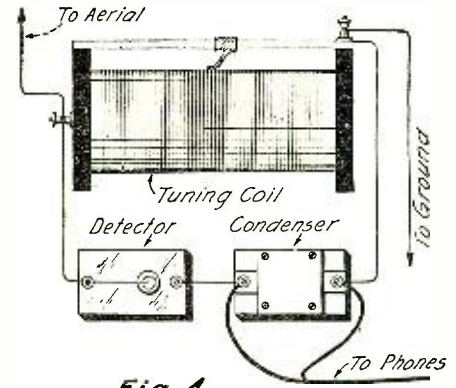

Fig. 4

Hook-up of a Single Slide Tuning Coil, With Crystal Detector and Telephone Condenser.

terial used between the metal conducting surfaces may be of an inferior character because it is not subjected to great strain. The metal surfaces for a fixed condenser may be made of copper, zinc or tinfoil, but iron should not be used. The material used between the opposing surfaces of receiving condenser may be paraffin paper, mica or bakelite; in fact, any material which is a non-conductor. The capacity of the condenser depends upon the area of the opposing plates, the distance they are apart and the material that separates them.

It is not of very great importance in the making of a fixed condenser, suitable for use in simple receiving circuits what kind of separating material is used, nor does the capacity itself make a great difference, and the general directions given here are merely indicated as one means of providing a suitable condenser. If the measurements are not strictly adhered to, little difference will be found when the condenser is put in service.

The condenser is composed of four sheets of tinfoil, 2" x 4", with a small extension left for connecting several surfaces together. The material between the surfaces is paraffin paper and should extend 1/4" outside the edges of the tinfoil, as shown in Fig. 1.

In order to assemble the condenser, lay one sheet of paraffin paper on a table or desk, place a metal sheet on it with the connecting strip extending, as shown in Fig. 1. Then place another piece of paraffin paper on top of the tinfoil and follow this with another strip of tinfoil, having its connecting strip extend, as shown in Fig. 2. Continue this assembling process until all the metal surfaces and paper are in their proper places and then fasten the assembly firmly together between cardboard plates wrapped with tape by any means at hand and immerse it in melted paraffin. Withdraw the unit from the paraffin and permit it to dry. It is then only necessary to make connection to the group of connecting strips, shown on each end of the condenser.

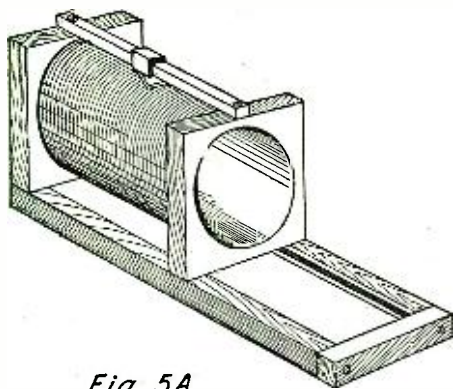

Fig. 5A

The Primary of the Loose Coupler Completed.

A suitable means for making this connection is obtained by the use of binding posts, as shown in Fig. 3.

The condenser may be clamped between two wooden plates, as shown in Fig. 3, or put in a wooden box or other container to suit the demands of the individual. This condenser is included in the circuit, as shown in Fig. 4.

The action of this condenser is as follows: A signal from a transmitting station picked up by the receiving antenna is carried to the crystal detector. The mineral in the crystal detector is a natural rectifier and permits the incoming signal to pass through it in one direction while it resists the passage of the signal in the opposite direction. This resisted signal then finds its way into the condenser and the condenser in turn discharges through the windings of the telephone receivers, resulting in a vibration of the diaphragm and the production of sound waves which are heard by the operator.

There are many sizes and forms of condensers designed to fill various needs, and the simple type here described cannot be used satisfactorily in circuits requiring these special designs, but it will give satisfaction in the simple circuits shown here in connection with the making of apparatus from broadcasting reception.

THE LOOSE COUPLER

The loose coupler or receiving transformer, as it is sometimes called, permits a somewhat better tuning arrangement than the single slide tuner, and it may be used in conjunction with circuits to be described later for the reception of signals over very long distances. There is nothing complicated about the making or operating of a receiving circuit employing a coupler.

If Fig. 2 of the first article in this series, which appeared last month, is compared to Fig. 5, it will be seen that in place of a single variable coil there are two variable coils and the connections to them follow the same general arrangement.

There is no connection between the windings of the coil marked primary and

the other marked secondary but when a received current passes through the former, it has the effect of setting up a similar current in the latter. The intensity of the current in the secondary with reference to that in the primary may be varied by moving the secondary coil in or out of the primary. It is very seldom that all of the turns in either coil are used, and therefore the greatest strength of signal is obtained when the center point of the active turns in the primary is directly above the center point of the active turns in secondary. However, this location sometimes tends to set up what is known as mutual induction between the coils themselves resulting in irregularities which may only be overcome by shifting the position of one coil with relation to the other. The advantage of this type of tuner is that variation of the coupling which is shifting the center points permits the best reception of desired signals and tends to eliminate undesired signals. A loose coupler may be made according to the following instructions and its use is highly recommended.

First procure two pieces of wood, 12" x 1 1/2" x 1/2", which are, with two other pieces, 5" x 1/2" x 1/2", used for the base, and three other pieces, 5" x 5" x 1/2", to form the ends of the primary and secondary. The base for the secondary being made with a piece, 5" x 2 1/2" x 1/2". Two cardboard cylinders, 4" and 3" in diameter, must then be procured. The dimensions given in the ac-

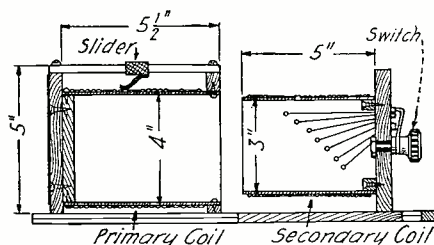

Fig. 5

Dimensions of a Loose-Coupler for Amateur Use. Note How the Taps From the Secondary Coil Are Taken.

companying illustration need not be strictly followed and a certain amount of leeway is left to the experimenter permitting him to take advantage of whatever material it is easiest for him to secure.

In making the loose coupler, two round pieces of wood must be procured to fit the inside of the two cardboard tubes tightly. The larger one mounted inside of the primary coil may be screwed by means of four small wood screws so that the surface of the disc is even with the edge of the cardboard tube. The smaller disc, which is mounted inside of the secondary, should be sawed into three parts, as shown in Fig. 5B, and only the outside sections be used, so that the switch and switch points may be mounted on the end of the secondary coil and connections made from the taps to the switch points.

One of the square pieces of wood, 5" x 5", should have a large hole cut in the center so that the primary coil may slide into it. The edge of the cardboard tube, upon which the primary is wound, should come flush with the surface of this end, as shown, in Fig. 5A.

The primary coil should be wound with No. 20 enameled wire, beginning about 3/8" from the end and up to 3/8" from the other end. The secondary coil is wound with No. 24 double cotton covered wire, in the same manner as the primary, but beginning 1/8" from the end of the tube, sliding inside of the primary. Taps should be taken at 3/8", 1", 1 3/4", 2 1/2", 3 1/2" and 4 5/8", that is, the end of the winding. To make the taps, a small hole is drilled in the cardboard tube, when the distance speci-

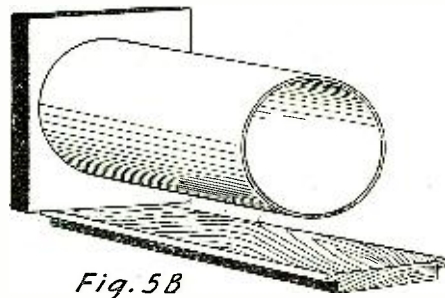

Fig. 5B

Here May be Seen the Secondary Mounted on its Base Which Slides Under the Primary Coil to Vary the Coupling.

fied above is reached, then the wire is bent so as to pass it through the hole easily, and the loop thus formed, is pulled inside of the tube, far enough to reach the end of the coil on which the switch is mounted.

Two binding posts should be mounted on the square end supporting the switch, and the end of the winding beginning 1/8" from the edge of the tube connected to one of them, the other one being connected to the switch lever. On the opposite end, to which is fixed the primary coil, should also be mounted two binding posts for the connection to the slider rod and to the end of the wire nearest the secondary coil.

The wire of the primary coil should be wound tightly so that the turns do not move when the slider runs along the turns, over the surface of which the enamel has been removed with a piece of sandpaper, or a fine file. The secondary coil, which is mounted on a piece of wood sliding between the two guides from the base, should be mounted so that it does not touch the primary coil when moved inside to tighten the coupling, this to be looked for if the space between the primary and secondary coils is small.

In order to receive long wave-lengths, it is necessary to use the single slide tuner described last month connected between the aerial and the primary. Where a single slide tuner is used in this manner it is called a loading coil and its purpose is to increase the number of turns of wire between the antenna and ground without increasing the size of the primary of the loose coupler.

The loose coupler when used in the foregoing circuits and in the circuits to be described later forms a very sensible means for tuning, and may be used with satisfaction without necessitating a great deal of study on the part of the experimenter. For reception over moderate ranges it is doubtful that a more suitable arrangement could be had.

Fig. 6 shows the connections of a loose coupler with a detector and phone condenser.

For best results, a variable condenser should be used across the secondary so as to provide a means of finely tuning this circuit. Another condenser may also be connected in series with the aerial.

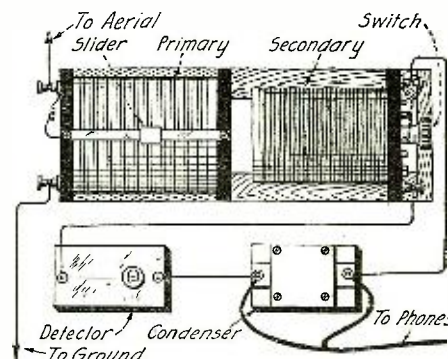

Fig. 6

Hook-up for the Loose Coupler Described in the Article.

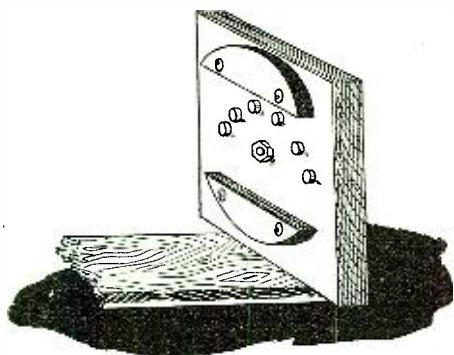

Fig. 5C

This is the End of the Secondary Coil. Note the Pieces Supporting the Coil and the Switch Points.

Some Useful Ideas

A UNIVERSAL DETECTOR.

Procure:
 A ruling pen.
 Three pieces of 1/4-inch copper tubing, 1 3/4 inches long.
 Two small binding posts.
 Two 1/8-inch brass machine screws, 3/4 inch long, having hexagonal nuts, 1/2 inch in diameter.
 One piece of spring brass wire, about 2 1/2 inches long.
 Base, 2 1/2 x 5 x 5/8 inches.

To one end of each piece of copper tubing solder the brass hexagon nuts. This should be done so that the machine screw can pass up into the tubes. On the other end of one of the tubes solder the ruling pen, which must have a joint, so that the pen will point horizontally when the tube is vertical. On the end of the other tube solder a small binding post.

For the contact point use the brass wire which should be filed to a point at one end. The wire should be bent into a spiral for about 1/2 inch.

To assemble, screw the tubes to the base by drilling an 1/8-inch hole and enlarging on the bottom to take the head of the screw. The mineral which is to be used should be put into the ruling pen, which can be tightened by means of the thumb screw.

The remaining two binding posts should go on the block, as shown in the drawing.

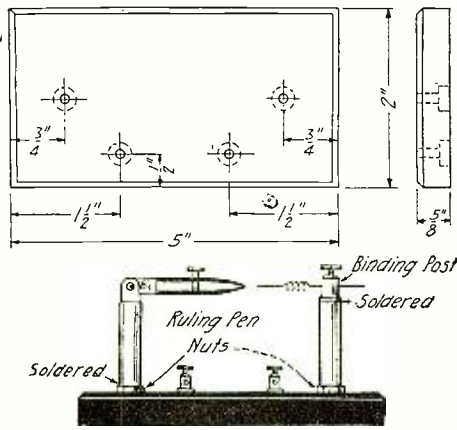

TUNING COIL HINTS.

To make contact with the slider, the insulation and the wire wound around a tuning coil must be removed. This is a tedious operation if only a knife is used for the purpose. A better plan is to nail two laths on one side of the tuning coil, spaced 1/2 inch, and scrape the insulation away by rubbing a wooden block covered with emery paper up and down in the groove formed between the two laths. The wooden block should be 1/2 inch high, 3 inch wide and 5 inch long. The emery paper should be glued on the longer side of the block. After the insulation has been scraped away, the laths may be removed.

The system is remarkably simple and effective. The insulation is easily removed with very little effort and comparative rapidity. The result is a straight and even line with no ragged edges and good contact is assured.

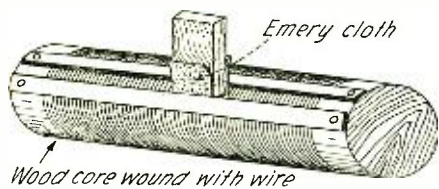

A SIMPLE HEAD-BAND.

A simple head-band may be made by bending a piece of No. 10 wire into the shape shown at A in the illustration, and twisting the wire together as at F. With a pair of pliers the two ends should be bent to fit into the two holes in the sides of the receiver case, allowing it to swing freely. With a little adjustment, it will fit the head snugly and is a very light and cheap arrangement.

A double head-band may be made as at B. If made of nickel plated brass or phosphor-bronze wire, it will be found neat, as well as useful.

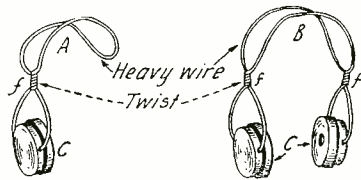

A SIMPLE VARIABLE CONDENSER.

Procure two tin cans so that one will fit snugly into the other. A 1-pound coffee can and a 1-quart molasses can are just the things. Wash off all the labels, etc., and paste a piece of paper on the smaller can, to insulate it from the larger one. Then give it two coats of shellac. Solder a wire to the larger can and fasten a binding post to the smaller (which also serves as a handle), and the condenser is complete. It will add much to the appearance of the condenser if the cans are painted and mounted on a base, or if they are hidden in a box and a long rod projecting through the box is used for a handle.

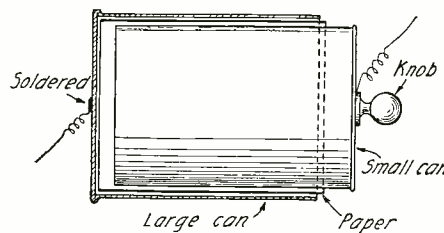

SIMPLE SILICON DETECTOR.

A pressure silicon detector may be made in the very simple manner illustrated in the drawing. Two pieces of brass are bent in the shape indicated to form the springs, between which a piece of silicon is inserted. Another piece of brass is bent in a semi-circle and with the springs screwed to a wooden base. Drill a hole at the top of the semi-circular piece of brass which will permit a nut to be wedged therein. A brass thumb screw through the nut adjusts the pressure on the silicon.

All the parts used in the construction of this crystal detector are odds and ends which may be found in any amateur's workshop. The springs of an old electric bell may be utilized and the nut from a worn-out battery.

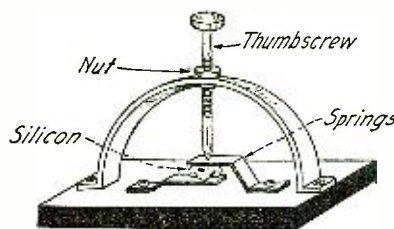

TO MAKE A SIMPLE VARIABLE CONDENSER.

Procure a piece of hard wood or rubber, about 6 1/2 inches long by 2 inches wide, and not over half an inch thick to serve as the base. Obtain two test tubes, one 6 inches long by 3/4 inch in thickness; the other the same length or a little longer and a trifle narrower, so that it will slide inside the first. The tubes must be covered with tin-foil. The foil only goes on the outside of each tube; a 4 1/2-inch strip of foil is laid on smoothly and fastened by shellac, the shaded portions of the figure representing the foil. The bare ends, which will be about 1/2 inch on the round end and 1 inch on the open end, should be covered with a varnish made by dissolving red sealing wax in alcohol. Fasten the large tube to the base by a brass clamp (G) in figure, and connect this by a wire (W) to the binding post (B).

Procure an 8-inch length of No. 30 D.S.C. wire and force a short piece of the bared end under the foil of the small tube. To obviate the danger of this pulling out it may be fastened with a small strip of tape (T); the other end is to be connected to binding post (B). By pulling the inner tube out the capacity is diminished, and by pushing it in the capacity is increased.

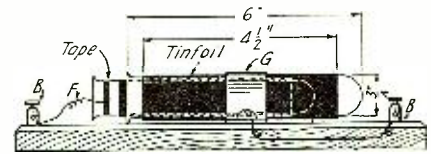

TO CONSTRUCT A TUNING COIL SLIDER.

If no space rod can be procured in your city, the following is a good way to proceed:

Materials—Round brass rod of any length, and about 3/8-in. diam.; one piece sheet copper, 3.5 x 1/2 in. of sufficient springiness to suit; one steel ball about 3/8-in. diam.

Instructions—First hammer the copper to make it springy, then bend it around the brass rod (see Fig. 1).

Fasten a wire along the length of the coil to keep the slider on to the polished surface of the wire, as shown in Fig. 2. Bore a hole in the copper at one end (see Fig. 3) a little smaller than the ball, so that the ball will revolve without slipping through.

The slider is moved along the brass rod in either direction to vary the inductance. This may be done by holding the copper slide itself or, with a little adaptation, an insulated handle may be attached to the slide.

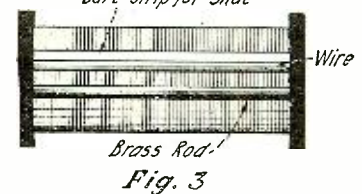
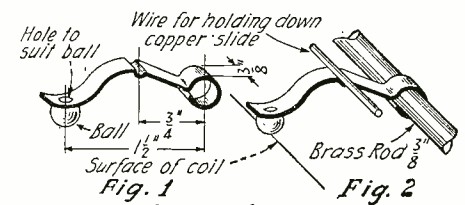

An Easily Constructed 180-800 Meter Regenerative Receiver

By JOHN R. MEAGHER

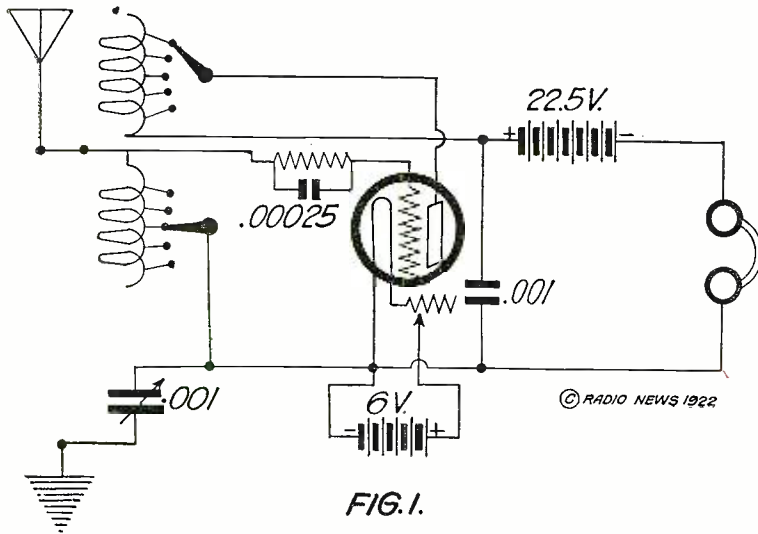

Complete diagram of connections of the short-wave regenerative receiver described in this article.

THE receiver to be described was constructed for a beginner who has found no difficulty in tuning the set. The circuit used is finding favor everywhere, due to its simplicity and ease of operation. The wave-length range, 180-800 meters, includes amateur, broadcasting, ship-shore and direction finding stations and is the range most desired by amateurs.

A very important item, to most of us, is cost; therefore, a complete list of material is printed at the end. The total cost, including everything, is less than \$50. If any material is on hand the extra cost will be that much less. Allowing \$15 for the storage battery and omitting the lightning switch and ground wire the set may be constructed for \$40. In any case the cost need not exceed \$50. Compare this price with that of any equally good set on the market.

To make the construction as simple as possible the various parts will be classified under separate letters.

Construction:—

(A) Aerial. A single wire 75' to 130' in length stretched from a window to a tree or supported between two chimneys on the roof of an apartment or in any of a hundred different ways will be the best for receiving and the easiest to erect. The lead from the wire may be of the covered stranded type used in lighting fixtures. The joints should be soldered. If no lead-in insulator is used, the covering may be waxed to prevent leakage through wet coverings. Small corrugated porcelain insulators may be purchased, although ordinary porcelain cleats will be satisfactory. Be sure that the aerial or lead does not swing close to any objects, otherwise C.W. and phone stations will swing in and out. Keep all of the outer wires taut. The lightning switch should be mounted on the outer window sill and a No. 4 wire run from one jaw to a suitable ground.

(B) Ground. It is well to experiment with the ground for the set. A fire-escape ground will do nicely. At present I am using a covered wire running along the moulding as a counterpoise ground, and it works extremely well. The wire is about 40' long and is directly below a portion of the aerial although the distance from aerial wire to counterpoise is about 30'.

(C) The set is composed of a tapped inductance for tuning, a tapped feed back plate inductance wound on the same form and adjacent to the tuning coil, a short wave condenser, grid condenser and the tube, phones, etc. Diagram, Fig. 1.

(D) The wiring form is a tube 3/4" in diameter and 8" long. I have used the long type of container from a soda store. Care must be taken that the position of the coils, as shown in Fig. 1, is maintained. That is, if 200-meter stations are being received, the used portion of the tuning coil must be next to the used portion of the feed back coil.

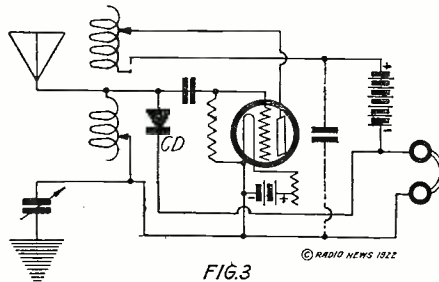

A Crystal Detector May be Used if Desired When the Batteries Are Down. It Should be Connected as Shown Here.

(E) Inductance coil. The wire is No. 23 single cotton covered and the wiring is started at the center of the form. There are 80 turns in this coil, with taps at 20, 25, 30, 35, 40, 50, 60 and the end of the wire connected to the last tap.

(F) Feed back inductance is wound in the same direction as the tuning coil and has 100 turns, with taps at 20, 30, 40, 50, 60, 70, 80, and the end of the wire connected to the last tap.

(G) The short-wave condenser should be of the 43-plate variety with a maximum capacity of .001 mfd. This had better be purchased.

(H) The grid condenser may be purchased or constructed and should conform to the requirements of the tube as stated by the manufacturer.

(I) The tube should be of the soft detector type. I have used G.E. (For sale under trade names of Audiotron and Radiotron), W.E. "J" tube and an old Meyer tube, all of which are satisfactory.

(J) Any good sturdy socket may be used. Be sure the spring connections are springy, and that it does not require brackets to mount on a panel.

(K) There are a quantity of good rheostats on the market, and you should select one that can stand heat. A vernier rheostat would be much better if handled at the right time when tuning. There are now several on the market.

(L) Any good storage battery may be purchased. It would be best to consult some "Ham" friend beforehand in order to lessen the possibility of getting "stung." If you can afford the extra cost, it would be better to buy a 6-volt 60-ampere battery, as it will not require charging so often.

(M) Phones are numerous and a good plan would be to ask someone who has had a chance to try out different phones and who will recommend a good pair. Almost any "B" battery will do. If you wish, a tapped battery may be substituted although the cost will be slightly more.

Although this article did not start off with a lengthy description of a cabinet, it is well to remember that a solid ivory cabinet will not increase the signal strength in the least. The various instruments may be mounted on a wooden board. The panel of this set was made of a three-ply veneer 12" square to avoid crowding; the parts were arranged as in Fig. 2.

This set was equipped with a crystal detector which was connected in the circuit, as shown in Fig. 3. The crystal could be used while awaiting the V.T. and storage battery. It is also good to show what can be done on it.

For tuning, set the plate inductance to include 40 turns or more, light the filament and change the wave-length tap. The condenser is used for tuning between taps. If voice is being received, the final adjustment will generally be the rheostat. You may have noticed that a smaller number of taps could have covered the range of wave-length, but it will always be found that different combinations of inductance and capacity will be best for different stations on the same wave. It will be advantageous to solder all connections.

Unless you are a beginner, I would dislike having you follow out this construction to a "T." If you have an idea that something else will work as well or, at least, no worse, try it. The question of double or single circuits has so many arguments for each that the total for both sides is about even. I have tried both and have settled upon the single circuit. I shall be very pleased to answer any questions regarding this set.

List of Material:

- One 6-volt 40-ampere battery.....\$15.00
- One detector tube..... 5.00
- One pair of phones..... 8.00

(Continued on page 1024)

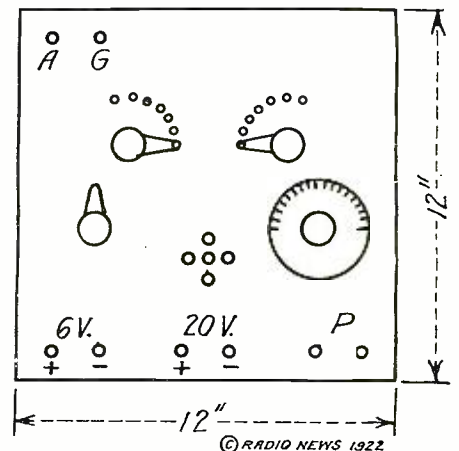

FIG. 2

Arrangement of Parts on the Front Panel of the Set.

Efficient Crystal Detector

By LEIGH E. CHARWICK

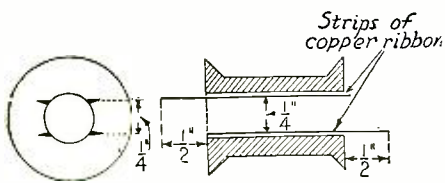

Fig. 1. In a Common Wooden Spool Insert Two Strips of Copper Ribbon in Slits Made on the Inside of the Spool.

IN spite of the present downward trend of V.T. prices, and the widely increasing popularity of their use as detectors, there are many amateurs who are compelled to stick to the old crystal. Anyone who has used the cat-whisker type of crystal detector knows the difficulty experienced in obtaining and preserving a sensitive adjustment.

One day, after a particularly trying hour with my detector, I began to cast about for some way of maintaining a permanent, sensitive adjustment, and finally hit upon the following plan:

A common spool was taken and four lengthwise slits were cut in the surface of the hole which runs through the middle of the spool.

Two strips of copper ribbon, $\frac{1}{4}$ " in width, and $\frac{1}{2}$ " longer than the spool, were then

cut. These were inserted in the slits so that they formed two parallel surfaces, one-quarter of an inch apart. One end of each strip was made flush with an end of the spool in such a way that each strip projected $\frac{1}{2}$ " beyond the end of the spool, with each projection at a different end of the spool.

Two small blocks of wood, cut so that they fitted snugly between the strips of ribbon and the surface of the spool, were next made. One of these was inserted at one end of the spool and pounded firmly into place. Then a quantity of crystal sufficient to nearly fill the space between the strips was ground to a mixture of powder and fine granules. This was poured in between the strips and the other wooden plug pounded firmly in.

The projecting ends of the copper ribbon

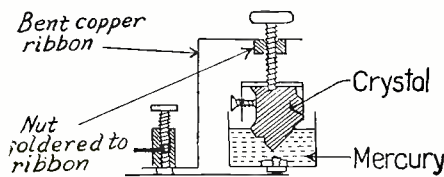

Fig. 3. Another Type of Crystal Detector. The Crystal is Immersed in Mercury. With Both These Types Continual Adjustment is Obviated.

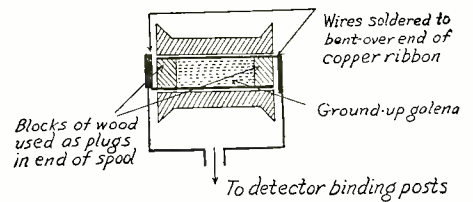

Fig. 2. Ground-up Galena Fills the Middle of the Spool and Wood Blocks Are Used to Plug the Ends. Connections Are Taken Off From the Copper Strips.

were then bent over flush with the ends of the spool and a short piece of wire soldered to each. These wires were led to the regular binding posts of the detector and the work was completed.

This detector was found to be in adjustment when first connected and I have since been unable, either by a gentle tapping or by the most vigorous shaking, to impair the fine degree of sensitivity the detector provides.

Several other methods were tried, among which the most successful was the inversion of the usual detector cup, immersing the exposed crystal in mercury.

The crystal used in the spool was galena, but I have no doubt that some other crystal, or perhaps a mixture of two or more kinds, might give even better results.

THE "TWO IN ONE" FOR RADIO AMATEURS

By ROY ANDERSON

UNDOUBTEDLY there are many who, like myself, have long-wave tuners with audion detectors, or with amplifiers also, but who are unable to secure short-wave sets. Now, a loose coupler, alone, is cheap, and, moreover, it can easily be made at home. But, of course, when used alone we know it does not work, so why not utilize the condensers of your large sets? After experimenting around quite a bit I found the best hook-up to be that which is shown in the diagram.

By placing the switches for the primary and secondary long-wave tuner on the dead-end taps, the signals are carried through the condensers, and the coils of the long-wave tuner exert absolutely no influence on the signal strength.

With a makeshift coupler and this hook-up and with only a bulb detector, I hear 600-meter stations and ships all over the coast,

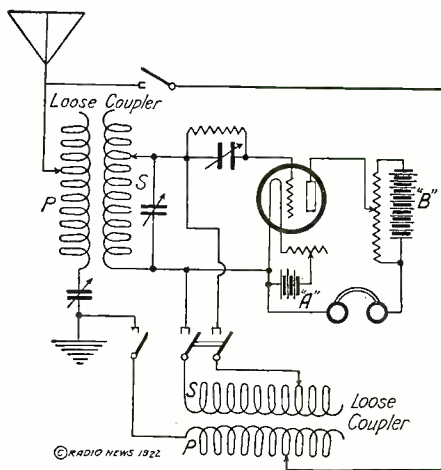

also the marine set at Pearl Harbor, Hawaiian Islands. I also heard the U. S. S. Kansas when she sent her TR report to Ketchikan, establishing a record for Navy 5. K. W. sets (only 4.2 at the time).

It might be well to add that many have

With This Hook-up the Same Condensers and Detector Are Used With Two Loose-Couplers for Long and Short Waves. A Four-Pole, Double-Throw Switch is All That is Needed.

used this circuit, but so many, especially beginners, go along worrying about not being able to get a short-wave set and are ignorant of any such hook-ups as the one described.

A USEFUL TURN COUNTER FOR WINDING COILS

By D. R. CLEMONS

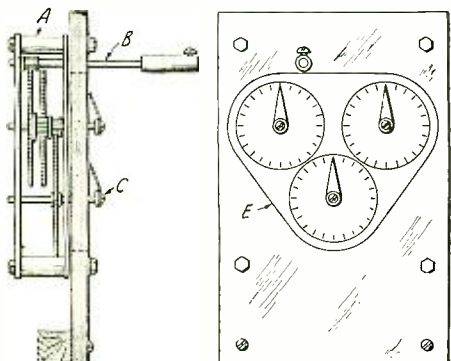

When Winding Transformers or Coils, This Turn Counter, Which May Easily be Made, Will Prove Useful.

IN winding coils of fine wire into transformer pies, secondaries, or otherwise, it is a great advantage to attach a revolution counter to the machine in order that the operator may know the exact number of turns that have gone into the coil. This is particularly desirable in doing original work where a new design may be tested and accurately duplicated. A very simple counter that may easily be made is shown in the sketch.

Here several cog and pinion wheels are mounted between two brass plates in such a manner as to revolve in greatly differing ratios. If pointers are attached to the protruding centers, their position will indicate the turns directly on the dial. Several large cog wheels may be removed from old clock works. These cog and pinion wheels may be mounted between two brass plates sepa-

rated by lengths of brass tubing slipped over the tie-rods at "A." A pinion is soldered to a brass driving rod at "B," which connects with the winding apparatus. All other parts are mounted so that the pinion of one engages the cog of the next. All gearing is clamped behind a thin wooden panel, the centers protruding, as shown at "C." A cardboard dial is glued to the panel at "E." Small metal pointers are soldered to the protruding shaft ends. The different scales may then be calibrated by hand and varnish applied. This particular counter reads in units of 14, 168, 2,016 turns, but readings will be different with another counter due to different ratios used.

It is possible to use a single set of alarm clock works by removing the balance wheel and rotating the parts. However, the above has given excellent results in original work.

Two-Step Amplifier for Twenty-five Dollars

By VICTOR ANDREW

WHEN a fellow doesn't have a two-step amplifier, it is usually because he can't afford one. Any one with a little time to spare does not need to pay the price of the amplifiers on the market. He can build one at a surprisingly low cost. The amplifier here described can be built for less

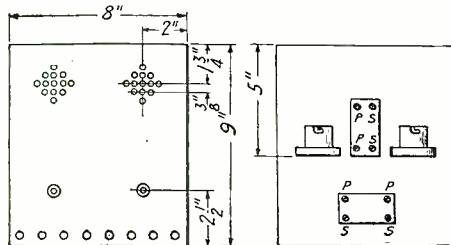

Front and Back Views of the Panel Showing Holes to be Drilled and Location of Transformers at Right Angles.

than \$25, and is equal to the best, both in appearance and operation. Here are the instruments, with prices:

2 Tubes	\$8.50
2 Sockets	2.00
2 Rheostats	1.50
2 Transformers	10.00
8" x 9" x 1/8" Panel.....	1.00

I obtained from a certain Radio Laboratory some old type G.E. tubes at \$4.25. These are very good amplifiers. The radiotron at \$6.50 would be my next choice.

The Murdock is a neat, serviceable receptacle, but there are other good ones at about \$1.

The Parkin rheostat is one of the smoothest and best operating rheostats on the market, and is now sold at 75 cents. If you prefer a back-mounting rheostat, the Remler Junior at \$1 is satisfactory.

The Acme amplifying transformer is the most popular today. There are several other good transformers at \$5, and some at less.

A 9" x 8" x 1/8" formica panel can be purchased for 88 cents. If a heavier one or a bakelite panel is used it will cost slightly more.

The only other materials necessary are eight binding posts, a little wire, a few screws, etc., found in any amateur's junk:

The drawings show the actual construction better than I can describe it. By mounting the amplifying transformers at right angles there is less chance of howling. Acme transformers are easily attached to the panel by drilling and tapping the legs a

10/32 thread, and putting short round head nickel plated bolts through the panel.

The rheostats may be tapped as shown in the wiring diagram to put a negative potential on the grids. If Parkin rheostats are used, wind a small resistance of a few turns of resistance wire, and put it between the

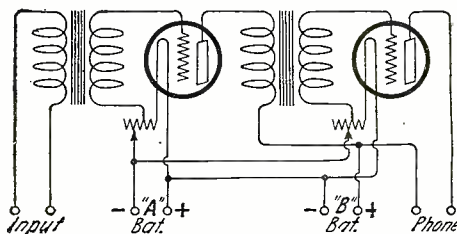

Wiring Diagram of the Two-Stage Amplifier Transformer. Secondaries Are Connected to Filament Rheostats to Place Negative Potential on the Grids.

rheostat and the tube. The grid circuit is connected to that. The proper point on the rheostat to connect the grid circuit should be found by varying it. The G.E. tubes mentioned seem to operate better without a negative potential.
(Continued on page 1034)

A Non-Inductive Resistance or Potentiometer

By B. FRANCIS DASHIELL

WIRELESS detectors that employ a local battery current require a very fine and even regulation of the current so as to obtain a satisfactory result in the detection circuit.

Two methods of obtaining this fine regulation are used. One, the most common is in the use of an ordinary rheostat, but this is always objectionable, due to the inductance and uneven resistance of the closely wound coils of resistance wire. The second or non-inductive type is gradual in the increase of resistance and can not cause any objectionable inductive effects in the circuits. It is this type that will be described and how it can be easily made.

The non-inductive potentiometer type is constructed as follows: The base is made of a neat piece of hard oak and should be approximately, 12" by 2" by 1/2". It should be neatly smoothed and the edges beveled and sandpapered and finished with two coats of shellac. The slider rod is made from a piece of 1/4" square brass rod and is 10" in length. Holes are drilled near each end so that 8/32 threaded brass bolts will pass through, as shown. Two pieces of square

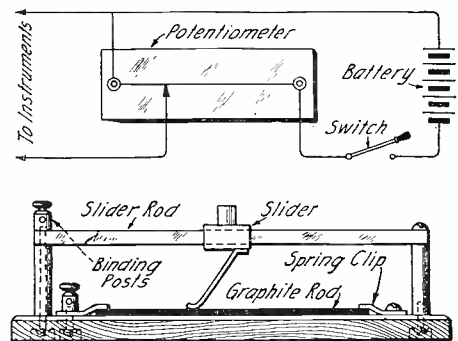

Wiring Diagram and Sketch of the Resistance or Potentiometer Employing Graphite Rod of a Pencil.

1/4" brass tube, each 1" long, are used as the supports for the slider rod, as shown. Two brass machine screws, 8/32 thread, are used to fasten all securely to the base. The resistance rod is a piece of graphite obtained by soaking a 6H "Kohinoor" drawing pencil in hot water to loosen the glue and remove

the wood protection. Two small spring clips screwed to the base, made of two small pieces of spring brass, hold the graphite rod securely in place under the slider rod. A slider is made in the same manner that the tuning coil sliders are built, or an old tuner slider may be adapted to this instrument. Binding posts are placed on the base and the proper connections made under the instrument.

The resistance will vary according to the piece of graphite used. The softer graphite has a greater resistance than hard graphite, owing to the difference in cohesion between the particles, but the softer graphite, while of higher resistance, has poor wearing qualities. The use of the lead out of a 4H drawing pencil is satisfactory and probably has a resistance of about 200 or more ohms.

I used a potentiometer for years of my own make when electrolytic detectors first came out about 15 years ago or a little less. I used six volts across it, or four dry cells and had perfect results. Possibly for Audion use, two such rods in series arranged with switches would give a higher resistance.

An Original Type of Tuner-Coupler Coil

By F. W. DRAPER

A NEW idea in tuning apparatus is illustrated in the accompanying sketch. This tuner may be used either as a single circuit tuning coil or as a loose copuler, by the simple process of throwing a switch. It will be found very convenient in operation and has the added advantage of giving a very close adjustment of inductance. Moreover, it is very simple to construct.

To make this tuner, procure a piece of wood measuring one-half inch by four inches by eight and a half inches; a board of larger proportions may be used if it is desired to receive a longer range of wavelengths. Beginning one-half an inch from one end, wind a coil of No. 24 enameled copper wire to a distance of two and a half inches. Leave a space of half an inch and wind the second coil of wire in the

same manner as the first. In the center of the space between the coils and three-quarters of an inch from each side of the board, fasten two rotary switches with two and a half inches radius arranged, as illustrated. The blade of one switch will rotate on one coil and the blade of the second switch will rotate on the other coil. Scrape the enamel off the wire where the blade comes in contact with the coils.

In the two and a half inch space remaining at one end of the tuner, place a 4-pole double-throw switch. This switch may be made from some strips of brass or a few other odds and ends that can usually be found in any workshop; otherwise, two double-pole switches may be used.

Arrange the wiring of the double-pole switch in such a way, that, by throwing the

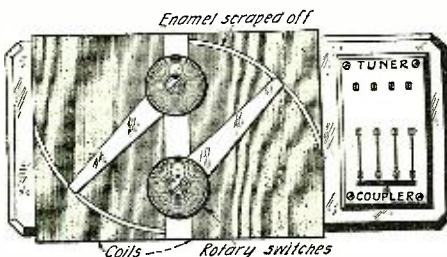

By Means of a Double Throw Switch This May be Made a Single Circuit or Loose-Coupled Tuner. Note the Simple Method of Varying the Inductance.

switch to one side the two coils are in series, and on the other side of the switch one coil will form the primary and the other coil the secondary of the coupler.

Sensitive Crystal Receiving Set

By HARRY L. GRAY

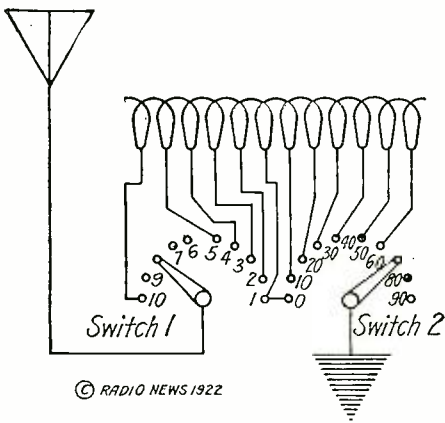

The Primary of the Loose Coupler Showing Method of Wiring the Tens and Units Switches.

MOST wireless enthusiasts will be interested in this simple and very sensitive set. The results to be had, compare very favorably with a single vacuum tube, with the added advantage of not having batteries and tubes to renew, and the expense of construction need not exceed \$5.

The great feature of this set is the unique and wonderfully sensitive crystal detector. The crystal used is the regular galena, which, of course, should be one of the tested crystals. The crystal is sealed within a tube and a contact sealed in the other end, and metal filings are used between. A knob is placed on one end and the tube is mounted on a panel. The filings used are half brass and half iron, and should be made from clean, bright metal. An old fountain pen barrel makes a fine tube, which only needs to be about 1½" or 2" long. The space between the contact and crystal should be about 1/8". As the right amount of filings is essential to the best working of the detector, a small hole should be left in the tube, as the amount of filings can be varied, and the hole is afterwards sealed up. The crystal should be broken in order that a new clean surface may be obtained, then it is handled only with tweezers, and after it is sealed in, it is never affected by dust or dampness and always retains its original sensitiveness.

To adjust, simply turn the knob and press the buzzer until signals come in loudest.

The rest of the set consists of a loose coupler, specially wound, fixed condenser of special capacity, and buzzer and battery for testing.

The whole outfit should be mounted in a

This Diagram Shows the Method of Assembling the Apparatus and is a Back View of the Completed Set. Note the Test Buzzer.

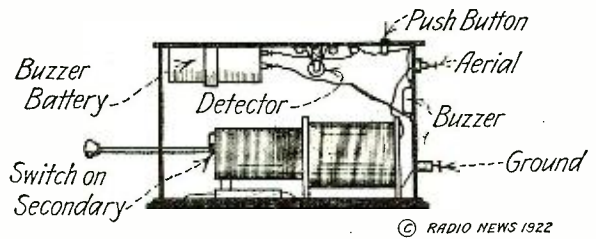

cabinet, or on a panel, according to the material at hand, and the preference of the constructor.

The loose coupler primary is 6' long, and 4" in diameter, and is wound with No. 24 silk covered or enameled wire. Two switches are used on the primary; the first 10 turns of the winding are tapped at every turn, and this is connected to the first switch. The balance of the winding is tapped at every 10 turns and connected to the second switch, thus the coil can be varied in steps of one turn. However, if the constructor

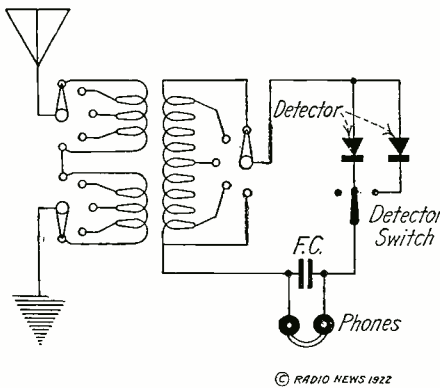

Complete Wiring Diagram of the Crystal Receiver. By Means of a Switch Either of Two Crystals May be Used.

wishes to use fewer switch points, the first coil can be tapped every two turns, and the second coil every 20 turns.

The secondary is 6' long and 3½" in diameter, and wound with No. 32 silk covered or enameled wire. It is tapped at every half inch, and the switch points are mounted on the end of the coil. A long rod should extend out through the cabinet to operate the switch and the same rod also operates the coupling. This tuner will tune up to 2,500 meters with an aerial 75' to 100' long, and will be found to work very efficiently with the crystal detector.

The fixed condenser to use should be

made of two pieces of tinfoil about 7" x 9"; this is used as the fixed condenser in any set, and if the experimenter has a variable he wishes to use, it should be connected across the secondary.

Two extra binding posts should be attached to the panel and wired so any auxiliary detector can be used. A switch is arranged with points marked 1 and 2 and "off," to switch to either detector. The accompanying diagram shows the wiring of the set.

All connections should be soldered and especially the taps to the switch points. The buzzer circuit is not connected to the detector circuit in any way. The buzzer should be mounted on a felt or rubber base to deaden the sound. If the buzzer is a double-tongued vibrator, the tongues can be soldered together and the buzzer will then give a high note. The buzzer should be so mounted that the adjust-screw can be easily reached without trouble. The push button is so mounted that the button projects through a hole in the case; the button should be removed from an ordinary push button and a hole bored to just fit it.

The writer is using a set as described with fine results; however, the constructor can use his own ideas in regard to the design of case and arrangement of apparatus. The coupler winding and fixed condenser capacity, as given, have been found to give the best results with this detector, but if an audion detector were to be used, the secondary of the loose coupler should be wound with No. 36 instead of the No. 32 wire.

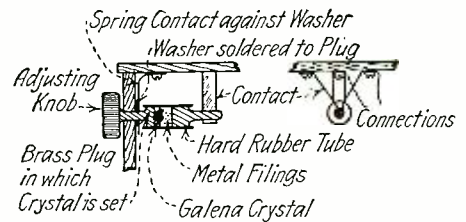

The Crystal Detector Consists of a Piece of Galena Set in a Brass Plug Which Revolves in Metal Filings. A Sensitive Position is Easily Found.

Money For The Amateur

By. R. DALTON

IN the large cities today, New York, Chicago, Newark, etc., there are powerful Wireless Telephone broadcasting stations which send out nightly concerts, wherein high salaried singers and musicians entertain all those who care to listen. These concerts are sent out at about 8 p. m.

Most up-to-date amateurs now have short-wave regenerative sets, and a one- or two-step audio frequency amplifiers. If the amateur who cares to test this scheme has not a Magnavox, he can either purchase a second-hand one, or a radio company will let him use one, for the publicity they get. The amateur could say this Magnavox lent by _____ Co., or if any of you are interested enough to purchase a set, you can

buy it from _____ Co., who kindly loaned us this horn. The music and speech with a regenerative, two-step and Magnavox will be heard at least 50 to 75 feet from the phones, depending upon the size of the aerial.

Here is the scheme: In the above-mentioned cities there are companies which own chains of theatres. The amateur might go to the general manager of the company and outline a plan which, briefly, is this: He can put up a one-wire antenna about 100 ft. long and run his lead in down to the stage. At about 8 p. m. the theatre lights are flashed on and reveal a young man sitting before the above-mentioned apparatus. The young man takes off the phones, arises and steps forward and addresses the audi-

ence in this manner: "Friends, you have all, at some time or another, heard about wireless. The Wireless Telephone is the latest invention of mankind; I will now endeavor to entertain you for a short time this evening by a concert sent out from KOKAS" (or mention location of station). "These messages travel through the air with no connecting wires. I will not bore you with technical details, but hope this little concert will please you." He could then go to another theatre owned by the same people, and so on. After visiting about ten theatres, he would have a neat sum of money in his pocket. Also many people would be buying sets to listen to these concerts, and this would mean quite a bit of money for the radio dealers.

A 30-Volt "B" Battery for One Dollar

By EDWIN W. WILSON

A GOOD "B" battery of long life is something that every amateur wants, but the expense of getting such a battery is too great for many amateur operators. The writer has made several very successful 30-volt batteries for use in the high voltage audion circuit and the cost of each has been somewhere in the neighborhood of one dollar.

One very good type of battery is made in test tubes. The materials needed for this battery are 15 test tubes, one 1" x 6", a small piece of sheet lead, $\frac{1}{8}$ " thick, a few old storage battery plates, both positive and negative, five or six wooden or threaded battery separators and about a pint of battery solution.

The test tubes can be purchased at a surgical supply house for forty cents a dozen. The electrolyte should have a specific gravity of 1,250 or 1,300, and can be secured at a battery service station, as can also the separators. While there, ask to see the junk pile and from it select several good positive and negative plates. Many of these are thrown out when batteries are repaired in order that all the plates may be new ones when the job is turned out. They are usually sold to the junk man for a few cents a pound, so you may be able to get them for nothing if you know the battery man.

The first job is to cut the plates. They should be cut $\frac{3}{4}$ " wide and about 5" long. Do not get them too long, or some of the active material, which is bound to fall out in small quantities after they are in use, will short your cell at the bottom. To cut them, lay the plate on a flat board, and following one of the ribs of the grid, saw them with a dull hack saw. Be careful not to break the active material out of the grid. For a 30-volt battery you will need 15 positives and 15 negatives. The plates are easily distinguishable, for the positives are brown and the negatives are lead colored.

Now, scrape the lead strip at one end of each plate bright and clean on both sides

and on the edge. Cut from your sheet lead 20 pieces, $\frac{3}{8}$ " wide by $1\frac{1}{2}$ " long and scrape about half an inch off each end on both sides. Lay a positive and negative end to end on a board with one of the lead connecting strips between them and butted up against each plate. Melt solder into the joint until the plate and the lead strip flow together. Be careful not to melt the end off the plate. Ten positive-negative pairs should be made thus, and the connecting strips bent so that the plates are parallel and $\frac{3}{4}$ " apart.

To each of the remaining plates solder a lead strip and drill a $\frac{1}{8}$ " hole in the free end of the strip for the binding post. Two of the connected pairs should also be drilled in the middle of the strip.

The binding posts are $\frac{8}{32}$ round head brass machine screws, $\frac{5}{8}$ " long. Every amateur should have a good supply of these screws with nuts to fit, as they are useful in any piece of apparatus you build. The screws cost the same as the nuts, \$1.20 a gross.

The next step is to make your battery box. Out of half-inch pine make a box with inside dimensions of $3\frac{1}{4}$ " x 6", and $2\frac{1}{2}$ " deep. Fill this one-third full of melted tar, or battery pitch and when it has cooled a little, push the tubes, which have been heated previously in water, clear to the bottom of the box. Your tubes will then be in five rows of three tubes each. Straighten them up as the pitch cools until they all stand firmly upright, then melt some paraffine in a shallow pan and dip the tops of the tubes into it quickly to a depth of $\frac{1}{2}$ ". This coating of paraffine is to prevent the acid from working over the tops of the tubes.

You are now ready to assemble your battery. In the first line of three tubes, place the two pairs of plates which carry the binding posts in their connecting strips, so that the middle tube has in it a positive and a negative plate. In each of the end tubes put a plate with a binding post attached,

being sure that each tube has in it a positive and a negative plate. Place the rest of the plates in like manner so that all the positive terminals are on one side and all the negatives on the other.

Cut separators from the wood or rubber sheets to fit between the plates of each cell. Make them $\frac{3}{4}$ " x 6", and if the sheets are ribbed, cut them so that the ribs run up and down. Pour in the electrolyte to within $\frac{1}{4}$ " of the top, and your battery is complete. A voltmeter will show about 25 volts for the 15 cells, if none of the plates touch inside the tubes; after it soaks for 12 hours, it is ready to charge.

For charging, connect all the posts on each side with a piece of wire, thus placing the cells in six-volt parallel, and charge at eight or nine volts. Do not give it more than two amperes for the entire bank, and stop charging about 15 minutes after they begin to gas freely. The first charge may take a full day, and the second one, given a few weeks later, will take an hour or so, but after that, 15 minutes will bring each cell up to over two volts.

For discharge, all the cells should be connected in series. Using this battery five or six hours a day, it will hold a charge a month. Every few months it should be pretty well run down on a lamp or other resistance, and immediately recharged. As the water evaporates, add distilled or rain water to keep the quantity and specific gravity of the electrolyte correct.

One of the advantages of this type of battery is that you can see the condition of the plates and also can tell whether or not the rate of charge is correct by the amount of gassing taking place. Remember that the slower the charge, the longer it will last.

A magnetic rectifier for charging your batteries is easy to construct. The writer made one, following specifications given in one of the wireless magazines, and wound it to give either 10 or 15 volts. With the higher voltage, two such batteries can be charged in series.

Wood Finishing

By ROBERT ROSS

WELL finished woodwork adds greatly to the appearance of a piece of apparatus, whether it be anything from a wireless cabinet to a piano. As I have seen many home made, crudely finished articles, I feel that some suggestions to amateurs as to how to finish wood surfaces properly may not be untimely.

There are several general processes used in wood finishing, namely: Sandpapering, Staining, Filling, Shellacking, Varnishing and Polishing. Each one of these shall be discussed in detail, and, while the directions are general, they may have to be varied to suit certain cases.

Sandpapering is the first thing to be considered. It is of the utmost importance that it be done carefully and thoroughly, as a good polish can not be obtained if we have a rough surface to begin with. After being planed to a smooth surface, the wood should be rubbed with No. 0 sandpaper. Turn the sandpaper up around a perfectly flat block, and rub with the grain. Do not press too hard, especially at the edges, as there is danger of rounding these off. The wood must now be thoroughly rubbed off and wiped with a cloth, so that no particle of dust remains that might roughen the surface after staining.

It is absolutely necessary to stain the wood. The stain changes the color, and this is not advisable with the more beautiful of the woods, such as oak, mahogany, black walnut and cherry.

There are two main kinds of stains on the market, oil stains and water stains. The oil stains are those in which the pigments are dissolved in turpentine, linseed oil, naphtha, etc., while water stains use water only as the solvent. The oil stains should be used on hard, close-grained woods, while water stains should be employed on the softer woods. Unless used in large quantities, it is best to purchase the stains ready-made. Do not get the so-called "varnish stains."

Having brought the wood to a smooth and even surface, the stain may be applied with a piece of soft cotton waste. The waste should first be dipped in the stain and then rubbed on the wood. If one coat does not leave the wood dark enough put on another. If the wood is rough after staining, it should be rubbed with a piece of fine sandpaper and another coat applied.

The wood should now be filled. The fillers usually consist of a mixture of siliceous stone ground in linseed oil, with the correct coloring pigment added. The filler should

be applied with a piece of waste, and as soon as it has dried a little (it must not get hard), it should be rubbed off. Continue to rub the surface until it is perfectly smooth, and all the pores have been filled. If one coat is not enough to do this, another should be used. All surplus filler should be carefully wiped off, and that remaining in the pores of the wood may now be allowed to get hard.

The surface is now ready for the shellac. Pure white shellac should be applied. It should be used rather thin, wood alcohol being added if it is too thick. All surplus shellac must be wiped off the brush before it is applied to the surface, for if too much is used it will fog over and will not be clear. After the first coat has dried (which will take about two hours) another should be put on. After this is dry, the surface should be rubbed off with the finest sandpaper obtainable. It must not be rubbed too hard, however, as there is danger of cutting completely through the shellac.

We are now ready for varnishing. The varnish must not be too cold, as this will prevent its flowing freely. Only the best grade of brushes should be used, as the cheaper ones will not give good results.

(Continued on page 1032)

Some Good Ideas

SIMPLE REGENERATIVE HOOK-UP.

Here is a hook-up that will pick up wireless telephones very efficiently. Signals have been heard from KDKA, the station of the Westinghouse Electric Co. at Pittsburgh, Pa. The set consists of two variometers, one in the grid and the other in the plate. Both station 1BHK and mine have heard KDKA. 1BHK is owned and operated by Leroy J. Beebe, 13 Robinson Street, Newport, R. I. Mr. Beebe was the originator of the idea of the variometers in Newport. He made a success of them and I tried them. Both he and I hear the Church Services from KDKA and we also hear the market reports. Long distance amateurs are heard very clearly. On the two that I constructed I hear amateurs in the following districts: 1, 2, 3, 4, 9 and occasionally Canada. Most of them are C.W. Phones are heard up to a distance of 300 miles. IXAD, of Pawtucket, R. I., is heard all over the room on one bulb. Mr. Henry Armbrust, of Jamestown, R. I., has heard KDKA on a variocoupler using one bulb. Has anybody tried this type of set? The variometers were wound on cardboard tubes, with 17 turns on both the secondary and primary. Experiments were tried with more turns on the secondary

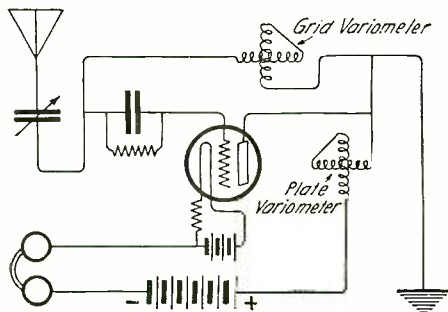

In This Simple Regenerative Hook-up Two Variometers Only Are Used.

than the primary, but they did not work as well. They were then cut down to 17, and KDKA was heard very clearly. I am sending in this hook-up and hope that the fellows who try it will have as much success as 1BHK and I have had. I will give as much information as possible regarding how I made them, on request.

I might also state that WGI is heard very QSA with them.

Contributed by
GEORGE MATHEWSON.

A NEW INDOOR AERIAL AND A STEADY CRYSTAL DETECTOR.

A simple remedy for amateurs living in apartment houses and unable to erect a suitable aerial is to simply connect a wire to one of the terminals of the door bell. This gives an aerial extending through the house which really gives results.

To keep a crystal detector in adjustment first find the most sensitive spot by means of a buzzer test and then very carefully put a drop of molten paraffin or beeswax around the point of the "cat whisker." This keeps the "cat whisker" in place, and in practice a detector has been kept in adjustment for months in this manner.

Contributed by WALTER G. VOSS.

COIL HOLDER AND HORN STAND.

If you have no place to keep your honey-comb coils, they become scattered about and

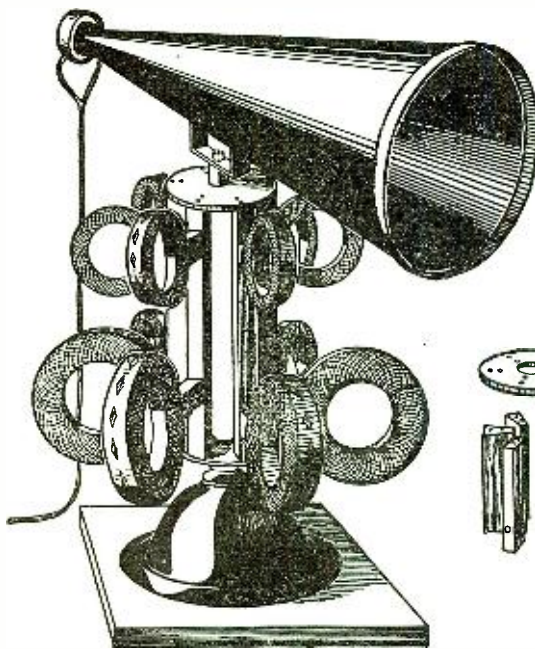

Here is a Clever Idea. This Combination Horn and Coil Stand Saves Space on the Operating Table.

look untidy. The only thing provided for the purpose so far is a wooden rack, which is all right, only sometimes there is no room for it. Why not let the horn stand do the work? The revolving coil-holder is easy to make, being of simple wooden strips screwed to a metal or fiber washer of the proper size at each end. For a standard, I used that of a discarded table gas lamp which makes a fine appearance. An ordinary megaphone with a 1,000-ohm receiver attached forms a good loud speaker.

Contributed by THOMAS REED.

CONSTRUCTION OF A LOOP AERIAL.

I am presenting an indoor aerial which I made and designed. It is simple in construction and can be made for about seventy-five cents.

As there are some amateurs who do not have the opportunity to buy and erect large aerials, I think this one is just the thing.

Here are the directions to erect an indoor aerial:

Take two boards 6' long and 2" square wide, and 1" plane, and sandpaper them.

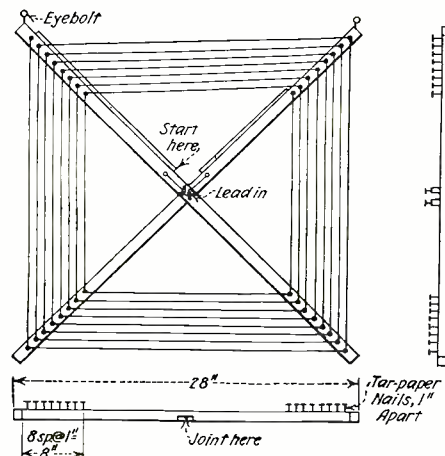

Such a Loop Used With a Detector and Two-Step Amplifier With Regenerative Effect Will Pick Up Radio Concerts Easily Within About 12 Miles of a Station.

then make your joint in the center. When this is done, nail them with tar paper nails, starting 1" from each end, as shown in the illustration.

Take your annunciator wire, and begin winding, as shown. After this is done, put two binding posts on the spots designated in the illustration, and connect the ends of the two wires to these.

Contributed by
ALPHA E. WATSON, JR.

A SIMPLE VARIABLE CONDENSER.

This book type variable condenser is similar to many used, but in my estimation it is much easier to make out of junk than other designs. The mica on the fixed plate could be changed for waxed paper, and anything could be used, instead of tinfoil, that is a conductor. As the diagram explains itself, nothing need be said of the construction. As you turn the knob the lever on the back of the panel turns nearer to the pulley and allows the upper plate to move toward the lower plate. When the lever is touching the pulley, the top plate should touch the bottom plate. The knob has to be rather light so

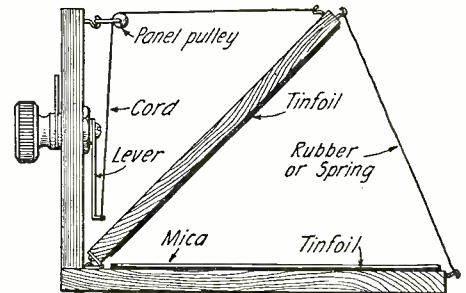

This Variable Condenser May Easily be Made to Tune Sharply Your Receiving Set, that the rubber can not pull it around.

Contributed by OWEN WILSON.

REMOTE LOUD TALKER.

Having seen several plans lately for having the loud-speaker of your radio set in the parlor or living room so all might enjoy it, I thought you might be interested to know how we do it. Having purchased a Vocaloud some months ago, we conceived the idea of buying about 60' of lampcord to be used as follows: From my room upstairs, where the radio set, consisting of Regenerative set and two step amplifier is set up, we connected one end of the lampcord to the proper phone terminals. We then carefully led the wire downstairs into the living room, and there connected the Vocaloud; as this type of horn requires no battery, this was easy. The wire does not show, as we have it carefully camouflaged above the door sills and other similar places. I find the horn works fine, signal strength being very little, if any, diminished by the distance from the apparatus. Though we are many miles from a very large radiophone station, from over 40 different phone stations received, more than half come in loudly enough to be enjoyed and heard easily down stairs, with the horn. As you probably know, the Vocaloud is not the least bit awkward looking for the parlor if placed upon or adjacent to the phonograph. In fact except that I am not using a loop aerial, this method appears to

(Continued on page 1025)

AN EASILY CONSTRUCTED VARIABLE CONDENSER.

A very good variable condenser may be made from scraps found in any amateur's workshop. The condenser consists of alternate pieces of sheet mica, 4 inches by 3 inches,

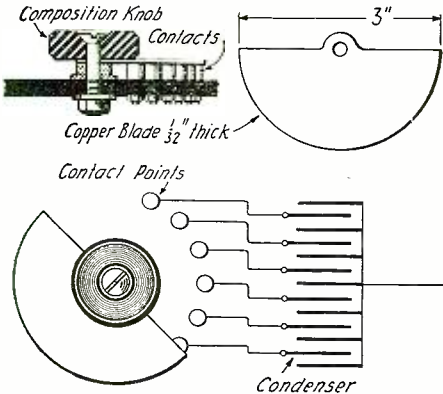

Here is a Good Type of Variable Condenser to be Used With a Slider Coil.

es, and strips of tinfoil measuring 2 inches by 3 inches.

Leads are taken from each tinfoil sheet and fastened to the contacts of a "fan" type switch. The switch is made with a piece of copper sheeting, hard rubber knob, a few washers, an 8/32 threaded brass rod and a few contact points.

The copper blade is cut and drilled as shown in the illustration, from a sheet of No. 22 gauge copper sheet. The knob is screwed to the threaded brass rod by means of the nuts and is held to the knob by another nut. The rest of the construction is clearly shown in the diagram.

Contributed by ARTHUR WINDSOR.

MULTI-CATWHISKER DETECTOR.

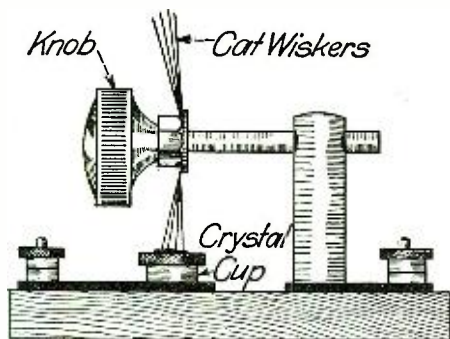

FIG. 1. © RADIO NEWS 1922

It is Easy to Adjust This Crystal Detector.

This type of crystal detector will be found very convenient. It obviates the necessity of reaching with a single catwhisker for a sensitive point on the crystal. By simply turning the handle the catwhisker will find one.

It may be made by using as a support a piece of round stock brass in which a hole

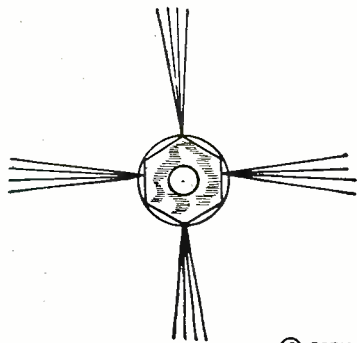

FIG. 2. © RADIO NEWS 1922

How the Cat Whiskers Are Mounted.

has been threaded to take the brass screw to which the catwhiskers are clamped by means of washers and nuts as shown in Fig. 1.

Fig. 2 shows the method of clamping the four sets of catwhiskers. The crystal cup is fastened to the base directly under the catwhiskers.

Contributed by W. A. CAMERON.

DEAD-END SWITCH.

Having obtained my useful ideas from the regular perusal of your magazine, I forward herewith details of an effective method of cutting out dead-end losses in coils, in the hope that same may be of assistance to amateurs.

The only addition to the usual stud and arm regulator is the series of springs attached to a semi-circular piece of ebonite above the studs, the coils being, of course, connected to suit the new arrangement.

"X" is a conductor beneath the insulator. An arm "Z" can be used or alternatively, a semi-circular disc. The one-half disc can be made wholly of fibre or ebonite with a small piece of brass let in on the underneath side at "X." The arm or semi-circular disc passes between each stud and the spring which normally rests on the stud. When "X" connects with Stud No. 8, all the sections of inductance are in circuit; when "X" connects with Stud No. 1, the spring "B" is disconnected because it then rests on the ebonite which is on top of the arm or semi-circular disc. All the other sections are simultaneously disc when "X" is on Stud No. 1. The semi-circular disc is preferable

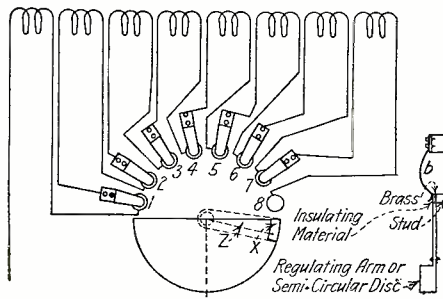

FIG.

An Efficient Switch for Long Wave Tuners.

to the arm because when it is used all the unused sections are each separate discs on both ends.

The springs "B" are all screwed to a semicircular piece of ebonite above the studs.

Contributed by W. F. WHITEMAN.

CEMENT FOR VACUUM TUBES.

In the past, when thermionic tubes have been received by the writer, they have come through the mail in a first class condition. A short time ago one was received which in some way had been drenched with water, and when this tube was inserted in its socket, it was found that the base was uncemented from the glass bulb. By twisting any bulb having a bayonet socket, naturally, there is going to be a short circuit at some time.

Sealing wax was tried, but this substance did not adhere to the glass. However, a mixture of calcium carbonate (CaCO₃) and sodium silicate (Na₂Si₂O₆) was used with success, and the tube is still in operation. The mixture, as used, was about one part of sodium silicate to nine parts of calcium carbonate making it into a thick paste which hardens rapidly into a solid and is further hardened by heat.

Sodium silicate is the technical name for waterglass used in preserving eggs, and calcium carbonate is a common product, used in the manufacture of lime, cement, soda, and glass. Thus, these are both easily obtained.

Contributed by ROGER R. SMITH.

A VARIABLE CONDENSER IN FIVE MINUTES.

A variable condenser can be made cheaply and quickly by using an envelope from which the end has been cut off, and a piece of cardboard. Cover the envelope and cardboard, as per illustration, with tinfoil and fasten leads to it. This will make a variable condenser which will work with perfect satisfaction.

Contributed by E. M. ABBOTT.

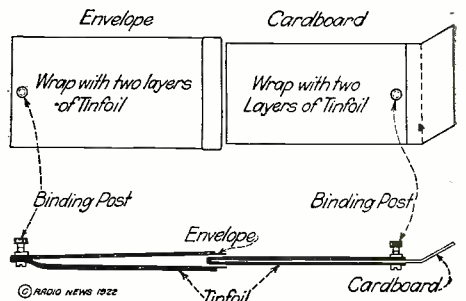

A Real Cheap Variable Condenser.

AN EASILY MADE JACK.

Doubtless many times you have wanted to use your best phones in your department circuit and have been without a jack. Here is one that will meet your requirements for that purpose, and it will hold as well as any; I am using one in my additional step of amplification, also one under my desk, hooked in my binding post.

This jack consists of 10 turns of No. 14 bare copper wire and the other connection is made of the same size of wire. Make the 10 turns on your plug and leave plenty of wire at each end so you can mount it. Mount the jack before making the loop for the other contact. After the jack is made secure, put your plug in and make the loop fast so it will rest on the ball of the plug.

Contributed by A. R. BERNSTEIN (3HF).

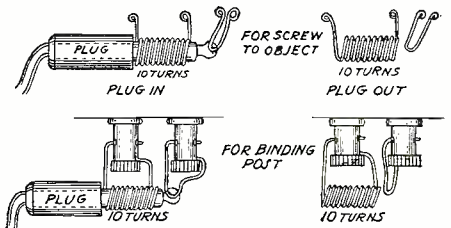

A Clever Idea to Use a Pair of Phones With a Plug.

HOW TO KEEP THE PHONES FROM FALLING OFF THE TABLE.

A peg placed on the Radio instrument table, over which the head phones may be hooked when not in use, will prevent them from being accidentally knocked onto the floor.

Contributed by W. J. MCGUFFAGE.

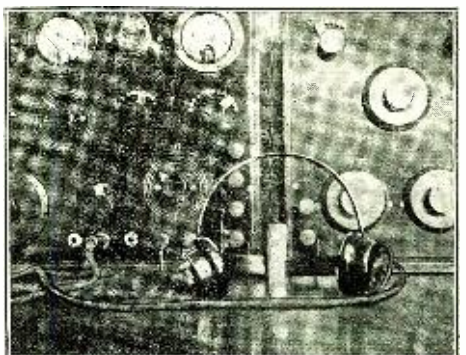

A Simple Means to Prevent the Phones From Falling.

Radio Digest

WOMEN INTERESTED IN RADIO-PHONE.

A series of radiophone talks of direct interest to the housewife were introduced when Miss D. H. Goodwin, of the Massachusetts Division of Markets, spoke March 22 from the Amrad Broadcasting Station at Medford Hillside.

"Marketing for the Home" was the subject of Miss Goodwin's first talk which is under the direction of the Massachusetts Division of the Department of Agriculture. Her talk will be supplemented by weekly market reports furnished by the Division, of interest not only to those who buy for the table, but for those who sell perishable merchandise including the storekeeper and roadside vendor.

Another feature arranged to meet the demand for programs of interest to women are the series of clothing talks given on Saturday evenings by Miss Harriet E. Ainsworth, Manager Clothing Information Bureau, William Filene's Sons Co., Boston.

When the first fashion talk was given several weeks ago, considerable doubt existed about the number of women radiophones who might care to hear it. Accordingly, the operator at the conclusion of the first talk, asked the women to write in if they liked it, and to advise whether it should be followed by others. A great many letters were received by the Amrad Company and it was decided to make "clothing talks" a regular feature.

DALLAS SUPERINTENDENT OF POLICE AND FIRE ALARMS SEEKS BY NOVEL MEANS TO IMPRESS RADIO ON PEOPLE.

About 9 o'clock, one night, recently, at the corner of Commerce and Ervay Streets in Dallas, Texas, jammed with traffic as is quite usual, while long strings of street cars and automobiles screamed for clearing of the four-way traffic, and policemen milled about, clearing the way here and there and untangling the impatient lines of motorists and pedestrians, a car drew up near the postoffice steps and waited in line, its engines purring.

Suddenly people for half a block on either side of the car realized they were listening to wonderful music.

They looked everywhere for the band, but none was seen in any direction.

In the car, accompanied by the Misses Marcile Turner and Letitia Garrett, was "Dad" Garrett, superintendent of the Dallas police and fire alarms. "Dad" is a fiend for putting over what he believes is the greatest invention of the age. In his car was a small amplifying instrument that was giving the crowds the advantage of a concert being broadcasted from the city's big radio station at City Hall.

"Dad" says he is going to keep on advertising the great adventure until every home in Dallas contains at least a receiving instrument.

"It makes one young to be able to annihilate space and time in the fashion they can do it with radio," said Dad.

"Work is becoming more and more play, and I believe a man who will fit into new conditions as they are being made will have years added to his life," remarked the grand old man of Radio in Dallas.

DALLAS NEWSPAPER TAKES BROAD VIEW OF RADIO.

The *Dallas News*, one of the most influential and conservative newspapers in the United States, has seen the vision, and made Radio a part of its service.

In its issue of March 9, the *News* announced that commencing at 9 o'clock P. M.,

March 9, and continuing every night thereafter, the *News and Journal* will begin broadcasting programs of interest to the people of Texas. The wireless telephone will be used. Arrangements have been made for the service and it is promised they will be elaborated upon as necessity occasions and developments warrant.

According to the owners of the *News-Journal*, who are also owners of the *Galveston Morning News*, the decision has been made because after investigation they have reached the conclusion that the wireless telephone is the most remarkable invention of the century, destined very shortly to revolutionize methods of rapid communication.

The service is to be for all Texas, and every wireless enthusiast in the State is invited to receive it.

Radio Articles Appearing in April Science and Invention

Announcement of prize winners in \$300.00 Simplest Radiophone Receiving Contest — With photos of first prize winner and apparatus.

Radio Controlled House In Paris.

The Radiophone Now a Household Necessity. By Mrs. Christine Frederick.

National Radio Broadcast by Bell System—with photo diagram showing how the telephone system will be linked up with a chain of radio broadcasting stations throughout the United States very shortly.

Radiophone Receiving Set in a Match Box.

Radio Loud-Talkers—Telling how to make a dozen different styles at slight cost and which will work as well as some of the higher priced instruments sold for the purpose. By Henry Townsend.

"The Radio Broadcast." Specially prepared authentic list of all the radiophone broadcasting stations in the United States, the first of its kind, complete with special large map showing the ranges and the locations of these stations.

Radio For the Beginner. By Armstrong Perry. No. 2 of the series.

Radio Oracle—Special Answer and Question Department—For radio queries only.

The intention, according to the *News-Journal*, is to make it a source of pleasure to all these and their friends.

The Automobile Club of Texas has invited the *News-Journal* to cooperate with it in its plans to make wireless the medium for informing the motorist the condition of the highways, in order that travel can be made comfortable.

FARMERS NEED RADIO SERVICE.

The importance of radio to the rural population of the country is the dominant note at the Radio Telephone Conference now in session at Washington. It is considered that the radio not only makes the isolation of the farm a thing of the past but brings quickly to the farmer the agricultural information needed in the intelligent conduct of the farm business.

The broadcasting of weather, crop and

market reports is the most important use to which the radio is now being put in the opinion of various radio experts attending the Conference.

"There is no single use of radio, except for marine and aerial purposes, that should take precedence over its utilization for the benefit of agriculture," stated W. A. Wheeler, delegate representing the United States Department of Agriculture at the Conference. "There are more than 32,000,000 people on farms, comprising nearly one-third the total population of the United States. Most of these people are located where they are practically cut off from immediate contact with the outside world. The radio is the only means of getting to them quickly at small cost the economic information necessary in the proper conduct of their business."

Mr. Wheeler outlined the Department's method of broadcasting weather, crop and market reports from radio telegraph and radiophone stations of the Post Office Department. Daily market reports on the live stock, grain, cotton, hay, feed, fruits and vegetable markets are broadcast over virtually the entire United States and farmers located almost anywhere can receive them either direct or with the assistance of amateur operators. A number of state bureaus of markets and agricultural colleges are also broadcasting both local and national markets and crop reports by radio telegraphy and radiophony.

With regard to the broadcasting of music and entertainment, Mr. Wheeler stated that "anything in the way of entertainment that will afford the farmer even a slight diversion from his daily labors will immeasurably redound to the benefit of the whole nation. In many instances the only entertainment the farmer has comes by radiophone."

The time element in dispatching weather, crop and market news is a big factor affecting the value of such reports, Mr. Wheeler said. In cutting hay or harvesting grain, for example, an hour's delay in the dispatch of weather reports may mean a loss of several thousand dollars. An early morning report on market conditions and the estimated receipts at the market that day is of great value to the live stock grower about to ship a carload of hogs to market. Prompt daily reports on the fruit and vegetable markets enables the farmer to determine when and where farm products are most needed and to arrange his shipments accordingly. A sudden frost may kill an entire fruit crop. By radio, warnings of severe temperature changes or of storms can be instantly flashed to an entire district.

"When thousands of tons of food products are threatened with destruction by impending storms or floods ordinary methods of communicating warnings are too slow," Mr. Wheeler said. "Market news to be of greatest value should be received the same day. The prompt receipt of reports on the condition of crops is also of great importance. The radio is the only means of quickly communicating these various kinds of information to the farmer."

A rapid movement in the formation of "Farm Radio Clubs," composed of farm boys and girls interested in radio, is taking place throughout the country, it was disclosed. Armstrong Perry, of the Boy Scouts of America, stated that the members of the Scouts organization were ready to lend every assistance in the dissemination of Government news.

RADIOPHONE iXE NOW WGI.

iXE, the radiophone broadcasting station
(Continued on page 1010)

Who's Who in Radio

No. 15

JOHN V. L. HOGAN

ONE of the best known radio engineers in the United States is John V. L. Hogan, who has been identified with the art for the past fifteen years or more. Like so many other workers in the field, Mr. Hogan began as an amateur; the first apparatus with which he experimented, in 1902, was of the coherer type and had a working range of only a few hundred feet. It was enough to catch and hold his interest in this new art, however, and within a few years he was breaking distance records for reception by using apparatus of his own design and construction. In 1906 and 1907 he worked with Dr. deForest as chief laboratory assistant in the development of the audion and the radio telephone; at that time the very first grid audion, the forerunner of the present day three-electrode vacuum tube, was produced and the first radio telephone broadcasting station was operated by Dr. deForest and Mr. Hogan, transmitting phonograph and Telharmonium music by wireless on daily programs. Early in 1908 Mr. Hogan secured permission to erect a receiving station on the top of the Times Building at 42nd street, New York, then one of the tallest buildings in the city; here he experimented with several interference-reducing devices of his own invention, and succeeded in copying many complete messages from stations as far distant as San Juan, Porto Rico, Guantanamo, Cuba, and Colon, Panama, through severe interference. In this same year his contributions to the technical press commenced to appear, among them "Methods of Wireless Tuning" in the *Electrical World* and articles on the Audion in *Modern Electrics*.

In 1909 Mr. Hogan filed his earliest applications for patent, while a student at Sheffield Scientific School of Yale University. His article on "Inductance Coils Used in Wireless Telegraphy" appeared, with several others from his pen, in the *Electrical World*. At Yale he took honors in physics and mathematics, and was granted the use of the Graduate Physics Laboratories for radio experimentation; here he carried on several investigations into detector, tuner and heterodyne phenomena, some of which have been described in his later patents and publications.

Having previously established connection with Prof. R. A. Fessenden by reason of his invention, Mr. Hogan joined the staff of the National Electric Signalling Co., as telegraph engineer in December, 1909. He proceeded to the experimental trans-Atlantic station at Brant Rock, Mass., in January, 1910, and there took charge of the plant's operations, including the preliminary tests between Brant Rock and the Scout

Cruisers, Birmingham and Salem, which preceded reinstallation of the 100-k.w. Fessenden transmitter at Arlington, Va. In this same year, 1910, Mr. Hogan's first U. S. patent (No. 950,781 on a crystal detector) was issued, and several of his articles appeared, including "The Wireless Telephone" in the *Electrical World*. Before the end of the year, Mr. Hogan had been promoted to the position of telegraph superintendent and his work extended to include cooperation in the design and development of new apparatus, as well as experimental



Mr. John V. L. Hogan, Consulting Engineer, Who Was One of the Pioneers of Radio.

supervision in connection with radio telephone installations.

Several technical papers, including "A Simple Wireless Telephone" and a study of the "Operation of Detectors in Wireless Telegraph Service", appeared over his signature, and he presented an address on "Applications of Multiphase Current to Wireless Signaling" before the Wireless Institute in New York. He was elected Secretary of the Society of Wireless Telegraph Engineers.

Early in 1912 Mr. Hogan supervised the erection of the Bush Terminal station (now "WNY") whose tall T-shaped structural steel towers are still one of the landmarks of New York. During this year several additional patents were issued to him; several papers, including "Standardization in Wireless Telegraphy" where published; and

he completed the consolidation of the Society of Wireless Telegraph Engineers and The Wireless Institute (in cooperation with Dr. A. N. Goldsmith, Secretary of the latter organization) into the Institute of Radio Engineers. Mr. Hogan was elected a Manager of the Institute of Radio Engineers and appointed by the American Institute of Electrical Engineers on the committee on organization of the International Electrical Congress.

The National Electric Signalling Company completed the installation of the U. S. Navy's first highpower station, at Arlington, Va., during 1913, and Mr. Hogan was given direction of the acceptance test operations between that plant, "NAA", and the U.S.S. "Salem." Using spark transmitters and heterodyne receivers, signals from the ship were copied reliably up to 1300 nautical miles, while the vessel copied all messages from Arlington up to a distance of 2,375 nautical miles, both entirely by daylight. Mr. Hogan's well-known paper on "The Heterodyne Receiving System" was presented in June, 1913, before the Institute of Radio Engineers, of which Society he was again elected a Manager, and his article on "Quantitative Results of Recent Radio-Telegraphic Tests Between Arlington, Va., and U.S.S. Salem" appeared in the *Electrical World* and the *Electrician*, of London.

Mr. Hogan was appointed Chief Research Engineer of the National Electric Signalling Company in 1914; his work was largely confined to the development of automatic high-speed recording apparatus for long-distance radio telegraphy, though radio telephony came in for some attention. Among his articles during the year were "Radio-Telegraphy at the Eiffel Tower," and "The Most Powerful Government Wireless Plant, at Arlington, Va." (*Scientific American*), "Wireless Telegraphy in Railroad Service" (*Railway Electrical Engineer*), "A New Marconi Trans-Atlantic Service" and "Trans-Atlantic Radio Station at Sayville, N. Y." (*Electrical World*). Further patents were issued to Mr. Hogan during the next two years, and he became still more closely identified with important patent litigation in radio. He addressed the New York Railroad Club, the American Institute of Electrical Engineers at Johns-Hopkins University (on "Physical Aspects of Radiotelegraphy") and presented a paper on the "Developments of the Heterodyne Receiver" before the Institute of Radio Engineers. During 1915 his articles, on "The Principles of Radio Telephony", "Radio Telegraphy and Telephony for Railroads" and "The Signaling Range in Radio Telegraphy" appeared in the *Scientific*

(Continued on page 1025)

The Attainment of Receiving Speed

By H. H. WEBB

THE advent of the radiophone did not materially lessen the importance of spark telegraphy and key interrupted C. W., as these forms of communication cannot be surpassed for accuracy.

One of the greatest difficulties an amateur has is that of attaining speed in reception. I am going to give a few "tips," based on commercial and amateur experience, which will probably be of some help.

The kind of receiving practice that will do you the most good in the attainment of speed is trying to copy a station which is sending slightly faster than you can easily receive. For instance, if you can copy twenty words a minute easily, and listen to signals at this speed almost exclusively,

it will take a much greater length of time to attain the same stage of proficiency that you would have reached by trying to copy twenty-five word a minute signals. The reason for this is nearly obvious. If you can get twenty a minute by languidly resting on the table and copying mechanically, it does not stimulate the brain as does intense concentration on each letter as it is being transmitted.

This brings up another question: Whenever you ask an old-timer who has had years of experience in radio how many letters you should keep behind the sending station he will invariably say a word and a half or two words, say, about ten letters. But this is utterly impossible to the novice

because his mind is not trained to concentrate on the letters, as they are being sent at the same time he is writing eight or ten letters behind. This is something that comes with experience. Its advantage lies in the fact that if the transmitting station makes an error, he has it corrected before it is written down at the receiving end. This results in a good, clean copy.

Then, summing up the two main principles that make for speed and clean copy, we find these two rules:

1. Try to copy faster stations than you are easily able to.
2. Cultivate the habit of keeping at least a few letters behind the transmitter.

Correspondence From Readers

THE RADIO CORPORATION EXPLAINS.

In reply to inquiries concerning the attitude of the Radio Corporation of America toward the forthcoming Government conference, where restrictions of radio telephony, and particularly amateur broadcasting, will be considered, Dr. E. F. W. Alexanderson, Chief Engineer of the Radio Corporation of America, and the inventor of the Alexanderson alternator, recently made the following statement:

"The Radio Corporation's engineers will cooperate with the amateurs of the United States by suggesting to the Government that adequate wave-lengths be set aside for their stations in order that their activities may be carried on and extended rather than restricted, except in so far as it may be necessary to do so in the interests of the general public. Engineers of the Radio Corporation of America have carefully studied the needs of the broadcast radio telephone situation for a long time. As is well known, the Radio Corporation has been furnishing musical and other entertainment to an already large and rapidly growing radio audience."

"Recognizing the public interest in this new and popular science with its opportunities for education, quick intelligence and the appreciation of music, the Radio Corporation has established elaborate musical studios, where talented singers, musicians and public speakers may be brought into contact with the widely scattered and enthusiastic listeners, who have provided themselves with suitable radio telephone receiving sets. These studios are necessarily research laboratories, as transmission of entertainment is still subject to greater perfection through experimentation."

"While in the long run, the public probably will obtain more enjoyment and education from broadcasting on a systematized basis, where the greatest good to the greatest number will be the guiding principle, the tendency in establishing restrictions should be rational and deliberate, especially in an art changing so rapidly."

"During periods when prepared concerts, or other important broadcasting activities, were under way, there have been complaints of interference—to the effect that transmitting stations have spoiled the enjoyment of those who were merely listening. This has caused some irritation, a radical suggestion resulting that the amateurs should not be permitted to operate, except for receiving during the progress of evening broadcast programs. Good manners and sportsmanship alone have been fairly successful in preserving the courtesies of the air."

"So far as the Radio Corporation of America is concerned, its own attitude, based upon research and study, is very clear. The engineers of the Radio Corporation desire to support the activities of the amateur. They go even further, as a matter of fact, feeling that in the present stage of development, amateur transmission and receipt on during the broadcast periods can be carried on with properly tuned selective transmitters without, in general, interfering with the important public, educational field of broadcast reception—where so many families are entertained and are informed quickly of current events, without any need for technical knowledge of radio or radio apparatus."

"It would seem desirable to extend amateur operations rather than restrict them under such regulations and using such quality of sending and receiving apparatus as will prevent interference with public enjoyment and at the same time encourage amateur activities."

"In the recent amateur trans-Atlantic tests in which hundreds of American radio sta-

tions competed, there is a striking example of the encouragement and support which the large commercial radio interests have shown in the success of this enterprise. In this instance, the Radio Corporation of America readily placed its high powered radio stations at the disposal of Mr. Paul F. Godley, the official representative of amateur men sent to Scotland to listen-in on his fellow countrymen during the test. This permitted the prompt reporting of progress made during the tests each day.

"It should be a matter of encouragement to the amateurs of the country to know that the engineers of the Radio Corporation of America take a position very similar to the one taken by the enlightened amateur leaders themselves, and will recommend to the government that extended and valuable wave-length privileges be granted to the amateur stations and that the present ban on amateur broadcasting be removed subject to the public interest."

"The radio art has progressed very rapidly. It will probably progress as rapidly in the future. Conditions which seem troublesome today may not seem so tomorrow. New discoveries may considerably reduce confusion resulting from interference. In the judgment of the Radio Corporation, the

sisting of a small loop, coupler, fixed condenser and phones, it is possible to receive concerts from distant cities. This gives people the idea that with this apparatus they will be able to receive Chicago Opera and stations over a thousand miles distant and in reality they would have to strain their ears to receive the local concerts, half a mile away.

J. NAMLIG.

RADIOPHONE BROADCASTING.

Editor RADIO NEWS:

The one discrepancy brought up by the amateur against concert broadcasting, is regarding the call announcement after each selection. Several of the many broadcasting studios make it a point to announce immediately after each selection, but they are an insignificant minority in comparison with those who merely announce what the next selection will be.

Now, an amateur who desires to ascertain just how many stations his apparatus is capable of receiving, does not want to sit and wait all evening, listening to one station in order to hear the "sign-off," consequently, that station remains unknown and loses that much publicity.

In view of these facts, and considering that it would benefit all parties concerned, why not cooperate in an endeavor to have each radiophone station, large and small, announce the name, call and location as frequently as possible?

S. M. BODDINGTON, 8BMD.

INSECT RADIOPHONE.

Editor RADIO NEWS:

Having read an article in the RADIO NEWS on "Do Insects Talk by Wireless?" I have come to the conclusion that I am still quite sane.

I have been experimenting along the same line as Mr. Horle, and I wish you would let him know that I have had considerable success, but not with the Moth; I have tried the Cockroach with good result and the Beetle with very poor result. I am sending a diagram of the outfit used.

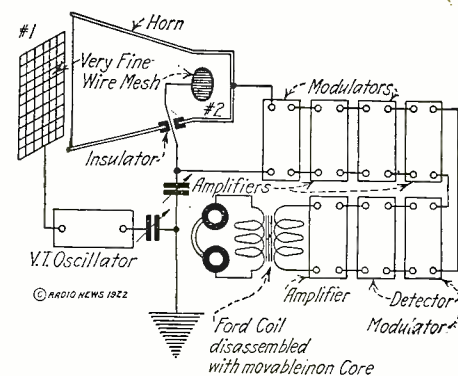

Some of the Interesting Articles Appearing in the March-April Issue of Practical Electricians

Telegraphic and Telephonic Transmission of Pictures. By Jacques Boyer, Paris Correspondent PRACTICAL ELECTRICIANS.

Antique Electric Motors. By T. O'CONNOR SLOANE, P.H.D.

Electricity from Fruit and Vegetables. By H. Winfield Secor, Assoc. Member, American Institute of Elec. Engineers.

Old and New Measurement of Light. Induction Test for Locating Armature Troubles.

Artificial Lighting. Communicated by J. W. Hammond, General Electric Co.

amateurs should be permitted to aid in the development of the art—and they unquestionably have aided—and attention should be given to the working out of regulations which will enable them to pursue their pleasure without interrupting the enjoyment of the listeners, who, of course, are in the majority. They should not be stopped from sending because such a course, for the present at least, is unnecessary."

RADIO CONDITIONS IN DETROIT.

Editor RADIO NEWS:

Just a word to let you know about radio conditions in Detroit. Radio has lately become popular here through the efforts of the largest newspaper, "The Detroit News," which has been broadcasting music from its station WBL and printing programs and instructions for building a simple receiver. People have taken to radio and even drug stores are stocking apparatus such as crystal detectors, loose couplers and phones, but not a dealer seems to know what a "V.T." is.

Lately I have hunted the town over in search of a soft tube, but not one was to be found, although they have loop aerials and advertise that with their apparatus, con-

We know when one roach finds food, a few moments after we have quite an army on the move; they can probably smell it? I say not. I have tried the sound proof box, also the jar, but still they come. If some one is interested enough to try this, I would like very much to compare results with the experimenter. I have found the wave-length to be somewhat longer than expected; it is between 1/2 and 1 in., with a very low frequency.

HOWARD ZIMMERMAN,
Master Signal Sgt.

Harrisburg, Pa
(We have a faint suspicion that Mr. Zimmerman is joshing us. Maybe not. And then again, maybe yes. Maybe not yes.—Editor.)

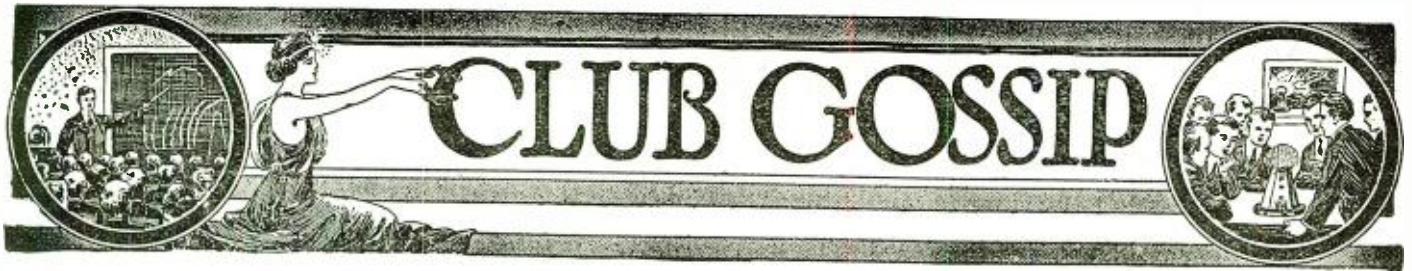

THE RADIO CLUB OF PUBLIC SCHOOL 166, NEW YORK CITY

The first meeting was held on Friday, Feb. 17, 1922. The club was formed to promote interest in radio among the older boys in the school. The eight charter members are: Aubrey Levy, Irving Chandler, Albert Rudintsky, Morris Rose, James Bergman, Carl Borjersson, William Eichold and Jack Froman. The officers are James Bergman, president; William Eichold, vice-president. Aubrey Levy, secretary-treasurer.

Dr. John Reigarts, the principal of the school, is the honorary president. At the first meeting we were taken up with organization details, but time was found to explain some of the principles of radio to those who had just become interested in radio. We would be glad to communicate with other clubs. Address the Radio Club of Public School 166, 132 West 89th St., New York, N. Y.

RIO GRANDE RADIO CLUB

The amateurs of the Rio Grande Valley met and formed the Rio Grande Radio Club, at San Benito, Texas, on January 13, 1922.

The club organization was perfected with a membership of six, and with the following officers: President, Roy Russell; vice-president, R. W. Thacker, and secretary-treasurer, B. G. Eubank. The officers form the board of directors. The president acts as code instructor and the secretary as theory instructor.

We now have some twenty-five members on our roll and also some thirty members of the Rotary Club as associate members. Through the efforts of Mr. McK. Douglas R. E., of Houston, who is a member of our club, we have interested the business men of our town in the club. Mr. Marrott has advanced the club sufficient money to purchase a \$246.00 Westinghouse two-stage amplifier and loud speaker. A complete radio telephone and C.W. set will be installed in the course of a few months. The club proposes to receive the market and weather report from the Postoffice Department at Washington, D. C., in co-operation with the Rio Grande Traffic Association and the local office of the Department of Agriculture, Bureau of Markets. We would appreciate letters from any of the clubs or individuals the world over, and we are also anxious to receive copies of the rules and by-laws of other clubs.

CLAYTON RADIO CLUB

The Clayton Radio Club has recently been organized for the purpose of promoting radio in the Thousand Island Region, of which Clayton is the center. The club now has thirteen members and is having a drive for more. Meetings are held every two weeks and a committee has gone before the village board to obtain rooms for the club in the fire station, from the tower of which can be erected a fine antenna. Mr. Earl Churchill is president, Emery Swartout vice-president, Jack Ross secretary-treasurer, and Gerald Marshall radio engineer. The dues are \$3.90 a year. The club has written the A. R. R. L. and Radio League of America that it hopes to join them soon. All are in favor of organized amateur radio.

NEW BRUNSWICK RADIO CLUB

On Saturday evening February 4 there was organized in this city a club to be known as the New Brunswick Radio Club, with a charter membership of thirty-five. Officers elected were: President, Norman Van Hoelval, 2AYV; vice-president, John Cost; recording secretary, Clifford Holman, 2AZY; treasurer, Walter Shepherd, 2BME; corresponding secretary, W. H. Everson, 2BMC. P. O. Box 434.

The club meetings are to be held at 8 o'clock on the first and third Saturdays of each month.

ASPINWALL RADIO CLUB

The Aspinwall Radio Club was organized with a membership of forty-two on Dec. 21st, 1921, with a two-fold purpose, for the betterment of conditions confronting the radio experimenter in the Pittsburgh district and for promotion of fellowship among local amateurs.

Meetings are held second and fourth Wednesday of each month. Club rooms will be secured presently. Local amateurs always welcome.

THE PASSAIC HIGH RADIO CLUB

The Passaic High Radio Club was organized in September, 1921, with the object of advancing the cause of amateur wireless through mutual suggestions and co-operation. The officers are: President, Joseph Chmielinski, 2APO; vice-president, Julian Van Riper, 2AJF; secretary, Alex. Havasy, 2AUA; treasurer Gilbert Holloway, 2ALR. The

Passaic High Radio Club is affiliated with the Second District Executive Radio Council. It is the first high school radio club to have done so. The official representatives to the council are Mr. Van Riper and Mr. Holloway. A short wave regenerative receiver with detector and two step amplifier is nearing completion and will soon be ready for use by the club members.

Address all communications to the Radio Club, Passaic High School, Passaic, N. J.

MILFORD RADIO ASSOCIATION

The first meeting of the Milford Radio Association was held at the home of Mr. W. H. Gilbert, 14 Center Street, Milford, Conn., on Tuesday evening, Jan. 24th. The officers were as follows: C. S. Keating, president; H. Kropper, vice-president; W. C. Baer, secretary; Fred E. Smith, treasurer. Four standing committees were also appointed: Welfare: H. D. Gates, chairman. Frank Reynolds, Verne Wallace, J. B. Maher, K. S. Seranton. Pep: Leslie Zimmerman, J. W. Fisher, Raymond Clark. House Committee: E. Farnlee, H. D. Gates, Jr., G. Furman. Publicity Manager: C. S. Hickox.

At this meeting about thirty-five members signed up. The dues are 25 cents per month. In the near future we hope to co-operate with the other clubs in the southern part of Connecticut and clear up traffic which has been so congested for the last few months. Any one interested in this association may write to W. C. Baer, 125 West Main Street, Milford Conn.

TOMPKINS SQUARE RADIO CLUB

The Tompkins Square Radio Club of The Boys' Club, Avenue A and 10th Street New York City, was organized in October, 1920, by Mr. E. C. Rundquist, former naval radio operator. The club is divided in two divisions—junior and senior. The junior division meets every Monday evening at 7:30 P.M., in the radio room, on the sixth floor. One hour is devoted to code practice and one hour to theory, with one half hour allotted to questions regarding equipment being erected by the members. Any member of the junior division who passes a speed test of 15 words per minute and a theory grade of 85% is transferred to the senior division. The senior division meets every Friday evening at 8 P.M., with the same schedule as the juniors. At the present time we only have one licensed operator but expect to have all senior members licensed by May 1st. The club expects to install a complete receiving and transmitting set during the next month, consisting of two five-watt tube, transmitter and detector and two-stage with Magnavox. At our summer camp, which is located at Jamesport, Long Island, 80 miles from New York City, we expect to install the same equipment as at our club in the city and be in continuous communication with the same. Last year we stood regular watches and published a daily newspaper, which was of great interest in keeping track of the progress of baseball, etc. Two thousand boys were served in this manner last year and we expect to serve 2,500 this year. A regular watch is maintained at our club from 7:00 to 9:30 P.M. and a log sheet is turned in every evening. Our present membership is thirty and we welcome anyone interested in the advancement of the radio art. An information bureau is also maintained on all matters pertaining to radio installation. The officers of the club are as follows: E. C. Rundquist, director; D. Silberman, president; A. Morenberg, vice-president; H. Schneider, secretary. Address all communications to E. C. Rundquist, care the Boys' Club, Avenue A and 10th Street, New York, N. Y.

ST. LOUIS RADIO ASSOCIATION

The St. Louis Radio Association held its last meeting at the Marquette Hotel on Feb. 17, 1922. Notice of the next meeting will be given as the meeting place is to be changed. Dr. Klink, president, and Mr. Kelso, have arranged to give radio concerts every Tuesday and Thursday evenings at 8 P.M. The traffic committee has been selected, with Mr. F. Schrame, acting chairman, SDFQ. The first issue of the club paper, "Hot Wire", has been published. The next issue will be out soon. The club is taking an interest in the new rules of the Executive Radio Council. We are trying to promote more interest in the radio game by giving concerts and news reports on the wave length of 240 meters every Thursday evening. These news reports are given by Dr. Klink of 9AAU. You will hear from us later.

THE CAZENOVIA RADIO CLUB

The Cazenovia Radio Club was organized Jan. 2, 1922, for the purpose of regulating local traffic and to promote interest in the most fascinating of hobbies.

The officers elected for a period of six months are: President Clive B. Meredith; vice-president, Ronald A. Marshall; secretary-treasurer, Nicholas L. Googin, Jr. The membership numbers fifteen. Meetings are held the first and third Mondays of each month. A half hour of code practice is given before each meeting. The club held two radio dances, one in Cazenovia and the other in Nelson, in order to raise money with which to purchase a receiving set. An orchestra was stationed in each hall, and between selections the loud speaker was cut in and poured out music, which was transmitted from a 10 watt set in town. The wireless proved a great drawing card—a delegation from Missouri was present. We are going to install our receiving set soon. Address all communications to the secretary, Cazenovia, N. Y.

CALAIS ACADEMY RADIO CLUB

Who said that the good die young? Don't know? Well we do not know either, but any way, it has been disproven many times and especially in the case of the Calais Academy Radio Club. This association was organized in 1919 under the name of the Experimental Science and Radio Club of Calais Academy (in those days paper was cheaper and long club names seemed prevalent), and carried on its important work of developing the art of amateur radio in this community. But during our business sessions of 1921 it was decided that if we shortened our club name we would have more time to talk about interesting subjects. So here you have it; the Calais Academy Radio Club, which is here considered a good club and yet as having passed its young stage. Meetings are held every Tuesday evening in the electric laboratory of Calais Academy, one meeting of the month being generally set aside for business, and the others taken up with interesting talks, demonstrations and code practice. The present officers are: Mr. Jack M. Allan, president; Mr. M. L. MacAdam, vice-president and club station operator, and Mr. W. Robert Dresser, secretary and treasurer, 310 Main Street, Calais, Maine. At present the club set is confined wholly to receiving as our DX traffic is more efficiently handled by our local relay stations, 1VT and 1BWD.

PHILADELPHIA AMATEUR RADIO ASSOCIATION

The Philadelphia Amateur Radio Association held its last meeting on Monday, March 6, 1922, at 8:30 o'clock in the Widner Memorial Library. The report of the treasurer was read. A paper on "British Aircraft Tube Transmission" was delivered by Mr. W. B. Martin and was of interest to all amateurs.

Some very amusing questions on radio taken from a New York paper were read by the president. Mr. Horace Van Seiver led a discussion on "Radio Frequency Amplification" and the subject was fully discussed. A letter was read which had been received by Dr. Velintine from the amateurs in Venezuela, South America, arranging a test to see how many Philadelphia amateurs can be heard in Venezuela. The attendance was large. All amateurs are invited to join.

GREENPOINT RADIO ASSOCIATION

At the thirty-second meeting of the Greenpoint Radio Association, a lecture was given by the consulting engineer, Mr. F. Matthews, on the function of the grid leak in the radio circuit. He illustrated his talk, and all members were permitted to give their ideas on the subject; he then explained in full, showing all the various points of this instrument.

Each Friday night a lecture is given on any topic of radio interest that is suggested.

Membership is now open for any desirable young man, and information can be obtained by sending your name and address to the secretary, H. W. Gerlach, 113 Oak St., Brooklyn, N. Y.

RADIO CLUB OF PATERSON HIGH SCHOOL

The Radio Club of Paterson High School now has about 30 members. Meetings are held every Monday afternoon and every other Wednesday night in the radio room of Paterson High School. At these Wednesday night meetings different kinds of receiving sets are demonstrated through the courtesy of the members, and the public is invited. Membership to the club is open to all students of Paterson High School. The club has a licensed station with the call 2CIX.

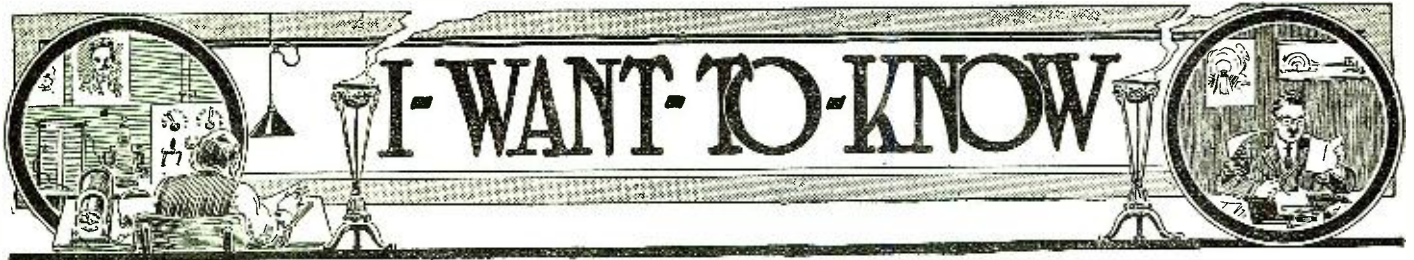

THIS Department is conducted for the benefit of our Radio Experimenters. We shall be glad to answer here questions for the benefit of all, but we can only publish such matter of sufficient interest to all.

1. This Department cannot answer more than three questions for each correspondent.
2. Only one side of the sheet should be written upon; all matter should be typewritten or else written in ink. No attention paid to penciled matter.
3. Sketches, diagrams, etc., must be on separate sheets. This Department does not answer questions by mail free of charge.
4. Our Editors will be glad to answer any letter at the rate of 25c for each question. If, however, questions entail considerable research work; intricate calculations, patent research, etc., a special charge will be made. Before we answer such questions, correspondents will be informed as to the price charge.

You will do the Editors a personal favor if you make your letter as brief as possible.

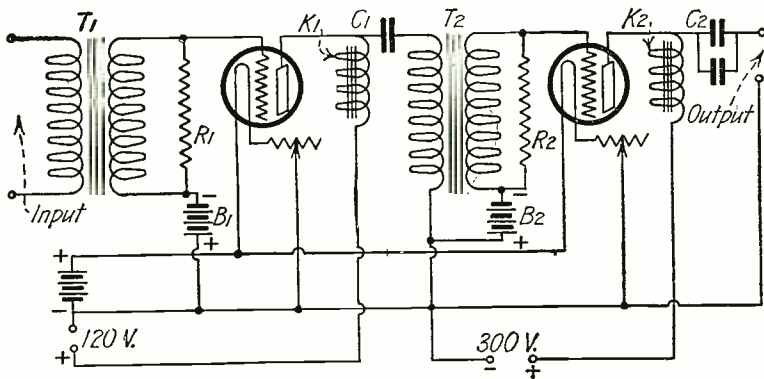

$B_1 = 4\frac{1}{2} V$ $B_2 = 45 V$ $C_1 \& C_2 = 2 M.F.$ $K_1 \& K_2 = 30$ Henrys
 $R_1 \& R_2 = 1.5$ Megohms $T_1 \& T_2 = UV712$ Amplifying Trans.

© RADIO NEWS 1922

Q341

POWER AMPLIFIER CIRCUIT

(341) C. A. N. Armstrong of Sterling, Colo., writes:

Q. 1. What is the best hook-up for two five-watt tubes and what distance should they work? What dimensions and kind of O.T. should be used?

A. 1. See Pages 690 of the June, 1920, issue of RADIO NEWS where you will find complete data for a very efficient two-tube set for both C.W. and phone.

Q. 2. How can 1 m.f. condensers be made to be used in a filter circuit and what is a good circuit?

A. 2. It would prove much cheaper to buy a ready-made telephone condenser of 1 MF capacity than to make one. You will find data for the choke coil of filter circuit on page 689 of the issue of RADIO NEWS mentioned above.

Q. 3. Through what circuit can 350 volts from motor generator unit be applied to plates of amplifying tubes for reception with Magnavox?

A. 3. The circuit you request is shown on this page. In this circuit for a two-stage power amplifier the high voltage is applied to the last tube only which must be a five-watt transmitting tube. The value of R1 and R2 given as 1.5 megohm is correct if Radio Corporation U.V. 712 or General Radio transformers are used. For Federal transformers the value of the resistances should be at least half megohm. It will be best, also, in connection with the motor generator, to use a filter circuit consisting of two choke coils each wound with 6,000 turns of wire shunted by an 8 microfarad condenser.

LOW POWER RADIOPHONE.

(342) John White, of Cleveland, Ohio, writes:

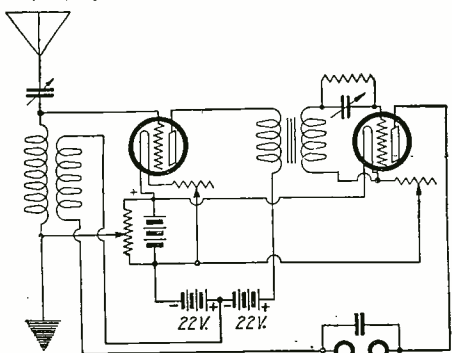

© RADIO NEWS 1922

Q342

This circuit may be used for a power amplifier in connection with a Magnavox. On the right is a very efficient one-tube telephone transmitting circuit.

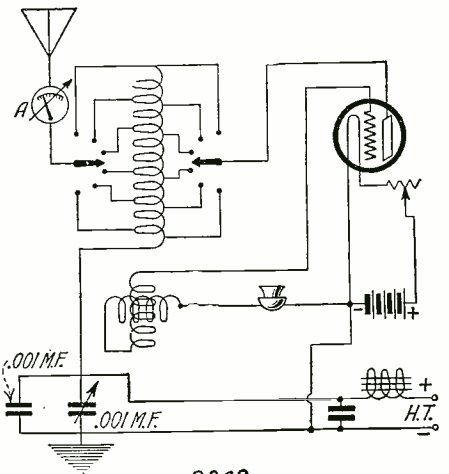

© RADIO NEWS 1922

Q342

variable inductive relation to the antenna inductance.

RADIO FREQUENCY AMPLIFIER.

(343) Alton R. Bowen, of Pleasantville, N. J., asks:

Q. 1. How could a one-step radio frequency amplifier be used successively in connection with the enclosed hook-up?

A. 1. A circuit you may use with a radio-frequency transformer is given on this page. The first tube is a hard amplifying tube and the second is a soft detector tube.

RADIO AND AUDIO FREQUENCY AMPLIFIER

(344) Mr. James Cosman, of Paterson, N. J., wants to know:

Q. 1. I should like to see the hook-up for a detector, one stage of radio frequency and two stages of audio frequency amplification with plug and jack system for filament control which may be used in connection with the Paragon RA 10.

A. 1. A circuit is here published which may be used with any regenerative receiver to provide tuned radio frequency amplification employing an amplifying tube for the purpose. The variometer of the receiver is used as an auto-transformer and tuned radio frequency amplifier is obtained on the wave lengths covered by this variometer. A two-step audio-frequency amplifier may be added to this circuit by connecting the input of the amplifier in place of the phones. Circuit for audio-frequency amplifier with filament control was published on page 288 of RADIO NEWS for October, 1921.

Q. 1. Please give a hook-up of a one-tube radio-telephone set that has proven the best in actual practice.

A. 1. Diagram of a very efficient circuit for a one-tube phone transmitter is given on this page. If desired, a modulation transformer may be used instead of having the microphone directly in the circuit. The inductance should be wound on a

The number of inquiries now being received by this department has so greatly increased that we suggest to our readers to first consult the back issues of RADIO NEWS for possible answers to your questions before writing us. The answers to many of the questions received daily have already been published several times.—Editor.

tube three inches in diameter with 24 turns of No. 12 D.C.C. wire spaced 1/32" with taps every two turns. The variometer stator may be wound on the same tube. Stator and rotor each consist of 32 turns of No. 28 D.C.C. wire.

Q. 2. What circuit is used in the enclosed regenerative receiver?

A. 2. This receiver is a single-circuit one consisting of a fixed inductance and variable condenser in series with the antenna and a tickler coil in

On the left is shown a one-stage radio frequency amplifier and feedback regeneration. On the right is shown how to change from one to two-step amplifier with a D.P.D.T. switch controlling filament of the second tube.

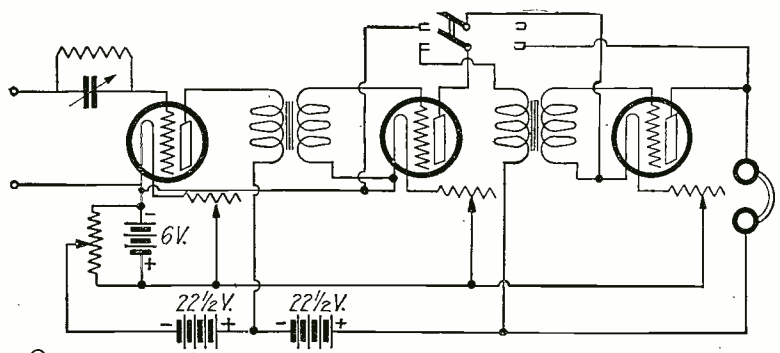

© RADIO NEWS 1922

Q344

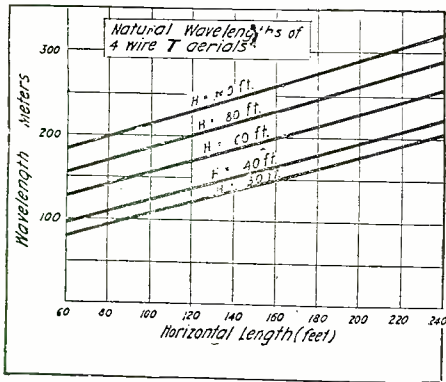

By Means of This Chart You May Calculate the Wave Length of a T Antenna From its Dimensions.

SWITCHING ARRANGEMENT FOR AMPLIFIER

(345) Donald Putt of Sugar Creek, Ohio, requests the following:

Q. 1. Please publish the following diagram: A circuit of a detector and two-step amplifier with a battery potentiometer for controlling the detector plate voltage and one or two anti-capacity switches for changing from detector to first or second step controlling the filament circuits at the same time.

A. 1. A circuit is here published showing how this may be done with one D.P.D.T. switch, which may be an anti-capacity switch, to change from the first to the second step of a two-stage amplifier, controlling also the filament of the second amplifying tube. A very complicated switching arrangement would be necessary to use the detector tube alone and we suggest that a much better method would be to use filament control jacks.

REGENERATIVE RECEIVER

(346) Leon Eisler, of 640 Riverside Drive, New York, asks:

Q. 1. Kindly publish an efficient hook-up for a detector and two-step regenerative set using the following articles for tuning. Fixed coupler, two 43 plate condensers and one variometer.

A. 1. You will find the circuit you request on these pages. If you wish to use a two-step amplifier, connect the input in place of the phones in the diagram. Connections of a two-step amplifier are shown in the answer to question 345.

MAGNAVOX HOOK-UP

(347) Roy Tarbet of Leavenworth, Kansas, wants to know:

Q. 1. How is wave length calculated?

A. 1. The wave length is calculated by dividing the velocity of electricity, 300,000,000 meters per second, by the frequency of the alternating current producing the wave. Thus, 200 meters is produced by oscillations of frequency of 1,500,000 cycles per sec.

Q. 2. Will a magnavox loud speaker give good results without an amplifying transformer on fairly loud music using a small loose coupler and an audion hooked up the main detector circuit? Can you suggest a better hook up for a magnavox?

A. 2. A magnavox will not operate efficiently unless about 100 volts is used in the plate circuit. If you can use an amplifying tube as a detector and 100 volts on the plate, it may be possible to obtain fair results with a magnavox in this manner. It would, however, be much better to use a two-step amplifier. The magnavox takes the place of the phones. See also the answer to question 341.

PHONE RECEPTION.

(348) E. E. Sayers of Sligo, Pa., wants to know:

Q. 1. How can I eliminate the annoyance of telephone rings coming in on my receiving set?

A. 1. In the position you are in you will probably find it difficult to do this. Try shunting your antenna and ground connections with a choke coil to provide a low frequency path. It might also help to change the direction of your antenna if this is possible.

Q. 2. Why is it that I am unable to tune WJZ in on the described set? This station is about 350 miles distant.

A. 2. There is no particular reason why you should be unable to receive WJZ unless you are not using the proper value of inductance coils. It may be also that you are too far from this station. To receive phone transmission, very careful and fine tuning is required.

Q. 3. What type of receiving set is considered good for receiving radio telephony from a broad-

casting station which is about 125 miles distant?

A. 3. Any short wave regenerative tuner would be satisfactory for this purpose.

AMPLIFIER ACTION.

(349) Herman Card, of Providence, Rhode Island, wants to know:

Q. 1. In a two-stage audio frequency amplifier the signals are rectified by the first tube and are then passed through transformers to the other two tubes. How is this possible when it is a positive fact that direct current cannot pass through a transformer?

A. 1. A rising and falling current will be repeated in the secondary of a transformer. What amounts to a rectified current will flow in the plate circuit of a T. when the grid is held at a certain potential or, in other words, either the positive or negative halves of the plate currents will be greater than the other. With the aid of a grid condenser an increasing negative charge is impressed on the grid throughout a wave train. This is repeated in the plate circuit by a reduction of the plate current throughout a wave train and return to normal at the end of each. This constitutes the audio frequency component of the plate circuit, and this rising and falling current will induce currents of the same frequency in the secondary of a transformer, the primary of which is connected in the plate circuit.

LICENSE REQUIRED TO MANUFACTURE CERTAIN APPARATUS.

(350) Frank Frisch of Mansfield, Ohio, asks:

Q. 1. Can I use two honeycomb coils for primary and secondary and a variometer for tickler?

A. 1. A variometer may be used for tuning the plate circuit to provide regeneration on short waves.

Q. 2. Is a license and permit necessary to sell homemade wireless apparatus?

A. 2. Permission would have to be obtained and royalties paid on the sale of apparatus which infringes any of the existing patents. If the apparatus or circuit used is not patented, no special permission would be required.

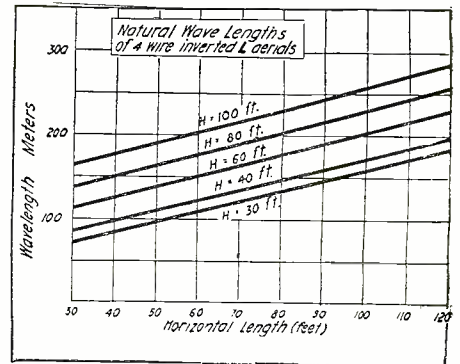

This Chart Will Enable You to Calculate the Wave-Length of an Inverted L Antenna From Its Length and Height.

would be one 18 inches in diameter, composed of six wires about sixty feet long and fifty or sixty feet in height, used with a counterpoise.

RADIO AND AUDIO FREQUENCY AMPLIFICATION

(352) W. E. Beall, of San Francisco, California, writes:

Q. 1. What is the difference between radio and audio frequency amplification?

A. 1. Briefly, audio frequency amplification makes louder signals that already have been detected, whereas radio frequency amplification strengthens weak impulses so that they may be detected. It is therefore possible, with radio frequency amplification, to detect signals from a great distance that would not be strong enough to be detected with one tube alone or with audio frequency amplification.

Q. 2. What different equipment to you use, if any?

A. 2. There are various methods of radio frequency amplification. When transformers are used they are of different design from those used for audio frequency amplification.

Q. 3. How and where can I obtain single back copies of Radio News when you refer to back copies in your answers to questions?

A. 3. Back copies may be obtained by writing for them to the circulation department of Radio News, 233 Fulton Street, New York City, and enclosing 25 cents for each copy.

AERIAL WAVE-LENGTH

(353) Clare Moore, of Westport, Conn., asks:

Q. 1. Where may I find out how much wire to wind on honeycomb coils?

A. 1. You can find this information in the catalogue of several radio dealers, or if you will let us know what wave length you wish to receive on we will be able to inform you how much wire to use.

Q. 2. What is the natural wave length of an aerial, 2 wires 120 feet long, the lead-in 125 feet long the ground five feet long?

A. 2. You may calculate the wave length of your antenna from its dimensions by using one of the charts on this page.

Q. 3. Where may I find the calls of the newer phone stations?

A. 3. You will find a complete list of all broadcasting stations contained in the article entitled "What anyone can hear" in the March issue of Radio News.

LOOP AERIAL

(354) G. A. Peple, Jr., of Lynchburg, Va., wants to know:

Q. 1. Can a loop aerial be used in connection with the short wave regenerative set described by Mr. W. H. Grace, Jr., in the December issue of Science and Invention?

A. 1. This set was not designed for use with a loop and the best results will only be obtained if a regular antenna is used.

Q. 2. Can the KYW station in Chicago be heard at a distance of 800 miles when using the loop aerial?

A. 2. It would be very difficult to receive at this distance with a loop. It may be accomplished, however, if sufficient amplification at radio frequency is used.

LOOP AERIAL DATA

(355) Chas. Gonnella, of Lima, Ohio, asks:

Q. 1. Is a loop aerial as effective as a flat top aerial using a V.T. detector?

A. 1. No, it is not so effective. Unless it is desired for short distance reception only it is necessary to use considerable amplification with a loop to obtain the same results as would be obtained by the use of a high antenna with less amplification.

(Continued on page 1029)

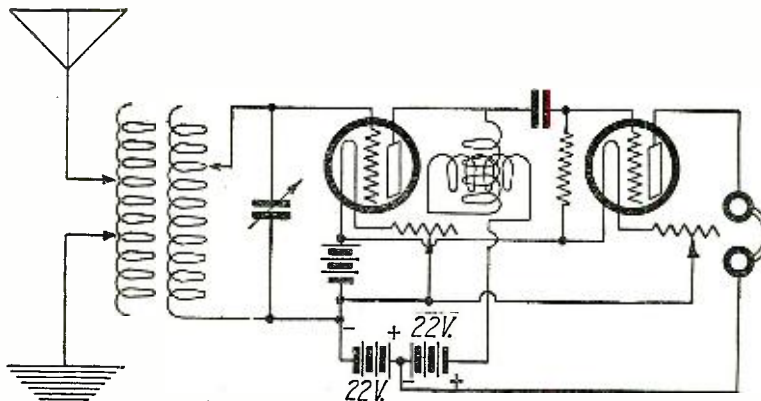

© RADIO NEWS 1922

Q344

This Shows the Circuit to Use in Changing a Short Wave Regenerative Tuner to a One-Stage Tuned Radio Frequency Amplifier.

AERIAL FOR C.W. SET.

(351) H. H. Olmsted, of Washington, D. C., wants to know:

Q. 1. Please publish a hook-up of detector and two-step amplifier using a DPDT switch to change from detector to amplifier.

A. 1. See answer to Question 345.

Q. 2. Which antenna is best for C.W. purposes, a cage or L?

A. 2. It has been found that a cage antenna is somewhat better than a flat-top antenna for transmission purposes.

Q. 3. What should be the height and length of an antenna recommended for 200-meter C.W. set?

A. 3. A good cage antenna for this purpose

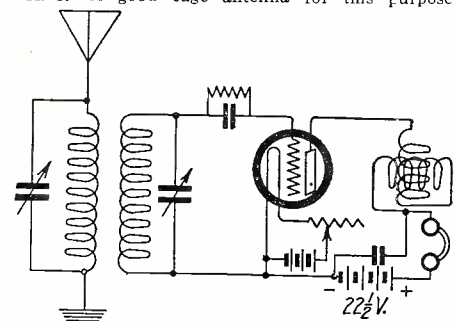

© RADIO NEWS 1922

Q346

A Variometer May be Used With a Fixed Coupler to Make the Set Regenerative on the Short Wave Lengths.

MURDOCK

radio necessities



MURDOCK REAL RADIO RECEIVERS have delivered complete satisfaction, on a "money-back" basis for 14 years. Those years of experience have so simplified and perfected our production that there are today no receivers quite so good at so low a price

The latest Murdock achievement, the No. 56 Receiver, is a highly sensitive instrument which retains all the rugged strength of previous types. Important features are, the improved comfortable headband, the "Murdock-Moulded" ear pieces shaped to exclude outside noise, and the moulding of all parts into one durable unit.

All models of Murdock receivers are sold with free trial offer and money back guarantee. Use them in direct comparison to any other phones for 14 days. Make any test you wish. Then at the end of the two weeks, if the Murdock Phones are not entirely satisfactory, return them and your money will be refunded!

Many of the complete "ready-to-operate" wireless sets now on the market include Murdock Phones as standard equipment. If the set you buy does not, be sure you get a set of Murdock receivers to complete your station. We strongly urge you to go to your dealer and convince yourself of the quality of Murdock receivers, by actual examination, before you buy. Prices \$4.50 to \$6.

Murdock Phones are the standard bearer for a complete line of "Made-by-Murdock" radio parts and instruments. This includes the famous Murdock condensers, couplers and variometers, and the new Murdock Rheostat at \$1.00.

*Buy Murdock Radio Apparatus
From Your Dealer*

WM. J. MURDOCK CO.



Electricity at your finger ends

Know the facts in Electricity. They mean more money and better position for you. Hawkins Guides tell you all you need to know about Electricity. Every important electrical subject covered so you can understand it. Easy to study and apply. A complete, practical working course, in 10 volumes. Books are pocket size; flexible covers. Order a set to-day to look over.

HAWKINS GUIDES

3500 PAGES \$1 A VOLUME
4700 PICTURES \$1 A MONTH

These hooks tell you all about—

Magnetism—Induction—Experiments—Dynamo—Electric Machinery—Motors—Armatures—Armature Windings—Installing of Dynamos—Electrical Instrument Testing—Practical Management of Dynamos and Motors—Distribution Systems—Wiring—Wiring Diagrams—Sign Flashers—Storage Batteries—Principles of Alternating Currents and Alternators—Alternating Current Motors—Transformers—Converters—Rectifiers—Alternating Current Systems—Circuit Breakers—Measuring Instruments—Switch Boards—Wiring—Power Stations—Installing—Telephone—Telegraph—Wireless—Bells—Lighting—Railways. Also many Modern Practical Applications of Electricity and Ready Reference Index.

SHIPPED TO YOU FREE

Not a cent to pay until you see the books. No obligation to buy unless you are satisfied. Send Coupon now—today—and get this great help library and see if it is not worth \$100 to you—pay \$1.00 a month for ten months or return it.

SEND NO MONEY

THEO. AUDEL & CO.,
72 Fifth Ave., N. Y.

Please submit for examination
Hawkins Electrical Guides
(Price \$1 each). Ship at once. Pre-
paid, the 10 numbers. If satisfactory, I
agree to send you \$1 within seven days and
to further mail you \$1 each month until paid.

Signature _____
Occupation _____
Employed by _____
Residence _____
Reference _____

Radio N

You Can Still Get in on This!



\$4.50

POSTAGE FREE

Those Amplifying Transformers:— We obtained a larger supply of these transformers than we had hoped for at this price. We can still supply them at \$4.50 each. Ask the fellows who got them last month. They Are The Berries! Here's another bargain! Two standard binding posts of the most useful size. Type 1A takes largest size phone cord tips while Type 2A is the ideal size for general use. Both are well finished and nickel plated.



Type 1A
7c each

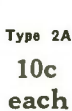

Type 2A
10c each

Include Postage

The HAYNES RADIO SHOP
629 Lexington Ave. (Bet. 53d and 54th Sts.) N.Y.C.

Read the classified ads on pages 1052, 1053 and 1054.

Station 9HY of Chicago, Ill.

(Continued from page 952)

mahogany office desk upon which it is mounted, a provision had to be made for the key under the detector and amplifier unit. A low cabinet with a drawer and an arch opening for the key was made for the above unit which elevates it to the level of the other cabinets. The complete receiving assembly is mounted on plate glass, as is the key. A typewriter is enclosed in the desk ready for use by raising a portion of the desk top.

Brown adjustable and Baldwin phones are used. A loud speaker with large horn is used, which gives good volume.

Flanked on both sides of the desk are the transmitting sets, the spark set on the left and the C.W. set on the right. The transmitting units, like the receiving units, are made to fit into a symmetrical scheme of arrangement. A narrow mahogany table was constructed for the spark set, upon which was built a much smaller table arrangement for enclosing the muffled rotary gap. This smaller table, placed upon the larger table, is covered on the side next to the desk with mahogany as is the top, while the front supports a switchboard. On the switchboard are mounted the antenna switch, a double-pole, single-throw switch for throwing the key either in the spark set circuit or the C.W. circuit, another double-pole single-throw switch for cutting in either quenched or rotary gaps, and a large Jewel 0 to 5 amp. thermo-couple meter.

On top of the little table are mounted an Acme 1/2-K.W. transformer, a Thordarson oil condenser, and a very large oscillation transformer. The oscillation transformer is supported over the transformer and condenser in a flat position by four legs. All insulation is very heavy and leads as short as possible. The rotary gap is designed to give the best results with the Acme non-resonant transformer, while an Amrad quenched gap with a line resistance can be used also.

The C.W. set uses four 5-watt UV202 Radiotrons, which can be used in two different modulating circuits. Flexibility has been the keynote in the design of this set, and experience the chief adviser. The English circuit described by Mr. Whittier is used for the oscillating circuit, with a grid coil wound with No. 12 coupled inside of the antenna inductance. Either Heising constant current modulation with two tubes as modulators may be used, or four tubes may be used as oscillators with a magnetic modulator for modulation. Four air core honeycomb chokes are mounted in a bracket directly underneath the socket shelf, so that a choke is connected near the sockets to each grid. This prevents one tube surging back into another.

Either rectified A.C. or motor generator can be used for the plate supply, the set being so wired that either may be used by throwing a four-pole double Federal switch. An Acme 200-watt 550-volt unit rectified through two DeForest rectifying tubes is used for the rectified A.C. supply. The motor generator is a special Ray-Di-Co unit with a double commutator generator delivering 750 volts at 150 watts. It will deliver 1,000 volts open space, and is rated at 150 watts conservatively. A Radio Corporation tone heel is coupled between the motor and generator, the 1,750 R.P.M. of the motor generator giving the desired frequency. The center of the tone wheel has turned out on a lathe and it is insulated from the motor generator with bakelite, so that it will not ground through this unit. A double brush is used. The filter system is made up of eight 1-M.F. Federal condensers and three 1 1/2-henry Acme chokes.

LEARN THE WIRELESS CODE BY THE RECCODE METHOD

One hour practice with the Reccode Method places in your mind a picture of each letter of the alphabet with the corresponding code in such a manner you cannot forget.

SIMPLEST EASIEST
QUICKEST WAY

\$6.50 PLACE YOUR ORDER NOW \$6.50

Joseph E. Campbell Co.
585 Forest Ave., East
DETROIT, MICH.

BANGERT ELECTRIC CO., Inc.

Headquarters for
RELIABLE
RADIO
RECEIVING SETS
SUPPLIES and PARTS

THREE STORES
297 Fulton St., JAMAICA, N. Y.
27 Main St., HEMPSTEAD, L. I.
16 W. Merrick Rd., FREEPORT,
L. I.

MANUFACTURERS OF
TESTED, MOUNTED, GUARANTEED
CRYSTALS

WRITE FOR DISCOUNTS

The Largest Mfr. of Galena Crystals (In The United States)



Mounted in Wood's Metal Guaranteed AAI Perfect
Arlington Tested)
Galena Crystal Mounted.....35c
Wrapped carefully and packed in individual boxes with your name, or in bulk.
Manufacturers, Jobbers, Dealers, write for our special quantity prices.
GALENA CRYSTAL MFG. CO.
464 Bushwick Ave. Brooklyn, N. Y.

RADIO FREE CATALOG

Eighty-four pages illustrated, complete sets and parts for assembly. Get Thordarson's Latest Amplifying Transformer, \$4.50 postpaid. Our sixty years' experience at your service in selecting equipment.
JULIUS ANDRAE & SONS CO.,
117 Michigan St. Milwaukee, Wis.

No. 6647 \$1.20 per 100
No. 7138 \$1.30 per 100
No. 71, like cut, 7 1/2c
No. 72, larger, 9c. Nickel polished, 75c 100 extra

CONTINENTAL ELECTRIC COMPANY
117-119 East 129th Street, New York, N. Y.

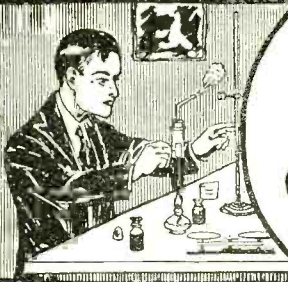

Dr. T. O'Conor Sloane will teach you **CHEMISTRY** Right in your own Home

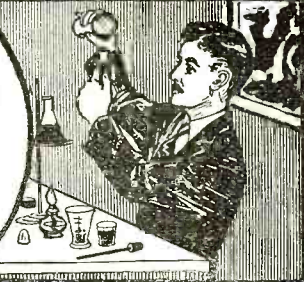

Good Chemists Command High Salaries



DR. T. O'CONOR SLOANE,
A.B., A.M., LL.D., Ph.D.
Noted Instructor, Lecturer and
Author, Formerly Treasurer American
Chemical Society and a practical
chemist with many well known
achievements to his credit. Not
only has Dr. Sloane taught chemis-
try in the class-room but he was
for many years engaged in com-
mercial chemistry work.

Industrial firms of all kinds pay tempting salaries to get the right men. Salaries of \$10,000 to \$12,000 a year are not unusual for chemists of exceptional abilities. Chemistry offers those who are ambitious and willing to apply themselves conscientiously the greatest opportunities of any vocation. Why be satisfied with small pay and hard, thankless work—learn the profession of Chemistry and your salary will depend only upon your own efforts and your own abilities.

The work of the chemist is extremely interesting. If you are fond of experimenting, if you like exciting and intensely interesting work, take up Chemistry. To the man who is dissatisfied with his present job, to the young man just deciding on his life work, Chemistry holds alluring charms, and countless opportunities. If you want to earn more money, the way is open through our course in Chemistry.

Now Is The Time To Study Chemistry

Never before has the world seen such splendid opportunities for chemists as exist today. The war has awakened the United States to the need of trained chemists and chemical engineers. Everywhere the demand has sprung up. In factories, mills, laboratories, electrical shops, industrial plants of all kinds, chemistry plays a vital part in the continuation and expansion of the business. In every branch of human endeavor the need for chemists has arisen. No profession offers such alluring opportunities and the next

ten years are going to show the greatest development in this science that this country has ever seen. Those who have the foresight and ambition to learn chemistry now will have the added advantages and greater opportunities afforded while the chemical field is growing and expanding.

You Can Learn At Home

Dr. Sloane will teach you Chemistry in a practical and intensely interesting way. Our home study course written by Dr. Sloane himself is practical, logical and remarkably simple. It is illustrated by so many experiments that are performed right from the start that anyone, no matter how little education he may have, can thoroughly understand every lesson. Dr. Sloane teaches

you in your own home with the same individual and painstaking care with which he has already taught thousands in the class room. And, Dr. Sloane personally examines and corrects all examination papers, pointing out your mistakes and correcting them for you. He will, in addition, give you any individual help you might need in your studies. This personal training will be of inestimable value to you in your future career.

Experimental Equipment Furnished to Every Student

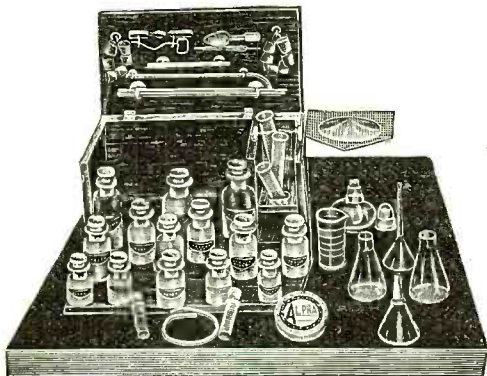

We give to every student without additional charge, this chemical equipment including forty-two pieces of laboratory apparatus and supplies and eighteen different chemicals and reagents. The fitted heavy wooden box serves not only as a case for the outfit but also as a laboratory accessory for performing countless experiments. Full particulars about this special feature of our course are contained in our free book "Opportunities for Chemists."

What Well-Known Authorities Say About Our Course

From Hudson Maxim,
"Dr. Sloane has done a much-needed work in a much better way than anything of the kind has, heretofore, been done."

"Dr. Sloane has a remarkable faculty of presenting Science for self-instruction of the student in such a clear and understandable way as to be most readily grasped and assimilated."

"I, therefore, unreservedly recommend and place my highest indorsement on his work."

From Dr. W. W. de Kerlor,
"I can not recommend your course too highly and I congratulate both you and Dr. Sloane on same."

From John A. Temian,
"This is something which has long been needed. Your long experience in the teaching of chemistry... assurance that the course will be practical as well as plain to the untrained students."

What the Students Say:

"Your course has been worth \$50,000 to my concern."

"This is just like reading some fascinating fiction story."

"I have just been made Assistant Chemist of my concern."

"Your course is just what a person wants to start in the wonderful science of Chemistry."

"I find that your course is very interesting. I wait patiently for the next lesson."

"I find the study of chemistry more and more interesting at every lesson and you may be sure that I am getting into studying habit even more than I ever did even in my school days."

"I am well pleased with your course and I think, from the way it starts out, I have found a good teacher and school."

"Your course is sure wonderful, easy to understand, and so well laid out. I like it immensely."

"The lessons are fine and I like them."

"I have written to different people about your course and they speak very highly of same."

"If I don't learn it isn't your fault for I find that your lessons contain a whole lot."

(Names and addresses on request)

Easy Monthly Payments

You don't have to have even the small price of the course to start. You can pay for it in small monthly amounts—so small that you won't feel them. The cost of our course is very low, and includes everything, even the chemistry outfit—there are no extras to buy with our course. Our plan of monthly payments places a chemical education within the reach of everyone. Write us and let us explain our plan in full—give us the opportunity of showing you how you can qualify for a highly trained technical position without even giving up your present employment.

SPECIAL 30 DAY OFFER

Besides furnishing the student with his Experimental Equipment, we are making an additional special offer for a short while only. You owe it to yourself to find out about it. Write today for full information and free book "Opportunities for Chemists." Send the coupon right now while it is fresh in your mind. Or just write your name and address on a postal and mail it to us. But whatever you do, act today before this offer is withdrawn.

**CHEMICAL
INSTITUTE
OF NEW YORK**
Home Extension
Division 4
140-R Liberty St.,
New York City

Please send me at once, without any obligation on my part, your free Book "Opportunities for Chemists," and full particulars about the Experimental Equipment given to every student. Also please tell me about your plan of payment and your special 30 day offer.

Don't Wait—Mail the Coupon NOW!

CHEMICAL INSTITUTE of NEW YORK, Inc.
140-R LIBERTY ST. Home Extension Division 4 NEW YORK CITY

NAME
ADDRESS
CITY..... STATE.....
R. N., Apr. '22.

Better Results and Longer Life from Your Tubes

Every make of tube should be operated at some specific voltage.

Tubes function best within extremely narrow limits. Unless you operate within these limits it is impossible to obtain the best results, and tube replacement expense runs up rapidly. It is foolish to regulate your tubes by the degree of illumination of the filament.

In the early days of power plants, operating engineers attempted to maintain voltage by the brilliance of a pilot lamp. Today, *such a practice is absolutely unheard of.* Voltage is established and maintained by means of accurate and reliable voltmeters.

In the very near future of radio, the filament voltmeter will be regarded as absolutely indispensable.

Will you follow the wise practice of voltmeter filament control *now*, or will you wait until bitter experience convinces you of your error?



Our Circular "J" describes in detail Weston Filament Voltmeters and other important instruments invaluable to owners of up-to-date receiving and transmitting sets. Send for a copy without delay, if your dealer cannot supply you.

**Weston
Electrical Instrument
Company**
173 Weston Avenue
Newark, N. J.
Branches in the Large Cities

When using motor generator, the filament winding of the Acme unit is used to light the filaments while the secondary is thrown out of the circuit. In this way the Acme unit serves both as a power unit and a filament heating unit. The motor generator is used for phone work and I.C.W., while rectified A.C. is usually used for straight C.W. Very good modulation is obtained on phone with no hum or objectionable carrier wave. A double-throw double-pole switch changes the generator commutator connections from series to parallel, giving either 750 or 550 volts respectively. A big jump in radiation is obtained with the highest voltage with no great stress on the tubes. Although rated at 5 watts, 20 to 40 watts are put into the tubes. The difference in the results did not warrant using larger tubes, and the 5-watt tubes certainly are better, from an economical standpoint.

All instruments are mounted on a base and panel, and the whole is placed in a cabinet with small doors in the sides and top for accessibility and ventilation. At the rear of the base is mounted the 200-watt Acme unit with condensers at each side, while over it is a fiber shelf upon which are mounted the two rectifying tube sockets, the chokes, and four Federal condensers. Thus the power and rectifying circuit, together with the filter, is all in one unit isolated from the rest of the set. Farther forward on the base are mounted two large fixed condensers over which are supported two 5,000-ohm grid leaks and two inductance coils. The antenna inductance is large, consisting of 36 turns of No. 8 brass wire 6" in diameter, and is supported by heavy brass uprights fastened to the brass panel supports.

On the panel are mounted an 0 to 600 volt Firco meter, a General Radio hot wire ammeter, a Jewel 0 to 200 milliammeter, and a Jewel 0 to 15 volt A.C. meter. A small dash pilot lamp is placed over the meters to light the dials. On each side of the meters a 6-ampere rheostat is mounted, one for the rectifying tubes and one as an auxiliary filament control to the oscillators and modulators. Below the meters are four glass peepholes in line with the tubes which are mounted on a shelf back of the panel. These holes are large, giving a full view of the elements of the tubes, and beveled nickel plated brass rims holding beveled plate glass are inserted in the holes to trim them up.

Below these holes are mounted four General Radio 2½-ampere rheostats, one for each tube filament. Each individual filament can be set and then all adjusted together with the auxiliary filament rheostat. Below the rheostats three variable condensers are mounted. Just above the condenser dials the two Federal switches are placed, one for sending and receiving, and one for phone, I.C.W. or C.W. The down position of this switch is for phone, the middle position for tone wheel, and the up position for straight C.W. No binding posts are used on the panel whatever, thus giving a clean appearance. The binding posts are mounted high in back of the panel on a terminal board, and a hard rubber shelf at right angles to the top of the panel acts as a guide with properly spaced holes to space and feed the leads to the terminal board. On top of this shelf are placed the binding posts for the motor generator and tone wheel, while the Federal switch for throwing from motor generator to rectified A.C. is mounted to one end of this shelf.

Three rotary switches are also mounted on this shelf. One switch is for shorting the milliammeter out of the circuit, which is subject to injury while sending straight C.W., due to its violent ducking when the key is pressed. Another switch cuts the high voltage plate meter out of the circuit, while the third switch cuts the antenna series condenser out of circuit which at times increases radiation. At other times

7

If your amplifier doesn't satisfy you, build a new one from designs in

Design of Modern Radio Receiving Sets

You will find an exceptionally good design in MODERN RECEIVING SETS for a detector and 2-step amplifier with jacks for plugging in any step. The panel can be mounted on support frames which carry the connections at the rear or put in a cabinet. The design has been worked out so that you can build the set in your "kitchen table workshop." All parts and panels drilled and engraved can be obtained from the G. A. Company or its distributors.

There are many other instruments described in MODERN RECEIVING SETS which will interest you.

The Price is
50c.

Postage 4c

The General Apparatus Co., Inc. 88-N Park Place
New York City
Send 10c for the new G. A. Catalog

The "QSA" Line of Radio Equipment

Larger business has made necessary larger space and larger stock. So we have moved into new quarters where we will be better able than ever to supply your wants. Items below are offered for IMMEDIATE DELIVERY.

Radiotron U.V. 200	\$5.00
Radiotron U.V. 201	6.50
Radiotron U.V. 202-5 watt power tube.....	8.00
Federal No. 226-W amplifying transformer.....	7.00
Eveready No. 766 variable B battery.....	3.00
FADA No. 120-A panel mounting rheostat.....	1.00
Saco Clad amplifying transformers.....	5.00
Paragon V.T. socket No. 30.....	1.00
45 Volt "B" battery, special at each.....	2.10
Combat Radio Storage Battery 6 v. 80 A.....	21.00

Catalog of "QSA" equipment will be sent for 10 cents which will be refunded on initial order or FREE with order from this advertisement.

Radiophone converts—Call, or write us for estimate on complete radio installation for receiving wireless music, etc. Come in and ask as many questions as you like.

Independent Radio Supply Co.
3239 Ogden Ave. CHICAGO, ILL.
"A Radio Store with a Conscience"

FROM CAT WHISKERS UP—

We can supply everything that's best in Radio, 1 or 101 of any article to user or dealer. Same day shipments.

Inquiries are welcome



DISTRIBUTORS
Wholesale & Retail
Westinghouse
Brondes Federal
Murdock, DeForest
Radio Corporation
and many others

At East Pittsburgh, Pa.—Next Door To KDKA



Eveready "B" Battery No. 766
Equipped with Fahnestock Spring Clip Binding Posts—An Exclusive Eveready Feature



Eveready "B" Battery No. 774
Equipped with Fahnestock Spring Clip Binding Posts—An Exclusive Eveready Feature

Keep your receiving set working at its best—

The supremacy of Eveready "B" Batteries is due to their sustained power, long life, and perfectly noiseless operation.

Eveready "B" Battery No. 766

Most popular size in use. Contains 15 cells of larger dimensions and longer service life. Equipped with 5 positive voltage taps ranging from 16½ to 22½ volts, making it the most desirable type for use with vacuum detector tubes such as Radiotron Model UV-200. The famous Fahnestock Spring Clip Binding Posts on all terminals. Length of battery 6⅝ in.; width 4 in.; height 3 in.; weight 3 lbs. 7 oz. Price \$3.00.

Eveready "B" Battery No. 774

Contains 27 cells and has a high voltage rating of 43 volts. Equipped with 6 positive voltage taps at 4½ volt intervals ranging down to 18 volts. This arrangement gives a wide range of plate circuit control. The lower voltage taps make it possible to use this battery on a detector tube requiring 18 or 22½ volts while also using it on an amplifying tube requiring 43 volts. It is especially suitable for many amplifier tubes such as Radiotron Model UV-201. The famous Fahnestock Spring Clip Binding Posts on all terminals. Length of battery 9 in.; width, 3⅛ in.; height, 3 7/16 in.; weight, 4 lbs. 14 oz. Price, \$5.00.

Eveready "B" Batteries are for sale by radio equipment dealers everywhere. If unable to secure them through your dealer, write to us direct.

Insist upon Eveready

EVEREADY

"B" BATTERIES

NATIONAL CARBON COMPANY, Inc., Long Island City, N. Y.

Atlanta

Cleveland

Chicago

Kansas City

San Francisco

Makers of the famous Columbia Dry Batteries for bells, buzzers, and gas engine ignition

FADA

*talks about
FADA equipment*

An observable fact about the 2nd District Radio Convention and Show at the Hotel Pennsylvania, New York City, last month was the prominence of FADA rheostats.

Many progressive manufacturers have adopted them as standard. The Z-nith detector-amplifiers use FADA rheostats. And one of the most sensational receivers exhibited, "the special Myers receiver with radio and audio frequency amplification" was equipped with FADA inductance and series-parallel switches and FADA rheostats.

FADA rheostats cost only

\$1.00



DEALERS: Write for the FADA trade catalog. You will find it profitable to stock FADA equipment.

F. A. D. ANDREA

Manufacturer of FADA Radio Products

1882-A Jerome Ave N. Y. C.

this condenser is necessary, however.

For flexibility and actual results, this C.W. set has exceeded expectations. On straight C.W., using only two 5-watt UV202 Radiotrons, 1,100 miles has been covered. Six stations in New York, Syracuse, Philadelphia and other stations in the east have all reported C.W. sigs. QSA. Langly Field, Va., also reported having heard phone, which is the best the set has done on phone. Modulation has been reported very good on phone with voice and music.

The spark set has been logged as far as Wilmington, N. C., but it is far from being the equal of the C.W. set.

Radiation on straight C.W. with two 5-watt UV202's has been as high as two amps., and seldom less than 1.8 amps.

All woodwork in the entire set is of antique brown mahogany, with a four coat rubbed piano finish. A 100-amp. hour 12-volt Willard battery furnishes the receiving filament supply with eight large cells from a farm light plant for reserve. A "Home-charger" charging unit of large size keeps the batteries up.

The antenna is composed of five stranded tinned copper wires 45' long and 70' high. Two masts 30' high elevate the antenna from the apartment building roof upon which it is located. It is of the "L" type with lead-in wires fanned to the edge of the roof. The end opposite the lead-in is fanned out. Hollow spruce masts are used to elevate the antenna and are guyed with eight guys apiece. The spreaders are also of hollow spruce, the masts and spreaders being well varnished.

Ground is made to the steam line and city water system; a counterpoise tuned to the ground system will be added.

It has been our contention that good results and good appearance should go together, and we have tried to bear this out in radio station 9HY.

The Crystal

(Continued from page 956)

"I'm gettin' hungry for supper."

He looked in his purse; not a cent. His wife, sensing something amiss demanded, "Why don't you hock them machines o' yours?" But Foster only recoiled from such a thought, although he well knew his remaining fantastic instruments would net him but little.

For a part of the evening, John sat beside his wife, thinking. Suddenly he gave a start and jumped to his feet. His wife heard him excitedly mutter, "The strong box!" and then he plunged into the basement.

His secreted strong box! Only he and his brother had used it; there it had lain, forgotten, for nearly a decade. Foster had no recollection of any money being left there, but it was as a straw to a drowning man.

After probing the brick wall, he finally dislodged a brick and drew forth a tightly-bound iron box. A rusty key he found behind a cross-beam opened the lock. Foster held his breath as he lifted the lid, but not a sou was to be seen. The only article within was a yellowed scrap of paper.

Foster carried this upstairs to examine it. Some cryptic characters were inscribed upon the paper, written in his brother's hand.

The paper read:
"To one H₂CuSeO₃ add (HCO.OH and H₂SO₄)."

For an instant, Foster was at a loss. Then he got a chemistry manual and looked up the chemicals corresponding to the formula, but in doing this, he failed to note what the results of the reaction might be. It must

NOTICE

I beg to announce that I am now located at

59-61 Park Place
New York City

In my new quarters I will be able to furnish my customers with all kinds of radio apparatus and parts.

FREDERICK WRINKLER, Jr.

Radio Supplies

ALL KINDS

Cunningham Tubes
A. P. Tubes
Paragon R. A. 10 Receivers
Clapp-Eastham Receivers
Baldwin Phones
Brandes Phones

ELECTRIC SUPPLY CO.

Everything in Radio

Port Arthur - - Texas

Enamel Wire No. 22 to 30, lb. \$.85

7 Strand Antenna Wire, per 100 ft.75

Bakelite Panels, 10"x15"x3/16".265

Bakelite Panels 5"x5"45

A. C. Voltmeters, 0-15 Volt. . . .8.00

The Quaker Light Supply Co.

728 ARCH STREET
PHILADELPHIA

DISCOMFORT ELIMINATED ~
~ LIMITATIONS REMOVED



RADIO
enjoyment
under difficulties

MAGNAVOX multiplies comfort and pleasure

No receiving set is complete without a Radio MAGNAVOX. No receiving set can even approach its best results or entire usefulness without a MAGNAVOX. Radio MAGNAVOX is the world's standard loudspeaker. "World's standard" because its famous movable coil and other patented mechanical features make its marvelous performance positively and exclusively its own. *There is NO substitute for the Radio MAGNAVOX.*

Properly energized, it will reproduce with equal facility and without distortion either radio music, radio messages, or radio telephone speech in volume so that any audience from a small family circle to a vast public assembly may distinctly hear every tone, every word, and every modulation.

It is easy to hook up—you simply substitute the MAGNAVOX for your head set, sit back, listen, and enjoy. *No adjustments necessary.* Where power amplification is desired, use a 2-stage or 3-stage MAGNAVOX Power Amplifier, such as is shown in the illustration at the right.

Make your set complete now. Make it the source of pride and center of enjoyment it should be. Go to your dealer today, and tell him to give you prices and full particulars on the world's standard loudspeaking apparatus—the Radio MAGNAVOX and the MAGNAVOX new POWER AMPLIFIERS.

THE MAGNAVOX CO., GENERAL OFFICES OAKLAND, CALIFORNIA
NEW YORK OFFICE, 370 7th Avenue, PENN. TERMINAL BUILDING

In writing, please address the MAGNAVOX office nearest you.



MAGNAVOX

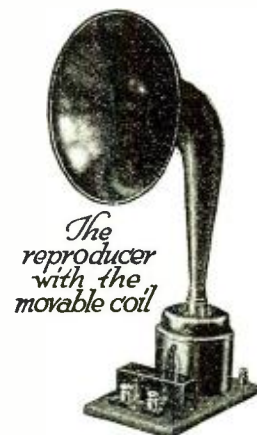

*The
reproducer
with the
movable coil*

Radio MAGNAVOX—the reproducer with the movable coil, world's standard loudspeaker, Type R-3, illustrated, with 14" horn, \$45. At your dealer.

MAGNAVOX NEW POWER AMPLIFIER



Add one of these to your set to get greater sound intensity and larger volume from your MAGNAVOX, without distortion. New 2-stage and 3-stage types, for use with transmitter tubes and high plate voltages. Simply throw the switches to operate. Solid mahogany case. Sits either flat or on edge. Ask your dealer for prices and particulars.

There is NO substitute for the Radio MAGNAVOX

Insist upon getting

N A A

(ARLINGTON - TESTED)

**DETECTOR
MINERALS**



for crystal detectors

It isn't just galena, silicon or other mineral that you want when you buy detector crystals. You want super-sensitiveness! You can be assured of loud signals and clear speech when you use NAA (Arlington Tested) crystals in your radio detector

NAA Crystals are the original tested minerals. Each piece is carefully tested and adequately wrapped and packed in convenient containers. For sale by good radio dealers everywhere or mailed, postage paid on receipt of price.

PRICE LIST

	Unmounted*	Mounted*
NAA GALENA	\$.25	\$.40
NAA GOLDITE	\$.25	\$.40
NAA SILICON	\$.25	\$.40

*Mounted Crystals are set in Wood's Metal in brass cups 3/8 inch diameter. Each crystal is furnished in a neat polished ebonized box.

Unmounted crystals are individually packed in our instantly recognized lithographed containers.

DEALERS: These reputable jobbers can supply NAA Minerals

- J. H. Bunnell Co. New York
- Manhattan Elec. Sup. Co. New York
- Stanley & Patterson Co. New York
- P. M. Dreyfuss Co. New York
- F. D. Pitts Co. Boston
- Doubleday-Hill Co. Pittsburgh
- Robbins Elec. Co. Pittsburgh
- Pittsburgh Radio & App. Co., Pittsburgh
- Radio Elec. Co. Pittsburgh
- Leo. J. Meyberg Co. San Francisco
- Remler Radio Co. San Francisco
- Herbert H. Frost Co. Chicago

The Newman-Stern®

Radio Department
Newman-Stern Building CLEVELAND

be some formula his brother had discovered, just before his disappearance! Foster mentally noted that he had been in the mountains at the time of the embezzlement. Perhaps it was the formula for the "Golden Crystal!"

Old John poked around in a box, after having gone to his laboratory, and selected a few bluish crystals labeled "Chalcomenite—H²CuSeO₅," he chose one, and according to the directions, mixed proportionate amounts of formic and sulphuric acids in a beaker. In this solution he dipped the crystal, then dried it on a scrap of filter paper. He set the beaker of acids to one side, near a lighted oil lamp.

John's hands trembled as he placed the mineral in the detector stand. It might yet be in time to save his wife and himself from abject hunger and despair.

The receiver was adjusted to 600 meters. As he put the phones to his head, he heard to his extreme delight, literally myriads of various tones. At last—his dream!

He ecstatically listened to Java, Germany, Russia, South Africa, and other even more distant stations. The receivers almost shook to pieces, as from time to time the nearby coastal stations roared and pounded in his ears. So people laughed when he had asserted that sparks could be heard further than arcs! Well, he mused, at least his seventh heaven of spark reception had been reached—reward enough!

Old John shouted to his wife to come and hear the marvel. She came feebly up the stairs, a worn shawl wound about her thin shoulders.

"We'll get a million dollars for this!" cried the old man excitedly; his faded eyes glowed with a new fire.

His wife only croaked back, "We've been gittin' them million dollars every week, hain't we?" She saw the slowly reacting acids in the beaker, and bent near to it; a question was framed on her lips, but she could not articulate. She raised a hand to her wrinkled brow, and then sank back on a chair, unconscious, and unnoticed by her husband.

The two evolving acids were slightly accelerated in their reaction by the proximity of the hot lamp; they silently generated their invisible product.

Foster was more than ever engrossed in the results of his brother's formula. The volume of signals increased. Now he heard Suez calling Paris; Moscow conversing with Poland; Greenland talking to Patagonia; Mars calling—

"Hm," the Inspector coughed, as he surveyed the laboratory of John Foster. He ordered that the cold and rigid bodies of Foster and his wife be taken away. "Sweeney," he commanded, pointing to the beaker which was full of an oily-looking solution, "throw all that vile stuff out the window." The subordinate obeyed.

The Inspector again read the little yellow scrap of paper in his hand, and grimly smiled. "Well," he commented, "this is the queerest case of carbon monoxide poisoning I've seen yet. The Borgias were rank amateurs compared to the writer of this little formula."

Station 7 X G at Portland Oregon

(Continued from page 953)

Magnavox Audio Frequency Power amplifiers.

The storage batteries are charged by means of a 75-volt 6-ampere General Electric Tungar Rectifier.

The transmitting and short-wave receiving aerial is of the "T" type. The flat top portion is 40' long and consists of four wires equally spaced on 10' spruce spread-

8

If you want to copy long wave stations, build the set shown in

Design of Modern Radio Receiving Sets

Complete details are given in this book for constructing a long wave receiver, which, with a 200-ft. single wire antenna and an audion detector will receive foreign stations operating on 12,000 to 20,000 meters. The set is easy to tune and operate because it has only two controls.

The design data for this set and other types of equipment will be found in MODERN RECEIVING SETS.

The Price is

50c

Postage 4c

The General Apparatus Co., Inc.

88-N Park Place
New York City

Send 10c for the new
G. A. Catalog

RAC-3

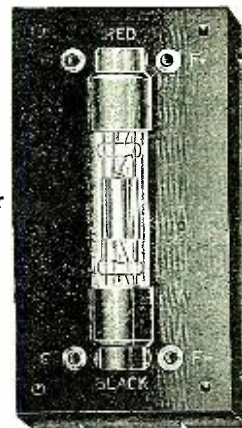

AUDION
\$4.00
The
Amplifier
Tube
You are
Looking
For

RECEP-
TACLE
\$1.00
SEND
FOR
ONE
TODAY

Half Size

New Jersey Radio Equipment & Installation Co.
120 BIDWELL AVE. JERSEY CITY, N. J.

ENAMEL SCC.

Size	1 lb.	1/2 lb.	1/4 lb.	1 lb.	1/2 lb.	1/4 lb.
22	.48	.28	.16	.95	.52	.30
24	.55	.31	.18	1.05	.57	.32
26	.60	.34	.19	1.21	.65	.36
28	.64	.36	.20	1.36	.73	.40
30	.68	.38	.20	1.70	.89	.48

LITZ WIRE, AERIAL WIRE
from 20c to \$1.25 per 100 ft.

TUBES for TUNING COILS

Etc. Etc. Etc. Etc. Etc. Etc.

REEL EASY PRODUCTS

I. R. NELSON COMPANY
BOND STREET
NEWARK, N. J.

Read what Godley says

Radio Corporation of America
233 Broadway
New York City

As the representative of the American Radio Relay League in England during the recent Trans-Atlantic Amateur Transmission Tests, I wish to call your attention to the assistance given by all members of your organization from whom assistance was asked, and the cheerful, wholehearted manner in which it was given.

I have endeavoured, both in the written accounts of my experiences as well as in verbal reports of it, to point out the great value of this assistance, and to call attention to the fact that Radio Corporation Detector Tubes Type **UV 200** were used during the reception at Arrossan in conjunction with the regenerative receiver and 2-stage tone, frequency amplifier. These tubes functioned admirably, and the results obtainable was a surprise to the several British amateurs who saw them in operation.

All Radio Relay men with whom I have spoken concerning the matter since my return are deeply grateful for the co-operation given by your company, and fully appreciate that the completeness of the success of the venture would have been lacking in great degree but for your co-operation.

Respectfully,

Paul F. Godley



It was a great triumph for the amateurs when they sent messages across the Atlantic to Scotland. But it was also a Radiotron triumph. Read what Paul F. Godley says in the letter here reproduced in facsimile.

There are two Radiotrons available for reception. For Detection — Radiotron UV — 200, the popular tube used by thou-

sands of amateurs and novices because of its long life and super-sensitiveness. Price \$5.

For Amplification — Radiotron UV — 201, the amplifier tube which gives maximum amplification without distortion and which, like UV — 200, is used throughout the nation for radiophone broadcasting reception. Price \$6.50.

Ask your nearest Dealer for Radiotrons

Radio  **Corporation**
of America

Sales Department, Suite 1802
233 Broadway, New York City

Red Devil Tools

"Red Devil" Pliers
Handy to use—
keep them at hand



YOU'LL always have use for them for making repairs and adjustments. They multiply the strength of your hand and wrist; they grip as your fingers can't possibly grip—no slipping—no bruised knuckles—no exasperation from trying to do good work with poor tools. Forged from tool steel and guaranteed.

"Red Devil" Combination Plier No. 700—5½ in. shown here, \$1.20 from dealers or us.

Write us for mechanic's tool booklet.

Smith & Hemenway Co., Inc.
Manufacturers of "Red Devil" Tools
273 Broadway New York, N. Y.

Unequaled Low Prices On RADIO CABINETS

Assemble your set in one of these handsome cabinets equal in appearance to the most expensive, yet priced unbelievably low. Everyone can afford them. A necessary protection against dirt, dust and atmosphere. Made of Oak; shipped knocked down, with full instructions for easy assembling and staining. Order today, cash or money order.



Panel Size	Inside High	Dimensions Wide	Deep	Price
6 x 7	5½"	8½"	7"	\$1.50
6 x 10½	5½"	10"	7"	2.00
6 x 14	5½"	13½"	7"	2.00
6 x 21	5½"	20½"	7"	2.25
9 x 14	8½"	13½"	10"	2.25
12 x 14	11½"	13½"	10"	2.25
12 x 21	11½"	20½"	10"	2.75

Radio Cabinet Co. of 1460 Hubbard Ave. Detroit, Mich.

Canadian Amateurs LOOK!

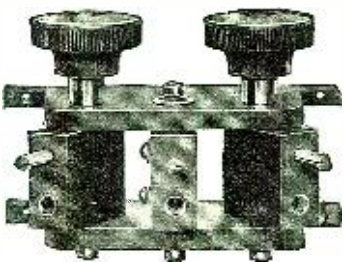

A 3-Coil (Mounting) to fit a standard Honeycomb Coil Plug for only \$5.00
Condensite Moulded Plugs for Coils.....65c
Fibre Plugs for coils.....40c

Send 5c for our new price list.

J. M. PAQUIN
THE ELECTRICAL SHOP
787 Queen St., W. Toronto, Ont.

ers. Each wire of the flat top portion is insulated at both ends with a Victor insulator. These insulators are 24" long and will withstand 100,000 volts on a wet arc test. The bridles are also carefully insulated at all points.

The long-wave receiving aerial is a seven-strand No. 20 phosphor bronze single wire, and is 350' long with an average height of 70'.

The poles supporting the flat top portion are both 100' high and 70' apart, each pole weighing 3½ tons and are 22" at the base and 8" at the top. These masts are one-piece and turned true on a lathe, and there are no guys whatsoever. They are bolted between concrete saddles with 1½" bolts and do not go into the ground; hence, will not rot at the base.

The lead-in consists of four wires brought together about 50' above the ground, forming a rat tail from that point to the instruments. The wire used is 7-strand No. 20 phosphor bronze. A 6-wire counterpoise made up of 7-strand No. 20 phosphor bronze wire runs parallel with the antenna flat top portion, and directly beneath the antenna, the wires being about 1½' apart and 70' long, and very carefully insulated. The counterpoise extends 15' beyond the antenna at both ends. This counterpoise is connected to the inductance on the transmitting set being used in addition to the ground. This gives greater radiation as it reduces the antenna resistance to a minimum. The transmitting set radiates 4 amperes on modulated voice and 5 to 5½ amperes on straight C.W., using two 50-watt tubes as oscillators. The lead-in insulators are 15½" electrose.

The ground system consists of four 6½ strips of three-inch flat copper ribbon, buried about 8" deep, directly underneath the aerial; each strip being spaced two feet apart.

Two Magnavox hand transmitters for talking and three different types of head phone sets for receiving are used, the receivers being the Brandes Navy type, Western Electric and the Baldwin Mica Diaphragm phones. A jack box is mounted on the table so the three sets of phones can be used at the same time. Also the large Magnavox and power amplifier can be used either with the short-wave or long-wave receivers.

The instrument table is 12' long and 3' wide, the top portion of the table being made of spruce and shellacked.

The latest type of electric-driven Victrola with Magnavox tone-arm is used for transmitting phonograph music, and a Steinway Grand piano with a specially constructive spruce tone chamber is used for transmitting vocal and instrumental music.

The operating room is very large, being 17' wide, 30' long with 8½' ceiling, inside measurements, concrete construction; electric lighted with 100-watt lights and steam-heated; has large fireplace and floors are covered with many genuine Navajo Indian rugs. A Western Union Master clock with 60-beat second hand and a Bell private line telephone completes the station.

The Northwestern Radio Manufacturing Co. is figuring on building for this station a 250-watt tube transmitting set, using one 250-watt tube as oscillator, one 250-watt tube as modulator, and one 50-watt tube as a speech amplifier. Also, the same company is going to build for this station an Armstrong Super Heterodyne Radio Frequency Receiver, which will have four steps of radio frequency amplification, this being in addition to two ordinary stages of audio frequency amplification and three power stages, which will give altogether four stages of radio and five stages of audio frequency amplification.

This station (7XG) has been heard on C.W., I.C.W., and modulated voice in the

"SHRAMCO PRODUCTS"

Amateurs: Send 5c in stamps, today for our new Catalogue L showing complete line of parts, raw materials and high grade apparatus.

Dealers: Write for our attractive proposition.

THE SHOTTON RADIO MFG. COMPANY, Inc.
8 Market St. Albany, N. Y.

WE ARE MANUFACTURERS of ELECTRICAL APPARATUS with a NATIONAL REPUTATION

Among our customers are the largest manufacturing concerns in the world. With our factory and facilities we are prepared to manufacture your Radio apparatus in whole or in part, giving you the very best of service and the benefit of our years of experience.

BRIGGS & STRATTON CO.
MILWAUKEE, WIS.

Order Your Complete Sets and Parts Where You Will Get Service

I handle all the standard lines of apparatus.

Clapp-Eastham Regenerative Receiver Type HR and two step amplifier. They work fine.

New Whitall V.T. base all composition, no noise, \$0.75. Exceptional value.

Postage paid. Send me your orders for any make of Radio Instruments.

SERVICE DEPT.
H. S. WEBSTER
LYNDON CENTER VERMONT

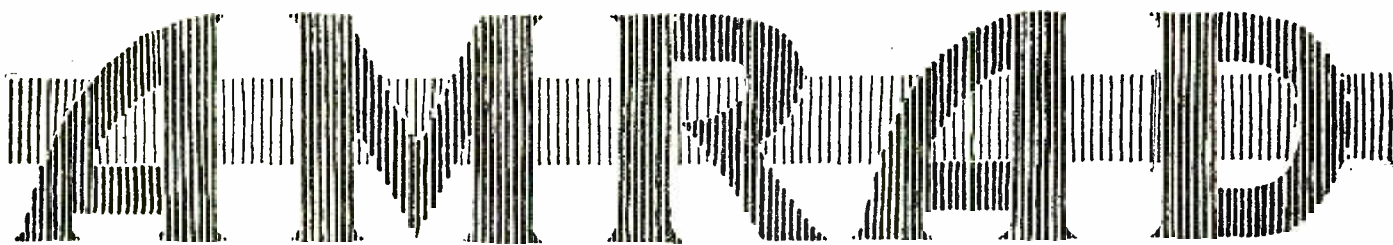

The Recognized Symbol of Superior Performance



GROUNDLED SHORT GAP
2797, Price \$4.50

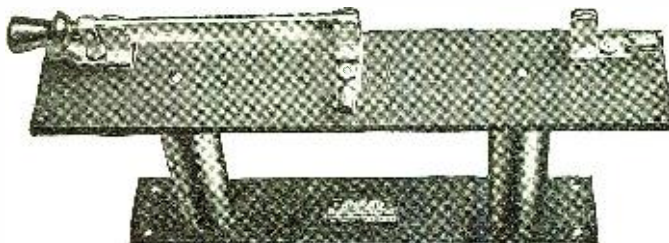

AMRAD LIGHTNING SWITCH
2796, Price \$7.50



SEND-RECEIVE SWITCH
2834, Price \$11.00

Regulations Will Be More Rigid—PREPARE

Amrad Grounded Short Gap

This Gap is the modern substitute for the Lightning Switch. It is the only protective device on the market which meets the present requirements of the National Board of Fire Underwriters. It is intended for use with receiving equipment. Summer with its thunder and electrical storms is coming and you should protect your property. Do not take chances with unapproved gaps. Insist on one which defies criticism of electrical inspectors. Order Now.

Amrad Lightning Switch

National regulations require a lightning switch when the aerial is used for transmitting as well as receiving. In construction the Amrad design is the only Lightning Switch which meets all the regulations. Better be safe than sorry.

Ground Lead Insulators

No. 2994 Ground Lead Insulators are among the Amrad Accessories designed to meet fire regulations. These and the protective devices illustrated on this page are described in Bulletin H sent free on request.

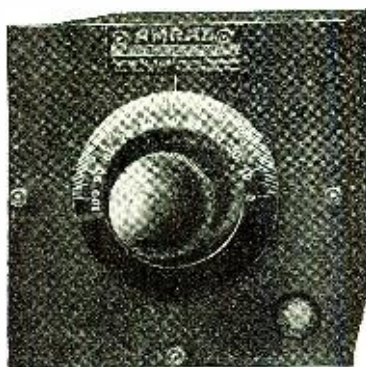

WAVEMETER
2793, Price \$14.50



V.T. 2-STAGE AMPLIFIER
2776, Price \$38.00

Amrad Send-Receive Switch

For shifting from receiving to transmitting and vice versa the Amrad Send-Receive Switch is convenient and economical. Give your Station that commercial look. Write for Bulletin H.

Amrad Wavemeter

Use of a good wavemeter is particularly important at this time when failure to transmit on legal wavelengths may cause drastic restrictions. The Amrad Wavemeter, illustrated, has a range of 150 to 400 meters. Its operation is very simple. By consulting the chart furnished with each instrument, the transmitting wavelength may be determined instantly without calculations. In addition the Amrad Wavemeter may be utilized in the receiving set. Bulletin H tells how.

Amrad VT Detector 2-Stage Amplifier

Our 2-Stage Amplifier 2776 is a component part of the Amrad Unit System. An Amplifier with a punch. This unit and six other vital units useful in fifteen various combinations are described in Bulletin F. Send for your copy.

AMERICAN RADIO AND RESEARCH CORPORATION

New York District Office
21 Park Row

General Office, Factory and Laboratory
203 College Avenue, Medford Hillside, Mass.

Chicago District Office
600 So. Dearborn St.

Here's the Receiving Set You Are Looking For—

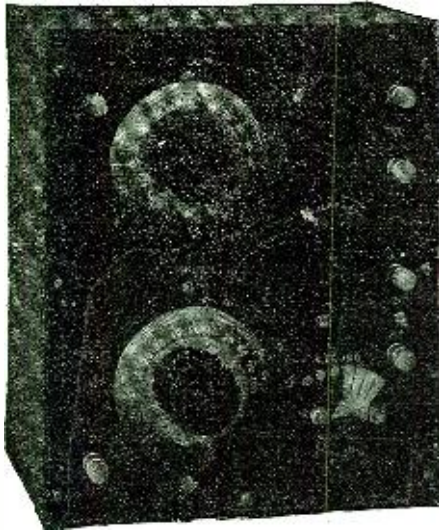

**The Clapp-Eastham,
Type HR Regenerative
Receiver.**

—price **\$40.00**

You can pay more money for a receiving set—if you want to—but you can't get any better results or greater satisfaction at any price.

Since we put this set on the market, we've been literally swamped with orders. Dealers, radio "fans," novices—everybody who has tried the instrument has become a booster for it.

Licensed under Armstrong U. S. Patent, No. 1,113,149.

Regeneration is perfect on all wave lengths between 180 and 825 meters. The range or distance from which signals are received and the clear, sharp tones are a revelation to the experienced radio man as well as to the person who "listens in" for the first time.

The specifications tell the story to the expert and the C-E guarantee of satisfaction protects every purchaser of a Clapp-Eastham Type H.R. Regenerative Receiving Set—expert and amateur alike.

If you're looking for 100% satisfaction—regardless of price—ask your dealer to show you this set. He may be temporarily out, but it's well worth waiting for—or you can write us direct.

If you haven't already received a copy, you should send 6c in stamps for the C-E Radio Catalog—it covers every essential radio requirement.

Specifications

Panel—Formica, handsomely finished.
Cabinet—Solid mahogany.
Condenser—Balanced type, 2 Rotary, 3 Stationary plates. Built on Vernier.
Dials—Indestructible metal. White figures on black ground.
Antenna Inductance—Wound in Formica Tube.
Plate Inductance—Wound on molded ball.
Binding Posts—Black rubber covered.
Switch—Fan Blade.
Rheostat—C. E. Type H400.
Circuit—Single circuit regenerative. Licensed under Armstrong U. S. Patent No. 1,113,149.
"B" Battery—Contained in compartment inside cabinet or external as desired.

CLAPP-EASTHAM COMPANY

RADIO ENGINEERS *and* MANUFACTURERS
120 Main Street CAMBRIDGE, MASS.

127-19

D. H. E. Co. Pittsburgh Broadcasting Station Call, K.Q.V.

Distributors for Stromberg-Carlson Radio Headsets

The Stromberg-Carlson No. 2A is a professional headset at the amateur's price. Exhibits sound engineering principles, correct design, high grade workmanship, durable finish, extreme sensitiveness and superior tonal qualities.

Order Above and Following Highest Grade Supplies by Mail
Enclose Certified Check or P. O. Money Order, Including Postage



Stromberg-Carlson
No. 2A Headset

\$7.50

CR 9 Grebe Receiver.....	\$130.00
CR 5 Grebe Receiver.....	80.00
RORK Grebe 2-stage Amplifier.....	55.00
R2 Magnavox Loud Speaker.....	110.00
R3 Magnavox Loud Speaker.....	45.00
UV 200 Radiotron Detector Tubes, each.....	5.00
UV 201 Radiotron Detector Tubes, each.....	6.50
No. 766 Eveready VT Batteries, each.....	8.00
D.H.E. 6 volt, 80 ampere storage batteries, each.....	18.00

Full List of Parts and Supplies with Prices on Request

DOUBLEDAY-HILL ELECTRIC CO.

715 Twelfth St., N. W., Washington, D. C. Radio Dept.—Desk B 719-21 Liberty Ave., Pittsburgh, Pa.

A welcome addition to your library! Send \$2.50 today, plus postage for 7 lbs., and your copy of bound volume No. 2 of Radio News will come forward by return mail.
Experimenter Publishing Company, Inc. 236a Fulton Street, New York City

Hawaiian Islands, near Honolulu, a distance of about 2,500 miles airline, this being verified by a signed statement from the operator of the station near Honolulu. This station (7XG) is located at 400 East 22nd Street North Portland, Oregon, and would be more than pleased to receive communications from any stations hearing 7XG on voice, C.W. or I.C.W. Anyone wishing further information can be assured that their inquiries will be promptly and cheerfully answered.

Methods of Transmission Used in Broadcasting Stations

(Continued from page 946)

waves be of fairly high frequency and completely steady or undamped.

Many experiments using arc and radio-frequency spark transmitters were conducted in the early days of radio telephony, but only by the perfection of the thermionic valve or audion and its use in the production of continuous waves and in the amplification of the modulations of the voice has it been possible to bring the radio telephone to its present efficient stage.

Various kinds of microphones for modulation purposes have been used. One type was the Fessenden condenser microphone, and consisted of a variable condenser, the movable plates of which were connected to the antenna and the stationary plates to the ground. The position of the movable plate was varied by the voice modulations and the antenna capacity varied accordingly. This had the effect of detuning the antenna in synchronism with the modulations of the voice.

The carbon-grain microphone, which is a very old method, is still used extensively and is, in fact, about as efficient as any. The vibrations of the microphone diaphragm produced by the voice, vary the resistance of the carbon-grains across which is connected the modulation circuit.

One of the most modern methods which is being used very extensively, is particularly adapted for orchestra music or singing voice, when the concentration effect of a horn would prove harmful to the tone of the music. This is known as the "Phonotron," and consists of a large paper diaphragm of special design which is attached to a small movable armature coil supported in the field of an electro-magnet. The vibrations produced in the diaphragm by the music or voice make the armature coil vibrate in the magnetic field at the same frequency. Current is, therefore, induced in the armature which is connected to the modulation circuit of the transmitter.

The New Radio Legislation

(Continued from page 944)

ing to operate radio telephone broadcasting service should be required to co-operate with municipal or state service in the use of the wave band, 275 to 285 meters, assigned to the latter service.

Note 6. When transoceanic radio telephone experiments are to be conducted the Department of Commerce should endeavor to arrange with other countries for the use of the wave band, 5,000 to 6,000 meters assigned for this purpose.

Note 7. The wave band from 1,550 to 1,650 meters is for use of radio telephonic communication over natural barriers, but is not exclusive of other services.

Note 8. The wave band from 700 to 750



Warp-Proof, Weather-Proof Radio Panels and Tubes

FORMICA panels and tubes absorb no moisture. They do not swell because of dampness, or shrink because of dryness. They keep their shape, and keep also their high dielectric strength and perfect insulating quality.

Dealers sell Formica in the right sized sheets for the panel you want to build. These dealers get it from us cut to size, or cut it themselves. All you need to produce a handsome panel is a drill.

The finish in high gloss—black or brown—is very handsome and produces a result you will always be proud of. Formica keeps its good looks, too. By sanding it you can easily produce a handsome satin finish.

Formica sheets are solid Formica—all the way through. There is no cheap moisture absorbing material in the middle that will cause warping and power losses later. Insist on the best radio insulation approved by the Navy and the Signal Corps.

Dealers: Formica is the most widely known and accepted radio insulation. It goes into about 90 per cent. of the sets which amateurs build for themselves and they are following manufacturers and commercial companies in their preference for Formica. We can supply you promptly with 42 by 36 sheets, or smaller sizes already cut for Radio panels. You can always get Formica and in any quantity!

The Formica Insulation Company

4618 Spring Grove Avenue
Cincinnati, Ohio

FORMICA
Made from Anhydrous Redmanol Resins
SHEETS TUBES RODS



“Chi-Rad” Storage “B” Battery

The hit of the season—a real Storage “B” Battery with pasted plates which can be re-charged as easily as your “A” Battery. Ideal for Laboratory and Experimental use as well as all Radio Equipment employing Vacuum Tubes. Equally desirable on detecting amplifying or transmitting tubes as source of plate voltage.

PRICES

22 Volt Battery as shown, \$6.00. (Add PP on 8 lbs.) Single Cells, \$0.50 (Add PP on 1/2 lb.). Wood Base, \$1.00 (Add PP on 1 lb.).

SPECIFICATIONS

Block size, 2 3/4" x 9".
Tubes, 1" Diam. 5" high.
Voltage per cell, 2 volts.

Shipped dry with simple directions for setting up and charging.
Capacity 2 Amp. Hours—will operate 1 tube 1000 hours on one charge.

Dealers—Chi-Rad Storage Batteries will be widely imitated but never excelled—why not sell your customers the 100% ORIGINAL Battery backed up by our guarantee? It will mean dollars in your pocket in the end. Send us your orders now!

GORTON ENGRAVING

New Gorton Engraving Machine just installed. We do work equal to any Commercial Maker of Radio Apparatus—have your set up to date with all parts neatly marked with engraved letters or figures. 5c per letter, minimum charge, \$2.00.

Radio Manufacturers.—Let us quote you on panels drilled and engraved to your specifications.

REMOVAL NOTICE

Don't forget we are now located in our new Ground Floor Salesroom at 415 South Dearborn St. Come and see us soon—we will carry the most complete stock of High Grade Radio Supplies in the Middle West.

CHICAGO RADIO APPARATUS CO., Inc.
415 South Dearborn Street Chicago, Illinois



If you want radio equipment that will always function properly under all conditions, make sure that it is made of

Condensite

Because there is no other material which possesses in such a high degree the properties essential to radio insulation.

Condensite Company of America
BLOOMFIELD, N. J.



Get a Handy Binder for your RADIO NEWS. Holds and preserves twelve issues, each of which can be inserted or removed at will. Price 65c. Experimenter Pub. Co., Inc., Book Dept., 236-A Fulton St., New York.

meters may be used for Government and public broadcasting in parts of the country farther than 700 miles from the sea coast.

Note 9. The restricted special amateur wave of 310 meters is for use by a limited number of inland stations and only where it is necessary to bridge large, sparsely populated areas or to overcome natural barriers.

Note 10. The wave band from 2,850 to 3,300 meters may be used for fixed service radio telephony only provided it does not interfere with service using continuous wave telephony.

Note 11. No definite allocation shall be made in the wave band from 1,050 to 1,500 meters until after a conference between the Government Departments concerned.

Note 12. Wave bands marked “non-exclusive” are available also for other types of transmission.

Note 13. Wave bands not included in this table and those bands marked non-exclusive are available for radiotelegraphy, subject to regulation.

B. It is recommended that the Secretary of Commerce assign a specific wave length to each radio telephone broadcasting station (except Government and amateur stations), this, of course, being within the bond pertaining to the particular service of that station.

C. It is recommended that the wave band assigned to amateurs, 150 to 275 meters, be divided into bands according to the method of transmission, damped wave stations being assigned the band of lowest wave lengths, interrupted or modulated continuous wave radio telegraph stations the next band, radio telephone stations the next band, and finally unmodulated continuous wave radio telegraph stations the band of highest wave lengths. It is recommended that amateurs be permitted to carry on broadcasting within the wave length band assigned by the Secretary of Commerce to amateur radio telephony.

D. It is recommended that the present regulations governing experimental stations remain in effect.

E. It is recommended that the establishment at any later date of any commercial transmitting stations having more than 1 kw. input to the antenna may, at the discretion of the Secretary of Commerce, be prohibited within 25 land miles of a Government or commercial station or in regions where congestion of radio traffic shall warrant such prohibition.

II. POWER LIMITATION, GEOGRAPHICAL DISTRIBUTION, AND HOURS OF OPERATION OF BROADCASTING STATIONS

A. It is recommended that the Secretary of Commerce assign to each radio telephone broadcasting station a permissible power based on the normal range of the station, such normal ranges for the different classes of service to have the following average values, larger or smaller values being discretionary where conditions warrant:

Government broadcasting stations, 600 (land) miles.

Public broadcasting stations, 250 miles.

Private and toll broadcasting stations, 50 miles. (Note. The Bureau of Standards of the Department of Commerce, should make a study of the relation between the normal reliable range of a station and the antenna power on the basis of the use of good available receiving apparatus. It is recognized that this relation may change with the development of the radio art.)

B. It is recommended that the same wave (or overlapping wave bands) not be assigned to stations within the following distances from one another, except that these distances may be lowered if the normal ranges of the stations are correspondingly lowered:

For government broadcasting stations, 1,500 miles.

For public broadcasting stations, 750 miles. For private and toll broadcasting stations, 150 miles.

(Note. The Bureau of Standards should make a study of the width of wave band (expressed in cycles per second) required for satisfactory radio telephony. It is recognized that this width depends on the methods of transmission and reception employed.)

C. It is recommended that the Secretary of Commerce cause an immediate study to be made

This special Radio Battery has all the Willard Threaded Rubber Battery features that are applicable to Radio work —plus many new ones found only in this battery.



Bring Your Set Up-to-Date with this All-Rubber Radio Battery

It's just as important in receiving, to have a good battery as to have a reliable and efficient set.

The Willard All-Rubber Radio Battery was designed and is being used especially for radio work. It gives you the same reliability in wireless work as the starting and lighting battery has always given in motor cars. These batteries are available at a considerable less cost than the motor car battery.

Willard Radio Batteries are made with the same care, and have the same Threaded Rubber Insulation as the larger batteries.

An important Radio feature is the All-Rubber Case. Cells and case are a solid piece of rubber that absolutely prevents leakage from cell to cell or to the ground, thus doing away with one of the most troublesome sources of noise.

Threaded Rubber Insulation and case are both tested with 24,000 volt wireless transformers before assembly. Freedom from leakage is thus assured.

For details about the Radio Battery, go to the nearest Willard Battery Station, or write us direct.

WILLARD STORAGE BATTERY CO., Cleveland, Ohio

Made in Canada by the Willard Storage Battery Company of Canada, Limited, Toronto, Ontario

Willard THREADED
RUBBER
BATTERY

Another **TELMACO** Achievement

The TELMACOPHONE

Here is the Height of Telmaco Perfection

Equipped with Baldwin Type C Unit, inverted horn, reflected tone. Equal to any other horn twice its length. Designed and perfected by expert acousticians. Complete in every detail.

Don't be misled into buying a loud speaker offered for less, and expect satisfaction; for a loud speaker of quality cannot be sold for less. Only after the most exhaustive tests and comparisons with the other loud speakers; and only after the most thorough research, laboratory tests, and field demonstrations has the Telmacophone been perfected, and offered now, for the first time, to the public.

Telmaco Amplifiers, Receivers, Detectors, Variometers and Variocouplers have earned a national reputation for quality, endurance and satisfaction not excelled by any other line. You can expect equal satisfaction from the Telmacophone.



No Extras to Buy.

Nothing to get out of order.

Price Complete \$20.00

Fully Guaranteed

Price without Baldwin Unit, but with cap attached, \$14.00.

We advise the purchase of the Telmacophone without unit for those who have Baldwin Unit of their own.

If you haven't our complete catalog "N", be sure to write for it now.

Dealers! We are distributors for nearly all standard lines. Full discounts on the Telmacophone. Write for proposition on our complete line.

RADIO DIVISION
Telephone Maintenance Co.
 20 South Wells St. Chicago, Ill.

BIESMANN STORAGE "B" BATTERY

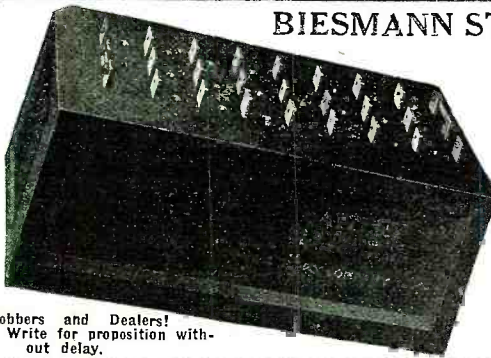

Here's What the Radio World Has Long Been Looking For. No "B" Battery to be replaced. Takes care of Detector and Amplifier.

Twenty-four cells, individually tapped permitting use of any voltage from 2 to 50 volts in steps of two volts each. Electrolyte is semi-solid; cannot spill or leak. Container is one piece cast composition block. Highly polished and neat in appearance. Pasted type plate especially developed for Radio Service. Battery may be charged with any vibrating rectifier by using the circuit provided with battery. Copy of instructions furnished with each battery.

Price \$14.00

RADIO DIVISION
TELEPHONE MAINTENANCE CO.
 20 S. WELLS ST. CHICAGO, ILL.

Jobbers and Dealers! Write for proposition without delay.

Atherton Batteries

FOR RADIO USE

- 40 Ampere Hour 6 Volts ... \$11.50
- 60 Ampere Hour 6 Volts ... \$14.00
- 80 Ampere Hour 6 Volts ... \$16.00

Crated with directions for charging or charged if you prefer.

Built especially for this work and will give perfect service. Guaranteed.

Atherton Storage Battery Co.
 MACOMB, ILL.

RADISCO

THE merit of "RADISCO RECOMMENDED" apparatus to the amateur, and the value of "RADISCO CONCENTRATED BUYING" to the dealer, has resulted in such an influx of business and mass of detail that we have had to curtail the well-known RADISCO advertising for this issue.

RADIO DISTRIBUTING CO.

Newark, New Jersey

of the best geographical distribution of broadcasting stations with the view of attaining the best service with a minimum of interference. A chart has been prepared showing an ideal distribution of broadcasting stations under various assumed conditions as to number of available wave bands and ratio of distance between stations having the same wave length to normal range of the stations.

D. It is recommended that in cases where congestion of radio telephone broadcasting traffic exists, or threatens to exist, the Secretary of Commerce assign suitable hour of operation to existing or proposed private and toll broadcasting stations.

III. CONSIDERATIONS TO BE FOLLOWED IN GRANTING LICENSES

A. It is recommended that in the case of conflict between radio communication services first consideration be given to the public not reached, or not so readily reached, by other communication services.

B. Subject to public interest and to the reasonable requirements of each type of service the order of priority of the services shall be Government, Public, Private, Toll.

C. It is recommended that the degree of public interest attaching to a private or toll broadcasting service be considered in determining its priority in the granting of licenses, in the assignment of waves, and in the assignment of permissible power, within the general regulations for these classes of service.

D. It is recommended that toll broadcasting service be permitted to develop naturally under close observation, with the understanding that its character, quality and value to the public will be considered in determining its privileges under future regulations.

E. It is recommended that direct advertising in radio broadcasting service be not permitted and that indirect advertising be limited to a statement of the call letters of the station and of the name of the concern responsible for the matter broadcasted—subject to such regulations as the Secretary of Commerce may impose.

F. It is recommended that when all available wave bands in any geographical region are already assigned, no further licenses for broadcasting be granted in that region until cause arises for the revocation of existing licenses.

G. It is recommended that private or toll broadcasting stations transmitting time signals shall transmit only official time signals and with authorization from and under conditions approved by the Secretary of Commerce.

H. It is recommended that the transmission of signals of such character or wave length as to deliberately interfere with the reception of official time signals constitutes grounds for the revocation of the transmitting license.

I. It is recommended that license requirements for the operator of a radio telephone transmitting station include a knowledge of the International Morse Code, sufficient to receive at a rate of not less than 10 words per minute.

IV. TECHNICAL METHODS FOR THE REDUCTION OF INTERFERENCE

A. It is recommended that the Secretary of Commerce at his discretion prohibit at any time the use of existing radio transmitting apparatus and methods which result in unnecessary interference, provided that such action should not be taken unless more satisfactory apparatus and methods are commercially available at reasonable prices and until an adequate time interval is allowed for the substitution of the more satisfactory apparatus.

B. It is recommended that the Secretary of Commerce at his discretion prohibit at any time the use of existing radio receiving apparatus which cause the radiation of energy, provided that such action should not be taken unless more satisfactory apparatus and methods are commercially available at reasonable prices and until an adequate time interval is allowed for the substitution of the more satisfactory apparatus.

C. It is recommended that the Bureau of Standards make a study of the technical methods for the reduction of interference, with a view to publishing their findings, giving special attention to the following:

(1) The reduction of the rate of building up (increment) of oscillations in radiating systems. (This rapid building up of oscillations occurs in damped wave and interrupted continuous-wave transmitters, and may, of course, be eliminated by the substitution of other types of transmitter. It may, however, be reduced in these types by proper circuit arrangements.)

(2) The reduction of harmonics in continuous wave transmitters and of irregularities of oscillation ("mush" in arc transmitters and "swinging" of the frequency in all types of continuous wave transmitters not employing a master oscillator).

(3) The comparison of the variable amplitude method with the variable frequency method of continuous wave telegraphy.

(4) The preferable methods of telephone modulation to avoid changes in the frequency of oscillation.

(Continued on page 993)

STANDARD RADIO GOODS AT ATTRACTIVE PRICES

PLATE CIRCUIT "B" BATTERIES

Look what you can save on these batteries. Don't pay more. We guarantee them to equal any on the market regardless of price. Absolutely uniform. Extra long life.

A180 Large Signal Corp type size 5x3x2 1/4. 15 cells, 2 1/2 volts. Each, \$1.10. Dozen \$11.25.

A182 Navy size, 6 1/2 x 4 x 3, 15 cells, 2 1/2 volts. Each, \$1.75. Dozen, \$19.00.

A184 Variable Navy size, 5 taps giving range from 10 1/2 to 22 1/2 volts in 1 1/2 volt steps. Each, \$2.25. Dozen, \$24.00.

A186 Double Navy size 6 1/2 x 4 x 6, 30 cells, 45 volts. Suitable for amplifier circuits and power tube use. Two or more of these units in series may be used in C.W. and radiophone circuits. Each, \$3.40. Dozen, \$36.00.

A188—Combination Tapped 45 volt, 30 cell, 6 1/2 x 4 x 6 battery. Tapped to give 22 1/2, 21, 19 1/2, 18 or 16 1/2 volts. Handles both detector and amplifier tubes. Each, \$3.90. Dozen, \$40.

VACUUM TUBES

Standard Brands—A. P. Moorehead, Cunningham, Radiotron. Every one guaranteed new and perfect. We will ship brand in stock unless you specify otherwise.

A105 Detector, each.....\$4.80
A110 Amplifier, each.....6.35
A115 5 Watt Transmitter.....7.25
A120 Rectifier, each.....6.95

FILAMENT CONTROL RHEOSTATS
Crosley—Wound on vulcanized fiber. Adjustable to any panel. Complete with knob, A130, each.....57c

Fada—Best made. High heat base. Diam. 2 1/4 in. 1 1/2 amp. Resist. 6 ohms. 1 1/4 in. Knob with pointer. A132, each.....95c

Remler No. B13—Bakelite base 2 3/4 in. diam. Handles two tubes. Cap. 3 amp. Resist. 6 ohms, complete with 1 1/4 in. knob and pointer, A134, each.....\$1.63

Signal Porcelain Base Rheostat for table mounting. Resist. 10 ohms. A136, each, 87c.

VACUUM TUBE SOCKETS
Our Special Socket. A wonderful value. Moulded entirely of Redmonol. Four binding post connection. A140, each, 75c. Dozen, \$8.05.

Porcelain Base and Tube A142 I.K. extra heavy, 48c. A144 Crosley for either panel or table mounting.....87c

Paragon combination type for panel or table mounting. A146, each.....\$1.18

VARIABLE GRID LEAK
Pencil mark type. Resistance may be varied exactly as needed. A160, each.....57c

GRID CONDENSER
A162 Remler—Mounting holes spaced to fit lugs of above leak. Cap. .00225 MF. 32c
A164 Mica Insulated, unmounted, each.....25c

DIAL AND KNOB
Neat clean cut design. Clear plain engraved scale, with enameled white letters contrasting with polished black finish of dial. Plated knob. A902—For 3/16" shaft—Each 75c; Dozen \$7.50.
A904—For 1/4" shaft—Each 75c; Dozen \$7.50

BATTERY CHARGING RECTIFIER
Charge your battery at home over night for a few cents. Simply connect to any 110 volt 60 cycle light socket, turn on current and rectifier does the rest.

Work for years without attention. Simple connections. Gives a tapering charge, which batteries should have. You can make it pay a profit charging your friends' auto batteries. Long connecting cords with pair of battery clips.
A201 for 6 volt battery.....\$14.50
A203 for 12 volt battery.....\$14.50

STORAGE BATTERY
A very high grade battery made especially for radio service. Guaranteed. Properly cared for will give years of service for filament lighting. A194, 6 volt, 40 ampere size, each, \$12.75. A196, 6 volt, 80 ampere size, each, \$14.75.

WE PAY TRANSPORTATION CHARGES EAST OF THE ROCKIES

THE PRICES QUOTED DELIVER THE GOODS TO YOUR DOOR

FAST SERVICE—TRY US AND BE CONVINCED

THIS GUARANTEE PROTECTS YOU—Examine the goods we ship you. They must suit you in every respect. If you are not satisfied with your purchase return the goods at once and we will refund the price you paid.



SPECIAL OFFER
Regenerative Tuner and Detector—Two Step Amplifier
A220—The two for.....\$67.50
This is a combination unequalled for clear long distance radiophone receiving. With a good aerial the range is only limited by the power of the transmitting set. Send for complete descriptive circular.



DETECTOR-TWO-STEP AMPLIFIER, A222—Price \$34.00

A very sensitive high grade instrument. Signals that cannot be heard with detector alone will be brought in strong. Has one detector and two amplifying circuits. Standard tube sockets, grid condenser in detector circuit, two amplifying transformers, 3 jacks and a plug. Satin finished Formica Panel. Fine Mahogany finish large size cabinet. Hinged top. Interior easily accessible. Binding posts for all necessary connections.

REGENERATIVE TUNER A224—Price \$35.00

This is a standard make Armstrong licensed set. Range from 180 to 600 meters. Will tune sharply and bring in signals strong even under difficult conditions. Fine Mahogany finished large size cabinet. Satin finished Formica Panel. Two high grade variometers with variocoupler for close tuning. Engraved dials, knobs, switches, binding posts for all necessary connections, etc. A high grade outfit worth much more than we ask.



ARLINGTON RECEIVING TRANSFORMER

Will tune in all stations up to 4,000 meters. Very efficient on short waves and for radiophone reception. Used with our Detector Two Step Amplifier it produces very excellent results. Also does good work with crystal detector. Still covered windings on formica tubes. Very fine mahogany finish woodwork. Base size 6x18 inches. Slider controls primary, 12 point switch on secondary. Can be tuned very close. A wonderful value at our price. A720, price.....\$7.50

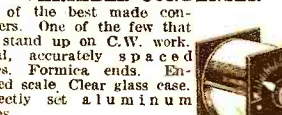

VARIABLE CONDENSER

One of the best made condensers. One of the few that will stand up on C.W. work. Rigid, accurately spaced plates. Formica ends. Engraved scale. Clear glass case. Perfectly set aluminum plates.
A806 43 plate .001 Mfd. \$4.75
A808 21 plate .0005 Mfd. \$3.85



TUNING COIL

Range up to 950 meters. Wound with bare copper wire, machine spaced. Ends of mahogany finished hard wood. Two easy sliding contacts on polished brass rods, four binding posts. Substantial, efficient, attractive. Length 8 1/2 in. A722, price.....\$3.15

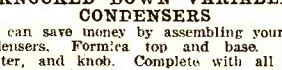

PANEL MOUNTING TYPE

Same high grade as above for panel mounting.
A812 43 plate .001 Mfd. \$4.45
A813 21 plate .0005 Mfd. \$3.55
A814 11 plate .00025 Mfd. \$3.15
Without Knob and Scale deduct 20c.

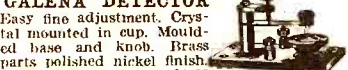

ENCLOSED DETECTOR

One of the finest crystal detectors on the market. Bakelite base. Supersensitive galena crystal enclosed in heavy glass shield. Quick positive adjustment. Brass parts polished nickel finish. A730, each.....\$2.10

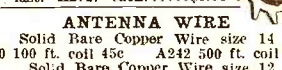

FIXED CONDENSERS

Moulded cases, nicked binding posts.
A802 .005 Mfd. Each. 68c
A804 .01 Mfd. Each. 87c

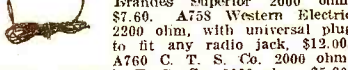

GALENA DETECTOR

Easy fine adjustment. Crystall mounted in cup. Moulded base and knob. Brass parts polished nickel finish. A732, each.....\$1.39



SPARK GAP ROTATOR

Bakelite center disc, aluminum teeth, shaft bushing with set screw. Diam. 5 1/2 inches. White they last. A272, each.....\$1.85

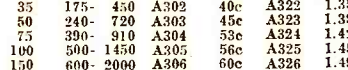

HEAD SETS "PHONES"

Double sets complete with head bands connecting cord.
A751 Murdock No. 55, 2000 ohm, \$4.85. A753 Murdock No. 56, 3000 ohm \$5.80. A754 Baldwin mica diaphragm Type C with universal plug to fit any radio jack, \$12.00. A756 Brandes Superior 2000 ohm, \$7.60. A758 Western Electric 2200 ohm, with universal plug to fit any radio jack, \$12.00.
A760 C. T. S. Co. 2000 ohm, \$4.85. A762 C. T. S. Co. 3000 ohm, \$5.80.

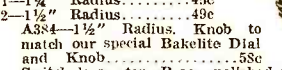

ANTENNA WIRE

Solid Bare Copper Wire size 14
A240 100 ft. coil 45c A242 500 ft. coil \$1.95
Solid Bare Copper Wire size 12
A244 100 ft. coil 72c A246 500 ft. coil \$2.85
Seven Strands No. 22 Copper Wire Cabled
A248 100 ft. coil 94c A249 500 ft. coil \$4.25

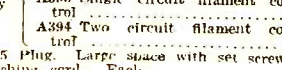

ANTENNA INSULATORS

A260 Size 1x3 1/4. Two for.....40c
A262 " Size 2 1/4x3 1/4. Two for.....62c
A264 " Size 1 1/2x4. Two for.....92c
A266 " Size 1 1/2x10 1/2. Two for.....\$1.40

VARIOMETER

A410—Price \$4.20

A wonderful value at our price. Perfect in design and construction. Accurate wood forms. Correct inductive ratios. Solid laked windings. Positive soldered cable circuit contacts. Highest efficiency. Will operate perfectly indefinitely. This variometer will equal in results most of the moulded variometers selling at much higher prices.



VARIO-COUPLER

A415—Price \$3.60

A wonderful value at our price. With this variometer and two loose couplers together with the necessary other parts a highly efficient regenerative set can be made. Easily mounted on panel. Windings on formica tubes. Inductively coupled for 180 to 600 meters. Multiple taps permit fine tuning.

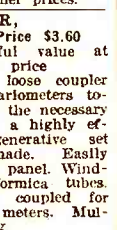

AMPLIFYING TRANSFORMER

Thordarson Make

An especially high grade transformer with correct characteristics for Cunningham, Radiotron or A.P. Tubes. Wonderful results without distortion on one, two or three steps. Low distributed capacity. Fully mounted on bakelite panel. A232, each.....\$4.00



OUR SPECIAL AMPLIFYING TRANSFORMERS

We believe these transformers to be the best on the market. We offer them with two winding ratios—the 10 to 1 for Radiotrons and Cunningham's, the 3 to 1 for A.P. Moorehead. These two types of tubes have entirely different characteristics and therefore require transformers of different winding ratios. As high as three stages can be used without howling due to proper impedance ratio, minimum distributed capacity, low core losses and proper insulation. Mounted style has bakelite panel with binding post connections. Unmounted has core and coils assembled with two holes in case for fastening to apparatus.
A234—10 to 1 Mounted, each.....\$4.15
A235—10 to 1 Unmounted, each.....3.20
A236—3 to 1 Mounted, each.....3.90
A237—3 to 1 Unmounted, each.....3.10

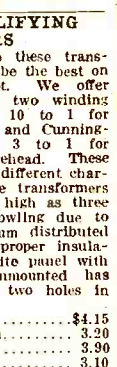

CABINETS

Fine looking cabinets, solidly built. Made of seasoned wood in waxed antique mahogany finish. Hinged tops. Front rabbeted to take panels. Panels not included.



SOLID GENUINE CONDENSITE CELERON PANELS

Notice our very low prices on this fine quality grade 10 genuine solid sheet Condensite Celeron (a product with mechanical chemical and electrical properties like formica and bakelite). Machines well without chipping. Won't warp. Waterproof. Highest mechanical and dielectric strength. Attractive natural polished. Black finish which can be sanded and oiled for extra fine work.

Panel Size	High	Wide	Deep	No.	Art.	Price Each
6x7"	5 1/2"	6 1/2"	7"	A120	A245	\$2.45
6x10 1/2"	5 1/2"	10"	7"	A122	A246	2.05
6x14"	5 1/2"	13 1/2"	7"	A124	A247	3.15
7x18"	6 1/2"	17 1/2"	10"	A126	A248	3.35
9x14"	8 1/2"	13 1/2"	10"	A128	A248	4.28
12x14"	11 1/2"	13 1/2"	10"	A130	A240	4.30

BINDING POSTS

Brass, polished nickel finish. Washer and 6/32" screw extending 5/8". A370 Large size—barrel and knob 3/16" long, Each 12c; Dozen \$1.30. A372 Smaller size—barrel and knob 3/16" long. Each 9c; Dozen \$1.02. A374 Large size with composition knob. Each 9c; Dozen \$1.02. A376 Large size with hole for phone tip or wire. Each 12c; Dozen \$1.30. A378 Small size with hole for phone tip or wire. Each 12c; Dozen \$1.30.

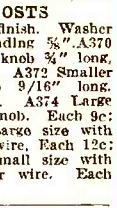

SWITCH CONTACT POINTS

Brass, polished nickel finish. All have 5/8" long size 6/32 screws.
A360 With head 1/4 x 1/4" and two nuts, per dozen.....45c
A362 With head 3/8 high 3/16 diam. and two nuts, per doz. 45c
A364 With head 1/4 x 1/4" and soldering lug, per dozen.....38c
A366 With head 3/8 x 1/8 diam. and soldering lug, per dozen.....35c

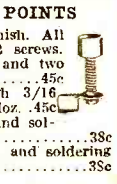

CROSLY RADIO PRODUCTS

"Better—Cost Less"

HARKO SENIOR RADIO RECEIVER

The HARKO SENIOR was developed to supply the demand for a low-priced, efficient audion detector receiving outfit with a range of from 150 to over 600 meters. The hook-up is special—of our own design—and is non-regenerative.

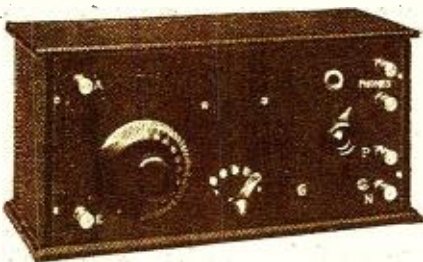

Radio telephone concerts and voice from New Jersey, Pittsburgh, Detroit, and other phones, are regularly copied in Cincinnati and other points with this Receiver. Over-all size of mahogany finished cabinet, is 11½ inches wide, 6 inches high and 4¾ inches deep. Price, complete as described, without "B" Battery, "A" Battery or phone—\$16.00.

CROSLY TWO STEP AMPLIFIER



This instrument was designed to give the very maximum in value and to match up with the Harko Senior, using the same sized cabinet. Complete with amplifying transformers, sockets, rheostats, switch, binding posts, etc., mounted on formica panel and mahogany finished cabinet. This instrument can also be used with any other apparatus requiring a two-step amplifier. Price, complete as shown in illustration—\$25.00.

THE CROSLY SHELTRAN

Ratio 9/1 Audio Frequency Amplifying Transformer Completely Shielded

High grade materials and excellent workmanship combine to give the CROSLY SHELTRAN the high efficiency and attractive appearance so often lacking—except in the most expensive transformers. At the same time we incorporated in the design of the CROSLY SHELTRAN all the characteristics that are necessary to obtain maximum amplification from the modern tubes. These tubes with their high amplification constant operate most effectively at large fluctuations in the grid potential. An examination of the characteristics given will show just how the CROSLY SHELTRAN accomplishes these results.

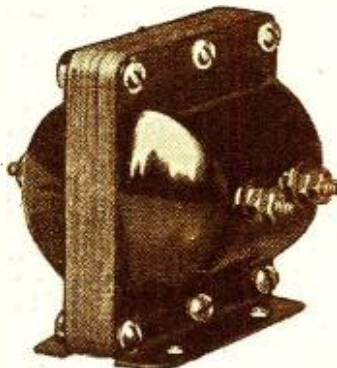

1. Ratio of Turns, 9/1
2. Useful Frequency range, 50-3200
3. Allowable current each winding, (9 milliamperes)
4. Test voltage between windings and between core and windings:
 - (a) Before assembling, 1500 volts
 - (b) After assembling, 400 volts

5. D. C. Resistance of windings:
 - Primary, 500 ohms
 - Secondary, 6000 ohms
 6. Inductance of windings at 1000 cycles (1.5 milliamperes), 20°C (approximate) henry
 - Primary with secondary open... 1.8
 - Primary with secondary shorted... .039
 - Secondary with primary open... 9.9
 - Secondary with primary shorted... 4.68
 7. Corresponding impedance at 1000 cycles (1.5 milliamperes), 20°C (approximate) ohms
 - Primary with secondary open... 11,300
 - Primary with secondary shorted... 520
 - Secondary with primary open... 950,000
 - Secondary with primary shorted... 30,000
- Physical Characteristics of the SHELTRAN
 Net weight 12¼ oz. Overall Length 2½ in.
 Overall Height 2¾ in. Overall Width 2½ in.
 Base area 1¼ in. x 2½ in.
PRICE \$4.00

CROSLY VARIABLE CONDENSERS

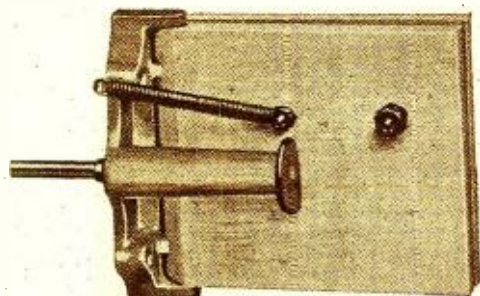

MODEL "C"

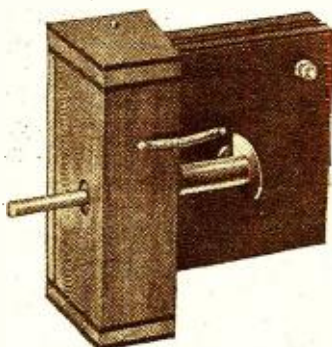

MODEL "A"

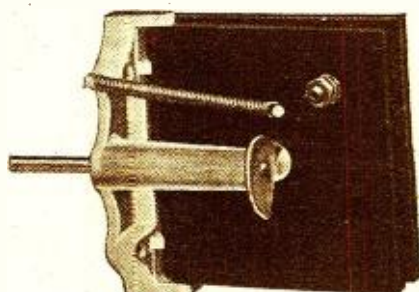

MODEL "B"

Crosly Variable Condensers have no appreciable body or hand capacity and are easier to tune in C.W. and I.C.W. than any other condenser made. Conservatively rated capacity .0005 MF., but careful tests have shown the maximum capacity of these models to frequently run better than .001 MF. The Model "A" CROSLY VARIABLE CONDENSER has a frame made of wood; the plates are high grade laminated wood which function perfectly under all conditions. The Model "B" CROSLY VARIABLE CONDENSER has die cast metal frame and best quality laminated wood plates extremely neat in appearance and occupies a space on the panel of 1¼x3¼x3¼" deep. The Model "C" CROSLY VARIABLE CONDENSER differs from the other Crosly Models in the size of the plates, material of which they are made and the capacity. The plates are made of porcelain and are ground true on the contact surfaces before the copper and mica are applied. The capacity is conservatively rated at .001 MF. Especially recom-



KNOBBS and DIALS

mended for radio phone work as it will not shower or break down. Tested under one thousand volts.

- PRICES**
- Model "A", without knob and dial... \$1.25
 - " " with knob and dial... 1.75
 - " " with knob and dial and mounted in mahogany finished cabinet, complete with binding posts... 2.50
 - Model "B", without knob and dial... 1.75
 - " " with knob and dial... 2.25
 - " " with knob and dial and mounted in mahogany finished cabinet, complete with binding posts... 3.00
 - Model "C", without knob and dial... 2.25
 - " " with knob and dial... 2.75
 - " " with knob and dial and mounted in mahogany finished cabinet, complete with binding posts... 3.50
 - CROSLY knobs and dials, each... .50
- All CROSLY VARIABLE CONDENSERS are furnished with ¼" shaft standard or ⅜" optional.

CROSLY MANUFACTURING COMPANY

Radio Department R-9

CINCINNATI, OHIO

CROSLY RADIO PRODUCTS

"Better—Cost Less"

Crosley Cabinets



MODEL "A-1"

Series "A" CROSLY RADIO CABINETS as illustrated, are designed especially for receiving radio apparatus and will accommodate vacuum tube detector, one and two-step amplifier, regenerative receivers, etc. CROSLY CABINETS may be adopted for other purposes as well.

Series "A" Cabinets are uniform in height and depth.

Series "B" are larger and higher and more especially suitable for radio telephones, for short and long wave receivers, honey-comb coil receivers, etc.



MODEL "A-2"

We also specialize in making cabinets of any odd sizes that may be required. The lids of CROSLY Cabinets are hinged. The rabbeted fronts of the cabinets permit the panels to be flush with the front, making an extremely attractive unit. All CROSLY Cabinets are staunchly constructed. Woods used are gum or mahogany in either dark antique or mahogany finish, or quartered oak in natural or antique finish.

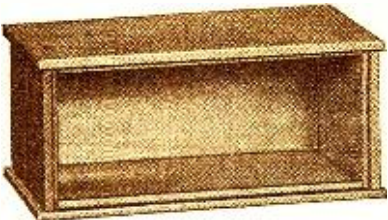

MODEL "A-3"

Price on CROSLY Cabinets range from **\$2.50 to \$10.50**

We also furnish formica panels cut to size desired, at 2¼c per square inch.



CROSLY DETECTOR UNIT

Furnished completely wired and mounted as shown in the illustration or in knocked down form. Price, completely assembled, \$7.50. Price of all parts, including formica or other panel of high dielectric composition, not drilled—\$6.00.

CROSLY RHEOSTATS

Complete with knob, pointers, etc., as shown in the illustration. Model "A"—over-all diameter 1½". Resistance 7 ohms. Will carry one ampere without heating. Price, each, 60c.

Model "B," resistance 4 ohms. Will carry 3 amperes without heating. Price, each, \$1.25.

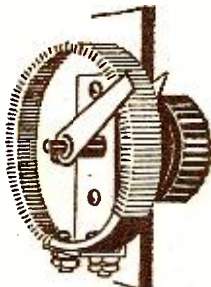

Every CROSLY Radio Product is **GUARANTEED** to give absolute satisfaction or money will be refunded. If your dealer cannot supply you, send us his name and order direct.

Dealers and Distributors: every item shown should be in your stock. Order now for early delivery.

HARKO RADIO RECEIVER

The most compact and complete efficient crystal receiving outfit on the market. Will tune from 200 to 600 meters, bringing in spark, voice and music with amateur antenna. A wonderful little instrument. Price, complete with battery, etc., \$9.00.

One thousand ohm single head set, 125 feet of antenna wire, regulators, etc.—\$6.00 extra.



Complete Outfit \$15.00

CROSLY VARIOMETER PARTS

Consist of two stators, one rotor and the necessary hardware for complete assembling. Shaft for knob and dial is ¼ in. in diameter. The wood parts are furnished either in poplar or mahogany as desired.

Price, complete, made of poplar wood\$1.50
Price, complete, made of mahogany wood...\$1.75
Winding Form30c.



CROSLY VARIO-COUPLER PARTS

Consists of formica tube, rotor, and the required hardware to completely assemble this unit. Price, complete as illustrated but not wound or assembled—\$1.50.

Rotor only40 cents.



CROSLY V-T SOCKET

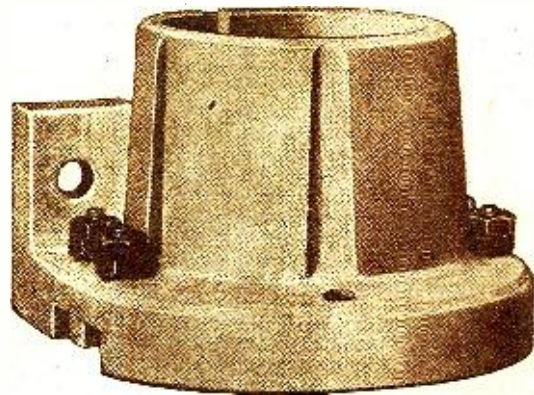

The biggest selling socket on the market today. The reason for its tremendous success is not due to its low price but because it is "BETTER". The bayonet catch embedded in a well of porcelain, adds to the strength of the socket and eliminates possibility of leakage through careless handling. Drop it on the floor—it will not break. It is built for base or panel mounting, which is an exclusive feature and it is the prettiest thing you ever saw assembled in a set. Now used by many manufacturers for standard equipment. Made of one piece of porcelain, no metal shell hence no ground hum. Better for power tube work as it withstands heat and will not melt. Price, each, 60c. (Patents Pending.)

CROSLY MANUFACTURING COMPANY

Radio Department R-9

CINCINNATI, OHIO

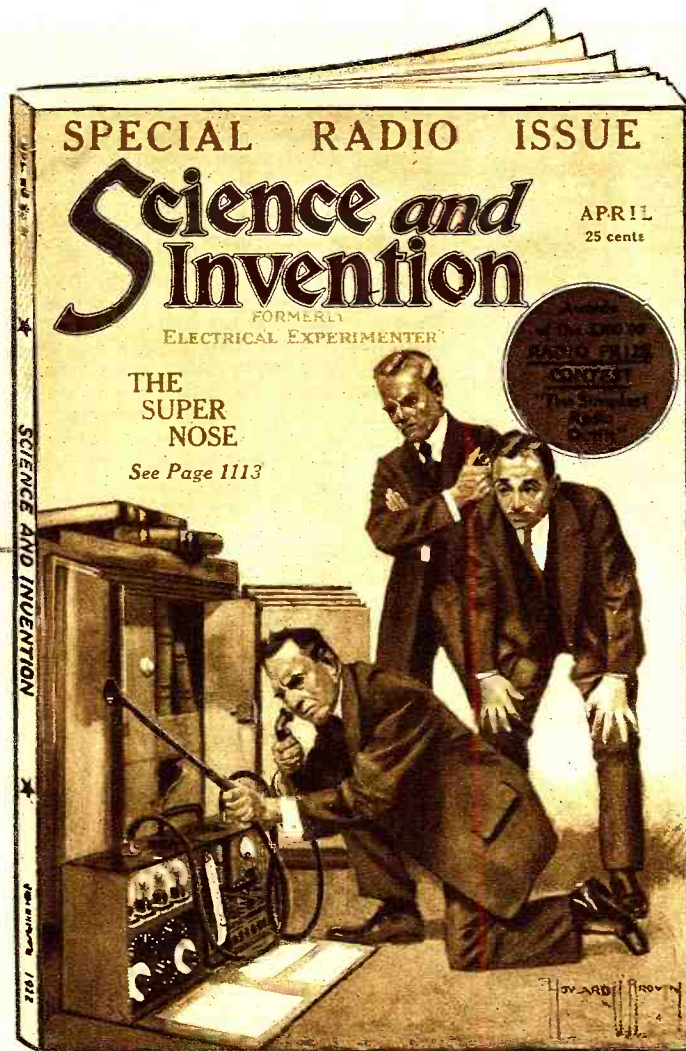

**104
PAGES**
**63
ARTICLES**
**192
ILLUSTRATIONS**
**16
PAGES
ROTOGRAVURE**

**ON ALL
NEWSSTANDS**
25c The Copy
**SUBSCRIPTION
PER YEAR**
(12 Numbers)
\$2.50
*(Add 50c outside
U. S.)*

EXCLUSIVE RADIO ARTICLES A SPECIAL FEATURE
Some of the Radio Articles in the April Issue

**RESULTS OF THE
\$300.00 PRIZE CONTEST**

A Simple Radiophone Receiver. Radio Controlled House in Paris. WDY to have New Station. The Radiophone now a Household Necessity. National Radio Broadcast by Bell System Radio Set in a Match Box. Radio Loud Talkers. The Radio Broadcast. First Authentic List of Radiophone Broadcasting Stations. Radio Broadcasting Map. Radio for The Beginner. Radio Oracle.

SCIENCE & INVENTION is just chock full of interesting articles and illustrations that appeal to everyone. It will hold your interest from cover to cover because it contains everything new in the field of science, invention and mechanics. Quoted by hundreds of newspapers and magazines all over the world every month.

Its editorial contributions constitute the brains of the scientific world. Its four color cover designs are both artistic and attractive

Partial Contents for April, 1922

THE SUPER NOSE.
PILOTLSS PLANE CROSSES ENGLISH CHANNEL.
WHY NOT DOUBLE-DECK SUBWAYS.
AIRSHIP "ROMA" FALLS AND BURNS UP.
AUTOMATIC TRAIN CONTROL.
DR. HACKRENSAW'S SECRETS—THE SUPER NOSE.
THE GRAVITY KING—SCIENTIFIC FICTION DE LUXE.
SNOW-FALL AND ROOF-FALL—WHY THE WASHINGTON THEATRE DISASTER OCCURRED.
FOOD ADULTERANTS DETECTED MICROSCOPICALLY.

STONES THAT TALK.
ELECTRIC COATING OF METALS.
FORTUNES FROM LITTLE THINGS—THE BOOK MATCH.
POPULAR ASTRONOMY—DARK MARKINGS IN THE SKY.
MOTOR HINTS—\$50.00 PRIZE CONTEST.
PRACTICAL CHEMICAL EXPERIMENTS.
PRACTICAL TELEPHONICS—HOW TO BUILD YOUR OWN TELEPHONE AND LOUD-SPEAKER EQUIPMENT.
HOW TO MAKE IT DEPARTMENT—\$30.00 PRIZE CONTEST.
WRINKLES—RECIPES—AND FORMULAS.

Experimenter Publishing Company
231 Fulton Street
New York

Gentlemen:
Please enter my subscription for Science and Invention for the term of one year for which I enclose herewith \$2.50 (add 50c for postage outside of United States.)
Name Town
Address State

(5) The proper circuit arrangements of regenerative (including oscillating) receivers to avoid radiation of energy (as by the use of a radio-frequency amplifier with an untuned antenna or with a coil aerial.)

(6) The use of highly selective receiving apparatus, including a list of approved forms.

(7) The use of receiving coil aeriels instead of antennae, with special reference to high selectivity.

(8) The reduction of interference with radio communication of other electrical processes, such as the operation of X-ray apparatus and electrical precipitation.

(9) The study and standardization of wave meters.

V. RECOMMENDATIONS OF THE COMMITTEE ON NOMENCLATURE

1. In place of the word "Wireless" and names derived from it, use the prefix "Radio"; Radio Telegraphy, Radio Telephony.

2. Instead of "Statics" or "X's", use "Atmospheric Disturbances" or "Atmospherics".

3. Disturbances produced by other stations to be designated as "Interference".

4. For the generic title of the vacuum tube, of any number of electrodes, and in any of its recognized modes of operation, use "Electron Tube."

For the specific title of the ordinary three-electrode tube, use "Triode".

For the title of a triode employed in one of its regular modes, use "Rectifier triode", "Amplifier triode", "Generator triode".

5. In describing coupling of high frequency circuits, use "Resistance Coupling", "Inductive Coupling" (by self-inductance or mutual inductance), "Capacity Coupling".

6. For the generic title for a system of conductors for radiating or absorbing radio waves, use "Aerial".

For an open circuit aerial use "Antenna".

For a closed circuit aerial use "Coil".

7. For a receiving arrangement in which beats are produced by a separate local oscillator, use "Heterodyne".

For a receiving arrangement in which the same electron tube is used for generating oscillations and detecting, use "Self Netto".

8. Classification of waves emitted by radio transmitters.

Type A—Continuous Waves.

Waves that in the permanent state are periodic and such that their successive amplitudes of oscillations are identical.

Type A1—Manipulated Continuous Waves.

Continuous waves of which the amplitude or frequency vary under the action of hand telegraphic manipulation.

Type A2—Continuous Waves with audible frequency modulation.

Continuous waves of which the amplitude or the frequency vary according to a periodic law of audible frequency. This is commonly referred to as ICW method of transmission.

Type A3—Continuous waves with speech modulation.

Continuous waves of which the amplitude or the frequency vary in accordance with speech vibrations (radio telephony).

Type B—Damped Waves

Waves composed of successive trains in which the amplitude of the oscillations after having reached a maximum decreases gradually. This refers to waves from spark transmitters or other types of transmitters having a characteristic decrement similar to spark transmitters.

Note 1. If in continuous wave transmitters the rectified plate voltage is not substantially constant direct voltage the station should be classed under Type A2.

Note 2. In ICW transmitting stations if the variation in the wave length or frequency of the transmitted wave is effected in a gradual way (sinusoidally) the station should be classed under Type A2. If the variation in frequency or amplitude is abrupt (chopper method) it should be classed in Type B.

In order to differentiate between the amateur and the experimenter the following definitions are suggested for consideration:

The amateur is one who operates a radio station transmitting, receiving, or both, in a professional way, merely for personal interest or in connection with an organization of like interest.

An experimenter is one who operates a transmitting or receiving station, or both, for exclusively technical or scientific investigations.

Note. Further recommendations on nomenclature to be added later.

Resistance in High Frequency Work

(Continued from page 932)

radio, there is another factor to be considered besides that of skin effect above explained. This factor is the stray or distributed capacity of the coil. It is well

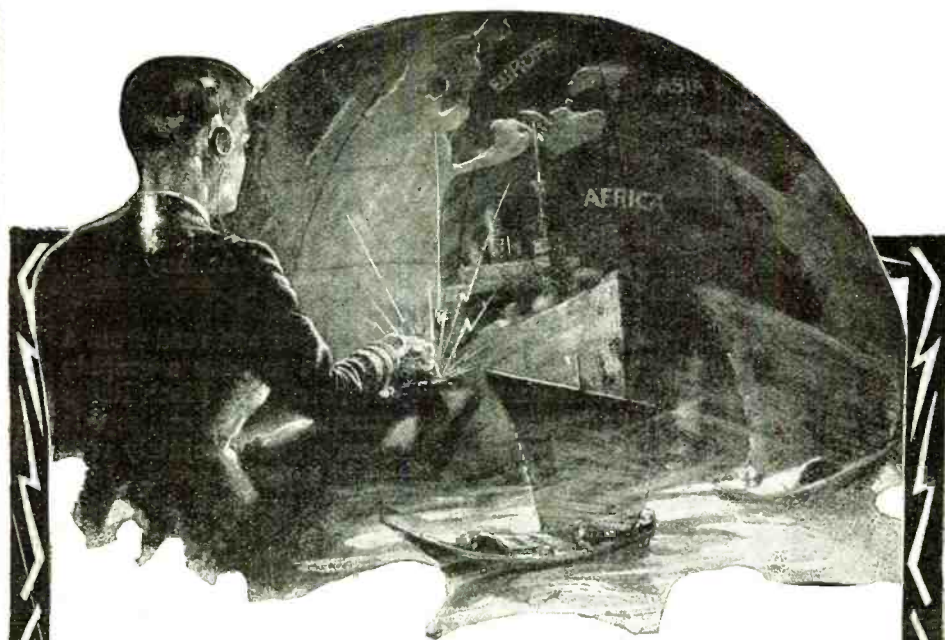

See the World as a Radio Operator

The radio operator of an ocean steamship is *paid* to roam the world. He enjoys, without expense, sights that the wealthy spend thousands of dollars to see. The picturesque ports of strange nations; the historic capitals of Europe—gay Paris, mighty London and eternal Rome; the towering Alps and other scenic beauties of the Old World! All these fascinating spots are as familiar to him as your own town is to you.

RADIO

An uncrowded, well-paid profession

Would you like to visit every corner of the globe as radio operator aboard a great steamship, with the finest of meals, luxurious private quarters and big pay? Or would you prefer an equally well-paid position in a land station in this or some other country? You may have your choice, for radio operators are constantly in demand at salaries ranging from \$2,000.00 to \$5,000.00 yearly. Thousands are needed for the 30,000 vessels of the U. S. Shipping Board alone. Take advantage of this urgent demand—decide now to get the simple training necessary to enter the uncrowded, well-paid field of Wireless Telegraphy.

Learn at home—at small expense

For over a quarter of a century the AMERICAN SCHOOL has been successfully training men by mail. It can prepare you—in your spare hours—to become a radio operator on land or sea. Everything you must know to obtain a government license is explained in plain language. Even instructions for making your own instruments are given. Best of all, the cost is low and may be paid as you progress. Sign and mail the coupon—NOW! It will bring you further particulars regarding this fascinating profession.

AMERICAN SCHOOL

Dept. W-485, Drexel Avenue and 58th Street, Chicago

AMERICAN SCHOOL, Dept. W-485, Drexel Ave. and 58th St., Chicago

Without any obligation to me, please send full information regarding your simplified course in Wireless Telegraphy. Also tell me more about the travel and money-making opportunities enjoyed by radio operators.

Name

Address

Read Code With Your Eyes! Not With Your Ears!

Finch Radio Relay Permits Messages To Be Copied on Paper Tape With Unerring Accuracy, At Any Speed and Over Any Distance.

Why worry about reading code when you can read from a tape at your leisure. How nice it would be to have a graphic record of news dispatches, market reports, etc. The Finch Radio Relay, which is now licensed for non-commercial use, makes this possible. It is inexpensive, easy to operate and absolutely reliable. Tremendously sensitive, yet rugged and fool-proof. May be used in connection with any vacuum tube receiver.

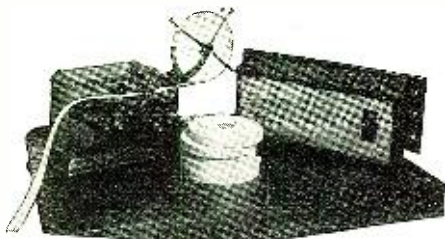

Patented and Patents Pending.

Literature describing other uses for the Finch Radio Relay gladly furnished upon receipt of stamp.

If you can't read code let the Finch Radio Relay read it for you. If you listen only to the broadcasting you are missing a lot of interesting things.

**PRICE OF RELAY
\$75.00**

**STANDARD TAPE REGISTER
\$40.00**

FINCH RADIO MFG. CO.
303 Fifth Ave. NEW YORK CITY

known that every coil has some distributed capacity, since each turn acts as the plate of a condenser toward every other turn, with a dielectric, the insulating material of the coil, between. These small capacities result in a total coil capacity. This distributed capacity has the effect of increasing the apparent resistance of the coil, and in the second place results in a power loss in the dielectric of the coil capacity. For minimum coil resistance, therefore, it is necessary to design the coil so that it will have a minimum distributed capacity, and to use very good insulating material on the coil in order to reduce the dielectric loss. Various methods of winding coils have been developed for this purpose, all of which are well known, namely, honeycomb, lattice winding, banked winding. In all of these the winding is so arranged that adjacent turns have a minimum potential difference between them, hence a minimum number of electric lines of force, and therefore, a minimum distributed capacity.

Another factor tending to increase the resistance of radio frequency circuits is the proximity of other circuits. In direct current work, a circuit has a definite resistance regardless of what is in the neighborhood. In radio work, this is entirely different. Suppose we have a circuit, No. 1 in Fig. 5, whose H. F. resistance we are measuring, and suppose another circuit No. 2 is in the neighborhood. On account of induction, a certain amount of energy will be induced in circuit No. 2 by No. 1. This means that energy is extracted from circuit No. 1, which is equivalent to the insertion of a resistance in circuit No. 1, which will absorb the same amount of energy as is induced in No. 2. Hence the apparent resistance of the circuit under test is increased by the presence of the other circuit. It is obvious that the nearer the natural frequency of the neighboring circuit is to the frequency of the circuit under test, the greater will be the amount of energy extracted and hence the higher the resistance of circuit No. 1. It follows that almost any body which has currents induced into it by another circuit will increase the resistance of that circuit. For even if the body be a piece of metal, the induced currents represent energy extracted from the first circuit, resulting in a rise of resistance. This is very well illustrated by the following occurrence. A cylindrical coil was being measured for H. F. resistance at 600 meters and found to be about 8 ohms. A metal ring of brass was placed co-axially with the coil close by and had enough H. F. current induced in it to make it extremely hot. The result was a rise in the coil resistance of about 20 to 25 per cent.

The amount of increase in resistance produced depends upon the nature of the material. The maximum rise in resistance is produced by the presence of iron or steel bodies. For not only is there the loss due to the eddy currents induced in the iron, but there is also a hysteresis loss and a redistribution of the flux around the circuit, which results in a high resistance increase. It is for this reason that the presence of steel buildings around a radio set and steel towers results in much diminished radiation.

Such phenomena as corona losses and brush discharge always accompany high voltages. These losses must be supplied by the circuit generating the high voltages and, therefore, result in an increase in the resistance of the circuit. Since these take place at points and jagged edges of circuits, they can be reduced to a minimum by seeing that all points and edges are rounded off as much as possible.

Finally the last phenomenon resulting in added resistance to radio circuits is radia-

COMBINATION OFFERS

Special Parado Offer No. 5

This complete outfit will give you a receiving set with 2-step amplifier with a range of 1,000 miles. It includes Parado Offer No. 1 advertised in the January Radio News, and Parado Offer No. 2 advertised in the March Radio News.

Complete Parado Receiving Set No. 1 \$34.80
Complete 2-step amplifier set..... 28.80

Entire Outfit, Parado Offer No. 5...\$63.60

NOTE—You can order both sets or either at the above prices.

Complete instructions for assembly and connections furnished FREE with order.

Write for other combination offers and FREE BULLETIN P-13

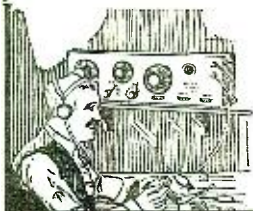

Peoria Radio Sales Co.
Dept. B
PEORIA, Illinois

DEALERS and AGENTS

We are making special offers to our dealers and agents to represent us all over the country. We are distributors of the best equipment. Get our prices on these lines of apparatus:

Acme Clapp-Eastham Grebe
Adams-Morgan DeForest Moorhead
Baldwin Jewell Murdock
Brandes Federal Pacent
Westinghouse Radio Corporation

Write today to

KLAUS RADIO CO.
Dept. 200
Eureka, Ill.



FIRST TESTED THEN SOLD

Write For Our FREE BOOKS On

PATENTS
MUNN & Co.

631 Woolworth Bldg. NEW YORK
Scientific American Bldg. WASHINGTON, D. C.
Tower Bldg. CHICAGO, ILL.
611 Hanna Bldg. CLEVELAND, O.
Hobart Bldg., 582 Market St., San Francisco, Cal.

De Forest Radio Equipment

Immediate deliveries from stock

Everyman Set	\$25.00
RadioHome Set	75.00
M. R. 6 Set	175.00
RadioHome with 2 step	125.00

ALL COMPLETE

Mail Orders promptly filled

UNITED STATES ELECTRICAL CO.
10 Ditmas Ave. Brooklyn, N. Y.

RADIO APPARATUS

Distributors of Reliable Radio Apparatus to Dealers, Schools, Colleges, Radio Clubs and Experimenters All Over the World!

"PITTSO"
SERVICE DISTRIBUTES "RADIO CORPORATION'S" PRODUCTS ALL OVER THE WORLD!
TRY US AND SEE!



"PITTSO"
NOW HAS THREE STORES! ALL CARRY "RADIO CORPORATION'S" COMPLETE LINE. ORDER TODAY!

AMPLIFIERS

No. DA Westinghouse, detector and two stage in mahogany cabinet	\$68.00
No. RORK Grebe, two stage with automatic filament control jacks	55.00
No. RORD Grebe, Det. and two stage with automatic fil. control jacks	75.00
No. 2634 Amrad, Det. and two stage in mahogany cabinet. Splendid value.	47.50

AMPLIFYING TRANSFORMERS

No. UV-712 Radio Corporation	7.00
No. QO Clapp-Eastham, semi-mounted	4.50
No. 50 Chelsea, new type	4.50

ANTENNA WIRE

"Pittsco" No. 14 hard drawn copper (80 ft. per lb.)	0.40
500 ft. special value at	2.25
"Pittsco" 7 strand No. 22 tinned copper, per ft.	0.01
500 ft.	4.25
1000 ft. Special value at	7.50
"Pittsco" 7 strand No. 20 phosphor bronze, per ft.	0.02
500 ft. special value at	7.50

"B" BATTERIES

No. 7623 Standard 22.5 volts, small	1.50
No. 7625 Standard 22.5 volts, large	2.65
No. 7600 Standard 22.5 volts, variable, 16½ to 22½ volts	3.00
No. 7650 Standard 22.5 volts, large, variable, 15 variations	3.50
No. 763 Everready 22.5 volts, small	2.25
No. 766 Everready 22.5 volts, large, 16½ to 22½ volts	3.00
No. 627 Ace, 45 volts, variable	3.50

COILS (Duo-Lateral)

DL-25	\$1.40	DL-300	1.75
DL-35	1.40	DL-400	1.80
DL-50	1.50	DL-500	2.00
DL-75	1.50	DL-600	2.15
DL-100	1.55	DL-750	2.35
DL-150	1.60	DL-1000	2.60
DL-200	1.65	DL-1250	3.00
DL-250	1.70	DL-1500	3.50

COIL MOUNTINGS

No. LC-100 De Forest 3 coil mounting with gears, reduced price	6.00
No. LA-101 De Forest 3 coil mounting with gears and wooden base	9.50
No. 400 Remler 3 coil mounting with base and extension handles	6.50

CONDENSERS (For CW work)

No. UC-1014 Radio Corp. .002 MF. 3000 volts	2.00
No. UC-1015 Radio Corp. .0003, .0004, .0005 MFD. 7500 volts	5.40

No. UC-1803 Radio Corp. .000025 MF. 10,000 volts	\$5.00
No. UC-1806 Radio Corp. .002 MF. 6,000 volts	7.00

CONDENSERS (Grid and Plate Types)

No. UC-570 Radio Corp. .0025 MF	2.00
No. UC-569 Radio Corp. .001 MF	1.50
No. UC-568 Radio Corp. .0005 MF	1.35
No. UC-567 Radio Corp. .00025 MF	1.20
No. UX-545 Radio Corp. Condenser Mtg.	5.00

CONDENSERS (Filter Type)

No. UC-1631 Radio Corp. .5 MF. 750 volts	1.35
No. UC-1632 Radio Corp. 1 MF. 750 volts	1.85
No. UC-1634 Radio Corp. .5 MF. 1750 volts	1.50
No. UC-1635 Radio Corp. 1 MF. 1750 volts	2.00

C.W. INDUCTANCES

No. UL-1008 Radio Corp.	11.00
No. P-1 Acme	8.00

C.W. POWER TRANSFORMERS

No. UP-1638 Radio Corp. 325 watts	25.00
No. UP-1016 Radio Corp. 750 watts	38.50
Acme 200 watt 350-550 volts, mtd.	20.00
Acme 200 watt 350-550 volts, unmtd.	16.00

FILTER REACTORS

No. UP-1626 160 Milliampere	11.50
No. UP-1627 300 Milliampere	15.75

GRID LEAKS (Radio Corporation)

No. UP-1719 for 5 watt tubes	1.10
No. UP-1718 for 50 watt tubes	1.65
No. UP-516 ½, 1, 1.5, 2 or 3 megohms each complete with mounting	1.25
Grid leaks only, each	.75

HOT WIRE METERS

No. P-1 Roller-Smith 0-2.5 amperes, flush mtg. Special value at	4.75
No. UM-530 Radio Corp. 0-2.5 amperes	6.00
No. UM-533 Radio Corp. 0-5 amperes	6.25

JACKS (Radio Type)

No. 61 Patent open jack	.70
No. 62 Patent closed jack	.85
No. 63 Patent 2 circuit	1.00
No. 65 Patent three spring automatic filament control type	1.20
No. 66 Patent five spring A. F. C.	1.50

LOUD SPEAKERS

No. R-3 Radio Magnavox, new type horn, very latest model	45.00
No. P-1 Vocaloud, station type	35.00
No. 400-W Federal Phonophone	14.00

MAGNETIC MODULATORS

No. UT-1643 ½ to 1½ amperes	9.50
No. UT-1397 1½ to 3½ amperes	12.50
No. UT-1367 3½ to 5 amperes	17.00

RECEIVING SETS (Crystal)

"Aeriola Jr." Westinghouse, complete with Brandes "Superior" phones	\$25.00
"Radiola" De Forest, complete with Brandes "Superior" phones	25.00
Radio Service "Type S-S without phones, splendid value	7.50

RECTIFYING DEVICES

No. UV-216 Radio Corp. "Kenotron" 20 watt type for UV-202 tubes	7.50
No. UV-217 Radio Corp. "Kenotron" 150 watt type for UV-203 tubes	26.50
No. P-1 DeForest 20 watt rectifying tube for use with 5 watt tubes	7.00

RECTIFYING DEVICES (for "A" Batteries)

No. P-1 Tungar, 5 ampere type, complete with bulb	28.00
No. P-2 Tungar, 2 ampere type with bulb	18.00
No. P-3 FF Battery Booster, 5 amp. type	15.00

REGENERATIVE RECEIVERS

No. CR-3 Grebe "Relay-Special" 175-680 meters	65.00
No. CR-5 Grebe 175-3000 meters, "Super-special" complete set	80.00
No. CR-8 Grebe 175-1000 meters, complete set, latest "Relay Special"	80.00
No. CR-9 Grebe 175-3000 meters, complete set with det. and 2 stage amplifier, self contained, "A" masterpiece	130.00
No. RA Westinghouse, 180-700 meters, very selective, mahogany cabinet	68.00
No. RC Westinghouse, RA receiver and DA Det. Amplifier combined in one cabinet, a splendid unit, compact	130.00

TELEPHONES

No. 56 Murdock 2000 ohm double	5.00
No. 56 Murdock 3000 ohm double	6.00
No. CW-834 Western Electric 2200 ohms	15.00
Brandes, "Superior" with new headband	8.00
Brandes "Trans-Atlantics" with new headband	12.00
Brandes "Navy Type" with new headband	14.00
Baldwins Type C	12.00
Baldwins Type E	13.00
Baldwins Type F	14.00
Baldwins Type C, unit only	6.00
Federal A. and N. Type 2200 ohms	8.00
Federal A. and N. Type 3200 ohms	10.50

VACUUM TUBES

No. UV-200 Radiotron detector	5.00
No. UV-201 Radiotron amplifier	6.50
No. UV-202 Radiotron 5 watt	8.00
No. UV-203 Radiotron 50 watt	30.00
No. UV-204 Radiotron 250 watt	110.00

Note.—All Radiotrons sent postage and insurance prepaid anywhere in U. S. A. Send us your orders for Radiotrons.

"Let 'PITTSO' products, super-service and delivery solve your Radio problems"

SEND US YOUR ORDERS TODAY!

F. D. PITTS CO., Inc.

12 PARK SQUARE

BOSTON MASS., U. S. A.

BRANCH

193 WESTMINSTER STREET
PROVIDENCE, R. I.

BRANCH

276 WORTHINGTON STREET
SPRINGFIELD, MASS.

TRADE **ESCO** MARK

MEANS THE LAST WORD IN

Motors—Dynamotors—Generators—Motor-Generators

Designed and Developed by PIONEERS

In Perfecting High Voltage Apparatus for Wireless Operation

ESCO PRODUCTS ARE STANDARD

*Sold by PRINCIPAL DEALERS Everywhere
Used by LEADING EDUCATIONAL Institutions*

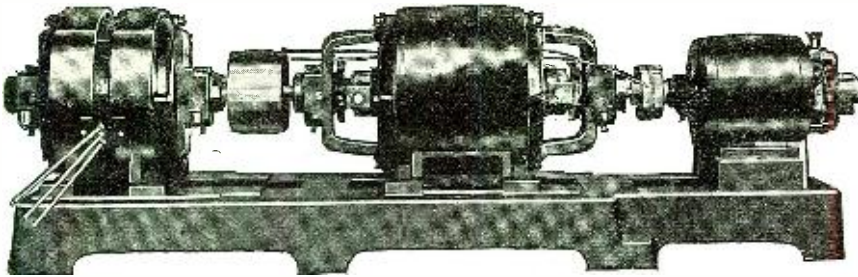

This outfit enabled 1BCG-GREENWICH, CONN., to be the first to get across the Atlantic in the recent Amateur Contest.

Ask for Bulletin 237
Listing over 200
Combinations

ELECTRIC SPECIALTY CO.

211 South St., STAMFORD, CONN., U. S. A.

tion. Every radio frequency circuit radiates some electromagnetic energy which comes from the circuit and hence the resistance of the circuit must be produced. The amount of this radiation or added resistance due to radiation depends upon the form of the radio frequency circuit. Generally speaking, closed circuits, that is circuits having lumped inductance and capacity, radiate extremely little, and open circuits having distributed capacity and inductance such as aerials, radiate much. In radio sets this is the one form of energy extraction which it is desirable not to reduce, as a matter of fact it should be increased. For this radiation is what is desired, and the greater the resistance added to a circuit on account of radiation the better the set; this is the only useful form of radio frequency energy. The manner in which radiation is effected and the principles of radiation, constitute a subject by itself for separate treatment.

Radiophone for Trains

(Continued from page 949)

system without switching from transmission to reception, just as is done with the ordinary land telephone. Furthermore, it may be used without disturbing at all the conversations carried on over the wires, as the currents traveling are of very high frequency.

Talking from Office to Ship at Sea

(Continued from page 949)

Thayer, of the American Telephone-Telegraph Co., also spoke directly to Captain Rind from his home in New Canaan, Conn. Martin L. Perry, New York Sun reporter, a passenger on the "America," communicated directly with his paper and sent in the first story to be received over the radiophone by a newspaper from a ship at sea. Other passengers talked to their friends on shore in their own homes and hundreds of amateurs were very much interested and amused to intercept possibly the first "wireless kiss" which was waited over the ether and land lines by a passenger on the S.S. "America" to a young lady sitting in her home in New Jersey.

The method by which conversation was exchanged and relayed on land wires is interesting in its simplicity. In talking to the ship the telephone subscriber was connected through a special exchange in the Telephone Building to the Deal Beach radio station. Here the voice was considerably amplified and sent out by radio on a wave length of 420 meters and picked up by the "America." In replying the "America" transmitted on a wave length of 380 meters. The speech was received at the Elberon station, amplified, and transferred through the land lines to the exchange in the Telephone Building and from there to the subscriber.

The phenomenal success that has attended these experiments promises great developments for the future. Undoubtedly more ships will be equipped with radio phones and in the near future we may expect passengers on ocean liners to be able to converse from their staterooms with their friends on shore in much the same manner as wire telephony is now accomplished between points on land. There remains to be developed a device for insuring the privacy of radio conversation and experiments are now being conducted with this end in view

Protect YOUR Receiving Set

and your Dwelling with

Horne Lightning Arresters

and Combined Ground Switches and Arresters

fulfilling the combined necessities of SAFETY and the Regulations of the National Board of Fire Underwriters

Their efficiency is certain when used in conjunction with

The Horne "Hydroground"

At all good dealers. If unobtainable, send us your order and dealers' name. We will supply you direct or through him.

Send 10c for complete catalogue of Horne Appliances

HORNE MANUFACTURING CO.

243 Mercer Street

Jersey City, N. J.

Manufacturers of Complete Receiving Sets and All Radio Parts Except Tubes and Phones

MANUFACTURERS' ATTENTION

We are now ready to receive orders in our new Radio Transformer Department. Amplifying Transformers and all other types. Send specifications at once to receive prompt attention.

THORNTON TRANSFORMER CO., INC.
30 Church Street, N. Y. C.

Vario-Coupler and Loose Coupler Use CARD BOARD TUBING

We have on hand 5", 3½", 4", 4½", 5", 5½" in 12" lengths, 25c a tube, any size. Set of 6 for \$1.00.

RUTHERFORD SUPPLY HOUSE
RUTHERFORD, N. J.

Marshall-Gerken Quality Parts

Stepping Stones to Thoroughbred Apparatus

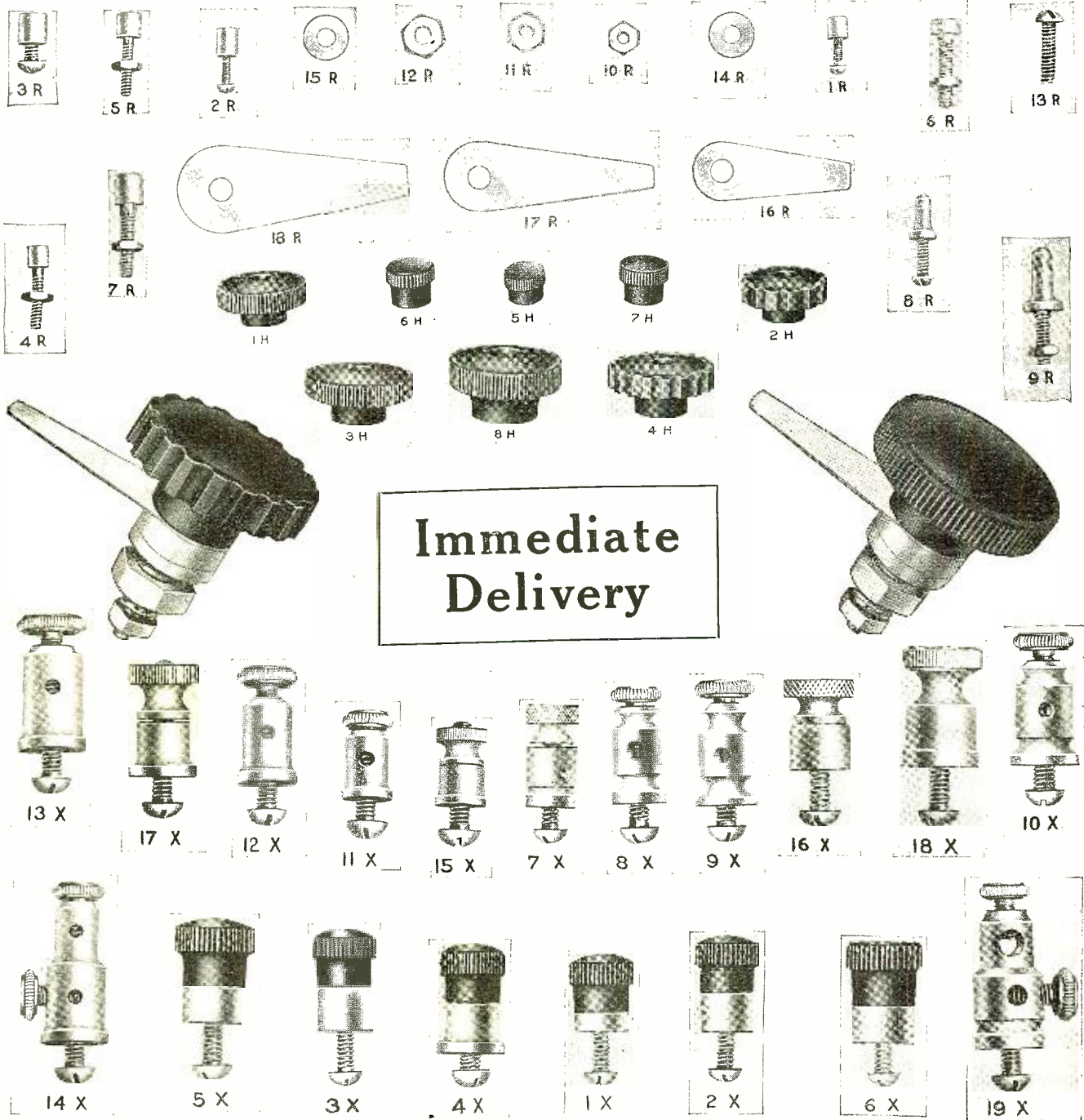

**Immediate
Delivery**

The Marshall-Gerken Co.
Manufacturers & Jobbers
Toledo, Ohio, U. S. A.

REMLER

APPARATUS THAT RADIATES QUALITY

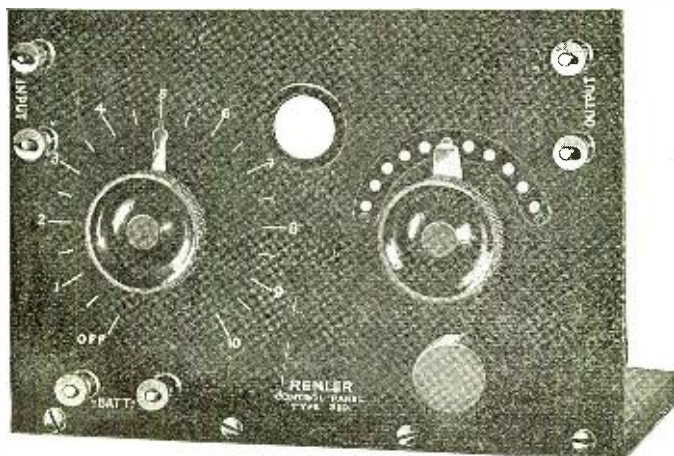

Note the exclusive Remler Features

TYPE 330

DETECTOR PANEL

PRICE \$8.00

*A-Battery
Potentiometer
Plate Voltage
Control*

THAT "Remler Apparatus Radiates Quality" and far excels other apparatus is conclusively proved by the following specifications of a Remler Panel when compared with that of any other panel on the market. Panel is genuine molded bakelite, $5 \times 7\frac{1}{4} \times 3\frac{1}{16}$ inches, with a highly polished glossy black surface; lettering and scale recessed and filled with white enamel. The filament current is controlled by REMLER No. 810 RHEOSTAT, back mounted, and provided with an open position. REMLER No. 93 POTENTIOMETER connected across the storage battery provides close adjustment of plate potential necessary for sensitive detector action. Flexible leads for the B. Battery connection provided for terminals at back of panel. The rheostat and potentiometer knobs are polished bakelite $1\frac{3}{8}$ in. diameter. The GRID LEAK is variable and grid condenser, back mounted, is the correct capacity for the new gas content detector tubes. Maximum filament insured by REMLER No. 92 V. T. SOCKET which is used to support the tube vertically. Induction and ground hums eliminated by its all bakelite construction. A view of filament permitted through an orifice in the panel. Binding posts and all metal parts are finished in polished nickel. The panel is mounted on a hardwood base $7\frac{1}{4} \times 3\frac{1}{2}$ inches, finished black, but can readily be mounted in a cabinet. The wiring is the approved bus bar type, and is laid out so that the input and output terminals are at opposite sides.

Send for Bulletin No. 1002 and 1003 on the Remler Bakelite Detector and Amplifier Panels, Types 330, 331 and 333. Two or more of these panels can be mounted in a cabinet to make any desired detector-amplifier combination.

DEALERS:—There is an exclusive and very profitable proposition for you on Remler apparatus. Write for full particulars.

AMATEURS:—Write for 32-page Remler Catalogue.

REMLER RADIO MFG. CO.
248 FIRST ST. SAN FRANCISCO, CAL. E.T. CUNNINGHAM GENERAL MGR. 154 W. LAKE ST. CHICAGO, ILL.



LEARN TELEGRAPHY

(Wireless or Morse)

AT HOME

In Half the Usual Time

Let the OMNIGRAPH Teach You Wireless

"Just Listen—The Omnigraph will do the teaching"

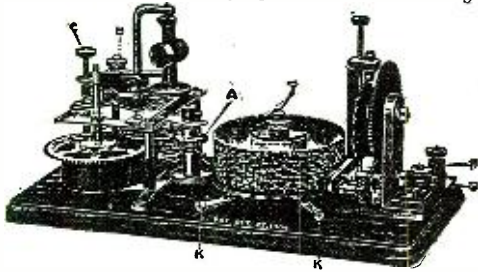

The Omnigraph is an Automatic Transmitter that teaches you both the Wireless and Morse Codes, at home, without any expense except the cost of the machine itself. Merely connect to battery and your Buzzer, or Buzzer and Head Phones, or to your Sounder and the Omnigraph will send unlimited messages by the hour, at any speed you desire.

USED BY THE U. S. GOVERNMENT

Write for Free Catalogue

For a few dollars you can have a complete outfit that will make you an experienced operator in the shortest possible time. No hard, laborious work—just learn by listening. The Omnigraph is adjustable so you can start receiving messages slowly, gradually increasing the speed as you become proficient. You'll be surprised how quickly you will attain speed. Even if you are already an operator the Omnigraph will help you. It will make you more proficient, more accurate and more confident. Thousands of Omnigraphs are in use today and thousands of operators owe their success to them.

The Omnigraph Mfg. Co., 20 Hudson St., New York City

We also manufacture the OMNIGRAPH RADIO RECEIVING SET. A complete Vacuum Tube Set including Tube, a pair of 2,000 ohm Phones, A and B batteries, Aerial Wire, Safety Switch, Insulators and Ground Clamp. All enclosed in a carrying case, handsome enough to install in your parlor or sitting room. Price \$48.00. Nothing to approach it at anything near the price. No previous knowledge of wireless required. Set comes to you completely wired. Nothing additional to purchase. Just erect your Aerial, place the Phones to your ears and listen-in. Absolutely guaranteed.

tion of orders to trains both moving and at rest, would undoubtedly pay large dividends for the prevention of disasters by rail and also accelerate the prompt dispatch of trains over the routes. Adaptions to fire and police departments obviously would be advantageous. In fact, the apparatus appears to have distinct advantages where its application would be economically successful in all parts of industry not touched upon in these few simple suggestions, and which cannot prophesy how far radio in the future will interlock with every industrial work in the future.

In taking up some possible points of the automatic device, it is well to consider the amount of energy flowing in an antenna from induction from a distant emitter. As it is generally necessary to employ acoustic reception, it is obvious that the actual received current is infinitely small compared with the energy flowing in the transmitting antenna. Even though the sound in the receiving phones is quite loud, that signifies, keeping in mind the sensitivity of modern phones, that even then the received current is infinitesimal.

A worked-out formula approximates the current in a receiving antenna issuing from a distant transmitter:

$$I_r = \frac{188 H_s H_r I_s}{R_r \text{ times wave-length}} \times \frac{L}{D} K(\log.)$$

$$\text{minus } \frac{PD}{\text{sq. root wave-length}}$$

where I is the received current, H is the antenna height, R is the resistance of the receiving antenna, D is the distance between the antennae, P varies with the dielectric absorption, according to daylight, night, cloudy, sunny, etc. The small "r" and small "s" refer respectively to receiving and sending, K is a log.

A sample solution of the formula for a given antenna with given constants, shows that the received current is altogether too small to be directly connected to a signaling device, and therefore some means of amplification must be devised. A number of vacuum tubes in cascade presents an immediate means of amplification although the latter may not be economical, yet the use of commercial frequency current with proper circuits would cost but little if utilized after proper rectification or otherwise for both plate and filament lighting or for plate alone as economy would dictate. Some arrangements similar to Mr. White's scheme would suggest itself as an excellent adaption. With the employment of the cascade arrangement, an appreciable current is available in the tertiary circuit. With the utilization of a mechanical relay of sorts, the variation of a considerable current may be accomplished and the last circuit connected directly to the alarm or summoning apparatus.

Referring to Fig. 1 the *modus operandi* may be well understood. The amplifying cascade augments the feeble received current. In the tertiary circuit of the last tube is connected a telephone receiver carrying a diaphragm of such size as to render the greatest mechanical movement under the stress of the plate current. The motion of the diaphragm is transmitted through the rigid pin "P" to the bar "B," which is hinged or pivoted at one end for vertical freedom of motion. The other end of the bar carries a contact which meets in close connection another contact of some form of matter such as carbon or platinum or alloy. The two contacts at the end of the bar are placed in series with an electromotive force and another relay of more or less similar form carry-

RADIO APPARATUS

All Orders Shipped Within 24 Hours

THE NEW IMPROVED CLAPP-EASTHAM SETS

- The Type H.R. short wave regenerative receiver and detector. Mahogany case.....\$40.00
- The Type H.Z. 2 step amplifier. Mahogany case.....\$40.00
- The above two units in one cabinet.....\$80.00

HEADSETS

- Connecticut.....\$7.00
- Baldwin type C.....12.00
- Baldwin type E.....13.00
- Baldwin type F.....14.00
- Baldwin type G.....15.00
- Baldwin type C unit.....6.00
- Phone cord double......80
- Phone cord single......50
- Headband......75

MAGNET WIRE

- Double Cotton Covered 4 oz. spools
- No. 18—37 ft......35
- No. 20—65 ft......35
- No. 22—105 ft......40
- No. 24—175 ft......45
- No. 26—265 ft......50
- No. 28 Single 8'xk 150 ft., .60
- No. 28—430 ft......60
- No. 30—625 ft......65
- No. 32—775 ft......85
- No. 34—1475 ft......90

SIGNAL VARIABLE CONDENSERS

- No. 34—43 Plate table mounted..... 5.10
- No. 35—21 Plate table mounted..... 4.10
- No. 76—43 Plate panel mounted..... 4.70
- No. 77—21 Plate panel mounted..... 3.50
- No. 78—11 Plate panel mounted..... 3.30

RADIO BOOKS

- How to Pass the United States Government Examination..... \$1.75
- Practical Amateur Wireless Stations..... .75
- Radio Instruments and Measurements..... 1.75
- Radio Telephoning..... 2.50
- Wireless Experimenter's Manual..... 2.25
- Vacuum Tubes in Wireless Communicator..... 2.25
- Practical Wireless Telegraphy..... 2.25
- The Whitall V.T. Socket—a better socket..... \$1.75
- The Signal R41 crystal detector with galena..... 1.50
- Klossner Vernier Rheostat..... 1.50
- Paragon Rheostat..... 1.50
- Our Special Variometer. Responds to 360 meter wavelength..... 6.00
- Our special Varioupler..... 6.50
- Strand copper aerial wire (tinned to prevent corrosion, per 100 ft.)..... 1.00
- 100 Amp. 600 volt comp. base lighting switch (approved)..... 3.00

The Whitall Electric Company

Springfield, Mass.

Rider Agents Wanted

Select from 44 Styles, colors and sizes of Ranger Bicycles. Ride and exhibit sample Ranger and make money. Delivered free, express prepaid, on Approval.

12 Months to Pay On any Ranger if desired. Write today for our marvelous prices and terms.

Tires, Lamps, horns, wheels, parts, equipment, and repairs at half usual price. Save \$10 to \$25 on your Ranger bicycle.

Mead Cycle Company Dept. B116 Chicago

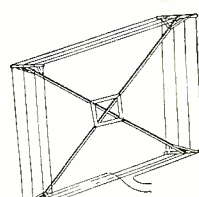

Receive on an INDOOR COIL AERIAL

Chart and tables giving proper number of turns to put on coil for any wavelength. Data covering 0 to 3600 meters 50c; 3600 to 24000, 50c. Stamps not accepted.

C. A. DAVIS & CO.
2371 Champlain St.
Washington, D. C.

WITHERBEE

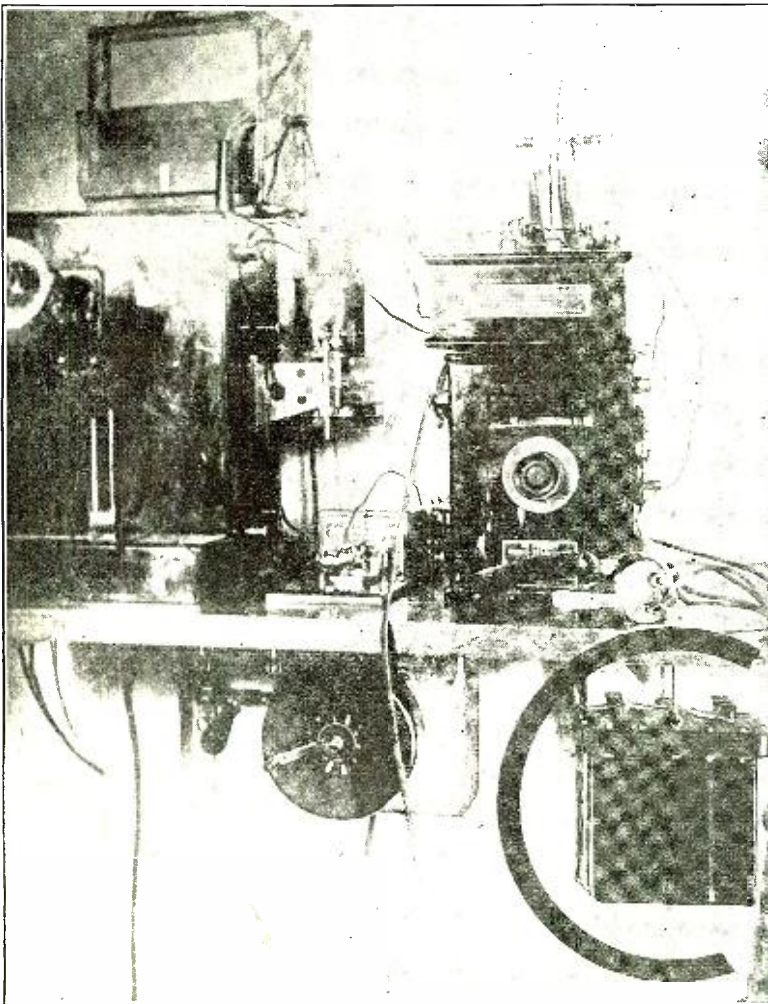

First Set of Wireless Telephone Instruments for the

UNITED STATES NAVY
Installed on the
FLAGSHIP "CONNECTICUT"

THE
WITHERBEE
RADIO
A
BATTERY

←
 IS THE SOLE SOURCE OF CURRENT

Ever since the first wireless flash Witherbee A Batteries have done the precise work required. They are not something new. They are not an experiment. They are not automobile Batteries done over to look the part. Witherbee A Batteries are built with special extra heavy plates and extra thick separators so processed as to insure constant voltage during discharge and to stand up under continuous cycles of complete discharge and long periods of idleness.

They are absolutely clean due to the **Witherbee one piece Hard Rubber case**, a feature devised by Witherbee engineers in 1903 for use where cleanliness and safety are absolutely essential. The Trade are cordially invited to write.

Witherbee Storage Battery Co., Inc.

643-655 West 43rd Street
 New York, U. S. A.

Builders since 1903 of quality storage batteries for motor cars, starting, lighting, ignition and for portable and stationary uses.



What Value Do You Place on Your 'Phones?



"Superior", 2,000 ohms, weight 14 ozs. complete with head band and polarity indicating cord. \$8.00.

Do your 'phones help or hinder your receiving outfit? Did you ever stop to consider what a great deal of harm a poorly designed set of 'phones can do to an otherwise good receiver? After all, no receiving outfit, no matter what its price, is a bit better than the 'phones used with it.

Give your outfit a chance with Brandes Matched Tone* Headsets. You don't know what your receiver is able to do until you hook a pair of Brandes on to it. Your dealer has them. They are sold on a ten-day trial basis.

*Trade Mark Registered U. S. Pat. Office.

Send 5 cents for Catalog G.

Dealers: We have a very interesting plan of co-operation.

C. BRANDES, Inc.

Room 723, 237 Lafayette Street, New York City

Member Radio Section Associated Manufacturers of Electrical Supplies.

*Trade Mark Reg. U. S. Pat. Office

BRANDES Matched-Tone HEADSETS

INSULATION

is the prime factor in building wireless apparatus inasmuch as it must have great dielectric strength, be moisture proof, mechanically strong, and yet easily machined.

These qualities are all embodied in

GENUINE BAKELITE—DILECTO

"The Perfect Insulation"

which we manufacture in sheets, rods, tubes and special shapes.

Bakelite-Dilecto should be used for panels, coil cores, and other insulating parts in your wireless outfit.

Write our nearest office for full information about all of our products.

THE CONTINENTAL FIBRE CO. NEWARK, DELAWARE

NEW YORK, 233 Broadway
PITTSBURGH, 301 Fifth Ave.
LOS ANGELES, 411 S. Main St.

CHICAGO, 332 S. Michigan Ave.
SAN FRANCISCO, 525 Market St.
TORONTO, Ont., Canada,
89 Wellington St., West.

FREED-EISEMANN RADIO CORP.

Manufacturers of the "Marvel"
255 Fourth Ave., New York City

DEALERS

	per cwt.
Insulators	\$15.00
Mounted Tested Galena.....	15.00
Unmounted Tested Galena.....	11.00

Write us for prices on quantity lots.

A. J. MORRIS SUPPLY CO.
202 Market Street Newark, N. J.

ing a higher EMF. As the feeble signals in wave form impinge on the receiving antenna, the cascade circuits function and the diaphragm movements cause a variation of a comparatively large EMF in the last relay circuit and which EMF may be employed to operate a signalling or alarm device. This form is practically the same as that used in some automatic inscription apparatus, and as far as selectivity for individual automatic summoning of operatives it is not selective in any sense except for station at short range, excluding further distant stations according to the sensitivity of the whole apparatus. However, in this type, especially with regard to stations receiving C. W. signals, there is the possibility of synchronizing the apparatus as a whole to a certain extent. If the received note is heterodyned so as to produce a certain frequency in the phone circuit through the adjustment of the receiving circuits, and that frequency is the same as that special audible period of frequency to which the diaphragm is attuned according to its mass and other mechanical characteristics, the sensitivity of the whole apparatus is greatly increased, and its selectivity greatly enhanced, likewise. In the apparatus here mentioned, the response of the bar to mechanical vibration may be somewhat varied by the change of its length or thickness or its width or the rigidity of the pivoted end. In practice the bar "B" is of thin fine steel of a definitely known consistency and quality. This type of apparatus is practically the same as that utilized in inscription as mentioned and efficient recording on tape has been accomplished over short distances employing no more than a galena detector with the relay circuits here illustrated.

Some developments have been going forward with regard to an annunciator which utilizes a delicate apparatus akin to a sensitive thermo-galvanometer and which has incorporated within the instrument a needle which possesses large mechanical inertia, which latter although being a fact, does not render any great resistance to a slow movement of the needle. If the instrument is inserted in the tertiary circuit of the last tube of a cascade arrangement, or in one of the circuits in which mechanical relays are attached to this tertiary circuit of the cascade, the needle will move in quite the same manner as the needle of a regulation thermo-ammeter. If, at the point of the maximum reading or point of travel of the needle, contacts of a circuit are placed, and these contacts open and close another circuit of a comparatively much higher EMF, a means of operating an alarm or annunciator is made possible, and will function with great dependability if all mechanical and electrical features are well planned and executed.

Keeping in mind the mechanical inertia of the pointer or needle, it is seen that when a radio station is emitting energy broken into short impulses such as the characters of the Morse code at a medium or even a comparatively low rate of speed, the annunciator will not function. At least the pointer will not move to the maximum point of reading, and thus the contacts of the last or annunciator circuit will remain open, but if the emitting station renders transmission in long dashes, the pointer will have time to overcome its entailed resistance to quick changes in position and the pointer will swing slowly over and close the contacts of the annunciator circuit, thus summoning the operatives to the apparatus.

Although this sort of apparatus may appear very crude and delicate, yet it cannot be said with surety that the delicacy would



Enjoy Wireless Music In Your Home

Hear, in your own parlor the marvelous wireless music, the prominent speakers, market reports and latest news before it is even on the press.

Get all this free entertainment and enlightenment when you want it without stirring from your fireside by installing an inexpensive receiving outfit and a

STROMBERG-CARLSON RADIO HEAD SET

The No. 2-A Radio Head Set comprises four distinct units; two receivers, head band and 5 foot cord.

THE RECEIVERS

Receivers are equipped with a one-piece bipolar permanent magnet, of high grade magnet steel; provided with phenol fiber spool heads, slotted soft iron pole pieces, corrosion proof diaphragm, enameled copper wire coils. All parts are encased in a receiver shell of cast non-magnetic insulating material, that is unaffected by either moisture or temperature changes. Each coil is wound to 500 ohms. The coils are connected in series. This gives a combined resistance of 2000 ohms for the 4 coils of a No. 2-A Radio Head Set.

THE HEAD BAND

A head band is furnished of the spring wire type, covered with heavy brown webbing, correctly shaped, light in weight and comfortable to the operator. Knurled thumb screws are provided on both ends to permit locking the adjustment after it is once fitted to the head. Exposed metal parts are nickel finished. Another feature of merit, in regard to the design of this head band is a provision for separating the receivers which permits two observers listening in on a circuit simultaneously with but one Stromberg-Carlson No. 2-A Head Set.

THE CORDS

Each No. 2-A Radio Head Set is equipped with a 5-ft. brown silk, moisture proofed, receiver cord which is forked in two branches, one branch for each receiver. This forked construction permits two persons to use the head set simultaneously when desired—a feature of great convenience.

Price
\$7.50

Stromberg-Carlson Telephone Mfg. Co.
Rochester, N. Y.

Send me your free bulletin 1029-R describing your No. 2-A Radio Head Set

Mail Coupon for Booklet 1029-R
describing these Radio Head Sets

Stromberg-Carlson Telephone Mfg. Co.
ROCHESTER, N. Y.

Name.....

Address.....

Everything—

The new branches—arcs and tubes—of the revised examination of the Department of Commerce are fully covered in the Home Study Course of the Radio Institute of America.

Enrollments are coming in by every mail. Why aren't you one of the wide-awake wireless men who have seen the new and greater opportunity opened to them by the Home Study Course, which is specially designed to land them one of the enviable jobs at the world's greatest radio station?

It will be equipped to work simultaneously with five other nations in widely separated and distant parts of the world.

A position at this station is the height of every operator's ambition, for it means unlimited opportunity to succeed and progress to higher, more responsible and better paying positions in the radio industry. So far as opportunity goes the successful future of these men is assured.

How about you?

The Radio Institute of America has been an established and successful institution for over fifteen years. It has trained over 6,000 men, 95% of whom have successfully engaged in this new branch of science and industry.

Write for our booklet and further details—*Now.*

The graduates of the Radio Institute of America enjoy a great and exclusive advantage in the close connection existing between the Institute and the Radio Corporation of America, the world's largest radio manufacturing and commercial radio company.

Prominent executives in the radio field are former students of the Institute. The Radio Corporation employs thousands of men, in its executive departments, on ships and at shore stations and in factories and laboratories. A large percentage of these men are graduates of the Institute.

HOME STUDY DIVISION

Radio Institute of America

(formerly Marconi Institute)

324 Broadway, New York

seriously hamper the functioning of the apparatus after an original and proper adjustment. In fact, it is doubtful if there has been made public any more efficient than the original and the latterly developed instrument about which this article has been written.

A Study of the Antenna System

(Continued from page 931)

tical portion of these antennae. Any antenna having a large capacity to ground apart from its vertical portion will give a uniform current distribution along its vertical portion, and will, therefore, be superior in its radiating qualities to the vertical wire antenna. But the flat top and umbrella antennae have still another important advantage over the straight vertical wire antenna. The relationship between current, voltage, frequency, and capacity of an antenna is expressed by the equation:

$$i = 2\pi fCV$$

where

i is the antenna current, f the frequency of the oscillations, C the antenna capacity, and V the antenna voltage.

With a given antenna voltage at a given wave-length or frequency, the antenna current is proportional to the antenna capacity. Consequently since the flat top antenna has a larger capacity than the vertical wire antenna, the same voltage in both will produce a larger current in the flat top than in the vertical wire antenna, thus giving still better radiation from the flat top. Likewise the umbrella antenna will have a larger current for the same voltage than either of the other two forms of antennae.

It is obvious, therefore, that the flat top is much superior to the vertical wire. There is not much difference between the inverted L and T types of flat tops and either form may be efficiently used. The inverted L has a more pronounced directional effect, the maximum radiation being in the direction opposite to the direction of the flat top.

The umbrella antenna requires more detailed discussion. It has been stated that the umbrella antenna has the largest capacity of those forms under discussion. This gives two favorable results. First it gives a more uniform current distribution in the vertical portion of the antenna as seen in Fig. 2, and second, for the same voltage, it gives a much higher current in the antenna, due to the expression $i = 2\pi fCV$, as explained above.

Both these effects result in greatly increased radiation. However, there is one factor in the case of the umbrella antenna which partially neutralizes these beneficial results. The umbrella antenna is constructed, as is well known, so that spreader wires lead down from the top of the vertical part of the antenna. The antenna current flows upward in the vertical portion and downward in the spreaders. Consequently there is present a "bucking" action and the field produced by the upward current in the vertical part is opposed and partially neutralized by the field produced by the downward current in the spreaders, thus resulting in a decrease in the effective radiation. However, this neutralization is more than counterbalanced by the two advantages mentioned above, and with the one further advantage of very low ground resistance—to be discussed below—leave the umbrella antenna superior to the others.

GROUNDING

The design of the ground system is no less important than that of the aerial wires.



7" Bell, 19" High
\$7.50

Standard Radio Horn



Pat. Applied For

Special Design

Will fit any receiver.
Heavy material, no blast.
Rubberoid Enamel finish.

Your Dealer can supply you

We figure on Special Horns
for Manufacturers.



5" Bell, 14" High
\$5.00

Standard Metal Mfg. Co.

237 Chestnut Street

Newark, N. J., U. S. A.

CONNECTICUT RADIO EQUIPMENT

Variable Condensers, Transmitters, Head Bands, Panel Switches, Etc.

Connecticut Tel. & Elec. Co., Meriden, Conn.

OWING to the unprecedented demand for Arnold Apparatus I wish to advise those who have sent inquiries for my Literature &c, same has not been forwarded because my entire output has been "sold out."

Literature will be forwarded in the near future and you will be able to get from your dealer Arnold apparatus as in the past.

J. F. ARNOLD, 2082 Lexington Ave., N. Y.
Manufacturer of the Arnold Loose Coupler
Established 1910 Tel. Conn.

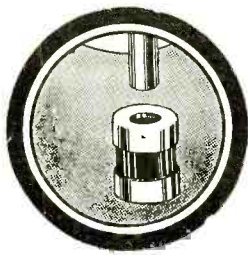
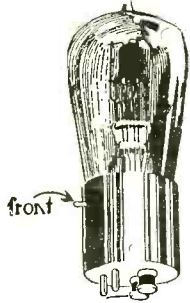

Will Make a Tube Last a Life Time

No matter what kind of a "short" or high amperage you get, even if accidental you can never "burn out" a tube protected by the

RADECO SAFETY FUSE

(patent pending)

Slipping directly on the filament terminals of any standard bulb used in any standard socket, this tiny fuse, built on the same electrical principle as any other fuse gives absolute protection to the filament.

Easy to attach and positively does not lower the efficiency of your set. Is equally good for protection of meters and other delicate apparatus.

Come only in packages of four

4 for \$1

Order by mail or from your dealer

Carrying capacity, 1/2, 3/4, 1, 1 1/4, 1 1/2, 2, 2 1/2 and 3 amperes.

DEALERS! Order now while we have stock on hand. Send for price list

STORAGE BATTERIES

6V 60-80 hour

U. S. L. standard Radio batteries. "De Luxe" stained wood box. Neatest on market and guaranteed new and good. Unusual value.

\$15

Delivery Prepaid

"B" BATTERIES

45 volt

Our own special make used and recommended by hundreds of amateurs. We guarantee these to give absolute satisfaction

\$3.60

Delivery Prepaid

2200 - PHONES

Holtzer - Cabot make. Extremely sensitive and of far better workmanship than ordinarily found at this price.

\$8 pr.

Delivery Prepaid

➔ We carry at all times a complete stock of Radio parts and sets. Order at standard prices from any standard catalog. ➔

RADIO EQUIPMENT CO.

630 Washington St. (4th Floor) Boston, Mass.

New England's Oldest Exclusive Radio Store

Send for Catalog

SEND 10c in stamps for the new Benwood Radio Catalog, comprising latest Price Directory. Our mail order department is complete in itself and will give you immediate service.

A CONDENSER FOR EVERY PURPOSE

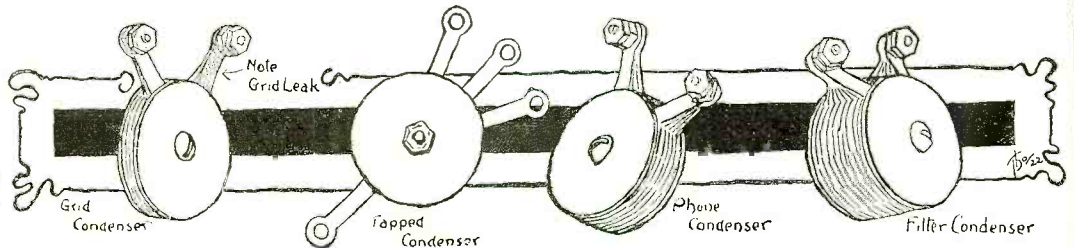

Make your own grid, phone, filter, antenna, tapped or variable condenser at exactly the right capacity for your individual set. The Benwood "Universal" condenser shown above consists of an assembly of mica washers and thin copper plates with lugs attached, held together by two brass end plates and machine screw through the center.

Use 2 plates for grid and combine grid leak as shown, 10 plates for phone, 35 for filter, or vary to get best results. Standard set of six plates and ten washers, price \$1.00 each. Extra set of ten coppers and ten mica washers, giving additional capacity of approximately .0005 M.F. Price 40 cents each.

THE BENWOOD COMPANY, INC., 1111 Olive St., ST. LOUIS, MO.

The First and the Best

Radio Frequency Transformer on the Market

The DX
Radio
Frequency
AMPLIFYING
TRANSFORMER



Will
Bring in that
Long Distance
RADIO
CONCERT

On Coil Aerial Work

Through Summer Static by Using
DX RF Amplifying Transformer with Coil Aerial

RF Amplifier
Circuit Diagrams, 25c.

Send for
Bulletin No. 11

Curves and Data
on Coil Aerials, 50c.

RADIO
INSTRUMENT COMPANY
WASHINGTON, D.C.

Transmitter and Receiver Parts



TYPE 156 SOCKET

The experimenter who has had previous experience with the assembly of receiving and transmitting sets has learned the necessity of having every unit perfect. Entirely aside from the gain in efficiency, he has found the advantage of using apparatus in which the greatest care has been given to construction details.

General Radio apparatus is designed with this end in view. A noteworthy example is the Type 156 Vacuum Tube Socket.

This socket is adapted to any of the standard American four-prong transmitting or receiving tubes. It is adapted to the Western Electric VT-2 tube, as well as to the Radiotron UV-200, 201 or 202 tubes. The contact springs are sufficiently rugged to carry the filament current of the five-watt transmitting tubes without arcing.

PRICE \$1.50

This is but one example. Others are Amplifying Transformers, Modulation Transformers, Tuning Inductances, Hot Wire Meters, etc. SEND FOR FREE BULLETIN 910-N, describing these and other instruments.

GENERAL RADIO COMPANY
MASSACHUSETTS AVENUE AND WINDSOR STREET
CAMBRIDGE 39 MASSACHUSETTS

Standardize on General Radio Equipment Throughout

"Aerial Wire"

Special

150 feet No. 14 copper wire, \$1.00
100 feet Stranded copper wire, \$1.00

Empire Radio Equipment Co.

271 West 125th St., New York City

AMRAD AND GREBE SETS

Special Prices This Month

MASSEY RADIO COMPANY

The Radio Store Winchester, Virginia

For the antenna current depends on the total antenna resistance, which is made up in part of the ground resistance. A poor ground may be almost as bad as no ground at all, whereas a good ground with very low resistance may result in double the radiation otherwise obtained.

It might be advisable at the start to make clear the reason for a ground. If the aerial system were charged by a spark gap or other source of high frequency oscillations, and its lower end were left free, that is, not connected to ground or counterpoise, there would be a very low antenna current, almost negligible in fact. The reason for this is that with no ground or counterpoise connection, the capacity of the antenna is extremely small. The charge on the antenna is given by the expression

$$q = CV$$

where q is the charge, C the capacity and V the voltage of the antenna. It follows that since C is extremely small, no matter how large we may make V , q will remain also very small. Hence the antenna current, which is the motion of the charge, will be too small for radiation purposes.

If now this aerial system has its lower end connected to earth or to an earth equivalent, namely "counterpoise" the capacity of the antenna will be enormously increased, for the earth is now the other large plate of the aerial condenser. Hence the antenna charge q and also the antenna current will be proportionately increased. Grounding is therefore necessary in order to furnish the high capacity required for charging the antenna to large amplitudes.

The spark gap or other source of high frequency oscillations which charges the antenna, also transfers this charge periodically from antenna to ground and vice versa. In order to do this with the least possible loss, the ground system must be designed to have a minimum resistance.

There are two main methods employed to secure this high capacity for the antenna, first direct grounding, second a "counterpoise ground." In direct grounding the lower end of the antenna is led directly into the ground and electrically connected to a metal body buried in the earth. This body may be a metal plate network of wires, or, as is most frequently the case with amateurs, a pipe. Since a pipe has a very small surface, it is equivalent to a metal plate of small area and will be treated as such.

A "counterpoise" consists generally of a net work of wire above the ground and insulated from it. This network generally has a much larger area than the usually used ground plate. The counterpoise net work is equivalent in action to that of a direct ground employing a large surface network, but is essentially superior to the plate or pipe ground. It is much easier for the amateur to build his counterpoise than a large earthed network, hence it is preferable to use the counterpoise rather than the absurdly poor grounds usually used. The superiority of the counterpoise over the usual plate or pipe ground will be evident when we consider the flow of electric lines of force from antenna to earth.

The lines of electric force which emanate from the antenna structure complete their circuits through the air and ground. Thus there exists an electric field in the ground as well as in the air, which produces ground currents. It is these ground currents which contribute the ground losses, reducing the set efficiency.

The distribution of the electric lines of force resulting from a "plate ground antenna" and a "counterpoise ground antenna" are shown in Figs. 3 and 4 respectively. It will be seen from Fig. 3 that the lines of

force in the plate ground antenna have very long earth paths to traverse before they reach the plate ground. Thus a greater ground resistance is interposed, obstructing the easy flow of ground currents, hence the earth losses in this type of ground must be large. This earth resistance is further increased for the following reason. The plate ground being small in area all the electric lines of force terminating in it must be concentrated in a small area. This means an increase in the electric field intensity in the ground, which always results in increased losses.

From Fig. 4 it is seen that in a counterpoise ground antenna most of the electric lines of force pass through the air and thence directly to the counterpoise ground. Relatively few lines, as compared with the plate ground antenna, must complete their path through the earth, hence earth losses are low, and ground resistance is low. By making the spread of the counterpoise larger so that it extends to the outer limits of the antenna structure in air, all the electric lines of force will pass from air directly to the counterpoise, avoiding the earth, and thus the earth resistance will be reduced to a minimum. This is the explanation of the extremely low resistance of antennae employing counterpoise grounds, as discussed by Buchbinder in "Effect of Counterpoise Grounds" which appeared in the September issue of *RADIO NEWS*. A large ground network in soil of high conductivity gives the same results as the counterpoise, but the counterpoise is easier to build.

From this discussion, it is evident that the amateur would gain considerably by spending a little more time and effort in the construction of his antenna and ground system, and by the use of the counterpoise instead of the pseudo grounds he has been regularly employing. The extra effort and time put in will be amply repaid in higher efficiency, greater antenna current, and increased satisfaction.

Design of Radio Receiving Loop Antenna

(Continued from page 933)

of the number of turns, thus a large loop will take a little more wire than a small one to produce a given inductance. Still another factor of no small importance, is that the loop, to be a good collector of energy, must have a good "grip" on the ether. This effect is ordinarily proportional to the product of the number of turns and the area of each turn. Thus a coil that has the greatest inductance possible for a given length of wire has more efficiency as a collector of energy, than another coil of the same inductance but having less turns and a greater area.

In order to have good tuning characteristics it is desirable to keep the capacity of the coil low. This can be done by spacing the turns. I have found that the best spacing seems to be about $\frac{1}{2}$ " between wire centers. The following data is based on this spacing, as a formula to include other spacing besides, becomes unwieldy and less adaptable for rapid computations in practical use.

The size of wire does not seem to have a great deal of influence on the efficiency of small loops for receiving. The main factor is that it must be large enough not to stretch and sag after continued use, when wound on the frame with moderate tension. Litzendraht is preferable only when it can



NEW! SOMERVILLE (RED BAKELITE) TUBE SOCKET 75c

1. Moulded in one piece, from real natural color bakelite, having very low leakage losses.
2. Absence of metal shell, eliminates ground hum.
3. The phosphor-bronze contact springs are laminated, and their shape permits a wiping contact on the sides of tube pins, as well as the usual contact with the extremities.
4. Contacts are arranged with maximum spacing to take care of high voltages used with power tubes.
5. Terminals are larger than usual, to permit the use of heavy conducting wires.

Don't Forget These Exclusive Features

SOMERVILLE 22 $\frac{1}{2}$ v. "B" BATTERY, now ready, \$1.75

Has 5 positive knurled terminals, 16 $\frac{1}{2}$ v., 18v., 19 $\frac{1}{2}$ v., 21v. and 22 $\frac{1}{2}$ volts. Made to our specifications by one of the world's foremost battery manufacturers. Twice the capacity of the small signal corps size. Should last six to nine months.



SOMERVILLE
HONEYCOMB
COIL PLUG, 55c
for
Panel Mounting

With Side Coil-Strap Plates, for mounting H-C Coils, 60c each.



SOMERVILLE
MICA CONDENSER
Mounted between bakelite
Power factor, 1 $\frac{1}{2}$,
500 volt

.00025 mfd. \$1.00
.0005 mfd.
.001 mfd.
.002 mfd. Postpaid

SOMERVILLE CONDENSERS THE LINE NOW COMPLETE

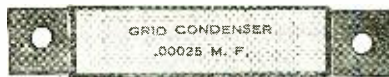

Grid Condenser, .00025 Mfd. \$.25
—Above, with $\frac{1}{2}$ Meg. Grid Leak.40
Grid Condenser, .0005 Mfd.25
—Above, with 1 Meg. Grid Leak.40
Phone Condenser, .001 Mfd.25
Phone Condenser, .002 Mfd.40
Phone Condenser, .005 Mfd.70

Quadrupled production of our famous CW Condenser enables us to make a new price schedule.

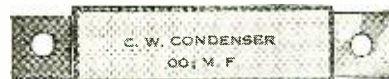

1000V. C.W. Condenser, .0005 Mfd. \$.60
1000V. C.W. Condenser, .001 Mfd.60
1000V. C.W. Condenser, .002 Mfd.60
750V. C.W. Condenser, .005 Mfd.89
500V. C.W. Condenser, .01 Mfd. 1.00

Above ratings are for D.C. only. When used with A.C., a safety factor of 75% should be observed. Each condenser is tested at double above ratings, and any found defective should be returned for replacement.

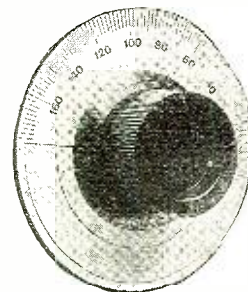

SOMERVILLE DIAL INDICATORS

For $\frac{1}{8}$, $\frac{1}{4}$ and $\frac{3}{8}$ in shafts
4 in. dia. \$1.75
3 $\frac{1}{4}$ in. dia. 1.60
Knob only .80

Postpaid from us by return mail, or from your local dealer.

This is the first metal dial with flanged knob and has the following exclusive advantages over imitations.

The knob is of real bakelite and will retain shape and finish.

The dial is of brass heavily plated with real silver and coated with a special non-peeling lacquer, which preserves the silver finish long after nickel dipped and "German" silver dials are mottled and tarnished.

The heavy brass bushings and special method of assembly, assures a dial which runs true on the shaft.

The surface finish permits writing call letters on the lower calibration space.

The dial is insulated from shaft bushing, and when grounded acts as a shield from capacity effect from body.

INSIST ON THE ORIGINAL AND BEST

EVERYMAN'S SECTION

The AERIOLA-SENIOR is admirably adapted for the hotel room or apartment as well as for an extended camping trip. It does away with the bulky storage battery, which must be charged constantly, as the vacuum tube requires but 1/25th the energy of the regular tube, and operates from a single dry cell, and small "B" battery.

Complete With Tube, Two Batteries, and \$8 pair Head Phones, \$67.25 Postpaid, East of Mississippi, West of Mississippi, \$1.00 Extra.

Temporary antenna may be made from a pound roll of annunciator wire, price 70c. STANDARD WESTINGHOUSE ANTENNA OUTFIT, \$7.50.

SPECIALS!

Amrad "S" Tube (Rectifier).....\$7.50
Porcelain Socket for above......15

HOLTZER-CABOT PHONES, \$8.00
2200 Ohms

With Patent Universal Plug, \$1.00 Extra

CHIRAD K-D SHORT WAVE SET, \$10.00
2 Variometers, 1 Variocoupler

CONDENSITE CELORON PANELS
3 $\frac{1}{2}$ in.; cut to size, per sq. in., 3c.

IF YOUR DEALER DOES NOT YET CARRY SOMERVILLE PRODUCTS, send us your entire order and find out why our mail order service is so popular; We pay the postage!

Our "Add-a-Page" Catalog sent for 25c. or free with your initial order.

SOMERVILLE RADIO LABORATORY
RETAIL - SALES - DIVISION
176-178 WASHINGTON ST., BOSTON, MASS.



10c. CHARGES YOUR STORAGE BATTERY AT HOME WITH AN F-F BOOSTER



So You will never have to give up in disgust when working a distant station. Is it not gratifying to feel that all the year round your Filament Battery will be ready when you want it? You know what it is like to have Friends call to "LISTEN IN" and then find Your Battery dead. **F-F BATTERY BOOSTERS** Charge Automatically and Operate Unattended. Screw Plug in Lamp Socket, Snap Clips on Battery Terminals and see the gravity come up. Both Waves of Current are Rectified thru Adjustable & Easily Renewable Infusible Carbon Electrodes, which Maintain a Constant Efficiency & Last thousands of hours. Also Charges Batteries right in Autos. No Skill Required. **AMMETER** Shows Current Flowing, eliminating Guess Work. **COMPLETE IN COMPACT SELF-CONTAINED PORTABLE AUTOMATIC CHARGING UNIT.** F-F Battery Boosters are Full Wave Magnetic Rectifiers for: 105-125 Volt 60 Cycle A.C. Current. **PRE-WAR PRICES.** Bantam Type 6 Charges 6 Volt Battery at 6 Amperes \$15 Bantam Type 12 Charges 12 Volt Battery at 5 Amperes \$15 Type 166 Charges 6 Volt Battery at 12 Amperes. \$24 Type 1612 Charges 12 Volt Battery at 7 Amperes. \$24 Type 1626 Charges Both 6 and 12 Volt Batteries. \$36 The Larger Types are for heavy batteries, or where time is limited. Shipping Weights 12 to 15 Pounds. Order from your Dealer or Send Check for Prompt Express Shipment. If via Parcel Post have remittance include Postage & Insurance Charges. Or have us ship Type desired C.O.D. Other F-F Battery Boosters Charge Batteries from Farm Lighting Plants & D. C. Circuits. For **GROUP CHARGING** use our Full Wave, Automatic F-F **ROTARY RECTIFIER** of 100 Volt. 36 cell capacity.

Order Now Or Write Immediately for **Free BOOSTER Bulletin No. 32 or ROTARY Bulletin No. 32A.**

THE FRANCE MFG. CO., OFFICES & WORKS
Cleveland, Ohio, U.S.A.
Canadian Rep: Battery Service & Sales Co., Hamilton, Ontario

LEARN THE CODE
NAVY RADIO OFFICER'S SHORT CUT

To International wireless Code, will enable you to instantly recognize in forty-eight hours, letters represented by incoming Dots and Dashes, that you hear in your receiver.

To each voice broadcasting station there are over 200 using Code. Interesting things, in the Code, are in the air. Day and night, coming from all over the world.

DON'T abandon your receiver when music stops. The interesting part of Radio is sent in Code; learn it; any one can.

This system was designed by a Naval Radio Officer, with years of experience as instructor, to hundreds of students in schools all over the country. A proven product. Failure impossible.

For Banker, Broker, Farmer, Boy or Girl. Beginner or Amateur.

No Dials, Records or Mechanical apparatus used. No tedious technical work. Complete instructions sent. A proven short cut and the Price is

— ONLY ONE DOLLAR —
Others Have Done It—So Can You.
Money Order—Cash—Stamps
Your dollar back if you don't get a dollars' worth.

ROBERTS RADIO SERVICE
1235 Old Colony Building, Chicago, Ill

Radio Special Storage Batteries

4 Volt, 60 Amp.....	\$10.00
6 Volt, 40 Amp.....	12.00
6 Volt, 60 Amp.....	14.00
8 Volt, 60 Amp.....	18.00

Fully Charged. **F. O. B. Boston**
No Charge for Crating.
Guaranteed for One Year.

Manufactured by
W. & G. TUFTS
336 Newbury St., Boston, Mass.

be procured free from breaks in some of the strands. Wire of this kind that has been used previously on other coils generally has a number of breaks and should not be used on antenna coils.

The design of the framework will be left entirely to the builder. It should be strong enough to keep its shape without requiring the aid of the wire to help brace it. It should be mounted to swing free on a vertical axis. If the loop is square, it makes little difference whether the sides are vertical and horizontal, or whether with the vertical axis it extends from corner to corner. However, it should be symmetrical and should stay without moving after being rotated to any position.

The main feature of this article, however, is to provide a method wherein the inductance of a loop may be predetermined, or the dimensions of the coil may be easily determined to produce a required inductance.

The wave-length depends upon the inductance and the capacity in the circuit. The inductance must include both that of the loop and that of the primary of the receiving transformer. The value for the latter may be readily obtained with a wavemeter if not known, or may be computed with a formula or obtained from computation charts which have recently appeared.

To receive wave-lengths of 180 meters the inductance value (total for the circuit) and the capacity value multiplied together should equal the value 10. For a wave-length of 600 meters the inductance times the capacity should equal 100, and for a wave-length of 3,000 meters the inductance times capacity value should be 2,500. These values are based on the "centimeter," as the unit of inductance and the microfarad as the unit of capacity.

For the reception of radiophone broadcasts, a maximum of 600 meters is sufficient range for all purposes, unless time signals are required. Having determined the inductance required of the loop antenna by dividing the value of 100 or 2,500, etc., selected above the capacity in the antenna circuit and subtracting from the quotient the value of the inductance of the primary coil, the next thing is to design the loop.

In the following formula the letter A signifies the length of one side of the square loop, in inches (a value selected according to the points mentioned previously in this article), and N refers to the number of turns, spaced two turns to the inch:

$$L = AN^2Q$$

wherein Q is a factor found on the following curve varying as the ratio of A divided by N.

Example 1.—A loop is made of 10 turns on a frame 4' square. Then $A \div N = 4.8$ and referring to curve Q = 65.0. Then $48 \times 100 \times 35 = 312,000$ centimeters. This inductance, together with a condenser of .0005 microfarad, would give a wave-length of about 750 meters.

Example 2.—A loop of 20 turns is 2' square, or 24". Then $A/N = 1.2$, and $Q = 34.0$. Then $L = 24 \times 400 \times 34 = 326,400$ centimeters, which is approximately the same inductance as in example 1. This latter example, however, although much more compact would have only about half of the energy induced in it that the first loop would have and in addition would have much more distributed capacity.

Example 3.—A loop 8' in diameter having six turns. $A/N = 16.0$ and $Q = 92$. $L = 96 \times 36 \times 92 = 318,000$ centimeters. The inductance is thus about the same as the other examples, but the signal strength would probably be over twice as strong as

WIRELESS DISTRIBUTORS
Handle **B. & P. INSULATORS**

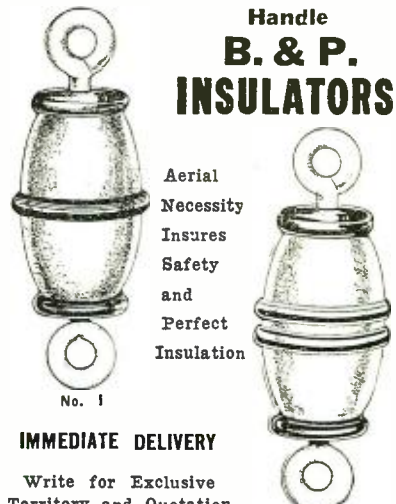

Aerial Necessity Insures Safety and Perfect Insulation

IMMEDIATE DELIVERY

Write for Exclusive Territory and Quotation

BANISTER & POLLARD CO.
206-208 Market St. Newark, N. J.

MORSCAN

Wireless Supplies and Equipment at Wholesale

MORSCAN RADIO CO.
196 Market Street, Newark, N. J.

LIST OF APPARATUS

The unprecedented influx of business with its resultant increase in detail has made it absolutely impossible for us to properly compile and print a new catalog.

We have just received from the printer, however, a complete list of apparatus, comprising several hundred items.

This, together with our Delivery Information Sheet will be sent to you on receipt of 2c postage.

A.H. CORWIN & CO.
Newark, New Jersey

"Follow Events by Radio"

RADIO PHONES
Supplied and Installed

Klein's Radio and Electric Shop
48 Fulton St. Near 3d Ave. L. NEW YORK
Phone Beekman 1767-2999

WISCONSIN AMATEURS!

Westinghouse	Magnavox
Remler	Brands
Murdock	Baldwin
Rhamstine	Western Electric
A. P. and Cunningham	Tubes
Willard	Radio Batteries
Eveready	Batteries, Panels, Wire, etc.

Order from any Standard Catalogue
CHAS. A. HONOLD CO., Sheboygan, Wis.

when using the loop in example 1, and nearly five times strong as in example 2. Such a loop would probably prove too bulky for most installations, however.

These examples show the steps necessary to determine the inductance with fair accuracy of such coils. The formula and curve are empirical. The effect of the leads from the antenna are not considered in the above, as their effect is negligible in comparison unless they are very long.

The Milwaukee Amateur Radio Club
(Continued from page 955)

Hammer Mfg. Co.; March 13, 1922 "Storage Batteries," by J. P. Schroeter, Electrical Engineer formerly Consulting Engineer, American School of Correspondence, Chicago, Ill. All radio men and other interested persons were invited to attend.

The Club has several committees through which much of its work is accomplished. Membership in one or more of these committees entitles the radio amateur to become actively engaged in the solution of the problems of local radio organization. There is a Committee on Interference and Relay which has for its duty to cooperate with the A. R. R. L. City Manager in the solving of problems of local radio traffic. Some other committees, the work of which is obvious from their names, are the Committee on Papers and Publications, Program Committee, Publicity Committee, and the Committee on Research and Development. The work of the last named committee is shortly to be transferred to a radio laboratory founded by several radio club members.

Membership appeals alike to the "DX" man, the radio experimenter, the beginner, and to those who have only a set for the reception of radio broadcasts. There are three classes of membership, viz.: Member, Associate, and Junior. Dues for the first two classes are fifty cents a month and for Juniors, twenty-five cents. An initiation fee of one dollar is charged. The direction of the Club is especially desirous of having for members all local members of the A. R. R. L., making the Club a real local section of the League.

There are several other radio clubs in Milwaukee and its suburbs, three of which are affiliated with this Club through the Milwaukee Radio Executive Council. They are as follows: Wauwatosa Radio Club, meeting on Monday evenings in the Wauwatosa High School; West Allis Radio Club, meeting on Friday evenings in the West Allis Public Library; South Side Radio Club of Milwaukee, meeting on Wednesday evenings in the South Side Branch of the Public Library. Although the Milwaukee Amateurs' Radio Club has a centrally located meeting hall and embraces a city-wide membership, its directors realize the expediency of having additional radio clubs in the suburbs and various sections of the city. The Milwaukee metropolitan district is large enough and boasts a sufficient number of amateurs to make it a multi-club one. The direction of this Club does not view these contemporary clubs as competitors but as organizations striving with this Club to make Milwaukee's radio organization a success.

The executive office to which all Club correspondence should be addressed is 601 Enterprise Building, Second and Sycamore Streets, Milwaukee, Wisconsin.

CORRECTION NOTICE.

The publishers wish to announce that an error appeared in the Sidbenel Radio Manufacturing Co.'s advertisement on page 879 of the March issue. It should have read

AT LAST

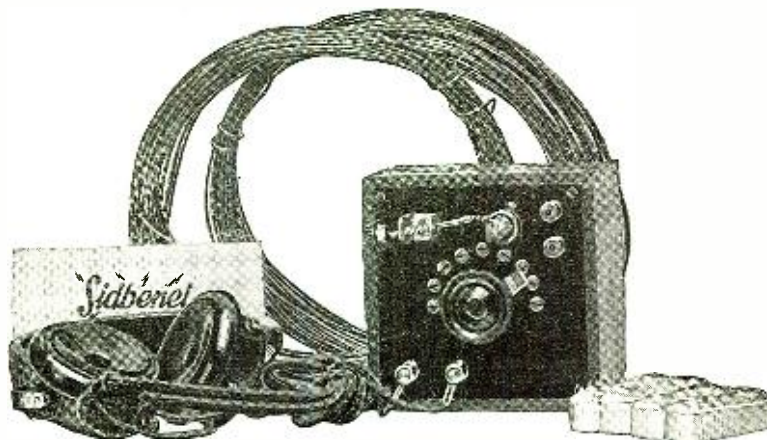

A Complete Radio Broadcasting News Receiver for \$10.00

HERE IS—The most practical and highly perfected Radio Broadcasting Receiver MADE. It will bring in Farm Reports, Voice and Concerts exceptionally loud and clear and will tune from 150 to 1,800 meters; so sharp is the tuning that no other Station other than the one to which you have tuned will interfere at the time you are receiving Broadcasting news. We daily receive hundreds of letters from all parts of the country telling us that this Receiver has brought in Concerts and Voice for a distance over 75 miles.

The complete outfit consists of a "SIDBENEL" highly sensitive specially wired tuning cabinet, handsomely finished in chestnut; 150 feet of solid copper wire for antenna; porcelain insulators; a 1,000 ohm super sensitive head receiver with leather headband and telephone cord; a highly tested crystal detector and complete instructions for installation and operation. Price ONLY..... \$10.00
With extra coil for long wave tuning..... \$11.50

DO NOT HESITATE—SEND YOUR MONEY IMMEDIATELY
GUARANTEE

"SIDBENEL" sets are guaranteed to equal or surpass in performance any outfits selling at triple the price—a statement we can prove by actual test.

If your dealer has not received his supply as yet, send check or money order direct for immediate shipment.
Send for catalog on vacuum tube sets.

SIDBENEL RADIO MFG. CO.

Box 10—Inwood Station

NEW YORK, N. Y.

CONDENSERS

A New Line

Of High Grade Variable Condensers Including 43 Plate, 23 Plate and 3 Plate

VERNIER

Switch Units with 14 Contacts and 1½ Lever

Crystal Detector
Price \$1.00

Patent Pending

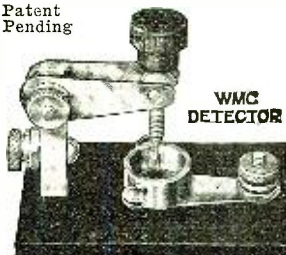

W

W

M

M

C

C

WESTFIELD MACHINE CO., Westfield, Mass.

THE McTIGHE STORAGE B BATTERY

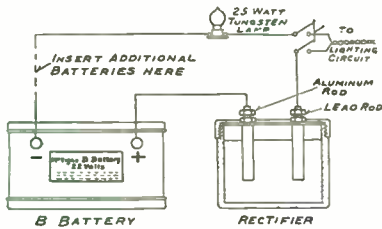

The McTighe Storage B Battery gives unexcelled service in the plate circuit and can be charged from your lighting circuit.

In ordinary service a one hour charge will last from two to three months.

The Battery is furnished in a 24 volt unit in an attractive case.

It is noiseless and cannot be injured by accidental short circuit, over charging or by standing idle.

Descriptive leaflet on request.

PRICES

Battery - - - - \$4.00

Rectifier - - - - \$1.50

Add postage Battery two lbs.
Rectifier one lb.

THE McTIGHE BATTERY CO.
WILKINSBURG, PA.

"However, one battery will supply five bulbs if only 25 volts is needed, or two batteries will supply all the bulbs on the set that needs 50 volts, etc."

Radio Digest

(Continued from page 967)

of the American Radio and Research Corporation, Medford Hillside, Mass., is now WGI, according to an announcement of the Department of Commerce. This change in call letters is in line with the Department's recent ruling limiting the broadcasting of lectures, speech, concerts, etc., to commercial stations only. WGE was an experimental license and will be retained as such, but the broadcasting station will henceforth be known as WGI.

Old WGE was called the "father of radio-phone broadcasting," being the first big sending station in the country operating on a regular daily schedule. When the ruling of the commercial stations was first announced, there was considerable excitement in radio circles, as it was feared this old-timer was to be silenced. WGI (WGE dressed-up) has a 1,000 mile radius and operates on 360 meters.

WIRELESS TELEPHONE MAKES BIG HIT IN CHINA.

The marvels of the wireless telephone have taken the Orient by storm, according to Professor C. H. Robertson, a noted American lecturer, who has been demonstrating the latest developments of electricity throughout China and Japan during the past six months. On the first day that he puzzled the Celestials of Shanghai by carrying on an intelligible conversation with some mysterious individual in empty space, it was estimated that more than 14,700 natives came to witness the performance. Before he had left the city his lectures on the wireless phone had been attended by an aggregate of at least 300,000 people.

Professor Robertson, who is being aided in his work by the China Electric Company, an allied company of the International Western Electric Company of New York, found that the easiest way of interesting the Asiatics was to take his wireless telephone station through the streets of the crowded cities on a big Chinese wheelbarrow. Every now and then he halted and carried on a wireless talk with his associates who had set up another station in their quarters. The stations were up to date models and were the identical ones that were used in the great Victory Way ceremonies in New York City.

The wireless demonstrations attracted widespread attention with the result that the professor was swamped with requests for his attendance before colleges, government officials and foreign associations. The officers of the Chinese Army were particularly interested. They staged several lectures under Professor Robertson's direction. They were impressed by conversations carried on through heavy masonry walls and the responses received simultaneously from several different directions. (Abstracted from *Electrical Record*.)

INSTITUTE OF RADIO ENGINEERS PROMOTES STANDARDIZATION.

In May, 1912, the Institute of Radio Engineers was formally established with a membership of less than fifty. Today it numbers about 1,800. The objects of the institute, as stated in its constitution, are "the advancement of the theory and practice of radio engineering and of the allied arts and sciences and the maintenance of a high pro-

U. S. STORAGE BATTERIES FOR WIRELESS USE

Special Prices

Volts	Amps.	Price
6	20	\$7.25
6	40	9.75
6	60	13.50
6	80-100	22.00

One year unconditional guarantee, free repair or a new battery at our option, shipped fully charged, ready for use.

Add \$.50 for special crating.

Distributors—Jobbers—Dealers—write for discounts and exclusive territories. If your dealer hasn't it, send check or money order direct.

P. M. DREYFUSS

Fourth Floor

150 Chambers St.

New York City

BAKELITE PANELS CUT TO ORDER

3/16" thick.....02c square inch
1/4" thick.....02 1/2c square inch

We also carry a complete line of magnet wire, tubing, radio outfits and parts.

MAIL ORDERS PROMPTLY FILLED

DEALERS.—We distribute for all leading manufacturers. Write for price list and discount schedule.

PITTSBURGH RADIO AND APPLIANCE COMPANY, Inc.

112 Diamond St. Pittsburgh, Pa.

Whitall Electric Co.

Distributors & Dealers

All Radio Coporation Material—The New General Electric Tuner with Radio Frequency Amplifier and Detector—Radio Frequency Transformers. Complete Clapp Eastham Line—Remler—Signal—Paragon—DeForest—General Radio—Murdock—Baldwin—Westinghouse.

Prompt delivery of famous Clapp Eastham HR Receiver and HZ Amplifier—Dealers and Amateurs write.

SEND 6c FOR CATALOGUE

WESTERLY, RHODE ISLAND

MAKE YOUR OWN RADIO TUNING COILS CARDBOARD TUBING

Any length tube desired.

3 in. dia., 1/8 in. wall, at.....25c per foot
3 1/2 in. dia., 1/8 in. wall, at.....30c per foot
4 in. dia., 1/8 in. wall, at.....35c per foot

Postage extra. Weight about 1 1/2 lbs. per foot.

SPECIAL DISCOUNTS TO DEALERS.

MICHIGAN PAPER TUBE & CAN CO.

2536 Grand River Avenue,
DETROIT, MICHIGAN

"SUPERIOR" RECEIVING SET

\$4.75

In cabinet complete as shown



Guaranteed to bring in signals as loud or louder than any other crystal set made, regardless of price. We will prove this to your satisfaction or refund your money.

Parts for "SUPERIOR" set ready for assembling \$3.25

GENUINE "STEINMETZ" TESTED GALENA

Absolutely the most sensitive that can be had.

In sealed tin box 15c

At your dealers or

STEINMETZ WIRELESS MFG. CO.
5706 Penn. Ave. Pittsburgh, Pa.

CONDENSERS

VARIABLE, 23 AND 43 PLATE
\$3.25 AND \$4.25; DIAL EXTRA

PHONOGRAPH ADAPTORS

FOR ANY COMBINATION OF RECEIVER AND PHONOGRAPH \$2.00

IMMEDIATE SHIPMENT

MANUFACTURER

STUCKEMAN BROS., Inc.

18 RUTH ST.

PITTSBURGH, PA.

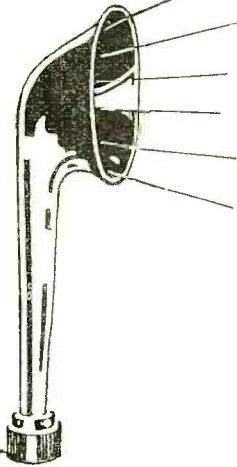

Your Radio Set is No Better Than Your Battery

TO SECURE long, uninterrupted service, it is necessary that the storage battery meet the exact requirements of your set. The capacity of the battery must be sufficient to maintain a steady voltage for a long duration of time. Without these qualifications your radio results will prove unsatisfactory.

The MARKO RADIO BATTERY is not simply a storage battery carrying a Radio label. Its development has kept step with the progressive evolution of the radio apparatus itself and fulfills every requirement.

The Government radio service and reliability tests during the war placed MARKO above all others.

For Sale at
all Marko
Stations
and Radio
Equipment
Dealers

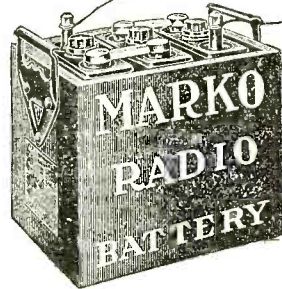

MARKO STORAGE BATTERY CO.
1402 ATLANTI AVE., BROOKLYN, N. Y.

- MOULDED - RADIO - ACCESSORIES -

MANUFACTURED OF
APPROVED MATERIAL

Specifications Solicited

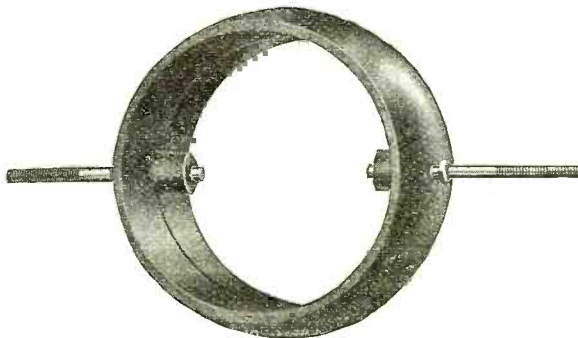

Knobs Dials Rotors Couplers Panels Stators

INTERNATIONAL INSULATING CORP.

RADIO DEPT.
25 West 45th St., NEW YORK CITY

FACTORY
SPRINGFIELD, MASS.



PITTSBURGH'S RADIO SHOP

SEND 10c FOR CATALOG

We carry the most complete stock of RADIO APPARATUS and SUPPLIES, all sizes of wire, brass rods and tubing, also instruction books.

A full line of Radio Receiving Sets or any part you may need if you wish to build your own.

U. S. EAGLE GALENA
25 cents

U.S. RADIO CO. of PENNA., Inc.

Manufacturers, Distributors and Importers
Corner Ferry and Diamond Streets
Pittsburg, Pa., U. S. A.

"It's a Wizard"

Has Practically Double the Life
of Other Small "B" Batteries.

For Your Wireless Set

Fresh Batteries direct from Manufacturer to You

These special "B" Batteries have practically double the life of ordinary small "B" Batteries. This is made possible by the special sized cells having a volume of 4.7 cu. inches as opposed to the small batteries of only 2.5 cu. inches volume.

Wizard's Two New Improved Type "B" Batteries

No. 1632—1 tap 45 Volt Var. Battery, Size 6x5x2 $\frac{3}{4}$ in. (Wt. 3 $\frac{3}{4}$ lbs.) Price \$2.80
No. 1630—6 tap 27 Volt Var. Battery, Size 6x3x $\frac{3}{8}$ in. (Wt. 2 $\frac{1}{2}$ lbs.) Price \$1.80

Order by mail and send for Booklet No. 6

WIZARD BATTERY CO.

Dept. R, 1315 42d Street

BROOKLYN, N. Y.



TO ALL AMATEURS AND BROTHER OWLS
We are distributors (wholesale and retail) for the Wizard Battery as advertised elsewhere in this issue. Send for our catalogue No. 6. Dealers send for our Bulletin D, giving special terms on these batteries. We are also agents for the following manufacturers:
Meyers 4 V. Tubes and Instruments
Marko 4 V "A" Battery for Tubes
E. S. K. Phonograph Attachment
Jewel Meters
No. 7 Standard Horn
50,000 volt 3/16 Ebonite Panels cut to order, 3 $\frac{1}{2}$ c sq. in. Holes drilled, 5c each.
Everything sent postpaid but Storage Batteries.
Manhattan Nest 1705
Order of Owls
RICHMOND HILL BATTERY & INST. HOUSE
Albert R. Wootton, Prop.
Richmond Hill, L. I., N. Y.
10726 110th St.

Electrical men with training are in demand. For more than a quarter of a century, this school has been training men of ambition and limited time, for the electrical industries. Condensed course in Electrical
Engineering enables graduates to secure good positions and promotions. Theoretical and Practical Electricity, Mathematics, Steam and Gas Engines and Mechanical Drawing. Students construct dynamos, install wiring and test electrical machinery. Course with diploma complete



In One Year
Over 3000 men trained. Thoroughly equipped fireproof dormitories, dining hall, laboratories, shops. Free catalog. 30th year begins Sept. 27, 1922
BLISS ELECTRICAL SCHOOL
407 Takoma Ave., Washington, D. C.

professional standing among its members." Its most important committee is the committee on standardization. This committee, composed of twenty of the foremost radio engineers in the country, was at work during the past year revising the definitions of radio terms in use since the beginning of the art and framing definitions of terms which have come into use during the past few years, when the advent of vacuum-tube devices introduced a long list of new terms. The international character of radio communications has made it advisable to cooperate in the standardization of terms with foreign technical bodies and with representatives of the communication departments of foreign governments. It is expected that a "Book of Standards" will be published by the Institute early in 1922. (Abstracted from *Electrical World*.)

Schedule for Radiophones Revised

(Continued from page 951)

3:00 to 4:00 p. m.—Precision Shop, Gridley. Concert.
MONDAY—
8:00 to 9:00 p. m.—Precision Shop, Gridley. Concert.
TUESDAY—
8:00 to 9:00 p. m.—Oard Laboratories, Stockton. Concert.
WEDNESDAY—
8:00 to 9:00 p. m.—Hobrecht, Sacramento. Concert.
THURSDAY—
8:00 to 9:00 p. m.—Precision Shop, Gridley. Concert.
FRIDAY—
8:00 to 9:00 p. m.—Oard Laboratories, Stockton. Concert.
SATURDAY—
8:00 to 9:00 p. m.—Hobrecht, Sacramento. Concert.

It was agreed to have the San Francisco stations broadcast on a wave length of 360 meters.

San Francisco Bay Radio-Telephone Schedule.

Every afternoon except Sunday—
3:30 to 4:30 p. m.—Atlantic-Pacific Radio Supplies Co. Concert.
4:30 to 5:30 p. m.—Leo J. Meyberg. Markets, news schedule and concert.
Every night except Sunday—
6:45 to 7:00 p. m.—Atlantic-Pacific Radio Supplies Co. Financial and crop.
7:00 to 7:15 p. m.—Leo J. Meyberg. General news and weather.
7:15 to 7:30 p. m.—Western Wireless School. Sports and foreign.
SUNDAY—
10:00 to 11:00 a. m.—Leo J. Meyberg Concert.
11:00 to 12:15 a. m.—Trinity Center. Sermon and sacred music.
12:15 to 1:00 p. m.—Warner & Linden Concert.
3:00 to 4:00 p. m.—Atlantic-Pacific Radio Supplies Co. Concert.
4:00 to 5:00 p. m.—Colin B. Kennedy Co. Concert.
5:00 to 6:00 p. m.—Herrold Laboratory. San Jose. Concert.
7:00 to 9:00 p. m.—Presidio. Concert and instruction.

MONDAY—
7:30 to 8:30 p. m.—Colin B. Kennedy. Concert and industrial news.
8:30 to 9:00 p. m.—Leo J. Meyberg. Concert.
TUESDAY—
12:15 to 1:00 p. m.—Warner & Linden. Concert.
7:30 to 8:15 p. m.—Hotel Oakland. Concert.
8:15 to 9:00 p. m.—The Radio Shop, San Jose. Concert.

TURNEY RADIO PRODUCTS

We are now making on a large scale at our new plant,
351 6th Ave., Newark, N. J. the following:

TUNERS	{ Spider Web Plex Spider Web Duplex	NEW TURNEY AMPLIFIER	{ Can be used with any Detector Set and is a fine looking piece of apparatus. Capacity—all you want.
CRYSTAL SET	{ VONOLA—The handsomest and most efficient Crystal Set yet produced. Capacity, 500 sets per day.	NEW TURNEY VITAFONE LOUD SPEAKER	{ Here is a real loud speaker, no batteries, no horns, and no distortion. It is the one you are looking for. Capacity — your judgment.
MONOPLEX COMPLETE TUBE SET	{ A highly amplified non-regenerative Detector Set embodying the new Turney Circuit (non-infringing). Capacity, 100 sets per day.	NEW TURNEY HEAD SET 3000 OHMS	{ The best all-around head set ever produced. New non-fatigue head band. Capacity, 1500 sets per day.
MULTIPLEX ONE STEP SET	{ Wonderfully sensitive, no distortion. Two controls, new Turney Circuit, beats them all. Capacity, 200 sets per day.	NEW TURNEY SOCKET	{ Bayonet type, nickel tube black base, Formica Insulation. Capacity 2000 per day.
NEW TURNEY TWO WAY PLUG	{ Takes two sets of phones and is electrically right. Capacity, 2000 per day.		

Send 10c in stamps for our new catalog which gives full particulars regarding the above apparatus, and DO IT NOW!

Our new plant will have the largest production of any RADIO plant in the world.

RESEARCH LABS. Radio Hill, Holmes, N. Y.	EUGENE T. TURNEY LABORATORIES, INC. <small>GENERAL OFFICE AND PLANT</small> 351 6th Avenue NEWARK, N. J. <i>Address all Communications to General Office</i>
--	--

PARAGON

TRADE MARK REGISTERED

the PIONEER

- 1915 First regenerative receiver ever manufactured bore the name PARAGON.
- 1916 First Trans-continental Amateur Reception (California from New York; not pre-arranged) effected with a PARAGON Type RA-6 Receiver.
- 1916 First Trans-continental Amateur Transmission (New York to California; not pre-arranged) effected by PARAGON designed transmitter.
- 1917-1918 PARAGON acknowledged supreme on Western Front.
- 1921 First Trans-Atlantic Amateur reception effected with PARAGON receiving equipment, at which time 27 different amateurs scattered thruout the Eastern section of the United States registered signals at Ardrossen, Scotland—3500 miles.

THERE'S A REASON!

2nd District Convention—Hotel Pennsylvania—New York, March 7th to 11th, 1922.

The **ADAMS - MORGAN CO.**

Manufacturers

UPPER MONTCLAIR, N. J., U. S. A.

"ILLINOIS" THE RELIABLE MADE RIGHT - STAYS RIGHT



STYLE No. 1



STYLE No. 2



VERNIEE

Three Styles: No. 1, Panel; No. 2, Open Type as shown; No. 3, Fully Encased. Anti Profiteer. Less than pre-war prices. Fully assembled and tested.

Style No.	1	2	3
67 Plates,	\$7.00	\$8.00	\$8.50
43 "	3.50	4.50	4.75
23 "	2.75	3.75	4.00
13 "	2.25	3.25	3.50

Money back if not satisfied. Just return condenser within 10 days by insured Parcel Post.

Options:—With Style No. 1—instead of Scale

and Pointer, a 3-inch Metal Dial at 50 cents extra, or a 3-inch Bakelite Dial at \$1.00 extra. Large Knobs. Both excellent values. Or we will, if desired, supply the Condenser with smooth 3-16 inch center staff, without Scale, Knob and Pointer, at 15 cents off the list to those who prefer to supply their own dial.

Vernier with single movable plate applied to 13, 23 or 43 plate condenser, \$3.00 extra.

We allow no discounts except 5 percent on orders of 6 or more.

Sent Prepaid on Receipt of Price Except: Pacific States, Alaska, Hawaii, Philippines and Canal Zone, add 10c. Canada add 25c.

Foreign Orders other than Canada not solicited.

G.F. JOHNSON, 625 Black Ave., Springfield, Illinois.

WEDNESDAY—

7:30 to 8:15 p. m.—Atlantic-Pacific Radio Supplies Co. Concert.

8:15 to 9:00 p. m.—Herrold Laboratory, San Jose. Concert.

THURSDAY—

7:30 to 8:30 p. m.—Leo J. Meyberg. Concert.

8:30 to 9:00 p. m.—Colin B. Kennedy. Concert.

FRIDAY—

12:15 to 1:00 p. m.—Warner & Linden. Concert.

7:30 to 8:15 p. m.—The Radio Shop, San Jose. Concert.

8:15 to 9:00 p. m.—Hotel Oakland. Concert.

SATURDAY—

7:30 to 8:15 p. m.—Warner & Linden. Concert.

8:15 to 9:00 p. m.—Atlantic-Pacific Radio Supplies Co. Concert.

Portable Radio Telegraph-Telephone Set

(Continued from page 925)

been marked on the knobs of various adjusting handles. The resistance controls are also of unusual smartness as well as appearance, while the same may be said of the send-receive switch and last but not least the special arrangement of the microphone transmitter, of which the mouth piece is turned in such a manner as to be in the direction of the person talking, while the instrument may be held in his hand with ease and comfort.

Improved Land and Marine Pattern Wireless Direction Finding Cabinets

(Continued from page 923)

3, 1,800 to 4,500 meters. The exact ranges depend, of course, upon the size of the aerial. The same type of aerial is used as described above for the marine pattern, the standard equipment being as illustrated in Fig. 7. This comprises one 70-foot central mast supporting two triangular aerials with inclined limbs 92' long, and horizontal limbs 140' long. The latter are broken at the center and led down to the instruments.

The D.F. component is mounted on the lower panel at the extreme left of the instrument. Fig. 3 shows diagrammatically the arrangement of the windings, and Fig. 8 gives the appearance of the component when removed from its compartment. The variable aerial tuning condenser is situated next to the D.F. component on the lower panel. A three-point switch mounted above the main condenser provides extra capacity in the form of block condensers for obtaining ranges 2 and 3. The transformer component, illustrated in Fig. 9, consists of three air-cored transformer elements for the three ranges, and the corresponding "Sense" resistance, together with the three-way key-switch (stand-by, Sense, D.F.) and the wave-changing switch. On the right of the transformer panel is a second variable capacity air condenser for tuning the amplifier circuit. The adjustment for various wave-lengths is indicated on a chart supplied with the instrument. On the extreme right of the instrument case and below the note magnifier is located the jigger panel. It comprises the three jigger windings, the jigger coupling coil, the oscillator coupling coil, and a three-position wave changing switch. The jigger coupling varies the coupling of the aerial circuit to the sec-

"ACE RADIO CONCERT RECEPTOR"

ACE

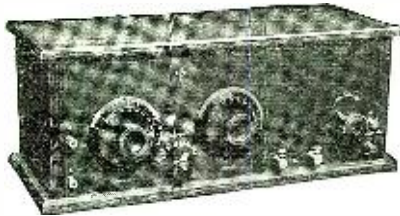

ACE

Licensed under Armstrong Patent 1,113,149

Type TRU Concert Receptor, \$50.00

This unit is especially designed for the efficient reception of Radio Telephone Concerts from even the most distant Broadcasting Stations. The ease with which this Receptor can be installed and the extreme simplicity of operation make it ideal for use by even the most inexperienced. No previous knowledge of radio necessary to secure results.

We stock a complete line of Radio Supplies and maintain a prompt, reliable Mail Order Service that reaches all over the world.

Send 5c in stamps for catalog to Dept. "A"

THE PRECISION EQUIPMENT CO., INC.

Manufacturers, Distributors and Retailers of Radio Apparatus
Cable Address: ACE Cincinnati
Peebles Corner Cincinnati, Ohio
Radio WMH 8XB

GALENA TESTED CRYSTALS — Wholesale Only

Condensers—11—21—41 Pl. K. D. use these in your manufacturing and put them in your new catalog.

Binding posts—switch points—switches. Wireless phone tuners—all prices and types. 24-page catalog—10c.

TRESCO - - Davenport, Pa.

Licensed Under Armstrong Patent No. 1113149

High Grade DETECTORS and DIALS

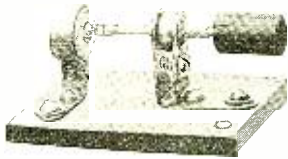

Highly nickelplated Detector with ball and socket joint. List price85c

Hard Rubber Moulded Knobs, 3 in. diameter for 3/8 in. shaft, marked 0-100 degrees; well made. List price.....\$1.00

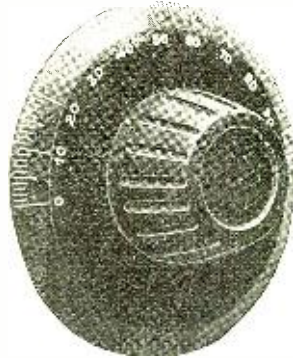

A handy Detector with a ball joint. This detector has a three-crystal cup so that galena, silicon and radiocite can be used. List price (without crystals) \$2.00 Complete\$2.50

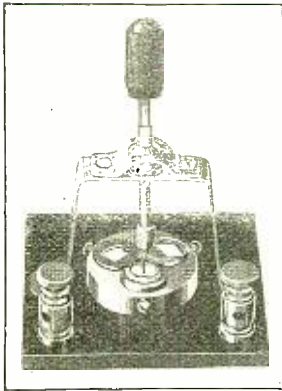

Send for Dealers' proposition

RADIO TELEPHONE & MFG. CO.
150-152 Chambers St. New York, N. Y.

DREYFUSS PHONES

CONCERT TYPE

\$8.00

per pair
list price

(2000 ohms)



Dreyfuss Phones are considered the Best Phones for Radio Telephony work

We are **NOW** Making Delivery

Designed by Telephony Engineers of over 18 years experience

Distributors:—Get in touch with us for open territories

P. M. DREYFUSS CO., Inc.
150-152 Chambers St. New York, N. Y.

DUCK'S NEW CATALOG No. 16

275 Pages A Catalog Deluxe

Type CV Crystal Receiving Set \$25.00

Beyond doubt the most advanced type of crystal set on the market for the clear and efficient reception of radio speech and music and telephone reception. Wave length range 700 meters.

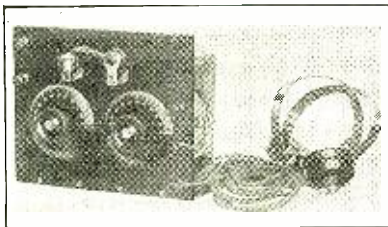

We caution the public unfamiliar with radio to be careful about the cheap, inefficient and poorly constructed crystal sets that are beginning to flood the market. We are the oldest dealers in America selling complete everything in radio. Established 1908.

In tests with this set the radio telephone station at Detroit (60 miles distant) was heard in Toledo with the greatest clearness and sweetness. Ideal set for persons residing within range of powerful radio stations in New York City, Springfield, Mass., Pittsburgh, Chicago and Detroit where wonderful concerts are broadcasted every evening.

"Over fifty pages of the latest hook-ups (wiring diagrams), and invaluable and up-to-date data and information on radio, including important instructions for building antenna."

"Send 25c in coin carefully wrapped for your copy of this wonderful book, the most unusual and complete catalog ever put between the pages of two covers. Not sent otherwise. It is not only a catalog, but a wonderful text book on radio. Enormous cost and tremendous demand prevents further distribution at a less retainer."

Never in the history of radio has there been such a catalog.

The radio data and diagrams embracing upwards of fifty pages gives the experimenter more valuable and up-to-date information than will be found in many textbooks selling for \$2.00, and \$1.00 could be spent for a dozen different radio catalogs before you could gather together the comprehensive listing of worth while radio goods found in this great catalog.

A brief summary of the radio goods listed in this catalog:

The entire radio catalog of the Radio Corporation, with a wealth of scientific and technical data on C.W. transmitting sets, and all the diagrams for the assembling of these sets; the complete Remler catalog, which embraces 25 pages, the Westinghouse, Firth, Murdock, Federal, DeForest, Clapp-Eastham, Brandes, Connecticut Company, Thordarson, Turney, Magnavox Company catalogs, the best products of Adams-Morgan, Signal and countless other manufacturers, including our own complete line of radio apparatus, and many individual items and parts used in radio work today.

DEALERS

We want live responsible dealers in every city and town in the United States, both for the sale of our extensive line of radio apparatus and all other worth while lines of radio goods on all of which we can quote attractive dealers discounts. We can offer you facilities and advantages that no other radio house can offer.

Send only 25c for copy of this wonderful catalog. You will need no other when you have Duck's, and you cannot find in all others combined what you will find in Duck's Wonder Catalog.

THE WILLIAM B. DUCK CO., 231-233 Superior St., Toledo, Ohio

Most Efficient Battery Made.

Radio Operators.—You owe it to yourself to try out the National "B" Battery. It is the most efficient Radio battery made. If your dealer does not handle them yet, send in your order to us, enclosing check for amount, and we will send you the most satisfactory battery you have ever used.

National "B" Battery

**LASTS LONGER
SERVES BETTER— COSTS LESS**

For amplifying tubes, detector and plate circuit. The National "B" Battery gives more hours of service, is moisture proof, silent and free from leaks.

"ONCE A NATIONAL, ALWAYS A NATIONAL"

No.	Type	Size	Voltage	Hrs. Service	Taps	Wt.	List Price
517	Plain	2 1/4 x 2 3/8	2 1/2	300		1 lb.	\$1.50
518	Variable	2 1/4 x 2 3/8	2 1/2	400	5	1 lb.	1.75
519	Plain	3 x 3 1/2	2 1/2	1100		5 lbs.	2.50
520	Variable	3 x 3 1/2	2 1/2	1400	5	5 lbs.	3.00
521	Plain	3 x 3 1/2	4 1/2	3000		10 lbs.	5.00
522	Variable	3 x 3 1/2	4 1/2	3000	6	10 lbs.	6.00

Also a complete line of Novelties and FlashLight Batteries

National Electric Novelty Co
53 Walker St New York



DEALERS
Write for special
offer and
discount



Mfr. Rad. LABORATORIES

R. F. AMPLIFYING TRANSFORMERS

TYPES T-11, T-11a, T-11b



WAVELENGTH RANGE

160-500 METERS

RADIO FREQUENCY AMPLIFICATION

- Use MU-RAD T-11 for one stage amplification..... \$6.00
- Use MU-RAD T-11 and T-11a for 2 stage amplification..... 6.50
- Use MU-RAD T-11, T-11a and T-11b for 3 stage amplification... 7.00

The different transformers in the different stages is exclusive with MU-RAD. It gives Super-amplification.

Immediate Deliveries

From your dealer or write direct to

MU-RAD LABORATORIES, Asbury Park, New Jersey

Distributors West of Mississippi

THE BENWOOD CO., ST. LOUIS, MO.

FREE

New Consolidated Radio Call Book with every order amounting to \$25.00 or more from our lists.

Send stamp for our latest catalogue. We pay transportation anywhere in the United States.

ASHTABULA RADIO SALES CO.
49 McGovern Ave., Ashtabula, Ohio

THE AMATEUR RADIO CENTRAL IN LONG ISLAND

We can make immediate delivery on
FADA accessories

RIDGEWOOD RADIO SHOP

1603 Myrtle Ave. Ridgewood, L. I.

ALL cars to Wyckoff Ave. reach our door.
Mail orders given immediate attention.

ondary windings, while the oscillator coupling coil, the ends of which are connected to the two terminals marked "Local Oscillator," provides for reception by the "beat" method. Fig. 6 shows that the amplifying detector is mounted on the center of the upright portion of the cabinet and that it has seven valves. The six on the right-hand side are for high frequency amplification, the seventh performing the function of a rectifier. The filament resistance and the potentiometer are mounted on a separate control panel to the left of the amplifier, and both are operated by a rotary instead of a sliding motion.

A bearing on a transmitting station from which signals are being received is obtained in three stages. In the first, the transmitting station is picked up and tuned in. In the second, its bearing is ascertained, and in the third, the sign or "sense" of the bearing is determined. Change from one to the other is effected by means of a key-switch situated on the transformer panel and having three positions marked, respectively, "Std-By," "DF" and "Sense."

With the switch in the "Std-By" position, the midpoints of the aerial loops are connected to earth through the primary or "Sense" winding of the air core transformer, and the circuits are arranged for "all round" reception. The e.m.f.'s induced in the aerials by incoming signals may be considered as producing two superimposed effects. The first or non-directional effect is due to the action of the combined loops functioning as a simple aerial-earth system. It does not influence the search coil and is transferred to the tuning circuits, and hence to the amplifying detector and telephones, by means of the sense winding of the transformer. The second is due to the action of the aerial loops as in ordinary loop or frame reception, and is directional. In this case the resulting circulating currents act upon the detector by way of the search coil and tuned intermediate circuits. The second effect is relatively small, and at "Std-By," reception is practically non-directional.

Placing the key-switch in the "D" position cuts out the sense winding so that the tuning circuits can only be affected through the medium of the search coil of the direction finder component, thus utilizing the second effect described above. The direction finder combines the signals received on the two aerials in such a manner that the movable search coil is influenced when it lies in a plane corresponding to the direction from which they are received, and remains unaffected when lying in a plane at right angles, as already outlined heretofore. The position of the search coil is indicated by a pointer which moves over a circular degree scale as the coil is rotated. A second but shorter pointer marked "Sense" is fixed at right angles to the first and is used as follows:

With the switch in the "DF" position, the instrument provides for an accurate determination of the plane of reception, but as there are two minima corresponding to two bearings 180 degrees apart, no indication is given of the actual direction. One of these bearings is towards, and the other away from the transmitting station, and in order to distinguish between them it is necessary to bring into action the sense winding. For this purpose the key-switch is put over to the "Sense" position and held there, while the sense pointer is put first at one of the previously determined minima and then at the other. A marked difference in signal strength will then be noted, and the circuits are so arranged that when in the position for weak or zero signals the sense pointer will be at or near the previously determined minimum corresponding to the

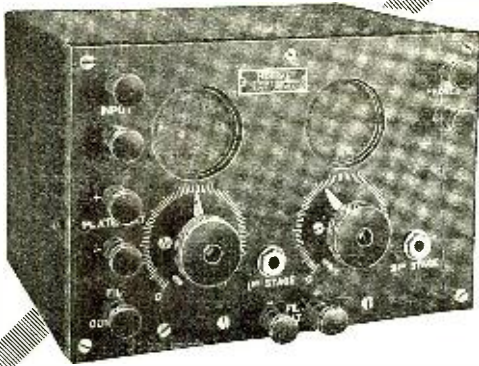

**FEDERAL No. 9—Two Step Amplifier
PRICE (IN U. S. A.) . . \$58.00**

Federal AMPLIFYING UNITS

THE FEDERAL Detector and Amplifier Units mark the highest stage of vacuum tube equipment development. In these new units are incorporated improvements that are distinct achievements in the art and innovations which make them vastly superior to devices of the same purpose that are available to the radio enthusiast today. They are designed with the same high grade engineering skill, built with the same careful attention to electrical and mechanical detail, and inspected with the same

precision that has held FEDERAL apparatus in its high place for the last 20 years.

FOR EXPERIMENTAL AND AMATEUR USE

Federal Apparatus is the Recognized Standard

Let Your Nearest Radio Dealer Give You Further Information

Federal Telephone and Telegraph Company

General Offices and Factory:
BUFFALO, N. Y.

N. Y. C. Sales Office:
WOOLWORTH BLDG., NEW YORK CITY

LOWER PRICES—BETTER PRODUCTS



VARIOMETER \$4.50

Get These Points:

All wooden parts carefully impregnated with a black high dielectric strength, non-inflammable, waterproof compound. All positive "Pigtail" contacts. Bearings will not bind. All metal parts white nicked. Rotor balls solid mahogany. Windings of green double cotton covered wire, guaranteed not to peel or come loose. White nicked shields furnished.

*Shipped immediately
from stock*



COUPLER \$3.75

Make your own highly efficient regenerative set with 2 of our variometers, a loose coupler and necessary parts at a small expense. As a special inducement and to assist you in keeping down your costs we offer the three at \$12.00

IMPROVED VARIOMETER

Binding posts have large knurled thumb nuts. Wood forms accurate. Minimum clearance between rotor and stator. Mounts easily, and is designed for low Di-Electric losses and maximum range of induction. Black rubberized finish will not chip or peel off. Effective tuning range 150 to 650 meters.

IMPROVED COUPLER

Primary windings on black formica tube. Has 6 taps for varied induction. Rotor held by spring clip making it possible to hold range when once found. Easily installed. Will operate perfectly and give highest efficiency. Save money by using this cheaper and better equipment.

DEALERS: WRITE FOR
OUR PROPOSAL



RADIO INSTRUMENT AND PANEL CO., Mfrs., Box 75, CICERO, ILL.

"E. S. X."

AMPLIFICATION without DISTORTION

RADIOIZE YOUR TALKING MACHINE



Let your family and friends enjoy the Wireless Telephone Broadcasting on your Phonograph. Attach your Wireless Receiving Set to your Talking Machine with the "E. S. X." Wireless Talking Machine Attachment.

The "E. S. X." WIRELESS TALKING MACHINE ATTACHMENT is the result of considerable time and expense in conducting tests into different ways of reproducing Wireless Music, Concerts, Speech, etc. For this we find the TONE CHAMBER of any Talking Machine manufactured at the present time to be superior to any Horn or Loud Speaker. If you have a Talking Machine, you already possess the best means obtainable for reproducing Wireless Music and Speech. This method gives you that tone and clearness characteristic of the Talking Machine that cannot be obtained in any other way.

Simply remove the Speaker Box from your Talking Machine and replace same with the "E. S. X. ATTACHMENT" allowing leg to rest on the Turn Table. This insures the proper height which is absolutely essential in order to obtain the full volume of sound.

The "E. S. X." is the first and only attachment that is absolutely Universal. It permits the phone or receiver from any Standard make of Head Set, and with the use of small adapters which we also furnish, it will fit ninety per cent of the Standard makes of Talking Machine.

The "E. S. X." is made of a Non-Magnetic Alloy and takes a very High Polish. This adds to its appearance which is permanent.

It is finished in keeping with the quality and appearance of the most expensive Talking Machines and Wireless Receiving Sets. It can be used with one or more stages of amplification.

Price \$3.00

Manufactured by

ESSEX WIRELESS SPECIALTY CO., 31 New Street, Newark, N. J.

Dealers write for proposition. When ordering by mail, mention make of your Talking Machine.

BRACH RADIO PROTECTORS

FOR RADIO TELEGRAPH AND RADIO TELEPHONE RECEIVING STATIONS

The National Electric Code Permits the use of Vacuum Tube Protectors in place of the Grounding Switch Formerly Required.

THE BRACH RADIO PROTECTOR TUBE MEETS THE REQUIREMENTS

Where Radio Transmitters are Operated from Public Service Mains, two Brach Radio Protectors connected in series, with midpoint grounded, furnish the least expensive, and the best protection against surges. Price \$2.50.

Order early to make sure of obtaining a supply. Patents allowed and pending.

Brach Porcelain Strain Insulators, 8c. ea.



Shipped 1,000 to Barrel. Send for Quantity Price List.

L. S. BRACH MFG. CO.

Manufacturers of Lightning Arresters, Signals,
Telephone and Wireless Specialties.

127-129 Sussex Ave. Newark, N. J.

BROOKLYNITES WE CARRY A FULL LINE of RADIO SUPPLIES AT SPECIAL PRICES

Radio Service V.T. Sockets	\$.80
002 M.F. Phone Condenser	.25
0005 M.F. Grid Condensers	.25
22 1/2 Volt B. Battery, Small	.90
22 1/2 Volt B. Battery, Large	1.60
No. 763 Eveready 22 1/2 Volt B. Battery	1.75
No. 766 Eveready 22 1/2 Volt Large Variable B. Battery	2.50
Arkay Loud Speakers	4.50
No. 14 Solid Copper Aerial Wire, lb.	.45
7-22 Stranded Copper Aerial Wire, 100 ft.	1.00
6 Volt 40-60 Amp. Titan Storage Battery	14.00
6 Volt 60-80 Amp. Titan Storage Battery	16.00

KENSINGTON RADIO SUPPLY CO.
4416 Eighteenth Ave. Open Evenings Brooklyn, N.Y.

Large Variometers, inside windings	\$5.00
Variocouplers, multiple and single turns on bakelite tubes	4.00
Large Variometer Balls	.80
22 DCC Magnet Wire, quarter pound	.30
(All Sizes Carried)	
Hard Maple Stators for variometers, per pair	1.20
Windings in place	1.60
Large Variometer Balls, wound and axles in place	1.60

OAK CABINETS

6"x14"x7" deep with hinged tops, and reinforced	\$3.25
7"x7"x7" deep with hinged tops, and reinforced	\$2.25
7"x10"x7" deep with hinged tops, and reinforced	\$3.00
7"x12"x7" deep with hinged tops, and reinforced	\$3.25
7"x18"x7" deep with hinged tops, and reinforced	\$4.25
12"x14"x7" deep with hinged tops, and reinforced	\$4.50

Dealers Write for Proposition.

MEADE BAKELITE AND RADIO APPARATUS
944 Jefferson Ave. Brooklyn, N. Y.

positive or actual direction of reception. The polar diagram of reception under these conditions approximates to a cardioid or heart shape, having a single minimum in the whole 360-degree sweep of the pointer. This result is obtained by a combination of the first and second effects previously referred to, extra resistance being introduced in series with the transformer sense winding, in order to reduce the current and for phasing purposes.

From the foregoing descriptions, and especially in the latter, added improvement to the direction finding apparatus now available for cooperation in the safe navigation of vessels at sea, it may be concluded that an important step forward has again been made. However, wonderful as the results secured so far may seem to the layman, scientists and inventors are still searching through the virgin territory ahead and any day may bring us yet greater results and achievements, not only due to the ingeniousness, but to the tenacity and perseverance of those men, whose tremendous services humanity may never sufficiently recompense.

The Operating Principles of a Radio Compass

(Continued from page 928)

E.M.F. is the same as position "C," but that the current flow is in the opposite direction. This second position is "D," Fig. 4. This point, of current reversal, is very important in the "Unilateral" radio compass system. If we add to the current induced in the coil, which reverses with each half-revolution, a non-reversing current, when the coil is in position "C," for example, the currents will be accumulative, and give a greater E.M.F. than before combining. If the same current is passed with the coil in position "D," the currents will react, and instead of being accumulative, they will be equal to the difference of the two E.M.F.'s combined. The non-directional effect of a single vertical wire as a receiving antenna is well established, and it is from this source that the non-reversing current for the "Unilateral" radio compass is obtained. The method of introducing this current into the compass circuits is shown in Fig. 6. The antenna circuit is coupled, inductively, to the coil circuit by the coils L₁ and L₂, which have fairly close and variable coupling. It is obvious here, that an excess of energy from the antenna would completely drown the directional effect of the coil. The amount of energy taken from the antenna is controlled by the degree of coupling between L₁ and L₂, Fig. 6. Only enough energy should be taken from the antenna to produce the reaction on the coil current. When tight coupling is used the set can be used as a non-directional receiver. The necessity for this adjustment will be shown later on, in the methods for "Stand By" for an unknown signal. As soon as the signal is heard, the coupling should be loosened and the "Unilateral" feature restored.

The reasons for selecting the maximas as working points should now be clear. It would be very difficult to secure a distinct reaction between the minimas and the non-reversing current because of their small value, whereas the maximas produce good results, so far as reaction go. This condition is unfortunate since the minima can be located, generally, more accurately than the maxima, due to increased sharpness. When a compass is used, "Bilaterally," the minima is used for the points of observation because of the increased accuracy.

The "Unilateral" system determines the approximate direction of the unknown, then the system is switched to the "Bilateral"

CONDENSITE CELORON

makes high type
**Radio
Panels**

CONDENSITE Celoron is radio insulation of the very finest type—extremely high in surface and volume resistivity—extremely high in dielectric strength—and low in dielectric losses.

Write today for our special "Radio Panel Guide", that gives complete details, quotes prices and enables you to determine the cost of any type of Celoron panel in standard or special size—plain, or fully machined, and engraved to your own specifications.

Dealers: Our Radio Panel Service enables you to sell panels completely machined and finished to the buyer's specifications. Write for our Special Dealers' Proposition.

Diamond State Fibre Company
 Bridgeport (near Philadelphia) Penna.
 Branch Factory and Warehouse, Chicago
Offices in Principal Cities
 In Canada: Diamond State Fibre Co. of Canada, Ltd., Toronto



CONSISTENT WITH CONDITIONS—

"Whether applied to a price or a service may mean a great deal"—
**WE DO ALL IN OUR POWER TO KEEP PRICES AND SERVICE
 IN CONDITION TO ENABLE US TO FACE ALL EMERGENCIES**

— This means a great deal to our Customers —

"B" BATTERIES

No. 763 Eveready 22½ volts \$2.25
 No. 766 Eveready 22½ volts tapped..... 3.00
 No. 5156 Burgess 22½ volts tapped..... 3.00
 No. 2156 Burgess 22½ volts, extra large..... 4.56

REGENERATIVE RECEIVERS

No. CR-4 Grebe 175-850 meters 65.00
 No. CR-5 Grebe 175-3000 meters 80.00
 NO CR-8 Grebe 175-1000 meters 80.00
 No. CR-9 Grebe 175-3000 meters with det. and
 two stage amplifier, complete..... 130.00
 No. RA Westinghouse 150-700 meters..... 68.00

VACUUM TUBES

No. UV-200 Detector 5.00
 No. UV-261 Amplifier 6.50
 No. UV-201 5 watt transmitter..... 8.00
 No. UV-203 50 watt transmitter..... 80.00
 No. UV-204 250 watt transmitter..... 110.00

Send us your orders for Tubes.
 Our stock is complete.



SOCKETS

No. 550 Murdock 1.00
 No. UL-552 Radio Corp. 1.50
 No. LR-542 Radio Corp. 1.00
 No. UT-541 Radio Corp. 2.50
 No. 30 Paragon 1.00

BRAIDED AEROPLANE ANTENNA WIRE

Per 100 ft.50
 No. 14 Bare copper wire, per 100 ft.35

LOUD SPEAKERS

No. A-3 Magravox, new type..... 45.00
 VOCALOUD, station type 30.00

AMPLIFYING TRANSFORMER

No. A-2 Acme semi-mounted..... 5.00
 No. UV-712 Radio Corp..... 7.00
 No. 231 Gen. Radio..... 5.00

JEWELL METERS

No. 54 for D. C. Standard readings..... 8.00
 No. 54 for D. C. 500 volts..... 16.00
 No. 54 for D. C. 1000 volts..... 23.00
 No. 54 for D. C. 1500 volts..... 29.00
 No. 64 Radio Frequency..... 12.00
 No. 74 A. C. Standard reading..... 8.00

TELEPHONES

Type C Baldwins 12.00
 Type E Baldwins 13.00
 Type F Baldwins 14.00
 No. 56 Murdock 2000 ohm..... 5.00
 No. 56 Murdock 3000 ohm..... 6.00

RHEOSTATS

No. 25 Paragon 1.50
 No. 214 General Radio 2.50
 No. 560 Murdock 1.00
 No. 120-A FADA new type..... 1.00
 No. 810 Remler 4 ohm..... 1.00

"We give all we can for what we get—Instead of—Getting all we can for what we give"

MISSOURI RADIO SUPPLY COMPANY
 4623 Maryland Ave. SAINT LOUIS MISSOURI

KEEP YOUR BATTERY FULLY CHARGED

WITH A

RIGGS RECTIFIER

The *SIMPLEST, LOWEST PRICED* and most *EFFICIENT RECTIFIER* on the market

Has only one adjustment and is absolutely foolproof. No amateur wireless outfit or up-to-date private garage is complete without this Rectifier, by means of which your wireless, or automobile battery is kept fully charged.

Sent P. P. Anywhere East of
The Rocky Mountains Upon Receipt of

\$12.50

AND YOUR MONEY BACK IF YOU ARE NOT FULLY SATISFIED.

THE RIGGS MFG. CO.
URBANA, OHIO

Attractive proposition to dealers.

LOUDER SIGNALS WITH LESS INTERFERENCE

Can Be Secured With the
**TYPE C & W REGENERATIVE
RECEIVER**
and
TWO STAGE AMPLIFIER

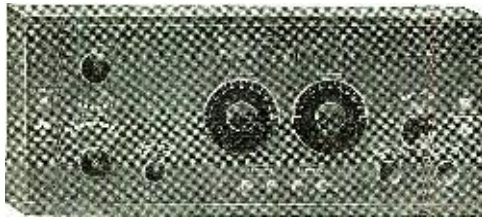

Two Instruments In One Cabinet Especially Designed for

RADIO TELEPHONE RECEPTION

This receiver is as SIMPLE TO OPERATE as the simplest regenerative receiver and, in addition, is more selective. It is DESIGNED and GUARANTEED by a COMMERCIAL RADIO COMPANY. Licensed under Armstrong Patents.

A descriptive circular will gladly be sent upon request.
Ask to see this receiver at your dealers.

CUTTING & WASHINGTON RADIO CORPORATION

Subsidiary

INDEPENDENT WIRELESS TELEGRAPH COMPANY, INC.

35 WATER STREET - - - - - NEW YORK, N. Y.
TELEPHONE BROAD 6500.

system and an accurate reading is found. It can be seen that the combination of these two systems gives an ideal combination, in that the good points of both systems can readily be obtained. One of the good points of the combination is the "Stand By" tune, using close antenna coupling. The set is non-directional on this tune, and functions as an ordinary receiver. When a call is heard, on the "Stand By" tune, the coupling is loosened to give the "Unilateral" effect, on which adjustment the approximate direction of the calling station is found. The system is then changed to the "Bilateral" and the exact bearing is found. This last change is made by the throw of a switch in the apparatus, while the first is merely a change of coupling.

A practical application of radio compass work is shown in Fig. 5. Let us assume that "C" is a ship in a fog, near a treacherous coast. The ship calls the radio compass stations at "A" and "B" and requests bearings from both points. First let us assume that both are "Bilateral" compasses. The operator at "A" finds that the bearing of "C" from his station is the line QP, but does not know on which side of him the unknown position is. The operator at "B" takes a similar bearing, in the line Q₁P₁ and like A he does not know which side "C" is on. If these two bearings are plotted on a chart of the coast, including "A" and "B," whose location is known, it will be found that the bearings intersect at a point which is "C," the desired position. It is clear, here, that neither "A" nor "B" alone can locate C.

It is quite possible that a ship might get very close to shore, in a dense fog, and a condition similar to the second case, using C₁ (Fig. 5) as the ship. It will be observed that there is a channel both sides of "B" and that "C₁" could be inside the bay, in position "C₂" so far as sufficient water is concerned. The "Bilateral" bearing for "C₁" is the same as for "C₂" which is inside the bay. There would be no way to distinguish, on the "Bilateral," between the two. Should the operator at "A" make an error of, say, 5 degrees, which is possible, it would intersect in the point "C₂" which is erroneous since "C₁" is the true position. If "B" in this case was a "Unilateral" station, this error would be impossible, since the direction indication from "B" would give two lines not intersecting, showing that there was an error, and that the bearing would have to be repeated. In the hands of an experienced operator, bearing errors do not average over 2 degrees.

It may be of interest to the reader who is not familiar with a radio compass, to know something of the details of the actual apparatus as used today in practice. The average radio compass coil consists of about 12 turns of wire on a square form, the size of which is about 3 ft. on a side. This coil is mounted on a shaft, which terminates in a handwheel in the radio room. On the shaft is mounted a set of rings to act as collectors for the antenna and loop current. The shaft is set in ball bearing for ease in turning, and to give a sense of direction, a dial, graduated into degrees, is mounted on the shaft with a "Lubber Line" or fixed point on the stationary frame of the compass.

The actual details of the tuner will have to be omitted, but a general description can be given. The tuner in question is U. S. N. type SE1012, a tuner made especially for this work. This tuner includes an audion control system, also an "Audion Send Crystal" switch which permits the use of a crystal detector. Inductive coupling is employed between the antenna and the coil circuits. A switch on the tuner panel marked "Bilateral Unilateral" changes from one system to the other. In this tuner a double coupling system between the audion

EDELMAN'S MULTITONE → **AMPLIFIERS**
→ **TRANSFORMERS**
→ **COMPLETE SETS**

- Attach to your set. Bring marvelous, loud clear volume. Guaranteed.
- 1. Audio transformer—no iron distortion. Has most efficient winding, price.....\$4.50
 - 2. 1 step amplifier, complete.....\$20.00
 - 3. 2 step amplifier, complete.....\$37.00
 - 4. Loud Speaker with scientific horn.....\$15.00
 - 5. 2 step amplifier and loud speaking horn....\$67.00
 - 6. V.T. sockets.....90c. Rheostats.....\$1.00
 - 7. Phonograph horn attachment.....\$5.00
- Mail Orders Filled Promptly—Agents Wanted.
USE THESE PARTS—GET LOUD RESULTS.

PHILIP E. EDELMAN, E. E. Radio Dept., 39 Cortlandt St., New York

To Receive Broadcasting Radiophones
THE RADIOHOME RECEIVER **THE DT-800 AMPLIFIER**

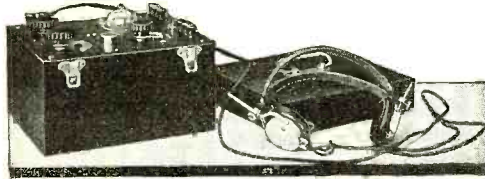

The Radiohome Receiver

field. Yet we have been manufacturing these sets for some time—for the general public. The Radiohome Receiver has a simple, two-slide tuning circuit with a range of 145-800 meters, a vacuum tube detector, and grid leak and rheostat. The price—less tube, batteries, receivers and antenna—is \$36. In a cabinet that is identical in size and finish with the cabinet of the Radiohome, is the DT-800, two-step amplifier. Three phone jacks are embodied in this instrument for detector, 1st step and 2nd step. Less tubes and batteries the price is \$35. We believe you will find no other set on the market to compare with this combination for the reception of radiophone programs by the newcomer in the field.

Catalog H, listing ALL DeForest Equipment has been out five weeks. It is yours for 12c in stamps.

DeForest Radio Telephone & Telegraph Co.
NEW YORK CITY

Every amateur is frequently being asked for advice as to what set should be purchased for the reception of radio telephone programs of music, news and stories. Many an amateur hesitates to recommend the standard amateur equipment as, to the average citizen, such terms as coupling, condenser, tube and "B" battery, mean nothing, and his friends would be confused and bewildered by the array of controls on the average set.

We illustrate two pieces of radio receiving apparatus which will, doubtless, appear unfamiliar to the amateur

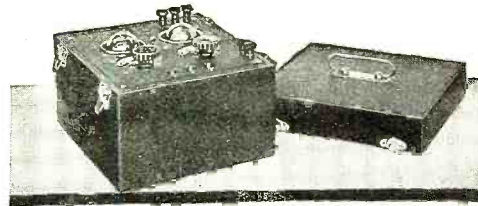

The DT-800 Two-Step Amplifier

Compare it with ANY
 It SPEAKS for ITSELF

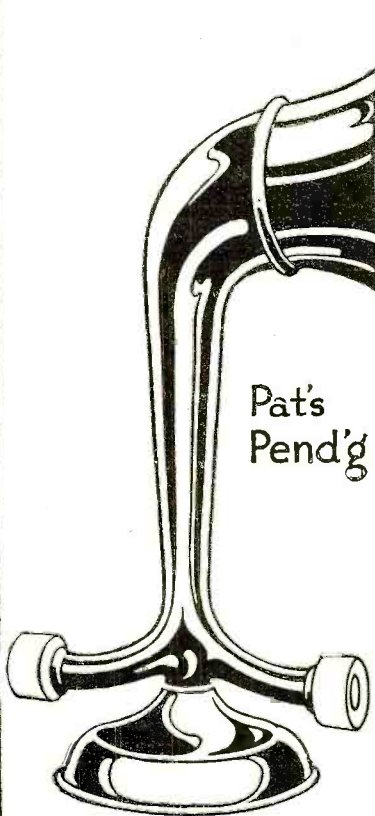

Pat's
 Pend'g

PRICE \$12.00
 F. O. B.—NEW YORK CITY

THE BIGGEST VALUE LOUD TALKER

Listen to the Concerts, News, and Dance with a KING "AM-PLI-TONE". Just slip your head phones on the "AM-PLI-TONE" and you and your friends will be SURPRISED. Polished Cast Aluminum Body with Nickel Plated Base and Horn. No Sheet Metal is used, the "Tinny" Sound is Left Out. The VOLUME is DOUBLED because TWO head phones are blended into one POWERFUL tone. A BIG HIT—A BIG SELLER and IMMEDIATE DELIVERIES.

DEALERS and DISTRIBUTORS—what more can you ask?

WRITE TODAY FOR TERRITORY.

Notice.—All infringers of this device will be vigorously prosecuted.

KING "AM-PLI-TONE"
 82 Church St., New York City

HOMCHARGE YOUR BATTERY for A Nickle



A perfect rectifier at last, fully automatic and foolproof in every respect. It can be operated by anyone.

The HOMCHARGER

Connects to any alternating current lamp socket, gives a taper charge—will fully charge any "A" battery over night. It is self-polarizing. Connect your battery either way and it will always charge. Automatically disconnects battery when power is interrupted. Restarts charging when connections are restored. Adjustable for wave form, frequency and voltage. Contains only one moving and two wearing parts, lasting thousands of hours, replaceable as a unit for \$1.00.

The highest charging rate, greatest efficiency, and simplest of any rectifier selling for less than \$100.00. Bulletin 828 proves it. Ask for your copy.

Manufactured in sizes for charging three or six cell batteries from both alternating and direct current circuits. Cannot injure battery—will last a lifetime—approved by underwriters—satisfaction guaranteed. For sale by all Radio, electrical and accessory dealers or shipped express prepaid for purchase price—\$18.50

ATTENTION MOTORISTS:
Send for special bulletin 58 showing how easy it is to "HOMCHARGE" your battery.

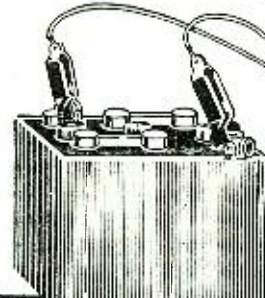

**THE AUTOMATIC ELECTRICAL
DEVICES CO.**
118 West Third St. CINCINNATI, OHIO
Canadian Distributors—Rowley & Moody, Ltd.,
Toronto

and the tuner exists. It has both inductive and capacitive coupling, as shown in Fig. 7. The tickler was found to be most efficient on short waves, while the capacitive coupling was more efficient on long waves. The audion coupling condenser, as it is called, consists of three brass plates so arranged that by varying the middle plate, a simultaneous decrease on one side and an increase on the other, resulted. This serves to keep the total capacity the same, and for that reason does not affect the wave-length. The tickler and audion condenser are on a common shaft.

The various other features of this tuner are common to all commercial tuners, so need not be taken up here.

Radio compass stations at the entrance to fog-bound waters and harbors are invaluable to shipping. The most complete systems of compasses in existence today are around the port of New York, where a chain of five or six keep traffic moving safely in thick weather.

A Five to Ten-Watt C.W. and Radiophone Transmitter

(Continued from page 937)

For this reason it is a question which must be answered thus: Is the increase of 25 per cent. in radiation worth \$8 to me? Some will say "Yes" and others "No." With one tube you can expect anywhere from 3/4 to 1 ampere radiation with careful tuning, and this should carry quite a distance. Eventually nine out of ten will buy another tube, and for this reason it is well to provide two sockets at the start.

To save a lot of time when learning to tune the set, it is suggested that the experimenter start with the sliding arm somewhere near the center of the coil. Once you get some indication of radiation, it is always easy to tune so that more will be obtained. A simple way to get a rough idea as to the wave-length emitted, if there is no wave meter available, is to listen to yourself in the receiving set and compare the setting where it is the loudest with that of some stations whose wave-lengths you know.

In some cases it may be found necessary to use a condenser in series with the antenna or ground. The easiest way to determine whether this applies to you is to "try it and see." If the radiation increases, or if there appears to be a pronounced peak with good radiation, the chances are that your antenna system is large enough to require one. My antenna is 40' long with a 45' lead in and I have to use a series condenser. Any good variable condenser, or a good mica, fixed condenser will serve the purpose. If a counterpoise system is used, this series condenser will be found unnecessary as a rule.

The use of a counterpoise and ground system together usually increases the radiation a good deal, if the ground and counterpoise are tuned with respect to each other. This may be done in two ways: by inserting a variable inductance in the counterpoise lead; or by inserting a series condenser in the ground lead. Very careful tuning is necessary for good results in C.W.

LIST OF MATERIALS.

- 41-plate variable condenser (panel mounting).
- Power tube rheostat (Shramco).
- Two vacuum tube sockets.
- Grid condenser.
- Grid leak.
- Formica tube, 6" long, 5" in diameter.
- Formica tube, 2" long, 4" in diameter.

(Continued on page 1024)

HIPCO MULTIPHONE PRICE \$5.00 COMPLETE

With 4 Sets of Head Phones
Yes, it also works on Crystal Sets



The Hipco Multiphone enables you to purchase four pair of receivers for less than the price of one. Reproduction 100% perfect—no trouble—absolutely nothing to get out of order. Your family or your friends may now enjoy radio concerts, lectures, etc., with perfect ease and comfort to all.

The Multiphone may be used in connection with any receiver. Simply place one of your receivers face down on Hipco Multiphone and draw the elastic bands over back of receiver to hold it firmly. The Multiphone will do the rest in a most pleasing manner.

Wireless B Battery

REFILLABLE VARIABLE

No. 100, 22 1/2 Volts.....	Price \$3.00
No. 140, 22 1/2 Volts.....	2.00
No. 110, 4 1/2 Volts.....	.65
No. 130, 4 1/2 Volts.....	.45

LIVE JOBBERS AND DEALERS WANTED

HIPWELL MANUFACTURING CO.

825-835 NORTH AVENUE
N. S. PITTSBURGH, PA.



KECO-RADIO STORAGE BATTERIES

The highest grade of battery built especially for the wireless instruments.

Solid oak box, natural finish, highly varnished, 6 Volt, 7 heavy "Cristol" Plates per cell, 60 Amp.

We are the largest builders of exclusive wireless batteries in the country. Thousands in use. Sold by all leading dealers or shipped direct, \$15.50 F.O.B.

KALB ELECTRIC CO. - - 7323 Manchester Avenue, St. Louis, Mo.

Dealers write for discounts for 1922



use A-P tubes for efficiency

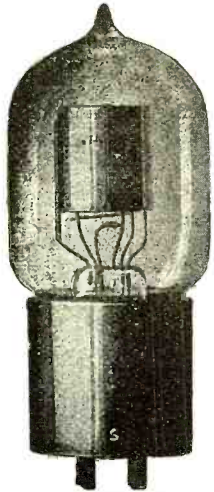

THE A-P ELECTRON RELAY

—the most sensitive detector of spark signals known to the radio art. Price \$5.00.

—“the tubes that are used by those who **KNOW**”

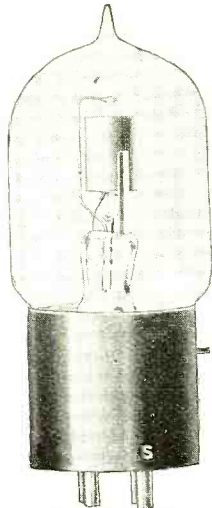

THE A-P VT AMPLIFIER OSCILLATOR

—the Amplifier used by the U. S. Navy. “Use the tube the Navy uses.” Price \$6.50.

A-P Tubes are licensed by the Radio Corporation of America under DeForest Audion and Fleming patents for amateur and experimental use in Radio communication.

Atlantic Pacific Radio Supplies Company

HENRY M. SHAW, PRESIDENT

638 Mission Street, San Francisco, California
Eastern Office: 5 Kirk Place, Newark, N. J.

National Distributors for the Moothead Laboratories, Inc.

A-P TUBES

are the pioneers

that paved the way over which radio has advanced to its present status of universal usefulness; and, progressing the meanwhile with the industry, have been fundamental factors in achieving new radio development and maintaining continued expansion. These are the tubes you should use—“the tubes that are used by those who know.”

USE A-P TUBES FOR EFFICIENCY

DON'T IMPROVISE — PACENTIZE!

If you still fuss around with binding post connections, you have not seen or heard about the Pacent Combination. You can change connections in a jiffy with the Pacent Universal Plug, The Pacent Twin-Adapter and the Pacent Multijack.



PRICE \$1.25

PACENT UNIVERSAL PLUG

This plug was the first radio plug to make an appearance and it remains the first radio plug in quality. A solderless, biting contact is made which will not give rise to disturbing noises. You can use the Pacent Plug with 'phones, Duo-Lateral Coils, microphones, keys, etc. The Pacent Plug fits any jack. With its soft, velvety black finish it will add a touch of beauty to any receiver.

Catalogue No. 50 PACENT UNIVERSAL PLUG, Price \$1.25



PRICE \$1.50

PACENT TWIN-ADAPTER

You can't put two plugs in a single jack, but you can make a single jack serve the purpose of two jacks with a Pacent Twin-Adapter. Just insert the Twin-Adapter and presto!—the usefulness of the jack is multiplied by two. Just the thing to use with a loud speaker; tune with the 'phones and then plug in the loud speaker. The Twin-Adapter has a multitude of uses in C.W. work.

Catalogue No. 51 PACENT TWIN-ADAPTER, Price \$1.50



PRICE \$1.50

PACENT MULTI-JACK

Here is another worthy member of the Pacent plug and jack combination. This is really three independent jacks built into a beautiful composition base. Screwed to the side of a receiving outfit it will allow three sets of 'phones to be plugged in or two sets of 'phones and a loud speaker. It may also be screwed to the table or the testing board. All standard plugs will fit into it, but it was designed especially for use with the Pacent Universal Plug or Pacent Twin-Adapter.

Catalogue No. 52 PACENT MULTI-JACK, Price \$1.50

Send for copy of circular N100

See the Pacent Radio Essentials at your dealers.

Dealers and Jobbers—Write for our sales plan



PACENT ELECTRIC COMPANY

INCORPORATED

LOUIS GERARD PACENT, President

150 NASSAU STREET

NEW YORK CITY

Member Associated Manufacturers Electrical Supplies.

ENAMEL }
SILK } Insulation
COTTON }

EASTERN &
WESTERN
STOCKS

All Sizes Immediate Delivery

MAGNET WIRE

Specializing in Sizes 38 to 44

Quality Guaranteed

Flexible Formed Cords for Headsets

R. W. LILLIE CORPORATION
50 Church St. 176 Federal St.
NEW YORK CITY BOSTON, MASS.

- One 1-m.f.d. condenser.
- Seven binding posts.
- One switch.
- Two switch points.
- No. 16 bare copper wire (about 65').
- 56' string.
- Hard rubber knobs and strip brass 1/2" x 1/8" x 4".
- One miniature socket.
- One small 3 1/2-V flashlight bulb
- Microphone transmitter, key, switches, etc.
- One wooden base, 7 1/2" x 12" x 3/4".
- One fibre, bakelite, or rubber panel, 8" x 12" x 1/4".

An Easily Constructed 180-800 Meter Regenerative Receiver

(Continued from page 950)

One variable condenser .001 mfd. (43-plate)	4.00
One lightning switch.....	3.75
20 ft. No. 4 wire for ground from lightning switch	1.60
One "B" battery.....	1.75
Two switches, 16 taps + stops.....	1.50
200 ft. aerial wire copper No. 14....	1.00
Socket	1.00
One rheostat	1.00
Eight binding posts at \$.08 each.....	.64
Four porcelain corrugated insulators at \$.15 each.....	.60
One grid condenser.....	.50
One crystal detector (if desired)....	.50
1/4 lb. No. 24 single cotton covered wire40
Total Cost	\$45.24

"MIRACO" VACUUM TUBE RADIO RECEIVER 150-600 Meters



Think of buying a complete Vacuum Tube Receiving Set including B Battery, Radiotron Vacuum Tube, Murdock 2000 Ohm Headset, 150 ft. Aerial Wire, Insulators and ground wire complete ready for use for only \$29.50 Prepaid. Only additional equipment necessary is a 6 volt storage battery or 4 dry cells and you are ready to experience the thrill of catching signals, voice and Radiophone Concerts out of the air.

Miraco Radio Receiver, without these accessories, \$18.00 Prepaid. Order direct from this ad or write for literature describing this apparatus. Prompt mail order service on any standard equipment. Give us a trial.

MIDWEST RADIO COMPANY, Dept. A, 3423 DRURY AVE. CINCINNATI, OHIO
"EVERYTHING FOR THE RADIO MAN"

Washington Notables Listen In

(Continued from page 948)

Mr. Brennan introduced the following joint resolution; which was referred to the Committee on the Merchant Marine and Fisheries and ordered to be printed.

JOINT RESOLUTION.

Providing for the installation and operation of radiotelephone transmitting apparatus for the purpose of transmitting the proceedings and debates of the Senate and the House of Representatives, and for other purposes.

Resolved by the Senate and House of Representatives of the United States of America and the Electrical World. Tech-Secretary of the Navy be, and he hereby is, authorized and directed to have installed, from stock now on hand in the Navy Department or available, and to maintain radiotelephone transmitting apparatus in the Capitol Building, Washington, or at the naval radio station, Radio, Virginia, with connection to the Capitol Building, suitable for transmitting for the greatest practicable distance the proceedings and debates of the Senate and House of Representatives. The Secretary of the Navy is further authorized and directed to furnish sufficient personnel from the Navy Department to operate such apparatus for the purpose herein mentioned.

Sec. 2. That such apparatus, when installed, shall be used to transmit the entire proceedings and debates of the Senate and of the House of Representatives insofar as may be practicable. When the Senate is not in actual session the President of the Senate shall have authority to designate any committee of the Senate to have the use of

THE ROTARY AMPLIFIER SWITCH WITH AUTOMATIC FILAMENT CONTROL

GIVES COMPLETE CONTROL OF DETECTOR AND ONE-TWO OR THREE STAGES



Patent Pending

JOBBERS-DEALERS

This switch is revolutionizing amplifier construction, owing to convenience of operation. It will be to your advantage to write or wire for our attractive proposition.

MANUFACTURERS

Why not use this switch in your sets Write for descriptive folder

Owing to greatly increased production we are now in a position to offer this improved model at..... **\$5.00**

UNIVERSAL IN USE

This switch is adjustable, by loosening one nut the cams may be adjusted to meet practically any switching requirements.

SPECIFICATIONS

INSULATION - BAKELITE
SPRINGS - NICKEL SILVER
CONTACTS - STERLING SILVER

STORM-RUCKELSHAUS CO.
Formerly Storm-Lee Radio App. Co.
NEWARK, NEW JERSEY

such apparatus in transmitting its hearings and proceedings, and the Speaker of the House of Representatives shall have corresponding authority with reference to committees of the House of Representatives.

Sec. 3. That such amount as may be necessary for the above purpose is hereby appropriated out of any money in the Treasury not otherwise appropriated."

Who's Who in Radio

(Continued from page 968)

American and the *Electrical World*. Technical papers and reviews by Mr. Hogan were published in various technical magazines, including those on "The Static-Coupled Receiving Tuner" and "Measurement of Signal Intensity". He appeared in Washington before Congressional Committees to oppose bills which had been introduced to establish Government Ownership of radio and to restrict commercial and amateur operations.

The National Electric Signalling Company changed its name to the International Signal Company in 1917, and Mr. Hogan was made Commercial Manager, having charge of operations and manufacturing work. During this period the United States entered the World War, and both Mr. Hogan and his company, were exceedingly busy in designing and producing radio outfits for submarine chasers, "Eagle" boats, and aircraft. He nevertheless found time to talk before the American Institute of the City of New York and the Brooklyn Institute of Arts and Sciences, and to write annual reviews of electrical communication, which appeared in the *Electrical World*, as well as a series entitled "Wireless Work in Wartime" for the *Popular Science Monthly*.

In 1918 he was made Manager of the International Radio Telegraph Company, and served as Chairman of the Radio Engineers Committee on National Defense. In 1920 he was made President of the Institute of Radio Engineers, and was admitted to Member grade in the American Institute of Electrical Engineers. He addressed the former organization on "Problems of Radio Regulation", and was active in opposing restrictive regulation, which the Government Ownership advocates in Washington were pressing before Congress. Several additional patents issued to him during this year, and, with the return of the coastal radio stations to private ownership and operation, the International Company began the organization (under his direction) of the coastal chain which has given so high a grade of radio service for the past few years. Work on these stations continued into 1921, and, the Westinghouse Electric & Manufacturing Co., having taken a substantial interest in the International Company, the marine radio service afforded was extended. During 1921 Mr. Hogan served as a Manager of the Institute of Radio Engineers, and on its Standards Committee, as well as on the Telegraph and Telephone sub-committee of the A. I. E. E. Standards Committee. His paper on "The Heterodyne Receiver" appeared in the *Electric Journal*, and he addressed the engineering students of Johns-Hopkins University on "Radio-Telephony; Its Principles and Use".

His interest in the present development of radio telephone broadcasting, as well as his earlier work in the improvement of radio technology (especially in the introduction of the detector-heterodyne receiver and static-balance antenna systems) are so well known as not to require comment. In the field of consulting engineering Mr. Hogan should have ample opportunity to continue effectively his efforts for the advance of the radio art

"WORKRITE PRODUCTS WORKRITE"



**WORKRITE
180° VARIOCOUPLER**

Finest
Material

Finest
Work-
manship

Finest
Finish

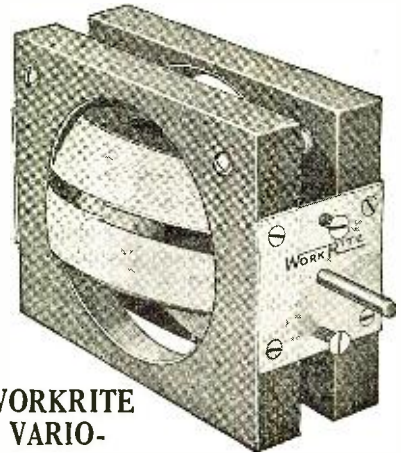

**WORKRITE
VARIO-
METER**

Here is the "Tuner Team" that radio fans have been going wild over wherever shown. Most dealers have their entire allotment sold before shipment is received. "They certainly do Work-Rite" is the verdict of all users.

One WorkRite Variocoupler and two Work-Rite Variometers are guaranteed to give you a tuner that cannot be excelled by anything on the market.

**WorkRite Variocoupler or Variometer
in Attractive Boxes - \$6.00 Each.**

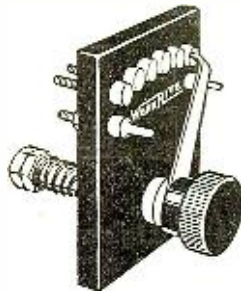

Just what you want. Remove the parts and use the block as a template for drilling your panel. Put up in neat individual boxes. Complete WorkRite Switch Sets, \$1.00.

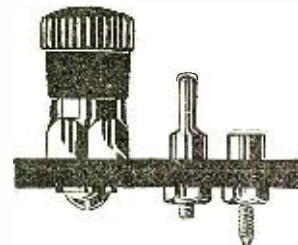

Work Rite Binding Posts, 12c.
Work Rite Switch Points, 4c
Work Rite Switch Stops, 6c
Work Rite Switch Arm with Bushing, 50c.

**TYPE "A"
WORKRITE
HYDROMETER**

Double the life of your battery by giving it proper care. Fill and test it regularly with a WorkRite Hydrometer. Never let it become discharged below 1150, or it will soon be ruined. Full instructions for testing and care of battery with each "WORKRITE". Get one now! PRICE \$1.00.



Insist that your dealer furnish a "WORKRITE". Accept no substitute. If he cannot supply you, we will ship direct by mail prepaid.

JOBBERs AND DEALERS—Write or Wire for Discounts

THE WORKRITE MFG. CO., 5604 Euclid Ave. Cleveland, Ohio.

Try REYNOLDS RADIO Service

"9ZAF" from DENVER "9ZAF"

Kennedy — RECEIVING OUTFITS — Grebe
PHONES: Baldwin Brandes Murdock Federal
Antenna Wire: Aluminum No. 14, per lb. \$1.00 (about 250 ft.) Copper No. 14, per lb. 60c (about 90 ft.)
REYNOLDS RADIO CO., Inc., 613 19th St., DENVER, COLO.
DISTRIBUTORS—Dealers, Write for Proposition

STOP! LOOK! and ACT!

We supply free of charge with each 50 watt U.V. 203 power tube, 1 price \$30.00, the R.C. of A. porcelain V.T. Socket, price \$2.50; and with each 5 watt U.V. 202 power tube, price \$8, your choice of either a Pade 5 ampere Nichrome power rheostat or R. C. of A. porcelain V.T. Socket. Unsatisfactory Radiotron Tubes will be replaced at once. No risk. Shipped post paid and insured. Immediate delivery. Distributors for Acme, R. C. of A., and Federal C.W. Apparatus.

THE KEHLER RADIO LABORATORIES, Dept. R, ABILENE, KANSAS

"COPPERWELD"
TRADE MARK REG. U. S. PAT. OFF.
Made by the Molten Welding Process

ANTENNA WIRE
50% Stronger Than Copper

Better than copper or strands for aerials.
Doesn't stretch or sag.

The permanently welded copper exterior makes it ideal because of "skin effect" phenomena of radio currents. Standardized by the largest manufacturers of radio equipments.

Sold everywhere in 100-foot and 200-foot cartons.

BUY IT IN CARTONS
We deliver from stock

COPPER CLAD STEEL COMPANY

Radio Department Braddock P. O., Rankin, Pa.

"COPPERWELD"

THE IDEAL RADIO ANTENNA

COPPERWELD IS 50% STRONGER than Copper can be strung taut, stays up when other wires stretch and break; and gives 100% electrical efficiency.

COPPER CLAD STEEL COMPANY
BRADDOCK P. O., RANKIN, PA.
Directions for Antenna construction on reverse side of carton

Some Good Ideas
(Continued from page 965)

me to be the equal of the "Radiotrola." We enjoyed Opera from KYW during the Opera season, getting Galli Curci in "Lucia De Lamermoor," etc. KDKA and WJZ come in well. The other night I got WBZ; WBL (Detroit News) is especially fine. Often, when dinner is ready, I leave WBL tuned, and go downstairs to eat to the tune of "Sawyer's 100 Piece Saxophone Band," or some other attraction which WBL is broadcasting. WBL comes in so strongly that I can get him fine with the phones alone, with no aerial whatsoever.

I hope this will be of interest and encourage others to try out their loud speakers.

Contributed by HUBERT E. NELSON.

GLASS PANELS.

I am presenting an idea for panels, but do not know whether it has ever been published before.

I used an ordinary piece of window glass for a panel on a regenerative receiver and of course my biggest job was getting the holes through the glass.

First I cut a board the same size as the panel and drilled the holes just where I wanted them. I then used another board to lay the glass on, placing the board with the holes in on top of the glass. The bottom board should be larger than the top so you can fasten them to keep the upper board from moving. I just drove a few nails close to the edge and used wooden wedges.

For drilling the holes I used a patent egg beater, but almost any kind of breast drill or automatic screwdriver will do.

For the bit, I used a piece of copper tubing of the same sizes as the holes.

To do the cutting I used dry emery dust and oil.

Care should be taken not to put too much weight on the drill nor to raise it up or down on the glass for it is very easy to crack it. Before you start drilling, drop a little emery dust in the hole in the board which you want to drill and a little oil. You will, of course, find it a slow job; it took me 15 minutes to make one hole.

Care should be taken when you get nearly through, for it is easy to knock a piece out of the under side.

The panel, the size of which is 7" x 8", cost me 25 cents.

Contributed by HENRY C. SMITH

LIGHTNING STORMS AHEAD
PUT IN PROTECTORS
"JACOBUS"

Type J. S. W.
The Vacuum
Aerial Protector
Eliminates
Switch Throwing

For use in place
of
Ground or Lightning
Switch

EVERY AERIAL MUST BE PROTECTED
\$2.00 From Your Dealer or Sent Direct
E. JACOBUS, 81 Orange St., Newark, N. J.
Arrester Division of Apex Electrical Specialty Co., Inc.

Useful Hints For The Amateur
(Continued from Page 939)

fine toothed blade. Place a piece of wood with a square edge upon the panel with the true edge lying directly on the line drawn on the panel, where it is to be cut, and clamp both together. This wooden piece will act as a guide for the saw and a straight-cut edge will be obtained.

If the edges of the panel are rough and unfinished, they may be smoothed off by placing the panel in a vice and, with a file which is quite sharp, removing the roughened section. If this takes too long, secure a three cornered scraper and use this to scrape the edges in the same manner as a spokeshave is used upon wood. (See Fig. 1) Take care to see that the scraper is not

Radio Service

We give our customers the best service possible—
Stand behind all goods we sell.
"Highest Efficiency" our motto—
We are distributors for all standard makes of Radio Apparatus—
Exhibitors of Westinghouse Radio Equipment at New York Edison Show Rooms—

Address all inquiries to Radio Dept.

We sell Anything and Everything Electrical

Western Electric Head Phones
(Type 1002)
Approved by and originally made for the U. S. Army and Navy.
These are not surplus or Salvage Government Property, but Western Electric Co. have recently been granted permission to release for amateur use. We are fortunate in being able to offer from the first shipment sent out from the factory.

Price, per Set \$15.00
Mail orders promptly filled when accompanied by certified check or money order.

H. Goldberg (Est'd 1894)
1373 Third Ave., Bet. 78th & 79th Sts.
NEW YORK, N. Y.

tilted and is held in a horizontal position at all times. This will insure a square edge, and the appearance will be similar to that of a machine-milled edge.

In holding the panel in the vice, place a piece of flat wood on each side, so that the jaws of the vice will not mar the surface of the panel.

When all holes have been drilled the surface of the panel should be polished. If a glossy effect is desired, merely clean the surface with machine oil and rub off until perfectly dry. If a satin finish is desired fasten the panel down to a flat surface by hammering a brad through several of the holes in the panel. Make sure that the head of the brad is below the surface of the panel. Wrap a piece of medium emery cloth around a flat block of wood and rub the panel with it. Rub along the length of the panel until all glossy spots have been removed. To secure a fine finish, it is necessary to take care to rub with the emery cloth in a direction parallel with the long edges of the panel. After all spots have been removed a finer grade of emery paper may be used upon the surface, but this is not absolutely necessary if the first operation is carried out correctly. Rub the panel with a cloth dipped in machine oil and then wipe dry, and a fine grained finish will result.

A good engraving composition can be made from equal parts of chalk and paraffine. Melt the paraffine, add the chalk, mix thoroughly and let stand to cool.

WIRING

One of the best rules to follow in wiring is to use bare wire and to make straight, sharp angled connections. This greatly adds to the interior appearance of a set. If difficulty is encountered, in straightening out the wire preparatory to making the connections, it will be found very helpful to cut off from the coil of wire to be used a piece about six feet long and fasten one end to a nail or hook screwed in the wall. The other end may be secured in the chuck of a brace or hand drill. Then, by slightly pulling on the wire and at the same time turning the drill first one way and then the other, a straight, stiff length of wire will be available. This may be cut up into shorter lengths with which it is easier to work. It is best to use a pair of pliers in making the sharp turns in the wire rather than to use the fingers.

The filament circuits of phone transmitters and receiving outfits are given an added degree of safety when wired with heavy copper wire. A good size to use in this case is No. 16 or 14 B.&S. gauge. If the wires of the filament circuit are covered with spaghetti or rubber tubing, it will decrease the chances of burning out a filament of the vacuum tubes by possible contact with the high voltage B batteries. Usually, the parts that go to make up this circuit can be assembled on the panel beforehand and wired up. The reason for doing this, is that, if all the parts for the entire set were assembled and then connected, it would make the work of soldering more difficult. If rubber top binding posts are used on the panel it is well to remove these rubber tops before soldering, as the heat from the iron will cause them to become soft and melt out of shape.

In amplifier units, where more than one tube is controlled by a single rheostat, it is best that this rheostat be of the "power" type.

In soldering the various wires to the units on the panel, it is necessary to use either soldering paste or muriatic acid so that the solder sticks to the metal parts. In using either of these, be careful to apply

ACE HARD RUBBER

TRADE MARK

RADION A FOR PANELS

REG. U.S. PAT. OFF.

AMERICAN HARD RUBBER CO., N.Y.

MANUFACTURERS and DEALERS

Our three great factories with their unequalled manufacturing facilities developed to supply the insulating needs of the Radio Telephone, Telegraph and Storage Battery Industries, have made us the largest manufacturers in the world of hard rubber products.

We are in a position to quote on special moulded hard rubber parts made exactly to your own specifications.

Prices and samples on request.

Prompt shipment of sheets, rods, tubes and 3 in. and 4 in. standard dials with knobs.

Look for trade mark on back.

Radion—a new special Radio quality of Ace Hard Rubber sheet, ideal for panels and bases. Supplied in three colors,—black, brown and mahogany (mahogany grain). Standard sheet sizes: 3/16 in. and 1/4 in. thick, 10 in. x 12 in. and 20 in. x 24 in. Special sizes on quantity orders.

**Ace Hard Rubber
Ideal Radio Insulating Material**

Ace Hard Rubber is a perfect insulating material, capable of withstanding enormously high voltage. Its high dielectric strength and its workability make this an ideal material for dials, knobs, tubes, rods, ear caps, receiver cases, boxes, bushings, switch handles, storage battery jars and parts, large tubes for variometers, etc.

Ace Hard Rubber can be easily cut or sawed, drilled, turned, sanded, threaded, stamped and engraved. It will not chip. It takes an exceptionally high, satin-polish which adds materially to the appearance of Radio apparatus. Sheets, Rods and Tubes are carried in stock in a wide range of sizes for immediate shipment.

“Specify Radion Quality Panels”



American Hard Rubber Co.
ESTABLISHED 1852
11 Mercer St. New York N.Y.
LARGEST MANUFACTURERS OF HARD RUBBER PRODUCTS

Wonderful Course in Wireless at Home



FREE INSTRUMENTS AND TEXT BOOKS

Best Theory Text Books

Best Instruments

This wonderful Set for learning the Code furnished FREE with our Course

In addition we furnish free a complete Vacuum Tube Radio Phone Receiving Set. Send at once for free catalog.

N. Y. WIRELESS INSTITUTE

258a BROADWAY, NEW YORK

MONEY FOR YOU—Add to your salary—Make extra pin money—Start a lucrative business of your own. Spend an hour each day taking subscriptions for the Radio News. We'll pay you well and you'll enjoy the work. Write for full particulars. Circulation Dept., Radio News, 236A Fulton Street, New York City.

HEARD THE LATEST? RAY-DI-CO'S PRICES ARE DOWN

Increased production and demand for Ray-Di-Co's Motor Generators make possible a big reduction in prices.

The following table gives correct sizes of machines to use:

Note these prices:

Type	Watts	Capacity in Tubes	Volts	M.A.	Driving Power	Price
Midget	15	1-UV202	300	50	110 V.A.C. or D.C.	\$42.35
Dynamotor	15	1-UV202	350	50	6 Volt D. C.	45.00
ST4	40	2-UV202	350	114	110 V.A.C.	64.75
ST15	150	6-UV202	500	300	110 V.A.C.	97.50
ST25	250	2-UV203	1000	250	110 V.A.C.	138.50

Above motors 60 Cycle. Other voltages and frequencies at slight additional cost.

IMMEDIATE DELIVERY

Mail Orders given prompt attention. If your dealer cannot supply you order direct from this ad.

RAY-DI-CO ORGANIZATION
1547A N. Wells Street CHICAGO, ILL., U. S. A.



**EASTERN
RADIO**

TEL
BACK BAY
5 9 6 4

INSTITUTE



**899 BOYLSTON ST.
BOSTON, MASS.**

RADIO today is commanding the interest of more people than any other industry! Splendid opportunities are NOW available for those who are alive enough to see the possibilities. My fifteen years' experience in Radio tells you that FORTUNES will be made within the next five years for those who train themselves now and take advantage of the present opportunities.

The EASTERN RADIO INSTITUTE is the OLDEST, LARGEST and BEST EQUIPPED Radio school in New England. THOUSANDS of satisfied graduates tell our story best! Day and Evening classes. Start any Monday.

REMEMBER:—Our ORGANIZATION with YEARS of PHENOMENAL EXPERIENCE and SUCCESS is behind EVERY man who enrolls!

"Ask any man in Radio—he will tell you!"

Our illustrated prospectus for the asking.

F. D. PITTS, Director.

VARNISHED TUBING

THE ORIGINAL "SPAGHETTI"

MAGNET WIRE

1/4—1/2—1 lb. Spools

VARNISHES

For Coils, etc.

ANTENNA WIRE

100—150—200 ft. Coils

PAINTS

Waterproofing

**MIRALITE
FOR RADIO PANELS**

Insoluble in alcohol, Turpentine and Weak Acids; Infusible and does not burn readily; oil and waterproof; withstands action of ozone; easily cut and drilled.

Varnished Cambric, Varnished Paper, Fibre, Compounds, Waxes, Etc.

LARGEST STOCK OF INSULATING MATERIALS IN THE UNITED STATES.

MITCHELL-RAND MFG. CO.
21 VESEY STREET, NEW YORK, N. Y.

as little as is necessary to make a soldered joint. If too much is used, it will melt and spatter over the panel, and if this gets in between several of the binding posts or wires carrying current, it will cause a high resistance, and a loss of energy will result. Any small amount of this soldering fluid or paste may be removed or dissolved by cleaning it off with a cloth dipped in alcohol.

CABINETS

The appearance of an outfit may be improved if the cabinets of the various instruments are of the same color and finish. A cabinet is easily constructed according to one's own design and there are various colors of stains that can be used. Crude oil gives a very fine oak stain. Mahogany, or mission black, may be obtained in any paint store. It is best to apply these stains to the cabinet with a cloth rather than to use a brush, as the brush will give a streaked appearance. Just apply enough to stain the wood, wipe off the surplus stains, and set to dry. When dry, a glossy finish may be obtained by rubbing the cabinet with wax which can be bought especially for this purpose.

For the amateur who intends to construct most of his own instruments this article will be of especial value if the facts herein enumerated are taken into consideration before the actual construction of a set is undertaken.

A Practical Loading Coil Unit

(Continued from page 934)

out a loop as at "A" in the sketch. Sections may be connected in circuit by plugs and jacks or by common contact points. In this case a portion of the end of bakelite tubing was cut away for admitting connections to the tube interior, while the protruding ends may be attached to a panel for mounting.

One loading unit of several sections will be required for both primary (aerial) and closed circuit, if the set is to be loosely coupled.

A tickler may work directly into the secondary loading coil for continuous waves. Tubes having a diameter of 4" or over could be used; cardboard will also serve. The first layer must be firmly glued to the tube to make a solid base for the remainder of the winding. After drying, the cords may be cut and removed. In mounting, arrange each unit at right angles; that is, the primary loading coil should be mounted vertically, and the secondary loading coil horizontally, as shown in the photograph, unless separated by 20" of space.

BOOK REVIEW

RADIO QUESTIONS AND ANSWERS.

By Arthur R. Nilson, A. M. I. R. E.

Cardboard covers, 86 pages, diagrams and illustrations. Published by the McGraw-Hill Book Co., Inc., New York.

This book by the Director of the East Side Y.M.C.A. Radio School, New York, is written especially for students and operators who are about to take the Government examination for a Radio operator's license. The material has been carefully chosen from many sources, and compiled from the commercial radio operator's standpoint.

It is assumed that the reader understands radio operation and theory completely, and that this book merely serve to bring out certain salient points as well as to show the general form of answering questions of this

kind. Mr. Nilson counsels all applicants who take the Radio operator's license examination not be brief but to answer all questions in full.

DIRECTIVE WIRELESS TELEGRAPHY

By L. H. Walter, M.A., A.M.I.E.E.

Cloth covers, 4" x 6½", 124 pages. Illustrations and diagrams. Published by Sir Isaac Pitman & Sons, Ltd., London, Eng.

The book covers the theory and practice of directive wireless transmission and reception as applied to the signalling and determination of direction and position on land, at sea and in the air. Those who are interested, will find in this work a short connected account of the principles of the method together with the essentials of directive wireless telegraphy. In contrast with the open handedness of the U. S. Signal Corps and Bureau of Standards, in making public the results of experiments conducted by them, most of the details of wartime experience with direction finding are held back in Great Britain.

This volume, though small in size, aims at giving an outline of all the information available. An interesting feature is the inclusion of a list of references giving the name of the publication with volume, number and page in which the original papers referred to by the author, may be found.

CONTINUOUS WAVE WIRELESS TELEGRAPHY.

By B. E. G. Mittell, A.M.I.E.E.

Cloth covers, 4" x 6½", 114 pages with diagrams and illustrations. Published by Sir Isaac Pitman & Sons, Ltd., London, Eng.

The writer of this book believes that there is a considerable number of people who will be glad to have an introduction to the subject of radio telegraphy from the engineer's point of view, and this small primer seeks to provide this introduction. It tries to do so without the use of mathematics and plunges directly into the subject without any preliminary discourse upon magnetism and electricity. It is hoped that this book may provoke recourse to some of the excellent treatises and papers to which reference is made.

RADIO EXPERIMENTERS' HANDBOOK.

By M. B. Sleeper.

Cloth covers, 4" x 6¼", 138 pages, with diagrams and illustrations. Published by the DeForest Radio Tel. & Tel Co., New York.

This elementary and well illustrated handbook is intended to answer the practical problems which confront those who are starting to feel the call of the most fascinating work to which boy or man can turn.

With the object of assisting those who may become discouraged by the seeming intricacy of modern radio apparatus all theoretical and mathematical discussions are omitted and the apparatus considered, limited to simple and practical instruments.

I Want to Know

(Continued from page 972)

Q. 2. For 175 to 400 meter reception how many turns of wire should be wound on a loop six feet square.

A. 2. Use four turns of wire with a tap to enable you to use only two turns for the shorter wave lengths. Shunt the loop with a .0005 M.F. variable condenser.

AERIAL WAVE LENGTH

(356) John Heyke, Jr., of Whitneyville, Conn., wants to know:

Q. 1. What is the wave length of an aerial 120 feet long, 3 feet wide with 3 wires, having a type T lead in? Would this be suitable for short-wave work?

Edison Radio Batteries

Operators and experimenters who demand the best radio equipment obtainable can now have EDISON BATTERIES built of the same materials as the thousands performing so satisfactorily in the service of the ARMY and NAVY.

Edison Radio Batteries are built of steel and have an alkaline electrolyte. They are strong, clean, long lived and have exclusive electrical features that are highly desirable in radio service.

The Edison Radio Cell Operates Silently

The voltage curve is flat, at the rate generally used. The terminals are convenient for "tapping in."

For filament circuits:		
6 volt	37.5 ampere hours	\$42.50
6 volt	75 ampere hours	58.75
6 volt	112.5 ampere hours	80.00
For tube circuits:		
2½ volt,	2½ ampere hours	\$2.50
22½ volt,	2½ ampere hours	22.50
Tray		1.50
22½ volt,	complete	\$24.00

All prices f. o. b. Orange, N. J.

Edison Radio Batteries can be furnished for any required voltage; prices on other assemblies quoted on request.

Edison Radio Batteries are an investment and not a continual source of expense.

Write for Bulletin 833.

Edison Storage Battery Company

Department C

ORANGE, N. J.



MINATURE PLUG

A new VICTOR product. A beautiful little plug highly polished bakelite shell nickel plated metal parts. For battery control or any switching purpose. Instant connection and disconnection. Mount pin jack shown in cut on your panel. More efficient and better looking than binding posts. With and without side screw. Without side screw for soldered lead 23 cents each P.P. With side screw 25 cents P.P. Nickel plated pin jack only with nut 11 cents P.P.

CORD TIP JACK. Similar to pin jack in cut only smaller and drilled to take receiver cord tips. For connecting receivers in series. Set of four mounted on bakelite base 55 cents P.P. Set of six 75 cents P.P. Type 2 Pin Socket. Will take any standard four prong tube including power tubes. Fused. Mail P. P. \$1.00. Pins only nickel plated 11 cents. Brass 10 cents. Fuse only 10 cents.

PINS FOR 50 WATT tubes. No "arcing or fusing" 20 cents each.

V. H. LAUGHTER DEALERS—Write for Prices P. O. BOX 78, MEMPHIS, TENN.



APEX SERVICE

All orders shipped same day as received. Give us a trial and we will give you Service. Price Bulletin sent on request. Local Amateurs invited to call and see our line. Open all day and every evening.

APEX RADIO CO., Inc., 1105 W. 69th St., Chicago, Ill.

A RADIOPHONE RECEIVER FOR \$25.00

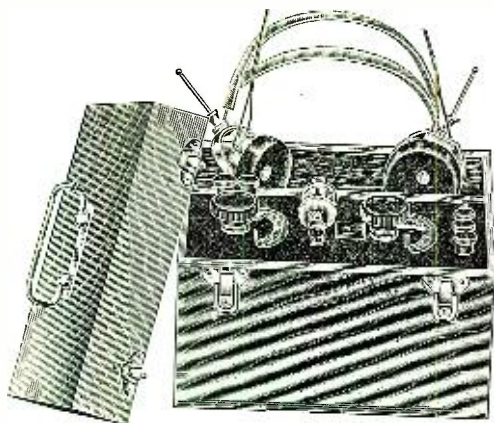

The Features of this set are: Enclosed Crystal Detector—Highly Selective Tuner—Telephone Head Set—Duolateral Coil Plug.

This De Forest Everyman Set is a simple, easily adjusted receiver designed to receive amateur, broadcasting and ship stations. By the addition of a "Duolateral Coil, the set will receive also the high power stations in this country. The instrument is encased in a handsome walnut finished cabinet with carrying handle, which contains space for "duolateral coils, head telephone receivers and pad and pencils. The weight complete is five pounds.

AERIAL EQUIPMENT

One Lightning Switch	\$2.94
One Lead-in Porcelain Tube07
One Ground Clamp14
Two pr. Porcelain Cletes08
30 ft. Covered Wire for Ground.....	.45
120 ft. of Hard Drawn Pure Copper Aerial Wire.....	.75
Total for Aerial equipment.....	\$4.43

LET US KNOW YOUR WANTS, BEACON CAN SUPPLY YOU

Beacon Radio & Electric Co., 246 Greenwich St., near Park Place
NEW YORK CITY

Spaulding HARD FIBRE

SPAULDING FIBRE is a strong durable material made primarily for electrical insulation and these features together with its low cost and machining possibilities make it the best proposition for wireless work.

DEALERS

We can give prompt delivery of Tubes, Sheets, Panels, Washers, Bushings or special parts.

Chemically Treated Radio Tubing in all diameters from 1 to 4" and engt hs up to 12" furnished within one week.

QUICK SERVICE AND BEST QUALITY

Write for Price List

J. SPAULDING & SONS CO., INC.
484 BROOME STREET NEW YORK CITY, N. Y.
15 Elkins St., So. Boston, Mass. Tonawanda-New York
Philadelphia Chicago



Radio Frequency Transformers

Type RT-1, for the amateur and broad-casting range, 175-500 meters. (Patent Pending.)

\$6.00

Will work on all tubes.
"The only completely shielded iron core R. F. transformer"



RADIO SERVICE LABORATORIES, Inc.
ASBURY PARK, NEW JERSEY

MONEY FOR YOU—Add to your salary—Make extra pin money—Start a lucrative business of your own. Spend an hour each day taking subscriptions for the Radio News. We'll pay you well and you'll enjoy the work. Write for full particulars. Circulation Dept., Radio News 236A Fulton Street, New York City.

A. 1. As you do not give height of your antenna it is difficult to approximate the wave length. For 200 meter work your antenna should be about 60 feet in height. A table is published on this page from which you may calculate the wave length of a T aerial.

32-V. LIGHTING BATTERY MAY BE USED FOR V.T.'s

(357) J. C. Cook, of Owosso, Mich., asks:

Q. 1. Would it be possible and practical to use the current of a 32-volt D.C. electrical plant to run a vacuum tube? Would it eliminate both storage and "B" battery?

A. 1. It would be quite possible to do this. For the purpose, you may regard the 32-volt battery as the filament and plate batteries of the vacuum tube in series. Tap three cells at the negative end for lighting the filament and apply the remainder of the battery to the plate of the V.T.

Q. 2. Is a one-wire aerial practical?
A. 2. A one wire aerial may be used satisfactorily for reception purposes. More wires should be used for an aerial for transmitting.

AERIAL CHARACTERISTICS

(358) E. J. Coulson, of Whitman, Mass., wants to know:

Q. 1. What is the natural wave length of an aerial 100 feet long, 35 feet high, composed of 4 strands spaced three feet apart on 12 foot spreaders?

A. 1. You may calculate the wave length of your aerial from the charts on this page.

Q. 2. What is the radiation resistance and capacity of same aerial?

A. 2. The capacity of this aerial would be about .0004 M.F., and its radiation resistance on 200 meters may be found exactly by the method described on page 703 of the February, 1922, issue of RADIO NEWS.

SHORT RANGE RADIOPHONE

(359) Walter J. Rabe, of Maywood, Ill., asks:

Q. 1. In using a Marconi Class 2 tube in a two-step amplifier, the detector being a Radiotron UV200 and the first step a Cunningham C301, is it necessary to put more plate voltage on the Marconi than on the others?

A. 1. About 18 to 22 volts should be used on the plate of the detector tube and up to 100 volts on the plates of the two amplifying tubes.

Q. 2. Is it true that a Marconi Class 2 tube can be used as a five to six watt output tube, as advertised in a certain catalog?

A. 2. No. The Class 2 tube corresponds to the present U.V.201 or any other hard amplifying tube for receiving and if used as power tube would furnish only two to three watts.

Q. 3. Using the enclosed hook-up and a four-wire aerial 50 feet long and about 35 feet high, how far could one transmit radiophone?

A. 3. You would not be able to transmit at all with the hook-up you submit. Use the circuit published in answer to question 342 in this issue.

DISTANT PHONE RECEPTION

(360) Edwin R. Fisk, of West Springfield, Mass., writes:

Q. 1. Is there a hook-up which will tune sharp enough to eliminate a nearby broadcasting station and allow getting one farther away who operates on a wave length of about 15 meters longer than the first one.

A. 1. If you are so located that the more distant station is not on the same plane as the nearby one, it is possible this could be accomplished by using a directional loop antenna. Tuned radio frequency amplifications would also assist in tuning out the nearby stations.

AERIAL WAVE LENGTH.

(361) H. F. Stroberg, of Macon, Ga., wants to know:

Q. 1. I have a six-wire aerial 90 feet long and 75 feet high. What would be the wave length?

A. 1. You may calculate the wave length from the charts published on this page.

Q. 2. What would be the wave length of a three-foot loop aerial with twenty turns?

A. 2. With a .001 M.F. condenser across this loop the maximum wave length would be about 2,000 meters.

RADIO FREQUENCY TRANSFORMERS

(362) Geo. B. Drakyr, of Kent, Conn., wants to know:

Q. 1. What is the address of the concern that sells the radio frequency amplifying transformers described on page 696 of Radio News for February, 1922.

A. 1. These transformers are manufactured by the Coto-Coil Co., of Providence, Rhode Island.

POWER AMPLIFIER SUPPLY

(363) J. B. Lee, of Merigold, Miss., writes:

Q. 1. I have a Magnavox 3-stage power amplifier and loud speaker in conjunction with my receiving set. Can I use a motor generator to supply the volts for the plate on the power amplifier? If so, which one would you suggest?

A. 1. You may use a Midget Ray-di-Co motor generator for this purpose with suitable filter circuit. See answer to question 340 for hook-up.

GROUNDING METALLIC MAST

(364) William Walker, of Philadelphia, Pa., wants to know:

Q. 1. I have constructed an aerial mast of three-quarter inch iron pipe about 20 feet high. Do the underwriters require this mast and guy wires to be grounded? If so, would this decrease the efficiency of my receiving or sending range?

A. 1. We do not believe the underwriters require this, although it would not affect your receiving or transmitting range.

Q. 2. I am using a regenerative receiving set employing vario coupler and two variometers when I tune the grid variometer up around 180 degrees for commercial stations the plate variometer will not oscillate the radiotron tube. Can you explain the trouble?

A. 2. If you connect a variable condenser, or a fixed condenser of about .0005 M.F., across the plate battery and telephones you will probably obtain better results. With some tubes, however, it is more difficult to make the tube oscillate at the higher wave lengths by tuning the plate circuit only. A feed-back action is required on the longer wave lengths.

COMBINATION TRANSMITTER AND RECEIVER

(365) Scott Abell, of Warren, Ohio, wants to know.

Q. 1. Please publish a hook-up for a two-stage amplifier regenerative and by means of a switch change to telephone sending set.

A. 1. A circuit of this description was published in this department of the RADIO NEWS for December, 1921.

PHONE RECEPTION WITH CRYSTAL

(366) George Vater, of Grandview, Iowa, asks:

Q. 1. Is it possible to receive radiophone from a distance of 30 miles using a single wire antenna 40 feet high and 80 feet long with a crystal detector set using a 75-ohm receiver?

A. 1. This should be possible if 2,000 or 3,000 ohm receivers are used. This would be pretty nearly the maximum range of a crystal detector set for radiophone reception.

How to Make a Regenerative Receiver and Single Stage Amplifier

(Continued from page 938)

stats, telephone jacks and peep-holes should be drilled about opposite the tube sockets. Holes should also be drilled for the switches and switch points of the vario-coupler seen at the left in the illustrations. Lastly, holes should be drilled for the binding posts and for the screws to attach the panel to the cabinet.

After all holes have been drilled in the proper positions the panel may, if desired, be given a good finish by rubbing it with sandpaper and oil.

After this is done, mount the switches and switch points, the rheostats, the telephone jacks and the binding posts on the panel, pass the center shafts of the vario-coupler, rotor and variometers through their respective holes in the panel and screw the panel to the cabinet.

In wiring the set use No. 12 or 14 solid copper wire and follow the wiring diagram. "Spaghetti" insulation will add to the appearance of the wiring. All joints should be soldered.

A Super Selective Receiver

(Continued from page 938)

cardboard tube 3" in diameter. The secondary also is wound on a tube 3" in diameter wound with the the same wire, but has 20 turns.

The primary and secondary should not be in inductive relation to each other, but should be about 6" apart. C1 is the antenna tuning condenser, C2 is the coupling con-

Mr. Manufacturer
Mr. Dealer
Mr. Amateur



Here's A Live Wire
"Listen In!"

BOYS' LIFE, the official Scout MAGAZINE, was the first publication covering the boys' field to recognize the possibility of the wireless and to take up the matter seriously.

MAJOR J. ANDREW WHITE, President of the National Amateur Wireless Association, is writing a full page article for **BOYS' LIFE** every month giving information and instruction for all interested in radio.

Boy Scouts are a wide-awake bunch. They are interested in

wireless more than any other class of boys, and they come from families with the purchasing power to buy what you manufacture or sell.

BOYS' LIFE is the one publication through which you can reach the scout field. Every Scout a buying prospect.

Your advertisement run opposite or alongside of these wireless articles will have double effect on **BOYS' LIFE** readers and double value to you.

For further information address

BOYS' LIFE
THE BOY SCOUTS' MAGAZINE

Advertisement Department

200 FIFTH AVENUE, N. Y.

Phone Gramercy 1000

NEWEST AND BEST YET

Type A Honeycomb Receiver and Detector Combined \$30.00

The ideal receiver for amateur use. Will receive radiophone broadcasting stations, commercial, ship and time stations. Set wired complete in solid oak cabinet with golden oak finish, waxed and hand rubbed. Is mounted on 9 x 10 1/2 grade M Formica panel with three coil mounting, two variable condensers, socket, grid leak and condenser, with dials, binding posts, rheostat, etc. Price \$30.00.

Type B Two Stage Amplifier \$30.00

An excellent two stage audio-frequency amplifier, mounted in same size cabinet as the above. Well known apparatus is used throughout. Jacks are provided, and the new shielded Thordarson transformer is used. The combination of Type A Receiver and Type B Amplifier constitutes a long distance receiving set without a peer. Binding posts so arranged as to allow shortest possible connections. Introductory price \$30.00.

FERBEND ELECTRIC CO., 19 East South Water Street, Chicago.

211 RADIO MANUFACTURERS and DEALERS are now using our BINDING POSTS, SWITCH POINTS, ETC.

The Reason **QUALITY, SERVICE, PRICE**

PREMIER DENTAL MFG. CO.
SCREW MACHINE PRODUCTS

60 N. 2d St., PHILA, PA.
Get Our Literature



Type TAW, Flush Model

A New Bulletin on Small Radio Instruments

is now ready. It covers not only our line of three and one-half inch thermal Instruments, but also our lines of A. C. and D. C. instruments in the same size cases. All ranges required in modern radio work are included.

You will be interested in this Bulletin which gives full details. In writing us mention Bulletin No. V-10. *IT IS FREE.*

ROLLER-SMITH INSTRUMENTS ARE SOLD BY ALL GOOD DEALERS

ROLLER-SMITH COMPANY
Electrical Instruments, Meters and Circuit Breakers



MAIN OFFICE:
15 Barclay Street, NEW YORK

WORKS:
Bethlehem, Pennsylvania

Offices in principal cities in United States and Canada

denser, C₃ is the secondary tuning condenser. L₁ is the plate variometer and is used as in the standard short-wave set to obtain regeneration and oscillations. I have not attempted to place this set in a cabinet as yet, but expect to do so in the near future. The coupling is decreased by decreasing the capacity of the coupling condenser and vice-versa. The capacity of the grid-condenser depends on the type of tube being used. If the radiotron U.V. 200 is used the correct capacity would be .00025 mfd. The resistance of the grid-leak is best obtained by experimenting with different values. The set would be tuned as any other type of set. For broad tuning large amounts of capacity in the coupling condenser are used, and for sharp tuning, small amounts are used. The sharpness of the tuning of this set will amaze one who tries it for the first time. With this receiver I can receive the DX stations through the terrific local QRM.

Wood Finishing

(Continued from page 964)

When varnishing, the brush should have just the right amount of varnish in it; a little experience will tell how much. It is best to rub the brush across the grain, and then finish it off by rubbing lightly with the grain. It must be allowed to dry for at least twenty-four hours, and become thoroughly hard.

The surface must now be rubbed perfectly smooth, using grade F F pumice stone for this purpose. A piece of soft cotton should be dipped in some linseed oil, and then in the pumice stone. The pumice will stick to the cloth, which should now be rubbed on the varnished surface, rubbing lightly with the grain. Continue to rub until all the minute depressions have disappeared. This may be ascertained by holding the surface up to the light at the correct angle, when the hollow places will appear as dark spots. All surplus pumice stone should now be carefully wiped off with a piece of cotton waste. If the wood is of coarse grain it will be necessary to use two coats of varnish before rubbing down with the pumice stone.

After the varnish has been rubbed down, the finish is called "dead." It may either be left this way, or it may be given a high polish. There are several methods of polishing, each of which has its advantages. These are called the "quick" method; the "slow" method; the "wax"; and the "oil" methods.

If you decide to use the "quick" method, make a mixture consisting of equal parts of peanut oil and alcohol. Into this dip a piece of raw cotton, and rub on the surface. This will give a fine polish in a short time. The chief drawback to this method is that it is not very durable. It gives a fine polish, however, and may be used when there is no rough handling of the object.

If one wishes to take the trouble of using the "slow" process he will be amply rewarded for his work. After the "dead" finish is arrived at, as above, still another coat of varnish must be applied. After this is hard, rub down again with the pumice stone, cleaning the surface off thoroughly. Dip a piece of felt in some linseed oil and then into some ground rotten stone; rub this over the surface in the same manner as the pumice stone. After the wood begins to shine, rub with the palm of the hand instead of the rotten stone; this will serve to clean off the surface, and give it a good lustre.

Wax polishing seems to be very popular. The great disadvantage of this method is that it is very easily scarred. It may be

THE NEW
LOUD
SPEAKER
\$6.50
The LITTLE
WONDER

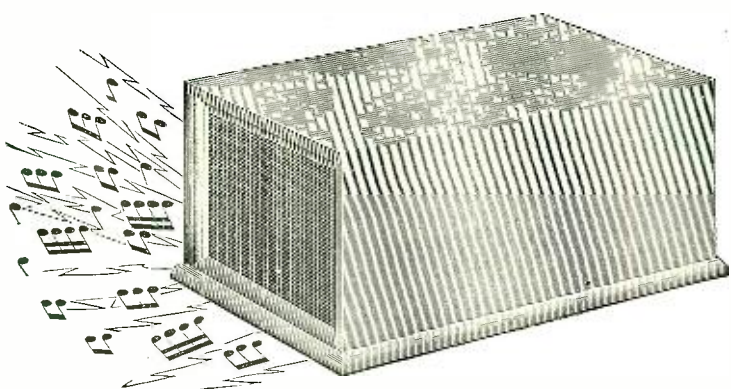

MAGAFONE

After twenty-five years of exhaustive tests and experimentation in the phonograph industry it has definitely been proven that the built in cabinet horn is far superior for reproducing and amplifying speech and music than any other horn. The little wonder MAGAFONE is a cabinet loud speaker properly designed and constructed to amplify radio phone music and signals with a pure natural tone which is impossible with any metal horn.

The little wonder MAGAFONE requires no batteries, no adjustments—simply insert your phone (Baldwin Type C recommended) in back of cabinet and music will come in QSA all over the house.

In Beautiful Mahogany Finish — \$6.50 — Direct or From Your Dealer

DEALERS WRITE FOR DISCOUNTS

HERMAN H. SOHN & CO., 65 DOUGLAS AVENUE PROVIDENCE, R. I.

READ THIS DOPE

Wesco Antenna Wire	250 ft.	500 ft.	1000 ft.
7-22 Stranded Copper	\$2.20	\$4.25	\$8.00
No. 14 Solid Copper	1.60	3.00	5.75
Wesco Magnet Wire—1/2 lb. Spools			
B and S, Ga.	Enam.	S.C.C.	S.S.C.
20 to 24	\$.55	\$.65	\$.90
26 to 30	.65	.95	1.30
32 to 36	.80	1.40	2.15
No. 23 Single Silk Covered, 90c per 1/2 lb. spool.			
Genuine Bakelite Panels—3/8 inch thick			
6 in. x 10 1/2 in.	\$1.30	8 in. x 10 in.	\$1.50
6 in. x 14 in.	1.50	12 in. x 14 in.	3.25
6 in. x 21 in.	2.25	12 in. x 21 in.	4.75
For 3/16 in. thickness add 50% to above prices.			

Wilmington Electrical Specialty Co.
912 Orange St. Dept. G-7 Wilmington, Del.

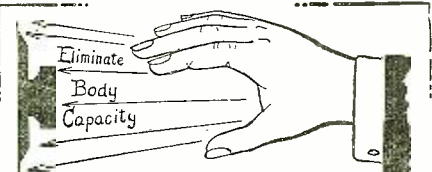

Does Your Hand to the Knob Spoil Your Tuning?

You can Eliminate by sending 50c. for One, or \$1.00 for Three Sets of well-made Parts, Post paid, to equip your Instruments in a Few Minutes and Not change their Appearance.

State diameter of your dials.
RADIO LABORATORY
259 Thomas St. West Haven, Conn.

readily renewed, however, which overcomes this objection as it applies to certain classes of work. It is not necessary to use varnish when wax is used, the wax being applied instead of the varnish. There are a number of ways to put the wax on. One of the best is to warm the wax and apply with a brush, in order to insure an even thickness over the whole surface. It may then be rubbed with a piece of chamois skin until it shines.

Oil polishing is unquestionably the best method of any, as it is very durable, and will not scar. It is very simple to apply, but exceedingly tedious. Linseed oil must be liberally applied to the surface, which is then rubbed until the polish is obtained. The rubbing is done with a piece of felt wrapped around a block of wood. The surplus oil may then be wiped off, and the polish finished up with a piece of chamois skin.

After the polishing has been done, the work may be considered completed. I feel sure that any one who follows correctly the directions here given, and does the work with care and zeal, will find the results thoroughly satisfactory.

Aerials

(Continued from page 929)

the straightaway and therefore we favor it for amateur use.

The effective length of any aerial in meters should never exceed three-quarters of the normal transmitting wave-length. The other quarter will then be made up for by the secondary of the oscillation transformer. This can be accomplished by making the effective length in feet equal to $6/10$ of the wave-length in meters, it being remembered that the effective length means the length of the flat top, plus the length of the lead-in right down to the instruments. Thus for an aerial to give best results on 200 meters its effective length should be

$$6/10 \text{ of } 200 = 120'$$

In order to obtain this, the aerial itself should be 90' or 100' long and the lead-in may then be 20' or 30'.

The number of parallel wires is not exceedingly important, but it is a wise policy to allow one wire for every 100 watts of transmitting energy. That is to say, for best results with a $1/2$ -K.W., set you should use a fine wire aerial. The minimum spacing between these wires should be $2/100$ of the effective length of the aerial in feet. Thus the minimum distance between the wires of an aerial working normally on 200 meters should be

$$2/100 \text{ of } 120 = 2.4'$$

or approximately $2\frac{1}{2}$ '.

It is important to note that there should be the same number of wires in your lead-in as there are in your aerial. If you use a three-wire aerial you should use three wires, preferably stranded together, in your lead-in. Should you use a three-wire aerial with a one-wire lead-in, the effect will be somewhat similar to placing a section of 1" pipe in a 3" water main, which is undesirable, to say the least.

The all-importance of efficient aerial insulation is universally known, but cannot be over emphasized. Especially should the insulation be thorough at the points farthest from the lead-in, as the greatest electrical strain is found at these points. Unless the insulation is carefully attended to there may be disastrous losses of energy with consequent decreases of radiation.

By following these brief instructions much of the haphazard guess work will be eliminated from the construction of aerials and better results will be obtained due to the fact that there will be maximum efficiency for the power and wave-length used.

A REAL QUALITY COMBINATION EFFECTIVE RECEPTION ON ALL WAVE LENGTHS FROM 175 TO 25,000 METERS

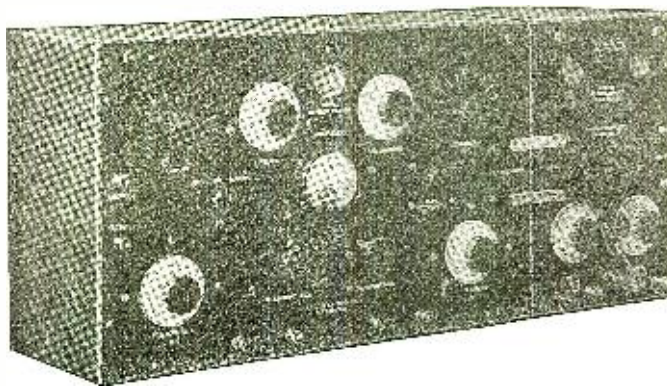

KENNEDY TYPE 110 UNIVERSAL REGENERATIVE RECEIVER
WITH TYPE 525 TWO STAGE AMPLIFIER

All Kennedy regenerative receivers are licensed
under Armstrong U. S. Patent No. 1,113,149.

For those who want radio reception with amplification over a broad range of wave lengths, this combination is unsurpassed.

The Kennedy Type 110 Universal Regenerative Receiver is all that its name implies. It affords convenient means of tuning from 175 to 25,000 meters with highly efficient reception over that entire range.

In many installations where this receiver is in use, it is accompanied by our Type 525 Two-stage amplifier as illustrated here. This amplifier matches the Type 110 receiver in height, depth and general finish, and, being built according to the high Kennedy standard is a worthy companion for it.

Send for Bulletins 101 and 501 describing these units

THE COLIN B. KENNEDY COMPANY
INCORPORATED

RIALTO BUILDING

SAN FRANCISCO

XX BAKELITE FOR PANELS

Cut accurately to your dimensions at
\$2.25 per lb. (20 cubic inches per lb.)

Everything in Radio

Write for interesting free catalogues

DAVID KILLOCH COMPANY
57 Murray Street New York City

A welcome addition to your library! Send \$2.50 today, plus postage for 7 lbs., and your copy of bound volume No. 2 of Radio News will come forward by return mail.
Experimenter Publishing Company, Inc. 236a Fulton Street, New York City

9

If you want a regenerative receiving set for 150 to 2,600 meters, buy

Design of Modern Radio Receiving Sets

One of the most popular receiving sets ever built is the single circuit tuner for 150 to 2600 meters. It is particularly efficient on wavelengths above 300 meters, making it well adapted for phone reception on long or short waves and for copying Arlington time signals. You will like the design of this set and its construction is made easy because you can buy the parts, including drilled and engraved panels from the G. A. Company. Other apparatus is also described in MODERN RECEIVING SETS.

The Price is
50c

Postage 4c

The General Apparatus Co., Inc. 88-N Park Place New York City
Send 10c for the new G. A. Catalog



RADIO CLUB PINS

Radio Clubs Everywhere have a special club pin. We make them to order, 25c to \$10.00 each. 1922 catalog of 48 pages showing designs of Radio, School and Fraternal pins and rings FREE. Samples loaned to officers. **METAL ARTS CO., INC.**
7755 South Ave. Rochester, N. Y.

Two-Step Amplifier for Twenty-five Dollars

(Continued from page 962)

ative potential on the grid. Then, of course, the extra resistance is not needed with the Parkin rheostat.

A small bracket may be put on each of the lower corners for fastening the panel to a table, or a cabinet may be made to fit it. The depth needs to be only enough to clear the amplifying transformers.

Connections can be made more conveniently if the sockets are turned so that the filament connections are next to the panel.

If the connections are made by rigid bus wiring with No. 14 or No. 16 hard drawn copper wire, the back of the panel has a very neat appearance. The connections from the grids to the transformers should be on the outer end of the secondaries. Before making permanent connections, try reversing the leads to the primaries, one transformer at a time. It is also advisable to test each step separately to see whether it is operating properly, and then the two, to see whether they work well together. While adjusting the set it is often more convenient to use something else than signals to test it. If you are anywhere near power lines just connect the input to your aerial and ground, and you will have a constant and unvarying hum to test the amplifier on. When the set amplifies correctly, try disconnecting to input to see whether the amplifier is as quiet as it should be.

The G. E. tubes mentioned amplify well on the same plate voltage usually used on the detector. They operate very well on 20 volts, but any common amplifier voltage will give about the same results.

The New York Radio Show

(Continued from page 927)

The exhibition concluded with the annual banquet of the Second District Council at which over 1,100 persons were seated. Mr.

HYGRADE SPECIALS

Save You Money

Audiotron tube, two filaments.....	\$5.50
Radio Service V.T. Sockets.....	.80
22½ Volt Cyclone Small B. Battery.....	.90
22½ Volt Cyclone Large B. Battery.....	1.60
45 Volt Cyclone Large Variable B. Battery.....	2.75
22½ Volt Large Eveready Variable B. Battery.....	2.50
Binding Posts (rubber cap), per doz.....	.75
.0005 Mf. Grid Condensers.....	.25
.002 Mf. Phone Condensers.....	.25
Variable Grid Leak, ½ to 3 Megohms Electrore Ball Insulators, each.....	.28
per dozen.....	3.00

MARKO STORAGE BATTERIES

4 Volt 40 Amp.....	7.50
4 Volt 60 Amp.....	10.50
6 Volt 40 Amp.....	10.50
6 Volt 60 Amp.....	14.00
6 Volt 80 Amp.....	18.00

We do not charge for crating. The above Prices are F.O.B. New York. Above Batteries are fully charged when shipped.

Hygrade Electrical Novelty Co.
41 West 125th Street New York

A NEW RHEOSTAT

Latest on the market. Critical adjustments, beats a vernier rheostat—one will control any number of tubes. Special.....\$3.50
Tuner and Audion Detector.....\$30.00
Two Stage Amplifier.....35.00
Detector and Two Stage.....40.00
Oak Cabinets, Formica Panel, Fine Finish
Cardboard Tubes, Seamless, Gray, ½-inch wall, 2½x12, 25c; 3x12, 30c; 3½x12, 35c; 4x12, 40c; 4½x12, 45c; 5x12, 50c; 6x12, 60c.

BRASS RODS, SQ., POLISHED and DRILLED			
⅜ x 7.....15c	¼ x 7.....20c	SLIDERS	
⅜ x 9.....15c	¼ x 9.....20c	⅜.....25c	
⅜ x 13.....20c	¼ x 13.....25c	¼.....30c	

MAGNET WIRE

Price per ½ lb. ¼ lb. ½ lb. ¾ lb. 1 lb. 1 ¼ lb.					
B.&S. Ga.	Enameled	D.C.C.	D.S.C.		
No. 18	—	\$.75	—	—	—
No. 20	\$.60	\$.30	.80	\$.40	\$1.00
No. 22	.65	.35	.85	.45	1.05
No. 23	.70	.40	.90	.50	1.10
No. 24	.70	.40	.90	.50	1.10
No. 25	.75	.45	.95	.55	1.15
No. 26	.75	.45	.95	.55	1.15
No. 28	.80	.50	1.00	.60	1.20
No. 30	.85	.55	1.05	.65	1.25

Prices net; parcel post prepaid anywhere in U. S. Send for our catalog FREE.
DEALERS WRITE US FOR PROPOSITION.

THE KING RADIO CO.
Century Bldg., PITTSBURGH, PA.

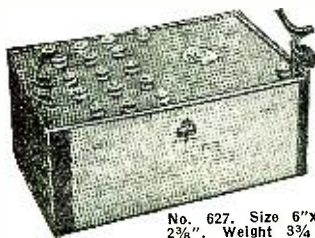

No. 627. Size 6"x5"x2 ¾". Weight 3 ¾ lb. Special at \$3.50

AN ACE IS ALL YOU NEED

to get the best "B" Battery results

With Your Radio Set

Long Life

ACE BATTERIES have a wonderfully long life. The reason for their standing up so creditably is that they are constructed by a concern which spent years in scientifically experimenting before offering the product to the radio field.

New Life

Our "ACE" 4½ Volt Block Battery is a proven powerful unit. It's just the thing to boost your weak "B" Battery. Five of these units connected together constitute one Navy size 22½ Volt "B" Battery.

ACE Quality is Superlative and ACE Price Lower

WRITE FOR CATALOG

(ACE Batteries are for sale at all leading dealers)

ACE BATTERY MFG. CO.

General Offices, 495 Broome St. NEW YORK CITY Factory, 395 W. Broadway No. 1,000. Size 1 ¾x4x3. Weight 1 lb. Price \$5.00



Panels for Your Set

We carry standard size panels of the following dimensions in stock

7" x 20" x ¾"	Regenerative size..	\$2.00
6" x 14" x ¼"	Consolidated size.	1.25
6" x 6" x ¾"50
7" x 10" x ¼"	1.00

We pay postage

L. FUNKE & CO.
223 Washington St. NEWARK, N. J.

J. O. Smith was the toastmaster and the speakers included Professor A. N. Goldsmith, Mr. David N. Sarnoff and Lieutenant Commander Patterson. A testimonial was given to Mr. Godley for his successful conduct of the trans-Atlantic tests.

To the banquet one ambitious amateur brought with him a storage battery, Magnavox and buzzer. This young man sat in the gallery and, with a few "HI"s and other appropriate comments at the right moment, conveyed to his fellow-amateurs, in unmistakable tones, his impressions of the various speeches.

A good time was had by all!!

The Super-phone

(Continued from page 924)

Multiplex-telephony is possible where more than one of the "super-phones" is accessible, thus offering opportunity for the transmission of a great number of conversations simultaneously over a single line without interference, one with another. When these portable outfits are employed in open overhead telephone or telegraph lines, the transmission of audible communications may be negotiated for a distance of 100 miles.

The power consumed in the operation of the apparatus is negligible. Or, when expressed in concrete terms, conversations can be flung for a considerable distance with the consumption of only one-tenth of a watt of current, which is one-five-hundredth of the electricity required in lighting a common electric lamp. Speech thus conveyed is said to be more distinct than ordinary conversations over the telephone. In actual operation, the line to which the unit is attached is tuned or adjusted to an ordinary radio set. Once this adjustment is effected, further changes are unnecessary. Offices employing the novel apparatus can either use batteries or 110-volt D.C.

Perhaps, it is permissible for one to contemplate the uses of this invention without being accused of indulging in excessive imaginary flights. The Secretary of State, in present or future cabinets, when transmitting an important document of State to the President, may employ this vehicle of communication, where privacy is insured for the contents of the message. Brokerages in New York City may negotiate their transactions in stocks and bonds, where the element of speculation demands privacy of communication, by use of the "super-phone." Banking establishments, removed from their branch institutions, can conduct business in secrecy by the application of this invention. Military strategists, with the element of future wars never entirely removed, may possibly safeguard their battlefield operations from the enemy by drafting the services of the latest offspring of "wired wireless" or "line radio."

A Compact Portable Loop Aerial Receiver

(Continued from page 924)

affords a means for adjusting the receiver to maximum sensitivity.

The trunk-line equipment in its entirety weighs barely 60 pounds. It is capable of receiving messages, when using a six-foot coil aerial, from broadcasting stations located at distances from 600 to 800 miles away. The wave-length range of the outfit is liberal enough to supply the needs of a variety of services—ranging from 180 to 2,700 meters. The coil aerial employed is collapsible and admirably fits into the scheme of things characteristic of this invention—which the writer describes as representing compactness and convenience.



FIRCO JACKS

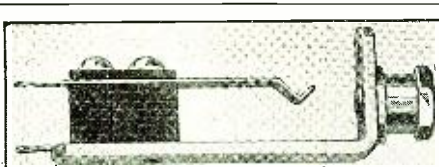

TYPE-202 J

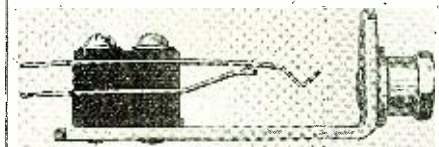

TYPE-201 J

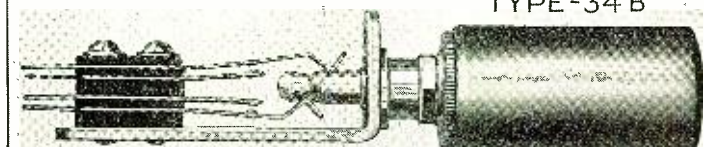

TYPE-200 J

The complete line, which engineers have pronounced the best on the market and in full keeping with the high standard of all "Firco" products.

99% STERLING SILVER CONTACTS

with nickel-silver springs. Try them out and test against others and note particularly their resiliency and perfect contact.

FIRCO BULL DOG PLUGS
Used with Firco Jacks

TYPE-34 B

"The Harder You Pull, the Tighter It Grips"

The one plug that you DO NOT need a screw driver or soldering iron to connect.

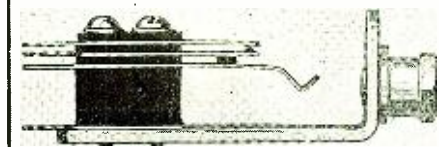

TYPE-204 J

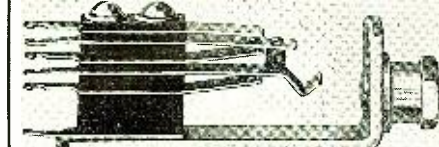

TYPE-203 J

FIRCO JACK PRICES

- Single Circuit open \$.70
- Single Circuit closed .85
- Double Circuit closed 1.00
- 3 Spring Automatic Filament control. 1.20
- 5 Spring Automatic Filament control. 1.50

Immediate Delivery Through your local dealer

JOHN FIRTH & CO., Inc.

18 Broadway

New York City

CANADIAN AMATEURS!

HEADQUARTERS FOR THE BEST RADIO EQUIPMENT

Write for Price List

SCIENTIFIC EXPERIMENTER, Limited
33 MCGILL COLLEGE AVENUE MONTREAL

Insure your copy reaching you each month. Subscribe to Radio News—\$2.50 a year. Experimenter Pub. Co., 236 A Fulton Street, N. Y.

MEMORIZE CONTINENTAL CODE ALMOST INSTANTLY BKUMA YRLSBUG

Two Hundred Beginners in Forty-Four States Have Reported Mastered Code in 30 Minutes. In 45 Minutes. In One Hour, One Evening, Etc., Etc. and With Little Practice Obtained License as Radio Operators.

Do not be Satisfied to Limit the Use of Your Radio Receiving Set to Periodical Broadcasts of Music, Weather and Market Reports, Etc.

Master Continental Code

and Understand everything you may hear at any time from anywhere. Eventually add a sending set to your outfit. Get in touch with the World. Talk Back, Ask and Answer.

Code Memorizing Records

MADE BY BEGINNERS WHO USED

Dodge One Dollar Radio Short Cut

AND PASSED GOVERNMENT EXAMINATION

W. A. Oettler, Woodhaven, N. Y.
Radio 2AOI 340 Woodland Ave.
Time required 30 minutes

E. Gundrum Elizabeth, N. J.
Radio 2BXY 303 Cherry St.
Time required one hour

Robert Gerbrick Philadelphia, Pa.
Radio 3BHP 2118 Hicks St.
Time required less than two hours

Mrs. Julia Garrett Fort Worth, Tex.
Radio 5PJ 303 So. Jennings Ave.
Time required odd moments ten days

J. E. Farquhar Hamilton, Ont.
Radio 3DW Canada 18 Albert St.
Time required one hour and half

W. M. Adler New York, N. Y.
Radio 2BGC 576 E. 143d St.
Time required forty minutes

David E. Day WINSTON SALEM, N. C.
Radio 4BM P. O. Box 48
Time required 45 minutes

Roland Richardson Oakland, Calif.
Radio 6AVH 4258 Foothill Blvd.
Time required one hour

INVESTIGATE

FOR TEN RED STAMPS

will mail Booklet containing information and Reports from 240 successfully self-instructed beginners—many of them now licensed operators.

No Instruments needed with this method. Entire necessary expense for Code instruction One Dollar, and limited study of Dodge Short Cut.

C. K. DODGE

Box 200 MAMARONECK, N. Y.

NEW MOTORS FOR ALL PURPOSES
STANDARD MOMENTS—LIFETIME PROMPT DELIVERY

ALL SIZES UP TO 5 H.P.

We Specialize In Small Motors & Generators

ALL PHASES AND FREQUENCIES IN STOCK AT ALL TIMES

Largest exclusive Mail Order Small Motor dealers in the world

CHAS. H. JOHNSTON, Box 161, West End, Pittsburgh, Pa.

WIRELESS, TELEPHONE GENERATORS
500 VOLT - 100 WATT - 3400 R.P.M.
FOR MOUNTING MOTOR GENERATOR SETS.

\$28.50 EACH

WRITE FOR CATALOG

TELEGRAPHY

(Morse and Wireless) and RAILWAY ACCOUNTING taught thoroughly. Big salaries; great opportunities. Oldest, largest school. Endorsed by Telegraph, Railway, Radio, and Government officials. Expenses low—opportunities to earn large portion. Catalog free. DODGE'S INSTITUTE, D. Stroet, Valparaiso, Ind.

The "niftiness" of this semi-portable radio receiving set is suggested by its adaptability for service when plugged in an electric-light socket in the home or office, and music and messages garnered from out of space. The upper compartment or receiving outfit proper may be placed on the library table while the accessories to the receiver may be snugly encased in the lower compartment and tucked away in a corner in the interest of sightliness. The practice as now prevailing in homes and offices where radio is gripping its occupants is to scatter the wireless accessories over a "wilderness of space" and without regard to orderly arrangement.

Suppose you desire to depart suddenly for the home of a neighboring friend with the object of enlivening the evening with the reception of music or other form of entertainment as it circulates through ether. This semi-portable outfit lends itself to "visiting" readiness almost instantly and can be installed with like dispatch. The upper and lower compartments of the equipment are easily detached and quite as readily renew their contact. Rubber cushions between the two compartments avoid abrasion or effacement of the twin-like outfit. Simply remove the strap which circumvents the two compartments when joined together and there is instantly a disunion of the Siamese twins, proverbially speaking.

How to Make a Radio Concerta

(Continued from page 930)

voltage is used on the plates of the last three tubes. B is the "B" Battery, which for maximum efficiency should have a voltage of 200 to 300 volts with taps for the detector, the radio amplifier, and the two first audio amplifier tubes. The grid leaks shown across the secondary windings of the audio frequency transformers are necessary only if a high voltage is used, so that the audio frequency amplifier acts as a power amplifier, their value varying with the make of transformer in use. For UV712 transformers, a resistance of 1½ megohms is suitable, while for other makes it may be slightly less.

These leaks are not indispensable, but in some cases have proved necessary.

The radio frequency transformers should preferably be of the iron core type and be so designed as to cover the band of wavelength which it is desired to receive, and a potentiometer P should be used so as to keep the grids of the two first tubes at the proper potential. The loud talker, not shown in the diagram, should be connected between the plate of the last tube, and the positive of the "B" Battery; the field coil being in parallel with the filaments of the tubes.

The arrangement of these instruments upon the board which may easily be removed from the cabinet, is shown in the photograph, Fig. 2. As may be seen, all the connections are made at the rear, with binding posts mounted on a strip of bakelite, from which the wires to the batteries run through a hole drilled in the separation in the middle of the cabinet. The loud talker is mounted in the battery compartment, and is adjusted to the wooden sound box installed in the phonograph cabinet. This disposition not only saves space, but also gives very good reproduction of the voice and music received, due to the shape and the material of which the sound box is made.

A very important point to which much attention should be paid is to use real good "B" batteries. These batteries are often the source of frying noises, remarkably loud and steady when produced by cheap batteries. If howling is experienced, it may be

If you need a simple crystal set for telephone reception, see the dope in

Design of Modern Radio Receiving Sets

The construction of an excellent crystal receiving set which tunes from 150 to 900 meters is described in this book. The outfit was planned for experimenters who are just taking up radio work, and want an outfit of the simplest type, yet suitable for radio telephone reception over a radius of 25 miles. The set is built entirely from G. A. Standardized parts which can be obtained from the General Apparatus Company or its distributors. More advanced apparatus is also shown in RADIO RECEIVING SETS.

The Price is
50c
Postage 4c

The General Apparatus Co., Inc. 88-N Park Place
New York City
Send 10c for the new G. A. Catalog

THE GOODMAN



PATENT PENDING

\$6.00 !!!

Nuff Sed

Send for Pamphlet

MADE AND SOLD BY
L. W. GOODMAN
Drexel Hill, Pa.

WHOLESALE DISTRIBUTORS
THE SAYRE-LEVEL RADIO CO.
905 Filbert Street, Phila. Pa.
Order direct or from your dealer

BUILD YOUR OWN
WIRELESS RECEIVING SET



You can SAVE at least \$25.00 By buying parts and assembling yourself

Think of the pleasure and practical experience you will gain in making your own set, with wavelength range from 170 to 2,500 meters. We furnish full-sized blueprint and complete detailed instructions for making this set and prices of parts for \$1.00.

Write today and get started
K. & G. WIRELESS SUPPLY CO.
Dept. 15A, 152 Chambers Street, New York City

stopped most of the time by connecting fixed condensers between the grids of the audio frequency amplifier and the "A" battery.

The loop aerial used in conjunction with this receiver should be about 3' square and wound with seven turns of insulated wire, spaced about 3/4" apart. The connections from this loop to the cabinet may be made with two pieces of soft cord not exceeding 3' or 4' in length, and attached to the plug which may be inserted in the jack J1 of the diagram, so that the loop aerial may be removed from the set and put aside when it is not in use. Such a receiver has, under good conditions, quite a long range, and signals from well known broadcasting stations installed in the vicinity of New York within about 20 miles, may be heard over a large sized room, thanks to the loud talker. At a greater distance the signals of course are not so strong, but may be heard loudly, if no external noise interferes. By using a pair of phones plugged in the second step of the audio frequency amplifier, signals from a great distance may be received.

In New York City, where the "Radio Concerta" is installed, five telephone broadcasting stations may be heard very strongly, while three others come in very clearly, though a little fainter. Such a receiving outfit may be installed in a parlor without marring the looks of the room, as other radio receivers generally do. The cabinet chosen may be of such a style as to match the other pieces of furniture, and the loop aerial may be easily hidden in some place, so that the complete outfit does not look at all like a radio set. It may be made by anyone having a little hand practice, since only the wiring and the mounting of the parts is to be made, and although it cannot be classified with the "cheap" outfits, it is undoubtedly the ideal type of receiver for the home.

The Construction of an Experimental Radio Set

(Continued from page 935)

as it may be. Fig. 2 shows how any combination of instruments are assembled and made to fit the cabinet. The juice panel used is that described in an article on "A and B Batteries From 110 A.C." by Mr. Swank in the Sept., 1921, issue of RADIO NEWS.

The main point about these panels lays in the terminal posts. The posts are No. 6/32 brass machine screws, 5/8" long, and each is equipped with two hexagon brass nuts. The terminals are restricted to the upper portion of the panels and are connected to their respective instruments with heavy copper wire, soldered. It is very easy to make and change connections by the use of these terminals. The best circuit for your set can easily be found and anyone who likes to experiment will find that there is nothing lacking. Solid copper wire should be used for exterior connections rather than stranded wire; the reason for this is apparent. A little thought will show why the terminals are placed on the top rather than anywhere else. The front wiring can be done neatly and will look very good. There are no dimensions on the panels, for each one of us has different instruments on hand and a different layout will be required. It is possible to start with a simple crystal detector outfit and progress as circumstances permit.

To eliminate any appearance of incompleteness in the panel, a few false ends may be constructed and the space not yet used for panels may be utilized, as shown in Fig. 2. Be careful to have each panel only the width required, no more. The terminals may be lettered with white photographer's ink; there is no necessity for engraving them. Information regarding the working

IT SPEAKS FOR ITSELF

\$5.00

ARKAY

Loud Speaker

RADIO HORN

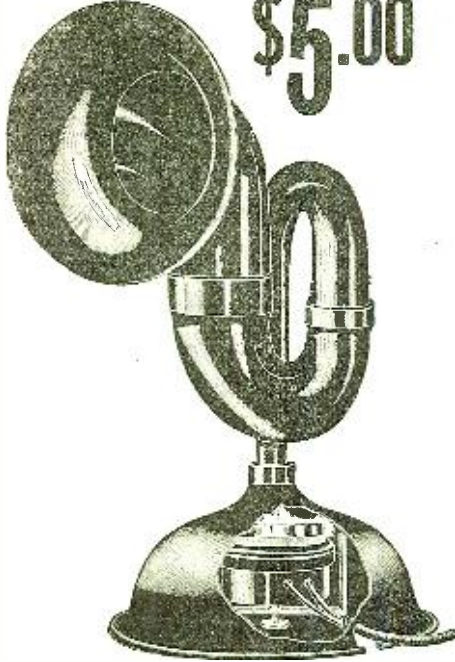

Will amplify your signals, speech or broad casted music without distortion.

This horn is constructed to fit any make of receiver through the use of an adapter under the base.

Works on one or two stages of amplification.

Price Black Enamel, without phone, \$5.00 each.

Price, Polished Nickel, without phone, \$6.00 each.

Order through your dealer or direct from us, remitting by money order the price of horns, plus parcel post to your address. Shipping weight 4 lbs.

DISTRIBUTED BY

<p>INDIANAPOLIS, IND. Hatfield Electric Co., Indianapolis, Ind.</p>	<p>NEW YORK CITY Continental Radio & Electric Corp., 6 Warren St. Manhattan Electric Supply Co., 17 Park Place Ship Owners Radio Service, Inc., 80 Washington St.</p>	<p>NEWARK, NEW JERSEY Economy Auto Supply Co., Inc., 268 Halsey St. Radio Distributing Co., 4 W. Park St.</p>
<p>TOLEDO, OHIO Marshall-Gerken Co., 27 Ontario St.</p>	<p>PITTSBURGH, PENNA. Ludwig Hommel & Co., 530 Fernando St. Robbins Electric Co., 830 Liberty Ave.</p>	

DEALERS—Write for Proposition.

RILEY-KLOTZ MFG. CO.

17-19 MULBERRY ST. NEWARK, N. J., U S. A.



USE JEWELL INSTRUMENTS

in Your C. W. Set

To properly time up a C.W. set, instruments in the various circuits are a necessity.

Jewell instruments for alternating, direct and radio frequency currents are designed especially for such work and are proving their value wherever used.



Order from your dealer

Jewell Electrical Instrument Co.
CHICAGO

STORAGE BATTERIES

Designed Especially For

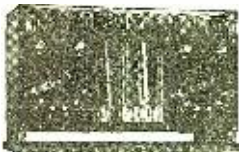
WIRELESS

KIMO "B" batteries give years of service. Are not harmed from short-circuiting, overcharging or standing idle. One charge lasts from three to six months while in the detector plate circuit. Can be recharged from your A.C. line in one hour. Money refunded if unsatisfied after ninety day trial. Prices as follows.

	(With Panels)	(Plain With Clips)
32 volts.....	\$11.00	\$8.00
48 volts.....	13.00	10.00
68 volts.....	18.00	12.00

KIMLEY ELECTRIC CO.,

KICO "A" batteries. No more acid eaten rags or furniture. Truly a parlor battery. Box and jars moulded in one piece from acid proof composition many times tougher than hard rubber. Guaranteed 18 months on Ford, Chevrolet or any car taking battery 9 1/2 x 7 1/2 inches, but will last several years as wireless "A" battery. Shipped ready for use with hydrometer for testing at \$24.00 or with wooden box and rubber jars. 6 volt, \$20.50; 8 volt, \$27.00; 10 volt, \$33.00. All 80 to 100 A.H.

Write for particulars

290 Winslow Avenue, BUFFALO, N. Y.

Insure your copy reaching you each month. Subscribe to Radio News
—\$2.50 a year. Experimenter Pub. Co., 236 A Fulton Street, N. Y.

IMMEDIATE DELIVERY



Price \$5.00

PANEL MOUNTING
Standard Variocoupler Parts

Variocoupler Rotors with rods.....	\$.75
Variocoupler Tubes45
Standards for Variocoupler.....	.70
½ lb. of No. 22 Magnet Wire.....	1.00
Bushing, screws and nuts for assembling25
Postage15
Total	3.30

“READ ‘EM”
Binding Posts—
16 Styles

Antenna	B Battery +
Ground	Plate
Condenser	Detector
Tickler	Secondary
Variable Condenser	Primary
A Battery —	Grid
A Battery +	Phones
B Battery —	Filament

Price 15c each



Switch Arms

Price 50c each
Knob 1½" Knurled or Fluted Bakelite. Lever 1½" Phosphor Bronze Nickel. Bushing to fit up to ¾" Panel. Switch arms, same as above with 1" radius knobs. price 40c.

Order from this Advertisement

The KUEBLER RADIO COMPANY
24 Boody Bldg.
Toledo, Ohio

of bakelite may be found in past issues of RADIO NEWS. It is well to keep the controls most used nearest the base where they are handiest. If the nuts on the terminals are kept tightened, there will be no danger of loose connections. The dimensions are on the drawings.

Regarding the selection of apparatus, the following notes may be of some advantage: Honeycomb or duo-lateral coils provide a set that may receive all wave-lengths, and if you are doubtful of them because you have heard that they are not as good as a variometer set for short waves, I would advise you to read carefully the article by Mr. J. S. Brown in the May, 1920, issue, on short-wave honeycomb coils. If you construct the set of coils there described you will have solved the short-wave question; that is, Mr. Brown has solved it for us.

Standardize on some inexpensive, good looking knob and dial and be careful in the purchase of small things such as rheostats and sockets. The amount that can be saved on each instrument by careful buying will be found to mount up to quite a sum. Inexpensive instruments do not necessarily have to be "cheap." Small, formed, porcelain receiving insulators will do instead of the more expensive moulded bakelite type.

It may prove of benefit to you if you look up the following articles in RADIO NEWS; they may be adapted to these unit panels: Sept., 1921, by Mr. Lewis, on I.C.W. for the Amateur; April, 1921, by Mr. Read on a long range receiver.

Note that the cabinet may be made very easily because all the wood is 4" with the exception of the 1" strips to which the panels are screwed.

Repairing Burned Out Amplifying Transformers

By Raymond Roof.

Amateurs who are using vacuum tube amplifiers and are experiencing a great deal of noise which can be traced to no definite source, had better test the windings of their amplifying transformers, to see if they are burned out. A pair of receivers should not be used as the capacity effect of the layers of winding of the transformer will generally be sufficient to cause a click in the phones. A fairly sensitive meter should be used, in connection, of course, with a battery. If one winding is found broken, the core should be removed from around the coil. If the primary is broken, the center of the coil is very carefully removed and if the lead-in wire connection is in good shape, the coil should be carefully unwound. Do not think the coil is ruined if you bring a layer or two out with the center. If this is done, simply break the wire and test the coil again for open circuit. If it is still open, continue unwinding.

As a matter of fact, the transformer is not burned out at all. The trouble will usually be found where the lead-in wires are soldered to the winding. A slightly acid soldering paste is sometimes used, and, if not entirely removed, will attack the wire, forming cupric chloride. This is a conductor and will actually carry the signal current, with a great deal of noise, however, due to the poor connection.

If the trouble is not found in the first primary connection, the primary should be completely unwound until the other connection is reached. If the wire breaks rather often, it will probably be necessary to re-wind it with some new wire. The new wire need not be as fine as that originally used, nor is it necessary to put on the same number of turns as was formerly wound on, particularly if the transformer is an older

WARREN RADIO LOOP

NO AERIAL NO STATIC

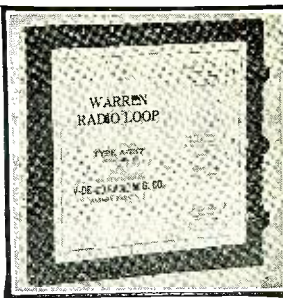

IF DAD SAYS—
"No AERIAL ON HIS HOUSE" don't allow his QRM to worry you, but purchase a WARREN RADIO LOOP

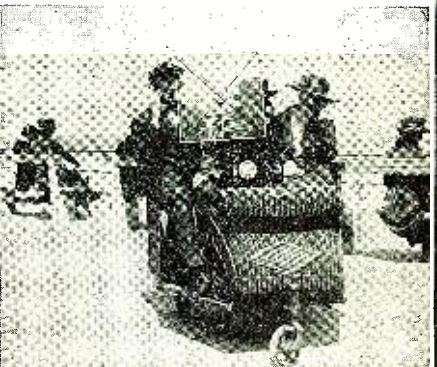

The LOOP that made the Radio Roller Chair famous on the Boardwalk at Asbury, Park, N. J.

Type A737 (300-700 meters).....	\$10.00
Type A7236 (175-1000 meters).....	12.00

Send your order through your dealer or direct to us with his name.

V-DE-CO RADIO MFG. CO.
Dep't. N ASBURY PARK, N. J.
Send for bulletin No. T101

RADIALL NEWS

Antenna Insulators	\$.20
Detector Crystals, mounted.....	.20
Detector Crystals, unmounted.....	.10
Grid Condensers20
Phone Condensers30
Binding Posts, Composition of 8/32.....	.08
Nickel plated Contact Points.....	.02
Wood Variometer Parts.....	1.75
Sliders10
Slider Rods15
2 Slide Tuning Coil Parts, Complete....	1.95
Switch Levers35
Tin Foil, enough for phone condenser..	.10

Magnet wire, all sizes

RADIALL ELECTRIC CO.
187 PASSAIC ST. PASSAIC, N. J.

CARDBOARD TUBING

Seamless—Grey
IN ANY LENGTH UP TO 28 INCHES

	Per in. or	Per
	Fraction	Ft.
2½, 3 and 3½ in. diameter....	3½c	30c
4 and 4½ in. diameter.....	4c	35c
5 in. diameter.....	4½c	42c
5½ and 6 in. diameter.....	5c	50c

Postage extra; shipping weight 1 lb. per ft.
Binding Post, Switch Levers, Magnet Wire, Switch Points, Sliders and Slider Rods.
Write for our prices.

Dealers Write for Discounts
MICHIGAN RADIO CO.
(Formerly Jeffery, Crawford Co.)
2173 Hilger Ave. Detroit, Mich.

Post - Paid
Anywhere

Radio Supplies
of Standard Makes

CHAS. G. ROSEWALL
93 Flatbush Ave.
Brooklyn, N. Y.

AMATEURS ATTENTION
If you want good radio apparatus at fair prices try
WILSON RADIO SHOP
272 Wilson Ave. Brooklyn, N. Y.

one. The turns ratio used now is often 9 to 1; formerly, it seldom exceeded 3 to 1. This is because the bulbs now on the market have different characteristics than those that were sold some years ago.

For instance, the transformers that I used in my set were purchased from one of the largest mail order houses in the country. They were excellent in their operation; using two steps, and an old phonograph horn on one receiver, NA could be heard almost a block away, on a good night. The turns ratio was 3 to 1, wound with No. 40 enameled wire. The primaries both went bad. One had to be rewound. I used a silk covered wire a size larger. The D.C. resistance was just half that before, i. e., 450 ohms. The wire was not wound in layers; about half the number of turns formerly used were wound on. Now they work even better than before, because the turns ratio is greater. Since adding a step, KDKA, about 400 miles away, can be heard all over the house, even down cellar; set is on second floor.

If the secondary is bad, and the outside connection is found O. K., then the primary will have to be unwound to get at the other end. Perhaps, if one is careful, the first inside layer of the secondary can be reached from one end, by pushing the paper away.

With a little patience and care, amplifying transformers can be made as good or even better than when new.

WIRELESS MARKET REPORTS USED BY MANY AGENCIES.

The wireless is now being used by State and Federal agents to broadcast national and local agricultural market reports throughout virtually the entire country. Re-

ports on the national markets are dispatched daily by the United States Department of Agriculture from wireless stations of the Post Office Department at Cincinnati, Omaha, Washington, North Platte, Neb.; Rock Springs, Wyo.; Elko, Nev., and Reno, Nev. These reports are received by hundreds of amateur wireless operators. National market reports are also received by State bureaus of markets and agricultural colleges, supplemented with local market reports, and relayed by wireless telegraphy and telephone to farmers, shipping associations, newspapers, banks and other agricultural interests.

The St. Louis University at St. Louis, Mo., was perhaps the first among educational institutions to broadcast market reports by wireless. These reports are received by hundreds of farmers, shipping associations, banks and other agricultural interests, and a telephone company in Eastern Illinois, which receives the reports, telephones the news regularly to its 5,000 subscribers.

At Lincoln, Neb., the University of Ne-

braska and the Nebraska Wesleyan University are cooperating in broadcasting crop and market reports furnished by the State bureau of markets. Both radio telephone and telegraph are used. At Wisconsin the State department of markets broadcasts national and local market reports from the University of Wisconsin wireless station at Madison. At Minneapolis, crop and market reports are broadcast from the University of Minnesota radio station. The Minnesota College of Agriculture has also assigned an extension representative to instruct the farmers in the use of wireless receiving apparatus. The College of Agriculture of Cornell University has assigned an expert for similar work, and to assist rural radio clubs that are being organized in New York.

A high-powered transmitting wireless telephone is being installed in the office of the Missouri State market bureau at Jefferson City, Mo., and will be ready for disseminating market information about January 10. Government reports from the larger market

STAR CRYSTAL DETECTOR

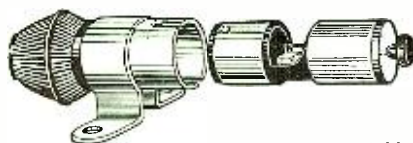

This is a small high grade Detector. Adjustment is easily and quickly made. Movable parts are light and perfectly balanced. Does not jar from position. Fits the same socket as the Radium Jewell STAR. Comes complete with crystal mounted. You can change crystal. Star and Jewell make a wonderful combination. Use Star to locate party then slip in Jewell and you are set for the evening. Both same price. Star 60c, Jewell 60c. Holder 40c. Jewell was advertised in March issue.

COMPLETE \$1.00

If your dealer can't supply we will mail direct.

Newark Electrical Supply Co., Distributors for New Jersey

STAR MFG. CO.,

Newark, N. J.

Condenser No. 3

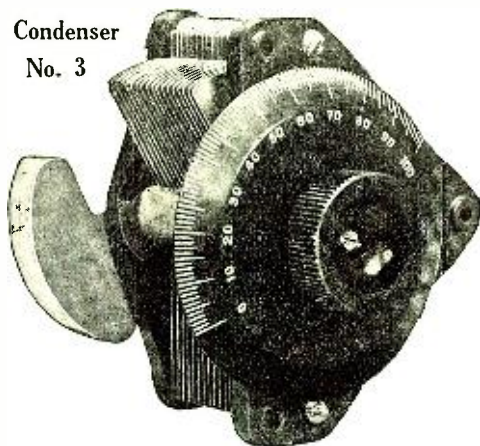

CHELSEA

Variable Condensers (Die-Cast Type)

No. 1.—0011 m. f. mounted.....	\$5.00
No. 2.—0006 m. f. mounted.....	4.50
No. 3.—0011 m. f. unmounted.....	4.75
No. 3.—0011 m. f. unmounted, without dial	4.35
No. 4.—0006 m. f. unmounted.....	4.25
No. 4.—0006 m. f. unmounted, without dial	3.85

Top, bottom and knob are genuine bakelite. shaft of steel running in bronze bearings, adjustable tension on movable plates, large bakelite dial reading in hundredths, high capacity, amply separated and accurately spaced plates.

Unmounted types will fit any panel and are equipped with counterweight.

Purchase from your dealer; if he does not carry it, send to us.

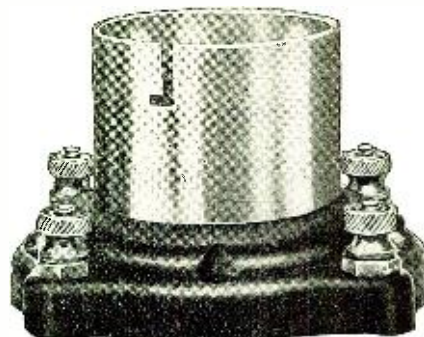

"Chelsea Bakelite Socket No. 60"

This socket has a bakelite base supporting four external, readily accessible binding posts. The tube receptacle is highly polished nickel and will take any standard detector and amplifier tube as well as the smaller size power tubes. It is primarily designed for receiving circuits, and may be mounted on either table or panel. Positive contact springs.

An added beauty to any radio station.

Price as shown, \$1.00

Purchase from your dealer.



NO. 50, PRICE AS SHOWN, \$4.50

The Chelsea Amplifying Transformer is a supreme attainment in the design of Audio Frequency Transformers. It embodies the highest grade of materials obtainable and proper design, which reflects the result attained namely high amplification factor. It is unequalled either in electrical characteristics or good appearance.

CHELSEA RADIO CO., 150 Fifth Street, Chelsea, Mass

Manufacturers of Radio Apparatus and Moulders of Bakelite

centers of the country will be received by means of a "drop" from the leased wire system of the United States Department of Agriculture, and transmitted by radiophone to all sections of Missouri. Demonstrations intended to interest farmers, dealers and shippers in installing the necessary wireless receiving apparatus will be held in various rural communities of the State, and it is anticipated that telephone offices, newspapers, chambers of commerce, county agricultural agents, banks, high schools and cooperative marketing associations will be among the first to install receiving sets.

A most complete program in the dissemination of market reports by wireless is being planned by the State bureau of markets in Ohio, a specially constructed radiophone transmitter of the most improved type being installed in the radio station of the University of Ohio for that purpose. The Texas markets and warehouse departments are also planning a market news service by radiophone for farmers, dealers and shippers in Texas, arrangements being made to use the radio equipment of the University of Texas at Austin.

The first national market report to be broadcasted by wireless anywhere in the world was sent out by the United States Department of Agriculture from the radio station of the United States Bureau of Standards only a little over a year ago. The department soon demonstrated the practicability of utilizing the radio for dis-

seminating market information, and rapid progress in expanding the work has been made possible through the cooperation of State and Federal agencies. To make the American farmer the best informed farmer in the world is the aim of these agencies, and equal progress during the coming year will go far toward securing that result, say officials of the Federal department.

How I Solved My "B" Battery Troubles

By P. J. Faulkner.

I may have been unfortunate in my selection of "B" batteries; I may even have short-circuited them occasionally, but whatever the cause, they certainly were troublesome. I finally conceived the plan of buying flashlight batteries and assembling them in cigar boxes, on the theory that I could test the cells one by one and discard those that showed what I thought too great a drop in voltage, replacement with new cells being easy. Somehow or other this plan did not work out satisfactorily; for one thing I was kept too busy testing and replacing cells until I got so that I hated the sight of a "B" battery. I at last decided I would have to make a "B" storage battery, the decision being prompted by an advertisement of a New England concern to sell Edison battery elements at 10 cents each, and I settled on the Edison type on the strength of the performance of an Edison "A" battery, which I had had over ten years, and which, so far as service was concerned, was as good as new. I stopped at a local carpenter shop one morning and bought two pieces of soft wood, 8" long, 7 1/2" wide and 1/2" thick, and two pieces, 21" long, 7 1/2" wide and 3/8" thick. These were for use in making the cabinet or stand for holding the cells, and were finished and assembled in the following manner: The two longest pieces, used for shelves, were ruled off into 1 1/2" squares, and at the intersecting points of the ruled lines 1" holes were bored, there being 52 holes in four rows of 13 holes each. The shelves were then mounted between the shorter pieces mentioned above, used as end pieces, one shelf 1/4" from the top, the other shelf 2 1/2" from the bottom. The whole thing was then painted thoroughly with hot paraffine. I then inserted in the

Recharge Your Battery at Home

Don't be without the use of your Radio Receiving Set while your battery is being charged by some Service Station. Get a Valley Charger and charge your battery right at home at one-tenth the usual cost.

Attach the Charger to your home lamp socket — attach the clips to the battery terminals and you will get a quick tapering charge which just exactly charges your battery, but cannot over-charge or harm it in any way. This Valley Charger has no troublesome bulb and will charge your automobile battery as well as radio battery. **GUARANTEED "Satisfaction or Money Back."** Send for one of these Chargers TODAY.

VALLEY ELECTRIC COMPANY
Department R. ST. LOUIS, MO.

----- Mail the Coupon -----
Valley Electric Co., Dept. R., St. Louis, Mo.

Gentlemen: I am enclosing money order (or check) for \$12.00 for which send me a Valley Battery Charger with black metal case, \$15.00 for which send me a Valley Battery Charger with five-panel glass display case and indicator. If not satisfactory, will return it and get money.

Name _____
Address _____
Town _____

\$12 and \$15
F. O. B. St. Louis

FROM-FACTORY TO YOU

GUARANTEED RADIO BATTERIES

Our new sales plan, selling direct from factory, now enables you to buy famous Bell Radio Storage Batteries less the dealers' and jobbers' commission—saving half! Guaranteed in writing for 1 1/2 years. Bank References

LOOK

6 Volt 20 ampere..	\$12.00
6 Volt 25 ampere..	15.00
6 Volt 30 ampere..	19.50

Bell Batteries are also built for every make and type of automobile and on our new plan of selling from factory to consumer you save 50%. Send \$5.00 and any battery will be expressed, balance C.O.D. subject to your approval. Catalog of auto batteries free.

INDEPENDENT BATTERY CO., 1988 Grand River Ave., Detroit, Mich.

50%

SAVES

Unconditionally Guaranteed for 1 Year

U. S. Storage Batteries

Supreme for Wireless Telephone

Telegraph, electric trains, motors, lighting toys, etc.

6 Volts 40 amp.	\$10.00
6 Volts 60 amp.	\$13.75
6 Volts 80 amp.	\$17.50

21 OTHER SIZES

Price list mailed free. Dealers write for discounts When the least money buys the best, why not save the difference.

Mail Orders filled upon receipt of price.

U. S. STORAGE BATTERY CO.
FAR ROCKAWAY, N. Y.

New York Distributors

Broadway Electrical Nov. House.....	324 Bowery
U. S. Storage Battery Co.....	4 Barclay St.
F. M. Dreyfuss.....	132 Chambers St.
Dreyfuss Sales Corp.....	179 Greenwich St.
Lyknu Auto Co.....	606 Bergen Ave., Bronx
Beacon Radio Elec. Co.....	246 Greenwich St., N. Y.
Kensington Storage Bat. Co.....	4416 18th Ave., Bklyn.
David Killoch Co.....	37 Murray St., N. Y.

Also on display and demonstrated at
N. Y. EDISON RADIO BUREAU
15th St. & Irving Pl. 124 W. 42nd St.
Tremont and Monterey Ave., Bronx

PLAN CAREFULLY AND SUCCESS IS ASSURED

Plan Bureau Blue Prints

Are especially prepared to serve the amateur or commercial man—expert or novice. Genuine goodness and low prices have made them extremely popular. We receive letters of commendation almost every day. OUR METHOD IS TO GIVE YOU CLEAR AND CONCISE BLUE PRINTS FOR USING STANDARD PARTS AND MATERIALS THUS ENABLING YOU TO BUILD CHEAPLY AND QUICKLY. WE DO NOT SELL PARTS.

Complete set of receiver plans. Just out. Details and shows you exactly how to make the following: Three different aeri-als. Short wave tuner. Long wave tuner. Detector unit. (VT)	One stage amplifier. Two stage amplifier. Three stage amplifier. Loud speaker.	Proven VT hook-ups for receiving. 12 separate blue prints for 50c.	Proven VT hook-ups for phone transmission. 12 separate blue prints for 50c.
---	---	--	---

Several cabinets. Several hook-ups. 18 blue prints in all giving every detail needed. Right up to date. Price \$2.00 postpaid.

THE PLAN BUREAU

1929 McCausland Ave. ST. LOUIS, MO.

RADIO

Supplies in stock.
Finished sets.
Parts for Receiving and Sending.
Radiotron Tubes, UV-200, UV-201, UV-202, UV-203.

For Immediate Delivery

Electric Service Engineering Co.
105 West 47th Street New York
Bryant 2743

holes in the shelves 52 test tubes. These measured 5" in length, and a trifle less than 1" in diameter, although I believe they were rated as 1" tubes. At any rate they fitted very comfortably in the 1" holes. I had already procured from the New England concern previously mentioned 52 Edison battery units, each consisting of one positive element between two negative elements, the elements being separated with strips of blotting paper, and the whole held together with rubber bands, one at the top and one at the bottom. Nickel wire, No. 18 gauge, cut into 4" lengths, was twisted around the elements for connectors. I tried soldering these the first time, but after two weeks' use found most of them loosened by corrosion, so I had to do the work again, twisting the leads on tightly but carefully, and they have given me no trouble since. After placing the elements in the cells the nickel wire leads were cut off about 1" above the tops of the cells, the projecting ends being given a slight twist and soldered, in series, of course; that is, the negative element of one cell to the positive negative of the next cell, etc. The free positive wire at one end of the battery, and the free negative wire at the other end, were clamped tightly under binding posts mounted in one of the end pieces of the cabinet, near the top. The battery was now ready for the solution or electrolyte, which was made by dissolving one pound of potassium hydroxide in four pounds of distilled water. The potassium, which comes in sticks or pencils, should be dropped in the water one stick at a time, and the solution allowed to cool before adding another stick. The chemical reaction between the potassium and water is quite violent, and considerable heat is evolved, hence the necessity for making the mixture gradually. Care should be exercised in handling the electrolyte, as it is quite irritating to the skin, and will quickly eat holes in one's clothing, also in carpets, rugs, table covers, etc. Using a small rubber syringe, each tube was filled sufficiently to cover the elements, and on top of the solution was placed a thin layer of paraffine oil to prevent evaporation, which takes place quite rapidly otherwise. The part of the city in which I live is supplied with 110 volts direct current, making it a simple matter to charge the battery by connecting it across the line in series with a 16 c. p. carbon lamp. The amount of charging required has been surprisingly small, notwithstanding the battery is used on a detector tube and two amplifying tubes, and for several hours a day. Those operators making such a battery, and having alternating current, will have to rig up a small electrolytic rectifier, which can be done without much trouble or expense. My battery has been in use since last May and has given no trouble whatsoever and has never failed us, which is a whole lot more than could be said of the dry batteries we used to buy in such numbers. At the present time the 52 cells show 68 volts. The total cost was \$10, and I have found it worth many times that amount in freedom from trouble, worry and inconvenience. For the benefit of others I append a detailed list of the various items, together with the cost.

- 1 lb. Potassium hydroxide, 90 cents.
- 52 test tubes, New York, \$1.80.
- No. 18 nickel wire, \$1.
- 52 Edison battery units, \$5.14.
- Miscellaneous—lumber, paraffine, paraffine oil, etc., about \$1.16. Total, \$10.

HOME SWEET HOME.

Dumb: "I hear they've built a home for wireless operators."

Bell: "What do they call it?"

Dumb: "Listen Inn."

By BERNARD SALZBERG.

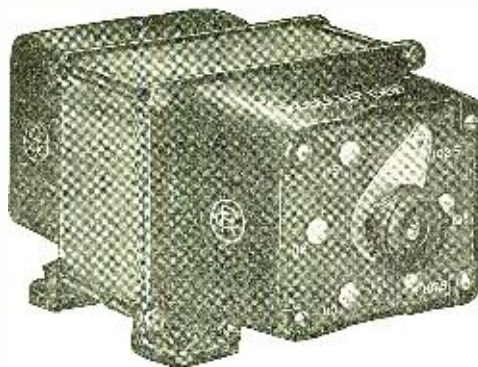

UP - 1368 - 325 W-C W - TRANSFORMER

EVERYTHING
Radio!



Trade Mark Registered

The Sales Division of the Philadelphia School of Wireless Telegraphy will hereafter be conducted under the name of the Philadelphia Wireless Sales Corporation.

We are authorized Radio Corporation jobbers including the famous Westinghouse line of Receivers.

The new General Electric Receivers will be carried by us as soon as released.

PHILADELPHIA WIRELESS SALES CORPORATION

1533 Pine Street

Philadelphia, Pa.

JOBBERS AND DEALERS IN RADIO

EXPERIMENTERS:

Buy your wire direct from the makers, and save money. The following prices on plain enameled magnet wire should interest you.

No. 12.....\$.29 per lb.	No. 22.....\$.44 per lb.	No. 32.....\$.75 per lb.
No. 13......30 per lb.	No. 23......46 per lb.	No. 33......79 per lb.
No. 14......31 per lb.	No. 24......48 per lb.	No. 34......83 per lb.
No. 15......32 per lb.	No. 25......50 per lb.	No. 35......88 per lb.
No. 16......33 per lb.	No. 26......53 per lb.	No. 36......95 per lb.
No. 17......35 per lb.	No. 27......56 per lb.	No. 37.....1.05 per lb.
No. 18......37 per lb.	No. 28......59 per lb.	No. 38.....1.15 per lb.
No. 19......39 per lb.	No. 29......63 per lb.	No. 39.....1.40 per lb.
No. 20......40 per lb.	No. 30......67 per lb.	No. 40.....1.90 per lb.
No. 21......42 per lb.	No. 31......71 per lb.	

No order accepted for less than \$1.00 or less than one pound of a size. Terms cash with order. Add 10c for each spool. Do not forget to add postage.

American Enameled Magnet Wire Co. Muskegon, Mich.

Insure your copy reaching you each month. Subscribe to Radio News—\$2.50 a year. Experimenter Pub. Co., 236-A Fulton St., N. Y. C.

MAKE NO MISTAKE!

The
**Klosner
Vernier
Rheostat**

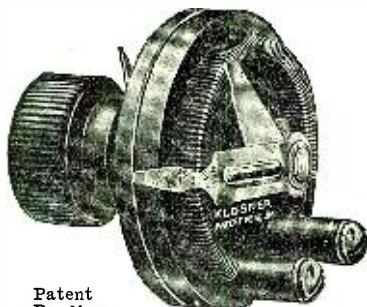

Patent Pending

is the only Vernier Rheostat made having the exclusive feature of using but

ONE SINGLE KNOB

for both rough and fine adjustments. This feature allows the symmetrical appearance of the single knob to be retained when mounted on a panel with other instruments, and, at the same time adds to the simplicity and ease of operation in obtaining the necessary fine adjustments for best results from the modern critical vacuum tubes, especially when receiving phone and C.W. signals.

We invite comparison with any other filament rheostat now made.

Look for the name **KLOSNER** moulded on the base.

Your Dealer has them or send direct to us.

Price \$1.50

Shipping Weight One Pound

A Two Cent Stamp Brings Interesting Literature.

Made Only by The Originators

The KLOSNER IMPROVED APPARATUS CO.

2404 Crotona Ave., New York, N.Y.

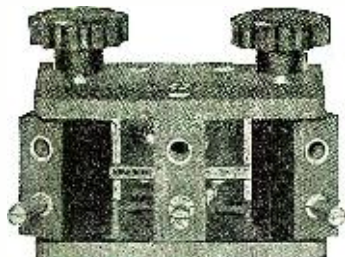

3-Coil Mounting, fits all standard coils. \$5.00 postpaid
Mica grid condenser and grid leak mounting. .50
Grid leak mounting25
Variable Condensers (Square Law): .0005 Mfd. \$4.50; .00075 Mfd., \$5.00; .001 Mfd., \$6.00; .0015 Mfd., \$7.50.

MONTROSE MFG. CO.

619 St. Johns Pl. Brooklyn, N. Y.

Radio Opportunity

By Howard S. Pyle

The writer has been keenly interested in the recent articles by Mr. Armstrong Perry, pointing out the vast field as yet uncovered by the radio dealer, or even by an amateur experimenter in a public way. Being much in sympathy with Mr. Perry's suggestions and often wondering why some of our numerous radio circles did not seize the opportunities to put radio before the public eye, a few efforts have been made by the writer to place radio on a more understandable basis to the general public. His efforts have been very successful, both in the line in which they were directed, and later in a financial way. Perhaps a few words on the methods used, will not be out of place.

Having been assigned as operator on an Alaskan commercial radio circuit, communicating with the States, the writer's duties located him at Ketchikan, Alaska. Upon investigation, it was found that radio was considered indispensable by the population, as a quick and sure means of communication with the United States, paralleling the army signal cables. However, the apparatus, its operation, functioning, etc., were all a mystery to practically the entire population of not only that particular town, a place of several thousand, but to the entire territory. And radio was closely associated with their everyday life.

It was determined that the only plausible way to promote an active interest in radio as a science, was through the younger generation, in an amateur way. Further investigation disclosed the fact that there was but one boy or young man who was really interested in radio work. A start was made with him. Simple apparatus was furnished, to enable him to hear local work in Alaskan waters. His interest grew, and also that of his parents. This led to a correspondence course in fundamental theory of radio. The next step was a vacuum tube receiver, capable of bringing in the long wave long distance arcs. His progress was steady, and it was not long before an amateur license was granted. A position as messenger boy for the army cable office put him in still closer touch with communication systems, and he has finally developed into a lad who can talk and write intelligently of radio subjects. This is easily proved by an article appearing in the October number of **RADIO NEWS**, entitled, "Radio Receiving at Ketchikan, Alaska," by R. A. Anderson. That's the lad, and its hard to believe, from the intelligent handling of radio phraseology apparent in his article, that but two years ago, his knowledge of radio was limited to an intense desire to "know what it was all about." More to his credit still, is the fact that all his problems were worked out by himself, there being no other really "dyed in the wool" ham within many miles. What little assistance the writer rendered him, only served to fire his desire for greater knowledge. With the start made by this one Alaskan lad, it is noted that there are now four licensed amateurs in Alaska, and in Ketchikan, several other young fellows were interested to the point of installing apparatus for receiving signals. Ketchikan is coming along nicely as an intelligent radio community.

Alaska is an extremely difficult place in which to start anything of the scope which radio experimenting should have. Its towns are many miles apart, separated by high mountains and impassable forests; its only coastal transportation by means of boat. Many hours are consumed in passing from one town to another, and the expense is great. Activities must then be limited to local territory. But not so in the States, to wit:

After fourteen months on the Alaskan circuit, the writer was transferred to his pres-

RECOLA



(Patent Pending)

Radio Sound Amplifier

Insert any standard telephone receiver and you will have a perfect clear tone loud speaker. Stands 14 inches high with a 10 1/2 inch bell.

Furnished in black enamel—\$12.50.

Shipping weight 6 pounds.

Dealers—Write for proposition.

Manufactured by
RADIO ELECTRIC COMPANY
Fremont, Ohio

Would You Spend a DOLLAR to Double the Value of Your Radio Receiving Set?

Then pin a dollar bill to a note with your name and address written plainly thereon and mail it to us, AT ONCE! We will send you postpaid, a handsome, novel and wholly original radio diary and instructor—in which you can record interesting and valuable radio news, concerts, lectures, essays, sporting events, for a year—starting any day you wish.

AYRE'S RADIO DIARY and Instructor

\$ 1.00

Diary also contains a treatise on instruction written by a radio expert especially for beginners. Get your copy of this diary by ordering one today. Supply is limited. **SPECIAL PROPOSITION FOR DEALERS IN RADIO MATERIALS TO HANDLE THIS DIARY IN ALL PARTS OF THE COUNTRY.**

WILLIAM W. AYRE & CO.
Dept. G Montclair, N. J.

PAPER TUBES FOR WIRELESS

ALL SIZES ON HAND FOR IMMEDIATE DELIVERY WHOLESALE & RETAIL

BAEHM PAPER CO., INC.

219 Fulton Street New York

Bet. Church and Greenwich Sts.

ent station, located in a town, which with its neighboring town, both side by side, has a combined population of twenty thousand. After getting settled down, the writer thought that certainly a place the size of these towns must surely have a considerable number of radio experimenters, particularly with a radio station and radio experimental laboratory located here. Accordingly, an automobile trip, covering all the passable streets in both towns was made, scouting for the tell tale span of wires from the family chimney to the nearest tree. The result was a total of three woeful appearing antennae. Surely there must be more interest in radio than the evidence showed, and, accordingly, the writer placed a notice in the local papers, inviting all local men and boys, interested in radio, to meet at his home a certain evening, to discuss plans for the formation of a radio club: a means never failing to promote interest in the art. Seating arrangements were made for about fifteen. At the time set, it was found necessary to carry in two planks and place them on boxes to accommodate the numbers. Twenty-six altogether!

Another ex-amateur, associated with me in my daily radio work, assisted in explaining to the gathering, just what possibilities there were in the game and what we hoped to do with the material then present. It was found that the club idea was strongly favored, and inquiry elicited the information that several half-hearted attempts had been made to form such an association, but nothing ever materialized. All the prospects were new to radio, other than a little fussing with crystal detectors and bed spring aeriels. There was no "before the war" amateur available to get them started. This, myself and associate proceeded to do. The result of our efforts is the present KITSAP COUNTY RADIO ASS'N, with a membership of thirty-five, and with a voice in the radio affairs of the Northwest. The association was only formed last February, with quarters in the local high school, but has since expanded to larger quarters, and installation of a club is soon to commence.

The writer rarely is home for half an hour before some budding radio genius is at one door or the other, with a request for a new hook-up, or proudly displaying a workable piece of home made apparatus, or perhaps wishing to delve into my "junk-box" for a few parts to complete a set. The apparatus is not "hay-wire" either. It is good standard stuff, and a number of excellent regenerative sets are installed. The man without a vacuum tube is now considered locally as the merest beginner, and less than eight months ago, there was no vacuum tube installation, other than the writer's, within our membership.

The demand for small parts, etc., or the large amount of radio construction among the local fraternity is so great, that up until recently, the writer has carried a small stock of such parts at home, at catalogue prices for the accommodation of the boys. He has succeeded in interesting a local electrical store in the radio game, and will arrange a stock of such parts as are ordinarily in demand for construction work.

Just recently, the Seattle *Post-Intelligencer*, a popular morning daily, has installed a radiophone, and gives musical selections and late news of the day in a regular evening schedule. This service also boosted radio in this vicinity, and the writer had a receiving apparatus and loud speaker working nightly in a popular down town poolroom for about six weeks, for public demonstrations. The entire world series, play by play, was received by this means, and the finals received several innings ahead of the regular leased wire service. All this made a sharp turn upward in the radio interest curve, in this locality, and the club

JAXON

"B" STORAGE BATTERY

\$5.75 Prepaid or from your dealer



Away with your "B" BATTERY TROUBLES

HERE IS THE "B" STORAGE BATTERY YOU HAVE BEEN WAITING FOR. PRICED TO ATTRACTIVE LEVELS WITHIN REACH OF ALL.

RECHARGEABLE At any service station; cost should not exceed 25c.

LARGE CAPACITY Over 2,000 Mille-Amp hours.

VARIABLE VOLTAGE 18—20—22—24 volts.

STOPS HISSING—Hissing, howling and frying noises eliminated.

FULLY CHARGED All batteries shipped fully charged ready for use.

PASTED PLATES Rubber and wood separators.



JAXON
JACKSON BATTERY CO.

JAXON

Armored Radio "A" Battery

One piece Rubber Compound "Permanenta" Case, Heat and Acid Resisting.

Non-Leakable
Non-Conductive
Non-Deteriorating

Rubber protected cedar insulation—the good qualities of both and none of their faults.

Sold singly or in combinations.

"A" 6 Volt Storage Battery with Cunningham Tube C 300

Amps.	Battery only	With C 300 Tube
60	\$17.50	\$22.00
100	22.50	27.00

Satisfaction guaranteed or money back. Sent by *express collect*. Tube only prepaid \$5.00. If Tube C301 is wanted in place of C300, add \$1.50.

JACKSON BATTERY CO.

1124 JACKSON BOULEVARD CHICAGO, ILLINOIS



Are YOU Old at 40?

Perhaps the most common cause is the disturbed condition of an important gland. Even men of iron constitution are not exempt from this amazingly common irregularity. We have for limited distribution, an ethically accurate, educational and interesting

FREE BOOK

Its message may prove of unsuspected value to you. It explains how a disturbed condition of this vital gland may cause sciatica, backache, painful and tender feet, interrupted sleep and other extremely uncomfortable and often serious conditions. It tells of Thermalaid, a simple means by which the essential of a new hygienic principle, done into convenient form corrects this prostate gland condition and its attendant health faults without medicine, massage, or knife. The record of its success for five years is incontrovertible. The book is free. Simply address

THE ELECTRO THERMAL CO.
6001 Main St., Steubenville, Ohio



Globe Radio Batteries

DESIGNED ESPECIALLY FOR WIRELESS

SAVE YOU 50% OF USUAL COST AND YOU GET AN UNCONDITIONAL WRITTEN 2-YEAR GUARANTEE

Compare the prices below with those of any other make of battery. You will find a marked saving in the Globe Battery and the guarantee is backed by an old established organization.

Volts	Amps.	Price	Volts	Amps.	Price
6	40	\$7.00	6	80	\$13.00
6	60	9.00	6	100	15.00

Shipped Fully Charged Ready for Installation

Begin now to get 100% battery service at half cost by sending us your order today.

GLOBE BATTERY COMPANY
1219 S. Wabash Ave., Dept. R, Chicago, Ill.

LEARN ELECTRICITY

Make your successful future a certainty. We teach practical work and scientific methods under practical working conditions. Specialists for 16 years in training young men for

ELECTRICAL ENGINEERING

WITH B. S. DEGREE IN 3 YEARS.

Electrotechnics 12 to 24 months. Electrical and Mechanical Drafting 9 months. Automotive Electricity 3 months. Armature Winding and Motor-Generator Repair 3 months. Practical Applied Electricity 6 months.

A place for every student regardless of age and education. Up to date laboratories—large faculty of Specialists, individual instruction, Low Tuition, Athletics and student activities. Write for latest catalog, mention age and education. New term soon starting.



SCHOOL OF ENGINEERING OF MILWAUKEE
R.N.—415 Marshall St.
Milwaukee, Wis.

\$1.75 LEARNERS SETS \$1.75
With Code and Instructions

60c BUZZERS 60c
Hightone; silver contacts; tone adjustments located on top.
All postpaid

Watch for the Ajax "All Vernier" Rheostat

AJAX ELECTRIC CO.
Palmer St. Cambridge, 38, Mass.

9 out of 10

radio men will DEMAND our STORAGE B BATTERIES for economy, efficiency, service and absence of tube noises, when shown how results will follow their use. Let us show you.

Amateurs and Dealers send for descriptive literature.

We also sell parts and supplies.

HUGHES ENGINEERING CO.
P. O. Box 57, Terrace Park, Ohio

has felt it in increased membership. The writer is often stopped and questioned regarding radio by persons entirely unknown to him, and it is gratifying to see the grip which the art is getting in this locality. A local newspaper even plans the installation of receiving apparatus for news purposes.

As for the future, our club will soon have automobile delegates visiting the surrounding small towns in the county, urging attendance at the weekly meetings of out-of-towners who are interested in radio. We will also demonstrate actual apparatus at public functions where possible. Future activities are unlimited. We are going strong, and have not yet suffered a set-back.

Summing all things up, it is certainly surprising, the opportunities that are available to get radio in the public eye. The formation of a local club works wonders, and gives a solid base from which to direct activities. Radio is not a passing fancy for a lad, or the older people either. Mothers and fathers appreciate the fact that their boys are kept from the evil influences which are so easily fallen in with when the minds are not occupied. A radio set at home is the finest means known to keep your boy off the streets, interested in a wholesome pastime, and at the same time learning something which he can put to actual commercial value should he so desire. And, too, Dad will often find it easier to keep the home fires burning brightly for the whole family, if a few of the many radiophones are tuned in of an evening. Get busy, dealers and local clubs. If there are neither in your locality, one of you live young fellows, get busy and start the ball rolling; there'll soon be both. Its the grandest game on earth and we want the whole world to know it. You tell 'em!

RADIO GUARDS SHIPS ON GREAT LAKES.

It is virtually impossible for mariners equipped with wireless to get lost in the Great Lakes today; the Navy maintains a chain of fifteen short stations from Duluth to Buffalo, three of which are located in the so-called "Graveyards" of the Lakes, and a ship can keep in constant touch with its home port provided its headquarters is fitted with radio.

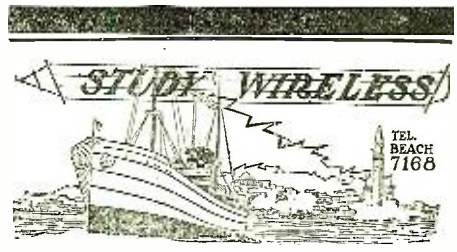

In response to a demand arising from our success in teaching commercial Radio we offer a

Special

CORRESPONDENCE COURSE IN CITIZEN RADIO

Giving in non-technical way complete instruction in fundamentals, and practical explanation of "hook ups" and a hundred details amateurs need to know.

Send 25c for First Lesson

The surplus of experienced commercial operators being absorbed, our resident school is again in position to guarantee positions for graduates. Both land and sea jobs now open. Our school has most successful record.

Send for 44 page Catalog Free

MASSACHUSETTS RADIO and TELEGRAPH SCHOOL, Inc.
18 Boylston St. Boston, Mass.
Formerly Boston School of Telegraphy. Established 1903

BARGAINS UNEQUALED

CHICAGO SALVAGE STOCK STORE

509 So. State Street
Chicago, Illinois

Complete line of

RADIO GOODS

Write for our attractive Price List

MAGNET WIRE AT LOW PRICES

ARE YOU GETTING YOUR SHARE?

Here is a chart showing the location of every Broadcasting Station in the United States together with the wave lengths they send at, that will tell you at a glance what stations you can "get" on your set.

There May Be Some You Are Missing

Full instructions furnished with each chart. Sent prepaid upon receipt of 50c in stamps or money order.

Address Dept. R. N. 4

RADIUS MAP CO.
827 St. Johns Place, Brooklyn, N.Y.



Pat. Pend'g.

WE WILL FILL YOUR ORDER FOR RADIO EQUIPMENT

Finest Stock — Lowest Prices — Prompt Service

Distributors for Amrad Equipment, Ace B. Batteries, Rad'O Loud and other first quality Radio Apparatus.

RAD'O LOUD

"Two in One"

COMBINATION LOUD SPEAKER AND PHONOGRAPH ATTACHMENT

"Listening in" on the broadcasting program no longer an effort but a pleasure with the Rad'O Loud

PRICE COMPLETE \$5.00

Send for descriptive matter.

WE CARRY FULL LINE OF COPPER WIRE:

- Tinned Antenna Wire 70c lb.
- 7 Strand Antenna Wire 65c lb.
- Plain Copper Wire 40c lb.

Fixed Condensers, G. W. Sliders and Rod, "American" knobs and dials of insulated material, white or black, price.....50c

Dealers—Write for discount. Mail orders promptly filled.

AT LAST! A PERFECT RADIO FREQUENCY TRANSFORMER PRICE \$6.00

AMERICAN RADIO EQUIPMENT CO.
31 NEW STREET, NEWARK, N. J.



Both owners and operators, it is said, are rapidly coming to install radio on their ships, several companies having their entire fleets and home stations so equipped, many of them through the purchase of surplus Naval radio equipment.

By the aid of the Naval compass stations, situated at Whitefish Point, Detour Point and Grand Marias, along the dangerous connecting link between Lakes Huron and Superior, cross bearings can be obtained at any time and vessels approaching each other in fog or snow can easily determine their relative positions.

The use of the Naval radio stations at Alpena, Buffalo, Chicago, Cleveland, Detroit, Duluth, Eagle Harbor, Great Lakes, Mackinac Island Manistique, Milwaukee and Whitefish Point, for relay purposes, saves delayed and expensive communication when contact with the owner or operating office is necessary. It is believed that very soon every ship on the Lakes will be equipped with radio just as all trans-Atlantic steamers are equipped, for safety and convenience.

EMERGENCY SEAPLANE TRANSMITTER.

Expressing his preference for flying over the land, a Southern native is said to have remarked, "When you fall on the land, dar you is, but over de water, when sumpin' happens and you lands, whar is you"? His fear of not knowing his position in a forced landing at sea, have been practically eliminated by recent Naval radio experiments.

An emergency transmitting equipment is now carried on all Naval multi-motored planes, which permits the sending of radio messages even after the plane has landed on the water, precluding the use of its trailing acrials employed when in the air. A second light antenna and two kites are now carried, one kite for light and one for strong winds, with the antennae attached to a reel. When a double-engined seaplane is forced down, the radio generator is put in the wind stream of the good engine, and the antenna wire flown on one of the kites. A special canvas screen rigged in the wind stream concentrates its force on the wind-driven generator fan so that, with the motor turning slowly, the radio generator will develop full power for sending messages, a distance 25 per cent. greater than from the air. The kite also offers an observable mark some distance over the sea.

The experimental and development work was done by Commander Albert H. Taylor and Lieut. C. D. Palmer, of the Anacostia Air Station, and representatives of the Bureau of Engineering. Although developed especially for bi-motored planes, it can be used by a single motored plane if the engine will operate, and in any event the kite will come in handy, as an aerial buoy for the searching party. It is pointed out that had the N. C. planes, which crossed the Atlantic three years ago, been so equipped, contact with them would never have ceased and two of them would not have been lost temporarily causing much concern to both themselves and the waiting world.

THE ARMY RADIO NET.

On April 1, the Army Signal Corps will take over the transmission of communications to practically every part of the United States proper, for the Government. Although few of the Government officials realize it today, on April 1 the Traffic Section will become the Message Center of the Army, and all Army communications from Washington will be cleared through it, whether radio or wire messages.

Not all of the Signal Corps war developments were revealed; some of them were preserved within its confines and by diligent work and constant effort a system of continental communication stretching from the Atlantic to the Pacific, and the Great Lakes

"SELECTOR"

Patent Pending

A RADIO SELECTIVE TUNER OR RADIO MULTIPLE CONTACT SWITCH

For Cutting in Vario Coupler, Loading Coil Taps, etc.

The "SELECTOR" reduces the leads to a minimum. Short Leads in Radio Instrument wiring are not alone necessary, but are imperative for proper functioning. The "Selector" combines all these very essentials, and in addition

NEAT COMPACT POSITIVE

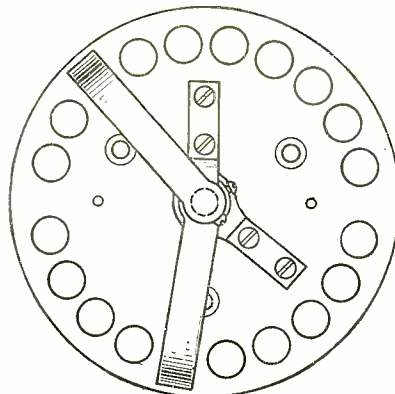

Rear View "SELECTOR" Wiping Contacts Positive and Sure.

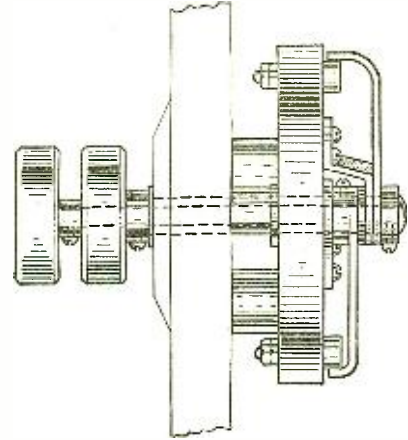

Side View

Mounted on Panel—two handles in one space—Compact also for table mounting. Replaces contacts on front of Panel. Saves space, labor and is compact.

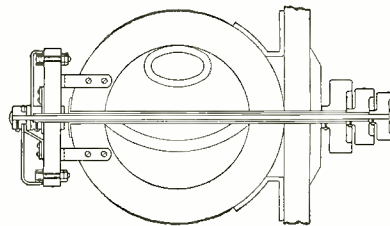

Can be mounted on Coupler or Coil Direct.

Price, \$4.25

including Parcel Post anywhere in United States

Twenty-five Years Experience Staplizes Our Product. We Know.

NORRIS ELECTRIC SPECIALTIES CO., Inc.

Radio Equipment Electric Engineering Specialties

126 Liberty Street

New York

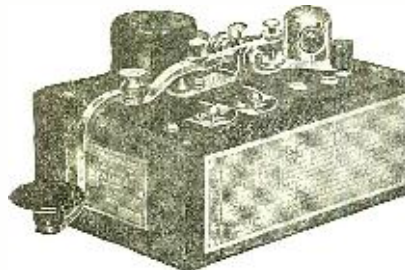

U. S. GOVERNMENT RADIO BLINKER SIGNAL SET

A model of perfection and all-around utility, officially adopted by the U. S. Army Air Service, U. S. Marine Corps and Navy Department Bureau of Steam Engineering. It is a self-contained unit, and may be operated on the table, in the lap, or in any position desired. Note detachable arm.

Special Price \$6.00

Ask your dealer or write us.

Frank B. Perry & Sons
Newton Center, Mass.
Providence, R. I.

Of high grade construction, designed for the purpose of instruction in audible or visual signals, with the International or other codes based on the dot and dash principle. It is scientifically made for efficiency, simplicity, compactness and durability.

A welcome addition to your library! Send \$2.50 today, plus postage for 7 lbs., and your copy of bound volume No. 2 of Radio News will come forward by return mail. Experimenters Publishing Company, Inc. 236a Fulton Street, New York City

INSTALL THIS RTS STANDARD DETECTOR PANEL



Front of Panel

ONLY \$5.95

Assembled (Without Tube) Prepaid by Insured Parcel Post

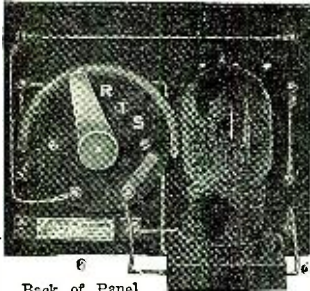

Back of Panel

RTS

Here is a correctly designed panel made of best grade Formica. Its signal strength is unequalled by any other tested in our laboratory. The exclusive use of silver plated wire greatly increases its efficiency.

We guarantee the RTS Detector panel to be exactly as represented and will refund your money if you are not satisfied.

Order TODAY before the price goes up

RTS RUBBER BINDING POSTS

These posts are as fine as any you can find. Bushing heavily nickel plated. Give the amateur's instruments the appearance of a first class outfit. Per Dozen, only \$1.25

RTS BUSHING LEVER

This Bushing Lever is well designed and beautifully finished. The knob is the well known Marconi type. Spring lever is 1 1/2" long with ground ends insuring smooth adjustment. A guide bushing raises the lever to proper height for all switch points. Price, each 60c.

AERIAL WIRE

A new shipment of Lake Superior solid copper No. 14 aerial wire. An exceptionally good buy at 58c. per 100 ft.

NEW CATALOG AND SIGNAL LIST

Send today for new illustrated catalogue which also gives list of signal abbreviations

RADIO TESTING STATION

Dept. R-4 25 Sturgis St. BINGHAMTON, NEW YORK

to the Gulf, has been perfected. As late as last week, the Signal Corps was asked if it could transmit a message by radio to a distant station, to which Capt. R. B. Wolverton, Chief of the Radio Traffic Station, replied that all but two of the eight corps areas could be reached and that within three weeks those would be added. During the Mexican trouble a radio communication system was installed within the Eighth Corps Area along the Border; this has been extended throughout other areas until today there are 2 stations operating with the Army Net. Within two months, it is planned to double the number of stations, making it possible to communicate by radio with any army post in the continental limits of the country. Even the smallest posts and such field parties as carry radio apparatus will be in touch with the whole army. By the first of June the Coast Artillery Posts will be coupled up with the net of the Signal Corps.

There are sixteen stations in Alaska, which are linked in with the army radio by means of the army cable to Alaska from San Francisco, incidentally the only cable owned by this Government.

By cooperation with the Naval Communication Service the Army can literally communicate around the Globe, from any of its stations.

Eleven of its radio stations are equipped with radio telephone apparatus and twelve more are being so equipped, enabling Army officers to speak directly with each other over a territory 300 miles in radius, and save considerable time.

A big significance of the new Army net is the fact that if all commercial means of communication failed in an emergency the country could turn to the Army with its essential business messages, and the Army could handle all Governmental matter. Within a short time every Army post will be in as close contact with the Department and General Pershing, as was his fighting unit in France from the front lines to the shores. A word from the Capital could call into service every soldier in the country or any part of it, and no one could cut the lines of communication.

If the requirements of Army and other departmental business do not demand its full time, which will probably be the case, it is possible that the Army may undertake the broadcasting of the farm service information of the Agricultural Department. Only an official order is awaited by the Signal Corps, for it has 23 broadcasting stations which could be used for the purpose. If the Post Office does not undertake the work, perhaps the Army will; it is ready in any event to serve the Government and the people.

Bulletin No. 1

Watch This Space Every Month

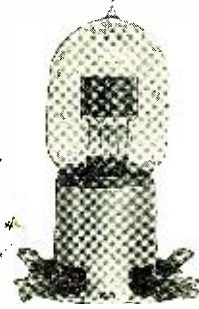

A Real Vacuum-Tube Socket at a Reasonable Price

(Not Moulded) **75c** (No Composition)

IMMEDIATE DELIVERY

We present to the radio fraternity what we honestly believe to be the very best vacuum tube socket on the market.

Some of its outstanding features—(1) unbreakable; (2) non-chipping; (3) non-heating; (4) easily mounted; (5) terminal contacts and elements directly in sight; (6) no soldering necessary.

Dealers write for our proposition

LARNEY SMITH RADIO MFG. CO.
149 Lafayette St. New York City



Head Receivers
Micro-Phones

Keys
Jacks
Plugs
Etc

HIGH GRADE WIRELESS

American Electric COMPANY

Manufacturers CHICAGO, U. S. A.



JENSEN ANTI CAPACITY SWITCH \$2.00
Add 4 Cents for Postage

This switch is designed to mount on 1/4 in. panel, but will also mount on thinner panels. It takes the place of two jacks and plug, it is an ideal series-parallel condenser switch, detector-amplifier change switch. It also eliminates any necessity for special plug terminals on phones, loud talker, etc. It is very attractive and durable. The amateur will also find a number of other uses wherever a four-poled double throw switch is required.

Ask your dealer or order direct. Circulars on request. Dealers wanted.

Manufactured by **S. H. JENSEN, 1933 Seward Ave., Detroit, Mich.**
Pat. Apd. For

RADIO CABINETS

We are manufacturers of cabinets. Best quality seasoned woods used.

Quotations to Manufacturers and Jobbers Only

Write for Prices on Job Lots

INTERSTATE WOODWORKING CO., Inc.
46-50 Wooster St. New York City, N. Y.

LOUD! NEW VOLATONE GIVES TREMENDOUS VOLUME

VOLATONE—Cabinet and Loud Speaker Combined

The VOLATONE was designed for convenience in mounting radio receiving set in same cabinet as loud speaker. It eliminates cumbersome additional unit for increasing the normal volume of sound for an audience. The VOLATONE loud speaker unit has the tonal qualities of the finest phonograph. It is the last word in loud speaking equipment.

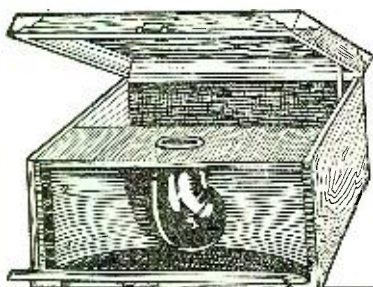

Use With Your Own Receiving Outfit

Space 10x10 1/2 x 5 1/2 back of VOLATONE unit for installing your own receiving equipment. Telephone receiver rests on special mounting on front of VOLATONE unit.

A complete portable cabinet unit solidly constructed and beautifully finished. Nickeled trimmings, handle and lock. Choice of genuine mahogany, oak or walnut.

Outside dimensions 15x11 1/2 x 7 1/2. Price complete as illustrated, \$15.00. Immediate delivery.

Order direct from this ad or write for information. Dealers write for attractive proposition.

THIS DOES IT \$15

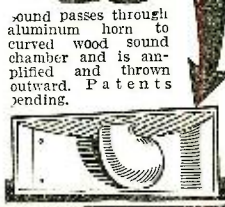

THE VOLATONE CO. 900 LAKESIDE PLACE. CHICAGO.

The cost of the installation of the radio net to date is said to be approximately half a million dollars, with the remaining cost approaching that figure also, but the savings effected in telegraph and long-distance telephone tools, which have been paid for years, will soon make up any loss, if it could be called that. Efficiency is the answer in any event, and who can gainsay the efficiency of a private system of intercommunication throughout the country, operated by experts, such as the Signal Corps has today or will have within a few days?

"Ode to a Bulb"

Dedicated to De Forest (with apologies!)

By S. P. W.

It's far from a thing of beauty, I know,
But for wonder, it hasn't a mate—
I'm speaking now of that little glass tube
With filament, grid and plate!

They cost like the devil, but still we buy;
We'll have them what'er the rate,
For you can't do much sans the little glass tube
With filament, grid and plate!

It puzzles us all as to just how it works,
But knowledge will come if we wait,
And some day, perhaps, we'll know all about
The filament, grid and plate!

Galena will please you when first you start.
But some day, sure as fate
You'll realize that after your soul's welfare
Comes a filament, grid and plate!

You'll put your galena in a box.
And for money your folks you'll bait
Till they "come through" with sufficient jack
For a filament, grid and plate!

And from that tube you'll get a thrill
Be you early in life or late,
For it's truly a joy, to hook your junk
To a filament, grid and plate!

And when you have a tube in your set
You'll turn down date after date,
For your only love, my lad, will be
A filament, grid and plate!

EPILOGUE

Of all the things that we don't like,
Our most particular hate
Is to burn out one of those dog-gone tubes
With a filament, grid and plate!

A Fool There Was

By George F. Patrick.

Joe Jennings was a funny, lad; the neighborhood agreed on that,
He did not fish, or hunt, or smoke he hardly ever cracked a joke,
He scorned ice cream and pop and such; he saved his dough to beat the Dutch.
He never gambled on the green, nor bothered with the baseball team,
The movies held no thrills for him; he passed them by and kept his tin;
A girl to him was just a bore; their line of chatter made him sore.
And since each one of us down here, in this depraved sad vale of tears
Have something in the line of joy, what think you, fell to this queer boy?
He had his line you just can bet; it was his joy, his love, his pet,
It was his home-made Radio set; the queerest thing in Albuquerque.
His aerial hanging from the roof, caused wise old owls to stand aloof;
"That 'lectric stuff is certain bad he'll sure bring sorrow to his dad,"
So spake the graybeards of the town, as on this boy they cast their frowns.

RADIO SERVICE PRODUCTS

Radio Service Type S100 Complete Radio Receiving Set

A wonderfully designed and constructed Radio Instrument. Made to receive wireless telephone speeches and music from amateur and ship stations, farm and market reports, time signals from Government station at Arlington, etc. Contains a *Variable Condenser* for tuning.

Price complete \$32.50
Receiving set only 25.00

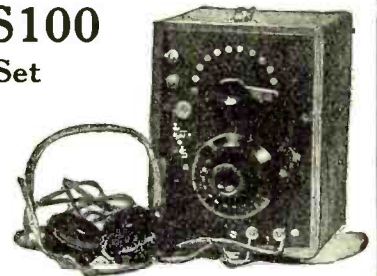

The Little Wonder Portable Radio Set

It's the wireless set everybody's talking about—built right and compact—perfected by four years' development and manufacture. Simple to operate.

Receiving Set Only, Type S8
\$7.50



Other Radio Service Products

- Single VT Sockets Type S2 \$1.50
- Single VT Sockets Type S10 1.00
- Double VT Sockets Type S3 2.25
- Triple VT Sockets Type S4 3.25
- Grid Condensers .0005 mf. Type S1535
- Phone Condensers .002 mf. Type S1635
- Grid Leak Condensers Type S3050
- Crystal Detector Stand Type S20 1.00
- Variable Grid Leak Type S40, 1/2 to 3 megohms75

We carry numerous other types of interest to Radio dealers and wireless men. Radio Service Products are for sale by all reliable dealers.

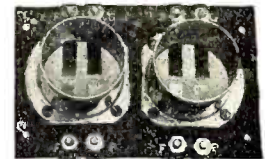

Type S3



Type S10



Type S20

RADIO SERVICE & MFG. Co.

Factory:
LYNBROOK
Long Island

Sales Office:
110 West 40th St.
New York City

N-E-W RADIO NECESSITIES

The N-E-W SHORT-GAP LIGHTNING PROTECTOR Complies with the requirements of the Fire Underwriter's Code, for Radio Receiving Stations. Protects your home and your apparatus from lightning or shorts from power lines. By mail with directions for mounting \$1.50

CHESTNUT CABINETS 7 in x 12 in. x 7 1/4 in. deep 3.50
Cabinet complete with 3/16 Formica Panel 5.00
FORMICA PANELS, 3/16 Grade "M" Polished 2c per sq. inch. Accurately cut to any length from widths of 7 in., 9 in., or 12 in.

TESTED DETECTOR CRYSTALS
GALENA, Large crystal 20c
SILICON, Large crystal 25c
GALENA, Mounted in N-E-W Metal 30c
SILICON, Mounted in N-E-W Metal 35c
N-E-W Metal for mounting crystals, per oz. 25c
N-E-W Metal melts in HOT Water.
All the above sent POSTAGE PREPAID.

NASSAU ENGINEERING WORKS
Baldwin, L. I., New York.

NEW ORLEANS

RADIO

APPARATUS and SUPPLIES

ROSE RADIO SUPPLY
604 Gravier St., New Orleans, La.
Send 10c for Latest Catalog

Get a Handy Binder for your RADIO NEWS. Holds and preserves twelve issues, each of which can be inserted or removed at will. Price 66c. Experimentor Pub. Co., Inc., Book Dept., 236-A Fulton St., New York.

If you haven't a radio frequency amplifier, build one from

Design of Modern Radio Receiving Sets

Get in line with the advanced experimenters and build one of the receiving sets with a radio frequency amplifier described in MODERN RECEIVING SETS. It is of the tune impedance type, assuring you of peak resonance adjustment. This type of circuit also gives extremely sharp tuning. Parts for this outfit, including drilled and engraved panels, can be purchased from the G. A. Company and its distributors.

A Variety of receiving equipment is described, in addition, in MODERN RECEIVING SETS.

The Price is **50c**

Postage 4c

The General Apparatus Co., Inc. 88-N Park Place New York City
Send 10c for the new G. A. Catalog

ANNOUNCING the ATLANTIC JR. CRYSTAL RECEIVER

\$18 Complete

Includes Receiver, Mahogany Cabinet
Telephones, Double Headset (2000 Ohms)
Antenna Equipment Complete

in Attractive Display Case
UNIQUE in DESIGN and CONSTRUCTION

Dealers Communicate With ATLANTIC INSTRUMENT CO., Inc. 13-21 Park Row New York
Tel. Barclay 6003

FREE TO BOYS!
LARGE SIZE SCOUT KNIFE!
EXACTLY LIKE CUT!
Given for selling 20 packages of a Household Article at 15c. WRITE NOW. SEND NO MONEY.
Martin Chemical Co., Dept. F.B., 204 N. J. R. R. Ave., NEWARK, N. J.

"He is a fool," the knowing said, "there's naught but sawdust in his head, He does not play like other boys, but wastes his time on those gillguys." His folks were apprehensive, too; they half thought Joe had loosened screws, But still his dad was sport enough, to let him go and show his stuff. The only one to give him cheer, in this hick town asleep for years, The teacher in the village school knew well that Joe was not a fool. He saw the boy was bright and smart, and had but one thing in his heart, He longed to have a Radio set, to equal any of the rest, He pored o'er books and magazines he grew great bumps upon his bean; From wearing phones and listening in to hear such stations as Berlin. The teacher counceled, "Joe, stick on, don't mind the other knocking ones, Your line is good, don't mind the jokes of these old musty country folks. They are a hundred years behind; they cannot savvy your young mind, You are in fact so far ahead of these galoos in Albuquerque That you can well afford to say, "Please stand aside, you're in my way," And so Joe Jennings stuck along, and strove for signals clear and strong, He bought each Radio book in sight, and studded o'er them day and night; Subscribed for every magazine that had this Radio for its theme. He tried out hook-ups by the peck, the express agent said, "By Heck, The packages this boy do get, would stock a store in Albuquerque, It must take quite a tidy sum, to pay for all this stuff, by gum." Joe's set grew better every day, you heard it howl a block away; His sender, too, was working grand; it covered ground to beat the band. The postman groaned beneath the load, of mail Joe got, he cursed the road That brought this flood of stuff each day, from towns and cities far away. From other nuts of Jennings' type, who heard his sigs and had to write. His set became so widely known, that soon a stranger came to town, He talked with Joe and saw his stuff, he saw it work and learned enough To wire his people, "Get this kid, he's got



G-W SLIDERS, RODS and DETECTORS

Pat. Pend Trade Mark Reg. U. S. Pat. Office

If you dealer can't supply you order direct. Dealers write for proposition.

DISTRIBUTORS WANTED AMATEURS TAKE NOTICE!

A new quality product neatly made
50,000 marketed in ten days has proven the efficiency of our slider.

3/16" Slider 25c
1/4" Slider 30c

Finished Brass Slider Rods Drilled

3/8" square, 8" long.....	15c each
3/8" square, 10" long.....	18c each
3/8" square, 12" long.....	20c each
1/2" square, 8" long.....	22c each
1/2" square, 10" long.....	25c each
1/2" square, 12" long.....	28c each

GEHMAN & WEINERT
Manufacturers of G-W Radio Products.
42 WALNUT ST. NEWARK, N. J.

BAKELITE RADIO PARTS



Moulded To Your Design

Northern Industrial Chemical Co.
11 Elkins St. Boston, Mass.

Moulders of Electrical Insulation

Quality Amplifier Unit

Entirely complete, ready to operate. Parts cost as much as this finished ultra efficient high power amplifier. Unequaled for loud speaker work with regular or power tubes. Gives wonderful results with power tubes using high voltage without danger of burning out windings. Use as many stages as you like. Fully shielded with aluminum grounding plates eliminating howling. Quality square coil 10-1 ratio transformer, the best produced today. Combined with Bakelite socket and rheostat. Eby clamping binding posts. Busbar wiring, an unusual special circuit and beautiful workmanship to produce this remarkable instrument; gives clearest, strongest signals you ever heard.

\$12.25 Immediate Delivery

QUALITY AMPLIFYING TRANSFORMER

The Trans with the Square Coil which gives such high power amplification. There is a Reason.

LIST 1	LIST 2
Filament Voltmeters\$3.75	Watch for our new nearly ready variable condenser—smaller, more efficient and compact than any other.
Baldwin Phones12.00	Variometers, variocouplers with new special design winding.
Quality Loud Speaker.....15.00	Ultra efficient single circuit tuner 125 to 2500 meters wave length.
Quality Phonograph Loud Speaker Attachment10.00	
Bakelite Sockets 1.00	
3 in. Bakelite Dials..... .50	
Murdock Rheostats 1.00	

Quick shipment on any make apparatus you order

QUALITY RADIO SHOP **Richmond, Indiana**

the dope, we need his speed." So Joe was hired and took a job designing stuff to sell the mob, He labored hard and hit the ball, his pay at first was pretty small, But when 'twas seen he had the goods, and orders came along in floods, They took him into partnership, he'd won his race and made a hit. When Joe now goes to Albuquerque, he gets attention, you can bet, The ones who thought the boy a nut, now grease their boots and slicken up To meet the genius of the town, the only one to win renown. The teacher of the Village school told me the tale of this young fool, And when I said I'd write it up, he thought it should make passing stuff. I asked him then to title it, he smiled a very little bit And quietly said with dancing eyes, "Just call it this, "A Fool There Was."

A New Portable Set

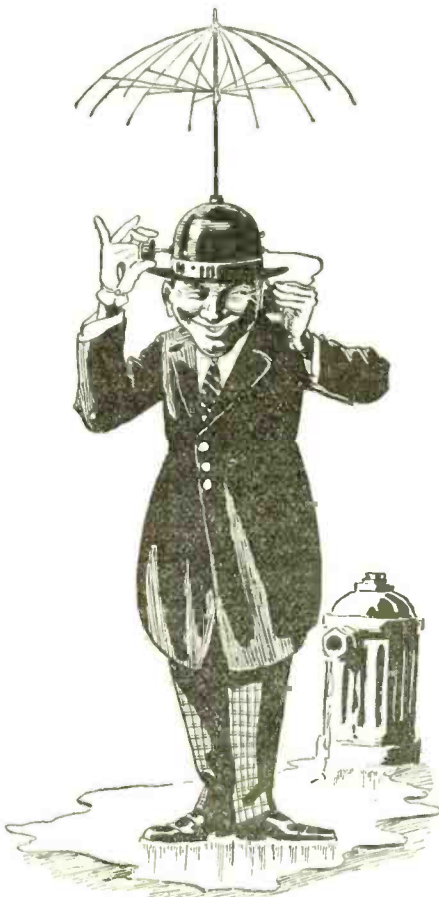
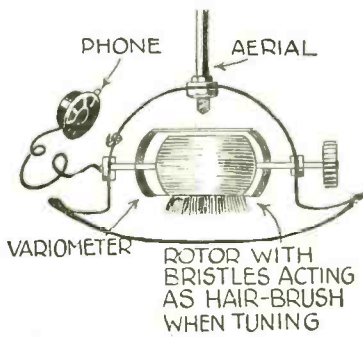

Here is the Real Portable Receiver for the Radio Fan. Thanks to the Patented Rotary Brush, You Can Give Your Hair a High Frequency Treatment With the Current Received.

TUSKA



The Tuska Moulded Variocoupler

equipped with a Tuska Knob and Dial is not only an instrument of striking beauty, but it is mechanically built and of superb electrical design.

You make no mistake in demanding

TUSKA APPARATUS

The C. D. Tuska Co.

24 Hoadley Place
HARTFORD
CONN.

Send 5 cents
For our Catalog
No. 2

Type
233

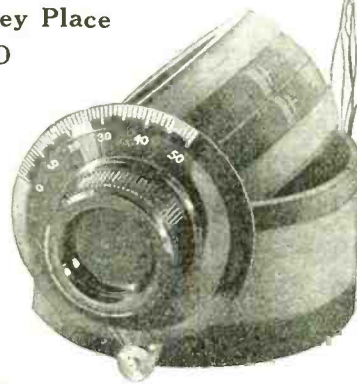

Price
\$7.00

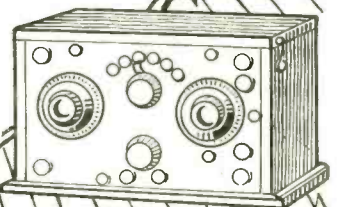

PATENTS TRADE-MARKS AND COPYRIGHTS

Before disclosing an invention, the inventor should write for our blank form "RECORD OF INVENTION". This should be signed and witnessed and if returned to us together with model or sketch and description of the invention we will give our opinion as to its patentable nature. Electrical cases a speciality.

Our illustrated Guide Book, "HOW TO OBTAIN A PATENT," sent Free on request. Highest References Prompt Attention Reasonable Terms

FREE COUPON

VICTOR J. EVANS & CO., Patent Attorneys

Chicago Offices: 1114 Tacoma Bldg. Pittsburgh Offices: 514 Empire Bldg. Philadelphia Offices: 714-715 Liberty Bldg. San Francisco Offices: Hobart Bldg. New York Offices: 1001 Woolworth Bldg.

MAIN OFFICES: 919 NINTH, WASHINGTON, D. C.

Name..... Address.....

When Marriage is a Crime



The man who marries a good, pure woman, knowing that he is not physically fit, commits the worst Crime known to civilization. Where do you stand? Are you fit to marry? Some sweet, innocent girl is trusting in your honor. You must not deceive her. You dare not marry until you are physically fit. The way looks hopeless to you, but cheer up—I can help you.

STRONGFORTISM—The Modern Science of Health Promotion will aid Nature in restoring your Flagging Powers and Manhood and Fit you for Marriage and Parenthood. I guarantee it.

Mention the ailments on which you want special confidential information and send with 10c to help pay postage, etc., on my free book, "Promotion and Conservation of Health, Strength and Mental Energy." It's a man-builder and a life saver. Send for it Right Now.

LIONEL STRONGFORT

Physical and Health Specialist
Dept. 794 Newark, New Jersey

Cut Out and Mail this Free Consultation Coupon

Mr. Lionel Strongfort, Dept. 794, Newark, N. J.—Please send me your book, "PROMOTION AND CONSERVATION OF HEALTH, STRENGTH AND MENTAL ENERGY," for postage on which I enclose a 10c piece (one dime). I have marked (X) before the subject in which I am interested.

- | | | |
|------------------------|---------------------|------------------------|
| • Colds | • Pimples | • Youthful Errors |
| • Catarrh | • Blackheads | • Vital Losses |
| • Asthma | • Increased Height | • Impotency |
| • Hay Fever | • Insomnia | • Falling Hair |
| • Obesity | • Short Wind | • Weak Eyes |
| • Headache | • Flat Feet | • Gastritis |
| • Thinness | • Stomach Disorders | • Heart Weakness |
| • Rupture | • Constipation | • Poor Circulation |
| • Lumbago | • Billiousness | • Bad Blood |
| • Neuritis | • Torpid Liver | • Skin Disorders |
| • Neuralgia | • Indigestion | • Despondency |
| • Flat Chest | • Nervousness | • Round Shoulders |
| • Deformity (Describe) | • Poor Memory | • Lung Troubles |
| • Successful Marriage | • Rheumatism | • Stoop Shoulders |
| | • Manhood Restored | • Muscular Development |
| | | • Great Strength |

Name
Age Occupation
Street
City State

Ask Sorsinc



The highly professional service which our seasoned radio men give—backed by complete stocks of the leading lines of equipment make it well worth your while to ask

before buying; we know from experience what each piece of apparatus will do.

Our Interesting Booklet

—the most comprehensive in print, sent for 6 cents in stamps. Get your copy now!

SHIP OWNERS RADIO SERVICE INC.

80 Washington St., New York, N. Y.
Branch Offices and Dealers Everywhere
"The Largest Radio Chain Store System in the World"

SORSINC, 80 Washington St., New York
Herewith 6 cents in stamps to pay mailing expense on my copy of your latest booklet.

HN-4-2

Radio Telephony

(Continued from page 943)

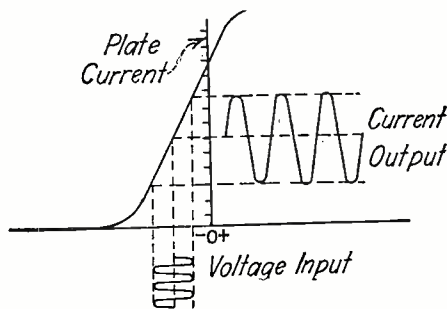

©RADIO NEWS 1922

Fig. 10C

This Curve Shows How Signals May be Amplified by a Vacuum Tube.

The curved portion of the characteristic is made use of for detection while for amplification, distortion is to be avoided and the straight portion of the curve must be used. Fig. 10C illustrates the correct grid potential to use for amplification and shows the similar impact voltage and output current.

It is hoped that this article has been of interest and use to the experimenter, who has taken up the study of radio telephony, and the auditor which is so closely related to the art.

WARNING TO AMATEURS.

The following notice appeared in a recent Radio Service bulletin of the Department of Commerce. Amateurs should pay particular attention to this official warning as violation will entail the cancellation of licenses and other penalties:

The Bureau has received a number of complaints recently of amateur stations using wave lengths in excess of those authorized in their licenses which has resulted in much unnecessary interference. Amateurs should, if possible, have their wave lengths measured to avoid violating the law.

Attention is invited to the 15th regulation, section 4, act of August 13, 1912, and the penalties provided in this section, following the 19th regulation on page 13, Radio Laws and Regulations.

It has also been reported that a number of amateur stations are using more power than necessary, which is a violation of the 14th regulation, section 4, act of August 13, 1912. The penalties noted above apply to violations of this character.

AN AID TO NAVIGATION.

The battleship Ohio, lying off the Ambrose Channel Light Vessel 50 miles, recently received distinct signals sent out on special under water sound oscillators from the Light Ship, by the means of a new sound receiving apparatus developed in the Radio Division of the Navy.

Ordinarily the submarine bell of the Light Vessel can be heard by mariners by means of a submarine listening device for 5 miles, but in the recent experiment, through the cooperation of the Light House Service, the Light Ship was equipped with a special sound oscillator operating under water. The battleship with her receiving devices picked up the signals sent out up to 50 miles, and with other types was able to increase the audible range of the regular submarine bell to more than double the usual range. The new sound receiving device will be of especial value to mariners in foggy weather as soon as the ships and light vessels can be equipped with oscillators.

12

If your customers want data on building receiving sets, sell them

Design of Modern Radio Receiving Sets

When experimenters want information on building crystal receivers, amplifiers, regenerative sets and other equipment don't spend your valuable selling time in giving them details and diagrams—sell them MODERN RECEIVING SETS in which they will find clear photos, scale drawings, and complete information on building apparatus so simply designed that it can be made in the kitchen table workshop, yet in appearance and operation equal to the best commercial equipment.

The price is
50c
Postage 4c

The General Apparatus Co., Inc. 88-N Park Place New York City
Send 10c for the new G. A. Catalog

CONDENSER — DETECTOR

\$3.00

Internally Wired, Ready for Use.



Fixed receiving condenser (001 MFD) neatly combined with a high-grade crystal detector. Phones hook on one end and tuning coil or loose coupler on the other end. Complete with Galena.



Aerial Insulators B & P 25c Moulded Composition Crystal Detector

Carefully made and tested in our own shop. Equipped with million point Galena. Equal to one audion tube



Complete with Galena Crystal \$1.50

Radio Supplies by Mail

Products of Fada, de Forest, Grebe, Acme and all leading manufacturers in stock. Immediate deliveries. DEALERS.—WRITE FOR OUR PROPOSITION

The RADIO SHOP of NEWARK 41 South Orange Avenue, Newark, N. J.

C. W. APPARATUS OF ALL KINDS
Detector and One-step Amplifier in cabinets\$35.00
C.W. Chemical Rectifiers, complete, 500 mill-amp. Cap. 14 jars, will handle 1/2 amp. at 1,000 volts or less. In cabinets 9.50
Prompt shipment

JONES ELEC. & RADIO MFG. CO. 120 E. Lexington St. Baltimore, Md.

20

TWENTY RADIOPHONE DIAGRAMS

20

The most complete selection of diagrams and hook-ups for **RADIO AMATEURS** enabling anybody to rig-up a wireless

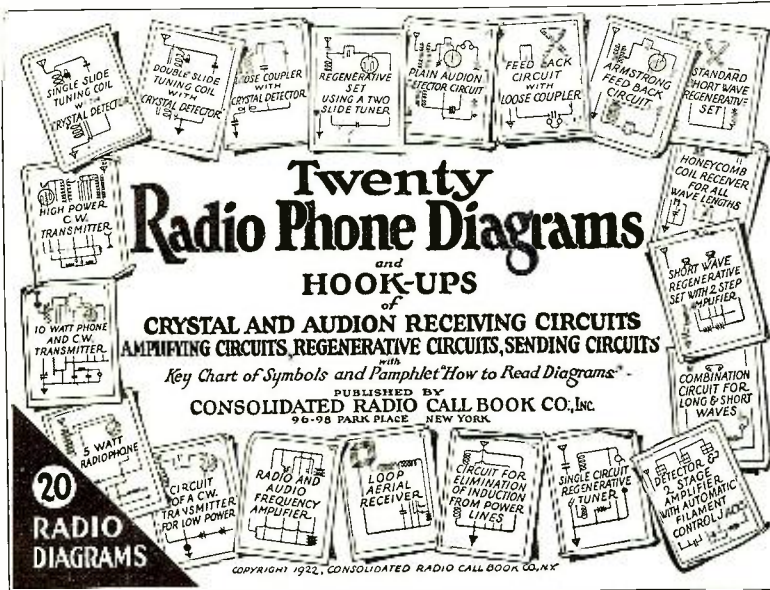

telephone outfit from the simplest crystal detector circuit, to the most ultra-modern regenerative and amplifying radio set.

TITLES of DIAGRAMS

1. Single Slide Tuning Coil with Crystal Detector.
2. Double Slide Tuning Coil with Crystal Detector.
3. Loose Coupler with Crystal Detector.
4. Regenerative set, using 2 slide tuner.
5. Plain Audion Detector Circuit.
6. Feed-back Circuit with a Loose Coupler.
7. Armstrong Feed-back Circuit.
8. Standard Short Wave Regenerative Set.
9. Honey-comb coil Receiver for all wave lengths.
10. Short wave regenerative set, with 2 step Amplifier.
11. Combination Circuit for Long and Short Waves.
12. Detector and Two stage Amplifier with automatic Filament control Jacks.
13. Single Circuit Regenerative Tuner.
14. Circuit for elimination of induction from power lines.
15. Loop Aerial Receiver.
16. Radio and Audion frequency amplifier.
17. Circuit of a C.W. Transmitter for low power.
18. 5 Watt Radio-phone.
19. 10 Watt Phone and C.W. Transmitter.
20. High Power C.W. Transmitter.

SET OF 20 RADIOPHONE DIAGRAMS

consisting of twenty blueprint diagrams, size 8½ x 11½ inches and one four page direction—pamphlet 8½ x 11½ inches containing: Illustrated Symbol Key Chart, Direction How to Read Diagrams, How to Follow Circuit, etc. and explanation of each diagram. All contained in heavy, two color printed envelope size 9 x 12 inches.

PRICE 50c Prepaid

Either Direct from us or for sale by the following responsible Dealers:

- | | | | |
|---|---|---|---|
| Alamo Sales Corp. Indianapolis, Ind. | Fergus Elec. Co. Zanesville, O. | New England Motor Sales Co., Green- wick, Conn. | Schmidt & Co., R. Rochester, N. Y. |
| Am. Electro Tech. App. Co., N. Y. City | Findley Electric Co. Minneapolis, Minn. | New Era Shop Milwaukee, Wis. | Sears, Roebuck & Co. Chicago, Ill. |
| American Hdw. Stores, Bridgeport, Conn. | Pleron & Son, M. M. Trenton, N. J. | Newman-Stern Co. Cleveland, O. | Service Radio School, Washington, D. C. |
| Andrea & Sons, Julius, Milwaukee, Wis. | Fuller Co., Seth W. Boston, Mass. | Nichols Radio Sup. Co., Big Green, Ky. | Shotton Radio Mfg. Co. Scranton, Pa. |
| Andrae & Sons, Julius, Mason City, Ia. | Galveston Wireless Sup. Co., Galveston, Tex. | Noia Radio Co. New Orleans, La. | Smith Radio Lab. Sarnia, Ont., Canada |
| Anthraco Radio Shop Seranton, Pa. | Gurd & Co., Wm. London, Canada | Noll & Co., E. P. Philadelphia, Pa. | Smith Novotoy Elec. Inc., Charlotte, N. C. |
| Atlantic Radio Co. Boston, Mass. | Hall Electric Co. Wm. Dayton, O. | Northern Radio & El. Co., Seattle, Wash. | So. California Elec. Co., Los Angeles, Cal. |
| Bamberger & Co., L. Newark, N. J. | Hatfield Electric Co. Indianapolis, Ind. | Northwest Radio Serv. Co., Seattle, Wash. | Southern Elec'l Sup. Co. San Diego, Cal. |
| Banister & Pollard Co., Newark, N. J. | Ileustis, A. E. Fitchburg, Mass. | N. S. W. Bookstall Co. Sydney, Australia | Southwest Radio Sup. Co. Dallas, Tex. |
| Benwood Specialty Co., St. Louis, Mo. | Ilickson Electric Co. Rochester, N. Y. | Paecent Electric Co. New York City | Sprott-Shaw Schl. Vancouver, B. C. |
| Bluebird Electric Shop Newark, N. J. | Iiro Wireless Sup. Co. Marion, Ill. | Paramount Radio Sup. Co. Atlantic City | Sterling Electric Co., Minneapolis, Minn. |
| Brodie Electric Co. Los Angeles, Cal. | Holt Electric Util. Co., Jacksonville, Fla. | Paul's Electric Stores Medford, Ore. | Stubbs Electric Co. Portland, Ore. |
| Brown, J. Edw. Glenbrook, Conn. | Hughes Elec'l. Corp. Syracuse, N. Y. | Pearman's Book Shop, Washington, D. C. | T. & H. Radio Co. Reading, Pa. |
| Bullock's New York, Neb. | Jenkins, Lester L. New Bedford, Mass. | Penn Radio Apparatus Co., Reading, Pa. | Tuska Co., C. S. Hartford, Conn. |
| Hunnell & Co., J. H. New York City | Karlowa Radio Corp. Rock Island, Ill. | Penn. Marconi Wireless Schl. Phila. | United Elec. Stores Co. Braddock, Pa. |
| Burham & Co., Deptford, S. E. England | Katzenbach & Co., P. S., Trenton, N. J. | Phila Schl of Wireless Tele. Phila., Pa. | United Electric Stores E. Pittsburg, Pa. |
| California Elec. Co., San Francisco, Cal. | Kendall Co., W. D. Worcester, Mass. | Piedmont Electric Co. Asheville, N. C. | U. S. Radio Co. Pittsburg, Pa. |
| Carter Electric Co., Atlanta, Ga. | Keubler Radio Co. Toledo, O. | Pioneer Electric Co. St. Paul, Minn. | Warner Bros. Oakland, Cal. |
| Catton, Neill & Co. Honolulu, T. H. | Killoch Co., David New York City | Pitts Co., P. D. Boston, Mass. | Western Radio Co. Kansas City, Mo. |
| Central Radio Co., Independence, Mo. | Kirk Radio Co. Pittsburgh, Pa. | Pitts. Radio Sup. Co. Pittsburgh, Pa. | West'n Radio Elec. Co., Los Angeles, Cal. |
| Central Radio Co., Kansas City, Mo. | Klaus Radio Co. Bureka, Ill. | Pitts. Radio & App. Co., Pittsburgh, Pa. | Wilson Co., Harold K., Grundy Center, Iowa. |
| Chaso, Geo. H. Newport, R. I. | Kluse, Arno A. Los Angeles, Cal. | Port Arthur Rad. Lab., Port Arthur, Tex. | Winner Radio Co. Aurora, Colo. |
| Chicago Radio Ap. Co. Chicago, Ill. | Krause & Co., A. F. Detroit, Mich. | Post Office News Co. Chicago, Ill. | Wireless Mfg. Co. Canton, O. |
| Cleveland Co., L. W. Portland, Me. | Kusel Co., D. & F. Watertown, Wis. | Precision Equipment Co. Cincinnati, O. | Wireless Press New York City |
| Cloud & Son N. Y. City | Lehigh Radio Co. Bethlehem, Pa. | Radio Development Co., Springfield, Mass. | Wolfe Electric Co. Omaha, Neb. |
| Con. Radio & Elec. Corp. New York City | Liberty Incandescent Sup. Co., Pittsburg, Pa. | Radio Distributing Co. Newark, N. J. | Y. M. C. A. Los Angeles, Cal. |
| Cutting & Washington New York City | Liberty Radio Sup. Co. Chicago, Ill. | Radio Equipment Co. Pittsburgh, Pa. | Zamoiski Co., Jas. M., Baltimore, Md. |
| Daily Battery & Equipment Co., Pitts- burg, Pa. | Lanza Elec'l Sup. Co. St. Louis, Mo. | Radio Equip't. & Mfg. Co., Minneapolis | Zibart Bros. Nashville, Tenn. |
| DeJancey-Felch & Co. Pawtucket, R. I. | Ludwig Hommel & Co. Pittsburgh, Pa. | Radioelectric Shop Cleveland, O. | |
| Detroit Electric Co. Detroit, Mich. | Luther, II. E. Centerville, Ia. | Ray-Di-Co. Chicago, Ill. | |
| Dewey Sptr. Goods Co. Milwaukee, Wis. | McCarthy Bros. & Ford, Buffalo, N. Y. | Reynolds Radio Denver, Colo. | |
| Doubleday-Hill Elec. Co. Pittsburgh, Pa. | McMillan Bros. Pittsburg, Pa. | Reuter Electric Co. Cincinnati, O. | |
| Dreyfuss Sales Co. New York City | Manhattan Elec. Sup. Co., N. Y. & Chic. | R. I. Elec. Equip't. Co. Providence, R. I. | |
| Duck & Co., Wm. B. Toledo, O. | Marshall-Gerken Co. Toledo, O. | Riverside Laboratory Milwaukee, Wis. | |
| Dunn, J. J. Pasadena, Cal. | Meter, Elec'l Const. Co., Oshkosh, Wis. | Rock Radio Supply New Orleans, La. | |
| Electric Motor & Eng. Co. Canton, O. | Meyberg Co., Leo J., San Francisco, Cal. | Roy News Co., Fre'k J. Toronto, Can. | |
| Electric Importing Co. N. Y. City | Mohawk Elec'l. Sup. Co., Syracuse, N. Y. | Sands Electric Co. Wheeling, W. Va. | |
| Elto Electric Shop El Paso, Tex. | National Radio Corp. Atlanta, Ga. | Sayre-Level Radio Co. Phila., Pa. | |
| Eric Book Store Erie, Pa. | Nat'l Radio Institute, Washington, D. C. | | |

Consolidated Radio Call Book Co., Inc., 98 Park Place, New York City

OPPORTUNITY AD-LETS

Follow these advertisements every month. Reliable advertisers from all over the country offer you their most attractive specials in these columns.

Classified advertising rate ten cents a word for each insertion. Ten per cent discount for 6 issues, 20 per cent discount for 12 issues. Name and address must be included at the above rate. Cash should accompany all classified advertisements unless placed by an accredited advertising agency. No advertisement for less than 10 words accepted.

Objectionable or misleading advertisements not accepted. Advertisements for the July issue must reach us not later than May 1st.

THE CIRCULATION OF RADIO NEWS IS OVER 175,000

EXPERIMENTER PUBLISHING CO. INC., 233 and 236 Fulton Street, New York, N. Y.

Aeronautics.

Model Aeroplanes that Fly.—Buy your complete outfit, scale drawings, fittings compressed air motors and all-best model aeroplane supplies from the Wading River Manufacturing Co., Established 1900. Our new 52-page catalog illustrated, 24 latest models and designs. Send 5¢ for your copy. Wading River Manufacturing Co., 672 J Broadway, Brooklyn, New York.

Agents Wanted.

Big Money and fast sales. Every owner buys gold initials for his auto. You charge \$1.50; make \$1.35. Ten orders daily easy. Write for particulars and free samples. American Monogram Co., Dept. 133, East Orange, N. J.

Amateur Agents Wanted in every city and town to sell radio apparatus. A few stocking agencies still open. Delfeico, 12 Meeting Street, Pawtucket, R. I.

Automobiles.

Automobile Owners, Garagemen, Mechanics, Repairmen, send for free copy of our current issue. It contains helpful, instructive information on overhauling, ignition troubles, wiring, carburetors, storage batteries, etc. Over 120 pages, illustrated. Send for free copy today. Automobile Digest, 528 Butler Bldg., Cincinnati.

Batteries

Edison "B" Batteries—See April 1921 "Radio News." Edison Storage Battery Elements \$0.6 paid. Wm. Stange, 2809 Walbrook Ave., Baltimore, Md.

Used Storage Batteries. 6 volt, 15 amp., \$3; 40 amp., \$6; 120 amp., \$10. Also batteries for farm lighting. H. W. Barracough, 3649 N. Tenth St., Phila., Pa.

Books.

Sex Books for Adults.—Illustrated catalog, 4c. Sme-tana & Co., Dept. 10, Oswosso, Mich.

Diseases, Cause and Natural Innate Remedy, 40c. Arthur Stevens, Wauseon, Ohio.

"Schemer Magazine." Alliance, Ohio, prints big profit schemes; one subscriber making \$25,000 from three; another \$10,000 from one. Try your luck. Yearly only \$1.00; three months, 25c.

We Buy and Sell back issues of Radio Amateur News and Electrical Experimenter. Boston Magazine Exchange, 109 Mountfort St., Boston, Mass.

Latest and Best Books on wireless, chemistry, automobiles, aviation, etc. Catalog D free. D. Altman Company, 223-225 East 110th Street, New York.

Electricians Examinations: Book of questions and answers with diagrams, symbols, tables, notes and formulas for preparation for license. \$1.25 by mail. Aaron Shapiro, 132 West 24th St., New York.

Garagemen, repairmen, mechanics and dealers will be greatly interested in each issue of American Garage & Auto Dealer, for it features a wide range of important subjects, including vulcanizing, welding, accounting, shop hints, business management, advertising, selling, etc. Here is what a North Dakota garageman writes: "I got one idea from you that will just double my sales in 1922." A southern dealer says: "Every issue is worth the subscription price—we can't get along without your wonderful magazine." 12 months for \$1.00 anywhere in U. S., \$1.50 (Canada or foreign). (Satisfaction guaranteed or money returned.) Mail dollar bill, check, or money order. American Garage & Auto Dealer, 1007 Lake View Bldg., Chicago.

Practical Instruction to inventors and patentees written by the manufacturer and inventor, Charles Hunsbuck, covering every problem relating to inventions. Experience has shown the best means of patenting, manufacturing and marketing inventions. Written in the plain style of an honest man. No patent lawyer connections. For sale by Thos. Connan, Exclusive Agent, 1231 North Capital St., Washington, D. C., \$1 prepaid. Satisfaction or money refunded.

Business Opportunities.

Advertise. Country town newspapers. List for stamp. Pennell, Covington, Kentucky.

Wanted. concern to take over manufacturing and sale of Fordson tractor accessory. Stops ignition troubles. Simple. Address, Jos. H. Jacobs, Paxton, Mont.

\$50 Per Week in Spare Time, collecting names for advertisers. Plans Free. Grindley, 1314 Troost, Kansas City, Mo.

Correspondence Courses.

Correspondence Courses at less than half original prices. Any school; any subject for men or women. Bulletin 1074 free. Courses bought. Instruction Correspondence Exchange 1966 Broadway, New York.

Dollars Saved—Used correspondence courses of all kinds sold, rented and exchanged. List free. (Courses bought.) Tee Mountain, Pisgah, Alabama.

For Men.

Tobacco, Kentucky's Natural Leaf Smoking, 10 lbs., \$2.25. Hand selected chewing, 3 lbs. \$1.00. Free receipt for preparing. Tobacco Growers Union, Murray, Ky.

For Advertisers.

Biggest Pullers on Earth.—Jacobus Letters, \$3.50. Jacobus Advertising Service, Irvington, N. J.

Your 25-word ad in 75 magazines \$1.00. Riley, Publisher, 1333 So. 50th Court, Cicero, Ill.

Games and Entertainment

Full Horoscope Readings, three questions answered, birthdate, 50c. Crystal gazing balls; instruction books, \$1.00. Delnora, 664 N. 12th, Philadelphia.

"Margo" Psycho-Sphere, the magical sex indicator and dividing ball. Amusing, Entertaining, Instructive, Descriptive circular free. James T. Herr, Desk D, 2919 W. North Ave., Baltimore, Md.

Health.

Tobacco or Snuff Habit Cured or no pay; \$1 if cured. Remedy sent on trial. Superba Co., SB, Baltimore, Md.

Pyorrhea (Rigg's disease—bleeding or swollen gums)—hundreds have been helped by "Pyorriden" the successful home pyorrhea treatment. Purifying, healing, preventative. Full month's treatment, consisting of a very beneficial massage paste and an antiseptic tooth-cleansing paste to be used in place of your ordinary dentifrice, together with full directions for treatment. \$1 postpaid. Or write for free booklet "R." Pyorriden Mfg. Co., 439 Seventh St., Brooklyn, N. Y.

Help Wanted.

Stop Daily Grind. Start silvering mirrors, auto headlights, tableware, etc. Plaus free, Clarence Sprinkle, Dept. 64, Marion, Indiana.

Be a Mirror Expert, \$3-\$10 a day; spare time home at first; no capital; we train, start you making and silvering mirrors, French method. Free prospectus. W. R. Derr, Pres., 579 Decatur St., Brooklyn, N. Y.

Detectives Earn Big Money. Excellent opportunity. Travel. Experience unnecessary. Particulars free. Write American Detective System, 1968 Broadway, N. Y.

Earn \$25 Weekly, spare time, writing for newspapers, magazines. Experience unnecessary; details free. Press Syndicate, 5665, St. Louis, Mo.

Manufacturer offers unusual opportunity to experienced sales manager capable of organizing crew to cover drug and grocery trade in your home territory. This is an opportunity of a lifetime for the right party. Product is fastest seller ever offered trade and the repeat business is simply phenomenal. Tremendous demand already existing with absolutely no competition. Profits should run from \$15,000 to \$35,000 per year. All replies considered confidential. State experience and qualifications fully. Beardsey Specialty Co., Rock Island, Ill., Dept. S.

Big Sample! Help Wanted, Information \$25. (Upn) LaFargeville, New York.

Instruction.

Learn Chemistry at Home—Dr. T. O'Connor Sloane, noted educator and scientific authority, will teach you. Our home study correspondence course fits you to take a position as chemist. See our full page ad on page 975 of this issue. Chemical Institute of New York, 140 Liberty Street, New York City.

Learn By Listening: We teach Hawaiian Guitar Using Our Phonograph Records. Send for particulars. Roach-Frankland, 307 East Fourth St., Cincinnati, Ohio.

Play Mouth-Organ.—Complete, easy instructor, 25c. Elsen Co., Bowling Green, Ohio.

Master Code for Radio love letters, etc. Used in war, 50c postpaid. P. L. Grasser, 1103 Dorchester Road, Brooklyn, N. Y.

Master Electricity in shortest time possible. Home study course scientifically taught. My system used by U. S. Government during world war. F. M. Manuel, E.E., South Connelville, Pa.

Manufacturing

Manufacturers Attention! All screw machine and stamped metal parts used in radio work, also formed insulation with or without metal inserts furnished promptly in quantity lots only. Send drawings; specifications or sample for prices. Immediate Service. Scientific Equipment Co., Ho-ho-kus, N. J.

Let us be your factory! Write today. Logan Machine Company, 222 South Clinton St., Chicago, Illinois.

We have plant and equipment to manufacture complete components or parts for wireless apparatus, for distributors and manufacturers. Based on extensive mechanical experience, our production and workmanship will compete with market demands. Diamond Tool & Mfg. Co., Inc., 91-97 Rynyon St., Newark, N. J.

Miscellaneous.

Luminous Paint, bottle 20. Laboratories E, Box 316, Portland, Oregon.

12-Tool Handy Set—Made of best steel. The most useful and practical tool on the market. Postpaid \$1.25. National Specialties, 32r Union Square, N. Y. City.

Motorcycles, Bicycles

Don't buy a Bicycle Motor Attachment until you get our catalog and prices. Shaw Mfg. Co., Dept. 6, Galesburg, Kansas.

Musical Instruments

Cornetists, Trombonists, Saxophonists, Clarinetists, send for "Free Pointers", mention instrument. Virtuoso School, Buffalo, N. Y.

News Correspondents

Earn \$25 Weekly, spare time, writing for newspapers, magazines. Experience unnecessary; details free. Press Syndicate, 566 St. Louis, Mo.

Office Devices

Addressing Machines, Multigraphs, Duplicators, Letter Folders, Multicolor Presses, Check Writers, Dictating Machines, Envelope Sealers, Suddies, about half new cost. Write for illustrated catalogue. Pruitt Company, 172 North Wells, Chicago.

Patent Attorneys.

Patents Secured. Prompt service. Avoid dangerous delays. Send for our "Record of Invention" form and Free Book telling How to Obtain a Patent. Send sketch or model for examination. Preliminary advise without charge. Highest references. Write Today. J. L. Jackson & Co., 356 Ouray Bldg., Washington, D. C.

Millions Spent Annually for Ideas! Hundreds now wanted! Patent yours and profit! Write today for free books—tell how to protect yourself, how to invent, ideas wanted, how we help you sell, etc., 301 Patent Dept., American Industries, Inc., Washington, D. C.

Patents.—Electrical cases a specialty. Pre-war charges. B. P. Fishburne, 340 McGill Bldg., Washington, D. C.

Patents For Sale.

New Rotary Spark Gap Machine, exceptional opportunity, high merits. Cash, Royalty, Rental. Information, prints. C. Teall, 1628½ Erie St., Toledo, O.

Personal.

Exchange jolly, interesting letters through our Club! Send stamp. Betty Lee, 28 East Bay, Jacksonville, Fla.

Printing.

Everything Printed.—Long run specialists. Samples. Quality Printery, Marietta, Ohio.

Everything in Printing. XXX Heavy White Envelopes, 1000 for \$2.50. The Press, Mayport, Pa.

Your name on fifty "Styloprint cards," 35c. Card case FREE. Imprimature Press, Waltham, Mass.

Printing—The Better Kind Special! 100 each of Letter-heads, Envelopes and Business or Calling Cards, prepaid, \$1.75. The Olde Tye Press, RN 328 Richards Ave., Dover, N. J.

Scenery for Hire.

Settings for all operas and plays. Catalog. Amelia Grain, Philadelphia.

Song Writers.

Song Writers!—Learn of the public's demand for songs suitable for dancing and the opportunities greatly changed conditions offer new writers obtainable only in our "Song Writers' Manual and Guide," sent free. Submit your ideas for songs at once for free criticism and advice. We revise poems, compose music, secure copyright and facilitate free publication or outright sale of songs. Knickerbocker Studios, 319 Gaicety Bldg., New York.

Telegraphy.

Telegraphy—(Morse and Wireless) and Railway Accounting taught thoroughly. Big salaries. Great opportunities. Oldest, largest school. All expenses low—can earn large part. Catalog free. Dodge's Institute, N. St., Valparaiso, Indiana.

Tricks, Jokes & Puzzles

Magic Paper, dip in water and picture appears. 20c per package. Jack Payne, Box 945, W. Palm Beach, Fla.

Chemistry

Learn Chemistry at Home—Dr. T. O'Connor Sloane, noted educator and scientific authority, will teach you. Our home study correspondence course fits you to take a position as chemist. See our full page ad on page 975 of this issue. Chemical Institute of New York, 140 Liberty Street, New York City.

Farms, Land, Etc.

Minnesota good wild land, part timber, splendid location. \$13.50 per acre. P. Fonos, New Richmond, Wis.

Wanted to Buy

Mail Old Gold, unused postage, war and thrift stamps, Liberty Bonds, silver, platinum, diamonds, jewelry, watches, false teeth, magnets, points, etc., new or broken. Cash immediately. Held ten days, returned if unsatisfactory. Ohio Smelting Co., 207 Lennox Bldg., Cleveland, Ohio.

Wireless.

Storage Batteries. Bo a battery man. We have all material and can give instructions for making them. Sample Plate 40c. Foreign countries 50c. Windsor Specialty Co., 5419 Windsor Ave., Chicago, Ill.

Memorize Continental Code in one hour. Quality quickly for amateur license. See our ad on page 1036 this issue. C. K. Dodge.

Experimenters Attention. Something distinctly new. Shielded condensate-colon. Copper shield built right into the panel which completely neutralizes all detuning effects caused by body capacities. Prices, panels cut to sizes given, 6x7x3/16", \$.85; 6x12x3/16", \$1.42; 6x18x3/16", \$2.37; 6x12x3/16", \$2.37; 6x21x3/16", \$4.97; 12x18x3/16", \$4.73. Colon Veneer. A new material which combines all of the easy machining properties and good looks of Condensate-Colon at a much lower price. Ideal for receiving sets or any application where high voltages at radio-frequencies are not present. Prices as follows: 6x7x3/16 in., \$.52; 6x12x3/16 in., \$.88; 6x18x3/16 in., \$1.47; 6x12x3/16 in., \$1.47; 6x21x3/16 in., \$2.98; 12x18x3/16 in., \$2.93. Prices on other sizes on application. Washington Radio Shop, 764 Gresham Place, N.W., Washington, D. C.

Smashed wire prices.—Copper aerial wire No. 14, 35c lb. Magnet wire S.C.C. No. 20—24c, 22—28c, 24—29c, quarter pound. All sizes and insulations carried. Write us. Wolverine Wire & Mfg. Co., Shelby, Mich.

Radio Concerts on Crystal.—Stop experimenting and build a complete crystal set. We sell blueprints of panel layout, hook-up and instructions, 35c. Large Blueprint of Wireless Symbols 25c (no stamps). Radio Blueprint Co., Shepherdstown, West Virginia.

Boys! Don't Overlook This. The "Rasco" Baby Detector. Greatest detector ever brought out with molded base. Fully adjustable. See former advertisements in this publication, or our catalogue. Detector with Galena Crystal, complete 50c, the same detector with Radiolite Crystal 75c prepaid. Send for yours to-day. Radio Specialty Company, 96-98 Park Place, New York City.

Attention!—50 Vacuum tube hook-ups. The greatest collection of vacuum tube circuits ever brought under two covers at such insignificant cost. These diagrams will be found in the great "Rasco" catalogue, which contains raw materials and parts in a greater profusion than any other catalogue. 15c in stamps, or coin, will bring the catalogue to you. Radio Specialty Co., 96-98 Park Place, N. Y.

Order Murdock, Clapp Eastham, DeForest, Acme, Firo, Radio Corp., Amrad and Westinghouse apparatus from Rocheleau's Store, Baltimore, Conn.

30 Day Offer. 10 percent discount on Radio apparatus. Willard and Exide Radio Batteries, vacuum tubes, rheostats, sockets, transformer, condensers, variometers, couplers, jacks, Baldwin, Federal and Murdock Phones, Aluminum Rectifier Plates. Send stamp. Reuben E. Shumaker, Galion, Ohio.

Genuine Bakelite Dilecto, price reduced. 3/16 in. thick, any size. 2c. per square inch. Remler Bakelite Dial and Knob 95c. C. Reverse Smith Radio Co., 108 Rose Farm Addition, Port Arthur, Tex.

Build Your Own Wireless Telephone and Musical Receiver. Don't wait for a set. We have Chicago, 900 miles, fine on good nights, Pittsburgh, Newark and New York come in good and loud. You can do the same on a single bulb. There is Radio music in the air each evening, and the living voices of the artists can be reproduced in your own home and enjoyed by you and your friends. Are you satisfied with your receiving set or would you like to build one that will receive over 6,000 miles on a single bulb and quit experimenting? One that will be equal to any regardless of claims and price—with which you can hear Honolulu, California, German, South American, French and English stations and practically all of the high powered foreign and domestic stations, as well as amateur stations as far west as New Mexico, and the phone and music. Anyone can assemble this outfit and wire it up, and the remarkable ranges that may be obtained will surprise you. Why not make a set up to date and efficient? Don't experiment with unknown circuits. We will promptly mail you our sample diagram of a complete short and long wave receiver, 175 to 20,000 meters, together with complete instructions for wiring and assembling, price of each part and where they can be bought, leaving nothing to guess about on receipt of fifty cents in coin or stamps. Here is a diagram no one can afford to be without. Virginia Novelty Co., Martinsburg, West Va.

Get That Synchronous tone, 1/8, 1/5 and 1/4 H.P. 220 and 110 volt synchronous motors suitable for gaps at very low prices. Stahl Rectifier Co., 1405 W. Jackson Blvd., Chicago, Ill.

Taps at 3c; headbands, 80° phones, Radio keys of reliable make at 30% reductions. Solomon Schiffshock, 209 Seigel St., Brooklyn.

Variable Condensers, Unassembled, consisting of Plates, Washers, Shafts, top, bottom, knob, pointer and scale. 23 Plate \$1.85; 43, \$2.85. Plate samples .10. Separate parts for condensers variometers and variocouplers. Gravenstedt, 84 Hancock Ave., Jersey City, N. J.

Mica Grid Condensers 30c; with leak 45c. Witteck Radio Supply, 3417 N. Hoyne Ave., Chicago, Ill.

Wireless Experimenters bargain. 200 watt electric soldering irons, used, only \$2.00 each. H. F. Weinert, 225 East Grand Ave., Detroit, Mich.

Record Time Signals as shown in February E. E. with Weston Model 30 Galvanometer Relay, \$12.50; 150 ohm Pony Telegraph Relay \$2.25; W. E. aeroplane Microphones \$4.00. Western Instrument Repair, 314 N. Fairfield, Chicago, Ill.

A Radio Panel Receiver, complete with phones for \$9.00. Send 50 cents (money order) for blueprint and directions. Satisfaction guaranteed. Radioprint Co., 61 Walden St., Boston, Mass.

Let us design and build that set. Radio sets built to order. Perrine Bros., Decatur, Ga.

Leumite the ultra-sensitive detector crystal. Signals and music marvelously clear. Guaranteed absolutely the best. Generous Crystal 25c. Leumas Laboratories, 311 Fifth Ave., New York.

How many amperes will a certain sized wire carry safely? Table showing this, also giving 26 "Q" signals, formulae for calculating inductance, capacity, etc. Sent for 40c. A. Beckwith, 614 North 32nd St., East St. Louis, Ill.

Carpenter & Dempsey fight broadcasting, which took place last July 2d was sent out on an excellent set, but we will send you a diagram of that set free if you send 50c for our 10 Best Hookups for undamp spark and phone, Box 72, East Boston (28), Mass.

Amplifying Transformers—Thorlanson amplifying transformers fully mounted on bakelite panel \$3.50, Acme fully mounted \$4.50; Polished Formica Panels 6x12x3/16 in., \$.85; 12x18x3/16 in., \$2.50; Burgess "B" Batteries, flexible wire or binding post taps, large size, 22.5 volts, \$2.50. Immediate deliveries and everything postpaid. Many other attractive bargains in Standard Radio Equipment. Write for list. Cambridge Radio Laboratory, Cambridge, Illinois.

Dual Grip Clips Lock to your A or B battery terminals Can be used for tapping the circuit anywhere at one-tenth the cost of plugs and jacks. Postpaid 25c each or 5 for \$1.00. Variable B batteries, 22 1/2 v. \$2.00 and \$5.00. Assorted coil springs, 75 for \$1.00. The Dual Tool Co., 12430 Euclid Ave., Cleveland, Ohio.

Attention, Amateurs! A 10 or 100 watt C.W. transmitter, using alternating current plate supply, full wave rectification. Blueprints, complete constructional and technical data for \$2.00. 500 miles on a 20watt Radiophone, using 4-5 watt power tubes and rectified alternating current plate supply. Blueprints, complete constructional and technical data for \$3.00. Frederick H. Graening, 232 Oregon Ave., Dundee, Ill.

Head Sets! 2,100 ohms, balanced sets for radio constructors or in quantity for manufacturers. Scientific Equipment Co., Ho-ho-kus, N. J.

Selling Out: Unwired Regenerative Set \$15.00; Detector and two step \$20.00; Magnetic Rectifier \$10.00; Brandes Superior Phones \$4.00; Arkay Loud Speaker \$2.50. Honeycomb coils—L.35, L.50, L.1000, L.1250, L.1500, at 25 per cent. off list price. Radiotron Detector \$2.50; 2 Moorhead Amplifiers at \$1.00; Grebe Crystal Detector \$1.25; 2 Relays at \$1.00; Double Tuning Relay \$1.50; Key 50c; 10-1 in. insulators at 15c; 1-16 in. insulators 50c; Lighting switch \$1.25. James M. Hollowell Jr., Chestnut Hill, Mass.

Variometers and variocouplers, \$2.95; parts for radio-phon receiver \$15.00; audion control \$3.75; two step amplifier \$13.95, assembled \$5.00 extra. Detector tubes \$4.75, amplifiers \$6.20. Large stock of parts. Discounts on standard apparatus. Haas, 2011 Atlantic Ave., Atlantic City, N. J.

Variable Grid Leaks 50. Grid Condensers 30c. Audion Panels \$7.00. Hudson Radio Supply, 262 Palisade Ave., Jersey City.

Clapp-Eastham 1/2 K.W. Plytone Set, \$70, F.O.B. James M. Hollowell, Jr., Chestnut Hill, Mass.

Fixed condensers, .0007 mfd, 90c postpaid. No waiting. Ship by return mail. W. E. Killingsworth, 226 Lobinger Ave., Braddock, Pa.

One-Half K.W. Transmitter, using Acme Transformer, Dublier condenser and Super-Berwood gap, \$50 F.O.B. James M. Hollowell, Jr., Chestnut Hill, Mass.

Navy Material 1/2 K.W. cycle Trunk Set, bargain \$85. Telefunken Ship Set complete, new, \$250. Three K.W. coils, \$25, etc. Kienzle, 501 E. 84th St., New York.

Kehler V.T. Special \$55. A complete set of 3 Federal automatic filament control jacks amounting to \$4.20 will be given as a premium with every order for 3 tubes consisting of 1 A.P. Moorhead detector \$5.00, and 2 A.P. Moorhead amplifiers at \$6.50 each. Only new and high grade equipment carried in stock. Unsatisfactory goods subject to return within five days. Don't forget the twelve-hour service with the postage and insurance prepaid by us. The Kehler Radio Laboratories, Dept. R, Abilene, Kansas.

Stop! Look! and Act! V.T.'s Accessories! With each of the listed tubes Radiotron U.V. 200, \$5, and A. P. Moorhead detectors, \$; Radiotron U.V. 201, \$6.50, and A. P. Amplifiers \$6.50, we will supply free of charge your choice of either of these six premiums: Latest Fada rheostat \$1. No. 810 Remler smooth running rheostat \$1. Paragon V.T. socket \$1, Murdock socket V.T. improved contact type \$1, DeForest V.T. socket \$1, Fada panel mounting V.T. socket bakelite base \$1.10. Either of the Federal single closed or double circuit jacks listed respectively at \$0.70, \$0.85 and \$1 will be given as premiums with each Federal 226W amplifying transformer \$7.00 or R.C. of A. \$7.00 U.V. 712, and the U.V. 1714 Radio Frequency amplifying transformer. Fada 5 ampere Nichrome power rheostats \$1.35 or R.C. of A. U.R.542 Porcelain V.T. socket supplied free of charge with each \$8.00 U.V. 202 power tube or A.P. Moorhead 5 watt Type C power tube \$7.50 for C.W. or Radiophone transmission or power amplification. We absolutely guarantee the foregoing apparatus. Only new and high grade equipment carried in stock. Unsatisfactory goods subject to return within five days. Twelve-hour service. Postage and insurance prepaid by us. (Specially saving time and money. Remember us. The Kehler Radio Laboratories, Dept. R, Abilene, Kansas.

Aerial Wire—100 foot coils; 7 strands No. 22 Hard Drawn Copper 90c; Tinned \$1.50; No. 14 Hard Drawn Copper 55c; Postage weight 2 pounds per coil. Chas. L. Manning, 1558 Miller St., Utica, N. Y.

Kehler Magnavox Premiums.—The Radio Magnavox, as is well known, is the only loud speaker which will reproduce radio Telephone Speech and Wireless music in any volume, without distortion and without injury to the apparatus. Type R-3 Radio Magnavox, with 14-inch horn, \$45, input 5 watts, premium 1 A.P. Moorhead amplifier \$6.50 each. Type R-2 Magnavox with large horn, \$85, input 20 watts, premium 2 A.P. Moorhead amplifiers \$6.50 each. For extreme and distortionless amplification of radio telephone speech and music the Magnavox Power Amplifier should be used. Magnavox two-stage power amplifier, Type A.C.-2 Model C, \$30.00, premium 2 A.P. Type C Power tubes at \$7.50 each or 1 Eveready 100-volt block battery \$15.00, 3-stage power amplifier Type A.C. 3, Model C, \$110.00, premium 3 A.P. Moorhead Type C power tubes at \$7.50 each. Backed by our usual guarantee. Shipments F.O.B. either Oakland, Calif.; New York City, or Abilene. The Kehler Radio Laboratories, Dept. R, Abilene, Kans.

Double Your C.W. and Radiophone Range! You can easily do it without adding another piece of apparatus or greatly changing your set. The new "Master Circuit" is the secret. Tested by many prominent ARRL Stations it more than doubled range of each station. One two watt set plus twenty watts into antenna; easily sends 2000 miles; tones 10000. Think of it! It's absolutely the best circuit out. Ideal for 200 meters. Guaranteed to double or increase your range regardless of what it is now. Send \$2 for complete confidential photographs of this wonder circuit. Get it working for you—be the first in your town—surprise your friends by your phenomenal results. Order today—immediately. Master Engineering Co., Omaha, Nebr.

Get Acquainted \$ \$ \$. Aside from our special premium offers on this page we have an excellent proposition for you which will save you many dollars on your purchase of well-known radio apparatus. We will be pleased to hear from you, and if you desire a representative set of bulletins, enclose 25c which may be deducted from your first order. The Kehler Radio Laboratories, Dept. R, Abilene, Kansas.

Himmel! 7x22 hard drawn aerial wire, 60c per 100 ft. 1100 feet for \$6.00. Just another way FAIL does save you money. Get on our list and keep up with the latest in low prices. Port Arthur Radio Laboratory, Port Arthur, Texas.

Baldwin Phones.—Why are Baldwin Phones so sensitive? Briefly because (1) the small armature is pivoted and designed to act as a fulcrum when connected to the diaphragm by a small link. There is not tension or springing of metal as in ordinary receivers. (2) Four pole pieces of a single solenoid act upon both sides of a lightly balanced armature. (3) The force is concentrated at the exact center of the mica-diaphragm (identically the same as used in all high grade photograph reproducers). Original Type C \$12.00; Improved Type E \$13.00; Lighter Type B \$14.00; Antistatic Type G \$15.00. Single loud speaker unit Type C without cord \$6.00. This is the same unit as used in the Vocotron and are excellent for making your own loud speaker. With each pair of phones purchased we shall give as premium one of the latest Federal Universal Plates, \$1.75. These well-known head sets are absolutely guaranteed and subject to return within five days if not satisfactory. Postpaid, insured and twelve-hour service. The Kehler Radio Laboratories, Dept. R, Abilene, Kansas.

Rectifier plates for C.W. 72 square inch piece of aluminum \$7.5. 72 square inch piece of lead \$6.00. Philadelphia Radio Supply, 5714 Inazel Ave., Philadelphia, Pa.

Grebe! Grebe! Grebe!!! Notice the attractive premiums we offer for a limited time on the latest Grebe regenerative sets and vacuum tube controls, Bakelite variometer, shielded, units and vernier controls. Type C.R.-8 and Type C.R.-5 \$80.00 each, premium 1 A.P. Moorhead or Radiotron detector bulb, C.R.-9 \$130.00, 2 Radiotron or A.P. Moorhead amplifiers, Type RORR detector and two stage amplifier \$75.00, premiums choice of either 2-stage amplifier \$55.00, premium one A.P. Moorhead amplifier. Absolutely new stock and guaranteed to be up to the usual well-known Grebe standard; without question the finest regenerative sets on the market. Representing the last word in radio engineering. The Kehler Radio Laboratories, Dept. R, Abilene, Kansas.

Grid and Fixed Condensers 25c. Tuning Coils \$1.50. Detectors 30c. Complete Receiving Sets \$5.00. Port Huron Radio Co., 1509 16th St., Port Huron, Michigan.

\$ \$ Brach Radio Protectors \$ \$. Do away with expensive lighting switch and use Brach Radio Vacuum tube protectors for radio telephone and telegraph receiving stations as illustrated elsewhere in this magazine. Safety all the time without the annoyance of forgetting to operate your lighting switch. Vacuum tube protector \$2.50 each. Special combination offer, with 500 feet 7 strand No. 22 tinned aerial wire, \$5 complete. The Kehler Radio Laboratories, Dept. R, Abilene, Kansas.

Expert radio repair and construction work. Estimates free. Work guaranteed. Apparatus made your specifications. C.W. specialists. Radiophone Service Co., Box 303, Gainesville, Florida.

Quality, Satisfaction, Service First. The Kehler Radio Laboratories.

I Hear You Calling Me. What. Yes, over my Jupiter Radio Receiving Outfit \$14.25 and up. Send for descriptive list of Radio bargains. Dayton Motorbike Bicycle \$16.00. Violin. Case, Bow, \$17.00. Maynard Ralston, Radio Dealer, North Baltimore, Ohio.

Quality, Satisfaction, Service First. The Kehler Radio Laboratories.

Rogers Receiving Radiometer. New patented variometer for panel mounting. Simple, compact, efficient \$4.00. Build your own receiver. Two radiometers, one variable condenser, directions and wiring diagram mailed upon receipt money order \$10.00. Rogers Radio Company, 5133 Woodworth St., Pittsburgh, Penn.

Twelve Hour Service. The Kehler Radio Laboratories.

Buy Direct From Manufacturers. mahogany cabinet containing short wave tuner with detector, \$30 with one stage amplification, \$45; two stage, \$60; three stages (Use loop), \$80. No jacks. Rear connections. Rogers Radio Company, 5133 Woodworth St., Pittsburgh, Pa.

Twelve Hour Service. The Kehler Radio Laboratories.

Amateurs! Get that Radio Music. Radiophone Receiver with Vacuum Tube, "B" Battery, Phones and Aerial Equipment \$30.00. Send for descriptive circular. Ritter Radio Co., 323 Lee Bldg., Kansas City, Missouri.

We can ship immediately.—Burgess 22 1/2 volt "B" batteries \$3.00, and the following Klansine Products—Adapt-O-Phone \$12.00, Amplifying Transformer \$3.50, Socket \$1.00, Plug and Jack \$1.50, Jack only \$.85. Postage prepaid. The L & B Radio Shops, Dept. R, 6195 McMillan Ave., Detroit, Michigan.

WIRE WIND YOUR OWN WIRE USE OUR WIRE WIRE

The prices we quote below are per 1/4 lb. (4 oz.), and include cost of spool and parcel post charges.

- - Remit with order - -

B.&S. Gauge	Sing. Cotton	Do'ble Cotton	Enamel Silk	Sing. Silk	Do'ble Silk
No. 20	.35	.40	.30	.52	.56
No. 22	.48	.53	.33	.57	.62
No. 24	.52	.57	.36	.62	.68
No. 26	.58	.63	.39	.68	.75
No. 28	.68	.73	.42	.75	.88
No. 30	.80	.85	.45	.88	1.00
No. 32	.95	1.05	.48	1.00	1.20

All other sizes, kinds and quantities. Dealers supplied.

RADIO SUPPLY STORES COMPANY
P. O. Box 896
NEW HAVEN, CONN.

CARD BOARD TUBING FOR COIL WINDING

2 1/2 INCH TO 5 INCH DIAMETER
2 1/2 in. and 3 in. diameter 25c per foot, increasing 5 cents per foot for each additional 1/4-in. diameter.

Large stock on hand for Immediate Delivery Parcel Post Prepaid

McCLOY ELECTRIC CO.
7131 Kelly Street PITTSBURGH, PA.
Dealers write for discount Manual Training Instructors write for special discounts.

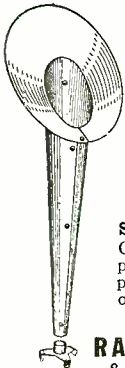

Stramcy Products

STRAMCY LILY HORN
Made of fibre
Highest efficiency
Best tone quality
Lowest price

STRAMCY COUPLER
Couples any Radio telephone to tone arm of principal makes of phonographs.

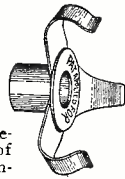

Dealers write to
RADIO DISTRIBUTING CO.
8 West Park St., Newark, N. J.

Prompt Shipment

made to Bethlehem, Allentown, Easton, Nazareth, Leighton, Bangor, Catsaqua, Slatington, Coplay, Lansford, Bangor, Emans, Hellertown and all other points in the Lehigh Valley and United States.

OUR MOTTO IS "All orders must leave the same day they are received. Satisfaction guaranteed."

FEDERAL, ACME, DEFOREST, MURDOCK, FADA, PARAGON, GREBE, BRANDES, BALDWIN, RADIO CORPORATION, WESTINGHOUSE, etc. Products carried in STOCK at all times.

Send us a Trial Order. Catalog mailed postpaid \$1.00 Bell phone 2548J

LEHIGH RADIO CO.
BETHLEHEM, PA.

Center & Fairview St. A. F. BREISCH, Gen. Man.

Exchange.

Amateur Agents wanted in every city and town to sell radio apparatus. A few stocking agencies still open. Delfeico, 12 Meeting Street, Pawtucket, R. I.

For Sale: 100 watt tube set of 1DF Western Electric tubes. A. H. Wood, Jr., 178 Tremont Street, Boston, Mass.

Bargain Sale. 4 Clapp Eastham Receiving Sets. 3 Paramount Receiving Sets. These 7 sets are latest and just out. All brand new and prices lower than rest ask. H. Welsh, Mayport, Penna.

For Sale. One pair of Brandes navy type receivers, \$7. James Wilson, 1588 W. 49th St., Los Angeles, California.

For Sale. 2 inch spark coil, gap and condenser for same, Murdock antenna switch, Murdock O.T. and key, all for \$18. R. Worgitzky, 2141 Sedgwick St., Chicago, Illinois.

Wanted—Vol. II "Radio News." Write me stating your price. John Hammock, 3743 1/2 Nicollet Ave., Minneapolis, Minn.

High-power Compound Microscope Outfit (enlarges up to 1700 times), new condition, cost \$180.00—will exchange for Amrad or Grebe CR9 (good condition), Regenerative Tuner No. 2596, and Detector 2 stage amplifier No. 2634. Brand new Savage .22 Hi-power rifle worth \$35.00, for new Vocaloud, station type. Arisman, 4719 Indiana Ave., Chicago.

Special: R.V.A. Audion Sockets 38c, 10 to 1 ratio shielded amplifying transformers \$3.98. Write for price list. Austin Radio Laboratories, 734 N. Pine Ave., Chicago, Ill.

600-20,000 Meters Receiver, including Radiotron, \$35.00. Box 205, Williamsport, Pa.

Navy Tuner and Detector in cabinets, with bulb, \$25. Arthur Briggs, 107 Victoria Pl., Syracuse, N. Y.

Brand New Five-Dial Omnigraph for \$15. Excellent condition. 7120 Carnegie Ave., Cleveland, Ohio. J. H. Brannon.

Marconi Receiver, like new. A \$500 set for \$125; photo and description for stamp. Box 107, Providence, Rhode Island.

For Sale: 2500 Navy type Loose coupler. First \$10 takes it. Cost \$21. Good condition. Oscar H. Bonter, 226 Ross Ave., Cambridge Springs, Pa.

For Sale: National Radio Institute correspondence course. Perfect condition, \$40. Clifford Bry, Oregon, Ill.

Bargain: Complete 1/2 K.W. Transmitting and short wave Regenerative receiver with Grebe Detector and two stage amplifier. \$175 takes complete set. Transmitter includes both rotary and quenched gap. William Cole, Jr., Ironwood, Mich.

Wanted: Used Radio Receiving Apparatus. Must be in good condition and cheap. Write Auld Carlson, 429 E. 153d St., New York City.

Write for circular describing our new audion receiver, price \$10. Cheney Radio Co., Cheney, Kansas.

Regenerative Sets with audion detector, 2 stage, bulbs, fones, loud talker, "A" Storage, "B" batteries, mounted in cabinets 21 x 7 x 5 in. Plug and jack control. Only a few at this price. All new apparatus. \$120.00. Remit by money order to F. W. Donnell, Hampton, N. H.

Memorize Continental Code in one hour. Quality quickly for amateur license. See our ad on page 1036 this issue. C. K. Dodge.

L. S. Estes, Harlan, Ky. I have Popular Pressman Camera. Cooke f/4.5 lens. Focal Plane Shutter. Cost \$166.00. Will exchange for complete Radio Receiving outfit. What have you to offer.

Rare Bargains. 2 new wireless telephone sets with detector and 1 stage in fine walnut cabinet \$70.00 each. 1 Willard 40 ampere-hour 12v. \$13.00 and 1 Willard 80 ampere-hour 6v. storage battery \$9.00, 4 1/2 lb new s.c.c. No. 20 copper wire \$4.00, 1 new acme telephone transformer \$4.00, 1 W.E. modulation transformer \$9.00. Arne Gudheim, Blacksburg, Va.

Sell—1/2 K.W. Clapp Eastham Hlytone with new Debillier cost \$250, good condition. Make offer. Variometer regenerative panel. Parts alone cost \$18. Sell \$12. Robert Gallery, Holy Cross College, Worcester, Mass.

Sale: 9 J D—3 step receiving set \$85.00. Radio fone transmitter complete with Sv-120-amp-hr. Bat. \$140.00. Less Bat. \$110.00. Phone 150 miles, CW 2000 miles. H. Gary, 600 Main St., Aurora, Ill.

Big Bargain: One K.W. Mignon transmitting cabinet, containing six Murdock condensers, quenched gap, oscillation transformer, hotwire ammeter. All units mounted on a bakelite panel in an oak cabinet and adjustable down to 1/4 K.W. input, \$50.00 cash. One Thordarson transformer 1/4 K.W. for \$5.00. Instruments in Good condition. Glenn Hayes, 668 Delaware Ave., Milwaukee, Wisconsin.

First Check for \$55 takes—New Detector and two step with bulbs, 90 volt "B" Battery, Filament and Plate controls, variable on Panel with cabinet, Arthur Holden, Myrtle Street, Middleboro, Massachusetts.

Wanted—Omnigraph or similar instrument. Swap new radio equipment. Send stamp. James Hoban, Cheboygan, Mich.

Wanted: An installing complete station. What have you reasonable? Give description and price. Orville Huish, 140 Byron St., Youngstown, Ohio.

Attention: Audion Bulb, receptacle, and grid condenser \$5.00 Postpaid. Hoboken Radio Shop, 404 Washington St., Hoboken, N. J.

Have late Model Harley Twin with side car, late model Indian twin, electrical equipped, both guaranteed to be in perfect mechanical condition; have also a double barrel hammerless shotgun arda Rem. umc. Automatic revolver. Want regenerative and Amp. receiving set or good C.W. or phone trans. set. What have you? A. F. Hood, Commerce, Ga.

For Sale: One long wave receiver complete with honeycomb coils up to six thousand meters. Price \$50.00. Also Regenerative tuner, practically new, price \$27; both home made. Send for photograph to Dana B. Hinckley, 518 State St., Bangor, Maine.

Sell: Grebe detector type Rrh, \$11. Aerial \$2.25. Lightning Switch \$1.50; A-1 condition, Willis Kulp, Rumilla, Pa.

Sale: Tresco tuners \$5.50 each. Crystallo detectors \$1.75, 5 watt C.W. set \$26.00. Swap 350-volt motor-generator set Midget type; other bargains; send stamps. Mack's Radio Shop, Ansonia, Conn.

5 Pf. B. Battery-Switch on 3x3x1/2 Formica Panel. Postpaid \$1.70. C. Marvin, 770 E. Berrein, Galesburg, Ill.

Bargain—15,000 meter loose coupler, good condition, price \$15. Cecil Moore, Holland, Texas.

For Sale: 1/2 K.W. Acme Transformer \$20. Enclosed eight tooth Benwood. Gap aluminum case \$18. 1/10 H.P. variable speed motor \$23. Three one-gallon size Leydon Jars \$10. Homemade Oscillation Transformer \$4. Eight tooth Hyrad rotor \$5. No. 2 Jr. 5 dial omnigraph \$10. Spark coil helix \$1. One inch spark coil \$4. Step down transformer six, eight, twelve volts \$2. Amrad wave meter \$4. For sale: Federal amplifier Transformer \$4, 1/20 H.P. motor \$5. Willard R. Morton, 12 North Park St., Bangor Maine. EAO 437059.

Sell No. 6 Erector with \$6 extra parts for 12. Oliver Malmanger, Huxley, Iowa.

Sell: No. 5 Omnigraph complete, with fifteen dials, ten dollars. David McIntire, Norton, Mass.

2 Jr. Omnigraph; hardly used; A1 condition, \$15.00. Kenneth Montgomery, Greencastle, Ind.

Have Quantity Salesman's Sample Regeneratives for sale, half price. Just the set you want. Wonderfully efficient. Made of best materials by master craftsmen. Encased in beautiful grained leather covered cabinet. Easy to operate; no capacity effects. A wonder for C.W. and phone. Equals a Paragon. Will be placed on market soon, retailing at fifty-five dollars; will sacrifice samples at \$24 each. This is a bargain! Everyone in excellent condition; like new. Fully guaranteed. Grasp this opportunity—order one today—now! (Photo free.) Master Engineering Company, Omaha.

For Sale—1 Deforest geared triple coil mounting—\$9. Duck's 6 volt 6 ampere generator never used—\$9. C.R.L. Amplifon aen 1., \$45. Raymond Naser, Anacortes, Wash.

Bargains: KZ-5 variometer regenerative, shielded circuit, \$28. Triple coil panel mounting \$4.50. 100 watt C.W. transformer, bulb and double filament connections, mounted. \$9. Send check. Arthur Osborn, 311 E. Daniel, Champaign, Ill.

Complete Transmitter 2 B.P., Dubilier, 21000 V.; 1/4 K.W. mounted Acme; quenched gap O.T.; heavy key; switches. Perfect condition. \$45. John Pollock, 230 West 99th St., New York City.

Wanted: D. C. High Voltage Generator for C.W. Write Post Office Box 1105, St. James St., Montreal, Can.

Sale: New 5-dial Omnigraph \$16; Spark coil transmitter \$5; 350-watt; coupler \$5; Stamp Collection, 600 varieties \$5. D. T. Rice, 1321 South 35th Ave., Omaha.

Wanted: Complete regenerative receiving outfits with detector and two stage amplifier or regenerative tuners of any standard make. We can sell almost anything in used radio apparatus for you. Write for details. If you want any used radio apparatus, write for bulletins. The Radio Exchange, 804 Helen St., Sioux City, Ia.

Sale: Twelve dollar Ukelete with case, \$10.00, or trade for receiving apparatus. Forest Reine, Broton, Minn.

Special Radio Storage Batteries, Edison, Lead all sizes. Radio Battery Service Station, 44 Bryant St., Malden, I.K.M.

W. E. Loud Speaker \$6.00. Audiotron Amplifier \$5.00. Murdock Lead Coil \$2.00. Knob & Dial \$5.00. Plugs and Jacks \$1.00. W. G. Schmeiss, 1430 So. Harding Ave., Chicago, Ill.

Wanted: Burned out VT's \$5.00 in cash for each. S. Strobel, 3923 N. 6th St., Phila., Pa.

Boys, Look—Adapters—a new kind—each \$1. E. Strobel, 3923 N. 6th St., Phila., Pa.

For Sale: New Navy coupler \$10.00. Wanted an omnigraph, state model, price, etc. Clifford Sedwick, Downers Grove, Ill.

Sell—Regenerative Receiver with 1 step amplifier, complete \$45. Other apparatus for sale. E. Schnessier, 2200 Wheeler St., Cincinnati, Ohio.

For Sale: Six honeycombs. 2—50's, 2—150's, 200, 400, \$8. One CRL Regenerette \$10. One Triple-coil mounting \$3.00. H. S. Schuler, Vandergrift, Pa.

Regenerative Receiver \$15, almost new, others. S. Strobel, 3923 N. 6th St., Phila., Pa.

Sell: \$22.50 Battery Chargers, new \$17.50, three new DeForest 901 variometer condensers \$9.50 each, unmounted. Emil P. Timm, 1114 Chambers St., St. Louis, Mo

Sale: Synchronous gap, with Emerson Rebuilt 1/4 H.P. motor, and Hyrad disc, complete \$25. Also, solid mahogany cabinet, 9 in. deep, for panel 18 x 24 in. Francis Tratt, 705 Main St., Whitewater, Wis.

For Sale: Storage "B" Batteries, 50 volt—40 step variable voltage—will last indefinitely—easily recharged—complete for \$15. Also, 150 ampere hour Edison cells—latest type—perfect condition at \$2 each. All inquiries answered. W. J. Travers, 815 Humboldt Parkway, Buffalo, N. Y.

Swap—Large Chemical "Lab"; want regenerative receiver or what have you? Willens, Roanoke, Ill.

For Sale: 43 Plate Condenser \$3.00; 23 Plate Condenser \$2.50; Amplifying transformer \$3.50; Socket \$0.75; Crystal Detector \$1.50; Murdock Phones \$3.50; Murdock Phones \$2.25; Detector Panel \$6.00; 2 GL Condensers \$1.00; 2 Honeycomb coils \$1.00; Ford Spark coil \$1.00; Water Motor \$2.50; Spark Gap \$1.00; Transmitting condenser \$1.00. J. C. Zwick, 71 Zenner St., Buffalo, N. Y.

All Kinds of Radio Apparatus—bought and sold. Fordham Radio Exchange, 2018 Webster Ave., Bronx.

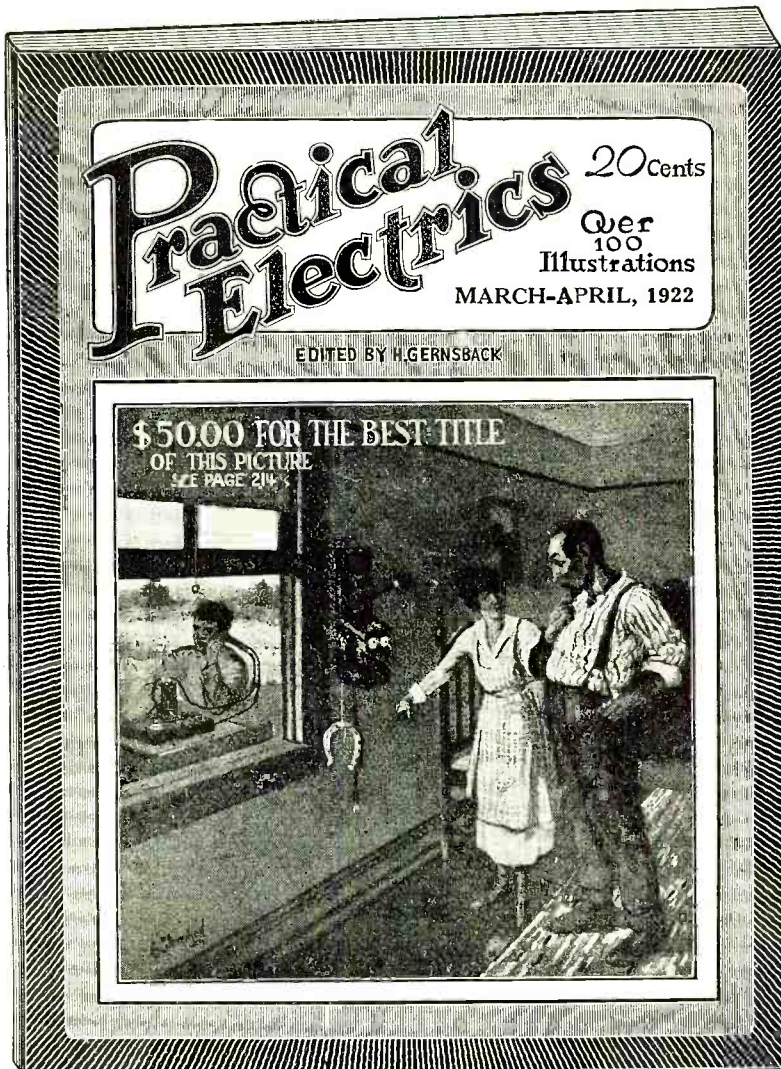

**100 Articles
Over 100 Illustrations**

**FOR SALE
AT ALL NEWS
STANDS**

20c.
The Copy
\$2.00
A Year
Canada and Foreign
\$2.50 A Year

**SEND
20c. FOR
SAMPLE
COPY
TODAY**

**SEE COUPON BELOW FOR
SPECIAL OFFER**

“The Electrical Magazine for Everybody”

PRACTICAL ELECTRICS is probably the most novel magazine of its kind ever conceived. It is personally edited by H. Gernsback, editor of SCIENCE & INVENTION and RADIO NEWS. Mr. Gernsback, who founded the old MODERN ELECTRICS as well as the ELECTRICAL EXPERIMENTER, knows thoroughly what the public wants and has wanted for many years. In presenting this new magazine he but heeds the thousands of letters received by him to establish a new 100% electrical magazine that will beat the best that was in MODERN ELECTRICS and ELECTRICAL EXPERIMENTER.

Electricity covers such a tremendous field that the man who does not keep abreast with it does himself a great injustice. PRACTICAL ELECTRICS covers that field from every angle. It is written in plain every-day language that all can understand. It portrays the

entire electrical development of the month faithfully in non-technical language. It caters to everyone interested in electricity, be he a layman, an experimenter, an electrician or an engineer—each will find in this magazine a department for himself and plenty more.

The March-April issue now on the news-stands contains 48 pages and over 100 different articles and over 100 illustrations, with an artistic cover in two colors. Professor T. O’Conor Sloane, Ph.D., is associate editor of the magazine.

Leading Articles in March-April Number

Telegraphic and Telephonic Transmission of Pictures. Antique Electric Motors. Electricity from Fruit and Vegetables. Old and New Measurement of Light. Induction Test for Locating Armature Troubles. Artificial Lighting.

PRIZES

This magazine offers a number of prizes, as follows:

\$50.00 Burnt-out Fuse Contest.
\$3.00 for the best picture of your electrical workshop.

\$3.00 for the best article on Elec-Tricks, the new department.

\$3.00 for the best “short-circuit,” the semi-humorous department.

In addition to this, the magazine pays high prices for all electrical experiments, electrical articles, etc.

See Current Issue for Full Details.

This issue also contains articles by some of the greatest living electrical writers, workers and students and the magazine will prove a revelation to any one interested in electricity.

Inasmuch as the new magazine has a circulation of only 27,000 copies, we urge you to place your monthly standing order with your newsdealer at once. Or if you wish, fill out the coupon below for your subscription and take advantage of our special offer.

Every issue besides its many other features contains the following departments:

- “New Things Electric”
- “Experimental Electrics”
- “Electrical Digest”
- “Junior Electrician”
- “My Laboratory”
- “Elec-Tricks”
- “Motor Electrics”
- “Short Circuits”
- “How and Why” (Questions and Answers.)

Make all checks payable to: “Practical Electrics Co.”

SPECIAL OFFER

Gentlemen:
Although your regular price is \$2.00 per year, you will accept my subscription at \$1.75 per year (Canada and foreign \$2.25) I enclose the money herewith and I have written my name and address in margin below.

PRACTICAL ELECTRICS CO., 236 Fulton Street, New York

R. N. 4-22

"RASCO HAS IT!"

THE Radio Specialty Co.—"Rasco" for short—is probably the most unique supply house in the United States, if not in the world to-day. This company makes a specialty of small orders, no order being too small to get immediate and prompt attention for the simple reason that most of our orders are small.

The reputation of this house was built upon service. Ask any of your acquaintances what they think of Rasco goods, Rasco service, Rasco promptness! Thousands of unsolicited testimonials on file to prove that we serve the public best! Be sure to get our great catalogue, containing several hundred different parts, which is illustrated below.

ORDER DIRECT FROM THIS PAGE. ALL GOODS SENT PREPAID IN 24 HOURS

1100 "RASCO" AUDIO FREQUENCY TRANSFORMER



We have compared many of the present transformers on the market but have finally decided upon a type that is the most efficient one we have seen so far. The best amplifying transformer is that in which the impedance of its primary is equal to or exceeds the impedance of the plate-to-filament circuit of the tube in which it is connected. We guarantee this transformer to equal any one on the market.

No. 1100, "Rasco" Audio Frequency Transformer (not assembled) each prepaid.....\$2.65

ANTENNA CONNECTOR

This antenna connector is made entirely of aluminum, is light and will not rust. The only connector of its kind. The 4 antenna wires go to the upper holes; the lower hole takes the lead-in. Don't solder your aerial, don't have loose connections. Dimensions 2" high, 1 1/4" wide, 3/8" thick.

No. 999, Connector, each.....\$0.35



PANEL KNOBS

No. 6241 is well made and has a good corrugation. Its diameter is 1", height is 1/2". hole 5/32". The shank is 3/4" high.

No. 6241, Knob, each.....\$0.08

MARCONI KNOB

Has a central hole of 5/32" and seat to hold the screw, dia. is 1 1/4", height 3/4".

No. 838, Marconi Knob, each.....\$0.15

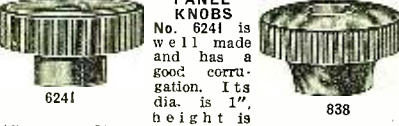

RASCO POSTS

These are our very own patterns. From our own designs and look mighty handsome on any instrument. The top knobs are of composition, the bottom parts brass nickel plated polish.

No. 202 is nickel plated at bottom part.

"Rasco" Binding Post, 8/32 thread, each, \$0.10 doz., \$1.00.

No. 202, Post, each,\$0.09

Nos. 650 and 651 made entirely in composition with a hexagonal brass nut in center.

No. 650 has 8/32 machine screw. No. 651 has bottom wood screw.

No. 650, Post, each.....\$0.08

No. 651, Post, each.....\$0.08

Dozen, each style.....\$0.90

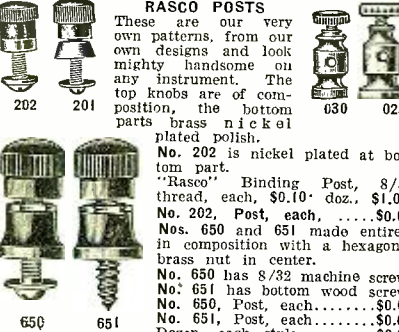

BRASS NICKEL POSTS

No. 029, Binding Post, each.....\$0.05

No. 030, Binding Post, each.....\$0.04

RASCO SWITCH POINTS

Nickel plated and polished. The following have been found the most popular.

No. 1 1/4" x 1/4", 6/32 thread, ea. \$0.03; doz., 35c

No. 2 3/16" high, 1/4" dia., 6/32 thread, ea. \$0.03; doz., 35c.

No. 3 3/16" x 3/16", 4-36 thread, ea. \$0.03; doz., 35c.

No. 4 1/4" dia.; 1/8" thick; stem 6/32, ea. \$0.03 1/2; doz., 40c.

No. 5 1/4" dia. 3/16" thick; stem 4-36, ea. \$0.03 1/2; doz., 40c.

No. 6 3/16" dia.; 3/16" thick; stem 4-36, ea. \$0.03 1/2; doz., 40c.

No. 7 3/16" dia.; 1/8" thick; stem 4-36, ea. \$0.03 1/2; doz., 40c.

No. 75, Switch Stop, 7/8" long, 4-36 thread, complete with nut, ea. \$0.05; doz., 50c.

No. 76, New style Switch Point, to be pressed into bakelite panels with forced fit. Wire is soldered to pin end. Head 3/4", dia., 1/16" thick, ea. \$0.03 1/2; doz., 40c.

No. 77, same as above, but head is 1/2" dia. x 3/16" thick, ea. \$0.03 1/2; doz., 40c.

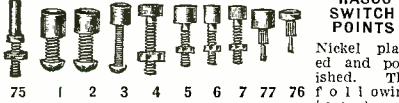

THE RASCO BABY DETECTOR

In presenting this little Detector, we feel sure that it fills a place never taken before by any small detector. It does a variety of things and does them all well and better than many \$5.00 detectors. The base is solid, black composition. Mounted on same is a nickel holder and binding post which holds a fluted hard rubber knob with its sliding rod member. The outstanding part of the Detector, is the patented nickel detector cup and binding post. The knurled cap unscrews and you place the Galena Crystal in the cup, then replace the knurled cap and the galena crystal is held secure. The circular hole in the cap allows enough of the crystal for ordinary purposes.

No. 1898, Rasco Baby Galena Detector. Price, prepaid.....\$0.50

No. 1899, Rasco Baby Detector with Galena and Radioelectric Crystals. Price, prepaid.....\$0.75



PANEL SWITCH LEVER

New style switch lever with lock fork. It is impossible for this lever not to make positive contact at all times. The blade radius is 1 1/4". It is nickel plated and polished. Fork is phosphor bronze. The lock fork holds the screw (in which it rotates), securely. A loose contact is impossible.

No. 200, Switch Lever, complete as illustrated.....\$0.30



LITZ WIRE

This wire is recognized as the only thing for winding coils for Radio instruments. Particularly recommended with our No. 343 Variocoupler Rotor, for vario-couplers, banked windings, etc.

No. 323, Litz Wire, 20 No. 38 strands, enameled double silk wire, per foot, \$0.02; per 100 feet, \$1.15

No. 890, Litz Wire, 10 strands No. 38 wire, per foot, \$0.01; per 100 feet, \$0.75

No. 891, Litz Wire, 16 coils of three strands No. 38 wire, per foot, \$0.03; per 100 feet, \$2.25.



NOTE: This page contains only a few of our 300 specialties.

PANEL KNOB

This is a very distinctive knob and can be used on dials, panels, switches, condensers, etc. It is exceptional and well made. Dia. 1 1/16"; height 11/16"; comes with 8/32" bushing.

No. 815, Knob, each.....\$0.18



VARIOCOUPLER ROTOR

This rotor is used by all up-to-date amateurs. Is accurately turned of hard wood and is used as a secondary coil. It takes any finish, either shellac or stain and can be drilled readily for any size hole. Large hole 2" dia. Width of spool is 2". Total dia. 3 3/4".

No. 343 Variocoupler Rotor, each.....\$0.75



"RASCO" NAME PLATES

Our name plates are of brass with a black back. Ground. Letters are polished nickel. Order by name and number.

807 "Phones".....\$0.05	810 "Ground".....\$0.05
809 "Aerial".....\$0.05	812 "Primary".....\$0.05
811 "Secondary".....\$0.05	814 "Detector".....\$0.05
813 "Audion".....\$0.05	866 "On".....\$0.05
865 "Off".....\$0.05	840 "Increase Current" (Left).....\$0.10
839 "Increase Current" (Right).....\$0.10	834 "Series".....\$0.05
813 "Vacuum Tube".....\$0.05	820 "Receiver".....\$0.05
821 "Transmit".....\$0.05	822 "2nd Step".....\$0.05
831 "3rd Step".....\$0.05	827 "Tickler".....\$0.05
819 "1st Step".....\$0.05	825 "Plate Variometer".....\$0.05
826 "Grid Variometer".....\$0.05	835 "B Battery".....\$0.05
823 "Secondary".....\$0.05	817 "Output".....\$0.05
836 "A Battery".....\$0.05	824 "Primary Condenser".....\$0.05
818 "Input".....\$0.05	828 "Parallel".....\$0.05
829 "Telephone".....\$0.05	837 "4".....\$0.05
833 "Detector".....\$0.05	841 "(Blank)" (takes pen or pencil writing).....\$0.05
822 "Coupling".....\$0.05	
808 "Load'g Coil".....\$0.05	

Price of all of our name plates in dozen lots, 50c, with the exception of the two "Increase Current"



BAKELITE PANELS

We list below six panels, the sizes of which have been selected after carefully checking up many dimensions of the most popular radio apparatus on the market. Note particularly that our prices are anywhere from 25 to 50% lower than those quoted by most other concerns. The reason is that we buy these panels in very large quantities, and we do not cut sheets to order. Remember always that when sheets are cut to order they cost you at least 50% more than our prices, because you must pay for the cutting and the necessary waste. Note also that we ship these panels prepaid. This alone amounts to a considerable saving.

No. 350 6" x 12" x 3/16" thick, each.....\$1.90
No. 351 6" x 18" x 3/16" " " ".....2.85
No. 352 9" x 12" x 3/16" " " ".....3.00
No. 353 12" x 18" x 3/16" " " ".....5.65
No. 354 6 1/2" x 19 1/2" x 3/16" " " ".....3.50
No. 355 6" x 7 1/2" x 3/16" " " ".....1.20



"RASCO" LUBRICATED PANEL SWITCH

A radio switch that has two nuts at the end is a monstrosity, for the reason that it will never stay put. Our patent spring fork holds the switch handle always under uniform tension, at the same time it insures the best contact possible. New wiping contact, which covers every point of the switch point. Another new improvement is the lock fork, which can assume three different positions to accommodate the switch to various thicknesses of panels.

No. 1921 "Rasco" Switch, as illustrated, each \$0.50.



KNOBS

These knobs are favorites with all experimenters. The size of both is: dia. 1 1/8", height 1/2". No. 4451 comes with 8/32 and 10/32 bushing.

No. 4451, Knob, each.....\$0.06

No. 199 (screw length 3/4") Knob, each.....\$0.10

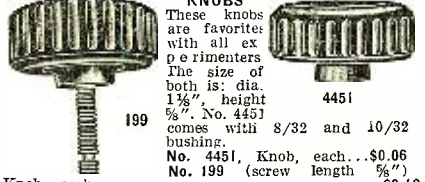

NAVY KEY KNOB

This navy key knob is now used on all standard wireless keys. It gives the right swinging motion and rests the fingers. It is a favorite with all advanced amateurs. Once used always used. The screw is 8/32 and will fit all keys.

No. 748, Key Knob, each.....\$0.28



THREADED BRASS ROD

We carry two styles, 6/32 and 8/32 thread. Only 6" lengths sold. No others.

No. 8032, Threaded Brass Rod 8/32 thread, per 6" length.....\$0.98

No. 6032, Threaded Brass Rod, 6/32 thread, per 6" length.....\$0.06



THE "RASCO" CATALOG

CONTAINS 50 VACUUM TUBE HOOK-UPS

Complete hook-ups of all important vacuum tube circuits are given in clear diagrams with complete explanation. Just to name a few—The V.T. as a detector and one-step amplifier; regenerative circuit; De Forest ultraudion; V.T. to receive undamped and spark signals; Armstrong circuits; one step radio frequency amplifier and detector; three stage audio-frequency amplifier; short wave regenerative circuits; V.T. radio telephone; 4-stage radio frequency amplifier; inductively coupled amplifier; Armstrong superautodyne; radio frequency amplifier and crystal detector; etc., etc. The catalog contains 200 illustrations. On account of its great cost, it cannot be distributed free of charge. Mailed only upon receipt of The catalog contains 200 illustrations. On account of its great cost, it cannot be distributed free of charge. Mailed only upon receipt of

15c in stamps or coin.



96-98 PARK PLAGE, NEW YORK CITY **DEALERS** Get Our Special Proposition

This business was originated with the sole purpose to cater to the amateur who has small orders. ALL OF OUR ORDERS ARE SMALL and that is why your small order will never be side-tracked by us. A trial order will make you a life customer. Order from the above illustrations. "We can only stick you once." Try us with a 50c order. ALL GOODS PREPAID.

Factories Brooklyn, N. Y.—Elkridge, Md.