

RADIO MAINTENANCE

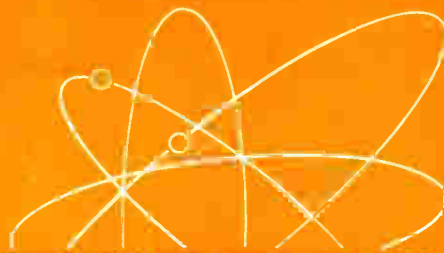

AM · FM · TV

FEBRUARY 1949

Engineering leadership is behind every

*C*unningham tube



*RCA Laboratories, Princeton, N. J.
RADIO CORPORATION of AMERICA*

SEE YOUR CUNNINGHAM DISTRIBUTOR TODAY



**A QUALITY PRODUCT OF THE
RADIO CORPORATION OF AMERICA**

World Radio History

你的難題
已竟解決了



Jensen Customode

Your Chinese puzzle mystery is solved. Perfect for your ever-expanding requirements of audio-video equipment for your Home Entertainment Center or Amateur Shack. Four basic units: Reproducer Cabinet—designed especially for a Jensen 15-inch coaxial loudspeaker; Small Utility Cabinet—for tuner, amplifier, recorder, record-changer; Medium Utility Cabinet—for larger receiver, television set, or communications equipment; Record Cabinet—holding more than 200 records. With these units, thousands of combinations are possible. Beautiful cabinetry in cordovan or muted blonde mahogany.

The puzzle of what to do with your equipment is solved. Write for literature and scale cut-up illustrations.

Jensen Manufacturing Company, 6637 S. Laramie Avenue, Chicago 38, Illinois. In Canada: Copper Wire Products, Ltd., 11 King Street W., Toronto.



Bias Supply
20 V 75 MA



B+ Supply Radio
130 V 75 MA



B+ Supply Pre-amplifier
130 V 50 MA



Trickle Charge Assembled
18 V 700 MA



B+ Supply Radio
130 V 100 MA



B+ Supply Radio-TV
130 V 150 MA

FEDERAL Miniature Selenium Rectifiers have opened the way to NEW CONCEPTS OF DESIGN



B+ Supply Television
130 V 200 MA



B+ Supply Television
130 V 250 MA



Vibrator 160 V.
160 V 100 MA



Vibrator Doubler
160 V 75 MA



Vibrator Doubler
160 V 100 MA



Vibrator Doubler
160 V 200 MA



B+ Supply Television
130 V 400 MA

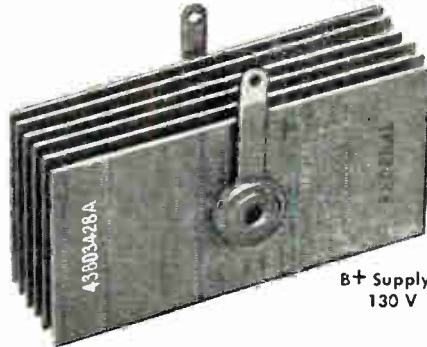

B+ Supply Television
130 V 500 MA

The Federal Miniature Selenium Rectifier has firmly established its position as a versatile new source of DC power in electrical and electronic design.

From a "Federal First" in 1946—when the nation's leading radio set manufacturers were quick to adopt it as a rectifier tube replacement—the field of application of Federal's Miniature Selenium Rectifier has expanded to a point where radio rectifier tube replacement is but one of an almost limitless variety of uses.

Today there are millions of Federal

"Miniatures" in use not only in radio sets but in television, electric shavers, electronic musical instruments, inter-communication systems, mobile radio and many special applications.

Now Federal offers a line of 18 different "Miniatures"—and still more are in development. It is our policy to work directly with you in specifying the right Federal Miniature Selenium Rectifier to meet your requirements. If there's not a Federal "Miniature" to handle your particular job, there can be. For information, write to Department F458.



KEEPING FEDERAL YEARS AHEAD... is IT&T's world-wide research and engineering organization, of which the Federal Telecommunication Laboratories, Nutley, N. J., is a unit.

Federal Telephone and Radio Corporation

SELENIUM and INTELIN DIVISION, 900 Passaic Ave., East Newark, New Jersey

In Canada: Federal Electric Manufacturing Company, Ltd., Montreal, P. Q.
Export Distributors: International Standard Electric Corp. 67 Broad St., N. Y.

Test Pointers

ON SIGNAL INJECTION

Signal-injection is probably the fastest known method of locating the point of signal-disappearance in defective radio receivers. Signal injection is also an economical approach because only a test oscillator is required and such an oscillator should be a part of every technician's equipment for precise alignment work.

Here's how to trouble-shoot a dead AM receiver by signal injection:

1. Make sure that the filter input resistance is over 2000 ohms. Repair filter, if necessary.
2. Turn power on, and check filter output voltage.
3. Inspect all tubes to see that heaters are operating.
4. Adjust test oscillator for maximum audio output. Connect ground clip of af cable to the receiver chassis, and touch probe of af cable to plate terminal of the output tube. (Use a series capacitor in all tests, unless the probes or generator contain blocking capacitors.) A low audio tone will be heard from the speaker if the output transformer and speaker are operative.
5. Reduce generator output and proceed progressively toward front end of set; touch probe to grid of output tube, to plate of audio tube, to grid of audio tube, and finally to diode load resistor. If sound from speaker ceases at some point, use an electronic volt-ohmmeter to locate the faulty component.
6. Adjust test oscillator for modulated output at the intermediate frequency of the receiver. Touch probe in turn to the detector diode, next to the plate terminal of the last if tube, then to the grid terminal, and proceed progressively to the mixer signal grid. The generator output must be progressively reduced; this reduction serves as a rough indication of stage gain. If signal disappears at one of the check points, use the volt-ohmmeter to "close in" on the defective component.
7. Re-adjust test oscillator to some frequency near the high end of the broadcast band, and tune receiver to this frequency. Touch probe to mixer signal grid. If signal comes through, the trouble is in the rf section. If the test signal does not come through, the trouble is in the oscillator.
8. Check for presence of oscillator bias with an electronic voltmeter. A substitution check of oscillator performance can also be made: turn modulation off and tune test oscillator to a frequency which is the sum of the intermediate frequency and the frequency of a strong local broadcast station. (Every service shop should be equipped with a good outside antenna.) The test oscillator output is substituted for the local oscillator output as shown in Fig. 1.

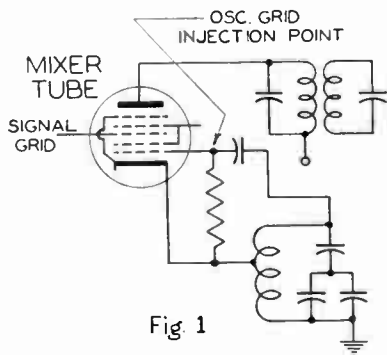

Fig 1

9. If set is still dead, and oscillator is ok, turn on modulation and tune both test oscillator and receiver to the same rf frequency. Touch probe to plate of rf tube, and work back progressively to the antenna.

These signal-injection tests usually require less than five minutes to complete. As the technician gains experience, he will find many short cuts which are beyond the scope of this article. To summarize, signal-injection techniques are speedy and versatile, and no specialized test equipment is required other than the test oscillator which is also needed for receiver alignment.



For speedy servicing...

the RCA WR-67A Test Oscillator

• A better job at a modest price . . . with more features than you'll find in most signal generators . . . that's the RCA WR-67A . . . an instrument specifically designed to cut servicing time on AM sets, where speed counts the most.

Signal injection and alignment work are rapidly and accurately accomplished with the WR-67A. The range switch gives you the quick selection of three fixed frequencies of 1500, 600, and 455 kc . . . or smoothly variable fundamental frequencies from 100 kc to 30 Mc, plus useful harmonics out to 90 Mc.

Other outstanding features include: a temperature-compensated oscillator . . . special signal injection probe . . . both step and vernier attenuators . . . double shielding . . . miniature tubes throughout . . . six-band drum dial with easy-to-read, four-foot scale spread . . . adjustable modulation level for internal and external modulation . . . power-line filter to minimize rf leakage . . . and 400-cycle signal source.

RCA WR-67A Test Oscillator combines speed, accuracy, convenience, and over-all dependability. Professional in appearance and professional in performance, it is one of eight *matched test units* engineered for modern AM, FM, and TV servicing. Get further details on the WR-67A from your RCA Test Equipment Distributor—or write RCA, Commercial Engineering, Section 51BX, Harrison, N. J.

SPECIFICATIONS OF WR-67A

Frequency Range	100 kc. to 30 Mc.
R-F Output	5 μ V to 1 volt RMS (Output impedance varies from 10 to 1000 ohms as attenuator is varied from 1 to 4).
Modulation Frequency (internal)	400 cycles (approx.)
A-F Output	25 RMS volts across 100,000 ohms at no load.
A-F Input	2 RMS volts required for 30% modulation.
Power Supply	105-125 volts, 50-60 cycles, 30 watts.
Dimensions	w. 13 $\frac{1}{2}$ " ; h. 10" ; d. 7 $\frac{1}{2}$ "
Weight	15 lbs.

Always keep in touch with your RCA Distributor



RADIO CORPORATION of AMERICA

TEST AND MEASURING EQUIPMENT

HARRISON, N. J.

RADIO

MAINTENANCE

INCLUDING
ELECTRONIC
MAINTENANCE

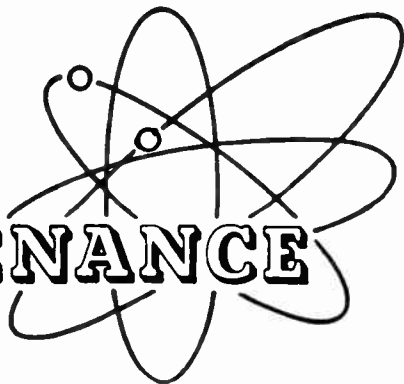

Volume 5

FEBRUARY 1949

Number 2

CONTENTS

Adjusting TV Traps	Matt Mandl	8
Procedures which lead to better servicing results		
Visual TV Receiver Analysis	John B. Ledbetter	12
Using test patterns for effective trouble shooting		
Audio Systems in F-M Receiver	J. Richard Johnson	16
Analysing some representative o-f section in f-m		
How to Plan Your Budget	Victor M. Turner	20
Continuing our series on successful advertising		
Juke Box Servicing	Max Alth	24
How the technician can establish a profitable sideline		
A Volt per Mil per 1000 Ohms	J. F. Cataldo	26
Simple mathematics to make the technician's work easier		
Electronically Speaking		28
Editorial		30
Over the Bench	John T. Frye	32
Trade Literature		34
The Industry Presents		38
The Notebook		40

WILLIAM F. BOYCE
Publisher

JOSEPH J. ROCHE
Editor

VICTOR M. TURNER
Art Director

MORTON SCHERAGA
Contributing Editor

THOMAS A. BYRNES
Director of Field Services

AL JOHNSTON
Circulation Manager

ADVERTISING REPRESENTATIVES

Eastern
Herbert J. Olsow
480 Lexington Ave.
New York 17, N. Y.
Plaza 9-0861

Midwestern
Stuart J. Osten
333 No. Michigan Ave.
Chicago 1, Ill.
Dearborn 2-3507

Copyright 1948, Boland & Boyce, Inc.

Radio Maintenance is published monthly by Boland & Boyce, Inc., at 34 No. Crystal St., East Stroudsburg, Pa., U.S.A.; Executive and Editorial Office, 460 Bloomfield Ave., Montclair, N. J. Subscription Rates: In U. S., Mexico, South and Central America, and U. S. possessions, \$3.00 for 1 year, \$5.00 for two years, single copies 40 cents; in Canada, \$3.50 for 1 year, \$6.00 for 2 years, single copies 45 cents; in British Empire, \$4.00 for 1 year, \$7.00 for 2 years, single copies 60 cents; all other foreign countries, \$5.00 for 1 year.

Entered as second class matter July 13, 1946, at Post Office, East Stroudsburg, Pa., under the Act of March 3, 1879.

Change of address: Four weeks' notice required for change of address. When ordering a change, please furnish an address stencil impression from a recent issue if you can. Address changes cannot be made without the old stencil as well as the new one.

**MAN! . . . This new
OHMITE
RESISTOR CABINET
sure saves me time!**



Get YOUR All-Plastic Cabinet by Purchasing the Resistor Assortment of 1/2-watt "Little Devils" . . \$1250

It's easy to find the *right* resistor . . . fast . . . in this handy, handsome, all-plastic OHMITE cabinet. Compact—only 9" x 5 1/4" x 4 3/4"—its 40 compartments are packed with a selected serviceman's assortment of 125 individually marked "Little Devil" resistors in 40 values from 10 ohms to 10 megohms. And, you pay only the regular price of the resistors . . . *nothing* extra for cabinet.



**LITTLE
DEVIL
Composition
Resistors**

See Your Distributor

BROWN DEVIL

Vitreous Enamel Resistors



A favorite with servicemen. Easily mounted by its timed wire leads. In sizes 5, 10, and 20 watts. Tol. ±10%.

DIVIDOHM

Adjustable Resistors

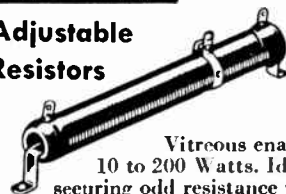

Vitreous enameled. 10 to 200 Watts. Ideal for securing odd resistance values.

OHMITE MANUFACTURING CO.
4912 Flournoy Street • Chicago 44, Ill.

Be Right with

OHMITE

RHEOSTATS • RESISTORS • TAP SWITCHES

Standard in the
RADIO AND TV FIELD



Kester Flux-Core Solders are as modern as today's TV receiver. The same high quality Kester Flux-Core Solders that are standard for the radio and television manufacturers are available to the service man for fast, efficient radio and television maintenance.

**R/x Prescription
 For Good Soldering**
 Insist upon Kester Plastic Rosin-
 Core Solder from your jobber.

**KESTER SOLDER
 COMPANY**

4201 Wrightwood Avenue, Chicago 39, Illinois

Factories Also At

Newark, New Jersey • Brantford, Canada



**THE READER
 SPEAKS**

THE article by A. K. O'Brien in the December '48 issue of *Radio Maintenance* on radio servicing business practices is timely and interesting. . . . But let's face it: Through bitter experience the radio public has learned to distrust servicemen and to make the best of a bad deal. Through Federal licensing, technical ability at least could be verified. The Better Business Bureau, and Chambers of Commerce, and other business organizations could assist in policing business operations.

Working conditions in the radio servicing field could stand considerable improvement—a 40-hour week, a clean shop, and pay commensurate with training and ability.

The theoretical side of radio can be taught successfully by correspondence. Often, there is no other way for a man to receive his training. But the practical training should be received in a supervised, regulated, resident school or in a shop under the guidance of a properly trained man. Reasonable tests and educational standards should be set up and adhered to, so that before a man is permitted to take training there is some evidence that he will be able to do the work properly.

The department head in a radio school should be capable of doing what the course teaches, and licensing should see to it that proper tests are given to determine the measure of ability. Tests every five years should be adequate—not renewal examinations, but real tests. Instructors should also hold proper licenses and prove ability. There are far too many incompetent teachers and technicians in radio today. I know — I've seen and worked with many of them.

Until licensing is put into effect, by an impartial authority, servicemen will have no real standing, no proof of ability. May that day come soon, to grant the industry a measure of decent respectability.

Willard Mooly

AUTO RADIO and HYTRON go together

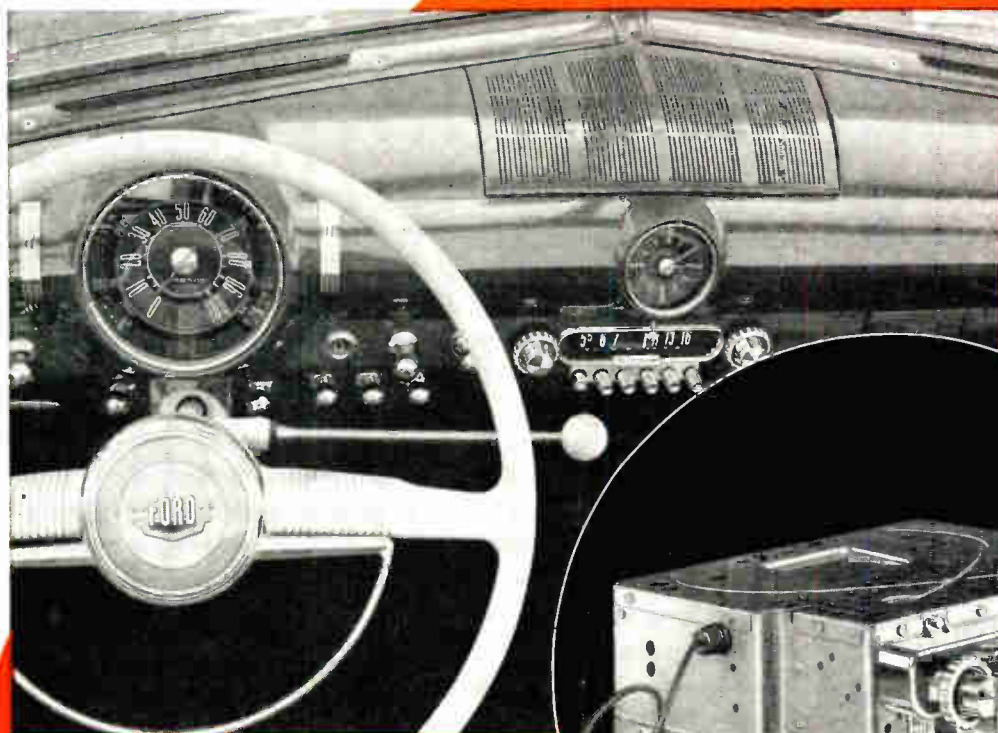

"A Ford in your future?" There will probably be a fine new Ford radio receiver on the dash. Chances are good this receiver will be equipped with tubes by Hytron. For Hytron is a major supplier of Ford auto radio tubes. That is only natural. Hytron *specializes* in auto radio tubes — both GT and miniature. Close engineering co-operation with leaders like Ford help make Hytron auto radio tubes leaders, too. 'Nuff said. Hytron and auto radio go together.

SPECIALISTS IN RADIO RECEIVING TUBES SINCE 1921.



HYTRON

RADIO AND ELECTRONICS CORP.

MAIN OFFICE: SALEM, MASSACHUSETTS



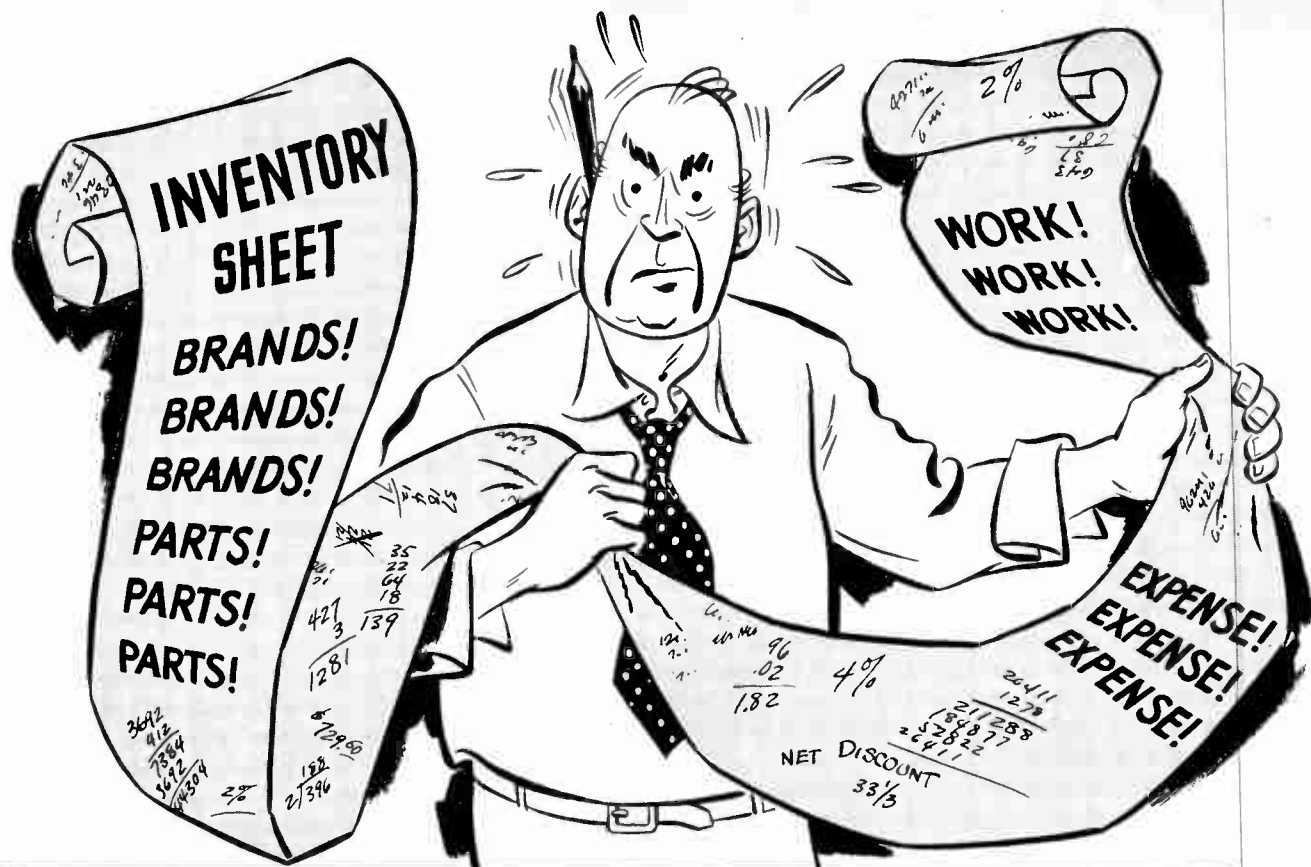

Concentrate on Philco

... the brand radio owners prefer

FOR A MORE PROFITABLE PARTS BUSINESS IN 1949

Your customers own more Philco radios by far, than any other make. Yes, they have been buying more Philcos for 18 straight years—creating for you the biggest replacement market for parts and accessories—a market you *know* prefers Philco. Take advantage of this preference by selling genuine Philco replacements. Streamline your stock, speed-up turnover, increase your profits by concentrating on Philco parts and accessories in 1949.

SEE YOUR PHILCO DISTRIBUTOR

Your Raytheon Tube Distributor Hands Prestige to You on a Platter

— A Service Guarantee BOND That Offers You Genuine Customer Insurance — Yet Costs You Nothing

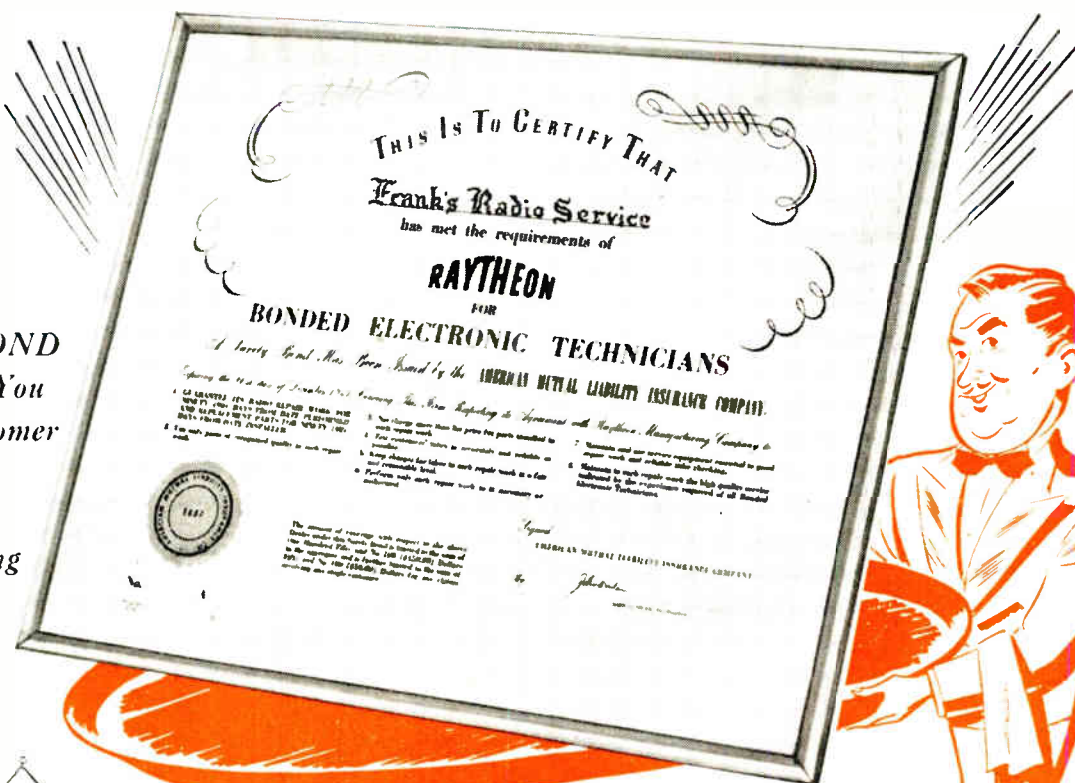

This RAYTHEON SURETY BOND is the best evidence you can give your customers that you stand out from the crowd when it comes to the quality and reliability of radio service. It's an iron-clad 90-day BONDED guarantee on your labor and parts backed by a nationally known insurance company with assets of close to a hundred million dollars!

Raytheon pays for this Bond

The Raytheon Tube Distributor in your area has it ready for you—if you can qualify. Get in touch with him at once and start getting the cream of the business in your locality.

Why RAYTHEON Tubes

- 1. Good tubes** — produced by one of the oldest and soundest manufacturers in the industry — with an unsurpassed reputation for engineering achievement in electronics, and with the most advanced methods and equipment for quality control.
- 2. Best Distributors** — Raytheon Tube distributors are carefully chosen. You'll recognize the one nearest you as one of the best parts distributors in town. He has to be, as sponsor of the Raytheon Bonded Dealer Program.
- 3. Consistently advertised** — Raytheon national advertising and point-of-sale display material constantly reminds your customers and prospects of the value of the Raytheon name on every tube.
- 4. Universally accepted** — From the biggest Magnetrons to the tiniest hearing aid tubes Raytheon stands for quality. Raytheon tubes are instantly accepted as the finest that can be had.

Why RAYTHEON Bantal Tubes



The new Raytheon Bantal Tube simplifies your tube stock while it gives you a better tube to sell — rugged eight pillar construction, completely shielded internally means superiority in performance. Eight fast-moving Bantals replace sixteen equivalent GT and metal types.

Always ask for Raytheon Bantals



Excellence in Electronics

RAYTHEON MANUFACTURING COMPANY

RADIO RECEIVING TUBE DIVISION

NEWTON, MASSACHUSETTS • CHICAGO, ILLINOIS • LOS ANGELES, CALIFORNIA

RADIO RECEIVING TUBES • SUBMINIATURE TUBES • SPECIAL PURPOSE TUBES • MICROWAVE TUBES

ADJUSTING TV TRAPS

Here is a discussion of an often neglected procedure in servicing television receivers. Read it. It will prove of value

by Matt Mandl

A PHASE of television receiver servicing often neglected is proper trap adjustments. Very often the reason for this neglect lies in the mistaken belief that such traps are of importance only in certain areas where adjacent channel interference prevails. Such is not the case, however, for improper trap settings can result in the attenuation of video and sound signals by virtue of their frequency riding too close to the signal i-f frequencies. This can be more clearly understood by an analysis of typical trap circuits and the reasons for their use.

Fig. 1 illustrates the condition set up when a typical receiver is set on Channel 3. If the local oscillator is 87 megacycles, it will heterodyne with both the video and f-m carriers to produce two i-f signals: one 25.75

Mc. and the other 21.25 Mc. Because receivers using 10" or larger picture tubes require a wide band-pass for good picture detail, there is a good chance for adjacent channel interference. When the video i-f stages are 4 megacycles wide, the resonance curve extends sufficiently beyond the desired band limits to amplify signals which are too close to the i-f frequency.

Fig. 2 shows what happens when adjacent channel signals get through the 6 Mc. r-f stage and heterodyne with the oscillator. Here the sound carrier of the next lower channel (No. 2) would mix with the local oscillator and produce a frequency of 27.25 megacycles. This would ride through the i-f stages and produce interference on the screen because it is sufficiently close to the video i-f

frequency to be acceptable to the i-f stages.

If Channel 4 is also on the air, its video carrier of 67.25 Mc would mix with the 87 megacycle local oscillator to produce 19.75 Mc., another potential source of interference to picture reception. Besides these, there is the factor of the sound i-f of the channel to which we are tuned. Thus, the 21.25 megacycle sound i-f would also be amplified by the video i-f stages and produce sound bars on the picture tube screen.

Trap Frequency Variations

The above indicates the need for three traps in such a receiver: one for the sound of the channel in use, the other for sound of the adjacent channel, and a final one for trapping out the heterodyne frequency of the

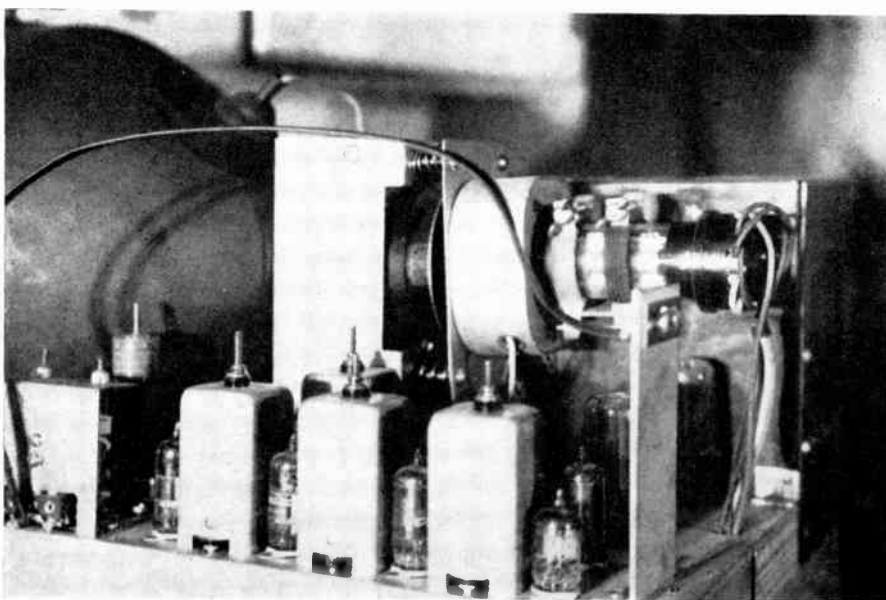

Three trap transformers and a converter transformer (left rear, next to picture tube) are shown here in a view of chassis of an Admiral TV Receiver. On most receivers, traps are located on top of the chassis. Their frequencies vary with different models

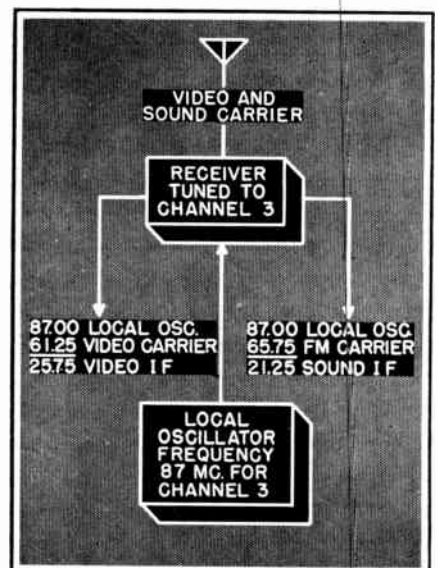

Fig. 1 Video and sound (f-m) carriers of Channel 3 mix with local oscillator to produce video and sound intermediate frequencies

carrier for the channel above the one in use.

These particular trap frequencies are only for sets having a video i-f of 25.75 Mc and a sound i-f of 21.25 Mc, such as the RCA 8TS30 or the Admiral 30A1. Other sets which use different i-f frequencies will have trap frequencies which vary accordingly. For instance, the General Electric Model 803 uses a video i-f of 26.5 Mc and a sound i-f of 21.9 Mc. Fig. 3 illustrates the resultant trap frequencies when adjacent channel carriers mix with the oscillator, which would be 87.65 Mc when the set is tuned to Channel 3.

Fig. 4 is a chart showing typical trap frequencies for several representative television receivers. Receivers using 7-inch tubes do not, as a rule, employ traps. The reason for this lies in the fact that the video i-f band-pass for 7-inch sets is usually 3 megacycles or less, which means that the relative gain per stage is greater as well as the over-all selectivity. The added selectivity is sufficient to obviate the necessity for traps, except in unusual signal areas.

The i-f band-pass corresponding to Fig. 2 is shown in Fig. 5. As with all video i-f response curves, the video i-f frequency is set on the slope of the resonance curve because attenuation here should be down due to the unwanted extra gain which would result from the vestigial section of the carrier. The traps, when properly set, will attenuate points as shown in the figure.

Fig. 6 indicates what happens if one of the traps is not properly adjusted. If any trap is off its frequency in the direction of the i-f response curve, it will trap out a section of the band-pass, thus seriously affecting picture gain or fine detail. This clearly illustrates the importance of trap adjustments even though the receiver is in an area free from adjacent channel interference. Trap adjustments, of course, are doubly important in areas where adjacent channel reception is possible, for improper adjustment will then result in herring-bone lines on the screen, sound bars, or other manifestations of adjacent channel heterodyning.

Trap Adjustments

Fig. 7 shows the location of the various traps in the video i-f section of the RCA 8TS30 receiver. The ar-

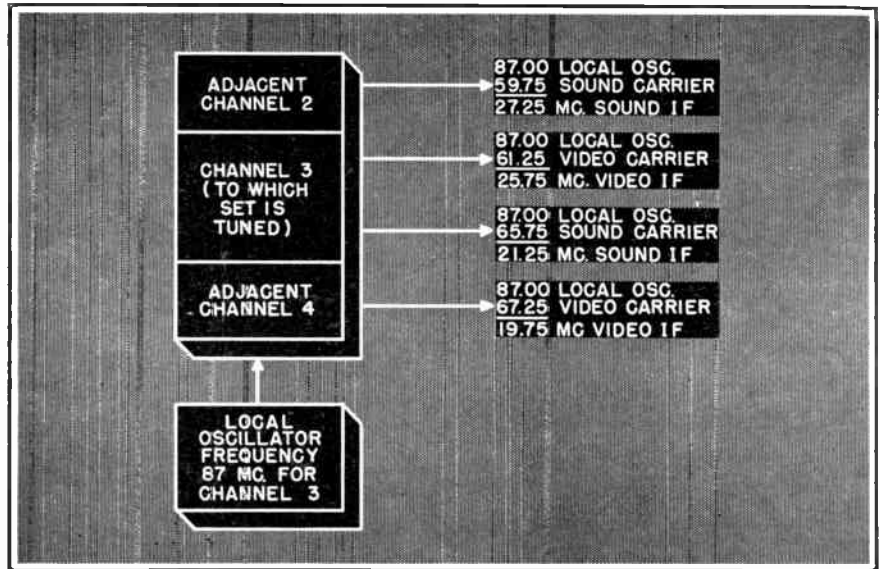

Fig. 2 This diagram shows how sound and video carriers of adjacent channels, mixing with the local oscillator, produce frequencies which must be trapped out

SET TUNED TO CHANNEL 3		Gives
Channel 2 sound 59.75	mixes with local osc. 87.65	----- 27.9
Channel 4 video 67.25	mixes with local osc. 87.65	----- 20.4
Channel 3 video 61.25	mixes with local osc. 87.65	----- 26.4 i-f
Channel 3 sound 65.75	mixes with local osc. 87.65	----- 21.9 i-f

Fig. 3 Listed in the above table are i-f and trap frequencies for various channels, generated with television receivers having i-f frequencies other than those shown in Fig. 2

Model Receiver	Video i-f Freq.	Sound i-f Freq & Trap	Lower Adjacent Sound Trap	Higher Adjacent Video Trap
RCA 630TS and 8TS30	25.75	21.25	27.25	19.25
General Electric 803	26.4	21.9	27.9	----
Philco 48-700	26.6	22.1	28.1	----
Motorola VF102-A-C	26.4	21.9	27.9	20.5
DuMont RA103	26.4	21.9	27.9	----
Admiral 30A1	25.75	21.25	27.25	19.75

Fig. 4 Typical trap frequencies for a number of representative television receivers are shown in this chart. Receivers using 7-inch picture tubes normally do not employ traps

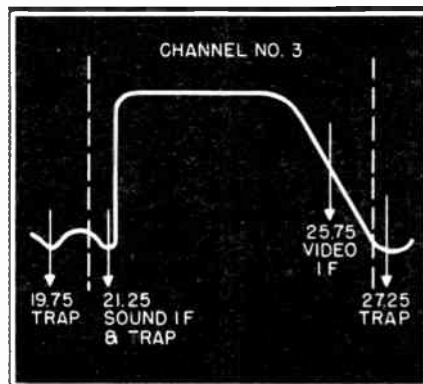

Fig. 5 Video i-f pass-band developed when heterodyned as in Fig. 2, traps properly set. Attenuation will be as shown in the figure

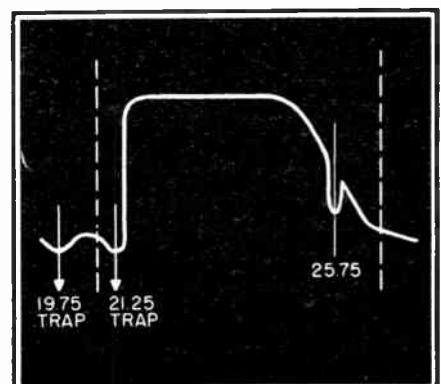

Fig. 6 Result of trap maladjustment. Because 27.25 trap was not correctly adjusted, a portion of band-pass slope is attenuated

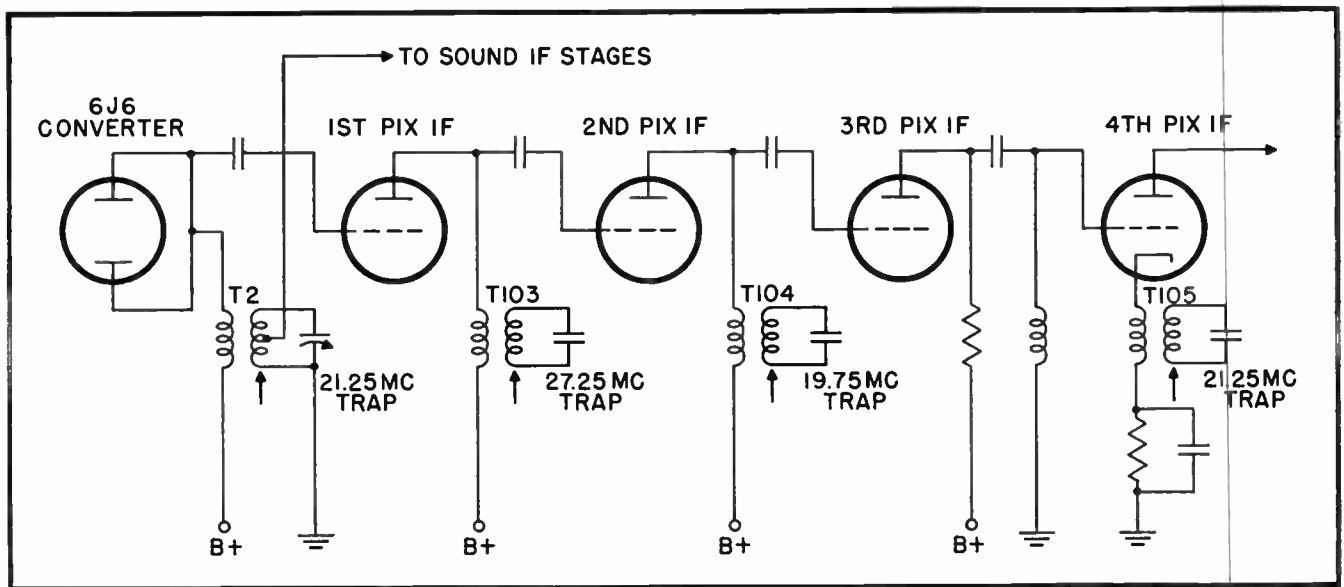

Fig. 7 LOCATION OF TRAPS in RCA Models 8TS30 and 630TS television receivers. The secondary T2 acts as the first sound trap. The other traps are ordinary absorption type circuits. These traps are fairly sharp

rows pointing upward indicate that these adjustments are available on the top of the chassis. Since these traps are fairly sharp, an ordinary signal generator is used, having a frequency range covering the traps. The secondary of T2 not only picks up the sound i-f signal, but also acts as the first sound trap for 21.25 Mc. The other traps are ordinary absorption type circuits.

Alignment of Traps

Before alignment of traps, allow the receiver to warm up for about 10 to 15 minutes so that there is no more danger of oscillator drift. Make sure the fine tuning control is set for maximum sound output. The channel switch should be set for a high channel where no transmitted signal is being received. A vacuum-tube voltmeter is then connected across the load resistor of the picture second detector and set to read low voltage d-c.

A signal generator is connected to the input of the mixer and on the RCA as well as some other sets a connection for this purpose is available through a hole in the side of the chassis next to the r-f tuner unit. In the absence of such a connecting point, or if the input is inaccessible due to the placement of the r-f tuner, the signal generator can be attached to the antenna terminals. Such a connection, however, means the signal from the generator will suffer attenuation because of the r-f unit being tuned to a different frequency. The local oscillator should be made

inoperative by removing the oscillator tube when antenna input is used.

It must be emphasized here that the use of any signal generator for television alignment should not be attempted unless the signal generator has been calibrated. Particularly in the case of traps, where sharp tuning is employed, it is important that exact frequencies be used.

The signal generator should first be set for 27.25 Mc and the trap corresponding to that frequency adjusted for *minimum* output on the vacuum-tube voltmeter. Next set the signal generator to 19.75 Mc and adjust that trap for minimum output on the vtm.

Now set the signal generator for 21.25 Mc and adjust the first of the two sound traps for minimum indication on the voltmeter. If no decrease can be obtained, the second trap (21.25 Mc) may be on its resonant frequency and cutting down the signal. In such cases, deliberately detune the second 21.25 Mc trap, and again try adjustment of the first trap (T2).

When the first trap has been adjusted, it will be difficult to align the second 21.25 Mc trap since the first one will absorb most of the energy. In order to properly tune the second trap, the signal generator must now be moved to the 3rd picture i-f grid, thus by-passing the trap effect of T2. Inject 21.25 Mc into this stage and adjust the second trap (T105) for a minimum on the meter.

A double check on the alignment can be made by modulating the sig-

nal generator with a 400 cps note and observing the sound bars which will appear on the picture screen. Tune the traps for a reduction of the sound bars on the screen.

Various Types of Traps

Alignment of traps for all sets follows the pattern which has just been detailed, even though all do not use absorption type traps. Some sets use cathode traps and others use series traps in the grid circuit, or the bridged "T" type shown in Fig. 8. Whatever method is employed, however, the adjustment procedures are the same, since all are intended to trap out the unwanted signals resulting from heterodyning of adjacent channel carriers.

The adjusting of traps without the use of a signal generator should not be attempted except under special circumstances, since interference or i-f attenuation may be made worse instead of better. The only exception would be in the case of a receiver located in an area where the adjacent channels are on the air and it is known that the mixer-oscillator stages are properly tracked. Under such conditions, Channel 3, for instance, could be tuned in, and the Channel 4 interference pattern on the screen tuned out, by adjusting the upper channel video trap. If Channel 2 is also on, and producing interference, the lower channel sound trap can be adjusted until the interference disappears. After these two traps have been set, the sound traps for the channel in use can be adjusted.

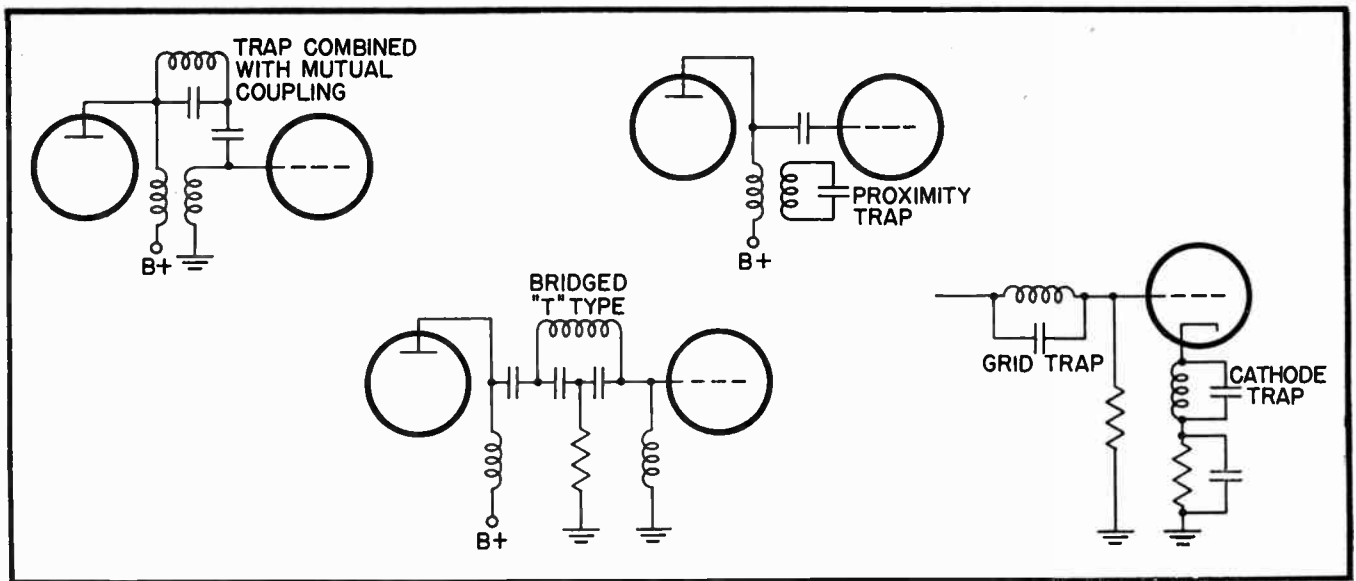

Fig. 8 VARIOUS TYPES of traps are used. However, whatever method is employed, adjustment procedures are the same, since all must trap out unwanted frequencies resulting from the heterodyning of adjacent channel carriers

Inasmuch as the above procedures can be followed by viewing the picture screen, chassis removal for attachment of a vtvm is not necessary. Adjustments are facilitated by placing a mirror before the screen so that changes can be observed while working on the traps from the rear of the set.

Sound Interference Traps

With respect to the sound traps, it is important to distinguish between the type of interference presented by the type of interference presented by the lower adjacent sound carrier and the sound i-f of the channel to which the set is tuned. For instance, a maladjustment of the 21.25 Mc traps in the RCA previously discussed will result in sound bars on the screen. This, however, will be true only when the f-m carrier is being modulated. During transmission of the pattern, a steady tone is also broadcast, and this would result in a stationary sound bar pattern if the traps are out. On the other hand, if a program is in progress, the sound bars would appear only when the actors are talking, or when some other sound accompanies the picture. In such instances, the interference from the sound of the channel to which the set is tuned will usually be distinguished by its disappearing when the sound from the speaker stops, and re-appearing when the speaker produces sound.

The sound carrier interference from the next lower channel, however, may appear as sound bars or it may appear as a herring-bone beat

→ to page 48

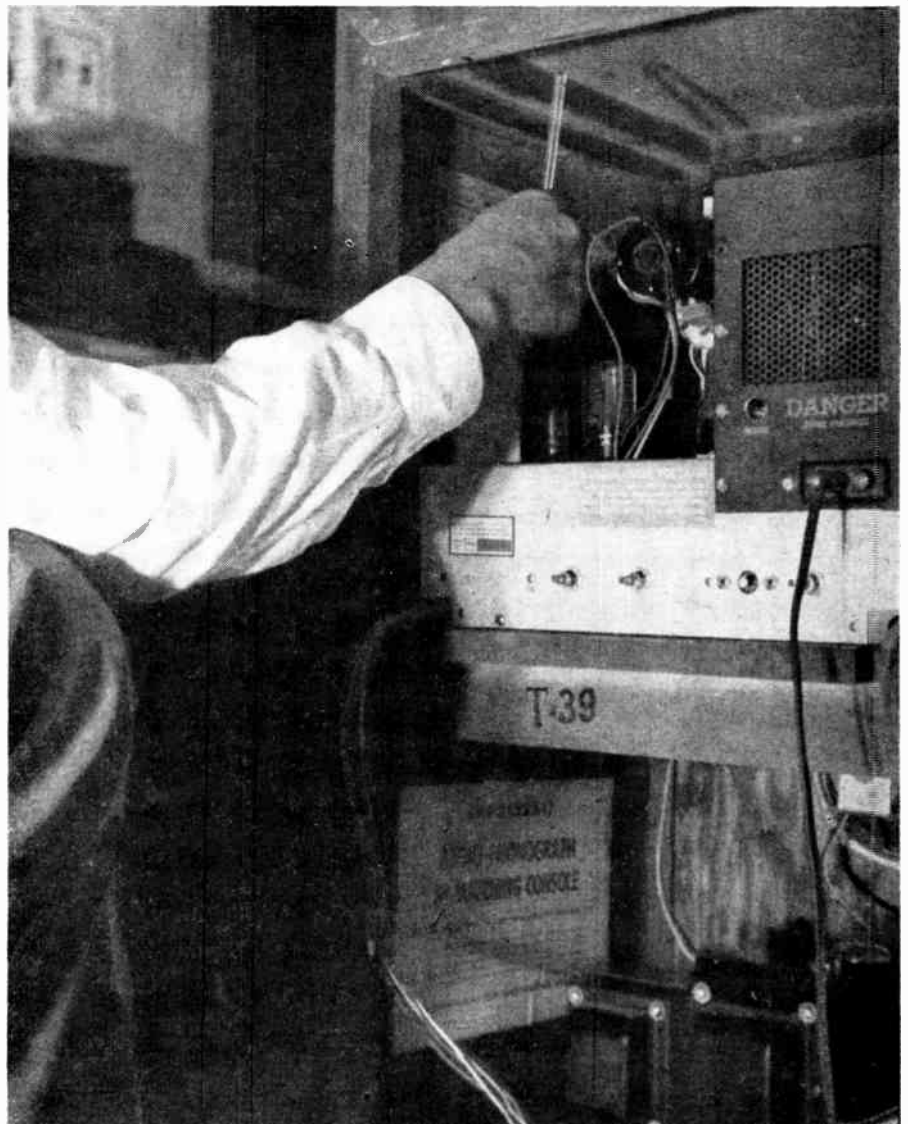

As shown in this picture, trap adjustments can be made without chassis removal and results can be checked by viewing picture screen. Place a mirror before screen, so that changes can be observed while traps are adjusted from the rear of the receiver

Visual receiver analysis

by John B. Ledbetter

In trouble-shooting television receivers, the service technician is provided with a very efficient and accurate test instrument: the television receiver itself

AS the serviceman becomes more familiar with the operating characteristics of video receivers, he will more or less develop his own technique or preferred method of testing. Ingenuity of the individual, along with solution of special and isolated problems, will suggest various short-cuts which may successfully be employed in routine servicing. Until such time, however, the simple preliminary analyses described herein will provide a sound basis upon which a "special" servicing technique can be built.

Generally, the television receiver may be treated as two separate units—*video* and *sound*. The sound channel is subject to the same troubles as a regular f-m or a-m receiver, and may be traced in much the same manner. Defects common to both video and sound channels will of course be apparent in one or more of the picture channels and can be successfully traced from that point.

For the purpose of this discussion, it will be assumed that the sound channel of the receiver, unless otherwise indicated, is functioning properly.

For alignment and the tracing of distortion and other troubles in the video section, the regular television test instruments must be employed. In the preliminary tests, however, much valuable time can often be saved by simple visual analysis of

the cathode ray tube screen. Any defects in the video section of the receiver will affect the resultant image and may be accurately diagnosed at this point. The very composition or reaction of the image or raster to cases point directly to trouble in a particular stage or channel.

First, Check Tubes

In any receiver, it is recommended that all tubes be checked and replaced is necessary before proceeding with the regular stage-by-stage measurements. Since the majority of receiver difficulties involves defective tubes, checking these items *first* will save much time and trouble, in many instances eliminating the need for proceeding with further tests. It is especially important in f-m and television receivers that necessary tube replacement be made *before* aligning, otherwise the sensitivity, band-width, and dial calibration of the receiver may be seriously affected.

It should also be borne in mind that the high-frequency ranges encountered in all tuned circuits, including the i-f stages, introduce certain peculiarities in operation which must be taken into consideration when checking the receiver. An i-f tube, for example, which may function perfectly at broadcast i-f frequencies, may contain sufficient residual gas to cause extreme instability

or loss of gain at the higher i-f frequencies of 11 Mc or 24.65 Mc. Oscillator drift or instability can also be due to a gassy condition, or to loose elements in the tube. For optimum performance, all tubes should be replaced when their emission checks 10 percent or more below normal, even though the tube checks good in other respects.

As a passing thought, it might be well to remember that a "good" indication obtained on a tube tester is not conclusive proof that the tube will function properly in the receiver. If there is reasonable doubt, try substitution. Noisy, intermittent, or microphonic tubes may best be checked by tapping with a small rubber mallet or with the finger while the set is operating (preferably while *tuned off the station*).

For preliminary visual analysis, the receiver should be connected to its recommended antenna and all controls set to their normal operating positions so that a more accurate indication may be obtained on the cathode ray tube screen.

No Image or Raster

Suppose no image, line, spot, or pattern can be seen on the cathode ray tube screen, even with the brilliancy control turned to its maximum position. This could indicate a defective cathode ray tube, failure in the high-voltage or kick-back power

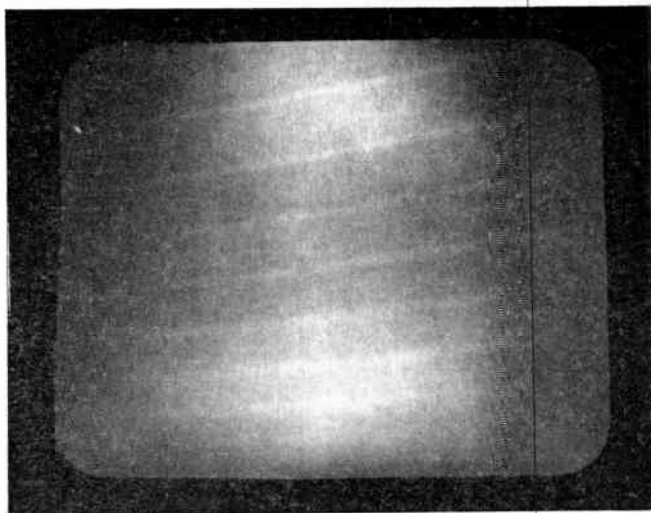

Fig. 1 No video signal is present (raster only)

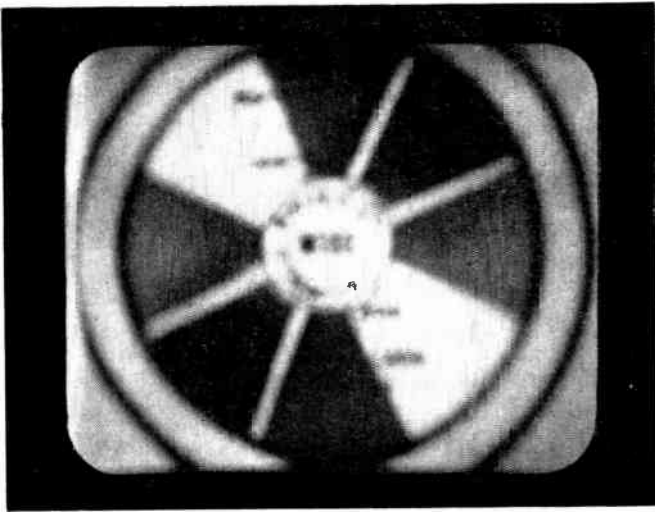

Fig. 2 Entire picture blurred, focus control requires adjustment

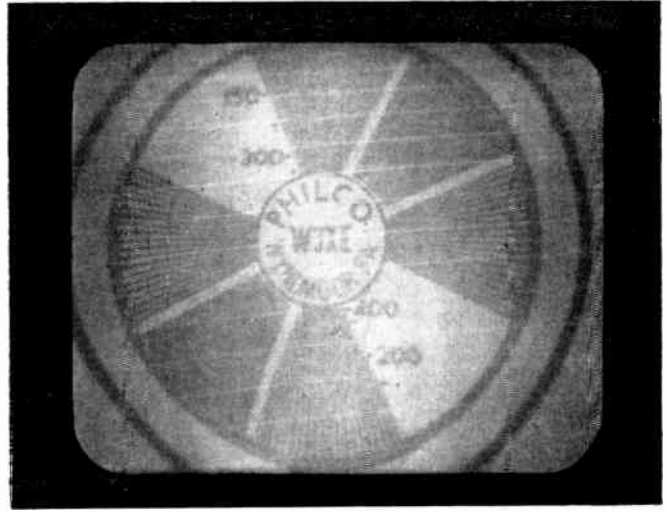

Fig. 3 Dim, distorted picture, background control needs adjusting

supply, excessive cathode ray tube grid bias, or an open or shorted condition in the cathode ray tube socket or leads. The kick-back and bias circuits should be checked for proper voltage. In checking the high-voltage supply, be sure to use heavily insulated test prods and avoid bodily contact with the receiver chassis or ground return (It is much easier to treat high-voltage circuits with respect than for someone to break the news to your widow). If proper voltages are indicated at the socket of the cathode ray tube, check adjustments of the beam centering controls. If these appear to be normal or have not been tampered with, replace the cathode ray tube.

The presence of a single stationary spot on the screen indicates lack of saw-tooth voltage on the horizontal and vertical deflecting plates. Trouble of this sort is usually due to a shorted filter condenser, defective rectifier tube, or a faulty connection in the common sweep power supply.

Raster, No Image

A number of defects may be indicated and localized by studying the screen raster (The raster only should resemble that shown in Fig. 1). Conditions of the raster may be observed by increasing the setting of the brilliancy control until the raster back traces are visible, and noting whether they are moving or stationary. A stationary raster indicates that the horizontal and vertical circuits are being properly controlled by sync pulses; a moving raster indicates failure of the sync pulses to control the vertical blocking oscillator.

If the raster is moving but no image is present and the sound channel is inoperative, trouble is indicated at some point ahead of the first i-f stage. All tubes and components in the mixer-first detector, oscillator and r-f stages should be checked and voltages measured at the tube sockets. Trouble often will be found in the low-voltage power supply. The pre-selector band switching and the antenna system should also be checked.

If the above conditions are noted but the sound channel is functioning, look for a defective video-frequency stage ahead of the clipper input. This includes the video detector and i-f system. If the no-image condition is accompanied by a stationary raster, check the video-frequency amplifier between the clipper input and the cathode ray tube.

It is possible that instead of a stationary spot a vertical line will be present on the screen, indicating lack of sawtooth voltage on the horizontal deflection plates. Trouble in this case is most likely due to a defective tube, part, or connection in the horizontal blocking oscillator. In this manner, presence of a horizontal line only is caused by failure of the vertical blocking oscillator.

Distorted Image

Distortion arising from, or introduced into, any part of the video section will be apparent on the cathode ray tube screen. A smeared picture, for example, with black or white shadow areas is due to loss of the lower frequencies in one of the video frequency stages, usually caused by

an open by-pass condenser in the plate or screen circuit of the video-frequency amplifier. This effect can also be due to defective condensers, coils or resistors in the video i-f and v-f coupled circuits. Loss of high video frequencies will result only in blurring or smearing of the finer details of the picture. Loss may be due to misalignment of video i-f circuits, or to defective condensers, resistors, or coils in the equalizing circuits of the video detector, i-f or v-f stages.

Blurring of the entire picture usually is due to an improperly adjusted focus control (see Fig. 2), or to incorrect voltage on the first anode of the cathode ray tube. If adjusting the focus control does not clear up the difficulty, check the cathode ray tube power supply unit.

A dim, highly distorted picture (Fig. 3), accompanied by interference patterns, poor contrast, and horizontal shifting, is caused by insufficient signal strength at the input of the clipper circuit. This may be due to a poor or defective antenna system, or to defects in one of the video stages ahead of the clipper. After checking each circuit, it is wise to readjust the horizontal control.

If the center and bottom portions of the picture are normal, but the top is distorted and exerts a fast pulling action in the horizontal plane (Fig. 4), the horizontal sweep is failing to hold to the sync impulses, or the video signal may be leaking through to the horizontal sweep generator. This action may also be caused if the pulses at the sweep generator input are too weak. All parts in the horizontal sweep gen-



Fig. 4 Top distorted, horizontal hold control needs adjustment

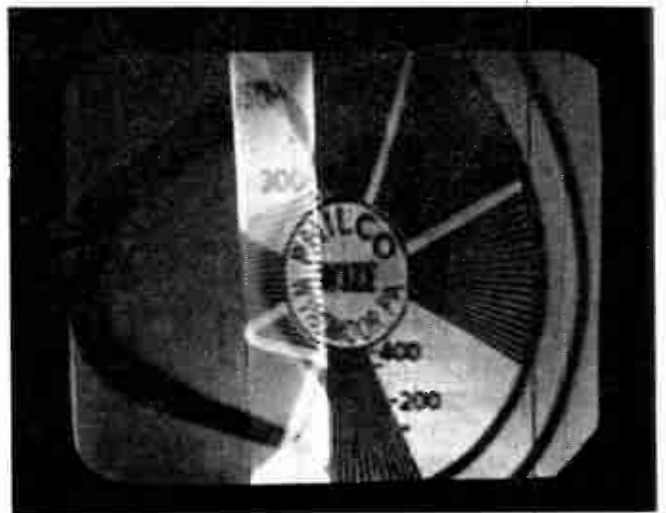

Fig. 5 Horizontal foldover indicates a faulty damping circuit

erator, clipper, and frequency separator should be adjusted if the trouble does not clear up with readjustment of the horizontal hold control. A picture folding horizontally (Fig. 5) indicates trouble in the damping circuit.

Interference

"Ghost" images are perhaps the most easily recognizable type of interference encountered in video receivers. Two or more super-imposed images of the same picture appear on the screen (Fig. 6). Since the primary cause of ghosts is multiple reception, the only method of elimination is to use a good directive antenna system erected in the clear and oriented to cancel the unwanted signal path.

Excessive a-c ripple or power line hum produces one or more dark horizontal lines on the screen. This

trouble may be due to an open plate cathode or screen by-pass condenser in the v-f amplifier, or to an open or leaky filter condenser in the power supply. Hum in the deflection coils of the cathode ray tube produces the effect shown in Fig. 7.

Ignition interference is characterized by white and black spots which move across the screen, accompanied on some bursts by loss of horizontal or vertical sync control. Diathermy interference and heterodyne interference from other radio sources creates a number of short diagonal bars or lines on the picture tube. The only practical solution is the installation of a directional antenna or, if interference is arriving over one particular frequency, installation of a television wave-trap in the receiver antenna circuit. A similar pattern can be produced by high frequency oscillation in the video channel. In

this case, the pattern will disappear when a television signal generator is connected to the receiver input.

Irregular shaped horizontal white and black lines, bars, or patterns may be generated *within* the receiver as a result of leakage from the sound channel to the video circuits (Fig. 8). Usually, this effect is due to an open by-pass condenser or misaligned sound i-f rejector. This trouble may also be caused by microphonic tubes or an incorrectly adjusted oscillator.

Excessive ripple, giving a "snow-storm" effect is due to insufficient gain in the video unit or to a poor antenna system. The snowstorm effect appears when the gain control must be turned abnormally high in order to receive the station.

Superfluous or Irregular Patterns

Most abnormal patterns are the

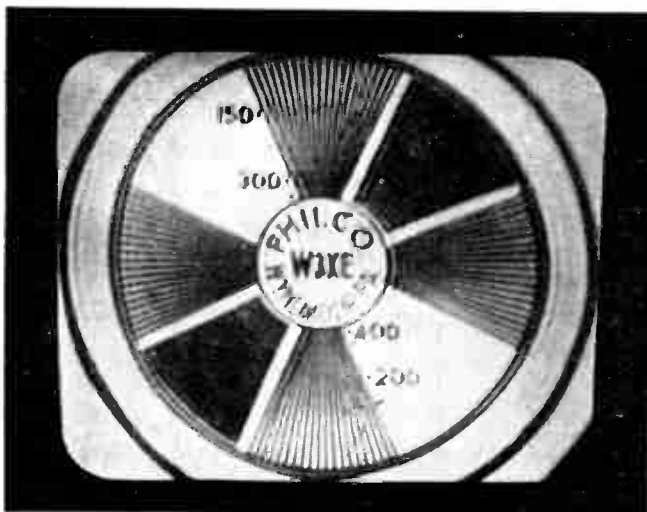

Fig. 6 Ghost images, primarily the result of multiple reception

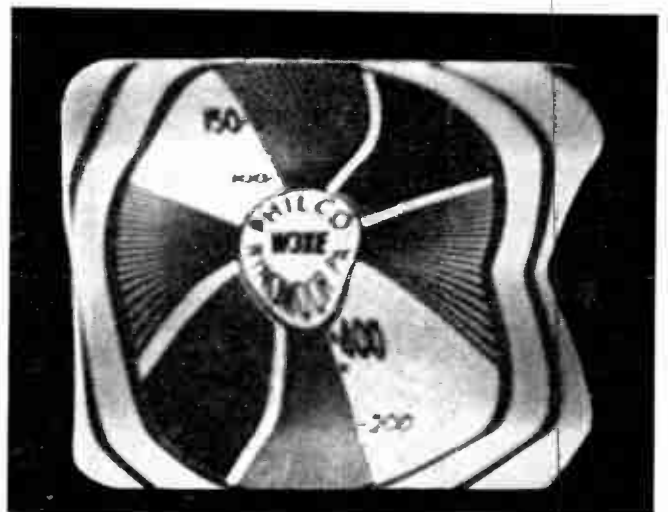

Fig. 7 Effect of hum in deflection coils of cathode ray tube

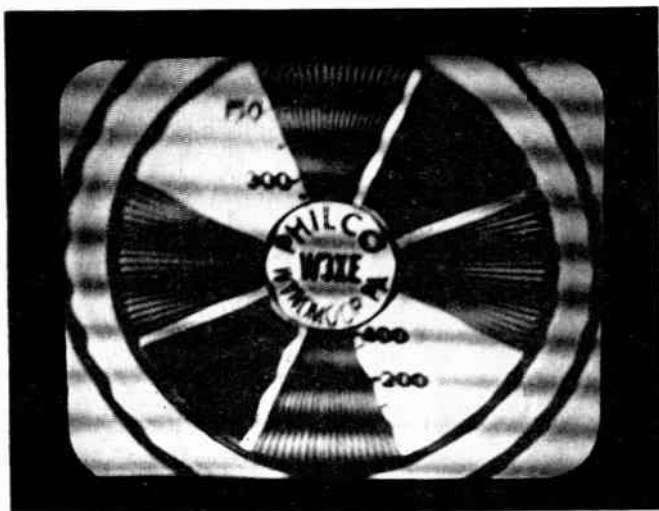

Fig. 8 Indicating leakage from sound channel to video circuits

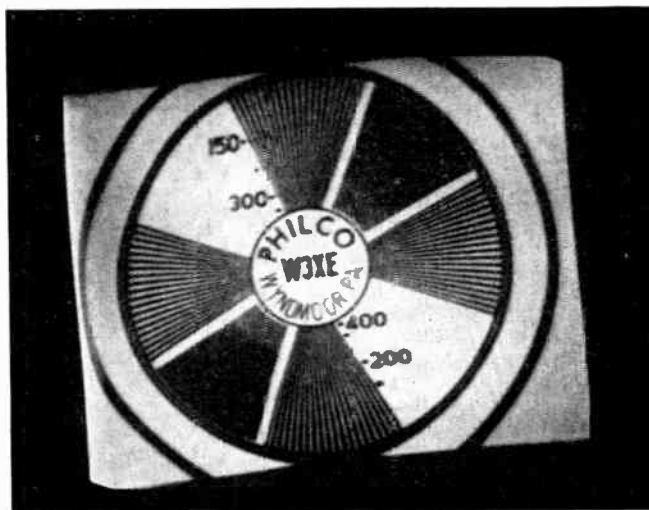

Fig. 9 Tilted picture, adjustment of deflection yoke required

result of incorrect control adjustments. Test patterns transmitted by television stations are useful in checking linearity of the horizontal sweep and may be used for test purposes when regular television programs are not being broadcast, as shown in the various illustrations in this article. Most of these illustrations are self-explanatory. Instruments, such as the Philco Cross-Hatch Generator are useful for making the necessary adjustments when the station is not on the air.

Insufficient height and width of picture frame are due, respectively, to improper setting of vertical and horizontal size controls. If adjustment of these controls fails to restore correct picture size, check tubes, components, voltages in the vertical and horizontal output stages and in the vertical sawtooth oscillator.

A tilted or off-center picture may be the result of improper adjustment of the vertical or horizontal beam centering controls, or incorrect positioning of the deflecting coils in cathode ray tubes of the electromagnetic-deflection type (Fig. 9). These coils carry high-voltage: Turn the power *off* before making adjustments. If the deflecting unit in a balanced electrostatic system is unbalanced, a trapezium-shaped picture will be obtained instead of the usual rectangular-shaped picture. Identical results will be obtained in an electromagnetic deflection system if adjacent turns of one of the deflecting coils are shorted.

The bottom half of a picture superimposed on the top half indicates the vertical sweep circuit is operating at *twice* its correct frequency. A right hand half-picture, superim-

posed on the left-hand half denotes a *horizontal* sweep operating at *twice its* correct frequency. In both cases the appropriate blocking oscillator controls should be adjusted to decrease the frequency to its proper value.

Two short, full-width pictures, one above the other, result when the vertical sweep is operating at *one-half* its normal frequency (Pictures are separated by a black horizontal bar). Two narrow, full-length pictures, separated by a black vertical bar, are due to half-cycle operation of the horizontal hold control. A beat pattern (Fig. 10) may be due to interference from a short-wave transmitter or to an improperly aligned sound i-f trap. Antenna orientation and proper trap alignment should remedy this type of trouble.

→ to page 44

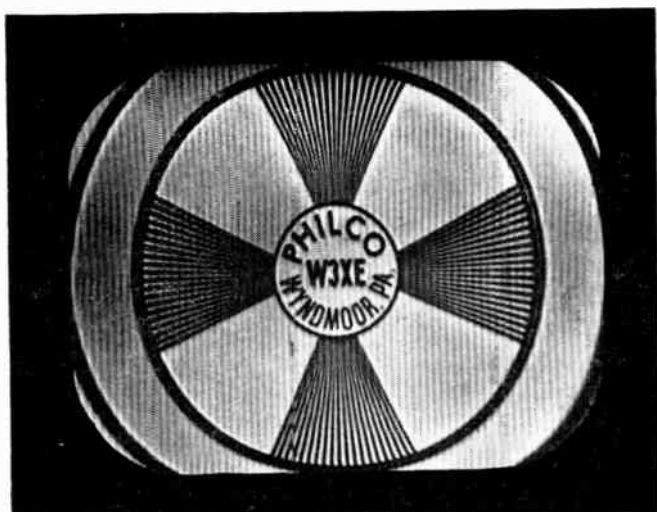

Fig. 10 A beat pattern may be due to short-wave interference



Fig. 11 Indicating that vertical hold control needs adjusting

AUDIO SYSTEMS IN F-M RECEIVERS

by J. Richard Johnson

The author discusses a number of representative circuits

IN our last article (*Radio Maintenance, December '48*) we discussed the importance of a knowledge of the nature of audio frequency distortion to the service technician. The three important types of distortion possible in f-m receivers were described as:

1. Harmonic distortion.
2. Intermodulation (cross modulation) distortion.
3. Inadequate frequency response range.

The first two types are also of some importance in connection with a-m receivers, but f-m receivers are much more subject to them because of the extra frequency response required.

Audio frequency amplifier sections in f-m receivers for home use vary widely with the design and price range of the receivers in which they are used. The degree to which the above factors are important depends upon the degree to which the receiver attempts to cover the full frequency response available in the frequency modulation signal.

A-M and F-M A-F Amplifiers

Basically, the purpose and design of the a-f amplifier are the same for f-m receivers as they are for a-m receivers. The a-f amplifier section is electrically composed of two parts, a voltage amplifier and a power amplifier. In small receivers, these parts

are represented by one amplifier tube and associated circuits for each. In very rare cases, one tube may even do the whole job.

Differences in a-f amplifier sections in f-m and a-m receivers, when they are present, are all due to the use of a special loudspeaker system, or a conventional loudspeaker fed so as to improve its acoustic frequency response. The more important circuit characteristics arising out of these differences are as follows:

1. More voltage amplification to make up for the somewhat lower output voltage of a ratio detector, as compared to that for the discriminator or a-m diode. However, in most cases this increased amplification is

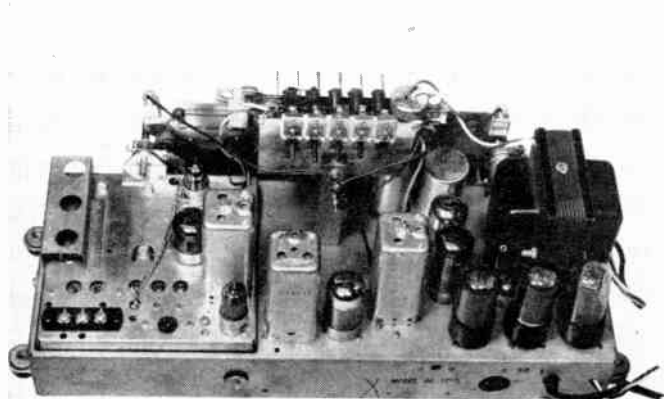
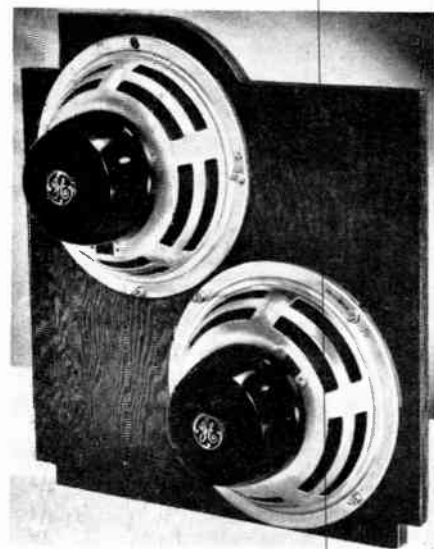

Shown here is a rear chassis view of a Philco f-m receiver model. It is similar to the one whose circuit is described in Fig. 3

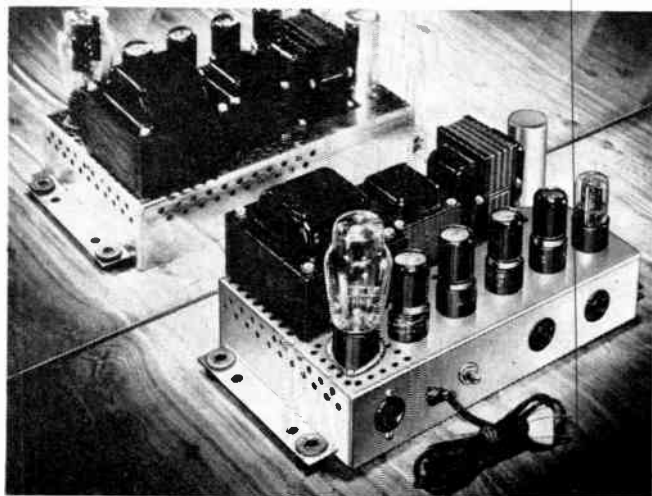

The power chassis of a General Electric "Musaphonic" model. The schematic of its elaborate a-f section is shown in Fig. 5

necessary to overcome the voltage loss in tone control and booster circuits. The increase in voltage amplification may be obtained by the use of two stages, or one high mu stage.

2. Treble and bass booster circuits are nearly always included in the large console models. These circuits are combinations of resistors and condensers arranged to increase amplification for the highest and lowest frequencies without affecting the amplification in the middle frequency range. The purpose of this is to compensate for the lowered response of the loudspeaker in the bass and treble regions of the audio frequency spectrum.

3. Power amplifier output stages are generally designed to be capable of greater power handling capacity than those for the same stages of a-m broadcast receivers. The increased power capacity is necessary because, in compensating for the loud speaker response characteristic by booster circuits, a relatively high power must be supplied to the loudspeaker in the boosted frequency ranges. At the same time, a substantial reduction in harmonic and intermodulation distortion is obtained by operating a power amplifier stage considerably below its maximum capacity, and by the use of two tubes in push-pull.

4. Output transformers are more critically designed in f-m receivers. The low distortion and wide frequency response requirements of high fidelity f-m receivers require that the output transformers meet certain rigid requirements. Physically, these transformers are larger in all dimensions and considerably heavier than the type ordinarily encountered in a-m broadcast receivers. Electrical performance requirements include all three types of distortion factors previously mentioned. Failure of, or incorrect substitution of the output transformer is one possible source of distortion in extended range amplifiers, such as those in f-m receivers.

5. Phase converters and push-pull output stages are frequently encountered in f-m. These provide more power output with less distortion than single-ended stages when operated at the same percentage of output rating.

6. Negative feedback is more frequently incorporated in f-m than in a-m receivers. This is because of

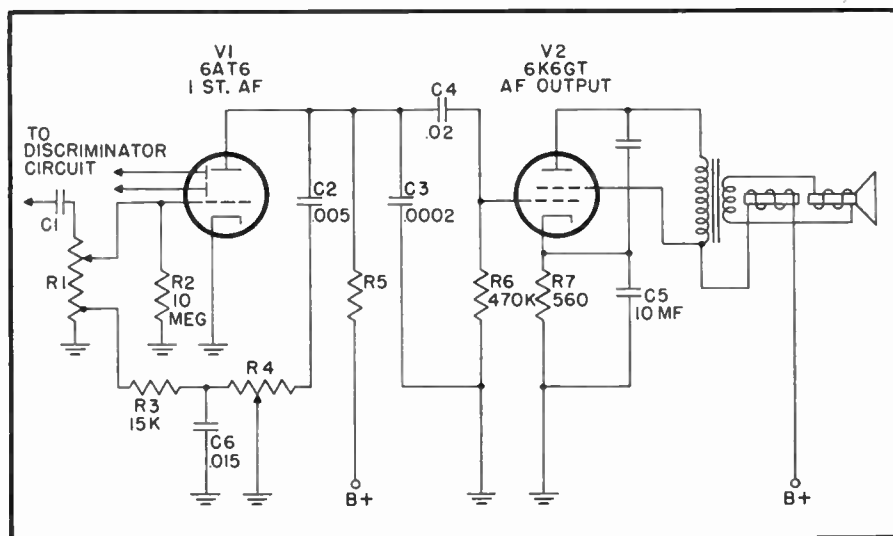

Fig. 1 Shown above is a schematic diagram of the a-f section (single ended type) of the Garod model 11FMT receiver

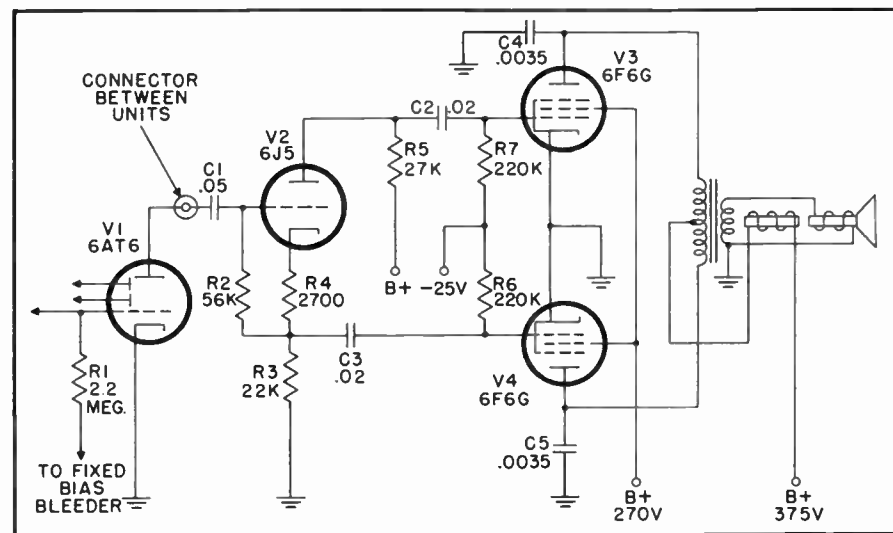

Fig. 2 a-f amplifier of RCA model 612VI f-m receiver, using single tube phase inverter, push-pull pentode output tubes

the higher peak power capabilities and the stabilizing and distortion-reducing property of feedback, necessary to provide the full quality advantages of the f-m system.

7. Tone control and booster circuits are more generally used and are more elaborate in f-m receivers. These circuits form an important subject by themselves and will be discussed in our next article.

Representative Circuits

In order to illustrate the actual application of the principles outlined above, the a-f amplifier circuits of five representative f-m receivers have been chosen and are shown in Figs. 1, 2, 3, 4, and 5 respectively.

The circuit of Fig. 1 illustrates the

single output tube or "single-ended" type. This arrangement is more representative of the smaller, table model receiver. As can be seen, it exhibits few, if any, differences in design from the average a-m broadcast receiver a-f section. In this amplifier, as in the other example, a combination tube V1 acts as both discriminator and first a-f amplifier stage. Several new tubes, such as the 6AT6 and the 7X7 have been developed especially for this purpose in f-m receivers.

The circuit of Fig. 2 shows the use of a first amplifier stage V1, a single phase inverter V2 and push-pull output tubes V3 and V4. The Fig. 3 circuit has a similar lineup with different tubes for the first amplifier

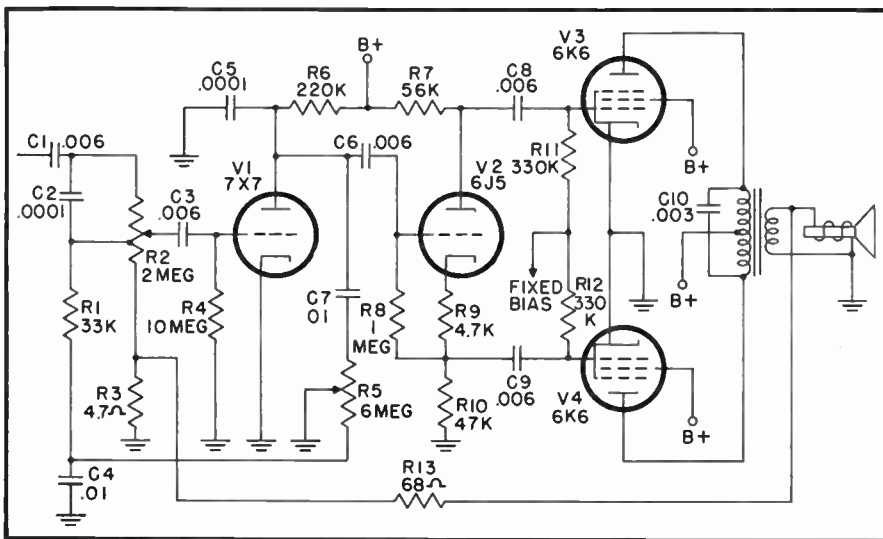

Fig. 3 a-f section of Philco model 47-1227. This circuit is similar to that in Fig. 2, except for the choice of tubes

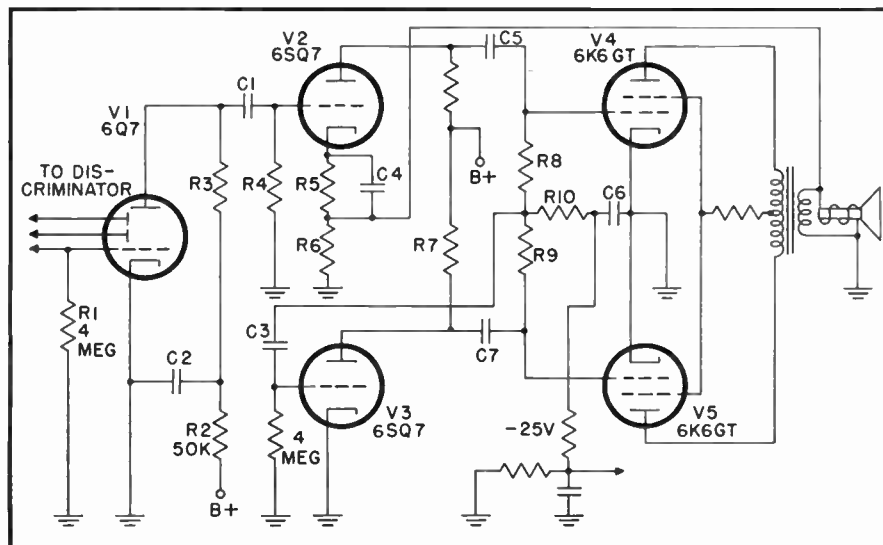

Fig. 4 The a-f circuit of the Fada model FM16, shown above, uses a two tube balanced phase inverter, negative feedback

and output stages, but the same type of phase inverter.

Fig. 4 illustrates the use of a two tube phase inverter preceding the output stage.

Fig. 5 is representative of the very elaborate type of a-f amplifier circuit. The first stage is a cathode follower V1. The arrangement is used to keep the impedance of the coupling circuit to a low value, thus reducing pickup hum. Then follow two amplifier stages V2 and the first section of V3. The second portion of V3 is a single tube phase inverter. Four tubes connected in push-pull parallel compose the high powered output stage, which drives two loudspeakers.

Now let's consider in detail some of the features found in most types of a-f amplifiers and applied in these examples.

Phase Inverters

Most of the larger FM receivers use a push-pull output stage. Because of this, some sort of phase inverter is required. The simplest phase inverter, of course, is a push-pull interstage transformer (the primary need only be "single-ended"). Although transformers make very satisfactory phase inverters, they are relatively expensive and heavy and take up more space than the compact tube type phase inverter.

As was previously explained fully in an earlier article by the writer ("Phase Inverters," *Radio Maintenance*, April '47), the need for phase inversion arises because in a push-pull stage the grid input signal voltages must have a definite relation to each other and *must both be above ground potential*. The grid voltages

must be 180 degrees out of phase with each other and have equal magnitudes with respect to ground. A single ended amplifier stage produces only one voltage above ground and can therefore supply only one of the output tube grids with signal. The function of the phase inverter is to add the second signal voltage for the other push-pull tube.

Our examples illustrate several popular methods of phase inversion. In Fig. 1, the output tube is single ended and consequently no phase inverter is required.

In Fig. 2, the out-of-phase voltage for the second power tube grid is supplied from a cathode resistor, R3, of the 6J5 phase inverter tube. Electrons flow away from ground in this resistor, instead of toward ground as in the plate resistor R5. The signal voltages across these two resistors are thus 180 degrees out of phase. The plate circuit supplies the grid of V3 with signal voltage and the cathode circuit supplies the grid of V4. This circuit is quite popular, and it will be noted that it is also used in the amplifier circuits of Fig. 3 and Fig. 5. In each case, two cathode resistors in series are used because the one connected to the cathode directly and used for bias must be relatively low in value. The lower end of the grid resistor connects to the lower end of the first cathode resistor (R4 in Fig. 2, R9 in Fig. 3 and Fig. 4), so that only this one cathode resistor is used to supply bias. Of course, in all cases in which a cathode resistor develops the out-of-phase signal voltage drop, this cathode resistor must be unbypassed or else all the signal voltage across it would be lost. Sometimes unbypassed screens are used to supply the signal voltage for the second push-pull output tube grid.

Another common method of phase inversion is illustrated in Fig. 4. This method requires the use of two inverter tubes, which in this case are V2 and V3. V2 acts as a straight amplifier and applies amplified signal voltage to the grid of V4. R8 and R10 act as a voltage divider across which this grid signal voltage is applied (C6 is large enough to have negligible reactance and acts as a short circuit as far as signal is concerned). The portion of the grid signal voltage which appears across R10 is then applied through C3 to the grid of V3. However, the signal

voltage has undergone a phase shift of 180 degrees in passing through V2 (this happens in any resistance coupled stage). The voltage across R10 and, accordingly the voltage on the grid of V3 is thus out of phase with the grid voltage of V2 by 180 degrees. The plate output signals of V2 and V3 are therefore 180 degrees out of phase, as desired for proper operation of the push-pull output tubes V4 and V5.

This inverter is known as the "balanced" type, since it supplies stabilizing negative feedback. The feedback is supplied as follows: After the signal is fed from across R10 back through V3, it is applied to the V5 grid through C7. This also causes it to be applied across the series combination R9-R10. Thus V3 has applied an additional signal across R10 which is in opposite phase to the signal originally applied from V2. This negative feedback has a stabilizing influence on the output of the amplifier and on the balance of loading between the two output tubes.

Negative Feedback

Negative feedback is very frequently incorporated into the a-f amplifier circuits of f-m receivers to keep the harmonic distortion to a minimum, especially when tetrode and pentode power tubes are employed. We noted above how feedback can be a sort of by-product of some other circuit, such as a phase

inverter. However, it is also often supplied by a separate circuit exclusively for this purpose.

Actually, any unbypassed cathode (or screen) has a *degenerative* effect (produces negative feedback). Examples of this are the cathode resistors of V2 in Fig. 2 and Fig. 3. The returning plate signal current develops across these resistors a signal voltage which is applied between the cathode and the grid in opposite phase to the signal arriving at the grid from the previous tube.

Often, the negative feedback voltage is derived from the secondary winding of the output transformer as in Fig. 3, 4, and 5. In Fig. 3 the feedback signal voltage thus obtained is applied across R3, which is connected in series with the grid resistor of the first a-f stage. The feedback voltage is in opposite phase to the signal arriving there from the discriminator and thus produces the desired degenerative effect.

In Fig. 4 and Fig. 5 the feedback voltage is applied to a cathode resistor and in opposing phase to the signal voltage developed across this cathode resistor.

Output Stage Design

The power output stages in f-m receivers are not much different from those in a-m receivers, except that the use of push-pull is more common and higher output power ratings are

encountered. Push-pull stages are generally operated A₁. Class AB₂ or class B is seldom found. Probable reasons for the lack of use of these types of operations are (1) class A₁ ordinarily gives adequate power in a push-pull stage and (2) amplifiers drawing grid current require a preceding power driver stage, adding to bulk and expense.

Fixed bias is quite popular, especially in push-pull amplifiers. It will be noted that the bias for the output stages in Fig. 2, 3, and 4 is of the fixed variety, while in Fig. 5 the cathode bias system is used. Fixed bias allows more output power at a given plate voltage, partly because some of the plate voltage is not used up in appearing across the cathode resistor.

The high power output stage used in the amplifier of Fig. 5 is unusual in home receivers, although it is of a type often found in public address systems. The circuit is a basic push-pull type. Each tube of the push-pull circuit is connected in parallel with another similar tube to double the power handling capacity. Thus V4 is connected in parallel with V5, and V6 is connected in parallel with V7. These two parallel groups are connected in push-pull with each other.

When output tubes are connected in such a circuit, there is danger of parasitic oscillations. These are oscillations developing in the inductance

→ to page 47

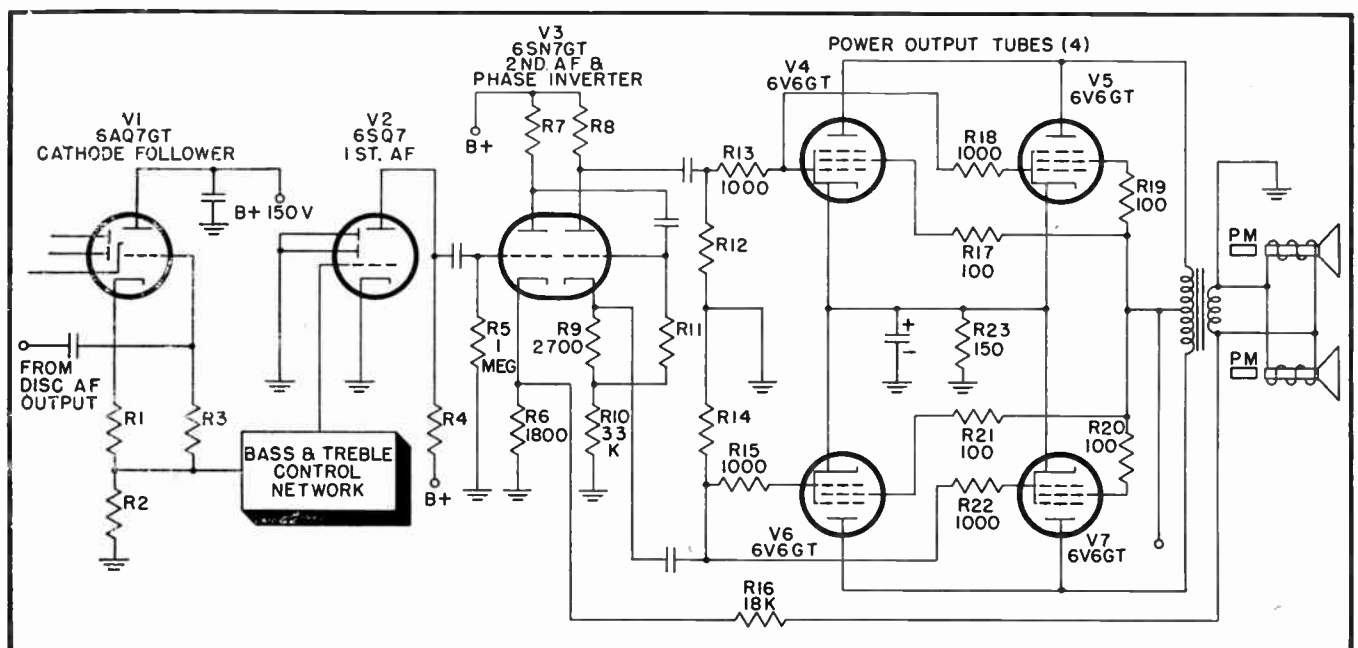
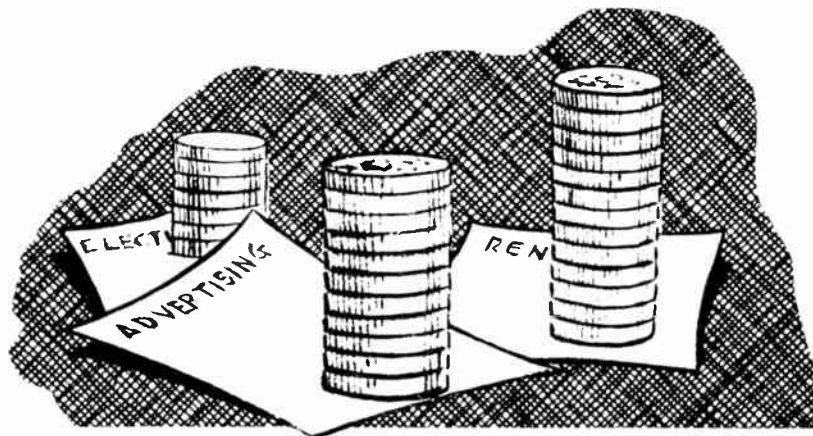

Fig. 5 The G-E "Musaphonic" features high power output to two loudspeakers, using 4 push-pull parallel output tubes



HOW TO PLAN YOUR BUDGET

In advertising, as in everything else, plan carefully, spend wisely, and don't waste a penny

IN our first article in this series on advertising, we endeavored to cover the advantages of business promotion. Now in this issue of RADIO MAINTENANCE, we'll talk about planning an advertising campaign.

In planning your campaign you should, of course, first determine how much you are going to spend on business promotion. This amount should cover everything that publicizes your shop in any way—such as signs or window display material, the lettering on your truck, postcards, newspaper ads, telephone calls, paper and postage for direct mail, fees or wages for others carrying out any part of your program, etc. This is important to keep in mind as there are costs involved in advertising that are not always obvious, especially to a beginner in the business.

The amount to set aside should be established as a fixed percentage of your gross income with an allowance for adjustment one way or another as conditions indicate. These conditions would be the actual returns from your advertising after it has been in effect for a while, or active promotion on the part of your competitors which may force you to increase your ad budget.

The amount to decide on will of course be up to you in the final analysis. We shall present the factors that influence a decision such as this, and some examples of expenditures in other businesses. There is no established custom in the radio service field as to the percentage of income

by Victor M. Turner

Advertising Manager, Radio Maintenance

to be spent for promotion, so it has not been pre-arranged for you.

In other fields the advertising budgets vary tremendously with the nature of the product or service sold. In the cosmetics, soap, and tooth paste categories, 25% and more of gross income is spent on advertising, while manufacturers of hard goods of many types spend only 1% or less on their promotion. The amounts also vary among the different companies in any one field. One of the largest radio manufacturer spends between one and one and a half percent; but since their gross income is tremendous compared to small local business, this one per cent buys an extensive amount of advertising coverage.

Study Your Situation

The outside influences that will affect the establishment of your budget

Some Recommended Books on Advertising

Tested Advertising Methods, by JOHN CABLES, Harper & Bros.
Small Space Advertising, by THE EDITORS OF "PRINTER'S INK" MAGAZINE, Funk & Wagnalls

Cutting Advertising and Printing Costs, by THE STAFF OF "PRINTER'S INK" MAGAZINE, Funk & Wagnalls

should be given careful consideration. As we said before, your competitors will have set a precedent that you must meet or compete with. Chances are that they are not spending so much on promotion that they cannot maintain the same budget indefinitely, so you will do well to observe all the space in the newspapers, etc., used by them. If these organizations are reaching all your prospective customers with their advertising, you must do one of two things: Either spend an equal amount to promote your business and tell a *better* story, or spend considerably more for advertising space and draw more attention by sheer weight. The former action is more practical and will be more successful in the long run.

There is, of course, a third approach to this problem and that is to develop a promotion campaign that is so clever and efficient in coverage that it will beat your competitor's even though it costs you much less than his campaign. This is being done constantly in every field of business activity but it takes exceptional promotion ability and much hard work.

Another outside influence on your ad budget is your locale in relation to your customers. This will generally have more effect on the technique of your program than on its size or expense, but it will influence this, too. For example, if you live in a small community you can reach most of its inhabitants through ads in the local paper which usually does not charge a high rate, while in bigger towns you

newspaper ad will cost more and in the large cities this medium of advertising may be out of the question. The newspaper rates are too high for a small local shop as the papers cover thousands of readers who live too far from you to consider your service.

An Occasional "Splash"

Some men who have just opened a new business or have completed a major expansion, allocate a larger than usual sum for announcing the event. However, rather than make a "splash" of this nature, a once-and-for-all thing, I believe in making this a regular yearly or twice-yearly feature of your program. Every advertising program should incorporate at least one or two of these special boosts every year; and they should be part of the regular budget. All successful businesses open up with heavier guns in their ad campaigns at periodic intervals to keep the program from getting stale.

After taking all these factors into consideration, you should determine how much you are going to spend on advertising. This amount should be fixed and adhered to until you've had time to study the effects of your promotion. After a period of six months, let us say, you should review your advertising and its "returns" to date. It may be that you will need to allocate more money to increase the influence on your market, or you may find some of your advertising superfluous and can thus cut your budget.

Your budget is for you to establish, as we said. If you are in doubt as to what to set aside even after surveying the conditions set forth above, I recommend no less than 3% of your gross income and no more than 10%, with 5% as the most effective and practical figure. Ten percent is too high for the average small business, unless there is a defi-

Glossary of Some Frequently Used Advertising Terms

Account or Client—*the individual or company to whom an advertising agency provides service.*

Agency Commission—*the sum paid to an ad agency by a newspaper or magazine in which the agency has placed an ad for a client.*

Art Work—*any drawing, lettering, border, etc., that must be created for an ad by hand.*

Copy—*the reading matter in an advertisement.*

Direct - mail — *advertisements which are mailed directly to prospective customers.*

Flyers — *direct-mail advertisements, usually a single sheet.*

Lead or headline—*the large type making up the attention-getting statement in an ad.*

Logotype—*the name and address and perhaps trademark of a firm appearing across the bottom of an ad.*

Mail-order ad — *an advertisement carrying a coupon or direct request for the reader to send in his order, usually with payment enclosed.*

Mailing piece—*a direct mail advertisement of any size or shape.*

Medium—*the vehicle for an advertisement, i.e., magazine, newspaper, catalog, etc.*

Research—*any work, done by an agency or anyone doing advertising, that tries to uncover as much established information as possible pertaining to a forthcoming ad campaign.*

Type—*letters set by a printer for an ad.*

nite program for intensive expansion, in which case a heavy advertising expenditure may be necessary. Three percent on the other hand, may be too low for an effective campaign.

Spend Wisely!

So much for the budget. Now let's go into some of the details of your advertising expenses. While doing this, we want to keep in mind that these advertising dollars are your hard earned money and that *every penny* must work twice as hard for you!

The first question that arises is—who should prepare your advertising material? Who shall write the copy, design the individual advertisements, select the type?

If you are a man doing all your own work in your shop, and your budget amounts to only a couple of dollars a week, the answer to that question is obvious. You will do your own advertising as you do everything else.

If you do a large volume of business and it warrants a large enough ad budget, you may want an advertising agency to do your promotion work.

In either case, the same rule still holds—make *every penny* count. If you are doing your own advertising work, go into it with enthusiasm and study up on advertising in every way you can. In the forthcoming articles in this series we shall give you all the pointers and concrete examples of good advertising technique that we can. Read and study them all. Go to your library and get books on advertising and study them. Advertising is as much a part of your business as fixing radios—so act accordingly. Never stop searching for a better way to tell your story to the public. It will not be an easy job—it isn't easy for the professionals.

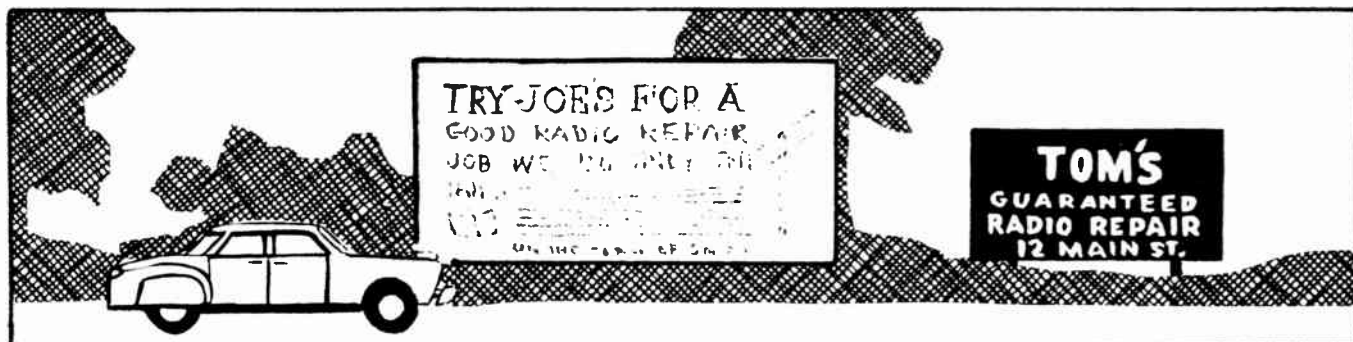

You must compete with other service advertising. It is possible, however, to spend less money and get more results

And the smaller your advertising budget, the more difficult a job it is—the more imperative the rule that you make every penny count.

If you have an agency working for you, your advertising problems are shared by that organization. But do not make the mistake of assuming that the entire burden is lifted from your shoulders. The agency is relieving you of all the cumbersome and time-consuming details and providing you with expert service in carrying out your program, but you also must take an active part in this program. You must pass on to the agency all that you know of your market and countless details of the service you provide to this market. If you don't do this, the agency must consume time and money (your money!) finding this out for itself. You must keep the agency advised as to the effectiveness of the work they are doing for you.

Agency Selection is Important

If you are about to select an advertising agency for the first time you should be very discriminating in your choice. If possible, engage an agency that is familiar with the radio field. If not, it should at least be familiar with promoting some local business similar to yours. Investigate the agency's record. If it has kept its present accounts over a period of time without constant dropping of old accounts and acquiring new ones, it shows the ability to provide satisfactory service and stability.

Agencies are not expensive to employ. An agency's income is derived from the commissions on advertisements placed in newspapers and magazines and from the professional services rendered the client. The commissions are paid to the agency by the newspaper or magazine in which your ad is run. The amount you pay for services depends on how much copy is written for the ad, the amount of art work necessary, if any, and advisory services rendered. However, many small agencies will charge very nominal fees for this work in order to build a list of clients and receive commissions for the ads placed.

Don't Relax Your Interest

In any case, whether you do your own promotion or whether you employ an agency, keep posted on your advertising progress. Do not lose interest or become discouraged. Let-

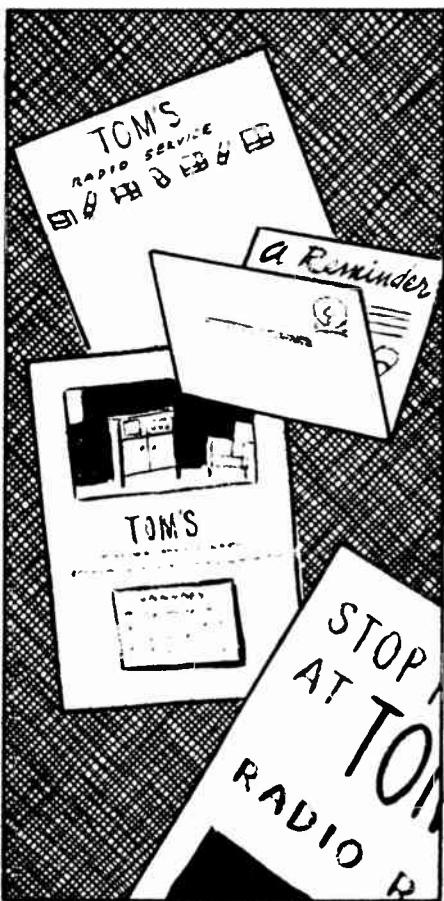

The radio and parts manufacturers can supply you with a great deal of helpful advertising material, such as posters, mailing pieces, mats and cuts for your newspaper ads, calendars, letterheads, business cards, etc. with your name imprinted on them. Take full advantage of this free material

ting your promotion sag in the middle is not as obviously a case of neglect as letting your shop go unswept or unpainted, but it is just as foolhardy.

When you practice your own advertising try to get as much out of every "free ride" as you can. Use the displays and selling aids provided by the manufacturers of the parts and equipment you carry. If you live in a small community, make friends with your newspaper editor. Very often these local papers carry feature stories on local businessmen; and if your paper does this, make sure it runs a story on you. This is very excellent free advertising.

When you buy advertising space in a paper or local periodical don't just have a constant ad carrying the same headline and flat announcement week in and week out. Put as much into each ad as your ingenuity can produce. And don't forget to take ad-

vantage of any cut in rates earned by long-term advertising.

Keep Reproduction Costs Low

On small budget advertising, use every means you can to cut the cost of individual promotion pieces. If you are sending out leaflets, have them mimeographed or multigraphed instead of printed. If you can get your story on a postcard, do so and save the cost of additional postage and paper and envelopes. Use this saving to send out more postcards instead. We'll cover these techniques in detail later but the point we want to get across right now is this: after planning a promotion piece, review the method of presentation carefully—is there any way you can cut the cost of its make-up distribution? If no cut is apparent to you, inquire around first of anyone you may know who does any promotion or reproduction work before you decide to go ahead.

When planning an ad, whether it's for newspaper, billboard or mailing piece, it's a good idea to carefully observe ads put out by your competitors and decide how you can improve on their technique. Look at ads put out by other small business concerns and carefully figure out ways that you can incorporate their good points. But in doing this, be careful not to become infatuated with some "trick" attention-grabber that many people are inclined to feature. This practice of using some totally foreign element to catch a reader's eye is widely used big-time advertisers who spend enough money and employ enough brains to know better. How often have you yourself been attracted by some extremely clever or sophisticated ad in a magazine? "How witty!" you exclaim. Or: "Gee, that's a beautiful ad!" you say. And then, after turning another page, the effect of the "trick" ad has been completely forgotten—you don't even recall noticing the name of the company, only the slogan which you may never associate with the product.

In general, and in small space advertising especially, a bold but simple presentation of your service and your name is most effective. In our next article we will go into the technique of good headline and copy creation and how to say as much as you can in small space advertising with utmost effect. " " "



Make More Money in the Expanding Servicing Field . . .

WITH CREI NEW, PRACTICAL "ON THE JOB" TRAINING IN TELEVISION & FM SERVICING

The next twelve months will produce some of the greatest opportunities that have ever been offered to alert men in the Servicing Field.

It is the year for you to make the big decision. Either you are going to catch up with the new developments in the industry, or you are going to be passed by.

We think your opportunities are so great, that over a two year period we have been developing this brand new, practical course. It is written for *today's* serviceman to meet *today's* problems and opportunities.

CREI knows what you need, and every effort has been made to keep this course practical and to the point. If you are now engaged in servicing work, you will be able to understand and apply each lesson. This course has been reviewed and checked by qualified service experts who know *what you must know* to get ahead in this booming field.

RADIO SERVICE DIVISION OF
CAPITOL RADIO
ENGINEERING INSTITUTE

An Accredited Technical Institute

Dept. 222A, 16th & Park Road, N. W., Washington 10, D. C.
 Branch Offices: N. Y. 7, 170 Broadway; San Francisco 2, 760 Market St.

Every lesson can be helpful in your daily work—you will soon have the technical knowledge necessary to handle all types of good paying Television and FM servicing business.

In offering this course at a popular price, CREI is enabling thousands of the "top third" now engaged in service work to enter the ultimate profitable field of television and FM installation and service.

This can be your big year! Write today for complete information. The cost is *popular*. The terms are *easy*. The information is *free*. Write today.

VETERANS! THIS COURSE IS G.I. APPROVED.

MAIL TODAY!

CAPITOL RADIO ENGINEERING INSTITUTE
 16th & Park Road, N. W., Dept. 222A Washington 10, D. C.

Gentlemen:

Please send me complete details of your new home study course in Television and FM Servicing. I am attaching a brief resume of my experience, education and present position.

NAME

STREET

CITY ZONE STATE

I AM ENTITLED TO TRAINING UNDER G. I. BILL.

JUKE BOX SERVICING

by Max Alth

A field of profit for the radio service technician

THERE are some 400,000 juke boxes in this country. Each box is serviced on the average once every ten days. Each box *must* be serviced at least once every month. Its oiling schedule calls for it.

Many of these boxes are individually owned. More of these boxes would be owned individually if satisfactory service were more readily available.

Many small-scale operators own a string of twenty or thirty boxes.

The rest of the boxes are owned and operated by large outfits whose machines may number in the hundreds, and whose locations may stretch for hundreds of miles across the country.

Each juke box contains radio equipment with which the radio service technician is familiar. A phono motor, and phono pickup and ampli-

fier. Some contain even more radio equipment, having remotely operated coin selector boxes which contain radio transmitters sending signals to the master box, which in turn has a receiver, and relays for interpreting the signals and giving the customer his desired selections.

In addition, these boxes contain coin mechanisms that credit the customer with the proper number of plays, and memory devices for recording the various records selected, complex changer mechanisms, and motor driven slides for making the colored lights in the front of the machine change.

Specialized Knowledge

This means that the juke box mechanism is well beyond the average handy man, well beyond the average mechanic. It calls for a specialized knowledge of radio and mechanics. It calls, therefore, for the experienced radio technician.

Most radio technicians with a sound, and thorough, background in electronic theory, and a working knowledge of mechanics can learn to repair these machines efficiently, and satisfactorily. They seem quite complex upon first examination. But, like the television receiver, they become simpler with experience and study. Unlike radio, juke box designs remain fairly constant through the years, making it very much easier for the repair man to catch up and keep up with the trade.

The tavern keeper who owns his own machine does not tamper with it if he is at all sensible. Tavern

keepers who own their own machines are in need of competent, dependable repair service.

The small operator with his twenty or thirty instruments cannot afford to hire a service man on a full-time basis. Juke boxes operate seven days a week, sometimes twenty-four hours a day. Service must be on tap accordingly; actually, until ten o'clock every night, the important money time for the boxes being from six P.M. until closing. This means that full-time service coverage requires two men. Obviously, the income from ten or twenty or even thirty machines does not warrant the hiring of two highly paid specialists. The small operator needs competent, part-time service.

Some of the larger operators confine their activities to one town, or to one area in a large town. But many would place a juke box in China if they thought it were profitable. When one of their distant machines needs attention, the cost of the repair becomes prohibitively high. It pays the chain operator to hire a local man, rather than to send his own man, and a truck over many miles. The large operator needs competent service for his outlying machines.

All the juke box owners, both large and small, often need the specialized knowledge only the radio man has for the repair of the amplifier, and the radio signaling system. Most of the owners, and many of the mechanics, have picked up their knowledge of juke box repairs hit and miss, simply working till the machine ran; and

→ to page 37

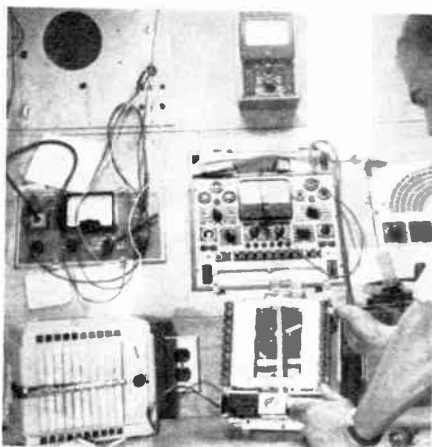
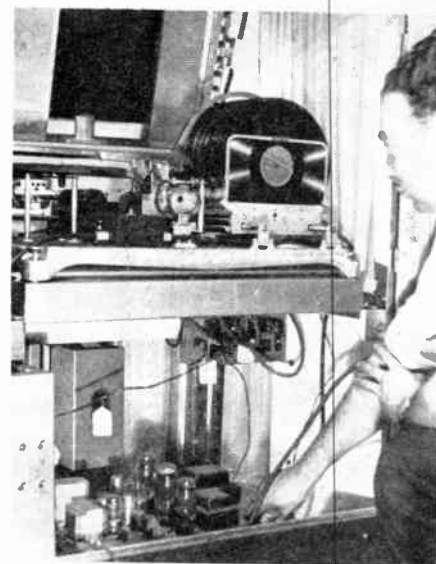

The Seeburg remote wireless coin box being adjusted here contains 2 6C4s. One acts as rectifier, the other as oscillator

**"It's KNOW-HOW
that counts!"**

—says Bud Ward, Owner of
Ward's Radio Service, 24 Town
Street, Norwichtown, Connecticut.



Bud Ward is an invalid paralyzed from the neck down. He mastered radio and repairs with his "voice" ... by directing the hands of an ex-Marine apprenticed to him under the G-I Bill. Though handicapped, Bud Ward is known as a radio wizard around Norwichtown and has built up a mighty successful servicing business. "My Rider Manuals are my bible of radio servicing," says Bud. "Having to use someone else's hands to do my work, the clear and concise service data is a 'must' with me."

**Leading Servicemen from Coast-to-Coast
Build Better Business with**

RIDER MANUALS

A ready-reference for all sets from 1930 to 1948 — Volumes 1 to 18 are at your Jobber's now. He also has Volume 1 of the Rider Television Manual.

**"I've got the ONE, now I'm
waiting for the TWO"—Bud Ward**

VOLUME

2

**RIDER
TELEVISION MANUAL
PLUS 2 Separate Books, "HOW IT
WORKS" and INDEX**

If you operate in a TV area, a John Rider TV Manual is as important to you as a pair of pliers. Rider Television Manuals contain the OFFICIAL, AUTHENTIC, RELIABLE DATA as supplied by the set manufacturers themselves. You don't have to guess ... you know immediately what's wrong and what's to be done. Each Manual includes GIANT SIZE Schematics to guide you and your men to a quick solution of any TV servicing problem.

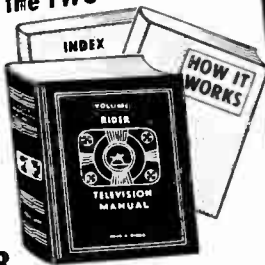

Your Jobber Has It!

RIDER PA MANUAL

The first industry-wide public address equipment Manual incorporating the amplifier production of 147 manufacturers from 1938 to 1948.

2024 Pages PLUS "How It Works" Book which explains theory of various PA circuits and method of rapidly locating faults. **\$18.00**
Including index.

RIDER MANUALS

Television Manual, Volume I, (plus How It Works and Index)	\$18.00
Volume XVIII	19.80
Volume XVII	16.50
Volume XVI	8.40
Volume XV	19.80
Volume XIV to VII (each volume)	16.50
Volume VI	12.50
Abridged Manuals I to V (one volume)	19.80
Record Changers and Recorders	9.00
Master Index, Covering Manuals, Vols. I to XV	1.50

Order Now!

VOLUME

18

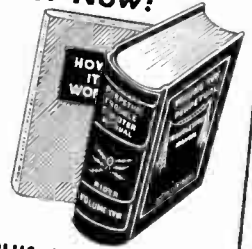

2036 Pages PLUS Separate "How It Works" Book and Cumulative Volumes XVI, XVII, and XVIII INDEX. Both Books, Complete . . . **\$19.80**

Rider Manuals Give You

- **GREATEST COVERAGE** . . . 27,000 models and 14,000 chassis in 25,830 pages . . . AM and FM.
- **AUTHORIZED FACTORY-FACTS** . . . servicing techniques direct from the set manufacturers themselves.
- **CIRCUIT THEORIES EXPLAINED** . . . "How It Works" Books explain electronic and mechanical innovations in sets covered by Manuals.
- **LOWER COST** . . . Rider Manuals deliver data at less than a penny per receiver model.

RIDER MANUALS mean SUCCESSFUL SERVICING

JOHN F. RIDER, PUBLISHER, Inc.
480 Canal Street, New York 13, N. Y.
Export Agent: Rocke International Corp., 13 E. 40th St., N.Y.C.
Cable, ARLAB.

NOTE: The Mallory Radio Service Encyclopedia, 6th edition, makes reference to only one source of radio receiver schematics—Rider Manuals.

ANOTHER NOTE: The C-D Capacitor Manual for Radio Servicing, 1948 edition No. 4, makes reference to only one source of receiver schematics—Rider Manuals.

a VOLT per MIL per 1000 ohms

by J. F. Cataldo

Here is a practical application of Ohm's Law which provides many shortcuts to the work of the radio service technician

A VOLT per mil per thousand ohms is a very simple mathematical system to calculate values of components and circuit constants in radio and communication equipment, used in conjunction with a practical application of Ohm's Law. By mastering this system you will be able to make rapid mental calculations. This ability is invaluable to the working technician.

Ohm's Law is simple, yet a very important law with respect to electric circuits. A brief discussion of it here is desirable in order to understand the meaning of "Volts per Ohm," "Volts per Milliampere," or "a Volt per mil per thousand Ohms."

Ohm's Law states:

$$E = I \times R$$

$$I = \frac{E}{R}$$

$$R = \frac{E}{I}$$

where

E = voltage in volts

I = current in amperes

R = resistance in ohms

Normally, the unit of current is amperes. However, other units may be used, such as milliamperes or microamperes, provided the correct multiplication factor is used. As an expedient, another unit may be used which eliminates the possibility of error in decimal point due to the use of multiplication or division factors.

For example, the basic formula for current is:

$$I = \frac{R \text{ ohms}}{E \text{ volts}} = \text{amperes}$$

In other words, one ampere equals a *volt per ohm*. This also means that a circuit must have as many ohms resistance as it has volts impressed across it in order to limit the current to one ampere.

K Ohms and Milliamperes

It can easily be seen by examining the above formulas that the units in which the formulas are written are not those frequently encountered in radio circuits; and necessary conversions, previously mentioned, would require the use of decimals and make for possible errors. The experienced radio service technician will agree that most resistances in radio or communication circuits are in units of

thousands of ohms, and that most currents in these same circuits are in milliamperes. Accordingly, if we have such a circuit, we can say that one milliampere equals a *volt per thousand ohms*.

Therefore, in accordance with Ohm's Law, such a circuit must have as many K ohms (K = 1,000) of resistance as volts impressed across it in order to limit the current to one milliampere. Consequently, if the current is two milliamperes, then only one-half the resistance is required and if the current is ten milliamperes, only one-tenth the resistance is required.

The basis of this system depends upon this simple application of Ohm's Law: *One milliampere flowing through one thousand ohms de-*

→ to page 36

TABLE I CONVERSIONS		
Formula	Conventional	Conversion
$E = I \times R$	E = volts	E = milliamps x K ohms
$R = \frac{E}{I}$	R = K ohms	R = volts per milliamps
$I = \frac{E}{R}$	I = milliamperes	I = volts per K ohms
To find voltage drop: $E = I \times R = \text{volts}$ $E = ma \times \frac{\text{volts}}{ma}$ = volts	To find current: $I = \frac{E}{R} = \text{milliamperes}$ $I = \frac{\text{volts}}{\text{volts per ma}}$ = milliamperes	To find resistance: $R = \frac{E}{I} = K \text{ ohms}$ $R = \frac{\text{volts}}{\text{volts per K ohms}}$ = K ohms

Have ALL THE FUN
SAVE 2/3 THE COST

Build
YOUR OWN

TEST EQUIPMENT

1 Heathkit VACUUM TUBE VOLTMETER KIT

Everything you want in a VTVM. Shatterproof solid plastic meter face, automatic meter protection in burn-out proof circuit, push pull electronic voltmeter circuit assuring maximum stability. Linear DC and AC scales. AC and DC full scale ranges of 3V-10V-50V-100V-300V-1000V. A total of 24 ranges. Isolated DC test prod for signal tracing and measurements of voltage while instrument is in operation. An ohmmeter section accurately measuring resistance of 1/10 ohm to one billion ohms with internal battery. Extremely high input resistance 11 megohms on all ranges DC and 6.5 megohms on AC. All these features and many more are the reasons hundreds of radio and television schools are using Heathkit VTVM's and recommending them to all students. Like all Heathkits, the VTVM kit is complete. 110V. 60 cycle power transformer, 200 microamp meter, tubes, grey crackle cabinet, panel, test leads, 1% ceramic precision divider resistors and all other parts. Complete instruction manual. Better start your laboratory now. **\$24.50**
Shipping weight 8 lbs.

Heathkits are beautiful factory engineered test equipment kits supplied complete but unassembled with all parts — tubes, grey aluminum cabinets, punched, formed and plated chassis, calibrated panels, ready wound coils and complete detailed instruction manuals for assembly and use. With costs zooming up, Heathkits save the labor cost of assembly enabling thousands to have equipment which they otherwise could not afford.



2 Heathkit SINE AND SQUARE WAVE AUDIO GENERATOR KIT

The ideal instrument for checking audio amplifiers, television response, distortion, etc. Supplies excellent sine wave 20 cycles to 20,000 cycles and in addition supplies square wave over same range. Extremely low distortion, less than 1%, large calibrated dial, beautiful 2 color panel, 1% precision calibrating resistors, 110V. 60 cycle power transformer, 5 tubes, detailed blueprints and instructions. R.C. type circuit with excellent stability. **\$34.50**
Shipping weight 15 lbs.

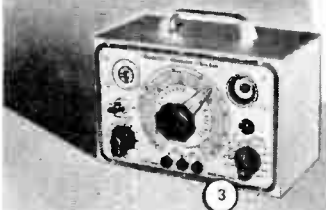

3 Heathkit CONDENSER CHECKER KIT

Checks all types of condensers, paper mica — electrolytic — ceramic over a range of .00001 MFD. to 1000 MFD. All on readable scales that are read direct from the panel. NO CHARTS OR MULTIPLIERS NECESSARY. A condenser checker anyone can read without a college education. A leakage test and polarizing voltage of 20 to 500 volts provided. Measures power factor of electrolytics between 0% and 50%. 110V. 60 cycle transformer operated complete with rectifier and magic eye tubes, cabinet, calibrated panel, test leads and all other parts. Clear detailed instructions for assembly and use. Why guess at the quality and capacity of a condenser when you can know for less than a twenty dollar bill. **\$19.50**
Shipping weight 7 lbs.

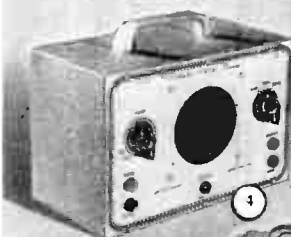

4 Heathkit SIGNAL TRACER KIT

Reduces service time and greatly increases profits of any service shop. Uses crystal diode to follow signal from antenna to speaker. Locates faults immediately. Internal amplifier available for speaker testing and internal speaker available for amplifier testing. Connection for VTVM on panel allows visual tracing and gain measurements. Also tests phonograph pickups, microphones, PA systems, etc. Frequency range to 200 Mc. Complete ready to assemble. 110V. 60 cycle transformer operated. Supplied with 3 tubes, diode probe, 2 color panel, all other parts. Easy to assemble, detailed blueprints and instructions. Small portable 9" x 6" x 4 3/4". **\$19.50**
Shipping Wt. 10 lbs.

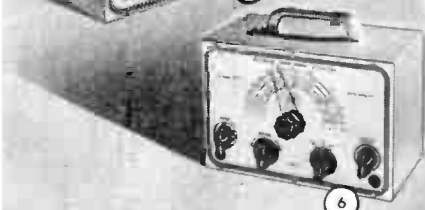

5 The NEW 1949 HEATHKIT 5-INCH OSCILLOSCOPE KIT

New improved model of the famous Heathkit Oscilloscope. Building an oscilloscope is the finest training for television and newer servicing technique and you save two-thirds the cost. All the features and quality of instruments selling for \$100.00 or more. Supplied complete with cabinet, two color panel, 5BP1 tube, 2 5Y5 tubes, 2 6SJ7 tubes and 884 generator tube. Power transformer supplies 1000 volt negative and 350 volt positive. Sweep generator 15 cycles to 30 M. cycles. Has vertical and horizontal amplifiers. Oil filled filter condensers for long life. Complete blueprints and instructions included. **\$39.50**
Shipping weight 25 pounds.
Express only

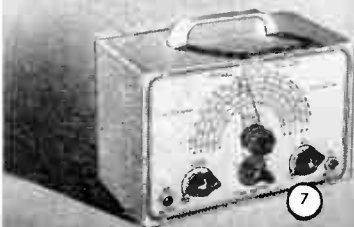
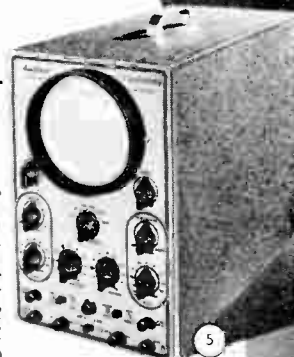

6 Heathkit FM AND TELEVISION SWEEP GENERATOR KIT

A necessity for television and FM. This Heathkit completely covers the entire FM and TV bands 2 megacycles to 230 megacycles. The unit is 110V. 60 cycle transformer operated. Uses two 6J6 tubes, two 6CA tubes and a 6X5 rectifier. An electronic sweep circuit is incorporated allowing a range of 0 to 10 MC. A sawtooth horizontal sweeping voltage and phase control are provided for the oscilloscope. The coils are ready assembled and precision adjusted to exact frequency. As in all Heathkits, the best of parts are supplied, Mallory filter condenser, zero coef. ceramic condensers, all punched and formed parts, grey crackle cabinet, 5 tubes, test leads, etc. Better get it built now and be ready for the FM and TV business. Shipping Wt. 6 lbs. **\$24.50**

7 Heathkit SIGNAL GENERATOR KIT

Every shop needs a good signal generator. The Heathkit fulfills every servicing need, fundamentals from 150 Kc. to 30 megacycles with strong harmonics over 100 megacycles covering the new television and FM bands. 110V. 60 cycle transformer operated power supply. 400 cycle audio available for 30% modulation or audio testing. Uses 6SN7 as RF oscillator and audio amplifier. Complete kit has every part necessary and detailed blueprints and instructions enable the builder to assemble it in a few hours. Large case to read calibration. Convenient size 9" x 6" x 4 3/4". Ship. Wt. 7 lbs. **\$19.50**

ORDER DIRECT FROM THIS AD.
WE WILL SHIP C.O.D.
Add Postage for Weight Shown

HEATH COMPANY
BENTON HARBOR 10,
MICHIGAN

ELECTRONICALLY SPEAKING



Higher and Higher. Television Receiver production established a new monthly record in its consistent climb toward the 100,000-sets-a-month mark. The Radio Manufacturers Association reports that its member companies reached an output of 95,216 television receivers during the month of October 1948. At this rate, most predictions of future TV receiver production will be exceeded by substantial margins in the months ahead.

New Television Channels. The early addition of new TV channels in the upper part of the spectrum was predicted by Wayne Coy, Chairman of the Federal Communications Commission. The impetus which this addition will give to the field of telecasting promises to be considerable. Chairman Coy forecast that within less than ten years the number of television stations on the air will have reached 1,000. At present, there are 45 stations operating. Television has only begun to grow.

Television for Our Schools. The U. S. Navy has already made definite plans to test the usefulness of television in its various instruction courses. Now word comes from Milwaukee that steps have been taken in that city to introduce the television receiver into the classroom as one of the ways of coping with the problem of overcrowded schools. Although the project is still in the discussion stage, developments in the educational as well as in the television field may soon make the television receiver a companion piece to the traditional blackboard.

18 x 24-Foot Video. The largest television screen, measuring 18 x 24 feet, was set up in the Bay Front Auditorium at Dinner Key, Fla., to enable 2,300 onlookers to witness the Orange Bowl Game being tele-

vised. In addition to the complete television station equipment which was brought to Miami to handle the pickup and transmission, the equipment used included an advanced developmental model large-screen television projector, an outgrowth of RCA's research into the use of TV in the motion picture industry. This may be a possible solution to the problem of overflow audiences at major football games.

Radio for Trolleys. New Yorkers may feel that the trolley car is gradually becoming extinct, but in Philadelphia they are about to make it a more efficient means of travel. Two-way radio will be installed in 14 new inter-urban cars. Using selective calling, speakers will be eliminated and communication will take place through hand sets. The purpose of this 'inter-com' system is to eliminate traffic jams and expedite general service. This is probably one of the first applications of selective calling two-way radio for trolley car use. Complete equipment is being furnished by General Electric.

Buy and Fly. Purchasers of Bendix television and radio sets are getting free airplane rides over New York City. This new wrinkle in television receiver sales technique was introduced by the Atlantic Aviation Corporation of Teterboro, N. J., which has entered the field of retail home radio and television sales. Not only does the actual customer get the free ride, but he can take along two of his friends. What next?

Bottleneck Broken. One of the major bottlenecks in the production of television picture tubes—and therefore television receivers—has been the slowness with which face plates were being produced. The Pittsburgh Plate Glass Co. has developed

a new technique which will speed up this process greatly. This achievement is the result of considerable research into the problem. Instead of the slow process of molding glass blanks and then putting them through rigorous optical grinding and polishing operations to obtain spherical perfection, the new technique enables a switch to a mass production basis. A specially developed glass is ground and polished while still flat (a standard operation) and then precision bent. The new face plates can be manufactured on a production line basis. Finally, the development of intricate testing devices has made possible a great reduction in inspection time to a few seconds for each plate. This is good news to the television industry.

Small-Town Television— Smaller cities may soon be in line for direct television coverage. RCA has announced that a new 500-watt television transmitter for operation in Channels 7 to 13 is now in production. The transmitter is intended for use in transmitting locations where a low-power transmitter will provide adequate signal coverage to a city and its suburban areas. Coupled with a six-section super turnstile, it is said to be capable of covering a radius of twenty miles under favorable conditions.

Listen While You Work. The world's largest public address system has been installed at the Kaiser-Frazer Willow Run plant. 600 speakers pipe news, music and service programs into every corner of the auto plant. In addition to providing news and entertainment to the 16,000 employees of the plant, the system provides an invaluable safety device in cases of emergencies. Installation of this huge P-A system was made possible through the solution of the problem of making broadcast clearly audible over variable machinery noises without blaring or distortion.

Silver Anniversary. The Radio Manufacturers Association will celebrate its 25th anniversary and 25 years of progress in Chicago, May 16-20. A "Silver Anniversary" banquet on the evening of Thursday, May 19, will climax the affair. Famous stars will participate in a radio and television broadcast over national networks during the industry dinner. " " "

82 TYPES



ONLY ONE OF THE REASONS THAT MAKE RADIART THE GREATEST REPLACEMENT VIBRATOR LINE

• Another reason for Radiart's nation-wide preference is the complete selection of vibrator types manufactured! There is a CORRECT Radiart replacement vibrator for most every need . . . to ORIGINAL SPECIFICATIONS! This completely eliminates guess work . . . and assures peak performance because no "next best" type is installed! Good jobbers everywhere carry almost all types in stock . . . or can get quickly any number you want! In addition . . . each of these 82 types is precision engineered . . . and manufactured under the most careful inspection that assures peak performance from every Radiart vibrator . . . always!

IT'S RIGHT WHEN IT'S RADIART



THE RADIART CORPORATION

CLEVELAND 2, OHIO

MANUFACTURERS OF THE FAMOUS RED SEAL VIBRATORS

No value equal to it...

Model 260 Volt-Ohm- Milliammeter

There's good reason why this is the world's most popular high sensitivity volt-ohm-milliammeter. In every part, from smallest component to overall design, no competing instrument can show superiority. It outsells because it outranks every similar instrument. And in the Simpson patented Roll Top safety case, shown here, it brings you important and exclusive protection and convenience.

Sub-Panel Assembly —Strong, Simple, Accessible

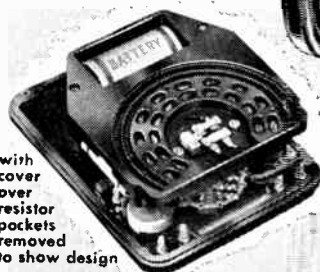

with cover over resistor pockets removed to show design

The ruggedness, the simplicity of design, and the consequent accessibility of components are shown here. Molded of the sturdiest bakelite, the sub-panel provides separate pockets for resistors. This separation makes for orderly assembly, highest possible accessibility, and added insulation for preventing shorts. All connections are short and direct. Cable wiring is eliminated. Each battery has its own compartment, again increasing accessibility.

High voltage probe (25,000 volts) for TV, radar, x-ray and other high voltage tests, also available.

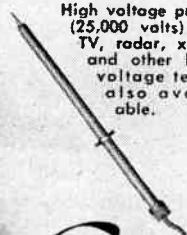

- in staying accuracy
- in functional design
- in useful ranges
- in sensitivity
- in ruggedness
- in precision



A flick of the finger opens or closes the Roll Top front.

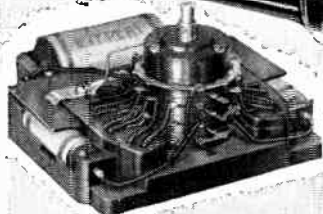

The New Simpson Switch Mechanism. You will find no other switch mechanism on the market like this Simpson switch. It is built of molded bakelite discs. Unusually sturdy contacts, of heavy stamped brass, silver-plated for superior conductivity are molded permanently into each disc. They can never come loose, never get out of position. When the discs are assembled into the complete switch, these contacts are self-enclosed against dust. Danger of shorts is automatically eliminated. As the switch is rotated from range to range, the contact is always positive and unvarying.

A ball-and-spring mechanism positions the switch at the selected range by a 3-point pressure. Switch is thus held securely in place, yet smoothly re-positions to each new range. This mechanism is also self-enclosed against dust in a bakelite housing.

RANGES

- 20,000 Ohms per Volt D.C., 1,000 Ohms per Volt A.C.
- Volts: A.C. and D.C.: 2.5, 10, 50, 250, 1000, 5000
- Output: 2.5, 10, 50, 250, 1000
- Milliamperes, D.C.: 10, 100, 500
- Microamperes, D.C.: 100
- Ampere, D.C.: 10
- Decibels (5 ranges): -10 to +52 D.B.
- Ohms: 0-2000 (12 ohms center), 0-200,000 (1200 ohms center), 0-20 megohms (120,000 ohms center).
- Model 260, Size: 3 1/4" x 7" x 3 3/8" \$38.95
- Model 260 in Roll Top Safety Case, as shown. Size: 5 3/8" x 7" x 4 3/4" \$45.95

Both complete with test leads and 32-page Operator's Manual

Ask your jobber or write for complete descriptive literature.



SIMPSON ELECTRIC COMPANY
5200-5218 W. Kinzie St., Chicago 44, Ill.
In Canada: Bach-Simpson, Ltd., London, Ont.

THE EDITOR SPEAKS

THE ending of a year has always been considered a time for prophesy, and last year was no exception. It ended with a loud prophetic note. What the prophets of television had to say was of particular interest to us. After considerable listening and reading, we were impressed with the lavishness of the predictions which constituted the year's crop. The picture painted had a distinctly rosy quality and, being possessed of a naturally suspicious mind, we determined to do a little investigating. There is nothing the poor prophet hates worse than a good memory, so we decided to refresh ours and do a little checking on past performance.

At the close of 1947 there were 300,000 television receivers in use and our friends with the crystal balls informed us that at the end of 1948 this number would increase to 750,000. We also looked up the figure on the number of stations in operation and found that at the end of 1947 there were 9. The prophets were telling us that 28 new ones would be on the air at the end of '48, bringing the total to 37 stations in operation. This was indeed a pleasant view of the future.

What actually happened in 1948? Were the prophets right or wrong? Here are the final figures. Slightly more than 1,000,000 television sets were in operation at the end of the year. Forty-four stations were on the air. In other words, the predictions were actually surpassed. The prophets, while not one hundred percent accurate, were on the low side and therefore could not be accused of wishful thinking. With confidence gained from this knowledge, we then set about to average the figures contained in this year's predictions for the purpose of presenting them to you as concisely as possible. In so doing, we feel we may have weeded out the wild and wooly, or at least balanced them off against

the pessimists. Speaking of pessimists, they are as always present to tell us that all this cannot possibly come true, and even if it does, it wouldn't do anyone any good.

Getting back to the predictions, we find that at the end of 1949 there will be 120 television stations in operations. During the year, receivers will be produced at a monthly rate well in excess of 100,000 to bring the year end total of sets in operation to approximately 2,750,000.

The past few months have seen many welcome improvements in programming, and with the completion of the coaxial link between the east and midwest and a vastly enlarged audience, this trend can be expected to continue at an accelerated pace. Better programs assure continued consumer interest, and willingness to buy. As stations go on the air to serve new areas, totally new markets will be opened. All of these facts point to the rapid sale of all television receivers as fast as they can be turned out.

Doing a little adding and subtracting we find that 1,750,000 new television receivers will have to be installed during the year. In addition, these and the 1,000,000 receivers already in use will have to be serviced.

With a few calculations based on present prices and charges we can determine what this represents in terms of dollars and cents. In round figures the total in new service and installation business a fantastic 100,000,000 dollars. It is hard to believe that this is only the beginning. In 1950 an even greater volume of installation and repair will be required.

These figures serve to illustrate what a tremendous opportunity television is offering to the wide-awake technician and shop owner. To make something of this opportunity the service industry will have to make a substantial investment in new equipment and in training. Within a few years it will probably be impossible to run a service organization profitably unless the organization is prepared to install and repair television.

JJR

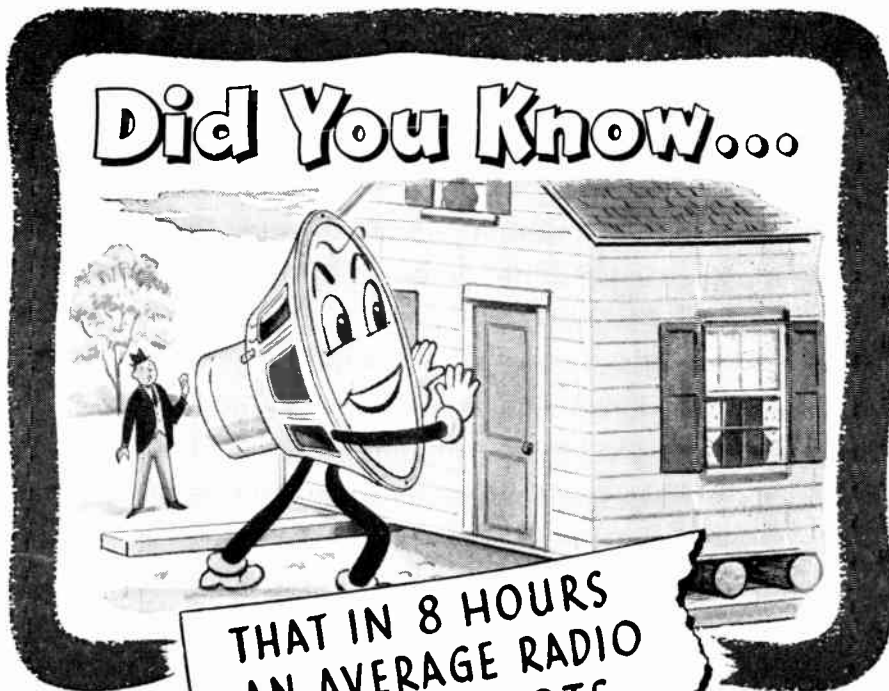

Did You Know...

THAT IN 8 HOURS
AN AVERAGE RADIO
SPEAKER EXERTS
ENOUGH ENERGY TO
MOVE AN AVERAGE
HOUSE 4½ FEET ?

The way some people use a speaker will shake a house . . . but, it's true that the amount of energy an average radio speaker exerts in 8 hours is sufficient to move an average house 4½ feet! This means that although OPERADIO builds speakers with the skill and care of a watchmaker . . . these speakers are sturdily constructed to stand up under heavy, continuous use. OPERADIO speakers are delicately balanced to authentically reproduce the sweetest high notes of a piccolo, yet, carry the tremendous power of a full orchestra crescendo.

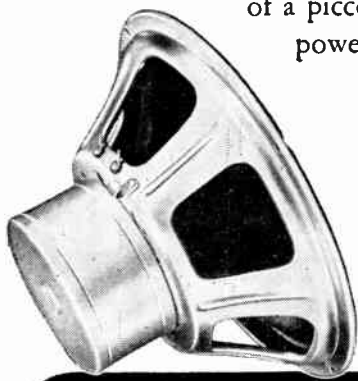

ASK FOR OPERADIO SPEAKERS —
A FULL LINE OF OUTSTANDING
SPEAKERS FOR EVERY PURPOSE!

OPERADIO

RADIO REPLACEMENT and PUBLIC ADDRESS SPEAKERS

OPERADIO MFG. COMPANY • St. Charles, Illinois

QUESTION

Why do so many television sets use Sprague KOOLOHM Resistors for all 5- and 10-watt wire wound power resistor requirements?

ANSWER

Because Koolohms far surpass other wire wound resistor types in the essential characteristic of resistance stability. Also because, being doubly insulated, Koolohms can be mounted anywhere—even directly against a metal chassis. Koolohms are highly heat- and moisture-resistant. One type—the standard type handles any job. No need to worry about choosing special coatings. Moreover, Koolohms cost no more than ordinary resistors, and are actually cheaper in many cases.

SERVICE HINT

Play safe by using Sprague Koolohms in all your work—not only in television, but wherever you want a really first class job. And remember: Koolohms can be used safely at their full wattage ratings, even in enclosed places. No need to buy a 10-watt resistor when the circuit only needs 5-watts. A 5-watt Koolohm dissipates a full 5 watts!

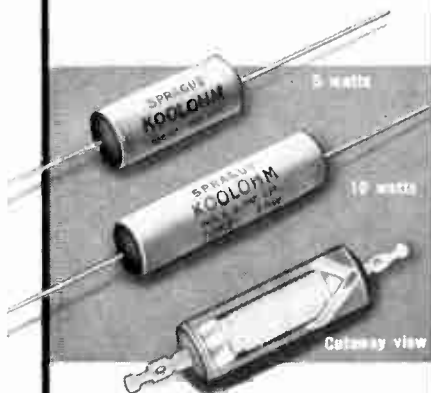

Wound with ceramic-insulated wire. More resistance in less space. Doubly protected, insulated and sealed by outer ceramic jacket. Highly resistant to moisture and heat.

SPRAGUE
KOOLOHM
REG. U. S. PAT. OFF.
WIRE WOUND RESISTORS

SPRAGUE PRODUCTS CO., North Adams, Mass.

(Jobbing distributing organization for products of Sprague Electric Co.)



by John T. Frye

WANTED. Experienced radio serviceman, \$45 per week.

WANTED. Carpenters, \$2.50 to \$2.75 an hour.

Charlie Erhardt, of Rego Park, Long Island, N. Y., wants to know why he sees contrasting ads like the two above almost every day. Why, he asks, do radio servicemen have such a low dollar-and-cents valuation placed upon their services?

The medium with which they work, he points out, is as modern as tomorrow. The apprenticeship they serve is a lengthy and studious one. They have to master the use of delicate and complicated tools. They must study and read and experiment constantly in order to keep abreast of their rapidly-advancing field. Yet these radio service technicians are, as a whole, paid far less than are other mechanics who learn their trade with a much smaller investment of time, effort, and money. In fact, they are often paid less than semi-skilled labor.

I cannot argue with Charlie's statement of fact, and I am not sure that I can explain this state of affairs to his complete satisfaction, but I shall try.

In the first place, the fact that radio servicing is such a new form of maintenance work is against us. The maintainers of any piece of equipment get little respect in the beginning. This is partly because, at first, the repair work is usually a sideline. You will recall that the first garage work was done by the village blacksmiths who liked to "tinker" with the new fangled gas buggies—not realizing that they were digging the grave of their centuries-old trade as they did so. In the same way, those aristocrats of the maintenance men, the doctors, first started playing around with the human machine as a sideline to their really important work, barbering.

How many radio service technicians do you know who deliberately chose this way of making a living, who educated themselves to that end, and who have stuck to it ever since they began? For every one you can name I can give you a dozen who drifted into radio servicing from ham radio, who started radio work to tide them over a lay-off period from their regular work, who have worked at it on and off in between other more lucrative jobs, etc., etc. It is hard to force respect for a trade that is manned by such haphazard recruiting.

Another reason why the public does not hold radio servicing in such high esteem is that our customers do not understand the nature of the service they pay for. They can see that an auto mechanic, in addition to having a lot of technical information, must work in difficult, awkward positions and get very dirty and greasy while doing it. The jeweler's work is obviously tedious and nerve-racking because of the tiny mechanisms upon which he works. The carpenter's job takes him out in all kinds of weather and forces him to risk his neck clambering around over rooftops and up and down high scaffolds.

But what does the radio man do? He punches around in the set with a pair of test probes. He snips out a bad part here and there and solders in a new one. He twists a few knobs on a funny-looking box, turns a few screws, and then says, "That will be five dollars and a quarter."

Why should he be paid that kind of money? The work is not hard and dirty like the garage man's, nor painstaking and delicate as the jeweler's, nor dangerous as the carpenter's. No, it is not these things; but what people do not realize and must be taught is that the radio repairman's work is more like a profession than a trade in at least one re-

spect: He is paid for what he knows and not for what he does.

The money paid to a doctor is not for manipulating a stethoscope, for turning the knobs on an x-ray machine, for writing out prescriptions. You pay him for analyzing the information that the use of his various instruments gives him and for knowing how to correct a wrong condition that he thus discovers. In the same way, a service technician is not paid for punching with probes, cutting wires with diagonal cutters, soldering, turning trimmer screws, etc. But until the public realizes that it is not paying him for these physical acts, it will be hard to raise his pay.

What the public thinks is important in determining the status of the radio service industry. But much more important is the attitude of the service technician himself toward his work. Far too often the serviceman, by his wrong thinking and acting, is doing serious harm to the whole servicing profession.

At the risk of bringing criticism down upon my head, I want to say that I honestly believe that those service technicians who offer free estimates, who have no minimum charge, and who do small radio service jobs without making a service charge are seriously harming the whole business of radio repairing and, in the long run, are doing themselves a great disservice as well. Engaging in these practices may result in a temporary increase in individual income, but this gain is obtained at a cost of respect for radio servicing in general; and sooner or later, chickens of that feather will come home to roost.

A young doctor starting up in business could quickly build up a flourishing practice by offering free diagnoses, by giving bargain prices on appendectomies, and by making no charge whatsoever for a call that did not take up more than fifteen minutes of his time. But you do not see any of them doing it, do you? They know better than to cheapen, for a temporary profit, the profession in which they expect to spend their lives. They remember the fable of the Goose that Laid the Golden Egg, and they know that if they engaged in such practices, they would soon find themselves working twice as hard for half as much pay as

— to page 43

TRANSVISION

PRESENTS
THE NEW

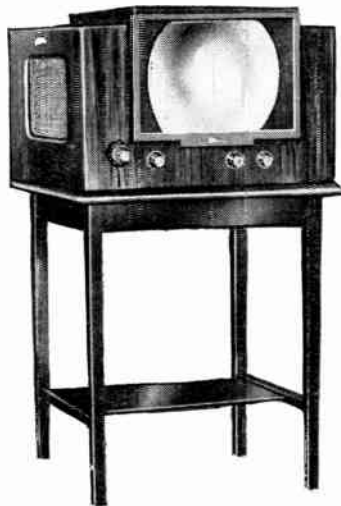

Model 12CL TV-FM Kit

Brings the biggest and best in television within the reach of everyone.

GIGANTIC VALUE!

OVER

200

**SQ. IN. PICTURE
VISIBLE from ALL ANGLES**

with FM Radio
(De Luxe continuous TV-FM input tuner)

(Picture much bigger than a tabloid newspaper page.)
IMAGE IS EQUAL to that of a 20" tube—even sharper and clearer—and it is visible from all angles.

MODEL 12CL TV-FM KIT

- Features 12½" tube fitted with All-Angle Lens, giving over 200 sq. inch picture which is visible from any place in a room.
- Gives ideal long-range reception with CONTINUOUS TUNING on ALL CHANNELS. has DeLuxe continuous TV-FM input tuner.
- COMPLETE with Cabinet, Lens, Roto-Table, Antenna, Lead-in Wire.
- A BIG PROFIT MAKER for service dealers. This kit is TOPS—ideal for homes, clubs, taverns, and other commercial installations.

EASY TO ASSEMBLE • • • NO TECHNICAL KNOWLEDGE REQUIRED

Transvision's simple step-by-step Instruction Sheet makes assembling a TV Kit a pleasure. Each kit comes complete with all-channel double-folded dipole antenna and 60 ft. of lead-in wire. *Nothing else to buy!*

TRANSVISION ALL-CHANNEL TELEVISION BOOSTER

To assure television reception in weak signal areas, or areas which are out of range of certain broadcast stations, Transvision engineers have designed this new booster. It increases signal strength on all television channels. Tunes all television channels continuously. Can be used with any type of television receiver. Unusually high gain in upper television channels.
Model B-1 LIST \$44.95

TRANSVISION COMPLETE LINE OF TELEVISION COMPONENTS

Essential units for building a quality television set. Transvision makes available a complete line of high quality parts competitively priced. Included in this line are Filter Chokes, all types of Transformers, Focus Coils, Deflection Yokes, Coils—and, of course, major units such as Picture Tubes, Antennas, Lenses, etc., etc.

WRITE FOR COMPONENT FOLDER P-1

RADIOMEN... You Can GET INTO the

TELEVISION BUSINESS IN A BIG WAY WITH THE TRANSVISION DEALER PLAN

Write for Dealer Folder D-1

TRANSVISION, Inc. Dept. RM New Rochelle, N. Y.

In Calif.: Transvision of California, 8572 Santa Monica Blvd., Hollywood 46
All prices 5% higher west of Mississippi; all prices fair traded. All Prices Subject to Change Without Notice

TRANSVISION REMOTE CONTROL UNIT KIT

Will operate any TV receiver from a distance. Turns set on, tunes in stations, controls contrast and brightness, turns set off. Ideal for installations where the television receiver is inaccessible. Tuner unit is a high gain, all-channel unit with about 50 micro-volt sensitivity. Easy to assemble in about an hour.
Model TRCU, with 25 feet of cable... Net \$69.00
Without cabinet Net \$65.00

ASSEMBLE Your Own CABINETS

Transvision's "MODULAR" Cabinets come in knock-down, unpainted units, offering an unlimited range of combinations, including even a bar. Finish them off to suit your taste.

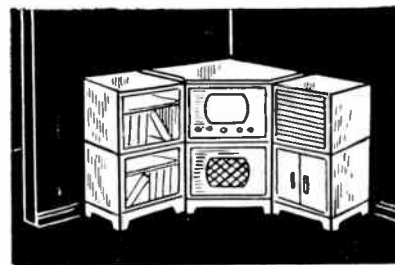

Corner piece, shown above, has room for TV, Phono, Record Storage, and open Book Case.
COMPLETE Net \$84.00

For other units and prices, write for "Modular" Catalog.

CHECK!

DISTORTIONLESS SOUND-SYSTEM CONTROLS!

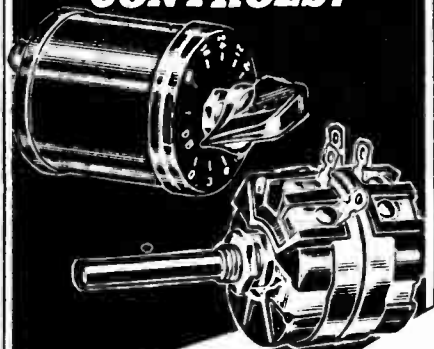

OUTPUT ATTENUATOR

Constant-impedance volume control handling up to 10 watts at any dial setting. Used as output level control for power amplifiers. Or as input attenuator for individual speakers in P.A. systems.

L-PADS AND T-PADS

Constant-impedance attenuators. These self-compensating volume controls eliminate distortion arising from mismatching of impedances.

PLUS THE "KNOW-HOW"

Clarostat can tell you how to eliminate distortion in sound-system volume control. Clarostat has made the bulk of the L- and T-pads, attenuators and faders, now in general use!

↑ CLAROSTAT



Ask your
Clarostat
jobber for
latest catalog. Or
write us.

Controls and Resistors

CLAROSTAT MFG. CO., Inc., Dover, N. H.

In Canada: CANADIAN MARCONI CO., Ltd
Montreal, P.Q., and branches

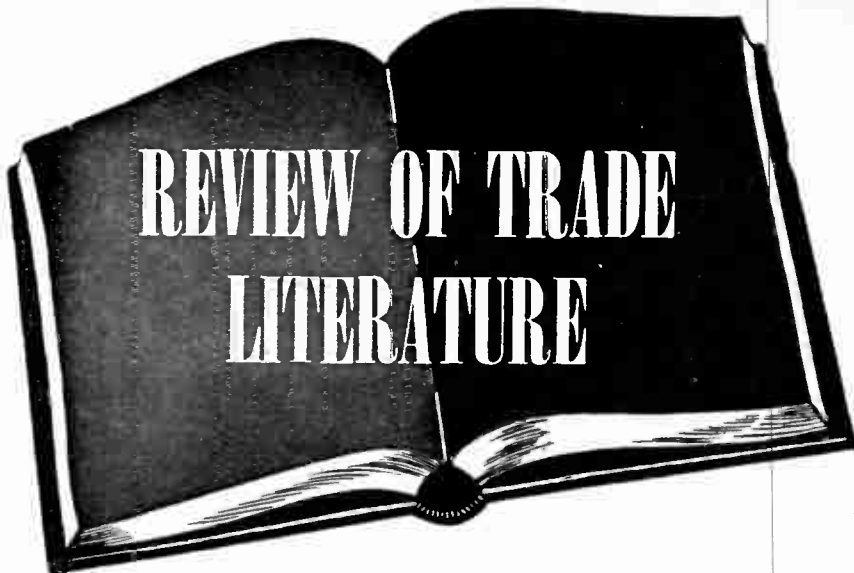

To avoid delay when writing to the manufacturer give issue and page number.

Radio Engineering, by E. K. SANDEMAN, (John Wiley & Sons, 775 pages, \$6.50) volume I.

Starting from the mechanics of broadcasting and the elements of electronics, and progressing into a discussion of radio transmitting equipment, this book is an attempt to furnish the answers to the problems of radio station maintenance. As it proceeds from the elemental to the complex, it is of interest to the beginner in the field as a source of new knowledge, and for the expert as a book of reference.

This first volume includes chapters on sine waves, currents, voltages, resonance and tuning, circuits, harmonics, thermionic valves, amplifiers, oscillators, drive equipment, modulators, and transmitter types and their maintenance. In addition, it has a detailed chapter on antennas. It includes information on a number of subjects such as r-f resistance, inductance of straight wires, impedance characteristics of feeders, and curves for finding the spectra of frequency modulated waves, which is normally not found in similar books.

The author of *Radio Engineering* was associated with the Engineering Division of the British Broadcasting Corporation. Most of the book is an outgrowth of that experience. As a result, there are occasional references to British broadcasting practices, BBC frequency bands and call signs, not entirely applicable to American conditions. The terminology, however, is up to date. A list of the main

conventional symbols at the head of selective chapters eliminates ambiguities, and will be of particular value to the beginner in the field. For the student, the numerical exercises and examples given at the end of applicable chapters will prove helpful. These examples consist of the questions, the methods of solution, and the answers.

The book is well filled with diagrams and graphs, all of which are clear and uncrowded. A number of tables, such as attenuator networks and db loss, characteristics of various S.W.G.s, a number of conversion tables, etc., will all be of value to the radio station maintenance engineer and the radio equipment designer.

Servicing the Modern Car Radio, by A. L. HURLBUT (Murray-Hill, 692 pages, \$7.50)

The purpose of this volume is to enable the practicing radio service technician to add automobile radio servicing to his operations. It presupposes a knowledge of fundamental radio on the part of the reader, and aims to enlarge this knowledge so as to be applicable to the special conditions of radio in the auto field.

In the first part of the book, which contains all the text material, the author discusses the car radio field generally. The considerations that affect a decision to enter the field, the differences between servicing car and home radios, the various major components (antenna, power supply,

→ to page 41

NOW...

SYLVANIA RECEIVING TUBES SPECIALLY PROCESSED

FOR FINER TELEVISION PERFORMANCE!

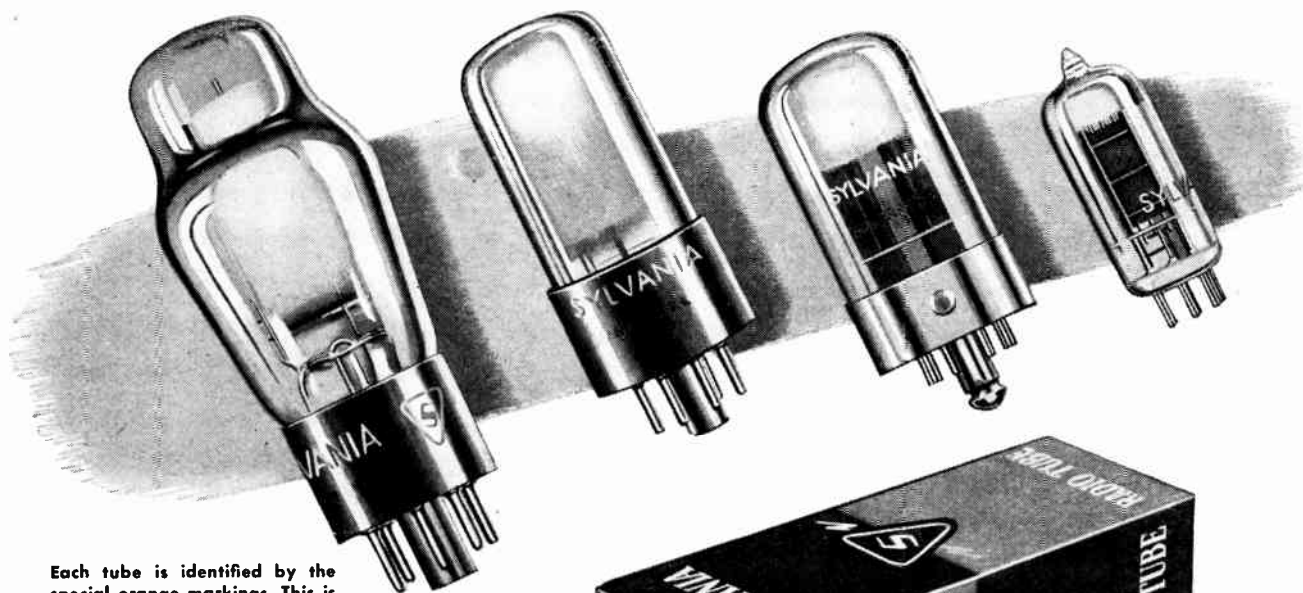

Each tube is identified by the special orange markings. This is your assurance of the higher quality demanded by television.

Now, when you replace worn-out receiving tubes in your customers' television sets, give them the finest in television reception with these new receiving tubes *specially processed* by Sylvania for the extra-tough requirements of television service.

These new Sylvania television tubes, in the new bright orange and green television cartons, actually undergo *three times more exacting tests* to insure they are unsurpassed! Their higher quality and superior performance more than justify their small additional cost.

They are not just good tubes, they are *superior* tubes . . . results of Sylvania's years of experience in the electronics field. Be sure you have a ready supply for increased television tube replacement business. See your Sylvania Distributor today! Sylvania Electric Products Inc., Radio Tube Division, Emporium, Pa.



LOOK FOR
THE BRIGHT ORANGE
AND GREEN CARTON

Replace worn tubes with these specially processed Sylvania tubes made to pass television's rigid requirements.

AVAILABLE NOW IN THE FOLLOWING TYPES

1B3GT	6J6	7F7
6AG5	6K6GT	7H7
6AL5	7B4	7N7
6BG6G	7B5	7Z4
	7C5	

SYLVANIA ELECTRIC

RADIO TUBES; CATHODE RAY TUBES; ELECTRONIC DEVICES; FLUORESCENT LAMPS, FIXTURES, WIRING DEVICES; PHOTOLAMPS; ELECTRIC LIGHT BULBS

**MORE CAPACITANCE
... LESS BULK...**

AEROVOX

**TWIST-PRONG
BASE**

ELECTROLYTICS



● It's the "new look!" See it right on the labels. Higher voltages and capacitances—without increase in sizes — in some numbers!

That makes these handy twist-prong base electrolytics handier than ever. Prongs extend through mounting surface and are twisted or bent to hold unit rigidly in place. May be mounted on fibre (insulated) or metal (grounded) socket-shaped washer riveted or eyeletted on chassis. Ideal for initial equipment. Indispensable for replacements.



● Our jobber stocks Aerovox twist-prong base Type AF electrolytics. See listings in latest catalog for your precise needs. Ask our jobber for your copy — or write us.



**FOR RADIO-ELECTRONIC AND
INDUSTRIAL APPLICATIONS**

AEROVOX CORP., NEW BEDFORD, MASS., U.S.A.
Export: 13 E. 40th St., New York 16, N.Y. • Cable: 'ARLAB'
In Canada: AEROVOX CANADA LTD., Hamilton, Ont

Volt per 1000 Ohms

— from page 26

velops a drop of one volt across the resistor. Those resistors which are less than one thousand ohms may be written as a decimal part of a thousand ohms, e.g., 150 ohms = 0.15 K ohms, 500 ohms = 0.5 K ohms; and the voltage drop across them is calculated by the proposed system.

To illustrate the use of this system, examples of actual calculations for conventional circuits will be made.

Examples

a) Suppose we want to calculate the cathode biasing resistor for a conventional beam power tube in an ac-dc radio receiver such as 25L6 or 50L6. Referring to the tube manual we find that the average cathode current (plate plus screen current), using a 2000 ohm load resistance, is approximately 57 milliamperes, and the required bias is 7.5 volts. Using this system, we can say that 57 milliamperes is 57 volts per thousand ohms. Since we require only 7.5 volts, we can readily see that the cathode resistance must be less than a thousand ohms, i.e., seven and one half 57th of a thousand ohm, or:

$$R = \frac{7.5 \text{ volts}}{57 \text{ volts per K ohms}} = 0.131 \text{ K ohms}$$

The above equation may be recognized as involving Ohm's Law, but the unit of current has been changed from ampere to volts per thousand ohms. In this way, volts above the division line cancel volts below the division line; and the answer comes out directly in K ohms.

b) To obtain a voltage drop, a resistance may be expressed in *volts per milliampere*. As an example, let us calculate the voltage drop across the plate load resistance of a 6SQ7 whose plate current under normal operating conditions is 0.8 milliamperes. The load resistance is usually 250 K ohms, which may be expressed as *250 volts per milliampere*. Therefore, multiplying the current in milliamperes with the resistance in *volts per milliampere*, we have:

$$E = 0.8 \text{ milliamperes} \times 250 \text{ volts per milliampere} = 200 \text{ volts}$$

where the answer comes out directly in volts.

c) Consider the case of calculating

the resistance required to drop the screen voltage for a pair (2) of 6SK7s. Our tube manual shows that with a 250 volt supply, the screen should be 100 volts with a screen current of 2.6 milliamperes. Using a common screen dropping resistor for both tubes, the total current through this resistor will be 5.2 milliamperes, or *5.2 volts per K ohms*. To impress 100 volts on the screens of the tubes, a drop of 150 volts (250 minus 100 volts) across the screen dropping resistor is necessary. In order for the answer to come out in ohms, we must divide the *volts per K ohms* into the voltage drop required. Therefore:

$$R = \frac{150 \text{ volts}}{5.2 \text{ volts per K ohms}} = 28.8 \text{ K ohms} = 28,000 \text{ ohms}$$

As in example a) volts cancel volts, and the answer comes out in K ohms.

d) Let us discuss one more case by calculating the line dropping resistor for an ac-dc filament circuit in which there are three 6.3 volt tubes and two 25 volt tubes connected in series making a total voltage drop of approximately 69 volts. To connect this filament circuit across a 117 volt supply line (the actual voltage in a 110 volt line), it is evident that we must drop 48 volts with a series resistor. The manual shows that these tubes have a current drain of 300 milliamperes which, in using our system, we term *300 volts per K ohms*. Then, dividing:

$$R = \frac{48 \text{ volts}}{300 \text{ volts per K ohms}} = 0.160 \text{ K ohms} = 160 \text{ ohms}$$

In conclusion, we wish to say that this system is a manipulation of Ohm's Law in which the basic electrical quantities of ohms, volts, and amperes are converted to other units so that the answer comes out directly in the units desired by the cancelling of the equivalent units in division or multiplication. For review, Table I has been prepared. This table shows the conversions that can be made. If the reader will practice this system every time he has to make a calculation, he will soon adopt it as part of his kit of tricks for rapid servicing.

Juke Box Servicing

→ from page 24

while they are usually good at the mechanical end, they lack the theory necessary for efficient electronic work.

A Juke Box Service Technician

Peter Manzoli, who owns and operates the Radana Radio Shop at 173 South Broadway in Yonkers, N. Y., services a string of fifteen juke boxes for a small local operator, along with his regular radio repair work.

He supplies this service at a flat rate of \$2.00 per week per box. He furnishes the labor, and the owner furnishes all parts. Each machine bears Pete's phone number, and when the location owner has trouble, he calls Pete directly. Pete answers service calls up until 10 o'clock each evening, seven days a week. When he goes on vacation or wants to take an evening off, he transfers his calls to a service man friend, who takes over. (Phone answering and message taking services can be had for about \$12 to \$15 a month)

Peter finds that he averages about one call per machine every ten days. When he first took over the route, he had many more calls to make. The machines were in very poor condition, and required a great deal of work. Now, most breakdowns are caused by some minor fault. Ten minutes per job is about average. Careful preventative maintenance keeps things that way.

The only addition to his regular radio tools are a box of juke box tubes and some parts, which he takes along on his jobs.

Business Promotion

Pete got into the business of servicing juke boxes through the recommendation of a customer who sent the operator around with a faulty amplifier. Pete plans to secure additional work by a direct mail campaign, followed, when practical, by personal visits to the operators. He also intends to make personal calls to the taverns and clubs in town to ascertain whether or not the box is leased. He will also write letters to the various manufacturers of juke boxes so that they may place his name on file in the event a box purchaser asks for the name of a nearby service man.

Here's your PORTABLE oscillograph for RADIO and TELEVISION SERVICING...

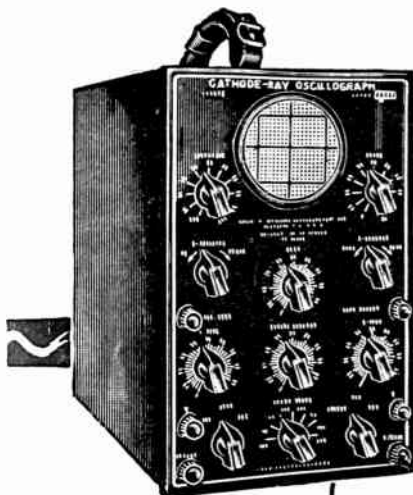

DU MONT

Type 164-E

RUGGED! LOW COST!

*Weights only 20 lbs!
Does a complete servicing job!*

TYPICAL USES

- Signal tracing.
- Correcting power-supply ripple.
- Detecting microphonic tubes.
- Replacing output transformers.
- Aligning video amplifiers.
- Trouble-shooting sync and sweep circuits of television receivers.

OTHER FEATURES

- Vertical amplifier response at full gain within 20%, from 5 cps to 100 kc.
- Identical amplifiers for vertical and horizontal deflection.
- Recurrent sweep from 15 to 30,000 cps.
- Return trace blanking.
- Sine wave test-signal output.

\$127.20

CAT. NO.
1064-A

• The Type 164-E is a rugged, low-cost, light-weight cathode-ray oscillograph capable of doing a complete radio and television job. Even though its price is low, nothing has been sacrificed in the way of quality in building this instrument for you.

In the design of the Type 164-E, emphasis has been placed on combining simplicity and portability with utility. Those are the things that are important to you.

And please remember too, the Type 164-E is a time-tested, proven oscillograph. This popular oscillograph, now in such general use among servicemen, has stood the test of many years' usage.

So when you buy your oscillograph for better servicing, if it's a Type 164-E you can be sure it's of the best.

DU MONT

**ALLEN B. DU MONT
LABORATORIES, Inc.**
Passaic • New Jersey
Cable Address: Albeedu, Passaic, N. J., U. S. A.



American Beauty

ELECTRIC SOLDERING IRONS

are sturdily built for the hard usage of industrial service. Have plug type tips and are constructed on the unit system with each vital part, such as heating element, easily removable and replaceable. In 5 sizes, from 50 watts to 550 watts.

TEMPERATURE REGULATING STAND

This is a thermostatically controlled device for the regulation of the temperature of an electric soldering iron. When placed on and connected to this stand, iron may be maintained at working temperature or through adjustment on bottom of stand at low or warm temperatures.

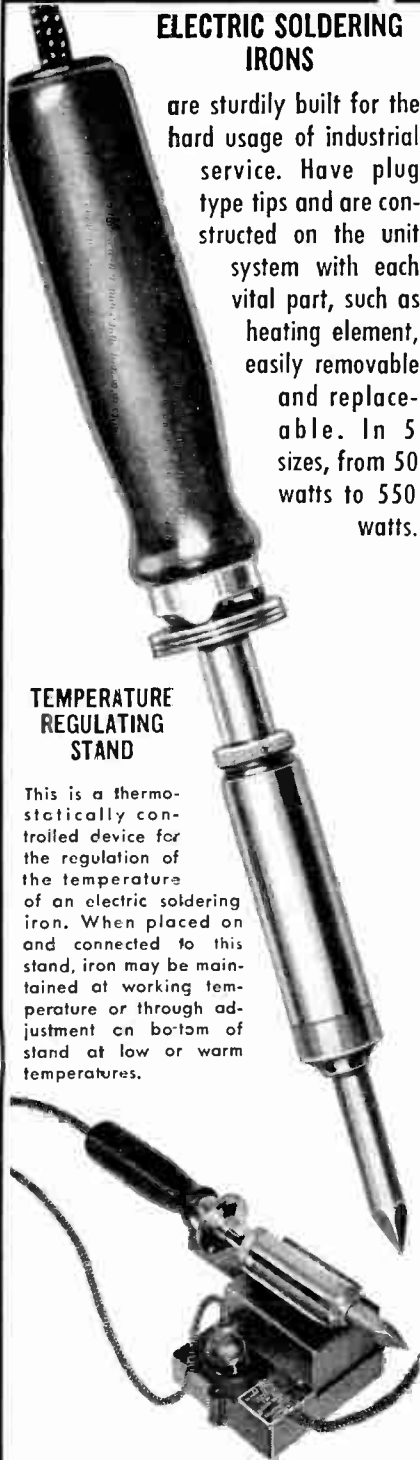

For descriptive literature write

110-1

**AMERICAN ELECTRICAL
HEATER COMPANY
DETROIT 2, MICH., U. S. A.**

THE INDUSTRY PRESENTS

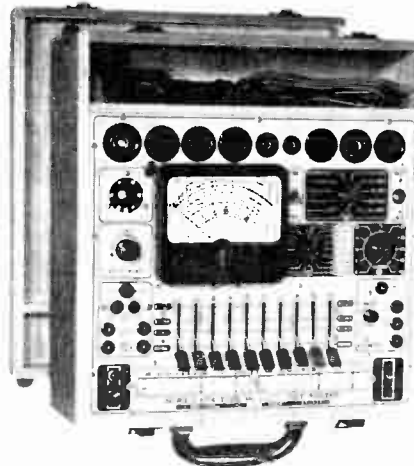

TEST EQUIPMENT

Series #654 is a combination of cathode conductance tube tester, dynamic (under-load) battery tester, and high sensitivity a-c and d-c circuit tester (20,000 ohms-per volt d.c.), produced by Precision Apparatus Co., Inc., 92-27 Horace Harding Blvd., Elmhurst, L. I., N. Y. The instrument handles all modern tubes with full anti-obsolescence features, and circuit tests all AM and FM units as well as TV, set up to 30,000 volts with the addition of the Series TV-2 Super-High-Voltage television test probe. The unit is available in 4 models (portable, laboratory portable, panel mount, and counter model). Additional information is obtainable by writing directly to the company.

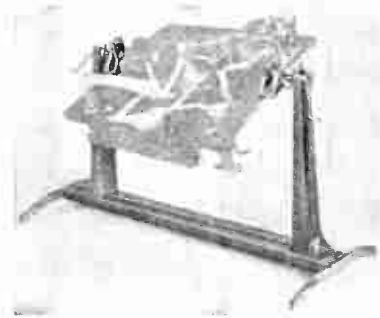

CHASSIS CRADLE

This cradle is an extra sturdy unit that holds any radio, amplifier, or record changer chassis in any position. It can be rotated and locks into position with a short turn of a locking lever. The unit provides finger tip control. Non-slip, jaw-type clamps are lined with protective rubber, and hold the chassis in a vise-like grip. Special design eliminates wobble. Manufacturer: Acro Tool & Die Works, 4552 Broadway, Chicago 40, Ill.

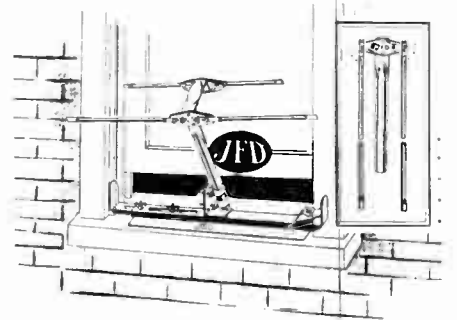

WINDOW ANTENNA

This antenna was especially designed for locations where no permanent installations are allowed. It employs a dipole and reflector for complete 12 channel reception. Installation time is about 1 minute and no special tools are required. When not in use, the antenna can be folded up like an umbrella and stored away. A bulletin describing and illustrating the JFD Quick-Rig Window Antenna is available upon request from the company. Manufacturer: JFD Manufacturing Co., Inc., 4117 Fort Hamilton Parkway, Brooklyn 19, N. Y.



PHONO AMPLIFIER AND PREAMP

Special Products Co., Silver Springs, Md., has announced the availability of its Model 309 phono amplifier and preamplifier combination. The unit may be used with low level pickups, such as Pickering or GE variable reluctance, as well as through a separate input tap for use with regular crystal cartridges for playing either standard or LP microgroove records. The response is essentially flat from 1000 cps to 14,000 cps, but provides necessary rising characteristics be-

low 1000 cycles with a boost up to 12 db at 50 cycles. The hum level is 40 db below maximum signal output.

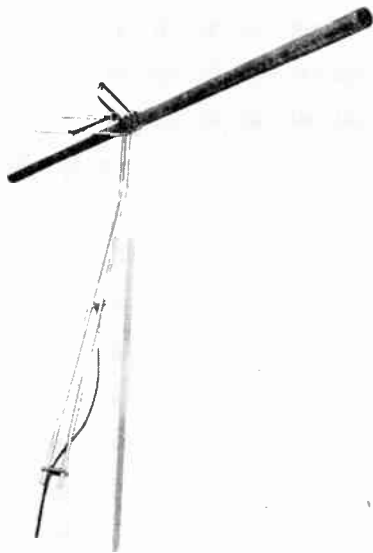

FRINGE AREA ANTENNA

This new Vee-D-X antenna, the Sky Monitor, is designed for reception in prime or near fringe TV areas, offering broad band characteristics and reasonably high gain. It provides a tunable "Q" section for matching line impedance, and high channel orientation independently of low channel orientation. Manufacturer: LaPointe Plascomold Corp., Unionville, Conn.



PORTABLE WIRE RECORDER

The Harrison Magnetic Wire Recorder, available from Progressive Marketers, 41 Union Square, New York 3, N. Y., is a compact machine weighing only 23 pounds, housed in a leatherette overnight case. Its overall dimensions are 8½ x 10 x 14 inches. To facilitate operation, the instrument is provided with a "roll-out" control panel. The features of this recorder include: recording and playback up to one hour, record player for 10 and 12 inch records, public address system, tone control, musical instrument amplifier, records from phonograph, radio or microphone, has built in 4 x 6 inch speaker, an extra speaker input jack for external speaker, and a recording level indicator. Extra accessories are available from the factory.

→ to page 44

12 WAYS TO CUT CONTROL INVENTORIES

You can reduce your stock of replacement controls, and profit in time and money with these 12 IRC Tap-In Shafts. IRC engineered for easy installation and dependable performance with IRC Tap-In Shaft Controls, they cut both service time and costly stocks of exact duplicates.

Accurately tapered sockets in IRC Tap-In Shaft Controls readily receive the closely machined shaft ends. A firm hammer tap permanently "freezes" the two units. "C" washers and other cumbersome locking arrangements are entirely eliminated. IRC Tap-In Shafts are quick, easy . . . and secure!

IRC Tap-In Shafts can be conveniently cut to desired lengths before being installed. In crowded chassis, they can be installed *after* control is assembled—eliminating any necessity to remove other parts.

There's an IRC Tap-In Shaft for most radio and television requirements. Used with IRC Tap-In Shaft Controls, you are sure of smooth, quiet, trouble-free service. Ask your distributor for IRC Controls—with the *dependable* Tap-In Shaft feature. International Resistance Company, 401 N. Broad Street, Philadelphia 8, Pa. In Canada: International Resistance Co., Ltd., Toronto, Licensee.

INTERNATIONAL RESISTANCE CO.



Wherever the Circuit Says ~~~~



SELL SPEAKER SERVICE

Build yourself a reputation for improved tone of every speaker job you handle. A.G. will back you with the finest reconing service.

- Cones and fields in stock for any speaker
- Full range frequency test
- Audio test at full power rating
- Professional workmanship

Send all of your defective speakers, parcel post, for quick reconing . . . 3"—\$1.40, 5"—\$1.50, 7"—\$1.95, 10"—\$2.70, 4x6—\$1.90 . . . others low too!

A. G. RADIO PARTS CO.

3515 N. 17th St.

Philadelphia 40, Pa.

It's For You...

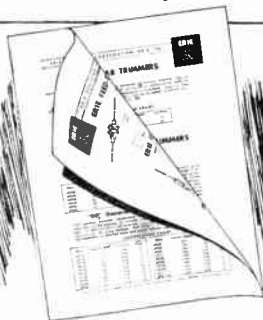

ERIE RESISTOR'S New Catalog

You can rely on the performance of Erie Resistor components when repairs call for replacement. If your distributor cannot supply you, write us for information, and ask for the new catalog.

Electronics Division
ERIE RESISTOR CORP., ERIE, PA.
LONDON, ENGLAND TORONTO, CANADA.

PROJECTION TELEVISION!

THE NEW SPELLMAN F1.9 PROJECTION TV LENS



Dimensions:
Length 7",
Diameter 4 1/4",
F1.9 EF.5 in.
(127mm). This
lens incorporates
in barrel a cor-
rective lens for
use with a 7TP4
projection tube.
It is easily re-
movable for use
with flat type

tubes. Lens can be utilized to project picture sizes from several inches to 7 x 9 ft. ONLY \$90 comp. with mounting ring. Machined slotted intc. ring available for hand focusing adjustment. \$8.00 extra.

30 KV RF POWER SUPPLY

Dimensions: Length 11", Width 11", Height 1 1/4"
New improved unit of exceptional regulation. Has a focus control pot built in for use with 3TP4 tube. Voltage variable from 27 to 30 KV. Supply utilizes 6 tubes. Net price including DC Power Supply \$99.50

HIGH VOLTAGE METER— 0 to 30 KV

A precision-made instrument with range from 0 to 30 KV, has 4" scale and only draws 20 microamps. Bakelite meter panel housed in solid oak cabinet. Meter has jack connector for convenient connection to oscilloscope in checking voltage wave forms. Net price \$67.50

SEND FOR FREE COMPLETE TECHNICAL DETAILS

REAR PROJECTION TELEVISION SCREENS

The surface consists of a conglomerate arrangement of plastic crystals that "Pin Point" the projected image providing unexcelled angular viewing with a minimum loss of light. It is estimated that there is a loss of approximately 10% of light viewing the image at 45 degrees off center. Stock sheets are available from 3x1 feet down. Specify inside dimensions of screen desired. If larger sizes are required, they can be made to order. Frames can be had on request, small sizes \$5.00—large sizes \$10.00. Net Price of screen, per sq. foot..... \$4.50 Include 25% Deposit With Order. Balance C.O.D.

Pioneers in Projection Television
SPELLMAN TELEVISION CO., INC.
130 WEST 24th STREET • NEW YORK 11, N. Y.



PHONO DRIVE REPAIR

When the complaint is a phonograph or record changer that plays too slow or is wavy, the trouble will usually be poor traction between the motor shaft and the idler pulley. The rubber drive will usually be very smooth, and that is what causes the trouble. I find that by dressing the idler pulley rubber down with finger nail emery board, a good flat surface is obtained and the transfer of power to the turntable is greatly increased.

Daniel Fieldman,
Cuyahoga Falls, O.

is not available, consists in placing a rubber tube of proper diameter onto the screwdriver in such a way that the rubber extension holds the screw in position. When the use of the rubber tube is not needed for holding the screw, a simple push back will leave the end of the screwdriver exposed for normal operation.

Jose Urteaga Unda
Santiago, Chile

ELECTRIC SHOCK

In some of the older receivers of the power transformer type, a bypass condenser is connected across from one side of the power line to ground at the transformer primary contacts. If attempts are made to connect ground wire while the receiver is on, a shock may be received. Reversing the plug will correct this condition, but a better method is to remove the ground end of the condenser from the chassis, or ground, and place it across the a-c line.

D. South Travis
Sherman, Texas

MICA CUTTER

The undercutting of mica on small commutators is an easy task if you use your 1/4" electric drill and a simple cutter made from an iron chassis

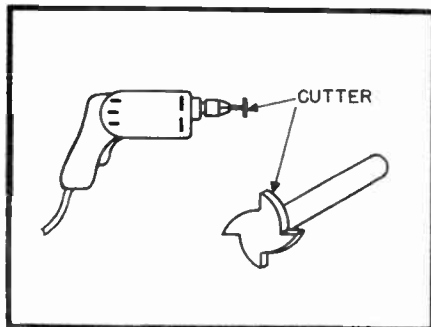

bolt. File the bolt head down to the mica thickness. Then file several notches in the head to form a saw.

Carl O. Williams
Argos, Indiana

SCREWDRIVER FOR INACCESSIBLE PLACES

A practical and easy way of placing screws in difficult and inaccessible places, when a special screwdriver

PHILCO 1001

If there is an absence of high voltage, check first current limiting resistors in series with the high voltage line. This one megohm carbon resistor may be open completely, or partially open and arcing across the gap. Many service technicians check for high voltage by shorting this circuit momentarily to ground, a practice which will ruin the resistor in short order.

Max Alth
Yonkers, N. Y.

Trade Literature

— from page 34

etc), setting up a car radio service station, installation and servicing of the equipment, and the special problem of auto radio interference.

The second part of the volume is taken up entirely by circuit and alignment data for over 200 models of automobile radios.

The information presented by the author is given in clear and relevant fashion. Step by step procedures, essential to the beginner in the field, are provided wherever applicable. Since the author has been active in the car radio field for many years, he draws on considerable practical experience to present his ideas. The text is well illustrated with drawings and diagrams, helping the reader get a better picture of the discussion.

Illustrations for the second part of the book do not always have the clarity that might be desired. Almost all of them were furnished by the respective manufacturers, and in the process of reproduction, clearness has been lost in some cases, making the reading of some diagrams and some parts lists difficult at times. In the vast majority of cases, however, both diagrams and parts lists are clear.

For the radio serviceman who wishes to enter the field of auto radio servicing, and who has been looking for a comprehensive source of up-to-date information (all auto radio models from the mid-thirties to the present are covered) which is complete as well as authentic, this book may well be what he has been seeking.

Rider Manual, Volume XVIII
(John F. Rider, 2000 pages, \$19.80)

The latest in the series of Rider servicing manuals is a collection of authentic manufacturer's radio service data covering a-m, f-m, automobile receivers, and record changers, up-to-date as of January 1949. Included in the volume is a cumulative index, covering volumes XVI, XVII, and XVIII, as well as the popular *Howe It Works* book. A breakdown of difficult multi-waveband receivers, the Rider Clari-Skematix, also comes with the book. This volume is bound in the standard Rider blue loose-leaf binder.

— to page 42



5" Scopes

for Television and FM

by

HICKOK

**Greater Sensitivity...
Higher Frequency...**

The only COMPLETE Cathode Ray Oscillograph. Built with the famous HICKOK quality and accuracy, and providing the following exclusive HICKOK features:

Wide band amplifiers—20 cycles to 1m.c.

Extremely sensitive vertical amplifiers—.015 V. per inch

Demodulator

Phasing control

Built-in FM oscillator (505 only)

Return eliminators

Sinusoidal and linear sweep

Mail this ad for literature and free copy of our regular 50c Service Instruction Manual.

Model 505 Illustrated
Contains separate oscillator for FM alignment. The only complete 'Scope.

Model 195B
For FM and Television. Another popular Hickok model—the most sensitive service man's 'Scope available. An ideal companion for the Hickok Model 610 TV Generator and the 288X FM-AM Generator. 105-125 VAC.



For over 35 years...
the finest in electrical
and electronic instruments

THE HICKOK ELECTRICAL INSTRUMENT CO.

10634 DUPONT AVE.

CLEVELAND 8, OHIO



Permoflux

SPEAKERS

POWER! FIDELITY! RUGGEDNESS!

Famous name manufacturers rely on their unvarying high quality. Satisfy your customers with Permoflux PM and EM replacements.

TWO COMPLETE FACTORIES TO SERVE YOU

PIONEER MANUFACTURERS OF PERMANENT MAGNET DYNAMIC TRANSDUCERS

WRITE FOR CATALOG

PERMOFLUX CORPORATION

4900 W. Grand Ave., Chicago 39, Ill. • 236 S. Verdugo Rd., Glendale 5, Calif.

**FOR YOUR BASIC
TELEVISION and FM SERVICE LAB**

**Series
E-400
WIDE RANGE
SWEEP SIGNAL GENERATOR**

- ★ **APPLICATION ENGINEERED** for TV, FM and other modern electronic requirements. Every necessary feature **BUILT-IN** without costly and cumbersome duplication of instruments you already own.
- ★ **PERFORMANCE DESIGNED** for practical operational simplicity and ruggedness, insuring long-lived trouble-free service.

NET PRICE **\$124.70**

Complete with test cables, quartz marker crystals and Technical Manual. Size 10½ x 12 x 6".

Convenient Terms Available
See your PRECISION Distributor



SUMMARY OF IMPORTANT FEATURES

- ★ Direct Frequency Reading 2 to 480 Mc. 5 ranges to 240 MC. 280-480 MC bands harmonically calibrated.
- ★ 1500 Point Vernier Scale.
- ★ High Output and Accuracy.
- ★ Voltage Regulated Oscillators. Crystal calibrated plus crystal control
- ★ Narrow and Wide Band Sweep. 0-1MC and 0-10MC.
- ★ Wide Range Phasing Control.
- ★ Multiple Crystal Marker-Calibrator Oscillator built-in. 4 rotary selected crystal sockets. 10.7MC and 2MC crystals furnished.
- ★ Terminated RG/U Coaxial Output cable and dual R. F. attenuators, triple shielded, stepless, quiet.
- ★ Simultaneous A.M. and F.M. test facilities.
- ★ Double-Pi Shielded Line Filter.
- ★ Tube Complement: 3 each 6J6 & 6C4. 1 each VR-105 & 6X5.
- ★ Fully Licensed under W.E., A.T.&T. and Remco patents.
- ★ PLUS other "Precision" refinements too lengthy to list.

YOU MUST SEE the Series E-400!

The New SERIES ES-500 HIGH SENSITIVITY 5" OSCILLOSCOPE

20 millivolt sensitivity, wide range vertical amplifier! The ideal companion unit to Series E-400 to complete your TV — FM service lab.

Net Price \$149.50. Complete with light shield calibrating screen and operating manual. Size 8¼ x 14½ x 18".

Also

Order Now

from your nearest authorized "Precision" distributor to assure earliest possible delivery.

See

the new Series E-400, ES-500 and the complete "Precision" line of A.M., F.M. and Television instruments.

PRECISION APPARATUS COMPANY, INC.

92-27 Horace Harding Boulevard, Elmhurst 5, New York
Export Division: 458 Broadway, New York, U.S.A. • Cables—Morhanex

PROGRESSIVE MARKETERS

Dave Kubrick — Irv Brown

RADIO-TELEVISION SALES SPECIALISTS

Eastern Factory Sales Representatives for:

Transvision Television
American Condenser Co.

Harrison Wire Recorder

Precision Transformer Co.
Boland & Boyce, Inc.

41 Union Square, N. Y. 3, N. Y.

ALgonquin 4-7486

Trade Literature

→ from page 41

Rider Public Address Equipment Manual, Volume I, (John F. Rider, 2024 pages, \$18.00)

Covering the period of 1938 through 1948, this manual presents servicing data of 147 public address equipment manufacturers, thereby constituting a valuable reference book for the p-a specialist. Being compiled alphabetically, reference is made easy. Included with the manual is the companion *How It Works* book, describing the special circuitry found in various public address systems. This volume comes complete with index.

Instruction and Service Manual for the T.A.C. Projection Television Assembly, Model P-520, prepared by JOHN F. RIDER LABORATORIES, in collaboration with GERARD R. FRANCOEUR. (79 pages, \$2.50)

Although this book was specifically written as an instruction manual for the assembly of Television Assembly Co.'s Model P-520 Projection Television receiver, it will prove of considerable value to all those who are interested in projection television, because so few books are available on the subject of projection television.

The double sized pages of the manual allow the text and illustrations to be uncrowded and clear. This, together with unambiguous instructions, make understanding easy.

Aside from the diagrams for assembly operation, the book contains a number of schematics on insert pages. Also included are sections on final adjustments, trouble shooting, a voltage and resistance chart, and an electrical and mechanical parts list.

This manual is provided free with each Model P-520.

Catalogs and Pamphlets

"Keep Your Iron In The Fire" is a booklet free of advertising, issued by IRC, pointing out the relationship between the number of hours the soldering iron is in operation and the serviceman's income. It shows eight ways more time can be devoted to actual soldering. Radio service technicians may obtain free copies from International Resistance Co., 401 N. Broad Street, Philadelphia 8, Pa.

A Guide to Midget Relays has been

published in the form of a catalog-bulletin by Struthers-Dunn, Inc. It contains complete information on the hundreds of Struthers-Dunn Midget industrial control relays with the exact contact arrangement, mounting details, and construction required for each application. A copy of this bulletin (No. 2100) may be obtained by writing to the manufacturer at 150 N. 13th Street, Philadelphia 7, Pa.

Soldering Tips is a 20-page booklet published by the Weller Mfg. Co., Packer Street, Easton, Pa., giving a condensed soldering course. It will instruct the beginner and refresh the memory of the proficient solderer. The booklet, illustrated with cartoons throughout, goes through the entire soldering process, step by step and in simple language. Even though you have been soldering for years, the 22 rules given in this handbook will prove interesting to you. Price 10c.

99 Questions has been prepared by the Engineering Department of the Amplifier Corporation of America, 396 Broadway, New York 13, N. Y. and is an attempt to answer inquiries most commonly made to the company about the Magnetape Twin-Trax Recorders. The 12-page booklet lists the 99 questions and gives the answer to each. Topics such as general theory, tape handling mechanism, performance, operating facilities, standard applications, special applications, variations in models, sales information, recommended accessories etc. are treated. Copies may be obtained free by writing to the company.

Advance Relays. The Advance Electric and Relay Company has released a catalog of its line of more than fifty types of relays. The catalog is illustrated throughout, and complete details are provided for each type relay.

Catalog 73 is a useful and convenient reference book published by the American Phenolic Corporation, 1830 South 54th Ave., Chicago 50, Ill. It is profusely illustrated and includes descriptions of each part or component listed. The more than 8,000 Amphenol items are grouped according to their uses and are alphabetically listed in the index. ✓✓✓

Over the Bench

→ from page 33

would have been theirs if they had spent their time improving their ability instead of trying to attract customers with give-away tactics.

In conclusion, I think that the radio service technician is steadily winning the respect of the public. As the equipment upon which he works increases in cost and complexity — and television receivers have certainly done both — the general public is being forced to realize that he is no "tinkerer" and cannot be expected to work for common-labor wages. At the same time, the increasing cost of service equipment and the high technical skill required for working on modern radio equipment are rapidly driving out of the picture those part-time, screwdriver-and-soldering iron servicemen who have always hurt the real service technician with their masquerade. Finally, and most importantly, the servicemen are beginning to think and act more like business and professional men and less like hobbyists. It will take some time yet, but we are on our way up! ✓✓✓



Proved...

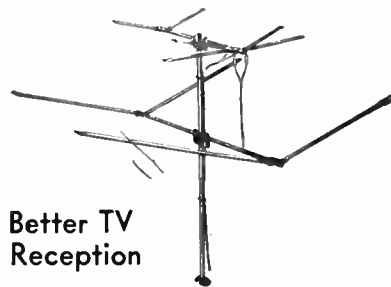

Better TV Reception

On All 12 Channels

Eliminates interference! Insures stronger signal! Covers ALL television channels! Easiest antenna to erect! Low cost to dealer or service man! Hundreds of satisfied dealers attest to the satisfactory reception being secured with the Premax T-448 all-channel antenna.

Send for specifications, test charts and prices.

PREMAX PRODUCTS
DIVISION CHISHOLM-RYDER CO., INC.

4907 HIGHLAND AVE., NIAGARA FALLS, N. Y.

RUGGED!

DURABLE!

A POWER SUPPLY THAT CAN REALLY "TAKE IT"

Electro
ELECTRICAL AND RADIO EQUIPMENT

MODEL "A"

6V or 12V DC filtered from
110/115 V 60 cycle power line



This model has proper rectifier, choke coil, condenser and transformer to provide heavy instantaneous output and still maintain rated output under unusual load and heat conditions.

Ideal long life power supply for testing auto radios with solenoid tuning and tone controls; 12 volt marine and aircraft radios; telephone circuits, laboratory apparatus, etc.

Write for complete information

ELECTRO PRODUCTS LABORATORIES

Pioneer Manufacturers of Battery Eliminators

549 W. Randolph St.

Chicago 6, Ill.



REMEMBER: It's Exclusive!

Only Quam manufactures the Adjust-A-Cone Speaker! It is designed with a voice coil, which instead of being permanently glued to the basket as in ordinary construction, can be adjusted laterally and accurately centered before leaving the factory.

This means that rubbing voice coils, generally so common when they are glued, are practically eliminated in Quam Adjust-A-Cone Speakers.

It is developments like this, ensuring perfect performance and customers satisfaction, that make Quam Speakers the logical choice of the serviceman!

Write for Catalog of
Quam Adjust-A-Cone
Speakers

QUAM-NICHOLS COMPANY
530 East 33rd Place
Chicago 16, Illinois

Quam Speakers are listed in
the Radio Industry Red Book

Visual Analysis

→ from page 15

Instability

If the picture is clean-cut, yet moves up or down (Fig. 11) the vertical sweep is not holding or the saw-tooth sweep pulses may be too weak.

If adjustment of the vertical hold control does not help, look for a defective part or tube in the frequency separator, clipper, vertical sweep, or any of the amplifier stages in the sync circuit. A similar vertical movement of the picture, accompanied by interference, indicates static or excessive interference pulses which evidently are controlling the vertical sweep circuit. The same trouble can be due to leakage of video signals through the clipper circuit to the vertical sweep generator. Check all parts and adjustments in these circuits.

If the picture background is unstable, trouble in the d-c restorer circuit is indicated. This condition may be determined by turning the contrast control to its extreme clockwise position and measuring the voltage from the picture-tube grid to the receiver chassis with a 20,000 ohm-per-volt meter. The voltage at this point should be 20 to 30 volts positive with a 2-volt peak-to-peak signal at the detector. If low-voltage is present, check all components in the restorer circuit, particularly those in the low-voltage power supply.

It is evident from the above discussion that the cathode ray tube is, in itself, an accurate and rapid means of isolating or narrowing the number of stages in which trouble is present. Correct interpretation of cathode ray tube screen images and test patterns will provide the serviceman with first hand information of the receiver's condition. ✓ ✓ ✓

Industry Presents

→ from page 39

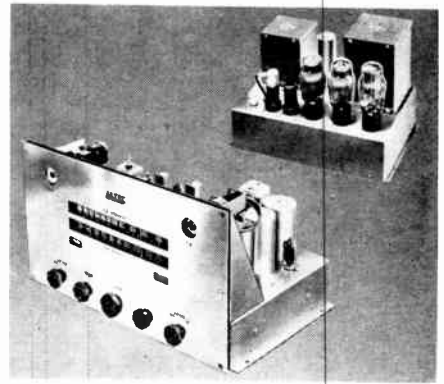

AM-FM TUNER AND AMPLIFIER

Altec Lansing Corporation, 161 Sixth Ave., New York, N. Y., is now marketing the new AM-FM tuner (ALC-101) and an associated high fidelity amplifier (A-323C). The tuner has a TRF circuit on the AM side and separate electron indicators for AM and FM. Also provided are inputs for television sound and phono, the latter permitting operation direct from magnetic pickups. The amplifier has flat frequency response within 1 db from 20 to 20,000 cycles, full power delivery within 1 db from 35 to 12,000 cycles, hum and noise 30 db below 6 milliwatts, less than 8% intermodulation or 2% total harmonic content at full 18 watt output.

DUAL RECORD CHANGERS

Webster-Chicago has now come out with two new record changer models that can play both standard and LP microgroove records. The Models 246 and 256 are dual speed and dual groove automatic changers, providing automatic and manual play for both types of records.

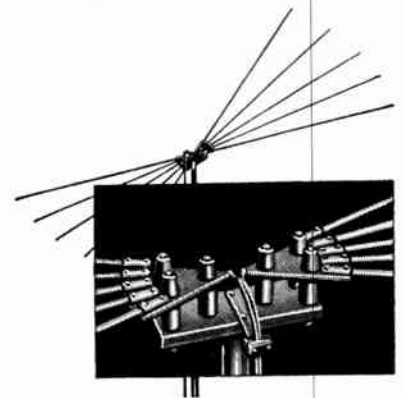

FM AND TV ANTENNA

The Andrew Type 710 Di-Fan is a new broadband receiving antenna, broadly tuned to receive all TV and FM channels. Its horizontal directivity pattern in TV channels 2 through 6 and in the FM band is a figure eight, broadside to the major axis of the antenna. For channels 7 through 13, the forward gain is decreased somewhat while the angle of acceptance is enlarged. The Di-Fan Antenna kit includes a 5-foot steel mounting mast and 60 feet of 300-ohm transmission line. Manufacturer: Andrew Corporation, 421 Seventh Ave., New York 1, N. Y.

BINDERS!

**PRESERVE YOUR RADIO MAINTENANCE
MAGAZINES IN THEM**

RADIO MAINTENANCE
460 Bloomfield Avenue
Montclair, N. J.

Please send me.....binders at \$2.00 each.

Total amount enclosed

Name

Address

City Zone

State

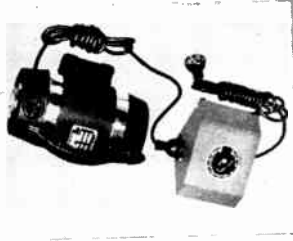

TV CONVERTER

The problem of TV in d-c areas is tackled by a new converter, enabling television reception from 115 volt d-c lines, and making picture reception equal to that obtained with a-c operation. The "Picture Control" is designed to regulate the converter frequency and to eliminate picture flutter. This control is designed to operate as a separate unit. The Carter Super Converter Model D1010CT is made to operate 7-inch receivers of 125 watts power or less from 115 volts d.c. The Carter Picture Control, however, is designed to allow steady and clear pictures over a range of 110 to 135 volts d-c input. For the larger-screen sets (10 and 12 inches), it is not always possible to obtain perfect picture control with a single converter. This problem is now being investigated by engineers of the company. Manufacturer: Carter Motor Company, 2644 N. Maplewood Ave Chicago 47, Ill.

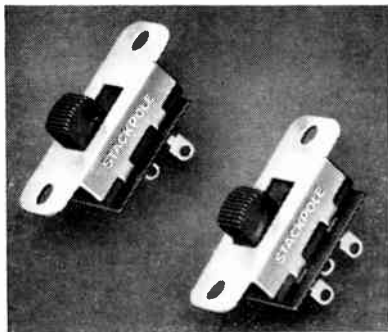

SLIDE SWITCHES

To meet the need for small, inexpensive and sturdy units, having sufficient current carrying capacity for electrical tools, fans appliances, etc., the Stackpole Carbon Co., St. Mary's, Pa., has produced two new slide switches. Both are rated 1 ampere at 125 volt, d.c., or 3 amperes at 125 volt a.c. They are 1 1/8" long and 17/32" wide. They are equipped with a 11/32" black trigger as standard. Type SS26-1 is single-pole double throw, Type SS-26 is single throw single pole. Both switches are Underwriters approved.



AMPLIFIER

Langevin Manufacturing Corporation, 37
→ to page 46

BACK NUMBERS...

get them while they last

APRIL 1947

ANTENNAS . . . FM AND TELEVISION,
PART II
PHASE INVERTER CIRCUITS
A UNIVERSAL SPEAKER
TELEVISION RECEIVERS . . .
THE HORIZONTAL SWEEP

MAY 1947

THE OPEN AND CLOSE CASES
VOLTAGE DOUBLERS
SIGNAL TRACER
TELEVISION RECEIVERS . . . THE
CATHODE RAY TUBE

JUNE 1947

WHEN THE CUSTOMER ISN'T RIGHT
TEST EQUIPMENT MAINTENANCE
CRYSTAL CONTROLLED SIGNAL
GENERATOR
TELEVISION RECEIVERS . . . THE
POWER SUPPLY

JULY 1947

SERVICING FM RECEIVERS
TEST EQUIPMENT MAINTENANCE, PART II
TELEVISION RECEIVERS . . .
FLYWHEEL SYNC

AUGUST 1947

SPEAKER MATCHING
TEST EQUIPMENT MAINTENANCE, PART III
SERVICING FM RECEIVERS PART II
TELEVISION . . . HF POWER SUPPLIES

SEPTEMBER 1947

SERVICING IS BIG BUSINESS
ANTENNA SYMPOSIUM
TELEVISION PICTURE TUBE
SERVICING FM RECEIVERS PART III

NOVEMBER 1947

TEST EQUIPMENT SYMPOSIUM
HOW'S YOUR SERVICING FUTURE?
TELEVISION TEST EQUIPMENT

DECEMBER 1947

ABOUT WIRE RECORDERS
RURAL RADIO SERVICE
AUTO RADIO NOISE
ALIGNMENT METHODS

JANUARY 1948

HOW TO IMPROVE YOUR SIGNAL
TRACING TECHNIQUES
SPECIAL F.M. CIRCUITS
WHAT'S NEW IN VIDEO SECTIONS?

FEBRUARY 1948

LET'S WORK TOGETHER
HOW TO USE SWEEP GENERATORS
VOLTAGE REGULATORS

MARCH 1948

HOW TO ELIMINATE HUM
TELEVISION INTERCARRIER SYSTEM
SWEEP GENERATORS FOR FM ALIGNMENT
PART II

APRIL 1948

NEW FM SIGNAL GENERATOR
DB CALCULATORS MADE EASY
GET THE MOST FROM YOUR VTVM
AFC IN FM

MAY 1948

TROUBLESHOOTING RECEIVER DISTORTION
INTERFERENCE
A POCKET FM SIGNAL GENERATOR
A SWEEP GENERATOR FOR F.M. & T.V.

JUNE 1948

INTERFERENCE PART II
HEATER-CATHODE HUM
SUPER SERVICE
F. M. AND YOU

JULY 1948

OHM'S LAW IN RADIO SERVICING
INTERFERENCE PART III
HOME SERVICE CALLS . . .
DO THEY PAY?
SERVICING RC FILTERS

AUGUST 1948

ADVERTISING WILL BUILD YOUR BUSINESS
INSTALLATION OF F.M. ANTENNAS
CUSTOM BUILDING
YGS-3 SIGNAL GENERATOR

SEPTEMBER 1948

SERVICING WITH VTVM
TRANSMISSION LINE PROBLEMS
RADIO PHOTOGRAPHS
RECEPTION UNLIMITED

NOVEMBER 1948

RECORD CHANGER REPAIRS
SIGNAL TRACING TV
NEW TV INSTRUMENTS
F.M. DETECTORS

RADIO MAINTENANCE MAGAZINE 460 BLOOMFIELD AVE., MONTCLAIR, N. J.

Please send me the back numbers checked here . . .
I am enclosing 35c for each copy, or \$2 for any 8 copies.

- | | | |
|---|--|---|
| <input type="checkbox"/> April 1947 | <input type="checkbox"/> November 1947 | <input type="checkbox"/> May 1948 |
| <input type="checkbox"/> May 1947 | <input type="checkbox"/> December 1947 | <input type="checkbox"/> June 1948 |
| <input type="checkbox"/> June 1947 | <input type="checkbox"/> January 1948 | <input type="checkbox"/> July 1948 |
| <input type="checkbox"/> July 1947 | <input type="checkbox"/> February 1948 | <input type="checkbox"/> August 1948 |
| <input type="checkbox"/> August 1947 | <input type="checkbox"/> March 1948 | <input type="checkbox"/> September 1948 |
| <input type="checkbox"/> September 1947 | <input type="checkbox"/> April 1948 | <input type="checkbox"/> November 1948 |

Have selected 8 copies . . . enclosing \$2.00

NAME

ADDRESS

CITY

ZONE STATE

30,000 SERVICE TECHNICIANS

Read RADIO MAINTENANCE Every Month
Every day is RADIO MAINTENANCE day in your shop!

RADIO MAINTENANCE 460 Bloomfield Ave., Montclair 1, N. J.

RM-2

Please send me RADIO MAINTENANCE for:

- 2 years at \$5.00 1 year at \$3.00 Check enclosed Bill me later

Name

Occupation

Address

City Zone

State

Tried and Proven . . .

13 CHANNEL TELEVISION RECEPTION PLUS FM

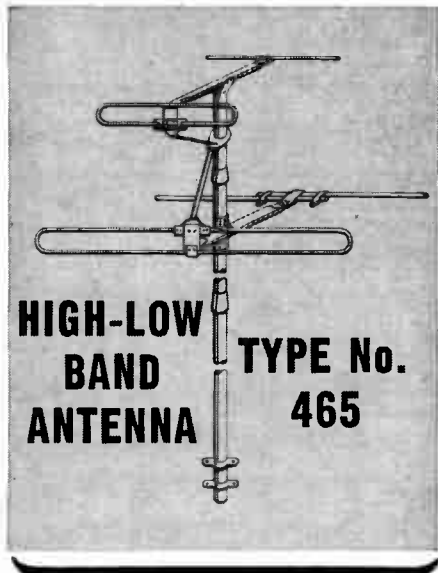

HIGH-LOW BAND ANTENNA TYPE No. 465

TACO Type 465 has been used in thousands of TV installations and has stayed put. Many of these installations have been replacements for other antennas that have not stood the electrical and mechanical requirements for good TV reception. TACO antenna equipment has that extra quality that keeps customers satisfied.

ASK YOUR TACO JOBBER

Find out about the complete TACO line of TV, FM, and AM antenna equipment.

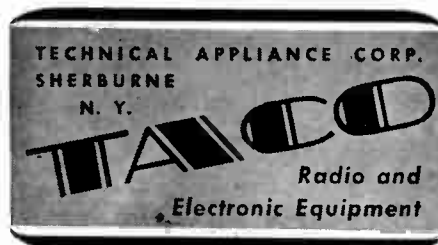

TECHNICAL APPLIANCE CORP. SHERBURNE N. Y. **TACO** Radio and Electronic Equipment

In Canada: Stromberg-Carlson Co., Ltd.

Industry Presents

→ from page 45

West 65th Street, New York 23, N. Y., has announced its new Music in Focus Amplifier, Type 127-A. The amplifier is equipped to operate with a radio tuner and a phonograph pickup, either variable reluctance type, crystal cartridge, or the new LP microgroove pickup cartridge.

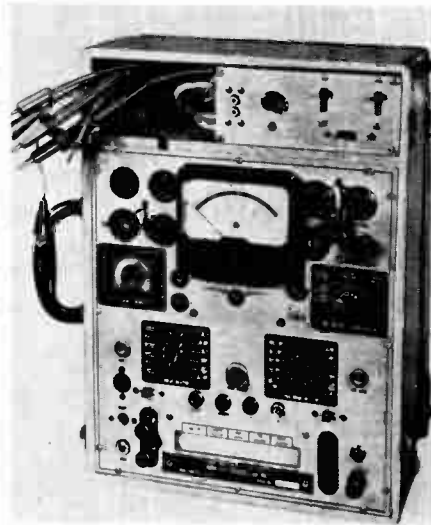

COMBINATION TEST INSTRUMENT

Radio City Products has brought out a new test instrument with the following performance data: Over 800 tube listings on roll chart, with jack for headphone tests for noisy tubes that do not otherwise read "bad"; germanium crystal rectifier; readable ohmmeter scale from 0.05 ohm to 25 megohm; d-c volts: 0-2.5-10-50-250-1000-5000; a-c volts: 0-10-50-250-1000-5000; d-c milliamps: 0-0.5-2.5-10-50-250-1000; d-c amps: 0-10; ohms: 0-250-2500-25000; megohms: 0-2.5-25; decibels: -8 to +15; 15 to 29, 29 to 49, 32 to 55; output voltmeter: 0-10-50-250-1000-5000. Overall size 12 1/2" x 12 3/4" x 5 1/4". Weight 18 pounds.



TELEVISION MAGNIFIER

Tele-Scope, a new magnifier now being manufactured by the Wavell Corporation, is the first flat, plastic, non-liquid lens developed for television. It increases the size of the image of an ordinary 10" tube to 172 square inches without distortion. This attachment comes in three sizes: 9 x 12 and 8 x 10 inches (for 7" sets), and 12 x 16 inches (for 10" sets). Weighing less than 3 pounds, the magnifier comes complete with mounting bracket which makes attachment easy, and allows fingertip adjustment to suit the individual's vision.

FREE



SERVICE MEN REPAIRMEN!

WALDOM REPLACEMENT CONE MANUAL

Just mail your name and address today for **FREE** copy of the big 20-Page **WALDOM Replacement Cone Manual**, listing replacement data for 69 different brands of speakers—from Admiral to Zenith! Manual also gives complete instructions, together with clear illustrations for installing cones properly. Invaluable reference guide for servicemen and repairmen. Get your copy **FREE!** Just send name and address.

FOR FINER TONE A WALDOM CONE

Waldom Replacement Cone Assemblies will satisfy the high standards of precision workmanship and performance set by you and by your customers because . . .

- **WALDOM CONE ASSEMBLIES** feature **HAWLEY** diaphragms with the patented thin, tapering edge that assures maximum speaker efficiency and true low frequency response.
- **WALDOM CONE ASSEMBLIES** are guaranteed unconditionally as to construction and performance. Only the very finest voice coils and spiders, precision made to exact specifications, are used.
- **WALDOM CONE ASSEMBLIES** carry full R. M. A. Warranty.

Write for Your FREE

REPLACEMENT CONE MANUAL! The big 20-Page **WALDOM Manual** puts every bit of replacement cone information at your fingertips, in seconds! It will speed your speaker repair work, and help you handle those jobs more profitably. Send your name, address for **Free** copy.

WALDOM ELECTRONICS, INC., Dept. RM
911 N. LARRABEE STREET CHICAGO, ILLINOIS

ALL IN 1

- TUBE TESTER
- SET TESTER
- BATTERY TESTER
- CONDENSER TESTER
- AUDIO R. F.-F. M.
- SIGNAL GENERATOR

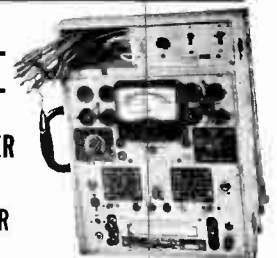

RCP Model 8573 at the record smashing price only \$99.95

Every square inch solid-packed with value! Look what you get in this phenomenally low-priced tester: (1) A complete tube tester with over 800 listings in its famous Rollindex roll chart, (2) A battery tester indicating actual voltage under rated load, (3) A capacitor tester, (4) A fixed point calibrated AM-FM signal generator, (5) An audio oscillator; and a dozen additional features.

Readable scale divisions on the ohm meter start at 0.05 ohm to 25 megohms.

- DC Volts: 0, 2.5, 10, 50, 250, 1000, 5000
 - AC Volts: 0, 10, 50, 250, 1000, 5000
 - DC Milliamps: 0, .5, 2.5, 10, 50, 250, 1000
 - DC Amps: 0, 10
 - Ohms: 0, 250, 2500, 25000
 - Megohms: 0, 2.5, 25
 - Decibels: -8 to +15, 15 to 29, 29 to 49, 32 to 55
 - Output Voltmeter: 0, 10, 50, 250, 1000, 5000
- Complete with tubes, batteries and test leads, output leads, etc., housed in natural finish oak case; hammer-tone gray panel. See this outstanding buy at your jobber today—or write for new catalogue 2M.

RCP INSTRUMENTS—BEST FOR EVERY TEST

RADIO CITY PRODUCTS CO., INC.

152 West 25th St. New York 1, N. Y.

Audio Systems in F-M Receivers

→ from page 19

and capacitance of the elements of the tubes, associated components, and the wiring. To damp out these oscillations, resistors R13, R15, R18, and R22 are connected in the respective grid leads and R17, R19, R20, and R21 are connected in the screen leads. The former have a value of 1,000 ohm each, the latter 100 ohm each. These resistance values are small compared to the total impedance of the respective circuits in which they are connected, but they are large enough to discourage parasitic oscillation.

Servicing Problems

The servicing of f-m a-f amplifiers involves all the basic problems connected with the same section in a-m receivers with a few extras. For instance, when two phase inverter tubes are used (Fig. 4), the failure of one of these tubes can cause the section to go "dead." The failure of the other tube simply lowers output with some distortion appearing, due to the fact that one output tube is not receiving grid signal voltage. Aging resistors can cause phase inverters to go out of balance, producing harmonic distortion.

Feedback circuits are an additional source of distortion if any of their components should fail. Often a feedback resistor, such as R13 in Fig. 3, will age to a higher value, reducing feedback and increasing hum and distortion. Or a short in this resistor causes R3 to shunt the voice coil of the loudspeaker and lower output with accompanying distortion effects.

Most a-f sections in f-m receivers have a high gain, making the possibility of hum pickup on the grid leads very great. Shielding is provided in the input circuits in the use of shielded wire, proper lead dress, and placement of components. Anything which might disturb this shielding and component arrangement should be a suspected cause of hum and a-f feedback.

Tone control and booster circuits have purposely not been discussed in this article because the principles of these circuits are to be treated separately in our next f-m article. ✓ ✓ ✓



Ed. H. Guilford
Vice-President

Be An FCC Licensed Technician

DOUBLE YOUR PAY

Add Technical Training to Your Practical Experience AND

Get your FCC COMMERCIAL RADIO OPERATOR LICENSE in a Few Short Weeks

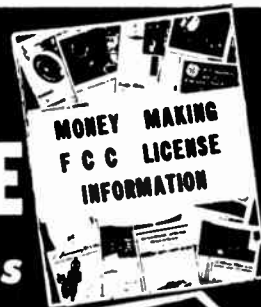

FREE

Get This Amazing New Booklet

It's EASY if you use CIRE Simplified Training and Coaching AT HOME in SPARE TIME

Thousands of new jobs are opening up—FM Television, Mobile Communication Systems. These are only a few of the radio fields which require licensed radio technicians and operators. Get your license without delay. Let Cleveland Institute prepare you to pass FCC license examinations, and hold the jobs which a license entitles you to, with CIRE streamlined, post-war methods of coaching and training.

1. TELLS OF THOUSANDS OF BRAND-NEW, BETTER-PAYING RADIO JOBS NOW OPEN TO FCC LICENSE HOLDERS.
2. TELLS HOW YOU WILL BENEFIT BY HOLDING AN FCC COMMERCIAL LICENSE.
3. TELLS HOW YOU CAN GET YOUR FCC COMMERCIAL RADIO OPERATOR LICENSE IN A FEW SHORT WEEKS—EASILY AND QUICKLY, BY USING CIRE SIMPLIFIED TRAINING AND COACHING AT HOME IN YOUR SPARE TIME.
4. TELLS OF HUNDREDS OF OUR SUCCESSFUL STUDENTS WHO NOW HAVE LICENSES AND NEW, BETTER-PAYING JOBS.
5. TELLS HOW WE PREPARE YOU TO PASS THE NEW FCC COMMERCIAL LICENSE EXAMINATIONS, WHICH NOW INCLUDE FM AND TELEVISION.
6. TELLS HOW WE GUARANTEE TO TRAIN AND COACH YOU UNTIL YOU GET YOUR LICENSE.
7. TELLS HOW WE HELP YOU TO GET A BETTER-PAYING, LICENSED JOB, WITH OUR FREE AND EXCLUSIVE SERVICE, WHICH PREPARES YOUR EMPLOYMENT APPLICATION FOR MAILING TO HUNDREDS OF EMPLOYERS, INCLUDING FM, AM AND TELEVISION BROADCAST STATIONS, RADIO MANUFACTURERS, POLICE RADIO STATIONS, AND RADIO-EQUIPPED TAXI, BUS AND PUBLIC UTILITY COMPANIES.

YOUR FCC TICKET IS ALWAYS RECOGNIZED IN ALL RADIO FIELDS AS PROOF OF YOUR TECHNICAL ABILITY

CIRE Graduates Find FCC License Pays Off

"I now hold ticket Number P-10-3787, and holding the license has helped me to obtain the type of job I've always dreamed of having. Yes, thanks to CIRE, I am now working for CAA as Radio Maintenance Technician, at a far better salary than I've ever had before. I am deeply grateful."

Student No. 3319N12

"I am writing to inform you that with the material I have learned from my course I have just recently obtained a Civil Service job as Electronics Operator and Repairman at the Ballistics Research Lab at Aberdeen Proving Grounds, Md., at a considerable increase in pay."

Student No. 2886N12

CLEVELAND INSTITUTE OF RADIO ELECTRONICS
Desk RM-2 4900 Euclid Bldg.
Cleveland 3, Ohio

APPROVED FOR VETERAN TRAINING UNDER "G. I. BILL OF RIGHTS"

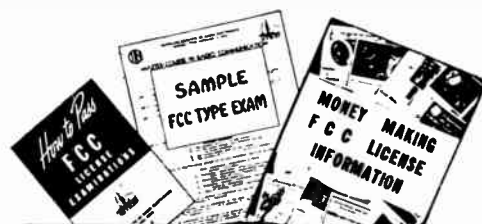

Get All 3 FREE

CLEVELAND INSTITUTE OF RADIO ELECTRONICS
DESK RM-2 4900 Euclid Building, Cleveland 3, Ohio
(Address to Desk No. to avoid delay)

I want to know how I can get my FCC ticket in a few short weeks by training at home in spare time. Send me your FREE booklet "Money Making FCC License Information," as well as a sample FCC-type exam and free booklet, "How to Pass FCC License Examinations" (does not cover exams for Amateur License.)

NAME

ADDRESS

CITY ZONE STATE

Veterans check for enrollment information under G.I. Bill

NO OBLIGATION NO SALESMEN

TV Traps

→ from page 11

note pattern due to the mixing process with the converter. This pattern will not follow the sound modulation of the carrier in use, but of the lower channel sound, and this fact must be studied to find out which trap is the one needing adjustment.

Before adjustments are made in a set which previously has given good performance, consideration must also be given to the fact that other types of interference can simulate the type procured when the traps need adjustment. This other type of interference can be due to x-ray machines, diathermy, or the harmonics of short wave stations in the vicinity. Only when it has been definitely ascertained that the interference lies in the trap circuits, should they be adjusted. ✓ ✓ ✓

Index of Advertisers

Aerovox Corporation	36
A. G. Radio Parts Co.....	39
American Electric Heater Co.....	38
Capitol Radio Engineering Inst.....	25
Clarostat Mfg. Co., Inc.....	34
Cleveland Institute	47
Allen B. Dumont, Inc.....	37
Electro-Products Laboratories	43
Eric Resistor Corp.....	40
Federal Telephone & Radio Corp.....	1
G-E Ken Rad.....	3rd Cover
Heath Co.	23
Hickock Electrical Inst. Co.....	41
Hytron Radio & Electronics Corp.....	5
International Resistance Co.....	39
Jensen Mfg. Co.....	2nd Cover
J. F. Rider, Publisher.....	27
Kester Solder Co.....	4
Ohmite Mfg. Co.....	3
Operadio	31
Permoflux Corp.	41
Philco Corporation	6
Precision Apparatus Co.....	42
Premax Products	43
Quam Nichols Co.....	44
Radiart Corporation	29
Radio City Products.....	46
Raytheon Mfg. Co.....	7
Radio Corporation of America	
1st Cover, 2	
Simson Electric Co.....	30
Spellman Television Company.....	40
Sprague Products Co.....	32
Sylvania Electrical Products, Inc.....	35
Technical Appliances Corp.....	46
Transvision, Inc.	33
Waldom Electronics, Inc.....	46

TWO GREAT BOOKS... COVERING EVERYTHING IN RADIO & TELEVISION

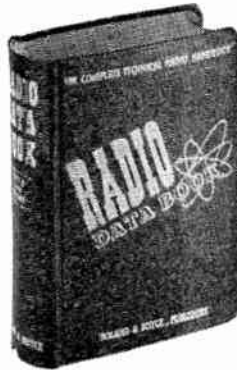

**EVERYTHING IN RADIO
AND ELECTRONICS
IN ONE BOOK!
THE MOST COMPLETE
TELEVISION MANUAL**



THE RADIO DATA BOOK

the only radio handbook of its kind . . . 1148 pages . . . 12 sections, each covering a radio subject more completely than any other book!

**12 complete books in one
only
Less than 42c per book!**

\$5.00

THE VIDEO HANDBOOK

768 pages . . . 14 sections, covering every phase in television . . . over 800 illustrations . . . handsomely bound in Du Pont Fabrikoid with red and silver letters.

**ADVANCE SALE
ORDER NOW!**

\$5.00

RM 2

**Mail This Coupon to Your Jobber Today—or direct to:
BOLAND & BOYCE, 460 Bloomfield Ave., Montclair, N. J.**

Send me 1 RADIO DATA BOOK

I enclose \$5.00 (\$5.50 Foreign)

I enclosed \$1.00 and will pay postman \$4.00 on delivery (in U. S. only)

Send me 1 VIDEO HANDBOOK

I enclosed \$5.00 (\$5.50 Foreign)

I enclosed \$1.00 and will pay postman \$4.00 on delivery (in U. S. only)

NAME

ADDRESS

CITY ZONE

STATE



"KEN-RAD TUBES BRING REPEAT BUSINESS!"



HUGH WATSON, Foreman, Grid Section, where grids are shown below going into 700-degree (centigrade) G-E furnace to be de-gassed and de-oxidized. Every precaution is taken in making Ken-Rad tubes to assure top performance, long life.

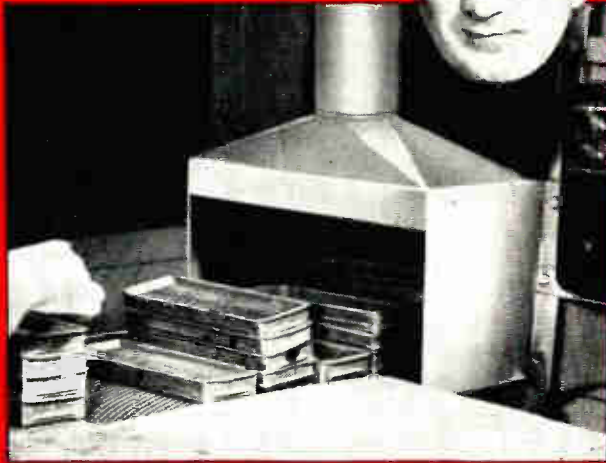

Says C. F. PATTERSON, J & M Radio Service Shop, 838 North Rampart, New Orleans, La. Like thousands of reliable service men, Mr. Patterson insists on Ken-Rad tubes because he knows quality pays off.

"I started in business in 1933 and I've been using Ken-Rad tubes ever since!

"In all that time I've never had a complaint. Ken-Rad tubes perform. They last. No other tube I know does a better job for you or your customers.

"This is important, because you've got to satisfy customers if you're going to build repeat business.

"Ken-Rad tubes always satisfied my customers. And that satisfies me."

"KEN-RAD TUBES ARE TESTED TUBES!"

"Ken-Rad tubes satisfy customers and build repeat business because they're tested tubes. Tops in quality, stamina, endurance.

"I know—because I've been supervising the making of Ken-Rad tubes for years.

"We make Ken-Rad tubes with the greatest of care. They're thoroughly tested for noise, microphonics, static, life, shorts, appearance, gas, air and hum.

"You can sell them with confidence. And you can rely on them to increase business, too!"

102-MA2-6950

KEN-RAD

Radio Tubes

PRODUCT OF GENERAL ELECTRIC COMPANY

Schenectady 5, New York

The Serviceman's Tube



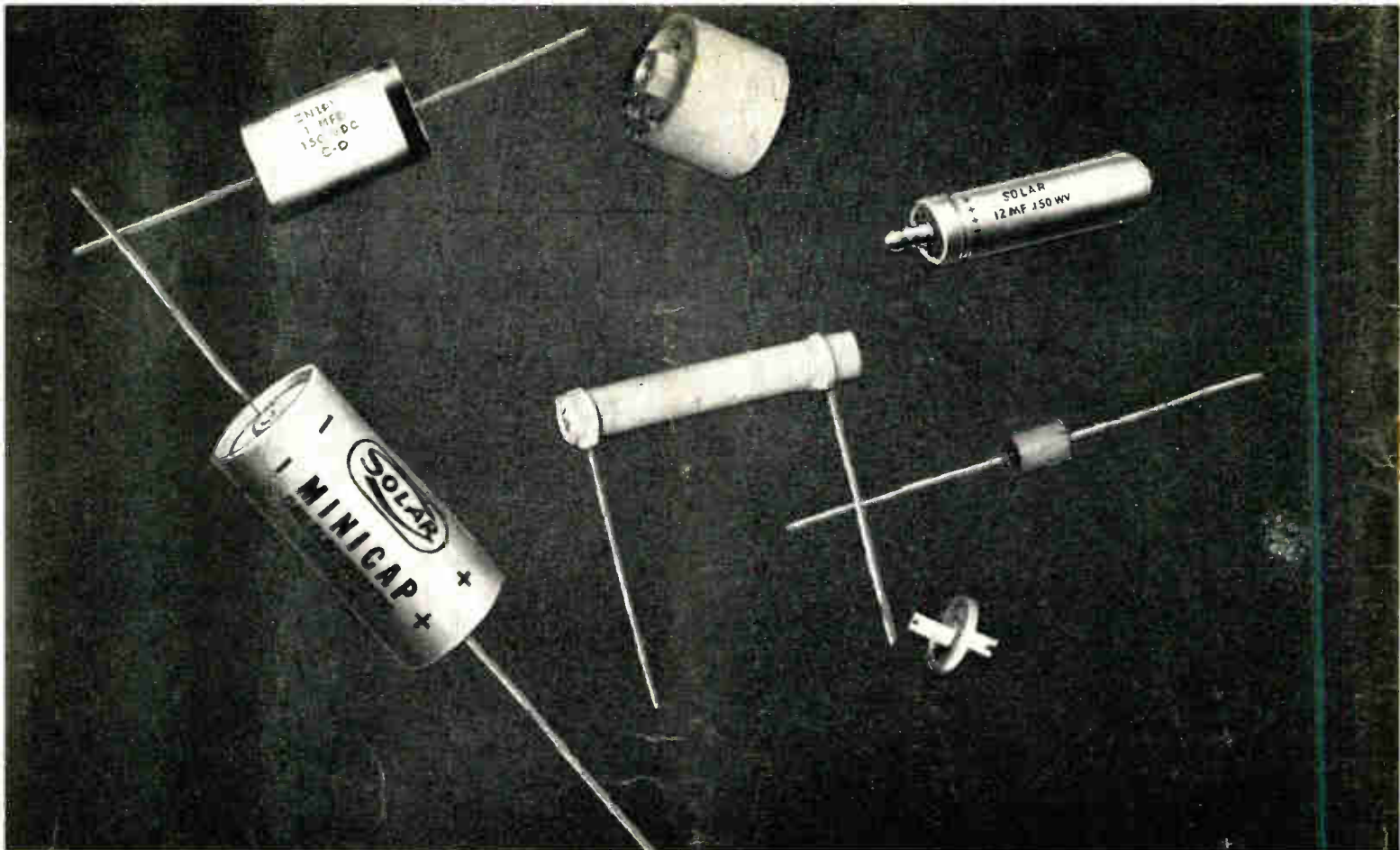

How to make more money in the servicing business!

Your local jobber believes in helping you—his best customer—to make more money, because then you will become a bigger customer and everyone will be happy!

In line with this policy, he pledges his high standard of service and better buys for radio servicemen . . . AND he will present ideas to help you expand your business. In the months to come he will feature a different subject each month on this back cover of **RADIO MAINTENANCE**. This may be in the nature of new moneymaking ideas, or announcements of special sales in his store, or suggestions on the proper equipment for your work. In all cases, the idea will be to help you—the radio serviceman—make more profit.

Of course his staff of experienced clerks are ready to serve you every day. Drop in his store today—browse around. He has all kinds of good buys you may want to look over. Just mention **RADIO MAINTENANCE**—and watch this back cover for extra profit for you!

RADIO MAINTENANCE

460 Bloomfield Ave.

Montclair, N. J.