

Fall Edition

Over 150,000 Copies

Fifty Cents

RADIO REVIEW

Reg. U.S. Pat. Off.

Combined With

Radio Listeners' Guide and Call Book

Edited by S. Gernsback

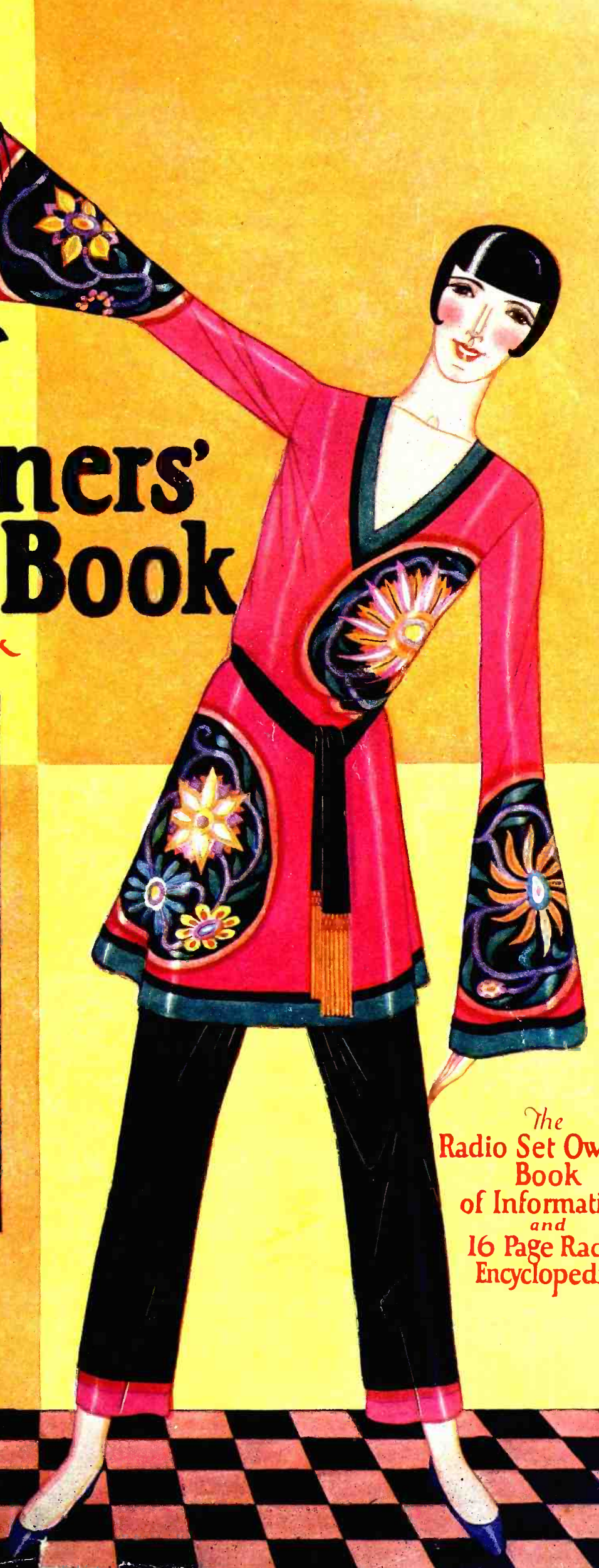
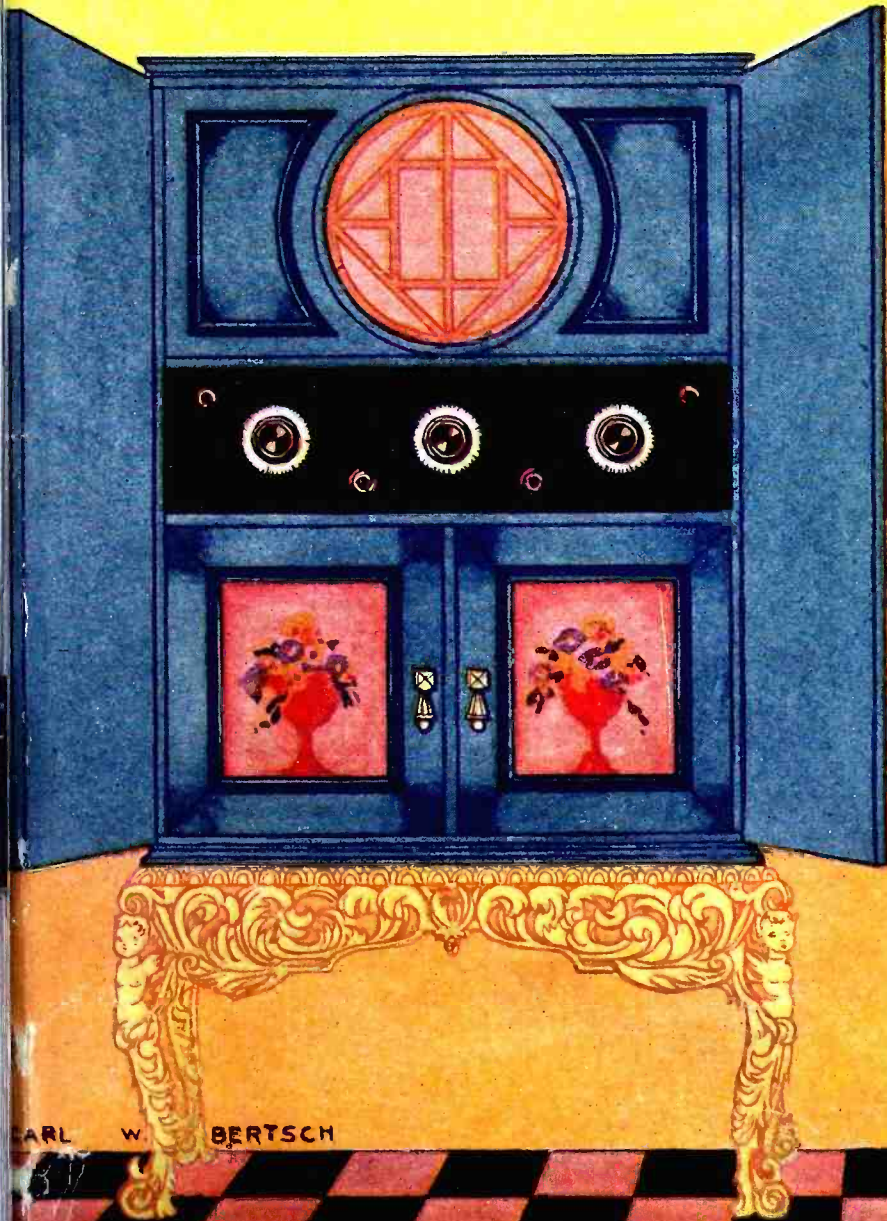

*The
Radio Set Owners
Book
of Information
and
16 Page Radio
Encyclopedia*

CARL W. BERTSCH

Just Seven Simple Tools



SUPER-HETERODYNE



THE TROPADYNE



THE NEUTRODYNE



5-TUBE COCKADAY



THE REFLEX

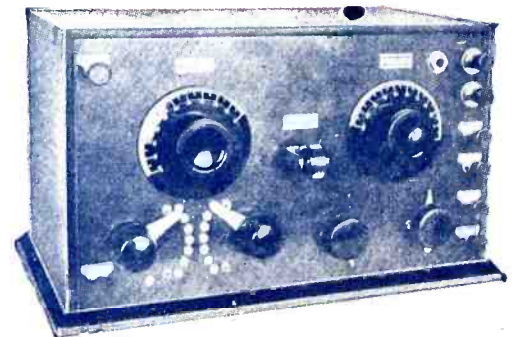

THE PORTABLE

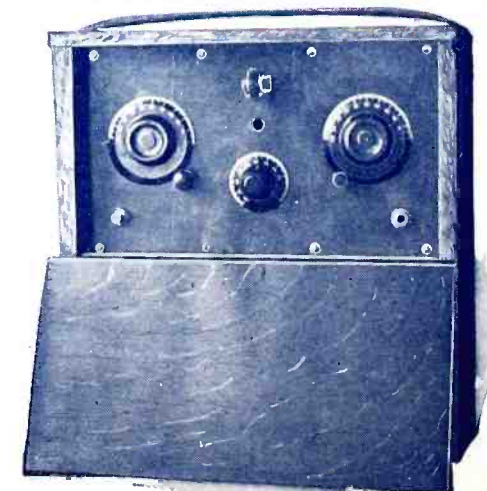

—and you can build the finest Radio Receivers *Quickly and Easily*

It takes but one or two evenings, using only the simplest tools to construct, at home, any one of the big, popular receivers shown on this page.

All you need is the well known CONSRAD Pattern that covers this particular receiver. CONSRAD Patterns are marvelously simple. You don't have to measure the spacing on the panel board or the placing of the parts. It is all drawn for you on the Blueprints the same as indications are given on a lady's dress pattern.

And you don't have to use 100 different tools to complete the job—just six or seven ordinary tools found in every household. A screwdriver, a pen-knife, a pair of pliers, etc., and you are ready to go ahead.

Visit your nearest Radio Dealer, ask him to let you look at some CONSRAD Patterns, select the one you want. Pay the Dealer 50c and you have complete instructions and blueprints for the construction of the Receiver.

IF YOUR DEALER CANNOT SUPPLY YOU, WRITE DIRECT, MENTIONING THE RECEIVER YOU WISH TO BUILD AND ENCLOSING FULL PRICE.

REMEMBER: CONSRAD Patterns—only 50c—give complete full sized blueprints and instruction booklet. Everything ready to build.

The CONSRAD COMPANY, 53 Park Place, New York

Consrad

EVERYTHING IN RADIO BOOKS, PATTERNS AND DIAGRAMS



I Will Train You At Home To Fill a Big Pay Radio Job



"I give you all this apparatus so you can learn quickly at home the *Practical Way*"

J.E.S.
FREE OF EXTRA COST

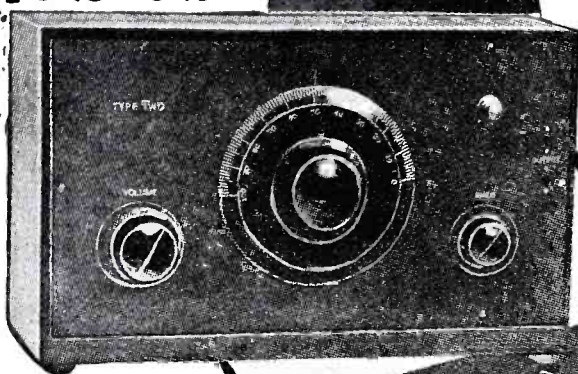

If you're earning a penny less than \$50 a week, clip coupon now. Send for AMAZING FREE BOOK, "Rich Rewards in Radio." Why go along at \$25 or \$35 or \$45 a week, when you could earn \$50 to \$250 in the same six days, as a Radio Expert? Hundreds of N. R. I. trained men are doing it—why can't you?

Earn \$50 to \$250 a Week—

RADIO EXPERTS IN BIG DEMAND

Radio needs trained men. Get into this new live-wire profession of quick success. It's the trained man, the Radio Expert, who gets the big jobs of this profession—paying \$75, \$100, \$200 a week and up. Every day N. R. I. trained men are taking good places in the Radio field—men just like you—their only advantage is TRAINING. You can prepare just as they did, by new practical methods. Our tested clear training makes it easy for you. Big Free Book contains all the proof.

You Learn Quickly In Spare Time

So sure am I that I can train you successfully for a better future in this new Big-Pay profession, that I guarantee your training with a money-back bond. Lack of experience or education won't hold you back—common schooling all you need to start. You can stay home, hold your job, and learn quickly and pleasantly in your spare time. My practical, helpful methods enable you to start RIGHT AWAY toward one of the bigger Radio jobs paying \$50 to \$250 a week. No delay, no losing time from work—no scrimping or scraping to get your training.



Operates WMAQ

"Accepted a position with the Chicago Daily News Station WMAQ. MY INCOME PRACTICALLY DOUBLED thanks to you. I handle all consultation, also do operating. Your course taught me not only the theoretical but also the practical knowledge that makes my work easy for me." Keith Kimball, Station WMAQ, Chicago, Ill.

You Get All of This

All instruments shown here and others sent to all my students free of extra cost under short time special offer. Clip coupon now—find out all about this big unequalled offer while you still have time to take advantage of it. This training is intensely practical—these instruments help you do the practical work. You learn workmanship and get added confidence in your ability.



\$70 In One Day For T. M. Wilcox

"I am in business for myself and RECENTLY MADE \$70 in ONE DAY. I was an electrician of rich experience, occupying a splendid position as telephone superintendent when I enrolled with you believing it would open up greater opportunities—have not been disappointed. Estimate Radio will be worth tens of thousands of dollars to me in next few years." T. M. Wilcox, Belle Island, Newfoundland.

World Famous Training That "Pays for Itself"

My Radio course World-Famous as the training that "pays for itself." Make more money QUICK when you take up this practical course. Work on millions of antennae, receiving sets, offers you big chance to make spare time cash while you're learning. I'll show you how—teach you the latest "dope," furnish you with business cards, show you how to get the business and make it pay. My students don't wait a year to increase their income—they report QUICK INCREASES as a result of this course—often two or three weeks after starting. Howard Luce, Friedens, Pa. made \$320 in 7 weeks during spare time. D. H. Suitt Newport, Ark., writes, "While taking the course I earned in spare time work about \$900." Earl Wright, Omaha, reports making \$400 in a short time while taking course—working at Radio in spare time! Sylvester Senso, Kaukauna, Wis., made \$500. These records not unusual—these men a few of hundreds.

Your Satisfaction Guaranteed

We who know the results this practical tested training gets—the increased earnings it has brought to men everywhere—stand behind it all the way with a signed guarantee bond that we give you when you enroll. On completion if you're not entirely satisfied in every way, you get back every cent you've paid us. No strings to this offer—you yourself are the only judge. Get started today! It's your big chance for one of the bigger Radio jobs—mail coupon NOW for my Big FREE BOOK and proof! No obligation.

Get This FREE BOOK

Most amazing book on Radio ever written—full of facts and pictures—tells all about the great new Radio field, how we prepare you and help you start. You can do what others have done—GET THIS BOOK. Send coupon today—no obligation.

J. E. SMITH, President
NATIONAL RADIO INSTITUTE
Dept. KW6, Washington, D. C.



J. E. SMITH, President
NATIONAL RADIO INSTITUTE
Dept. KW6, Washington, D. C.

Dear Mr. Smith—Without obligating me in any way, send me your free book, "Rich Rewards in Radio" and all information about your practical, home-study Radio Course.

EMPLOYMENT SERVICE TO ALL GRADUATES

Originators of Radio Home-Study Training

Name..... Age.....
Street Address.....
Town..... State.....

RADIO REVIEW

Reg. U.S. Pat. Off.

Combined With

Radio Listeners' Guide and Call Book

Volume I

Number 10

SEPTEMBER, 1926

Contents of This Issue

	<i>Page</i>		<i>Page</i>
Radio Broadcast Stations of the U. S. by Call Letters	5	Super-Heterodynes—Which One?	107
Radio Broadcast Stations of the U. S. by Wave-lengths	35	Making Your Set More Selective.....	114
Radio Broadcast Stations of the U. S. by States and Cities	45	How and When to Use Power Tubes.....	115
Radio Broadcast Stations of Canada, by Call Letters	55	Developments in Design of Radio Sets.....	118
Radio Broadcast Stations of Canada, by Provinces and Cities	59	New Tendencies in Radio Unit Construction.....	119
Foreign Broadcast Stations, including U. S. Possessions	61	Adding a Stage of Radio Frequency to Your Receiver	121
Slogans of U. S. and Canadian Broadcast Stations	69	How to Build the Improved Browning-Drake Receiver	124
Air-Line Distance Between Cities.....	72	The Callies Super-Heterodyne	130
Health Exercises in the Home Via Radio.....	74	A New Method of Amplifier Coupling.....	134
Opportunities in Radio.....	78	The Improved "Diamond of the Air".....	135
How to Modernize Your Old Radio Set.....	83	A Balanced Tuned R. F. Receiver.....	137
All About "B" Battery Eliminators.....	91	An Easily Constructed Power Amplifier and "B" Supply Outfit	139
Loud Speakers and Their Relative Merits.....	95	The New B-6 Donle Detector	141
Loops and Outside Antennae for Radio Sets.....	100	Building the Raytheon B-Eliminator.....	144
Modern Types of Radio Receivers.....	103	Readers' Problems.....	146
		Your Radio Tubes and Good Reception.....	158
		S. Gernsback's Radio Encyclopedia.....	177

**RADIO REVIEW, Combined with RADIO LISTENERS' GUIDE AND CALL BOOK
VOLUME I, NUMBER 10
SEPTEMBER, 1926**

Published quarterly by The Consrad Co., Inc., 53 Park Place, New York, N. Y., telephone number Barclay 7220; H. Gernsback, President; S. Gernsback, Vice-President and Treasurer; R. W. De Mott, Secretary. Price 50c a copy; subscriptions \$1.75 a year in the United States of America, Canada and all countries within the domestic postal zone; elsewhere \$2.00 a year, payable in advance. Subscriptions only acceptable in U. S. currency or stamps. No foreign currency or stamps. Checks and money orders should be drawn to the order of THE CONSRAD CO., Inc.

When subscribing to RADIO REVIEW, combined with RADIO LISTENERS' GUIDE AND CALL BOOK, send your name and remittance to The Consrad Company, Inc., 53 Park Place, New York, N. Y. Mention that you desire to subscribe to RADIO REVIEW. We also publish and distribute CONSRAD PATTERNS, E. I. COMPANY BOOKS, etc. Write clearly.

Entered as second class matter, March 10, 1925, at the Post Office at New York, N. Y., and Long Island City, N. Y., under the Act of March 3, 1879.

Copyrighted, 1926, by The Consrad Co., Inc., N. Y.

Printed in U. S. A.

New England Advertising Representative
T. F. Magrane
Park Square Building, Boston, Mass.

Western Advertising Representatives
S. B. Darmstader
337 W. Madison St.,
Chicago, Ill.

Pacific Coast Advertising Representatives
A. J. Norris Hill Co.
Hearst Bldg., San Francisco, Calif.

General Advertising Department
53 Park Place
New York City

AMPERITE

REG. U.S. PAT. OFF.

The "SELF-ADJUSTING" Rheostat

A BASIC Need in Every Circuit

BECAUSE—AMPERITE not only modernizes any set—it keeps it modern.

- 1—Eliminates Hand Rheostats, thereby simplifying control.
- 2—Permits use of the latest types of tubes or any combination of tubes.
- 3—Simplifies and reduces set-wiring, thereby making for greater compactness and avoids losses.
- 4—No moving parts, hence no grinding noises; clear and full tones.
- 5—Prolongs tube-life by keeping filaments at a constant temperature.
- 6—No filament meters needed.
- 7—Brings the most out of each individual tube—automatically—no guessing.
- 8—Makes every set-owner a master operator, no knobs to turn.

Write today for
FREE
Hook-Ups

Sold Everywhere
\$1.10 complete with mounting

AMPERITE is used in every popular present-day construction set. Why? Because of its many outstanding exclusive features, and because it solves the perplexing problem of tube-control—**COMPLETELY** and **AUTOMATICALLY**.

There is an AMPERITE for every tube

Radiall Company

Dept. R. R.-3

50 Franklin Street

New York City

Mf's of "TUNE-RITE" Straight-Line-Frequency Dial

Be sure that the set you buy or build is equipped with AMPERITE.



Obsolete

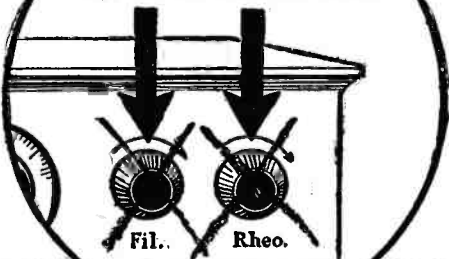

RADIO REVIEW READERS' BUREAU

Time and Postage Saver

IN every issue of RADIO REVIEW AND RADIO LISTENERS' GUIDE AND CALL BOOK you undoubtedly see numerous articles advertised about which you would like to have further information.

To sit down and write an individual letter to each of these respective concerns, regarding the article on which you desire information, would be quite a task.

As a special service to our readers, we will write the letters for you, thus saving your time and money.

Just write the names of the products about which you want information, and to avoid error, the addresses of the manufacturers, on the coupon below and mail it to us.

If the advertiser requires any money

or stamps to be sent to pay the mailing charges on his catalogue or descriptive literature, please be sure to enclose the correct amount with the coupon.

We will transmit to the various advertisers your request for information on their products.

This service will appear regularly every month on this same page in RADIO REVIEW AND RADIO LISTENERS' GUIDE AND CALL BOOK.

If there is any Manufacturer not advertising in this month's issue of RADIO REVIEW AND RADIO LISTENERS' GUIDE AND CALL BOOK, from whom you would like to receive literature, write his name, address and the product in the special section of the coupon below.



TEAR ALONG THIS LINE

READERS' SERVICE BUREAU,
The Consrad Co., Inc., 64 Church Street, New York, N. Y.

RR-9-26

Please advise the firms listed below that I would like to receive detailed information on their product as advertised in the..... issue of RADIO REVIEW AND RADIO LISTENERS' GUIDE AND CALL BOOK.

DO NOT USE THIS COUPON FOR TECHNICAL QUESTIONS

NAME	ADDRESS (Street—City—State)	List here specific article on which you wish literature	If Catalogue of complete line is wanted check in this column.
.....
.....
.....
.....
.....
.....
.....
.....

Use this space if you desire information from a manufacturer whose advertisement does not appear in this month's issue.

NAME	ADDRESS (Street — City — State)	
.....
.....
.....

Your name..... Dealer's name.....

Your address..... His address.....

If you are a dealer, check here. City..... State..... City..... State.....

Radio Review

Combined With

Radio Listeners'

GUIDE and CALL BOOK

Sidney Gernsback, Editor W. G. Many, Managing Editor

THE CONSRAD COMPANY, Inc., 53 Park Place, New York, N. Y.
PUBLISHERS

RADIO BROADCAST STATIONS OF THE UNITED STATES

with Time Table

Indexed Alphabetically by Call Letters

The following list of stations has been so arranged that it can be readily referred to in finding the location, name, power, wave length, frequency and time of a station, providing the call letters are known.

Radio Call Letters	BROADCAST STATIONS Location and Owner	Power Watts	Wave Length (Meters)	Frequency (Kilocycles)	Time at Station	Sending Hours
KD	KDKA—Pittsburgh, Pa. (Transmitter is in East Pittsburgh)—Westinghouse Elec. & Mfg. Co.....	Var.	309.1	970	Eastern	Mon., 7:15 to 8; 9:45; 11:55 am; 12 am; 4:20; 5:45; 6:30; 8; 8:15; 9:55 pm; Tue., 7:15 to 8 am; 9:45; 10; 11:55 am; 12 am; 4:20; 5:45; 6:30; 8; 8:15; 8:30; 9:55; 11:35 pm; Wed., 7:15; 8; 9:45; 11:55 am; 12 am; 4:20; 5:45; 6:30; 8; 8:15; 9; 9:55 pm; Thu., 7:15; 9:45; 11:55 am; 12 am; 4:20; 5:45; 6:30; 8; 8:15; 8:30; 9; 9:55; 11 pm; Fri., 7:15; 9:45; 10; 11:55 am; 12 am; 12:20; 4:20; 5:45; 6:30; 8; 8:15; 9; 9:30; 9:55; 10:10 pm; Sat., 11:55 am; 12 am; 5:45; 6:30; 8; 8:30; 9:55 pm. Sun.: 11 am; 4; 4:45; 6:10; 6:30; 7:15; 7:45 pm.
	KDLR—Devils Lake, N. D. —Radio Elec. Co.....	5	231	1300	Central	Daily: 12:10 am and 6:15; 9:30 to 12 pm Mon. Sun. and Holidays: 11 am; 4 pm.
	KDYL—Salt Lake City, Utah. —Newhouse Hotel.....	50	246	1220	Pacific	
KF	KFAB—Lincoln, Nebr. —Nebraska Buick Auto Co.....	1000	340.7	880	Central	Daily: 3:15 to 3:45; 5:30 to 6:30; 8:30 to 10:30 Thu., silent; 12 to 2 am Sat. Sun. and Holidays: 4 to 5 pm; 9 to 11 pm.
	KFAD—Phoenix, Ariz. —Electrical Equipment Co.....	100	272.6	1100	Mountain	Mon., silent; Tue., 6 to 7 pm; 8 to 9 pm; Wed., 6 to 7 pm; 8 to 9 pm; 9 to 11 pm; Thu., 6 to 7 pm; 8 to 9 pm; Fri., 6 to 7 pm; 8 to 9 pm; Sat., 6 to 7 pm; 8 to 9 pm. Sun.: 11 am to 12:30 pm.
	KFAF—San Jose, Calif. —Alfred E. Fowler, Montgomery Hotel.....	50	217.3	1380	Pacific	
	KFAU—Boise, Idaho —Independent School District of Boise.....	750	280	1070	Mountain	Mon., Wed., Fri., 12:30 to 1 pm; Tue., 12:30 to 1 pm; 7:30 to 9:30 pm; Thu., 12:30 to 1 pm; 8 to 10 pm; Sat., 12:30 to 1 pm; 7:30 to 9 pm.
	KFBB—Havre, Mont. —F. A. Buttrey Co.....	50	275	1090	Mountain	Daily: 12:45 to 1:30 pm only.
	KFBC—San Diego, Cal. —W. K. Azbill, 5038 Cliff Place.	50	215.7	1390	Pacific	
	KFBK—Sacramento, Calif. —Kimball Upson Co., 607 K St.....	100	248	1210	Pacific	Mon., 6 to 7 pm; Thu., 7:30 to 10 pm; Sat., 7:30 to 10 pm.
	KFBL—Everett, Wash. —Leese Bros., 2814 Rucker Ave.	100	224	1340	Pacific	Daily: 7:30 to 8:30 pm.
	KFBS—Trinidad, Colo. —School Dist. No. 1.....	15	238	1260	Mountain	
	KFBU—Laramie, Wyo. —The Cathedral, Bishop N. S. Thomas.....	500	270	1110	Mountain	
	KFCB—Phoenix, Ariz. —Nielsen Radio Supply Co., 311 N. Central Ave.....	100	238	1260	Mountain	Mon., 7:30 to 8:30 pm; Wed., 8 to 9 pm; Sat., 7 to 8 pm and 11 pm to 1 am. Sun. and Holidays: 9:30 to 10:30 am.
	KFDD—Boise, Idaho —St. Michaels Episcopal Cathedral	50	278.6	1080	Mountain	Sun.: 11 am to 12:30 pm; 7:30 pm to 9:15 pm.
	KFDM—Beaumont, Tex. —Magnolia Petroleum Co...	500	315.6	950	Central	

Radio Call Letters	BROADCAST STATIONS Location and Owner	Power Watts	Wave Length (Meters)	Frequency (Kilocycles)	Time at Station	Sending Hours
KF KFDX	Shreveport, La.—1st Baptist Church.....	100	250	1200	Central	
KFDY	Brookings, S. Dakota—South Dakota State College.....	100	273	1100	Central	Daily: 12:15 pm; Tue., 11 am; Thu., 7:30 pm.
KFDZ	Minneapolis, Minn.—H. O. Iverson, 2510 Thomas Ave. South.....	10	231	1300	Central	Tue., 9 pm. Sun.; 5:45 pm.
KFEC	Portland, Oregon—Meier & Frank Co.....	50	248	1210	Pacific	Daily: 12 am; 4 to 5 pm.
KFEL	Denver, Colo.—Eugene P. O'Fallon.....	50	254	1180	Mountain	Mon., 11 am; 2 pm; 5 pm; Tue., 11 am; 2 pm; 5 pm; 9 pm; 10 pm; Wed., 11 am; 2 pm; 5 pm; Thu., 11 am; 2 pm; 5 pm; 8 pm; 9 pm; 10 pm; Fri., 11 am; 2 pm; 5 pm; Sat., 11 am; 2 pm; 5 pm. Sun. and Holidays: 9 am only.
KFEQ	Oak, Nebr.—John L. Scroggin.....	500	268	1120	Central	Daily: 2 to 3:15 pm. Sun. and Holidays: 4 to 6 pm; 8:30 to 10 pm.
KFEY	Kellogg, Idaho—Bunker Hill & Sullivan Mining & Concentrating Co.....	10	233	1290	Pacific	Mon. and Wed., 8 pm. Sun.; 7:30 pm; 11 am.
KFFP	Moberly, Mo.—First Baptist Church.....	50	242	1240	Central	Alternate Thu., at 8 pm. Sun.: 9:45 am; 10:45 am; 7:30 pm.
KFGQ	Boone, Iowa—Crary Hardware Co.....	10	226	1330	Central	Tues., 10 to 11 pm; 8:30 to 9:30 pm, Fri.
KFH	Wichita, Kans.—Hotel Lassen.....	500	268	1120	Central	Daily: 9 am; 10 am; 11 am; 12 am; 1 pm; 2 pm; 10 to 11 pm. Sun.: 9:40 to 10:40 am; 10 to 11 pm.
KFHA	Gunnison, Colo.—Western State College of Colo.....	50	252	1190	Mountain	Tue. and Fri., 7:30 to 9:30.
KFHL	Oskaloosa, Iowa—Penn College.....	10	240	1250	Central	Mon., 9:45 am; Tue., 9:45 am and 7:15 pm; Wed., silent; Thu., 9:45 am; Fri., 9:45 am and 7:15 pm; Sat., silent. Sun.: 4 pm.
KFI	Los Angeles, Calif.—Earle C. Anthony, Inc., Packard Motor Car Bldg.....	4000	467	640	Pacific	Mon., 10:45 and 11:05 am; Wed. and Fri., 10:45 am; 5:30 pm to 11 pm daily and to 2 am on Sat. Sun., 10 am and 4 pm; 5:30 to 11 pm.
KFIF	Portland, Ore.—Benson Polytechnic School.....	100	248	1210	Pacific	Tue., 8:15 to 9:15 pm.
KFIO	Spokane, Wash.—North Central Radio Club, North Central High School.....	100	265.3	1130	Pacific	Fri., 8 to 9:30 pm.
KFIQ	Yakima, Wash.—I. M. Miller.....	100	256	1170	Pacific	Wed., 7 pm; Sat., 7 pm. Sun.: 11 am; 3:30 pm; 7:30 pm.
KFIZ	Fondulac, Wis.—Daily Commonwealth & Wis. Radio Sales, 22 Forest Ave.....	100	273	1100	Central	
KFJB	Marshalltown, Iowa—Marshall Electric Co....	10	248	1210	Central	
KFJC	Junction City, Kans.—Episcopal Church.....	10	218.8	1370	Central	
KFJF	Oklahoma, Okla.—National Radio Mfg. Co....	500	261	1150	Central	Mon., 9:40 am; 12:15 pm; 2:15 pm; 6 pm; 6:30 to 7:30 pm and 8:15 to 10:45 pm. First Mon. of each month, 8 pm. Tue., 9:40 am; 12:15 pm; 2:15 pm; 6 pm; 6:30 to 7:30 pm; 10 pm. Wed., 9:40 am; 12:15 pm; 2:15 pm; 6 pm; 6:30 to 7:30 pm; 7:40 pm; 8:15 to 10:30 pm; and 11 to 12 pm; Thu. Fri. and Sat., 9:40 am; 12:15 pm; 2:15 pm; 6 pm; 6:30 to 7:30 pm; 8:15 to 10:45 pm. Sun.: 9:40 am; 10 am; 11 am; 12:15 pm; 7:30 pm; 10 pm.

Radio Broadcast Station KFI

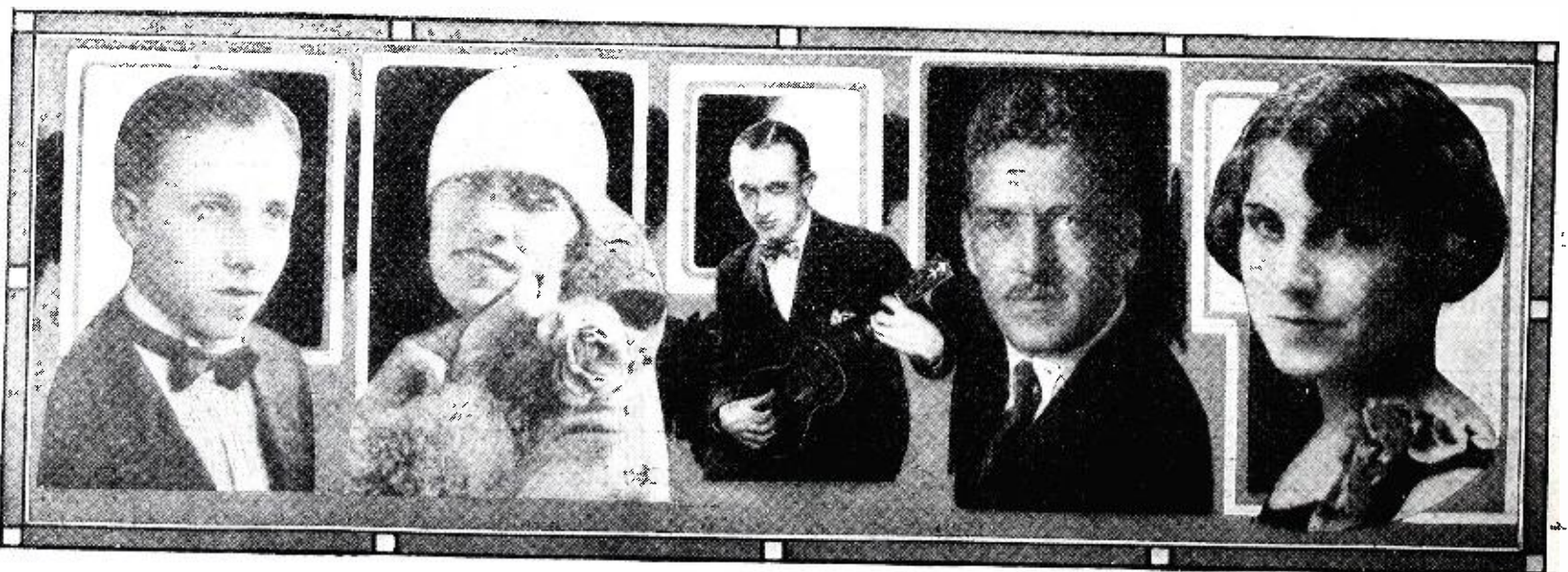

Al Lyman.

Eugenia Whisevort.

Mert Denman.

H. J. Tandler.

Lenore Killian, Contralto.

Radio Call Letters	BROADCAST STATIONS Location and Owner	Power Watts	Wave Length (Meters)	Frequency (Kilocycles)	Time at Station	Sending Hours
KF KFJI—Astoria, Ore.—Liberty Theatre (E. E. Marsh)...		10	246	1220	Pacific	
KFJM—Grand Forks, N. D.—University of N. D.....		100	278	1080	Central	Mon., 6 to 7 pm; Tue., 6 to 7 pm; Wed., 6 to 7 pm; Thu., 8:45 to 10 pm; Fri., 6 to 7 pm; Sat., 6 to 7 pm. Sun.: 6 to 7 pm.
KFJR—Portland, Ore.—Ashley C. Dixon & Son (Associated with Ralph Schneeloch Co.), 1350 East 36th St.....		50	263	1140	Pacific	Mon., 7:30 to 8:15 pm; Tue., 7:15 to 8:15 pm; 9 to 10:30 pm; Wed., 7:30 to 8:30 pm; Thu., 7:30 to 8:30 pm; 9 to 10:30 pm; Sat., 1:30 to 3 pm.
KFJY—Fort Dodge, Iowa—Tunwall Radio Co., 13 N. 10th St.....		50	246	1220	Central	Mon., 5:45 pm; Tue., 5:45 pm; Wed., 5:45 pm; Thu., 5:45 pm; 6 pm; 7 pm; Fri., 5:45 pm; 6 pm; Sat., 5:45 pm; 11 pm.
KFJZ—Fort Worth, Tex.—W. E. Branch.....		50	254	1180	Central	
KFKA—Greeley, Colo.—Colorado State Teachers College.....		50	273	1100	Mountain	Tue., 8 to 9 pm; Thu., 8 to 9 pm; Wed., 10 to 11 am.
KFKU—Lawrence, Kans.—University of Kansas.....		500	275	1090	Central	Mon., 7 pm to 8 pm; Thu., 7 pm to 8 pm.
KFKX—Hastings, Neb.—Westinghouse Elec. & Mfg. Co.....		5000	288.3	1040	Central	
KFKZ—Kirksville, Mo.—Chamber of Commerce.....		10	226	1330	Central	
KFLR—Albuquerque, N. Mex.—University of New Mexico.....		100	254	1180	Mountain	
KFLU—San Benito, Tex.—San Benito Radio Club....		20	236	1270	Central	Mon. Thu. Sat., 8 to 9 pm.
KFLV—Rockford, Ill.—Swedish Evangelical Mission Church.....		100	229	1310	Central	
KFLX—Galveston, Tex.—Geo. R. Clough, 1214 40th St.		10	240	1250	Central	
KFLZ—Anita, Iowa—Walnut Grove Co.....		100	273	1100	Central	Daily: 11:50 am and 12:30 pm. Sun. and Holidays: 8:30 pm to 10 pm.
KFMR—Sioux City, Iowa—Morningside College.....		100	261	1150	Central	
KEMX—Northfield, Minn.—Carleton College.....		500	336.9	890	Central	Daily time signals: 10:25 to 10:30 am; Tue., 9:30 to 10 pm; Wed., 9 to 10 pm; Fri., 10 to 11 pm. Sun.: 7 to 8 pm.
KENF—Shenandoah, Iowa—Henry Field Seed & Nursery Co.....		1000	263	1140	Central	Daily: 7 to 8 am; 10 to 11 am; 12:15 to 1:35 pm; 2:45 to 4 pm; 7 to 9 pm. Sun.: 10:45 to 12:15 pm; 2:30 to 4 pm; 6:30 to 8:30 pm.
KFOA—Seattle, Wash.—Rhodes Department Store....		1000	454.3	660	Pacific	Daily: 10 am to 10:45 am; 12:30 pm to 1:30 pm; 3 to 4 pm; 4:15 to 5 pm; 6 to 6:30 pm; 6:45 to 8:15 pm; 8:15 to 10 pm; 10 to 11 pm. No Sun. broadcast. Holidays same as regular schedule.
KFOB—Burlingame, Calif.—KFOB Inc.....		50	226	1330	Pacific	Tue., 8 to 12 pm; Thu., 8 to 12 pm; Sat., 5:30 to 6 pm.; 8 to 12 pm.
KFON—Long Beach, Calif.—Nichols & Warinner, Inc., Markwell Building.....		500	233	1290	Pacific	Daily: 2:30 to 4:30 pm; 6:30 to 11 pm. Sun. and Holidays: 2:30 to 4 pm; 7:15 to 11 pm.
KFOO—Salt Lake City, Utah—Latter Day Saints University.....		250	236	1270	Pacific	Station KFOO is not operating this year.
KFOR—David City, Neb.—David City Tire & Elec. Co.		100	226	1330	Central	Mon., 7 to 8 pm; Thu., 7 to 9 pm. Sun.: 3:30 to 4 pm.

Radio Broadcast Station WBAL

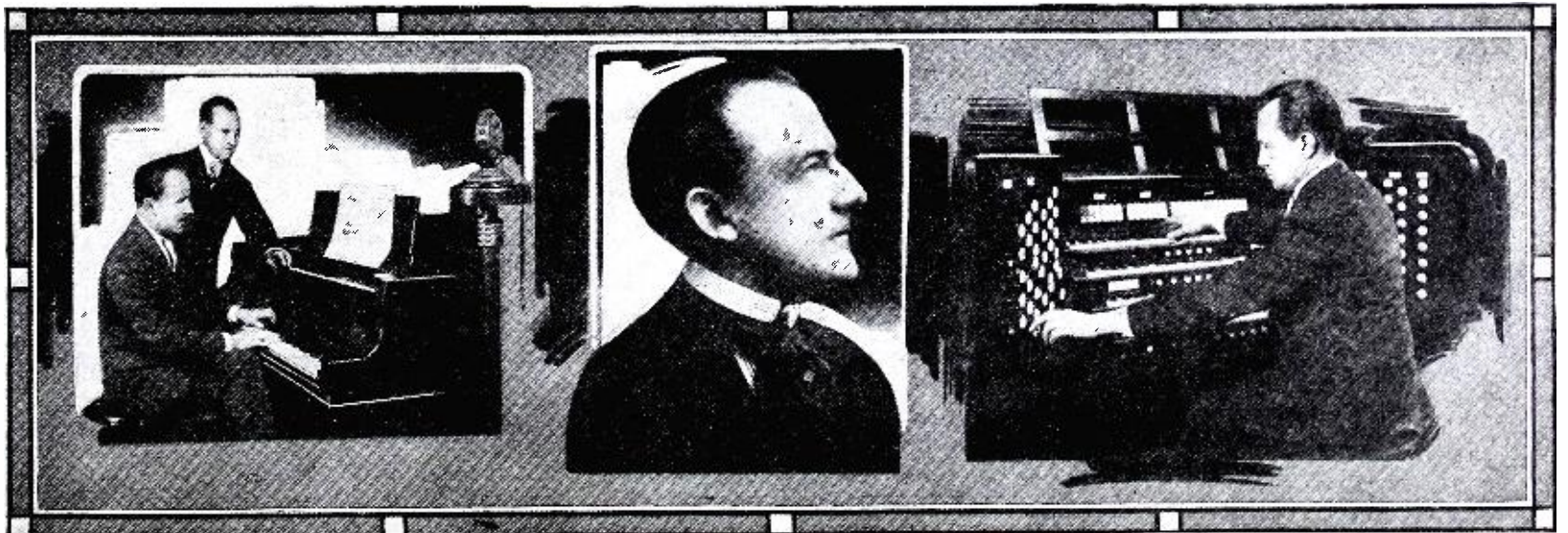

Gustav Kleem, at piano, and John Wilbourn.

Henry Hadley.

Frederick D. Weaver, staff organist.

Radio Call Letters	BROADCAST STATIONS Location and Owner	Power Watts	Wave Length (Meters)	Frequency (Kilocycles)	Time at Station	Sending Hours
KF KFOT	Wichita, Kans.—College Hill Radio Club (College Hill Methodist Church)	50	231	1300	Central	Fri., 12 to 2 am; Sat., 11:15 pm to 1:30 am; Sun.: 11 to 1 pm and 7:30 to 9 pm.
KFOX	Omaha, Neb.—Technical High School (Board of Education)	100	248	1210	Central	No regular schedule.
KFOY	St. Paul, Minn.—Beacon Radio Service (M. G. Goldberg), 711 Dayton Ave.	50	252	1190	Central	
KFPL	Dublin, Tex.—C. C. Baxter, 205 Grafton St.	15	252	1190	Central	
KFPM	Greenville, Tex.—The New Furniture Co.	10	242	1240	Central	Mon., 1 pm and 9 pm; Tue., 1 pm; Wed., 1 pm and 8 pm; Thu., 1 pm; Fri., 1 pm and 9 pm; Sat., 1 pm; Sun.: 11 am.
KFPR	Los Angeles, Calif.—Los Angeles County Forestry Dept.	500	230.6	1300	Pacific	
KFPW	Cartersville, Mo.—St. Johns M. E. Church, South. (L. E. Stewart)	20	258	1160	Central	Tue., 8 to 9 pm; Fri. 8 to 9 pm. Sun.: 1 to 2 pm.
KFPY	Spokane, Wash.—Symons Investment Co.	100	266	1130	Pacific	Mon., 7 to 8 pm; 9:30 to 10:30 pm; Wed., 7 to 8 pm; 9 to 12 midnight; Thu., 7 to 8 pm; 10 to 11 pm; Fri., 7 to 8 pm; Sat., 7 to 8 pm; 11 pm to 12 midnight. Sun.: 9:55 to 10:40 am; 9 to 10 pm.
KFQA	St. Louis, Mo.—The Principia, 5539 Page Ave. *5000 * (KFQA and KMOX sharing use of same transmitter. Not yet permitted to use full power.)	280.2	1070	Central		Sun.: 8 pm.
KFQB	Fort Worth, Tex.—Searchlight Publishing Co., 408 Throckmorton St., Broadcasting from First Baptist Church	1000	508.2	590	Central	Sundays only: 8:30 to 9:30; 10 to 11 am; 3 to 5; 6:30 to 9:30; 11 to 12 pm.
KFQP	Iowa City, Iowa.—Geo. S. Carson, Jr., 906 E. College St.	10	223.7	1340	Central	Wed., 8 to 9 pm.
KFQU	Alma (Holy City), Calif.—W. E. Riker	100	217.3	1380	Pacific	Daily: 9 to 10 pm. Sun. and Holidays: 11 am to 12 am; 9 to 10 pm.
KFQW	North Bend, Wash.—Carl F. Knierim	50	215.7	1390	Pacific	
KFQZ	Hollywood, Calif.—Taft Radio & Broadcasting Co., Inc., 5653 DeLongpre Ave.	50	226	1330	Pacific	Daily: 8 to 11 pm. Sun. and Holidays: 8 to 11 pm
KFRB	Beeville, Tex.—Hall Bros.	250	248	1210	Central	
KFRC	San Francisco, Calif.—City of Paris Dry Goods Co.	50	267.7	1120	Pacific	Mon., 10 to 11 am; 5:30 to 10 pm; Tue., 11 to 12:30 pm; 5:30 to 11 pm; Wed., 10 to 12 am; 5:30 to 12 pm; Thu., 11 to 12 am; 4 to 10 pm; Fri., 12 to 12:30 pm; 4 to 11 pm; Sat., 11 to 11:30 am; 4 pm to 1 am. No change for holidays. Sun.: 6:30 to 12 pm.
KFRU	Columbia, Mo.—Stephens College. A Junior College for Women	500	499.7	600	Central	Mon., 4:30 pm; 6:15 pm., Tue., 8:45 am; 4:30 pm 6:15 pm; Wed., 4:30 pm; 6:30 pm; 9 pm; Thu. 8:45 am; 4:30 pm; 6:15 pm; Fri., 4:30 pm; 6:15 pm; 12 midnight; Sat., 4:30 pm. Sun., 7:30 am. 9:30 am; 4 pm; 7:30 pm.
KFRW	Olympia, Wash.—G. & G. Radio and Electric Shop	50	218.8	1370	Pacific	
KFSD	San Diego, Calif.—Airfan Radio Corp., 402 B. St.	1000	245.8	1220	Pacific	Daily: 9 pm to 1 am.
KFSG	Los Angeles, Calif.—Echo Park Evangelistic Assn., 1100 Glendale Blvd.	500	275	1090	Pacific	

Radio Broadcast Station KFOA

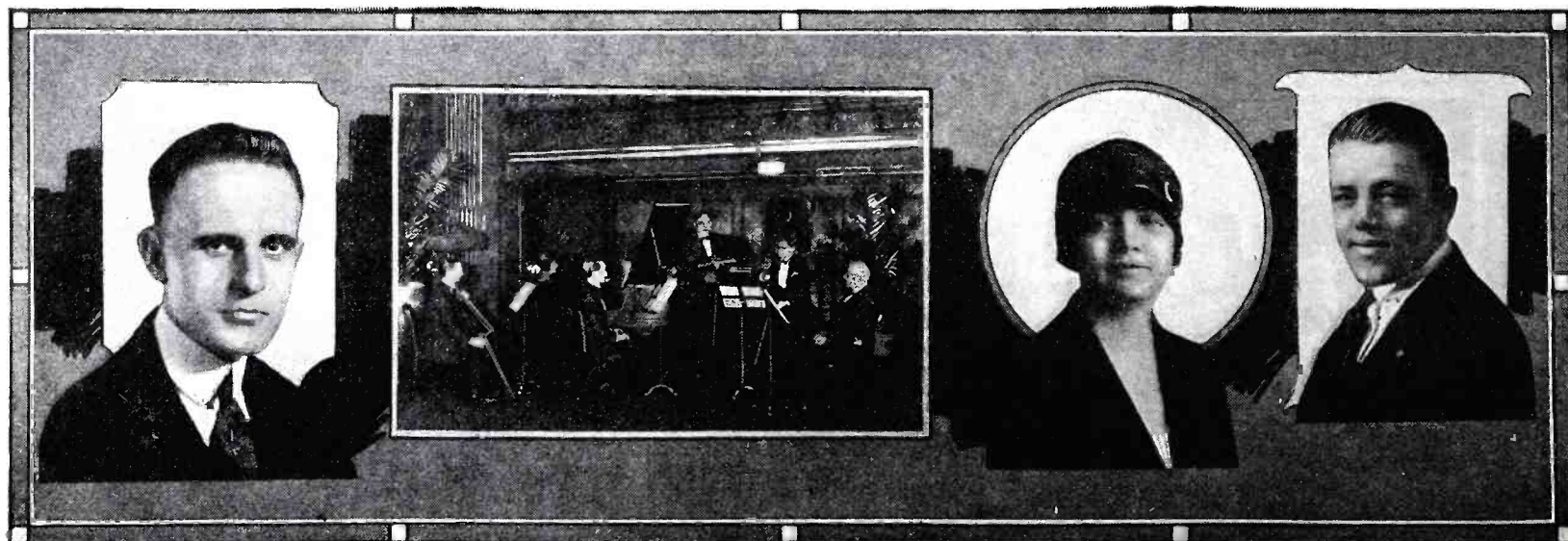

Paul Gale, station engineer

Hofmann's Olympic Hotel
Concert OrchestraMary Gordon,
program director.Carl E. Haymond, chief
announcer and station manager.

Radio Call Letters	BROADCAST STATIONS Location and Owner	Power Watts	Wave Length (Meters)	Frequency (Kilocycles)	Time at Station	Sending Hours
KF KFUL	Galveston, Texas—Thos. Groggan and Bros. Music Co., 2126 Market St.	50	258	1160	Central	
KFUM	Colorado Springs, Colo.—Corley Mountain Highway	100	239.9	1250	Mountain	Mon., 8 to 10 pm; Thu., 8 to 10 pm. Sun.: 11 am and 9 pm.
KFUO	St. Louis, Mo.—Concordia Theological Seminary	500	545.1	550	Central	Mon., 3 pm and 8 pm; Tue., 3 pm and 6:30 pm; Wed., 3 pm and 9:15 pm; Thu., 3 pm; Fri., 3 pm and 9:30 pm; Sat., 7:45 pm. Sun.: 4 pm and 9:15 pm.
KFUP	Denver, Colo.—Fitzsimons General Hospital	50	234	1280	Mountain	
KFUR	Ogden, Utah—Peery Building Co., 420 Twenty-fifth St.	50	224	1340	Pacific	
KFUS	Oakland, Calif.—Louis L. Sherman, 529 Twenty-eighth St.	50	256	1170	Pacific	Daily: 6:30 to 7:30 pm. Sun.: 9 am; 2:30 to 3:30 pm; 3:30 to 4:30 pm.
KFUT	Salt Lake City, Utah—University of Utah	100	261	1150	Pacific	Tue., 12 to 1 pm; Thu., 12 to 1 pm.
KFUU	Oakland, Calif.—H. C. Colburn and E. L. Mathewson, Flint Motor Car Building	100	220	1360	Pacific	Daily: 10:45 am to 11:45 am; 6:30 to 7:30 pm; 8 to 10:30 pm. Sun.: 8 to 10 pm.
KFVD	San Pedro, Calif.—McWhinnie Elec. Co., 1825 So. Pacific Ave.	50	205.4	1460	Pacific	
KFVE	St. Louis, Mo.—Film Corp. of America, 6800 Delmar Blvd.	500	240	1250	Central	
KFVG	Independence, Kans.—First Methodist Episcopal Church	15	236	1270	Central	
KFVI	Houston, Texas—Fifty-sixth Cavalry Brigade, Headquarters Troop	10	240	1250	Central	
KFVN	Fairmont, Minn.—Carl E. Bagley	50	227	1320	Central	Mon. Wed. and Fri., 9 pm. Sun.: 3 pm.
KFVR	Denver, Colo.—Eugene Rossi	50	244	1230	Mountain	
KFVS	Cape Girardeau, Mo.—Hirsch Battery and Radio Co.	50	224	1340	Central	Daily: 12:15 pm; Thu., 7 pm. Sun.: 11 am and 7 pm.
KFVY	Albuquerque, N. Mexico—Radio Supply Co., 407 West Central Ave.	10	250	1200	Mountain	
KFWA	Ogden, Utah—Browning Bros. Co., 2451 Kiesel Ave.	500	261	1150	Pacific	
KFWB	Hollywood, Calif.—Warner Bros. Pictures (Inc.), 5842 Sunset Blvd.	500	252	1190	Pacific	
KFWC	San Bernardino, Calif.—L. E. Wall	5	211.1	1420	Pacific	Mon., silent; Tue., 8 am to 12 am; 1 pm to 1 am; Thu., 8 am to 12 am; 1 pm to 1 am; Fri., 8 to 12 pm; Sat., 8 to 12 am. Sun.: 8 am to 1 pm.; 7 pm to 2 am.
KFWF	St. Louis, Mo.—St. Louis Truth Center, Rev. Emil C. Hartmann, 4030 Lindell Blvd.	250	214.2	1400	Central	Tue., 7 pm; 8 pm; Thu., 10:45 am; 12 am; 7:45 pm; 9 pm. Sun.: 10:45; 7:45; 9 pm.
KFWH	Chico, Calif.—F. Wellington Morse, Jr., 522 Grand Ave., Oakland, Calif.	100	254	1180	Pacific	

Radio Broadcast Station WBZ

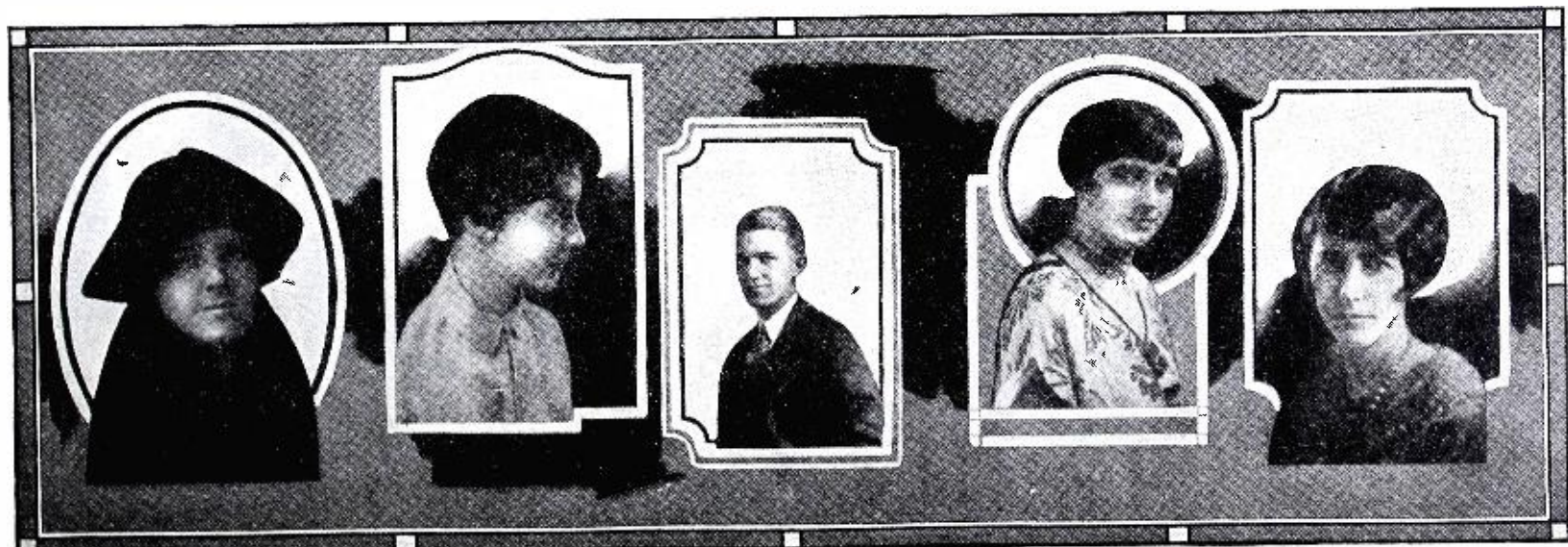

Dorothy Birchard Mulroney, pianist and accompanist.

Anne L. Lawless, charming hostess at the Hotel Brunswick studio.

John D. Kuhns, announcer from the Boston studio.

Bernice Mosher, young soprano.

Mildred L. Hanifin, program director.

Radio Call Letters	BROADCAST STATIONS Location and Owner	Power Watts	Wave Length (Meters)	Frequency (Kilocycles)	Time at Station	Sending Hours
KF KFWI	San Francisco Calif. (Transmitter is in So. San Francisco, Calif.)—Tom Catton.....	500	226	1330	Pacific	Mon., 10:45 to 11:30 am; 1 to 2; 6:30 pm to 1 am; Tue., 11 to 1 am; Wed., 10:45 to 11:30 am; 1 to 2; 6:30 pm to 1 am; Thu., Silent; Fri., 10:45 to 11:30 am; 6:30 pm to 1 am; Sat., 1:30 to 3:30 am. Sun.: 1 to 2; 8 to 12:30 pm.
KFWM	Oakland, Calif.—Oakland Educational Society, 1520 8th Ave.....	250	207	1450	Pacific	Mon., 8 to 10; Tue., 2 to 2:30; Wed., 2 to 2:30; Thu., 8 to 10; Fri., 2 to 2:30; Sat., 8 to 10. Sun.: 9:30 to 11 am; 1 to 2 pm.
KFWO	Avalon, Catalina Island, Calif.—Major Lawrence Mott, Signal Corps, U. S. Army....	250	211.1	1420	Pacific	Mon., 12:30 to 1:30 pm; 6 to 10 pm; Tue., 12:30 to 1:30 pm; 5 to 9 pm; Wed., 12:30 to 1:30 pm; 6 to 10 pm; Thu., 12:30 to 1:30 pm; 6 to 9 pm; Fri., 12:30 to 1:30 pm; 6 to 11 pm; Sat., 12:30 to 1:30 pm; 6 to 9 pm. Sun.: 12:30 to 1:30 pm; 5 to 10 pm.
KFWU	Pineville, La.—Louisiana College.....	100	238	1260	Central	
KFWV	Portland, Ore.—Wilbur Jerman, 385 East Fifty-eighth St., So.....	50	212.6	1410	Pacific	
KFXB	Big Bear Lake, Calif.—Bertram O. Heller....	500	202.6	1480	Pacific	Daily: 5 to 5:30 pm; 8 to 8:30 pm. Sun.: silent.
KFXD	Logan, Utah—Service Radio Company.....	10	205.4	1460	Mountain	
KFXF	Colorado Springs, Colo.—Pikes Peak Broadcasting Co., 226 Hagerman Bld.....	500	250	1200	Mountain	
KFXH	El Paso, Texas—Bledsoe Radio Co., 115 S. El Paso St.....	50	242	1240	Central	
KFXJ	Edgewater, Colo.—R. G. Howell.....	10	215.7	1390	Mountain	Daily: 9 to 11 am; 5:30 to 6:30 pm. Night programs pending.
KFXR	Oklahoma, Okla.—Classen Film Finishing Co., 132½ W. Main Street.....	15	214.2	1400	Central	
KFX Y	Flagstaff, Ariz.—Mary M. Costigan (Orpheum Theatre).....	50	205.4	1460	Mountain	
KFYF	Oxnard, Calif.—Carl's Radio Den, 207—5th St.	10	205.4	1460	Pacific	Daily: 5:05 to 6 pm; 9 to 11 pm on 2nd and 4th Thu. each month. Programs on Tue. and Thu. by special announcement.
KFYJ	Houston, Texas—(Portable) Houston Chronicle Pub. Co.....	10	238	1260		
KFYO	Texarkana, Texas—Buchanan-Vaughan Co....	10	209.7	1430	Central	
KFYR	Bismark, N.D.—Hoskins Meyer, 200 Fourth St.	10	248	1210	Central	Daily: 6:30 to 7:30 pm. Extra hours on extra programs. Sun.: 3 to 5 pm.
KG KGO	Oakland, Calif.—General Electric Co.....	4000	361.2	833	Pacific	Mon., 7:15; 7:45; 8:15; 8:30; 10:40; 11:30 am; 1:30; 3; 4 to 5:30; 5:30 to 6; 6 to 6:55; 8 to 10 pm; Tue., 7:15; 7:45; 8:15; 8:30; 11:30 am; 1:30; 4 to 5:30; 6 to 6:55; 8 to 10 pm; Wed., 7:15; 7:45; 8:15; 8:30; 11:30 am; 1:30; 3; 4 to 5:30; 6 to 6:55 pm; Thu., 7:15; 7:45; 8:15; 8:30; 10:40; 11:30 am; 1:30; 4 to 5:30; 8 to 10 pm; Fri., 7:15; 7:45; 8:15; 8:30; 11:30 am; 1:30; 3; 4 to 5:30; 5:30 to 6; 6 to 6:55 pm; Sat., 7:15; 7:45; 8:15; 8:30; 11:30 am; 12:30; 4 to 5:30; 8 to 10 pm. Sun.: 11 am; 3:30 to 5 pm; 7:45 pm.
KGTT	San Francisco, Calif.—Glad Tidings Temple and Bible Inst.....	50	207	1450	Pacific	Tue., 2:30 to 3:30 pm; 8 to 10 pm; Wed., 2:30 to 3:30 pm; 8 to 10 pm; Thu., 2:30 to 3:30 pm; Fri., 2:30 to 3:30 pm; 8 to 10 pm. Sun.: 2:30 to 5 pm; 8 to 10 pm.

Radio Broadcast Station KFWB



Bill Blake, lyric tenor.

Dan Gridley, California's golden voiced tenor.

Mabel Leonard, pianist and studio accompanist.

Charlie Wellman, manager-announcer and vocalist.

Radio Call Letters	BROADCAST STATIONS Location and Owner	Power Watts	Wave Length (Meters)	Frequency (Kilocycles)	Time at Station	Sending Hours
KG	KGW—Portland, Ore.—The Oregonian Pub. Co.	1000	492.5	609	Pacific	Mon., 6 to 10 pm; Tue., 6 to 12 pm; Wed., 6 to 11 pm; Thu., 6 to 10 pm; Fri., 6 to 12 pm; Sat., 6 to 12 pm. Sun.: 7 to 10 pm.
	KGY—Lacey, Wash.—St. Martins College	50	246	1220	Pacific	Tue., 8:30 to 9:30 pm; Thu., 8:30 to 9:30 pm. Sun.: 8:30 to 9:30 pm.
KH	KHJ—Los Angeles, Calif.—Times Mirror Co., 100 N. Broadway	500	405.2	740	Pacific	Daily: 12:30 to 1:30 pm; 6:30 to 10 pm; Wed.: same only 2:30 to 3:30 pm. Sun. and Holidays, 4 to 5 pm; 8 to 10 pm; also Sun.: 10 am to 12 am.
	KHQ—Spokane, Wash.—Louis Wasmer, Davenport Hotel	1000	394.5	760	Pacific	
KJ	KJBS—San Francisco, Calif.—Julius Brunton and Son Co., 1380 Bush St.	5	220	1360	Pacific	Daily: 9 to 10:40 am; 2 to 2:30 pm; Mon. and Wed., 8 to 10 pm; Fri., 8 to 11:30 pm. Sun.: 5 to 6:30 pm.
	KJR—Seattle, Wash.—Vincent I. Kraft	1000	384.4	780	Pacific	Daily: 10:30 to 11:30 am; 11:30 to 12; 5 to 6; 7 to 8:30; 8:30 to 10; Thu., 10 to 12 pm. Sun.: 11 to 12:30; 7 to 9; 9 to 10:30.
KL	KLDS—Independence, Mo.—Reorganized Church of Jesus Christ of Latter Day Saints	1000	440.9	680	Central	Mon., 12:15 to 11 pm; Tue., 6:30 am; 12:15; 2:30; 8 pm; Wed., 12:15; 6 pm; Thu., 12:15; 2:30; 8 pm; Fri., 6:30 am; 12:15; 2:30 pm; Sat., 8 pm. Sun.: 11 am; 3; 6:30; 9:15 pm.
	KLS—Oakland, Calif.—Warner Bros. Radio Supplies Co., 2201 Telegraph Ave.	250	250	1200	Pacific	Sun.: 10 am. and 11 am.
	KLX—Oakland, Calif.—The Oakland Tribune	500	508	590	Pacific	Mon., 6:30 to 7:30 pm and 8 to 10:30 pm; Tue., 3 to 5 pm; 7 to 7:30 pm; Wed., 3 to 5 pm; 6:30 to 7:30 pm; 8 to 10:30 pm; Thu., 3 to 5 pm; 7 to 7:30 pm; Fri., 3 to 5 pm; 7 to 7:30 pm; 8 to 10:30 pm; Sat., 3 to 5 pm; 7 to 7:30 pm. No Sun. broadcasting. Holidays same as usual.
	KLZ—Denver, Colo.—Reynolds Radio Co., 1534 Glenarm Street	250	266	1130	Mountain	Mon., 3 to 4 pm; 6 to 7 pm; 8 to 1 am; Tue., 6:30 to 9 pm; 10 to 11 pm; Wed., 3 to 4 pm; 6 to 7 pm; 8 to 10 pm; Thu. Silent; Fri., 6 to 7 pm; 8 to 10 pm; Sat., 3 to 4 pm; 6:30 pm to 1 am. Sun.: 5 to 6 pm; 6:30 to 8 pm; 9 to 10:30 pm.
KM	KMA—Shenandoah, Iowa—May Seed and Nursery Co.	500	252	1190	Central	Mon., 5:30 to 7; 9; 11:30 am to 12:30 pm; 6 to 7; 9 to 11 pm; Tue., 5:30 to 7; 9; 11:30 am to 12:30 pm; 2; 6 to 7; 9 to 11 pm; Wed., 5:30 to 7; 9; 11:30 am to 12:30 pm; 2; 6 to 7; 9 to 11 pm; Thu., 5:30 to 7; 9; 11:30 am to 12:30 pm; 2 to 3; 4 to 5; 6 to 7; 9 to 11 pm; Fri., 5:30 to 7; 9; 11:30 am to 12:30 pm; 2 to 3; 6 to 7; 9 to 11 pm; Sat., 5:30 to 7; 9; 11:30 am to 12:30 pm; 2; 6 to 7; 9 to 11 pm. Sun.: 12:15; 4 to 5; 5 to 6 pm.
	KMJ—Fresno, Calif.—Fresno Bee	50	234	1280	Pacific	
	KMMJ—Clay Center, Nebr.—M. M. Johnson Co.	1000	229	1310	Central	
	KMO—Tacoma, Wash.—Love Elec. Co., 738 Pacific Ave.	250	250	1200	Pacific	
	KMOX—St. Louis, Mo. (Transmitter is in Kirkwood, Mo.)—Voice of St. Louis, Inc.	1500	280.2	1070	Central	Daily: 8:40 to 12:40, Market Reports at Half Hour Intervals; 12:30 to 1:30; 3 to 5 pm; 6 to 11:30 pm; Thu., Silent after 5 pm. Sun.: 9 to 10:30 pm.
	KMTR—Hollywood, Calif.—K. M. Turner Radio Corp., 1517 N. Wilton St.	500	238	1260	Pacific	Daily: 9 am; 2:30 pm; 5 pm; 6 pm; 8 to 10 pm; Tue. Thu. Sat., 9:30 pm; Mon. Wed. Fri., 10 to 11 pm. No regular broadcast on Sun.
KN	KNRC—Los Angeles, Calif.—Kierulff and Ravenscroft, 1630 So. Los Angeles St.	250	208	1440	Pacific	Mon., 1 to 3 pm; 5:45 to 10 pm; Tue., 1 to 3 pm; 5:45 to 10 pm; Wed., 1 to 3 pm; 5:45 to 10 pm; Thu., 2 to 3 pm; 5:45 to 10 pm; Fri., 2 to 3 pm; 5:45 to 10 pm; Sat., 2 to 3 pm; 5:45 to 11 pm.

Radio Broadcast Station WCAP

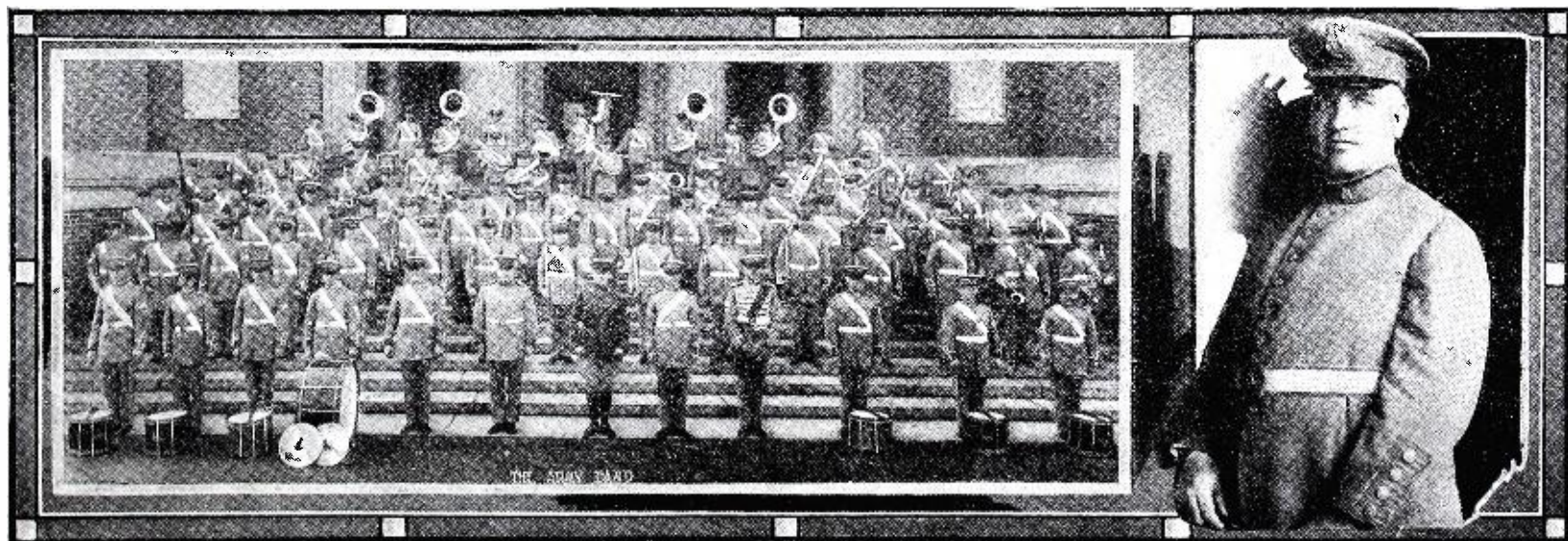

The U. S. Army Band.

Capt. Wm. J. Stannard, Leader, U. S. Army Band.

Radio Call Letters	BROADCAST STATIONS Location and Owner	Power Watts	Wave Length (Meters)	Frequency (Kilocycles)	Time at Station	Sending Hours
KN	KNX—Los Angeles, Calif.—Los Angeles Evening Express, 6116 Hollywood Blvd.....	1000	336.9	890	Pacific	
KO	KOA—Denver, Colo.—General Electric Co., 1370 Krameria St.....	5000	322.4	930	Mountain	Mon., 11:45 am to 1:15 pm; 6 to 10 pm; Tue., 11:45 am to 1:15 pm; 3:15 to 4:30; 6 to 8:30 pm.; Wed., 11:45 am to 1:15 pm; 6 pm to 12 pm; Thu., 11:45 to 1:15 pm; 3:15 to 4:30; 6 to 8 pm; Fri., 11:45 to 1:15 pm; 3:15 to 4:30; 6 to 10 pm; Sat., 11:45 to 1:15 pm; 9 pm to 12 pm. Sun.: App, 11 am; 4; 7:30 pm.
	KOAC—Corvallis, Ore.—Oregon Agricultural College...	500	280.2	1070	Pacific	Mon., 12:15 to 12:45 pm; 7 to 8:30 pm; Wed., 2 to 3 pm; 7:20 to 8:15 pm; Thu., 2 to 3 pm; Fri., 7:30 to 9 pm.
	KOB—State College, N. Mex.—New Mexico College of Agriculture and Mechanic Arts.....	1000	348.6	860	Mountain	Daily: 11:55 am to 12:30 pm; 9:55 pm to 10:10 pm; Mon., 7:30 to 8:30 pm; Fri., 7:30 to 8:30 pm
	KOCH—Omaha, Nebr.—Central High School.....	250	258	1160	Central	Mon., 8:30 to 10; Tue., 8-30 to 10; Thu., 8:30 to 10. Sun.: 3:30 pm.
	KOCW—Chickasha, Okla.—Oklahoma College for Women.....	200	252	1190	Central	
	KOIL—Council Bluffs, Iowa—Mona Motor Oil Co....	500	278	1080	Central	Mon., 6 pm to midnight; Tue., Thu., Fri., 6 to 9 pm; 11 to 12 pm; Wed., Silent; Sat., 6 to 9 pm; 11 to 1 am. Sun.: 11 am; 4; 7 to 9 pm; 11 to 12 pm.
	KOIN—Portland, Ore.—H. B. Read, 441-6th St.....	1000	319	940	Pacific	
	KOWW—Walla Walla, Wash.—Blue Mountain Radio Association. (Frank A. Moore).....	500	256	1170	Pacific	
KP	KPO—San Francisco, Calif.—Hale Bros. and the San Francisco Chronicle.....	1000	428.3	700	Pacific	Mon., 7 to 8:30 am; 1 to 2; 2:30 to 4:30; 5:15 to 7:30; 8 to 11 pm; Tue. Wed. and Thu., same as Mon.; Fri., 7 to 8:30 am; 12:45 to 2 pm; 4 to 7:30 and 8 to 11 pm; Sat., 7 to 8:30 am; 2:30 to 5:30-6 to 7:30 and 8 to 12 pm. Sun.: 9:45 to 10:45 am, 5 to 10 pm.
	KPPC—Pasadena, Calif.—Pasadena Presbyterian Church.....	50	229	1310	Pacific	Wed., 7:15 to 9 pm. Special broadcasts as announced. Sun.: 10:30 am to 12:30 pm; 6:45 pm to 9 pm.
	KPRC—Houston, Texas—Houston Post Dispatch.....	500	296.9	1010	Central	Daily: Fri., silent 10:55 am; 11 am; 12 am; 5:30 pm; 7:30 pm; 8 pm; 8:30 pm; 9 pm; 9:30 pm. Daily and Sun.: 11 pm Wed. and Sat. only. Sun.: 10:45 am; 7 pm; 9:30 pm.
	KPSN—Pasadena, Calif.—The Star-News.....	1000	315.6	950	Pacific	Mon., Silent; Tue., 8 to 9 pm; Wed., silent; Thu., 8 to 9 pm; Fri., silent; Sat., 8 to 10 pm. Sun.; 8:45 to 9:45 pm.
KQ	KQV—Pittsburgh, Pa.—Doubleday-Hill Electric Co., 719 Liberty Ave.....	500	275	1090	Eastern	Mon., 10:30 to 11 am; 3 to 4:30 pm; Tue., 10:30 to 11 am; 3 to 4:30 pm; 6:30 to 7:30; Wed., 10:30 to 11 am; 3 to 4:30 pm; Thu., 10:30 to 11 am; 3 to 4:30 pm; Fri., 10:30 to 11 am; 3 to 4:30 pm; Sat., 10:30 to 11 am; 3 to 4:30 pm.
	KQW—San Jose, Calif.—First Baptist Church of San Jose, Montevina Ave.....	500	231	1300	Pacific	Mon. Tue. Wed. Thu. Fri. 6:30; 7. Sun.: 9:40 to 12:30; 7:30 to 9:30.
KR	KRE—Berkeley, Calif.—Berkeley Daily Gazette.....	100	256	1170	Pacific	Daily: 11:15 am to 11:45 am; 5:30 pm to 6 pm; Mon. and Thu., 8 to 10 pm; Tue., 9 to 10; Fri. 9 pm to 1 am; Sat., 8 pm to 1 am. Sun. and Holidays: 10 to 11 am; 6:30 to 7:30 pm; 8 to 9 pm.
KS	KSAC—Manhattan, Kans.—Kansas State Agricultural College.....	500	340.7	880	Central	

Radio Broadcast Station KGO



Rose Brown, leading lady for the KGO players.

Arion Trio, a regular feature on the program of this station.

Wilda Wilson Church, director of KGO players.

Howard I. Millholland, studio manager and chief announcer.

Radio Call Letters	BROADCAST STATIONS Location and Owner	Power Watts	Wave Length (Meters)	Frequency (Kilocycles)	Time at Station	Sending Hours
KS	KSD—St. Louis, Mo.—Pulitzer Publishing Co.—The St. Louis Post Dispatch.....	500	545.1	550	Central	Mon., 9:40; 10:40; 11:40; 12:40 pm; 1:40; 2:40; 3:40 pm; 7; 9 to 10:30 pm; Tue., 7 to 11 pm; Wed., 7 to 9:15 pm; Thu., 7 to 11 pm; Fri., 7 to 9:20; 10 to 11 pm; Sat., 7 to 7:45; 8 to 11 pm. Mon. Wed. and Fri., 10 am and 11 am. Sun.: 6:15 to 9:15 pm.
	KSL—Salt Lake City, Utah—Radio Service Corp. of Utah, 505 Templeton Bldg.....	1000	299.8	1000	Mountain	Mon., 7:30 am; 6 pm to 11 pm; Tue., 7 pm to 11 pm; Wed., 7:30 am; 10 am; 6 to 11:30 pm; Thu. 7 pm to 11 pm; Fri., 7:30 am; 10 am; 6 pm to 11 pm; Sat., 7:15 pm to 11 pm. Sun.: 11 am; 4 pm to 11 pm.
	KSMR—Santa Maria, Calif.—Santa Maria Valley R. R. Co.....	100	209.7	1430	Pacific	Mon. Wed. and Fri., 7:45 to 8:15 pm; Tue. Thu. and Sat., 7 to 10 pm.
	KSO—Clarinda, Iowa—A. A. Berry Seed Co.....	500	242	1240	Central	Mon., 12:30 pm to 7 pm; Tue., 12:30 pm to 7 pm; Wed., 12:30 pm to 7 pm; Thu., 12:30 pm; 3 pm to 4:30; 7 pm; Fri., 12:30 pm; 7pm; Sat., 12:30 pm.
KT	KTAB—Oakland, Calif.—The Associated Broadcasters.	1000	240	1250	Pacific	Daily: 9 to 9:30 am; 12 to 1 pm; 8 to 10 pm. Sun.: 9:45 to 10:45 am; 11 am to 12:30; 7:45 to 9:15 pm; 9:30 to 11 pm.
	KTBI—Los Angeles, Calif.—Bible Institute of Los Angeles.....	750	293.9	1020	Pacific	
	KTBR—Portland, Ore.—Brown's Radio Shop, 172 Tenth St.....	50	263	1140	Pacific	Mon., 1:30 to 2:30 pm; 8:45 to 9:45 pm; Tue., 1:30 to 2:30 pm; 8:30 to 9 pm; Wed., 1:30 to 2:30 pm; 8:30 to 10:30 pm; Thu., 1:30 to 2:30 pm. 6:15 to 7:15 pm; Fri., 1:30 to 2:30 pm; 6 to 10 pm. Sat., 3 to 4 pm; 11:30 to 1:30 am. Sun.: 3 to 4 pm.
	KTCL—Seattle, Wash.—American Radio Telephone Co.	1000	305.9	980	Pacific	
	KTHS—Hot Springs Nat'l Park, Ark.—New Arlington Hotel Co.....	750	374.8	800	Central	Mon., 12:30 to 1 pm; 9 to 11:30 pm; Tue., 9 to 11:30 pm; Wed., 12:30 to 1 pm; 9 to 11:30 pm; Thu., 12:30 to 1 pm; 9 to 11:30 pm; Fri., 12:30 to 1:30 pm; 9 to 11:30 pm; Sat., 12:30 to 1:30 pm; 9 to 11:30 pm. Sun.: 11 am to 12:15 pm; 9 pm to 12:45 am.
	KTNT—Muscatine, Iowa—Norman Baker.....	500	256	1170	Central	Daily: 12 to 12:30 pm; 6:45 to 7:45 pm; 9 to 10:30 pm; 11 to 12 pm; Sat., silent; 9:30 each Mon Night "Common Sense Talks," by N. Baker. Sun.: 9 to 10:30 pm.
	KTW—Seattle, Wash.—The First Presbyterian Church of Seattle, Wash.....	1500	454.3	660	Pacific	Sun.: 11 am to 12:30 pm; 3 to 4:30 pm; 7:30 pm to 10 pm.
KU	KUOA—Fayetteville, Ark.—University of Arkansas....	750	299.8	1000	Central	Mon., 7:30 to 9; Tue., 8 to 10; Thu., 8 to 10.
	KUOM—Missoula, Mont.—State University of Montana	500	244	1230	Mountain	Daily: 6:30 pm; Mon. and Thu., 8 pm. Sun.: 9:15 pm.
	KUSD—Vermillion, S. D.—University of South Dakota.	100	278	1080	Central	Wed., 8 to 10 pm. Sun.: 3:30 pm; 9 pm.
	KUT—Austin, Texas—University of Texas.....	500	231	1300	Central	Mon., 8 pm; Wed., 8 pm. Sun.: 11 am; 3:30 pm.
KV	KVOO—Bristow, Okla.—Southwestern Sales Corp., Tulsa and Bristow, Okla.....	500	375	800	Central	Daily: 7 to 9 am; 11:30 to 12:30 pm; 3 to 4; 6 to 9 pm. Sun.: 12:30 to 7 pm (continuous); 7:30 to 9 pm.
KW	KWCR—Cedar Rapids, Iowa—H. F. Paar, 1444 Second Ave., E.....	500	278	1080	Central	Mon., 9 to 10:30; Wed., 9 to 10:30; Fri., 9 to 10:30; Afternoon programs, 4:15 pm; Mon. Wed. and Fri. Sun.: 11 am; 5:15 pm; 9:30 pm.
	KWG—Stockton, Calif.—Portable Wireless Telephone Co., 530 East Market St.....	50	248	1210	Pacific	

Radio Broadcast Station WCAP

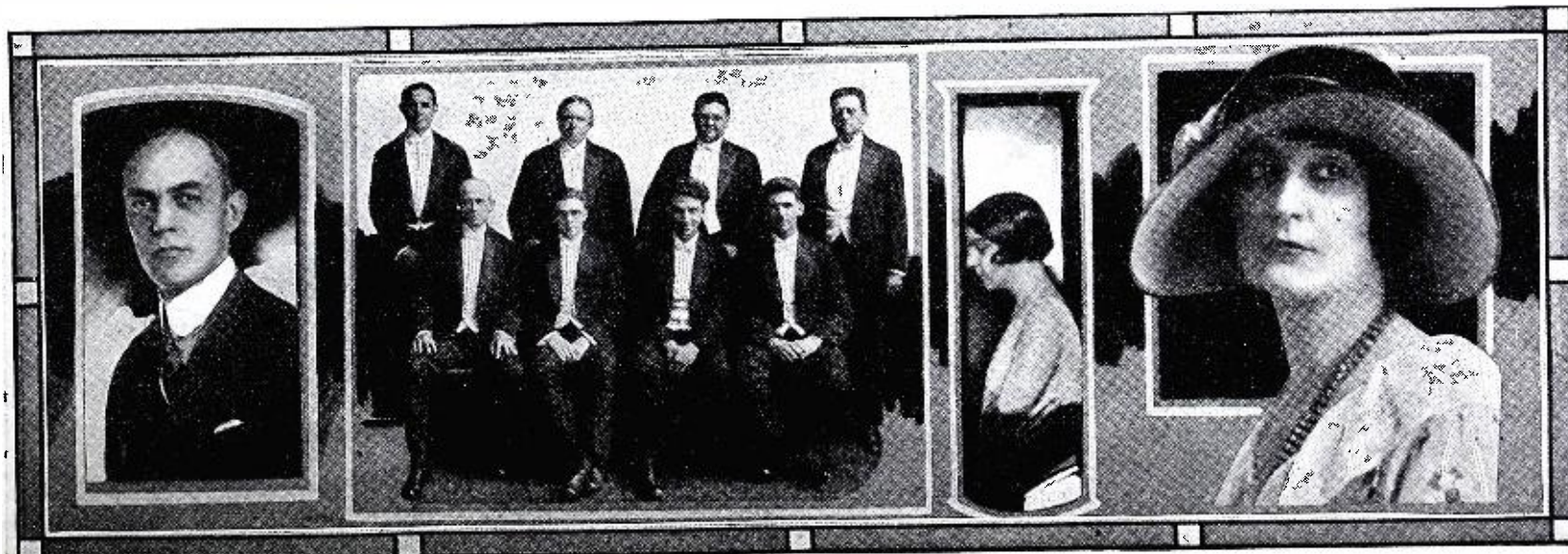

P. S. Ridsdale, Editor, Nature Magazine, who talks on "Queer Quirks of Nature."

The Criterion Octette of Baltimore.

Mary S. Apple, contralto.

Gretchen Hood, soprano.

Radio Call Letters	BROADCAST STATIONS Location and Owner	Power Watts	Wave Length (Meters)	Frequency (Kilocycles)	Time at Station	Sending Hours
KW	KWKC—Kansas City, Mo.—Wilson Duncan Broadcast- ing Studios, Werby Building.....	100	236	1270	Central	Tue., 7 and 9 pm; Wed., 7 and 9 pm; Thu., 7 and 9 pm; Fri., 7 and 9.
	KWKH—Shreveport, La. (Transmitter is in Kennon- wood, La.)—W. K. Henderson Iron Works and Supply Co.....	1000	329	911	Central	Mon., 8 to 9 pm; Tue., 9-12 pm; Wed., Silent or special program; Thu., 8 to 9 pm; Fri., 9 to 12 pm. Sat., 9 to 12 pm. Sun.: 9:30 to 10:30 am; 5 to 6 pm.
	KWSC—Pullman, Wash.—State College of Washington	500	348.6	860	Pacific	
	KWUC—Le Mars, Iowa—Western Union College.....	50	252	1190	Central	Mon., 7:30 to 9 pm; Wed., 8 to 9 pm; Fri., 7 to 8 pm. Sun.: 3 to 4 pm.
	KWWG—Brownsville, Texas—Chamber of Commerce..	500	278	1080	Central	Daily: 12 noon; 6 pm; Mon. and Thu., 8:30 pm; Tue. and Fri., 12:01 am. Sun.: 11 am.
KY	KYW—Chicago, Ill.—Westinghouse Electric and Mfg. Co.....	2000	536	560	Central	Daily: 11 am; 12 am; 1 pm; 2:35 to 4 pm; Tue. Thu. and Sat., 5:45 to 6; 6:30 to 7 pm; 8 to 12 pm. Sun. and Holidays: 11 am; 2:30; 4:30; 7 and 9:30 pm.
KZ	KZM—Oakland, Calif.—Preston D. Allen, 13th and Harrison Streets.....	100	240	1250	Pacific	Daily except Sunday: 6:30 to 7 pm.
NA	NAA—Arlington, Va.—United States Navy.....	1000	434.5	690	Eastern	Daily: 10:05 to 10:20; 11:55 to noon; 3:45 to 4; 9:55 to 10; 10:05 to 10:20 pm; Wed., 7:45 to 8 pm; 8:45 to 9:20 pm; Fri., 8:45 to 9:20 pm.
WA	WAAD—Cincinnati, Ohio—Ohio Mechanics Institute..	25	258	1160	Central	
	WAAF—Chicago, Ill.—Chicago Daily Drivers Journal.	200	278	1080	Central	
	WAAM—Newark, N. J.—I. R. Nelson, 1 Bond St.	500	263	1140	Eastern	Mon., 11 to 12 am; 6 to 11 pm; Tue., 10:15 to 12 am; 6 to 11 pm; Wed., 11 to 12 am; 6 to 11 pm; Thu., 11 to 12 am; 6 to 7:30 pm; Fri., 10:15 to 12 am; 6 to 11 pm; Sat., 6 to 11 pm. Sun.: 11 am to 12:30 pm.
	WAAW—Omaha Neb.—Omaha Grain Exchange.....	500	384.4	780	Central	Daily except Sat.. 9:30 am; 9:45 every half hour to 1:15 pm. Last Broadcast on Sat., 12:45 pm. Evenings at 8 pm. Broadcast only market reports.
	WABB—Harrisburg, Pa.—Harrisburg Radio Co.....	10	204	1470	Eastern	
	WABC—Asheville, N. C.—Asheville Battery Co., 19 Haywood St.....	20	254	1180	Central	
	WABI—Bangor, Me.—First Universalist Church.....	100	240	1250	Eastern	Sun.: 10:30 to 12 am; 7:30 to 9:30 pm.
	WABO—Rochester, N. Y.—Lake Ave. Baptist Church..	100	258	1160	Eastern	Sun.: 10:30 to 12 am; 7:30 am to 9 pm.
	WABQ—Haverford, Pa.—Haverford College Radio Club.....	100 1000	261	1150	Eastern	Mon., 7:30 pm. to 12:30 am; Fri., 7:30 pm. to 12:30 am.
	WABR—Toledo, Ohio—Scott High School.....	50	263	1140	Eastern	Program variable, depending upon the activities in and about school.
	WABW—Wooster, Ohio—College of Wooster.....	50	206.8	1450	Eastern	9:30 to 10 on Tue., Wed. and Thu. Otherwise very irregular as broadcast college programs.
	WABX—Mount Clemens, Mich.(near)—Henry B. Joy, 1830 Penobscot Bldg., Detroit, Mich.....	500	246	1220	Central	
	WABY—Philadelphia, Pa.—John Magaldi, Jr., 815 Kimball St.....	50	242	1240	Eastern	

Radio Broadcast Station KGW

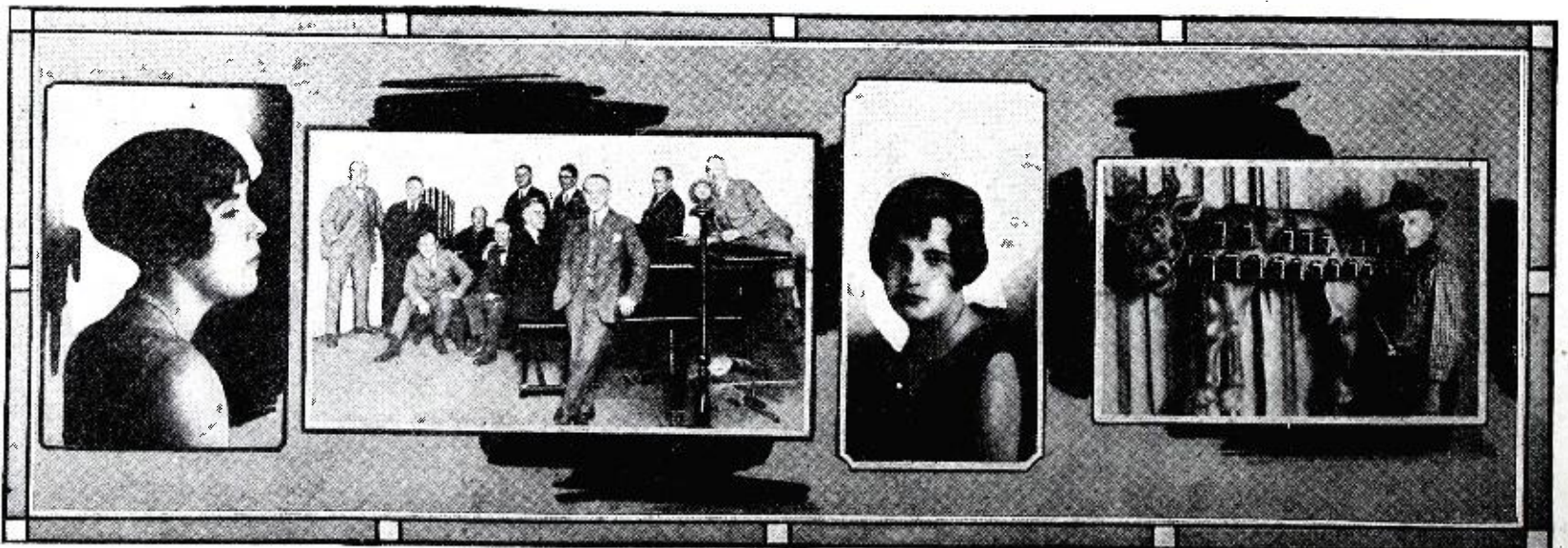

Merl Rice, program director.

The official degree team of the "Keep Growing Wiser" Order of Hoot Owls.

Clarabelle Stegnor, pianist.

Chuck Whitehead and Rosie, the harmonious heifer.

Radio Call Letters	BROADCAST STATIONS Location and Owner	Power Watts	Wave Length (Meters)	Frequency (Kilocycles)	Time at Station	Sending Hours
WA WABZ	New Orleans, La.—Coliseum Place Baptist Church.....	50	275	1090	Central	Sun.: 11 to 12:30 pm; 7:30 to 9 pm.
WADC	Akron, Ohio—Allen T. Simmons.....	500	258	1160	Eastern	Mon., 11 am to 12 am; 6:30 to 7:30 pm; Tue., 1 am to 3 am; 11 am to 12 am; 6:30 to 7:30 pm; 8 to 11 pm; Wed., 11 to 12 am; 6:30 to 7:30 pm; Thu., 11 am to 12 am; 6:30 to 7:30 pm; 9:30 to 11 pm; Fri., 11 am to 12 am; 6:30 to 7:30 pm; 8 to 11 pm; Sat., 11 am to 12 am; 6:30 to 7:30 pm. Sun.: 12:30 to 1:30 pm; 6:30 to 7:30 pm.
WAFD	Port Huron, Mich.—Albert B. Parfet Co., 1432 Military Road.....	500	275	1090	Eastern	Mon., 8 to 10 pm; Wed., 8 to 10 pm; Fri., 8 to 10 pm; Sat., 8 to 10 pm. Sun. and Holidays: 12:30 am to 2 am; 10 am to 12 am; 7:30 pm to 9:15 pm.
WAGM	Royal Oak, Mich.—Robert L. Miller.....	50	225.4	1330	Eastern	Mon., 7:30 pm to 12:30 am; Wed., 7:30 pm to 10:30 pm; Fri., 7:30 pm to 10:30 pm.
WAHG	Richmond Hill, N. Y.—A. H. Grebe and Co..	500	315.6	950	Eastern	Mon., 11:50 am; 12:02; 8; 9:45; 9:55; 10:15; 10:30; 12 pm; Tue., 11:55 am; 12:02 pm; Wed., 11:50 am; 12:02; 8:45; 9:20; 9:55; 10:02; 10:30 pm; Thu., 11:55 am; 12:02 pm; Fri., 11:50 am; 12:02; 8; 9; 9:55; 10:02; 10:30 pm; Sat., 11:55 am; 12:10 pm. Sun.: Silent.
WAIT	Taunton, Mass.—A. H. Waite and Co., Inc., 32 Weir St.....	10	229	1310	Eastern	Wed., 7 to 8 pm; Fri., 7 to 8 pm.
WAIU	Columbus, Ohio—American Insurance Union..	500	293.9	1020	Eastern	Mon., 11:55 am to 4 pm; 6 pm to 7:15 pm; 8 pm to 9:30 pm; 10 pm to 12 pm; Tue., 11:55 am to 1 pm; 2 pm to 4 pm; 6 to 7 pm; 9:15 pm to 1 am; Wed., 11:55 am to 1 pm; 2 to 4 pm; 6 to 7 pm; Thu., 11:55 am to 1 pm; 2 to 4 pm; 6 to 7 pm; Fri., 11:55 am to 1 pm; 2 to 4 pm; 6 to 7 pm; 8 to 9:30 pm; 10 pm to 1 am; Sat., 11:55 am to 1 pm; 2 to 4 pm; 9:15 pm to 1 am. Sun. 2 pm to 4 pm; 6 pm to 7 pm.
WAMD	Minneapolis, Minn.—Hubbard and Company and Radisson Radio Corp.....	1000	243.8	1230	Central	Daily: 12 am to 12:15 pm; 6:15 pm; 6:55 pm; 7 pm; 7:05 pm; 7:10 pm; 8 pm; 11 pm. Sun.: 10:30 am; 3 pm; 6:15 pm; 6:45 pm; 9:30 pm.
WAPI	Auburn, Ala.—Extension Service Alabama Poly- technic Institute.....	1000	248	1210	Central	Mon., 7 to 8:30 pm; Tue., 7 to 8:30 pm; Wed., silent; Thu., 7 to 8:30 pm; Fri., 8 to 11 pm; Sat., 6:30 to 10 pm. Sun.: Irregular.
WARC	Medford Hillside, Mass.—American Radio and Research Corp.....	100	261	1150	Eastern	
WATT	Boston, Mass. (Portable)—Edison Electric Illuminating Company of Boston.....	100	243.8	1230		
WB WBAA	Lafayette, Ind.—Purdue University.....	250	273	1100	Central	Daily: 9:50 am; Mon. and Fri., 7:15 pm.
WBAK	Harrisburg, Pa.—Pennsylvania State Police...	500	275	1090	Eastern	Daily except Sun.: 10 to 1:30 to 5:45; 7:30; 12 am
WBAL	Glen Morris, Md. (near)—Consolidated Gas, Electric Light and Power Co.....	5000	246	1220	Eastern	Mon., 6 pm to 8 pm; Tue., 7:30 pm to 10 pm; Wed., Silent; Thu., 6 pm to 8 pm; Fri., 7:30 pm to 10 pm; Sat., Silent. Sun.: 6:30 to 7:30 pm.
WBAO	Decatur, Ill.—James Millikin University.....	100	270	1110	Central	
WBAP	Fort Worth, Texas—Carter Publishing Co., Inc.	1500	475.9	630	Central	Daily: 6; 7:30; 9:30; 11 pm; Wed., Silent. Sun.: 11 am; 5; 9:30 pm.
WBAW	Nashville, Tenn.—Braid Elec. Co. and Wal- drum Drug Co.....	100	242	1240	Central	
WBAX	Wilkes-Barre, Pa.—John H. Stenger, Jr., 66 Gildersleeve St.....	100	256	1170	Eastern	

Radio Broadcast Station WEAF

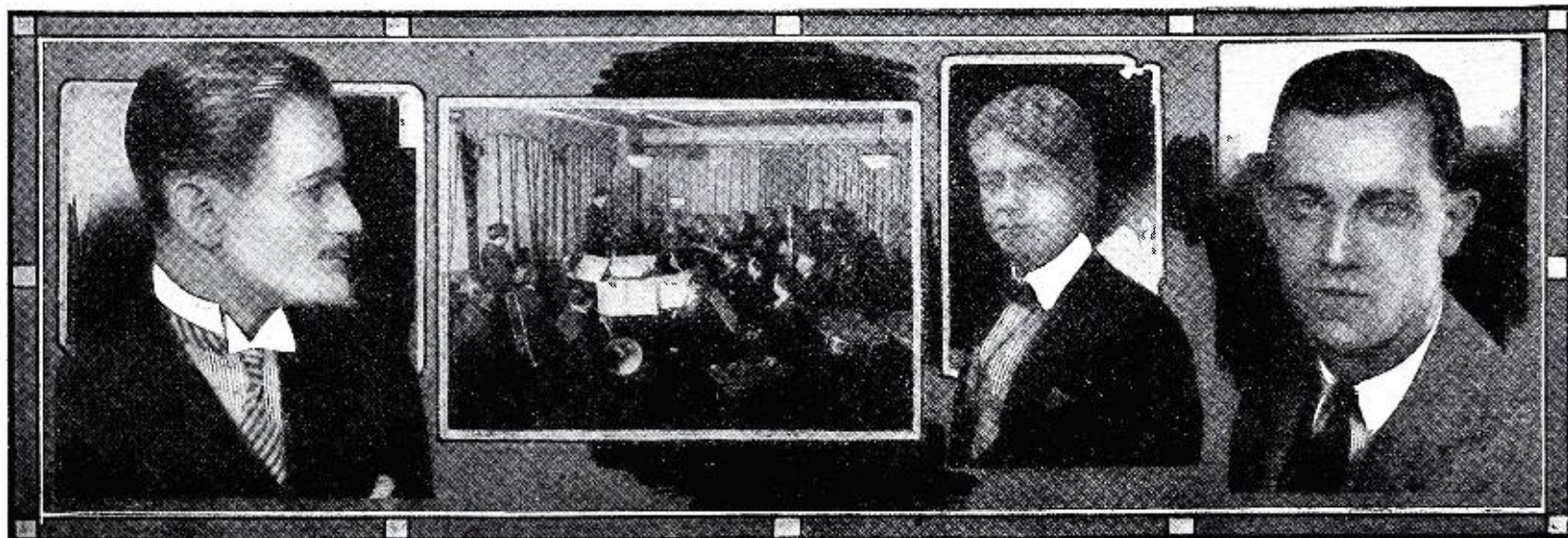

Arnold Morgan, one of WEAF's popular announcers.

WEAF Grand Opera Company under the leadership of Cesare Sodero.

Edwin Franko Goldman, conductor of the Goldman Band.

Leslie Joy, popular announcer.

Radio Call Letters	BROADCAST STATIONS Location and Owner	Power Watts	Wave Length (Meters)	Frequency (Kilocycles)	Time at Station	Sending Hours
WB WBBL	Richmond, Va.—Grace-Covenant Presbyterian Church.....	50	229	1310	Eastern	Tue., 8 pm to 10 pm. Sun.: 11 am and 7:45 pm.
WBBM	Chicago, Ill.—Atlas Investment Co., 1554 Howard St.....	1500	225.4	1330	Central	Mon., 4 to 7 pm; Tue., 4 to 6 pm; 8 to 12 pm.; Wed., 4 to 6 pm; 8 to 10 pm; 12 pm to 2 am.; Thu., 4 to 6 pm; 8 to 12 pm; Fri., 4 to 6 pm; 8 to 10 pm; Sat., 4 to 6 pm; 8 pm to 2 am; Sun.: 12:30; to 2 pm; 4 to 6 pm; 8 to 10 pm; 12 to 3 am.
WBBP	Petoskey, Mich.—Petoskey High School.....	200	238	1260	Central	Tue., 9 to 10:30 pm; Fri., 8 to 9:30 pm. Sun. and Holidays: 10:30 to 12 am; 3 to 4 pm.
WBBR	Rosville, N. Y.—People's Pulpit Assn., 124 Columbia Heights, Brooklyn, N. Y.....	500	416.4	720	Eastern	Mon., 8 to 9 pm; Thu., 8 to 9 pm; Fri., 8 to 9 pm Sun.: 10 am to 12:30 pm; 2 to 4 pm; 9 to 10:30 pm
WBBS	New Orleans, La.—First Baptist Church.....	50	252	1190	Central	Sun.: 11 am and 7:45 pm.
WBBW	Norfolk, Va.—Ruffner Junior High School.....	50	222	1350	Eastern	
WBBY	Charleston, S. C.—Washington Light Infantry	10	267.9	1120	Eastern	Community furnishes artists about once a week.
WBBZ	Chicago, Ill. (Portable)—C. L. Carrell, 1506 No. American Building.....	50	215.7	1390		
WBCN	Chicago, Ill.—Foster and McDonnell, 728 West Sixty-fifth St.....	500	266	1130	Central	Daily: 9:45 to 11 am; 12 am to 1 pm; 3 to 6 pm; 7 to 8 pm; 10 to 12 pm. Sun.: 10:45 am to 12:30 pm; 4 to 6; 7:30 to 9:15 pm.
WBDC	Grand Rapids, Mich.—The Baxter Laundry Company.....	500	256.4	1170	Eastern	Mon., 12:30 pm to 1:30 pm; 5:30 to 6 pm; 7 to 8 pm; Tue., 12:30 to 1:30 pm; 5:30 to 6 pm; 7 to 8 pm; Wed., 12:30 pm to 1:30 pm; 5:30 pm to 6 pm 7 to 8 pm; Thu., 12:30 pm to 1:30 pm; 5:30 pm to 6:30 pm; Fri., 12:30 pm to 1:30 pm; 5:30 pm to 6 pm; 7 to 8 pm; Sat., 5:30 pm to 6 pm; 7 to 7:40 pm; 7:50 to 8 pm. Sun.: 11 to 12:15 pm.
WBES	Takoma Park, Md.—Bliss Electrical School....	100	222	1350	Eastern	
WBNY	New York, N. Y.—Shirley Katz, 145 W. 45th St.	500	322	930	Eastern	Mon., 7 pm to 11 pm; Tue., 7 pm to 11 pm; Wed., 7 pm to 11 pm; Thu., 7 pm to 11 pm; Fri., 7 pm to 11 pm; Sat., Silent. Sun.: 2:30 pm to 6 pm.
WBOQ	Richmond Hill, N. Y.—A. H. Grebe & Co., 70 Van Wyck Boulevard.....	100	236	1270	Eastern	
WBRC	Birmingham, Ala.—Bell Radio Corporation, Age-Herald Bldg.....	50	248	1210	Central	Mon., 8 to 10 pm; Wed., 8 to 10 pm; Sat., 9 pm to midnight.
WBRE	Wilkes-Barre, Pa.—Baltimore Radio Exchange, 17 West Northampton St.....	100	231	1300	Eastern	Mon., 2 to 3:30 pm; Tue., 2 to 4 pm; Wed., 2 to 3:30 pm; 8:30 to 11:30 pm; Thu., 2 to 4 pm; Fri. 2 to 3:30 pm; 8:30 to 12 midnight; Sat., 2 to 4:30 pm; Sun: 9 to 12 Midnight
WBT	Charlotte, N. C.—Charlotte Chamber of Commerce.....	250	275	1090	Eastern	Daily 6 to 7 and 9 to 11 pm. Sun.: 11 am and 7:30 pm.
WBZ	Springfield, Mass. (Transmitter is in East Springfield)—Westinghouse Elec. and Mfg. Co.	2000	331.1	900	Eastern	Daily: 6:25 to 10 pm and sometimes to 10:30 pm. Sun. and Holidays: 10:50 am and 7 to 10 pm.
WBZA	Boston, Mass.—Westinghouse Electric and Mfg. Co.....	250	242	1240	Eastern	
WC WCAC	Storrs, Conn.—Connecticut Agricultural College.....	500	275	1090	Eastern	Mon., 8 to 9 pm; Wed., 8 to 9 pm; Fri., 8 to 9 pm.

Radio Broadcast Station KFWB

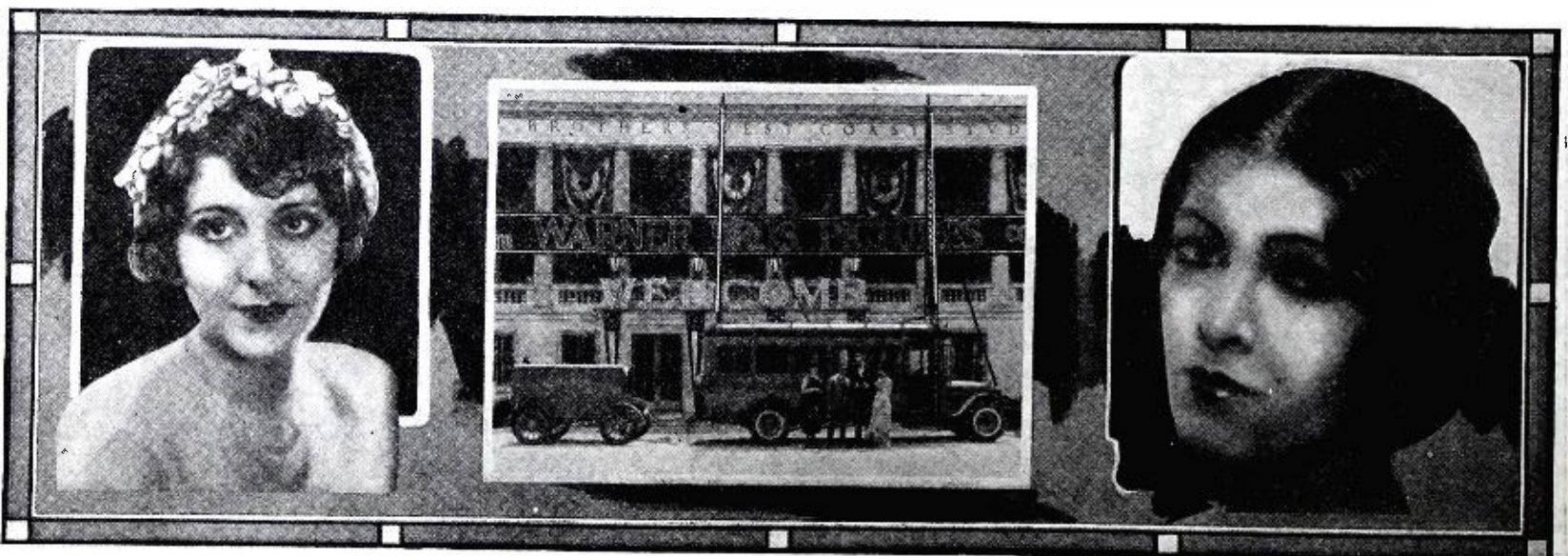

Patsy Ruth Miller, screen star and guest announcer.

Warner Brothers' Motion Picture Studios Portable Broadcasting Station 6XBR.

Myrna Loy, screen player and guest announcer.

Radio Call Letters	BROADCAST STATIONS Location and Owner	Power Watts	Wave Length (Meters)	Frequency (Kilocycles)	Time at Station	Sending Hours
WC WCAD	Canton, N. Y.—St. Lawrence University.....	250	263	1140	Eastern	Mon., 11 am to 11:20 am; Tue., 11 am to 11:20 am; Wed., 11 am to 11:20 am; 8 pm to 11 pm; Thu., 11 am to 11:20 am; 7:30 to 11 pm; Fri., 11 am to 11:20 am; 7:30 to 11 pm; Sat., 11 am to 11:20 am.
WCAE	Pittsburgh, Pa.—Pittsburgh Press and Kaufmann and Baer Co., 6th and Smithfield Streets	500	461.3	650	Eastern	Mon., 10:45 am; 12:30 pm; 4:30 pm; 6, 7, 8, 9, 10, 11 pm; Tue., 12:30 pm; 4:30, 6, 7, 8, 9, 10, 11 pm; Wed., 10:45 am; 12:30 pm; 4:30 pm; 6, 7, 8, 9, 10, 11 pm; Thu., 12:30 pm; 4:30, 6, 7, 8, 9, 10, 11 pm; Fri., 10:45 am; 12:30 pm; 4:30 pm; 6, 7, 8, 9, 10, 11 pm; Sat., 12:30 pm; 4:30 pm; 6, 7, 8, 9, 10, 11 pm. Sun.: 10:45 am; 4 pm; 6:30 pm; 7:20 pm; 9:15 pm.
WCAJ	University Place, Neb.—Nebraska Wesleyan University.....	500	254	1180	Central	Mon., 4:30 pm; Tue., 4:30 pm; Wed., 4:30 pm; 8 pm; Thu., 4:30 pm; Fri., 4:30 pm; 7 pm. Occasionally Chapel talks, 10 am.
WCAL	Northfield, Minn.—St. Olaf College.....	500	336.9	890	Central	Mon., 9:45 am; 8:30 pm; Tue., 9:45 am; Wed., 9:45 am; Thu., 7 pm; Fri., 9:45 am; 7:30 pm; 8:30 pm; Sat., 9:45 am. Sun.: 8:30 am; 9:15 pm.
WCAM	Camden, N. J.—City of Camden.....	250	236	1270	Eastern	
WCAO	Baltimore, Md.—Albert A. and A. Stanley Brager, 842 N. Howard St.....	100	275	1090	Eastern	
WCAP	Washington, D. C.—Chesapeake and Potomac Telephone Co.....	500	469	640	Eastern	Mon., 6 to 11 pm; Tue., Silent; Wed., 6 pm to 12 midnight; Thu., Silent; Fri., 6 pm to 12 midnight; Sat., Silent. Sun.: 11 am; 4 pm; 6:20 pm; 7:20 pm; 9:15 pm.
WCAR	San Antonio, Texas—Southern Radio Corp. of Texas, 101 West Pecan St.....	2000	263	1140	Central	Daily (except Sun.): 8 to 10 pm.
WCAT	Rapid City, S. D.—South Dakota State School of Mines.....	50	240	1250	Mountain	
WCAU	Philadelphia, Pa.—Universal Broadcasting Co. (Durham and Co.).....	500	276.6	1080	Eastern	Mon., 6:30 to 12 midnight; Tue., 6:30 to 12 midnight; Wed., 6:30 pm to 1 am; Thu., 6:30 to 12 midnight; Fri., 6:30 to 12 midnight; Sat., Silent. Sun.: 11 am to 12:30 pm; 5 pm to 11 pm.
WCAX	Burlington, Vt.—Extension Service, University of Vermont.....	100	252	1190	Eastern	Fri., 7 to 8 pm.
WCBA	Allentown, Pa.—Charles W. Heimbach, 1015 Allen St.....	200	254	1180	Eastern	Mon., 2 am to 3 am; 7:30 pm to 9 pm; Wed., 2 am to 3 am; 7:30 pm to 11 pm; Fri., 6:45 pm to 11 pm; Sat., 9 pm to 12 midnight. Sun.: 10 am; 5:30 pm; 7 pm; 9 pm.
WCBD	Zion, Ill.—Wilbur G. Voliva.....	5000	344.6	870	Central	Tue., 8 to 10:30 pm; Wed., 12:30 to 1 pm; Thu., 2:30 to 3:45; 8 to 10:30 pm. Sun.: 9 to 10:45 am; 8 to 10:30 pm.
WCBE	New Orleans, La.—Uhalt Bros., 1219 No. Rampart St.....	5	263	1140	Central	Daily: 10:30 am to 11:30 am; 7:30 pm to 8:30 pm. Sun., and Holidays: 12:30 pm to 2:30 pm; 8 pm to 9 pm; 9:30 pm to 11:30 pm.
WCBH	Oxford, Miss. (near)—University of Mississippi	50	242	1240	Central	Tue., 9 pm; Thu., 9 pm; Sat., 9 pm.
WCBM	Baltimore, Md.—Hotel Chateau, Charles St. and North Ave.....	50	229	1310	Eastern	Mon., 10 pm; Thu., 10 pm. Sun.: 9:45 pm.
WCBR	Providence, R. I. (portable)—Chas. H. Messter, 42 Doyle Ave.....	100	209.7	1430		Daily: 4 to 5 pm; 8 to 10 pm. Sun.: 3 to 5 pm.

Radio Broadcast Station KGW

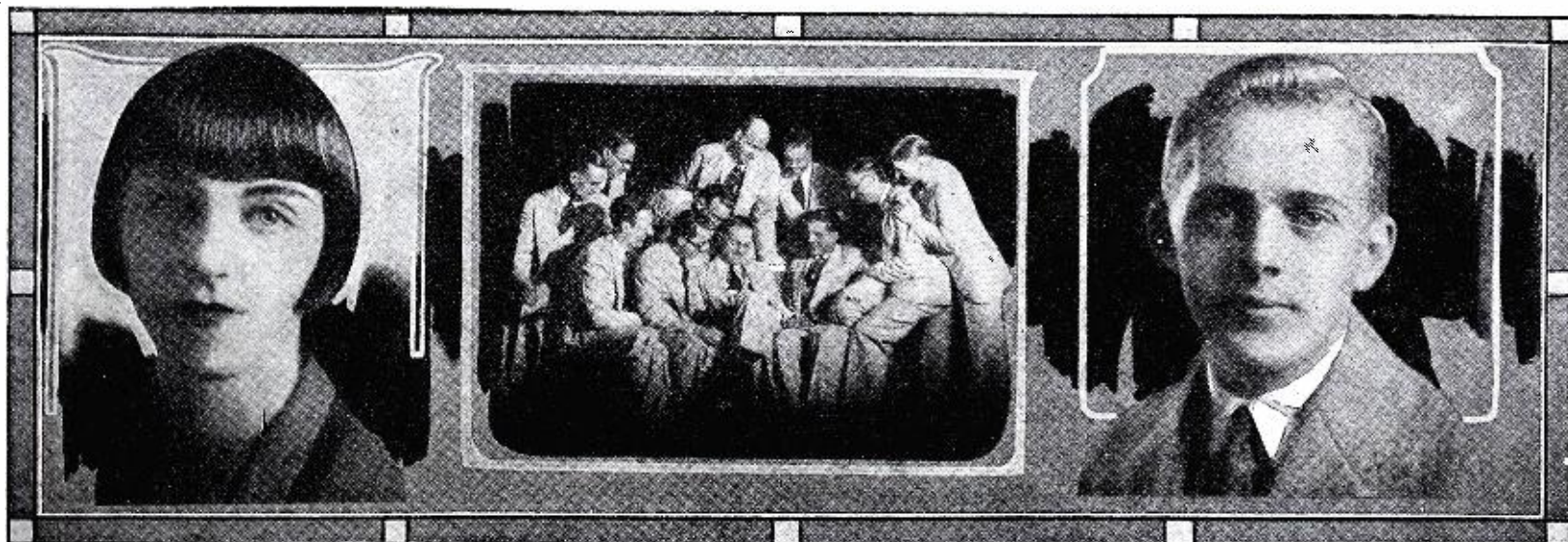

Dorthea Schoop, pianist.

Cole McElroy's Dance Orchestra.

Gordon Onstad, soloist.

Radio Call Letters	BROADCAST STATIONS Location and Owner	Power Watts	Wave Length (Meters)	Frequency (Kilocycles)	Time at Station	Sending Hours
WC	WCCO—St. Paul - Minneapolis, Minn.—Washburn - Crosby Co.	5000	416.4	720	Central	Mon., 9:30 am; 10:30 am; 10:45 am; 11:30 am; 12 am; 1:30 pm; 2 pm; 2:30 pm; 3 pm; 4 pm; 5:30 pm; 6:30 pm; 7:45 pm; 8 pm; 9 pm; 10 pm; Tue., 9:30 am; 10:30 am; 11:30 am; 1:30 pm; 2 pm; 2:30 pm; 3 pm; 3:30 pm; 4 pm; 5:30 pm; 6:15 pm; 7:30 pm; 9:30 pm; 10 pm; Wed., 9:30 am; 10:30 am; 10:45 am; 11:30 am; 1:30 pm; 2 pm; 2:30 pm; 3 pm; 4 pm; 5:30 pm; 6:30 pm; 7:30 pm; 9 pm; 10 pm; 10:05 pm; 11:30 pm; Thu., 9:30 am; 10:30 am; 11:30 am; 12 am; 1:30 pm; 2 pm; 3 pm; 4 pm; 5:30 pm; 7 pm; 10 pm; 10:05 pm; 10:30 pm; Fri., 9:30 am; 10:30 am; 10:45 am; 11:30 am; 1:30 pm; 2 pm; 3 pm; 4 pm; 5:30 pm; 6 pm; 6:15 pm; 7:45 pm; 8 pm; 8:15 pm; 9 pm; 10 pm; 10:05 pm; Sat., 9:30 am; 10:30 am; 11:30 am; 12:30 pm; 1:30 pm; 2:30 pm; 6:15 pm; 8 pm; 8:15 pm; 10 pm; 10:05 pm; Sun., 10:50 am; 3 pm; 4:10 pm; 6:20 pm; 8:15 pm; 9:15 pm.
	WCFL—Chicago, Ill.—Chicago Federation of Labor ...	500	491.5	610	Central	
	WCLO—Camp Lake, Wis.—C. E. Whitmore	50	230.6	1300	Central	Daily except Sun.: 3:30 to 5 pm; 7:39 to midnight.
	WCLS—Joliet, Ill.—Harold M. Couch	150	214.2	1400	Central	Tue., 11 am; 7 pm to 8 pm; 8:30 pm to 12 midnight; Wed., 8:30 pm to 12 midnight; Thu., 11 am; 7 to 8 pm; Fri., 8:30 pm to 12 midnight; Sat., 11 am; 7 to 8 pm; and 9 pm to 12 midnight. Sun.: 11 am; 2:30 pm; 10 pm to 12 midnight.
	WCMA—Culver, Ind.—Culver Military Academy	100	222	1350	Central	
	WCOA—Pensacola, Fla.—City of Pensacola	500	222	1350	Central	Mon., Wed. and Fri., 10:30 am; 12:30 pm; 7 pm to 11 pm. Sun.: 12:30 pm.
	WCSH—Portland, Me.—Henry P. Rines, Congress Square Hotel Co.	500	256.3	1170	Eastern	Mon., 12 am to 1:30 pm; 6:15 to 7:30 pm; 8:30 pm to 9:15 pm; Tue., 10:30 to 11:15 am; 12 am to 1:30 pm; 3 to 5 pm; 6 to 7:45 pm; 8 to 10:30 pm; Wed., 12 am to 1:30 pm; 6:15 to 7:30 pm; 9 to 11:30 pm; Thu., 10:30 am; 11:15 am; 12 am to 1:30 pm; 4 to 5 pm; 6:15 to 7:45 pm; 9 to 9:30 pm; Fri., 12 am to 1:30 pm; 3 to 4:30 pm; 6 to 7:30 pm; 9 to 10 pm; Sat., 12 am to 1 pm; 6:15 to 11:30 pm. Sun., 10:30 am to 12 am; 1:30 to 2:30 pm; 4 to 5:30 pm; 6 to 7 pm; 7:20 to 10 pm.
	WCSSO—Springfield, Ohio—Wittenberg College	100	248	1210	Central	
	WCWS—Providence, R. I. (Portable)—Chas. W. Selen, 69 Exchange St.	100	209.7	1430		Mon., 8 to 9 pm; Tue., 8 to 9 pm; Wed., 8 to 10 pm; Thu., Silent night; Fri., 7:30 to 10:30 pm; Sat., 8 to 9 pm. Sun.: Silent.
	WCX—Pontiac, Mich.—Detroit Free Press	5000	516.9	580	Eastern	Mon., 4 pm; 6 to 7 pm; 8 to 9 pm; Tue., 4 pm; 6 to 7 pm; 8 to 9 pm; 10 pm; Wed., 4 pm; 6 to 7 pm; 8 to 9 pm; Thu., 4 pm; 6 to 7 pm; 8 to 9 pm; Fri., 4 pm; 6 to 7 pm; 8 to 9 pm; 10 to 11 pm. Sun.: 7:15 pm.
WD	WDAD—Nashville, Tenn.—Dad's Auto Accessory and Radio Store, 160 Eighth Ave., North	150	226	1330	Central	Daily except Thu.: 11:45 am to 1 pm; 3:30 pm to 5 pm; 8 pm to 10 pm; Thu., Silent. Sun.: 3 to 5 pm.
	WDAE—Tampa, Fla.—Tampa Daily Times	250	273	1100	Eastern	
	WDAF—Kansas City, Mo.—The Kansas City Star	1000	365.6	820	Central	Mon., 10:45 am to 11:05 am; 6 to 7 pm; 8 to 10 pm; 11:45 pm to 1 am; Tue., 3:30 to 4:30 pm; 6 to 7 pm; 11:45 pm to 1 am; Wed., same as Mon.; Thu., same as Tue.; Fri., same as Mon.; Sat., same as Tue. Sun.: 3 to 4 pm; 4 to 4:45 pm.
	WDAG—Amarillo, Texas—J. Laurance Martin, 605 East Fourth Street	100	263	1140	Central	
	WDAH—El Paso, Texas—Trinity Methodist Church	50	267.7	1120	Mountain	Wed., 8:30 to 10 pm. Sun. Morning and Evening Church Services.

Radio Broadcast Station WIP

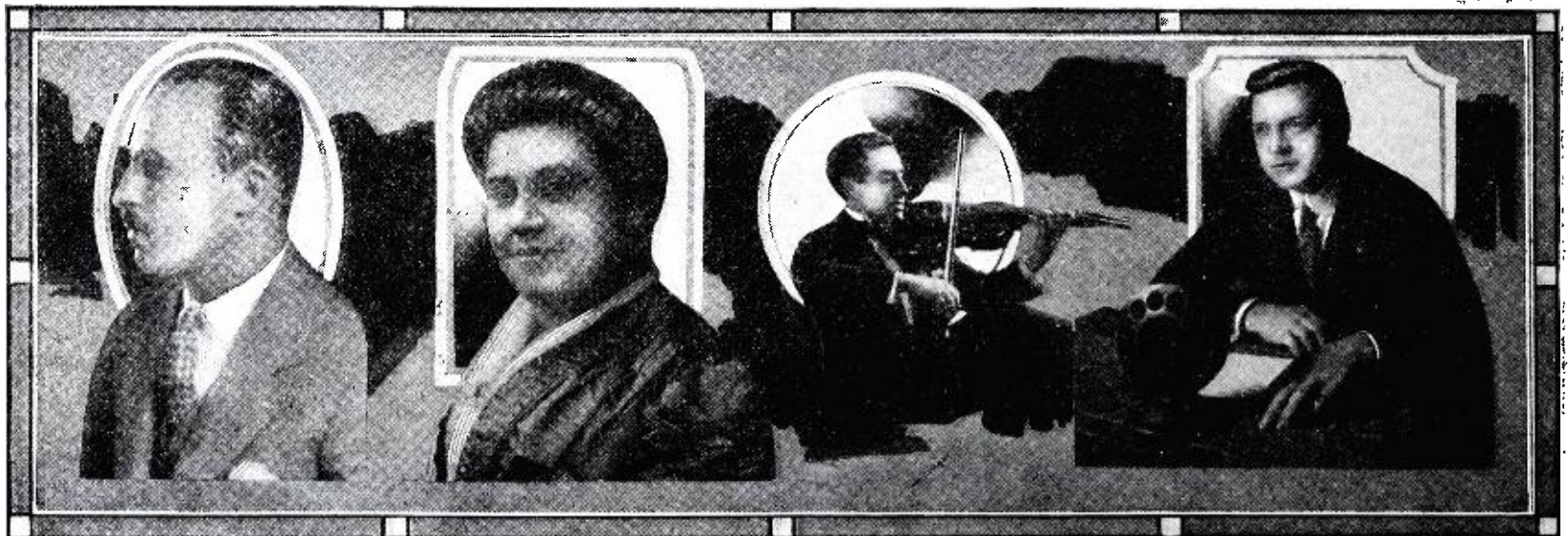

Dr. Francois D'Elisen who gives the setting up and reducing exercises.

Mrs. Anna B. Scott, nationally known Food Economist.

Ben Stad, conductor.

Uncle Wip, bedtime story teller.

Radio Call Letters	BROADCAST STATIONS Location and Owner	Power Watts	Wave Length (Meters)	Frequency (Kilocycles)	Time at Station	Sending Hours
WD	WDAY—Fargo, N. D.—Radio Equipment Corp., 119 Broadway.....	50	261	1150	Central	
	WDBE—Atlanta, Ga.—J. M. High Co., 35 Cone St.....	100	270	1110	Central	Tue., 7 to 8 pm; Fri., 7 to 8 pm.
	WDBJ—Roanoke, Va.—Richardson-Wayland Electric Corp., 106 Church Ave., S. W.....	50	229	1310	Eastern	Daily: 12 to 1 pm; 5:30 to 6 pm; Wed. and Sat., 9 to 11 pm; Mon., 8 to 9 pm. Sun.: 7:30 to 9 pm.
	WDBK—Cleveland, Ohio—S. J. Broz, Mgr. of Broz Furniture, Hardware and Radio Store, 13920 Union Ave.....	50	327	917	Eastern	Tue., 8:30 pm to midnight; Fri., 8:30 pm to midnight.
	WDBO—Winter Park, Fla.—Central Florida Broadcast Station, Inc.....	500	240	1250	Eastern	Daily: 7; 7:10; 7:30; 9 pm (except Wed.); Wed. only, 8 pm; Fri. only, 7:45 pm. Sun.: 11 am; 7:30 pm.
	WDBZ—Kingston, N. Y.—Kingston Radio Club (Boy Scouts of America, Ulster County Council)...	10	233	1290	Eastern	
	WDEL—Wilmington, Del.—Wilmington Elec. Specialty Co., 405 Delaware Ave.....	50	266	1130	Eastern	Daily: 7 to 9 pm.
	WDGY—Minneapolis, Minn.—Geo. W. Young, 2219 North Bryant Ave.....	500	263	1140	Central	Mon., 6 to 8; Wed., 7 to 9; Thu., 6 to 7; 9 to 10; Fri., 8 to 9. Sun.: 1 to 3; 7 to 8.
	WDOD—Chattanooga, Tenn.—Chattanooga Radio Co., Inc., 615 Market St.....	500	256	1170	Central	Mon., 6:30 to 10 pm; Tue., 9 to 9:30 pm; Wed., 6:30 to 10 pm; Fri., 6:30 to 10 pm. Sun.: 11 to 12 noon; 4 to 5:15 pm; 7:30 to 9 pm; 9:15 pm to 10:15 pm.
	WDRG—New Haven, Conn.—Doolittle Radio Corporation, 115 Crown St.....	100	268	1120	Eastern	
	WDWF—Cranston, R. I.—Dutee W. Flint and Lincoln Studios, Inc.	500	440.9	680	Eastern	Sun.; 9:45 am; 4:45 pm (Oct. to May).
	WDZ—Tuscola, Ill.—Jas. L. Bush.....	100	278	1080	Central	Mon. to Sat., incl: 9 am Markets every half hour to 1 pm; 1:15 pm; 2:40 pm. No regular hours for musical programs.
WE	WEAF—New York, N. Y.—Broadcasting Co. of America, Inc., 195 Broadway.....	5000	491.5	610	Eastern	Mon., 6:45 to 8; 10:45 am to 12:20 pm; 4 to 6 to 12 pm; Tue., 6:45 to 8; 11 am to 12 am; 4 to 6; 6 to 12 pm; Wed., 6:45 to 8; 10:45 am to 12:20 pm; 4 to 6; 6 to 12 pm; Thu., 6:45 to 8; 11 am to 12 am; 4 to 6; 6 to 12 pm; Fri., 6:45 to 8; 10:45 am to 12:20 pm; 4 to 6; 6 to 12 pm; Sat., 6:45 to 8; 4 to 6; 6 to 12 pm. Sun.: 2 to 10:15 pm.
	WEAI—Ithaca, N. Y.—Cornell University.....	500	254	1180	Eastern	
	WEAM—North Plainfield, N. J.—Borough of North Plainfield (W. G. Butfield).....	250	261	1150	Eastern	
	WEAN—Providence, R. I.—The Shepard Co.....	500	270	1110	Eastern	Daily: 11:45 am to 10 pm. Sun.: 10:45 am; 1:30 pm; 7:30 pm.
	WEAO—Columbus, Ohio—The Ohio State University..	500	293.9	1020	Eastern	Mon., 9 am; 9:45 am; 11 am; 1 pm; 4 pm; Tue., 9 am; 9:45 am; 11 am; 1 pm; 4 pm; 7 pm; Wed., 9 am; 9:45 am; 11 am; 1 pm; 4 pm; 4:10 pm; 8 pm; Thu., 9 am; 9:45 am; 11 am; 1 pm; 4 pm; 8 pm; Fri., 9 am; 9:45 am; 11 am; 1 pm; 4 pm; Sat., 9 am; 9:45 am; 11 am; 1 pm; 4 pm.

Radio Broadcast Station KOIL



Francis Mulholland, a very young and talented artist.

Kathleen Shaw, soprano.

John Wolfe and Ned Tollinger.

Howard Martin, program director and announcer.

Radio Call Letters	BROADCAST STATIONS Location and Owner	Power Watts	Wave Length (Meters)	Frequency (Kilocycles)	Time at Station	Sending Hours
WE WEAR	Cleveland, Ohio—Willard Storage Battery Co.	1000	389.4	770	Eastern	Mon., 11 to 12:15 pm; 3:30 to 4:15 pm; 7 to 8 pm; Tue., 11 to 12:15 pm; 3:30 to 4:15 pm; 7 to 11 pm; Wed., 11 to 12:15 pm; 3:30 to 4:15 pm; 7 to 8 pm; Thu., 11 to 12:15 pm; 3:30 to 4:15 pm; 7 to 11 pm; Fri., 11 to 12:15 pm; 3:30 to 4:15 pm; 7 to 12 pm; Sat., 11 to 12:15 pm; 7 to 8 pm. Sun.: 3:30 to 5 pm; 7 to 10 pm.
WEAU	Sioux City, Iowa—Davidson Bros. Co.	100	275	1090	Central	Daily: 9:35 am; 10:35 am; 11:35 am; 12:20 pm; 1:20 pm; 5 pm.
WEBC	Superior, Wis.—Superior Telegram-Ross Elec. Co., 1225 Tower St.	100	242	1240	Central	Mon., 6:15 to 8 pm; Tue., Silent; Wed., 8 to 10 pm; Thu., Silent; Fri., 6:15 to 8 pm; Sat., 10 to 12 pm. Sun.: 10:30 to 12 am; 3 to 4:30 pm.
WEBH	Chicago, Ill.—Edgewater Beach Hotel Co., 5349 Sheridan Road	2000	370	810	Central	Daily except Mon.: 7 pm to 8 pm; 9 pm to 10 pm; 11 pm to 12 midnight. Sun.: 5 pm to 9 pm.
WEBJ	New York, N. Y.—Third Ave. Railway Co., 2396 Third Ave.	500	272.6	1100	Eastern	Tue. and Fri., 7 to 9 pm; Wed., 8 to 10 pm.
WEBL	United States (Portable) Radio Corp. of America	100	226	1330		
WEBQ	Harrisburg, Ill.—Tate Radio Co., 700 West Robinson St.	10	225.4	1330	Central	Daily: 7:15 pm. Sun.: 3 to 4 pm.
WEBR	Buffalo, N. Y.—Howell Broadcasting Co., Inc., 54 Niagara St.	100	244	1230	Eastern	Mon., 6:15 to 11:30 pm; Tue., 6:15 to 7:30 pm; Wed., 6:15 to 11:30 pm; Thu., 6:15 to 7:30 pm; Fri., 6:15 to 11:30 pm; Sat., 6:15 to 7:30 pm. Sun.: 10:15 am to 11 pm.
WEBW	Beloit, Wis.—Beloit College	500	268	1120	Central	Mon., 8 to 9:30 pm. Sun.: 4:30 to 5:30 pm.
WEBZ	Savannah, Ga.—Savannah Radio Corp., 11 East York St.	50	263	1140	Eastern	Mon., 2 pm; 6 pm; 8 pm; Tue., 2 pm; 6 pm; Wed., 2 pm; 6 pm; 8 pm; Thu., 2 pm; 6 pm; Fri., 2 pm; 6 pm; 8 pm; Sat., 2 pm.
WEEL	Boston, Mass.—The Edison Electric Illuminating Co. of Boston	500	348.6	860	Eastern	Daily: 6:45 am to 8 am; 10:15 am to 11:20 am; 2 pm to 5 pm; 6 pm to 11 pm. Sun.: 10:50 am to 10:15 pm.
WEHS	Evanston, Ill.—Robert E. Hughes	10	202.6	1480	Central	
WEMC	Berrien Springs, Mich.—Emmanuel College	500	286	1050	Central	Mon., 8 am; 8:15 pm; Tue., 8 am; Wed., 8 am; 8:15 pm; Thu., 8 am; Fri., 8 am; 9 pm. Sun.: 11 am; 8:15 pm.
WENR	Chicago, Ill.—All American Radio Corporation, 4201 Belmont Ave.	1000	266	1130	Central	Mon., Silent; Tue., 1 to 3 pm; 6 to 7 pm; 8 to 9 pm; 9 to 10 pm; Wed., 1 to 3 pm; 6 to 7 pm; 8 to 10 pm; 12 pm to 1 am; Thu., 1 to 3 pm; 6 to 7 pm; 8 to 10 pm; Fri., 11 am to 12 am; 1 to 3 pm; 6 to 7 pm; 8 to 10 pm; 12 pm to 2 am; Sat., 1 to 3 pm; 6 to 7 pm; 8 to 10 pm; 12 pm to 2 am; Sun.: 2 to 3 pm; 3 to 4 pm; 6 to 7 pm; 9:30 to 12 pm.
WEW	St. Louis, Mo.—St. Louis University	1000	248	1210	Central	Mon., 9 am; 10 am; 2 pm; 5 pm; Tue., 9 am; 10 am; 2 pm; 5 pm; 7 pm; Wed., 9 am; 10 am; 2 pm; 5 pm; Thu., 9 am; 10 am; 2 pm; 5 pm; 7 pm; Fri., 9 am; 10 am; 2 pm; 5 pm; Sat., 9 am; 10 am; 2 pm; 5 pm. Sun.: 2 pm; 7:15 pm to 7:45 pm.
WF WFAA	Dallas, Texas—Dallas News and Dallas Journal	500	475.9	630	Central	
WFAM	St. Cloud, Minn.—Times Publishing Co., Inc.	10	273	1100	Central	No definite days. Mostly Mon., 8 to 10 pm.
WFAV	Lincoln, Neb.—University of Nebraska, Dept. of Electrical Engineering	500	275	1090	Central	
WFBC	Knoxville, Tenn.—First Baptist Church	50	250	1200	Central	

Radio Broadcast Station WJZ

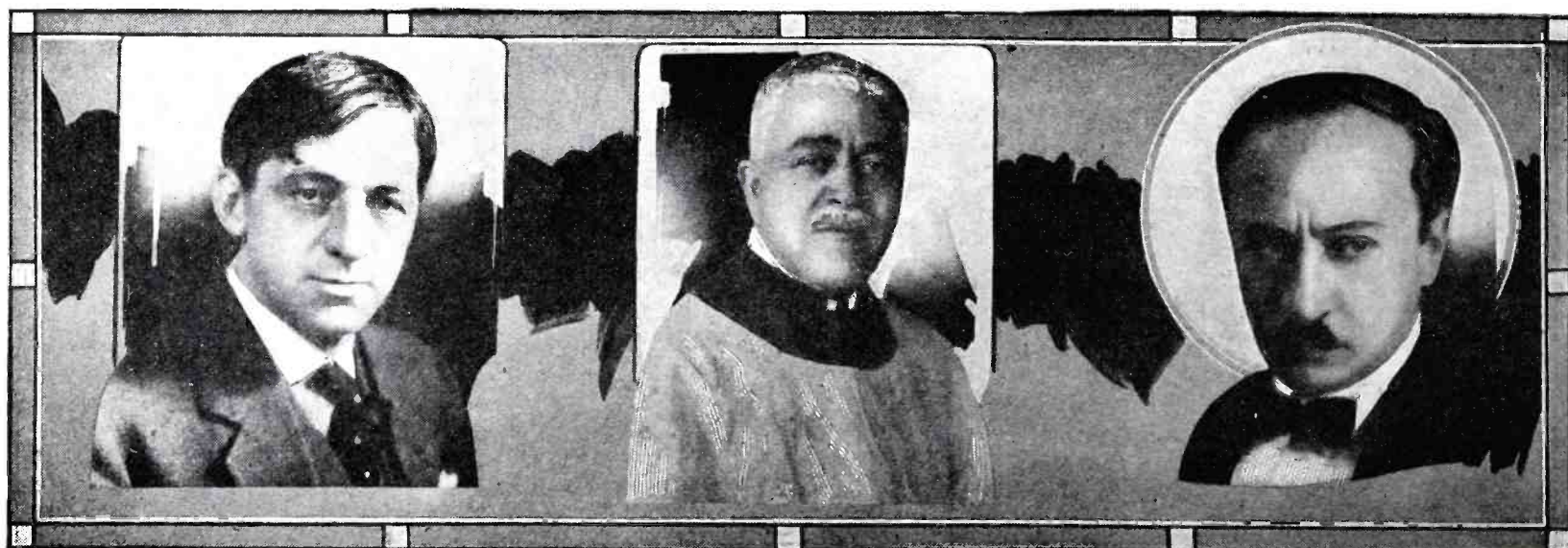

Harry T. Burleigh, appears 4 o'clock every Sunday afternoon.

Dr. Karl Reiland, rector of St. Georges.

Hugo Riesenfeld, appears 8 o'clock every Sunday night.

Radio Call Letters	BROADCAST STATIONS Location and Owner	Power Watts	Wave Length (Meters)	Frequency (Kilocycles)	Time at Station	Sending Hours
WF WFBE	Seymour, Ind.—Van DeWalle Music and Radio Co., 208 West Second St.	10	226	1330	Central	
WFBG	Altoona, Pa.—The William F. Gable Co.	100	277.8	1080	Eastern	Daily: 11:45 to 12:45 pm; 3:30 pm to 4:15 pm; 6:30 to 7:30 pm; 7:45 pm to 8 pm; 8:30 to 10:30 pm; Thu. and Fri., special. 11:15 pm to 1:30 am. Sun.: 10:45 am to 12:30 pm; 3, 4, 5, 6, 7:30 and 9:15 pm.
WFBH	New York, N. Y.—Concourse Radio Corporation, Hotel Majestic	500	272.6	1100	Eastern	Mon., 2 to 7 pm; 11:30 pm to 2 am; Tue., 2 to 7 pm; 11:30 pm to 2 am; Wed., 2 to 8 pm; 11:30 to 2 am; Thu., 2 to 8 pm; 11:30 pm; Fri., 2 to 7 pm; 11:30 pm; Sat., 2 to 8 pm; 11:30 pm.
WFBJ	Collegeville, Minn.—St. John's University	100	236	1270	Central	Sun.: 5 to 5:45 pm.
WFBL	Syracuse, N. Y.—Onondaga Hotel	100	252	1190	Eastern	Mon., 12 to 1; 3 to 4; 6 to 8; Tue., 12 to 1; 3 to 4; 6 to 11; Wed., 12 to 1; 3 to 4; 6 to 8; Thu., 12 to 1; 3 to 4; 6 to 12:30 am; Fri., 12 to 1; 3 to 4; 6 to 11; Sat., 6 to 8; 10 to 11. Sun.: 3 to 9.
WFBM	Indianapolis, Ind.—Merchants Heat and Light Co.	250	268	1120	Central	Mon., 6 pm to 12 pm; Tue., 6 pm to 10:30 pm; Wed., 6 pm to 12 pm; Thu., 6 pm to 10:30 pm; Fri., 6 pm to 12 pm. Sun. and Holidays: 9:30 am to 12:30 pm; 2 to 5 pm; 7:30 to 9 pm.
WFBR	Baltimore, Md.—Fifth Infantry Maryland National Guard, Fifth Regt. Armory	100	254	1180	Eastern	Mon., 12 to 2 pm; Tue., 12 to 3 pm; 8 to 12 pm; Wed., 12 to 3 pm; Thu., 12 to 3 pm; 8 to 12 pm; Fri., 12 to 3 pm; Sat., 12 to 2 pm; 8 to 12 pm. Sun.: 11 am to 12:30 pm; 2 to 3:30 pm; 9 to 10:30 pm.
WFBZ	Galesburg, Ill.—Knox College	20	254	1180	Central	
WFDF	Flint, Mich.—Frank D. Fallain, Police Building	100	234	1280	Eastern	Mon., Wed. and Fri., 8 pm.
WFI	Philadelphia, Pa.—Strawbridge & Clothier	500	394.5	760	Eastern	Daily: am., 10 to 11; pm, 1 to 2; 3 to 4:30; 6 to 7:30; Tue. Thu. Sat., 8 pm to mid. Sun.: 4:30 to 6 pm; 9:30; or alternating 10:30 am to noon; 7:30 to 9:30 pm.
WFKB	Chicago, Ill.—Francis K. Bridgman, 4536 Woodlawn Ave.	500	217.3	1380	Central	Mon., Silent; Tue., 7 to 10 pm; Wed., 7 to 10 pm; Thu., 7 to 10 pm; Fri., 7 to 10 pm Sat., 7 to 10 pm.
WFRL	Brooklyn, N. Y.—Robt. M. Lacey and Jas. A. Bergner (Flatbush Radio Labs.), 1421 E. 10th St.	100	205.4	1460	Eastern	On the Air every day but hours subject to change until after completion of new studios.
WG WGAL	Lancaster, Pa.—Lancaster Elec. Supply & Construction Co., 23 East Orange St.	10	248	1210	Eastern	
WGBB	Freeport, N. Y.—Harry H. Carman, 217 Bedell St.	100	244	1230	Eastern	Mon., 8 to 11 pm; Wed. and Fri., same as Mon. Sun.: 10:40 am.
WGBC	Memphis, Tenn.—Radio Bible Class, First Baptist Church	10	278	1080	Central	Sun.: 9:30 to 10:30 am; 7:30 to 8:45 pm.
WGBF	Evansville, Ind.—Finke Furniture Co., 307 South Seventh St.	500	236	1270	Central	Mon., 7:15 am; 12:10 pm; Tue., 7:15 am; 12:10 pm; 7:15 pm to 10 pm; Wed., 7:15 am; 12:10 pm; Thu., 7:15 am; 12:10 pm; Fri., 7:15 am; 12:10 pm; 8 to 10 pm; 11 pm to 2 am; Sat., 7:15 am; 12:10 pm.
WGBI	Scranton, Pa.—Scranton Broadcasters, Inc., 608 Linden St.	10	240	1250	Eastern	Mon., 5:15 to 6:30 pm; Tue., 5:15 to 6:30 pm; Wed., 5:15 to 6:30 pm; 8 to 12 pm; Thu., 5:15 to 6:30 pm; 8 to 12 pm; Fri., 5:15 to 6:30 pm; Sat., 5:15 to 6:30 pm; 8 to 11 pm. Sun.: 3 to 5 pm; 7 to 9 pm.

Radio Broadcast Station KYW

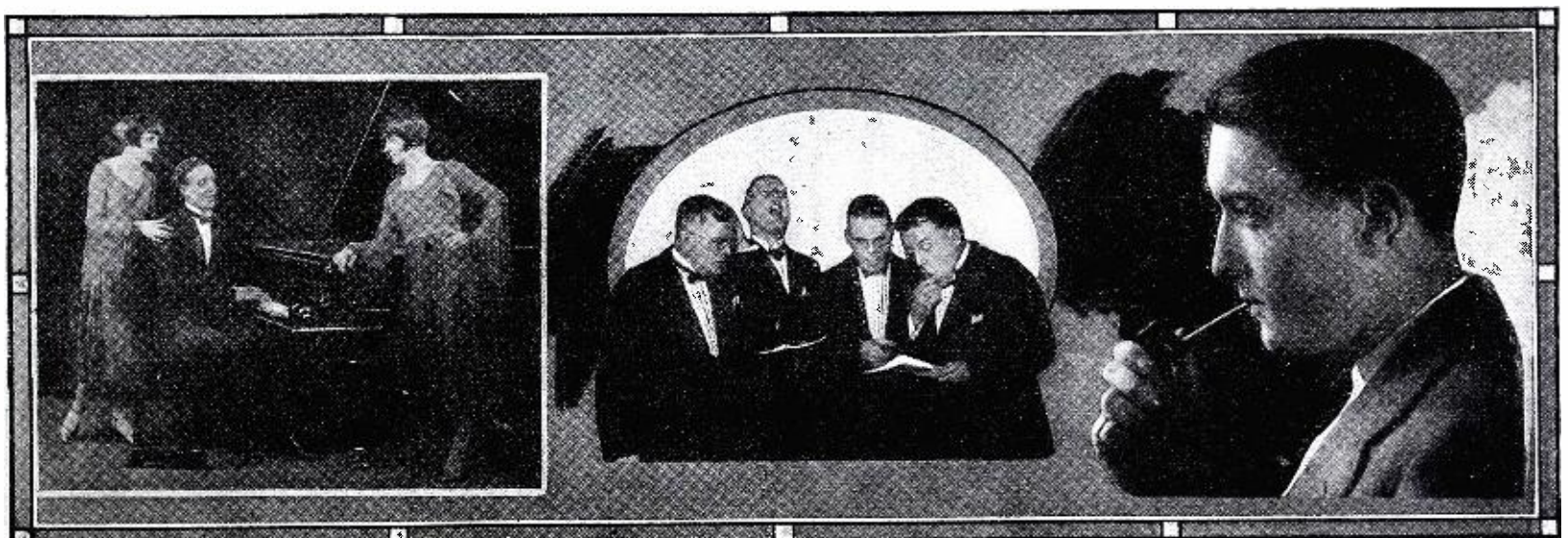

Golden Harmony Trio, Scotty Welsh and Madison Sisters.

Apollo Male Quartette, left to right, A. H. Carpenter, bass; W. F. Willard, 2nd tenor; Lloyd Rowles, baritone; Omar Covert, 1st tenor.

Edwin Harper, announcer.

Radio Call Letters	BROADCAST STATIONS Location and Owner	Power Watts	Wave Length (Meters)	Frequency (Kilocycles)	Time at Station	Sending Hours
WG	WGBR—Marshfield, Wis.—Geo. S. Ives, 731 West Fifth St.	10	229	1310	Central	
	WGBS—New York, N. Y.—(Transmitter is in Astoria, L. I.), Gimbel Bros.	500	315.6	950	Eastern	Mon., 10 to 11 am; 1:30 to 2:30 pm; 3 to 4 pm; 6 to 7:30 pm; Tue., 10 to 11 am; 1:30 to 2:30 pm; 3 to 4 pm; 6 to 11:30 pm; Wed., same as Mon.; Thu., same as Tue.; Fri., same as Mon.; Sat., same as Tue. Sun.: 3:30 to 4:30 pm; 9:30 to 11:30 pm.
	WGBU—Fulford-by-the-Sea, Fla.—Florida Cities Finance Co.	500	278	1080	Eastern	
	WGBX—Orono, Me.—University of Maine.	500	234.2	1280	Eastern	Wed., 7:30 to 9 pm. Sun.: 2 to 3 pm.
	WGCP—Newark, N. J.—May Radio Broadcast Corp. 380 Central Ave.	500	252	1190	Eastern	Mon., 6; 6:15; 6:30; 8:30; 8:45; 9:45; 11; 11:15; 11:30; 11:45 pm; Tue., 7; 7:30; 7:45; 8; 8:15 pm; Wed., 7; 8; 8:30; 9; 9:30; 12 pm; 12:15; 12:30; 12:45; 1:15 am; Fri., 7; 7:15; 7:30; 7:45; 8; 8:15; 12 pm. Sun.: 5; 5:15; 7; 8; 8:30; 8:45; 9 pm.
	WGES—Chicago, Ill.—(Transmitter is in Oak Park, Ill.), Coyne Electrical School.	500	250	1200	Central	Mon., 5 pm; Tue., 5 to 7 pm; 8 to 9 pm; Wed., 11 pm to 1 am; Thu. Fri. Sat., same as Tue. Sun.: 10:15 am to 12 am; 5 to 7:40 pm; 11 pm to 12 pm.
	WGHB—Clearwater, Fla.—(Transmitter is in Dunedin), The Chamber of Commerce of Clearwater, Fla.	500	266	1130	Eastern	Mon., 6:30 to 7:30 pm; 8:30 to 10 pm; 11:45 to 1 am; Tue. Wed. Thu. Fri. Sat., same as Mon.
	WGHP—Detroit, Mich.—Geo. H. Phelps, 110 Rowena St.	1500	270	1110	Central	
	WGMU—Richmond Hill, N. Y.—(portable), A. H. Grebe & Co.	100	236	1270		
	WGN—Chicago, Ill.—The Tribune (Drake Hotel)	1000	303	990	Central	Mon. to Sat., incl., 9 am to 12 am; 12 am to 5 pm; Mon., 6 to 7 pm; Tue., to Sat., inc., 6 to 7 pm; 8 to 11 pm. Sun.: 12 m to 5 pm and 6:15 to 11 pm.
	WGR—Buffalo, N. Y.—Federal Radio Corp., 1738 Elmwood Ave.	750	319	940	Eastern	Mon., 10:45 am to 1 am; Tue., 10:45 am to 11 pm; Wed., 10:45 am to 11 pm; Thu., 10:45 am to 11 pm; Fri., 10:45 am to 1 am; Sat., 10:45 am to 11 pm; Sun.: 10:45 am to 12 am; 7:45 to 10:15 pm.
	WGST—Atlanta, Ga.—Georgia School of Technology.	500	270	1110	Central	Mon., 9 to 1 pm; Thu., 7 to 8 pm.
	WGY—Schenectady, N. Y.—General Electric Co.	10000	379.5	790	Eastern	Mon., 2 to 3 pm; 6 to 9 pm; Tue., 2 to 3 pm; 6 to 11 pm; Wed., 6 to 10 pm; Thu., 2 to 3 pm; 6 to 11 pm; Fri., 2 to 3 pm; 6 to 11:30 pm; Sat., 9 to 12 pm. Sun.: 10:30 am to 12 am; 7:30 pm to 10 pm.
WH	WHA—Madison, Wis.—University of Wisconsin.	750	535.4	560	Central	Mon., 8 to 9 pm; Wed., 8 to 9 pm; Fri., 8 to 9 pm.
	WHAD—Milwaukee, Wis.—Marquette University and Milwaukee Journal.	500	275	1090	Central	Mon. and Tue., 12 am; 4; 6; 6:15; 8:30 pm; Wed., 12 am; 4; 6; 6:15; 10:30; 11:30 pm; Thu. and Fri., 12 am; 4; 6; 6:15; 8:30 pm; Sat., 12 am; 4; 6; 6:15 pm. Sun.: 3:30 pm.
	WHAM—Rochester, N. Y.—University of Rochester (Eastman School of Music).	100	278	1080	Eastern	
	WHAP—New York, N. Y.—W. H. Taylor Finance Corp., 426 West 31st St.	500	431	695	Eastern	Mon., 6:30 to 11 pm; Wed., 6:30 to 11 pm; Fri., 6:30 to 11 pm. Sun.: 2:30 to 4 pm.

Radio Broadcast Station WKAF

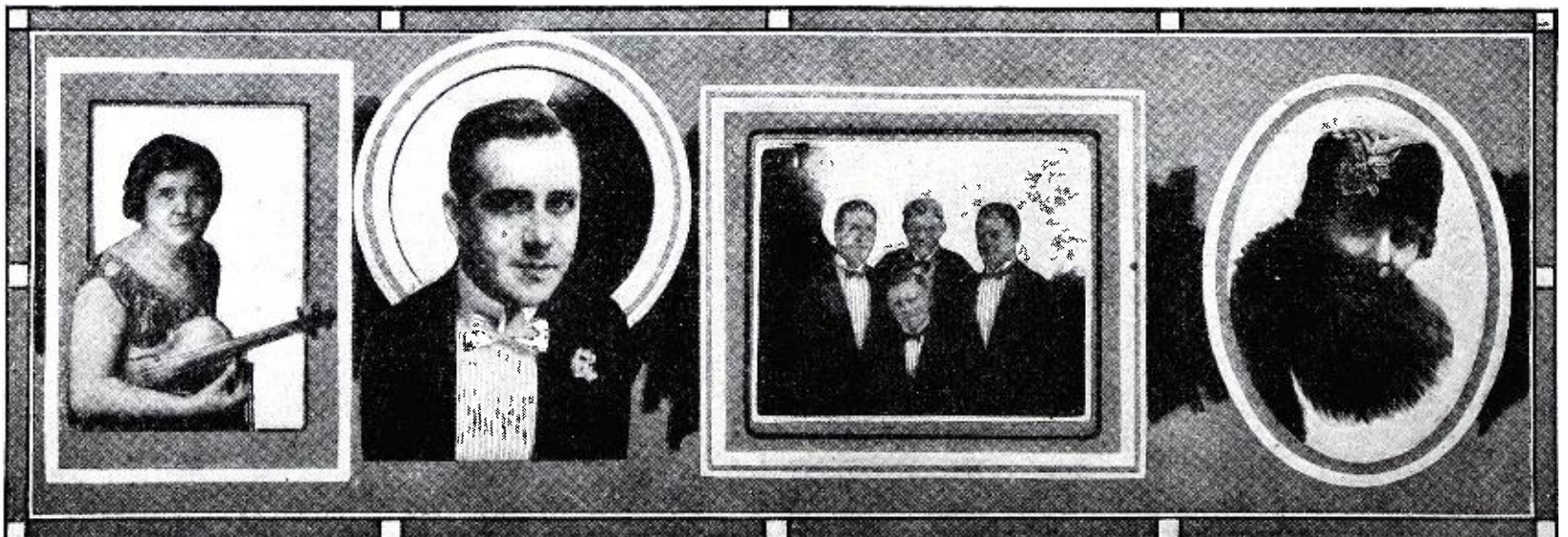

Mrs. H. J. Collins, violiniste.

Robert F. (Bob) Hall, announcer and studio director.

The National Quartette, left, G. A. Ludington, tenor; above, N. W. Olson, Bass; below, E. R. Barnett, tenor; right, E. G. Carlson, bass.

Ethel Brenk, soprano soloist.

Radio Call Letters	BROADCAST STATIONS Location and Owner	Power Watts	Wave Length (Meters)	Frequency (Kilocycles)	Time at Station	Sending Hours
WH WHAR	Atlantic City, N. J.—F. B. Cook's Sons, Owners, Seaside Hotel.....	500	275	1090	Eastern	Mon., 2 pm; 7:30 pm; 8 pm; 11 pm; Tue., 2 pm; 7:30 pm; 8 pm; Wed., Silent; Thu., 2 pm; 7:30 pm; 8 pm; 11 pm; Fri., 2 pm; 7:30 pm; 8 pm; Sat., 2 pm; 7:30 pm; 8 pm. Sun.: 10:45 am; 2:15 pm; 2:45 pm; 7:50 pm; 9 pm.
WHAS	Louisville, Ky.—Courier-Journal and Louisville Times.....	500	399.8	750	Central	Daily except Mon.: 7:30 to 9 pm. Sun.: 10 am; 4:30 to 5:30 pm.
WHAZ	Troy, N. Y.—Rensselaer Polytechnic Institute	500	379.5	790	Eastern	Mon., 9 to 12 pm; 2nd Mon. of each month from 12 pm to 1:30 am Tue.
WHB	Kansas City, Mo.—Sweeney Automotive and Elec. School, Sweeney Building.....	500	365.6	820	Central	Mon., 2 to 3 pm; 7 pm; 8 pm; Tue., 7 pm; 10 pm. Wed., 7 pm; 8 pm; Thu., 7 pm; 10 pm; Fri., 7 pm; 8 pm; Sat., Silent night. Sun.: 9:40 am; 12:30 pm; 8 pm; 9:15 pm; 11:15 pm; 1 am.
WHBA	Oil City, Pa.—Shaffer Music House.....	10	250	1200	Eastern	
WHBC	Canton, Ohio—Rev. E. P. Graham, 627 McKinley Ave., N. W.....	10	254	1180	Eastern	Mon., 8 to 8:30 pm.
WHBD	Bellefontaine, Ohio—Chamber of Commerce.	20	222	1350	Central	
WHBF	Rock Island, Ill.—Beardsley Specialty Co., 217 Eighteenth St.....	100	222	1350	Central	Mon., 7 to 9 pm; Wed., 7 to 9 pm; Sat., 2 to 4 pm and 7 to 9 pm.
WHBG	Harrisburg, Pa.—John S. Skane, 1810 North Fourth St.....	20	231	1300	Eastern	Tue., Thu. and Sat., 12:01 to 1 pm; 5:30 to 11 pm; Sun.: 10:20 am to 12:01 pm; 1 to 2; 6:15 to 9 pm.
WHBJ	Fort Wayne, Ind.—Laurer Auto Co., 2315 South Calhoun St.....	50	234.4	1280	Central	Tue., 6 to 6:30 pm; 8 pm to 12 pm; Wed., 6 to 6:30 pm; Thu., 6 to 6:30 pm; Fri., 6 to 6:30 pm; 8 to 12 pm; Sat., 6 to 6:30 pm. Sun.: 4 to 5 pm; 7 to 8 pm.
WHBL	Chicago, Ill.—(Portable), C. L. Carrell.....	50	215.7	1390		
WHBM	Chicago, Ill.—(Portable), C. L. Carrell, 1536 South State St.....	20	215.7	1390		
WHBN	St. Petersburg, Fla.—First Ave. Methodist Church.....	10	238	1260	Eastern	
WHBP	Johnstown, Pa.—Johnstown Automobile Co., 101 Main St.....	100	256	1170	Eastern	Mon., 12:30 pm to 1:30 pm; Tue., 12:30 pm to 1:30 pm; Wed., 12:30 pm to 1:30 pm; Thu., 12:30 pm to 1:30 pm; Fri., 12:30 pm to 1:30 pm; Sat., 12:30 pm to 1:30 pm; 10 pm to 12 pm. Sun.: 2:30 to 4 pm.
WHBQ	Memphis, Tenn.—Men's Fellowship Class of St. Johns Methodist Episcopal Church South	50	233	1290	Central	
WHBU	Anderson, Ind.—Rivera Theatre and Bing's Clothing Store, 1002 Meridian St.....	10	218.8	1370	Central	Daily: 9 to 9:30 am; Wed., 7 to 9 pm; Fri., 7 to 9 pm. Sun.: 7 to 9 pm.
WHBW	Philadelphia, Pa.—D. R. Kienzle, 4916 Chestnut St.....	100	216	1390	Eastern	Mon., 8:30 to 10:30 pm and 11:15 pm to 12:15 am. Thu., 8:30 to 11 pm; Sat., 7:45 to 10 pm.
WHBY	West De Pere, Wis.—St. Norbert's College...	50	250	1200	Central	Daily: 5 to 6 pm; Mon., 8 to 10 pm; other nights irregular.
WHDI	Minneapolis, Minn.—Wm. Hood Dunwoody Industrial Institute.....	500	278	1080	Central	Mon., 8 to 9 pm; Wed., 9 to 10 pm; Fri., 9 to 10 pm.

Radio Broadcast Station KFWB

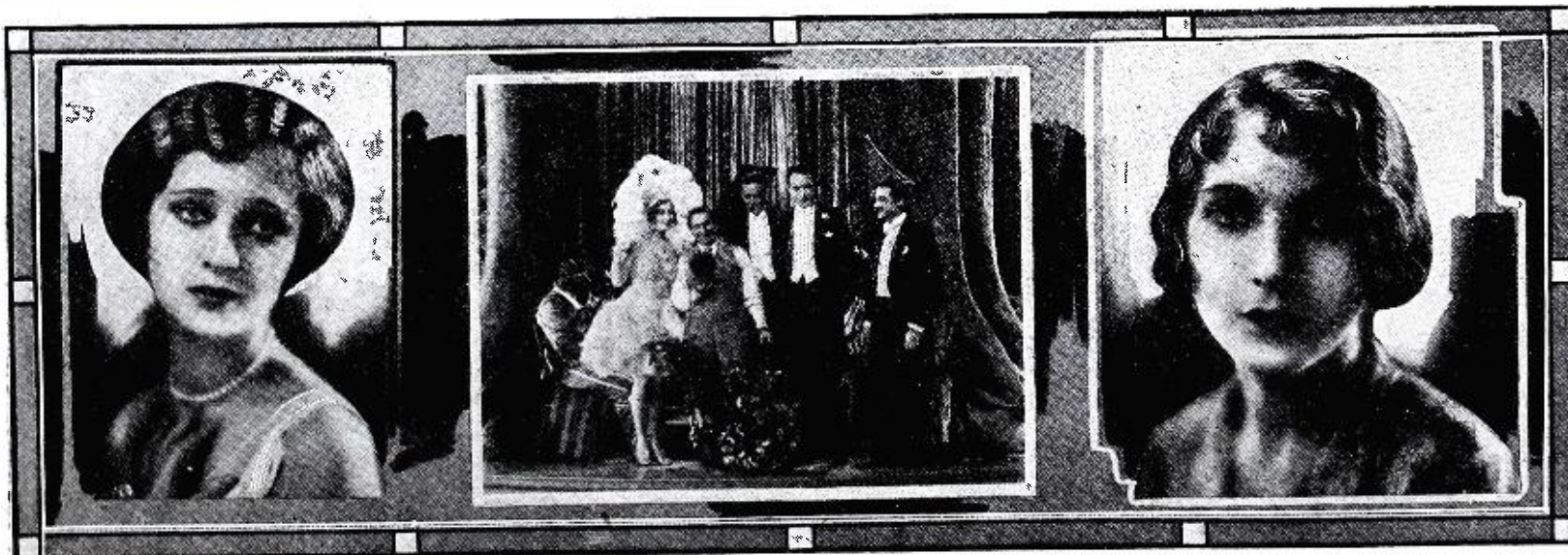

Dolores Costello, screen star and guest announcer.

The Ernst Lubitsch Production for Warner Brothers of "So This Is Paris."

Jane Winton, screen player and guest announcer.

Radio Call Letters	BROADCAST STATIONS Location and Owner	Power Watts	Wave Length (Meters)	Frequency (Kilocycles)	Time at Station	Sending Hours
WH	WHEC—Rochester, N. Y.—Hickson Electric Co., 36 South Ave.	100	258	1160	Eastern	
	WHK—Cleveland, Ohio—Radio Air Service Corp., 1220 Huron Road.	1000	272.6	1100	Eastern	Daily except Fri.: 6:30 pm to 10:30 pm. Sun.: 9:30 am to 11 am; 6:30 pm to 10:30 pm.
	WHN—New York, N. Y.—Loew's Inc., 1540 Broadway	500	360.1	833	Eastern	Daily: 2:15 pm to 5:30 pm; 7 pm to 12 pm. Sun. and Holidays: 11:30 to 12:30 pm; 12:30 to 1 pm; 2 to 3 pm; 3 to 4:30 pm; 5 to 5:30 pm; 7:30 to mid.
	WHO—Des Moines, Ia.—Bankers Life Co., 6th & Grand	5000	526	570	Central	Mon., 9:45 am; 12 am; 2 pm; 7:30 pm; 11 pm; Tue., 9:45 am; 12 am; 2 pm; 7:30 pm; 11 pm; Wed., 9:45 am; 12 am; 2 pm; 3:30 pm; 7:30 pm; 11 pm; Thu., 9:45 am; 12 am; 2 pm; 7:30 pm; 11 pm; Fri., 9:45 am; 12 am; 2 pm; 3:30 pm; 7:30 pm; 11 pm; Sat., 9:45 am; 12 am; 2 pm; 7:30 pm; 11 pm. Sun.: 11 am; 4 pm; 7:30 pm; 11 pm. Holidays generally same as week days.
	WHT—Chicago, Ill.—(Transmitter is in Deerfield, Ill.) Radiophone Broadcasting Corp., 410 North Michigan Blvd., Chicago, Ill.	3500	238	1260	Central	Mon., 10; 10:45; 11:15; 11:40; 11:50 am; 12 am; 12:45; 6; 7 pm; Tue., 10; 10:20; 10:45; 11; 11:40; 11:50 am; 12 am; 12:45; 6; 6:40; 6:50; 7:45; 9:15; 9:35; 9:50; 10:10; 11:30; 12 pm; Wed., 10; 10:45; 11:15; 11:40; 11:50 am; 12 am; 12:45; 6; 6:50; 7:54; 9:15; 9:30; 10:05; 11:15; 11:30; 12 pm; Thu., 10; 10:15; 10:45; 10:50; 11:40; 11:50 am; 12 am; 12:45; 6; 6:30; 6:45; 9:15; 9:30; 10:10; 11:30; 12 pm; Fri., 10; 10:45; 11; 11:40; 11:50 am; 12 am; 12:45; 6; 6:50; 7:45; 9:15; 9:30; 10:05; 11:30; 12 pm; Sat., 10; 10:45; 11; 11:40; 11:50 am; 12 am; 6; 6:50; 7:45; 9:15; 9:30; 9:50; 10; 11:30; 12 mid. Sun.: 12 am; 12:45; 1:15; 1:30; 1:45; 2; 2:30; 2:45; 5:30; 6; 6:30; 9:30; 10:30 pm.
WI	WIAD—Philadelphia, Pa.—Howard R. Miller, 6318 North Park Ave.	100	250	1200	Eastern	Tue., 9 pm; Fri., 9 pm.
	WIAS—Burlington, Iowa—Home Electric Co.	100	254	1180	Central	Mon., 8 to 9 pm; Fri., 8 to 9 pm. Sun.: 10:30 to 12 am.
	WIBA—Madison, Wis.—Capital Times Studio, 237 West Gilman St.	100	236.1	1270	Central	Mon., 8:45 to 10:30 pm; Wed., 8:45 to 10:30 pm; Fri., 9 to 10:30 pm; Sat., 10:45 to 12 pm.
	WIBG—Elkins Park, Pa.—St. Paul's Protestant Episcopal Church.	50	222	1350	Eastern	
	WIBH—New Bedford, Mass.—Elite Radio Stores, 55 Hillman St.	30	209.7	1430	Eastern	
	WIBI—Flushing, N. Y.—Frederick B. Zittell, Jr., 49 Boerum Ave.	50	218.8	1370	Eastern	
	WIBJ—Chicago, Ill.—(Portable), C. L. Carrell, 1506 N. American Bldg.	50	215.7	1390		
	WIBM—Chicago, Ill.—(Portable), Billy Maine, 36 West Randolph St.	10	215.7	1390		Daily: 2:30 to 4:30 pm; 8 to 10 pm.
	WIBO—Chicago, Ill.—Nelson Bros. Russo & Fiorito	1000	226	1330	Central	Mon., 2 to 4 pm; Tue., 2 to 4 pm; 6 to 8 pm; mid. to 3 am; Wed., 2 to 4 pm; 6 to 8 pm; 10 pm to 12 pm; Thu., 2 to 4 pm; 6 to 8 pm; mid. to 3 am; Fri., 2 to 4 pm; 6 to 8 pm; 10 pm to 2 am; Sat., 2 to 4 pm; 6 to 8 pm. Sun.: 10:15 am; 2 to 4 pm; 6 to 8 pm; 10 pm to 12 pm.
	WIBR—Weirton, W. Va.—Thurman A. Owings	50	246	1220	Eastern	

Radio Broadcast Station WGY

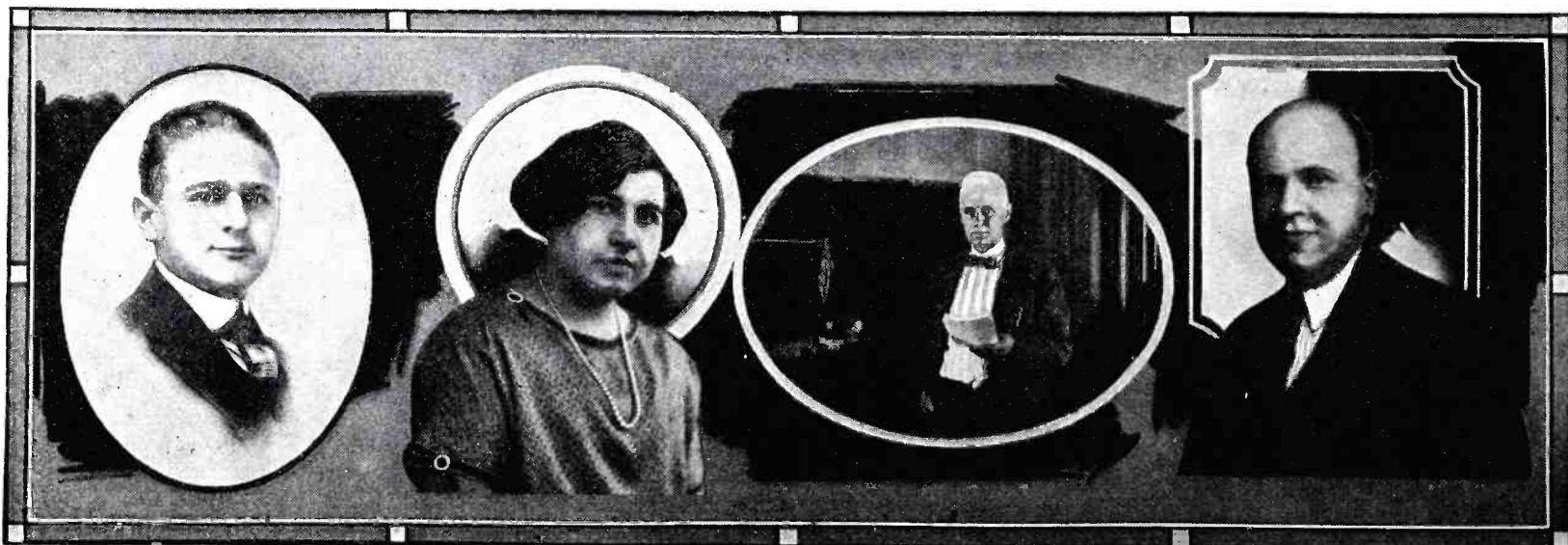

Elmer Tidmarsh, organist of Union College.

Ethel Osterhout, piano accompanist.

Dr. Sigel Rousch, lecturer and writer.

William T. Jacob, "Book Chat" reader of WGY.

Radio Call Letters	BROADCAST STATIONS Location and Owner	Power Watts	Wave Length (Meters)	Frequency (Kilocycles)	Time at Station	Sending Hours
WI	WIBS—Elizabeth, N. J.—(Portable), Lieut. Thos. F. Hunter.....	10	202.6	1480		
	WIBU—Poynette, Wis.—The Electric Farm.....	20	222	1350	Central	
	WIBW—Logansport, Ind.—Dr. L. L. Dill, Barnes Bldg.....	100	220	1360	Central	Mon., 4:15 to 5:15 pm; Tue., 4:15 to 5:15; 6 to 7 pm; Wed., 4:15 to 5:15 pm; Thu., 4:15 to 5:15; 8 to 9 pm; Fri., 4:15 to 5:15; 6 to 7 pm; Sat., 4:15 to 5:15 pm. Sun.: 7:30 to 8:30 pm.
	WIBX—Utica, N. Y.—WIBX (Inc.), 236 Genesee St....	150	205.4	1460	Eastern	Tue., 12 am to 1 pm; 6:30 to 9 pm; Thu., same as Tue.; Fri., same as Tue. Sun.: 10:30 to 12 am 3 to 4 pm; 7 to 8 pm.
	WIBZ—Montgomery, Ala.—A. D. Trum, 217 Catoma St.....	10	230.6	1300	Central	Tue., 8:30 to 9:30; Wed., 9 to 10; Thu., 11 to 12; Sun.: 9:30 to 10:30.
	WIL—St. Louis, Mo.—St. Louis Star & Benson Radio Co.....	250	273	1100	Central	Mon., 10 to 12 pm; Tue., 4 to 5 pm; Wed., 9 to 11 pm; Thu., 4 to 5; 8 to 10 pm; Fri., 9 to 11 pm; Sat., 4 to 5; 10 to 12 pm.
	WIOD—Miami Beach, Fla.—Carl G. Fisher Co.....	1000	247.8	1210	Eastern	Daily: 8:30 to 12:30 am; Tue., Silent. Sun.: 11 am to 12:15 pm; 8:45 to 9:45 pm.
	WIP—Philadelphia, Pa.—Gimbel Bros.....	500	508.2	590	Eastern	Daily: 6:45 am to 7:30 am; 10 am to 11 am; 1 to 2 pm; 3 to 4:30 pm; 6 to 7:30 pm; Tue., Thu. and Sat. also 8 pm to 12 pm. Sun.: 10:45 pm. to 12:30 pm; 4 pm to 5:30 pm. Alternate Sun.: 7:15 to 12 pm.
WJ	WJAD—Waco, Tex.—Frank P. Jackson.....	500	352.7	850	Central	
	WJAG—Norfolk, Neb.—Norfolk Daily News.....	250	270	1110	Central	Daily: 12:15 pm. Evenings by special arrangement. Sun.: Special programs only by arrangement.
	WJAK—Kokomo, Ind.—J. A. Kautz, Kokomo Tribune, 1531 Washington St.....	50	254	1180	Central	Daily: 11:45 pm; Mon., 7:30 pm.
	WJAM—Cedar Rapids, Ia.—D. M. Perham, 322 Third Ave. W.....	100	268	1120	Central	
	WJAR—Providence, R. I.—The Outlet Co.....	500	305.9	980	Eastern	Mon., Wed. and Fri., 10 to 11 am; Daily: 11:05 pm; Mon., 7:45 to 11 pm; Tue., 7:30 to 10 pm; Wed., 7:30 to 11 pm; Thu., 7:45 to 11 pm; Fri., 7:45 to 10:30 pm; 11 to 12. Sun.: 6 pm to 10:15 pm.
	WJAS—Pittsburgh, Pa.—Pittsburgh Radio Supply House, 963 Liberty Ave.....	500	336.9	890	Eastern	Daily: 2 pm; 7:45 pm; 8 pm to 12 pm.
	WJAX—Jacksonville, Fla.—City of Jacksonville.....	1000	336.9	890	Eastern	
	WJAZ—Chicago, Ill.—(Transmitter is in Mount Prospect, Ill.), Zenith Radio Corp., 312 South Michigan Ave.....	5000	329.8	910	Central	Mon., Silent; Tue., 9 pm to 1 am; Wed., 9 pm to 1 am; Thu., 9 pm to 12 pm; Fri., 9 pm to 1 am; Sat., 9 pm to 2 am. Sun.: 7 to 9 pm.
	WJBA—Joliet, Ill.—D. H. Lentz, Jr., 301 Whitley Ave.....	50	206.8	1450	Central	
	WJBB—St. Petersburg, Fla.—Financial Journal, J. E. Dadsure, Publisher, 126 13th St. N.....	10	254	1180	Eastern	Daily: 2 to 4 pm; 7 pm to 12 pm.
	WJBC—LaSalle, Ill.—Hummer Furniture Co., 2nd & Joliet Sts.....	100	234.2	1280	Central	Daily: 12:30 to 1:30 pm; Mon., 8 to 10 pm. Sun.: 7 to 10 pm.
	WJBI—Red Bank, N. J.—Robt. S. Johnson, 63 Broad St.....	250	218.8	1370	Eastern	

Radio Broadcast Station WOR

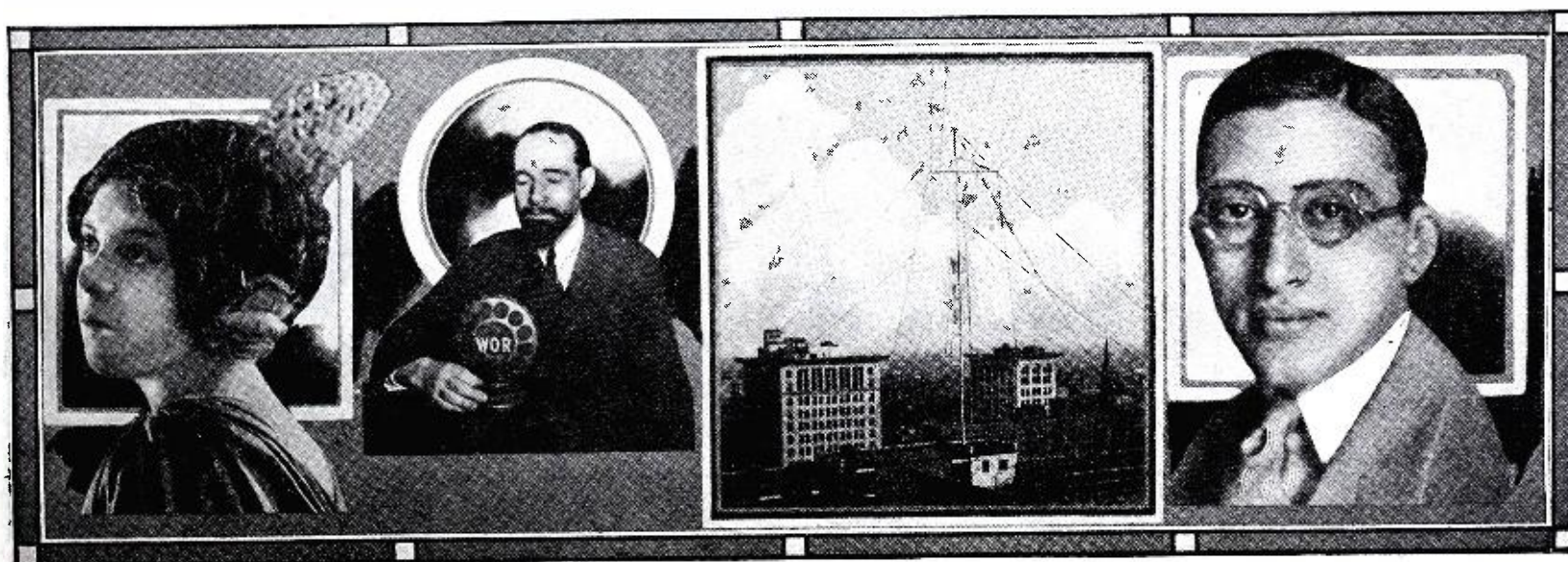

Mildred Delma

Mr. Wilkins, explorer.

L. Bamberger & Co.

Joseph M. Barnett.

Radio Call Letters	BROADCAST STATIONS Location and Owner	Power Watts	Wave Length (Meters)	Frequency (Kilocycles)	Time at Station	Sending Hours	
WJ	WJBK—Ypsilanti, Mich.—Ernest F. Goodwin, 803 Congress St.	10	233	1290	Central		
	WJBL—Decatur, Ill.—Wm. Gushard Dry Goods Co., 301 N. Water St.	500	270	1110	Central	Mon., 9:30 to 11 pm; Wed., 9 to 10:30 pm; Sat., 9:30 to 11 pm. Sun.: 10:45 am; 3 to 4:30 pm.	
	WJBO—New Orleans, La.—Valdemar Jensen, 119 S. St. Patrick St.	100	268	1120	Central	Fri., 8 to 11 pm. Sun.: 2:30 to 4:30 pm; 12 pm to 1 am.	
	WJBR—Omro, Wis.—Gensch & Stearns.	50	227.1	1320	Central	Mon., 8 to 10:30 pm; Thu., 8 to 10:30 pm. Sun.: 2 to 4 pm; 8 to 10:30 pm.	
	WJBU—Lewisburg, Pa.—Bucknell University.	100	211.1	1420	Eastern		
	WJJD—Mooseheart, Ill.—Supreme Lodge, Loyal Order of Moose.	500	370.2	810	Central	Daily: 12 to 1 pm; 2 to 3 pm; 4 to 5 pm; 5:30 to 7 pm; 8 to 9 pm; 10 to 11 pm; 12:30 to 2 am. Sun. and Holidays: 7:45 am; 9:40 am; 2:30 to 5 pm.	
	WJR—Detroit, Mich.—(Transmitter is in Pontiac, Mich.), Jewett Radio & Phonograph Co.	5000	516.9	580	Central		
	WJY—New York, N. Y.—Radio Corp. of America.	1000	405.2	740	Eastern		
	WJZ—New York, N. Y.—(Transmitter is in Bound Brook, N. J.), Radio Corp. of America.	50,000	455	660	Eastern	Daily: 1 to 2 pm; 4 to 6 pm; 7 to 12 pm. Sun.: 9 to 12 am; 2 to 6 pm; 7 to 10:30 pm.	
	WK	WKAF—Milwaukee, Wis.—Kesselman O'Driscoll-Hotel Antlers Co., 130 Second St.	500 5000	261	1150	Central	Mon., 10 to 11 pm; Wed., 10 to 11 pm; Thu., 2 to 3 pm; 8:30 to 9:45 pm; Fri., 7 to 7:30 pm; 10 to 11 pm; Sat., 8:30 to 9:45 pm. Sun.: 4 to 6 pm.
WKAR—East Lansing, Mich.—Michigan State College		1000	285.5	1050	Central	Mon., 12 to 12:30 pm; 8 to 9 pm; Tue., 12 to 12:30 pm; Wed., 12 to 12:30 pm; 7:45 to 9 pm; Thu., 12 to 12:30 pm; Fri., 12 to 12:30 pm; 7:45 to 9 pm; Sat., 12 to 12:30 pm. Sun.: Silent.	
WKAU—Laconia, N. H.—Laconia Radio Club.		50	224	1340	Eastern	Fri., 7 pm. Sun.: Church Services.	
WKBB—Joliet, Ill.—Sanders Bros., 607 Jefferson St.		100	214.2	1400	Central		
WKBE—Webster, Mass.—K. & B. Electric Co., 59 Emerald Ave.		100	231	1300	Eastern	Mon., 8 to 11 pm.	
WKBG—Chicago, Ill.—(Portable), C. L. Carrell, 36 So. State St.		100	215.7	1390			
WKRC—Cincinnati, Ohio—Kodel Radio Corp., 507 E. Pearl St.		1000	{325.9 422.3	920 710	Central	Mon., 6 to 7 pm; 8 to 10 pm; 12 pm. to 2 am; Tue., 10 to 12 pm; Wed., same as Mon.; Thu., 10 to 12 pm; Fri., Silent; Sat., 10 to 12 pm. Sun.: 6:45 to 7:30 pm; 10 pm to 1 am.	
WKY—Oklahoma, Okla.—E. C. Hull & H. S. Richards 1911 W. Ash St.		100	275	1090	Central		
WL		WLAL—Tulsa, Okla.—First Christian Church.	100	250	1200	Central	
		WLAP—Louisville, Ky.—W. V. Jordon, 306 West Breckenridge St.	20	275	1090	Central	
	WLB—Minneapolis, Minn.—University of Minnesota	500	277.6	1080	Central		
	WLBL—Madison, Wis.—(Transmitter is in Stevens Point, Wis.), Wisconsin Department of Markets	500	278	1080	Central	Mon., 8:45 am; 9:45 am; 10:45 am; 11:45 am; 12:30 pm; 1:45 pm; 6 to 7 pm; Tue., 9:45 am; 10:45 am; 11:45 am; 12:30 pm; 1:45 pm; 8 pm; Wed., 8:45 am; 9:45 am; 10:45 am; 11:45 am; 12:30 pm; 1:45 pm; Thu., same as Wed.; Fri., same as Mon.; Sat., same as Wed.; also 8 pm to 12 pm.	
	WLIB—Chicago, Ill.—Liberty Weekly.	4000	303	990	Central	Mon., Silent; Tue., 7 pm to 8 pm; 11 pm to 12:30 pm; Wed., 7 pm to 8 pm; 11 pm to 12:30 pm; Thu., 7 pm to 8 pm; 11 pm to 12:30 pm; Fri., 7 pm to 8 pm; 11 pm to 12:30 pm; Sat., 7 pm to 8 pm; 11 pm to 12:30 pm. Sun.: 5 to 6:15 pm.	

Radio Broadcast Station WBAL

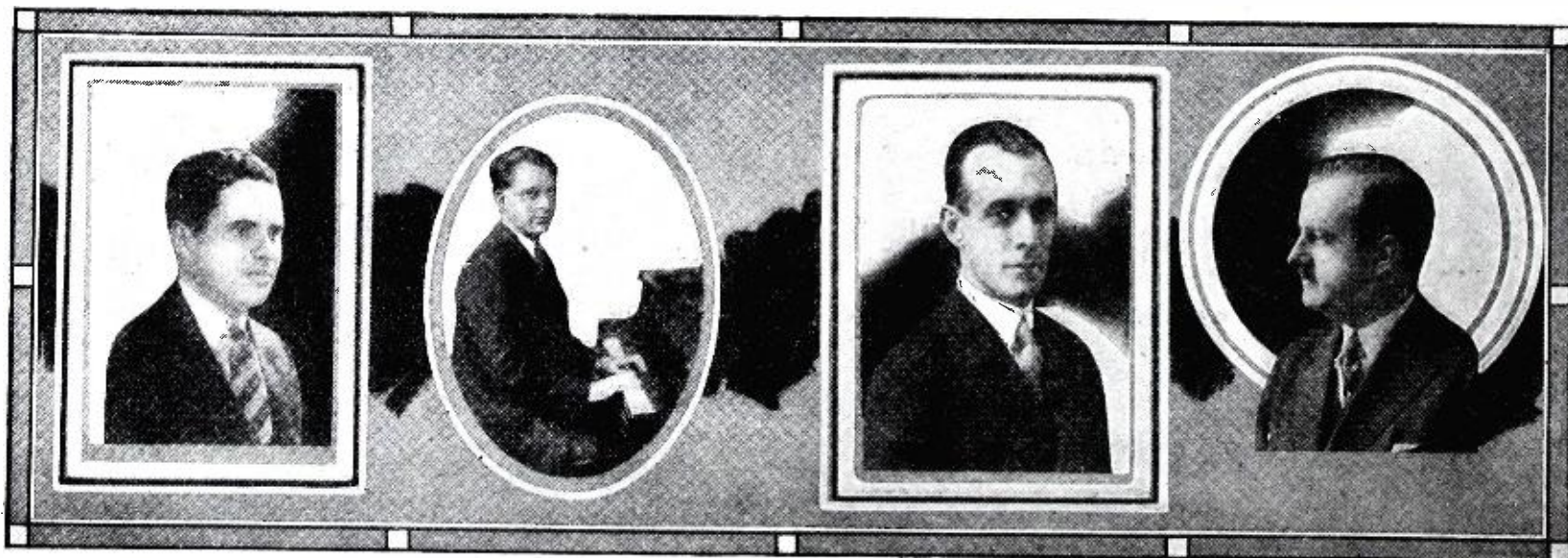

Broughton Tall, author of musical scenarios to be broadcast once a month over WBAL.

George Bolek, pianist who broadcasts a program every Tuesday night.

Walter N. Linthicum, bass, who is a member of the WBAL mixed quartet.

Stanley W. Barnett, studio manager and announcer.

Radio Call Letters	BROADCAST STATIONS Location and Owner	Power Watts	Wave Length (Meters)	Frequency (Kilocycles)	Time at Station	Sending Hours
WL	WLIT—Philadelphia, Pa.—Lit Bros.	500	304.5	700	Eastern	Daily: 12 am to 1 pm; 2 pm to 3 pm; 4:30 to 5:30 pm; 7:30 to 11 pm Mon., Wed. and Fri.; 7:30 to 8 pm; Tue., Thu. and Sat. Sun.: 2 to 4 pm, also from 6:30 to 9:30 pm on alternate Sun.
	WLS—Chicago, Ill.—(Transmitter is in Crete, Ill.), Sears Roebuck & Co.	5000	345	870	Central	Mon., 9 to 7; Tue., 6:30 to 8:30; Wed., 6:30 to 1 am; Thu., 6:30 to 8:30 pm; Fri., 6:30 am to 1 am; Sat., 7:30 am to 12 pm. Sun.: 6 to 8 pm.
	WLSI—Cranston, R. I.—Dutee W. Flint & Lincoln Studios, Inc.	500	440.9	680	Eastern	Daily: 5 to 6 pm; 8 to 10 pm; Sat., Silent. Sun.: 9:45 am a-d 4:45 pm.
	WLTS—Chicago, Ill.—Lane Technical High School, Hotel Flanders.	100	258.5	1160	Central	Mon., 1 to 2 pm; 6 to 7 pm; Tue., 7 to 8 pm; 10 pm to 2 am; Wed., 1 to 2 pm; 6 to 7 pm; 10 pm to 12 pm; Thu., 7 to 8 pm; 10 pm to 2 am; Fri., 1 to 2 pm; 6:30 to 7 pm; 10 pm to 12 pm; Sat., 7 to 8 pm; 10 pm to 12 pm. Sun.: 12 pm to 3 am.
	WLW—Cincinnati, Ohio—(Transmitter is in Harrison, Ohio), Crosley Radio Corp., Cincinnati, Ohio	5000	422.3	710	Central	Mon., 7:30 am; 8 am; 10 am; 11 am; 11:55 am; 12:05 pm; 1:30 pm; 1:40 pm; 3 pm; 4 pm; 4:30 pm; 6:50 pm; 7 pm; 7:30 pm; 7:40 pm; 10 pm; Tue., 7:30 am; 8 am; 10 am; 11 am; 11:55 am; 12:10 pm; 1:30 pm; 1:40 pm; 3 pm; 4 pm; 4:10 pm; 4:30 pm; 6 pm; 6:30 pm; 7 pm; 7:20 pm; 7:30 pm; 7:50 pm; 8 pm; 8:50 pm; 9 pm; Wed., 7:30 am; 8 am; 10 am; 11 am; 11:55 am; 12:05 pm; 1:30 pm; 1:40 pm; 3 pm; 3:30 pm; 4 pm; 4:30 pm; 4:45 pm; 6:50 pm; 7 pm; 7:30 pm; 7:40 pm; 10 pm; 11 pm; 11:15 pm; Thu., 7:30 am; 8 am; 10 am; 11 am; 11:55 am; 12:05 pm; 12:30 pm; 1:30 pm; 1:40 pm; 2 pm; 3 pm; 4 pm; 4:30 pm; 5 pm; 6:15 pm; 6:45 pm; 6:50 pm; 7 pm; 7:30 pm; 7:40 pm; 10 pm; 10:03 pm; 10:40 pm; 11 pm; 11:30 pm; 12:15 am; Fri., 7:30 am; 8 am; 10 am; 11 am; 11:55 am; 12:10 pm; Sat., 10 am; 11:55 am; 1:30 pm; 1:30 pm; 6:50 pm; 7 pm; 7:30 pm; 8 pm; 8:30 pm; 9 pm. Sun.: 9:30 am; 10:30 am; 11 am; 5 pm; 7:30 pm; 8:30 pm.
	WLWL—New York, N. Y.—Universal Broadcasting Corp., 415 West 59th St.	3500	288	1040	Eastern	Mon., 9 to 11 pm; Tue., 9 to 11 pm; Wed., 9 to 11 pm; Thu., 8:30 to 11 pm. Sun.: 8 pm.
WM	WMAC—Cazenovia, N. Y.—Clive B. Meredith	100	275	1090	Eastern	
	WMAF—Dartmouth, Mass.—Round Hills Radio Corp.	1000	440.9	680	Eastern	
	WMAK—Lockport, N. Y.—Norton Laboratories	500	266	1130	Eastern	
	WMAL—Washington, D. C.—M. A. Leese Co., 720 Eleventh St., N. W.	100	212.6	1410	Eastern	Tue., Thu. and Sat.,
	WMAN—Columbus, Ohio—W. E. Heskett, 507 North High St.	50	286	1050	Eastern	Sun.: 10:30 am; 7:30 pm.
	WMAQ—Chicago, Ill.—Chicago Daily News	1000	447.5	670	Central	Mon., 12 am to 3 pm; 4 to 7 pm; Tue., 12 am to 3 pm; 4 to 7 pm; 8 to 10 pm; Wed., 12 am to 3 pm; 4 to 7 pm; 8 to 10 pm; Thu., 12 am to 3 pm; 4 to 7 pm; 8 to 10 pm; Fri., 12 am to 3 pm; 4 to 7 pm; 8 to 10 pm; Sat., 12 am to 3 pm; 4 to 7 pm; 8 to 10 pm.
	WMAY—St. Louis, Mo.—Kingshighway Presbyterian Church	100	248	1210	Central	
	WMAZ—Macon, Ga.—Mercer University	500	261	1150	Eastern	Mon., 9 to 11 pm; Wed., 10 to 12 pm; Fri., 9 to 11 pm.
	WMBB—Chicago, Ill.—American Bond & Mortgage Co., 6201 Cottage Grove Ave.	500	250	1200	Central	Daily: 7 to 8 pm and 9 to 11 pm; Mon., Silent. Sun.: 3 to 5 pm; 7:40 to 9 pm; 9 to 11 pm.

Radio Broadcast Station WTIC

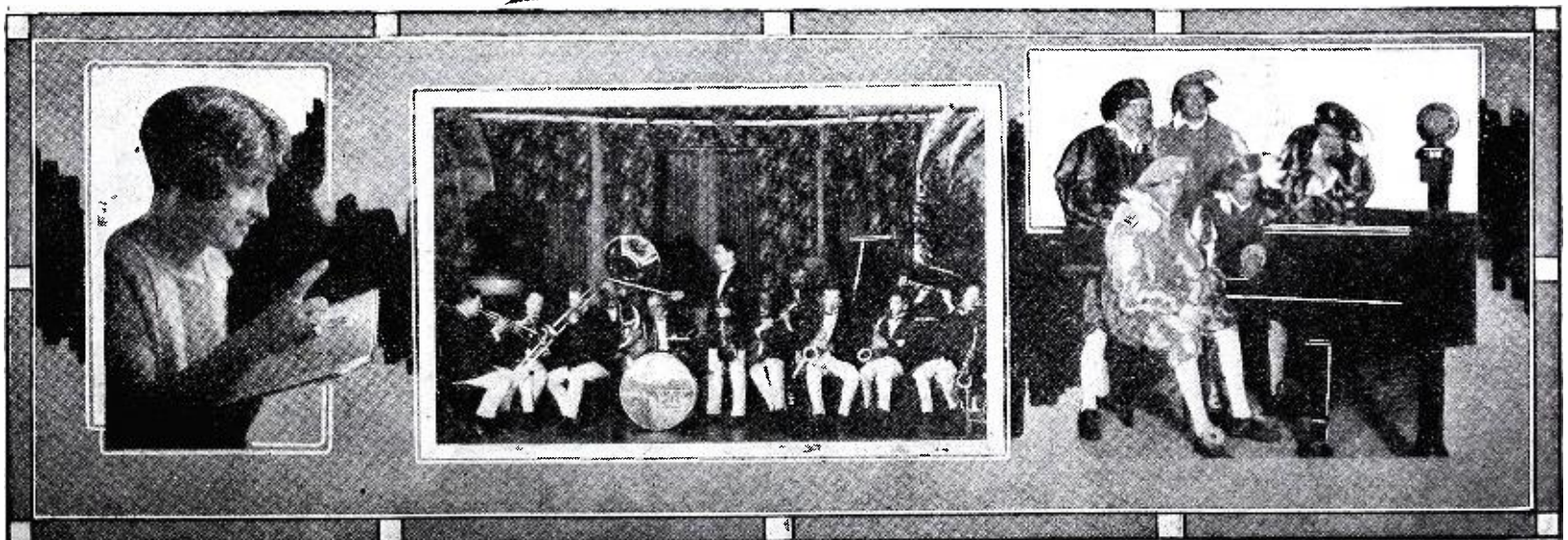

Beatrice Bangs, announcer.

Emil Heimberger's Hotel Band Orchestra.

Travelers Jongleurs.

Radio Call Letters	BROADCAST STATIONS Location and Owner	Power Watts	Wave Length (Meters)	Frequency (Kilocycles)	Time at Station	Sending Hours
WM	WMBC—Detroit, Mich.—Mich. Broadcasting Co.	100	256.4	1170	Eastern	
	WMBF—Miami Beach, Fla.—Fleetwood Hotel Corp. . .	500	384.4	780	Eastern	Daily: 7 to 8 pm; 8 to 9 pm; 10 pm to 1 am; Tue., Silent.
	WMC—Memphis, Tenn.—The Commercial Appeal. . . .	500	499.7	600	Central	Mon., 9:45 am; 11:30 am; 2:30 pm; 7:15 to 8 pm; 8:30 to 10 pm; Tue., same as Mon.; also 11 to 12 pm; Wed., silent; Thu., same as Mon.; Fri., same as Tue.; Sat., same as Mon. Sun.: 11 am to 12:30 pm.
	WMCA—New York, N. Y. (Transmitter is in Hoboken, N. J.)—Associated Broadcasters, Inc.	500	341	880	Eastern	Daily: 10:30 to 5 pm; 6 pm to 12:15 am. Sun.: 11 to 12:15 am; 2:50 to 10 pm.
	WMSG—New York, N. Y.—Madison Square Garden Broadcasting Corp.	500	302.8	990	Eastern	
WN	WNAB—Boston, Mass.—The Shepard Stores.	100	250	1200	Eastern	Daily: 3 to 4 pm; Special.
	WNAC—Boston, Mass.—The Shepard Stores.	500	280.2	1070	Eastern	Daily: 10:30 to 11:30 am; 1 to 2 pm; 4 pm; 5 pm; 6 pm; 7:35 pm; 8 to 10 pm or later. Sun.: 11 am; 1:30 to 2:30 pm; 6:45 to 8:30 pm.
	WNAD—Norman, Okla.—University of Oklahoma. . . .	500	254	1180	Central	Mon., 12:50 to 1:20; 7 to 11 pm; Tue., 12:50 to 1:20; 7 to 8 pm; Wed., 12:50 to 1:20; 7 to 8 pm; Thu., 12:50 to 1:20 pm; Fri., 12:50 to 1:20 pm. Sun.: 9:30 pm.
	WNAL—Omaha, Neb.—Omaha Central High School. . .	50	258	1160	Central	Fri., 9 pm; Sat., 9 pm.
	WNAT—Philadelphia, Pa.—Lennig Bros. Co., Spring Garden and 9th Sts.	100	250	1200	Eastern	Wed., 6:50 pm to mid; Sat., 7:30 pm to mid. Sun.: 4:30 to 7:30 pm.
	WNAX—Yankton, S. D.—Dakota Radio Apparatus Co. .	100	244	1230	Central	
	WNBH—New Bedford, Mass.—New Bedford Hotel (Irving J. Vermilya).	250	248	1210	Eastern	Mon., Wed. and Fri., 6 to 10 pm; Tues., Thu. and Sat., Silent. Sun.: 11 am to 12:15 pm; 2 to 3 pm; 4:30 to 5:30 pm; 7 to 9 pm.
	WNJ—Newark, N. J.—Radio Shop of Newark (Herman Lubinsky), 89 Lehigh Ave.	150	348.6	860	Eastern	
	WNOX—Knoxville, Tenn.—People's Telephone and Telegraph Co.	100	268	1120	Central	
	WNRC—Greensboro, N. C.—Wayne M. Nelson.	10	224	1340	Eastern	
	WNYC—New York, N. Y.—City of New York, Dept. of Plants and Structures.	1000	526	570	Eastern	Daily: 6 to 11 pm. Sun.: Irregular.
WO	WOAI—San Antonio, Texas—Southern Equipment Co. .	2000	394.5	760	Central	Daily: 10 am; 12:15 pm; 2:30 pm; 3 pm; 6:10 pm; 8:30 pm. Sun. and Holidays: 11 am; 7:35 pm; 9:30 pm.
	WOAN—Lawrenceburg, Tenn.—Jas. D. Vaughn.	500	282.8	1060	Central	Daily except Sat.
	WOAW—Omaha, Neb.—Woodmen of the World.	1000	526	570	Central	Daily: 6 pm to 7:30 pm; 9 to 11 pm (except Wed.); Sat., 6 to 12 pm. Sun. and Holidays: 9 to 11 am; 1:30 to 4 pm; 6 to 7 pm; 9 to 11 pm.
	WOAX—Trenton, N. J.—Franklyn J. Wolff, Top of the Monument Pottery Co.	500	240	1250	Eastern	Daily: Noon, 12:15 pm; 6 to 7 pm; Tue. and Fri., special 8:30 to 10:30 pm; Sat., 9:30 to 11 pm. Sun.: 9:30 pm to 11 pm.
	WOC—Davenport, Iowa—The Palmer School of Chiropractic.	5000	483.6	620	Central	Mon., 12:15; 1:55; 2; 3; 6; Tue., 12:15; 1:55; 2; 3; 6; 6:30; 7; 9; Wed., 12:15; 1:55; 2; 3; 4; 5:45; 6; 6:30; 9; Thu., 12:15; 1:55; 2; 3; 6; 6:30; 7; 11; Fri., 12:15; 1:55; 2; 3; 4; 5:45; 6; 6:30; 8; 9; Sat., 12:15; 1; 5:45; 6; 6:30; 9; 11. Sun.: 1; 6:30; 8:15; 9:45.

Radio Broadcast Station WOR

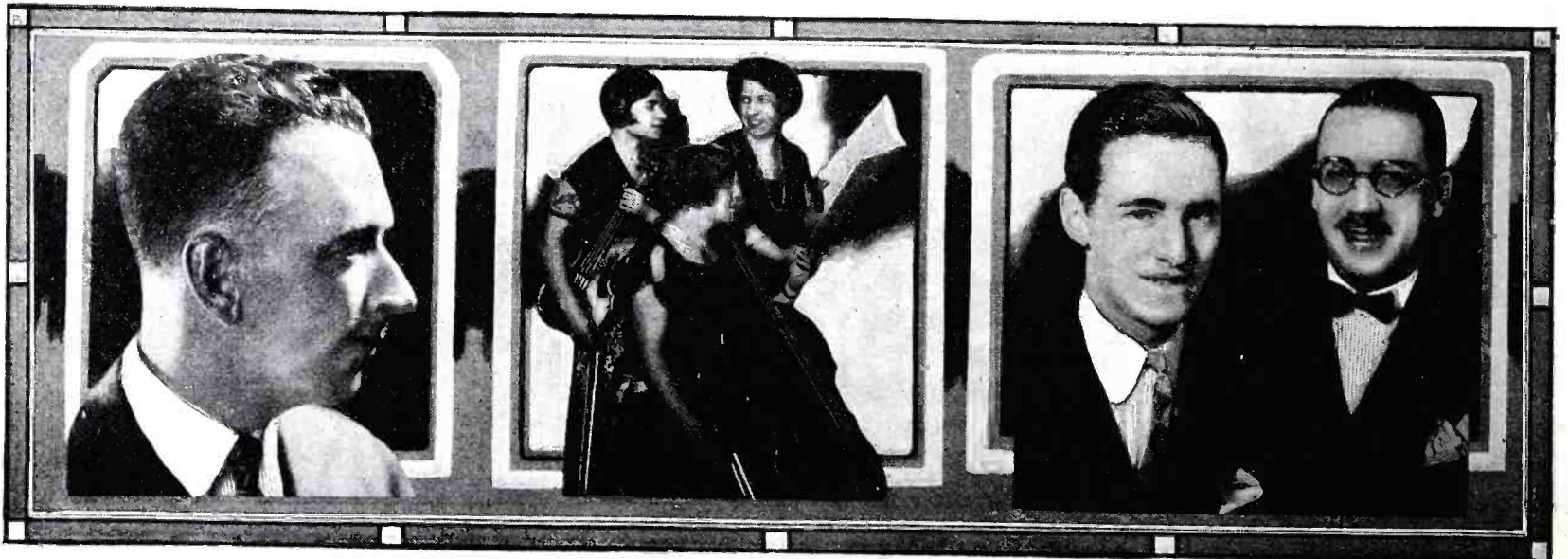

Edward S. Breck.

Allan String Trio.

Ballin & Race, piano-duo.

Radio Call Letters	BROADCAST STATIONS Location and Owner	Power Watts	Wave Length (Meters)	Frequency (Kilocycles)	Time at Station	Sending Hours
WO	WOCL—Jamestown, N. Y.—A. E. Newton, for the Jamestown Furniture Market Assn	15	275.2	1090	Eastern	Mon., 9 to 12 pm. Sun.: 10:30 am and 7:30 pm.
	WODA—Paterson, N. J.—O'Dea Temple of Music	250	224	1340	Eastern	
	WOI—Ames, Iowa—Iowa State College	750	270	1110	Central	Daily: 9:30 am; 10:30 am; 12:30 pm; 12:45 pm; Mon. and Thu., 7:30 and 7:50 pm; Tue. and Thu. 10:30 am. Sun.: 10:45 am to 11; 11 am to 12 am.
	WOK—Chicago, Ill. (Transmitter is in Homewood, Ill.) Neutrowound Radio Mfg. Co., 1721 Prairie Ave.	5000	217.3	1380	Central	
	WOKO—Peekskill, N. Y.—Harold E. Smith	50	233	1290	Eastern	Daily: 8 to 12 pm.
	WOO—Philadelphia, Pa.—John Wanamaker	500	508.2	590	Eastern	Daily: 11 am; 12 to 1 pm; 4:45 pm; 7:30 pm; Mon., Wed. and Fri., 8 to 11. Sun.: Alternate Sun. Morning and Evening, 10:30 am and 7:30 pm. Every Sun., 6 to 7 pm; every other Sun., 9:15 to 10:15 pm.
	WOOD—Grand Rapids, Mich.—Hotel Rowe	1000	242	1240	Central	Daily: 10 am; 9 pm to mid.; Thu., Silent.
	WOQ—Kansas City, Mo.—Unity School of Christianity	1000	278	1080	Central	Mon., 11 am; Tue., 11 am; 8 to 9:30 pm; Thu., 11 am; 7 to 10 pm; Sat., 11 am; 8 pm to 12 pm. Sun.: 11 am to 12:30 pm; 7 to 7:45 pm; 7:45 pm to 9:30 pm.
	WOR—Newark, N. J.—L. Bamberger and Co.	500	405	740	Eastern	Daily: 6:45 am; 2:30 to 4 pm; 6:15 to 7:30 pm; Mon., Wed. and Sat., until 12 pm. Not on Sun. but every holiday.
	WORD—Batavia, Ill.—People's Pulpit Assn., 18 Concord St., Brooklyn, N. Y.	5000	275	1090	Central	Tue., 7 to 7:45 pm; 9 to 10 and 11 to 12 pm; Wed., 7 to 8 pm and 9 to 10 pm; Thu., 8 to 10 pm; Fri., 7 to 8; 9 to 10 pm; Sat., 7 to 8; 9 to 10 pm. Sun.: 10 to 11 am; 2:30 to 4 pm; 6 to 7 pm; 9 to 10:30 pm.
	WOS—Jefferson City, Mo.—Missouri State Marketing Bureau	500	440.9	680	Central	
	WOWL—New Orleans La.—Owl Battery Co., 901 Carondelet St.	10	270	1110	Central	Mon., Wed., Thu., Fri., Sat., 11:30 am to 12:30 pm; 2 to 3; 4:30 to 6:30 pm; Tue., 11:30 am to 12:30 pm; 2 to 3; 4:30 to 6:30 pm; 8:30 to 10:30 pm.
	WOWO—Fort Wayne, Ind.—The Main Auto Supply Co., 213 West Main St.	500	227	1320	Central	Mon., 8 to 12 pm; Wed., 8 to 12 pm; Thu., 8 to 12 pm. Every noon except Sat. and Sun.
WP	WPAK—Fargo, N. D.—North Dakota Agricultural College	100	275	1090	Central	Mon., 7:30 pm; Wed., 7:30 pm; Fri., 7:30 pm.
	WPCC—Chicago, Ill.—North Shore Congregational Church	500	258	1160	Central	Wed., 7 to 8 pm; Fri., 7 to 8 pm. Sun.: 11 am 3:30 pm; 8 pm.
	WPDQ—Buffalo, N. Y.—Hiram L. Turner, 121 Norwood Ave.	50	205.4	1460	Eastern	
	WPG—Atlantic City, N. J.—Municipality of Atlantic City	500	299.8	1000	Eastern	Daily: 6:30 to mid. with occasional luncheon and tea music at 1:30 and 4:30 pm. Sun.: 3:15 to 5 pm; 9 to 11 pm.
	WPRC—Harrisburg, Pa.—W. Arthur Wilson, Prop., Wilson Printing and Radio Co., Fifth and Kelker Streets	100	215.6	1390	Eastern	Mon., 9 to 11 pm; Wed., 9 to 11 pm. Sun.: 7:20 to 10:30 pm.
	WPSC—State College, Pa.—Pennsylvania State College, Dept. of Elec. Engineering	500	261	1150	Eastern	Mon., 7:30 to 10:30 pm; Wed., 7:30 to 10:30 pm; Fri., 7:30 to 10:30 pm.
WQ	WQAA—Parkersburg, Pa.—Horace A. Beale, Jr.	500	220	1360	Eastern	

Radio Broadcast Station WSM

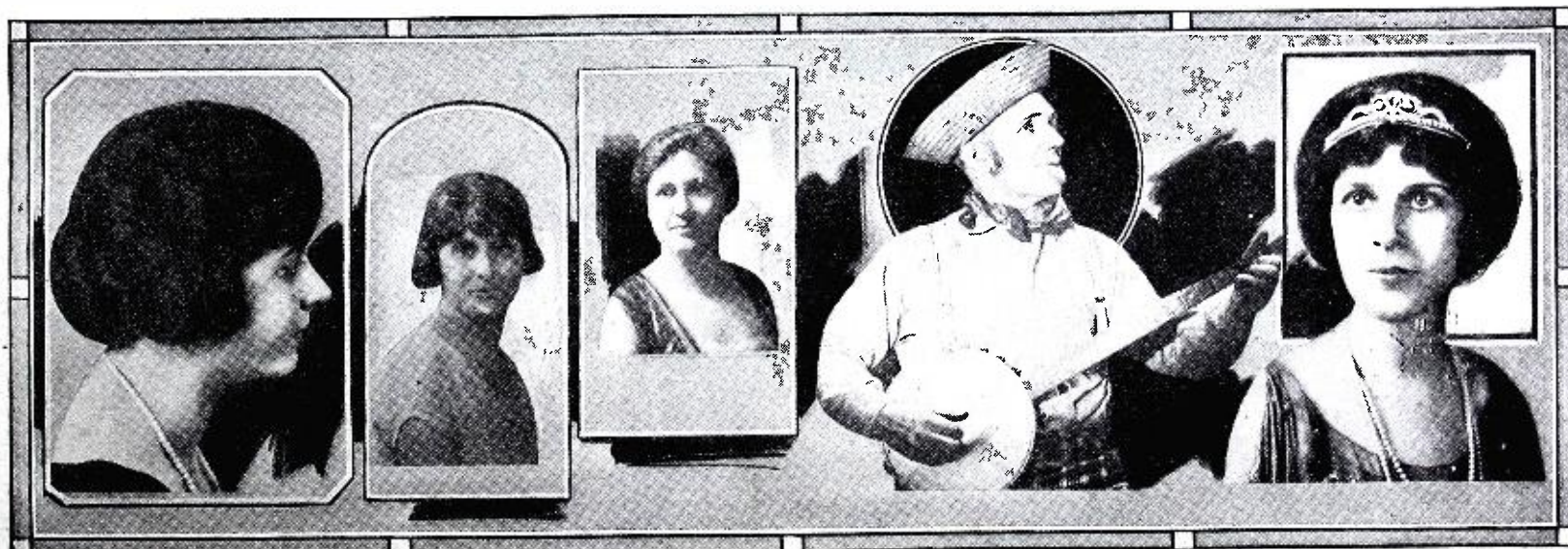

Daisy Hoffman, pianist.

Mrs. Daisy Fentress, contralto.

Mrs. Robert Caldwell, contralto.

Uncle Dave Macon, champion banjo picker of the South.

Mary Cornelia Malone, soprano.

Radio Call Letters	BROADCAST STATIONS Location and Owner	Power Watts	Wave Length (Meters)	Frequency (Kilocycles)	Time at Station	Sending Hours
WQ	WQAC—Amarillo, Texas—Gish Radio Service.....	100	234	1280	Central	Mon. to Sat., incl.: Sunrise; Sunset; 10 am; 11 am; noon and 8 pm. Sun.: Sunrise; Sunset; 11 am and 8 pm.
	WQAE—Springfield, Vt.—Moore Radio News Station..	50	246	1220	Eastern	
	WQAM—Miami, Fla.—Electrical Equipment Co., 42 Northwest Fourth St.....	100	263	1140	Eastern	Daily: 6 to 6:30 pm; 7:30 to 9 pm; 10:30 to 12:30 pm. Sun. and Holidays: 10:30 to 12 am; 7:30 to 9 pm.
	WQAN—Scranton, Pa.—Scranton Times.....	100	250	1200	Eastern	Daily: 12:30 to 1:30; 4:30 to 5:30 pm; except Sun., Fri. and Tue. nights, 8 to 11 pm; Sat. night 11 to 12 pm.
	WQAO—New York, N. Y.—Calvary Baptist Church...	100	360	833	Eastern	
	WQJ—Chicago, Ill.—Calumet Baking Powder Co. and Rainbo Gardens.....	500	447.5	670	Central	Daily: 11 am to 12 am; 3 to 4 pm; 7 to 8 (except Mon.); 10 pm to 2 am (except Sat.); Sat., 10 to 3 am. Sun.: 10 to 12 am; 3 to 4 pm; 8 to 10 pm
WR	WRAF—Laport, Ind.—The Radio Club, Inc.....	100	223.8	1340	Central	Mon. and Thu., 8 to 10 pm. Sun.: 10:45 am to 12:15 pm; 7:30 pm to 9 pm.
	WRAK—Escanaba, Mich.—Economy Light Co., 1105 Ludington St.....	100	256.3	1170	Central	
	WRAM—Galesburg, Ill.—Lombard College.....	100	243.8	1230	Central	Mon., 7 pm; 8 pm; 9 pm.
	WRAV—Yellow Springs, Ohio—Antioch College.....	100	263	1140	Central	
	WRAW—Reading, Pa.—Avenue Radio and Electric Shop, 460 Schuylkill Ave.....	10	238	1260	Eastern	Tue., 9 pm; Thu., 10 pm.
	WRAX—Gloucester City, N. J.—Flexon's Garage, 410 Jersey Ave.....	500	268	1120	Eastern	
	WRBC—Valparaiso, Ind.—Immanuel Lutheran Church	500	278	1080	Central	Mon., 7:30 pm. Sun.: 7:30 pm. During July, Aug. and Sept., 10:30 am.
	WRC—Washington, D. C.—Radio Corporation of America.....	1000	468.5	640	Eastern	
	WRCO—Raleigh, N. C.—Wynne Radio Co., 226½ Fayetteville St.....	100	252	1190	Eastern	
	WREC—Coldwater, Miss.—Wooten's Radio and Elec- tric Co.....	10	254	1180	Central	
	WREO—Lansing, Mich.—Reo Motor Car Co.....	500	285.5	1050	Eastern	Daily except Sun.: 6 to 7 pm; Tue., 8:15 pm; Thu., 8:15 pm; Sat., 10 to 12 pm. Sun.: 10; 10:30 am; 7:30 pm.
	WRHF—Washington, D. C.—Washington Radio Hos- pital Fund, 525 Eleventh St., N. W.....	50	256	1170	Eastern	Tue., Thu. and Sat., 6 to 7 pm.
	WRHM—Minneapolis, Minn.—Rosedale Hospital Co., Inc.....	50	252	1190	Central	Mon., 1:15 pm; Tue., 11 pm; Wed., 9 pm; Thu., Silent; Fri., 1:15 pm; Sat., Silent. Sun.: 9:30 am; 2 pm; 9 pm.
	WRK—Hamilton, Ohio—Doron Bros. Electrical Co...	00	270	1110	Central	
	WRM—Urbana, Ill.—University of Illinois.....	500	273	1100	Central	
	WRMU—Richmond Hill, N. Y. MU-1 (Yacht)—A. H. Grebe and Co., Inc.....	100	236	1270		No fixed schedule.

Radio Broadcast Station WSM



Joseph T. McPherson, bass baritone.

F. Arthur Henkel, pipe organist.

The Andrew Jackson Hotel Trio; left to right, Mrs. H. O. Olson, cellist; Mrs. Joe Shannon, pianist, and Miss Clair Harper, violinist.

Radio Call Letters	BROADCAST STATIONS Location and Owner	Power Watts	Wave Length (Meters)	Frequency (Kilocycles)	Time at Station	Sending Hours
WR	WRNY —New York, N. Y.—Experimenter Publishing Co., 53 Park Place	500	371.8	800	Eastern	Mon., 11 am to 1 pm, 6:50 to 11:45 pm; Tue., 11 am to 1 pm, 6:45 to 11:45 pm; Wed., 11 am to 1 pm, 6:15 to 10:45 pm; Thu., 11 am to 1 pm, 6:45 to 12 pm; Fri., 11 am to 1 pm, 5:00 to 1 am; Sat., 11 am to 1 pm, 11:45 am to 12:30 am, 6 pm
	WRA —Dallas, Tex.—City of Dallas, Police and Fire Signal Department	500	246	1220	Central	
	WRST —Bay Shore, N. Y.—Radnet Mfg Co., 5 First Ave.	250	215.7	1390	Eastern	
	WRVA —Richmond, Va.—Larus & Brother Co., Inc., 22nd & Cary Sts.	1000	276	1170	Eastern	Mon., 8 to 11 pm; Tue., 11 to 1 am; Wed., 8 to 11 pm; Thu., 8 to 11 pm; Fri., 7 to 11 pm; Sat., 8 to 11 pm
	WRW —Tarrytown, N. Y.—Tarrytown Radio Research Laboratories (Koenig Bros.)	500	273	1100	Eastern	
WS	WSAI —Cincinnati, Ohio—(Transmitter is in Mason, Ohio), United States Playing Card Co., Cincinnati, Ohio	5000	325.9	920	Central	Mon., 8 to 9 pm (alternate months Fri., 8 to 10 to 12 pm); Tue., 5:30 to 10 pm; Wed., 6:45 to 8 pm; 10 to 12 pm; Thu., 7 to 10 pm; Fri., 8 to 10 pm; Sat., 6:40 to 10 pm; 12 pm to 1 am; Sun., 3 to 4:30 pm and 7:45 to 10:15 pm
	WSAJ —Grove City, Pa.—Grove City College	250	279	1110	Eastern	Daily, 10 to 11 pm
	WSAN —Allentown, Pa.—Allentown Call Publishing Co.	100	229	1310	Eastern	
	WSAR —Fall River, Mass.—Doughty & Welch Electric Co., Inc., 46 N. Main St.	100	254	1180	Eastern	Daily, 10 to 11 pm; 12 to 1 am; Sat., 10:30 to 11:15 pm
	WSAX —Chicago, Ill.—(Portable), Zenith Radio Corp., 332 South Michigan Ave.	100	268	1120		
	WSAZ —Pomeroy, Ohio—Chase Electric Shop	50	244	1230	Eastern	
	WSB —Atlanta, Ga.—The Atlanta Journal	1000	428.3	700	Central	Daily, 1 am to 1 pm, 7 pm to 6 pm, 8 to 9 pm; 10:45 pm, 3 pm (weekend); Sun., 9:30 am; 10:45 am, 5 to 6 pm, 7:30 pm
	WSBC —Chicago, Ill.—World Battery Co., 1219 South Wabash Ave.	1000	210	1430	Central	Tue. to Sun. and 6:30 pm to 8:30 pm and 10 pm; 1 am; Sun., Special Town Program, 2 am to 4 am; Mon., 5:30 pm to 7 pm
	WSBF —St. Louis, Mo.—Stuy, Barr & Fuller Dept. Store	250	273	1100	Central	Daily, Noon to 1 pm to 3 to 4 pm; Mon., Wed. and Fri., 7:30 to 9 pm; Wed., 11 pm to 1 am; Sun., 9 pm to 10:30 pm
	WSBT —South Bend, Ind.—South Bend Tribune	500	275	1090	Central	Mon., 7 to 10 pm; Wed., 7 to 9, 11:45 to 1 am; Fri., 7 to 10 pm
	WSDA —New York, N. Y.—The City Temple (Seventh Day Adventist Church, 120th St. Lenox)	250	263	1140	Eastern	
	WSKG —Bay City, Mich.—World's Star Knitting Co.	100	261	1150	Eastern	Mon., 8 to 11 pm; Wed., 9 to 11 pm; Sat., 9 pm to 2 am; Sun., 10:30 to 12
	WSM —Nashville, Tenn.—The National Life & Accident Ins. Co.	1000	282.8	1060	Central	Mon., 6:30 to 9; 10 to 11 pm; Tue., 10 to 12 pm; Wed., 6:30 to 9, 10 to 11 pm; Thu., Silent; Fri., 6:30 to 9; 10 to 11 pm; Sat., 6:30 to 12 pm; Sun.; Alternate morning and Evening Church Services.
	WSMB —New Orleans, La.—Sienger Theatres, Inc., & Maison Blanche Co.	500	319	940	Central	Daily, 12:30 to 1:30 pm, 6:30 to 7:30 pm; Mon., Wed., Thu., Sat., 8:30 pm
	WSMH —Owosso, Mich.—Shattuck Music House, 207 Washington St.	20	240	1250	Eastern	Wed., 8 to 10 pm; Sat., 10 to 12 pm; Sun., 10 to 11:30 am

Radio Broadcast Station WBZ

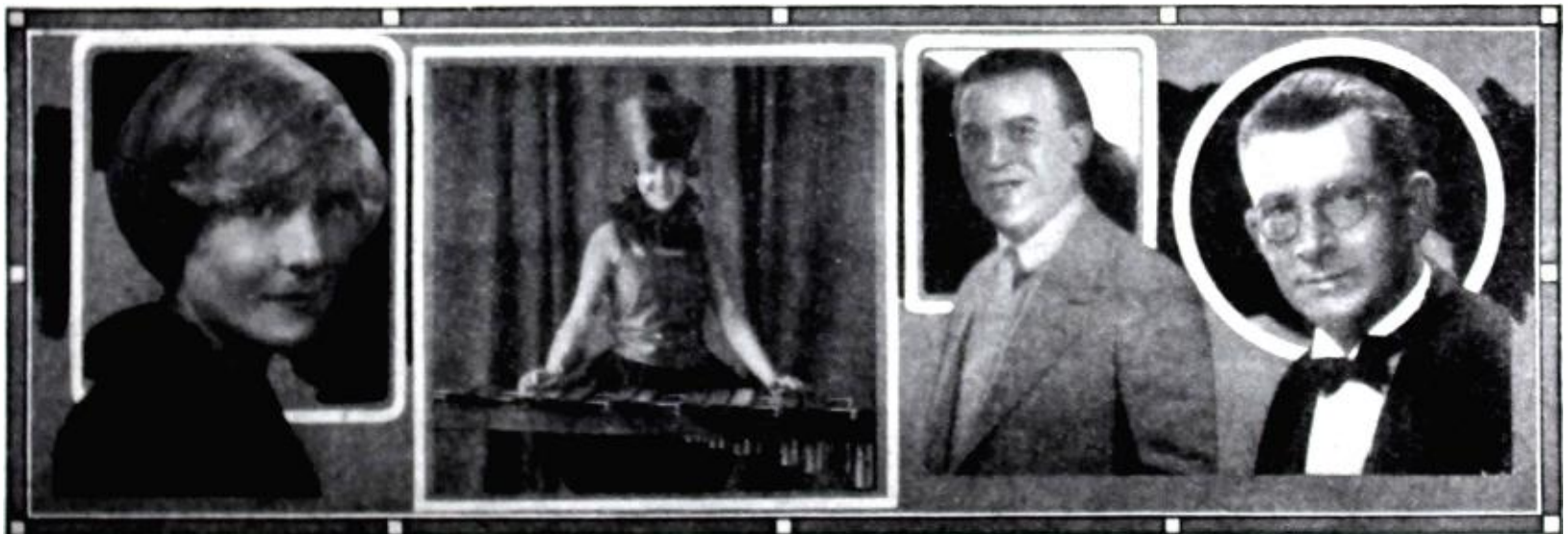

Peg Entwistle, of the Repertory Theatre.

Mary Zoller, xylophonist.

Philip Spitalny, director of the Loew's State 40-piece Concert Orchestra.

W. Edward Boyle, leader of the Copley Plaza orchestra, Boston, whose Sunday night concerts from WBZ meet with popular favor.

Radio Call Letters	BROADCAST STATIONS Location and Owner	Power Watts	Wave Length (Meters)	Frequency (Kilocycles)	Time at Station	Sending Hours
WS	WSMK—Dayton, Ohio—S. M. K. Radio Corporation, 39 East Third St.	500	275	1090	Central	
	WSOE—Milwaukee, Wis.—School of Engineering of Milwaukee, 415 Marshall St.	500	246	1220	Central	
	WSRO—Hamilton, Ohio—The Radio Co., 409-421 High St.	100	252	1190	Central	Tue., 8 to 10 pm; Fri., 8 to 10 pm. Sun.: 2 to 4 pm.
	WSSH—Boston, Mass.—Tremont Temple Baptist Church.	100	261	1150	Eastern	Mon. and Fri., 7:30 to 9 pm. Sun.: 10:30 am to 12 am; 6:30 pm to 9 pm.
	WSUI—Iowa City, Iowa—State University of Iowa	500	484	620	Central	Daily except Sat. and Sun.: 12:30 pm; Mon. of alternate weeks 4 pm; Mon., 7:30 to 8:30 pm; Wed., 9 to 9:30 am; 7:30 to 8:30 pm. Occasional programs are broadcast Sat. at 7:30 pm. Sun.: 9:30 pm to 10 pm. About once a month a Vesper Service program is broadcast at 4 pm.
	WSVS—Buffalo, N. Y.—Seneca Vocational School, Seneca & Hydraulic Sts.	50	219	1370	Eastern	Mon., Wed. and Fri., 9 pm.
	WSWS—Wooddale, Ill.—Illinois Broadcasting Corp.	1000	275	1090	Central	
WT	WTAB—Fall River, Mass.—Fall River Daily Herald	100	266	1130	Eastern	
	WTAD—Carthage, Ill.—Robt. E. Compton	50	236	1270	Central	
	WTAG—Worcester, Mass.—Worcester Telegram Pub. Co.	500	545.1	550	Eastern	
	WTAL—Toledo, Ohio—Toledo Radio & Electric Co., 316 Jackson St.	10	252	1190	Eastern	Mon., 7:30 to 10:30 pm; Tue., 7:30 to 9 pm; Wed. 7:30 to 10:30 pm; Thu., 7:30 to 9 pm; Fri., 7:30 to 10:30 pm; Sat., 7:30 to 9 pm. Sun.: 4 to 6 pm
	WTAM—Cleveland, Ohio—Willard Storage Battery Co.	1000	389.4	770	Eastern	Mon., 6; 8; 10 pm; Wed., 6; 8; 11 pm; Sat., 6; 8 pm.
	WTAP—Cambridge, Ill.—Cambridge Radio & Electric Co.	50	242	1240	Central	
	WTAQ—Eau Claire, Wis.—C. S. Van Gorden	100	254	1180	Central	
	WTAR—Norfolk, Va.—Reliance Electric Co., 519 West 21st St.	100	261	1150	Eastern	Mon., 6:15 pm; Tue., 8 to 9 pm; Wed., 6:15 pm; Thu., 6:15 pm; Fri., 6:15 pm; Sat., 6:15 pm.
	WTAW—College Station, Tex.—Agricultural & Mech- anical College of Texas.	500	270	1110	Central	Wed. and Fri., 8 to 9:30 pm. Sun.: 11 to 12 am.
	WTAX—Streator, Ill.—Williams Hardware Co., 115 So. Vermillion St.	50	231	1300	Central	Thu., 8 to 12 pm.
	WTAZ—Lambertville, N. J.—Thos. J. McGuire	15	261	1150	Eastern	
	WTIC—Hartford, Conn.—Travelers Insurance Co.	500	475.9	630	Eastern	Mon., 11 am to 12 am and 5:30 to 11 pm; Tue., Silent; Wed., 5:30 to 9 pm; Thu., 5:30 to 6:30 pm; Fri., 11 am to 12 am and 5:30 to 11 pm; Sat., 5:30 to 10:30 pm.
WW	WWAE—Plainfield, Ill.—Lawrence J. Crowley	500	242.2	1240	Central	Mon., Silent; Tue., Wed. and Thu., 9 to 12 pm; Fri., 9 pm to 3 am; Sat., 9 pm to 12 pm. Sun.: 9 pm to 12 pm.
	WWJ—Detroit, Mich.—Detroit News	1000	352.7	850	Eastern	Daily: 7:30 to 8:30 am; 9:30 to 9:50 am; 12 to 12:45 pm; 3 to 4 pm; 4 to 5:30 pm; 6 to 7 pm; 8 to 11 pm. Sun.: 11 am to 12:30 pm.
	WWL—New Orleans, La.—Loyola University	100	275	1090	Central	

This list has been corrected up to and including July 31, 1926.

Radio Broadcast Station WKAF

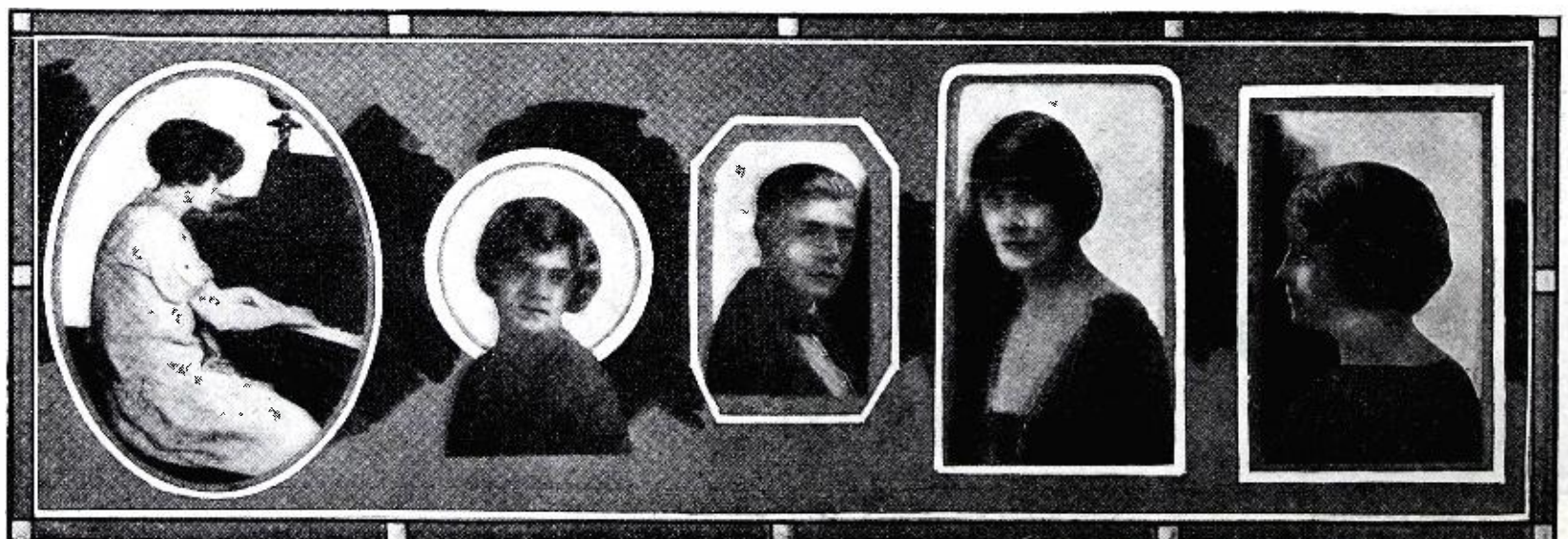

Viola Sontag, pianist.

Olga Christensen, soprano.

Jerry Crittenden, tenor.

Anita De Witte Hall, pianist, composer, hostess.

Della Frederickson, contralto.

Radio Broadcast Station WRNY



Ben Bernie, the maestro himself, as he looks when broadcasting over WRNY.

Helen Koster is a very beautiful and inspiring singer recently come to America.

Olive Wyndham, famous leading woman was guest artist of the Radio Theatre Players.

Helena Rubenstein. She advises WRNY fans on "Beauty."

Radio Broadcast Station WRNY

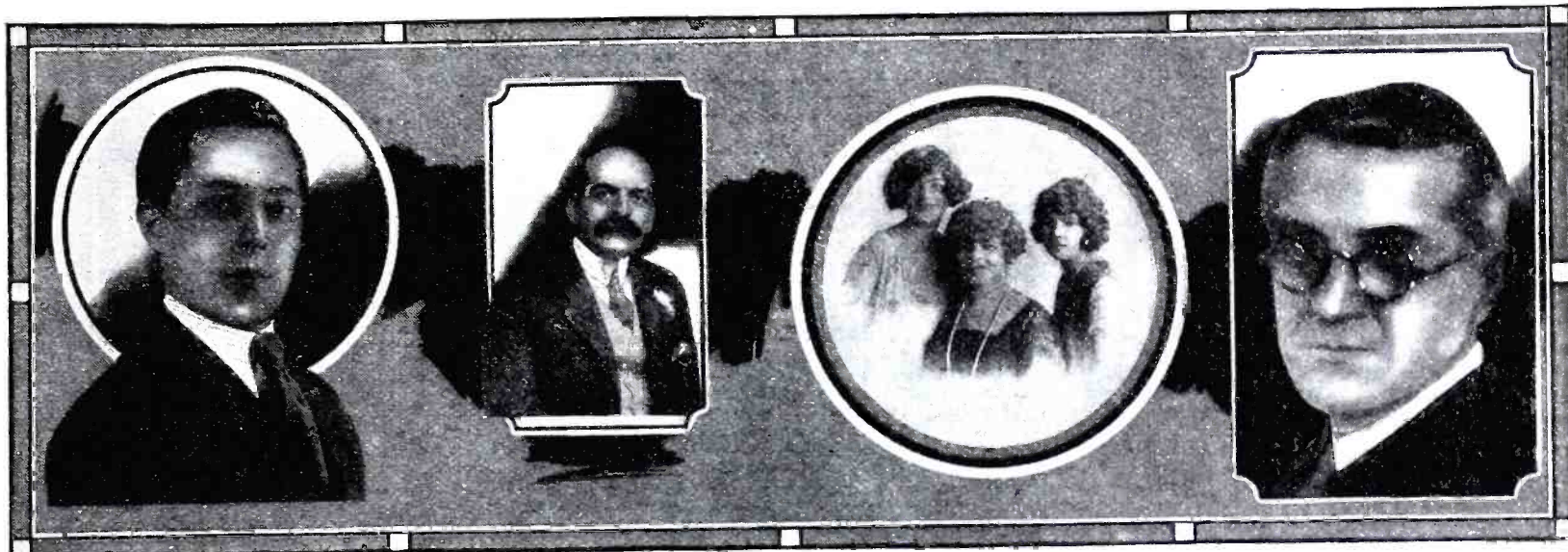

Alfred Rigali is the director of the Radio Theatre Players.

Felix M. Warburg, is one of the world's greatest philanthropists.

The Hulsman Trio, mother and daughters sing and play delightful music.

Geo. Ryken, is the celebrated violinist of Belgium.

Radio Broadcast Station WRNY

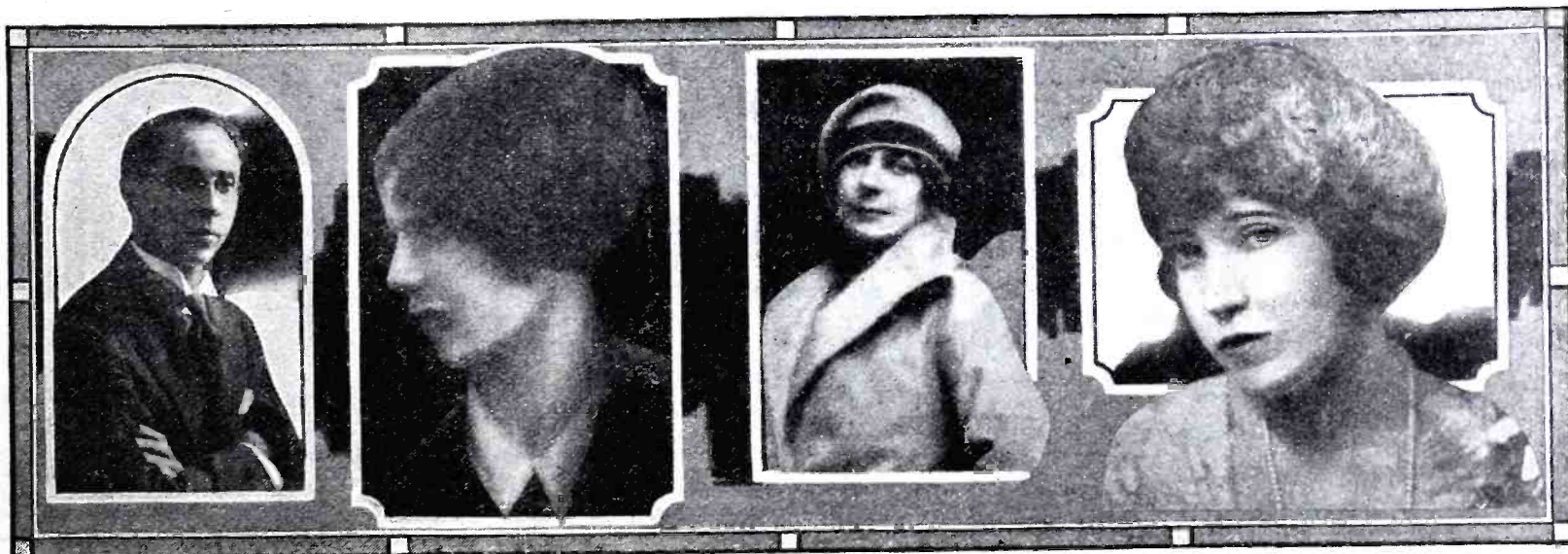

Vladmir Graffman is a well known violinist of Russia.

Florence Gerringer, the peppy little player of popular jazz.

Heleno Romanoff, celebrated Russian singer.

Ruth Connie, who tells women how to dress.

Radio Broadcast Station WEAF

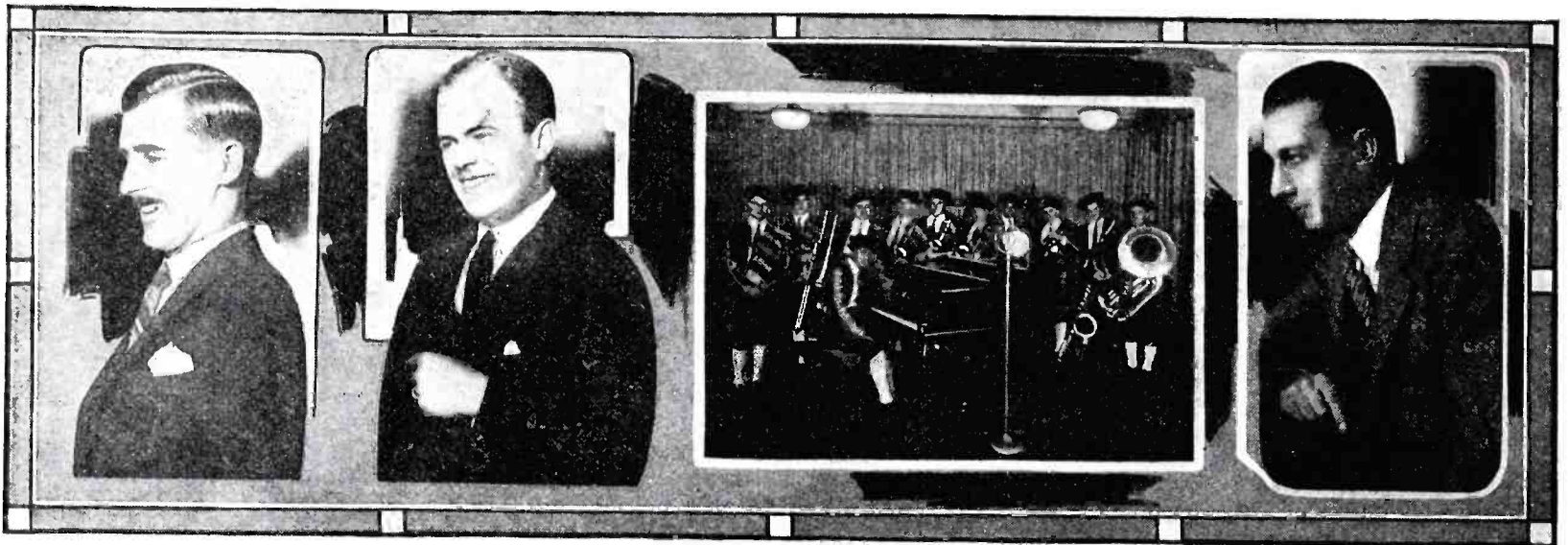

James Haupt, assistant to musical director.

Phillip Carlin, announcer.

"Ipana Troubadours," who are heard every Wednesday evening in a program of dance music from 9:00 to 9:30.

Graham McNamee, announcer.

Radio Broadcast Station WGY

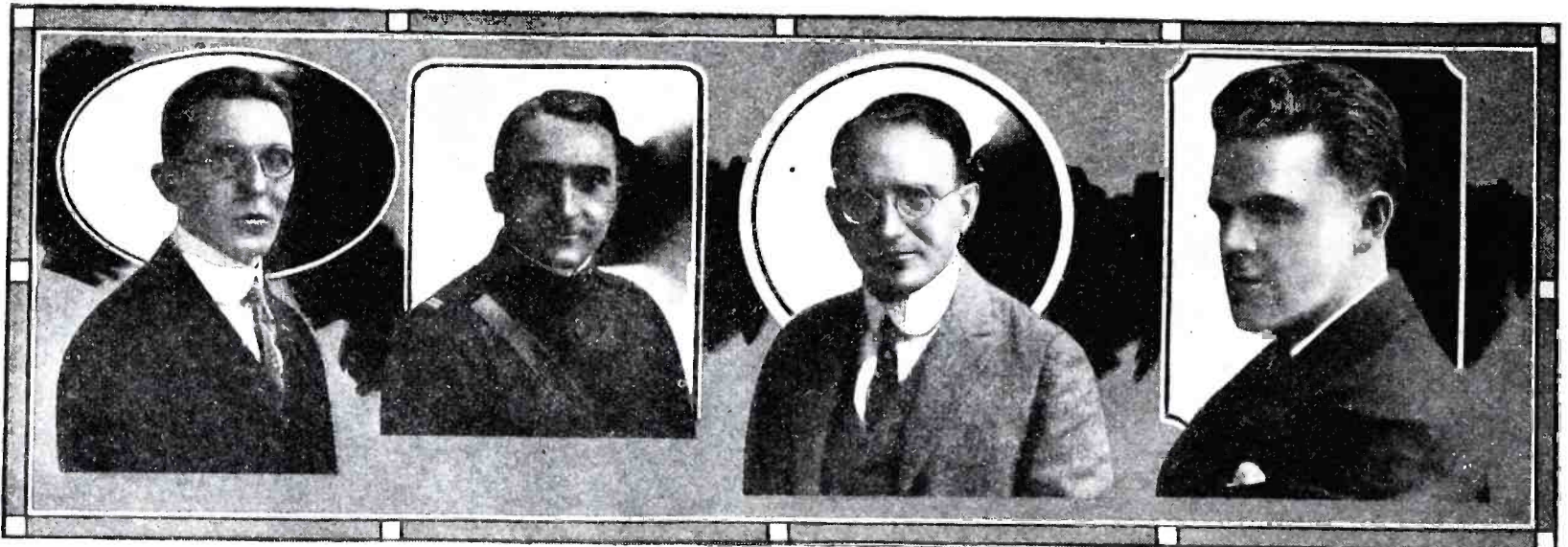

John T. Quinlan, baritone.

Dr. C. W. Woodall, radio physician.

L. A. Huguemont, gives French lessons from WGY.

Walter Reagles, lyric tenor.

Radio Broadcast Station WBAL

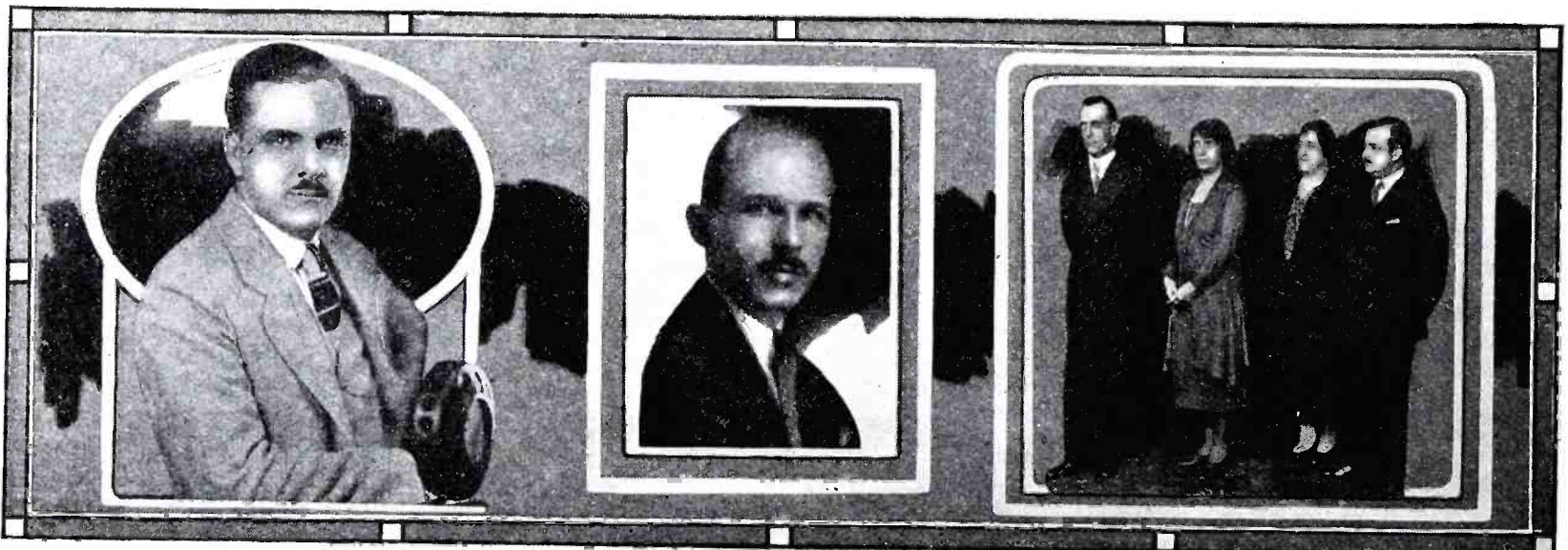

John L. Wilbourn, ballad singer, and assistant studio manager.

Gustav Klemm, director of concert orchestra and program supervisor.

WBAL mixed quartet broadcasts a program every Thursday night from 8.30 to 9; left to right; John Wilbourn, tenor; Louise Cline, soprano; Maud Albert, contralto; Walter N. Linthicum, baritone.

RADIO BROADCAST STATIONS OF THE UNITED STATES

By Wavelengths and Frequencies

Wave Length (Meters)	Frequency (Kilocycles)	Power (Watts)	Call Letters	Location
202.6	1480	500	KFXB	Big Bear Lake, Cal.
202.6	1480	10	WEHS	Evanston, Ill.
202.6	1480	10	WIBS	Elizabeth, N. J.
204	1470	10	WABB	Harrisburg, Pa.
205.4	1460	50	KFVD	San Pedro, Cal.
205.4	1460	10	KFXD	Logan, Utah
205.4	1460	50	KFXY	Flagstaff, Ariz.
205.4	1460	10	KFYF	Oxnard, Cal.
205.4	1460	100	WFRL	Brooklyn, N. Y.
205.4	1460	150	WIBX	Utica, N. Y.
205.4	1460	50	WPDQ	Buffalo, N. Y.
206.8	1450	50	WABW	Wooster, Ohio
206.8	1450	50	WJBA	Joliet, Ill.
207	1450	250	KFWM	Oakland, Cal.
207	1450	50	KGTT	San Francisco, Cal.
208	1440	250	KNRC	Los Angeles, Cal.
209.7	1430	10	KFYO	Texarkana, Tex.
209.7	1430	100	KSMR	Santa Maria, Cal.
209.7	1430	100	WCBR	Providence, R. I.
209.7	1430	100	WCWS	Providence, R. I.
209.7	1430	30	WIBH	New Bedford, Mass.
210	1430	1000	WSBC	Chicago, Ill.
211.1	1420	5	KFWC	San Bernardino, Cal.
211.1	1420	250	KFWO	Avalon, Catalina Island, Cal.
211.1	1420	100	WJBU	Lewisburg, Pa.
212.6	1410	50	KFWV	Portland, Oregon
212.6	1410	100	WMAL	Washington, D. C.
214.2	1400	250	KFWF	St. Louis, Mo.
214.2	1400	15	KFXR	Oklahoma Okla.
214.2	1400	150	WCLS	Joliet, Ill.
214.2	1400	100	WKBB	Joliet, Ill.
215.6	1390	100	WPRC	Harrisburg, Pa.
215.7	1390	50	KFBC	San Diego, Cal.
215.7	1390	50	KFQW	North Bend, Wash.
215.7	1390	10	KFXJ	Edgewater, Colo.
215.7	1390	50	WBBZ	Chicago, Ill.
215.7	1390	50	WHBL	Chicago, Ill.
215.7	1390	20	WHBM	Chicago, Ill.
215.7	1390	50	WIBJ	Chicago, Ill.
215.7	1390	10	WIBM	Chicago, Ill.
215.7	1390	100	WKBG	Chicago, Ill.
215.7	1390	250	WRST	Bay Shore, N. Y.
216	1390	100	WHBW	Philadelphia, Pa.
217.3	1380	50	KFAF	San Jose, Cal.
217.3	1380	100	KFQU	Alma, (Holy City) Cal.
217.3	1380	500	WFKB	Chicago, Ill.
217.3	1380	5000	WOK	Chicago, Ill.

Wave Length (Meters)	Frequency (Kilocycles)	Power (Watts)	Call Letters	Location
218.8	1370	10	KFJC	Junction City, Kans.
218.8	1370	50	KFRW	Olympia, Wash.
218.8	1370	10	WHBU	Anderson, Ind.
218.8	1370	50	WIBI	Flushing, N. Y.
218.8	1370	250	WJBI	Red Bank, N. J.
219	1370	50	WSVS	Buffalo, N. Y.
220	1360	100	KFUU	Oakland, Cal.
220	1360	5	KJBS	San Francisco, Cal.
220	1360	100	WIBW	Logansport, Ind.
220	1360	500	WQAA	Parkersburg, Pa.
222	1350	50	WBBW	Norfolk, Va.
222	1350	100	WBES	Takoma Park, Md.
222	1350	100	WCMA	Culver, Ind.
222	1350	500	WCOA	Pensacola, Fla.
222	1350	20	WHBD	Bellefontaine, O.
222	1350	100	WHBF	Rock Island, Ill.
222	1350	50	WIBG	Elkins Park, Pa.
222	1350	20	WIBU	Poynette, Wis.
223.7	1340	10	KFQP	Iowa City, Ia.
223.8	1340	100	WRAF	Laport, Ind.
224	1340	100	KFBL	Everett, Wash.
224	1340	50	KFUR	Ogden, Utah
224	1340	50	KFVS	Cape Girardeau, Mo.
224	1340	50	WKAV	Laconia, N. H.
224	1340	10	WNRC	Greensboro, N. C.
224	1340	250	WODA	Paterson, N. J.
225.4	1330	50	WAGM	Royal Oak, Mich.
225.4	1330	1500	WBBM	Chicago, Ill.
225.4	1330	10	WEBQ	Harrisburg, Ill.
226	1330	10	KFGQ	Boone, Iowa
226	1330	10	KFKZ	Kirksville, Mo.
226	1330	50	KFOB	Burlingame, Cal.
226	1330	100	KFOR	David City, Neb.
226	1330	50	KFQZ	Hollywood, Cal.
226	1330	500	KFWI	San Francisco, Calif.
226	1330	150	WDAD	Nashville, Tenn.
226	1330	100	WEBL	U. S. (Portable)
226	1330	10	WFBE	Seymour, Ind.
226	1330	1000	WIBO	Chicago, Ill.
227	1320	50	KFVN	Fairmont, Minn.
227	1320	500	WOWO	Ft. Wayne, Ind.
227.1	1320	50	WJBR	Omro, Wis.
229	1310	100	KFLV	Rockford, Ill.
229	1310	1000	KMMJ	Clay Center, Nebr.
229	1310	50	KPPC	Pasadena, Cal.
229	1310	10	WAIT	Taunton, Mass.
229	1310	50	WBBL	Richmond, Va.
229	1310	50	WCBM	Baltimore, Md.
229	1310	50	WDBJ	Roanoke, Va.
229	1310	10	WGBR	Marshfield, Wis.
229	1310	250	WSAJ	Grove City, Pa.
229	1310	100	WSAN	Allentown, Pa.
230.6	1300	500	KFPR	Los Angeles, Cal.
230.6	1300	50	WCLO	Camp Lake, Wis.
230.6	1300	10	WIBZ	Montgomery, Ala.
231	1300	5	KDLR	Devils Lake, N. D.
231	1300	10	KFDZ	Minneapolis, Minn.

Wave Length (Meters)	Frequency (Kilocycles)	Power (Watts)	Call Letters	Location
231	1300	50	KFOT	Wichita, Kans.
231	1300	500	KQW	San Jose, Cal.
231	1300	500	KUT	Austin, Tex.
231	1300	100	WBRE	Wilkes-Barre, Pa.
231	1300	20	WHBG	Harrisburg, Pa.
231	1300	100	WKBE	Webster, Mass.
231	1300	50	WTAX	Streator, Ill.
233	1290	10	KFEY	Kellogg, Idaho
233	1290	500	KFON	Long Beach, Calif.
233	1290	10	WDBZ	Kingston, N. Y.
233	1290	50	WHBQ	Memphis, Tenn.
233	1290	10	WJBK	Ypsilanti, Mich.
233	1290	50	WOKO	Peekskill, N. Y.
234	1280	50	KFUP	Denver, Colo.
234	1280	50	KMJ	Fresno, Cal.
234	1280	100	WFDF	Flint, Mich.
234	1280	100	WQAC	Amarillo, Tex.
234.2	1280	500	WGBX	Orono, Me.
234.2	1280	100	WJBC	La Salle, Ill.
234.4	1280	50	WHBJ	Fort Wayne, Ind.
236	1270	20	KFLU	San Benito, Tex.
236	1270	250	KFOO	Salt Lake City, Utah
236	1270	15	KFVG	Independence, Kans.
236	1270	100	KWKC	Kansas City, Mo.
236	1270	100	WBOQ	Richmond Hill, N. Y.
236	1270	250	WCAM	Camden, N. J.
236	1270	100	WFBJ	Collegeville, Minn.
236	1270	500	WGBF	Evansville, Ind.
236	1270	100	WGMU	Richmond Hill, N. Y.
236	1270	100	WRMU	Richmond Hill, N. Y. (Yacht)
236	1270	50	WTAD	Carthage, Ill.
236.1	1270	100	WIBA	Madison, Wis.
238	1260	15	KFBS	Trinidad, Colo.
238	1260	100	KFCB	Phoenix, Ariz.
238	1260	100	KFWU	Pineville, La.
238	1260	10	KFYJ	Houston, Tex.
238	1260	500	KMTR	Hollywood, Cal.
238	1260	200	WBBP	Petoskey, Mich.
238	1260	10	WHBN	St. Petersburg, Fla.
238	1260	3500	WHT	Chicago, Ill.
238	1260	10	WRAW	Reading, Pa.
239.9	1250	100	KFUM	Colorado Springs, Colo.
240	1250	10	KFHL	Oskaloosa, Iowa
240	1250	10	KFLX	Galveston, Tex.
240	1250	500	KFVE	St. Louis, Mo.
240	1250	10	KFVI	Houston, Tex.
240	1250	1000	KTAB	Oakland, Cal.
240	1250	100	KZM	Oakland, Cal.
240	1250	100	WABI	Bangor, Me.
240	1250	50	WCAT	Rapid City, S. D.
240	1250	500	WDBO	Winter Park, Fla.
240	1250	10	WGBI	Scranton, Pa.
240	1250	500	WOAX	Trenton, N. J.
240	1250	20	WSMH	Owosso, Mich.
242	1240	50	KFFP	Moberly, Mo.
242	1240	10	KFPM	Greenville, Tex.
242	1240	50	KFXH	El Paso, Tex.

RADIO BROADCAST STATIONS OF THE U. S. BY WAVELENGTHS AND FREQUENCIES

Wave Length (Meters)	Frequency (Kilocycles)	Power (Watts)	Call Letters	Location
242	1240	500	KSO	Clarinda, Iowa
242	1240	50	WABY	Philadelphia, Pa.
242	1240	100	WBAW	Nashville, Tenn.
242	1240	250	WBZA	Boston, Mass.
242	1240	50	WCBH	Oxford, Miss.
242	1240	100	WEBC	Superior, Wis.
242	1240	1000	WOOD	Grand Rapids, Mich.
242	1240	50	WTAP	Cambridge, Ill.
242.2	1240	500	WWAE	Plainfield, Ill.
243.8	1230	1000	WAMD	Minneapolis, Minn.
243.8	1230	100	WATT	Boston, Mass.
243.8	1230	100	WRAM	Galesburg, Ill.
244	1230	50	KFVR	Denver, Colo.
244	1230	500	KUOM	Missoula, Mont.
244	1230	100	WEBR	Buffalo, N. Y.
244	1230	100	WGBB	Freeport, N. Y.
244	1230	100	WNAX	Yankton, S. D.
244	1230	50	WSAZ	Pomeroy, Ohio
245.8	1220	1000	KFSD	San Diego, Cal.
246	1220	50	KDYL	Salt Lake City, Utah
246	1220	10	KFJI	Astoria, Oregon
246	1220	50	KFJY	Fort Dodge, Ia.
246	1220	50	KGY	Lacey, Wash.
246	1220	500	WABX	Mount Clemens, Mich.
246	1220	5000	WBAL	Glen Morris, Md. (near)
246	1220	50	WIBR	Weirton, W. Va.
246	1220	50	WQAE	Springfield, Vt.
246	1220	500	WRR	Dallas, Tex.
246	1220	500	WSOE	Milwaukee, Wis.
247.8	1210	1000	WIOD	Miami Beach, Fla.
248	1210	100	KFBK	Sacramento, Cal.
248	1210	50	KFEC	Portland, Oregon
248	1210	100	KFIF	Portland, Oregon
248	1210	10	KFJB	Marshalltown, Ia.
248	1210	100	KFOX	Omaha, Neb.
248	1210	250	KFRB	Beeville, Tex.
248	1210	10	KFYR	Bismark, N. D.
248	1210	50	KWG	Stockton, Cal.
248	1210	1000	WAPI	Auburn, Ala.
248	1210	50	WBRC	Birmingham, Ala.
248	1210	100	WCSO	Springfield, O.
248	1210	1000	WEW	St. Louis, Mo.
248	1210	10	WGAL	Lancaster, Pa.
248	1210	100	WMAY	St. Louis, Mo.
248	1210	250	WNBH	New Bedford, Mass.
250	1200	100	KFDX	Shreveport, La.
250	1200	10	KFVY	Albuquerque, N. Mex.
250	1200	500	KXFX	Colorado Springs, Colo.
250	1200	250	KLS	Oakland, Cal.
250	1200	250	KMO	Tacoma, Wash.
250	1200	50	WFBC	Knoxville, Tenn.
250	1200	500	WGES	Chicago, Ill.
250	1200	10	WHBA	Oil City, Pa.
250	1200	50	WHBY	West De Pere, Wis.
250	1200	100	WIAD	Philadelphia, Pa.
250	1200	100	WLAL	Tulsa, Okla.
250	1200	500	WMBB	Chicago, Ill.
250	1200	100	WNAB	Boston, Mass.

Wave Length (Meters)	Frequency (Kilocycles)	Power (Watts)	Call Letters	Location
250	1200	100	WNAT	Philadelphia, Pa.
250	1200	100	WQAN	Scranton, Pa.
252	1190	50	KFHA	Gunnison, Colo.
252	1190	50	KFOY	St. Paul, Minn.
252	1190	15	KFPL	Dublin, Tex.
252	1190	500	KFWB	Hollywood, Calif.
252	1190	500	KMA	Shenandoah, Iowa
252	1190	200	KOCW	Chickasha, Okla.
252	1190	50	KWUC	Le Mars, Iowa
252	1190	50	WBBS	New Orleans, La.
252	1190	100	WCAX	Burlington, Vt.
252	1190	100	WFBL	Syracuse, N. Y.
252	1190	500	WGCP	Newark, N. J.
252	1190	100	WRCO	Raleigh, N. C.
252	1190	50	WRHM	Minneapolis, Minn.
252	1190	100	WSRO	Hamilton, Ohio
252	1190	10	WTAL	Toledo, Ohio
254	1180	50	KFEL	Denver, Colo.
254	1180	50	KFJZ	Fort Worth, Tex.
254	1180	100	KFLR	Albuquerque, N. M.
254	1180	100	KFWH	Chico, Calif.
254	1180	20	WABC	Asheville, N. C.
254	1180	500	WCAJ	University Place, Neb.
254	1180	200	WCBA	Allentown, Pa.
254	1180	500	WEAI	Ithaca, N. Y.
254	1180	100	WFBR	Baltimore, Md.
254	1180	20	WFBZ	Galesburg, Ill.
254	1180	10	WHBC	Canton, Ohio
254	1180	100	WIAS	Burlington, Iowa
254	1180	50	WJAK	Kokomo, Ind.
254	1180	10	WJBB	St. Petersburg, Fla.
254	1180	500	WNAD	Norman, Okla.
254	1180	10	WREC	Coldwater, Miss.
254	1180	100	WSAR	Fall River, Mass.
254	1180	100	WTAQ	Eau Claire, Wis.
256	1170	100	KFIQ	Yakima, Wash.
256	1170	50	KFUS	Oakland, Calif.
256	1170	500	KOWW	Walla Walla, Wash.
256	1170	100	KRE	Berkeley, Calif.
256	1170	500	KTNT	Muscatine, Iowa
256	1170	100	WBAX	Wilkes-Barre, Pa.
256	1170	500	WDOD	Chattanooga, Tenn.
256	1170	100	WHBP	Johnstown, Pa.
256	1170	50	WRHF	Washington, D. C.
256	1170	1000	WRVA	Richmond, Va.
256.3	1170	500	WCSH	Portland, Me.
256.3	1170	100	WRAK	Escanaba, Mich.
256.4	1170	500	WBDC	Grand Rapids, Mich.
256.4	1170	100	WMBC	Detroit, Mich.
258	1160	20	KFPW	Cartersville, Mo.
258	1160	50	KFUL	Galveston, Tex.
258	1160	250	KOCH	Omaha, Neb.
258	1160	25	WAAD	Cincinnati, Ohio
258	1160	100	WABO	Rochester, N. Y.
258	1160	500	WADC	Akron, Ohio
258	1160	100	WHEC	Rochester, N. Y.
258	1160	50	WNAL	Omaha, Neb.

Wave Length (Meters)	Frequency (Kilocycles)	Power (Watts)	Call Letters	Location
258	1160	500	WPCC	Chicago, Ill.
258.5	1160	100	WLTS	Chicago, Ill.
261	1150	500	KFJF	Oklahoma, Okla.
261	1150	100	KFMR	Sioux City, Iowa
261	1150	100	KFUT	Salt Lake City, Utah
261	1150	500	KFWA	Ogden, Utah
261	1150	100-1000	WABQ	Haverford, Pa.
261	1150	100	WARC	Medford Hillside, Mass.
261	1150	50	WDAY	Fargo, N. D.
261	1150	250	WEAM	North Plainfield, N. J.
261	1150	500-5000	WKAJ	Milwaukee, Wis.
261	1150	500	WMAZ	Macon, Ga.
261	1150	500	WPSC	State College, Pa.
261	1150	100	WSKC	Bay City, Mich.
261	1150	100	WSSH	Boston, Mass.
261	1150	100	WTAR	Norfolk, Va.
261	1150	15	WTAZ	Lambertville, N. J.
263	1140	50	KFJR	Portland, Ore.
263	1140	1000	KFNF	Shenandoah, Iowa
263	1140	50	KTBR	Portland, Ore.
263	1140	500	WAAM	Newark, N. J.
263	1140	50	WABR	Toledo, Ohio
263	1140	250	WCAD	Canton, N. Y.
263	1140	2000	WCAR	San Antonio, Tex.
263	1140	5	WCBE	New Orleans, La.
263	1140	100	WDAG	Amarillo, Tex.
263	1140	500	WDGY	Minneapolis, Minn.
263	1140	50	WEBZ	Savannah, Ga.
263	1140	100	WQAM	Miami, Fla.
263	1140	100	WRAV	Yellow Springs, Ohio
263	1140	250	WSDA	New York, N. Y.
265.3	1130	100	KFIO	Spokane, Wash.
266	1130	100	KFPY	Spokane, Wash.
266	1130	250	KLZ	Denver, Colo.
266	1130	500	WBCN	Chicago, Ill.
266	1130	50	WDEL	Wilmington, Del.
266	1130	1000	WENR	Chicago, Ill.
266	1130	500	WGHB	Clearwater, Fla.
266	1130	500	WMAK	Lockport, N. Y.
266	1130	100	WTAB	Fall River, Mass.
267.7	1120	50	KFRC	San Francisco, Cal.
267.7	1120	50	WDAH	El Paso, Tex.
267.9	1120	10	WBBY	Charleston, S. C.
268	1120	500	KFEQ	Oak, Neb.
268	1120	500	KFH	Wichita, Kans.
268	1120	100	WDRC	New Haven, Conn.
268	1120	500	WEBW	Beloit, Wis.
268	1120	250	WFBM	Indianapolis, Ind.
268	1120	100	WJAM	Cedar Rapids, Iowa
268	1120	100	WJBO	New Orleans, La.
268	1120	100	WNOX	Knorrville, Tenn.
268	1120	500	WRAX	Gloucester City, N. J.
268	1120	100	WSAX	Chicago, Ill.
270	1110	500	KFBU	Laramie, Wyo.
270	1110	100	WBAO	Decatur, Ill.
270	1110	100	WDBE	Atlanta, Ga.

Wave Length (Meters)	Frequency (Kilocycles)	Power (Watts)	Call Letters	Location
270	1110	500	WEAN	Providence, R. I.
270	1110	1500	WGHP	Detroit, Mich.
270	1110	500	WGST	Atlanta, Ga.
270	1110	250	WJAG	Norfolk, Nebr.
270	1110	500	WJBL	Decatur, Ill.
270	1110	750	WOI	Ames, Iowa
270	1110	10	WOWL	New Orleans, La.
270	1110	100	WRK	Hamilton, Ohio
270	1110	500	WTAW	College Station, Tex.
272.6	1100	100	KFAD	Phoenix, Ariz.
272.6	1100	500	WEBJ	New York, N. Y.
272.6	1100	500	WFBH	New York, N. Y.
272.6	1100	1000	WHK	Cleveland, Ohio
273	1100	100	KFDY	Brookings, S. Dak.
273	1100	100	KFIZ	Fondulac, Wis.
273	1100	50	KFKA	Greeley, Colo.
273	1100	100	KFLZ	Anita, Iowa
273	1100	250	WBAA	Lafayette, Ind.
273	1100	250	WDAE	Tampa, Fla.
273	1100	10	WFAM	St. Cloud, Minn.
273	1100	250	WIL	St. Louis, Mo.
273	1100	500	WRM	Urbana, Ill.
273	1100	500	WRW	Tarrytown, N. Y.
273	1100	250	WSBF	St. Louis, Mo.
275	1090	50	KFBB	Havre, Mont.
275	1090	500	KFKU	Lawrence, Kans.
275	1090	500	KFSG	Los Angeles, Cal.
275	1090	500	KQV	Pittsburgh, Pa.
275	1090	50	WABZ	New Orleans, La.
275	1090	500	WAFD	Port Huron, Mich.
275	1090	500	WBAK	Harrisburg, Pa.
275	1090	250	WBT	Charlotte, N. C.
275	1090	500	WCAC	Storrs, Conn.
275	1090	100	WCAO	Baltimore, Md.
275	1090	100	WEAU	Sioux City, Iowa
275	1090	500	WFAV	Lincoln, Neb.
275	1090	500	WHAD	Milwaukee, Wis.
275	1090	500	WHAR	Atlantic City, N. J.
275	1090	100	WKY	Oklahoma, Okla.
275	1090	20	WLAP	Louisville, Ky.
275	1090	100	WMAC	Cazenovia, N. Y.
275	1090	5000	WORD	Batavia, Ill.
275	1090	100	WPAK	Fargo, N. D.
275	1090	500	WSBT	South Bend, Ind.
275	1090	500	WSMK	Dayton, Ohio
275	1090	1000	WSWS	Wooddale, Ill.
275	1090	100	WWL	New Orleans, La.
275.2	1090	15	WOCL	Jamestown, N. Y.
276.6	1080	500	WCAU	Philadelphia, Pa.
277.6	1080	500	WLB	Minneapolis, Minn.
277.8	1080	100	WFBG	Altoona, Pa.
278	1080	100	KFJM	Grand Forks, N. D.
278	1080	500	KOIL	Council Bluffs, Iowa
278	1080	100	KUSD	Vermillion, S. D.
278	1080	500	KWCR	Cedar Rapids, Iowa
278	1080	500	KWWG	Brownsville, Tex.
278	1080	200	WAAF	Chicago, Ill.

Wave Length (Meters)	Frequency (Kilocycles)	Power (Watts)	Call Letters	Location
278	1080	100	WDZ	Tuscola, Ill.
278	1080	10	WGBC	Memphis, Tenn.
278	1080	500	WGBU	Fulford-by-the-Sea, Fla.
278	1080	100	WHAM	Rochester, N. Y.
278	1080	500	WHDI	Minneapolis, Minn.
278	1080	500	WLBL	Madison, Wis.
278	1080	1000	WOQ	Kansas City, Mo.
278	1080	500	WRBC	Valparaiso, Ind.
278.6	1080	50	KFDD	Boise, Idaho
280	1070	750	KFAU	Boise, Idaho
280.2	1070	5000	KFQA	St. Louis, Mo.
280.2	1070	1500	KMOX	St. Louis, Mo.
280.2	1070	500	KOAC	Corvallis, Ore.
280.2	1070	500	WNAC	Boston, Mass.
282.8	1060	500	WOAN	Lawrenceburg, Tenn.
282.8	1060	1000	WSM	Nashville, Tenn.
285.5	1050	1000	WKAR	East Lansing, Mich.
285.5	1050	500	WREO	Lansing, Mich.
286	1050	500	WEMC	Berrien Springs, Mich.
286	1050	50	WMAN	Columbus, Ohio
288	1040	3500	WLWL	New York, N. Y.
288.3	1040	5000	KFKX	Hastings, Neb.
293.9	1020	750	KTBI	Los Angeles, Cal.
293.9	1020	500	WAIU	Columbus, Ohio
293.9	1020	500	WEAO	Columbus, Ohio
296.9	1010	500	KPRC	Houston, Tex.
299.8	1000	1000	KSL	Salt Lake City, Utah
299.8	1000	750	KUOA	Fayetteville, Ark.
299.8	1000	500	WPG	Atlantic City, N. J.
302.8	990	500	WMSG	New York, N. Y.
303	990	1000	WGN	Chicago, Ill.
303	990	4000	WLIB	Chicago, Ill.
305.9	980	1000	KTCL	Seattle, Wash.
305.9	980	500	WJAR	Providence, R. I.
309.1	970	Var.	KDKA	Pittsburgh, Pa.
315.6	950	500	KFDM	Beaumont, Tex.
315.6	950	1000	KPSN	Pasadena, Cal.
315.6	950	500	WAHG	Richmond Hill, N. Y.
315.6	950	500	WGBS	New York, N. Y.
319	940	1000	KOIN	Portland, Ore.
319	940	750	WGR	Buffalo, N. Y.
319	940	500	WSMB	New Orleans, La.
322	930	500	WBNY	New York, N. Y.
322.4	930	5000	KOA	Denver, Colo.
325.9	920	1000	WKRC	Cincinnati, Ohio
325.9	920	5000	WSAI	Cincinnati, Ohio
327	917	50	WDBK	Cleveland, Ohio
329	911	1000	KWKH	Shreveport, La.
329.8	910	5000	WJAZ	Chicago, Ill.
331.1	900	2000	WBZ	Springfield, Mass.
336.9	890	500	KFMX	Northfield, Minn.
336.9	890	1000	KNX	Los Angeles, Cal.
336.9	890	500	WCAL	Northfield, Minn.
336.9	890	500	WJAS	Pittsburgh, Pa.
336.9	890	1000	WJAX	Jacksonville, Fla.
340.7	880	1000	KFAB	Lincoln, Nebr.
340.7	880	500	KSAC	Manhattan, Kans.

Wave Length (Meters)	Frequency (Kilocycles)	Power (Watts)	Call Letters	Location
341	880	500	WMCA	New York, N. Y.
344.6	870	5000	WCBD	Zion, Ill.
345	870	5000	WLS	Chicago, Ill.
348.6	860	1000	KOB	State College, N. Mex.
348.6	860	500	KWSC	Pullman, Wash.
348.6	860	500	WEEI	Boston, Mass.
348.6	860	150	WNJ	Newark, N. J.
352.7	850	500	WJAD	Waco, Tex.
352.7	850	1000	WWJ	Detroit, Mich.
360	833	100	WQAO	New York, N. Y.
360.1	833	500	WHN	New York, N. Y.
361.2	833	4000	KGO	Oakland, Cal.
365.6	820	1000	WDAF	Kansas City, Mo.
365.6	820	500	WHB	Kansas City, Mo.
370	810	2000	WEBH	Chicago, Ill.
370.2	810	500	WJJD	Mooseheart, Ill.
374.8	800	750	KTHS	Hot Springs National Park, Ark.
374.8	800	500	WRNY	New York, N. Y.
375	800	500	KVOO	Bristow, Okla.
379.5	790	10000	WGY	Schenectady, N. Y.
379.5	790	500	WHAZ	Troy, N. Y.
384.4	780	1000	KJR	Seattle, Wash.
384.4	780	500	WAAW	Omaha, Neb.
384.4	780	500	WMBF	Miami Beach, Fla.
389.4	770	1000	WEAR	Cleveland, Ohio
389.4	770	1000	WTAM	Cleveland, Ohio
394.5	760	1000	KHQ	Spokane, Wash.
394.5	760	500	WFI	Philadelphia, Pa.
394.5	760	500	WLIT	Philadelphia, Pa.
394.5	760	2000	WOAI	San Antonio, Tex.
399.8	750	500	WHAS	Louisville, Ky.
405	740	500	WOR	Newark, N. J.
405.2	740	500	KHJ	Los Angeles, Cal.
405.2	740	1000	WJY	New York, N. Y.
416.4	720	500	WBRR	Rossville, N. Y.
416.4	720	5000	WCCO	St. Paul-Minneapolis, Minn.
422.3	710	1000	WKRC	Cincinnati, Ohio
422.3	710	5000	WLW	Cincinnati, Ohio
428.3	700	1000	KPO	San Francisco, Cal.
428.3	700	1000	WSB	Atlanta, Ga.
431	695	500	WHAP	New York, N. Y.
434.5	690	1000	NAA	Arlington, Va.
440.9	680	1000	KLDS	Independence, Mo.
440.9	680	500	WDWF-WLSI	Cranston, R. I.
440.9	680	1000	WMAF	Dartmouth, Mass.
440.9	680	500	WOS	Jefferson City, Mo.
447.5	670	1000	WMAQ	Chicago, Ill.
447.5	670	500	WQJ	Chicago, Ill.
454.3	660	1000	KFOA	Seattle, Wash.
454.3	660	1500	KTW	Seattle, Wash.
455	660	50000	WJZ	New York, N. Y.
461.3	650	500	WCAE	Pittsburgh, Pa.
467	640	4000	KFI	Los Angeles, Calif.
468.5	640	1000	WRC	Washington, D. C.
469	640	500	WCAP	Washington, D. C.
475.9	630	1500	WBAP	Fort Worth, Tex.
475.9	630	500	WFAA	Dallas, Tex.

Wave Length (Meters)	Frequency (Kilocycles)	Power (Watts)	Call Letters	Location
475.9	630	500	WTIC	Hartford, Conn.
483.6	620	5000	WOC	Davenport, Iowa
484	620	500	WSUI	Iowa City, Iowa
491.5	610	500	WCFL	Chicago, Ill.
491.5	610	5000	WEAF	New York, N. Y.
492.5	609	1000	KGW	Portland, Ore.
499.7	600	500	KFRU	Columbia, Mo.
499.7	600	500	WMC	Memphis, Tenn.
508	590	500	KLX	Oakland, Cal.
508.2	590	1000	KFQB	Fort Worth, Tex.
508.2	590	500	WIP	Philadelphia, Pa.
508.2	590	500	WOO	Philadelphia, Pa.
516.9	580	5000	WCX	Pontiac, Mich.
516.9	580	5000	WJR	Detroit, Mich.
526	570	5000	WHO	Des Moines, Iowa
526	570	1000	WNYC	New York, N. Y.
526	570	1000	WOAW	Omaha, Neb.
535.4	560	750	WHA	Madison, Wis.
536	560	2000	KYW	Chicago, Ill.
545.1	550	500	KFUO	St. Louis, Mo.
545.1	550	500	KSD	St. Louis, Mo.
545.1	550	500	WTAG	Worcester, Mass

This list has been corrected up to and including July 31, 1926.

Radio Broadcast Station WEAF



Mathilde Harding, the newest addition to WEAF's staff of hostess-accompanists.

A. & P. Gypsies, who are heard on Monday evenings, from 9:00 to 10:00.

Ralph G. Wentworth, one of WEAF's popular announcers.

Louis Katzman, leader of Whittal Anglo-Persians.

Radio Broadcast Station WBZ

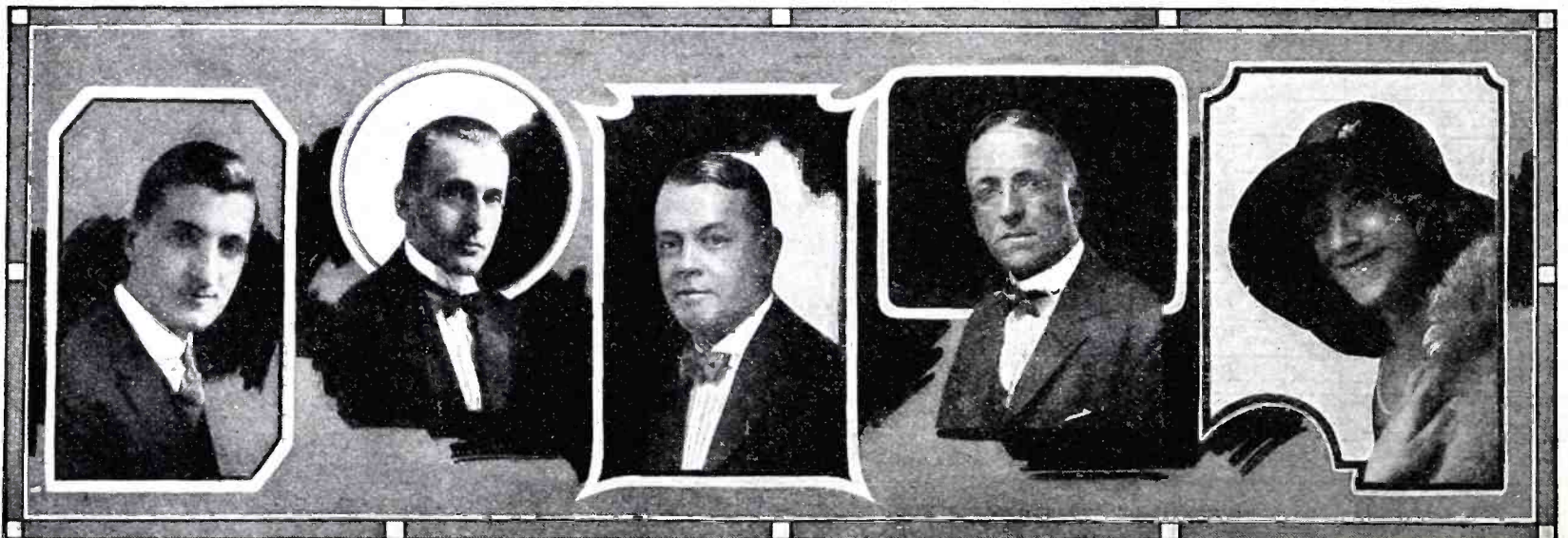

Alwyn E. Bach, "The Singing Announcer."

Paul A. Noffke, National known magician.

Dr. Frank D. Stanton, widely known physician and professor.

Thornton W. Burgess, naturalist and story writer.

Emiler W. Sturtevant, program director.

RADIO BROADCAST STATIONS OF THE UNITED STATES

By States and Cities

States	Cities	Call Letters	Wave Length (Meters)	Power Watts
ALABAMA	Auburn	WAPI	248	1000
"	Birmingham	WBRC	248	50
"	Montgomery	WIBZ	230.6	10
ARIZONA	Flagstaff	KFXV	205.4	50
"	Phoenix	KFAD	272.6	100
"	Phoenix	KFCB	238	100
ARKANSAS	Fayetteville	KUOA	299.8	750
"	Hot Springs, National Park	KTHS	374.8	750
CALIFORNIA	Alma (Holy City)	KFQU	217.3	100
"	Avalon, Catalina Island	KFWO	211.1	250
"	Berkeley	KRE	256	100
"	Big Bear Lake	KFXB	202.6	500
"	Burlingame	KFOB	226	50
"	Chico	KFWH	254	100
"	Fresno	KMJ	234	50
"	Hollywood	KFQZ	226	50
"	Hollywood	KFWB	252	500
"	Hollywood	KMTR	238	500
"	Long Beach	KFON	233	500
"	Los Angeles	KFI	467	4000
"	Los Angeles	KFPR	230.6	500
"	Los Angeles	KFSG	275	500
"	Los Angeles	KHJ	405.2	500
"	Los Angeles	KNRC	208	250
"	Los Angeles	KNX	336.9	1000
"	Los Angeles	KTBI	293.9	750
"	Oakland	KFUS	256	50
"	Oakland	KFUU	220	100
"	Oakland	KFWM	207	250
"	Oakland	KGO	361.2	4000
"	Oakland	KLS	250	250
"	Oakland	KLX	508	500
"	Oakland	KTAB	240	1000
"	Oakland	KZM	240	100
"	Oxnard	KFYF	205.4	10
"	Pasadena	KPPC	229	50
"	Pasadena	KPSN	315.6	1000
"	Sacramento	KFBK	248	100
"	San Bernardino	KFWC	211.1	5
"	San Diego	KFBC	215.7	50
"	San Diego	KFSD	245.8	1000
"	San Francisco	KFRC	267.7	50
"	San Francisco	KFWI	226	500
"	San Francisco	KGTT	207	50
"	San Francisco	KJBS	220	5
"	San Francisco	KPO	428.3	1000
"	San Jose	KFAF	217.3	50
"	San Jose	KQW	231	500
"	San Pedro	KFVD	205.4	50
"	Santa Maria	KSMR	209.7	100
"	Stockton	KWG	248	50

States	Cities	Call Letters	Wave Length (Meters)	Power Watts
COLORADO	Colorado Springs	KFUM	239.9	100
"	Colorado Springs	KFXF	250	500
"	Denver	KFEL	254	50
"	Denver	KFUP	234	50
"	Denver	KFVR	244	50
"	Denver	KLZ	266	250
"	Denver	KOA	322.4	5000
"	Edgewater	KFXJ	215.7	10
"	Greeley	KFKA	273	50
"	Gunnison	KFHA	252	50
"	Trinidad	KFBS	238	15
CONNECTICUT	Hartford	WTIC	475.9	500
"	New Haven	WDRG	268	100
"	Storrs	WCAC	275	500
DELAWARE	Wilmington	WDEL	266	50
DIST. OF COLUMBIA	Washington	WCAP	469	500
"	Washington	WMAL	212.6	100
"	Washington	WRC	468.5	1000
"	Washington	WRHF	256	50
FLORIDA	Clearwater	WGHB	266	500
"	Fulford-by-the-Sea	WGBU	278	500
"	Jacksonville	WJAX	336.9	1000
"	Miami	WQAM	263	100
"	Miami Beach	WIOD	247.8	1000
"	Miami Beach	WMBF	384.4	500
"	Pensacola	WCOA	222	500
"	St. Petersburg	WHBN	238	10
"	St. Petersburg	WJBB	254	10
"	Tampa	WDAE	273	250
"	Winter Park	WDBO	240	500
GEORGIA	Atlanta	WDBE	270	100
"	Atlanta	WGST	270	500
"	Atlanta	WSB	428.3	1000
"	Macon	WMAZ	261	500
"	Savannah	WEBZ	263	50
IDAHO	Boise	KFAU	280	750
"	Boise	KFDD	278.6	50
"	Kellogg	KFEY	233	10
ILLINOIS	Batavia	WORD	275	5000
"	Cambridge	WTAP	242	50
"	Carthage	WTAD	236	50
"	Chicago	KYW	536	2000
"	Chicago	WAAF	278	200
"	Chicago	WBBM	225.4	1500
"	Chicago	WBBZ	215.7	50
"	Chicago	WBCN	266	500
"	Chicago	WCFL	491.5	500
"	Chicago	WEBH	370	2000
"	Chicago	WENR	266	1000
"	Chicago	WFKB	217.3	500
"	Chicago	WGES	250	500
"	Chicago	WGN	303	1000
"	Chicago	WHBL	215.7	50
"	Chicago	WHBM	215.7	20
"	Chicago	WHT	238	3500
"	Chicago	WIBJ	215.7	50
"	Chicago	WIBM	215.7	10
"	Chicago	WIBO	226	1000
"	Chicago	WJAZ	329.8	5000

States	Cities	Call Letters	Wave Length (Meters)	Power Watts
ILLINOIS	Chicago	WKBG	215.7	100
"	Chicago	WLIB	303	4000
"	Chicago	WLS	345	5000
"	Chicago	WLTS	258.5	100
"	Chicago	WMAQ	447.5	1000
"	Chicago	WMBB	250	500
"	Chicago	WOK	217.3	5000
"	Chicago	WPCC	258	500
"	Chicago	WQJ	447.5	500
"	Chicago	WSAX	268	100
"	Chicago	WSBC	210	1000
"	Decatur	WBAO	270	100
"	Decatur	WJBL	270	500
"	Evanston	WEHS	202.6	10
"	Galesburg	WFBZ	254	20
"	Galesburg	WRAM	243.8	100
"	Harrisburg	WEBQ	225.4	10
"	Joliet	WCLS	214.2	150
"	Joliet	WJBA	206.8	50
"	Joliet	WKBB	214.2	100
"	La Salle	WJBC	234.2	100
"	Mooseheart	WJJD	370.2	500
"	Plainfield	WWAE	242.2	500
"	Rockford	KFLV	229	100
"	Rock Island	WHBF	222	100
"	Streator	WTAX	231	50
"	Tuscola	WDZ	278	100
"	Urbana	WRM	273	500
"	Wooddale	WSWS	275	1000
"	Zion	WCBD	344.6	5000
INDIANA	Anderson	WHBU	218.8	10
"	Culver	WCMA	222	100
"	Evansville	WGBF	236	500
"	Fort Wayne	WHBJ	234.4	50
"	Fort Wayne	WOWO	227	500
"	Indianapolis	WFBM	268	250
"	Kokomo	WJAK	254	50
"	Lafayette	WBAA	273	250
"	Laport	WRAF	223.8	100
"	Logansport	WIBW	220	100
"	Seymour	WFBE	226	10
"	South Bend	WSBT	275	500
"	Valparaiso	WRBC	278	500
IOWA	Ames	WOI	270	750
"	Anita	KFLZ	273	100
"	Boone	KFGQ	226	10
"	Burlington	WIAS	254	100
"	Cedar Rapids	KWCR	278	500
"	Cedar Rapids	WJAM	268	100
"	Clarinda	KSO	242	500
"	Council Bluffs	KOIL	278	500
"	Davenport	WOC	483.6	5000
"	Des Moines	WHO	526	5000
"	Fort Dodge	KFJY	246	50
"	Iowa City	KFQP	223.7	10
"	Iowa City	WSUI	484	500

States	Cities	Call Letters	Wave Length (Meters)	Power Watts
IOWA	Le Mars	KWUC	252	50
"	Marshalltown	KFJB	248	10
"	Muscatine	KTNT	256	500
"	Oskaloosa	KFHL	240	10
"	Shenandoah	KFNF	263	1000
"	Shenandoah	KMA	252	500
"	Sioux City	KFMR	261	100
"	Sioux City	WEAU	275	100
KANSAS	Independence	KFVG	236	15
"	Junction City	KFJC	218.8	10
"	Lawrence	KFKU	275	500
"	Manhattan	KSAC	340.7	500
"	Wichita	KFH	268	500
"	Wichita	KFOT	231	50
KENTUCKY	Louisville	WHAS	399.8	500
"	Louisville	WLAP	275	20
LOUISIANA	New Orleans	WABZ	275	50
"	New Orleans	WBBS	252	50
"	New Orleans	WCBE	263	5
"	New Orleans	WJBO	268	100
"	New Orleans	WOWL	270	10
"	New Orleans	WSMB	319	500
"	New Orleans	WWL	275	100
"	Pineville	KFWU	238	100
"	Shreveport	KFDX	250	100
"	Shreveport	KWKH	329	1000
MAINE	Bangor	WABI	240	100
"	Orono	WGBX	234.2	500
"	Portland	WCSH	256.3	500
MARYLAND	Baltimore	WCAO	275	100
"	Baltimore	WCBM	229	50
"	Baltimore	WFBR	254	100
"	Glen Morris (near)	WBAL	246	5000
"	Tokoma Park	WBES	222	100
MASSACHUSETTS	Boston	WATT	243.8	100
"	Boston	WBZA	242	250
"	Boston	WEEI	348.6	500
"	Boston	WNAB	250	100
"	Boston	WNAC	280.2	500
"	Boston	WSSH	261	100
"	Dartmouth	WMAF	440.9	1000
"	Fall River	WSAR	254	100
"	Fall River	WTAB	266	100
"	Medford Hillside	WARC	261	100
"	New Bedford	WIBH	209.7	30
"	New Bedford	WNBH	248	250
"	Springfield	WBZ	331.1	2000
"	Taunton	WAIT	229	10
"	Webster	WKBE	231	100
"	Worcester	WTAG	545.1	500
MICHIGAN	Bay City	WSKC	261	100
"	Berrien Springs	WEMC	286	500
"	Detroit	WGHP	270	1500
"	Detroit	WJR	516.9	5000
"	Detroit	WMBC	256.4	100

States	Cities	Call Letters	Wave Length (Meters)	Power Watts
MICHIGAN	Detroit	WWJ	352.7	1000
"	East Lansing	WKAR	285.5	1000
"	Escanaba	WRAK	256.3	100
"	Flint	WFDF	234	100
"	Grand Rapids	WBDC	256.4	500
"	Grand Rapids	WOOD	242	1000
"	Lansing	WREO	285.5	500
"	Mount Clemens	WABX	246	500
"	Owosso	WSMH	240	20
"	Petoskey	WBBP	238	200
"	Pontiac	WCX	516.9	5000
"	Port Huron	WAFD	275	500
"	Royal Oak	WAGM	225.4	50
"	Ypsilanti	WJBK	233	10
MINNESOTA	Collegeville	WFBJ	236	100
"	Fairmont	KFVN	227	50
"	Minneapolis	KFDZ	231	10
"	Minneapolis	WAMD	243.8	1000
"	Minneapolis	WDGY	263	500
"	Minneapolis	WHDI	278	500
"	Minneapolis	WLB	277.6	500
"	Minneapolis	WRHM	252	50
"	Northfield	KFMX	336.9	500
"	Northfield	WCAL	336.9	500
"	St. Cloud	WFAM	273	10
"	St. Paul	KFOY	252	50
"	St. Paul-Minneapolis	WCCO	416.4	5000
MISSISSIPPI	Coldwater	WREC	254	10
"	Oxford (near)	WCBH	242	50
MISSOURI	Cape Girardeau	KFVS	224	50
"	Cartersville	KFPW	258	20
"	Columbia	KFRU	499.7	500
"	Independence	KLDS	440.9	1000
"	Jefferson City	WOS	440.9	500
"	Kansas City	KWKC	236	100
"	Kansas City	WDAF	365.6	1000
"	Kansas City	WHB	365.6	500
"	Kansas City	WOQ	278	1000
"	Kirksville	KFKZ	226	10
"	Moberly	KFFP	242	50
"	St. Louis	KFQA	280.2	5000
"	St. Louis	KFUO	545.1	500
"	St. Louis	KFVE	240	500
"	St. Louis	KFWF	214.2	250
"	St. Louis	KMOX	280.2	1500
"	St. Louis	KSD	545.1	500
"	St. Louis	WEW	248	1000
"	St. Louis	WIL	273	250
"	St. Louis	WMAY	248	100
"	St. Louis	WSBF	273	250
MONTANA	Havre	KFBB	275	50
"	Missoula	KUOM	244	500
NEBRASKA	Clay Center	KMMJ	229	1000
"	David City	KFOR	226	100
"	Hastings	KFKX	288.3	5000

States	Cities	Call Letters	Wave Length (Meters)	Power Watts
NEBRASKA	Lincoln	KFAB	340.7	1000
"	Lincoln	WFAV	275	500
"	Norfolk	WJAG	270	250
"	Oak	KFEQ	268	500
"	Omaha	KFOX	248	100
"	Omaha	KOCH	258	250
"	Omaha	WAAW	384.4	500
"	Omaha	WNAL	258	50
"	Omaha	WOAW	526	1000
"	University Place	WCAJ	254	500
NEW HAMPSHIRE	Laconia	WKAV	224	50
NEW JERSEY	Atlantic City	WHAR	275	500
"	Atlantic City	WPG	299.8	500
"	Camden	WCAM	236	250
"	Elizabeth	WIBS	202.6	10
"	Gloucester City	WRAX	268	500
"	Lambertville	WTAZ	261	15
"	Newark	WAAM	263	500
"	Newark	WGCP	252	500
"	Newark	WNJ	348.6	150
"	Newark	WOR	405	500
"	North Plainfield	WEAM	261	250
"	Paterson	WODA	224	250
"	Red Bank	WJBI	218.8	250
"	Trenton	WOAX	240	500
NEW MEXICO	Albuquerque	KFLR	254	100
"	Albuquerque	KFVY	250	10
"	State College	KOB	348.6	1000
NEW YORK	Bay Shore	WRST	215.7	250
"	Brooklyn	WFRL	205.4	100
"	Buffalo	WEBR	244	100
"	Buffalo	WGR	319	750
"	Buffalo	WPDQ	205.4	50
"	Buffalo	WSVS	219	50
"	Canton	WCAD	263	250
"	Cazenovia	WMAC	275	100
"	Flushing	WIBI	218.8	50
"	Freeport	WGBB	244	100
"	Ithaca	WEAI	254	500
"	Jamestown	WOCL	275.2	15
"	Kingston	WDBZ	233	10
"	Lockport	WMAK	266	500
"	New York	WBNY	322	500
"	New York	WEAF	491.5	5000
"	New York	WEBJ	272.6	500
"	New York	WFBH	272.6	500
"	New York	WGBS	315.6	500
"	New York	WHAP	431	500
"	New York	WHN	360.1	500
"	New York	WJY	405.2	1000
"	New York	WJZ	455	50000
"	New York	WLWL	288	3500
"	New York	WMCA	341	500
"	New York	WMSG	302.8	500
"	New York	WNYC	526	1000
"	New York	WQAO	360	100
"	New York	WRNY	374.8	500
"	New York	WSDA	263	250

States	Cities	Call Letters	Wave Length (Meters)	Power Watts
NEW YORK	Peekskill	WOKO	233	50
"	Richmond Hill	WAHG	315.6	500
"	Richmond Hill	WBOQ	236	100
"	Richmond Hill	WGMU	236	100
"	Richmond Hill	WRMU	236	100
"	Rochester	WABO	258	100
"	Rochester	WHAM	278	100
"	Rochester	WHEC	258	100
"	Rossville	WBBR	416.4	500
"	Schenectady	WGY	379.5	10000
"	Syracuse	WFBL	252	100
"	Tarrytown	WRW	273	500
"	Troy	WHAZ	379.5	500
"	Utica	WIBX	205.4	150
NORTH CAROLINA	Asheville	WABC	254	20
"	Charlotte	WBT	275	250
"	Greensboro	WNRC	224	10
"	Raleigh	WRCO	252	100
NORTH DAKOTA	Bismark	KFYR	248	10
"	Devils Lake	KDLR	231	5
"	Fargo	DAY	261	50
"	Fargo	WPAK	275	100
"	Grand Forks	KFJM	278	100
OHIO	Akron	WADC	258	500
"	Bellefontaine	WIBD	222	20
"	Canton	WHBC	254	10
"	Cincinnati	WAAD	258	25
"	Cincinnati	WKRC	325.9—422.3	1000
"	Cincinnati	WLW	422.3	5000
"	Cincinnati	WSAI	325.9	5000
"	Cleveland	WDBK	327	50
"	Cleveland	WEAR	389.4	1000
"	Cleveland	WHK	272.6	1000
"	Cleveland	WTAM	389.4	1000
"	Columbus	WAIU	293.9	500
"	Columbus	WEAO	293.9	500
"	Columbus	WMAN	286	50
"	Dayton	WSMK	275	500
"	Hamilton	WRK	270	100
"	Hamilton	WSRO	252	100
"	Pomeroy	WSAZ	244	50
"	Springfield	WCSSO	248	100
"	Toledo	WABR	263	50
"	Toledo	WTAL	252	10
"	Wooster	WABW	206.8	50
"	Yellow Springs	WRAV	263	100
OKLAHOMA	Bristow	KVOO	375	500
"	Chickasha	KOCW	252	200
"	Norman	WNAD	254	500
"	Oklahoma	KFJF	261	500
"	Oklahoma	KFXR	214.2	15
"	Oklahoma	WKY	275	100
"	Tulsa	WLAL	250	100
OREGON	Astoria	KFJI	246	10
"	Corvallis	KOAC	280.2	500
"	Portland	KFEC	248	50

States	Cities	Call Letters	Wave Length (Meters)	Power Watts
OREGON	Portland	KFIF	248	100
"	Portland	KFJR	263	50
"	Portland	KFWV	212.6	50
"	Portland	KGW	492.5	1000
"	Portland	KOIN	319	1000
"	Portland	KTBR	263	50
PENNSYLVANIA	Allentown	WCBA	254	200
"	Allentown	WSAN	229	100
"	Altoona	WFBG	277.8	100
"	Elkins Park	WIBG	222	50
"	Grove City	WSAJ	229	250
"	Harrisburg	WABB	204	10
"	Harrisburg	WBAK	275	500
"	Harrisburg	WHBG	231	20
"	Harrisburg	WPRC	215.6	100
"	Haverford	WABQ	261	100-1000
"	Johnstown	WHBP	256	100
"	Lancaster	WGAL	248	10
"	Lewisburg	WJBU	211.1	100
"	Oil City	WHBA	250	10
"	Parkersburg	WQAA	220	500
"	Philadelphia	WABY	242	50
"	Philadelphia	WCAU	276.6	500
"	Philadelphia	WFI	394.5	500
"	Philadelphia	WHBW	216	100
"	Philadelphia	WIAD	250	100
"	Philadelphia	WIP	508.2	500
"	Philadelphia	WLIT	394.5	500
"	Philadelphia	WNAT	250	100
"	Philadelphia	WOO	508.2	500
"	Pittsburgh	KDKA	309.1	Var.
"	Pittsburgh	KQV	275	500
"	Pittsburgh	WCAE	461.3	500
"	Pittsburgh	WJAS	336.9	500
"	Reading	WRAW	238	10
"	Scranton	WGBI	240	10
"	Scranton	WQAN	250	100
"	State College	WPSC	261	500
"	Wilkes-Barre	WBAX	256	100
"	Wilkes-Barre	WBRE	231	100
RHODE ISLAND	Cranston	WDWF	440.9	500
"	Providence	WCBR	209.7	100
"	Providence	WCWS	209.7	100
"	Providence	WEAN	270	500
"	Providence	WJAR	305.9	500
SOUTH CAROLINA	Charleston	WBBY	267.9	10
SOUTH DAKOTA	Brookings	KFDY	273	100
"	Rapid City	WCAT	240	50
"	Vermillion	KUSD	278	100
"	Yankton	WNAX	244	100
TENNESSEE	Chattanooga	WDOD	256	500
"	Knoxville	WFBC	250	50
"	Knoxville	WNOX	268	100
"	Lawrenceburg	WOAN	282.8	500
"	Memphis	WGBC	278	10
"	Memphis	WHBQ	233	50
"	Memphis	WMC	499.7	500

States	Cities	Call Letters	Wave Length (Meters)	Power Watts
TENNESSEE	Nashville	WBAW	242	100
"	Nashville	WDAD	226	150
"	Nashville	WSM	282.8	1000
TEXAS	Amarillo	WDAG	263	100
"	Amarillo	WQAC	234	100
"	Austin	KUT	231	500
"	Beaumont	KFDM	315.6	500
"	Beeville	KFRB	248	250
"	Brownsville	KWWG	278	500
"	College Station	WTAW	270	500
"	Dallas	WFAA	475.9	500
"	Dallas	WRR	246	500
"	Dublin	KFPL	252	15
"	El Paso	KFXH	242	50
"	El Paso	WDAH	267.7	50
"	Fort Worth	KFJZ	254	50
"	Fort Worth	KFQB	508.2	1000
"	Fort Worth	WBAP	475.9	1500
"	Galveston	KFLX	240	10
"	Galveston	KFUL	258	50
"	Greenville	KFPM	242	10
"	Houston	KFVI	240	10
"	Houston	KFYJ	238	10
"	Houston	KPRC	296.9	500
"	San Antonio	WCAR	263	2000
"	San Antonio	WOAI	394.5	2000
"	San Benito	KFLU	236	20
"	Texarkana	KFYO	209.7	10
"	Waco	WJAD	352.7	500
UTAH	Logan	KFXD	205.4	10
"	Ogden	KFUR	224	50
"	Ogden	KFWA	261	500
"	Salt Lake City	KDYL	246	50
"	Salt Lake City	KFOO	236	250
"	Salt Lake City	KFUT	261	100
"	Salt Lake City	KSL	299.8	1000
U. S.	Portable	WEBL	226	100
VERMONT	Burlington	WCAX	252	100
"	Springfield	WQAE	246	50
VIRGINIA	Arlington	NAA	434.5	1000
"	Norfolk	WBBW	222	50
"	Norfolk	WTAR	261	100
"	Richmond	WBBL	229	50
"	Richmond	WRVA	256	1000
"	Roanoke	WDBJ	229	50
WASHINGTON	Everett	KFBL	224	100
"	Lacey	KGY	245	50
"	North Bend	KFQW	215.7	50
"	Olympia	KFRW	218.8	50
"	Pullman	KWSC	348.6	500
"	Seattle	KFOA	454.3	1000
"	Seattle	KJR	384.4	1000
"	Seattle	KTCL	305.9	1000
"	Seattle	KTW	454.3	1500
"	Spokane	KFIO	265.3	100
"	Spokane	KFPY	266	100
"	Spokane	KHQ	394.5	1000

States	Cities	Call Letters	Wave Length (Meters)	Power Watts
WASHINGTON	Tacoma	KMO	250	250
"	Walla Walla	KOWW	256	500
"	Yakima	KFIQ	256	100
WEST VIRGINIA	Weirton	WIBR	246	50
WISCONSIN	Beloit	WEBW	268	500
"	Camp Lake	WCLO	230.6	50
"	Eau Claire	WTAQ	254	100
"	Fondulac	KFIZ	273	100
"	Madison	WHA	535.4	750
"	Madison	WIBA	236.1	100
"	Madison	WLBL	278	500
"	Marshfield	WGBR	229	10
"	Milwaukee	WHAD	275	500
"	Milwaukee	WKAF	261	500 - 5000
"	Milwaukee	WSOE	246	500
"	Omro	WJBR	227.1	50
"	Poynette	WIBU	222	20
"	Superior	WEBC	242	100
"	West De Pere	WHBY	250	50
WYOMING	Laramie	KFBU	270	500

This list has been corrected up to and including July 31, 1926.

Radio Broadcast Station KYW



Lawrence Salerno, baritone

Arthur Wellington, announcer.

Sallie Menkes, staff pianist.

Z. Earl Meeker, operatic baritone.

Canadian Radio Broadcast Stations

Indexed Alphabetically by Call Letters

Radio Call Letters	BROADCAST STATIONS Location and Owner	Power Watts	Wave Length (Meters)	Frequency (Kilocycles)	Time at Station	Sending Hours
CF CFAC	—Calgary, Alberta—The Calgary Herald.....	500	434.5	690	Mountain	Mon., 1 pm to 9 pm; Tue., 1 pm to 8 pm; Wed., 1 pm; 5 pm to 8 pm; Thu., 1 pm; 7 pm to 9 pm (under call CNRC); Fri., 1 pm to 7 pm; Sat., 12 am to 1 pm; Silent; Sun.: 11 am to 7:30 pm alternating.
CFCA	—Toronto, Ont.—Star Publishing & Printing Co., S. W. Cor. Yonge St. and St. Clair Ave.....	500	356.9	840	Eastern	Daily except Sun.: 12 am to 1 pm; 5 to 6:30 pm. Mon., 6:30 to 8 pm; Wed., 6:30 pm to 2 am; alternate Thu. and Sat., 8 pm to 2 am; alternate Thu., 7 to 9 pm; alternate Sat., 8 to 9 pm. Sun.: 10 am to 1 pm; 6 to 9 pm.
CFCF	—Montreal, Que.—Canadian Marconi Co. (Ltd.), Canada Cement Bldg.....	1650	410.7	730	Eastern	Daily except Sun.: 12:40 to 1 pm; Tue. and Sat., 4:45 to 5:45 pm (except in June, July and August); Mon. and Fri., 7 to 11:30 pm.
CFCK	—Edmonton, Alberta—Radio Supply Co., Ltd., Royal George Hotel.....	100	516.9	580	Mountain	Daily except Sun.: 4 to 5 pm; 9 to 11:30 pm.
CFCN	—Calgary, Alberta—W. W. Grant (Ltd.), 708 Crescent Rd., N. W.....	1800	434.5	690	Mountain	Daily except Sun.: 8:45 to 9 pm; Tue. and Wed., 9 to 10 pm; Thu., 8 to 9; Tue., 11:30 to 1 pm to am; Fri., 10 to 1 pm to am.
CFCQ	—Vancouver, B. C.—Sprott-Shaw Radio Co., 153 Pender St., W.....	5	410.7	730	Pacific	Daily except Sun.: 7:30 to 8:30 pm.
CFCT	—Victoria, B. C.—G. W. Deaville.....	500	329.5	910	Pacific	Mon., Silent; Tue., Silent; Wed., 8 pm; Thu., 10:30 pm alternating; Fri., 8 pm; Sat., 10 pm; Sun.: 11 am and 7:30 pm; 9 pm.
CFCY	—Charlottetown, P. E. Island—Island Radio Co.	50	312.3	960	Atlantic	Wed. and Thu., 7:30 to 9:30 pm; Sun.: 11 am and 7 pm.
CFDC	—Vancouver, B. C.—Arthur Holstead & Wm. Hanlon.....	10	410.7	730	Pacific	Daily except Sun.: 6 to 7 pm; Mon. and Wed., 9:30 to 11:30 pm; Thu., 10:30 to 11:30 pm. Sun.: 10 to 12 pm.
CFGC	—Brantford, Ont.—The Brant Radio Supply Co., Colborne St.....	50	296.9	1010	Eastern	
CFJC	—Kamloops, B. C.—N. S. Dalgleish & Sons, and Weller & Weller, 186 Victoria St.....	15	267.7	1120		
CFLC	—Prescott, Ont.—Radio Assoc. of Prescott, Vic- toria Hall.....	50	296.9	1010		
CFMC	—Kingston, Ont.—Monarch Battery Co., 290-2 Princess St.....	20	267.7	1120	Eastern	
CFQC	—Saskatoon, Sask.—The Electric Shop, Ltd., 144 2nd Ave. N.....	500	329.5	910	Mountain	Daily: 9 to 10; 1 to 2; Wed., 8 to 10 pm; Fri., 9 to 12 pm; Sun.: 11 to 12; 7 to 8:30.
CFRC	—Kingston, Ont.—Queens University, Dept. of Electrical Engineering.....	500	267.7	1120	Eastern	
CFVC	—Burnaby, B. C.—International Bible Students Assoc., 2243 Royal Oak Ave.....	500	410.7	730		
CFXC	—New Westminster, B. C.—Westminster Trust Co., Columbia & Begbie Sts.....	20	291.1	1030	Pacific	Mon., Wed. and Fri., 7:30 to 8:30 pm.
CFYC	—Burnaby, B. C.—Commercial Radio Ltd., Royal Oak Ave.....	500	410.7	730	Pacific	Daily except Sun.: 12 to 1:30 pm; 2:30 to 3:30 pm. Daily except Sun. and Wed.: 4:30 to 5:30 pm. Daily except Sun. and Mon.: 6:30 to 7:30; Mon., 6:30 to 8:30; 9:30 to 11:30; Thu., Sat., 7:30 to 8:30; Sat., 10:30 to 11:30. Sun.: 7 to 7:30 pm; 9 to 10 pm.

(License Cancelled as from May 22, 1926.)

Radio Call Letters	BROADCAST STATIONS Location and Owner	Power Watts	Wave Length (Meters)	Frequency (Kilocycles)	Time at Station	Sending Hours
CH	CHCO—Huntsville, Ont.—A. Staples, Ginsburg Bldg....	5	247.8	1210		
	CHCS—Hamilton, Ont.—The Hamilton Spectator, Spectator Bldg.....	10	340.7	880		
	CHCY—Edmonton, Alberta—Int'l Bible Students Assoc., King Edward Park.....	250	516.9	580		
	CHIC—Toronto, Ontario—Northern Electric Co., Ltd. Uses Station CKNC, Canadian Nat'l Carbon Co., Toronto, Ontario.....	500	356.9	840	Eastern	Mon., 8 to 9 pm; Sat., 10:30 to 11:30 am; 10:00 to 12 pm; Sun.: 5 to 6 pm.
	CHLC—Summerside, P. E. I.—R. L. Holman, Ltd., Holman Bldg.....	25	267.7	1120		
	CHNC—Toronto, Ont.—Toronto Radio Research Soc., 46 Lauder Ave. (Uses Station CKNC, Cana- dian Nat'l Carbon Co., Toronto, Ont.....	500	356.9	840	Eastern	No regular schedule.
	CHNS—Halifax, N. S.—Northern Elec. Co.....	100	322.4	930	Atlantic	
	CHRC—Quebec, Que.—E. Fontaine, 11 Fifth St.....	5	340.7	880		
	CHUC—Saskatoon, Sask.—The International Bible Students Assoc., Cor. Ave. D and 26th St....	500	329.5	910	Mountain	Tue. and Thu., 8 to 9:30 pm. Sun.: 1 to 2 pm; 7 to 9:30 pm.
	CHWC—Regina, Sask.—R. H. Williams & Sons, Ltd., Cor. Hamilton St. and 11th Ave.....	15	296.9	1010		
	CHXC—Ottawa, Ont.—J. R. Booth, Jr., 28 Range Rd.	250	434.5	690	Eastern	Fri., 8:30 to 10 pm. Sun.: 2 to 3 pm.
	CHYC—Montreal, Que.—Northern Electric Co., Ltd., 121 Shearer St.....	750	410.7	730	Eastern	Wed., 7 to 12:30 pm; Sun.: 11 to 12 am; 7 to 11 pm.
CJ	CJCA—Edmonton, Alberta—The Edmonton Journal, Ltd., Journal Bldg.....	500	516.9	580	Mountain	Daily except Sun.: 12:30 pm; Mon., 7:30 to 8 pm; 8:30 to 10 pm; Tue., 7:30 to 8 pm; Wed., 8:45 to 9 pm; 9 to 12 pm; mid to 1; Thu., 6 to 8 pm; Fri., 7:30 to 8 pm; 8:30 to 10:30 pm; Sat., 7:30 to 8 pm; 10 to 12 pm; mid. to 1; Sun.: 7:30 to 9 pm.
	CJCF—Kitchener, Ont.—O. Rumpel, 39 S. Cameron St.	25	247.8	1210	Eastern	
	CJGC—London, Ont.—London Free Press Printing Co., 430 Richmond St.....	500	329.5	910	Eastern	Daily except Sun. and Mon.: 1 to 2 pm; 7 to 9 pm. Sun.: 11 am and 7 pm. Alternate Sun.: 2:30 to 3:30 pm.
	CJOC—Lethbridge, Alberta—J. E. Palmer, 1235-5 Avenue A, South.....	50	267.7	1120		
	CJSC—Toronto, Ont.—The Evening Telegram. (Uses station CKCL, the Dominion Battery Co., 20 Trinity St., Toronto, Ont.).....	500	356.9	840	Eastern	No regular program schedule.
	CJWC—Saskatoon, Sask.—The Wheaton Electric Co., Ltd., 33rd St. and Ave. C, North.....	250	329.5	910	Mountain	Mon., 12 to 1; 8 to 10 pm; Tue. and Thu., 12 to 1; 5 to 6; 6 to 7 pm; Sun.: 3:45 to 5 pm.
	CJYC—Scarboro Station, Ont.—Universal Radio of Canada, Ltd.....	500	291.1	1030		
CK	CKAC—Montreal, Que.—La Presse Publishing Co., Ltd., Cor. St. James St. & St. Lawrence Blvd.	1200	410.7	730	Eastern	Daily except Sat.: 4 pm 4:30 pm; Mon., Wed. and Fri., 1:45; 4:30 pm; Tue., Thu. and Sat., 7; 7:30; 8:30; 10:30 pm. Midnight Frolics, first and third Thu. of each month, at 11:30 pm; Sun., 2:45 pm.
	CKCD—Vancouver, B. C.—Vancouver Daily Province, 142 Hastings St. W.....	1000	410.7	730	Pacific	Wed. and Sat., 8:30 to 9:30 pm; Tues. and Fri., 8:30 to 8:50 pm; Mon., 8 to 9 pm; Thu., 8:30 to 10:30 pm.
	CKCK—Regina, Sask.—Leader Publishing Co., Ltd....	500	296.9	1010	Mountain	Daily except Sun.: 9:45 to 10:30 am; 1 to 2 pm. Tue., 7:30 to 8:15 pm. Sun.: 9 to 10 pm.

Radio Call Letters	BROADCAST STATIONS Location and Owner	Power Watts	Wave Length (Meters)	Frequency (Kilocycles)	Time at Station	Sending Hours
CK CKCL	Toronto, Ont.—Dominion Battery Co., Ltd., 20 Trinity Street.....	500	356.9	840	Eastern	Daily except Sat.: 10:30 to 11:30 am; 3 to 4:30 pm; Mon., Wed. and Fri., 7 to 8 am; Tue., 7 to 12 pm; alternate Thu., 7 to 8; Sat., 7 to 8 pm; Sun.: 3 to 4:55 pm.
CKCO	Ottawa, Ont.—Dr. G. M. Geldert, 282 Somer- set St. W.....	100	434.5	690	Eastern	Tue., 7 to 10 pm. Sun.: 7 to 10 pm.
CKCW	Burketon Jct., Durham Co., Ont.—Canadian Broadcasting Corp.....	5000	329.5	910	Eastern	
CKFC	Vancouver, B. C.—United Churches of Canada	50	410.7	730	Pacific	Sun.: 11 am to 1 pm; 3 pm to 5:30 pm; Alternate Sun.: 7:30 to 9 pm.
CKNC	Toronto, Ont.—Canadian National Carbon Co.	500	356.9	840	Eastern	Mon., 8; 9 to 11 pm (alternate); Sat., 4; 8 pm.
CKOC	Hamilton, Ont.—H. Slack, Wentworth Radio Supply Co., Ltd., 31 John St. N.....	50	340.7	880	Eastern	Mon., 6:15 to 7:15 pm; Thu., 5 to 6 pm; Fri., 6 to 7 pm; Sat., 2:30 to 6:30 pm; Sun.: 11 am to 12:30 pm; 6:30 to 8:30 pm.
CKPC	Preston, Ont.—Wallace Russ, 40 Russ Ave., Eagle St.....	7½	247.8	1210		
CKY	Winnipeg, Manitoba—Manitoba Telephone Sys- tem, Sherbrooke St.....	500	384.4	780	Central	Mon., 10:50; 11 am; 12:30; 12:40 to 12:45; 1:15; 1:30; 2:15; 2:35; 4; 4:25; 4:45; 4:50; 5; 8; 8:30; 10:30; 11; 12 pm; Tue., 10:50; 11 am; 12:30; 12:40; 12:45; 1:15; 1:30; 2:15; 2:35; 4; 4:25; 4:45; 4:50; 5 pm (evening usually silent); Wed., 10:50; 11 am; 12:30; 12:40; 12:45; 1:15; 1:30; 2:15; 2:35; 4; 4:25; 4:45; 4:50; 5; 7:30; 11 pm; Thu., 10:50; 11 am; 12:30; 12:40; 12:45; 1:15; 1:30; 2:15; 2:35; 4; 4:25; 4:45; 4:50; 5; 8:30; 10; 11 pm; Fri., 10:50; 11 am; 12:30; 12:40; 12:45; 1:15; 1:30; 2:15; 2:35; 4; 4:25; 5 pm (evenings usually silent); Sat., 10:50; 11 am; 12:30; 12:40; 12:45; 1; 1:15; 1:30; 8; 8:30; 11 pm; Sun., 7; 9; 10 pm.
CN CNRA	Moncton, N. B.—Canadian National Railways. (Operating temporarily on 291.1 meters 1030 K/C).....	500	322.4	930	Atlantic	Daily: 2:45 to 3:45; Tue., 7:30 to 12; Fri., 9 to 12 pm.
CNRC	Calgary, Alberta—Canadian National Railways (Uses station CFAC, Calgary Herald, Calgary, or station CFCN, W. W. Grant, Lt., Calgary).	500	434.5	690	Mountain	Wed. and Thu., 9 to 11 pm.
CNRE	Edmonton, Alberta—Canadian National Rail- ways. (Uses station CJCA, Edmonton Jour- nal Ltd., Edmonton, Alberta).....	500	516.9	580	Mountain	Fri., 7:30 to 8 pm; 8:30 to 10:30 pm.
CNRM	Montreal, Que.—Canadian National Rail- ways. (Uses station CHYC, Northern Elec. Co., Ltd., Montreal; CKAC, LaPresse Pub. Co., Ltd., Montreal; CFCF, Canadian Marconi Co., Montreal, P. Q.).....	1000- 1650	410.7	730	Eastern	4th Wed. of each month, 8:30 to 10:30 pm; 1st, 2nd and 3rd Thu. of each month, 8:30 to 10:30 pm; 5th Fri. of each month (when any), 8:30 to 10:30 pm.
CNRO	Ottawa, Ont.—Canadian National Railways..	500	434.5	690	Eastern	Wed., 7 to 7:30 pm; 7:30 to 8; 8 to 8:30; 8:57 to 10:15; 11 to 12:30 pm; Sat., 7:30 to 8; 8 to 8:30; 8:57 to 10:15; 11 to 12:30 pm.
CNRR	Regina, Sask.—Canadian National Railways. (Uses station CKCK, Leader Pub. Co., Ltd., Regina, Sask.....	500	296.9	1010	Mountain	Tue., 8 to 10 pm.
CNRS	Saskatoon, Sask.—Canadian National Rail- ways. (Uses station CFQC, Elec. Shop, Ltd., Saskatoon, Sask.).....	500	329.5	910	Mountain	Daily: 2:30 to 3:30 pm.
CNRT	Toronto, Ont.—Canadian National Railways. (Uses station CFCA, Star Printing & Pub. Co., Toronto, Ont.).....	500	356.9	840	Eastern	Fri., 6:30 pm to 2 am.
CNRV	Vancouver, B. C.—Canadian National Rail- ways, (Transmitter is on Lulu Island, B. C.)....	500	291.1	1030	Pacific	Tue., 3:30 to 11:30 pm; Fri., 3:30 to 11:30 pm.
CNRW	Winnipeg, Manitoba—Canadian National Railways. (Uses station CKY, Manitoba Tel. System, Winnipeg, Manitoba.).....	500	384.4	780	Central	Wed., 8:30 to 11 pm.

Radio Broadcast Station WBZ

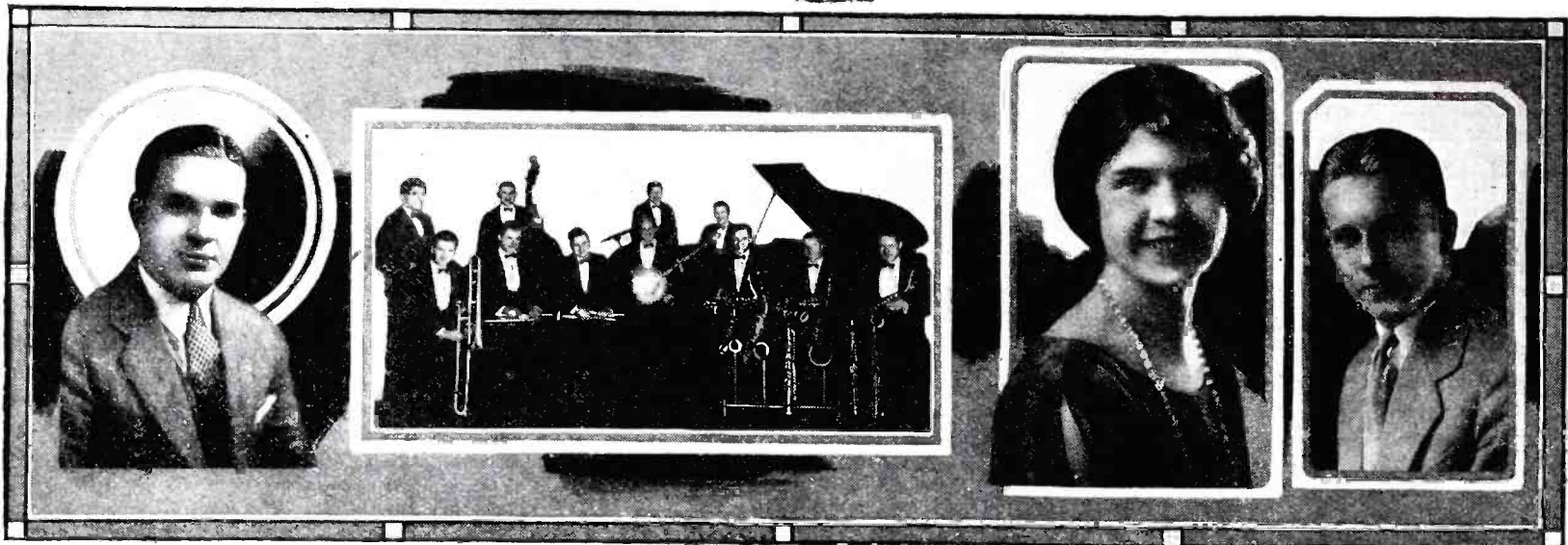

Frederick L. Wade, lyric tenor.

Leo Reisman and his Hotel Brunswick Orchestra.

Miss Dorothy Curtis, charming young pianist.

W. Gordon Squan, announcer.

Radio Broadcast Station WREO

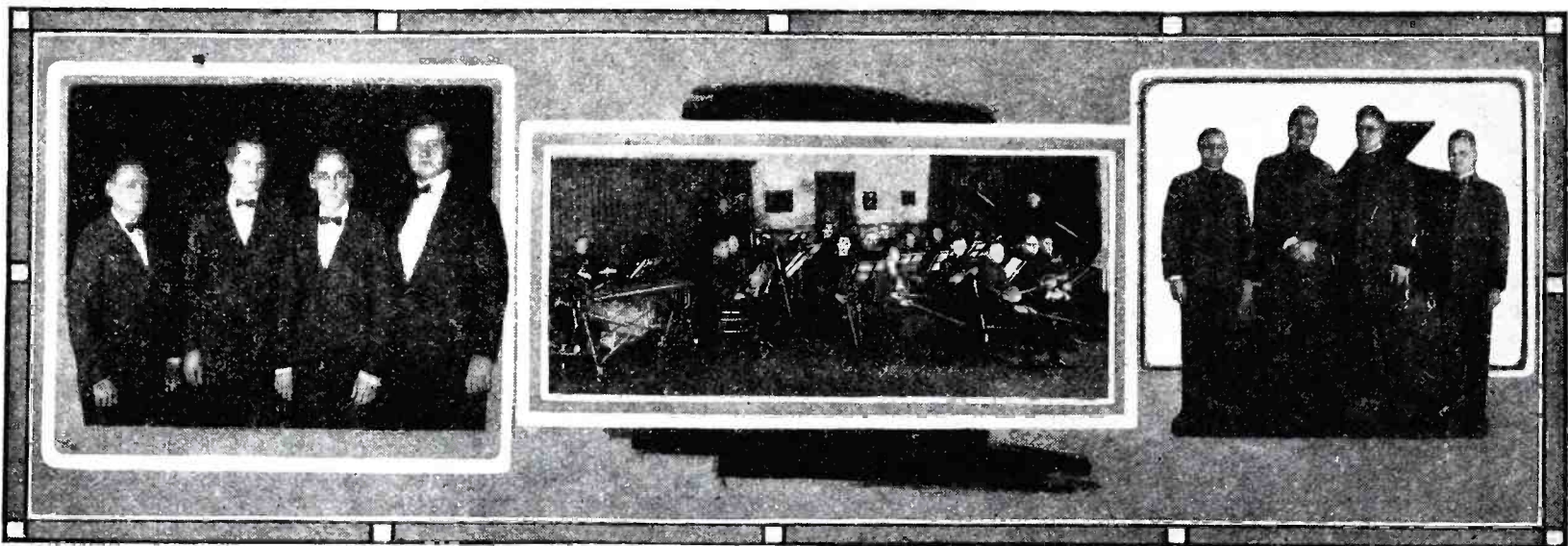

WREO Quartette. Left to right; Raymond Hamilton, James Lyon, Kenneth Buckingham, Raymond Lyon Bowers.

WREO broadcasting orchestra.

WREO broadcasting band.

Radio Broadcast Station WOR

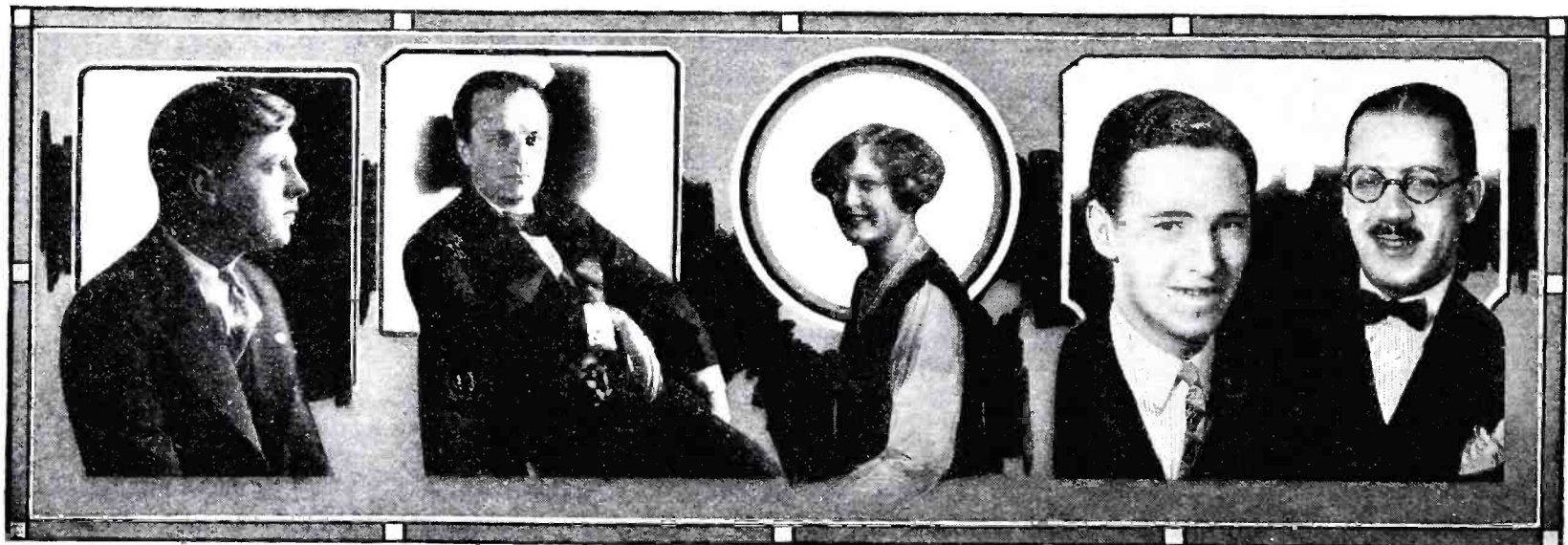

Julius Koehl, noted American pianist and teacher.

Basil Sidney.

Frances Pehl, pianist.

Ballin and Race, piano-duo.

Canadian Radio Broadcast Stations

By Provinces and Cities

Provinces	Cities	Call Letters	Wave Length (Meters)	Power (Watts)
ALBERTA	Calgary	CFAC	434.5	500
"	Calgary	CFCN	434.5	1800
"	Calgary	CNRC	434.5	500
"	Edmonton	CFCK	516.9	100
"	Edmonton	CHCY	516.9	250
"	Edmonton	CJCA	516.9	500
"	Edmonton	CNRE	516.9	500
"	Lethbridge	CJOC	267.7	50
BRITISH COLUMBIA	Burnaby	CFVC	410.7	500
"	Burnaby	CFYC	410.7	500
"	Kamloops	CFJC	267.7	15
"	New Westminster	CFXC	291.1	20
"	Vancouver	CFCQ	410.7	5
"	Vancouver	CFDC	410.7	10
"	Vancouver	CKCD	410.7	1000
"	Vancouver	CKFC	410.7	50
"	Vancouver	CNRV	291.1	500
"	Victoria	CFCT	329.5	500
MANITOBA	Winnipeg	CKY	384.4	500
"	Winnipeg	CNRW	384.4	500
NEW BRUNSWICK	Moncton	CNRA	322.4	500
NOVA SCOTIA	Halifax	CHNS	322.4	100
ONTARIO	Brantford	CFGC	296.9	50
"	Burketon Jct., Durham Co.	CKCW	329.5	5000
"	Hamilton	CHCS	340.7	10
"	Hamilton	CKOC	340.7	50
"	Huntsville	CHCO	247.8	5
"	Kingston	CFMC	267.7	20
"	Kingston	CFRC	267.7	500
"	Kitchener	CJCF	247.8	25
"	London	CJGC	329.5	500
"	Ottawa	CHXC	434.5	250
"	Ottawa	CKCO	434.5	100
"	Ottawa	CNRO	434.5	500
"	Prescott	CFLC	296.9	50
"	Preston	CKPC	247.8	7½
"	Scarboro Station	CJYC	291.1	500
"	Toronto	CFCA	356.9	500
"	Toronto	CHIC	356.9	500
"	Toronto	CHNC	356.9	500
"	Toronto	CJSC	356.9	500
"	Toronto	CKCL	356.9	500
"	Toronto	CKNC	356.9	500
"	Toronto	CNRT	356.9	500
P. E. ISLAND	Charlottetown	CFCY	312.3	50
"	Summerside	CHLC	267.7	25

Provinces	Cities	Call Letters	Wave Length (Meters)	Power (Watts)
QUEBEC	Montreal	CFCF	410.7	1650
"	Montreal	CHYC	410.7	750
"	Montreal	CKAC	410.7	1200
"	Montreal	CNRM	410.7	1000-1650
"	Quebec	CHRC	340.7	5
SASKATCHEWAN	Regina	CHWC	296.9	15
"	Regina	CKCK	296.9	500
"	Regina	CNRR	296.9	500
"	Saskatoon	CFQC	329.5	500
"	Saskatoon	CHUC	329.5	500
"	Saskatoon	CJWC	329.5	250
"	Saskatoon	CNRS	329.5	500

Licenses Required for Both Transmitters and Receivers in Canada

All radio stations, whether used for transmitting or receiving purposes are required to be licensed in Canada. The penalty on summary conviction for operating an unlicensed radio station is a fine not exceeding \$50.00, and on conviction or indictment a fine not exceeding \$500.00, with imprisonment for a term not exceeding 12 months, in addition to forfeiture of all unlicensed apparatus. The different classes of stations for which licenses are issued and their license fees vary from \$1.00 for a private receiving set to \$50.00 for a public commercial station.

The issue of licenses for transmitting stations is limited to British subjects or to companies incorporated under the laws of the Dominion of Canada or its provinces. Licenses for private receiving sets are issued to any person irrespective of nationality. Licenses for receiving sets are obtained from the Postmaster of the larger towns and cities in the Dominion, radio dealers, Royal Canadian Mounted Police, Department of Radio Inspectors, Departmental Agencies or from the Department of Marine and Fisheries. Licenses for all other classes of stations are obtained from the Department of Marine and Fisheries at Ottawa.

Radio Broadcast Station WOC

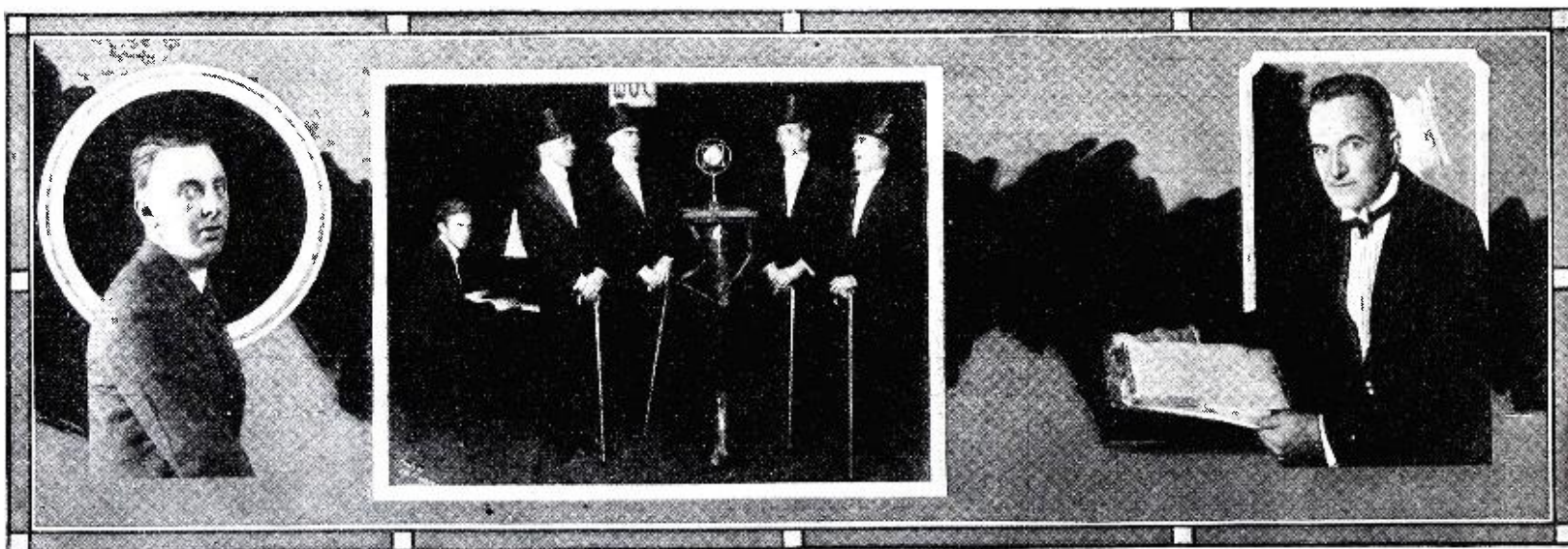

Alfred C. Bruzlin,
engineer and chief operator.

"The Moline Plow Boys,"
heard every Thursday evening.

Peter MacArthur, chief announcer.

Foreign Radio Broadcast Stations

Including U. S. Possessions

Countries and Cities	Owner	Call Letters	Wave Length (Meters)	Power (Watts)
ALASKA				
Juneau	Alaska Elec. Light & Power Co.	KFIU	226	10
ALGERIA				
Algiers	Colin & Fils	8DB	180	100
ARGENTINE				
Buenos Aires	Radio Titanic	LON	206.9	500
" "	Radio Prieto	LOO	250	1000
" "	Tomas Torres	LOQ	206.8	1000
" "	Diario "Critica"	LOR	222	1000
" "	Municipality of Buenos Aires	LOS	285.7	5000
" "	Francisco J. Brusa	LOV	352.9	1000
" "	Grand Splendid	LOW	300	1000
" "	Radio Cultura	LOX	375	500
" "	Sociedad Radio Nacional	LOY	315.8	1000
" "	"La Nacion" Soc. A. B. C.	LOZ	333.3	1000
" "	Gino Bocci Hnos.	B2	275	100
" "	Gino Bocci Hnos.	A11		
" "	Sociedad Radiotelefonica	A1		
" "	Francisco J. Brusa	B1		1000
" "	Facultad de Ciencias Medicas	C1		
" "	Departamento Nacional de Higiene	C2		
Cordoba	Antonio Vanelli	H4	275	20
"	Sociedad Radio Comercial de Cordoba		381	100
"	Jorge Coen	HA8	255	50
"	Diario "Los Principios"	H6	250	20
Hurlingham, FCP.	Felix Gunther	DA-1		
La Plata, FCS.	Universidad Nacional	LOP	425	1000
Mendoza	Ministerio de Obras Pul.licas	LOU	380	500
"	Pedro B. Baldasarre	M6	348	100
Monte Grande, FCS.	Argentine Broadcasting Assn.			
Ovivos, FCCA.	Eugenio A. Vautier	LOT	272.7	1000
Rio Cuarto	Arturo Rodriguez	H5	275	100
Rosario	Manuel Fugardo	F4	260	100
San Fernando, FCCA.	Americo Liberti	D3	235.3	100
Santa Fe	Jose Roca Soler	F1	279	20
" "	Sociedad Rural de Cerealistas	F2	270	100
AUSTRALIA				
Adelaide	Central Broadcasting Co.	5CL	395	5000
"	F. J. Hume	5DN	313	500
"	Millswood Auto & Radio Co.	5MA		
"	Marshall & Co.	5MC	273	500
Bathurst		2MK		
Brighton		3PB		
Brisbane	Dr. V. McDowell	4CM	278	250
"	Radio Manufacturers Ltd.	3MB	337	250
"	Queensland Government	4QG	385	5000
Hobart	Associated Radio Co.	7ZL	525	250
Melbourne	Associated Radio Co.	3AR	484	1600
"	Broadcasting Co. of Australia	3LO	371	5000

Countries and Cities	Owner	Call Letters	Wave Length (Meters)	Power (Watts)
AUSTRALIA				
Melbourne	O. J. Nilson & Co.	3UZ	319	100
"	L. J. Hellier	3WR	303	100
Mildura	R. J. Egge	3EO	286	100
Newcastle	H. A. Douglas	2HD	288	100
Northbridge	Otto Sandel	2UW	263	500
Perth	Westralian Farmers, Ltd.	6WF	1250	5000
Rockhampton	Queensland Government	4RN	323	500
Sydney	The Electrical Utilities Supply Co.	2UE	297	250
"	Burgin Electric Co.	2BE	326	100
"	Farmer & Co., Ltd.	2FC	1100	10000
"	Broadcastings Sydney Ltd.	2BL	353	5000
Toowoomba	Gold Radio Elec. Service	4GR	294	100
AUSTRIA				
Graz	Oesterreichische Radio-verkehrs Gesellschaft		404	500
Vienna	Oesterreichische Radio-verkehrs Gesellschaft	ORV	530	1500
BELGIUM				
Brussels	Radio Belgique Co.	BAV	265	1500
BOLIVIA				
Oruro	Radio Club Boliviano	CPM	50—200	50
BRAZIL				
Bahia	Radio Sociedade de Bahia		250—450	500
Bello Horizonte	Radio Sociedade Mina Geraes		400	500
Ceare	Radio Club Cearense			50
Curytiba	Livio Moreira			
Fortalzea	Radio Club			300
Goyanna	Benedicto Ravello			
Matto Grosso	Radio Club de Campo Grande			
Minas Geraes	Juiz de Fora			100
Para	Radio Club de Para			100
Parana			370	300
Parahyba	Radio Sociedade de Parahyba			
Pelotas	Radio Sociedade Pelotense			
Penedo	A. G. Oliveira			
Pernambuco	Radio Club de Pernambuco		310	1000
"	Cia Radiotelegrafica Brasileira		250—380	500
"	Radio Sociedade Jader de Andrada			
"	Radio Sociedade de Garanfaus			
Petropolis	Radio Club de Petropolis			
Porto Alegre	Radio Sociedade Riograndense	RSR	381	80
Praia Vermelha	Radio Club de Brazil	SQIB	320	500
Rio de Janeiro	Radio Sociedade de Rio de Janeiro		381	1000
" " "	Radio Club de Brazil	SPE	312	500
" " "	National Telegraph Service		450	500
Sao Paulo	Sociedade Radio Educadora		310	1000
" "	Radio Educadora Paulista	SQIG	345	1000
" "	Radio Club de Sao Paulo		350	100
" "	Radio Bandeirantes		370	50
" "	Dias Carneiro & Cia.		380—420	100
CANARY ISLANDS				
La Laguna	Servando Ortoll Delmotte	EAJ5	280	50
Las Palmas	Canary Islands Radio Club		300	6
CHILE				
Antofagasta	Oficina Jose Santos Ossa	CLAC		50
"	Oficina Jose Francisco Vergara	CLAD		50
Iquique	Gildemeister & Cia.	CLAE		100
"	Oficina San Pedro	CLAF		100
"	Oficina Peña Chica	CLAG		100

Countries and Cities	Owner	Call Letters	Wave Length (Meters)	Power (Watts)
CHILE				
San Eugenia	Rene Doneaud		230	25
Santiago	Radio Corporation of Chile	CBC	400—600	250
"	Chilean Radiophone Club	CHAC	300	200
"	Ferrocarril Transandino Chileno	CLAA		200
"	Carlos Buin Walsen	CMAA	240	20
"	Sociedade Radio Chilena	CMAB	480	1500
"	Castagneto Felli	CMAD	320	100
"	Ministerio de Higiene	CMAF	400	1350
"	Sociedade Broadcasting de Chile	CRC	385	350
"	"El Mercurio"	CMAC	360	1000
"	Radio Commercial	CMAE	280	500
"	Pedro Arroyo	CMAG	250	250
"	Cia Radio Transandino	CMAI	260	100
"	Universidad de Chile	CMAU	440	100
"		CRC	430	
"		RC	350	50
"	Harvey Diamond	CNAA		
"	Jose Bellalta	CNAC		
Tacna	Ministerio de Relaciones Exteriores	CMAT	365	1000
Valparaiso	Cia Radio Transandina	CNAD	265	500
"	Cia de Salitres de Antofagasta	CLAB		50
Vilna del Mar	Antonio Cornish Besa	ACB	400	50
" " "	Antonio Cornish Besa	CNAB		
CHINA				
Shanghai	Kellogg Switchboard & Supply Co.		365	100
Victoria (Hongkong)	Government			1500
COSTA RICA				
San Jose	Government			
CUBA				
Caibarien	Maria J. Alvarez	6EV	250	50
Camaguey	Pedro Noguera	7AZ	225	10
"	Salvador Rionda	7SR	350	500
Camajuani	Diego Ibarra	6YR	200	20
Central Tuinicu	Frank H. Jones	6KW	340	100
" "	Frank H. Jones	6KJ	275	100
Ciego de Avila	Eduardo V. Figueroa	7BY	235	20
Cienfuegos	Jose Ganduxe	6BY	260	200
"	Antonio T. Figueroa	6CX	170	20
"	Eduardo Terry	6DW	225	10
"	Luis Del Castillo	6GR	250	10
"	Juan Pablo Ros	6GF	190	50
"	Eligio Cobelo Ramirez	6JQ	275	10
"	Valentin Ullivarri	16AZ	200	20
Havana	Credito y Construcciones Co.	2HP	295	100
"	Julio Power	2JP	270	20
"	Frederick W. Borton	2CX	320	10
"	Alberto S. Bustamante	2AB	235	10
"	Cuban Telephone Co.	PWX	400	500
"	Jose Leiro	2JL	275	50
"	Alvara Daza	2K	200	20
"	E. Sanchez de Fuentes	2KD	350	50
"	Fausto Simon	2MN	270	30
"	"El Pais"	2EP	355	400
"	Humberto Giquel	2CG	350	15
"	Bernardo Barrie	2BB	255	15
"	Frederick W. Borton	2BY	260	100
"	Luis Casas	2LC	250	30

Countries and Cities	Owner	Call Letters	Wave Length (Meters)	Power (Watts)
CUBA				
Havana	Westinghouse Elec. Co.	2EV	220	100
"	Julio Power	2HS	180	50
"	Jose Lara	2LR	235	50
"	Manuel y Guillermo Salas	2MG	280	20
"	R. B. Waters	2MK	85	20
"	Maria Garcia Velez	2OK	360	100
"	Oscar Collar Orta	2OL	300	100
"	Roberto E. Ramirez	2TW	230	20
"	Roberto E. Ramirez	2UF	265	10
"	Manuel Karman	2RK	310	20
"	Raul Karman	2RY	275	10
"	Homero Sanchez	2SZ	180	10
"	Amadeo Saenz	2WW	210	20
"	Antonio A. Ginard	2XX	150	50
"	Raul Perez Falcon	2JD	105	20
"	Heraldo de Cuba	2HC	275	500
Matanzas	Leopoldo T. Figueroa	5EV	360	10
"	Ernesto V. Figueroa	5AZ	200	50
"	Leon Gonzalez Velez	5BY	190	10
Nueva Gerona	Isle of Pines Telephone Co.	8JQ	225	20
Puerto del Rio	Antonio Sarasola	1AZ	275	50
Sagua la Grande	Santiago Ventura	6HS	200	10
Santiago	Alfredo Vinnet	8FU	225	15
"	Pedro C. Anduz	8DW	275	50
"	Alfredo Brooks	8AZ	240	20
"	Ceferino Ramos	8IR	190	20
"	Alberto Ravelo	8BY	250	100
"	Guillermo Polanco	8HS	200	20
Tuinicu	Frank H. Jones	6XJ	275	50
CZECHOSLOVAKIA				
Brunn	Radio Journal	OKB	750	1000
Prague	Radio Journal	OKP	513	5000
DENMARK				
Copenhagen	Copenhagen Radio Broadcasting Station		348	500
Soro	Ministry of War		1150—2400	1000
EQUADOR				
Guayaquil	J. Puig Verdaguer			
FINLAND				
Hango	Nuoren Voiman Liiton Radiohydists		259.6	200
Helsingfors	Civil Guards of Finland		522	500
Jyvaskyla	Nuoren Voiman Liiton Radioyhdistys		301.5	100
Mikkeli	Nuoren Voiman Liiton Radioyhdistys		561	100
Pori	Nuoren Voiman Liiton Radioyhdistys		255.3	100
Skatudden	Military Station Radio Div.		318	750
St. Michel	Nuoren Voiman Liiton Radioyhdistys		561	500
Tammerfors	Nuoren Voiman Liiton Radiohydists	3NB	393	250
Tampere			373	250
Uleaborg			233	100
FRANCE				
Agen	Dept. of Lot et Garonne		318	250
Grenoble	Ministry of P. T. T.		380	150
Issy-les-Moulineaux	Ministry of War	QGA	1800	500
Lyon	Ministry of P. T. T.	YN	482.3	500
"	Radio Lyon		280	2000
Marseilles	Ministry of P. T. T.		340.1	300
Mont-de-Marsen			366	300
Montpellier	Societe Languedocienne de T. S. F.		168	100

Countries and Cities	Owner	Call Letters	Wave Length (Meters)	Power (Watts)
FRANCE				
Paris	Ecole Superieure de P. T. T.	FPTT	459.4	500
"	Eiffel Tower, Army	FL	2200	4000
"	Societe Francaise Radioelectrique	8AJ	1780	100
"	Petit Parisien		345	500
"	Cie. Francaise de Radiophone		1750	4000
Pic du Midi			350	
St. Etienne	Radio Club Forezien		220	50
Toulouse	Aerodrome	MRD	315	2000
"	La Radio		435.1	2000
GERMANY				
Berlin	Koenigswusterhausen	AFP	1300	5000
"	Vox Haus	AB	507	2250
Bremen	Nordischer Rundfunk		279	1500
Breslau	Schlessische Funkstunde		414.8	4000
Dresden	Mitteldeutscher Rundfunk		292	750
Frankfort-on-the-Main	Sudwest Deutscher Rundfunk Dienst	LP	470.4	750
Gleitwitz			251	1500
Hamburg	Nordischer Rundfunk		392.1	750
Hanover	Nordischer Rundfunk		296	1500
Kassel	Sudwestdeutscher Rundfunkdienst		283	750
Koenigsberg	Ostmarken Rundfunk		463	750
Leipzig	Mitteldeutscher Rundfunk	MR	454	750
Munster	Westdeutsche Funkstunde		410	750
Munich	Deutsche Stunde in Bayern	WM	485	750
Nuremberg	Deutsche Stunde in Bayern		340	750
Stuttgart	Suddeutscher Rundfunk	OKP	446.1	1500
HAWAII				
Honolulu	Marion A. Mulrony	KGU	270	500
HUNGARY				
Budapest	Muegyetemi Radio Club	MTI	546	1000
"	Magyar Tavirati Iroda		1050	2000
ICELAND				
Reykjavik			430	500
IRISH FREE STATE				
Dublin	Government	2RN	390.9	1500
ITALY				
Milan	Unione Radiofonica Italiana	IMT	308	1280
Rome	Unione Radiofonica Italiana	IRO	434	1200
INDIA				
Bangalore	Indian Broadcasting Co.			
Bombay	Walter Rogers & Co.	2AX	226	
"	Bombay Presidency Radio Club	2FV	387	220
Calcutta	Indian States & Eastern Agency	5AF	425	1500
Karachi	Karachi Radio Club		425	40
Madras	Crampton Elec. Co.		220	120
Rangoon	Radio & Wireless Club of Burma		450	40
JAPAN				
Nagoya	Nagoya Radio Broadcasting Co.	JOCK	360	1500
Osaka	Osaka Radio Broadcasting Co.	JOBK	385	500
Tokyo	Tokyo Radio Broadcasting Co.	JOAK	375	1000
LATVIA				
Riga			480	2000
MEXICO				
Chihuahua		CZF	325	250
"	Telefonos Del Gobierno del Estado de Chihuahua	ZCF	310	250
"	Compania Telefonica	XICE	500	500
Guadajajara	Radio Club—Degollado Theatre		280	10

Countries and Cities	Owner	Call Letters	Wave Length (Meters)	Power (Watts)
MEXICO				
Guadelajara	Federal Military Command	FAM	490	1000
Mazatlan	Castulo Llamas	CYR	475	250
Merida	Partido Socialista del Surestan	CYY	549	100
Mexico City	Efran R. Gomez	CYA	300	500
" "	Jose J. Reynosa (El Buen Tono)	CYB	275	500
" "	Miguel S. Castro (La High Life)	CYH	375	100
" "	"El Universal"	CYL	400	500
" "	Martinez y Zetina	CYO	425	100
" "	Excelsior Parker	CYX	325	500
" "	La Liga del Radio	CYZ	400	100
" "	Departamento de Educacion	CZE	350	500
" "		CZI	450	100
" "	Fabrica Nacional de Vestuario	IJ		500
" "	F. C. Stephenex	IR	250	100
Monterrey	Roberto Reyes	CYM	275	100
Oaxaca	Federico Zonilla	CYF	265	100
Puebla	Augustin del P. Saenz	CYU	312	100
Saltillo	Colegio Ateneo Fuente		450	135
Tampico		CYE	360	100
" "	Alberto Isaak	CYQ	322	100
Vera Cruz	Ministerio de Comunicaciones	CYC	300	500
" "		CYD	250	500
MOROCCO				
Casablanca	Radio Club de Moroc	CNO	250	500
NEW ZEALAND				
Auckland	Newcomb (Ltd.)	1YL	260	500
" "	Auckland Radio Service	1YA	260	200
" "	La Gloria Gramophone Co.	1YB	260	50
Christchurch				500
Dunedin	Otago University	4XO	140	
" "	British Electrical & Engineering Co.	4YA	310	500
" "	Radio Supply Co.	4YO	370	500
Gisborne	Gisborne Radio Co.	2YM	335	500
Wellington	Broadcastings Ltd.	2YB	275	15
" "	Dominion Radio Co.	2YK	275	500
NETHERLANDS				
Hilversum	Nederlandische Seintoellen Fabriek	HDO	1050	1000
NETHERLANDS EAST INDIES				
Soerabaya	Radiotelegraph Cluk		90	
NORWAY				
Bergen	Bergen Broadcasters		358	500
Oslo	Broadcasting Co. A. S.	OSLO	381.2	1500
PERU				
Lima	Peruvian Broadcasting Co.	OAX	380	1500
" "	German Gallo	5OA	250	20
" "	Enrique Perez	4OA	250	20
" "	Augusto Gilardi	3OA	250	20
PHILIPPINE ISLANDS				
Iloilo		KPM	400	500
Manila	I. Beck, Inc.	KZIB	260	20
" "	Radio Corp. of the Philippines	KZKZ	270	500
" "	Far Eastern Radio, Inc.	KZRQ	222	500
" "	F. Johnson Elser	KZUY	370	100
POLAND				
Warsaw	Government	PTR	380	700
PORTO RICO				
San Juan	Radio Corp. of Porto Rico	WKAQ	340	500

Countries and Cities	Owner	Call Letters	Wave Length (Meters)	Power (Watts)
PORTUGAL				
Lisboa	Grandes Armazeins do Chiado	PIAA	320	500
Montesanto	Government Wireless Station	CTV	2450	1500
RUSSIA				
Moscow	Sokolniki		1010	2000
"	Trade Union		450	2000
"	Lubovitch		365	
"	Union of Soviet Workers		675	
"	Comintern	RDW	1450	12000
"	Radio-Peredatcha		400	2000
Leningrad			310-240	2000
Niji-Novgorod			253	1000
Kiev			1000	2500
SAN SALVADOR				
San Salvador	Division of Telephones and Telegraphs	AQM	450	500
SENEGAL				
St. Louis	Senegal Radio Club		300	100
SPAIN				
Barcelona	Radio Barcelona (Hotel Colon)	EAJ1	325	1000
"	Radio Catalana	EAJ13	460	1000
Bilbao	Radio Club Vizcaina	EAJ9	415	200
"	Radio Vizcaya	EAJ11	418	200
"	Armando de Otera		383	200
Cadiz	Radio Cadiz	EAJ3	360	200
"	Juan Iaborra-Iahera	EAJ10	330	1000
Cartagena	Enrique de Orbe	EAJ16	335	150
"		EBX	1200	1000
Madrid	Radio Espana	EAJ2	334	300
"	Escuela Superior	PTT	458	1000
"	Antonio Castilla	EAJ4	305	1000
"	Radio Iberica	EAJ6	392	1000
"	Union Radio	EAJ7	372.4	1000
"	Radio Espanola	EAJ15	490	1000
"		EGC	1650-2200	2000
Malaga	Spanish Telecommunication Co.	EAJ25	325	2000
"	Alfonso Villota		325	200
Oviedo (Cima)	Arturo Cima	EAJ19	340	1000
"		EAJ12	345	1000
Salamanca		EAJ22	290	1000
San Sebastian	Sabino Ucelayeta	EAJ8	344.6	500
Sevilla	Manuel Garcia Ballesta	EAJ17	330	100
"	Jorge la Riva	EAJ21	300	1000
"	Radio Club Sevillano	EAJ5	350	150
Valencia		EAJ24	360	1000
"	Jose Lopes Azcar	EAJ14	400	500
Zaragoza		EAJ23	325	1000
STRAIGHTS SETTLEMENTS				
Singapore	Amateur Wireless Soc. of Malaya		270	100
SWEDEN				
Boden	Radiotjanst	SASE	1350	500
Eskilstuna	Radio Club	SMUC	243	150
Falun	Radiotjanst	SMZK	370	40
Gaevle		SMXF	325	200
Goteborg	Radiotjanst	SASB	290	500
Jonkopings	Jonkopings Rundradiostation	SMZD	265	200
Karlsborg	Radiotjanst	SASF	1350	50

Countries and Cities	Owner	Call Letters	Wave Length (Meters)	Power (Watts)
SWEDEN				
Karlskrona			196	200
Karlstad	Karlstad Rundradiostation	SMXG	355	80
Linköping	Radio Club	SMUV	467	25
Malmö	Radiotjänst	SASC	270	500
Norrköping	Radio Club	SMVV	260	175
Stockholm	Radiotjänst	SASA	427	100
Sundsvall	Radiotjänst	SASD	545	500
Trollhattan	Trollhattans Rundradiostation	SMXQ	345	50
SWITZERLAND				
Berne	Gen. Post & Telegraph Office		302	1500
Geneva	Radio Broadcasting Soc. of Geneva		760	500
Lausanne	Lausanne Radio Society	HB-2	318	500
Zurich	Zurich University	RGZ	515-650	500
"	Zurich Radio Genossenschaft		514.1	500
TUNISIA				
Tunis	French Army	OCTU—TUA	1450—45	500
UNION OF SO. AFRICA				
Cape Town	Cape Publicity Assn.	WAMG	375	1200
Durban	Town Council		400	1200
Johannesburg	Associated Scientific & Technical Societies	JB	438	1000
UNITED KINGDOM				
Aberdeen	British Broadcasting Co.	2BD	497.1	1500
Belfast	British Broadcasting Co.	2BE	438.7	1500
Birmingham	British Broadcasting Co.	5IT	476.6	1500
Bournemouth	British Broadcasting Co.	6BM	385	1500
Cardiff	British Broadcasting Co.	5WA	351.6	1500
Daventry	British Broadcasting Co.	5XX	1600	16000
Dundee	British Broadcasting Co.	2DE	330.5	200
Edinburgh	British Broadcasting Co.	2EH	328	200
Glasgow	British Broadcasting Co.	5SC	421.6	1500
Hull	British Broadcasting Co.	6KH	335	200
Leeds-Bradford	British Broadcasting Co.	2LS	343.5—310	
Liverpool	British Broadcasting Co.	6LV	313	200
London	British Broadcasting Co.	2LO	362	3000
Manchester	British Broadcasting Co.	2ZY	376.8	1500
Newcastle	British Broadcasting Co.	5NO	403.9	1500
Nottingham	British Broadcasting Co.	5NG	326	1500
Plymouth	British Broadcasting Co.	5PY	338	200
Sheffield	British Broadcasting Co.	6FL	303.5	200
Stoke-on-Trent	British Broadcasting Co.	6ST	306	200
Swansea	British Broadcasting Co.	5SX	482	200
URUGUAY				
Montevideo	Radio Sudamericano	CWOZ	320	500
"	Diario "El Dia"	CWOR	375	500
"	Danree & Cia	CWOF	300	200
"	Templo Metodista	CWOG	325	100
"	Instituto Meteorologico	CWOB	240	500
"	General Electric Co. of Uruguay	CWOS		
VENEZUELA				
Caracas	Empresa Venezolana de Radio-telefonía		360	1000
YUGOSLAVIA				
Belgrade	Cie. Generale De T. S. F.	HFF	1650	2000

Slogans of Broadcast Stations in U. S. and Canada

KDLR—DEVILS LAKE, N. D.
North Dakota's Own Station. Voice of the Lake Region.

KFAB—LINCOLN, NEBR.
Home Sweet Home Station.

KFAD—PHOENIX, ARIZ.
The Voice of Phoenix—The Gold Spot of America.

KFAU—BOISE, IDAHO.
KFAU and Voice of Idaho.

KFBK—SACRAMENTO, CALIF.
Sacramento, The Heart of California.

KFBL—EVERETT, WASH.
The Spark Plug of the North West.

KFBU—LARAMIE, WYO.
The Top of the World.

KFEL—DENVER, COLO.
Come Live in Colorado

KFEY—KELLOGG, IDAHO.
Voice of the Coeur D'Alenes.

KFFP—MOBERLY, MO.
The Gospel Messenger of the Air.

KFGQ—BOONE, IOWA.
Daniel Boone Station.

KFH—WICHITA, KANSAS.
Kansas' Finest Hotel.

KFHA—GUNNISON, COLORADO.
Where the Sun Shines Every Day.

KFHL—OSKALOOSA, IOWA.
Keen For Higher Learning.

KFI—LOS ANGELES, CALIF.
The Radio Central Super-Station. A National Institution.

KFJY—FT. DODGE, IOWA.
Where the Tall Corn Grows.

KFKA—GREELEY, COLO.
We Are The Bears.

KFKX—HASTINGS, NEBR.
Pioneer Repeating Station of the World.

KFMR—SIOUX CITY, IOWA.
The College by the Sioux.

KFNF—SHENANDOAH, IOWA.
Known for Neighborly Folks. Keep Friendly, Never Frown.

KFOB—BURLINGAME, CALIF.
Kind Fellows of Burlingame.

KFON—LONG BEACH, CALIF.
Where Your Ship Comes In

KFOR—DAVID CITY, NEBR.
The Voice of David City.

KFPM—GREENVILLE, TEXAS.
The Biggest Little Ten Watts on the Air.

KFPW—CARTERVILLE, MO.
Keeping Pace With Christ Means Progress.

KFQB—FORT WORTH, TEXAS.
Keep Folks Quoting Bible.

KFRC—SAN FRANCISCO, CALIF.
Keep Forever Radiating Cheer.

KFRU—COLUMBIA, MO.
Where Friendliness is Broadcast Daily.

KFUM—COLORADO SPRINGS, COLO.
Known for Unsurpassed Mountain Scenery.

KFUO—ST. LOUIS, MO.
Gospel Voice.

KFVN—FAIRMONT, MINN.
The Voice of Martin County.

KFVR—DENVER, COLO.
Denver's Mighty Little Fifty Watt Broadcasting Station

KFVS—CAPE GIRARDEAU, MO.
The City of Opportunity.

KFWC—SAN BERNARDINO, CALIF.
The Gate City.

KFWF—ST. LOUIS, MO.
The Voice of Truth.

KFWM—OAKLAND, CALIF.
The Golden West Station KFWM.

KFWO—AVALON, CALIF.
Katalina for Wonderful Outings.

KFXB—BIG BEAR LAKE, CALIF.
Rim of the World Station.

KFXJ—EDGEWATER, COLO.
America's Scenic Center, and Edgewater, Not Chicago, Colorado.

KFYF—OXNARD, CALIF.
The Voice from the Radio Den.

KGTT—SAN FRANCISCO, CALIF.
Glad Tidings.

KGW—PORTLAND, ORE.
Keep Growing Wiser.

KGY—LACEY, WASH.
Out Where the Cedars meet the Sea.

KJR—SEATTLE, WASH.
Radio Headquarters.

KLDS—INDEPENDENCE, MO.
The Station Dedicated to Knowledge, Liberty, Divinity and Service.

KLS—OAKLAND, CALIF.
The City of Golden Opportunity.

KLX—OAKLAND, CALIF.
Oakland, Where Rail and Water Meet.

KLZ—DENVER, COLO.
Way Out West in Denver.

KMA—SHENANDOAH, IOWA.
Keeps Millions Advised.

KNRC—LOS ANGELES, CALIF.
The Friendly Station.

KOA—DENVER, COLO.
Rocky Mountain Broadcasting Station.

KOAC—CORVALLIS, ORE.
Science for Service.

KOB—STATE COLLEGE, N. MEX.
Sunshine State of America.

KOCH—OMAHA, NEBR.
Voice of 2,000 Students.

KOIN—PORTLAND, ORE.
KOIN and the Portland News.

KPO—SAN FRANCISCO, CALIF.
The Voice of San Francisco, the City by the Golden Gate.

KPRC—HOUSTON, TEX.
Where Seventeen Railroads Meet the Sea.

KQW—SAN JOSE, CALIF.
King's Quickening Word. Pioneer Broadcasting Station of the World.

KSL—SALT LAKE CITY, UTAH.
Salt Lake City, The Center of Scenic America.

KSMR—SANTA MARIA, CALIF.
The Valley of Gardens.

KSO—CLARINDA, IOWA.
Keep Serving Others.

KTAB—OAKLAND, CALIF.
Knowledge Truth and Beauty.

KTHS—HOT SPRINGS NAT'L PARK, ARK.
Kum to Hot Springs.

KTNT—MUSCATINE, IOWA.
The Home of the Calliophone, the first new tone in 40 Years.

KTW—SEATTLE, WASH.
Serve the Lord, Preach the Gospel, Evangelize the World.

KUOA—FAYETTEVILLE, ARK.
The Voice of the Ozarks.

KUSD—VERMILLION, S. D.
South Dakota U for South Dakotans.

KUT—AUSTIN, TEX.
Kum to the University of Texas.

KVOO—BRISTOW, OKLA.
The Voice of Oklahoma.

KWKC—KANSAS CITY, MO.
Keep Watching Kansas City.

KWUC—LEMARS, IOWA.
The Best 50 Watt Station on the Air.

KWWG—BROWNSVILLE, TEX.
Kum to the World's Winter Garden.

WAAM—NEWARK, N. J.
The Sunshine Station.

WAAW—OMAHA, NEBR.
Where Agriculture Accumulates Wealth.

WABI—BANGOR, ME.
The Community Voice.

WABZ—NEW ORLEANS, LA.
The Station with a Message.

WAFD—PORT HURON, MICH.
Gateway to Great Lakes.

WAIT—TAUNTON, MASS.
We Are in Taunton.

WAMD—MINNEAPOLIS, MINN.
The Call of the North.

- WBAW—NASHVILLE, TENN.
We Can't Be Quiet.
- WBBL—RICHMOND, VA.
The Gateway North and South.
- WBBM—CHICAGO, ILL.
WBBM, The Stewart-Warner Station.
- WBBP—PETOSKEY, MICH.
There's only one Petoskey.
- WBBS—NEW ORLEANS, LA.
The Gospel Wave.
- WBBY—CHARLESTON, S. C.
Seaport of the Southeast.
- WBDC—GRAND RAPIDS, MICH.
Your Friendly Station.
- WBNY—NEW YORK, N. Y.
The Voice of the Heart of New York.
- WBRC—BIRMINGHAM, ALA.
The Biggest Little Radio Station in the World.
- WBT—CHARLOTTE, N. C.
Queen City of the South.
- WBZ—SPRINGFIELD, MASS.
The Broadcasting Station of New England.
- WCAC—STORRS, CONN.
From the Nutmeg State.
- WCAD—CANTON, N. Y.
The Voice of the North Country.
- WCAL—NORTHFIELD, MINN.
At St. Olaf, the College on the Hill.
- WCAU—PHILADELPHIA, PA.
Where Cheer Awaits U.
- WCAX—BURLINGTON, VT.
The Voice of the Green Mountains.
- WCBD—ZION, ILL.
Where God Rules Man Prospers.
- WCBE—NEW ORLEANS, LA.
2nd Port U. S. A.
- WCBR—PROVIDENCE, R. I.
New One in Every City Where I Am.
- WCCO—ST. PAUL—MINNEAPOLIS, MINN.
Gold Medal Station WCCO.
- WCLO—CAMP LAKE, WIS.
The Play Ground of the Lake Region.
- WCOA—PENSACOLA, FLA.
Wonderful City of Advantages.
- WCSH—PORTLAND, ME.
The Voice from Sunrise Land.
- WCWS—PROVIDENCE, R. I.
The Birthplace of the American Cotton Industry.
- WDAD—NASHVILLE, TENN.
The Athens of the South. Where Dollars are Doubled.
- WDAF—KANSAS CITY, MO.
The Nighthawks, the Enemies of Sleep.
- WDBE—ATLANTA, GA.
We Distribute Better Equipment.
- WDBK—CLEVELAND, OHIO.
Broz-Casting from Cleveland.
- WDEL—WILMINGTON, DEL.
Wilmington—First City of First State.
- WDGY—MINNEAPOLIS, MINN.
See Young Again.
- WDOD—CHATTANOOGA, TENN.
Wonderful Dynamo of Dixie.
- WEAN—PROVIDENCE, R. I.
We Entertain a Nation.
- WEBC—SUPERIOR, WIS.
Head of the Great Water Way.
- WEBH—CHICAGO, ILL.
Voice of the Great Lakes.
- WEBQ—HARRISBURG, ILL.
Blue Bird Station.
- WEBR—BUFFALO, N. Y.
We Extend Buffalo's Regards.
- WEBZ—SAVANNAH, GA.
Savannah, Georgia's Port.
- WEEL—BOSTON, MASS.
The Friendly Voice.
- WEMC—BERRIEN SPRINGS, MICH.
The Radio Lighthouse.
- WENR—CHICAGO, ILL.
Makers of Radio for Years to Come.
- WFAM—ST. CLOUD, MINN.
Granite City of the World.
- WFBG—ALTOONA, PA.
Original Gateway to the West and Wish You All the Very Best.
- WFBH—NEW YORK, N. Y.
Voice of Central Park.
- WFBJ—COLLEGEVILLE, MINN.
In the Heart of a Landscape Paradise.
- WFBM—INDIANAPOLIS, INDIANA.
Good Will Station.
- WFBR—BALTIMORE, MD.
Home of the Star Spangled Banner.
- WFDF—FLINT, MICH.
The Vehicle City.
- WFRL—BROOKLYN, N. Y.
The Voice of Brooklyn.
- WGBB—FREEPORT, N. Y.
The Voice of the Sunrise Trail.
- WGBF—EVANSVILLE, IND.
Gateway to the South.
- WGES—CHICAGO, ILL.
World's Greatest Electrical School.
- WGHB—CLEARWATER, FLA.
The Springtime City Uniting the World.
- WGR—BUFFALO, N. Y.
Key City of Industry.
- WHAR—ATLANTIC CITY, N. J.
Pioneer Broadcasting Station of Atlantic City.
- WHAS—LOUISVILLE, KY.
My Old Kentucky Home.
- WHAZ—TROY, N. Y.
The Oldest College of Science and Engineering in America.
- WHB—KANSAS CITY, MO.
The Heart of America.
- WHBF—ROCK ISLAND, ILL.
Where Historic Blackhawk Fought.
- WHBG—HARRISBURG, PA.
Where Harrisburg Broadcasts Gladness.
- WHBJ—FT. WAYNE, IND.
In the Middle of the Middle West.
- WHBP—JOHNSTOWN, PA.
The Voice of the Friendly City.
- WHBU—ANDERSON, IND.
The Home of Chief Anderson.
- WHN—NEW YORK, N. Y.
The Station of the Great White Way.
- WIAD—PHILADELPHIA, PA.
The Voice from the Birthplace of Liberty.
- WIAS—BURLINGTON, IOWA.
On the Mississippi.
- WIBA—MADISON, WIS.
Four Lakes City.
- WIBM—CHICAGO, ILL.
The Gypsy Station.
- WIBW—LOGANSPOUT, IND.
On the Banks of the Wabash.
- WIBX—UTICA, N. Y.
The Hub of New York State.
- WIL—ST. LOUIS, MO.
Watch It Lead.
- WIOD—MIAMI BEACH, FLA.
Wonderful Isle of Dreams.
- WIP—PHILADELPHIA, PA.
Watch Its Progress.
- WJAG—NORFOLK, NEBR.
The Home of the Printer's Devil.
- WJAR—PROVIDENCE, R. I.
The Southern Gateway to New England.
- WJBB—ST. PETERSBURG, FLA.
Land of Perpetual Sunshine.
- WJBC—LA SALLE, ILL.
Better Homes Station.
- WJBR—OMRO, WIS.
Omro, the Center of the State of Lakes.
- WJJD—MOOSEHEART, ILL.
Call of the Moose.
- WKAV—LACONIA, N. H.
The Voice from the Winjipesaukee Lake Region.
- WLBL—MADISON, WIS.
Wisconsin Land of Beautiful Lakes.
- WLIT—PHILADELPHIA, PA.
The Quaker City Siren.
- WLSI—CRANSTON, R. I.
The New England Station.
- WLW—CINCINNATI, OHIO.
The Station With a Soul.
- WMBB—CHICAGO, ILL.
Station on the Trianon Ballroom.
- WMBF—MIAMI BEACH, FLA.
Down in the Land of Palms and Sunshine—Down Where It's Always June.
- WMC—MEMPHIS, TENN.
Memphis, Down in Dixie.
- WMCA—NEW YORK, N. Y.
Where the White Way Begins.
- WNAD—NORMAN, OKLA.
Voice of Soonerland.
- WNAL—OMAHA, NEB.
Pioneer Broadcast Station of Omaha.

- WNAT—PHILADELPHIA, PA.**
We Never Are Tired in Philadelphia.
- WNBH—NEW BEDFORD, MASS.**
The Gateway to Cape Cod.
- WOAN—LAWRENCEBURG, TENN.**
Watch Our Annual Normal.
- WOAW—OMAHA, NEB.**
WOAW, the Omaha Station.
- WOAX—TRENTON, N. J.**
Trenton Makes, The World Takes.
- WOC—DAVENPORT, IOWA.**
Where the West Begins and the State Where the Tall Corn Grows.
- WOCL—JAMESTOWN, N. Y.**
WOCL—We're on Chataugua Lake and "Jamestown" the Pioneer Furniture City.
- WOKO—PEEKSKILL, N. Y.**
The Pioneer Radio Service Station.
- WOOD—GRAND RAPIDS, MICH.**
The Furniture Capital of America.
- WOWL—NEW ORLEANS, LA.**
Where Owl Batteries Are Made.
- WOWO—FT. WAYNE, IND.**
Wayne Offers Wonderful Opportunities.
- WPCC—CHICAGO, ILL.**
We Preach Christ Crucified.
- WPG—ATLANTIC CITY, N. J.**
WPG—World's Playground Atlantic City.
- WPRC—HARRISBURG, PA.**
The Capital City of the Keystone State.
- WPSC—STATE COLLEGE, PA.**
The Voice of the Nittany Lion.
- WQAC—AMARILLO, TEX.**
Where Quality Alone Counts.
- WQAM—MIAMI, FLA.**
Most Southern Broadcasting Station in the United States.
- WQAN—SCRANTON, PA.**
The Voice of the Anthracite.
- WRAF—LAPORTE, IND.**
The Voice of the Maple City.
- WRAW—READING, PA.**
The Schuylkill Valley Echo.
- WRBC—VALPARAISO, IND.**
World Redeemed By Christ.
- WREO—LANSING, MICH.**
Watch—Reo.
- WRNY—NEW YORK, N. Y.**
The Radio News Station.
- WSAR—FALL RIVER, MASS.**
Fall River Looms Up.
- WSBC—CHICAGO, ILL.**
It Won't Be Long Now.
- WSBT—SOUTH BEND, IND.**
Voice of the Hoosier State.
- WSKC—BAY CITY, MICH.**
Where the Summer Trails Begin.
- WSM—NASHVILLE, TENN.**
We Shield Millions.
- WSMH—OWOSSO, MICH.**
Watch Shattuck Music House.
- WSRO—HAMILTON, OHIO.**
We Sell Radio Only. (The Oldest Exclusive Radio Store in the West.)
- WSSH—BOSTON, MASS.**
Strangers Sunday Home.
- WSVS—BUFFALO, N. Y.**
Watch Seneca Vocational School.
- WTAD—CARTHAGE, ILL.**
We Travel All Directions.
- WTAL—TOLEDO, OHIO.**
The Gateway to the Sea.
- WTAR—NORFOLK, VA.**
Down in Old Virginia.
- WTAX—STREATOR, ILL.**
Tappa Keg O' Nails.
- WTIC—HARTFORD, CONN.**
The Insurance City.
- CFCT—VICTORIA, B. C.**
The Mecca of the Tourists.
- CFCY—CHARLOTTETOWN, P. E. ISLAND.**
The End of the Black Fox Trail.
- CJWC—SASKATOON, SASK.**
The Voice of Saskatoon. The University City.
- CKCO—OTTAWA, ONT.**
Ottawa's Radio Voice.
- CKNC—TORONTO, ONT.**
In the Land of the Sky Blue Water.
- CKY—WINNIPEG, MANITOBA.**
Manitoba's Own Station.
- CNRA—MONCTON, N. B.**
The Voice of the Maritimes.
- CNRV—VANCOUVER, B. C.**
Voice of the Pacific.

Radio Broadcast Station WBAL

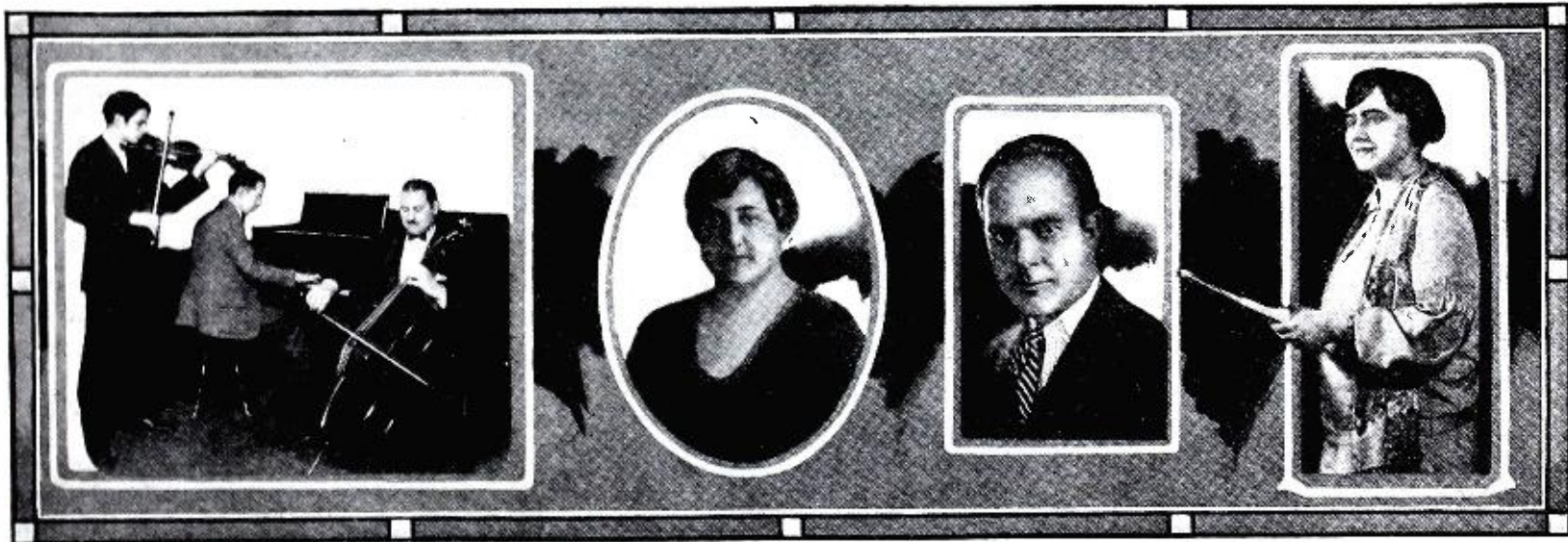

WBAL Ensemble; left to right, Michael Weiner, violinist; Leroy Evans, pianist; Samuel M. Stern, cellist.

Maud Albert, contralto.

Frederick R. Huber, director.

Hilda Hopkins Burke, soprano.

Air-Line Distances in Statute Miles Between

FROM/TO	N. Mex.					Tex.					N. Y.					Ill.					Ohio					Colo.					Iowa					Mich.					Tex.					N. Dak.					Tex.					Tex.					Ark.					Mich.					Fla.					Mo.					Calif.				
	Albuquerque	Atlanta	Baltimore	Boise	Boston	Brownsville	Buffalo	Chicago	Cincinnati	Cleveland	Denver	Des Moines	Detroit	El Paso	Fargo	Fort Worth	Galveston	Hastings	Hot Springs	Houghton	Jacksonville	Kansas City	Los Angeles																																																														
Albuquerque, N. Mex.	----	1273	1670	774	1967	838	1577	1126	1248	1417	332	833	1360	228	968	561	803	588	773	1252	1492	717	663																																																														
Atlanta, Ga.	1273	----	575	1830	933	960	695	583	368	550	1208	738	595	1293	1112	750	688	901	498	947	286	675	1935																																																														
Baltimore, Md.	1670	575	----	2055	358	1525	273	603	423	305	1505	913	398	1750	1143	1239	1245	1154	964	808	682	962	2313																																																														
Boise, Idaho	774	1830	2055	----	2266	1610	1872	1453	1663	1754	637	1155	1671	969	975	1263	1538	934	1384	1367	2098	1158	663																																																														
Boston, Mass.	1967	933	358	2266	----	1881	398	849	737	550	1766	1159	613	2067	1304	1574	1598	1415	1302	922	1015	1250	2590																																																														
Brownsville, Tex.	838	960	1525	1610	1881	----	1575	1234	1184	1402	1047	1102	1398	682	1445	471	287	1013	650	1543	1025	923	1370																																																														
Buffalo, N. Y.	1577	695	273	1872	398	1575	----	454	392	175	1368	762	218	1690	923	1221	1289	1019	956	560	880	862	2195																																																														
Chicago, Ill.	1126	583	603	1453	849	1234	454	----	249	307	918	310	236	1249	571	820	954	566	585	367	861	413	1741																																																														
Cincinnati, Ohio	1248	368	423	1663	737	1184	392	249	----	218	1090	509	234	1333	818	839	897	742	569	589	628	541	1892																																																														
Cleveland, Ohio	1417	550	305	1754	550	1402	175	307	218	----	1223	617	94	1521	838	1046	1116	871	787	518	768	700	2044																																																														
Denver, Colo.	332	1208	1505	637	1766	1047	1368	918	1090	1223	----	607	1153	554	642	643	925	353	749	970	1468	555	828																																																														
Des Moines, Iowa	833	738	913	1155	1159	1102	762	310	509	617	607	----	545	980	397	640	851	256	488	458	1024	180	1433																																																														
Detroit, Mich.	1360	595	398	1671	613	1398	218	236	234	94	1153	545	----	1475	745	1018	1111	800	761	427	832	643	1976																																																														
El Paso, Tex.	228	1293	1750	969	2087	682	1690	1249	1333	1521	554	980	1475	----	1161	543	723	757	802	1422	1481	836	702																																																														
Fargo, N. Dak.	968	1112	1143	975	1304	1445	923	571	818	838	642	397	745	1161	----	973	1218	440	875	593	1400	548	1426																																																														
Fort Worth, Tex.	561	750	1239	1263	1574	471	1221	820	839	1046	643	640	1018	543	973	----	283	544	273	1093	943	460	1212																																																														
Galveston, Tex.	803	688	1245	1538	1598	287	1289	954	897	1116	925	851	1111	723	1218	283	----	808	375	1277	799	677	1423																																																														
Hastings, Nebr.	588	901	1154	934	1415	1013	1019	566	742	871	353	256	800	757	440	544	808	----	513	666	1178	226	1177																																																														
Hot Springs, Ark.	773	498	964	1384	1302	650	956	585	569	787	749	488	761	802	875	273	375	513	----	901	728	326	1437																																																														
Houghton, Mich.	1252	947	808	1367	922	1543	560	367	589	518	970	458	427	1422	393	1093	1277	666	901	----	1216	633	1787																																																														
Jacksonville, Fla.	1492	286	682	2098	1015	1025	880	861	628	768	1468	1024	832	1481	1400	943	799	1178	728	1216	----	952	2153																																																														
Kansas City, Mo.	717	675	962	1158	1250	923	862	413	541	700	555	180	643	836	548	460	677	226	326	633	952	----	1352																																																														
Los Angeles, Calif.	663	1935	2313	663	2590	1370	2195	1741	1892	2044	828	1433	1976	702	1426	1212	1423	1177	1437	1787	2153	1352	----																																																														
Louisville, Ky.	1174	317	498	1623	823	1093	483	268	92	309	1035	477	315	1253	818	751	807	693	480	636	595	480	1825																																																														
Memphis, Tenn.	938	395	792	1506	1133	777	802	481	410	627	878	485	621	978	882	448	492	591	176	830	591	370	1602																																																														
Miami, Fla.	1710	610	958	2368	1258	1100	1184	1190	957	1088	1732	1398	1156	1662	1721	1150	941	1468	983	1545	328	1247	2355																																																														
Minneapolis, Minn.	980	905	948	1140	1125	1335	733	356	603	632	699	235	542	1156	219	870	1087	399	722	272	1192	413	1522																																																														
Missoula, Mont.	895	1790	1947	252	2124	1706	1740	1348	1578	1640	670	1074	1552	1115	819	1312	1595	891	1385	1208	2070	1117	910																																																														
Nashville, Tenn.	1117	218	597	1631	941	952	626	394	239	456	1018	523	468	1169	900	643	666	697	370	760	502	472	1777																																																														
New Orleans, La.	1030	427	1001	1713	1359	536	1087	831	708	922	1079	825	938	986	1221	470	288	870	358	1187	511	678	1675																																																														
New York, N. Y.	1810	747	170	2153	188	1695	291	711	568	404	1628	1023	483	1902	1213	1398	1415	1275	1125	849	838	1097	2446																																																														
Norfolk, Va.	1696	507	167	2137	467	1465	435	696	474	429	1562	983	522	1755	1258	1226	1198	1216	955	946	548	1009	2252																																																														
Oklahoma, Okla.	518	753	1173	1138	1490	659	1117	689	755	946	503	469	905	578	786	188	456	357	260	926	988	293	1182																																																														
Omaha, Nebr.	718	815	1026	1044	1280	1061	883	432	620	738	485	122	666	875	390	590	828	135	490	547	1098	165	1312																																																														
Philadelphia, Pa.	1748	663	90	2113	268	1614	278	664	501	343	575	972	444	1834	1186	1394	1335	1222	1051	827	758	1037	2388																																																														
Phoenix, Ariz.	930	1592	2002	733	2295	1023	1904	1451	1578	1745	585	1154	1685	347	1225	858	1065	901	1094	1550	1800	1045	2357																																																														
Pittsburgh, Pa.	1498	520	194	1863	478	1424	178	411	258	115	1320	718	208	1592	952	1097	1140	967	825	630	703	784	2135																																																														
Portland, Me.	2015	1022	446	2282	100	1961	438	892	802	603	1803	1197	637	2126	1313	1642	1678	1454	1371	924	1113	1300	2631																																																														
Portland, Oreg.	1107	2172	2367	349	2553	1944	2167	1765	1987	2063	985	1479	1975	1286	1248	1612	1685	1271	1733	1638	2442	1397	625																																																														
Richmond, Va.	1628	470	128	2060	471	1428	375	618	399	353	1498	905	445	1695	1180	1170	1154	1142	897	870	953	937	2283																																																														
St. Louis, Mo.	938	467	731	1389	1036	975	662	259	308	490	793	270	452	1033	658	568	697	455	325	591	755	238	1585																																																														
Salt Lake City, Utah	483	1580	1858	292	2099	1317	1701	1260	1450	1567	372	952	1490	689	865	977	1949	708	1116	1242	1840	922	577																																																														
San Francisco, Calif.	893	2133	2451	516	2696	1675	2298	1855	2037	2163	946	1547	2087	993	1447	1454	1693	1297	1648	1833	2375	1500	345																																																														
Scheneotady, N. Y.	1823	840	278	2120	150	1770	249	702	605	408	1618	1012	467	1930	1157	1445	1487	1267	1175	776	960	1107	2445																																																														
Seattle, Wash.	1178	2180	2341	405	2508	2015	2130	1743	1974	2035	1020	1470	1945	1373	1206	1658	1938	1288	1759	1588	2450	1505	956																																																														
Shreveport, La.	764	548	1064	1433	1410	510	1080	725	688	904	799	624	891	752	1002	209	233	615	142	1043	733	326	1420																																																														
Spokane, Wash.	1028	1960	2110	290	2279	1852	1900	1514	1746	1804	827	1243	1715	1238	976	1470	1753	1061	1562	1360	2239	1286	939																																																														
Springfield, Mass.	1889	863	282	2196	79	1805	325	774	659	473	1692	1085	540	1990	1240	1495	1524	1340	1224	860	957	1173	2515																																																														
Vermillion, S. Dak.	742	917	1083	973	1314	1161	916	479	694	785	468	187	705	920	284	689	938	167	605	510	1203	280	1291																																																														
Washington, D. C.	1648	542	33	2045	392	1493	290	594	403	303	1490	895	397	1726	1141	1210	1214	1139	936	813	647	943	2295																																																														

All About Standard Time

The United States adopted standard time in 1883, on the initiative of the American Railway Association, and at noon of November 18th, 1883, the telegraphic time signals sent out daily from the Naval Observatory at Washington were changed to the new system, according to which the meridians of 75°, 90°, 105°, and 120° west from Greenwich became the time meridians of Eastern, Central

Cities Compiled By the U. S. Dept. of Commerce

Louisville, Ky.	Memphis, Tenn.	Miami, Fla.	Minneapolis, Minn.	Missoula, Mont.	Nashville, Tenn.	New Orleans, La.	New York, N. Y.	Norfolk, Va.	Oklahoma, Okla.	Omaha, Nebr.	Philadelphia, Pa.	Phoenix, Ariz.	Pittsburgh, Pa.	Portland, Me.	Portland, Oreg.	Richmond, Va.	St. Louis, Mo.	Salt Lake City, Utah	San Francisco, Calif.	Schenectady, N. Y.	Seattle, Wash.	Shreveport, La.	Spokane, Wash.	Springfield, Mass.	Vermillion, S. Dak.	Washington, D.C.																																																																																																																																					
1174 938	1710 980	895 1117	1030	1810 1696	518 718	1748	330 1498	2015 1107	1628	938 483	893 1823	1178	764 1028	1889 742	1648	317 335	610 905	1790 218	427	747 507	753 815	663	1592 520	1022 2172	470	467 1580	2133 840	2180	548 1960	863 917	542	498 792	958 948	1947 597	1001	170 167	1173 1026	90	2002 194	446 2367	128	731 1858	2451 278	2341	1064 2110	282 1083	33	1623 1506	2368 1140	252 1631	1713	2153 2137	1138 1044	2113	733 1863	2282 349	2060	1389 292	516 2120	405	1433 290	2198 973	2045	823 1133	1258 1125	2124 941	1359	188 467	1490 1280	268	2295 478	100 2553	471	1036 2099	2696 150	2508	1410 2279	79 1314	392	1093 777	1100 1335	1706 952	536	1695 1465	659 1061	1614	1023 1424	1961 1944	1428	975 1317	1675 1770	2015	510 1858	1805 1161	1493	483 802	1164 733	1740 626	1087	291 435	1117 883	278	1904 178	438 2167	375	662 1701	2298 249	2130	1080 1900	325 916	290	268 461	1190 356	1348 394	831	711 696	689 432	664	1451 411	892 1765	618	259 1260	1855 702	1743	725 1514	774 479	594	92 410	957 603	1578 239	708	568 474	755 620	501	1578 258	802 1987	399	308 1450	2037 605	1974	688 1746	659 694	403	309 627	1088 632	1640 456	922	404 429	946 738	343	1745 115	603 2063	353	490 1567	2163 408	2035	904 1804	473 785	309

Table For Making Time Transitions

Eastern Standard Time	1	2	3	4	5	6	7	8	9	10	11	12
Central Standard Time	12	1	2	3	4	5	6	7	8	9	10	11
Mountain Standard Time	11	12	1	2	3	4	5	6	7	8	9	10
Pacific Standard Time	10	11	12	1	2	3	4	5	6	7	8	9

HOW TO USE TIME TRANSITION TABLE

If a station is giving a program at 8 o'clock Mountain time and you wish to find what this is equivalent to in Central time, find 8 o'clock in the third or Mountain time row. Then immediately above it in the same vertical column will be found the figure 9 in the Central time row. This indicates that the program would be heard at 9 o'clock Central time.

Health Exercises in the Home Via Radio

THE gospel of good health is now being preached daily over the radio through the broadcasting of physical exercises designed to develop and condition the entire body. These exercises are broadcast regularly by a number of the most important stations throughout the country. Milady can now perform her reducing exercises in her boudoir each morning to the rhythmic tunes issuing from her radio set. In many

various setting-up exercises as broadcast under the auspices of Bernarr Macfadden in his "Early Bird Gym Classes" from station WOR, Newark,

N. J. Tables of ideal measurements for men and women are also included as well as some important health hints advocated by Mr. Macfadden.

Health Hints

1. Ventilate every room you occupy.
2. Breathe deeply—especially when outdoors and when exercising.
3. Wear light weight, loose, porous clothing—be comfortable but let your body breathe.
4. Bathe daily the entire body in cool water—the morning cold bath, splash or shower is fine.
5. Hot soap bath once or twice weekly.
6. Don't overeat.
7. Eat some bulky food, some fresh fruits and vegetables and salads daily.
8. If not hungry at one meal time, wait until the next meal.
9. Every day eat some raw food and hard food.
10. Masticate thoroughly; eat slowly.
11. Drink sufficient water daily.
12. Keep the bowels acting regularly, thoroughly and frequently by proper diet, exercise and plenty of water.
13. Avoid patent medicines. Do not poison your body with drugs.
14. Walk until slightly fatigued each day.
15. Keep your teeth and mouth clean.
16. Consult the doctor when needed. An examination once or twice a year is valuable.
17. Keep happy, serene and calm. Don't fret or worry. Love your fellowmen and cultivate their companionship.
18. Sleep, work, play—temperately.
19. Vitolyze—

homes, these exercises are being followed religiously each morning, with every member of the family actively participating.

While exercise is one of the essential requisites of good health, it must be remembered that exercise alone cannot be depended upon to result in real vibrant health. Correct and sufficient exercise, in order to accomplish best results must be aided by an abundance of fresh air, sufficient sunlight, favorable working conditions, proper natural food and ample sleep. Exercises should be done in front of an open window or in a well-ventilated room. It is recommended that as little clothing as possible be worn while exercising and that the exercises be followed by a warm bath or a dry rub-down with a coarse towel, finishing up with a cold splash. The accompanying charts given in the following pages show the

PHYSICAL CULTURE TABLE OF IDEAL MEASUREMENTS FOR MEN

Height in feet and inches, weight in pounds, girths in inches and tenths of inches.

Height	Weight	Neck	Upper arm	Fore arm	Chest	Waist	Hips	Thigh	Calf
5 3	143	15.4	13.2	11.9	41.2	31.0	38.0	22.4	14.3
5 4	147	15.5	13.3	12.0	41.5	31.2	38.3	22.5	14.4
5 5	151	15.6	13.4	12.1	41.7	31.4	38.5	22.6	14.6
5 6	155	15.7	13.5	12.2	41.9	31.6	38.8	22.8	14.7
5 7	159	15.8	13.6	12.3	42.2	31.8	39.1	22.9	14.9
5 8	163	15.9	13.7	12.5	42.4	32.0	39.3	23.0	15.0
5 9	167	16.0	13.8	12.6	42.6	32.2	39.6	23.1	15.1
5 10	170	16.1	13.9	12.8	42.9	32.4	39.9	23.2	15.2
5 11	174	16.2	14.0	12.9	43.1	32.6	40.1	23.4	15.4
6 0	178	16.3	14.1	13.0	43.4	32.8	40.3	23.5	15.5
6 1	182	16.4	14.2	13.1	43.6	33.0	40.6	23.6	15.6

PHYSICAL CULTURE TABLE OF IDEAL MEASUREMENTS FOR WOMEN

Height in feet and inches, weight in pounds, girths in inches and tenths of inches.

Height	Weight	Neck	Upper arm	Fore arm	Chest	Waist	Hips	Thigh	Calf
4 11	110	12.1	10.3	8.9	32.0	24.6	35.6	21.6	13.1
5 0	114	12.2	10.4	9.0	32.2	24.8	35.8	21.7	13.2
5 1	118	12.3	10.5	9.1	32.4	25.0	36.0	21.8	13.3
5 2	122	12.4	10.6	9.2	32.6	25.2	36.3	21.9	13.4
5 3	126	12.5	10.7	9.3	32.8	25.4	36.5	22.0	13.5
5 4	130	12.6	10.8	9.4	33.0	25.6	36.8	22.1	13.6
5 5	134	12.7	10.9	9.5	33.2	25.8	37.0	22.2	13.8
5 6	139	12.8	11.0	9.6	33.4	26.0	37.3	22.4	13.9
5 7	143	12.9	11.1	9.7	33.6	26.2	37.5	22.5	14.0
5 8	147	13.0	11.2	9.8	33.8	26.4	37.8	22.6	14.1
5 9	152	13.1	11.3	9.9	34.1	26.6	38.1	22.8	14.2

The following Broadcast Stations are broadcasting Setting-Up Exercises every morning:

Station	Town	Wave Length
KMA	Shenandoah, Iowa	252
KNX	Los Angeles, Calif.	336.9
KPO	San Francisco, Calif.	428.3
KSL	Salt Lake City, Utah	299.8
KVOO	Bristow, Okla.	375
WEAF	New York, N. Y.	491.5
WEEI	Boston, Mass.	348.6
WGBF	Evansville, Ind.	236
WIP	Philadelphia, Pa.	508.2
WOR	Newark, N. J.	405
WWJ	Detroit, Mich.	352.7



1

STARTING POSITION

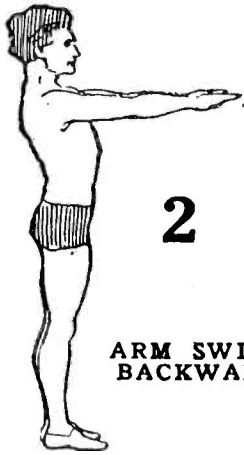

2

ARM SWING BACKWARD



3

RESISTANCE FOR NECK AND SPINE

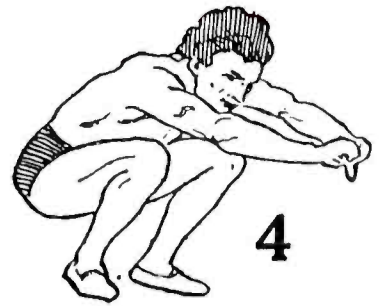

4

DEEP KNEE BEND AND ARM STRETCH

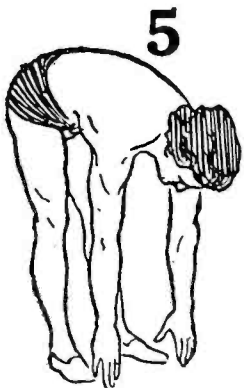

5

BACK STRETCH KNEES STRAIGHT



6

FULL BODY STRETCH

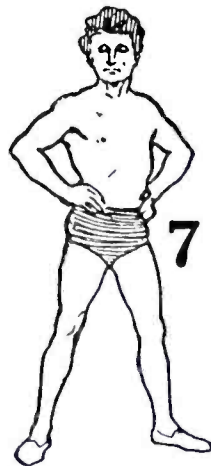

7

BODY TWIST FROM WAIST

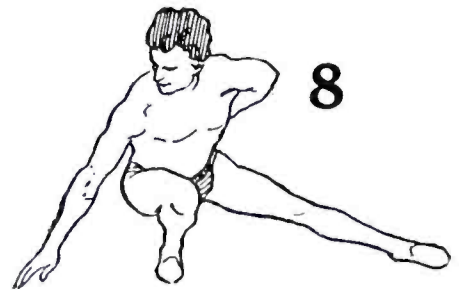

8

FLOOR TOUCH—RIGHT AND LEFT

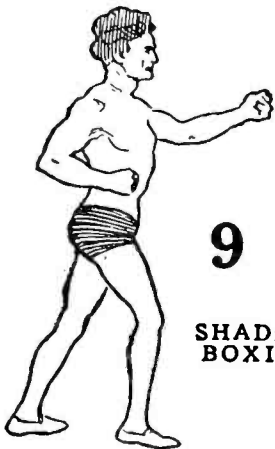

9

SHADOW BOXING

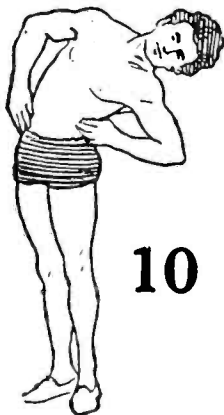

10

SIDE BENDING

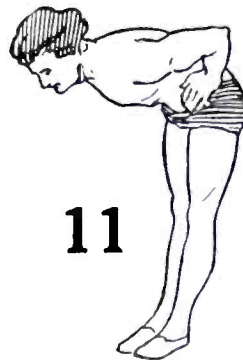

11

FORWARD BEND

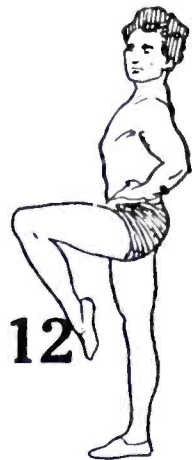

12

KNEE RAISING AND JUMPING

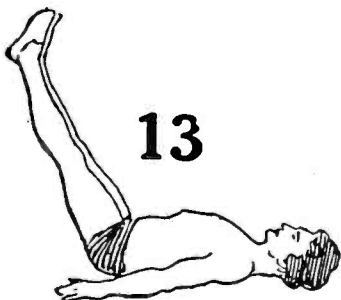

13

STOMACH STRENGTHENER

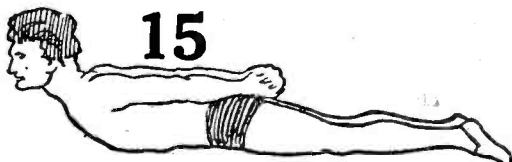

15

SPINE AND BACK STRETCH

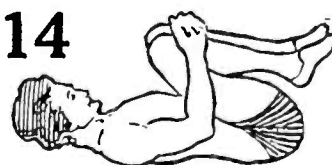

14

KNEE PULL AGAINST CHEST

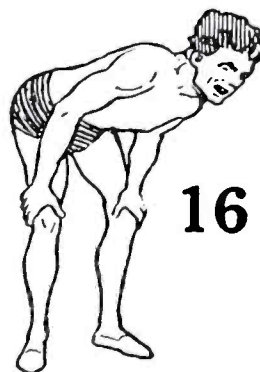

16

START AND FINISH OF LAUGHING EXERCISE

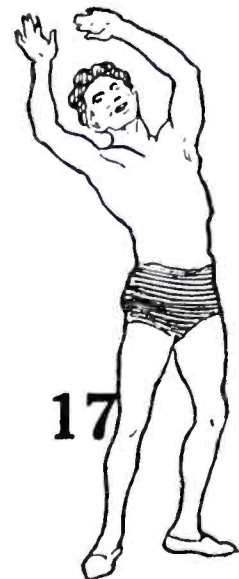

17

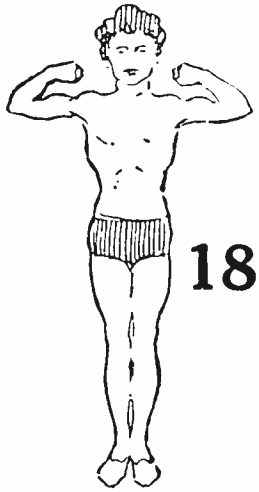

FLEX—STRETCH
—BREATHE

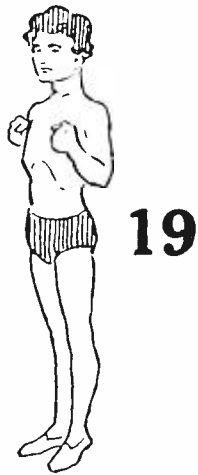

STRIKING

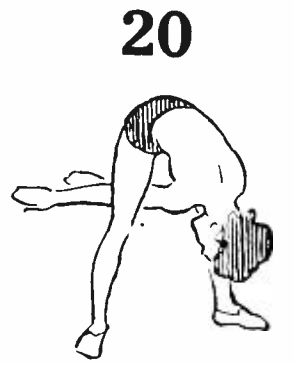

BENDING STRETCH

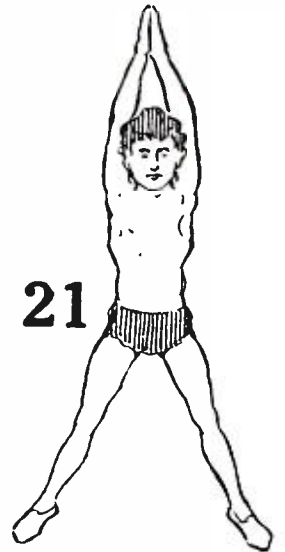

SWING AND
SPREAD

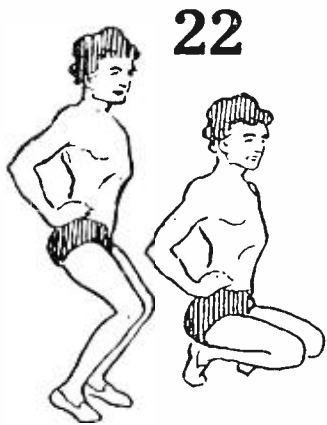

KNEE BEND

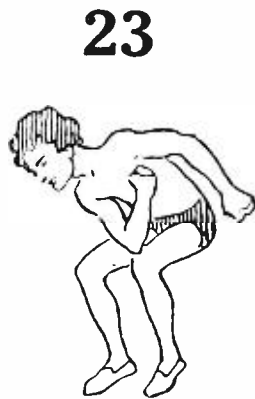

ELBOW TOUCH



HEAD CIRCLE

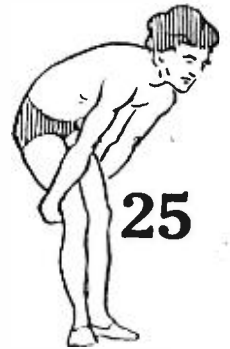

LIFTING

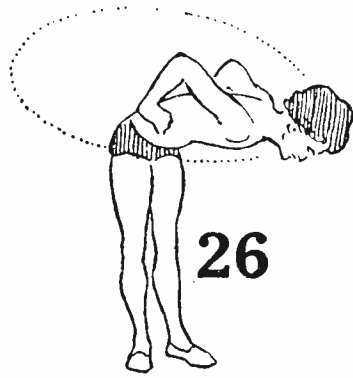

BODY CIRCLE

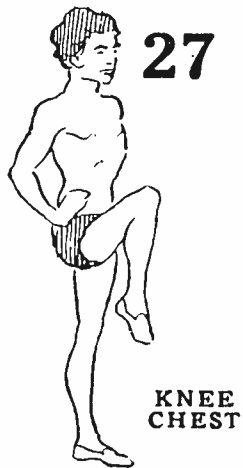

KNEE
CHEST

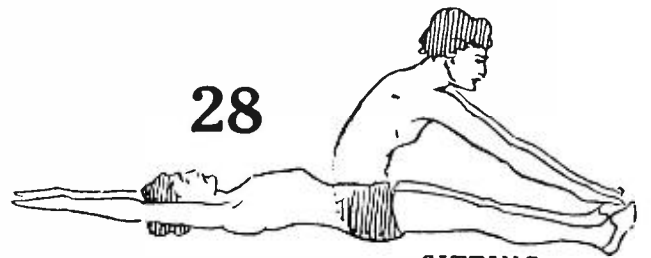

SITTING—
STRETCH

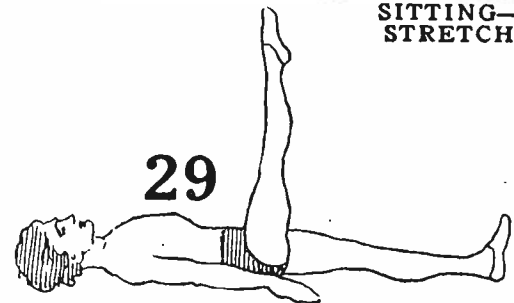

LEG RAISE

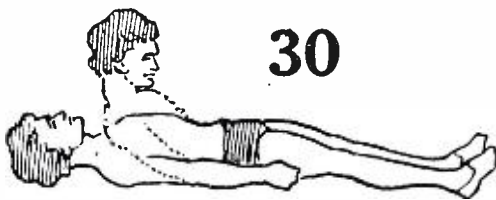

HEAD—SHOULDERS RAISE

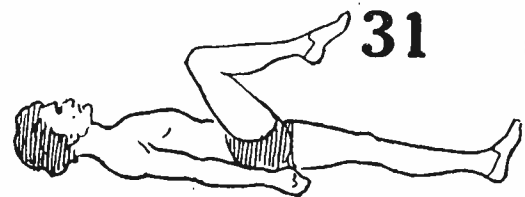

LEG THRUST

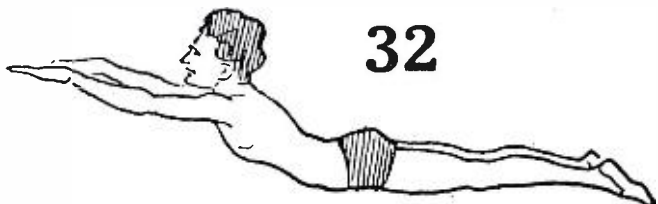

CHEST RAISE

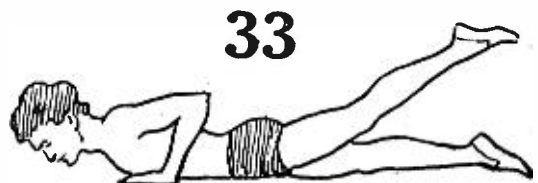

BODY RAISE

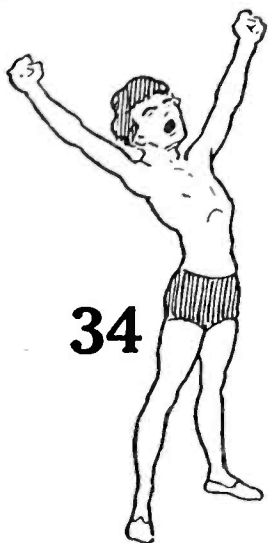

34

YAWN AND STRETCH

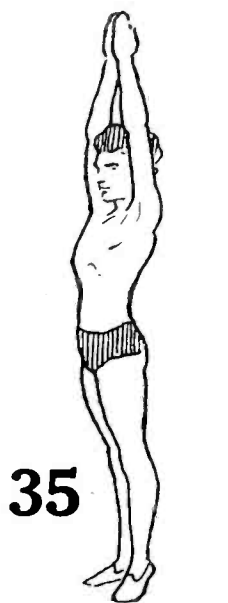

35

CHEST BREATHING



36

ONE ARM CIRCLE

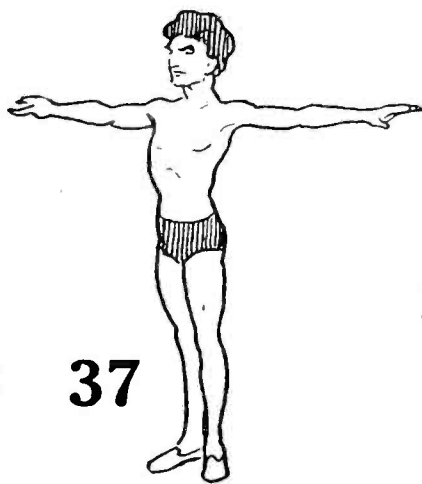

37

TWO ARM SWING



38

RAISE SHOULDERS

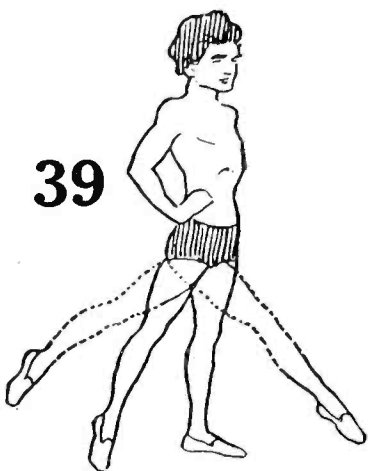

39

LEG STRETCH

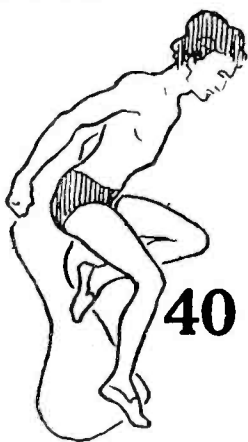

40

ROPE JUMPING

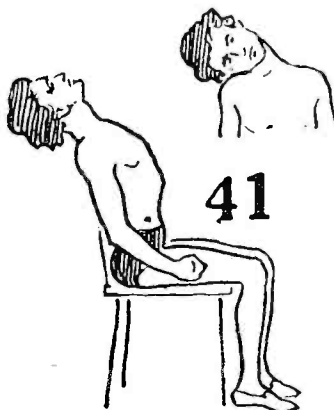

41

NECK FLEXING



42

VITAL PRESSURE

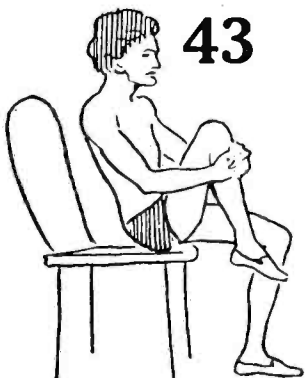

43

LEG-CHEST PULL

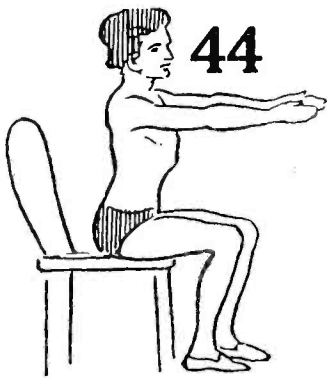

44

CHEST EXPANDER

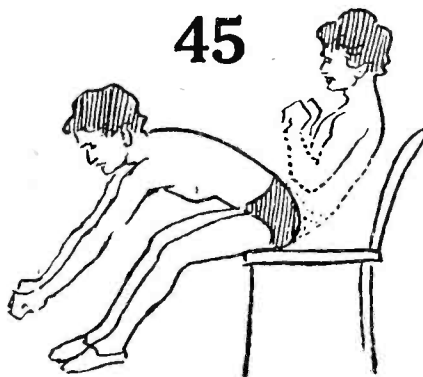

45

ROWING

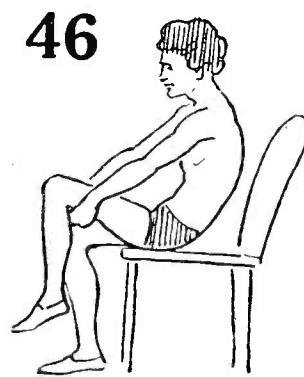

46

ARM LIFT

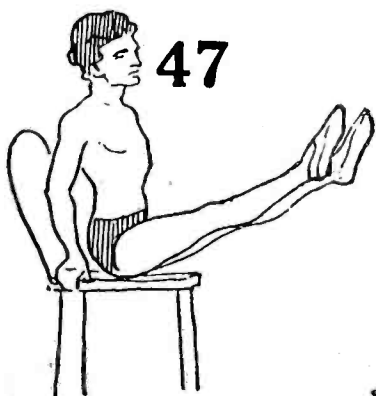

47

ABDOMEN FLEXER

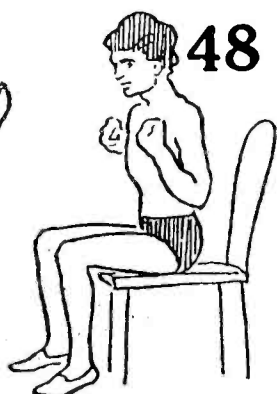

48

STRIKING

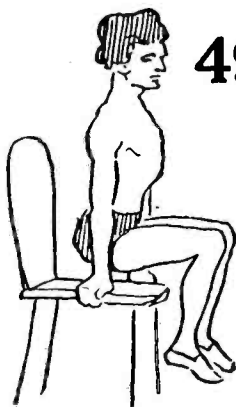

49

ARM LIFT



50

BACK LIFT

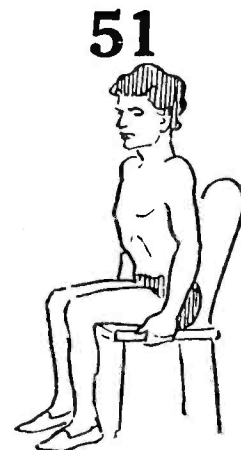

51

SHOULDER LIFT

Opportunities in Radio

By H. G. CISIN, M. E.

THE era of radio broadcasting has opened up a vast new field of endeavor which offers most unusual rewards for exceptional merit. The radio industry, as constituted at present, caters almost entirely to the amusement and entertainment of the public. This fact alone ensures more than adequate material compensation to the constructive pioneers since it is a proved fact that the American public is willing to pay and pay well for its amusements. The rapid growth and developments in the automotive, phonograph and motion picture industries bear witness to this fact.

The radio industry may be considered as being divided into two broad classifications, *engineering* and *commercial*. Each of these, supports and is supported by the other. In the case of radio, the most rapid engineering developments came during the World War. The commercial developments followed the start of broadcasting late in 1920. During the past five years expansion in both fields has proceeded at a rapid pace, although the commercial side of radio has trailed far behind the engineering. Methods of distribution have been especially weak. Lack of distribution, coupled with over production and absence of advertising knowledge have caused the collapse of a great many radio concerns. The best way to get the radio set into the home of the ultimate user has been more or less of a puzzle to the entire radio industry and strange indeed have been some of the devices offered as a solution to this riddle. One concern consummated a deal with a chain of cigar stores throughout the country, whereby its radio sets were displayed and demonstrated from the various cigar stores. On paper this plan of distribution had great merit. Its only defect was that the public refused to buy. Several other companies saw fit to engineer big deals with department stores and in this way they sold large quantities of their radio sets at cut prices, but also at a sacrifice of their reputation with their dealers and the buying public. Every known legitimate method of distribution has been or is being tried. Some radio manufacturers sell through recognized jobbers only, others sell direct to the dealer and recently several companies have inaugurated a policy of selling direct from the factory to the consumer. As a result, the prospective purchaser of a radio set can buy practically the same thing at a wide variety of prices. Consequently, there has been a condition

of unrest and instability in the entire radio industry. Radio offers practically unlimited compensation to the men capable of placing the industry on a firmer foundation. The spectacular

LEE DE FOREST

Dr. Lee De Forest is one of the pioneer American radio inventors. His audion tube is the basis of radio telephony as we now know it. Dr. De Forest was born in Council Bluffs, Iowa, August 26, 1873. He graduated from Yale University (Sheffield Scientific School) in 1896. In 1899 he received his Ph.D. degree. He is the inventor of a system of wireless telegraphy used by the United States and

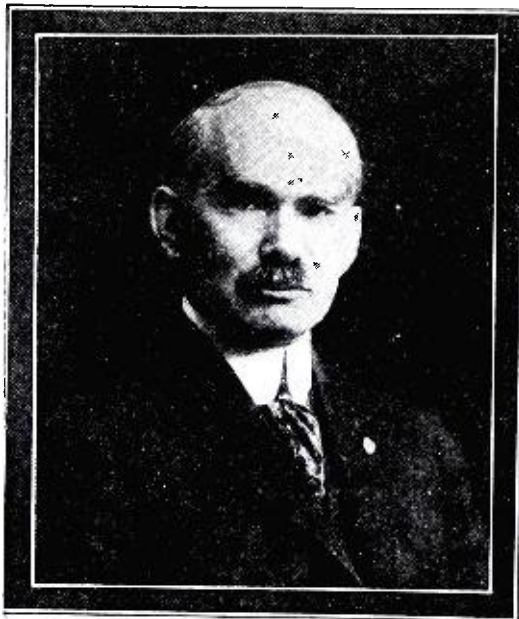

Dr. Lee De Forest.

foreign governments. In 1905 De Forest invented the audion or three-electrode vacuum tube. De Forest was the first to broadcast music. In 1908 he equipped 24 battleships of the United States Navy with radio. It may be stated without exaggeration that the De Forest inventions entirely revolutionized the art of radio telephony. Since 1919 Dr. De Forest has devoted his attention to the phonofilm, photographing sound waves directly on motion picture film so that the sounds can be reproduced in exact synchronism with the picture. Dr. De Forest was awarded the cross of the Legion of Honor by the French government in appreciation of the services rendered by the audion to the Allies during the war. In 1922 he was awarded the Elliot Cresson Medal by the Franklin Institute; in the same year he was also awarded a medal by the Institute of Radio Engineers.

successes of Sarnoff, Andrea, Freshman and Crosley will seem insignificant in comparison with the commercial achievements certain to come in radio within the next ten years. Although there is a crying need in this industry for a sales genius, radio has not as yet produced a single outstanding figure in the field of distribution. The commercial development of the phonograph, the sewing machine, or the vacuum cleaner have been orderly and systematic in comparison with that of the radio set. Just how the commercial developments and improvements in radio will be brought about it is impossible to say. Undoubtedly, there will be a vast weeding out process, not only among manufacturers, but also in the ranks of the jobbers and dealers. Sales efforts will necessarily be more highly specialized and intensified. It is conceivable that some of the radio manufacturers of the future will distribute their sets through their own chains of retail stores. Each store will have a corps of expert house-to-house canvassers and outside salesmen in addition to its clerks. In any event, the methods of distribution now in vogue in the radio industry will seem extremely crude a few years hence.

Manufacturing Possibilities

From the manufacturing standpoint, radio offers enormous possibilities. This statement, however, must be carefully qualified. When broadcasting first popularized radio, a brand new crop of "manufacturers" was created almost overnight. Most of these have now resumed their previous occupations, realizing the wisdom in the adage "Shoemaker, stick to your last." Their lack of success in radio may be ascribed in general to lack of knowledge, lack of capital and lack of ability. Of these three requisites, knowledge and ability have proved far more important than capital during the past few years, but with increasing stabilization, adequate capital will become a stronger and stronger factor. This does not mean that capital alone can insure success as a radio manufacturer. As an example, a well established and highly-rated concern decided about a year ago to enter the radio field as a manufacturer of a loud speaker. This concern had been manufacturing bicycles for the past twenty years, selling their entire output through a very limited number of jobbers and mail order houses. Since the demand for bicycles fell off in the winter, whereas the demand for radio increased at that

period of the year, this company figured that radio apparatus was just the thing for them to manufacture. They started off with no technical advice, no knowledge of distribution sources or of national advertising. They purchased a cheap loud speaker unit and made a poorly designed fiber horn at their factory. They bought an obsolete list of radio wholesalers and engaged the services of an advertising agency knowing as much about the radio business as they did. The agency forthwith laid out an ambitious program, contracted for expensive advertisements in weekly magazines having national circulation and also for a series of advertisements in leading newspapers. Due to lack of proper distribution to start with, the money thus spent was as good as thrown out of the window. The loud speaker was advertised as a superior product, which it most certainly was not. However, the public evidently never got a chance to test these statements, as the jobbers would not handle the speaker, due to the fact that their discount was not made attractive enough. Here was a typical example of failure due to lack of knowledge and ability.

What to Manufacture

In deciding to manufacture radio apparatus, the services of a first class radio engineer are cheap at almost any price. The radio market has become highly competitive and it is extremely hazardous to attempt to make a radio set or an accessory such as a loud speaker or even a part used to build a radio set, if this does not show some improvement in efficiency or operation over previous designs. For example, there are a large number of good, bad and indifferent five-tube tuned radio frequency sets now on the market. Another set of similar design would have a poor chance of success. On the other hand, a really good power operated set which would bring in distant stations without hum and which could be sold at a reasonable price, would undoubtedly find a suitable market. So also would a really efficient "A" battery eliminator, a static eliminator, an interference eliminator, a highly improved loud speaker, a cold cathode vacuum tube or in fact any device which would effect a marked improvement in radio transmission or reception. While it is true that useful radio improvements and inventions have unlimited markets, the manufacturer must be prepared to purchase the technical, advertising and sales knowledge just as certainly as he will have to buy the raw material out of which the finished product is to be made.

The Manufacturer's Organization

This leads to a consideration of the man power, or one might say, the brain power required by the properly organized radio manufacturer. Fig. 1 shows an organization chart of a typical radio set manufacturer. On the technical

GRAHAM McNAMEE

"Good evening, ladies and gentlemen of the radio audience." While no official copyright has been secured on this phrase, the radio listener can rest assured that it is Graham McNamee, one of the popular announcers of WVEAF. One day, in the early summer of 1923, Graham McNamee "walked in"—as he puts it—to WVEAF's reception room, wondering whether he possessed the qualifications

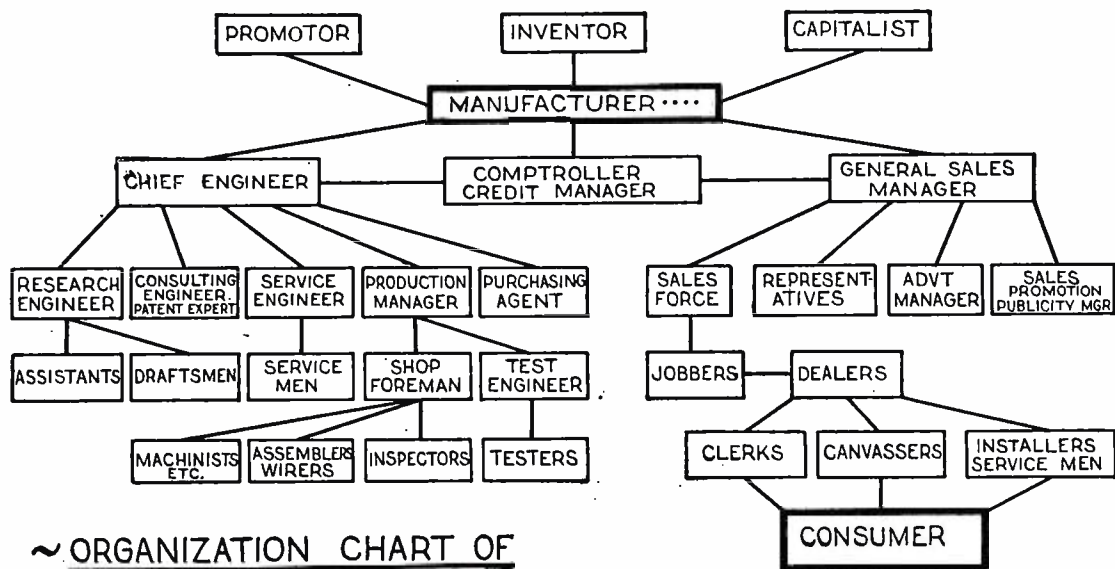

Photo by Foto Topics, Inc.
Graham McNamee.

for the position of radio announcer. He was given a voice test and a day or so later informed that he was to be "taken on." From that day McNamee's fame grew. His most famous assignment of announcing and reporting was the Democratic National Convention, but politics are far from being the limit of his ability. He is an active sport follower, keen and quick-sighted, as his descriptions of leading football games and boxing contests have shown. McNamee's last national assignment was the inauguration of President Coolidge.

side, the position of *chief engineer* is all important. This position is usually held by a graduate of a technical university who has specialized in radio. Of course, there are notable exceptions to this rule, but the inherent characteristics of radio apparatus compel the radio engineer to have a thorough understanding of the principles of electrical engineering. In the manufacturing of a radio receiving set, the chief engineer must select and specify materials, must approve the circuits to be used and he is responsible for the correct working of the completed set. In fact he is the final judge as to all matters pertaining to the actual engineering and construction of the set. He must necessarily possess that rare combination of thorough theoretical knowledge and seasoned practical ability. In addition he must possess well marked powers of leadership. Under the direction of the chief engineer are the production manager, the purchasing agent, the research engineer and the service engineer.

The *production manager* must be a man accustomed to getting results—a practical man, not a dreamer. He is responsible for the entire factory organization. In some cases he is also the factory foreman, although in the larger plants, this position is usually delegated to an assistant. The parts or the raw materials come into the factory and it is up to the production manager to see that these go out in the form of a tested and finished product according to an agreed upon production schedule. The production manager must introduce labor saving devices wherever possible, he must organize so that production can be greatly increased at short notice if necessary, and he must arrange a system of testing so that the product will be thoroughly tested and perfect both mechanically and electrically, when it leaves the factory. Very often the final testing of a radio set is in the hands of a *test engineer*. The *shop*



~ ORGANIZATION CHART OF A RADIO SET MANUFACTURER ~

Fig. 1. This chart shows the various departments in a set manufacturer's organization.

JOHN V. L. HOGAN

Among those who have earned a position of honor in the technical development of radio, John V. L. Hogan deserves a prominent place. He was born at Philadelphia, Pa., and was educated at Sheffield Scientific School, Yale University where he made a special study of physics and mathematics. In 1906 he became assistant to



John V. L. Hogan.

Dr. Lee De Forest and in 1909 he joined the engineering staff of the National Electric Signalling Company. Hogan is the holder of a number of patents relating to radio and in addition has written many articles on this subject. He is a past president of the Institute of Radio Engineers, member of the American Institute of Electrical Engineers, of the American Association for the Advancement of Science, of the Radio Club of America and of other societies. Hogan has been identified with important patent litigation as principal technical witness.

foreman works under the direct supervision of the production manager. He "hires and fires" the various factory workers and is responsible for the factory discipline. In the manufacture of a radio set, there will be employed in addition to machine operators, assemblers, coil winders, testers, inspectors, etc.

The *purchasing agent* must have a thorough knowledge of materials and prices. He must be able to buy materials and parts which will work well and which will stand up under continued use. In addition he must know where to purchase at the lowest market prices and where to get materials when there is a threatened scarcity. He must order materials in large enough quantities to supply current demands and also to obtain maximum

discounts, but at the same time must avoid overstocking.

The *research engineer* is given his duties by the chief engineer. He is continually trying to devise means to improve the product or to cheapen production costs. Some companies maintain very large research departments and spend thousands of dollars trying out new ideas, circuits, etc. The research engineer is generally a college graduate who has specialized in physics or engineering and has demonstrated an aptitude for laboratory research work.

The *service engineer* and his assistants test all returned apparatus, determining if possible what has caused the trouble so that this can be eliminated in the future. Very often unexpected trouble develops in a shipment of radio sets after these have been sent half-way across the continent. In such cases, it is often more economical to send the service engineer to the city where the sets are located, rather than to have the shipment returned. The service engineer must be an expert on radio circuits, construction and trouble finding. Such a man is invaluable to the radio manufacturer.

A number of the larger radio companies retain the services of *consulting engineers* who are called upon to work out special problems. The consulting engineer is usually a man of high scientific attainments, generally being an inventor or one who has distinguished himself in radio research. Among the notables in this branch of radio may be mentioned E. H. Armstrong, John V. L. Hogan, Professor Michael I. Pupin, E. F. W. Alexanderson, Greenleaf Whittier Pickard, etc. Some consulting engineers specialize in radio patent litigation, others in research and invention. It has been stated by Alexanderson, himself an inventor of note, that among all the technical arts, radio has given the greatest opportunity to the inventor.

Success Depends on Sales

The invention, design and actual construction of a radio set or other radio apparatus undoubtedly calls for the highest grade of technical skill. Nevertheless, from a commercial standpoint, the engineering and the manufacturing are the least important of the manufacturers' problems. The hard task is to properly distribute, advertise and *sell* the product after it has been made. Perhaps the most important man in the entire organization of the radio manufacturer is the *General Sales Manager*. He must determine the sales policies, deciding whether to concentrate his sales in one section of the country or to spread them over a wide territory. He must determine the methods to be used in distribution, whether the product is to be sold through jobbers, exclusive distributors, or franchised dealers. The sales man-

MICHAEL IDVORSKY PUPIN

Michael Idvorsky Pupin was born in 1858 at Idvor (Serbian Province of Banat), of Serbian ancestry. He was educated at the village school of his native town and at a military school at Prague. In 1874 he came to America, landing at Castle Garden with a few dollars in his pocket. He graduated from Columbia in 1883 and studied mathematics and physics at Cambridge and at Berlin (Ph.D. 1889). While abroad he held the John Tyndall Fellowship of Columbia. Upon his return to America he was appointed instructor in mathematical physics at Columbia University, in 1892 adjunct professor of mechanics, and in 1901 professor of electromechanics. He was elected a member of the National Academy of Science in 1906. During the war he was chairman of the War Research Committee with the War Department.

Professor Pupin's most important researches were in electrical resonance, in theoretical and experimental consideration of the magnetization of iron, and in electrical wave propagation, a field in which he applied his researches to the long-distance telephone and to multiplex telegraphy. The Bell Telephone Company in the United States and the German telephone interests in



Professor Michael I. Pupin.

Europe acquired rights in Professor Pupin's telephone patents.

ager must organize and direct an active sales force. He must appoint representatives in territories not covered by his own men. The successful sales manager spends only a portion of his time at his desk. He usually finds it expedient to have first-hand knowledge of the territory where his products are being sold. The best type of sales manager couples executive ability with superior sales ability. He is capable not only of telling his men how to

DAVID SARNOFF

The rise of David Sarnoff from telegraph operator to Vice-President and General Manager of the Radio Corporation of America is one of the romances of American industrial opportunity. Mr. Sarnoff is now only 35 years of age but holds one of the most active and pivotal positions in the radio industry. He came to the United States in 1900 as a poor immigrant, being forced at the age of 14 to support himself, his mother and younger brothers by selling newspapers. Later on he was employed as a messenger boy with the Commercial Cable Company. At the age of 16 he entered the employ of the Marconi Wireless Telegraph Company of America as office boy. At this time radio itself was in its infancy. Sarnoff is the man who took the message in New York from the S. S. Olympic, 1400 miles at sea, giving first confirmation of the sinking of the S. S. Titanic; he is also the man who, when radio telegraphy alone was considered an accomplished fact, presented a plan to his superiors which conceived a simple radio telephone "music box" for every home boasting of a talking machine. This plan is today the essence of broadcasting.

Accepting a variety of assignments from office boy to radio operator on

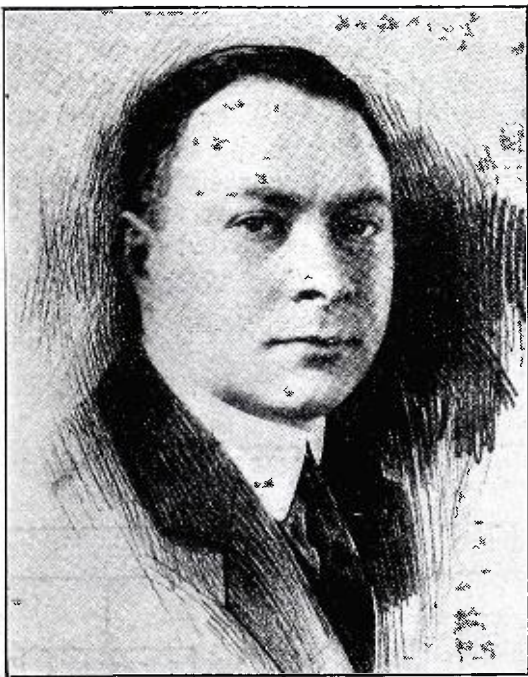

Photo courtesy of Radio Corporation of America
David Sarnoff.

ship and inspector on shore which brought him in contact with traffic conditions existing within shipboard and land stations, Mr. Sarnoff developed a sound understanding of the vital problems of commercial radio communication.

In 1917 he accepted still greater responsibilities by assuming entire charge of the commercial department.

The Radio Corporation of America appointed Mr. Sarnoff to the office of General Manager in 1921, and then to Vice-President and General Manager on September 8th of 1922.

make sales but also if the need arises of actually making the sales himself.

Radio *salesmen* who are part of a manufacturer's organization may sell to jobbers and wholesalers or in certain cases may sell direct to the dealers.

The entire sales organization must co-operate very closely with the advertising department. In some instances, the sales manager also acts as the *advertising manager*, although in the larger organizations these two positions are necessarily separate. The *advertising manager* plans the advertising campaign, decides what mediums to advertise in, gets out all advertising literature, broadsides, circulars, window displays, dealer helps, etc. The actual advertising copy used in the various publications is worked up by the agency which places the advertising. This copy must be approved by the advertising manager.

The sales promotion manager usually takes care of all promotional and publicity work. It is his duty to devise new sales plans, new ways of helping the dealers move merchandise, etc. In the publicity line, an effort is made to keep the name of the product continuously before the public. The publicity department sends out a continuous stream of publicity matter and propoganda to the magazines, trade papers and daily papers. In some cases, the sales promotion manager visits the various jobbers who are representing the manufacturers, teaching the jobbers' salesmen the most effective methods of selling the product.

The above outlines in a general way the organization of the typical radio manufacturer. Of course, various radio organizations will differ according to the nature of the product, the volume of production, etc. In smaller organizations, the engineering department will be smaller than that described above, and the sales and advertising may be combined under one head.

The radio jobbers and the radio dealer form the connecting link between the manufacturer and the consumer. A limited number of jobbers handle radio exclusively. Radio apparatus is also wholesaled by hardware jobbers, phonograph jobbers, electrical, drug, sporting goods, automotive, and dry goods jobbers. In like manner radio sets are now being retailed by every conceivable kind of dealer. During the past year however, there has been a tendency towards a reduction in the diversity of those retailing radio. The legitimate radio dealer and the music dealer seem to be gaining a larger proportion of the retail business. These are the ones who have concentrated on quality and service. The average radio fan requires a great deal of attention from the dealer after the radio set has been sold. For this reason, the successful dealer maintains an efficient service force.

CHARLES FRESHMAN

Charles Freshman was born in Chicago and educated in the New York and Chicago public schools and at the City College of New York. Previous to entering the radio business he was engaged in the rubber business in Akron, Ohio.

The Chas. Freshman Co., Inc., commenced operations in 1922 with a capi-



Charles Freshman.

tal of \$500, to manufacture receiving sets and accessories. Early products were mainly accessories for set builders. In August, 1924, the first Freshman sets were made.

Asked how he had made such a whirlwind success in a new industry, Freshman said: "I surrounded myself with good men and paid them well. I would not have an associate who could not make money." Mr. Freshman believes that most men can be successful if they would only use their brains. He is of the opinion that there is no point of saturation in the radio industry any more than there is in the automobile, piano, or phonograph industries. The radio today, he says, "is as much a commercial and educational factor as it is a pleasure machine. The farmer depends on his radio receiving set for weather reports and large numbers of people are receiving the equivalent of a college education over the radio."

Asked whether he thought radio was a young man's field, Mr. Freshman declared that as far as engineering and sales were concerned, radio belonged entirely to the younger generation. But as regards executive control and business financing, the older men, who had had more experience in the business world, were more suited for work of that nature. He qualified this by stating that that did not mean that the younger generation had not succeeded in filling these positions, but rather that he felt it more desirable to have older men for a more efficient management.

Former Radio Operators Now Industrial Leaders

It is a significant fact that many who have risen to eminence in the radio industry started their careers as radio operators. In addition to positions open to operators aboard ship, there are also numerous opportunities of this

EDWIN H. ARMSTRONG

Edwin H. Armstrong is a noted radio engineer and inventor. Armstrong was born in the United States,



Major E. H. Armstrong.

December 18, 1890. He was educated at Columbia University, where he specialized in radio engineering. He worked under Professor M. Pupin at Columbia University in the Hartley Research Laboratory. Armstrong is a director of the American Institute of Radio Engineers, the medal of which he has been awarded. He began experiments with wireless at the age of fifteen, and in 1913, while he was still a student at Columbia, he discovered the now famous feedback or regenerative circuit. In March, 1915, he described the circuits which he employed with the Pliotron or three-element vacuum tube. Armstrong was the first to reveal that, with a certain value of feed-back coupling between the plate and grid circuit, a vacuum tube would become a high-frequency generator. His patent was dated Jan. 31, 1913. His fame became world-wide when he announced his discovery of the super-regenerative circuit, one of the most widely discussed and important developments in Radio. The various circuits devised by Armstrong include the regenerative, super-regenerative and the superheterodyne.

nature at the commercial land stations and also with the broadcasting stations.

Figure 2 shows an organization chart of a typical present day broadcasting station. The station is very often in charge of a *general manager* who directly represents the owners. The chief engineer, program director and commercial director are responsible to the general manager. The *chief engineer* takes care of all technical problems which may arise. He has charge of the entire operating and engineering force of the station. The apparatus must be kept at full efficiency and broadcasting must be carried on at the assigned wave length. The engineering staff may consist of a chief operator, a remote control supervisor, radio operators and remote control operators.

The position of *program director* is a most important one. The program director decides what shall and what shall not go on the air. He selects the artists and entertainers and the degree of skill with which he does this determines to a great extent the popularity of the station. The program director has numerous subordinates and assistants to help him carry out his duties. Some of the more important of these are indicated on the organization chart. Perhaps to the general public, the most familiar personality in a broadcasting station is that of the announcer. The position of *announcer* calls for rather rigid qualifications along certain lines. The announcer's voice must sound clear and distinct over the radio and it must have a pleasing quality. The announcer himself must be versatile, well read and cultured. He must be able to describe with equal ease the plays of a World's series, a political

direct advertising medium offers the only practicable way of satisfying this demand. The *commercial director* of a broadcasting station holds a position corresponding to sales manager in an industrial concern. He must sell the idea of advertising over the air to progressive concerns. In spite of the fact that radio has cut into the profits of the motion picture industry, the phonograph industry and theatres, these interests are now utilizing the wonderful publicity possibilities of radio to reawaken and stimulate public interest. Concerns in every line have become interested in the use of radio for "institutional" advertising and "name publicity" and practically all those who have started have found it a paying proposition, well worth keeping up. The amount of advertising which the Happiness Candy Stores have obtained through their entertainers the "Happiness Boys" must have been worth hundreds of thousands of dollars. It is safe to say that the publicity obtained by the Atwater Kent Company through their unequalled series of concerts given over the radio was worth more to them than all their billboard, magazine and newspaper advertising combined. An interesting side-light is the fact that the radio artists themselves have greatly enhanced their popularity with the public as proved by increased box office receipts during subsequent tours of the country. Radio will undoubtedly have much to offer entertainers and artists in the future. Compensation will be higher than that paid for similar work in the theatre or elsewhere. Vast audiences will be reached with ease and superior talent will be recognized and rewarded overnight.

The advent of radio has in truth

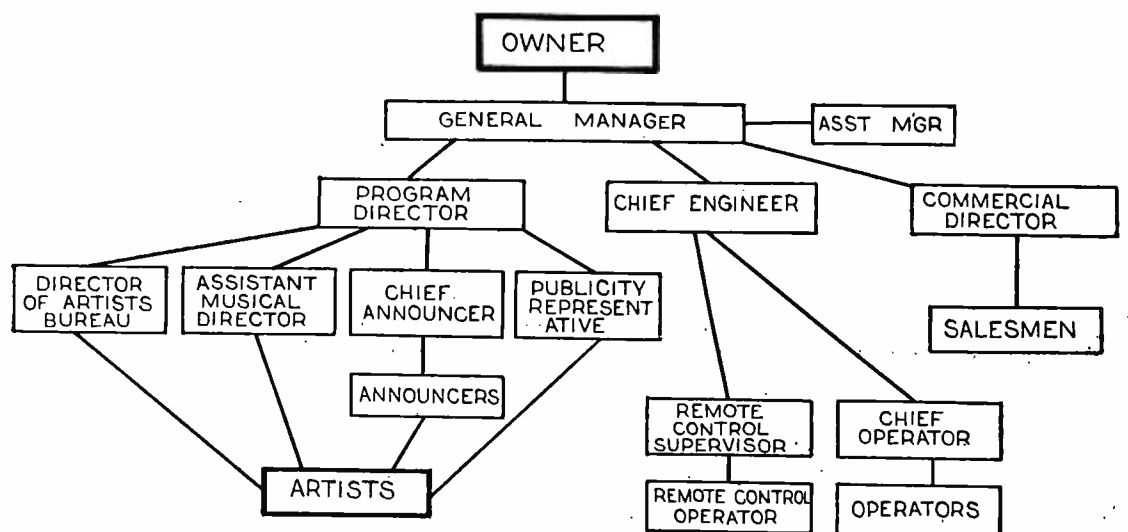

ORGANIZATION CHART OF A TYPICAL BROADCASTING STATION

Fig. 2. The organization of a typical broadcasting station showing the personnel.

convention, or the technique of a Philharmonic concert.

The commercial possibilities of broadcasting have just begun to be recognized. The public is demanding better and better quality of entertainment and the use of radio as an in-

created a new field of human endeavor. The arts and sciences have met at last on a common plane. The forces of nature have been harnessed to provide entertainment, communication and education. Will you be one of those to profit by this new opportunity?

How to Modernize Your Old Radio Set

By A. M. POWERS

MANY of the radio sets purchased several years ago are still giving satisfactory service. However, as new sets and accessories have appeared on the market, worthwhile improvements have been developed and added. Fortunately, it is possible to equip the out-of-date set with many of these new devices and thus to make it very nearly equal to the most modern receiver.

The principal developments incorporated in present-day receiving sets are the elimination of troublesome batteries, increased wave-length range, greater selectivity, simplified control, improved tubes, increased volume, vastly better tone quality, improved loud speakers and finally finer design and appearance.

One of the most satisfactory developments has been that of the power operated set. This has resulted from the insistent demand from radio fans for a set which could be operated from the electric light socket thus doing away with all battery bother. The fan who has purchased a good storage battery, need not discard this in order to obtain what is virtually the same as power operation. A trickle charger, such as the Balkite permanently connected to the battery and the use of a good "B" battery eliminator will do the work and do it well. In trickle charging the

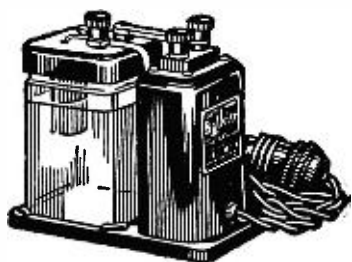

Illustrations by courtesy of Fansteel Products Co., Inc.

A trickle charger which provides "A" current from the light socket.

power is supplied from the alternating current source (i.e.—the light socket). The charger is permanently connected to the line. This charger rectifies the alternating current into direct current and charges the battery at a low rate. The rectified current is stored in the battery and is used as required to supply current to the tube filaments. The charger being always turned on, automatically replaces any current expended by the battery in operation, and keeps the battery at full charge at all times. Trickle charging combines the advantages of both primary batteries and alternating current and eliminates to a great extent, their disadvantages. If for any reason the alternating cur-

rent line ceases to function temporarily, the battery has stored enough reserve power to operate the apparatus. On the other hand, the rectifier being in constant operation, keeps the battery at full charge, so that there is no possibility of failure due to exhaustion. In the ordinary storage battery installation



An electrolytic "B" eliminator for sets of 6 tubes or more.

the battery has always been only a temporary means of supplying low voltage direct current at isolated points. After the storage battery has been used for a while it has to be recharged and this means all the inconvenience of removal to a charging station or of attaching to the ordinary charger. In trickle charging, the battery ceases to be a makeshift. The battery and the charger, in this case, form a completely installed unit. Together they form an automatic, permanent installation for furnishing filament current whenever it is needed, practically direct from the alternating current source. Having installed a good trickle charger, the installation is made automatic by the use of an efficient "B" eliminator. "B" battery eliminators are available which



Illustration by courtesy of Mayolian Radio Corp. A "B" eliminator which uses the Raytheon tube.

will operate with nearly every type of radio set. They can be divided into two general classes, those using rectifying tubes and those using electrolytic (chemical) rectification. The tube

eliminators can be further classified according to whether tubes are without filaments, as in the case of eliminators using Raytheon tubes such as Acme, Majestic, Webster, Mayolian, All-American, General Radio, Modern, etc., and those using filament tubes either of the Tungar or 201-A type. Among the "B" eliminators using 201-A type tubes may be mentioned the Apco "Rectodyne," Epom, Freshman, Kellogg, Kodol, and Martin "Aero-B." The Super-Ducon "B" eliminator uses a special two filament bulb known as the Rectron UV-196. In an effort to obtain a greater current output than is possible with the standard tubes, of the 201-A type, numerous special types have been placed on the market. Among these may be mentioned the UX-213 which is a full wave rectifier made especially for the operation of



Illustration by courtesy of The Davy Electrical Corporation. An "A" battery eliminator.

"B" battery eliminators. Ordinarily two tubes are required for changing alternating house-current into uni-directional receiving-set current, because each tube rectifies only half the wave. Since one tube takes the place of two in the case of the UX-213, space and money are saved and a smoother current is delivered. The UX-213 will safely pass 65 milliamperes, which is sufficient to operate any multi-tube receiver. The UX-216-B is a half-wave rectifier used to supply uni-directional current from an alternating current source. The rated output of this tube is 65 milliamperes, and it is generally used together with a similar tube to give full wave rectification. In this case the total output capacity is 130 amperes. The characteristics and operation of "B" battery eliminators utilizing Raytheon tubes are taken up in detail in other articles in this issue. A typical electrolytic "B" battery elimina-

tor is the Balkite "B." This is made in two models, one for sets having six tubes or less and one for sets having six tubes or more. The smaller model

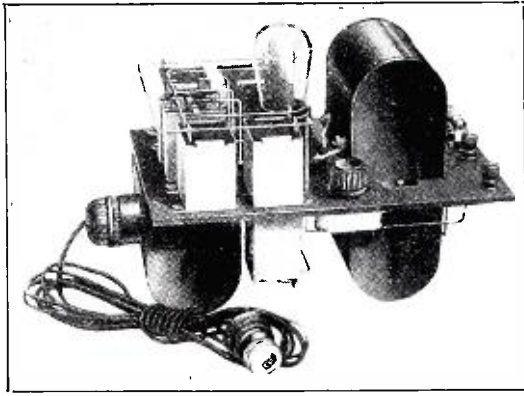

Photo by courtesy of All-American Radio Corp. Another style of "B" eliminator using the Raytheon tube.

is designed to serve sets requiring not more than 20 milliamperes at 90 volts. In most cases it will fit the present dry cell compartments found in the average set. As current consumption is very low, cost of operation is about 1/10 cent per hour. It operates from any 110-120 alternating current 60 cycles source. The larger model is similar to the other one, except that it is universal in application and will serve any radio set including sets having eight tubes or more. Other electrolytic "B" eliminators are the Ferbend and the Dewitt-La France.

For those who wish to dispense with all batteries, including the storage battery, there are now on the market a number of eliminators which will supply "A," "B" and "C" battery current. The Radio Corporation of America manufactures a cone-type loud speaker

Radio" delivers current for "A" circuit up to 9 tubes at 1¼ amperes each, "B" circuit up to 100 volts, and "C" circuit. A more recent "A," "B" and "C" eliminator is that made under the name of Paul Ware. There are also several eliminators made for "A" current only such as the Kodak "A" power unit, Davy "A" power, Dewitt-La France electrolytic "A" eliminators, etc.

Another device recently developed known as the "Powerformer" furnishes audio amplification while acting as a "B" eliminator. The purpose of this machine is to transform any radio set into a producer of great volume while at the same time giving realistic tone quality. It is a power amplifier operating in conjunction with the first stage of audio amplification. For local signals or for powerful distant signals it will function with the detector alone. The Powerformer is especially suited to the purpose of bringing old style two, three or even four tube sets up to date.

One of the most noticeable differences between the old type and up-to-the-minute sets is that of wave-length range. Many of the older sets are unable to cover the entire range of present broadcasting, especially on the lower wave-lengths. In most cases, these sets may be modernized by removing the old radio frequency coils or inductance units and substituting new ones having the proper wave-length range. In most cases such a substitution will result in increased selectivity and sensitivity also since the new coils are built on low-loss principles. In fact, it has been stated that the most outstanding key in present day

frequencies employed in broadcasting. It was found after exhaustive experimentation, that the inherent characteristics of coils were dependent upon several factors. Since it follows that high frequency currents do not travel in the wire itself, but on the outer surface of the wire, any substance on which the coil is wound, or in the electromagnetic field surrounding the coil, increases to



Illustrations by courtesy of Aero Products, Inc. Three interchangeable low-loss short-wave coils.

an enormous extent the losses in the coil. These losses, in actual figures, are very small, but taking into consideration, the infinitesimal amount of energy derived from the antenna, the effect of these losses is enormous. Other apparatuses or parts besides coils, contribute to the losses present in all receivers, but to a much smaller extent. The leakage path of the conden-

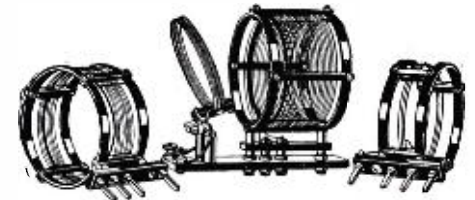

Tuned radio frequency low-loss coils. The units are matched and the antenna coupler has a variable primary.

sers is usually very narrow and up to an inch in length. The leakage path of coils is from turn to turn and extends completely around the coil. Laboratory measurements and comparative tests seem to indicate the superiority of the single layer cylindrical wound coil. The reason for this can be readily seen. An important factor in coil construction is a very slight air spacing between each two turns. If the turns are crowded closely together, greatly increased distributed capacity and leakage is the result. If spaced too widely, decreased mutual inductance results, which is undesirable. This air-spacing can be accurately produced only in single layer coils. Again, in winding coils with one turn on top of another, considerable tension must be used. This causes the top layers to press heavily upon the lower ones, flattening out the insulation and causing the adjacent turns of wire carrying current to practically touch each other. In such a case the leakage path is very short and is a partial conductor. The dielectric of coils is tremendously inferior to the poorest air condenser. Losses manifest themselves by faint reception of distant stations, lack of selectivity, and distorted tone qualities. If the coils are wound on tubing the tubing is the dielectric. If the coils are wound on tubing coated with shellac, varnish, etc.,

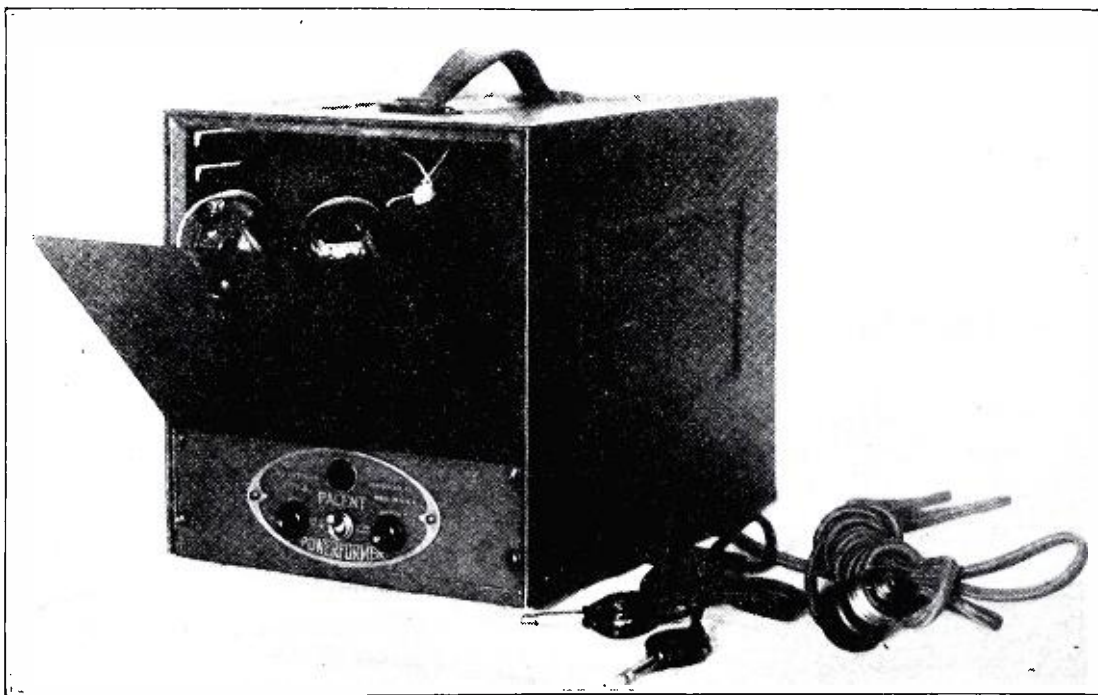

Photo by courtesy of Pacent Electric Co., Inc. The "Powerformer" furnishes audio amplification while acting as a "B" eliminator.

which includes a power amplifier and a rectifier unit which when used in conjunction with their "A.C. Package" can be used to do away with all batteries "A," "B," and "C." The entire outfit is included in a single cabinet. Another eliminator known as the "Run-a-

radio engineering is the attention being paid to the loss characteristic of inductances and other essential apparatus. The importance of designing such equipment as would conserve the minute energy received from the antenna lead to an investigation of coils at fre-

the distributed capacity, leakage, resistance and dielectric absorption are increased, with a proportionate increase of energy losses. Because of this, a large portion of the extremely small amount of energy collected by the an-

tubes used, such as radio frequency amplifiers, detectors and audio frequency amplifiers. A very slight change in potential applied to the grid of the first radio frequency tube causes a corresponding fluctuation of greatly increased

loss were not present, the station could be clearly heard on the loud speaker. From the foregoing it is apparent that the greatest care to avoid losses must be taken before the energy is impressed upon the grid of the detector tube. As



At the left is shown a low-loss three-circuit tuner. At the right is an oscillator for improving the performance of the oscillator circuit of superheterodynes.

tenna is lost in the tuning inductance and tuned radio frequency transformers, before it even reaches the detector tube.

The presence of any material near the coils, especially metal, increases the



The tapped three-circuit tuner and the radio frequency coil shown will improve the operation of old style four-tube regenerative radio-frequency sets.

distributed capacity and high frequency resistance, and absorbs energy when the electromagnetic field, which is building out and collapsing around the coil thousands of times a second, cuts through it. The losses due to this cause may be



An interchangeable low loss R.F. coil having a range of 125 to 250 meters.

decreased by mounting the coils farther from the condensers and by keeping unnecessary metal work out of the densest part of the electromagnetic field radiated by the coils. Briefly the losses are caused by (1) winding the coils on tubing, (2) using shellac or varnish, (3) using too thinly insulated, colored, or too small wire, (4) mounting the coils too near condensers or other metal work, (5) using multi-layer or self-supporting coils with turns touching.

Losses in tuners and radio frequency transformers affect the operation of receivers tremendously more than is commonly supposed. For example, in a receiver employing radio frequency amplification, with a tuned inductance for each stage, energy losses in the tuning inductance and each stage of tuned radio frequency transformer, decrease to a great extent the reception range, broaden tuning and give poor, distorted reception. The effect these losses have on range, selectivity and volume can be more simply explained by noting briefly the action of vacuum

course, energy below a certain signal strength will not operate the detector tube. It can be readily seen, then, that a small loss in the tuning inductance or radio frequency transformers of a receiver may entirely prevent the reception of a distant station, whereas, if the

stages of radio frequency amplification will also give increased sensitivity and selectivity. Looser coupling between the primary and the secondary of the radio frequency transformer increases the selectivity also.

The use of the straight-line fre-

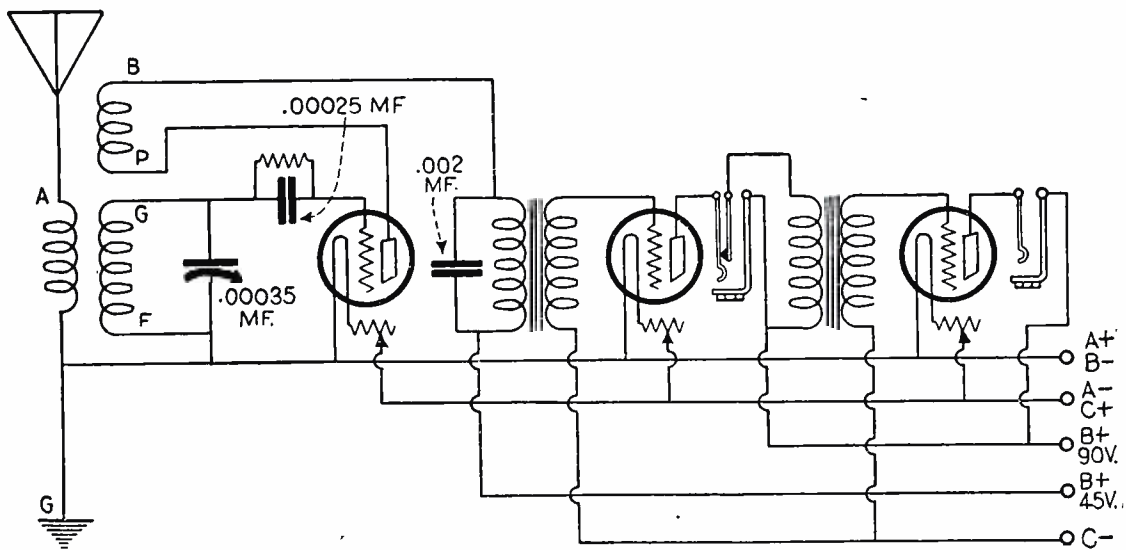

Hook-up of a three-circuit regenerative receiver in which low-loss three-circuit tuner shown above can be substituted to advantage.

magnitude in the space current of the plate circuit. If energy is lost in the inductance preceding the tube, a decrease in the potential applied to the grid results. The resulting space current is then only a small portion of what it would be if the loss were not present. In a two-stage radio frequency amplifier, this change occurs twice.

We all know that the sensitivity of a vacuum tube detector is approximately proportional to the square of the voltage applied to it. Hence the losses in the three coils preceding the detector cause very great reductions in the plate circuit of the detector and audio frequency amplifying tubes. Naturally this causes a marked decrease in the sensitiveness of the receiver, together with broadened tuning and inferior tone qualities. And of

the tuner and radio frequency transformers are connected in the circuit before the detector, care must be taken to see that they are of the low-loss type. The circuits shown in the accompanying illustrations are typical of ones in which modern low-loss coils such as Aero coils or National may be substituted with surprising results. There are interchangeable coils now on the market made with plugs which fit into special mountings, thus allowing reception of different wave-lengths from 15 to 550 meters merely by plugging in a different coil. Several of these are illustrated.

In addition to the use of low-loss coils there are several other methods by which the selectivity of a radio set may be increased. Sometimes shortening the antenna will produce the desired result. The adding of one or more

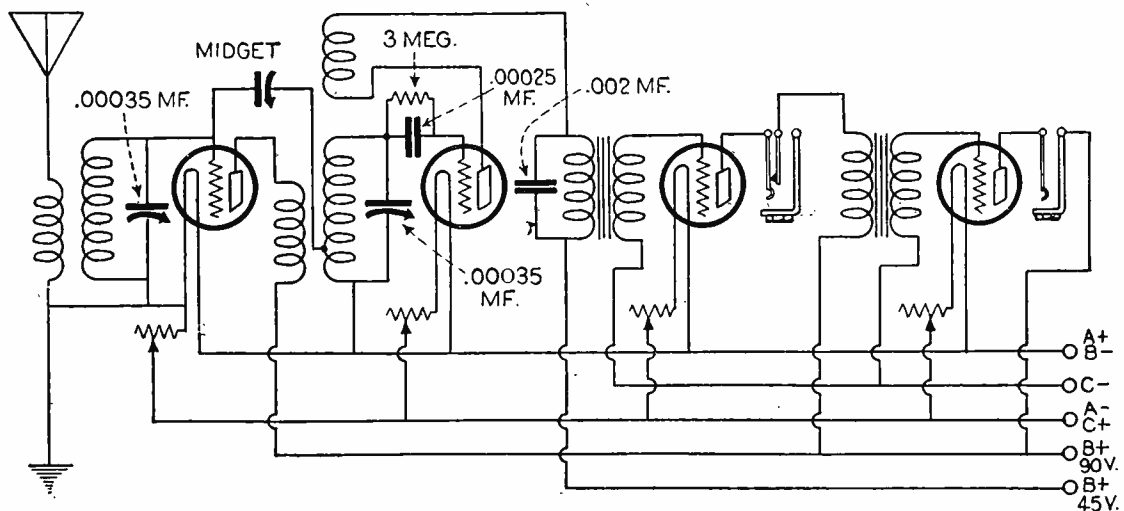

Diagram of a four-tube tuned R.F. regenerative receiver. The low-loss coils illustrated when substituted in a set using this hook-up, will greatly improve the performance.

frequency condensers has become standard in present-day sets. These condensers tune evenly over the entire dial scale. Typical examples of modern straight line frequency condensers are shown in the accompanying illustrations. For those fans who do not want to go to the trouble and expense of installing new condensers, there are now on the market straight-line frequency dials, which when applied to any existing

For the purpose of cutting out undesired signals and for clarifying and amplifying the signals of the station especially desired, a device has been made by the All-American Radio Corp. called the Filtrola. It is claimed that this unit shuts out any station completely, eliminating even high powered broadcasting. The unit has two dials which can be manipulated to tune out unwanted stations thus allowing the

Rejector circuit. The combination of these filter circuits give the greatest degree of efficiency in the elimination of interference. The rejector circuit is tuned by the left hand dial and has the effect of drawing off the unwanted signals to ground. The absorption circuit, tuned by the right hand dial, removes all trace of the interfering station, thus giving the radio set a most unusual degree of selectivity.

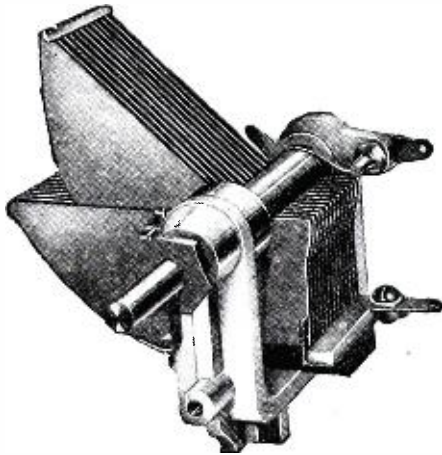

Illustration by courtesy of Hammarlund Mfg. Co. A modern straight-line frequency condenser.

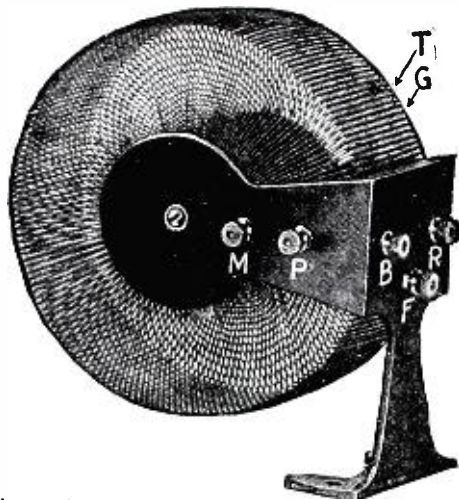

Illustration by courtesy of Bremer-Tully Mfg. Co. Low-loss Toroidal coil.

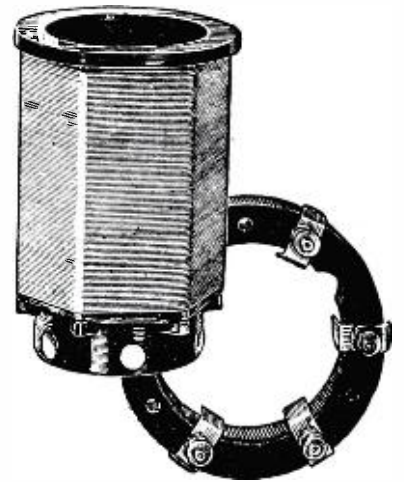

Illustration by courtesy of Silver-Marshall, Inc. Interchangeable low-loss coil and mounting.

radio receiver equipped with ordinary condensers, convert it in such a way that the stations are separated evenly over the dial scale, this effect being otherwise possible only with straight-line frequency condensers.

This conversion is made possible in one type by means of an ingenious ar-

listener to tune in distant stations on much closer wave-lengths to the interfering station than would otherwise be

With reference to shielding, this has its purpose, but when done improperly or when used if not needed, it may cause excessive losses. Where modern low-loss condensers are used having metal end plates and rotary plates con-

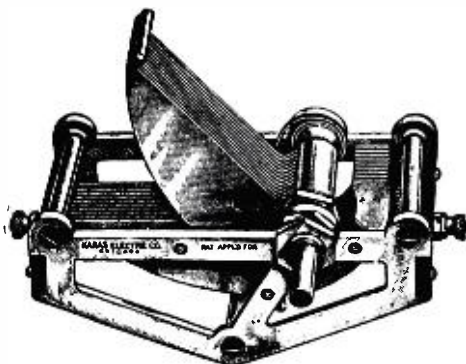

Illustration by courtesy of Karas Electric Co. Another typical straight-line frequency condenser.

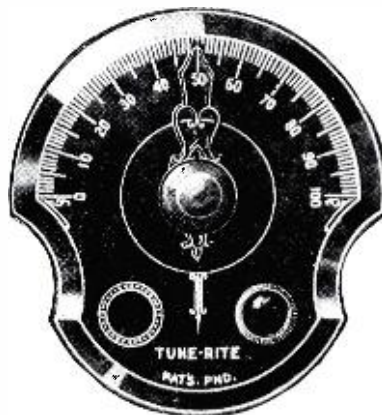

Photo by courtesy of Radiall Corp. A straight-line frequency dial. The illustration below shows how it works.

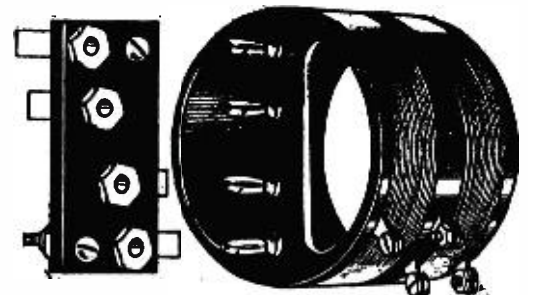
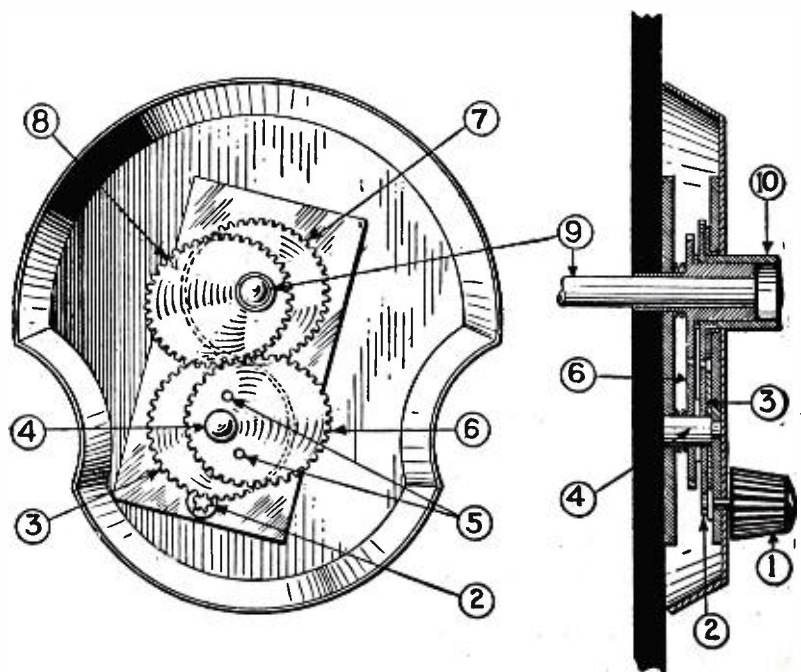

Illustration by courtesy of General Radio Co. Another type of interchangeable coil with mounting at the left.

possible. Two types of filter circuits are employed in combination in the Filtrola—the absorption circuit and the

needed to these end plates they act as shields within themselves and in such cases it is not necessary to place a

arrangement of two sets of gear trains. The two gear trains move independently of each other in such a way that, while one moves a pointer at a uniform rate over the graduated scale of the dial, the other train rotates the condenser. This latter gear train comprises eccentric gears, which work in such a way that at the lower readings of the pointer the condenser moves slower than the pointer. This, as can be readily seen, causes the stations at low wave-lengths to be separated on the scale and to bring stations of higher wave-lengths closer together. This dial is easy to mount, no drilling of holes being at all necessary and it is indeed fortunate for those who desire selectivity that there is in existence such a device, that can accomplish with little expenditure and in a few minutes' time all that rebuilding a set would accomplish.



Pinion 2 turns circular gear 3, also turning circular gear 7, to which the dial pointer is fastened, at the same time. Elliptical gear 6 is carried (rigidly) by 3, and rotates elliptical gear which moves the condenser shaft, at 9, at a variable rate.

metal shield behind the panel between the panel and the condenser. If the low-loss condensers are properly con-

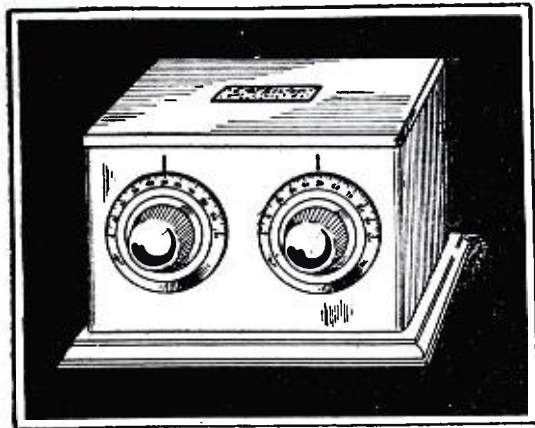

Illustration by courtesy of All-American Radio Corp. The Filtrol—an efficient wave trap.

nected in the circuit no body capacity will be noted when the hand is removed from the tuning dial. In compact neodyne sets, where the condensers are crowded, there may be severe feed-back from one condenser to the next. In this case it may be desirable to insert metal partitions or shields between the condensers, connecting the shields to ground. While this expedient will prevent feed-back it will also introduce losses.

Shielding will be necessary in an audio frequency amplifier using transformer coupling and having more than two stages. In such a case the intro-

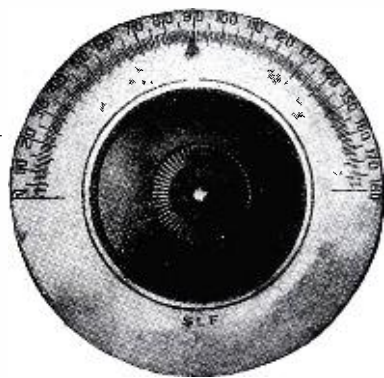

Photo by courtesy of Walbert Mfg. Co.

A straight-line frequency dial of unique design.

duction of shielding will not cause appreciable losses. Copper or brass shielding of about No. 12 gauge should be used. Iron or sheet steel of the same thickness would not be as effective.

In placing shielding in radio frequency circuits care should be taken not to put the shielding nearer than one inch to coils, condensers, or tubes. The Super-Heterodyne is one of the comparatively few standard circuits which requires shielding. Shielding should be complete, in fact almost airtight in order to be of any use. Tin-foil, etc., is practically non-effective.

The tendency toward simplified control in modern sets has given us the single dial method of operating three condensers. This has been accomplished by gearing the condensers in various ways and by operating all the condensers from a single shaft. Unfortunately, the average old-type set

does not easily lend itself to the substitutions of gang condensers although these are available in all required capacities. Another method of simplification has been the elimination of filament rheostats by means of automatic filament control. Formerly, with a change in voltage, the hand rheostat had to be adjusted in order to feed the correct amount of current to the tube, for unless just the right amount of current passes through the tube filament—all the time—poor reception is obtained and frequent blow-outs.

It is a fundamental law of radio that the temperature and current passing through the tube filament must be kept within a very narrow range and a device such as Amperite performs this function automatically.

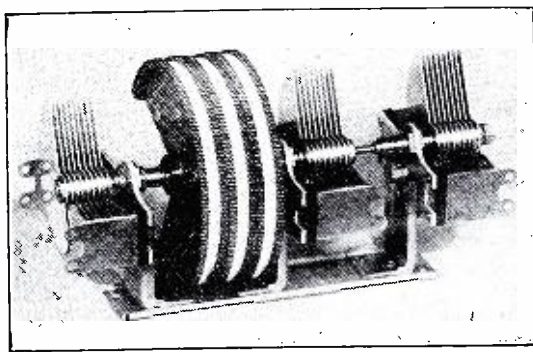

Photo by courtesy of Alden Mfg. Co. In this condenser the three controls are brought through a single opening in the panel so that the tuning is done from one point.

The Amperite contains a certain kind of metallic alloy, which possesses the unique quality of increasing its resistance under heat to such an extent as to exactly counterbalance the voltage passing through it. If the voltage applied to it is high, as it will be from a newly charged battery, it heats up, thereby increasing its resistance and limiting the current passing through it

It is clear, therefore, that, with Amperite in control, it is just as if an expert operator were constantly adjusting

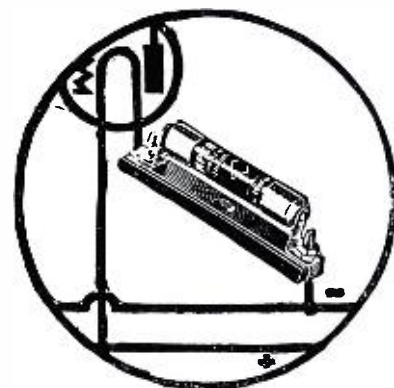

Illustration by courtesy of Radiall Corp. Schematic diagram showing how Amperite is connected in the filament circuit of a vacuum tube.

the filament current and that the Amperite greatly simplifies the operation of a set; the tubes obviously last longer and give the best that is in them.



Illustration by courtesy of Henry G. Bosselli Mfg. Co. A one-dial control attachment adaptable to present type three-control receivers and which permits adjustment of all controls in one operation.

Another method of automatic filament control is known as the Elkay Tube Equalizer System. The Elkay system assumes a six-volt source of filament current and provides suitable resistors to adapt any tube to any circuit. Equalizers are also made for controlling two tubes from the same source—a particular advantage for two stages of radio frequency or two stages of audio where both tubes operate together continuously. In case an automatic filament jack is used and one of

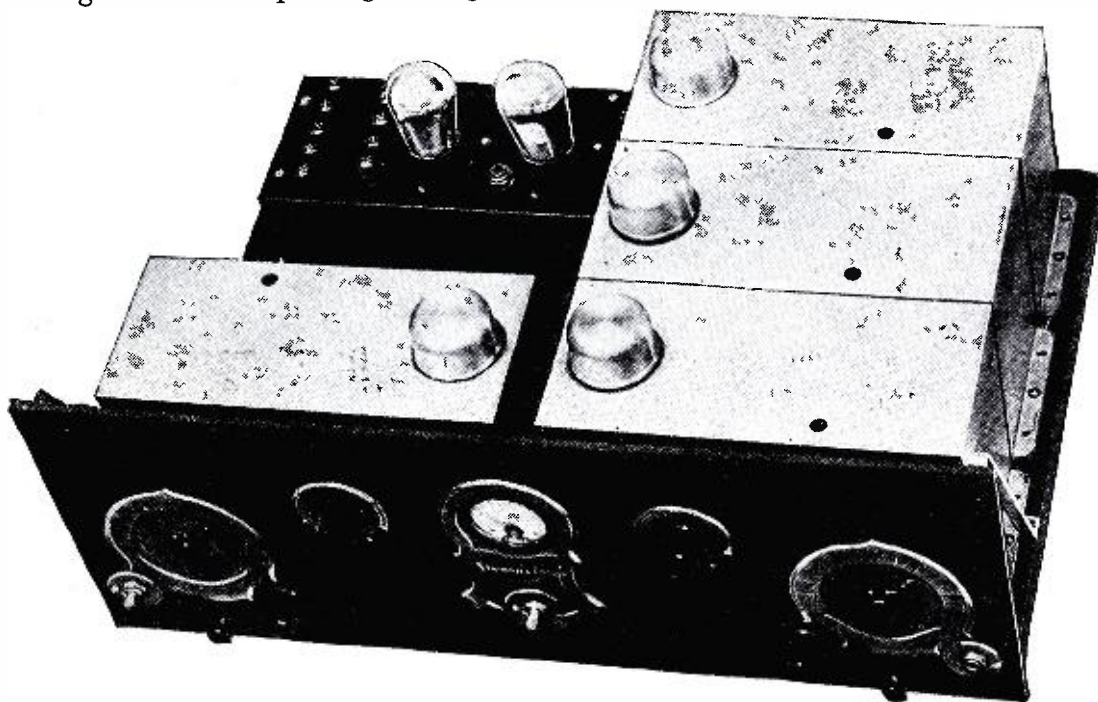

Photo by courtesy of Stromberg-Carlson Telephone Mfg. Co. An example shielding in a modern radio set.

to the tube filament. When, on the other hand, the voltage drops, its resistance decreases, permitting the correct amount of current to pass to the tube filament.

the tubes is turned off, individual Equalizers should be provided.

Importance of Vacuum Tubes

Many radio fans fail to appreciate the importance of the vacuum tube in

securing the utmost from the radio set. It should be kept in mind that radio tubes wear out and become less and less efficient the longer they are used. Hence if the set has been in use for a considerable period of time, one of the most certain means of improving it is

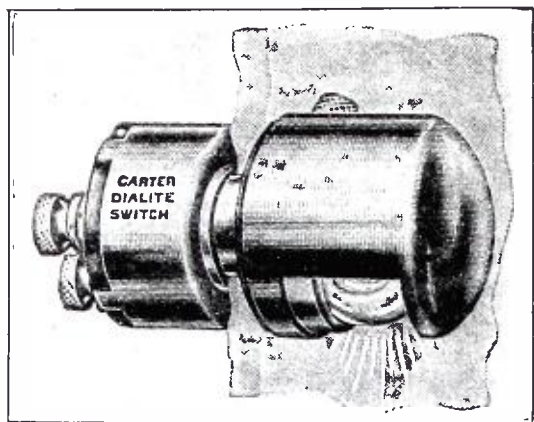

Photo by courtesy of Carter Radio Co.

A convenient combination dial light and filament switch.

to obtain a new set of tubes. Inasmuch as there has been considerable development in tubes recently, the fan should avail himself of the opportunity when he is re-equipping his set, of obtaining the latest and most efficient tubes. A new detector tube has been developed called the UX-200-A (CTX-200-A) which will give greater selectivity and longer distance reach than tubes formerly used as detectors. The use of the new Donle-Bristol detector tube results in greatly increased sensitivity. In the radio frequency sockets and the first audio stage an effort should be made to use the best tubes obtainable. A tube having a relatively high ampli-

plate voltage of 45 to 135 volts. The filament current is 0.27 ampere. The Cleartron radio frequency tube gives a higher voltage amplification per stage, therefore an increase in radio frequency amplification. This increase in amplification serves a duofold purpose. First, it brings in weak distant stations louder and second, it brings in distant stations never heard before. Since the Cleartron radio frequency tube takes the same filament voltage as the 201-A type, it may be used with these tubes on the same rheostat. While the radio frequency tubes are designed to be used in the radio frequency stages of a receiving set, the same tube also makes an excellent detector tube.

For increased volume and finer tone, the UX-112 or the UX-171 should be used in the last audio stage (if the set is of the 6-volt type). Adapters are available which can be inserted in the socket of the last audio tube and these have connections properly labelled which allow the use of the correct "B" and "C" voltage on the tube. In other words, these new tubes require additional voltage, thus the UX-112 requires a plate voltage of from 90 to 135 volts for best operation and a negative "C" battery voltage of from 6 to 9 volts.

The UX-112 will deliver far more energy than the average loud speaker requires. If two UX-112's are used in the audio frequency circuit, very remarkable results will be obtained. Just as the UX-112 takes the place of the UX-201-A in the last stage of 6-volt audio frequency circuit, so the UX-120 can be used to take the place of the

An exceedingly efficient power tube is known as the model CTX 171 Cleartron "Super Power Tube." This tube uses a filament voltage of 5 volts, a plate voltage of 90 to 180 volts and a negative grid voltage of $16\frac{1}{2}$ to $40\frac{1}{2}$ volts. The filament current is 0.5 ampere. This tube has been designed to supply a large volume of undistorted output to the loud speaker. It is intended for use only in the last stage of an audio amplifier. The plate potential used on this tube should never exceed 180 volts, but up to this point the amount of power which it can supply without distortion, rapidly increases as the plate voltage is raised.



Illustrations by courtesy of Alden Mfg. Co.
A simple adapter for using the UX-120 power tube without rewiring the set.

Very often the judicious addition of fixed condensers to a receiving set, will result in vastly improved tone quality. The accompanying diagram shows condensers placed across the secondaries of the audio frequency transformers for the purpose of improving quality of reception.

The use of the new power tubes has necessitated the design of loud speakers capable of handling increased current and also of delivering the additional volume faithfully. The Western Electric Company has recently perfected a 36 inch cone speaker. It is claimed that the increased diameter facilitates the handling of the additional volume.

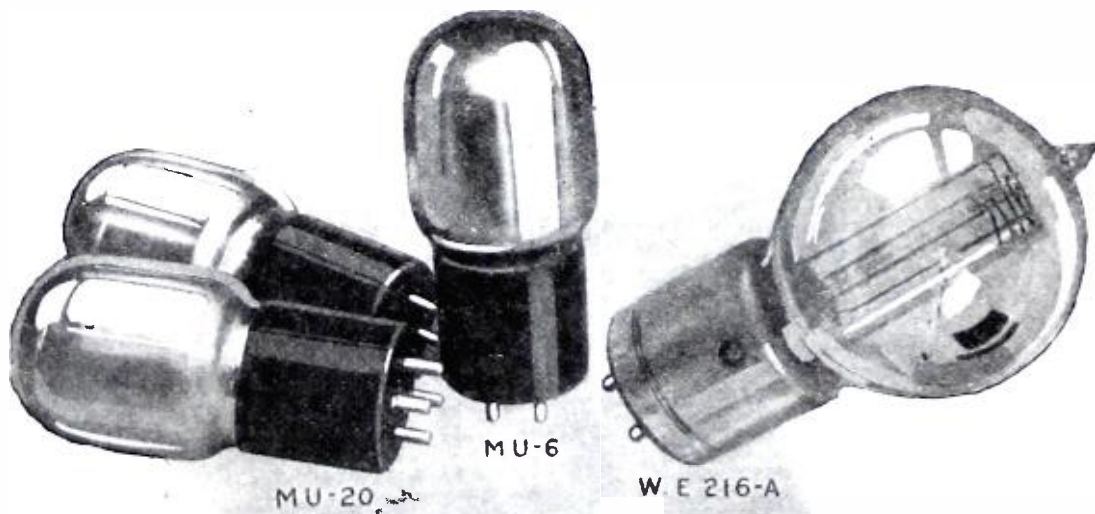

The MU-20 tubes shown above are designed specifically for use in resistance- or impedance-coupled A.F. amplifiers. They have an exceptionally high amplification factor and a high output impedance. Both the MU-6 and the W.E. 216-A are power amplifiers for use in the last stage of any type of A.F. amplifier. They both have a low output impedance.

fication constant known as the Cleartron radio frequency tube, has recently been placed on the market. It is claimed to possess qualities which make it superior to the ordinary radio frequency tubes.

This tube has been designed especially for use in the radio frequency stages of a radio receiver. It requires a filament voltage of 5 amperes and a

UV-199 tube in the last audio stage of dry cell sets. Of course, an adapter must be used in the tube socket.

The UX-171 (CX-271) or tubes of the 171 type are medium power tubes using plate voltage of 90 to 135 volts and grid voltages of 165 to 27 volts. These deliver a plate current of 134 to 165 milliamperes which is sufficient for most ordinary purposes.



An adapter which enables the use of the UX-112 without requiring changes in wiring of set.

The Stromberg-Carlson cone speaker uses a sound board around the cone to add timbre and volume. The newer speakers in addition to being able to handle the greater power, are also designed to cover more of both upper and lower registers and the result is extremely faithful reproduction of all musical sounds. In fact the developments along this line have been nothing short of marvelous, when one considers the early contraptions placed on the market under the name of loud speakers. Anyone now using an old style loud speaker, owes it to himself to invest in one of the modern types.

Examples of medium priced modern loud speakers of exceptional tone quality are the Amplion and the Teletone.

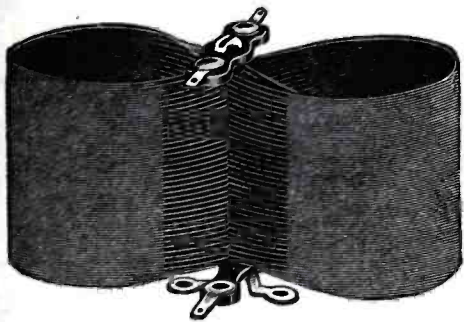

Illustration by courtesy of Bodine Electric Co. A low-loss R.F. transformer

This latter speaker is exceptionally clear and sweet in tone and seems to eliminate the harsh sounds. Other speakers of note are the R.C.A. Rice Kellogg speaker mentioned above and

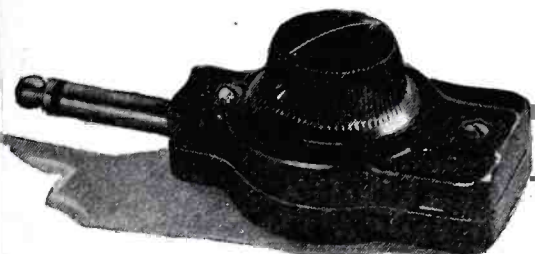

Photo by courtesy of Central Radio Laboratories. By turning the knob on this phone plug, a rheostat varies the volume.

The horn made by the Miller Rubber Company using a six-foot air column.

The use of the new power tubes has necessitated additional protection for the loud speaker which should no longer be placed directly in the plate circuit of the audio frequency tubes where it will carry the plate current of the last tube.



A new storage-battery type power amplifier tube, for use in the last stage audio amplifier only. This tube takes the same filament voltage and filament current as the No. 112 tube shown above, but employs a "B" voltage of 180 and a 40½-volt "C" battery. Special means should be provided for handling its heavy output.

Such high current may cause a break-down of the delicate windings and often results in rattling when loud signals are coming in due to the magnetic effect of the plate current drawing the diaphragm towards one of the pole pieces. To overcome this trouble, it is desirable that the windings of the loud-speaker should be isolated so as merely

to carry the necessary signal current fluctuations, and not the heavy direct plate current of the last tube. To over-

tially of the choke A and the condenser C1. The passage of direct current through the loud speaker L.S. is com-

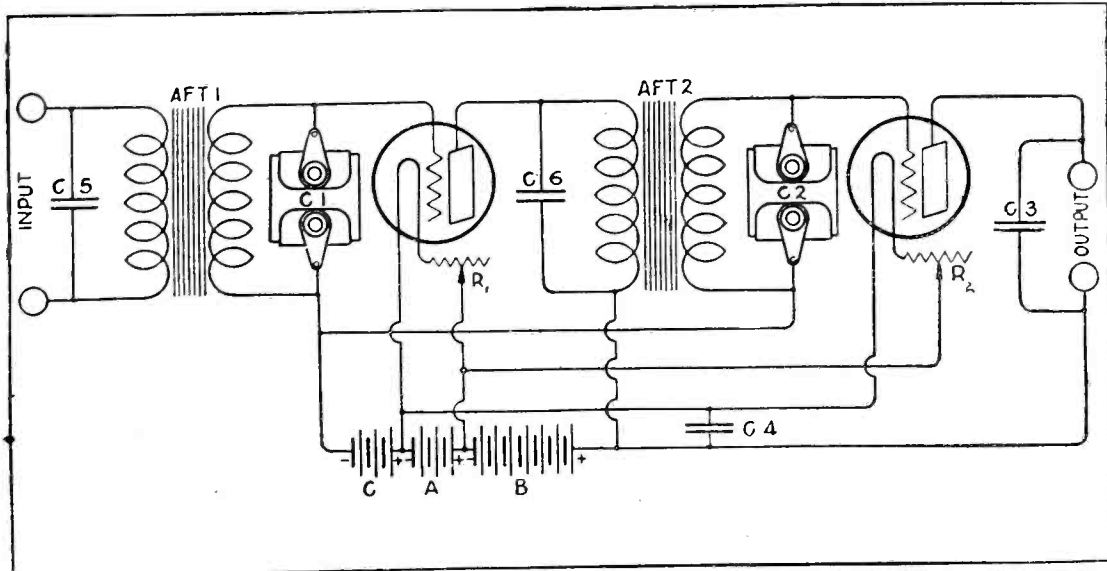

Illustration by courtesy of Dubilier Condenser and Radio Corp. Condensers C₁ and C₂, placed across the secondaries of the audio frequency transformers, will improve the quality of reception.

come this difficulty a simple type of filter circuit, such as that about to be described, may be used.

The Arrangement Used

Referring to the circuit diagram on next page you will see a transformer coupled stage of audio frequency amplification which may be taken to represent the last stage in any set. Even if resistance, capacity, or choke coupled, the essential part to which we wish to

pletely stopped by this condenser, but the fluctuating currents representing signals are communicated through it



Illustration by courtesy of Bruno Radio Corp. The use of this handy light switch gives a visual indication from the front of the panel when the set is in operation.

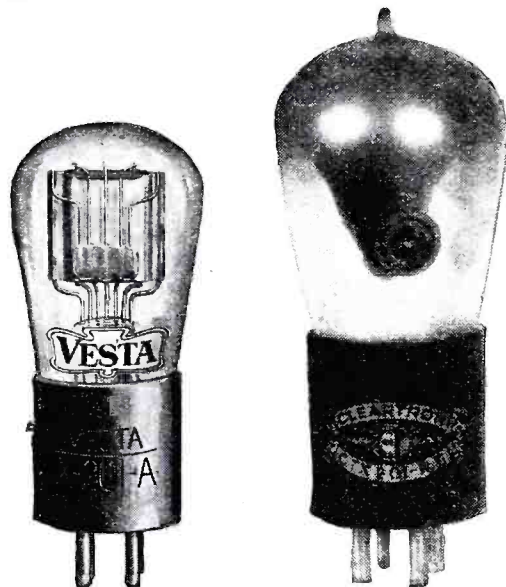

At the right is shown the Cleartron radio frequency tube. At the left is the Vesta 201-A tube.

refer will remain unaltered, namely, the arrangement shown in the plate circuit of the tube V. Within the dotted

and actuate the loud speaker. The direct current supply to the plate of the tube is, however, carried by the choke

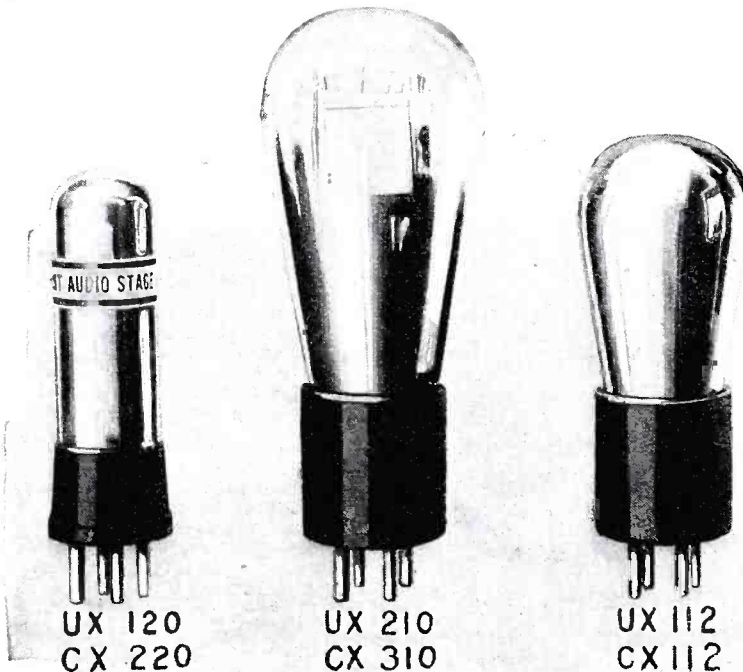

These power amplifier tubes are designed for use in the last stage of an audio frequency amplifier. On the left is a dry cell tube which requires a 4½-volt "A" battery. The center tube employs exceptionally high "B" battery voltage, and is usually employed with an amplifier that operates from the house current. This tube can also be used for transmitting purposes. The right-hand tube is of the storage battery type and has a very rugged filament. It makes an excellent detector tube as well as a power amplifier.

lines on this diagram is what is known as a filter circuit. This consists essen-

Z, and does not pass through the loud speaker windings. Thus, by this de-

vice, the loud speaker windings merely carry signal impulses, and the danger of breakdown is considerably reduced. The condenser C2 is that normally connected across the loud speaker for

this condenser is too low, the tone will tend to be shrill and somewhat tinny, whilst if too high the stage of "mellow-ness" can be passed and the resulting signals become "woolly" or "fluffy" in nature.

Changes in radio set appearance during the past year have been as marked as those of design. Everywhere the

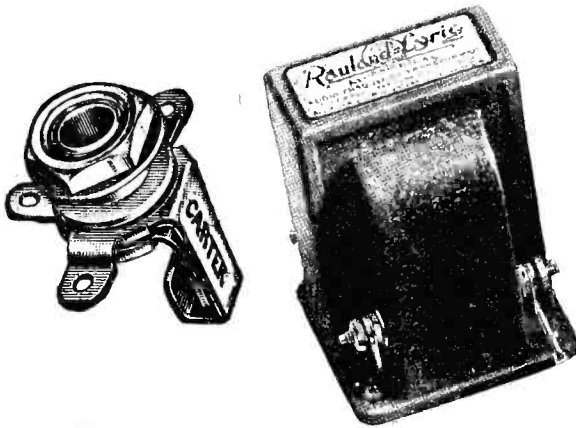
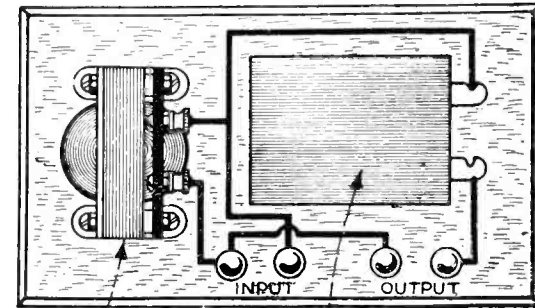

Illustration at left by courtesy of Carter Radio Co.; at right by courtesy of All-American Radio Corp. At left is shown a novel, compact jack of efficient design; at the right is the Rauland-Lyric audio transformer. The use of this transformer is certain to improve reception.

"tone" control purposes. C1 is of fairly large value since it has to pass frequencies of the audible range and must have a low impedance to them.



Using a choke coil and condenser for protecting the loud speaker.

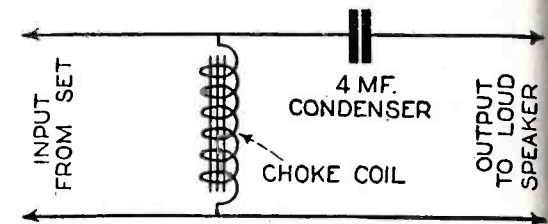
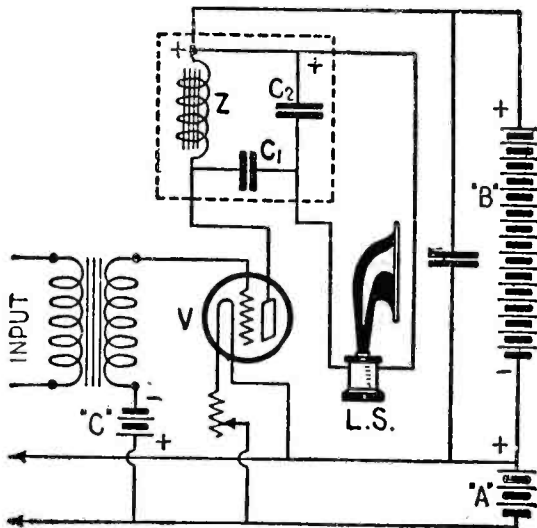

Diagram showing method of connecting choke coil and condenser to protect the loud speaker.

shown in the illustration is a typical example of what can be done along the line of improving set appearance.

tendency has been towards the elimination of all suggestion of technicalities. The modern radio set is first and fore-



The last stage of an audio frequency amplifier with the filter circuit incorporated.

In practice, a value of 1 to 2 mfd. is used in this position, and in the unit to be described is actually of 2 mfd. capacity. The value of C2 will, of

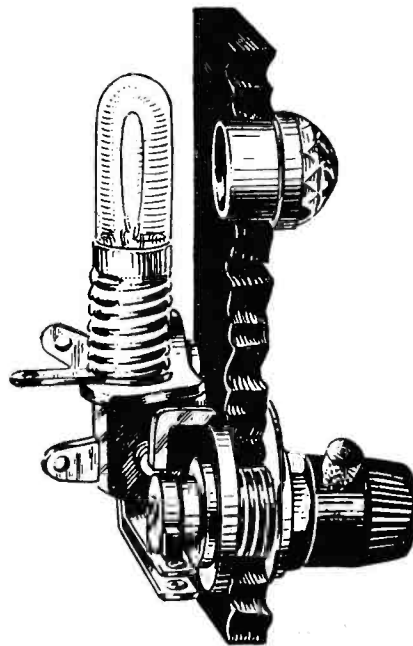
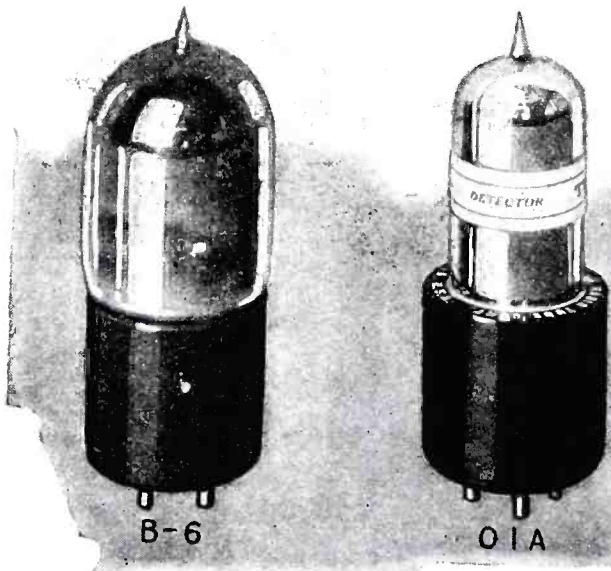

Illustration by courtesy of Yaxley Mfg. Co. A combination battery switch and pilot lamp.

most pleasing to the eye as well as the ear. In every case it is a highly de-



Photo by courtesy of C. E. Jacobs. A Molliformer choke coil suitable for use as an output choke between the loudspeaker and the last tube.



Left: The B-6 tube is a new type of detector operating on a different principle from the standard vacuum tube. It is very sensitive and can be used in any but a regenerative circuit. O1-A, and G, at the right, are high-impedance tubes with high amplification factors designed for use in resistance- and impedance-coupled A.F. amplifiers. Type F is a power amplifier for use in the last stage of any type of A.F. amplifier.

course, depend upon the type of loud speaker used, and will generally vary from .001 to .01. mfd. If the value of

veloped instrument enclosed in a beautiful piece of furniture. Here again, it is possible in most cases for the owner



Photo by courtesy of Stromberg-Carlson Telephone Mfg. Co. An example of modern cabinet craftsmanship.

From the above, it can be seen that the various radio improvements of the past few years are available to everyone who cares to take advantage of them.

All About "B" Battery Eliminators

By A. P. PECK, Assoc. I.R.E.

WHEN radio sets first became well known to the public, and in more or less general use, a question that was frequently asked was: "Why cannot I use my house current for operating my radio set instead of using batteries?" At that time the answer was merely that it could not be done. "B" battery eliminators were almost unknown, and had not been developed outside of the

laboratory stage. Even a good many persons intimately connected with radio did not know of the then rather complicated methods that would make house current available for radio set operation. It was a difficult thing in those days to explain to the uninformed radio set owner, why house current could not be used, and since the knowledge on this subject is even now not very widely spread, a few words regarding it will not be amiss.

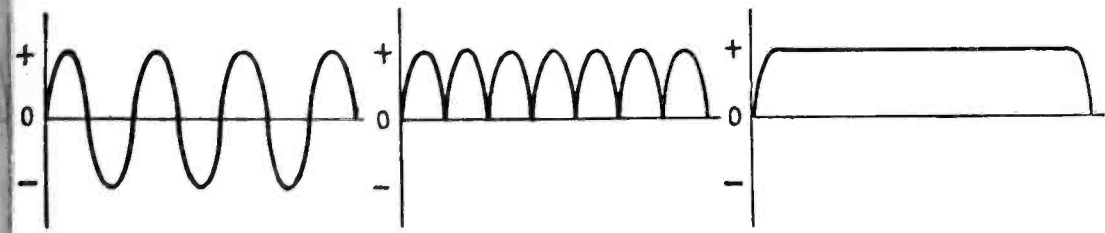

FIG. 1

FIG. 2

FIG. 3

Graphs showing alternating current, direct pulsating current and direct non-pulsating current.

laboratory stage. Even a good many persons intimately connected with radio did not know of the then rather complicated methods that would make house current available for radio set operation. It was a difficult thing in those days to explain to the uninformed radio set owner, why house current could not be used, and since the knowledge on this subject is even now not very widely spread, a few words regarding it will not be amiss.

The average household is equipped with electric lighting current of the type that is known as alternating. Some few have installed what is known as direct current or DC. The majority of the eliminators on the market today are designed for operation on alternating current or AC, only. Never attempt to use a DC eliminator on AC, or vice versa.

Let us first consider AC and find out why comparatively complicated apparatus is necessary in order to employ this current for operating our radio sets.

Let it be noted here that we are going to discuss the use of house current for "B" or high voltage supply only—not for the filament current or "A" supply.

Alternating current is just exactly what its name implies. It does not flow steadily in one direction, but instead, dashes back and forth very rapidly. In what is known as 60 cycle current, this reversal takes place 60 times per second, and an engineer could draw a picture of the current after the manner shown in Fig. 1. Here the straight horizontal line marked zero, indicates the point of

zero potential, or the crossing point from negative to positive current flow. The voltage first rises from zero to its full value in one direction and falls to zero, goes to full value in the opposite direction and falls back to zero. This change takes place many times per second, and the exact number of changes is expressed in cycles. A cycle is constituted by the building up

of the current from zero to full, its fall to zero, its rise to full in the opposite direction, and its fall to zero once more.

It is comparatively well known that it is necessary to have a very steady

noisy. This would be the case, only to a far greater extent, if ordinary alternating current were used for the "B" supply. You would get a loud roar in the phones or loud speaker, making reception absolutely impossible. Therefore, it is obvious that alternating current must be changed before it can be used, and this change is known as rectification. In simple language, what happens is that the current that formerly flowed in the opposite direction to the initial current, is forced to flow in the same direction as the initial current. This may be done in several ways. Either an electrolytic rectifier or a tube rectifier may be used. There are manufactured instruments on the market today using both systems. In any event the results are the same, and the direction of the current delivered by the rectifier is shown in Fig. 2. Notice that the current now flows all in one direction, but it still fluctuates in strength. This is still undesirable, and the rectified current is not yet ready to operate a radio set. It must be

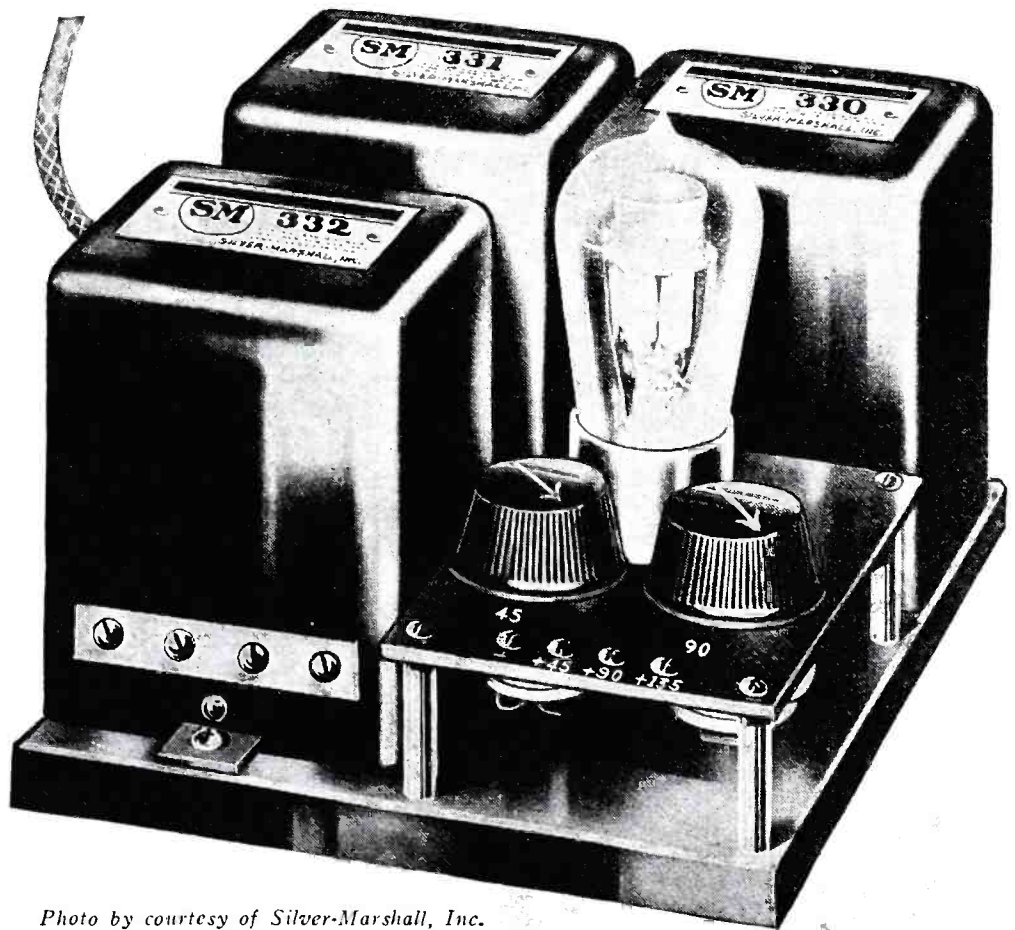

Photo by courtesy of Silver-Marshall, Inc.

A compact and efficient "B" eliminator. Transformer, choke and condenser bank employed in this eliminator are neatly contained in three separate cases. The Raytheon tube socket and Clarostat variable resistances and terminals are mounted on a small panel.

source of current for the "B" supply for a radio set. Just notice the trouble that is encountered when the "B" battery falls in voltage due to age, and its out-put fluctuates. The set becomes

smoothed out before it can be put to this use, and the combination of instruments which accomplishes this smoothing is known as the filter. The exact action of an electrical filter is

rather difficult to explain to the average layman, and, furthermore, such an explanation would mean very little. It is sufficient to say, that just as the pressing iron smoothes out wrinkles in a shirt, so does the filter press out wrinkles in electric current and give a

a battery and phone connected in series with the secondary. If a click is heard in the phones when the circuit is closed, the wiring is continuous and can be used.

The rectifier unit of this "B" eliminator is very easy to construct. Four or-

not touch the polished surfaces of the metal with your fingers. The strips are next placed in the jars and the ends of the strips bent so that they will hang over the edge. One aluminum and one lead strip is placed in each jar, and the eight pieces of metal are connected as shown in the diagram. Each jar is then filled to within about 1/2" of the top with a solution consisting of two ounces of borax to a quart of water. Ordinary household borax may be used and the water need not be distilled. After each jar is filled, a layer of paraffin oil about 1/4" deep is poured over the surface of the electrolyte. This effectively prevents evaporation and lengthens the life of the eliminator.

Besides the rectifier and the filter, it is necessary to have a controlling resistance so that the proper "B" voltage for the detector tube can be obtained. This is an ordinary variable resistance having a range of from 5000 to 25,000 ohms. It is connected in the circuit as shown in the diagram, Fig. 4.

After the eliminator is hooked up as shown, and connected to the radio receiving set, light the filaments of the tubes in the set and turn on the 110 volt AC circuit. This can best be accomplished by having a flexible cord connected to the in-put and a plug connected to the opposite end of the cord.

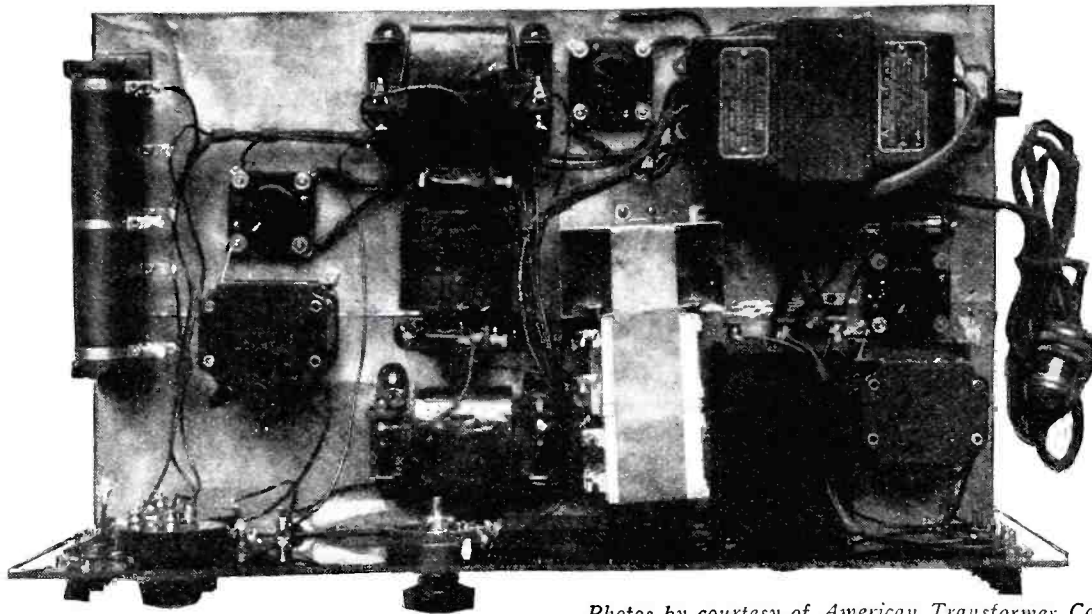

Photos by courtesy of American Transformer Co.

A combined 350-volt "B" eliminator and two-stage power amplifier using filament type tubes.

resulting current which appears when pictured as in Fig. 3. Here the current rises from zero to full potential, and continues to flow at that value until the current is turned off. This direct current is now satisfactory for use in connection with radio receiving sets.

For those who desire to experiment with the construction of a "B" eliminator and do not desire to spend a lot of money in doing so, the following description will be of value. This eliminator gives quite satisfactory results on receiving sets using not more than three tubes and it will be quite free from any annoying hum. The eliminator uses the electrolytic principle of rectification, and its filter system consists of some small fixed condensers and the secondary of an audio frequency transformer. Possibly you have a transformer, the primary of which has been burned out. If so, this instrument is still in good enough con-

ditionary jelly glasses and some strips of sheet aluminum and lead should first be obtained. Four strips of each metal 3/4" wide by 4" long must be cut. A

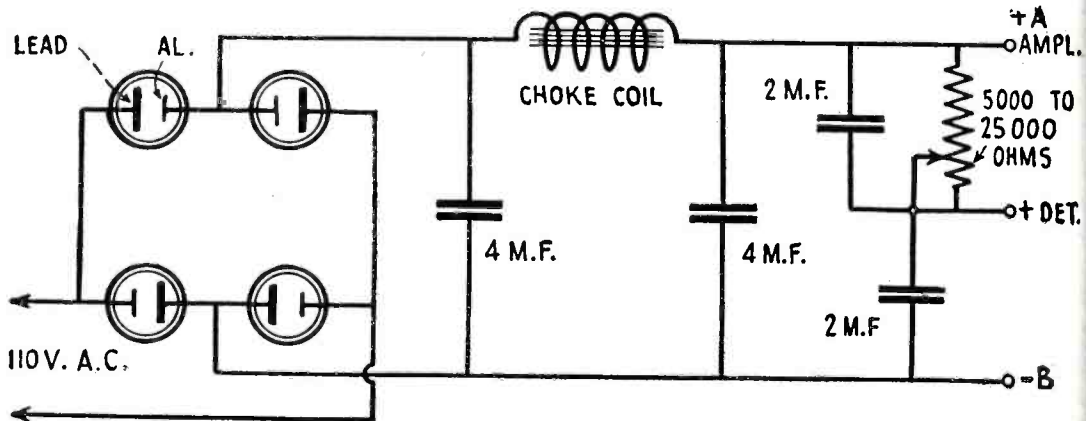

Fig. 4. Circuit diagram of an electrolytic type rectifier and filter with variable resistance for controlling the "B" voltage for the detector.

hole is drilled in one end of each strip, and a bolt and nut fastened in the hole to be used as a binding post for connections. After the four strips of each

This is then inserted in any convenient receptacle. The set will at once begin to operate, and probably a hum will be heard. This is because the plates of the rectifier are not yet formed, but the hum will persist for only a few minutes and then the eliminator will operate properly throughout its entire life. If, however, the set is not used for a week or more, the film that forms on the aluminum plates may be destroyed, and the forming process will have to be gone through again before the eliminator will operate properly. This forming process is, however, practically automatic, and needs no particular attention on the part of the operator.

The filter system of the home-made eliminator may be seen in the diagram. Every filter system consists of what is known as a choke coil, consisting of several thousand turns of wire on a wire core, and several fixed condensers. In this particular unit, the choke coil



Front panel view of the "B" eliminator and power amplifier shown in the photo on this page.

dition to use in an experimental eliminator. You must, however, be sure that the secondary circuit is still complete. This can be tested by means of

metal are cut and drilled, both surfaces of each strip must be thoroughly cleaned and polished with fine sand paper. After this has been done do

is to be the secondary of an audio frequency transformer. Because we are dealing with low voltages, the fixed condensers may consist of ordinary by-pass instruments. Two having a capacity of 4mf. each, or four having a capacity of 2mf. each are required. Also it is advisable to have an additional 2mf. condenser connected across the resistance which controls the detector out-put, and another one from the positive detector wire to the negative. This filter will be found quite satisfactory for all around work with the particular type of electrolytic rectifier described above.

The grid leak value that is used in the average radio receiving set is usually far too high for the same set and detector tube when the plate current is supplied by a "B" eliminator. If such is the case, it will be indicated by an unusual hum from the reproducing unit. If your grid leak is of the fixed type, and this trouble arises, change it for one of a lower value. With a variable grid leak, it is merely necessary to adjust it for best results. In any event, do not neglect the leak. It has a very important function and if it is not right, the operation of the set will not be all that is desired. Find the right value for best results and leave it alone.

Of late, a new type of vacuum tube has appeared on the market, which has made "B" eliminators most popular. It is a tube that does not have any filter, and serves as a double wave rectifier, eliminating the use of two tubes that are necessary with some other types of vacuum tube rectifiers. This tube is illustrated in one of the accompanying photographs. It makes use of a unique principle of rectification, and is practically fool proof. In operation it needs absolutely no attention, and has an unlimited life. Tests up to three thousand continuous operating hours have failed to affect the operation of this tube, and no depreciation in results has been found. This tube is always to be employed in connection with a step-up transformer so that the voltage supplied is in excess of 200

There are several types of eliminators on the market today which use this new type of tube and which are equipped with well designed transform-

ary tubes. True, some eliminators have been designed and marketed which use the same type of tubes as those employed in radio receiving sets.

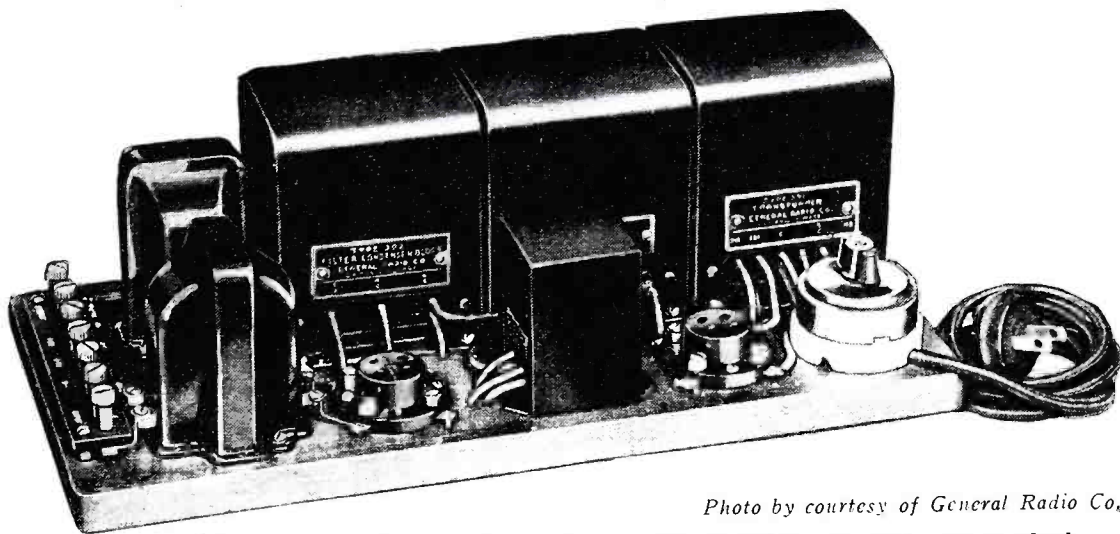

A combined "B" battery eliminator and one-stage power amplifier. In this unit standard filament type power and rectifier tubes are employed.

ers and filter systems. Several of these manufactured units are illustrated in this article.

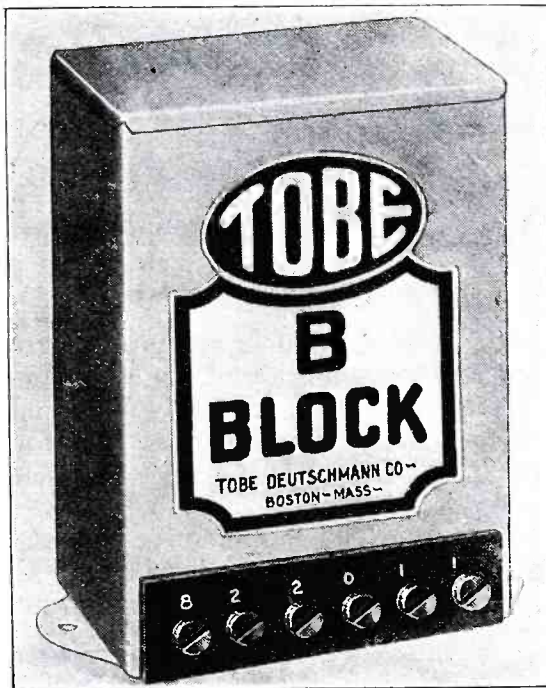

The above shows a photo of a block condenser which contains specially constructed filter condensers for use in "B" eliminators.

However, manufacturers of tubes have made it quite plain that receiving set tubes are not suitable for use in "B" battery eliminators. Used in this way they have a comparatively short life, and are in every way quite unsatisfactory. It is always advisable to shun the use of receiving set tubes in connection with "B" battery eliminators, and to use tubes that are designed for that particular purpose. One of the vacuum tubes using a filament that is designed for "B" battery eliminator use, has only one plate, and accomplishes only single wave rectification. Therefore, for all around use, two of these tubes are necessary. There is, however, another one of a similar type, but which has two plates and which accomplishes double or full wave rectification. With this, only one tube is necessary.

The circuit of a standard "B" battery eliminator is shown in Fig. 5. We have shown this diagram with the filamentless tube described above. However, in most respects the same circuit is used for the double wave filament rectifier tube or where two single wave tubes having filaments are used. This circuit is given for general information purposes, and is the one that is almost universally employed with the so-called Raytheon tube. Note the filter circuit and the connecting of the two variable control resistances which allow the use of a different voltage in the RF amplifier from that applied to the AF amplifier.

The average experimenter will probably want to assemble his own eliminator and for this reason manufacturers have been simplifying apparatus so that the assembling troubles will be reduced. One of the greatest advances is in the condenser part of the filter circuit. Formerly, it was necessary to use several separate fixed condensers and the result was a lot of wiring and an irksome task. Now, however, it is possible to purchase a

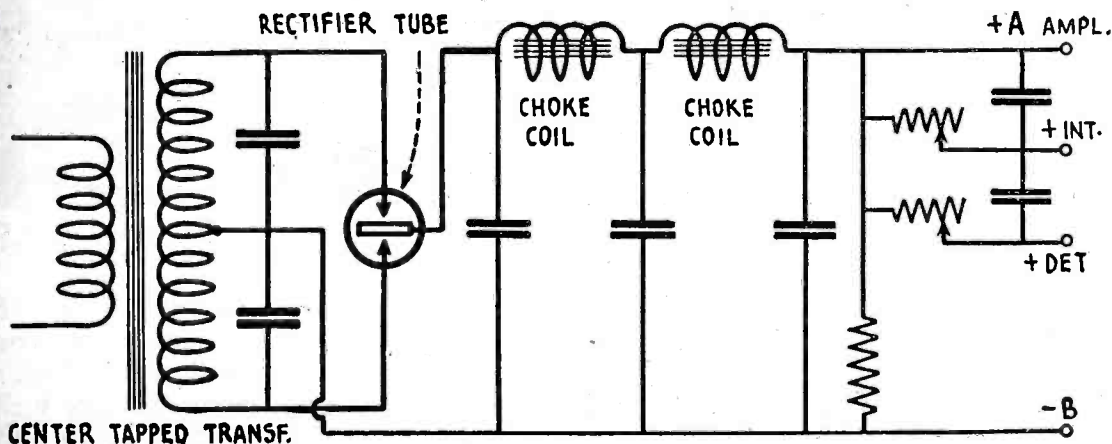

Fig. 5. A standard full wave rectifier employing the filamentless type tube.

volts. The transformer used with this tube is of the type having a tap in the centre.

in radio receiving sets. These tubes use a filament and a plate but do not have a grid as is the case of the ordin-

block containing all of the filter condensers. This block is equipped with convenient terminals and a lot of the condenser wiring is done inside the casing. With this unit, shown in an accompanying photo, an eliminator can

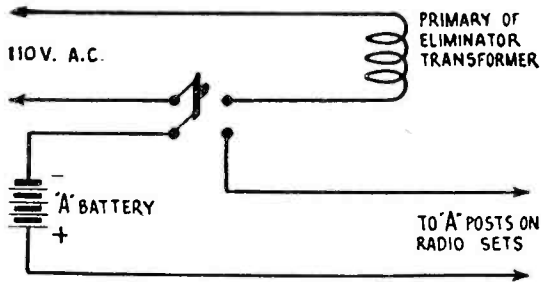

Fig. 6. A circuit diagram showing how the "B" eliminator and "A" battery may be turned off together by means of a D.P.S.T. switch.

be assembled with the least possible trouble.

The problem of switching a "B" eliminator into and out of the circuit is quite a big one. Under ordinary circumstances the average person only remembers to turn off the filaments of the receiving set, and will often allow the "B" battery eliminator to run. While not consuming much current when the filaments of the radio receiving set tubes are turned off, still the "B" battery eliminator uses some, and it is always best to turn off the 110-volt AC circuit when not in use. Possibly the best way to accomplish this is to turn off both circuits at the same time. Use a double pole, single throw switch connected as shown in Fig. 6. One blade is in the "B" eliminator primary circuit, and the other is in the "A" battery circuit. Opening the switch cuts off both, and prevents the possibility of leaving the eliminator turned on. It is possible to procure a switch of the snap type that can be used in this particular circuit. Inquire at your local electrician's store, and tell him that you want a double pole, single throw snap switch. If he has not got one, he can obtain one in short order.

Another switch arrangement that is quite popular for "B" eliminator use is shown in Fig. 7. When the operator is through using the receiving set, he throws the switch to the opposite side from the working position and by doing this disconnects the "B" eliminator and the "A" battery, and at the same time connects the trickle charger to the "A" battery so that the latter will be charged while the set is not in use. By using a "B" battery eliminator and a trickle charger in connection with a storage "A" battery, most of the battery troubles of the radio fan will be solved. If this switch arrangement just described is installed, still more trouble will be avoided, and everything can be carried on with the utmost dispatch.

Whenever a switch is employed that cuts out both the "B" eliminator and the "A" battery, the "A" battery switch that is incorporated in the set should be short circuited so as to prevent its use.

Aside from the "B" eliminators that supply in the neighborhood of 135 volts, there are others that are so arranged to deliver about 350 volts for use on a power amplifier using a tube such as the UX 210. These units usually use single wave rectification with a highly efficient filter system. A rectifier tube having a filament is employed. Some experimenters prefer to combine such a high voltage "B" supply with the power amplifier of one or two stages and one of our photographs shows such an arrangement. All of the parts of such a unit may be purchased on the market and readily assembled by the layman. Variable or tapped fixed resistances are so placed in the circuit that the correct plate voltages can be had. The usual procedure with a unit of this type is to use a UX 201A in the first stage of amplification and a UX 210 in the sec-

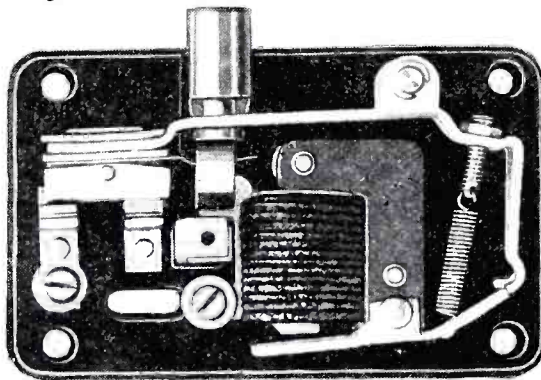

Photo by courtesy of Precise Mfg. Co.
A "B" eliminator circuit breaker.

ond. The resistances allow the operator to apply the desired plate voltages. Remember that high plate voltage calls for a high grid voltage. Use the proper "C" battery for the tube and plate potential used.

Since the "B" eliminator is connected directly in the house lighting circuit, some means of protecting the lines and

as a circuit breaker and as a switch for opening and closing the eliminator circuit. It can be obtained with its adjustment set to open the circuit when over three amperes passes. Thus, if a short circuit occurs in the eliminator, the primary circuit will be opened immediately and no damage will be done to either the radio apparatus or the lighting line.



Illustration by courtesy of Allen-Bradley Co.
A variable high resistance used in various types of "B" eliminators.

Where direct current is available, a really high powered "B" battery eliminator is not possible or practical. This is because of the impossibility of stepping-up the direct current with any ordinary means and thereby obtaining the high voltage that is necessary for present day sets. However, with 110 volts DC, about 90 volts can be obtained and applied to a radio receiving set, and this will be quite satisfactory for all three tube receivers and for some five tube sets. While direct current such as supplied by public service companies does not have as much fluctuation as the rectified alternating current pictured in Fig. 2, still it has a certain ripple that must be smoothed out before the current can be used for radio work. This is accomplished by using a filter system such as is employed in connection with a rectifier for "B" eliminator use on AC. This filter, as described in connection with the electrolytic "B" eliminator, may

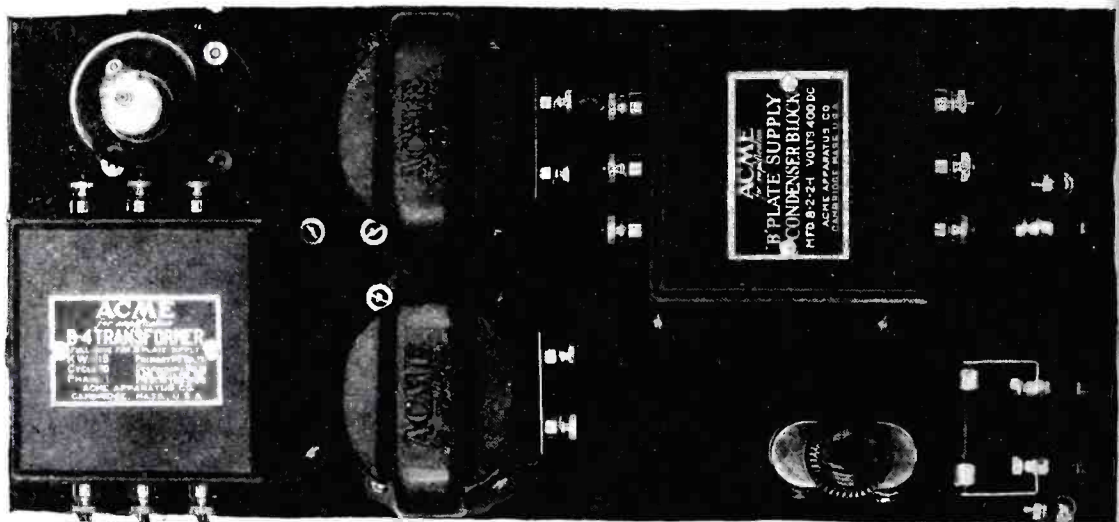

Photo by courtesy of Acme Apparatus Co.
Another Raytheon type "B" eliminator assembled from standard parts.

the eliminator should be used. One way is to insert fuses in the circuit at the eliminator, using fuses that will "blow" at about 5 amperes. This arrangement is not very flexible, however, and it is preferable to employ a circuit breaker. One very good type, designed especially for "B" eliminator use is shown in these columns, and is so arranged that it can be used both

consist of an ordinary audio frequency transformer and a few fixed condensers hooked up as shown in Fig. 4. This eliminator is comparatively inexpensive to make, and should give quite satisfactory results under all conditions.

In summing up the subject of "B" battery eliminators, the following
(Continued on page 160)

Loud Speakers and Their Relative Merits

By CLYDE J. FITCH

ONE usually begins at the beginning, but in this story of loud speakers I am going back a step farther and begin with the audio frequency amplifier. I could go back a few more steps and mention the effects that the detector, radio frequency amplifier, and regeneration have on the quality of reproduction; but these effects are slight compared with that caused by the average audio frequency amplifier. Therefore, I will limit this introduction to a few words on the audio amplifier, because if your amplifier is faulty, and you try out a few loud speakers, the results may not coincide with the following and you may think that I don't know what I am talking about.

If you are using a standard type of two-stage transformer coupled amplifier,

of the second transformer helps to control volume and in some cases eliminates amplifier squeal. Many amplifiers oscillate at a very high frequency

an iron diaphragm or reproducing member. Some of the present loud speaker units differ very slightly from this early telephone. You will note

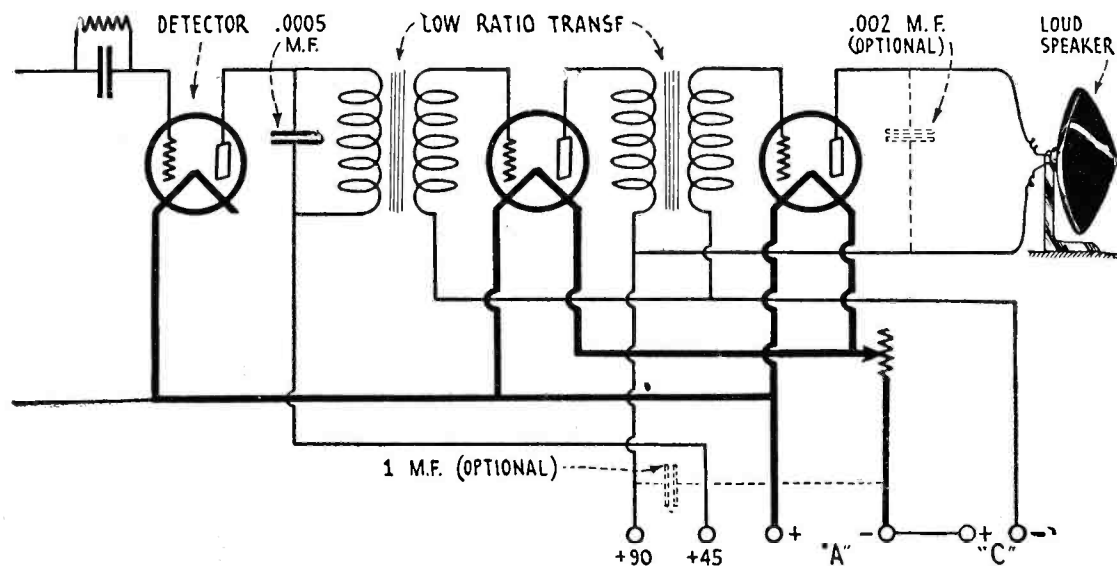

Fig. 1. Diagram showing the connections of a standard two-stage transformer coupled amplifier. Note that low ratio transformers are specified, a necessity for quality reproduction.

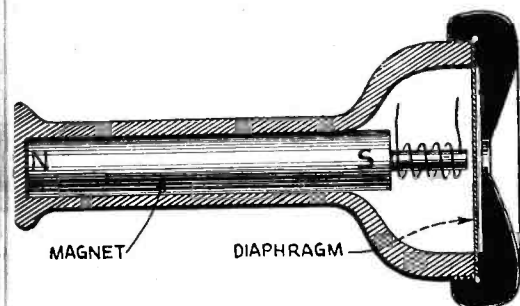

Fig. 2. The original Bell telephone receiver in which a bar permanent magnet was used. This represents the first step in the development of a loud speaker unit.

—almost inaudible. This causes the reproduced music to sound broken and harsh. The resistance will eliminate this. Another method that is sometimes effective is to connect a one mfd. condenser across the B battery. This is shown in the diagram in dotted lines.

that this telephone has a magnetic circuit, an electric circuit, and a reproducing member for converting the mechanical vibrations into sound waves. If any one of these features are faulty, the 'phone unit fails to give the proper volume. The volume obtained from this early 'phone was obviously very little. The first improvement was made in the magnetic circuit. This is shown in Fig. 3. Instead of using a bar magnet a horse-shoe type magnet was used. This is the type of receiver used on the present day line telephones.

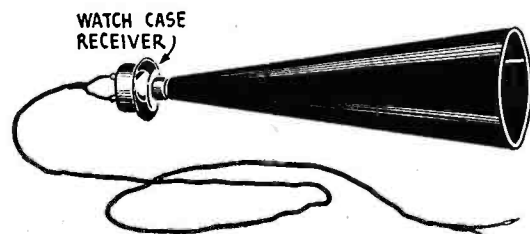

Fig. 5. The first loud speaker was made by attaching a megaphone or horn to a reproducing unit such as the one illustrated at Fig. 4. The efficiency of this loud speaker is low compared with that of our present loud speakers.

The watch case receiver shown in Fig. 4 is identical with that shown in Fig. 3 except that the horse-shoe magnet is shaped so as to make the instrument very compact.

The receivers used in telephones are

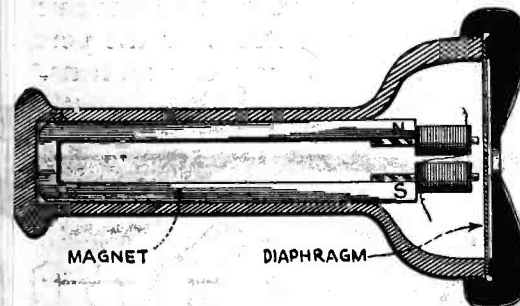

Fig. 3. A great improvement over the original Bell receiver depicted in Fig. 1 was made by using a horse-shoe magnet instead of a bar magnet. This illustrates the general construction of our present line telephone receivers.

Its use is recommended even though your amplifier does not squeal, because it may squeal when your B batteries are run down and their internal resistance increases.

If you are one of the few who have built a resistance coupled or a choke-coil coupled amplifier, you probably know all the kinks required to remove distortion, and I will not mention any here. While these amplifiers are slightly better than transformer coupled amplifiers, the difference can hardly be detected by ear when using a good loud speaker. This brings us to the beginning of our article on

Loud Speakers

The original Bell telephone receiver shown in Fig. 2 comprised a bar permanent magnet, an electromagnet, and

of comparatively low impedance, having a direct current resistance of about 75 ohms. The advent of radio created a demand for a high impedance receiver that would match the impedance of the crystal detector or vacuum tube used. Therefore, the early head sets used in radio were of the same construction as

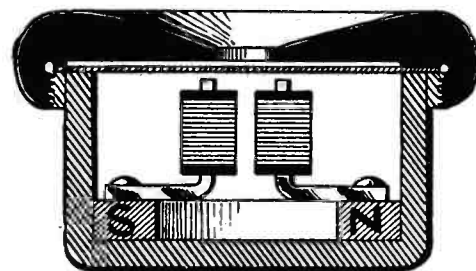

Fig. 4. By properly shaping the horse-shoe magnet a very compact reproducing unit was evolved. Many of our present loud speaker units are designed along this principle.

condenser connected across the primary of the first transformer.

The condenser shown in dotted lines across the speaker terminals sometimes improves quality when using a cone speaker. It should not have a capacity greater than .002 mfd. A variable resistance connected across the secondary

the watch case receiver illustrated above with the exception that the electromagnets were wound for a higher impedance. The direct current resistance of this type of unit is about 1,000 ohms.

Before broadcasting started, crystal sets and single tube sets were the only types in general use. With the advent

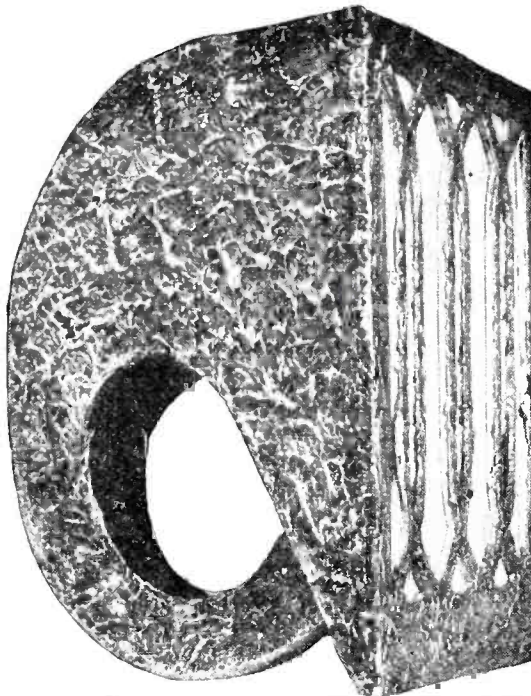

Photo by courtesy of Rahem Horn Corp.
Fig. 6. A well designed horn type radio loud speaker. Note the graceful curve of the horn, giving compactness as well as proper acoustical effects.

of broadcasting and the increased use of vacuum tube amplifiers, a loud speaker for radio use was in great demand. The first loud speakers were made by simply taking one of the ear phones of the head set and placing a horn on it. This type is shown in the illustration Fig. 5.

With more research and development work, the efficiency of the unit was increased; an air gap adjustment was added; and the proper shape and size of the horn was determined. Consequently we now have available some excellent horn type loud speakers using an improved type of unit similar to those used years ago on the telephones.

As an example of a good horn speak-

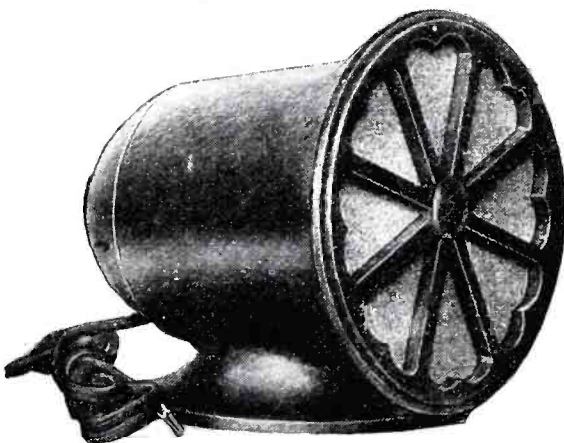

Photo by courtesy of Chas. Freshman Co., Inc.
Fig. 10. A very compact horn speaker employing a powerful balanced unit. The speaker is 6 inches high, 5 inches wide, and 7½ inches deep.

er, take a look at the illustration Fig. 6. This speaker not only has a powerful adjustable unit, but the horn is made

of the proper shape and material and the whole speaker is so designed so as to be compact in size and of pleasing appearance. It may be set down, as shown, on the table or radio set, or it may be placed inside of the radio cabinet. The horn of this particular speaker is 24 inches long, condensed in such a manner as to occupy a space of 10 inches high 8¼ inches wide and 8¼ inches deep.

The horn type loud speaker illustrated in Fig. 7 is of excellent electrical and acoustical design as well as of pleasing appearance. The gracefully curved panelled wooden horn is highly finished. It measures 14½ inches in diameter at the opening. The acoustically correct "dragon shape" of the sound conduit provides—in compact space—exceptionally long tone travel with gradual amplification. Also, the conduit is non-resonating, being rubber insulated at both ends. Crystalline enamel on both sound conduit and unit add further beauty to appearance. The weighted nickel-plated base is hinged to permit tilting the horn to any angle. The "floating diaphragm" unit may be taken off and with proper adaptor attached to a phonograph whenever desired. No battery or power amplifier is required.

The demand for more volume and the increasing use of loud speakers for public address systems made it necessary to design a loud speaker unit that

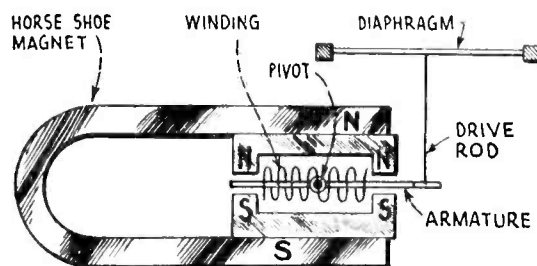

Fig. 8. The general construction of the balanced type unit used in many radio speakers. Note that the permanent flux from the horseshoe magnet does not pass lengthwise through the light floating armature.

would operate with great volume on power amplifiers. The balanced type unit shown in Fig. 8 was developed for this purpose. The illustration shows only one form of this unit. Many slight variations have been made without departing from the general principle. For example, Fig. 9 shows a semi-balanced one.

The balanced unit has what is called a floating armature. The armature is pivoted midway between the poles of the permanent magnet, and the magnetic circuits are so arranged that the permanent flux does not pass through the armature. Therefore, very powerful permanent magnets may be used with no possibility of saturating the armature. The armature carries only the variable magnetic flux produced by the amplified audio currents. This unit, being more sensitive than the plain type, employs longer air gaps, which makes an adjustable feature unneces-

sary and eliminates the possibility of blasting or chattering on excessive volume. The semi-balanced unit is similar except that one end of the armature is fixed.

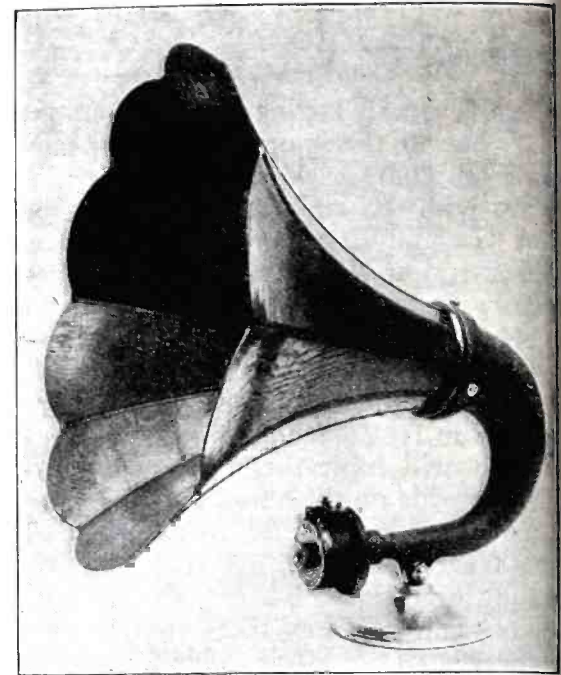

Photo by courtesy of The Amplion Corp. of America

Fig. 7. A horn type loud speaker of unusually good design. The wooden horn and adjustable unit are insulated from the metal conduit with rubber, which absorbs horn vibrations.

When this type of unit is used on a horn speaker a drive rod connects one end of the floating armature to the center of a diaphragm, which may be of mica or metal. When a metal diaphragm is used it is usually corrugated for stiffness.

A horn type loud speaker of very compact design that employs a floating armature type of unit is shown in Fig. 10. The compactness of this speaker is obtained by mounting the unit on the end of a small horn which opens up into a reflecting tone chamber. The sound waves are reflected out through the front from the non-metallic chamber, giving the equivalent of 24" upright horn.

So far, I have only mentioned the recent developments and improvements made in the unit itself, or the permanent and electro magnetic systems. I

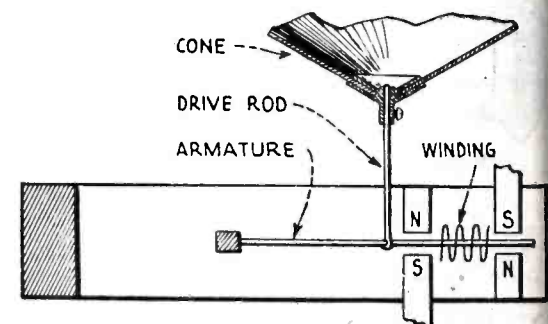

Fig. 9. A semi-balanced unit. In this case one end of the armature is fixed, the other being free to vibrate. Many cone speakers employ this type of unit.

shall now mention some of the recent improvements made in the reproducing member or diaphragm. This brings us to the subject of

Cone Speakers

The use of a cone as a diaphragm or reproducing member was known as

far back as 1900, but it was not until 1911 or '12 that it was fully developed for use on the phonograph. The cone took the place of the horn. Recently the cone has replaced the horn in many radio loud speakers. A simple cone speaker can be constructed by glueing a disc of drawing paper about 12 inches in diameter in a shape of a cone and fastening it with sealing wax to the center of the diaphragm of any of the telephone units shown above. This cone may not give great volume but the quality of sound is pleasing.

In one of the first speakers utilizing this principle the cone was securely clamped around the periphery with metal rings. An armature was used on the unit in place of a diaphragm and a drive rod connected this armature to the apex of the cone. This type of construction is shown in Fig. 11. Note

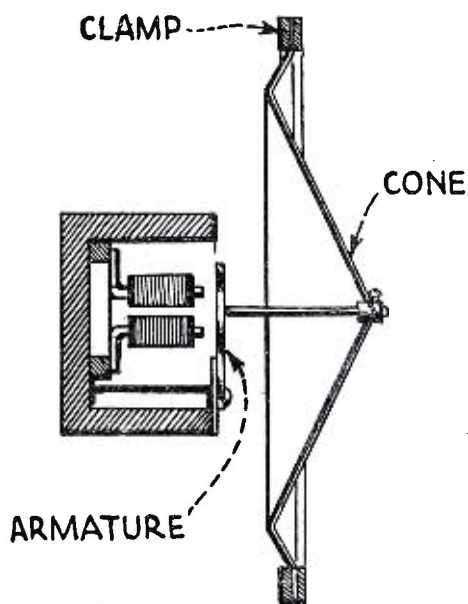

Fig. 11. This shows the general construction of one of the first radio cone speakers. The ordinary type of unit, with an armature substituted for the diaphragm, was used.

rectly in back of the oval aperture in the beautiful cabinet. This reproducer not only consists of a loud speaker, but also employs a built-in power amplifier operated directly from the house light-

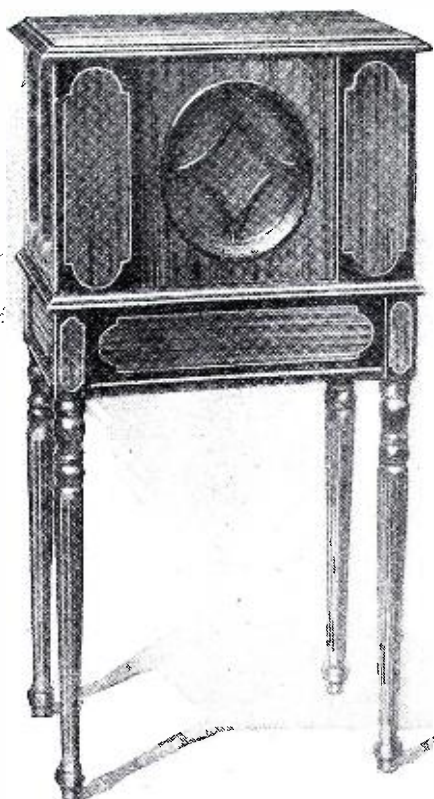

Photo by courtesy of Radio Corp. of America. Fig. 13. A radio reproducer comprising a built-in power amplifier and floating cone speaker. The amplifier is operated from the house lighting line. Quality at any desired volume is possible with this combination.

ing circuit. Enormous volume with excellent tonal quality is obtained from this reproducer.

If you construct a single cone speaker and mount it on a unit you will find that when placed in a cabinet the volume is increased. The cabinet not only acts as a sound chamber, but it reflects the sound waves out from the convex side of the cone. Another way of obtaining this same effect is to place a baffle plate around the cone. This may

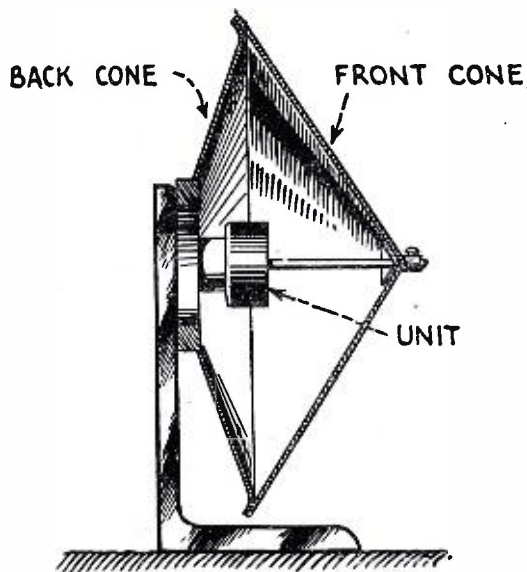

Fig. 12. This type of construction is quite popular among cone speaker manufacturers. The back cone is used merely as a support for the front cone, it having no acoustical advantages. In fact, the enclosed effect is detrimental.

be a wooden ring about two or three inches wide, as shown in Fig. 14. Note how the sound waves are forced to continue propagating from the front. A

speaker built on this principle is shown in the reproduced photograph, Fig. 15.

There are other unique types of speaker reproducing members that give satisfactory results. Some employ pleated paper diaphragms, and some paper cylinders. Vibrating lamp shades also have been used. These odd types are little used in this country and I won't take up any more of your time in talking about them. Let us now pass on to

Loud Speaker Distortion

To understand the causes of distortion in loud speakers, one must investigate thoroughly the character of musical tones. Each tone has a fundamental frequency of its own, giving it pitch. For example, the lowest pitched note on the piano has a frequency of 27 cycles per second, and the highest pitched one a frequency of 4096 cycles. Middle C has a frequency of 256 cycles.

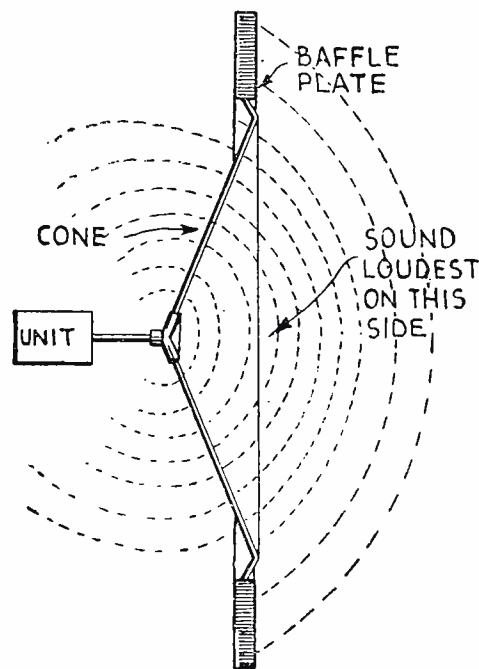

Fig. 14. A baffle plate around the periphery of a cone increases the volume. Note that the sound is louder at the concave side, which should be the front.

that a reduction in motion of about 2:1 is obtained by the lever action of the armature.

Fig. 12 shows another popular type of cone speaker. The front cone of this speaker is supported by the frustum of a similar back cone as shown. The unit is of the floating armature type and is mounted inside. While this type of speaker gives greatly improved results over many of the earlier types, it still has the disadvantage of a slight muffling effect of the sound due to the enclosed air space.

If you make a simple paper cone and attach it to a driving unit, you will note that the volume of sound given off by the cone is much greater on the concave side than it is on the convex side. Therefore, the more recent cone speakers employ a single cone with the concave side facing out. The cone is of the free edge type or flexibly supported around the periphery. An example of this type of construction is depicted in Fig. 13 although this illustration shows little as far as the cone is concerned. It seems necessary to add that the ten inch cone of heavy paper has the convex side facing out; it is mounted di-

These are the figures of the scientific scale which differ slightly from those of the musical scale. You can see, therefore, that the ideal loud speaker should operate uniformly over a frequency range of 27 cycles to 4096 cycles, which is the range of the piano keyboard. However, each tone is composed of a fundamental frequency, and several harmonics of higher frequency, giving it timbre. To get the true tonal color of the highest notes of the piano the speaker should reproduce the higher harmonics of these notes which include frequencies as high as 8000 cycles per second. Most speakers operate very well up to about 10,000 cycles and little trouble is experienced in operating them on this end of the scale. The difficulty is in designing a speaker to operate on the lower end of the scale. Few speakers reproduce tones below middle C on the piano, faithfully. When these tones are played, you hear the harmonics, and not the fundamental, which makes

the reproduced music sound "tinny."

The average horn type speaker reproduces the higher tones very well. You have probably noticed that some of these speakers are high pitched and

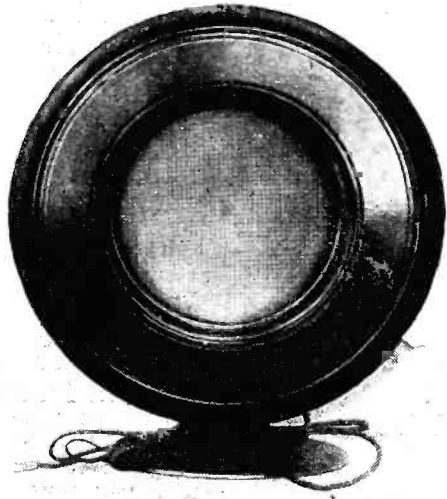

tain over the front of the cabinet. Then, if the unit is powerful, and it must needs be, to drive so large a cone, it is not necessary to use a power amplifier. When extreme volume is desired, a power amplifier can be employed, and with a unit designed to

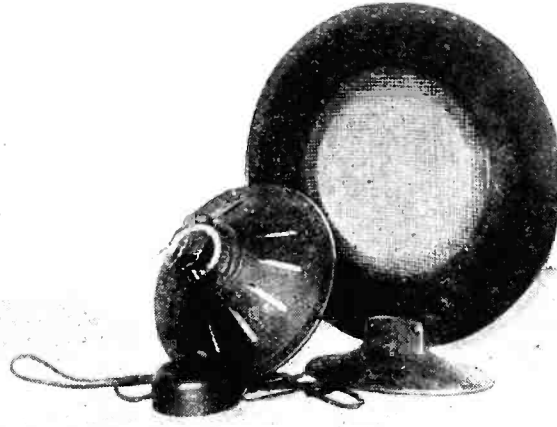

Fig. 15. Front and rear views of a commercial cone speaker employing a baffle plate.

some low pitched. As a rule the larger the horn and the greater the diameter of the diaphragm, the lower the pitch. Cone speakers, that may be considered horn speakers with an extra large diaphragm, are usually lower pitched than the conventional horn speakers.

This leaves us with two methods for obtaining low tones from a speaker. First, the horn must be extra large, or, second, the diaphragm must be of large diameter. Fig. 16 shows a horn speaker of great length that was actually built for obtaining true reproduction of the lower tones. Note the peculiar shape of this horn; it follows the exponential curve found by test to be the best for proper acoustical effects in this instance. It is needless to say that this loudspeaker reproduces the low tones with virtually no effect on the quality of reproduction of the high tones. Such a speaker is obviously impractical for any but laboratory use, and far less a commercial possibility. In the second case, the use of a large diaphragm merely lowers the pitch of a horn speaker, so we are forced to use a large cone. This principle has been carried out in the speaker illustrated in Fig. 17. This speaker employs a cone having a diameter of thirty-six inches. Note that a single, flexibly supported cone is used, with the convex side facing the front. The objection to size has here been overcome by designing the frame so that it supports the radio set and also houses the batteries if desired.

The disadvantages of this type of speaker are few and insignificant in comparison with its obvious virtues. True, it means a slight diminution in volume, probably not noticeable to the ear however, and it is of course more or less vulnerable to roving objects, such as cats, etc. The former statement is also applicable to almost any cone speaker regardless of the size of cone. The latter objection may be overcome by placing an ornamental cur-

overcome the inertia of this comparatively great mass of paper, the blasting and dissonance prevalent in many

horn type speakers, are not present.

A powerful three foot cone speaker designed for faithful reproduction over the entire musical scale is illustrated in Fig. 18. This instrument stands approximately 49 inches high. It is also designed for wall mounting in case the floor pedestal is not desired. The design is such that the low notes of the cello, organ, and piano, and the brass instruments of the lower register are faithfully reproduced. This gives to the reproduction of instrumental music true depth and richness. While particular stress has been laid on the reproduction of the low notes, it also reproduces the high notes of the scale with great fidelity.

The artificial parchment used for lamp shades is unsatisfactory for cone speakers. This material is nothing but a heavy paper, oiled to make it translucent. The oil deadens the sound. The paper used by the majority of cone speaker manufacturers is a special cover stock known as Alhambra. This paper is particularly applicable to cone speakers due to the fact that it has

Photo by courtesy of The Rola Company

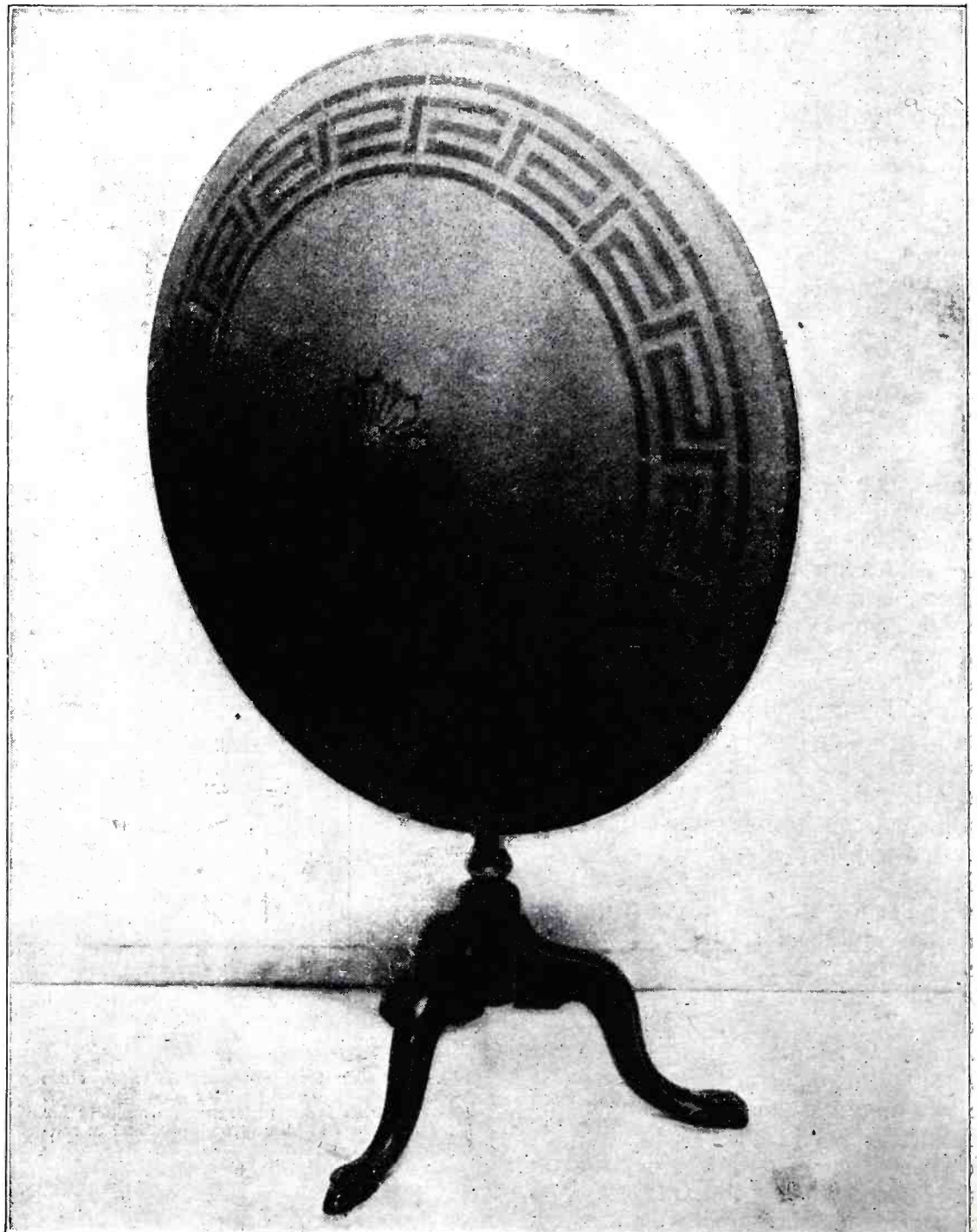

Fig. 18. To get true reproduction of the bass notes, a cone at least 30 inches in diameter is required, as those who have heard this three-foot speaker know. It stands approximately 49 inches high.

Photo by courtesy of Western Electric Co.

practically no grain. It is made up of a foundation skin or grained paper, completely covered or loaded with a mass of pulp. This construction causes the cone to reproduce the various frequencies more uniformly than if a heavy grained paper were used. The grain seems to increase the bad effects of resonant peaks inherent in all cone speakers.

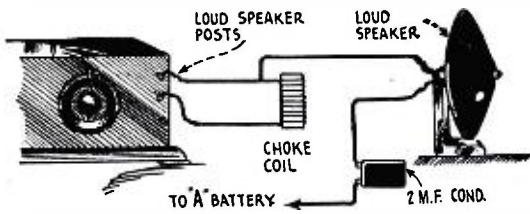

Fig. 20. The use of a choke coil and condenser to prevent the plate current from passing through the speaker windings. This circuit is recommended for speakers employing balanced units.

Operation

For ordinary home use any of the speakers described above when used on the average radio set with the type 201-A tubes gives very good results. Speakers employing balanced type units work better when connected according to either the circuits of Fig. 19 or 20. In Fig. 19 an output transformer is connected between the radio set and the loud speaker. This transformer should have a ratio of about 1:1. The use of this transformer prevents the direct current from the B batteries from passing through the windings of the balanced unit and unbalancing it. Fig. 20 will give identically the same results. A choke coil and condenser are used in place of a transformer. The choke coil in this case serves as a 1:1 ratio auto-transformer.

There is another reason why the circuits of Fig. 19 and 20 are recommended. When using power tubes such as the UX112 or the UX117 in the last stage with two or three hundred volts on the plate for power amplification, there is a possibility of damaging the speaker unit if connected directly to the high voltage circuit. Therefore, by using either the output transformer or the choke coil, the speaker is protected. If anything blows up it will be the transformer or coil. There is a rare possibility of this happening because we are not crowded for space in the transformer or coil design, and comparatively larger wire is used in their windings.

The operation of two or more speakers in series or in parallel has often been done for improving quality. For example, a high pitched horn and a low pitched one give very pleasing results. It is obvious that the use of two such horns widens the frequency band over which the system responds, and more natural reproduction results. Another method which is recommended is the use of a small high pitched horn speaker operating in conjunction with a large low pitched cone speaker. Whether or not the speakers work bet-

ter in series or in parallel must be determined by test. If both speakers have the same impedance it would make little difference which way they were connected; but with the wide range of impedances found in commercial speakers the best method of operation can only be found by trial.

It has always been thought that the inertia of the vibrating members of a loud speaker or loud speaker unit greatly affect the quality as well as the volume of sound produced. For this reason the diaphragms of many of the early telephone units were made extremely light and of thin material. For the average head set this construction is very good as it gives great sensitivity. For the operation of cone speakers where a large amount of material is vibrated the design of the unit has to be altered. Instead of using a very light diaphragm or armature, the armature of the average cone unit is made of comparatively heavier material and of much more rugged construction. As a rule, the larger the diameter of the

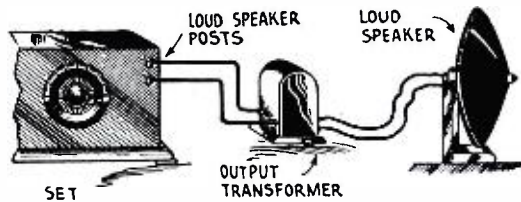

Fig. 19. An output transformer connected between the set and speaker is the simplest way to insulate the speaker from the high voltage "B" battery circuit.

diaphragm or cone the less distance it must vibrate to produce the same volume of sound. Therefore, a heavy armature designed to vibrate at a very small amplitude in a proportionately small air gap is employed for cone

the cone by a lever arm. By mounting the cone at different points on the lever arm different results are obtained.

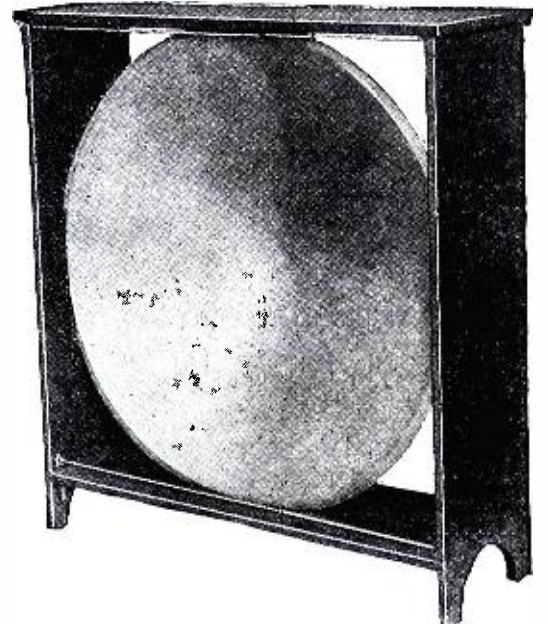

Photo by courtesy of Engineers' Service Co. Fig. 17. A three-foot cone speaker designed by the author. Note that a single, flexibly supported cone with concave side facing the front is used. The stand may also support the radio set and accessories. An ornamental curtain (not shown) across the front improves the appearance.

There seems no limit to the amount of weight that can be vibrated by means of a good cone unit provided the point of contact between the weight and the lever arm is at the proper place. As Archimedes said, "give me a place to stand and I will move the earth." So it is with the cone speaker unit. With the proper reduction ratio of motion there seems no limit to the amount of weight that can be vibrated. I have attached such a unit to the framework of a wooden building, and the whole building vibrated. The music could be heard in the basement with the unit attached

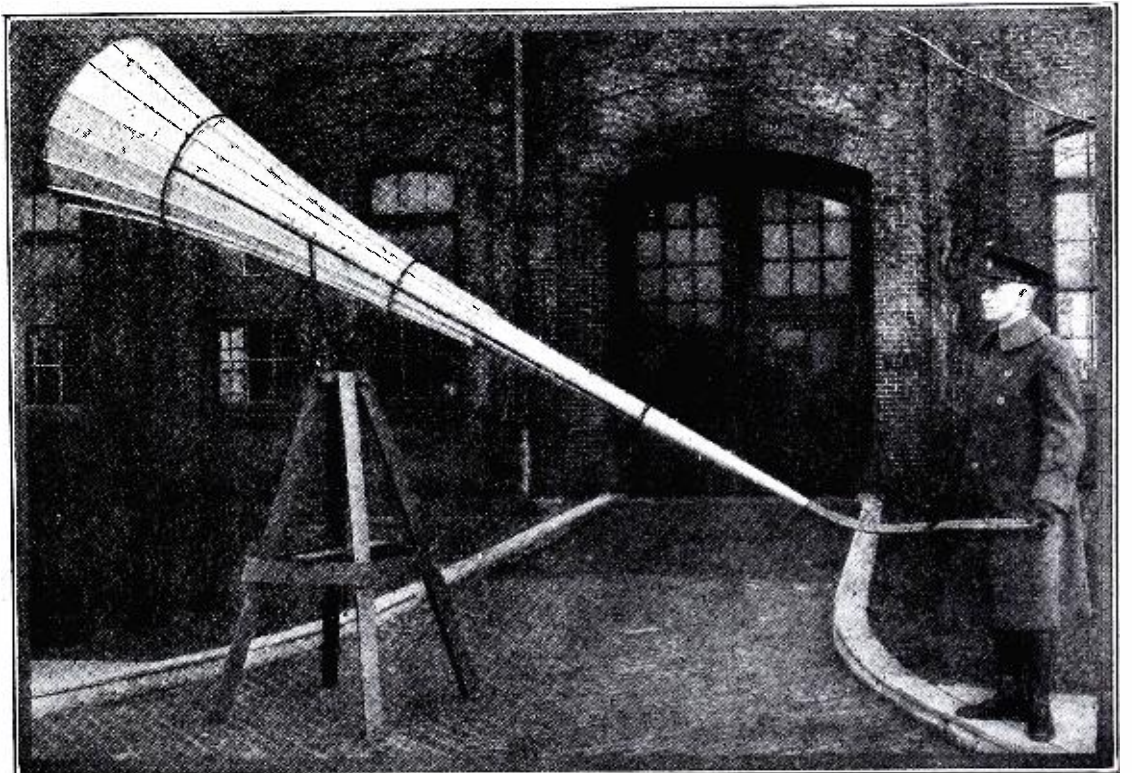

Fig. 16. Capt. Hiram B. Ely, head of the Government sound laboratory at the Frankford Arsenal, Philadelphia, with experimental 12-foot exponential horn, designed by him for use in sound investigation.

speaker operation. In addition, a reduction of motion of about 2 to 1 is usually effected between the unit and

to the roof. While this seems unbelievable, one may prove it to himself by experiment.

Loops and Outside Antennae for Radio Sets

By M. L. MUHLEMAN

THE importance of the role which the antenna plays in modern radio reception does not seem to be fully appreciated by the radio public as a whole. Too little stress is laid generally upon the fact that the antenna—and the antenna alone—is the sole means of collecting the energy sent out by a broadcast station. The energy is relatively minute and it is very important indeed that the proper type of antenna be employed, in order that as much as possible of the energy sent out by the transmitting station be brought to the input terminals of the receiver.

Let us consider the two main classes of antennae—the outside and the loop. In these days of 1926 where nearly every house in town has some sort of an antenna on the roof or in the yard, there is little need of explaining the many different classes of outside antennae. If the reader wishes to learn these several classifications he is referred to the June, 1926 issue of *Radio Review combined with Radio Listeners' Guide and Call Book*.

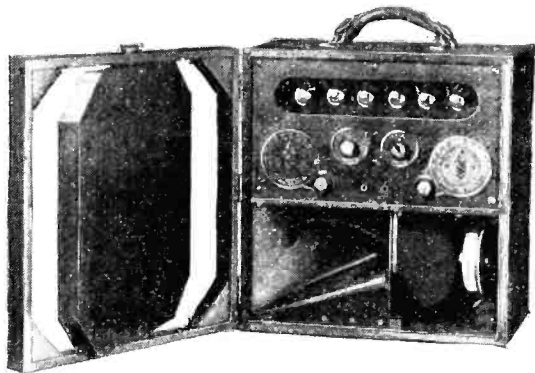

Another portable super-heterodyne receiver with a loop antenna of another design.

The loop antenna is perhaps not so well known generally and is certainly not used to as great an extent. This is perhaps just as well, because unless a receiver is especially adapted for a loop antenna the results obtained will be far from satisfactory. However, when a receiver is designed for a loop antenna, there is no reason at all why reception will not be every bit as good as a set operating from an outside antenna.

Let us consider for a moment what takes place in an antenna. Assume that we have an antenna strung from the highest point of a house of ordinary height to some other high point and that the length of the wire between the two insulators is one hundred feet. Now again assume an incoming radio wave from a broadcast station coming in contact with our antenna. This incoming wave, being of a very high frequency alternating current, sets up, by induction, currents of the same high

frequency in the wire of the antenna. These small currents are carried down to the antenna binding post of the re-

able condenser and inductance in the antenna circuit.

The action of the incoming wave on a loop antenna is about the same as in one placed outdoors. Assume that an incoming wave strikes the side of the loop that is nearer the broadcast station. This portion of the wave sets up an alternating current in the wire of the loop, which, we will say, flows in a clockwise direction. Then the remainder of the wave strikes the same side of the loop and a current in the opposite direction flows as a result. As these waves are of high frequency there is a corresponding high frequency current generated in the wire of the loop.

Then again we must also consider an antenna system as a condenser, the antenna being one plate and the ground the other. Now it is very easy to see that a loop antenna has nowhere near the capacity to ground that an antenna strung outdoors would have. This capacity is very important for reasons which are too complicated to state here, but all these objections may be overcome by the proper design of the receiver.

The question at once presents itself, "What receivers are adapted for use with a loop antenna and what for an outside one?" Before we go into details, let us first look over a few generalities.

As the loop antenna is incapable of collecting as much energy as an outside antenna, we must provide some means whereby what energy is picked-up will

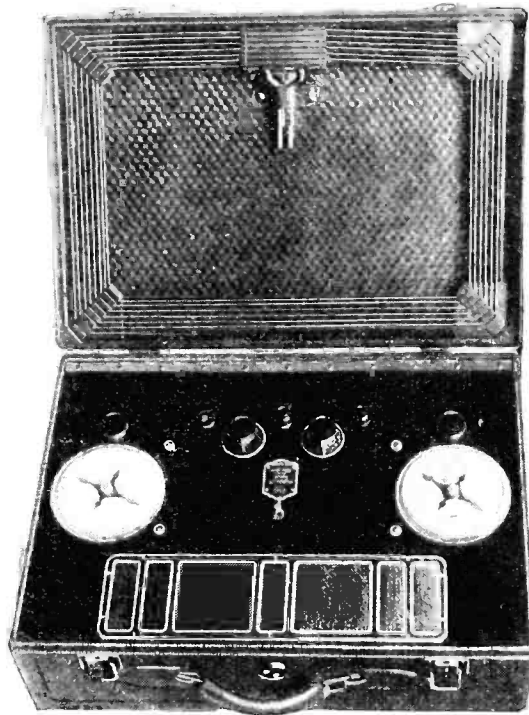

Photos by courtesy of Radio Corp. of America
Fig. 1. A portable super-heterodyne receiver employing a loop antenna.

be amplified to loud-speaker volume by vacuum tubes, transformers, etc.

Now the effective part of the antenna is that portion of wire one hundred feet in length. This length is the most efficient one for all around use in receiving the broadcast stations in the United States and this length has been determined by the wave-length of the trans-

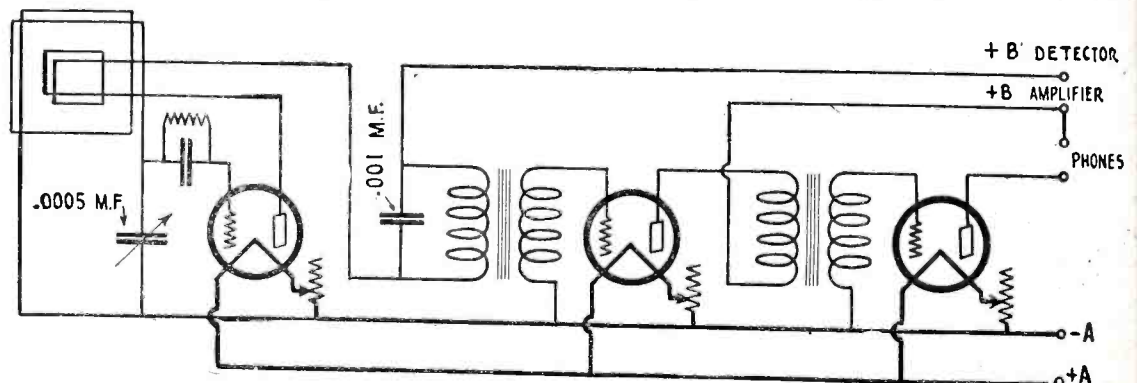

Fig. 3. A circuit that uses a regenerative loop is here shown. Constructional data is on the next page.

mitting stations. The antenna length for maximum efficiency should be $\frac{1}{2}$, $\frac{1}{4}$, $\frac{1}{8}$, etc., or equaling the wave-length to be received. This is of course impossible for we cannot have an antenna for every station to which we wish to listen, therefore we must have some means of varying the electrical constants of the antenna system. This is done generally by means of a vari-

able used to the best advantage. In order to get the proper amount of volume from the loud-speaker it will be necessary to build up this small amount of energy by the only means available, by the use of vacuum tubes as amplifiers. It thus stands to reason that if we have less energy to start with and wish the same results as when there was more energy, we must use more tubes; or in

other words, amplify the signals more.

The question now arises which sets have this means of amplifying signals that is necessary with a loop antenna. First there is the super-heterodyne type of receiver. Briefly the action in this set is that the incoming signal is heterodyned with a local oscillator and the resulting beat note is amplified at a super-audible frequency and then detected and amplified at audio frequency in the usual manner. Here is means for plenty of amplification, because as many as four stages of intermediate frequency amplification may be used with good results and besides this, the usual two stages of audio frequency amplification. Such a receiver is shown in Fig. 1.

In Fig. 2 is a typical reflex circuit that will operate very satisfactorily on a loop antenna. Here we find that there are three stages of radio frequency amplification and to be on the safe side, it might be well to say that the use of a loop antenna should not be thought of unless there are three stages of radio frequency amplification or an equivalent amount, as in the case of a super-heterodyne. There are reflex circuits that will operate on a loop antenna that have but two stages of radio frequency amplification, but it will be generally found that the stations received consistently are local ones, although distant stations might be tuned in occasionally under good conditions.

A circuit that is very interesting from the view-point of the experimenter is that shown in Fig. 3. It is a tuned regenerative loop circuit and one of the remarkable features of the set is that there is no inductance used in the receiver outside of that which is incorporated within the loop itself.

For those who wish to experiment with this three tube circuit, the dimensions of the loop is here given. The outside loop has 24 turns, a tap being taken off at the twelfth turn. The

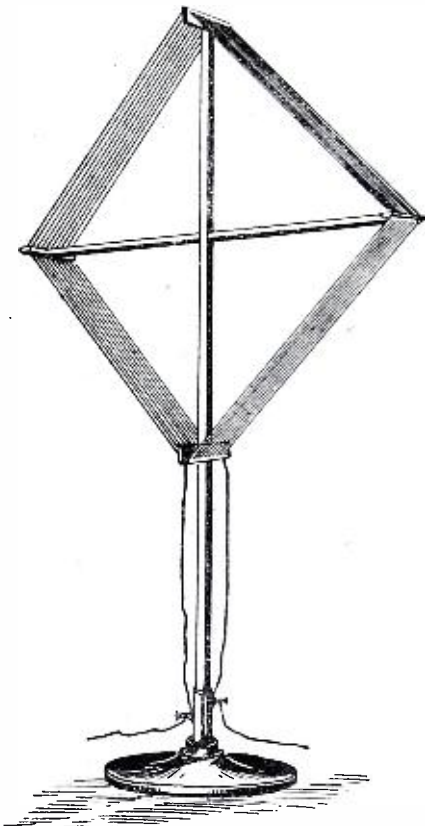

A solenoid type of loop antenna.

inner loop, or tickler, has 12 turns and is not tapped. The ends of the two loops are brought out to appropriate binding posts at the base. The dimensions of the outer loop are eight inches in width, the long stretch being $1\frac{3}{4}$ inches and the four short stretches being $5\frac{1}{2}$ inches. The angle at the end is 90 degrees. The long side of the inner loop are 13 inches in length and the short sides are $4\frac{1}{4}$ inches.

cast station it must remain in the position in which maximum signal strength is received and the tickler coil must therefore be rotated independently for the adjustment of regeneration. This is relatively simple to do and is left to the builder's ingenuity.

As in the case of the reflex circuits mentioned above, the tuned radio frequency receivers work well on a loop, provided that there is sufficient radio frequency amplification available. There is no use in trying to get any satisfactory results in respect to distance when using two stages of radio frequency amplification and a loop antenna. It will do for local stations, but it is, in the majority of cases, time wasted.

As for the receivers that can be used with an outside antenna, their name is legion. The outside antenna is really the ideal method for collecting the radio energy and there are very few sets that will not respond better to an antenna strung outdoors than they will to a loop. Everything from the simple crystal receiver to the most complicated of super-heterodynes will function better when they are connected to an antenna that is outside the house; certainly more distant stations will be tuned in and the signals will be of greater volume.

If there are such great advantages to be gained from the use of an outdoor antenna, why do people persist in using loops? This question may well be asked as it would seem idiotic on the face of it to use something that is not so very efficient. Yet there are times and places where a loop antenna is very nearly indispensable. For instance in the summer time, when there is more or less static in the ether, the use of a loop antenna will be found to

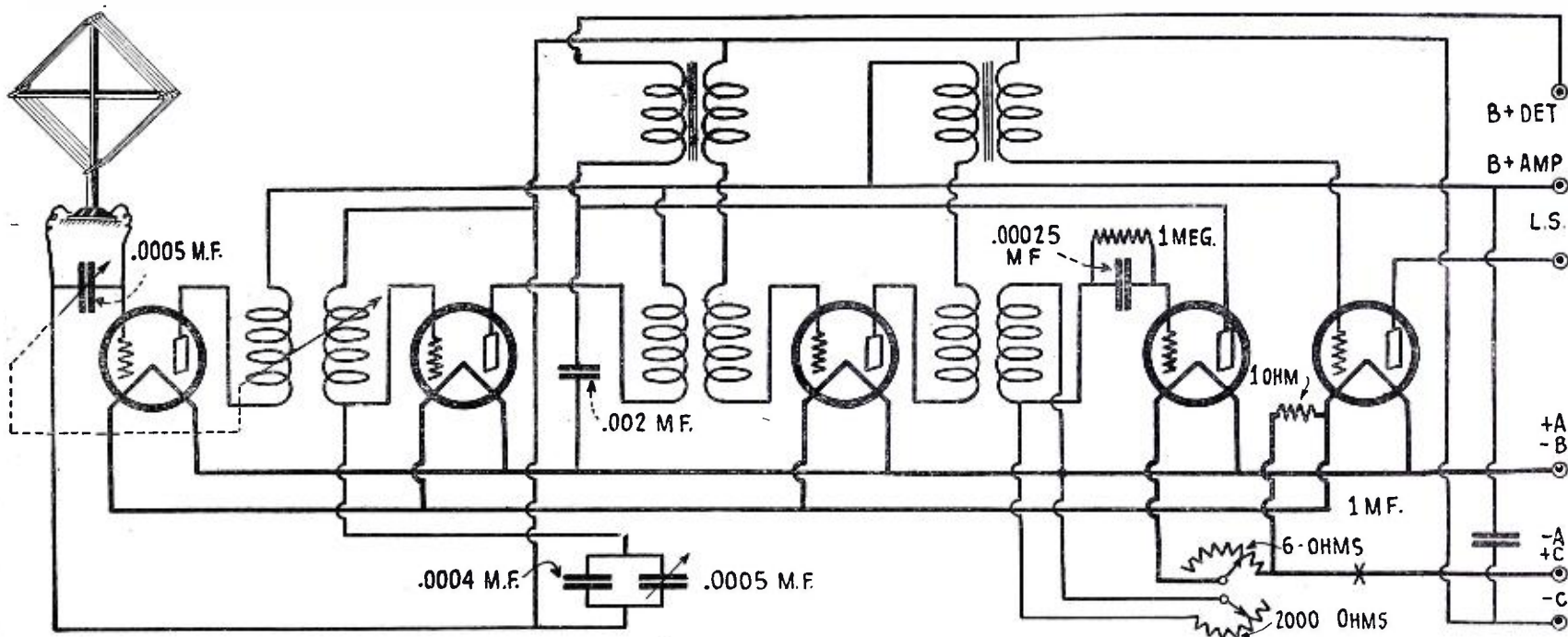

Fig. 2. This reflex circuit of five tubes will give excellent reception when used with a loop antenna.

This loop is built in two sections, one which rotates within the other, the smaller one acting as the tickler or feed-back inductance of the detector tube.

It should be remembered that these two loops must be so built that they can be moved independently of one another. This is because when the outer loop is pointed in the direction of some broad-

reduce the effect of this nuisance to a remarkable extent. Then there is the case when someone is near a powerful broadcast station, which he has difficulty in entirely getting rid of. Here

the directional properties of the loop antenna will show up to a great advantage, for it is possible, by merely rotating the loop, to tune in a station that would be impossible to get if an outside antenna were used.

There are also vast numbers of people who live in sections where it is impossible to erect an outdoor antenna,

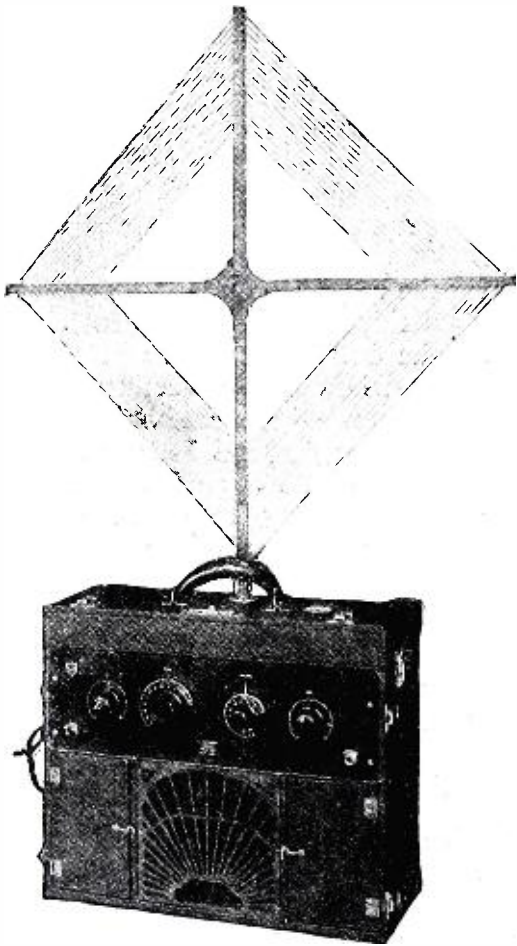

A portable receiver with detachable loop antenna.

either from man-made or natural laws. Think of the thousands of people in New York City alone, who are prevented from putting up an outside antenna. If these people wish the joys of radio reception they must either use an inside antenna strung around the room or a loop antenna. Of course in some sections of the country, where there is a broadcast station every few miles, as there are in New York, almost any kind of an antenna may be used to bring in the local stations, but for distant work this is not the case. To the folks living in areas where loop antennae are about the one and only solution to their problems, this type of antenna is a godsend. They can cut out stations which interfere by rotating the loop and if the proper type set is used, there is no reason at all why they can not bring in distant stations with fair volume.

The directional qualities of a loop antenna are very important. It is to this quality that the radio compass, that is used in navigation work, is due. In the reception of broadcast programs, this property is often made use of, when some station that is particularly difficult to tune in is wanted. The loop antenna is pointed in the direction of the station

desired and any stations, that are now at right angles to the plane of the loop, are automatically cut out or weakened to such an extent that they do not interfere.

It has been mentioned above that a loop antenna has very definite directional qualities and it might be of interest to see just why this is so. There are several ways that this explanation can be given, but the most simple is to consider the loop antenna as an inductance coil, which is threaded by the magnetic field of varying intensity, which is associated with a radio wave. It has been proven that this magnetic field is at right angles to the direction of travel of the wave, and is horizontal.

Now when the wave is traveling in the plane of the loop, or coil, the maximum number of lines of magnetic force are linked with the coil. When the wave is traveling in a direction that is perpendicular to the plane of the coil, no lines of magnetic force are linked with the coil and there is, therefore, no corresponding high frequency alternating current set up in the loop. It is obvious that if the loop is mounted on a frame, which can be rotated about a vertical axis, then for a wave approaching from any given direction the position of the coil can be adjusted so that the maximum signal will be obtained in the receiving apparatus.

Now that we have mentioned more or less about the theory and use of the loop antenna, it is quite fitting that some details of construction be incorporated in this article. The turns of a loop antenna have a distributed capacity of their own, and as has been previously mentioned it has a funda-

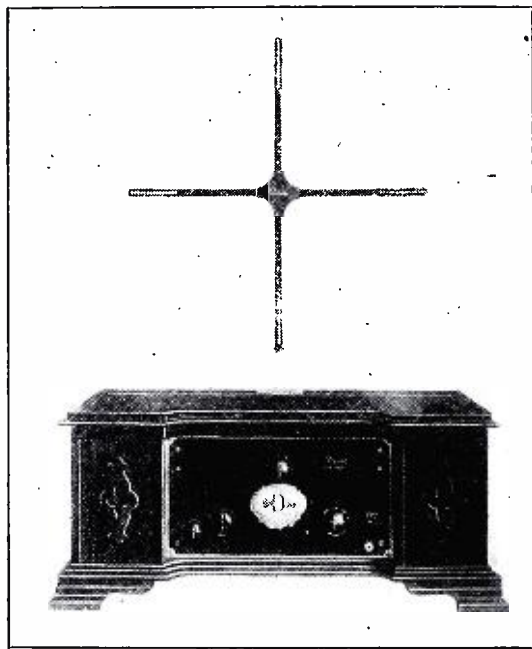

This loop is an integral part of the receiver.

mental wave-length also. The fundamental wave-length of a loop antenna is the wave-length that is radiated by the coil when oscillating freely by itself without being loaded by any other capacity or inductance. As a guiding rule, it should be said that a loop antenna should not be used to receive

waves which are shorter than two or three times its fundamental wave-length. However, satisfactory results can be obtained by using a loop near its natural wave-length. That is, to receive short waves a coil of small inductance and small distributed capacity should be utilized. Such a loop as this must have very few turns and conversely if long waves are to be received a larger number of turns must be used. Experience has shown that the best results are obtained with one or two turns covering a large area for use with short waves, and for long waves loops with 20 to 30 turns, or even more, not so large in area.

There are two types of loop antenna; those wound in a flat spiral, i.e., all the turns in the same vertical plane, and the square loop, in which all the turns are in the same horizontal plane. The latter type is by far the easier of the two types to construct and what is more, it is the more efficient of the two. So we will only consider the latter type.

The usual type of loop antenna consists of one or more turns of wire wound on a square or rectangular frame. One or two turns of copper wire wound on a simple wooden frame three or four feet square will make a loop that will be suitable for some purposes. For indoor use for all ordinary purposes the wire used for a loop antenna may be No. 20 or 22 insulated copper wire having a solid conductor. The spacing of the turns of wire depends on the capacity of the loop. Spacings of $\frac{1}{2}$ inch and 1 inch are common, although there are many cases when smaller spacings are often used.

There have been many experiments performed on the size of the frame and the number and spacings of the turns and for a general all-around loop antenna we recommend the following: Build a frame of light, but yet strong wood, of the proper dimensions that will allow a length of wire equal to four feet on each of the four sides. This means that the two cross pieces will be approximately $5\frac{1}{2}$ feet in length. On the ends of these cross pieces fasten slotted pieces of some sort of insulating material (bakelite, hard rubber, etc.) on which the wire of the loop will rest. There will be four slots needed, as there are four turns of No. 20 wire to be strung, and these slots are space half an inch apart. Arrange the frame of the loop so that it may be easily rotated about the base and provide two binding posts to which the ends of the loop wire are attached and which are connected to the input terminals of the receiving set. With a variable condenser having a capacity of 0.0005 mf. the wave-length range of the broadcast stations in this country should be very well covered.

Modern Types of Radio Receivers

By G. C. B. ROWE

SINCE the beginning of the present radio era, which we may say began in 1920, there has been a development of receiving apparatus that is nothing short of marvelous. It is common knowledge how radio broadcasting has caught the public's fancy and the demand for receiving sets made their manufacture an industry that is taking its place among those leaders in almost every country in the world.

The sets that were put on the market in those early days of broadcasting, it will be remembered, had many, many controls. In fact, it seemed that the manufacturers put on the panel as many dials and knobs as they could and the radio enthusiasts of that day evidently got the idea that a receiver was not very good unless everything inside was tuned from the condensers down to the binding posts.

However, as the popular saying goes, "Them days have gone forever." As more and more people became interested in the new indoor sport, the de-

come to the correct conclusion that it is not the man of the house that tunes the radio set, but Mother and Sister as well; and therefore, sets that are more simple than ever to control have appeared on the market.

set be found down in the cellar or up in the attic, as a thing that would spoil the looks of any parlor. The women have seen that radio is here to stay and consequently as long as it is getting to be so important, it must have a housing

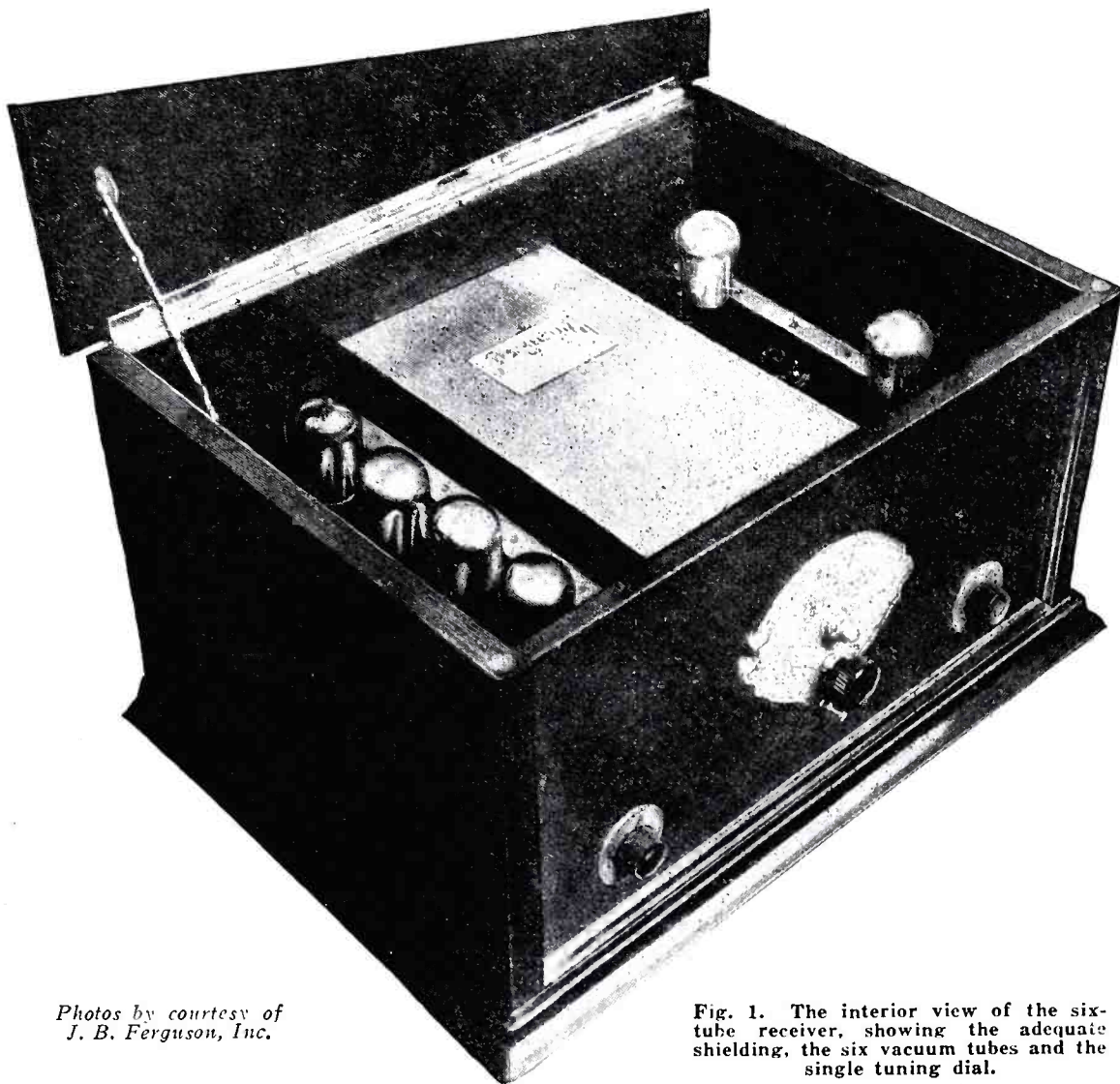

Fig. 1. The interior view of the six-tube receiver, showing the adequate shielding, the six vacuum tubes and the single tuning dial.

Photos by courtesy of J. B. Ferguson, Inc.

It must not be thought that men in general care for multiple control sets. Far from it! In the Ideal Set Contest, which was recently conducted by *Radio News Magazine*, and in which people were asked to indicate their ideal receiver, with respect to the number of controls, built-in loud-speaker, loop, etc., the majority wanted a set which had but a single control for tuning, with one or two volume controls, a built-in loud-speaker, a built-in loop antenna, and various other minor refinements.

Another feature that heretofore was very lightly taken into consideration and which now appears as a most important item in every set circular, is the wood and its finish of which the cabinet or console is made. As radio has become more and more a part of American home life the receiving set has been given a more prominent place in the house. No longer will the radio

that will correspond with and fit into the general scheme of the house furnishings. Cabinets and consoles now are made in almost every conceivable wood and finish, so that it is a simple matter to match the furniture of any room with the new radio receiver.

It has been mentioned above that the number of tuning controls on sets have been reduced to the minimum in modern receivers, but there has been a corresponding increase in the number of vacuum tubes used. This, as will be very easily seen, has called for great ingenuity on the part of designing engineers, for on first thought it would seem that the greater the number of tubes the more controls there would have to be. This seeming impossibility has been made a fact. In one of the receivers described below there is but one tuning control and yet there are six vacuum tubes inside the cabinet.

Lately there have also appeared on

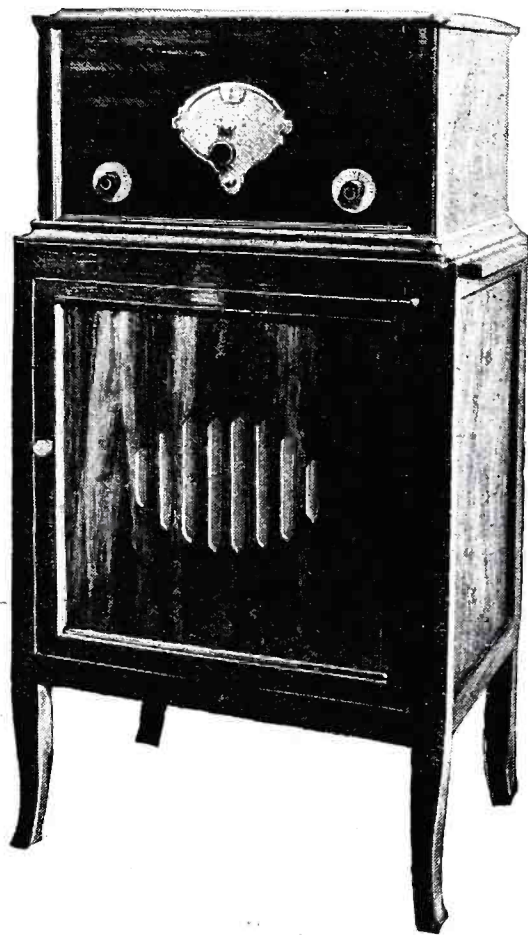

Fig. 2. The panel view of the single dial receiver. The stand has ample battery space and also room for a cone loud-speaker behind the grill work on the door. A speaker may also be placed on the shelf on the right.

mand for sets that could be easily tuned became greater. In looking over radio publications this trend may be very easily noticed by the receivers that are shown. Lately the manufacturers have

the market various types of instruments that do away with the necessity of "A" and "B" batteries. These battery eliminators, as they are generally called, get their power from the A.C. house

of the filaments of the first two tubes in the radio frequency stages, also controls the volume of the output of the receiver.

It will also be noticed in the circuit

methods discussed for amplifying the signals after they have been detected with almost as many different results. One of the best types of audio frequency amplification, however, is that

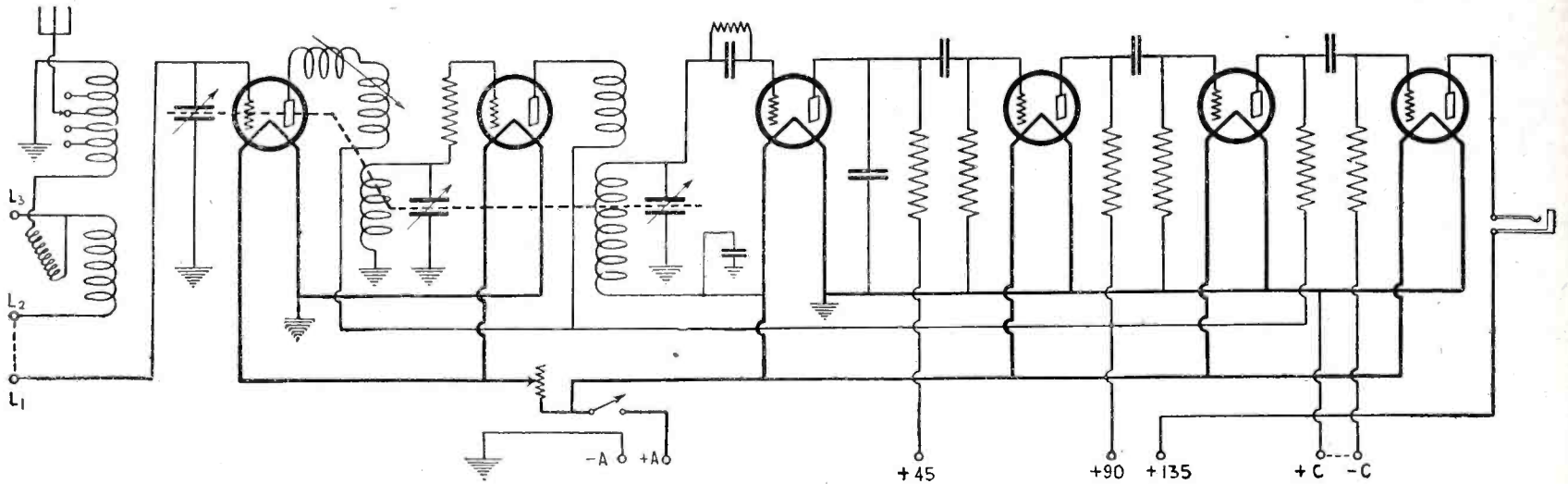

Fig. 3. The schematic diagram of the receiver shown on the preceding page. The dotted line indicates that the three condensers operate from the one dial.

lighting current and their upkeep is far below the cost of batteries. Also the various types of loud-speakers have been improved, but there are so many new instruments and accessories on the market that it is impossible to tell about them all here.

A Single Control Receiver

A receiving set, that has recently appeared on the market and which doubtless will appeal to the popular taste, has but a single control for tuning, and is shown in the illustrations on page 104, Figs. 1 and 2. Although there are six vacuum tubes used in the circuit, the tuning is far easier than many sets that have fewer tubes, for the dial is divided into wave-lengths, so that there is not any need to keep a log of the stations received; merely a list of stations and the wave-lengths on which they broadcast.

The circuit of this receiver is shown in Fig. 3 and it is interesting to note that there are various innovations incorporated in it. In many of the mod-

ern receivers the volume is controlled by detuning the set or by resistances placed at various points in the radio or audio frequency stages of amplification. In this single control set, however, the rheostat that controls the temperature

diagram that in the antenna circuit there is a tapped switch that throws more turns of the primary of the antenna coupler into the circuit. As mentioned above the dial is calibrated in wave-lengths and this inductance

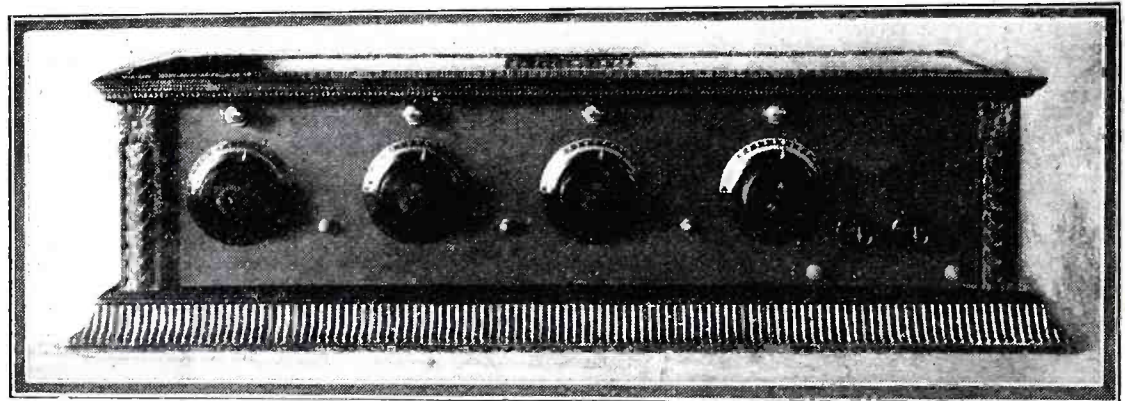

Fig. 4. The four dials of this receiver do not make the tuning difficult, as they all have approximately the same dial settings.

switch is used in order that no matter what length of antenna wire is used, the figures on the dial may always be correct.

One of the most important factors

are no transformers in the circuit with their ratio of turns to increase the voltage, there being only fixed resistances and condensers for coupling purposes. However, the quality of reproduction that is possible by using these three stages of resistance coupled audio frequency amplification is of the highest order.

As there recently appeared on the market several types of power amplifier vacuum tubes that are in general used in the last stage of audio frequency amplification, there is provision made in this receiver for tubes of this type. These amplifier tubes require a higher plate voltage and also a higher grid bias than the ordinary type of amplifier tube, therefore at the point marked X in the grid circuit of the last audio frequency tube in Fig. 3, there are two binding posts so that the proper grid bias may be applied. There is also provision made for higher voltage on the plate of this same tube.

Let us consider the mechanical features of this receiver. It will be noticed in Fig. 3 that there are three variable condensers across the secondaries of the radio frequency transform-

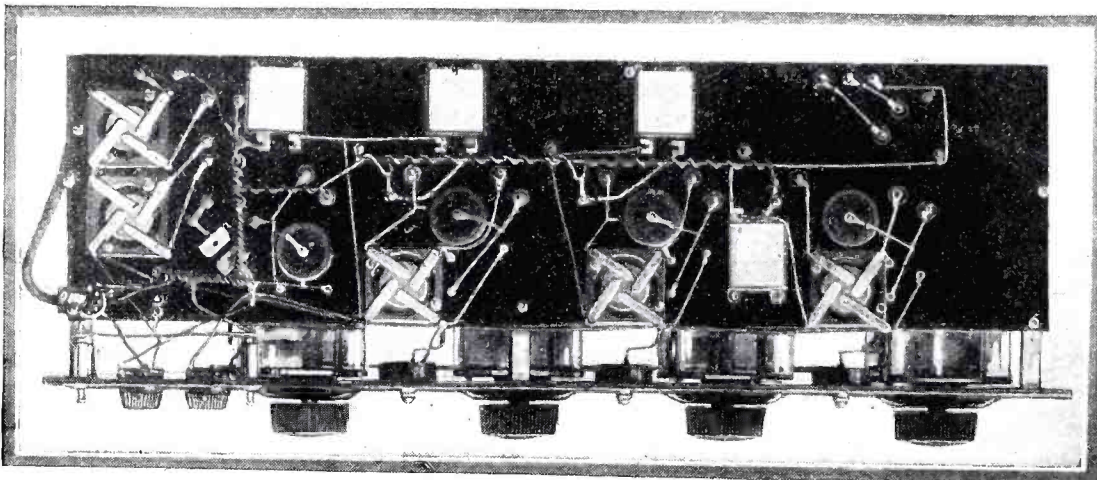

Photos by courtesy of Walbert Mfg. Co.

Fig. 5. By the method of wiring employed in this receiver, chances of oscillations in the circuit are greatly reduced.

ern receivers the volume is controlled by detuning the set or by resistances placed at various points in the radio or audio frequency stages of amplification. In this single control set, however, the rheostat that controls the temperature

in present day receivers is the quality of reproduction. In the young days of radio this was far from being very widely discussed, but for the last year great stress has been laid upon this point. There have been many different

ers. In order to simplify the tuning these three condensers are mounted on the same shaft and rotated by the one dial. Also to facilitate tuning, the primary of the first radio frequency transformer is wound in two parts, one of which is wound on the same tube as the secondary and the other is wound on a rotor, which is mounted on the same shaft as the three variable condensers. It will also be seen by referring to Fig. 3 that there is a condenser in parallel with each of the three main tuning condensers. These are compensating condensers and are set at the factory.

The inductance switch that was mentioned above is for the adjusting of the set to any type of antenna. Almost any length of antenna may be used and due to the radio frequency amplification, an indoor wire will give excellent results, although the volume and the distance received will not be as great as if an outside antenna were used. The cabinet housing of this receiver is of dark wood, which will harmonize with almost any type of interior furnishing and the main tuning elements are thoroughly shielded.

An All Capacity Bridge Receiver

As an example of a set which goes to the other extreme of the scale and which has four tuning dials, the reader is referred to Figs. 4, 5 and 6. Although the four controls may seem indicative of complicated tuning, yet this receiver has been put upon the market only a short time ago. It will be of interest to look into the reasons for these many dials.

The manufacturer of this receiver evidently believes that it is better to tune each stage of radio frequency amplification—and there are three of

that if the multi-dial receiver is properly balanced, there is not any reason whatsoever why the tuning can not be made every bit as simple as that of a

set accurately; therefore, the circuit is so designed that it will cut out the very powerful local stations and bring in distant stations through bad interference.

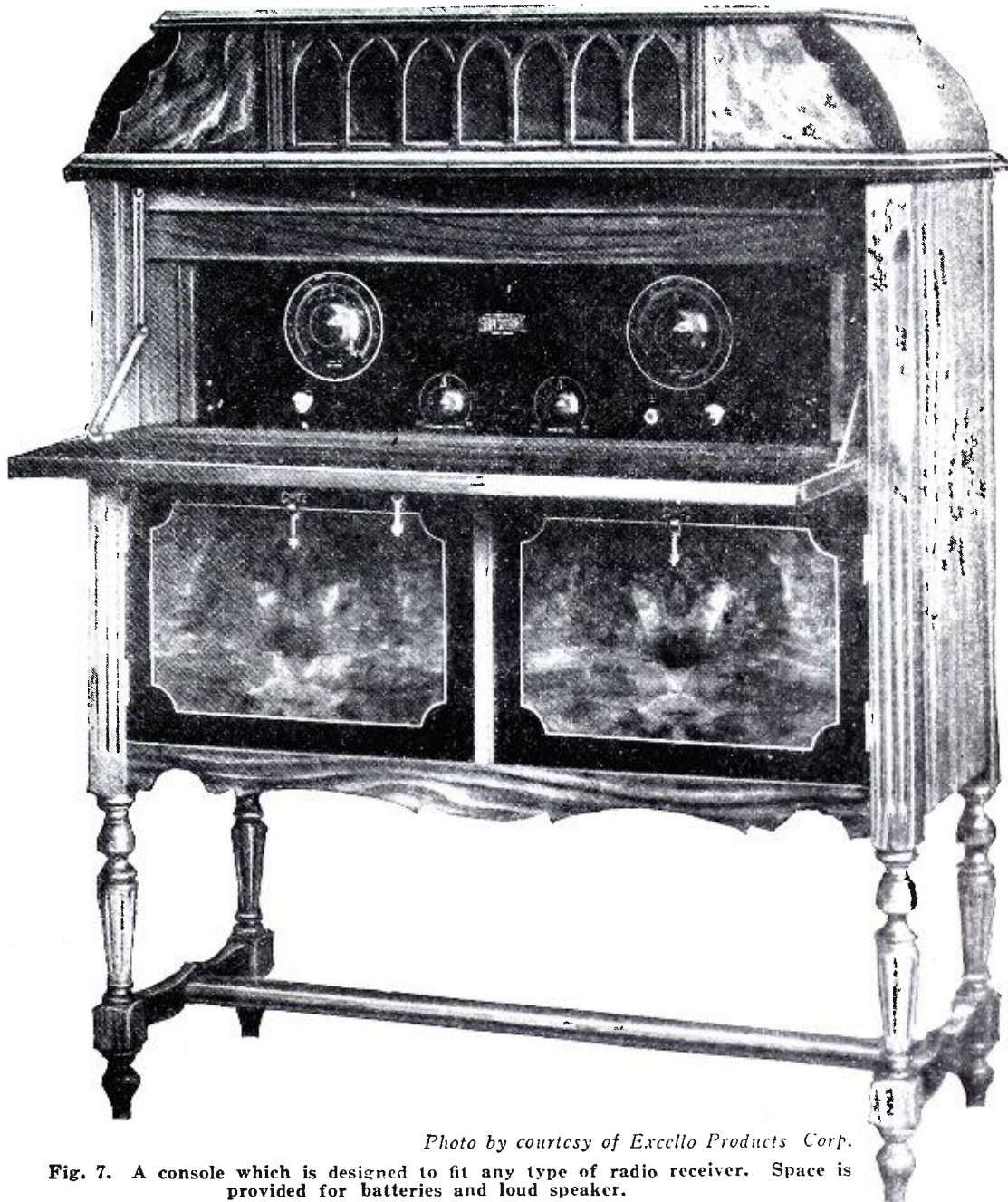

Photo by courtesy of Excello Products Corp.
Fig. 7. A console which is designed to fit any type of radio receiver. Space is provided for batteries and loud speaker.

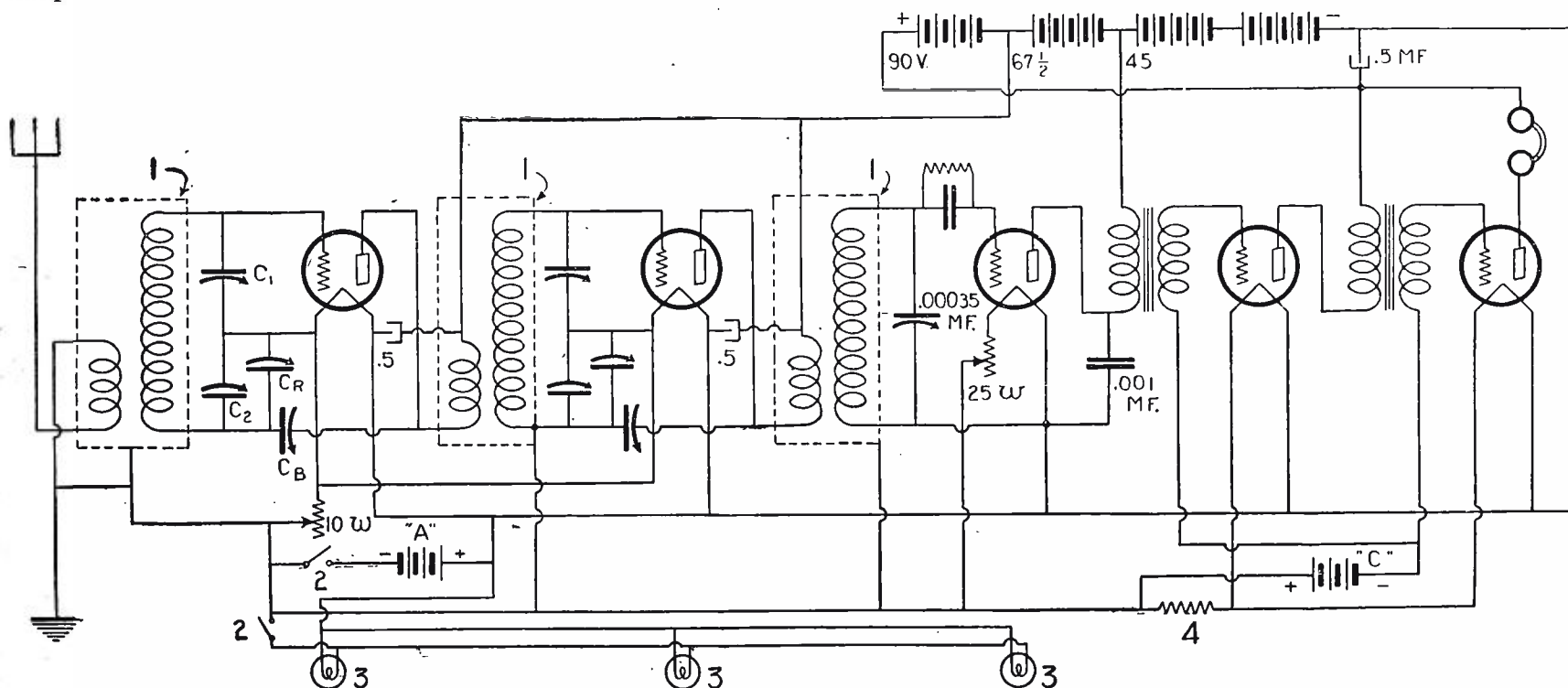

Fig. 6. The circuit diagram of the receiver shown on the preceding page. No. 1 indicates the shielding around the inductances; 2, switches; 3, panel lights for illuminating the dials, and 4, filament resistance.

them—with a separate dial than to risk more or less broad tuning with less controls. This is merely a matter of opinion and it might be said in passing

receiver having but one or two dials. By this is meant that the dial readings will all be approximately the same and it takes only a few seconds to tune the

If the reader will notice the schematic diagram of this circuit in Fig. 7 he will see that each of the radio frequency stages forms a perfectly bal-

anced Wheatstone bridge, and also that the tuning process does not unbalance the bridge at any point within the wavelength range. The small balancing condensers are not controlled by knobs, as they are once set when the vacuum

from a radio viewpoint, but will go well with any sort of furniture.

Consoles Without Sets

There are many times doubtless that someone has a favorite circuit that he

rebuild the set to fit a standard size cabinet? Evidently the latter alternative is out of the question, for the set works now and most likely it would not perform so satisfactorily if rebuilt. As for the former case, we will suppose that our radio fan knows nothing about the mysteries of cabinet making. What is he to do?

In Fig. 8 he will find his answer. Here is shown a console that will fit any size panel and a baseboard that is reasonably wide in proportion to its length. On each side of the space in the front that accommodates the panel of the set there is an adjustable sliding panel that will snugly rest against the vertical edges of the receiver's panel. These consoles are 16 inches deep so there is plenty of room for the baseboard.

As may be seen from inspection of Fig. 8 there is a front panel of the console that drops down to form a shelf. Beneath this shelf there are two cupboards that may be used to house the "A" and "B" batteries, or their equivalent eliminators, and any other accessories that is necessary to get out of the way. The left hand compartment is for the storage battery, as in its bottom there is a sliding leaf on which the "A" battery rests. In this way the storage battery may be easily slid out for inspection, testing, etc.

Over the panel of the receiver shown mounted in the console, there may be seen an open-work grill. This is the outlet of the horn built in the lid of the cabinet to which may be attached the loud-speaker unit. This horn is of special construction and it is claimed that the quality of reproduction from

tubes are placed in the set and need only be readjusted when new tubes are installed. The adjustments are made with a screwdriver, as the shafts of these small condensers bear slots like the head of a screw. These condensers are protected after being adjusted, by small caps that screw over them and thereby prevent accidental de-tuning.

A glance at any of the illustrations (Figs. 4, 5, or 6) will show the advance in mechanical design that has been made in comparison with sets of a few years ago. For instance, in the top view of the receiver, notice how the variable condensers are protected from dust by the celluloid covers and the coils that form the radio frequency transformers are adequately shielded by means of metal containers, which remove all chances of feed-back and consequent oscillations.

In the panel view of the receiver over the four dials will be seen small panel lights, which are run from the storage battery supplying the power for the vacuum tubes. These small lights are extremely useful, as many times sets are not placed in a good light and more illumination is not wanted in the room. It will be found that these small lights aid the operator, as the same stations are brought in at the same dial loggings night after night.

The bridge system used in this circuit is another engineering feat. It tends to suppress all oscillations and make it extremely free from all noises; as much so as any receiver can be made at the present time. As can be seen the cabinet of this set is distinctive; the carving is well done and the set as a whole will not only give satisfaction

has evolved after much time and experimenting. This circuit will bring in stations we will suppose, with excellent volume and quality from a great distance. In fact, to our radio fan it is the only receiver that ever worked. The time has now come to purchase a cabinet for it and here our friend is up against a real proposition.

Perhaps this marvel of a set was constructed on a panel that was not a standard size and perhaps the base-

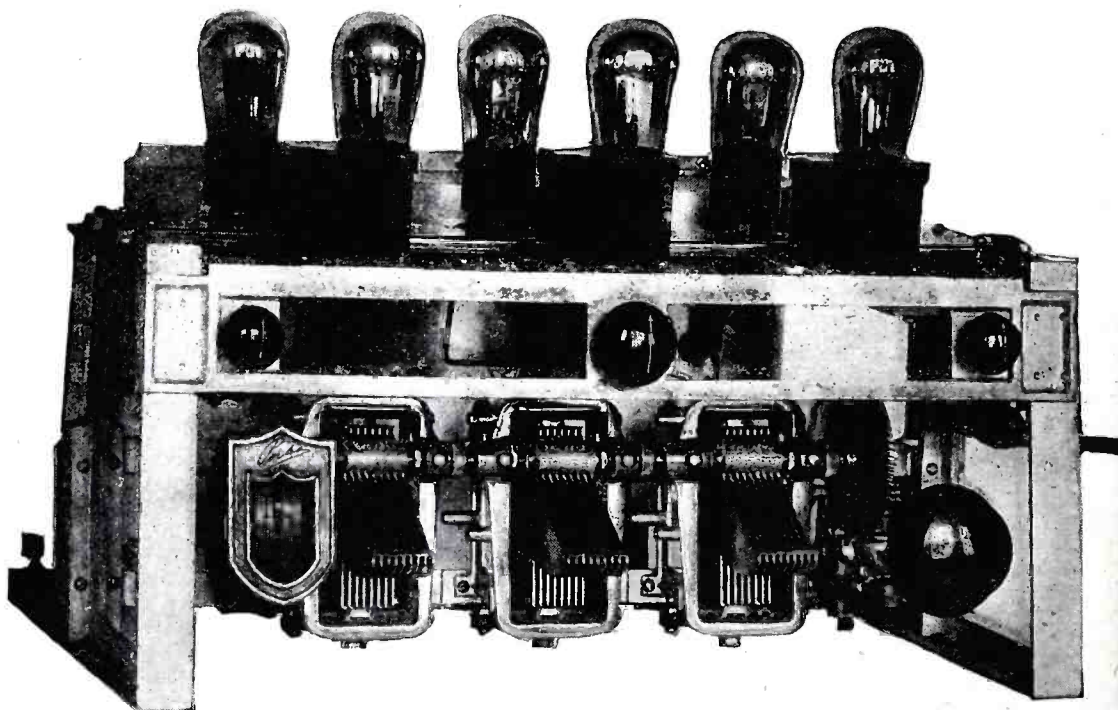

Fig. 8. Here is an adaptation of the condensers in a receiver described in the accompanying text. It is easily seen that the construction of such a set would be quite simple.

Fig. 9. This illustration shows the excellence of the construction, allowing space for coils, tubes, etc.

board was very wide in order to accommodate a special arrangement of apparatus. No cabinets are available to fit his set and then he is faced with the problem,—Shall he build a cabinet to fit the receiver as it stands or shall he

a good unit in combination with this horn is hard to surpass.

In order to make these consoles adaptable to any home furnishings they

(Continued on page 166)

Super-Heterodynes—Which One?

By H. WINFIELD SECOR

THE writer has been interested in super-heterodynes ever since they came fairly well known, and he has built and tried out a number of the leading types. There is a lot of misinformation on super-heterodynes which has been given in various radio periodicals, and only actual experience will demonstrate the fallacies of some of these suggestions given by various writers, who frequently claim to obtain wonderful results if you will only follow their method of operating this type of radio broadcast receiver.

To begin with the writer will mention a few important points of a general nature in regard to super-hetero-

transformers are preferable. The first super-heterodyne the writer built utilized tuned air-core transformers, and hearing so much about the greater volume from the set when using iron core intermediate transformers, he made it a point to obtain two different sets of well-known makes of these transformers with iron cores. After testing the set fitted with the iron core transformers in the radio frequency stages, there seemed to be no improvement in the volume at all, and the general tuning of the set was not as satisfactory as when the tuned air-core transformers were used. The set is broader in tuning with the iron core transformers, and

tector. From the experience of others, coupled with my own experience, it seems much simpler and practically the same in the results obtained, to use four stages of intermediate radio frequency, in preference to placing one stage of radio frequency ahead of the first detector. In either case nine tubes are necessary if two stages of audio frequency are to be utilized.

For ordinary volume on the loud speaker, it is usually the case that one stage of audio frequency, especially if a power tube is used with high plate voltage, will be sufficient. This also reduces distortion and gives much more stable operation, especially with some

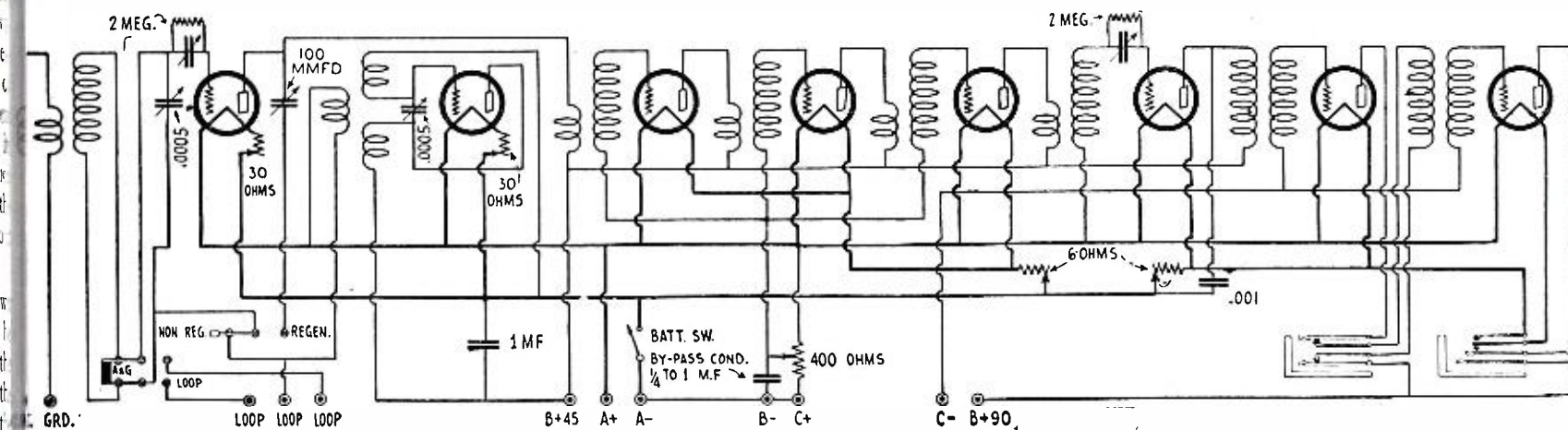

Fig. 1. The super-heterodyne circuit shown above is the Victoreen with switches permitting the use of aerial and ground as well as loop with regeneration. Note that the 400 ohm potentiometer is shunted by by-pass condenser having anywhere from $\frac{1}{4}$ to 1 M.F. capacity. The regeneration control is effected by a small vernier condenser having about 100 M.M.F.D. capacity. The antenna coupler may be any standard type or else the one furnished by the manufacturers. For any super-heterodyne the antenna and ground may be coupled through a standard vario-coupler, either removing the tickler or else leaving it disconnected. This is one of the best sets ever tested by the author.

types which he has found to be either good or else worthless. It is not a good policy to be too dogmatic about any such thing as a super-heterodyne perhaps, but after you have tried out repeatedly some of the suggestions which you read in radio magazines and also in textbooks, and find that they are either good or else very poor, you at least have some basis for your arguments.

Those really interested in the super-heterodyne should certainly study the excellent work on the subject, "Modern Radio Reception," prepared by Mr. Neutz. They should also read every article on super-heterodynes which they can lay their hands on, and then you will have some good general ideas which will prove very valuable in trying out the various transformers and other apparatus on the market intended for this particular form of radio receiving set.

The first great battle among the super-heterodyne enthusiasts is the one regarding the use of iron core versus air-core intermediate transformers. The writer has tried both and in his humble judgment, the tuned air-core

another bad feature which the writer found, was that the potentiometer had to be adjusted very critically and changed to bring in each station when using the iron core transformers, while with the tuned air core transformers the station could be heard invariably, no matter where the potentiometer arm happened to be at the moment. This experience checks up with that of other experimenters who have played with super-heterodynes, and there are two very good tuned air core transformer kits for super-hets now on the market, the circuits of which will be shown and discussed in the present article. Both of these super-heterodynes have accomplished Trans-continental reception, and one of them also received the European broadcast stations in the tests conducted the past winter.

Various arrangements of super-heterodynes, including two to four stages of intermediate radio frequency, have been tried out; also the opposite arrangement where greater sensitivity is attempted by utilizing the usual three stages of intermediate radio frequency, with one stage of radio frequency connected ahead of the first de-

sets, as has been found in practice. One advantage of super-heterodynes built with intermediate transformers of the iron core type, lies in the fact that they are finished with iron shells, which act as shields, and these help to keep the set more stable and free from body capacity effects or extraneous magnetic and radio fields. One of the air core super-hets to be described herein has no shields on the coils, but the second and newest type does have metal shields on the transformers, which are grounded to the negative "A" side of the circuit, thus eliminating body capacity effects and also preventing the intermediate stages from picking up strong radio waves, thus causing the tuning to be broadened, and engendering interference.

A very important point about super-heterodyne operation is the value of the plate voltage applied to the first six tubes comprising two detectors, oscillator, and three intermediate amplifiers. After trying various voltages on these tubes, and also the trick of applying gradually increasing values of plate voltage to the successive stages, the writer has found the best all-around

performance when the first six tubes are supplied with 45 volts plus B. If less voltage is used on some of the tubes, the signals are markedly weakened; if a higher plate potential is applied, you will get more noise. This latter point is not so noticeable if you are using the small, three volt tubes of the UX-199 type.

Here is one of the best tricks in the operation of a super-heterodyne if you are looking for efficiency. Many people draw the line on a broadcast re-

tion of this, is to utilize regeneration on the first or second detector and to cut out all of the intermediate frequency stages when listening to locals. The method the writer prefers, however, is to use the super-heterodyne "as is", as the operation is certainly much simpler and more satisfactory in every way. Here is the way to get real efficiency, and it gives nearly the same results both in range and volume, as if you were burning eight 201-A tubes which run down the battery a little too

all of the transformers, and the writer has tried out about a dozen different makes, both air core and iron core, the two types of tubes may be interchanged indiscriminately with very little difference. Without question the most efficient set you can operate is the eight-tube standard super-heterodyne, using 199 type tubes in the eight sockets. This gives very fair volume, and there is now available a small type power tube for the second audio socket, UX-120, drawing .125 ampere, adapted

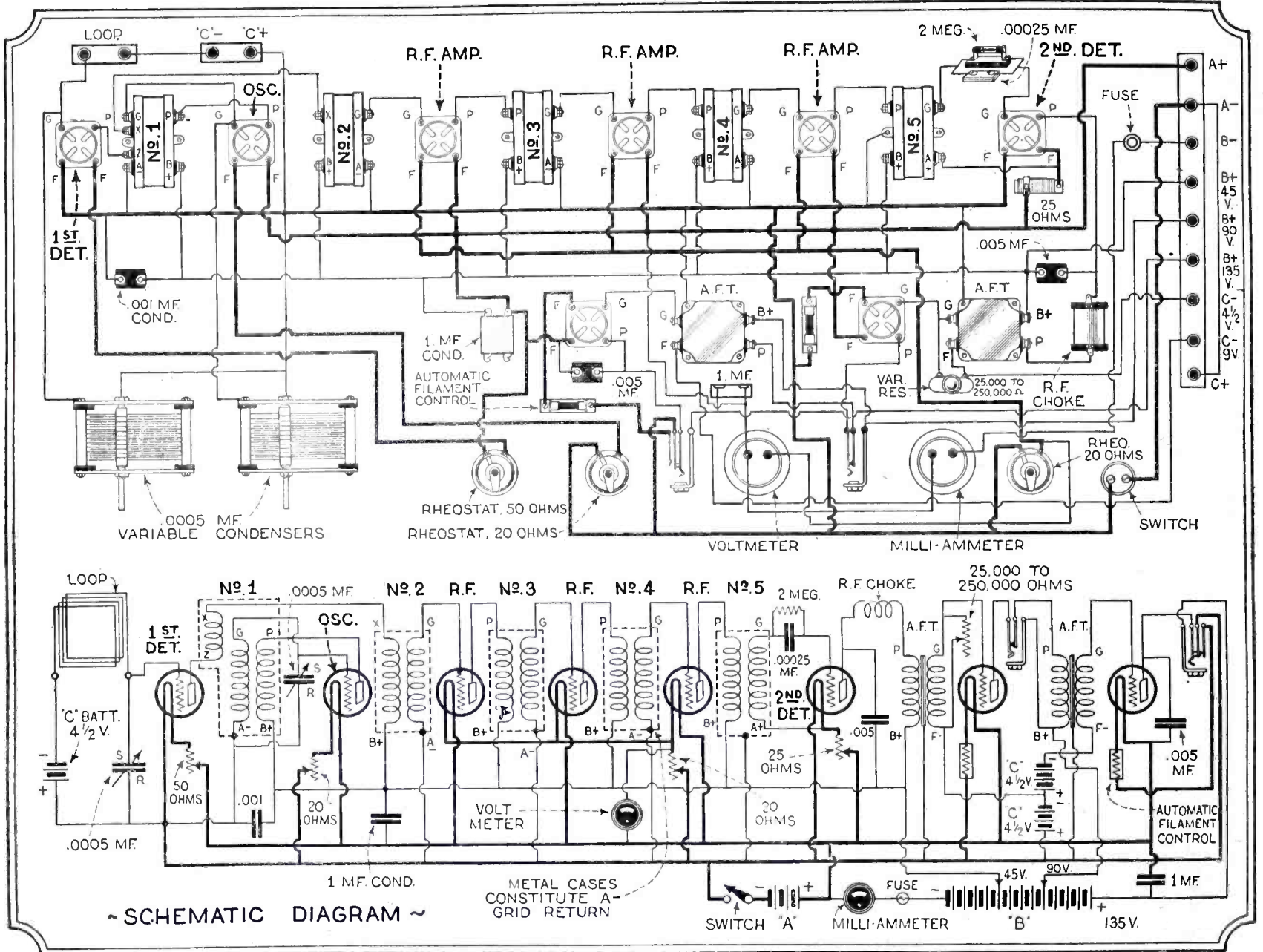

Fig. 2. This new type of super-heterodyne employs accurately tuned air core transformers for the oscillator and intermediate stages of radio frequency amplification. This circuit and the specially built heterofomers are arranged in a new and novel manner. As will be seen by studying the circuit, the pickup coil of the oscillator is placed in the plate circuit instead of the grid circuit of the first detector. No potentiometer or "C" battery is used on the grids of the intermediate frequency tubes, and also no grid leak or grid condenser is utilized for the first detector, a 4 1/2 volt "C" battery taking its place, by connection in the loop circuit, as shown. All of the heterofomers are shielded in metal cases, grounded to the negative "A" lead. This super-heterodyne is not subject to body capacity effects.

ceiving set which has to burn eight tubes to hear a concert from a local station, or even one twenty-five miles away. "Why should I use a super-heterodyne with eight or nine tubes, when my neighbor receives the concerts beautifully on a three-tube regenerative set?" you may ask. There are two ways to answer this question, and the writer has tried them out successfully as follows.

The first way to overcome this problem is to have a simple switch, whereby but one or two stages of intermediate radio frequency are utilized for receiving local stations. A varia-

quickly to suit some people. Instead of using 201-A tubes in the first six sockets, the writer frequently employs six UX-199 tubes, and then he places two 201-A's in the audio stages. If you have never tried this trick, you will be agreeably surprised at the very favorable results obtained. A Bradleystat or other rheostat is placed in series with the -A lead feeding these six tubes, so as to reduce the filament voltage to three volts. Some of the experts state that you should use special intermediate transformers adapted to the 199 type tubes, due to their different electrical capacity, but with most

for a plate voltage of 135 with a grid bias or C battery potential of 22 1/2.

In some of the many articles on super-heterodynes, you have doubtless seen the suggestion made that instead of using a potentiometer to vary the grid bias on the intermediate frequency tubes, that a C battery could be used instead. Perhaps you will like it but the writer didn't, and he certainly swears by the potentiometer; except in those circuits where neither C battery or potentiometer are required. The best method in building an experimental super-heterodyne of no matter what type, is to build a potentiometer

in the set, and then you always have it when you want it, and it can be tried in any circuit at any time, no matter what the inventor says about it.

Another great battle-ground among the super-heterodyne "Bugs" is the question as to whether regeneration is necessary or desirable in the set. Mr.

super-heterodyne, and usually it will only result in squealing when tuning the station in, unless the potentiometer is continually and everlastingly reset to the point where oscillation does not take place. There is a certain amount of regeneration always present in the super-heterodyne anyway, and while

untoward feature is to utilize an oscillation transformer with one of its coils wound on a rotor, the shaft of which is brought out to a dial on the front of the super-het panel.

Of course this is an added control feature, but it doesn't amount to much. The finest results the writer

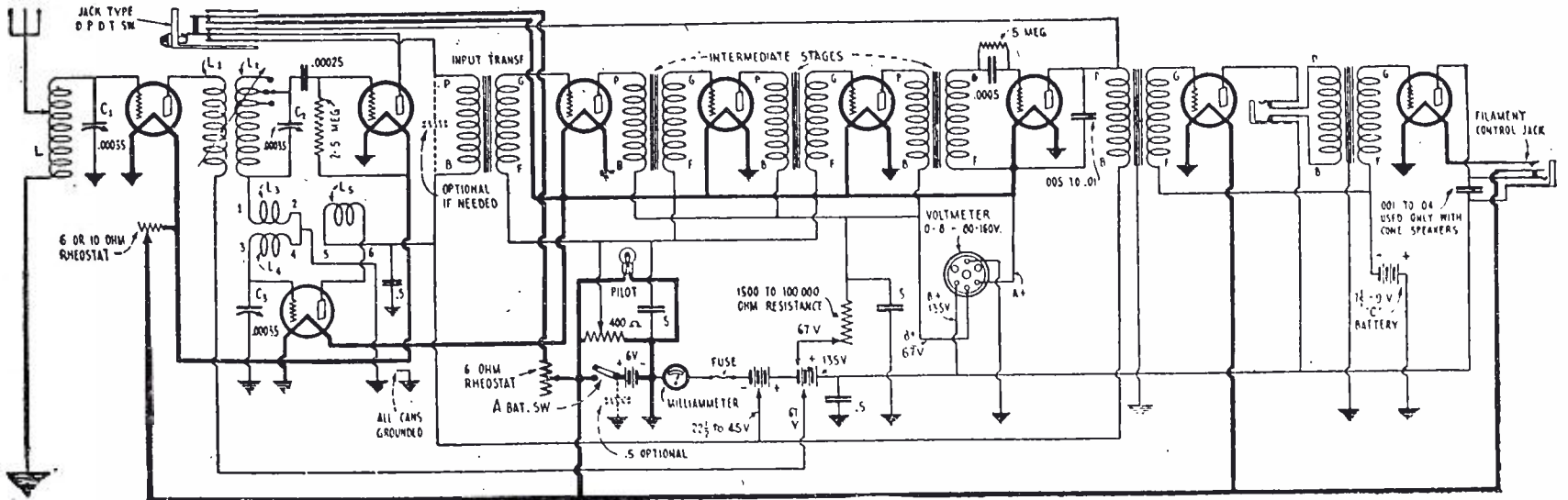
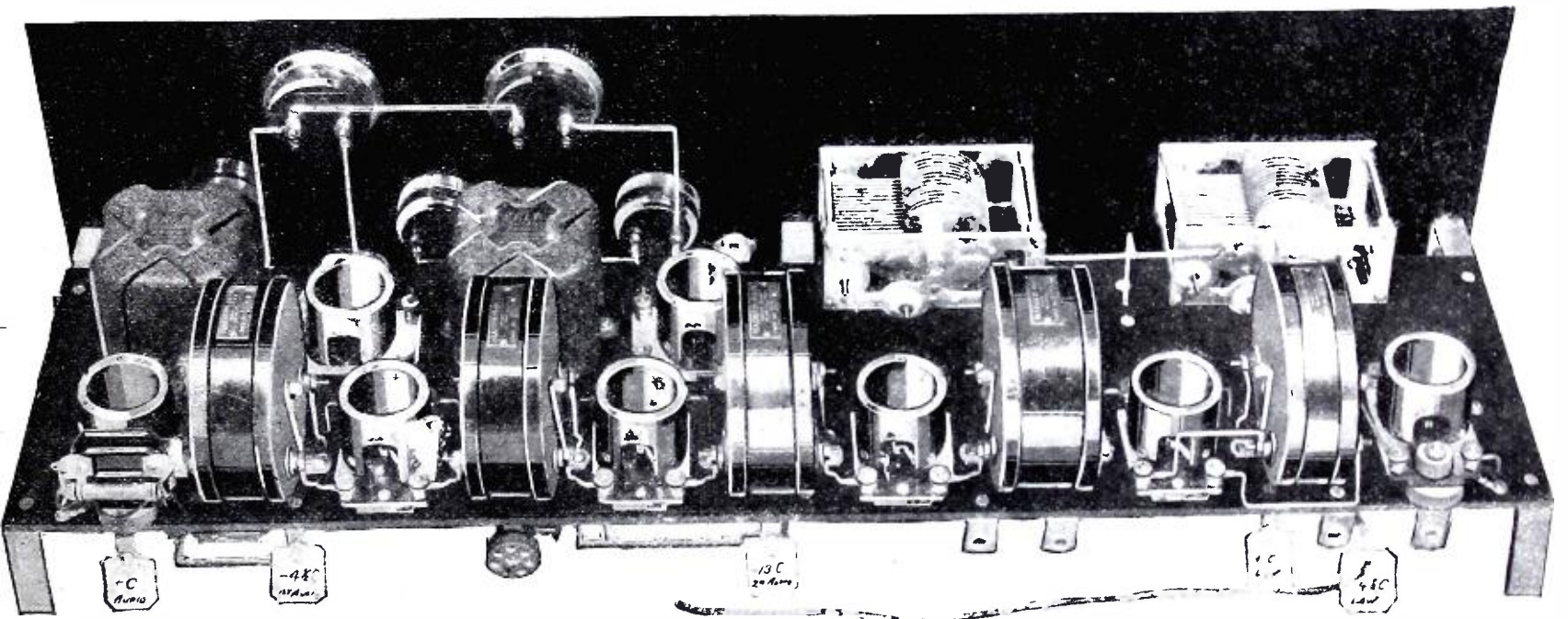

Fig. 3 above shows the Fenway super-heterodyne with a jack-switch for cutting out the intermediate tubes when listening to powerful local stations which gives more efficiency. The oscillation coupler may be a standard one and the antenna coupler as well as the radio frequency coupler, L_1-L_2 , may be standard couplers. The individual stages of this super-heterodyne, according to its originator, Mr. Fenway, are to be shielded in copper boxes, as described fully in radio journals some months ago. This set employs nine tubes with one stage of tuned radio frequency ahead of the first detector.

Leutz, one of the best known super-heterodyne engineers, and whose work I have already referred to, states the case technically and clearly in regard to regeneration on a super-heterodyne. As he puts the case, regeneration is not necessary nor desirable, as it only makes the set more squeamish in handling, and what you gain by regeneration in one part of the set you lose in another, the arguments pro and con in this case being too lengthy for the space at the writer's disposal here.

one of the present circuits shows a method of using regeneration with a loop, the writer does not advocate it. Principally you will finally want, after you have cut your eye-teeth and had some real experience in operating a super-heterodyne or two, fair sharpness of tuning; coupled with the fact that once you log a station you can return to the setting and again locate the station. There are two things which many super-heterodyne enthusiasts do to their disadvantage, i. e., broaden the

has obtained, as well as those of many of his friends, have been obtained with super-heterodynes fitted with a fixed oscillator coupler, i. e., one having the grid and plate coils, as well as the pick-up coils fixed in a stationary position. Some manufacturers have put out these oscillator couplers with one of the windings, either the pick-up coil or perhaps the plate coil, wound on a rotor inside the main winding. This is all right when the rotor is adjusted when the set is first tuned up. If you bring



The photograph above shows the Madison-Moore super-heterodyne, an eight-tube set of extra fine quality. Each of the heterodyners are shielded in nickel-plated metal shields, and if you want to be free from noises and howls, use shock-proof sockets. The two variable condensers for tuning the aerial and oscillator circuits should be of the straight line frequency type. The two audio frequency transformers are extra large concert type, the first stage of audio being all that is necessary for average reception on a loud speaker.

Some enthusiasts would not own a super-heterodyne without regeneration as they have repeatedly told the writer, but my experience with regeneration is decidedly negative. As Mr. Leutz has said, there seems to be no necessity for regeneration in a properly operating

tuning in some cases, or again they throw the logging off, so that they cannot count accurately on bringing in the station on the same setting. The first thing they do is to add regeneration which will invariably throw the logging off on the dials, and the second

a control knob from this rotor out on to the front panel, however, and then start playing around with it while you are "fishing" for a station, you will probably not hear the station for the simple reason that you have changed the inductive values in the circuits and

thrown the logging off. Suppose for instance you have a log of 70 degrees for a certain station on the oscillator dial, and that it comes in within a quarter of a degree for sharpness. If you had tuned this station in a day before for instance, with the oscillator coupler rotor in one position; and the next night you are fishing for this station again and, inadvertently, you have the oscillator rotor in *another* position—the chances are you will not hear the station, unless you happen to have the oscillator dial set on another position and find it by accident.

The writer has tried out the two distinct types of oscillator couplers, i.e., those with and without rotors, and in view of the fact that the R. C. A. and other well-known and superior types of super-heterodynes do not use an oscillator coupler with a rotor, you can rest assured you lose nothing by using a fixed coupler for this part of the circuit. The rotor, if used, should be set once when trying out the set at first.

Those interested in experimenting with super-heterodynes will be pleased to know perhaps that every time you try out a new set of intermediate transformers, you do not have to have a new oscillator coupler. This advice is important for there are a number of concerns who build very good iron or air-core super-het transformers, but who do not supply an oscillator coil. In other words, if you have a good oscillator coupler that you have been using with your super-het, you can leave it in position, and connect the new intermediate transformers in the place of the old ones and try them out.

Some very excellent information on

note in studying over the various super-hets; in the first class come those utilizing a tuned grid coil, while in the other, the oscillator tuning condenser is connected between the grid and the plate coils, as in the Victoreen super-het, diagram of which accompanies this article. (See Fig. 1.)

One thing that should be mentioned is the fact that either resilient shock-

combination one tube oscillator and first detector. The writer prefers the orthodox eight tube set with no reflexing and with no fancy combination oscillator-detectors. If you want to keep out of trouble, stay away from them. Among other troubles that such super-hets frequently manifest are those of causing the station to tune in at more than two points on the oscillator dial.

Leading Types of Super-Heterodynes

The Victoreen super-heterodyne diagram appears at Fig. 1. This is a warm friend of the writers, and he has found it very reliable, simple to operate, and a set that provides practically as much volume as any of those he has tried. This super-het employs eight tubes, arranged in a standard hook-up, the intermediate frequency transformers being of the tuned air core type. The set is sharp and the potentiometer control is very insensitive, which is highly desirable. Fig. 1 shows switches for loop, with or without regeneration.

If you build a set like this and then want to try out iron core or other intermediate transformers, all you have to do is to interchange them in the place of the air-core transformers ordinarily used in this circuit. The same oscillator coil can be left in place as well as the antenna coupler if one is used. The filter coupler is placed before the second detector.

Any standard antenna coupler having an aperiodic primary for instance, can be used to couple antenna and ground to the set when the static is not too severe and you want to reach out for more distance than the loop affords. When using a loop alone, which is the usual method of operating a super-het, you may try a ground connection to one side of the loop, which strengthens the signal, but frequently in summer, brings in objectionable static or ground currents. The negative A side of the circuit is the one to be grounded if a ground is used, and whenever metal shields are used between or enclosing intermediate transformers, they are grounded to the negative A lead also.

In regard to the Victoreen lay-out of super-heterodyne, you will find this a very excellent standard circuit to experiment with, and as aforementioned, you can try out other transformers if you care to, using the same hook-up. Be careful in purchasing grid leaks and condensers to see that you buy those of the best quality. The variable condensers used for the oscillator and loop tuning should of course be of the latest straight line frequency type, in order to separate the short wave stations in better shape. The arm of the potentiometer and one side of the winding should be short-circuited by a by-pass condenser of at least .006, and $\frac{1}{4}$ or $\frac{1}{2}$ M. F. is better. The "B" batteries as well as the "A" batteries are best shunted by by-pass condensers of $\frac{1}{4}$ to 1 M. F.

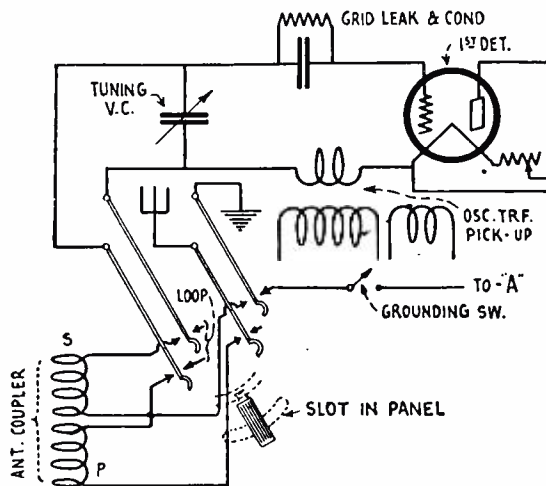

Fig. 5 above shows author's arrangement of Federal anti-capacity switch so that when the single handle is thrown to one side, the antenna and ground are connected to super-heterodyne; while when thrown to the other side, the loop is connected to the set. A separate grounding switch is provided to negative A side of the circuit. In case of excessive noise, the ground circuit can be left open.

proof sockets should be used for all the tubes, or else the sockets should be mounted on a strip of bakelite, which is in turn suspended on rubber bands. This class of receiving set is so sensitive that microphonic noises, such as those coming from the loud speaker may effect the tubes and cause a howl to be set up. This trouble once bothered the writer for quite a time until he mounted all the sockets on a rubber

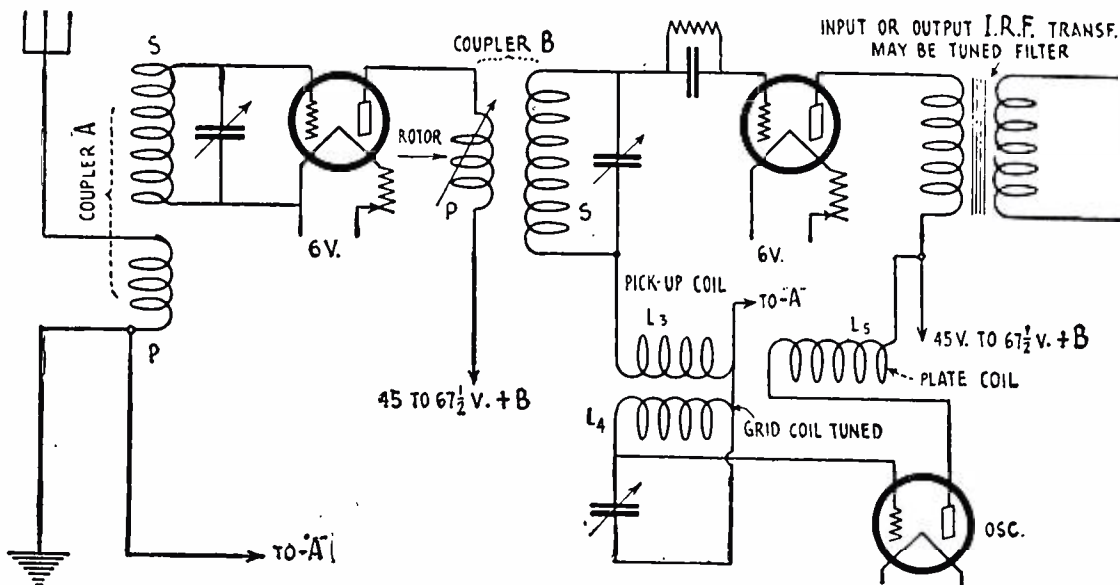

Fig. 4 above shows a close-up of the main feature of the Fenway super-heterodyne illustrated in Fig. 3. As will be seen standard vario-couplers or antenna couplers marked A and B may be used in this super-heterodyne to couple up the tuned radio frequency set ahead of the first detector. The oscillation coupler comprising windings L_3 , L_4 and L_5 , may be any standard super-het oscillation coupler. Ordinarily 45 volts on the plates of all tubes except the audio-frequency stages gives the quietest and most satisfactory results.

super-hets is given in the *Radio News Amateur's Handibook*, as well as in "The Super-Heterodyne—Theory and Construction", and data is also given therein on the windings for the oscillator coupler. There are two principal types of oscillator coil, as you will

suspended bakelite strip. Since then there has been no more trouble of this nature. The leading experts on super-heterodynes, such as Mr. Leutz and others, recommend the orthodox straight eight-in-line set, and do not recommend reflexing or the use of a

The regeneration feature for use with a tapped loop does not require a regular variable midge condenser. This can be set for maximum regeneration at the lower frequencies without oscillation and left in this adjustment. For this reason the X-L variocoupler is used. It has a capacity range of 20 to 100 micro-microfarads, a low dielectric loss gives smooth variation of capacity and stays put at any set value. The same units but with a range of 100 to 500 micro-microfarads are used for the grid condensers. These can be adjusted for the best capacity for the particular tubes used and in this way permit the best operating characteristics of the tubes.

Features of Madison-Moore Super-Het

The accompanying photos and diagram, Fig. 2, show the full construction details of the very latest super-heterodyne which has achieved trans-continental reception this spring in a loop without any ground or aerial whatever. The president of the concern sponsoring this super-heterodyne received Los Angeles on the loud speaker in his New York hotel room on April at 8:00 o'clock in the evening.

Some of the remarkable features of this new super-heterodyne are that there are no body capacity or other inductive effects or pick-up due to the fact that all of the accurately tuned air-core transformers employed are shielded, all of the metal shields being grounded to the negative A terminal of the circuit. One can touch any part of the circuit without causing any capacity effects or change in tuning, while a signal is coming in, contrary to most super-heterodynes. The oscillator is specially designed and connected in an entirely different manner than heretofore, the pick-up coil being placed in the plate circuit of the first detector, as the diagram shows. This helps to eliminate noise and other effects due to placing the pick-up coil in the grid circuit; moreover it eliminates the usual super-het annoyance of tuning in a station on two or more points on the dials of the condensers.

No potentiometer is employed in this super-heterodyne circuit, and no "C" battery is used on the intermediate frequency amplification tubes, as is the case in other previous circuits where a potentiometer was eliminated. A potentiometer may be inserted in the circuit for controlling the grid bias on the intermediate frequency tubes if desired. One source of noise, namely, the grid leak and grid condenser in the first detector circuit is eliminated by the use of the $4\frac{1}{2}$ volt "C" battery connected in series with the loop and grid, as the diagram clearly shows. High resistance rheostats are used on the tubes in order to give accurate and smooth control over a considerable range, the tubes having to burn only at a dim bril-

liancy, thus eliminating another source of noise. The writer has found that it is best to use shock-proof sockets for all tubes, or else to mount the sockets on a piece of bakelite suspended on rubber bands. The metal shields on all the air-core transformers constituting the super-het proper are grounded to negative "A" terminal, except in the case of the No. 5 unit which has a wire running from negative "A" to the lug on the shield. A radio frequency choke coil is placed in series with the primary of the first audio transformer. The iron cores or shells of the transformers are grounded to the negative A as well as the rotary plates of the two main tuning condensers. It is best to place one of the new protective fuses in series with the negative "B" battery line.

stat will cause changes in the frequency, and the signal will fade and the set will not be satisfactory. Cheap bypass condensers are another bad offender, in that they begin to leak perhaps, and the operator never suspects that these are the source of the noise which may be a steady steaming sound.

As one of the diagrams herewith shows, the tuned air core transformers of the shielded type utilized in this set may be placed about three inches apart in a row at the rear of the base, with six of the tube sockets spaced in between them. When using these shielded transformers, there is no danger of picking up noises from house lighting circuits, etc., and unlike other super-heterodynes of the unshielded type, it is impossible to pick up a station un-

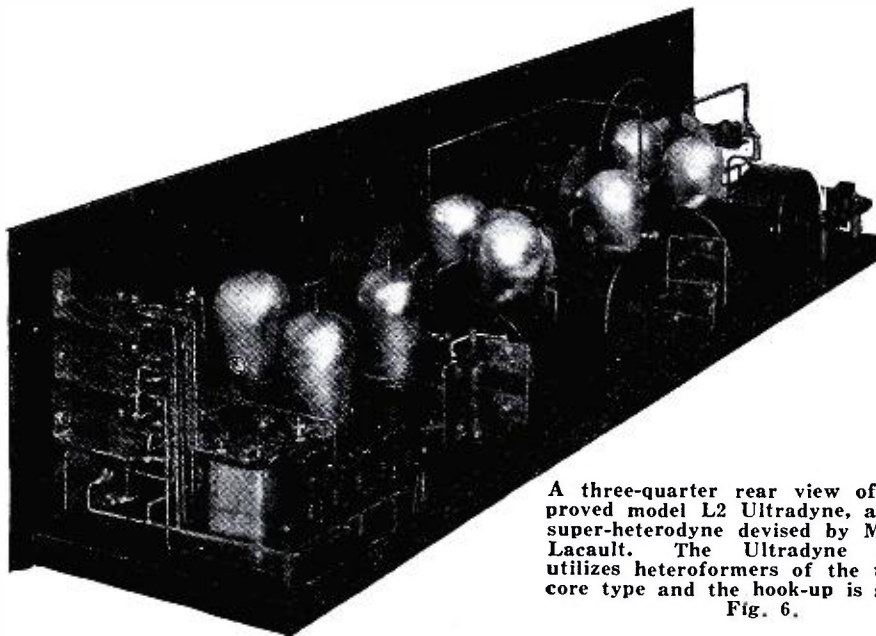

A three-quarter rear view of the improved model L2 Ultradyne, a form of super-heterodyne devised by Mr. R. E. Lacault. The Ultradyne super-het utilizes heteroformers of the tuned air core type and the hook-up is shown in Fig. 6.

If fairly strong signal or voice is desired on the loud speaker, a tube such as a UX-112 can be used with a separate audio stage, using a 9 volt "C" battery, as shown in the diagram, Fig. 2. The $4\frac{1}{2}$ volt "C" battery is sufficient for both audio frequency tubes if UX-201 A tubes are employed throughout. UX-199 three-volt tubes can be used in this super-het, the manufacturers supplying specially designed tuned air core transformers for these tubes. The small 199 type tubes can be used with the transformers supplied for use on the UX 201-A, but not as satisfactory results are obtained as when the proper transformers are used for the type of tube selected, the makers claim. Volume control comprising a graphite compression unit (Bradley-ohm) giving 25,000 to 250,000 ohms range, is connected across the secondary of the first audio frequency transformers. The voltmeter and milliammeter may be dispensed with if the constructor does not care to purchase them. Only the best grade of rheostats and by-pass condensers should be purchased as these are two particular sources of noise, especially in super-heterodynes. The rheostat used to control the oscillator tube should be of the very highest quality, as variations in the resistance due to a faulty rheo-

less the loop is actually connected to the set. When this is not the case, it shows that the various intermediate transformers are doubtlessly picking up radio waves, and it can readily be seen that a set which does this is not likely to tune sharply; also there is liable to be trouble in picking up more than one station at a time, as well as interference from nearby power circuits.

The transformers used in this new super-heterodyne are wound and calibrated with the very highest precision in the radio engineering laboratory connected with the manufacturer's establishment, the secondary of each transformer being shunted by a fixed condenser of the highest quality. Unlike one well-known super-het, the transformer condenser is not varied to tune the transformer in connection with an oscillator and wave meter, but the number of turns on the transformer secondary are changed until the circuit is balanced to a fraction of one per cent accuracy. This lay-out makes one of the best looking super-heterodyne jobs from a radio engineer's point of view that has ever been brought out, and it looks as if the coming season will see a host of friends gained by this newest super-het to enter the field.

Note that the grid return of the sec-

ond detector goes to the filament plus instead of battery plus. Be sure to test all rheostats and all condensers, including the fixed units, to see that they are not short-circuited or open-circuited before you install them. It is important to keep the "A" battery always well charged in operating super-heterodynes and a storage "B" battery or a good "B" battery eliminator will serve very nicely for this set. The wave-length range for this super-heterodyne is 200 to 600 meters, and for those desiring to use a ground instead of a loop an-

coupler "B" may be an ordinary vario-coupler, using the secondary or tickler as the rotor P, the secondary of the coupler being tuned by a suitable size variable condenser, V. The oscillator coupler with the three coils, L-3, L-4, and L-5, may be of any standard form, or else constructed according to Mr. Fenway's specifications, as given in articles referred to. The intermediate transformers may be of any well-known make, Mr. Fenway specifying those of the iron core type. This super-heterodyne requires three tuning

this nature, it is advisable to place a fuse, such as the Gem type, in the negative "B" battery line to prevent blowing out the whole set of tubes in case of a short-circuit in the oscillator condenser, or due to other accidental cross-overs between the circuits at any time. This trouble is not present in the Victoreen super-het in which the negative B and negative A are joined together.

The Model L-2 Ultradyne

Some of the best results ever ob-

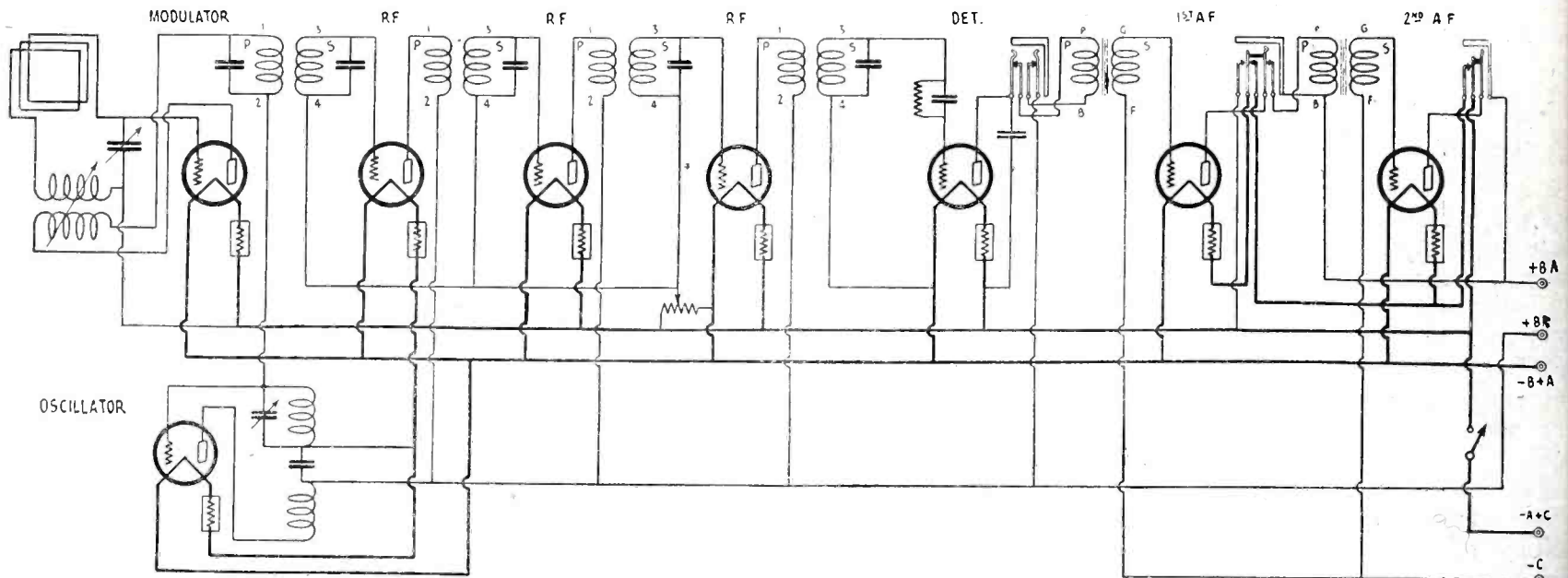

Fig. 6 above shows the hook-up of the Ultradyne super-het. This set is not radically different from the average super-heterodyne and some very fine DX work has been accomplished with this particular set. The heteroformers are of the tuned air core type and the filter is shown at the input side of the circuit. Aerial and ground as well as loop may be used with this set, and instead of super-imposing the oscillator current on the incoming antenna wave, he here causes the antenna wave to modulate the current delivered by the oscillator to the primary coil of the filter transformer. Otherwise the action of this super-het is the same as any other type.

tenna, the manufacturers supply a shielded antenna coupler of an aperiodic primary type.

Fenway Super-Het Features

One of the latest super-heterodynes which comprises simply a few improvements in the general circuit arrangement, coupled with one stage of tuned radio frequency ahead of the first detector, and shielding, to increase the range of reception, is known as the Fenway. The Fenway circuit appears at Fig. 3.

On studying this circuit you will see that you can utilize the features of this super-het if you already own one, by simply adding one stage of tuned radio frequency ahead of the first detector. Mr. Fenway in his super-het shields various parts of the circuit, and those interested in these desirable features should peruse carefully the articles which have appeared in various radio journals.

Referring to Fig. 3, the diagram of the Fenway super-heterodyne, you will note the antenna coupler. This may be any standard coupler with or without a rotor which is not used, the proper size of variable condenser being used to tune the secondary of course.

Next for our consideration comes the radio frequency coupler labeled L-1 and L-2. As diagram Fig. 4 shows, this

controls or variable condensers, and it is the writer's opinion that the same results can be obtained with a nine tube line-up, utilizing an extra stage of intermediate radio frequency (4 stages in all), as pointed out previously.

Miscellaneous

In the diagram Fig. 5, there is shown the connection of a Federal anti-capacity switch for quickly connecting either the loop or else the antenna coupler to a super-heterodyne. The connection to ground is made through a single pole switch mounted on the panel and marked "grounding switch," as indicated in Fig. 5.

Only the best quality of rheostats and potentiometers should be used if the most satisfactory control and noiseless operation is to be obtained of the super-heterodyne. It is important that a very good rheostat is used to control the filament of the oscillator tube, for if the resistance of this rheostat changes while the set is operating due to poor quality mechanical construction, the frequency will change and the signal will periodically weaken. The writer in building super-heterodynes, connects separate rheostats to each tube, excepting the three (or four if used) intermediate frequency tubes, which may be controlled by one rheostat. This gives much better control all around, and for most of the circuits of

tained with super-heterodynes have been accomplished with the circuit arrangement known as the Ultradyne, developed by Mr. R. E. Lacault, well-known radio engineer. The circuit of the improved model L-2 Ultradyne, incorporating regeneration, is illustrated at Fig. 6. A picture showing a rear view of the set complete is also appended.

The long wave intermediate transformers in the L-2 Ultradyne are accurately tuned to a wavelength of 3000 meters, a very desirable wavelength for this class of amplification. Referring to the diagram at Fig. 6, it will be noted that a special form of oscillator, comprising a grid and plate coil L-5 and L-6, are used together with an oscillator tuning condenser C-2, connected across the grid coil. C-3 is a bypass condenser. The first tube which is usually the first detector in the standard super-heterodyne circuit, functions a little differently in the Ultradyne, and is known as a modulator tube. The Ultradyne in its improved form here shown, employs regeneration in the modulator tube circuit by means of the coupler L-3, L-4. L-3 is merely a small inductance connected in series with the loop when plugged into jack J-1, or in series with the secondary L-2 of the antenna coupler, the primary of which appears at L-1. Regeneration is accomplished by inductively coupling

the plate of the modulator tube to the small inductance coil L-4 placed in inductive relation to the coil L-3 of the grid circuit. This trick is identical with the method shown in other super-heterodyne circuits, where the usual three circuit coupler is specified, the tickler being connected in series with the plate of the first detector tube.

This regeneration feature helps to strengthen signals from distant stations, but does not give markedly greater volume on local stations. When tuning the Ultradyne with this regeneration feature, the rotor of the regeneration coupler is placed in the zero position

book, *Volume No. 2*. The advantage of the four coil hook-up for providing regeneration, as shown in Fig. 6 for the Ultradyne however, is that regeneration is still retained when using a loop. The identical results, however, are obtainable with the Victoreen regenerative hook-up shown at Fig. 1 in this article.

With regard to the oscillator, the grid and plate coils, L-5 and L-6, are the same as in any standard oscillator, as shown in all the previous circuits, and the inductance values of which can be obtained from the book just mentioned in the previous paragraph,

problem, for instance Madison-Moore and earlier super-heterodynes, the grid is caused to function properly in this part of the circuit by impressing a negative charge upon it. In the circuit at Fig. 6, this negative charge is that resulting from connection to the negative "A" of the 6 volt storage battery. This action may be augmented by connecting a "C" battery in the circuit, when found desirable.

The second detector, following usual practice, has a grid condenser and grid leak of the usual values, and the two audio frequency stages shown, are provided with filament-control jacks. The

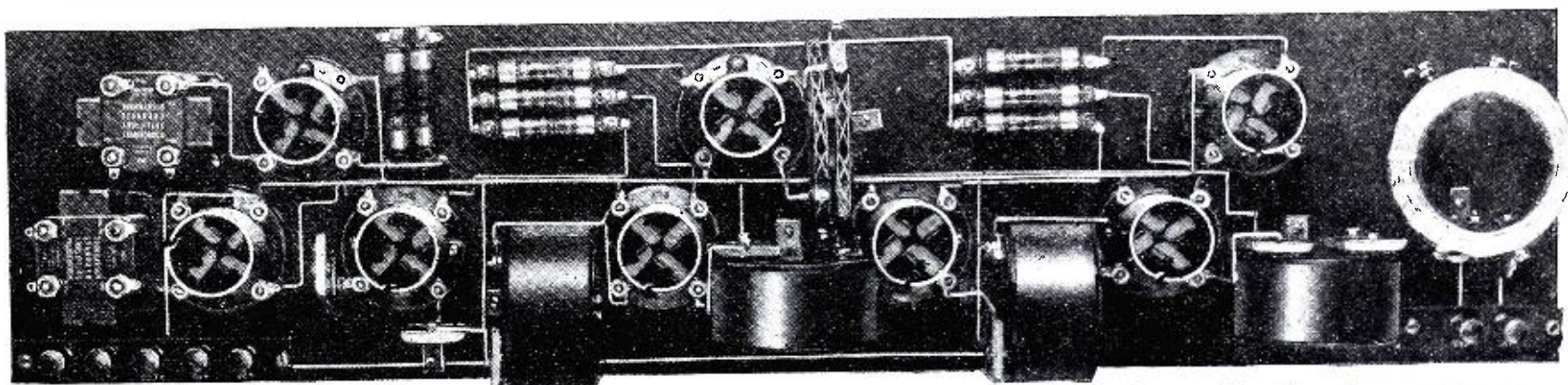
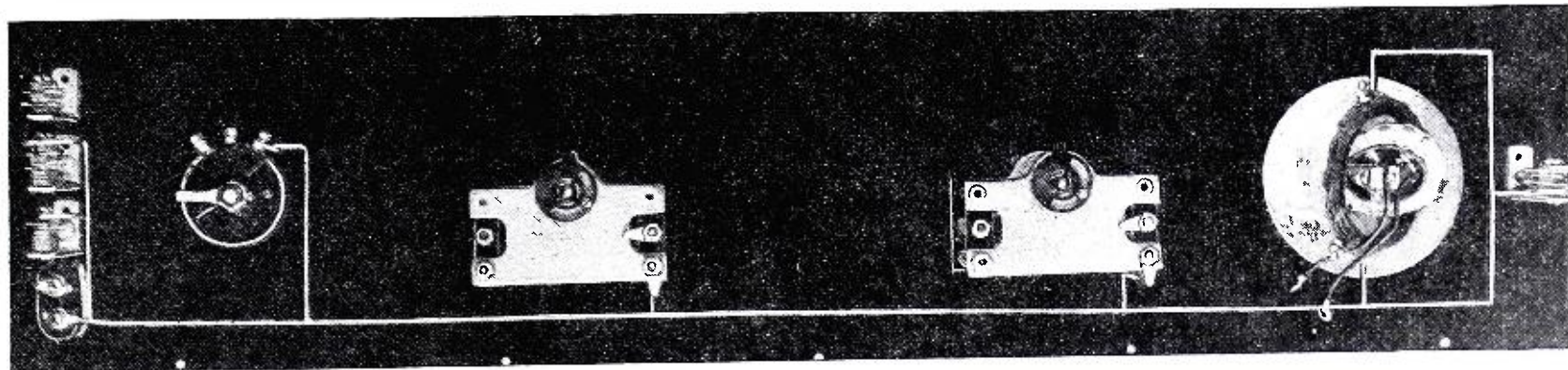

The photographs above show assembly views of the improved Ultradyne super-het. The oscillation coupler as well as the antenna coupler are composed of spider-web type, basket-wound coils. Amperites are used instead of rheostats to regulate the filament current. The two variable condensers for tuning the antenna and oscillator circuits are shown mounted on the rear of the panel at the top part of the picture, as well as potentiometer and jacks for plugging in to detector or either one of the two audio stages.

or at right angles ordinarily. The usual tuning process for all super-heterodynes is followed, such as watching the control of the potentiometer R-2; moving the oscillator control condenser one degree at a time, while the main tuning condenser C-1, is rotated through several degrees, repeating this process until a station is heard. Usually the station will be picked up by noting a hiss as the carrier wave is intercepted by the set, and if after carefully tuning the main condenser dials the station is weak, then the regeneration control is moved until the signal strength builds up.

If you wish to try out this circuit, the best way to do it is to obtain a set of the Ultradyne parts, but failing this, regular standard super-heterodyne transformers of either the iron core or tuned air-core type may be employed. As aforementioned, you can use either the four coils, L-1, L-2, L-3, and L-4, or else you can use a three-circuit coupler, L-4 being represented by the tickler of the coupler, as shown in the super-heterodyne circuit on page 53 of the *Radio News Amateur Handi-*

or in the book by Mr. Webb, also cited in the earlier part of this article; leaving out the pick-up coil of a few turns, which is here dispensed with owing to the manner of impressing the oscillator output on to the plate of the modulator tube. It will be noted that the action of the Ultradyne is based upon the fact that the incoming signal is impressed upon the grid of the so-called modulator tube, the resultant action being that these grid pulsations, corresponding to the incoming voice currents, act like a trigger on the oscillator current flowing in the plate circuit. Owing to this change in the form of the oscillator and first detector tube circuits, and due to the desirable feature, as pointed out by several radio engineers previously, wherein no B battery charge is placed directly on the plate of the modulator tube, it is claimed that much smoother operation is obtained. It will be noted that the first detector or modulator, as Lacault calls it, has no grid leak or grid condenser which is also a good feature (eliminating noise), and in the same way as other engineers have solved the same

tubes are operated without rheostats, using Amperites or their equivalent instead.

If you want to be sure that your super-heterodyne is operating at the highest efficiency, you should have the ultraformers (or other tuned air core transformers) checked with a wave meter to see that they are all accurately tuned. Temperature changes as well as mechanical shocks may alter the adjustment of the condensers or coils and change the tuning, and if this happens, it will cause the super-het to tune in a very erratic and degenerate manner. If one of the ultraformers is not tuned properly, you will find stations coming in at more than two points on the oscillator dial. With such sets as this where the tuned air-core transformers, to which class the ultraformer belongs, are off their calibration as to wavelength, stations have been heard at four or more points on the oscillator dial, and of course this is undesirable and unnecessary, denoting that something is wrong in the circuit or its component apparatus.

Making Your Set More Selective

By SYLVAN HARRIS

THE problem of separating the various broadcasting stations from one another, although not a new one, is a problem that is becoming of more importance day by day. The reason for this is that in spite of all that has been said about the broadcasting

which employs three stages of cascaded radio frequency amplification, and although the selectivity problem has been solved as far as the locals are concerned, there is still considerable heterodyning from the distant stations.

In other words, with this receiver it is possible to "get through the locals" and pull in the distant stations, but in many cases there is no use in trying to do this, as it is found that when receiving a station in one city, that a station in another city whose frequency differs from that of the first stations by 10 kilocycles, will cause heterodyning and the accompanying whistling in the loud-

Chicago, where there are twenty or more stations, that is about all that he can do. If he tries to make it more selective, he will make it correspondingly more difficult to operate, and will spoil the quality of reproduction by cutting off some of the side bands, in the radio frequency amplifier.

The reason for the great interference, which by the way, lies only in certain portions of the broadcasting band of frequencies, is the manner in which the channels have been distributed. Figure 1 illustrates what I mean. In this chart the horizontal axis has been laid off in the bands of 100

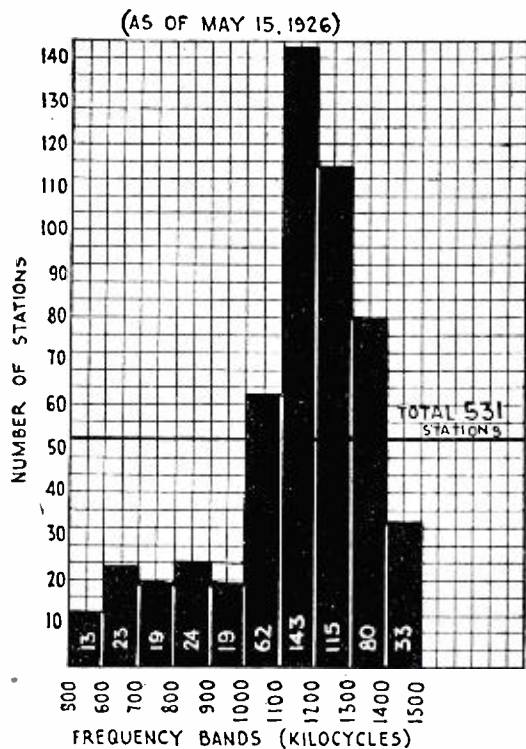

Fig. 1. Showing the various frequency bands of 531 broadcast stations.

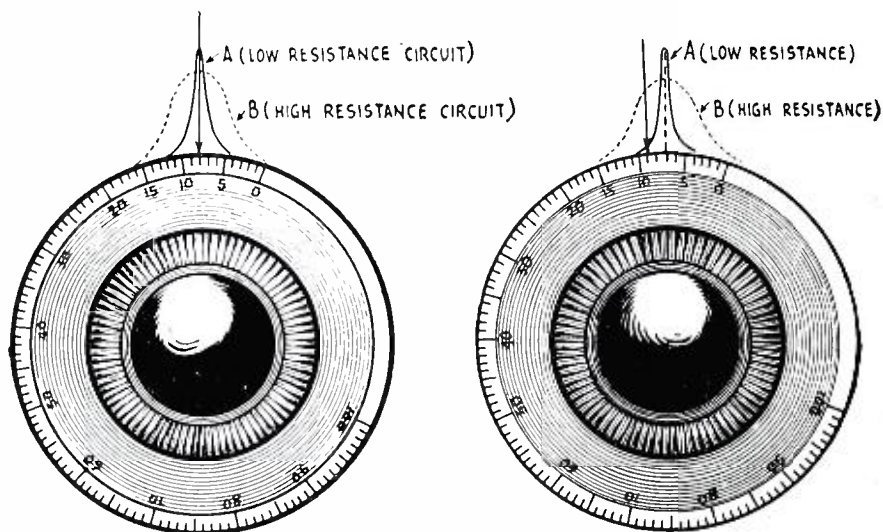

Fig. 3. Illustrating the dial setting tandem condensers controlled with a single dial.

situation, and in spite of all the remedies that have been suggested, the congestion of the ether has been relieved little if at all.

It is possible to make radio receivers as selective as one can desire, even so

speaker. This is not very often the case when receiving the locals, as these are generally so strong as to make the

kilocycles and the number of broadcasting stations lying within each of these 100 kilocycle bands is indicated.

Now according to the way in which we are to understand the wave channels are allotted, the stations are to be separated by a frequency band of 10 kilocycles. This means, that if one channel is assigned to only one station, there would be accommodations for only 10 stations in each frequency band of 100 kilocycles. If, however, we allow six stations to each channel, separating them according to location in the country and also dividing their time, we would have accommodations for 60 stations in each 100 kilocycle band.

In other words, the shaded areas in Figure 1 should be all of the same height. As the matter stands now, this is not what is actually the case. For some reason or other 80 percent of the broadcasting stations are distributed over 50 percent of the broadcasting frequency band.

Of course there are other considerations than the wave-length which must
(Continued on page 174)

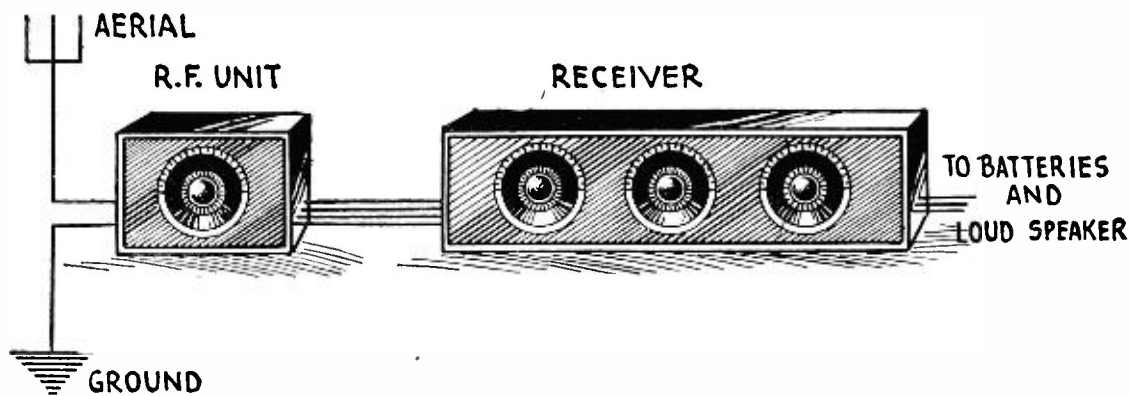

Fig. 2. Illustrating how an auxiliary radio frequency unit is added to a set to increase selectivity.

selective as to cut off the side bands which carry the musical and voice frequencies, which it is the prime function of the receiver to translate into sounds emanating from the loud-speaker, but even this high degree of selectivity does not seem to solve the problem. The writer has been using a very selective receiver at his home for some time,

heterodyne note, so that while a musical or other number is on the air the whistling is not noticeable.

It is seen therefore, that little is to be gained by attempting to make a radio receiver ultra-selective. If it is made sufficiently so to enable the operator to separate the local stations, especially in cities like New York or

How and When to Use Power Tubes

By JOSEPH BERNSLEY, Assoc. I.R.E.

MUCH confusion is noted by the writer amongst radio set constructors, experimenters and the ordinary set user, concerning the application of power tubes, that is, when to use them or how to use them. Many of the readers of this article will undoubtedly recall my status with the *Radio News* magazine, that of "I Want to Know" editor, and thereby associate the reasons for making the above mentioned statement. This particular department has received a considerable number of inquiries concerning the adaption of power tubes, but these show a surprising lack of knowledge of—why power tubes should be used,—when they should be used,—what to really expect of them,—the various types that are now on the market, and how to adapt them.

Without any introductory delay, let us delve right into the subject by starting with "What are power tubes, and why?"

Three or four years ago the radio listener was not quite as enthusiastic about improving the quality of reception from his receiver, as much as that of improving the distance getting possibilities of the set. "My set gets Denver, Colorado and Dallas, Texas, every night," or "I'm going to add a two stage radio frequency amplifier to my set tonight,—watch me get Los Angeles," were some of the familiar expressions that were heard not so very long ago. But radio began to appeal to the music lover, the critic or in other words, brought the "intelligencia" to the realization that here was a novel method of obtaining entertainment,

there," and manufacturers of radio apparatus found that they were up against a new proposition, that of either developing new apparatus and receivers, and satisfying the desires of the radio

resemble the natural tones. This undoubtedly accounts for the boom of low loss instruments a few years back, and the improvement in design of audio frequency transformers and amplifiers,

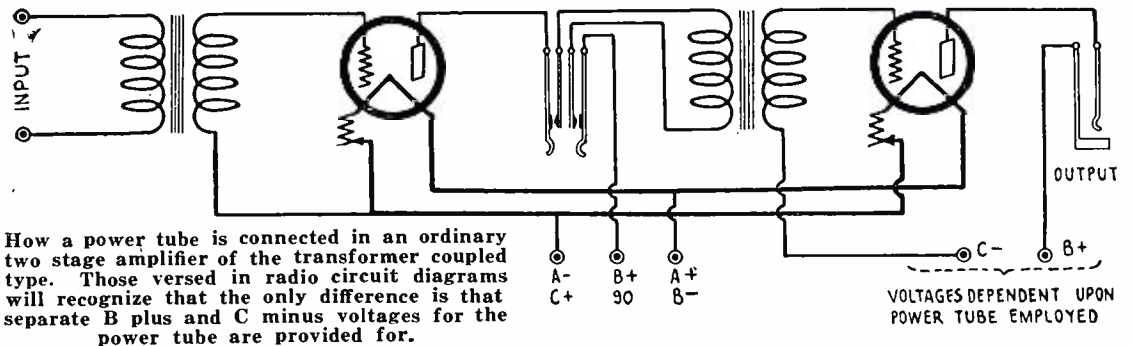

How a power tube is connected in an ordinary two stage amplifier of the transformer coupled type. Those versed in radio circuit diagrams will recognize that the only difference is that separate B plus and C minus voltages for the power tube are provided for.

fascinated public who were increasing in number daily, or allowing the more progressive manufacturer to forge ahead and monopolize the radio market. An analysis of radio receivers as they

—also the adoption of resistance coupled audio amplifiers.

In an analysis of the audio frequency amplifier portion of the receiver, laboratory engineers found that due to the enormous amplification that occurred, the last tube of the amplifier was fed more current than it could satisfactorily take care of. This would result in distortion, tube blocking, audio frequency howls, and poor amplification both as regards volume and clarity, in the last stage. How to correct this was the problem. Push pull audio amplification was one satisfactory means and consisted of practically connecting two tubes in parallel, and thus dividing the load between two tubes. Although this method is very efficient it necessitates special input and output transformers besides an additional tube. The other solution to the problem was in the adaptation of power tubes. We can easily see how a specially designed tube capable of withstanding greater current than the average tube can, would satisfactorily perform its necessary function in the last audio stage. However, the mere placing of a power tube in the last audio socket is not all that is necessary. Radio tubes are somewhat eccentric and a slight change in design would require different plate and grid voltage to enable that tube to operate correctly. Power tubes now on the market require higher plate voltages than the conventional tubes, ranging from 135 volts upwards. The amount of grid bias or C battery ranges from approximately $4\frac{1}{2}$ volts to 45 volts, depending upon the type of power tube that is to be used.

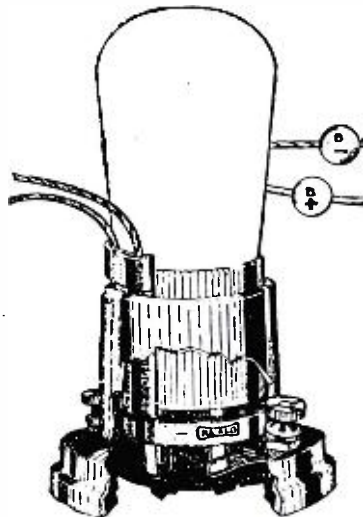

Illustrating a novel means of connecting a UX or CX power tube in the last stage of a receiver, without any internal wiring changes being necessary. The two flexible leads which protrude from the adaptor connect to the additional B plus and C minus voltages desired.

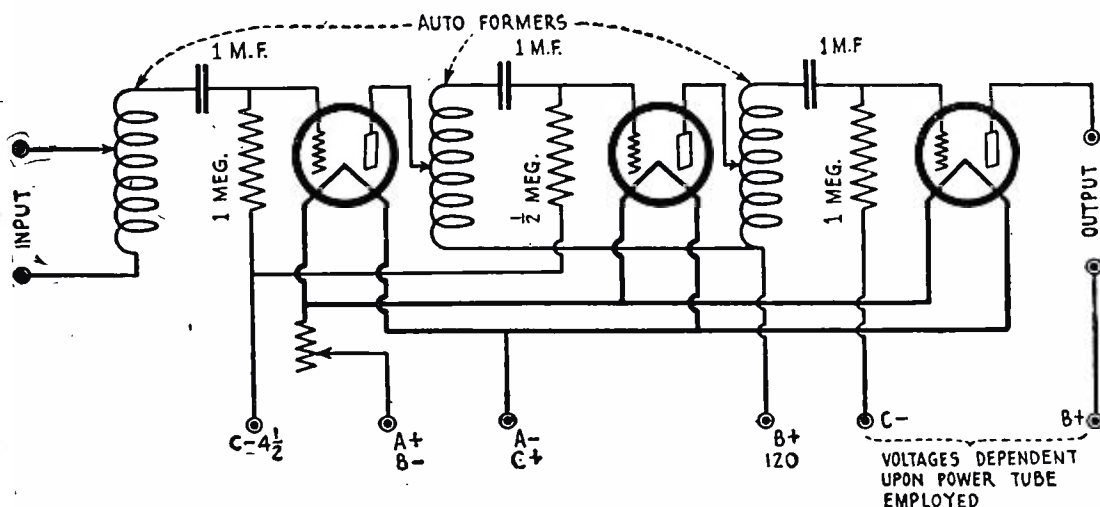

The method of connecting a power tube in an audio amplifier of the "Autoformer" type.

amusement, and an extraordinary chance of hearing their favorite musical selections. But the quality of reproduction was not entirely satisfactory. Flaws were found "here and

were manufactured at that time readily shows that an improvement in the design of various items was necessary to obtain greater efficiency and an improved quality that would more closely

The following is a chart in which all of the power tubes and their characteristics are mentioned, and in which are included the more common types. Reference is made to the function at which each tube performs best.

When to Employ Power Tubes
 Many seem to think that by simply removing the ordinary tubes from the

use of power tubes will only enable the operator to obtain a better quality of reproduction. Whether or not there

and grid voltages are used. This factor can be easily determined by simply consulting the chart below, and noting

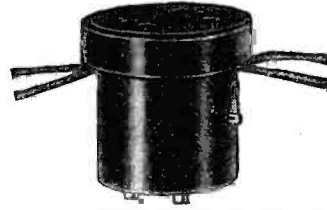
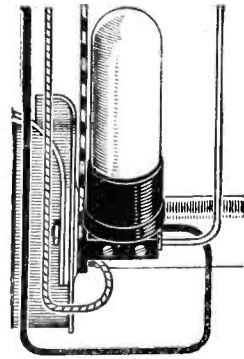
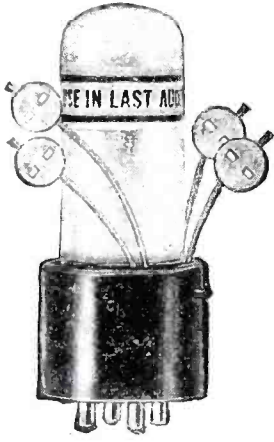

Illustrations by courtesy of Alden Mfg. Co.

Various types of UX and CX and power tube adapters. Either the dry cell or 6-volt type can be adapted to any receiver by means of these devices.

audio amplifier circuit, and replacing them by the power type of tubes an immediate increase in volume, from 50 to 200 per cent, should be noted. This assumption is entirely incorrect. The

will be an increase in volume is dependent upon several factors. First, and most important is whether the power tube is adapted to the audio stage correctly, and whether the proper plate

how much B battery and C battery to employ on each tube.
 Does your receiver slightly distort signals? Do you get much better quality from the first stage, than you do

Chart of Vacuum Tube Characteristics

TYPE	USE	"A" bat. v. (supply)	Fil. terminal volts.	"A" bat. current amp.	"B" bat. Det.	Volts Amplif.	Neg. C bat. volts	Volt. amp. factor	Output res. ohms
UV. UX-199									
C. CX-299	D. or A.	4.5	3	.06	45	90	4.5	6.25	15,000
UV. UX-200									
C. CX-300	D. only	6	5	1.0	16 to 22½				
UX-200-A									
CX-300-A	D. only	6	5	.25	Max. 45				
UV. UX-201-A							4.5	8	12,000
C. CX-201-A	D. or A.	6	5	.25	45	90 to 135	9.0	8	11,000
UX-120	Pow. amp.								
CX-220	(Lst. stg. only)	4.5	3	.125		135	22.5	3.3	6,600
UX-112									
CX-112	D. or A.	6	5	.5	22½ to 45	135	9.0	Var.	Var.
UX-171	Pow. amp.								
CX-371	(Lst. stg. only)	6	5	.5		180	40.5		
UX-210	Pow. amp.								
CX-310	Oscillator	6	6	1.1		90 to 425	4.5 to 35	Var.	Var.
WD-11									
C-11	D. or A.	1.5	1.1	.25	22½	90	4.5	5.6	14,000
WD. WX-12									
WX. CX-12	D. or A.	1.5	1.1	.25	22½	90	4.5	5.6	14,000
3VB-199									
3VBX-199	D. or A.	4.5	3	.06	20	80	4.5	6.0	
3V-A									
3VAX	D. or A.	4.5	3	.12	20	90	4.5	6.5	
5V-A									
5VAX	D. or A.	6	5	.25	20	100	4.5 to 9.0	9.4	9,400
5VC	Pow. amp. or								
5VX	Det.	6	5	.5	22½	90 to 157½	6 to 10.5	8.6	5,900
99									
99X	D. or A.	4.5	3	.06	22½	90 to 150	3 to 12		
01A									
01X	D. or A.	6	5	.25	22½	90 to 150	3 to 12		
Mu-20	A. amp.	6	6	.25		90 to 150	4.5 to 10.5	20	40,000
MU-6	Pow. amp.								
	(Lst. stg. only)	6	6	.5		90 to 150	4.5 to 10.5	6	5,000
B-6	Det. only	6	5	.25	16 to 22½				
A	D. or A.	6	5	.25	20	120	4.5 to 9		
BC	D. or A.	4.5	3	.06	20	80	4.5		
E	Pow. amp.								
	(Lst. stg. only)	4.5	3	.125		135	22.5		
F	Pow. amp.								
	(Lst. stg. only)	6	5	.5		90 to 180	4.5 to 9		
G	Audio amp.	6	5	.25		90 to 180	4.5 to 9		
DC—	D. or A.	4.5	3	.06	45	90	4.5	6.3	16,500
DC—	D. or A.	6	5	.25	45	90	4.5	8.5	10,000
DC—	Pow. amp.								
	(Lst. stg. only)	4.5	3	.125		112 to 135	13 to 22.5	3.3	6,300
	(Lst. stg. only)								
DC—	Pow. amp.	6	5	.5		90 to 157.5	6 to 10.5	8.0	8,500

from the second? Is there a slight howl or whistle which you are sure is not due to run-down B batteries? Then the answer is—employ a power tube in the last stage to remedy the above mentioned defects. Additional B and C battery will of course be required, but the improvement will more than compensate for the additions. We can in each of these cases expect some increase in volume, especially where the old tube was working to full capacity, and was attempting to perform all that was forced on it, but was unable to do so. The Power tube, it must be remembered, was especially designed for the purpose of being capable of receiving and delivering greater current.

In resistance coupled audio amplifiers, a power tube should be employed in the last stage. If the storage battery type of tubes are designed, then the UX-112 or the UX-210 or the UX-171 should be employed. Likewise in the impedance coupled audio amplifier, the abovementioned types can be used in the last stage. In fact, it is advisable that the set user employ these tubes if maximum efficiency is desired. If the dry cell or 199 tubes are employed, then the UX-120 power tube is the type that

tremendous power is generated, it is advisable to place a power tube in the last audio amplifier or socket.

Where extraordinary power amplification is desired, a power amplifier should be designed within which the power transformers and power tubes should be used.

advisable for the average layman to rush and grab a soldering iron and a pair of pliers, after completing this article, and make the wiring changes that he thinks might be necessary and which would help him to successfully use power tubes. A little technical experience is necessary and some understand-

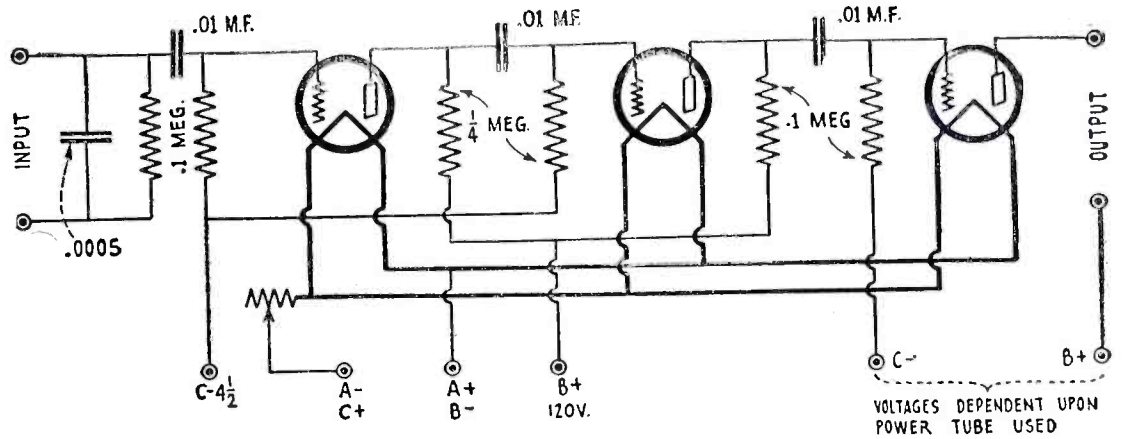

The method of connecting a power tube and providing separate binding posts for additional plate and grid voltages for the tube, in a resistance coupled audio amplifier.

In any case where the quality of the receiver is to be improved upon, or where slightly more volume is desired, the adaptation of power tubes is advisable.

ing of audio amplifier circuits. A very prominent radio manufacturer, realizing the inexperience of the radio public and their dislikes for technicality has placed on the market a complete line

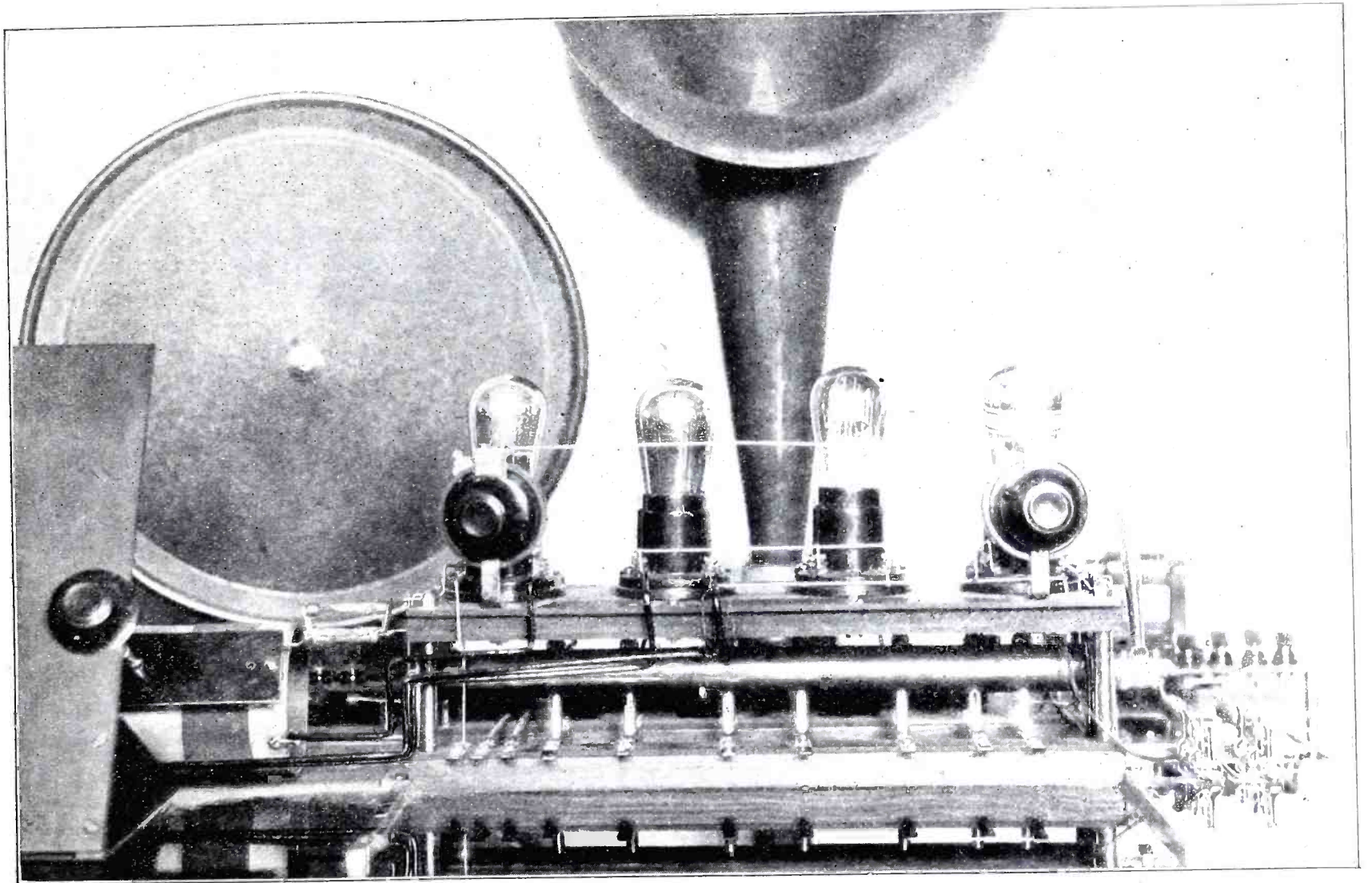

Instruments employed in some very interesting experiments which show the enormous advantage of power tubes in audio amplifiers, (this photograph employs a new type of audio amplifier circuit, recently developed) as compared to ordinary "all purpose" vacuum tubes.

should be used in the power stage. The manner of connecting or adapting these tubes in the abovementioned type of amplifiers is illustrated in Figures 1 and 2.

In five-tube sets or greater, where

Adaptation of Power Tubes

"How can I employ a power tube in my receiver without making any complicated wiring changes within the receiver" is a question often asked our technical department. It would be in-

of what is commonly known as "adaptors." It is in other words, an attachment which is fitted to the socket, and into which the power tube is placed, and permits connecting any power tube
(Continued on page 143)

Developments in Design of Radio Sets

A New Receiver Built for Service as Well
as Efficiency Exemplified

By J. C. TULLY

SOMEONE has said that in the old days, if a traveller missed a stage coach he was content to sit around and wait two or three days for the next, but nowadays the majority of people

each season but would prefer to have "permanent model" receivers. The circuit employed in the receiver shown is the Counterphase, whose efficiency has been thoroughly tested. One of the

operation, the tuning knob and switches are unobtrusive, being set back in a recess and also at an angle which makes for comfort—the open shelf serving as a hand rest if desired. The front of the cabinet is of solid construction and this arrangement seemingly has a universal appeal.

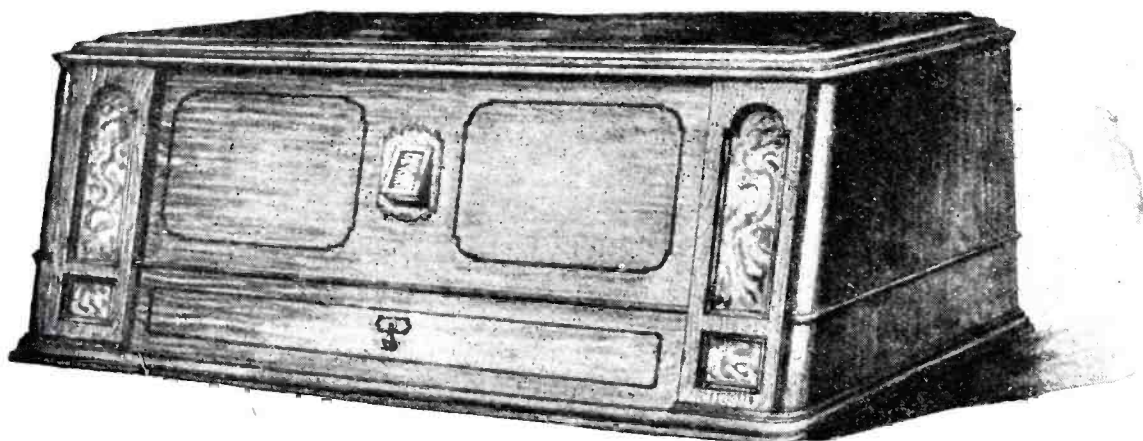

Photos by courtesy of Bremer-Tully Mfg. Co.
This is termed a "permanent model" receiver. It employs the "Counterphase" circuit.

feel that they are imposed upon if they are delayed to the extent of missing one section in a revolving door.

Whether the author of this observation was thinking of the radio fan is not known. Nevertheless, the feeling has existed among large numbers that anything that has been on the market since longer than the day before yesterday is more or less hopelessly out of date. Undoubtedly this feeling has been augmented by certain manufacturers whose necessity for existence, has required that they foist upon the public some new breath-taking innovation of such a revolutionary nature, allegedly, that another round of business is assured; under cover of which the old product, having failed in its purpose can be dumped through the channels which exist for disposing of bargain merchandise.

Happily the public has made fair progress in learning that most of the projected improvements are nothing more than re-arrangements, and it is quite true that many of the succeeding products have been worse rather than better. This has been particularly true where the merit of the circuit, technical knowledge, judgment, etc., is of such small proportions that lowering the price is the main factor in securing business.

The receiver illustrated herewith is the product of a firm which believes that the time has now come when the public will not demand something entirely new each ninety days or even

greatest requirements, particularly in leading centers, is that of selectivity and this receiver gives special emphasis

In the "eight" model there are five tuned stages including the rejector stage which serves its greatest purpose in aiding selectivity. The output stage is arranged for a power tube if desired, and for all ordinary tuning there are but two controls, one of which operates the station indicating tape passing beneath the window. The other one is a volume control. "Oscillation control" is not necessary in this circuit since it has been refined to a point where maximum sensitivity is obtained over the complete range without the use of any variable oscillation control. To counteract the "blooper" evil, the set is so arranged that it cannot be made to radiate, oscillate, or regenerate, nor is it

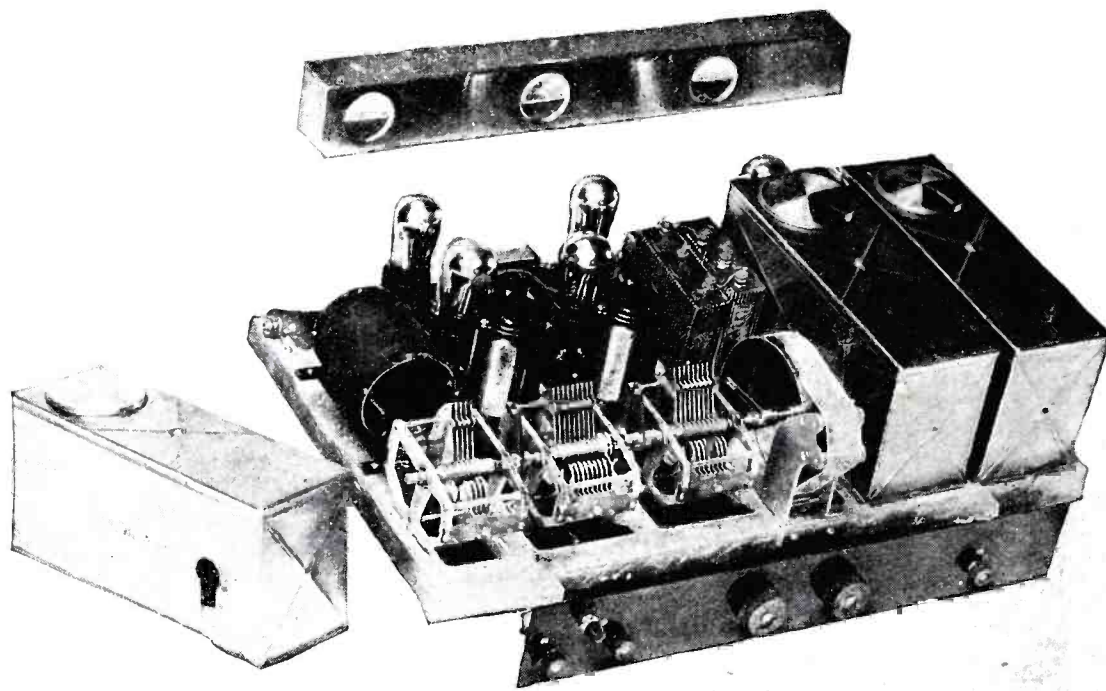

Note the sturdy construction, shielding and simplified control of this receiver.

to that feature. A departure that shows the trend of thought in design is evident in the cabinet, one of the first of the table type to disguise its object. That is to say, with the exception of the station-indicating window, there is nothing to distinguish the cabinet from any other piece of high-grade living room furniture. There are no dials in evidence, and even when the small panel at the lower front is open for

possible to make it whistle or squeal.

Both the "eight" and the "six" models are completely shielded, the chassis being constructed on a framework of cast aluminum, thus insuring correct alignment of all movable parts and a degree of rigidity which prevents parts from being bumped or jarred out of place. This latter feature eliminates one of the greatest contributing causes for repairs and service calls.

New Tendencies In Radio Unit Construction

Localized Control Condenser and Improved Type of Audio Amplifier for the Simplification and Efficiency of Radio Receivers.

By SYLVAN HARRIS

ONE of the outstanding features of the automobile industry is the servicing that is given by manufacturers and dealers to the owners of all styles and kinds of cars. This is made possible by the reason of the fact that the various parts going into the make-up of an automobile are more or less easily removable and replaceable. It is also a well-known fact that a considerable part of the growth of the automobile industry is due to this servicing.

It is doubtful if such extensive servicing will ever be required in radio excepting insofar as the charging and maintenance of batteries is required. Moreover, with the growing popularity of eliminators the need for such servicing is further diminished. On the other hand, however, it must be recognized that whatever is built by human hands or by machines designed by human beings is liable to be faulty and is susceptible of break-down. The design of the parts which enter into the radio receiver in such a manner as to permit of such servicing is not necessarily an admission of inferiority on the part of the manufacturer, but is merely an expedient to take care of such contingencies as arise in our human experience.

As another point on which our present article hinges, we must consider the assembly of the radio receiver. It

such design would simplify materially the assembly of the receiver, and undoubtedly would go far toward increasing its effectiveness.

The illustrations shown in this article bring out clearly what we are driv-

ing at. In figure 1 we have shown a three condenser chassis which can be used in any type of radio frequency amplifier which uses three tuned circuits, such as many of the five tube sets now on the market. The manufacturer of this device has recognized the difficulties attendant in attempting to tune three stages simultaneously by means of a single dial or control, which is generally accomplished by making the individual stages of sufficiently

Fig. 2. This is the Tru-Phonic amplifier, which is designed about a circuit arrangement due to H. P. Donle. The circuit of this amplifier and a full description is contained in an article by Mr. Donle in this issue. Reproduction by amplifier is very faithful and true to life, and is not subject to overloading.

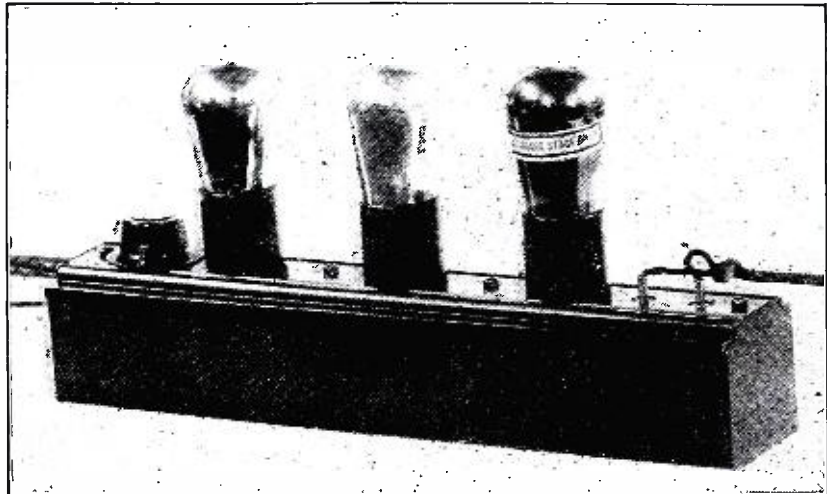

third shaft is on the left of the tuning wheels. Each driving shaft can be turned separately by means of the three tuning wheels on which are placed graduated paper strips to allow for logging.

The condensers and driving mechanism are mounted on a rigid framework to which coils may be attached. These coils may be of any shape or type, and can be fastened to the lugs seen on the back of each condenser, or may be placed in the bottom of the chassis if they are small enough. The arrangement is admirable because of its flexibility. In figure 3 we have an example of how a certain make of shielded coil is placed inside the framework beneath the condensers.

There is also shown in figure 1 a metallic plate which is fastened to the panel where it is cut out to accommodate the tuning wheels. This lends a very pleasing and finished appearance to the job, and also furnishes indices by means of which the dials are read.

In figure 2 we have shown the next unit of the receiver. In the present case it is a three-tube audio frequency amplifier, the original design of which is due to Mr. Harold P. Donle, the well-known radio inventor. This type of amplifier was described in detail in this issue of *Radio Review*. It is notable for its remarkable clearness and fidelity of reproduction.

The particular amplifier illustrated here is designed to accommodate a power tube in its last stage, thereby reducing the possibility of overloading, which is one of the most frequent causes of distortion.

In figure 3 we have shown a completed receiver built up of these units.

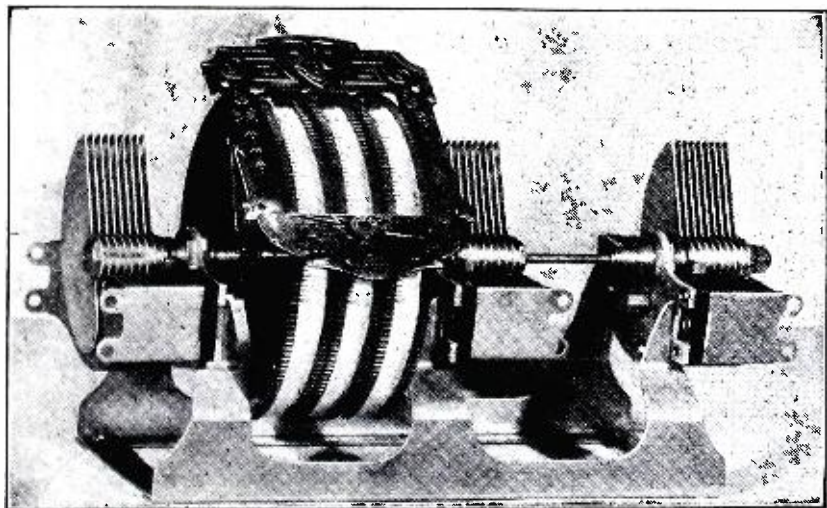

Fig. 1. The arrangement of the condensers on coaxial shafts makes it possible to bring the tuning wheels close together, where they can all be moved at the same time or one at a time. The graduated strip fastened on the peripheries of the wheels furnishes a means of calibrating the receiver in which the outfit is employed, and the metal plate shown adds an attractive appearance to the panel. This plate is fastened over the hole cut in the panel to allow the wheels to come through.

is apparent that a radio receiver consists mainly of three important parts: the tuning elements of the radio frequency amplifier, the tubes associated with this, and the audio frequency amplifier with its associated tubes. There is no reason therefore, why the receiver could not be designed in accordance with this division of parts;

high resistance as to make their tuning broad enough to allow for the inherent lack of uniformity in the construction of the coils and condensers. For this reason the condensers shown in the illustration are each controlled separately; each condenser is controlled by its own driving, one of which passes through another which is hollow. The

The extreme simplicity of assembly is very noticeable, and beside this there is also a very noticeable lack of wiring. The coils are mounted beneath the condenser and the audio amplifier is located in the rear. This particular set uses six tubes, viz., two radio frequency amplifiers, detector, and three audio amplifiers.

connected to the output of the new amplifier and all is "jake." Simply remove the tubes from the audio amplifier of the set and go ahead and operate. In other words, when you have an old set with a poor audio amplifier, simply do not use this amplifier, but buy one of the new ones shown in figure 2, plug it into your

To go back to our opening paragraph, this method of construction seems to have great possibilities. As far as servicing is concerned, we are wondering if it would not be an interesting thing for a manufacturer of units such as these to have service stations located at various parts of the country. Then, like the owner of an automobile, when something goes wrong with the set, say the audio amplifier, he goes to the service station, has the old one removed and a new one installed, all in about ten minutes, and goes away happy. But this is perhaps looking a great distance into the future. It is sufficient for the present to consider the advantages in the way of speed of assembly, reduced possibility of making errors in the connections, the reduced number of joints in the wiring, the great reduction in the wiring itself. These points, and many others, are very important ones—not less important for the manufacturer of radio receivers than for the experimenter or home-set builder.

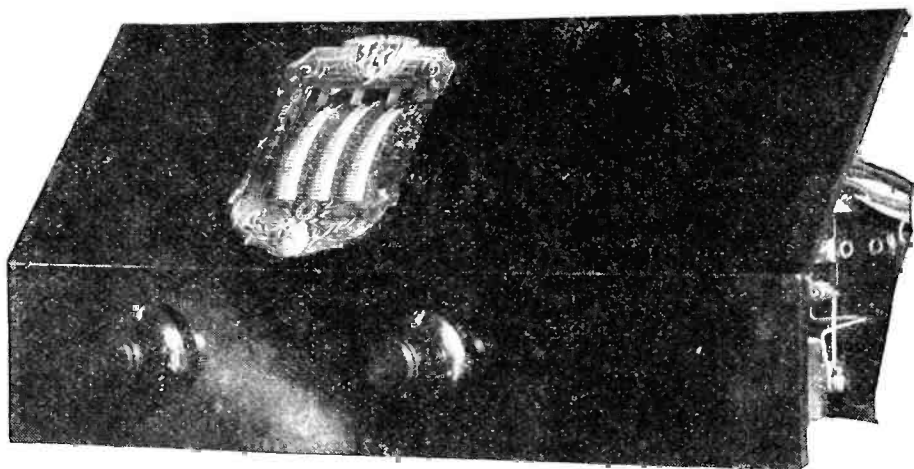

Fig. 4. This is a front view of a receiver, the rear view of which is shown at the bottom of the page. Note the simplicity and pleasing appearance of this receiver. The two knobs shown at the bottom are rheostats.

There is a very interesting feature in connection with the audio amplifier which is shown in figure 2 which makes it possible for anyone who is not satisfied with the quality which he is getting from his old receiver to so improve the quality at little expense and no labor that his friends would fail

detector socket, and enjoy true lifelike reproduction.

In figure 4 is shown the front view of the receiver shown in figure 3. The two lower knobs are rheostat knobs, but these could very easily have been eliminated if filament ballast resistances and a filament switch had been

It is strange that the unit idea in the construction of receivers has not been followed more closely in the past few years. There is much to commend it, as can be seen in the products described here. Such construction not only adds

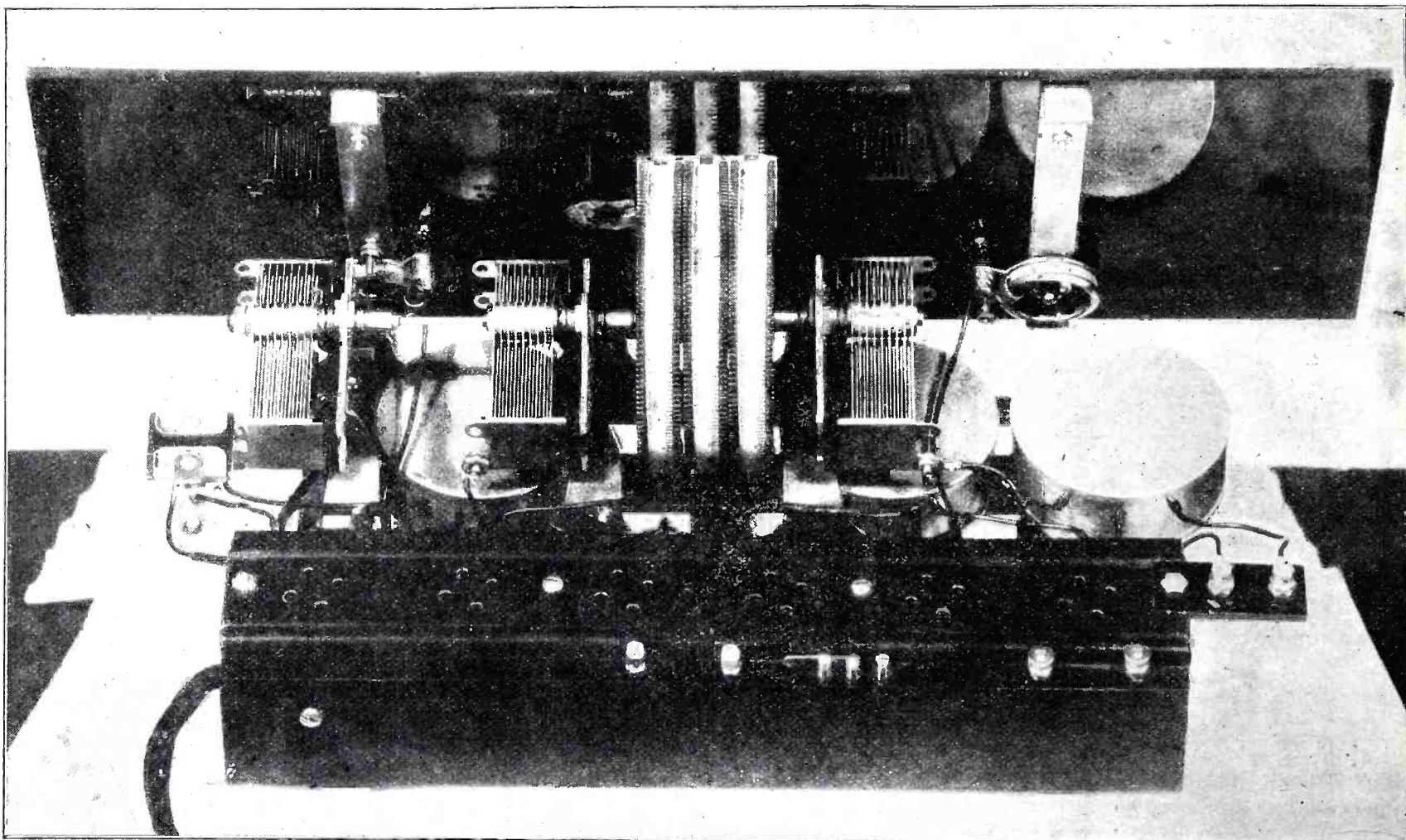

Fig. 3. A rear view of the receiver pictured above. Note the unit arrangement; in the rear of the photograph is the condenser chassis; the shielded coils are located beneath the condensers and are carried by the framework. In the front of the photo is seen the audio amplifier, having accommodations for the three audio amplifier tubes, the detector tube and two radio frequency tubes.

to recognize it. The cable connected to the amplifier of figure 2 is fitted with an adapter which can be plugged into the socket of the detector tube of his receiver. The loud speaker is then

used. The appearance of the receiver is very pleasing and satisfying, and is quite in accordance with its operation, ease of construction and maintenance.

to the appearance of the receiver and simplifies the assembly, but makes room for further improvements in efficiency. Let us hope that there will be more of this style in the future.

Adding a Stage of Radio Frequency to Your Receiver

By JOSEPH H. KRAUS

MANY of our readers regularly write to us asking us how it is possible to make their sets more selective or how they can get greater distances or how they can add a stage of radio-frequency to their present receiving set. Generally, one would have to know the circuit of the receiving set about which the user is inquiring before one could advise exactly how the stage of radio can be added.

Sometime ago this same question was put before the writer and the set in question was a regular neutrodyne receiver. At first hand, one would say just get another coil, a tube, a socket, a condenser and a neutralizing condenser, and go to it. Yet such is not the case at all. It will be found far more difficult to add another stage of tuned radio-frequency to your present neutrodyne than it will to add this to any other form of receiving set. In accordance with the question previously repeated, the writer attempted to build a neutrodyne, employing three stages of tuned R. F. instead of the usual two stages. A panel was carefully drilled and the coils mounted. The tubes were inserted after the entire set had been wired together, and then the trouble started. Such squeals and howls which that set materialized are rarely heard, but they certainly poured forth from this outfit and it was not the Western Electric Loud Speaker which was at fault; it was the set. New attempts were made to effectively neutralize it. First the two stages were neutralized which was accomplished without any difficulty. Then the clips were taken off the primary of the sec-

Over-all neutralization was then attempted, in which one single neutralizing condenser was connected from the two extreme leads and even this proved decidedly unsatisfactory. Then a coil of wire of approximately six turns was

with any of the previous experiments. As a last resort, we decided to solder a lead to the schims and ground that lead, and in this way, after carefully neutralizing again we approached a quiet reproduction. An interesting stunt was

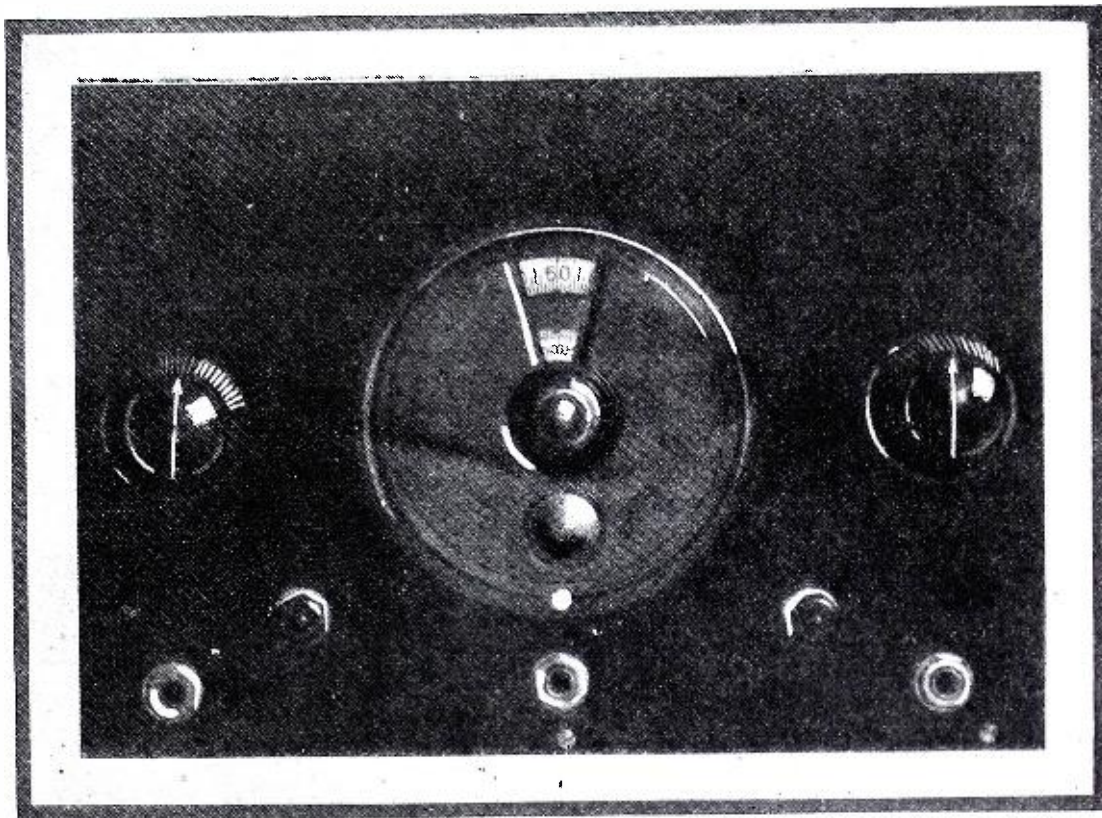

The above photograph shows the front view or panel layout of the stage of tuned radio frequency which may be added to any radio receiving set. The knob in the center at the right is a plate-resistance control and that at the left is a potentiometer. These controls are only regulated once for your receiving set, thereafter remaining fixed.

placed into the top of each transformer; the ends of the wire were bared and short-circuited. It was thought that by this method some of the energy would be absorbed and thus oscillation between the various stages would be pre-

now tried and that was to remove one of the schims while we were listening to a station. When this was done, the volume of the music increased fully 30%. On removing the first tube we could still hear the voice of the station announcer, so we temporarily decided that perhaps the three stages of tuned R.F. were not so good after all. In order to test our decision further, we removed the tube out of the first socket and disconnected the "B" battery lead, and plugged the aerial and ground on the primary of the second coil. What a difference! We now heard music without distortion, and music such as can be produced by only a Western Electric Loud Speaker when it is operating perfectly. But the unusual feature was that the music now was louder than with the three stages. Of course, tuning was not nearly so sharp, but who cares about extremely sharp tuning if the volume is not there to warrant the use of the extra tube? Why burn battery current and consume tubes when you are getting nothing in

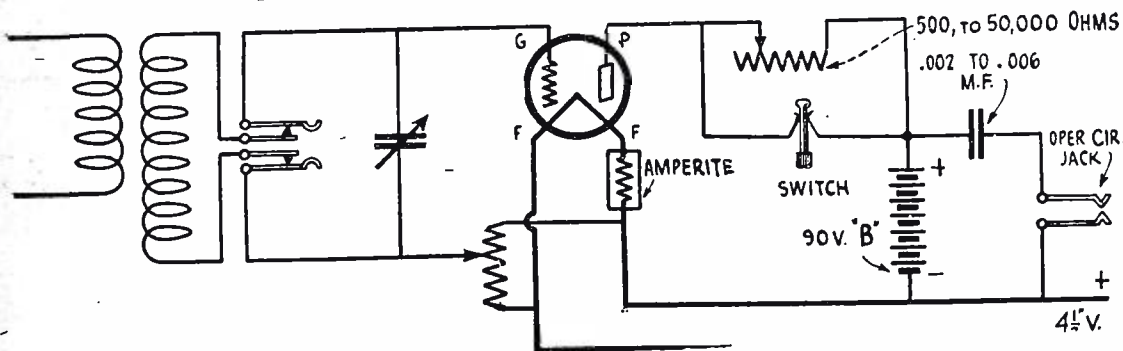

The diagram above shows the circuit which can be employed with any single circuit receiver. Notice that there is a jack provided for the insertion of a loop in case the owner of a set desires to convert it into a loop receiver by the addition of this stage of tuned radio frequency.

ond transformer and attached to the primary of the first transformer, throwing all three coils into the circuit. The writer then neutralized the set until he was blue in the face and the tubes themselves were red hot from their rage at being so abused, but the stunt didn't work.

vented, but this cut down the effectiveness of the receiving set and did not in any way entirely eliminate the noise. Strips of brass schim were then cut to fit the inside of each of the coils, forming the R. F. transformers, and immediately we discovered that the results were as unsatisfactory as they had been

return? Therefore, our experiments took a different turn.

We decided that we would next mount everything on a wood board and experiment with it there instead of trying to monkey with the outfit on the panel. Having a duplicate set of coils at our disposal and having plenty of sockets, it was not necessary to tear down the layout we had already made, and which we were so sure would operate perfectly. The apparatus was then mounted on a board and after

The full efficiency of a neutrodyne thus built is not possible with this arrangement. It is an assured fact that the copper-shielding does minimize noise. At the same time it materially decreases the sensitivity of the set. This set, thus arranged, was not as sensitive as a similar set without shielding, using a potentiometer to control the negative bias on the grids of the R.F. tubes.

The above experiments are interesting not only from an historical point

two prime controls should be sensitive and upon them would depend the sensitivity of the set. With the three stages of tuned R. F. the setting of the first condenser was very critical as was the second and the third, but the condenser controlling the input to the detector was quite broad. This was just the reverse of the usual neutrodyne.

The next step was to build a superhet, but the less said about that particular venture the better. Not only was one super tried but four supers were built. The writer reasoned this way: If one has to burn eight or nine tubes to get stations on a loop which can be obtained with four or five tubes using an outside antennae, and if one does not get better quality, greater distance and greater volume, or more selectivity, why use the extra tubes? So accordingly, the supers were wrapped up and put on a shelf until such time as the spirit again moves to work upon them and remedy their many defects. No doubt a super-heterodyne, when well built, is the best thing there is in radio, but the average amateur, (and probably class myself with him), can not build a super which will work 100% satisfactorily with most of the parts available on the market. If there are such parts, the writer has not yet been apprised of the fact.

The set that was finally decided upon was one stage of tuned R.F. and a detector with regeneration using a stage of audio and a stage of push-pull power. This set was described in a prev-

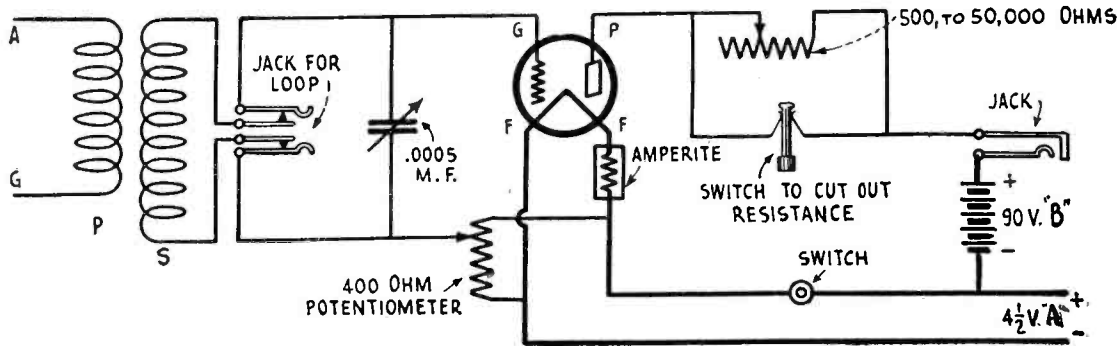

The same circuit as indicated in the previous diagram is illustrated above, except that this particular form is made for the two-circuit receiver. These two diagrams are given so that if the user intends to employ the circuit on a certain type of set he need not go to the expense of purchasing an extra jack and an additional condenser as indicated in the universal outfit which is the subject of this particular article.

the coils were spaced twelve inches apart we found it a relatively easy matter to properly neutralize the set. But the instant that the coils approached closer than eight inches the howlings would commence and they would continue regardless of what was done, except for one thing. After shifting the coils back and forth and forth and back and trying to rearrange them on the board in such a way that they would fit

of view but also from the purely experimental side.

We frequently read of sets that others have built and of remarkable results they have obtained therefrom, and then we attempt to build the set ourselves and run into a series of hopeless tangles from which we find it almost impossible to extricate ourselves.

The neutrodyne when built was difficult to tune and did not come up to the

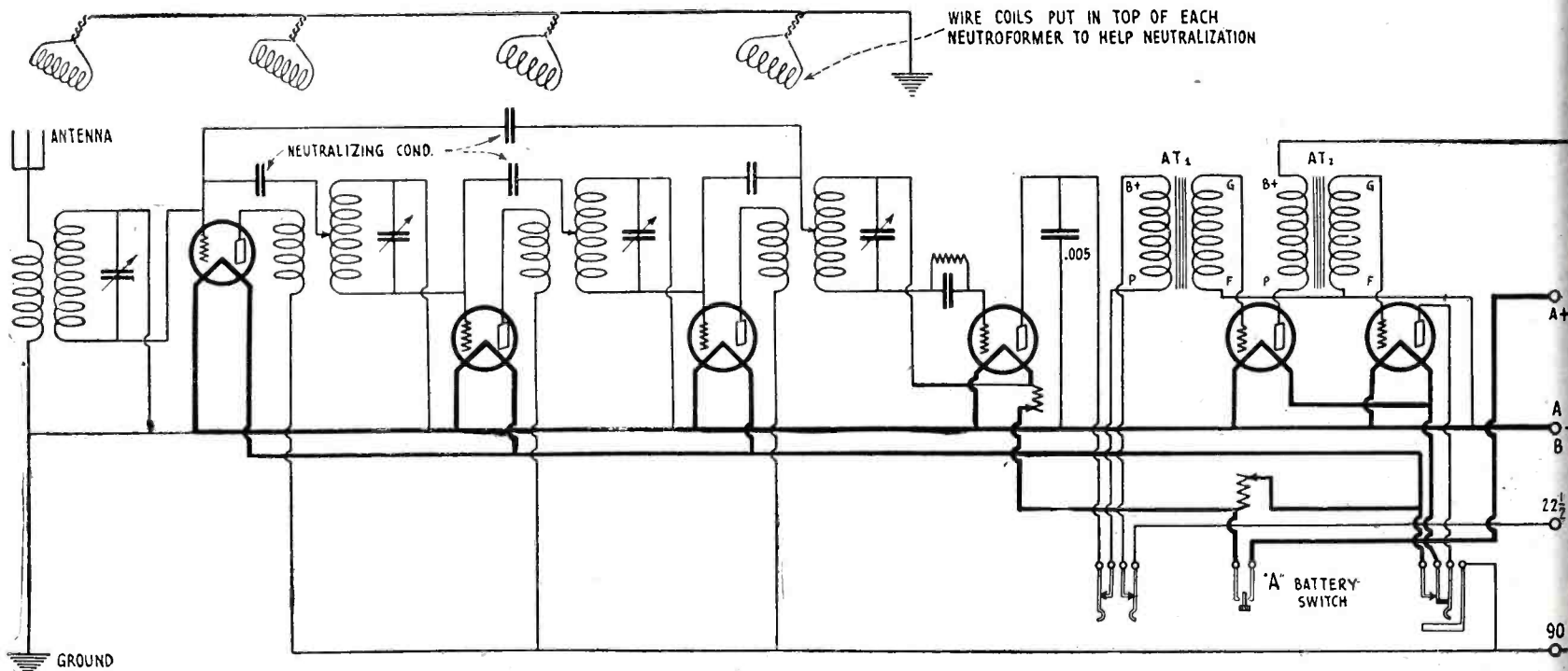

The above diagram shows some of the experiments which were attempted in stabilizing three stages of tuned radio frequency. Notice that the over-all neutralization method was attempted by adding one more neutralizing condenser across the entire group. Also, observe that short-circuited coils of wire are illustrated at the top of the diagram. These coils were placed inside of each neutroformer, then connected together with a wire and the wire was grounded so as to prevent interaction between the coils. The author explains that closely placed coils were unsatisfactory.

the 36" panel we were using, we gave up this attempt.

We finally resorted to the method of shielding, and by this means the set was finally assembled and made to operate. Each individual condenser, transformer and tube was enclosed in its own copper box, the shields being grounded to the negative "A" lead.

writer's idea of the way a good set should handle itself. A human being has only two arms. This is sad but true. Consequently, the greatest number of controls which can possibly be manipulated are two in number. A third control might be added on condition that it did not need very much attention and that it was broad. The

ious issue of this magazine, and judging by the many reports which the writer received, the set is producing splendidly. But all these incidences although they are of benefit to the average radio amateur, are apart from the subject in hand. The question that we started to solve was, "How can we add a stage of tuned R.F. to my r-

iving set?" Therefore, it is necessary for us to design such tuned R.F. outfit that it may be attached to any receiver regardless of the type. Accordingly, in the particular circuit here illustrated, we find quite a few seemingly unnecessary controls. For instance, the Electrad Royalty Resistance 500 to 50,000 ohms or a clarostat placed in the plate circuit of the R.F. tube may at first seem unnecessary. Nevertheless, the reader must remember that this circuit was designed for its being attached to any receiver on the market or any receiver which the amateur may have built. Certain sets tend to break into oscillation very easily, and with not only the plate control but also the potentiometer regulating the negative bias of the grid of the first tube, the maximum efficiency can be obtained, and yet the unit will not cause the set to oscillate. When once this outfit has been regulated, the potentiometer and the plate resistance need no longer be changed. It will be observed that the primary inductance used in this particular outfit is an Aero-coil such as is similarly furnished for tuned R.F. circuits. The Aero-coil has an adjustable primary, which when once regulated, need not be changed. The primary consists of eight turns of rather stiff wire wound over a form and then clamped between two small, bakelite pieces. The coil is 2 1/8" in diameter and about No. 16 double-cotton-covered wire can be used. The secondary measures 3" in diameter and consists of sixty turns of No. 20 double-cotton-covered wire held in a bakelite form in such a manner that the wire is braced by four narrow strips of bakelite. It is not essential that the Aero-coil be used in this circuit, but that is the particular type which was actually employed in this construction. Practically any form of radio frequency coil

to control the grid bias on this tube an Electrad potentiometer was inscribed across the "A" battery, and the movable arm of the potentiometer was connected to the grid return. For filament control of the tube, a 4V-199

tiny metallic filament, the property of which is to heat and increase its resistance in proportion to the current passing through it, and through the tube filament. Thus, when a battery is newly charged, the voltage is higher

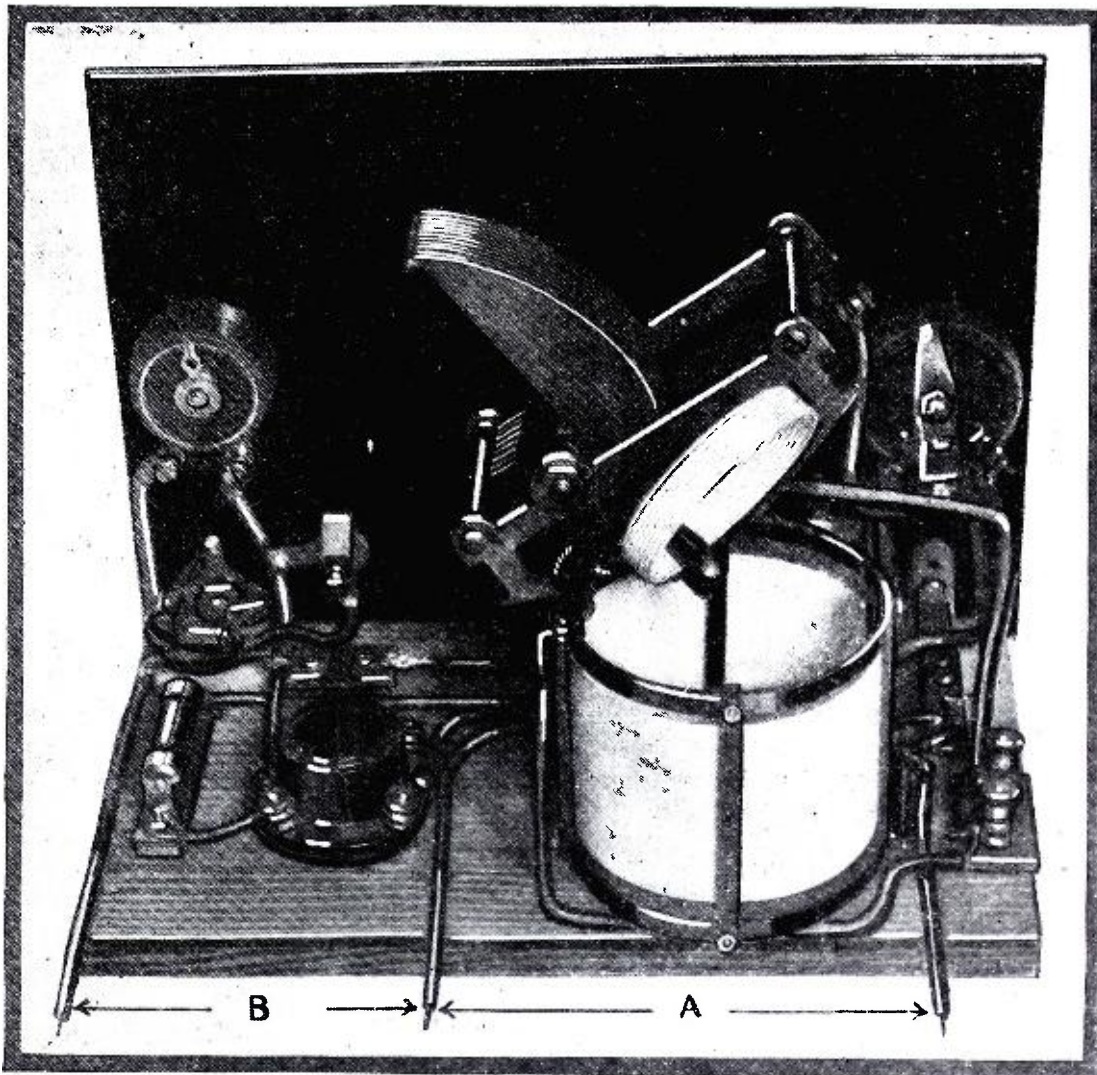

The above photograph shows a back view of the stage of tuned R.F. The primary of the coupler is variable with relation to the secondary and this feature will aid greatly in permitting of critical operation of the first tube. A and B are battery leads which connect directly to the battery in this unit cabinet.

ly any form of radio frequency coil

Amperite automatic or self-regulating rheostat was inserted. The writer has found that Amperites are thoroughly reliable in all types of circuits. As a

and a greater amount of current is passed. This overheats the tube filament and decreases its life. But an

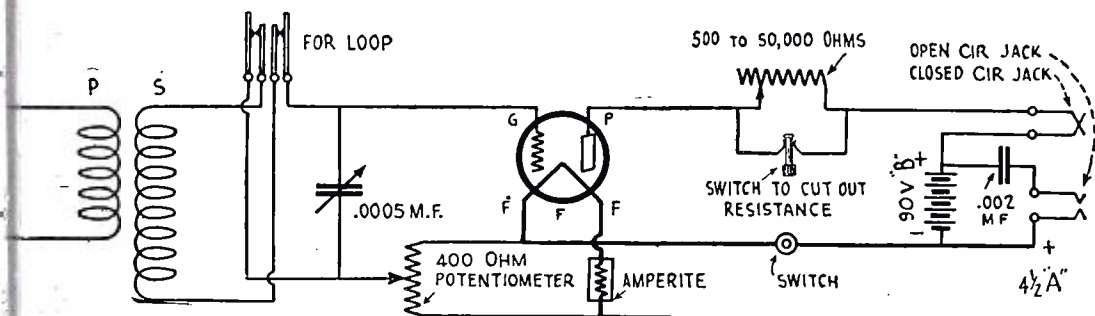

The diagram above illustrates the circuit of the apparatus described in this article. With it very satisfactory results were obtained. The entire stage of tuned radio frequency is self-contained, the A and B batteries being within the cabinet. In this way the device may be instantly attached to any radio set and may be as quickly removed.

ould be substituted, but it is always advisable to use one with an adjustable primary. It will be noted further that there is a jack across the secondary of this coil and between it the condenser. The purpose of this is to allow for the insertion of the loop in event that the set you are now using is a loop set. The primary or the secondary of the R.F. coil is tuned with a .0005 Karas condenser. This condenser is, of course, the straight line frequency type. In order

matter of fact, they are far better than tying up a bunch of tubes on one rheostat, because if the tubes are not exactly balanced one of them will possibly tend to oscillate and another may be working at a very low efficiency and it would be impossible to correct the faults with but one filament control. With the Amperite, one of which is tied in for each tube, the manual control of the tubes is unnecessary, yet it exists automatically. This device consists of a small glass tube, in which we find a

PARTS NEEDED

Parts employed in the construction of this R.F. unit are listed below:

- 1 Aero-coil
- R.F. Coil with movable primary
- 1 .0005 Karas Var. Condenser
- 1 U.V. 199 Tube
- 1 U.V. Naald Socket
- 1 4U. 199 Amperite for filament control
- 1 Electrad Potentiometer
- 2 Electrad Filament Switches
- 1 Electrad Royalty Resistance 500 to 50,000 ohms or Clarostat
- 1 Ever-Ready "B" Battery
- 1 4 1/2 Volt "C" Battery used as a source of "A" supply for the filament
- 1 25 turn Honey-comb Coil from which 13 turns were removed and one condenser .002 mfd.
- 1 Cabinet baseboard and panel 7"x10"
- 1 Piece of Brass Shim for shielding
- 1 Double Circuit Jack
- 1 Closed Circuit Jack (Electrad)
- 1 Open Circuit Jack (Electrad)

Amperite controls this condition and prevents the tube filament from being
(Continued on page 154)

How to Build the Improved Browning-Drake Receiver

New Developments in This Receiver Improve Tone Quality and Make It Economical in Operation

By ARTHUR H. LYNCH

THE work of Messrs. Browning and Drake in the field of radio frequency amplification and reduction of losses in radio frequency circuits, is now well recognized in the radio industry. The highly efficient combination of neutralized tuned radio frequency plus a regenerative detector developed

In designing a receiver for the home builder, this is a matter which must be given serious attention by the author as must also the matter of availability in all parts of the country of the particular units used in making up the model. By employing circuits which are recognized as particularly effective, and in-

of the coils to approximately 7 ohms on a wave-length of 300 meters. The lowest resistance of coils heretofore used for this purpose, has been in the neighborhood of 11 ohms at the same wave-length. When these coils are coupled with particularly low loss condensers, it is obvious that very little improvement over them can be expected in the tuning element of the circuit used. Following the detector of the original Browning-Drake circuit, we have applied an audio frequency amplifier which for general adaptability and particularly fine tone quality, it is very difficult to surpass. This amplifier consists of one stage of transformer coupling and two stages of resistance coupling. The first two tubes of the receiver are of the 199 type as are the first two audio frequency amplifier tubes while the fifth or output tube is of the new type and may very well be either The Radio Corporation's 112 or 171 or a CeCo type "F" power tube. The latter has been found particularly satisfactory by the author. A slight variation in the tubes has resulted in more amplification and a maintenance of the fine tone quality by varying the coupling resistors as will be indicated a little later. The change in the tubes is merely the substituting of the small type high mu tubes made by the CeCo Company in place of the ordinary type 199 in the first two stages of the resistance coupled amplifier. This receiver has been designed for operation from a storage battery of 6 volts rating. In order to reduce the number of controls to an absolute minimum, the first two tubes are connected in series and connected directly across the 6 volt line, each being supplied by a filament voltage of approximately 3. This is also true of the first two audio tubes. The power tube is connected in series with a balancing resistor of the half ampere carrying capacity. Therefore there are no rheostats at use at all and the only controls appearing on the panel are the filament switch, the two tuning dials and the volume control. The dials are spaced far enough on the panel so that when sitting in a chair before the receiver, the position ordinarily taken by the hands will make it possible for the hands to fall directly on the two tuning controls,

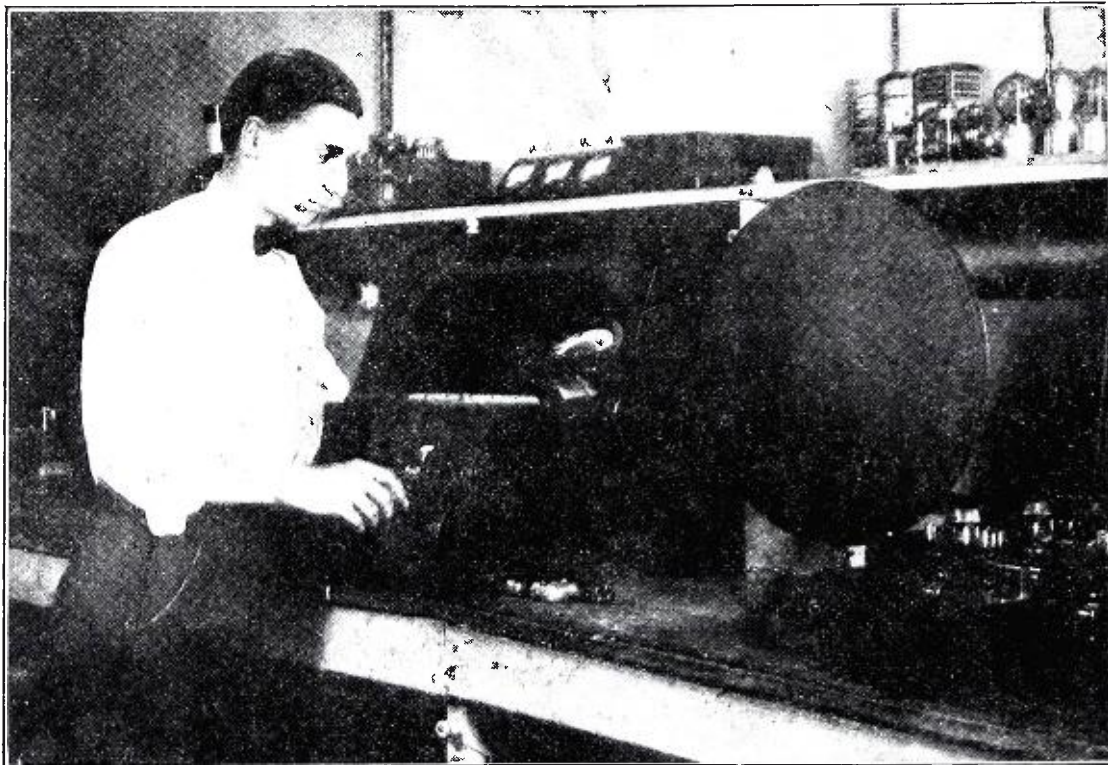

Illustrations by courtesy of Popular Radio (New York)

Checking up on the "B" current consumption of the improved Browning-Drake receiver. The author testing the set in the Popular Radio laboratory.

by these gentlemen some few years ago, is now recognized by most radio authorities as one of the best systems for all-round radio use which has as yet been brought to the attention of the public. In some sections of the country, this receiver is particularly popular and it is rapidly gaining in popularity in many of the other places where it has been practically unknown heretofore.

Many variations of the same idea have appeared from time to time under other names. For instance, a similar arrangement is found in the radio frequency tuning end of several of the most popular receivers employed last year. In the Browning-Drake circuit, all of the guess work has been eliminated; and several years of satisfactory performance in all parts of the world proved conclusively, that it is a receiver which is in the radio field to stay.

corporating in them, units which are known to be of excellent quality, we can design for the home constructor, receivers which it is difficult to duplicate in any other way. Then too, receivers of this character are particularly applicable to experimental work where the experimenter is keenly interested in improving existing types.

What the Improved Browning-Drake Receiver Is

As we have mentioned, this receiver employs the Browning-Drake circuit for its tuning; and since nearly every radio fan is familiar with this tried and true arrangement, little more need be said concerning it. It may be well to point out that because of Browning's most recent work an improvement in the coil design has been effected which reduces the radio frequency resistance

The Receiver Design and the Parts Employed

In the design of this receiver, the author has made it a point to have the completed units not only satisfactory as a laboratory proposition, but also as a piece of furniture. For this reason, a sloping panel has been used and the layout of the individual units employed in the complete design is such that they may be very well assembled on a base board and the entire units dropped right into a standard cabinet of the regular commercial type. In selecting the various units used in this receiver, the author has made an effort to pick out those which would deliver the results expected as well as those which could be purchased without any great difficulty by the home constructor in small towns as well as the home constructor in our large distribution centers. From the list of parts used, it will be seen that equipments of manufacturers whose distribution is good and the quality of their products is also

constructor should be particularly careful to assure himself that the units he is to use are as good in every way as those which have been used in the model.

Because this receiver has been built in a standard sized cabinet, it is possible for the home constructor to procure in addition to this cabinet, a console type of table on which the cabinet may very well be mounted and in which he may house his storage battery, charger, the necessary "B" battery or other plate supply.

Regarding Design

Particular consideration has been given to reducing to or as far as possible, the current consumption, in both the filament and the plate circuit without impairing the tone quality produced by the loud speaker. The current consumption in the filament circuit is well under $\frac{3}{4}$ of one ampere which means that a 60 ampere hour storage battery may be used to operate the receiver over a rather extended period of time.

not recommended for use of this kind. Where plate batteries are used with this tube in connection with this receiver, the heavy duty type batteries should be employed and the experimenter should be certain to have the proper negative bias applied to the last tube in order to reduce the current consumption as far as possible. Ordinarily, the author would not recommend the 171 tube for use with any kind of batteries on the average receiver, because its drain in combination with the drain of the other tube is so great as to make the use of batteries very uneconomical. However with the four small tubes preceding the 171 in this design, the drain is not particularly great and the heavy duty type of "B" batteries will last under ordinary operating conditions for approximately eight or nine months.

The CcC σ type of power tube which has been used by the author with extremely satisfactory results, is about midway between the 112 and the 171.

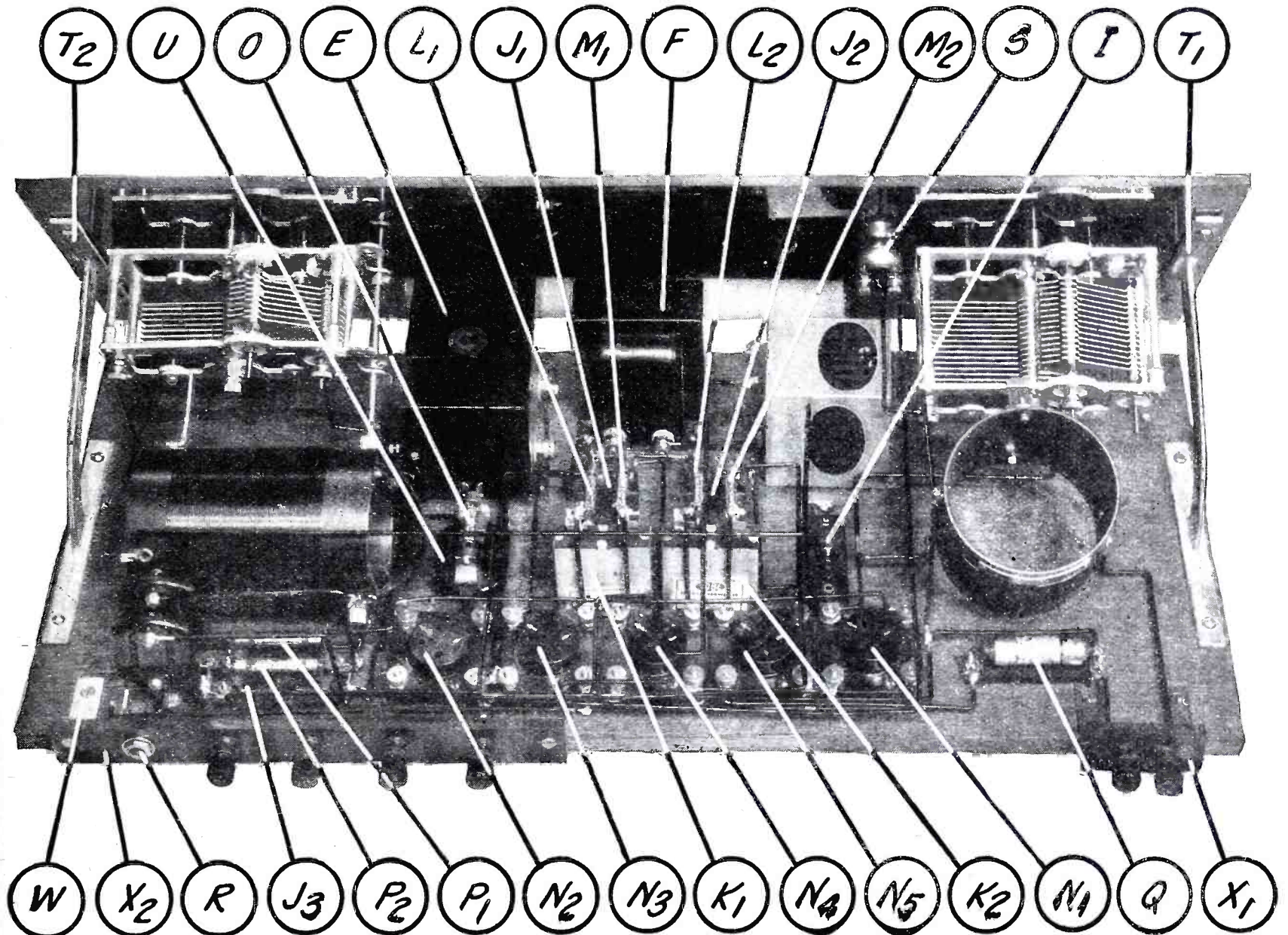

Fig. 1. A view of the receiver from the rear. The general arrangement of practically all the instruments that are fastened to the panel or base. The exact locations for the instruments are shown in the working drawings on the following pages.

well recognized, has been selected. It should be borne in mind that any or all of these units may be substituted by others designed for the same purpose where the units used in the author's model, are not available. Where such substitution is made however, the home

The plate current consumption is also very low and for this reason ordinary type "B" batteries will last approximately one year, except where a power tube of the 171 type is employed. The drain on the battery caused by this tube at 180 volts, is so great that it is

It will withstand rather heavy plate voltages and at the same time not draw too heavily on the "B" batteries. Where 135 volts is used, this tube may very well be employed with the ordinary type "B" batteries. Where 180 volts or more is applied to the plate,

this tube should be used with the heavy duty type of "B" batteries.

Operating from the Light Socket

Where plate current supply devices such as those employing the Raytheon tubes are used, it has been found with

circuit applicable to all conditions, the author has used one stage of transformer coupling, employing of course a transformer of good design. This is followed by two stages of resistance coupling and if any hum is indicated when the A.C. "B" supply is used, it

used in the vicinity of powerful local broadcasting stations, pick up a certain amount of their signals from the leads running through the battery as well as in the curves of the receiver itself. In order to have the sharpest possible tuning, the number of leads

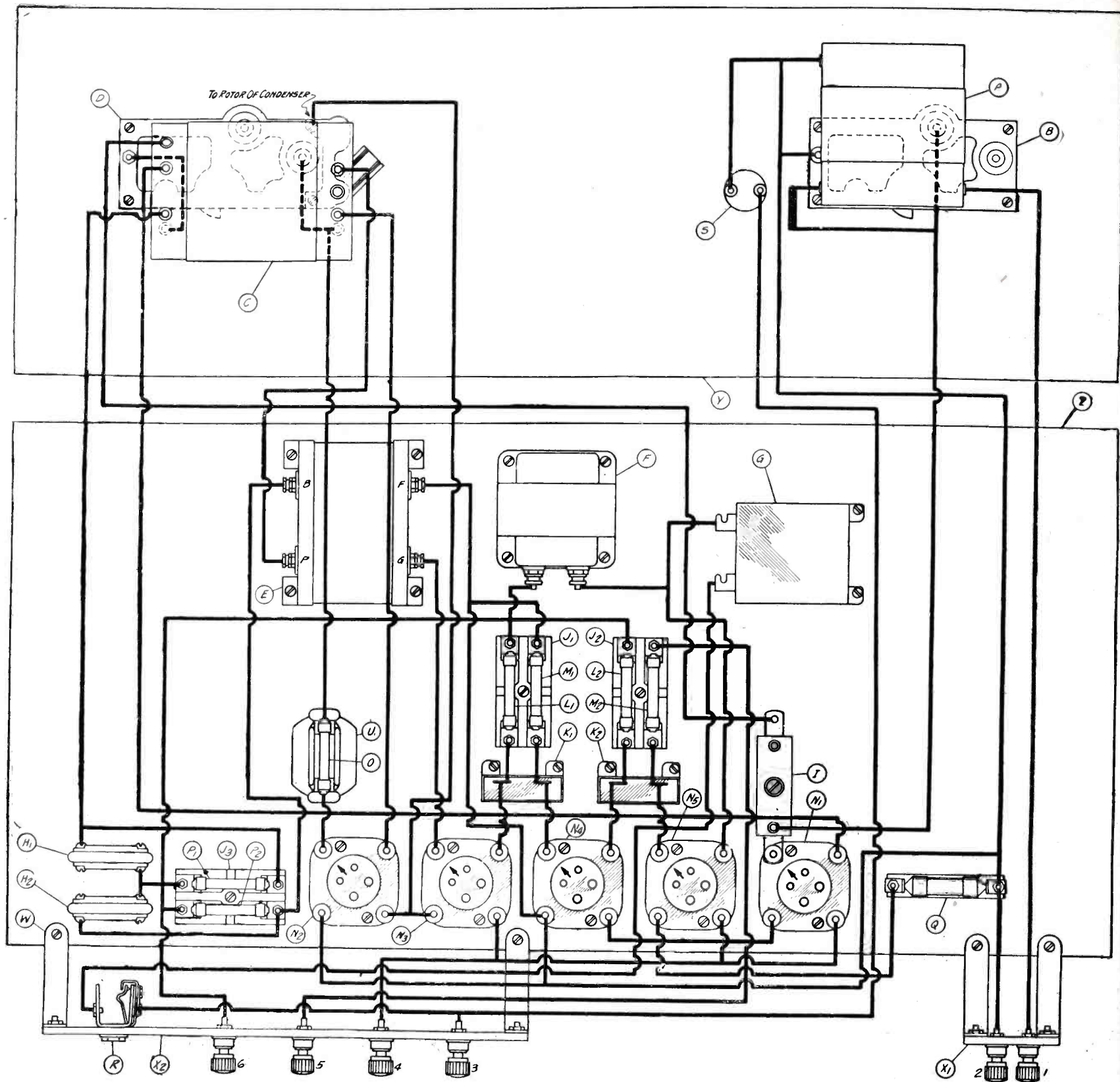

A, B - COIL AND VARIABLE CONDENSER, RESPECTIVELY, OF THE NATIONAL ANTENNA TUNING UNIT;
 C, D - COUPLING COILS AND VARIABLE CONDENSER, RESPECTIVELY, OF THE NATIONAL DETECTOR TUNING UNIT;
 E - JEFFERSON "CONCERT TUNE" SEALED AUDIO-FREQUENCY TRANSFORMER;
 F - THORNDARSON FILTER CHOKES (SAME AS USED FOR "B" ELIMINATOR WORK);
 G - TOBE PAPER FILTER CONDENSER, 4 MFDS.;
 H1 - SANGAMO MICA FIXED CONDENSER, .002 MFD.;
 H2 - SANGAMO MICA FIXED CONDENSER, .006 MFD.;
 I - X-L VARIOCOILER, TYPE N;
 J1, J2, J3 - LYNCH DOUBLE RESISTANCE MOUNTINGS;
 K1, K2 - TOBE PAPER FILTER CONDENSERS, .1 MFD.;
 L1, L2, M2 - LYNCH METALLIZED RESISTORS, .1 MEG.;
 M1 - LYNCH METALLIZED RESISTOR, 5 MEG.;
 N1, N2, N3, N4, N5 - BENJAMIN VIBRATIONLESS SOCKETS FOR UX TUBES;
 O - LYNCH METALLIZED RESISTOR, 6 MEG.;

P1, P2 - LYNCH METALLIZED RESISTORS, .025 MEG. AND .09 MEG., RESPECTIVELY;
 Q - BRACH STAT, CODE 2-B, WITH MOUNTING;
 R - FROST GEN-JAC, NO. 954;
 S - CARTER BATTERY SWITCH;
 T1, T2 - TRIT BRACKETS;
 U - SANGAMO MICA FIXED CONDENSER, .0005 MFD. WITH GRID LEAK CLIPS;
 V - CORBETT SLOPING PANEL CABINET FOR 8 X 22 INCH PANEL;
 W - SMALL BRASS BRACKETS FOR MOUNTING CONNECTION BLOCKS;
 X1 - ANTENNA CONNECTION BLOCK;
 X2 - BATTERY CONNECTION BLOCK;
 Y - DECORATED BAKELITE PANEL, 8 X 22 INS. (DIAMOND STATE FIBRE CO.);
 Z - HARDWOOD BASE BOARD, 9 1/4 X 21 3/4 INCHES;
 6 EBY BINDING POSTS.

Fig. 2. A picture wiring diagram of the Improved Browning-Drake Receiver. All instruments are clearly indicated by letters given above.

the ordinary resistance coupled amplifier, that a certain amount of difficulty is experienced. This difficulty is certainly eliminated in this receiver because of the design of the audio frequency circuit. In order to make this

may be entirely cut out by changing the values of the grid leak resistors in the audio frequency coupling circuit.

Reducing Parasytic Coupling

It is very well known that receivers

running to the battery should be reduced as far as possible in length and should be reduced as far as practicable in number. In the receiver under discussion, the plate supply for the radio frequency tube as well as the detector

be provided from the high voltage side of the "B" battery or the current supply device as the case may be and the proper voltage is obtained by using a fixed resistor in series with the power voltage supply. In order to prevent any bad effects from the introduction of this resistance in the circuit, it is

part of the circuit serves this purpose very nicely. In the power tube plate circuit, it is desired to have as great a voltage as the batteries will deliver and for this reason a low resistance choke coil is used in series with the plate supply. Around this choke coil, the loud speaker and a four to six micro-

How to Construct the Set

The following is a direct quotation from the present author's article from the August, 1926 number of *Popular Radio*.

"After all of the instruments and materials for building the set have been procured, the panel (shown in Figures

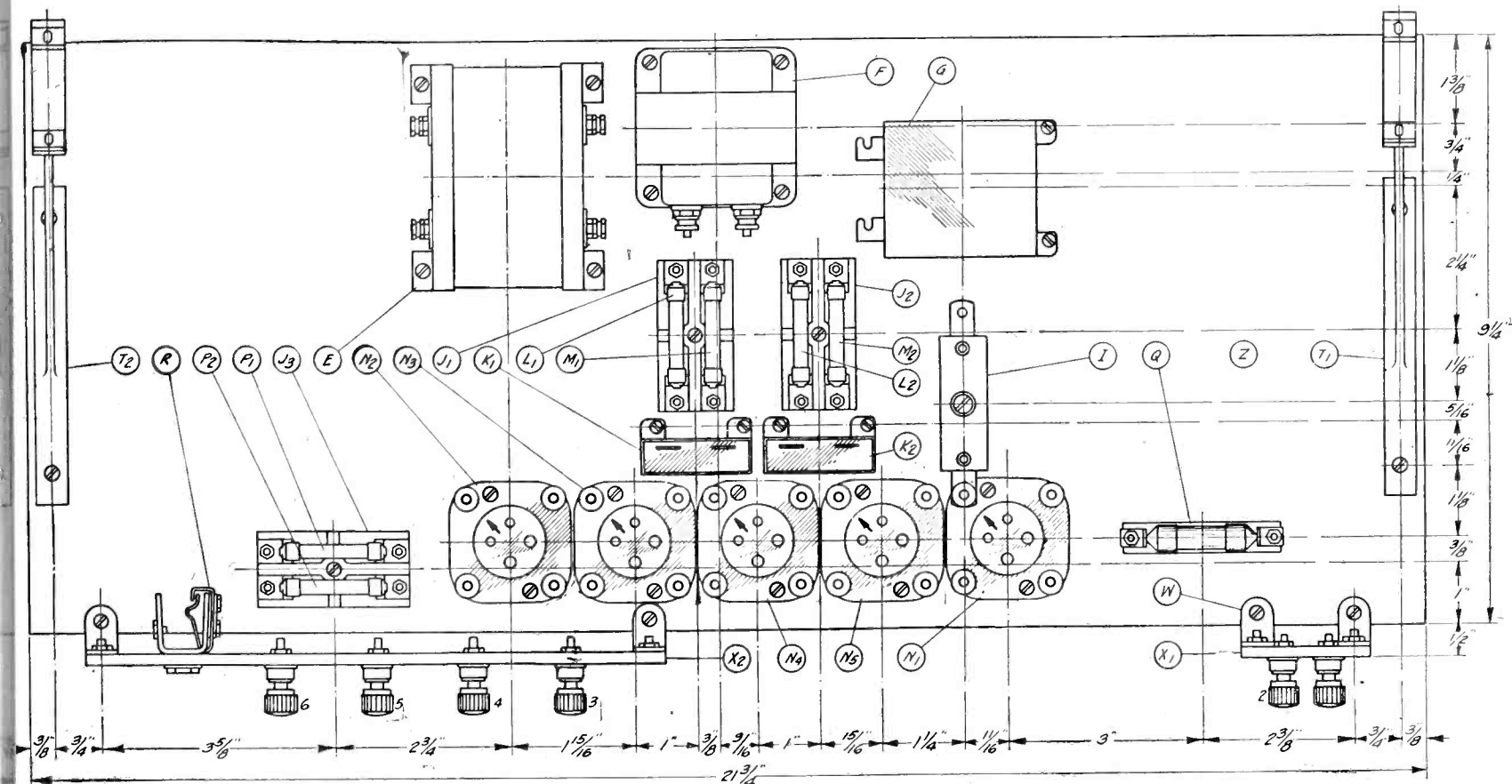

Fig. 3. Constructional details of the base is shown in this diagram with all center to center dimensions.

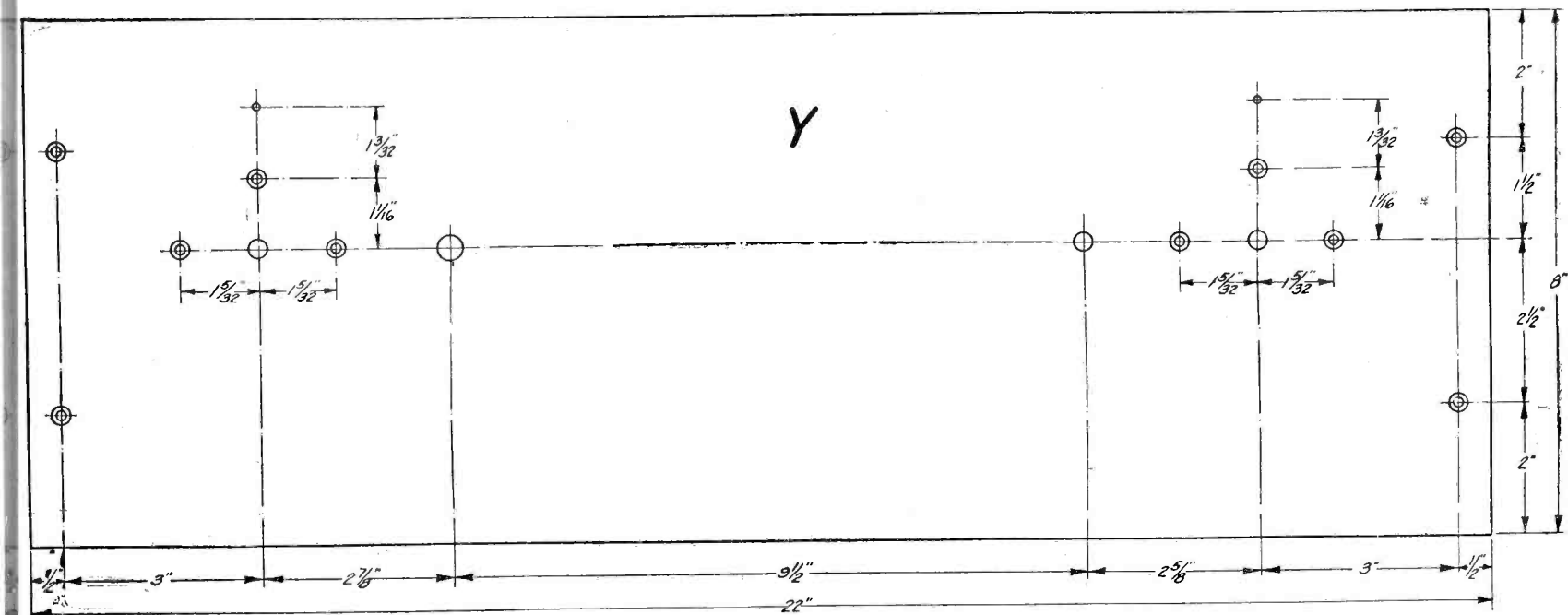

Fig. 4. The exact positions for the holes that must be drilled in order to mount the panel itself and also to mount the instruments on the panel. The holes outlined with a double circle should be countersunk.

sheltered by a very good sized condenser. In most of the experiments carried on by the author, this condenser has been of one microfarad capacity, which has been found very satisfactory. A table of resistance values for given plate voltages in order to obtain satisfactory plate voltages on the plate of the radio frequency and the detector tube, is given a little later on. Since this plate voltage is ordinarily taken care of in the first two audio frequency amplifier tubes, no need for such resistors is necessary, in fact the coupling resistors used in the resistance coupled

farad condenser are centered. This choke serves the double purpose of reducing the resistance between the battery and the plate of the tube as well as keeping the direct current high voltage out of the loud speaker winding. This latter effect is particularly desirable where the new power tubes are employed because when they are used, the current which would ordinarily flow through the loud speaker windings, is too great, the windings sometimes become overheated and in many instances they have been known to burn out.

1, 2 and 4) should be prepared.

First of all, cut the panel to the correct size, 8 by 22 inches. Then, square up the edges smoothly with a file.

The centers for boring the holes, which are used in mounting the instruments, should then be laid out on the panel, as shown in Figure 4. A convenient method is to lay out all center holes on a piece of paper the same size as the panel and then to fasten the piece of paper on the panel and to mark the centers directly on it by punching through the paper with a sharp pointed instrument.

If all of the holes are started first with a small drill, one-sixteenth of an inch in diameter or less, they may be more nearly centered.

The holes that are outlined with a double circle, in the diagram, should be countersunk so that the flat-head machine screws that are used for fastening the instruments may be flush with the

If a "tailor-made" drilled and engraved panel is bought this work will be unnecessary, as the drilling and finishing have already been done by the manufacturer of the panel.

After the panel has been prepared the experimenter is ready to mount the instruments upon it.

First of all, mount the tuning unit

easy to mount the instruments in their proper positions).

Begin by mounting the five vacuum-tube sockets, N1, N2, N3, N4, and N5, care being taken to place them with the arrows pointing in the proper direction, as shown in Figure 3.

Fasten to the baseboard, Z, the transformer, E, by means of four wood

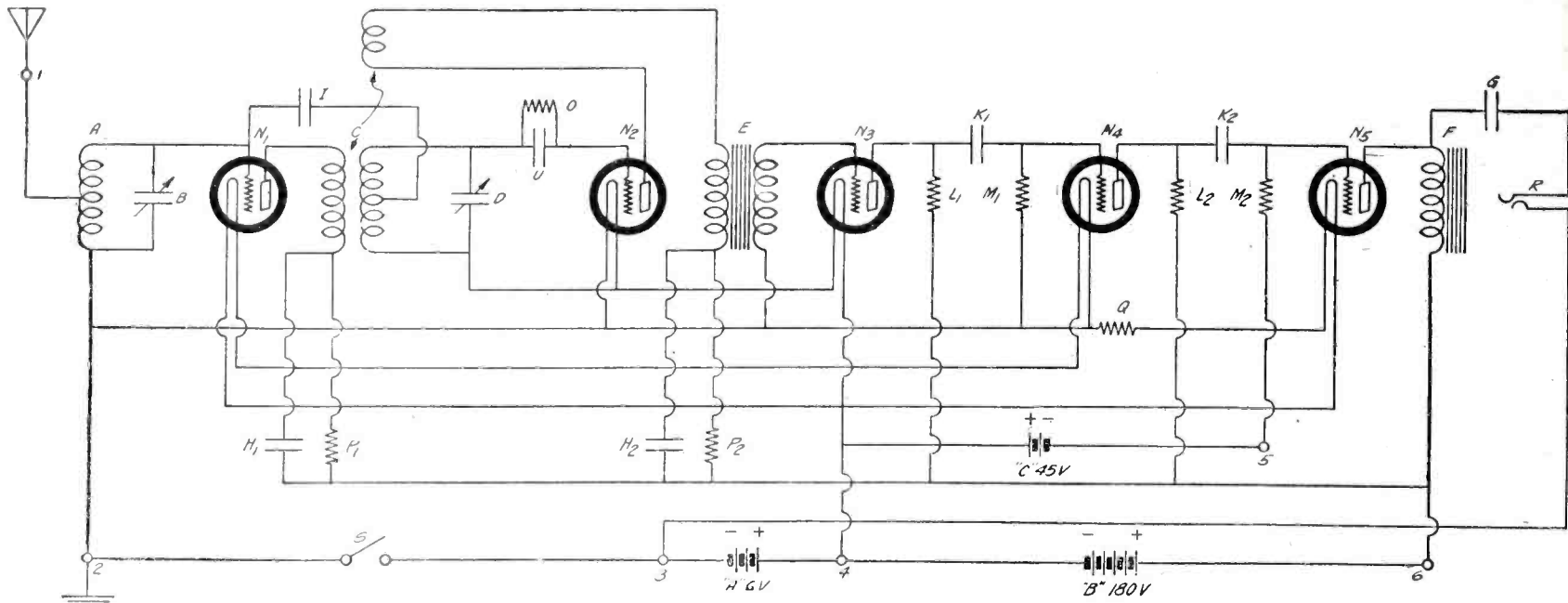

Fig. 5. A schematic diagram of the set. All the symbols for the various instruments bear designating letters which are used in the list of parts given beneath the picture wiring diagram, Fig. 2.

panel. All the rest of the holes are straight, drill holes. Sizes for the diameters of these holes have not been given; but the builder may easily find what size holes are necessary by measuring the diameter of the screws and shafts of the instruments that must go through them.

When the panel is drilled, the builder may give it a dull finish by rubbing the

AB. To do this properly the coil A, which is attached to the condenser, B, must be taken off and the supports reversed so that the coil A sticks out in an opposite direction, as shown in Figures 1, 2, 6, and 7. The coil, A, is fastened to the condenser, B, by means of two screws. When this has been done, the unit may be fastened directly to the main panel Y by means of three screws.

Next, attach the dial to the tuning unit, AB, taking care that the small pin in the top of the dial engages through the hole drilled directly above the center line for the shaft. This pin is used to keep the dial from tuning.

Then prepare the second tuning control, CD, for mounting on the main panel, Y. The coil unit C that forms a part of this tuning unit should also be reversed so that the small inside coil will face to the right instead of to the left when looking from the rear of the set. Attach this tuning unit to the panel Y by means of three screws with the volume-control shaft and the condenser shaft protruding through the panel.

Attach the tuning dial to this instrument and also the small volume-control dial. The volume-control dial simply screws on to the threaded shaft. Then mount on the panel Y the small battery switch S. This is mounted next to the tuning dial of the tuning unit AB, as shown in Figures 1 and 8.

This completes the mounting of the instruments directly on the panel Y, and you are now ready to mount the instruments that go on the baseboard Z that is supplied with the cabinet V. (Reference to Figure 3 will make it

screws, as shown in Figure 3. It should be attached with the grid and filament terminals turned to the right-hand side, as viewed from the back of the set.

Mount the choke coil, F, by means of four screws, as also shown in Figure 3.

Now the condenser G may be mounted with the two terminals in the position shown in Figure 3. This should

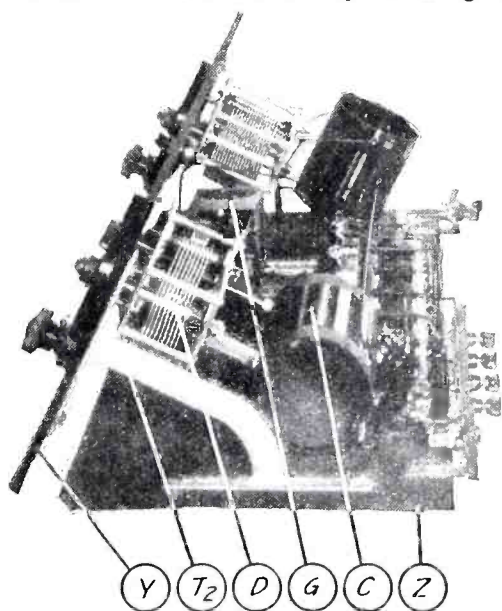

Fig. 6. This end view from the right of the set gives a general idea of how the tuning units and adjacent apparatus are mounted.

face of the panel lengthwise with fine sandpaper until it is smooth. This process then should be repeated, except that light machine oil should be applied during the second rubbing.

Finally rub the panel dry with a piece of cheesecloth. A permanent dull finish will be the result. Or, the panel may be left with its original shiny-black finish, if care has been exercised not to scratch it during the drilling.

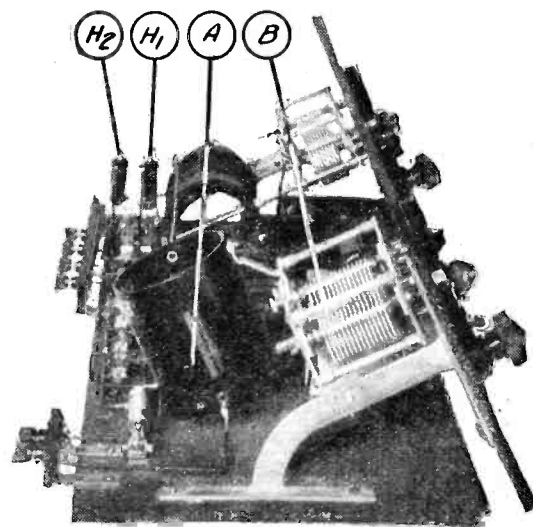

Fig. 7. A left hand view showing the way in which the antenna tuning coil has been inverted on its condenser and the manner in which the panel is fastened to the brace with heavy angle brackets.

also be fastened by means of four small wood screws.

The next job will be to mount the two double resistor units J1 and J2, as shown in Figure 3. These are mounted by means of one screw to each mounting. The third-double resistor mounting, J3, should be placed in position, as shown in Figure 3, and attached to the baseboard with a single screw.

Then, the two condensers K1 and

K2 should be attached to the baseboard, Z, with the terminals placed as shown. These should be fastened down to the baseboard by means of two screws to each instrument. The mounting for the automatic-filament control, Q, may then be placed as shown and fastened to the baseboard with a single screw.

The two binding-post connection blocks X1 and X2 should be prepared as described in Figure 9. When the binding-posts and the jack, R, have been fastened in their correct places, attach the small brackets, W, to the proper holes at the extreme end of each block. The two blocks may then be fastened to the baseboard by means of two flathead wood screws to each brass bracket.

This completes the work on the baseboard Z, and the main panel, Y, is ready to be fastened to the baseboard itself. Attach the two aluminum brackets T1 and T2 to the panel by means of two flat-head machine screws and nuts.

Now, place the baseboard, Z, in the cabinet, V, and adjust it in place so that the connection blocks X1 and X2 are

leads have been so arranged that the shortest possible connections may be used.

Because of this, the set should be wired with bus-bar. Either a tinned-copper, round bus-bar or an insulated, round bus-bar such as "Celatsite" may

specifically to the picture diagram in Figure 2 for the exact way in which to run the wires.

Start by running the most inaccessible wires in the receiver.

The hardest wires to attach are those that run from the primary of the trans-

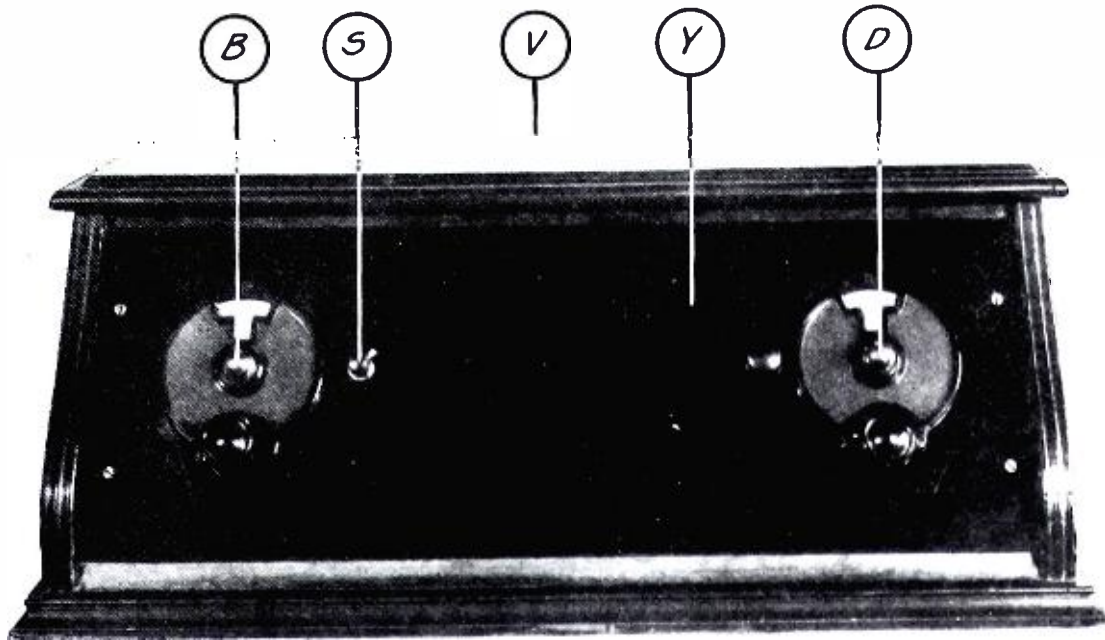

Fig. 8. A front view of the receiver. The knobs and dials are marked with letters corresponding to the instruments to which they are attached. The small number of tuning controls show how operation has been simplified.

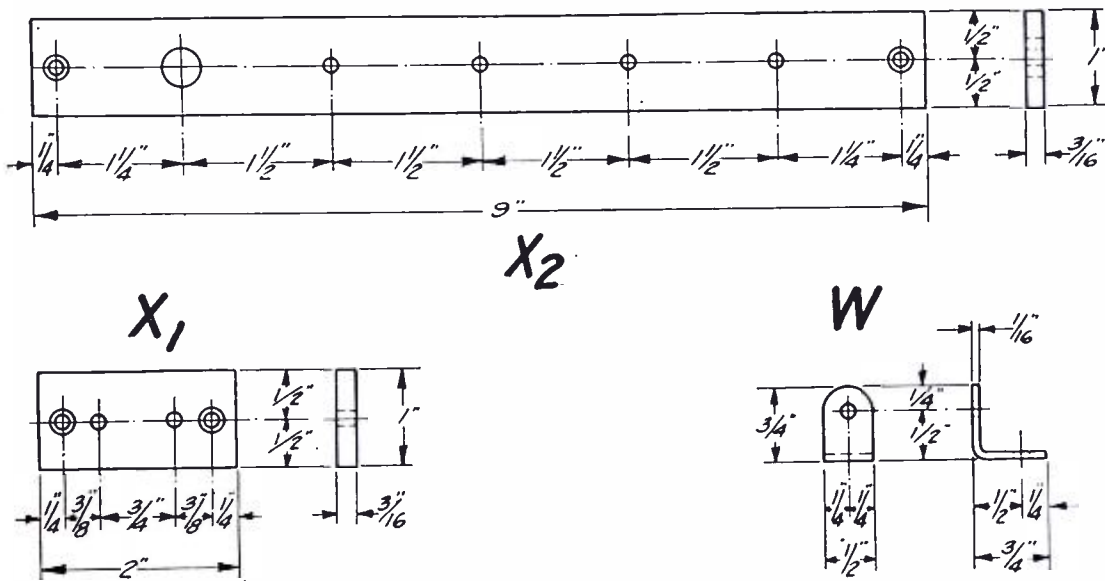

Fig. 9. Details of small parts. The necessary data for making the insulated blocks on which the binding posts are to be mounted as well as the dimensions for the small brackets that are used to fasten these connection blocks to the base are given directly above.

flush with the outside back of the cabinet. Then, place the panel, Y, in its proper place in the cabinet and mark the centers for the screw holes in the two aluminum brackets T1 and T2, as they come opposite to the proper places on the baseboard.

Then, take the baseboard and the panel out of the cabinet again and fasten two strong wood screws through each of the aluminum brackets into the baseboard itself. This makes a good fit for the whole outfit and holds the panel rigidly in place.

You are now ready to start in wiring as the construction work is completed.

How to Wire the Set

The design of the receiver is such that the wiring of the grid circuit of each of the three tubes is as short as possible and is isolated from the other parts of the circuit. In fact, this idea has been employed throughout; and the

be used for all connections. All wires should first be shaped to fit; and all connections should be made permanent by soldering.

It is best to refer constantly to the wiring diagram in Figure 5 and more

former E, to the tuning unit, CD, and the resistor, P1. Wire up the filament circuits, as shown in the picture wiring diagram Figure 3 and follow through with the plate and grid circuits of each tube. If the picture wiring diagram is strictly adhered to the reader will have no trouble in making a proper connection for all of the instruments.

The neutralizing condenser, L, should be fastened in place to the grid binding-post of socket N1; this is all that is required to hold it in place. The three fixed condensers, H1, H2 and U, are held in place by the wires themselves and should be placed in about the positions shown in Figure 2.

After the wiring has been completed, it should be carefully rechecked with the picture diagram to be certain that

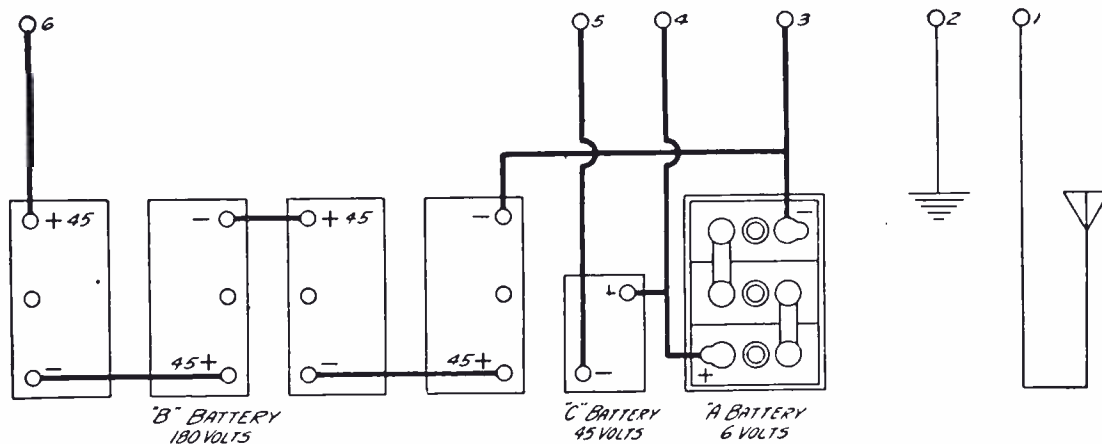

Fig. 10. How to connect the batteries, aerial and ground. The builder cannot make a mistake in connecting the batteries to the terminals of the receiver if he follows these instructions carefully. The terminals that are shown in the wiring diagrams are marked with numbers that correspond exactly to the numbers that are given here.

there have been no wires left out or no wrong connections made. When the wiring has been completed and the various resistances and the automatic filament units placed in the holders, the

(Continued on page 150)

The Callies Super-Heterodyne

Tone Quality, Selectivity and Appearance Are the Predominating Features in This Circuit

By CHARLES H. CALLIES

NEITHER an excuse nor an apology is offered in presenting this—another article on a circuit *which has* already been given a considerable amount of publicity. Neither is it the endeavor to enter into a discussion of the merits and demerits of the various classes of the higher types of receiving

Under those conditions only a portion of the scale of audible tones has been allowed to enter our speaker.

If the instructions that follow are carefully adhered to and if parts similar to those that have been described or parts of equal quality are incorporated you can rest assured that you will have

equally frank it is also to be said that the west coast failed to be heard, however, this is due to the season of the year in which we are operating.

Next to tone quality and selectivity the first requisite of a receiver is appearance. This receiver is attractive and if housed in a proper cabinet will fit in nicely with the best of living room equipment. (See Fig. 1.) On the front panel we find two Vernier dials for the oscillator and loop. There are three control knobs, the first from the left being the oscillator filament control, the second the potentiometer functioning in the grid return of the intermediate frequency amplifier and the filament rheostat on these intermediates. From an experience covering more than five years, mainly on super-heterodyne circuits, I am led to make a definite statement that no super-heterodyne should be built without some readily accessible filament control leading to the oscillator tube. This control enables one not only to rectify signals from stations with poor modulation but in many cases will help to clear up interference where this would be impossible without a variable control. The potentiometer and rheostat on the intermediate tubes work together, one depending upon the other. The potentiometer also functions as a volume control. The only other items on the front panel are small midget condenser, filament switch and the output jack.

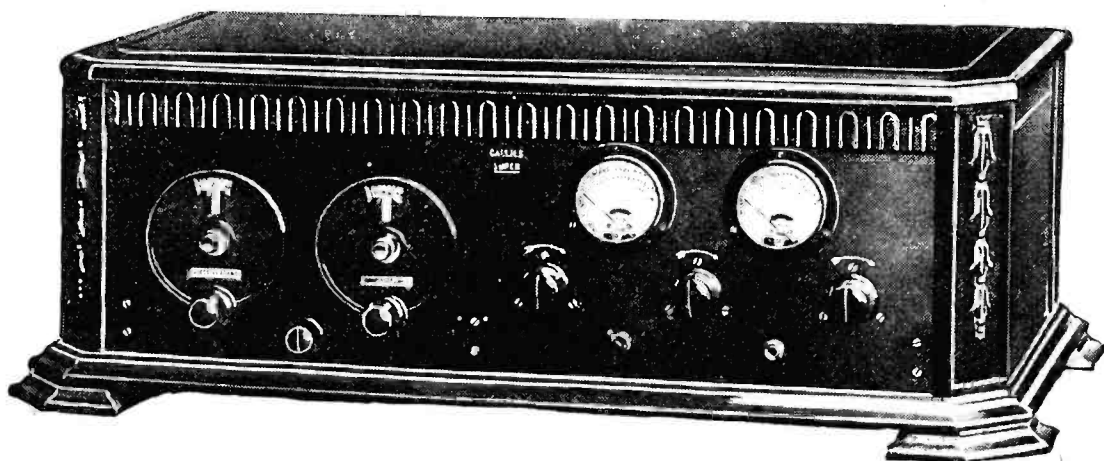

Fig. 1. This is the complete receiver housed in a 7 x 24 cabinet. The cabinet is a regular stock cabinet having considerable distribution and may be purchased in most localities.

circuits that are in evidence. It is to be conceded, however, that for all around simplicity in tuning, ability to get what you are after, range and sensitivity, the super-heterodyne has justly earned the title that many people have given it—"the peer of radio receivers." There is nothing new or startling about the circuit that I will describe. It is a conventional super-heterodyne and as far as the circuit diagram is concerned it will be found to contain points of similarity with many other super-heterodyne circuits that we have seen before. The receiver itself, however, was built with a real purpose in mind—the utmost in selectivity without a sacrifice anywhere in respect to tone quality. All the experimental work on this set was done in a locality in Chicago that is considered absolutely the worst section in the city—completely surrounded by high powered broadcasting stations ranging from one-quarter mile away to four miles away.

While on the subject of selectivity there is this to be said about every receiver—and there is no use in kidding ourselves or the radio public on this subject—extreme selectivity can be very easily obtained *but only at the expense of the tone quality.* A receiver can be sharpened so that the side bands can be trimmed without trouble but then what has happened to our tone?

a receiver that will enable you to pick out practically every instrument in an orchestra. With the proper kind of a speaker you will be able to separate the kettle drums from the base drums and at the same time render in a "true to color" tone both the high pitched notes of the clarinet and the low notes of a bass tuba. So much for tone quality. Now for selectivity—a few evenings after this set was completed, as a matter of fact on Monday evening, June

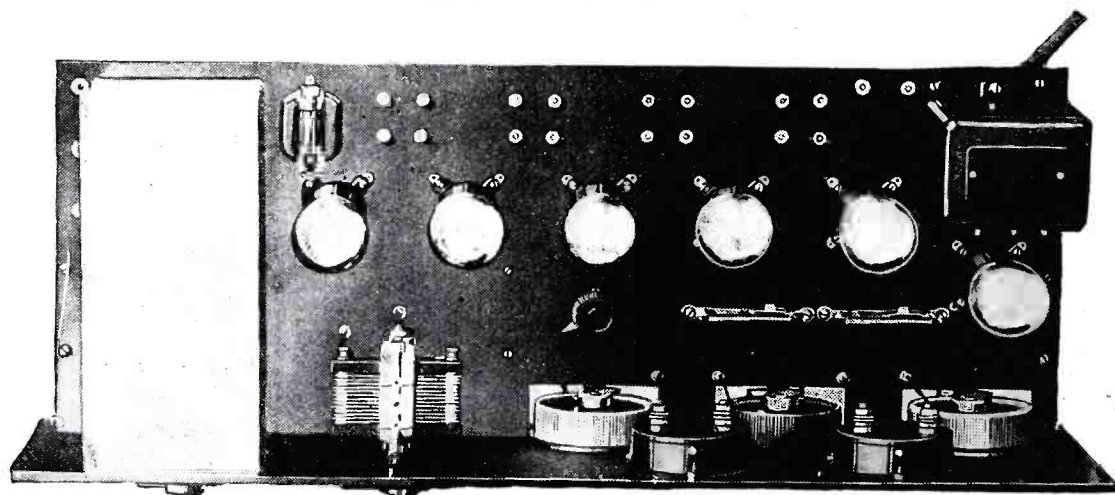

Fig. 2. This is an aeroplane view of the set. Note the clean appearance—no wiring in evidence.

21st, forty stations were tuned in without any endeavor to try to break a receiving record. The stations came in from all over the extreme east coast, Canada, south and southwest. To be

To the front panel we have attached a bakelite baseboard which has been slotted in three places to accommodate the rheostats and potentiometer. This baseboard is supported in the

front by three panel brackets $1\frac{5}{8}$ " up and is supported in the rear by the four long wave transformers which are exactly of this height. The set is therefore very rigid and there is no danger of it falling apart from handling. A glance at figures 2 and 3 will probably tell more of a story than we could tell here in words. In addition to tone quality and selectivity, neatness and a pleasing appearance have been the predominating factors. I have therefore arranged the entire layout of the receiver so that only six wires are to be seen when the lid of the cabinet is opened. These wires run from the two meters to the baseboard and from the loop tuning condenser to the baseboard. They are spaghetti covered and are therefore almost unnoticeable. These wires run from the instruments to lugs that have been affixed to the baseboard. This has been done for the sake of rigidity. At the bottom side of the baseboard under the same screw that holds the lug at the top of the baseboard is another lug that carries the wire to the proper portion of the circuit.

Looking at the interior of the set with the front panel next to us we find at the extreme left of the baseboard the three small imp or pup jacks. These are the loop terminals. The one nearest to the front panel is that portion of the loop which goes to the rotor of the variable midget and loop tuning condenser, the one in the middle is the lead going to the negative "A" and the one furthest from us is the one going to the stator of the loop tuning condenser. The next item very much in evidence is the shielded oscillator. In this con-

shield can be removed by simply lifting it up. Of course, the front of the shield will have to be slotted to accommodate the shaft of the single hole variable oscillator condenser. In this shield are incorporated all the components of the oscillator circuit, making this portion of the set entirely self

up they point down and run through the baseboard. To these terminal screws—under the baseboard—lugs are affixed and the nut that keeps the lug in place also anchors the socket to the baseboard. The long wave transformer terminals have been handled in just the opposite manner: these screw terminals

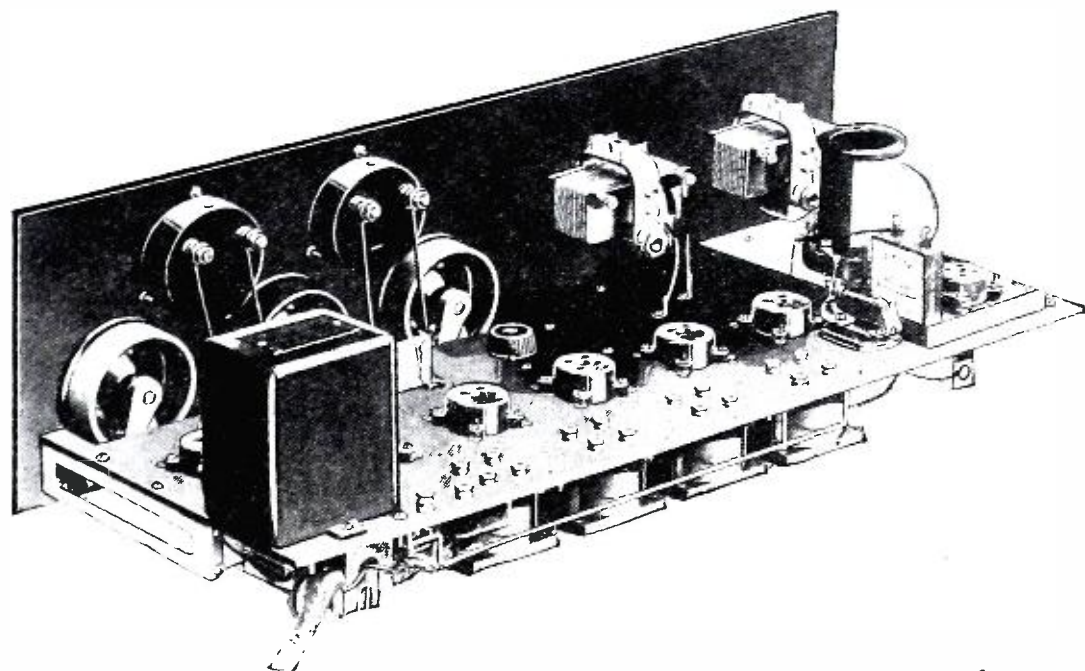

Fig. 3. This is the rear view of the Callies Super. Note particularly the long wave transformers at the rear of the set and how they support the sub-base.

contained—avoiding all magnetic coupling with other portions of the receiver. The shield contains the oscillator condenser, a Silver-Marshall 515 coil socket, the 111-A coil, tube socket and one of the .5 bypass condensers. This shielded can, of course, is attached in the negative "A" line.

The other tubes in the set follow in their natural sequence. The first tube next to the oscillator shield is the first

project through the baseboard. The transformers themselves form the support for the rear end of the sub-panel. From a wiring standpoint it will be found, and this can easily be appreciated from the photographs, that the lugs from the tube sockets are close enough to the lugs on the transformers so that our grid lugs touch as well as our plate to plate lugs. These lugs therefore are simply soldered together.

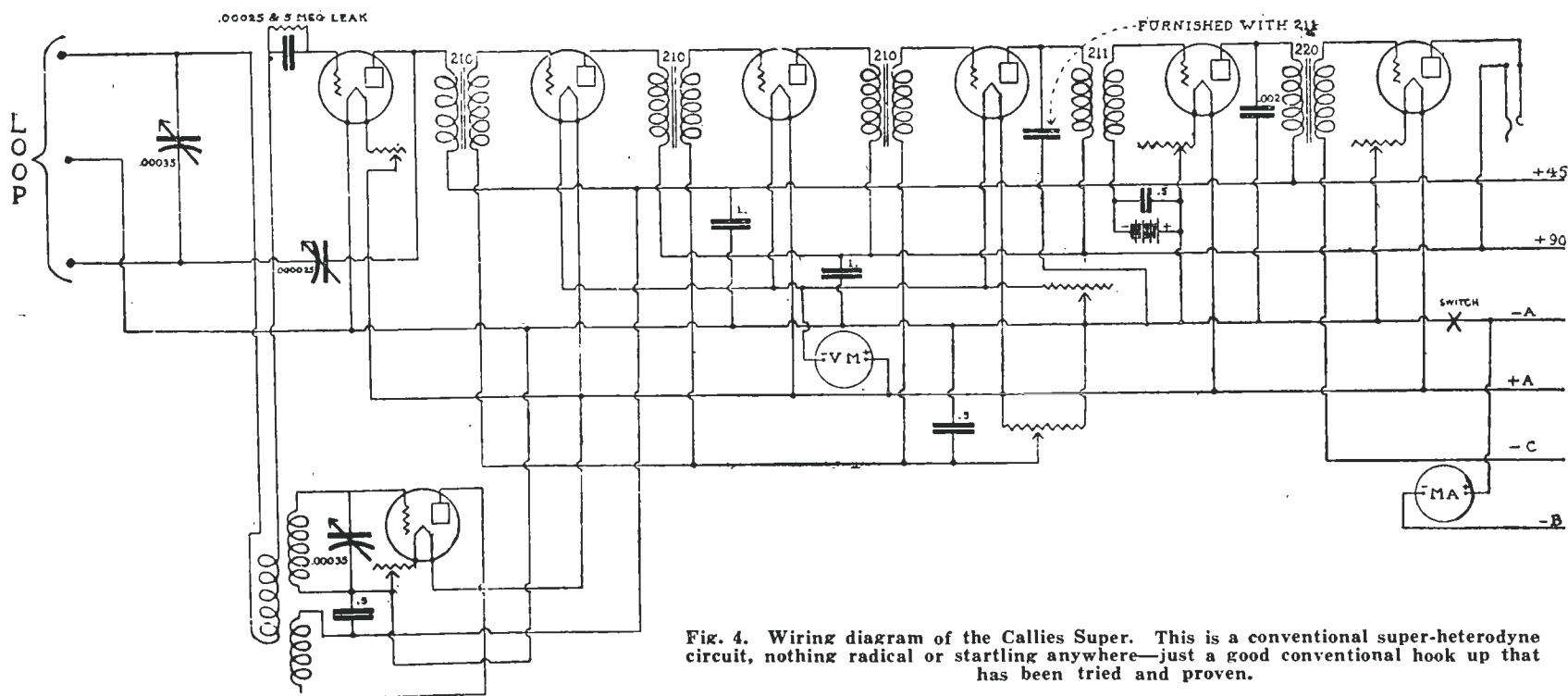

Fig. 4. Wiring diagram of the Callies Super. This is a conventional super-heterodyne circuit, nothing radical or startling anywhere—just a good conventional hook up that has been tried and proven.

struction I have used the Silver-Marshall 631 stage shield. This has a removable bottom making all parts within the shield readily accessible and very easy to wire. As all of the leads are carried through to the bottom of the set the upper portion of this stage

detector, the next three are in the intermediate frequency train, then comes the second detector and lastly the audio tube. It will be noticed that on all of these six tube sockets the terminal screws have been reversed. In other words, instead of the screws pointing

One of the important items in laying out the entire set has been the thought of obtaining short leads in this intermediate frequency train. Here short leads should be the by-word. The grid condenser is held in place by screws which also contain the lugs which are

wired into the circuit. The leads from the grid condenser to the grid on the first detector tube is another case of simply soldering the two lugs together.

The intermediate frequency amplifier deserves a paragraph all to itself. This is probably the most important part of the super-heterodyne circuit—this is where trouble most often occurs and most of the time this is that portion of the circuit on which selectivity hinges. Under all circumstances use a set of good matched intermediates together with a filter that is matched to function with these transformers. I have used the No. 210 Silver-Marshall long wave transformer and the accompanying 211 filter. These transformers are matched to peak at the same point at the factory. All of the laboratory work so often necessary here has been done before the transformers are offered for sale. These can be obtained in measured groups together with a filter that has the proper characteristics to function with them.

I have now covered in a rather general way some of the outstanding features in the front end of this set. To go on, the second detector circuit has been handled a little different from the conventional. Our signal is rectified through detector action obtained through the use of a "C" battery in the grid return rather than through the use of the conventional grid condenser and leak. This plan enables us to rectify the comparatively low frequencies which are handled in the super-heterodyne circuits to much better advantage than we could through the use of the regular method.

The audio end of the circuit remains. This is a conventional transformer

have used will reproduce real "true to color" tones—as far from the tinny reproduction that we have become accustomed to as anything that can be imagined. We have ended our set but with one stage of audio. This is sufficient for average reception and by average I mean reception from stations one and two thousand miles away with sufficient volume to fill an average sized room. If more audio amplification is desired my recommendation would be not to add another stage in the set but rather to incorporate this in what is called a power pack assembly which also carries the "B" eliminator. Amplification beyond one stage of audio is not feasible or practical without the use of a power tube and power units and these of course demand higher voltages than are ordinarily employed. A power pack assembly is entirely self contained as not only is the "B" current for the power tube obtained from the "B" eliminator portion of this assembly but the "A" filament is taken care of as well. Of course, a power pack will supply "B" current to the entire receiver as well as to the power tube which is contained in it.

Construction and Wiring Data

It is best to first lay out and drill the front panel according to the diagram that accompanies this article. If the parts are used which I have specified in the set the diagram can be followed exactly, if other parts are used alterations to accommodate mountings of other material must be made. It is advisable to mount all of the parts on this front panel immediately. In mounting the rheostats and potentiometer

section of the set in addition to the holes that accommodate the necessary mounting screws, drill holes for leads to the 45 volt "B" battery line, holes for the pick up coil leads, positive and negative "A" filament leads. The negative "A" lead going to the oscillator coil should be soldered directly to the bottom of the shielding as the shielding also is grounded in the negative "A" filament line. The only other place on the baseboard where we need lead holes is in connection with the audio transformer. Four small holes are drilled adjacent to the terminals on the transformer and these leads are carried through the sub-base to their respective portion of the circuit. To make everything just as clear as possible a sub-panel layout will be found accompanying this article. It is advisable to lay out this sub-base scratching all hole lines on the underneath portion of this bakelite panel and then checking the measurements against the instruments before the holes are drilled. The size of the screw holes in no instance has been specified as this is a very easy matter for the constructor to determine himself with all of the necessary parts before him. As has been said before the screws that hold the grid condenser to the sub-panel, also carry the lugs for the leads. The screw terminals on all of the tube sockets, with the exception of the oscillator, also carry the lugs for all of their leads. Lugs on all of the intermediate frequency transformers are carried between the bottom of the sub-panel and the transformer—the final locking nut only appearing on top of this sub-base. The first detector rheostat on the sub-panel is mounted in the conventional

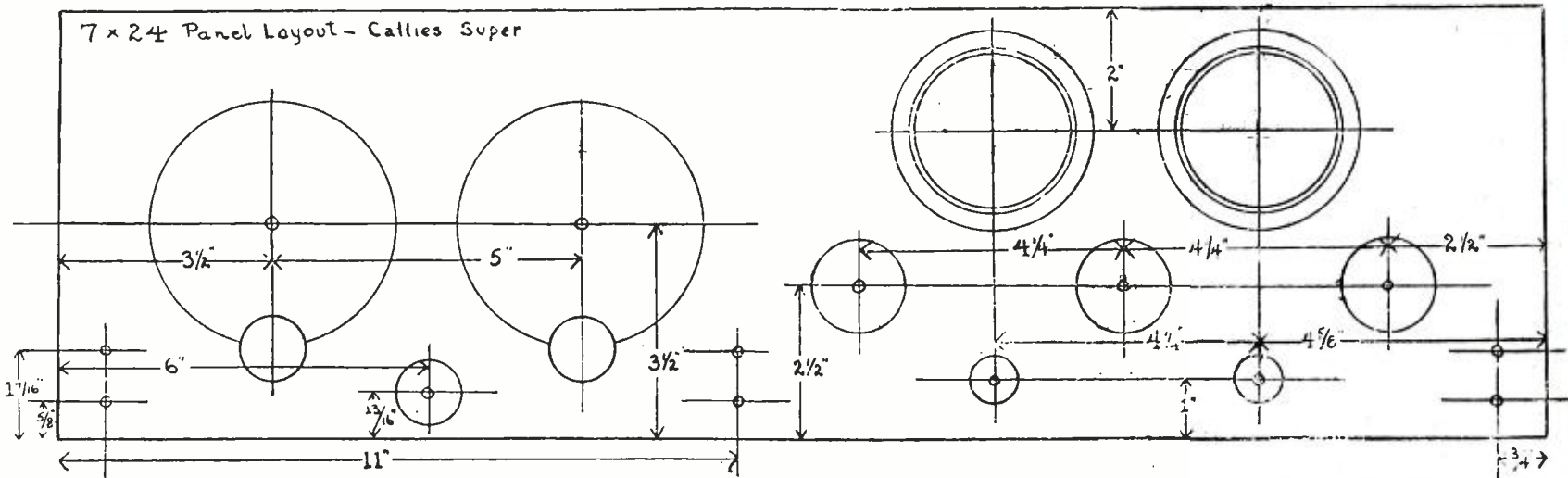

Fig. 5. Front panel layout. Center holes only have been indicated. Size of holes can be determined easily by the constructor.

coupled circuit. One of the new four pound audio transformers has been used here. In a set of this kind the audio end of the circuit should be given just as much attention as the possibly more critical portions of the circuit up ahead of it. From the standpoint of tone quality an audio transformer as a rule may be measured by its weight. The more core and more turns of wire that it contains the better the tone quality. The 220 transformer that we

meter, be sure that the terminals on these instruments are at the extreme bottom so that the wiring will be concealed. The next thing in order is the drilling of the baseboard. First the baseboard must be slotted to accommodate the two rheostats and potentiometer on the front panel. Then the mounting holes must be drilled for the tube sockets, long wave transformers, audio transformer, oscillator, etc. Holes for wire leads are few. In the oscil-

manner. The screws holding the Yaxley resistances to the sub-base also carry the lugs for the necessary wiring. In wiring the bottom of the set it is advisable to first solder those lugs together which have been made to touch each other. It is then advisable to lay in the negative "A" leads. This can be followed by the positive "A," 45 volt "B" and 90 volt "B" wires. For a multi-tube set the wiring is extremely simple. Nothing very much need be

said about it except that in wiring grid and plate leads these should be kept so that there will be no magnetic coupling in evidence. Before too much of the wiring is done it would be well for the constructor to spot two places for the remaining four bypass condensers. The Dubilier bypass condensers are comparatively small and can be carried in groups of twos, one condenser on top of the other. The leads are then carried to the batteries by the six wire cable. There is no possibility of making a mistake as long as some definite color scheme is adhered to in the handling of this battery cable.

Points About Tuning

The super-heterodyne circuit after it is once understood probably is as simple a circuit to tune as any we have with us today. After the batteries are turned on advance the oscillator knob of the rheostat so that it is about half way in. Advance the rheostat on the intermediate frequency tubes so that you have a reading slightly in excess of four volts on the voltmeter. Advance the potentiometer to a point just this side of where the intermediate train will oscillate. The potentiometer arm approaching too closely to the negative end of this potentiometer will create an oscillating condition which is evident at once either by a thump or a squeal or a series of squeals. The receiver is working to the utmost when the potentiometer arm is placed just before the point where the oscillations take place. Adjust the arm on the variable resistance going to the second detector so that it is at about a 45 degree angle. This is one tube we do not want to

overload. The resistance on the first audio tube can be turned on full. The

rotating of the dials on the two condensers with settings approximately the same, providing a loop is being used that is designed to work with a .00035 condenser, will now bring in one local after another as the dials are moved. It will be found there is only one "best" setting on the loop condenser dial while there are two points on the oscillator dial for every station that will bring in the signal with equal results. This condition is because of the inherent characteristics of the super-heterodyne which we believe are sufficiently understood and about which a discussion will not be entered into here. After the tuning of the locals has once been mastered it is only a step to bring in the more distant stations.

One item about which nothing has been said up to this point has been the meters. I have avoided saying very much about the meters because the set will operate without them, however, we can tell to such a degree of accuracy just what the set should be doing by a glance at the meter readings that the use of the meters is indeed recommended. The set working properly should show a pull of about 24 to 28 milliamperes with 45 volts on the oscillator and detectors and 90 volts on the other tubes.

In spite of the fact that this is about the fiftieth super-heterodyne that I have built I am more enthusiastic about it than any of the previous models. Every one that has listened to it has had an agreeable surprise at the tone quality of the set and as I have said before the selectivity is such that any of the out of town regulars should be brought in at any and all times.

- PARTS NEEDED**
- 2 Silver-Marshall 316 condensers (.00035)
 - 1 Silver-Marshall 515 Universal coil socket
 - 1 Silver-Marshall type 111-A oscillator coil
 - 7 Silver-Marshall 510 tube sockets
 - 3 Silver-Marshall 210 long wave transformers
 - 1 Silver-Marshall 211 long wave filter
 - 1 Silver-Marshall 631 stage shield
 - 1 Silver-Marshall 220 audio transformer
 - 1 Silver-Marshall 340 midget condenser
 - 3 Silver-Marshall No. 540 panel brackets
 - 1 General Radio 20 ohm rheostat (large size)
 - 1 General Radio 6 ohm rheostat (large size)
 - 1 General Radio 400 ohm potentiometer (large size)
 - 1 General Radio 30 ohm rheostat (small size)
 - 2 Yaxley filament resistances 25 ohms
 - 1—0 to 50 Weston type 301 milliammeter
 - 1—0 to 7½ Weston type 301 volt meter
 - 1—.00025 Sangamo grid condenser and 5 meg. leak
 - 3 Dubilier .5 bypass condensers
 - 2 Dubilier 1. bypass condensers
 - 3 imp or pup jacks
 - 1—.002 Dubilier mica condenser
 - 1 filament switch
 - 2 Silver-Marshall No. 801 Vernier dials
 - 1—7 x 24 x 3/16 bakelite panel
 - 1—9 x 23 x 1/8 bakelite baseboard
 - 5 or 6 feet of 6 wire cable
 - Miscellaneous screws, nuts, bolts and hook up wire
 - 2—4½ volt "C" batteries
 - 1 cabinet

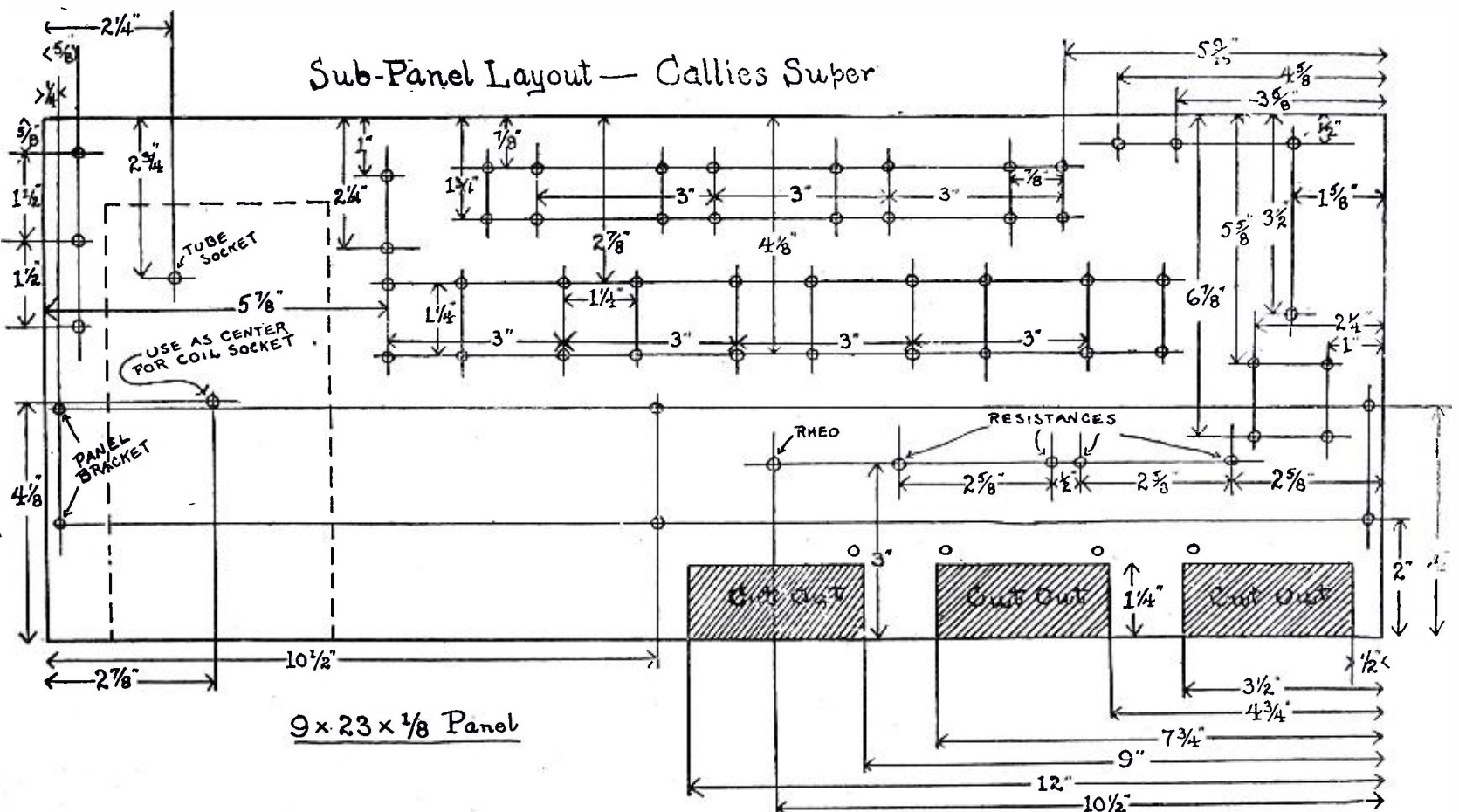

Fig. 6. Diagram of the baseboard layout. This can be followed closely if the parts indicated in the article are used. It is advisable to lay this out on the reverse side of the panel exactly as shown above and then check all the instruments against the hole markings.

A New Method of Amplifier Coupling

Author Develops New Type of A. F. Amplification Which Should Prove of Great Interest to Those Concerned with Quality Reproduction

By H. P. DONLE

IN the early days of radio broadcasting the transformer system of coupling audio amplifiers was almost universal, because the efficiency of this system is very high and it does not require many tubes. Furthermore, the standards of quality at that time were much lower than those of today. Transformer coupling is remarkably efficient on weak signals; but its performance differs considerably from that of other systems of coupling, in the fact that this high efficiency decreases very rapidly as the signal intensity is increased. This is a transformer characteristic which is not often considered but which, without doubt, gives rise to considerable distortion on account of the fact that the weak signals are amplified more than the stronger ones. It is, furthermore, difficult to use more than two stages of transformer coupling because there is a marked tendency for audio-frequency regeneration to take place, which not only increases distortion but produces

other by means of a small condenser; supplying the plate current to the first tube through a resistance which is usually of the order of one-tenth of a megohm; and connecting the grid of

tendency for the grids of the amplifier tubes to load up and introduce distortion as the volume of signal increases. Unless a grid leak of very low resistance is employed, which reduces the efficiency of the system, this arrangement is not capable of giving much volume.

The New Donle Coupling

A system of audio-frequency amplifier coupling has been developed by the writer, which overcomes most of the disadvantages of previously known systems. It permits a quality of reproduction which is equal to the very best which can be secured with resistance coupling under the most favorable conditions of weak signals. It is a much more efficient method of coupling tubes than resistance or impedance and thus affords a considerably greater amount of amplification per stage. It does not share the disagreeable characteristic of transformer coupling, amplifying weak signals to an excessive degree. It may be readily used in three stages without

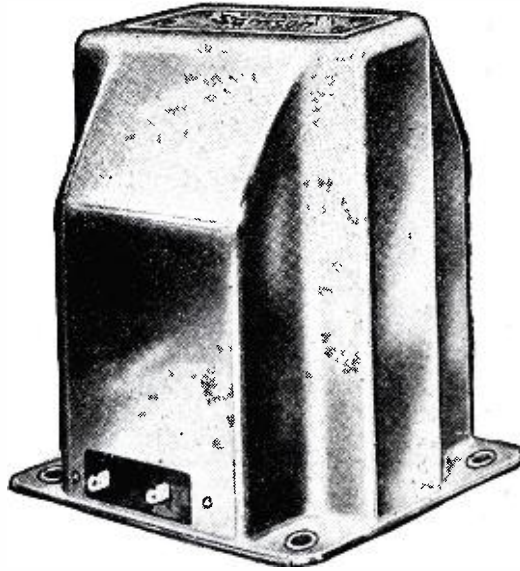

Photo by courtesy of Samson Electric Co.
Fig. 3. One of the coupling devices now on the market utilizing Mr. Donle's principle.

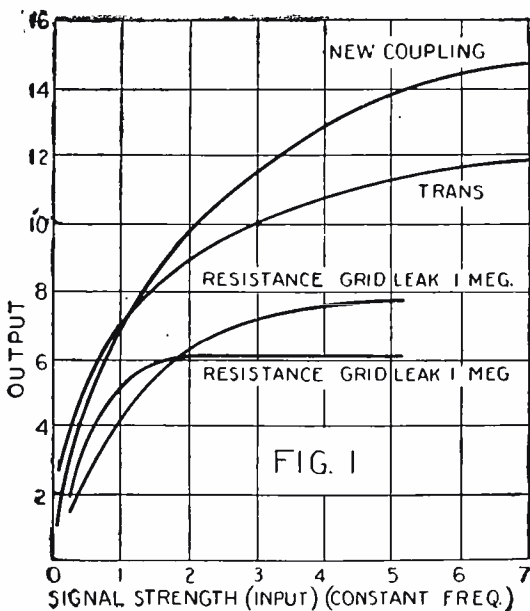

Fig. 1. Curves illustrating capability of various types of coupling devices to respond to signals of varying strength.

a howl or squeal in the loud speaker. And while this howl may be lessened, and more stages introduced by various methods of stopping regeneration, these methods themselves always introduce losses into the circuit; and thus decreases the volume of reproduction and neutralize to a large extent the expected gain from addition stages.

Resistance Coupling

Resistance coupling consists essentially of connecting the plate of an audio amplifier tube to the grid of an-

the second tube to the negative filament terminal through a resistance of from one-tenth to one megohm. This system, although very inefficient, has one advantage; it is capable of giving excellent quality of reproduction, only so long as the signal intensity is not too great. And since there is no tendency for regeneration to take place between stages, it is possible to use several stages, which allows a sufficient amount of amplification to be secured even though the individual stages are inefficient. Aside from the inefficiency of this system, it has the considerable disadvantage of inability to handle large signals, because the grids of the amplifier tubes accumulate charges too rapidly to be properly taken care of by the grid leaks. Furthermore, this effect is noticeable on signals of medium intensity, as manifested in a certain amount of blurring and distortion which increases as the signal intensity increases.

The so-called impedance system of amplifier coupling differs from resistance coupling only in that the resistance, through which the plate circuit of the amplifier tube is supplied, is with this system replaced by a choke coil. The rest of the circuit is the same. This system, while it has an efficiency per stage somewhat higher than resistance coupling, has the disadvantages of resistance coupling in the

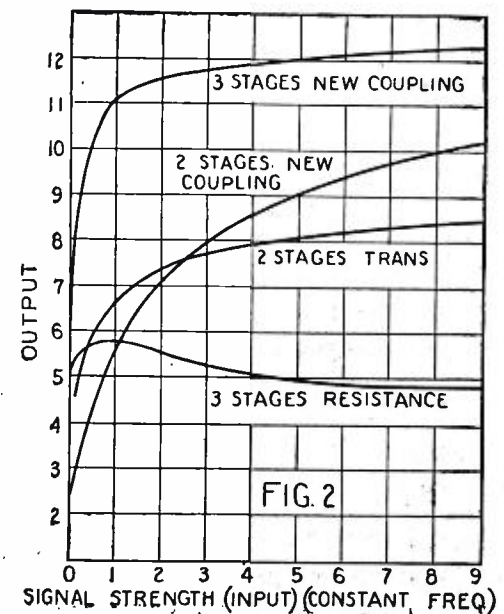

Fig. 2. Comparison of efficiencies of various types of amplifiers taken under the same conditions as the curves of Fig. 1, excepting that the latter curves are for one stage only.

the slightest tendency towards audio-frequency regeneration or howling; and when so used, will give a signal intensity for any input far greater than can be secured with any other known system of coupling an equal number of stages.

The system used is diagrammed in Fig. 4, by which it will be seen that an impedance leak is used instead of a resistance leak. By this method high impedance is presented to the alternating

(Continued on page 171)

The Improved "Diamond of the Air"

Constructional Data on the New Five-Tube Tuned Radio Frequency Set

By ROBERT HERTZBERG, Assoc. I.R.E.

WITHOUT doubt the most easily assembled radio receiver, from the standpoint of the home constructor, is one incorporating a single stage of tuned radio-frequency amplification, a regenerative detector, and an audio amplifier system comprising one stage of transformer coupled and two of resistance. Such an outfit represents a paragon of simplicity combined with ease of mechanical construction and dependability of electrical operation. Without frills or unnecessary embellishments, it permits its user to enjoy radio broadcasting without suffering the numerous pains that more complicated and less easily handled sets usually cause him.

One of the most successful receivers of this class is the one described in this article, which was designed by a radio engineer of New York City. It is by no means a freak outfit, or one requiring special constructed components, but uses standard, easily obtained parts in what many radio fans will recognize as a very satisfactory circuit possessing many good points and few, if any, bad ones. The fact that the various coils, condensers, transformers and so forth are available in any radio shop especially recommends it to the man who has attempted to buy Iodoform coils

erally accepted form, involves one stage of tuned R.F., comprising a straight, unalloyed solenoid coil and a variable

bility and all-round practicability of the combination.

The set is completely contained on

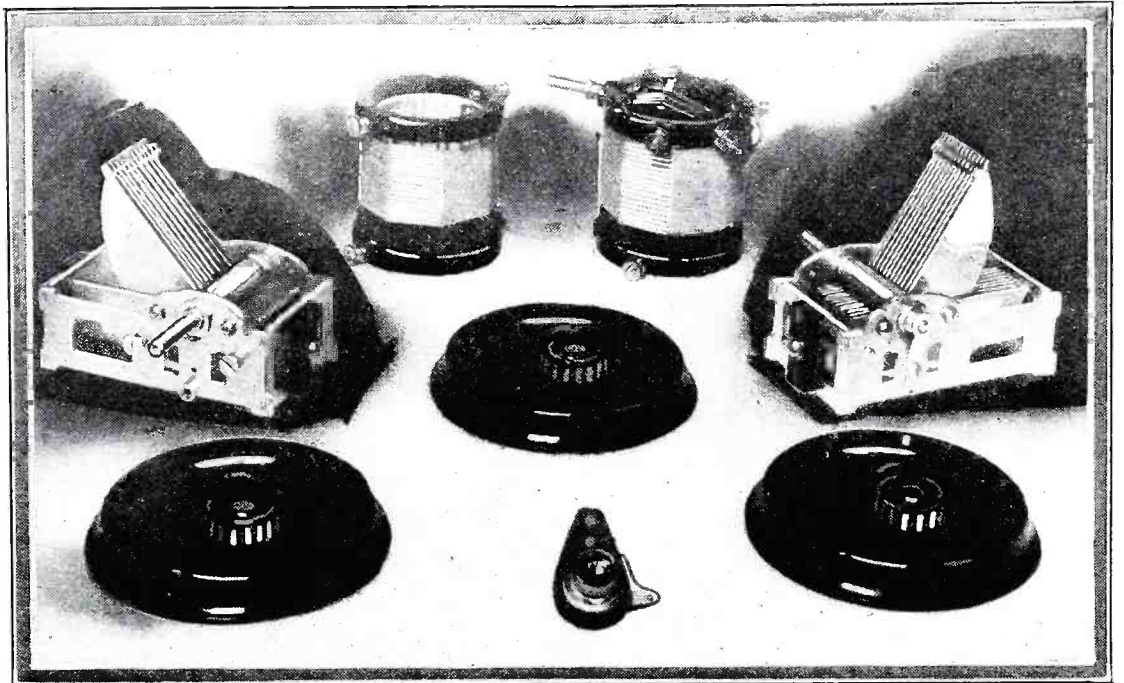

Photos by courtesy of Bruno Radio Corp.
Here are the principal parts used in the assembly of the "Diamond of the Air" receiver. The two coils in the center are the R. F. coil and three-circuit tuner. The other parts are the two .0005 mfd. variable condensers, three vernier dials and "A" battery panel light switch.

condenser; a regenerative detector, the regeneration being invoked with the aid of our old friend the a standard 7" by 24" bakelite panel, with a narrow rear sub-panel, supported by two Bruno aluminum brackets, holding

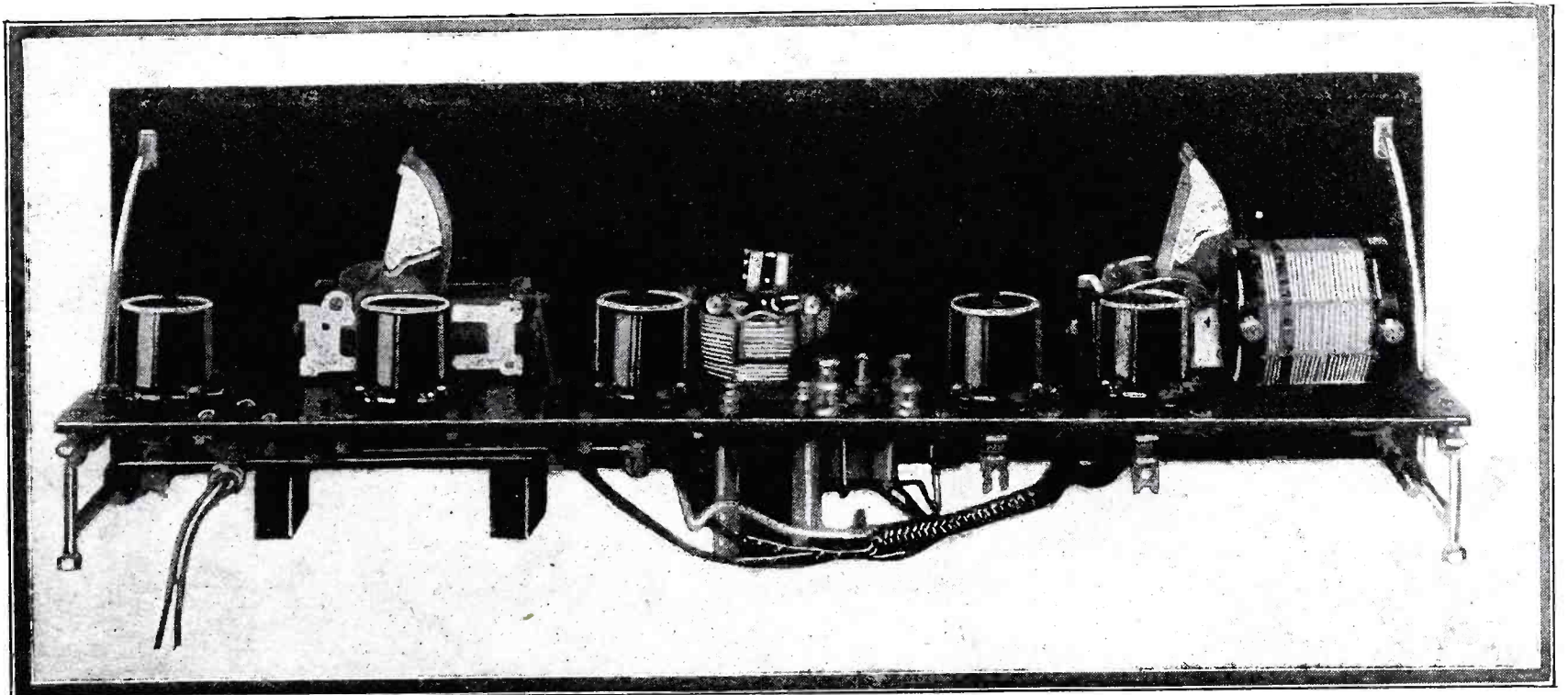

A rear view of the Improved "Diamond of the Air." The five-tube pocket can be seen mounted on the sub-panel. A cable lead is employed for battery connections.

for that inviting looking but tricky Iodyne circuit.

This receiver, which has been named the "Diamond of the Air," in its gen-

tickler coil, and one stage of transformer and two stages of resistance coupled A.F. No radio man in his right senses will challenge the desira-

the tube sockets, one R.F. coil and the various audio amplifier essentials. There is no awkward wood baseboard to make the wiring a nuisance of a job;

everything is accessible to all times because of the convenient skeleton construction.

Parts Required

The parts required are not many. They are: One 7" by 24" by 1/4" com-

For the convenience of the constructor who has little tool equipment at home, these parts are available in kit form. A screw driver, pair of pliers, soldering iron and about two hours of time are all that will then be necessary. If the radio fan already has some parts,

clear the backs of the variable condensers and the three-circuit coil quite comfortably.

Mounting the Transformer

On the extreme left-hand of the sub-panel is mounted the Bruno R.F. trans-

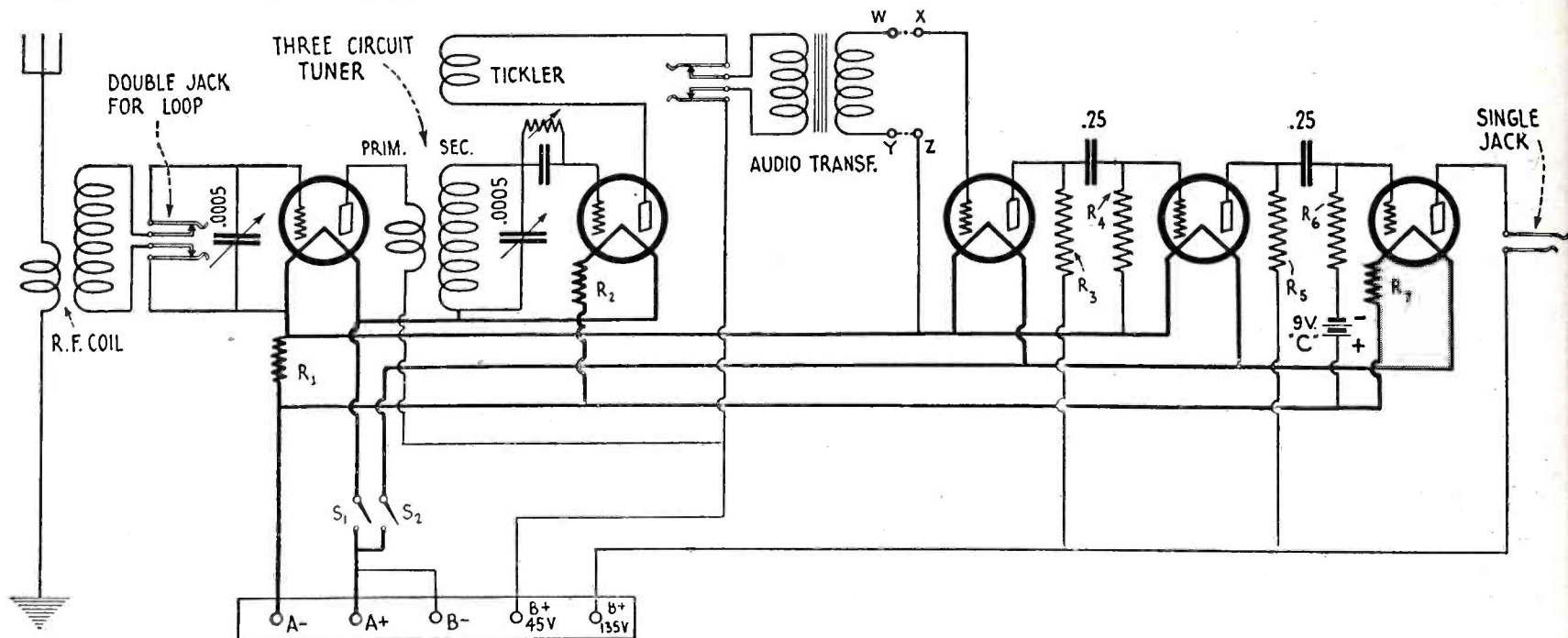

A schematic wiring diagram of the set. R₃, R₄, R₅, and R₆ are the resistances of the resistance coupled audio amplifier while R₁, R₂, and R₃ are Amperites for controlling the filament current to the tubes.

position panel; two .0005 mfd. Bruno bakelite shaft straight line frequency condensers, with Bruno micrometer dials to fit; two double circuit and one single circuit standard telephone jacks; two push-pull battery switches, five Na-Ald shock-proof sockets, Bruno type No. 99 three-circuit coupler; two Bruno shelf brackets, one Thordarson low ratio audio transformer; two .25 mfd. standard fixed condensers; four Veby tubular resistance mountings, with three 100,000 and one 500,000

ohm resistors; one Veby 3/4 ampere ballast resistance with mounting; one 1/4 and one 1/2 ampere Amperites; four binding posts, Bretwood variable grid leak; bakelite sub-panel, 2 by 23 inches, to fit between brackets; standard five-wire battery cable; .00025 mfd. grid condenser, without leak mounting.

such as jacks, switches, sockets, etc., he can pick the rest of the instruments at his own discretion. At any event, the drilling of the front and rear panels is a simple task. As the photographs show, the front panel holds the two variable condensers, in the left and right hand sections; the three-circuit coil, in the exact center; the two double circuit jacks, below and on each side of the left-hand condenser dial; the grid leak, directly beneath the center dial; one filament

former, which is a straight solenoid, with primary and secondary wound on quartzite rods. The primary terminals of this coil face to the rear, and are used directly as aerial and ground posts, without intermediate connection. Immediately next is placed a socket, which is for the first R.F. bulb. The coil, the socket and the adjacent variable condenser on the front panel form the R.F. stage, and, as they are close together, allow themselves to be connected with very short wires. An ex-

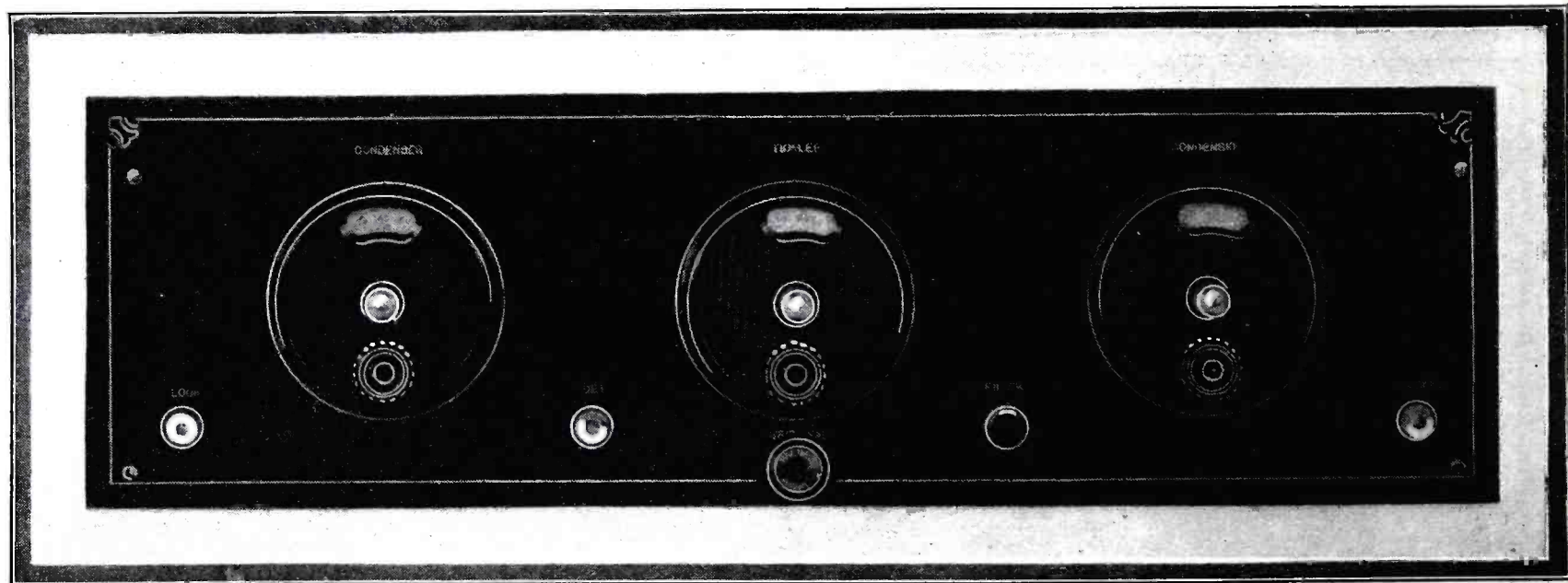

A front panel view. The first dial is the condenser control, the second the tickler of the three-circuit tuner, and the third the second variable condenser. The knob below the center dial is the variable grid resistance.

switch S1, between the center and right hand dials; and, finally, the single circuit jack, at the extreme right. The two brackets fasten to the back of the panel near its sides, and three-quarters inch from the edges. These extend back far enough to permit the narrow sub-panel, fastened to them, to

terminal-loop aerial may be plugged into the left-hand jack, and will work very well on local stations. It increases the selectivity considerably, and is useful in crowded city districts. The next socket, for the detector tube, is placed directly behind the three-

(Continued on page 172)

A Balanced Tuned R.F. Receiver

Oscillations Are Completely Under Control At All Times
With This Set

By JOHN M. KIRKLAND

ONE of the greatest drawbacks of receivers employing one or more stages of tuned radio frequency amplification is the probability that in the middle of a top-hole program they will break into violent oscillation, with or without any apparent cause. There have been cries that rang to the blue heavens for a circuit that has tuned radio frequency amplification, but will not oscillate on any occasion, after it has once been instructed not to.

In the receiver shown in the accompanying illustrations a circuit is used that more or less fills the bill in overcoming this disadvantage of tuned radio frequency circuits in general. A multitude of systems have been created for the elimination of oscillations in this type of receiver; all the way from the old-fashioned potentiometer to the newest-fangled idea in left-handed gadgets; but most of them are fairly difficult to adjust and the tuning is rather complicated. However, in this circuit, there is but one slight adjustment to make for the elimination of the unwelcome oscillations, and that is the variation of the small five-plate condenser (No. 8 in the views.)

The circuit for this receiver has one stage of balanced tuned radio frequency amplification, a detector which is tuned and its sensitivity controlled by a resist-

ance method, and two stages of transformed coupled audio frequency amplification. A feature of the set as built is that there are separate terminals for the last stage of the audio amplifier, so that the plate and grid bias voltages may be varied and the best results thereby obtained. Often, the experimenter will recollect, he has wished to try a different "B" or "C" voltage on

stats, while there is another rheostat in series with the radio frequency tube, which serves as a control for the volume.

A couple of minor changes might be made in the circuit as shown in the accompanying diagram. In the first stage of the audio frequency amplifier there might be substituted a 6:1 ratio transformer, instead of the 2:1 as in-

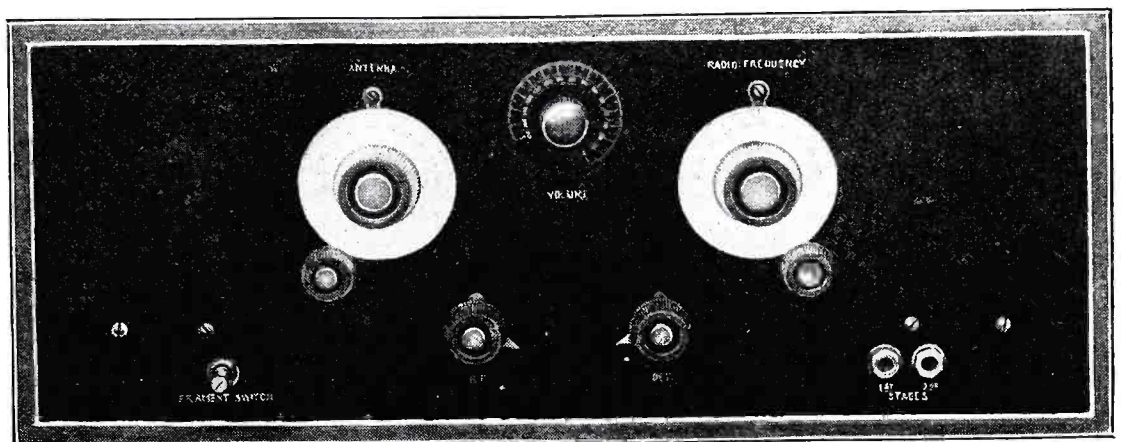

Photos by courtesy of General Radio Co.

The panel view of the tuned R.F. receiver. There are only two tuning controls, making it a simple matter to pick up stations.

the second stage than that used on the first; and these extra terminals are provided for this purpose. Instead of rheostats ballast resistances are used in the audio amplifier. However, the detector and radio frequency tubes' filaments are controlled by the usual rheo-

dedicated. This suggestion is for experimenters, who live at a considerable distance from a broadcast station and who desire more than the usual volume from their set. If a tube of the UX-120 type is to be used in the last stage of the amplifier, this change is advisable,

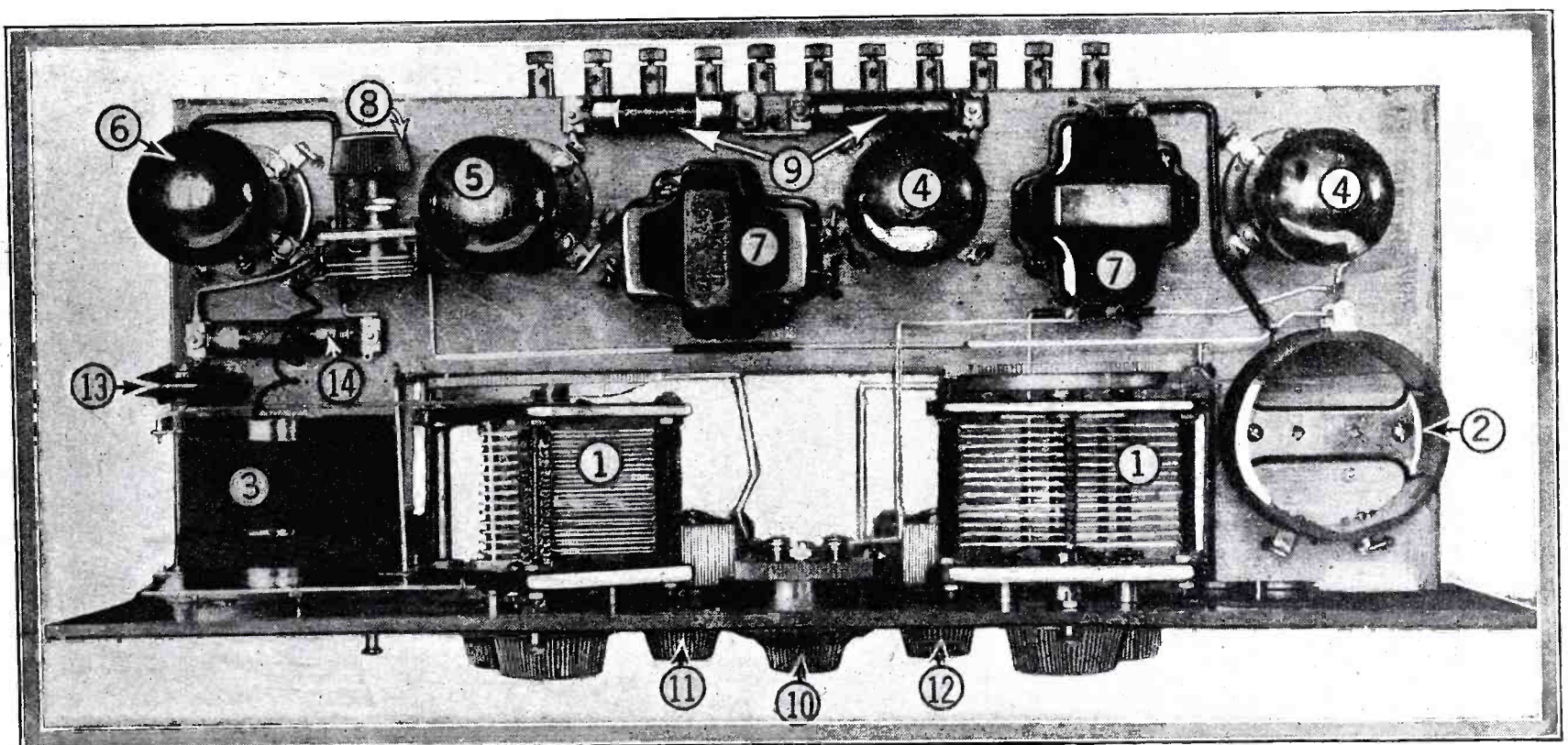

No. 1 indicates the variable condensers; 2, the R.F. transformer; 3, antenna coupler; 4, A.F. amplifier tubes; 5, detector tube; 6, R.F. tube; 7, A.F. transformers; 8, 5-plate condenser; 9, automatic filament controls; 10, high resistance rheostat; 11 and 12, filament rheostats; 13, grid condenser, and 14, grid leak.

as this type of tube has a low amplification factor. If UV-199 tubes are to be used in both stages of the amplifier this change should not be made.

The other change that might be made in the diagram is the introduction of a double-circuit jack in the plate circuit of the first tube of the audio frequency amplifier. This is for fans who live in the vicinity of large cities where there are broadcast stations whose volume would be too great for the house.

condensers and the three rheostats. Then the wooden baseboard is prepared by cutting out the section immediately under the two variable condensers. The baseboard is 7 x 17 x 1/2 inches and the cutout section is 11 x 3 inches, allowing 3 inches at each end of the baseboard for the two inductances as shown. The apparatus is placed temporarily in position on the baseboard, and then holes of a diameter that will permit bus bar wire to enter are drilled

each other, as are the two audio frequency transformers.

The two inductances are wound with No. 24 D.S.C. wire on tubes of insulation, which are about 2 1/4 inches long and 2 3/4 inches in diameter. On these tubes first wind 59 turns of the wire, with a tap at the 30th turn in one case and at the 35th in the other. The latter is the secondary of the radio frequency transformer; and the primary consists of 15 turns wound on a thin

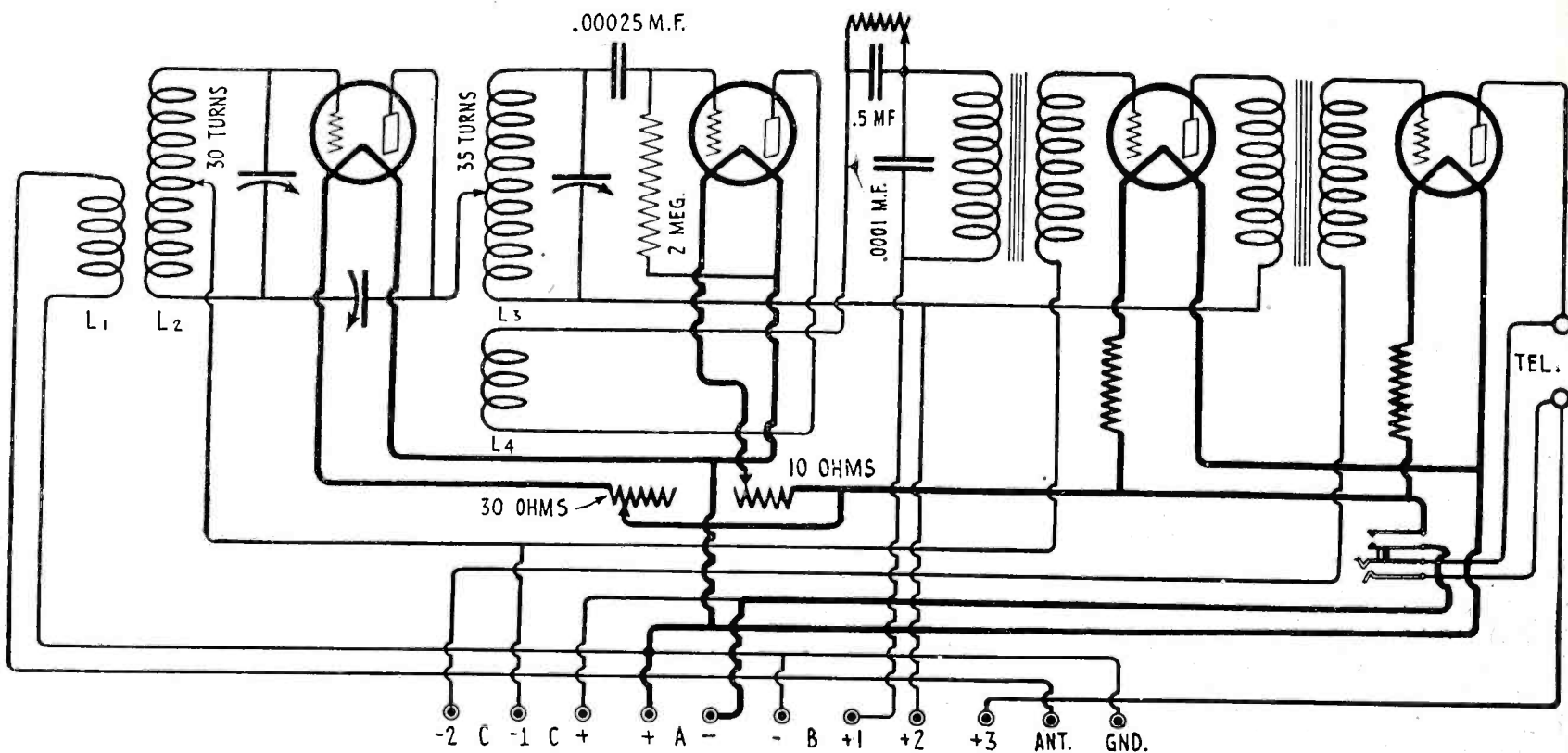

Above is shown the circuit diagram of the four tube receiver. It will be noticed that the terminals marked +1, +2 and +3 are those for plate voltages. The last two may be connected if 90 volts are used on both A.F. tubes.

Construction

From the front view of the panel and the other illustrations a good idea can be had of the position of the various instruments. The panel, which is 7 x 18 inches, is first drilled for the

through the board, to permit ease in wiring through the board, to permit ease in wiring and to shorten the length of the leads to the various instruments. It should be noticed that the two inductances are placed at right angles to

strip of insulation and slipped over one end of the secondary. This is all the construction. The inductance which has its secondary tapped at the 30th turn is placed in the antenna circuit, (Continued on page 162)

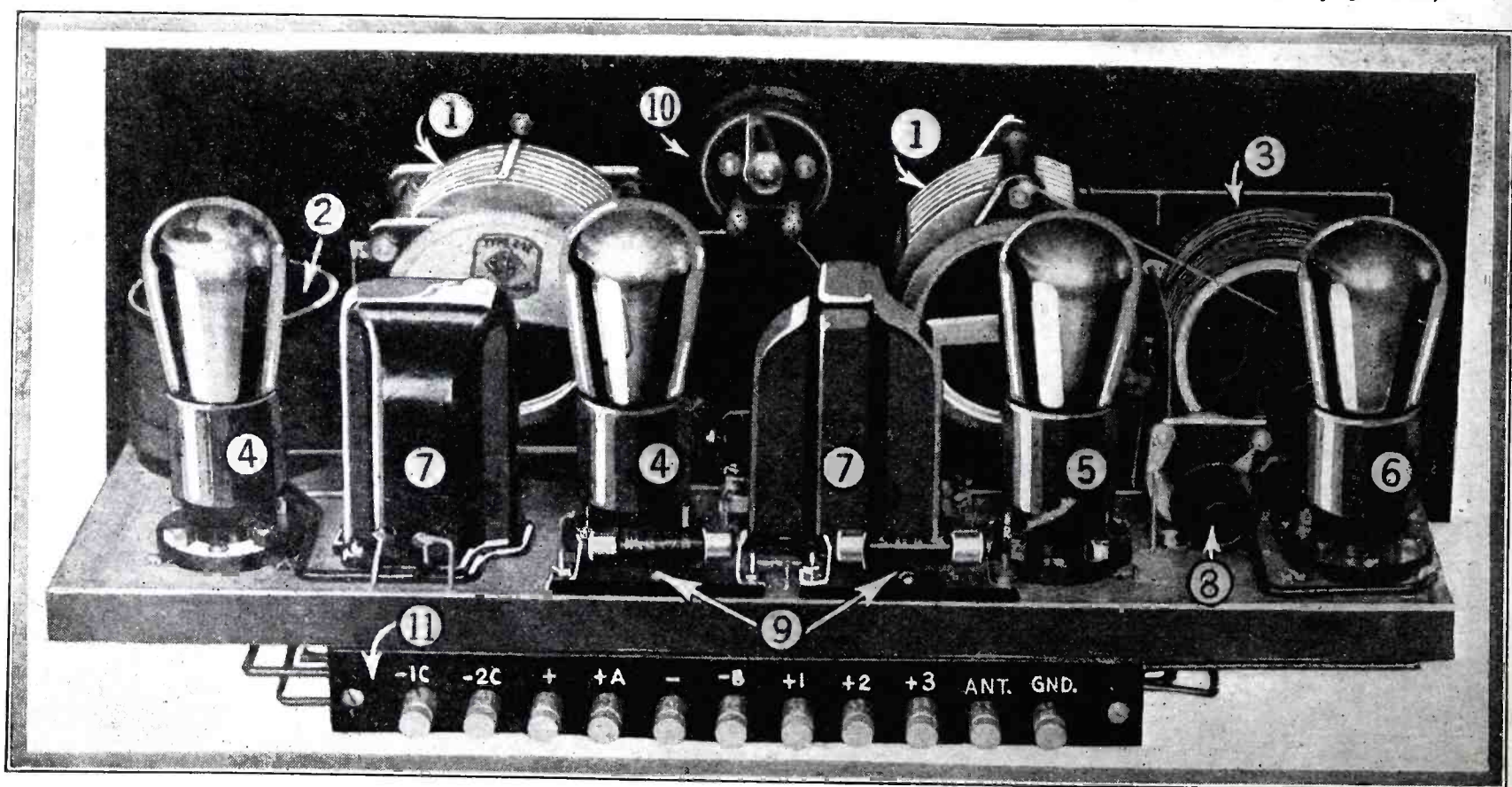

The rear view of the receiver: 1, the variable condensers; 2, the R.F. transformer; 3, the antenna coupler; 4, A.F. amplifier tubes; 5, detector; 6, R.F. tubes; 7, A.F. transformers; 8, compensating condenser; 9, self-adjusting rheostats; 10, high-resistance rheostat; 11, terminal board.

An Easily Constructed Power Amplifier And "B" Supply Outfit

This Power Amplifier Gives Perfect Tone Quality and is Combined
With "B" Battery Eliminator

By J. E. COOMBES

POWER amplification is the increase of the strength of radio reception, without distortion, through the use of larger capacity tubes, capable of handling many times the volume of the tubes ordinarily employed.

"But," you may say, "my set has plenty of volume as it is,—more, in fact, than I can listen to in comfort; and the quality is excellent."

Power amplification has a much

road at a speed of not more than thirty miles an hour we could get along with much less power than the average car possesses. But there are times when we need a good pick-up, there are occasional steep hills and mud holes or sand pits that require many times the power used in the normal run. We do not make a practice of travelling through traffic at 60 miles an hour, but there are times when we need that power.

of a flute. Likewise it is easy to understand that the consumption of *electrical* energy must be proportionate to the mechanical energy expended. A radio tube with the capacity just sufficient to amplify comfortably the music of a violin cannot be expected to do justice to the tones of the heavier bass instruments.

The development of the U.X. 210 and the C.X. 310 power amplifying

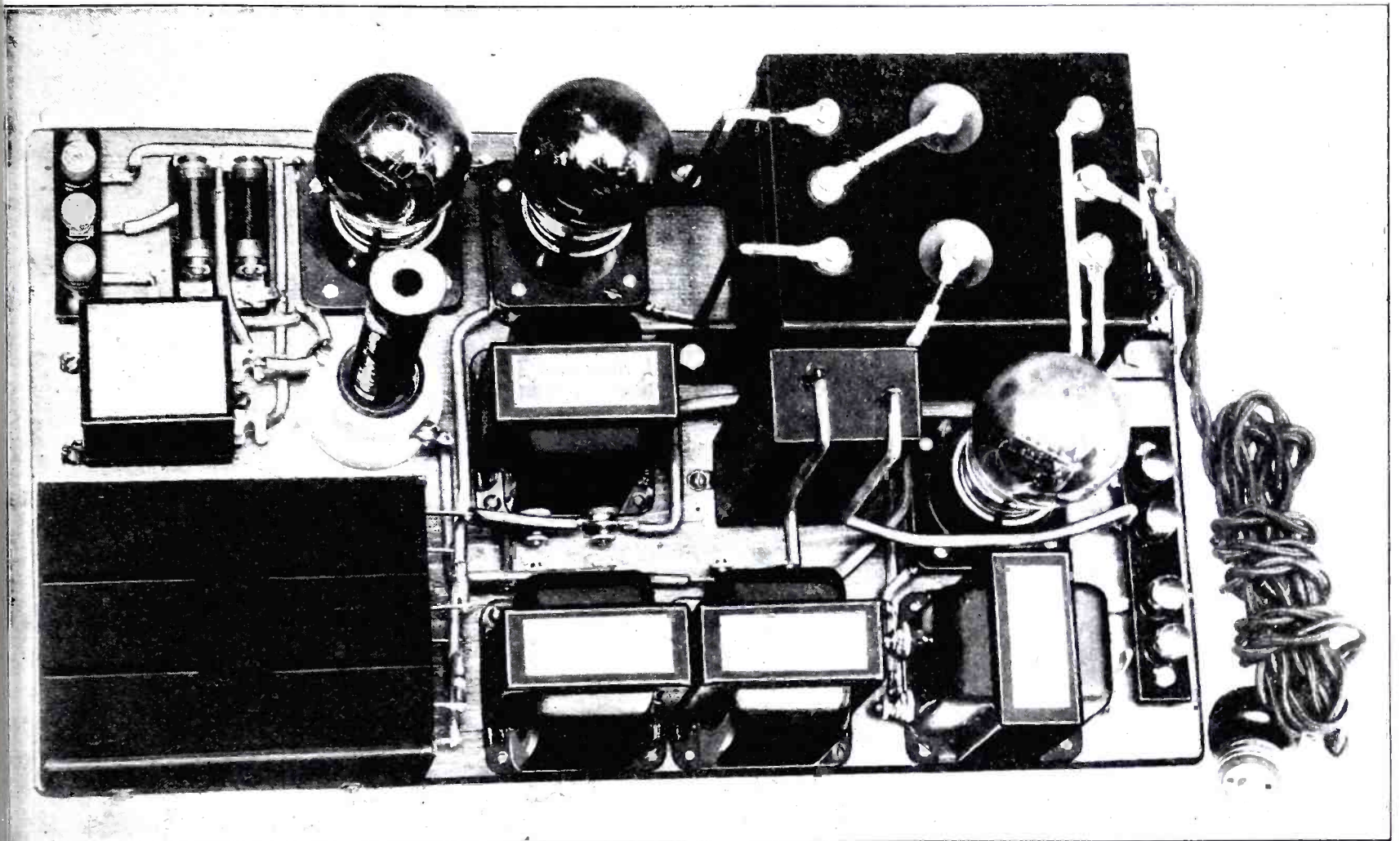

Top view showing complete assembly of power amplifier combined with "B" battery eliminator. Illustrations by courtesy of Thordarson Elec. Mfg. Co.

more important function than merely to increase volume. It gives the set power to reproduce the heavier tones and overtones which cannot find release, even at moderate volume, through the customary method of amplification. Power amplification gives radio reproduction the fullness of a third dimension, reproducing every sound from the highest treble to the deepest bass of the broadcast program with almost unbelievable realism.

If driving a car were narrowed down to moving smoothly along a level paved

If radio reception were put to no greater task than reproducing the music of the violin, power amplification would be unnecessary. There are times, however, when broadcast reproduction demands many times the power consumed in duplicating the music of the original violin.

It is not difficult to appreciate the fact that the beat of a drum or the deep vibrations of the pedal diapason of the organ require a much greater expenditure of *mechanical* energy than does the bowing of a violin or the playing

tubes has meant much in the advancement of quality reproduction. The standard amplifying tubes in common use today—the U.X. 201-A and C.X. 301-A—have a maximum undistorted power output of .015 watts when operated at the normal of 90 volts on the plate. The undistorted power output of the power tubes mentioned above is much greater,—measuring 1.54 watts, or more than 100 times the output of the ordinary amplifying tube. This is sufficient to amplify the music of any broadcast program without tube

distortion or sacrifice of bass notes.

Operates from the Light Circuit

A tube producing so much more power necessitates the use of more power to operate it. These power tubes require the special voltage of 7½ on the filament and 425 on the plate for maximum results. Batteries, to supply the current of proper values, would be so costly, inconvenient, and bulky as

Sketch (G) represents the power unit for the U.X.210 tube and the B-supply for the entire receiver.

Sketch (H) represents the stage of power amplification (transformer coupled), which may be built either with the supply unit or installed in the receiver itself by converting the last audio stage to conform with this diagram.

Before laying out your apparatus or beginning your wiring remember that

high voltage condensers are grouped together, or if the apparatus is mounted on a metal base plate, insulate the case of the condenser of the power amplifier (sketch H) from the cases of the other high voltage condensers. The

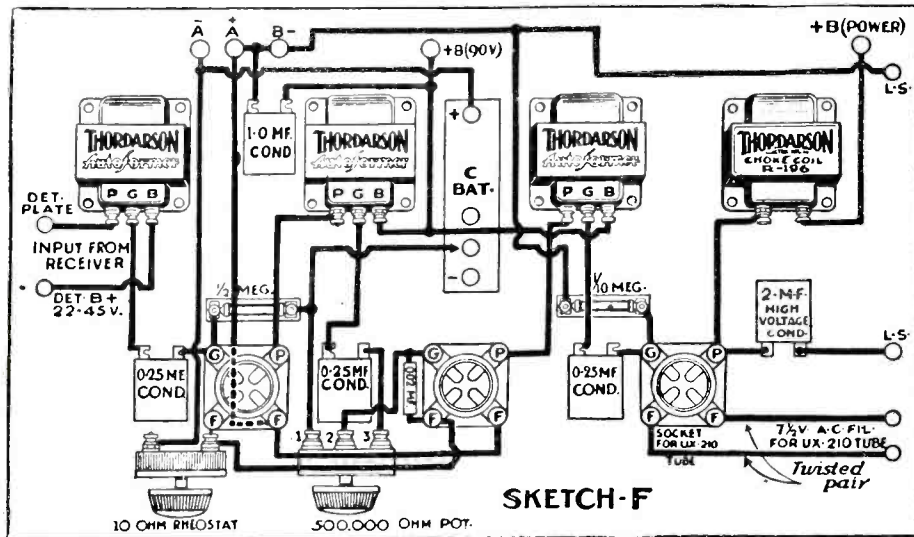

This sketch illustrates the method of installing the power amplifier with the Autoformer coupled amplifier.

to make their use prohibitive. The Thordarson power supply transformer R-198 furnishes the proper values of current for both plate and filament of this power tube.

The current for the plate is rectified from A.C. to D.C. through the radio-tron U.X. 216-B tube designed for this purpose, after which it is "ironed out" through the usual filter circuit of condensers and chokes.

One very convenient feature of the Thordarson power amplifier is the use of the voltage regulator tube, U.X. 874, which eliminates all controls, making manual voltage regulation unnecessary. This makes it possible to put the amplifier in the battery compartment, out of the way.

In addition to serving as the supply for the power tube, the complete assembly shown in sketch (G) also provides the proper values of B-voltage to take care of the needs of the entire receiver, furnishing 45 volts for the plate of the detector tube and 90 volts for the stages of ordinary amplification. This B-elimination feature operates, as does the amplifier itself, with no internal hum or other noises. It would be well for the man contemplating the construction or purchase of a B-eliminator alone to bear in mind the great advantage of the combination of power amplification with B-elimination which this circuit affords him at but a slight increase in cost.

Installation Instructions

The combined pictorial diagrams (G) and (H) illustrate a layout that can be followed by the most inexperienced novice in radio affairs.

you are dealing with alternating current voltages up to 500,—strong enough to give a very uncomfortable shock to the unwary. Use rubber covered wire or bus bar wire covered with rubber tubing when connecting up the amplifier.

Mounting the Condensers

Where space permits, we recommend following the layout of the accompanying sketches. If space for this arrange-

- PARTS REQUIRED**
See Sketches (G)
- 1 Thordarson Power Supply Transformer (R-198)
 - 2 Thordarson Chokes, 30 henries, (R-196)
 - 3 2 Mfd. high voltage condensers. (Not less than 400 volts normal load and 1500 volts D.C. flash test. Dubilier Tobe Deutschman)
 - 2 1 Mfd. condensers (standard bypass type)
 - 1 4 Mfd. condenser (standard bypass type)
 - 1 8,000 ohm resistor (capacity to carry 40 milliamperes. Ward Leonard)
 - 2 10,000 ohm resistors (grid leak type)
 - 1 1,000 ohm resistor (capacity to carry 25 M.A. current)
 - 1 U.X. 216-B or C.X. 316-B rectifying tube
 - 1 U.X. 874 or C.X. 374 voltage regulator tube
 - 2 Standard tube sockets
- See Sketch (H)
- 1 Thordarson R-200 Amplifying Transformer
 - 1 Thordarson Choke, 30 henries (R-196)
 - 1 2 Mfd. high voltage condenser (same specifications as above)
 - 1 U.X. 210 or C.X. 310 power amplifying tube.
 - 1 Standard tube socket.

purpose of this is to prevent the 60 cycle hum of the light circuit from being induced into the power amplifier itself. To further prevent any inductive pick-up in the power amplification stage, it is advisable to twist the 7½

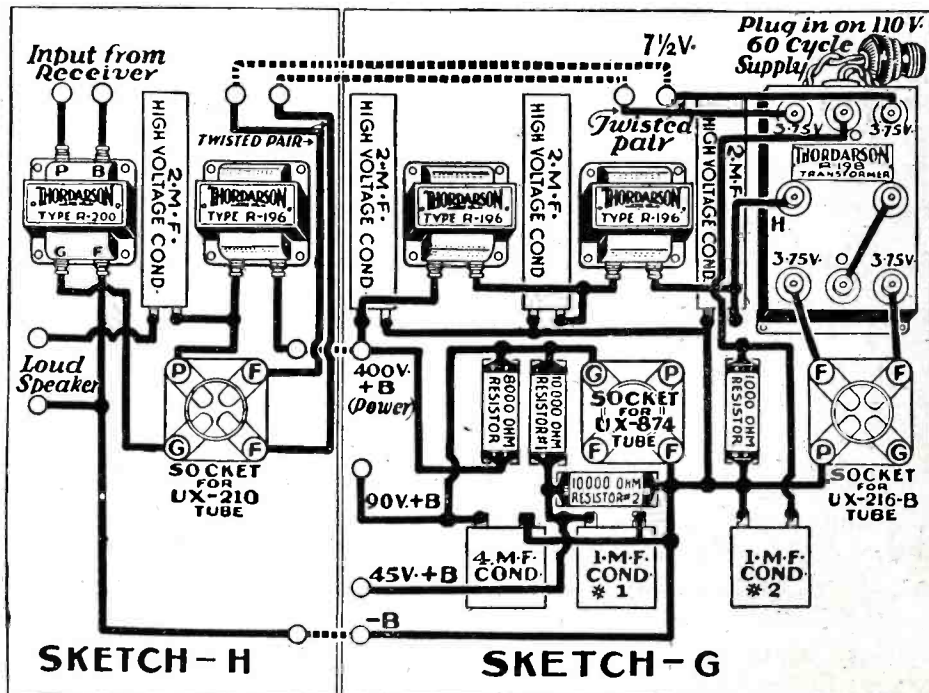

Sketch G represents the power unit for the UX210 tube and the "B" supply for the entire receiver; sketch G is the stage of power amplification.

ment is not available, much room may be saved by mounting the condensers under the chokes. The three high voltage condensers of the power supply (sketch G) may be placed side by side with their cases touching. If all four

volt filament leads of the U.X. 210 and the U.X. 216-B tubes. These are the leads extending from either end of the transformer (R-198).

The 8,000 ohm resistor between the
(Continued on page 156)

The New B-6 Donle Detector

Radio Enthusiasts Will Be Interested in This New Detector Tube

By H. P. DONLE

THE majority of radio enthusiasts, who have either built a radio receiving set or bought one ready-made, are vitally interested in any method of increasing their radius of reception and the volume of their received signals. The means whereby this can be done, in the majority of cases, are decidedly limited; for this increase must in all cases be secured without loss or sacrifice of signal quality and without the addition of other controls.

To secure an increase in volume-sensitivity of a receiving system usually implies considerable additions and alterations to the circuit, in both radio and audio stages.

There is one way, however, in which these very desirable improvements may be secured, by the simple substitution of a "sensitive detector" for the ordinary "hard" tube; and thus, without any changes in the circuit, the radius of reception and volume of signals secured with the outfit will be greatly increased. Furthermore, a considerable improvement will be secured in tone quality from the set.

There have been several types of "sensitive" detectors used in the last few years, but only two of these have ever been sufficiently satisfactory to become popular. These are: first, the

quently a large filament current. The critical adjustment of this type of detector is a decided disadvantage, be-

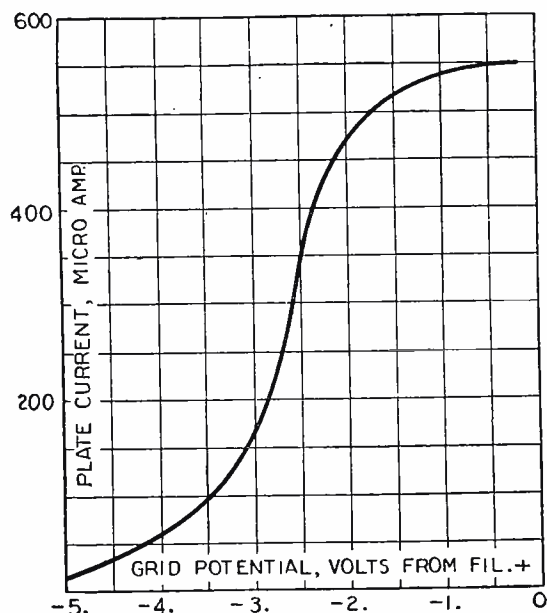

Fig. 2. The static characteristic curve of the Donle B-6 detector tube is reproduced above.

cause with the average radio set it is not practical to make these adjustments and, furthermore, these gas detectors do not give the quality of signals which can be secured by a properly-designed detector.

The Sodian detector gave far more satisfactory results than any detector

Needs No Critical Adjustment

A new detector has been developed by the writer which gives very satisfactory results under all conditions: it is more sensitive than any detector previously used, it does not require critical adjustments, and it gives that round, full quality of tone so desirable in a receiving set. The adjustments of this tube are so broad that it may be inserted in any standard receiving set, which has previously been operating with a hard tube, without even altering the rheostat. In fact, with this new tube, the adjustment of the rheostat is a factor of minor importance and may be eliminated entirely, particularly if the value of "B" potential applied to the tube is properly adjusted.

The structure of this new tube is very simple and much like that of any

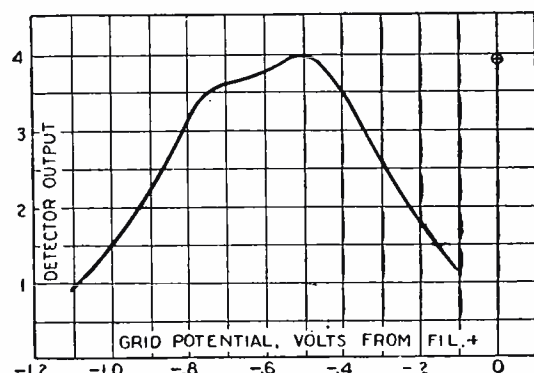

Fig. 3. Here is plotted the intensity of the signal at various values of grid voltage.

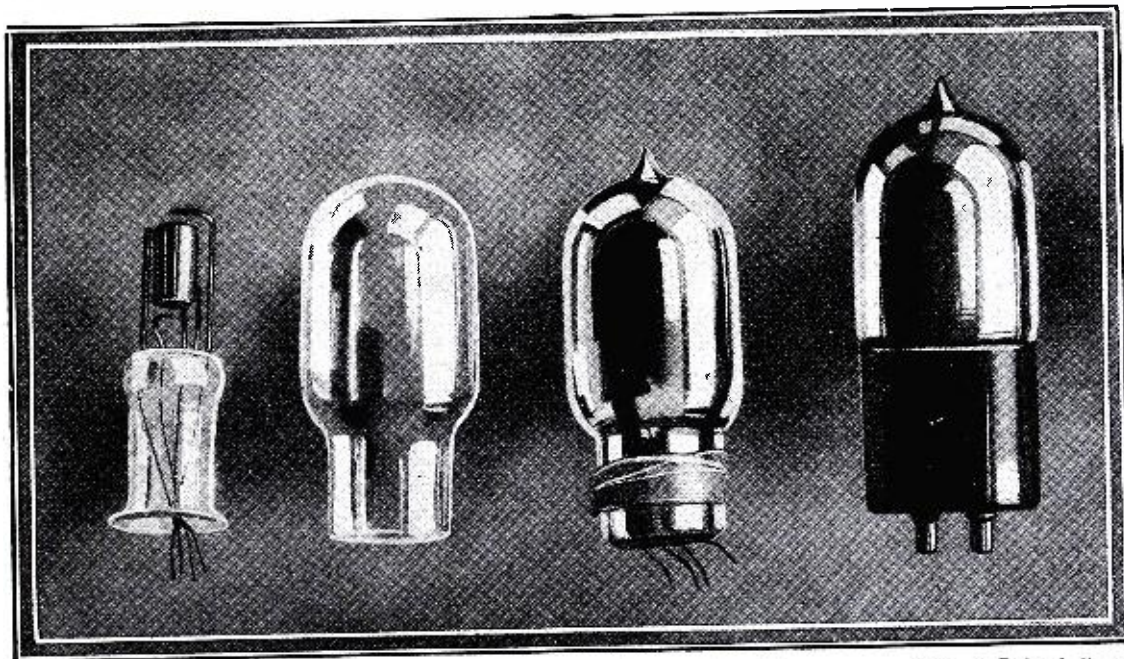

Fig. 1. The elements of the B-6 tube are shown at the left; the glass tube is next; the resistance that is in series with the filament is then shown wrapped around the glass and last is the finished tube.

gas detectors such as the UV-200; and, secondly, the alkali-metal detector known as the Sodian. All detectors in which a gas such as argon is used require critical adjustments, and fre-

used previously, on account of its simple and broad adjustment and its quality of signal. But for various reasons this detector has been withdrawn from the market.

ordinary tube, as shown in Fig. 1. The essential parts and their arrangement are as previously stated, quite ordinary. The extreme sensitivity and quality of signals, secured from this tube depend, not so much on the structure, as on the gas contained in the bulb, which for patent reasons may not be completely described at the present time.

Automatic Current Control

In practice the resistance "R" is wrapped around the neck of the tube and is connected in series with the filament. This resistance plays an important part in the tube operation and has a distinct bearing on the blunt filament-current characteristic. The potential across the terminals of the filament in this tube is only 1.1 volts, but the potential across the outer terminals of the tube base is 5 volts. The difference between these two values is taken up in this resistance "R." The resistance consists of a short length of wire having a high temperature-coefficient of resistivity, and tends to maintain the

filament current constant with varying battery voltages; thus practically eliminating one of the most disagreeable features connected with the use of a sensitive detector, that of critical filament-current adjustment.

methods shows a considerable variation for signals of different intensity; nevertheless, in general equally good results will always be secured with this tube without a grid-leak and condenser, particularly with the use of a potentiometer, which allows the grid potential to be fixed at the most appropriate value.

curves indicate a very great gain on weak signals, decreasing as the signal increases, until both tubes give substantially the same results on the strongest signals. The point, however, where the performance of these tubes becomes nearly equal, is at a signal intensity which has practically saturated each tube; saturation occurring on the "sensitive" detector at a slightly lower signal than on the "hard" detector.

The means whereby these last curves were obtained may be of some interest. The circuit used is shown in Fig. 5, where the signal is secured from a buzzer-excited wavemeter placed at some distance from the detector testing circuit, and arranged so that its relation in regard to the inductance in the latter circuit may be readily altered. The grid circuit of the detector is connected to the usual type of capacity-inductance circuit.

The output of the detector passes into an ordinary two-stage audio amplifier. The output of this audio amplifier is connected to a loud speaker which is in series with the primary of a transformer. The secondary of this transformer is connected to a microammeter through a crystal detector. This transformer is used for the purpose of separating the A.C. and D.C. components in the plate circuit of the audio amplifier, in order that the microammeter may indicate only the alternating component, which is rectified by the crystal detector and indicated as a direct current on the meter.

This circuit is exceedingly simple and allows direct comparisons to be made of various types of detector, the results of which may be read directly upon a meter, thus eliminating the uncertainty and errors accompanying the

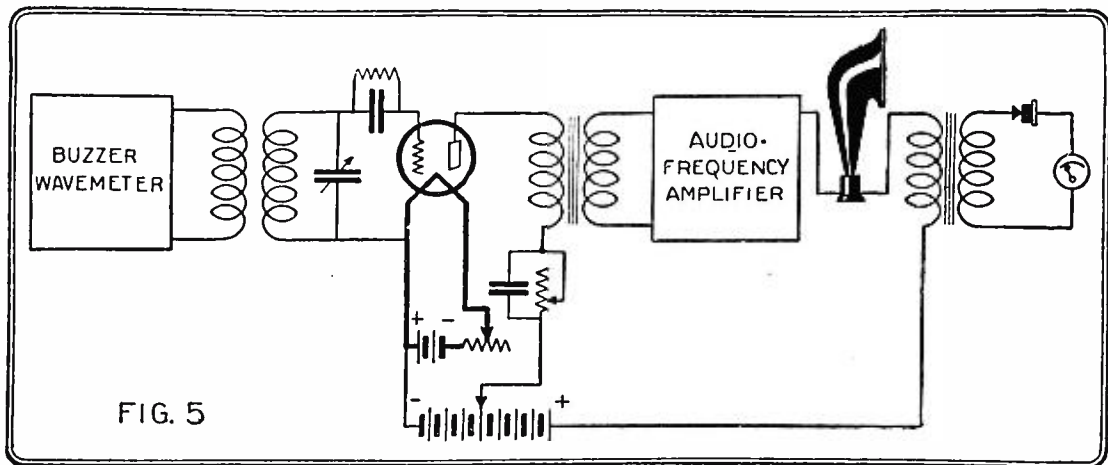

FIG. 5 How the apparatus was connected to obtain the curves in Fig. 4. The variable distance is between the two inductances at the left.

The static characteristic of this tube is in many ways similar to that of any other tube, particularly to one in which ionization exists. Its curves are shown in Fig. 2, and were taken under the usual conditions. The particular point of interest in connection with these curves is that contrary to the usual idea, detection does not take place at a sharp kink or bend in the static characteristic.

In Fig. 3 the intensity of the received signal is shown, taken at various values of grid potential with a constant value of applied signal, this latter value being measured from the positive end of the filament. This curve indicates that the maximum response is secured at a point on the static characteristic at which there is no abrupt bend, and detection is due to another factor entirely.

Eliminating Grid-Leak and Condenser

Fig. 3, described above, which shows the intensity of signal at various grid voltages, is quite interesting because it indicates the very large signal which can be secured from this tube without the usual grid-leak and condenser. In order to show the relative magnitude of signal, detected with and without grid-leak and condenser, the signal with

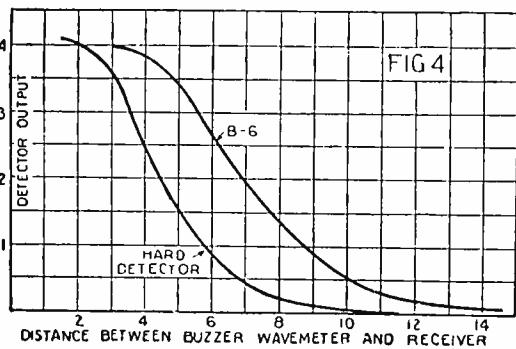

These curves show that the B-6 gives a greater output over most of the range than an ordinary hard detector tube.

performance under actual operating conditions; that is, the output which it will give for applied signals of different

Sensitivity on Weak Signals

The matter of greatest interest in connection with this tube is its per-

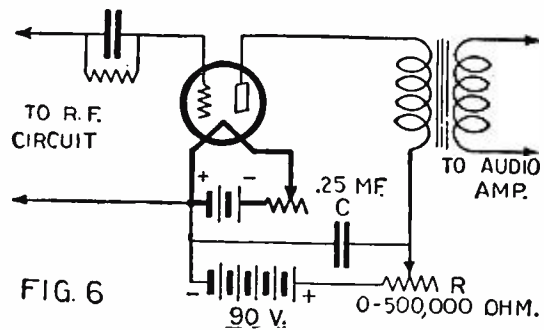

FIG. 6 This diagram shows the connections necessary for obtaining the correct plate voltage.

formance under actual operating conditions; that is, the output which it will give for applied signals of different

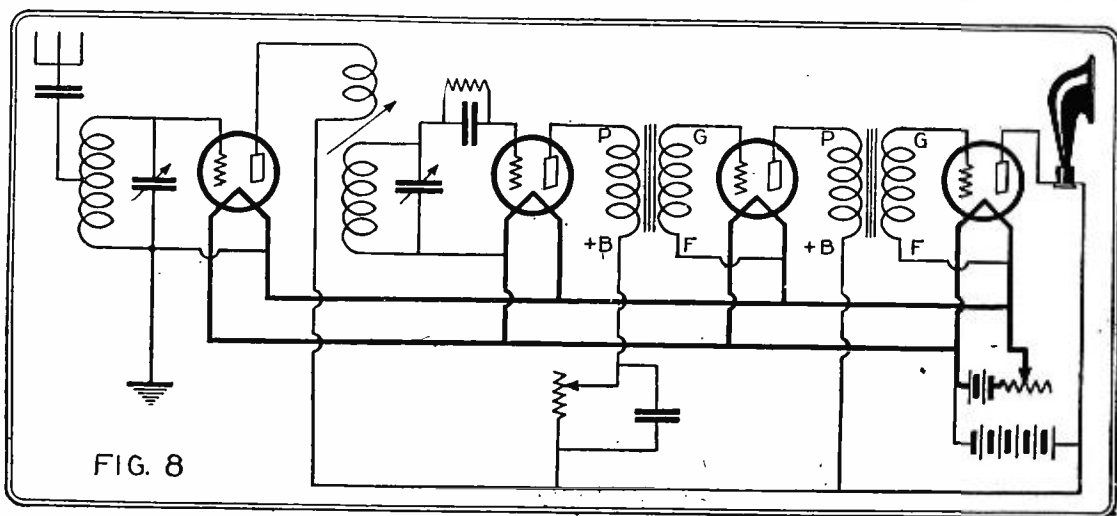

FIG. 8 The circuit diagram of a receiver in which is incorporated the Donle B-6 detector tube. Notice the rheostat in the plate circuit to vary the voltage.

intensity, and how it compares under these conditions with the usual detector. The results of such a test are shown in the curves of Fig. 4 which shows the response in telephone current, or current supplied to the audio amplifier system, given in arbitrary units for applied signals of varying intensity both with the new sensitive detector and with a typical "hard" tube. These

use of audibility measurements. Furthermore, slight differences in operation which would be difficult and almost impossible to detect by means of audibility measurements are most clearly indicated with this circuit. The horizontal scale of Fig. 4 shows the distance between the coil of the buzzer wavemeter and the coil connected to the detector tube being investigated.

the grid-leak and condenser, taken for the same value of applied signal, is shown on this curve by the crossed circle. The comparison of these two

Adjustment of "B" Voltage

The sensitivity of this tube is affected to a considerable degree by the value of plate potential used and it is highly desirable in all cases, in order to secure the best results, that this be carefully adjusted. The method whereby this adjustment can be made most readily, and which simplifies to a certain extent the receiving circuit, is shown in Fig. 6. A rheostat with a high resistance range is connected in series with the plate circuit of the detector tube and is shunted by a fixed condenser and connected to the 90-volt terminal of the "B" battery instead of the usual 22½ volts. This rheostat is adjusted until a signal of maximum volume and quality is obtained and, will not require further readjustment at any time.

The results obtained by the use of this adjustment are shown in Fig. 7, which is a curve showing the output of detector with a fixed value of applied

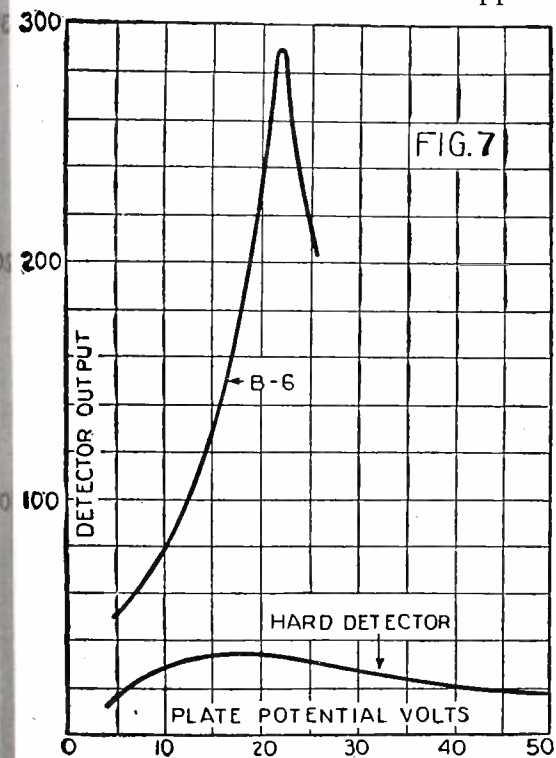

These curves show how critical the plate potential is for the Donle tube, and the opposite for a hard detector.

signals for various values of plate potential. On this same curve is also shown, taken under similar conditions, the performance of a typical "hard"

detector. While these curves show that reasonably good results can be secured with the new detector without this adjustment, still there is in practice a substantial gain by its use, particu-

a neutrodyne circuit, for example, this can be accomplished quite readily; but in some other types it is rather difficult to rebalance and, therefore, the gain secured by the use of this tube will not

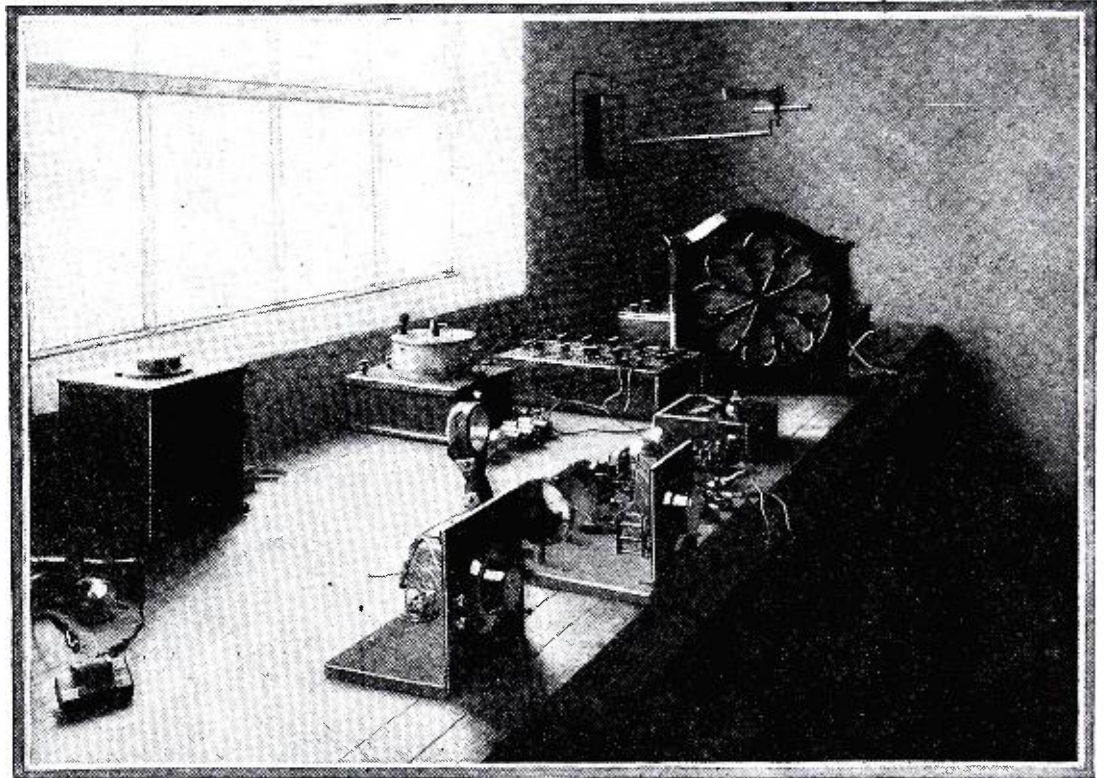

The apparatus used for obtaining the comparison curves in Fig. 4 in Mr. Donle's laboratory.

larly as these new detectors vary somewhat in this characteristic.

Rebalancing Sometimes Desirable

When this detector is used in any circuit where one or more stages of radio frequency precede it, the gain due to the more sensitive detector is modified to a greater or less extent by the effect of the detector-input-circuit impedance upon the balance of radio frequency circuits. In other words, a circuit, which has been balanced for a "hard" detector tube having a certain value of input impedance, may not be in proper balance when this new detector is used. Fortunately the difference in the value of this impedance is not sufficiently great to cause any material embarrassment; but it is desirable, if the means are available, to rebalance the radio frequency circuit with the new detector in operation. On

be equal to what it should be under most favorable conditions, although it is decidedly worth while.

This tube is most particularly adapted to a receiving circuit where no regeneration in the detector is employed. A circuit particularly designed for the new detector, incorporating all the desirable features which allow the maximum operation from the detector to be secured is shown in Fig. 8. It is extremely sensitive, gives excellent signal quality and volume and, furthermore, is simple to construct and operate. Various other forms of circuits are being designed for use with this detector, which depend largely upon sensitive detection for their operation, rather than upon the addition of many stages of radio and audio amplification; thus eliminating multiplicity of tubes, noisy operation and distorted signals, common to the usual radio set.

How and When to Use Power Tubes

(Continued from page 117)

to any socket, and to the tubes, proper B and C voltage by means of flexible wires, which protrude from the adaptor. This of course, means that no internal wiring changes are necessary, the adaptor being so designed as to save the set user all this unnecessary trouble.

"What are the best power tube or tubes to employ, there are so many now on the market," is another question often asked. Well, the first considera-

tion is "what sort of a receiver have you," and "does it employ the dry cell or storage battery type of tubes." The only data we have on dry cell power tubes is that of the UX-120 or CX-220. This eliminates any confusion that may exist with owners of the abovementioned type of set. In resistance coupled amplifiers, Mu-20 tubes should be employed and a power tube having the characteristic of Mu-6 (data furnished by the manufacturer of the

tube) placed in the last socket or stage.

With receivers operating with the storage battery type of tubes, we have the choice of any of the following types. The UX or CX-112, the UX or CX-171, UX-210 or CX-310. The UX-112 or CX-112 power tube would be the most advisable to employ, and their characteristic data may be found in the chart contained within this article.

Building The Raytheon B-Eliminator

By CHARLES GOLENPAUL

VERY little more need be told about the efficiency of the Raytheon type eliminator as by this time radio devotees are fully aware of the value of full wave rectification with its economical operation in employing the alternating-current electric light supply for the B-battery supply of the up-to-date receiver.

Raytheon B-eliminators are obtainable today in manufactured form and in the form of parts and kits for those who prefer to build their own. The necessary transformers, choke coils and condensers are now being offered by several well-known manufacturers.

The Raytheon rectifier tube has been specially designed for use in B-battery eliminator circuits such as that shown in the accompanying diagram. When employed in connection with the proper transformer, choke coils, and condensers, which are now on the market, the Raytheon will give ideal performance with any type of receiver. Not only does it provide a reliable, continuous and unvarying source of plate voltage at all times, but the reserve power of the Raytheon assures that smooth and distortionless flow of current so essential to clear reception.

The circuit diagram shown is the result of many months of development by eminent engineers, and the constructor is strongly advised to take advantage of this experience in building his own eliminator. Thorough investigation has proved that this circuit has unique features that give superior re-

sults in producing a source of high-quality B power.

sults in producing a source of high-quality B power.

In the accompanying diagram, T, is a specially designed transformer with tapped secondary to provide approximately 275 volts to each anode of the Raytheon tube. The anodes of the tube, *aa*, will be connected to the terminals marked "F" or "Filament" in the standard socket for vacuum tubes. The cathode, *c*, will be connected to the plate terminal of the same socket. (The grid terminal on the socket is not used.) C1 and C2 are high-voltage filter cir-

cuit condensers of 2 mfd. each. C3 is a high-voltage condenser of 8 mfd. C4 is a by-pass condenser of 0.5 mfd. choke coils and condensers should be connected to the — B lead. Make sure that one terminal of your "A" battery is grounded.

cuit condensers of 2 mfd. each. C3 is a high-voltage condenser of 8 mfd. C4 is a by-pass condenser of 0.5 mfd.

Caution: A B-battery eliminator is necessarily of much greater power than a radio receiver. It must be treated as an electrical appliance of high power and voltage, otherwise damaging short-circuits or shocks may result.

Referring to the smaller diagram, it will be noted how an intermediate tap may be added to the standard Raytheon B-eliminator circuit. R1, R2, and C3 and C4 are the same values as in the regular Raytheon circuit. C7 is a 1 mfd. by-pass condenser. The voltage that will be obtained at the intermediate tap is obviously dependent upon the current drawn. Hence it will vary with the number of tubes using this tap. A variable resistance R3 is obtained with a Clarostat, so as to take care of all possible combinations of tubes.

In general the use of higher plate voltages, with correspondingly high C battery voltage, is recommended for radio as well as audio amplification.

The radio constructor who is interested in building his own Raytheon B-eliminator is recommended to the manufacturers of Raytheon parts and kits advertising in this magazine. Whether to use one make of parts instead of another make is largely a matter of individual choice, since the Raytheon circuit manufacturers are all dedicated to the one cause even if their respective offerings may differ to a greater or less degree. The one essential feature, however, is to employ approved and efficient variable resistances such as Clarostats which will ensure the necessary range of resistance, silent operation, and long life. Whatever troubles have been experienced with B-eliminators in the past have been overwhelming due to faulty variable resistances which could not stand the necessary current and soon became noisy and even defective.

The Raytheon Tube in the Home-Made Eliminator

From the preceding we have gathered a general idea of the nature of the Raytheon tube and how it is applied to B-battery elimination. It is now our purpose to learn ways and means of applying the Raytheon tube in the simplest yet most efficient manner possible for an inexpensive home-made B-battery eliminator, which may be assembled from standard Raytheon

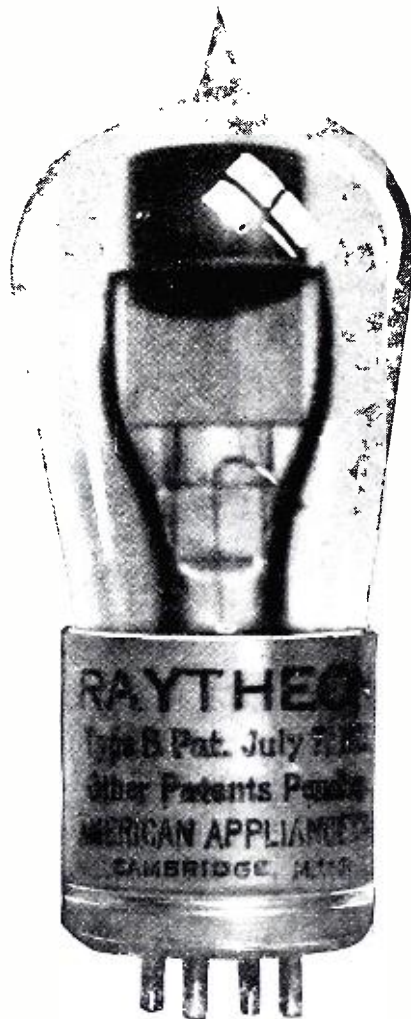

Above is a Raytheon gas content tube which has been especially designed for use in B-battery eliminator circuits.

(The above values of capacity may be increased if desired). C5 and C6 are

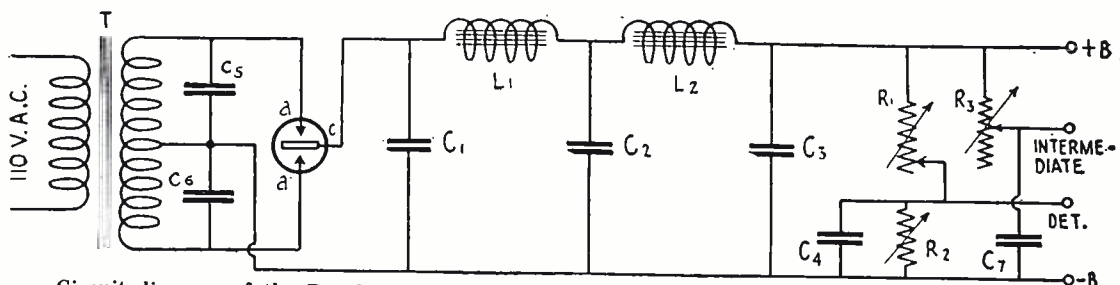

Circuit diagram of the Raytheon B-eliminator. R₁, R₂, and R₃ are variable resistances used to regulate the voltages of different tubes in the radio receiving set.

equipment by anyone with normal ability.

The Raytheon B-battery eliminator herein described will provide all necessary voltages for the various tubes in the regular radio receiver, namely, the detector, audio amplifier and radio frequency stages. This eliminator operates from the regular alternating-current house lighting circuit, with a transformer especially designed to supply the various voltages, while the Raytheon tube, as the double-wave rectifying member, converts the alternating current which is then ironed out smooth, so to speak, without ripples or irregularities to cause noise or hum, by means of a collection of fixed condensers.

For the transformer, choke coils and condensers, the builder is referred to the products of manufacturers who now make complete eliminator kits and eliminator components, while the variable high resistances should preferably be Clarostats.

The power supply set or eliminator in question, may be mounted either on a board alone, or may be furnished with a panel for cabinet mounting.

The transformer for this outfit must be designed for operation on 110 volts alternating current, while the second-

foregoing apparatus is all that is needed to deliver a rectified current, but such current is quite unfit for radio use as the direct current is pulsating or produces a hum in the radio loud-speaker. To eliminate the pulsating characteristic or hum, a filter is required. The parts for constructing the filter are:

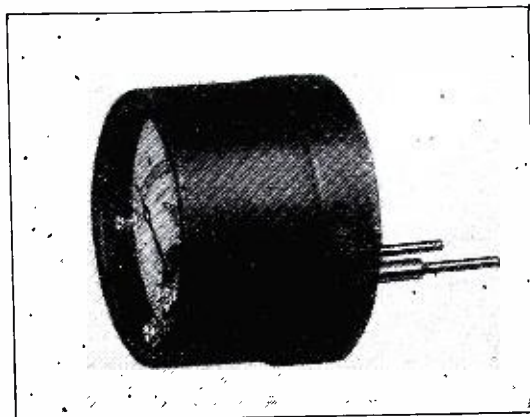

Photo by courtesy of Jewell Elec. Instrument Co. A high resistance voltmeter especially designed for testing the "B" battery is the only type of instrument to employ in testing the voltage of the Raytheon B-eliminator.

two choke coils of 30 henrys or more, with the resistance held as low as possible, say around 350 ohms. Together with these filter condensers, two of 4 mfd., three of 0.5 mfd. two of 2 mfd., and two of 0.1 mfd. For controlling

with the current switch alongside or on the panel in front of the transformer, then the Raytheon tube, followed by the two condensers of 0.1 mfd., which are used with the tube itself. The chokes and filter condensers come next, and finally the Clarostats are arranged in a row, either on the baseboard by means of their convenient bracket mountings, or on the panel, in the cabinet-mounting type. At the extreme end of the board, opposite the input, are placed the binding-posts for the direct current output. This makes for a most convenient and simple layout. The accompanying sketch shows the general arrangement of the various components, and if a panel is used, the same arrangement holds except that the switch, Clarostats and even terminals if desired, are placed on the panel.

Now as to installing the power set: keep it some distance from the set proper, as some hum may be introduced by the components of the supply set itself either through induction or through mechanical vibration. If the components are well shielded, the induction feature is eliminated, while the mechanical vibration may have little or no effect on the receiving tubes; especially if these happen to be of the non-microphonic type or at least mounted in

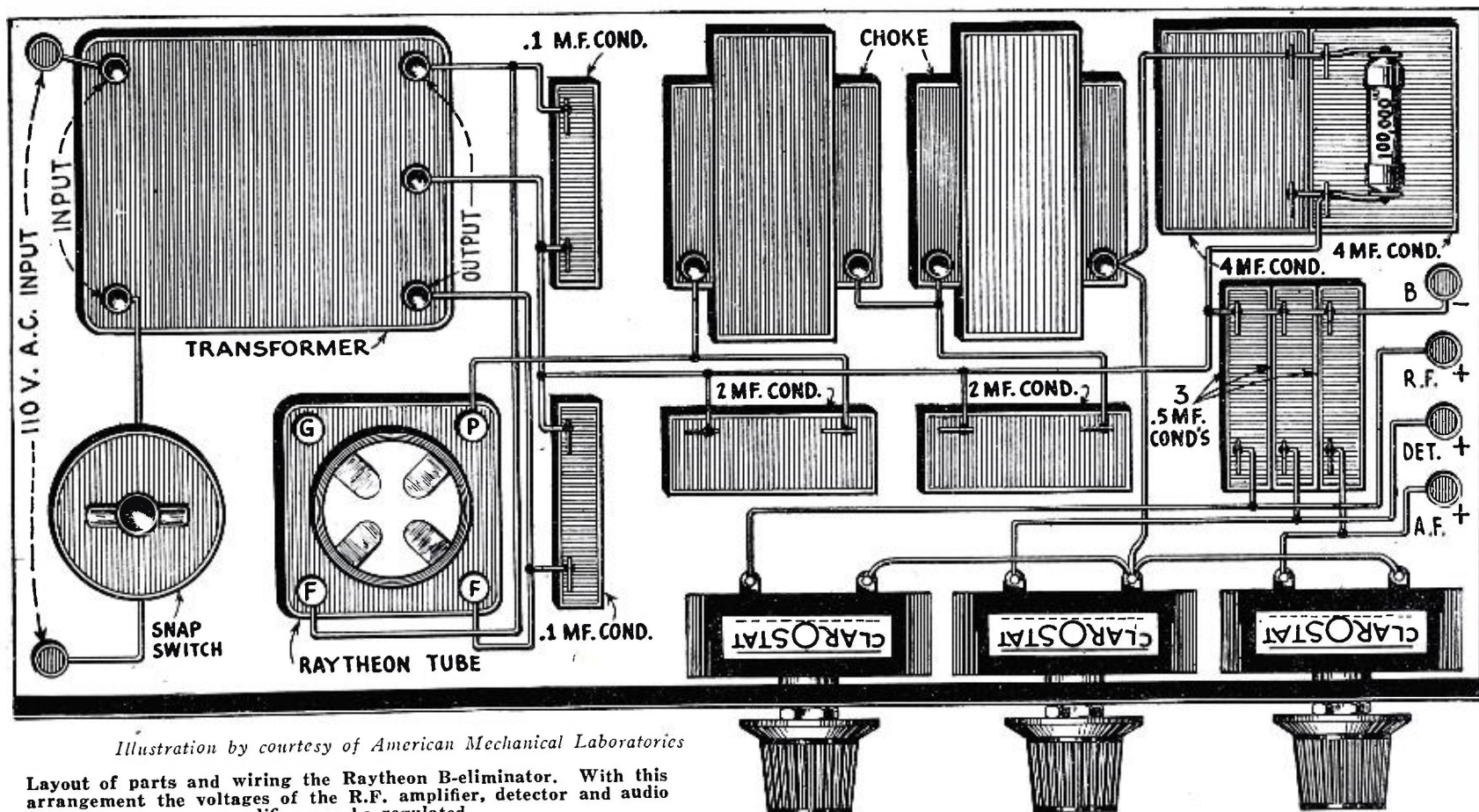

Illustration by courtesy of American Mechanical Laboratories

Layout of parts and wiring the Raytheon B-eliminator. With this arrangement the voltages of the R.F. amplifier, detector and audio amplifier can be regulated.

ary should deliver 400 volts, with a tap in the exact center, which will provide 200 volts on each side of the tap. As there is no filament in the Raytheon tube, no other windings are needed on the transformer. A standard tube socket is required for mounting the tube, and connections are made to the filament and plate terminals, the grid connection being unnecessary. The

the output, three Clarostats are required.

The mounting of the components should be such as to present the least wiring, and the output of the outfit should be kept as far away from the 110 volt input as is practical. A good scheme of layout is to place the transformer at one end of the board on which the components are mounted,

springy or suitably cushioned sockets.

After the receiver is connected with the power set, the resistance of the Clarostats are adjusted for best operating conditions. Do not try to use an ordinary pocket type voltmeter, such as is employed in testing B batteries, to adjust the voltage of the power supply set, as the resistance of this type

(Continued on page 152)

Readers' Problems

THIS Department is conducted for the benefit of our Readers. We shall be glad to answer here questions for the benefit of all, but we can publish only such matter as is of sufficient interest to all.

1. This Department cannot answer more than three questions for each correspondent. Please make these questions brief.
2. Only one side of the sheet should be written upon; all matter should be typewritten or else written in ink. No attention paid to penciled matter.
3. Sketches, diagrams, etc., must be on separate sheets.
4. Please do not ask for construction data on manufactured parts, such as transformers, kits, etc., as such data cannot in all cases be obtained from the manufacturers.
5. We are obliged to request that every inquiry which the reader wants to be answered by mail be accompanied by a remittance of one dollar to defray a part of the cost of the work involved.

(61) Mr. F. J. Graham, Bound Brook, N. J.

Q. 1. I am having considerable difficulty tuning out WJZ since they have gone on super-power and would greatly appreciate it if you could favor me with some information as to enable me to overcome this difficulty, if possible. It is just possible that others may also be having the same difficulty as I am having.

A. 1. The engineers at WJZ's Bound Brook station received numerous complaints from local listeners, and these engineers have advised that series and shunt trap circuits should be used, and in some cases a combina-

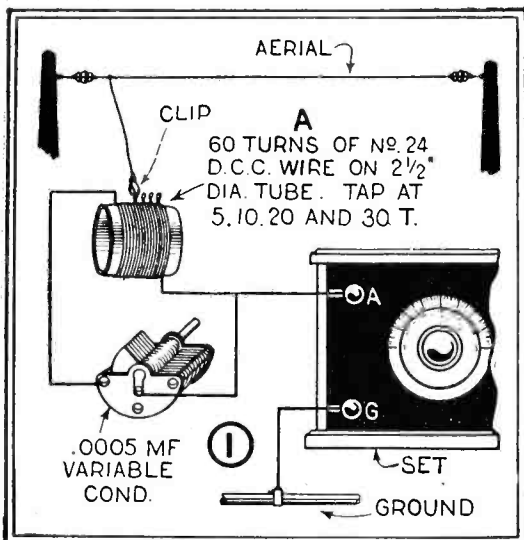

Fig. 1. A series wave trap.

tion of both, with the result that the fans who have installed such circuits have reported that there is a reduction in the interference. These circuits are by no means complicated and do not necessitate any change in the present construction of the receiver, being an auxiliary unit which is attached to the present receiver. The various circuits which have been recommended are as follows:

Fig. 1 shows a simple series circuit the function of which is to offer an obstruction to the station causing the interference and yet not offer resistance to other stations on other waves.

To construct this trap an inductance, variable condenser, a test clip and several binding posts are necessary. The inductance is made by winding 60 turns of No. 24 DCC wire on a bakelite or cardboard tube 2 1/2 inches in diameter. The condenser should have

a capacity of .0005 mfd. Taps should be made at the 5th, 10th, 20th and 30th turns, the tapped end of the coil being connected to the rotary plates of the

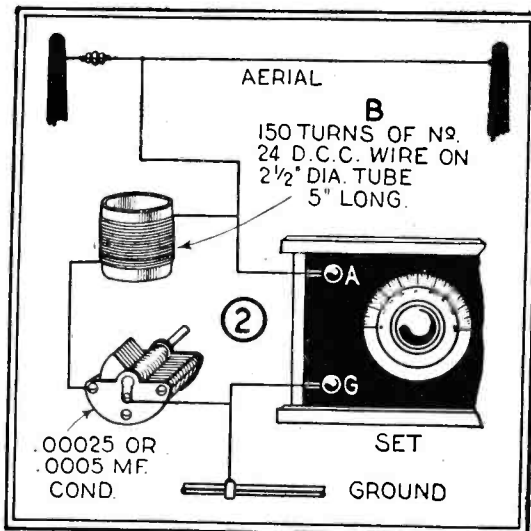

Fig. 2. In this illustration the shunt wave trap is shown.

variable condenser and the other end of the coil to the stationary plates. A flexible wire with a clip attached is connected to the aerial binding post of this wave trap, this flexible wire being for the purpose of connecting to the various taps on the inductance coil so as to obtain the best results. If desired, the coil and condenser can be neatly mounted in a small cabinet so as to make an attractive appearing unit. If it is not desired to wind an inductance coil, a honeycomb coil of 50 or 75 turns may be substituted.

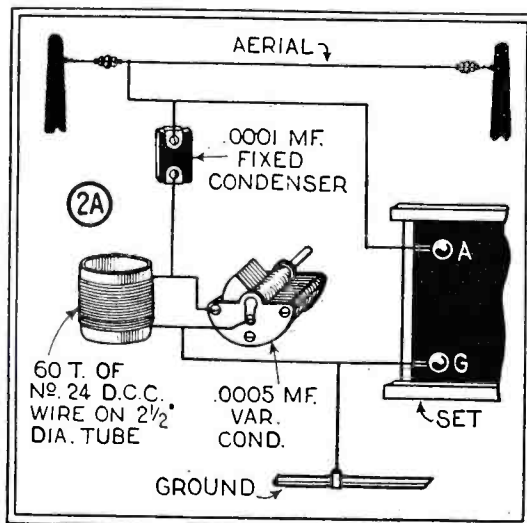

Fig. 2-A. A shunt trap with a fixed condenser in the aerial lead.

In constructing these wave traps care should be taken that the variable condenser and inductance coil are well separated. If these are too close to-

gether it will present sharp tuning.

The operation of the receiver is practically the same with the wave trap installed as without it. First adjust the receiver until the interference is relatively weak but still audible, then tune the trap until the interference is eliminated. Then retune the receiver so the interference can be heard and then a finer adjustment of the trap is made. If there is only one station which interferes it is not necessary to again touch the trap after it is once adjusted.

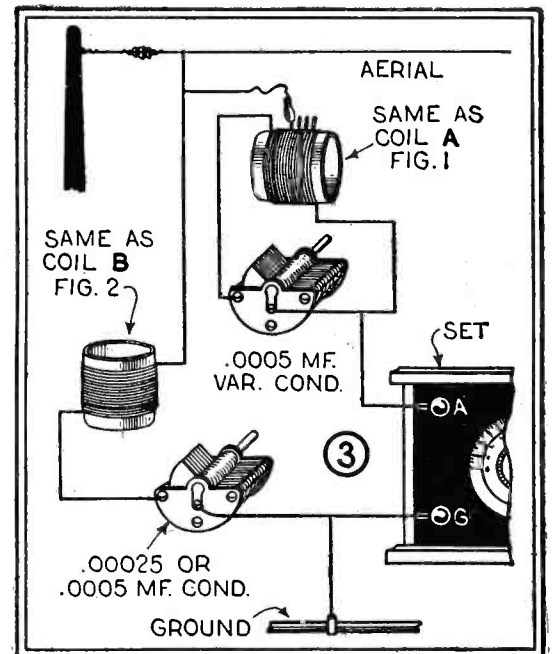

Fig. 3. A combination series and shunt wave trap.

Occasionally the series trap may not give total relief from interference and in this event a "shunt trap" may be tried. This is shown in Figure 2. The construction of the inductance "B" in Figure 2 is as follows: 150 turns of No. 24 DCC wire on 2 1/2 inch diameter tube 5 inches long, and the condenser here may be either .00025 or .0005 mfd. The tuning of this trap is the same as previously described. The purpose of this trap is to offer a low resistance path to lead the interfering signal direct to the ground so that it will not enter the receiver.

The series trap described in Figure 1 can also be changed into a shunt trap (without the taps) as shown in Figure 2-A. A .0001 mfd. fixed condenser is connected between the inductance coil and the aerial as shown in Figure 2-A. Sometimes it may be necessary to use both series and shunt traps simultane-

Announcement To Set Builders

HERE is the real guide for the fan and set builder, the book that hundreds of thousands of radio enthusiasts turn to when they want the latest and best in radio. It's the handiest and most reliable radio reference guide you could ask for, and a big money-saver besides. Keep up to date by utilizing Barawik service. It will help you to solve many a radio problem as well as saving you tremendous sums on the very things you need and use most. You may experiment all you want with the various circuits, for BARAWIK always gets you the parts specified by the famous circuit designers of the world.



The Most Complete Radio Guide

The Barawik Company, pioneers in radio, now offers you through its Radio Catalog and Guide, greater bargains than ever before in standard sets, parts, kits and supplies. No matter what parts you want, for whatever circuit or hook-up you may prefer, we can supply them to you at substantial savings. Special prices on tubes, batteries, cone speakers, cabinets, chargers, power supply units, etc.

Get Our Prices on the Famous Circuits Shown in Radio Review

It will pay you to get our prices for complete parts for the RADIO REVIEW circuits and all the popular circuits advertised and heralded by various publishers.

All merchandise guaranteed and of highest quality as required and specified.

Write today for our new 1926-27 Radio Catalog and Builder's Guide, showing radio's newest creations. Also please include name of other radio fans when writing.

**PIONEERS
IN
RADIO**

The Barawik Co.
540 Monroe St., Chicago, Ill.

BARAWIK CO., 540 Monroe St., Chicago.
Send me my copy of your new Radio Catalog and Builder's Guide.

Name.....
Address.....
Name of Firm.....
Address.....

ously, as shown either in Figures 3 or 4. The series inductance coil "A" is wound and tapped the same as the inductance coil described in Figure 1,

ceiver and the signals still come in, it shows that a direct pick up of energy is taking place. Under such conditions

it is necessary to use a trap on the coils themselves, as shown in Figure 5. With some types of receivers it is im-

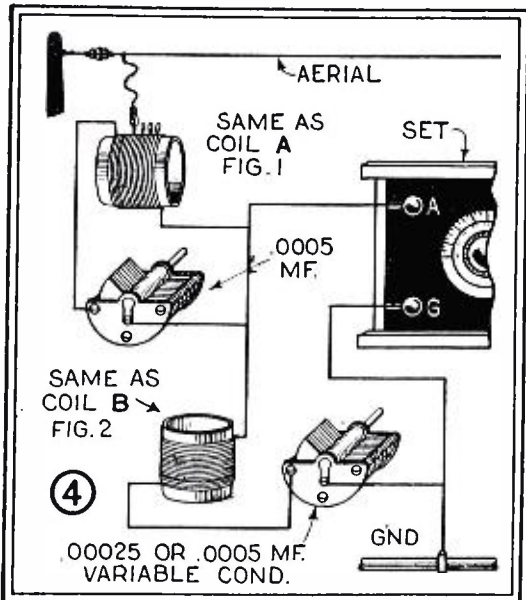

Fig. 4. Another combination series and shunt trap.

and the shunt coil is identical to coil B in Fig. 2. The variable condenser in shunt with coil "A" is .0005 mfd.,

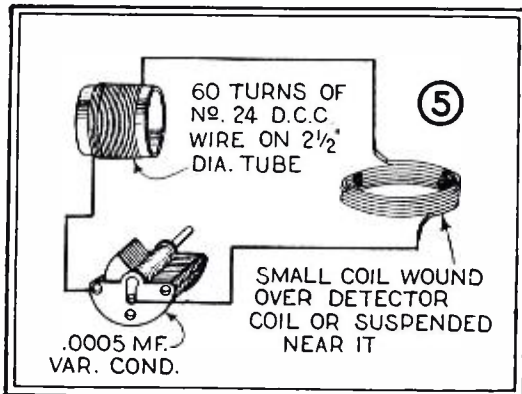
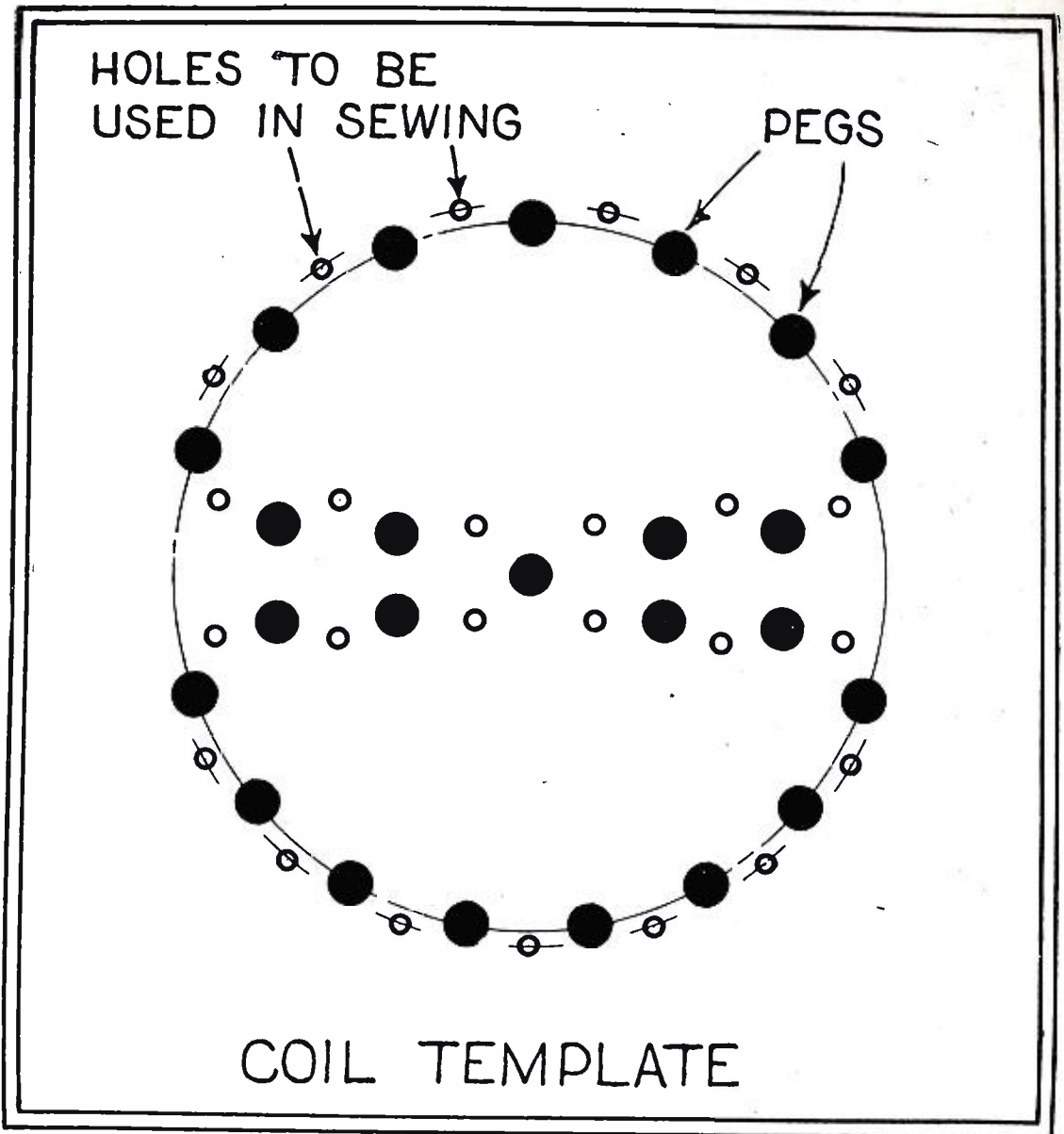

Fig. 5. An inductive type wave trap.

and the condenser in series with coil "B" is either .00025 or .0005 mfd.

trapping out interference in the aerial system will not decrease interference

possible to insert a wave trap in the cabinet and therefore a small coil



Above is shown a correct coil winding template in response to Mr. Denzer's inquiry.

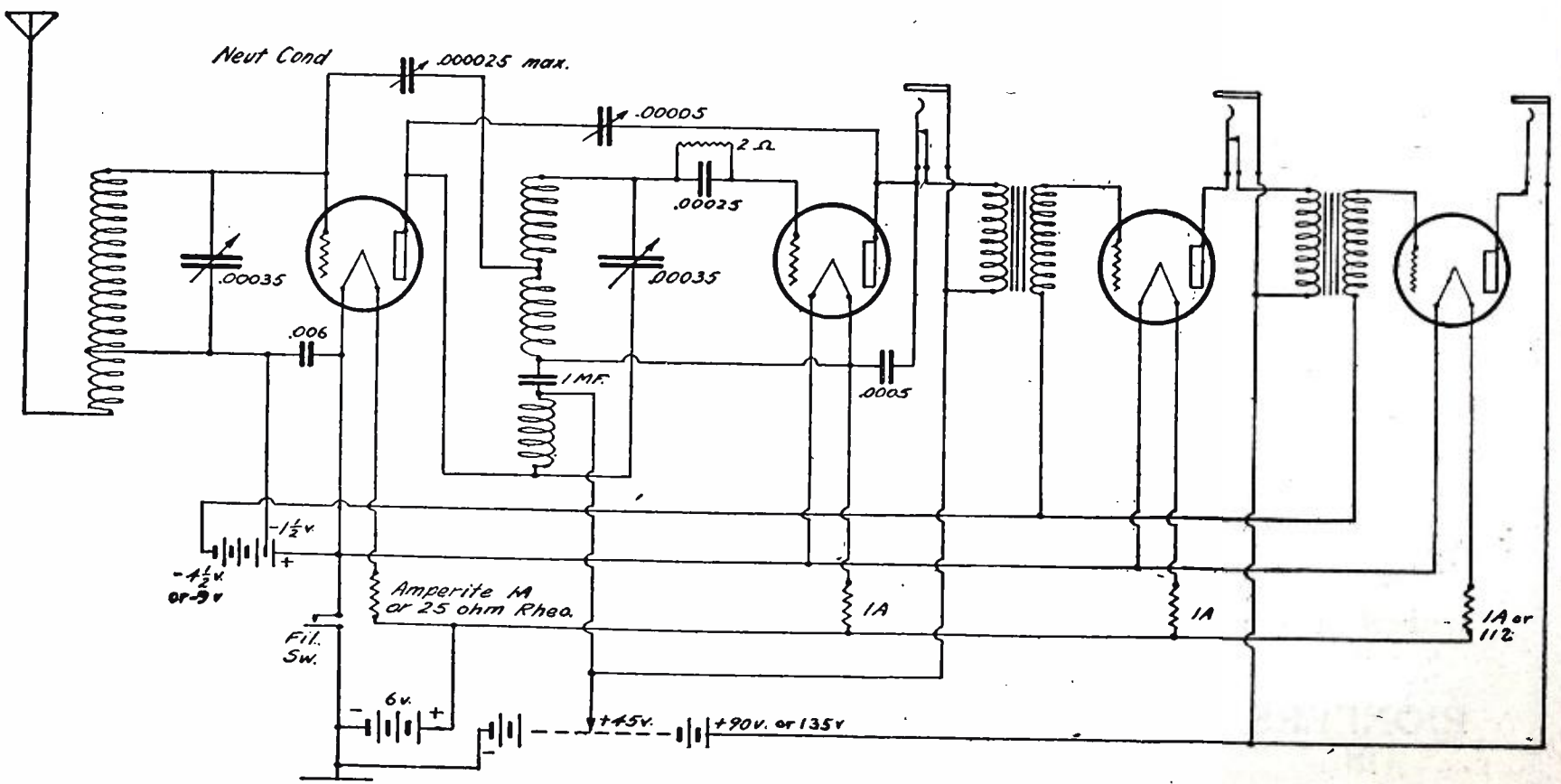

The schematic diagram of the L-C circuit using a two-stage transformer coupled audio amplifier.

Sometimes when the aerial and ground are disconnected from the receiver.

picked up directly by the coils in the receiver. When this condition exists

should be coupled to the radio frequency- (Continued on page 168)

The Diamond of the air!

Complete Kit
for the
DIAMOND
—of the air

Sold by
B. C. L. RADIO
SERVICE CORPORATION

1 Complete Bruno Diamond Basic Kit and 3 ¼ Amp. Mounted Ballast Amperite, 1 ½ Amp. Mounted Ballast Amperite, 1 3½ to 1 Audio Transformer Bruno, 2 0.1 meg. resistor General Resistor, 1 1.0 meg. leak General Resistor, 1 0.5 meg. leak General Resistor, 1 Variable Grid Leak Bretwood, 2 Double Circuit Jacks, 1 Single Circuit Jack, 1 7x24 drilled and engraved panel, 1 Socket strip complete with 5 sockets, 1 Pr. Bruno Brackets, 2 0.25 mfd. fixed condensers, 1 5-strand multi-colored battery cable De Luxe, 1 A Switch, 5 Battery cable markers, 4 Binding posts, Bus bar, screws, nuts and spaghetti.

Complete book of instruction and blue print.

PRICE

\$37.50

B. C. L. RADIO
SERVICE CORPORATION

223. Fulton Street
New York - - N. Y.



22.50

Licensed Under
Armstrong Patent
1,113,149

Its brilliance outshines them all

JUST like its name "DIAMOND" of the air—this receiver stands out by its brilliant performance, head and shoulders above the ruck of mediocrity. Beautiful tone, instant thrilling power and knife-like selectivity are all combined in the "DIAMOND." Now you can not only get the thrill of building a good receiver at home—but the additional thrill of constructing one of Radio's finest—by using the new "DIAMOND" kit shown above.



† † †

*The Kit, as shown above, consists
of the following parts*

All parts in this kit are ready for use. It consists of the following parts: 1 Bruno 99 Tuning Coil, 1 Bruno 99 R. F. 2 Bruno S. F. Condensers (Bakelite Shaft) 3 Bruno Vernier Dials, 1 Bruno Light Switch.

THE BRUNO RADIO CORPORATION
Long Island City, New York, N. Y.

Two New Wonderful Tube Developments!

 <p>TYPE "G" HIGH MUTUAL, For Impedance or Resistance Coupled Receivers</p> <p>Fil. V. 5.0 Fil. Amp. 0.25 Plate Volts 90-180 Gives clearer reproduction with increased volume. Price \$2.50</p>	 <p>CECO TUBES MAKE ANY GOOD RECEIVER Better</p>	<p>TYPE "H" SPECIAL DETECTOR</p> <p>Rating 5.0 Fil. V. 0.25 Fil. Amp. 67-90 Plate Volts Improves reception especially, on DX or distant Stations. Price \$2.50</p> 
--	--	---

There's a CECO tube for every Radio need. Use CECO for detectors and amplifiers. You will see the difference in volume, tone, clearer reception, greater distance and longer life.

You can SEE the difference with CECO Tubes

You practise true economy when you buy the best. Insist on CECO. CECO tubes are "best by test" in the laboratory — "best by performance" in the home.

C. E. MFG. CO., Inc.
Providence, R. I.

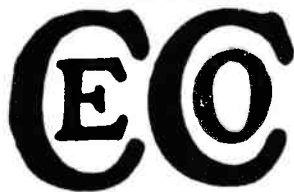

THE CECO PLANT AT PROVIDENCE

LARGEST IN THE WORLD MAKING TUBES EXCLUSIVELY

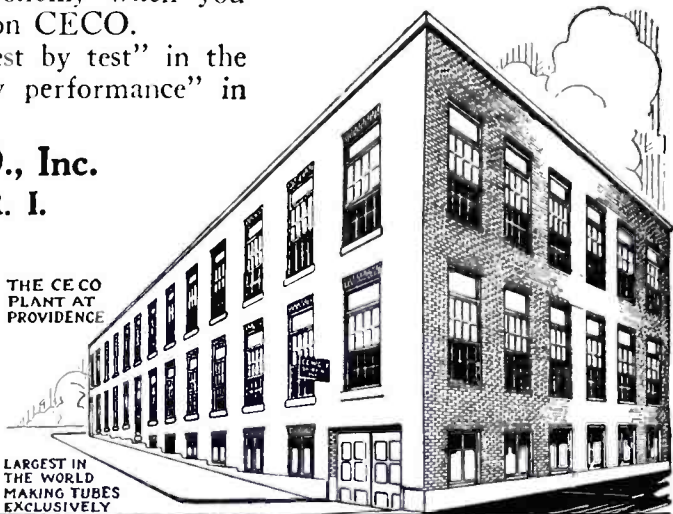

How to Build the Improved Browning-Drake Receiver

(Continued from page 129)

set is ready to be installed and placed in operation.

The Batteries

We now come to the "A," "B" and "C" batteries.

It will be seen from Figure 10 that there are but four battery binding-posts which are connected as follows:

Looking at the set from the rear, the left-hand binding-post is connected to the "B" plus (+), the next to the "C" minus (-), the third from the left to the "A" plus (+) and the "C" plus (+) and the right-hand post to the "A" minus (-). The connection to the "C" plus (+), however, must be varied, according to the type of output tube used, in the following manner.

When a UX-171 tube is employed, and this tube is recommended, and 180 volts are applied to the plate, the best connection for the "C" battery which should be a small size 45-volt battery, is, positive "C" to positive "A" and the negative side of the "C" battery to the second terminals from the left-hand end.

When the 171 is used with 180 volts on the plate, the drain on the "B" batteries is rather high and the large size is advisable. The author has also procured very satisfactory results with this tube by using the high voltage tap on a Mayolian "B" supply unit employing a standard Raytheon tube.

When a UX-171 tube is used with less than 180 volts on the plate, the best "C" battery connection may be found by placing a milliammeter in the negative lead of the "B" battery and watching the milliammeter on a strong local signal. Adjust the voltage of the "C" battery until no variation in plate current occurs.

When this receiver is employed at some distance from local stations, it will be found that the output tube is not so likely to overload and that UX-112 or 201A-tube may work out in a fairly satisfactory manner. When a UX-201A- is used for the output, the plate voltage should also be 135 and the "C" voltage between minus 4½ and minus 8. A ¼-ampere filament ballast should then be used at Q.

The variation of the voltage applied to the radio-frequency tube and to the detector tube may be had by replacing the fixed resistors in these circuits according to the following scale:

When 180 volts are used for the plate supply, a resistance of 25,000 will provide 90 volts for the radio-frequency plate and a resistance of 90,000

(Continued on page 169)

Get more from your Receiver



Use this big bookful of shortcuts, hints and practical helps

A big book full of short cuts, hints and practical ideas. The 500 RADIO WRINKLES BOOK is a very comprehensive compilation of the best time and money saving hints that can be effected. Under fifteen separate and

distinct headings, the entire field of radio apparatus and instruments has been covered in simple, understandable language. It is divided into sections covering Antennae, Batteries, Coil Mountings, Condensers, Crystal Detectors, Inductances, Lightning Protectors, Loop Antennae, Loud Speakers, Resistances, Sockets, Switches, Transformers, Vernier Dials. There are no ifs nor buts to complicate directions. The Beginner as well as the more advanced radio man will soon find that this book contains a veritable storehouse of practical, inexpensive hints toward improving his radio apparatus.

PRICE Large Size 9 x 12 inches, 100 Pages Illustrated

50c AT ALL NEWSSTANDS

If your newsdealer cannot supply you, order direct. We pay postage charges.

Experimenter Publishing Co., Inc., 53 Park Place, New York, N. Y.

The Thrill of Building Your Own!

YOU can't build automobiles on a kitchen table. If you could, they'd be home-built by the thousands. Dependable Radios *are* being built by many thousands.

You, too, can build your own set.

The thrill of building your own Radio! Of making your own creation work, and work well!

There is no cooked-up enthusiasm or inspirational bunk in this idea. It is real. The writer of this advertisement has experienced it. The manufacturer knows it. That is probably why he went into Radio.

The distributor and the dealer know it. We all shall know it again and again,—new and real each time,—keeping abreast of an ever unfolding art,—keeping ahead of the finished-set mass-production,—building Radio ourselves.

NATIONAL PARTS for SET-CONSTRUCTION

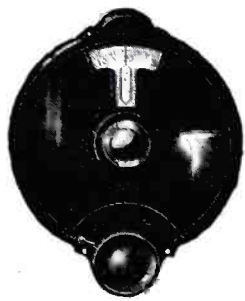

For Tuning Control

The NATIONAL
Velvet-Vernier Dial,
Type B

Gives velvety, even movement of condenser shaft with *variable* reduction ratio of from 6-1 to 20-1. Large, easily operated knob without *any* back-lash—clear yet mathematically accurate dial with simple logging guide—heavy, lasting Bakelite case; easy to mount and gives precise and fine tuning on any set.

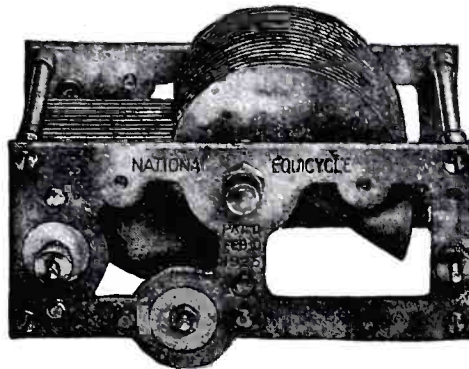

For Tuning The NATIONAL "Equicycle" Condenser

True straight-line-frequency—but in three-quarters instead of a half-turn—spreading out crowded stations still more,—rigid frame, plates,—bearings smooth, yet without suspicion of end-play. Made to stand up, to log the same next year as this, and with the same high efficiency.

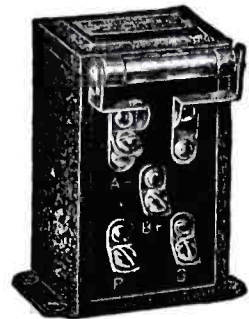

For Audio-Frequency Amplification

The NATIONAL
Impedaformer,
Type B

Three to a set—making possible, in the compactest form, true and faithful audio-amplification, from notes too low to be reproduced in phones or cone, to shrillnesses out of reach of our mortal ears. Each Impedaformer cases a high-inductance choke—a 0.1 Mfd. TOBE Coupling Condenser—a Lynch Resistor—and the first one an R. F. choke, without which impedance - amplification is like meat without salt.

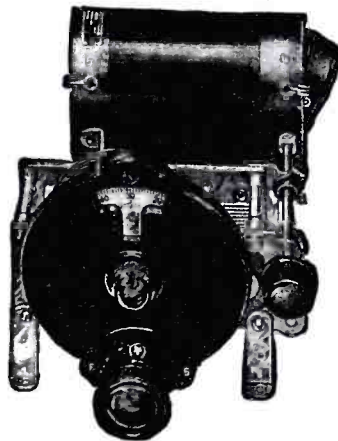

For Radio-Frequency Amplification

The Genuine NATIONAL Browning-Drake Radio-Frequency Transformers

With their scientifically computed coil-constants—product of research of G. H. Browning and F. H. Drake at Harvard University. Their theoretically correct *space-wound* enamel wire coils withstand rough handling; without alteration of characteristics—yet tests show lowest R. F. resistance recorded for coils of this type. Their simple supports make them units with their "Equicycle" Condensers, but hold them far enough away to prevent absorption losses or increase their resistance.

These NATIONAL Radio-Set Essentials with the required sockets, panels, wire and accessories,—may be put together EASILY by you into a modern receiving-set:—sensitive to distant signals, selective in its separation of closely-spaced stations, capable of lifelike, *faithful* reproduction,—simple to operate. Be sure you get genuine NATIONAL products.

NATIONAL COMPANY, INC.

W. A. READY, Pres.

ENGINEERS and MANUFACTURERS

110 BROOKLINE STREET

CAMBRIDGE, MASS.

Write for Bulletin 110-RR

*The Greatest
Variable Resistor*

CLAROSTAT

Endorsed and used by:

- Acme Apparatus
- All-American
- American Electric
- Amertran
- Dongan
- Erla
- General Radio
- Grigsby-Grunow-Hinds
- Jefferson
- King
- Kodel
- Kokomo
- Mayolian
- Raytheon
- Modern Electric
- Silver-Marshall
- Sterling
- Storad
- Thordarson
- Webster
- Zenith

because--

the CLAROSTAT provides a positive, gradual, durable, reliable and fool-proof adjustment over a resistance range of from practically zero to 5,000,000 ohms . . . and

CLAROSTAT is *absolutely noiseless* in operation, even at its maximum carrying capacity of 20 watts. It is extremely rugged and guaranteed.

Dealers and Jobbers:

Power Supply is the biggest development this year. Raytheon publicity in scores of magazines and newspapers has specified CLAROSTAT as the *only* variable resistor for battery eliminators. Your customers will demand it this fall. Write us now!

Manufacturers:

Special types of *fixed* and *variable* RESISTORS to meet any and all requirements of receiver and Power Supply manufacturers.

AMERICAN MECHANICAL LABS., Inc.
285-287 North 6th St., Brooklyn, N. Y.

A complete set of diagrams and a booklet are yours for 4c in stamps. Address

Dept. R. G.



\$2.25

BRING YOUR RESISTOR PROBLEMS TO CLAROSTAT

Building the Raytheon B-Eliminator

(Continued from page 145)

of meter is so low that the current required to operate the meter causes a considerable drop in the Raytheon eliminator output and therefore gives a false voltage reading. Also, as an additional word of caution do not handle any part of the eliminator or the receiver without first shutting off the power. A power supply set delivers a very high voltage, especially with no load connected with it, and for this reason there is danger of shock.

The only type of voltmeter that will measure the voltage with any degree of accuracy is an especially designed type for this purpose such as the Jewell B-battery voltmeter, or one with very high resistance. The only practical way for the radio listener to adjust his power supply set is to do it while the set is connected with the receiver and in operation. The various Clarostats are adjusted until best results are obtained. With an outfit of this type, the regeneration of a receiver can be controlled by varying the radio frequency amplifier voltage, or the detector voltage, depending on the kind of circuit used.

A B-battery eliminator of this kind requires no attention whatsoever. The tube employed, being the Raytheon gas-filled tube without filament, will last for thousands of hours of actual service, or, in terms of radio life, for several years. The Raytheon is the most economical rectifier tube available today. The output from this eliminator is sufficient for the super-heterodyne or eight-tube receiver, just as it is available for the one-tube set.

In wiring this type of radio layout, it is suggested that rubber-covered wire be used, or at least a wire with a good insulation, since the high voltages are apt to cause trouble if the wires become crossed or if bare hands come in contact with live wires. At any rate, bare bus wire should not be used.

The radio receiver, connected with the Raytheon B-battery eliminator just described, will operate in the normal manner but with a volume and tone quality that will be a revelation to those heretofore acquainted only with B-battery operation. With such an eliminator, plus a power tube in the last audio stage, it becomes possible to operate the largest cone speaker with full volume and without distortion. It should be remembered that the rich bass notes, so desirable if real music is to be obtained from the radio receiver, requires far more energy than the usual run of middle and high notes. Hence ample plate current and the necessary voltage must be supplied if good tone quality is desired.



Oh boy!

**KESTER
Rosin Core
Radio SOLDER**

Sure! is Safe and Simple

RECOGNIZED by Radio Engineers and Manufacturers as the proper combination of solder and flux Kester Radio Solder comes to the consumer as a product approved by the leaders of the field.

It is simple and ready to use—"Requires Only Heat." For this reason Kester Radio Solder saves time and material in the shop, and assures workmanship like joints for the home-builder.

The pure rosin flux that is fed from the inside of the solder to the job eliminates leakages commonly incurred by the use of fluxes derived from chemicals.

The use of Kester Radio Solder promotes greater clarity—volume and D.X. possibilities in any type of hookup.

Hundreds of enthusiastic testimonial letters from both manufacturers and amateurs on file.

Our Research and Experimental Laboratory is at the disposal of interested manufacturers for the purpose of assisting in solving their soldering problems. Address—Research Engineer.



APPROVED BY
RADIO ENGINEERS

CHICAGO SOLDER COMPANY

4252 Wrightwood Ave., Chicago

Originators and World's Largest Manufacturers of Self Fluxing Solder

YOUR DEALER CAN SUPPLY YOU



SM

The 220 and 221 AUDIO TRANSFORMERS



THE Silver-Marshall 220 audio transformer has introduced principles in transformer construction that has placed it far ahead of competition. In its design the shortcomings of modern broadcasting have been taken into consideration. It is the first transformer manufactured with a rising low note characteristic which compensates for conditions of a reverse nature in our speakers. It is the largest, huskiest transformer on the market and it delivers quality such as you simply never heard.

The 221 output transformer should be used (optionally) between the last power tube and speaker in any audio amplifier. In this position it will improve low note reproduction and increase the loud speaker capacity for strong signals several hundred percent.

Price \$6.00 each.

"PLUG-IN B"

The S-M type 650-B "Plug-In B" has an extremely high power output plus remarkable filtration. It will supply 300 volts with sufficient current to operate not only the UX-210 power amplifier but a whole receiver as well—"A," "B" and "C" power to an entire set including power amplifier stage. This is because of its generous design and the absolutely new Clough filter principle that leaves no trace of hum with the best of amplifiers. Completely assembled and wired, ready for operation, \$39.50.

INTERCHANGEABLE COILS

Designed for extremely low loss and permanent uniformity. They may be used for a variety of purposes in practically all circuits to cover any frequency range for common use. They are interchangeable—all fitting the Universal 515 coil socket. They are ideal for gang condenser assemblies because of the uniformities of their manufacture—and uniformity closer than one-quarter of one percent. "A" types, 190 to 550 meters, "B" types, 70 to 200 meters, "C" types, 30 to 75 meters, "D" types 500 to 1500 meters. Price "A," "B" and "C" types, \$2.50. "D" type \$3.25.

LONG WAVE TRANSFORMER

The 210 and 211 long wave transformers are measured and guaranteed. They are tested with equipment approximating actual receiving conditions, and actual amplification to the fraction of one percent is predicted in the tests that these transformers have to pass. The 210 is an untuned iron core transformer and the 211 is a sharply tuned air core filter. Supplied, measured in any quantity for 199 or 201A tubes. Each \$6.00.

631 STAGE SHIELD

The S-M type 631 stage shield is in aluminum case $7\frac{1}{2} \times 5 \times 3\frac{3}{4}$ inches pierced for a condenser, coil socket, tube socket, choke, bypass condenser and lead wires. It opens at the bottom allowing easy wiring, yet the top seals it tightly from outside interference. A unit that will allow you to keep in step with the latest engineering advances in individual circuit shielding. Price \$2.00.

"THE SECRET OF QUALITY"

This booklet contains laboratory data never before available even to many manufacturers. It is the only authoritative treatise on all types of audio amplification written in non-technical language ever published. 10c is the price of this 96-page book. Get a copy from your dealer.



SILVER-MARSHALL, Inc.

866 W. JACKSON BLVD., CHICAGO, U. S. A.

Radio Ops See Foreign Lands

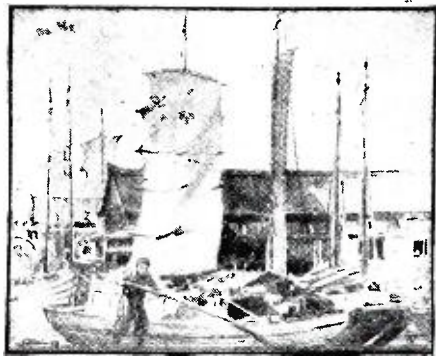

Radio operators on ships have marvelous opportunity for travel and adventure. They earn good pay—in addition to board and sleeping quarters.

Study at home now for a voyage next summer.

Radio Institute of America—world's oldest radio school—offers Home Study Courses that qualify you to pass the U. S. Government Commercial or Amateur License examinations.

Radio Institute of America instruction is the finest obtainable at any price.

RADIO INSTITUTE OF AMERICA

formerly Marconi Institute
Established in 1909

324-A Broadway, New York City

Mail coupon for complete description of course.

CUT HERE

Radio Institute of America
324A Broadway, New York City

I

Please send me full information about your Home Study Course of radio instruction.

I am interested in the complete course including code instruction.

I am interested in the technical course without code instruction.

Name.....

Address.....

Adding a Stage of R.F. to Your Receiver

(Continued from page 123)

overloaded. On the other hand, when the voltage drops, the resistance in this small automatic device decreases, permitting a greater amount of current to flow through the tube. The switches in the negative "A" and across the Royalty Resistance 500 to 50,000 ohms are of the Electrad type, and always work satisfactorily.

It will be noted that two binding posts are provided for, for connecting to your receiving set. All of the batteries being enclosed within the unit, the device may be freely tried on any type of receiver, and inasmuch as it is portable, you can quickly tell your friends whether a stage of tuned R.F. would improve their receiving set.

There are, however, several words of advice which must be carefully followed, and these constitute a distinct caution. If, after building this device, you decide to try it on your receiving set, there are two things which you must be careful to follow. If you fail to do so in circuit 1 it may cause you the loss of your tubes. If your receiving set is of the two-circuit variety and contains a distinct primary and secondary, or if it is of the three-circuit type containing primary, secondary and tickler then you must make sure that the lead from the aerial connects directly with the primary coil and the lead from the ground also connects with that coil. These leads should not in any way tie up with the set. In other words, the path of the current should be direct from the aerial to the ground, passing through the coil. If this is the case, then the binding posts may be connected directly to the aerial and ground posts of your present receiving set. If not, then a small coil of 12 turns of wire should be connected to these binding posts and this coil should be wound of a diameter similar to the antenna coil in your receiving set, and should be placed in juxtaposition with it, either right on top of the winding or just in front of it. This latter method is undoubtedly better because there is little possibility of putting the "B" battery across your filament. For this purpose, a small honeycomb coil of ten or twelve turns can be employed, which may be pushed inside of your present tuning coil.

In event that your receiver is a loop receiver, then two honeycomb coils should be substituted, a small one of 12 turns being connected in series with the two binding posts as indicated and the second one of 55 turns on a 3" spool or tube should be substituted for your present loop, and the loop placed in the jack provided for it in the R.F. unit. For the inexperienced, the writer does

Another Karas Surprise!

First there was Harmonik

—the original high-quality transformer

Then came Orthometric

—the straight frequency line condenser

The last triumph was Micrometric

—the precision vernier dial without back-lash

NOW Karas has Equamatic

—the perfect system of broadcast reception and oscillation control

1. The Equamatic System gives maximum and equal sensitiveness and amplification over the entire tuning range.
2. It develops greater selectivity without distortion or loss of harmonics.
3. It assures perfect balance on all wavelengths without employing "losser" methods.
4. It conserves the life of "A" and "B" batteries.
5. It simplifies operation of all sets by perfect synchronization of the first dial with the others.
6. It eliminates fundamental wavelength antenna absorption.
7. It provides simple adjustment to meet varying conditions, permitting perfect balance of tubes, antenna, and associated apparatus.

The essential parts for the building of an Equamatic receiver are made by Karas Electric Company, manufacturers of the well-known Orthometric condenser, the Harmonic transformer and the Micrometric vernier dial. A booklet fully explaining the Equamatic System, what it accomplishes and how it does it, will be sent on receipt of 10c in coin or stamps.

KARAS ELECTRIC CO.

Factory: N. Rockwell Street

Offices: 1136 Association Bldg., Chicago

READ

"AMAZING STORIES"

The Most Amazing Story Magazine in Years

SOLD ON

ALL NEWSSTANDS

25c

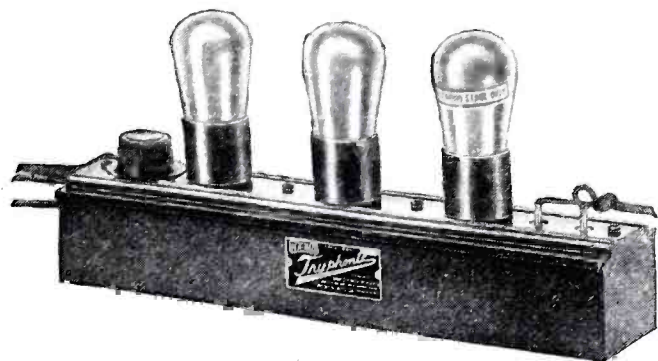

Na-Ald Truphonic Coupler

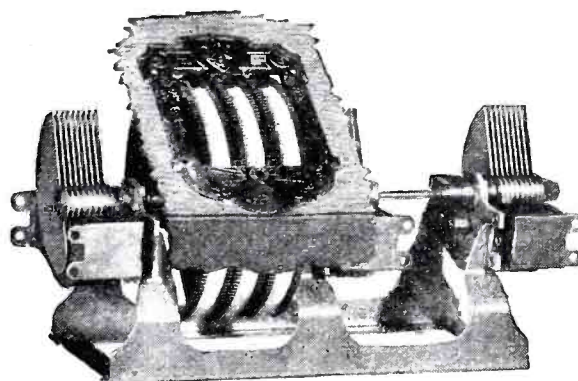
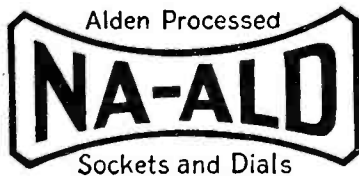

Na-Ald Localized Control Tuning Unit

For Those of You—
awaiting
perfect reproduction

A YEAR ago the phonograph was only a phonograph, and then came the Orthophonic. You will remember the amazement and admiration which this machine caused. Today, in radio circles the Na-Ald Truphonic Coupler is causing the same amazement and admiration, and for the same reasons. The Na-Ald Truphonic Coupler gives the same thrilling distinctness and fidelity, the same quality and depth of tone, and at a volume far greater than hitherto thought possible. Listen to the announcer's voice. The diction is as crisp and clear as if he himself were in the room. A flute is playing—up, up it goes, and still the notes maintain their flawless purity. A piano plays and no longer do the keys sound out the stale and hollow flatness of a gong but the notes themselves with all their own true ringing clarity and even the delicate overtones are preserved in perfect harmony. An organ, too is heard—beautiful with that full deep throated resonance which belongs to it alone. And now, the full symphony orchestra,—not the pale thinness of a single sound but a complete ensemble of instruments with the individuality of each so clear that you can follow the themes of everyone—the French horns as they burst forth to blend again with the whole, or, the bass viols as they pursue their lone and solitary air. And the applause? A jumbled roar? No! The staccato clapping of separate hands. The Na-Ald Truphonic Coupler does more than reproduce. It recreates and brings to you that vivid, breathing, fragile thing—the soul of the music itself.

The Na-Ald Truphonic Coupler is a new instrument; new in principle, new in design, and new in construction. It is neither an impedance, resistance or transformer coupling but a new invention of H. P. Donle which co-ordinates each component in perfect proportion for precise undistorted and beautifully perfect amplification. Almost overnight it has revolutionized the science of amplification.

Attaching the Na-Ald Truphonic Coupler to your set takes but a jiffy. Connect the battery cables, slip in the tubes, plug in the loud speaker and there it is.

Words won't convince you of the performance of the remarkable little device. A demonstration will. Call at your dealers and he will gladly make you one; and, you, yourself, will hear the radio of which you've always dreamed.

Price—Complete amplifier ready to attach \$20.00

(Includes battery leads, sockets, output unit for protecting loud speaker with power tubes, connecting adapter.)
Individual Truphonic Couplers or Output Unit, per stage \$5.00
Complete amplifier parts for set builders \$20.00
(3 couplers, output unit, sockets, catacomb, battery leads)

For Full Particulars Write

ALDEN MANUFACTURING CO.
Dept. Q4 : : Springfield, Mass.

ALL tuning condensers easily controlled by the touch of but three fingers of one hand. This amazingly simple tuning device reduces the complications of tuning to a single motion! All three condensers are operated at the same opening of the panel. All can be moved to either or each can be moved separately. The result is exact tuning from station to station with the touch of one hand.

Price—Quadruple \$16.00

Triple \$10.00

Double \$8.00

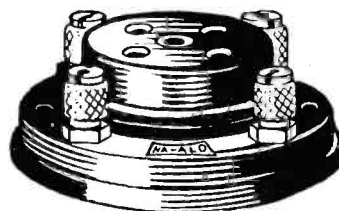

Na-Ald 481-XS
Cushion Mount Socket

IMPROVED amplification demands a cushion socket if microphonic disturbances within the tube are to be removed. The Na-Ald 481-XS Cushion Mount Socket, by means of a perfected resilient mounting that practically floats the tube, gives complete protection by absorbing BOTH vertical and lateral shocks. The only socket on the market with this feature. Fits all tubes.

Price 50c



Na-Ald 112
Connectorald



Na-Ald 120
Connectorald

THE improved tone and quality of the new power tubes 171, 112 and 120 can now be had on any set without the need of rewiring for the additional B and C batteries required. Na-Ald Connectoralds function as adapters and, at the same time provide, cables for attaching the necessary B and C batteries without affecting the rest of the set.

Price \$1.25

A NEW and BIGGER Bradleyohm for B-Eliminators

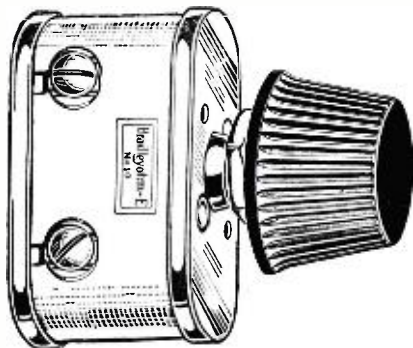

Announcing the Bradleyohm-E

Perfect Adjustable Resistor for B-Eliminators

THE rapid development of B-Eliminators for radio receivers has created a growing demand for an adjustable resistor of high resistance to regulate the plate voltages to the radio set.

Bradleyohm-E is a new, large size Bradleyohm of increased capacity and ample range for B-Eliminator service. It is made in several ranges for various types of circuits.

If you are building a B-Eliminator, be sure to ask your dealer for Bradleyohm-E of correct range and you will be assured of complete satisfaction regardless of the length of time your B-Eliminator is in service.

Mail the Coupon for interesting literature on Allen-Bradley Perfect Radio Devices

Allen-Bradley Company
292 Greenfield Avenue
Milwaukee, Wisconsin

Please send me your latest literature on Allen-Bradley Perfect Radio Devices including the Bradleyohm-E.

Name.....

Address.....

.....

not advocate cutting any leads in your present receiver, but advises that the method in Circuit 2 be used.

In Circuit 2 it will be noted that the plate of the R.F. tube connects with your present receiver through a condenser. This should be of a capacity of .002 to .006 M.F. In all other respects, the circuit is practically the same. This particular system is more universal than the one using the coil and described in Circuit 1, but one does not get quite as good results with the condenser system as with the coil.

In circuit 3 both of the above systems are combined and the position of the plug designates which circuit is in use. This is the circuit indicated in the photograph.

An Easily Constructed Power Amplifier and "B" Supply Outfit

(Continued from page 140)

(power) B+ tap and the 90 v. B+ tap should always have a capacity of not less than 15 watts continuous duty rating. The Ward Leonard Company make such a resistor which mounts conveniently into a standard electric lamp socket.

The 10,000 ohm resistor, designated as No. 1, is of the proper value for supplying one tube (detector) with 45 volts on the plate. If 45 volts B-supply is desired for more than one tube, it is necessary to decrease the resistance with the increase in the number of tubes used. Some sets, particularly superheterodynes, use 45 volts as the B-supply for five and six tubes. In this case, a 2,000 resistor should be used as No. 1.

Power Amplifier with Autoformers

Sketch (F) illustrates the method of installing power amplification with the Autoformer coupled amplifier. The step-up impedance coupling of the Autoformer gives equal attention to every note in the musical scale; and when this coupling method is used with tubes capable of carrying the bass notes, the resulting reproduction is nothing short of astounding.

It is always wise to bear in mind the high voltage of this instrument. Never attempt to make adjustments or touch the apparatus unless the light switch is turned off.

The assembly of the power amplifier and B-supply shown in the accompanying illustrations is simple. The only tools necessary are a soldering iron, a pair of pliers, a screw-driver and a small drill. Following the above instructions, and using quality apparatus, you will be able to build this amplifier in an evening's time.

You Can Build THE BEST B-UNIT

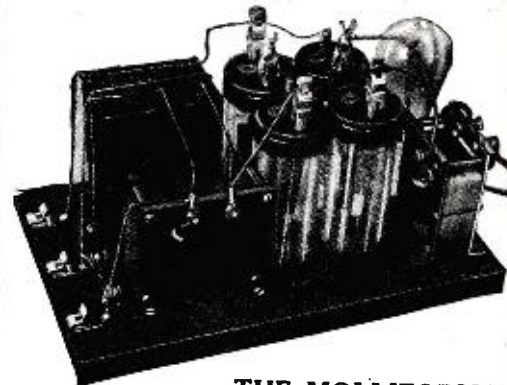

THE MOLLIFORMER B-UNIT

Low in Cost
Unequaled Tone Quality
Ample, Uniform Power

GUARANTEED

The Molliformer is guaranteed to give you finer reception than B-Batteries can afford. A-C Hum is absolutely eliminated, even on the phones. There is no B-Unit on the market that can equal the amazing performance of the Molliformer. It solves once and for all every question of B power, and guarantees the user a B current that is ideal—strong, steady and dependable always. Only through the improved Molliformer Choke with a capacity of 125 henries and the Molliformer rectifier is it possible to secure the uniform power so essential for true tonal reproduction.

Get the best. You can build the Molliformer and save money. Detailed building instructions with each kit—Nothing critical—In use for over two years—Sold on a guarantee of satisfaction or your money back.

THE MOLLIFORMER B-UNIT

COMPLETE KIT—All parts—
110-125 volts—60 cycle..... **\$17.00**

ASSEMBLED UNIT—Ready for
service **\$22.00**

Add \$2.00 for 25 or 40 cycle current

DEALERS

The Molliformer will make friends for you.
Write for Discounts.
Exclusive territory granted.

C. E. JACOBS, SOLE MFR.
2801-5 N. Kedzie Ave.
CHICAGO

Have You Seen

MONEY MAKING

The Magazine of Opportunities



ON ALL

NEWSSTANDS—SEPT. 10TH

PRICE 25c

Fully Amplifies

every note!

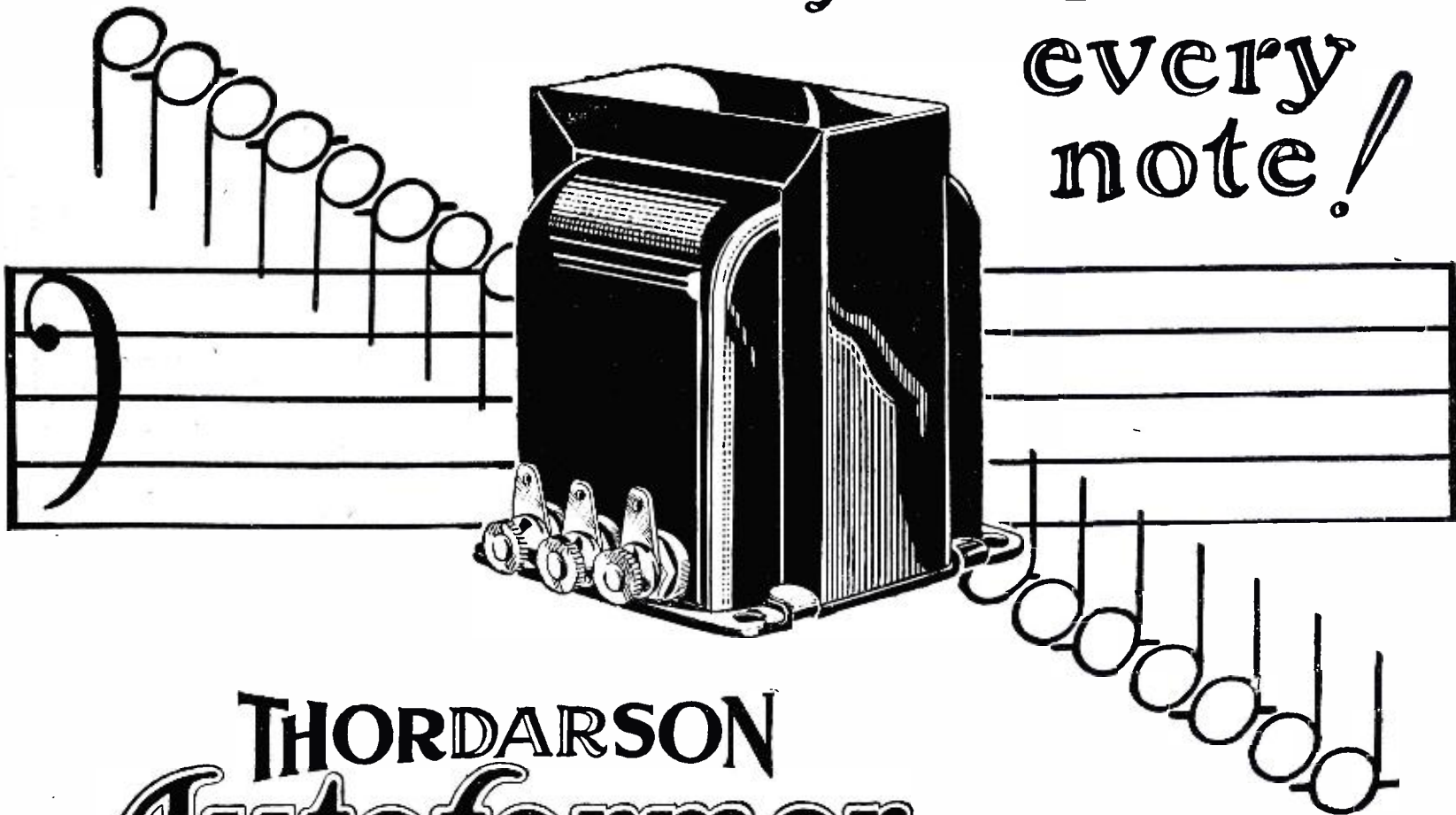

THORDARSON Autoformer

Step-up Impedance Coupled Amplifier

Full Amplification
of Bass Notes

Greater Clarity
on all Programs

Improved Reception
of Weaker Stations

Better Volume Control

Impedance coupling is universally accepted as the most perfect form of amplification from a reproductive standpoint—But the amplification increase of the straight impedance is low.

The Thordarson Autoformer is an impedance with a step-up ratio—It combines the faithful reproduction of the impedance with the amplification increase of the transformer, paving the way for the release of the deeper tones with increased volume and unrestrained quality.

Price each - \$5.00

Note: Only Thordarson makes the Autoformer

POWER From the A. C. Line

Power Amplifier Supply Transformer R-198

furnishes current for both plate and filament of the power stage using the U. X. 210 power tube with 400 volts on the plate and 7½ volts on the filament. In addition furnishes complete B-supply for the set.



Price.....\$12.00

B-Eliminator Transformer R-195 is designed for use with the Raytheon tube, furnishing



B voltages for the entire receiver. Capable of supplying 140 volts at 40 milliamperes. Conservatively rated. Will not heat up in continuous service.
Price.....\$7.00

30 Henry Choke Coil R-196 is used in the filter circuits of power amplifiers and B-eliminators operating from the house lighting current. D. C. resistance 280 ohms. Capacity 70 milliamperes.



Price.....\$5.00

THORDARSON ELECTRIC MANUFACTURING CO.
Transformer specialists since 1895
WORLD'S OLDEST AND LARGEST EXCLUSIVE TRANSFORMER MAKERS
Chicago, U.S.A.



Your receiver, whether it is an old model or the very latest type, can be improved by the installation of a high quality B-Power unit.

EVERYONE realizes the advantage of reliable B-Power, but few have the facilities or the time to select the right B-Power unit from the scores that are now offered.

THE RAYTHEON Laboratories have simplified the choice. By selecting and approving only those that pass certain minimum requirements, we have made it possible for the radio owner to select his unit from a few good ones, rather than from a hundred of doubtful value.

RAYTHEON B-Power units are now made in a variety of styles that satisfy the needs of every receiver, and meet the approval of every pocketbook. Your dealer will recommend a Raytheon B-Power unit best suited to your needs. Raytheon spells reliable reception.

RAYTHEON, TYPE B, is a non-filament rectifier of ample capacity to eliminate B-batteries on even the largest ten-tube set.

RAYTHEON B-POWER units are manufactured by Companies selected for their excellent engineering and production facilities.

RAYTHEON MANUFACTURING COMPANY
CAMBRIDGE, MASS.

RAYTHEON

Your Radio Tubes and Good Reception

By M. OPENSHAW

YEARS ago, when radio was in its infancy, one of the prominent leaders in radio science made the statement that when the operation of a radio set has been reduced to the same level of simplicity as the phonograph, it will bestride the narrow world like a colossus.

Radio today seems well launched on its march of conquest, made possible by the striving after the ever greater simplicity of a most technical proposition. The greatest achievement in this direction has been the proper control of vacuum tubes such as used in your set—the most important problem in radio.



Fig. 1. A micro-photograph of a tungsten filament. Note how fibres are bunched together. This state is obtained when operated at correct temperature.

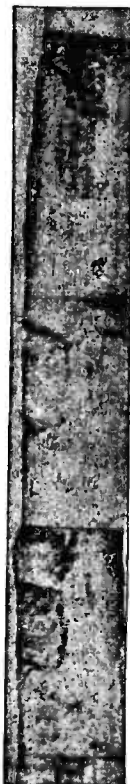

Fig. 2. Micro-photograph showing change in structure of tungsten filament due to under-heating when the ordinary hand adjusted rheostats are used.

Illustrations by courtesy of the Radiall Co.

How to control the tubes automatically, thereby assuring the proper regulation and at the same time doing away with unnecessary knobs on the panel, was solved at one stroke about five years ago by the introduction of a cartridge-like tube known as Ampérite. This has been to radio what the self-starter has been to the automobile.

The problem as solved really is a long, romantic story of scientific development. However, in order that we may understand the circumstances more intimately, let us consider the radio tube and its filament.

Glance at the various incandescent lamps burning in your home or office. Irrespective of their size, you will ob-

(Continued on page 167)

A Powerful LOUD SPEAKER!

\$10

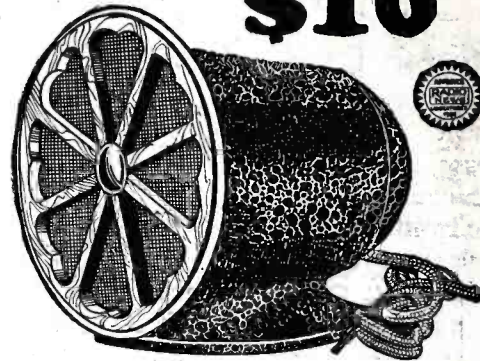

FRESHMAN MASTER SPEAKER

Only 6 inches in size, artistic in appearance, the Freshman Master Speaker is an ornament for any room.

A triple reflex speaker with powerful unit, it has volume equivalent to a 24 inch upright horn and tone quality unexcelled by speakers costing many times as much.

Sold by Authorized Freshman Dealers Only

CHAS. FRESHMAN Co., Inc.
Freshman Building 2626 W. Washington Blvd. New York Chicago

"Outsell, Because They Excel"

Empire All Types

Including NEW Detector (EX-200) High MU and Power Amplifier
Ask for Folder "R" Dealers and Jobbers Write for Prices
EMPIRE ELECTRICAL PRODUCTS COMPANY
Sales Office—132-134 Greene St., New York
Laboratories & Factories—Kearny, N. J.
Also Mfrs. of Empire Cone & Loud Speakers

PATENTS
PROMPTLY PROCURED. SEND A SKETCH OF YOUR INVENTION.
FREE INVENTION RECORDING BLANK
NAME.....
ADDRESS.....
MAIL TODAY

Z. H. POLACHEK
PATENT ATTORNEY
CONSULTING ENGINEER
70 WALL ST.
NEW YORK

Books, Patterns and Diagrams on every important radio circuit

Write for circular

The Consrad Co., Inc.
53 Park Pl. New York

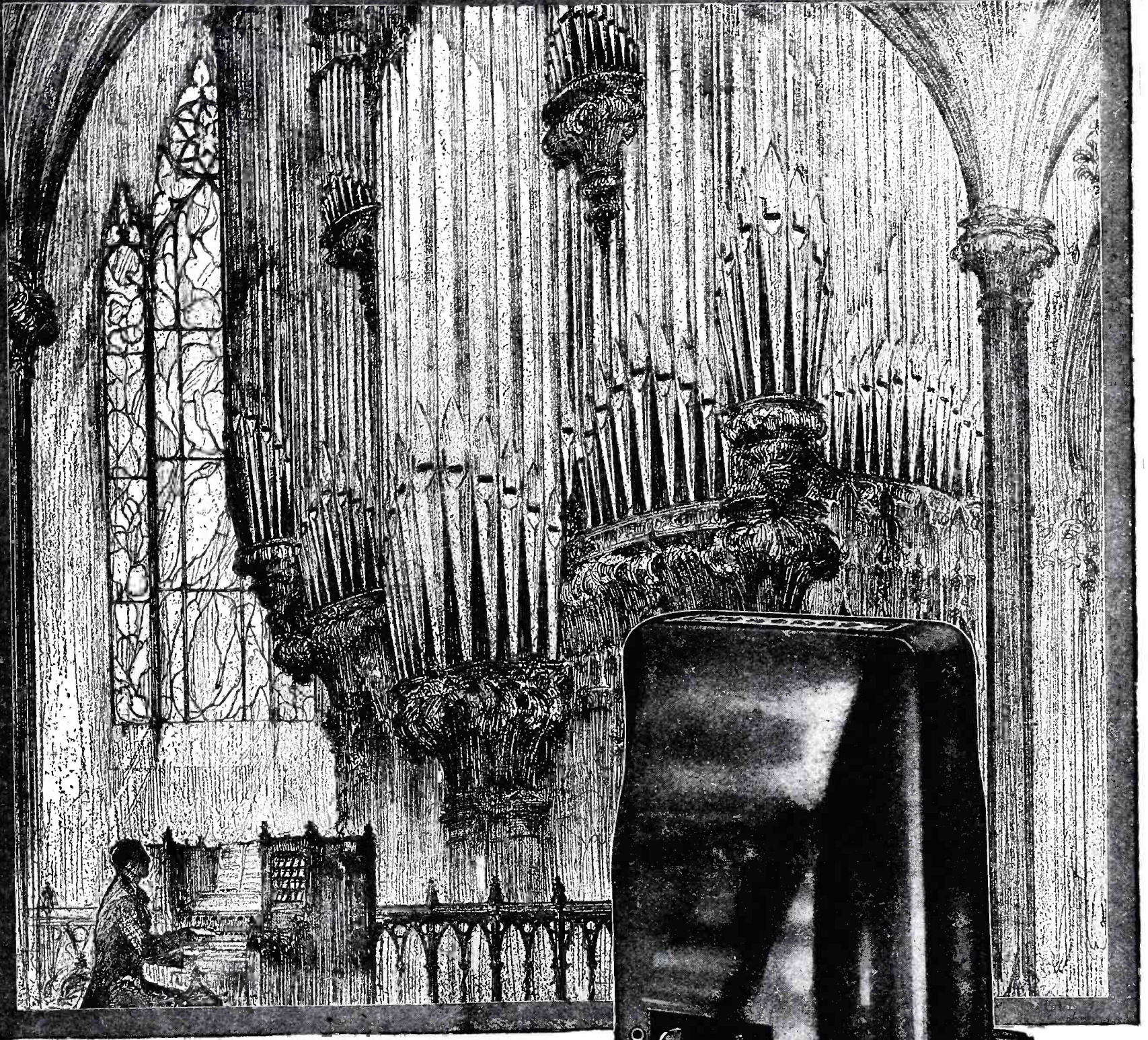

Samson Audio Units

are capable of uniform and faithful amplification well in excess of the most exacting broadcast requirements.

Their range extends from the lower fundamentals through the higher harmonics enabling them to reproduce, with equal clarity, the dull rumble of the tom-tom or the thin shrill of the flute.

This ability to reproduce the harmonics or higher multiple frequencies is what gives tone-color or background to sound—is what permits the listener to distinguish notes of the same pitch but from different instruments—results not possible with audio units which cut off at comparatively low frequencies.

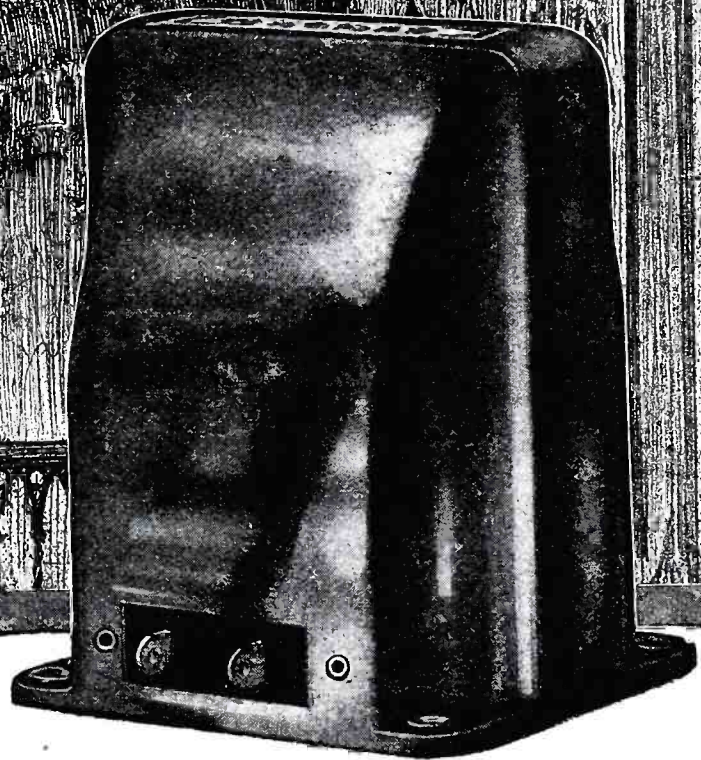

In a word—with a loud speaker of corresponding range—

Samson Audio Units

insure the sort of radio you've hoped to hear—the quality of radio that will make you think you've been translated from a broadcast listener to one of an audience which is listening, firsthand, to a speech or to music.

For 1926-27 the Samson Electric Company offers eleven different audio units:

Symphonic Transformers	Type X	\$9.00
Push-Pull Input Transformer	Type HW-A3	5.50
Standard Transformers	Type D	5.00
Dual Impedance	Type O (Donle Design)	5.00
Output Impedance	Type Z	5.00
Push-Pull Output Impedance	Type P	4.50
Plate Impedance	Type G	4.50
Grid Impedance	Type No. 3	3.00
Audio Frequency Choke		

Our book—"Audio Amplification"—already accepted as a manual of audio design by many radio engineers—contains much original information of greatest practical value to those interested in bettering the quality of their reproduction. Sent upon receipt of 25c.

SAMSON ELECTRIC COMPANY

Main Office, Canton, Mass.

Factories at Canton and Watertown, Mass.

Manufacturers
Since 1882



M & H

**Radio's largest
Kit Supply
House**

**Kit Complete Parts
Browning \$59
Drake Set**

As described in *Radio Review*. All sets include everything except antenna, batteries and tubes.

All Kits Tested in Our Laboratory

**Kit Complete Parts
Diamond \$35
of the Air Set**

Exactly as described in *Radio Review*. Our Radio Engineers report wonderful success with this.

All Parts Matched
No Substitutes Used

**Kit Complete Parts
Amplifier & \$98
B Eliminator**

Parts as described in *Radio Review*.

Buy All Your Parts In One Place

**Kit Complete Parts
Silver-Marshall
Chas. H. Callies
Shielded \$93
Circuit**

Parts as described in *Radio Review*. One of wonders of season.

All Orders Promptly Attended To
Established 30 Years



**Complete Parts
for this
Wonderful \$88
10-Tube Set**

A ten-tube receiver. Three stages intermediate frequency amplification at 95 meters. No "mush" or self-harmonics at this frequency. Considered one of best circuits for distance, selectivity, volume.

Our Catalog Will be ready
October 1st. It
will pay Set Builders to send for it.

M. & H. SPORTING GOODS CO.
512 Market St., Phila.

**All About "B" Battery
Eliminators**

(Continued from page 94)

statements and suggestions are made and should be heeded.

When an eliminator is to be used on a receiving set having four or more tubes and requiring a current of more than 10 milliamperes, one should be chosen that uses a step-up transformer. If this precaution is not taken the eliminator will probably not deliver sufficient voltage and current for the purpose.

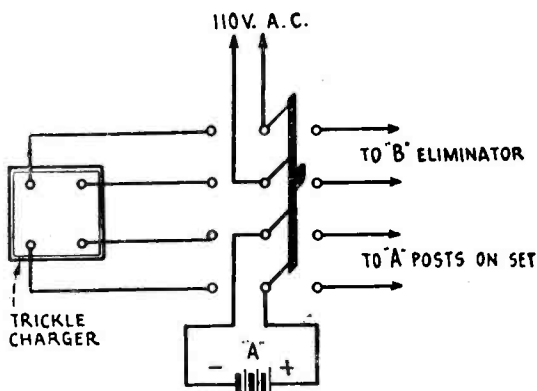

Fig. 7. A popular switch arrangement which allows the trickle charger to be connected to the "A" battery when the power is disconnected from the set.

The electrolytic type of eliminator such as the home-made one described above will not give satisfactory results on a set using more than three tubes. Do not expect it to operate a five or six-tube set.

When installing a "B" battery eliminator make provision for some kind of switch arrangement so that the eliminator will not be left connected to the house lighting circuit when it is not in actual use.

A home-made eliminator should be encased in a metal box and the box should be connected to the ground wire of the radio receiving set. This will often aid in eliminating a hum in the reproducing unit.

If possible, the eliminator should be placed two or three feet away from the radio set proper. This will be a further aid in eliminating hum.

Ground the cores of the choke coils and transformer as well as the metal condenser cases.

In all cases where an eliminator is used which does not employ a transformer, a large fixed condenser having a capacity of 1mf should be connected in series with the ground of the radio set. This is important, because without the condenser a short-circuit may take place through the eliminator which may burn out the tubes in your radio receiving set.

Always have one or more variable resistances in your "B" battery eliminator circuit so that the plate voltages can be carefully controlled. Failure to do this will mean unsatisfactory results

**MOTO-RAY
Quick-Hot
Metal Mender**

Solders with an Electric Arc

Works from any low voltage wet battery circuit. Carbon point becomes hot instantly, when circuit is closed—no waiting. Economical because high resistance of heating element prevents current waste. Solders through paint, grease, oil, dirt and moisture and on inverted and perpendicular surfaces. Sturdy but compact; nothing to get out of order. Convenient for inaccessible work. Anyone can solder with Moto-Ray "Quick-Hot" Metal Mender.

**MOTO-RAY
MANUFACTURING
Co., Inc.**
169 Massachusetts Ave.
Boston, Mass.

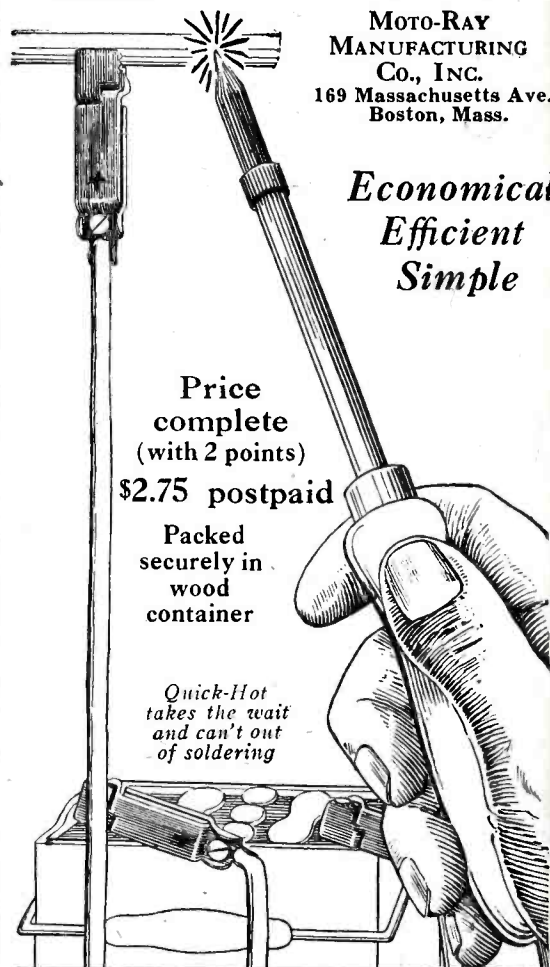

*Economical
Efficient
Simple*

Price
complete
(with 2 points)
\$2.75 postpaid

Packed
securely in
wood
container

*Quick-Hot
takes the wait
and can't out
of soldering*

**The Electric Welding Principle
Applied to Soldering**

**NO MORE
BATTERIES \$2**

Build it yourself—any amateur or fan can do it! Eliminate all batteries, both "A" and "B." Smooth steady flow of current (either Direct or Alternating) for any type of tubes or number; or any kind of a set. Complete plans, blueprints and instructions fully guaranteed for \$2. State type of current used and send for this set of blueprints TODAY.

H. E. Marshner 1601 Macombs Rd.
New York City

**BOOKS, PATTERNS AND
DIAGRAMS ON EVERY IM-
PORTANT RADIO CIRCUIT.**

Write for Circular

THE CONSRAD CO.
53 PARK PLACE NEW YORK CITY

BUILD YOUR OWN RADIO SET!

FREE THIS VALUABLE 68-PAGE BOOK

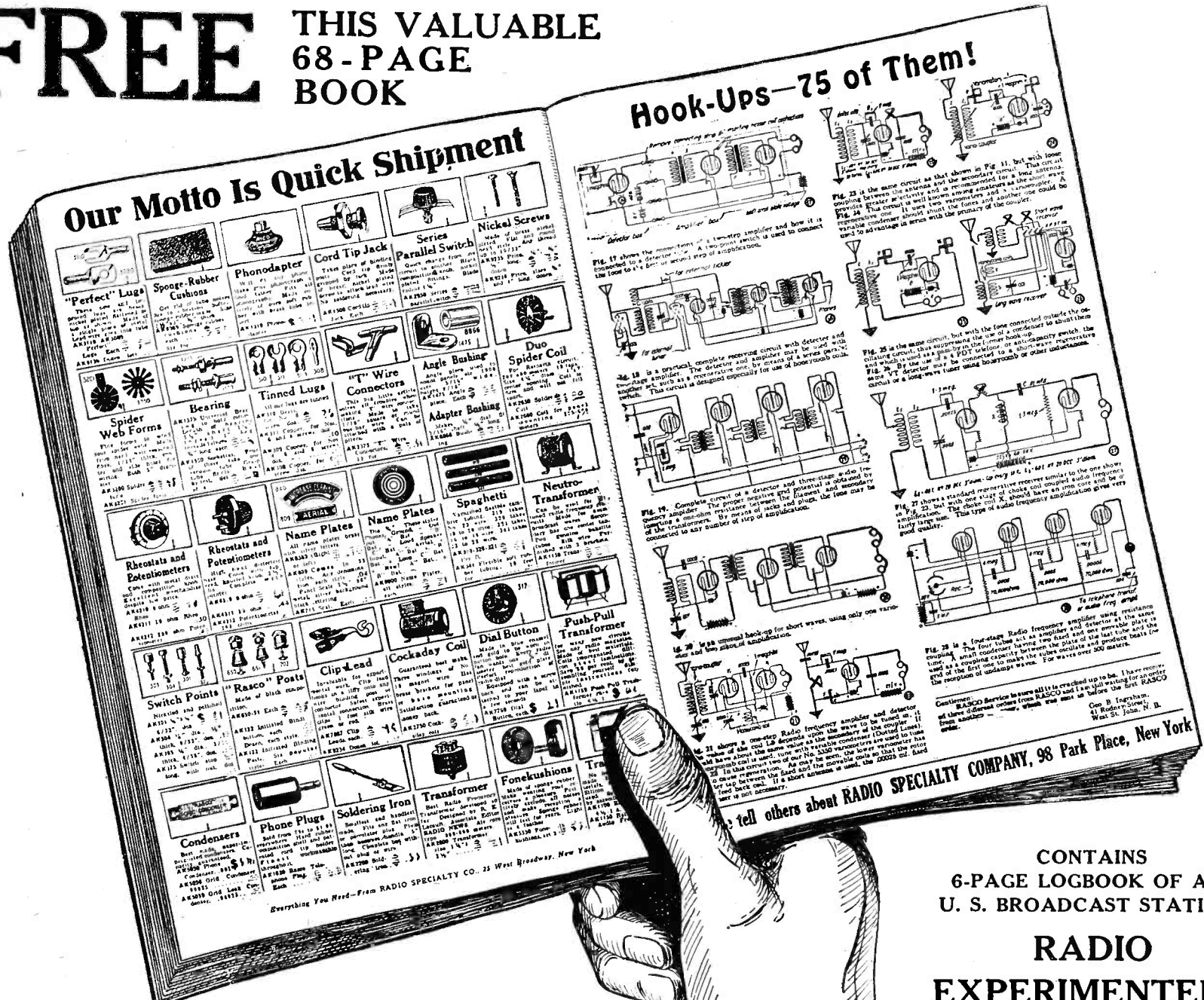

NEW 1926 SPRING CATALOGUE
No. 16 JUST OUT
68 Pages—600 Illustrations

CONTAINS
6-PAGE LOGBOOK OF ALL
U. S. BROADCAST STATIONS

RADIO
EXPERIMENTERS,
SEND FOR THIS
FREE BOOK
TODAY

Buy from Radio's oldest Mail Order House

THE NEW RASCO
CATALOG No. 16
 Contains the Following Hookups.

All Armstrong Circuits: These important circuits are explained clearly, all values having been given. Just to name a few of the Vacuum Tube circuits: The V.T. as a detector and one-step amplifier; Super Regenerator; one-step radio frequency amplifier and detector; three-stage audio frequency amplifier; short wave regenerative circuits; one-stage radio frequency amplifier; radio and audio frequency amplifier; Inductively coupled amplifier; all Reflex Circuits

This catalog is crammed full of small parts and radio findings; literally thousands of them. In addition there is much useful information contained herein.

WE are the oldest established, exclusive radio mail order house in the country. Our motto is "Quick Shipment." All orders are shipped within 24 hours. Quick, prompt, courteous service. We carry a larger variety of radio parts and findings than any other radio house in the country.

"RASCO HAS IT"

If you are in need of certain small radio parts that other radio and mail order houses do not bother to carry, get the Rasco parts catalog, and you will find them there, anything from a screw to copper ribbon and telephone diaphragms, as well as thou-

If you will paste this coupon on a post card and mail today, we will be pleased to send you our new Catalog at once.

sands of other small radio findings. Just to mention a few:

Lugs, nuts, dials, vernier dials, jacks, plugs, every kind of knob, cords, panels, screws, sliders, washers, selenium, tinfoil, switches, crystals, cap nuts, Litz wire, cord tips, brass rods, resistances, name plates, spring binding posts, switch parts, metal ribbon, carbon balls, binding posts, all types, switch points, switch levers, lock washers, carbon grains, ground clamps, metal pointers, insulated tubing, low melting metal, antenna connectors, bus bar wire, as well as thousands of others.

WE CARRY THE LARGEST VARIETY OF SMALL RADIO PARTS IN THE WORLD.

RADIO SPECIALTY CO., R.R.-9-26
 98-R Park Place, New York
 You may send me, without charge or obligation, your NEW CATALOG No. 16. (Write on margin if you desire).

Name
 Street
 P. O. State

RADIO SPECIALTY CO.
98-R Park Place New York City

The UNIVERSAL Standards of Quality

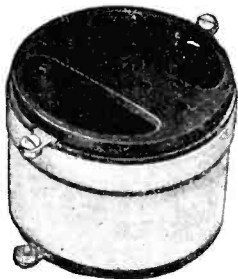

Type 277-D
Coupling Coil
Price \$1.50

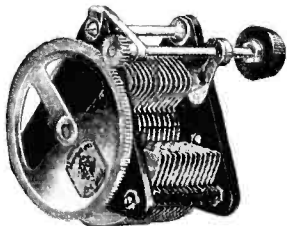

Type 247-H
Vernier Condenser
Price \$5.00



Type 368
Micro-Condenser
Price \$1.25

In building a radio receiver, remember that its performance depends primarily upon two things: an efficient circuit, and the use of good parts.

Wherever you find a popular circuit you will invariably find General Radio parts.

The General Radio Company has contributed more in scientific apparatus for laboratory use than any other one Company in the history of radio. The same outstanding craftsmanship and materials are embodied in General Radio parts for use in the construction of broadcast receivers.

Through the merits of design, performance, and price, the General Radio instruments for the scientist or set-builder are universally recognized as the Standards of Quality.

Every instrument made by the General Radio Company is thoroughly guaranteed.

Write for Bulletin 925-V

GENERAL RADIO CO.
Cambridge, Mass.



Type 285
Audio Transformer
6 to 1 or 2 to 1
Price \$6.00

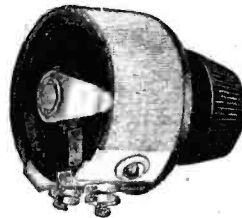

Type 301
Rheostat
6, 12, 25 ohms
Price \$1.25

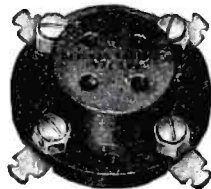

Type 349
UX Socket
Price 50c.

GENERAL RADIO

INSTRUMENTS

"Behind the Panels of Better Built Sets"

Read the best in radio!

116 Pages of Selected Radio Articles by the
Most Eminent Radio Engineers

The "RADIO NEWS" Amateurs' Handibook is a large 116 page magazine size book containing a wide, varied and carefully selected array of the finest and most helpful radio articles that have appeared in the pages of Radio's Greatest Magazine, RADIO NEWS.

The cream of practical, up-to-the-minute, circuits and miscellaneous information and data is culled from RADIO NEWS and presented in compact form in this book. It embraces every phase of radio, but particularly the new and more practical receivers and circuits developed for modern reception.

Contains 116 Pages, Illustrated

Price, 50c.

AT ALL NEWSSTANDS

If your newsdealer cannot supply you, order direct.
We pay postage charges.

EXPERIMENTER PUB. CO., INC.
53 Park Place, New York City

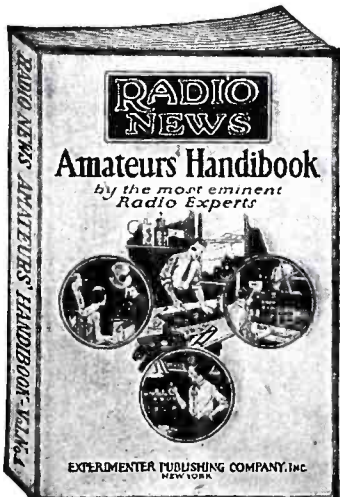

and the operation of the set will not be as flexible as might be desired.

Remember that a "B" battery eliminator is a power device and treat it with respect. A rather painful shock can be obtained from most "B" battery eliminators and, therefore, you should never work around an eliminator unless the in-pu current is completely turned off.

Satisfactory results will never be obtained if inferior instruments are used. This is particularly true of the eliminator delivering in the neighborhood of 150 volts out-put or higher. Always use the best apparatus. There are a good many concerns manufacturing "B" eliminator parts today, and there is no excuse for not using good standard apparatus. Reference to the advertising columns of any radio publication will show a variety of apparatus for use with different types of "B" eliminator rectifiers.

A Balanced Tuned R.F. Receiver

(Continued from page 138)

and the other is used as the radio frequency transformer.

The Operation

As mentioned before, there are separate binding posts provided for the "B" and "C" connections of the audio frequency amplifier tubes. The proper

LIST OF PARTS REQUIRED

- 1 Panel 7" x 18"
- 1 Baseboard (wood) 7" x 17" x 1/2"
- 1 Royalty type C 500 to 50,000 ohms variable resister
- 2 General Radio type 277D coils
- 2 General Radio type 247H condensers
- 2 General Radio type 310 dials
- 4 General Radio type 349 sockets
- 1 General Radio type 368 micro condenser
- 1 General Radio type 301 rheostat 10 ohms
- 1 General Radio type 301 rheostat 30 ohms
- 1 General Radio type 285 6:1 transformer
- 1 General Radio type 285L 2:1 transformer
- 1 General Radio type 236 0.5 MF fixed condenser
- 1 Phone plug and jack
- 1 .0001 MF fixed condenser
- 1 .00025 MF fixed condenser
- 1 Durham grid leak and mounting 2 megohms
- 2 Amperites (correct resistance values for tubes to be used)
- 1 Terminal strip 9 3/4" x 1 1/4" x 3/16"
- 11 Binding Posts
- 1 Yaxley Filament switch
- 2 Brackets 1 1/2" x 1 1/2" x 1/2" (may be obtained at any hardware store)

voltage to use in these two places cannot be considered as too important; for many times this spells the difference between good and mediocre reception and quality. It is suggested that the

Thousands of Radio Fans use these Ingenious TRANSMITTER UNITS!

HERE ARE A FEW OF THE USES FOR THESE UNITS

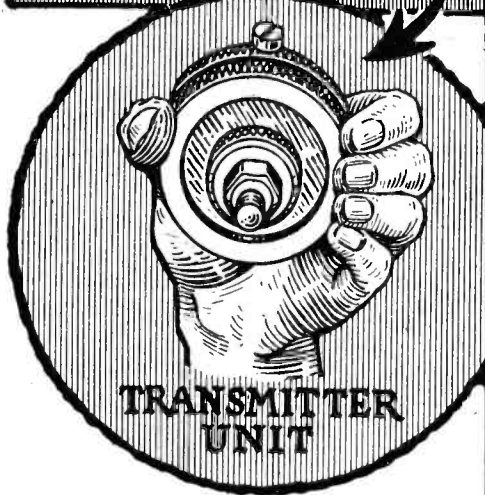

Here's a marvel of Engineering design — a practical miniature transmitter, used by thousands of radio fans and experimenters for amplification purposes.

It is a most novel unit, having hundreds of uses. Every amateur should have two or three of these amplifiers in his laboratory.

With each unit is mailed an eight-page instruction pamphlet. It shows how to use these units.

Our supply is limited; avoid disappointment by ordering today. The coupon below is for your special convenience—just fill in your name and address, mark in the number of units you desire, enclose the necessary amount and we will ship them to you at once postpaid.

SPECIALLY PRICED

WHILE THEY LAST

95^c PER UNIT

OR TWO FOR \$1.75

THE PRESS GUILD

66 W. Broadway, New York, N. Y.

ORDER BLANK

<p>~LOUD SPEAKER RETRANSMISSION~</p>	<p>PHONOGRAPH MUSIC AT A DISTANCE</p>	<p>~PHONOGRAPH AMPLIFIER~ 5 OHM REC. WITH HORN BUTTON SOUND CHAMBER DIAPHRAGM</p>
<p>~GRID LEAK~</p>	<p>BATTERY BUTTON DIAPHRAGM RECEIVER TO HEADSET OR LOUD SPEAKER ~AMPLIFIER~</p>	<p>PIANO TELEPHONE DRY CELL</p>
<p>~ONE STAGE AMPLIFICATION~ BUTTON MICROPHONE TRANSFORMER HIGH RES. PHONE 6 VOLT BATTERY</p>	<p>~RADIO AMPLIFIER~ MICROPHONE TRANSFORMERS HIGH RES. PHONES AND BUTTONS 6 VOLT BATTERY LOUD TALKER</p>	<p>~TWO STAGE AMPLIFICATION~</p>
<p>BATTERY BUTTON DIAPHRAGM LAMP ~TALKING LIGHT~</p>	<p>TO AERIAL TUNING COIL PHONES BUTTON TO GROUND ~DETECTOR~</p>	<p>TIN CAN BUTTON RECEIVER ~ELECTRIC STETHOSCOPE~</p>
<p>~CODE PRACTICING DEVICE~ FIBER RING 5 OHM RECEIVER IRON DIAPHRAGM KEY CAP WITH ENLARGED HOLE</p>	<p>~BALDWIN PHONE AMPLIFIER~ BALDWIN DIAPHRAGM REMOVED. THIN ROD R SOLDERED TO PHONE LEVER L AND TO BUTTON FLEXIBLE WIRE 3 VOLT BINDING POSTS</p>	<p>~TELEPHONE~</p>
<p>~PHONOGRAPH AMPLIFIER~</p>	<p>HEAD PHONE HORN A B C ~AMPLIFIER~</p>	<p>~HAND MICROPHONE~ STRIP SPRING BRASS SPRING FASTENED HERE, FREE HERE PRESS TO TALK HANDLE</p>

THE PRESS GUILD, 66 West Broadway, New York, N. Y.

Enclosed find ^{95c}\$1.75 for which send me postpaid ^{one}two amplifier units as advertised.

Name

Address

City, State

R. R.-9

The above and innumerable other interesting experiments are possible with these amplifiers. Every amateur should have at least one or two in his "Lab" or workshop. An eight-page instruction pamphlet is sent with every unit showing scores of experiments.

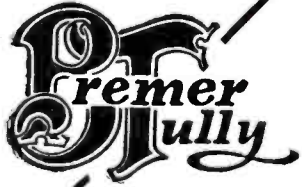

Each succeeding year more radio enthusiasts are enlisted as B-T Boosters. This ever increasing prestige is the inevitable result of QUALITY recognition. It had to come and it must continue because—

It's our greatest ambition to retain the B-T Reputation

B-T's latest effort is the—

COUNTERPHASE EIGHT

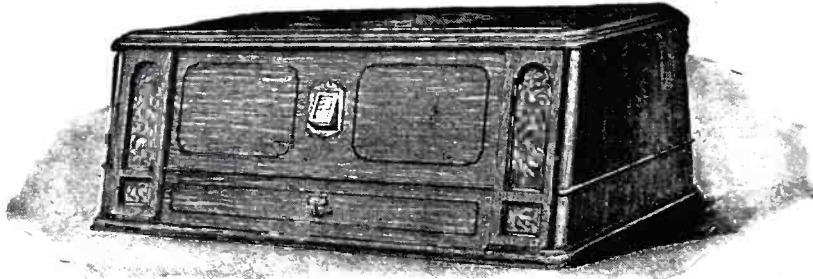

B-T skill and ingenuity are apparent on every point. You'll marvel at the new cabinet design, clever, different but sensible. It will set a style is our prediction.

When you examine the "innards" you're bound to emit a word of approval—"Beautiful job" is what most people say—

—and when you turn the one dial and your favorite station comes in without a squeal or howl—THEN you'll know that B-T has "delivered" again!

All that you expect of B-T is there!

We can't thrill you by describing this new set on paper—treat yourself to a demonstration at any Authorized Dealers. They are always glad to demonstrate a *Counterphase*.

Circulars free—address

BETTER TUNING

The 10th edition tells all about the new COUNTERPHASE Set models, B Power Units and gives the B-T viewpoint on all the latest developments in Radio. You'll enjoy reading it. Price 10c.

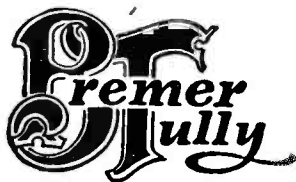

Manufacturing Co.

532 So. Canal Street, Chicago

No guess-work — no knobs to turn with the new B-T B Power Unit. The user knows at all times the exact voltage delivered to the set. Different and we believe, better.



experimenter read over carefully the data furnished with his tubes and try different potentials at these points, in order to get the maximum results from his receiver. The "B" battery terminals are numbered 1, 2, and 3, each with a plus sign.

It should be noted that the "B" battery terminals are marked + 1, + 2, and + 3; + 1 is the detector; + 2 is the terminal for the R.F. tube and the first stage of the amplifier, and + 3 is the terminal for the last stage of the amplifier. It will be unnecessary to have a separate wire to this last-mentioned terminal if, for instance, 90 volts are used on the plates of the two tubes in the amplifier. It will suffice merely to short terminals +2 and + 3. The "C" battery terminals are marked in the same manner. C-2 is connected to the secondary of the audio frequency transformer in the last stage, in case a power tube is used in that position and a greater voltage bias is desired. In case tubes of the same type are used in both stages of the amplifier, then the terminals, as mentioned above, may be shorted.

Tuning the Receiver

Outside of the usual tuning operations, there is but one adjustment to be made on the completed receiver, and that is the fixing of the small five-plate variable condenser. This adjustment is made as follows: a broadcast station, the wave-length of which is in the neighborhood of 300 meters, should be tuned in with the detector in oscillation. The condenser shunted across the secondary of the R.F. transformer should be varied until the whistle is quite loud, and then the antenna condenser should be tuned. It will be noticed that the whistle will change in pitch as this last-mentioned condenser is varied. Then the balancing condenser should be adjusted until the antenna condenser change effects no difference in the pitch of the whistle. This indicates a balanced condition in the receiver. It is important that the balancing condenser be varied very little at a time, each time noting the change in pitch of the whistle. On one side of the balancing point the whistle will be found to fall in pitch, and to rise on the other.

When a station is to be tuned in, the high resistance in series with the primary of the R.F. transformer is varied until the carrier waves of the stations are heard as the condenser dials are rotated. When a station is selected the tuning dials are adjusted and the resistance again varied until the whistle entirely disappears.

150 RADIO HOOKUPS

What more could you ask?—150 of the very finest, selected hookups most popular today. Each one completely explained and fully illustrated so that a complete receiver can be constructed from the information. No out-of-date Hookups—all the finest and best in common use today.

Don't miss this opportunity—All Radio and news dealers have fresh copies Now. If there is no dealer near you write us direct enclosing 25 cents.

25c

The Copy

64 Pages, Illustrated.
Large Size, 6 x 9 Inches
Sold on all newsstands. If your newsdealer cannot supply you, order direct.
We pay postage charges.

THE CONSRAD CO., INC.

53 PARK PLACE :: NEW YORK CITY, N. Y.

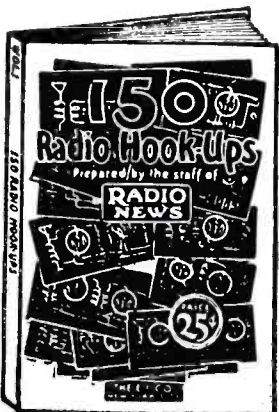

\$75 A WEEK BUILDING RADIO SETS

Earn \$3.00 an Hour Upwards In Your Spare Time Servicing Radio Sets

If you want to make money, spare time or full time, join the Radio Association of America, and learn how to build and repair radio sets.

The Association will train you, show you how to build sets that will undersell those offered by stores, even start you out in business if you wish. After receiving its training, you'll be able to be the radio "doctor" in your community—to install and repair sets—to make \$3 an hour and more.

Earns \$500 In Spare Hours

"I have at last found myself," writes *Lyle Follick*, Lansing, Michigan. "I have already made over \$500."

Werner Eichler, Rochester, N. Y., writes: "... have made over \$50 a week in my spare time."

Our members are starting radio stores, increasing their salaries, securing better positions, earning big money spare time through their membership in the Association.

Be a Radio Expert

As a member of the Association, you will be trained by Mr. A. G. Mohaupt, Graduate Electrical Engineer, University of Wisconsin, former radio instructor for the U. S. Government, author of "Practice and Theory of Modern Radio."

He will give you his personal attention, helping you with your individual problems, answering your questions, working with you at every stage, guiding you, directing you to your goal to be a Radio Engineer. We prepare you to successfully pass the government examination for an operator's license.



Join The Association Now!

If you're interested in Radio for either pleasure or profit, join the Association now. We have a Special Plan whereby your membership need not cost you a cent. Write now as there are only a limited number of these memberships available. Write now before it is too late. Just mail the coupon.

FREE

5-Tube Tuned Radio Frequency Set Given to Each New Member

RADIO ASSOCIATION OF AMERICA,
Dept. K-9—4513 Ravenswood Avenue, Chicago.

Send me details of your Special Radio Association Membership Plan.

Name

Address

City..... State.....

RADIO ASSOCIATION OF AMERICA

Dept. K-9—4513 RAVENSWOOD AVENUE

CHICAGO, ILLINOIS

SPECIAL SUBSCRIPTION OFFER

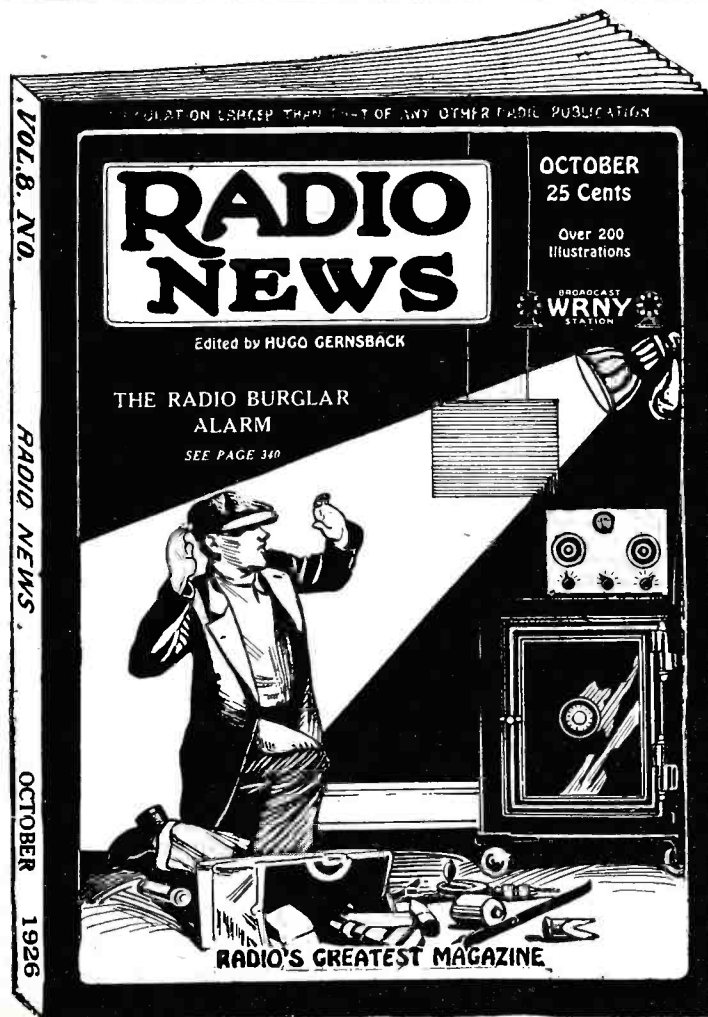

116 PAGE BOOK
GIVEN FREE
WITH EVERY 5 MONTHS
SUBSCRIPTION TO



Radio's Greatest Magazine

RADIO NEWS, with its 240 pages, is the largest radio magazine published. It is the outstanding authority in the radio field, carrying more new developments, more hookups and more news than any other radio magazine.

RADIO NEWS carries in every issue more than a dozen separate departments that cover every angle of the great industry from the beginner to the professional broadcaster or ship operator.

RADIO NEWS has been radio's greatest magazine since the very beginning of radio broadcasting.

(Regular Newsstand Price \$1.25 the Year)

SEND ONLY \$1 FOR FIVE MONTHS SUBSCRIPTION AND GET A COPY OF "HOW TO MAKE IT" FREE.

FREE

Big 116 Page Illustrated Book "HOW TO MAKE IT"

Building your own home furniture, cameras, radio cabinets, sport devices, etc., is easy if you know what materials you need, and have an illustrated explanation on how to proceed. Then too, you can save a good deal of money by making these valuable things yourself.

"How to make it" a big book compiled from the great magazine "SCIENCE & INVENTION," is full to the brim with hundreds of up-to-date things to make at home. Things that can be made by any man with only a few simple tools.

Every home in the U. S. should have one of these books handy—worth its weight in gold.

116 Pages
200 Illustrations
Size 9 x 12 Inches

EXPERIMENTER PUB. CO., Inc.
53 Park Place, New York, N. Y.
Gentlemen: I enclose \$1 for 5 months' subscription to RADIO NEWS and one FREE copy of "HOW TO MAKE IT."
Name

Address

City..... State.....

The Experimenter Publishing Co., Inc., 53 Park Pl., N. Y.

DID YOU GET YOUR COPY OF OUR

FREE

RADIO SUMMER BARGAIN BULLETIN?



TESTED PARTS

All parts offered in our catalog including those combined in knockdown KITS have been carefully tested and approved by our graduate Radio Engineers. Satisfactory results are guaranteed!



PANEL FOR KITS

A completely drilled and engraved panel is included with each of our kits. Makes set building easy and sure. No other concern gives this FREE service.

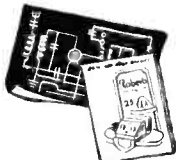

BLUE PRINTS

Complete BLUE PRINTS and easy-to-understand INSTRUCTION BOOK included with each of our KITS. No technical knowledge required to build your own set.



JUST off the press! Our special Summer Bargain Bulletin. Pages of parts, accessories, kits and sets—all the best and the latest. A \$1,000,000.00 Radio Stock to choose from. A copy of this unusual catalog is yours for the asking. Just drop us a line—now.

SAVE MONEY

Our enormous buying power permits us to pay spot cash and get rock bottom prices. Be sure to see our catalog before you buy—save money. Write for your free copy today.

Dep't RR

CHICAGO SALVAGE STOCK STORE

509 S. STATE ST.

CHICAGO, U. S. A.

Modern Types of Radio Receivers

(Continued from page 106)

may be had in any number of woods. Evidently these consoles and cabinets will fill a long felt want, for they supply both a useful radio receiver container and a beautiful piece of furniture.

For the Home Constructor

One of the greatest problems with which the radio experimenter is confronted is the arrangement of the apparatus of his set on the panel and baseboard. It is quite natural that there is a different arrangement for every type of circuit and to find this arrangement, the experimenter sometimes has to waste valuable time before he hits upon the correct solution to the problem.

However, in tuned radio frequency receivers this arrangement is generally the same in every case. There are as many variable condensers as there are stages of radio frequency amplification and they are generally mounted on the front panel with the radio frequency transformers immediately behind them. To the right of these stages follow the detector tube and any audio frequency amplification.

In order to simplify matters for the experimenter a manufacturer has placed upon the market a unit that will greatly aid him in his experiments. Two of these units are shown in Figs. 8 and 9. It will be seen that there are three variable condensers mounted on a frame of metal and on this same frame may be mounted coils, transformers, vacuum tube sockets, etc. These three condensers are so mounted that they operate from the same dial and instead of having three dials to log, there is on the left of the condensers a circular scale, which fits behind a small window in the front panel. This scale is also mounted on the same shaft with the condensers.

From an inspection of the two illustrations it will be seen that coils, condensers, vacuum tube sockets, transformers, etc., are so placed that there is no waste space and that the leads connecting the various pieces of apparatus will be very short. This latter point is particularly of interest, as it is here that many constructors fall down. They do not seem to realize that the leads can do any harm and in some of the more sensitive receivers, it has been found that it is here that most of the troubles originate.

These receivers described in this article are only a few of the high spots of the first half of the year 1926, and it is hard to predict just what the last half of the year will find in the radio field.

Novelties—How to Make Them

Make Hundreds of Remarkable Things at Home

Almost every home has an old clock around—Do you know that a great many surprising, fun making and useful novelties can be made just from the old springs, the gears, etc.

NOVELTIES, the new book, compiled by the staff of SCIENCE & INVENTION, shows you how to make hundreds of wonderful Novelties, mostly out of old scrap things laying around the house. 116 Pages, in this book, show pictures, diagrams and explanations of remarkable, interesting things to make in your spare time.

PRICE
50¢

116 Pages, 300 Illustrations,
Size 9 x 12 inches

Sold on all newsstands. If your newsdealer cannot supply you, order direct. We pay postage charges.

EXPERIMENTER PUBLISHING CO., INC.
53 PARK PLACE :: NEW YORK CITY, N. Y.

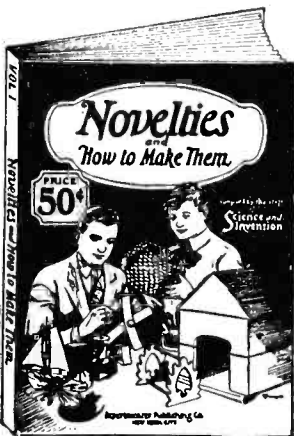

Your Radio Tubes and Good Reception

(Continued from page 158)

serve that the tungsten filament in all of them seems to burn at the same temperature—the temperature which gives them maximum life. Tungsten in its original state is an extremely brittle metal and it was only after years of experimenting that it has been possible to change the original egg-shell structure of this metal into a ductile form and to draw it into wire less than one-thousandth of an inch thick, thereby making it available for use in vacuum tubes.

In order to keep this tungsten filament in the proper ductile form, it must be operated at a definite temperature—neither too low nor too high. As illustration note Figure 1 herewith. This shows a micro-photograph of a tungsten filament—greatly enlarged. Observe how the fibres are all bunched together like a bundle of sticks. This



Fig. 3. Showing how the Amperite is connected to the vacuum tube.

is tungsten in its ductile form, which remains in this condition only if operated at the proper temperature. If this tungsten filament is over-heated it evaporates and eventually “goes up in smoke” and your tube is dead. On the other hand, if the filament is under-heated by manipulating hand rheostats it assumes the structure illustrated in Figure 2. Note below how the fibres have been changed to a boxcar structure. This is tungsten in its brittle form and at the slightest vibration the filament breaks and the tube is ruined. Consequently, you will observe it has you coming and going.

Manipulating the filament of your tube with a hand rheostat is inadequate, as at no time will you be able to satisfactorily maintain the proper temperature within its narrow limits. Unless you are an expert operator and there is an accurate meter in the circuit you are constantly either underheating or overheating your tube.

This problem has now been solved automatically and completely by a de-

(Continued on page 170)



Instruments

ARE

Necessary—

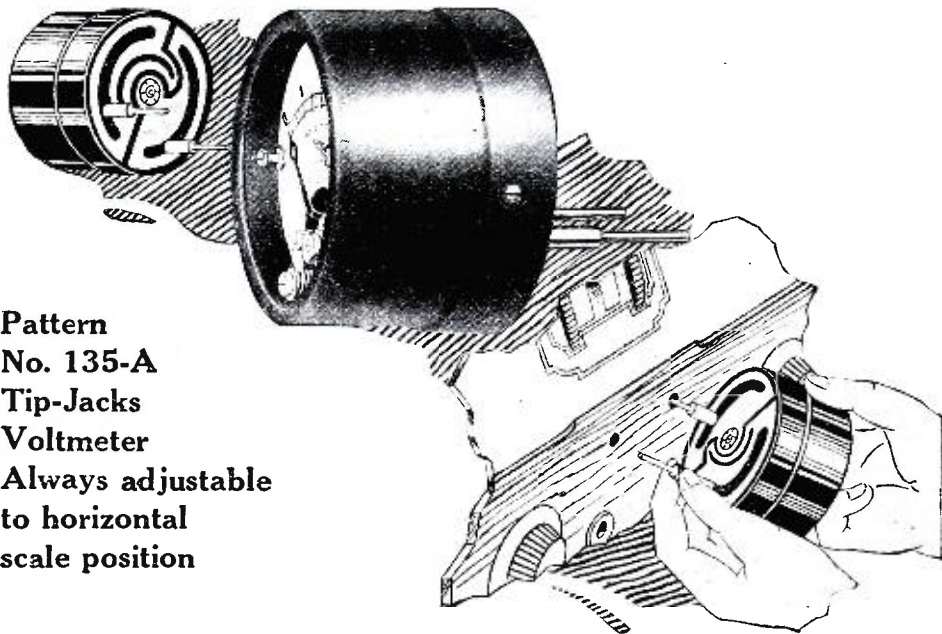

Pattern No. 135-A
Tip-Jacks
Voltmeter
 Always adjustable to horizontal scale position

It is recognized, as evidenced by the fact that many set manufacturers are either incorporating a voltmeter or providing tip-jacks for the use of one on their sets, that regulated filament voltage is essential for consistent maximum reception and intelligent operation of your set. The only way that filament voltage can be controlled is by use of an instrument.

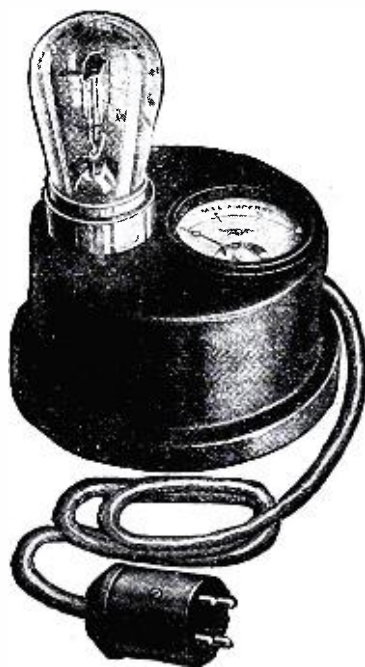

Pattern No. 107
Junior Tube Checker

Pattern No. 135-C
Portable Voltmeter

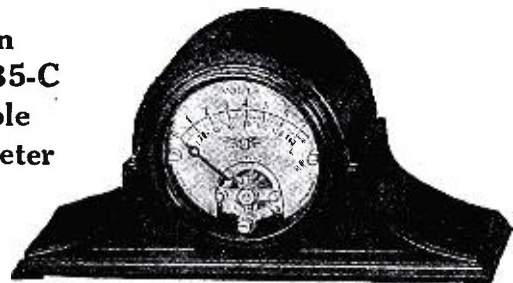

Pattern No. 135-C—Portable double reading voltmeter in beautiful black bakelite case furnished with phone tipped leads for plugging into tip-jacks.

Pattern No. 107—Junior tube checker for checking tubes at home. Tests all three and five-volt tubes while in actual operation.

Send for descriptive circulars

Jewell Electrical Instrument Co.

1650 W. Walnut Street

Chicago

Twenty-six Years Making Good Instruments

Reader's Problems

(Continued from page 148)

cy transformers and leads brought out to the regular trap, which may be placed behind the receiver, or to one side. Where there are several stages of radio frequency amplification the listener may be undecided where he should place the pick-up coil of the trap. It is advisable to use it on the coil feeding into the detector tube. In this manner energy from the interfering station can be blocked out of the detector, which is the whole idea of the trapping circuits,—to keep the detector free from interference. A few turns of wire can be wound directly over the detector coil or suspended near it. The inductance and condenser used with it are the same construction as indicated in Figure 1 but without taps.

Sometimes there are cases when loop receivers do not tune out the nearby stations as they should. Some loops are very directional and can be pointed away from the cause of the interference, while others do not have such a pronounced directional effect. In such cases a wave trap can be installed directly on the loop. It is then merely necessary to use enough inductance to enable the listener to tune to the wave length of the interfering station with the variable condenser employed. About twenty turns of No. 24 DCC wire wound around a 45 volt "B" battery measuring 7 inches by 8 inches will give the desired inductance. The wire is then removed from the battery and taped or tied together and placed close to the loop. The condenser, either .00025 or .0005 mfd., connected across this inductance is then varied to tune out the undesired station.

(62) Mr. F. Denzler, Ponomo, Calif.

Q. 1. In your January Radio Review I started to build the Hetro-Five. I started to wind the Figure "8" described on Page 29 of that issue and found template wrong. The description calls for 24 pegs and template shows only 23 holes for pegs, and I can't figure out where to drill the extra hole. Please let me have a correct sketch.

A. 1. We are giving you a corrected template on a preceding page. However, as this type of coil represents difficulties to the layman in winding and since the Bureau of Standards report shows that the ordinary solenoid wound coil is even more efficient than any other type of coil, you may desire to use the solenoid wound coil. In this case use a bakelite type not less than three inches in diameter and not more than three and one half inches, winding thereon of exactly the same putting a

AERO COIL

SUPER-SENSITIVE

INDUCTANCE UNITS for EVERY SET



Tuned Radio Frequency Kit

Consists of 3 matched units. Antenna coupler has variable primary. Furnished complete with 8 page color circuit, layout and instruction sheet for building super-sensitive 5-tube Aerodyne. Uses .00035 condenser.

Price..... \$12.00

Low Wave Tuner Kit

Completely inter-changeable. Adopted by experts and amateurs everywhere. Range from 15 to 130 meters. Includes 3 coils and base mounting covering U. S. bands, 20, 40 and 80 meters. Uses .00014 condenser on secondary and .00025 on feedback control.

Price..... \$12.50

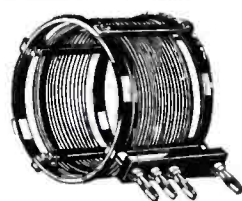
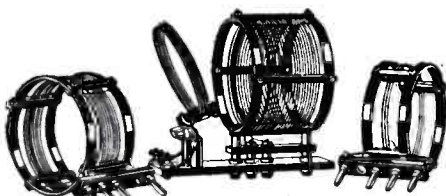

Coil No. 4

Increases range of short wave tuner to 250 meters. Fits standard base supplied with short wave kit and uses same condensers.

Price..... \$4.00



Coil No. 5

Increases range from 235 to 550 meters giving complete coverage of broadcast band. Fits standard base supplied with short wave kit and uses same condensers.

Price..... \$4.00

Aero Coil 3-Circuit Tuner

The true low-loss tuner. We believe it the most efficient 3-circuit tuner ever offered. Has variable primary. Wave length range below 200 and above 550 meters when shunted with .00035 condenser.

Price..... \$6.50

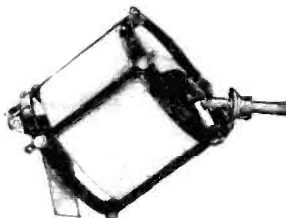

Radio Frequency Regenerative Kit

Consists of one radio frequency coil and one tapped 3-circuit tuner. Makes the most powerful, most selective 4-tube non-radiating set possible to build.

Price..... \$10.00



Aero Oscillator

Greatly improves the performance of the oscillator circuit of Super-Heterodynes. Uses .0005 condenser.

Price..... \$5.50



Wave Trap Unit

Also used for crystal sets. Very effective by reason of the characteristics made possible by patented Aero coil construction. Uses .00035 condenser.

Price..... \$4.00

Complete description of all Aero products on request. Order from your dealer or send his name with your order to

AERO PRODUCTS, Inc.

1772 Wilson Ave., Chicago, Ill.

Pacific Coast Representative:

Henger Seltzer, 1111 Wall St., Los Angeles, Calif.

377 Brannan Street, San Francisco, Calif.

A Book for Every Radio Set User

THE RADIO TROUBLE FINDER

No matter how much or how little you know of your radio receiver, this new "Radio Trouble Finder" book is going to be a big help.

It explains the common and special faults of all the standard receivers of today; tells how to recognize instantly, by various sounds, where the trouble lies and also gives special simple tests by which you can determine what is wrong with your receiver. Then for each particular fault there is explained the proper procedure for correcting it.

All troubles and their remedies are arranged in simple charts so that even the most inexperienced radio user will have no trouble in keeping his set at all times in first class condition.

All parts of the radio set are illustrated to show the layman how to proceed in correcting faults.

200 Illustrations. Size 6 x 9 Inches

SOLD ON ALL NEWSSTANDS

THE CONSRAD CO., Inc.

53 PARK PLACE
NEW YORK, N. Y.



The Copy

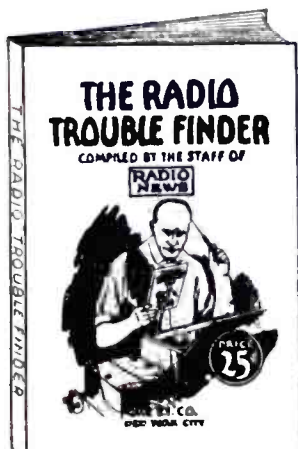

number of turns as specified in the article.

(63) Mr. R. M. Masterson, El Paso, Tex.

Q. 1. In the January, 1926, issue on Page 55 you have shown "The L-C Circuit." On page 56, in Figure 1 you give a schematic diagram, but apparently this is incorrect as it shows 5 tubes with resistance coupling whereas the set calls for 4 tubes with transformer coupling amplification. Will you kindly let me have corrected diagram.

A. 1. The diagram as shown in Fig. 1, Page 56, of the January issue is essentially the L-C circuit, although this arrangement is for resistance coupling. We are giving you on a preceding page the transformer coupling hook-up which should be substituted for the one given in the January issue to which reference is made.

How to Build the Improved Browning-Drake Receiver.

(Continued from page 150)

will provide about 50 volts for the detector plate. The resistance values for various plate voltages from a given plate supply are included in the accompanying table.

Before placing any of the tubes in the sockets, it is advisable to disconnect the "B" battery and to turn the filament switch, S, to the "off" position. Then, place the power tube in socket N5, the second socket from the left, looking from the front of the receiver, and turn on the filament switch.

Place the last two UX-199 or CeCo type "C" tubes in their sockets N3 and N4 and follow the same procedure. If all of the tubes light satisfactorily, the negative lead to the "B" battery should be put in place.

Then, the positive lead should be lightly touched to the high voltage side of the "B" battery. If the tubes brighten when this momentary connection is made, it is an indication that some of the wiring has not been carried out correctly and that the tubes are likely to burn out. If no increase in brilliancy occurs, it is safe to go ahead with the operation of the receiver. In making this test it is always better to use not more than 45 volts of "B" battery. If this does no damage it is safe to go to the high voltage."

The LYNCH Metallized RESISTOR ASSORTMENT

Contains the following:—

Three	.1 Meg.
One	1 "
One	.5 "
One	.25 "
One	2 "
Complete, \$4.25	

METAL long has been recognized as the best of electrical conductors. The Lynch Metallized Resistor has received the unqualified endorsement of leading engineers, experimenters and test laboratories because it is absolutely silent in operation and remains permanently accurate.

Comprising a concentrated metallized deposit one-thousandth of an inch thick upon a glass core and sealed within a glass tube, each LYNCH METALLIZED FIXED RESISTOR wins in the exacting tests of time and service.

Warranted—
Absolutely Noiseless
Permanently Accurate
Dependable!

If your dealer cannot supply you, we will ship by return mail. You take no risk as Lynch products are sold on a money-back guarantee. Use the Convenience Coupon below.

PRICES	.25 to 10 Megohms	.50
	above .01 to .24 "	.75
	.001 to .01 "	\$1.00
	Single Mounting	.35

ARTHUR H. LYNCH, Inc.
 Manufacturers of Radio Devices
 Fisk Bldg., B'way & 57th St.
 New York, N.Y.



[Dealers —
Write us!]

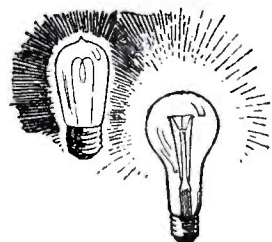

The old carbon lamp consumed more current to give less light. Tungsten, which is metal, proved more efficient, more dependable. The Lynch Metallized Resistor gives non-arcing, conductive resistance. It marks as great an advance as did the tungsten lamp.
 Arthur H. Lynch

ARTHUR H. LYNCH, Inc., FISK BLDG., New York, N.Y.
 Send me the Lynch Assortment described above (7 Lynch Metallized Resistors) with the understanding that I am to receive my money back if not satisfied. I will pay postage.
 (Name) _____
 (Address) _____
 O. enc. check or money order and save postage.

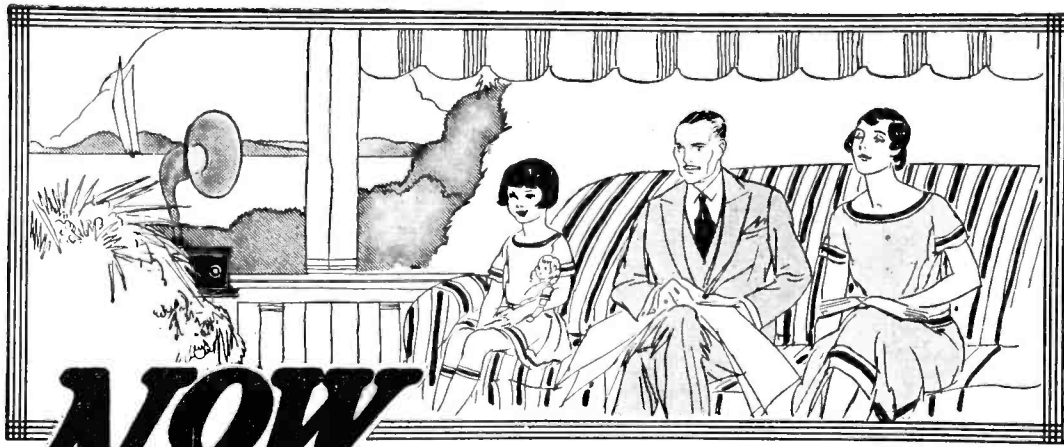

Now you can have Radio at its best summer or any time!

You can at last forget the mechanics of radio, for a simple switch releases all the power you need for any program. Power—clean—constant—abundant! Power that instantly responds to high soprano, and as easily brings you the full resonance of an orchestration!

No Filament To Burn Out

All Majestic "B" Current Supply units are manufactured complete in our factory and are equipped with the famous Raytheon Non-filament Tube. No acids or back surge. Tests of the Majestic "B" on the oscillograph demonstrate that all A-C hum is entirely eliminated.



Majestic "B" Current Supply

delivers pure direct current—From your light socket

The same electric current that supplies your lights delivers "B" power for your radio. No fuss. No worry. No acids. No "hum." Nothing but reliable, unvarying power direct from your light socket. *And at an average cost of one-tenth cent an hour!*

Economical, powerful—lasts as long as any receiver

Fully guaranteed. Its low purchase cost and the saving it will mean to you in just a short time makes it an investment that soon pays for itself. Don't delay—see your dealer at once or write for free booklet.

Majestic Standard "B"	
Especially adapted for sets having not more than seven 201-A tubes, or, six 201-A plus one 135-150 volt power tube.	
Price	\$32.50
West of Rocky Mts.	35.00
Majestic Super "B"	
Capacity 1 to 12 tubes, including the use of 135-150 volt power tubes.	
Price	\$35.00
West of Rocky Mts.	37.50
Majestic Master "B"	
Rating 60 mills at 150 volts. Particularly adapted for Radiola 25-28- & 30 and super heterodynes. Will operate on super power tubes UV 171 (180 volts). Unequalled for sets having very heavy current draw.	
Price	\$42.50
West of Rocky Mts.	45.00

GRIGSBY-GRUNOW-HINDS CO.

4574 Armitage Avenue

Chicago, Illinois, U. S. A.

Read

"AMAZING STORIES"

The Magazine of Scientifiction

STORIES BY

H. G. WELLS

JULES VERNE

GARRETT P. SERVISS

25c—ON ALL NEWSSTANDS

Your Radio Tubes and Good Reception

(Continued on page 167)

vice which eliminates the need of hand rheostats and meters and makes everyone an expert operator. This contrivance, known as Amperite, is constructed as follows: It consists of a specially treated filament which has the unique property of changing in resistance in relation to the varying voltage of the "A" battery. Thus when the "A" battery is fully charged, it allows only the proper amount of current to enter the filament. As the battery runs down through use the resistance of the filament in the device itself decreases so as to tend to maintain a constant current through the tube filament at all times. In other words, it performs automatically exactly what must be done in order to operate your set at maximum efficiency; namely, the tubes are constantly maintained within the proper operating temperature as indicated above.



Fig. 4. This shows method of mounting the Amperite.

The Amperite filament operates on the thermo-electric principle. It is contained in a hermetically sealed glass tube filled with an inert gas and is so constructed as to make it serve properly—all the time. There is no hand adjustment required; no knobs to turn. It is hooked up simply in series with the tube filament and the "A" battery line as indicated in Figure 3 and you may forget all your tube troubles.

In Figure 4 the method of mounting the Amperite is clearly shown. The leads are connected to the binding posts at each end while the cartridge is held between the two brass clips. It can readily be seen that the addition of Amperite to a radio set not only greatly simplifies operation but also offers no further complication as regards construction or connections.

Under the standard conditions of use the life of a unit of this kind is practically indefinite. They are built sturdily and the only way in which they may be burned out is due to an accidental over-voltage occurring in the filament line and when this occurs the particular tube in the circuit is usually saved.

A New Method of Amplifier Coupling

(Continued from page 134)

signal, but the resistance to the grid charge is unusually low. How well this system performs is shown by the accompanying curves (Figs. 1 and 2) in comparison to two well-recognized systems, that is, transformer and resistance coupling.

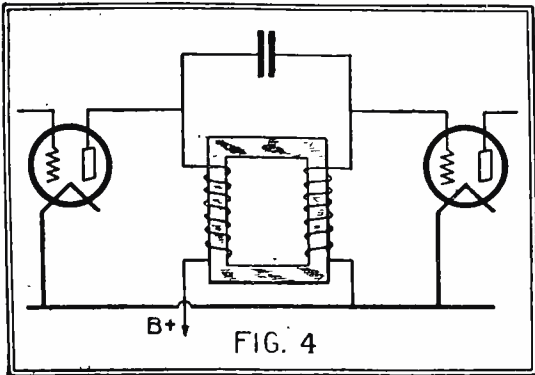

Fig. 4 (above). Circuit diagram of the Donle coupling system. The two windings are on a single core; the grid charges leak off through the winding on the right.

Fig. 1 shows the operation of the Donle system, in comparison with the others. On this curve the input and output are given in arbitrary units; it shows very clearly most of the characteristics mentioned above. For example, with transformer coupling the efficiency falls off very rapidly as the input increases. The curve for the Donle system crosses the transformer curve at a relatively low input and rises to a considerably higher value.

The curve of resistance coupling, with the grid leak of one megohm, shows in a very interesting manner the low efficiency of the system on weak signals and the attainment of saturation at a very low input. With resistance coupling, if a large output is desired it is necessary to use a grid leak of low resistance. The effect of this is shown in the same figure on the curve for a grid leak of 0.1 megohm—a lower efficiency on weak signals but saturation at a higher value.

From the curves of Fig. 1 it is obvious that the transformer is an efficient coupling device for weak signals but incapable of handling signals of great volume. Resistance coupling is inefficient and will handle still less volume than transformer coupling. And that, furthermore the new system of coupling is more efficient for signals of all intensities than resistances and yet is capable of handling a greater volume than the transformer.

Comparison of Several Stages

In Fig. 2 curves are shown, taken under similar conditions to those of Fig. 1 and the results given in arbitrary units, for the performance of two and three stages of this new system of amplifier coupling compared with two stages of transformer coupling and

A B-6 DETECTOR IN YOUR SET ASSURES THE UTMOST IN QUALITY, VOLUME AND DISTANCE. FOR THOSE WHO PREFER TO "BUILD THEIR OWN" WE HAVE PREPARED DETAILS OF A SPECIAL CIRCUIT WHICH WILL BE MAILED ON REQUEST.



PRICE \$5
BOOKLET ON REQUEST

THE
DONLE-BRISTOL CORPORATION

MERIDEN ::: CONN.

The Radio News Super-heterodyne Book

A complete history of this most popular circuit including full details of all patents touching on Superheterodynes.

100 Pages 9 x 12 inches fully illustrated

50c on all newsstands or direct

WE PAY POSTAGE CHARGES

EXPERIMENTER PUBLISHING COMPANY, INC.

53 PARK PLACE :: :: NEW YORK CITY, N. Y.

Distance --- Quality --- Selectivity

WITH THE NEW IMPROVED

Browning-Drake Receiver

Complete List of Parts

Coil and variable condenser, respectively, of the National Co. Antenna Tuning Unit.....	\$24.00	3—Lynch metallized resistors, .1 meg..	2.25
Coupling coils and variable condenser, respectively, of the National Co. detector tuning unit.....		3—Lynch metallized resistor, .5 megohms..	.50
Jefferson "Concertone" sealed audio-frequency transformer.....	6.00	5—Benjamin vibrationless sockets for UX tubes.....	3.75
Thordarson filter choke (same as that used for B eliminator work).....	5.00	Lynch metallized resistor, 6 megohms..	.50
Tobe paper filter condenser, 4 mfd....	3.75	2—Lynch metallized resistors, .025 megohms; and .09 megohms, respectively.....	1.50
Sangamo mica fixed condenser, .002 mfd.....	.50	Brach-Stat Code 2-B, with mounting...	1.00
Sangamo mica fixed condenser, .006 mfd.....	.85	Frost Gem-Jac, No. 954.....	.25
X-L variodenser, type N.....	1.00	Carter battery switch.....	.65
3—Lynch double-resistance mountings.	1.50	2—Tait brackets.....	2.00
2—Tobe paper filter condensers, .1 mfd.	1.40	Sangamo mica fixed condenser, .005 mfd. equipped with grilleleak clips.	.50
		Small brass brackets for mounting connection blocks.....	.20
		Antenna connection block.....	.15
		Battery connection block.....	.25
		Decorated bakelite panel, 8 x 22 inches.	7.50

COMPLETE Parts \$65.00

DEALERS WRITE FOR WHOLESALE CATALOG

Genuine Mahogany Corbett Cabinet, 8 x 22, including baseboard for the new Browning-Drake Receiver \$15.00

Complete Parts for the New **CALLIES SUPER** as described in this magazine **\$98.65**
CABINET FOR THIS SET.....\$9.50

HEINS & BOLET

Radio and Electric Supply Corporation

48 PARK PLACE WHOLESALE AND RETAIL NEW YORK

three stages of resistance coupling. The results indicated are too obvious to require a lengthy description. There are a few points, however, which should be mentioned. In the first place the two stages of the new system show considerably less efficiency than two stages of transformer coupling for signals of weak intensity; but as the intensity increases the new system equals transformer coupling and finally exceeds it, because the two stages of transformer coupling have become nearly saturated at a relatively low intensity.

The three stages of the new system show a very high efficiency for all signal intensities compared to two stages of transformer coupling. The curve for three stages of resistance coupling shows the usual characteristic of this system; that is, the attainment of saturation at relatively low input and even a falling off of the output as the input increases beyond the saturation point. It might be stated here that, on these curves for resistance coupling, above the point where saturation takes place the quality of reproduction is ruined, and the signal quality almost is totally destroyed when the input increases that point.

Quality with Efficiency

The advantages of the new system may be summarized as follows: A very high quality of reproduction on signals of all intensities, with an efficiency per stage equalled only by a transformer on signals of low intensity, and equalled by no other system on signals of greater intensity. On account of the lack of regeneration between stages with the new system it may be used, and will in fact give the best performance, with three stages; under this condition it will exceed in efficiency the operation of two stages of transformer on signals of all intensities and will handle a signal volume considerably in excess of any other system. Furthermore, it may be arranged in a compact manner, is not readily affected by stray fields and may be connected into an ordinary circuit without the slightest difficulty.

CARTER

"HI-OHM" Universal Volume Control for All Circuits

New "SHORT" Jacks



Half Size

500,000 Ohms Complete with knob **\$2**

Small, simple and accurate. The contact arm slides on protecting wires covering special moisture-proof resistance element, insuring long life and unvarying electric characteristics. "HI-POT" same size in Potentiometer form, complete \$2.25.

Write for illustrated folder of circuits, etc.

In Canada—Carter Radio Co., Limited, Toronto

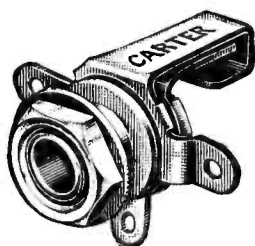

(FULL SIZE)

Open Circuit 25c. ea.
Closed Circuit 30c. ea.

New design, for use in small space. Same high quality and workmanship as other Carter products. Wide spaced solder terminals. Heavy bakelite insulators. Sleeve terminal marked +. Insulation for mounting on metal panel. 10c. each.

Any dealer can supply



Write us for catalog.

The Improved "Diamond of the Air"

(Continued from page 136)

circuit coil. The space between it and the first receptacle is used for four binding posts arranged in a little square, with the second battery switch, S2, in the center, and for the audio transformer, which is mounted on the under side of the bakelite strip. The purpose of the switch and posts will be explained shortly.

The other three sockets are distributed evenly along the remaining

RADIO BOOKS AND PATTERNS OF EVERY DESCRIPTION

If you want to build a new set, or want to learn more of your present set, write for our complete list of Books and Patterns.

THE CONSRAD CO., INC.

53 Park Pl., New York, N. Y.

free right-hand section of the sub-panel.

The under side of the latter holds the divers resistances, audio transformer and fixed condensers for the resistance amplifier. The three-quarter ampere ballast resistance is mounted beneath the right-hand edge of the R.F. coil. The transformer comes next and just clears the mounting screws of the second socket; it is fastened to the bakelite by means of its binding post screws, which pass simply through holes in the bakelite and which are then tightened down with machine nuts. The one-quarter ampere amperite fits directly beneath the second socket, to which it is connected.

Between the third and fourth sockets is fastened one of the .25 mfd. fixed condensers, which is flanked on either side by a resistor-mounting clip. The other condenser and clips are similarly mounted between the fourth and fifth receptacles. Finally, beneath the last socket, goes the one-half-ampere amperite.

This sounds like a lot of work, but it isn't at all. All the parts mount in place readily with the aid of small nuts and bolts which fit in holes drilled in the bakelite sub-panel. A little vigorous wristplay with a screw-driver has everything tightly in position within a half-hour's time.

The wiring, of course, is a little more of a task, but a pleasant one at that, because of the nice wide openings between the front and rear panels into which the soldering iron can be poked. The circuit is shown and can be followed through easily.

The primary of the single R.F. coil, as noted, is connected to the aerial and ground without further ado. The secondary goes to the inside springs of the double circuit jack to the left of the left-hand condenser on the panel, the outside springs being shunted by the condenser itself and the grid of the first socket. Rotary plates, of course, go to the filament leg of the circuit.

Wiring the Tuner

The primary of the three-circuit tuner is interposed between the plate of the first tube and the "B" battery amplifier wire. The secondary is bridged by the right-hand condenser, and proceeds to the grid of the second socket, the filament return being made to the "A" plus as usual. The tickler winding is connected as in a regenerative set between the "P" of the socket and the second double circuit jack. Both the detector and the R.F. amplifier are fed 45 volts through the wire marked "B" detector. This comparatively low voltage most decidedly stabilizes the circuit; it is as effective as some neutralizing systems which must operate with plate potentials 90 volts.

The connection between the inner springs of the detector jack is made to the primary of the amplifying trans-

in 1925

the Ultradyne L-2 was the first receiver to listen in on London in the International broadcast tests. Thousands of experimenters built this set because of its marvelous results recorded in the radio press.

in 1926

again—Dr. J. D. Hullinger of Clinton, Ia., won first prize in the Radio Digest contest for best verified foreign reception during International Broadcast Week. He employed the Ultradyne L-2 of course.



A Home Built Ultradyne

THE Ultradyne L-2 is a consistent distance getter. From 7.30 P.M. Friday, February 26 to 5.10 A.M. Saturday, February 27th, Aaron Whitener of La Grange, Texas, logged 72 stations, totaling 69,000 miles of reception. The most distant station was Sydney, Australia, 9600 miles away.

Like Mr. Whitener, thousands have successfully built the Model L-2 Ultradyne, and claim it the most wonderful receiver they have known for great distance on the loud speaker.

In no other receiver is found the "Modulation System" of radio reception—the most sensitive form of detection.

With the application of regeneration to the "Modulation System" the Ultradyne is capable of detecting the faintest broadcast signal, regenerating and making it audible on the loud speaker.

In addition, the Ultradyne is the most selective receiver known. Regardless of close similarity in wave length, it selects any station within range—brings in broadcasting clearly, distinctively, faithfully. We guarantee the Ultradyne L-2 will give better results than any other set operating under the same conditions.

In addition to Ultradyne Kits, we carry a stock of Kits for other standard Nationally Advertised circuits.

WRITE FOR FREE DESCRIPTIVE CIRCULAR AND CATALOG OF STANDARD PARTS AND SETS

ULTRADYNE

MODEL L-2

Special Repair Service Station maintained for all Ultradyne L-2 Owners.

MADISON RADIO CORPORATION
114-116 E. 28th STREET NEW YORK CITY

The Ultradyne Kit

Consists of 1 Low Loss Tuning Coil, 1 Special Low Loss Coupler, 1 Type "A" Ultraformer, 3 Type "B" Ultraformers, 4 Matched Fixed Condensers.

\$30.00



How to Build and Operate the Ultradyne

32 page illustrated book giving the latest authentic information on drilling, wiring, assembling and tuning the Model L-2 Ultradyne Receiver **50c**

1001 Radio Questions and Answers

—by the Staff of "RADIO NEWS"

A Book Full of Everyday Radio Problems and How to Solve Them

In presenting this most valuable assortment of questions and in answering them in the best and most understandable way, the staff of "RADIO NEWS" feels that it has created a book in which appears the cream of every radio man's problems and the best method of coping with them. There is contained invaluable information on every phase of radio. Information on hundreds of simple and complex hookups is given in clear and concise language. Information on practically every type of receiving set, manufactured receivers, vacuum tubes, miscellaneous circuits, and in short just what the radio enthusiast needs as an **unerring guide and aid.** This book abounds in priceless data that is worth far more than the nominal price at which it sells.

116 PAGES. 300 ILLUSTRATIONS. SIZE 9x12 INCHES.

SOLD ON ALL NEWSSTANDS

If Your Newsdealers Cannot Supply You, Order Direct We Pay Postage Charges

EXPERIMENTER PUBLISHING CO., INC.
53 PARK PLACE :: NEW YORK CITY, N. Y.

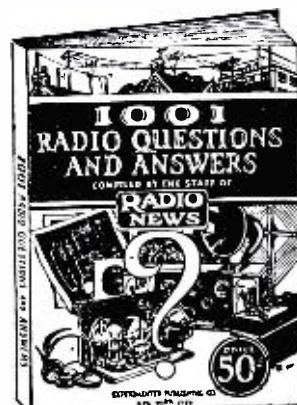

PRICE 50c

YAXLEY

APPROVED RADIO PRODUCTS

Cable-Connector-Plug

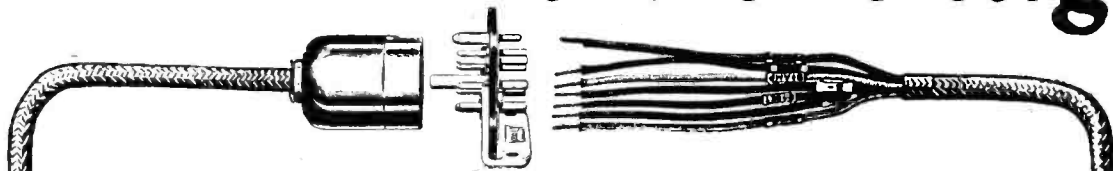

Bakelite Construction

One of the most practical accessories to a radio outfit. Simplifies your battery wiring and makes an instant and correct battery connection. Banishes the old-fashioned unsightly mass of battery wires. Bakelite construction, neat and handsome in appearance. Metal cable markers and colored template (RMA standard color code) permanently attached to the connector plate make it easy to wire any set. The phosphor bronze double contact springs are mounted in Bakelite and cannot work loose. Shorting is impossible.

The Connector Plate mounts upon a bracket which is reversible or may be entirely removed for subpanel mounting. Extra fine quality seven strand cable (RMA standard colors) 5 feet, and six extra markers to match your wiring arrangement furnished.

No. 660—Cable Connector Plug, complete..... **\$3.50**

Order from your dealer or jobber or send his name direct with your order to

YAXLEY MFG. CO.

9 South Clinton Street

CHICAGO

former through the four binding posts on the sub-panel. In ordinary use posts W and X and Y and Z respectively, are kept short-circuit by short lengths of bus-bar, but if it is desired to use the very excellent audio amplifier of the receiver with some other tuner, still in the experimental stage, the amplifier is available at posts X and Z after the bus wires have been removed. This is a useful little scheme and will be taken advantage of quite frequently by the owner of the set. The additional switch keeps the amplifier tubes turned on, with the R.F. and detector bulbs turned off by means of the front panel switch.

The rest of the audio amplifier is standard. Resistances R3, R5 and R6 are 100,000 ohms, while R4 is 500,000. A nine volt "C" battery is used, connection to it being made by flexible wires extending from the back of the right hand section of the sub-panel.

Filament Control

Ballast resistance R1, which is $\frac{3}{4}$ ampere in size, controls the R.F. and first two A.F. tubes together. R2 is a separate $\frac{1}{4}$ ampere amperite for the detector, while R7 is the $\frac{1}{2}$ ampere one for the last audio bulb, a UX-112 tube. The use of the fixed resistance for the detector may be criticized by some, but it works to perfection; the tickler coil provides smooth and even control of the regeneration over the entire broadcast wave-length band.

The first four tubes are UX-201's, the last a UX-112. Therefore the "A" battery is a regular six-volt storage, and the "B" a 135 volt one. No binding posts for the batteries are used on the sub-panel; a five wire cable is more easily handled and is employed instead. The five wires are of different colors and are appropriately tagged for identification.

Making Your Set More Selective

(Continued from page 114)

be taken into account. There must also be considered the power of the stations; but it seems to me that, in these days, when receivers are being built which bring in 5 or 10 watt stations over distances of several thousands of miles as well as the 5000 watt stations, the matter of power is a secondary one, excepting where the receiver is located very close to a super-power station. The number of receivers located 'neath super-power towers, however, is a very small percentage of the four and a quarter million receivers in operation over the country.

However, to get back to selectivity, there are several ways in which receivers can be made selective. It is

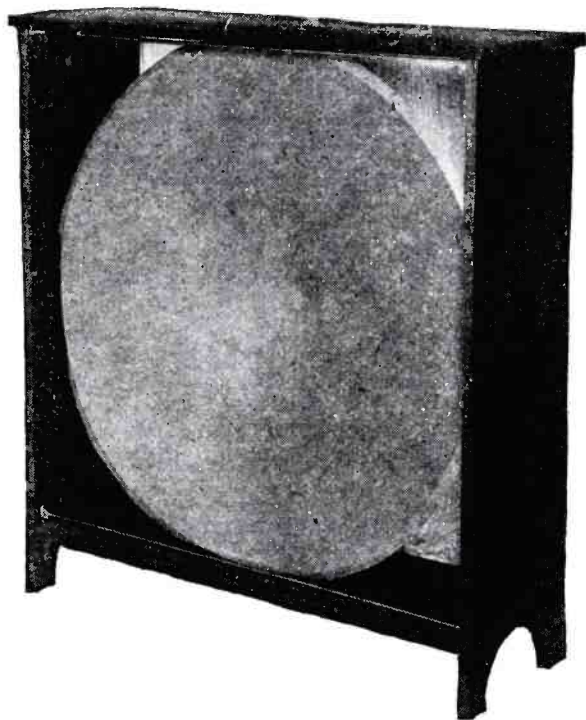

3 FOOT CONE SPEAKER

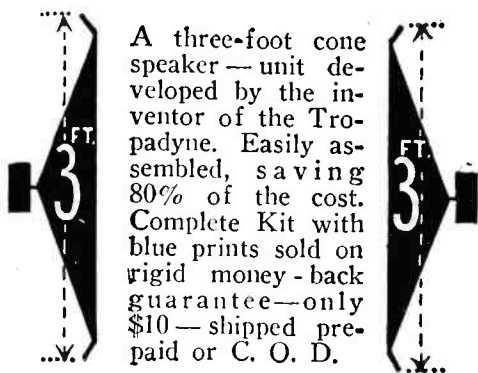

A three-foot cone speaker — unit developed by the inventor of the Tro-padyne. Easily assembled, saving 80% of the cost. Complete Kit with blue prints sold on rigid money-back guarantee—only \$10—shipped prepaid or C. O. D.

ENGINEERS' SERVICE COMPANY

25 CHURCH STREET

NEW YORK

LEARN THE CODE AT HOME with the OMNIGRAPH

"Just Listen—The Omnigraph will do the teaching"



THE OMNIGRAPH Automatic Transmitter will teach you both the Wireless and Morse Codes—right in your own home—quickly, easily and inexpensively. Connected with Buzzer, Buzzer and Phone or to Sounder, it will send you unlimited messages, at any speed, from 5 to 50 words a minute.

THE OMNIGRAPH is not an experiment. For more than 15 years, it has been sold all over the world with a money back guarantee. The OMNIGRAPH is used by several Depts. of the U. S. Govt.—in fact, the Dept. of Commerce uses the OMNIGRAPH to test all applicants applying for a Radio license. The OMNIGRAPH has been successfully adopted by the leading Universities, Colleges and Radio Schools.

Send for FREE Catalogue. DO IT TO-DAY.
THE OMNIGRAPH MFG. CO., 13L Hudson St., New York City

If you own a Radio Phone set and don't know the code—you are missing most of the fun.

interesting to note that whatever is done to increase the selectivity of a receiver also goes toward enhancing its sensitivity. Take for instance, the regenerative receiver. When the tickler coil is adjusted to the point of maximum regeneration the receiver is in its most sensitive state. At the same time, since the apparent resistance of the input circuit of the tube has been decreased by the regeneration, the tuning of the set becomes very sharp.

The point is that selectivity is increased by reducing the resistance of the tuned circuits. This means that a selective receiver requires low resistance components, or, in common parlance, it should be "low-loss." How "low-loss" it is to be made depends



Fig. 4. An auxiliary tuned radio frequency unit which can be connected to practically any type of receiver.

upon many things; it will be found that little can be gained in the way of reducing the losses in condensers. It is possible to reduce the resistance of coils considerably, but here we run against the problem of size and cost. It is found that when trying to make the resistance of a coil as low as possible, and the turns are properly spaced and wire of sufficient size be used, the coil becomes rather bulky. A compromise must be effected; we are between the devil and the deep blue sea, and must do the best we can.

There is another thing that will increase the selectivity of a receiver, and that is the addition of radio frequency amplifiers. (See Fig. 2). Every stage of r.f. added in cascade increases, not only the sensitivity, but the selectivity as well. There is, however, a limit here, just as there is in everything else. Every stage of r.f. added increases the number of controls and increases the tendency to oscillate.

Single Dial Control Sets

As regards the number of controls, in spite of the fact that there has been a tendency toward one-dial sets, this is not good practise, at least from the economical point of view. Where tan-

The Latest Development in Radio

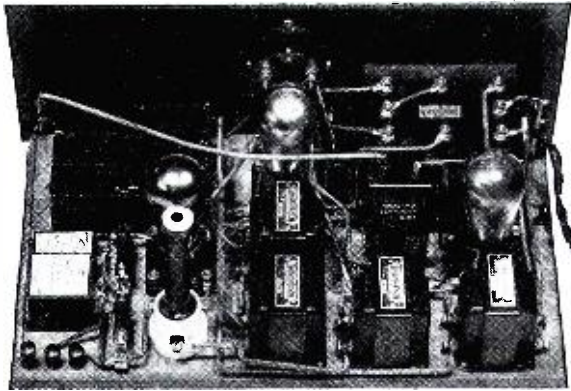

As Specified in RADIO REVIEW

Newark Super Power

COMBINATION Amplifier & B Eliminator

1 Thordarson R-200 Transformer	\$ 8.00
3 Thordarson No. 196 Chokes @ \$5.....	15.00
3 2 mf Dubilier Power Supply Condensers @ \$5.50.....	10.50
1 4 mf Dubilier Fixed Condenser No. 658.....	3.00
1 2 mf Dubilier Power Supply Condenser No. 903.....	5.50
2 1 mf Dubilier Fixed Condenser No. 656 @ .90.....	1.80
3 Standard sockets @ .75.....	2.25
1 Jewell No. 135 -0-25 milliamper meter.....	7.00
1 Thordarson No. 198 Power Amplifier Transformer.....	12.00
3 Daven No. 50 mountings @ .35.....	1.05
2 10,000-Ohm Aerovox Fixed Resistors @ \$1.00.....	2.00
1 1000-Ohm Aerovox Fixed Resistor.....	1.00
1 8000-Ohm Ward & Leonard Fixed Resistor with socket.....	4.50
1 Carter Universal Hi Pot.....	2.25
1 UX 874 Voltage Regulator Tube.....	5.50
1 UX 210 Power Tube	9.00
1 UX 216 B Rectifier Tube	7.50
7 Eby Binding Posts @ .15 (1 Amp. +, 2 input, 1 Speaker —, 1-45 volt, 1 B Battery, 1 Speaker +).....	1.05
1 Blue Print	Free

\$98.90

Parts as listed above sent prepaid upon receipt of remittance for \$98.90, or will be sent C. O. D. upon receipt of \$25.00 deposit, balance to be paid upon arrival plus postage.

NEWARK ELECTRIC CO.

"Nothing But Radio"

226 WEST MADISON STREET

CHICAGO, ILL.

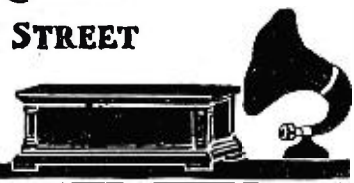

HAVE YOU SEEN THE NEW MAGAZINE ?

For Men and Women Who Want to Become Independent



The Magazine of Opportunity

Earn a Second Income

25c ON ALL NEWSSTANDS

SEE THAT SCREW

A screw driver adjusts it in crowded places



X-L VARIO CONDENSER

Results are easier tuning, more distance, volume and clarity, greater stability. Indorsed by leading radio authorities.

MODEL N—A slight turn obtains correct tube oscillation on all tuned radio frequency circuits. Nuetrodyne, Roberts two tube, Browning-Drake, McMurdo Silver's Knockout, etc., capacity range 1.8 to 20 micro-micro farads. Price, \$1.00.

MODEL G—With grid clips obtains the proper grid capacity on Cockaday circuits, filter and intermediate frequency tuning in heterodyne and positive grid bias in all sets. Capacity range, Model G-1 .00002 to .0001 MFD.; Model G-5 .0001 to .0005 MFD.; Model G-10 .0003 to .001 MFD. Price, \$1.50.

PUSH POST—Push it down with your thumb, insert wire, remove pressure and wire is firmly held. Releases instantly. Price, 15c.

Push Post Panel permanently marked in white on black insulating panel. In box including soldering lugs, raising bushings and screws for mounting, etc. Price, \$1.50.

X-L RADIO LABORATORIES
2431 Lincoln Avenue, Chicago, Ill.
Write for details.



dem control is desired, the tuning circuits must have sufficient resistance so that they tune rather broadly. The reason for this is to enable the condensers to tune several stages simultaneously. (See Figure 3). This must be done, as it is not generally possible to make the coils *exactly* identical, at least in production, so that the condensers are likely to run out of step as we go around the dial.

Broadened Tuning

At the same time as the tuning is broadened, the sensitivity of the receiver is decreased, due to the increased resistance in the tuned circuit, so that in order to bring the set back to its original sensitivity it is necessary to add another stage of radio frequency amplification. This is the reason for many of the six tube *single-dial* sets now on the market. An important item in the matter of selectivity is the length of the antenna system. It is generally found that the shorter the antenna the greater is the selectivity. The reason for this is that the shorter antenna picks up less energy and appreciable signal strength is not obtained unless the tuning is exact. At the same time however, it will be found correspondingly more difficult to pull in the distant stations. The receivers of today are generally sufficiently sensitive to bring in about all that one could desire on an antenna not exceeding 100 feet in length. Of course the higher the antenna the better.

Coupling of Coils

The coupling between the primary and the secondary of the r.f. transformers also has a great deal to do with selectivity. The looser the coupling the greater the selectivity. The sensitivity does not follow the same rule, as it will be found that maximum energy transfer through such an r.f. oscillation transformer takes place at only one particular frequency. For frequencies higher than this or lower than this particular frequency the energy transfer is less, but of course, this is counteracted by the increased tendency to regenerate on the shorter wave-lengths. There is, however, a general tendency for the amplification to fall off on the lower frequencies, or longer wave-lengths.

The matter of selectivity, therefore, at the present time, seems to me to be not one of set design, for many of the receivers now available are about as selective as one could want, but is one of proper distribution of the broadcasting stations in the frequency channels. When the stations are uniformly distributed in the frequency channels, there will be at the most, six stations operating on the same wave-length, instead of having as many as 24 stations operating the same frequency of 1098 kilocycles.

A New Way to Sell Radio Cabinets—Whoever Heard of Such a Thing Before?

We have placed on the market two NEW STYLES on which we give you choice of stock sizes at the same price. Our "Piedmont" is made of hardwood, fancy nickeled hinges, three coats of the new lacquer varnished rubbed to a hard, smooth, glossy finish, mahogany finish only.

Sizes 7" x 18" x 10", 7" x 21" x 10", 7" x 24" x 10", 7" x 26" x 10"—YOUR CHOICE AT ONLY \$2.65 EACH. Cash with order, no C. O. D., f. o. b. Hickory.

We challenge anyone to show us a cabinet of this fine quality selling at such a low price. We have been making cabinets for four years—a few cents profit on each one but a big production.

SEND FOR CATALOGUE—IT'S FREE.

THE SOUTHERN TOY COMPANY, Inc. **Hickory, North Carolina**

SPECIAL SUBSCRIPTION OFFER

FREE



This genuine VALET Auto Strop Razor with every 5 months subscription to

SCIENCE AND INVENTION

In order to acquaint the readers of this book with SCIENCE and INVENTION, we are making, for a limited time, special reduced rates and are also giving FREE one complete VALET Auto-Strop Razor shown here.

For only \$1 (Regular Newsstand price \$1.25) you can obtain this magazine for five months and also, one FREE Razor—

SCIENCE and INVENTION thoroughly covers every important and interesting event of the scientific or inventive world that occurs from day to day. All of the latest developments in Electrics, Patents, Chemistry, Mechanics, Magic and Psychic Phenomena, Automotive Subjects, etc., etc., are written up and illustrated. This fascinating magazine also makes a big hit with the radio beginner. In every issue the sound practical fundamentals of radio are carefully and completely explained and simplified.

This shaving outfit consists of a highly-polished, nickel-plated, self-stropping Razor; one blade, and a leather strop especially prepared. The razor case is of metal, finished in maroon, crystallized effect. Lined throughout with velvet, harmonizing with the pleasing color scheme of the entire package.

The only razor in the world that sharpens its own blades.

USE THE COUPON TODAY

Experimenter Publishing Co., Inc., Dept. R.R.9
53 Park Place, New York, N. Y.

Gentlemen—Enclosed is \$1 for 5 months' subscription to SCIENCE and INVENTION. You are also to send me one complete razor as advertised FREE.

Name

Address

City, State

Sept.

1926

S. Gernsback's Radio Encyclopedia

Tenth
Installment

POUNDAL
to
SKINDERVIKEN
TRANSMITTER
BUTTON

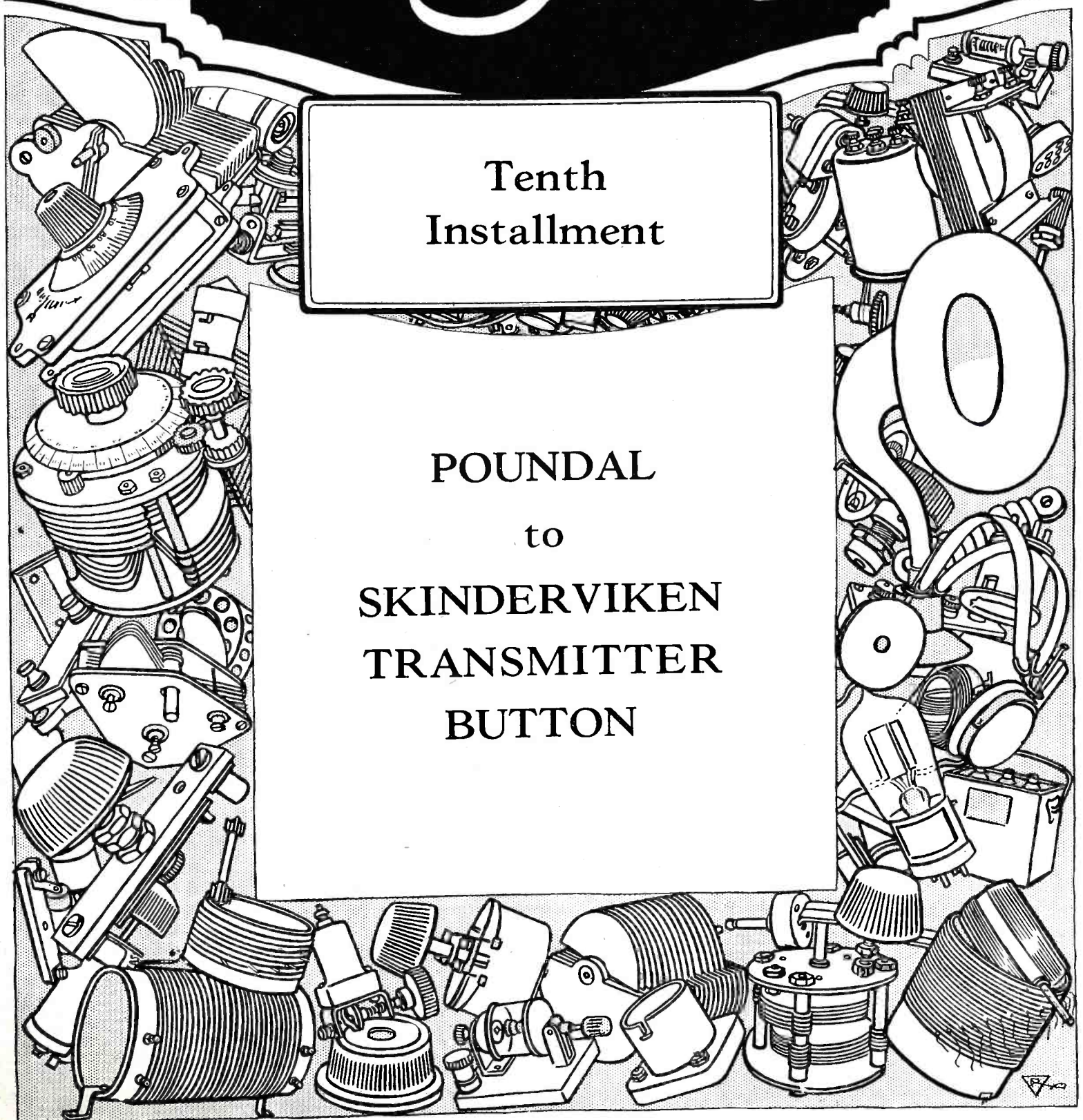

PREVIOUS INSTALLMENTS



- FIRST INSTALLMENT** Consisting of definitions from "A" BATTERY to ARC OSCILLATOR, contained in the May, 1925, issue of Radio Review, Vol. 1, No. 1.

- SECOND INSTALLMENT** Consisting of definitions from ARC SPARK to CAPACITY OF CONDENSERS IN PARALLEL, contained in the July, 1925, issue of Radio Review, Vol. 1, No. 2.

- THIRD INSTALLMENT** Consisting of definitions from CAPACITY OF CONDENSERS IN SERIES to COUPLING COEFFICIENT, contained in the September, 1925, issue of Radio Review, Vol. 1, No. 3.

- FOURTH INSTALLMENT** Consisting of definitions from COUPLING, DEGREE OF to EDISON, THOMAS A., contained in the October, 1925, issue of Radio Review, Vol. 1, No. 4.

- FIFTH INSTALLMENT** Consisting of definitions from EDISON EFFECT to GALVANI, LUIGI, contained in the November, 1925, issue of Radio Review, Vol. 1, No. 5.

- SIXTH INSTALLMENT** Consisting of definitions from GALVANOMETER to INDUCTANCE, ANTENNA, contained in the December, 1925, issue of Radio Review, Vol. 1, No. 6.

- SEVENTH INSTALLMENT** Consisting of definitions from INDUCTANCE COILS to LENGTH OF AERIAL, contained in the January, 1926, issue of Radio Review, Vol. 1, No. 7.

- EIGHTH INSTALLMENT** Consisting of definitions from LENTZ'S LAW to MOTOR, contained in the March, 1926, issue of Radio Review, Vol. 1, No. 8.

- NINTH INSTALLMENT** Consisting of definitions from MOTOR-ALTERNATOR to POULSEN, VALDEMAR, contained in the June, 1926, issue of Radio Review, Vol. 1, No. 9.

The Conrad Co. has the above back numbers in stock and to accommodate readers, we will sell these nine numbers of Radio Review at \$1.50, prepaid. Please use the coupon below:

THE CONRAD CO., INC., 53 Park Place, New York City.

Enclosed find \$1.50 for which please send me the nine back numbers of Radio Review containing the first nine installments of the Radio Encyclopedia.

Name.....

Address.....

POUNDAL—A unit of force. That force which acting on a mass of one pound gives it a velocity of one foot per second. It is equal to the weight of a pound mass divided by the acceleration of gravity; equal to 13,825 dynes or approximately half an ounce.

POWER—The rate of doing work. A certain amount of work may be done in a day or in a week. In the former case, more power is expended than in the latter case. Mechanical power is measured in *horse power* (q.v.). One horse power is equivalent to 33,000 foot-pounds per minute. Since power is the rate of doing work, the expression for power must contain a time element and a work element. Work is a measure of a force exerted through a distance. Hence the foot-pound measures work. Electrical power is the product of voltage times amperage. It is measured in *watts* (q.v.). (See *Kilowatt*.)

POWER AMPLIFIER—See *Power Amplification*.

POWER AMPLIFICATION—Amplification by means of apparatus consisting of a combination of power vacuum tubes, designed to carry larger currents than the ordinary tubes and specially designed transformers. Power amplifiers provide additional audio amplification and are used in connection with radio receiving sets where great volume is required as in the case of apparatus used for public address systems and for use with power operated loud speakers. (See *Amplifier*.)

POWER AMPLIFICATION COEFFICIENT—The ratio of the plate output power to the grid input power of a vacuum tube. This value may be as high as 10,000. The output power of a vacuum tube comes from the plate battery. When the grid is operated at low or negative voltage, the input power needed to produce the changes in grid voltage may be made very small compared with the output power of the tube.

POWER, APPARENT—The product of the voltage and the current in an alternating current circuit expressed in volt-amperes. This expression does not take into account any difference in *phase* (q.v.) between the voltage and the current. Thus in an extreme case (theoretical) where an alternating current flows in a purely inductive circuit, the current will lag behind the voltage by a phase angle of 90 degrees. In such a circuit, the *true power* (q.v.) would be zero, since the cosine of the phase angle between the current and the voltage would be zero, whereas the apparent power might be quite high and a heavy current might be flowing in the circuit. Apparent power is ordinarily expressed in *kilovolt-amperes* (q.v.). (See *Power Factor*.)

POWER FACTOR—The ratio of the *true power* (watts) in an alternating current circuit to the *apparent power* (volt-amperes). Where the wave form of the alternating current is sinusoidal, the power factor is equal to the cosine of the angle between the voltage and the current. Expressed as an equation, power P is equal to the product of the current I and the component of the impressed electromotive force which is in phase with the current, $E \cos \Phi$, where Φ is the angle of phase displacement between the current and the voltage ($P = IE \cos \Phi$). Expressed in another way, the power factor is the fractional amount which, if multiplied by the effective values of the current and the voltage, will give the value of the power expended. (See *Effective Electromotive force*,

Power, Apparent, also *Power, True*; *Kilovolt-ampere*, *Kilowatt*.)

POWER, TRUE—The product of the *apparent power* and the *power factor* (q.v.) in an alternating current circuit. A wattmeter will measure true power, inasmuch as it takes into account the *phase displacement* (q.v.) between the current and the voltage. A voltmeter and an ammeter cannot be used to measure power, however, since the product of the two readings only gives the apparent power.

POWER TUBE—See *Vacuum Tube, Power*.

PRACTICAL UNITS—In the practical system of electrical units, the ohm, the ampere and the volt are the fundamental units. While the practical system is based originally on the Centimeter Gram Second systems, it is in no way dependent upon these systems for practical use. When used with the fundamental units of length and time, all other electrical as well as magnetic units can be derived from the fundamental units of the practical system. At the recommendation of the Chicago International Electrical Congress in 1893, the fundamental electrical units of the practical system were adopted as legal units in the United States by an act of Congress, July 12, 1894.

P R B—International Radiotelegraphic Convention abbreviation. Followed by question mark it means, "Do you wish to communicate by means of the International Signal Code?" Without the question mark it means, "I wish to communicate by means of the International Signal Code." (See *Abbreviations, International Radio Telegraphic Conventional*.)

PRESSURE—See *Potential, Electric*.

PRESSURE, ELECTRICAL—The term is synonymous with *voltage* (q.v.) or *electromotive force* (q.v.). Electrical pressure is the cause of current flow. It is measured in *volts* (q.v.). The flow of electricity along a conductor is analogous to the flow of water through a pipe. In order to make water flow, a pump is often used to force the water or in other words to apply pressure. Similarly, electrical pressure must be applied in order for an electric current to flow.

PRIMARY CELL—A device for transforming chemical energy into electrical energy. It consists of two different conductors placed in a liquid which acts chemically on one conductor, or more on one conductor than on the other, thus keeping a difference of potential between them. While the cell is being discharged either one or both of the conductors is used up and the liquid is also consumed. In many types of primary cells these can be replaced. The liquid is called an *electrolyte* (q.v.). In some cases an acid is used while in others a salt solution is the *electrolyte*. (q.v.) (See *Cell, Cell Secondary; Cell, Theory of Primary; Electrolysis, Local Action, Polarization, also Storage Cells*.)

PRIMARY CIRCUIT—A circuit supplying current to another which is called the secondary circuit. The two circuits are usually coupled by means of a transformer, the primary winding being in the primary circuit and the secondary winding being in the secondary circuit.

PRIMARY CURRENT—See *Current, Primary*.

PRIMARY ELECTRONS—The main stream of electrons given off by the hot filament of a vacuum tube, as differentiated from *secondary electrons* (q.v.) which may be detached from the plate by the impact of the primary

electrons. (See *Negative Resistance*.)

PRIMARY TUNING INDUCTANCE—A variable inductance in the primary circuit of a radio transmitter. It is also referred to as the *aerial tuning inductance*. The aerial inductance coil may be continuously variable utilizing a sliding contact which bears on an edgewise copper strip or it may be of the drum type, in this case being made of stranded copper cable. (See *Inductance Coils, also Pancake Coils*.)

PRINCE, Charles Edmond—British radio expert. Born in 1874 at Cape Town and educated at Clifton and Faraday House, he joined the Marconi Wireless Telegraph Company in 1907, where he was concerned chiefly in research work on wireless telephony. In 1909 he carried out experiments in Italy and Switzerland with the first Marconi Field Station and made a number of valuable improvements in the Bellini-Tosi direction finder. In the World war, he joined the Royal Flying Corps and in 1915 he installed the first radio telephone on aircraft.

PRINTER, MORSE—See *Morse Inker*.

PROTON—A unit of positive electricity. The smallest quantity of positive electricity capable of existing in a free state. A minute particle or quantity of positive electricity carried by the nucleus of a hydrogen atom. See *Electron Theory, also Free Electrons*.

PULSATING CURRENT—A periodic current, that is to say a current passing through the successive equal cycles of values, the average value of which is not zero. A pulsating current is the sum of an alternating and a direct current. A current which varies regularly in magnitude is said to be pulsating while if it remains the same in magnitude it is called continuous. (See *Continuous Direct Current, also Current, Pulsating Direct*.)

PULSATING DIRECT CURRENT—See *Pulsating Current*.

PUPIN, Michael—American radio authority. Born in Hungary, October 4th, 1858, he came to the United States at the age of 10, and was educated at Columbia University. He also studied at Cambridge University, England. In 1891 he was appointed professor of



Michael Pupin.

mathematical physics at Columbia University, where he carried out an important series of researches in radio telegraphy and telephony. He is the holder of a large number of patents relating to telephony and radio, has done valuable research work on reso-

nance and has developed radio circuits of extreme selectivity.

PUSH-PULL AMPLIFICATION—A method of connection in a vacuum tube receiving set, for supplying more power to the loud speaker than that ordinarily obtainable from a one or two stage audio amplifier. In the push-pull amplifier two tubes are used in the final stage of the amplifier, connected in such a way that they are used alternately on the two halves of

are usually used for the other two transformers. These have connections brought out from the center point of one of the windings as shown. The transformer between the two stages has a split secondary while the last transformer has a split primary. In cases where a tapped wound transformer is not available, two transformers can be used instead. In this case the two primary windings are connected in series and the two secondary windings are also connected in

one tube during one half of the cycle and the other tube during the other half of the cycle. While the terminal of the secondary transformer winding leading to the grid of the tube is at a positive potential with respect to the middle of the winding, the tube is effective. During the remaining half of the cycle when the terminal is negative with respect to the tap, the tube is not

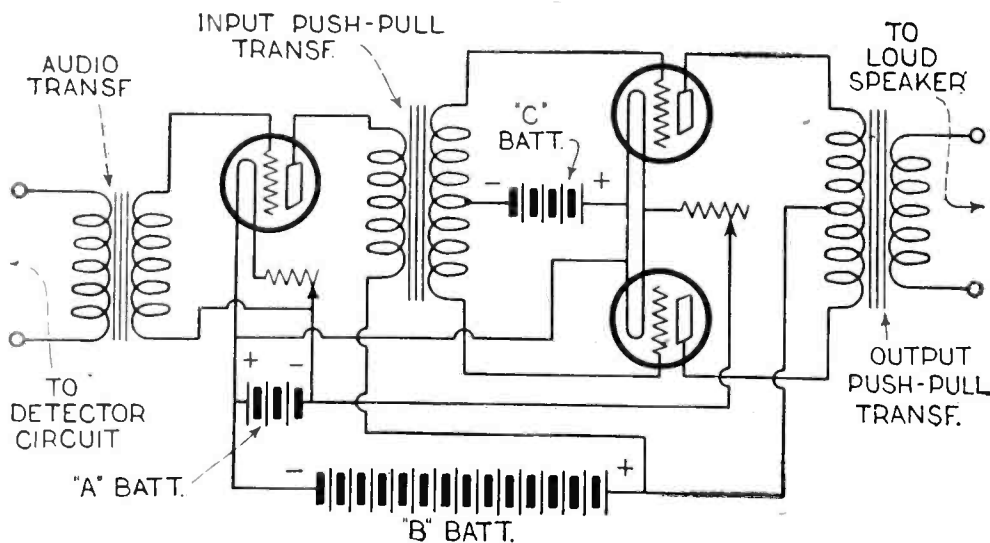

Fig. 1. Diagram of a push-pull amplification circuit.

each audio frequency cycle. A push-pull amplification circuit is shown in Figure 1. The first tube at the left gives the first stage of amplification and the other two in combination give the second stage. An ordinary audio frequency amplifier transformer is connected to the grid and filament of the first tube. Special transformers

series. Figure 2 shows the method of connecting two transformers for this purpose, a connection being made to the mid-point between the secondary windings. It is essential that the two windings in series be connected so that they are continuous in the same direction around the transformer cores. In theory, the push-pull amplifier uses

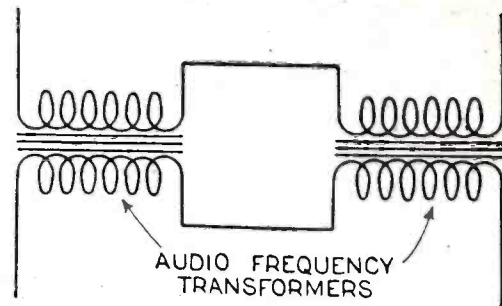

Fig. 2. Method of connecting two transformers where a tapped wound transformer is not available.

operating. The action however is such that one tube is effective at all times. Although ordinary amplifier tubes can be used in the push-pull amplifier circuit it is desirable to use special power tubes which have a high amplification coefficient.

PYRITES—Compounds of iron or copper and sulphur. Three of these are *Ferrous Sulphide* (FeS), *Bisulphide* (FeS₂), and an intermediate known as *Magnetic Pyrites* (Fe₃S₄). Pyrites crystals have been used in radio as detector crystals. (See *Crystal*, also *Crystal Detector*.)

PYRON DETECTOR—A *crystal detector* (q.v.) having an iron pyrites crystal and a copper or other metallic contact point.

Q

Q SIGNALS—International Radiotelegraphic Convention abbreviations. When the signal is followed by a question mark it asks the question. Otherwise the answer is indicated. A list of these abbreviations and their meanings follow:

Abbrev'n	Question	Answer
QRA	What ship or coast station is that?	This is
QRB	What is your distance?	My distance is
QRC	What is your true bearing?	My true bearing is . . . degrees.
QRD	Where are you bound for?	I am bound for
QRF	Where are you bound from?	I am bound from
QRG	What line do you belong to?	I belong to the . . . Line.
QRH	What is your wave length in meters?	My wave length is meters.
QRHH	What tune shall I adjust for?	Adjust to receive on tune
QRJ	How many words have you to send?	I have words to send.
QRK	How do you receive me?	I am receiving well.
QRL	Are you receiving badly? Shall I send 20 . . . — . for adjustment?	I am receiving badly. Please send 20 . . . — . for adjustment.
QRLL	Request permission to test . . . minutes.	Permission to test granted.
QRM	Are you being interfered with?	I am being interfered with.
QRN	Are the atmospherics strong?	Atmospherics are very strong.
QRO	Shall I increase power?	Increase power.
QRP	Shall I decrease power?	Decrease power.
QRQ	Shall I send faster?	Send faster.
QRS	Shall I send slower?	Send slower.
QRT	Shall I stop sending?	Stop sending.
QRU		{ I have nothing to transmit.
QRV	Are you ready?	{ I have nothing for you.
QRW	Are you busy?	I am ready. All right now.
		I am busy (or, I am busy with Please do not interfere).
QRX	Shall I stand by?	Stand by. I will call you when required.
QRY	When will be my turn?	Your turn will be No.
QRZ	Are my signals weak?	Your signals are weak.
QSA	Are my signals strong?	Your signals are strong.
QSB	Is my tone bad? Is my spark bad?	The tone is bad. The spark is bad.
QSC	Is my spacing bad?	Your spacing is bad.
QSD	What is your time?	My time is
QSF	Is transmission to be in alternate order or in series?	Transmission will be in alternate order.
QSG		Transmission will be in a series of 5 messages.
QSH		Transmission will be in a series of 10 messages.
QSJ	What rate shall I collect for?	Collect

Abbrev'n	Question	Answer
QSK	Is the last radiogram cancelled?	The last radiogram is cancelled.
QSL	Did you get my receipt?	Please acknowledge.
QSM	What is your true course?	My true course is degrees.
QSN	Are you in communication with land?	I am not in communication with land.
QSO	Are you in communication with any ship or station (or: with)?	I am in communication with (through)
QSP	Shall I inform that you are calling him?	Inform that I am calling him.
QSQ	Is calling me?	You are being called by
QSR	Will you forward the radiogram?	I will forward the radiogram.
QSS	Are my signals fading?	Your signals are fading.
QST	Have you received the general call?	General call to all stations.
QSU	Please call me when you have finished (or: at . . o'clock).	Will call when I have finished.
QSV	Is public correspondence being handled?	Public correspondence is being handled. Please do not interfere.
QSW	Shall I increase my spark frequency?	Increase your spark frequency.
QSX	Shall I decrease my spark frequency?	Decrease your spark frequency.
QSY	Shall I send on a wave length of meters.	Let us change to a wave length of meters.
QSZ		Send each word twice. I have difficulty in receiving you.
QTA		Repeat the last radiogram.
QTC	Have you anything to transmit?	I have something to transmit. I have one or more radiograms for
QTE	What is my true bearing?	Your true bearing is degrees from
QTF	What is my true position?	Your true position is . . latitude longitude.

QUADRANT—A term formerly in use as the unit of *inductance* (q.v.), now called the *henry* (q.v.). Inductance has the same dimensions as length and this unit is equivalent to 10⁹ cm., this being approximately the length of one quadrant of the earth.

QUADRANT ELECTROMETER—A sensitive *electrometer* (q.v.) which in its calibrated form is known as an *electrostatic voltmeter* (q.v.). In the usual type, the "needle" consists of a thin aluminum plate suspended on delicate knife edges, with a pointer extending from the upper part to a scale. Two pairs of quadrant plates, having opposite faces metalically connected together, are placed on either side of the movable plate and parallel to its face. Each pair is insulated from the other pair. When the pairs of quadrants are subjected to a difference of potential, the needle, if highly charged, will be attracted into one pair or repelled out of the other. (See *Kelvin's Electrostatic Voltmeter*.)

QUADRATURE—The differing in *phase* (q.v.) of two alternating current quantities by 90 degrees. For example, when the current lags behind the impressed voltage by 90 degrees, as in the case of pure inductance in a circuit, the current and the voltage are said to be in quadrature. (See *Lag, Lead, also Leading Current*.)

QUANTITY OF ELECTRICITY—When referring to static electricity, it is the amount of the charge. Referring to electricity in motion, or an electric current, it is the amount of current flowing in a given time. Quantity of electricity is measured in *coulombs* (q.v.). The coulomb is the quantity of electricity which has passed when a current of one ampere flows for one second. The symbol which is usually used to signify quantity of electricity is Q.

QUANTOMETER—A type of ballistic galvanometer in which the swing of the movable system is proportional to the quantity of electricity passing through the instrument. A *galvanometer* (q.v.) of this type is used for magnetic testing as in the case of the *fluxmeter* (q.v.).

QUARTER PHASE—A two-phase alternating current system. An alternating current system having two currents differing in phase by 90 degrees or in other words by one-quarter of a cycle.

QUARTZ LAMP—A mercury vapor lamp which utilizes a tube of quartz

instead of a glass container. Increased current densities can then be employed, since higher temperatures can be used with quartz than with glass.

QUARTZ OSCILLATOR—The piezoelectric quartz plate may be used as a *resonator* (q.v.) or as an *oscillator* (q.v.). When used as an oscillator it may be used either as a *master oscillator* controlling the frequency of a radio transmitting station's output or as a frequency indicator. All three of these uses are applicable to the work of maintaining station frequencies constant. The applicability of the piezo oscillator as a frequency indicator in broadcasting stations has been tested carefully by the United States Bureau of Standards, and found to be useful and satisfactory. This method gives a means of maintaining an extremely accurate check of the transmitting station frequency. (See *Master-Oscillator System*, also *Frequency Meter*.)

QUENCHED GAP—See *Quenched Spark Gap*.

QUENCHED SPARK—See *Quenched Spark Gap*.

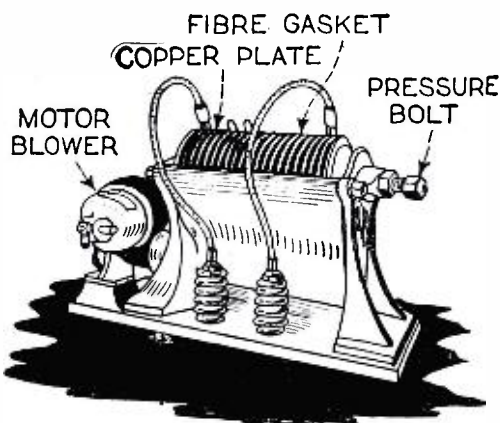

A typical quenched spark plug.

QUENCHED SPARK GAP—A spark discharger in a wireless telegraph transmitting circuit in which the spark is deionized to prevent the gap remaining conductive after the spark has passed. In this way only a few sharply defined oscillations are permitted to occur. The particular advantages of the quenched spark gap is that it enables the aerial to oscillate at its own frequency regardless of the period of the spark system. In one form of construction, a number of heavy copper plates are used, separated by micanite, fiber insulating washers

or other insulating material. These are placed in an iron rack and compressed by means of a pressure bolt. The inside edge of the washer rests upon a groove which is cut in each plate. This makes it impossible for the spark to discharge over the edge of the washer. In order to make the discharge surface airtight, the washers are specially treated and as a result this helps in quenching the primary oscillations and makes the discharge noiseless. A small motor driven blower is mounted at the base of the spark discharger for the purpose of forcing air through the base of the rack against the cooling flanges of the plates. (See *Deionization, Musical Spark, Kinraidy Spark Gap, also Quenched Spark Transmitter*.)

QUENCHED SPARK TRANSMITTER—A radio telegraph transmitter which employs a quenched spark gap. The quenched spark transmitter is not used for very high powers as it is not satisfactory for such use. In this case, a form of disc discharger is usually used. The quenched spark transmitter, however, has no moving parts and is noiseless in operation. In addition it gives large values of antenna current because closer coupling is possible. (See *Quenched Spark Gap*.)

QUICK BREAK SWITCH—A switch provided with auxiliary contacts which are released after the main contacts. The auxiliary contacts are separated rapidly, regardless of the speed with which the switch handle is pulled. This action is obtained by the tension of a spring connected between the main

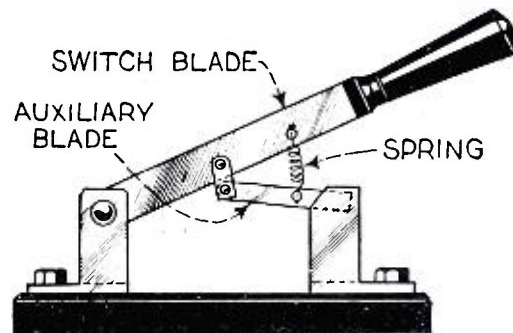

Quick Break Switch. Note the auxiliary spring-controlled blade.

switch blade and the auxiliary blade, as shown in the illustration.

QUIESCENT AERIAL—In a radio telephone transmitter, an aerial operated in such a manner that the carrier wave is suppressed when transmission is not actually taking place.

R

"R"—Symbol for *resistance* (q.v.)

RADIANT ENERGY—Energy transmitted through space by means of vibrations of the ether, such as electromagnetic energy, light or heat. (See *Actinic Ray*.)

RADIANT HEAT—Infra-red radiation (q.v.) as for example radiation from substances at temperatures insufficient to cause visible light rays.

RADIATING CIRCUIT—An electrical circuit which emits energy in the form of ether waves. In a transmitting system, the aerial circuit. Any circuit which radiates energy is a radiating circuit.

RADIATION—The transference of energy in waves through space which is not necessarily occupied by matter. Transference of energy through ether (q.v.). Electric or electromagnetic radiation refers to the radiation by means of electromagnetic induction. The radiation field is transmitted by wave motion. Various types of electromagnetic waves may be sent out by a radiating system. In one system the waves are known as *damped waves* (q.v.), in another *undamped waves* (q.v.) are used.

RADIATION EFFICIENCY—The radiation efficiency of an antenna at a given wave length is the ratio of the power radiated to the total power delivered to the antenna (resistance).

RADIATION FROM ANTENNA—In the case of a simple vertical antenna, electromagnetic waves are radiated in semi-loops since the lower end of the aerial is grounded. Fig. 1 gives an

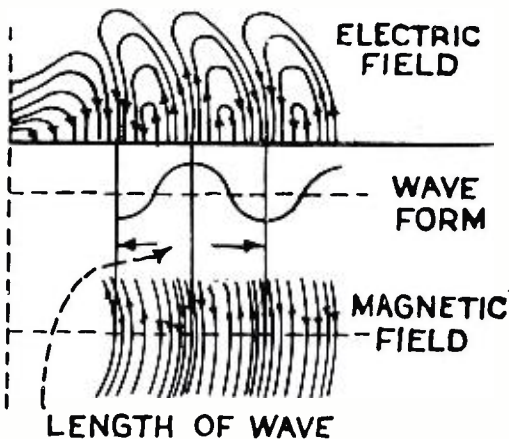

Fig. 1. Electric and magnetic fields about a vertical wire aerial.

idea of the way in which the intertwined electric and magnetic fields radiate from the antenna. It should be noted that the electric and the mag-

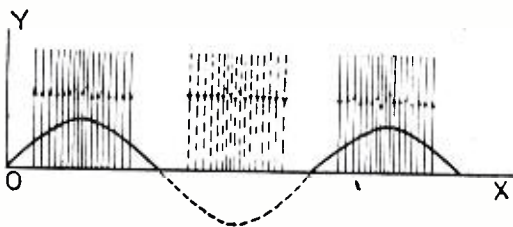

Fig. 2. Electric lines of force shown after the wave has travelled some distance from the aerial.

netic fields are in planes which are at right angles to each other. The electric lines are shown in elevation while the magnetic lines appear in plan, with the wave form common to both being shown between. At any single point in space, the lines separate and come together like a bellows. After the wave has travelled a certain distance, the lines can be regarded as

sections of planes and the electric lines can be represented by the diagram shown in Fig. 2. The magnetic lines can be shown by the same figure, provided this is considered to have been rotated about its horizontal axis through an angle of 90 degrees. Regardless of whether the aerial is of the open or closed coil type, the radiation will take place in the same general way, *loops* (q.v.) being formed and detached as described. (See *Electromagnetic Waves*, also *Height of Aerial*.)

RADIATION RESISTANCE—The ratio of the total power radiated by an antenna to the square of the effective current at the point of maximum current. The property of an antenna by means of which radiation of energy takes place. Some of the power supplied to a circuit, carrying radio currents, is radiated in the form of electric waves. The radiation is a measure of the useful work obtained from the circuit. The greater the power radiated in comparison with the power dissipated in the circuit itself, the better will be the transmission. At any frequency, the power radiated is proportional to the square of the current flowing, hence the radiative effect may be regarded as causing artificially, an increase in the effective resistance of the circuit. This resistance increase is known as "radiation resistance" and is directly proportional to the square of the frequency or inversely proportional to the square of the wave length. (See *Antenna Resistance*.)

RADIATION TRANSMISSION—See *Radiation from Antenna*.

RADIO—The transmission of intelligence by means of electromagnetic waves through the ether. Radio falls under two general classifications; *radio telephony* (q.v.) and *radio telegraphy* (q.v.). (See *Radio Channel*, *Radio Communication*, *Radio Control*, also *Radio Frequencies*.)

RADIO-ACTIVITY—The emanation of energy by certain substances, such as radium, caused by a continuous detachment of electrons from the substance.

RADIOCAST—A term sometimes used instead of *Broadcast* (q.v.). To transmit speech, music or other sounds by *radio telephony* (q.v.).

RADIO CHANNEL—A band of wave lengths or frequencies of a width sufficient to permit of its use for radio communication without the radiation of subsidiary waves of more than a certain intensity at wave lengths or frequencies outside of such a band.

RADIO COMMUNICATION—The transmission of intelligible signals by means of electromagnetic waves. The signals may be in the form of code as in radio telegraphy or in the form of speech or music as in radio telephony. They may be transmitted through the ether (q.v.) without the use of intervening conductors as in ordinary radio, or along conductors as in *wired wireless* (q.v.).

RADIO COMPASS—A simple form of *radio direction finder* especially used for marine work. The radio compass depends for its principle of operation upon the directional effect of a coil antenna. Hence a coil antenna mounted on a vertical axis so that it can be rotated freely, is an essential part of the radio direction finder. By

rotating the coil while a particular station is transmitting, it is possible to fix the line of direction of the station. The coil may be mounted so that the maximum signal will be received when the transmitting station lies in the plane of the coil. The device may also be set for minimum signal reception in which case the transmitting station lies in a direction perpendicular to the face of the coil. It is possible to obtain a much sharper determination of direction by setting the coil on the minimum position and hence this method is generally used for direction finder work. (See *Goniometer*.)

RADIO CONTROL—The control of motor driven devices such as marine vessels, trains, torpedoes, automobiles, etc., by means of special radio receiving apparatus designed to respond to radio impulses. E. P. Glavin's radio controlled automobile is an example of the radio controlled vehicle. *John Hays Hammond, Jr.* (q.v.) has invented radio controlled torpedoes, radio controlled ships and also radio controlled air craft.

R.F.—Abbreviation for radio frequency.

RADIO FREQUENCIES—Frequencies higher than those corresponding to normally audible sound waves. (See *Frequency, Radio*; *Frequency, High*; *Audio Frequency*; also *Frequency, Low*.)

RADIO FREQUENCY COILS—*Inductance coils* (q.v.) used to carry radio frequency currents or to couple radio frequency circuits. Radio frequency transformers (q.v.) may be of either iron core or air core types although the air core transformers are more generally used. (See *Low Loss Coils*, also "*D*" Coils.)

RADIO FREQUENCY CURRENT—An alternating current having a frequency of from 20,000 to 2,000,000 cycles per second. There is no hard and fast rule regarding the upper and lower limits, since much higher or much lower frequencies may still be considered as radio frequency currents. (See *High Frequency Current*.)

RADIO FREQUENCY SELECTIVITY—The radio frequency selectivity of a simple element of a receiving system is the ratio of resonant response (in terms of effective voltage or current measured at the indicator) to the non-resonant response when the radio frequency portions of the elements of that system are detuned by one percent of the resonant frequency. In this case, a simple element refers to a combination of an inductance, a capacitance and optionally a resistance.

RADIO FREQUENCY SIGNALS—Currents flowing in a radio receiving circuit up to the point of rectification. The currents flowing in the antenna circuit are radio frequency currents corresponding to the currents flowing in the transmitting aerial. (See *Amplifier, Radio Frequency*.)

RADIO GONIOMETER—See *Goniometer*.

RADIOGRAM—A message sent in code by radio. A radio telegraphic message.

RADIOPHARE—A radiotelegraphic "lighthouse" intended to aid navigation by emitting characteristic signals. By estimating the bearings of two charted radiophares, the mariner may determine the position of his ship.

RADIO TELEGRAPHY—The transmission of messages by means of electro-

magnetic waves using dot and dash code signals. A transmitter furnishes a source of high frequency alternating current which oscillates rapidly in the antenna system thus sending out electromagnetic waves. These are intercepted at the receiving station by the receiving aerial. At the receiving aerial, the electromagnetic waves are changed back into alternating current which is rectified by a detector in the receiving apparatus, then amplified and made audible in a *head telephone* (q.v.) or *loud speaker* (q.v.). Of course, a means of interrupting the current to produce dots and dashes must be present in the transmitter and suitable tuning devices are used in both the transmitter and the receiver.

RADIO TELEPHONY—The transmission of speech, music or other sounds by means of electromagnetic waves. In the standard systems of radio telephony continuous waves are used of a much higher frequency than those of audible sounds. The amplitude of these is modulated by the connection of a microphone in the transmitting circuit. The receiving apparatus is similar to that employed in radio telegraphy and is arranged so that the head set or loud speaker responds to the modulations of the waves and reproduces the sounds as originally produced at the transmitter.

RADIO TRANSMISSION—The sending of signals, speech, music, or other sounds by means of electromagnetic waves. The transmission of intelligence through the ether. (See *Radio Communication, Radio Control, Radio Telegraphy, also Radio Telephony.*)

RAT-TAIL—A single wire, or a group of wires used to connect the main part of an aerial with the *lead-in* (q.v.) wire.

RATIO—Relative values of quantities of the same kind, or number of times one quantity is contained in the other.

RATIO OF TRANSFORMATION—The ratio between the primary and secondary windings of a transformer. This determines the ratio of the primary to the secondary voltages. Thus if a transformer has a ratio of transformation of 3 to 1, then the secondary will have three times as many turns as the primary and the secondary voltage will be, approximately triple that of the primary voltage.

RATIO OF UNITS—The ratio of the unit pole in the electromagnetic system to the unit pole in the electrostatic system, or of the unit charge in the electromagnetic system to the unit charge in the electrostatic system. Its numerical value is approximately 3×10^{10} .

RAYLEIGH, John William Strutt—British physicist. Born at Langford Green, Essex, November 12th, 1842. He was educated at Trinity College, Cambridge. In 1879 he was appointed Cavendish professor of experimental physics in succession to Clerk-Maxwell, a post he held until 1884. In 1887 he became professor of natural philosophy at the Royal Institution and was appointed president of the Royal Society in 1905. In 1908 he was appointed Chancellor of Cambridge University, and died June 30th, 1919. Rayleigh was considered by many to have been one of the most brilliant experimental physicists of the nineteenth century. He not only had a remarkable power of mathematical analysis, but was equally skillful in carrying out the experimental proofs of his theoretical researches. Many of his experiments were made with

home-built apparatus. He threw a fresh light on nearly every branch of physics, from the theory of gases to wave theories and electric and magnetic problems. Due to the care with which he carried out his experiments, he was the first to detect the presence of neon in the atmosphere, this being the forerunner of the discovery of a number of inert gases in the atmosphere. The Rayleigh balance for absolute current measurement is as well known as it is important. Lord Rayleigh was one of the original members of the Order of Merit. In 1882 he was awarded the Royal Medal, in 1899 the Copley Medal of the Royal Society and in 1904 the Nobel Prize for physics.

REACTANCE—That property of an electric circuit, aside from its ohmic resistance, which tends to oppose the flow of an alternating current. Mathematically, reactance is defined as the square root of the difference between the square of the *impedance* (q.v.) and the square of the effective resistance of a given portion of an electric circuit. Expressed as an equation $x = \sqrt{z^2 - r^2}$ where z is the impedance and r the resistance of the part of the circuit under consideration. Reactance due to capacity in a circuit is capacity or condensive reactance. The reactance of a condenser of capacity C to an alternating current (of sine wave form) of frequency f is expressed by the equation $X_c = \frac{1}{2\pi f C}$. Reactance

due to inductance in a circuit is *inductive reactance* (q.v.). The reactance of an inductance coil of inductance L to an alternating current (of sine wave form) of frequency f is expressed by the equation $X_L = 2\pi f L$. Reactance is measured in *ohms*.

REACTANCE COIL—REACTION COIL—Terms used in England to describe the *tickler coil* (q.v.) used in regenerative sets to couple back part of the energy in the plate or output circuit to the input circuit.

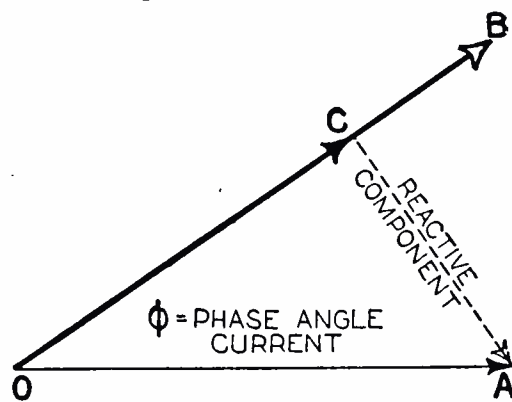

- OB - VOLTAGE
- OA - AMMETER READING
- OC - ACTIVE COMPONENT
- AC - REACTIVE COMPONENT

The current represented by vector OA may be considered as divided into two components, OC in phase with the voltage, and CA the reactive component.

REACTIVE COMPONENT—The component of an alternating current used to overcome the reactance of the circuit. This component acts at an angle of 90 degrees from the voltage. It is also known as *wattless current* (q.v.).

REACTIVE CURRENT—See *Reactive Component*.

REACTIVE DROP—The portion of the voltage drop in an alternating current circuit, due to the reactance.

REAL POWER—See *True Power*.

RECEIVER—A term rather loosely applied to cover the entire radio receive-

ing apparatus within a station. Also sometimes used as a synonym for *Detector* (q.v.)

RECEIVING AERIAL—A wire or group of wires suspended at a suitable height and connected to a radio receiving set. The purpose of the receiving aerial is to intercept the electromagnetic waves. It should be placed well above surrounding buildings if possible, and should be well insulated from the ground. (See *Aerial, also Directional.*)

RECEIVING CIRCUIT—Any electrical circuit used in connection with the reception of radio. The more important vacuum tube receiving circuits are the *super-heterodyne* (q.v.), the *neutrodyne* (q.v.), the *reflex circuit* (q.v.), the *regenerative circuit* (q.v.) and the *tuned frequency circuit* (q.v.). There are various modifications and combinations of these circuits.

RECEPTACLE—A form of socket into which a plug is inserted for making electrical connections.

RECONSTRUCTED MICA—See *Mica-nite*.

RECORDER—A telegraphic instrument which automatically records messages sent over a telegraph system.

RECORDING WATTHOUR METER—An instrument for measuring and recording the total amount of electrical energy being consumed in a circuit. (See *Integrating Wattmeter.*)

RECTIFICATION—The changing of alternating current to direct current. In the usual radio receiving circuit rectification is accomplished by means of the vacuum tube, although the ordinary crystal detector rectifies the alternating current also. Before a storage battery can be charged from an alternating current source, the current must first be changed to direct current. Hence the battery charger designed to work on alternating current must be equipped with a rectification device, or rectifier (q.v.).

RECTIFIED CURRENT—An *alternating current* (q.v.) which has been changed to uni-directional or direct current either by preventing alternate waves from flowing or by reversing their direction. (See *Rectified Signals, Rectification, also Rectifier.*)

RECTIFIED SIGNALS—Radio signals which have passed through a detector, such as a vacuum tube or a crystal. Rectification of the oscillations results in audible or audio frequency currents which can be heard in a telephone receiver. (See *Rectification, Rectifier, Rectifying Tube, also Rectifying Action of Crystal Detector.*)

RECTIFIER—An apparatus for converting alternating current to uni-directional or direct current. Examples of rectifiers are certain crystals used as crystal detectors, the commutators of direct current motors and generators, vacuum tubes, electrolytic devices used for charging batteries, etc. (See *Rectified Signal, Rectification, Rectifying Tube, Rectifying Action of Crystal Detector, Rectified Current, Rectifier, Full Wave, Full Wave Rectification, also Half Wave Rectifier, Electrolytic Rectifier, Mercury Arc Rectifier, Charger, Storage Battery, Chemical Rectifier, Tungar, Rectigon.*)

RECTIFIER, FULL WAVE—A device for converting alternating current to direct current, in which both the positive and negative alternations are utilized. This differs from the half-wave rectifier which rectifies by suppressing alternate waves. (See *Full*

Wave Rectification, also Half Wave Rectifier.)

RECTIFYING ACTION OF CRYSTAL DETECTOR—The crystal detector has the property of allowing radio frequency alternating currents to flow through it in one direction only. In other words the alternating current is rectified. (See *Crystal Detector-Theory of Operation, Crystal Detector, Crystal Rectifier, Rectified Signals, also Rectified Current.*)

RECTIFYING TUBE—A vacuum tube used to convert alternating current into direct current. Rectification can be accomplished by a two-electrode tube, having filament and plate. In this case the electron flow is from the hot filament to the plate. A two-electrode vacuum tube made especially for rectifying purposes is known as the *kenotron* (q.v.). Another recent type of rectifying tube, known as the *helium tube* (trade name, *Raytheon*) utilizes a different operating principle, known as the "short path" principle, whereby the rarefied gas acts as an insulator between points which are in close proximity. This is in apparent contradiction of the observed phenomenon that the smaller the distance between two points the more readily a spark will jump between them due to the ionization of the gas. How-



Fig. 1. A Raytheon tube.

ever, if the distance is small enough and a suitable gas is used at a low enough pressure, an electron may encounter no gas molecules in its path between the points and there will be no ionization by collision. Consequently, the inert gas helium, may be made to act as a perfect insulator at low pressures. Furthermore, it has been found that when a larger electrode of a gas conduction tube is negative, there is a greater current flow than when the smaller electrode is negative and that the smaller the positive relative to the negative electrode, the smaller is the back current and hence the more complete is the rectification. Figure 1 shows a typical helium tube, while Figure 2 illustrates its construction. The two small positive electrodes A, A, are carried through two small glass tubes imbedded in a lava insulating block L so as to project very slightly into a lava cup C whose wells constitute the negative electrode, being connected to the negative terminal through the base. The diameters of the small wires and the diameters and positions of the holes whereby they enter the cup are so proportioned as to give the necessary short path to the negative electrode. The cup C contains helium gas at such low pressure as to prevent gaseous conduction.

This gives an insulation of great reliability and long life and makes possible extremely small anode surfaces which reduce the back current to a negligible quantity.

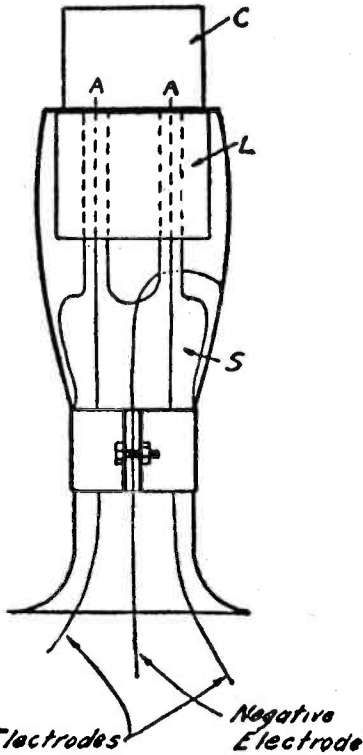

Fig. 2. Construction of the Raytheon tube.

RECTIFYING VALVE—This usually refers to a *rectifying tube* (q.v.) although it may refer to an *electrolytic rectifier* (q.v.)

energy striking it. A conductor parallel to the direction of motion of a wave serves to guide the direction of the wave. The reflection and other modifications of radio waves serves to explain *fading* (q.v.) and other irregularities of broadcast signals. It has been found that broadcast signals will have most uniform intensity when long waves are used and during the daytime. Moreover, transmission will be better over a uniform conducting surface, such as the ocean. It is assumed that the space through which a radio wave travels is bounded by the surface of the earth and by an upper region which during the day is a fairly good conductor. The transmitted waves are guided by the two conducting mediums but in addition are assisted materially by reflection especially during the time that the air is partially ionized by the radiation of the sun.

REFLECTION COEFFICIENT—(Of a surface of discontinuity between two media.) The ratio of the reflected field intensity near the surface to the incident field intensity near the surface.

REFLEX—See *Reflex Circuit*.

REFLEX CIRCUIT—A radio receiving circuit invented by Marius Latour in which the vacuum tubes are made to perform double duties as both radio and audio frequency amplifiers. The incoming radio frequency current is amplified at radio frequency, rectified by a detector (which may be a crystal detector) and then amplified at audio frequency, using the same tube.

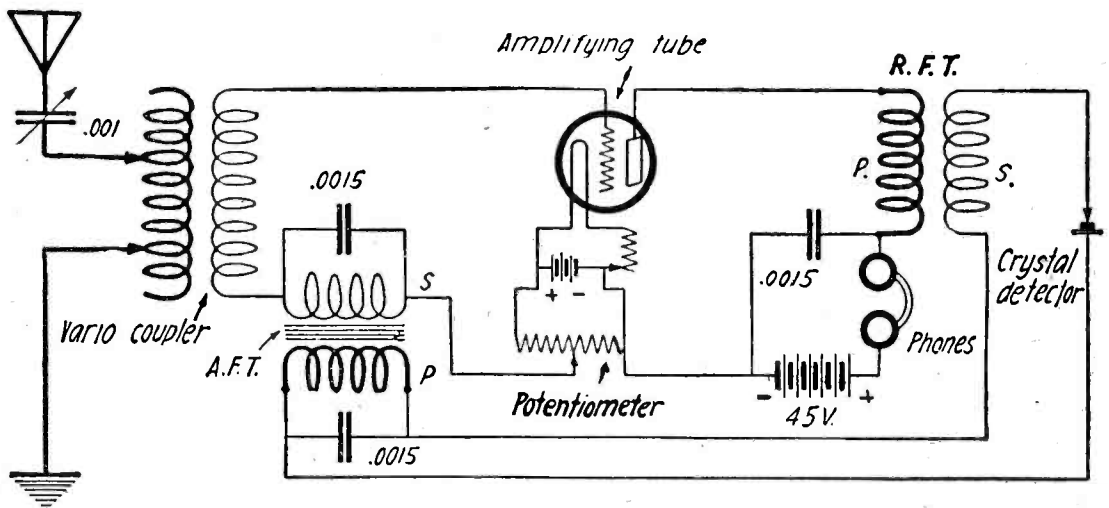

A typical reflex circuit using one tube and a crystal detector.

RECTIGON—The trade name of a storage battery charger which utilizes the vacuum tube rectifier principle. (See *Charger, Storage Battery, also Rectifying Tube.*)

RED MAGNETISM—An obsolete term for the lines of force coming from the north pole of a magnet.

REDUCE WAVE-LENGTH OF AERIAL—The wave-length of an antenna may be reduced by the use of series condensers. However, this method should be avoided where possible, since it results in a loss of power. Shortening the aerial is a preferable method of reducing wave-length.

REFLECTING GALVANOMETER—See *Mirror Galvanometer*.

REFLECTION—Radio waves are reflected and also refracted when they pass into a region of different dielectric constant. A perfect conducting sheet would reflect all of the wave

A typical four tube reflex set uses the second and third tubes as amplifiers simultaneously for both the radio and the audio frequency amplification. As a result the four tubes are made to produce the effect of six. Reflexing may be accomplished in a number of different ways. In some cases all the tubes are made to work twice. In other cases, only a part of the tubes are used for dual amplification. A variation of the reflex circuit, is the *Inverse Duplex Circuit* (q.v.). In this system the incoming signal reaches the first tube where it is amplified at radio frequencies and passes to the second tube, where it is again amplified at radio frequencies. From the second radio frequency tube, it is passed to the detector tube, where it is converted to audio frequency. The current then flows back to the second radio frequency tube which is now used as an audio frequency amplifier. Thence it flows to the first radio frequency tube which acts as the second

stage of audio frequency amplification.

REFRACTION—The refraction of electric waves is analogous to the refraction of light. The electric (radio) waves are refracted when they pass into a region of different dielectric constant. That is to say, their direction is slightly altered. (See *Fading, Gliding Theory, also Reflection.*)

REFRACTION AND REFLECTION OF ELECTROMAGNETIC WAVES—See *Reflection, also Refraction.*

REGENERATION—The amplifying properties of the three-electrode vacuum tube can be used to obtain what is termed *regeneration*. Since it is possible to have greater output energy than input energy, part of the output may be returned to the input side, thus resulting in amplification of energy or in regeneration. By *feeding back* the correct amount of energy and in the right phase relation a constant reamplification may be obtained, and the tube can be made to act as a generator of sustained oscillations. (See *Armstrong Circuits, Feed-Back, Feed-Back Coil, Feed-Back Coupling, Feed-Back Effect, also Regenerative Circuit.*)

REGENERATIVE—See *Regenerative Circuit.*

REGENERATIVE CIRCUIT—A method of connecting up vacuum tubes for radio reception in which the amplified variations of the plate circuit are superimposed inductively on the grid or input circuit thus producing a reinforcing effect which results in increased sensitivity. (See *Armstrong Circuits.*)

REGENERATIVE COUPLING—A radio receiving system designed to increase amplification in a vacuum tube, by coupling the plate or output circuit back to the grid or input circuit thus producing regeneration. (See *Feed-Back, Feed-Back Coil, Feed-Back Coupling, Feed-Back Effect, also Regenerative Circuit.*)

REINARTZ CIRCUIT—A selective regenerative circuit devised by John L. Reinartz in which a *spider-web* inductance coil is used, the coil acting as primary, secondary and tickler. Capacity *feed-back* (q.v.) is accomplished

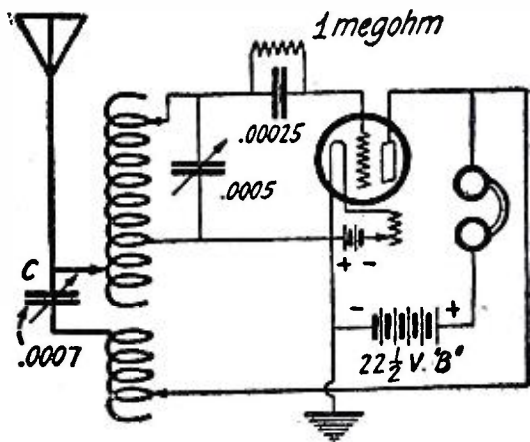

Diagram showing Reinartz circuit

by means of a variable condenser. In the improved Reinartz a variocoupler is used, connected as a variometer, in addition to the condenser feed-back.

REJECTOR—See *Rejector Circuit.*

REJECTOR CIRCUIT—A circuit consisting of a combination of inductance and capacity for filtering out or preventing the passage of currents of certain frequencies. This circuit is used in connection with a radio receiving set to obtain greater selectivity. The inductance and the capacity are ar-

ranged in parallel to form a resonant circuit. The constants of this circuit are chosen so that at the particular frequencies to be filtered, the capacity current will exactly equal the inductive current, thus giving zero resultant current. The primary application of the rejector circuit is as an *interference eliminator* (q.v.) or *wave trap* (q.v.). Figure 1 shows the application of the rejector circuit applied to a radio receiving set. The circuit shown is a combination *acceptor-rejector* circuit. The rejector circuit is shown in heavy

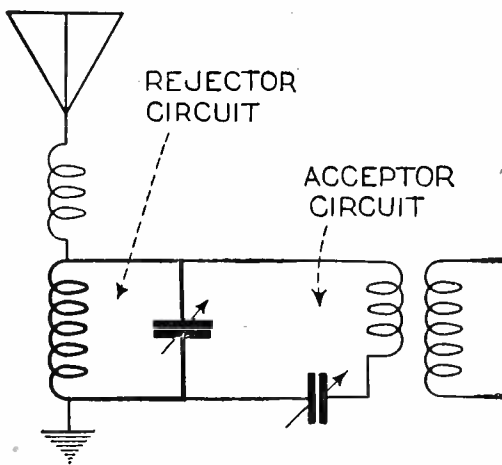

Fig. 1. An acceptor-rejector circuit used as a wave trap.

lines. The inductance and the capacity are connected in parallel with each other and with the acceptor circuit and this latter is inductively coupled to the receiving set circuit. Both the acceptor and the rejector circuits are tuned to the wave length of the receiving aerial. By using more than one

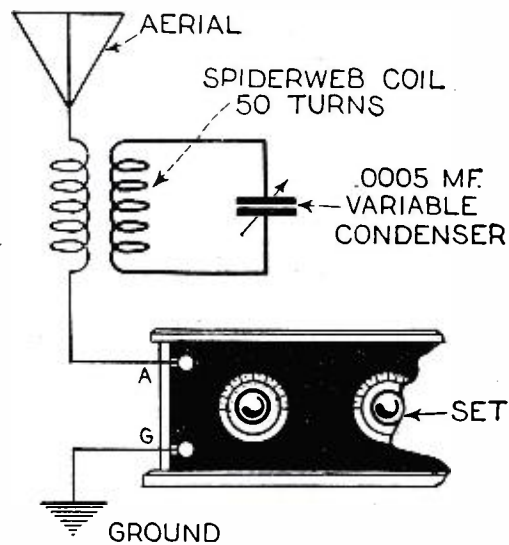
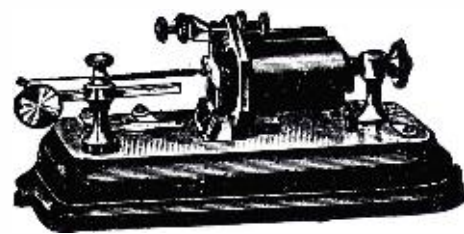

Fig. 2. A rejector circuit designed to filter out undesired spark signals.

rejector and acceptor circuit increased selectivity can be obtained. A rejector circuit used to filter out undesired spark signals is shown in Figure 2. A small inductance of about ten turns is employed in this circuit and this is inductively coupled to a closed tuned circuit and wired in series with the aerial, and the aerial terminal of the set. If a spider-web coil is used in the closed circuit, a suitable value for broadcast wave lengths is a 50 turn coil, placing the aerial coil in such a position as to get closest coupling. The variable condenser should have a capacity of .0005 mfd. (See *Acceptor.*)

RELAY—An electromagnetic device by means of which contacts in one circuit are operated by a change in conditions

in the same circuit or in one or more associated circuits. (See *Magnifier.*)



A telegraphic relay.

RELUCTANCE—Magnetic resistance. The reluctance of a magnetic circuit is analogous to electrical resistance. All magnetic circuits offer reluctance to flux. The name *rel* is widely used as the unit of reluctance. The rel is the reluctance of a magnetic circuit which will have one line of force in it, upon application of one *ampere-turn*. The reluctance of a cylinder of air, or of any other non-magnetic material, one square inch in cross-sectional area, and 3.19 inches long. The flux through a magnetic circuit is equal to the *magnetomotive force* (q.v.) divided by the reluctance. (See *Magnetic Properties.*)

RELUCTIVITY—The *reluctance* (q.v.) per unit length and per unit cross-section. The reluctance per inch³ or per cm³. Reluctivity may be defined as specific magnetic resistance. It is the reciprocal of *permeability*. (q.v.)

REMANENCE—The term applied to the magnetism remaining in a magnet after the magnetizing force is removed.

REMOTE CONTROL—A control system whereby a radio transmitting or receiving apparatus may be operated at any desired distance from the apparatus. The chief advantage of remote control lies in the fact that the high tension apparatus and the tall aerial masts may be located in outlying districts whereas the studio can be located at any desired, convenient point. In addition it is possible to broadcast concerts, theatrical entertainments, prize fights, etc., direct from the scenes of action by utilizing remote control.

REPEATING COIL—A transformer of unity ratio used in telephone practice.

RE-RADIATION—The relaying of a radio wave through the action of a receiver employing regeneration. This phenomenon is most commonly observed in receivers of the *super-heterodyne* type.

RESIDUAL CHARGE—The residuary electricity retained by a condenser after discharge. This is also known as *electric residue* or *soakage*. After the condenser is discharged in the ordinary way, the residual charge permits a second discharge, smaller than the first. (See *Soaking in.*)

RESIDUAL MAGNETISM—The magnetism retained by a piece of iron, after the magnetizing force is withdrawn. After a mass of iron has become magnetized, some of the magnetism will remain, even though the magnetizing force has been taken away. The amount of residual magnetism depends on the quality of the iron. Pure wrought iron, in general, retains very little residual magnetism, whereas wrought iron which has gone through a hardening process, or which contains a large percentage of impurities and also cast iron possess a much larger amount of residual magnetism.

RESINOUS ELECTRICITY—An obsolete term for negative charges of electricity, adopted because of the fact that resinous bodies become negatively charged by friction. (See *Vitreous.*)

RESISTANCE—Symbol Ω (Omega)—Every conductor of electricity offers opposition to the flow of electricity. Resistance is a property of the conductor itself. It increases with increased length of conductor, decreases with increased cross-sectional area, and is greater or less depending upon the material of the conductor. Resistance is measured in *ohms*. (q.v.). The ohm is equal to 10^9 C.G.S. electromagnetic units.

RESISTANCE BOX—A box containing a number of wire coils of known resist-

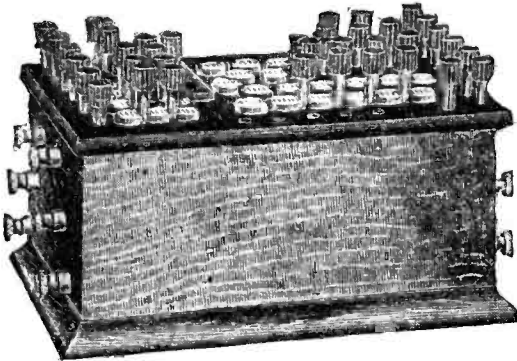

A resistance box.

ances connected in various combinations, by means of switches or plugs, to produce any desired total resistance.

RESISTANCE COUPLED AMPLIFIER—A type of *amplifier* (q.v.) which utilizes high resistances for interstage coupling. Resistance coupled ampli-

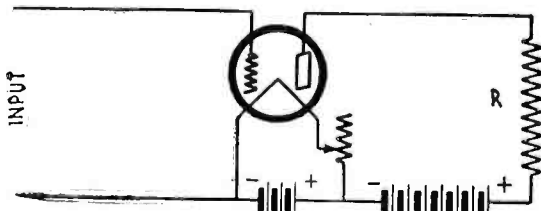

Fig. 1. The introduction of the non-inductive resistance in the plate circuit of the tube is the first step for explaining the principles involved.

fication is generally used only for audio frequency amplification although it may be used for radio frequencies above 1000 meters. The chief advantage of resistance coupling consists in the purity of tone obtainable and the absence of distortion. In addition radio receivers of this type are comparatively inexpensive to build. It should be noted, however, that with resistance coupled amplification, the amplification per tube is much less than with transformer coupled amplification and furthermore the drain on the "B" batteries is also much greater. Of course,

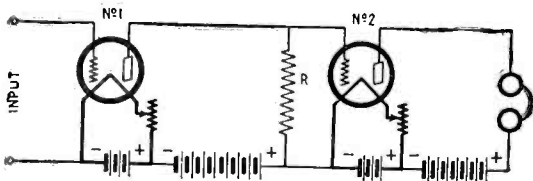

Fig. 2. In this circuit there must be two sets of batteries, but even then the grid of tube No. 2 will have a positive bias, which is undesirable.

where a "B" eliminator is used "B" battery consumption is not a consideration. The resistances used for resistance coupling are non-inductive and may have resistances of from .1 megohm to 2 megohms. Figure 1 shows an elementary circuit utilizing a non-inductive resistance in the plate circuit of the tube. When a signal is impressed upon the grid circuit of this amplifying tube, there is a corresponding voltage set up in the plate circuit. The resistance R in the plate circuit

causes a voltage drop to take place in two places in the tube. The total resistance of the plate circuit is equal to the internal resistance of the tube added to the resistance R , and if the

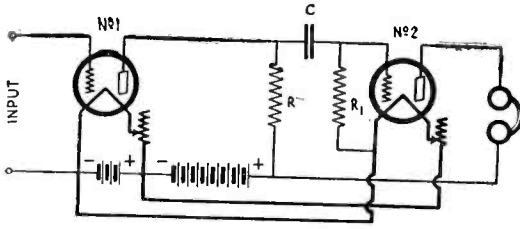

Fig. 3. The resistance coupled amplifier circuit with the introduction of a grid leak and condenser. The reasons for this are explained in the accompanying text.

"B" battery has 90 volts and if R is equivalent to the tube resistance at that moment the voltage drop across the tube will be 45 volts with the same drop across R . Theoretically it is possible to vary the voltage drop across R from zero to almost 90 degrees. Discounting the small resistances of the "A" and "B" batteries, a changing voltage will occur across the filament and plate when the grid potential varies, and also across the resistance R . Naturally these last variations depend upon the tube resistance and upon the value of the resistance R . These variations will be largest when R has a greater resistance than that of the tube. The resistance or impedance of the tube is constantly in a state of change and can assume very high values. For this reason the value of R should be equal to the higher values of the tube impedance in order to maintain maximum effectiveness. As used with ordinary amplifier tubes, a value of 100,000 ohms has been found to give satisfactory results. The next step is to apply the voltage variations across R to the grid circuit of the next tube. In Figure 2, the resistance R lies in the grid circuit of tube 2 as well as in the plate circuit of tube 1. Hence the magnified changes in tube 1 are

number of tubes in an amplifier. In order to do this the grids of the tubes must be separated electrically from the high voltage of the plates of the preceding tubes, but only as far as the steady voltage is concerned, while the fluctuating voltage of these plates must be impressed on the grids of the following tubes. This is done by introducing condensers between the two resistances. These effectively block the direct currents while they afford easy passage to alternating currents. Figure 3 shows the introduction of the condenser between the plate resistance and the grid resistance. Inspection of this diagram shows that although tube No. 1 remains the same, the plate instead of being connected directly to the grid of tube No. 2 is separated from the latter by means of the condenser C . If voltage fluctuations now occur across the resistance R , they will also be effective across the grid and filament of tube No. 2, because R exerts its influence between plate and filament of tube No. 1. As the condenser, C , conducts the variations very easily, the voltage fluctuations against R are then effective across the filament and grid of tube No. 2. It is necessary that tube No. 2 be provided with a grid leak, R_1 , for the accumulated negative charges to leak off the grid to the filament. This grid leak at the same time serves the purpose of a by-pass for voltages, occurring due to possible leaks in the condenser C , which would tend to make the grid positive, thus allowing a grid current to flow and stopping the perfect action of the tube as an amplifier. Since the grid leak R_1 is a direct shunt across the grid and filament of tube No. 2, it must have a relatively high value in order to retain the highest possible amplification. R_1 should have a value lying between 500,000 and 2,000,000 ohms. If this resistance is made variable, it will be possible to control the resulting amplification completely. The value of the condenser C , must be chosen so that its re-

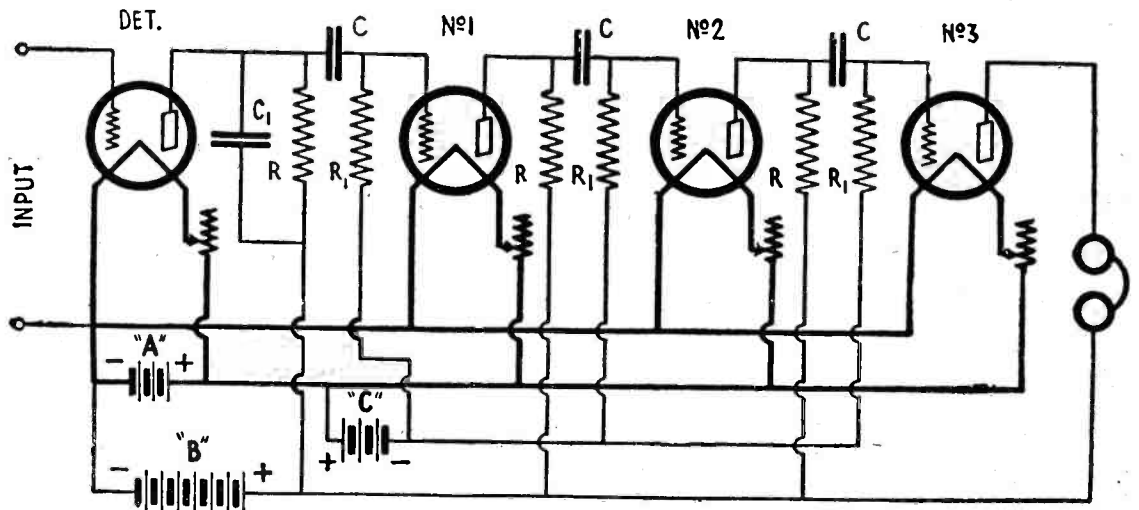

Fig. 4. Diagram showing three stages of resistance coupled amplification.

transferred from R to the grid and filament of tube 2, thus the latter tube will be affected directly by the output circuit of the first tube and thus there will be amplification in both tubes thereby causing a resultant magnified signal to be heard. However, in such a hook-up, the same "A" and "B" battery cannot be used since this would mean that there would be a positive charge on the grid of tube No. 2, which would then be unable to function. Naturally, it would be impracticable to use a circuit having so many batteries, so a means must be found whereby it is possible to have a power supply consisting of but one filament battery and one plate battery for any given

resistance to the flow of alternating current will be as low as possible. Figure 4 shows three stages of resistance coupled amplification with a "C" battery used to give proper grid bias. The value of the resistance R , in the plate circuit of the tubes is 100,000 ohms and the value of the resistance in the grid circuits is 1,000,000 ohms (1 megohm). The condenser C has in each case a capacity of 0.05 mfd. The value of the "C" battery is about $4\frac{1}{2}$ volts, but this should be determined by experiment for best results.

RESISTANCE COUPLING—RESISTIVE COUPLING—The transference of electrical energy from one circuit to

another, by means of resistance common to both. (See *Resistance Coupled Amplifier*.)

RESISTANCE, HIGH FREQUENCY—

The increased resistance of a conductor to high frequency currents, due to concentration of current at the surface of the conductor. This phenomenon is known as *skin effect* (q.v.) Skin effect becomes more pronounced, the greater the frequency of the impressed electromotive force. Skin effect also increases with increased cross-section of the conductor, with increased conductivity of the conductor and with increased magnetic *permeability* (q.v.). As a result of skin effect, the actual resistance of a conductor to alternating currents is greater than to direct currents.

RESISTANCE OF GROUND CONNECTION—

The connecting wire leading from the radio apparatus to the ground should be of low resistance. If possible, the ground should be made by burying a copper plate in moist earth. The usual way to obtain a ground is to fasten a copper strap or *ground clamp* (q.v.) around a water or a steam pipe.

RESISTANCE (RADIATION)—

This is the ratio of the total energy radiated (per second) by the antenna to the square of the root-mean-square current at a potential node (generally the ground connection).

RESISTANCE, RADIO FREQUENCY—

The ratio of the heat produced per second, in watts, to the square of the root-mean-square current (radio frequency), in amperes, in a conductor.

RESISTIVITY— See *Resistivity of a Material*, also *Resistivity, Surface*.

RESISTIVITY OF A MATERIAL—

SPECIFIC RESISTANCE— Symbol ρ (rho)—The resistance in ohms of unit length and unit cross-section of the material under consideration. Resistivity may be measured in ohms per inch cube or per centimeter cube, but more commonly it is measured in ohms per *mil-foot* (q.v.). The material of a conductor has an important bearing upon its resistance. Thus a unit length and unit cross-section of aluminum has about one and one-half times the resistance of copper having the same dimensions. Platinum has about six times the resistance.

RESISTIVITY, SURFACE—

Referring to an insulating substance, surface resistivity is the resistance between two opposite edges of a surface film, 1 centimeter square. Surface resistivity depends to a considerable extent on humidity.

RESONANCE—

A condition which exists in an electrical circuit where the frequency of the applied electromotive force is the same as the natural frequency of the circuit. Resonance is the cumulative effect produced by a periodic force in a circuit, so adjusted in frequency that the effect can attain the highest value. The effect measured is usually the current and the circuit when adjusted for maximum current, is said to be in resonance with the force, or with the circuit from which the force comes. The effect of resonance is to bring the current into phase with the electromotive force. Resonance in a circuit has the effect of bringing the reactance due to the inductance (inductive reactance) in exact opposition to the reactance due to capacity (capacity reactance). The total reactance is therefore zero and therefore the impedance is equal to the resistance. When two or more circuits have the same natural frequency they are said to be in resonance. Res-

onance of a circuit to a given exciting alternating electromotive force is that condition due to variation of the inductance or capacity in which the resultant effective current (or voltage) in that circuit is maximum. Instead of varying the inductance and the capacity, the frequency of the exciting field may be varied. The condition of resonance is determined by the frequency at which the current or voltage is maximum.

RESONANCE CURVE—A curve showing the relationship between the current induced in an oscillatory circuit and the frequency of the inducing current. In the case of two oscillating circuits placed near each other so that

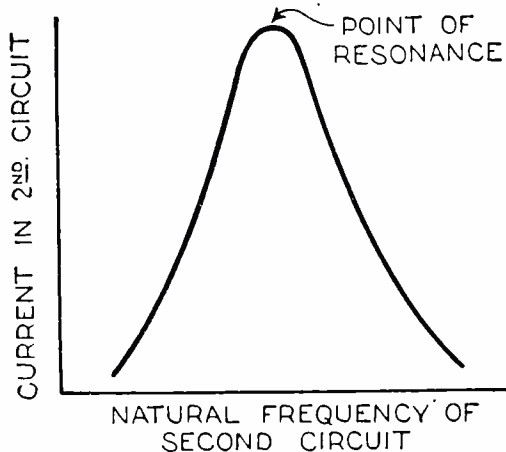

A typical resonance curve.

oscillations in one circuit will induce oscillations in the other, the induced oscillations will be weak or strong depending whether or not the second circuit is in tune with the first one. The capacity and the inductance of the second circuit can be varied until it is exactly in tune with the first at which time maximum current will flow in it. The resonance curve is obtained by measuring the current in the second circuit for various noted oscillation constants, and plotting the curve with the ordinates representing the current and the abscissae the corresponding natural frequency of the second circuit. The diagram shows a typical resonance curve. The peak of the curve is the point where the two circuits are in tune, or in other words, the point of resonance.

RESONANCE INTENSIFIER—An automatic receiver used for the reception of high-speed radio telegraph signals.

RESONANCE TRANSFORMER—Any loose-coupled tuning inductance having a primary and secondary each with a variable condenser in the circuit. Tuning the secondary circuit brings it in resonance with the primary, thus enabling signals to be heard with greatest volume.

RESONANT—See *Resonance*.

RESONATOR—A device for detecting by resonance, oscillations produced by an oscillator. This term is also used to refer to the sound box employed with the telegraph sounder.

RESONATOR, ACOUSTIC—A vessel containing a volume of air which can easily be set into vibration by sound waves or by the oscillation of a solid object. Typical forms are cylindrical or spherical and the ear is applied to a small tube opening into the air chamber.

RETARDATION COIL—A reactance coil used in a circuit for the purpose of selectively reacting on currents which vary at different rates.

RHEOSTAT—A variable resistance used to control current flow. Rheostats may

be made of resistance wire or of carbon or for special purposes liquids may be used. In radio work, rheostats are connected in series with the filaments of vacuum tubes and the "A" battery in order to control the amount of current flowing in the filaments.



A rheostat constructed of resistance wire.

R. M. S.—Abbreviation for *Root Mean Square* (q.v.)

ROBERTS, Joseph Harrison Thomson

—Born in 1890, he was educated at Liverpool and Cambridge Universities. He carried out many physical researches at the Cavendish Laboratory, Cambridge, and did a great deal of work on thermionics and other radio problems. He is a doctor of science and a Fellow of the Institute of Physics. He has several radio patents to his credit and is an expert in electrical, optical and acoustical sciences.

ROBINSON, James

—British radio inventor. Born in 1884, he was educated at Durham and Gottingen Universities. He was appointed lecturer in physics at Durham University, 1906-07, lecturer in physics Sheffield University, 1910-12, and lecturer in physics at the East London College, London University, 1912-15. Robinson is known chiefly for his direction finding apparatus. He is a member of the Radio Society of Great Britain.

ROBINSON, Samuel S.

—Rear-Admiral, U.S.N. He was born May 10th, 1867, and was educated at the United States Naval Academy, from which he graduated. He wrote the *Manual of Wireless Telegraphy for Naval Electricians*, and was in charge of the Bureau of Equipment, Navy Department.

ROOT MEAN SQUARE—

The square root of the mean value of the square of an alternating current or voltage. An alternating current whose root-mean-square value is one ampere has the same heating effect as a direct current of one ampere. Root mean square is also referred to as *effective* or *virtual value*. The root mean square is derived as follows. In electrical measurements, it is necessary to compare direct and alternating currents. Moreover, the same units of measurement, the *ampere* (q.v.) and the *volt* (q.v.) are used in referring to both direct and alternating currents. However, in a direct current, a certain voltage will produce a steady current, whereas in an alternating current, both the voltage and the current are constantly varying both in magnitude and direction. The common basis of measurement is found in the value of the alternating current which will produce the same amount of heat as a certain direct current. Heating effect, according to *Joules Law* (q.v.) is directly proportional to the square of the current. Hence, in an alternating current varying according to a sine law, it is necessary to square each ordinate, find the mean or average value of these squares, and then extract the square root of this mean. Stated in concise terms, it is necessary to find the root mean square. An alternating current having a *maximum* value of one ampere would have a root mean square value of .707 amp. (See *Form Factor*.)

ROOT-MEAN-SQUARE VALUE—See *Root-Mean-Square*.

ROTARY CONDENSER—A synchronous motor used on a power line to advance the *phase* (q.v.) of the current. As a result there is an improvement in the *power factor* (q.v.). The action of the synchronous motor is similar to that of a condenser, whence the name rotary condenser.

ROTARY CONVERTER—A device for converting alternating current into direct current or vice versa. The rotary converter is also known as a *synchronous converter*. It is built like a direct current generator, except that it has certain commutator segments or conductors in the armature, connected to slip rings. Two, three, four, or six rings may be used. When the armature is rotated there is an alternating voltage between the rings. If the converter is driven by a motor or by an engine, it may be used as a *double current generator*, direct current being obtained from the brushes and alternating current from the slip rings (collector rings). When the collector rings are supplied with alternating current, the converter runs as a synchronous motor and direct current can be obtained from the brushes on the commutator. It should be understood that there is only one set of windings on the rotary converter which act simultaneously as alternating current motor and direct current generator. A converter which is used to convert direct current to alternating current is called an *inverted converter*. In the *single-phase* converter, there are two slip rings connected to the windings by as many equally spaced taps as there are poles. In the three-phase converter, three rings are used, with three equally spaced taps for each pair of poles. The single phase rotary converter must be brought up to synchronous speed by external power as it will not start itself. The polyphase con-

verter will start itself from the alternating current side, but since it draws a very great lagging current, it should be started whenever possible from the direct current side. (See *Converter*.)

ROTARY CURRENT—A term infrequently used to denote *polyphase* (q.v.) current.

ROTARY DISCHARGER—A rotating disc discharger used in wireless transmitters in which the sparks occur between metal studs mounted on a motor driven disc. (See *Disc Discharger*.)

ROTARY FIELD—A magnetic field rotating in space. It may be due to rotating windings or stationary windings properly spaced through which polyphase currents are flowing.

ROTARY GAP—A form of rotating spark gap utilizing two or more rotating discs carrying studs between which the sparks pass. Spark gaps of this type were formerly used in wireless telegraph transmitters. (See *Discharger*, also *Disc Discharger*.)

ROTARY HYSTERESIS—Hysteresis (q.v.) produced by a rotating field as distinguished from that produced by a changing field.

ROTARY SPARK GAP—See *Rotary Discharger*.

ROTARY TICKER—A *ticker* (q.v.) in which the interruptions are produced by the chattering of a springy brush on a rapidly rotating metal wheel.

ROTOR—The rotating part of any electrical apparatus. It may refer to the revolving portion of a *motor* (q.v.) or *generator* (q.v.) or to the rotatable part of a variable *condenser* (q.v.). The rotor in a direct current motor or generator is the armature. In an alternator or an alternating current motor, the rotor may be either the armature or the field.

ROTOR, GROUNDED CONNECTION—This refers to the grounding of the rotors of variable condensers in a ra-

dio receiving set. This is often done to eliminate hand capacity. Sometimes the rotors are connected to the shielding, which is grounded.

ROUGH CALIBRATION—Meters such as voltmeters, ammeters, etc., are often calibrated by comparison with standard instruments. In case such instruments are not available, it may be necessary to use less accurate methods. As an example of rough calibration, an experimental wave meter could be calibrated roughly by tuning in on various broadcasting stations whose wave lengths are known. (See *Calibration*.)

RUHMKORFF COIL—See *Induction Coil*.

RUTHERFORD, Sir Ernest—British physicist. Born at Nelson, New Zealand, he was educated at Canterbury College, Christchurch, New Zealand University, and Trinity College, Cambridge. From 1898 to 1907 he held the position of MacDonald professor of physics at Manchester University. In the latter year he was appointed Cavendish professor of physics and director of the Cavendish laboratory at Cambridge. Rutherford is an extremely brilliant physicist and has carried out a series of researches on the ultimate composition of matter. Many of these experiments have confirmed the researches of J. J. Thomson and others. Some of Sir Rutherford's experiments have revolutionized the theories of matter. He has received many honors for his brilliant researches including the Nobel prize for chemistry awarded to him in 1908. He has written extensively on radio activity, his books including "Radioactivity," 1904; "Radioactive Transformations," 1906; "Radioactive Substances and their Radiations," 1913; as well as many papers for technical journals. Sir Ernest was knighted in 1914.

S

SAFETY GAP—A spark gap which is connected in parallel with a condenser or other apparatus, and which protects the apparatus from excessive voltage. When the voltage exceeds a predetermined limit, the gap breaks down, thus passing the current around the apparatus. (See *Gap*, *Micrometer*.)

SAL AMMONIAC—A term commonly used for ammonium chloride. This substance is a white crystal, very soluble in water, and is used as an electrolyte in primary cells and also in many electroplating processes. (See *Cell*.)

SATURATED—The magnetic condition of a substance when increase of magnetizing force produces no further increase in flux density. A point is reached in every magnetic material, where further increase of magnetic intensity will not produce any increase of flux density. At this point, the material is said to be saturated. Cast iron becomes saturated at a lower flux density than steel or wrought iron.

SATURATION—See *Saturated*.

SATURATION, MAGNETIC—See *Saturated*.

SECONDARY CELL—A unit consisting of a positive and a negative electrode immersed in an *electrolyte* (q.v.) which becomes active only after the passage of an electric current. The electrodes are of metal or of a metallic

compound. An electric current, flowing into a secondary cell causes certain chemical actions to take place whereby electrical energy is transformed into chemical energy. This process is termed "charging." After the cell is charged, the reverse action takes place and chemical energy is transformed into electrical energy. In this case, the cell is able to deliver an electric current to an outside circuit. This process is termed "discharging." The secondary cell is also known as an *accumulator* or *storage cell*. However, the cell does not store electricity. It merely holds or stores the chemical energy for immediate transformation into electrical energy. It is usual practice for several positive plates to be connected in multiple to form one positive electrode and for several negative plates to be connected in parallel to form a single negative electrode. The *storage battery* consists of two or more storage cells. The operation of the storage cell depends upon the fact that certain metals immersed in an electrolyte may differ in potential. In the secondary cell, no electrical action takes place until after charging. Thereafter, chemical action maintains a difference of potential until the stored energy has been retransformed. While the negative electrode is used up to a certain extent during the process of discharging, it is replaced electrochemically during the

charging process, due to the flow of current through the electrolyte in the opposite direction to that of discharge. The two principal types of storage cells are the lead cell and the nickel-iron-alkaline (or Edison Cell). In lead cells, the negative electrode is made of spongy lead and the positive electrode is of lead peroxide. The electrolyte is dilute sulphuric acid. The following chemical action takes place within the lead cell. When the cell is charged, hydrogen is released at the negative plate, and oxygen at the positive plate. The oxygen combines with the lead of the positive plate to form lead peroxide while the hydrogen reduces the oxide in the negative plate. When the cell is discharged, both electrodes are changed to lead sulphate and the liberated hydrogen combines with the oxygen to form water. Care must be taken not to allow the cell to discharge too far as in this case, too great an amount of lead sulphate may form and this may cause buckling of the plates or may make it very difficult to recharge the cell. The indications of a completely charged cell are increased gassing of electrolyte together with a stop in the rising of the voltage and the specific gravity. In the Edison-type secondary cell, the active materials are of nickel and iron. Nickel hydrate forms the active material of the positive plate, while iron oxide forms the active material of the nega-

tive plate. The electrolyte is a 21 per cent. solution of potassium hydrate combined with a small amount of lithium hydrate. The chief advantage of the *Edison cell* (q.v.) is that it can be left idle indefinitely in a fully charged, semi-charged, or fully discharged state without any harm to the cell. In addition it is lighter and smaller than the same capacity lead cell. The unit used for measuring the capacity of storage cells is the *ampere-hour* (q.v.). This is based on the rate of discharge normally used in measurement, the eight-hour rate. As an example, an 80 ampere-hour storage battery will furnish a continuous current of 10 amperes for 8 hours. If the battery is discharged at a more rapid rate, it will not have the rated capacity.

SECONDARY CURRENT—The current flowing in the secondary windings of inductive apparatus. Current induced in a secondary winding due to the action of *primary current*. (See *Current, Primary*.)

SECONDARY ELECTRON EMISSION—See *Secondary Electrons*, also *Secondary Emission*.

SECONDARY ELECTRONS—Electrons emitted by the plate of a vacuum tube when struck by the electron stream from the filament. (See *Negative Resistance*, also *Secondary Emission*.)

SECONDARY EMISSION—Electron emission in which the exciting agency is bombardment of the emitting material by electrons. The emission of electrons from cold electrodes under the impact of other electrons. (See *Negative Resistance*.)

SELECTIVE—See *Selectivity*.

SELECTIVITY—The sharpness with which a radio receiving set can be tuned to a particular wavelength. A selective set is one which tunes sharply, whereas a non-selective set tunes broadly. Too long an aerial will often result in making a set tune broadly. A short aerial makes the receiving set more selective but reduces the volume.

SELECTOR—A tuning device connected in a radio receiving circuit for the purpose of eliminating undesired stations. (See *Wave Trap*.)

SELENIUM CELL—A cell constructed of a thin layer of the metal selenium. This metal is extremely sensitive to light. In its crystalline form, it is a conductor of electricity, its conductivity varying with the amount of light allowed to fall on it. As a result it is possible to regulate the flow of current in a circuit by varying the light. The selenium cell thus offers a means of transmitting pictures by wire or radio. Selenium cells are also being used in experimental devices for the transmission of motion pictures and for obtaining *television* (q.v.).

SELF-CAPACITY—The capacity of a circuit or a portion of a circuit. Every electrical circuit possesses inherent capacity, which varies in degree, depending upon the shape, size, etc., of the circuit. Self-capacity is also referred to as *distributed capacity* (q.v.). In general self-capacity is detrimental, especially in radio circuits, since it introduces losses. By using special forms of windings, the self-capacity of coils can be greatly reduced. (See *Low Loss Coils*.)

SELF-EXCITED GENERATOR—A generator which depends upon its own current for its field excitation. Such a generator must build up its magnetic field and hence its voltage, gradually. In order to get a start, it depends upon the *residual magnetism*

(q.v.) present in the iron of the poles. There are three types of self-excited generators, the *shunt generator* (q.v.), the *series generator* (q.v.) and the *compound generator*. (See *Compound Wound*.)

SELF-HETERODYNE—A system of reception of continuous wave signals by the production of audio frequency beats, through the use of a device which is both a radio frequency generator and a detector of the audio frequency beat currents produced.

SELF-INDUCTANCES—See *Inductance, Self*.

SELF-INDUCTION—Inductance due to the field produced by the circuit itself. Changes in current are always accompanied by self-induction. When the current is decreasing, the electromotive force of self-induction is in the same direction, thus tending to prevent the decrease. When the current is increasing, the electromotive force of self-induction tends to prevent the increase. (See *Inductance, Self; Mutual Inductance*, also *Induction*.)

SELF-INDUCTION COEFFICIENT—The ratio of the number of lines of induction produced by a current flowing in the circuit divided by the current in the circuit. The coefficient of self-induction of a conductor of finite cross-section may be defined as the ratio of twice the energy of the magnetic field produced by the current flowing to the square of the current. The following factors affect the coefficient of self-induction of a circuit: the cross-section and shape of the conductor, the size and shape of the circuit, the permeabilities of the surrounding medium and of the conductor itself. Where the skin effect is large, the frequency of the current and the specific resistance of the conductor will also affect the coefficient of self-induction.

SELF-OSCILLATION—The tendency for the vacuum tubes in a radio receiving set to act as generators of radio frequency oscillations. (See *Body Capacity*, also *Boltho Circuit*.)

SENSITIVE SPOTS—Points on the mineral of a crystal detector which show a greater response to incoming oscillations than others. Dust, grease, or dampness reduce the sensitivity of these spots and therefore the crystal should be properly protected.

SEPARATELY EXCITED GENERATOR—A generator in which current for producing the magnetic field is obtained from some source external to the generator itself. This source is either another generator or else a storage battery. Separately excited generators are generally used only for special work such as battery charging, electroplating and testing.

SERIES—See *Series Connection*.

SERIES CONNECTION—When two or more parts of an electrical circuit are so connected that the same current

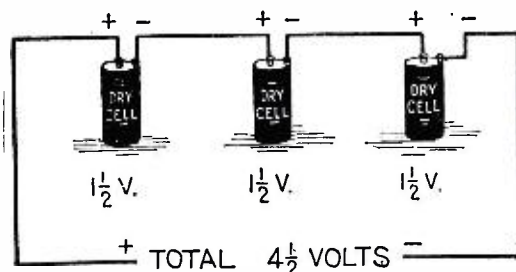

The three dry cells are here shown connected in series.

flows through them they are said to be in *series* and the circuit is called a *series circuit*, the connection being a

series connection. In order to connect primary or other cells in series, it is necessary to connect the positive terminal of one to the negative terminal of another, etc. In this case, the total voltage of the battery equals the sum of the separate voltages.

SERIES GENERATOR—A generator in which the exciting winding is connected in series with the armature and the load. This type of generator is of small commercial importance being used mainly for certain constant current systems.

SERIES MOTOR—A commutator-type motor having the field and armature windings connected in series. Ordinarily, the series motor is a direct current motor, but with minor modifications, such as lamination of the field as well as armature, this motor can be used for alternating current also. With the applied voltage constant, the greater the load, the less will be the speed of a series motor. As the load is lessened, the motor will speed up, and if the load is entirely removed, it will "run away." The *torque* (q.v.) characteristic is the most important feature of a series motor. Instead of varying directly with the current as in the shunt motor, the torque increases with the square of the current.

Hence, if the current is doubled, the torque will be increased four times, while if the current is quadrupled, the torque will be increased sixteen times. For the same current, the torque of the series motor is higher than that of the shunt and in addition, the series motor has a much better starting torque.

SERIES-PARALLEL—This refers to a circuit which is a combination of a

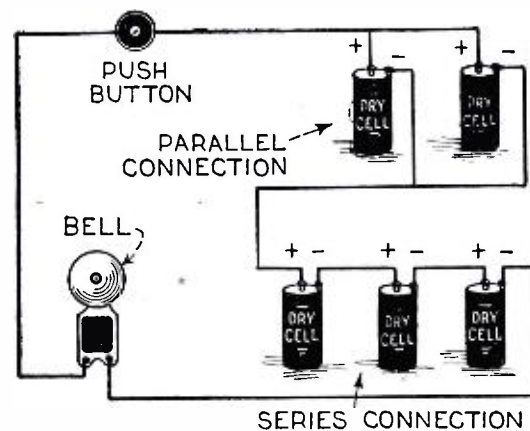

A series-parallel circuit. The three dry cells are connected in series with each other and with the bell and the push button. They are also in series with the other two dry cells, these latter being in parallel with each other.

series circuit and a *parallel circuit*. The term *series-parallel* is generally used to indicate a series circuit having certain minor branches in parallel; the term *parallel-series* denotes a parallel circuit having certain minor branches in series. The illustration shows a series parallel circuit having two dry cells in parallel and three dry cells in series. The push button and the bell are also in series. (See *Parallel Connection, Series Connection*, also "A" *Battery*.)

SERIES RESONANCE—When a single lumped capacity and a single lumped inductance are connected in series between terminals to which an alternating electromotive force is applied, and the inductance or capacity or frequency is varied, the condition of series resonance exists, when the current is a maximum. (See *Resonance*, also *Resonance Curve*.)

SHARPNESS OF RESONANCE—A quantity expressing the fractional change of current in a simple series circuit for a given fractional change in either capacitative or inductive reactance.

SHARPNESS OF TUNING—See *Selectivity*.

SHARP WAVE—A wave in which the energy radiated is confined to a single frequency of oscillation. Tight coupling of the oscillation transformer tends to give a broad wave, whereas loose coupling gives a sharp wave. (See *Decrement*.)

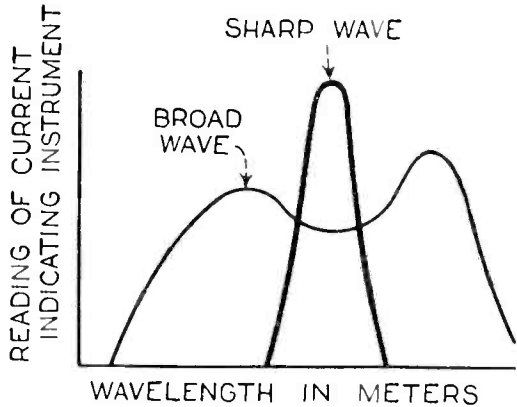

Graph showing difference between sharp and broad waves.

SHIELDED TRANSFORMER—An audio or a radio frequency transformer surrounded by a metal casing. Shielding of radio frequency transformers prevents interference from external

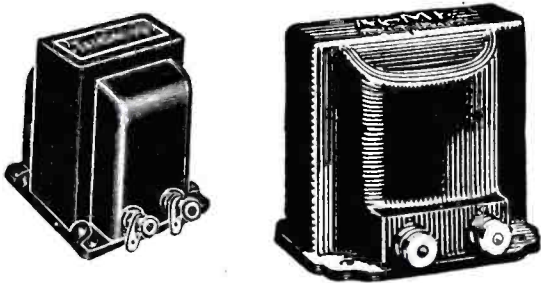

Typical shielded transformers.

fields and also keeps body capacity from affecting the tuning. Audio frequency transformers are shielded mainly to prevent interaction between the flux from the transformer and other parts of the radio set.

SHIELDING—Metallic screening placed around radio apparatus to prevent interference from stray electromagnetic or electrostatic fields. In radio sets, the inside surface of the panel is often shielded by means of a metallic lining, thus eliminating body capacity. It is usual to ground the shielding. In sets having more than two stages of radio frequency amplification complete shielding is essential. (See *Induction Screen*.)

S.H.M.—Abbreviation for *Simple Harmonic Motion* (q.v.).

SHOCK EXCITATION—See *Impact Excitation*.

SHORT—See *Short Circuit*.

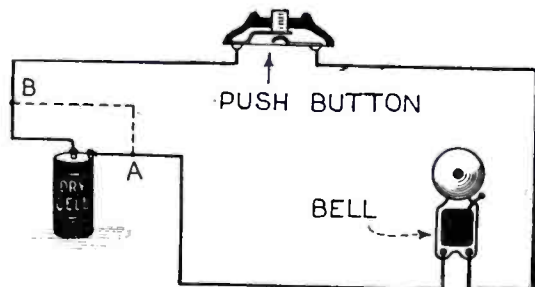

The dotted line between A and B represents a conductor short-circuiting the dry cell.

SHORT CIRCUIT—A short circuit re-

fers to a condition of an electrical circuit whereby an external path of low resistance is connected across the source of electrical energy. A short circuit is accompanied by an increase in current flow, although this current is no longer usefully employed. Apparatus may be protected from short circuits by means of *circuit breakers* (q.v.) or *fuses* (q.v.).

SHORTENING CONDENSER, or ANTENNA TUNING CONDENSER—A condenser connected in series with the antenna and the ground, for the purpose of diminishing the natural wave length.

SHUNT WOUND GENERATOR—A generator in which the field winding is shunted across the armature terminals. The resistance of the shunt winding is made high enough so that only a small percentage of the load current flows through it.

SHUNT WOUND MOTOR—A motor in which the field winding is connected in parallel with the brushes (and the armature winding). The speed of a shunt motor is practically constant, but falls to a slight extent as the load is increased. The drop in speed may be only a few per cent between no load and full load, for large motors, while for small ones it may be as high as 15 per cent. As the load on a shunt motor is increased, the torque

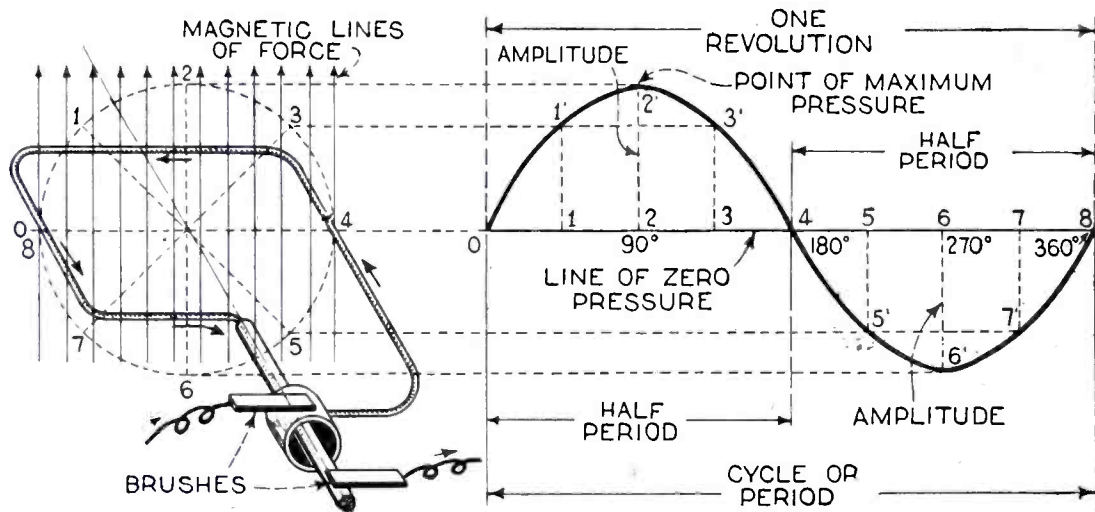

A sine curve is shown at the right. At the left a coil is shown rotating in a magnetic field. As the coil cuts the magnetic lines it generates the varying electromotive force represented by the sine curve.

which the motor develops will increase and the armature current will also increase in almost direct proportion.

S.I.C.—Abbreviation for *Specific Inductive Capacity* (q.v.).

SIDE BANDS—A group or band of frequencies formed by the interaction of the *Carrier Wave* (q.v.) and the modulations above and below the main carrier wave frequency. (See *Harmonics*.)

SIGNAL, STRAY RADIO—See *Strays*.

SILICON—A metalloid occurring widely in nature. It is a component of most of the rocks forming the earth's crust. Silicon crystals are used as detectors in radio work. (See *Crystal*, also *Silicon Detector*.)

SILICON DETECTOR—A *crystal detector* (q.v.) using silicon as its crystal. The silicon is used in a crystalline state and a *cat-whisker* (q.v.) is generally used to locate the *sensitive spots* (q.v.) and make contact.

SIMPLE HARMONIC—Referring to a *simple harmonic motion* (q.v.). If a point moves at a uniform rate around a circle and the point be projected in

a straight line in the plane of the circle, the back and forth motion of the projected point is referred to as *simple harmonic motion*. True simple harmonic motions are the motions of a pendulum, a vibrating tuning fork, particles of water in a wave, etc. Other motions which are not precisely simple harmonic motions may be treated as resulting from several such motions. Examples of these are motions occurring in alternating currents in light waves, in electric waves and in sound waves.

SIMPLE HARMONIC MOTION—Abbreviation S.H.M.—The motion executed by the foot of a perpendicular let fall on the diameter of a circle from a particle moving with uniform velocity in that circle. The piston rod of a steam engine, turning a crank uniformly approximates a simple harmonic motion.

SIMPLE HARMONIC VIBRATIONS—The vibrations of a body such as a tuning fork which follow the law of *simple harmonic motion* (q.v.). (See *Angular Velocity*, also *Simple Harmonic*.)

SINE CHARACTERISTIC OF ALTERNATING CURRENT—See *Sine Curve*, also *Sine Wave*.

SINE CURVE—A curve whose perpendicular at any point is proportional to the sine of the angle corresponding to that point. The sine curve is used to represent the changes in direction and

strength of an alternating current or voltage. The coil illustrated at the left in the accompanying diagram generates a sine wave current as it revolves through the magnetic field shown by the arrows. When the coil is moving parallel to the magnetic flux, no electromotive force is induced and hence current flow is zero. As the coil is rotated in a clockwise direction, it cuts the flux at a greater and greater angle, until the maximum is reached when the flux is cut at a right angle. This gives a gradually increasing electromotive force (and hence current) until maximum is reached, then when the angle at which flux is cut decreases, the electromotive force decreases until the coil again moves parallel to the flux, at which point electromotive force is again zero. Then when the coil starts to cut the flux in the opposite direction, electromotive force is reversed, increasing to a maximum and then decreasing to zero thus completing the *cycle* (q.v.). Current (positive) is represented by the height of the ordinates of the sine curve above the line, while current in the re-

verse direction is represented by the height of the ordinates below the line. The horizontal distances (abscissae) represent time generally measured in phase angles (position of coil at any particular instant). (See *Alternating Current*, also *Curve of Sines*.)

SINE WAVE—As referring to an alternating current, a sine wave or a simple alternating current, is a current whose wave shape is sinusoidal. The wave shape is the shape of the curve obtained when the instantaneous values of the current are plotted against time in rectangular co-ordinates. The wave shape is independent of the frequency and of the scale to which the curve is plotted.

SINE WAVE OF ALTERNATING CURRENT OR E.M.F.—See *Sine Wave*.

SINGING ARC—See *Duddell Singing Arc*.

SINGING SPARK—A spark used in a wireless telegraph transmitter which produces a singing note in the receiving head set. A spark which occurs at regular intervals and at an audible frequency such as that obtained in a quenched spark system of wireless telegraphy.

SINGLE CIRCUIT TUNER—A regenerative receiving circuit in which the antenna and grid circuits are conductively coupled. *Feedback* (q.v.) is obtained by placing the plate circuit in inductive relation with the primary.

SINGLE-PHASE—This term is used to refer to an alternating current, an alternating current system of distribution, or to alternating current apparatus. A single phase system or circuit is one energized by a single alternating electromotive force. A single phase circuit is usually supplied through two wires. The currents in these two wires counted outwardly from the source, differ in phase by one-half a cycle (180 degrees). In the single phase generator the voltage per phase is the same as the voltage between the lines and the current per phase is the same as the current per line. Since there is a great saving of copper in the use of three phase transmission of power, three phase generators are more frequently used than single phase machines. (See *Alternator*.)

SINOIDAL VIBRATION—See *Simple Harmonic Motion*.

SIPHON RECORDER—A moving coil galvanometer originally used for recording messages sent over long submarine cables. The received currents are passed to a coil suspended in a strong magnetic field. This coil carries a fine glass syphon which discharges ink onto a moving paper tape. In cable signaling, dots and dashes are usually indicated by opposite deflections which result in a wavy line being produced on the tape.

SKINDERVIKEN TRANSMITTER BUTTON—A small carbon grain microphone (q.v.) button less than an inch in diameter and about half an inch high containing a polished metal-



Fig. 1. Skinderviken Transmitter Button.

lic button affixed to a mica diaphragm and a surrounding case of brass, the space between the case and the pol-

ished button being partially filled with a good grade of carbon granules. The button is very sensitive to sound waves when it is attached to any form of a

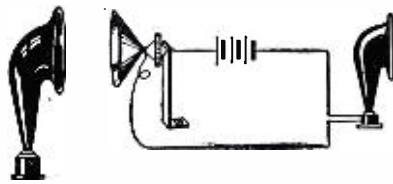

Fig. 2. Retransmitting radio programs.

diaphragm, thus making it applicable wherever a sensitive telephone transmitter should be used. Fig. 1 shows the external appearance, full size, of the Skinderviken button. This transmitter button has a number of applications in radio work and can be used in connection with speech amplifiers,

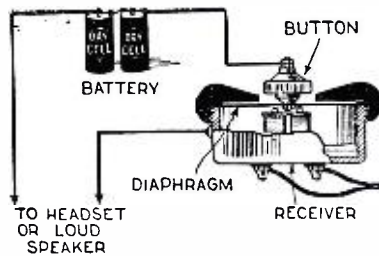

Fig. 3. Retransmission from ear phone.

telephone transmitters, detectaphones, etc. It can be made to transmit in any position, either horizontal or vertical. It is small enough to be readily concealed. Fig. 2 shows how radio music can be re-transmitted to distant points and incidentally amplified at the same time. The microphone but-

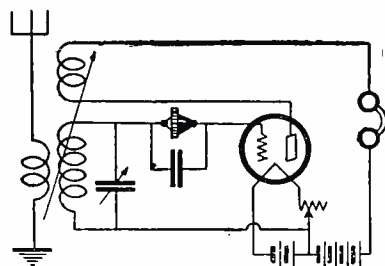

Fig. 4. Button used as grid leak.

ton is shown fastened to a cone and mounted in front of the loud speaker. The leads from the button are connected in series with several dry cells and another loud speaker at a distant point. Fig. 3 shows how the trans-

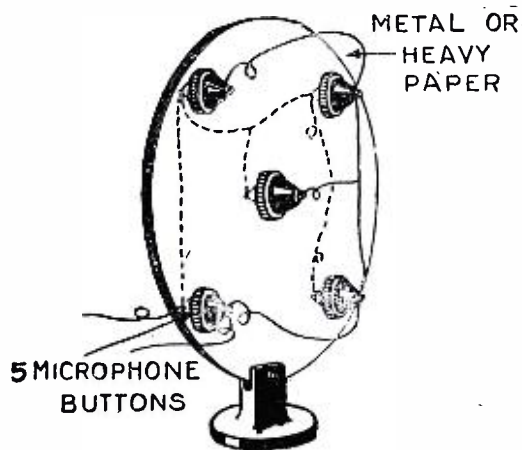

Fig. 5. Combining buttons to form sensitive microphone.

mitter button can be attached to an ordinary receiver to produce the same effect. In this case also, the leads are

connected in series with several dry cells and with a low resistance phone at the distant end. In Fig. 4 the transmitter button is shown in use as a grid leak in a regenerative circuit. Where it is desired to get greater sensitivity and volume for either radio telephone transmitting or for ordinary phone transmission the system illustrated in Fig. 5 will be found highly suitable.

Fig. 6 shows the construction of a hand microphone for transmitting sets

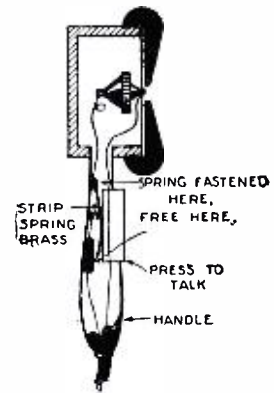

Fig. 6. Construction of hand microphone.

or for inter-departmental telephone circuits. A very simple circuit closer is mounted in the handle of the microphone which in this particular case is simply an ordinary piece of wood hollowed out to receive the switch and the wires. This wooden handle is then fastened to the rubber case of a telephone receiver. The coils and magnets in the telephone receiver are removed, a small hole is drilled or punched in the diaphragm, and the transmitter button is fastened as indicated in the diagram.

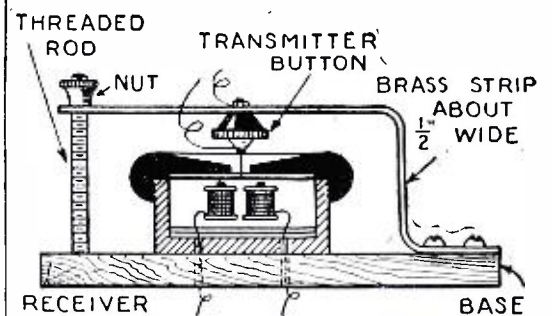

Fig. 7. Method of fastening a button to ear phone.

Another method of fastening a transmitter button to a telephone receiver is illustrated in the diagram in Fig. 7. Here the transmitter button is mounted on a brass strip which is bent so that the center of the button will rest upon the diaphragm of the telephone receiver fixed to the base. A threaded rod and nut regulate the pressure of the button against the diaphragm. In the event that it is not desired to make any changes to a pair of telephone receivers, the transmitter button can be

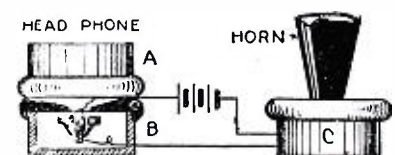

Fig. 8. A simple form of amplifier.

fastened in the shell of an old receiver, B in Fig. 8, and the head phone may be rested on the shell. For

use with a Baldwin receiver, a microphone transmitter button is fastened to it in the following manner: The diaphragm of the Baldwin receiver is

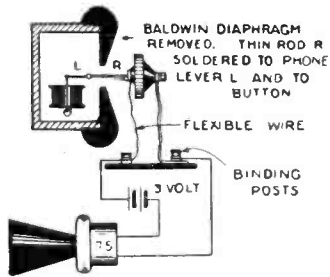

Fig. 9. Button attached to Baldwin 'phone.

first removed, and a thin rod is soldered to the lever, as indicated in Fig. 9. The transmitter button is then soldered to the rod as shown. Another

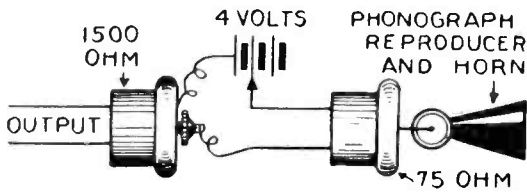

Fig. 10. Loud speaker operation from 1-tube set.

way of making a loud speaker set from an ordinary one-tube receiving set is illustrated in Fig. 10. Where a phonograph is available, the hook-up illustrated may be employed, placing the reproducer of the phonograph on the

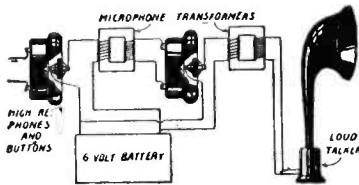

Fig. 11. An effective radio amplifier.

receiver, which should be placed in a suitable position on the turntable. Inasmuch as the movement of the diaphragm of the seventy-five ohm receiver is an up and down one, the reproducer of the phonograph should be turned as it would be for "hill and dale" records. A tiny drop of solder should be dropped upon the diaphragm of the seventy-five ohm receiver and a small nick placed in the center of the solder for receiving the needle of the phonograph reproducer.

Very often it is desired to further amplify the music or sounds picked up by a transmitter button. For this purpose, microphone transformers, or as they are better known, modulation or telephone induction transformers, are employed. In Fig. 12 this instrument is illustrated, together with the circuit for its use. Here the incoming radio

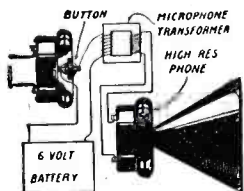

Fig. 12. A single stage amplifier.

signals are made to operate the microphone fastened to the receiver. The current which the microphone passes then goes through the primary of the microphone transformer, the second-

ary of which is connected to another receiver similarly fitted with another transmitter button. The output of the second microphone transformer is then connected to a loud speaker. A dia-

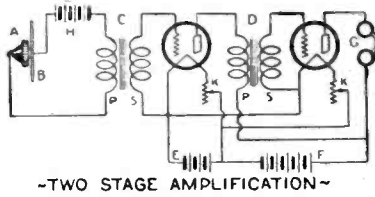

Fig. 13. A 2-stage vacuum tube amplifier.

gram for using but one stage of amplification through transformers is illustrated in Fig. 12. For the better class of work, however, it is desirable to use a standard vacuum tube amplifier as illustrated in Fig. 13. Here the microphone button is placed in series with the primary of a modulation transformer, and in series with several dry cells or flash light batteries. The secondary of the modulation transformer then connects to the grid and filament, the same as it would in a standard vacuum tube amplifying circuit. The music from

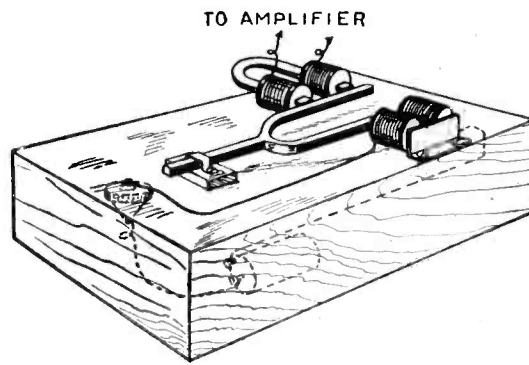

Fig. 14. A tuning fork oscillator.

the output is, of course, very loud.

A very splendid oscillator is illustrated in Fig. 14. Here a tuning fork of standard frequency is mounted on a suitable holder in a cigar box. Two low resistance coils, about five to

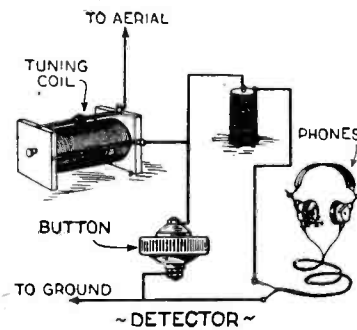

Fig. 15. Transmitter button used as radio detector.

seventy-five ohms, are then placed under one prong of the tuning fork. These are connected in series with the transmitter button fastened in the cigar box, which serves as a base for mounting the tuning fork. The batteries may be concealed in the cigar box. Thus when the tuning fork is struck, it will continue to vibrate as long as the current is applied to the microphone. To use this as an oscillator, a pair of magnets from a telephone receiver and the permanent magnets are mounted near the other vibrating prong. The current constantly being changed by means of the vibrating bar of steel produces a standard frequency, which when amplified can be used for making radio measurements of different kinds. Fig.

15 shows the transmitter button connected in a radio circuit for use as a detector of radio waves. Fig. 16 shows a method of making a code practice device. An audio frequency howl is produced which will enable an instructor to teach an entire classroom the radio code. Sometimes the key, instead

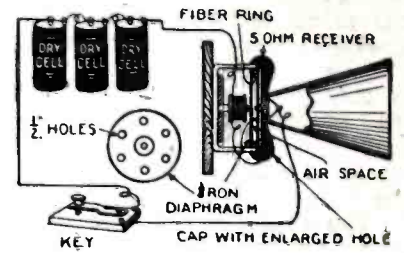

Fig. 16. A code practice machine.

of interrupting the circuit, merely shunts a small portion of the current passing through the transmitter button, and for this purpose the key

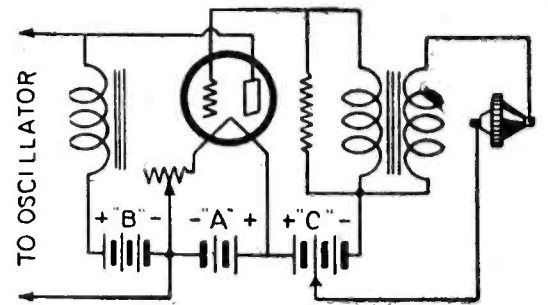

Fig. 17. Use of button in Heising modulation system.

would have to be placed directly across the transmitter button and in series with a small resistance. Fig. 17 shows

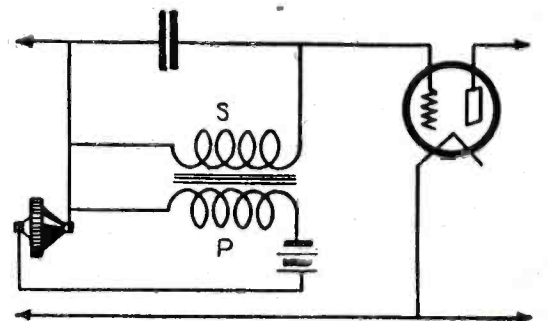

Fig. 18. Method of varying grid voltage of oscillator tube.

how the transmitter button may be used in Heising modulation. Fig. 18 indicates its adaptation to the variation of grid voltage of the oscillator

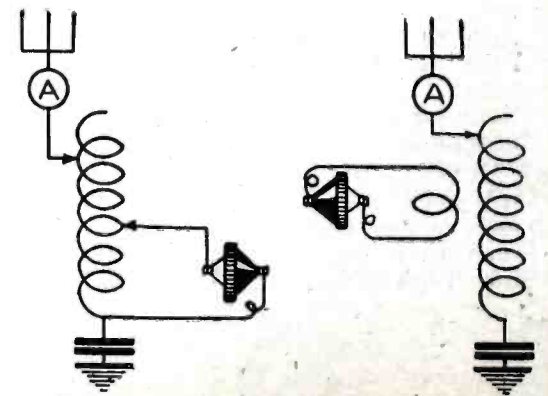

Fig. 19. Method of modulating output current.

tube and Fig. 19 shows how the transmitter button may be hooked up to modulate the output current. These last three figures indicate the use of transmitter buttons in vacuum tube transmitters.

Here's the biggest radio magazine you can buy

*Radio Doing by Engineers, Amateurs,
listeners all combined and published
in this great Magazine*

RADIO NEWS, with its 240 pages, is the largest radio magazine published. It is the outstanding authority in the radio field carrying more new developments, more hookups and more news than any other radio magazine.

RADIO NEWS carries in every issue more than a dozen separate departments that cover every angle of the great industry from the beginner to the professional broadcaster or ship operator.

RADIO NEWS has been radio's greatest magazine since the very beginning of radio broadcasting.

Ask your local newsdealer to let you see a copy today.

Published and Distributed by

Experimenter Publishing Co., Inc.

53 Park Place

New York, N. Y.



25^c THE COPY

SOLD ON ALL
NEWSSTANDS AND
AT RADIO STORES

Marvelous Everyday Science for the layman

Wonders of Science, and the
Invention of the Master Scientists
in Pictures

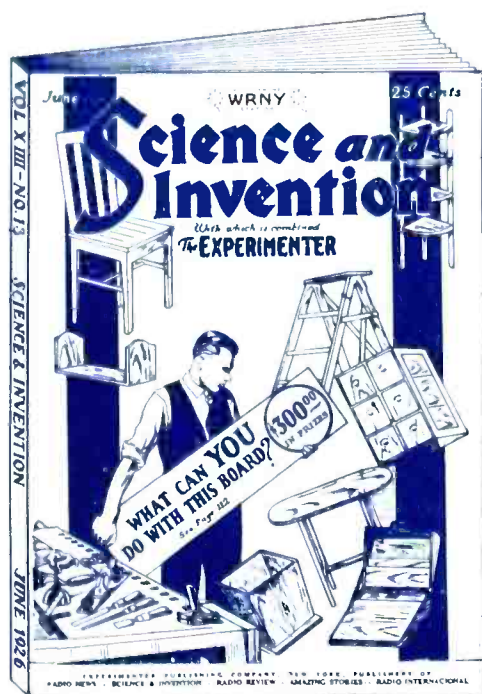

25^c THE COPY

AT ALL NEWSSTANDS
AND RADIO STORES

EVERY day, in all corners of our busy world, Scientists are at work on new Inventions, developing marvelous machines for the progress of the world or compounding strange chemicals for many uses. All these things are shown in the novel magazine "SCIENCE AND INVENTION."

There is also a big Radio Section to "SCIENCE AND INVENTION," for beginners, giving the practical fundamentals of radio in a simple, easy, pictorial manner.

"SCIENCE AND INVENTION" can be obtained on all newsstands or at Radio Stores. Ask your nearest dealer to let you see a copy.

Published and Distributed by

Experimenter Publishing Co., Inc.

53 Park Place

New York, N. Y.

A Fine Piece of Furniture to Contain Your New Radio Set— or Your Old One

The Excello Radio Console
embodies years of experience
in fine cabinet making.

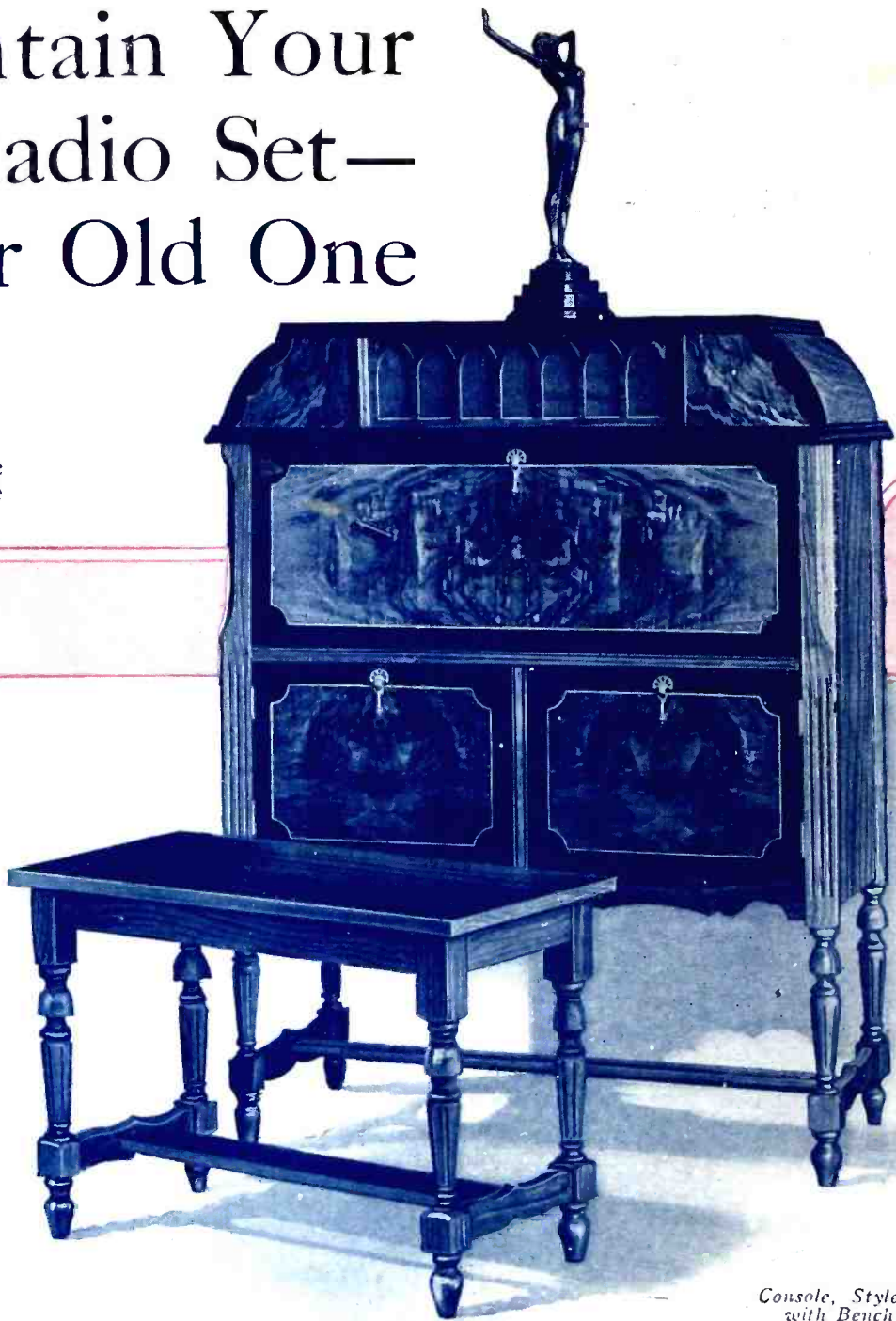

*Console, Style No. R-23,
with Bench to match*

THIS Console is designed in three compartments, the tone chamber, the receiver compartment and the battery space. The tone chamber is of wood with metal throat for perfect tone production. The receiving set compartment has adjustable filler pieces to accommodate any panel not exceeding 10½" x 32". The battery space measures 14" x 32" and the A battery sets on a leaf which pulls forward for easier filling or testing. Matched wood door panels of Butt Walnut, two-tone effect. Ask to see the Excello at your dealers or write for catalog.

*Sketch showing
accessibility of
all parts of set
and equipment*

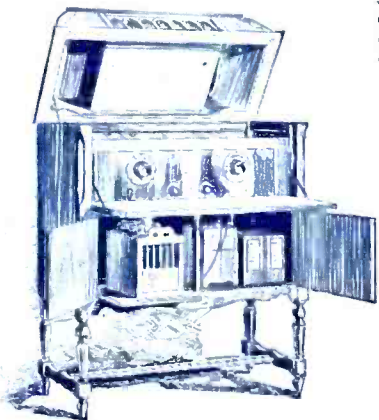

Distributors and dealers
—attractive territory
still open. Write for
interesting proposition.

EXCELLO
Radio
Consoles & Cabinets

EXCELLO PRODUCTS CORPORATION

4821-29 West 16th Street, Cicero, Illinois, (Suburb of Chicago)