

Fall Edition



Fifty Cents

# Radio Listeners' Guide and Call Book

Edited by S. Gernsback

*A Quarterly Magazine*

*C.M. Cahill*



# The Complete Resistance Line

## LYNCH RESISTORS



**Filament Equalizers**

are used in the filament circuits to keep the filaments at their best operating points. The Lynch Equalizer consists of a special alloy encased in a glass cartridge having metal end-pieces. The cartridge can be inserted or removed from its mounting so that the proper resistance may be employed for different types or combinations up to six "A" type tubes. Equalizer cartridges are furnished complete with mountings.

Filament Equalizers, all sizes, \$1.00 complete with mountings.



**Resistance-Coupled Amplifier Kit**

The Lynch kit is a complete unit containing the essential parts for building a high quality resistance-coupled amplifier unit.

Price of complete kit . . . . . \$9.00



**Grid Suppressors**

are special resistance units designed for use in tuned radio frequency circuits to stop oscillation and improve reception without broadening tuning. The Grid Suppression method of tuned radio frequency amplification is rapidly increasing in popularity, especially in connection with power operated receivers. Suppressors are furnished complete with mountings in resistance values of from 100 to 1800 ohms varying in even hundred units.

Price, all sizes, \$1.50 complete with mounting.

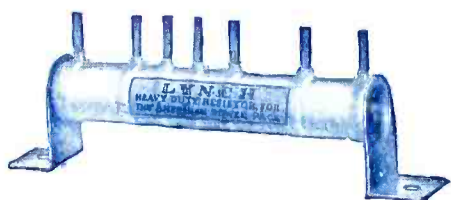

**Special, Tapped Wire-Wound Heavy Duty Resistors**

There is a special Lynch Heavy Duty, Wire-Wound Resistor for every popular "B" eliminator and Power Pack. The Lynch AmerTran Resistor, illustrated, is a sample of this type of resistor. Units for use in the AmerTran, Mayolian, Thordarson and Silver Power Packs are but a few of the types available, as well as resistors for use with new Mayolian R-71 AC Driver unit.

Tapped resistors may be had in any resistance value with any number of taps on special order!

Lynch AmerTran Tapped Heavy Duty, Wire-Wound Resistor, \$8.50.



**Type "P", Heavy Duty Resistors, Wire-Wound in Porcelain**

Lynch Type "P" Heavy Duty Resistors are conservatively rated at 20 watts carrying capacity and are designed for power circuits where the use of high voltages make ordinary resistors impractical.

They are made in a variety of sizes, carefully selected to meet the requirements of the average eliminator and other power circuits. The stock sizes range from 2,000 to 100,000 ohms.

Any other size or form to suit special requirements can be made to order. Lynch Type "P", Heavy Duty Wire-Wound Resistors, \$1.25 to \$4.00 according to resistance value.

### Which do you need?

SOMETIME, somewhere, you will need some one resistor whether it be in constructing a new set or to replace those in your present receiver.

There are but two points to remember when that time comes.

One is that any one resistor will not meet all resistance requirements in radio.

The other is that when you know, or want to know, what your resistance requirements are, go to your nearest dealer and ask for LYNCH Resistors.

There you will find the most complete Resistance Line from which to choose, and our free booklet which fully explains the proper use of Resistance in Radio.

If your dealer can't supply you, write direct.

### Arthur H. Lynch, Inc.

1775 Broadway at 57th Street  
General Motors Bldg, New York, N.Y.



**Metallized Resistors**

give continuous, non-arcing and noiseless resistance. Available in sizes from .25 to 10 megohms at 75 cents each; .012 to .2 megohms at 75 cents each and .0005 to .01 megohms at \$1.00 each.

For heavier duty use Type "C" Metallized resistor, made in sizes from .0005 to .1 megohm. These units are capable of dissipating 2.5 watts.

Also suited for use in battery eliminator circuits and resistance-coupled power amplifier plate circuits where the output voltage is less than 180 volts. Price of type "C" Metallized resistors, \$1.50.

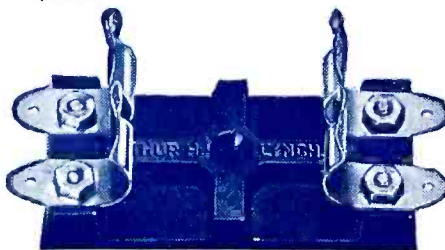

**Leak-proof Double Mountings**

have all the good features of the single mountings, rugged construction, single-hole mounting feature, low surface leakage and mechanical strength.

Double mounting . . . . . \$0.50



**Leak-Proof Single Mountings**

are made of highly polished genuine Bakelite. This fact, coupled with the skillful design, gives the mountings their extremely low surface leakage. The springs are made of heavy phosphor bronze, nickel plated. They are held rigidly in grooves by a screw and nut to prevent turning. The head of the screw is sunk well into the base so as to permit mounting the base on metal surfaces. Spring and soldering lug are one piece, thus eliminating poor and noisy contacts.

Single mounting . . . . . \$0.35

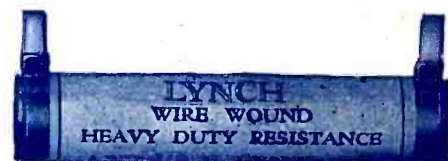

**Type "C", Heavy Duty Resistors, Wire-Wound on Glass**

The Type "G" Heavy Duty Resistors are designed for use in circuits where the ability to withstand high voltages and heavy currents is not of primary importance. They are also adapted for use as grid biasing resistors.

This type of resistor is available in the same resistance values as the Type "P" resistors but is conservatively rated at 7 watts carrying capacity. Special sizes may be had to order.

Lynch Type "G" Heavy Duty Wire-Wound Resistors, \$1.00 to \$3.75 according to resistance value.



**I**f you're making a penny less than \$50 a week, clip coupon now for **FREE BOOK** that tells you about big money opportunities in **RADIO**. Better conditions **NOW** than ever before, in this wonderful new industry! The reason is: television accomplished, trans-Atlantic Radio telephony now in use, many other wonderful advances and inventions constantly widening the field of Radio opportunity. Radio needs trained men **NOW!** And you can get the necessary training easily and quickly—**AT HOME**—through new, practical, tested methods that already have helped hundreds gain success in the Radio field. Yes, right at home in your spare hours, you can get all the knowledge you need for success in Radio—Big Free Book contains all the proof—send for it today!

**Extra Dollars For You  
Almost At Once**

Think of earning \$15, \$20, \$30 extra "on the side" every week without interfering with your regular job, beginning only a few weeks after you start this training! You can—my Radio training course is world-famous as the "Training That Pays For Itself." My thorough, practical usable training methods show you how to pick up this extra cash in your spare hours, while all the time you're preparing for the bigger Radio job ahead. In this way, you can pay for your course and put money in the bank, all through profits I teach you to make right after you start with me. And then, after only a few months of spare time training, you're ready to take the bigger Radio positions!

**Send Today For 64-Page  
FREE BOOK—Mail Coupon**

Send the coupon below, and I'll send you my 64-page book—it's free. Hundreds of pictures and facts about the opportunities for big money in the Radio field, how I help you take advantage of them, the 6 outfits of practice material I send you that you can build into 100 Radio circuits, and the other pay-raising facts you want to read. No previous Radio experience needed to take advantage of this offer, and no special schooling is necessary. Find out all the facts for yourself—mail coupon today.

**Address J. E. SMITH, President  
NATIONAL RADIO INSTITUTE  
Dept. KC-5, Washington, D. C.**

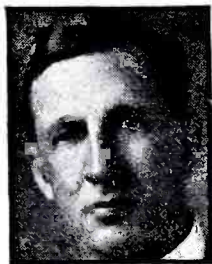

**J. E. Smith, President, National Radio Institute, is one of the leading Radio educators of the world. He has helped hundreds of men to success in the Radio Profession.**

**C O U P O N**

**J. E. SMITH, President,  
National Radio Institute,  
Dept. KC-5, Washington, D. C.**

Dear Mr. Smith: Please send me your free 64-page book with all the facts about learning Radio for bigger pay. I understand this places me under no obligation.

Name.....

Address.....

Town..... State.....

*Here's the coupon that Fetzer and Chambers clipped*



**Fetzer Says  
"You Made My  
Success Possible"**

Dear Mr. Smith: I am now Chief Engineer of Station WEMC, which I designed and built myself from the ground up. Six months were required for the work, and the equipment was designed for 5,000 watts. Previous to building this station I had designed and built two others, one a 500-watt station. I visited all the important Radio stations of Europe and the eastern half of the United States before designing WEMC, in order to get all the latest ideas. I am very happy in my work, feel that I have "arrived" in the Radio profession, and I give your thorough training the credit.

Cordially yours,  
**John E. Fetzer,**  
Station WEMC, Berrien Springs, Mich.

**Builds  
\$100,000  
Broadcast  
Station**

**Find Out FREE How Fetzer,  
Chambers and Hundreds of  
Others Have Gained Success in  
RADIO**

**Mail Coupon Below For Free Book**

**"My Salary Three Times What  
It Was, Thanks To You"  
Says Chambers**

Dear Mr. Smith: Herewith a photograph of myself in my Radio laboratory here at Detroit. I am making almost three times what I made before taking your course, and will receive another substantial increase very soon. As you know, in the capacity of Radio Engineer here I am in full charge of Radio activities apart from the sales department. So far I have met with steady advancement, and I expect more for the future. The knowledge I got from you enabled me to get where I am today, and believe me, I shall always be a booster for your fine school.

Sincerely,  
**E. L. Chambers,**  
6050 Cass Ave., Detroit, Mich.

**Chief  
Engr. At  
Stewart  
Warner  
Branch**

# Radio Listeners' Guide and Call Book

*A Quarterly Magazine*

Volume II

Number 2

SEPTEMBER, 1927

## Contents of This Issue

	Page		Page
Radio Broadcast Stations of the U. S. by Call Letters .....	15	How to Build the Strobodyne.....	74
Radio Broadcast Stations of the U. S. by Wavelengths .....	36	The Camfield Super-Selective 9.....	81
Radio Broadcast Stations of the U. S. by States and Cities .....	42	The Improved Nine-in-Line.....	86
Radio Broadcast Stations of Canada by Call Letters .....	49	The New World's Record Super 10.....	91
Radio Broadcast Stations of Canada by Provinces and Cities .....	52	The Improved Laboratory Super-Heterodyne.....	94
Foreign Broadcast Stations, including U. S. Possessions .....	54	The New Karas 2-Dial Equamatic.....	97
The Lynch Suppressor Circuit.....	65	Power Supply from the House Lighting Current	101
The Aero-Seven Broadcast Receiver.....	70	The "Unipac" Power Amplifier and A.B.C. Supply .....	103
		A Compact A.B.C. Power Unit.....	105
		The Harkness Tuned Audio Amplifier.....	108
		Experiments with Transmitter Buttons.....	112
		The Listeners' Accessory Guide.....	116

### RADIO LISTENERS' GUIDE AND CALL BOOK

VOL. II, No. 2

SEPTEMBER, 1927

Published quarterly by The Consrad Co., Inc., 230 Fifth Ave., New York, N. Y., telephone number Ashland 9344; H. Gernsback, President; S. Gernsback, Vice-President and Treasurer; R. W. De Mott, Secretary. Price 50c a copy; subscriptions \$1.75 a year in the United States of America, Canada and all countries within the domestic postal zone; elsewhere \$2.00 a year, payable in advance. Subscriptions only acceptable in U. S. currency or stamps. No foreign currency or stamps. Checks and money orders should be drawn to the order of THE CONSRAD CO., Inc.

When subscribing to RADIO LISTENERS' GUIDE AND CALL BOOK send your name and remittance to The Consrad Company, Inc., 230 Fifth Ave., New York, N. Y. Mention that you desire to subscribe to RADIO LISTENERS' GUIDE AND CALL BOOK. We also publish and distribute CONSRAD PATTERNS, E. I. COMPANY BOOKS, etc. Write clearly.

Entered as second class matter, March 10, 1925, at the Post Office at New York, N. Y. under the Act of March 3, 1879.

Copyrighted, 1927, by The Consrad Co., Inc., N. Y.

Printed in U. S. A.

Published by the Same Management:  
RADIO NEWS — SCIENCE AND INVENTION — AMAZING STORIES  
FRENCH HUMOR — SPARE-TIME MONEY MAKING

General Advertising Dept., 230 Fifth Ave., New York City

#### ADVERTISING REPRESENTATIVES

S. B. Darmstader, 326 W. Madison St., Chicago, Ill.  
Davies, Dillon & Kelly, 15 West 10th St., Kansas City, Mo.  
T. F. Magrane, Park Square Bldg., Boston, Mass.  
A. J. Norris Hill, Leary Bldg., Seattle, Wash.

Roy Buell, Donovan Bldg., Detroit, Mich.  
Harry E. Hyde, 548 Drexel Bldg., Philadelphia, Pa.  
A. J. Norris Hill Co., 5 Third St., San Francisco, Calif.  
412 West 6th St., Los Angeles, Calif.

**"AMPERITE"**  
Watch Dog  
of your  
Tubes

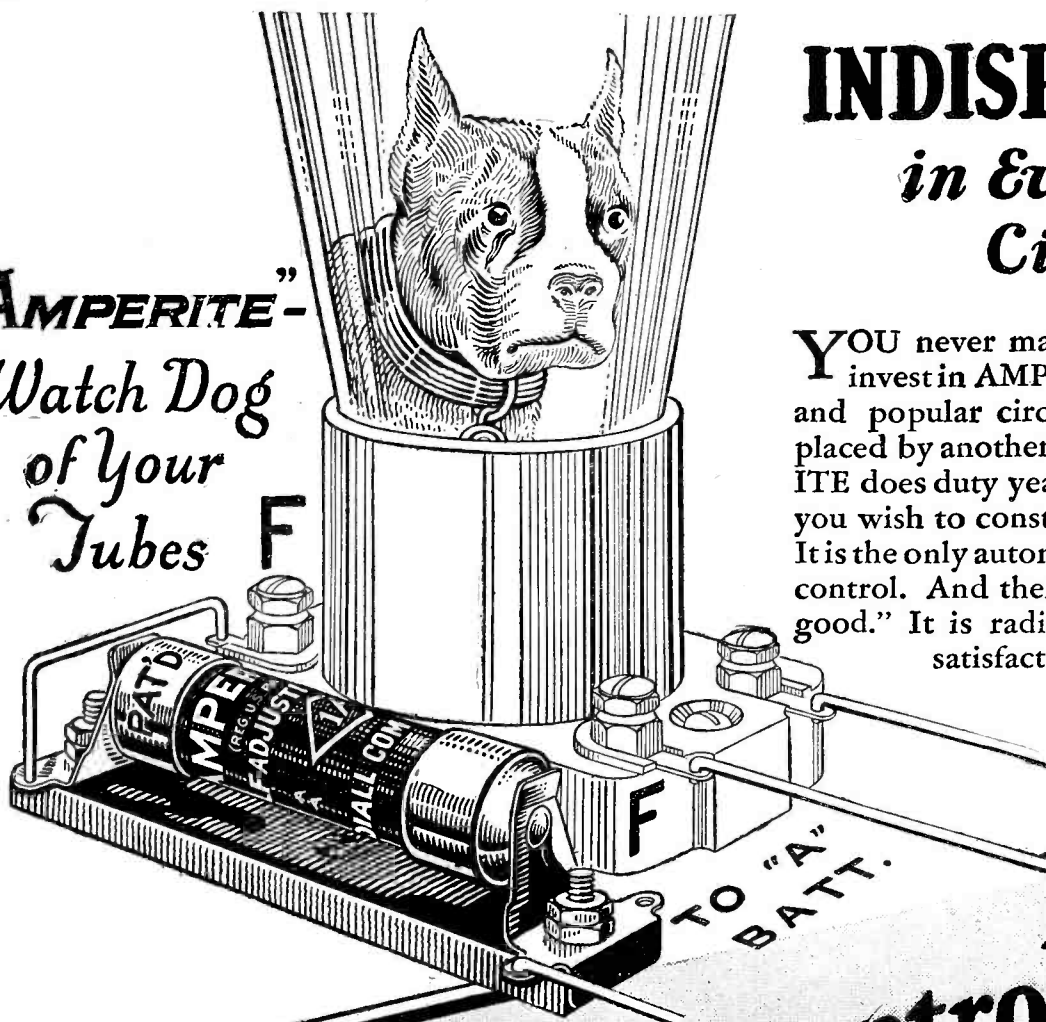

# INDISPENSABLE! in Every Radio Circuit

**Y**OU never make a mistake when you invest in AMPERITES. The most clever and popular circuit of today may be replaced by another tomorrow. But AMPERITE does duty year after year in any circuit you wish to construct. It never wears out. It is the only automatic self-variable filament control. And there is nothing else "just as good." It is radio's most permanent and satisfactory investment.

**solves the tube control problem**

**Obsolete**

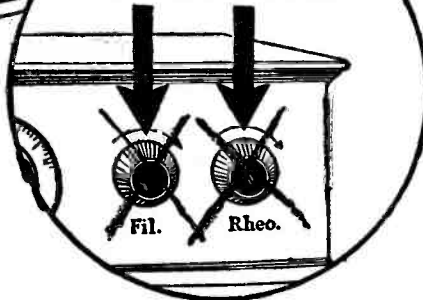

**Season's Best  
Hook-ups FREE**

Write today for new "AMPERITE Book" just off press. A veritable jewel for last minute information on the season's most popular hook-ups and construction data. Address Dept. R R 4

AMPERITE simplifies wiring and operation. Insures just the proper filament current for each and every tube. Does away with all hand rheostats on the panel. Precludes tube damage from under or excessive "A" current—resulting in both increased tube life and at all times maximum tube performance.

If you want AMPERITE performance you must insist upon AMPERITE. Nothing else will do. More essential than ever if you use a battery eliminator or trickle charger. Types for every tube. Sold everywhere. Price complete with mounting \$1.10 (In U. S. A.).

*Specified  
in the*

Hi-Q  
Strobodyne  
Magnaformer  
Browning-Drake  
Equamatic  
Lincoln Quality  
Camfield Super  
Infradyne  
Ultra 5  
Citizens Super 9  
Bodine Twin 8  
Lodge N Circuit  
L C-27  
DX Special  
Super-Sensitive 5  
Planofier 7  
Find-All-5 and 6

*and all other  
GOOD Circuits*

*Radiall Company*  
50 FRANKLIN ST. NEW YORK



# AMPERITE

REG. U. S. PAT. OFF.

**The "SELF-ADJUSTING" Rheostat**

# INDEX TO ADVERTISERS

A	Page	E	Page	K	Page	S	Page
Acme Wire Co.	134	Eby Mfg. Co., H. H.	174	K-T Products Co.	142	Radio Institute of America	120
Aero Products, Inc.	133, 143	Electrad, Inc.	166	Karas Electric Co.	130, 149	Radio Service Co.	175
Alden Mfg. Co.	122	Elliott Radio Corp.	5	Keystone Radio Lab.	170	Radio Specialty Co.	12
All Radio Co.	170	Emerson Radval Corp.	175	Kodel Radio Corp., The	123	Rowan Battery Supply Co., Walter	144
Allan Mfg. Co.	175	Engineers' Service Co.	122	Kurz-Kasch Co., The	132		
Alter Co., The Harry	156	Equitable Industries Ass'n.	164			<b>S</b>	
American Auto & Radio Mfg. Co.	144, 146, 166, 170, 172	Excello Products Co.	127	<b>L</b>		Scott, Mr. E. H.	8, 9
American Hard Rubber Co.	142	Experimenter Publishing Co. 128, 132, 134, 136, 148, 154	127	Lacault Radio Elec. Labs., R.E.	122	Setbuilders Supply Co.	141
American Mechanical Labs., Inc.	153			Lynch, Inc., Arthur H. Inside Front Cover		Shanklin Mfg. Co.	170
American Radio Hardware Co.	156	<b>F</b>				Shure Radio Co.	152, 154
Amco Products, Inc.	158	Fansteel Products Co., Inc.	6	<b>M</b>		Silver-Marshall, Inc.	125
Arco Electrical Corp.	151	Fast & Co., John E.	158	M & H Sporting Goods Co.	164	Smith, B. Hawley	142
Audel & Co., Theo.	174	Formica Insulation Co.	142	Madison Radio Corp.	124	Southern Toy Co., Inc.	150
Aviation Institute of U. S. A.	175	Freshman Co., Inc., Chas.	168	Martin-Copeland Co.	136	Steinite Radio Co.	165
		Fritts & Co., D. H.	174	Metro Electric Co.	14, Back Cover	Sterling Mfg. Co., The	135
<b>B</b>				Midland Wholesale Co.	170	Straus & Schram	121
B. C. L. Radio Service Co., Inc.	168	<b>G</b>		Midwest Radio Corp.	117	Supertron Mfg. Co.	171
Barawik Co.	152	General Manufacturing Co.	157	Miniature Ship Models	145		
Benjamin Elec. Mfg. Co.	166	Graymore Radio Corp.	122	"Modern" Laboratories	162	<b>T</b>	
Birnback Radio Co.	167	Grigsby-Grunow-Hinds Co.	140	Muter Co., Leslie F.	126, 159	Telephone Maintenance Co.	160
Blackburn Specialty Co.	136					Thordarson Elec. Mfg. Co.	119
Bodine Electric Co.	157	<b>H</b>				Timing Gears Corp.	170
Braun Co., W. C.	176	Hamilton-Carr Corp.	11	<b>N</b>		Townsend Radio Labs.	172
Browning-Drake Corp.	168	Hammarlund Mfg. Co.	173	National Co., Inc.	130		
		Harco Co., The	148, 160	National Radio Institute	1	<b>V</b>	
<b>C</b>		Harkness, Inc., Kenneth	155			Van Doorn Co.	128
Camfield Radio Mfg. Co.	129	Havekost & Simonds	170	<b>P</b>			
Carter Radio Co.	4	High Frequency Labs.	147	Polachek, Z. H.	136	<b>W</b>	
Central Radio Labs.	118			Press Guild, Inc, The	10	Walker Co., Geo. W.	146
Chaslyn Co.	172	<b>I</b>				Ward Leonard Electric Co.	161
Chicago Salvage Stock Store	146	Independent Elec. Works	142	<b>Q</b>		Western Radio Mfg. Co.	163
Chicago Solder Co.	137	International Correspondence Schols	146	Q. R. S. Music Co., The	131	Westingale Electric Co.	166
Cloverleaf Mfg. Co. Inside Back Cover						White Co. Lab., J.	170
Continental Corp.	166	<b>J</b>		<b>R</b>		Wile, Eugene G.	144
		J-M-P Mfg. Co.	150	Radiall Co.	3		
<b>D</b>		Jacobs Mfg. Co., C. E.	148	Radiart Labs. Co.	166	<b>X</b>	
Deutschmann Co., Tobe	152	Jewell Electrical Instrument Co	7	Radio Association of America	13	X-L Radio Labs.	172
		Jones, Howard B.	154	Radio Equipment Co.	138		
				Radio Fundamental Co.	152	<b>Y</b>	
						Yahr-Lange, Inc.	144
						Yaxley Mfg. Co.	169

# CARTER PARTS

*Specified—as usual—in these circuits as described in  
Radio Listeners' Guide and Call Book*

- |                                      |                          |
|--------------------------------------|--------------------------|
| Lynch Suppressor Circuit             | Q. R. S. A B C Unit      |
| H.F.L. Nine-in-Line                  | World's Record Super Ten |
| Camfield Super-Selective Nine        |                          |
| 1927 Improved Laboratory Model Super |                          |

In these and in all the really popular circuits Carter parts are the unanimous choice of the country's leading engineers.

Tireless experimenting together with a complete and exact knowledge of what is expected of them have enabled Carter engineers to set the pace in their field.

*Carter reputation is your strongest guarantee.*

Have you seen the new Carter line of

- Fixed Condensers
- Resistances for "B" Eliminators
- Resistors for AC Tubes

- 110 Volt Power Switches
- Automatic Power Switches
- "IMP" Short Jack Switches

*The most complete line of up-to-date Radio Parts in the field*



Offices  
in principal  
cities of the  
world



In Canada:  
Carter Radio Co., Ltd.  
Toronto

**\$100  
DOWN**

**Brings You Either  
OF THESE SUPER "A" or "B"  
Eliminators**

**ELECTRIFY  
ANY SET  
No battery  
No charger  
No tubes  
No noise  
No hum**

**SUPER "A"  
ELIMINATOR**

**No More Storage Battery or Chargers —Takes the  
Place of Both—A Real "A" Eliminator**

Not a so-called power unit small capacity battery trickle charger and relay. Has large capacity rectifier, changing alternating lighting current to direct current. High average, heavy duty filter system with extremely high capacity condenser. Smooths out pulsating, direct current into constant, humless current. Brings better results than obtained from even a fully-charged storage battery. Can be used in connection with any good "B" eliminator for complete electrification.

**DEPENDABLE POWER**

Always ready at touch of switch. No complicated parts—just plug in to electric socket. Requires no adjustment. Delivers constant current at 6 volts regardless of line variations. Can be connected up in a few minutes—requires no changes in set or circuit. Simply attach filament to post and plug cord into light socket. Uses current only when set is in use. Does not deteriorate—needs no charging. Specially priced at \$31.50 to be paid in easy installments.



**\$31<sup>50</sup>**

**NOTHING TO WEAR OUT OR REPLACE—  
NO MOVING PARTS**

**SUPER  
"B" ELIMINATOR**

**Eliminate the Expense of Repurchasing "B" Bat-  
teries and Always Obtain Maximum Results  
From Your Set by a Steady Full-  
Voltage "B" Current Supply**

Complete with Raytheon tube, doing away with the "B" batteries and their troubles. Easily and instantly attached to any light socket. Delivers steady flow without hum, pulse or distortion. Built with heavy chokes, transformer and finest condenser in the filter circuits. Written guarantee for one year against mechanical and electric difficulties goes with each unit. The case is beautifully finished in olive green Duco-panel black etched in gold. Equipped with rubber covered cord and socket plug. High voltage taps and variable adjustments so that any new power tubes may be used. Variable adjustment delivers any desired detector voltage. Raytheon tube makes possible delivery of great current at high voltage. Will deliver up to 180 volts. Indefinite life because it has no filament to burn out. Complete instructions with each unit.

**UNBELIEVABLY LOW PRICE**

The "B" eliminator operates from the light socket 110 to 120 volts—50-60 cycle A. C.—output 6 volts direct current for all sets up to 12 tubes—NOW offered at the lowest price ever made. Only \$29.50 that can be paid for in easy installments. Simply sign the coupon today while this remarkable offer lasts.

**ELLIOTT RADIO CORPORATION  
709 West Lake Street Chicago, Ill.**

**NO MORE "B" BATTERIES  
OR RUN DOWN SETS**



**\$29<sup>50</sup>**

**QUICKLY AND EASILY INSTALLED**

**Mail This Coupon Now!**

ELLIOTT RADIO CORP.

709 West Lake Street, Dept. 63,  
Chicago, Illinois.

Attached find \$1.00 for which you agree to send me  
( ) "A" Eliminator @ \$31.50 { Check here whether "A"  
( ) "B" Eliminator @ \$29.50 { or "B" is desired. Send  
as described in your ad. Full particulars will be sent me by  
return mail and my money refunded if I do not accept your  
offer.

Name .....  
Address .....  
City ..... State .....

# Pioneering is important but performance is more so



**BALKITE "AB"** A complete unit, replacing both "A" and "B" batteries and supplying both "A" and "B" current from the light socket. Contains no battery in any form. Operates only while the set is in use. Turns on and off at the light switch. Two models. 135 volts "B" current, \$59.50. 180 volts, \$67.50.



**BALKITE "A"** Like Balkite "AB" above, but for the "A" circuit only. One of the most remarkable developments in radio. Price \$32.50.



**BALKITE "B"** Like Balkite "AB" above, but for the "B" circuit only. The accepted "B" power supply. Has probably the longest life of any device in radio. Three models at remarkably low prices. 90 volts, \$22.50. 135 volts, \$32.50. 180 volts, \$39.50.



**BALKITE CHARGER** The standard battery charger for radio "A" batteries. Noiseless. Can be used during reception. Three models, all trickle chargers. Prices, \$17.50, \$9.50, \$7.50.

*Prices are slightly higher West of the Rockies and in Canada.*

Most of the great improvements in radio power have been made by Balkite. First noiseless battery charging. Then successful light socket "B" power. Then trickle charging. And today, most important of all, Balkite "AB," a complete unit containing no battery in any form, supplying both "A" and "B" power directly from the light socket, and operating only while the set is in use.

Important as this pioneering has been, yet it has not been the most important factor in making Balkite the leader. The real factor has been Balkite performance in the hands of its owners. With 2,000,000 units in the field Balkite has a record of long life and freedom from trouble seldom equalled in any industry. The first Balkite "B," purchased 5 years ago is still in use and will be for years to come. To your radio dealer Balkite is a synonym for quality. The electrolytic rectification developed and used by Balkite is so reliable that today it is standard on the signal systems of most of the railroads of the country. These facts have made Balkite one of the best-known names in radio.

Today, whatever type of set you own, whatever type of power equipment you want, Balkite has it. And production is so enormous that prices are astonishingly low. Balkite today costs no more than ordinary equipment. Your dealer will recommend the particular equipment you need for your set.

FANSTEEL PRODUCTS COMPANY, Inc.  
North Chicago, Illinois

FANSTEEL  
**Balkite**  
*Radio Power Units*





JEWELL



INSTRUMENTS

# Good Instruments— —Better Radio



Pattern No. 135-B—Double scale, panel mounting voltmeter

The use of good instruments in connection with your radio testing and checking is certain to improve reception.

Jewell instruments are good instruments. Their widespread use among amateurs and set builders, and by broadcast stations, testify to their quality. Panel mounting and portable instruments are available in such styles and ranges as to practically give the set owner his own choice of scale readings.

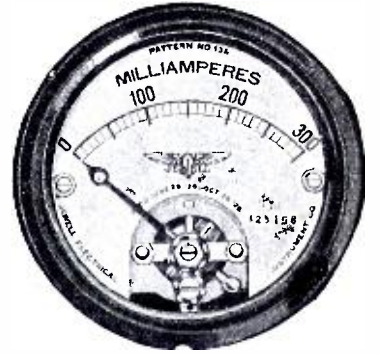

Pattern No. 135—Milliammeter. Matches Pattern No. 135-B in size and appearance

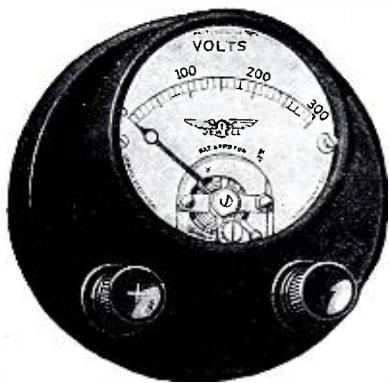

Pattern No. 139—High resistance voltmeter for the set owner

Pattern No. 135-B.—The perfect radio voltmeter for panel mounting, 0-7.5-150 volts, covers all ordinary requirements for A and B battery checking. A handy switch allows an instant change from one range to the other.

Pattern No. 135.—Milliammeter matches Pattern No. 135-B in size and appearance. Used with Pattern 135-B gives the most complete indication of set conditions. To be used in the grid or plate circuit to show current flowing.

Pattern No. 139.—A high resistance voltmeter for the set owner for use in checking and adjusting B-eliminator voltages. Highly accurate but priced low.

Pattern No. 57.—A portable voltmeter suitable for testing battery and filament voltages and for testing currents. This instrument is a great favorite among set owners.

Pattern No. 107.—Junior Tube Checker for testing tubes at home. It helps the set owner to keep only the best radio tubes in his set. It gives tube characteristics under actual operating conditions.

Pattern No. 135-C 0-7.5-150 volts. This is the most beautiful portable voltmeter on the market. It tests batteries, circuits and filament voltages. It is a most desirable instrument for radio use.



Pattern No. 107—Jr. tube checker for testing tubes at home



Pattern No. 57—Double scale voltmeter for set testing or battery checking

Write for a copy of our Radio Instrument Catalog No. 15-C which describes all Jewell Radio Instruments in detail.

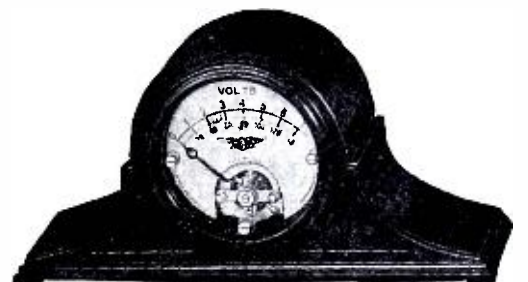

Pattern No. 135-C—A beautiful portable double scale voltmeter for filament adjustment.

## Jewell Electrical Instrument Co.

1650 Walnut St. - Chicago

"27 Years Making Good Instruments"

# Build Radio's New

Mr. E. H. Scott, himself, will tell you how he designed the original DX receiver, with which he made the four World's Records described on the opposite page—how that set has been duplicated hundreds of times, each one performing as well as the original—how later developments and refinements have enabled him to improve on the original in the New World's Record Super 10—and how you can, even without any previous experience, build a World's Record Super 10 for yourself.

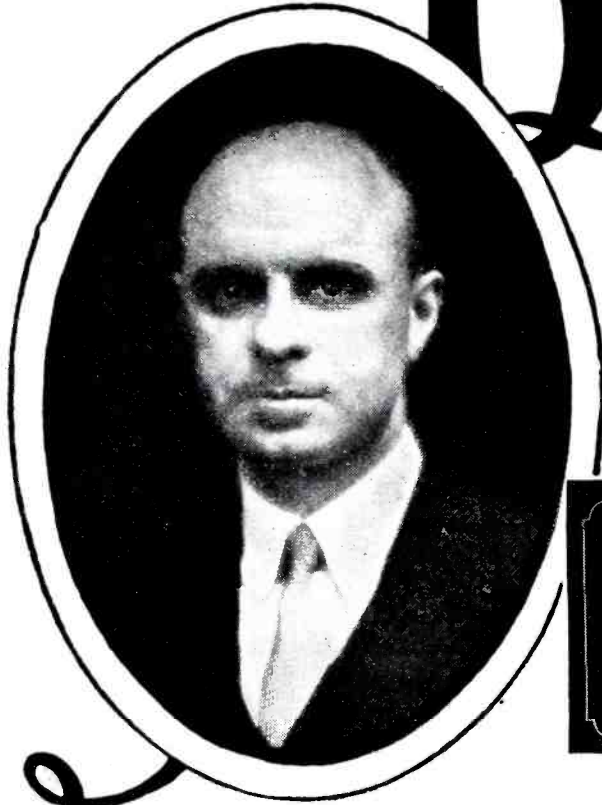
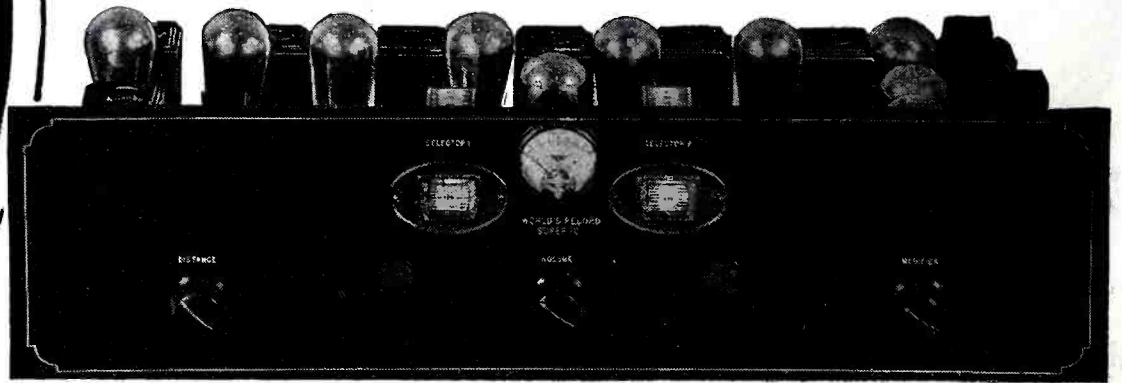

**DISTANCE**—Here is the receiver for the man who wants the most powerful and sensitive set it is possible to build. Many claim to have received far distant stations once or twice, but Mr. Scott with his World's Record Super proved his claims to record honors by bringing in consistently, night after night, stations distant six thousand miles or more. The new World's Record Super 10, in actual comparative tests with the original receiver on which the records were made, has proved that it is even more powerful and brings in the far distant stations with almost unbelievable volume.

No other receiver has approached the marvelous DX records that the World's Record Super has established, and it is safe to say none will for years to come.

**REMARKABLE SELECTIVITY**—Here is a receiver for today's conditions. In Chicago, where there are about forty broadcasting stations, the New World's Record Super 10 cuts through with the greatest of ease. It brings in distant stations only a few meters apart with such volume that you think you have a local station until you hear the call letters and find you are listening to a station hundreds of miles away.

**NATURAL TONE QUALITY**—A receiver may have great DX ability and wonderful selectivity, but what good is it if the tone is raspy or distorted? When you hear the New World's Record Super 10, you will

realize that here at last is a receiver that it is a pleasure to listen to.

**EASY TO BUILD**—With the parts here listed, any one can build an exact duplicate of the New World's Record Super 10. The only tools required are a screw driver, pliers, and soldering iron. The building instructions and full size blue prints show exactly where to place each part and how to run every connection, and are so simple and easy to follow that any one, even without previous experience in building a radio receiver, can duplicate this marvelous receiver and own the finest radio set available today.

## — LIST OF PARTS —

1 Formica panel drilled and engraved 26x7x <sup>3</sup> / <sub>16</sub>	\$ 6.70	10 Benjamin sockets No. 9044	5.00
1 Formica sub panel drilled 25x10x <sup>3</sup> / <sub>16</sub>	7.00	1 pr. Benjamin brackets No. 8629	.75
1 Remler 3-in-line condenser No. 633 00035	15.00	1 Carter Imp. rheostat 1R-15S ohms	1.50
1 Remler condenser No. 638 00035	5.00	1 S. M. balancing condenser No. 340	1.50
2 Remler drum dials No. 110	9.00	1 Carter power rheostat MW-1 ohm	.75
2 Remler R. F. choke coils No. 35	1.80	1 Carter Imp. pot. 1R-400 ohms	1.25
2 Thordarson audio transformers R200	16.00	1 Carter fixed condenser 00025 with grid clips	.50
1 Thordarson output transformer No. 76	6.00	1 Carter fixed condenser 002	.50
2 Selectone L. W. transformers No. B500	12.00	1 pr. No. 10 Carter pin jacks	.20
2 Selectone L. W. transformers No. B510	12.00	1 Jewel Voltmeter 0.8v Pat. 135	7.00
2 Selectone R. F. transformers No. 520	10.00	4 Tobe Bypass condensers 1 Mfd	3.60
1 Selectone Antenna coupler No. 530	5.00	1 Tobe grid leak	.50
1 Selectone Oscillator coupler No. 540	5.00	1 Jones 10 contact multi-plug and 4 ft. cable type BM	3.50
		40 Kellogg soldering lugs	.25
		30 ft. rubber covered hook-up wire	.50

Here's your chance to build a radio set that will give you all that radio has to give—distance, selectivity, clear and natural tone. Experience is not required, for full instructions will be sent you by Mr. Scott himself. Don't hesitate—don't delay. Send *now* for full details. Then you can't forget it, and you'll never regret it.

# Greatest DX Receiver

## World's Record Super 10

### Here Are the Verified Records

The authenticity of the startling achievements of the World's Record Super (as listed below) is based upon hundreds of verifications by leading Broadcasting Stations and Publications from Coast to Coast.

- 1** On March 17th established new World's Record for *loop aerial reception*—8,375 miles with Loud Speaker Volume.
- 2** On the night of March 29th established new World's Record with the reception of *six foreign stations* distant 6,000 miles or more.
- 3** Established new World's Record for *greatest number of broadcasting stations* heard that are located 6,000 or more miles away.
- 4** Established new World's Record for *most consistent reception*, night after night, of Stations 6,000 miles or more distant—117 programmes from 19 different Foreign Stations, heard between December 27th and April 10th.

**Selectone Transformers** cut through the local stations with ease, and their tremendous amplification brings in the distant stations with great volume. They are supplied in perfectly matched sets, insuring maximum amplification and the finest tone quality.

**The new Remler Three-in-Line Condenser** with the Remler Drum Dial represents the last word in gang condenser construction. Balancing condensers are integral with the main unit, and are easily and quickly adjusted. A special staggered connection of plates makes it self-shielding, preventing interstage coupling. All insulation is of genuine Bakelite.

**Thordarson Amplifying Transformers** were used in the original World's Record Super, designed by Mr. Scott. Because of the unusual tone quality obtained Thordarson apparatus is again selected. Two Thordarson R-200 Amplifying Transformers and one R-76 Output Transformer are used in this receiver. If you enjoy good music, insist on Thordarson amplification.

**The famous Benjamin Spring Cushioned Shock Absorbing Socket** was the choice of Mr. E. H. Scott in his original World's Record Super.

Mr. Scott has paid the very highest tribute to the efficiency of Benjamin Shock Absorbing Sockets by again selecting them for this newest and greatest of radio receivers.

**Tobe Condensers.** Only the highest grade parts were selected by Mr. Scott for the World's Record Super 10, and the fact that Tobe parts are specified is one more proof of their claim for leadership in the condenser field.

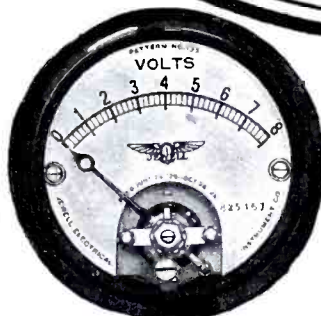
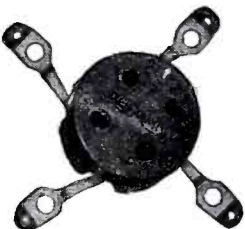
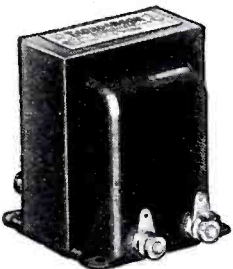
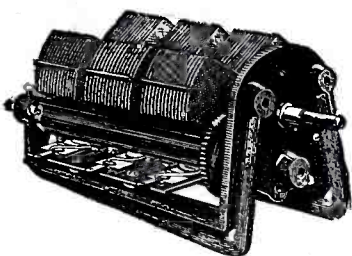
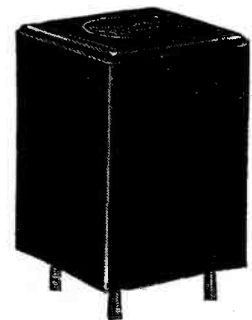

Half Size

In the careful selection of parts and accessories for the New World's Record Super 10, it is quite natural that a Jewell Pattern No. 135 Radio Voltmeter should be chosen. The black enameled case encloses a fine, D'Arsonval, moving coil type movement having silvered parts and equipped with a zero adjuster. The scale is silver etched with black characters. A special mounting arrangement makes it easy to mount in a radio panel. It is the ideal instrument for filament control.

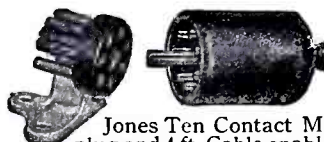

Jones Ten Contact Multi-plug and 4 ft. Cable enable all batteries to be placed out of sight and simplify wiring. Now used on over one million receivers; endorsed by leading radio engineers.

**Carter Rheostats** are so designed that they are self-cooling and contact arm shaped so that it provides smooth contact with constant pressure at all times, making control of filaments noiseless.

Send Coupon for Full Details

MR. E. H. SCOTT,  
7620 Eastlake Terrace,  
Chicago, Ill.  
Without obligation, please send me details of  
the World's Records you made with your  
Super 9, and full instructions for build-  
ing your NEW World's Record  
Super 10.  
Name.....  
Address.....



# Some Practical Experiments with a miniature unit of a thousand uses

## The SKINDERVIKEN TRANSMITTER BUTTON

### Loud Speaker Operating Crystal Receiver

Operate loud speaker with no tubes, batteries or eliminators. SKINDERVIKEN BUTTON provides additional power.

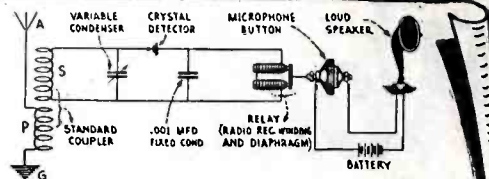

### Radio Amplifier and Grid Leak

Improve your Radio Set, add Amplification in any quantity with these Units—also used as Grid leaks.

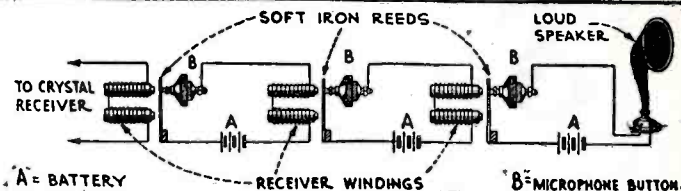

### Detectaphone

The Unit makes a real, practical listening outfit, sensitive, efficient, simple to make. Attaches to wall. Plenty of fun and real detective work.

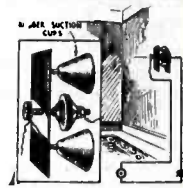

### Phonograph Amplifier

Want to give your phonograph new pep—and greater volume? SKINDERVIKEN UNITS bring the old machine to life—try one—and be surprised.

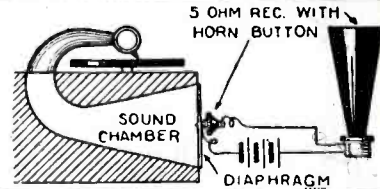

### Stethoscope

The stethoscope, the wonder of modern medical instruments, can be made at home. Hear real heart beats. Apparatus simple and costs only a few cents.

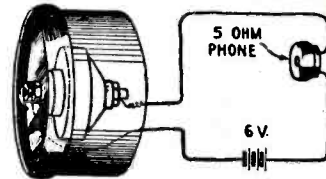

### Telephone Amplifier

Build a home telephone—Talk from room to room or house to house—These units make a genuine, clear transmitting apparatus.



### Loud Speaker Amplifier

Double the volume of your Radio Loud Speaker with a SKINDERVIKEN BUTTON—or amplify speaker's voice through horns at outdoor gatherings.

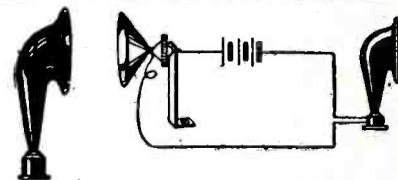

### Underwater Sound Detector

SKINDERVIKEN BUTTON with a few simple parts makes great underwater sound detector—same principle as that used during World War to detect submarines.

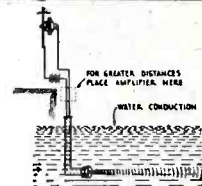

### Electrical Experiments

Make talking lights and many marvelous electrical experiments with these units. Experimenters can develop many more valuable uses.

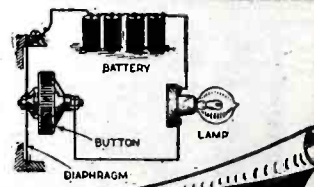

**95<sup>c</sup> Per Unit**  
**TWO FOR \$1.75**  
 PRESS GUILD, INC.  
 16 E. 30th St., N. Y.

**FREE**  
 8 page circular  
 fully explaining  
 these and many  
 other uses for these  
 units sent with  
 every order

PRESS GUILD, INC.  
 16 E. 30th St., New York.

Gentlemen: I enclose \$..... for.....  
 SKINDERVIKEN BUTTONS as advertised.

Name .....

Address .....

City ..... State .....

# Radio Dealers

## Get This Valuable 1928 Catalog FREE

The new 136-Page Colored and Illustrated 1928 Hamilton-Carr **Wholesale Radio Catalog** is ready. It has been carefully compiled after an exhaustive study of all radio sets and radio accessories on the market or to be introduced. We have examined these sets, accessories and parts and tested them in our own laboratories and know their value. You can be sure that you will find in this complete new catalog an accurate and reliable illustration and listing of everything pertaining to radio.

### ALL THE CALL BOOK KITS

We show the latest Radio Listeners' Guide Kits, including complete Parts for the following at the best dealers' prices:

Tyrman Ten, Karas 2-Dial Equamatic, Improved Infradyne, Best's 45 K. C. Super, Citizen's Super, Camfield Duoformer 7, Scott's World Record Ten, Camfield Super 9, Bodine Electric, Aero Seven, Aerodyne, Improved 9-in-Line, Hot Spot 14, Magnaformer-9-8, Best Lincoln 8, Silver Shielded Super, S.M. Unipac.



### All Electric Radio Sets

This year electric (socket-power) radio receivers are very popular. The demand for them is constantly on the increase. In the Hamilton-Carr catalog you will find a complete showing of six, seven and eight-tube electric and non-electric sets. And you can be sure that both are of the finest quality—sure to deliver satisfaction. Easy to sell on demonstration. Styles of receivers in both table models and console models have been made to meet all requirements.

### Nationally Advertised Accessories

All the fast-selling, nationally advertised accessories, parts and kits are shown in the new Hamilton-Carr Catalog. Many of these are advertised in this magazine now or have been in the past. All the recognized successful methods of converting old sets into electric sets are explained.

### "A" and "B" Eliminators

The success and sale of "A" and "B" **Eliminators** is unquestioned. There is always a call for them. This new catalog shows all the latest improved models at **astorishingly big discounts**. You will want to stock them at once for immediate sales. You can win hundreds of customers with these great values.

### Thousands of Other Amazing Values

Get this new catalog today and keep it handy. You will find in it everything you want in radio, including all new types of loud speakers and chargers. During the last few months cabinet and console designers have created many beautiful new models. All of these are shown.

### Hamilton-Carr Service to Dealers

The Hamilton-Carr Radio Corporation is not new. They pioneered in the radio business and have devoted all their efforts exclusively to radio and bettering their service to dealers. The thousands and thousands of dealers now doing business with Hamilton-Carr show how successful we have been. We have perfected our organization in every department. Orders received are shipped when they are wanted without fail. We unconditionally stand back of all merchandise bought from us whether of our manufacture or not.

### Write for the New Catalog Today

Of course, you want this new Hamilton-Carr Catalog. Write for it today on your letterhead. Silver-Marshall Kits and Parts in stock. It is new from start to finish—and packed full of the greatest values ever offered. **Write now while it is fresh in your mind.**

## HAMILTON-CARR RADIO CORP.

711 West Lake Street Dept. 64 Chicago, Illinois

# WHOLESALE PRICES

--- For Dealers, Community Set Builders, General Repairmen and Agents ---

WE have just issued a new catalog with net prices to the radio trade. This company is Radio's oldest radio parts mail order house, and the new confidential discounts on standard Radio Merchandise are given only for resale purposes. We are ready now to appoint several thousand additional radio dealers and radio agents all over the country, so if you are contemplating going into the radio business, be sure to get in touch with us at once.

IN SENDING IN YOUR COMMUNICATION TO US, BE SURE TO USE YOUR LETTERHEAD.

In case you are not entitled to whole sale prices, address your request for our No. 17 Catalog to our Retail Department, and note that our retail prices are considerably less than current radio prices and less than those of most radio mail order supply houses.

—and don't forget, on practically all retail orders—we pay all transportation!

**1927**  
Edition

No. 17

500  
Illustrations

**NEW**

Enlarged  
Edition



**THIS  
100 PAGE  
RADIO  
CATALOGUE  
FREE**

**75 HOOKUPS**



**BUY!!**

from Radio's Oldest  
Mail Order House

WE are the oldest established, exclusive radio mail order house in the country. Our motto is "Quick Shipment." All orders are shipped within 24 hours. Quick, prompt, courteous service. We carry a larger variety of radio parts and findings than any other radio house in the country.

**"RASCO HAS IT"**

If you are in need of certain small radio parts that other radio and mail order houses do not bother to carry, get the Rasco parts catalog and you will find them there, anything from a screw to copper ribbon and telephone diaphragms, as well as thousands of other small radio findings. Just to mention a few:

Lugs, nuts, dials, vernier dials, jacks, plugs, every kind of knob, cords, panels, screws, sliders, washers, selenium, tinfoil, switches, crystals, cap nuts, Litz wire, cord tips, brass rods, resistances, name plates, spring binding posts, switch parts, metal ribbon, carbon balls, binding posts, all types, switch points, switch levers, lock washers, carbon grains, ground clamps, metal pointers, insulated tubing, low melting metal, antenna connectors, bus bar wire, as well as thousands of other articles.

We carry the Largest Variety of Small Radio Parts in the World. BUT We also carry ALL standard radio merchandise. ANYTHING IN RADIO

**RADIO SPECIALTY CO.**

102W PARK PLACE  
NEW YORK CITY, N. Y.

# CASH IN ON RADIO Now



**BUILD SETS FOR  
YOUR NEIGHBORS**



**HELP YOUR  
DEALER**



**ACT AS A  
RADIO  
DOCTOR**

## EARN \$75<sup>00</sup> a Week in your spare time

**Follow the Example of Thousands—Join the Radio Association—Learn Radio—  
Take Advantage of its Big-Pay Opportunities**

**THE RADIO ASSOCIATION OF AMERICA** will help you make money in Radio, full or part-time. It will teach you how to build and repair sets; start you in business, if you wish.

**Earned \$500 in Spare Hours**

Hundreds of members earn \$3 an hour serving their communities as "radio doctors." Member Lyle Follick, Lansing, Mich., has already made \$500 in his spare time. Member Werner Eichler, Rochester, N. Y., is earning \$50 a week. Member F. J. Buckley, Sedalia, Mo., is earning as much money in his spare time as he receives from his employer.

The Association will train you to be a "radio doctor" and to build sets "tailored" to your neighborhood needs, that you can sell for less than the "ready-made" sets offered by your local dealers.

**We Will Start You in Business**

If you prefer a business of your own to becoming a Radio Engineer, our co-operative plan will start you in a business of your own without capital.

This plan gives the ambitious man his opportunity to establish himself in his community.

Many have followed this plan and established radio stores.

**Doubled His Income in Two Months**

Member W. E. Thon, Chicago, was a clerk in a hardware store when he joined the Association. The training we gave him enabled him to secure the managership of the Radio Department of a large store at a 220% increased salary.

"I attribute my success entirely to the Radio Association," he writes. "Your method of instruction is wonderful." Membership in the Association has increased the salaries of innumerable men. Some turned their extra hours into cash being "radio doctors" for their neighbors; others by accepting employment with neighborhood radio dealers. Scores of our members are now connected with big radio organizations in different capacities. Others are proprietors of prosperous stores.

**From Clerk to Owner**

"In 1922 I was a clerk," writes Member K. O. Benzing, McGregor, Ia., "when I enrolled. Since then I have built hundreds of sets—from 1-tube Regenerative to Superheterodynes.

"I am now operating my own store and my income is 400% greater than when I joined the Association. My entire success is due to the splendid help you have given me."

**Membership Privileges**

If interested in Radio as a profession or a profitable hobby, join the Association. You will receive a comprehensive and practical training in Radio that will fit you for Radio's big-pay opportunities.

You will have the benefit of proven business-building plans. Our Employment Service will be at your disposal. You will have the privilege of buying radio parts at wholesale. You will have the Association behind you in carrying out your ambitions.

**ACT NOW—If You Want the No-Cost Membership Plan**

Now is the time for you to join. The success of the Association was so tremendous during 1926 that we are still able to offer a limited number of Memberships that may not—need not—cost you a cent. To secure one of them, write today without fail. We will send you details and also our book, "Your Opportunity in the Radio Industry," that will open your eyes to the possibilities in Radio for you. Let us hear from you at once.

**RADIO ASSOCIATION OF AMERICA**  
4513 Ravenswood Avenue  
Chicago, Ill. Dept. RR-9

Gentlemen:

Please send me by return mail full details of your Special Membership Plan and also a copy of your book, "Your Opportunity in the Radio Industry."

Name .....

Address .....

City ..... State .....

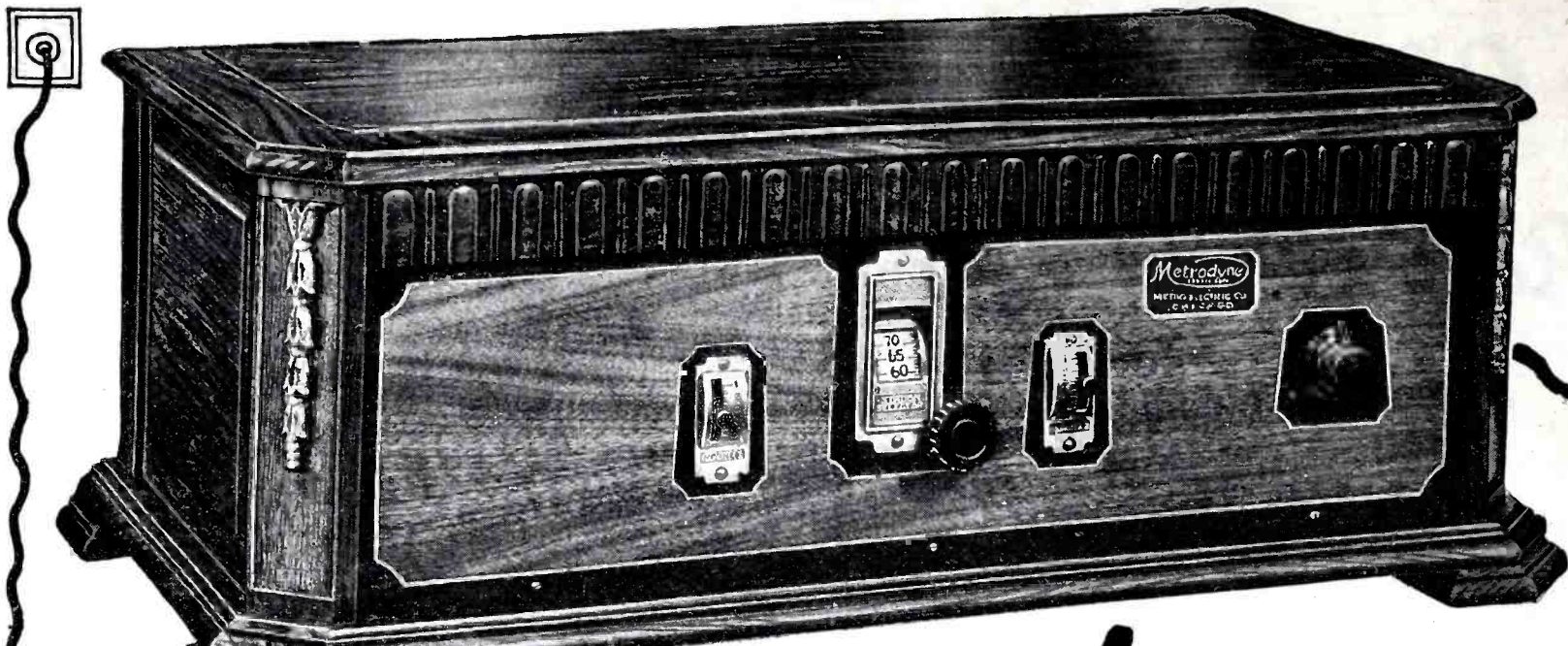

**30 Days Free Trial**

**Now! A Real Electric Radio Set**

**Three Year Guarantee**  
 Shipped direct from our factory at rock bottom prices—cost less than most battery sets

**No Batteries, Chargers or Eliminators**  
 No Acids; No Liquids—Plug In—Press Button—“Tune In”

**Metrodyne**  
**ALL ELECTRIC RADIO**

**AGENTS! DEALERS! BIG PROFITS!**

Make big money taking orders for Metrodynes. All or part time. Metrodyne All Electric Radios are in a class by themselves. Unequalled for quality, performance and price. Demonstrate at home and take orders. Lowest wholesale prices. Your demonstrating set on 30 days' free trial. Mail coupon below for details.

**7 Tubes—Single Dial Set**

**100% Electric Radio**

**BEAUTY—EFFICIENCY DEPENDABILITY**

At last! The radio you've dreamed about! If you have electricity in your home you can now really enjoy coast to coast radio reception without the care, bother and muss of batteries, chargers, eliminators, etc. The Metrodyne All Electric is a real, genuine batteryless radio set. Simply insert the plug in the socket, press the switch button and “tune in.” You could not possibly buy a better radio set than the Metrodyne All Electric, no matter what price you paid.

The Metrodyne All Electric Radio is a 7 tube, single dial set. Only the highest quality low loss parts are used throughout. Solid walnut cabinet, beautiful two-tone effect, with handsome gilt metal trimmings. Size of cabinet, 28 inches long, 13 inches deep, 10 inches high. Has electrically lighted dial so that you can log stations in the dark. Only one dial to tune in all stations. Excellent tone qualities—wonderful volume—very selective.

**Costs Less Than Most Battery Sets**

Do not confuse the Metrodyne electric radio with ordinary light socket sets, because the Metrodyne is truly an all electric radio—consumes less than 2c worth of power a day. Comes to you direct from the factory. Its low cost brings it down to the price of an ordinary battery set. We are so confident that you will be delighted with this wonderful, easy-to-operate batteryless radio that we offer to ship it to your home for thirty days' free trial—you to be the judge.

**Mail This Coupon**

We are one of the pioneers of radio. The success of Metrodyne sets is due to our liberal 30 days' free trial offer, which gives you the opportunity of trying before buying. Thousands of Metrodynes have been bought on our liberal free trial basis—**WRITE TODAY!**

**METRO ELECTRIC COMPANY**  
 2165 N. California Ave., Dept. 636  
 Chicago, Illinois

Gentlemen:  
 Send me full particulars about Metrodyne All Electric Radio and your thirty days' free trial offer.

Name.....

Address.....  
 If you are interested in AGENT'S proposition place an "X" in the square

**MAIL COUPON NOW!**

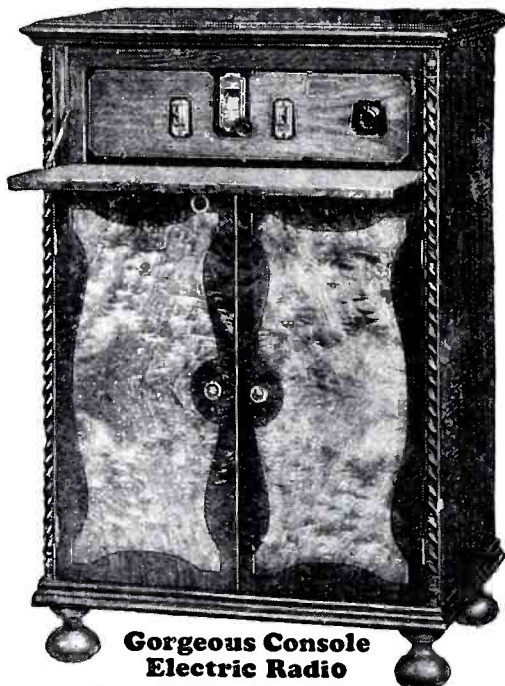

**Gorgeous Console Electric Radio**

Here is the Metrodyne All Electric Console Radio—a gorgeous, genuine walnut cabinet, in a beautiful two-tone finish. Has a built-in genuine Metro-Cone large size speaker. Brings in programs with great volume, reproducing the entire range from the lowest to the highest notes with remarkable clearness and distinction. All metal parts are finished in old gold. Wonderful electric radio, in a cabinet that will beautify the appearance of any home.

**METRO ELECTRIC COMPANY**

2165 N. California Ave. Dept. 636 Chicago, Illinois



# RADIO LISTENERS' GUIDE and CALL BOOK

*A Quarterly Magazine*

*Sidney Gernsback, Editor*      *W. G. Manly, Managing Editor*

## RADIO BROADCAST STATIONS OF THE UNITED STATES

Indexed Alphabetically by Call Letters

Radio Call Letters	BROADCAST STATIONS Location and Owner	Power Watts	Wave Length (Meters)	Frequency (Kilocycles)	Time at Station
<b>KD</b>	<b>KDKA—East Pittsburgh, Pa.—</b> Westinghouse Elec. & Mfg. Co.....	30000	315.6	950	Eastern
	<b>KDLR—Devils Lake, N. D.—</b> Radio Elec. Co.....	15	230.6	1300	Central
	<b>KDYL—Salt Lake City, Utah—</b> Intermountain Broadcasting Corp., 1009 Ezra Thompson Bldg.....	100	258.5	1160	Pacific
<b>KE</b>	<b>KELW—Burbank, Calif.—</b> E. L. White, 3702 Magnolia Ave. (Divides time with KPPC).....	250	228.9	1310	Pacific
	<b>KEX—Portland, Ore.—</b> Western Broadcasting Co. ....	2500	239.9	1250	Pacific
<b>KF</b>	<b>KFAB—Lincoln, Nebr.—</b> Nebraska Buick Auto Co. (5000 watts before 7 P. M.).....	2000	309.1	970	Central
	<b>KFAD—Phoenix, Ariz.—</b> Electrical Equipment Co.....	500	272.6	1100	Mountain
	<b>KFAU—Boise, Idaho—</b> Independent School, District of Boise (4000 watts Daytime).....	2000	285.5	1050	Mountain
	<b>KFBB—Havre, Mont.—</b> F. A. Buttrey Co.....	50	275.1	1090	Mountain
	<b>KFBC—San Diego, Calif.—</b> W. K. Azbill and Dr. A. W. Yale, 5038 Cliff Place.....	100	247.8	1210	Pacific
	<b>KFBK—Sacramento, Calif.—</b> Kimball Upson Co., 610 California St.....	100	535.4	560	Pacific
	<b>KFBL—Everett, Wash.—</b> Leese Bros., 2814 Rucker Ave.	100	223.7	1340	Pacific
	<b>KFBS—Trinidad, Colo.—</b> Trinidad High School.....	15	238	1260	Mountain
	<b>KFBU—Laramie, Wyo.—</b> St. Mathews Cathedral, Bishop N. S. Thomas.....	500	428.3	700	Mountain
	<b>KFCB—Phoenix, Ariz.—</b> Nielsen Radio Supply Co., 311 N. Central Ave.....	125	243.8	1230	Mountain
	<b>KFCR—Santa Barbara, Calif.—</b> Santa Barbara Broadcasting Co.....	50	211.1	1420	Pacific
	<b>KFDM—Beaumont, Tex.—</b> Magnolia Petroleum Co....	500	374.8	800	Central
	<b>KFDX—Shreveport, La.—</b> First Baptist Church.....	250	236.1	1270	Central
	<b>KFDY—Brookings, S. D.—</b> South Dakota State College.	500	394.5	760	Central
	<b>KFDZ—Minneapolis, Minn.—</b> H. O. Iverson, 2510 Thomas Ave., So.....	10	215.7	1390	Central
	<b>KFEC—Portland, Ore.—</b> Meier & Frank Co. (Divides time with KFIF).....	50	214.2	1400	Pacific
	<b>KFEL—Denver, Colo.—</b> Eugene P. O'Fallon, Argonaut Hotel.....	250	247.8	1210	Mountain
	<b>KFEQ—St. Joseph, Mo.—</b> Scroggin & Co. Bank.....	1000	230.6	1300	Central
	<b>KFEY—Kellogg, Idaho—</b> Bunker Hill & Sullivan Mining & Concentrating Co., 834 McKinley Ave.....	10	232.4	1290	Pacific

Radio Call Letters	BROADCAST STATIONS Location and Owner	Power Watts	Wave Length (Meters)	Frequency (Kilocycles)	Time at Station
<b>KF</b>	<b>KFGQ—Boone, Iowa—Boone Biblical College, 924 W. Second St.</b> .....	10	209.7	1430	Central
	<b>KFH—Wichita, Kans.—Rigby-Gray Hotel Co., Hotel Lassen</b> .....	500	245.8	1220	Central
	<b>KFHA—Gunnison, Colo.—Western State College of Colorado</b> .....	50	254.1	1180	Mountain
	<b>KFHL—Oskaloosa, Iowa—Penn College</b> .....	10	212.6	1410	Central
	<b>KFI—Los Angeles, Calif.—Earle C. Anthony, Inc., 1000 So. Hope St.</b> .....	5000	468.5	640	Pacific
	<b>KFIF—Portland, Ore.—Benson Polytechnic School (Divides time with KFEC)</b> .....	50	214.2	1400	Pacific
	<b>KFIO—Spokane, Wash.—North Central High School (Divides time with KFPY)</b> .....	100	245.8	1220	Pacific
	<b>KFIQ—Yakima, Wash.—Dr. I. M. Miller</b> .....	100	208.2	1440	Pacific
	<b>KFIZ—Fond du Lac, Wis.—Fond du Lac Commonwealth Reporter, 22 Forest Avenue</b> .....	100	267.7	1120	Central
	<b>KFJB—Marshalltown, Iowa—Marshalltown Elec. Co.</b> .....	15	247.8	1210	Central
	<b>KFJF—Oklahoma City, Okla.—National Radio Mfg. Co. (1000 watts Daytime)</b> .....	750	272.6	1100	Central
	<b>KFJI—Astoria, Ore.—Liberty Theatre (E. E. Marsh), (Divides time with KMED)</b> .....	15	249.9	1200	Pacific
	<b>KFJM—Grand Forks, N. Dak.—University of N. D.</b> .....	100	333.1	900	Central
	<b>KFJR—Portland, Ore.—Ashley C. Dixon &amp; Son, 1350 E. 36 St. (Divides time with KTBR)</b> .....	100	282.8	1060	Pacific
	<b>KFJY—Fort Dodge, Iowa—Tunwall Radio Co., 1004 Central</b> .....	100	239.9	1250	Central
	<b>KFJZ—Fort Worth, Tex.—W. E. Branch, 3rd and Main Sts.</b> .....	50	249.9	1200	Central
	<b>KFKA—Greeley, Colo.—Colorado State Teachers College</b> .....	200	399.8	750	Mountain
	<b>KFKB—Milford, Kans.—J. R. Brinkley, M. D. (2500 watts Daytime)</b> .....	1500	241.8	1240	Central
	<b>KFKU—Lawrence, Kans.—University of Kansas (Divides time with WREN)</b> .....	500	254.1	1180	Central
	<b>KFKZ—Kirksville, Mo.—State Teachers College</b> .....	15	225.4	1330	Central
	<b>KFLU—San Benito, Tex.—San Benito Radio Club</b> .....	15	236.1	1270	Central
	<b>KFLV—Rockford, Ill.—Swedish Evangelical Mission Church</b> .....	100	267.7	1120	Central
	<b>KFLX—Galveston, Tex.—Geo. R. Clough, 3327 Ave. P.</b> .....	100	270.1	1110	Central
	<b>KFMR—Sioux City, Iowa—Morningside College</b> .....	100	440.9	680	Central
	<b>KFMX—Northfield, Minn.—Carleton College (Divides time with WCAL)</b> .....	500	236.1	1270	Central
	<b>KFNF—Shenandoah, Iowa.—Henry Field Seed &amp; Nursery Co. (Divides time with KMA)</b> .....	1000	270.1	1110	Central
	<b>KFOA—Seattle, Wash.—Rhodes Dept. Store, 6144 Arcade Bldg.</b> .....	1000	447.5	670	Pacific
	<b>KFON—Long Beach, Calif.—Nichols &amp; Warriner, Inc., Jergins Trust Bldg.</b> .....	500	241.8	1240	Pacific
	<b>KFOR—Lincoln, Nebr.—Lincoln Hatchery</b> .....	100	217.3	1380	Central
	<b>KFOX—Omaha, Nebr.—Technical High School (Divides time with KOCH, WNAL)</b> .....	100	258.5	1160	Central
	<b>KFOY—St. Paul, Minn.—Beacon Radio Service, 376 Robert St.</b> .....	250	285.5	1050	Central
	<b>KFPL—Dublin, Tex.—C. C. Baxter, 205 Grafton St.</b> .....	15	275.1	1090	Central
	<b>KFPM—Greenville, Tex.—The New Furniture Co.</b> .....	15	230.6	1300	Central

Radio Call Letters	BROADCAST STATIONS Location and Owner	Power Watts	Wave Length (Meters)	Frequency (Kilocycles)	Time at Station
<b>KF</b> <b>KFPR</b>	Los Angeles, Calif.—Los Angeles County Forestry Dept. (Divides time with KFQZ).....	250	232.4	1290	Pacific
<b>KFPW</b>	Cartersville, Mo.—St. Johns M. E. Church....	50	263	1140	Central
<b>KFPY</b>	Spokane, Wash.—Symons Investment Co. (Divides time with KFIO).....	250	245.8	1220	Pacific
<b>KFOA</b>	St. Louis, Mo. (Transmitter in Kirkwood)—The Principia, 5539 Page Ave.....	50	322.4	930	Central
<b>KFOB</b>	Fort Worth, Tex.—Lone Star Broadcast Co., 205 Worth Bldg.....	1000	260.7	1150	Central
<b>KFQU</b>	Alma (Holy City), Cal.—W. E. Riker.....	100	249.9	1200	Pacific
<b>KFQW</b>	Seattle, Wash. (Transmitter in Wenatchee)—Carl F. Knierim.....	100	217.3	1380	Pacific
<b>KFOZ</b>	Hollywood, Calif.—Taft Radio & Broadcasting Co., Inc., 1641 N. Argyle (Divides time with KFPR).....	100	232.4	1290	Pacific
<b>KFRC</b>	San Francisco, Calif.—Don Lee, Inc. (1000 watts Daytime).....	500	454.3	660	Pacific
<b>KFRU</b>	Columbia, Mo.—Stephens College, Administration Bldg.....	500	249.9	1200	Central
<b>KFSD</b>	San Diego, Calif.—Airfan Radio Corp., 402 "B" St.....	1000	440.9	680	Pacific
<b>KFSG</b>	Los Angeles, Calif.—Echo Park Evangelistic Association, Angelus Temple.....	500	275.1	1090	Pacific
<b>KFUL</b>	Galveston Tex.—Thos. Groggan and Bros. Music Co., 2126 Market St.....	500	258.5	1160	Central
<b>KFUM</b>	Colorado Springs, Colo.—W. D. Corley, Ford Vollmer Bldg.....	100	236.1	1270	Mountain
<b>KFUO</b>	St. Louis, Mo.—Lutheran Church of the Missouri Synod, Concordia Theological Seminary (Divides time with KSD).....	500	545.1	550	Central
<b>KFUP</b>	Denver, Colo.—Fitzsimons General Hospital, Red Cross Bldg.....	100	227.1	1320	Mountain
<b>KFUR</b>	Ogden, Utah—Peery Building Co., 420—25 St.....	50	225.4	1330	Pacific
<b>KFUS</b>	Oakland, Calif.—Louis L. Sherman, 529—28 St. (Divides time with KRE).....	50	256.3	1170	Pacific
<b>KFUT</b>	Salt Lake City, Utah—University of Utah....	50	499.7	600	Pacific
<b>KFVD</b>	Venice, Calif.—McWhinnie Elec. Co., 1825 So. Pacific Ave. (Divides time with KGFJ).....	250	208.2	1440	Pacific
<b>KFVE</b>	St. Louis, Mo.—Benson Broadcasting Corp., Hotel Chase (2000 watts Daytime).....	1000	234.2	1280	Central
<b>KFVG</b>	Independence, Kans.—First Methodist Episcopal Church.....	50	225.4	1330	Central
<b>KFVI</b>	Houston, Tex.—Headquarters Troop 56th Cavalry.....	50	238	1260	Central
<b>KFVN</b>	Fairmont, Minn.—Carl E. Bagley.....	100	228.9	1310	Central
<b>KFVS</b>	Cape Girardeau, Mo.—Hirsch Battery & Radio Co., 312 S. Fred St.....	50	223.7	1340	Central
<b>KFWB</b>	Los Angeles, Calif.—Warner Bros. Pictures, Inc., 5842 Sunset Blvd.....	500	361.2	830	Pacific
<b>KFWC</b>	San Bernardino, Calif.—L. E. Wall.....	100	222.1	1350	Pacific
<b>KFWF</b>	St. Louis, Mo.—St. Louis Truth Center, 4030 Lindell Blvd.....	250	214.2	1400	Central
<b>KFWH</b>	Eureka, Calif.—F. Wellington Morse, Jr., Hotel Vance.....	100	254.1	1180	Pacific
<b>KFWI</b>	San Francisco, Calif. (Transmitter in So. San Francisco)—Radio Entertainments, Inc., 1400 Van Ness Ave.....	500	267.7	1120	Pacific
<b>KFWM</b>	Oakland, Calif.—Oakland Educational Society, 1520—8 Ave., (1000 watts Daytime).....	500	236.1	1270	Pacific
<b>KFWO</b>	Avalon, Catalina Island, Calif.—Major Lawrence Mott, Signal Corps, U. S. Army.....	250	218.8	1370	Pacific
<b>KFXD</b>	Jerome, Utah—The Service Radio Co.....	15	204	1470	Mountain

Radio Call Letters	BROADCAST STATIONS Location and Owner	Power Watts	Wave Length (Meters)	Frequency (Kilocycles)	Time at Station
<b>KF</b>	<b>KFXF—Denver, Colo.—Pikes Peak Broadcasting Co., Brown Palace Hotel.....</b>	500	282.8	1060	Mountain
	<b>KFXH—El Paso, Tex.—Bledsoe Radio Co., 115 S. El Paso St.....</b>	100	241.8	1240	Central
	<b>KFXJ—Edgewater, Colo.—R. G. Howell.....</b>	15	215.7	1390	Mountain
	<b>KFXR—Oklahoma City, Okla.—Classen Film Finishing Co., 132½ W. Main St.....</b>	50	223.7	1340	Central
	<b>KFXY—Flagstaff, Ariz.—Mary M. Costigan, Orpheum Theatre.....</b>	25	205.4	1460	Mountain
	<b>KFYF—Oxnard, Calif.—Carl's Radio Den, 207—5th St.</b>	25	238	1260	Pacific
	<b>KFYR—Bismarck, N. D.—Hoskins Meyer, Inc., 200 4th St. (500 watts Daytime).....</b>	250	239.9	1250	Central
<b>KG</b>	<b>KGA—Spokane, Wash.—Northwest Radio Co., 325 Rowan Ave.....</b>	2000	260.7	1150	Pacific
	<b>KGAR—Tucson, Ariz.—Tucson Citizen, 80 So. Stone St.</b>	100	234.2	1280	Mountain
	<b>KGBS—Seattle, Wash.—A. C. Dailey, 844 E. 58 St....</b>	100	202.6	1480	Pacific
	<b>KGBX—St. Joseph, Mo.—Foster-Hall Tire Co., 1221 Fred Ave.....</b>	100	277.6	1080	Central
	<b>KGBY—Shelby, Nebr.—Dunning &amp; Taddiken.....</b>	50	202.6	1480	Central
	<b>KGBZ—York, Nebr.—Federal Live Stock Remedy Co., 303 West 5th St.....</b>	100	212.6	1410	Central
	<b>KGCA—Decorah, Iowa—Chas. W. Greenley.....</b>	10	247.8	1210	Central
	<b>KGCB—Oklahoma City, Okla.—Wallace Radio Inst., 105 W. 13 St. (Divides time with KGFG)....</b>	50	215.7	1390	Central
	<b>KGCG—Newark, Ark.—Moore Motor Co.....</b>	100	223.7	1340	Central
	<b>KGCH—Wayne, Nebr.—Wayne Hospital.....</b>	250	293.9	1020	Central
	<b>KGCI—San Antonio, Tex.—Liberto Radio Sales, 409 So. Flores St. (Divides time with KGRC)....</b>	15	220.4	1360	Central
	<b>KGCL—Seattle, Wash.—Louis Wasmer and Archie Taft, 609 Washington Blvd. (Divides time with KPCB).....</b>	50	230.6	1300	Pacific
	<b>KGCM—Concordia, Kans.—Concordia Broadcasting Co., 1117 So. Hill St.....</b>	50	208.2	1440	Central
	<b>KGCR—Brookings, S. D.—Cutler's Radio Broadcasting Service, Inc., 415 Main St.....</b>	15	208.2	1440	Central
	<b>KGCU—Mandan, N. D.—Mandan Radio Assoc.....</b>	100	208.2	1440	Central
	<b>KGCX—Vida, Mont.—First State Bank of Vida.....</b>	10	243.8	1230	Mountain
	<b>KGDA—Dell Rapids, S. D.—Home Auto Co. (Daytime only).....</b>	15	234.2	1280	Central
	<b>KGDE—Barrett, Minn.—Jaren Drug Co.....</b>	50	205.4	1460	Central
	<b>KGDJ—Cresco, Iowa—R. Rathert, 316—5th Ave.....</b>	10	202.6	1480	Central
	<b>KGDM—Stockton, Calif.—Victor G. Koping and E. F. Peffer, 42 S. California St.....</b>	10	217.3	1380	Pacific
	<b>KGDP—Pueblo, Colo.—Pueblo Council, Boy Scouts of America.....</b>	15	223.7	1340	Mountain
	<b>KGDR—San Antonio, Tex.—Radio Engineers Assoc...</b>	15	202.6	1480	Central
	<b>KGDW—Humboldt, Nebr.—Frank J. Rist.....</b>	100	206.8	1450	Central
	<b>KGDX—Shreveport, La.—Wm. Erwin Anthony.....</b>	250	212.6	1410	Central
	<b>KGDY—Oldham, S. D.—J. Albert Loesch.....</b>	15	206.8	1450	Central
	<b>KGEF—Los Angeles, Calif.—Trinity Methodist Church</b>	500	263	1140	Pacific
	<b>KGEH—Eugene, Ore.—Eugene Broadcasting Station...</b>	50	201.2	1490	Pacific
	<b>KGEK—Yuma, Colo.—Beehler Elec. Equipment Co., 109 W. Second Ave.....</b>	10	263	1140	Mountain
	<b>KGEN—El Centro, Calif.—E. R. Irely and F. M. Bowels</b>	15	225.4	1330	Pacific
	<b>KGEO—Grand Island, Nebr.—Raymond D. Chamber- lain, 116 N. Locust St.....</b>	100	205.4	1460	Central
	<b>KGEQ—Minneapolis, Minn.—Fred W. Herrmann, 920 Fifth Ave, N.....</b>	50	202.6	1480	Central

Radio Call Letters	BROADCAST STATIONS Location and Owner	Power Watts	Wave Length (Meters)	Frequency (Kilocycles)	Time at Station
<b>KG</b>	<b>KGEB</b> —Long Beach, Calif.—C. Merwin Dobyns, 435 Pine Ave. (Divides time with KRLO).....	100	215.7	1390	Pacific
	<b>KGES</b> —Central City, Nebr.—Central Radio Elec. Co....	10	204	1470	Central
	<b>KGEU</b> —Lower Lake, Calif.—I. W. Clement.....	50	227.1	1320	Pacific
	<b>KGEW</b> —Fort Morgan, Colo.—City of Fort Morgan....	10	218.8	1370	Mountain
	<b>KGEY</b> —Denver, Colo.—J. W. Dietz, 1631 California St.	15	201.2	1490	Mountain
	<b>KGEZ</b> —Kalispell, Mont.—Flathead Broadcasting Assoc.	100	205.4	1460	Mountain
	<b>KGFB</b> —Iowa City, Iowa—A. C. Dunckle.....	10	223.7	1340	Central
	<b>KGFF</b> —Alva, Okla.—Earl E. Hampshire.....	25	205.4	1460	Central
	<b>KGFG</b> —Oklahoma City, Okla.—Full Gospel Church (Divides time with KGCB).....	50	215.7	1390	Central
	<b>KGFH</b> —La Crescenta, Calif.—Frederick Robinson, Box 163 (Divides time with KMIC).....	250	223.7	1340	Pacific
	<b>KGFI</b> —San Angelo, Tex.—M. L. Eaves.....	15	220.4	1360	Central
	<b>KGFJ</b> —Los Angeles, Calif.—Ben S. McGlashan, 2333 W. 21st St. (Divides time with KFVD).....	100	208.2	1440	Pacific
	<b>KGFK</b> —Hallock, Minn.—Kittson County Enterprise..	50	223.7	1340	Central
	<b>KGFL</b> —Trinidad, Colo. (Transmitter in Paton, N. M.) —Trinidad Broadcasting Co., 219 W. Main St.	50	222.1	1350	Mountain
	<b>KGFM</b> —Yuba City, Calif.—Geo. W. Johnson, 336 Plumas St.....	15	211.1	1420	Pacific
	<b>KGFN</b> —Aneta, N. D.—Haraldson & Thingstad.....	15	199.9	1500	Central
	<b>KGFO</b> —Terre Haute, Ind.—Brandt Radio Power Co..	100	204	1470	Central
	<b>KGFP</b> —Mitchell, S. D.—Mitchell Broadcast Co., 113 W. 4th Ave.....	10	212.6	1410	Central
	<b>KGFW</b> —Ravenna, Nebr.—Otto F. Sothman, 318 Grand Ave.....	10	299.8	1000	Mountain
	<b>KGO</b> —Oakland, Calif.—General Elec. Co.....	5000	384.4	780	Pacific
	<b>KGRC</b> —San Antonio, Tex.—G. Roth & Co., 103 San Pedro Ave. (Divides time with KGCI).....	50	220.4	1360	Central
	<b>KGRS</b> —Amarillo, Tex.—Gish Radio Service, 108 E. 8 St.	150	243.8	1230	Central
	<b>KGTT</b> —San Francisco, Calif.—Glad Tidings Temple and Bible Inst.....	50	206.8	1450	Pacific
	<b>KGW</b> —Portland, Ore.—The Oregonian Pub. Co.....	1000	491.5	610	Pacific
	<b>KGY</b> —Lacey, Wash.—St. Martins College.....	50	243.8	1230	Pacific
<b>KH</b>	<b>KHJ</b> —Los Angeles, Calif.—The Times Mirror Co.....	500	405.2	740	Pacific
	<b>KHQ</b> —Spokane, Wash.—Louis Wasmer, Davenport Hotel.....	1000	370.2	810	Pacific
<b>KI</b>	<b>KICK</b> —Anita, Iowa—Atlantic Automobile Co.....	100	461.3	650	Central
<b>KJ</b>	<b>KJBS</b> —San Francisco, Calif.—Julius Brunton & Sons Co., 1380 Bush St.....	50	220.4	1360	Pacific
	<b>KJR</b> —Seattle, Wash.—Northwest Radio Service Co., 614 Terminal Sales Bldg.....	2500	348.6	860	Pacific
<b>KK</b>	<b>KKP</b> —Seattle, Wash.—City of Seattle, Harbor Dept....	15	265.3	1130	Pacific
<b>KL</b>	<b>KLDS</b> —Independence, Mo.—Reorganized Church of Jesus Christ of Latter Day Saints.....	1500	238	1260	Central
	<b>KLIT</b> —Portland, Ore.—Lewis I. Thompson, 475—21 St.	10	206.8	1450	Pacific
	<b>KLS</b> —Oakland, Calif.—Warner Bros. Radio Supplies Co., 2201 Telegraph Ave. (Divides time with KZM).....	250	245.8	1220	Pacific
	<b>KLX</b> —Oakland, Calif.—The Oakland Tribune.....	500	508.2	590	Pacific
	<b>KLZ</b> —Denver, Colo.—Reynolds Radio Co., 1534 Glenarm St.....	250	267.7	1120	Mountain
<b>KM</b>	<b>KMA</b> —Shenandoah, Iowa—May Seed & Nursery Co. (Divides time with KFNF).....	500	270.1	1110	Central
	<b>KMED</b> —Medford, Ore.—W. J. Virgin (Divides time with KFJI).....	50	249.9	1200	Pacific

Radio Call Letters	BROADCAST STATIONS Location and Owner	Power Watts	Wave Length (Meters)	Frequency (Kilocycles)	Time at Station
<b>KM</b>	<b>KMIC—Inglewood, Calif.</b> —J. R. Fouch, 217 Market St. (Divides time with KGFH).....	250	223.7	1340	Pacific
	<b>KMJ—Fresno, Calif.</b> —Fresno Bee.....	50	365.6	820	Pacific
	<b>KMMJ—Clay Center, Nebr.</b> —M. M. Johnson Co. (Divides time with WCAJ).....	500	379.5	790	Central
	<b>KMO—Tacoma, Wash.</b> —KMO, Inc., Hotel Winthrop.....	250	254.1	1180	Pacific
	<b>KMOX—St. Louis, Mo.</b> (Transmitter in Kirkwood)—The Voice of St. Louis, Inc., Mayfair Hotel... ..	5000	299.8	1000	Central
	<b>KMTR—Los Angeles, Calif.</b> —KMTR Radio Corp., 1025 N. Highland Ave.....	500	526	570	Pacific
<b>KN</b>	<b>KNRC—Santa Monica, Calif.</b> —C. B. Juneau.....	500	374.8	800	Pacific
	<b>KNX—Los Angeles, Calif.</b> —Los Angeles Evening Express, 6116 Hollywood Blvd.....	500	336.9	890	Pacific
<b>KO</b>	<b>KOA—Denver, Colo.</b> —General Elec. Co. (10000 watts until 7 P. M.).....	5000	325.9	920	Mountain
	<b>KOAC—Corvallis, Ore.</b> —Oregon Agricultural College... ..	500	270.1	1110	Pacific
	<b>KOB—State College, N. Mex.</b> —New Mexico College of Agriculture and Mechanic Arts (Divides time with KWSC and KTW).....	5000	394.5	760	Mountain
	<b>KOCH—Omaha, Nebr.</b> —Omaha Central High School, 22nd and Dodge (Divides time with WNAL and KFOX).....	250	258.5	1160	Central
	<b>KOCW—Chickasha, Okla.</b> —Oklahoma College for Women.....	250	252	1190	Central
	<b>KOIL—Council Bluffs, Iowa</b> —Mona Motor Oil Co. (4000 watts Daytime).....	2000	277.6	1080	Central
	<b>KOIN—Portland, Ore.</b> —KOIN, Inc.....	1000	319	940	Pacific
	<b>KOLO—Durango, Colo.</b> —Gerald K. Hunter.....	5	199.9	1500	Mountain
	<b>KOMO—Seattle, Wash.</b> —Bert F. Fisher, 604 Home Savings Bldg.....	1000	305.9	980	Pacific
	<b>KOW—Denver, Colo.</b> —The Olinger Corp.....	250	475.9	630	Mountain
	<b>KOWN—Walla Walla, Wash.</b> —Blue Mountain Radios Assoc.....	500	299.8	1000	Pacific
<b>KP</b>	<b>KPCB—Seattle, Wash.</b> —Pacific Coast Biscuit Co., 505 Central Bldg. (Divides time with KGCL).....	50	230.6	1300	Pacific
	<b>KPJM—Prescott, Ariz.</b> —Wilburn Radio Service, Journal Mines Bldg.....	15	214.2	1400	Mountain
	<b>KPLA—Los Angeles, Calif.</b> —Pacific Development Radio Co.....	500	252	1190	Pacific
	<b>KPNP—Muscatine, Iowa</b> —Central Radio Co., East Second St.....	100	211.1	1420	Central
	<b>KPO—San Francisco, Calif.</b> —Hale Bros. and the San Francisco Chronicle.....	1000	422.3	710	Pacific
	<b>KPPC—Pasadena, Calif.</b> —Pasadena Presbyterian Church (Divides time with KELW).....	50	228.9	1310	Pacific
	<b>KPRC—Houston, Tex.</b> —Houston Post Dispatch.....	500	293.9	1020	Central
	<b>KPSN—Pasadena, Calif.</b> —The Star-News.....	1000	315.6	950	Pacific
<b>KQ</b>	<b>KQV—Pittsburgh, Pa.</b> —Doubleday-Hill Elec. Co., 719 Liberty Ave. (Divides time with WJAS).....	500	270.1	1110	Eastern
	<b>KQW—San Jose, Calif.</b> —First Baptist Church of San Jose, Montevina Ave.....	500	296.9	1010	Pacific
<b>KR</b>	<b>KRAC—Shreveport, La.</b> —Caddo Radio Club, Fair Grounds.....	50	220.4	1360	Central
	<b>KRE—Berkeley, Calif.</b> —First Congregational Church of Berkeley (Divides time with KFUS).....	100	256.3	1170	Pacific
	<b>KRLD—Dallas, Tex.</b> —Dallas Radio Labs., 208 N. St. Paul St.....	500	461.3	650	Central
	<b>KRLO—Los Angeles, Calif.</b> —Freeman Lang and A. B. Scott, 218 N. Larchmont Blvd. (Divides time with KGER).....	250	215.7	1390	Pacific

Radio Call Letters	BROADCAST STATIONS Location and Owner	Power Watts	Wave Length (Meters)	Frequency (Kilocycles)	Time at Station
<b>KR</b>	<b>KRSC—Seattle, Wash.—Radio Sales Corp., 1202 Fifth Ave.</b>	50	211 1	1420	Pacific
<b>KS</b>	<b>KSAC—Manhattan, Kans.—Kansas State Agricultural College.</b>	500	333 1	900	Central
	<b>KSBA—Shreveport, La.—Shreveport Broadcasting Co.</b>	1000	267 7	1120	Central
	<b>KSCJ—Sioux City, Iowa—Perkins Bros. Co. (Divides time with KWUC).</b>	500	243 8	1230	Central
	<b>KSD—St. Louis, Mo.—Pulitzer Pub. Co. (Divides time with KFUC).</b>	500	545 1	550	Central
	<b>KSEI—Pocatello, Idaho—KSEI Broadcasting Assoc.</b>	250	333 1	900	Mountain
	<b>KSL—Salt Lake City, Utah—Radio Service Corp. of Utah, 505 Templeton Bldg.</b>	1000	302 8	990	Mountain
	<b>KSMR—Santa Maria, Calif.—Santa Maria Valley R. R. Co.</b>	100	272.6	1100	Pacific
	<b>KSO—Clarinda, Iowa—A. A. Berry Seed Co.</b>	500	227 1	1320	Central
	<b>KSOO—Sioux Falls, S. D.—Sioux Falls Broadcast Assoc., 609 Minnehaha Bldg.</b>	250	209 7	1430	Mountain
<b>KT</b>	<b>KTAB—Oakland, Calif.—The Associated Broadcasters, Inc., 1410 Tenth Ave.</b>	500	280 2	1070	Pacific
	<b>KTAP—San Antonio, Tex.—Robert B. Bridge, Radio Service Shop, 2412 Main Ave.</b>	20	228 9	1310	Central
	<b>KTBI—Los Angeles, Calif.—Bible Institute of Los Angeles.</b>	500	288 3	1040	Pacific
	<b>KTBR—Portland, Ore.—Brown's Radio Shop, 172 Tenth St. (Divides time with KFJR).</b>	50	282 8	1060	Pacific
	<b>KTCL—Seattle, Wash.—American Radio Tel. Co.</b>	500	277 6	1080	Pacific
	<b>KTHS—Hot Springs Nat'l. Park, Ark.—New Arlington Hotel Co.</b>	1000	384.4	780	Central
	<b>KTNT—Muscatine, Iowa—Norman Baker (5000 watts Daytime).</b>	3500	256.3	1170	Central
	<b>KTSA—San Antonio, Tex.—Alamo Broadcasting Co.</b>	2000	265.3	1130	Central
	<b>KTUE—Houston, Tex.—Uhalt Electric Co., 614 Fannin St.</b>	5	212.6	1410	Central
	<b>KTW—Seattle, Wash.—The First Presbyterian Church of Seattle (Divides time with KWSC and KOB)</b>	1000	394.5	760	Pacific
<b>KU</b>	<b>KUJ—Seattle, Wash.—The Puget Sound Radio Broadcasting Co., Inc., 5811—5 Ave., N. E.</b>	10	199.9	1500	Pacific
	<b>KUOA—Fayetteville, Ark.—University of Arkansas.</b>	500	296.9	1010	Central
	<b>KUOM—Missoula, Mont.—State University of Montana.</b>	500	374.8	800	Mountain
	<b>KUSD—Vermillion, S. D.—University of S. Dak.</b>	250	483.6	620	Central
	<b>KUT—Austin, Tex.—University of Texas.</b>	500	232.4	1290	Central
<b>KV</b>	<b>KVI—Tacoma, Wash.—Puget Sound Radio Broadcasting Co., Inc., Ninth and A Sts.</b>	50	234.2	1280	Pacific
	<b>KVOO—Bristow, Okla.—Southwestern Sales Corp.</b>	1000	348.6	860	Central
	<b>KVOS—Seattle, Wash.—L. I. Jackson and L. Kessler, 1208 Tenth Ave.</b>	50	209.7	1430	Pacific
<b>KW</b>	<b>KWBS—Portland, Ore.—Schaeffer Mfg. Co., 226 E. 41 St.</b>	15	199.9	1500	Pacific
	<b>KWCR—Cedar Rapids, Ia.—H. F. Paar, Cedar Rapids Broadcasting Corp., 1444—2nd Ave., E. (Divides time with WJAM).</b>	250	384.4	780	Central
	<b>KWG—Stockton, Calif.—Portable Wireless Telephone Co., 530 E. Market St.</b>	50	344.6	870	Pacific
	<b>KWJJ—Portland, Ore.—Wilbur Jernian, 385 E. 58 St., So.</b>	50	228.9	1310	Pacific
	<b>KWKC—Kansas City, Mo.—Wilson Duncan Broadcasting Studios, Werby Bldg.</b>	100	222.1	1350	Central
	<b>KWKH—Shreveport, La.—W. K. Henderson.</b>	1000	394.5	760	Central
	<b>KWLC—Decorah, Iowa—Norwegian Lutheran College.</b>	50	247.8	1210	Central

Radio Call Letters	BROADCAST STATIONS Location and Owner	Power Watts	Wave Length (Meters)	Frequency (Kilocycles)	Time at Station
<b>KW</b>	<b>KWSC—Pullman, Wash.</b> —State College of Washington, Mechanic Arts Bldg. (Divides time with KTW and KOB).....	500	394.5	760	Pacific
	<b>KWTC—Santa Ana, Calif.</b> —Dr. John W. Hancock, 1101 North Ross St.....	5	352.7	850	Pacific
	<b>KWUC—Le Mars, Iowa</b> —Western Union College (Day-time only. Divides time with KSCJ).....	1500	243.8	1230	Central
	<b>KWWG—Brownsville, Tex.</b> —Chamber of Commerce...	500	277.6	1080	Central
<b>KX</b>	<b>KXL—Portland, Ore.</b> —KXL Broadcasters, 501 Pantage Bldg.....	50	220.4	1360	Pacific
<b>KY</b>	<b>KYA—San Francisco, Calif.</b> —Pacific Broadcasting Co.	500	309.1	970	Pacific
	<b>KYW—Chicago, Ill.</b> —Westinghouse Elec. & Mfg. Co., 508 S. Michigan Ave. (Divides time with KFKX).....	2500	526	570	Central
<b>KZ</b>	<b>KZM—Oakland, Calif.</b> —Preston D. Allen, 13th and Harrison Sts. (Divides time with KLS).....	100	245.8	1220	Pacific
<b>WA</b>	<b>WAAD—Cincinnati, Ohio</b> —Ohio Mechanics Inst.....	25	267.7	1120	Central
	<b>WAAF—Chicago, Ill.</b> —Chicago Daily Drovers Journal (Divides time with WBBM and WJBT).....	500	389.4	770	Central
	<b>WAAM—Newark, N. J.</b> —I. R. Nelson, 1 Bond St. (Divides time with WGBS).....	500	348.6	860	Eastern
	<b>WAAT—Jersey City, N. J.</b> —Bremer Broadcasting Corp., 210 Jackson Ave. (Divides time with WGBB and WSOM).....	500	245.8	1220	Eastern
	<b>WAAW—Omaha, Nebr.</b> —Omaha Grain Exchange (Before 7 P. M. only).....	300	348.6	860	Central
	<b>WABC—New York, N. Y.</b> —Atlantic Broadcasting Corp., 113 W. 57 St. (Divides time with WBOQ).....	2500	325.9	920	Eastern
	<b>WABF—Pringleboro, Pa.</b> —Markle Broadcasting Corp., 294 Wyoming Ave.....	250	205.4	1460	Eastern
	<b>WABI—Bangor, Me.</b> —First Universalist Church, Park St.	100	389.4	770	Eastern
	<b>WABO—Rochester, N. Y.</b> —Hickson Elec. Co. (Divides time with WHEC).....	100	232.4	1290	Eastern
	<b>WABQ—Philadelphia, Pa.</b> —Keystone Broadcasting Co.	500	260.7	1150	Eastern
	<b>WABR—Toledo, Ohio</b> —Scott High School (Divides time with WTAL).....	50	280.2	1070	Eastern
	<b>WABW—Wooster, Ohio</b> —College of Wooster.....	50	247.8	1210	Eastern
	<b>WABY—Philadelphia, Pa.</b> —John Magaldi, Jr.....	50	247.8	1210	Eastern
	<b>WABZ—New Orleans, La.</b> —Colis Place Baptist Church.	50	247.8	1210	Central
	<b>WADC—Akron, Ohio</b> —Allen T. Simmons.....	500	296.9	1010	Eastern
	<b>WAFD—Detroit, Mich.</b> —Albert B. Parfet Co., Charlotte St. and Woodward Ave. (Divides time with WRAV).....	100	340.7	880	Eastern
	<b>WAGM—Royal Oak, Mich.</b> —Robert L. Miller, 309 So. Main St.....	50	225.4	1330	Eastern
	<b>WAGS—Somerville, Mass.</b> —Transmitter in Lexington—Willow Garages, Inc., 131 Willow Ave.....	5	215.7	1390	Eastern
	<b>WAIT—Taunton, Mass.</b> —A. H. Waite & Co., 32 Weir St.....	10	214.2	1400	Eastern
	<b>WAIU—Columbus, Ohio</b> —American Insurance Union (Divides time with WEAO).....	5000	282.8	1060	Eastern
	<b>WALK—Willow Grove, Pa.</b> —Albert A. Walker.....	50	201.2	1490	Eastern
	<b>WAMD—Minneapolis, Minn.</b> —Radisson Radio Corp..	500	225.4	1330	Central
	<b>WAPI—Auburn, Ala.</b> —Alabama Polytechnic Inst. (Day-time only).....	1000	325.9	920	Central
	<b>WARS—Brooklyn, N. Y.</b> —Amateur Radio Specialty Co., 77 Cortlandt St., N. Y. (Divides time with WSDA and WBBC).....	500	227.1	1320	Eastern
	<b>WASH—Grand Rapids, Mich.</b> —The Baxter Launderers and Cleaners.....	250	256.3	1170	Eastern



Radio Call Letters	BROADCAST STATIONS Location and Owner	Power Watts	Wave Length (Meters)	Frequency (Kilocycles)	Time at Station
<b>WA</b>	<b>WATT—Boston, Mass. (Portable)—Edison Elec. Illuminating Co.</b> .....	100	201.2	1490	
<b>WB</b>	<b>WBAA—West Lafayette, Ind.—Purdue University (Divides time with WRN).</b> .....	500	272.6	1100	Central
	<b>WBAK—Harrisburg, Pa.—Pennsylvania State Police (Divides time with WPSC)</b> .....	500	299.8	1000	Eastern
	<b>WBAL—Baltimore, Md.—Transmitter in Glen Morris—Consolidated Gas, Elec. Light &amp; Power Co.</b> ...	3000	285.5	1050	Eastern
	<b>WBAO—Decatur, Ill.—James Millikin University</b> .....	100	267.7	1120	Central
	<b>WBAP—Fort Worth, Tex.—Carter Publishing Co. (Divides time with WFAA).</b> .....	1500	499.7	600	Central
	<b>WBAW—Nashville, Tenn.—Waldrum Drug Co.</b> .....	100	247.8	1210	Central
	<b>WBAX—Wilkes-Barre, Pa.—John H. Stenger, Jr., 66 Gildersleeve St. (Divides time with WBRE)</b> ..	100	249.9	1200	Eastern
	<b>WBBC—Brooklyn, N. Y.—Brooklyn Broadcasting Corp., 2123 Troy Ave. (Divides time with WARS and WSDA).</b> .....	500	227.1	1320	Eastern
	<b>WBBL—Richmond, Va.—Grace-Covenant Presbyterian Church, 1627 Monument Ave.</b> .....	100	247.8	1210	Eastern
	<b>WBBM—Chicago, Ill.—Atlass Investment Co., 1554 Howard St. (Divides time with WJBT and WAAF).</b> .....	1000	389.4	770	Central
	<b>WBBP—Petoskey, Mich.—Petoskey High School</b> .....	100	239.9	1250	Central
	<b>WBBR—Rossville, N. Y.—People's Pulpit Assoc., 124 Columbia Heights, Brooklyn (Divides time one-half with WJBI—WEBJ).</b> .....	1000	256.3	1170	Eastern
	<b>WBBW—Norfolk, Va.—Ruffner Junior High School</b> ....	50	236.1	1270	Eastern
	<b>WBBY—Charleston, S. C.—Washington Light Infantry</b>	75	499.7	600	Eastern
	<b>WBBZ—Chicago, Ill. (Portable)—C. L. Carrell, 1506 No. American Bldg.</b> .....	100	204	1470	
	<b>WBCN—Chicago, Ill.—Great Lakes Broadcasting Co., 728 W. 65th St. (Divides time with WENR)</b> ..	250	288.3	1040	Central
	<b>WBES—Tacoma Park, Md.—Bliss Electrical School</b> ...	100	296.9	1010	Eastern
	<b>WBET—Boston, Mass.—Boston Transcript</b> .....	500	265.3	1130	Eastern
	<b>WBIS—Boston, Mass.—The Shepard Stores (Divides time with WSSH)</b> .....	100	302.8	990	Eastern
	<b>WBKN—Brooklyn, N. Y.—Arthur Faske, 1515 Eastern Parkway (Divides time with WWRL, WIBI and WBMS).</b> .....	100	267.7	1120	Eastern
	<b>WBMH—Detroit, Mich.—Braun's Music House, 13214 E. Jefferson Ave.</b> .....	100	211.1	1420	Central
	<b>WBMS—Union City, N. J.—George J. Schowerer, 837—34 St. (Divides time with WBKN, WWRO and WIBI).</b> .....	100	267.7	1120	Eastern
	<b>WBNY—New York, N. Y.—Baruchrome Corp., 400 E. 139 St. (Divides time with WHAP—WMSG)</b>	250	236.1	1270	Eastern
	<b>WBOQ—New York, N. Y.—Atlantic Broadcasting Corp., 113 W. 57 St. (Divides time with WABC)</b> .....	500	325.9	920	Eastern
	<b>WBRC—Birmingham, Ala.—Birmingham Broadcasting Corp., Age-Herald Bldg.</b> .....	250	243.8	1230	Central
	<b>WBRE—Wilkes-Barre, Pa.—Baltimore Radio Exchange, 17 W. Northampton St. (Divides time with WBAX)</b> .....	100	249.9	1200	Eastern
	<b>WBRL—Tilton, N. H.—Booth Radio Labs., 23 Summer St.</b> .....	500	232.4	1290	Eastern
	<b>WBRS—Brooklyn, N. Y.—North American Broadcasting Corp. (Divides time with WCDA, WCGU and WRST)</b> .....	100	211.1	1420	Eastern
	<b>WBSO—Wellesley Hills, Mass.—Babson's Statistical Organization (Divides time with WDFW)</b> ....	100	384.4	780	Eastern

Radio Call Letters	BROADCAST STATIONS Location and Owner	Power Watts	Wave Length (Meters)	Frequency (Kilocycles)	Time at Station
<b>WB</b>	<b>WBT—Charlotte, N. C.</b> —Charlotte Chamber of Commerce, 500 West Trade St. (Uses 1000 watts Daytime).....	500	258.5	1160	Eastern
	<b>WBZ—Springfield, Mass.</b> —Transmitter is in East Springfield—Westinghouse Elec. & Mfg. Co., Hotel Kimball.....	15000	333.1	900	Eastern
	<b>WBZA—Boston, Mass.</b> —Westinghouse Elec. & Mfg. Co., Hotel Brunswick.....	500	333.1	900	Eastern
<b>WC</b>	<b>WCAC—Mansfield, Conn.</b> —Connecticut Agricultural College (Divides time with WDRC).....	500	275.1	1090	Eastern
	<b>WCAD—Canton, N. Y.</b> —St. Lawrence University (1000 watts Daytime).....	500	365.6	820	Eastern
	<b>WCAE—Pittsburgh, Pa.</b> —Kaufmann Bros. and Baer Co., Sixth and Smithfield Sts.....	500	516.9	580	Eastern
	<b>WCAH—Columbus, Ohio</b> —Entrekin Elec. Co., 321 W. 10th Ave.....	250	535.4	560	Eastern
	<b>WCAJ—Lincoln, Nebr.</b> —Nebraska Wesleyan University (Divides time with KMMJ).....	500	379.5	790	Central
	<b>WCAL—Northfield, Minn.</b> —St. Olaf College (Divides time with KFMX).....	500	236.1	1270	Central
	<b>WCAM—Camden, N. J.</b> —City of Camden, Civic Centre.....	500	223.7	1340	Eastern
	<b>WCAO—Baltimore, Md.</b> —Monumental Radio, Inc., 848 N. Howard St. (Divides time with WCBM).....	250	384.4	780	Eastern
	<b>WCAT—Rapid City, S. D.</b> —South Dakota State School of Mines.....	100	247.8	1210	Mountain
	<b>WCAU—Philadelphia, Pa.</b> —Universal Broadcasting Co.....	500	260.7	1150	Eastern
	<b>WCAX—Burlington, Vt.</b> —University of Vermont.....	100	254.1	1180	Eastern
	<b>WCAZ—Carthage, Ill.</b> —Carthage College.....	50	340.7	880	Central
	<b>WCBA—Allentown, Pa.</b> —Chas. W. Heimbach, 1015 Allen St. (Divides time with WSAN).....	100	222.1	1350	Eastern
	<b>WCBD—Zion, Ill.</b> —Wilbur G. Voliva (Divides time with WLS).....	5000	344.6	870	Central
	<b>WCBE—New Orleans, La.</b> —Uhalt Bros., 1219 N. Rampart St.....	5	227.1	1320	Central
	<b>WCBH—Oxford, Miss. (near)</b> —University of Mississippi.....	100	241.8	1240	Central
	<b>WCBM—Baltimore, Md.</b> —Hotel Chateau, Charles St. and North Ave. (Divides time with WCAO).....	100	384.4	780	Eastern
	<b>WCBR—Providence, R. I. (Portable)</b> —Chas. H. Messer, 42 Doyle Ave.....	100	201.2	1490	
	<b>WCBS—Springfield, Ill.</b> —Harold L. Dewing and Chas. H. Messter.....	250	209.7	1430	Central
	<b>WCCO—Minneapolis, Minn.</b> —Washburn-Crosby Co., (7500 watts Daytime).....	5000	405.2	740	Central
	<b>WCDA—Cliffside, N. J.</b> —Italian Educational Foundation Corp. (Divides time with WRST, WBRS and WCGU).....	250	211.1	1420	Eastern
	<b>WCFL—Chicago, Ill.</b> —Chicago Federation of Labor, 166 West Washington St. (Divides time with WLTS).....	1500	483.6	620	Central
	<b>WCGU—New York, N. Y.</b> —Chas. G. Unger, 1587 Broadway. (Divides time with WCDA, WBRS and WRST).....	500	211.1	1420	Eastern
	<b>WCLO—Camp Lake, Wis.</b> —C. E. Whitmore.....	100	227.1	1320	Central
	<b>WCLS—Joliet, Ill.</b> —WCLS, Inc., 301 E. Jefferson St. (Divides time with WKBB).....	150	215.7	1390	Central
	<b>WCMA—Culver, Ind.</b> —Culver Military Academy.....	250	258.5	1160	Central
	<b>WCOA—Pensacola, Fla.</b> —City of Pensacola.....	500	249.9	1200	Central
	<b>WCOC—Columbus, Miss.</b> —Crystal Oil Co.....	100	230.6	1300	Central
	<b>WCOM—Manchester, N. H.</b> —172nd Field Artillery, N. H. N. G.....	100	238	1260	Eastern
	<b>WCOT—Olneyville, R. I.</b> —Jacob Conn, 1849 Westminster St. (Divides time with WFCI).....	50	225.4	1330	Eastern

Radio Call Letters	BROADCAST STATIONS Location and Owner	Power Watts	Wave Length (Meters)	Frequency (Kilocycles)	Time at Station
<b>WC</b>	<b>WCRW—Chicago, Ill.</b> —Clinton R. White, 650 Waveland Ave. (Divides time with WFKB, WPPC)	500	223.7	1340	Central
	<b>WCSH—Portland, Me.</b> —Henry P. Rines, Congress Square Hotel Co.	500	361.2	830	Eastern
	<b>WCSO—Springfield, Ohio</b> —Wittenberg College	500	256.3	1170	Central
	<b>WCWK—Fort Wayne, Ind.</b> —Chester W. Keen, 1729 Lafayette St. (Divides time with WOWO)	500	228.9	1310	Central
	<b>WCWS—Danbury, Conn.</b> —Connecticut Portable Broadcasting Corp.	100	214.2	1400	Eastern
	<b>WCX—Pontiac, Mich.</b> —Detroit Free Press	5000	440.9	680	Eastern
<b>WD</b>	<b>WDAD—Nashville, Tenn.</b> —Dad's Auto Accessory and Radio Store, 171 Eighth Ave., North (1000 watts Daytime)	500	225.4	1330	Central
	<b>WDAE—Tampa, Fla.</b> —Tampa Daily Times	500	267.7	1120	Eastern
	<b>WDAF—Kansas City, Mo.</b> —The Kansas City Star	1000	370.2	810	Central
	<b>WDAG—Amarillo, Tex.</b> —J. Laurance Martin, 655 E. 4th St.	250	263	1140	Central
	<b>WDAH—El Paso, Tex.</b> —Trinity Methodist Church, Cor. Blod and Misa Ave.	100	234.2	1280	Mountain
	<b>WDAY—Fargo, N. D.</b> —Radio Equipment Corp., 119 Broadway	250	361.2	830	Central
	<b>WDBJ—Roanoke, Va.</b> —Richardson-Wayland Electric Corp., 106 Church Ave., S. W.	250	230.6	1300	Eastern
	<b>WDBK—Cleveland, Ohio</b> , Transmitter in Akron, W. F. Jones (Divides time with WJAY)	250	227.1	1320	Eastern
	<b>WDBO—Orlando, Fla.</b> —Central Florida Broadcast Station, Inc. (1000 watts Daytime)	500	288.3	1040	Eastern
	<b>WDBZ—Kingston, N. Y.</b> —Under Management of Kingston Chamber of Commerce Boy Scouts of America (Divides time with WOKO)	50	215.7	1390	Eastern
	<b>WDEL—Wilmington, Del.</b> —Wilmington Elec. Specialty Co., 405 Delaware Ave.	100	265.3	1130	Eastern
	<b>WDGY—Minneapolis, Minn.</b> —Geo. W. Young, 909 W. Broadway	500	260.7	1150	Central
	<b>WDOD—Chattanooga, Tenn.</b> —Chattanooga Radio Co., 615 Market St.	500	245.8	1220	Central
	<b>WDRC—New Haven, Conn.</b> —Doolittle Radio Corp., 115 Crown St. (Divides time with WCAC)	250	275.1	1090	Eastern
	<b>WDWF—Cranston, R. I.</b> —Dutee W. Flint and Lincoln Studios, Inc. (Divides time with WBSO)	500	374.8	800	Eastern
	<b>WDWM—Asbury Park, N. J.</b> —Radio Industries Broadcast Co., 20 Central Ave.	500	361.2	830	Eastern
	<b>WDZ—Tuscola, Ill.</b> —Jas. L. Bush (Daytime only)	100	277.6	1080	Central
<b>WE</b>	<b>WEAF—New York, N. Y.</b> —(Transmitter at 463 West St.)—National Broadcasting Co., Inc., 195 Broadway	5000	491.5	610	Eastern
	<b>WEAI—Ithaca, N. Y.</b> —Cornell University	250	483.6	620	Eastern
	<b>WEAM—North Plainfield, N. J.</b> —Borough of North Plainfield (Divides time with WOAX)	250	239.9	1250	Eastern
	<b>WEAN—Providence, R. I.</b> —The Shepard Co., 122 Mathewson St. (Divides time with WNAC)	500	319	940	Eastern
	<b>WEAO—Columbus, Ohio</b> —The Ohio State University (Divides time with WAIU)	750	282.6	1060	Eastern
	<b>WEAR—Cleveland, Ohio</b> —Willard Storage Battery Co. (Divides time with WTAM)	1000	399.8	750	Eastern
	<b>WEBC—Superior, Wis.</b> —W. C. Bridges	250	241.8	1240	Central
	<b>WEBE—Cambridge, Ohio</b> —R. W. Waller, 319 Wall Ave.	10	247.8	1210	Eastern
	<b>WEBH—Chicago, Ill.</b> —Edgewater Beach Hotel Co., 5300 Sheridan Rd. (Divides time with WJJD)	2000	365.6	820	Central
	<b>WEBJ—New York, N. Y.</b> —Third Ave. Railway Co., 2396 Third Ave. (Divides time [one quarter] with WJBI—WBBR)	500	256.3	1170	Eastern

Radio Call Letters	BROADCAST STATIONS Location and Owner	Power Watts	Wave Length (Meters)	Frequency (Kilocycles)	Time at Station
<b>WE</b>	<b>WEBQ—Harrisburg, Ill.</b> —Tate Radio Co., 700 W. Robinson St.	15	223.7	1340	Central
	<b>WEBR—Buffalo, N. Y.</b> —Howell Broadcasting Co., 54 Niagara St.	200	241.8	1240	Eastern
	<b>WEBW—Beloit, Wis.</b> —Beloit College	500	258.5	1160	Central
	<b>WEDC—Chicago, Ill.</b> —Emil Denmark Broadcasting Station, 3860 Ogden Ave. (Divides time with WGES)	500	241.8	1240	Central
	<b>WEEI—Boston, Mass.</b> —The Edison Elec. Illuminating Co.	500	447.5	670	Eastern
	<b>WEHS—Evanston, Ill.</b> —A. T. Becker, 1318 Elmwood Ave.	100	215.7	1390	Central
	<b>WEMC—Berrien Springs, Mich.</b> —Emmanuel Missionary College, (Divides time with WCFL and WLTS)	1000	483.6	620	Central
	<b>WENR—Chicago, Ill.</b> —Commonwealth Edison Co. (Divides time with WBCN)	500	288.3	1040	Central
	<b>WEPS—Gloucester, Mass.</b> —Matneson Radio Co., 209 Main St.	100	296.9	1010	Eastern
	<b>WEW—St. Louis, Mo.</b> —St. Louis University	1000	352.7	850	Central
<b>WF</b>	<b>WFAA—Dallas, Tex.</b> —Dallas News and Dallas Journal, Baker Hotel (Divides time with WBAP)	500	499.7	600	Central
	<b>WFAM—St. Cloud, Minn.</b> —Times Publishing Co.	10	252	1190	Central
	<b>WFBC—Knoxville, Tenn.</b> —First Baptist Church	50	234.2	1280	Central
	<b>WFBE—Cincinnati, Ohio</b> —Garfield Place Hotel Co.	250	245.8	1220	Central
	<b>WFBG—Altoona, Pa.</b> —The William F. Gable Co.	100	280.2	1070	Eastern
	<b>WFBJ—Collegeville, Minn.</b> —St. John's University	100	272.6	1100	Central
	<b>WFB�—Syracuse, N. Y.</b> —The Onondaga Co.	750	258.5	1160	Eastern
	<b>WFBM—Indianapolis, Ind.</b> —Merchants Heat & Light Co.	250	225.4	1330	Central
	<b>WFBR—Baltimore, Md.</b> —Fifth Infantry National Guard	100	225.4	1330	Eastern
	<b>WFBZ—Galesburg, Ill.</b> —Knox College (Divides time with WRAM)	50	247.8	1210	Central
	<b>WFCI—Pawtucket, R. I.</b> —Frank Crook (Inc.), 103 Exchange St. (Divides time with WCOT)	50	225.4	1330	Eastern
	<b>WFDF—Flint, Mich.</b> —Frank D. Fallain, Police Bldg.	100	348.6	860	Eastern
	<b>WFHH—Clearwater, Fla.</b> —(Transmitter in Dunedin)—Fort Harrison Hotel	500	365.6	820	Eastern
	<b>WFI—Philadelphia, Pa.</b> —Strawbridge & Clothier (Divides time with WLIT)	500	405.2	740	Eastern
	<b>WFIW—Hopkinsville, Ky.</b> —Acme Mills, Inc. (1000 watts Daytime)	500	280.2	1070	Central
	<b>WFKB—Chicago, Ill.</b> —Francis K. Bridgman, 4536 Woodlawn Ave. (Divides time with WCRW)	500	223.7	1340	Central
	<b>WFKD—Philadelphia, Pa.</b> —Foulkrod Radio Engineering Co.	10	205.4	1460	Eastern
	<b>WFLA—Boca Raton, Fla.</b> —Boca Raton Radio Club	1000	212.6	1410	Eastern
<b>WG</b>	<b>WGAL—Lancaster, Pa.</b> —Lancaster Elec. Supply and Construction Co., 23 E. Orange St.	15	252	1190	Eastern
	<b>WGBB—Freeport, N. Y.</b> —Harry H. Carman, 217 Bedell St. (Divides time with WAAT and WSOM)	400	245.8	1220	Eastern
	<b>WGBC—Memphis, Tenn.</b> —First Baptist Church	15	277.6	1080	Central
	<b>WGBF—Evansville, Ind.</b> —Finke Furniture Co., 307 So. Seventh St.	250	236.1	1270	Central
	<b>WGBI—Scranton, Pa.</b> —Scranton Broadcasters, Inc., 608 Linden St. (Divides time with WQAN)	250	230.6	1300	Eastern

Radio Call Letters	BROADCAST STATIONS Location and Owner	Power Watts	Wave Length (Meters)	Frequency (Kilocycles)	Time at Station
<b>WG</b>	<b>WGBS—New York, N. Y.</b> —(Transmitter in Astoria, L. I.)—Gimbel Bros., 33rd and Broadway) (Divides time with WAAM).....	500	348.6	860	Eastern
	<b>WGCP—Newark, N. J.</b> —Lauter Piano Co., Broad & Washington Sts. (Divides time with WNJ)....	500	280.2	1070	Eastern
	<b>WGES—Chicago, Ill.</b> —(Transmitter in Oak Park)—Oakleaves Broadcasting Corp., Coyne Electric School, 128 N. Crawford Ave. (Divides time with WEDC).....	500	241.8	1240	Central
	<b>WGHP—Mount Clemens, Mich.</b> —Geo. H. Phelps, 110 Rowena St.....	750	319	940	Central
	<b>WGL—New York, N. Y.</b> —(Transmitter in Secaucus, N. J.)—International Broadcast Corp., Hotel Majestic.....	500	293.9	1020	Eastern
	<b>WGM—Jeanette, Pa.</b> —Verne & Elton Spencer, 501 Cowan Ave.....	50	208.2	1440	Eastern
	<b>WGMS—Minneapolis, Minn.</b> —University of Minnesota.....	500	245.8	1220	Central
	<b>WGMU—New York, N. Y. (Portable)</b> —Atlantic Broadcasting Corp. (Divides time with WRMU)....	100	201.2	1490	
	<b>WGN—Chicago, Ill.</b> —The Chicago Tribune, Drake Hotel (Divides time with WLIB).....	15000	305.9	980	Central
	<b>WGR—Buffalo, N. Y.</b> —Federal Radio Corp., Hotel Statler.....	750	302.8	990	Eastern
	<b>WGST—Atlanta, Ga.</b> —Georgia School of Technology (Divides time with WMAZ).....	500	270.1	1110	Central
	<b>WGWB—Milwaukee, Wis.</b> —Radiocast Corp. of Wisconsin, 144 Broadway.....	500	218.8	1370	Central
	<b>WGY—Schenectady, N. Y.</b> —General Electric Co. (Divides time with WHAZ).....	30000	379.5	790	Eastern
<b>WH</b>	<b>WHA—Madison, Wis.</b> —University of Wisconsin (Divides time with WLBL).....	750	319	940	Central
	<b>WHAD—Milwaukee, Wis.</b> —Marquette and Milwaukee Journal (Divides time with WTMJ).....	500	293.9	1020	Central
	<b>WHAM—Rochester, N. Y.</b> —Stromberg-Carlson Telephone Mfg. Co. (Will use 5000 watts from Aug. 15).....	500	277.6	1080	Eastern
	<b>WHAP—New York, N. Y.</b> (Transmitter in Carlstadt, N. J.)—Defenders of Truth Society, Inc., 9 W. 96th St. (Divides time with WBNY and WMSG).....	1000	236.1	1270	Eastern
	<b>WHAR—Atlantic City, N. J.</b> —F. B. Cook's Sons, Inc., Seaside Hotel (Divides time with WPG).....	750	272.6	1100	Eastern
	<b>WHAS—Louisville, Ky.</b> —Courier-Journal and Louisville Times.....	500	461.3	650	Central
	<b>WHAZ—Troy, N. Y.</b> —Rensselaer Polytechnic Inst. (Divides time with WGY).....	500	379.5	790	Eastern
	<b>WHB—Kansas City, Mo.</b> —Sweeney Automotive and Elec. School. Sweeney Bldg. (Divides time with WOQ).....	500	336.9	890	Central
	<b>WHBA—Oil City, Pa.</b> —Shaffer Music House.....	10	260.7	1150	Eastern
	<b>WHBC—Canton, Ohio</b> —St. John's Catholic Church, 627 McKinley Ave., N. W.....	10	236.1	1270	Eastern
	<b>WHBD—Bellefontaine, Ohio</b> —Chamber of Commerce.....	100	222.1	1350	Central
	<b>WHBF—Rock Island, Ill.</b> —Beardsley Specialty Co., 217 Eighteenth St.....	100	222.1	1350	Central
	<b>WHBL—Chicago, Ill. (Portable)</b> —C. L. Carrell.....	100	204	1470	
	<b>WHBM—Chicago, Ill. (Portable)</b> —C. L. Carrell, 1536 So. State St.....	100	201.2	1490	
	<b>WHBN—St. Petersburg, Fla.</b> —First Ave. Methodist Church.....	10	296.9	1010	Eastern
	<b>WHBP—Johnstown, Pa.</b> —Johnstown Automobile Co., 101 Main St. (500 watts Daytime).....	250	228.9	1310	Eastern
	<b>WHBQ—Memphis, Tenn.</b> —WHBQ, Inc., Dermon Bldg.....	100	232.4	1290	Central
	<b>WHBU—Anderson, Ind.</b> —Citizens Bank, 1002 Meridian St.....	15	220.4	1360	Central

Radio Call Letters	BROADCAST STATIONS Location and Owner	Power Watts	Wave Length (Meters)	Frequency (Kilocycles)	Time at Station
<b>WH</b>	<b>WHBW—Philadelphia, Pa.</b> —D. R. Kienzle, 4916 Chestnut St. (Divides time with WIAD).....	50	220.4	1360	Eastern
	<b>WHBY—West De Pere, Wis.</b> —St. Norbert's College ...	50	249.9	1200	Central
	<b>WHDI—Minneapolis, Minn.</b> —Wm. Hood Dunwoody Industrial Inst., 818 Superior Blvd. (Divides time with WLB).....	500	245.8	1220	Central
	<b>WHEC—Rochester, N. Y.</b> —Hickson Elec. Co., 36 South Ave. (Divides time with WABO).....	100	232.4	1290	Eastern
	<b>WHFC—Chicago, Ill.</b> —Triangle Broadcasters, Hotel Flanders, 4145 Broadway.....	200	215.7	1390	Central
	<b>WHK—Cleveland, Ohio</b> —Radio Air Service Corp., 116 Carnegie Hall (Divides time with WJAY) (1000 watts Daytime).....	500	265.3	1130	Eastern
	<b>WHN—New York, N. Y.</b> —George Schubel, 1540 Broadway (Divides time with WQAO and WPAP).....	500	394.5	760	Eastern
	<b>WHO—Des Moines, Ia.</b> —Bankers Life Co., 1110 Liberty Bldg.....	5000	535.4	560	Central
	<b>WHPP—New York, N. Y.</b> —Bronx Broadcasting Corp., 953 Southern Blvd.....	10	206.8	1450	Eastern
	<b>WHT—Chicago, Ill.</b> (Transmitter in Deerfield)—Radio- phone Broadcasting Corp., 410 N. Michigan Blvd. (Divides time with WIBO).....	5000	416.4	720	Central
<b>WI</b>	<b>WIAD—Philadelphia, Pa.</b> —Howard R. Miller, 6318 North Park Ave. (Divides time with WHBW).....	100	220.4	1360	Eastern
	<b>WIAS—Burlington, Iowa</b> —Home Elec. Co., 315 N. 3 St.	100	475.9	630	Central
	<b>WIBA—Madison, Wis.</b> —Capital Times Studio, and Strand Theatre Corp., 14 E. Mifflin St.....	100	239.9	1250	Central
	<b>WIBG—Elkins Park, Pa.</b> —St. Paul's Protestant Episcopal Church (Sunday's Daytime only).....	50	440.9	680	Eastern
	<b>WIBI—Flushing, N. Y.</b> —Frederick B. Zittel, Jr., 369 Amity St. (Divides time with WBKN, WWRL and WBMS).....	100	267.7	1120	Eastern
	<b>WIBJ—Chicago, Ill. (Portable)</b> —C. L. Carrell, 1506 No. American Bldg.....	100	201.2	1490	
	<b>WIBM—Chicago, Ill. (Portable)</b> —C. L. Carrell, 1506 No. American Bldg.....	100	201.2	1490	
	<b>WIBO—Chicago, Ill.</b> —WIBO Broadcasters, Inc., 6312 Broadway (Divides time with WHT).....	500	416.4	720	Central
	<b>WIBR—Steubenville, Ohio</b> —Thurman A. Owings.....	50	249.9	1200	Eastern
	<b>WIBS—Elizabeth, N. J.</b> —Lieut. Thos. F. Hunter (Divides time with WTRC and WLBX).....	150	204	1470	Eastern
	<b>WIBU—Poynette, Wis.</b> —Wisconsin State Journal.....	20	217.3	1380	Central
	<b>WIBW—Chicago, Ill. (Portable)</b> —C. L. Carrell, 1506 No. American Bldg.....	100	204	1470	
	<b>WIBX—Utica, N. Y.</b> —WIBX, Inc., Hotel Utica.....	150	238	1260	Eastern
	<b>WIBZ—Montgomery, Ala.</b> —A. D. Trum, 217 Catonia St.....	15	230.6	1300	Central
	<b>WICC—Bridgeport, Conn.</b> —Bridgeport Broadcasting Co., Inc.....	250	214.2	1400	Eastern
	<b>WIL—St. Louis, Mo.</b> —Benson Radio Co.....	250	258.5	1160	Central
	<b>WIOD—Miami Beach, Fla.</b> —Carl G. Fisher Co.....	1000	247.8	1210	Eastern
	<b>WIP—Philadelphia, Pa.</b> —Gimbel Bros., Market St. Bldg., (Divides time with WOO).....	500	508.2	590	Eastern
<b>WJ</b>	<b>WJAD—Waco, Tex.</b> —Frank P. Jackson.....	500	447.5	670	Central
	<b>WJAG—Norfolk, Nebr.</b> —Norfolk Daily News.....	250	285.5	1050	Central
	<b>WJAK—Kokomo, Ind.</b> —J. A. Kautz, 1531 Washington St.....	50	234.2	1280	Central
	<b>WJAM—Cedar Rapids, Ia.</b> —D. M. Perham, 322 Third Ave., W. (Divides time with KWCR).....	100	384.4	780	Central
	<b>WJAR—Providence, R. I.</b> —The Outlet Co.....	500	483.6	620	Eastern

Radio Call Letters	BROADCAST STATIONS Location and Owner	Power Watts	Wave Length (Meters)	Frequency (Kilocycles)	Time at Station
<b>WJ</b> WJAS	Pittsburgh, Pa.—Pittsburgh Radio Supply House, 10th and Pennsylvania Ave. (Divides time with KQV).....	500	270.1	1110	Eastern
WJAX	Jacksonville, Fla.—City of Jacksonville.....	1000	336.9	890	Eastern
WJAY	Cleveland, Ohio—Cleveland Radio Broadcasting Corp., Hotel Hollenden (Divides time with WHK).....	500	227.1	1320	Eastern
WJAZ	Chicago, Ill. (Transmitter in Mount Prospect)—Zenith Radio Corp., 3620 Iron St. (Divides time with WMBI).....	5000	263	1140	Central
WJBA	Joliet, Ill.—D. H. Lentz, Jr., 301 Whitley Ave.....	50	322.4	930	Central
WJBB	St. Petersburg, Fla.—Financial Journal, 126—13th St., N.....	250	344.6	870	Eastern
WJBC	LaSalle, Ill.—Hummer Furniture Co., 2nd & Joliet Sts.....	100	227.1	1320	Central
WJBI	Red Bank, N. J.—Robt. S. Johnson, 63 Broad St. (Divides time [one quarter] with WBBR—WEBJ).....	250	256.3	1170	Eastern
WJBK	Ypsilanti, Mich.—Ernest F. Goodwin, 803 Congress St.....	15	220.4	1360	Central
WJBL	Decatur, Ill.—Wm. Gushard Dry Goods Co., 301 N. Water St.....	250	212.6	1410	Central
WJBO	New Orleans, La.—Valdemar Jensen, 119 S. St. Patrick St.....	100	263	1140	Central
WJBR	Omro, Wis.—Gensch & Stearns.....	100	227.1	1320	Central
WJBT	Chicago, Ill.—John S. Boyd, 1554 Howard St. (Divides time with WBBM and WAAF).....	500	389.4	770	Central
WJBU	Lewisburg, Pa.—Bucknell University, Engineering Bldg.....	100	214.2	1400	Eastern
WJBW	New Orleans, La.—C. Carlson, Jr., 2743 Du-maine St.....	30	238	1260	Central
WJBY	Gadsden, Ala.—Electric Const. Co., 517 Broad St.....	50	234.2	1280	Central
WJBZ	Chicago Heights, Ill.—Roland G. Palmer and A. Coppotelli, 144 E. 16 St.....	100	208.2	1440	Central
WJJD	Mooseheart, Ill.—Supreme Lodge, Loyal Order of Moose (Divides time with WEBH).....	1000	365.6	820	Central
WJPW	Ashtabula, Ohio—J. P. Wilson, 192 Prospect St.....	50	208.2	1440	Eastern
WJR	Detroit, Mich. (Transmitter in Pontiac)—WJR, Inc. & Detroit Free Press, Cadillac Hotel.....	5000	440.9	680	Central
WJZ	New York, N. Y.—(Transmitter in Bound Brook, N. J.)—National Broadcasting Co., 195 B'way	30000	454.3	660	Eastern
<b>WK</b> WKAR	East Lansing, Mich.—Michigan State College (Divides time with WREO) (Uses 1000 watts Daytime).....	500	285.5	1050	Central
WKAV	Laconia, N. H.—Laconia Radio Club, 533 Main St.....	50	223.7	1340	Eastern
WKBB	Joliet, Ill.—Sanders Bros., 607 Jefferson St. (Divides time with WCLS).....	150	215.7	1390	Central
WKBC	Birmingham, Ala.—H. L. Ansley, 1428 N. 12th Ave.....	10	218.8	1370	Central
WKBE	Webster, Mass.—K. & B. Elec. Co., 59 Emerald Ave.....	100	228.9	1310	Eastern
WKBF	Indianapolis, Ind.—Noble B. Watson, 233 Iowa St.....	250	252	1190	Central
WKBG	Chicago, Ill. (Portable)—C. L. Carrell, 36 S. State St.....	100	201.2	1490	
WKBH	La Crosse, Wis.—Callaway Music Co., 221 Main St.....	500	220.4	1360	Central
WKBI	Chicago, Ill.—Fred L. Schoenwolf, 1917 Warner Ave.....	50	322.4	930	Central
WKBL	Monroe, Mich.—Monrona Radio Mfg. Co., 16 S. Monroe St.....	15	205.4	1460	Eastern

Radio Call Letters	BROADCAST STATIONS Location and Owner	Power Watts	Wave Length (Meters)	Frequency (Kilocycles)	Time at Station
<b>WK</b> WKBM	Newburgh, N. Y.—WKBM Radio Broadcast- ing Co., 130 Broadway.....	100	208.2	1440	Eastern
WKBN	Youngstown, Ohio—Young Men's Christian Ass'n (Divides time with WMBW).....	50	214.2	1400	Eastern
WKBO	Jersey City, N. J.—Camith Corporation, 2866 Boulevard (Divides time with WKBQ and WLTH).....	500	218.8	1370	Eastern
WKBP	Battle Creek, Mich.—Battle Creek Enquirer and News.....	50	212.6	1410	Eastern
WKBQ	New York, N. Y.—Starlight Amusement Park, Inc., 1100 E. 177 St. (Divides time with WKBO and WLTH).....	500	218.8	1370	Eastern
WKBS	Galesburg, Ill.—P. N. Nelson 227 Duffield, Ave. (Divides time with WLBO).....	100	217.3	1380	Central
WKBT	New Orleans, La.—First Baptist Church.....	50	252	1190	Central
WKBU	New Castle, Pa. (Portable)—Harry K. Arm- strong.....	50	204	1470	
WKBV	Brookville, Ind.—Knox Battery & Elec. Co., 1058 Main St.....	100	217.3	1380	Central
WKBW	Buffalo, N. Y.—Churchill Evangelistic Assoc..	500	217.3	1380	Eastern
WKBZ	Ludington, Mich.—Karl L. Ashbacker, First National Bank Bldg.....	15	199.9	1500	Eastern
WKDR	Kenosha, Wis.—Edward A. Dato, 936 N. Michigan Ave., Chicago, Ill.....	15	322.4	930	Central
WKEN	Buffalo, N. Y.—H. L. Turner, 121 Norwood Ave. (Divides time with WSVS).....	250	204	1470	Eastern
WKJC	Lancaster, Pa.—Kirk Johnson Co., 16 W. King St. (Divides time with WGAL).....	50	258.5	1160	Eastern
WKRC	Cincinnati, Ohio—Kodel Radio Corp., 507 E. Pearl St.....	500	333.1	900	Central
WKY	Oklahoma City, Okla.—WKY Radiophone Co., Huckins Hotel.....	150	288.3	1040	Central
<b>WL</b> WLAC	Nashville, Tenn.—Dad's Auto Accessory & Radio Store (1000 watts Daytime).....	500	225.4	1330	Central
WLAP	Louisville, Ky.—Virginia Ave. Baptist Church, 2600 Virginia Ave. (1000 watts Daytime).....	50	267.7	1120	Central
WLB	Minneapolis, Minn.—University of Minnesota (Divides time with WHDI).....	500	245.8	1220	Central
WLBC	Muncie, Ind.—D. A. Burton, 2224 So. Jefferson St.....	50	209.7	1430	Central
WLBF	Kansas City, Mo.—Everett L. Dillard, 300a E. 33 St.....	50	209.7	1430	Central
WLBG	Petersburg, Va.—R. A. Gamble.....	100	214.2	1400	Eastern
WLBH	Farmingdale, N. Y. (Portable)—Joseph J. Lombardi.....	30	232.4	1290	
WLBI	East Wenona, Ill.—Wenona Legion Broadcast- ers, Inc.....	250	238	1260	Central
WLBL	Stevens Point, Wis.—Wisconsin Dept. of Markets (Divides time with WHA).....	1000	319	940	Central
WIBM	Boston, Mass.—Browning-Drake Corp., 353 Washington St.....	50	230.6	1300	Eastern
WLEN	Chicago, Ill. (Portable)—Wm. E. Hiler, 339 S. Homan Ave.....	50	204	1470	
WLBO	Galesburg, Ill.—Frederick Trebbe, Jr. (Divides time with WKBS).....	100	217.3	1380	Central
WLBP	Ashland, Ohio—Robert A. Fox.....	15	202.6	1480	Eastern
WLBQ	Atwood, Ill.—E. Dale Trout.....	25	202.6	1480	Central
WLBR	Belvedere, Ill.—Alford Radio Co.....	15	322.4	930	Central
WLBT	Crown Point, Ind.—Harold Wendell.....	50	322.4	930	Central
WLBV	Mansfield, Ohio—Mansfield Broadcasting As- soc.....	50	206.8	1450	Central



Radio Call Letters	BROADCAST STATIONS Location and Owner	Power Watts	Wave Length (Meters)	Frequency (Kilocycles)	Time at Station
<b>WL</b>	<b>WLBW—Oil City, Pa.—</b> Petroleum Telephone Co. . . . .	500	293.9	1020	Eastern
	<b>WLBX—Long Island City, N. Y.—</b> John N. Brahy, 283 Crescent St. (Divides time with WBS, WMBQ and WTRC). . . . .	250	204	1470	Eastern
	<b>WLBZ—Dover-Foxcroft, Me.—</b> Thompson L. Guernsey.	250	208.2	1440	Eastern
	<b>WLCI—Ithaca, N. Y.—</b> Lutheran Assoc. of Ithaca. . . . .	50	247.8	1210	Eastern
	<b>WLIB—Chicago, Ill.—</b> Liberty Weekly (Divides time with WGN). . . . .	500	305.9	980	Central
	<b>WLIT—Philadelphia, Pa.—</b> Lit Bros. (Divides time with WFI). . . . .	500	405.2	740	Eastern
	<b>WLS—Chicago, Ill.—</b> (Transmitter in Crete, Ill.)—Sears Roebuck & Co. (Divides time with WCBD). . . . .	5000	344.6	870	Central
	<b>WLSI—Cranston, R. I.—</b> Dutee W. Flint and Lincoln Studios, Inc., 335 Westminster St. (Divides time with WBSO). . . . .	500	384.4	780	Eastern
	<b>WLTH—Brooklyn, N. Y.—</b> Flatbush Radio Labs., 1421 E. 10 St. (Divides time with WKDQ and WKBO). . . . .	250	218.8	1370	Eastern
	<b>WLTS—Chicago, Ill.—</b> Lane Technical High School (Divides time with WCFL). . . . .	100	483.6	620	Central
	<b>WLW—Cincinnati, Ohio—</b> (Transmitter in Harrison)— Crosley Radio Corp. . . . .	5000	428.3	700	Central
	<b>WLWL—New York, N. Y.—</b> Paulist Fathers, 415 W. 59 St. (Divides time with WMCA). . . . .	1000	370.2	810	Eastern
<b>WM</b>	<b>WMAC—Cazenovia, N. Y.—</b> Clive B. Meredith (Divides time with WSYR). . . . .	500	225.4	1330	Eastern
	<b>WMAF—South Dartmouth, Mass.—</b> Round Hills Radio Corp. . . . .	500	428.3	700	Eastern
	<b>WMAK—Lockport, N. Y.—</b> Norton Labs. . . . .	750	545.1	550	Eastern
	<b>WMAL—Washington, D. C.—</b> M. A. Leese Radio Co., 720 Eleventh St., N. W. . . . .	120	302.8	990	Eastern
	<b>WMAN—Columbus, Ohio—</b> Heskett Radio Station, 507 N. High St. . . . .	50	234.2	1280	Eastern
	<b>WMAQ—Chicago, Ill.—</b> Chicago Daily News, 15 N. Wells St. (Divides time with WQJ). . . . .	1000	447.5	670	Central
	<b>WMAY—St. Louis, Mo.—</b> Kings Highway Presbyterian Church. . . . .	100	247.8	1210	Central
	<b>WMAZ—Macon, Ga.—</b> Mercer University (Divides time with WGST). . . . .	500	270.1	1110	Eastern
	<b>WMBA—Newport, R. I. (Portable)—</b> LeRoy Joseph Beebe. . . . .	100	204	1470	
	<b>WMBB—Chicago, Ill.—</b> American Bond & Mortgage Co., 6201 Cottage Grove Ave. (Divides time with WOK). . . . .	500	252	1190	Central
	<b>WMBC—Detroit, Mich.—</b> Michigan Broadcasting Co. . . . .	100	243.8	1230	Eastern
	<b>WMBD—Peoria Heights, Ill.—</b> Peoria Heights Radio Laboratory, 107 E. Glen Ave. . . . .	250	205.4	1460	Central
	<b>WMBE—St. Paul, Minn.—</b> Dr. C. S. Stevens, 2018 Grand Ave. . . . .	10	208.2	1440	Central
	<b>WMBF—Miami Beach, Fla.—</b> Fleetwood Hotel Corp. . . . .	500	384.4	780	Eastern
	<b>WMBG—Richmond, Va.—</b> Havens & Martin, 914 West Broad St. . . . .	15	206.8	1450	Eastern
	<b>WMBH—Chicago, Ill. (Portable)—</b> Edwin Dudley Aber, 1526 E. 53 St. . . . .	100	204	1470	
	<b>WMBI—Chicago, Ill.—</b> Moody Bible Inst. of Chicago, 153 Institute Place (Divides time with WJAZ)	500	263	1140	Central
	<b>WMBJ—Monessen, Pa.—</b> Wm. Roy McShaffrey. . . . .	50	232.4	1290	Eastern
	<b>WMBL—Lakeland, Fla.—</b> Benford Radio Studios, 14 Marble Arcade Bldg. . . . .	50	228.9	1310	Eastern
	<b>WMBM—Memphis, Tenn.—</b> Seventh Day Adventist Church. . . . .	10	209.7	1430	Central
	<b>WMBO—Auburn, N. Y.—</b> Radio Service Labs., 17 South St. . . . .	100	220.4	1360	Eastern

Radio Call Letters	BROADCAST STATIONS Location and Owner	Power Watts	Wave Length (Meters)	Frequency (Kilocycles)	Time at Station
<b>WM</b>	<b>WMBQ—Brooklyn, N. Y.</b> —Paul J. Gollhofer, 95 Leonard St. (Divides time with WTRC, WIBS and WLBX).....	100	204	1470	Eastern
	<b>WMBR—Tampa, Fla.</b> —F. J. Reynolds .....	100	252	1190	Eastern
	<b>WMBS—Harrisburg, Pa.</b> (Transmitter in Lemoyne)—Mack Battery Co. ....	250	234.2	1280	Eastern
	<b>WMBU—Pittsburgh, Pa.</b> —Paul J. Miller, 1133 Creedmoor Ave. ....	50	217.3	1380	Eastern
	<b>WMBW—Youngstown, Ohio</b> —Youngstown Broadcasting Co., 647 Market St. (Divides time with WKBN).....	50	214.2	1400	Eastern
	<b>WMBY—Bloomington, Ill.</b> —R. A. Isaacs, 108 E. Front St. (Divides time with WNBL).....	15	199.9	1500	Central
	<b>WMC—Memphis, Tenn.</b> —The Commercial Pub. Co., Commercial Appeal Bldg. ....	500	516.9	580	Central
	<b>WMCA—New York, N. Y.</b> —(Transmitter in Hoboken, N. J.)—Associated Broadcasters, Inc., Hotel McAlpin (Divides time with WLWL).....	500	370.2	810	Eastern
	<b>WMCO—Detroit, Mich.</b> —Transmitter in Saginaw, W. T. Thomas Radio Co., Whittier Hotel (Divides time with WAFD) .....	250	218.8	1370	Eastern
	<b>WMES—Boston, Mass.</b> —Educational Society, Barristers Hall.....	100	211.1	1420	Eastern
	<b>WMPC—Lapeer, Mich.</b> —First Methodist Protestant Church .....	30	234.2	1280	Eastern
	<b>WMRJ—Jamaica, N. Y.</b> —Peter J. Prinz, 10 New York Blvd. (Divides time with WTRL and WHPP) .....	10	206.8	1450	Eastern
	<b>WMSG—New York, N. Y.</b> —Madison Square Garden Broadcasting Corp., 319 W. 49 St. (Divides time with WBNY and WHAP).....	500	236.1	1270	Eastern
<b>WN</b>	<b>WNAC—Boston, Mass.</b> —The Shepard Stores .....	500	352.7	850	Eastern
	<b>WNAD—Norman, Okla.</b> —University of Oklahoma.....	500	239.9	1250	Central
	<b>WNAL—Omaha, Nebr.</b> —R. J. Rockwell, 5019 Capital Ave. (Divides time with KOCH and KFOX) ..	250	258.5	1160	Central
	<b>WNAT—Philadelphia, Pa.</b> —Lennig Bros. Co., Spring Garden and 9 Sts. (Divides time with WRAX) ..	100	288.3	1040	Eastern
	<b>WNAX—Yankton, S. D.</b> —Gurney Seed & Nursery Co. ...	250	302.8	990	Central
	<b>WNBA—Forest Park, Ill.</b> —M. T. Rafferty, 810 Desplaines Ave. ....	200	208.2	1440	Central
	<b>WNBF—Endicott, N. Y.</b> —Howitt-Wood Radio Co., 117 W. Main St. ....	50	206.8	1450	Eastern
	<b>WNBH—New Bedford, Mass.</b> —New Bedford Broadcasting Co. ....	250	260.7	1150	Eastern
	<b>WNBK—Knoxville, Tenn.</b> —Lonsdale Baptist Church... ..	50	206.8	1450	Central
	<b>WNBL—Bloomington, Ill.</b> —Harvey R. Storm, 107 E. Front St. (Divides time with WMBY).....	15	199.9	1500	Central
	<b>WNBO—Washington, Pa.</b> —John B. Spriggs, 319 E. Bean St. ....	15	211.1	1420	Eastern
	<b>WNBQ—Rochester, N. Y.</b> —Gordon P. Brown, 192 S. Goodman St. ....	15	202.6	1480	Eastern
	<b>WNBR—Memphis, Tenn.</b> —Popular Radio Shop, 883 Poplar Ave. ....	20	228.9	1310	Central
	<b>WNBW—Carbondale, Pa.</b> —Home Cut Glass & China Co., 21 Salem Ave. ....	5	258.5	1160	Eastern
	<b>WNBX—Springfield, Vt.</b> —First Congregational Church .....	10	241.8	1240	Eastern
	<b>WNJ—Newark, N. J.</b> —Herman Lubinsky, 89 Lehigh Ave. (Divides time with WGCP).....	500	280.2	1070	Eastern
	<b>WNOX—Knoxville, Tenn.</b> —People's Telephone and Telegraph Co., 313 Commerce Ave. ....	1000	265.3	1130	Central
	<b>WNRC—Greensboro, N. C.</b> —Wayne M. Nelson .....	500	223.7	1340	Eastern
	<b>WNYC—New York, N. Y.</b> —Dept. of Plants and Structures, Municipal Bldg. ....	500	535.4	560	Eastern
<b>WO</b>	<b>WOAI—San Antonio, Tex.</b> —Southern Equipment Co. ...	5000	302.8	990	Central
	<b>WOAN—Lawrenceburg, Tenn.</b> —Jas. D. Vaughn .....	250	285.5	1050	Central
	<b>WOAX—Trenton, N. J.</b> —Franklyn J. Wolf, The Monument Pottery Co. (Divides time with WEAM) ..	500	239.9	1250	Eastern
	<b>WOBR—Shelby, Ohio (Portable)</b> —Earl Smith.....	10	204	1470	

Radio Call Letters	BROADCAST STATIONS Location and Owner	Power Watts	Wave Length (Meters)	Frequency (Kilocycles)	Time at Station
<b>WO</b> WOC	Davenport, Iowa—The Palmer School of Chiropractic, 1002 Brady St.	5000	352.7	850	Central
WOCL	Jamestown, N. Y.—A. E. Newton	25	223.7	1340	Eastern
WODA	Paterson, N. J.—James K. O'Dea, Inc., 115 Ellison St. (Divides time with WGL)	1000	293.9	1020	Eastern
WOI	Ames, Iowa—Iowa State College (5000 watts daytime 6 to 6) (Divides time with WSUI)	2500	265.3	1130	Central
WOK	Chicago, Ill.—(Transmitter in Homewood)—Trianon, Inc. (Divides time with WMBB)	5000	252	1190	Central
WOKO	Peekskill, N. Y.—Harold E. Smith	250	215.7	1390	Eastern
WOKT	Rochester, N. Y.—Titus-Ets. Corp.	500	209.7	1430	Eastern
WOMT	Manitowoc, Wis.—Mikadow Theatre	50	222.1	1350	Central
WOO	Philadelphia, Pa.—John Wanamaker (Divides time with WIP)	500	508.2	590	Eastern
WOOD	Furnwood, Mich.—Walter B. Stiles	500	260.7	1150	Central
WOQ	Kansas City, Mo.—Unity School of Christianity, (500 watts Daytime) (Divides time with WHB)	250	336.9	890	Central
WOR	Newark, N. J.—(Transmitter in Kearney)—L. Bamberger & Co.	5000	422.3	710	Eastern
WORD	Batavia, Ill.—People's Pulpit Assoc., 124 Columbia Heights, Brooklyn, N. Y. (Divides time with WTAS)	5000	275.1	1090	Central
WOS	Jefferson City, Mo.—Missouri State Marketing Bureau	500	468.5	640	Central
WOW	Omaha, Nebr.—Woodmen of the World Life Insurance Assoc.	1000	508.2	590	Central
WOWO	Fort Wayne, Ind.—The Main Auto Supply Co., 213 W. Main St. (Divides time with WCWK)	1000	228.9	1310	Central
<b>WP</b> WPAP	Cliffside, N. J.—Palisades Amusement Park (Divides time with WHN)	500	394.5	760	Eastern
WPCC	Chicago, Ill.—North Shore Congregational Church	500	223.7	1340	Central
WPCH	New York, N. Y.—Concourse Radio Corp., Park Central Hotel (Divides time with WRNY)	500	309.1	970	Eastern
WPEP	Waukegan, Ill.—Maurice Mayer	250	215.7	1390	Central
WPG	Atlantic City, N. J.—Municipality of Atlantic City (Divides time with WHAR)	5000	272.6	1100	Eastern
WPRC	Harrisburg, Pa.—Wilson Printing & Radio Co., Fifth and Kelker Sts.	100	209.7	1430	Eastern
WPSC	State College, Pa.—Pennsylvania State College (Divides time with WBAK)	500	299.8	1000	Eastern
WPSW	Philadelphia, Pa.—Philadelphia School of Wireless Telegraphy	50	202.6	1480	Eastern
<b>WQ</b> WQAA	Parkersburg, Pa.—Horace A. Beale, Jr.	500	215.7	1390	Eastern
WQAE	Springfield, Vt.—Moore Radio News Station	50	249.9	1200	Eastern
WQAM	Miami, Fla.—Electrical Equipment Co., 42 Northwest Fourth St.	750	322.4	930	Eastern
WQAN	Scranton, Pa.—Scranton Times (Divides time with WGBI)	250	230.6	1300	Eastern
WQAO	Cliffside, N. J.—Calvary Baptist Church (Divides time with WHN)	500	394.5	760	Eastern
WQJ	Chicago, Ill.—Calumet Rainbo Broadcasting Co. (Divides time with WMAQ)	500	447.5	670	Central
<b>WR</b> WRAF	Laport, Ind.—The Radio Club, Inc., 719 Michigan Ave.	100	208.2	1440	Central
WRAH	Providence, R. I.—Stanley N. Read, 191 Alabama Ave.	250	199.9	1500	Eastern

Radio Call Letters	BROADCAST STATIONS Location and Owner	Power Watts	Wave Length (Meters)	Frequency (Kilocycles)	Time at Station
<b>WR</b>	<b>WRAK</b> —Escanaba, Mich.—Economy Light Co., 1105 Ludington St.	50	282.8	1060	Central
	<b>WRAM</b> —Galesburg, Ill.—Lombard College (Divides time with WFBZ)	50	247.8	1210	Central
	<b>WRAV</b> —Yellow Springs, Ohio—Antioch College	100	340.7	880	Central
	<b>WRAW</b> —Reading, Pa.—Avenue Radio & Elec. Shop, 460 Schuylkill Ave.	100	238	1260	Eastern
	<b>WRAX</b> —Philadelphia, Pa.—Berachach Church, Inc., 1608 Allegheny Ave. (Divides time with WNAT)	250	288.3	1040	Eastern
	<b>WRBC</b> —Valparaiso, Ind.—Immanuel Lutheran Church	250	238	1260	Central
	<b>WRC</b> —Washington, D. C.—Radio Corp. of America	500	468.5	640	Eastern
	<b>WRCO</b> —Raleigh, N. C.—Wynne Radio Co., 226½ Fayetteville St.	250	217.3	1380	Eastern
	<b>WRCV</b> —Norfolk, Va.—Radio Corp. of Virginia	100	209.7	1430	Eastern
	<b>WREC</b> —Memphis, Tenn.—WREC, Inc.	50	254.1	1180	Central
	<b>WREN</b> —Lawrence, Kans.—Jenny Wren, Inc. (Divides time with KFKU)	750	254.1	1180	Central
	<b>WREO</b> —Lansing, Mich.—Reo Motor Car Co.	500	230.6	1300	Eastern
	<b>WRES</b> —Quincy, Mass.—Harry L. Sawyer, 335A Newport Ave.	50	217.3	1380	Eastern
	<b>WRHF</b> —Washington, D. C.—Washington Radio Hospital Fund, 525 11 St., N. W. (Daytime only)	150	319	940	Eastern
	<b>WRHM</b> —Minneapolis, Minn.—Rosedale Hospital Co., Andrews Hotel (Divides time with WDGY)	1000	260.7	1150	Central
	<b>WRK</b> —Hamilton, Ohio—Doron Bros. Elec. Co., 3 Railroad St.	100	205.4	1460	Central
	<b>WRM</b> —Urbana, Ill.—University of Illinois (1000 watts before 6 P. M.) (Divides time with WBAA)	500	272.6	1100	Central
	<b>WRMU</b> —New York, N. Y. (Portable)—Atlantic Broadcasting Corp., 113 W. 57th St.	100	201.2	1490	
	<b>WRNY</b> —New York, N. Y.—(Transmitter in Coytesville, N. J.)—Experimenter Pub. Co., 230—5th Ave. (Divides time with WPCH)	500	309.1	970	Eastern
	<b>WRPI</b> —Terre Haute, Ind.—Rose Polytechnic Inst.	100	208.2	1440	Central
	<b>WRR</b> —Dallas, Tex.—City of Dallas, Police and Fire Signal Dept.	500	352.7	850	Central
	<b>WRRS</b> —Racine, Wis.—Racine Radio Co.	50	322.4	930	Central
	<b>WRSC</b> —Chelsea, Mass.—Wm. S. Pote	15	205.4	1460	Eastern
	<b>WRST</b> —Bay Shore, N. Y.—Radiotel Mfg. Co., Carleton Theatre (Divides time with WCDA, WBRB and WCGU)	250	211.1	1420	Eastern
	<b>WRVA</b> —Richmond, Va.—Larus & Brother Co., 22nd and Cory Sts.	1000	254.1	1180	Eastern
<b>WS</b>	<b>WSAI</b> —Cincinnati, Ohio (Transmitter in Mason)—United States Playing Card Co.	5000	361.2	830	Central
	<b>WSAJ</b> —Grove City, Pa.—Grove City College	250	223.7	1340	Eastern
	<b>WSAN</b> —Allentown, Pa.—Allentown Call Pub. Co. (Divides time with WCBA)	100	222.1	1350	Eastern
	<b>WSAR</b> —Portsmouth, R. I.—Doughty & Welch Elec. Co., 46 N. Main St.	100	252	1190	Eastern
	<b>WSAX</b> —Chicago, Ill. (Portable)—Zenith Radio Corp., 332 So. Michigan Ave.	100	204	1470	
	<b>WSAZ</b> —Huntington, W. Va.—McKeller Elec. Co.	100	241.8	1240	Eastern
	<b>WSB</b> —Atlanta, Ga.—The Atlanta Journal	1000	475.9	630	Central
	<b>WSBC</b> —Chicago, Ill.—World Battery Co., 1219 South Wabash Ave. (Divides time with WWAE)	500	232.4	1290	Central
	<b>WSBF</b> —St. Louis, Mo.—Mississippi Valley Broadcasting Co., 6th and Washington Sts.	250	440.9	680	Central
	<b>WSBT</b> —South Bend, Ind.—South Bend Tribune (Divides time with WEMC)	500	238	1260	Central

Radio Call Letters	BROADCAST STATIONS Location and Owner	Power Watts	Wave Length (Meters)	Frequency (Kilocycles)	Time at Station
<b>WS</b>	<b>WSDA—New York, N. Y.—</b> Seventh Day Adventist Church, 120 St. and Lenox Ave. (Divides time with WARS and WBBC).....	250	227.1	1320	Eastern
	<b>WSEA—Virginia Beach, Va.—</b> Virginia Beach Broadcasting Co., 17th St. and Atlantic Ave.....	500	218.8	1370	Eastern
	<b>WSIX—Springfield, Tenn.—</b> Tire & Vulc. Co.....	150	212.6	1410	Central
	<b>WSKC—Bay City, Mich.—</b> World's Star Knitting Co...	250	491.5	610	Eastern
	<b>WSM—Nashville, Tenn.—</b> The National Life & Accident Ins. Co.....	5000	340.7	880	Central
	<b>WSMB—New Orleans, La.—</b> Saenger Amusement Co...	500	322.4	930	Central
	<b>WSMK—Dayton, Ohio—</b> S. M. K. Radio Corp., 39 E. 3rd St.....	200	296.9	1010	Eastern
	<b>WSOE—Milwaukee, Wis.—</b> School of Engineering, 415 Marshall St.....	500	270.1	1110	Central
	<b>WSOM—New York, N. Y.—</b> Union Course Labs. (Divides time with WGBB and WAAT).....	500	245.8	1220	Eastern
	<b>WSRO—Hamilton, Ohio—</b> H. W. Fahrlander, 421 High St.....	100	384.4	780	Central
	<b>WSSH—Boston, Mass.—</b> Tremont Temple Baptist Church.....	1000	249.9	1200	Eastern
	<b>WSUI—Iowa City, Iowa—</b> State University of Iowa (Divides time with WOI).....	500	422.3	710	Central
	<b>WSVS—Buffalo, N. Y.—</b> Seneca Vocational School, 666 E. Delavan Ave. (Divides time with WKEN).	50	205.4	1460	Eastern
	<b>WSYR—Syracuse, N. Y.—</b> Clive B. Meredith, Hotel Syracuse (Divides time with WMAC).....	500	225.4	1330	Eastern
<b>WT</b>	<b>WTAD—Quincy, Ill.—</b> Illinois Stock Medicine Broadcasting Corp.....	250	236.1	1270	Central
	<b>WTAG—Worcester, Mass.—</b> Worcester Telegram Pub. Co., 18 Franklin St.....	500	516.9	580	Eastern
	<b>WTAL—Toledo, Ohio—</b> Toledo Broadcasting Co., Hotel Waldorf (Divides time with WABR).....	100	280.2	1070	Eastern
	<b>WTAM—Cleveland, Ohio—</b> Willard Storage Battery Co. (Divides time with WEAR) (5000 watts Day-time).....	3500	399.8	750	Eastern
	<b>WTAQ—Eau Claire, Wis.—</b> C. S. Van Gorden.....	500	254.1	1180	Central
	<b>WTAR—Norfolk, Va.—</b> Reliance Elec. Co., 519 W. 21 St.	500	275.1	1090	Eastern
	<b>WTAS—Batavia, Ill.—</b> Richmond, Harris & Co.....	3500	275.1	1090	Central
	<b>WTAW—College Station, Tex.—</b> Agricultural & Mechanical College of Texas.....	500	309.1	970	Central
	<b>WTAX—Streator, Ill.—</b> Williams Hardware Co., 115 So. Vermillion St.....	50	322.4	930	Central
	<b>WTAZ—Lambertville, N. J.—</b> Thos. J. McGuire.....	15	220.4	1360	Eastern
	<b>WTFF—Mount Vernon Hills, Va.—</b> Independent Publishing Co.....	50	204	1470	Pacific
	<b>WTIC—Hartford, Conn.—</b> Travelers Ins. Co.....	500	475.9	630	Eastern
	<b>WTMJ—Milwaukee, Wis.—</b> Radio Service Corp. (Divides time with WHAD).....	1000	293.9	1020	Central
	<b>WTRL—Midland Park, N. J.—</b> Technical Radio Labs. (Divides time with WMRJ and WHPP).....	15	206.8	1450	Eastern
<b>WW</b>	<b>WWAE—Chicago, Ill.—</b> Lawrence J. Crowley (Divides time with WSBC).....	500	232.4	1290	Central
	<b>WWJ—Detroit, Mich.—</b> Evening News Assoc.....	1000	374.8	800	Eastern
	<b>WWL—New Orleans, La.—</b> Loyola University.....	100	275.1	1090	Central
	<b>WWNC—Asheville, N. C.—</b> Asheville Chamber of Commerce, 101 Patton Ave.....	1000	296.9	1010	Central
	<b>WWRL—New York, N. Y.—</b> W. H. Reuman 1587 Broadway (Divides time with WBKN, WJBI, WIBI and WBMS).....	100	267.7	1120	Eastern
	<b>WWVA—Wheeling, W. Va.—</b> John C. Stroebel, Jr.....	100	389.4	770	Eastern

*This list has been corrected up to and including August 15, 1927*

# RADIO BROADCAST STATIONS OF THE UNITED STATES

By Wavelengths and Frequencies

Meters	Kilocycles	Power	Call Letters	Location	Meters	Kilocycles	Power	Call Letters	Location
199.9	1500	15	KGFN	Aneta, N. Dak.	205.4	1460	15	WKBL	Monroe, Mich.
199.9	1500	5	KOLO	Durango, Colo.	205.4	1460	250	WMBD	Peoria Heights, Ill.
199.9	1500	10	KUJ	Seattle, Wash.	205.4	1460	100	WRK	Hamilton, O.
199.9	1500	15	KWBS	Portland, Ore.	205.4	1460	15	WRSC	Chelsea, Mass.
199.9	1500	15	WKBZ	Ludington, Mich.	205.4	1460	50	WSVS	Buffalo, N. Y.
199.9	1500	15	WMBY	Bloomington, Ill.	206.8	1450	100	KGDW	Humboldt, Nebr.
199.9	1500	15	WNBL	Bloomington, Ill.	206.8	1450	15	KGDY	Oldham, S. Dak.
199.9	1500	250	WRAH	Providence, R. I.	206.8	1450	50	KGTT	San Francisco, Cal.
201.2	1490	50	KGEH	Eugene, Ore.	206.8	1450	10	KLIT	Portland, Ore.
201.2	1490	15	KGEY	Denver, Colo.	206.8	1450	10	WHPP	New York, N. Y.
201.2	1490	50	WALK	Willow Grove, Pa.	206.8	1450	50	WLBV	Mansfield, Ohio
201.2	1490	100	WATT	Boston, Mass.	206.8	1450	15	WMBG	Richmond, Va.
201.2	1490	100	WCBR	Providence, R. I.	206.8	1450	10	WMRJ	Jamaica, N. Y.
201.2	1490	100	WGMU	New York, N. Y.	206.8	1450	50	WNBF	Endicott, N. Y.
201.2	1490	100	WHBM	Chicago, Ill.	206.8	1450	50	WNBJ	Knoxville, Tenn.
201.2	1490	100	WIBJ	Chicago, Ill.	206.8	1450	15	WTRL	Midland Park, N. J.
201.2	1490	100	WIBM	Chicago, Ill.	208.2	1440	100	KFIQ	Yakima, Wash.
201.2	1490	100	WKBG	Chicago, Ill.	208.2	1440	250	KFVD	Venice, Calif.
201.2	1490	100	WRMU	New York, N. Y.	208.2	1440	50	KGCN	Concordia, Kans.
202.6	1480	100	KGBS	Seattle, Wash.	208.2	1440	15	KGCR	Brookings, S. Dak.
202.6	1480	50	KGBY	Shelby, Nebr.	208.2	1440	100	KGCU	Mandan, N. Dak.
202.6	1480	10	KGDJ	Cresco, Iowa	208.2	1440	100	KGFJ	Los Angeles, Calif.
202.6	1480	15	KGDR	San Antonio, Tex.	208.2	1440	50	WGM	Jeanette, Pa.
202.6	1480	50	KGEQ	Minneapolis, Minn.	208.2	1440	100	WJBZ	Chicago Heights, Ill.
202.6	1480	15	WLBP	Ashland, Ohio	208.2	1440	50	WJPW	Ashtabula, Ohio
202.6	1480	25	WLBQ	Atwood, Ill.	208.2	1440	100	WKBM	Newburgh, N. Y.
202.6	1480	15	WNBQ	Rochester, N. Y.	208.2	1440	250	WLBZ	Dover-Foxcroft, Me.
202.6	1480	50	WPSW	Philadelphia, Pa.	208.2	1440	10	WMBE	St. Paul, Minn.
204	1470	15	KFXD	Jerome, Utah	208.2	1440	200	WNBA	Forest Park, Ill.
204	1470	10	KGES	Central City, Nebr.	208.2	1440	100	WRAF	Laport, Ind.
204	1470	100	KGFO	Terre Haute, Ind.	208.2	1440	100	WRPI	Terre Haute, Ind.
204	1470	100	WBBZ	Chicago, Ill.	209.7	1430	10	KFGQ	Boone, Iowa
204	1470	100	WHBL	Chicago, Ill.	209.7	1430	250	KSOO	Sioux Falls, S. D.
204	1470	150	WIBS	Elizabeth, N. J.	209.7	1430	50	KVOS	Seattle, Wash.
204	1470	100	WIBW	Chicago, Ill.	209.7	1430	250	WCBS	Springfield, Ill.
204	1470	50	WKBU	New Castle, Pa.	209.7	1430	50	WLBC	Muncie, Ind.
204	1470	250	WKEN	Buffalo, N. Y.	209.7	1430	50	WLBF	Kansas City, Mo.
204	1470	50	WLBN	Chicago, Ill.	209.7	1430	50	WLBY	Iron Mountain, Mich.
204	1470	250	WLBX	Long Island City, N. Y.	209.7	1430	10	WMBM	Memphis, Tenn.
204	1470	100	WMBA	Newport, R. I.	209.7	1430	500	WOKT	Rochester, N. Y.
204	1470	100	WMBH	Chicago, Ill.	209.7	1430	100	WPRC	Harrisburg, Pa.
204	1470	100	WMBQ	Brooklyn, N. Y.	209.7	1430	100	WRCV	Norfolk, Va.
204	1470	10	WOBR	Shelby, Ohio	211.1	1420	50	KFCR	Santa Barbara, Cal.
204	1470	100	WSAX	Chicago, Ill.	211.1	1420	15	KGFM	Yuba City, Calif.
204	1470	50	WTFE	Mt. Vernon Hills, Va.	211.1	1420	100	KPNP	Muscatine, Iowa
205.4	1460	25	KFXE	Flagstaff, Ariz.	211.1	1420	50	KRSC	Seattle, Wash.
205.4	1460	50	KGDE	Barrett, Minn.	211.1	1420	100	WBMH	Detroit, Mich.
205.4	1460	100	KGEO	Grand Island, Nebr.	211.1	1420	100	WBRS	Brooklyn, N. Y.
205.4	1460	100	KGEZ	Kalispell, Mont.	211.1	1420	250	WCDA	Cliffside, N. J.
205.4	1460	25	KGFF	Alva, Okla.	211.1	1420	500	WCGU	NEW YORK, N. Y.
205.4	1460	250	WABF	Pringleboro, Pa.	211.1	1420	100	WMES	Boston, Mass.
205.4	1460	10	WFKD	Philadelphia, Pa.	211.1	1420	15	WNBO	Washington, Pa.

Meters	Kilocycles	Power	Call Letters	Location	Meters	Kilocycles	Power	Call Letters	Location
211.1	1420	250	WRST	Bay Shore, N. Y.	220.4	1360	50	KJBS	San Francisco, Cal.
212.6	1410	10	KFHL	Oskaloosa, Iowa	220.4	1360	50	KRAC	Shreveport, La.
212.6	1410	100	KGBZ	York, Nebr.	220.4	1360	50	KXL	Portland, Ore.
212.6	1410	250	KGDY	Shreveport, La.	220.4	1360	15	WHBU	Anderson, Ind.
212.6	1410	10	KGFP	Mitchell, S. Dak.	220.4	1360	50	WHBW	Philadelphia, Pa.
212.6	1410	5	KTUE	Houston, Tex.	220.4	1360	100	WIAD	Philadelphia, Pa.
212.6	1410	1000	WFLA	Boca Raton, Fla.	220.4	1360	15	WJBK	Ypsilanti, Mich.
212.6	1410	250	WJBL	Decatur, Ill.	220.4	1360	500	WKBH	LaCrosse, Wis.
212.6	1410	50	WKBP	Battle Creek, Mich.	220.4	1360	100	WMBO	Auburn, N. Y.
212.6	1410	150	WSIX	Springfield, Tenn.	220.4	1360	15	WTAZ	Lambertville, N. J.
214.2	1400	50	KFEC	Portland, Ore.	222.1	1350	100	KFWC	San Bernardino, Cal.
214.2	1400	50	KFIF	Portland, Ore.	222.1	1350	50	KGFL	Trinidad, Colo.
214.2	1400	250	KFWF	St. Louis, Mo.	222.1	1350	100	KWKC	Kansas City, Mo.
214.2	1400	15	KPJM	Prescott, Ariz.	222.1	1350	100	WCBA	Allentown, Pa.
214.2	1400	10	WAIT	Taunton, Mass.	222.1	1350	100	WHBD	Bellefontaine, O.
214.2	1400	100	WCWS	Danbury, Conn.	222.1	1350	100	WHBF	Rock Island, Ill.
214.2	1400	250	WICC	Bridgeport, Conn.	222.1	1350	50	WOMT	Manitowoc, Wis.
214.2	1400	100	WJBU	Lewisburg, Pa.	222.1	1350	100	WSAN	Allentown, Pa.
214.2	1400	50	WKBN	Youngstown, Ohio	223.7	1340	100	KFBL	Everett, Wash.
214.2	1400	100	WLBG	Petersburg, Va.	223.7	1340	50	KFVS	Cape Girardeau, Mo.
214.2	1400	50	WMBW	Youngstown, Ohio	223.7	1340	50	KFXR	Oklahoma City, Okla.
215.7	1390	10	KFDZ	Minneapolis, Minn.	223.7	1340	100	KGCG	Newark, Ark.
215.7	1390	15	KFXJ	Edgewater, Colo.	223.7	1340	15	KGDP	Pueblo, Colo.
215.7	1390	50	KGCB	Oklahoma City, Okla.	223.7	1340	10	KGFB	Iowa City, Iowa
215.7	1390	100	KGER	Long Beach, Calif.	223.7	1340	250	KGFB	La Crescenta, Calif.
215.7	1390	50	KGFG	Oklahoma City, Okla.	223.7	1340	50	KGFK	Hallock, Minn.
215.7	1390	250	KRLO	Los Angeles, Calif.	223.7	1340	250	KMIC	Inglewood, Calif.
215.7	1390	5	WAGS	Somerville, Mass.	223.7	1340	500	WCAM	Camden, N. J.
215.7	1390	150	WCLS	Joliet, Ill.	223.7	1340	500	WCRW	Chicago, Ill.
215.7	1390	50	WDBZ	Kingston, N. Y.	223.7	1340	15	WEBQ	Harrisburg, Ill.
215.7	1390	100	WEHS	Evanston, Ill.	223.7	1340	500	WFKB	Chicago, Ill.
215.7	1390	200	WHFC	Chicago, Ill.	223.7	1340	50	WKAV	Laconia, N. H.
215.7	1390	150	WKBB	Joliet, Ill.	223.7	1340	500	WNRC	Greensboro, N. C.
215.7	1390	250	WOKO	Peekskill, N. Y.	223.7	1340	25	WOCL	Jamestown, N. Y.
215.7	1390	250	WPEP	Waukegan, Ill.	223.7	1340	500	WPCC	Chicago, Ill.
215.7	1390	500	WQAA	Parkersburg, Pa.	223.7	1340	250	WSAJ	Grove City, Pa.
217.3	1380	100	KFOR	Lincoln, Nebr.	225.4	1330	15	KFKZ	Kirksville, Mo.
217.3	1380	100	KFOW	Seattle, Wash.	225.4	1330	50	KFUR	Ogden, Utah
217.3	1380	10	KGDM	Stockton, Calif.	225.4	1330	50	KFVG	Independence, Kans.
217.3	1380	20	WIBU	Poynette, Wis.	225.4	1330	15	KGEN	El Centro, Calif.
217.3	1380	100	WKBS	Galesburg, Ill.	225.4	1330	50	WAGM	Royal Oak, Mich.
217.3	1380	100	WKBV	Brookville, Ind.	225.4	1330	500	WAMD	Minneapolis, Minn.
217.3	1380	500	WKBW	Buffalo, N. Y.	225.4	1330	50	WCOT	Olneyville, R. I.
217.3	1380	100	WLBO	Galesburg, Ill.	225.4	1330	500	WDAD	Nashville, Tenn.
217.3	1380	50	WMBU	Pittsburgh, Pa.	225.4	1330	250	WFBM	Indianapolis, Ind.
217.3	1380	250	WRCO	Raleigh, N. C.	225.4	1330	100	WFBR	Baltimore, Md.
217.3	1380	50	WRES	Quincy, Mass.	225.4	1330	50	WFCI	Pawtucket, R. I.
218.8	1370	250	KFWO	Avalon, Catalina Is., Cal.	225.4	1330	500	WLAC	Nashville, Tenn.
218.8	1370	10	KGEW	Fort Morgan, Colo.	225.4	1330	500	WMAC	Cazenovia, N. Y.
218.8	1370	500	WGWB	Milwaukee, Wis.	225.4	1330	500	WSYR	Syracuse, N. Y.
218.8	1370	10	WKBC	Birmingham, Ala.	227.1	1320	100	KFUP	Denver, Colo.
218.8	1370	500	WKBO	Jersey City, N. J.	227.1	1320	50	KGEU	Lower Lake, Calif.
218.8	1370	500	WKBQ	New York, N. Y.	227.1	1320	500	KSO	Clarinda, Iowa
218.8	1370	250	WLTH	Brooklyn, N. Y.	227.1	1320	500	WARS	Brooklyn, N. Y.
218.8	1370	250	WMCO	Detroit, Mich.	227.1	1320	500	WBBC	Brooklyn, N. Y.
218.8	1370	500	WSEA	Virginia Beach, Va.	227.1	1320	5	WCBE	New Orleans, La.
220.4	1360	15	KGCI	San Antonio, Tex.	227.1	1320	100	WCLO	Camp Lake, Wis.
220.4	1360	15	KGFI	San Angelo, Tex.	227.1	1320	250	WDBK	Cleveland, O.
220.4	1360	50	KGRC	San Antonio, Tex.	227.1	1320	500	WJAY	Cleveland, Ohio

Meters	Kilocycles	Power	Call Letters	Location	Meters	Kilocycles	Power	Call Letters	Location
227.1	1320	100	WJBC	LaSalle, Ill.	236.1	1270	500	WMSG	New York, N. Y.
227.1	1320	100	WJBR	Omro, Wis.	236.1	1270	250	WTAD	Quincy, Ill.
227.1	1320	250	WSDA	New York, N. Y.	238	1260	15	KFBS	Trinidad, Colo.
228.9	1310	250	KELW	Burbank, Calif.	238	1260	50	KFVI	Houston, Tex.
228.9	1310	100	KFVN	Fairmont, Minn.	238	1260	25	KFYF	Oxnard, Cal.
228.9	1310	50	KPPC	Pasadena, Calif.	238	1260	1500	KLDS	Independence, Mo.
228.9	1310	20	KTAP	San Antonio, Tex.	238	1260	100	WCOM	Manchester, N. H.
228.9	1310	50	KWJJ	Portland, Ore.	238	1260	150	WIBX	Utica, N. Y.
228.9	1310	500	WCWK	Fort Wayne, Ind.	238	1260	30	WJBW	New Orleans, La.
228.9	1310	250	WHBP	Johnstown, Pa.	238	1260	250	WLBI	East Wenona, Ill.
228.9	1310	100	WKBE	Webster, Mass.	238	1260	100	WRAW	Reading, Pa.
228.9	1310	50	WMBL	Lakeland, Fla.	238	1260	250	WRBC	Valparaiso, Ind.
228.9	1310	20	WNBR	Memphis, Tenn.	238	1260	500	WSBT	South Bend, Ind.
228.9	1310	1000	WOWO	Ft. Wayne, Ind.	239.9	1250	2500	KEX	Portland, Ore.
230.6	1300	1000	KFEQ	St. Joseph, Mo.	239.9	1250	100	KFJY	Fort Dodge, Ia.
230.6	1300	15	KFPM	Greenville, Tex.	239.9	1250	250	KFYR	Bismarck, N. D.
230.6	1300	50	KGCL	Seattle, Wash.	239.9	1250	100	WBBP	Petoskey, Mich.
230.6	1300	50	KPCB	Seattle, Wash.	239.9	1250	250	WEAM	No. Plainfield, N. J.
230.6	1300	100	WCOC	Columbus, Miss.	239.9	1250	100	WIBA	Madison, Wis.
230.6	1300	250	WDBJ	Roanoke, Va.	239.9	1250	500	WNAD	Norman, Okla.
230.6	1300	250	WGBI	Scranton, Pa.	239.9	1250	500	WOAX	Trenton, N. J.
230.6	1300	15	WIBZ	Montgomery, Ala.	241.8	1240	1500	KFKB	Milford, Kans.
230.6	1300	50	WLBM	Boston, Mass.	241.8	1240	500	KFON	Long Beach, Calif.
230.6	1300	250	WQAN	Scranton, Pa.	241.8	1240	100	KFXH	El Paso, Tex.
230.6	1300	500	WREO	Lansing, Mich.	241.8	1240	100	WCBH	Oxford, Miss.
232.4	1290	10	KFEY	Kellogg, Idaho	241.8	1240	250	WEBC	Superior, Wis.
232.4	1290	250	KFPR	Los Angeles, Cal.	241.8	1240	200	WEBR	Buffalo, N. Y.
232.4	1290	100	KFQZ	Hollywood, Cal.	241.8	1240	500	WEDC	Chicago, Ill.
232.4	1290	500	KUT	Austin, Tex.	241.8	1240	500	WGES	Chicago, Ill.
232.4	1290	100	WABO	Rochester, N. Y.	241.8	1240	10	WNBX	Springfield, Vt.
232.4	1290	500	WBRL	Tilton, N. H.	241.8	1240	100	WSAZ	Huntington, W. Va.
232.4	1290	100	WHBQ	Memphis, Tenn.	243.8	1230	125	KFCB	Phoenix, Ariz.
232.4	1290	100	WHEC	Rochester, N. Y.	243.8	1230	10	KGCX	Vida, Mont.
232.4	1290	30	WLBH	Farmingdale, N. Y.	243.8	1230	150	KGRS	Amarillo, Tex.
232.4	1290	50	WMBJ	Monessen, Pa.	243.8	1230	50	KGY	Lacey, Wash.
232.4	1290	500	WSBC	Chicago, Ill.	243.8	1230	500	KSCJ	Sioux City, Iowa
232.4	1290	500	WWAE	Chicago, Ill.	243.8	1230	1500	KWUC	Le Mars, Iowa
234.2	1280	1000	KFVE	St. Louis, Mo.	243.8	1230	250	WBRC	Birmingham, Ala.
234.2	1280	100	KGAR	Tucson, Ariz.	243.8	1230	100	WMBC	Detroit, Mich.
234.2	1280	15	KGDA	Dell Rapids, S. Dak.	245.8	1220	500	KFH	Wichita, Kans.
234.2	1280	50	KVI	Tacoma, Wash.	245.8	1220	100	KFIO	Spokane, Wash.
234.2	1280	100	WDAH	El Paso, Tex.	245.8	1220	250	KFPY	Spokane, Wash.
234.2	1280	50	WFBC	Knoxville, Tenn.	245.8	1220	250	KLS	Oakland, Calif.
234.2	1280	50	WJAK	Kokomo, Ind.	245.8	1220	100	KZM	Oakland, Calif.
234.2	1280	50	WJBY	Gadsden, Ala.	245.8	1220	500	WAAT	Jersey City, N. J.
234.2	1280	50	WMAN	Columbus, O.	245.8	1220	500	WDOD	Chattanooga, Tenn.
234.2	1280	250	WMBS	Harrisburg, Pa.	245.8	1220	250	WFBE	Cincinnati, Ohio
234.2	1280	30	WMPC	Lapeer, Mich.	245.8	1220	400	WGBB	Freeport, N. Y.
236.1	1270	250	KFDX	Shreveport, La.	245.8	1220	500	WGMS	Minneapolis, Minn.
236.1	1270	15	KFLU	San Benito, Tex.	245.8	1220	500	WHDI	Minneapolis, Minn.
236.1	1270	500	KFMX	Northfield, Minn.	245.8	1220	500	WLB	Minneapolis, Minn.
236.1	1270	100	KFUM	Colorado Springs, Colo.	245.8	1220	500	WSOM	New York, N. Y.
236.1	1270	500	KFWM	Oakland, Calif.	247.8	1210	100	KFBC	San Diego, Cal.
236.1	1270	50	WBBW	Norfolk, Va.	247.8	1210	250	KFEL	Denver, Colo.
236.1	1270	250	WBNY	New York, N. Y.	247.8	1210	15	KFJB	Marshalltown, Ia.
236.1	1270	500	WCAL	Northfield, Minn.	247.8	1210	10	KGCA	Decorah, Iowa
236.1	1270	250	WGBF	Evansville, Ind.	247.8	1210	50	KWLC	Decorah, Iowa
236.1	1270	1000	WHAP	New York, N. Y.	247.8	1210	50	WABW	Wooster, Ohio
236.1	1270	10	WHBC	Canton, Ohio	247.8	1210	50	WABY	Philadelphia, Pa.



Meters	Kilocycles	Power	Call Letters	Location	Meters	Kilocycles	Power	Call Letters	Location
247.8	1210	50	WABZ	New Orleans, La.	258.5	1160	250	WNAL	Omaha, Neb.
247.8	1210	100	WBAW	Nashville, Tenn.	258.5	1160	5	WNBW	Carbondale, Pa.
247.8	1210	100	WBBL	Richmond, Va.	260.7	1150	1000	KFQB	Fort Worth, Tex.
247.8	1210	100	WCAT	Rapid City, S. D.	260.7	1150	2000	KGA	Spokane, Wash.
247.8	1210	10	WEBE	Cambridge, Ohio	260.7	1150	500	WABQ	Philadelphia, Pa.
247.8	1210	50	WFBZ	Galesburg, Ill.	260.7	1150	500	WCAU	Philadelphia, Pa.
247.8	1210	1000	WIOD	Miami Beach, Fla.	260.7	1150	500	WDGY	Minneapolis, Minn.
247.8	1210	50	WLCI	Ithaca, N. Y.	260.7	1150	10	WHBA	Oil City, Pa.
247.8	1210	100	WMAY	St. Louis, Mo.	260.7	1150	250	WNBH	New Bedford, Mass.
247.8	1210	50	WRAM	Galesburg, Ill.	260.7	1150	500	WOOD	Furnwood, Mich.
249.9	1200	15	KFJI	Astoria, Ore.	260.7	1150	1000	WRHM	Minneapolis, Minn.
249.9	1200	50	KFJZ	Fort Worth, Tex.	263	1140	50	KFPW	Cartersville, Mo.
249.9	1200	100	KFQU	Alma (Holy City), Calif.	263	1140	500	KGEF	Los Angeles, Calif.
249.9	1200	500	KFRU	Columbia, Mo.	263	1140	10	KGEK	Yuma, Colo.
249.9	1200	50	KMED	Medford, Ore.	263	1140	250	WDAG	Amarillo, Tex.
249.9	1200	100	WBAX	Wilkes-Barre, Pa.	263	1140	5000	WJAZ	Chicago, Ill.
249.9	1200	100	WBRE	Wilkes-Barre, Pa.	263	1140	100	WJBO	New Orleans, La.
249.9	1200	500	WCOA	Pensacola, Fla.	263	1140	500	WMBI	Chicago, Ill.
249.9	1200	50	WHBY	West De Pere, Wis.	265.3	1130	15	KKP	Seattle, Wash.
249.9	1200	50	WIBR	Steubenville, Ohio	265.3	1130	2000	KTSA	San Antonio, Tex.
249.9	1200	50	WQAE	Springfield, Vt.	265.3	1130	500	WBET	Boston, Mass.
249.9	1200	1000	WSSH	Boston, Mass.	265.3	1130	100	WDEL	Wilmington, Del.
252	1190	250	KOCW	Chickasha, Okla.	265.3	1130	500	WHK	Cleveland, Ohio
252	1190	500	KPLA	Los Angeles, Calif.	265.3	1130	1000	WNOX	Knoxville, Tenn.
252	1190	10	WFAM	St. Cloud, Minn.	265.3	1130	2500	WOI	Ames, Iowa
252	1190	15	WGAL	Lancaster, Pa.	267.7	1120	100	KFIZ	Fond du Lac, Wis.
252	1190	250	WKBF	Indianapolis, Ind.	267.7	1120	100	KFLV	Rockford, Ill.
252	1190	50	WKBT	New Orleans, La.	267.7	1120	500	KFWI	San Francisco, Calif.
252	1190	500	WMBB	Chicago, Ill.	267.7	1120	250	KLZ	Denver, Colo.
252	1190	100	WMBR	Tampa, Fla.	267.7	1120	1000	KSBA	Shreveport, La.
252	1190	5000	WOK	Chicago, Ill.	267.7	1120	25	WAAD	Cincinnati, Ohio
252	1190	100	WSAR	Portsmouth, R. I.	267.7	1120	100	WBAO	Decatur, Ill.
254.1	1180	50	KFHA	Gunnison, Colo.	267.7	1120	100	WBKN	Brooklyn, N. Y.
254.1	1180	500	KFKU	Lawrence, Kans.	267.7	1120	100	WBMS	Union City, N. J.
254.1	1180	100	KFWH	Eureka, Calif.	267.7	1120	500	WDAE	Tampa, Fla.
254.1	1180	250	KMO	Tacoma, Wash.	267.7	1120	100	WIBI	Flushing, N. Y.
254.1	1180	100	WCAX	Burlington, Vt.	267.7	1120	50	WLAP	Louisville, Ky.
254.1	1180	50	WREC	Memphis, Tenn.	267.7	1120	100	WWRL	NEW YORK, N. Y.
254.1	1180	750	WREN	Lawrence, Kans.	270.1	1110	100	KFLX	Galveston, Tex.
254.1	1180	1000	WRVA	Richmond, Va.	270.1	1110	1000	KFNF	Shenandoah, Iowa
254.1	1180	500	WTAQ	Eau Claire, Wis.	270.1	1110	500	KMA	Shenandoah, Iowa
256.3	1170	50	KFUS	Oakland, Cal.	270.1	1110	500	KOAC	Corvallis, Ore.
256.3	1170	100	KRE	Berkeley, Cal.	270.1	1110	500	KQV	Pittsburgh, Pa.
256.3	1170	3500	KTNT	Muscatine, Iowa	270.1	1110	500	WGST	Atlanta, Ga.
256.3	1170	250	WASH	Grand Rapids, Mich.	270.1	1110	500	WJAS	Pittsburgh, Pa.
256.3	1170	1000	WBBR	Rossville, N. Y.	270.1	1110	500	WMAZ	Macon, Ga.
256.3	1170	500	WCSSO	Springfield, Ohio	270.1	1110	500	WSOE	Milwaukee, Wis.
256.3	1170	500	WEBJ	New York, N. Y.	272.6	1100	750	KFJF	Oklahoma City, Okla.
256.3	1170	250	WJBI	Red Bank, N. J.	272.6	1100	100	KSMR	Santa Maria, Cal.
258.5	1160	100	KDYL	Salt Lake City, Utah	272.6	1100	500	WBAA	West Lafayette, Ind.
258.5	1160	100	KFOX	Omaha, Neb.	272.6	1100	100	WFBJ	Collegeville, Minn.
258.5	1160	500	KFUL	Galveston, Tex.	272.6	1100	750	WHAR	Atlantic City, N. J.
258.5	1160	250	KOCH	Omaha, Neb.	272.6	1100	5000	WPG	Atlantic City, N. J.
258.5	1160	500	WBT	Charlotte, N. C.	272.6	1100	500	WRM	Urbana, Ill.
258.5	1160	250	WCMA	Culver, Ind.	275.1	1090	50	KFBB	Havre, Mont.
258.5	1160	500	WEBW	Beloit, Wis.	275.1	1090	15	KFPL	Dublin, Tex.
258.5	1160	750	WFBL	Syracuse, N. Y.	275.1	1090	500	KFSG	Los Angeles, Calif.
258.5	1160	250	WIL	St. Louis, Mo.	275.1	1090	500	WCAC	Mansfield, Conn.
258.5	1160	50	WKJC	Lancaster, Pa.	275.1	1090	250	WDRC	New Haven, Conn.

Meters	Kilocycles	Power	Call Letters	Location	Meters	Kilocycles	Power	Call Letters	Location
275.1	1090	5000	WORD	Batavia, Ill.	302.8	990	750	WGR	Buffalo, N. Y.
275.1	1090	500	WTAR	Norfolk, Va.	302.8	990	120	WMAL	Washington, D. C.
275.1	1090	3500	WTAS	Batavia, Ill.	302.8	990	250	WNAX	Yankton, S. D.
275.1	1090	100	WWL	New Orleans, La.	302.8	990	5000	WOAI	San Antonio, Tex.
277.6	1080	100	KGBX	St. Joseph, Mo.	305.9	980	1000	KOMO	Seattle, Wash.
277.6	1080	2000	KOIL	Council Bluffs, Iowa	305.9	980	15000	WGN	Chicago, Ill.
277.6	1080	500	KTCL	Seattle, Wash.	305.9	980	500	WLIB	Chicago, Ill.
277.6	1080	500	KWWG	Brownsville, Tex.	309.1	970	2000	KFAB	Lincoln, Nebr.
277.6	1080	100	WDZ	Tuscola, Ill.	309.1	970	500	KYA	San Francisco, Cal.
277.6	1080	15	WGBC	Memphis, Tenn.	309.1	970	500	WPCH	New York, N. Y.
277.6	1080	500	WHAM	Rochester, N. Y.	309.1	970	500	WRNY	New York, N. Y.
280.2	1070	500	KTAB	Oakland, Calif.	309.1	970	500	WTAW	College Station, Tex.
280.2	1070	50	WABR	Toledo, Ohio	315.6	950	30000	KDKA	Pittsburgh, Pa.
280.2	1070	100	WFBG	Altoona, Pa.	315.6	950	1000	KPSN	Pasadena, Cal.
280.2	1070	500	WFIW	Hopkinsville, Ky.	319	940	1000	KOIN	Portland, Ore.
280.2	1070	500	WGCP	Newark, N. J.	319	940	500	WEAN	Providence, R. I.
280.2	1070	500	WNJ	Newark, N. J.	319	940	750	WGHP	Mt. Clemens, Mich.
280.2	1070	100	WTAL	Toledo, Ohio	319	940	750	WHA	Madison, Wis.
282.8	1060	100	KFJR	Portland, Ore.	319	940	1000	WLBL	Madison, Wis.
282.8	1060	500	KFXF	Denver, Colo.	319	940	150	WRHF	Washington, D. C.
282.8	1060	50	KTBR	Portland, Ore.	322.4	930	50	KFQA	St. Louis, Mo.
282.8	1060	5000	WAIU	Columbus, Ohio	322.4	930	50	WJBA	Joliet, Ill.
282.8	1060	750	WEAO	Columbus, Ohio	322.4	930	50	WKBI	Chicago, Ill.
282.8	1060	50	WRAK	Escanaba, Mich.	322.4	930	15	WKDR	Kenosha, Wis.
285.5	1050	2000	KFAU	Boise, Idaho	322.4	930	15	WLBR	Belvedere, Ill.
285.5	1050	250	KFOY	St. Paul, Minn.	322.4	930	50	WLBT	Crown Point, Ind.
285.5	1050	3000	WBAL	Baltimore, Md.	322.4	930	750	WQAM	Miami, Fla.
285.5	1050	250	WJAG	Norfolk, Nebr.	322.4	930	50	WRRS	Racine, Wis.
285.5	1050	500	WKAR	East Lansing, Mich.	322.4	930	500	WSMB	New Orleans, La.
285.5	1050	250	WOAN	Lawrenceburg, Tenn.	322.4	930	50	WTAX	Streator, Ill.
288.3	1040	500	KTBI	Los Angeles, Cal.	325.9	920	5000	KOA	Denver, Colo.
288.3	1040	250	WBCN	Chicago, Ill.	325.9	920	2500	WABC	NEW YORK, N. Y.
288.3	1040	500	WDBO	Orlando, Fla.	325.9	920	1000	WAPI	Auburn, Ala.
288.3	1040	500	WENR	Chicago, Ill.	325.9	920	500	WBOQ	NEW YORK, N. Y.
288.3	1040	150	WKY	Oklahoma City, Okla.	333.1	900	100	KFJM	Grand Forks, N. D.
288.3	1040	100	WNAT	Philadelphia, Pa.	333.1	900	500	KSAC	Manhattan, Kans.
288.3	1040	250	WRAX	Philadelphia, Pa.	333.1	900	250	KSEI	Pocatello, Idaho
293.9	1020	250	KGCH	Wayne, Nebr.	333.1	900	15000	WBZ	Springfield, Mass.
293.9	1020	500	KPRC	Houston, Tex.	333.1	900	500	WBZA	Boston, Mass.
293.9	1020	500	WGL	NEW YORK, N. Y.	333.1	900	500	WKRC	Cincinnati, Ohio
293.9	1020	500	WHAD	Milwaukee, Wis.	336.9	890	500	KNX	Los Angeles, Calif.
293.9	1020	500	WLBW	Oil City, Pa.	336.9	890	500	WHB	Kansas City, Mo.
293.9	1020	1000	WODA	Paterson, N. J.	336.9	890	1000	WJAX	Jacksonville, Fla.
293.9	1020	1000	WTMJ	Milwaukee, Wisc.	336.9	890	250	WOQ	Kansas City, Mo.
296.9	1010	500	KQW	San Jose, Cal.	340.7	880	100	WAFD	Detroit, Mich.
296.9	1010	500	KUOA	Fayetteville, Ark.	340.7	880	50	WCAZ	Carthage, Ill.
296.9	1010	500	WADC	Akron, Ohio	340.7	880	100	WRAV	Yellow Springs, Ohio
296.9	1010	100	WBES	Takoma Park, Md.	340.7	880	5000	WSM	Nashville, Tenn.
296.9	1010	100	WEPS	Gloucester, Mass.	344.6	870	50	KWG	Stockton, Calif.
296.9	1010	10	WHBN	St. Petersburg, Fla.	344.6	870	5000	WCBD	Zion, Ill.
296.9	1010	200	WSMK	Dayton, Ohio	344.6	870	250	WJBB	St. Petersburg, Fla.
296.9	1010	1000	WWNC	Asheville, N. C.	344.6	870	5000	WLS	Chicago, Ill.
299.8	1000	10	KGFV	Ravenna, Nebr.	348.6	860	2500	KJR	Seattle, Wash.
299.8	1000	5000	KMOX	St. Louis, Mo.	348.6	860	1000	KVOO	Bristow, Okla.
299.8	1000	500	KOWW	Walla Walla, Wash.	348.6	860	500	WAAM	Newark, N. J.
299.8	1000	500	WBAK	Harrisburg, Pa.	348.6	860	300	WAAW	Omaha, Neb.
299.8	1000	500	WPSC	State College, Pa.	348.6	860	100	WFDF	Flint, Mich.
302.8	990	1000	KSL	Salt Lake City, Utah	348.6	860	500	WGBS	New York, N. Y.
302.8	990	100	WBIS	Boston, Mass.	352.7	850	5	KWTC	Santa Ana, Calif.

Meters	Kilocycles	Power	Call Letters	Location	Meters	Kilocycles	Power	Call Letters	Location
352.7	850	1000	WEW	St. Louis, Mo.	422.3	710	1000	KPO	San Francisco, Calif.
352.7	850	500	WNAC	Boston, Mass.	422.3	710	5000	WOR	Newark, N. J.
352.7	850	5000	WOC	Davenport, Iowa	422.3	710	500	WSUI	Iowa City, Iowa
352.7	850	500	WRR	Dallas, Tex.	428.3	700	500	KFBU	Laramie, Wyo.
361.2	830	500	KFWB	Los Angeles, Calif.	428.3	700	5000	WLW	Cincinnati, Ohio
361.2	830	500	WCSH	Portland, Me.	428.3	700	500	WMAF	South Dartmouth, Mass.
361.2	830	250	WDAY	Fargo, N. D.	440.9	680	100	KFMR	Sioux City, Iowa
361.2	830	500	WDWM	Asbury Park, N. J.	440.9	680	1000	KFSD	San Diego, Calif.
361.2	830	5000	WSAI	Cincinnati, Ohio	440.9	680	5000	WCX	Pontiac, Mich.
365.6	820	50	KMJ	Fresno, Calif.	440.9	680	50	WIBG	Elkins Park, Pa.
365.6	820	500	WCAD	Canton, N. Y.	440.9	680	5000	WJR	Detroit, Mich.
365.6	820	2000	WEBH	Chicago, Ill.	440.9	680	250	WSBF	St. Louis, Mo.
365.6	820	500	WFHH	Clearwater, Fla.	447.5	670	1000	KFOA	Seattle, Wash.
365.6	820	1000	WJJD	Mooseheart, Ill.	447.5	670	500	WEEI	Boston, Mass.
370.2	810	1000	KHQ	Spokane, Wash.	447.5	670	500	WJAD	Waco, Tex.
370.2	810	1000	WDAF	Kansas City, Mo.	447.5	670	1000	WMAQ	Chicago, Ill.
370.2	810	1000	WLWL	New York, N. Y.	447.5	670	500	WQJ	Chicago, Ill.
370.2	810	500	WMCA	New York, N. Y.	454.3	660	500	KFRC	San Francisco, Calif.
374.8	800	500	KFDM	Beaumont, Tex.	454.3	660	30000	WJZ	New York, N. Y.
374.8	800	500	KNRC	Santa Monica, Calif.	461.3	650	100	KICK	Anita, Iowa
374.8	800	500	KUOM	Missoula, Mont.	461.3	650	500	KRLD	Dallas, Tex.
374.8	800	500	WDWF	Cranston, R. I.	461.3	650	500	WHAS	Louisville, Ky.
374.8	800	1000	WWJ	Detroit, Mich.	468.5	640	5000	KFI	Los Angeles, Calif.
379.5	790	500	KMMJ	Clay Center, Nebr.	468.5	640	500	WOS	Jefferson City, Mo.
379.5	790	500	WCAJ	Lincoln, Nebr.	468.5	640	500	WRC	Washington, D. C.
379.5	790	30000	WGY	Schenectady, N. Y.	475.9	630	250	KOW	Denver, Colo.
379.5	790	500	WHAZ	Troy, N. Y.	475.9	630	100	WIAS	Burlington, Iowa
384.4	780	5000	KGO	Oakland, Calif.	475.9	630	1000	WSB	Atlanta, Ga.
384.4	780	1000	KTHS	Hot Spgs. Natl. Pk., Ark.	475.9	630	500	WTIC	Hartford, Conn.
384.4	780	250	KWCR	Cedar Rapids, Iowa	483.6	620	250	KUSD	Vermillion, S. D.
384.4	780	100	WBSO	Wellesley Hills, Mass.	483.6	620	1500	WCFL	Chicago, Ill.
384.4	780	250	WCAO	Baltimore, Md.	483.6	620	250	WEAI	Ithaca, N. Y.
384.4	780	100	WCBM	Baltimore, Md.	483.6	620	1000	WEMC	Berrien Springs, Mich.
384.4	780	100	WJAM	Cedar Rapids, Iowa	483.6	620	500	WJAR	Providence, R. I.
384.4	780	500	WLSI	Cranston, R. I.	483.6	620	100	WLTS	Chicago, Ill.
384.4	780	500	WMBF	Miami Beach, Fla.	491.5	610	1000	KGW	Portland, Ore.
384.4	780	100	WSRO	Hamilton, Ohio	491.5	610	5000	WEAF	New York, N. Y.
389.4	770	500	WAAF	Chicago, Ill.	491.5	610	250	WSKC	Bay City, Mich.
389.4	770	100	WABI	Bangor, Me.	499.7	600	50	KFUT	Salt Lake City, Utah
389.4	770	1000	WBBM	Chicago, Ill.	499.7	600	1500	WBAP	Fort Worth, Tex.
389.4	770	500	WJBT	Chicago, Ill.	499.7	600	75	WBBY	Charleston, S. C.
389.4	770	100	WWVA	Wheeling, W. Va.	499.7	600	500	WFAA	Dallas, Tex.
394.5	760	500	KFDY	Brookings, S. D.	508.2	590	500	KLX	Oakland, Calif.
394.5	760	5000	KOB	State College, N. Mex.	508.2	590	500	WIP	Philadelphia, Pa.
394.5	760	1000	KTW	Seattle, Wash.	508.2	590	500	WOO	Philadelphia, Pa.
394.5	760	1000	KWKH	Shreveport, La.	508.2	590	1000	WOW	Omaha, Nebr.
394.5	760	500	KWSC	Pullman, Wash.	516.9	580	500	WCAE	Pittsburgh, Pa.
394.5	760	500	WHN	New York, N. Y.	516.9	580	500	WMC	Memphis, Tenn.
394.5	760	500	WPAP	Cliffside, N. J.	516.9	580	500	WTAG	Worcester, Mass.
394.5	760	500	WQAO	Cliffside, N. J.	526	570	500	KMTR	Los Angeles, Calif.
399.8	750	200	KFKA	Greeley, Colo.	526	570	2500	KYW	Chicago, Ill.
399.8	750	1000	WEAR	Cleveland, Ohio	535.4	560	100	KFBK	Sacramento, Calif.
399.8	750	3500	WTAM	Cleveland, Ohio	535.4	560	250	WCAH	Columbus, Ohio
405.2	740	500	KHJ	Los Angeles, Calif.	535.4	560	5000	WHO	Des Moines, Iowa
405.2	740	5000	WCCO	St. Paul-Minneapolis, Minn.	535.4	560	500	WNYC	New York, N. Y.
405.2	740	500	WFI	Philadelphia, Pa.	545.1	550	500	KFUO	St. Louis, Mo.
405.2	740	500	WLIT	Philadelphia, Pa.	545.1	550	500	KSD	St. Louis, Mo.
416.4	720	5000	WHT	Chicago, Ill.	545.1	550	750	WMAK	Lockport, N. Y.
416.4	720	500	WIBO	Chicago, Ill.					

*This list has been corrected up to and including August 15th, 1927*

# RADIO BROADCAST STATIONS OF THE UNITED STATES

## By States and Cities

State and City	Call Letters	Wave Length	Power	State and City	Call Letters	Wave Length	Power
<b>ALABAMA</b>							
Auburn	WAPI	325.9	1000	Pasadena	KPPC	228.9	50
Birmingham	WBRC	243.8	250	Pasadena	KPSN	315.6	1000
Birmingham	WKBC	218.8	10	Sacramento	KFBK	535.4	100
Gadsden	WJBY	234.2	50	San Bernardino	KFWC	222.1	100
Montgomery	WIBZ	230.6	15	San Diego	KFBC	247.8	1210
<b>ARIZONA</b>				San Diego	KFSD	440.9	1000
Flagstaff	KFX Y	205.4	25	San Francisco	KFRC	454.3	500
Phoenix	KFAD	272.6	500	San Francisco	KFWI	267.7	50
Phoenix	KFCB	243.8	125	San Francisco	KGTT	206.8	50
Prescott	KPJM	214.2	15	San Francisco	KJBS	220.4	50
Tucson	KGAR	234.2	100	San Francisco	KPO	422.3	1000
<b>ARKANSAS</b>				San Francisco	KYA	309.1	5000
Fayetteville	KUOA	296.9	500	San Jose	KQW	296.9	500
Hot Spring National Park	KTHS	384.4	1000	Santa Ana	KWTC	352.7	5
Newark	KGCG	223.7	100	Santa Barbara	KFCR	211.1	50
<b>CALIFORNIA</b>				Santa Maria	KSMR	272.6	100
Alma (Holy City)	KFQU	249.9	100	Santa Monica	KNRC	374.8	500
Avalon, Catalina Island	KFWO	218.8	250	Stockton	KGDM	217.3	10
Berkeley	KRE	256.3	100	Stockton	KWG	344.6	50
Burbank	KELW	228.9	250	Venice	KFVD	208.2	250
El Centro	KGEN	225.4	15	Yuba City	KGFM	211.1	15
Eureka	KFWH	254.1	100	<b>COLORADO</b>			
Fresno	KMJ	365.6	50	Colorado Springs	KFUM	236.1	100
Hollywood	KFQZ	232.4	100	Denver	KFEL	247.8	250
Inglewood	KMIC	223.7	250	Denver	KFUP	227.1	100
La Crescenta	KGFH	223.7	250	Denver	KFXF	282.8	500
Long Beach	KFON	241.8	500	Denver	KGEY	201.2	15
Long Beach	KGER	215.7	100	Denver	KLZ	267.7	250
Los Angeles	KFI	468.5	5000	Denver	KOA	325.9	5000
Los Angeles	KFPR	232.4	250	Denver	KOW	475.9	250
Los Angeles	KFSG	275.1	500	Durango	KOLO	199.9	5
Los Angeles	KFWB	361.2	500	Edgewater	KFXJ	215.7	15
Los Angeles	KGEF	263	500	Fort Morgan	KGEW	218.8	10
Los Angeles	KGFJ	208.2	100	Greeley	KFKA	399.8	200
Los Angeles	KHJ	405.2	500	Gunnison	KFHA	254.1	50
Los Angeles	KMTR	526	500	Pueblo	KGDP	223.7	15
Los Angeles	KNX	336.9	500	Trinidad	KFBS	238	15
Los Angeles	KPLA	252	500	Trinidad	KGFL	222.1	50
Los Angeles	KRLO	215.7	250	Yuma	KGEK	263	10
Los Angeles	KTBI	288.3	500	<b>CONNECTICUT</b>			
Lower Lake	KFEU	227.1	50	Bridgeport	WICC	214.2	250
Oakland	KFUS	256.3	50	Danbury	WCWS	214.2	100
Oakland	KFWM	236.1	500	Hartford	WTIC	475.9	500
Oakland	KGO	384.4	5000	Mansfield	WCAC	275.1	500
Oakland	KLS	245.8	250	New Haven	WDRC	275.1	250
Oakland	KLX	508.2	500	<b>DELAWARE</b>			
Oakland	KTAB	280.2	500	Wilmington	WDEL	265.3	100
Oakland	KZM	245.8	100	<b>DISTRICT OF COLUMBIA</b>			
Oxnard	KFYF	238	25	Washington	WMAL	302.8	120
				Washington	WRC	468.5	500
				Washington	WRHF	319	150

State and City	Call Letters	Wave Length	Power	State and City	Call Letters	Wave Length	Power
<b>FLORIDA</b>				<b>Chicago</b>			
Boca Raton	WFLA	212.6	1000	Chicago	WLS	344.6	5000
Clearwater	WFHH	365.6	500	Chicago	WLTS	483.6	100
Jacksonville	WJAX	336.9	1000	Chicago	WMAQ	447.5	1000
Lakeland	WMBL	228.9	50	Chicago	WMBB	252	500
Miami Beach	WIOD	247.8	1000	Chicago	WMBH	204	100
Miami Beach	WMBF	384.4	500	Chicago	WMBI	266	500
Miami	WQAM	322.4	750	Chicago	WOK	252	5000
Orlando	WDBO	288.3	500	Chicago	WPCC	223.7	500
Pensacola	WCOA	249.9	500	Chicago	WQJ	447.5	500
St. Petersburg	WHBN	296.9	10	Chicago	WSAX	204	100
St. Petersburg	WJBB	344.6	250	Chicago	WSBC	232.4	500
Tampa	WDAE	267.7	500	Chicago Heights	WJBZ	208.2	100
Tampa	WMBR	252	100	Decatur	WBAO	267.7	100
<b>GEORGIA</b>				Decatur	WJBL	212.6	250
Atlanta	WGST	270.1	500	East Wenona	WLBI	238	250
Atlanta	WSB	475.9	1000	Evanston	WEHS	215.7	100
Macon	WMAZ	270.1	500	Forest Park	WNBA	208.2	200
<b>IDAHO</b>				Galesburg	WFBZ	247.8	50
Boise	KFAU	285.5	2000	Galesburg	WKBS	217.3	100
Kellogg	KFEY	232.4	10	Galesburg	WLBO	217.3	100
Pocatello	KSEI	333.1	250	Galesburg	WRAM	247.8	50
<b>ILLINOIS</b>				Harrisburg	WEBQ	223.7	15
Atwood	WLBO	202.6	25	Joliet	WCLS	215.7	150
Batavia	WORD	275.1	5000	Joliet	WJBA	322.4	50
Batavia	WTAS	275.1	3500	Joliet	WKBB	215.7	150
Belvedere	WLBR	322.4	15	LaSalle	WJBC	227.1	100
Bloomington	WMBY	199.9	15	Mooseheart	WJJD	365.6	1000
Bloomington	WNBL	199.9	15	Peoria Heights	WMBD	205.4	250
Carthage	WCAZ	340.7	50	Quincy	WTAD	236.1	250
Chicago	KYW	526	2500	Rockford	KFLV	267.7	100
Chicago	WWAE	232.4	500	Rock Island	WHBF	222.1	100
Chicago	WAAF	389.4	500	Springfield, Ill.	WCBS	209.7	250
Chicago	WBBM	389.4	770	Streator	WTAX	322.4	50
Chicago	WBBZ	204	100	Tuscola	WDZ	277.6	100
Chicago	WBCN	288.3	250	Urbana	WRM	272.6	500
Chicago	WCFL	483.6	1500	Waukegan	WPEP	215.7	250
Chicago	WCRW	223.7	500	Zion	WCBD	344.6	5000
Chicago	WEBH	365.6	2000	<b>INDIANA</b>			
Chicago	WEDC	241.8	500	Anderson	WHBU	220.4	15
Chicago	WENR	288.3	500	Brookville	WKBV	217.3	100
Chicago	WFKB	223.7	500	Culver	WCMA	258.5	250
Chicago	WGES	241.8	500	Crown Point	WLBT	322.4	50
Chicago	WGN	305.9	15000	Evansville	WGBF	236.1	250
Chicago	WHBL	204	100	Fort Wayne	WCWK	228.9	500
Chicago	WHBM	201.2	100	Fort Wayne	WOWO	228.9	1000
Chicago	WHFC	215.7	200	Indianapolis	WFBM	225.4	250
Chicago	WHT	416.4	5000	Indianapolis	WKBF	252	250
Chicago	WIBJ	201.2	100	Kokomo	WJAK	234.2	50
Chicago	WIBM	201.2	100	Lafayette	WBAA	272.6	500
Chicago	WIBO	416.4	500	Laport	WRAF	208.2	100
Chicago	WIBW	204	100	Muncie	WLBC	209.7	50
Chicago	WJAZ	263	5000	South Bend	WSBT	238	500
Chicago	WJBT	389.4	500	Terre Haute	KGFO	204	100
Chicago	WKBG	201.2	100	Terre Haute	WRPI	208.2	100
Chicago	WKBI	322.4	50	Valparaiso	WRBC	238	250
Chicago	WLBN	204	50	<b>IOWA</b>			
Chicago	WLIB	305.9	500	Ames	WOI	265.3	2500
				Anita	KICK	461.3	100
				Boone	KFGQ	209.7	10

State and City	Call Letters	Wave Length	Power	State and City	Call Letters	Wave Length	Power
<b>IOWA—Con.</b>				<b>MASSACHUSETTS</b>			
Burlington	WIAS	475.9	100	Boston	WATT	201.2	100
Cedar Rapids	KWCR	384.4	250	Boston	WBET	265.3	500
Cedar Rapids	WJAM	384.4	100	Boston	WBIS	302.8	100
Clarinda	KSO	227.1	500	Boston	WBZA	333.1	500
Council Bluffs	KOIL	277.6	2000	Boston	WEEI	447.5	500
Cresco	KGDJ	202.6	10	Boston	WLBM	230.6	50
Davenport	WOC	352.7	5000	Boston	WMES	211.1	100
Decorah	KGCA	247.8	10	Boston	WNAC	352.7	500
Decorah	KWLC	247.8	50	Boston	WSSH	249.9	1000
Des Moines	WHO	535.4	5000	Chelsea	WRSC	205.4	15
Fort Dodge	KFJY	239.9	100	Gloucester	WEPS	296.9	100
Iowa City	KGFB	223.7	10	New Bedford	WNBH	260.7	250
Iowa City	WSUI	422.3	500	Somerville	WAGS	215.7	5
Le Mars	KWUC	243.8	1500	South Dartmouth	WMAF	428.3	500
Marshalltown	KFJB	247.8	15	Springfield	WBZ	333.1	15000
Muscatine	KPNP	211.1	100	Taunton	WAIT	214.2	10
Muscatine	KTNT	256.5	3500	Webster	WKBE	228.9	100
Oskaloosa	KFHL	212.6	10	Wellesley Hills	WBSO	384.4	100
Shenandoah	KFNF	270.1	1000	Wollaston	WRES	217.3	50
Shenandoah	KMA	270.1	500	Worcester	WTAG	516.9	500
Sioux City	KFMR	440.9	100	<b>MICHIGAN</b>			
Sioux City	KSCJ	243.8	500	Battle Creek	WKBP	212.6	50
<b>KANSAS</b>				Bay City	WSKC	491.5	250
Concordia	KGCN	208.2	50	Berrien Springs	WEMC	483.6	1000
Independence	KFVG	225.4	50	Detroit	WAFD	340.7	100
Lawrence	KFKU	254.1	500	Detroit	WBMH	211.1	100
Lawrence	WREN	254.1	750	Detroit	WJR	440.9	5000
Manhattan	KSAC	333.1	500	Detroit	WMBC	243.8	100
Milford	KFKB	241.8	1500	Detroit	WMCO	218.8	250
Wichita	KFH	245.8	500	Detroit	WWJ	374.8	1000
<b>KENTUCKY</b>				Escanaba	WRAK	282.8	50
Hopkinsville	WFIW	280.2	500	Flint	WFDF	348.6	100
Louisville	WHAS	461.3	500	Furnwood	WOOD	260.7	500
Louisville	WLAP	267.7	50	Grand Rapids	WASH	256.3	250
<b>LOUISIANA</b>				Iron Mountain	WLBY	209.7	50
New Orleans	WABZ	247.8	50	East Lansing	WKAR	285.5	500
New Orleans	WCBE	227.1	5	Lansing	WREO	230.6	500
New Orleans	WJBO	263	100	Lapeer	WMPC	234.2	30
New Orleans	WJBW	238	30	Ludington	WKBZ	199.9	15
New Orleans	WKBT	252	50	Monroe	WKBL	205.4	15
New Orleans	WSMB	322.4	500	Mt. Clemens	WGHP	319	750
New Orleans	WWL	275.1	100	Petoskey	WBBP	239.9	100
Shreveport	KFDX	236.1	250	Pontiac	WCX	440.9	5000
Shreveport	KGDY	212.6	250	Royal Oak	WAGM	225.4	50
Shreveport	KWKH	394.5	1000	Ypsilanti	WJBK	220.4	15
Shreveport	KRAC	220.4	50	<b>MINNESOTA</b>			
Shreveport	KSBA	267.7	1000	Barrett	KGDE	205.4	50
<b>MAINE</b>				Collegeville	WFBJ	272.6	100
Bangor	WABI	389.4	100	Fairmont	KFVN	228.9	100
Dover-Foxcroft	WLBZ	208.2	250	Hallock	KGFK	223.7	50
Portland	WCSH	361.2	500	Minneapolis	KFDZ	215.7	10
<b>MARYLAND</b>				Minneapolis	KGEQ	202.6	50
Baltimore	WBAL	285.5	3000	Minneapolis	WAMD	225.4	500
Baltimore	WCAO	384.4	250	Minneapolis	WDGY	260.7	500
Baltimore	WCBM	384.4	100	Minneapolis	WGMS	245.8	500
Baltimore	WFBR	225.4	100	Minneapolis	WHDI	245.8	500
Tokoma Park	WBES	296.9	100	Minneapolis	WLB	245.8	500

State and City	Call Letters	Wave Length	Power	State and City	Call Letters	Wave Length	Power
<b>MINNESOTA—Con.</b>				<b>NEW HAMPSHIRE</b>			
Minneapolis	WRHM	260.7	1000	Laconia	WKAV	223.7	50
Northfield	KFMX	236.1	500	Manchester	WCOM	238	100
Northfield	WCAL	236.1	500	Tilton	WBRL	232.4	500
St. Cloud	WFAM	252	10	<b>NEW JERSEY</b>			
St. Paul	KFOY	285.5	250	Asbury Park	WDWM	361.2	500
St. Paul	WMBE	208.2	10	Atlantic City	WHAR	272.6	750
St. Paul-Minneapolis	WCCO	405.2	5000	Atlantic City	WPG	272.6	5000
<b>MISSISSIPPI</b>				Camden	WCAM	223.7	500
Columbus	WCOC	230.6	100	Cliffside	WCDA	211.1	250
Oxford (near)	WCBH	241.8	100	Cliffside	WPAP	394.5	500
<b>MISSOURI</b>				Cliffside	WQAO	394.5	500
Cape Girardeau	KFVS	223.7	50	Elizabeth	WIBS	204	150
Cartersville	KFPW	263	50	Jersey City	WAAT	245.8	500
Columbia	KFRU	249.9	500	Jersey City	WKBO	218.8	500
Independence	KLDS	238	1500	Lambertville	WTAZ	220.4	15
Jefferson City	WOS	468.5	500	Midland Park	WTRL	206.8	15
Kansas City	KWKC	222.1	100	Newark	WAAM	348.6	500
Kansas City	WDAF	370.2	1000	Newark	WGCP	280.2	500
Kansas City	WHB	336.9	500	Newark	WNJ	280.2	500
Kansas City	WLBF	209.7	50	Newark	WOR	422.3	5000
Kansas City	WOQ	336.9	250	North Plainfield	WEAM	239.9	250
Kirksville	KFKZ	225.4	15	Paterson	WODA	293.9	1000
St. Joseph	KFEQ	230.6	1000	Red Bank	WJBI	256.3	250
St. Joseph	KGBX	277.6	100	Trenton	WOAX	239.9	500
St. Louis	KFQA	322.4	50	Union City	WBMS	267.7	100
St. Louis	KFUO	545.1	500	<b>NEW MEXICO</b>			
St. Louis	KFVE	234.2	1000	State College	KOB	394.5	5000
St. Louis	KFWF	214.2	250	<b>NEW YORK</b>			
St. Louis	KMOX	299.8	5000	Auburn	WMBO	220.4	100
St. Louis	KSD	545.1	500	Bay Shore	WRST	211.1	250
St. Louis	WEW	352.7	1000	Brooklyn	WARS	227.1	500
St. Louis	WIL	258.5	250	Brooklyn	WBBC	227.1	500
St. Louis	WMAY	247.8	100	Brooklyn	WBKN	267.7	100
St. Louis	WSBF	440.9	250	Brooklyn	WBRS	211.1	100
<b>MONTANA</b>				Brooklyn	WLTH	218.8	250
Havre	KFBB	275.1	50	Brooklyn	WMBQ	204	100
Kalispell	KGEZ	205.4	100	Buffalo	WEBR	241.8	200
Missoula	KUOM	374.8	500	Buffalo	WGR	302.8	750
Vida	KGCX	243.8	10	Buffalo	WKBW	217.3	500
<b>NEBRASKA</b>				Buffalo	WKEN	204	250
Central City	KGES	204	10	Buffalo	WSVS	205.4	50
Clay Center	KMMJ	379.5	500	Canton	WCAD	365.6	500
Grand Island	KGEO	205.4	160	Cazenovia	WMAC	225.4	500
Humboldt	KGDW	206.8	100	Endicott	WNBF	206.8	50
Lincoln	KFAB	309.1	2000	Farmingdale	WLBH	232.4	30
Lincoln	KFOR	217.3	100	Flushing	WIBI	267.7	100
Norfolk	WJAG	285.5	250	Freeport	WGBB	245.8	400
Omaha	KFOX	258.5	100	Ithaca	WEAI	483.6	250
Omaha	KOCH	258.5	250	Ithaca	WLCI	247.8	50
Omaha	WAAW	348.6	300	Jamaica	WMRJ	206.8	10
Omaha	WNAL	258.5	250	Jamestown	WOCL	223.7	25
Omaha	WOW	508.2	1000	Kingston	WDBZ	215.7	50
Ravenna	KGFW	299.8	10	Lockport	WMAK	545.1	750
Shelby	KGBY	202.6	50	Long Island City	WLBX	204	250
University Place	WCAJ	379.5	500	Newburgh	WKBM	208.2	100
Wayne	KGCH	293.9	250	New York	WABC	325.9	2500
York	KGBZ	212.6	100	New York	WBNY	236.1	250

State and City	Call Letters	Wave Length	Power	State and City	Call Letters	Wave Length	Power
<b>NEW YORK—Con.</b>							
New York	WBOQ	325.9	500	Cincinnati	WSAI	361.2	5000
New York	WCGU	211.1	500	Cleveland	WDBK	227.1	250
New York	WEAF	491.5	5000	Cleveland	WEAR	399.8	1000
New York	WEBJ	256.3	500	Cleveland	WHK	265.3	500
New York	WGBS	348.6	500	Cleveland	WJAY	227.1	500
New York	WGL	293.9	500	Columbus	WAIU	282.8	5000
New York	WGMU	201.2	100	Columbus	WCAH	535.4	250
New York	WHAP	236.1	1000	Columbus	WEAO	282.8	750
New York	WHN	394.5	500	Columbus	WMAN	234.2	50
New York	WHPP	206.8	10	Dayton	WSMK	296.9	200
New York	WJZ	454.3	30000	Hamilton	WRK	205.4	100
New York	WKBQ	218.8	500	Hamilton	WSRO	384.4	100
New York	WLWL	370.2	1000	Mansfield	WLBV	206.8	50
New York	WMCA	370.2	500	Shelby	WOBR	204	10
New York	WMSG	236.1	500	Springfield	WCOS	256.3	500
New York	WNYC	535.4	500	Steubenville	WIBR	249.9	50
New York	WPCB	309.1	500	Toledo	WABR	280.2	50
New York	WRMU	201.2	100	Toledo	WTAL	280.2	100
New York	WRNY	309.1	500	Wooster	WABW	247.8	50
New York	WSDA	227.1	250	Yellow Springs	WRAV	340.7	100
New York	WSOM	245.8	500	Youngstown	WKBN	214.2	50
New York	WWRL	267.7	100	Youngstown	WMBW	214.2	50
Peekskill	WOKO	215.7	250	<b>OKLAHOMA</b>			
Rochester	WABO	232.4	100	Alva	KGFF	205.4	25
Rochester	WHAM	277.6	500	Bristow	KVOO	348.6	1000
Rochester	WHEC	232.4	100	Chickasha	KOCW	252	250
Rochester	WNBQ	202.6	15	Norman	WNAD	239.9	500
Rochester	WOKT	209.7	500	Oklahoma City	KFJF	272.6	750
Rossville	WBBR	256.3	1000	Oklahoma City	KFXR	223.7	50
Schenectady	WGY	379.5	30000	Oklahoma City	KGCB	215.7	50
Syracuse	WFBL	258.5	750	Oklahoma City	KGFG	215.7	50
Syracuse	WSYR	225.4	500	Oklahoma City	WKY	288.3	150
Troy	WHAZ	379.5	500	<b>OREGON</b>			
Utica	WIBX	238	150	Astoria	KFJI	249.9	15
<b>NORTH CAROLINA</b>				Corvallis	KOAC	270.1	500
Asheville	WWNC	296.9	1000	Eugene	KGEH	201.2	50
Charlotte	WBT	258.5	500	Medford	KMED	249.9	50
Greensboro	WNRC	223.7	500	Portland	KEX	239.9	2500
Raleigh	WRCO	217.3	250	Portland	KFEC	214.2	50
<b>NORTH DAKOTA</b>				Portland	KFIF	214.2	50
Aneta	KGFN	199.9	15	Portland	KFJR	282.8	100
Bismarck	KFYR	239.9	250	Portland	KGW	491.5	1000
Devils Lake	KDLR	230.6	15	Portland	KLIT	206.8	10
Fargo	WDAY	361.2	250	Portland	KOIN	319	1000
Grand Forks	KFJM	333.1	100	Portland	KTBR	282.8	50
Mandan	KGCU	208.2	100	Portland	KWBS	199.9	15
<b>OHIO</b>				Portland	KWJJ	228.9	50
Akron	WADC	296.9	500	Portland	KXL	220.4	50
Ashland	WLBP	202.6	15	<b>PENNSYLVANIA</b>			
Ashtabula	WJPW	208.2	50	Allentown	WCBA	222.1	100
Bellefontaine	WHBD	222.1	100	Allentown	WSAN	222.1	100
Cambridge	WEBE	247.8	10	Altoona	WFBG	280.2	100
Canton	WHBC	236.1	10	Bethayres	WALK	201.2	50
Cincinnati	WAAD	267.7	25	Carbondale	WNBW	258.5	5
Cincinnati	WFBE	245.8	250	E: Pittsburgh	KDKA	315.6	30000
Cincinnati	WKRC	333.1	500	Elkins Park	WIBG	440.9	50
Cincinnati	WLW	428.3	5000	Grove City	WSAJ	223.7	250
				Harrisburg	WBAK	299.8	500



State and City	Call Letters	Wave Length	Power	State and City	Call Letters	Wave Length	Power
<b>PENNSYLVANIA—Con.</b>				<b>Sioux Falls</b>	<b>KSOO</b>	209.7	250
Harrisburg	WMBS	234.2	250	Vermillion	KUSD	483.6	250
Harrisburg	WPRC	209.7	100	Yankton	WNAX	302.8	250
Jeanette	WGM	208.2	50	<b>TENNESSEE</b>			
Johnstown	WHBP	228.9	250	Chattanooga	WDOD	245.8	500
Lancaster	WGAL	252	15	Knoxville	WFBC	234.2	50
Lancaster	WKJC	258.5	50	Knoxville	WNBK	206.8	50
Lewisburg	WJBU	214.2	100	Knoxville	WNOX	265.3	1000
Monessen	WMBJ	232.4	50	Lawrenceburg	WOAN	285.5	250
New Castle	WKBU	204	50	Memphis	WGBC	277.6	15
Oil City	WHBA	260.7	10	Memphis	WHBQ	232.4	100
Oil City	WLBW	293.9	500	Memphis	WMBM	209.7	10
Parkersburg	WQAA	215.7	500	Memphis	WMC	516.9	500
Philadelphia	WABQ	260.7	500	Memphis	WNBR	228.9	20
Philadelphia	WABY	247.8	50	Memphis	WREC	254.1	50
Philadelphia	WCAU	260.7	500	Nashville	WBAW	247.8	100
Philadelphia	WFI	405.2	500	Nashville	WDAD	225.4	500
Philadelphia	WFKD	205.4	10	Nashville	WLAC	225.4	500
Philadelphia	WHBW	220.4	50	Nashville	WSM	340.7	5000
Philadelphia	WIAD	220.4	100	Springfield	WSIX	212.6	150
Philadelphia	WIP	508.2	500	<b>TEXAS</b>			
Philadelphia	WLIT	405.2	500	Amarillo	KGRS	243.8	150
Philadelphia	WNAT	288.3	100	Amarillo	WDAG	263	250
Philadelphia	WOO	508.2	500	Austin	KUT	232.4	500
Philadelphia	WPSW	202.6	50	Beaumont	KFDM	374.8	500
Philadelphia	WRAX	288.3	250	Brownsville	KWWG	277.6	500
Pittsburgh	KQV	270.1	500	College Station	WTAW	309.1	500
Pittsburgh	WCAE	516.9	500	Dallas	KRLD	461.3	500
Pittsburgh	WJAS	270.1	500	Dallas	WFAA	499.7	500
Pittsburgh	WMBU	217.3	50	Dallas	WRR	352.7	500
Pringleboro	WABF	205.4	250	Dublin	KFPL	275.1	15
Reading	WRAW	238	100	El Paso	KFXH	241.8	100
Scranton	WGBI	230.6	250	El Paso	WDAH	234.2	100
Scranton	WQAN	230.6	250	Fort Worth	KFJZ	249.9	50
State College	WPSC	299.8	500	Fort Worth	KFQB	260.7	1000
Washington	WNBO	211.1	15	Fort Worth	WBAP	499.7	1500
Wilkes-Barre	WBAX	249.9	100	Galveston	KFLX	270.1	100
Wilkes-Barre	WBRE	249.9	100	Galveston	KFUL	258.5	500
<b>RHODE ISLAND</b>				Greenville	KFPM	230.6	15
Cranston	WDWF	374.8	500	Houston	KFVI	238	50
Cranston	WLSI	384.4	500	Houston	KPRC	293.9	500
Newport	WMBA	204	100	Houston	KTUE	212.6	5
Olneyville	WCOT	225.4	50	San Angelo	KGFI	220.4	15
Pawtucket	WFCI	225.4	50	San Benito	KFLU	236.1	15
Portsmouth	WSAR	252	100	San Antonio	KGCI	220.4	15
Providence	WCBR	201.2	100	San Antonio	KGDR	202.6	15
Providence	WEAN	319	500	San Antonio	KGRC	220.4	50
Providence	WJAR	483.6	500	San Antonio	KTAP	228.9	20
Providence	WRAH	199.9	250	San Antonio	KTSA	265.3	2000
<b>SOUTH CAROLINA</b>				San Antonio	WOAI	302.8	5000
Charleston	WBBY	499.7	75	Waco	WJAD	447.5	500
<b>SOUTH DAKOTA</b>				<b>UTAH</b>			
Brookings	KFDY	394.5	500	Jerome	KFXD	204	15
Brookings	KGCR	208.2	15	Ogden	KFUR	225.4	50
Dell Rapids	KGDA	234.2	15	Salt Lake City	KDYL	258.5	100
Mitchell	KGFP	212.6	10	Salt Lake City	KFUT	499.7	50
Oldham	KGDY	206.8	15	Salt Lake City	KSL	302.8	1000
Rapid City	WCAT	247.8	100				

State and City	Call Letters	Wave Length	Power	State and City	Call Letters	Wave Length	Power
	WCAX	254.1	100	Seattle	KTW	394.5	1000
	WNBX	241.8	10	Seattle	KUJ	199.9	10
	WQAE	249.9	50	Seattle	KVOS	209.7	50
				Spokane	KFIO	245.8	100
				Spokane	KFPY	245.8	250
h Hills	WTFF	204	50	Spokane	KGA	260.7	2000
	WBBW	236.1	50	Spokane	KHQ	370.2	1000
	WRCV	209.7	100	Tacoma	KMO	254.1	250
	WTAR	275.1	500	Tacoma	KVI	234.2	50
	WLBG	214.2	100	Walla Walla	KOWW	299.8	500
	WBBL	247.8	100	Yakima	KFIQ	208.2	100
	WMBG	206.8	15	WISCONSIN			
	WRVA	254.1	1000	Beloit	WEBW	258.5	500
	WDBJ	230.6	250	Camp Lake	WCLO	227.1	100
	WSEA	218.8	250	Eau Claire	WTAQ	254.1	500
				Fond du Lac	KFIZ	267.7	100
	WSAZ	241.8	100	Kenosha	WKDR	322.4	15
	WWVA	389.4	100	La Crosse	WKBH	220.4	500
				Madison	WHA	319	750
				Madison	WIBA	239.9	100
	KFBL	223.7	100	Manitowoc	WOMT	222.1	50
	KGY	243.8	50	Milwaukee	WGWB	218.8	500
	KWSC	394.5	500	Milwaukee	WHAD	293.9	500
	KFOA	447.5	1000	Milwaukee	WSOE	270.1	500
	KFQW	217.3	100	Milwaukee	WTMJ	293.9	1000
	KGBS	202.6	100	Omro	WJBR	227.1	100
	KGCL	230.6	50	Poynette	WIBU	217.3	20
	KJR	348.6	2500	Racine	WRRS	322.4	50
	KKP	265.3	15	Stevens Point	WLBL	319	1000
	KOMO	305.9	1000	Superior	WEBC	241.8	250
	KPCB	230.6	50	West De Pere	WHBY	249.9	50
	KRSC	211.1	50	WYOMING			
	KTCL	277.6	500	Laramie	KFBU	428.3	500

*This list has been corrected up to and including August 15th, 1927*



**STATION WBAL  
SOPRANO, BALTIMORE**

**BROADCAST STATION KFI-LOS ANGELES  
PROGRAM MANAGER WITH CUP  
AWARDED IN POPULARITY CONTEST**

**STATION KDKA  
FREDERICK RODGERS, SINGER-ANNOUNCER**

# Canadian Radio Broadcast Stations

## Indexed Alphabetically by Call Letters

Radio Call Letters	BROADCAST STATIONS Location and Owner	Power Watts	Wave Length (Meters)	Frequency (Kilocycles)	Time at Station
<b>CF</b>	<b>CFAC—Calgary, Alberta—The Calgary Herald, Herald Bldg.</b>	500	434.5	690	Mountain
	<b>CFCA—Toronto, Ont.—Star Publishing &amp; Printing Co., S. W. Cor. Yonge St. and St. Clair Ave.</b>	500	356.9	840	Eastern
	<b>CFCF—Montreal, Que.—Canadian Marconi Co., Mount Royal Hotel.</b>	1650	410.7	730	Eastern
	<b>CFCH—Iroquois Falls, Ont.—Abitibi Power &amp; Paper Co., Ltd.</b>	250	499.7	600	Eastern
	<b>CFCN—Calgary, Alberta—W. W. Grant (Ltd.), 708 Crescent Rd., N. W.</b>	1800	434.5	690	Mountain
	<b>CFCQ—Vancouver, B. C.—Sprott-Shaw Radio Co., 153 Pender St., W.</b>	10	410.7	730	Pacific
	<b>CFCT—Victoria, B. C.—G. W. Deaville, 1405 Douglas St.</b>	500	329.5	910	Pacific
	<b>CFCY—Charlottetown, P. E. Island—Island Radio Co., 176 Kent St.</b>	100	312.3	960	Atlantic
	<b>CFGC—Brantford, Ont.—The Brant Radio Supply Co., 90 Colborne St.</b>	50	296.9	1010	Eastern
	<b>CFJC—Kamloops, B. C.—N. S. Dalglish &amp; Sons, and Weller &amp; Weller, 186 Victoria St.</b>	15	267.7	1120	Pacific
	<b>CFLC—Prescott, Ont.—Radio Assoc. of Prescott, Victoria Hall.</b>	50	296.9	1010	Eastern
	<b>CFMC—Kingston, Ont.—Monarch Battery Co., Montreal St.</b>	20	267.7	1120	Eastern
	<b>CFNB—Fredericton, N. B.—James S. Neill &amp; Sons, Ltd., 212 Waterloo Row.</b>	25	247.8	1210	Atlantic
	<b>CFQC—Saskatoon, Sask.—The Electric Shop, Ltd., 1322 Osler St.</b>	500	329.5	910	Mountain
	<b>CFRB—York Co., Ont.—Standard Radio Mfg. Corp., Ltd., Township of King.</b>	1000	291.1	1030	Eastern
	<b>CFRC—Kingston, Ont.—Queen's University, Dept. of Electrical Engineering, Fleming Hall, Queen's University.</b>	500	267.7	1120	Eastern
	<b>CFYC—Burnaby, B. C.—International Bible Students Assoc., 2243 Royal Oak Ave.</b>	500	410.7	730	Pacific
<b>CH</b>	<b>CHCS—Hamilton, Ont.—The Hamilton Spectator, Spectator Bldg.</b>	10	340.7	880	Eastern
	<b>CHCY—Edmonton, Alberta—Int'l Bible Students Assoc., King Edward Park.</b>	250	516.9	580	Mountain
	<b>CHGS—Summerside, P. E. I.—R. T. Holman, Ltd., Holman Bldg.</b>	25	267.7	1120	Atlantic
	<b>CHIC—Toronto, Ontario—Northern Electric Co., Ltd., Hillcrest Park. (Uses Station CKNC, Canadian Nat'l Carbon Co., Toronto, Ontario).</b>	500	356.9	840	Eastern
	<b>CHMA—Edmonton, Alberta—Christian &amp; Missionary Alliance, 9618—106A Ave.</b>	250	516.9	580	Mountain
	<b>CHNC—Toronto, Ont.—Toronto Radio Research Soc., Hillcrest Park. (Uses Station CKNC, Canadian Nat'l Carbon Co., Toronto, Ont).</b>	500	356.9	840	Eastern
	<b>CHNS—Halifax, N. S.—Northern Elec. Co., Carleton Hotel, Cor. Prince and Argyle Sts.</b>	100	322.4	930	Atlantic

# Canadian Radio Broadcast Stations

## By Provinces and Cities

Provinces	Cities	Call Letters	Wave Length (Meters)	Power (Watts)
<b>ALBERTA</b>	Calgary	CFAC	434.5	500
"	Calgary	CFCN	434.5	1800
"	Calgary	CJCJ	434.5	250
"	Calgary	CNRC	434.5	500
"	Edmonton	CHMA	516.9	250
"	Edmonton	CJCA	516.9	500
"	Edmonton	CKUA	516.9	500
"	Edmonton	CNRE	516.9	500
"	Red Deer	CKLC	356.9	1000
<b>BRITISH COLUMBIA</b>	Burnaby	CFYC	410.7	500
"	Kamloops	CFJC	267.7	15
"	Mission City	CJCU	247.8	5
"	Sea Island	CJOR	291.1	50
"	Vancouver	CFCQ	410.7	10
"	Vancouver	CHPC	410.7	1000
"	Vancouver	CKCD	410.7	1000
"	Vancouver	CKFC	410.7	50
"	Vancouver	CKWX	410.7	10
"	Vancouver	CNRV	291.1	500
"	Victoria	CFCT	329.5	500
<b>MANITOBA</b>	Winnipeg	CKY	384.4	500
"	Winnipeg	CNRW	384.4	500
<b>NEW BRUNSWICK</b>	Fredericton	CFNB	247.8	25
"	Moncton	CNRA	322.4	500
<b>NOVA SCOTIA</b>	Halifax	CHNS	322.4	100
<b>ONTARIO</b>	Bowmanville	CKCW	312.3	5000
"	Brantford	CFGC	296.9	50
"	Cobalt	CKMC	247.8	5
"	Hamilton	CHCS	340.7	10
"	Hamilton	CKOC	340.7	50
"	Iroquois Falls	CFCH	499.7	250
"	Kingston	CFMC	267.7	20
"	Kingston	CFRC	267.7	500
"	London	CJGC	329.5	500
"	Midland	CKPR	267.7	50
"	Ottawa	CKCO	434.5	100
"	Ottawa	CNRO	434.5	500
"	Prescott	CFLC	296.9	50
"	Preston	CKPC	247.8	7½
"	Scarboro Station	CJYC	291.1	500
"	Scarboro Station	CKCX	291.1	500
"	Toronto	CFCA	356.9	500
"	Toronto	CHIC	356.9	500
"	Toronto	CHNC	356.9	500
"	Toronto	CJBC	291.1-356.9	500
"	Toronto	CJSC	356.9	500
"	Toronto	CKCL	356.9	500
"	Toronto	CKNC	356.9	500
"	Toronto	CKSM	291.1	1000
"	Toronto	CNRT	356.9	500
"	York Co.	CFRB	291.1	1000

Provinces	Cities	Call Letters	Wave Length (Meters)	Power (Watts)
<b>P. E. ISLAND</b>	<b>Charlottetown</b>	<b>CFCY</b>	312.3	100
"	<b>Summerside</b>	<b>CHGS</b>	267.7	25
<b>QUEBEC</b>	<b>Montreal</b>	<b>CFCF</b>	410.7	1650
"	<b>Montreal</b>	<b>CHYC</b>	410.7	750
"	<b>Montreal</b>	<b>CKAC</b>	410.7	1200
"	<b>Montreal</b>	<b>CNRM</b>	410.7	1000-1650
"	<b>Quebec</b>	<b>CHRC</b>	340.7	5
"	<b>Quebec</b>	<b>CKCI</b>	340.7	22½
"	<b>Quebec</b>	<b>CKCV</b>	340.7	50
"	<b>Quebec</b>	<b>CNRQ</b>	340.7	50
"	<b>St. Hyacinthe</b>	<b>CKSH</b>	312.3	50
<b>SASKATCHEWAN</b>	<b>Moose Jaw</b>	<b>CJRM</b>	296.9	50
"	<b>Regina</b>	<b>CHWC</b>	312.3	15
"	<b>Regina</b>	<b>CJBR</b>	312.3	500
"	<b>Regina</b>	<b>CKCK</b>	312.3	500
"	<b>Regina</b>	<b>CNRR</b>	312.3	500
"	<b>Saskatoon</b>	<b>CFQC</b>	329.5	500
"	<b>Saskatoon</b>	<b>CHUC</b>	329.5	500
"	<b>Saskatoon</b>	<b>CJWC</b>	329.5	250
"	<b>Saskatoon</b>	<b>CNRS</b>	329.5	500
"	<b>Unity</b>	<b>CHSC</b>	267.7	50
"	<b>Yorkton</b>	<b>CJGX</b>	475.9	500

### *Licenses Required for Both Transmitters and Receivers in Canada*

All radio stations, whether used for transmitting or receiving purposes are required to be licensed in Canada. The penalty on summary conviction for operating an unlicensed radio station is a fine not exceeding \$50.00, and on conviction or indictment a fine not exceeding \$500.00, with imprisonment for a term not exceeding 12 months, in addition to forfeiture of all unlicensed apparatus. The different classes of stations for which licenses are issued and their license fees vary from \$1.00 for a private receiving set to \$50.00 for a public commercial station.

The issue of licenses for transmitting stations is limited to British subjects or to companies incorporated under the laws of the Dominion of Canada or its provinces. Licenses for private receiving sets are issued to any person irrespective of nationality. Licenses for receiving sets are obtained from the Postmaster of the larger towns and cities in the Dominion, radio dealers, Royal Canadian Mounted Police, Department of Radio Inspectors, Departmental Agencies or from the Department of Marine and Fisheries. Licenses for all other classes of stations are obtained from the Department of Marine and Fisheries at Ottawa.



**WOR**  
BROADCAST STATION  
LOUIS O. WITTEAR  
ANNOUNCER

BROADCAST STATION WOR  
VIRGINIA NEWBEGIN  
NEWARK, N.J.

BROADCAST STATION WJZ  
GODFREY LUDLOW  
NEW YORK

# Foreign Radio Broadcast Stations

## Including U. S. Possessions

Countries and Cities	Owner	Call Letters	Wave Length (Meters)	Power (Watts)
<b>ALASKA</b>				
Anchorage	Anchorage Radio Club		227.1	100
Juneau	Alaska Elec. Light & Power Co.	<b>KFIU</b>	226	10
Ketchikan	Alaska Radio & Service Co.	<b>KGBU</b>	229	500
<b>ALGERIA</b>				
Algiers	Colin & Fils	<b>8DB</b>	310	100
<b>ARGENTINE</b>				
Buenos Aires	Enrique Caride	<b>LOK</b>	280.5	500
" "	Radio America	<b>LOL</b>	236	500
" "	Telegrafo de la Provincia	<b>LOM</b>	450	1000
" "	Radio Fenix	<b>LON</b>	210	2000
" "	Radio Prieto	<b>LOO</b>	252	1000
" "	Radio Buenos Aires	<b>LOQ</b>	261	500
" "	Sociedad Radio Argentine	<b>LOR</b>	330	1000
" "	Municipality of Buenos Aires	<b>LOS</b>	291.2	5000
" "	Francisco J. Brusa	<b>LOV</b>	361.5	2000
" "	Grand Splendid	<b>LOW</b>	303	2000
" "	Radio Cultura	<b>LOX</b>	380	500
" "	Sociedad Radio Nacional	<b>LOY</b>	315.8	1000
" "	"La Nacion"	<b>LOZ</b>	330	1000
" "	Gino Bocci y Hno.	<b>B2</b>	215	100
" "	Gino Bocci Hnos.	<b>A11</b>		
" "	Radio Club Argentine	<b>A1</b>		
" "	Francisco J. Brusa	<b>B1</b>		1000
" "	Facultad de Ciencias Medicas	<b>C1</b>	229.2	100
" "	Departamento Nacional de Higiene	<b>C2</b>		
Cordoba	Antonio Vanelli	<b>H4</b>	275	20
" "	Sociedad Radio Comercial de Cordoba		381	100
" "	Jorge Coen	<b>HA8</b>	255	50
" "	Diario "Los Principios"	<b>H6</b>	250	20
Hurlingham, FCP.	Felix Gunther	<b>DA-1</b>		
La Plata, FCS.	Universidad Nacional	<b>LOP</b>	425	1000
Mendoza	Ministerio de Obras Publicas	<b>LOU</b>	380	500
" "	Pedro B. Baldassarre	<b>M6</b>	348	100
Monte Grande, FCS.	Argentine Broadcasting Assn.			
Olivos, FCCA.	Radio Broadcasting	<b>LOT</b>	400	1000
Rio Cuarto	Arturo Rodriguez	<b>H5</b>	275	100
Rosario	Manuel Fugardo	<b>F4</b>	260	100
San Fernando, FCCA.	Americo Liberti	<b>D3</b>	235.3	100
San Luis	Santoalla	<b>Q4</b>	205.1	60
Santa Fe	Jose Roca Soler	<b>F1</b>	285.8	100
" "	Sociedad Rural de Cerealistas	<b>F2</b>	275	100
Tucuman	Radio Club	<b>K4</b>	311.8	250
<b>AUSTRALIA</b>				
Adelaide	Central Broadcasters Ltd.	<b>5CL</b>	395	5000
" "	F. J. Hume	<b>5DN</b>	313	500
" "	Millswood Auto & Radio Co.	<b>5MA</b>		
" "	Marshall & Co.	<b>5MC</b>	273	500
Bathurst	Mockler Bros.	<b>2MK</b>	250	50
Brighton		<b>3PB</b>		
Brisbane	Dr. V. McDowell	<b>4CM</b>	278	250
" "	Radio Manufacturers Ltd.	<b>3MB</b>	337	250

Countries and Cities	Owner	Call Letters	Wave Length (Meters)	Power (Watts)
<b>AUSTRALIA</b>				
Brisbane	Queensland Radio Service	4QG	385	5000
Hobart	Tasmanian Broadcasting Pty.	7ZL	535	1500
Melbourne	Associated Radio Co.	3AR	484	1600
"	Broadcasting Co. of Australia	3LO	371	5000
"	O. J. Nilson & Co.	3UZ	319	100
"	L. J. Hellier	3WR	303	100
Mildura	R. J. Egge	3EO	286	100
Newcastle	H. A. Douglas	2HD	288	100
Northbridge	Otto Sandel	2UW	263	500
Perth	Westralian Farmers, Ltd.	6WF	1250	5000
Rockhampton	Queensland Government	4RN	323	500
Sydney	The Electrical Utilities Supply Co.	2UE	297	250
"	Burgin Electric Co.	2BE	316	100
"	Theosophical Broadcasting Service	2GB	316	1000
"	Trades Hall Broadcasting Station	2KY	280	300
"	Farmer & Co., Ltd.	2FC	442	5000
"		2WA	462	100
"	Broadcasters Sydney, Ltd.	2BL	353	5000
Toowoomba	Gold Radio Elec. Service	4GR	294	100
<b>AUSTRIA</b>				
Graz	Oesterreichische Radio-verkehrs Gesellschaft		404	500
Vienna	Oesterreichische Radio-verkehrs Gesellschaft	ORV	577	1500
<b>BELGIUM</b>				
Brussels	Radio Belgique Co.	BAV	508.5	1500
"	Radio Belgique Co	SBR	481	1500
<b>BOLIVIA</b>				
La Paz			175—300	50
Oruro	Radio Club Boliviano	CPM	50—200	50
<b>BRAZIL</b>				
Bahia	Radio Sociedade de Bahia	SQID	425	50
Bello Horizonte	Radio Sociedade de Mina Geraes		400	500
Ceare	Radio Club Cearense			50
Curytiba	Livio Moreira			
Fortaleza	Radio Club			300
Goyanna	Benedicto Ravello			
Matto Grosso	Radio Club de Campo Grande			
Minas Geraes	Juiz de Fora			100
Para	Radio Club de Para			100
Parana			370	300
Parahyba	Radio Sociedade de Parahyba			
Pelotas	Radio Sociedade Pelotense			
Penedo	A. G. Oliveira			
Pernambuco	Radio Club de Pernambuco		310	1000
"	Cia Radiotelegrafica Brasileira		250—380	500
"	Radio Sociedade de Jader de Andrada			
"	Radio Sociedade de Garanhuns			
Petropolis	Radio Club de Petropolis			
Porto Alegre	Radio Sociedade Riograndense	RSR	381	80
Praia Vermelha	Radio Club do Brasil	SQIB	320	500
Rio de Janeiro	Radio Sociedade de Rio de Janeiro	SQIA	400	2000
" " "	Radio Club do Brasil	SPE	312	500
" " "	National Telegraph Service		450	500
Sao Paulo	Sociedade Radio Educadora		310	1000
" "	Sociedade Radio Educadora Paulista	SQIG	360	1000
" "	Radio Club de Sao Paulo		350	100
" "	Radio Bandeirantes		370	50
" "	Dias Carneiro & Cia.		380—420	100

Countries and Cities	Owner	Call Letters	Wave Length (Meters)	Power (Watts)
<b>CANARY ISLANDS</b>				
La Laguna	Servando Ortoll Delmotte	EAJ5	280	50
Las Palmas	Canary Islands Radio Club		300	6
Teneriffe	Cervanado Ortoll Delmotte	EAR5	280	50
<b>CEYLON</b>				
Colombo			800	1500
<b>CHILE</b>				
Antofagasta	Sr. J. Pedreny	CHAO		40
"	Oficina Jose Santos Ossa	CLAC		50
"	Oficina Jose Francisco Vergara	CLAD		50
Iquique	Gildemeister & Cia.	CLAE		100
"	Oficina San Pedro	CLAF		100
"	Oficina Pena Chica	CLAG		100
San Eugenio	Rene Doneaud		230	25
Santiago	Radio Corporation of Chile	CBC	400—600	250
"	Chilean Radiophone Club	CMAH	300	100
"	Ferrocarril Transandino Chileno	CLAA		200
"	Carlos Buin Walsen	CMAA	240	20
"	International Machinery Co.	CMAB	480	1500
"	Castagneto Felli	CMAD	320	100
"	Ministerio de Higiene	CMAF	400	1350
"	Sociedad Broadcasting de Chile	CRC	385	350
"	"El Mercurio"	CMAC	360	1000
"	Radio Commercial	CMAE	280	100
"	Pedro Arroyo	CMAG	250	250
"	Cia Radio Transandino	CMAI	260	100
"	Universidad de Chile	CMAU	440	100
"		ORC	430	
"		RC	350	50
"	Harvey Diamond	CNAA		
"	Jose Bellalta	CNAC		
"	Fratelli Castagneto		320	100
"	Commercial Radio Co.		350	50
Tacna	Ministerio de Relaciones Exteriores	CMAT	365	1000
"	Chilean Government	CRCT	550	200
Valparaiso	Cia Radio Transandina	CNAD	265	500
"	Cia de Salitres de Antofagasta	CLAB		50
Vilna del Mar	Antonio Cornish Besa	ACB	400	50
" " "	Antonio Cornish Besa	CNAB		
<b>CHINA</b>				
Shanghai	Kellogg Switchboard & Supply Co.	KRC	335	150
"	Radio Supply Co. of Nanking Road	RSC	235	10
Tientsin	Gisho Electric Co.	GEC	288	50
Victoria (Hongkong)	Hongkong Radio Society	5HK	475	150
<b>COSTA RICA</b>				
San Jose	Government			
<b>CUBA</b>				
Caibarien	Maria J. Alvarez	6EV	250	50
Camaguey	Pedro Noguerras	7AZ	225	10
Camajuani	Diego Ibarra	6YR	200	20
Central Elia	Salvador Rionda	7SR	350	500
Central Tuinicu	Frank H. Jones	6KW	340	100
" "	Frank H. Jones	6JK	272	100
Ciego de Avila	Eduardo V. Figueroa	7BY	235	20
Cienfuegos	Jose Ganduxe	6VY	260	200
"	Antonio T. Figueroa	6CX	170	20
"	Eduardo Terrv	6DW	225	10
"	Luis Del Castillo	6GR	253	10



Countries and Cities	Owner	Call Letters	Wave Length (Meters)	Power (Watts)
<b>CUBA</b>				
Cienfuegos	Juan Pablo Ros	6GF	190	50
"	Eligio Cobelo Ramirez	6JQ	275	10
"	Valentin Ullivarri	16AZ	200	20
Havana	Credito y Construcciones Cia.	2HP	295	100
"	Julio Power	2JP	185	20
"	Frederick W. Borton	2CX	320	10
"	Alberto S. Bustamante	2AB	220	10
"	Cuban Telephone Co.	PWX	400	500
"	Jose Leiro	2JL	275	5
"	Alvara Daza	2K	200	20
"	E. Sanchez de Fuentes	2KD	350	50
"	"El Pais"	2EP	355	400
"	F. W. Borton	2CG	350	15
"	Bernardo Barrie	2BB	250	15
"	Frederick W. Borton	2BY	260	100
"	Julio Power	2HS	180	50
"	Jose Lara	2LR	32	50
"	Manuel y Guillermo Salas	2MG	284	20
"	R. B. Waters	2MK	85	20
"	Maria Garcia Velez	2OK	360	100
"	Oscar Collado	2OL	225	100
"	Roberto E. Ramirez	2TW	270	20
"	Benito Veita Ferro	2UF	265	10
"	Raul Karman	2RK	315	20
"	Raul Karman	2RY	170	5
"	Homero Sanchez	2SZ	418	10
"	Amadeo Saenz	2WW	210	20
"	Antonio A. Ginard	2XX	150	5
"	Raul Perez Falcon	2JD	105	20
"	Heraldo de Cuba	2HC	275	500
Matanzas	Leopoldo T. Figueroa	5EV	360	5
Nueva Gerona	Isle of Pines Telephone Co.	8JQ	130	20
Puerto del Rio	Antonio Zarazola	1AZ	275	5
Sagua la Grande	Guillermo Polanco	6HS	200	10
Santiago	Alfredo Vinnet	8FU	225	15
"	Pedro C. Anduz	8DW	275	50
"	Alfredo Brooks	8AZ	240	20
"	Ceferino Ramos	8IR	190	20
"	Alberto Ravelo	8BY	250	100
"	Guillermo Polanco	8HS	200	20
Tuinicu	Frank H. Jones	6KW	340	100
"	Short Wave Experimental Station	6XJ	30½	100
<b>CZECHOSLOVAKIA</b>				
Bratislava		OKR	300	500
Brunn	Radio Journal	OKB	441.2	2500
Koszice (Kassa)			1870	
Prague	Radio Journal	OKP	1110	1000
<b>DANZIG</b>				
Danzig			272.7	
<b>DENMARK</b>				
Copenhagen	Copenhagen Radio Broadcasting Station		337	2000
Ryvang			1150	1500
Soro	Ministry of War		1153.8	1500
<b>EGYPT</b>				
Cairo		SRE	255	
<b>EQUADOR</b>				
Guayaquil	J. Puig Verdaguer			

Countries and Cities	Owner	Call Letters	Wave Length (Meters)	Power (Watts)
<b>ESTONIA</b>				
Tallinn			285.7	2250
<b>FINLAND</b>				
Bjorneborg	Nuoren Voiman Liiton Radiohydistys		311	200
Hango	Nuoren Voiman Liiton Radiohydistys		260	250
Helsingfors	Civil Guards of Finland		375	2000
Jacobstad			275.2	
Jyvaskyla	Nuoren Voiman Liiton Radiohydistys		297	250
Lahtis			318	
Mikkeli	Nuoren Voiman Liiton Radiohydistys		566	250
Pori	Nuoren Voiman Liiton Radiohydistys		255.3	100
Skatudden	Military Station Radio Div.		318	750
St. Michel	Nuoren Voiman Liiton Radiohydistys		566	250
Tammerfors	Nuoren Voiman Liiton Radiohydistys	3NB	393	250
Tampere			373	250
Uleaborg			250	250
Viborg			214.3	750
<b>FRANCE</b>				
Agen	Dept. of Lot et Garonne	2BD	297	250
Angers	Radio Anjou		275.2	500
Bordeaux			419.5	2000
Dijon			207.5	1000
Grenoble	Ministry of P. T. T.		588.2	1500
Issy-les-Moulineaux	Ministry of War	QGA	1800	500
Juan-les-Pins			230	500
Lille			287	500
Lyon	Ministry of P. T. T.	YN	478.1	1000
"	Radio Lyon		291.3	1500
Marseilles	Ministry of P. T. T.		309	500
Mont-de-Marsen	Radio Club Landrais		400	500
Montpelier	Societe Languedocienne de T. S. F.		252.1	1000
Paris	Ecole Superieure de P. T. T.	FPTT	464	500
"	Eiffel Tower, Army	FL	2650	5000
"	Societe Francaise Radioelectrique	8AJ	1780	100
"	Lucien Levy		350	250
"	Petit Parisien	5NG	340.9	500
"	Cie. Francaise de Radiophone		1750	6000
"	Radio Paris	CFR	1750	3000
"	Radio Vitus		308	1000
Pic du Midi			350	
Reims			204.1	500
Reziers			178	500
St. Etienne	Radio Club Forezien		220	50
Strasbourg	Military Station Radio Club	8GF	222.2	250
Toulouse	Aerodrome	MRD	315	2000
"	La Radio		389.6	3000
<b>GERMANY</b>				
Berlin	Koenigswusterhausen Deutsche Welle A. G.	AFP	4000-2900	18000
"	Koenigswusterhausen Station	AFT	1250	8000
"	Vox Haus Funkstunde	AB	566-483.9	2000-4000
"	Witzleben Funkstunde A. G.		483.9	4000
"	Wolff's Bureau		2525	5000
Bremen	Nordischer Rundfunk	BMN	400	1500
Breslau	Schlessische Funkstunde		315.8	5000
Dortmund	Westdeutsche Funkstunde		283	750
Dresden	Mitteldeutscher Rundfunk		294.1	750

Countries and Cities	Owner	Call Letters	Wave Length (Meters)	Power (Watts)
<b>GERMANY</b>				
Elberfeld	Westdeutsche Funkstunde		259	
Frankfort-on-the-Main	Sudwestdeutscher Rundfunkdienst	LP	428.6	4000
Freiburg im Breisgau	Suddeutscher Rundfunk		577	9500
Gleitwitz	Schlesische Funkstunde		250	750
Hamburg	Nordischer Rundfunk	EG	394.7	10000
"		HA	394.7	4000
Hanover	Nordischer Rundfunk		297	750
Kassel	Sudwestdeutscher Rundfunk		272	750
Kiel	Nordischer Rundfunk		254.2	750
Koenigsberg	Ostmarken Rundfunk		329.7	4000
Langenberg		LA	468.8	25000
Leipzig	Mitteldeutscher Rundfunk	MR	365.8	4000
Munich	Deutsche Stunde in Bayern	WM	535.7	1500
Munster	Westdeutsche Funkstunde	MS	241.9	1500
Norddeich		KAV	1800	
Nuremberg	Deutsche Stunde in Bayern		303	750
Stettin	Funkstunde A. G.		252.1	500
Stuttgart	Suddeutscher Rundfunk	OKP	379.7	4000
<b>HAITI</b>				
Port-au-Prince	Haitien Government	HHK	361.2	1000
<b>HAWAII</b>				
Honolulu	Honolulu Advertiser	KGU	270	500
<b>HUNGARY</b>				
Budapest	Hungarian States' Post and Telegraph	MTI	546	1000
"	Magyar Tavirati Iroda		1050	2000
"	Hungarian Telephone & Radio Co.		555.6	3000
<b>ICELAND</b>				
Reykjavik			333.3	500
<b>INDIA</b>				
Bangalore	Indian Broadcasting Co.			
Bombay	Walter Rogers & Co.	2AX	226	
"	Bombay Residency Radio Club	2FV	375	220
Calcutta	Radio Club of Bengal	2BZ	800	500
"	Indian States & Eastern Agency	5AF	425	1500
Karachi	Karachi Radio Club		425	40
Madras	Crompton Elec. Co.		220	120
Rangoon	Radio Club of Burmah	2HZ	350	40
<b>IRISH FREE STATE</b>				
Cork		6CK	400	1500
Dublin	Government	2RN	319.1	1500
<b>ITALY</b>				
Milan	Unione Radiofonica Italiana	IMI	322.6	1500
Naples	Unione Radiofonica Italiana	INA	333.3	1500
Nice			362	1000
Rome	Unione Radiofonica Italiana	IRO	449	3000
<b>JAPAN</b>				
Nagoya	Nagoya Radio Broadcasting Co.	JOCK	360	1000
Osaka	Osaka Central Broadcasting Co.	JOBK	385	1000
Tokyo	Tokyo Central Broadcasting Co.	JOAK	375	1000
<b>JAVA</b>				
Batavia	Bataviasche Radio Vereeninging	JFC	220	40
<b>JUGOSLAVIA</b>				
Agram (Zagreb)			310	500
<b>KWANTUNG</b>				
Dairen	Government Bureau of Communications		390	200
<b>LATVIA</b>				
Riga			526.5	2000

Countries and Cities	Owner	Call Letters	Wave Length (Meters)	Power (Watts)
<b>LITHUANIA</b>				
Kovno			2000	2000
<b>LUXEMBURG</b>				
Luxemburg		LOAA	217.4	250
<b>MEXICO</b>				
Chihuahua	Federal Government	CZF	310	250
"	Telefonos Del Gobierno del Estado de Chihuahua	ZCF	310	250
"	Compania Telefonica	XICE	500	500
Guadajajara	Radio Club—Degollado Theatre		280	10
"	Federal Military Command	FAM	490	1000
Mazatlan	Castulo Llamas	CYR	475	250
Merida	Partido Socialista del Surestan	CYY	549	100
Mexico City	Efran R. Gomez	CYA	300	500
" "	Jose J. Reynosa (El Buen Tono)	CYB	275	500
" "	Miguel S. Castro (La High Life)	CYH	375	100
" "	General Electric Co.	CYJ	410	1000
" "	"El Universal"	CYL	400	500
" "	Martinez y Zetina	CYO	425	100
" "	Excelsior Compania Editorial	CYX	260	750
" "	La Liga del Radio	CYZ	400	100
" "	Departamento de Educacion	CZE	357	1000
" "	Secretaria de Industria, Comercio y Trabajo	CZI	450-505	750
" "	Fabrica Nacional de Vestuario	IJ		500
" "	F. C. Stephenex	IR	250	100
Monterrey	Roberto Reyes	CYM	275	100
"	D. Constantino de Tarnava, Jr.	CYH		
"	Constantino de Tarnava	CYS	311	250
Oaxaca	Federico Zonilla	CYF	265	100
Puebla	Augustin del P. Saenz	CYU	312	100
Saltillo	Colegio Ateneo Fuente		450	135
Tampico		CYE	360	100
Vera Cruz	Ministerio de Comunicaciones	CYC	300	500
" "		CYD	250	500
<b>MOROCCO</b>				
Casablanca	Radio Club de Moroc	CNO	250	500
<b>NETHERLANDS</b>				
Amsterdam		PCFF	2125	
Bloemendaal			566	
De Bilt		PCFF	1100	1250
Eindhoven	Phillips Lamp Works	PCJJ	30.2	
Scheveningen			1950	2500
Hilversum	Nederlandische Seintoellen Fabriek	PFBI	1000	10,000
"		HDO	1060	5000
<b>NETHERLANDS EAST INDIES</b>				
Soerabaya	Radiotelegraph Club		90	
<b>NEW ZEALAND</b>				
Auckland	Newcomb (Ltd.)	1YL	260	500
"	The Radio Broadcasting Co. of New Zealand	1YA	420	200
"	La Gloria Gramophone Co.	1YB	275	50
"	L. R. Keith	IZO	330	50
Christchurch	Radio Broadcasting Co., of New Zealand	3AC	240	10
"	Radio Broadcasting Co. of New Zealand	3YA	400	
Dunedin	Otago University	4XO	140	
"	British Electrical & Engineering Co.	4YA	310	500
"	Radio Supply Co.	4YO	370	500
"	Radio Broadcasting Co.	VLDN	380	750
Gisborne	Gisborne Radio Co.	2YM	260	500

Countries and Cities	Owner	Call Letters	Wave Length (Meters)	Power (Watts)
<b>NEW ZEALAND</b>				
Napier	B. C. Spackman	2YL	190	100
Wellington	Broadcastings Ltd.	2YB	275	15
"	Radio Broadcasting Co.	2YK	295	120
Whangarei	N. C. Shepherd	1YC	250	15
<b>NORWAY</b>				
Bergen	Bergen Broadcasters		370.4	1500
Fredrikstad	Broadcasting Co. A. S.		384.8	750
Hamar	Broadcasting Co. A. S.		566	750
Natodden	Broadcasting Co. A. S.		447.8	
Oslo	Broadcasting Co. A. S.	OSLO	461.5	1500
Porsgrund	Broadcasting Co. A. S.		504	750
Rjuken	Broadcasting Co. A. S.		443	250
Stavanger			277.8	250
Tromso	Tromso Broadcasters		500	
Trondhjem			243.9	
<b>PERU</b>				
Arequipa	Augusto Gilardi	30A	240	10
Lima	Peruvian Broadcasting Co.	OAX	380	1500
"	German Gallo	50A	250	20
"	Enrique Perez	40A	250	20
<b>PHILIPPINE ISLANDS</b>				
Baguio		KZUY	359.9	500
Iloilo		KPM	400	500
Manila	I. Beck Inc.	KZIB	260	10
"	Radio Corp. of the Philippines	KZKZ	270	500
"	Radio Corp. of the Philippines	KZRM	413	1000
"	Radio Corp. of the Philippines	KZRQ	400	500
<b>POLAND</b>				
Cracow			422	1500
Posen			270	1500
Warsaw	Government	PTR	380	700
"		AXO	1111	10000
<b>PORTO RICO</b>				
San Juan	Radio Corp. of Porto Rico	WKAQ	340.7	500
<b>PORTUGAL</b>				
Lisbon	Grandes Armazens do Chiado	PIAA	310	150
Montesanto	Government Wireless Station	CTV	2450	1500
<b>SAN SALVADOR</b>				
San Salvador	Government of el Salvador	AQM	452	500
<b>SENEGAL</b>				
St. Louis	Senegal Radio Club		300	100
<b>SPAIN</b>				
Barcelona	Radio Barcelona (Hotel Colon)	EAJ1	344.8	1500
"	Radio Catalana	EAJ13	462	1000
Bilbao	Radio Club Vizcaina	EAJ9	436	1000
"	Radio Vizcaya	EAJ11	418	2000
"	Armando de Otera		383	200
Cadiz	Radio Cadiz	EAJ3	400	500
"	Radio Lehera	EAJ10	297	1000
Cartagena	Enrique de Orbe	EAJ16	279	1000
"		EBX	1200	1000
Madrid	Radio Espana	EAJ2	393	3000
"	Escuela Superior	PTT	458	1000
"	Antonio Castilla	EAJ4	375	6000
"	Radio Iberica	EAJ6	392	1000
"	Union Radio	EAJ7	373	3000
"		EAJ12	306	2000

Countries and Cities	Owner	Call Letters	Wave Length (Meters)	Power (Watts)
<b>SPAIN</b>				
Madrid	Radio Espanola	EAJ15	490	1000
"		EGC	1650-2200	2000
Malaga	Spanish Telecommunication Co.	EAJ25	325	1000
"	Alfonso Villota		325	200
Oviedo (Cima)	Arturo Cima Fernandez	EAJ19	340	1000
Salamanca		EAJ22	402.5	500
San Sebastian	Sabino Ucelayeta	EAJ8	346	2000
Sevilla	Manuel Garcia Ballesta	EAJ17	400	1000
"	Jorge la Riva	EAJ21	300	1000
"	Radio Club Sevillano	EAJ5	344.8	1000
Valencia		EAJ24	360	1000
"	Jose Lopes Azcar	EAJ14	500	500
Zaragoza		EAJ23	325	1500
<b>STRAIGHTS SETTLEMENTS</b>				
Singapore	Malaya Amateur Wireless Society		330	150
<b>SWEDEN</b>				
Boden	Radiotjanst	SASE	1200	1500
Boras		SMBY	230.8	250
Eskilstume	Radio Club	SMUC	250	250
Falun	Radiotjanst	SMZK	400	1500
Gaeve	Radio Club	SMXF	204.1	250
Goteborg	Radiotjanst	SASB	416.7	1000
Halmstad		SMSB	215.8	250
Helsingborg		SMYE	229	250
Jonkopings	Jonkopings Rundradiostation	SMZD	201.3	500
Kalmar		SMSN	252.1	250
Karlsborg	Radiotjanst	SASF	1350	50
"		SAJ	1365	5000
Karlskrona		SMSM	196	2000
Karlstadt	Radio Club of Karlstad	SMXG	221	150
Karlstadt		SMXZ	221	250
Kristinehamn		SMTY	202.7	250
Linkoeeping	Radio Club	SMUV	467	25
"		SMUW	497.5	250
Malmo	Radiotjanst	SASC	260.9	500
Motola			1305	30000
Norrkoeping	Radio Club	SMVV	275.2	250
Orebro		SMTI	218	250
Ostersund			720	1000
Saffle		SMTS	252.1	500
Stockholm	The Swedish Broadcasting Co.	SASA	454.5	1500
Sundsvall	Radiotjanst	SASD	545.6	500
Trodhattan	Trodhattans Rundradiostation	SMXQ	277.8	250
Uddevalla		SMZP	294.1	250
Umea		SMSN	229	250
Varborg		SMSO	297	250
<b>SWITZERLAND</b>				
Basle		HB3	1100	250
Berne	Radio-Genossenschaft	HBA	411	5000
Geneva	Radio Broadcasting Soc. of Geneva	HBI	760	1500
Lausanne	Lausanne Radio Society	HB-2	318	500
Zurich	Zurich University	RGZ	515-650	500
"	Zurich Radio Genossenschaft	HBZ	496	1000
<b>TUNISIA</b>				
Tunis	French Army	OCTU-TUA	1450-45	500
<b>UNION OF SO. AFRICA</b>				
Cape Town	African Broadcasting Assn.		375	1500

Countries and Cities	Owner	Call Letters	Wave Length (Meters)	Power (Watts)
<b>UNION OF SO. AFRICA</b>				
Durban	Town Council		400	1500
Johannesburg	African Broadcasting Co.	JB	450	500
<b>UNION OF SOVIET SOCIALIST REPUBLICS (formerly Russia)</b>				
Astrakhan		RA26	700	1000
Baku		RA45	760	1250
Bogorodsk		RA8	750	
Ekaterinburg		RA15	750	250
Homel		RA39	925	1250
Irkutsk			1300	
Ivanovo Voznesensk		RA7	800	1000
Kharkov		RA43	640	4000
"		RA24	475	4000
Kiev		RA5	775	1000
Kniepropetrovsk			560	1000
Krasnodar		RA38	513	1000
Leningrad		RA6	940	2000
"		RA42	1000	10000
Minsk		RA18	950	1250
Moscow	Sokolniki		1010	2000
"	Trade Union	KAZ	450	2000
"	Lubovitch		365	
"		MSK	650	2000
"	Union of Soviet Workers	RA4	675	500
"	Kominern	RDW-RAI	1450	40000
"	Radio-Peredatcha		420	2000
Niji-Novgorod		RA13	1400	1500
Novosibirsk		RA33	700	4000
Odessa		RA40	1000	1250
Rostov-on-Don		RA14	820	1250
Saratoff			700	1000
Sevastopol		RA9	800	1000
Stavropol		RA20	655	1250
Tashkent		RA27	800	4000
Tifis			870	4000
Tver		RA44	965	1250
Ust-Syssolsk		REG	1000	1250
Veliky Ustjuk		RA16	1010	1250
Vladivostok		RA17	456	1250
Voronesh		RA12	950	1250
<b>UNITED KINGDOM</b>				
Aberdeen	British Broadcasting Co.	2BD	500	1500
Belfast	British Broadcasting Co.	2BE	306.1	1500
Birmingham	British Broadcasting Co.	5IT	326.1	1500
Bournemouth	British Broadcasting Co.	6BM	491.8	1500
Cardiff	British Broadcasting Co.	5WA	353	1500
Chelmsford	British Broadcasting Co.	2BR		
Daventry	British Broadcasting Co.	5XX	1604.3	5000-10000
Dundee	British Broadcasting Co.	2DE	288.5	200
Edinburgh	British Broadcasting Co.	2EH	294.1	200
Glasgow	British Broadcasting Co.	5SC	405.4	1500
Hull	British Broadcasting Co.	6KH	288.5	200
Leeds-Bradford	British Broadcasting Co.	2LS	277.8-254.2	200
Liverpool	British Broadcasting Co.	6LV	297	2000
London	British Broadcasting Co.	2LO	361.4	3000
Manchester	British Broadcasting Co.	2ZY	384.6	1500
Newcastle	British Broadcasting Co.	5NO	312.5	1500
Nottingham	British Broadcasting Co.	5NG	275.2	200

Countries and Cities	Owner	Call Letters	Wave Length (Meters)	Power Watts
<b>UNITED KINGDOM</b>				
Plymouth	British Broadcasting Co.	5PY	400	200
Poldhu	British Broadcasting Co.	2YT		
Sheffield	British Broadcasting Co.	6FL	272.7	200
Stoke-on-Trent	British Broadcasting Co.	6ST	288.5	200
Swansea	British Broadcasting Co.	5SX	288.5	200
<b>URUGUAY</b>				
Montevideo	Radio Sudamericano	CWOZ	320	500
"		CWOA		1000
"	Diario "El Dia"	CWOR	350	500
"	Danree & Cia	CWOF	300	100
"	Templo Metodista	CWOG	280	10
"	Instituto Metereologico	CWOB	250	50
"	General Electric Co. of Uruguay	CWOS	380	500
<b>VENEZUELA</b>				
Caracas	Empresa Venezolana de Radiotelefonía	AYRE	375	1000
<b>YUGOSLAVIA</b>				
Belgrade	Cie. Generalle De T. S. F.	HFF	225.6	1000
Zagreb			310	1000





# The Lynch Suppressor Circuit

by Joseph Calcaterra

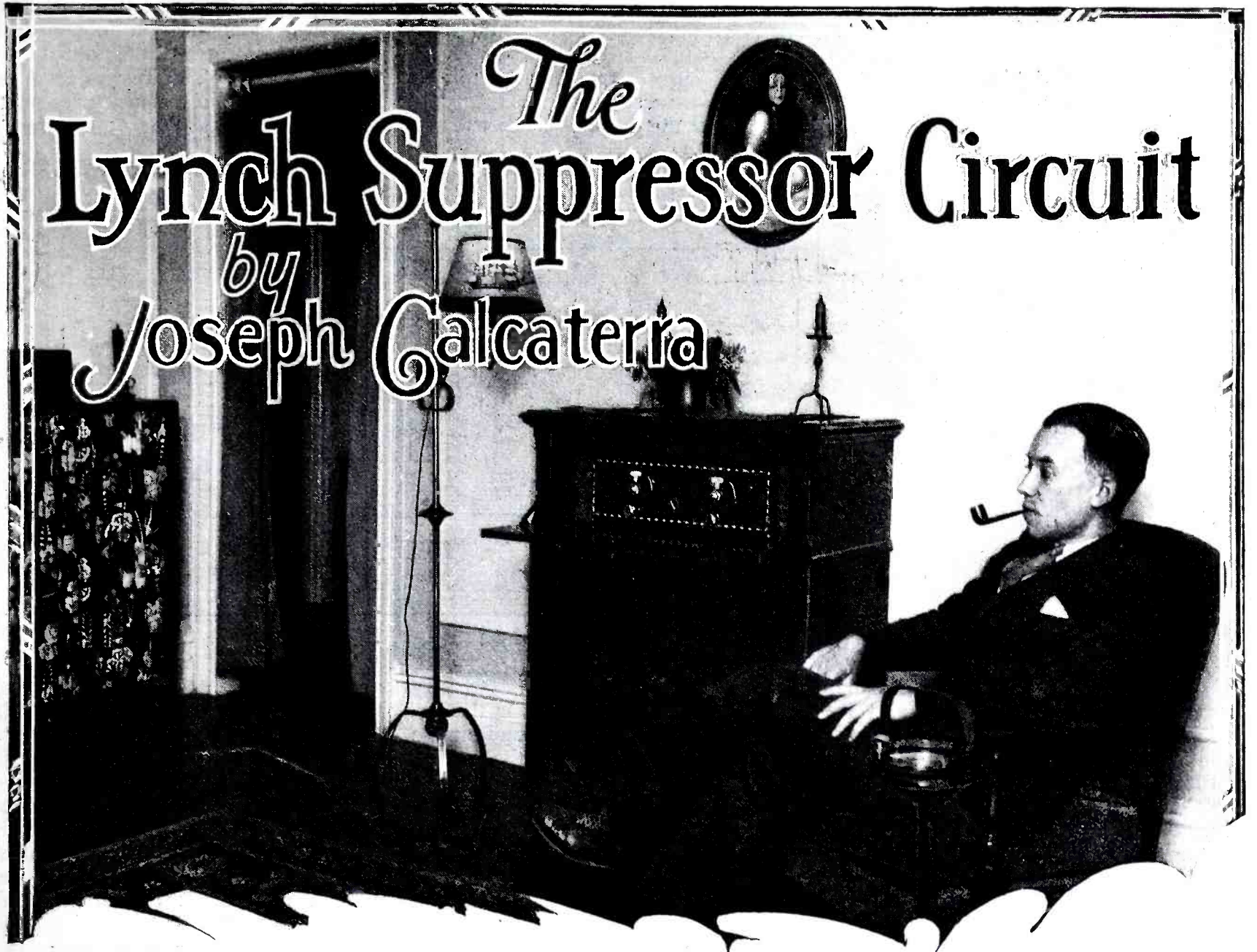

FOLLOWING the vogue of neutro-dynes and other "dynes" which has prevailed for the past two years it is a decided relief to find that engineers have discovered other and far more simple means for providing efficient radio frequency amplification that is free from oscillation but at the same time involves no critical adjustments of neutralizing or balancing devices.

This should not be taken as a general denunciation of all neutralized or balanced circuits, because there can be no question about the high degree of efficiency of some of the receivers of these types that have been developed during the past year or so. It will be found, however, that practically without exception these good receivers are complicated in design and construc-

tion; involve the use of elaborate shielding and filtering systems; employ special bridge circuits; and on the whole present a difficult construction problem even for engineers and commercial manufacturers.

The Lynch suppressor circuit provides a welcome contrast to the complexities of these other radio frequency circuits. It consists of two stages of

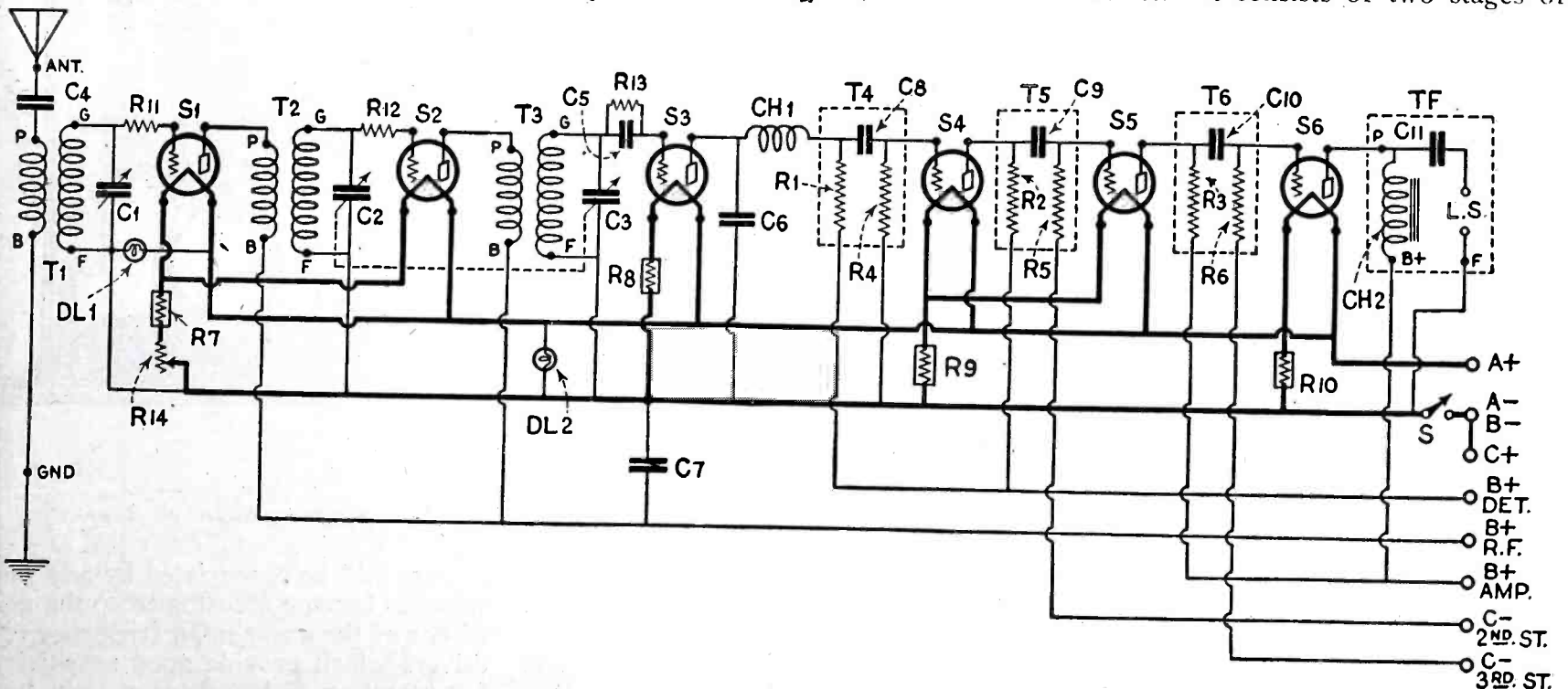

Schematic wiring diagram of the Lynch Suppressor Circuit. Lettering corresponds with that on picture diagram.

highly efficient, tuned radio frequency amplification, a detector and three stages of resistance-coupled audio frequency amplification. Every precaution has been taken in its design to obtain an extremely high degree of

oscillation cannot take place. Actually this is not the case. The function performed by these resistors is to prevent a flow of current in the grid circuits. If the resistances used for this purpose are of the correct values and are

development is the fact that the radio-frequency amplification obtained is practically uniform throughout the entire waveband. This results from the fact that the radio frequency resistance of the suppressors (or of any resist-

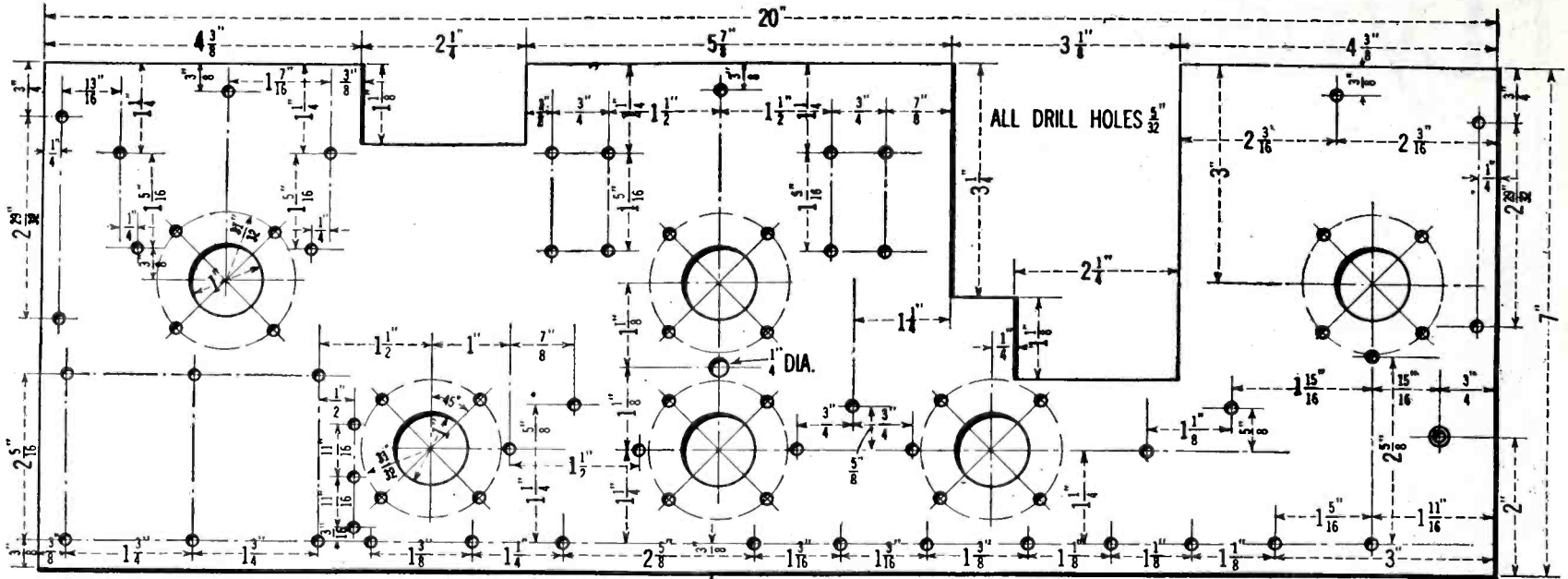

Dimensions for cutting out and drilling the sub-panel.

efficiency, combined with good volume and excellent tone quality; and all this with the minimum number of parts and the maximum simplicity of construction.

The required stability in the radio frequency amplifier is obtained through the use of a 700 ohm Lynch suppressor, R11 and R12, in the grid circuit of each of the two radio frequency

so constructed as to have an extremely low capacity there is no loss in the circuit except the loss of the undesirable current flow which causes the oscillation. By the more technical fan this will be understood when it is realized that when the flow of current is stopped by the use of a sufficiently high resistance there can be no voltage drop across the resistance itself, and in that

ance unit) automatically increases with the frequency. Therefore, on the lower wavelengths where there is a greater tendency toward oscillation the attendant increase in the radio frequency resistance of the suppressors still is adequate to prevent the current flow in the grid circuits. Thus at all frequencies the resistance is just enough to prevent oscillation. This

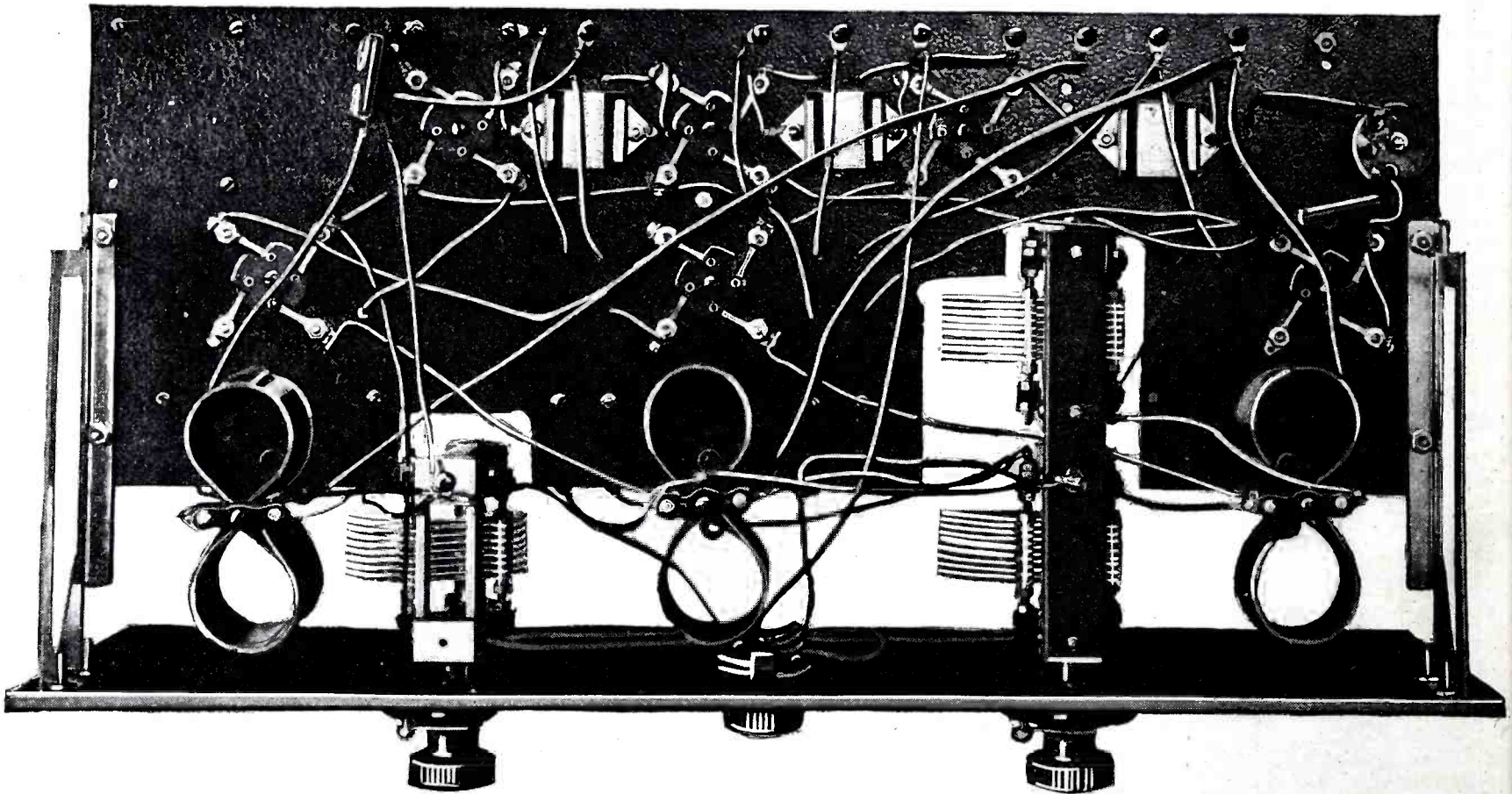

How the set appears from the underside of the sub-panel. All wiring is made with Celatsite flexible hook-up wire in the fashion shown.

amplifier tubes. At first glance this would seem to include this circuit in the "losser" class; that is, as a circuit which controls oscillation by reducing the efficiency to a point where

case the full signal voltage is applied to the tube grid just as though the resistance were not in the circuit.

Another feature which marks the use of suppressors as an outstanding

feature will be appreciated by any fan who has become accustomed to the use of one of the many radio frequency receivers which provide good sensitivity for reception of low wave stations but

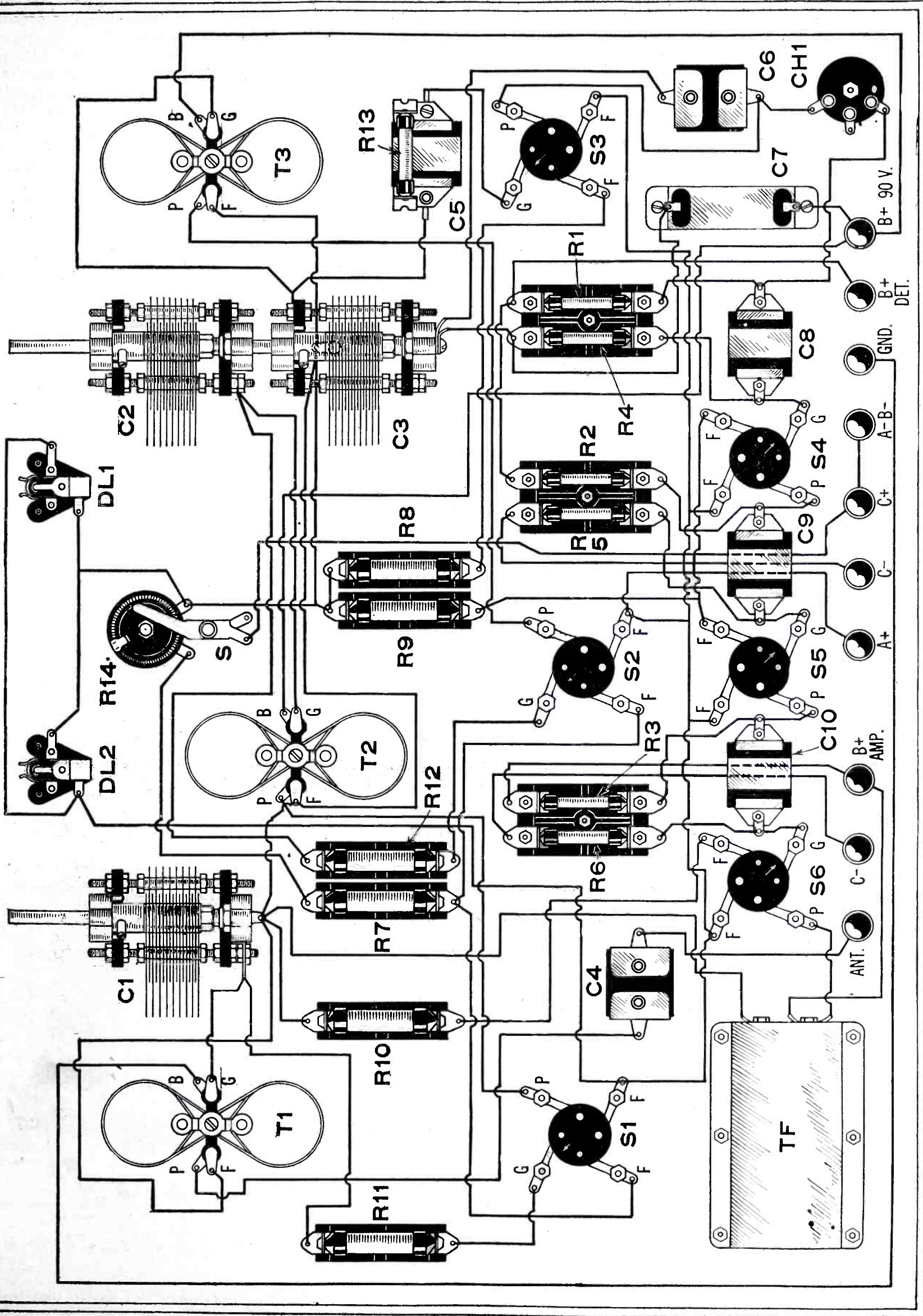

will scarcely bring in any stations up around five hundred meters.

The coils used in the radio frequency stages, T1, T2 and T3, are the Bodine "Twin Eight" matched radio

These coils are tuned by means of the three variable condensers, C1, C2 and C3. In order to reduce the number of tuning controls to two in number, condensers C2 and C3 are mounted

standard grid leak and condenser, and employs a 300 A type tube. With this arrangement the maximum sensitivity is obtained and at the same time the fine quality is maintained. This latter is partially accounted for by the use of a radio frequency filter, consisting of the radio frequency choke CH1 and the fixed condenser C6. This choke serves to block the passage of the radio frequency current in the detector output and the condenser by-passes this current back to the filament circuit. Thus the radio frequency currents are kept out of the audio frequency circuits where they would be highly undesirable. The large by-pass condenser C7 is used to by-pass the radio frequency currents around the "B" batteries.

The three stages of resistance-coupled audio frequency amplification provide reproduction of highest quality and more than ample volume for ordinary home use. The new type 340 high mu tubes are used in the first and second stages. It is the use of these tubes, with coupling condensers and resistances of the highest quality that accounts for the superior results obtained from this amplifier. The high voltage amplification obtained with the high mu tubes provides a degree of amplification per stage that compares favorably with the volume of amplification obtained with any other coupling means, and the quality obtained is exceptional.

**LIST OF PARTS REQUIRED FOR LYNCH SUPPRESSOR SET**

- One 7" x 21" x 3/16" Formica panel
- One 7" x 20" x 3/16" Formica sub-panel
- Two Benjamin No. 8629 subpanel brackets
- One set Bodine matched "Twin Eight" R. F. transformers; T1, T2 and T3
- One National .00035 mfd. Equitune variable condenser, C1; with illuminated dial, DL1.
- Two National .00035 mfd. Equitune variable condensers, C2 and C3; with illuminated dial DL2, gauged together with a strip of Formica fastened to their bases and a brass rod through both shafts.
- Six Benjamin No. 9044 sockets; S1, S2, S3, S4, S5, and S6
- Three Lynch double resistor mountings; T4, T5 and T6
- Three Lynch .25 megohm metallized resistors; R1, R2 and R3
- Three Lynch 2 megohm metallized resistors; R4, R5 and R6
- Three Lynch type 2 equalizers; R7, R9 and R10
- One Lynch type 4 equalizer; R8

- Two Lynch 700-ohm Grid Suppressors; R11 and R12
- One Lynch 2-megohm Metallized resistor; R13
- One Carter M-S-6, combination 6-ohm midjet rheostat and battery switch; R14, S
- One National tone filter; TF (includes CH2 and C11)
- Two Dubilier, type 601, .0005 mfd. fixed condensers; C4, C6
- One Dubilier, type 640-G, .00025 mfd. grid condenser; C5
- One Dubilier, type 907, 1 mfd. fixed condenser; C7
- Three Dubilier, type 640, .006 mfd. fixed condensers; C8, C9 and C10
- One Silver-Marshall R. F. choke coil; CH1
- Ten X-L Radio Labs. aluminum binding posts with suitable markers.
- One package Kester radio solder.
- 25 feet Acme Celatsite hook-up wire
- Two 301-A type tubes
- One 300-A type detector tube
- Two 340 type high Mu tubes
- One 371 or 112 type power tube

frequency transformers. These coils, which are of the double-barrel type, have the advantage that they reduce the undesirable interstage coupling and are less inclined to direct pick-up than are coils of the solenoid type. The

on a single shaft. The vernier tuning controls are provided with pilot lights DL1 and DL2 which serve the double purpose of showing when the receiver is turned "on," and also of illuminating the tuning scales so that tuning may be

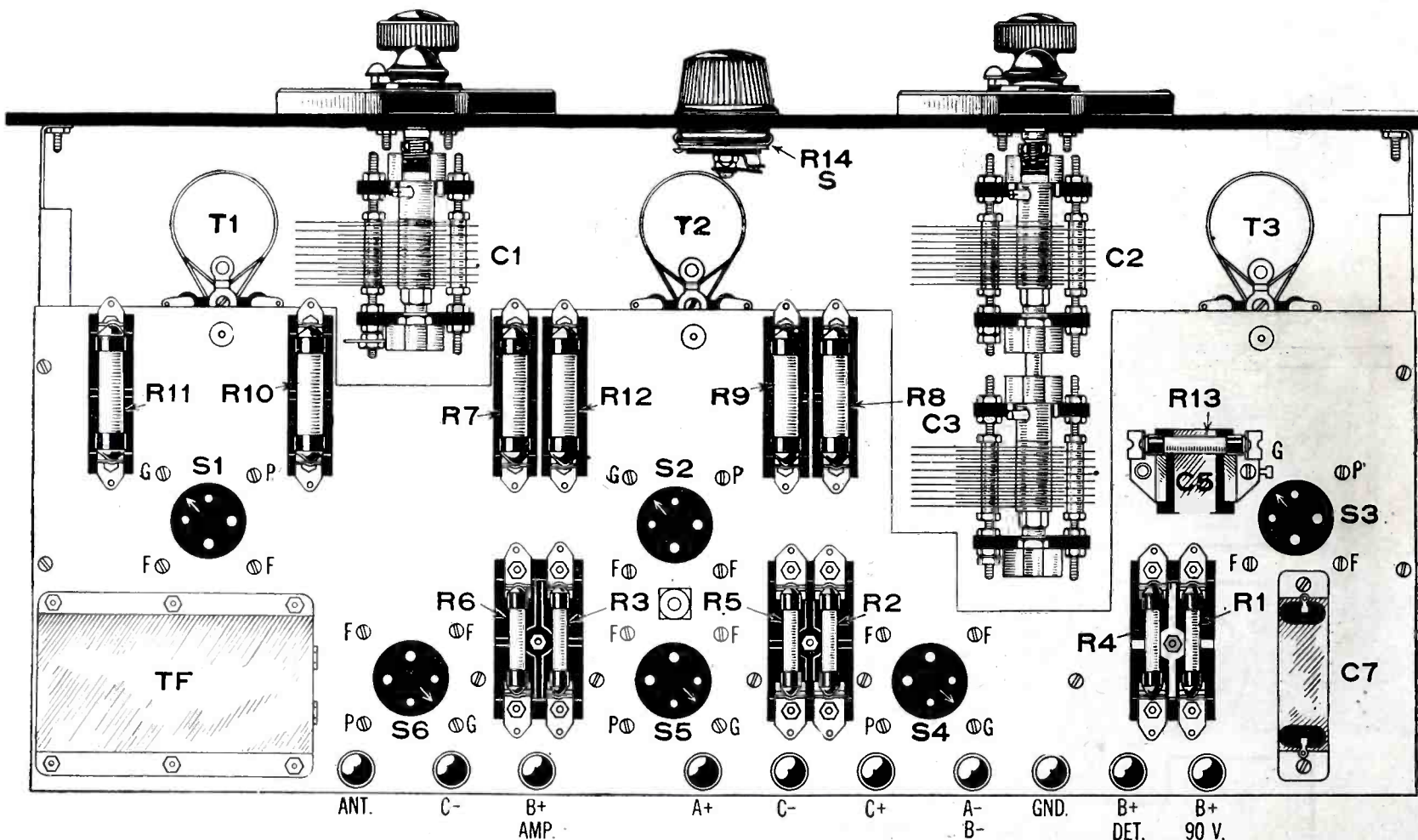

Layout of parts on the front and sub-panel. This layout can be easily followed by comparing the component parts with those as indicated in the picture diagram.

latter feature increases the selectivity of the receiver, particularly in cutting out powerful, nearby stations.

readily accomplished, even in a darkened room.

The detector circuit makes use of a

Experiment has shown that best results are obtained with this amplifier if the plate resistances R1, R2 and R3

are of .25 megohm each; and the grid resistances R4, R5 and R6 are each of 2 megohm resistance. The coupling condensers C8, C9 and C10 are Du-bilier mica condensers of .006 micro-farad capacity. The use of such com-

to prevent the heavy direct current from the batteries from passing through the windings of the loud-speaker. Thus the speaker is pro- tected from magnet depolarization, dis- tortion and burnout.

This voltage is to be used where the "B" voltage is around 135. Where the "B" voltage is around 180 then the "C" voltage should be from 1½ to 3 volts. The "C" voltage on the last tube can best be determined by the tone

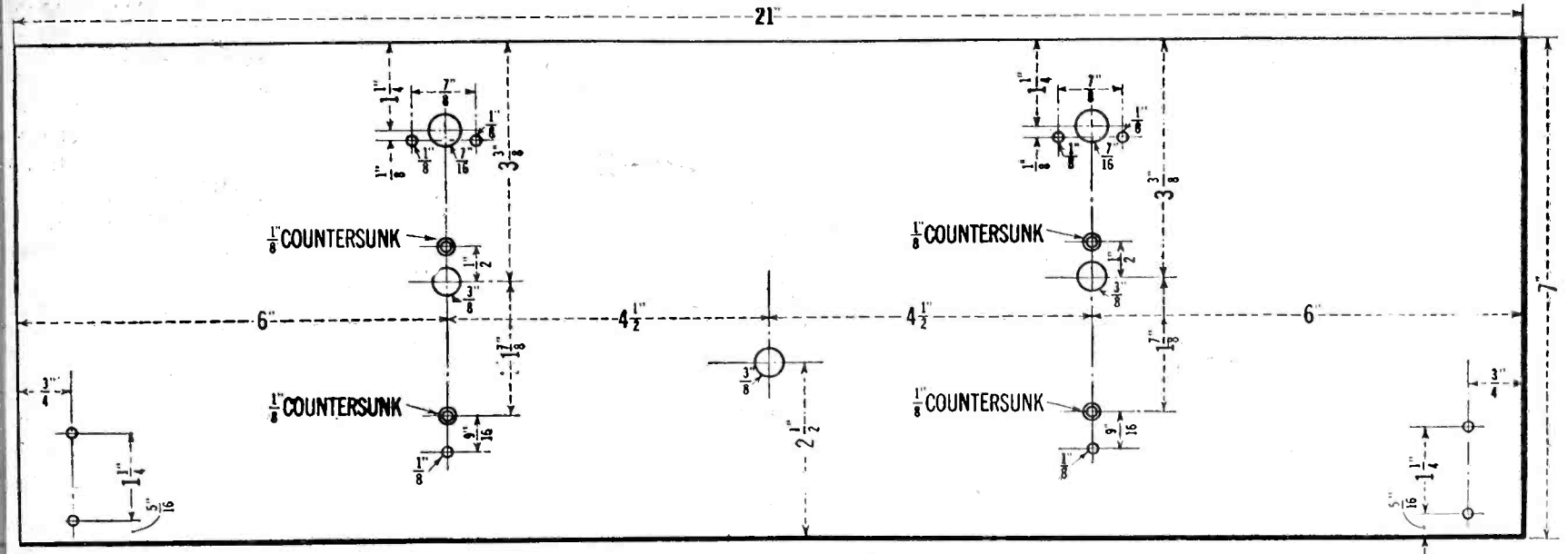

Front panel drilling layout. All dimensions for drilling the necessary holes are given.

paratively low capacity is made permis- sible by the use of the high mu tubes and represents a decided advantage in the matter of cost.

The last audio stage should be a power stage, using a 371 type tube in socket S6. If it is desired to use lower "B" voltages, however, a 112 type tube may be used to advantage in

The output circuit should be ar- ranged as shown in the diagram. To connect it in this way it is necessary to break the wire connection between the "B" and "F" terminals of the tone filter. No jacks or binding posts are provided in the receiver for the loud- speaker. Instead, its tips are inserted in the tip jacks which are included in

quality of reproduction, and from the instructions which come with the power tube. It might be added that the "C" voltage on the last tube is not particu- larly critical but the higher the "C" voltage, the lower the current drain on the "B" batteries. The "C" voltage on the 2nd audio tube is critical. So much so that 1½ to 3 volts more than

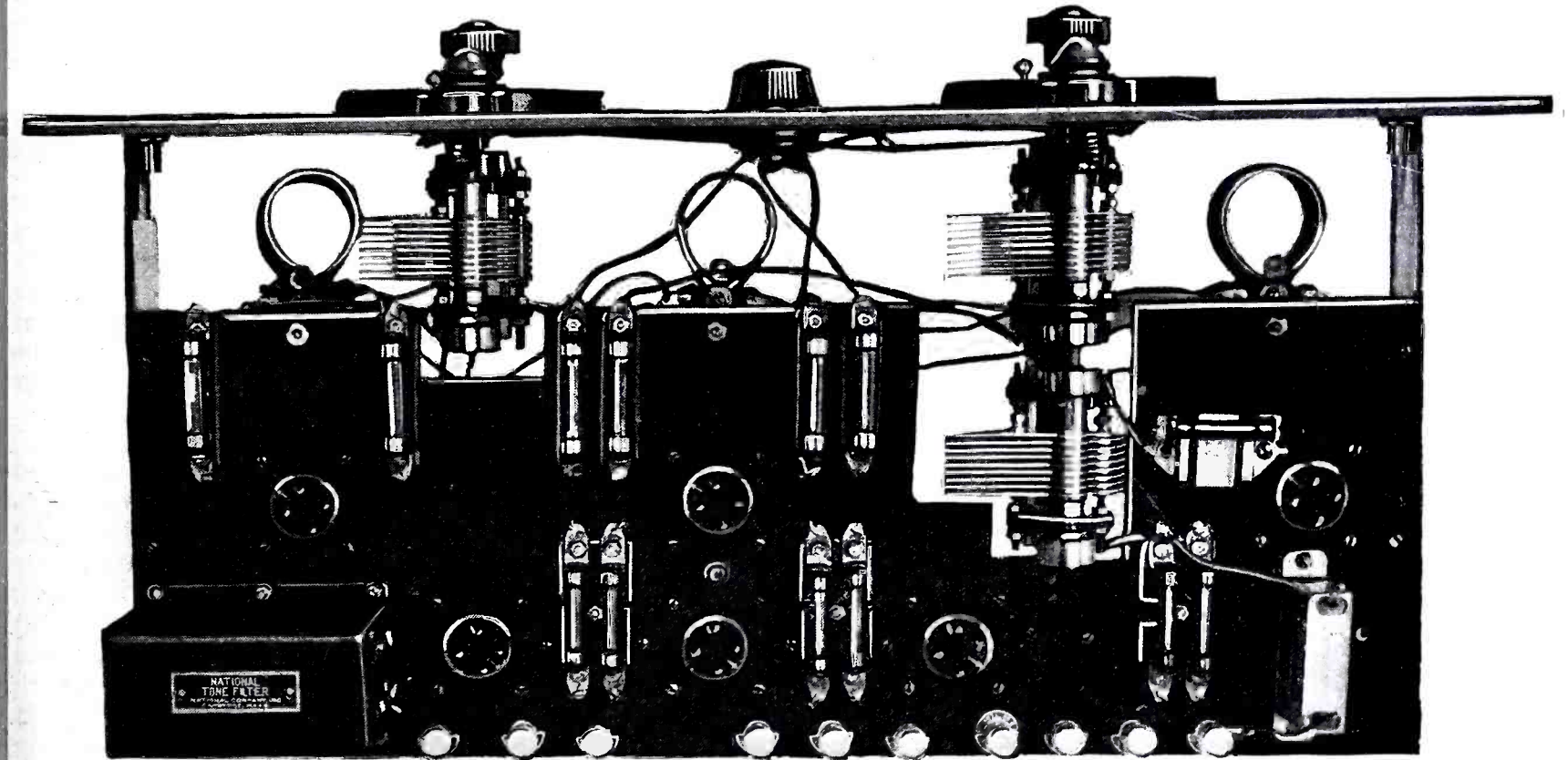

A photographic view of the set looking down on the sub-panel.

this stage. When more than 135 volts of "B" battery is to be used an output filter device should be used in the plate circuit of the last audio tube. In this receiver the National Tone filter is used and is shown as TF in the dia- gram. This filter consists of the choke coil, CH2, and the filter condenser, C11. The purpose of this device is

the tone filter and are designated as "LS" and "F" on the outside of the filter case.

The "C" bias on the second and third audio stages must be determined by the amount of "B" battery voltage used and the type of tube used in the last audio stage. The bias on the 2nd stage will lie between 0 and 3 volts.

the voltages specified above will render the receiver inoperative.

The receiver is intended for use with a six volt storage battery or its equiva- lent, as the supply source for the fila- ment lighting voltage. This voltage is reduced to the individual requirements of the tubes through the use of suitable

(Continued on page 154)

# The AERO-SEVEN BROADCAST RECEIVER

*Zeh  
Bouck*

*by*

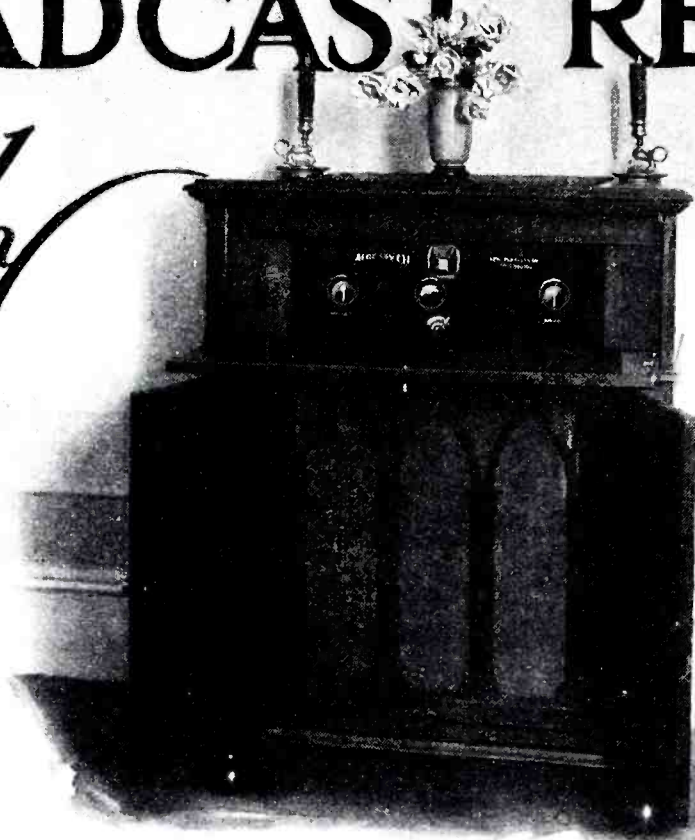

A GENERAL consensus sums up the characteristics of the ideal broadcast receiver, with logic and justice, as follows: First of all the number of tuning dials should be limited to unity. A single dial receiver is certainly most easily tuned, a simplicity that reflects the fact that radio has been graduated from the laboratory stage and has now become an instrument of pleasure, to be operated by the casual pass of the hand from an easy chair. Selectivity should be perfect. That is, it should tune neither too sharply nor too broadly. Either variation from the optimum is most undesirable. If a station tunes too broadly, interference will be experienced. One local station will often interfere with another, not to mention the impossibility of tuning through locals for distance when the lure of many miles impels. If a receiver tunes too sharply, side bands, frequencies which constitute the higher audio notes, will be cut off, with resulting distortion. The receiver is then said to have a high cut off. The effect is similar to certain types of poor audio amplifying transformers. The tone is drummy—muffled. It should be possible to control the selectivity of the receiver, from a comparatively insensitive state to the point where it readily detects relatively small impulses. In other words the volume control should be confined to the radio frequency circuit. If a receiver operates at all times at maximum sensitivity, the noise level will always be at its highest point, regardless of whether distant or local stations are being received. The extreme sensitivity required for the re-

ception of DX necessarily sensitizes the receiver to extraneous and stray waves. Such sensitivity is quite unnecessary

erally results in overloading various tubes with resulting loss in quality.

The volume or sensitivity control also should effect the desired control without broadening tuning to more than a negligible degree.

Assuming these various approaches to perfection in the radio frequency section of the receiver, an audio amplifier of comparable worth is essential to justify the electrical efficiency achieved.

## The Aero-Seven

To call the Aero-Seven "just another circuit" would do this receiver a gross injustice. As a matter of fact it is not another circuit. It is a combination of well known circuits so modified that its action conforms very closely to the requirements for the ideal receiver outlined above.

Single dial control, of several r.f. circuits, is achieved by well designed tandem tuning. The problem of simultaneous tuning has always been the alignment of the various circuits. For successful tandem tuning the inductive values and the capacitive values in each circuit must be accurately matched at all frequencies. It has been very difficult to do this for two reasons. It is a painstaking and highly scientific task to match all coils and condenser sections. Even with these elements carefully checked the capacitive and inductive effects of the proximity of parts and wiring introduce perplexing discrepancies. Also, the antenna coupling to the first r.f. tube often renders the tuning line of the first circuit inconsistent with that of succeeding circuits—an inconsistency which varies with the electrical characteristics of antennas.

### LIST OF PARTS FOR THE AERO-SEVEN

- 1 Aero-Seven Foundation Unit
- 1 Aero Choke Coil No. 60
- 1 Aero Kit of Coils U-12
- 1 Silver-Marshall Drum Dial
- 1 Carter "Imp" Battery Switch
- 1 Carter "Imp" 200-Ohm Potentiometer
- 1 Carter "Imp" 6-Ohm Rheostat
- 1 Carter H-1000 Resistor
- 1 Carter H-1 Resistor
- 1 Carter .00025 Mfd. Condenser
- 1 Carter .001 Mfd. Condenser
- 2 Carter one-half mfd. by-pass condensers
- 10 X-L Binding Posts, lettered—aerial ground, "A" battery plus, "A" battery minus, 2 "C" batteries minus, "B" + 90 volts, speaker positive, speaker minus, amplifier B +.
- 1 Amsco Floating Socket
- 6 Amsco Plain sockets
- 1 Amsco .0005 Mfd. Triplet Condenser, No. 1526
- 1 Amsco Grid-Gate Mounting
- 1 Amsco 5 Meg. Grid-Gate
- 1 Amsco Resistance coupled audio kit
- Excello Console, Style R-31

on local stations, where, aside from introducing disturbing noises, it gen-

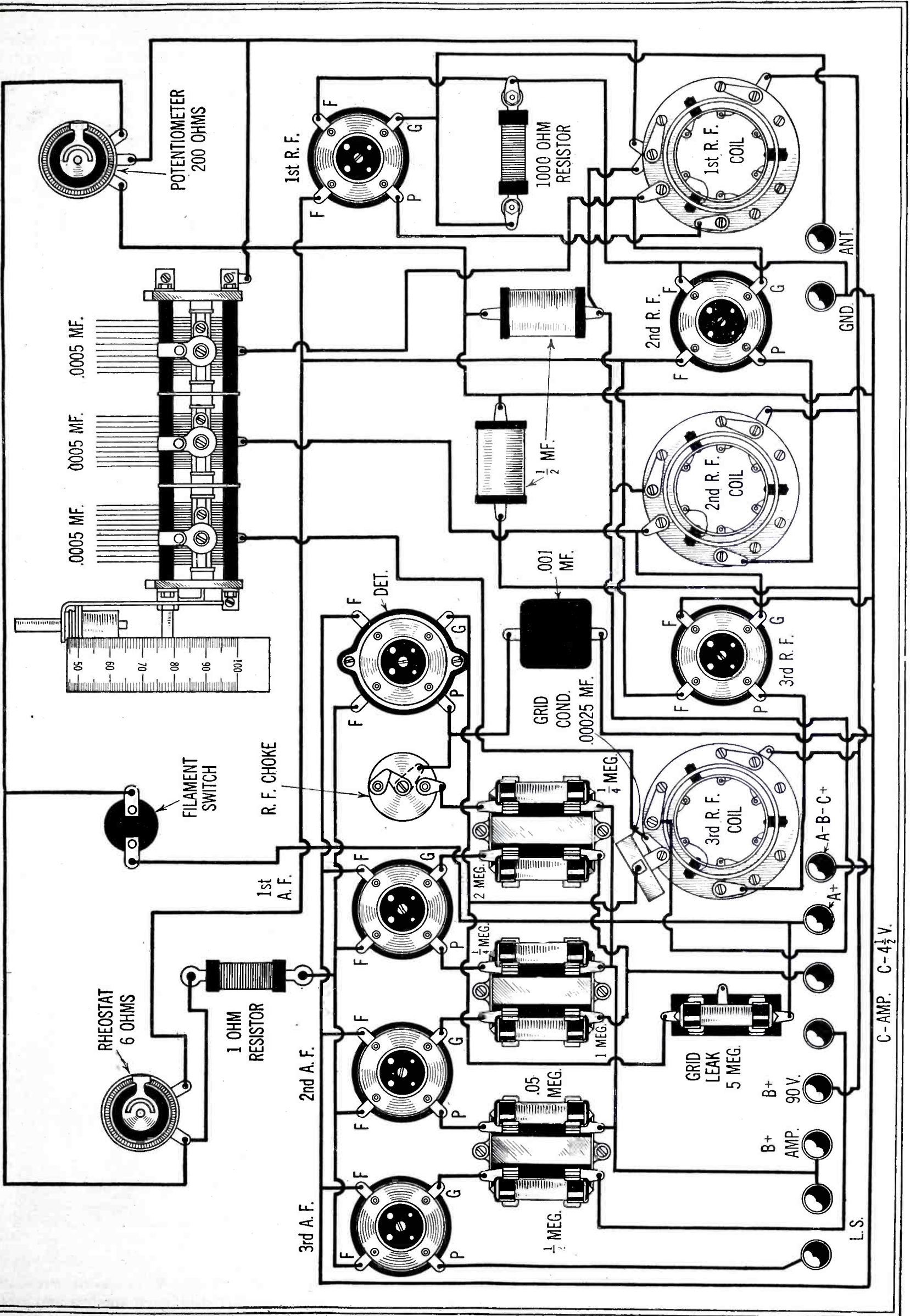

C-AMP. C-4 1/2 V.

**Matching of Coils and Condensers**

The Aero coils are matched with a satisfactory degree of precision, im-

section of this condenser is equipped with a small equalizing or compensating capacity which can be varied to compensate stray circuit capacities. Stray inductive effects are matched by

the picture layout followed in every detail.)

The effect of the antenna circuit on the first tuned circuit is eliminated in the Aero-7, by coupling the antenna to

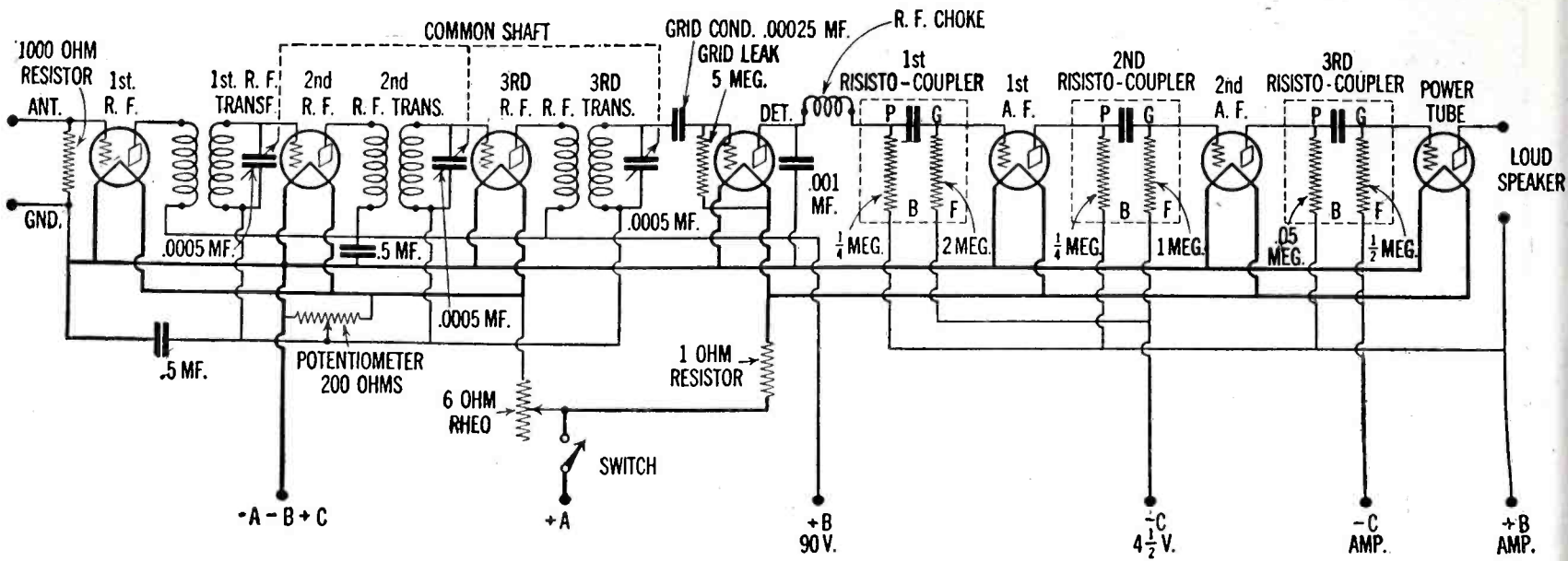

Schematic wiring diagram of the Aero-Seven Broadcast Receiver.

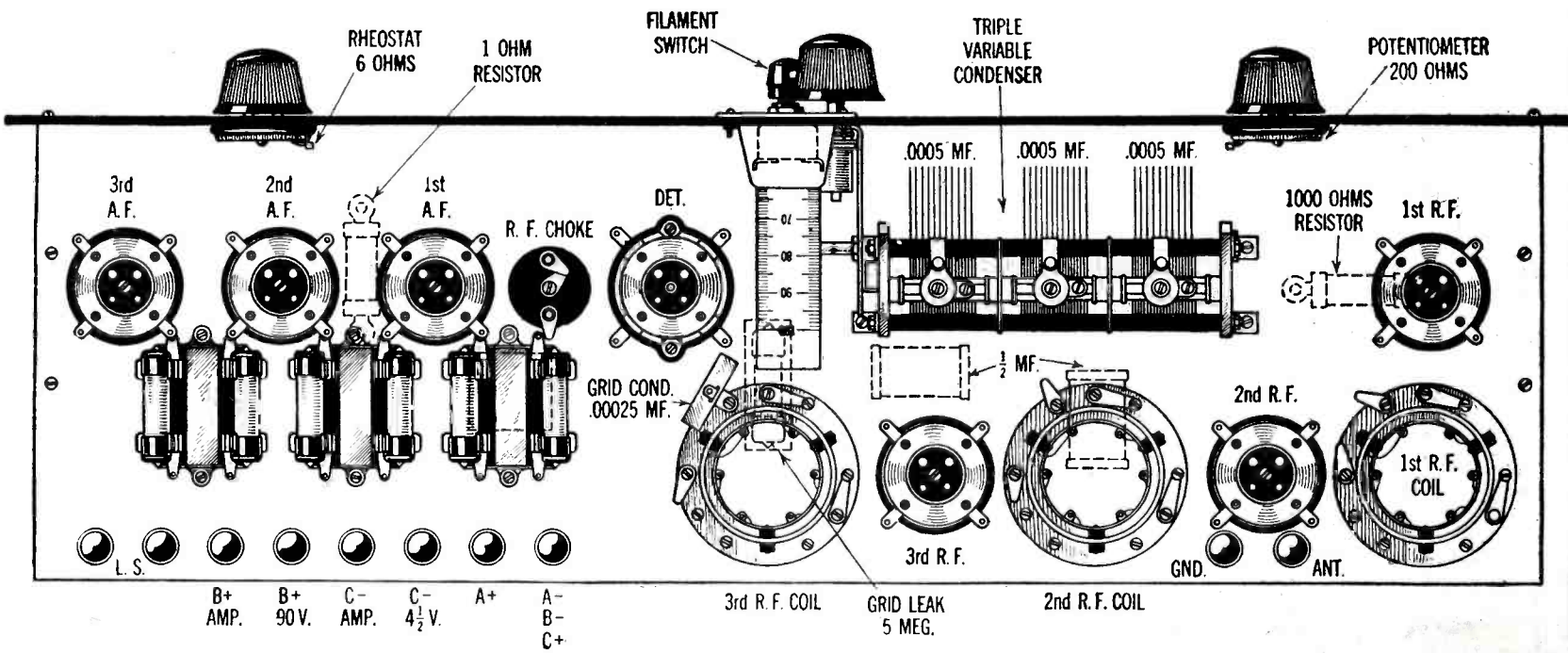

Layout of parts as they are mounted on the sub-panel.

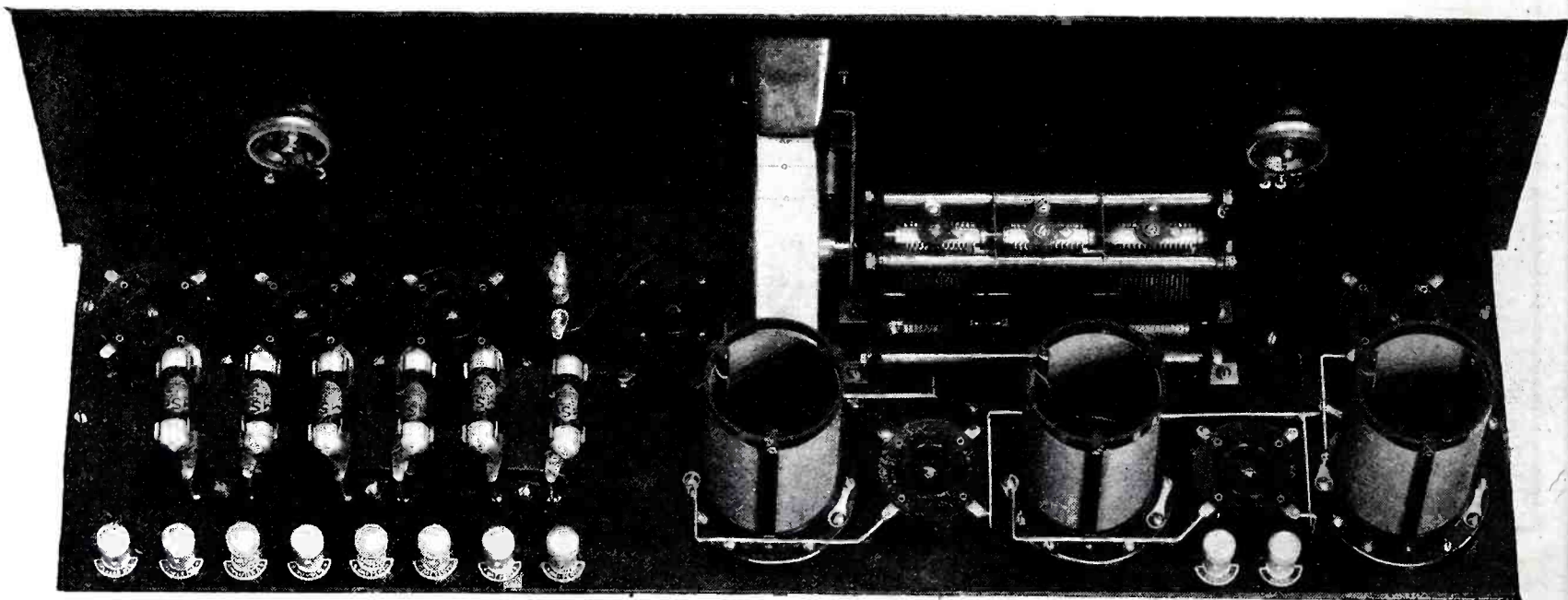

A photographic view of the Aero-Seven Broadcast Receiver seen from the rear of the set.

mediately eliminating a possible factor for failure. The same may be said of the Amsco Triplet condenser. Each

careful layout and design of wiring. (It is therefore important that drilled panels be secured for this receiver, and

the first tube by means of a resistance connected between antenna and ground as shown in the schematic diagram.



The first r.f. tube therefore acts as an untuned radio frequency amplifier.

combination with an efficient gain or sensitivity control.

a thoroughly satisfactory degree of selectivity.

The optimum value of selectivity has

Extreme sensitivity can be obtained with this receiver. The coils are char-

The potentiometer volume control is not included in the tuned oscillatory

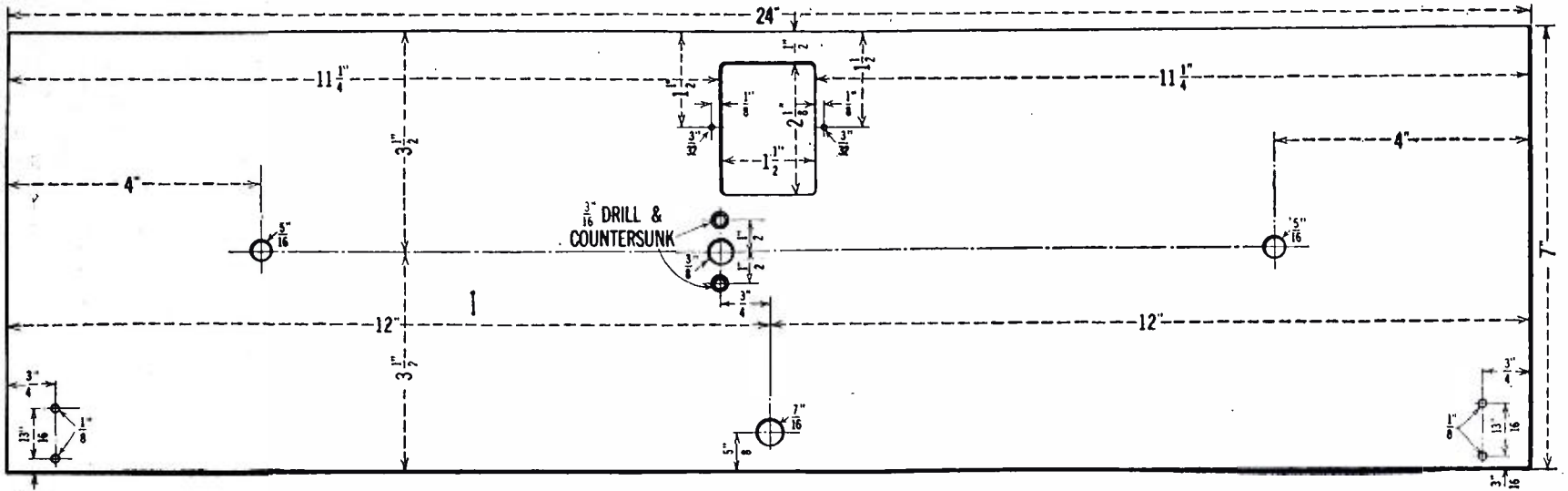

Dimensions for drilling the front panel.

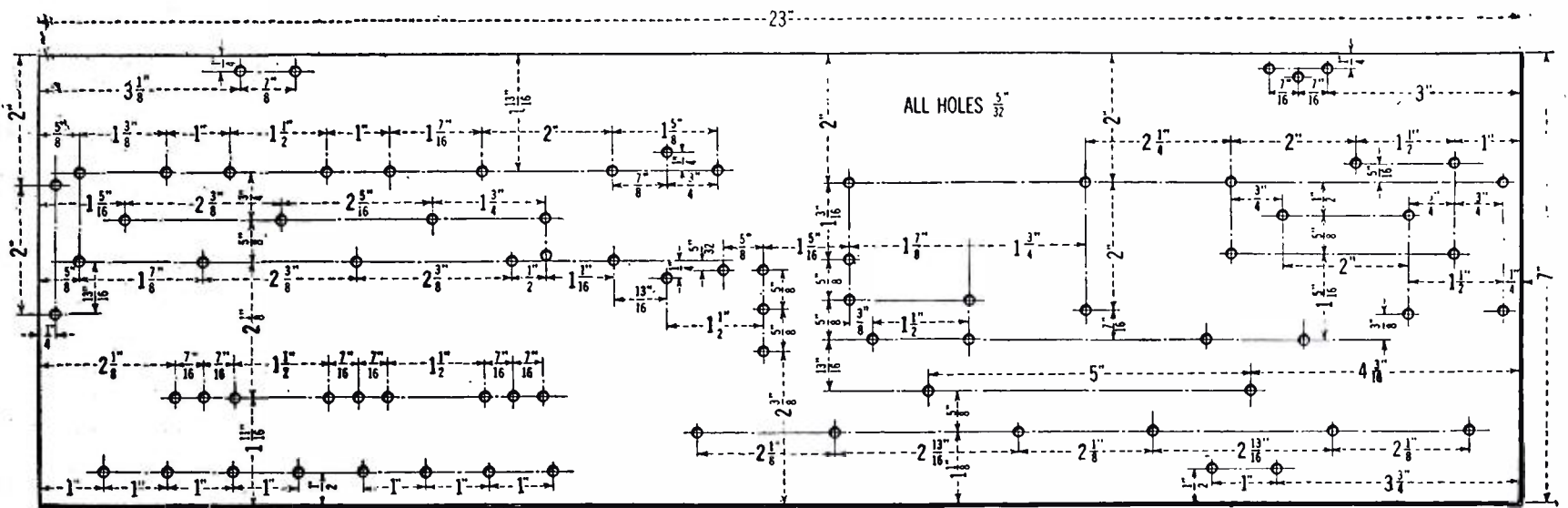

All dimensions for drilling holes in the sub-panel are given in the layout directly above.

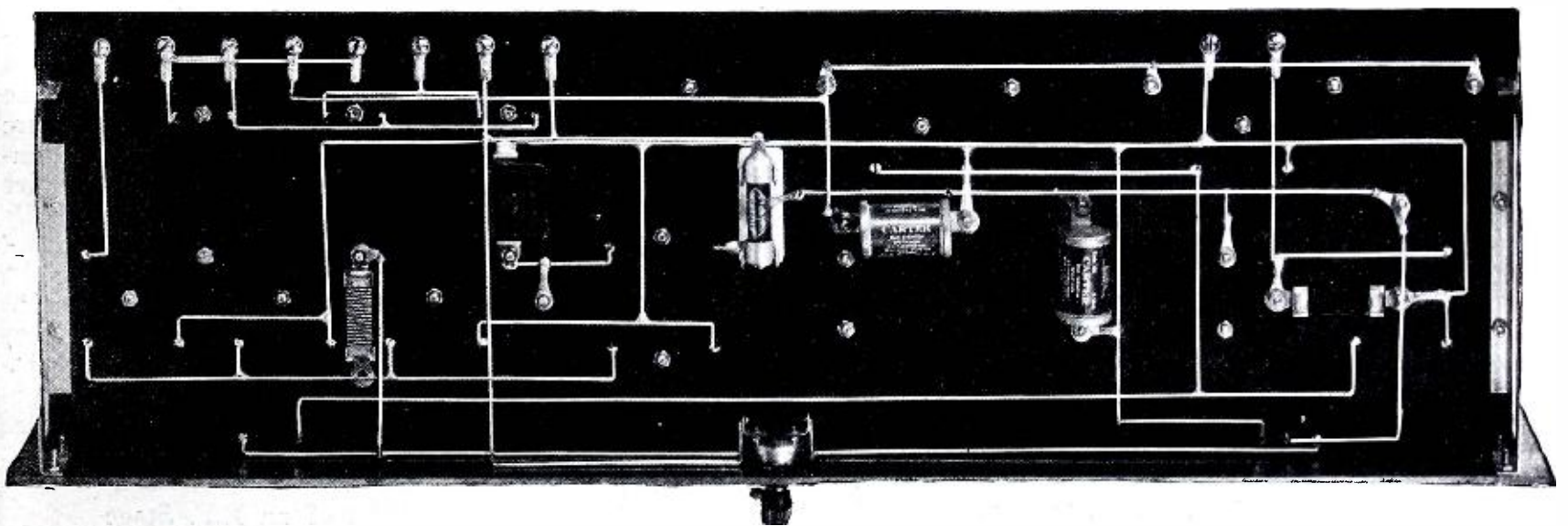

A view of the set beneath the sub-panel showing parts and wiring.

been attained in this receiver. The circuits cover, over a wide range of wavelengths, a frequency band closely approximating ten kilocycles—five kilocycles on each side of the fundamental frequency. This condition is achieved through careful coil design in com-

acterized by low radio frequency resistances (genuinely scientific, low loss construction) which results in a high amplification factor. Also, the design of the coils is such that there exists little inter-stage coupling. Amplification therefore approaches a true cascade effect, with high amplification and

circuits. It therefore has no effect on the damping of these circuits with resulting broadening of tuning. Whatever broadening exists is due to reduced regeneration, but never exceeds a highly satisfactory tuning characteristic.

(Continued on page 140)



# How to Build The STROBODYNE

By LUCIEN CHRÉTIEN

## An Ambitious Program

(1) The set has been designed to use the smallest possible energy-collecting device, *i. e.*, the loop antenna; and with the set used in Paris a loop one foot square was employed. (However, the set described in this issue has been designed for use with an outdoor antenna, and the results mentioned above were obtained while using this type of collector.)

(2) I have tried to obtain the greatest possible selectivity in order to receive, in districts where there are a number of broadcast stations, the maximum number of distant broadcasters with a minimum of interference.

(3) I have endeavored to obtain the best quality of reproduction which is possible with the available apparatus on the market.

(4) The receiver has been designed to have as much "reserve power" as possible, in order to overcome partially the fading of distant stations. This, of course, is of great advantage.

It is easy to describe these conditions, but it is an entirely different matter to obtain them. It should be noted that some of these conditions are antagonistic. For instance, a very sensitive receiver is generally not selective and a very selective receiver generally causes distortion. Since we are not limited in the number of tubes to be used, we can overcome these apparent contradictions in the results. It is entirely possible to obtain sensitivity together with selectivity, if enough stages of radio-frequency amplification are used.

## Use of an R.F. Stage

When designing the set the question arose, whether radio-frequency amplification should be used ahead of the frequency-changer. In previous experiments with a standard super-heterodyne receiver it had been found that amplification of this type aided reception to a very great extent. For example, while I was listening to Berne (Switzerland) on a small loop, the

*The Strobodyne receiver described in the following article has been built with standard American parts in order that the American radio public can take advantage of this remarkably efficient receiver which has been proclaimed as one of the season's greatest sets. The circuit embodied in the Strobodyne is borrowed from the principle of optical illusion created by means of the Stroboscope.*

*Mr. R. E. Lacault, widely known Super-Heterodyne expert and designer of the Ultra-dyne receiver, has undertaken the work of adapting this novel and interesting circuit to American standards under the auspices of RADIO NEWS Magazine, by whose permission the following article is republished.—EDITOR.*

**W**HEN I designed the Strobodyne circuit, I might have announced it as a revolution in radio. I am aware of the fact, however, that this has been done so many times before that I might better desist.

I would much rather leave any extravagant claims to my American radio confrères, who no doubt will find enough adjectives themselves after they have built the Strobodyne for their own use.

There is only one point on which I admit that I am puzzled. What claims can be made for the Strobodyne? How can I make myself understood and prove to you that this new circuit is not merely a new adaptation of an old system? This, as we are all aware, has been done many times, too, and the radio builder has become pretty much discouraged for that reason.

I should, therefore, much rather say that the Strobodyne is not a revolution, but, to be more exact, an evolution.

Perhaps I may be pardoned for saying that the Strobodyne will prove to be a revelation.

However, better to permit the readers to judge for themselves. The constructional data of the Strobodyne are given in the following article, and radio enthusiasts will be able to form their own opinions; even though I do not call it "The King of the Ether," or the "Emperor of the Waves."

## Distance with Selectivity

It may be well to mention the results obtained with this receiver, which any reader should be able to duplicate. Thus, for instance, the short-wave transmission of WGY at Schenectady was picked up (in Paris) on the loud speaker in the middle of the evening, and I mean by this that the reception was such that we heard it over a room of average size. Other stations in all parts of Europe were received with much better volume. (With the American-built set described in this article, stations over a radius of fifteen hundred miles were picked up *in the heart of New York City* with excellent volume and no trouble at all from interference.) Stations come in at but one point of the dials, if the dials are turned together. However, if the tuner dial is left fixed and the oscillator condenser varied, then the other beat note will be heard. Also, if the stations produce harmonics, these can not be eliminated.

We have tried, and succeeded, in incorporating in this Strobodyne the following characteristics:

fading was very pronounced and the local (Paris) station PTT was heard in the background. When a stage of radio-frequency amplification was placed ahead of the super-heterodyne, the fading was not so noticeable and the interfering station was entirely cut out, which seems to indicate a gain in both amplification and selectivity. Of course, this requires one more tube and another control to adjust. However, since the input circuit and radio-frequency unit are tuned to the same wavelength, they can be controlled by a tandem variable condenser, as in the set here described.

It is of advantage to use three stages of intermediate-frequency (long-wave) amplification. Although the third stage does not produce much amplification, it provides the reserve of power mentioned before. In practice a third stage may be eliminated if one wishes to eliminate a tube; but it will be found very advantageous to use three stages in order to secure the best results. If it is desirable to reduce the number of tubes, it is better to cut out one of the stages of the intermediate-frequency amplifier, rather than the R.F. before the frequency-changer.

**Grid-Bias Control**

The intermediate-frequency stages are controlled by a potentiometer, the value of the latter being in the neighborhood of four or five hundred ohms. This value is not critical and affects

to bring them near the point of oscillation, where they are most sensitive.

Before adopting transformer-coupling in the A.F. system, I hesitated between resistance and transformer coupling. The former has the advantage that, if all the proper precautions are taken, an approximately straight-

former; besides we can eliminate a tube.

**The Fundamental Circuit**

Fig. 1 shows the circuit of the frequency changer. The coil L1 is used to apply the signal through the tube; coils L2 and L3 form the oscillating

**LIST OF PARTS FOR THE STROBODYNE**

- |   |  |
|---|--|
| 3 Hammarlund .00035 mfd. Variable Condensers (C1, C2, C5) | 1 Carter filament switch (SW)                              |
| 1 Hammarlund special tapped auto couple (L1)              | 2 Carter short jacks, 1-2 circuit and 1-1 circuit (J1, J2) |
| 1 Hammarlund special auto couple coil (L2)                | 12 X-L Binding Posts                                       |
| 1 Hammarlund regular auto couple coil (L3)                | 2 National Dials   |
| 4 Radio Elec. Labs. plug-in type tuned R.F. Units (L4)    | 4 Radiall Filament Ballasts, 5 volts, 1/4 ampere (R3)      |
| 5 Radio Elec. Labs. matched fixed condensers (C7)         | 1 Radiall Filament Ballast, 5 volts, 1/2 ampere (R4)       |
| 3 Hammarlund shields                                      | 2 Hammarlund Balancing Condensers (C3)                     |
| 2 Samson A.F. transformers (T1, T2)                       | 1 Electrad 100,000 ohm Variable Resistor (R5)              |
| 1 Interstate Output filter (OF)                           | 1 Micarta Panel, 8" x 24" x 1/8"                           |
| 1 Samson R.F. Choke (RFC)                                 | 1 Micarta sub-panel, 12" x 25 1/4" x 1/4"                  |
| 1 Cardwell Compensator Condenser, 2 stators—1 rotor (C6)  | 6 doz. machine screws, 6/32-1" long with nuts              |
| 3 Carter Rheostats, 20 ohms (R1, R2, R7)                  | 1 1/2 ft. Angle Brass, 1/2" x 1/2"                         |
| 1 Carter 400 ohm potentiometer (R6)                       | 2 Belden Rolls of Wire, rubber covered                     |
| 4 Dubilier .5 mfd. by-pass condensers (C4)                | 1 Fritts Cabinet for panel 8" x 24" x 12 1/8"              |
| 1 Dubilier .002 mfd. fixed condenser (C8)                 | 1 Hammarlund Brass Shaft, 1/4" diameter—10 1/4" long       |
| 8 Benjamin UX type sockets                                | 7 CeCo 201-A type Vacuum Tubes                             |
|   | 1 CeCo 112 type Vacuum Tube                                |
|   | 1 package of Kester radio solder                           |

line amplification curve can be obtained. However, in resistance coupling three tubes are required to give the same volume that can be obtained with

circuit to which is coupled the feedback coil L4, which is inserted in the plate circuit of the tube. Also, in the plate circuit, there is inserted the pri-

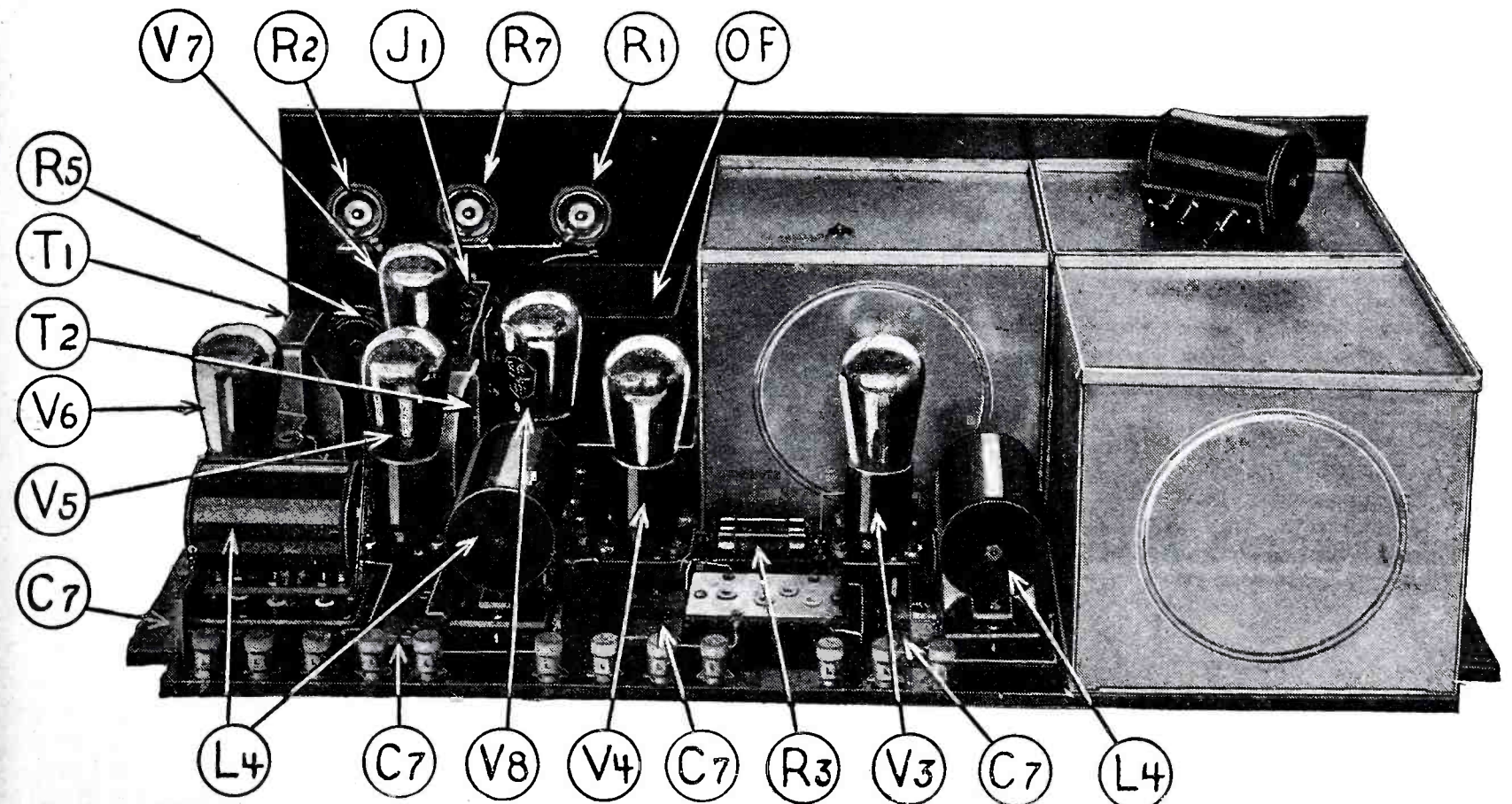

Rear view of the 8-Tube Strobodyne receiver, with one of the long-wave R.F. units on top of one of the shields (right) to show the base into which it is plugged. C7, fixed condensers, which tune the coils, L4; V3, V4, and V5, long-wave amplifier tubes; V6, detector; V7 and V8, A.F. amplifiers; T1 and T2, A.F. transformers; R1, R.F. rheostat; R2, frequency-changer rheostat; R7, detector rheostat.

only the amount of "A" battery current flowing through the potentiometer winding. This instrument is used to vary the grid potential of the tubes and

two tubes when transformers are used. Transformer coupling was therefore decided upon, as excellent quality may be had with a good make of trans-

mary of the first intermediate-frequency transformer; this primary being shunted by a by-pass condenser, C1. The frequency-changing system as

employed in the Stroboddyne circuit should be so adjusted that the oscillations produced are of the proper amplitude. This amplitude may be ad-

should be small and the instrument should have one rotor and two stators, as indicated in Fig. 1.

This receiver is designed to amplify

with an aerial, either outdoor or indoor; and any length up to about 120 feet is suitable. In the following we shall explain how the receiver is built.

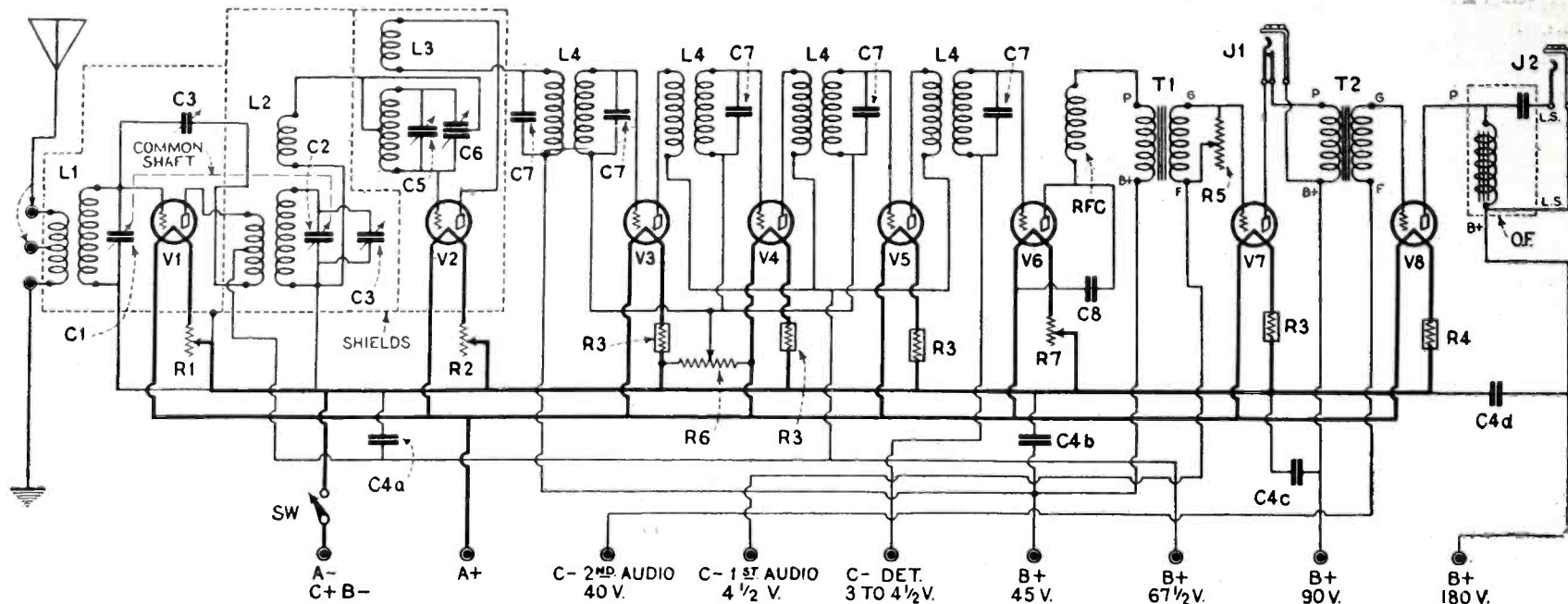

The circuit diagram of the 8-Tube Stroboddyne Receiver is shown above. The symbols indicating the different pieces of apparatus are the same as those which appear on the other illustrations in this article and in the list of parts.

justed in several ways, viz.:

- (a) By varying the size of the feedback coil, L4.
- (b) By varying the coupling between L2, L3 and L4.
- (c) By adjusting the voltage on the plate of the tube.

It should be noticed, however, that if any of these methods are employed, the adjustment is good for only one

the received signals after their frequency has been lowered through the Stroboddyne oscillator. Therefore, the usual precautions taken in circuits using a frequency-changer must be observed in this case also. In the American adaptation, shielding has been used to prevent interaction or feed-back between the various radio-frequency units; and provisions have been made in the binding-post arrangement for

### Constructing the Set

The first thing to do, after all the parts required are on hand, is to drill the panel and sub-panel, as shown in Figs. 2 and 2A. The panel should then be fastened to the sub-panel by means of pieces of angle-brass, cut and drilled as shown in Fig. 3. Machine screws, No. 6/32 about 1 inch long, are used for this and the mounting of the parts

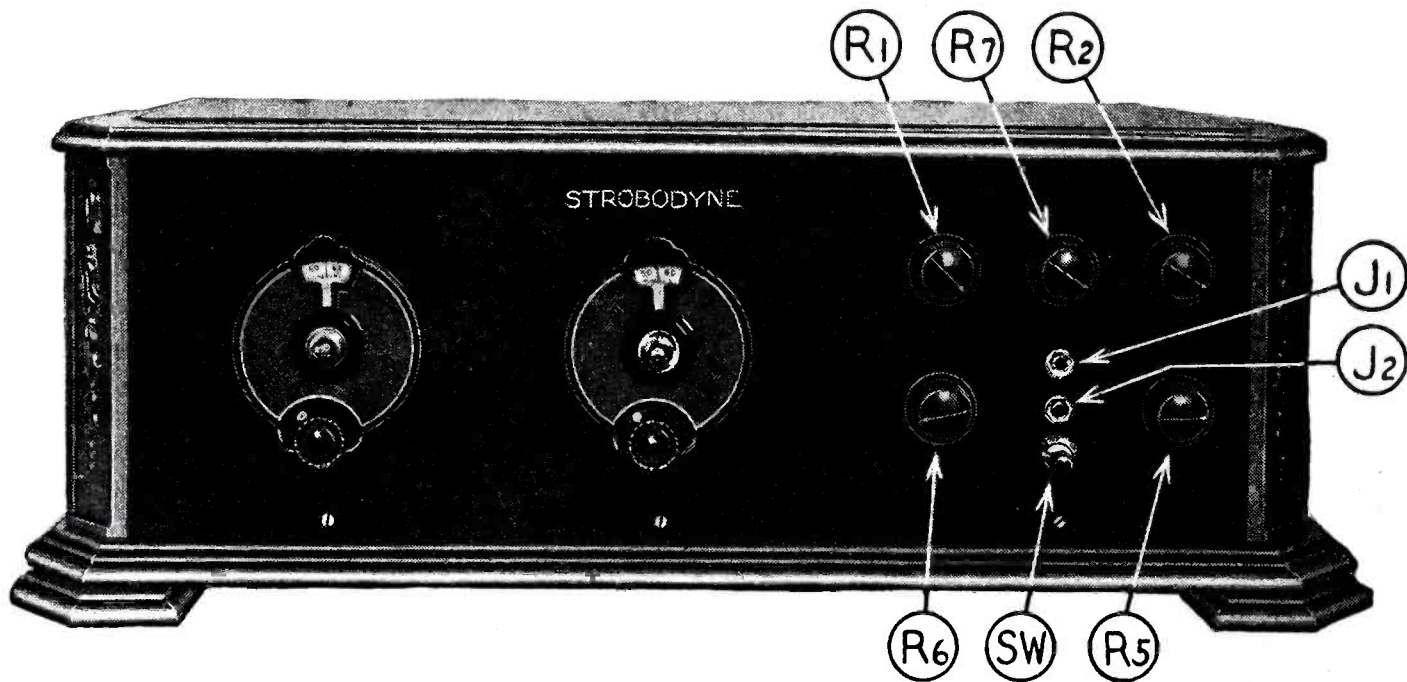

The front view of the Stroboddyne Eight-Tube receiver, R1, R2, R5, R6, and R7 are rheostat controls; J1 and J2, jacks; and SW is the filament switch.

wavelength and has to be varied for every signal that is tuned in. However, the necessity of readjusting the controls has been eliminated by using a large inductance in L2 and L3 and a small tuning condenser, together with a low plate voltage. The compensating condenser, Cp, should have as small a capacity as possible, as it is in parallel with the variable condenser, CV1 which has a capacity of .00035-mf. The capacity of the compensating condenser

the use of a power tube in the second audio stage, and to insure a suitable choice in the voltages, depending upon the tube used, etc.

The Stroboddyne may be equipped with either batteries or any good socket-power unit supplying enough current. If desired 199-type tubes may be used with dry cells; but the 1/4-ampere tubes are to be preferred. The present model is designed for operation

on the sub-base. The same screws used for fastening the sub-base to the angle brass also hold the shield in place, and these may be mounted at the same time. The No. 1 shield is the left forward one. The back and right shields are No. 2 and are different, in that the back partition is not drilled. The back of the sub-base is raised, by means of either a piece of brass strip bent to form a letter "U," or pieces of wood of the proper thickness. The

space under the sub-base is used to wire the set with soft rubber-covered, or other flexible insulated wire, and to provide space for the by-pass condensers used across the "B" circuit. These condensers are fastened on pieces of angle brass if their legs are at the ends of the condenser; but, if the legs are in the plane of the back of the condenser, no angle brass is required.

**Mounting the Condensers**

After the bottoms of the shields have been placed on the sub-base, the forward left condenser should be mounted on the panel. This holds the front of the forward shield in place.

Next mount the R.F.-stage variable condenser on the front of the back shield and the back of the front shield, placed back to back. The mounting screws hold these in place.

loosening the two set screws on each rotor, and replaced by the 10 1/4-inch shaft, which is pushed through both condensers to line them up. The rotor set-screws are then tightened when the

means of the bracket and screws furnished with the coil, and remove the long machine screw which limits the motion of the primary on the coil. This is not used; because the primary is made to move up and down inside of the secondary by means of the cam which must be fastened on the end of the shaft.

The three-circuit auto-couple coil is mounted in the same way on the frame of the forward variable condenser and the cam slipped over the shaft so as to move the primary out of the secondary when the plates are all unmeshed. Note that these two coils are mounted with the movable coil at the bottom.

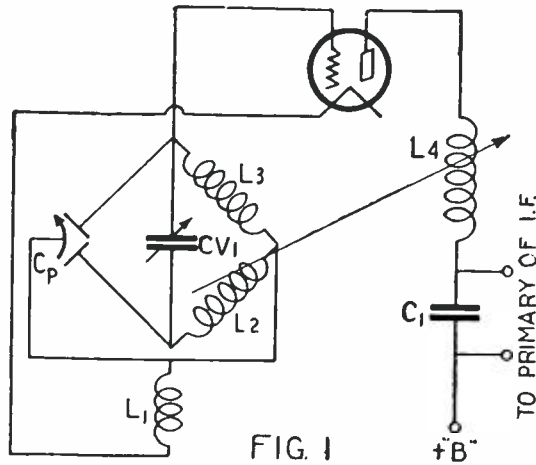

**FIG. 1**  
The "bridge circuit" of the frequency-changer, which is the heart of the Strobodyne circuit. The letters in this circuit do not correspond with those in the other diagrams and illustrations.

**The Strobodyne Unit**

As the oscillator uses a bridge circuit, it is necessary to insulate the variable condenser from the shield.

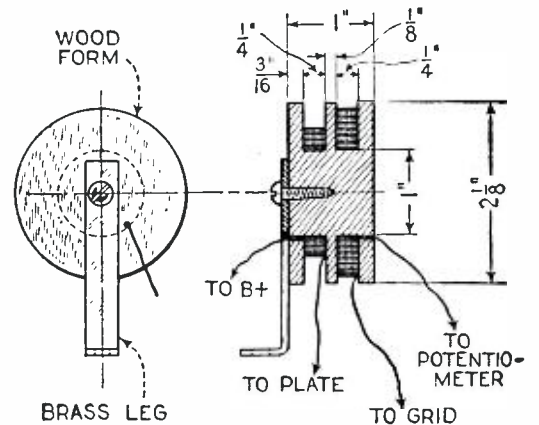
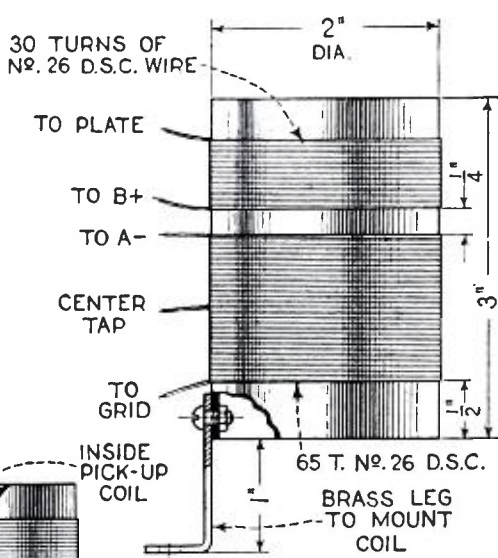
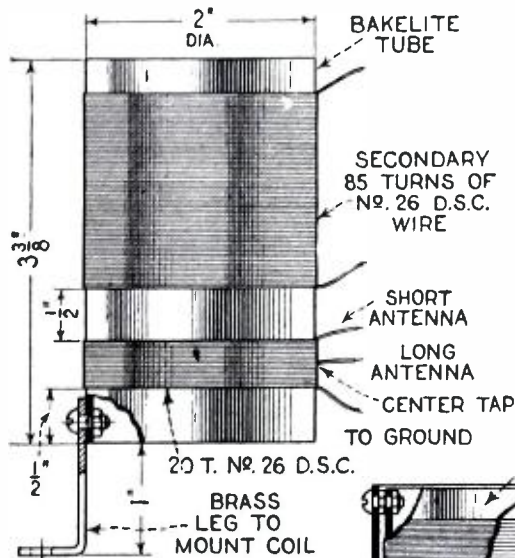

PRIMARY - 200 TURNS OF NO. 28 D.S.C. WIRE  
SECONDARY - 400 TURNS OF NO. 28 D.S.C. WIRE  
BOTH WINDINGS IN SAME DIRECTION AND WOUND IN LAYERS

~ LONG WAVE TRANSFORMER ~

~ RADIO FREQUENCY AND INPUT COILS ~

IN THE INPUT COIL A SMALLER COIL WOUND WITH 30 TURNS OF NO. 30 D.S.C. WIRE SHOULD BE MOUNTED AT THE TOP, SO THAT THE UPPER TURN OF EACH IS ON THE SAME LEVEL.

~ TAPPED COIL ~

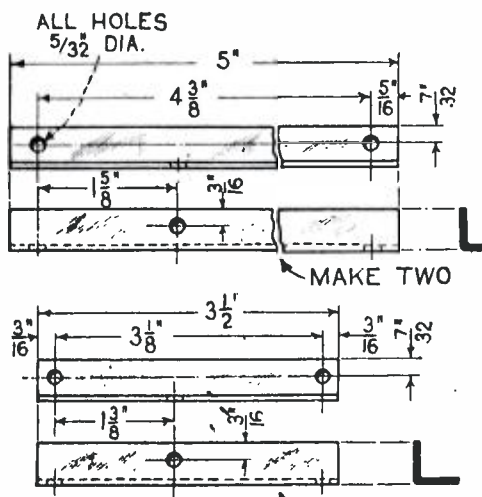

~ SUB-PANEL MOUNTING BRACKETS ~  
1/2" X 1/2" X 1/16" ANGLE BRASS

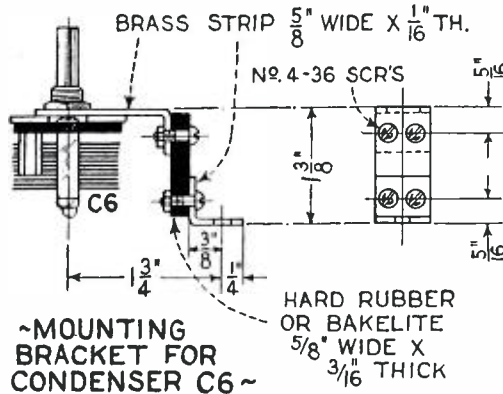

**Fig. 3.** Above are given the specifications for constructing some of the apparatus for the Strobodyne receiver. Directions should be carefully followed, in order that the apparatus may fit perfectly in the allotted space.

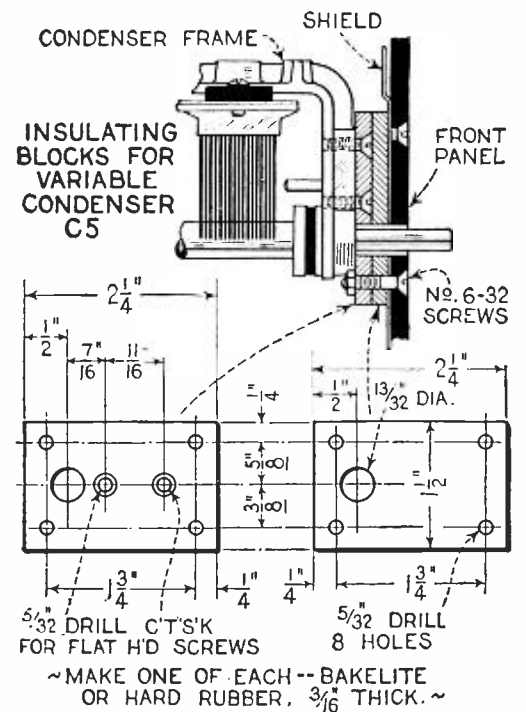

~ MAKE ONE OF EACH -- BAKELITE OR HARD RUBBER, 3/16" THICK. ~

Note that the small shields furnished with each condenser are not used; the large threaded bushing provided on each condenser for single-hole mounting is not required, either, and should be taken out. The short shafts of each condenser should be taken out by

two rotors are completely meshed in the stators, and the two shield partitions are screwed down on the sub-base so that the rotors turn freely without binding at any point.

Next mount the auto-couple coil on the back variable-condenser frame, by

This is done by mounting the condenser on a piece of bakelite, which is covered with another in order to insulate the heads of the mounting screws; both of these strips being fastened on the panel as shown in Fig. 3. When mounting this condenser be

sure that the shaft is not touching the shield. With some types of dials, some hand-capacity may be noticed and it may be necessary to replace the con-

tapped auto-couple coil is mounted on the frame of the condenser with the movable coil *on top*. In this case the long machine-screw is used to adjust

mounted as shown in Fig. 3, to insulate it from the bottom of the shield upon which it is mounted.

The wiring diagram shows clearly

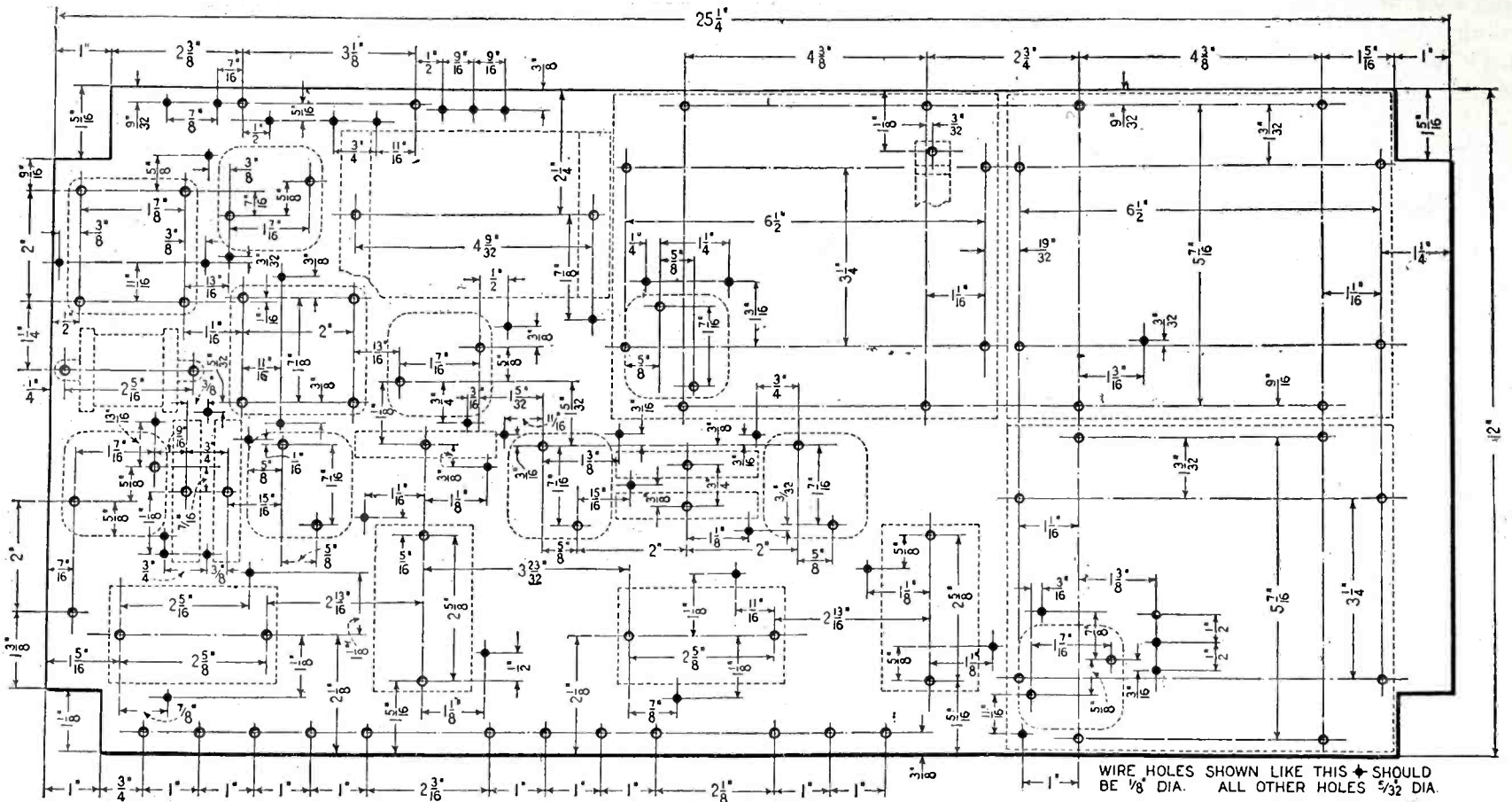
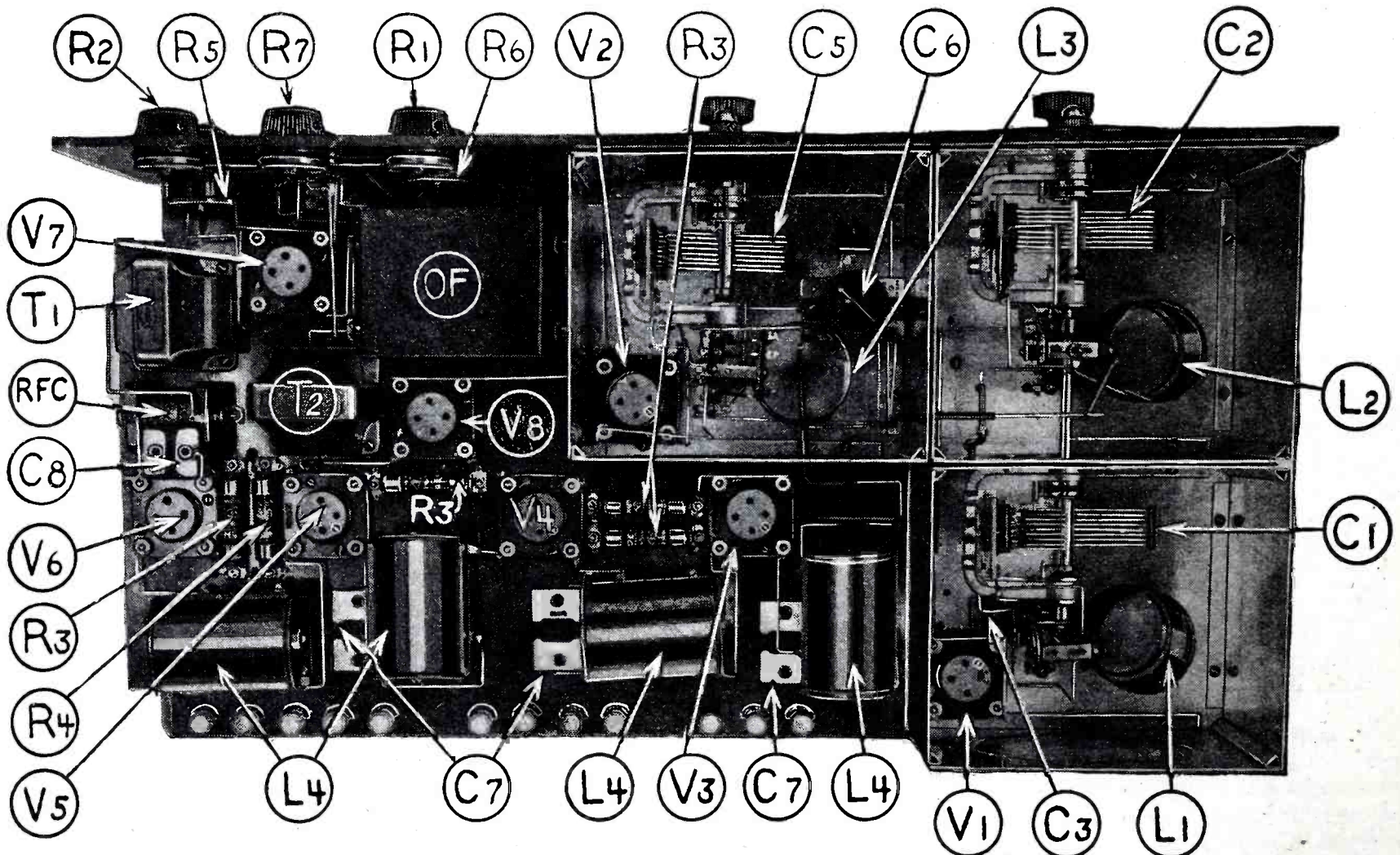

Fig. 2A. The drilling specifications for the sub-panel of the 8-Tube Stroboddyne Receiver. To make it easier for the constructor the outlines of the different apparatus are drawn in dotted lines about the holes for mounting them on the sub-panel. The solid black holes are those through which the connections are run, from the upper to the lower side of the sub-panel, as shown in the wiring diagrams.



The interior of the 8-Tube Stroboddyne Receiver, with the tops of the shields removed. C1, C2 and C5, variable condensers; L1, L2 and L3, R.F. coils mounted on the rear of the variable condensers; C6, compensating condenser; R3 and R4, filament ballasts; RFC, R.F. choke coil; V1, R.F. amplifier; V2, frequency changer; C8, by-pass condenser; OF, output filter; R5, 100,000 ohm variable resistor; R6, potentiometer.

denser shaft by a piece of 1/4-inch bakelite rod; which has been done in the receiver here described. The

the coupling and the cam is not necessary.

The small balancing condenser is

the location of the other parts on the sub-base. Therefore, this layout should be followed.

Ever since the advent of the power tubes of the 112 and 171 type for use in the last stage of audio-frequency

some protective device be inserted in the output circuit of the power tube. The plate voltage required by these

speaker windings will burn them out or cause some other damage.

The protective device mentioned

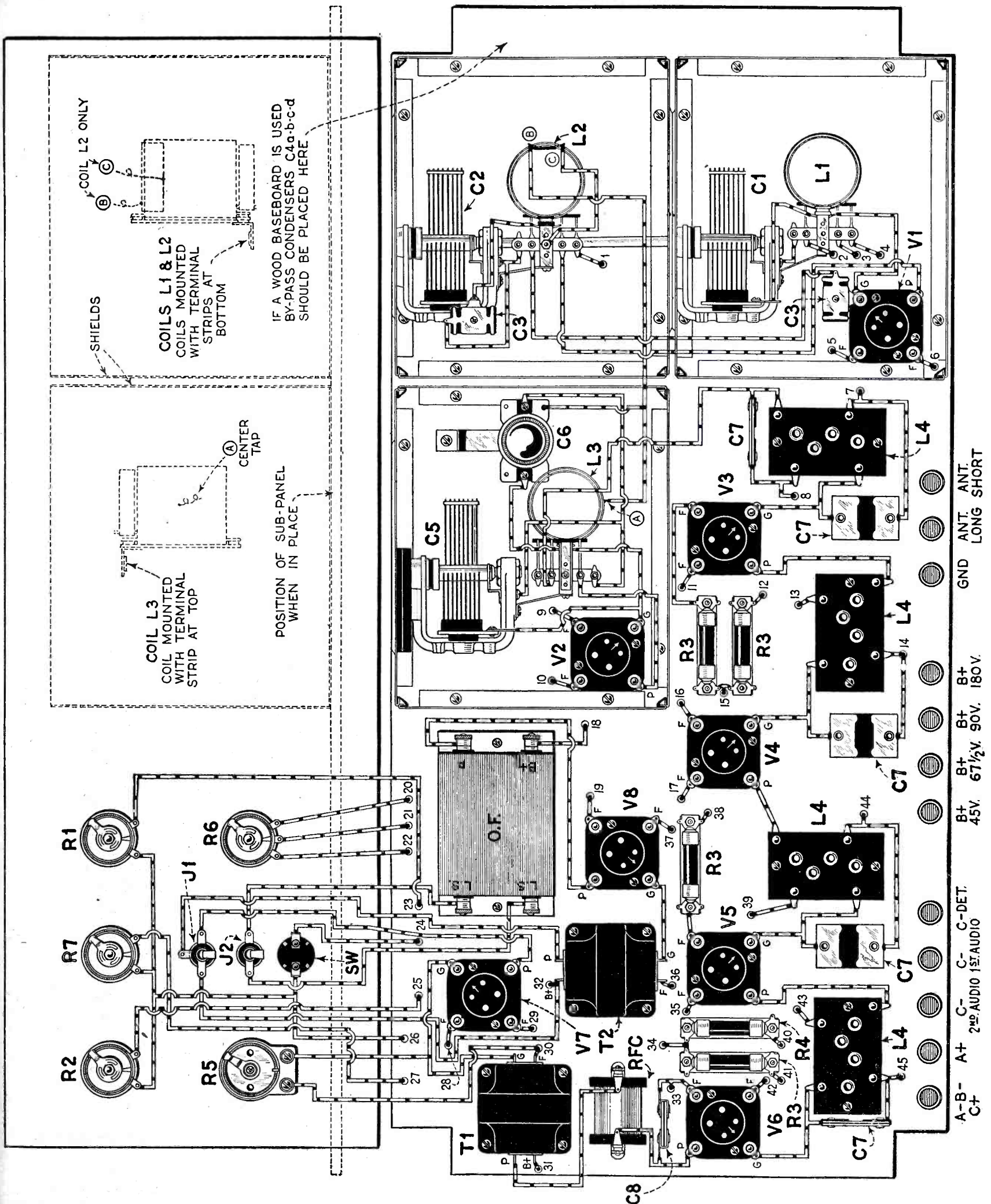

The wiring diagram of the panel and the upper side of the sub-panel of the 8-Tube Strobodyne Receiver. On another page will be found that for the under side of the sub-panel. The holes which are numbered correspond with identical holes shown in the other drawing, and the connecting wires are run through these holes. Notice the change in layout if a wooden baseboard is used.

amplifiers, there is an attendant danger that some damage may be done to the windings of the loud speaker, unless

tubes is anywhere from 135 to 180 and, in the majority of cases, such a voltage flowing through the loud-

above generally takes the form of either a 1:1-ratio transformer or an audio-frequency choke coil with a large

fixed condenser placed in the plate lead of the power tube. By either of these means the high voltage is supplied to the plate of the tube without passing through the loud-speaker coils. In the

post and running the wire to the various instruments in the circuit. The wire is looped, passed through the hole in the sub-base and after being cut, connected to the terminals of the va-

Turn the rheostats up and the switch on, and see if all the tubes light. If they do, leave the "A—" lead connected, touch the "A+" lead to the various "B+" terminals, and notice if

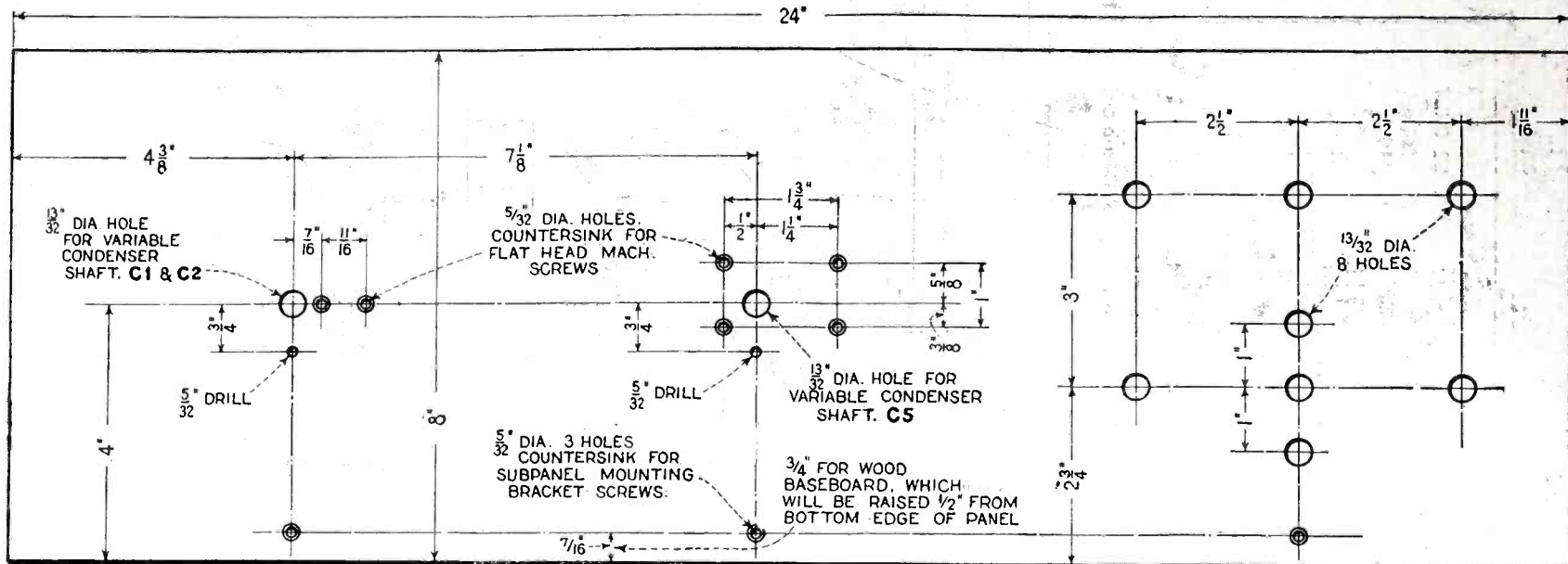

Fig. 2. The drilling specifications for the front panel of the 8-Tube Strobodyne Receiver. Notice that, if a wooden baseboard is used, the dimensions of the mounting screws are changed.

Strobodyne receiver the choke coil and condenser combination is used, as is indicated in the illustrations at O.F. In this system of protection the condenser prevents any of the high voltage from passing to the loud speaker, without impeding its progress to the plate; and the choke successfully stops any of the audio-frequency currents from

various apparatus. (See diagram below).

The wiring above the sub-base, which includes the grid, plate and other high-frequency leads, is made with bus bar covered with spaghetti where it passes through the shields. The rigid wiring is preferable because, once it is in place, the receiver may be balanced and the extra capacities caused by the

any of the tubes light. If some of them do there is a wrong connection or a short circuit, which would burn out the tubes if the "B" voltage were applied. If none of the tubes lights during this test, everything is O. K., and the set may be completely hooked up for operation.

Before attempting to tune in sig-

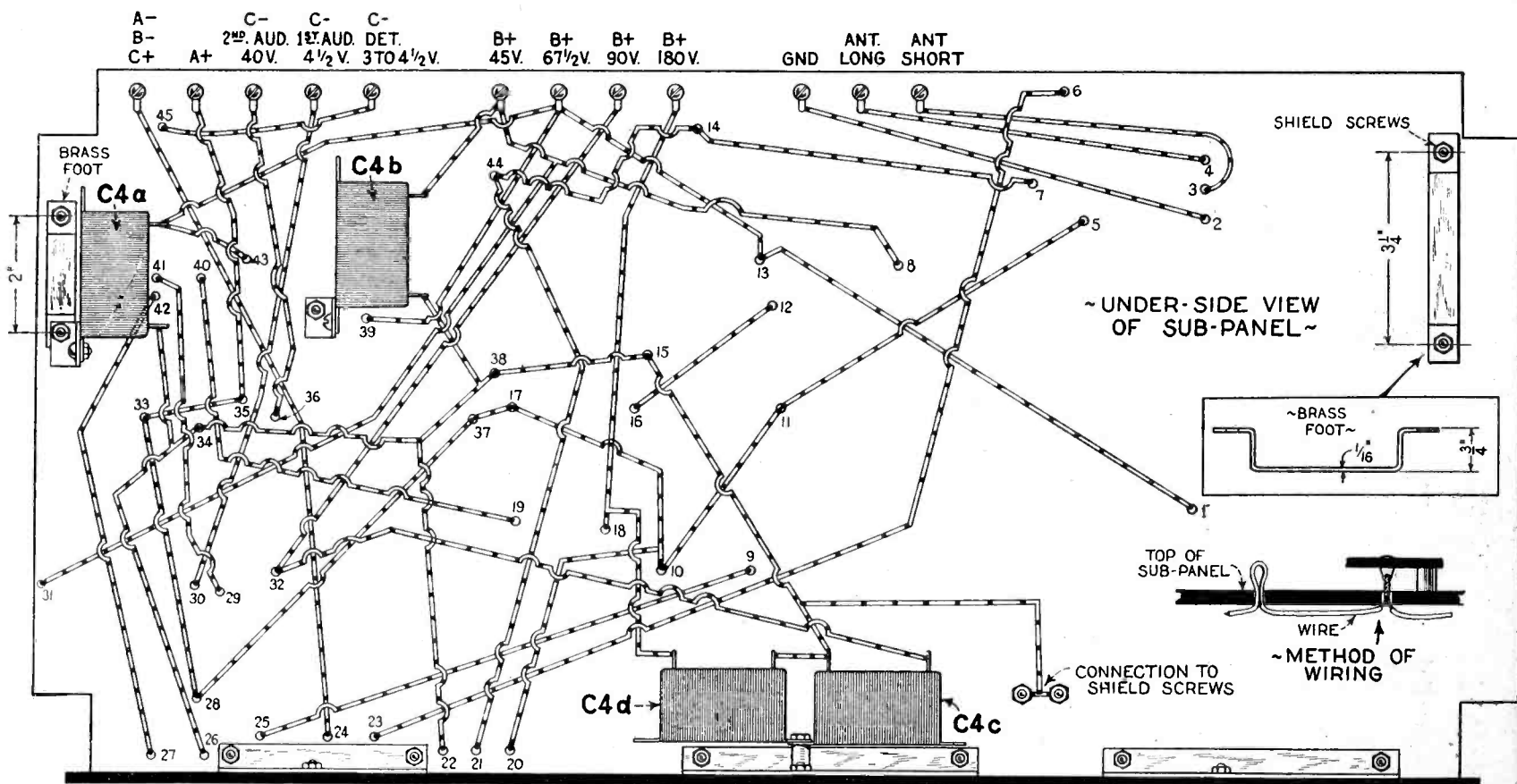

The wiring diagram for the under side of the sub-panel of the 8-Tube Strobodyne. The four condensers C4a, C4b, C4c and C4d are by-pass condensers. Notice, in the lower right-hand corner, the method which is used for running the connections between the different instruments.

getting into the "B" circuit, at the same time allowing free passage for the "B" voltage.

### Wiring the Set

The wiring on this set should be done by starting from each binding

proximity of the wiring to the shield may be compensated.

After the wiring is completed, check it carefully to make sure no lead has been left out or connected wrong. Then connect the "A" battery only and plug all the tubes into the sockets.

nals one should adjust the equalizer mounted on the grid terminal of the R.F.-tube socket. This may be set so that there is a gap of about 1/16 to 1/8 of an inch between the copper plate and the mica sheet. It may have to be

(Continued on page 138)



# The Camfield Super- Selective 9



**T**HE circuit used in the Camfield Super-Selective 9 has been developed to fill the requirements for a super-sensitive and super-selective receiver that could be satisfactorily operated in congested broadcasting districts such as the Metropolitan areas of New York and Chicago as well as being sensitive and powerful for the reception of distant stations from any location in the United States or Canada.

For several years the Super-Heterodyne circuit has been very popular whenever extreme sensitivity combined with selectivity has been desired. About three years ago the Super-Heterodyne was considered to be the most satisfactory circuit for use under any conditions, but with the large number of broadcasting stations now on the air in the metropolitan areas a serious drawback of this type of circuit has developed. This difficulty is the presence of so-called oscillator harmonics.

Many Supers that were popular several years ago can be operated in congested broadcasting districts today with the oscillator tube entirely removed from the circuit. A Super that is designed to operate on an Intermediate Frequency of 50 Kilocycles will receive any local broadcasting station regardless of the oscillator dial setting if there happens to be another local station on the air having a frequency of 50 Kilocycles above or below the first station. This condition spoils the selectivity of the Super, which was one of the chief advantages, and has resulted in decreased popularity of this type of circuit for use in Metropolitan areas.

In the Camfield Super 9 this condition of oscillatory harmonics has been entirely eliminated. This is accomplished by the use of two stages of tuned radio frequency amplification ahead of the first detector tube and also by the choice of an Intermediate Frequency of 95 Kilocycles. There are no stations in the United States that

are exactly 95 Kilocycles apart. Furthermore when the two radio frequency stages are tuned to resonance with the

Kilocycles above or below the station being received. Hence, no energy from such stations can get to the first detector tube to heterodyne with the incoming signal and thereby spoil selectivity and cause squeals and howls or heterodyne beat notes in the loud speaker, as would be the case with the previous type loop-operated Super.

## Radio Frequency Amplifier Adds Sensitivity

In any Super-Heterodyne there must be a definite minimum of input energy to the first detector tube before the circuit will function. This factor forms one of the most important limits to the sensitivity of the circuit.

Signals so weak that they will not actuate the first detector tube in an ordinary Super are picked up and amplified through two stages of tuned radio frequency amplification before reaching the first detector tube in the Camfield Super-Selective 9. This makes it possible to get satisfactory reception of distant stations with this new circuit that could not be received at all with the previous type of Super.

The Camfield Super-Selective 9 is the first circuit made available to radio fans using a Band Pass Filter in the Intermediate Frequency Amplifier.

A Band Pass Filter is a network of inductance and capacity designed to pass a particular band of frequencies with uniform amplification and to reject all other frequencies.

The filter used in the Camfield Super-Selective 9 has been designed to

### PARTS REQUIRED

- 1 Camfield No. 251 .00025 Equaltune Variable Condenser
- 1 Camfield No. 351 .00035 Equaltune Variable Condenser
- 1 Camfield No. 352 .00035 Equaltune Variable Condensers (2-gang)
- 1 Camfield No. 22K Kit of 3 Camfield Duoformers
- 1 Camfield No. 620 Coupling Unit
- 1 Rusco No. 10KC Band Pass Filter
- 2 Rusco No. 95KC I. F. Transformers
- 1 Dubilier No. 601 .002 Fixed Condenser
- 2 Dubilier No. 601G .00025 Grid Condensers
- 2 Dubilier 2 Megohm Grid Leaks
- 2 Tobe ½ mfd. Condensers
- 2 Silver-Marshall No. 220 Audio Transformers
- 1 Frost No. 806 6 ohm Rheostat
- 2 Frost No. 824 400 ohm Potentiometers
- 3 National Vernier Dials
- 9 Benjamin No. 9040 Sockets
- 3 Karas Brackets
- 1 Carter Midget Battery Switch
- 1 Carter No. 6 Jack Switch
- 5 X-L Laboratories Binding Posts
- 1 Jones Type BM Multi-Plug (Sub-Panel)
- 2 Amperites, No. 4-A
- 1 Formica 7 x 30" x 3/16" Panel
- 1 Formica 10 x 29 x 3/16" Sub-Panel
- Miscellaneous lugs, wire, screws, etc.

station that it is desired to receive they will not pass signals from stations broadcasting at a frequency 90 or 100

pass a band of frequencies 10 Kilocycles wide between 90 and 100 Kilocycles. All Frequencies lying within this band are amplified equally by the

a loop. It is well known that the loop does not pick up as much energy as even a short Antenna and for this reason many experimenters have at-

the first detector tube is connected direct to the audio frequency amplifier. When the switch is thrown to the right the other 4 tubes are automatically

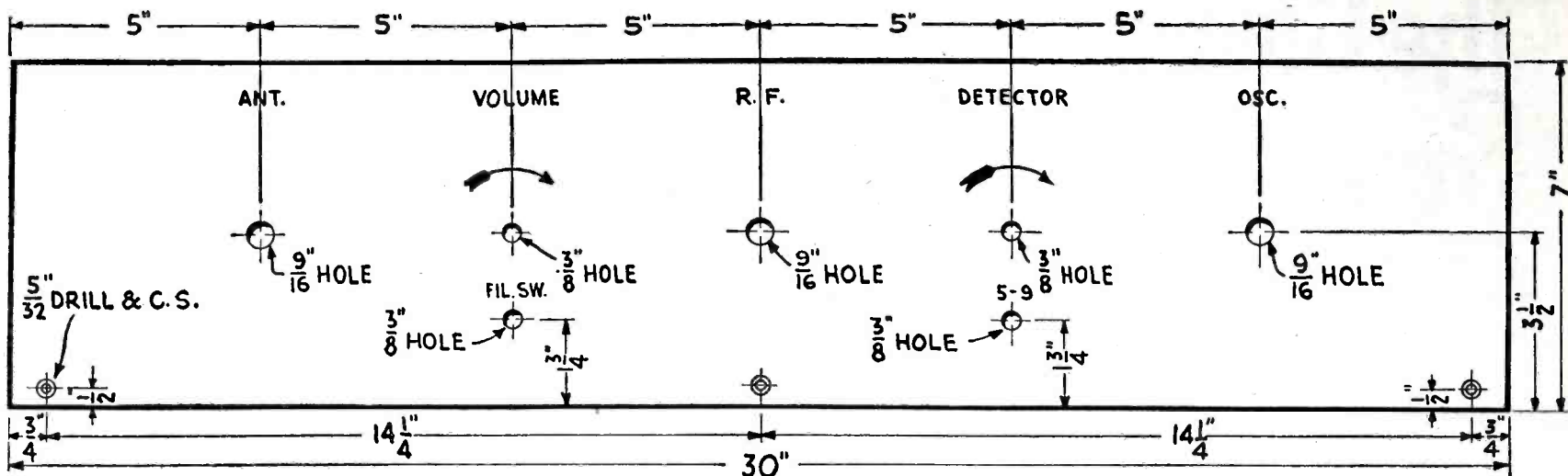

Fig. 1. Dimensions for drilling the front panel of the set.

intermediate stages of the Camfield Super-Selective 9. The filter is designed to cut off very sharply on both sides of this band and the circuit, therefore, has excellent selectivity.

It must be remembered that the frequency of a broadcasting station on any given wavelength is not absolutely constant. It is modulated by the frequency of the voice or music being transmitted and, therefore, varies about 5 kilocycles above and below the rated frequency. If a circuit is not designed to give practically uniform amplification over a band of frequencies 5 kilocycles above and below that of the incoming wave some of the voice or music frequencies will not be properly amplified and distortion results. This

tempted to couple an Antenna to a Super-Heterodyne. The result has always been to utterly spoil the selectivity.

In the case of the Camfield Super 9 the use of the band pass filter gives such perfect selectivity that it is possible not only to use an Antenna, but also to use two stages of radio frequency amplification. This naturally results in greater sensitivity than can be obtained with any other type of circuit.

#### Combination 5 and 9 Tube Receiver

The Camfield Super 9 may be operated either as a 5 tube two control tuned radio frequency set or as a 9

lighted and the proper circuit connections are made for the operation of the set as a 9 tube Super.

This feature provides for the economical operation of the receiver when the reception of local stations only is desired. This is an exclusive feature of the Camfield Super 9 and is not found in any other circuit. Furthermore this arrangement of the wiring makes it possible to construct the receiver in two units. It fills the requirements of those who at present can only afford a 5 tube set but who will want a 9 tube Super at some later date. The 5 tube end of the circuit may be constructed first and the other 4 tubes added at any later date without changing any of the original wiring.

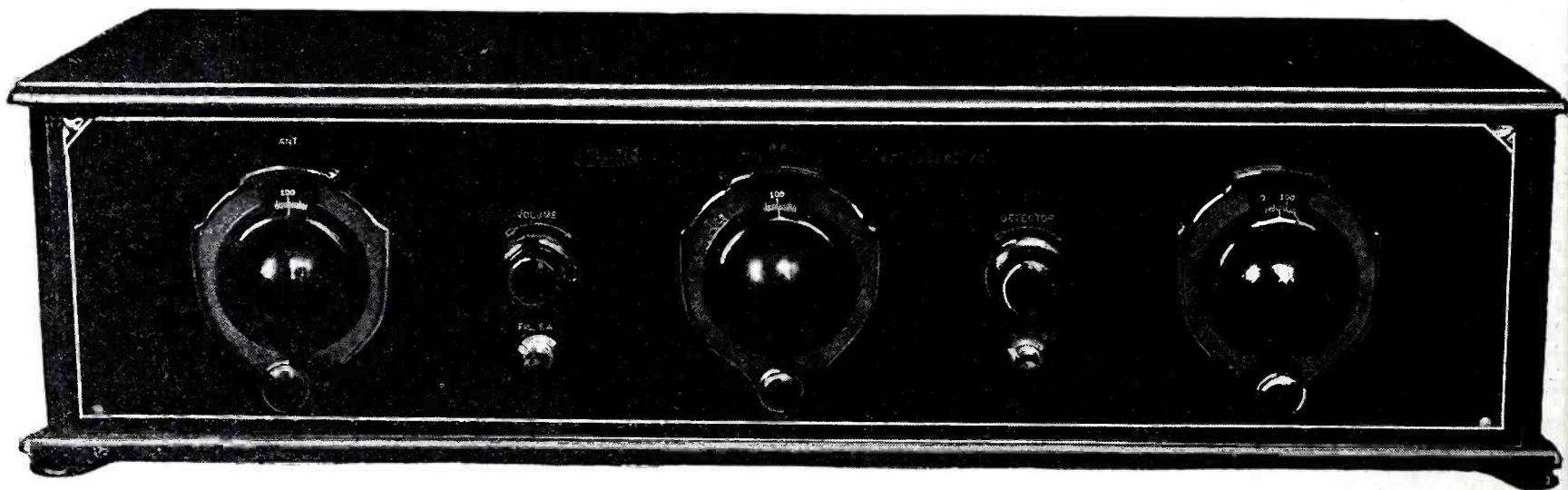

Fig. 2. The Camfield Super-Selective 9 installed in a table type cabinet. The switch beneath the detector rheostat, between the second and third dials, is used to turn on either five or nine tubes.

action and consequent distortion has been very noticeable in Super-Heterodyne circuits where extreme selectivity was obtained by the use of the so-called peak Intermediate Frequency Transformers.

In the Camfield Super-Selective 9 the use of the 10 Kilocycle Band Pass Filter absolutely eliminates this cause of distortion.

All former Super-Heterodyne circuits have been designed to operate on

tube Super-Heterodyne. This transfer from 5 to 9 tubes is accomplished by a jack switch mounted on the front panel as shown in Fig. 2. The manner of connecting this switch in the circuit is illustrated in the schematic wiring diagram of Fig. 3. The circuit is so arranged that when the switch is thrown to the left only the two radio frequency tubes, the first detector and the audio amplifier tubes are lighted. When operated this way the output of

In the Camfield Super-Selective 9 squeals and whistles due to oscillator harmonics have been eliminated in the manner described above. Further stability is obtained by designing the circuit and the parts used so as to prevent oscillation of the radio frequency amplifier tubes.

Special construction of the Camfield Duoformers used as the Radio Frequency Transformers in the Camfield Super 9 prevents disturbing oscillations

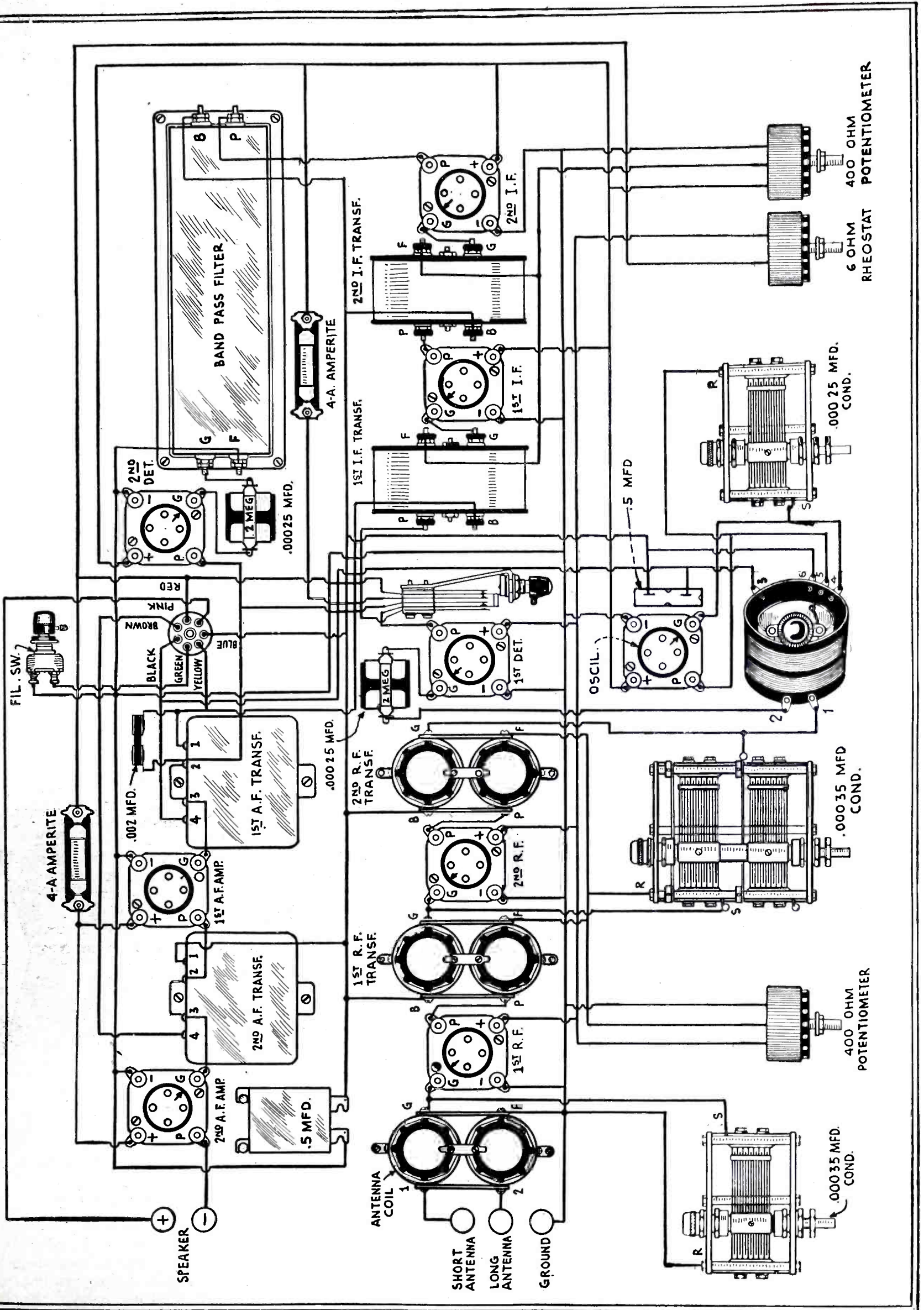

in the radio frequency end of the circuit.

Oscillation in a tuned radio frequency amplifier is caused by coupling between the plate or output circuit of the tube and the grid or input circuit. One or more of the following forms of

been designed to minimize its effective external magnetic field. Thus, when three of these transformers are used in a set, magnetic coupling between them is negligible.

The second cause of oscillation may be eliminated by the proper arrange-

fed-back from the plate circuit to the grid circuit through the tube capacity have been developed. The most noteworthy of these is the use of some means to feed back additional energy from the plate circuit to the grid circuit in such a manner that it is out of

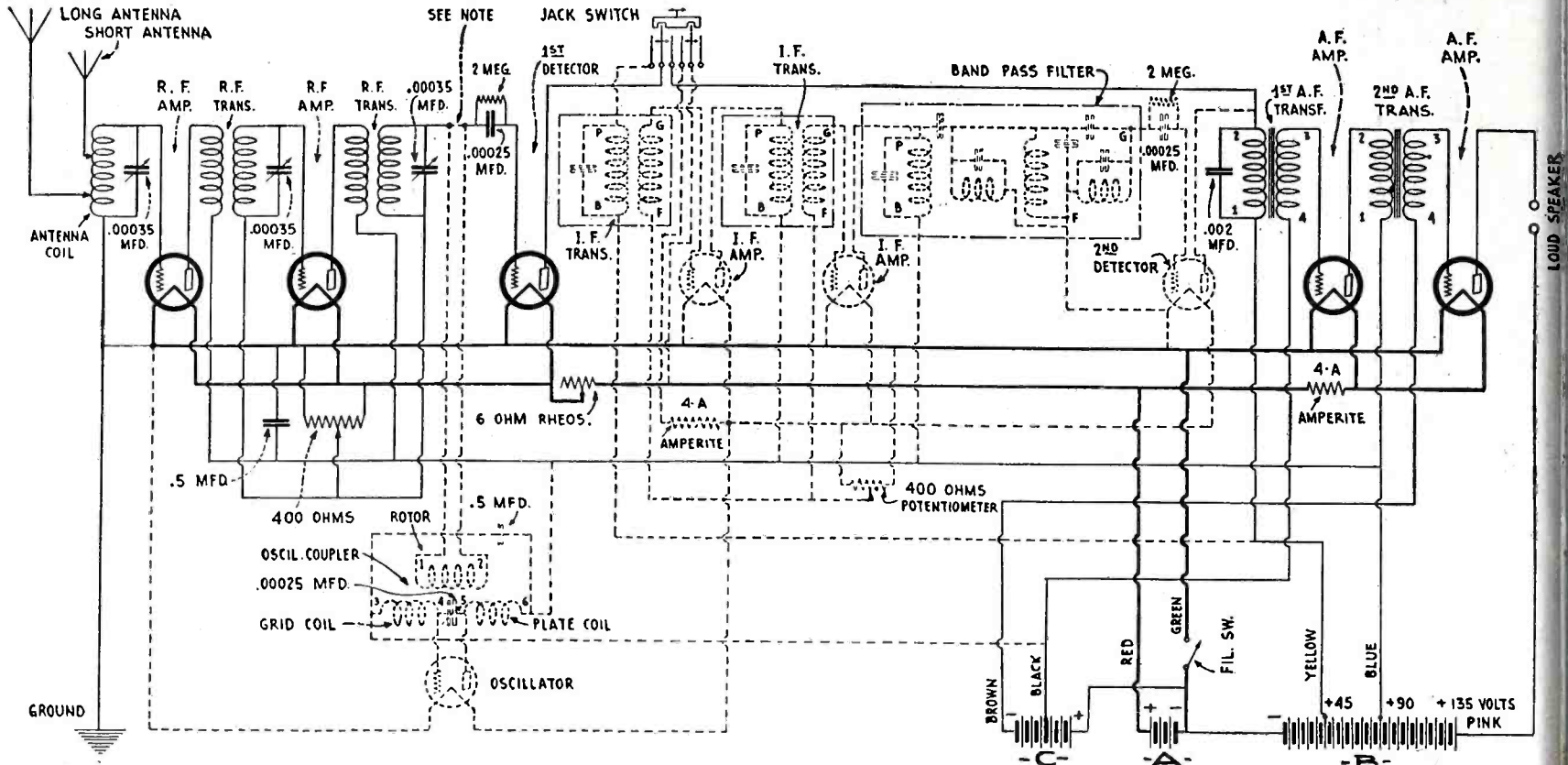

Fig. 3. Schematic wiring diagram of the Camfield Super-Selective 9. Connections indicated in dotted lines are made when nine tube set is built. Solid lines are the connections for the five tube set. The jack switch is employed in the combination receiver to turn on either five or all nine tubes.

coupling are always inherent to some degree in tuned radio frequency amplifier circuits:

First—Inductive coupling between the windings of interstage radio frequency transformers.

Second—Capacity and inductive coupling in the wiring of the set.

Third—Capacity coupling between

ment of parts and wires in the set and the proper use of by-pass condensers. This has been done in the set layout recommended for the Camfield Super-Selective 9, and for this reason it is advocated that the builder of the set follow our detailed instructions as closely as possible.

The third cause of oscillation, that

phase with the energy fed back through the tube, thus preventing oscillation. Several different ways of doing this are in use today, and some of them unquestionably have a great deal of merit. However, this system has several disadvantages, principal among them being that the means of feeding back compensating energy is often very

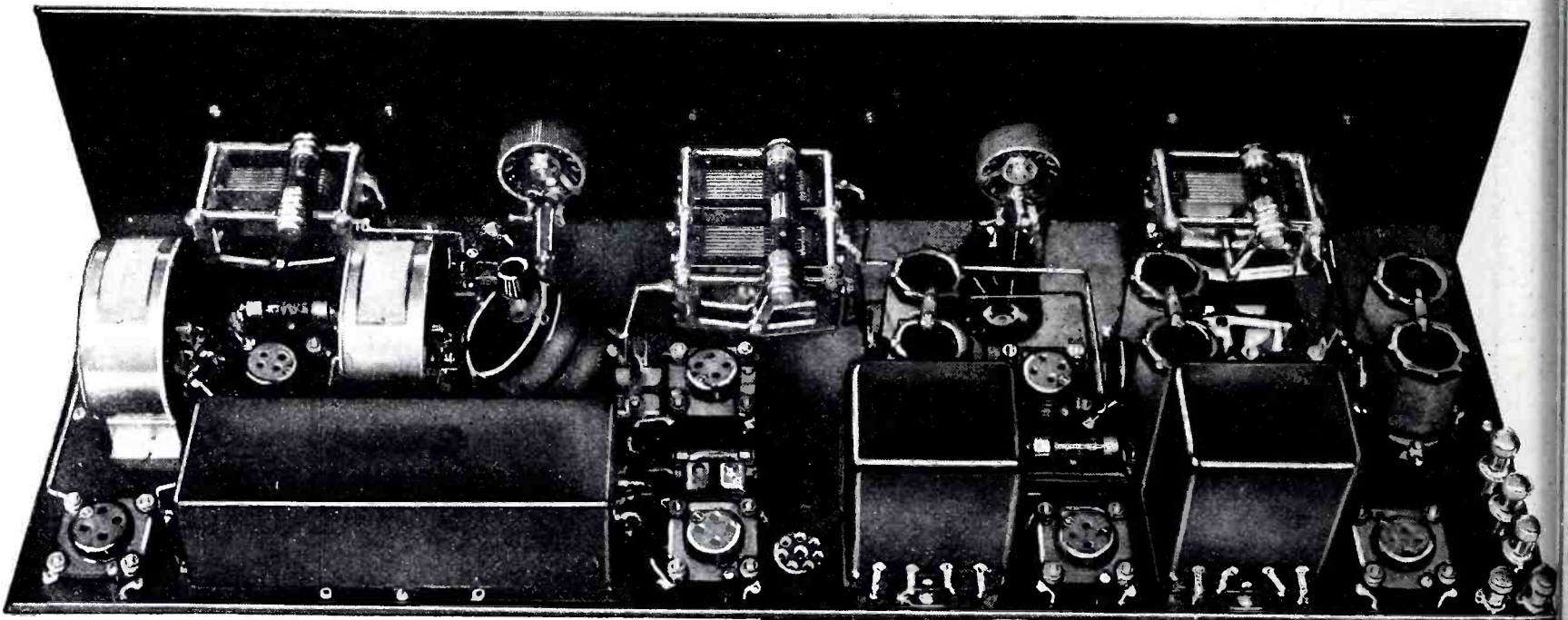

Fig. 4. A back panel view of the completed receiver. The encased unit in the foreground at the left is the band pass filter.

the two circuits due to the capacity between the grid and plate of the vacuum tube.

The first and second causes of oscillation are comparatively easy to eliminate. The Camfield Duoformer has

is, the grid-plate capacity of the vacuum tube, cannot be eliminated without entirely changing the design of the tube itself.

In the past few years, several methods of compensating for the energy

critical in its adjustment, and that circuits using it are not equally efficient over the full range of wave lengths.

Another means of preventing oscillation in general use today is to place a resistance, or in some other manner to

introduce a loss, in the grid circuit of the tube. It is very easy to prevent oscillations in this manner, but at the expense of decreasing the sensitivity of the circuit and broadening its tuning.

Some set and part manufacturers

the upper range of the broadcasting scale.

In support of this comparatively inefficient type of transformer, some manufacturers and technical writers have made the radical statement that

Morecroft, Chapter Six, page 432:

"It would seem as though the capacity (electrostatic) of a vacuum tube is so small as to be negligible, but such is far from the truth. The internal capacity of a tube may have very great

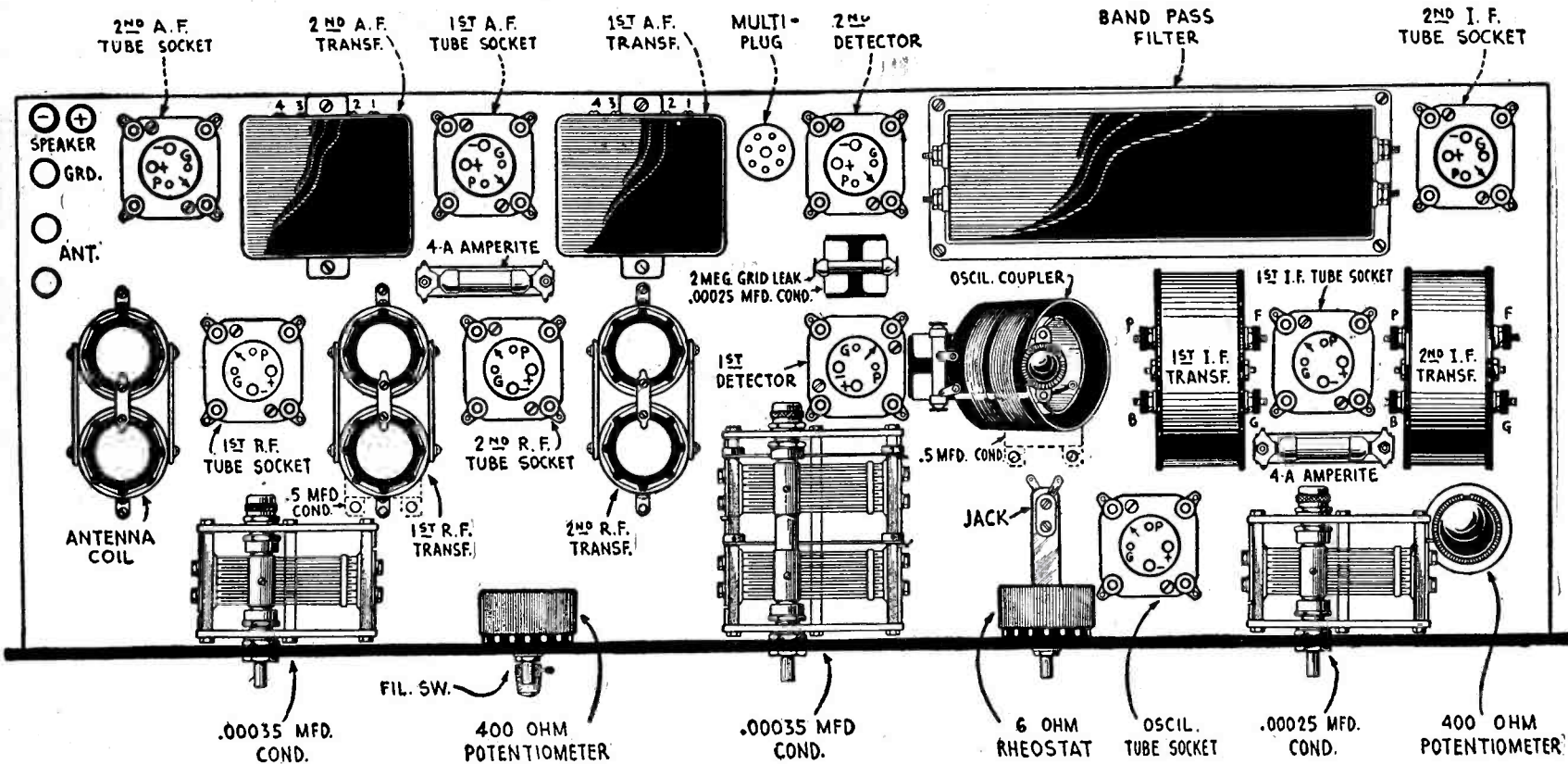

Fig. 5. Diagram showing the layout of parts on the sub-panel as seen when looking down on the set.

prevent oscillation by using tuned radio frequency transformers of very low efficiency, so that the over-all gain in each stage of the radio frequency amplifier is so low that oscillations are not produced. This is generally accomplished by making the primary in-

the minute capacity between the grid and plate of a tube does not cause a sufficient transfer of energy to produce oscillation. They claim that oscillations are caused entirely by coupling between transformers and coupling in the wiring, and that it can be over-

effect on its operations, especially at high frequency."

In designing the Duoformer, the engineers of the Camfield Radio Manufacturing Company fully recognized the existence of feedback through the tube capacity and the necessity of compen-

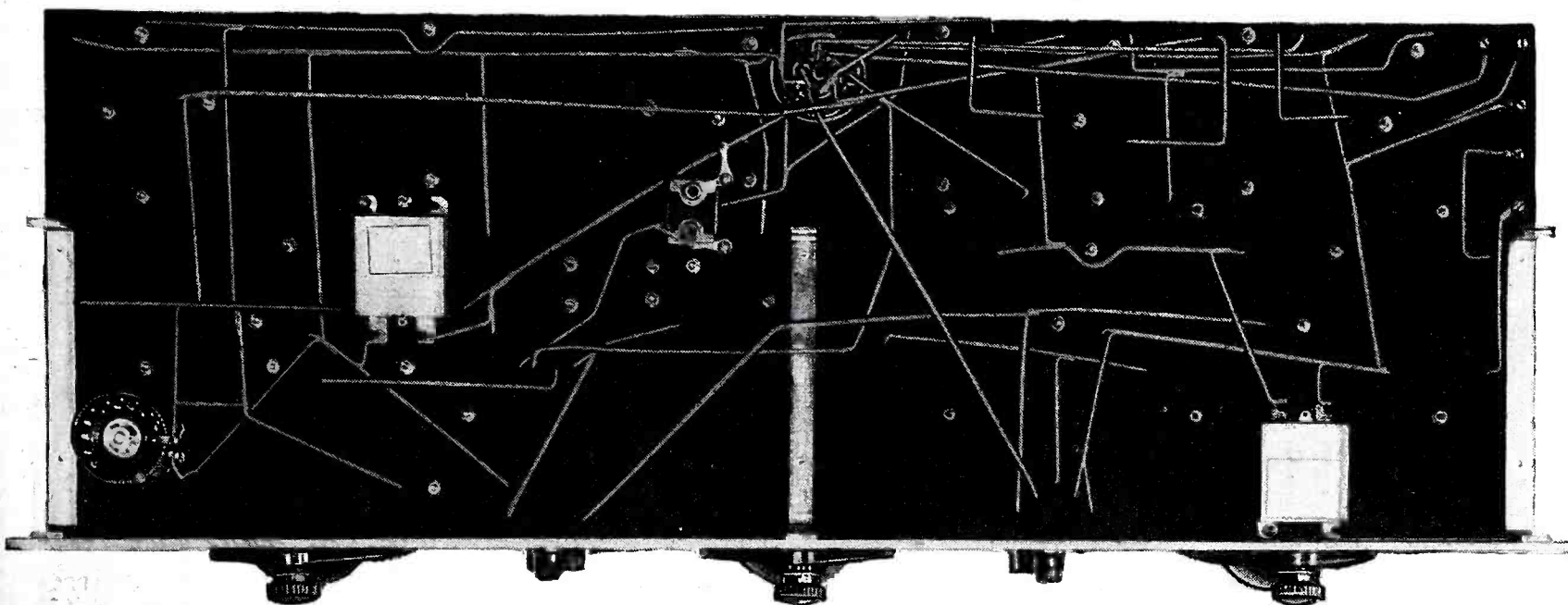

Fig. 6. A photographic view of the wiring beneath the sub-panel of the Camfield Super-Selective 9.

ductance so small that the proper degree of coupling between the primary and secondary is not obtained. Practically all transformers that do not necessitate the use of some form of compensating feed-back or resistance in the grid circuit are made in this manner. They usually have the characteristics of being fairly efficient on the low wavelengths and efficient on

come by the use of the close-field transformers. This, however, is not the case. Feed-back due to tube capacity does exist in all well designed radio frequency amplifiers and must be compensated for if the circuit is to be prevented from oscillating. To substantiate this the following statement is quoted from "Principles of Radio Communications," by Professor J. H.

sating for it in order to prevent oscillations when all stages of the radio frequency amplifiers are tuned to resonance. Not satisfied with the means previously employed, which resulted either in inefficient operation or in the necessity of making critical internal adjustments, their engineers worked along an entirely new line.

(Continued on page 128)



# The Improved "Nine-in-Line"

By A.M. Powers

**R**ECEIVERS may come and receivers may go but the super-heterodyne receiver does seem to go on forever. From the date of Armstrong's origination of this circuit principle in France during the war, the super-heterodyne receiver has opened up intriguing vistas to the dyed-in-the-wool radio fan. The builder and owner of a good super-heterodyne receiver is in a class apart from the ordinary run of radio devotees.

some features to recommend it above all others. In every stage of the development and popularization of radio reception the receivers which incorporate the super-heterodyne principle have managed to keep just a step ahead of others. In fact there is no other receiver or type of circuit that has been able to hold the popular favor of the radio public for anything like the length of time that the "super" has remained in favor.

the great trans-oceanic radio stations the super-heterodyne receiver is used for reception. Practically all of our broadcasting stations use super-heterodyne receivers for listening in on their own and other broadcasters, and for the constant watch that is kept for S O S calls.

The reason for all of this is that the super-heterodyne will do everything that any other receiver will do—and in most cases do it better. In sen-

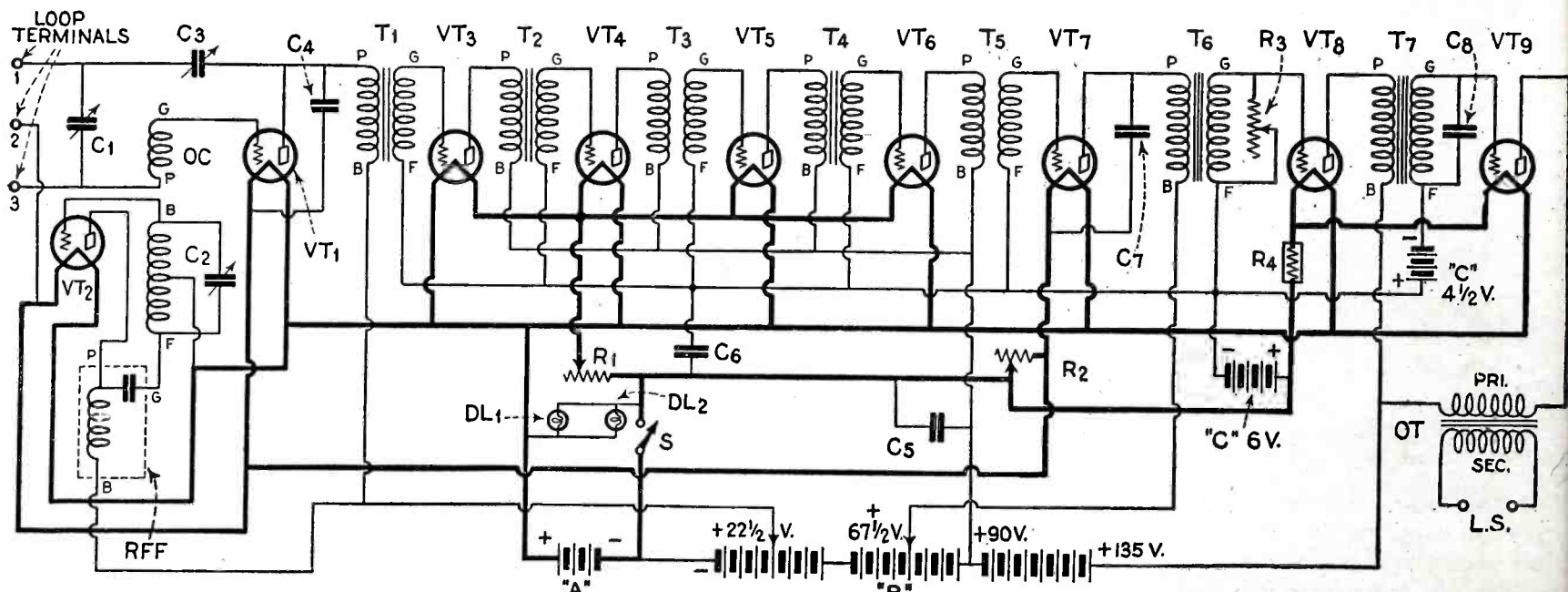

Schematic wiring diagram of the Improved Nine-in-Line.

It stands to reason that a single type of circuit could not hold its intense popularity through the entire period of radio broadcasting to date unless it had

Most of the outstanding records of distance reception on the broadcasting or higher wavelengths have been made with super-heterodyne receivers. In

sensitivity it is incomparable. Its volume is tremendous and its quality is governed only by the quality of the audio amplifier included in its make-up.

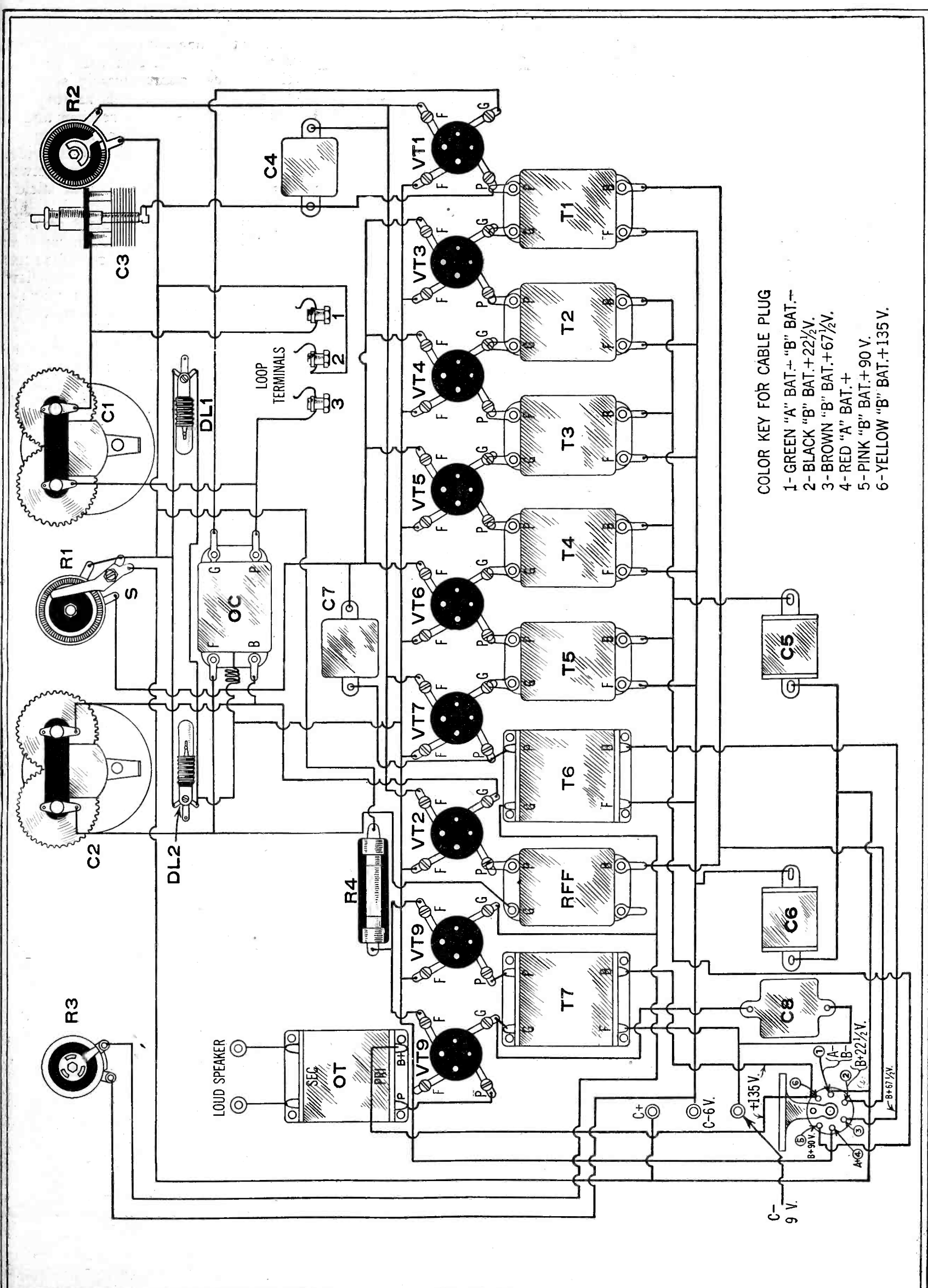

COLOR KEY FOR CABLE PLUG  
1-GREEN "A" BAT.+ "B" BAT.-  
2-BLACK "B" BAT.+ 22½V.  
3-BROWN "B" BAT.+ 67½V.  
4-RED "A" BAT.+  
5-PINK "B" BAT.+ 90 V.  
6-YELLOW "B" BAT.+ 135 V.

Aside from all its other advantages, this type of receiver may be used without an outdoor antenna of any kind and without a ground connection. Connected with an ordinary receiver a small loop antenna resting on the receiver cabinet, and with no other external wires, provides so little "pick-up" that, except in the case of reception from local stations, the average receiver would not be able to reproduce broadcast signals at all. But connect the same loop to a super-heterodyne receiver and stations all over the country may be tuned in. The tremendous amplification obtained with a super-heterodyne receiver is capable of overcoming this obstacle of extremely minute "pick-up" and reproducing the signals with strong loud-speaker volume.

Of course the whole trick lies in the fact that the amplification is obtained at a high wavelength where radio-frequency amplification is vastly more efficient than it is at the ordinary broadcast wavelengths. A long wave amplifier is also far more stable than one which amplifies at broadcast wavelengths and this fact permits the use of more R. F. amplifier stages in the "super." Where two stages of R. F. are the practical limit in an ordinary, unshielded type of broadcast receiver, it is quite possible and practicable to use three and even four stages in a super-heterodyne. Also, the amplification per stage in the latter is considerably higher than that of the average broadcast receiver.

But with all this sensitivity and volume there is still another feature to recommend this type of receiver—its selectivity. In spite of the good already accomplished by the radio commission in Washington, there is still an overcrowded condition on the air

early evening when the locals were going full force, and with an ordinary receiver, seem to be gone for good.

it. But not so with a good super-heterodyne receiver. With such equipment the local stations are confined to one or two degrees on the dials. With such confinement, and with local stations spaced approximately seven degrees apart on the dials as they now are with an up-to-date receiver and the 50 kilocycle separation between stations that now prevails, it is evident that there is plenty of room between the local stations for going far afield in the world of DX.

There have been constant improvements in the super-heterodyne receiver. The fundamental circuit remains pretty much the same but almost unbelievable refinements have been made in the parts used in the circuit. The original receivers of this type were extremely complicated in operation and in the construction. If memory serves correctly there were something like 34 adjustments to be made in some of the earlier models in order to bring them up to full efficiency.

Perhaps nowhere are the numerous refinements in this circuit exemplified as in the H. F. L. "Nine in Line" super-heterodyne receiver. The physical simplicity is evident from the top and bottom views of the receiver, shown below. The circuit itself is rather complex; although not more so than that of other super-heterodyne receivers; but the design of the individual parts and the carefully designed layout result in the most simple kind of assembly and wiring. The entire receiver, in spite of its nine tubes, requires less connecting wire than many three tube receivers. The grid and plate leads are all short and direct and there is no possibility for the constructor to go wrong.

An unusual feature of this receiver is the fact that it makes use of *four*

#### LIST OF PARTS REQUIRED FOR THE NINE-IN-LINE

- 3 H. F. L. No. H210, iron core intermediate frequency transformers; T1, T2, T4
- 2 H. F. L. No. H215, air core intermediate frequency transformers; T3, T5
- 2 H. F. L. No. C.16, audio frequency transformers; T6, T7
- 1 H. F. L. No. L.425, R. F. Choke coil unit; RFF
- 1 H. F. L. No. L.430, Oscillator coupler unit; OC
- 1 H. F. L. No. C.25, output transformer; OT
- 9 Benjamin Sub-panel mounting sockets No. 9044
- 2 Remler .0005 mfd. variable condensers with drum controls; C1, C2
- 1 pair Benjamin No. 8629 Sub-panel brackets
- 1 Hammarlund, .000045 mfd. midget variable condenser; C3
- 2 Carter 1 mfd. by-pass condensers; C5, C6
- 1 Carter .0005 mfd. fixed mica condenser; C4
- 2 Carter .002 mfd. fixed mica condensers; C7, C8
- 1 Carter No. M-S6 combined 6 ohm rheostat and battery switch; R1-S.
- 1 Carter No. M-6, 6 ohm rheostat; R2
- 1 Amperite No. 3-A or Carter,  $\frac{3}{4}$  ampere filament resistance unit; R4
- 1 Jones, Type B M, Multi-Plug, connection cable
- 5 Carter No. 10 tip jacks
- 1 Formica panel, 7" x 26"
- 1 Formica sub-panel, 7" x 24"
- 1 Carter 200,000 ohm variable resistance; R3
- 1 Excello console cabinet
- 1 Bodine, De Luxe loop
- 1 package Kester radio solder
- Flexible, insulated hook-up wire.

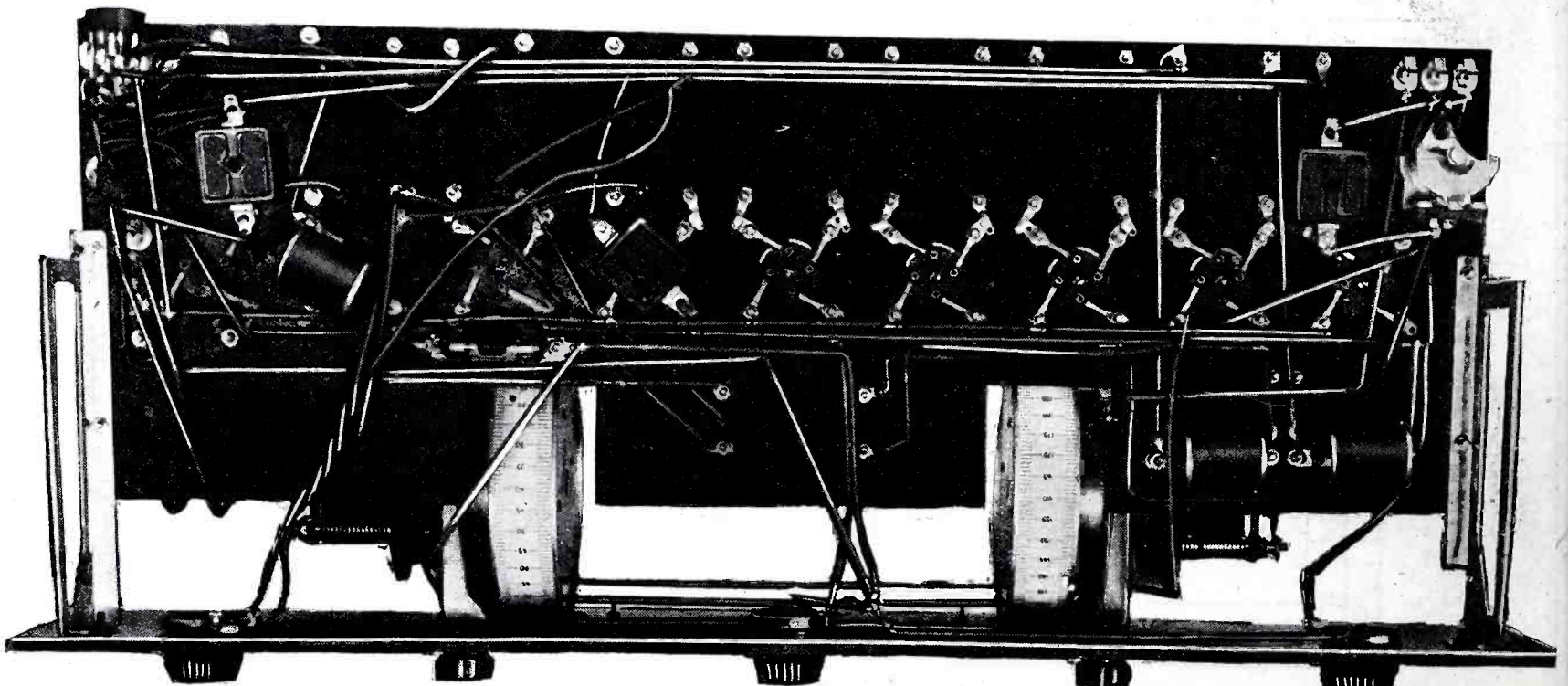

A view of the set from beneath the sub-panel showing the placement of parts and wiring.

as every radio listener knows. The old days when any number of out of town stations could be tuned in during the

If one desires to listen to out of town stations now he must, except in rare instances, burn the midnight oil to do

stages of intermediate frequency amplification to provide unprecedented sensitivity, and *two of these are sharply*



tuned to provide a degree of selectivity even in excess of the average good super-heterodyne receiver.

The intermediate-frequency amplifier consists of an untuned input transformer followed by another untuned transformer in the first stage. Next

tuned transformer, the output of this stage is in the form of a narrow frequency band. But wishing to go even further than this the designers of this receiver added another untuned, intermediate stage for the sake of additional amplification, and followed this with a

plifier stage is obtained, without adding another tuning control.

The input and frequency changer circuits are not unusual and employ a tried and true circuit. The broadcast signal energy picked up by the loop antenna is applied to the grid of

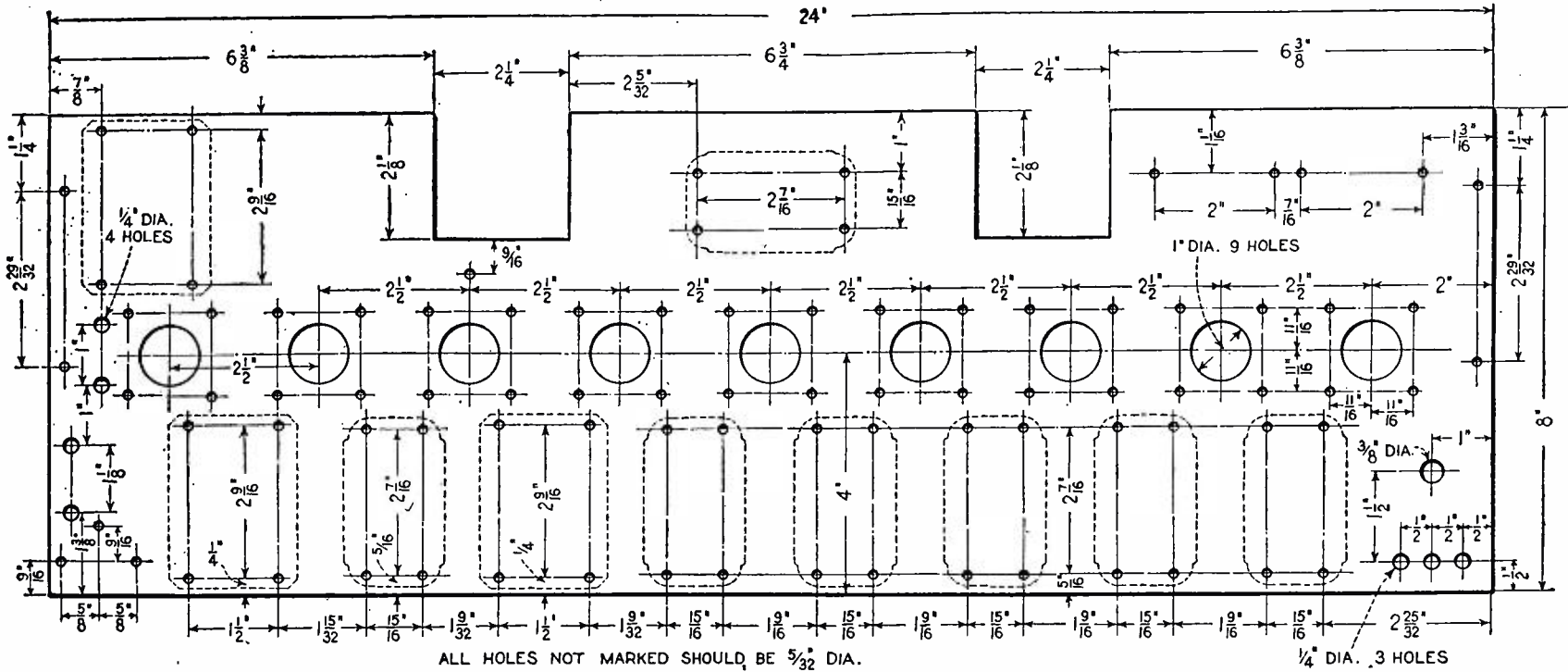

The drilling specifications for the sub-panel of the Nine-in-Line.

comes a tuned transformer, then an untuned transformer in the third stage and this is followed by another tuned transformer. Each of the untuned transformers will pass a wide band of frequencies. Their function is to provide coupling which will result in a high degree of amplification. But selectivity cannot be neglected and it is for this purpose that the tuned transformers

second tuned stage, for greater selectivity. This arrangement will surely appeal to the radio fan as being a most logical method of obtaining the maximum sensitivity and selectivity.

Another feature which tends to increase sensitivity is the inclusion of regeneration in the circuit of the first detector. It is a known fact that regeneration, at broadcasting frequencies,

the first detector tube, VT1. The regeneration in this circuit is provided by the center tapped loop and is controlled by the midget variable condenser C3. In the lead from the loop to the grid of the first detector a small coil is inserted and this coil is coupled to the tuned circuit of the oscillator, VT2. Through this coupling medium a locally generated frequency is also

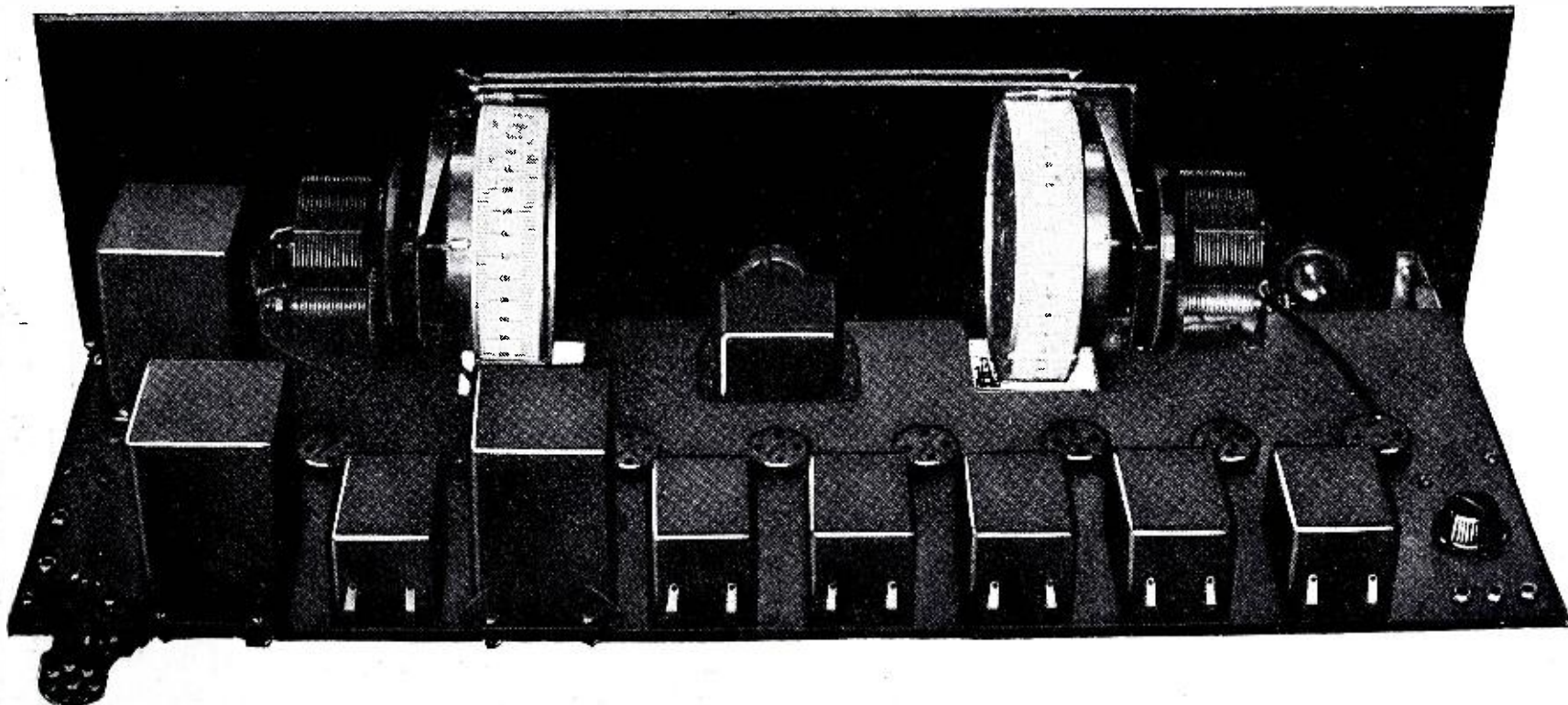

A rear view of the set. The units in the rectangular casings are the H.F.L. transformers.

are included. The broad band of frequencies passed by the untuned transformers are applied to the stage which contains the first tuned transformer. Because of the effect of this sharply

is approximately the equivalent of a stage of tuned radio frequency amplification. Therefore, by including regeneration in the circuit of the first detector the effect of an additional am-

impressed on the first detector. This latter frequency is, of course, the frequency to which the oscillator circuit is tuned. The output of the detector tube is therefore a composite of the

two impressed frequencies. An incoming signal of any frequency can be changed to any other pre-determined frequency by simply varying the frequency of the local oscillator. In this particular case it is desired to have the detector output correspond in frequency to that to which the intermediate amplifier is tuned. This is accomplished by tuning the detector input circuit by means of the condenser

the regeneration control condenser C3 may be set at zero and left that way. The only time it is used is when it is desired to tune in some very distant station, in which case it can be moved up until the detector circuit is just below the oscillating point.

After the signal passes through the intermediate amplifier it is impressed on the grid of the second detector, VT7. Here the "plate detection"

flowing in the plate circuit of the power tube used in the last stage, an output transformer, OT, is included in this circuit. The direct current can flow only through the primary of this transformer, while the useful, alternating current which comprises the signal energy is transferred to the secondary by induction and flows on through the speaker winding.

The construction of the receiver can

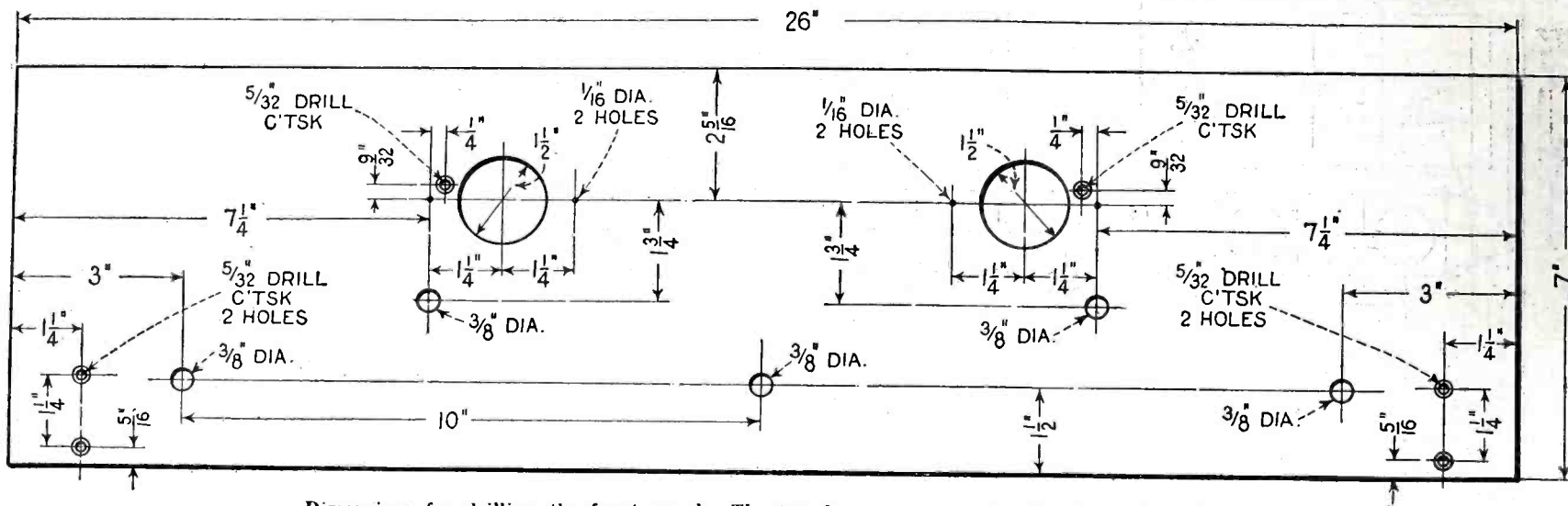

Dimensions for drilling the front panel. The two large holes are for the drum dial windows.

C1 to the wavelength of the broadcasting station to which it is desired to listen, and then adjusting the oscillator tuning condenser to a frequency which will combine with the incoming signal frequency to form a third frequency equal to that to which the intermediate amplifier is tuned.

method is used, which eliminates the grid leak and grid condenser. The signal then passes on through the two stage audio frequency amplifier. Normally the output of the second audio stage would be too great in volume, even on distant stations. To permit the operator to control volume to suit

be accomplished through the diagrams and illustrations which accompany this article. The panel and sub-panel templates are given, and show the location of all instruments. All of the parts except the condensers and resistances are identical in form. Each of these bears a type number, and these type

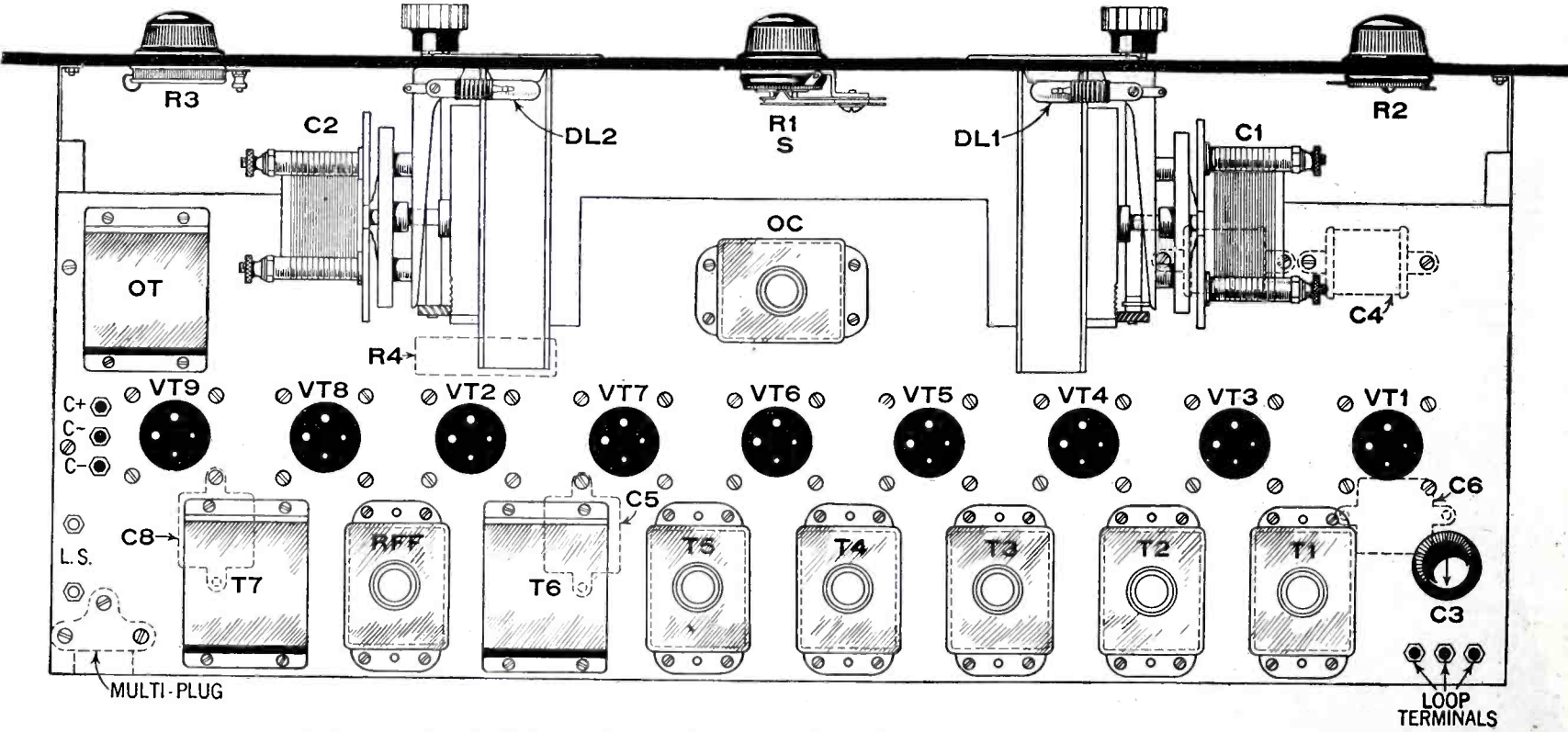

Instrument layout of the receiver. All parts are lettered to correspond with wiring diagrams.

The two variable condensers C1 and C2 are therefore the only tuning controls for the entire receiver. The principle of frequency changing as described may sound complicated but in tuning this principle may be forgotten and tuning accomplished in just the same manner as with any two control receiver. For all ordinary reception

his taste a variable resistance, R3, is included across the secondary of the first audio transformer. This resistance is mounted on the panel and is controlled by means of the knob shown at the right hand end of the front panel.

In order to protect the loudspeaker winding from the high direct current

numbers are shown in the layout diagrams so there is no possibility of the constructor misplacing any of the units. The "Nine in Line" receiver employs eight tubes of the 301-A type and either a 312 or a 371 type in the last audio stage, which is the last socket at the right. If a "B" supply of over  
(Continued on page 136)

# The New World's Record Super 10

by Felix Anderson

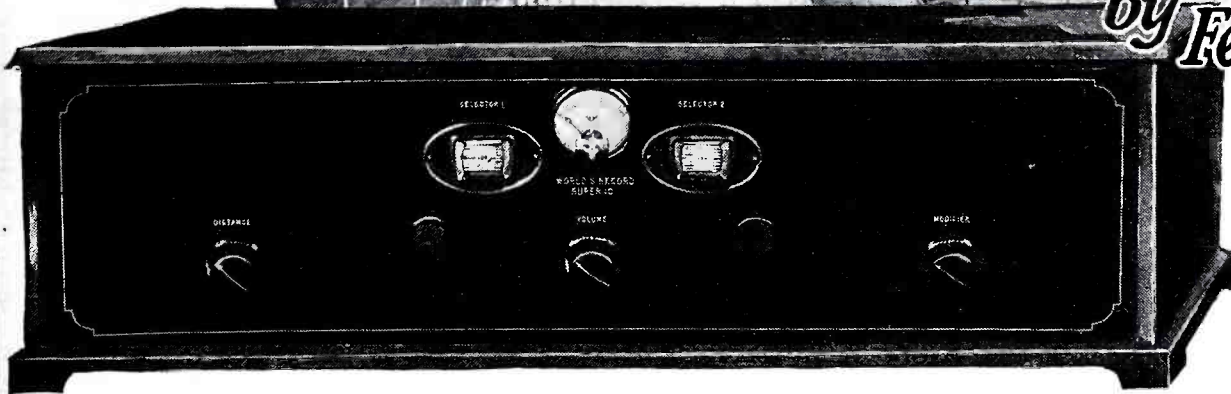

HEADING a long line of highly efficient superheterodynes, the new World's Record Super 10 is the latest development of E. H. Scott, well-known designer of the original World's Record Super with which so many distance records have been made.

Those who have followed the history of the various models of superheterodynes which Mr. Scott has designed, each one developed for maximum distance, highest selectivity and truest tone quality, will now find in the new World's Record Super 10 as described herewith a culmination of all the virtues of its predecessors, with generous use of all the latest refinements of proven merit.

In sharp contrast to the previous models the new Super 10 is designed for antenna operation in answer to the requests of thousands of superhet experimenters who wanted to secure the highest amount of original radio frequency pickup possible and who felt that their loop was not able to furnish it, usually because of absorption conditions in their own location.

With antenna operation it then became possible to use two stages of

have been a matter of added controls and a possibility of an unbalanced set. However, with the Remler three gang condenser the two added stages of r.f. as well as the tuned detector stage may

tion of designing radio frequency coils that would match and permit peak efficiency over the entire scale, became an important one. Therefore, the especially designed radio frequency coup-

## PARTS REQUIRED FOR NEW WORLD'S RECORD SUPER 10

- |  |   |
|--|---|
| 1 Formica Panel, drilled and engraved, 26x7x3/16 | 1 Selectone Oscillator Coupler No. 540                    |
| 1 Formica sub-panel, drilled 25x10x3/16          | 10 Benjamin Sockets (without bases)                       |
| 1 Remler 3 in line condenser No. 633 .00035      | 1 Pair Benjamin brackets No. 8629                         |
| 1 Remler condenser No. 638 .00035                | 1 Carter Imp Rheostat 1R-15 Ohms                          |
| 2 Remler Drum dials No. 110 (1 each 110 & 110-R) | 1 Carter Imp Rheostat IR-30-S Ohms (with filament Switch) |
| 2 Remler R.F. Choke Coils No. 35                 | 1 Carter Power Rheostat MW-1 Ohm                          |
| 2 Thordarson Audio transformers R200             | 1 Carter Imp Pot. IR-400 Ohms                             |
| 1 Thordarson output transformer No. 76           | 1 Carter fixed condenser .00025 with grid clips           |
| 2 Selectone L.W. transformers No. B 500          | 1 Carter fixed condenser .002                             |
| 2 Selectone L. W. transformers No. B 510         | 1 Pair No. 10 Carter pin jacks                            |
| 2 Selectone R. F. transformers No. 520           | 1 Jewell Voltmeter 0-8 Volts, type No. 135                |
| 1 Selectone Antenna Coupler No. 530              | 4 Tobe By-Pass condensers 1 Mfd.                          |
|  | 1 Tobe grid leak  |
|  | 1 Jones 10 contact Multi-Plug and 4 ft. cable             |
|  | 40 soldering lugs and Kester radio solder                 |
|  | 30 Feet Belden rubber covered hook-up wire                |

be operated effectively and with the same major control used in other loop

plers as employed in this set assure perfect operation. These couplers, as

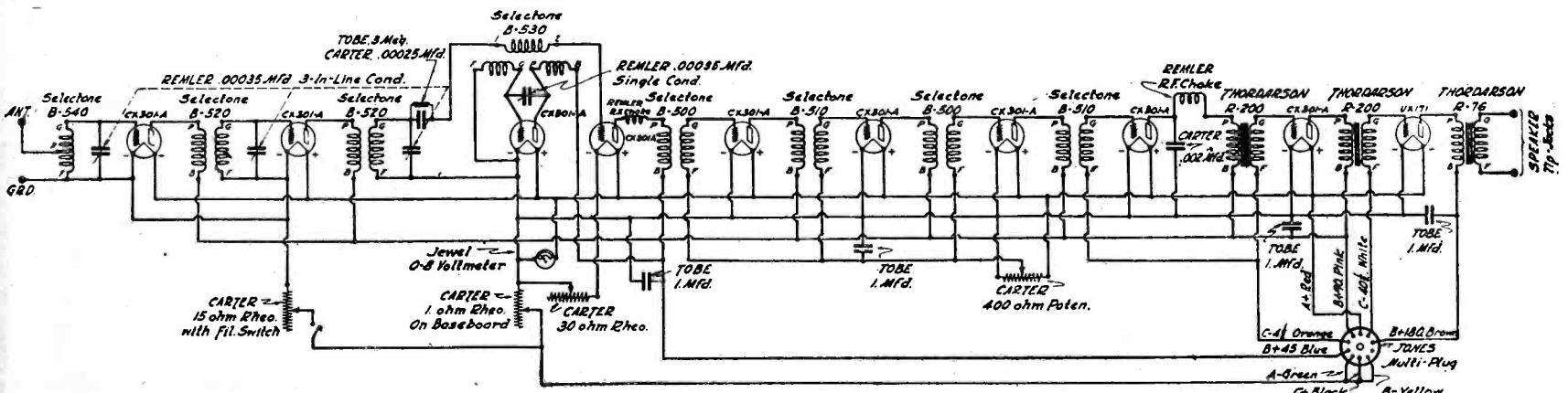

Fig. 1. Wiring diagram of the new World's Record Super 10. All connections are clearly indicated to correspond with markings on the component parts of the set so the constructor will have little difficulty in following this diagram.

tuned r.f. ahead of the detector and thus provide that tube with a signal the strength of which would never be possible with the loop pickup arrangement. Under ordinary conditions this would

operated superheterodynes. The oscillator, of course, is operated on a single condenser.

As others have found when using tuned r.f. ahead of a super the ques-

the photos show, are housed in the same type of containers that enclose the intermediate frequency transformers, so all units present a similar and compact appearance.

The frequency values of the transformers used in this set are very closely matched and the same applies to the r.f. couplers, with the result the entire r.f. and i.f. train functions with a great

receiver, with its controls cut to a minimum consistent with ample flexibility. In Figure 5 may be seen the scaled drawing of the front panel, while Figure 6 gives the builder a correct and

of the .00035 mfd. sections of the Remler three gang condenser, the full scope of the broadcast band is covered; that is, from 1500 kc at the lowest wavelength to 550 kc at the highest.

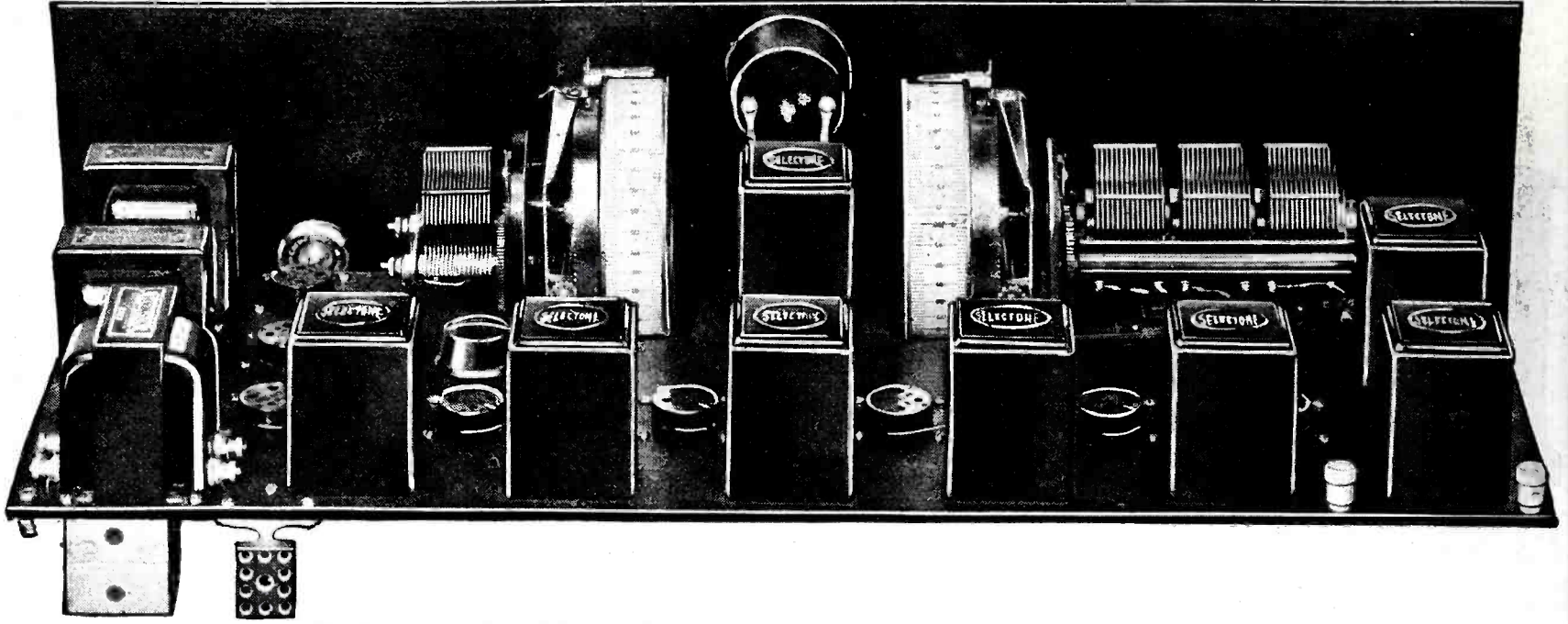

Fig. 2. A rear view of the set showing the arrangement of parts mounted on the sub-panel.

degree of efficiency. In the case of the audio transformers, the two Thordarson type R-200 will give exceptionally good audio quality.

Before going into the constructional description of this circuit the reader might secure a keener understanding of the receiver by examining the photographs and diagrams which accompany this article.

Schematically the receiver is illustrated in Figure 1. A rear view of the completed set is found in Figure 2.

exact method of duplicating this latest model superheterodyne, showing the exact position of each part.

Because of its subpanel construction the assembly of the set is even easier than in previous models. All leads may be carried below the subpanel and as a result lengthy leads are eliminated. Either flexible wire, or solid busbar may be used in hooking up the set, depending upon the desires of the home constructor.

Examining the schematic diagram,

Succeeding the first r.f. stage is the type B-520 of which there are two, one in the second r.f. and one in the detector stage. The inductance value of these two units is identical with that of the first one, and the range is covered with the three section condenser. Each condenser section on the Remler gang is isolated from the next, and a small trimmer capacity is provided to balance the main capacity and to correct any slight inequality that may exist due to differences in wiring. Once these

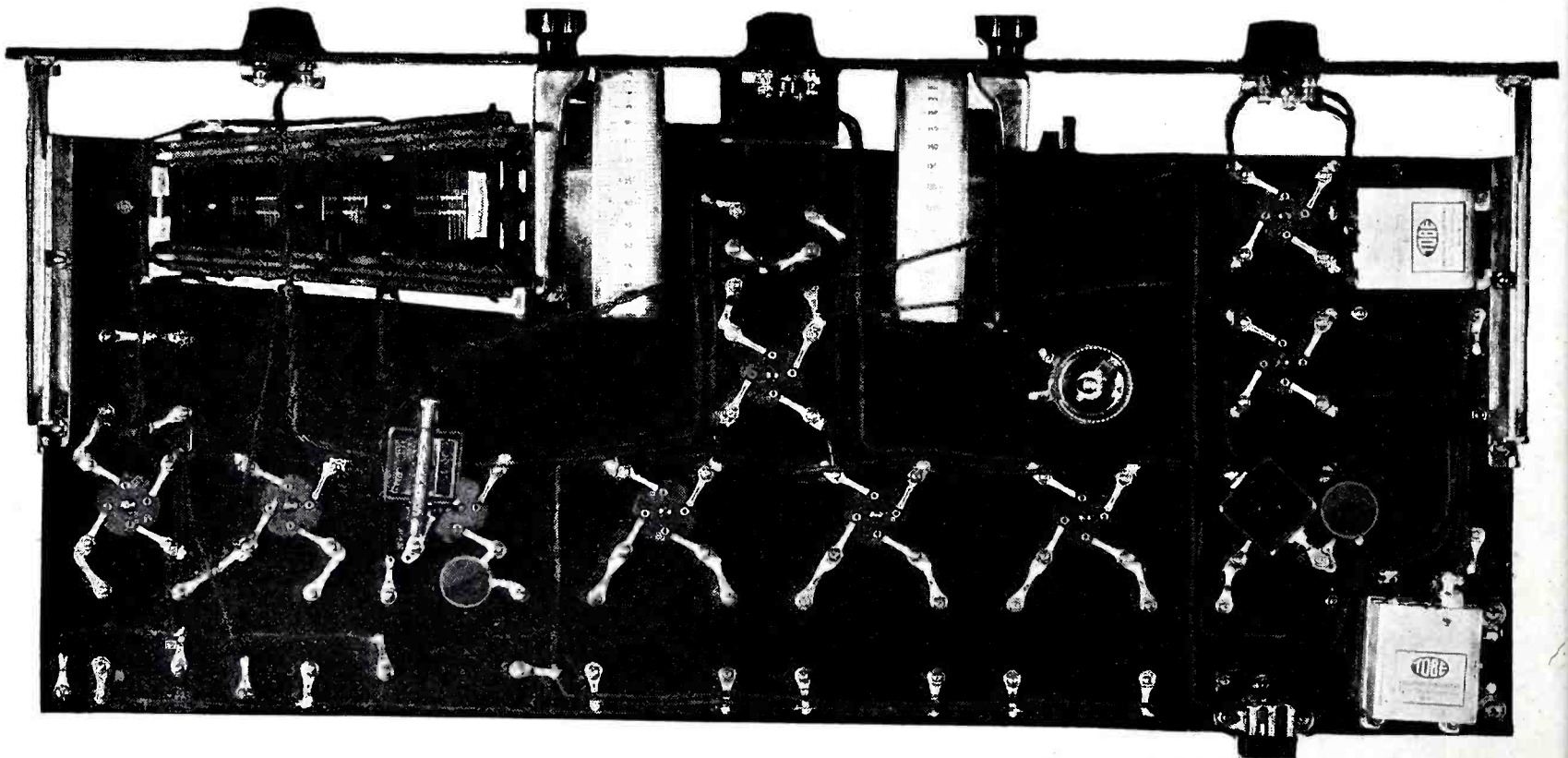

Fig. 3. The layout of parts and wiring beneath the sub-panel.

Extremely short plate and grid leads are to be seen in the photograph showing the bottom sub-panel view of the Super 10, Figure 3. Figure 4 gives the builder an idea of the beauty of the

from which of course all wiring should be done, we see the first r.f. coupler, designated as Selectone B-540. It consists of an inductance tapped for antenna connection. When tuned by one

trimmer capacities are set, if that is required, they are left alone and the r.f. train will remain in balance.

No regeneration is used in the detector stage, this being another depart-

ure from previous models made necessary when two added stages of r.f. are used. It also results in leaving off one minor control, adding to the simplicity of the set's operation. Sensitivity con-

On the first detector another refining control is used in the form of a 30 ohm rheostat in series with the 1 ohm rheostat supplying the oscillator, first, second, and third intermediates, second

and two type B-510. The oscillator, for plate to grid tuning with a .00035 mfd. Remler variable condenser (single) is shown as Selectone type B-530. Its pickup winding is placed in

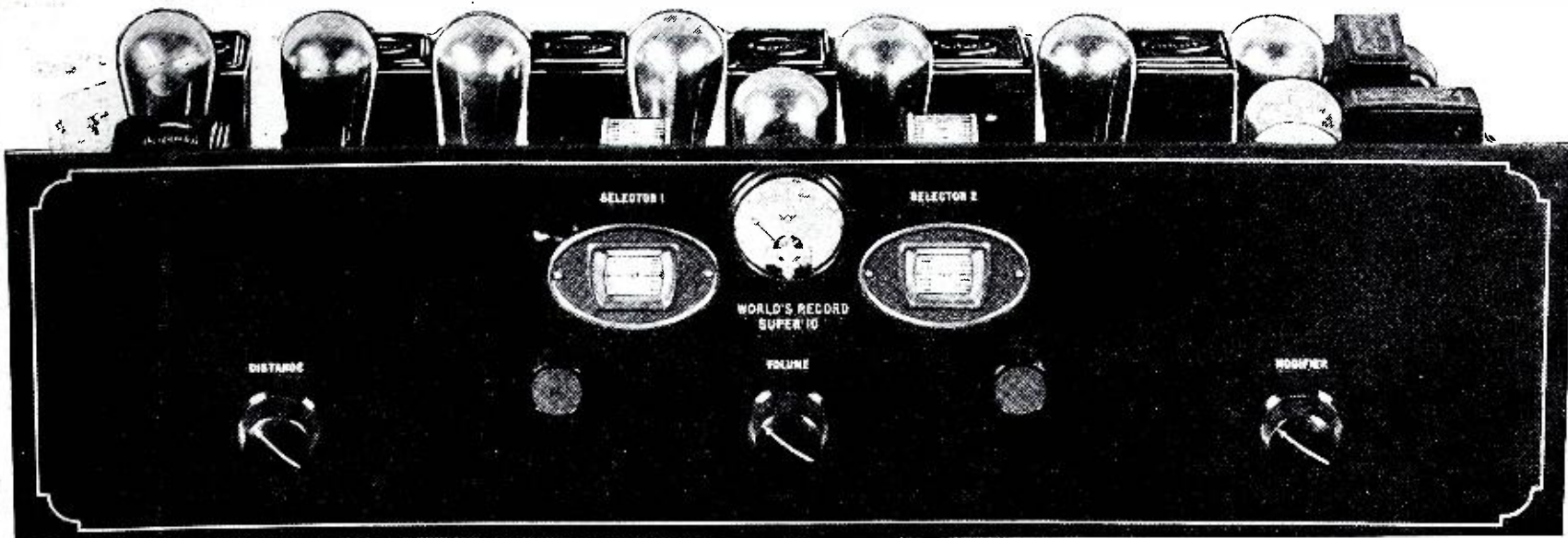

Fig. 4. A close-up of the front panel. Balance in panel design is another feature of this new set. The number of controls have been reduced to minimum consistent with ample flexibility.

trol in the first and second r.f. is accomplished with a 15 ohm rheostat. This rheostat is placed in the negative filament where it is common with the negative B battery, the positive of the

detector, and first and second audio. With the detector rheostat the input to that stage may be altered at will, being reduced on locals and increased on distant signals.

series with the grid of the first detector where grid leak and condenser rectification is used.

In the second detector circuit grid bias rectification is used on account of

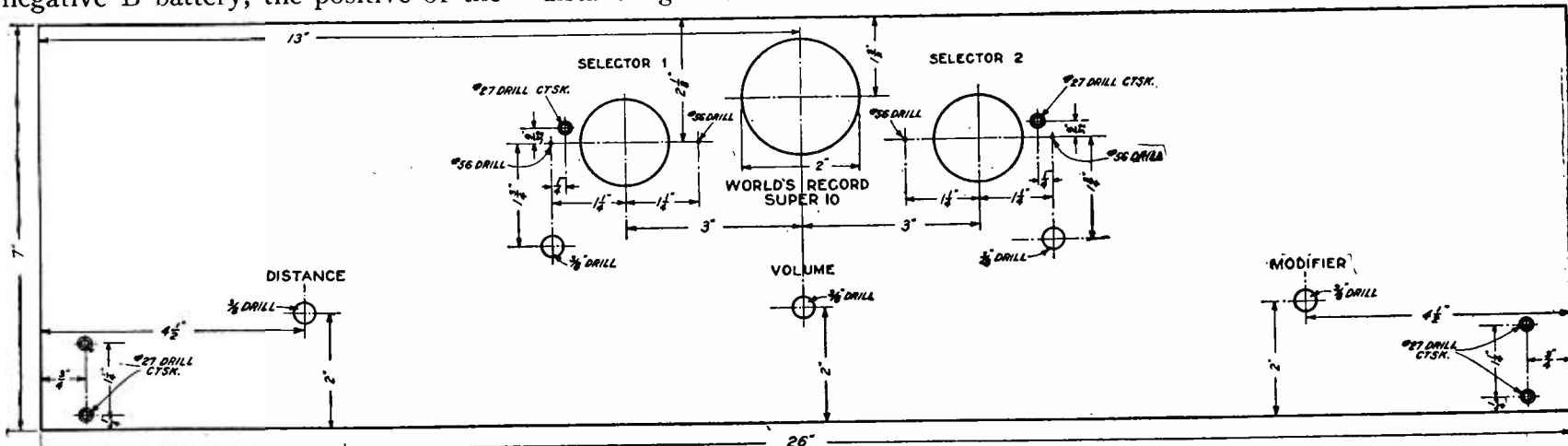

Fig. 5. The panel drilling layout of the set with dimensions.

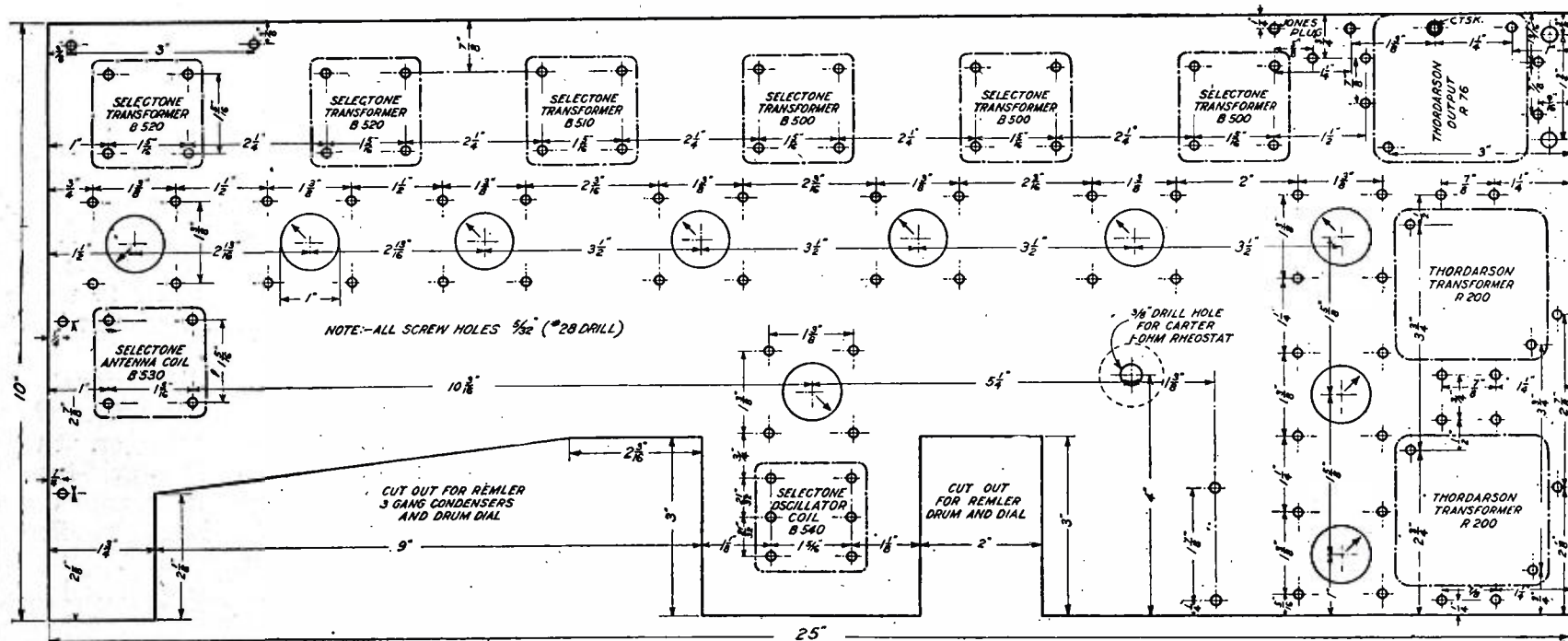

Fig. 6. Sub-panel drilling layout giving placement of parts.

C battery, and with the ground, and the control is quite smooth and effective. It also has combined with it the filament switch.

The Selectone transformers, accurately peaked and matched, are located ahead of the second detector, there being two type B-500 transformers,

greater stability, less possibility of detector overload and freedom from noise. The bias for detection is fur-

(Continued on page 152)

# The IMPROVED LABORATORY SUPER-HETERODYNE

By E. R. PRAFF

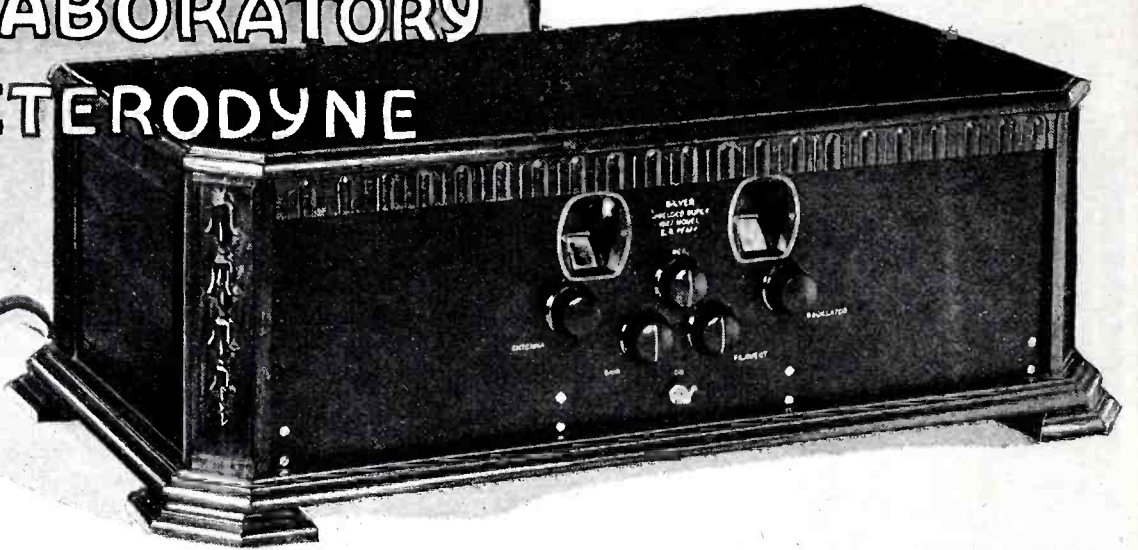

**I**N the Improved Laboratory Super-Heterodyne is at last found a receiver free of the almost age-old bugaboo of individually matched long wave transformers, for the long wave amplifier is a sealed, laboratory-calibrated unit that will not vary one kilocycle in operation with standard tubes. Almost every builder of a super-heterodyne has either been disappointed in his set's not possessing the expected knife-like selectivity, or, if he has employed really sharp, efficient transformers, they only too frequently do not function properly. This condition is not always due to the individual transformers not having been properly matched to begin with, but because individual assembly conditions result in altered circuit capacities and operating conditions which do not duplicate the laboratory conditions under which the transformers were first matched. Then, again, any of the popular iron-core 30, 40, 50 or 60 kilocycle transformers have very low winding capacities, for operation with low circuit, and low tube capacities. Since the operating frequency of the transformers is largely determined by the total circuit capacity, and since winding capacity is low, it follows that any small variations in wiring, assembly, or tube capacity will represent a large proportionate change of the total capacity, with the result that individual receiver stages built with accurately matched transformers may often be as far as 15 to 20 kilocycles apart. This, of course, means little or no selectivity, even if there still remains fair amplification.

The logical way to build an intermediate amplifier is to use, not iron-core—air-core transformer combinations, but to follow along the lines of best R.F. amplifier design practice, and use low resistance air-core transformers thruout, tuned with large fixed capacities, so that variations in tube capacities represent such a small

percentage change of the whole as to be ineffectual. Exactly this course has been followed in the Laboratory Super, but it has been carried a step farther, and the whole amplifier built into a single, carefully tested unit, so that two causes of variation have been eliminated, and the remaining third—tube

plification jumps tremendously. Actually, shielding adds at least 50 to 100 per cent in volume on weak stations—exactly as it would intelligently applied to any multi-stage RF amplifier. This is because of the elimination of detrimental feedbacks, always and invariably present with unshielded amplifier stages.

Eight tubes are employed in the Improved Laboratory Model Super-Heterodyne—a first detector, an oscillator, three long wave amplifiers, a second detector, and two audio stages. The first detector circuit is very similar to the conventional short wave regenerative circuits so popular, and, in fact, on short waves the first detector system alone of the new set will bring in European amateur stations on headphones! The circuit is regenerative, a small 75 mmf. midget condenser controlling regeneration; while a .00035 modified SLW-SLF condenser does the tuning. The coil system is a conventional S-M plug-in coil, so connected that both regeneration and tuning condenser are at ground potential, with consequent total absence of hand-capacity effect. No provision is made to use a loop, as it has been found that for extreme selectivity the use of an antenna—the coupling to which is variable—provides for greater flexibility than a loop.

The oscillator circuit is designed to keep harmonics at a minimum so that stations are heard at but one, or, at the most, two dial points. It is grid-tuned with a 350 mmf. condenser with consequent absence of hand capacity effect. Its output at different wavelengths is sufficiently constant for practical requirements, as is its calibration; while the coupling to first detector is variable.

A copper can 15 inches long, 5 inches wide, and 3 inches deep holds the I.F. amplifier and second detector. It contains four individual stage compartments, each holding an RF trans-

## PARTS REQUIRED

- 1 Van Doorn panel and chassis unit, pierced, with hardware
- 1 Carter .00015 condenser with leak clips
- 1 Carter M-200 potentiometer
- 2 Carter ½ mf. condensers
- 1 Carter 3 ohm rheostat
- 1 Carter battery switch
- 4 Carter No. 10 tipjacks
- 1 Polymet 2 megohm leak
- 2 S-M 220 audio transformers
- 4 S-M 511 tube sockets
- 2 S-M 805 vernier drum dials
- 1 S-M 275 RF choke
- 1 S-M 342 .000075 mf. condenser
- 1 S-M 440 time signal amplifier
- 2 S-M 515 coil sockets
- 2 S-M 111A coils
- 2 S-M 320 .00035 condensers
- 9 X-L binding posts

With each chassis should come the following items of hardware, contained in a small envelope:

- 9 sets binding post insulating washers (1 plain, 1 extruded to a set)
- 4 sets tipjack insulating washers (1 plain, 1 extruded to a set)
- 3 sets instrument insulating washers (1 plain, 1 extruded to a set)
- 27 ¾" 6/32 RHNP brass screws
- 1 1¼" 6/32 RHNP brass screws
- 29 6/32 N.P. brass nuts

capacity—rendered so small a percentage change as not to affect operation. On top of this, the whole amplifier is completely shielded, each of the RF stages and detector being housed in individual compartments of a copper-brass catacomb. The amplifier without shielding is remarkably efficient, but when the shielding is added, the am-

former and its tuning capacity, a tube socket, and the necessary wiring and bypass condensers. Three RF stages and a detector are employed, with the whole unit tuned to exactly 112 kilocycles. The reason for the selection of this immediate frequency is that very very satisfactory low resistance air-core tuned RF transformers may be built for operation there. If a lower frequency were used, serious cutting

erally spaced on even 10 kilocycle separations, so that the odd 112 kilocycle frequency is a greater aid to selectivity. Coil pick-up is, of course, absent in the shielded amplifier, and wiring pick-up is almost negligible since all wiring is very close to the grounded metal panel or chassis. Complete shielding of first detector and oscillator sections prevents pick-up of strong local stations on the coil systems themselves, though for

and the prevalent heterodyne squeals. The amplification of the set is tremendous, due to careful design of every individual circuit. The very sensitive first detector gives an amplification of 200 times or more on a very weak signal when carefully operated. The computed, and actual measured gain of each RF stage is about 20, while the gain of the audio stages is also about 20. Regarding the over-all am-

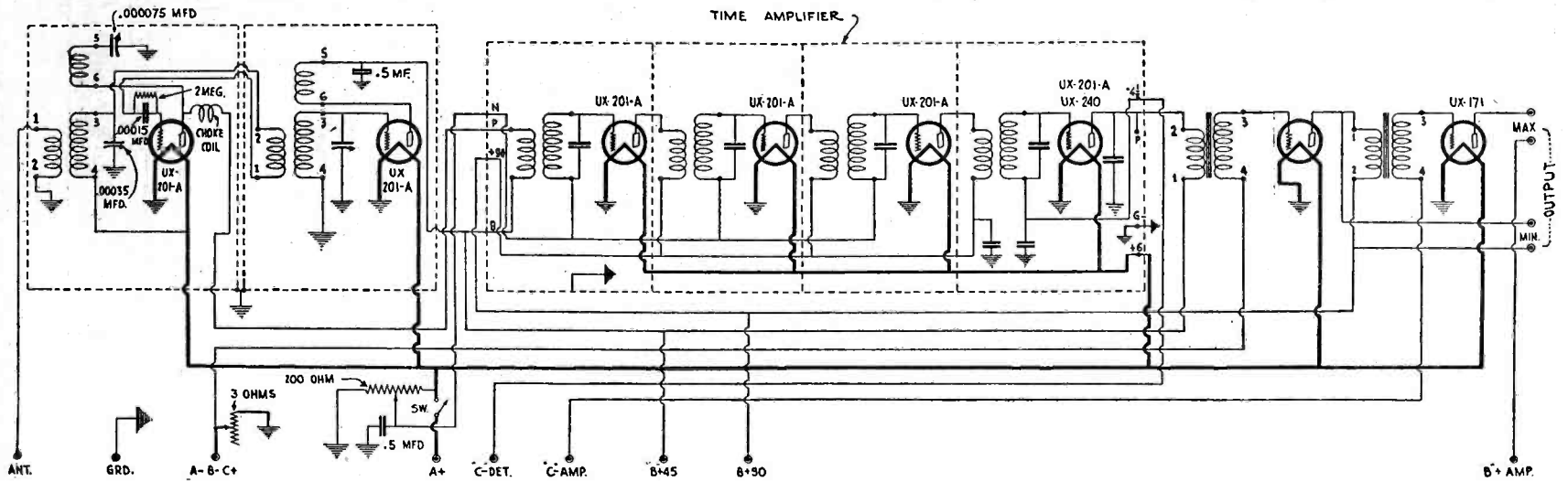

Schematic wiring diagram of the set. The dotted lines around portions of the circuit indicate the parts in shielded casings.

of side-bands would result, or poor selectivity as pointed out. The 112-kilocycle amplifier frequency results in decreased interference possibilities. Normally, in a super employing, say, a 50 kilocycle intermediate frequency, two stations 50 kilocycles away will heterodyne each other and be received without the use of the local oscillator at all, selectivity being dependent upon the selectivity of the antenna tuner and the local coil pick-up. As the intermediate frequency is increased, this possibility decreases, since it is far easier for an antenna tuner to discriminate between stations 112 kilocycles

receivers to be operated in the country, or in non-congested broadcasting centers, these two shields might be omitted.

### Amplification of the Set

The audio amplifier offers a very unusual point of very great value in an ultra-selective receiver. This is the 5,000 cycle cut-off, or decrease in amplification, which aids receiver selectivity. Frequencies above 5,000 cycles do not contribute to realism of reproduction, according to no less an authority than the Bell Telephone Labora-

plification in the most conservative light, a gain of 25 is assumed for the first detector—one eighth that experienced on a weak signal. The gain of the RF amplifier is split in half for the sake of conservatism—to 10 per stage. The audio gain may be considered as 20 per stage. Thus the over-all amplification may be conservatively taken as  $25 \times 10 \times 10 \times 10 \times 10 \times 20 \times 20 = 100,000,000$  times. Considering an average eight tube super employing iron-core transformers, and without as careful first detector design, the computed, and measured gain of a typical popular set works out about as fol-

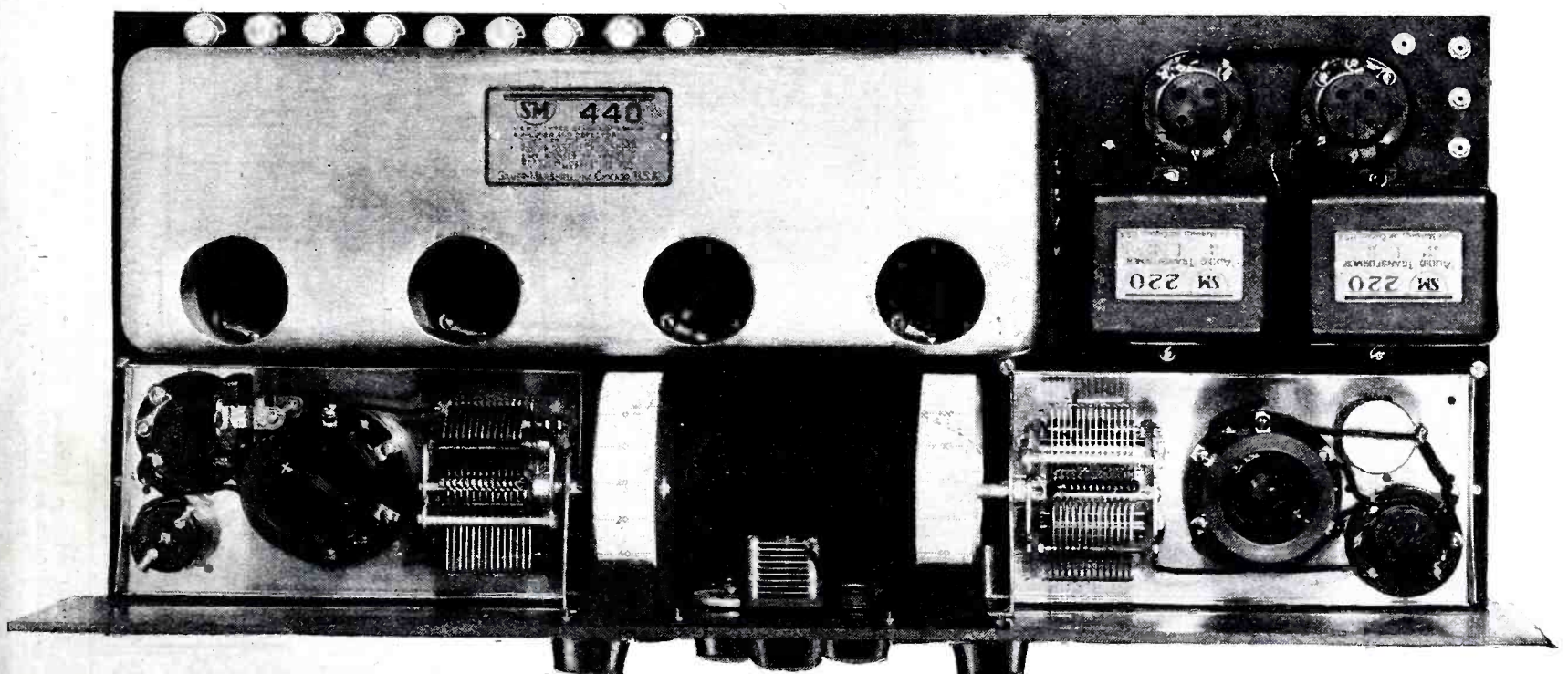

A top view of the Improved Laboratory Super-Heterodyne. The first detector is shielded in the casing in the lower left hand corner of the above photo. The first and second audio stages are seen in the upper right hand corner. The oscillator with the shielded casing is in the lower right hand corner.

apart, than between powerful locals 30, 50, or even 60 kilocycles apart. Further, powerful stations are gen-

erally spaced on even 10 kilocycle separations, so that the odd 112 kilocycle frequency is a greater aid to selectivity. Coil pick-up is, of course, absent in the shielded amplifier, and wiring pick-up is almost negligible since all wiring is very close to the grounded metal panel or chassis. Complete shielding of first detector and oscillator sections prevents pick-up of strong local stations on the coil systems themselves, though for

erally spaced on even 10 kilocycle separations, so that the odd 112 kilocycle frequency is a greater aid to selectivity. Coil pick-up is, of course, absent in the shielded amplifier, and wiring pick-up is almost negligible since all wiring is very close to the grounded metal panel or chassis. Complete shielding of first detector and oscillator sections prevents pick-up of strong local stations on the coil systems themselves, though for

$\times 5 \times 5 \times 20 \times 20 = 1,250,000$  times, or only one eightieth of that of the Laboratory Model!

which it has been tried, either tuned RF or super-heterodyne. Generally, it will bring in on the loud speaker sta-

—simply because every tube is worked to the absolute limit of performance. Located in Chicago, the set is selec-

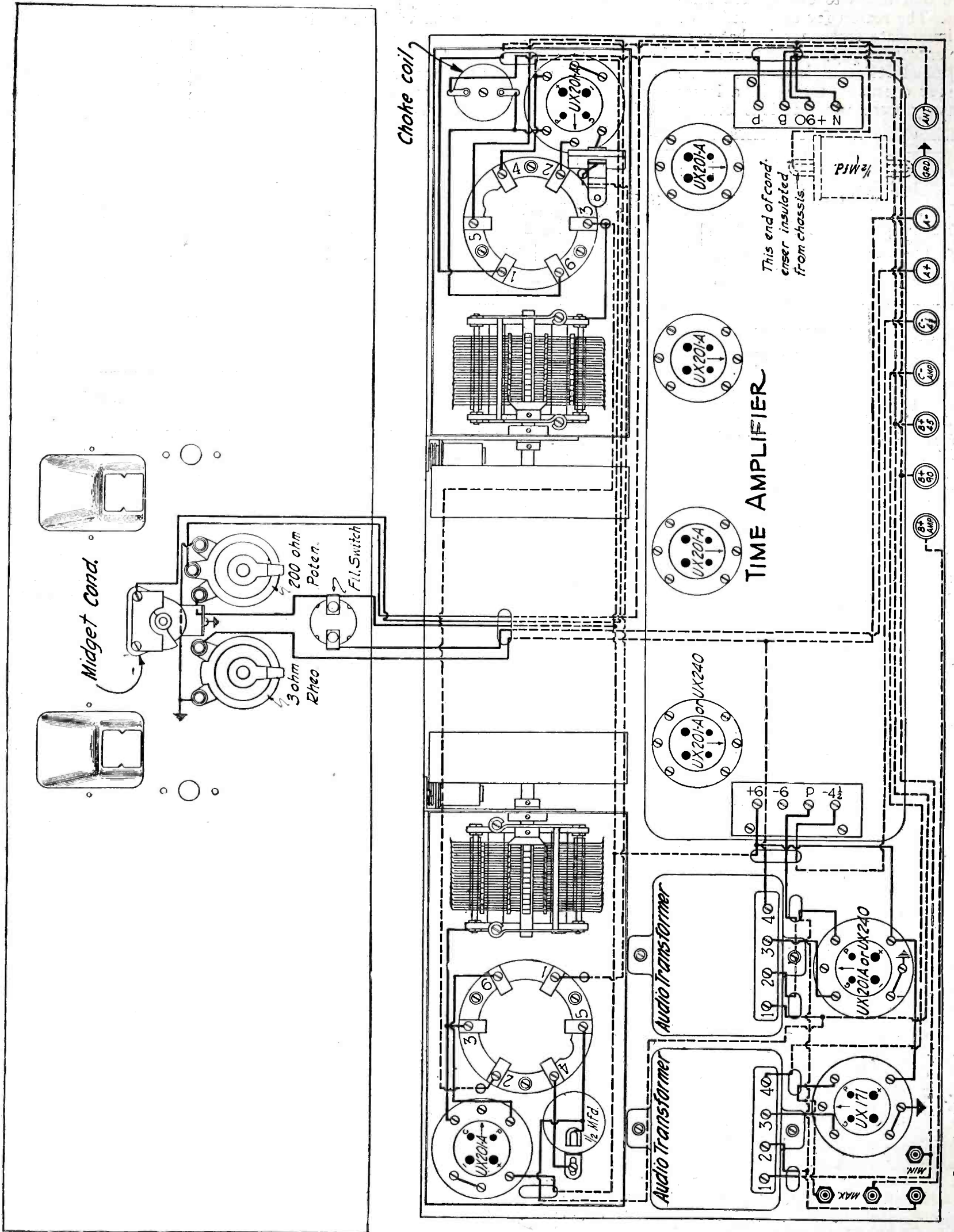

Layout wiring diagram of the Improved Laboratory Super-Heterodyne. All A—, Filament, and Circuit connections made through Metal Chassis, Long Wave Amplifier Shield, and Detector and Oscillator Shields, if latter are used. Oscillator and Detector Stage Shields need not be used, except in congested broadcasting centers. The Circuit may not be changed, practically, for Loop Operation. Small 20 to 60 feet single wire Indoor Antenna will give greater sensitivity and selectivity.

These figures are borne out in practice, for the Laboratory Set will out-perform all other eight tube sets against

tions only rarely heard, or not at all on other sets. Compared against two ten tube supers, it out-performed them

tive enough to cut thru to out-of-town stations within 10, and sometimes 5 or (Continued on page 122)



# The New Karas 2-Dial EQUAMATIC

By Jos. Calcaterra

JUST the other day, in going over some laboratory records of years gone by the writer was brought up with a start to find a number of records of distance reception, accomplished with one tube regenerative receivers. For instance, during the evening of election day, 1920 (or 1921—the records were not clear as to which of these two years) the log of a single tube, three coil honey-comb receiver, operated in New York City, shows reception of radio broadcast programs from St. Louis, Kansas City, Chicago and a number of other mid-western cities. This was not a remarkable record for those days—not by any means. But it is rather startling to realize that practically the same DX ability was demonstrated in those days

the broadcasting station, it is doubtful that the average present day receiver with its two stages of radio frequency amplification would bring in more distant stations than some of the old one tube receivers. But of course this is not all the story.

The one claim for the old one, two and three tube sets was sensitivity. They were quite lacking in selectivity—as we know selectivity today. They were likewise innocent of any semblance of good tone quality. They were an experimenter's plaything—and something to strike wonderment to the minds of the uninitiated. But had they continued in existence, radio would not be where it is today.

Fortunately these receivers have long since gone into the discard. In

But the comparatively greater sensitivity of the old time receivers provides considerable room for thought. An analysis of their differences from the present day receivers shows three outstanding differences, besides the difference in the number of tubes. The first is that they all employed regeneration and that this regeneration was always under the exact control of the operator. While many of the present day receivers employ regeneration in one form or another, it is either out of control or is so suppressed as to be useless.

Secondly, the old time receivers usually employed a tuned antenna circuit. This provided the maximum amount of "pick-up" of the signal energy. The

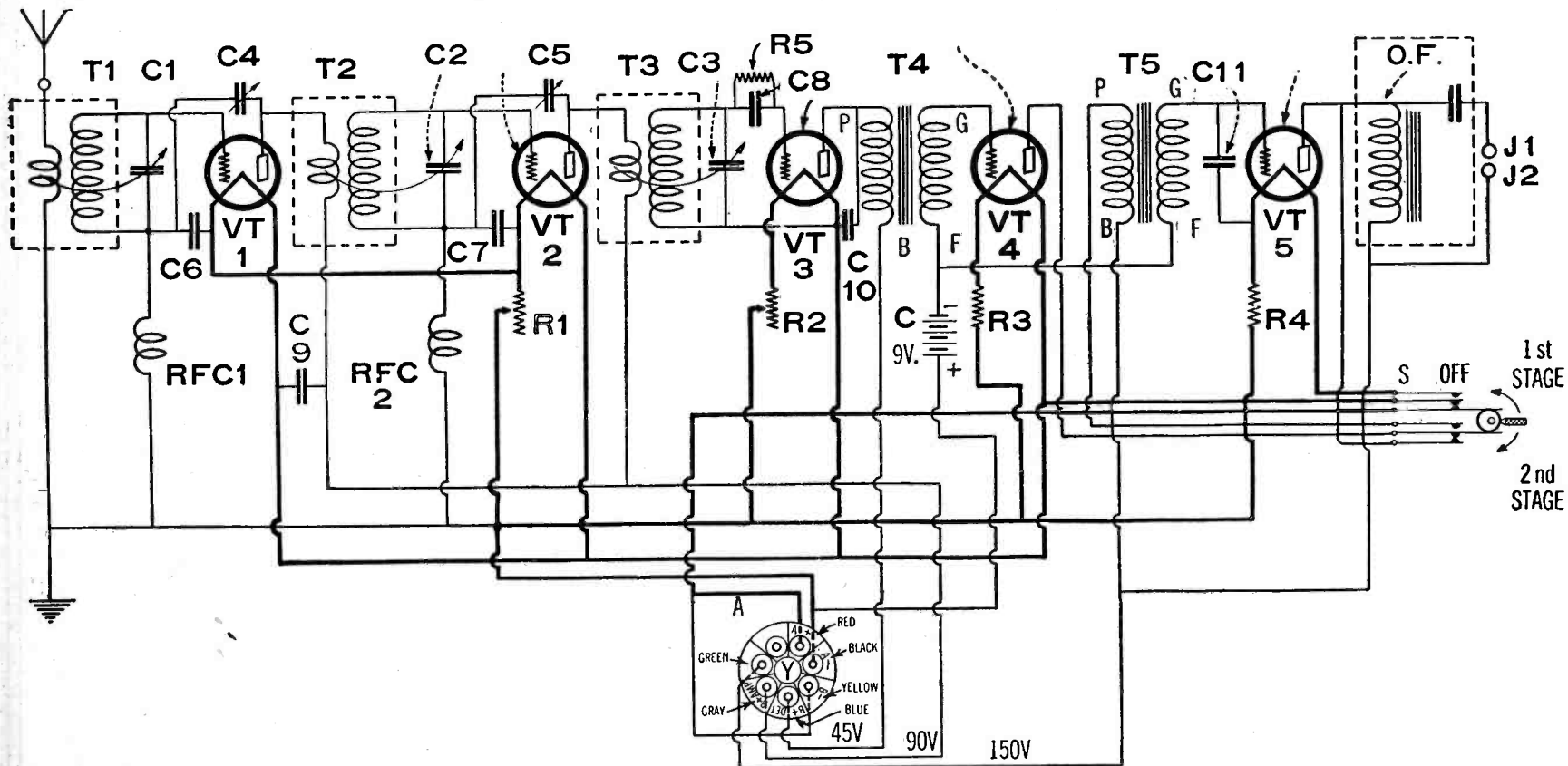

Schematic diagram of the New Karas Equamatic receiver.

with from one to three tubes and with no radio-frequency amplifiers, as is accomplished today with the average five and six tube receiver.

Greater distances can be covered today, of course, but on the other hand many of the broadcasting stations are using up to 40 times the power used in the old days. Given the same power at

their place we have receivers of adequate selectivity to cope with the abnormally large numbers of stations on the air today; receivers that are capable of reproducing fine music in a most life-like manner; receivers that are so simple in operation that a child can operate them at maximum efficiency.

necessity for simplifying the operation of present day receivers has made it necessary to eliminate this feature, thus eliminating one control.

The third reason for the superior sensitivity of the old timers was the variable coupling which was universally employed. Through this variable coupling the receivers could be oper-

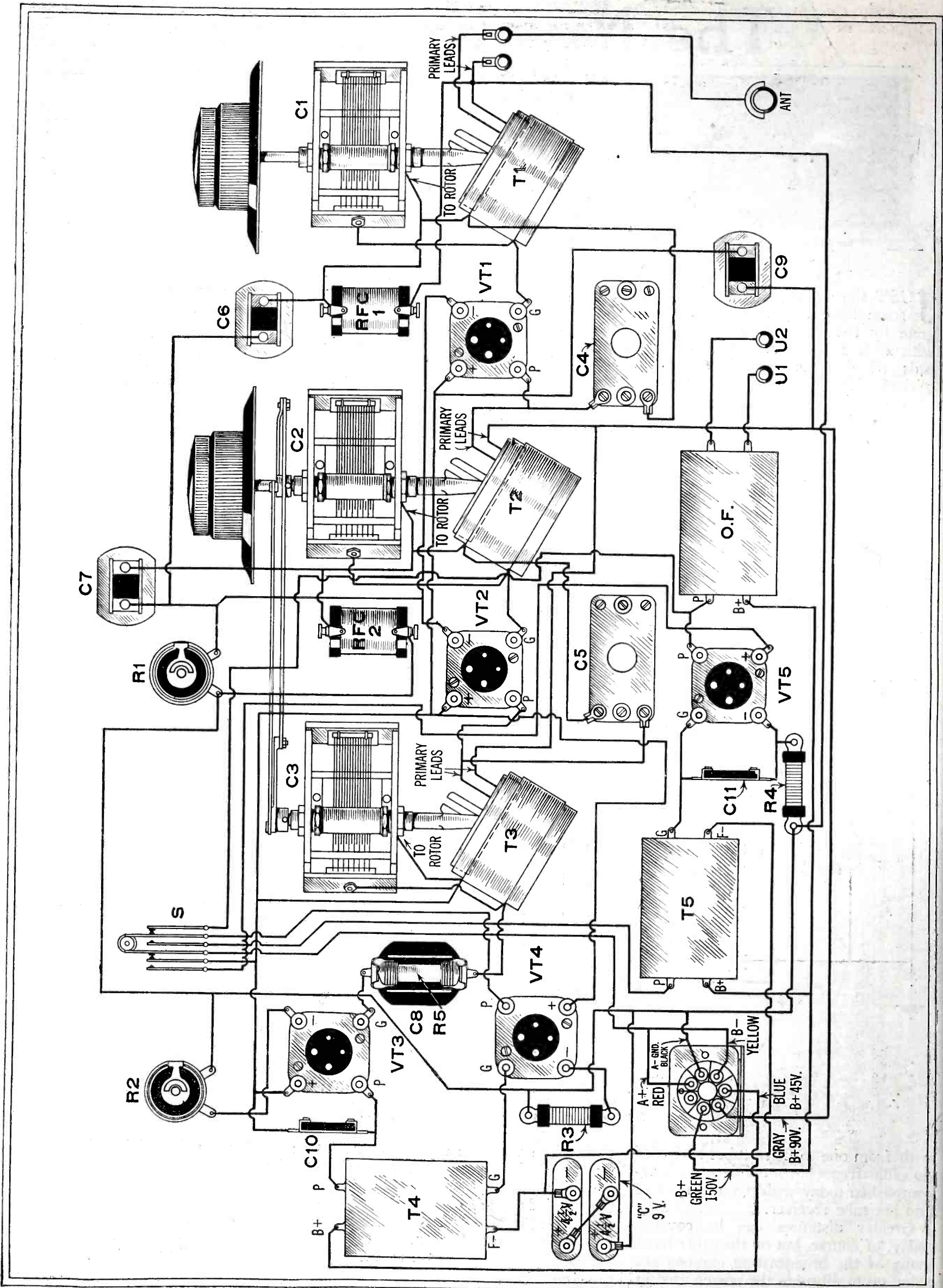

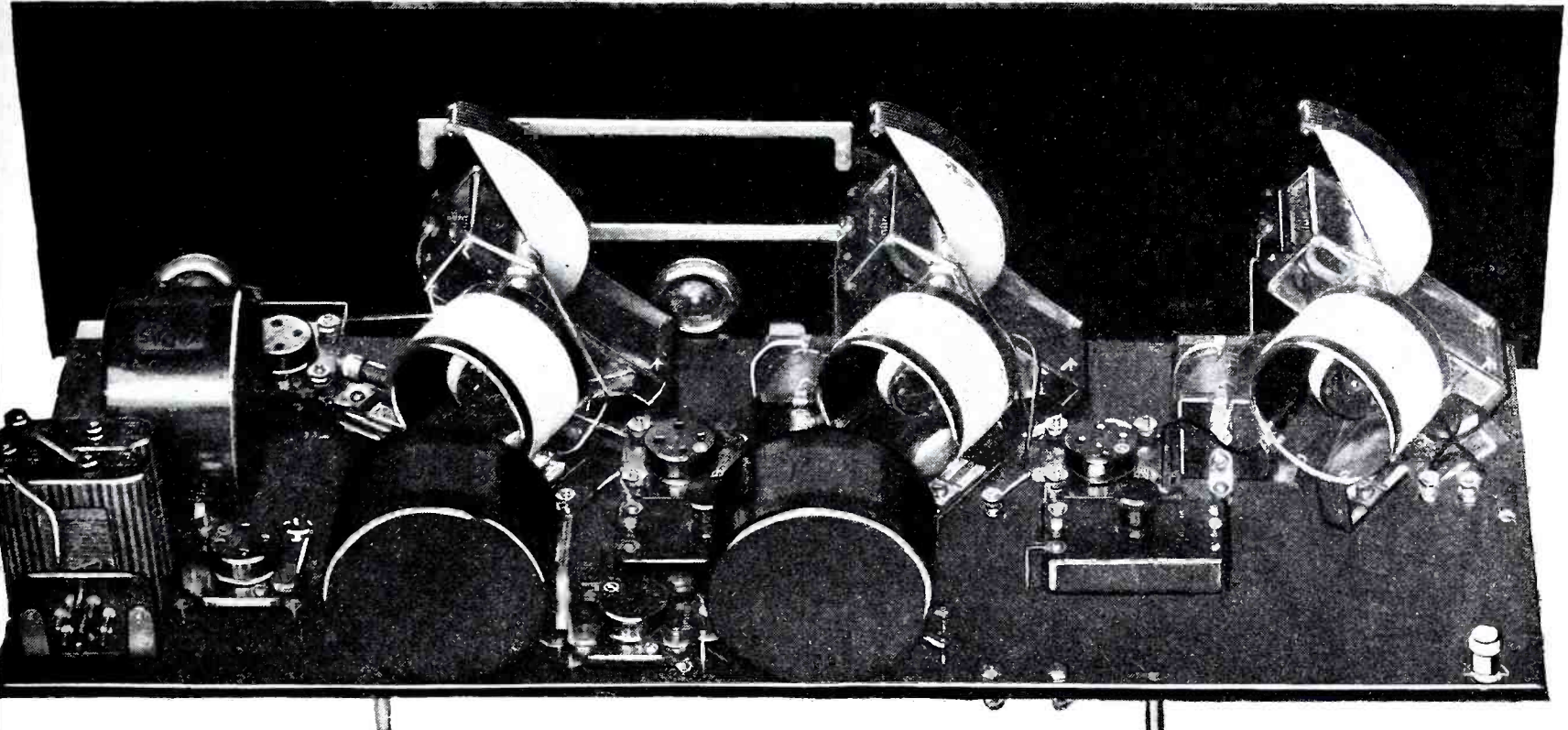

A rear view of the set showing how the parts are mounted on the sub-panel. The two round units in the foreground are the second audio frequency transformer and output filter choke (right) while that at the left behind the two "C" batteries is the first A.F. transformer.

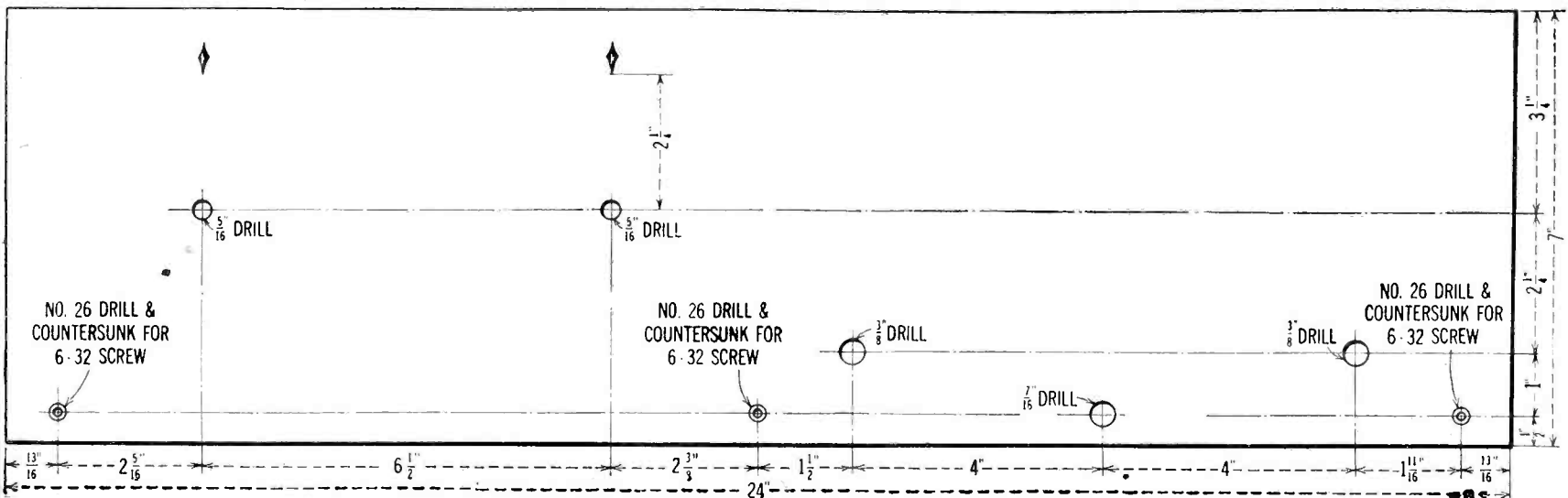

Dimensions for drilling the front panel. The shaft holes for the Equamatic radio frequency units are indicated at the left side.

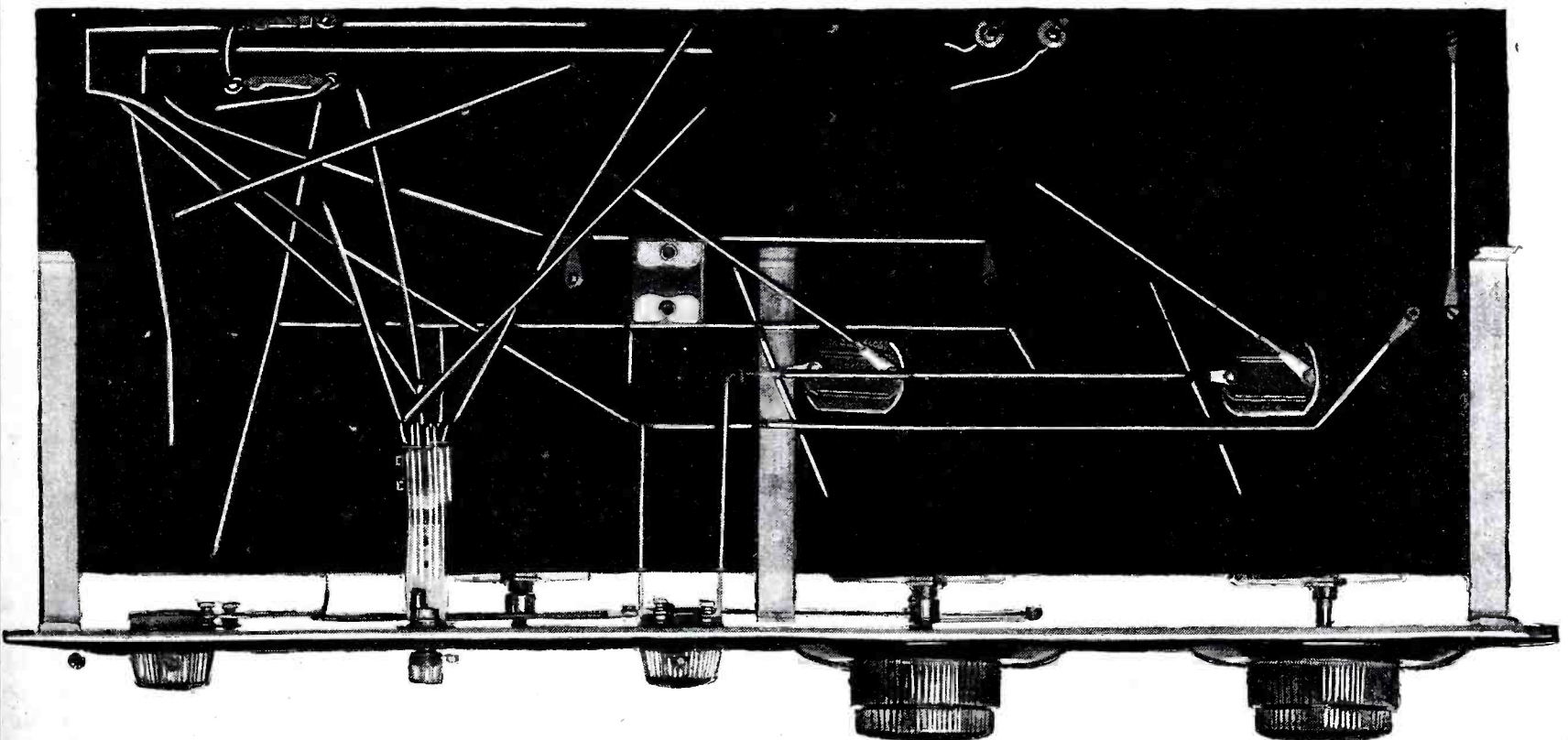

All wiring beneath the sub-panel is made directly from one terminal to another as seen in the photo immediately above.

ated at maximum efficiency at any wavelength within the broadcast band. Today variable coupling has been eliminated almost entirely and one of the results of this elimination is the uneven amplification obtained at different

to be provided to make the tube approach the oscillating point.

Of even greater significance today is the fact that there is far greater tendency for a multi-tube receiver to oscillate at some wavelengths than at others.

tion is greatest. That is, a certain amount of regeneration is usually obtainable but no actual oscillation. This provides good sensitivity and good selectivity at these wavelengths. But at the higher wavelengths the case is dif-

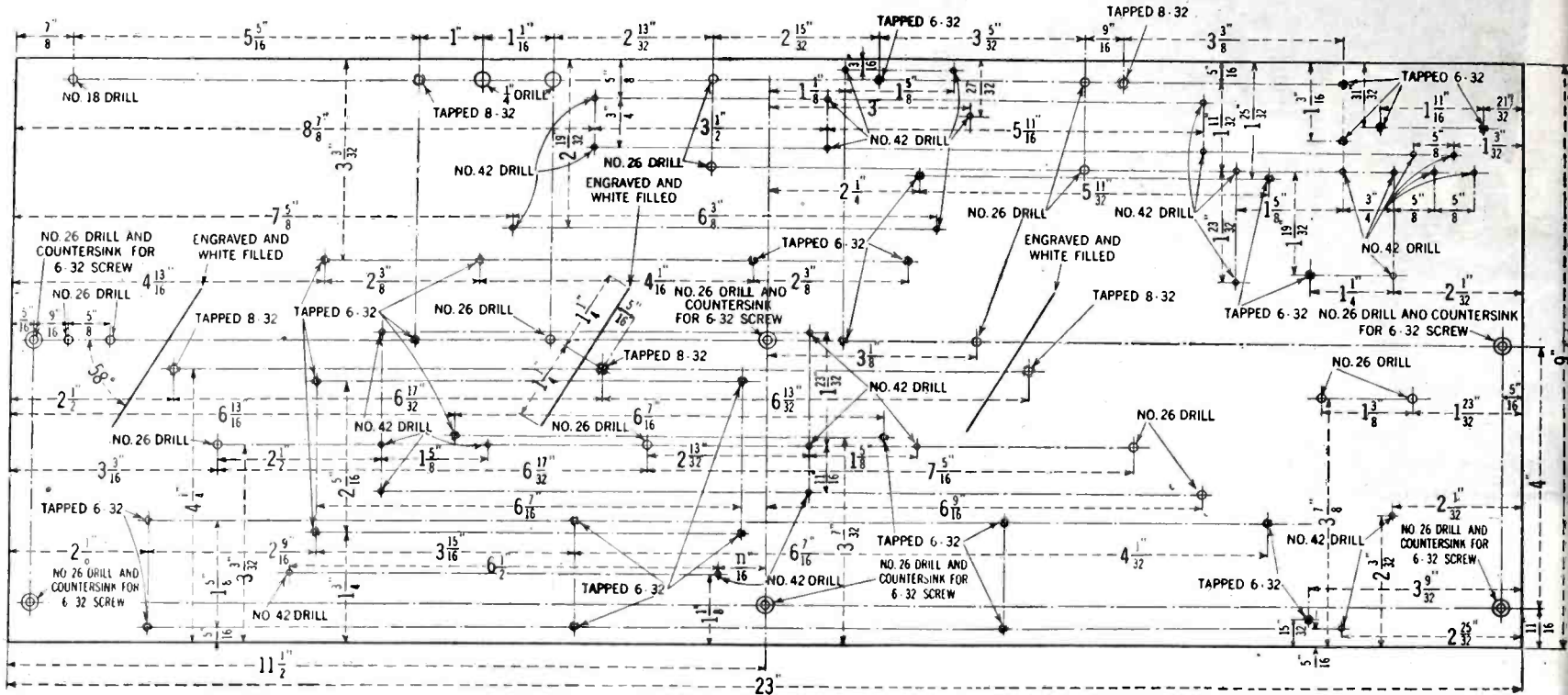

All dimensions for drilling holes in the sub-panel are given in the above layout.

wavelengths. With few exceptions the receivers of today provide an amplification of from three to ten times greater on some wavelengths than on others. One of the exceptions to this statement is the Karas Equamatic receiver, which is to provide the subject for this article.

Therefore a device to limit oscillation at one wave-length is not adequate for this purpose at some other wavelengths where the tendency to oscillate is greater. Or, if a device is included which will suppress oscillation at the wavelengths where the tendency for oscillation is greatest, then there will

be no regeneration at all and the low interstage coupling necessary to prevent oscillation at the lower wavelengths is not adequate for sufficient energy transfer at the higher wavelengths. The total result is that when tuned to the high wavelengths the receiver is much less efficient than at the lower waves.

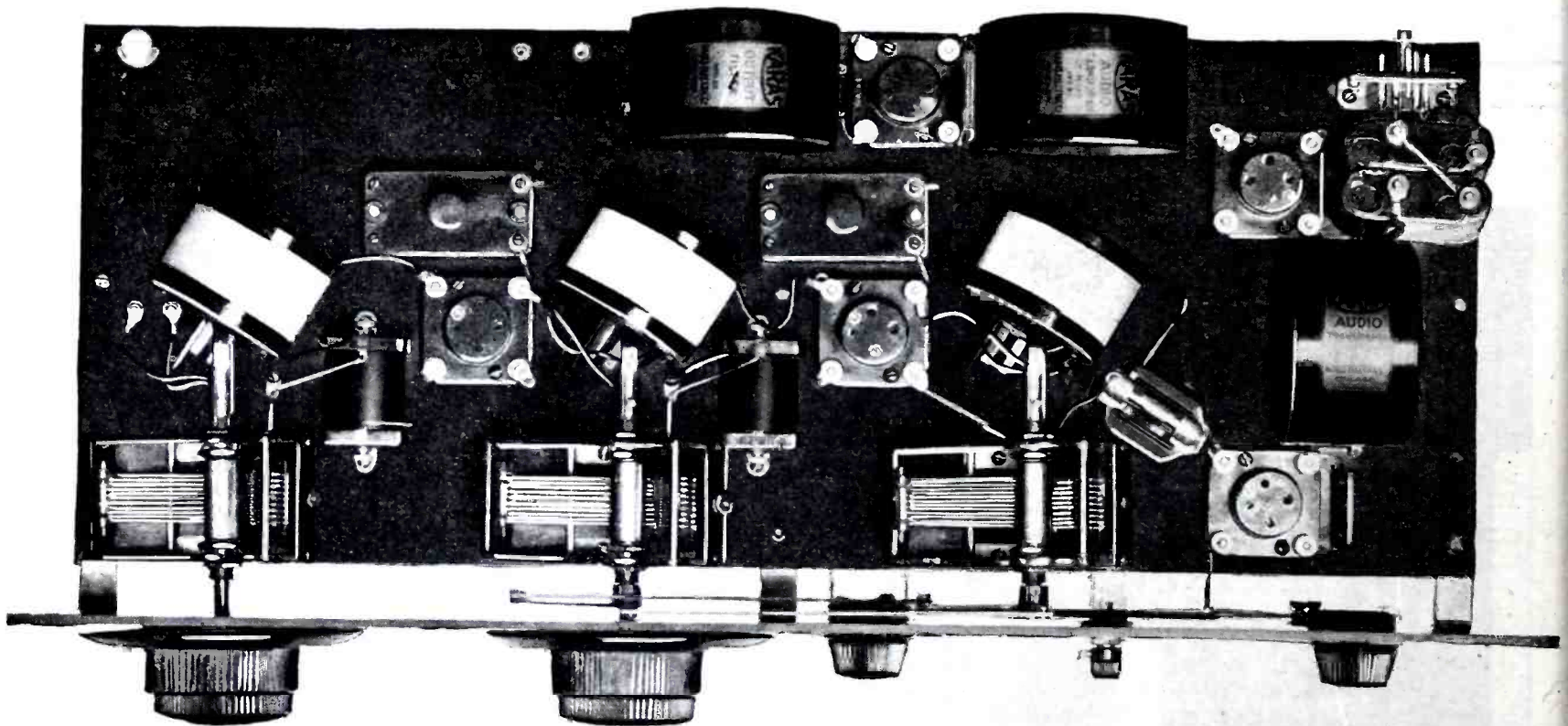

A top view of the Karas set looking down on the sub-panel.

In any receiver that employs one or more stages of radio frequency amplification it is essential that some precautions be taken to prevent oscillation, or over-regeneration. In the old regenerative detector circuit this was not necessary. As a matter of fact, means had

be no regeneration and also low efficiency at the wavelengths where the tendency for oscillation is least.

Coming down to cases, most receivers today are designed in such a way as to prevent oscillation at the lower wavelengths, where the tendency for oscilla-

If the coupling is such as to make the receiver efficient at the high wavelengths then it will be uncontrollable at the low wavelengths, or will be so close to the point of oscillation that the received signals will be distorted and

(Continued on page 151)

# Power Supply from the House Lighting Current



**T**HERE is probably no element of radio receiver operation that has caused more trouble, exasperation, faulty reception and annoyance than the sources of power to supply the electric current required to operate the receiver.

As a result, most of the effort expended in perfecting radio receivers has rightfully been devoted to developing some means of supplying power for radio receivers, that would eliminate charging and replacing of batteries with their consequent annoyances.

Most radio engineers realized that before the radio receiver could take its rightful place in the line of home necessities, it would have to be stripped of the technical phases that required the members of the family to know all about "A," "B" and "C" batteries; how to test the batteries; how to order the proper number and size of bat-

teries; how to charge storage batteries and how to disconnect and reconnect the batteries without running the dan-

ger of blowing out a perfectly good and expensive set of tubes or worse still causing a short circuit that might easily result in a fire.

The aim of radio engineers has been to reduce the power supply of the radio receiver to a matter as simple as plugging a vacuum cleaner plug into the electric light socket.

Various means for eliminating "B" batteries have been tried with very fine results, but simply eliminating the "B" battery is not enough. The only real solution of the problem lies in the use of a power unit which will supply all the power, "A," "B" and "C" for the receiver and will do so month after month and year after year without

rectifier and filter circuit capable of handling the current required for filament operation. The recent production of a rectifier tube capable of handling 400 milliamperes of full-wave rectified current has solved this last obstacle in the way of full light socket operation of radio receivers.

The Q. R. S. 400 milliampererectifier tube used for this purpose is a gaseous rectifier tube very similar to the usual lower current capacity rectifier tubes used for "B" eliminators.

The power unit itself is very easy to build. In fact, two hours is ample time to lay out the apparatus on a panel or baseboard and wire it up ready for operation.

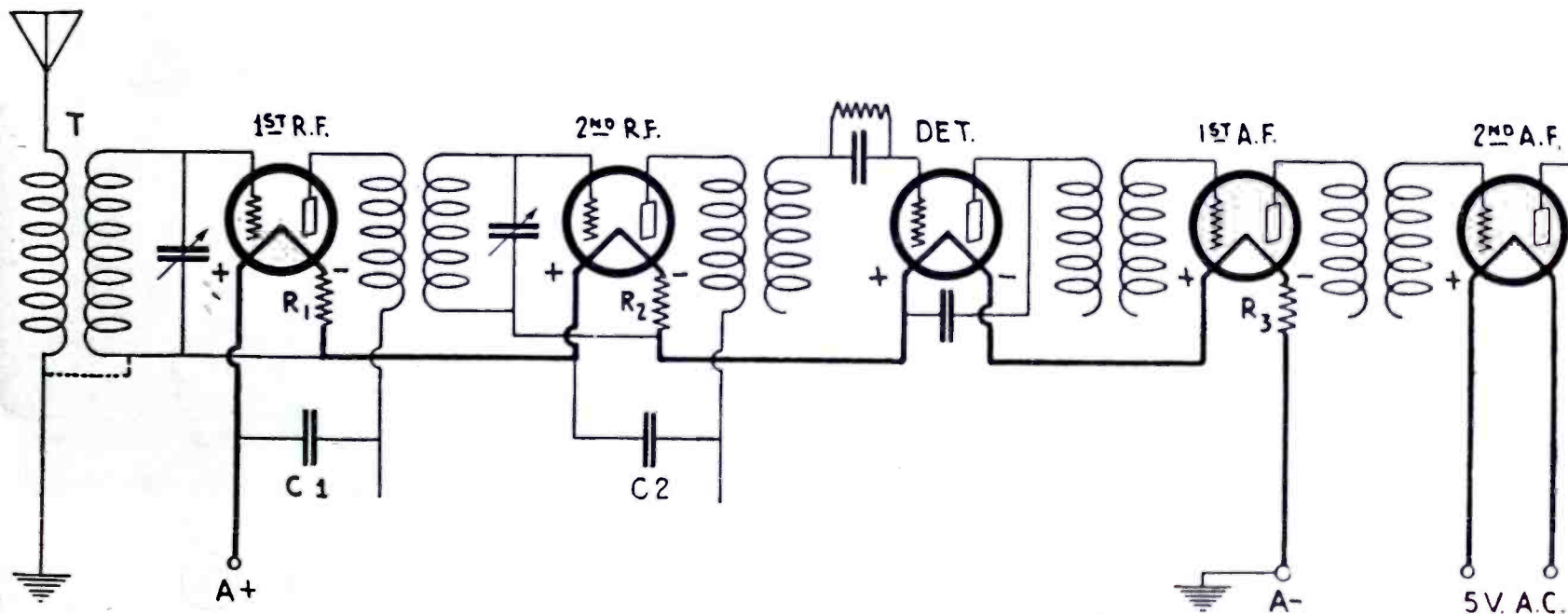

Fig. 1. A skeleton wiring diagram of a five tube set showing the series wiring of the filament circuit for use with the power supply unit described.

teries; how to charge storage batteries and how to disconnect and reconnect the batteries without running the dan-

constant servicing or replacements. The only obstacle to the building of such a unit has been the lack of a

To avoid any possibility of this unit being used directly with an unsuitable receiver, it is well to mention that to

use this type of power unit, the filaments of the receiver must be connected in series instead of in parallel as is common practice when using a storage battery as the source of supply for "A" current.

Changing the connections of a receiver which has already been built is a rather simple procedure. The wiring diagram shown in Fig. 1 shows a skeleton wiring diagram of the essential connections affected by a series connection of the filaments. It is important to bear in mind that the antenna circuit can be connected in the manner shown only when there is no connection between the primary and secondary circuits of transformer "T" of Fig. 1 which couples the antenna and grid circuit together. If there is a connection between the primary and

to the negative side for the 200A type tubes.

No matter what type of set you are using or plan to build, the filaments can be wired in series. A few changes made in the grid returns as shown in

to give the radio frequency tubes a negative grid bias of one volt each. A similar resistance of 20 to 24 ohms is inserted in the filament circuit of the first audio frequency tube to give the first audio tube a negative C bias of

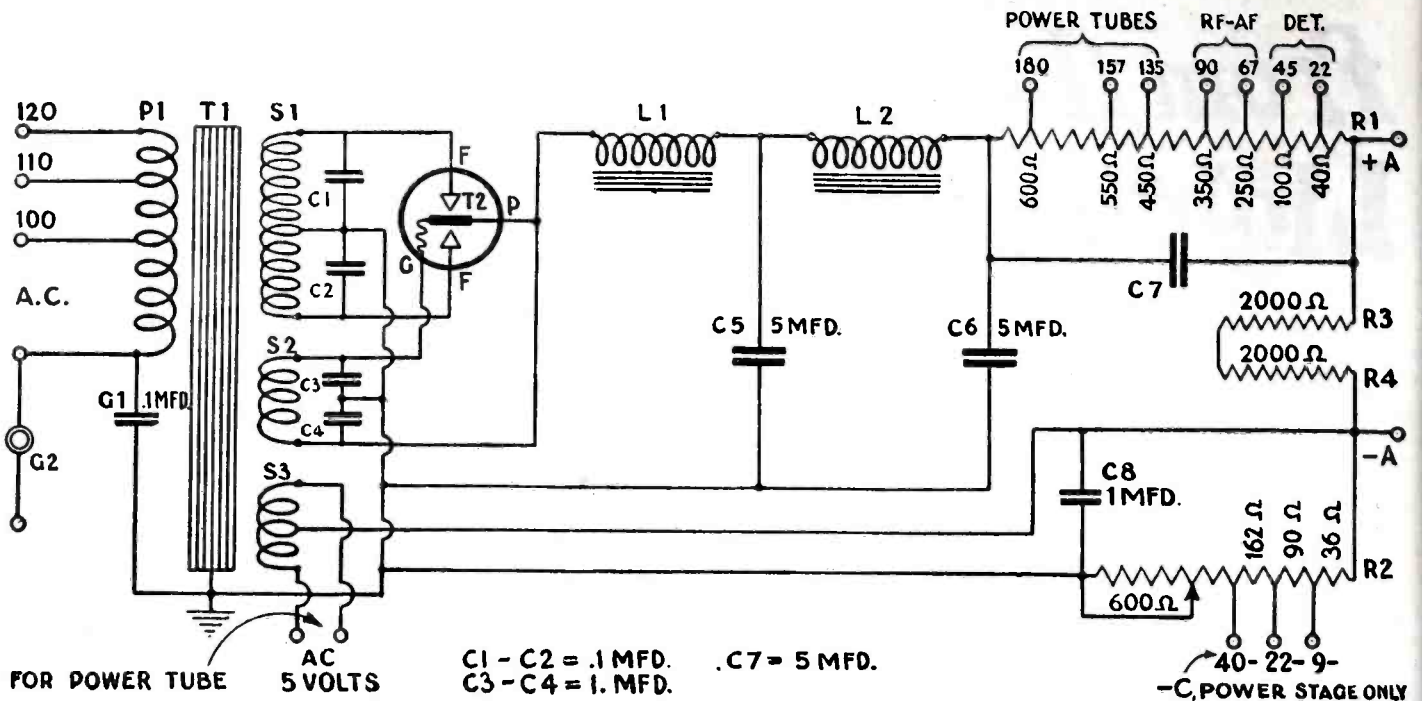

Fig. 2. Schematic diagram of the Q. R. S. power unit.

the diagram and a check up of the antenna coupling transformer is all that is necessary to change over from a battery to a light socket operated set.

The series wired set possesses more tone and stability than the battery operated set due both to the series connection of the filaments which gives a steady voltage across the tube filaments and the fact that the grids of the tubes are properly biased.

A four ohm fixed resistance is

approximately four and a half volts.

In the wiring diagram, the last audio tube is shown operated from five volts alternating current with the proper C bias coming from resistances in the power unit. This is optional, for the regular 201A type tube may be used in this stage wired in series with the other tubes and with a 24 ohm fixed resistance in series with the filament wiring to give a C bias voltage for the grid. In the diagram the filament ter-

**PARTS FOR THE UNIT**

- 1 Thordarson Transformer, type T-2291, (T1)
- 2 Fast 250 v. condensers 1.0 mfd. (G1, C8)
- 4 Fast filter condensers, 600 volts D.C. working voltage, (C1, C2) .1 mfd. each and (C3, C4) 1. mfd. each
- 1 Q.R.S. 400 Mill Rectifier tube, (T2)
- 2 Thordarson Choke Coils, type T-2029, 3 to 5 Henries at 300 mills and D.C. resistance 100 ohms maximum, (L1 and L2)
- 1 Electric lamp socket and one 3 ampere fuse (G2)
- 2 Carter Voltage control resistance units, 600 ohms each, (R1 and R2) and two 2000 ohm resistors (R3, R4)
- 3 Fast filter condensers, 400 volts D.C. working voltage, 5 mfd. each, (C5, C6 and C7)
- 5 Eby binding posts
- 1 Wooden baseboard 15 x 30 inches
- Six feet of electric lamp-cord, socket plug, Acme Celastic hook-up wire.

secondary winding of this transformer as shown by the dotted line, no ground connection is necessary to the antenna coil. The ground connection to the "A—" binding post as shown will provide all the ground connection required. Connecting two grounds to the set in that case would result in a short circuit of the power unit.

The placing of the proper fixed bypass condensers and the grid returns of the radio frequency tubes are shown. The grid return in the detector stage will depend on the type of detector tube used, being on the positive side for the 201A type tube and

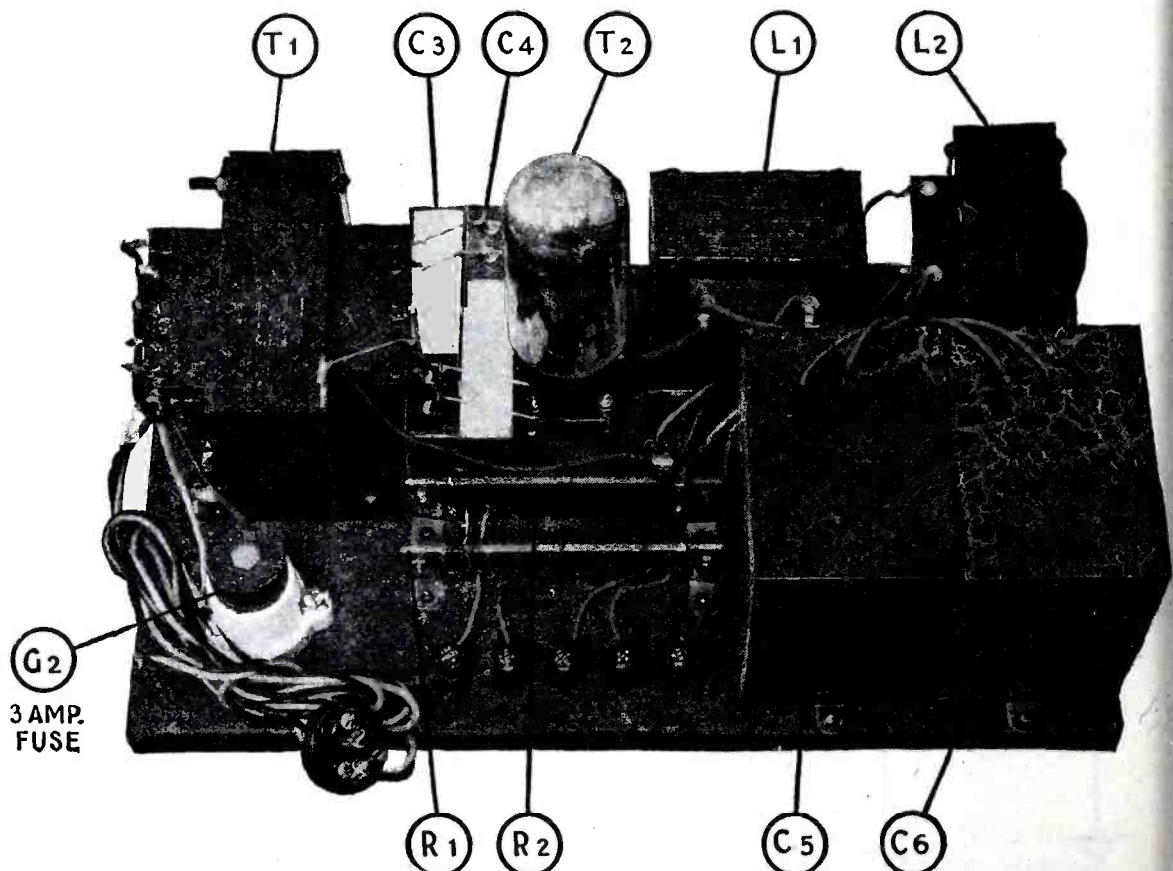

Fig. 3. A photographic view of the parts mounted on baseboard. Components are marked to correspond with wiring diagram Fig. 2.

placed in the filament lead to each of the two radio frequency tubes. This furnishes a one-volt drop that is used

minerals are marked positive and negative according to the marking on the sockets  
(Continued on page 164)

# The "UNIPAC" Power Amplifier and A.B.C. Supply

TODAY, every radio fan realizes that to obtain the finest possible quality of reproduction, not only must his whole receiver be most carefully designed, with particular attention paid to the audio amplifier, but the later must include a high power output tube operated upon four hundred volts or more if good, undistorted reproduction at normal home volumes is to be anticipated. The incorporation of such a powerful output stage in a radio set is both impractical and unsafe—hence the development of the power-pack—a stage of power amplification and receiver B supply combined, the amplifier drawing its power direct from any A. C. light socket.

The unit to be described is an unusually powerful device, and of very wide application, since operated from the light socket, it will provide a stage of practically distortionless power amplification for any radio receiver, B power for any standard set, A, B, and C power for any receiver employing A. C. tubes, or it will, without alteration, serve in conjunction with a magnetic record pick-up and a loud speaker, to convert any phonograph at all into the latest type of electrical reproducing instrument. The universal nature of its uses justifies the term "Unipac" and its many advantages, together with construction and operating details will be described. The Unipac consists of a stage of power amplification, and an ABC power plant in a single metal cabinet. The amplifier consists of a very high grade input transformer feeding a CX310 power amplifier tube, together with an output transformer to prevent damage to a loud speaker due to the high plate current involved. This stage may be joined to a radio receiver as a final high power output stage. For phonograph use, a CX326 amplifier tube is used, connected between the record pick-up and the input transformer primary, thus providing two amplifier tubes in all, the pair serving to develop ample volume for dancing in a small auditorium, or even outdoors, so great is the amplification and undistorted power output.

Power for the operation of the amplifier tubes is obtained from two power transformers which feed raw A.C. direct to the filaments, and which also provide the high voltage necessary for the two CX 316B rectifier tubes, the output of which, properly filtered, is used for plate and grid voltages. A portion of the rectifier output is taken through a voltage dividing resistor, to be used for the B (and C) circuit of any standard receiver. In order to provide constant unfluctuating power to a radio receiver B circuit, a voltage regulator tube is used.

- PARTS REQUIRED  
FOR THE UNIPAC**

  - 2—S-M 330A power transformers
  - 1—S-M 331 Unichoke
  - 1—S-M 220 audio transformer
  - 1—S-M 221 output transformer
  - 5—S-M 511 tube sockets
  - 1—Ward-Leonard 16,500-ohm resistor
  - 2—Frost FT64 resistors
  - 4—Frost 253 tipjacks
  - 1—Frost 953 jack
  - 3—Eby posts (Neg., +45, +90)
  - 1—Van Doorn chassis & cabinet (hdwe. included)
  - 1—Tobe 662 condenser block
  - 25 ft.—Kellogg hook-up wire

**Tubes Needed**

  - 2—CX 316B rectifiers
  - 1—CX310 amplifier
  - 1—CX374 regulator
  - 1—CX326 AC amplifier

The power transformers each have an extra 1.5 volt winding, one winding of one transformer being used to light the CX326 input amplifier tube filament. This, as well as the other winding, may be used to light the CX326 tubes of a receiver, while both windings also connected in series will serve to light a CX327 detector tube.

The need for a power amplifier output stage in conjunction with any re-



ceiver is today generally recognized, for it is now known that none of the smaller receiving amplifier tubes such as the 201A, 112, or even 171 type can possibly deliver, without distortion, the power necessary for home entertainment at ordinary volumes. The maximum undistorted power output of a 201A tube is 55 milliwatts; of a 112, 195 milliwatts; and of a 171 tube, 700 milliwatts. The absolute inadequacy of any and all of the low power amplifier tubes for last audio stage operation is painfully evident when it is realized that from 1,000 to 1500 milliwatts of undistorted power are required at the low frequencies simply for adequate home entertainment volume. In fact, the only tube at present available that, for second or last stage audio operation, will give the 1,000 to 1,500 milliwatts of undistorted power output necessary is the 210 type. In the Unipac a 210 amplifier is employed, with an undistorted power output of from 1500 to 1700 milliwatts—more than can be delivered by any other of the popular "210 power packs." The input and output transformers feeding this tube are the well-known Silver-Marshall 220 and 221 audio and output transformers, which give a rising amplification curve, so that the amplifiers deliver greatest power to a loud speaker such as the Western Electric cone, at 30 cycles. This is desirable since the efficiency of all speakers falls off at low frequencies, and the Unipac am-

plifier thus tends to compensate for this failing. Above 5,000 cycles, the amplifier rapidly "cuts off," or ceases to amplify. This valuable and exclusive feature means that with the Unipac, receiver selectivity will actually be increased in that ordinary high frequency "hiss" or background noise, as well as the all too prevalent heterodyne whistles of present-day reception, will be almost entirely eliminated.

receiver audio amplifier and ABC power supply.

Despite the popular conception, the use of a 210 power output tube does not do away with distortion—far from it. The superiority and excellent qualities of the 210 only appear at plate voltages above 400—operated at 300 volts or less, the 210 is actually inferior to a 171 from an undistorted power output angle. Ordinarily, a 210

For this reason the Unipac employs not one, but two 216B rectifier tubes, the actual working voltage of which is from 425 to 450 volts, with receiver and input tube current drains considered. Of course, a new type 281 rectifier tube could be used, and one would give the same output voltage as two 216B's, and need but one power transformer. It must be remembered, though, that the filtration of a single-

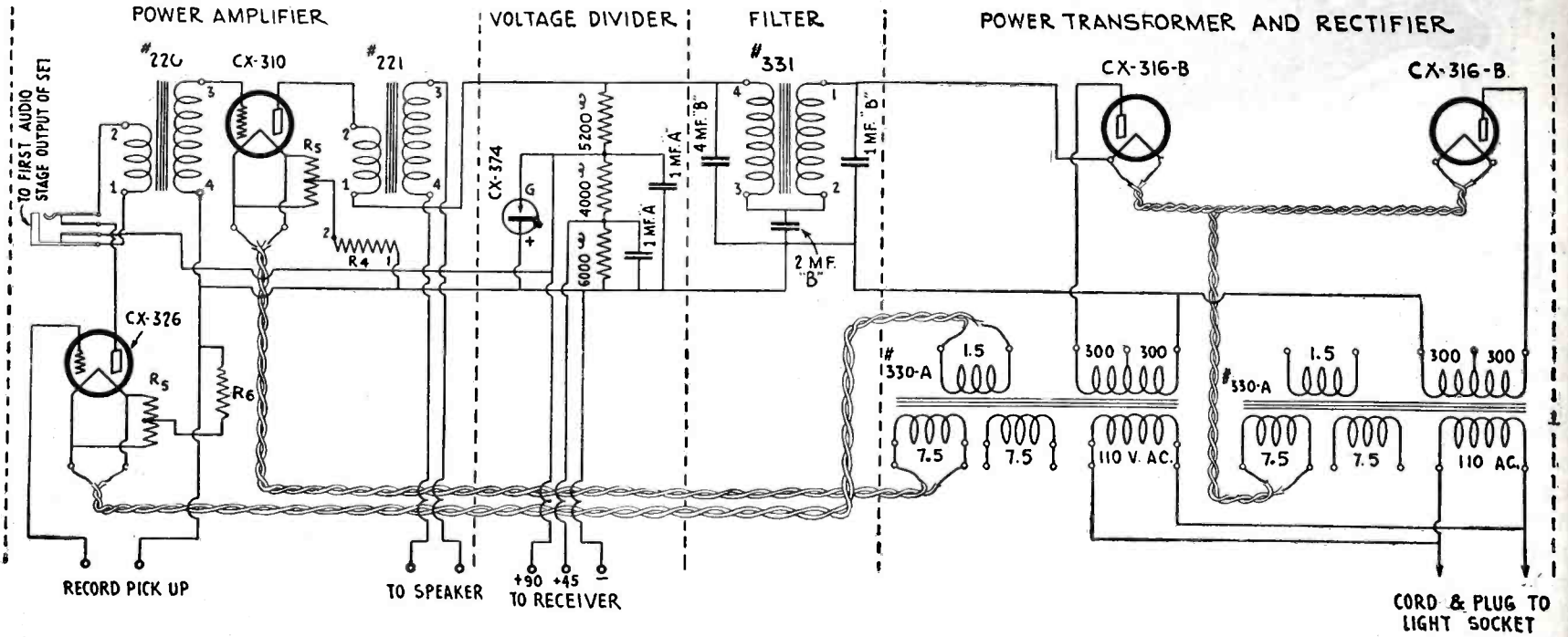

Wiring diagram of the Unipac. All terminal markings are clearly indicated as they actually appear on the apparatus. The completed unit used with a phonograph pick-up device is shown in the photo heading of this article.

The power stage is connected directly to the first stage output of a radio set, but in cases where the receiver has no audio amplifier, or one so old as to be discarded because of distortion introduced, the extra 326 input tube in the Unipac may be used as a first stage amplifier by simply joining the detector

power pack employs but a single 216B rectifier tube, the actual output voltage of which is supposed to be 400 or more. This voltage is obtained when the 216B is used *only* to supply B and C voltage to the 210 tube alone. As soon as receiver B current is drawn from it, or the extra current necessary

wave rectifier is always poorer than that of a two-wave rectifier. Thus, the residual hum of a power pack employing only one rectifier tube, be it 216B or 281, is quite pronounced, and often objectionable. In the Unipac, employing two 216B tubes, there is practically no loud speaker hum at all.

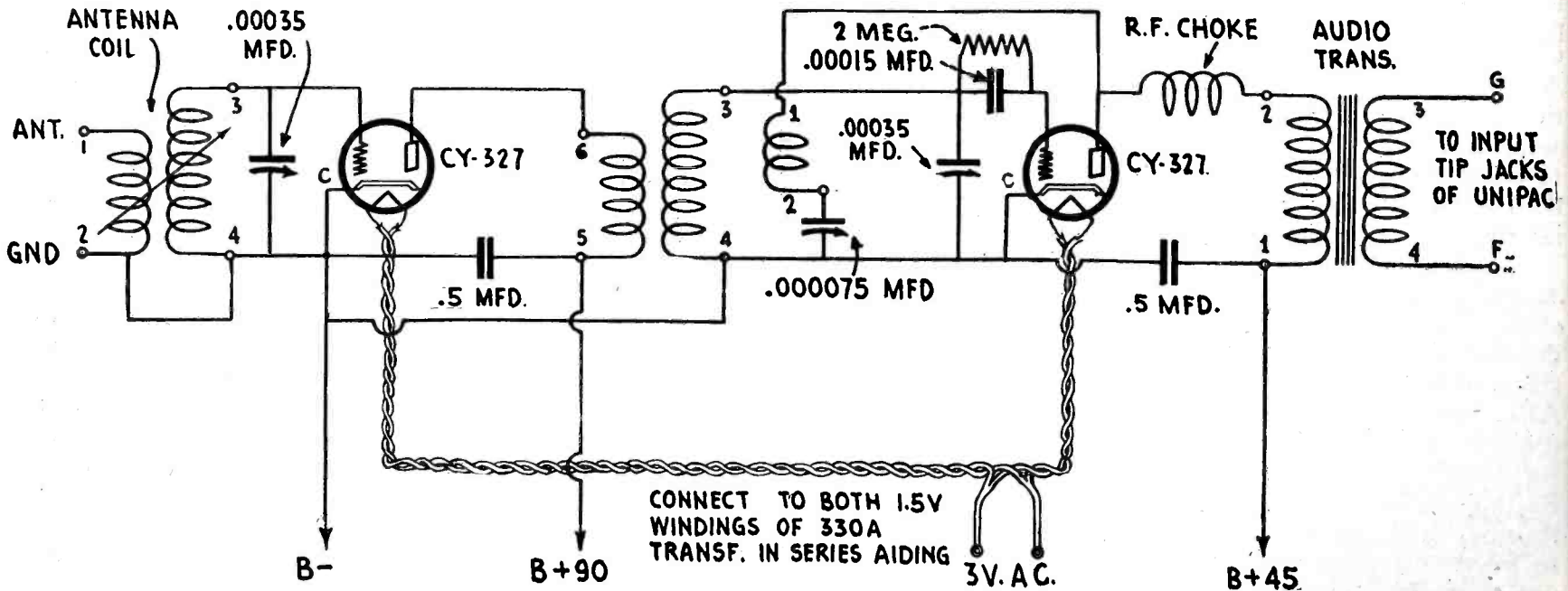

Circuit diagram of a modified Browning-Drake set wired for use in connection with the Unipac power amplifier and A. B. C. supply unit. This receiver can be built as the constructor's fancy suits.

output to the Unipac input through the medium of a good audio transformer or a resistor coupled unit. Ordinarily, this 326 input tube serves to amplify the output of a magnetic phonograph record pick-up up to the value needed to be impressed on the 210 power stage. but, used as a first stage audio tube as well, the Unipac becomes a complete

for a glow tube, or a phonograph input tube, the output falls to 300, 250, or even 200 volts in some popular power packs. Obviously, a 210 power pack using but one 216B rectifier does not take full advantage of the 210's possibilities, and a good 171 pack would give as good results much more cheaply.

Two values of receiver B voltage are available from the Unipac—45 volts at up to 10 milliamperes, and 90 volts at up to 45 milliamperes. Both voltages are constant under varying current drains as a result of the use of a 374 voltage regulator tube. There is absolutely no tendency to motorboating or  
(Continued on page 162)



# A COMPACT A-B-C POWER UNIT

by PERRY S. GRAFFAM

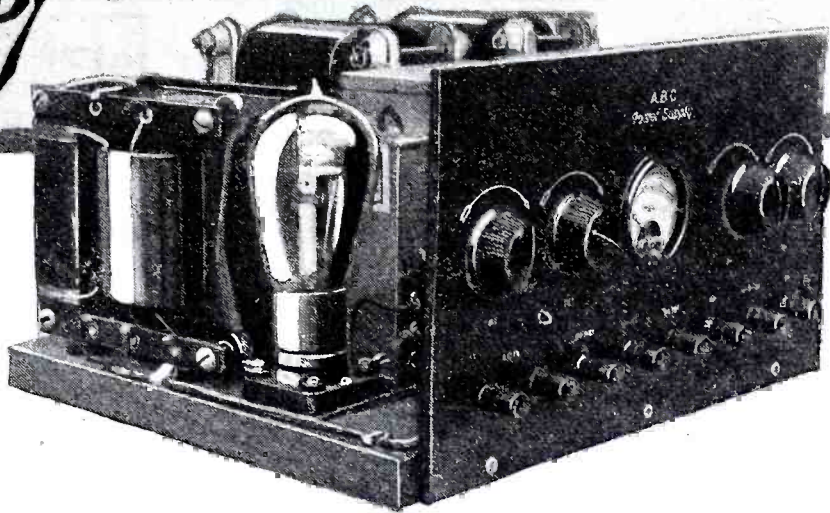

TO operate any radio receiving set direct from the house lighting circuit is the aim of manufacturers. Several nationally known sets are now so arranged. In fact the present season has seen several such arrangements whereby very satisfactory results were attained with the use of 199 type tubes in series.

To use 201-A type tubes is however what the radio public most desires, and with this thought in mind the various manufacturers have been working the past few months on such type of apparatus.

To develop a rectifier of sufficient capacity to carry the current necessary also necessitates the development of a heavy duty filter system together with its heavy duty resistance controls.

The Raytheon B A 350 milliamperere tube will rectify enough current to operate 3, 5, 7 or even more, if necessary, 201-A type tubes. The "A-B-C" outfit to be described employs this tube. The only difference in this unit and others previously described for the 199 type tube is that all the parts used must be of a heavy duty type to properly rectify and filter 300 milliamperes of current.

A brief description of these parts will be given.

The transformer used in this unit has a 110 volt primary winding with a heavy duty four ohm resistance in series. This is important to maintain a constant voltage and is essential for the best operation of the completed unit. This resistor also prevents the transformers from drawing an excessive current from the 110 volt line when the unit is turned on and it acts as a protective device to the other parts of the unit in case of a short circuit or a momentary flash-over of the tube. The secondary winding has a step up to 760 volts with a mid-tap. An additional secondary winding of 5.6 volts is provided for lighting the filament of the power tube. A.C. current is necessary for this tube as its current drain is  $\frac{1}{2}$  ampere. This is not a disadvantage as superior results will thus be obtained.

The filter system consists of two chokes and two special Tobe "A-B-C" condenser blocks. The choke coils have an inductance of over 10 henries at 300 milliamperes DC and a DC re-

controls which are the Universal Range Clarostats as used in "B" eliminator power units.

A Jewell No. 135 zero to three hundred milliamperere meter control is placed in the unit or in the set itself as it is very necessary that the

adjustments of the filaments be kept at 250 milliamperes. The meter should be placed in the A plus lead, as the load of the set will not be over 40 milliamperes and as that together with the filament load will be under the rating of the tube it is not necessary except to observe the load of the tubes.

By referring to the accompanying drawings it will be seen that all the various parts are clearly shown and no particular detail description is necessary as to connections.

The parts are mounted on a sub-base 11"x13"x $\frac{3}{4}$ ". The transformer and chokes on account of their weight should be bolted to the base. The other parts may be fastened with wood screws. The arrangement as shown permits an ideal arrangement and ease of wiring. The wire should be copper tinned of 14 or 16 gauge and should have a good insulation; flexible wire is preferred. All joints should be carefully soldered and any excess flux should be removed.

The leads from the AC filament winding of the transformer to the binding posts should be twisted together or run in Belden's flexible copper tubing and when so used the tubing should be grounded to the transformer frame. The transformer chokes and condensers should be wired first, and the panel with its various controls wired separately and then all that remains is to connect the two with 5 short jumper wires.

As it is necessary that the filaments be connected in series a brief description of series filaments and proper grid biasing will be given.

Any set can be converted with these two principles in mind; first the manner in which grid bias is to be obtained and second, the proper order in which the tubes shall be arranged in sequence. The best results can per-

## LIST OF PARTS REQUIRED

- 1 Raytheon BA Tube (T)
- 1 Acme BA1 Transformer (TF)
- 2 Acme BA 2 Chokes (H, H-1)
- 1 Tobe A-B-C Block Unit (C-1)
- 1 Tobe A-B-C Block Unit (C-2)
- 1 Tobe condenser block, two 0.1 m.f. (C)
- 2 Universal Range Clarostats (R-4, R-5)
- 1 Universal Range Power Clarostat (R-2)
- 1 Centralab 150 ohm potentiometer (R)
- 1 Amsco 800 ohm 40 watt resistor (R-3)
- 1 Tobe Veritas 10000 ohm 10 watt resistor (R-1)
- 1 Jewell N. 135 0 to 300 milliamperere meter
- 1 Benjamin tube socket
- 8 Eby or X-L Lab. Binding Posts
- 1 Formica panel 10" x 7"
- 1 Wood sub-base 11" x 13" x  $\frac{3}{4}$ "  
Stained, shellacked and dipped in hot paraffin if possible.
- Necessary screws, Acme Celatsite hook-up wire and Kester radio solder.

sistance of 352 ohms for the two, which is a medium resistance and which will safely pass the current necessary.

The condensers are made especially for this unit and are the heavy voltage type. For the home constructor, special care should be given in substituting resistances for others than those used in the unit described. The author has worked many days finding resistors of proper value and capable of handling the current without overheating. The ones used are satisfactory and are of a heavy duty type with the exception of the B plus detector and B plus Int.

haps be obtained by removing all the present wiring from the two filament posts of the sockets. Omit the switch as this is no longer required, it being

nected, one rheostat should be removed entirely and a 400 ohm potentiometer or 0-5,000,000 ohm Clarostat substituted in its place, the use of which will

should go directly to the detector socket. After that may come the first a.f. and second a.f. in resistance or impedance coupled, otherwise to be fol-

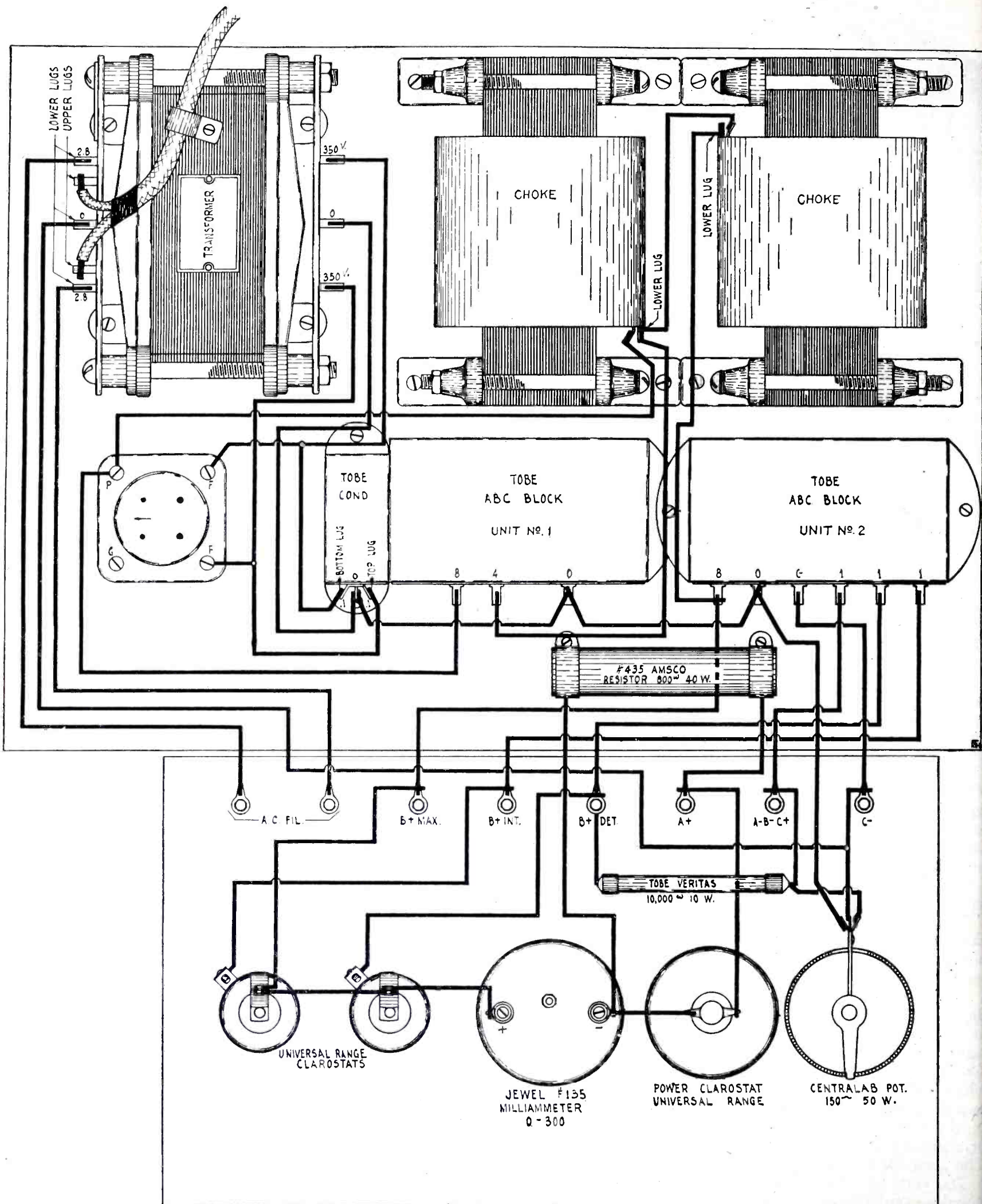

Picture wiring diagram of the compact A-B-C Power Unit. This diagram also shows the arrangement of parts on the panel and baseboard.

necessary to shut off the power supply unit at the house supply end. All ballasts or rheostats should be discon-

be described herein. The order in which the tubes are arranged is as follows: The minus B or ground point

lowed by the radio frequency stages until the chain has been completed. The last Audio tube which will of

course use a 1/2 ampere filament should be run in twisted paired wire to two additional binding posts.

The method of obtaining grid bias is to place resistance in series with

rheostats and then adjusted to any required value. Another satisfactory method is to get the proper grid bias from the tubes themselves. As each tube has 5 volts drop in voltage, plac-

pearance in a set when so arranged.

Each socket filament should be bypassed with a 1 m.f. condenser with the The control of the volume is very de-exception of the power tube socket.

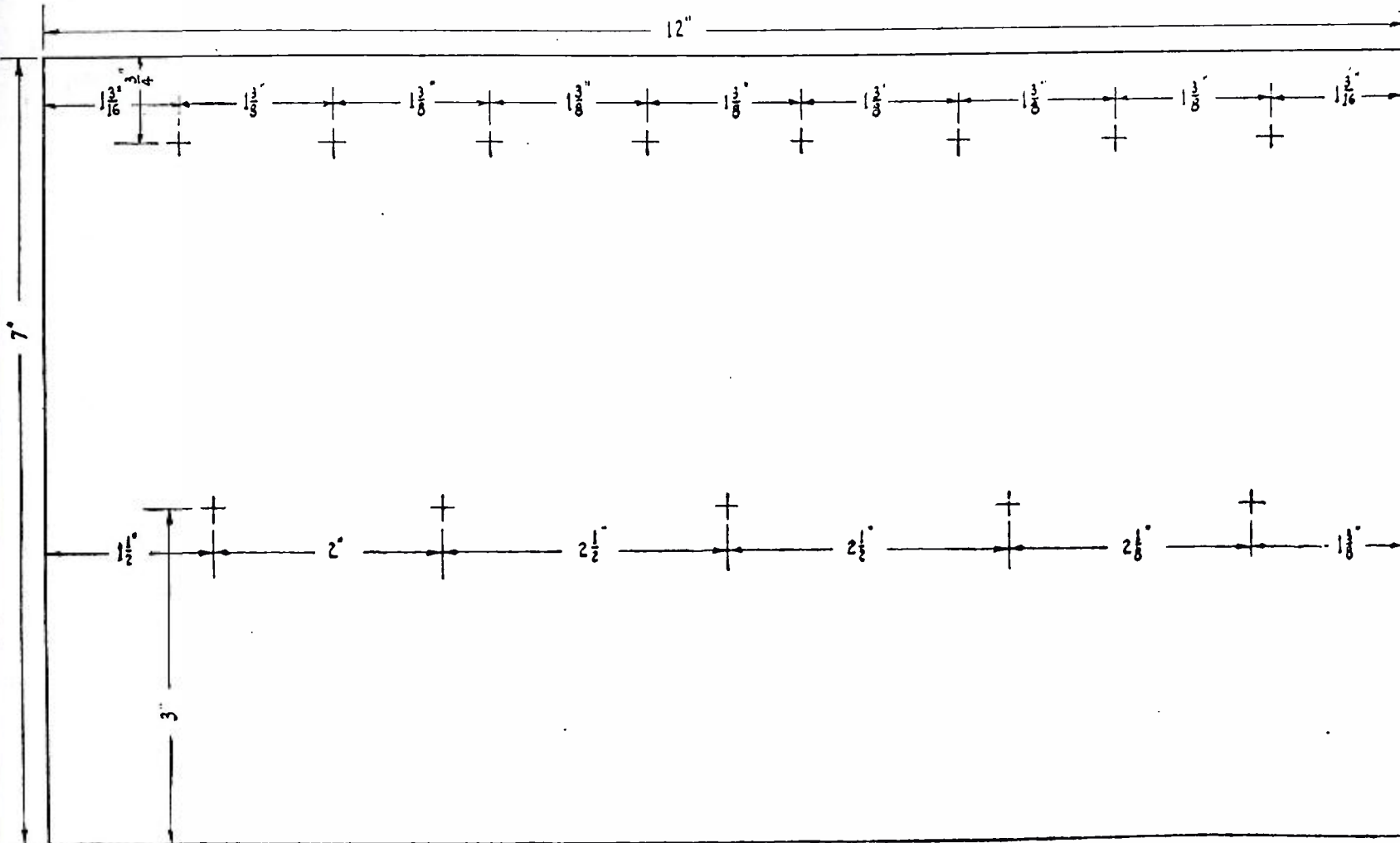

Panel drilling layout. All dimensions are given for the spacing of the hole centers for mounting parts.

the filaments of proper value, whose voltage drop will give the required grid bias. This value of resistance depends upon the amount required, and is equal

ing the grid return on the further side from negative or minus terminal will give a bias depending upon the number of tubes. As it is very easy

sirable and may be made in two ways. By placing a 400 ohm potentiometer directly across the filament of the first R.F. socket, the middle connection and

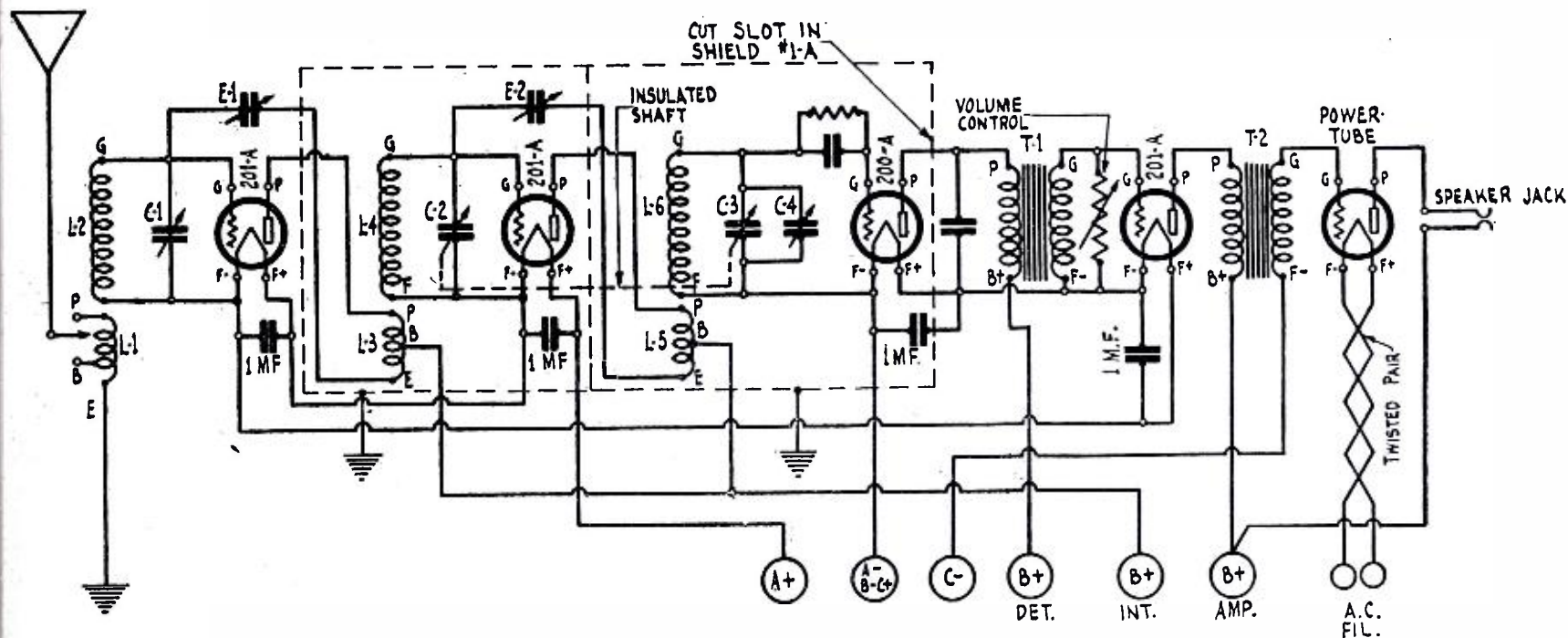

Wiring diagram of the Hammarlund-Roberts "Hi-Q" receiver for use with the power unit described herewith.

to the required voltage multiplied by 4. For example: If 4.5 volts grid bias is desired, this is obtained by a resistance of 4.5x4 or 18 ohms.

These resistors carry the full 1/4 ampere of current which the tubes require and may be made from 20 ohm

to become mixed up and fail to make the proper grid bias return it is suggested that the plus and minus markings of the sockets be rigidly followed in making all connections. Series filaments are easier to wire than parallel and the wiring makes a very neat ap-

one side of the potentiometer is used. A second way which is very satisfactory is to place a Universal Range Clarostat across the secondary of the first A.F. transformer as shown in wiring of the "Hi-Q" receiver, given above. (Continued on page 120)



# The Harkness Tuned Audio Amplifier

by Kenneth Harkness

THE tone quality of any receiving set is largely determined by its audio amplifier. If the audio amplifier magnifies signals without appreciable distortion the quality of reproduction will be good. In this respect the audio amplifier is the most important part of the receiver.

In this article we describe a new type of audio amplifier which can be

attached to any receiving set by means of a battery cable or mounted directly on the front panel of a receiver to form a component part of the set.

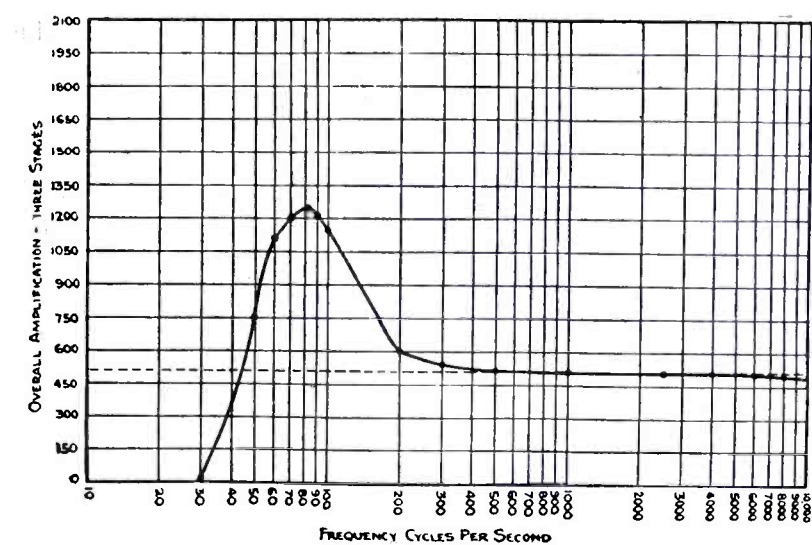
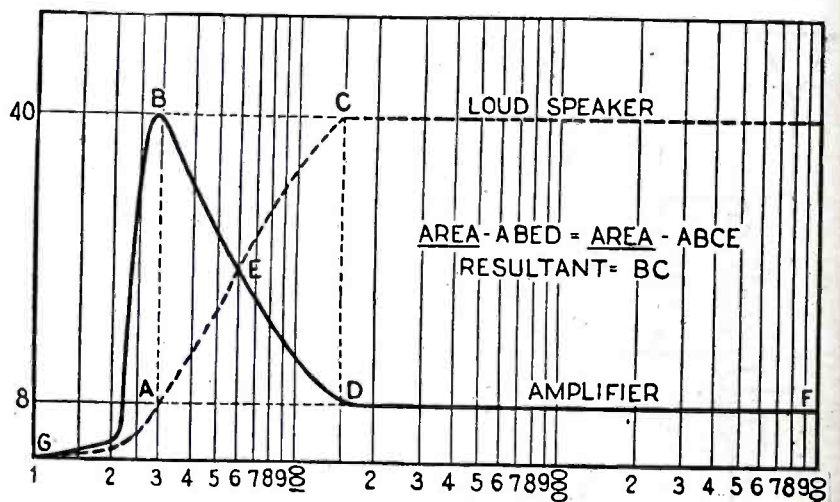

Fig. 1. Frequency characteristic curve of the Harkness tuned double impedance audio amplifier. Note the increased amplification of frequencies between 40 and 200 cycles.

The amplifier uses an entirely new system of amplification on which patents have recently been granted. The system is known as "Tuned Double Impedance." The reproduction of voice and music which can be obtained with this amplifier is quite remarkable. Every musical note, from the deepest bass to the highest treble, is reproduced with full volume and with all its intricate and distinctive tone-color. The loudest passages of music are just as clear and distinct as the softer passages and just as free from distortion.

Moreover, this realistic reproduction is obtained with an ordinary 112 or 171 tube in the output stage. The plate current is supplied by ordinary B batteries or a standard B-eliminator. 135

Fig. 2. Frequency characteristic curve of the average loudspeaker plotted against the curve of the Harkness tuned double impedance audio amplifier. The result shows uniform "loudspeaker" output of all frequencies.



of "motor-boating." The amplifier can be used with any B-eliminator without any chokes, resistances or condensers to prevent fluttering or "motor-boating."

3. The undistorted power output of the amplifier is four times greater than that of any other type of amplifier operating under the same conditions. This explains the perfect reproduction of the amplifier with ordinary receiving tubes and comparatively low plate voltages.

4. "Tube blocking" is completely eliminated. The use of impedances as

volts is sufficient, although 180 volts can be used if more power is desired.

The characteristics of this amplifier are interesting and unusual. Briefly, they may be summarized as follows:

1. Uniform loudspeaker output from 40 to 10,000 cycles. To offset the poor response of the average loudspeaker below 200 cycles the amplifier is tuned to give increased amplification of low frequencies.

2. Complete and automatic elimina-

tion of "motor-boating." The amplifier can be used with any B-eliminator without any chokes, resistances or condensers to prevent fluttering or "motor-boating."

## LIST OF PARTS REQUIRED

- 1 Formica panel  $6\frac{3}{8}$ " x 9" x  $\frac{3}{32}$ "
- 2 Formica strips  $1\frac{1}{4}$ " x 9" x  $\frac{3}{32}$ "
- \*3 Benjamin Tube sockets or American U. X. Prong contacts for sub-panel mounting.
- 3 Harkness tuned Double Impedance Couplers (First, second and third stage types)
- 1 Harkness Output Filter Unit
- 1 Pair Silver-Marshall sub-panel brackets
- 1 Carter fixed resistance, 1 ohm.
- 1 Carter short jack (open circuit).
- 1 Saturn toggle switch
- 9 X-L Push-Posts

\*In the model amplifier illustrated the tube sockets are riveted to the sub-panel.

tance and impedance-coupled amplifiers.

5. High voltage amplification per

stage. The amplifier utilizes the maximum voltage amplification of the tubes employed. There are no low resistance grid leaks to reduce the amplification.

## The Tuned Effect Described

The first characteristic, outlined above, is decidedly unusual. The average receiving set does not accurately reproduce musical sounds below 200 cycles and most loudspeakers give very poor response at low frequencies. This does not mean that the loudspeaker cannot reproduce low tones. A good cone speaker can reproduce musical

tones down to 30 cycles. If the energy is available the loudspeaker can reproduce low tones just as well as high tones. It is necessary, however, to supply *much more energy* to the loudspeaker at low frequencies to enable it

to operate the loudspeaker at low frequencies is supplied by the amplifier and the sound output is uniform.

The effect of this characteristic on the quality of reproduction can well be imagined. Deep-toned and percussion

“Motor-boating” is a low frequency oscillation caused by the filter system of the B-eliminator. The frequency of this oscillation is always below 30 cycles. If the audio amplifier of a receiving set magnifies frequencies below 30 cycles it will “motor-boat.” To eliminate the fluttering it is usually necessary to connect a high capacity condenser across the terminals of the B-eliminator or to insert choke coils and condensers between the eliminator and the set. These precautions, however, are not needed when the tuned double impedance amplifier is used. This amplifier does not amplify frequencies below 30 cycles to any extent. Although the amplification from 40 to 200 cycles is extremely high, the amplification below 30 cycles is practically zero. As shown in Fig. 1 the amplification curve drops to zero at 30 cycles. As there is little or no amplification below 30 cycles the amplifier cannot oscillate below this frequency; in other words, it cannot motor-boat.

#### Large Distortionless Power Output

The third unusual characteristic of the amplifier is a very important one. As stated above, the undistorted power output of the amplifier is four times greater than that of any other type of audio amplifier operating under the same conditions.

It is recognized that considerable volume, or power output, is necessary to obtain good tone quality. The quality of reproduction obtainable with any audio frequency amplifier depends not only upon the “frequency characteristic” of the amplifier; it also depends upon the “amplitude characteristic.” In other words, it depends upon how

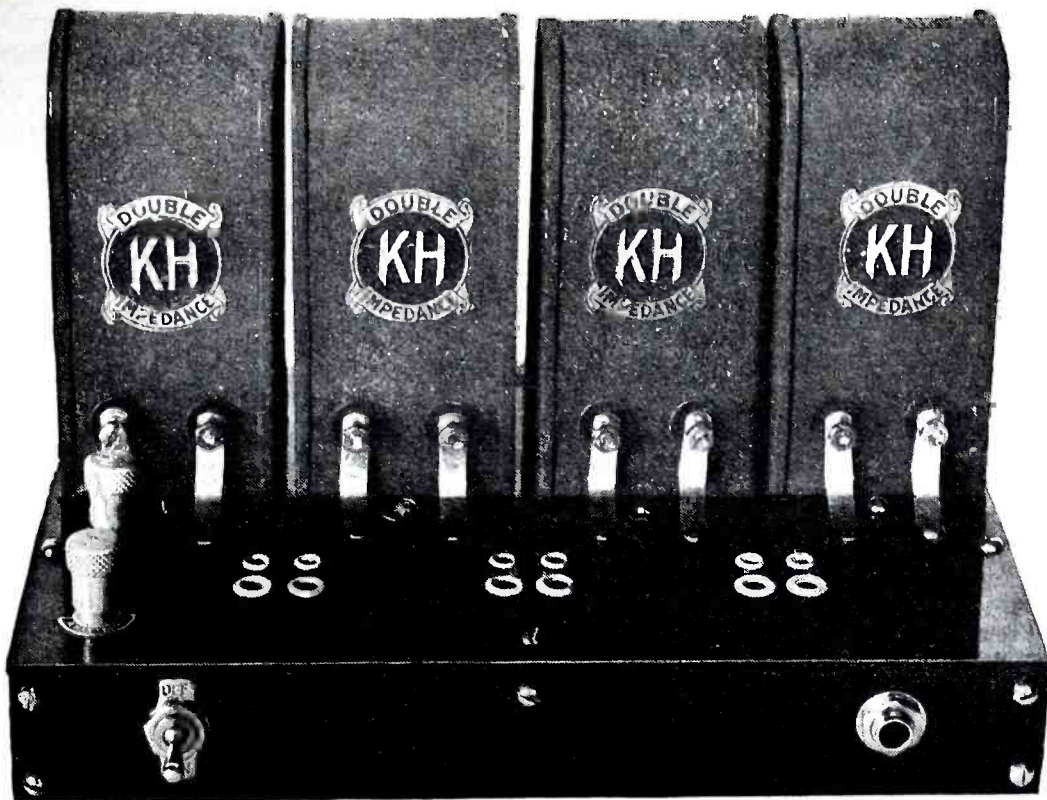

Fig. 3. Front view of the Harkness tuned audio amplifier. The unit on the extreme right is the output filter.

to reproduce these low tones at the same volume as high tones. The ordinary audio frequency amplifier cannot supply this additional energy. The amplification falls off below 200 cycles. Consequently, the important low tones of music are not accurately reproduced.

The tuned Double Impedance amplifier is designed to give greatly *increased* amplification of frequencies between 40 and 200 cycles, thereby enabling the loudspeaker to operate efficiently at these low frequencies. The increased amplification is obtained by tuning each stage of the amplifier by means of fixed condensers connected between the plate and grid of each tube. These condensers are inside the double impedance coupling units and their values are chosen to give the best results when the amplifier is used with the average cone speaker. The condensers, of course, also serve as blocking condensers in the usual manner.

The diagrams Figs. 1 and 2 clearly illustrate and explain this interesting feature of the tuned double impedance amplifier. Fig. 1 is the frequency characteristic curve of the amplifier. Note the increased amplification of low frequencies and the uniform amplification of frequencies above 200 cycles. Fig. 2 shows how uniform *loudspeaker* output is obtained when this amplifier is used with the average cone speaker. The loudspeaker curve falls off below 200 cycles. The amplifier curve, however, rises below 200 cycles. The additional energy required

instruments, so essential in orchestral music, are heard with full volume and contribute their true share to the resulting harmony of sound.

#### Why the Amplifier Does Not “Motor-Boat”

The second important characteristic of this amplifier is the automatic elim-

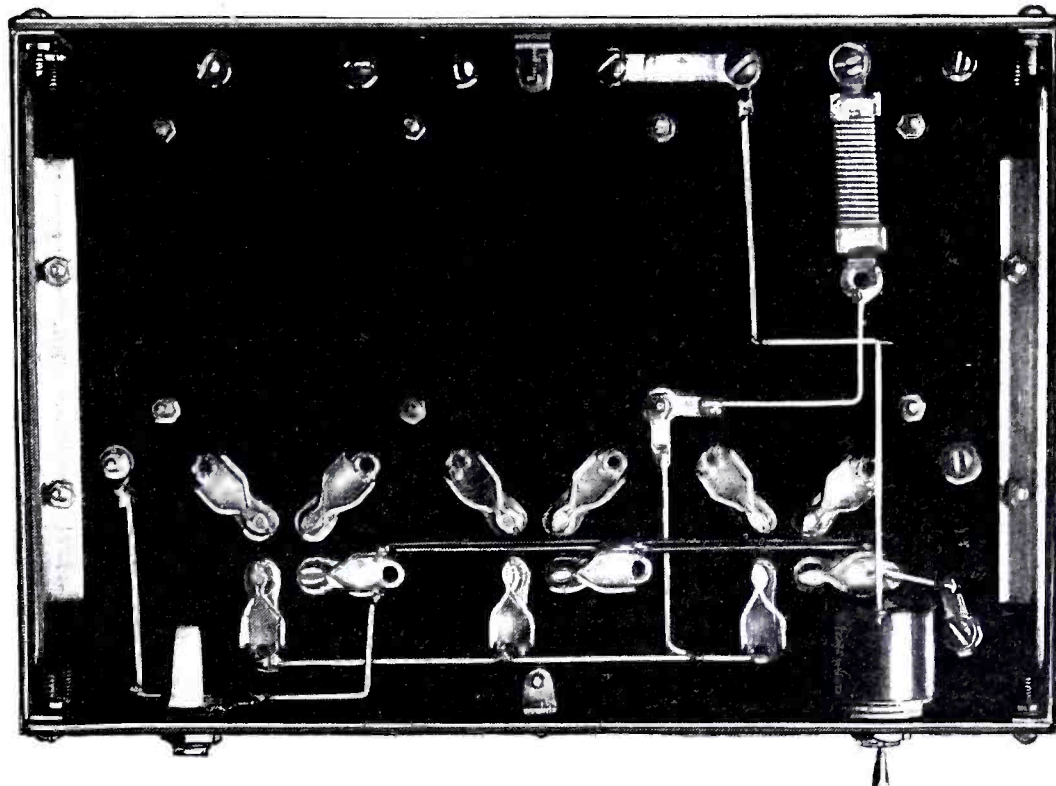

Fig. 4. Bottom view of the amplifier showing the simplicity of the wiring. Note position of the ohm resistor which controls the filaments of all three tubes.

ination of “motor-boating.” The amplifier can be used with any standard B-eliminator and will not motor-boat.

much volume or power output the amplifier can handle without distortion taking place. The greater the available

distortionless power output the better the tone reproduction will be, even if all the available power is not utilized.

be uniform, indicating that the amplifier should deliver good tone quality. Actually, however, the tone quality

ume without distortion. This explains why some resistance and impedance-coupled amplifiers do not reproduce as

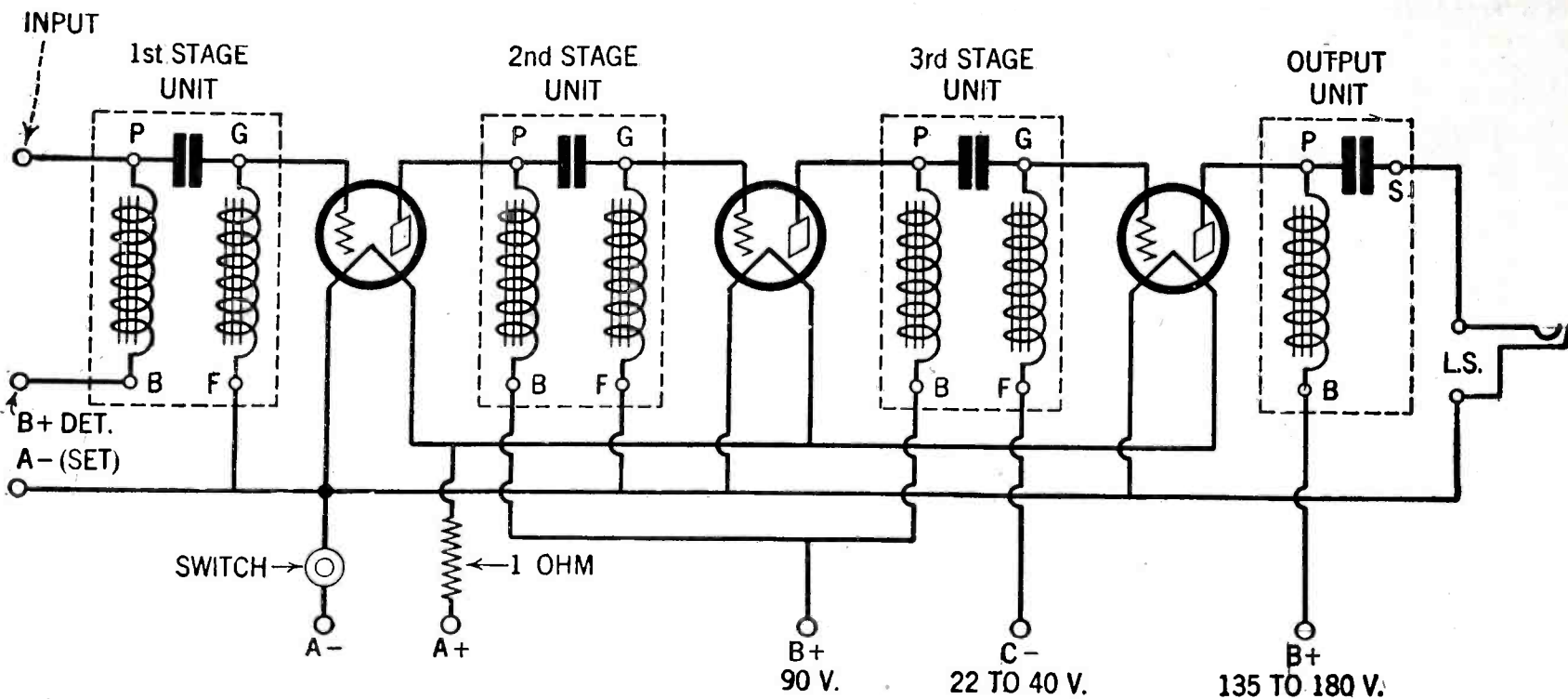

Fig. 5. Schematic wiring diagram of the tuned audio amplifier.

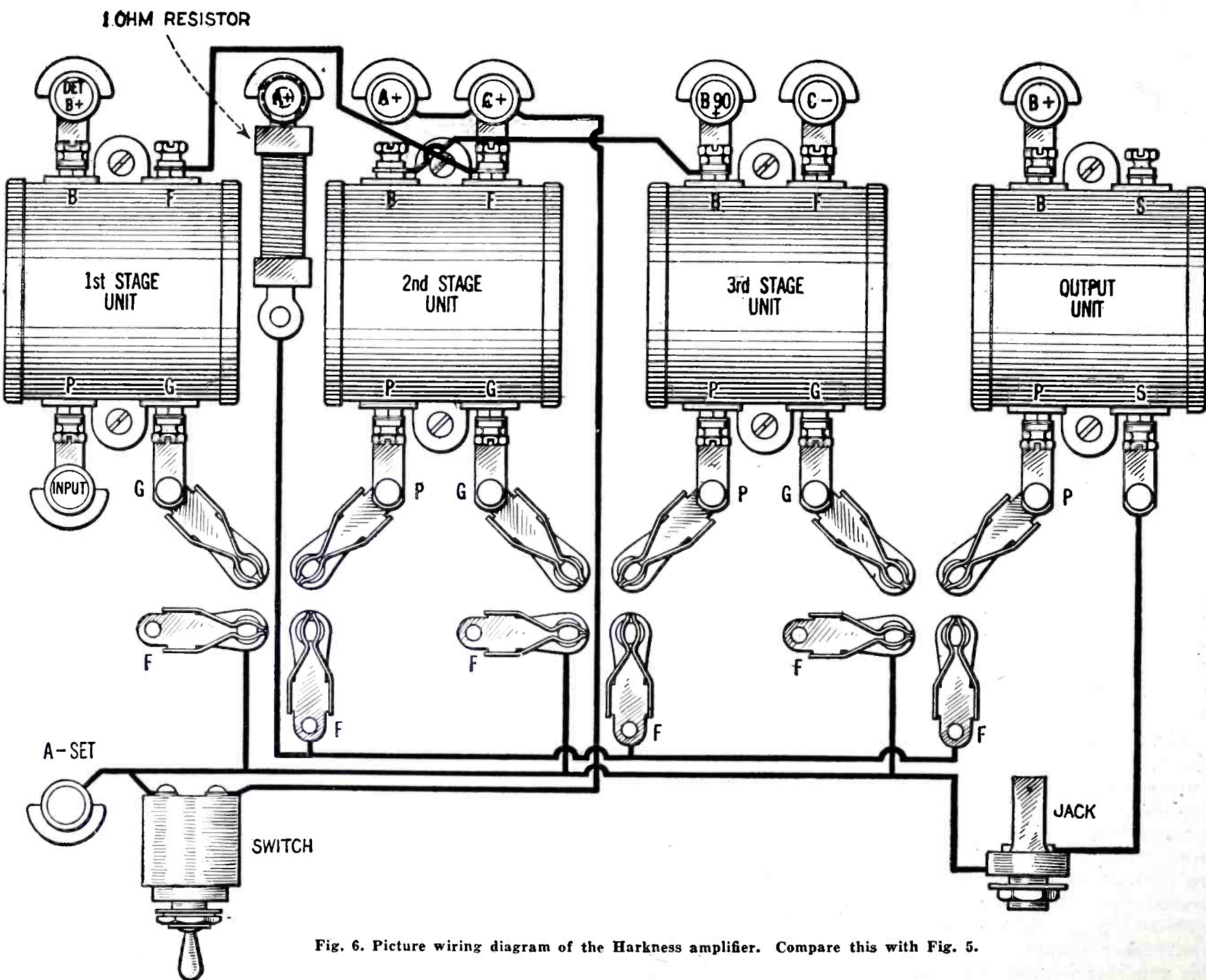

Fig. 6. Picture wiring diagram of the Harkness amplifier. Compare this with Fig. 5.

Some amplifiers may show a satisfactory frequency characteristic; the amplification of all audio frequencies may

with even a moderate amount of volume may be very bad, due to the inability of the amplifier to handle vol-

well as transformer-coupled amplifiers, even though the frequency characteristics of the former are superior.

The amount of distortionless power output which can be obtained from any audio amplifier mainly depends upon the type of tube used in the output stage and the amount of plate voltage employed.

However, the maximum available power output of any tube cannot be obtained with most audio frequency

former is partially shorted and the external impedance of the preceding tube is reduced. The voltage across the secondary of the transformer is lowered and bad distortion results.

The power output of the tuned double impedance amplifier is not limited by any of the above effects. The maximum available distortionless pow-

### High Voltage Amplification

The maximum voltage amplification of each tube employed in the amplifier is utilized. There are no low resistance grid leaks to cut down the amplification. If a 112 tube is used in the output stage, 201A tubes in the first two stages will furnish ample amplification.

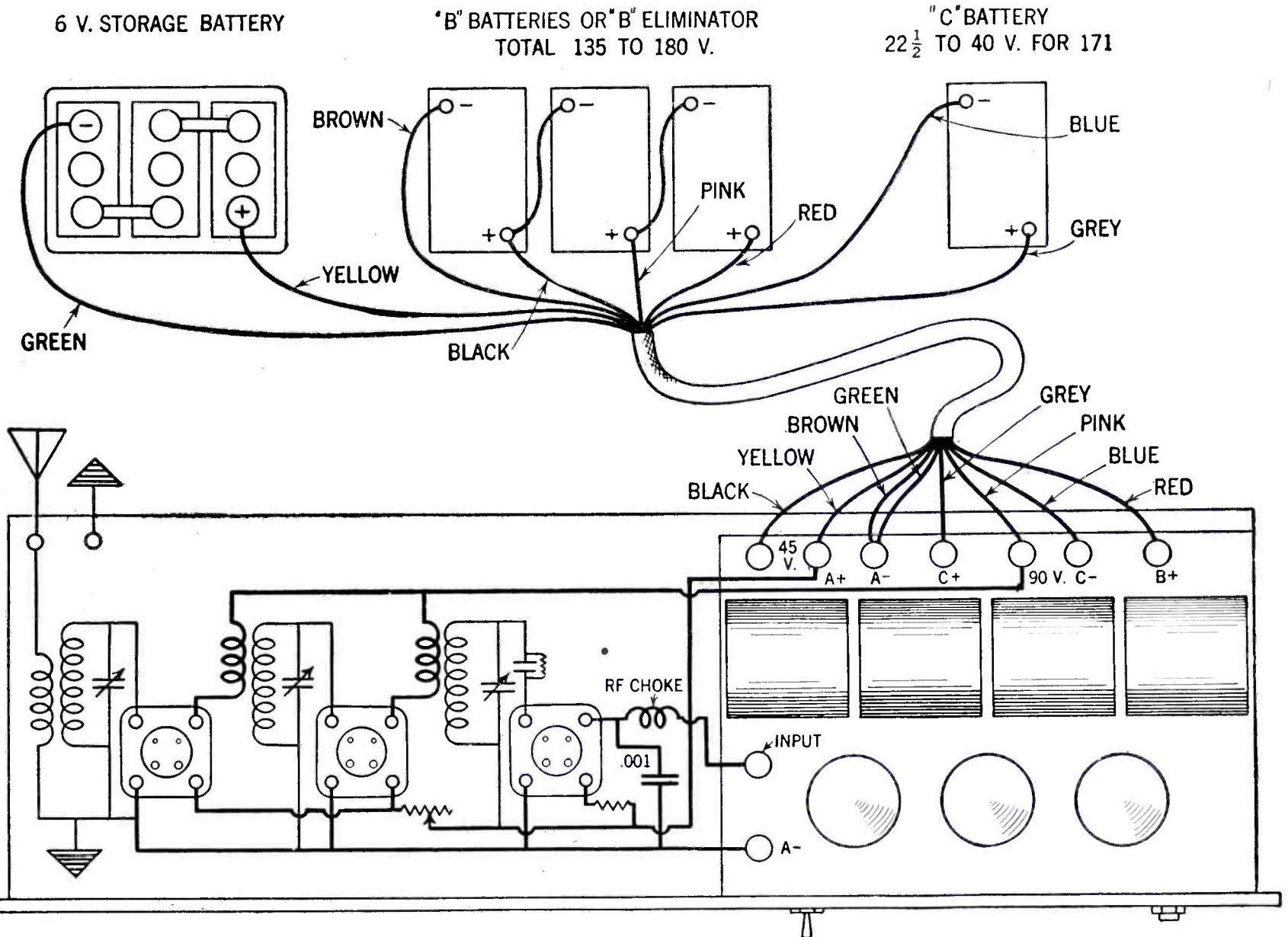

Fig. 7. This diagram offers a suggestion to set-builders who wish to use the amplifier as a component part of a receiver. The amplifier battery switch controls all tubes.

amplifiers. The power output of resistance-coupled and impedance-coupled amplifiers with high resistance grid leaks is curtailed by rectification and "tube blocking" which make it impossible for these amplifiers to handle much power. (Unless low values of coupling condensers are used which, however, affects the frequency characteristic and reduces the amplification of low frequencies). The power output of a transformer-coupled amplifier is limited by the fact that it is necessary to prevent the generation of grid currents. The normal operating potential of the grid must be held at a sufficiently negative value to prevent signal variations of the grid potential from causing the grid to become positive with respect to the filament. If the grid becomes positive, grid currents are generated, the secondary of the trans-

er output of any tube can be obtained. This large distortionless power output is obtained by the use of impedances as grid leaks, and by the elimination of magnetic coupling between the stages of the amplifier. The impedance grid leaks prevent all possibility of rectification and "tube blocking." The absence of magnetic coupling permits the generation of grid currents without distorting the wave form of signals. The normal operating potential of the grid can be adjusted to the center of the straight portion of the characteristic curve of the tube without considering the effects of grid current when the grid goes positive.

The large distortionless power output of the amplifier makes it unnecessary to use more than 180 volts on the plate of the last tube. For most homes, 135 volts is sufficient.

If a 171 tube is used in the output the voltage amplification is lowered, although it is still sufficient. If desired, a Hi-Mu tube can be employed in the first stage to increase the amplification.

### How to Build the Amplifier

The tuned Double Impedance amplifier illustrated on these pages may be built as a separate unit and attached to any receiving set by means of a battery cable. The A and B batteries used to operate the set are also used to supply power to the amplifier. The amplifier takes the place of the audio amplifier of the receiving set. It does not matter what kind of set is used. The amplifier will work equally well with a one-tube set or with a super-heterodyne. Moreover, the amplifier may also be mounted directly on the front panel of (Continued on page 118)

# EXPERIMENTS *with* TRANSMITTER BUTTONS *by Joseph Kraus*

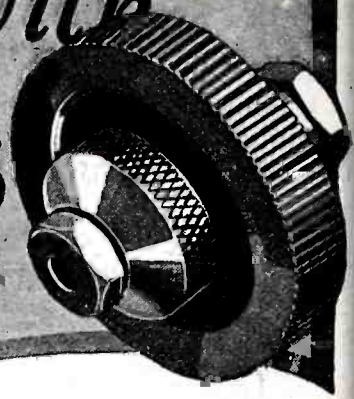
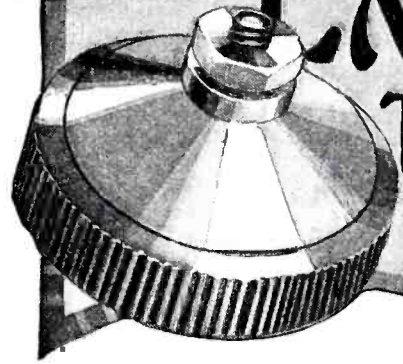

SINCE the first article on Experiments with Transmitter Buttons appeared in RADIO REVIEW, numerous questions have been asked as to how the transmitter button can be made to work properly. In each and every case, the answer is simple: "the button has not been hooked up in accordance with directions." There is no electrical circuit that is simpler to couple than an ordinary transmitter button and a receiver. The experimenter should remember that every transmitter button requires a diaphragm of some sort or a substitute therefor. The size of this diaphragm depends entirely upon the work which is to be accomplished or the nature of the matter to be broadcast or amplified.

For ordinary speech, a diaphragm approximately 2½ inches in diameter is better suited than one 14 or 18 inches in diameter. The smaller diaphragm enables the listener to recognize the voice of the person transmitting, whereas the larger diaphragm has a tendency to decrease the pitch of the transmitted voice. But when doing detective work, it might become necessary to attach a transmitter button directly to a large canvas picture. In this particular case the conversation that is picked up is the all-important consideration and one does not care about the quality of the sound just as long as the speech can be recorded.

Now here is a hint to the experimenter which will enable him to make his transmitter buttons react far more sensitively. Take the button apart by turning the large knurled screw to the left. Do this over a sheet of paper so that you will not lose the carbon granules. Then, by the aid of a small pair of pliers, unscrew the polished brass button from the mica diaphragm. You may find that there are two pieces of mica in your button. This is due to the fact that the mica sometimes sticks together and consequently, in modern rapid assembling methods, it is difficult to make sure that only one of them is

placed in a button. At other times this is done purposely so as to prevent breakage in shipment. If you locate two mica diaphragms, remove one of them, then reassemble the entire button. Make sure that the mica diaphragm is not broken while doing this; otherwise the sound reproduced will be inferior. Now as to the quan-

button can be increased to from 22 to 45 volts, dependent upon the resistance in the primary of the transformer. If the reproduced voice develops a frying sound, the button is being overloaded; if not, then the voltage should be increased until it is just below this frying point.

An interesting figure is reproduced here by permission of Mr. Lesca-boura who employed the transmitter button with a resistance coupled amplifier for amplifying the sound of the phonograph. The details follow herewith. With a relatively small investment of money, plus a liberal investment of ingenuity, the old phonograph can be brought back into the good graces of the family. The marvelous advances scored in phonographic reproduction can be enjoyed side by side with the best radio has to offer.

The essentials of modern phonographic reproduction are, first of all, the new electrically-cut records which contain the wealth of tone and the full depth of the original studio rendition. The old-time records simply have not the necessary ingredients for quality reproduction, and it is a waste of time and effort to use them for quality reproduction. Secondly, we must have a device to translate the record groove wiggles into corresponding wiggles of an electric current. Thirdly, we must have a means of amplifying the delicate electrical wiggles many times, without distortion. Fourthly, we must have a loud-speaker device fully capable of translating the complex electrical variations into a prototype of the original music.

The simplest means of obtaining the desired volume and quality of amplification is by means of a good audio

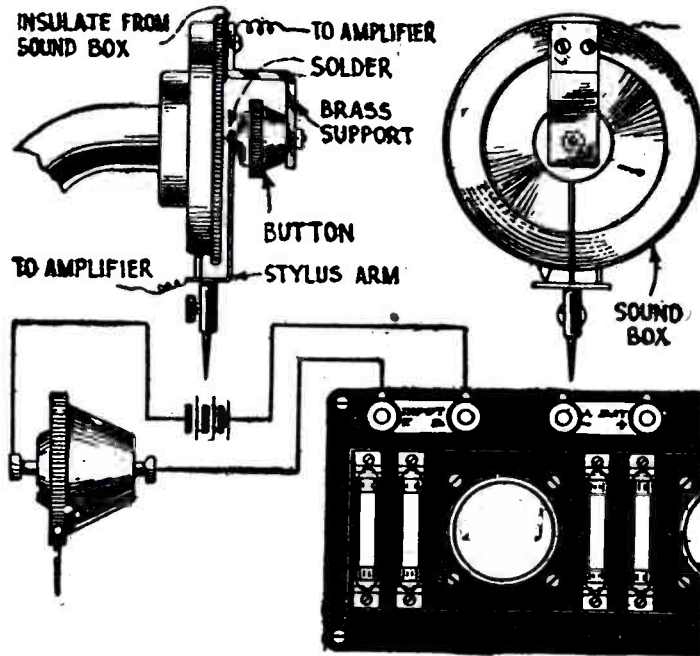

Fig. 1. At the upper left is shown the method of fastening the Skinderviken button to the sound box. The electrical circuit is shown below.

tity of carbon granules in this button. Slightly more than half is a splendid proportion. For more sensitive work, the quantity should be decreased and for very crude work, the button can practically be filled up. Therefore, the fewer carbon granules in the button (of course within limits) the more sensitive will be the nature of the pick-up. Coincidentally, a frying noise might be produced when there is not a sufficient amount of carbon granules to properly distribute the current (frying being also due to too much current). At no time should the current through these buttons be so high that it will produce a frying noise. While the previous article advocated the use of a 4½ to a 6-volt battery, the use of telephone transformers was likewise suggested, but for those readers desiring to use the standard radio transformers (audio frequency types) the voltage on the

\* Those desirous of obtaining the first article, a reprint from the RADIO REVIEW, March, 1926, can secure the same by writing to the editor, who will be glad to send a copy to interested readers.



amplifier such as a resistance coupled unit. A resistance coupled amplifier unit is relatively inexpensive and provides faithful amplification and ample volume for the largest living room, in conjunction with a good cone reproducer.

So far, so good. We are merely following radio practice. But there still remains the problem of the pick-up, or device for converting the needle vibration into electrical variations. Here the simplest method is to take the standard phonograph sound box and attach a Skinderviken button, as shown in the sketch. The results will prove a revelation. The electrical circuit is shown in the lower part of the accompanying illustration. At the upper left, the method of fastening the Skinderviken button to the phonograph sound box is clearly illustrated.

For the information of those who have not as yet experimented with the Skinderviken button, this interesting

can be removed as a whole. Care should be taken in punching or drilling a hole through the mica so that the mica itself is not cracked. A cracked mica will

directly to the grid and negative "C" circuit of a standard audio frequency amplifier. The figure 2 shows another unique variation which might for this

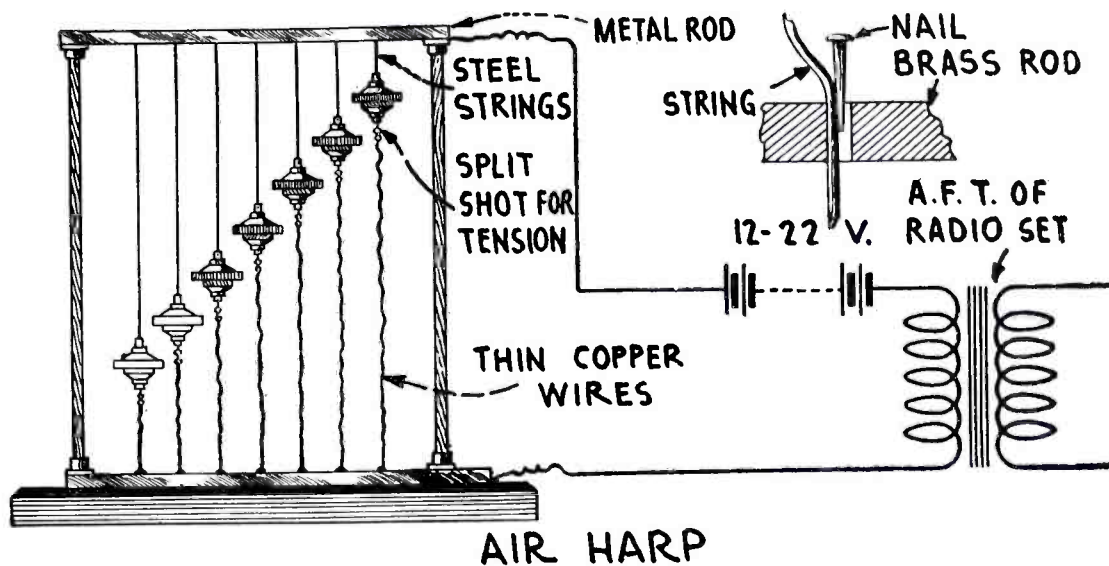

Fig. 3. Here is the layout for the proposed air harp which, when set on the window-sill will produce unusual music, not at all rhythmic, but very melodious, depending entirely upon the way in which the strings are tuned. Observe how the strings are gripped by a nail in place in the top metal rod. The tension of the string is regulated by adding a few split shots. The main tone variation is produced by shortening or lengthening the string.

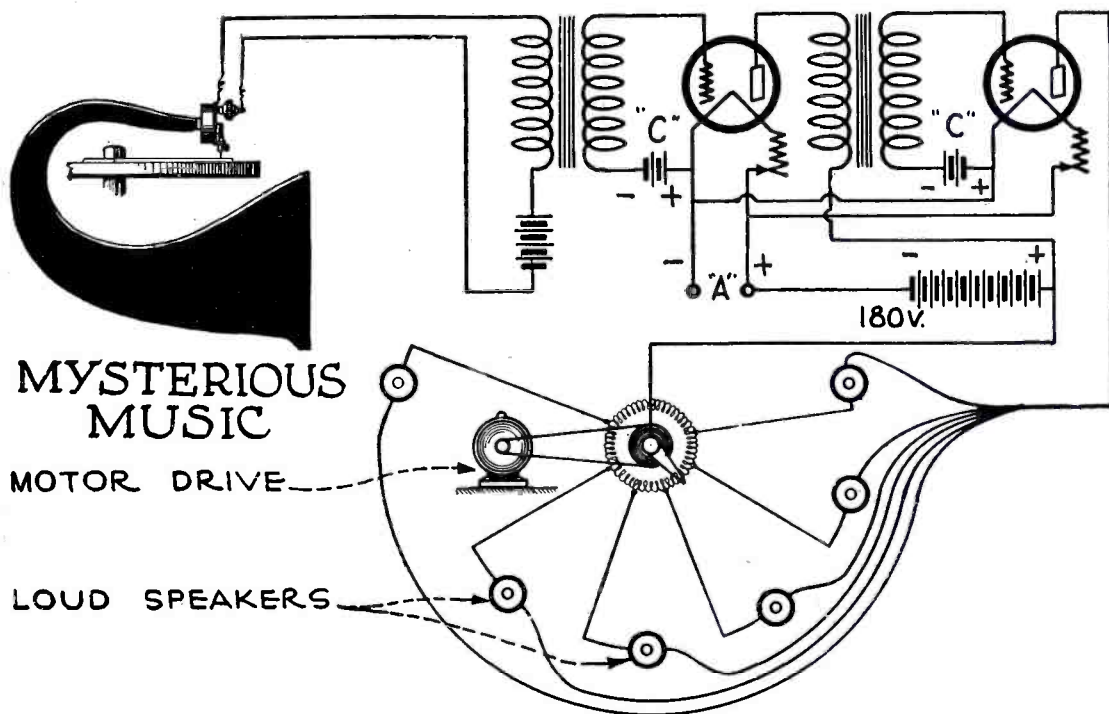

Fig. 2. Here is the layout for mysterious music in which the reproduced sound is picked up by a transmitter button, amplified through a vacuum tube amplifier and then distributed to a number of loud speakers through the agency of a motor-driven resistance-type distributor. At no time are any of the loud speakers thrown out of the circuit, yet the music intensity of any one of them constantly varies.

device is a small carbon grain microphone button, less than an inch in diameter and about a half an inch high, containing a polished metallic button affixed to a mica diaphragm and a surrounding case of brass. The space between the case and the polished button is partially filled with a good grade of carbon granules. The button is very sensitive to sound waves when it is attached to any form of diaphragm.

Another method of attaching the button to the diaphragm of a phonograph is to drill a tiny hole through the mica diaphragm of the phonograph immediately above the center and high enough so as to permit the button to clear the level communicating with the phonograph needle. To do this, the needle stylus must be removed from its holder by loosening the screws holding it in place and then the sound box must be opened so that the mica diaphragm

not reproduce well. The leads from the button are then taken as indicated in the diagram, whence they lead to the

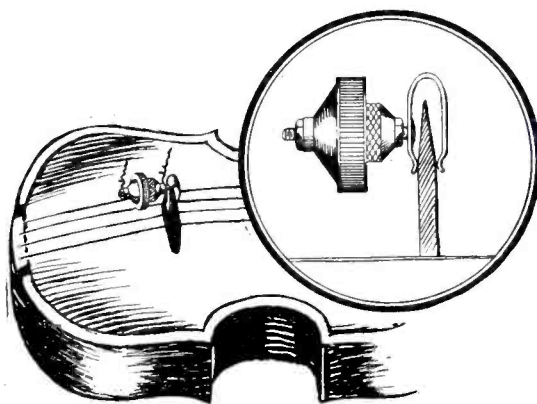

Fig. 4. Here is a method of attaching a transmitter button to the bridge of a musical instrument such as a ukelele, violin or any other similar article.

primary of an audio frequency transformer in series with a 22½ volt "B" battery. The secondary is then led

article be called the "mysterious music." It will be observed that there are a group of speaker units connected in parallel through the agency of a rheostat in one side of the circuit. The arm on this rheostat is fitted with a grooved pulley wheel and is revolved by some form of a motor drive which might be a clock work or a toy motor geared down so that the arm will not rotate too rapidly. Now then, when the arm assumes the position indicated in the diagram, those speaker units which are nearest it will receive the greatest amount of current, whereas those units further away from the arm will receive very little current. Consequently, the music apparently will come from a different horn every few seconds. At no time is there a complete block in the

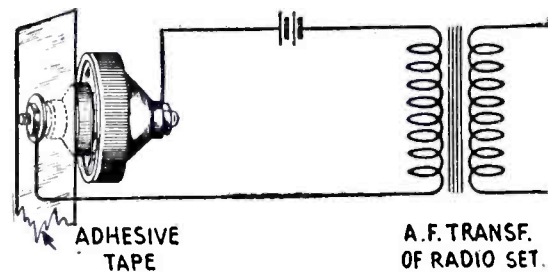

Fig. 5. Attaching the transmitter button to a piece of adhesive tape makes it applicable to any type of musical instrument.

unit and, therefore, the click usually heard when a loud speaker is thrown into a circuit is not found in this particular arrangement. The units being preferably of the same make, you receive the same amount of current in the divided circuits and therefore the mysterious music coming from them will come from different sources which should preferably be concealed. At no time could the audience in the theatre or the visitors at home tell where the sound is actually coming from. For theatre work or for the large home, and for the radio lawn party, this system can hardly be beaten.

### Singing Harp

An interesting singing harp is indicated in Fig. 3. Here we have two wooden uprights mounted on a suitable base and provided with a metal rod running across the top and likewise one at the bottom. A series of steel strings varying in thickness and the length of which will have to be determined by experimentation are twisted around the metal rod at the top or inserted into holes in the brass rod and locked in place with a small brass nail. This latter system is preferred because it makes a perfect contact with the steel wire, yet at the same time permits variation in the length of the string. To the end of each string we attach a transmitter button and to the bottom of each button a very thin bare copper wire is affixed and then loosely

sion to this device if we intend to place it in the window and let the wind play it for us. In order to vary the pitch of any string, the string should be

under a slight tension. The music from this kind of a harp should preferably be amplified with your radio receiving sets in accordance with instructions to be given subsequently. This same type of harp can be built up and played by the fingers, the strings being but lightly plucked in order to produce the very sweet pure notes which have the peculiar faculty of vibrating much longer than the ordinary harp strings.

### Banjo or Ukelele Amplification

Perhaps you frequently found that when you entertained a crowd of young folks at your home, your ukelele was hopelessly unfit for the occasion. For some reason or other it did not respond loudly enough to be heard above the din and roar of those guests who are having a good time. The first thought comes to your mind, "I'll amplify the music," and then the next, "Yes, but how?" The problem is very simple. Out of a piece of brass make a small spring clip to saddle the bridge

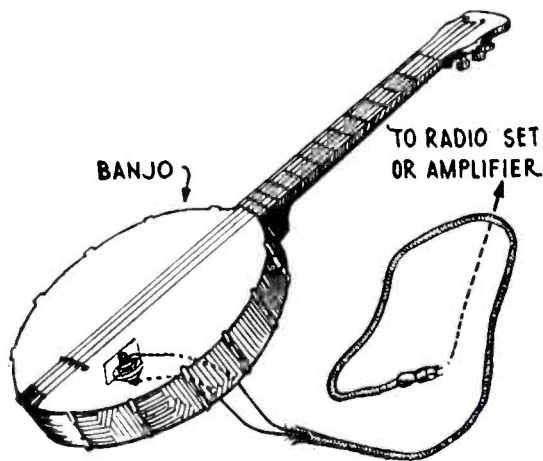

Fig. 6. Here is the way adhesive tape is used to attach a transmitter button to the head of a banjo.

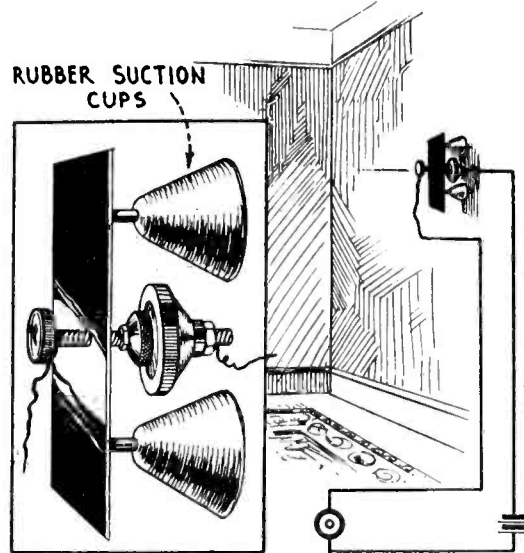

Fig. 8. This shows the layout for making a super-sensitive detectophone with which you can listen through solid walls.

shortened to raise the note or increased in length to lower it. On the very

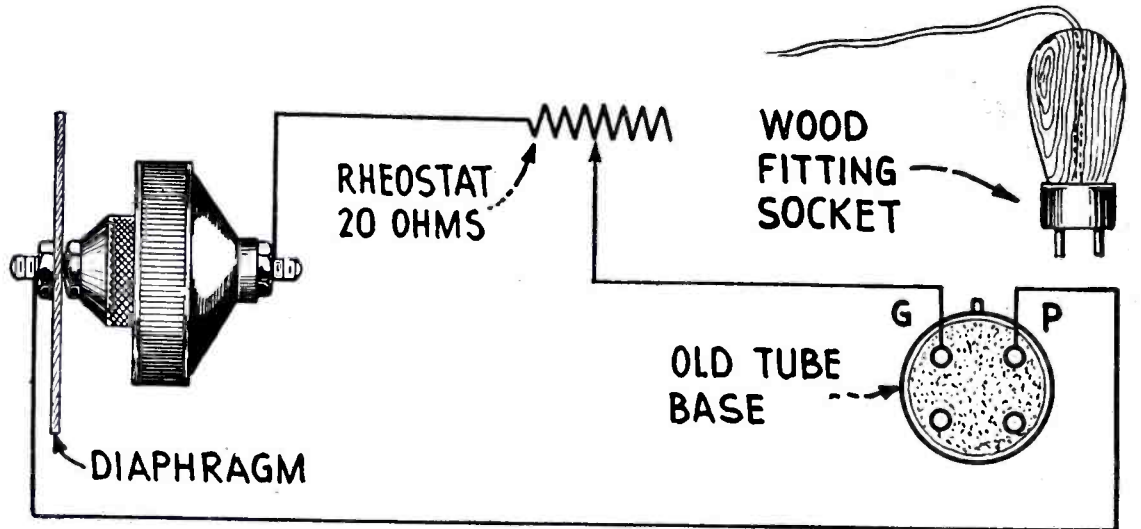

Fig. 7. The method for attaching a transmitter button to your ordinary radio set. A dummy socket provided with grid and plate contacts is substituted for the detector tube. The rheostat regulates the current which is obtained directly from the "B" battery ordinarily in this circuit.

of the ukelele. Then run two flexible leads directly from the transmitter button attached to this clip, to the radio receiving set. Practically every home is equipped with one and the only apparatus that you need carry with you is the clip, the button, a rheostat and a wooden plug made in the form of a vacuum tube and provided with four prongs as indicated in Fig. 7. The spring clip itself should be high enough so that the button can clear the strings of the ukelele or the body of this instrument.

The transmitter button can also be used for amplifying the sound of a banjo. Here, however, the problem which we have to confront is a more difficult one because putting the button on the bridge will interfere with the player's fingers and one could scarcely be expected to punch a hole in the \$6.50 pigskin head of the banjo to accommodate the button. The following stunt has been decided upon and it works very well indeed. The transmitter button is fastened directly to

led down to the brass rod at the bottom where the wire may be soldered for a good electrical connection. When any string is lightly plucked, a note is produced which will vary in frequency

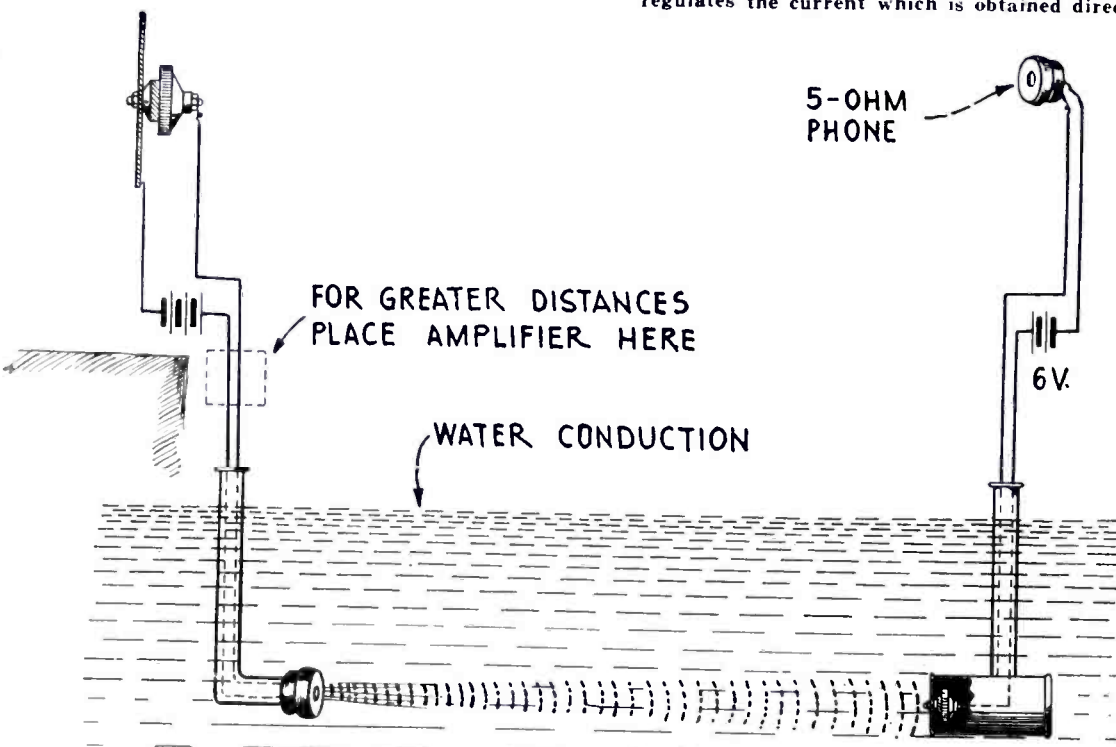

Fig. 9. Conducting sound through water is very easily accomplished, by the layout above indicated.

with the length and thickness of the string as well as the tension thereof, but we do not desire to apply any ten-

high notes two or three split shots such as are employed by fishermen in fishing will assist in placing a string

a piece of adhesive tape. A hole is punched through the tape, then a small metal washer is put upon the end of the screw thrust through the hole, and the bolts are tightened up. A small piece

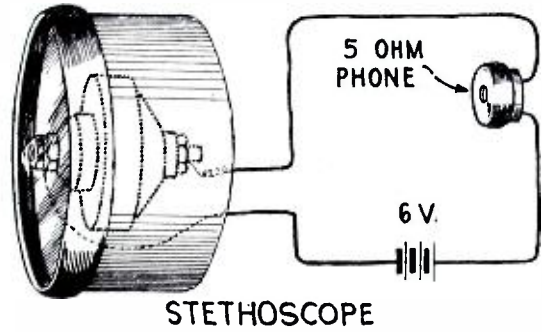

Fig. 10. A stethoscope can be built as indicated in the diagram here, the transmitter button being attached to a diaphragm and being likewise connected in series with a source of current supply and a low resistant phone.

of metal is then placed on the banjo directly beneath the screw and the adhesive tape firmly stuck to the head of the banjo. Two wires leading from the banjo couple directly to the radio set or audio frequency amplifier. To remove the adhesive tape, drop a small quantity of gasoline from the pocket cigar lighter on the end of the adhesive tape, let it soak for a moment and it will come off cleanly. (Figs. 5 and 6.)

Many experimenters have inquired as to how they could connect a transmitter button to the radio set so that the loud speaker of the radio set will reproduce voice or music. The various means of attaching the button to phonographs and the various methods of making microphones have already been described in this and the previous article. Of course, one can build up a complete amplifier to be used purely for transmitting circuit experiments, but ordinarily the experimenter does not know how to wire an audio frequency amplifier or had we better say, he does not care to do this work, nor may he desire to go to the expense of purchasing several other sockets, tubes, rheostats and batteries when he already has these same materials on hand. The question is how to connect the button to the receiving set without opening any other connections and in general mon-

brass pins into the base in the same positions the prongs of a tube occupy. Round-head wood screws could also be used for this purpose. A pin is then driven in the side and the wires leading from the transmitter button and rheostat are connected to the grid and plate pins as indicated. A far superior way to make this type of a plug is to take an old burnt-out tube, remove the glass and then connect the flexible leads to the grid and plate pins as before. An "UX" tube should be used if possible because some sets are not equipped with sockets to take the old

"B" batteries of the set are used and it is preferable to remove the radio frequency tubes from the circuit or else turn off the filaments in those tubes.

Listening Through Walls

In Fig. 8 we show a method for mounting a transmitter button so that it can be employed to listen to what is going on in the room next door. It is well known that when a person places his ear against the partition, he can hear the entire conversation in an adjoining room, provided that the conversation is loud enough and that the

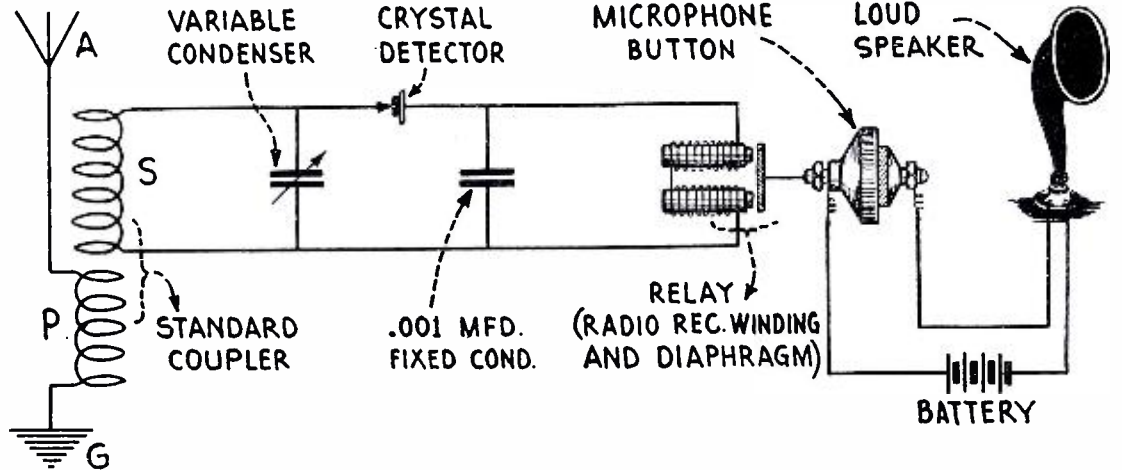

Fig. 12. A crystal detector can be made to operate a loud speaker by employing the circuit here illustrated. The loud speaker in this particular case has a winding of relatively low resistance. It is the European type of speaker, many of which do not possess a resistance of greater than 100 ohms.

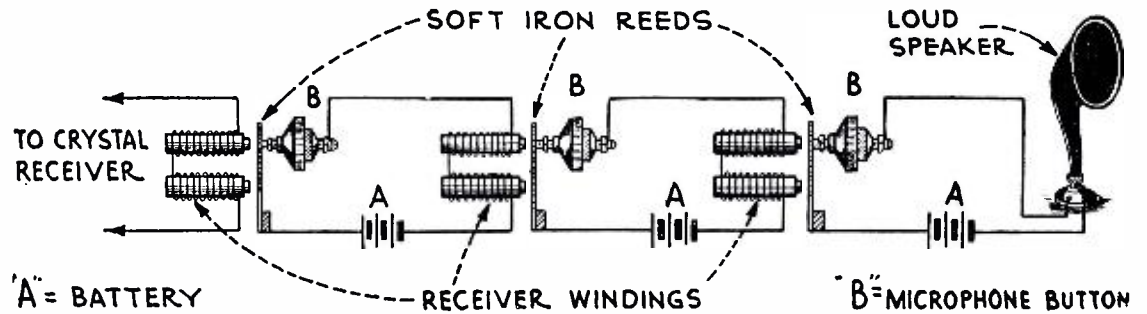

Fig. 13. The diagram shows a three stage audio frequency amplifier of the microphone type. This kind of an amplifier was used many years ago in the large trans-Atlantic stations for amplifying both code and voice signals. A indicates the batteries; B, the transmitter buttons.

style of tubes. The "UX" tube will generally fit both the old short pin sockets and the modern "UX" sockets. The rheostat has a resistance of approximately 20 ohms and is used to control the volume. A 400-ohm potentiometer or other control such as a

wall itself is not sound-proof. This position is tiresome both for the listener as well as impossible for detective purposes. The article described in Fig. 8 is a microphone button which can be affixed to the wall instantaneously. It consists of a small plate of metal, brass or the like, to which two rubber suction cups are affixed as indicated. The transmitter button itself is mounted at the end of a long screw with a thumb or knurled nut for adjustment. In operation, the rubber suction cups are moistened with a little glycerine to make them adhere more firmly to the rather porous wall to which they are to be attached. After the suction cups are firmly in place, the thumb nut is turned to the right until the button just touches the wall. The receiver, which in this case is a 5 to 75-ohm receiver, reproduces the sounds with the proper degree of accuracy. A 4 to 6 volt battery is placed in the circuit and the detective operating the device can sit at a desk and copy down

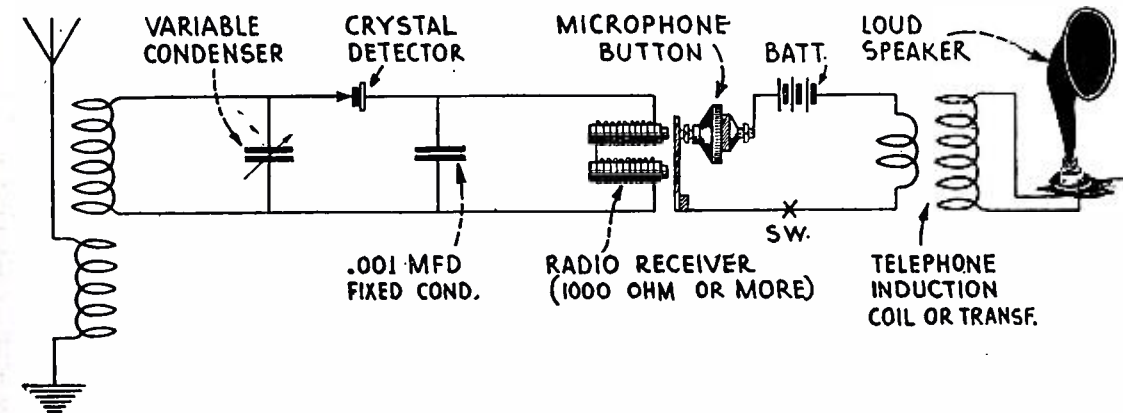

Fig. 11. In this hook-up a telephone induction coil or a transformer is used to step up the voltage so that an ordinary radio loud speaker can be used with a transmitter button amplifier. The circuit shows the operation of a loud speaker from a crystal detector radio receiving circuit.

keying around with what is a perfectly good radio outfit. The answer is simple. Make a wood block about the size of a tube and drive four nails or

Clarostat, a Bradley ohm or other variable resistance might well be employed to control the volume of the loud speaker. In this type of circuit the

(Continued on page 144)



# The LISTENERS' ACCESSORY GUIDE

## A Novel Aerial

Because of the unsightliness of the ordinary outdoor aerial, many radio fans have tried to secure results with loops and indoor antennas. It is well known that they are much less efficient than the outdoor type and their use reduces the efficiency of the receiver.

Manufacturers, from time to time, have placed devices on the market to

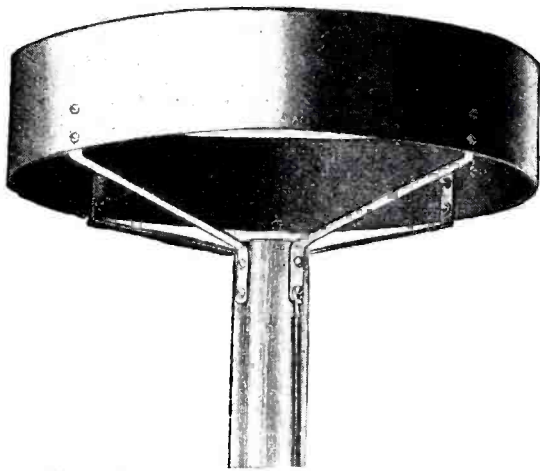

Photo Courtesy American Radio Hardware Co.

The circular antenna.

remedy this condition. The vast majority of these "aerial eliminators" have been condenser arrangements, designed to utilize one side of the commercial lighting circuit by being plugged into the light socket. These aerials are not always very efficient however, because of the varied conditions found in the power circuits.

A prominent radio manufacturer, realizing this, has placed a device on the market which produces the efficiency of an outside installation, without the unsightly wires. As may be seen in the illustration, it is composed of a large cylinder of aluminum, suitably mounted on a pipe so that it may be easily installed on the roof. Another advantage of this aerial is that it is entirely non-directional. Several of these aerials may be installed within a small radius without any interference being experienced.

## A Five-Inch Cone Speaker

A very interesting radio novelty which takes the form of a midget cone speaker has been recently placed on the market by an eastern manufacturer. This small speaker, which actually works to perfection, realizing all its

limitations, stands only 5 inches in height, has an adjustable unit and reproduces music and voice with a high degree of volume and clarity.

The base and baffle board are made of a soft, non-resonant wood attractively finished to correspond with the cone, which is made of heavy cone paper. The cone driving unit, which consists of a double pole magnetic driver, the armature of which is adjustable and which is directly coupled to the apex of the cone, is sturdily made after the best methods of cone speaker unit construction.

This cone speaker, besides being of great use when the family have retired, when it may be plugged in and a quiet "listening hour" instituted, may also be employed for many forms of amusement. It is so tiny that it can be easily placed inside the set itself, or in a table drawer, or under the dining room table, or in the library table or stuck in the chandelier, and will produce some remarkable results, which a speaker of

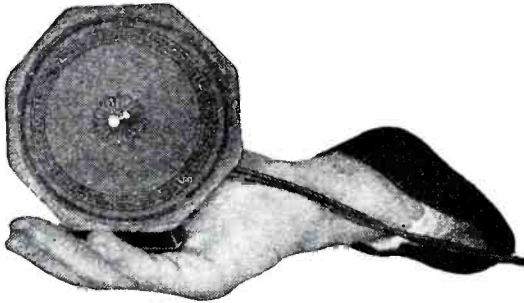

Photo courtesy Alden Mfg. Co.

The small size of the midget cone speaker is evident in this photograph.

the usual size could not produce. Due to its sturdy construction it can be handled much more easily than the larger speakers without fear of its being damaged.

## Another "B" Power Unit

This "B" battery eliminator has been placed on the market after an extensive survey of the needs, both engineering and merchandising, in the eliminator line. The results of this survey were carefully compiled, after which a unit was designed to meet the conditions. Fixed controls are used, with separate voltage taps, giving ample range as well as enabling the user to definitely know the voltage he is getting. The rectifier uses a full wave system and will supply enough current to operate a ten tube set. The manufacturer has found that

by producing every part in quantity, he was able to supply a remarkably efficient eliminator at a reasonable price. Special high voltage tested condensers are used in this eliminator to insure

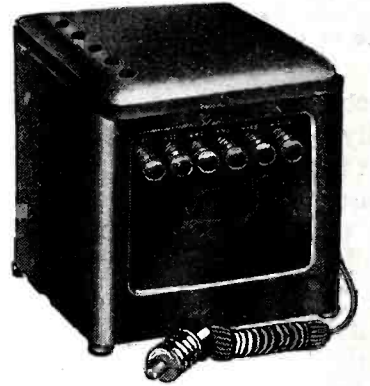

Photo courtesy Leslie F. Muter Co.

The fixed voltage full wave "B" battery eliminator.

constant use without a chance of breakdown. It will supply 40 milliamperes at 150 volts and is equipped with a 180 volt tap for the new 171 type vacuum tube.

## An Automatic Switch for Power Circuits

The power switching relay which is illustrated herewith is one of the sturdiest devices of its kind on the market. In general it is a device which automatically switches the 110 volt current used for the A and B circuits to the A and B circuit power lines, or cuts them off when the set is switched off.

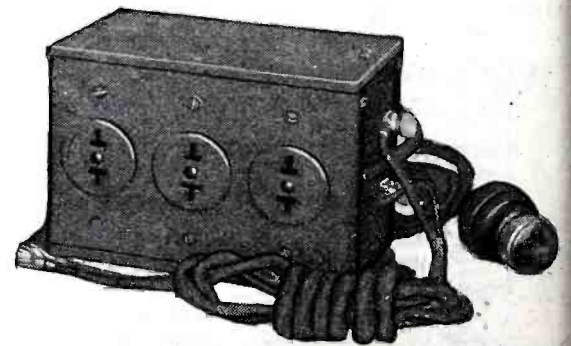

Photo courtesy Stromberg-Carlson Telephone Mfg. Co.

General view of the switching relay.

The relay consists of an electromagnetically operated double pole double throw switch amply insulated to prevent short circuit, encased in a handsome metal case. Three regulation outlets are provided into which there are

(Continued on page 166)



**FACTORY PRICES - SAVE 50%**  
Choice of beautiful cabinets offered

**TRY IT 30 DAYS FREE**  
BEFORE YOU BUY

**ALL METAL SHIELDED CHASSIS**

**8 tube - one dial**  
**MIRACO**  
TRADE MARK REGISTERED

Only **\$69<sup>75</sup>**  
Retail List Completely Assembled

**MAGNIFICENT TONE - SUPER SELECTIVE - POWERFUL DISTANCE GETTER**

**All Electric or Battery Set!**

America's big, old, reliable Radio Corporation\* (8th successful year) *guarantees* its big, powerful, latest 6, 7 and 8 tube Miraco sets to give "the finest, most enjoyable performance obtainable in *high grade* radios." Unless 30 days' use in your home fully satisfies you and everybody who hears it that a Miraco is unbeatable at any price for beautiful, clear cathedral tone, razor-edge selectivity, powerful distance reception, easy operation, etc. — *don't buy it! Your verdict final*—absolutely no strings to this. Save or make lots of money on sets and equipment by writing for testimony of nearby users and *Amazing Special Factory Offer.*

choice. Many thousands of Miraco users—who bought after thorough comparisons—testify they enjoy programs Coast to Coast, Canada to Mexico, loud and clear—with the magnificent cathedral tone quality of costliest sets. Don't confuse Miraco's with cheap, "squawky" radios. Miraco's have finest parts, latest approved shielding, metal chassis, etc.—as used in \$200 sets.

**Deal Direct with Big Reliable Makers**  
Your Miraco reaches you completely assembled, rigidly tested, fully guaranteed. Easy to connect and operate. *30 days free trial.* 1 year guarantee if you buy. Choice of beautiful consoles [with latest built-in orthophonic type speakers having 8 feet of tone travel] and table cabinets, also offered. You take no risk, you insure satisfaction, you enjoy *rock-bottom money-saving prices* by dealing direct with one of radio's oldest, most successful builders of fine sets.

**!Big Discounts to User-Agents**



MIRACO "Powerplus" sets—both in 8 and 7 tube models—have magnificently beautiful, clear cathedral tone quality. Turn one dial for stations everywhere. Ultra-selective. Miraco multi-stage distance amplification gives "power-plus" on far-off stations. Latest all-metal shielded chassis. Illuminated dial. Fully guaranteed. *Try one free for 30 days!* Choice of beautiful cabinets.

**7 tube one dial**  
METAL SHIELDED CHASSIS  
**\$49<sup>75</sup>**  
RETAIL LIST

**Run from Light Socket or Batteries**  
Miraco's work equally fine on electric house current or with batteries. Take your **Dealers Write!**

**USER-AGENTS! Make big profits showing your Miraco set to friends**  
\*MIDWEST RADIO CORPORATION, Cincinnati, O.

**BEAUTIFULLY ILLUSTRATED CATALOG AND AMAZING SPECIAL OFFER**

**SEND NO MONEY. — 30 DAYS' TRIAL Special Wholesale Price Offer to User-Agents, Bank References and testimony of nearby Miraco users—sent with catalog.**

**Free!**

Famous powerful big Miraco Super 6, 1928 model—ultra selective. Thousands find it outperforms and outdistances sets of much higher price. Fully Guaranteed.

**6 tube Super \$36<sup>75</sup> RETAIL LIST**

**Electrify Any Radio with MIDWEST NO-BATTERY "A.C." Light Socket Power Units**

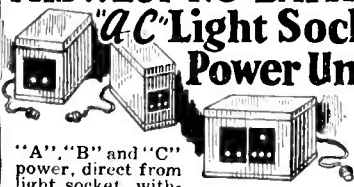

"A", "B" and "C" power, direct from light socket, without batteries! Write for Midwest prices and discounts. Midwest Units are highest grade—lastingly dependable, quiet in operation, fully guaranteed.

Mail Coupon Right, Now

MIDWEST RADIO CORPORATION  
Pioneer Builders of Sets  
566-A Miraco Building, Cincinnati, Ohio.

**THIS COUPON IS NOT AN ORDER**

Without obligation, send free catalog, AMAZING SPECIAL OFFER. testimony of nearby Miraco users.

NAME

ADDRESS

Amazing value in 30 Days' Trial Will Prove

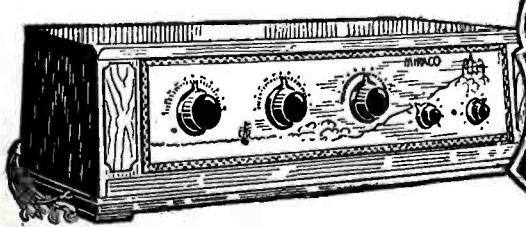

**New!**



**Centrallab  
Power Rheostat  
and  
Potentiometer**

This new unit is warp-proof, heat-proof. Constructed without fibre, permitting continuous operation at temperatures of 482 F and beyond, in socket power circuits. Resistance wire is wound on metal core, asbestos insulated. Core expands with wire insuring smooth action. Narrow resistance strips give small resistance jumps per turn, further assurance of even regulation. Compact 2" diameter, 1" behind panel. Ohms—500, 250, 150, 50, 15, 6, 3, .2, .5—price \$1.25. The new Power Potentiometer is identical except for an additional terminal, and is especially suited to obtain variable voltages for detector tube and Variable "C" Bias in socket power currents. 150, 250 ohms, \$1.50; 2,000, \$1.75; 6,000, \$2.00.

**4th Terminal  
Centrallab  
Potentiometer**

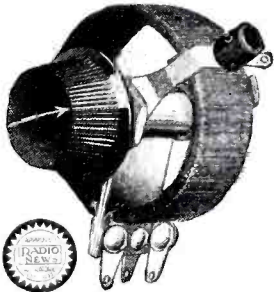

This new three terminal unit is identical to the above units, except for added semi-variable contact arm, adjustable behind panel to any resistance value. 175 ohm unit gives 2 variable voltages in "A-B-C" power circuits. 250 ohms gives 2 variable taps for 67 volts and intermediate voltage in "B" output of the new Raytheon "A-B-C" power circuit. 2,000 ohms gives 2 variable "C" biases in "B" power circuits. Two 6,000 ohm units in series across "B" filter output give all necessary output voltage taps with ideal load regulation. 175, 250 ohms, \$2.00; 2,000, 6,000, \$2.25.

**Wire Wound Centrallab  
Fixed Resistor**



Break-proof under high temperatures, dissipating 50 watts in open air below 480°F. Heavy current capacity for A & B socket power circuits. The wire is wound on asbestos, held firm with heat-proof cement. Length 5", width 1 1/2", 1/16" thick, gives ample heat dissipating area. Several resistors can be mounted side by side with same two screws, saving space. Without taps, 50 ohms, \$.80; 100, 250, \$.90; 2,000, \$1.10; 4,000, \$1.10. Tapped: 209 ohms, tapped at 57 ohms, \$1.00; 250, tapped at 40 and 100, \$1.10; 350, tapped at 50, 150, 250, \$1.20; 3161, tapped at 861, \$1.40.

**Easy Chair  
Centrallab  
Modu Plug  
20 Feet of Cord**



Tune with your dials to maximum strength and clarity of station, then from your easy chair use Modu plug to smooth it down to any degree of tone without changing ratio of high and low notes. No more jumping up to adjust dials for changes in character of program. Also use to connect two speakers in series at a distance from set. Price \$3.00.

At your dealer's, or C. O. D. Send for new A-B-C- power circuits.

**CENTRAL RADIO LABORATORIES**  
11 Keefe Avenue, Milwaukee, Wis.



**The Harkness Tuned  
Audio Amplifier**

(Continued from page 111)

a receiving set designed for the purpose. The width of the unit is only 9 inches and the depth 6 3/8".

Experienced set-builders will also realize that it is a very simple matter to use this system of amplification in any receiving set without actually building

are marked for use in the first, second and third stages respectively. It is important that they be connected in the order indicated as special values of coupling condensers are used in each stage.

The first step in the construction of the amplifier is the cutting and drilling of the panels. Any dealer, equipped for the purpose, will cut the panels to the sizes specified.

The drilling templates are shown in Fig. 8. Lay out the holes to be drilled

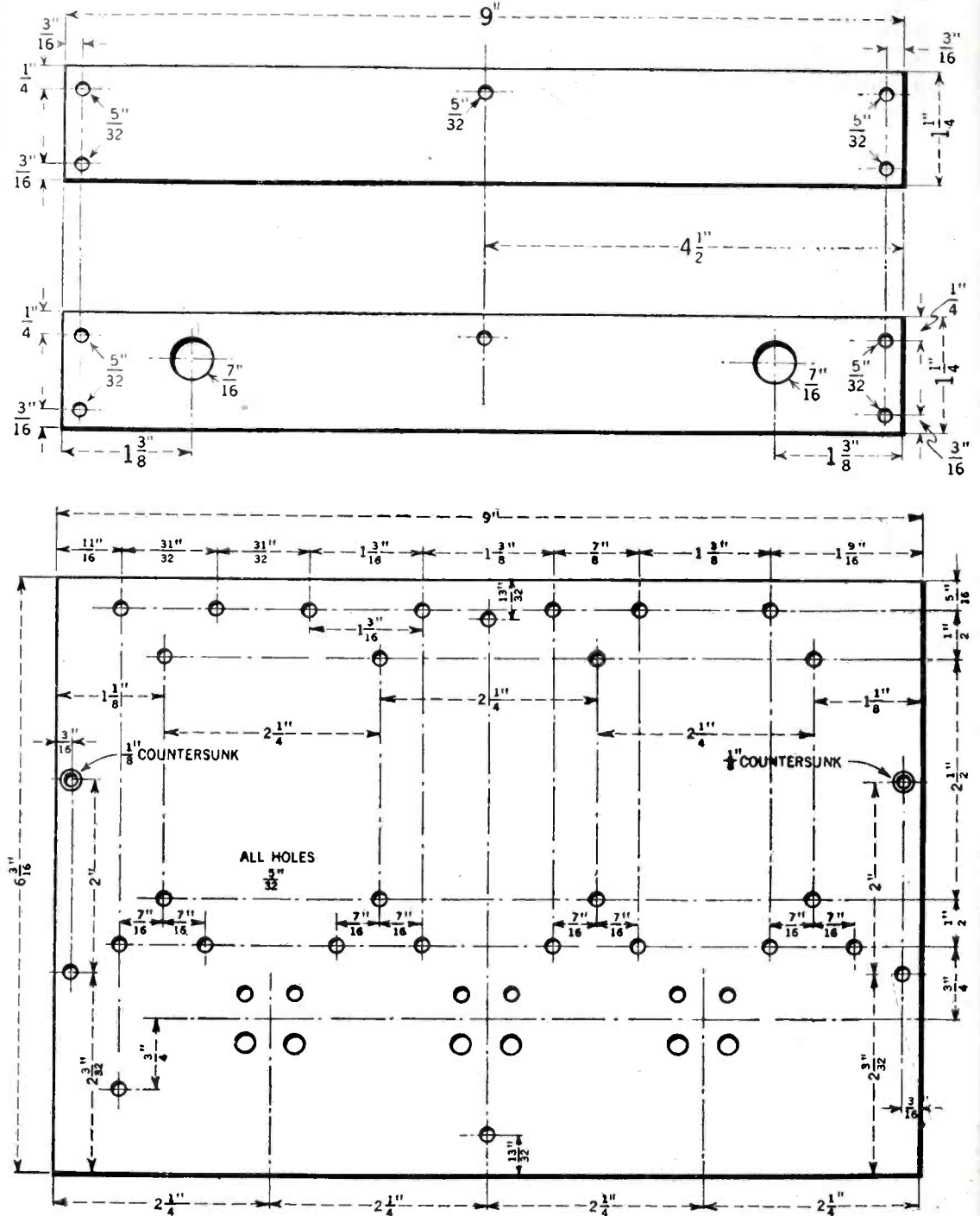

Fig. 8. Drilling templates of the sub-panel and the two bakelite strips. If different tube sockets are used, drill mounting holes required.

a separate amplifier. The three tuned double impedance couplers and the output unit can be mounted directly on the sub-panel or base-board of any receiver and wired as shown in the diagrams. For many purposes, however, it is very convenient to have a separate audio amplifier which may be used with any receiving set (or phonograph) and the construction of the amplifier will be described.

The parts required to build the amplifier are listed in a separate column. The tuned double impedance couplers

on the panels; then center-punch the holes and drill as indicated. It will be noticed that the model amplifier illustrated is equipped with sockets which are riveted to the panel. The holes for these sockets are shown in the drilling template. Any tube sockets can, of course, be used. Drill the panel for the type you procure.

When the panels have been drilled, assemble the amplifier as shown in the photographs. First, mount the sub-panel brackets on the large panel; then  
(Continued on page 155)

*New*



**130 M. A. FULL WAVE RECTIFIER**

Here is a power unit that will satisfy the ever increasing demand for improved quality of reception. A split secondary 550 volts either side of center, makes possible full wave rectification, using two 216-B or two 281 tubes. Current capacity, 130 milli-amperes. The low voltage secondary, 7½ volts, will supply two UX-210 power tubes, enabling the use of push-pull amplification in last audio stage. The Double Choke Unit 2099 is designed for this power unit. Contains two individual chokes of 30 henries, 130 milli-amperes capacity each.

T-2098 Transformer, 4½" x 5¼" x 5¾"

List Price, \$20.00

T-2099, Choke Unit

3¼" x 4⅞" x 5⅝"

high

List Price

\$14.00

*Realistic tone quality, that elusive but much talked of characteristic of radio reception— can be obtained only through the use of apparatus of the finest materials and workmanship. For years Thordarson transformers have been the choice of many discriminating manufacturers of quality receiving sets. Follow the lead of the leaders. If you enjoy good music specify Thordarson transformers*

**THORDARSON**

**POWER TRANSFORMERS**



**POWER PUSH-PULL TRANSFORMER and CHOKE**

Quality reproduction that cannot be obtained with straight audio amplification, is made possible through the Thordarson power push-pull combination. This arrangement is designed for use with power tubes only and has sufficient capacity for all tubes up to and including the UX-210. Makes an ideal power amplifier when used with power supply unit T-2098.

Input transformer couples stage of straight audio to stage of push-pull. Output choke is center-tapped with 30 henries on either side of center tap. Dimensions of both transformer and choke, 2½" x 2½" x 3" high.

Input Transformer T-2408

List Price, \$8.00

Output Choke T-2420

List Price

\$8.00



**A. C. TUBE FILAMENT SUPPLY**

The new R. C. A. and Cunningham A. C. filament tubes will be very popular with the home constructor this season. The Thordarson Transformer T-2445 is designed especially for these tubes. Three separate filament windings are provided.

Sec. No. 1, 1½ volts, will supply six UX-226 amplifier tubes.

Sec. No. 2, 2½ volts, will supply two UX-227 detector tubes.

Sec. No. 3, 5 volts, will supply two 5 volt power tubes.

In addition to the above, this transformer is equipped with a receptacle for the B-supply input plug. Supplied with six-foot cord and separable plug for attachment to the light circuit. Transformer in compound filled, crackle-finished case. Dimensions — 2¾" x 5¾" x 4¾".

A. C. Tube Supply, T-2445

List Price, \$10.00

**THORDARSON ELECTRIC MANUFACTURING CO.**

*Transformer Specialists Since 1895*

**WORLD'S OLDEST AND LARGEST EXCLUSIVE TRANSFORMER MAKERS**

*Huron and Kingsbury Streets — Chicago, Ill. U.S.A.*

THORDARSON ELECTRIC MFG. CO.  
500 W. Huron St., Chicago, Ill.  
Gentlemen:  
Please send me your booklets describing your new power supply transformers.

Name.....  
Address.....  
City.....State.....

(3562)N

# On to Success in RADIO!



Mr. R. L. Duncan,  
Director of the  
Radio Institute  
of America.

**R**ADIO is a profession well worth following. The work is interesting—fascinating. The pay is high. The demand for new men—skilled men—is strong.

You can embark, right now, on a successful career in radio. With a few months study under the expert instruction of the Radio Institute of America you can pass your U. S. Government Commercial or Amateur Radio License Examination and be ready for your first real radio job.

## Study in spare time

There's no need to give up your present work. Study at home in spare time. If you really want to make a success in radio, fill in and mail the coupon to the Radio Institute of America for information on the world's finest theoretical and practical radio courses.

### RADIO INSTITUTE OF AMERICA

Formerly Marconi Institute  
Established 1909

324-a Broadway New York City

Radio Institute of America  
324-a Broadway, New York City.  
Please send me full information about your Home Study Course of radio instruction.

I am interested in the complete course, including code instruction, which qualifies for the U. S. Gov't Commercial or Amateur Radio License.

Name.....

Address.....

## A Compact A-B-C Power Unit

(Continued from page 107)

in detail. This diagram of rewiring of the "Hi-Q" will serve two purposes; it will illustrate how this particular receiver may be converted and it can be used as a typical example for converting any radio receiving set to series filaments.

employed in this unit can not be substituted in any of the present "B" eliminators for other types of tubes. This tube will not properly function unless 200 milliamperes of current is drawn, and also the present "B" eliminators are not of the heavy duty type and can not stand up under a load of this nature.

Any set may be converted to series filaments; however, a receiver which uses tandem condensers is perhaps

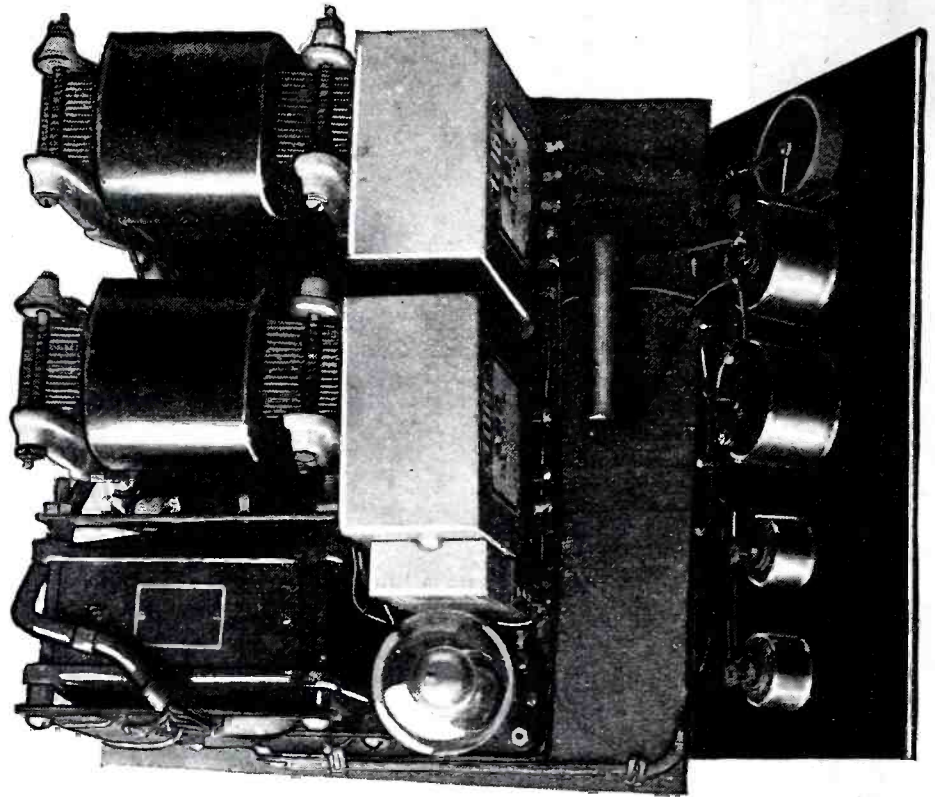

A top view of the assembled A-B-C Power Unit with the front panel tilted forward to show how the Clarostats, meter and variable resistance are mounted.

If all connections are properly made and the "A-B-C" unit built as described, no appreciable hum will be heard in the loud speaker when operated.

more difficult and for this reason the author has chosen a popular receiver of this type, namely the "Hi-Q."

To convert the "Hi-Q" in the first place it is necessary to isolate the two

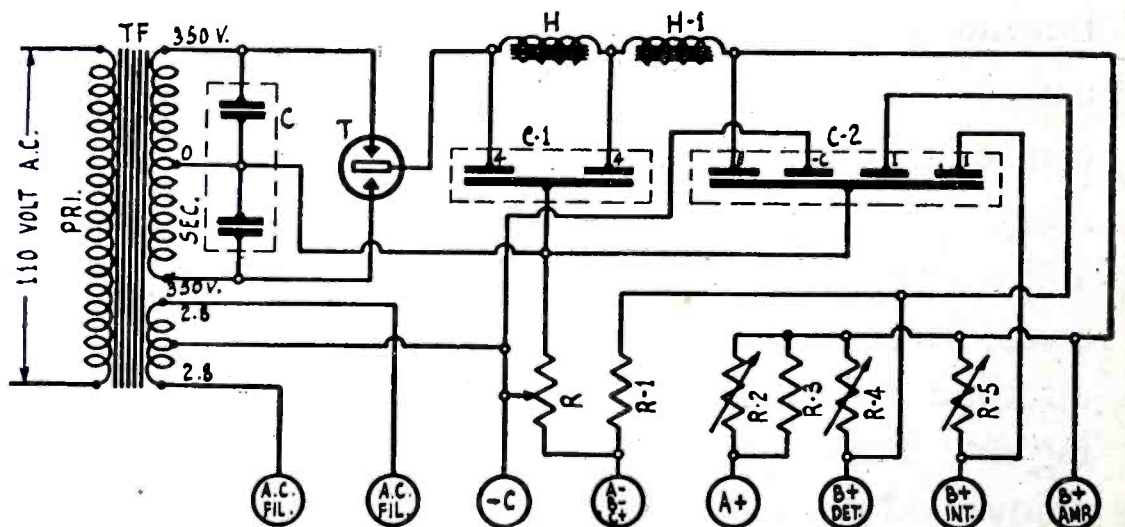

Schematic wiring diagram of the Compact A-B-C Power Unit. Lettering corresponds to that given in the list of parts in the foregoing part of this article.

A word of caution is always in order when making a device of this nature. Do not work on the unit when the house current is turned on to the transformer. Perhaps it also should be made clear that the rectifying tube as

tuning condensers which have a common shaft and their frame grounded to the shield. This may be done by substituting a Bakelite shaft for the one furnished. To do this, loosen the  
(Continued on page 153)



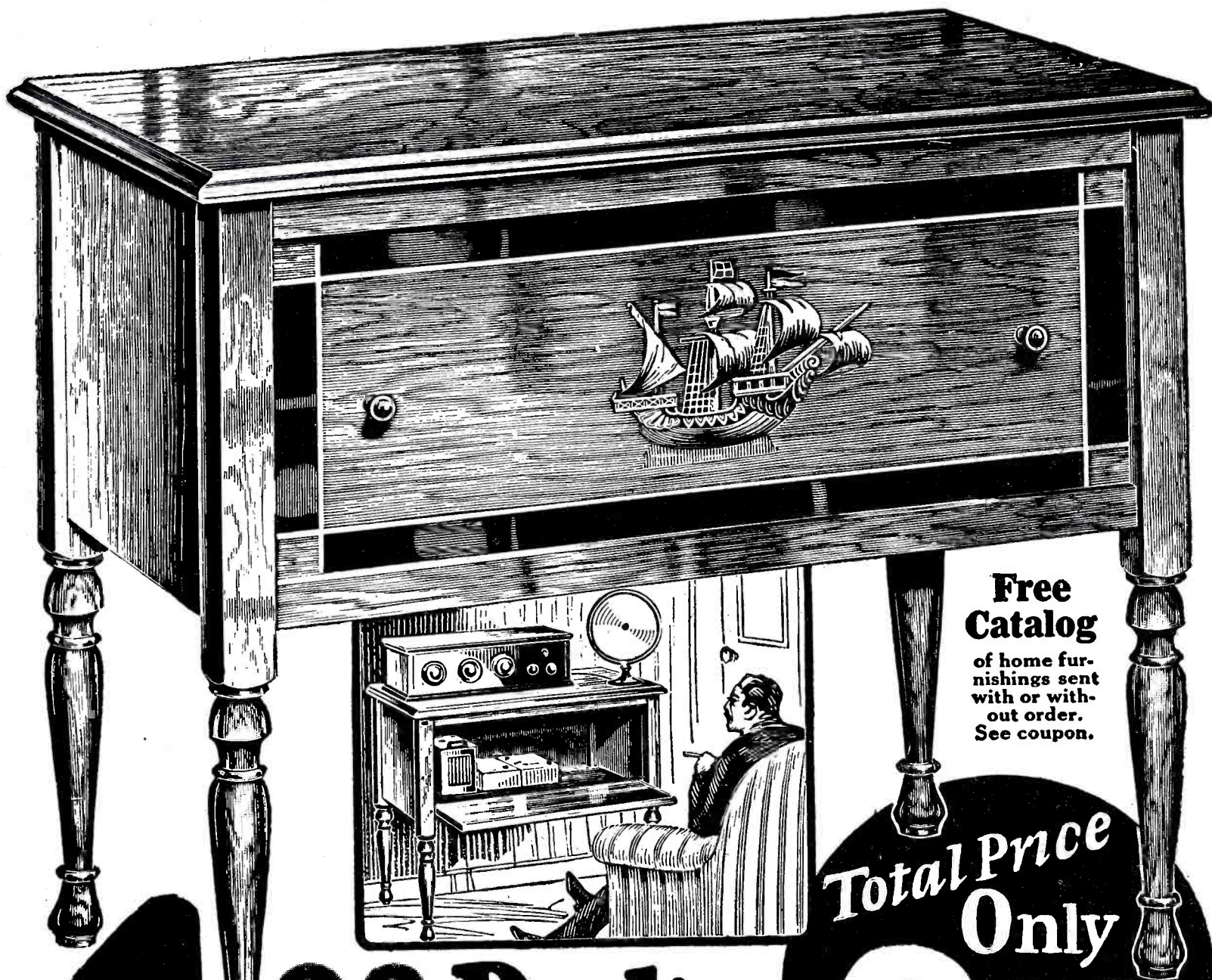

**Free Catalog**  
of home furnishings sent with or without order. See coupon.

Total Price Only

**\$1.00 down brings this Radio Cabinet \$9.90**

**Free Trial** Yes, only \$1.00 with coupon brings this stupendous cut price bargain to your home on 30 days' trial. A handsome radio cabinet with ample room inside for all batteries, charger and eliminators. All unsightly accessories out of sight in a splendid piece of furniture. Made of beautifully grained, thoroughly seasoned selected hard wood. Elegant **Walnut Finish** Will not warp. Highly polished outside surfaces; front panel in popular two-tone effect, ornamented with Galleon Ship in full colors, giving hand-painted effect. Rich gold border countersunk on front panel, will not wear off. Neatly turned legs and beaded edges. Strongly built; all joints reinforced. Top 30 1/4 inches x 16 3/4 inches, ample for any radio and loud speaker. Height 30 3/4 inches.

**\$1.00 a Month** After 30 days' trial, if not satisfied, send it back at our expense and we'll refund your \$1.00 plus all transportation charges you paid. Or keep it and pay only \$1.00 a month till you've paid our smashed cut price for this sale—only \$9.90. Our credit price beats cash prices anywhere. Order by No. B9859A. Shpg. wgt. about 60 lbs.

**Send Coupon NOW!**

**STRAUS & SCHRAM Dept. R-3566 Chicago**

**Straus & Schram, Dept. R-3566 Chicago**

Enclosed find \$1.00. Ship Walnut Finish Radio Cabinet. I am to have 30 days free trial. If I keep the cabinet I will pay you \$1.00 monthly. If not satisfied, I am to return the cabinet at your expense and you are to refund my money and any freight or express charges I paid.

**Walnut Finish Radio Cabinet, No. B9859A, \$9.90**

Name \_\_\_\_\_

Street, R.F.D. \_\_\_\_\_  
or Box No. \_\_\_\_\_

Shipping Point \_\_\_\_\_

Post Office \_\_\_\_\_ State \_\_\_\_\_

Married or Single \_\_\_\_\_ Nationality or Color \_\_\_\_\_

If you want **ONLY** our free catalog of home furnishings mark X here

# R. E. Lacault

Originator and designer of the nationally known "ULTRADYNE," Radio Engineer, and former Editor with many years' practical experience on Super-Heterodynes—

Constructed and tested the Radio News Laboratory model of—

The 8-Tube

## Strobodyne Receiver

R. E. LACAULT has specialized in the greatest and most powerful of all Radio Circuits, "The Super-Heterodyne," and in the Strobodyne he has developed a receiver of marvellous perfection.

We Are Prepared to Furnish

## Complete Parts

AS SPECIFIED With Large Simplified BLUE PRINTS

Send for NEW 1927-1928 FREE Handbook

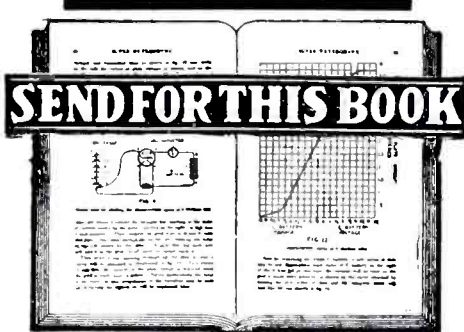

## Super-Heterodyne Construction & Operation

By R. E. Lacault, E. E. ORIGINATOR OF ULTRADYNE

This is a bound book full of practical information and many illustrations for the owners and builders of Super Heterodyne receivers. Written in plain, non-technical language so that everyone can understand it. It explains the how and why of each part, how to improve your present set, how to locate and remedy troubles, how to build a power amplifier, and completely describes the latest design of the New L.R.4 by R. E. Lacault. \$1.97 Complete set of correct and accurate full size drawings for the construction of the L.R.4—his latest circuit. Price.....\$1.00

**R. E. LACAULT**  
Radio Electric Laboratories  
1931 Broadway New York

R. E. Lacault, Mail Order Dept.,  
1931 Broadway, New York.  
Enclosed find \$1.97; please send me copy of  
Super-Heterodyne Construction and Operation.

Name .....  
Address ..... State.....  
City .....

## The Improved Laboratory Super-Heterodyne

(Continued from page 96)

7. kilocycles of powerful locals—a degree of selectivity duplicated by no other set tested. The wavelength range of the receiver with standard coils is from 30 to 3,000 meters. Regular broadcast range coils cover the range of 200 to 550 meters, but it can be seen that the receiver is adapted to any class of broadcast reception by virtue of its wavelength flexibility.

The parts required to build the 1927 Model Improved Laboratory Super have been most carefully selected for the perfect coordination of the operating characteristics of the receiver. It is imperative that the exact parts specified be used in building the set if its truly remarkable performance is to be realized to the fullest possible extent. known and reputable manufacturer. Every item is the product of a well and unconditionally guaranteed.

### Assembly

Upon the chassis should be mounted the detector and oscillator assemblies, inside the stage shield pans if shields are to be used. The end mounting screw of each 511 tube socket is used to join the A— to the chassis, so a lug should be placed under the screw head, to be soldered to the F— socket terminal, and the under side of the chassis scraped bright for good contact with the fastening nut. One terminal of the .00015 grid condenser should be bent at right angles and fastened directly under the "G" terminal screws. The single long screw holds the 275 choke coil in the detector stage assembly.

The binding posts mount in the nine holes at the rear of the chassis using the insulating washers to positively insulate them from the chassis, as do the four tipjacks. The "Ground" post grounds to the metal chassis, and the fastening screw of this post holds one end of the second 1/2 mfd. condenser tightly to the chassis, while the free end must be bent up clear and free of the metal chassis.

The A— connection is made to the amplifier thru a contact between amplifier shield and chassis to which it is fastened with four screws. The two audio amplifier tube sockets mount using their rear fastening screws to connect the F—posts to the chassis. All possible wiring should be done on the chassis before proceeding further, leaving free the wire ends that will connect to the instruments on the front panel; and to the two audio transformers which mount last. The potentiometer should be mounted as shown, using insulating washers to thoroughly insulate its frame from the panel. The

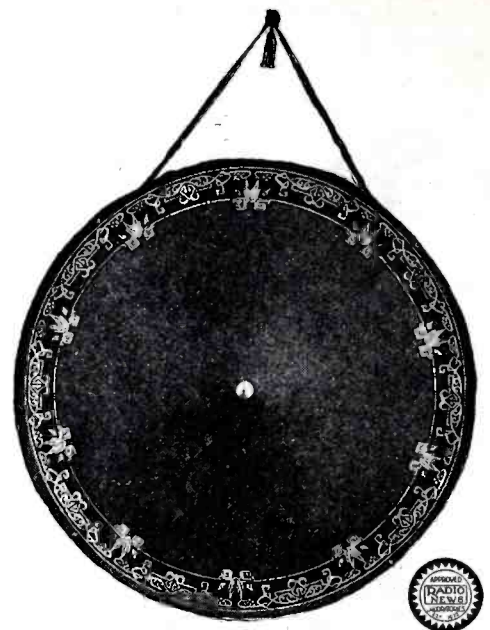

## YOU CAN BUILD The World's Greatest Cone

The 3-foot "Ensco" cone has been enthusiastically acclaimed by the leading engineers, magazines and newspapers as the greatest speaker development of modern radio. Every tone is faithfully reproduced. Its 3-foot diameter brings out the bass and at the same time the tones of the middle and treble register are faithfully reproduced. It reduces static and brings in the programs through the heaviest static periods.

### With the "ENSCO" KIT

and our complete instruction book you can easily build the "Ensco" cone, in any one of 6 designs. No soldering; a screw driver, a pair of pliers, scissors and some paste is all that is required. The "ENSCO" Unit is the only direct-drive unit for large cone speakers. Works on any set with any power. No filters or chokes necessary. 90 to 250 volts without protection or 1500 volts with transformer.

### Fully Patented

Manufactured under U. S. Patent No. 1,630,119; "Ensco" Cushion Drive Patent No. 1,163,854; Cone Diaphragm Patent No. 1,003,655, and other patents pending. Six different types to choose from—wall, pedestal or console—all of them easy to put together with our complete instructions. At last it is possible for everyone to have a 3-foot cone speaker at a reasonable price.

### \$10 and an Hour's Time

The complete "Ensco" Kit is only \$10.00; and with hardwood wall frame \$11.00. In less than an hour after you receive your kit you will be enjoying music you never thought your set capable of. If your dealer cannot supply you we will send a kit direct from any of the offices listed below. We pay shipping charges. Send money order, check or cash or we will ship C. O. D. Order today. Absolute (money-back) guarantee.

### Engineers' Service Co.

25 Church Street, New York  
73 Cornhill, Boston  
28 E. Jackson Blvd., Chicago  
331 Bay Street, Toronto, Canada  
MEMBERS RMA.

### "STROBODYNE" CIRCUIT

We carry a complete stock of the specified parts for the new Strobodyne circuit, as specified in Radio Listeners' Guide. Send for free literature and our beautiful 48-page catalogue.

**GRAYMORE RADIO CORP.**  
142 Liberty St. New York City.

## NA-ALD

UX POWER TUBES installed in any set without rewiring, by Na-Ald Adapters and Connectorals. For full information write Alden Manufacturing Co., Dept. Q-8, Springfield, Mass.

SAVE TIME and MONEY  
Use the "Radio Trouble Finder"  
SEE PAGE 146

# Revolutionizing Radio Socket Power!

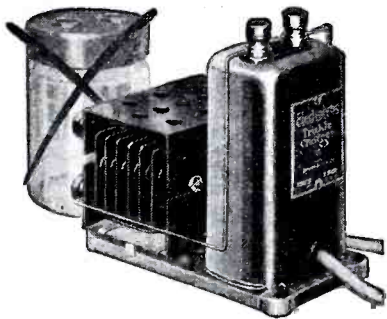

**Modernize Your Trickle Charger or Power Unit!**

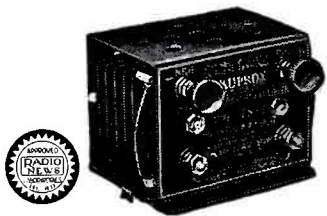

**KUPROX**  
No Bulbs • No Liquids • No Noise  
REPLACEMENT UNIT

Eliminates Acids, Liquids and Charging Bulbs

Makes any electrolytic unit dry, noiseless. Requires no watering or other attention. Increases charging rate.

Throw away the acid jar on your present trickle charger or power unit. Install the new KUPROX all-metal Replacement Unit in its place. In less than two minutes banish all the bother of watering and other attention—the danger of ruined rugs and clothing. Very easy to attach. Requires but two simple binding post connections. Makes your charger absolutely dry, and gives a higher charging rate. Fits all standard electrolytic chargers and power units. List Price, complete with full instructions.

**\$4.50**

**from any Radio Dealer**

No acids, liquids, or charging bulbs....  
**Dry permanent power that requires no attention**

At last, radio power as dependable and permanent as your house current, that requires no more attention than the snap of a switch. KUPROX, the new, dry metallic rectifier supplies all radio power, A, B, and C, constantly, dependably — probably the greatest of all developments in light socket radio power.

With KUPROX Devices your set is truly electric. KUPROX is all-metal—dry—it needs no watching or watering—it cannot wear out. Various models, from Trickle Chargers to the Combinations which supply all radio power from a single compact unit.

**[ FREE BOOKLET FOR YOU: "The Secret of Successful Battery Elimination," describing KUPROX Devices, will be mailed Free on request. Write for it. ]**

**THE KODEL RADIO CORPORATION**  
519 E. Pearl St., Cincinnati, Ohio

## KUPROX RADIO POWER DEVICES

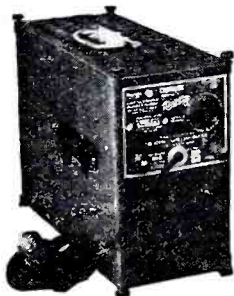

**KUPROX "A" TRANSIFIERS**—Batteryless, noiseless, electric "A" power. Dry, dependable, needs no attention. Operates any receiver. 4-volt or 6-volt, \$28.50 and up.

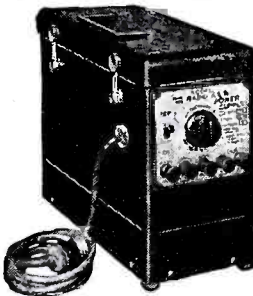

**KUPROX A & B TRANSIFIERS**—All radio power from a single unit. Controlled from set switch. Absolutely dry, requires no attention. \$57.50 and up.

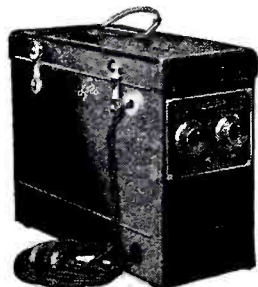

**KUPROX "B" TRANSIFIERS**—Dry, permanent, free of hum. Guaranteed voltage at rated output. Models for all sets and circuits, \$14.50 and up.

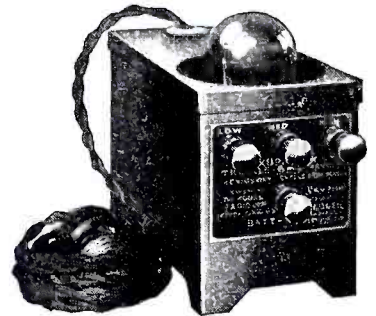

**Recharge Your Dry "B" Batteries**

Now you can make your dry cell B batteries last many times as long as before. One of the outstanding achievements of the past year in radio is this new system for rectifying ordinary dry cell B batteries.

**KUPROX**  
No Bulbs • No Liquids • No Noise  
TRICKL-B RECHARGER

Makes a "B" Power Unit of any set of dry cell "B" batteries. Connected to the light socket it performs like the trickle charger on the "A" battery, supplying new life constantly into the dry cell "B" batteries. With this new system "B" batteries can be made to last indefinitely. Very simple to operate and very economical. Simply attach to your "B" batteries, turn on the light socket and forget it. Uses no acids or liquids of any kind. List price, complete with tube

**\$10.00**

**from any Radio Dealer**

# USE MADISON ULTRAFORMERS

(Designed by R. E. Lacault)

## In the New STROBODYNE

**\$4.00 ea.**

(subject to regular trade discount)

Type B Ultraformers have a primary of 200 turns and a secondary of 400 turns.

### MADE AS SPECIFIED FOR THE STROBODYNE

according to specifications on page 134 of the August issue of RADIO NEWS

#### Our Policy of LOWEST WHOLESALE PRICES

—that is, to endeavor to sell day by day for less than the prices of our legitimate competitors—is made possible because we sell for cash only.

We are not infallible. Others may on occasion cut our prices—may on occasion sell merchandise for one reason or another at prices lower than we, until we find it out.

We thank our customers who report any items on which we are being undersold. In other words, we will meet the price of any legitimate competitor if our customers will furnish us with the name of the concern, together with the page number of the catalog in which the lower price is quoted. In comparing prices be sure to remember that we allow a cash discount of 3 per cent when cash accompanies order.

That our policy is believed in and appreciated is clearly proved by our rapid growth.

We give no credit. We give no extra discounts to a favored few. We are the headquarters of the thrifty dealers and professional set builders who pay as they go.

**Five specially  
matched fixed  
condensers  
for Ultradyne  
and Strobo-  
dyne circuits  
List Price  
\$1.75**

#### Send for New Catalog

giving whole-sale prices on all new kits and parts needed to construct all circuits shown in this magazine.

#### Set Builders

We refer all inquiries for Custom Built sets to you. Register with us now and earn big money in your spare time.

## MADISON RADIO CORPORATION

35-37 WEST 31st STREET

NEW YORK, N. Y.

# RALPH 124C 41+

An Amazing Story of the Year 2660

By Hugo Gernsback, Editor of *Amazing Stories*  
*Radio News and Science & Invention*

Against an amazing background of mechanical, electrical and chemically altered life of mankind there is set a brilliant and colorful romance in the life of the greatest living scientist of that age. Ralph's love for the beautiful stranger, his conquest of his rival and the worsting of the great saturnine Martian, culminating in a running fight in space with tragedy and terror conquered by almost unbelievable and incredible weapons, make one of the most interesting and gripping stories ever told.

PRICE, \$2.15 EXPERIMENTER PUB. CO., INC., 230 Fifth Ave., N. Y.

rheostat and the midget condenser are similarly mounted, except that care is taken to make good contact between them and the panel.

The drive mechanisms of the dials should be dropped into the bracket bearings intended for them, the shafts pushed thru the holes in the front panel, and the two brackets bolted to the panel using the screws provided. One variable condenser fastens to either bracket, using the shaft mounting nut provided. A drum should be slipped over each condenser shaft, with set screw loosened, and pushed up until the drum scale edge is just ready to enter the crack in the drive mechanism shaft. With a knife blade this crack should be widened to receive the drum scale edge, and the drum pushed well up on the condenser shaft. The scale should then be adjusted to read 100 degrees against the indicator points in the panel windows, when the condenser plates are entirely unmeshed, upon which the set screw in the drum dial hub should be tightened on the condenser shaft. With the knobs fastened on the drive shafts, the condenser dials should rotate if the knobs are turned.

The connections to the condensers, rheostat and potentiometer should be made before fastening the panel to the chassis. After they have been put in, machine screws and nuts serve to hold panel and chassis together. The on-off switch mounts in the one remaining panel hole, with insulating washers to thoroughly insulate it from the panel and chassis. (It may have been previously connected in circuit, and allowed to hang on the wiring until ready to be mounted.) In wiring, a little slack should be left in each connecting wire.

After testing, all wiring may be bunched and laced into neat cables, using very heavy waxed shoemaker's thread. Two leads should not be joined or included in the cable. They are the wires running from the detector stage along the bottom of the chassis and up to posts 1 and 2 of the oscillator coil socket.

#### Operation

To operate the set, all tubes (a total of six CX301A, one CX340, and one CX371 tubes, are needed) should be inserted, except the first detector tube. The CX371 goes in the right rear socket; the CX340 in the adjacent rear socket. With the on-off switch on, the rheostat should be turned to within  $\frac{1}{8}$  inch to  $\frac{1}{4}$  inch of the full right position. If the potentiometer "GAIN" knob is turned to the right, a "plunk" will be heard at some point. This can be detected by varying the oscillator drum, which should cause a number of shrill whistles to be heard. The "GAIN" knob should always be oper-

# SM

## S-M is ready— for A.C. Tubes or Any New Developments!

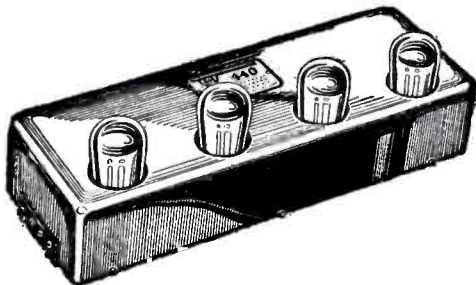

**T**HE 440 time signal amplifier is a fully assembled three stage, 112 K. C., long wave amplifier-detector catacomb. It consists of three air-core low-resistance tuned R. F. stages and detector, with all necessary by-pass condensers, etc., mounted in a copper and brass catacomb providing individual stage and over-all shielding.

Each 440 amplifier is accurately matched in the S-M laboratories to exactly 112 K. C., and every amplifier is guaranteed to within one-half of one percent. The selectivity of the 440 is tremendous—it may be made 10 K. C., or even 5 K. C. at will, while the sensitivity is guaranteed greater than that of any amplifier that might be built of individual parts. Price \$35.00.

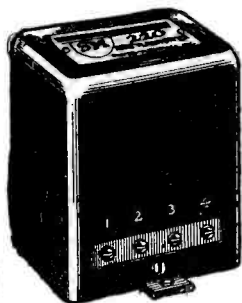

The fall season finds S-M 220 audio and 221 output transformers still the acknowledged leaders in the high-quality transformer field. And they are accorded the sincerest form of flattery—imitation—for this year other manufacturers, profiting by their phenomenal success copy the 220 characteristics introduced by S-M a year ago—5000 cycle cut-off, rising low frequency characteristics, and plenty of iron and copper to make a good job.

But S-M audio transformers stand supreme as the finest available—the only types ever backed by a guarantee of BETTER reproduction or your money back. That's the S-M guarantee—and the return average is less than one in every 4000 sold—3999 satisfied customers out of every 4000. 220 Audio Transformer, Price \$8.00. 221 Output Transformer, \$7.50.

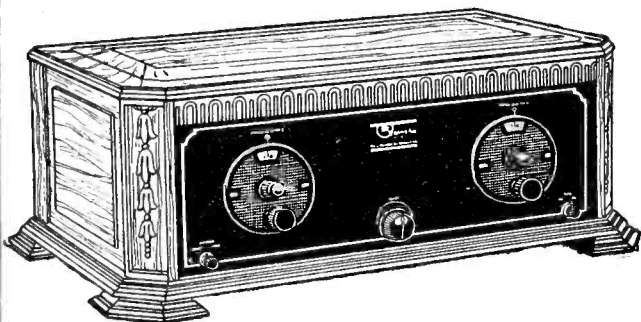

The S-M Unipacs, introduced this June, have taken the country by storm. Everywhere, builders are realizing what true distortionless reproduction really is—for the larger Unipacs (power amplifiers and ABC power supplies) can deliver from 5 to 300 times more—and purer signals—than any standard receiver amplifier, which they replace. Prices range from \$62.00 to \$93.25 for wired and unwired models.

The new 1927 model Improved Shielded Six has all the points that made the original the most popular high-priced TRF kit ever offered. The new "Six" has greatly improved selectivity—so great that it will allow 10 to 20 K. C. separation of local and distant stations. The volume has been increased. The tone quality of the new 630 is just as fine as last year's model—**GUARANTEED UNCONDITIONALLY** to be equal or superior to any other set, regardless of price.

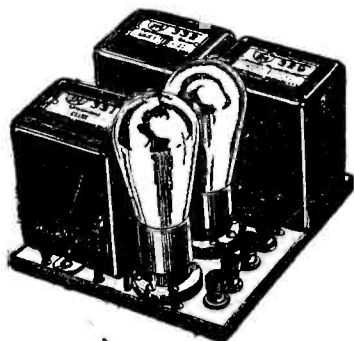

The new 630 can be built for battery, eliminator or complete A. C. operation. The A. C. model is absolutely batteryless, and uses the 652A, ABC power supply. (Any 1926 Shielded Six can easily be brought up to date, or adapted for complete A. C. operation). No matter what developments come, the 630 will always be one of the finest of sets, amply satisfying the most discriminating of fans. Price \$95.00.

The S-M 652A unit is the famous 652 "Reservoir B" supply, developed into a complete ABC power supply. Thus, with a 652A kit at \$36.50, plus as many A. C. tubes as your set needs, you make it entirely A. C. operated, with all batteries eliminated. Or any new set you are building can dispense with batteries if you use the 652A. Or if you want to change over your present B eliminator, new S-M ABC power transformers are available.

We can't tell you the whole story of new S-M developments, so if you'll just fill in the coupon, and mail it with 10c to cover postage, we'll send you free more up-to-the-minute advance radio information than you could buy in a text book.

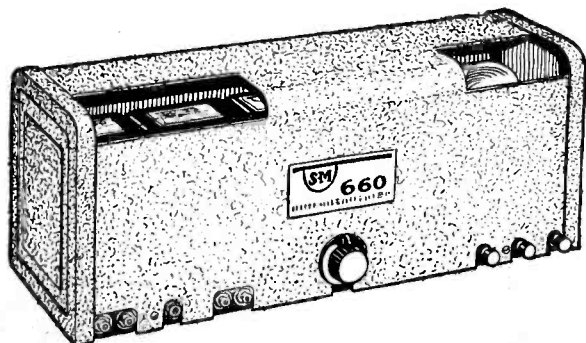

**SILVER-MARSHALL, INC.**  
866 West Jackson Blvd.  
Chicago, U. S. A.

Please send me information on new S-M developments, for which I enclose 10c.

Name .....

Address .....

# What Kind of Voice Has Your Loud Speaker?

## Does It Sn-narl?

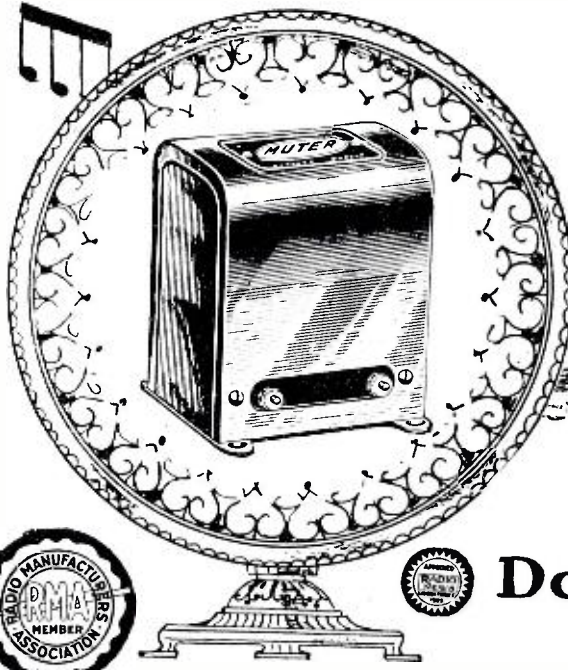

## Does It Whine? or Does It~

# Register Clear, Natural Human Tones? The Muter Clarifier

[NEW OUTPUT TRANSFORMER]

on your set will astonish and delight you by immediate, almost unbelievable improvement in reception. In nine cases out of ten that weak, distorted voice issuing from the speaker unit is suffering paralysis from high "B" Voltage. The Clarifier protects Speaker coils from this shattering current, assuring longer life as well as strong, full tone, clarity and volume.

If your speaker is one of the great majority that fail to respond properly to the output of the set—you need a Muter Clarifier. It's the only thing that will remedy the cause. Easily attached in a few seconds without disturbing set. Try it out to your own satisfaction on our liberal guarantee—you won't recognize your set!

**SEE YOUR DEALER—or SEND DIRECT**

Dealers can easily secure Muter Products for you from leading Jobbers. If, however, you have any difficulty in obtaining from your dealer, mail coupon direct to us. Prompt shipment will be made upon receipt of price or C.O.D. if preferred. Give your speaker a chance to produce its utmost. Mail coupon today.

**LESLIE F. MUTER CO.**

76th & Greenwood Ave., Dept. 585-M, CHICAGO, ILL.



**DEPENDABLE PRODUCTS**  
The complete Quality Popular Priced Line  
Send for comprehensive catalog

### Use This Coupon!

**LESLIE F. MUTER CO.**

76th & Greenwood Ave., Dept. 585-M, Chicago, Ill.

- Send Muter Clarifier at once, postage prepaid. \$5.00 is enclosed.
- Send C. O. D.
- Send complete Muter Catalog.

Name.....  
Address.....  
City..... State.....



## SPARETIME MONEY HANDBOOK

### —do you have to be shown?

Do you need plans, concrete, workable schemes that have been successful for others in earning a large spare time income?

Here's a book with 67 selected plans all completely outlined with sales methods, etc., for reaping big returns.

Altogether you have before you complete, accurate Spare Time businesses that have returned hundreds of dollars to others.

Sparetime Money contains 100 pages, of the large magazine size, 9 x 12 inches—with handsome colored covers, over 100 illustrations.

116 Pages :: 9 x 12 inches

SOLD EVERYWHERE

If your dealer cannot supply you—write direct

CONSRAD CO., Inc., 230 5th Ave., N. Y.



PRICE 50¢

ated just to the left of the "plunk" point—to the right of which squeals were heard when the "OSCILLATOR" dial was varied. The receiver is least sensitive when the "GAIN" knob is at the left, and most sensitive when the gain knob is just to the left of the "plunk" point.

The first detector tube should be inserted, and the midget condenser set all out. The antenna coil rotor should be set at 45 degrees—the oscillator rotor all in. A small antenna 30 to 60 feet long should be used, or even a larger one if the set is not too close to powerful local stations. Stations may be tuned in using the two drum adjustments only. Weak stations may be intensified by turning up the "REGENERATION" condenser on the front panel. This condenser functions similarly to the "GAIN" knob, in that, as it is turned to the right to interleave the plates, signal strength on weak stations will increase up to the point where the first detector oscillates, and the signal turns into a squeal. Adjusting the midget condenser will react slightly on the setting of the "ANTENNA" drum. The position of the antenna coil rotor should generally be at about 45 degrees. With a small antenna, it may work best all in—with a large antenna at nearly right angles. The sharpness of tuning of the antenna dial depends upon the setting of this rotor, as well as that of the midget condenser. The oscillator rotor should be adjusted once on a very weak signal at about 300 to 350 meters, and once set for maximum volume, may be left alone.

### Light Socket Operation

The Laboratory Super-Heterodyne may be operated from standard A, B, and C battery equipment, or it may be operated from light socket power equipment, either partially or wholly—using the standard CX301A, CX340, CX112, and CX371 tubes; either a 6 volt storage A battery with trickle charger (known, when both units are combined, as an "A Power Unit") or from a direct true A power unit such as the new Abox A supply. As there is considerable variation in B power units, a type employing a glow tube voltage regulator is recommended. Dry C batteries should be used. The receiver may be adapted for use with McCullough, Sovereign, or other A.C. tubes.

### Power Amplification

It is highly desirable that an output transformer such as Silver-Marshall 221 or 222 be used between the receiver and the loud-speaker. This unit has not been included in the set, since the ideal way to build it is to leave out the audio stages entirely and use, instead, a power pack such as the Unipac described elsewhere in this issue—a

# New and Distinctive Radio Consoles from the "EXCELLO" Line

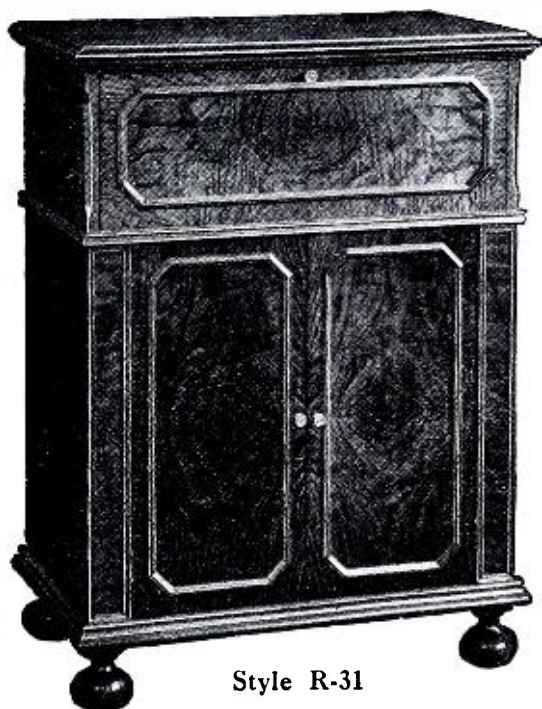

Style R-31

The creation of these smart designs so closely in keeping with the present trend is an achievement to delight all radio fans. These Consoles come with or without horn speaker of long air travel type. Accommodates 22 inch cone type speaker as well as batteries, charger or eliminator.

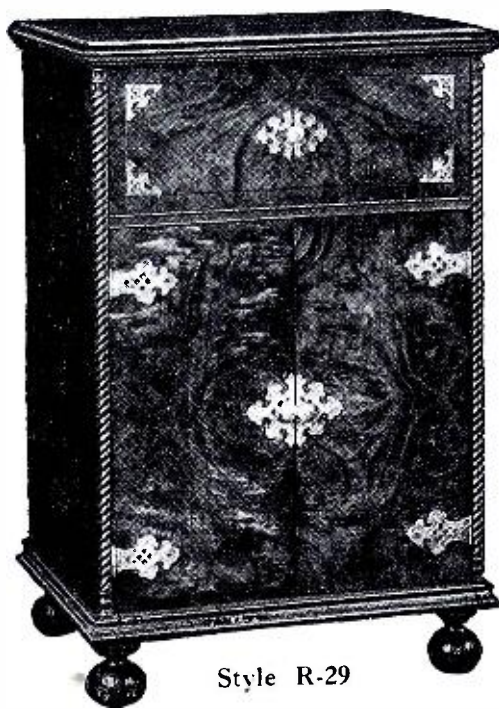

Style R-29

The sound chamber is so designed that confusing vibrations arising when a cone is enclosed in a cabinet are entirely eliminated. This is accomplished by open grill in front and back. All parts of set and accessories instantly accessible.



Style R-34

Special filler panels are furnished without extra charge for any Excello Console to accommodate Atwater-Kent, Fada, Freed-Eisemann, Grebe, Stromberg-Carlson, Kellogg as well as all other standard receivers.

Quality cabinet work of true Excello type. Doors of 5 ply butt walnut.

DEALERS AND DISTRIBUTORS write for interesting proposition in open territory.

## EXCELLO Radio Consoles

See the new Excello Consoles at your dealer or write us for descriptive catalog.

### EXCELLO PRODUCTS CORPORATION

4821-29 West 16th Street, Cicero, Illinois  
(Suburb of Chicago)

# This All Metal Cabinet Will House All The Latest Hook-ups

Big boon to set builders. Built to accommodate all late 1927-1928 hook-ups—A. C. or Battery Sets. Model 250  
Low price a big feature.

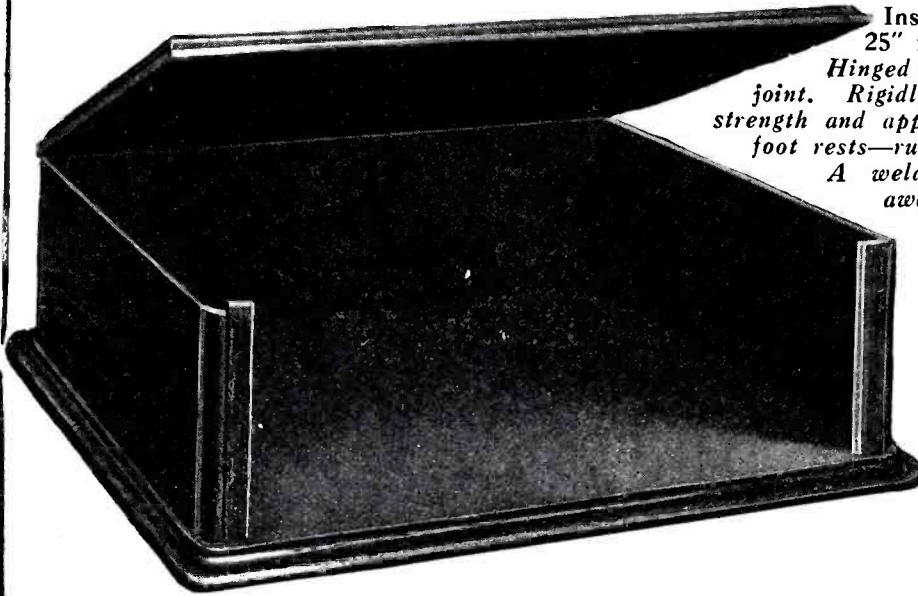

Inside Dimensions  
25" x 14 1/4" x 9 1/8"  
Hinged top—with stay joint. Rigidly formed for strength and appearance. Felt foot rests—rubber lid stops. A welded job doing away with troubles of swelling, shrinking, cracking, splitting and uncertain fit.

For Sets Using  
7 x 18  
7 x 21  
8 x 18  
8 x 21  
Panels

Vee Dee Chassis and panel for the improved 1927 laboratory model Superheterodyne.



Vee Dee Metal Cabinets, Metal Panels and Chassis. We carry standard size panels and chassis in stock for immediate delivery.

All the original beauty of natural wood grains combined with the efficiency of all metal construction! That strikes a new note in cabinet artistry. By our photo litho process, we reproduce mahogany and walnut hardwood, and novelty finishes, so gorgeous in their conception that they excite the admiration of all who see them.

Spacious interior dimensions are demanded for housing all the latest hook-ups! Vee Dee metal cabinets are designed for that purpose. 90% of all the 1927-1928 hook-ups are covered by the dimensions of Vee Dee No. 250 cabinet. Thus, we combine the extremely beautiful with the intensely practical. And consider the low price! Stronger and more beautiful than wood—but costs less.

**S C 2  
Assembly  
Unit**  
Panel, chassis and accessories.



Designed and drilled for this popular receiver, but dimensions are such as to make it easily adapted for any Power Pack assembly.

**JOBBER  
DEALERS**  
Write for  
Prices and  
Details  
  
Set Builders!  
If your dealer  
cannot supply you—  
write direct.



**UNIPACK HOUSING**  
Especially designed and provided for Silver-Marshall Power Hook-ups—including cabinet and chassis, drilled and with all small hardware.

## The Van Doorn Company

160 N. La Salle St.

Factory—QUINCY, ILL.

CHICAGO, ILL.

power amplifier and B supply combined. The first audio tube may be built into the Unipac as a CX326 tube with the first audio transformer in the set itself. In this case, the Unipac would serve beautifully as a phonograph amplifier with a record pick-up connected to the CX326 input tube's grid circuit, or as a two stage amplifier for the radio set with the secondary of the single audio transformer in the set connected to the Unipac in place of the record pick-up by means of a single phone cord.

## The Camfield Super-Selective 9

(Continued from page 85)

Under the usual conditions existing in tuned radio frequency amplifiers, the current fed back from the plate circuit to the grid circuit through the tube capacity is of such phase as to add to the voltage already existing between the grid and filament of the tube, and therefore cause oscillation. It obviously follows that, if the right phase relation is obtained between the current fed back through the tube and the current existing in the grid circuit, oscillation will not be caused.

### Coupling Between Stages Eliminated

It is well known that the phase relation between current and voltage in any circuit or group of circuits depends upon the relative constants of such circuits, namely, the inductance, the resistance and the capacity. In the case of transformers, the mutual inductance and the distributed capacity must also be taken into consideration.

In designing the Duoformer the relative proportions of all the constants mentioned above were arranged in such a manner that the current fed back from the plate to the grid circuit in a manner to prevent oscillations.

This feature, combined with the physical design of the Duoformer Coils, which practically eliminates all electro-magnetic coupling between successive stages, and a circuit design embodying the proper use of by-pass condensers, makes it possible to build a Five-tube tuned radio frequency set that is extremely simple to construct, and that has a high and uniform efficiency over the entire range of broadcast wavelengths.

### Three Tuning Controls Provide Greater Efficiency

In the Camfield Super-Selective 9 three tuning controls are used in order to provide for maximum efficiency in

# 1000 HOURS---of the Best Fun You Ever Had—Get Your Copy of

## SAM LOYD'S TRICKS and PUZZLES

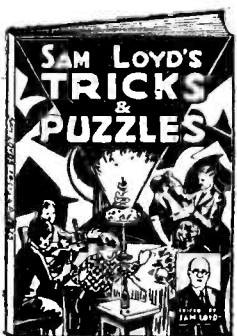

The year's most unique book—Barrels of fun, 120 pages—crammed to the full with every conceivable kind of tricks, puzzles, games, conundrums, etc. Size 9 x 12 inches—illustrations on every page. Fun for every member of the family.

50c On All Newsstands

EXPERIMENTER PUB. CO., INC.  
230 Fifth Avenue  
New York, N. Y.



# Camfield Super-Selective "9"

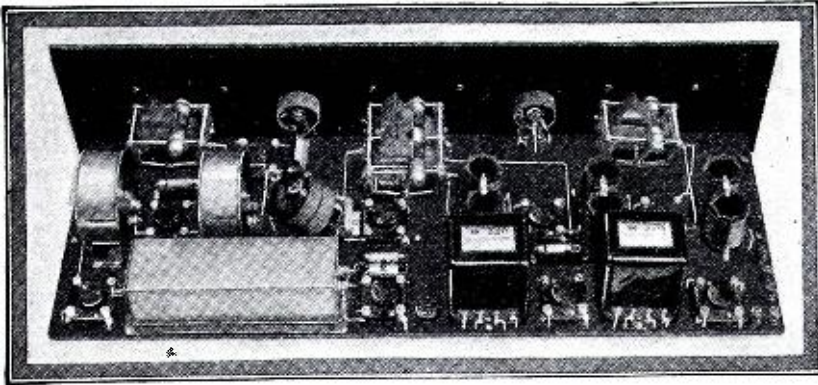

Using the Famous Rusco Band Pass Filter is the Most Sensitive and Selective Circuit ever developed.

The circuit used has many features of proven merit never before incorporated in a radio receiving set. Outstanding among these features is the use of the famous Rusco Band Pass Filter in the intermediate frequency amplifier. This filter is designed to pass a band of frequencies 10 kilocycles wide. The amplification over this band is uniform and the cut-off on either side is extremely sharp. The result is perfect selectivity between wave bands of only 10 kilocycle separation in frequency. The uniform amplification over the band maintains perfect tone quality. The selectivity of this device is so perfect that it permits the use of radio frequency amplification ahead of the Super and the operation of the set on an antenna. This makes the Camfield Super-Selective 9 the most sensitive receiver ever developed. The net result is the simultaneous increasing of both sensitivity and selectivity to a degree heretofore considered impossible.

The turning of a switch on the panel converts this set from a five-tube two-control radio frequency receiver for the reception of local stations to a nine-tube super-selective and super-sensitive circuit capable of tuning through powerful local stations and receiving distant stations from coast to coast on a 10-kilocycle separation of frequencies.

This new circuit is easy to construct and simple to operate and comparatively inexpensive. It is entirely free from disturbing oscillator harmonics and it will out-perform any radio set you have ever used.

## Camfield EQUALTUNE CONDENSERS

Unequaled for

- ACCURACY
- MECHANICAL DESIGN
- ELECTRICAL EFFICIENCY
- WORKMANSHIP
- APPEARANCE
- GENERAL UTILITY

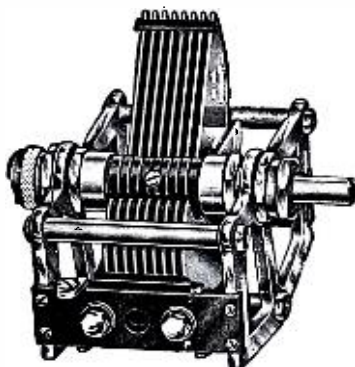

Manufactured in

- ALL POPULAR CAPACITIES
- AND IN UNITS OF
- ONE TO FIVE GANGS.
- ESPECIALLY ADAPTED
- FOR USE WITH THE
- NEW TYRMAN DRUM DIAL

### "A TRIBUTE TO A LEADER"

Camfield Equaltune Condensers are the unanimous choice of discriminating manufacturers, jobbers, dealers and set builders. There is proof of this in the fact that they are being officially specified in the following circuits for the 1927-28 season:

- Camfield Super-Selective 9.
- The Tyrman Ten.
- Madison Moore Super.
- Madison Moore AC Operated
- Radio Frequency Circuit.
- Citizens Super 8.

- Camfield Duoformer 7.
- The New St. James U240.
- Camfield Duoformer 5.
- Thompson Super 7.
- Hagerman's Organtone.
- Dar-Mac Nine.
- And many others.

Jobbers, Dealers, Set Builders and Set Manufacturers!  
Write for Detailed Information

CAMFIELD RADIO MANUFACTURING COMPANY

35 EAST WACKER DRIVE, DEPT. L. G., CHICAGO, ILLINOIS

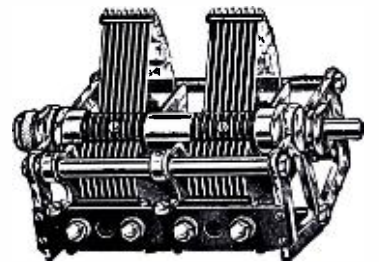
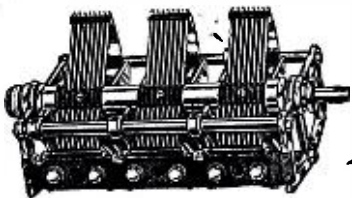

#### Prices—Camfield Products

Type	Capacity	Price
131 (Single)	.00015	\$ 5.00
251 (Single)	.00025	5.50
252 (Two Gang)	.00025	10.00
253 (Three Gang)	.00025	14.00
351 (Single)	.00035	5.75
352 (Two Gang)	.00035	10.50
353 (Three Gang)	.00035	15.00
354 (Four Gang)	.00035	18.00
355 (Five Gang)	.00035	21.00
501 (Single)	.0005	6.00
502 (Two Gang)	.0005	11.50
503 (Three Gang)	.0005	16.00
11 Mounting Brackets (per pair)		.25
22K (Duoformer Kit)		10.00
620 (Coupling Unit)		3.50



# NEW NATIONAL RADIO PRODUCTS



2 1/2 ampere Charger. Employs one Raytheon "A" Rectifier. Complete with cord and plug, rubber-covered battery leads and terminals.  
Price, \$11.50



NATIONAL Duo Range Chargers, 2 1/2 or 5 amperes. Complete with fuses, tell-tale lamp, cord, black rubber-covered leads and battery clips and two Raytheon "A's."  
Price, \$19.00



With the coming on the market of excellent phonograph pick-up devices, there has been great activity in the conversion of phonographs, for use with the audio end of Radio sets. In order to perfect the reproduction by this means, National Company has brought out a new device which takes out the noise of the needle scratch without affecting in any way the tone of the instrument.

National Scratch Filter  
Instantly attached to any phonograph pickup device.

Price, \$5.50

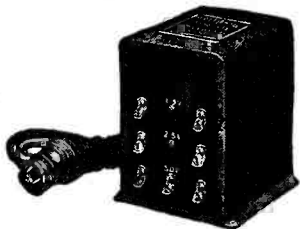

For Use with the New A.C. Tubes

This fall the new A.C. Tubes will come into general use. New sets will be built using them and old sets rebuilt to accommodate them. A small transformer is needed to operate the tubes, and here it is.

National A.C. Tube Transformer

for 110-115 volts, 60-cycle A.C. —three secondaries give 1.5 volts, 2.5 volts, and 5 volts.

Price, \$10.00

Send for our new pamphlet G-9

NATIONAL CO., INC. - W. A. READY, Pres. - MALDEN, MASS.

the reception of distant stations. It would be possible to use a 3-gang condenser to tune the three Radio Frequency Coils, but this would result in the loss of some of the efficiency due to the fact that it is impossible to make the Antenna Coil tune exactly the same over the full range of wave lengths as the two Radio Frequency Transformers. By providing a separate tuning condenser for the Antenna Coil greater efficiency is obtained particularly in the reception of weak signals from distant stations. This gives the circuit two tuning controls when it is operated as a 5 tube set and three controls when it is operated as a 9 tube set. However, these three controls are not hard to handle even by an inexperienced operator, as will be explained later in connection with notes on balancing and tuning.

### The Construction of the Receiver

Substitutions in the accompanying list of parts should not be made except in the case of Rheostats, Switches, Fixed Condensers and Grid Leaks. For these parts any good make may be used provided their electrical characteristics conform to the specifications given.

The 7 x 30 inch front panel and the 10 x 29 inch sub-panel may be purchased with all holes drilled. If the builder prefers to do this drilling the panel drilling layout, Fig 1 can be followed.

The first step in the construction is to mount the sub-panel on the 3 Karas Brackets as shown in Fig. 6. Next mount all of the parts that are to be secured to the sub-panel. Next secure the front panel to the sub-panel by means of the Karas Brackets and then mount the three condensers, the 6 ohm Rheostats, one 400 ohm Potentiometer, the Filament Switch and the transfer switch to the front panel.

The set is now ready for wiring. It is advisable to wire the negative filament and ground circuit first. Next make all of the positive filament connections. The rest of the wiring should be completed by starting with the Antenna circuit and making all of the connections to the first Duoformer Coil, the Antenna tuning condenser and the first tube socket. Next make the grid and plate connections to the second tube and so on throughout the entire circuit, wiring each tube in order. All of the B and C battery leads from the Jones Plug to the various parts of the circuit should be put in last.

The wiring of the set is very simple and no difficulty will be encountered if the builder will closely follow the schematic wiring diagram of Fig. 3 and the actual wiring as shown in the accompanying pictorial diagram.

After the set has been completely wired the wiring should be checked and

# KARAS

Harmoniks Tried and Tested and the Standard in Radio for 3 Years



A \$7.00 Audio Transformer

For Only \$5.00

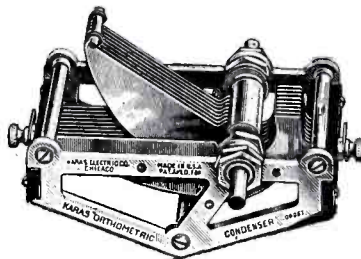

Karas Orthometric Straight Frequency Line Variable Condensers

- 23 plate .0005 mfd. .... \$7.00
- 17 plate .00037 mfd. .... 6.75
- 11 plate .00025 mfd. .... 6.50
- 7 plate .00014 mfd. .... 6.50
- 5 plate .0001 mfd. .... 6.50
- Special 17 plate with extended shaft for Equamatic System 3-Dial Set..... 7.00

KARAS ELECTRIC CO.

4037-I N. Rockwell St., Chicago

Your "B" Battery Eliminator  
will give you better service with

**Q · R · S**

(Trade Mark Registered)

**Gaseous  
Rectifier Tubes  
Are Better**

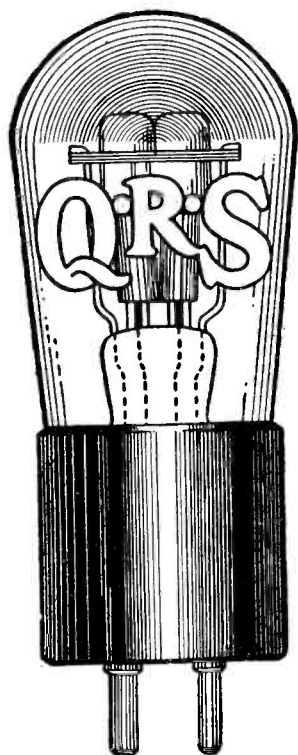

60 Milliamperes	-	-	\$4.50
85 Milliamperes	-	-	4.50
400 Milliamperes	-	-	7.00

Ask for Catalog of full line of Standard Tubes.

**Guaranteed**

The standing of the Q-R-S Company, manufacturers of quality merchandise for over a quarter of a century, establishes your safety.

Orders placed by the leading Eliminator Manufacturers for this season's delivery, approximating Four Million Dollars' worth of Q-R-S Rectifier Tubes, establishes the approval of Radio Engineers. Ask any good dealer.

**THE Q · R · S COMPANY**

MUSIC

*Manufacturers*

**Executive Offices: 306 S. Wabash Ave., Chicago**

Factories: Chicago—New York—San Francisco—Toronto, Canada—Sydney, Australia—Utrecht, Holland

*Established 1900. References—Dun, Bradstreet, or any bank anywhere*

# A Super Selection

for the

## CAMFIELD SUPER-SELECTIVE 9

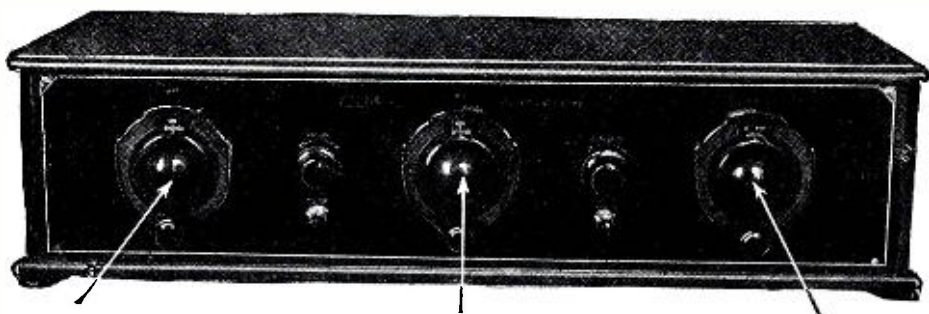

### KURZ-KASCH DIALS

**T**HE Engineers who selected Kurz-Kasch Dials for the Amazing Camfield Receiver have only agreed with many thousands of users—on the ideal Dial.

For beauty, for ease of operation, for scientific construction and adaptability of mounting to any receiver, none surpasses the Kurz-Kasch.

Kurz-Kasch is a dominant Organization in the field of moulded products—each dial is backed by a reputable, sound and experienced group of practical engineers and designers.

Your set will be the better for a set of Kurz-Kasch Dials.

## THE KURZ-KASCH CO.

*Moulders of Plastics*

DAYTON

OHIO

### 160 PAGES OF PRACTICAL FORMULAS

### 1001 FORMULAS

Here's a book that you can use daily—a tremendous assortment of those practical formulas to make paints, inks, stain removers, and hundreds of others.

Over a thousand in all—and all valuable.

160 Pages :: A Thousand Illustrations

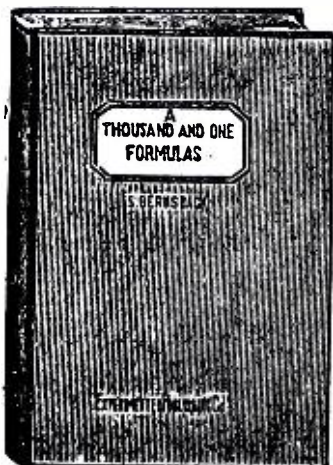

**\$1 the Copy** EXPERIMENTER PUB. Co., 230 Fifth Ave., N. Y.

re-checked several times to be sure that absolutely no mistakes have been made.

The next step is to hook up the batteries with the Jones Plug using the color code given in the pictorial wiring diagram. After the batteries have been connected insert a tube in the first radio frequency socket. This tube should light up when the filament switch is thrown to the right. It should remain lighted regardless of whether the 5 and 9 tube transfer switch is thrown to right or left. It should also respond to variations of the 6 ohm Rheostat on the right of the panel above the transfer switch. If the tube functions properly in the first socket it should be inserted in each succeeding socket in rotation. Its action in the second radio frequency stage and in the first detector should be the same as when in the first socket.

When the tube is inserted in the oscillator socket it should light only when the filament switch is thrown to the right and when the transfer switch is thrown to the right it should not respond to variations of the rheostat on the panel. This action should be the same when the tube is inserted in both Intermediate Frequency Amplifier sockets and the second detector socket.

When the tube is inserted in the audio amplifier sockets it should light when the filament switch is thrown to the right and remain lighted regardless of the position of the transfer switch and it should not respond to variations of the 6 ohm Rheostat.

After this checking has been done the set is ready for an actual test on the air.

### Balancing, Tuning and Operating the Camfield Super-Selective 9

It is important that the 2-gang condenser be installed exactly as received. Do not try to make any adjustment until after the set is in operation. Camfield Condensers and Coils are manufactured with a high degree of accuracy and little or no adjustment of the condenser is required when it is used with the Duoformer Coils.

When the set is completely assembled, wired and ready for test you should first attempt to operate only the 5 tube set. When the jack switch is thrown to the left you will have a 5 tube two control receiver. This part of the circuit should give satisfactory reception on all local stations and outside stations within a radius of two to three hundred miles. After you are satisfied that this 5 tube set is operating satisfactorily on the local stations you should then proceed to balancing the 2-gang condenser. To accomplish this tune in a station on the lowest wave length possible. A weak signal just audible in the loud speaker should be used. When this is obtained tune the second dial, that is, the one on the



# AERO-SEVEN RECEIVER

# 10-Kilocycle Selectivity

## Utilizing New 340 Tubes

## Unique Features

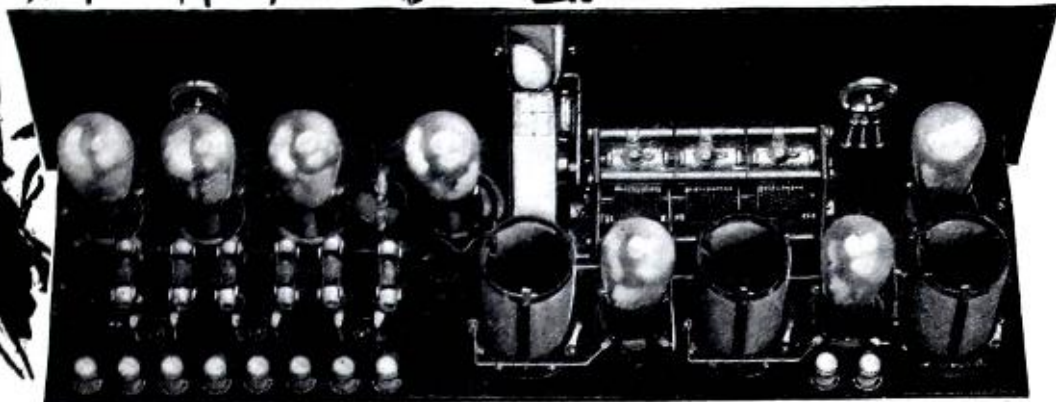

The Aero-Seven Receiver, which is being featured in the prominent radio magazines and newspapers, is a new tried and tested tuned R. F. circuit, incorporating the most modern radio improvements at a popular price. It is a distinct innovation in a tuned R. F. receiver, utilizing three stages of R. F. and three stages of resistance-coupled audio. Circuit is built around the famous improved Aero Universal Coils, with improved Amsco S. L. tuning 3-gang condenser, S-M single-control drum dial and the tried and tested parts of other famous manufacturers. Such names as Carter, X-L, Westinghouse, Aero, Amsco and Silver-Marshall assure you of a circuit that is the final word in perfection.

Distinct features are: the new Hi-Mu tube at input and in R. F. stages, potentiometer control, higher amplification, 10-kilocycle selectivity and true single control.

The Aero-Seven has a broadcast range from below 200

meters to over 550 meters (1500-500 kc) and requires no shielding as with the small Aero coils, direct pick-up is negligible and coupling between coils is the very minimum. The coils are twice-matched at both high and low frequencies of the broadcast band, thus eliminating many difficulties in single dial control and overcoming one of the principle causes of disappointments.

The adjustable compensators on the Amsco condensers facilitate the equalization of circuits, solving the major problem of tandem tuning.

The extremely sharp selectivity of the Aero-Seven circuit is due to the low resistance of the coils. The high voltage gain per stage, due to the extremely low loss construction, assures extreme distant reception and greatest volume and sensitivity is assured through the high efficiency of the coil windings.

### New and Unique Hookup 3 Stages of Radio Frequency 3 Stages of Audio Amplification

The Aero-Seven has a new and unique hook-up that incorporates three stages of R. F. and three stages of audio. There are two stages of tuned radio frequency and a special coupling stage, the secondary function of which is to prevent antenna detuning, thereby giving single control which is both theoretically and practically perfect. This independent antenna circuit is of a new and efficient design and employs a resistance connected between the antenna and ground inputting to the first grid circuit. Five CX340 tubes are used—3 in the R. F. circuit, one detector and one in the audio.

In the three audio stages, one 171 power tube is used, one 201A tube and the one CX340 tube in the input.

The circuit, therefore, is different from the usual 7-tube R. F. circuits, which variations contribute to its optimum selectivity, perfect quality and thrilling volume.

The combination of all the various parts, the matching of the Aero Universal Coils, together with the Amsco compensating 3-gang condenser, with true single control and potentiometer control, greatly simplifies operation and tuning, while adding efficiency to the circuit.

### First Use of New CX340 Tubes— 1-6/10 Times Better

Utilizing the new CX340 Cunningham tubes in place of the usual 201A, gives the Aero-Seven the distinction of being the first circuit using this superior method. CX340 tubes are 1-6/10 times more effective than 201A tubes, having a 5-volt filament and .25 amperes; plate, 180 volts maximum. In this receiver 90 volts is used constantly on the plate for the R. F. circuit, something seldom attempted but efficiently worked out here. It is a High Mu tube, having a high amplification factor (Mu-30) and is used both as a detector and as a radio and audio amplifier. The Aero-Seven is specially designed to operate with this new and better CX340 tube and the results secured will be a pleasing revelation to you. It is surprising what tone and volume is secured with a minimum use of current.

### Resistance Coupled Audio Amplification

Resistance coupled audio amplification in the Aero-7 attains a quality of reproduction unapproachable in other systems. It preserves the extraordinary quality consistently achieved by Aero-7's 10-kilocycle selectivity.

### 10 Kilocycle Selectivity Now a Real Fact

Ten kilocycle selectivity is OPTIMUM Selectivity. It means a receiver that tunes sharply enough to eliminate interference and yet does not tune so sharply as to cause distortion. It is the ideal tuning characteristic. "Optimum tuning," says the engineer, when he means a perfect set.

Why bother with anything but the best? Why put up with anything but 10-kilocycle selectivity, as represented in the Aero-Seven circuit?

Due to the low-loss construction of the coils and condensers in the Aero-Seven and the great selectivity introduced into the circuit itself, you get selectivity so sharp that you cannot get two stations at one time under present broadcast regulations, at the same time providing adequate frequency margin to prevent high "cut off"—distortion.

Imagine what this means in perfect radio reception. Selectivity, the ability to tune in clearly, sharply, without fear of disturbance in getting the station you want whenever you want it—that's something every radio fan has long desired. It is an actuality in the Aero-Seven—a feature that is necessary in an up-to-date circuit—a feature that you get in the Aero-Seven when you build it.

### New, Modern, Proved Features in Aero-Seven

10 Kilocycle selectivity.  
Resistance coupled amplification.  
Uses new CX340 tubes instead of 201A.  
3 stages of R. F.  
3 stages of audio amplification.

Extreme D-X reception.  
Potentiometer control.  
Silver-Marshall single drum dial.  
True single control.  
Aero Coils are twice matched at both high and low frequencies.

Amsco adjustable condensers.  
Carter resistances.  
Westinghouse Foundation Unit.  
X-L Posts.  
High quality parts throughout.  
Range below 200 to above 550 meters (1,500-500 KC).  
Low loss characteristics throughout.

Perfectly compensated—variation in antenna circuit doesn't affect it.

Wiring underneath sub-panel.

Simple construction.

Easy to build in quick time.

The most popular-priced 7-tube circuit.

The Aero-Seven-tube Receiver assures you of the very latest in radio. It has everything—beautiful tone, 10 kilocycle selectivity—extreme long range and a volume at your command that can be raised to music-hall proportion or lowered to slumbering whispers. The particularly meritorious application of resistance coupling creates a most remarkable tone. It gives you a receiver that is in a class all its own—a real conqueror of space—a companion that you can depend upon absolutely in any emergency. It delivers quality that is quality, and yet its construction is so low in cost as to be almost unbelievable.

### An Opportunity for Set Builders

The set builder will find the Aero-Seven a most profitable receiver to build. It is an extremely simple circuit—efficient, high grade and having a record of exceptional performance. It could hardly be duplicated in a factory-built set at double the cost.

You can make big money building this set for your friends and get a real "kick" out of it yourself.

Complete parts, drilled and engraved panels and foundation units are being distributed through the jobbing trade and are available at leading radio stores everywhere. If your dealer cannot supply you, order direct giving your dealer's name and we will see that you are supplied promptly.

A full-size working blueprint and booklet of assembly and operating instructions with complete data is furnished, which makes it both practical and easy to build this circuit quickly. Build yours early—get the jump on the other fellow.

Get the facts. Mail the coupon and 10c stamps for this valuable booklet. Send today—NOW!

See article  
in this issue

**Get the Facts — MAIL NOW →**

**AERO PRODUCTS, INC.**  
1768 Wilson Ave., Dept. 109 Chicago, U. S. A.

Aero Products, Inc.  
Dept. 109, 1768 Wilson Ave., Chicago.

Dear Sirs: Enclosed find 10c for which please send me life-size blueprints, assembly diagrams, construction data and all the facts in building the new Aero-Seven Receiver.

Name .....

Address .....

Associated Manufacturers—Amsco, Aero, Westinghouse-Micarta, Silver-Marshall, X-L.

## ACME Antenna

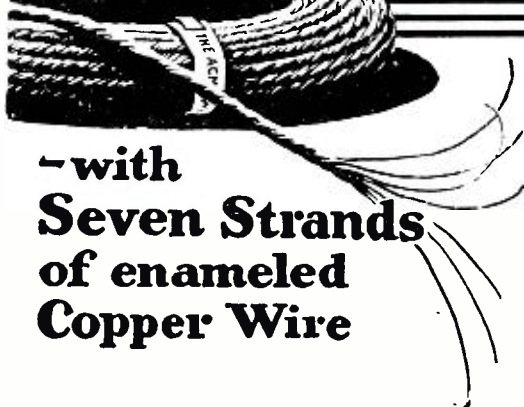

-with  
**Seven Strands  
of enameled  
Copper Wire**

Made of seven strands of copper wire thoroughly enameled, then twisted into a firm cable. This type of antenna resists corrosion and presents maximum surface to the incoming wave, thus greatly improving the signals. Made in size to equal Nos. 14 and 16 solid enameled antenna wire. (We also make solid and stranded bare, and stranded tinned antenna.)

### Acme Loop Antenna

Sixty strands of No. 38 bare copper wire for flexibility, 5 strands of No. 36 phosphor bronze to prevent stretching. Green or brown silk covering; best loop wire possible to make.

### Acme Flexible Celatsite

A cable of fine, tinned copper wires with non-inflammable Celatsite insulation. Ideal for sub-panel or point-to-point wiring. Strips easily, solders readily. Nine beautiful colors; sold only in 25 ft. coils, in cartons colored to match contents.



### Acme Solid Celatsite

Tinned copper bus bar hook-up wire with non-inflammable Celatsite insulation, in 9 beautiful colors. Strips easily, solders readily, won't crack at bends. Sizes 14, 16, 18, 19; 30 inch lengths.



### Acme Spaghetti Tubing

Oil, moisture, acid proof; highly dielectric—used by leading engineers. Nine colors, for wire sizes 12 to 18; 30 inch lengths. (We also make tinned bus bar, round and square, in 2 and 2½ ft. lengths.)

### Acme Battery Cable

A thoroughly insulated cable of five, six, seven, eight or nine Flexible Celatsite wires all enclosed in a brown rayon braid; for connecting batteries or eliminator to set. Each wire is of a different color and plainly tabbed; easy to connect. Gives set an orderly appearance. The workmanship and material are of the best. One to a box, with or without terminals.

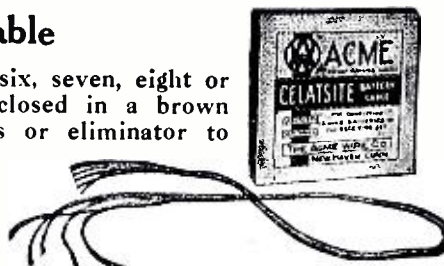

Write to Dept. T for Folder

THE ACME WIRE CO., Main Office and Works, NEW HAVEN, CONN.

Branches at

New York, 52 Vanderbilt Ave.

Chicago, 427 West Erie St.

Cleveland, Guardian Bldg.

# ACME WIRE

For greater certainty in radio circuits

## Learn Picture Transmission The Marvel of the Century

Here is the first and only book in print that gives you the complete story of television from earliest experiments to the present day machines.

The book is the most complete publication of its kind. It gives you the history, the facts and the full instructions on how to build, in your own home, an up-to-date model Television apparatus.

116 pages, illustrated, size 9 x 12 inches.

**50c the Copy—Everywhere  
or order direct**

EXPERIMENTER PUB. CO., 230 5th Ave., N. Y.

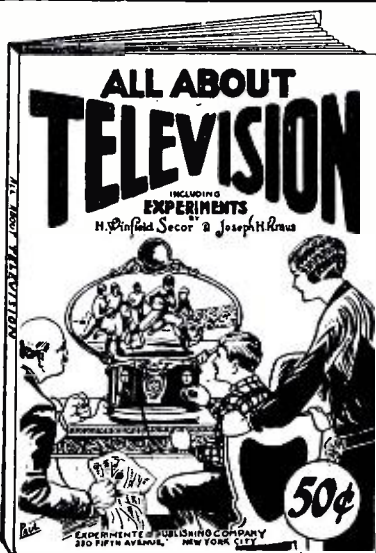

two gang condensers, for maximum volume. Then loosen the set screws on one of the shield plates, move this shield plate back and forth on the rod, adjusting for maximum volume. When maximum volume is obtained tighten the set screws and lock the shield plates in place. Next tune in a station on approximately 300 meters. Then take the tool provided with the 2-gang condenser and loosen the nuts on the righthand side of one of the stator plate sections. Then insert the other end of the tool in the hole between the nuts and move the handle of the tool back and forth, to and from the panel. You will note that this motion shifts the entire section of stator plates. Make this adjustment for maximum signal strength. Leave the stator plates set in the position for maximum signal strength and lock them in that position by tightening the nuts. Next repeat this operation with the other section of stator plates. Then tune in some high wave length station at about 500 meters or higher if possible and repeat the same series of stator plate adjustments but from the left-hand side of the condenser. After these adjustments have been made your two radio frequency circuits will be practically in perfect balance over the full range of wave lengths. A little experimenting will enable one to determine the wavelength range of the circuits in order to make these adjustments.

### Changing from Five to Nine Tubes

After the 5 tube set is operating properly leave the first two dials tuned in on some station, throw the transfer switch over to the 9 tube position and pick up the station again by turning the oscillator dial. On all of the lower wave length stations there are two possible settings of the oscillator dial. The correct one to use is the one that occurs lowest on the scale. As soon as this station has been received and tuned in for maximum volume adjust the potentiometer mounted on the sub-panel for the maximum volume consistent with good tone quality. Once this potentiometer is adjusted it may be left fixed for the reception of stations on all wave lengths and the adjustments will not have to be changed until tubes are changed or until the batteries become considerably run down. Next adjust the rotor of the 620 Coupling Unit for maximum volume. This adjustment is not critical, about 50% coupling generally gives best results.

When you are tuned in to any distant station you can in many cases receive the station broadcasting on the next wave length above or below by merely moving the oscillator dial up or down a degree or two. After this station has been received you can then adjust the other two dials for maximum volume.

# Complete "A" and "B" Light Socket Power that works - and Keeps on Working

STERLING Socket Power Units, both "A" and "B", have made good on performance. In the homes of hundreds of radio owners they have shown themselves to be as thoroughly reliable as good designing, honest workmanship, fine materials can make them.

"Light Socket" your set the Sterling way and say good-bye to batteries once and forever. Know for the first time the pleasure of continuous full powered light socket operation . . . without batteries, without chargers . . . with nothing more to do than turn on your set switch.



R-96

R-94, 4-volt "A" Power unit for Radiolas, \$32.00 complete.

Sterling  
"A" Power R-96

This unit entirely takes the place of the storage "A" battery. It uses the famous Raytheon A—the little unbreakable copper cylinder that displaces the rectifying tube. Has a steady output of 6 honest volts. Is meter equipped and fully automatic. Price \$47.00 complete.

RT-41, especially designed "B" unit for Radiolas. Price \$27.00 complete.

Sterling  
"B" Power R-81

For 3 to 8 tube sets including power tube. Output at 35 mils. is 150 volts. All three voltages Detector, Medium and High are adjustable within wide limits. On and Off switch. List Price: including Raytheon B-H tube, \$28.50.

R-98, a universal "B-C" power supply. Price \$38.00 complete.



R-81

R-97, "Heavy Duty" "B-C" Model for very largest sets. Price \$53.50 complete.

## Radio Sterling Products



R-415

Test Your  
"B" Power Voltage

To get full value from your "B" Power Unit you should know that your Power Unit is delivering the correct voltage to the detector, amplifier and power tubes. Low resistance battery testing voltmeters are worthless for testing socket power units. This specially designed Voltmeter is accurate for both. Tests all D. C. circuits up to 300 volts.  
R-415 DC Model, 0-300 volts . . . . . \$8.50  
R-417 AC Model, 0-150 volts . . . . . \$7.50

Test Your Radio  
Tubes

The Sterling Tube Tester shows at a glance whether your tubes are performing at their best or whether they are "all shot". No calculations. Simple to use. For large tubes.

R-411 . . . . . \$7.50



R-411

THE STERLING MANUFACTURING COMPANY, 2831 PROSPECT AVENUE, CLEVELAND, OHIO

# FRENCH HUMOR



## ARRIVES IN AMERICA

FRANCE, the magic land of humor, wit and keen, knife-edged "parlay," now offers humor-loving Americans its choicest, finest humor through the new weekly magazine, "FRENCH HUMOR." Americans (who have never been in France) invariably hold the opinion that anything French in humor or jokes must be smutty with a Capital S. This is of course all tommy-rot. The average far-famed Gallic wit is no more smutty than the average Chicago citizen is a Gun-man.

This new magazine will show America what makes the Frenchman laugh—also that humor is international. It will foster a better

understanding between Americans and Frenchmen as a whole. Illustrated jokes in "FRENCH HUMOR" are printed first in French and then in the English translation—this will be of great interest and help to those who are studying or who have a smattering of this important world language.

The first copy of "FRENCH HUMOR" will prove what we say—it's the funniest, wittiest and most entertaining magazine you have ever read.

Copies are sold on all newsstands, large size magazines 9x12 inches, profusely illustrated with genuine French Illustrations.

PRICE 10c. THE COPY.

10c Weekly - - -  
On All Newsstands

Experimenter Publishing Co., Inc.  
230 Fifth Ave. New York, N. Y.

## The Improved "Nine-in-Line"

(Continued from page 90)

135 volts is available, the use of the 371 type power tube is recommended. Otherwise the 312 type tube should be used. The grid bias voltage values for this stage will depend on the type of tube used.

In spite of the use of nine tubes, the plate current drain on the "B" batteries is no higher than that of the average five tube receiver. This is due to the use of comparatively high "C" battery voltage on the intermediate frequency amplifier tubes. The total "B" battery drain, including that of the power tube in the last audio stage is from 20 to 30 milliamperes, depending on the type of power tube used. This makes practical the use of heavy duty "B" batteries, if desired.

The filament supply voltage is obtained from a six volt storage battery. The two detectors and the oscillator draw their supply through a six ohm rheostat R2. The four intermediate amplifier tubes are controlled through a combination rheostat and battery switch, R1 and S. The audio tubes are provided with a fixed resistance, R4. It is also advisable to include fixed resistances in series with rheostats R1 and R2 to prevent higher than five volts being applied to the tubes, even when the rheostats are turned up full.

The "B" supply is tapped at 22½ volts for the first detector and oscillator and 67½ volts is applied to the second detector. The four intermediate stages are provided with 90 volts. This may in some cases be increased to 112 to good advantage. The second detector is tapped in at 67½ volts. 135 volts is required for the first audio tube, and also for the second audio stage provided a 312 type tube is used. If a 371 tube is used here the "B" voltage should be 180 for best results. In this latter case a separate lead should be brought out from this last tube because this voltage cannot be applied safely to the first audio tube.

It will be found easiest to wire up the instruments on the sub-panel before the front panel is attached. Then the panel may be attached and it will only be necessary to bridge wires over from the panel instruments to their proper connections on the sub-panel.

The appearance of the receiver is considerably enhanced by installing it in a style R-16 Excello radio console. This particular console is of the wall type and is provided with a special tone chamber above the receiver panel space to which the constructor's favorite speaker unit can be attached. In the battery compartment below this console there is ample room for either "A" and "B" batteries or eliminator.

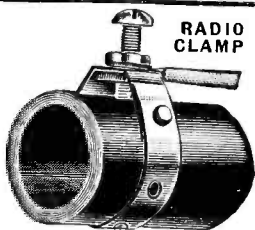

### BLACKBURN GROUND CLAMPS

Telephone companies using MILLIONS. Adjustable—fits any size pipe. Requires no pipe cleaning—screw bores through rust and scale. Send 12 cents for sample and postage.

### BLACKBURN SPECIALTY COMPANY

1972 East 66th Street Cleveland, Ohio

MAR-CO Illuminated  
back-panel controls  
set the 1927 style.

**NEW YEAR - NEW IDEA**  
**PATENT YOUR IDEAS**  
Call or send me a sketch of  
your invention. Phone LONGacre 3088  
**FREE** Inventors Recording Blank  
Confidential Advice  
U. S. and Foreign Patents secured by  
**Z.H. POLACHEK** Reg. Patent Attorney  
Consult. Engineer  
1234 BROADWAY, NEW YORK

Complete STROBODYNE Construction Book See page 162



# There are many fluxes for soldering but only *one* — is safe for Radio!

**F**LUX for soldering is a general term; it embraces, as a class, all types of soldering fluxes. To designate a flux as safe for radio construction is specific; *it means rosin*. Chloride pastes, acids and fluid solutions are soldering fluxes, and are well adapted for certain work, *but conductive and corrosive properties forbade their use for radio assembly*. Their active elements, zinc and ammonium chlorides, display spreading, creeping tendencies that promote leakage and will eventually cause increased resistance in the wiring.

Rosin, an organic mixture, *is a non-conductor and non-corrosive*. The glass-like surface of this material does not readily lend itself to the collection of dust (carbon particles) as will the sticky organic greases of paste. Nor will rosin attract moisture from the atmosphere; the chlorides of pastes and fluids will. *Moisture plus carbon particles defeat the best insula-*

*tions produced. Moisture plus chlorides direct a slow but determined corrosive attack upon supporting metals*. Such slow corrosion in wiring causes a steadily increasing resistance to the flow of electrical energy.

Kester Rosin Core Radio Solder scientifically combines radio's premier flux, Rosin, with a solder alloy of unvarying quality. The use of Kester Radio Solder furnishes the user with a means of accomplishing Safer, Faster, and Cleaner set wiring. Constructors who solder-protect wiring with Kester Radio Solder enjoy increased receptive range, improved tonal quality and the satisfying assurance that their receivers will never be forced into the discard through the corrosive and conductive action of a chloride flux.



**A Kester Soldered Receiver Is a Better Set**

*Manufacturers of Radio Sets and Equipment:* Tests conducted with the various types of commercial fluxes are under constant observation in our laboratory. Can we assist you in your soldering problems?

## KESTER *Radio* SOLDER

CHICAGO SOLDER COMPANY

4252 Wrightwood Avenue, Chicago, U. S. A.

*Originators and World's Largest Manufacturers of Self-fluxing Solder*

*Convince Yourself Without Expense*

**USE THIS COUPON NOW!**

CHICAGO SOLDER CO., 4252 Wrightwood Ave., Chicago, U.S.A.	R. R. 9-27
Gentlemen: Please send me a test sample of Kester Radio Solder, together with descriptive literature.	
Name .....	
Address .....	
City.....	State.....
Dealer .....	

**Blue Ribbon**  
**5 TUBE NEODYNE**  
RADIO KIT-COMLETE

**Only \$16.95**

**Can be built in 2 hours**

**FREE!**  
GENUINE 20 INCH  
ERLA CONE  
LOUD SPEAKER &  
5 TUBES

**COAST to COAST RECEPTION**

Latest 5-tube circuit designed by one of the foremost radio engineers in the country. Clear and realistic reception guaranteed. Solid bakelite panel and sub-panel. Panel beautifully engraved. Sub-base marked for all connections. 2-dial control; Kurz-Kasch bakelite indicator knobs. New type UX sockets. Low ratio transformers for improved tone quality. All hook-up wire and colored battery cable included. Tubes are 201-A type, tested and matched. Value \$60.00; our price \$16.95.

### TESTED AND PROVED

*Severe laboratory tests have proved the remarkable efficiency of this set.*

*Owners everywhere are sending us letters praising its wonderful receptive qualities.*

### Complete Set of Simple Plans and Directions to Build

**MAKE MONEY IN YOUR SPARE TIME!**

Very easy to build this set with the plans and instruction we furnish. No complicated drawings. Can be built in two hours. Instruction for operation also included. Make money by building these sets in your spare time and selling them to your friends.

**SEND NO MONEY**

Just write your name and address on a post card and ask us to send you this great kit together with the Erla Cone loud speaker and 5 tubes. We will ship them right away. When they arrive, pay only \$16.95 plus a small delivery charge. That is all. Write today to

**RADIO EQUIPMENT CO., Dept. L. 549 S. Wells St., Chicago, Ill.**

### EVEN RADIO SETS HAVE "PARTY MANNERS"

Radio Receivers know no rules of etiquette—they cannot be taught to act on best behavior when company and friends are judging them—but they can be made to act properly if the operator understands the few simple factors that effect tuning or the proper adjustment of the Receiver's controls.

The 64 page, illustrated book on How to Tune Your Radio Set (Conrad—25c) is a carefully prepared, yet simplified, instruction book on tuning alone. It will surprise you—Buy a copy today—at the nearest Radio Shop. Only 25c. You'll get three times that value out of it.

**"HOW TO TUNE YOUR RADIO SET"—25 cents the Copy**

*If your dealer cannot supply you write direct*

**CONSRAD CO., INC., 230 Fifth Ave., New York, N. Y.**

## How to Build the Strobodyne

(Continued from page 80)

readjusted later if a whistle is noticed when turning the tuning condenser, but for most tubes this adjustment is about correct.

Next, the balancing condenser connected across the tapped auto-couple coil should be set so that the rotor is equally meshed with each of the two stators; and the long screw on top of the same coil should be turned so that the primary is just out of the secondary. Since the screw protrudes beyond the level of the shield cover, it is necessary to drill or cut a hole in the cover; this hole should be large enough so that the screw does not touch the shield.

Set the equalizer mounted on the forward left condenser to leave a gap of about  $\frac{1}{8}$  inch between the copper plate and the mica. After these adjustments are made, turn the three rheostats on almost full and set the potentiometer so that the sliding arm is about in the center. Do not forget to turn the volume control up also. Then turn the two dials simultaneously to about the same readings. If the set is working properly, some signals should be heard; especially if the set is installed within a reasonable range of some broadcast stations.

To adjust everything to the point of greatest efficiency tune in a weak signal or use only a few feet of wire as an aerial and listen in with a pair of phones plugged in the first-stage jack. Then readjust the equalizer on the forward condenser with a small wooden-handled screwdriver until the signal is loudest. (Do not touch the metal of the screw driver, as this would produce an increase in capacity.) The weaker the signal, the easier it is to notice the point of best adjustment.

Next readjust the three rheostats for best reception and leave them at this point. Adjust also the balancing condenser and the coupling of the tapped coil, until the weak signal comes in best. These adjustments, once made, need not be varied.

The readings on the two condensers are not exactly alike over the entire scale, but they are sufficiently close to make the tuning easy especially since, after a few stations are logged, it is easy to note the difference between the low and high figures on the scale.

For the more ambitious constructor, who wants to build everything himself, the complete constructional details are given for the coils. In order to have the set work right these should be very carefully made; otherwise the results will not come up to expectation.

*Combines the Best Features of Every Circuit*  
*Radio's most amazing set*

*The* **STROBODYNE**

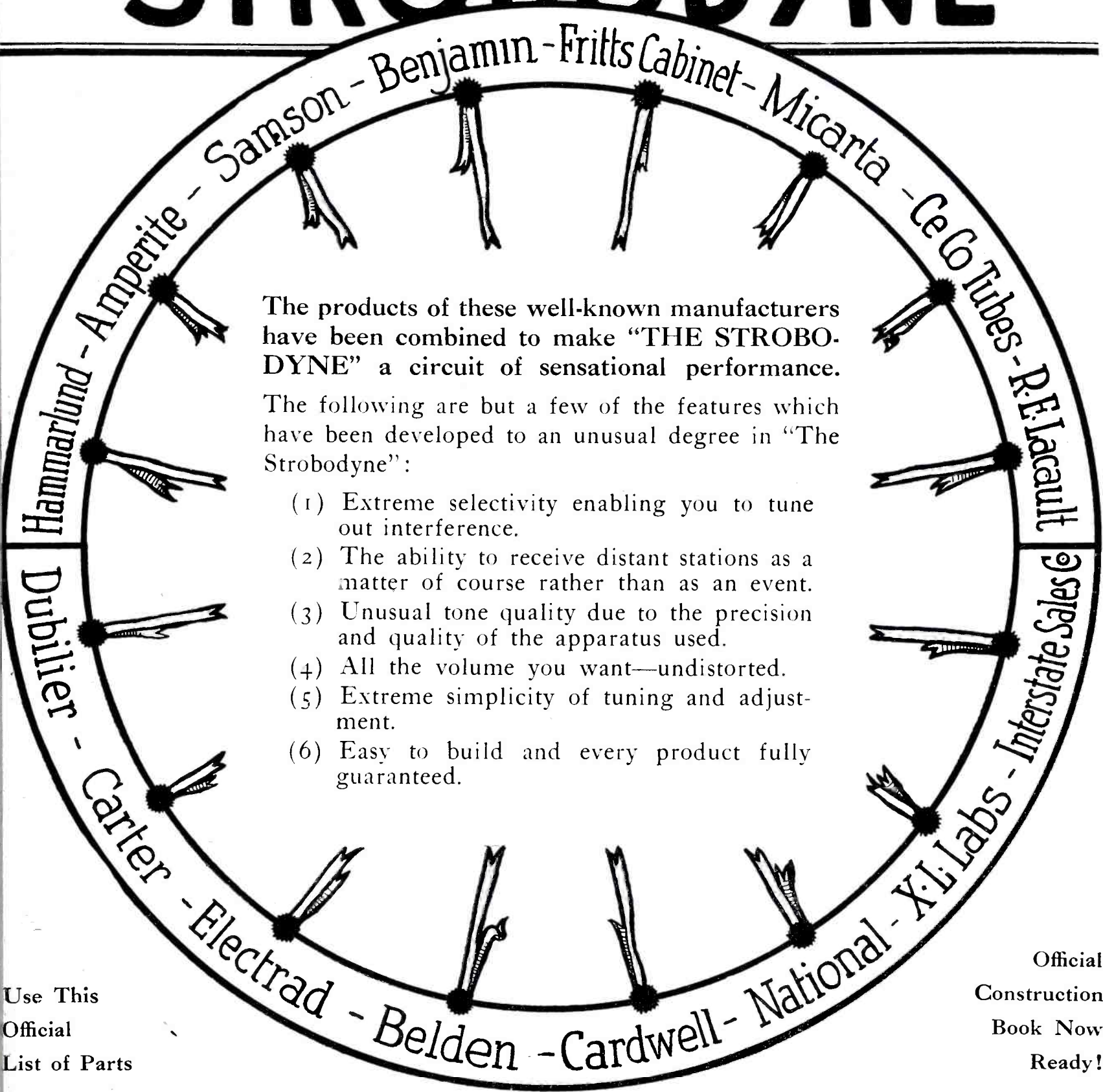

The products of these well-known manufacturers have been combined to make "THE STROBODYNE" a circuit of sensational performance. The following are but a few of the features which have been developed to an unusual degree in "The Strobodyne":

- (1) Extreme selectivity enabling you to tune out interference.
- (2) The ability to receive distant stations as a matter of course rather than as an event.
- (3) Unusual tone quality due to the precision and quality of the apparatus used.
- (4) All the volume you want—undistorted.
- (5) Extreme simplicity of tuning and adjustment.
- (6) Easy to build and every product fully guaranteed.

Official  
Construction  
Book Now  
Ready!

Use This  
Official  
List of Parts

- 3 Hammarlund Variable midline condensers .00035 mf.
- 1 Set Hammarlund Strobodyne coils
- 3 Hammarlund Shields
- 2 Hammarlund Equalizing Condensers
- 1 Hammarlund Brass Shaft 10 3/4 inches long
- 2 Samson Symphonic Transformers
- 1 Samson No. 85 Choke
- 4 Radio Electric R.F. Units Type 1'
- 5 Radio Electric Fixed Matched Condensers
- 1 Micarta Fabricator Panel 8" x 24" x 3/16"
- 1 Micarta Fabricator Sub Panel 12" x 25 1/4" x 1/4"
- 1 Interstate Sales Output Filter
- 3 Carter No. M-20 Midget Rheostats 20 ohm
- 1 Carter No. M-400 Midget Potentiometer 400 ohm

- 1 Carter No. 1 Short Jack Open Circuit
- 1 Carter No. 2A Short Jack Closed Circuit
- 1 Carter Imp Battery Switch
- 1 Cardwell Balancet Type 618A
- 4 Dubilier By-Pass Condensers .5 mf. Type 907
- 1 Dubilier Fixed Condenser .002 mf. Type 601
- 8 Benjamin Sockets UX Type 9040
- 12 X-L Binding Posts
- 2 National Co. Dials
- 4 Radiall Amperites Type 1A
- 1 Radiall Amperite Type 112
- 1 Electrad Royalty Variable Resistance Type B
- 2 25 ft. coils Belden Colorubber
- 7 CeCo Vacuum Tubes Type 201A
- 1 CeCo Vacuum Tube Type 112
- 1 Fritts Cabinet for Panel 8" x 24" x 12 1/4"

"STROBODYNE"  
230 Fifth Ave., New York

I enclose 50c. for one copy of the official construction book, giving all data on the STROBODYNE, and all supplementary information.

Name .....

Address .....

City .....

State .....

Address all inquiries to "STROBODYNE," 230 Fifth Ave., New York

IN GREATER POPULAR DEMAND  
AT NEW PRICES

# Majestic

CURRENT SUPPLY UNITS

Greater Radio Power  
National Reputation  
HIGHEST QUALITY  
LOWEST PRICES

## MAJESTIC SUPER B

Recognized as the leader in popularity, sales, efficiency. For sets 1 to 12 tubes. List price complete with Majestic Super Power Tube. **\$29.50**



## MAJESTIC MASTER B

The precision B-Power Unit Offering complete control of all output voltage taps. List price complete with Majestic super-power tube... **\$32.50**

## MAJESTIC SPECIAL MASTER B

Similar to Master B but equipped with four B+ taps, for sets requiring same. List price complete with Majestic super-power tube... **\$32.50**

CRIGSBY - GRUNOW - HINDS - CO  
4582 ARMITAGE AVE, CHICAGO-ILL

## The Aero-Seven Broadcast Receiver

(Continued from page 73)

### The Audio End

Thus it is seen that the radio frequency section of the Aero-7 is so designed to provide a high degree of radio frequency efficiency compatible with perfect quality. The entire reproduction of the detector tube is preserved throughout the audio amplifier. Amplification is effected by means of resistance coupling, acknowledged by the majority of engineers to give the closest approach to distortionless amplification.

The accompanying list of the parts are those used in the construction of this receiver. Considering the equalizing problems involved in tandem tuning arrangements, it is recommended that the amateur confine himself strictly to the recommended apparatus, even in such seemingly inconsequential parts as by-pass condensers, rheostats and resistors.

### Construction

The actual building of the Aero-7 is best described in the detail photographs and in the instrument layout drawings. (Do not confuse the picture wiring diagram with the layout diagram. The picture wiring diagram spreads the parts in a manner to show most clearly the connections between them, irrespective of the exact spacing of the parts or the exact directions taken by the wires.) Check your wiring against all illustrations and diagrams as the set nears completion.

The condenser is mounted so that the compensating condensers are up. That is with the shaft extending to the right and the rotors opening in toward the front panel.

The correct instrument layout will be greatly facilitated by using the specially prepared front and sub-panels.

This receiver is not at all difficult to build—but any job worth doing is worth doing well.

### Adjustment

There is only one set of adjustments to be made on this receiver, and these are effected when it is completely finished and wired to the usual power sources for reception. These are the compensating condensers on the Amsco triplet condenser. The condenser leaves the factory with the compensators screwed down tightly. Turn these two full turns counter-clockwise. (It is desirable, in making all adjustments on the compensators, to use a wooden screw driver. This will eliminate over-compensation due to body capacity effects. Any small stick can be shaved down into a satisfactory

## S. GERNSBACK'S RADIO ENCYCLOPEDIA

The First Radio Book for Every Home,  
Every Library and Every Laboratory

S. GERNSBACK'S RADIO ENCYCLOPEDIA is the only standard work ever published in America attempting to classify alphabetically the countless words used in the highly specialized science of RADIO. The ENCYCLOPEDIA is written in plain English so that everybody can understand the definitions and descriptions.

It is published in one volume—168 pages—size 9 x 12 inches, nearly an inch thick and nicely accommodates the beautiful illustrations and the large, easy to read type.

Every page is replete with illustrations—to make the text easily understandable.

SEND NO MONEY—Just forward your name and address. We will send you the Book at once. You pay postman \$2, plus postage on delivery.

Order Direct from

S. GERNSBACK - - 230 Fifth Ave., New York



# The Improved SHIELDED LABORATORY Receiver

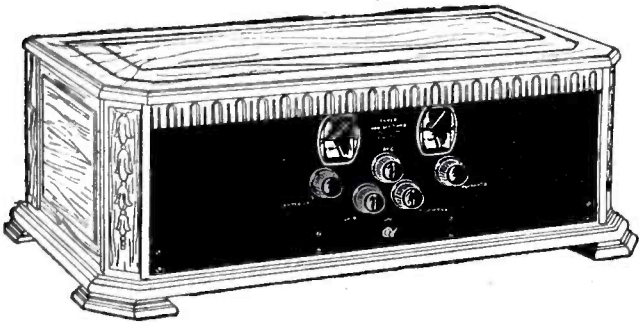

## FACTS

**Sensitivity:** The Laboratory Receiver, in direct comparative tests, will bring in with loud speaker volume stations barely audible upon seven and eight tube shielded neutrodynes. Compared to other superheterodynes, it will give greater volume, and generally bring in more stations, than any other eight or nine tube sets.

**Selectivity:** Located in Chicago, the Laboratory Receiver will allow reception of out-of-town stations within 7 to 10 kilocycles of powerful locals. In comparative tests, it will give greater selectivity than any eight or nine tube super that can be built from standard parts. In fact, the set is so selective that it will take a week's careful combing of the broadcast band to log all stations within range!

**Range:** On short waves below 200 meters, the range is unlimited—5,000 to 12,000 mile reception is not at all unusual. In the 200 to 550 meter broadcast band, the range is 1,000 to 10,000 miles, but is guaranteed equal to or greater than that of any other receiver. Between 500 and 3,000 meters, the range is guaranteed greater than that of any other receiver.

**Volume:** It can only be stated that the volume of the Laboratory Receiver is equal to that of any standard receiver, and is guaranteed equal or greater than that of any eight to ten tube set.

**Wavelength Range:** 30 to 3,000 meters with standard interchangeable plug-in coils.

**Amplification:** The first detector and oscillator give a voltage amplification of 25; the long wave and second detector 10,000 (10 x 10 x 10 x 10 for four tubes); and the audio amplifier, 400 (20 x 20 for two stages). The over-all amplification is thus seen to be 100,000,000—about 80 times that of average eight tube superheterodynes; about twice that of the best eight tube neutrodynes, and 20 times that of average seven tube shielded neutrodynes. The one hundred million amplification figure for the Laboratory Receiver is without extremely critical adjustment—critically adjusted for a very weak station, it will go up to a billion times or more!

FROM the Setbuilders Supply Co. you can get all parts for the new Laboratory Receiver, each and every item most carefully inspected and checked, and with a guarantee that your set, assembled from those parts, will give you results you've never had before on any set. You can also buy tubes, batteries, cabinets and loud speakers specially approved and tested for the Laboratory Super by McMurdo Silver and Ernest R. Pfaff. It goes without saying that you want to own the Laboratory Receiver, just as you want the best of anything. And the Laboratory Receiver is the best, for it has features that you won't find in the most expensive factory set you could buy. Take its selectivity for instance—it will tune in out of town stations through local interference that paralyzes ordinary sets. It's so sensitive it brings in these same stations with tremendous punch—when other sets don't even get through. Then, its appearance is in the three to five hundred dollar class, though you're not handicapped by a factory cabinet—you can put your set in any cabinet or console that suits your taste.

### TESTED AND GUARANTEED PARTS EXACTLY AS SPECIFIED FOR THE LABORATORY RECEIVER

1 Van Doorn panel and chassis unit, pierced, with hardware	\$8.50
1 Carter .00015 condenser with leak clips	.50
1 Carter M-200 potentiometer	.75
2 Carter No. 105, 1/2 mfd. condensers, @ .90	1.80
1 Carter 3 ohm rheostat	.50
1 Carter battery switch	.50
4 Carter No. 10 tipjacks @ .10	.40
1 Polymet 2 megohm leak	.25
2 S-M 220 audio transformers @ 8.00	16.00
4 S-M 511 tube sockets @ .50	2.00
2 S-M 805 vernier drum dials @ 3.00	6.00
1 S-M 275 RF choke	.90
1 S-M 342 condenser	1.50
1 S-M 440 time signal amplifier, 112 K.C.	35.00
2 S-M 515 coil sockets @ 1.00	2.00
2 S-M 111A coils @ 2.50	5.00
9 X-L binding posts @ .15	1.35
2 S-M 320 .00035 condensers @ 3.25	6.50
	<hr/>
	\$89.45

### GUARANTEE

The Setbuilders Supply Company unconditionally guarantees the performance of any receiver built from the parts listed above to be superior to that of any other eight-tube receiver.

### Setbuilders Supply Co.

504-C South Peoria St.

Chicago, U. S. A.

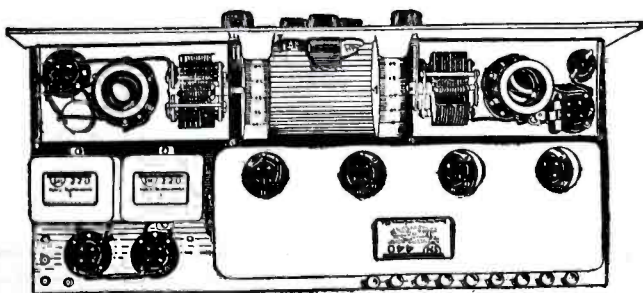

*This  
Brings  
All the  
Details!*

Please send me all data on the Laboratory Receiver for which I enclose 10c.

# IMPROVE YOUR RECEPTION

*Without Inconvenience*

## Keen Tone



Base Originated by Harekost & Simonds

**Duplex Base POWER TUBES**  
Types X-112 and X-171

Duplex Base Power Tubes can be used without any changes whatever in the set wiring or without using adapters. Simply insert in last audio socket and connect extra "B" and "C" batteries to binding posts on Duplex base. Fully Guaranteed.

## K-T-PRODUCTS COMPANY

68 William St. New York, N. Y.

K-T-PRODUCTS COMPANY,  
68 William St., New York, N. Y.

Gentlemen:

Please send me complete information on the Keen Tone Duplex base power tubes.

Name .....

Street .....

City ..... State.....

### New Complete Pattern FOR THE STROBODYNE JUST PUBLISHED!

Four full-size blueprints—all supplementary instructions and illustrations—included in regular 9x12 board-covered book.

50c THE COPY

CONSRAD CO., 230 Fifth Ave., N. Y.

tool.) Tune in a station, preferably a local. Adjust the compensators, one at a time, by screwing in, until the station tunes the sharpest. Retune with the main dial following every adjustment of the compensators. Temporary adjustment of compensator can be effected by pushing it down slightly with the wooden adjusting tool while the main dial is tuned. This will show immediately what particular compensator should be screwed down. That is all there is to it. Once adjusted, the condenser need never again be touched.

### Tubes Used in Set

Either Cunningham or R. C. A. tubes should be used in the Aero-7. Note that high mu tubes are used in the first five sockets. The Aero coils are designed to take advantage of the high amplification constant of 30 which characterizes these tubes. Radio Frequency coils must be especially designed to do this. The second audio stage employs a 201-A tube to add additional stabilization to the amplifier, and to take care of unusual power surges. A 171 type power tube is used in the output stage to provide unusual volume without distortion. It is desirable, though not absolutely necessary, to couple this tube to the speaker through some output arrangement such as the AmSCO Orthophone.

### Installing the Set in a Console

In the photographic heading of this article the Aero-Seven is shown installed in an Excello style R-31 console which makes the completed set a handsome addition to the furnishings of the modern home. The special loud speaker horn may be used as provided with this model cabinet ready for the attachment of the builder's favorite loud speaker unit; or the constructor may prefer to build in one of the Ensco cone speaker arrangements such as described in a previous issue of RADIO LISTENERS' GUIDE AND CALL BOOK.

### Operation

The operation of the Aero-7, in accordance with our opening paragraph, is simplicity itself. It is merely a matter of turning the tuning dial to the selected station, and adjusting the column control to the desired point.

The receiver will operate from any antenna, short or long, indoor or outdoor, excepting a loop. It will operate from A, B and C batteries or eliminators, or any battery-eliminator combination.

# 90 Volt Power Unit :: \$12.75

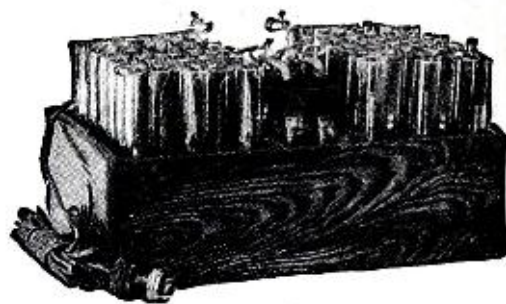

Hums, line noises, etc., positively impossible with this new advanced unit. Plug in and forget Non-acid and noiseless. All detector and intermediate voltages plainly marked. Simpler to hook up than dry cells. Operates any type set 1 to 12 tubes.

Greater volume and clearness guaranteed. If not thoroughly satisfied return after using 30 days for complete refund. Guaranteed further 2 years. For 110-120 volts A.C. 25 to 60 cycle current. 90 volts, \$12.75; 112½, \$15.25; 135, \$17.50; 157½, \$19.50; 180, \$24.00; 202½, \$26.00.

Also built for D.C. current 110 and 32 volts at only \$3.00 additional, any size above. Ample stocks—same day shipments. Simply say—ship C.O.D. or write for my interesting literature, testimonials, etc.

## B. HAWLEY SMITH

334 Washington Ave., Danbury, Conn., U.S.A.

## \$75 to \$125 Weekly

Charging Batteries Starts You

Let me show you how to make big money right from the start. I've prepared a FREE book explaining all details. First week's profit pays for all equipment. You can get all the battery charging business in your community with my Service Station Charger—it's years ahead of ordinary chargers—handles 50% to 70% more batteries. I explain everything—start you in a business of your own and put you on the way to big money. Write for FREE BOOK.

C. F. HOLMES, Chief Engineer, Dept. LG  
Independent Electric Works  
5116 Ravenswood Ave. Chicago, Ill.

**FREE BOOK—Just Out**

### FORMICA KIT PANELS

Formica panels decorated in Gold by the Veri Chromé process are available for many popular kits including: Bremer Tully Power Six; Browning Drake; Victoreen Superheterodyne, I.F.L. Nine-in-line; Madison Moore Superheterodyne; Karas Equamatic.

**The Formica Insulation Co.**  
4659 Spring Grove Ave.  
Cincinnati, Ohio

# FORMICA

Made from Anhydrous Bakelite Resins  
SHEETS TUBES RODS

FOR BEST RESULTS

## RADION PANELS

WHATEVER SETS YOU BUILD

AMATEURS' HANDBOOK  
1927 Edition  
SEE PAGE 158

# ANNOUNCING NEW AND IMPROVED

## AERO COIL SUPER-SENSITIVE

### INDUCTANCE UNITS

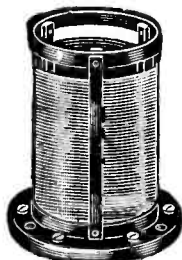

#### The Improved AERO Universal Coil

At last—a true universal coil. This improved coil is suitable for any straight tuned radio frequency circuit, both bridge and loss balance. It is easily and ideally adaptable to 3, 4, 5, 6 or 7 tube sets and can be used with all types of tubes—201-A, 199, 112, and the new 240 tubes and A.C. tubes.

Sharp selectivity, true tone quality, distance and volume, to a heretofore unknown degree, are assured where these coils are used. For that reason the improved Aero 6, Aero 7, Aero 4, and other circuits built around these coils will be more popular than ever during the coming season.

### New AERO Kits Employing the Improved AERO Universal Coil The AERO Universal Tuned Radio Frequency Kit

#### Kit of 4 Coils (For Improved Aero-Dyne 6)



Code No. U-16

Kit consists of 4 twice matched units—adaptable to all standard tubes. Tuning range below 200 to above 550 meters. This kit will make any set better in selectivity, tone and range. Will eliminate losses and give the greatest receiving efficiency. Each kit is carefully matched at both ends of the broadcast range.

For .0005 Condenser, Code No. U-16.....Price \$15.00  
For .00035 Condenser, Code No. U-163.....Price \$15.00

### The AERO Universal Tuned Radio Frequency Kit

#### Kit of 3 Coils (For Aero-Seven)



Code No. U-12

Consists of 3 twice matched units. Coils are wound on Bakelite skeleton forms, assuring a 95% air dielectric. Range from below 200 to above 550 meters. Each kit carefully matched at both ends of the broadcast range.

For .0005 Condenser, Code No. U-12.....Price \$12.00  
For .00035 Condenser, Code No. U-123.....Price \$12.00

### AERO Universal 3-Circuit Tuner



In the form of a 3 circuit tuner with a fixed tickler, this Aero Coil will improve any circuit. Adaptable only to 201-A, 199, 112, or the new A.C. Tubes. Has variable primary for governing selectivity. Code U-55 (For .0005 Condenser) or Code U-553 (for .00035 Condenser)..Price \$4.00

### AERO Radio Frequency Regenerative Kit

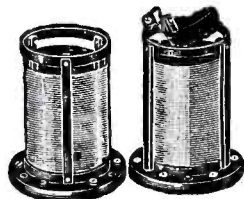

The supersensitive kit, used in the new Aero 4 and The Chicago Daily News Receiver, will improve the efficiency of any circuit. For use with 201-A, 112, 199, and the new A.C. Tubes. Use .00025 variable condenser to tune fixed tickler. Code U-95 (for .0005 Condenser) or Code U-953 (for .00035 Condenser)..Price \$8.00

### AERO Universal Antenna Coupler



A highly efficient low-loss antenna coupler with variable primary; adaptable to 201-A, 199, 112, 240 and the new A.C. Tubes. Code No. U-96 (for .0005 Condenser) or Code No. U-963 (for .00035 Condenser). Price \$4.00

### AERO Universal Wave Trap Unit

Makes an excellent wave trap due to low distributive capacity and low high frequency resistance. Helps greatly in eliminating interference. Can also be used to improve efficiency of Crystal Sets. Code No. U-4 (for .0005 Condenser) or Code No. U-43 (for .00035 Condenser) .....Price \$4.00



### AERO Choke 60

Has uniform choking action over a wide range of wave lengths. Eliminates customary "holes" in the tuning range—so common with ordinary chokes. You will find the Aero Choke 60 perfect in every respect. Price each .....\$1.50

### AERO Short Wave Kit

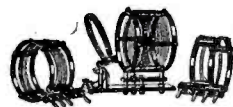

The most efficient and satisfactory short wave kit ever offered. Completely interchangeable, and covers U. S. Bands range 15 to 130 meters. Kit consists of 3 coils and base mountings. Code No. L.W.T. 125.....Price \$12.50

### AERO Transmitter Kits



An interchangeable Transmitter Kit at last! Kit 2040-K has range of 16.5 to 52 meters. Kit 4080-K has range of 36 to 90 meters. Kit includes two mounting bases and two choke coils that are interchangeable. Price (each kit).....\$12.00

### AERO Choke 248



Designed for use with Aero Transmitter Kits and other circuits. Presents a high impedance over usual amateur wave lengths. Price each .....\$1.50

#### IMPORTANT NOTICE

We furnish foundation units, drilled and engraved by Westinghouse Micarta for the Aero Short Wave, Aero 6, Aero 7, Aero 4, Aero Transmitter, and The Chicago Daily News 4 tube circuits. This is a special service for the home set builder. Full working blue prints with each unit. Dealers may secure samples of blue prints to show their trade for 25c each.

Any of these Aero Kits, Coils and Chokes should be available at your dealers. If he cannot supply you, order direct from the factory. Be sure to specify code or key numbers when ordering.

**AERO PRODUCTS, INC., Dept. 111**  
1772 Wilson Avenue  
Chicago, Ill.

# EUGENE G. WILE

7 NORTH TENTH ST.,  
PHILADELPHIA, PA.

WE HAVE COMPLETE  
KITS FOR ALL SETS DESCRIBED  
IN THIS AND OTHER  
MAGAZINES

## AERO-SEVEN

\$40.00

NEW HAMMARLUND-ROBERTS  
SHIELDED HI-Q SIX

Prices on Application

## RAYTHEON A-B-C POWER SUPPLY

\$52.00

NINE-IN-LINE SUPER

\$79.00

## STROBODYNE

Price on Application

## CAMFIELD SUPER-SELECTIVE 9

\$83.00

MADISON MOORE ONE SPOT  
BATTERYLESS TRANSFORMERS

Price on Application

NEW BROWNING-DRAKE  
SEVEN-TUBE KIT

Price on Application

WORLD'S RECORD SUPER TEN

Price on Application

SEND FOR DESCRIPTIVE PAMPHLETS

TERMS

10 Per Cent with Order  
Balance C. O. D.

## Experiments with Transmitter Buttons

(Continued from page 115)

the entire conversation in the otherwise protected room. This form of eaves-dropping is far more legitimate than the method of installing detectaphones in rooms to be subsequently occupied by people suspected of a crime.

### Conduction of Sound Through Water

Submarine signalling has been employed ever since the war. Microphones placed under the surface of the seas have demonstrated their ability to pick up sounds of submarines and steamers and relay them to those desirous of knowing what was coming down the bay. During the war, German submarines frequently picked up the noises of the propellers by means of sub-sea microphones and coincidentally, one submarine was able to converse with another by this same method. Radio, although operable, possessed the added difficulty of making the presence of its user known to the enemy. By means of the radio compass the enemy could locate the approximate position of a submarine, but with sound signalling, the efforts at location were made much more difficult and only those equipped with sub-sea ears could know what was going on. The same effect can be duplicated by the aid of a microphone button which for this particular purpose is fastened to the lid of a coffee can. Two flexible rubber covered wires are then brought up to the surface, one of them being attached to the microphone button and the other being soldered to the can. The entire apparatus can be coated with paraffin wax to prevent water leakage. A battery is placed in series with the microphone button and then a receiver is connected to the wires as indicated.

At the transmitting end, the transmitter button is on shore and the receiver is placed beneath the surface of the water. The receiver here should preferably be a loud speaker unit, having a resistance of approximately 75 ohms if no amplifier is employed or it could be a regular radio loud speaker unit, if a vacuum tube amplifier is inserted into the circuit as indicated by the dotted box. Much greater distances will be covered with the latter form of device. A Baldwin unit could be used under the water, care being taken to make it impervious to the elements. Paraffin wax will do this or the user might conveniently employ a rubber toy balloon for this purpose. The sound will be conveyed through the water for a distance of four times its audible distance on land. In this way and with apparatus of this nature, one party could talk to another on the other side

## Get the Station You Want Without Interference

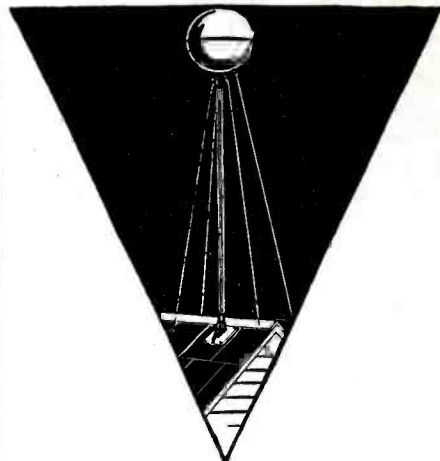

# "Super Ball" Antenna

Easy to install. Efficient on all circuits—non-directional so more stations are logged. Reduces static and interference. 30 Day Unqualified Guarantee By Manufacturer! Try this remarkable antenna. You'll be amazed at the result.

YAHR-LANGE, Inc.

Milwaukee, Wis.

## The Radio Man's Buyer's Guide

# FREE

Set Builders and Dealers can save money on all standard radio parts and accessories. Buy direct from the largest Jobbing house in the middle west. Parts for all the latest hook-ups, as described in this and other leading radio publications now in stock—ready for shipment. Try us for quick, accurate service. No delays—No substitutions.

WRITE today for the RADIO MAN'S BUYER'S GUIDE, our new FREE Catalog. It's yours for the asking—without obligation. Thousands of items are illustrated and described.

WALTER ROWAN  
BATTERY SUPPLY CO.

229 N. Peoria St.

Chicago, Ill.



## RADIO WHOLESALE

Write for my Big 1928 Radio Catalog—just off the press. Thousands of marvelous bargains in nationally advertised goods. All the LATEST IN RADIOS and equipment. Lowest wholesale prices. Agents Wanted.

FREE

It's a regular encyclopedia on Radio. All about trouble finding. FREE Log and Call Book and Catalog. Get your copy today. Send postcard now!

American Auto & Radio Mfg. Co.  
HARRY SCHWARTZBERG, PRES.  
Dept. 213 American Radio Bldg., Kansas City, Mo. 5

DEALERS  
NEW  
1928  
CATALOG

## 1927 AMATEURS' HANDIBOOK JUST OUT

Greatest edition of them all  
See Page 158

BUILD THE NEW, SHIELDED

## Hammarlund ROBERTS Hi-Q SIX

Send 25c for Construction Book

Hammarlund-Roberts, Inc., 1182-S Bway, N.Y.





# The Melody Ship

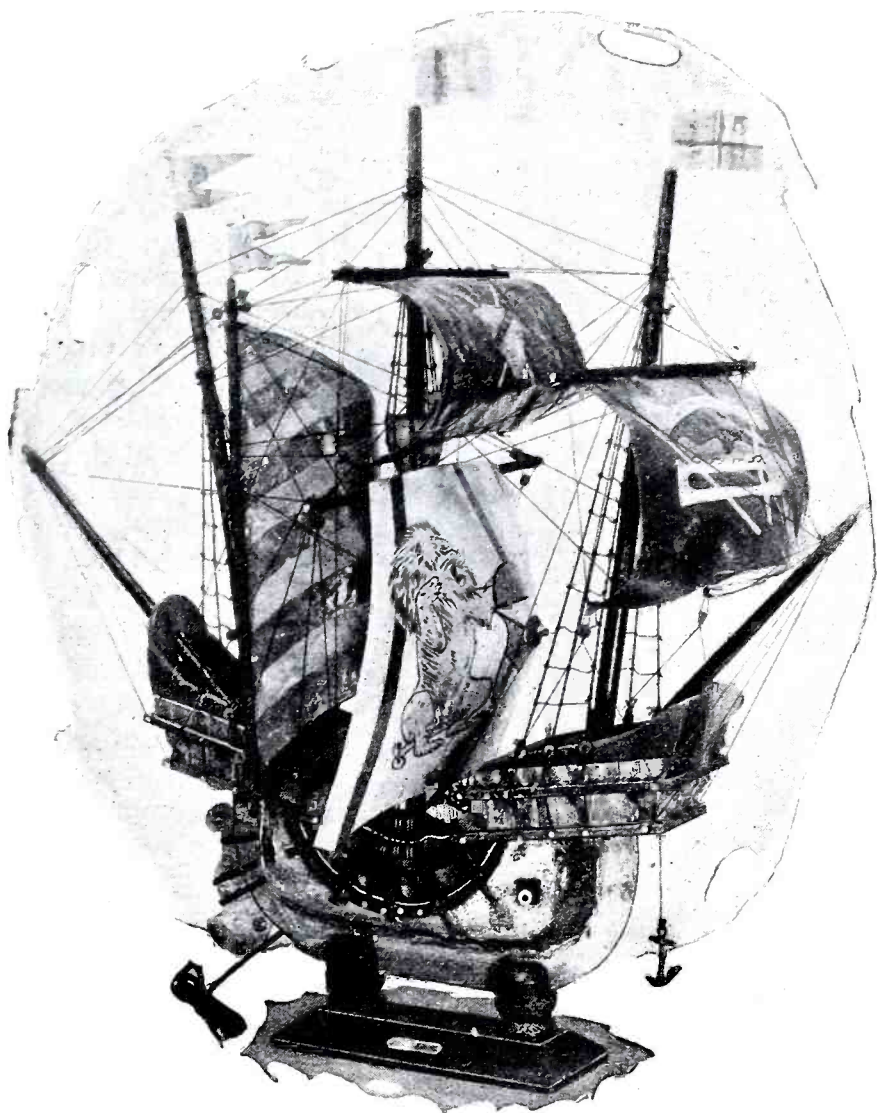

**Radio's Newest and  
Greatest Loud Speaker**

You can build this  
beautiful ship model loud  
speaker in a few hours

**A**WAY with the unsightly loud speaker that strikes a jarring note in the interior decoration scheme. The newest and most popular loud speaker is the Melody Ship, a ship model into which has been incorporated a loud speaker.

The Melody Ship is made entirely of wood. A positive free edge cone speaker with a unit of the electro magnet type, powerful enough to operate a 72-inch cone, is attached to the main-mast. This insures splendid service and ample volume with no distortion.

The loud speaker is made in the shape of a sail and does not alter or change the appearance of the ship in any way. The sails are artistically painted with the various designs and figures of the period represented by the models.

The tone of this loud speaker is far superior to any cone of its size on the market today. This is made possible by our patented melody sail.

Write for our beautiful illustrated catalog.

Fill in the coupon below and we will act upon it immediately.

To all outward appearance the Melody Ship is a handsome ship model, but upon close observation you will find that the beautifully decorated main sail is the diaphragm of a loud speaker and the unit is concealed behind it, attached to the main mast.

It is the only loud speaker on the market that appeals to the eye as well as the ear.

Miniature  
Ship Models,  
Dept. Y,  
3818-20-22-24  
Baring Street, Phila-  
delphia, Pa.

Please send me complete parts for the Melody Ship cut to fit and ready to assemble for the model La Pinta as shown above. I will pay the postman \$12.50 plus postage (a few cents).

PLEASE PRINT NAME AND ADDRESS PLAINLY

Name.....  
Street or R. F. D.....  
City.....  
State.....

## Miniature Ship Models

3818-20-22-24 Baring Street  
Philadelphia, Pennsylvania

# There's money for you in RADIO



*Wonderful opportunity for ambitious men to win success in this fast-growing profession*

THE Radio industry is expanding so rapidly that trained men are at a premium. There is a constant, urgent demand for operators—factory superintendents—engineers—service men—designers—salesmen.

There is no better way for you to succeed in this fascinating business than to study the Radio Course of the International Correspondence Schools. This course is new and complete. It was written by practical authorities in this field. It is endorsed by leading radio experts and radio manufacturers.

Quincy J. Workman, of Scranton, Penna., writes that he has "nearly doubled his salary" since he took up the I. C. S. Radio Course. He is now manager of the Radio Department in a large store.

This same course enabled John M. Paynter, of the U. S. Lighthouse Service, Charleston, S. C., to get a position as Radio Operator and Ship's Electrician. Scores of other men in radio factories, laboratories and stores report similar progress.

You, too, can get in on the ground floor if you act quickly. But don't delay too long. Mark and mail the coupon today and let us tell you all about the I. C. S. Radio Course and what it can do for you.

**Mail the Coupon for Free Booklet**

International Correspondence Schools  
Box 7872, Scranton, Penna.

Without cost or obligation, please send me all the facts about the new I. C. S. course in

## RADIO

Name.....

Street Address.....

City..... State.....



### 5 TUBE RADIO

ONLY \$19.98

It's a wonder for power and selectivity. Famous ART circuit. Coast to coast reception! Finely built of selected, tested parts. Thousands now in use. FREE Log and Call Book and New 132-p. Catalog with thousands of nationally advertised bargains. Latest in radio big savings. Write for Free copy.

AMERICAN AUTO & RADIO MFG. CO.  
HARRY SCHWARTZBERG, PRES.  
Dept. 211 American Radio Bldg., Kansas City, Mo.

AMERICAN  
RADIO  
BARGAINS

## SET BUILDERS

Before you build get our special prices on the parts you are planning to use. We'll save you money. Largest and most complete stock in U. S. A.

**Chicago Salvage Stock Store**  
Dept. R.R., 509 S. State St., Chicago, Ill.

of a stream without running a submarine cable between the two points.

Recently it was the writer's desire to employ a stethoscope for picking up heart beats with the intention of amplifying them for radio broadcasting purposes. A microphone that worked admirably is the one indicated in Fig. 10. This consisted of an ordinary wooden pill box. A diaphragm of heavy paper was stretched across this and the microphone button was then centered and attached to the paper. The cover of the pill box was partially cut away, leaving an opening in the center, but the rim itself was kept intact so as to hold the paper diaphragm as illustrated. The smaller the pill box, the better, and if you can obtain one an inch in diameter, the heart sounds picked up will be clearer. The apex beat will then not be confused with any other valve sounds. An ordinary 4½ volt battery and a 75-ohm receiver or a 5-ohm receiver can be employed in this circuit, or the sounds can be amplified, as they were in our particular experiments, through an audio frequency amplifier, either Western Electric or resistance coupled.

The number of freak musical instruments which can be built and which will depend upon the transmitter button for the reproduction of their sounds is so great that it would be impossible to list them all in this short article. For instance, the button could be attached to the side of a kazoo or to a frying pan, provided with strings and made to imitate a banjo, or a broom can be arranged as a one string violin. The string itself is mounted at the bottom of the broom, runs along the entire length of the broom stick to the tuning peg at the top. A small bridge holding the transmitter button is then placed near the bottom and the handle should be planed down so as to give a flat surface for the fingers and string, making a regular flat finger-board. It would be curious to see an entire band composed of a number of these freak dish-pan and household utensil strings. Every one of them would have its own microphone button and they could all be brought in to the circuit of an amplifier through a suitable mixing panel. This mixing panel can consist of several 400-ohm rheostats, one for each instrument. By controlling the rheostats, the volume of the electric broom can be made to approximately equal that of the banjo frying pan. With concealed loud speakers such a band might get a handsome offer from some theatrical agency for an engagement on a recognized circuit. When they do, the writer hopes they will not forget to give credit to this publication for which the scheme was originated.

## Build a VICTOREEN for real radio pleasure

A Victoreen Super has range, selectivity, volume and clarity. Tens of thousands of fans build Victoreen sets every year. The results come up to full expectations.

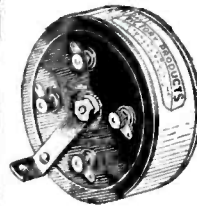

**VICTOREEN TRANSFORMERS**

are the heart of the circuit—air core construction—tuned to 1-3 of 1% precision—use No. 170 for storage battery tubes—

No. 171 for dry cell tubes. Each \$7.00. Other VICTOREEN Parts—

**Rheostats.** Large number of turns of wire—three terminal type. 2, 6, 10, 20, 30 ohms. Each \$1.20.

**Potentiometers,** 200, 400 ohms, \$1.50.

**Master Control Unit.** A compensating single control unit for sets using two or more condensers of equal capacity. Price \$19.50. Extra condensers \$4.50 each.

**Audio Control Unit.** Three rheostats of proper ohmage controlling detector and audio tubes. Each \$4.50.

Ask your dealer or write direct for literature giving complete information.

**The George W. Walker Co.**  
2825 Chester Ave.  
Cleveland, Ohio

## RADIO SETS NEED NOT CAUSE YOU TROUBLE OR WORRY.

**THE RADIO TROUBLE FINDER**  
COMPILED BY THE STAFF OF  
**RADIO NEWS**



64 Page Book — Illustrated

PRICE 25c

**Simplified chart system locates trouble when your set goes wrong.**

Radio Sets can be repaired far more easily than you imagine, if you know where to look for trouble and just how to correct it.

Here's a 64-page book on trouble finding and set repairing—all charted so that you can systematically check all parts of the set.

Size 6 x 9 inches—fully illustrated—"THE RADIO TROUBLE FINDER."

**PRICE 25c  
SOLD EVERYWHERE**

**THE CONSRAD CO., INC.**  
230 Fifth Ave., New York



# TRANSFORMERS



*Endorsed by America's Leading Radio Engineers*

Designed to fulfill the exacting requirements of set builders who demand efficiency, sensitivity, precision and high quality

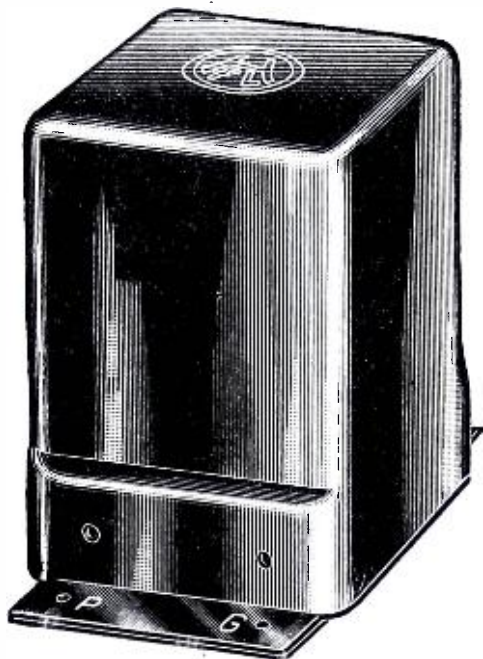

*The Supreme Achievement in Audio Amplification*

H.F.L. now gives you scientifically perfect audio amplification.

The new H.F.L. Audio Frequency transformer C-16 and the H.F.L. output transformer C-25 together are now introduced to the radio set builders as the most perfect means of Audio Amplification known to the science of radio. These new products are the final achievement of nationally known acoustical experts and electrical scientists. Their work has been enthusiastically endorsed by the most critical and skeptical of listeners.

C-16 and C-25 H.F.L. Transformers will give you audio amplification of almost unbelievable purity. Through them you will get, with absolute fidelity, every note and overtone on the entire musical scale and you will get this perfect amplification at all frequencies and at any volume.

Distortion and "mushiness" are entirely eliminated. Any type of speaker may be used with C-16 and C-25 with absolute safety and with equal perfection.

Electrically, scientifically and acoustically, the new H.F.L. C-16 and C-25 transformers are the finest and most perfect means of audio amplification known to radio.

**JOBBER—WRITE FOR FURTHER DETAILS**

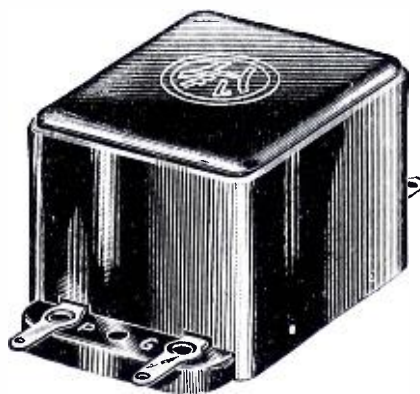

*Tried - Tested - and Approved*

H.F.L. Units have been used, approved and most highly endorsed by Radio News, Citizens' Radio Call Book, Radio Review, Radio Age, Radio Engineering, Radio Mechanics, Chicago Evening Post, the Daily News and others. Thousands of engineers and fans, who have turned to H.F.L. Units for better reception, hail them as the finest transformers known to radio—unexcelled for Power, Selectivity and Purity of Tone.

Perfectly matched, skillfully designed, carefully made, rigidly tested—in a word, H.F.L. transformers are technically correct to the minutest detail.

All H.F.L. transformers are designed for baseboard mounting or invisible subpanel wiring—each unit is enclosed and sealed in a genuine bakelite moulding.

H.F.L. Units are easily connected into the assembly, simplify set construction, and make a beautifully finished job.

## OUR GUARANTEE

We positively guarantee each and every H.F.L. Transformer against any mechanical or electrical defect.

Furthermore, we will exchange—free of charge—any H.F.L. Transformer that fails to give complete satisfaction, providing that the shells and terminals are not damaged.

**JOBBER—WRITE FOR FURTHER DETAILS**

### PRICES

No. H-210 Transformer	... \$8.00
No. H-215 Transformer	... 8.00
No. C-16 Transformer	... 8.00
No. L-425 R.F. Choke	... 5.50
No. L-430 R.F. Transformer	5.50
No. C-25 Output Transform.	8.00

Dealers—Set Builders

If your jobber cannot supply you with H.F.L. Transformers, write us direct for nearest jobber's name.



# HIGH FREQUENCY LABORATORIES

131-A NORTH WELLS STREET

CHICAGO, ILLINOIS

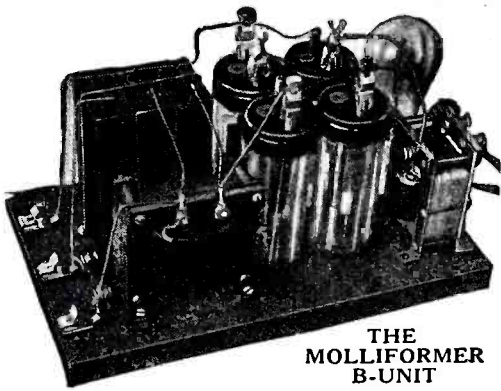

THE  
MOLLIFORMER  
B-UNIT

Specially Adapted for  
**25-40-60**  
Cycle Current

## THE MOLLIFORMER "B" UNIT

Supplies "B" Current for ANY Receiver

Whether you build it yourself or buy it complete, you are assured of the BEST "B" SUPPLY when you use a MOLLIFORMER "B" UNIT. Three years of marvelous performance and perfect satisfaction to every owner has proven this statement. Each unit is sold with the usual GUARANTEE of perfect satisfaction or your money cheerfully refunded.

MOLLIFORMER "B" UNITS are absolutely free from AC hum, tube noises and breakdown trouble. Equipped with improved silixite aluminum rectifier which will outlast 6 to 8 rectifier tubes.

**PRICES RANGE FROM \$17 TO \$30**

*Send for descriptive folder, mentioning your type of receiver*

**Dealers and Set Manufacturers**

MOLLIFORMER "B" UNITS make money for you and save you grief. Improved resistances eliminate costly service calls. Write today for attractive discounts on a strictly quality product. Exclusive territory available.

**C. E. JACOBS MFG. CO.**  
2801-5 N. Kedzie Ave. CHICAGO

A POST CARD WILL DO

*The Catalog every Set  
Builder should have*

**ITS  
FREE**

**Everything for the Set Builder**

Every Set Builder and Dealer who wants to buy at real wholesale prices should have a copy of this large 100-page Harco Catalog. It is chock full of real radio bargains in merchandise covering every need of the Set Builder and Dealer. You can't afford to be without it.

**Prices That Save You Money**

All that is new in radio is in the Harco Catalog. All the latest and most popular kits are shown at prices that save you real money. Harco Service gets the parts to you when you want them. Write for the catalog now and try Harco Service on your next order.

**THE HARCO COMPANY**  
1255 So. Wabash Ave. Chicago, Ill.



*The* **HARCO COMPANY**

1255 SO. WABASH AV.

CHICAGO

### How to Operate Loud Speaker from Crystal

Mr. Winfield Secor, managing editor of *Science and Invention*, recommends the following method:

For several years our English cousins have been able to purchase on the open market a radio amplifier of the microphonic type, which enables one to operate a loud speaker from a crystal detector, thus obviating the use of vacuum tubes, "B" batteries, etc.

In the diagram in Fig. 12 there is shown a simple form of circuit utilizing a crystal detector such as galena or iron pyrites, and across the terminals of the fixed blocking condenser or else across the crystal detector, there is shunted in the manner shown, a 1000 ohm or higher resistance radio receiver of the watch-case type. A Baldwin phone is very useful for this purpose as it gives a greater movement of the diaphragm (or reed) for a certain signal strength than do other receivers. If a microphone button is secured to the center of the diaphragm, or else to the reed which actuates the diaphragm, we will have a "microphonic relay." Every time an incoming radio signal actuates the diaphragm or reed attached thereto, the electrical resistance of the microphone button will be varied correspondingly, and the current from the battery in series with the button and the loud speaker will fluctuate accordingly. In the European type of loud speaker used for this particular purpose, the resistance of the windings is made lower than that found in the average loud speaker, so that no excessive voltage is required in the microphone button circuit in order to properly operate a high resistance type speaker.

In the diagram at Fig. 12, there is shown one method of using the ordinary loud speaker, which should by the way, be fairly sensitive, that is, not requiring a lot of energy to reproduce a certain strength of signal. In this hook-up, shown in Fig. 11, a telephone induction coil may be used, or else a transformer which has a fairly low resistance primary winding, such as that found in the Western Electric modulation transformer. In any event, the resistance of the winding, whether it be that of a transformer or speaker, is to be overcome by using a sufficiently high battery voltage in series with the microphone button. On the other hand, it is well to remember that extra high voltages are very undesirable in microphone circuits, as they are liable to cause arcing whenever the carbon grains shift around. Potentials up to 25 volts are fairly common in microphone circuits (24 volts is used in telephone exchange practice) and thus a "B" battery of the 22½ volt type is frequently requisitioned for such purposes as this.

**BUILD the STROBODYNE**

Official construction book with all blueprints and information  
now ready

SEE PAGE 162

# KARAS Scores Again for 1927-28

## with the NEW 2-Dial EQUAMATIC Sensation

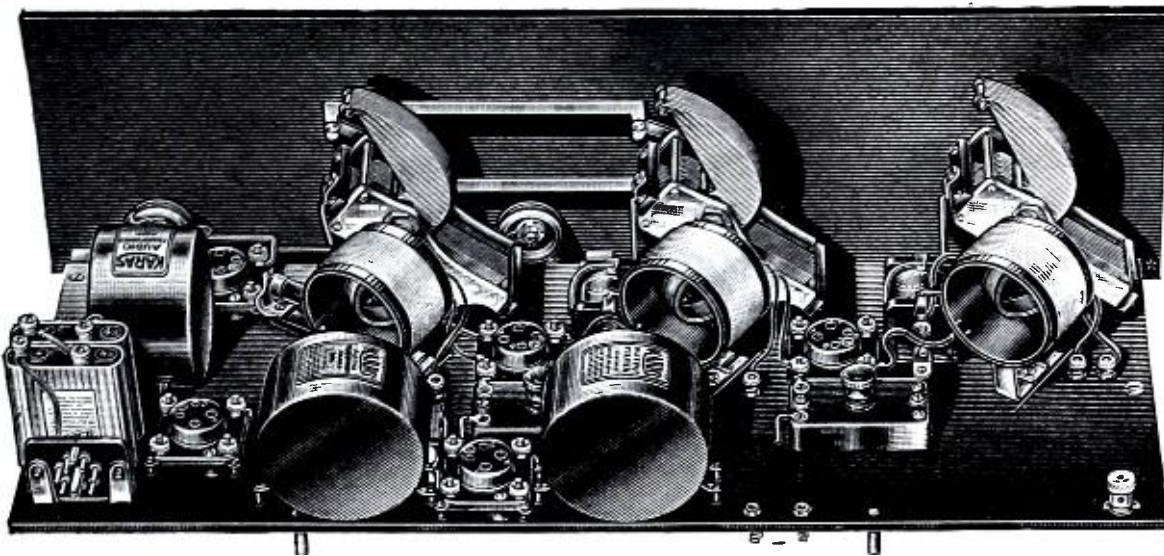

**KARAS**  
PRODUCTS

### The 5-Tube Receiver That Leads the World in Performance!

**O**UTSTANDING among all of the season's radio receivers is the NEW Karas 2-Dial Equamatic—the 1927-28 Sensation that leads them all in performance. This marvelous new Equamatic has 2-Dial Control, insuring simplified, easy tuning, with maximum and equal efficiency over the entire broadcast waveband. *The Karas 2-Dial Equamatic is completely balanced and perfectly neutralized.* It offers set builders who want utmost volume and superb tone quality the very pinnacle of perfection in these two all-important requisites. In addition, the Karas 2-Dial Equamatic makes use of a 24-inch panel and baseboard, thus shortening the set and simplifying its assembly.

The three Karas Type 17 S. F. L. Removable Shaft Condensers are of the latest design. Two of these condensers are operated together by means of the Karas 2-Dial Control System, giving wonderfully accurate tuning in conjunction with the Karas Micrometric Vernier Dials.

For a tremendous volume of round, clear, pure, undistorted, full, mellow tones you will not find a rival to equal the Karas 2-Dial Equamatic. To build this great receiver you will need the Karas parts listed and illustrated here, plus certain other standard parts easily obtainable anywhere. Mail the coupon for complete information about this receiver and about the NEW Karas parts now at your dealer's.

#### KARAS PARTS FOR THE 2-DIAL EQUAMATIC

3 Karas Equamatic R. F. Transformers.....	each \$4.00	\$12.00
3 Karas Equamatic Type 17 Removable Shaft S.F.L. Variable Condensers.....	each 5.25	15.75
2 Karas Micrometric Vernier Dials.....	each 3.50	7.00
2 Karas Type 28 Impregnated Audio Transformers.....	each 8.00	16.00
1 Karas Output Filter.....		8.00
3 Karas Subpanel Brackets, set of 3.....		.70
1 Karas 2-Dial Control System, complete with three extra shafts and all necessary assembly hardware for entire set		3.00

### The New KARAS Products for 1927-28 are Superlatively Better

For the 1927-28 Season Karas offers several new products of superlative quality and distinction. Among these is the NEW Karas Type 28 Audio Transformer. This new transformer is scientifically impregnated and is housed in a lifetime steel clad, spun-sealed case which effectively guards its marvelous amplifying qualities. The Type 28 gives full, clear, undistorted amplification of all low notes as well as perfect reproduction of high notes, and has tremendous volume. Two of these transformers are used in the Karas 2-Dial Equamatic. The new Karas S. F. L. Variable Condensers, Types 11, 17 and 23, have removable shafts, allowing for subpanel, baseboard or single hole mounting from either side, and permitting the use of 0-100 or 100-0 dials. This right or left hand single hole method of mounting is an exclusive Karas achievement. These condensers are true straight

frequency line type, separating all adjoining wave-lengths by equal distances on the dial. In the Karas 2-Dial Equamatic 3 Type 17 S. F. L. Condensers are used. The new Karas Output Filter sweetens and clarifies tone qualities and prevents demagnetization and eliminates chattering of the loud speaker. This new Karas Filter exactly matches our new Type 28 Transformer in size, and because of their compact design two transformers and a filter occupy no more space in the set than is needed for two ordinary large size transformers. The Karas Output Filter is equipped with choke of 100 henrys and a large capacity paper condenser. You can see and order this new Karas apparatus NOW at your dealer's. Get in touch with him today for these and other Karas parts you will need in building your Karas 2-Dial Equamatic.

**KARAS ELECTRIC CO., 4037-I North Rockwell Street, CHICAGO**



The NEW Karas Type 28 Audio Transformer, Price, \$8.00



The NEW Karas Output Filter, Price \$8.00



The NEW Karas S.F.L. Condenser with Removable Shaft, Price, .00025 mfd., \$5; .00037 mfd. \$5.25; .0005 mfd. \$5.50

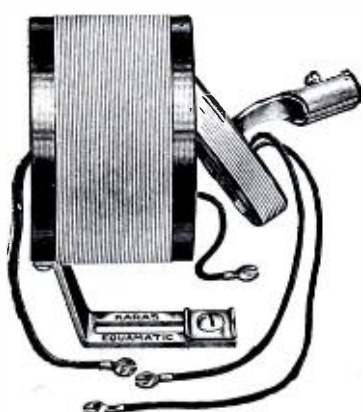

Karas Equamatic Inductance Coils, Set of 3, \$12.00



Karas Micrometric Vernier Dials, Price \$3.50

#### Mail This Coupon for Literature

Fill out and mail the coupon below for complete information about the NEW Karas products for 1927-28, and complete data on the Karas 2-Dial Equamatic Receiver.

**KARAS ELECTRIC CO.**  
4037-I North Rockwell Street, Chicago

Send me complete particulars about your new Radio Products, including data on the new Karas 2-Dial Equamatic.

Name .....

Address .....

City..... State.....

## Changes Your Set Into a Short Wave Receiver

Sent postpaid anywhere in U. S. upon receipt of \$15.00 M. O. or C. O. D. plus postage upon receipt of \$1.00 to guarantee carrying charges.

When ordering state kind of set so that detailed directions for use may be given if necessary. Also state type of tubes such as UX199, UV199, WD11 or 201A.

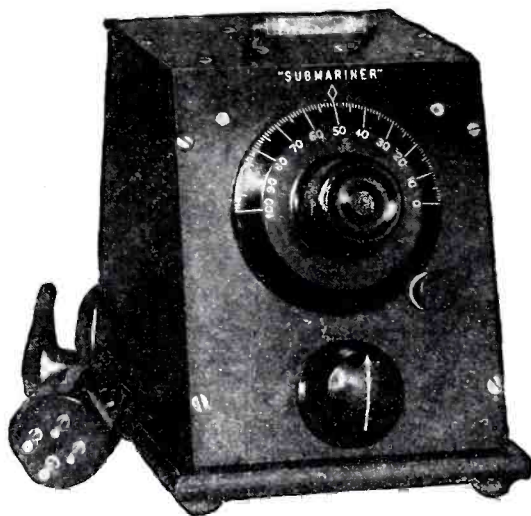

# The SUBMARINER

Regardless of the kind of set you have, this device will permit you to listen to short wave stations between 30 and 75 meters. Operates with sets such as T R F, Neutrodyne, Super-Heterodyne, regenerative sets and all other types. No additional tubes or batteries required. No changes to the wiring of the set. A short aerial and ground is connected to the "Submariner," and a cable and plug attaches it to the set. Requires less than a minute to attach or detach. Operates as a wave changer with Super-Heterodynes, and as a detector unit with others.

## DISTANT RECEPTION

practical because short waves penetrate better, and there is less static. There are several powerful stations using the wave band covered by the "Submariner" for broadcasting programs. You may also learn code by listening to amateurs from all parts of the world. Get a thrill by tuning in a station your friends cannot get. You will have a highly efficient short wave receiver when the "Submariner" is attached to your set. Nothing else like it on the market. Take a trip in the low waves on board the "Submariner."

## ORDER TO-DAY

*We guarantee to refund if the "Submariner" fails to operate.*

ADDRESS

**J-M-P Manufacturing Company Dept 118X, Milwaukee, Wis.**

**\$5.50 buys this famous cabinet!**

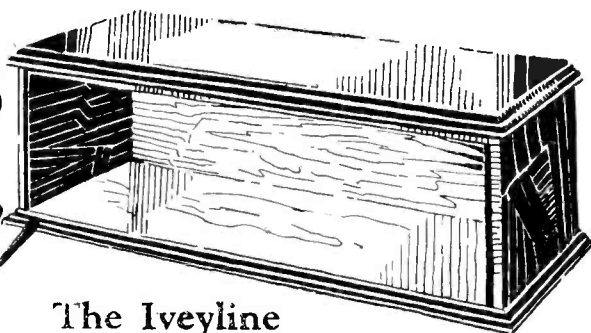

The Iveyline

Our dealing direct brings this cabinet to you at half the usual retail price. Made either from selected hardwood, with Mahogany finish or from solid Walnut, rubbed to a beautiful piano lustre, the Iveyline Cabinet makes a fitting climax to your set-building efforts. It has full length, nicked piano hinge, nicked lid support, rubber feet to prevent vibration and lid splined to avoid warping. Fully illustrated catalogue available. Just write. If you send us your order today, the cabinet will be on its way within 12 hours from receipt of order. Select your size and finish and mail your order today. Cash with order or if C. O. D. half price with order.

### Dimensions

### Prices

Dimensions	Prices	
	Mahogany Finish	Solid Walnut
7x18x10	\$5.50	\$6.50
7x21x10	6.00	7.00
7x24x10	6.25	7.50
7x26x10	6.75	8.00
7x28x10	7.00	8.50
7x30x10	7.25	8.75
7x18x12	7.00	8.00
7x21x12	7.50	8.50
7x24x12	7.75	9.00
7x26x12	8.25	9.50
7x28x12	8.50	10.00
7x30x12	8.75	10.25

12 Hour Service—Factory to You

All prices f. o. b. Hickory

**Southern Toy Co. Inc.**  
Manufacturers Hickory N.C.

OFFICIAL CONSTRUCTION BOOK NOW READY

## The STROBODYNE

Complete BOOK containing FULL-SIZED BLUEPRINTS and all other information necessary to build complete receiver

SEE PAGE 162

The diagram at Fig. 13 shows a three stage audio-frequency amplifier of the microphone type. This form of amplifier was used sometime ago in the large trans-Atlantic stations for amplifying both code and voice signals. The winding of the first amplifier may be of 1000 ohms or more in value, while the second and third relay windings may be of much lower resistance, say 75 ohms, such as that found in the ordinary telephone receiver.

The microphone buttons are preferably placed on soft iron reeds. The fluctuations, in the current passing through the receiver windings placed before the iron reeds, cause the latter to vibrate, and in turn the microphone buttons are vibrated also. Thus variations in the resistance of the microphones are occasioned, and the corresponding fluctuations in the battery current cause the successive relays to simultaneously vibrate the microphone buttons, until the loud speaker is reached; and here we will hear either the code signal or the voice reproduced and greatly amplified.

It may require quite a little experimenting and adjusting in order to get the microphone relays to work just the way you want them to, especially for voice reproduction. It is important to mention at this point that frequently it pays to vary the amount of carbon granules in the microphone buttons. It is also possible to improve the operation of such microphone relay apparatus by varying the current passing through the circuits, by inserting a suitable adjustable rheostat in series with the microphone button circuit. In some cases the same result is obtained by shunting a 400 ohm potentiometer across the microphone, and thus shunting more or less of the battery current by it. Where quite high voltage is necessary in the microphone circuit, in order to operate a high resistance relay, loud speaker, etc., a high resistance potentiometer shunted across the button will help to absorb any sparking which may take place between the granules; the same effect being attainable by shunting a suitable size condenser across the microphone button.



# The New Karas 2-Dial Equamatic

(Continued from page 100)

the tone quality of low-wave reception will be no better than that of the old-time regenerative receivers.

There is a way of getting around these difficulties to a nicety and that is to maintain the efficiency over the entire waveband by varying the inter-stage coupling with the wave-length. At the low wavelengths the coupling may be very loose and still the efficiency may be high. As the receiver is tuned to higher wavelengths where the efficiency would normally be less, the coupling can be increased, thereby providing a greater energy transfer between stages and in this way providing good efficiency, even on the highest wavelengths.

But like all other solutions that appear so simple, there is a hitch in this. To provide this variable coupling between stages means the addition of one more tuning control for each stage of radio frequency amplification. That is, the normal five tube, three control receiver would have six tuning controls instead of three. Such an arrangement would, of course, be out of the question because of the complications in operation. It would require long practice to learn how to operate it, and even then it would be a decided nuisance to have to manipulate six controls every time another station was to be tuned in.

It is here that the automatic coupling of the Karas Equamatic receiver comes in. Variable coupling between stages is provided without the addition of extra controls. Inasmuch as the coupling increase should approximately correspond to the decrease in the frequency to which the receiver is tuned the designing engineers concluded that the logical thing was to attach the variable coupling coils to the shafts of the tuning condensers. Then as the condensers are tuned to the lower frequencies (higher wavelengths) the coupling will increase at the same time. Conversely, as the condensers are tuned down to the lower wavelengths the coupling will decrease. Thus this complicated problem is solved in an extremely simple manner.

Not satisfied with accomplishing the six tuning operations with only three tuning controls, the engineers who designed this circuit went further and designed a device which would permit the operation of two of the tuning condensers with but a single tuning control. This reduced the total number of controls to two. The design and construction of the component parts of the radio frequency amplifier, fortu-

(Continued on page 158)

ARCO—ARCO—ARCO—ARCO—ARCO—ARCO

# NEW RADIO JOY!

Arco Socket Power Units will really improve radio reception for you—for Arco Units are built to bring the best of radio enjoyment. Constant, sure full power without care or attention. Attractive, well-made cases with delicate adjustments for the full automatic "AB", "A" and "B" units. Arco prices are lower. Compare Arco with any of equal appearance or performance.

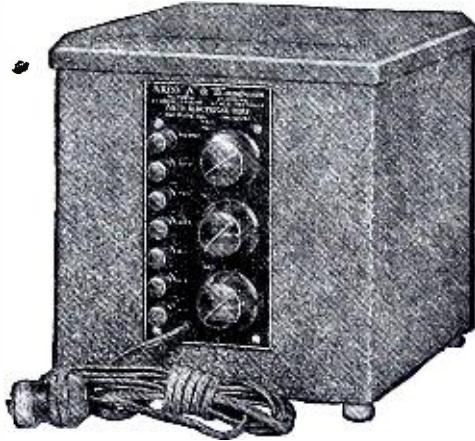

Arco "AB" Power. Just plug in and forget it. 2 1-2 amp. at 6 V and 80 M. A. at 180 V. Complete \$67.00



Arco "A" Power. Automatic. 2 1-2 amp. at 6 V, \$37.00



Arco "B" Eliminator. 50 Mil. Amp. at 180 V. Complete \$32.50



Arco "A" Power. 60 amp. battery with 2 1-2 amp. charger, automatic control. Complete \$33.00 to \$37.00



Hi-Rate Charger [HRC3] same as HRC 1 except less automatic cutout. 2 1-2 amp. \$12.50—5 amp. \$19.50



Hi-Rate Charger [HRC1] Automatic cut-out—attach to your present "A" battery and you have a power unit. 2 1-2 Amp. \$18.50—5 Amp. \$25.00



Hi-Rate Charger 6 [HRC6] same as HRC1 except less case and automatic cutout. 2 1-2 amp. \$11.50 5 amp. \$18.00



Arco Power Controller transforms "A" battery and HRC Unit and "B" power unit into an automatic socket power unit \$7.50



Arco Automatic Radio Power Switch controls trickle charger combination automatically from radio switch, \$3.50

Prices slightly higher West of Rockies and in Canada.

ARCO ELECTRICAL CORP.  
825 BARR STREET  
FORT WAYNE, INDIANA

Please send me details on Arco \_\_\_\_\_  
Send me miniature catalog [ ].

Name \_\_\_\_\_

Address \_\_\_\_\_

City \_\_\_\_\_ State \_\_\_\_\_

ARCO—ARCO—ARCO—ARCO—ARCO—ARCO

# RADIO CATALOG *free*

**2000**  
**Exceptional**  
**Radio**  
**Values**

SEND TODAY FOR  
THIS GREAT BOOK

Compiled exclusively for dealers in radio sets, radio parts and for set builders. An amazing catalog containing the newest things in the world of radio. Unbeatable values in radio parts, kits and supplies of National fame. A complete array of cabinets and consoles, in all the latest styles, finishes and popular sizes, and at unmatched prices.

**Radio Listeners' Guide Kits** We can supply complete kits for any of the circuits described in this issue of the Radio Listeners' Guide; such as Silver-Marshall Laboratory Model Super, Nine-in-Line, Tyrman 10, and all others.

**Short Wave Section** Our catalog contains a section devoted to a showing of the highest grade short wave receiving and transmitting apparatus. Also the finest electrical appliances for use in the home. Whatever your radio needs may be, you will find them in our 1928 catalog. Write for a copy today. Send your request on your letterhead—but write immediately.



**LOWEST  
PRICES  
to  
DEALERS**

Take orders direct from our list price catalog. The high quality of our products eliminates loss. Speedy shipments insure your customers' good will and bigger profits for you.

**Shure Radio Co.** 335R-MADISON ST. CHICAGO, ILL.

# TOBE

Trade Mark Reg'd U. S. Pat. Office

## CONDENSERS

TOBE Condensers are constantly specified by:

James Millen  
Keith Henney  
Volney Hurd  
Zeh Bouck  
Austin Lescarboura  
Jos. Calcaterra  
Milton Sleeper  
Hollis DeNeefe  
Wilmer S. Trinkle  
Stuart Rogers  
Laurence Cockaday  
McMurdo Silver  
Lloyd C. Greene  
Perry Graffam  
Kendall Clough  
Glen Browning  
Gerald M. Best  
E. M. Sargent  
John B. Brennan  
Herman Bernard

They are standard in the following recent successful power supplies, power amplifiers and radio sets:

Raytheon A.B.C. 350 MA Rectifier  
QRS A.B.C. 400 MA Rectifier  
Silver-Marshall Unipac  
Thordarson No. 171 and No. 210 Compacts  
Amertran Power Pack  
Browning-Drake  
R. B. Lab. Receiver  
L-C 27  
World's Record Super  
Nine-in-Line Super  
Samson Super  
Infradyne  
Hammarlund-Roberts Hi-Q  
Lincoln Super

Send for our latest pamphlet G-9

**Tobe Deutschmann Company**

Cambridge

Massachusetts

**Radio Fundamental Co.**

Hearst Square, Chicago

Specializing in radio and allied problems—both mathematical and practical. Analysis. Criticisms. Economical production. Expert designing. Radio power supply. Small and large tube design. Also plant construction. Photo electric problems. Set design. Translations. Patent problems, cost systems, etc. Write us in confidence.

**FREE RADIO GUIDE**

Gives special hook-ups with illustrations. Shows the latest sets, the newest developments in radio at startlingly low prices. Get the set you want here and save up to 50%. Everything in parts. Kits, complete factory built sets and supplies. Orders filled same day received. Write for free 164-page copy NOW, also please send name of one or more radio fans.  
**BARAWIK CO.,** Dept. LG9 Chicago, U. S. A.

## The New World's Record Super 10

(Continued from page 93)

nished by the  $4\frac{1}{2}$  volt tap on a C battery whose total voltage is 40 to 45 volts, this high value being required for the operation of the 171 tube in the power stage. To effectively curb any stray r.f. in the first and second detector plate circuits, a Remler No. 35 r.f. choke coil is used.

Four Tobe by-pass condensers will be found at the required points, one from the positive 45 terminal to the negative line, one from the positive 90 volt tap, and one from the positive 180 volt terminal. These by-passes, as well as the one spanning the center arm of the 400 ohm potentiometer and the negative, are rated at one microfarad.

In the audio end are found two Thordarson R200 transformers, while an R-76 output transformer is used in the plate circuit of the power tube to isolate the d.c. potential from the speaker windings. Grid bias for the first audio is derived from the  $4\frac{1}{2}$  volt C battery tap as shown in the schematic.

Convenience in testing the set as well as simplicity and permanence of wiring, dictated the use of the new Jones base mounting plug, shown at the left in the photograph, Figure 2.

Tubes throughout are of the 201-A type with the exception of the power stage where a 171 is used. When the intermediate units are accurately matched, matching of tubes is not required for excellent results. The only requirement is that the tubes be good ones and not deteriorated from abuse.

Where in previous models the potentiometer method of biasing the intermediate frequency grids has not been used, in the present Super 10 it is permissible since there is considerable filtering effect in the preceding r.f. train so that selectivity is maintained, and enables the intermediates to be operated at the most efficient point. The potentiometer also affords another means of volume control, this added flexibility desired by the true experimenter and distance seeker.

Benjamin sockets of the cushion type for subpanel mounting are used and insure freedom of noise from tubes jarring. A Jewell 0-8 d.c. voltmeter shows the operator the condition of his filament supply at all times and enables him to keep the exact voltage on his tubes.

In connecting up the r.f. couplers to the three gang condenser it is worth noting that the grid returns of the first and second r.f. and 1st detector are to the negative filament. Usually where condenser and grid leak rectification is



used, the return is to positive filament, but in this particular receiver better results are secured with a negative return. If desired, a 200-A tube can be used as 1st detector and will give a little more volume on distant stations. However, it is noisier than the 201-A, the recommended tube.

After the set has been completely assembled as shown in the photos and wired according to the accompanying schematic diagram, it is ready for installation in a cabinet. This of course is left to the choice of the builder: The set can be either installed in any of the well made table type cabinets such as can be found advertised in this magazine, or one of the handsome Excellor or United consoles.

In the operation of the Super 10, Selector 1 controls the r.f. input (corresponding to the loop condenser on the older models) while Selector 2 turns the oscillator condenser. The set logs readily, its selectivity is above par and the tone quality is such that its owner may well be proud to build it and demonstrate to his friends.

## A Compact A-B-C Power Unit

(Continued from page 120)

two set screws in each rotor and the screw in the two cams and shaft will then be free. When the present brass shaft has been removed a small slot slightly larger than the space occupied by the condenser nearest the panel should be cut in the aluminum shield (1A). This will not be difficult. Re-mount condenser to panel as before making sure the condenser does not touch the shield at any place. Insert the bakelite shaft and tighten all set screws.

To wire the filaments in series proceed by running a wire from A minus to F minus of detector socket. Connect F plus to F minus of 1st Audio and F plus of 1st audio to F minus of 1st R.F. socket. Connect F plus to F minus of 2nd R.F. socket and return F plus to A plus binding post. Make the grid return of each R.F. and first Audio to their respective F minus terminals. The detector grid return is arranged for 200-A detector tube and should a 201-A tube be used it will be necessary to make this a positive grid bias and this may be done by connecting to F plus of detector socket instead of F minus as shown. The filament leads for the second audio should be run in twisted paired wire to two binding posts. As the first C minus post is not longer used and the 67 B plus post may be made vacant by connecting the lead to the 90 B plus post, these two posts are now available for the AC filament leads.

# Mathematics or Results-Which?

**Y**OU can't get away from "variables" in the radio power unit. Line voltage fluctuations, changes in receiver tubes, differences in rectifier tubes, lowered rectifier output with age, unequal drain for different yet inter-related circuits—well, there are many "variables" present and for which you must compensate with suitable resistance values.

Of course, if you are an expert mathematician and engineer, preferring to work the slide rule than to enjoy radio programs, then by all means get the fun out of figuring the necessary resistance values. And don't forget to change the resistors from time to time to compensate for the changing conditions.

But if you are just the average radio enthusiast, seeking the best results with the least trouble, then use variable resistors to take care of all "variables." And when you say variable resistor—that means CLAROSTAT, the recognized leader. Here's the dope—



## The POWER CLAROSTAT

A husky variable resistor for handling real power. In several turns of knob, it covers wide range. Handles up to 40 watts of energy. Obtainable in three resistance ranges—0 to 10 ohms for line-voltage and primary group voltage control; 25-500 ohms for series-connected filament control with B-voltage tap resistances in series; 200-100,000 ohms for series-connected filament control, with or without shunted fixed resistance. And there are countless other uses. Price \$3.50.

## The STANDARD CLAROSTAT

Too well known to require lengthy introduction, this device has more applications than ever. It is the ideal B-voltage tap control, providing the precise voltage for each circuit and for any type of tube. In several turns of its knob, it offers a universal resistance range of from practically 0 to 5,000,000 ohms, with a current-carrying capacity of 20 ohms. The Clarostat is noiseless, non-packing, foolproof and indestructible within its working capacity. Price \$2.25



Both Power and Standard CLAROSTATS are finding wide use in the heavy-duty B-eliminators and the A-B-C power units now coming into favor. Read in RADIO LISTENERS' GUIDE how Perry S. Graffam, well-known radio engineer and designer, has selected both types for the simplest solution of the resistance controls for the filament and plate circuits. And note how in many other popular layouts, Clarostats are specified because there is no other variable resistor which combines the great resistance range, the fine adjustment, the positive operation, the complete absence from noise, the large current-carrying capacity, and the long life found in every Clarostat.

*Clarostat is being imitated. Insist on seeing the name on every genuine unit.*

**GET THE FACTS!** Ask your local dealer regarding Clarostats and how you can apply them in that new or even in the old radio power unit. And if he cannot supply you with descriptive literature, write us. Better still, send a quarter for our big 32-page book, "The Gateway to Better Radio," which contains a vast fund of information on radio in general.

AMERICAN MECHANICAL LABORATORIES, INC.

Specialists in Variable Resistors

285-87 NORTH SIXTH STREET :: :: :: BROOKLYN, N. Y.

# CLAROSTAT

# Jones MULTI-PLUG

THE STANDARD SET CONNECTOR

Fully covered by U. S. and Foreign Patents allowed

## SPECIFIED FOR STANDARD CIRCUITS

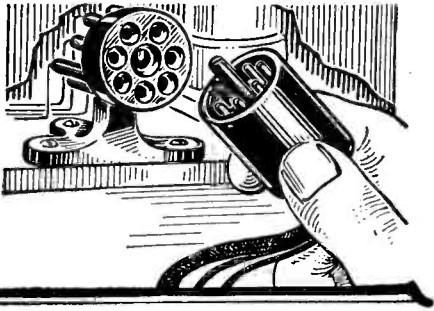

**Type B.M.**—Picture above and below shows B.M. socket mounted at back of sub-panel. Plug and cable lead to any convenient place for batteries. 4 ft., cpt. 2.50; 8 ft., cpt. 2.75.

The standard connector in leading sets and circuits. Specified among others in the H.F.L., Camfield and Scott's World's Record Super 10. Instantly connects or disconnects all wires of a set. Can't be plugged in wrong. Has all necessary connections. 8 ft. cable permits batteries to be placed apart from set if desired. Various types illustrated meet every radio requirement. A great time, labor and trouble-saver—a necessity in every up-to-date set and circuit. Write for descriptive folder and price list—free. For sale by leading dealers and jobbers.

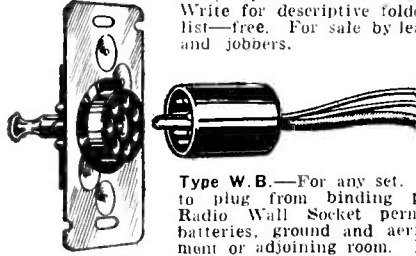

**Type W.B.**—For any set. Cable leads to plug from binding posts; Jones Radio Wall Socket permits placing batteries, ground and aerial in basement or adjoining room. Radio socket conforms in size and shape with electrical socket. 4 ft. cable. 2.50 cpt.

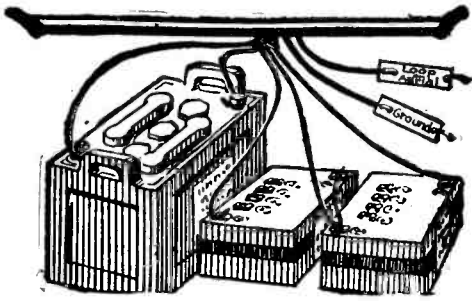

**Type B.P.**—For any set. Socket wires lead from binding posts; plug wires lead to batteries, ground and aerial. Just push in plug to connect set with current supply. 4 ft. cable. 2.75 cpt.



**Type P.M.**—Same as B.M.—but without bracket. Mounted right in sub-panel. 4 ft. cable. 2.25 cpt.

HOWARD B. JONES, 2300 Wabansia Ave., Chicago

## The Lynch Suppressor Circuit

(Continued from page 69)

Lynch equalizers. Tubes S1 and S2 draw their filament supply through the equalizer R7. In series with this equalizer is a combination 6 ohm rheostat and battery switch (S and R14). The switch part of this unit controls the entire receiver supply while the rheostat portion provides a means for manual variation of the supply to the two tubes S1 and S2. This is the volume control. At first glance it may seem superfluous to use both an equalizer and a rheostat to control these two tubes. The purpose of the arrangement is to safeguard the tubes because, even with the rheostat turned on full, the voltage applied to the tubes cannot exceed their normal working voltage of 5 due to the presence of the equalizer.

The other four tubes are controlled by equalizers. A type 4 equalizer controls the supply to the detector tube; a type 2 equalizer to supply the 1st and 2nd audio tubes; and a type 2 equalizer for the power tube.

It will be noticed that the same plate voltage is supplied to the detector and the first audio stage. This is a rather unusual arrangement but it serves the excellent purpose of eliminating the bugaboo "motorboating" which is frequently experienced when a resistance coupled amplifier obtains its plate supply from a "B" eliminator.

Binding posts are provided for the antenna, ground and battery connections. Marked binding posts are a convenience and also help to guard against wrong connections. The "A" and "C" voltage values have already been discussed. The detector "B" supply should be 45 volts; the radio frequency supply is best at 90 volts. The high voltage can best be 180 volts if a 371 type tube is used in the last audio stage, or 135 volts if a 312 type tube is used. Binding posts are provided for all battery as well as antenna and ground connections.

The construction of the receiver is greatly simplified by the use of the sub-panel, and further through the elimination of neutralizing devices in the radio frequency amplifier. The detailed placement of the various parts on the front panel and the sub-panel is shown in the illustrations. If the two panels are drilled according to the drilling diagrams given herewith, the location of the various instruments will take care of itself as they need only be matched up with the holes provided for them. In mounting the coils it is necessary to mount them by means of a single ma-

(Continued on page 157)

FREE

# The Greatest RADIO CATALOG

Every set builder needs this book. Every live dealer in radio sets, parts, accessories, supplies, etc., should have a copy of this bargain catalog. You will be amazed at the thousands of money saving radio items illustrated and listed in this storehouse of everything you could possibly need in radio.

**Radio's Newest Products**

The book contains all the latest and most popular kits—all the famous, nationally known radio parts, accessories and supplies—the very newest types and designs of table cabinets and consoles—everything at prices that mean bigger profits for you.

**Radio Listeners' Guide Kits**

We can supply complete kits for any of the circuits described in this issue of the Radio Listeners' Guide; such as, Silver-Marshall Laboratory Model Super, Nine-in-Line, Tyrman 10, and all others.

**Short Wave Section**

Our catalog contains a section devoted to a showing of the highest grade short wave receiving and transmitting apparatus. Also the finest electrical appliances for use in the home.

**Dealers! Make More Money**

Tie up with a house that carries large, complete stocks—that gives you the highest quality radio parts—that insures speedy shipments and 100% satisfactory service. Tie up with Shure. Our wholesale vest pocket price list and discount sheet, together with the 1928 bargain catalog will be sent to you on request. Write on your business stationery—but write quickly.

Real  
Bargains  
to  
Dealers

## SHURE RADIO COMPANY

**335-B Madison Street Chicago, Ill.**

# The Harkness Tuned Audio Amplifier

(Continued from page 118)

attach the two bakelite strips to the front and rear of the brackets, mounting the battery switch and loudspeaker jack on the front strip. Then mount the binding posts, arranging the markings in the manner shown in the picture diagram of Fig. 6. When mounting the binding posts follow this diagram closely, noting particularly the connection strips (supplied with the tuned double-impedance couplers) which slip over some of the binding post screws on top of the panel. Note also that the 1 ohm fixed resistance is attached to the A plus binding post underneath the panel.

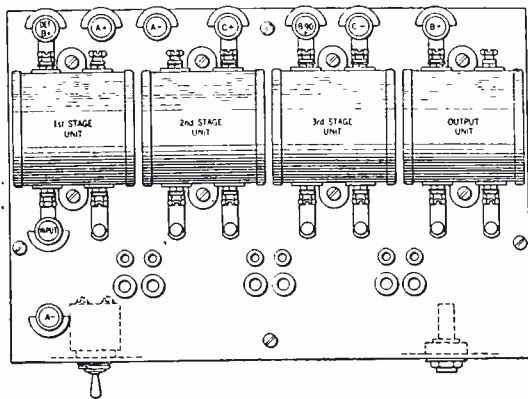

Fig. 9. Actual lay-out of parts on sub-panel.

Finally, mount the three double impedance couplers and the output filter unit on the panel. Mount the couplers with the P and G posts toward the tube sockets and the output filter with the P and S posts toward the sockets.

## Wiring the Amplifier

The wiring is very simple. It should not take more than fifteen minutes. The amplifier is arranged so that very little wiring is necessary. The diagram of Fig. 5 shows the actual circuit, but the picture diagram should be followed as this indicates the use of the connection strips in wiring. Before doing any soldering, attach the connection strips as shown in Fig. 6 between the double impedance couplers and the tube sockets and binding posts. Then, on top of the sub-panel, wire the two "B" posts of the second and third double impedance couplers together. Similarly wire together the two "F" posts of the first and second couplers. Then turn the amplifier over and complete the wiring as shown in the picture diagram.

## How to Install the Amplifier

To use the amplifier as a separate unit in connection with a receiving set, attach a seven-conductor battery cable to the binding posts along the rear of

# HARKNESS

## Tuned Audio Amplifier

Uniform *loudspeaker* output from 40 to 10,000 cycles. No "motor-boating." No "tube blocking." Undistorted power output four times greater than any other system. An amazing development. Licensed under U. S. Patents 1589692 and 1615224.

Completely wired. Ready to operate **\$29.50**

### Tuned Double Impedance Kit

For set-builders, to install in new or old receivers. Contains set of three tuned double impedance couplers and one output filter unit. **\$19.50**

Jobbers } Write for  
Dealers } Price List of  
Set-Builders } Complete Line

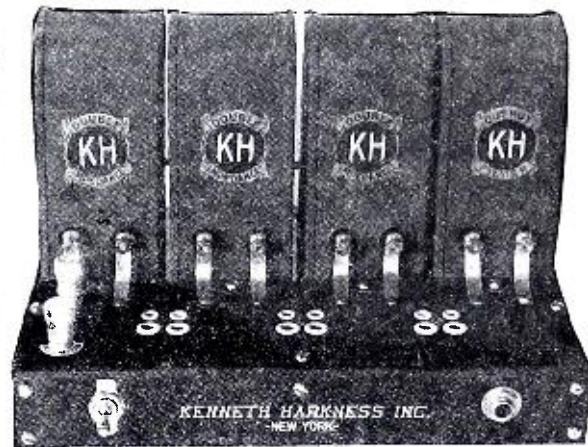

## Makes Tone Perfection a Thrilling Reality!

THE reproduction of the Harkness tuned audio amplifier is clearer and more realistic than anything you have ever heard before. Orchestral music, pianoforte, grand opera, dance music—all are reproduced in pure, rich, natural, full-rounded tones. Every musical note, from the deepest bass to the highest treble, is heard with full volume and with all its distinctive tone-color. Never before has it been possible to re-create musical sounds with such marvelous fidelity.

### New Patented Amplifying Principle

The amazing tone quality of the Harkness amplifier is obtained by the use of an entirely new system of audio amplification on which patents have been granted. This new "tuned double

impedance" system has made possible the reproduction of voice and music with a more natural, life-like quality than has ever before been achieved.

### Your Satisfaction Guaranteed

The Harkness amplifier will greatly improve the volume and tone quality of your set. You can attach it in a few minutes, without tools, and without making any change in your set. It can be used with any radio receiver, new or old. Your satisfaction is guaranteed. Mail the coupon below and the amplifier will be sent you by return. Attach it to your set and hear the improvement. If you are not entirely satisfied, return the amplifier and your money will be instantly refunded.

## Send Coupon!

If your dealer cannot supply you, mail this coupon. Send no money in advance. Pay the expressman when he delivers your package. Satisfaction guaranteed or your money back. Mail the coupon NOW!

**Kenneth Harkness, Inc.**  
Suite 32, 181 Sullivan Street  
New York City

KENNETH HARKNESS, Inc.,  
Suite 32, 181 Sullivan St., New York.

You may send me a Harkness tuned audio amplifier. On delivery I will pay the expressman \$29.50 plus express charges. It is understood that if I am not entirely satisfied with my purchase you will instantly refund every cent I have paid.

Name .....

Full Address .....

## \$MONEY\$

Real Money can be earned in your sparetime taking subscriptions to popular, nationally known magazines.

Selling these magazines is easy—just a few minutes a day—after school—after work—or after household duties will net you BIG PROFITS and a STEADY INCOME. Hundreds of others are receiving large sums of money weekly through our plan.

### LIBERAL COMMISSIONS

Write today for application blank and full particulars  
AGENCY DIVISION

Experimenter Pub. Co., Inc., 230 Fifth Ave., New York, N. Y.

**A DISTINCT DEPARTURE FROM ORDINARY AERIALS—THE**  
 ← ACTUAL SIZE →  
 14 INCHES



**New American All-Direction Antenna**  
 The most perfect antenna of today with which *COAST to COAST* reception is possible.

**WHY YOU CAN'T BEAT IT!**  
 Because it receives radio reception from all directions. Gives greater volume, distance and clarity. Distortion and interference is practically eliminated by the "American-All-Direction Antenna." The results that are brought forth by this well-constructed and perfected antenna are amazing. Merely mount at top of straight pole. Requires little room. Actual size only 14 inches. Ideal for city and country use. Comes ready to mount. Price complete, \$4.

Price Postpaid **\$4.**  
 American All Direction Antenna

**\$4.**  
 The lowest priced quality antenna on the market.

**SHIELD YOUR RADIO SET**

With a Few Pairs of **AMERICAN Aluminum Shields** **30c Per Pair**



Why pay big money for the privilege of owning a shielded set when you can shield your present receiver with three or four pairs of AMERICAN shields. Merely mount AMERICAN ALUMINUM SHIELDS on your baseboard or sub-panel, between the coils, transformers and tubes at points where radiating inductance noises clash! It takes but a few moments and is practically a sure cure for crackling, blurred, noisy reception. AMERICAN shields fit practically all receivers. At all good dealers or sent direct. Address MAIL ORDER DEPT.

**New Catalog Now Ready—Send For It**

**AMERICAN RADIO HARDWARE CO.**  
 135 GRAND STREET, NEW YORK CITY

the amplifier and connect the other end of the cable to the batteries used to operate the set, as shown in Fig. 8. Disconnect the detector B plus connection from the B battery to the receiving set but leave all other battery connections in place in the usual manner. Then, with an insulated flexible wire, join the "Input" binding post of the amplifier to the plate terminal of the detector tube socket in the receiver. In the case of a super-heterodyne receiver it is sometimes advisable to insert a radio frequency choke in series with this lead as suggested in the diagram of Fig. 7. If the set with which the amplifier is used is regenerative, the input binding post connects, of course, to the tickler, which, in turn, connects to the plate of the detector.

When the above connections have all been made, take the tubes out of the audio stages of the receiving set. Then insert two 201A tubes in the first two stages of the tuned double impedance amplifier and a type 112 or type 171 in the last stage. Be sure to use the correct value of C battery, depending upon whether you use a 112 or 171 in the last stage. Fig. 10 indicates the correct values to use. Plug the loud-speaker into the jack at the front of the amplifier.

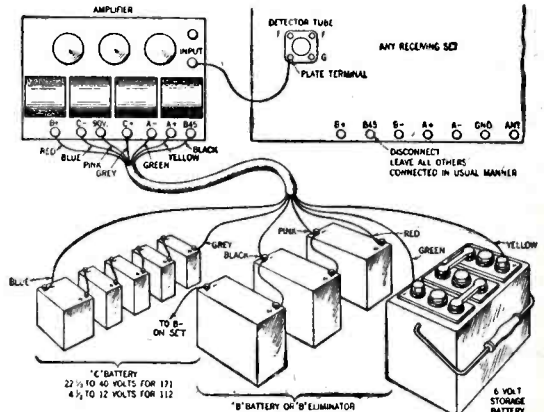

Fig. 10. This shows how to attach the Harkness amplifier to any receiving set. Connect battery terminals of receiver in usual way, omitting the detector lead.

When using this amplifier as a component part of a receiving set the entire amplifier may be mounted directly on the front panel as indicated in Fig. 7. Drill holes in the front panel of the set, using the front strip of the amplifier as a template. When the amplifier is mounted in position the jack and battery switch will protrude through the front panel. The radio frequency amplifier and detector should be mounted to the left of the audio amplifier. The binding posts of the audio amplifier can then be used to connect to the batteries and connections run from the amplifier to supply filament and plate current to the remainder of the set. Fig. 7 illustrates the connections of a typical two stage radio frequency amplifier and detector used with the audio frequency amplifier, behind the same panel.

Any type of receiving set can be built round this audio amplifier in the same manner as suggested in Fig. 7.

**ARE YOU PAYING TOO MUCH**

If you are a dealer, investigate! If your competitor is buying for cash from The Harry Alter Co., he is paying less and making more profit on receiving sets, kits, parts and accessories of every kind. And he is getting "same day" shipments from America's largest stock.

**Write for Harry Alter's New "Radio Book"**  
 Compare its rock-bottom wholesale prices for your own protection. Sent free to retailers only. Write today.

**The Harry Alter Co.**  
 1784 Michigan Ave., Chicago

TOFTIN-WHITE THORDARSON  
 BENJAMIN WEISER  
 BODINE DEJUR  
 SM  
 HAMMARIUND  
 POTTER  
 REMLER  
 FROST-RADIO  
 SAMSON  
 FORMICA PANELS  
 DUBLIN METALLIZED  
 AERO COIL

**Save Money! Build Home Necessities Yourself—with "HOW TO MAKE IT"**

Building your own home furniture, cameras, radio cabinets, sport devices, etc., is easy if you know what materials you need, and have an illustrated explanation on how to proceed. Then, too, you can save a good deal of money by making these valuable things yourself.

"How To Make It," a big book compiled from the great magazine "Science and Invention," is full to the brim with hundreds of up-to-date things to make at home. Things that can be made by any man with only a few simple tools.

Contains 116 Pages, 300 Illustrations  
 Large Size 9 x 12 Inches

**50c — SOLD EVERYWHERE**

If your dealer cannot supply you—write direct  
**EXPERIMENTER PUBLISHING CO., 230 Fifth Avenue, N. Y.**



# The Lynch Suppressor Circuit

(Continued from page 154)

chine screw and nut. They should be mounted under the sub-panel in such a way that the primary terminals are next to the sub-panel and the "P" and "F" terminals are toward the end of the sub-panel on which the tone filter is mounted.

The use of flexible, insulated bus wire is recommended for the connections. Practically all of the wiring is underneath the sub-panel and is out of sight. This does not mean an opportunity for slipshod wiring but it does mean that most of the wires may be run direct between terminals with no necessity for right angle bends and other kinks to improve symmetry of appearance. Where connections terminate above the sub-panel it is best to drop them down through holes in this panel and run them along underneath. So far as possible the wiring under the sub-panel should be kept fairly close to the panel. In no case should it be so far beneath the panel that it will extend beyond the bottom of the sub-panel brackets when the receiver is placed right side up.

The operation of the receiver calls for no detailed instructions. There are the two tuning controls and the volume control. The tuning controls will show similar dial settings for any given wavelength. The left hand control, looking at the receiver from the front, will be the most critical in adjustment, although in tuning in distant stations both dials will tune sharply. To tune in the first station slowly rotate the two dials in unison until a station is heard. Then readjust each dial until the station comes in loudest. During this time the volume control should be turned about half way on. With the station tuned in as loud as possible on the tuning dials the volume control should be adjusted to provide just the desired amount of volume. As this control is turned in a clockwise direction the volume will increase until a certain setting is reached, when the receiver will start to oscillate. The receiver is in its most sensitive condition when this control is set just below the point of oscillation. To turn the receiver "off," it is only necessary to turn the volume control knob all the way to the left.

For local reception the volume control will, of course, be turned well down. In a large room, however, it may be desired to operate the receiver at or near maximum volume. The builder of this receiver is due for a surprise when he does this for the first time. The music comes pounding in in most realistic reproduction and includ-

# Secure Best Results with the Lynch Suppressor Circuit by using BODINE TWIN-EIGHT COILS

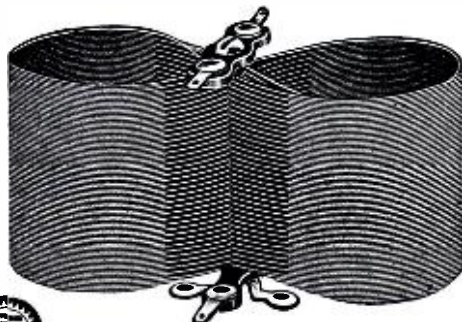

No other T. R. F. coil will produce the same remarkable results in this receiver, as Twin-Eights.

The close field and tight magnetic coupling between primary and secondary with small capacity coupling and low radio frequency resistance of the Twin-Eight provides remarkable amplification per stage and accounts for the astounding results it produces with the Lynch and other T. R. F. circuits.

Twin-Eight Coils also make a marked improvement in selectivity and sensitiveness when substituted for coils in other circuits.

Try these coils to rejuvenate your old set. You will find them easy to install and they will give it lots of new pep.

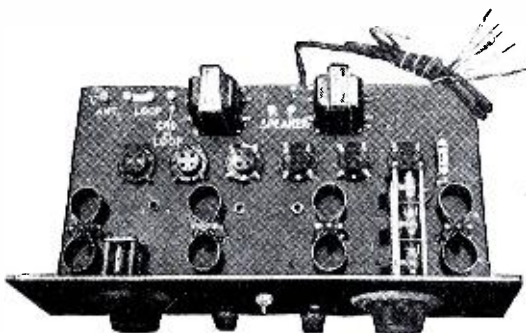

Chassis view of Bodine Six-tube Twin-Eight Receiver

Write for free reprints of the best constructional articles using Twin-Eight Coils. All coils \$2.00. Three matched coils \$6.00. Specify capacity of condenser when ordering.

## Bodine DeLuxe Loop

The Bodine DeLuxe Loop is a graceful bit of solid Walnut furniture that enhances the most attractively decorated room. Its surpassing beauty is only equalled by its remarkable signal pick-up ability, and high tuning efficiency. Attractive in size and shape. It is only 28 inches high with 6-inch turning radius. Can be mounted on any radio set and does not appear awkward. The exclusive plug and jack mounting eliminates connection wires. A unique device keeps wires taut. Order model L-500 for .0005 mfd. and L-350 for .00035 mfd. condensers. Either model \$12.00.

### Mail this Coupon

for free reprints of constructional articles on receivers using Twin-Eight Coils, also complete data on Twin-Eight Coils and the Bodine DeLuxe Loop.

Address: Bodine Electric Company,  
2262 West Ohio Street, Chicago.

Name .....

Address .....

## GEN-ERAL REGISTERED For COILS Manufacturers

**\$2.50 Special**

← If you have a "B" battery eliminator or a trickle charger this switch is indispensable. It turns them on and off automatically.

**WRITE**

**FREE INFORMATION**

CHICAGO'S FAVORITE 4-TUBE SET  
THE DUO-FORMER 5-TUBE SET

Name .....

Street .....

State .....

**GENERAL MFG. CO.**  
**6639 Cottage Grove, Chicago, Ill.**



New Automatic Switch



# A Truly Fine Product

## The AMSCO compensated Triplet condenser

Engineering precision, from the formula for the curve of the tuning line to the final adjustment of the equalizing condensers, justifies the quiet commendation of engineers.

The two outstanding receiver developments of 1927, the Bodine Twin-8 and the Aero-7, use this condenser. We shall be pleased to send literature on these circuits.

The inclusion of Amsco Products—rheostats, sockets, resistors and condensers—in any receiver adds a touch of real beauty and the assurance of electrical efficiency.

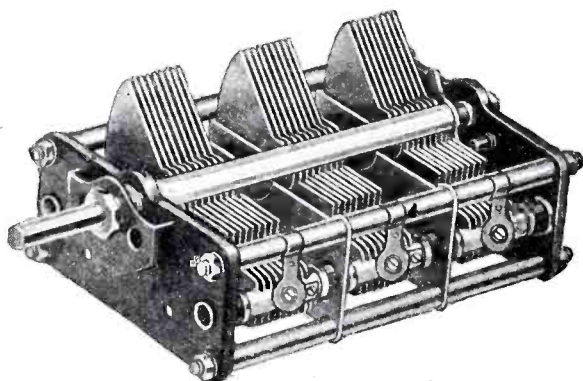

ing everything from the shrill treble of the wood-winds to the boom-boom of the kettles and bassdrum.

At the extreme left, in the photographic heading of this article can be seen an Ensco three-foot cone speaker, which has been employed to reproduce these full rich tones. Besides this, the set is shown installed in an Excello style R-31 console, which is equipped with a horn, and is used either separately or together with the three-foot cone for complete fidelity of tone.

The sensitivity and selectivity of the set are of an order that permits tuning in out of town stations with good volume while the local stations are going full blast.

In spite of this perfection and efficiency, the construction of the receiver is so simple that the veriest novice will have no trouble with it. As long as all connections are carefully soldered there seems to be no possibility for trouble of any kind.

AMSCO PRODUCTS, Inc., Broome & Lafayette St., N. Y. C.

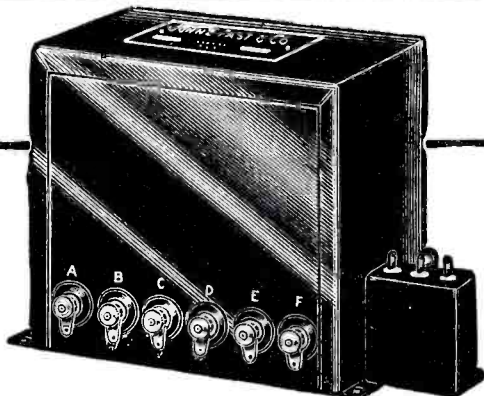

## Raytheon—Q. R. S. A. B. C. Unit Condenser Packs

Fast Hi-Test Filter Condenser Pack, designed especially for use with the A. B. C. current supply, using the Raytheon BA-350 M. A. rectifying tube. No. 1230 — Raytheon Condenser Kit, complete ..... \$22.25

Fast condensers are the product of long research and experience, and have been in use since 1919 in millions of radio sets and eliminators. The ones illustrated are exclusively designed for use with the Q. R. S. and the Raytheon A. B. C. power units, or others of similar character. The successful operation of all socket power devices depends greatly on the use of proper condensers. Fast condensers more than meet all requirements.

Filter packs mounted in handsome black enameled cases having fixed tinned combination knurled nut, terminal soldering lugs, permitting ready wiring as desired. Capacities subjected to high potential surges, are constructed to withstand higher voltages than usually required. Short path type of rugged construction, absolutely non-inductive, and of high efficiency.

Fast condensers will operate any A. B. C. current supply unit, whether specified or not. Write us if in doubt. Send for special condenser booklet—free. Dealers and jobbers, write for prices and discounts.

JOHN E. FAST & CO.

Dept. B, 3982 Barry Ave. Chicago, U. S. A.

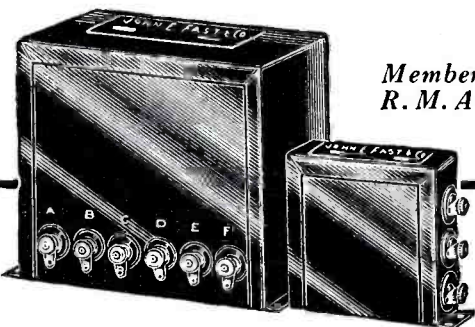

Member R. M. A.

Fast Hi-Test Filter Condenser Pack, designed especially for use with the A. B. C. current supply, using the Q. R. S. 100 Mil Rectifying tube. No. 1220—Q. R. S. Condenser Kit, complete...\$23.00

## NEW! 1927 EDITION

"RADIO NEWS"

## AMATEURS' HANDIBOOK

Here is the greatest Radio Handibook ever published! Right up to date—a brand new edition of the very finest selected articles that have appeared in "RADIO NEWS," Radio's Greatest Magazine, this year.

116 pages—all new Radio—Plenty of latest model circuits with blue-print diagrams, ready for building. This is the most popular Radio Book ever published. The past three editions were completely sold out.—And you we offer the biggest and best edition of them all. Get your order in early—send it in today. See your dealer or send your 50c in direct.

50c EVERYWHERE

or direct from

EXPERIMENTER PUB. CO.

230 Fifth Ave.

New York

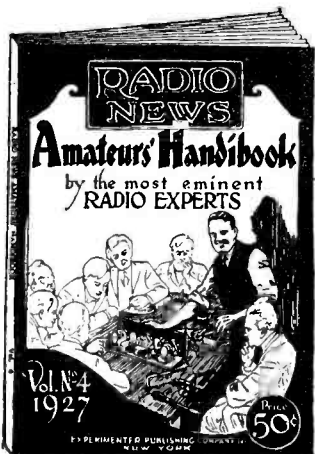

## The New Karas 2-Dial Equamatic

(Continued from page 151)

nately, were precise and accurate enough to permit of this tandem arrangement of two of the condensers.

The coupling coils or radio frequency transformers used in this receiver are unique in design. They consist of the large secondary winding which is equipped with an adjustable metal bracket to permit this coil to be turned at any angle desired after it has been mounted in the receiver. This mounting is accomplished by means of a single machine screw and nut. With this arrangement it is a simple matter to turn the coils of the various stages at just the desired angle in their relation to one another.

The smaller primary coils are not attached to the secondary coils in any way. Instead, they are equipped with a metal arm and collar for attachment directly to the protruding shaft of the variable condensers. Thus when the secondary coil is mounted behind the variable condenser, the primary, or rotor coil, lies within the secondary winding. The desired degree of average coupling is obtained by moving the secondary coil toward or away from the condenser; by changing the angle of the secondary in its relation with the primary, and by changing the angle of the primary by means of the swivel arrangement on which the primary coil is mounted on its metal arm. Once

these adjustments have been made they remain fixed, but there is always the advantage that these coupling relations can be changed to adapt the receiver to new tubes or other changes in the receiver which might alter its characteristics and coupling requirements. The important thing is that these angle adjustments are simply to regulate the fundamental coupling range so that it is just right at the highest and lowest wavelengths. When so regulated and fixed, the coupling within the range is varied automatically with the tuning of the receiver.

The Karas Equamatic circuit is shown in schematic form in one of the accompanying illustrations. Here the variable coupling coils are represented as T1, T2 and T3. The secondary windings are tuned by individual Karas variable condensers C1, C2 and C3. One of the reasons for the efficiency and simplicity of this circuit lies in these condensers. They are of rigid and precise construction and have several novel features. In their relation to this circuit probably the most important of these features is the single hole arrangement for panel mounting and the fact that the shafts can be removed entirely by simply loosening two setscrews. This permits moving the shaft back so as to project from the rear of the condenser to furnish means for mounting the primaries of the coupling coils thereon.

In order to facilitate the original adjustment of the variable coupling arrangement the tuned, radio frequency stages are balanced by means of the small variable condensers C4 and C5. This balancing scheme reduces the tendency toward oscillation, thus making the coupling adjustment extremely stable. Radio frequency choke coils RFC1 and RFC2, and by-pass condensers C6 and C7 serve as radio frequency filters to isolate the individual stages and in this way confine the radio frequency currents to their respective circuits.

In the audio frequency amplifier this receiver employs two transformer coupled stages of highest quality. The transformers used are the new Karas Type 28. These are cylindrical in shape and for that reason require less space for mounting than do the ordinary types of transformers. They are completely shielded and are thoroughly sealed in a compound which makes them impervious to moisture and unusual atmospheric conditions.

An output filter, O. F., is used in the plate circuit of the last tube to improve the tone quality and to protect the windings of the loudspeaker from the heavy direct current drawn by the power tube used in the last stage. This filter consists of an iron core choke coil of high inductance and a high capacity bypass condenser. The direct current, which serves no useful purpose to the loudspeaker, passes easily

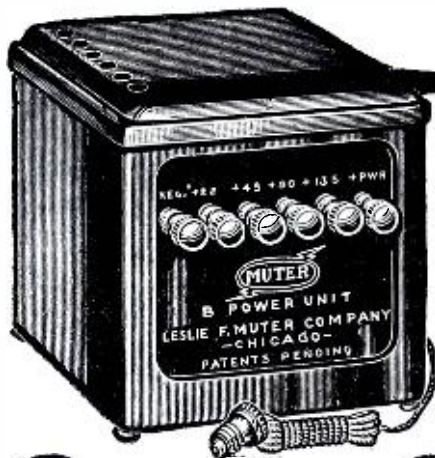

*Recognized Dependability of MUTER Products Makes This*

# Standard "B" Power Unit Your Best Buy

# \$24.50

Until we could produce one standardized, dependable "B" Power Unit for all sets we stayed out of this field.

NOW we have ready for you the best possible "B" Power Unit at one standard popular price. Parts are made and assembled in the Muter factory under a high degree of workmanship fully assuring exactness in every stage of manufacture.

### Outstanding Characteristics Uniform—Constant—Power

Fixed Controls used with separate fixed voltage taps, giving ample range and definite knowledge of voltage gotten.

Capacity ten tubes, or seven with a power tube.

Rating 40 mils at 150 volts. Will deliver 180 volts for new type 171 power tube.

Condensers, Muter filter condensers of ample capacity and acknowledged quality ensure long life and uniform output.

Uses Standard Cunningham or Radio Corp. Full Wave Vacuum Rectifying Tube because of long life and stability. Used on 110 to 120 volt, 60 cycle A. C. current only.

### No Noise—No Vibration



### Dependable Products

*The Complete Quality Popular Priced Line*  
Send for comprehensive catalog

### Ask Your Dealer—or Send Coupon

Prompt shipment will be made upon receipt of price, and we will pay postage—or C. O. D. plus postage, if you prefer. You will find the Muter "B" Power Unit supremely satisfactory in every way, so see your dealer or mail coupon for yours today.

### LESLIE F. MUTER CO.

76th and Greenwood Ave. Dept. 585-M.X.  
CHICAGO, ILL.



Leslie F. Muter Co., Dept. 585-M.X.  
76th and Greenwood Ave., Chicago, Ill.

Send Muter "B" Power Unit  
 I enclose \$24.50—you pay postage.  
 Send C. O. D.—I will pay postage.  
 Send complete Muter Catalog.

Name .....  
 Address .....  
 City .....  
 State .....  
 My Dealers Name .....

## The first "AMAZING STORIES" ANNUAL

featuring  
The Master Mind of Mars  
By EDGAR RICE BURROUGHS

There has never been presented a more elaborate and thrilling provoking collection of scientific fiction. Included among the famous authors are Edgar Rice Burroughs, author of the famous Martian stories and creator of the Tarzan series: A. Merritt, author of the "Moon Pool," "The People of the Pit," etc.; Murray Leinster, well-known author who needs no introduction to AMAZING STORIES readers for the creation of his hero Burl of "The Red Dust," and "The Mad Planet;" H. G. Wells, a writer of international fame, who possesses the virtues of versatility in writing on scientification. All stories are complete—116 pages of them, with full page illustrations. Size of Book 9 by 12 inches.

50c—ON ALL NEWSSTANDS

or you can order direct from

EXPERIMENTER PUB. CO. 230 Fifth Ave., N. Y.

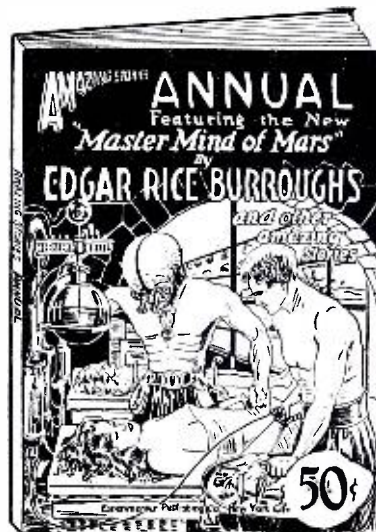

# FREE

**WHOLESALE RADIO CATALOGUE**  
*The Book they are all talking about*

## GET YOUR COPY **Now!**

This **BIG** 100-page catalog is chock full of unusual bargains in all the latest kits, standard parts, complete sets, furniture and accessories. Don't place your order until you get a copy of this money-saving book.

**100 Pages Full of Radio Bargains**

Every page of this **BIG** Harco Catalog shows you the way to savings and bigger radio profits. Every Set Builder and Dealer who wants to buy at real **WHOLESALE PRICES** should write for a copy of this catalog.

**All of the Latest and Most Popular Kits**

All of the latest and most popular kits are shown at prices that save you money. Write now for your copy and see for yourself the wonderful values we offer.

A POST CARD WILL DO

**THE HARCO CO., 1255 So. Wabash Ave., Chicago, Ill.**

The HARCO CO. 1255 So. Wabash Ave., Chicago.

## Greater—Better Radio Values

### IN THE WORLD'S GREATEST RADIO CATALOG

**ALL** under one roof. You don't need to look elsewhere. Complete stock carried. Prompt, efficient, dependable service. All orders, small or large, filled promptly.

You must have this catalog if you want everything—the best in radio, at a big saving. Contains all the information that you need. Answers all radio questions that you ought to know. It won't cost you a cent. Just drop us a card today.

Established  
**1918**



**TELEPHONE MAINTENANCE COMPANY**  
123-A S. WELLS ST. CHICAGO, ILL.

**IT'S FREE!** →



WHOLESALE ONLY

CHICAGO'S OLDEST RADIO HOUSE

through the choke coil but will not pass through the condenser and therefore cannot enter the windings of the loudspeaker. On the other hand the audio frequency component of the output circuit and this is the portion that actuates the loudspeaker, passes readily through the condenser and into the loudspeaker windings; but cannot pass through the choke.

- #### THE PARTS REQUIRED
- 2 New Karas, Type 28 audio transformers; T4, T5
  - 1 New Karas Output filter, O. F.
  - 3 New Karas, Type 17 variable condensers; C1, C2, C3
  - 3 New Karas Equamatic coupling coils; T1, T2, T3
  - 2 Karas Micrometric dials, 0-100
  - 3 Karas subpanel brackets
  - 1 Karas control system, including complete hardware
  - 2 Karas R. F. chokes, 100 millihenry
  - 1 Bakelite front panel, engraved
  - 1 Bakelite base panel, drilled
  - 1 Carter 10 ohm rheostat and knob with gold engraved arrow; R1
  - 1 Carter 20 ohm rheostat and knob with gold engraved arrow; R2
  - 1 Carter H-2 filament control resistance, 2 ohms; R4
  - 1 Carter H-4 filament control resistance, 4 ohms; R3
  - 1 Yaxley No. 69-B interstage switch (gold); S
  - 2 Carter tip jacks, No. 10; J1, J2
  - 1 Sangamo .00025 mfd. fixed condenser with grid leak clips; C8
  - 1 Amsco or Lynch grid leak, 2 megohms; R5
  - 1 Yaxley cable plug
  - 5 Benjamin cushion sockets; VT1, VT2, VT3, VT4, VT5
  - 2 Samson variable neutralizing condensers, range 0 to .0007 mfd. capacity; C4, C5
  - 2 Mica fixed condensers, .0001 mfd.; C6, C7
  - 1 Mica fixed condenser, .006 mfd.; C9
  - 2 Mica fixed condensers, .001 mfd.; C10, C11
  - 2 4½ volt "C" batteries
  - 3 2 foot lengths insulated sleeving
  - 9 2 foot lengths round bus bar wire (tinned)
  - 1 XL aluminum binding post with "antenna" marker
  - 1 package Kester radio solder
  - 1 Table mounting cabinet or "Ex-cello" console cabinet

An automatic switch, S, is included in this receiver. This switch has three positions. When set in one position the receiver is turned off through the breaking of one side of the "A" battery circuit. When the switch is thrown to the second position the last tube is automatically cut out of the circuit and the output filter and loudspeaker are connected directly to the output of the first audio tube. This is for use in the reception of loud local stations where two stages of audio amplification would provide more than enough volume. This constitutes a real saving where the receiver is tuned to locals most of the time because when the last tube is cut out of the circuit the "A" battery consumption is reduced by ¼. When

# SAVE 25% to 60% on every book you buy

**FREE BULLETIN NUMBER 5**  
sent on request

You can cut the cost of your books in half. Fiction, Science, Biography and general books of every kind all at big reductions in regular prices. All regular and latest editions—Hundreds of famous authors, including the finest of latest works.

**CONSRAD COMPANY, INC., 230 Fifth Ave., New York**



the switch is thrown to the third position the receiver operates with its full five tubes to provide maximum volume.

Tubes of the standard 301-A type are employed in the two radio frequency stages and in the first audio frequency stage. One may also be used in the detector circuit, VT3, but the use of the new 300-A type tube is recommended here because of its superior sensitivity. A power tube is used in the last audio stage. The 112 type is recommended for this purpose. If it is desired to use one of the 371 type the "B" and "C" battery voltages applied to this tube must be altered accordingly.

Rheostats and fixed resistances are both shown in the diagram, for controlling the current to the filaments of the tubes. It is advisable to use a rheostat to control the filament current of the radio frequency tubes because then this rheostat may be used as the volume control. This is the one shown as R1 in the diagram. The rheostat R2 and the fixed resistances R3 and R4 may be replaced with an amperite if desired. However, if a ready drilled panel is purchased it will be best to stick to the rheostat, as there is a mounting hole provided for it in the panel.

The operation of the receiver is simple. There are only two tuning controls and these are equipped with Karas "Micrometric" dials, which provide a vernier adjustment ratio of 63 to 1. There are no auxiliary adjustments to be made in operating the receiver except the adjustment of the rheostat R1 to provide just the desired degree of volume. The other rheostat, R2, need not be readjusted after its proper setting has once been determined.

The construction and wiring of the receiver are likewise simple. If the front panel and base panel are purchased already drilled the assembly job is simply one of matching the parts up with their mounting holes and all the effort involved in laying out and drilling is eliminated. If the constructor wishes to prepare his own panels it is recommended that the layout shown in the illustrations be adhered to.

It will be noted that no binding posts are used in the receiver with the single exception of the one for the antenna connection. All battery circuit wiring terminates in a Yaxley cable plug at the rear of the receiver. This provides an easier and quicker means of connecting the receiver to the batteries than would be the case if binding posts were used.

Round, tinned bus wire is recommended for use in wiring up the receiver. From the illustrations it will be noted that most of the wiring is underneath the base panel. This does much to add to the neat appearance of the finished receiver and has the further advantage that wires do not have to be bent at all sorts of angles in order to avoid the various instruments,

# There is a VITROHM RADIO RESISTOR for EVERY power unit

More than 90 standard Vitrohm Resistors and Rheostats cover the resistance need of every socket power circuit now on the market.

Resistance is the heart of power circuits. Make sure of quiet, permanent, and unfailing service by insisting on Vitrohms for radio.

Vitrohm Resistors and Rheostats are guaranteed unconditionally for continuous-duty in any circuit where they operate within their watts dissipation rating—Vitrohm Resistors have the highest continuous-duty rating without resistance change of any resistor.

## New Vitrohms

The list below of new resistors and rheostats is partial. A full description of new Vitrohms for Radio is available without charge. Send for it.

### Raytheon 350 M. A. Units

Vitrohm Resistor 507-70	\$7.50
Vitrohm Rheostat 507-59	5.50

### QRS 400 M. A. Circuits

Vitrohm Resistor 507-62	\$7.50
Vitrohm Rheostat 507-59	5.50

### Silver-Marshall Units

Vitrohm Resistor S-M 653	\$2.50
Vitrohm Resistor S-M 655	2.50
Vitrohm Resistor S-M 657	5.00

### Thordarson Power Packs

Vitrohm Resistor for R-171	\$2.15
Vitrohm Resistor for R-210	2.65
Vitrohm Resistor for R-210 with UX874 Regulator Tube	4.90

## The Adjustat

A new Vitrohm Rheostat, dissipating 20 watts, having 15 steps of resistance. The Adjustat is priced at \$3.00.

11 types are available in the following resistances and current capacities:

507-79, 1 ohm, 4 amp.—507-71, 2 ohms, 3 amp.—507-72, 6 ohms, 1.5 amp.—507-73, 20 ohms, 1.0 amp.—507-74, 30 ohms, 0.75 amp.—507-80, 50 ohms, 650 m.a.—507-81, 600 ohms, 180 m.a.—507-75, 1000 ohms, 125 m.a.—507-76, 2250 ohms, 90 m.a.—507-77, 10,000 ohms, 40 m.a.—507-78, 25,000 ohms, 10 m.a.



**Ward Leonard Electric Company**  
31-41 South Street Mount Vernon, N. Y.

## Before You Buy a Radio Receiver Consult this Book!

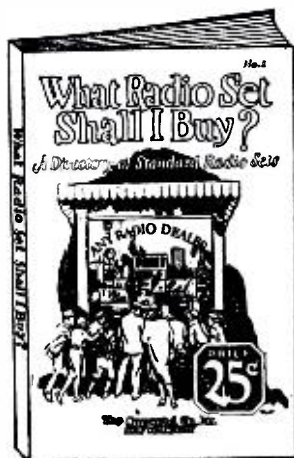

THERE is one easy—simple way to decide on what Radio Set to buy. If you are particular as to the style of the set, the power, the sensitivity, the price, or anything that has to do with a manufactured set you will find a complete answer in the "DIRECTORY OF STANDARD RADIO SETS."

Photographs of all standard manufacturers are shown together with an exhaustive printed description furnished by the manufacturers themselves.

This book is absolutely impartial. It is the only printed book in existence that gives you this information.

40 pages of descriptions and illustrations, size 6 x 9 inches with handsome colored cover.

**PRICE 25c**

Sold On All Newsstands

**CONSRAD CO. INC., 230 Fifth Ave., N. Y.**



## Make Your Radio A "MODERN" Shielded Set

No unshielded set complete without them, no reception as perfect as it could be with them. "MODERN" Shields give each tube a chance to function unhampered by interference from magnetic and static fields, prevalent in all unshielded sets regardless of make or hook-up as many interferences some of which sound like static are manufactured within the set itself and can only be remedied by metallic grounded shields. "MODERN" Shields protect the tubes from microphonic sound waves by insulating them from the surrounding ether and by three rubber tipped spring fingers inside of shield which press tightly against the tube, arresting any vibrations set up by jars, sound waves or telephonic vibrations in the cabinet; the rubber tips eliminate any possible conductive leakage from shield to tube. "MODERN" Shields confine the heat around the tube, causing quicker action, greater efficiency, less power, longer battery life and modified summer static. "MODERN" Shields are recommended for sets or tubes that squeal, whistle, howl, chock, snap or produce indistinct or mushy reproduction. Tone and volume are greatly improved by their use. "MODERN" Shields should be placed over each

tube in the set to obtain maximum results, connect copper wire in series to binding post on each shield and to ground post on set. "MODERN" Shields are pressed from special alloy metal fitted with rubber cushion base which eliminates transmission of telephonic vibrations to the tubes, each shield is adjustable to any tube, height or spring tension desired. The base of each shield is dipped in a special insulation to assure against shorts or grounds in their application. Complete instructions come with each shield. "MODERN" Shields retail for \$1.00 each, none genuine without the "MODERN" trade mark. Ask your dealer for a set of "MODERN" grounded shields today or order direct from

"MODERN" LABORATORIES

205 No. Washington St. Manufacturers Owosso, Michigan  
Distributors, Dealers and Agents Wanted.



as would be the case if the wiring were done above the base panel. Where there are fairly long stretches of wire, or where wires are run close together, it is advisable to cover such wires with insulated sleeving or so-called "spaghetti." This will preclude the possibility of short circuits later on. In undertaking the construction of this receiver the builder can feel assured that his time and effort will be well repaid. Even without the automatically variable coupling this receiver would be the equal of other present day, standard receivers. It is therefore entirely logical that, with this variable coupling feature, as described above, this receiver should show results considerably superior to those obtained with standard circuits.

When equipped with a suitable cabinet of good quality, or installed in a console cabinet such as the "Excello," this receiver is equal in appearance to the higher priced commercial sets and is a fit adornment for any home. It is an outfit in which not only the constructor but the whole family can take great pride.

## The "STROBODYNE"

Complete, New and Improved "Conrad" Book Pattern  
just published for this marvelous receiver

**T**HE sensational Strobodyne Circuit, the greatest of Super-Heterodyne receivers that combines the best features of every circuit; the circuit that has amazed Radio, is now ready for home and community set builders.

Conrad, the greatest Pattern publishers in Radio, have printed an entirely different kind of Pattern for this amazing circuit.

Instead of a simple envelope or soft cover—the complete Strobodyne building information with all blueprints is contained in a *regular, handsome board covered book*, with a 2 color beautiful cover. Size 9 x 12 inches.

The book contains the complete authentic description of the circuit to the last detail.

### FULL SIZE BLUEPRINTS

Also carefully arranged, folded and bound into the book are the following blueprints—all full size.

- No. 1—Panel layout Blueprint—Size 11 x 27 inches.
- No. 2—Underside view of Sub-Panel Blueprint, size 15 by 27 inches.
- No. 3—Template for Sub-Panel—size 16 by 27 inches.
- No. 4—Wiring for Apparatus—(Shown in perspective form) size 23 by 27 inches.

Until you have studied the Strobodyne you are a back number in Radio—a man of the older school—The Strobodyne is not just a new circuit—It is an epoch in Radio.

This official book is sold only direct from Conrad—or through the official Strobodyne headquarters.

**Price 50 Cents**

CONSRAD CO., Inc. - - 230 Fifth Avenue, New York

## The "Unipac" Power Amplifier and A.B.C. Supply

(Continued from page 104)

other noises when the Unipac is used as a receiver B power supply. Extra windings on the power transformer provide 1.5 volts for the lighting of the new 1.5 volt A.C. tubes as used in a radio set, while the two 1.5 volt windings of the two transformers if connected in series will also serve to light a standard 2.5 volt heater type detector. (The transformer voltage is then 3, but about 1/2 volt is lost in the wiring, so that the 2.5 volt tube may be lighted direct from the 3 volt source.)

All in all, the Unipac is an excellent addition to any receiver, or an excellent foundation around which to construct a receiver, for its quality of reproduction and operating features are so far in advance of present designs that it may be relied upon for years to come as a power supply and power amplifier for audio or phonograph operation that cannot be improved upon.

The accompanying list gives parts needed to build the Unipac, all standard and available from any good dealer or mail-order house.

The construction of the Unipac is quite simple. All transformers are mounted on the chassis, leaving the condenser until last (its mounting feet are clamped under two of the tube sockets.) The binding posts and jacks are mounted upon the chassis edge, using the insulating washers accom-

panying it. The resistor is mounted by having two of its lugs soldered to the +45 and +90 binding posts. The small FT64 resistors are mounted directly on the amplifier tube sockets, the socket mounting screws falling under them being left out.

While no pictorial diagram appears, no difficulty should be found in following the schematic as all terminal markings are exactly as on the instruments themselves. After the Unipac has been wired, it should be carefully gone over to see that no connection errors have been made, and that the twisted filament lines from the amplifier tube sockets to the power transformers are isolated from the rest of the wiring.

To test the Unipac, both attachment plugs should be inserted in a two-way receptacle and all tubes inserted—326 at left, then 310, 374, 316B and 316B. All should light—the 326 very dull, the 310 and 316B's fairly bright, CX374 in the center socket, and the 374 should glow with a pinkish discharge.

With all amplifier tubes also in place, and a speaker connected to the output jacks, a roar should be heard, disappearing if the input tipjacks are shorted, or decreasing to a slight hum if a record pick-up is connected to the input tipjacks. Reversing one of the attachment plugs will probably decrease the hum.

For operation with a receiver, a pair of leads from the first audio stage output should terminate in a plug, to be inserted in the double-circuit jack of the Unipac. This connection drops the input tube, which is then only used with a record pick-up. Of course, the first audio stage receiver tube may be dropped, and the grid lead of the receiver first audio stage transformer connected to the input tipjack connecting to the grid of the 326 tube. The grid return is then made through the negative B connection from Unipac to receiver.

For phonograph operation, a Pacent Phonovox with the regular needle-scratch filter and modulator plug is recommended. The pick-up unit should connect directly to the input tipjacks of the Unipac, with the needle-scratch filter and modulator both connected in parallel across the input jacks. Only electrically cut records will do justice to the quality obtainable from the combination, and these played with a carefully selected grade of needles. It must be remembered that the phonograph reproduction will never have quite the richness or fullness of tone experienced in reception of a good radio broadcast program, though the record reproduction obtained from the Unipac will be equal or superior to that obtained with any of the expensive electric victrolas selling at from five hundred to several thousand dollars.

The Unipac may be used with any good radio receiver, but in order to

# The Big Friendly Radio House

Write  
for  
this



## BIG RADIO CATALOG

**DEALERS  
AGENTS  
SET-BUILDERS**

YOU will want this dealer catalog. It lists everything in radio — standard quality at the right price!

*It means more profit for you!*

GET this up-to-the-minute, 1928 Book of Bargains! Popular, nationally advertised sets, parts, eliminators and accessories at prices that mean real values. Parts for Tyrman Ten, Silver-Marshall Unipacs, Melo-Heald Super's, Camfield Super Selective Nine, Victoreen Super, Remler Infra-dyne, World's Record Super, and many other popular circuits

Send for this Great Book Today!

# WESTERN RADIO MFG. CO.

128 W. Lake St. Dept. 17

Chicago, Ill.

### SUPER HETERODYNE

Construction and Operation

R. E. LACAULT, E. E., I. R. E.

### R. E. LACAULT

has written this book for you

R. E. LACAULT has been an Editor of Radio magazines for many years. He has specialized in the greatest and most powerful of all Radio Circuits, "The Super-Heterodyne." He has studied, originated and developed to marvelous perfection the "ULTRADYNE" Super-Heterodyne. He has advised thousands of set owners and builders in Super-Heterodyne problems.

—and now he has used his immense experience, his clear mind and his editorial ability to write, by far the most lucid, interesting, instructive and plainly written book on the theory and construction of Super-Heterodynes that has ever been published. You who already own Super-Heterodynes will find this book especially helpful in locating and correcting troubles. A special trouble chart is printed for detecting and correcting common faults.

**SEND NO MONEY** Just send us a card mentioning the book with your name and address. We will mail you the book. You pay the postman \$1.97 plus a few cents postage on delivery.

Distributed by

**THE CONSRAD CO., Inc.**

230 Fifth Ave.

New York, N. Y.

# M&H

Radio's largest  
kit supply house

ESTABLISHED 30 YEARS

## The STROBODYNE

### A REVELATION

Something absolutely new in circuits. The great French development.

### WE HAVE

ORIGINAL DESIGNERS' KITS

### CAMFIELD SUPER SELECTIVE 9

The marvelous combination of Tuned Radio Frequency and the Super-Heterodyne. **\$83.00**

### "LYNCH" SUPPRESSOR CIRCUIT

The ideal circuit for those who demand real tonal quality. **\$50.00**  
BUILD WITH OUR KIT

### THE AERO-SEVEN

Unique uncontrolled Tuned Radio Frequency set with resistance coupled Amplification. **\$40.50**

### THE IMPROVED LABORATORY SUPER-HET

The set that meets all present-day requirements. Improved, shielded. List... **\$84.60**

### THE NINE-IN-LINE SUPER-HETERODYNE

9-tube, powerful, efficient super set of fine modern characteristics. **\$79.00**

### Q. R. S. A, B AND C SUPPLY UNIT

Complete Kit A fully developed and practical unit to replace all batteries. **\$40.00**

### OUR CIRCULAR

IS NOW READY

It Will Pay Set Builders to Send for This

M & H SPORTING GOODS Co.  
512 Market St. Philadelphia, Pa.

### GET INTO THE RADIO BUSINESS! TACKLE IT RIGHT THIS NEW WAY!

Establish, operate, and manage an "EIA Custom-Made Radio Manufactory" in your locality. We furnish everything. Real opportunity. The business includes local manufacture, sales and service, also special mail order sales, all under the true co-operative system pioneered by EIA. The EIA chain of such local "Manufactories" is now being extended to all localities not already franchised. If you are a young, industrious married man, a permanent resident of your locality, if you like radio and are determined to succeed with your own business, even though starting small in spare time, it will pay you to apply by letter. Be sure to name your county. No need to clip this ad. Write directly to **EQUITABLE INDUSTRIES ASS'N.** Radio RL Division, 350-352 Broadway, New York.

Custom-Made  
Radio Specialists



Ability to Achieve  
and to Serve

Save Time and Money!  
REPAIR YOUR RADIO YOURSELF  
See Page 146

illustrate the use of A.C. tubes in conjunction with the Unipac, functioning as an ABC power supply, the circuit herewith is given. The receiver shown can be constructed as the fancy suits, and, completely AC operated, will give a quality of reproduction obtainable from no factory-built set. Its selectivity is excellent, and it will bring in stations up to 1,000 miles distant with loud-speaker volume under favorable conditions. The installation is ideal for a simply operated combination phonograph and radio set of superb tone quality.

## Power Supply from the House Lighting Current

(Continued from page 102)

Two 1.0 mfd. fixed condensers "C1" and "C2" are placed in the receiver running from the positive plate supply to the two radio frequency tubes to the positive A wires on the sockets. A by-pass condenser of .001 mfd. capacity is shown connected from the primary of the first audio transformer to the filament lead.

The remainder of the set is absolutely standard, using air core tuned radio frequency transformers of any reliable construction with variable condensers to cover the broadcasting band. Good apparatus pays and it is poor policy to use poor parts in the construction of the set and blame the power unit later on for poor performance.

Now for the power unit.—This may be assembled on a baseboard 15 x 30 inches with the parts mounted as shown in the picture, Fig. 3. The rear of the board should be occupied reading from left to right as follows: Transformer (T1) buffer condensers (C1; C2; C3; C4) tube socket (T2), and choke coils (L1 and L2). Directly in front of the choke coils should be placed the condenser pack and to the left of that the resistances and binding posts.

Parts should be carefully wired with flexible Celatsite hook-up wire and connections soldered with Kester rosin core radio solder.

A 3-ampere fuse should be placed in the circuit to protect the transformer against overloads. This is shown (G2) in the lower left-hand corner.

This arrangement has been found best, for all wires are short and the current progresses from one piece of apparatus to another without any back wiring and with a minimum of lost space. The usual transformer has a third winding (S3) for lighting the filament of the power tube and supplying the C bias for it. This may be dis-

# R.E. Lacault \* Knows- SUPER-HETERODYNES

★ Originator and Designer of the nationally known "ULTRA-DYNE," Radio Engineer and former editor, with many years of practical experience in Super-Heterodynes.

He has written  
this book for you

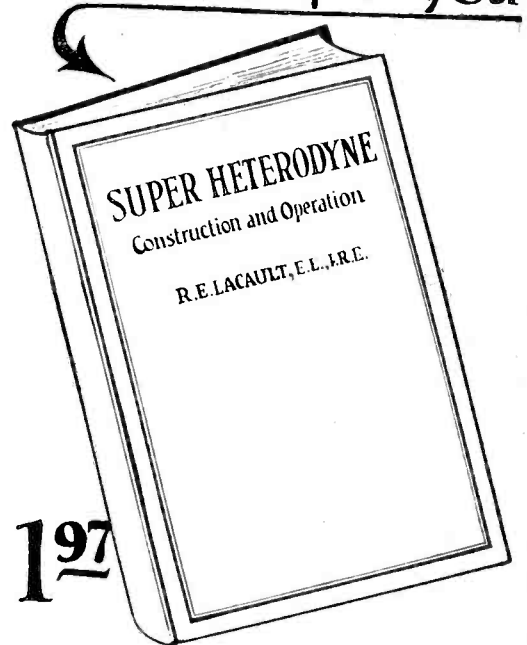

R. E. LACAULT has been an Editor of Radio magazines for many years. He has specialized in the greatest and most powerful of all Radio Circuits, "The Super-Heterodyne." He has studied, originated and developed to marvelous perfection the "ULTRA-DYNE" Super-Heterodyne. He has advised thousands of set owners and builders in Super-Heterodyne problems.

—and now he has used his immense experience, his clear mind and his editorial ability to write, by far, the most lucid, interesting, instructive and plainly written book on the theory and construction of Super-Heterodynes that has ever been published.

You who already own Super-Heterodynes will find this book specially helpful in locating and correcting troubles.

### SEND NO MONEY

Just send us a card mentioning this book with your name and address. We will mail you the book. You pay the postman \$1.97 plus a few cents postage on delivery.

Distributed by

**The Consrad Co., Inc.**  
230 5TH AVE., NEW YORK, N. Y.

regarded if one wishes to use a 201A tube in this stage. If one plans to use a power tube, it is best to mount this socket with the rest of the apparatus in the power unit and not in the receiver proper for the reason that short filament and high plate voltage wires may then be made. The power tube is not included in the picture of the base-board layout nor is the biasing resistance.

As high voltages are to be handled in all wiring, it is best to use only heavy rubber covered flexible wire in making connections.

To construct the power unit the following list of parts is needed: One power transformer (T1) with tapped primary (P1) for operation at 100-110-120 volts alternating current, with three secondary windings. S1 should have a total of 750 volts with a center tap, S2 is a winding delivering four volts and five amperes for the ionizer of the rectifier tube, and S3 a five-volt winding for supplying one ampere of current for a power tube.

Two choke coils (L1 and L2) of 3 to 5 henries inductance at 300 mills and capable of carrying 300 milliamperes of current continually without overloading. Their D.C. resistance should not exceed 100 ohms.

One 1.0 mfd. fixed condenser capable of standing 250 volts (G1); two buffer type fixed condensers of 0.1 mfd. capacity (C1 and C2) for operation at 600 volts D.C. current working voltage; two 1.0 mfd. fixed condensers (C3 and C4 600 volts working voltage); three 5.0 mfd. 400 volts filter condensers (C5) (C6) and (C7); one 1.0 mfd. filter condenser to operate at 250 volts D.C. (C8); one 3 ampere fuse (G2); one 400 milliampere Q. R. S. Rectifier tube (T2).

R1, R2, R3 and R4 are resistances tapped as indicated on the diagram. R1 and R2 must be capable of passing 300 milliamperes of current. R3 and R4 are 2000 ohms resistance and must be capable of passing 70 milliamperes of current, used for the purpose of preventing undue voltage from building up due to the sudden removal of a tube or a break in the circuit. When the set is in operation these resistances draw but 7 milliamperes.

If trouble is experienced in getting the set to operate, if the tubes fail to light up and the circuit has been checked through, investigate all fixed condensers for breakdown. If a condenser breaks down, it places a short in the rectifier tube and prevents building up sufficient voltage to operate the set.

In experimenting with the set it is well to turn off the power to the unit before removing tubes from their sockets or making changes or repairs to the wiring.

# Announcing

## The new

# Steinite

## NO BATTERY

# Radio Receiver

Built in one complete synchronized unit, licensed under Radio Corporation of America patents for Radio Amateur, Experimental and Broadcast reception.

*Ready for Delivery*  
**SEPTEMBER FIRST**



DEALERS — JOBBERS  
 Write for Complete Descriptive Literature

SALES OFFICES  
 506 SOUTH WABASH, CHICAGO, ILL.

Steinite Radio Co.

Atchison, Kans.

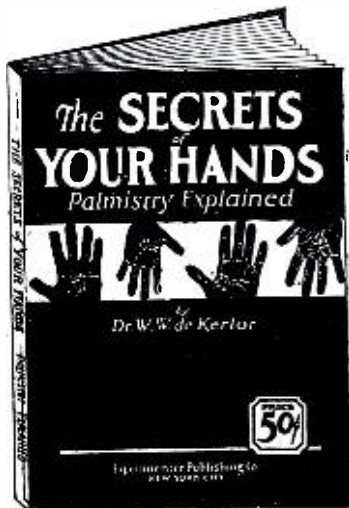

## Learn the SECRETS of Your HANDS

FINGERPRINTS are used throughout the world as a means of apprehending criminals—but fingerprints are but a small portion of the secrets of your character that your fingers, your palm, even your handshake reveals.

Every inch of your hand has been charted by the experts of this highly developed science, and so simply and accurately that anyone can learn the telltale signs by heart.

Here is a brand new book with all the latest information—written in such a way that you can quickly master "Palmistry."

Everything is simplified, easy to understand, the book contains 96 pages, hundreds of illustrations and is the large size 9 x 12 inches.

50c THE COPY EVERYWHERE  
 EXPERIMENTER PUB. CO., 230 Fifth Ave., New York

# BENJAMIN

## Cle-Ra-Tone Sockets

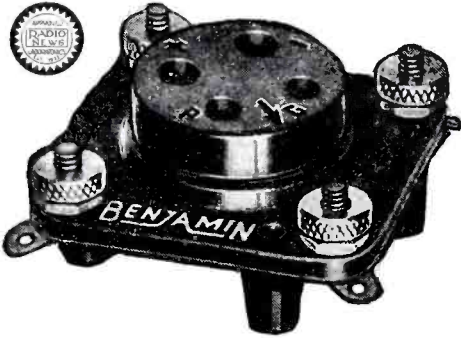

Spring Supported Shock Absorbing

USED the world over by set builders who know and want the best.

Stop tube noises. Anti-microphonic. The greatest contribution to the non-noisy operation of the set.

Tube "floats" on finely tempered springs. One-piece terminal to tube connection. Knurled nuts for binding post connection or handy lugs for soldering.

The choice for practically every prominent circuit for several years. Among the most recent hook-ups for which it has been specified are:

- Camfield Super-Selective 9
- Lynch Suppressor Circuit
- H. F. L. Nine-in-Line
- World's Record Super 10
- Stroboddy 8

At all Radio Jobbers and Dealers

Made by

Benjamin Electric Mfg. Co.

120-128 S. Sangamon St., Chicago

247 W. 17th St. New York

448 Bryant St. San Francisco

Manufactured in Canada by the Benjamin Electric Mfg. Co. of Canada, Ltd., Toronto, Ontario

## RADIO AGENTS

Make Big Money

EASY to sell American Radios and Supplies. Nationally advertised, high quality merchandise at wholesale. Big profit on every sale. No capital to invest. No stock to carry. Order direct from my huge warehouse as you sell. Get My Liberal Offer and also Big New 132-page Catalog and Guide—"How to Sell Radios"—Free. Full of Bargains—all latest in Radio. Write today. AMERICAN AUTO & RADIO MFG. CO. HARRY SCHWARTZBERG, PRES. Dept. 216 American Radio Bldg., Kansas City, Mo.



## RADIO AT HALF USUAL COST

NOW—we give 30 Days' Free Trial on newest 5-tube ONE DIAL—Coast to Coast Radio. Buy direct from factory—save half and get 2-year guarantee. Full line table type, consoles or complete outfits at prices that will surprise you. Over 15,000 satisfied owners. Don't buy any Radio until you write us for FREE Catalog. Low prices and 50-Day Trial Offer.

Westingale Electric Co., 1758 BELMONT AVE. CHICAGO

## The Listeners' Accessory Guide

(Continued from page 116)

plugged the connector cords of the A and B socket power units, and the charger.

It is the shunt type relay which means the electromagnet that actuates the switch is connected directly across the A battery circuit of the receiver, so that the moment the switch to light the filaments is turned on, it is actuated and disconnects the 110 volts from the charger to the B battery eliminator.

To connect the relay it is merely necessary to plug the socket-power units in the outlets at the side, attach the connector cord to the lamp socket and connect two lengths of flexible wire from the set to the binding posts on the relay.

A relay of this type is really indispensable to the owners of receivers who desire real socket-power operated receivers. Otherwise there are a multiplicity of switches to be turned on and off, and possibly a chance of a short circuit and damage to the receiver. By the use of a device of this type, it is impossible to have any occurrence of this sort happen, as should through chance a short circuit occur, it will cause the relay to cease operation which in reality protects the set.

-- AND NOW DEAR RADIO AUDIENCE, THIS COMPLETES MY TALK ON "THE USE OF INSECT POWDERS IN PATAGONIA" --- I HAVE ENGAGED A STAFF OF FIVE SECRETARIES TO TAKE CARE OF ALL THE QUESTIONS AND COMMENTS THAT YOU MAY WISH TO SEND ME BY MAIL ---

**A "RADIOPTIMIST"**

Licensed by Rider Radio Corporation  
Pats. Pending  
Pat'd 5-2-'16  
Pat'd 7-27-'26

## Stop Oscillation Troubles Phasatrols

A True Balancing Device for All Radio Frequency Amplifiers

Price, \$2.75

NOW'S the time to perfect the set you have built! Eliminate those squeals due to oscillation by installing Phasatrols. Very easy to install in home-built or standard receivers, but if you prefer, your dealer or service man will gladly install it. Write for free hook-up circular for any set or circuit. Dept. 75, 175 Varick St., New York, N. Y.

# ELECTRAD

### Sensational! Prices Reduced

Continental Standard Meter Test RADIO TUBES  
Formerly \$1.75 Now Only \$1.00

The greatest and most sensational price reduction ever offered in high quality, standard, meter test guaranteed radio tubes. No job lot or old style base tubes but genuine CONTINENTAL tubes, "firsts" of our very best grade. Increased production and large volume business enables us to offer CONTINENTAL quality tubes at the now established standard price of only \$1.00. Never before has a standard quality radio tube been offered to the public at this low price. Take advantage of this opportunity now to get your radio tubes at a real saving. Each tube packed in individual box, carefully tested and marked perfect and unconditionally guaranteed in the 201-A type to show an emission reading of 55-60 at 45 volts or 65-70 at 90 volts and in the 199 type a reading of 20-25. That's real quality!

**LOOK AT THESE NEW LOW PRICES**

Type UX-201-A, \$1.00; 199 (UV, UX and standard base), \$1.25; type X-120 Power, X-112 Power with adapter base; type X-112 Power, X-171 Power and 200-A Power Detector, \$2.50.

For sale by progressive dealers. If your dealer cannot supply, order direct, giving his name. Dealers and Jobbers: Write for special offer.

**CONTINENTAL CORPORATION**  
Dept. L. G., 179 W. Washington St., Chicago, U.S.A.

## Magnaformer

Set Builders, be first — send NOW for the NEW Magnaformer 9-8 Hook-up. The Commander-in-Chief of 1928 Circuits. Now being featured in the Radio Magazines. The very last word in Receivers. Two years ahead of field in Design and Performance. Amazing tone quality. A fiend for distance. Double amplification each B. F. stage. A world of volume. No interference. Its equal has never been achieved. A beautiful looking job. Easy to build. Just the set to build for yourself or for others. Full size circuit blue prints and NOVEL wiring diagram, complete wiring instructions and detailed story of development and accomplishments of Magnaformer, the perfect Long Wave Transformer sent at once for 10 cents. SEND NOW. Be first.

**RADIART LABORATORIES COMPANY**  
19 S. La Salle Street Dept. 36 Chicago

SAVE TIME and MONEY  
Use the "Radio Trouble Finder"  
SEE PAGE 146

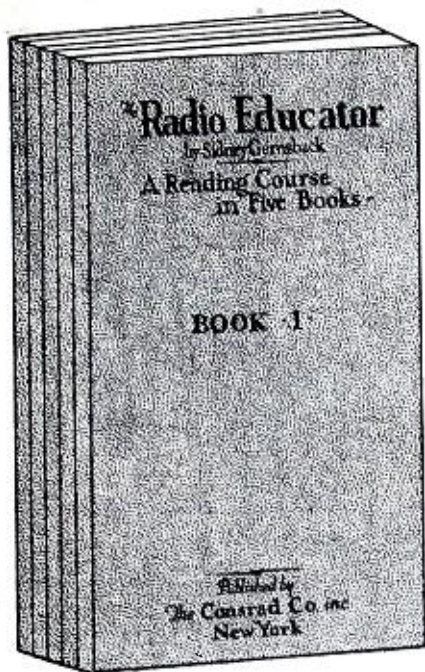

Price \$1.97

# A RADIO EDUCATION

IN 5 VOLUMES

## "THE RADIO EDUCATOR"

Theory, Design, Construction, Operation and Maintenance

LEARN AT HOME

THESE five component parts of a complete Radio Instruction Course are outlined in five volumes that contain not merely the essentials as so many books do, but more, they contain all that any modern up-to-the-minute textbook on any subject would cover. They are in themselves a COMPLETE radio education teaching every possible portion of Radio science.

Size of each book 6 by 9 inches, handsomely bound and illustrated with charts, diagrams, descriptions of equipment, etc. Each volume 52 pages.

SEND NO MONEY for these books. Just forward your name and address. We send you the books at once. On receipt of same you pay the postman \$1.97 plus a few cents postage and then they are yours.

Distributed by

**The Conrad Co.**

Incorporated

230 Fifth Ave., New York, N. Y.

## Trickle Charging 4 Volt Storage Batteries

A six volt trickle charger can be easily adapted to the charging of four volt batteries, at no great expense to the set owner, and without any changes in its regular construction. It is only necessary to attach the resistance windings of a six ohm rheostat to one of the posts of the charger, as illustrated in the photograph. The unit used in

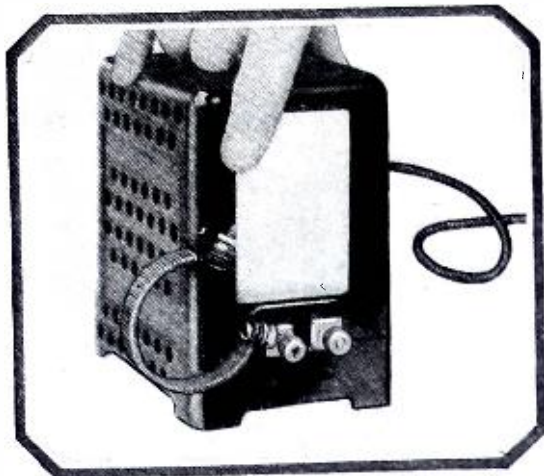

The above photo shows how the wire resistance unit from a six ohm rheostat is connected to one of the terminals on a trickle charger.

one of the air-cooled rheostats is best for this purpose, as it is easier to remove, has a stouter core and is more sturdy in construction.

It will be found that by this means a charger can be made to serve a double purpose, that of a four and six volt trickle charger, and if at any time the set owner decides to use six volt tubes in his receiver instead of the small tubes, it will not be necessary to purchase a new charger, simply remove the resistance and use the charger at its regular rating.

## Overhaul Your Antenna

After a set has been in operation for a year or so, it will generally be noticed that reception can be improved by overhauling the antenna system. By this is not meant putting up new wires and insulators, but by cleaning the insulators in carbon tetrachloride, tightening up the connections, and in short, repairing the ravages of time and weather on the installation.

A wire can be strung up and tightened as far as possible, but due to the weight of the wire itself, as well as to the wind and pull of the lead-in, it will in time develop a slack which is harmful to distance reception. This slack should be remedied.

It will be found that by simply cleaning the soot off the insulators that a material improvement is noticed.

# A BIRNBACH BATTERY CABLE

for EVERY

## Circuit and Purpose

Made of durable flexible stranded colored rubber insulation for connecting A, B and C Batteries or eliminator to set. Each conductor of separate solid color in accordance with R. M. A. Standards, and assembled with brass lug terminals which prevent loose connections. Made in 5, 6, 7, 8, 9 or 10 Wires.



No.	Wires	Length	Price
110-5	54	inches	\$0.50
111-6	54	inches	.60
112-7	54	inches	.70
113-8	54	inches	.85
126-9	54	inches	1.00
119-10	54	inches	1.15
111-5	10	foot	1.25
113-6	10	foot	1.55
117-7	10	foot	1.85
118-8	10	foot	2.15
127-9	10	foot	2.45
128-10	10	foot	2.75



### Birnbach Riga Battery Cable

These Cables are made of flexible stranded conductors for A, B and C Batteries. Assembled with storage Battery Clips for the A Battery and soldered brass lug terminals.

No.	Wires	Length	Price
100-5	60	inches	\$1.00
160-5	54	inches	.90
161-6	54	inches	1.05
162-7	51	inches	1.20
163-8	51	inches	1.40
164-9	51	inches	1.55
165-10	51	inches	1.70
150-5	10	foot	1.60
152-6	10	foot	1.80
153-7	10	foot	2.25
151-8	10	foot	2.55
153-9	10	foot	2.85
150-10	10	foot	3.15

### Birnbach Radio Battery Connectors

These Connectors are made of flexible stranded wire with soldered lug terminals for use in connecting Dry Cell Batteries, B, and C Batteries.

No.	Size	Price
RC3	3-in. Connectors	each \$0.04
RC6	6-in. Connectors	each .05
RC8	8-in. Connectors	each .06
RC12	12-in. Connectors	each .07

### Birnbach Loud Speaker Extension Cord Units



You can move your Loud Speaker into any room desired. A BIRNBACH EXTENSION CORD UNIT improves the tone quality when power tubes are used

by placing the Speaker away from the Set. Made in six sizes and furnished complete with Connector.

No.	Length	Price
166	10 foot, complete	\$0.75
120	20 foot, complete	1.00
121	30 foot, complete	1.40
122	40 foot, complete	1.80
123	50 foot, complete	2.20
124	100 foot, complete	4.20

### Birnbach "60" Bakelite 3-Circuit Tuner

This 3-Circuit Tuner is wound on colored Bakelite and will improve any Circuit. A marvel for performance. Use BIRNBACH TUNERS for the best tone quality, long range distance, and volume. For use with .0005 Mfd. Condenser. Tuning range 200 to over 550 meters.



No. 60	Colored Bakelite 3-Circuit Tuner	\$2.00
No. 60	Colored Bakelite Radio Frequency Coll.	1.25

### Birnbach "180" Bakelite 3-Circuit Tuner

This Tuner is larger in size than our No. 60 and in this form it is the most efficient TUNER ever designed. Distant stations can be tuned in with greater volume and the very best tone quality. For use with .0005 Mfd. Condenser.



No. 180	BIRNBACH Colored Bakelite 3-Circuit Tuner	\$3.50
No. 180	BIRNBACH Colored Bakelite Radio Frequency Coll.	1.50



# BIRNBACH RADIO CO.

254 West 31st Street  
New York City

# BUILD

the Most  
POPULAR  
KIT SET!



## Browning-Drake

BROWNING-DRAKE, in the summer of 1924, gained an unprecedented popularity that has never waned despite the fact that countless designs for home construction have come and gone since that time. Nearly three times as many Browning-Drake parts are sold as those of the nearest competitor. Such popularity is explained by the fact that Browning-Drake has been founded on the sound, scientific research work of Prof. Glenn H. Browning and Dr. Frederick H. Drake at Cruft Laboratory of Harvard University. The way to build the Official Browning-Drake is made easy by essential instructions contained in every kit, or sent in booklet form upon receipt of twenty-five cents. If your dealer cannot supply you with the Browning-Drake Corporation Kit, send us his name and address and we will take care of your requirements immediately.

*DEALERS: The Official Browning-Drake Kit and the other genuine specified parts of associate manufacturers can be obtained from your distributor. If he cannot supply you WRITE or WIRE us and your needs will be met at once.*

**Browning - Drake Corp.**  
CAMBRIDGE :: :: MASS.

**BROWNING-DRAKE**  
RADIO

**FREE RADIO BOOKLET**  
**FULL OF BARGAINS**  
SEND FOR IT TO-DAY  
**B.C.L. RADIO SERVICE CO. INC**  
221 FULTON ST. DEPT. R.R. N.Y.C.

Save 25% to 60% on every  
book you buy.

WRITE FOR  
BOOK BARGAIN BULLETIN  
NUMBER 5

**CONSRAD CO., INC.**

230 Fifth Ave.

New York

## Veneered Wood Makes Handsome Panels

Radio set builders are getting away from the use of material which tend to give radio receivers a technical appearance. Hard rubber formed to counterfeit wood, as well as hard rubber with a thin veneer of wood, are being used more and more by the fan who desires the up to date appearance in his set.

How the fan may circumvent the expense involved in this and at the same time use panel material which

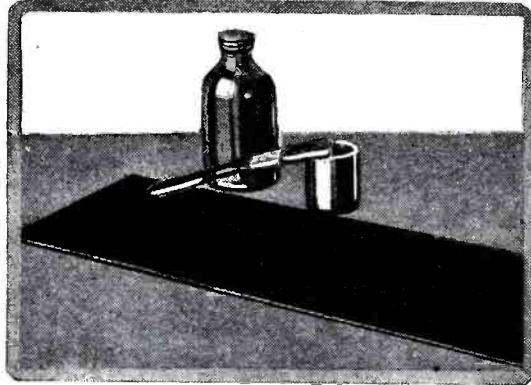

Fig. 1. The veneered panel is carefully stained with a color to correspond with the cabinet to be used.

not only gives the appearance of the grain of the wood—but which is wood—is explained in the following.

Obtain a piece of three or five-ply wood with the grain running crosswise, the length of the panel. Carefully cut it to size and sand the surface. Apply a coat of good oil stain to the surface, and allow it to dry, under the pressure of clamps, such as shown in Fig. 2. When clamping it down, make sure

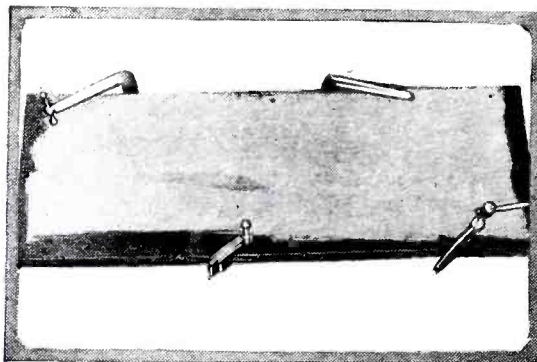
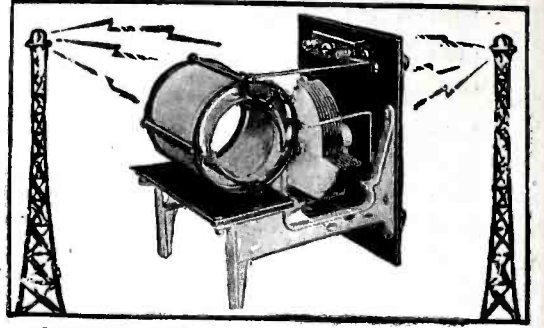

Fig. 2. In drying, the panel is clamped to a dry and heavier board to prevent warping.

that a piece of board heavier than the panel material is used. When the first coat of stain has dried, the panel may be varnished with a good grade of spar varnish and rubbed down with rotten stone and a drop or two of oil. The resulting panel will be found to be far more beautiful than the imitation.

Several manufactured types of receivers employ panels of veneered wood, and if the constructor prefers to take the time and care in preparing a panel as explained above he can produce equally the same appearance with a home-made set.

WHEN ~ ~  
stations crowd the air  
& spoil your programs



use a  
**wave trap!**

Improve your Reception—  
build a wave-trap with  
a Consrad Pattern

NO matter how large or small, how expensive or inexpensive a Radio Set may be, it can be decidedly improved with a good WAVE-TRAP.

The new Consrad pattern contains a gigantic blueprint, 27 1/4 inches by 20 1/2 inches, containing simplified Panel Layout, Front View, Top View, Side View and Picture Wiring diagram. All measurements are shown actual size. A complete illustrated Pamphlet is enclosed that shows exactly how to proceed throughout the entire construction; these are enclosed in a heavy folder envelope size 9 1/4 x 9 1/2 inches.

**ONLY 25c—EVERYWHERE**

If your dealer cannot supply you, write direct  
The Consrad Co., Inc., 230 5th Ave., N.Y.

## Freshman The Electric Radio

Always Ready—  
Always Right

**NO** ACIDS  
WATER  
TROUBLE  
EXCUSES  
BATTERIES  
MAKESHIFTS

Write for complete literature illustrating and describing the entire Freshman Electric Line.

**CHAS. FRESHMAN CO., INC.**  
Freshman Bldg. New York



## Don't Overlook Jacks and Switches

The broadcast receiver owner occasionally notices that his set has apparently deteriorated in some peculiar fashion. Signals which used to come booming in are only heard with fair volume, and distance which was clearly heard on the loud speaker is only faintly heard. When the usual test of batteries, tubes, sockets and loose connections has failed to reveal any cause for this condition, look at the jacks and switch contacts in the set.

These are neglected places in the set where trouble originates, yet where very few experimenters look. The double circuit jacks often develop high resistance contacts where the output lugs make contact with the primary transformer lugs. The best way to overcome this is to pass a very fine nail file between the upper and lower contact points a few times, and then see that the tension is perfect. If, due to the constant spreading action of the plug, the upper and extreme lower lug have lost some of their springiness, bend them with a pair of fine-nosed pliers. Of course this should be done with batteries disconnected.

In the matter of switches, a piece of fine sandpaper run over the contacts will usually correct any high resistance connections. Many fans do not realize that a high resistance at the filament switch can cause low signal volume or fluctuating signals, but this is entirely true.

It is especially necessary to see that all these points make good contact after the warm weather. Metal will sweat, due to humidity and heat and cause corrosion in some of the most unexpected places, and it is generally in these unthought of spots that the trouble can be located.



WHAT A BOON RADIO IS FOR BOW-LEGGED TENORS!

# Modernize Your Radio



Improvements will bring you a new standard of convenience and comfort in radio entertainment.

### Radio Convenience Outlets



To give you greater joy with your radio, with less muss and fuss with its accessories, these Radio Convenience Outlets permit the wiring of the home so that batteries are out of sight, a loud speaker can be placed in any room, and the aerial and ground can be tapped like your regular electric convenience outlets. Fit any standard switch box or may be attached directly to plaster laths or studding.

- No. 135—For Loud Speaker Connections ..... \$1.00
- No. 136—For Aerial and Ground Connections ..... 1.00
- No. 137—For Battery Connections... 2.50

### Automatic Power Control



Cuts in the B eliminator, cutting out the trickle charger when the set is turned on. The B eliminator is cut out and the trickle charger cut in when the set is turned off. Easily attached. Makes your receiver a power operated set. Thoroughly dependable.

No. 444—Series Type Automatic Power Control—Keeps the voltage drop less than two-tenths (2/10) volts when used with sets having a current draw equivalent to four 199 type of tubes up to eleven 201 type of tubes ..... \$5.00

### Rheostat and Switching Rheostat



The Air-Cooled Rheostat has its filament suspended to permit ventilation. Smooth, quiet action, with extremely close adjustment. Bakelite base. The Switching Rheostat serves as a filament switch and rheostat in one, thus doing away with an extra switch; otherwise it is the same as the standard Air-Cooled Rheostat.

- Air-Cooled Rheostat—from 2 to 100 ohms ..... \$1.35
- Switching Rheostat—from 2 to 100 ohms ..... 1.75

Yaxley also makes Midget Battery Switches, Potentiometers, Jacks, Jack Switches, Special Switches, Phone Plugs, Midget Jacks and Plugs, Pilot and Panel Lights, Pilot Light Switches, Resistances, Name Plates, etc.

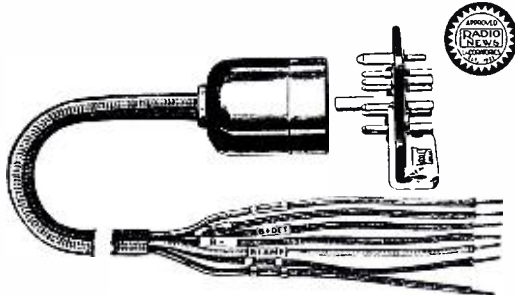

### Cable Connector Plug

Of Bakelite construction, handsome appearance, easily wired to set, metal cable markers, seven strands (RMA standard colors). Makes hooking up of batteries safe and simple. The Plug has phosphor bronze double contact springs, which cannot work loose. Shorting is impossible. Plug cannot be inserted incorrectly.

- No. 670—Cable Connector Plug—for sets equipped with binding posts. Has 15" pigtailed for attaching to set. .... \$3.50
- No. 660—With mounting bracket, for installing right into the set 3.00

Write for new illustrated and descriptive price list

At your dealer's. If he cannot supply you, send his name with your order to

**YAXLEY MFG. CO.**

Dept. I, 9 South Clinton Street Chicago, Ill.

## 116 PAGES of POPULAR MAGIC

by "DUNNINGER"

The Greatest and Highest Paid Magician of Today

(SECOND EDITION)

EVERYBODY'S buying this book. The first time "Dunninger" has revealed his tremendous store of marvelous parlor and professional tricks and magic in one volume. Second big edition of 100 pages, crammed full of mystery. Illustrated—large size 9 x 12 inches. They are going faster and faster. Orders are pouring in. We believe there never was a magic book like this. It may never be reprinted—so order now. Delivery within 24 hours.

THERE'S NOVELTIES — FUN — MYSTERY IN "POPULAR MAGIC" ONLY 50c

If your dealer cannot supply you, order direct

EXPERIMENTER PUB. CO., Inc.

230 Fifth Ave.

New York



# Shanco

Grip-tite

## Battery Clips

4 Sizes

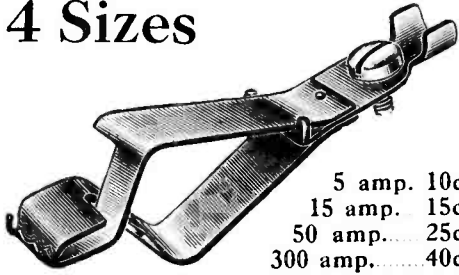

5 amp. 10c  
15 amp. 15c  
50 amp. 25c  
300 amp. 40c

SHANCO Griptite Battery Clips assure free and uninterrupted flow of electrical current. There are no springs to heat up, burn or drop out. Made of powerful-tension, tempered spring steel, solidly riveted together, with all parts electro lead plated before assembly. This uniform lead coating is positive assurance against corrosion at the joints. Acid-resisting. Jaws open wide and are easily applied.

The Griptite bulldog teeth are so arranged that the clip cannot fall over and "short" the battery.

Terminals are wide and screws amply large for cable connections.

No parts of Shanco Clips can be lost or displaced—everything is one compact solidly built unit.

Shanco Clips will last longer and give greater satisfaction.

At all good radio stores and battery stations, or order direct from this advertisement, giving dealer's name. Dealers and jobbers write for discounts and special proposition.

SHANKLIN MFG. CO.

Dept. 21, Springfield, Ill.

## Testing the Voltage of a B Eliminator

A fact not generally known among home set builders is that the pocket type of voltmeter is not at all suitable for testing the voltages of B eliminators. The resistance of these small voltmeters is so low that inaccurate readings always result, and proper voltage regulation is an impossibility.

For accuracy a voltmeter should have a very high resistance per volt reading. Resistance as high as 1000 ohms per volt scale reading are common with the best and most accurate meters, and allow correct scalings to be taken while the set is in operation, due to the fact that they operate at very small current. The smaller meters are accurate enough for readings of B batteries, due to the low resistance, but will not register correctly in the case of the B eliminators.

Before purchasing a voltmeter for testing the B eliminator it would be advisable to explain to the dealer or the manufacturer that you intend using it to test the voltage of a B eliminator, in order that he can therefore advise you as to what type to employ.



The flexible wires of a special voltmeter are touched to the output terminals of the eliminator in order to test the voltage before being encased.

Testing of the voltages should always be done before the completed unit is encased in its protective cover. A popular make of voltmeter with the necessary high resistance qualities is shown in the lower front of the illustration. The test is made from the output of the filter system. This is a much more methodical method of testing than first building the entire unit, encasing it in its shield and then testing, only to find that the voltages are not correct. In the matter of shielding, it is best to encase the entire unit in a metal cabinet, which should be grounded to the minus terminal. This will eliminate any chance of hum being picked up by the set during operation.

## FOR BETTER RECEPTION

W-E-B-B  
CHI-CA-GO  
BALL AND SOCKET  
FULL ADJUSTABLE  
AERIAL  
PAT-PETID



Install W-E-B-B Aerial supports and end your faulty receiving. Finest receiving sets are no better than their aerials. Use this type and enjoy your radio.

Combines attractive appearance and steady, permanent support with perfect tension. Made with two styles ball-and-socket base. One (illustrated) fits side wall, flat or sloping roof; other fits gable ridge. Both styles in two sizes; for 1/2 inch pipe, at \$1.50; and 1 inch, price \$3.00. See this equipment at leading radio stores or write direct to

TIMING GEARS CORP.

2801-15 FULTON STREET  
CHICAGO, ILLINOIS

## LISTENERS' GUIDE

# D. X. SPECIAL

THE set that holds verified reception from 2FC, Sydney, Australia; 3AR, Melbourne, Australia; 4QG, Brisbane, Australia; EAJ7, Madrid, Spain; OAX, Lima, Peru, etc.

Photo sent free for self-addressed envelope. Picking up Australia, 10,800 miles, 3 times in one year is probably world's record for standard broadcast reception from 200 to 550 meters. If you want a set that will step out get exact hook-up that established above record with names of every unit employed from its original designer. PRICE \$1.00.

J. WHITE CO. LABORATORY  
217 Wyckoff Ave. Brooklyn, N. Y.

**BIG** DEALERS DISCOUNTS thousands of! **NATIONALLY ADVERTISED** RADIO SETS, PARTS, KITS

Lowest Wholesale Prices on Radio Supplies

Just Out Write for FREE BOOK

Midland Wholesale Co. Dept. L. G. 5116 W. Ravenswood Ave. Chicago, Ill.

## Keystone Inexpensive

5-Tube Receiver Parts as specified in June issue of RADIO LISTENERS' GUIDE. Complete \$17.65. KEYSTONE RADIO LAB., Dept. RR2, 129 N. Jefferson, Chicago

## DUPLEX

POWER TUBES No Rewiring—No Adapters Write for information HAVEKOST & SIMONDS 154 Nassau St. New York, N. Y.

## Classified Advt.

## INSTRUCTION

Refinish and decorate furniture. Rub, polish, burn in, antique, polychrome, etc. Easy to learn. Instructions \$1.00. Stamp brings circular. Bairs System, P. O. Box 2327, Cleveland, O.

**RADIO ACCESSORIES at WHOLESALE**

Radio Sets, "B" Eliminators, Chargers, Tubes, Kits, Parts—everything new in Radio at lowest wholesale prices. Thousands of nationally advertised bargains. All listed and illustrated in my Big New Catalog and FREE Call Book. 132 Pages of valuable Radio information—trouble finding, set building—Radio knowledge of all kinds. Write today. HARRY SCHWARTZBERG PRES. AMERICAN AUTO & RADIO MFG. CO. Dept. 214 American Radio Bldg. Kansas City, Missouri

**FREE BIG BARGAIN CATALOG**

## EVERYTHING IN RADIO

AT ATTRACTIVE PRICES. SETS OR PARTS. Orders shipped exactly as ordered. Prompt Service. Write for Prices. Mail Order Only. Send Your Address. ALL RADIO COMPANY 417 North Clark Street Chicago

## Volume Control for Power Tubes

It is often the case when a power tube is used in the last stage of a set equipped with a B eliminator, that the power on most local stations will be excessive. The usual stunt is to turn down on the filament current and thus control the volume. This is bad practice, and from the standpoint of quality of reproduction, it will be found that tones will be unnatural. It has been pointed out numerous times but seemingly to no avail, that it is most important to operate a tube at its correct filament current regardless of the volume desired, and to control the volume through some other means.

Possibly the simplest means of controlling the volume without harming the quality is by the utilization of a fairly high resistance in the plate lead of the last or power tube. A compact pressure resistance such as the Clarostat, Bradleyohm or similar instrument is simply placed in series with the power lead from the B eliminator and this is adjusted until the volume is satisfactory.

This method controls the volume, and allows the undistorted music, speech or song to go through all the circuits with no chance of distortion due to underfeeding of the tubes.



# Two Good!

## The New Departure Supertrons

*by a chemical process*



You may be satisfied with your present reception—but wouldn't you like to BETTER it if possible without obligation on your part?

Try the New Departure Supertrons. If they are not better your dealer will refund your money.

*That's fair enough!*

They cost you no more at all good dealers.

## The Cage Antenna

*by Supertron*



Complete  
\$10.00

A hundred feet of enamel covered copper wire perfectly insulated and concentrated into a compact unit.

It takes five minutes to install anywhere *outside*. If it is not satisfactory your dealer will refund your money.

*You can't beat that!*

*All good dealers will serve you—or we will.*

**SUPERTRON MFG. CO.**  
Hoboken, N. J.

When Radio Stations Crowd the Air and Spoil Your Programs  
Use A

## WAVETRAP

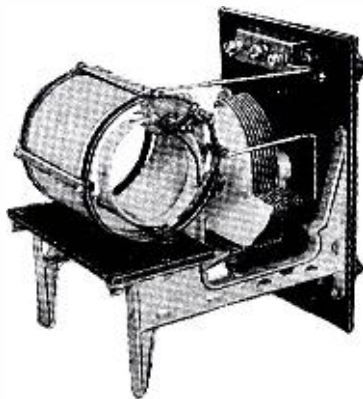

NO matter how large or small, how expensive or inexpensive a Radio Set may be, it can be decidedly improved with a good WAVE-TRAP.

The new Consrad pattern contains a gigantic blueprint, 27 1/4 inches by 20 1/2 inches, containing simplified Panel layout, Front View, Top View, Side View and Picture Wiring diagram. All measurements are shown actual size. A complete illustrated Pamphlet is enclosed that shows exactly how to proceed throughout the entire construction; these are enclosed in a heavy folder envelope size 9 1/4 x 9 1/2 inches.

**ONLY 25c—AT ALL DEALERS**

OR DIRECT FROM

**THE CONSRAD CO. INC.**

**230 FIFTH AVE., NEW YORK**



Tune quickly — adjust accurately — eliminate distracting noises — get correct tube oscillation—with X-L VARIO DENSERS in your circuit. Designers of all latest and best circuits specify and endorse.

**Model "N"** Micrometer adjustment easily made, assures exact oscillation control in all tuned radio frequency circuits, Neutrodyne, Roberts 2-tube, Browning-Drake, Silver's Knockout, etc. Capacity range 1.8 to 20 Mfd.

Price, \$1.00

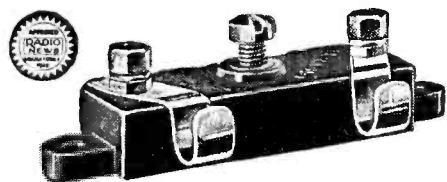

Model "C"

**Model "G"** Obtains the proper grid capacity on Cockaday circuit, filter and intermediate frequency tuning in super-heterodyne and positive grid bias in all sets. Capacity range, Model G-1 .00002 to .0001 Mfd. Model G-5 .0001 to .0005 Mfd. Model G-10 .0005 to .001 Mfd. Price, each with grid clips, \$1.50.

**X-L PUSH POST**—Push it down with your thumb, insert wire, remove pressure, wire is firmly held. Vibrations will not loosen, releases instantly. A push post that excels in appearance, action, service and convenience.

Price, each 15c.



X-L Push Post



X-L Push Post Panel

**PUSH POST PANEL**—7 push posts mounted on black insulating panel with permanent white markings. Soldering lugs, raising bushings, screws for mounting, etc., in box complete. Price \$1.50.

Free wiring diagrams showing use of X-L units in the new LOFTIN-WHITE constant coupled radio frequency circuit, and in other popular hook-ups. Send for yours today.

## XL Radio Laboratories

### 6 TUBE RADIO

**One Dial** Latest advanced circuit. All steel chassis totally shielded. Balanced parts of best quality. Marvelous power and selectivity. Gets the long range stations as clear as a bell. One dial single control. An unsurpassed value—just one of our many mighty bargains.

**FREE Log and Call Book** and **Big New Catalog**—just off the press. Full of Radio Bargains. Send for your free copy now!  
 American Auto & Radio Mfg. Co.  
 Harry Schwartzberg, Pres.  
 Dept. 212 American Radio Bldg.,  
 Kansas City, Mo.



### AMATEURS' HANDBOOK

1927 Edition  
 SEE PAGE 158

## A Set Protector

When making changes in his set, the experimenter sometimes has the misfortune of dropping a tool into it and blows out all of his tubes. Of course one way to overcome this difficulty would be to carefully disconnect all batteries and eliminators when making changes. However, a device has recently been placed on the market, which will automatically disconnect the "B" eliminator if anything goes wrong in

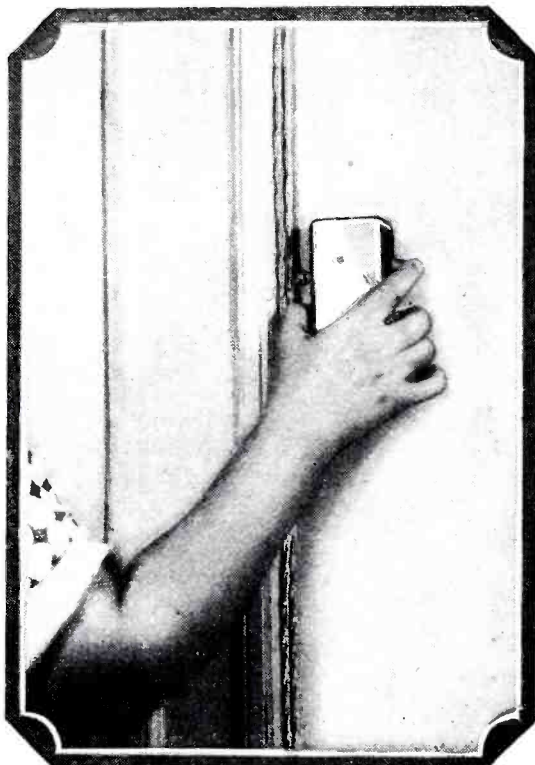

The automatic cut-out can be placed on the wall behind the door or some other remote place.

the set. It is in the form of a cut-out connected in the primary circuit of the eliminator and may be conveniently screwed to the wall or the back of the cabinet where it will not be seen. If the cut-out does open, one merely has to find the short circuit in the set, repair it, and push the button on the right hand side of the instrument. This is a very handy accessory for those fans who are continually changing their receivers.



## Marvelous Townsend "B" Socket Power Unit

Complete—NOW  
**\$6.85**  
 \$1 Down  
 Balance C.O.D.

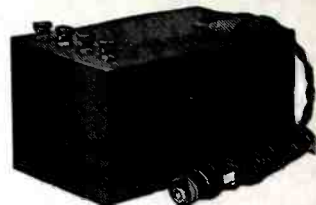

### Replaces "B" Batteries

Enjoy greatly improved reception and forget unreliable "B" battery nuisance. Every part in the Townsend "B" Socket Power Unit is made and assembled in our own factory. That is why we can give you a high grade instrument at a startlingly low price, with a real guarantee of money back if not satisfied. Delivers up to 100 volts on any set, on direct or alternating current—any cycle. Full tone, clarity and volume.

### ORDER TODAY

Just put your name and address on a piece of paper, pin a \$1.00 bill to it and mail today. Your "B" Socket Power Unit will be sent promptly. Deposit only \$5.85, plus postage, with the postman. Try out for ten days—then if not delighted by improvement in reception, return it to us and purchase price will be refunded. Send today.

TOWNSEND LABORATORIES  
 Dept. 32  
 713 Townsend St. Chicago, Ill.



## TEST YOUR BATTERY

Easily—Quickly—Accurately

### S O S Hydrometer

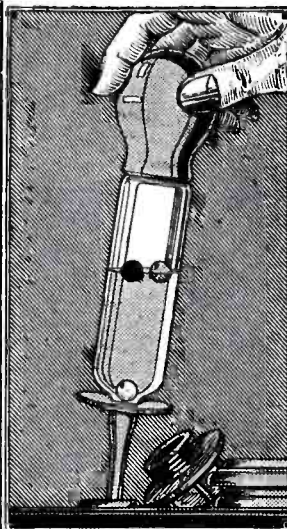

Test you battery without withdrawing the Hydrometer. Balls make reading simple and easy. Swim all three, charged fully. Sinks the white, charge still right. Sinks the green, charge is lean. Sinks the red, charge is dead. Accurate—durable—no float to read or break. Millions of patented Chaslyn balls used yearly as original equipment by leading battery manufacturers in Glass-cased Batteries and Power Units. Ask your dealer. If he can't supply, send seventy-five cents to

THE CHASLYN COMPANY  
 4619 Ravenswood Ave.  
 Chicago

## BEGINNERS! AMATEURS! ENGINEERS!

— need —

### H. GERNSBACK'S RADIO FOR ALL

A permanent, comprehensive Reference Book on Radio. A Thousand Textbooks and pamphlets combined in one. For everyone interested in the art of Radio.

PRICE \$2.00 POSTPAID

Order Direct from  
 EXPERIMENTER PUBLISHING CO.  
 230 Fifth Avenue New York

## Preventing Battery Acid Damage

As many radio set owners have found out to their sorrow, battery electrolyte creeps or spreads if it is given the chance. The ordinary rubber storage battery mat is generally sufficient to keep a storage battery from damaging a cabinet, but it will not prevent damage due to creeping electrolyte in the case of a battery kept up to full charge by means of a trickle charger. In this case, the gassing of the battery causes sprinkling of an acid solution over the top of the battery, and if the charge is heavy enough this sprinkling will overreach the sides of the battery

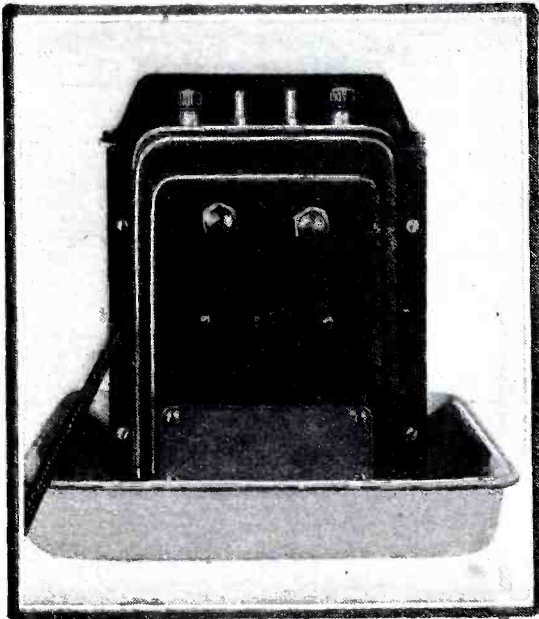

Stand the storage battery in a large photographic developing tray.

and sprinkle on the floor or base of the battery compartment. After this has happened there is little that can be done, except to wash the damaged parts with a solution of aqua ammonia or some other strong alkaline neutralizing agent.

To prevent this trouble from occurring, obtain a large glass or porcelain photographic developing tray, an inch or two larger all around than the diameters of the battery, and stand the cells in the center. Any electrolyte that does splash will be caught in this tray and will not spread, as the acid electrolyte will not spread on glass or porcelain.

Should acid from the battery get on the rugs or clothes, wash them immediately in a solution of aqua ammonia and water, equal parts, or a 20 per cent solution of plain aqua ammonia. Never wash the top of the battery with this solution, however, as ammonia has a strong affinity for sulphuric acid, and if by chance a slight amount is allowed to get into the jars themselves damage to the cells will result. A chemical action will also ensue, causing the formation of ammonium sulphate, the salt produced by the acid combination. Pure water is the safest medium to use in washing a battery case.

## Two New Quality Products

*by the makers of the famous*

## Hammarlund Condensers

The New  
Hammarlund R. F. Choke

**M**ODERN engineering practice has improved the value of R. F. chokes for confining radio-frequency currents to their proper channels, thus preventing unbalanced circuits and consequent distortion. This is a quality idea, ideally exemplified in the use of the new style Hammarlund Choke. Made in two sizes: 85 and 250 millihenries, effective over the entire broadcast and amateur wave-band.

*Wherever radio is known throughout the world, Hammarlund's reputation for precision quality is recognized. No other introduction is required for these two worthy new members of the Hammarlund radio family.*

*Write for Literature*

An Improved  
"Hammarlund Jr."

**T**HE famous Hammarlund Midget Condenser has been simplified. The new "Hammarlund Jr." has all essential features of the former model—soldered brass plates, aluminum frame, one-hole or baseboard mounting. Knob included. In addition, it is equipped with a rotor lock which fixes the rotor in any position—an important advantage when used for neutralizing. Four sizes.

**HAMMARLUND MANUFACTURING CO.**  
424-438 W. 33rd Street, New York

For Better Radio  
**Hammarlund**  
PRECISION  
PRODUCTS



## CASH from LIMERICKS

**Fatten Your Bankroll on Limerick Contests—Learn How Winners are Picked and What Makes Them First Choice**

LIMERICKS can be manufactured with tremendous success by studying the construction of last lines, by studying the special kinds of rhyming words that are most effective and by learning the "inside dope" on how limericks are judged.

This book gives the first and only specially prepared *Rhyming Dictionary* of words especially fine for Limericks and the similar words that rhyme with them. It is prepared by one of America's leading authorities who had much experience in how limericks are judged.

Sixty-eight pages of instruction, large-sized book 6 by 9 inches, the only book of its kind. Price 50c.

**50c HELPS YOU WIN BIG PRIZES**

**THE CONSRAD CO.**

230 Fifth Ave.

New York, N. Y.

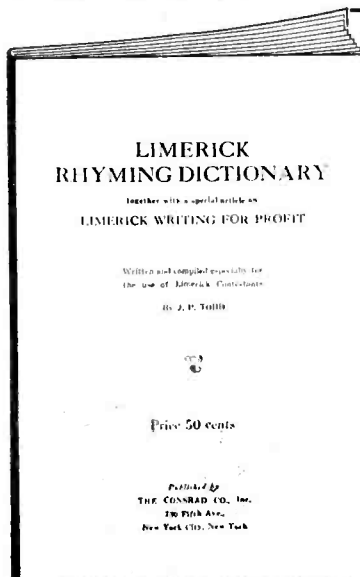

## A Practical Dial Hint for Combination Dials

It is oftentimes very confusing to the uninitiated to operate a set incorporating dials made for both clock and counter-clockwise condensers. Most all of the popular makes of window vernier dials on the market today incorporate this feature, mainly as a protection to the dealer, as it does not necessitate a stock of two types of dials.

This confusion, and oftentimes consequent chance of disturbing the settings of the dials, due to turning the dial past the zero or 100 mark, can be eliminated very easily, once the direction of rotation of the dials is determined. How this should be done is clearly illustrated in the photograph. The instrument should first be taken apart, and the unnecessary markings on the dial removed by covering them over with

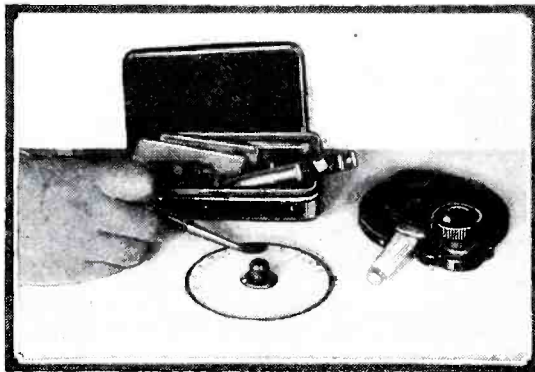

The half of the dial which is not used is blackened with india ink or chemicals as explained in the text.

white water paint. If a good match is made between the paint and the dial, it will be impossible to distinguish between the original celluloid and the painted-out figures. This makes it impossible to disturb the dial settings of the receiver due to turning past the end markers.

In some cases, where the celluloid dial is used as an indicator, with a pilot light showing through the dial, to throw the numbers into relief, the white paint will not hide the numerals on the unused part of the dial completely. In this case, it will be necessary to blacken that part of the dial by using india ink or heavy black water paint. If the dial happens to be of metal, a permanent black finish can be easily etched on the unused part of the dial by the use of any sulphur oxidizing compound of which there are any number. Sulphur dioxide is excellent for this purpose and is easily obtainable at most any drug store or chemical supply house. Care should be taken when it is being applied to just cover the space where the scale is not desired.

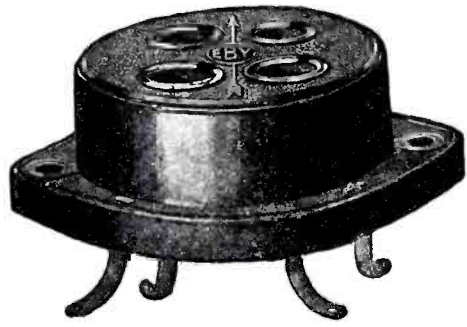

### 40c NEW and Much Better!

The prongs are completely enclosed and can't spread. No more socket trouble to shoot!

After all, a socket's only job is to provide a perfect contact. The Eby 3 point wiping spring contact is the most scientifically perfect type known.

Easy to mount above or below Bakelite, wood or metal.

Specified in the leading popular circuits. List price 40c.

Eby Binding Posts, the standard of quality for six years, are specified in nearly every popular circuit. The tops don't come off.



**H. H. EBY MFG. Co.,**  
INCORPORATED  
4710 Stenton Ave. Philadelphia

**DON'T FAIL**  
to write for —

**BOOK BARGAIN BULLETIN NO. 5**

Remarkable savings on all kinds of Books

CONSRAD COMPANY, INC.  
230 Fifth Ave., New York

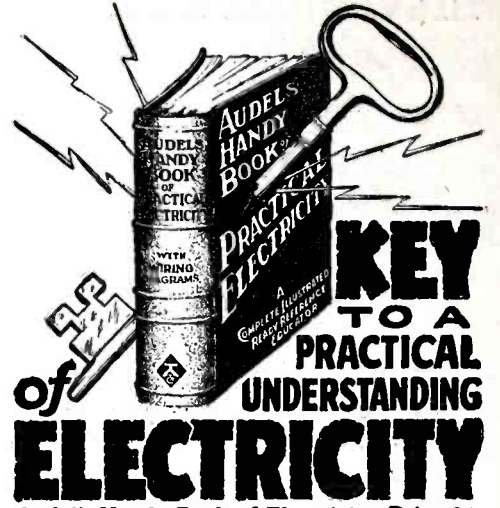

**Audel's Handy Book of Electricity, Price \$4.**  
A quick simplified ready reference, giving complete instruction and inside information. Handy to use. Easy to understand. For Engineers, Professional Electricians, Students and all interested in Electricity. A reliable authority and a handy helper for every electrical worker.

**INFORMATION**  
The 1040 pages and 2600 diagrams give accurate, up-to-date and complete information on—Rules and Laws, RADIO, Storage Batteries, WIRING DIAGRAMS, Power and House Wiring, Automatic Phones, Auto Ignition, Motor Troubles, ARMATURE WINDING, Cable Splicing, Elevators and Cranes, Sign Flashers, Transformers, Practical Management, Modern Applications—READY REFERENCE on every electrical subject. *Pocket Size*, handsomely bound in flexible Red LEATHER. Easy Terms. Shipped for *Free Examination*. No obligation to buy unless satisfied.

**FREE EXAMINATION COUPON**  
The Audel Co., 65 W. 23 St., New York  
Please send me Audel's Handy Book of Practical Electricity for free examination. If satisfactory, I will send you \$1 in 7 days, then \$1 monthly until \$4 is paid.

Name.....  
Address.....  
Occupation.....  
Employed by..... RADIO

## FRITTS

The adopted quality Cabinet for the new Radio News Circuit

"The Stroboddyne"

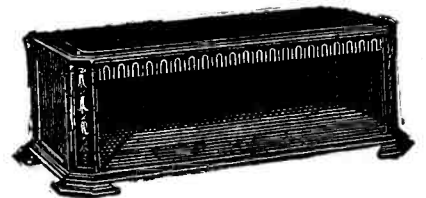

SOLID WALNUT

Fritts Radio Furniture maintains its leadership strictly on fine workmanship, character in design and lasting beauty.

Our product is all made with the one thought of adding dignity to any setting, and is worthy of housing the finest Radio Receiver made.

Fritts Radio Furniture includes Consoleettes and Radio Tables.

Descriptive leaflet and prices on request.

**D. H. Fritts & Company**  
RL-604 Hearst Square, Chicago, Ill.

**BIG NEW CATALOG FOR RADIO BUILDERS**  
**FREE** My big 1928 Rad'o Catalog, Call Book and Trouble Finder. 132 pages about Radio. Chock full of newest circuits—kits, transmitter parts, short wave outfits, eliminators and speakers. Thousands of bargains at lowest wholesale prices. A regular Radio Encyclopedia—Free. Write today.  
**American Auto & Radio Mfg. Co.**  
HARRY SCHWARTZBERG, PRES.  
Dept. 215 American Radio Bldg., Kansas City, Mo.

**LATEST RADIO CIRCUITS**

*What others say*  
of this **IMPROVED** Line



**They Give Satisfaction In Every Channel of Merchandising and Stay Sold**

Out of three hundred (300) of your radio tubes sold to date, have had only one complaint. This is most exceptional in comparison to the average run of tubes.

**DEALER** Clifford Bros. Successors to Wieners Hartford, Conn.

We have used several different kinds of tubes but find yours superior to any.

**DEALER** M. C. Humbarger R. F. D. No. 1 Clayton, Michigan

I've tuned in such stations as Mexico City, Havana, Atlantic City and Jersey City in your state, New York, Clearwater, Florida, Jacksonville, New Orleans, and Los Angeles with your tubes. The new detector made this possible.

**CONSUMER** Kenneth C. Fiebelkorn P. O. Box 47-28520 Jefferson City, Mo.

All your types of tubes are the best we've ever used. Keep up this splendid quality.

**DEALER** Elec. Fix. & Supply Co. 504 Prospect Ave., S. E. Cleveland, Ohio

Baker & Fitzgerald, Inc., of Los Angeles, are satisfied with our tubes to the extent of having them put up under their own label. They will use about five thousand (5000) this coming season. Advise.

**JOBBER** Allan Mfg. Co. Harry A. Lasure, Mgr. 487 Chamber Commerce Bldg. Los Angeles, California.

Your tubes have been in my Diamond T set for six (6) months and still going strong. Have logged about two hundred (200) stations including PWX and KFT, which are hard to get in this state. Wishing you further success.

**CONSUMER** Wm. G. Hoffman 106 N. Denny Street Indianapolis, Indiana

**VOGUE  
NONPAREIL**

Folder on Request.

**ALLAN MFG. CO., Harrison, N. J.**

Los Angeles Chicago

487 Chamber Commerce Bldg. 100 W. Chicago Ave.

## A Few Dont's For Radio Owners

Don't connect new batteries in the same circuit with old ones. It is poor economy, as the new cells are forced to use good energy in overcoming the higher resistance of the old cells. It will sometimes shorten the life of new cells or batteries as much as 30 percent.

Don't connect an A, B, C eliminator to a set before first finding out if the minus side of the A circuit of the set is grounded. If such is the case, break the lead between the ground connection and the minus side of the A circuit before attempting to connect the eliminator. Otherwise damage might be caused to the set by a serious short circuit through the light mains.

Don't expect good results from a receiver which you build unless you follow the specifications. Take it for granted that the writer of the article has tried all the possible combinations that you can think of before he allowed the publishing of the material. Changes may seem improvements or innovations, but they are sure to make a difference in the operation at some point.

Don't buy cheap tubes and then complain when your receiver doesn't give good results. A carpenter may be able to build a good house with inferior tools, but a set cannot work unless the tubes are the best that can be purchased.

Don't expect the storage A battery to give unlimited service without charging. A battery that is kept charged always gives longer and better service than one which is allowed to run completely down before being recharged.

Don't expect long service from a speaker if the leads are connected in the wrong manner. De-magnetization will take place and the eventual result will be extreme loss of volume, poor tone quality and finally failure of the speaker to reproduce at all.

Don't use power tubes without proper C battery voltage, and when more than 150 volts are to be put on the plate, see that an output filter system is used. Otherwise damage to the loud speaker windings is sure to result.

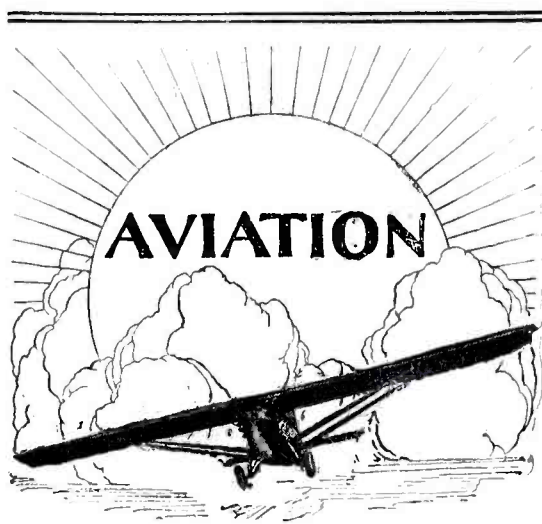

## The Sun Rises offering a great new Opportunity

**T**HE big new field of Aviation is open to every ambitious young man. There are 53 different trades in the industry, many ground jobs. The business is humming. Manufacturing of machines and parts is growing by leaps and bounds. There are now 4,000 air ports operating in America—6,000 privately owned planes. Men in Aviation earn up to \$100.00 weekly and more.

Wide awake men are needed as mail pilots, commercial flyers, instructors, inspectors, riggers, mechanics at flying fields, besides the thousands of positions in factories.

### Radio men needed but they must be trained in Aviation

At home, in your spare time, you can learn the fundamentals of Aviation. Lieut. Walter Hinton, first Trans-Atlantic flyer, and his staff of experts will guide your instruction from beginning to end.

The Aviation Institute Course teaches you everything you need to know, right up to the point of actual flight instruction in the air. All the principal ground work, so absolutely necessary to qualify, is secured in a comparatively short time at home. When you have graduated from the Institute and received your credentials, you are ready to take your place in Aviation.

If you wish to become a pilot, final flying instructions are given in all parts of the United States in cooperation with the Institute, at reasonable rates. Five to ten hours with an instructor and you can fly alone.

Get all the facts about the Institute course and the way it leads to Opportunity. Do it now.

**FREE**

**This Book Tells All**

Aviation Institute of U. S. A.

Walter Hinton, Pres.



Aviation Institute of U. S. A., Suite 439  
71 West 45th St., New York, N. Y.

You may send me without obligation a Free copy of "Aviation and You."

Name.....  
Age (Not under 16).....  
Street.....  
City.....State.....



## EMERSON MULTIVALVE

Seven-element tube with 201A filament, three plates and three grids. Uses any battery. Operates on 5 volts. Draws only 1/4 ampere. Fits any standard socket. Can be used with many circuits. Write for information. List Price \$6.50

Exclusive Licensees and Manufacturers

**Emerson Radval Corp.**

25 West 43rd St., N.Y.C.

## IRELAN WONDER STATION FINDER

More distance—Volume—More selectivity—Tone quality. Saves tubes and batteries. A decided improvement to any set. No extra wiring is necessary. \$1.25

If your dealer cannot supply you—send to us direct

**RADIO SERVICE COMPANY**  
603 West Erie Avenue  
PHILADELPHIA, PENNA.



# 12-Hour Service

*That Is a Fact and Not Just a Promise*

**A New, Larger Home, a Greater Organization Makes it Possible!**

**B**ECAUSE of the steady expansion of our business, we have been forced to move into larger quarters, increasing our floor space several fold. Our working staff has been doubled. A group of expert radio merchants, assisted by an able corps of assistants, stand ready to give the quickest and most efficient distribution service ever afforded in the radio business.

From the beginning, we believed that the substantial future of radio retailing lay through the distributor carrying the burden of stock and investment and allowing the retailer to devote his entire resources and efforts to the proper handling of the consuming public. That our views in this direction were sound has been eloquently proven by the truly amazing upward growth of our business.

That we might carry this purpose to the furthestmost point, we have provided warehouse space and operating facilities so that today we may give the same day service to every radio dealer in the country on practically all the leading lines of parts, accessories, equipment and finished sets. Most orders are shipped same day of receipt.

*Make the Best of the Greatest Year in Radio History*

**I**T is the belief of all those intimately associated with the industry that this will be the greatest year in radio history. The quality of radio apparatus has reached a high point of perfection. Broadcasting conditions were never better. Distribution facilities were never more highly developed. The public has never indicated a more wholesome confidence and appreciation of the desirability of radio in the home and the reliability of most of the apparatus now offered for its use.

All these factors form a basis of opportunity for selling radio which has not been paralleled in this field during the past two or three years. All indications point to a real boom for this Fall and Winter. Thousands of homes never yet graced by radio will this year be equipped, because there is a wide-spread feeling that broadcasting and reception equipment can now be depended upon. The dealer who does not take advantage of this opportunity, will in our opinion, pass up a chance that he will likely never see again.

We have made vast preparations in anticipation of the rush of business which we know will come this Fall and Winter. Our lines have been strengthened and our stocks sufficiently ample to care for our thousands of dealers and the new ones which we know will come to us.

*Follow Braun's Year 'Round Profit Guide*

**B**Y the time of the appearance of this announcement, our new Fall and Winter Catalog will be off the press. In it you will find more than 200 pages listing practically all the leading reliable radio apparatus on the American market. In the column to the left, you will find a partial list of the nationally known lines which we carry. We believe this book has been a means of establishing thousands of dealers upon a sound basis of retailing. Pointing as it does to a source for practically every radio article in demand, it gives the dealer an opportunity to service his trade with a minimum investment, and together with our service make a rapid turn-over on his capital.

If you are not now on our list, we would suggest that you write us immediately on your official letterhead, and if you are not rated, give us the names of three wholesale establishments from which you now purchase. As it has to thousands of other dealers, let this book of ours be in truth, your Profit Guide in Radio.

**W. C. BRAUN COMPANY**

Pioneers in Radio

Wholesale Only

563 to 571 W. Randolph, at Jefferson Street - Chicago, Ill.

## Distributors for these Nationally Known Radio Lines

All-American	Naxon	Remler
Aero	Sonatron	Hoyt
Jewel	Magnaformer	Acme
Amsco	Timmons	Continental
Pacnet	Cunningham	Allen-Bradley
Bremer-Tully	Marvelo	Victoreen
Camfield	R. C. A. Tubes	Signal
Silver-Marshall	Spartan	Ultradyn
Raytheon	Monroe Sets	Stevens
Browning-Drake	Saal	Madison-Moore
Kingston	Elkay	Freshman
Cockaday	Kursch-Kasch	Precise
Belden	Trav-Ler	Eagle
Lynch	Centralab	National
Bosch	Kodel	H. F. L.
St. James	Marco	Eby
Gould	Balkite	Tyrman
Scott	Micamold	X-L
Ruster	Akradyne	Hammarlund-Roberts
Pioneer	Baldwin	Cutler-Hammer
Hammarlund	Thordarson	Frost
Daven	Trim	Durham
Karas	Excello	Yaxley
Valley	Samson	Walnat
Benjamin	Thorola	Muter
Jefferson	Carter	Apex
Hanscom	Polymet	Consrad
Amertran	Pilot	U. S. L.
Workrite	Cardwell	Na-Ald
General	Hazeltine	Steinite
Musselman	Mathieson	Q. R. S.
Dubilier	McCullough	Maximite
Van Horne	Chelton	Korach
Sangamo	Concert Master	Exide
Eveready	Aalco	Graydie
Sterling	Burgess	De Jur
Weston	Thomas	Jones
Standard	Majestic	
Bruno	Bodine	



*We invite all our dealers to visit us. Our new home has provided a ground floor Display Room and Service Counter with a skilled staff of attendants.*



**EASY TO INSTALL**

No climbing on slippery, dizzy roof tops, no dang- sticks to put up, no dang- ling lead-in wires. Just dig a small hole in the ground. Bury SUBANTENNA. In accord with instructions furnished. Anyone can do it in a few minutes. Never again needs attention. Never gets torn down by wind or storm like an aerial does.

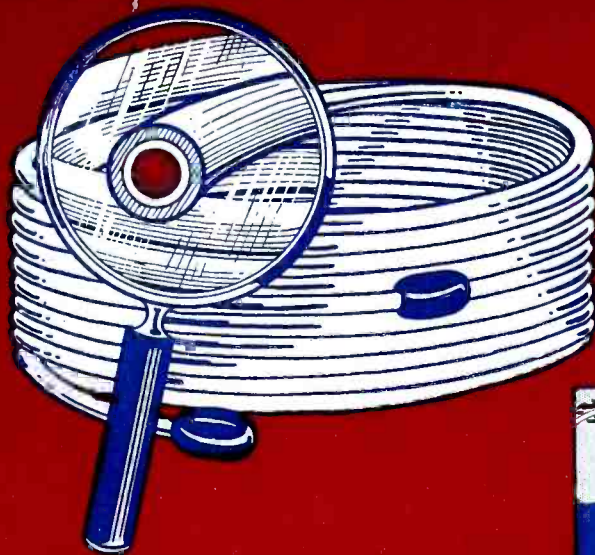

This graph-picture tells the greatest radio story ever told. Send coupon for the complete explanation of the difference between noisy air waves and static-free ground waves.



# Oh—the joy of Radio! with a SUBANTENNA

“I get plenty of stations with my Subantenna, on the loud speaker, that I have never been able to reach with my outside aerial. It absolutely cuts down interference to the minimum, **cuts static out, too — not just partly out — but ALL out!**”  
H. S. M., North Carolina

And besides that he gets stations with his Subantenna that he never could coax out of the air with an aerial! Read what Mr. H. S. M. of North Carolina thinks of Subantenna, in his letter which we have reprinted in brackets at the top of this column. He is just one of many thousands of fans who are enjoying clearer, louder, better long distance radio reception since discarding the unsightly, static-collecting, up-in-the-air type of aerial, and using in its stead, Subantenna, the new *underground* antenna.

**Every Night a Good Radio Night — Now an Actuality**

Gone is the time when the first warm day is the signal for pushing the radio back in the corner until cold weather comes again. A thing of the past is the disappointment of having an evening's radio fun spoiled by an unexpected storm or attack of static. Install a Subantenna and your radio will be as dependable as the sunrise. On any night, in any season, in any weather you can get real “distance,” enjoyable clarity and bigger usable volume than you ever could before — all you need is a Subantenna.

**What Scientists Found Out**

For years the heads of great laboratories have been trying to perfect a means of tun-

ing static out of radio impulses received from the air. And all this time they knew not only that the same radio wave which travelled thru the air also travelled thru the ground, but that the ground is practically free from static! Knowing this, a group of inventors set out to develop a device by which the radio wave could be satisfactorily picked up from the ground. Result! Subantenna — already tested and proved by thousands of users — and offered to YOU to test on an unconditional, unqualified guarantee basis. Read herewith, a few more of the voluntary letters of praise which Subantenna users have sent in. Then get the whole explanation of Subantenna — why the ground is almost static-free — why Subantenna increases the distance-getting capabilities of practically any set — why it increases volume and improves selectivity. Get this information from your dealer, or mail the coupon from this announcement for booklet and our *free trial* offer. Now, read:

**Says its WONDERFUL!**

“After 4 years of testing aerials I at last found the master in the Subantenna. The first night I used it was a very hot summer night. Static was very bad on my outdoor aerial. I connected my Subantenna and one could hardly believe the results. It was wonderful.” — F. L. C., Mass.

**Works Fine with “B” Eliminator**

“We have the Subantenna installed and it is all you claim it to be. It works fine and

we enjoy it very much. We also have a B Battery Eliminator and the two together work fine. We would not want to go back on the high-in-the-air aerial again as we get so much better reception on Subantenna.” — A. J. L., Maine.

**SURPRISED!**

“I received the Subantenna and installed it the same night and believe me I was surprised with the result for I was quite suspicious about it. I am well satisfied.” — R. E. G., Canada.

## FREE TRIAL

**Make This Convincing Test**

Install SUBANTENNA. Leave your old aerial up. Select a bad night when DX is almost impossible with the ordinary aerial. Make a comparison station for station connecting first your aerial, then SUBANTENNA. If, from stations that are just a mess of jumbled noise with the old aerial, you don't get reception that rivals local in sweetness and clarity the instant you switch to SUBANTENNA, this test won't cost you even a single penny. Obtain a SUBANTENNA from your dealer or send coupon at once for scientific explanation of SUBANTENNA and for particulars of GUARANTEE and FREE TRIAL OFFER. SEND COUPON NOW!

# SUBANTENNA

**The New Underground Antenna**

Made by CLOVERLEAF MANUFACTURING CO.  
2715-D CANAL STREET CHICAGO, ILLINOIS

**CLIP AND MAIL AT ONCE**

CLOVERLEAF MFG. CO.,  
2715-D Canal Street, Chicago, Illinois  
Tell me all about SUBANTENNA, your unqualified, unconditional guarantee and your FREE TRIAL OFFER.

Name.....

Address.....

# 7 Tube Set Single Dial Radio

**30  
DAYS  
FREE  
TRIAL**

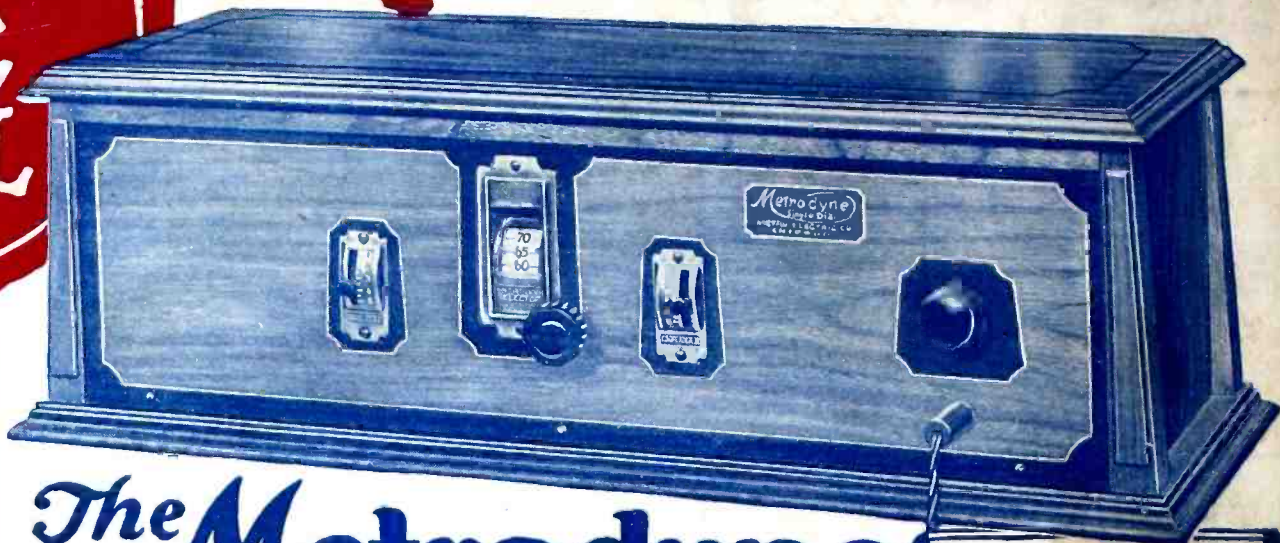

**Metrodyne  
Radio Sets**

Are Equipped  
For

**BATTERY or  
ELECTRIC  
operation**

*The* **Metrodyne**  
ONLY ONE DIAL TO TUNE

**RETAIL PRICE**

**\$75<sup>00</sup>**

**Completely Assembled  
Big Discounts to  
Agents and Dealers**

Wonderful offer direct from the factory! The world's greatest radio! A perfect working, single dial control, 7 tube receiver! And just to prove our claims, we will ship it to your home for **30 days' free trial**. Test it under all conditions. Test it for distance, volume and tonal quality—and if you are not convinced that it is the best single dial set you ever heard, return it to the factory. We don't want your money unless you are completely satisfied.

**Three Year Guarantee**

## Metrodyne Super-Seven Radio

A single dial control, 7 tube, tuned radio frequency set. Tested and approved by Popular Science Institute of Standards, Popular Radio Laboratory, Radio News Laboratory and by America's leading Radio Engineers. Designed and built by radio experts. Only the highest quality low loss parts are used. Magnificent, two-tone walnut cabinet with beautiful, gilt metal trimmings. Very newest 1928 model, embodying all the latest refinements.

Easiest set to operate. Only one small knob tunes in all stations. The dial is electrically lighted so that you can log stations in the dark. The volume control regulates the reception from a faint whisper to thunderous volume, 1,000 to 3,000 miles on loud speaker! The Metrodyne Super-Seven is a beautiful and efficient receiver, and we are so sure that you will be delighted with it, that we make this liberal **30 days' free trial offer**. You to be the judge.

### BIG PROFITS TO AGENTS AND DEALERS

Our Agents and Dealers make big money selling Metrodyne Sets. You can work all or part time. Demonstrate the superiority of Metrodynes right in your home. Metrodyne Radios have no competition. Lowest wholesale prices. Demonstrating set on 30 days' free trial. Greatest money-making opportunity. Send coupon, a letter or a postal for our agent's proposition.



**30 Days' Free Trial—3 Year Guarantee**

## Metrodyne Super-Six

Another triumph in radio. Here's the new 1928 model Metrodyne 6 tube, two dial, long distance tuned radio frequency receiving set. Approved by leading radio engineers of America. Highest grade low loss parts, completely assembled in a beautiful walnut cabinet. Easy to operate. Dials easily logged. Tune in your favorite station on same dial readings every time—no guessing.

Mr. Howard, of Chicago, said: "While five Chicago broadcasting stations were on the air I tuned in seventeen out-of-town stations, including New York and San Francisco, on my loud speaker horn, very loud and clear, as though they were all in Chicago."

We are one of the pioneers of radio. The success of Metrodyne sets is due to our liberal 30 days' free trial offer, which gives you the opportunity of trying before buying. Thousands of Metrodynes have been bought on our liberal free trial basis.

**6  
Tube Set  
\$48<sup>50</sup>**  
RETAIL PRICE  
Completely  
Assembled

**MAIL THIS  
COUPON**  
or send a postal or letter. Get our  
proposition before buying a radio.  
Deal direct with manufacturer—  
**SAVE MONEY—WRITE NOW!**

### MAIL COUPON BELOW

Let us send you proof of Metrodyne quality—our **30 days' free trial offer and 3 year guarantee**

Mrs. Wm. Leffingwell, Westfield, N. J., writes: "The Metrodyne Radio I bought of you is a wow! This is as good as any \$225 machine I have ever seen."

N. M. Greene, Maywood, Ill., writes: "My time is up and the Metrodyne works fine. I got Havana, Cuba, Oakland, Calif., Denver, Colo., Toronto, Canada, all on the loud speaker."

J. W. Woods, Leadville, Colo., writes: "Received the 7-tube Metrodyne in fine condition. Had it up and working same day received. Was soon listening to Los Angeles, San Diego, Oakland and other California points; also St. Louis, Kansas City and other east and south stations—all coming in fine. Am more than pleased. Sure enjoying it."

We will send you hundreds of similar letters from owners who acclaim the Metrodyne as the greatest radio set in the world. A postal, letter or the coupon brings complete information, testimonials, wholesale prices, and our liberal **30 days' free trial offer**.

**METRO ELECTRIC COMPANY**  
2161-71 N. California Ave., Dept. 36  
Chicago, Illinois

Gentlemen:

Send me full particulars about Metrodyne 6 tube and 7 tube sets and your **30 days' free trial offer**.

Name.....

Address.....

If you are interested in AGENT'S proposition, place an "X" in the square

**METRO ELECTRIC COMPANY**  
2161-71 N. California Ave. • Dept. 36 • Chicago, Illinois