

2,00

RTJ

*Radio & Television* JOURNAL

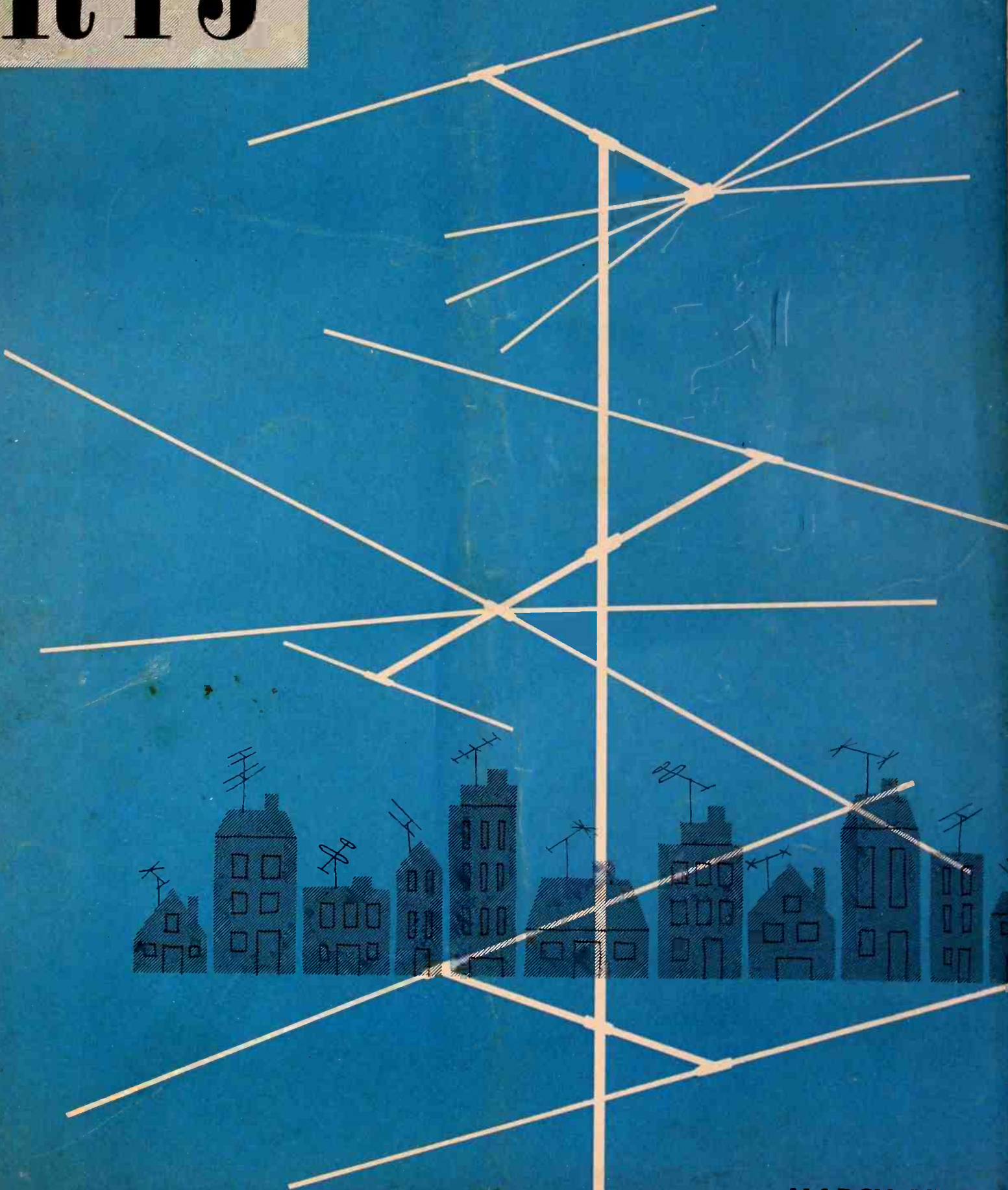

**MARCH 1952**

America's new skyline

# MERIT

TV full-line\* Components For  
Improvement, Replacement, Conversion

## SELL IMPROVED RECEPTION

MERIT "TV" Kit No. 1000 consists of matched units for sharp, edge to edge focus — the MDF-70 Cosine Yoke, the HVO-7 Universal Flyback and the MWC-1 Width Linearity Control. Keep a MERIT "TV" Kit handy on service calls — when you spot fuzzy edge focus you'll get plus business and a reputation for real "know-how."



MERIT MDF-70 . . . original of the "cosine" series — low horizontal and high vertical inductance. Now used by such famous sets as Radio Craftsman, the cosine series will improve 10,000,000 sets now on the market!

## MERIT . . .

### HQ for TV Service Aids

MERIT'S new 1952 Catalog #5211 is now available . . . introducing MERIT IF-RF Coils and giving complete MERIT Coil and Transformer data and listings. Other MERIT service aids for TV improvement, replacement and conversion problems: TV Replacement Guide #404, September 1951 issue — covers 3000 models and chassis of 82 manufacturers; Cross Reference Data on IF-RF Coils, Form #14.

Write: Merit Coil and Transformer Corporation, 4425 North Clark Street, Chicago 40, Illinois.

## These three MERIT extras help you:

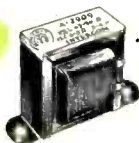

..... Exclusive: Tapemarked with specifications and hook-up data

- Full technical data packed with every item
- Listed in Howard Sams Photofacts



\*Merit is meeting the TV improvement, replacement and conversion demand with a line as complete as our advance information warrants!

**GUARANTEED!**

◦ 150 MILE

**TELEVISION**

**RECEPTION!**

PRECISION

**hallicrafters**



Such unqualified endorsement, with money back *guaranteed*, can be based only upon the *fact of performance!* It is a major television development attained *only* by Hallicrafters.

You'll find the answer in the single word which describes every Hallicrafters product: *precision*. Precision means... "the very best".

Conquering distance is but one Hallicrafters *extra*. Others are the famed Hallicrafters picture... the *clearest* in television, and cabinetry with "that Hallicrafters look" of style and beauty. And... its a pleasure to know you *can afford to own the very best!*

The magazine dedicated to the business of television, radio, sound, servicing, phonographs and records

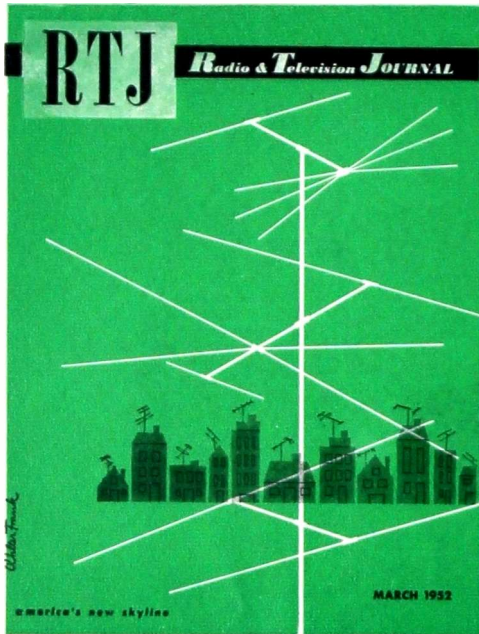

Publisher  
**ALEX H. KOLBE**

Editor  
**NAT BOOLHACK**

Associate Editor  
**JOHN A. RICHARDS**

Business Department  
**AARON LAFER**  
**PAUL SILBERMAN**

Art Director  
**VINCENT T. COSTELLO**

Circulation Manager  
**MARY LOUISE KAUFFMAN**

Member of

**CCA**

OVER 30,000

**Controlled Circulation Audit, Inc.**

**THE COVER** —For a number of years now the housetops across the nation have been presenting a 'new look' as the multitude of antennas has increased. Those lacy and spidery antennas, outlined against the sky, are the symbol of the fastest growing industry in America. But the antenna is more than a symbol . . . it is the magnet which pulls in the picture, and oftentimes is the key to good relations between the dealer and the customer. For the latest information and sales data on antennas, turn to page 35, in this issue, where Section 2 begins.

Vol. 69

No. 3

## IN THIS ISSUE

<b>Television Roundup</b> .....	<b>6, 8</b>
A concise review of the month's happenings in radio and television.	
<b>Washington Report</b> .....	<b>14</b>
<b>See-for-yourself Service Sells TV Sets</b> .....	<b>16-18</b>
This Glenside, Pa., dealer makes his service department a showcase and a salesman.	
<b>Merchandising Memo</b> .....	<b>20, 21</b>
<b>New Transitor May Revolutionize Radio-TV Design</b> .....	<b>24</b>
<b>Charlie Schultz Sez: "Give Them What They Want"</b> .....	<b>28, 29</b>
Satisfaction brings customers back to this Newark dealer.	
<b>New Data on the TV Freeze</b> .....	<b>94</b>

### RTJ'S ANTENNA SECTION—II

<b>To Every Dealer Who Asks: Where's My Profit on TV Antennas?</b> .....	<b>37</b>
<b>A-B-C of TV Antennas</b> .....	<b>38-41</b>
<b>TV Service Usually Starts on the Roof</b> .....	<b>42</b>
<b>How to Make Money With Indoor Antennas</b> .....	<b>44</b>
<b>The Indoor Antenna Is Still a Powerful Sales Magnet</b> .....	<b>48, 49</b>
<b>How to Make Old Customers 'Receptive' to Better Reception</b> .....	<b>56</b>
<b>New Equipment for Television Service and Installation</b> .....	<b>52, 60, 63, 64, 66, 67, 68, 70</b>
<b>Directory of Manufacturers of Antennas, Boosters, and Accessory Hardware</b> .....	<b>72, 74</b>

## Departments

<b>New Products</b> .....	<b>26, 32, 34, 88, 90</b>
(Radios, Television, Consoles, Phonographs, Accessories)	
<b>Personalities and Salesmanship</b> .....	<b>82</b>
<b>Picture Pages</b> .....	<b>84, 85</b>
<b>News and Notes of Manufacturers and Distributors</b> .....	<b>95</b>
<b>New Appointments</b> .....	<b>96, 97</b>
<b>Editorial</b> .....	<b>98</b>
<b>Advertisers' Index</b> .....	<b>98</b>

RADIO & TELEVISION JOURNAL WITH WHICH IS COMBINED RADIO & APPLIANCE JOURNAL and ELECTRIC APPLIANCE JOURNAL IS THE COMPLETE BUSINESS MAGAZINE FOR RETAIL DEALERS WHO BUY AND SELL RADIOS, TELEVISION RECEIVERS, APPLIANCES, PHONOGRAPHS, RECORDS, MASTER SERVICING COMPONENT PARTS; AND IS PUBLISHED MONTHLY FOR RADIO & TELEVISION DEALERS, JOBBERS, AND SERVICE MEN BY KOLBE PUBLICATIONS, INC., RADIO CITY, 1270 SIXTH AVENUE, NEW YORK 20, N. Y. PHONE: CIRCLE 7-5842. ALEX H. KOLBE, PRESIDENT AND TREASURER. SUBSCRIPTIONS \$3.00 PER YEAR IN U. S. A., ITS POSSESSIONS, SOUTH AMERICA, CANADA AND ALL OTHER COUNTRIES \$4.00 PER YEAR PAYABLE IN AMERICAN CURRENCY IN ADVANCE. PRICE 35 CENTS PER COPY. NO MATERIAL IN RADIO & TELEVISION JOURNAL MAY BE REPRINTED WITHOUT CONSENT OF PUBLISHER.

PRINTED IN U. S. A.

**TO HELP YOU KEEP THE SALES CURVE CLIMBING ALL SUMMER LONG**

**ZENITH** gives you  
the hottest merchandise our  
industry has seen in years!

**New Zenith Deluxe Clock Radio.**

An extra powerful performer with amazingly sensitive Long Distance AM reception. Built-in Wavemagnet antenna. Handsome plastic cabinet in Bisque, Walnut, Ebony, Ivory and Dawn Grey,

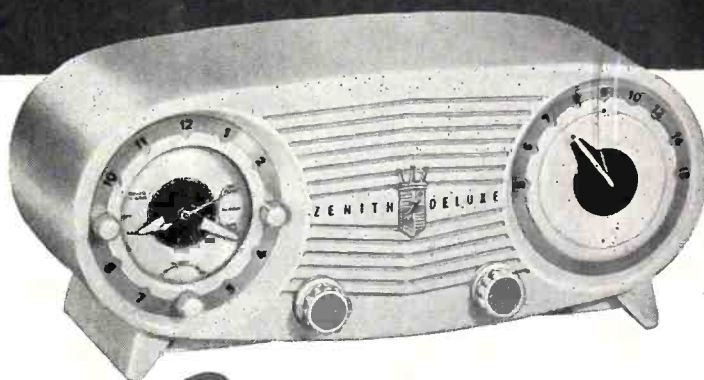

**2 GREAT  
Clock Radios**

**WITH "BIG SET" TONE—  
DISTANCE—PERFORMANCE!**

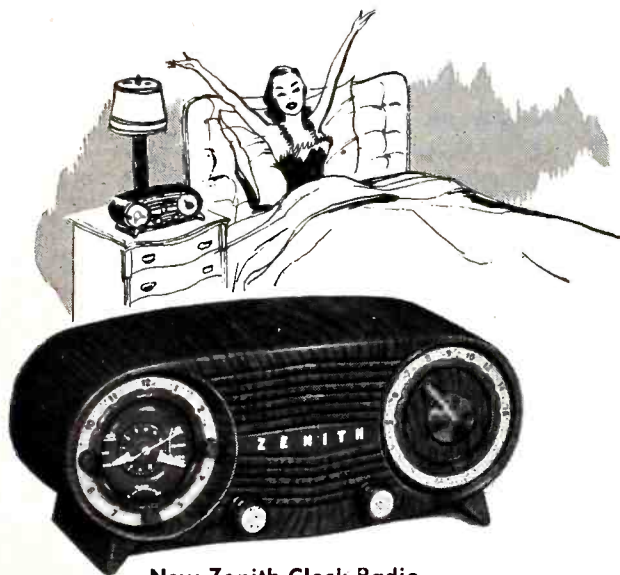

**New Zenith Clock Radio.**

A moderately priced set featuring famous Zenith Long Distance AM reception. Built-in Wavemagnet antenna. Gleaming Ebony, Walnut, Ivory, French Green and Dawn Grey plastic cabinets.

Let's keep that sales curve climbing — 'round the clock and 'round the seasons. And to help you do just that Zenith brings you two sure-fire 'round the seasons sales hits, certain to keep sales high—and profits climbing—even during the usual summer doldrums.

Yes, it had to be Zenith to bring you these two magnificent new style Clock Radios.

They're entirely new—entirely different. They boast "Big Set" Radio Quality—Tone—Distance—Performance!

And they sell on sight—because they're so different, so beautiful, so moderately priced. They come in an array of customer-winning, fashion-keyed colors to blend with any room—any decorative scheme.

One more thing about these profit-leaders. They take little room—and are easy to stock. A simple counter display is certain to pull in sales galore.

So don't miss out. Keep that sales curve high. Stock up! Display! Sell Zenith's great new Clock Radios!

R-216



ZENITH RADIO CORPORATION • Chicago 39, Illinois • Also Makers of Fine Hearing Aids

# TELEVISION ROUNDUP

## Trans-Ocean TV

Trans-oceanic television may not be far off, predicts Dr. E. F. W. Alexander, one of TV's early scientific pioneers. Events could be recorded on motion picture film and the film then transmitted by radio facsimile for processing and televising the same day, or within hours of the event. Trans-ocean television would give a big lift to TV.

## Price-Cutting

This industry has always had more than its fair share of price-cutting, but in recent months, particularly since the Supreme Court decision on fair trade, the rash of price-cutting among television and appliance dealers has been particularly severe. Severe enough to force one Long Island, N. Y. dealer who had expanded to a chain of eight stores since 1945 to announce that he was going to liquidate his stocks and close down four of his stores. "Couldn't make a profit with present methods of price-cutting," said this dealer. Are television and appliance dealers indifferent to the threat presented by price-cutting? Do they fail to understand its implications and how the entire market and structure of the industry can be jeopardized if things are allowed to continue this way?

So believes Harry B. Price, Jr., a dealer in Norfolk, Virginia, who also happens to be vice-president of the National Appliance & Radio-TV Dealers Association. Says Mr. Price: "Price-cutting is an armament race nobody can win. Its result is a ravished market and a discredited industry. It is caused by two conditions: (1) the dealer, who, because of economic distress or a desire to make a quick killing, sets off a chain reaction which others follow like a bunch of stupid sheep, regardless of the cost of the original merchandise or its replacement, and (2) lack of business, which dealers seek to stimulate by bribing consumers with their profits."

The cure for these conditions, says Mr. Price, who incidentally has been in business for a good many years as a legitimate dealer and has seen price-cutters come and go, is to study and analyze the price-cutter's offers for weaknesses to which prospects must be educated. These weaknesses might be lack of service, shoppers' reports of attempts to switch to off-brands, or simply questioning whether that dealer will be here later to make good if the product goes bad.

## May Unveiling for 27-inch Bulb

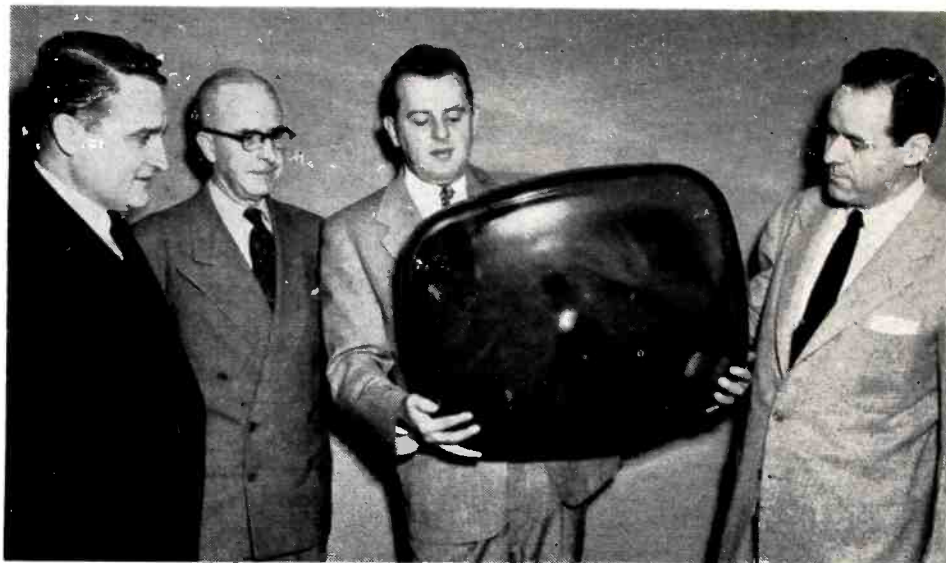

Executives of the electrical products division of Corning Glass Works are shown examining the new 27-inch rectangular, all glass bulb for use in the manufacture of TV picture tubes. Scheduled for volume production in May, it offers a 375-square-inch picture and has new cylindrical face design.

## Where Five Million TV Sets Went in 1951

Over five million television sets were shipped to dealers during 1951. The 5,095,563 sets shipped during 1951 compares with 7,068,000 sets shipped in 1950. During the year sets were shipped into every state and the District of Columbia. The difference between the number of sets shipped during 1951 and the estimated industry production for the year of 5,384,798 television sets is accounted for by the delay in distribution of sets by the manufacturers.

The number of television sets shipped to dealers in each state during 1951 were estimated as follows:

State	Total	State	Total
Alabama	41,938	Nebraska	45,301
Arizona	12,561	Nevada	122
Arkansas	8,681	New Hampshire	15,848
California	437,172	New Jersey	237,171
Colorado	64	New Mexico	4,225
Connecticut	122,815	New York	776,419
Delaware	15,796	North Carolina	80,158
District of Col.	59,561	North Dakota	42
Florida	51,305	Ohio	475,043
Georgia	65,828	Oklahoma	45,717
Idaho	52	Oregon	40
Illinois	350,643	Pennsylvania	540,489
Indiana	160,176	Rhode Island	38,241
Iowa	85,702	South Carolina	18,349
Kansas	24,513	South Dakota	922
Kentucky	61,284	Tennessee	47,918
Louisiana	27,715	Texas	123,952
Maine	5,019	Utah	22,673
Maryland	95,492	Vermont	3,062
Massachusetts	231,755	Virginia	71,920
Michigan	281,515	Washington	55,412
Minnesota	78,094	West Virginia	30,331
Mississippi	6,525	Wisconsin	86,614
Missouri	151,188	Wyoming	77
Montana	123	<b>TOTAL:</b>	<b>5,095,563</b>

RTMA Report

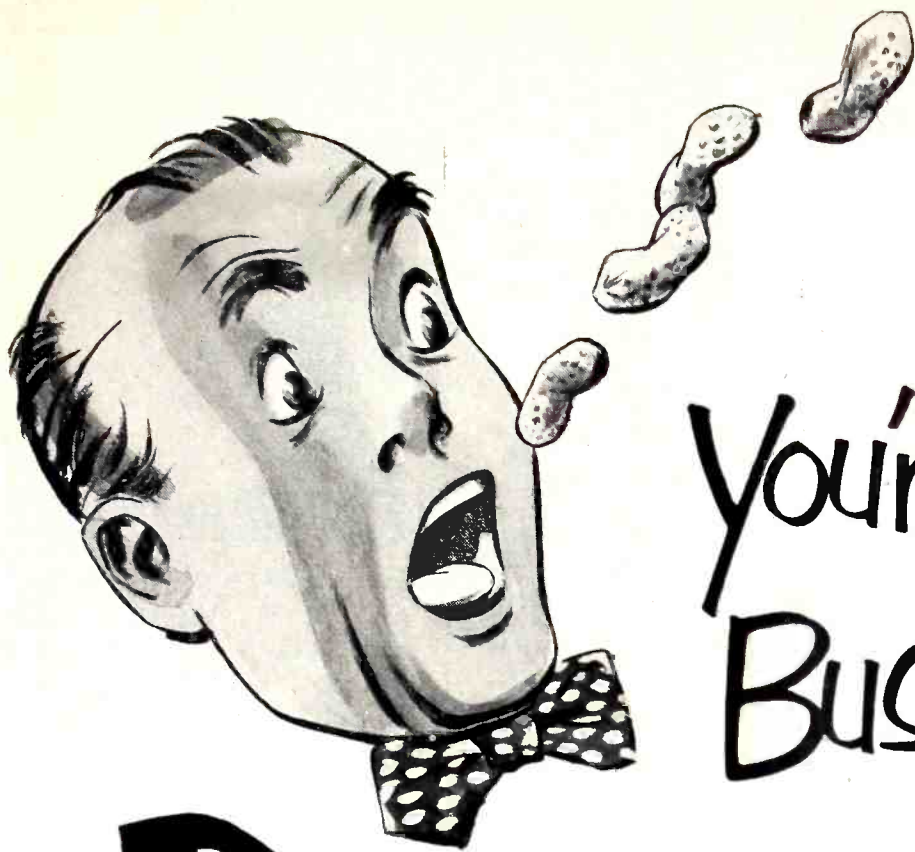

You're not in  
Business for

# Peanuts!

You're entitled to a decent profit—and you can get it with Tele King for two mighty good reasons!

1. Biggest mark-up in television.
2. The Golden 5 Minutes!

We're not being mysterious. The Golden 5 Minutes is a sales pitch that may change your entire sales outlook. It shows how to present Tele King's quality-value story—the most factual in television!



**BEST ENGINEERED TUNER  
IN TELEVISION!**

*Less moving parts than  
on any other—less parts  
to get out of order!*

Send for this valuable free book  
—it's loaded with selling ideas! ➡



# Tele King

THE BEST IN TELEVISION AT ANY PRICE

TELE KING • 601 WEST 26TH STREET, NEW YORK 1, N. Y.

YES—send the Golden 5 Minutes

Name \_\_\_\_\_

Address \_\_\_\_\_

City \_\_\_\_\_ Zone \_\_\_\_\_ State \_\_\_\_\_

# TELEVISION ROUNDUP

## **Radio Entering a New Era of Prosperity**

The fascinating question of whether television means the end of radio, a question which has bemused some of the best minds in the industry during recent years, was again brought to the forefront recently when Robert W. Galvin, executive vice president of Motorola Inc., branded this notion as a fallacy by stating "Radio now is entering a new era of continuing growth and one which will see program quality attain its highest level." Mr. Galvin, whose company is one of the industry's largest producers of both radio and television sets, cited the increase in radio ownership of nearly 10,000,000 sets in the past twelve months alone. Pointing out that radio has not only continued to hold its own against television, but has actually gained ground, spectacularly in rural areas still without television. Mr. Galvin said, "and the improvement in radio programming will continue, in my opinion, and make radio even more secure than it is today." The history of American industry seems to prove Mr. Galvin's thesis: every new development such as motion pictures, the

## **Just Keeps on Growing All the Time**



Evolution of television in recent years is graphically demonstrated by this young lady who compares the screen size of pioneering 7-inch TV receiver built in 1947 with this huge TV-radio-phonograph combination just developed by Admiral Corporation engineers. The 7- and 10-inch sets which were called "big screen television" only a few years ago, now are obsolete.

phonograph, the automobile, radio and now television has not stopped the others' growth but generally has found a secure place itself and has tended to stimulate the growth of other developments.

## **Self-Regulation**

Under a new administrative plan designed to uphold a system of voluntary standards for the advertising and selling of radios, television receivers and servicing, the results of the first two weeks show almost complete cooperation among the advertisers, announces the Better Business Bureau of New York City. The plan initiated by BBB with the help of many of the leading TV distributors and dealers in the metropolitan area provides for the writing of registered letter by the Bureau to an advertiser found violating any provision of the standards, with a copy to the advertising involved. The offending advertiser is requested to reply within 72 hours, expressing his willingness to comply with the standards in question, or explaining why he thinks he was in compliance. Any situations involving disagreement as to interpretation on any standards is to be discussed before an advisory panel selected from members of the television industry if the advertiser so requests. Some of the most frequent types of violations noted by the BBB were: failure adequately to describe advertised or stated guarantees and warranties; the use of the word "free" in large type, followed by the phrase "of extra charge" or "at no extra charge," which is a violation of the standards provision that the word "free" not be used when a purchase of some other item is required.

Other types of violations involve offering of advertised merchandise not available; an offering including new and second-hand merchandise, with comparative prices for all items; and no indication which items are second-hand; misuse of terms 'custom built' and "fully guaranteed;" an incorrect description of cabinet wood; an offering of a trade-in allowance on an item where no trade-in was in fact allowed; and the use of a former original price list which is misdescribed as the "regular" price.

## **Quality in Selling**

More than 2,800 dealers who attended a Town Meeting of Television Dealers in Buffalo, N. Y. on February, 27, sponsored by all the major TV distributors in the area, heard speakers

## **Here's TV Color to Please Everyone's Taste**



A new versatility and flexibility in TV cabinets is shown here as Hy Cohn, a White Plains, N. Y. dealer (right) changes the colorful insert door panels on DuMont's "Banbury" television receiver. Looking on with evident admiration is Fred A. Lyman, distributorship manager. The interchangeable door panels enable the set buyer to suit his own taste on color and to match other furniture or draperies in the room.

say that the television industry must build and sell receivers that represent the best in design, workmanship and materials if it is to maintain the respect and confidence of the American public, and improve its present market. One of the speakers, J. B. Elliott, vice president in charge of consumer products for RCA Victor Division, frankly warned that any attempt "to grab quick profits by lowering the quality of merchandise would hurt the industry and its chances for strong, prosperous development.

The responsibility for maintaining quality on a high level does not rest solely with the manufacture, said Mr. Elliott, pointing out to the dealers that their sales people are in the industry's front line, and therefore cannot sell effectively unless they are thoroughly familiar with the merchandise they sell.

The tendency among some dealers to sell on a price basis only also came in for its share of condemnation. "Some of the people who sell television seem unaware that the customer might be interested in something besides price. Every time they hear of a price cut in a brand name other than the ones they are handling, they get buck fever, and as far as these fellows go, if they can't undersell, they can't sell at all."



# Andrea *New York's leading quality TV line goes national*

## Leaders of the '52 line

"ANDREA'S record in television's toughest market, New York City, has been remarkable. And it has been built primarily on just two factors—topflight quality and trouble-free service.\*

"No, ANDREA hasn't sold the most receivers. But ANDREA has sold the most satisfaction . . . to the consumer and the trade alike.

"Today I feel the national TV market is ready for what ANDREA has to sell. People are fed up with the 'bargain set' that bounces back so often for service. Dealers are sick and tired of slow-moving inventory and skimpy margins. And distributors don't last long with dissatisfied customers.

"Would you like the ANDREA franchise for your area? Would you like a quality line with sales-leading models . . . competitive prices . . . no service headaches . . . and best of all, margins with room for real profits per sale? Write me immediately, *you're the kind of distributor or dealer we're looking for.*"

*\*Independent surveys prove that ANDREA receivers average less than one service call per year.*

*Frank A. D. Andrea*

PRESIDENT, ANDREA RADIO CORP.



STRATFORD... 20-INCH... FM RADIO... FULL DOORS



GOTHAM... 17-INCH... FM RADIO... TABLE MODEL



BREWSTER... 17-INCH... FM RADIO... CONSOLE

### ANDREA—THE STABILITY LINE FOR '52

1. NO SERVICE "RED INK" . . . Independent surveys show Andrea with the lowest service incidence in the TV industry. It's the *stability* set of the industry.
2. LONG DISCOUNTS . . . One Andrea sale is worth two ordinary sales—more margin—extra profit for you.
3. FAST-MOVING INVENTORY . . . Just 6 basic models, geared to 1952 popular demand. No white elephants on your hands.
4. RESTRICTED DISTRIBUTION . . . No "next door" competition—more prospects for you—room for real sales.
5. QUALITY LEADERSHIP . . . finest product of Frank A. D. Andrea's 32 years as a pioneer in radio and television.



®

**STABILITY... today's biggest TV value**

ANDREA RADIO CORP. • 27-01 Bridge Plaza North, Long Island City, N. Y.

BRILLIANT

*New*

PERFORMANCE...



**MODEL 52X**—Woven plastic front panel, matching the de luxe Ivory, Maroon or Walnut selected plastic cabinet. Clear plastic selector guide and dial trim. Oval speaker, AC-DC.

IN WALNUT  
**\$29<sup>95</sup>\***

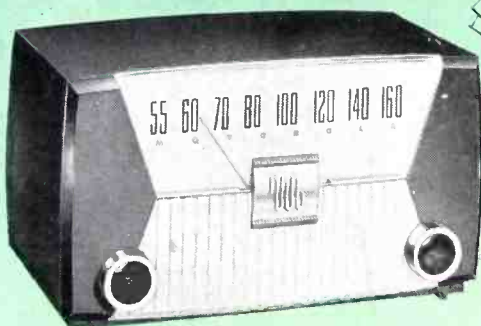

**MODEL 62X**—Extra powerful chassis; sparkling clear plastic and metallic trim on a Green, Ivory or Walnut plastic cabinet. Oval speaker, thrilling tone. AC-DC.

IN WALNUT  
**\$36<sup>95</sup>\***

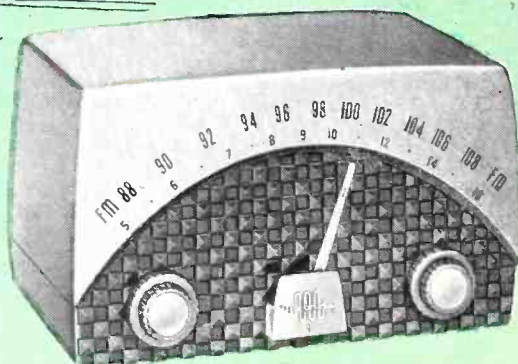

**MODEL 72XM**—High Fidelity FM with "coaxial" type tuner for sharpest selectivity and stability; plus long-range "Golden Voice" AM, in a smart two-tone gray plastic cabinet. AC-DC.

**\$54<sup>95</sup>\***

\*Suggested retail prices

*New* 1952  
**Motorola**  
TABLE AND CLOCK RADIOS

**Styled to be a Sales Sensation!** Designs and colors to harmonize with any room in any home—sure to build a bright sales record for you! Extraordinary reception power, famous "Golden Voice" tone, concentrated-power chassis design to outperform most others! Long-range Aero-vane loop antenna (in all except Model 52R, with magnetic core antenna) and specially designed Alnico V dynamic speakers. These new Motorola Radios have everything your customers want, from styling and power to new low prices!

# New

## LOW PRICES



### OUTPERFORM OTHERS... ANYTIME, ANYWHERE!

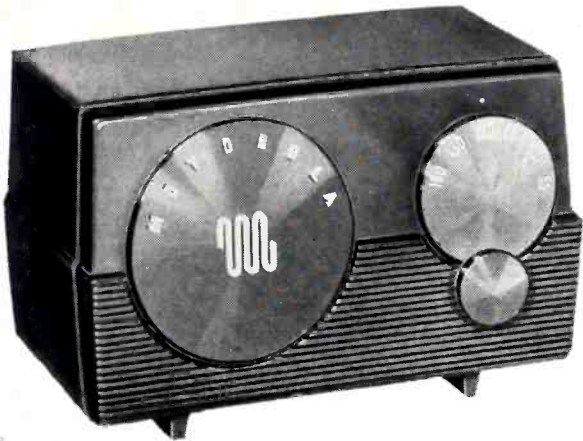

**MODEL 52R**—A low-price leader in six brilliant "decorator" colors for every room! Self-trimmed plastic cabinet in Red, Green, Gray, Maroon, Ivory and Walnut. New magnetic core antenna, wide-sweep tuning, "big-set" tone, AC-DC.

IN WALNUT  
**\$1795\***



**MODEL 52H**—Crystal-clear plastic adds sparkling trim and protects the wide-sweep selector. Aero-vane loop antenna, dynamic Alnico V speaker. Selected plastic cabinet in Green, Gray, Ivory or Walnut. AC or DC.

IN WALNUT  
**\$2495\***

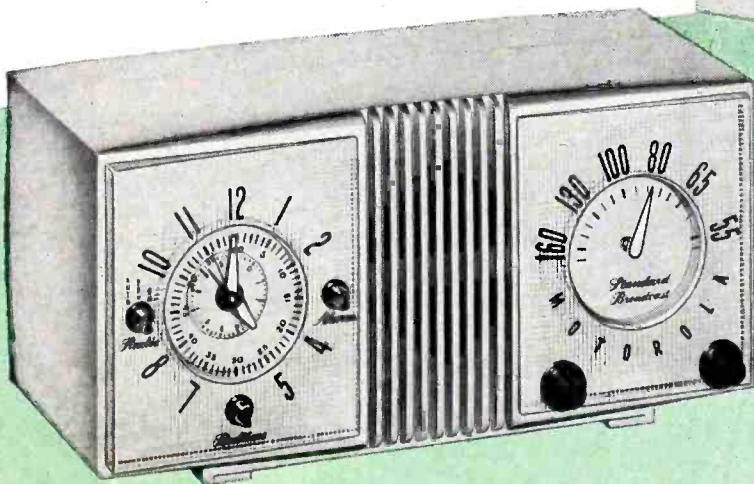

**4-IN-1 APPEAL!** Fast becoming the radio no home can do without... because it's an electric clock, alarm, automatic appliance timer and control as well as a high quality radio! "Golden Voice" radio with "lullaby" turn-off switch, automatic turn-on. Walnut, Ivory or Green plastic cabinet with clear plastic face, luminous indicators, appliance outlet on back. AC only.

MODEL 52C  
IN WALNUT  
**\$3695\***

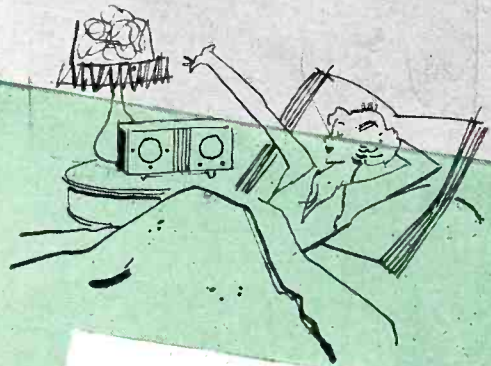

SURE AND SPEEDY PROFITS  
FOR YOU IN '52

# Motorola

the "Golden Voice" of RADIO

Prices and specifications subject to change without notice. Slightly higher South and West.

NEW 1952 MOTOROLA TABLE AND CLOCK RADIOS... AT YOUR DISTRIBUTOR'S NOW!

*Styled* FOR SALES . . .



A



B

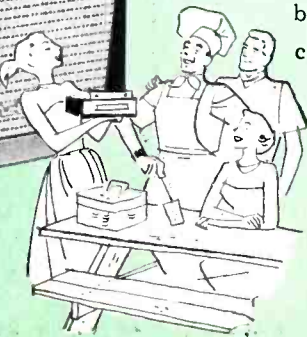

**new 1952**  
**Motorola**  
**PORTABLE RADIOS**

**OUTPERFORM OTHERS . . . ANYTIME, ANYWHERE!**

**never before such beauty . . .** designed with irresistible sales appeal, smart enough to go anywhere in style! Cases are of sturdy weather-resistant premium plastic or smooth "shatterproof" metal, with vinyl-covered easy-grip handles, recessed dials.

**extra powerful reception . . .** even where many larger sets fail! Famous long-distance "Aerovane" loop antenna in Model 52M, new magnetic core antenna in others. Tuned RF stage, exceptional sensitivity and selectivity, low current drain, longer battery life, automatic battery-saver switch.

**brilliant tone . . .** large, Alnico V speakers, acoustically designed for maximum resonance and power. Engineered for 3-way battery, AC or DC reception . . . except 42B, battery only.

**DE LUXE** *"Town and Country"*

Powerful reception with longer-life, extra battery power . . . compact, lightweight plastic case in Gray, Maroon or Green with matching "tweed" woven plastic front panel. Concealed dial-panel tilts forward for tuning . . . radio plays with panel open or closed, upright or flat on molded back-rests. AC, DC or battery.

- a) Plays upright with dial-panel closed.
- b) Plays with dial-panel open.
- c) Plays on back, dial-panel open or closed.

MODEL 62L  
**\$4995\***



C

AND *Priced* TO SELL!



*"Playmate Jr."* —sturdy metal case  
Plays anywhere, anytime . . . on battery, AC or DC power! Rich "Golden Voice" tone, long-range reception. Maroon, Green or Gray enameled "armored" metal case with golden metallic trim; Aerovane loop antenna in matching plastic flip-up cover, spring-grip handle.

MODEL 52M **\$39<sup>95</sup>\***

Motorola  
3-Way *"Escort"*

The same smart styling, but for AC-DC and battery reception.

MODEL 52B **\$29<sup>95</sup>\***

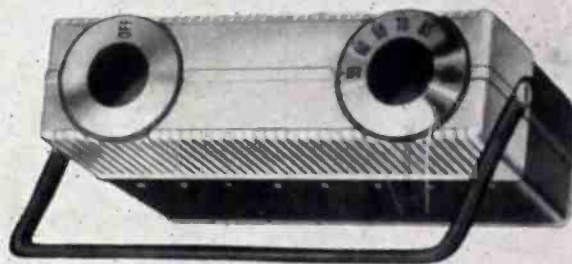
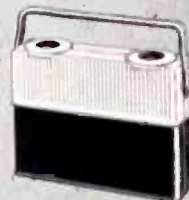

SMART LITTLE

*"Escort Jr."*

Compact as a camera and handsomely designed in silvery metal and extra-durable black Royalite composition in leather-like finish. Long-range battery reception, "big-set" tone, the largest speaker of any radio this size! Plays upright or leaned on its sturdy handle.

*Priced to be a sensation!*

MODEL 42B **\$24<sup>95</sup>\***  
(Battery only)

\*Suggested retail price, without batteries.



New 1952 Motorola  
PORTABLE RADIOS . . . at your distributor's NOW!

Prices and specifications subject to change without notice.  
Slightly higher South and West.

**Motorola**

# Washington Report



## Still Healthy

Despite material shortages and a severe sales slump in the spring and summer, production of radio and television receivers in 1951 maintained a high level, according to preliminary estimates made recently by the Radio-Television Manufacturers Association.

Covering members and non-members of the association, RTMA's estimates showed production of 5,384,798 TV sets for 1951 compared with 7,463,800 units manufactured in the record-breaking year of 1950. Radio output was estimated at 12,299,146 last year as against 14,589,900 sets produced in 1950.

A breakdown of the year's radio output showed 6,584,960 home sets, 1,264,319 portables and 4,449,867 auto sets. Radio sets with FM facilities produced during 1951 totaled 942,927 compared with 1,471,000 in the previous year. In addition, 296,081 TV receivers with FM circuits were manufactured in 1951 as against 756,120 such sets in 1950.

## Strike at Misuse

The engineering department of the Radio-Television Manufacturers Association is moving to prevent the failure of electronic equipment through the misuse of components in end items, according to an announcement by Associate Director Virgil M. Graham.

Mr. Graham revealed that the department is establishing an engineering committee to gather information to be furnished to end equipment designers relative to the proper ratings and environmental conditions of tubes and other components. The committee is being set up with members from the RTMA engineering sections, together with representatives from the Joint Electron Tube Engineering Council, and members from several outside organizations concerned with the problem.

## Expanded Services

To meet the intricate problems presented by the expanded electronics program of the U. S. government, RTMA has formed a Government Relations Section to provide a forum for its member-companies through which industry

problems may be presented to government officials. Consisting of five task committees, the new section is under the chairmanship of Ben Edelman, Western Electric Co., Inc.

The military electronics program is now at an annual going rate of more than \$1.5 billion, with indications that it will be stepped up to more than \$2.5 billion by the middle of this year and reach \$3.5 billion annually by the end of 1952.

## CR Tube Sales

Sales of television picture tubes to receiver manufacturers in 1951 totaled 4,434,126 units valued at \$106,150,834, according to RTMA.

Rectangular tubes 16 inches and larger in size accounted for 88 per cent of the 1951 sales. In 1950, tubes of this category consisted of only 34 per cent of manufacturers' purchases. Picture tube sales to manufacturers in 1950 amounted to 7,473,614 units valued at \$198,737,428.

In 1951, sales of picture tubes for all purposes, including new sets, renewals, U. S. government, and export, amounted to 5,135,799 units valued at \$122,224,186.

## Components Progress

Several hundred of the nation's leading technical authorities in the electronics field are scheduled to gather in Washington on May 5-7 for a "Symposium on Progress in Quality Electronic Components." The three-day conference, to be held in the Interior Department Auditorium, will cover a wide range of technical subjects in both the production and developmental fields.

The meeting is to be jointly sponsored by the American Institute of Electrical Engineers, the Institute of Radio Engineers, and the Radio-Television Manufacturers Association. It will have the active support of agencies of the Department of Defense and the National Bureau of Standards.

More than two-score technical papers stressing new electronic components, materials and fabrication techniques are to be presented at the meetings by recognized authorities in industry and government.

## Kalb Re-elected PMA President



Roland J. Kalb was re-elected president of the Phonograph Manufacturers Association for another year at the organization's recent annual elections. Mr. Kalb is vice-president of Steelman Phonograph & Radio Co., Inc.

## Comparative Sales

Comparative sales of receiving tubes for 1951 as against 1950 showed a drop in sales for new sets, increased sales for replacements, export, and government purchases, RTMA reports.

Receiving tubes in 1951 totaled 375,643,697 units compared with 382,960,599 in the preceding year.

Following is a breakdown of 1951 sales: 247,855,249 for new sets; 94,596,563 for replacements; 24,438,351 for export, and 8,753,534 to government agencies. By comparison, 1950 sales were as follows: 301,483,350 for new sets; 69,324,540 for replacements; 10,767,831 for export, and 1,384,878 to government agencies.

## "Freeze" Highlighted

Highlighted in reports at the recent Radio-Television Manufacturers Association three-day industry conference at the Roosevelt Hotel, New York City, were the anticipated effects of the lifting of the "freeze" on new TV station construction, final revisions of proposed trade practice rules for the radio-television industry, various sales and promotion campaigns, and mobilization activities of RTMA and associated committees.

Meanwhile the board of directors of the association, under chairman Robert C. Sprague, approved a plan for the annual appointment of honorary directors and authorized a special proxy meeting of members of the association to amend RTMA by-laws.

# Sensational combination offer introduces Arvin's new 3-way portable

This \$8.95 picnic case

**at no  
extra cost**  
with every set you sell



Arvin Vacationer will be extensively advertised in May and June issues of national magazines, offering this smart plastic shoulder picnic or beach bag at no extra cost. Regular \$8.95 retail value! Keeps foods or beverages hot or cold for hours. Fibreglas-insulated, waterproof, washable, odorless, scuffless. Ideal for picnics, motor trips, school lunches, nursing bottles, frozen food shopping.



Model 650P

# Arvin *Vacationer*

with the sensational new

**super-powerful Magnetenna**

- Stunningly styled plastic cabinet with leatherette midriff, in 3 color combinations, with touch-o-gold trim.
- Battery, AC/DC—switches from one to the other with no warm-up delay.
- Unique revolving dial with unbreakable mirror in center.
- Handle folds flat when not in use.
- Five tubes plus selenium rectifier.
- Mighty "Magnetenna"—radically new, super-sensitive ceramic core rod antenna with amazing pulling power.
- Alnico V PM speaker, Arvin Velvet Voice tone.
- Weight, complete with batteries, only 6 $\frac{3}{4}$  lbs.

**\$44<sup>95</sup>**

less batteries

Radio & Television Division

**ARVIN INDUSTRIES, Inc., Columbus, Indiana**

(Formerly Noblitt-Sparks Industries, Inc.)

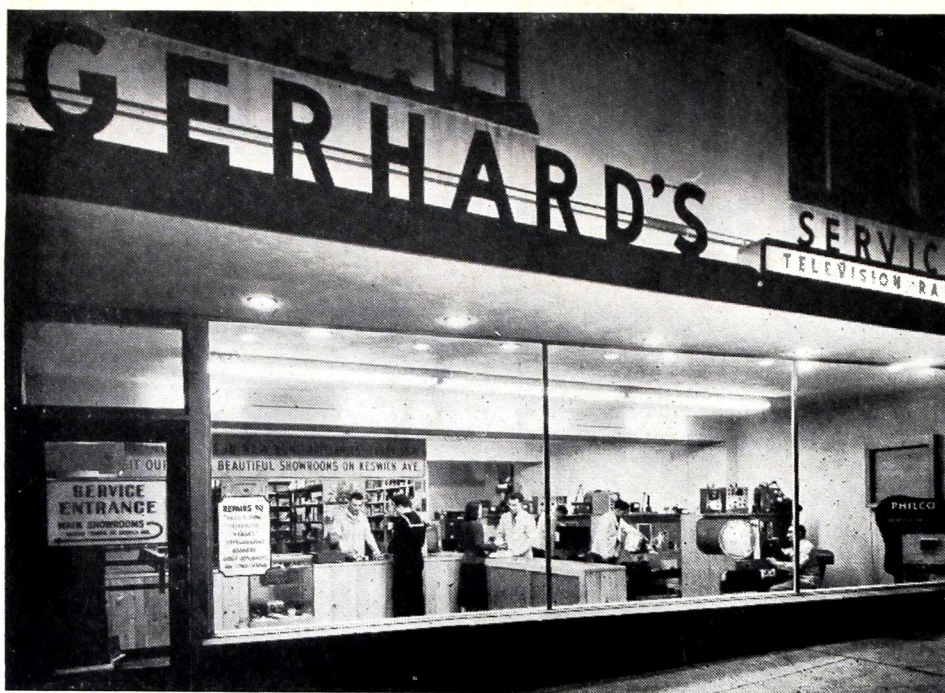

• Pedestrian and automobile traffic gets a full view of Gerhard's operation at one glance. Arrow on the door, left, and overhead sign inside direct customers to main showrooms.

# See-for SER Sell

How a Glenside, Pa., dealer uses service as his ace salesman

ANYTIME a television customer steps inside Gerhard's in Glenside, Pa., he is shown what an elaborate, \$75,000 modern service building can offer in the way of customer service.

"And if a customer broaches the question of a TV set discount," says a spokesman for Gerhard's, "we flatly tell him the facts. We point to our service staff and tell him we would have to fire everyone in the service department and turn our backs on any and all requests for television service."

This suburban Philadelphia dealer has always run a store in which one of the business pillars was efficient service. But only a month ago the firm took a significant step forward. It moved into its new, modern \$75,000 service building which adjoins its main showrooms.

### See for Yourself

The new service building fronts on Easton Road in Glenside, and is on open display both day and night. Through the huge show windows, the public can see the firm's service men working at their modern work benches, repairing television sets, radios, phonographs and small appliances. The shop is open from 8 a. m. to 10 p. m. Bright fluorescent fixtures light up the service area and give a daylight atmosphere to the interior during both the day and night. Emblazoned across the interior, above the main counter, is the firm's well-known slogan, "Famous for Dependable Service." This legend is clearly visible to anyone who gets

within twenty feet of the store window.

Bustling in and out of this spacious service area are 26 service men and twelve trucks which answer an average of 125 television calls a day. The service department itself is broken down into two selling operations—wholesale and retail. To save independent television service men from making frequent trips into the city, Gerhard's maintains enough stock to sell to these industry men on a wholesale basis. This includes radio, phonograph and television parts. Regular customers are, of course, sold at retail prices. One glance at what Gerhard offers in the way of guaranteed service and any customer can see for himself why this must be so.

### Wedded to Sales

Above the parts counter at Gerhard's is a large sign reading "For the finest in new home appliances and television visit our large beautiful showrooms on Keswick Avenue."

The sign refers to the store's main showrooms, including the spacious one devoted exclusively to television and to an elaborate record department. TV sets operating in the homey atmosphere of an exclusive display area are made doubly attractive by the relaxed but thorough demonstrations given by well-trained, aggressive salesmen. No lackadaisical selling is tolerated at Gerhard's. There is no flipping of price tags, followed by asking a customer if he wants to buy the product.

By casually calling a customer's attention to the firm's main showrooms,

Hello:

I left this little message. I hope you don't mind I thought you as a television set owner would be interested in knowing how we can prevent costly TV failures and inconveniences

FIRST CLASS  
PERMIT NO. 115  
GLEN SID, PA. 19038

BUSINESS REPLY CARD  
No Postage Stamp Necessary if Mailed in the United States

POSTAGE WILL BE PAID BY

GERHARD'S  
TELEVISION HEADQUARTERS  
EASTON ROAD AND KESWICK AVENUE  
GLEN SID, PA.

**TUNE-UP WITH SPRING** and PREVENT SUMMER TELEVISION FAILURES!

GERHARD'S FAMOUS TELEVISION SERVICE DEPT. WILL GIVE YOUR SET A COMPLETE SPRING CHECK-UP FOR ONLY \$5.95

Just look what this includes:

1. Set brought to shop for complete check on our Oscilloscope and Signal Generator	4. Alignment checked
2. Tubes checked	5. Picture tube cleaned
3. Tuner cleaned and adjusted	6. Controls serviced and tested
	7. Picture controlled and tested
	8. Picture focused

Plus: The use of a loaner set while yours is being checked

MAIL THE RETURN CARD TODAY

DON'T MISS THOSE IMPORTANT HOME BALL GAMES

Mail this card today . . .

Dear Sir:

I would like to have my television set given a Spring check-up for \$5.95. Please have your representative call

NAME \_\_\_\_\_

ADDRESS \_\_\_\_\_

COUNTY \_\_\_\_\_ PHONE \_\_\_\_\_

Service Man \_\_\_\_\_

This "Spring Tune-Up" promotion swamped the service department with business and turned up prospects for bigger set trade-ins.



# yourself VICE TV Sets

the service function has been wedded happily to actual TV sales. In fact, service men are even more sales conscious than usual at Gerhard's. They are that way because of an unusual feature display, a lighted island one on which reposes a television set labeled "Our Best Bargain." If a customer brings in a small television receiver for repairs, the service men refer the customer to the bargain, suggesting that he might like to consider trading in his small screen set for a larger one. Actual records show this approach produces many sales, not only in TV but also in radios and small appliances. When any products are old beyond repair, a customer is usually sold a new product at once to replace the outworn item.

## Trade-ins

To keep the flow of older television sets moving into the store as trade-ins and newer, larger-screen sets moving back into customer homes, Gerhard's has inaugurated an unusual sales approach which has proven highly successful. Next to the service department is a department which the firm labels "Gerhard's Steal Department." Pedestrian traffic and car traffic alike have grown accustomed to taking just a little "peak" at what the latest "steal" in the Gerhard window is. Price tags are printed up special for each item and a huge yellow placard serves as a sales card, on which is the legend, "It's a steal for only ....." For any discontinued model the original price is prominently shown.

The firm operates on the theory that the price for which these sets are going makes each one an unusual bargain. Customers are in almost unanimous agreement that the bargains are really bargains, for it becomes more and more difficult for the firm to keep the window in this particular department filled with trade-in sets. They are in and out, sold almost as quickly



• The "Steal" department has become an institution at Gerhard's. No sooner are the bargains displayed in the window than customers appear to put their money on the line.



• By featuring a "best buy" display, service men can sometimes step out of their service role and clinch a trade-in sale.

as they are displayed. Each of these trade-in bargains is inspected and put into top operating condition by the service department.

## Promote to Sell

Regular advertising in city and local papers is only one of the ways in which Gerhard's keeps its name in the public eye. It maintains a direct mail list of customers totaling about 8,000. Billboards and television spots are likewise

used. Every one of the firm's 12 trucks has a panel which allows for a change of advertising copy each month so as to coincide with any regular or special promotion which the store is conducting.

Most unusual of its outdoor advertising devices is Gerhard's "black light" billboard, built exclusively for the firm by the Landau Outdoor Advertising

(Continued on Page 18)

## TV Conducts Streamlined Plant Tour



RCA Victor's global TV production team recently chalked up another performance first for TV by taking 200 Foote Mineral Co. stockholders on a 45-minute streamlined tour of the firm's 81-acre Exton, Pa., plant. Twelve receivers in the cafeteria did the trick.

## Philips Announces Plan to Produce TV Sets in Italy

Plans for the production of television receivers in limited quantities for the home consumption market in Italy were recently disclosed by the Societa Philips e Philips Radio of Milan. The company, which is a branch of the great Philips Company of Holland will import receiving tubes from Holland, and the first receivers are expected to be available prior to the opening of first television network in April, 1952.

So far, very few Italian radio manufacturers have made the plunge into television production, preferring to let competitors start first and gain the expensive "know-how" required for mass producing so intricate an electronic item as television. The Philips Company, however, admits that it is receiving technical information and actual production experience from the parent plant in Holland. The majority of Italian radio manufacturers, however, have adopted a wait-and-see attitude as regards television, and the Philips plans are being looked upon with great interest throughout the trade.

## 'See-For-Yourself' Service Sells TV Sets

(Continued from Page 17)

Co. of Philadelphia. It is situated in the Broad Street Subway Terminal, where it is viewed by no less than an average of 82,000 commuters every day. This "black light" sign costs considerably more than outdoor billboards, the firm is ready to acknowledge. But it has more than paid for itself in the response from consumers, and it ties in very well with all of the firm's newspaper advertising.

Sales from this pointed advertising are not long in coming. From one full-page newspaper ad captioned "Television Security—Not Just Fine Television but Guaranteed Entertainment," 32 television set sales in a single day resulted. The appeal to customers hit home when the security and stability of sound, efficient service was offered. All Gerhard's advertising hits hard and to the point. It strives to maintain the reputation of the firm as an institution in the community, and is designed to impress the public over and over again that the firm is an excellent place with which to do business.

### Spring Tune-Up

When Gerhard's turns its efforts to direct mail, it doesn't waste time on mailings which are going to wind up in

a customer's wastebasket. Take for instance the sales stimulating "Spring Tune-Up."

A mailing card was made up advertising a spring tune-up for a television set for \$5.95. Eight thousand cards were mailed to the direct mail list. In addition, service men distributed cards at every home where there was a TV antenna on the roof, affixing his name to the card. As an incentive for the widest possible distribution, service men were granted \$1 for every request for a "Spring Tune-Up."

That was only the start of the promotion. The response, in the words of an official of the firm, was "terrific." The mailing and distribution brought in more repair jobs than Gerhard's could handle. A great percentage of these tune-up sets were small screens. During the two days it took for the set tune-up, Gerhard's replaced the set in the home with a large screen TV model. Salesmen began contacting these customers with the new view on TV, asking how they enjoyed the larger screen. In every case the response was the same. They loved it and showed an interest in talking trade-in and terms. Through this simple promotion the firm sold over 20 sets and had an abundance of repair work

besides. There was more than immediate evidence that the mailing had an effect. Customers continued to mail cards back for the following three months, indicating that this was one mailing which did not wind up in wastebaskets.

This sort of aggressiveness is typical of Gerhard's approach to selling. It is reflected in the follow-up by each salesman of every TV set sale, to verify that a customer is perfectly satisfied. It is reflected in the prompt and immediate attention given to installations by expert service crews. Above all, it is reflected in the sales-minded service department, where no opportunity is missed to sell a prospect a set when the initial contact was a service contact.

Because of the close marriage between sales and service at Gerhard's, the firm's reputation has spread far beyond Glenside. Customers come from urban Philadelphia and environs, and from parts of New Jersey. They have heard of Gerhard's from friends or through the multiple forms of advertising by which the firm spreads its reputation. When they come to the vast showrooms and elaborate service center, the salesmen and service personnel do the rest—they translate the good will of these customers into sales.



**Jewel "Wakemaster" Model 5040**  
Wake up to music... with today's lowest priced automatic clock radio. Banish "alarm clock nerves"! This "easy-on-the-budget" beauty comes in ivory, walnut, ebony and red.



**Jewel "Wakemaster" Model 935**  
Lulls you to sleep! Then Lullaby Switch shuts off automatically! Also "wake-up-to-music" alarm, and "electronic reminder" that buzzes gently till you get up. Walnut or ivory. Model 920A—Above features, less Lullaby Switch.



**Jewel "Wakemaster" Model 5057**  
with Electronic Appliance Switch  
The ultimate in fully automatic clock radios! Not only "wake-up" and Lullaby "shut-off" features, but a special electronic switch that automatically turns on other electrical appliances. Ebony, walnut or ivory.



**Jewel Model 5100 Superhet**  
Enjoy today's high styling... yesterday's low price... in this "eye-catching—ear-pleasing" beauty! Adaptable to every room in the house. Choice of four popular colors—ivory, walnut, ebony and red.

choose from  
a complete line  
of smartly styled  
radios by

*Jewel*

RADIO CORPORATION

10-40 45th Ave.,

Long Island City, N. Y.



**Jewellette Model 5020**  
Radio-Phonograph  
Finest console-tone radio, with Webster Record Changer. Automatically plays 7, 10, 12-inch records... at speeds of 33 $\frac{1}{3}$ , 45 or 78 rpm... micro-groove home recordings! Mahogany, walnut or blond finish.

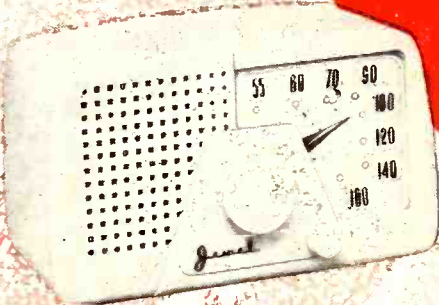

**Jewel Model 956 Superhet**  
Here's a beauty, in tone and design... "at home" anywhere in the house. Built-in Duraloop antenna does away with outside aerials and ground wires. Big, bold dial, easy to read. Ebony, walnut or ivory.



**Jewel "Fifty-fifty"**  
AC-DC Battery Portable  
Get two radios for the price of one! With carrying handle up, it's a sporty portable. With handle in easel position as illustrated, it's a luxury table radio. Immensely popular! Available in luxury colors.



**Jewel Model 960 Superhet**  
Enjoy "full-sweep" tuning... in an entirely new concept of dial design. The big handsome indicator sweeps full across the face of the set. Easy to tune, easy to listen to. Five-inch speaker. Walnut or ivory.



**Jewel Model 5010—3-Way Portable**  
Ready-for-action portable... room size volume! No warm-up delay. Just switch on to play... for AC, DC or battery. Black simulated morocco; maroon alligator; or 2-tone light tan and brown covering.

# Radio & Television JOURNAL

## merchandising memo

for  
Spring  
Sales

**By Nat Boolhack, Editor**  
**Radio & Television Journal**

### The Task Each Day

"When I was a small boy in Denmark, studying geography, I was astounded one day to learn that there is enough water on earth to cover the whole sphere with water two miles deep. That thought must have been as frightening to me as I imagine the atom bomb must be to today's young people. But as I grew older, I realized I didn't have to worry and I began to have faith that the world and man could survive anything. Our task each day is to do the best we can where we are and let the earth take care of itself." (Quoted from Jean Hersholt, movie star.)

### Art of Listening

A successful dealer once told me: "I'm never too busy to listen to a customer. What he wants to say is just as important to him as the salesman's words are to the salesman." How often do so-called salesmen make the mistake of doing all the talking, never giving the customer an opportunity to say what he wants, what he would like, what his problems are as concerns the particular item he plans to buy. The art of listening is a gentle one and usually requires patience and experience. But being a good listener as well as a good talker not only creates friendship. It also creates customers.

### Stock

Select your stocks and other investments as a wise man selects his new friends: make sure they are associated with reputable companies. That is why name brand merchandise can help so greatly to build a dealer's reputation in a community. One of the largest stores in the world, Gimbel's, has built its renown on name brand merchandise. It is the name brands which made radio and television and it is the name brands which will continue to advance this industry and the dealers along with it.

### Loyalty

A retail business is composed of many things, and not the least among these are the faith of its public and the loyalty of its employees. Any dealer who has earned these two essentials is well on the road to progress and success in the conduct of his business. Loyalty of customers can only be obtained by fair dealing and honest service. But employee loyalty is more complex. It is compounded from intelligent management, adequate compensation and progressive promotion. It may be likened to a "happy ship" — which can only result from having a good captain.

It is not your merchandise or your service that is your fortune in business, but your customer.

Enthusiasm builds its own technique. In fact, enthusiasm, whether in life or in business, is a mighty technique in itself.

## Housing Boom

The home building boom, which started in earnest in 1948, and produced more houses in the next three years than during any previous period in our history, shows no sign of letting down in 1952, despite government restrictions on various materials. In fact, the NPA has just promised builders that they will loosen up on

supplies, thus assuring continued peak construction which is necessary to meet the demands of growing population, high marriage rate and increasing standards of living. Are you keeping informed of all new homes being built in your area? They're prime prospects for everything you sell.

## Living Standards

Speaking of standards of living, folks today accept as routine those products which before the war were reserved for the wealthy. The personal radio in every room, the dishwasher, two television sets in the home, these are not felt to be out of the scheme of things for the average family. And this is all to the good. America was built by looking ahead . . . never being satisfied with what it had. Are you satisfied with last year's sales quota?

## Positive People

We all like to be with people who make us feel good. Instinctively we turn away from those who are always trying to hand us a "crying towel." Those who tell us about their business troubles, their illnesses, their disappointments, are people to avoid. They lower our vitality. But the cheerful, the positive, the creative people—they cause our spirits to soar. They lift us onto a higher plane, and we are thankful to them.—Thomas Dreier

## Frozen Out?

Is your city without television? Have your assets practically frozen to death while waiting for the F.C.C. to unlock the 'freeze' which has prevented you from jumping on the TV bandwagon? Well cheer up, because the freeze is starting to thaw at last. (See page 94 in this issue). More than 100 new permits for TV stations will be granted this year; a total of 340 by 1953. What planning are you doing to welcome television to your city? It may come much sooner than you expect because many existing buildings can be converted and the transmitting equipment is ready to be shipped to at least 21 new stations.

## Spring

The annual miracle has happened once again: Spring has come and the buds are bustin' out all over. Have you given your store and window display a Spring cleaning. How about offering your customers a free garden tool with each new labor-saving appliance they purchase. The gimmick? Why, the customer will now be able to spend lots more time in the garden because housework will be a 'breeze'. And right along with this, sell a new television set, because they'll have a great deal more leisure to enjoy.

## Price

"But we hadn't planned to spend \$399 on a television set," says the customer.

"That sounds like a lot, I know," says the smart salesman, "but look at it this way: This is a well-built, beautifully-designed television receiver. You'll be proud to have it in your home and it will give you many years of good service. Your friends will admire you and wish they had one. Now, on our special, easy payment plan, etc., etc."

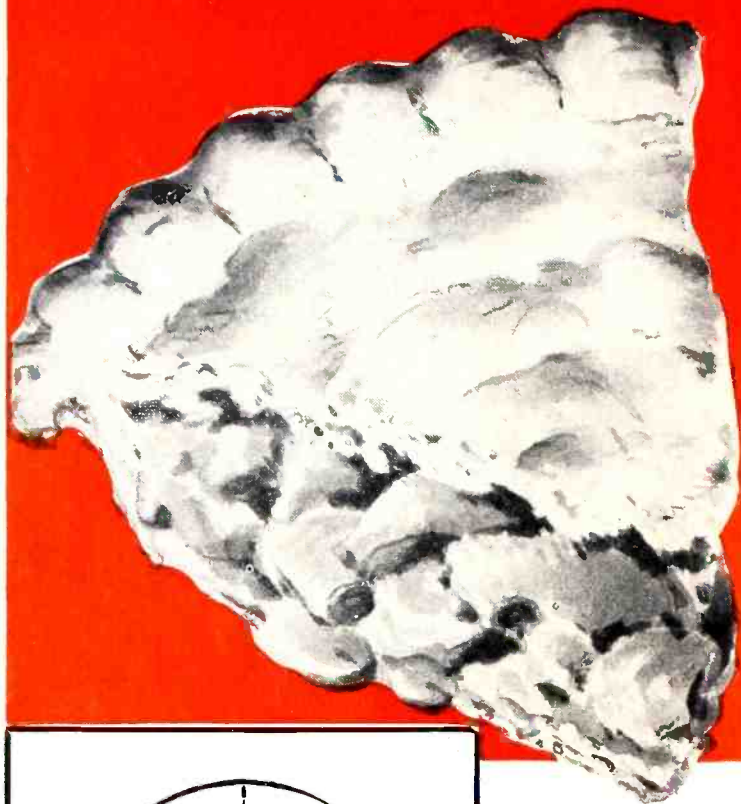

# Pie for

● With a "Prepared" Market of 12,800,000 Emerson Owners

"Emersonized" millions in local and fringe areas — PLUS substantial response from the overall market.

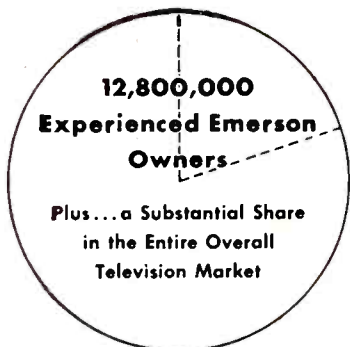

## Emerson Dealers' Share of the Television and Radio "Pie"

Yes, 12,800,000 "conditioned" prospects. SATISFIED Emerson owners. All over America—in local and fringe areas. They will favor Emerson Television and Radio on the basis of past experience.

Why are we so sure? Because of dealer reports—because we've checked thousands of their television purchases against former radio buying.

This is the *distinguished* market—PLUS millions in the overall market—enthusiastically receptive to YOUR tie-up with Emerson's greatest promotion program.



Nothing — No, Nothing — Equals Performance of the New

# Emerson

## Emerson "700" Series

With 17-inch and 20-inch consoles and table models—with Super-Powered Long-Distance Circuits, specially engineered for fringe and high-signal area reception—with built-in *Super Fringe Compensator*—with removable front bezel for cleaning—with handsome cabinetry—here are ALL the advance features and performance superiority you need for immediate acceptance and profitable retail operation.



EMERSON 17-INCH CONSOLE MODEL 714

EMERSON RADIO AND PHONOGRAPH CORPORATION • NEW YORK, N. Y.

# You in 52!

With "U. S. T." Proved Products  
and a Mighty Promotion  
Campaign

Unbeatable combination of local and  
national PROFIT-MAKING sales cooperation for  
ALL dealers.

the Local and Fringe Area  
1952 Area Engineered

# Television

## Emerson Area ENGINEERING

Has brought 7,000,000  
EXTRA customers  
within viewing and  
BUYING range

Emerson engineers thoroughly check performance in each viewing area—taking every special field condition into consideration.

Every Emerson television set—with built-in *Fringe Area Compensator*—is individually adjusted for absolutely best reception in each viewing area.

Emerson Area Engineering and Emerson Super-Power have enormously widened the scope of television performance and sale.

FIELD TESTS OF 5 LEADING TELEVISION BRANDS					
Performance tested 100 miles from nearest Television stations. (3 stations tested.) Conducted by impartial, independent U. S. TESTING COMPANY engineers.					
	EMERSON	SET B	SET C	SET D	SET E
Contrast	Very Good	Good	Fair-Good	Fair-Good	Good
Detail	Very Good	Good	Fair	Good	Fair
Focus	Very Good	Very Good	Very Good	Very Good	Very Good
Smear	None	Present	Present	None	Present
Brightness	Adequate Plus Reserve	Adequate	Adequate	Adequate	Adequate
Picture Interference	Low	Medium-Low	Medium	Medium	Medium-Low
Sound Volume	Adequate Plus Reserve	Adequate Plus Reserve	Adequate	Adequate	Adequate Plus Reserve
Tone	Very Good	Very Good	Very Good	Muffled	Very Good

U. S. Testing Company Test E-4212, Report dated Feb. 1, 1952

## Proof Positive!

In Independent Tests by  
U. S. TESTING COMPANY

The chart tells the story. Here, in actual comparative tests of 5 leading makes, conducted by independent, impartial engineers—100 miles from point of broadcast—100% proof of Emerson's superior reception in ALL localities, including fringe areas. Similar tests were conducted in city center locations with same proved results.

### EMERSON MODEL 706

New style and performance sensation. Big "Small Radio" value. Only 6½" high. In wide range of colors. One of many new developments coming your way.

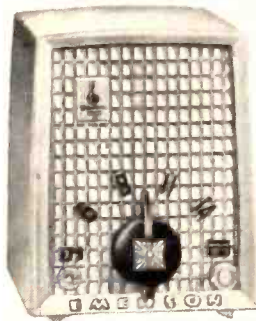

**Emerson Radio**  
FOR EVERY PURPOSE—EVERY PURSE

EMERSON RADIO AND PHONOGRAPH CORPORATION • NEW YORK, N. Y.

# New Transistor May Revolutionize Radio-TV Design

**It's no larger than a pencil point and yet can perform many of the functions of a vacuum tube. The long awaited wrist watch radio is now a definite possibility.**

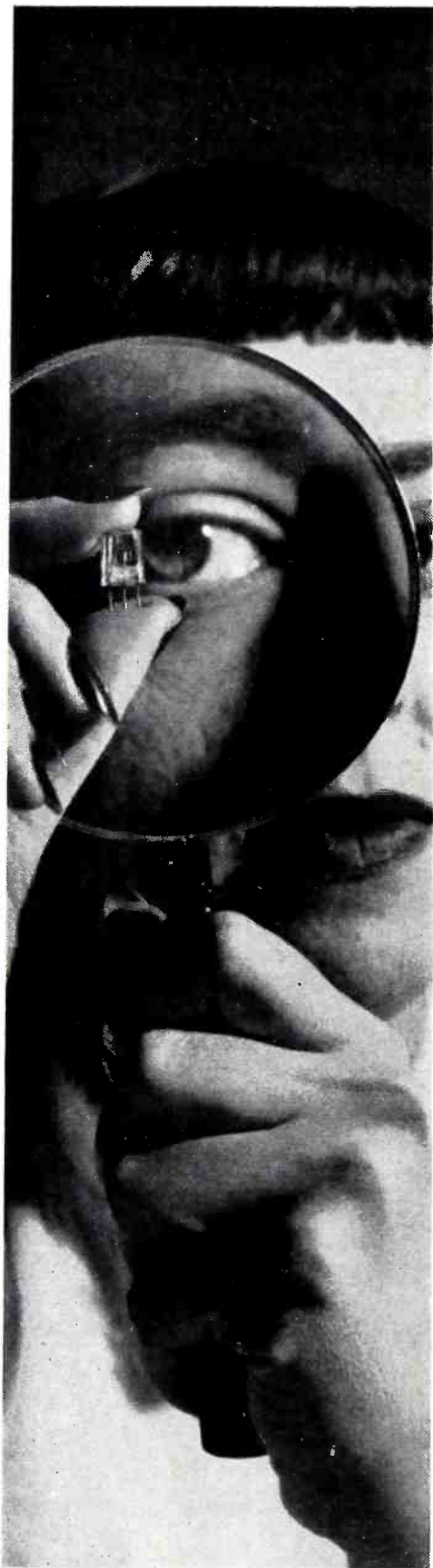

• The tiny transistor controls flow of electrons, does most of work of electron tube, and makes possible small-size, lower-power electronic products.

**A**N amazing new device, called a transistor, which is actually a tiny germanium amplifier which holds promise of revolutionizing the radio, television and electronics industry, has been developed and is ready for use in highly specialized capacities for the present.

The transistor, which was shown for the first time several weeks ago by the Radio Corporation of America, has working parts which are smaller than a pencil point in size and can perform many of the functions of a vacuum tube, and can also substitute for it in many applications.

According to Dr. E. W. Engstrom, vice-president in charge of RCA Laboratories Division, where the transistor was developed as part of a broad program of research and development initiated at RCA's David Sarnoff Research Center in Princeton, New Jersey, this tool will open vast new horizons in the electronics art, "just as the vacuum tube made possible the modern miracles of radio, television, and radar."

Among the devices which engineers predict will be possible with fully refined transistors are:

## ***Vest Pocket Radio***

A vest-pocket personal radio with many of the features of present table models. RCA engineers have already experimented with such a model. Built around transistors, the radio is about the size of a cigarette package. Although a finished commercial model is still in the future, and dependent on fully developed transistors, such a radio could run for many months on one set of batteries.

A battery-less, watch-size radio receiver, which may operate solely on the power furnished by the heat of the human body.

A radio receiver and transmitter, smaller than a telephone handset.

A compact, portable electronic computer which will be much simpler than the present electronic computers which often contain 4,000 electron

tubes. By using transistors, both the great bulk and heat generated by present-day computers should virtually disappear.

In both appearance and size the RCA point-transistor resembles a corn kernel, with three tiny wires, the terminals protruding from one end. Overall, the transistor measures  $6/10$ " by  $3/10$ " by  $2/10$ ".

## ***Semi-Conductor***

Some of the main advantages of transistors are: long life, small size, resistance to shock, low power requirements, and no "warm-up" period. When properly made and not abused, a transistor should almost never wear out. The basic difference between a transistor and an electron tube is that the transistor has no heated filament operating in a vacuum. In an electron tube this filament, when heated by electric power, "boils off" the needed electrons in the vacuum. In the transistor, the electrons are harnessed in a piece of solid matter and are controlled as they move about within this solid. At present, the solid material used is germanium, an element which physicists call a semi-conductor because it does not conduct electrical energy nearly as well as copper; but neither is it an insulator.

## ***Some Advantage***

A semi-conductor can be made to conduct current well in one direction, and poorly in the opposite, a phenomenon which does not occur in the metals normally used for conducting electricity.

"The transistor, first announced by Bell Telephone Laboratories in 1948, is a special form of device making use of the knowledge of electronically active solids," said Dr. Engstrom in demonstrating the device, adding. "out of all this theoretical, fundamental, and applied research, we are assembling a fund of know-how which will permit us to develop electronic devices which were undreamed of fifty years ago."



# VALUE LEADERS FROM

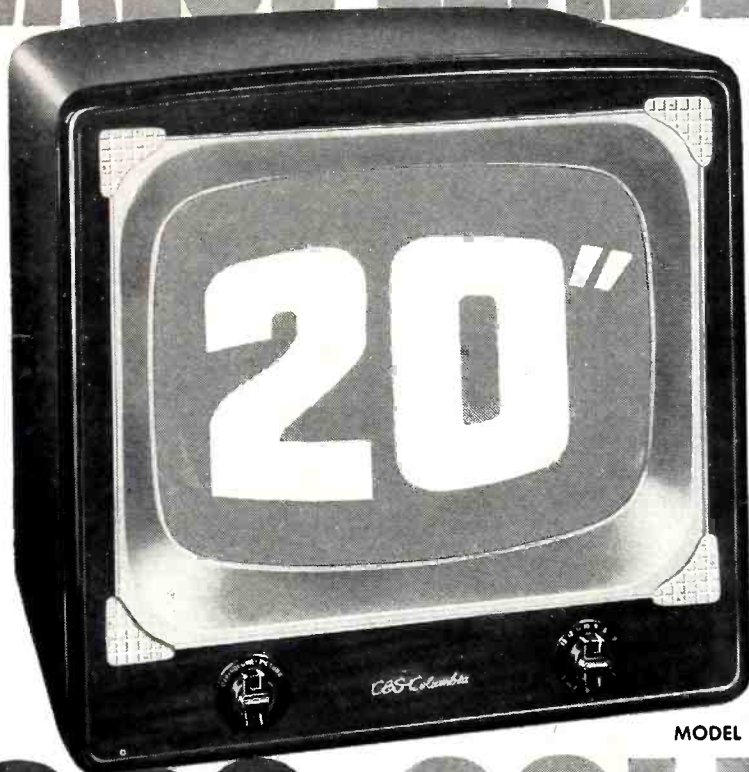

MODEL 20M1

## 2 Smart Table Models Priced and Styled for Action

Strikingly designed metal cabinets with simulated mahogany grain picture frames in both 17 and 20 inch screen sizes. Contrasting mask and matching mountings. CBS-Columbia engineered for dependable performance. Powerful! Compact! Lively traffic builders. Order now from your CBS-Columbia distributor.

**\$219<sup>95</sup>\***  
Plus F.E.T. and warranty.

\*Prices slightly higher South and West.

# CBS-COLUMBIA

MODEL 17M1

**CBS-COLUMBIA**  
THE MAGIC NAME IN  
TV MERCHANDISING

**HEARD** BY MILLIONS  
EVERY DAY

**SEEN** BY MILLIONS  
EVERY DAY

**KNOWN** BY MILLIONS  
EVERYWHERE

**\$179<sup>95</sup>\***  
Plus F.E.T. and warranty.

\*Prices slightly higher South and West.



*CBS-Columbia*

CBS-COLUMBIA INC.—A Subsidiary of COLUMBIA BROADCASTING SYSTEM

# FOR VOLUME SALES!

# New Products for Spring Business

*Radios*  
*Television*

*Consoles*  
*Recorders*

*Phonographs*  
*TV Accessories*

## Crosley's 17-inch TV

Mfd. by Crosley Division, Avco Mfg. Corp., Cincinnati, Ohio



Incorporating a 17-inch rectangular picture tube, this table model TV receiver features a safety plate glass window, slanted to cut glare, and removable for cleaning. Has "slide-rule" tuning dial, built-in dual dipole antenna, retrace line eliminator, and provision for UHF tuner. Cabinet is finished in mahogany.

## Crosley Table Radio

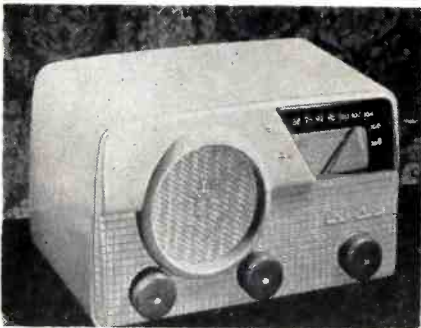

Four color choices are offered in this new AM-FM table radio. The set is housed in moulded phenolic cabinet and is available in blue, tan, green and maroon. Has built-in loop antenna for AM, and built-in power line antenna for FM. "Drift-free" tuning mechanism for maximum reception, AM and FM.

Say you saw it in *Radio & Television Journal*, March, 1952

## New RCA "45"

Mfd. by RCA Victor Division, RCA, Camden, N. J.



This latest "45" table phonograph features an 8-inch electro-dynamic speaker and a continuously variable tone control. Plays up to 14 records without changing. Instrument is housed in a maroon plastic cabinet with a grille front and a hinged lid. Special package, with record library, is offered to schools.

Say you saw it in *Radio & Television Journal*, March, 1952

## Garrard Record Player

Manufactured by Garrard Sales Corp., 164 Duane St., New York 11, N. Y.



With a four-pole, heavy-duty motor, a heavily weighted turntable for fly-wheel action, and parallel lift tone arm, this manual record player is designed for long-playing record needs. Has interchangeable plug-in heads, making it possible to use any cartridge, crystal or magnetic.

Say you saw it in *Radio & Television Journal*, March, 1952

## Arvin Portable Radio

Manufactured by Arvin Industries, Inc., Columbus, Indiana



The "Vacationer" is a three-way portable radio cased in polystyrene plastic with leatherette in its center section. Handle is plastic and metal, folding flat. Five tubes, plus selenium rectifier; built-in ferrite ceramic core antenna; Alnico V PM speaker. Operates on batteries or on AC/DC. Weighs less than 6½ pounds.

Say you saw it in *Radio & Television Journal*, March, 1952

## Westinghouse's "Westley"

Mfd. by Westinghouse Electric Corp., Home Radio Division, Sunbury, Pa.

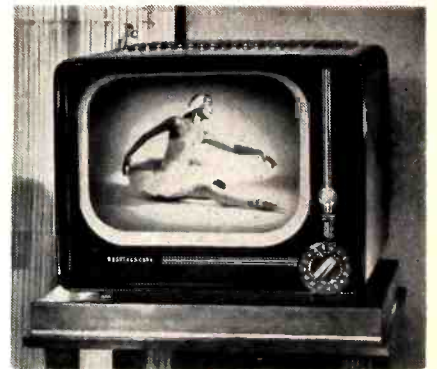

Sixteen-inch rectangular black glass picture tube is featured in this table model television receiver known as "The Westley." Set also features an electronic clarifier. Tuning is done with a single dial to one side of the set. Modern cabinet is of brown plastic.

Say you saw it in *Radio & Television Journal*, March, 1952

Exciting New View for '52!

**STROMBERG-CARLSON**

**PANORAMIC VISION\***



New cylindrical tube!  
More can watch



New automatic  
focusing



Curved  
safety-glass front!  
It's glare-proof



New customized  
Tru-Lok tuning



New VHF-UHF  
strip-type  
tuner



More power  
in fringe areas



The PANATOMIC

**BIG 21" TELEVISION!**



The PAN-AMERICAN. 21" console. 3/4-length, curved doors. Curved safety glass—removable for cleaning. Tru-Lok tuning. Phono jack. Ready for UHF. Hand-rubbed mahogany veneers. \$465†

Now see the television development of the year! It's PANORAMIC VISION—the new 21" cylindrical tube scientifically adapted by Stromberg-Carlson to give true wide-angle viewing, extra picture size without glare.

It's exclusive! It's different! It's something you can get prospects excited about!

Feature PANORAMIC VISION—another great product of Stromberg-Carlson engineering.

The PANATOMIC. (shown above) 21" table model. Curved, removable safety glass. Tru-Lok tuning. Phono jack. Ready for UHF. Compact cabinet... Pyro-Veneer with mahogany finish—19" deep, \$329.50†

†Zone 1. Includes excise tax. Installation, warranty—extra.

\*Patent applied for



The INVADER. 21" console. Curved, removable safety glass. Phono jack. Tru-Lok tuning. Ready for UHF. Compact cabinet—19" deep. Mahogany veneers, hand rubbed. \$395†

"There is nothing finer than a **STROMBERG-CARLSON**®"

Stromberg-Carlson Company, Rochester 3, N. Y. — in Canada, Stromberg-Carlson Co., Ltd., Toronto

# Charlie Schultz Se

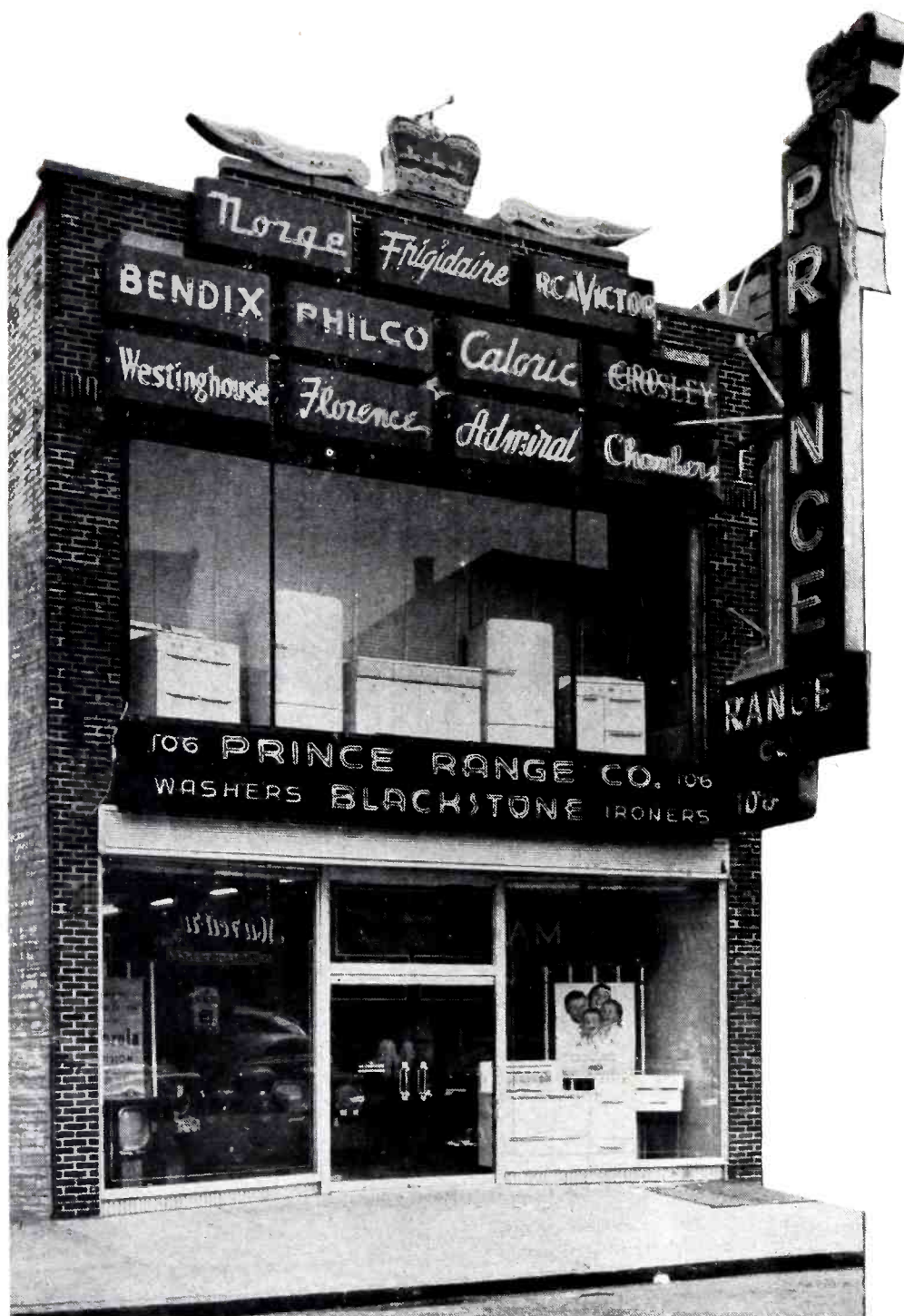

• Today the modernized home of Prince Range looks like this.

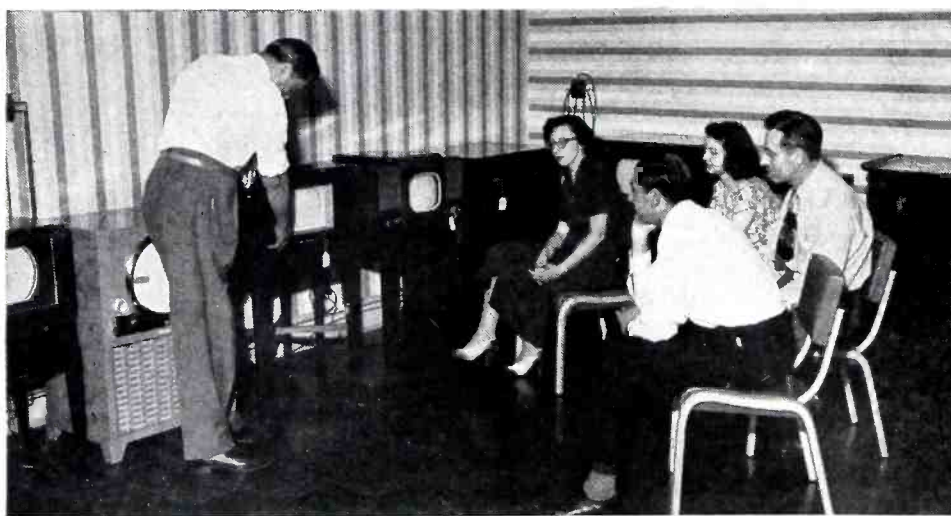

• Elaborate demonstrations are a key to the firm's aggressive selling.

**G**IVE them what they want," says Charlie Schultz. "Give them value, give them quality, give them standard brands, give them lower prices and give them service. Guarantee their satisfaction, and you can't miss." That's the sound advice passed out by Charlie Schultz, owner of Prince Range one of America's fastest growing, most aggressive retail TV and appliance operations.

Located in Newark, New Jersey, in what many dealers consider the most highly competitive market in the East, Prince Range operates at the same address where its founder, Hall Schultz, started as housewares dealer. Doing business at 106 Prince Street for many years prior to Charlie Schultz's entrance into the firm and before he took over the management reins, the Prince Range Company early developed its reputation for value and satisfaction.

From that foundation, Charlie Schultz has built a business in radio, major appliances and television that has made his store an acknowledged leader in its class in the state.

### A Plan

It all started with a plan, a long-range plan, that sought to extend the store's operation, its ideas and its services to every point of the compass in New Jersey. Knowing that his friends were his customers, and his customers automatically became his friends, Charlie Schultz wanted to spread the gospel far beyond the limits of the sales promotional and advertising media ordinarily available to a store located in what could not be considered a 100 per cent location.

As far back as the late Thirties, the management of the Prince Range Company, with Charlie Schultz at the helm, set its sights on becoming the most aggressive dealer in the East, and sought out ways to tell the people of the state of N. J. that the Prince Range store "gave value, gave service, gave quality, sold standard brands at lowest prices, and guaranteed satisfaction."

Since no one newspaper covered the entire area, Charlie Schultz decided that the best possible outlet for the Prince Range Company's advertising dollar was radio. Experimenting first with foreign language programs and

# "Give Them What They Want"

**This is the business philosophy followed by one of New Jersey's most aggressive dealers**

then entering the larger market with regular scheduled daily and weekly shows on New Jersey stations such as WAAT and WVNJ, the store steadily began its climb toward achieving its ambition. It used cooperative advertising wherever possible to augment the store's own expenditures, the company's budget for promotion and advertising rising steadily until it became the largest single store expenditure for such sales promotion in the State. As many as eight full 15-minute programs a day were being broadcast in season to sell refrigerators, washing machines, gas ranges, television and radios for "Newark's major store for major appliances."

## Enter TV

When WATV first began telecasting over Channel 13, Charlie Schultz was among the first to recognize the tremendous potential for sales on the new medium. The store took the plunge with the heaviest retail television advertising program in the Metropolitan market. Using as much as ten hours a week to tell its story, the Prince Range name quickly became a "buy-word" among wrestling fans, and Charlie Schultz became known as the "Prince Ranger" among western enthusiasts who flocked to see the western blood and thunder films he presented every night.

The success of this heavy and unprecedented promotion via the new medium was almost instantaneous. One TV manufacturer, new to the field and with practically no dealer distribution, enthusiastically cooperated with Prince Range in sharing the cost of some of the shows. Within a short period of weeks, dealers everywhere in the State began asking for the line. Another manufacturer of washing machines, pioneering with the Prince Range store in the new medium, has continued to cooperate in presenting the Prince Range story, and the story of its own products, throughout all the years to the present date.

Leaning heavily on cooperative advertising in presenting its story to the

public, the Prince Range Company qualifies its acceptance of such funds by agreeing to go along with makers of standard brands, refusing to have Prince Range associated in any medium of advertising with anything other than what the store could guarantee as "the finest possible merchandise at the lowest possible prices." As Charlie Schultz so aptly says, "If we're sold on the manufacturer, and the manufacturer is sold on us, we're both going to sell goods and plenty of 'em. When we take cooperative money from a distributor, we give that distributor a fair deal, we see that his merchandise is displayed properly and sold properly, that there is plenty of push behind the line and that the public gets its money's worth."

## Wide Markets

On his attempt to secure the State-wide market through radio and television expenditures, Charlie Schultz did not overlook the local Newark market. A heavy full-page advertising campaign, supplemented by strong cooperative advertising in the local Newark news-

papers, backed up the radio and television schedule. A consistent week-in and week-out program carried the Prince Range message to the local market.

From the outset, Schultz had the aid and guidance of one of Newark's leading advertising men, Bill Scheer, who directed his voluminous promotional efforts. It was Scheer who sized upon the forceful, dynamic personality of Charlie Schultz and created the phrase "Charlie Schultz sez." Schultz' photograph and his slogan became the central identifying theme for Prince Range. Film commercials were even developed stressing Charlie Schultz' personal interest in the good will of every customer who entered his store. Schultz was featured as he greeted customers and passed them on to his salesman. Newspaper ads carried the photograph of Charlie Schultz at their masthead. Radio programs carried the message, "Charlie Schultz sez you can save and save at the Prince Range store." Gradually the store took on a definite sales-minded personality of its own.

This concentration of sales promotional effort brought its natural results, expansion. The store, originally at 106 Prince Street, required more room for the additional lines the public began

*(Continued on Page 82)*



• Charlie Schultz regards every customer who steps into his store as "his customer." Above, left foreground, he is discussing product quality with a prospect.

# NEW.

# RCA VICTOR -



Brings exciting,

*Most complete line*

Twelve exciting Super Sets in all. And here are the new 21-inch Super Sets you asked for — the Selfridge, shown on console base, and the Meredith, a handsome open-face console. Both sets have built-in RCA Victor craftsmanship . . . tested and proven Picture Power. Television's greatest 21" line offers your customer the choice of the right model at the right price. Prove it yourself.

*The Selfridge Ensemble—Big 21-inch Super Set. Designed for customers who want "Something more" in table models. Comes in beautiful compact cabinet with matching console base. Walnut or mahogany finish. 21T159.*

These are the RCA Victor features that make RCA Victor Television easy to sell.

- |  |  |                                     |
|--|--|-------------------------------------|
| 3-Position "Personalized" Tone Control | New Intercarrier Sound System              | "Golden Throat" Tone System         |
| RCA Victor Phono-Jack and Switch       | An RCA Victor First! Double Shielded Tuner | Completely Shielded Chassis         |
| Functionally Grouped Front Controls    | 24-Tuned Sound Circuits                    | 40 Megacycle I-F Amplifier          |
| Illuminated Station Selector Dial      | 21-Tuned Picture Circuits                  | Maximum Desirable Band Width        |
| Improved Sound Gain                    | Improved Brightness Range                  | Nation-Wide Factory Service         |
| Optically Treated Kinescope Face       | Exclusive "Stay-Put" Doors                 | UHF Adaptability                    |
| New Type Pastel Kinescope Mask         | Rear View Cabinet Styling                  | Underwriters' Laboratories Approval |
| Protective Glass Front                 | Luxurious Cabinetry Design                 | Best "Fringe Area" Performance      |
| New Compensated Contrast Control       | New Automatic Gain Control (AGC)           | Best Metropolitan Performance       |

# NEW.



*The Meredith — Big 21-inch Super Set. This handsome, open-face console is a real sales-maker. Your choice of walnut or mahogany finish. 21T165.*



ONLY RCA VICTOR HAS  
THE "GOLDEN THROAT"

**RCA VICTOR** — World Leader in Radio . . . First in Recorded Music

# Leader in 21-inch Television

new models to Television's greatest line

*Quality performance*

*Easy to sell*

In the most difficult areas—deep in the city or far out in the country—you get the sharpest possible picture clarity—virtually interference-free. You can assure your customers that RCA Victor gives all they want in a television set. Here's quality performance that's customer-proof—a confidence-builder that will bring you more repeat business.

More television prospects are asking for RCA Victor sets than any other brand. Actually, RCA Victor has outsold all makes since television—and continues to do so. There are more sold because RCA Victor engineering know-how has made it the set that performs best in the home. Definitely, they're easy to sell and you can prove it yourself.

## NEW 17" Super Sets



▲  
The Calhoun—17-inch Super Set. Here is majestic Regency styling that has "sell" in every line—every feature. Comes in walnut or mahogany finish. 17T173.

▶  
The Crafton—17-inch Super Set. Perfect wedding of fine furniture and superlative performance. Open-face console. Mahogany, walnut or limed oak finish. 17T163.



▼  
The Colby—17-inch Super Set. The price leader in this exciting, new line. Metal cabinet in mo- roon finish with matching con- solette base (at slight extra cost). 17T150.



▲  
The Glenside Ensemble—17-inch Super Set. Here is the distinctive "look" in an eco- nomical set. Comes with matching con- solette base. Mahogany finish 17T151.



Two table models, an open-face console and a two-door console, add more variety to complete the RCA Victor 17" line. You can please more customers—make more sales. The same RCA Victor better-performance features that established 21" popularity are also built into these sets. For all-round performance . . . for superb cabinet design—they can't be beat. They, too, are easy to sell and you can prove it yourself.

### NEW "Victrola" 45 Table Model

Here's real-life, listening quality in a compact, smartly styled, table-model phonograph. 8-inch speaker. Blends with any décor. Maroon cabinet with golden trim, Model 45EY4.



**RCA VICTOR**  
DIVISION OF RADIO CORPORATION OF AMERICA



... First in Television.

"Victrola" T.M., Reg. U. S. Pat. Off.

### Stromberg-C's "Panatomic"

Manufactured by Stromberg-Carlson Co.,  
Rochester, N. Y.



Phono jack, PM speaker and tapered base are some of the features of this new television receiver. Utilizes a 21-inch picture tube. Safety glass is easily removable. New high-gain tuner is quickly adaptable for UHF. Cabinet is in Perma veneer mahogany finish.

Say you saw it in *Radio & Television Journal*, March, 1952

### Sylvania's "Pierce"

Mfd. by Sylvania Radio & TV Division,  
254 Rano St., Buffalo, N. Y.



Incorporating a bookcase in its cabinet design, the "Pierce" offers a 20-inch black picture tube and the firm's super-power chassis. Has 19 receiving tubes, eight of them multi-purpose, four rectifiers, plus picture tube. Power outlet provides for UHF reception.

Say you saw it in *Radio & Television Journal*, March, 1952

### New Zenith Combo

Manufactured by Zenith Radio Corp.,  
6001 W. Dickens Ave., Chicago 39, Illinois



A 145-square-inch picture is provided by the 17-inch rectangular black picture tube of this TV-radio-phonograph combination. Has provision for UHF reception and for Phonovision, if and when approved. AM reception range from 540 through 1600 kcs. Has "Cobra-Matic" variable speed changer, which changes all size records automatically. Speaker is 7½-inch. Breakfront cabinet in mahogany veneers and selected hardwoods.

Say you saw it in *Radio & Television Journal*, March, 1952

### New S-W Clock Radio

Mfd. by Stewart-Warner Corp.,  
1826 Diversey Parkway, Chicago 14, Ill.



This new clock radio features an automatic volume control, beam power output, Alnico 5 PM speaker, and 'glow-lite' tuning indicator. Has rear socket for operation of any appliance. "Sleep switch" and "set alarm button" for automatic turn-off and turn-on of radio or appliance.

Say you saw it in *Radio & Television Journal*, March, 1952

### Electro-Voice's "Royal"

Manufactured by Electro-Voice,  
425 Carroll St., Buchanan, Mich.



A new folded corner horn enclosure designed for 15-inch coaxial speakers and for 800 cps separate two-way and three way speaker systems. Adaptable baffle board allows mountings without modification. Cabinet is in mahogany veneers. Front grille has brushed-brass antique finish.

Say you saw it in *Radio & Television Journal*, March, 1952

### New Philco TV

Manufactured by Philco Corp.,  
Tioga & C Streets, Philadelphia, Pa.



A new television console with a 21-inch "optic-engineered" picture tube. The set incorporates the "Colorado" tuner and balanced beam picture. Based on scientific optic principles, tube is designed optically to reject glare and reflections. Cabinet is of contemporary design, with top and sides of genuine striped mahogany veneers.

Say you saw it in *Radio & Television Journal*, March, 1952



# Best By Test in Fringe Areas~

THE ALL-NEW 1952

## Du Mont TELESETS\*

Here are the results of a mobile unit test made on Du Mont and four other leading competitive sets, using the same antenna.

This test shows that in fringe area operation Du Mont is far out in front in sensitivity, picture quality, brightness and sound, as well as in static and interference resistance.

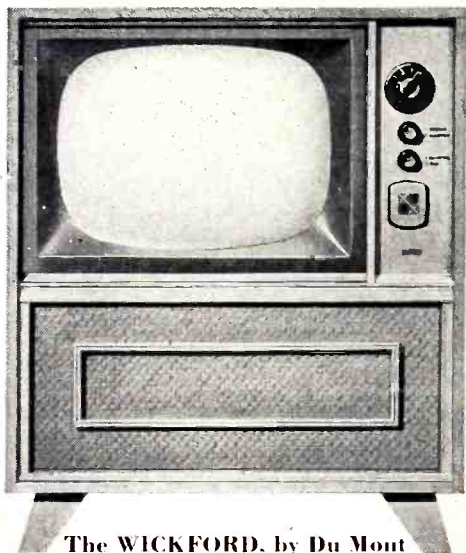

The WICKFORD, by Du Mont

One of a complete line of new Du Mont Telesets. Giant 21-inch rectangular tube. Plug-in for record player. In mahogany or lined oak veneers. List. \$399.95†; in lined oak, \$419.95†.

†Slightly higher in South and West.  
Warranty included. Fed. excise tax extra.

### TABLE OF COMPARISON Typical Fringe Area

	PICTURE QUALITY	SOUND	SENSITIVITY‡
Du Mont	High Definition	Good	Picture fairly usable through snow
Set A	Fair Definition	Fair	Picture unusable (heavy snow)
Set B	Fair Definition	Poor	Picture barely visible through snow
Set C	Smear	Weak	Picture barely visible through snow

‡75 miles from transmitter

Thanks to the new Du Mont Distan-Selector\* the new Du Monts perform as beautifully in normal as they do in fringe areas. Add the new Du Mont Selfocus\* Tube, giving automatic focusing. Add the new Du Mont Static Eraser\*, screening out static and interference. And you'll see why dealers from coast to coast are unanimous in their opinion that the new 1952 Du Mont Telesets are the most advanced television receivers ever built.

\*Trade Mark



LOOK INSIDE  
then compare!  
See Why  
Du Monts Do More

*Harvest of 21 years pioneering*  
by **DU MONT**  
First with the Finest in Television

For best results, while replacing a picture tube, be sure to make it a Du Mont Teletron\*



Allen B. Du Mont Laboratories, Inc. Television Receiver Division, East Paterson, New Jersey, and the Du Mont Television Network, 515 Madison Avenue, New York 22, New York

### Fada's "President"

Mfd. by Fada Radio & Electric Co., Inc.,  
525 Main St., Belleville, N. J.

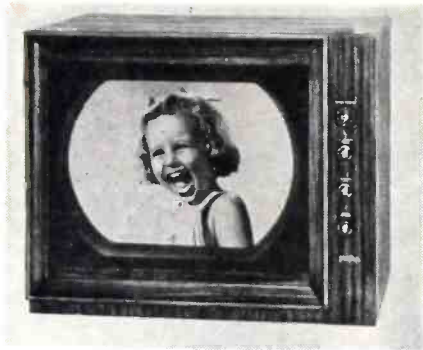

One of 11 new models now available from this firm, the "President" is a table type television receiver with a 24-inch picture tube. Provides "Power-Plus" control, which blocks fringe interference and noise, boosts signal for strong picture. Turret tuner has Cascode RF amplifier, and is adaptable for UHF by changing tuning strips.

Say you saw it in *Radio & Television Journal*, March, 1952

### New Magnavox TV

Manufactured by Magnavox Co.,  
Fort Wayne, Indiana



The "Deluxe Belvedere" is a television-radio-phonograph combination with a 20-inch picture tube. Has two speakers, a 15-inch bass and 5-inch treble. TV chassis employs 20 tubes, including two rectifiers and picture tube. AM-FM radio chassis incorporates 11 tubes, including one rectifier. Has three-speed record changer for automatic play.

Say you saw it in *Radio & Television Journal*, March, 1952

### New GE Table TV

Manufactured by General Electric Co.,  
Electronics Park, Syracuse, N. Y.



Featuring a 20-inch, black picture tube, this table model television receiver can be converted to a floor model by screwing legs into its base. Primary dual control knobs are visible, with bold character designations for easy reading, while secondary tuning controls are concealed behind hinged plastic escutcheon. Cabinet is mahogany veneer.

Say you saw it in *Radio & Television Journal*, March, 1952

### Sheraton's 24-inch TV

Manufactured by Sheraton Television Corp.,  
Penn Terminal Bldg., 370 7th Ave., N. Y.



Latest model in this firm's television line is this 24-inch open-faced console. In addition to the giant-screen, the set features a 30-tube #630 chassis. Has Cascode circuit tuner. Is available in hand-rubbed mahogany and in limed oak.

Say you saw it in *Radio & Television Journal*, March, 1952

### Zenith's Radio-Phono

Manufactured by Zenith Radio Corp.,  
6001 W. Dickens Ave., Chicago 39, Ill.

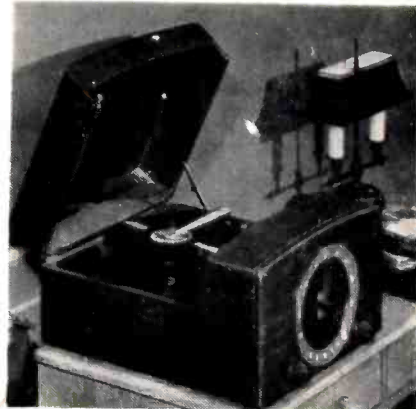

Radio in this radio-phonograph provides coverage from 540 through 1600 kcs. Combination uses 7½-inch Alnico speaker. "Wavemagnet" antenna is built in. Phonograph changes all size records automatically, plays all speeds from 10 to 85 rpm. Also permits manual operation of old-time records, recorded at different speeds. Styled in natural-grained mahogany color Pyroxylin.

Say you saw it in *Radio & Television Journal*, March, 1952

### Majestic Table TV

Mfd. by the Majestic Radio & Television  
Div. of the Wilcox-Gay Corp., Brooklyn, N.Y.



Cordovan mahogany provides a luggage finish case for this table model television receiver. Used in the set is a 17-inch 'sight-saver' rectangular picture tube. Features "Eagle Eye" tuning and built-in "channelized" antenna.

Say you saw it in *Radio & Television Journal*, March, 1952



**To the housetops comes a new world...**

*Illustration Courtesy of the Eastman Kodak Co.*

## **ANTENNAS, 1952...**

**A**UTHORITATIVE sources (Antenna Manufacturers Industry Advisory Committee) estimate that the 1952 demand for antennas will range between eight and 11 million. This figure includes the antenna replacements which will be needed for the four to five million television sets installed before 1950. The growing popularity of TV in the fringe areas, plus the prospect of the

lifting of the 'freeze' mean that the demand for antennas, boosters, towers and all kinds of installation accessories will be greater than ever in the months ahead.

Smart dealers know that the antenna can provide the link to profitable customer relations. On the pages which follow, we present a series of timely, informative articles which will help you skim the cream off the housetops.

# LOOK— NO NOISE!

Boosts the signal . . .  
not local lead-in noise!

Eliminates effect of  
external interference!

Gives higher signal-to-  
overall-noise ratio!

Tunes itself automatically  
on all channels.

Lowest internal noise  
factor—means less "snow."

Exclusive all-electronic  
4-tube broadband circuit.

Uniformly high usable gain—  
no limiting peaks.

Single twin-lead line\* carries  
power up—signal down.

MOUNTS AT ANTENNA WHERE A BOOSTER BELONGS

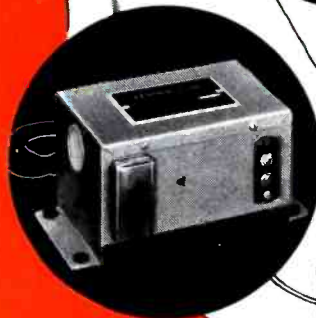

Junction Box  
Concealed Behind  
TV Set

AUTOMATIC SELF-TUNING

## Tenna-Top TV BOOSTER



### PICTURES ARE SHARPER, BRIGHTER! SOUND IS CLEARER!

You can see and hear the difference when you hook up the TENNA-TOP. Because it is mounted at the antenna ahead of the lead-in...it amplifies only the wanted TV signals, not any local noise interference produced by automobile ignition systems, neon signs, diathermy, or other external noise picked up by the lead-in. You have the further advantage of E-Y low-noise circuit. All this guarantees the best possible results with any TV set anywhere...even in toughest fringe areas or in all noisy locations. The TENNA-TOP is completely automatic. Turns "On" or "Off" with the TV receiver switch. It is easy to install, highly stable, trouble-free.

Model 3010 Tenna-Top TV Booster. List Price . . . \$88.00

Send today for Bulletin No. 163



**EY**  
**Tune-O-Matic**  
**TV BOOSTER**

First with completely automatic self-tuning. Turned "On-Off" by TV receiver switch. Instantly boosts signal on any channel selected on TV set. Uniform high gain—low noise circuit assures better pictures and sound. Easily concealed in, or behind TV set or elsewhere. All-electronic. Insures long-life service. Proved in thousands of installations.

Model 3000. Super Tune-O-Matic. 4-stage. List \$57.50  
Model 3002. Tune-O-Matic. 2-stage. List \$39.50

# Electro-Voice

428 CARROLL STREET • BUCHANAN, MICHIGAN  
Export: 13 E. 40th St., New York 16, U.S.A. Cables: Arlab  
TV BOOSTERS • MICROPHONES • HI-FI SPEAKERS • PHONO-PICKUPS

\*Patent Pending

# To Every Dealer Who Asks:



By *Walter L. Schott,*  
President, *Walter L. Schott Co.*

## Where's My Profit on TV Antennas?

**T**IME has come for dealers and installers to "take inventory" on profits. There seems to be a chronic disease spreading through the television industry that threatens to upset the profit structure of those who buy and install TV antennas. Yet, these are some who allow themselves to be lured into the false belief that they can save money by passing off to the consumer an inferior, off-brand antenna that may cost them a dollar less. This is the surest form of suicide for the installer. And the sooner they come to realize this fact, the sooner they can hope to establish a stable, secure margin of profit.

The past year has conclusively proven, beyond a shadow of a doubt, that there is no such thing as a "cheap" antenna. It's either a *good* antenna . . . or it's costly. What some installers fail to realize is that each *service call* to repair or replace the inferior antenna quickly eats up their profit. The original "saving," or what they *thought* was a saving, soon becomes a complete loss. Because many times

the installer finds it necessary to spend five times the original cost of the "cheap" antenna to make the necessary adjustments. And, of course, there is always the loss of customer good will.

The cost of the antenna represents only a small fraction of the total cost of the installation. Yet a call-back to repair or replace the faulty antenna can mean the complete loss of a dealer's profit. The difference in original cost between a quality antenna and a "bargain" imitation is usually only \$1.00 or \$1.50. But those who have been willing to gamble on a cheaper product soon discover that during the course of a year they were forced to replace about one out of every five of the bargain antennas. For example, a dealer in Chicago recently reported that in less than a year he had "managed to save \$2,000 by installing cheaper antennas." However, he quickly apologized by admitting that he has since *discontinued* this practice because the call-backs during the year had cost him "a little over \$5,000 in servicemen's time and for replacements."

It just doesn't pay. Obviously, the cost of the serviceman's *time* in making these frequent replacements eliminates the installer's profit. *Time* is a big factor in TV antenna installation's. Hence, the sooner dealers begin to measure their profits in terms of *time*, the sooner they can expect a reasonable, secure profit margin on all antenna installations. Those of us who have grown up with the industry know that the only *lasting* profit comes from giving your customers quality they can trust. Inferior, off-brand antennas give you no such assurance, and are therefore a hazard to the man who is working to build a reputable service business.

This past season of severe weather in practically every section of the country should have clearly demonstrated to every dealer, jobber, serviceman and technician that it pays to install a *quality* antenna, backed by a reliable manufacturer. This is the surest way for an installer to eliminate that costly question, "Where's My Profit?"

# A-B-C's of TV Ant

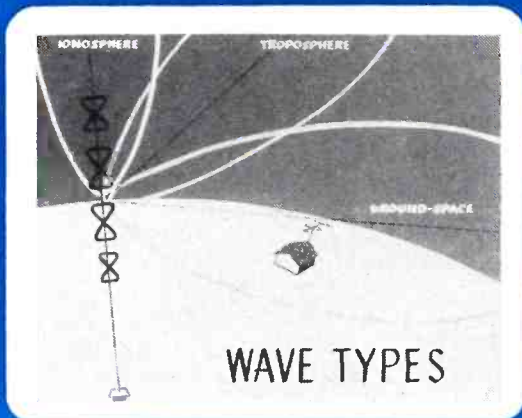

WAVE TYPES

1. Here we see the lobes that contain the three general wave types: Ionosphere, Troposphere, and Ground. Most of the transmitted signal is concentrated within the Ground lobe area because its low angle serves best the normal and reliable transmission zone.

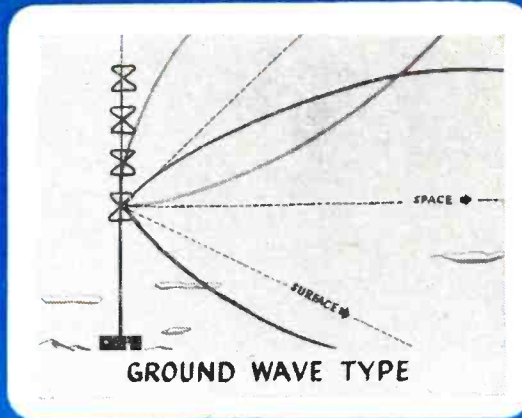

GROUND WAVE TYPE

2. Ground waves consist of two parts: the surface wave and the space wave. Surface waves hug the earth and are quickly absorbed within a short distance from the transmitter. But the space wave provides most of our television reception.

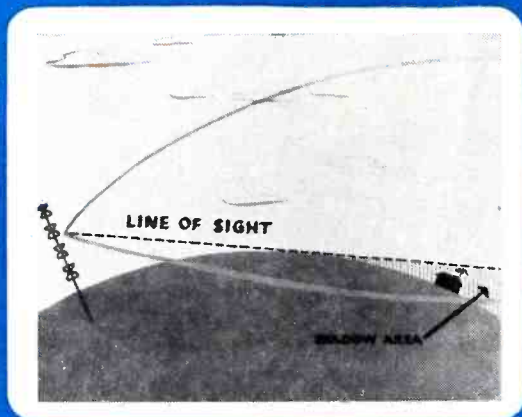

3. Although we think of the television signal following a "line of sight" path which does not follow the earth's curvature, this very fact creates a "no signal" or "shadow" area in those locations below this line of sight. However, Diffraction may bend the wave slightly in mountainous terrain.

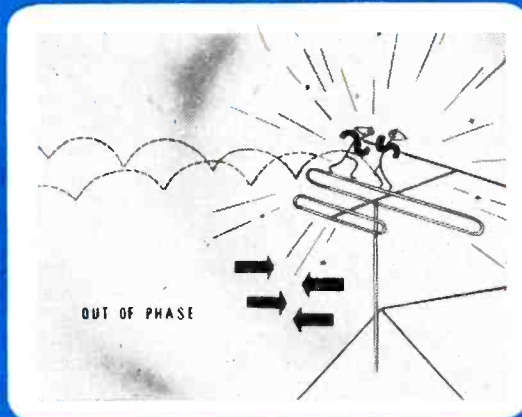

6. The Space wave's two components, the Direct and Ground Reflected waves, act just like brothers. But, beware of those locations where the brothers decide to fight it out and are out of phase. Then, they cancel each other out and your reception may be only half as good as your neighbor's.

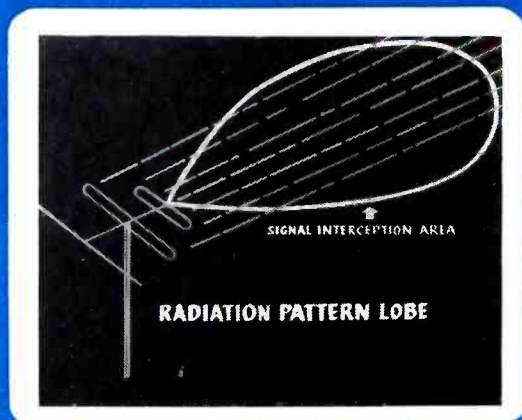

RADIATION PATTERN LOBE

9. The Radiation Patterns of a TV antenna represent the lobe areas in which TV signals, or interferences, if present, are intercepted. The volume and placement of these lobes can vary with frequency. They contribute to the signal delivered to the set and also affect picture quality.

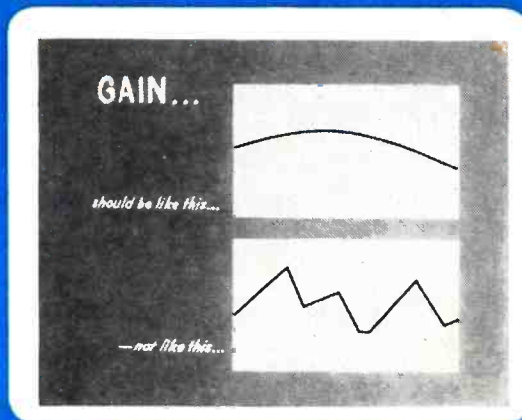

10. Therefore, the Gain of the antenna should be as "flat" across the desired frequencies as possible so that the picture quality is not affected.

# nas..... A Primer for Dealers and Salesmen

Illustrations Courtesy American Phenolic Corp., Chicago

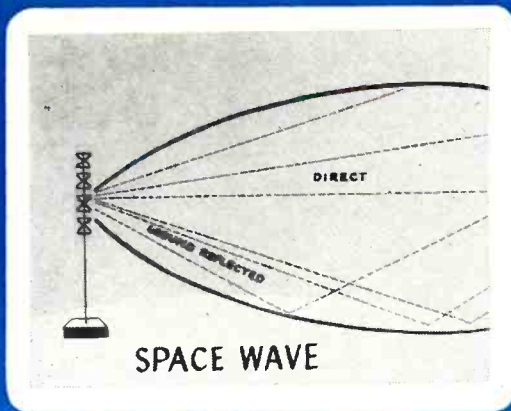

**3.** Space waves consist of two parts: the direct and the ground reflected components. The space wave, on its travels to the viewer's home can be affected by Reflection, Refraction, and Diffraction.

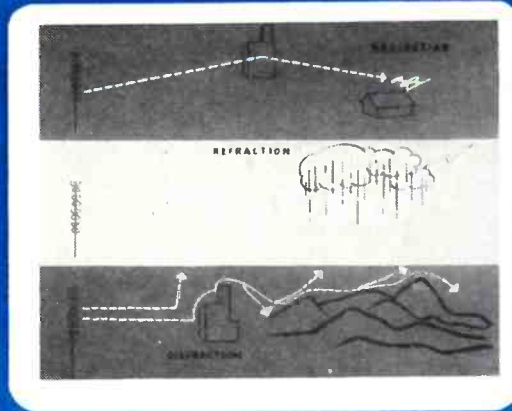

**4.** Reflection can cause the wave to bounce off structures or moving objects resulting in "Ghosts" or multiple images. Refraction is caused when the wave changes due to differences in temperature, moisture, or atmospheric density. Diffraction is caused when an object impedes the wave's forward progress.

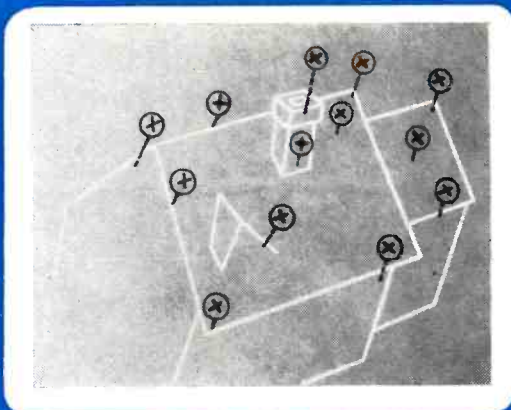

**7.** This brings up the importance of probing your customer's roof to determine the best TV reception. The difference of only a few feet, up, down, or sideways, in the location of the antenna can make a significant change in television reception.

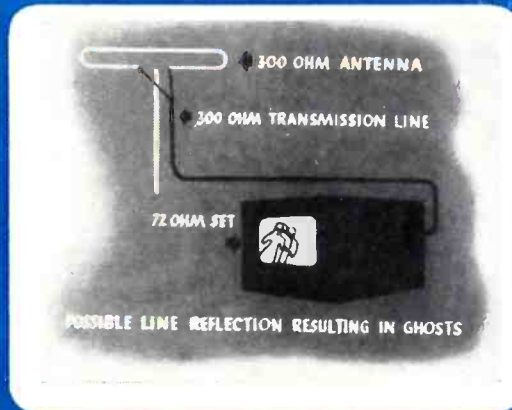

**8.** Now we come to the subject of Impedance, which is the ratio of the voltage to the current at the antenna's terminal. A possible line reflection condition and signal loss may occur if the Impedance of the antenna is not the same as the Impedance of the transmission line.

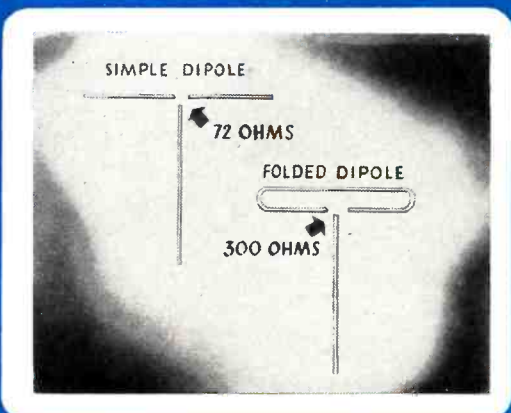

**11.** The Impedance of a simple Dipole at its designed frequency is 72 ohms and that of a folded Dipole, 300 ohms. Their jobs are bi-directional and at their widest point have a width of about 100 degrees. This width provides little directivity and no forward gain.

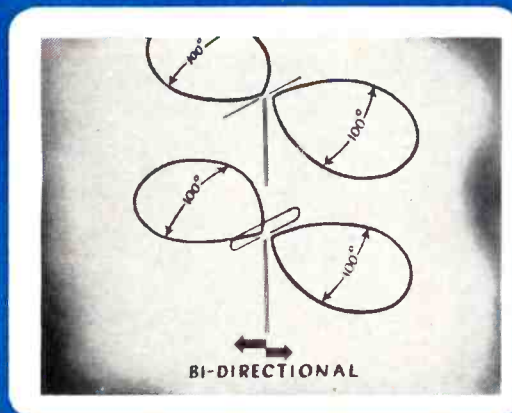

**12.** In addition to being bi-directional, we find their usefulness is usually associated with single channel reception. Its extremely wide lobes may not only intercept the signals, but also adjacent noise or reflected signals in the same fields.

(Continued on Pages 40-41)

# TV Service Problems Usually Start on the Roof

**S**ERVICE statistics have proved beyond question that a very high percentage of the troubles encountered by TV set users are on the roof rather than in the receiver. Once the servicing is made, the installation house takes the attitude that "this is for all time" and that any further trouble which develops must be with the receiver.

In making the installation, very few installation men protect the hardware

from rust and corrosion. As a result, as rust and corrosion set in, a high impedance circuit is formed at the takeoff points, which in turn causes the slow disintegration of the picture. A very common complaint by the TV set user is that "I'm now getting a ghost which I never had before."

## Checking

The serviceman will go up to the house, go on the roof, and rearrange

the antenna to no avail. He will report to the customer or his service manager that the set needs realignment, and the set will be pulled to the shop unnecessarily.

Actually, this ghost is caused by a standing wave due to the change in impedance of the antenna. After making a number of useless calls, the serviceman generally goes back to the roof, finds the hardware rusted, and proceeds to work for about half an hour to free the bolts. He cuts off a short piece of cable, retrims the wire, then reassembles the antenna with the rusted bolts, only temporarily improving the situation. Even a well protected antenna should be inspected at least once a year. Where rust is found to have formed, the hardware should be changed. Where the element has started to oxidize under the clamp, it should be sanded to provide a clean surface; then the antenna completely reassembled, and sprayed with any number of plastic sprays now on the market. Wall brackets and chimney mounts should be checked, and any defective hardware replaced. All stand-offs should be checked, and the lead-in hardware and wire pulled taut, as in longer runs the wire has a tendency to stretch. Flapping lead-in should always be avoided.

## Extending Life

Following this procedure will give the antenna another year of life. However, a TV antenna is not indestructible, and after being exposed to the elements for two years it is advisable that it be replaced.

This will not only provide the customer with far better pictures, but will provide the service and installation companies with an added source of revenue.

The complete overhaul of the antenna can be made for approximately \$5, and this, too, will provide the serviceman with an added source of income. A file can be kept on all installations, and as the year ends a mailing piece sent to the customer. This advises him that a TV set and antenna, like a human being, must be checked periodically to insure proper functioning, and that a \$5 investment today will prevent a \$30 investment tomorrow. The serviceman will, in addition to boosting his income, be establishing good will.

Every installation man should carry with him at the time of the initial installation, a can or bottle of plastic spray preparation to protect the terminals.

**MORE TV OUTLETS PER DOLLAR!**

## AMPLIFIED, ALL-CHANNEL MASTER ANTENNA SYSTEMS

FOR 2 TO 2000 TV SETS

**NO** Special connectors  
**NO** Matching transformers  
**NO** Engineers  
**NO** Individual channel equipment

**INSTALLED WITH THE TURN OF A SCREW**



**BLONDER-TONGUE** systems are based on the use of "no loss" Distribution Amplifiers which split the signal from the antenna into the desired number of outlets... all having the same signal level and picture quality as though each TV set used the antenna alone.

The B-T Automatic, All-Channel systems, using three basic units in any desired number and combination, can be easily installed by any TV service man.



**DISTRIBUTION AMPLIFIER, MODEL DA8-1-M**  
8 TV Outlets  
Amplified and Isolated  
List Price \$87.50



**Model #CA-1-M**  
Commercial Antensifier  
(30 Times Gain)  
Use As Pre-Amplifier, Line Amplifier or de-luxe Booster  
List Price \$77.50



**B-T HOME ANTENSIFIER MODEL HA-2-M**



**MODEL #DA2-1-M**  
Distribution Amplifier  
2 TV Set Outlets  
List Price \$39.50

Finest All-Channel TV Booster. Fully Automatic, 16 Times Gain. In Metal Cabinet. List Price \$57.50

**FREE INSTRUCTION BROCHURE ON MASTER ANTENNA SYSTEMS..Write Today. Dept. J-2**

## Blonder-Tongue Labs., Inc. Mt. Vernon, N. Y.



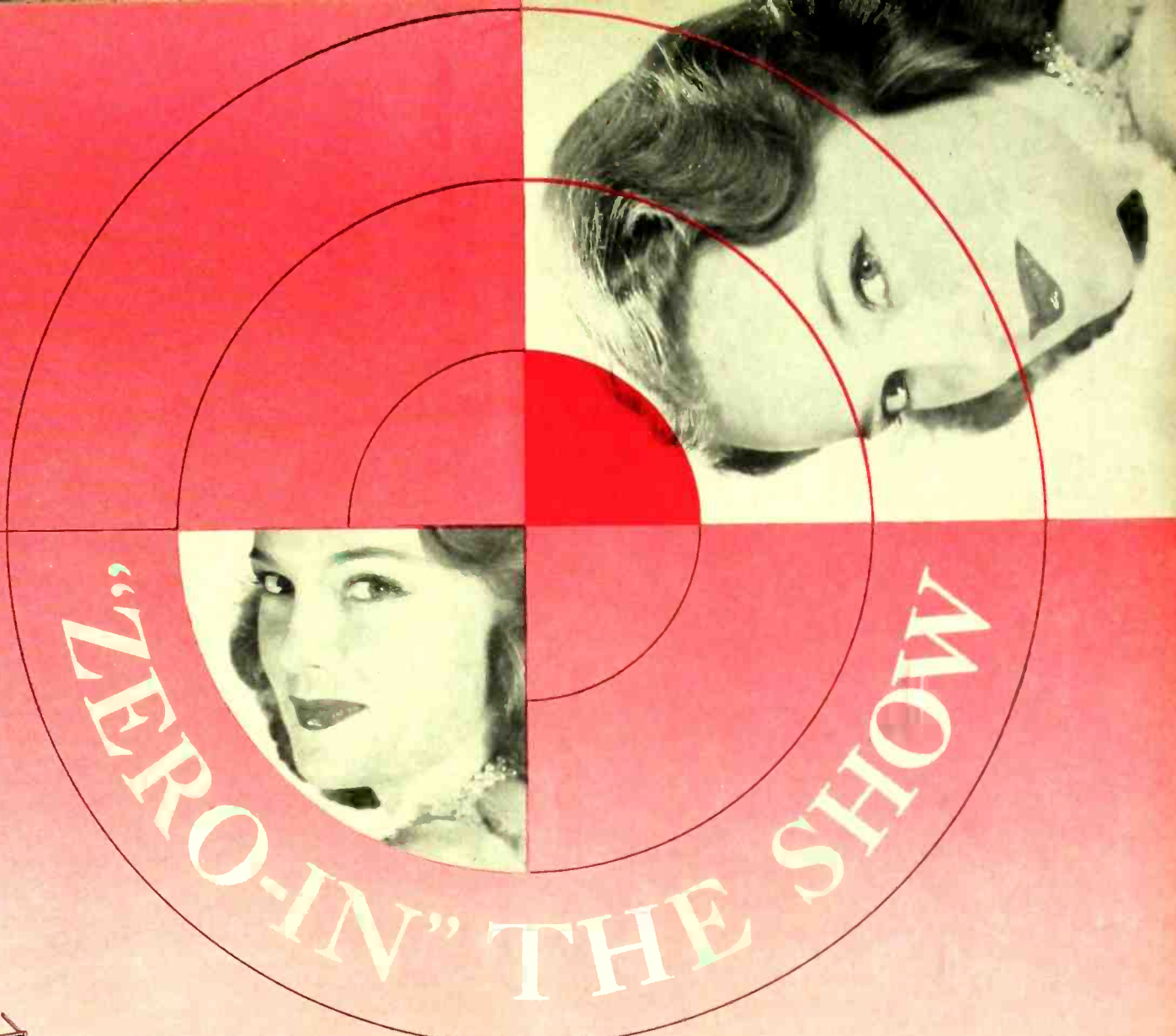

**"ZERO-IN" THE SHOW**

JFD "CORSAIR" PRE-ASSEMBLED

# Yagis

JFD all-aluminum "Corsair" Yagi antennas really "Zero-In" The Show, reaching far out on exact channel wavelength to bring in the strongest signal for the sharpest picture. They're completely preassembled, fast and easy to install—just swing the QUIK-RIG elements into position. Available in 3, 4 and 5-element single, and stacked arrays.

FOR FREE DATA SHEET #59, WRITE—JFD MFG. CO., BROOKLYN 4, N.Y.



WORLD'S LARGEST MANUFACTURER OF TV ANTENNAS AND ACCESSORIES

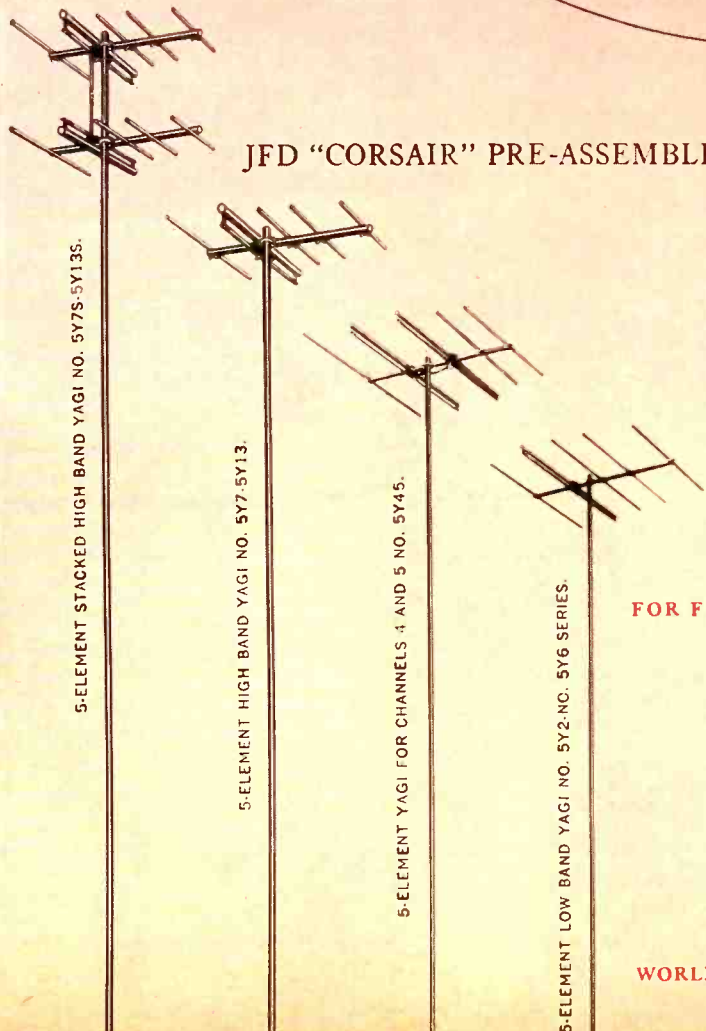

5-ELEMENT STACKED HIGH BAND YAGI NO. 5Y7S-5Y13S.

5-ELEMENT HIGH BAND YAGI NO. 5Y7-5Y13.

5-ELEMENT YAGI FOR CHANNELS 4 AND 5 NO. 5Y45.

5-ELEMENT LOW BAND YAGI NO. 5Y2-NC. 5Y6 SERIES.

# ***How to Make Money With Indoor Antennas***



**By Dan O'Connell,  
Sales Manager, Radion Corp.**

These are the days when one hears considerable conversation about the cream being skimmed off the bottle and that from now on dealers will really have to dig for sales. There is still one consolation in that there's a greater percentage of milk than cream in every bucket that comes out of the TV cow.

However, it is a fact that the days of taking orders are over and the days of selling are here. How to make money on indoor TV antennas? Ask yourself these questions:

- 1) Do you know your market?
- 2) Do you know your product?
- 3) Have you ever thought of merchandising your TV antenna? Have you actually laid a plan, taken advantage of every fact, and gone out to try and move antennas? Well, you'd better or you won't make the money you should.

Do you know your market? Remember, on a national average, 30% of initial installations are made with indoor antennas. Of these 20% remain indoor antenna installations and the remaining 15% switch to another type. These figures are the result of a spot survey conducted in the principal TV cities last year. One manufacturer alone has manufactured over 2½ million antennas. The industry has produced in the neighborhood of 15 million sets.

How does this apply to your own local market? You can safely figure that in a metropolitan area one out of five or six installations is made with an indoor antenna. The potential is obvious on first set sales, but there is a second-set installation and replacement sale potential.

## ***Initial Sale***

First, take initial set sales and indoor antennas. Since the picture is the

ultimate factor that determines whether an installation is a good one, there is little sense in one manufacturer advising indoor and another advising outdoor antennas. None of them do.

*The net is—know your product in relation to your market.* Whatever does the job, sells the set, and keeps the customer happy, puts the ducats in a bank account. Know each neighborhood market. Don't sell the indoor TV antenna short. Don't sell a Cadillac to the man who needs a Ford. Remember what was first regarded as an upstart now has long pants. With the passage of time, advent of increased station power, and improvement in sets it's a recognized, technically proven method of installation. So, where it does the job, don't sell the customer more than he needs. Sell him something else later on.

## ***How to Merchandise***

How to merchandise antennas. How to get the most out of them in return for your investment. It all adds up this way. Of all merchandising ideas, some are tried and true, work year after year. Some are new. All are the result of someone's thought. Think of antennas as something to be sold, and make money on them. Listed below are some methods of selling indoor antennas.

- 1) Sell indoor antennas with a set on low cost installation appeal. This is probably the oldest and most successful of all promotions. It's still good. Don't consider it old hat just because it's been tried before. Probably no other single factor has been responsible for the TV set sales in the country.
- 2) Save time with an indoor installation. Time is money. This too is common practice. You can make far more installations a day, get

more sets in operation in the customer's home, and return later on to make an outdoor installation if the customer needs one.

- 3) Save money on manpower. These days the time of technicians is valuable. Let your driver make an initial installation by himself. This too is proven evidence.
- 4) Here's a new twist to an old idea: Unload your trade-in sets with a package deal. If you've a small screen trade-in on hand, make your customer a deal, an indoor TV antenna plus a set.
- 5) Sell second TV sets with an indoor antenna: This is a natural that a lot of dealers are keeping in the bottom drawer. Many homes are divided homes these days. No cause for divorce, but with the variety of shows on the air, every member of the family has his own tastes in entertainment that he wants gratified. This is particularly a case in homes with children. The second set sale is usually a table model. In fact the portable set is on its way back up. Nothing is a better partner to the second set than the indoor antenna. It's portable, requires no rewiring of any present installation, and can be adjusted on the spot.
- 6) Sell a package clean-up deal. This is a new idea and particularly adaptable to summer months when business slacks off. For ten dollars or whatever price you want, offer your customer this deal. You take his set and clean it up. Clean the screen, seal it, get the dust off the chassis and give him a new indoor antenna. Somebody is bound to ask: Where do you get the leads for this sort of a deal? They won't fall into your lap. You have to

*(Continued on Page 46)*



**Radion**

**originated the indoor TV antenna**

**still makes the best**

**still sells the most**

**SPECIFY Radion... IT PAYS!**

The Radion Corporation—1130 W. Wisconsin Ave.—Chicago 14

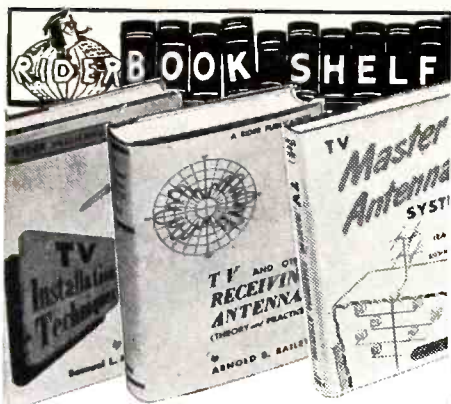

## THE ANTENNA TRIO

### 1. TV INSTALLATION TECHNIQUES, by Marshall.

A practical, timely "how-to-do-it" book written to help the TV installer make the best possible antenna installations. Contents, in 9 chapters: Nature of Television; Radio Propagation; Antennas; Transmission Lines and Special Antenna Systems; Materials and Methods Used in Installations; High Masts and Tower Installations; Problems Arising in Television Installations; Receiver Adjustment and Service in the Home; Municipal Regulations. 336 pages (5½ x 8½") 270 illustrations, cloth bound... \$3.60

### 2. TV AND OTHER RECEIVING ANTENNAS, by Bailey.

A comprehensive, up-to-date source book covering practically all types of VHF, UHF, parasitic and other directional antennas. Mathematics are replaced by charts and graphs. Contents, in 12 chapters: Review of Definitions and Terminology; The TV Signal and Its Bandwidth; Problems of TV Reception; The Electromagnetic Wave; The Radio Path; Theory of Signal Interception; The Center-Fed Zero-db Half-Wave Antenna; Comparison of Zero-db Half-Wave Antennas; Horizontally Polarized Antennas; Vertically Polarized and Special Types; Practical Aspects of TV Receiving Antennas. 606 pages (5½ x 8½") illustrated, cloth bound... \$6.00

### 3. TV MASTER, ANTENNA SYSTEMS, by Kamen and Dorf.

A practical, working manual that treats master antenna problems and solutions from beginning to end. Covers all popular distribution systems now in manufacture, with schematics, performance figures and design data. Contents, in 7 chapters: Basic TV Antenna Systems; The Need for Master Antenna Systems; Non-Amplified Systems; Amplified Systems; Installing Systems; Video Distribution Systems; Merchandising Master Antenna Systems; Appendix: A. Temporary Landlord Agreement; B. Sample Electrical Specifications; C. Survey Report, Landlord Agreement, Tenant Letter; D. Cautions. 356 pages (5½ x 8½") illustrated, cloth bound... \$5.00

Buy these books now at your jobbers... leading bookstores... or

MAIL THIS COUPON—TODAY

JOHN F. RIDER, Publisher, Inc.  
480 Canal Street, New York 13, N. Y.

Please send me book(s) circled. I understand, if not satisfied, I may return them within 10 days for full refund.

1      2      3

NAME \_\_\_\_\_

ADDRESS \_\_\_\_\_

CITY \_\_\_\_\_ ZONE \_\_\_\_\_ STATE \_\_\_\_\_

(Please Print) RTJ-3

Prices subject to change without notice.

## How to Make Money With Indoor Antennas

(Continued from Page 44)

dig for them. But here are some practical tips:

- a) Take a walk. It's good for your constitution, anyway. Walk up and down the streets of your neighborhood at night. Note the number of homes and apartments with indoor antennas. Get the names. Call them up or drop them a 2c post card. You'll be surprised at the response.
  - b) Check through your own past store sales. Give the customer a call. He may turn thumbs down on the deal, but in the process you may sell him something else. At the least, the customer is gratified that he's sufficiently important to you that you're concerned with his satisfaction.
- 7) Sell indoor TV antennas in the store: Indoor antennas are just the same as other things created. They wear out. They get broken. People are sufficiently used to TV now that they think they know something about it. One thing is certain. They know how to operate an indoor antenna. From here it's a step to buying their own. Like any piece of merchandise, to be sold it has to be displayed. Put one in your window. Put one on the counter. In other words, offer it for sale. And here let me chide you a bit. Don't put the cats and dogs out in public view. Put one out that doesn't have the lead-in coiled like a python around the dipoles. There's a terrific mark-up in indoor antennas. Your margin of profit in the item will more than repay you for the effort you put into sales.

There's plenty of money to be made in indoor antenna sales. Initial installations, second set sales, portable set sales, replacement sales (either house to house type or store) package deals, and so on. The cash is yours if:

- 1) You know your market . . . your own neighborhood or trading area.
- 2) You know your product. Its sales points, its appeals, its limitations. You can get all this from your distributors or from the manufacturers literature.
- 3) You merchandise indoor antennas. Recognize that it is an item that can sell sets and help your service department. Above all, it sells at a tremendous margin of profit. There's a lot of milk left in old bossy TV.

## STEEL TOWERS and MASTS Tubing - Roof Mounts - Guy Rings PRODUCTS for T-V and ELECTRONICS

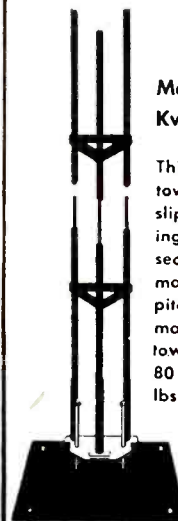

Model 100 —  
Kwick Climb Tower

This light weight tubular steel tower comes in 10' sections with slip joints that require no bolting. Safe and easy to climb. Top section has sleeves for up to 2¼" mast. Base adaptable to any pitch roof. Additional sections may be added to 100 feet. 30' tower complete with base weighs 80 lbs. Additional sections 22 lbs. each.

MODELS 130 and 140, 30 foot and 40 foot  
Manually Telescoping Masts. Priced for that  
inexpensive installation.



Model 115 —  
Krank Up Mast

27' telescoping crank up mast complete with all hardware. Cranks to any positive position from 10' to 27'. Made of sturdy 2", 1½" and 1¼" tubing. Easily installed.

Model 125 —  
Krank Up Mast

47' telescoping crank up mast complete with all hardware. Same as Model 115 in construction. Will telescope to any positive position from 20' to 47'. Weight 45 lbs.

A locking device on both of the above models removes all the strain from the cable.

Pat. Pending

### ROOF MOUNTS

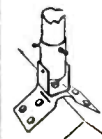

Model A-5 — Apex Roof Mount  
A sturdily constructed Roof Mount with 4-way swivel. Fully adaptable to any type of mounting. Will take up to 2¼ inch tubing.

ALSO

MODEL S, Rotary 4-way T-V mast base mount

MODEL P, 2-way swivel T-V mast base mount

RUGGEDLY CONSTRUCTED MOUNTS - LOW PRICED

QUALITY PRODUCTS SOLD THRU  
RECOGNIZED JOBBERS

JOBBERS and DISTRIBUTORS  
WRITE FOR PRICES AND LITERATURE

JONTZ MANUFACTURING CO.  
1101 E. MCKINLEY AVE.  
MISHAWAKA, INDIANA

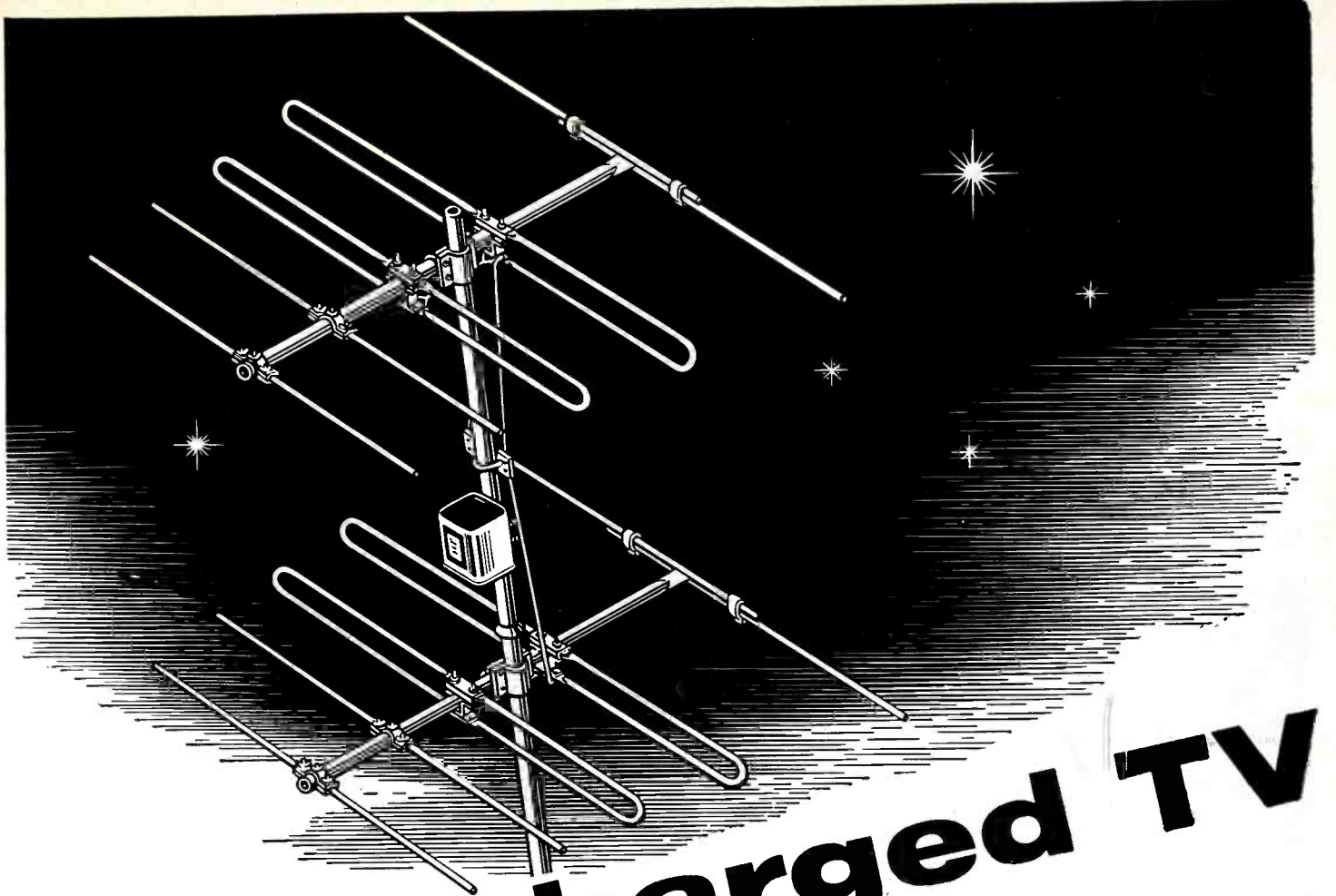

# supercharged TV

The Finest--

When Results Count!

Here is the unbeatable Taco team. Made up of the Super 980 Yagi and the Antenna Supercharger this combination offers you 25 db gain *plus* a clarity of signal unparalleled due to the sharp directivity of the antenna and the sharp tuning of the Supercharger.

*If it's results you're after -- try this combination!*

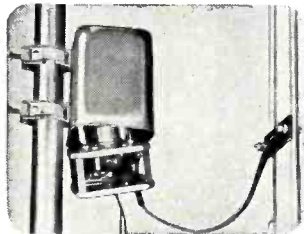

### Taco Antenna Supercharger

A power amplifier mounted up at the antenna. Provides powerful gain with maximum signal-to-noise ratio. Can be used with any good yagi-type antenna, but performs better with the . . .

### Taco Super 980 Yagi

Combines all the advantages of the 5-element design with the best features of the Twin-driven design. Tops in gain, directivity and mechanical dependability. (For high-band use Taco 5-element Yagi)

### Tacoplex

Distribution systems for apartments, hotels, schools, and community installations.

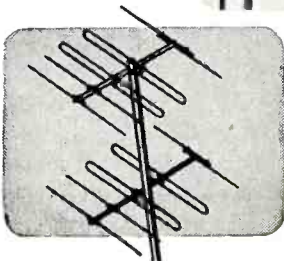

\*AVAILABLE AT YOUR TACO DISTRIBUTOR

## TACO

TECHNICAL APPLIANCE CORPORATION  
ONE TACO AVE., SHERBURNE, N.Y.

Tacoplex Master Antenna Systems, Taco Antennas, Taco  
Antenna Superchargers Taco Antenna Accessories.

In Canada: Stromberg-Carlson Co., Toronto 4, Ont.

# The Indoor Antenna Is Still a Powerful Sales Magnet

By Frank J. Klancnik,  
President, Hi-Lo TV Antenna Corp.

“ANYBODY knows that the indoor TV antenna stands on top of a television set.”

Such may be the glib remark of a local wit to the question, “Where does the indoor television antenna stand today?”

But dealers in the radio and television industry know another answer.

They know that the indoor television antenna has a specific place—a very important one—in their sales program.

The indoor TV antenna very early carved a niche for itself in the dealer’s merchandising operations. It became an accepted thing in early TV selling days for customers to buy at least an indoor antenna. When highly-satu-

rated metropolitan areas were stricken with outdoor antenna problems, the indoor TV antenna became the answer for viewer headaches. When landlords prohibited the installation of antennas on rooftops, set owners fell back on indoor antennas. They soon found the indoor antennas gave more than satisfactory performance. Over-strong signal areas, or locations where orientation to the originating signal was poor, also proved excellent testing grounds for the indoor TV antenna. Dealers found more and more customers purchasing an indoor antenna at the time they purchased the TV set.

## Cut Investment

For one thing, the purchase of an indoor antenna minimized the initial investment. Many times purchasers had carefully budgeted their accounts so as to provide for the advent of the TV set in the home. The same budgets could not stand the stiff strain of too many “extras.” The indoor antenna became the solution. In addition, the indoor antenna came to be regarded as a way of eliminating installation costs and an opportunity to have the set in operation in the shortest possible time. More than one set owner decided to replace an outdoor antenna with an indoor one. For them, it cut down the cost of service calls without causing any great reception problem. In such cases, reception from an indoor antenna had been proven more than adequate.

## Strong Seller

The satisfied customer has been one of the greatest assets to increased TV set sales. Indoor television antennas have enabled dealers to increase their list of satisfied customers, thereby adding to sales. As volume producers, indoor antennas have been able to “stand on their own legs.” In small town areas, with considerable fringe area to account for, indoor antenna sales have been unusually high per capita. Alert and aggressive dealers are cashing in on the indoor antenna’s ability to produce dollar volume. They are selling these antennas in quantity and at full list price.

In some areas, of course, the outdoor antenna is difficult to replace. It cannot and should not be replaced. But the indoor antennas are modern in design, and provide good reception at a low price. Evidence that indoor antennas can be sold in large quantities comes from a recent promotional effort by one of the largest department store chains in the country.

## Continuous Promotion

This particular store had a television program on the air one hour a day,  
(Continued on Page 49)

FOR  
perfection  
IN  
reception  
IN  
fringe areas  
INSTALL



**FINCO** 20 in 1

**T V A N T E N N A**

- Clear pictures up to 120 miles and more from station!
- 12 driven elements on high band!
- High gain—low noise!
- 8 driven elements on low band!
- One antenna—one transmission line!
- Total weight only 8 lbs.!



The new patented FINCO Model # 400 20-in-1 Co-Lateral Antenna is constructed on an entirely different principle than any other unit in the market today. Thousands of FINCO installations are giving TV owners perfect reception in fringe areas over 100 miles away from broadcasting stations. To provide complete TV satisfaction to customers in fringe areas, use FINCO every time!

**THE FINNEY COMPANY**  
4612 ST. CLAIR AVE. • CLEVELAND 3, OHIO

five days a week. On one 15-minute segment, indoor television antennas were advertised. The antennas were illustrated. They were only mentioned three times during the segment. As a result of this promotional effort, hundreds of indoor TV antennas were sold each week by the store.

An additional form of successful promotion of antennas was the consistent use of television spots, in specific, selected market areas. Like the promotional effort on the television program, this sort of spot television advertising had its effect. Dealers found that the demand for indoor television antennas increased, and that sales took a significant spurt.

In these instances, simple promotion and advertising quickly boosted the sale of indoor TV antennas. The same sales prospects are in store for those dealers who will concentrate on the promotion and sale of indoor antennas. Display them prominently in showrooms, prepare special demonstrations on operating TV sets, and above all sell them with vigor and aggressiveness.

The customer interest is there, whenever a dealer puts forth a sales effort. Indoor TV antennas are "standing," waiting for every dealer to get behind them, to sell the tremendous market that exists in every television area.

#### TV Interference

Television interference may be caused by any one or a group of factors. Knowing some of these causes can help salesmen and installation servicemen to handle irate customers more intelligently. Following is a list of these "TVI" causes:

1. Diathermy.
2. Receiver radiation.
3. Co-Channel interference.
4. Spark plug interference.
5. Airplane flutter.
6. Multiple images caused by reflections off buildings.
7. Germicidal lamps.
8. Oscillator radiation from FM and short wave receivers.
9. Image response of receivers.
10. FM broadcast transmitters.
11. Amateur TVI.
12. Sound bars from TV sound channel; faulty trap adjustment or tuning of TV set.

# Alprodco

## ALUMINUM TOWERS

TV • FM • AM

BROADCASTING  
AND  
RECEIVING

The Height of  
Perfection

### ALPRODCO AIRCRAFT ALUMINUM TOWERS

Lower Cost per Installation  
Easy to Install  
Light Weight  
Strong  
Long Lasting  
Attractive

Alprodco Towers are sold  
through local parts distributors.

Write for literature and  
full details.

ADDRESS DEPT. H

# Alprodco, Inc.

KEMPTON, INDIANA  
MINERAL WELLS, TEXAS  
DUBLIN, GEORGIA

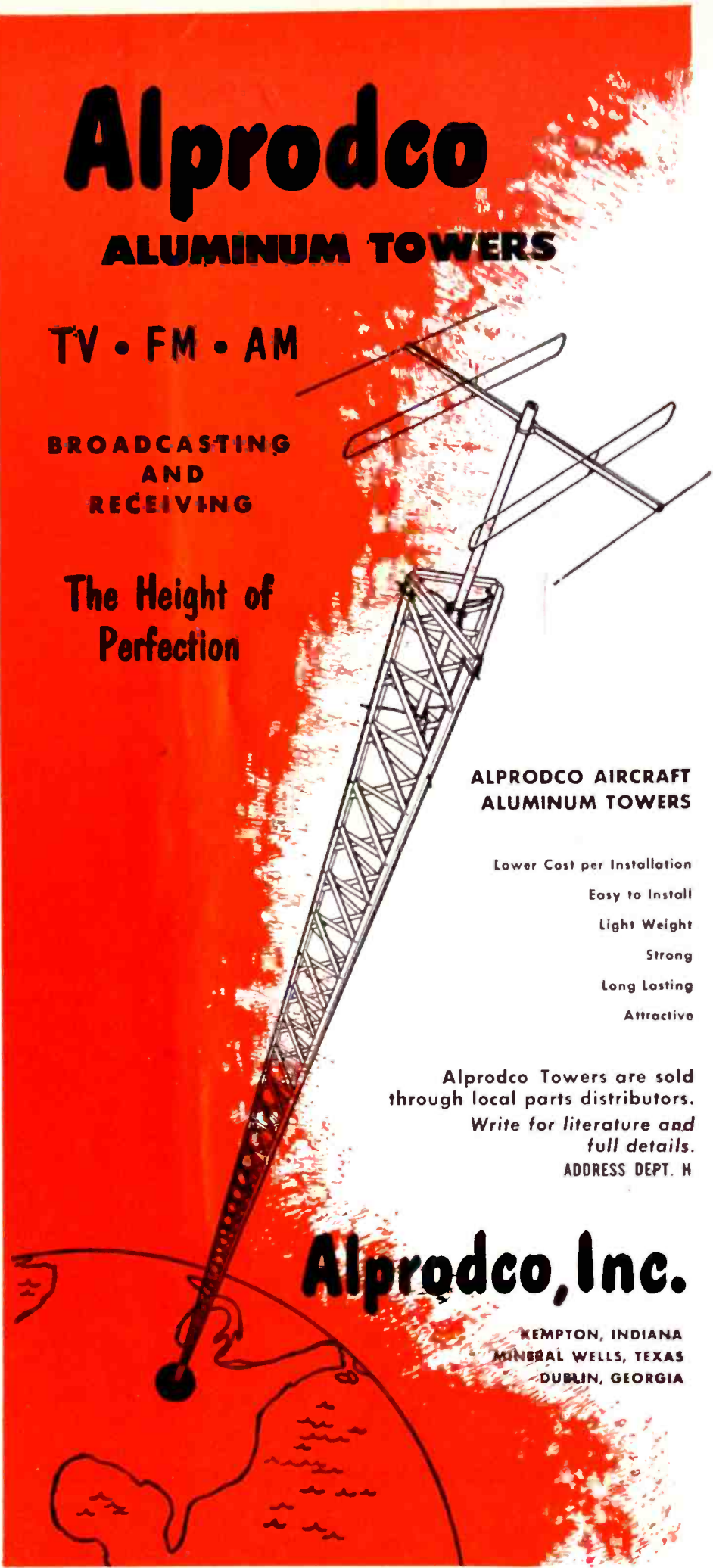

# Admiral

**New tuning control panel of Admiral  
Television Receiver with Radio**



**Admiral Makes Television  
History Again with  
Spectacular New Features  
Sensational Low Prices!**

Now . . . brand new for '52! Another spectacular "first" from Admiral . . . the leader in television. Think of it! Television with radio built-in . . . *both* together in compact table models or consoles no bigger than required for television alone . . . *both* for less than other nationally advertised sets with television alone!

And what a radio! It's not to be confused with an ordinary table model worth \$25 to \$30! Because here is a radio with full *console* power and tone, with unmatched selectivity and sensitivity achieved by utilizing the full power of Admiral's famous triple-X television chassis.

Compare its performance . . . compare its full rich tone with the most expensive console radio-phonograph built today. You be the judge!

More than ever before your customers will want a dependable radio handy to hear, as well as view on television, the history making events to be unfolded in this all important election year. Many outstanding programs will be aired exclusively on radio. With a new 1952 Admiral you can switch from television to radio in a flash.

## **New '52 Triple-X Chassis Revolutionizes Television Performance**

Brand new and better than ever in '52 is Admiral's famous triple-X chassis . . . most powerful in television . . . now copper-clad for lifetime dependability. Most TV sets will give you a reasonably good picture these days. The real test of outstanding performance, however, is how close you can sit to the picture screen. With an Admiral you can sit as far, or as close, as you please and enjoy the sharpest, clearest pictures in television. That's why any room that will take a 9x12 rug is more than ample even for sets with Admiral's biggest-of-all 21" picture tube!

## **Gets UHF! No Converter Needed!**

Hundreds of new UHF stations are promised for the coming months . . . several thousand will be

★ ★ ★ **Engineered to Outperform Any Set,**



**World's Largest Television Manufacturer  
Brings You Sensational News!**

# TV WITH RADIO at No Extra Cost!

on the air in the next year or two. You will be able to receive any and all of them with an Admiral . . . and *without* the use of an unsightly and costly outside or inside converter. That's because every Admiral television receiver is equipped with the built-in super turret tuner which provides for reception of new UHF stations by means of readily interchanged, inexpensive tuning strips.

## **New "Glare-Trap" Stops Reflections**

Outstanding among Admiral's spectacular new features for '52 is a newly designed 21" all-glass tube with cylindrical face. Curved like a section of a giant drum standing on end, this brilliantly engineered picture tube completely rejects annoying reflections from room lights . . . provides 245 sq. inches of glare-free viewing surface. It's 20% bigger than a conventional 20" tube!

Other features to increase viewing and listening pleasure include variable tone control for TV sound as well as radio . . . plug-in socket for record player . . . built-in directional Roto-Scope antenna . . . sensational cascode amplifier that makes possible amazing "fringe" area reception. Yes, feature for feature, Admiral television for

'52 is engineered to outperform any set, anywhere, any time!

## **Greatest Values in Admiral History**

Thirty-four brilliant new Admiral models are now in production . . . the greatest values in Admiral history. Think of it! An Admiral 17" table model with super-powered triple-X chassis for as little as \$189.95\*! A 17" half-door TV console with radio for \$299.95\*! A 20" table model priced as low as \$239.95\*! A brilliantly styled consolette with 21" cylindrical face picture tube and built-in radio for only \$349.95\*. Why let your customers settle for an obsolete, "carry-over" model even at a reduced price when they can get a brand new '52 Admiral with all the latest features, at the lowest prices in Admiral history!

*Compare performance! Compare value! Compare features with this all important fact in mind. Every Admiral, beginning with the popular priced 17" table model at \$189.95, has a built-in Roto-Scope antenna! Every Admiral features the super-powered triple-X chassis with full complement of tubes. Compare, and the Number 1 brand in your store is certain to be Admiral television.*

*\*Includes one year picture tube warranty—Federal Tax extra. Prices slightly higher South and West . . . Subject to change without notice.*

**Anywhere, Anytime...Admiral TV for '52!**

## New Equipment for Television Service and Installation

The efficient use of the latest equipment in the installation and servicing of television receivers is one of the major factors in deciding whether the service operation will be profitable. Each month, Radio and Television JOURNAL carries a large volume of advertisements from manufactures of TV picture tubes, boosters, antennas, rotators, and all types of service accessory equipment which can help you in your business. We suggest that you study these advertisements carefully, cut out those which are of interest to you, and write directly to the manufacturer. The intensive use of our advertising columns is the key to operating in the black.

### Anchor's Booster

Manufactured by Anchor Radio Corp.,  
2215 South St. Louis Ave., Chicago 23, Ill.

Single knob construction in this television booster makes it possible to turn the unit on and switch and tune it all on the same knob. Has high signal-to-noise ratio. Is of two-stage construction. Incorporates firm's RF stage development. Of modern styling with streamlined plastic es-cutchion, soft mahogany leatherette finish.

Say you saw it in Radio & Television Journal, March, 1952

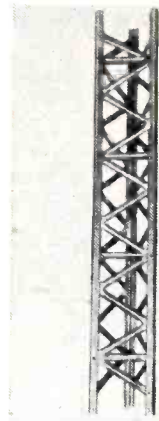
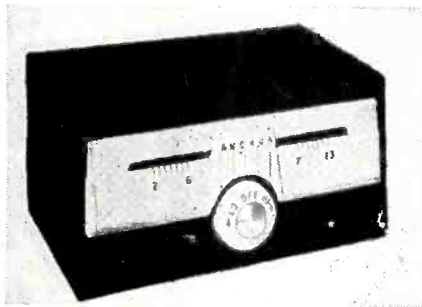

This tower section, No. AT-6C, is factory assembled. It has steps built right into the tower segment. Part of a heavy-duty commercial tower, it weighs 1½ lbs. per foot, measures 11¼ inches on a side. As part of a tower, section can be added to section to a height of 150 ft., with vertical static load capacity of 400 pounds. Mast kit, guy brackets and base cap are additional items needed.

Say you saw it in Radio & Television Journal, March, 1952

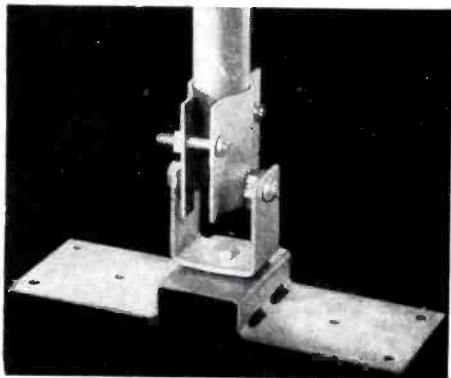

Pat. App. for above and below

### A ONE-MAN JOB

Do it the Easy,  
Low Cost Way

Use The **WAMCO**  
#177 UNI-BASE

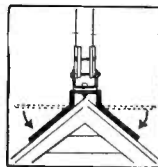

Real one man Mounting. Fits any surface, roof Flat, Gable or Ridge. Only three parts and four bolts.—360 degree rotation—Full hinge action for raising mast and Guying. Strong, Durable, Rust resistant. No damage to roof. Clamp is adjustable for any size tubing ¾" to 2" incl. Swivel feature makes very simple and very substantial mounting. Pat. Pend.

### ← WAMCO DX7 ANTENNA

All aluminum, including seamless tubing, brackets, & phasing harness. Four stack. Full wave length. All band. Very successful in fringe areas. Highly directional, brings in contracts. Eliminates shadow effects. Fits all television sets.

Write for information and prices

WALNUT MACHINE CO. Dept. J52  
1525 S. Walnut St. South Bend 14, Ind.

Kindly send me.....(state how many)  
WAMCO #177 UNI-BASES, at \$1.95.

Name.....

Street.....

City..... Zone..... State.....

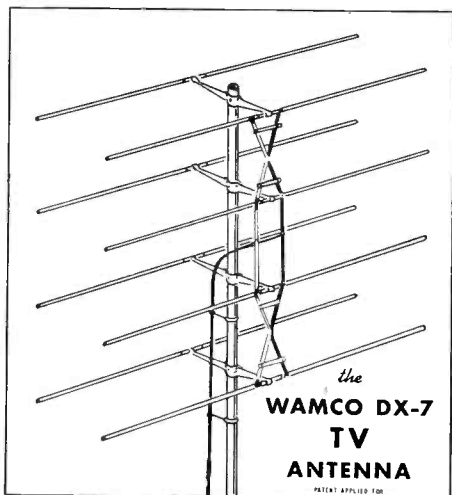

the  
**WAMCO DX-7**  
**TV**  
**ANTENNA**

**WALNUT MACHINE COMPANY**  
1525 S. Walnut St. South Bend 14, Ind.



**YOU NEED THESE FOR  
TELEVISION JOBS**

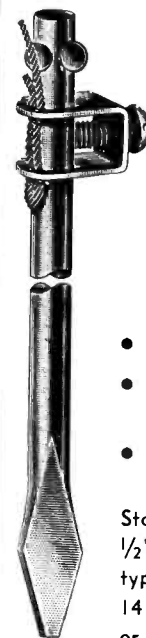

## Ground Rods

- Copper Plated Steel
- Pointed for Easy Driving
- Quick, Secure Clamp

Stocked in ¾" by 4' and 6' and ½" by 5', 6' and 8' with screw-type clamp that takes No. 4 to 14 conductor. Also in plain, hole or pigtail type. Send for prices.

**PREMAX PRODUCTS**  
DIVISION CHISHOLM-RYDER CO., INC.

5210 Highland Ave., Niagara Falls, N. Y.

**peak performance** for indoor TV reception!

**the Hi-Lo  
TV Spiral Indoor  
ANTENNA**

Countless satisfied television set owners are proof that the Hi-Lo TV indoor Spiral ANTENNA provides the clearest, sharpest, finest pictures. Original design and excellent engineering have produced the best-performing, best-appearing indoor TV antenna. Hi-Lo works where others don't . . . Hi-Lo is better where others merely function.

**Here's why:**

- high signal gain
- tuned to high and low TV channels
- no switches or rods to adjust
- receives clear picture immediately
- screwdriver only necessary for rapid installation
- gleaming gold appearance
- height 20" — width 32"
- bakelite base
- aluminum bars
- modern design to blend with any furniture



Model 101\*

**\$9<sup>95</sup>**  
LIST PRICE

\*U. S. Patent No. 2,495,579  
Canadian patents 1951

**Model 101 R & W\* for Outdoor Use**

- Window Installation
- Roof Installation
- Attic Installation



**ORDER Hi-lo TV Spiral ANTENNAS today!**

HI-LO TV Spiral Indoor and Outdoor antennas are sold through recognized jobbers. ORDER NOW for assured delivery.

**Hi-Lo TV ANTENNA CORP.**  
3540 N. Ravenswood • Chicago 13, Illinois

# ANCHOR BOOSTERS



Ask your Distributor about Anchor's  
Easel Presentation on successful fringe installations

**ANCHOR RADIO CORP.**

ANCHOR ENGINEERING ALWAYS A YEAR AHEAD

*ring the "fringe"*  
*the BEST in TV reception*



5 South St. Louis Avenue Chicago 20, Illinois

# How to Make Old Customers 'Receptive' to Better Reception

By Ira Kamen,  
Gen. Sales Mgr., Brach Mfg. Corp.

EVERY time the pendulum swings in the TV industry from terrific to just good, some manufacturers, distributors, and dealers cry, "depression," and throw in the towel, when all they need is a plan, promotion, and good old-fashioned salesmanship.

There are actually some tried and proven dealer plans for persuading those customers who now have TV sets to spend money buying more TV products and service.

It is known that those set owners who were the first purchasers of TV are now potential customers for their second set, a new outdoor TV antenna installation, or a changeover from indoor antenna, to outdoor, or to attic antenna installations. A dealer working on old customers can use "Bull's Eye" type of promotion. He knows the size and make of TV set the customer has, the type of antenna, how long it has been installed, and most important of all, he knows the customer's financial responsibility.

To begin with, a dealer should open his files and go after his old customers. First, he lists all those who bought small-screen TV sets from 1947 to 1949. He lists their addresses and phone numbers, thereby fixing the targets for his field salesman. With the targets set, the dealer's field salesman can now focus the customer in his sites with a well-organized phone "pitch."

## The Approach

Salesman: "Hello Mrs. Smith, my name is John Jones, I am a TV sales specialist with 'TV Stores' who sold you your TV set. We hope you are still enjoying its performance."

Mrs. Smith (usual answer): "Yes, we are enjoying our TV set."

Salesman: "Fine, and now we would like to demonstrate a new device which will allow you and your family greater enjoyment from television. May I come to visit you and make a simple home demonstration at no cost to you.

Perhaps, you can be the first in your neighborhood with this sensational new TV device."

Mrs. Smith: "What is this device?"

Salesman: "It must be demonstrated to be understood. Do you still live on Elm Street? Can I be there on Monday afternoon?"

The TV salesman takes a big-screen TV set and a two-set coupler device along when he keeps his appointment at the Smith's. At Mrs. Smith's home, he places the large screen TV set close to the existing small-screen set. Then he connects both the large and small-screen sets to the installed antenna through the two-set coupler device.

## Demonstration

Salesman: "Mrs. Smith, the TV industry has now developed a device which enables two sets to operate from one antenna with equal performance and without interference. Incidentally, you will notice how much brighter and sharper the pictures are on the new, big-screen TV set which shows how much progress the TV industry has made in TV set design since you bought your small-screen set. (At this time he explains the features of the set and then has Mrs. Smith operate the set. The smart salesman compliments Mrs. Smith on her quick grasp of the set's operation.) He then

(Continued on Page 58)

▼ TV set owners who originally bought when screens were small-sized are always susceptible to the idea of buying a large-screen set. Dealers can sell them on the idea of retaining their old set and making theirs a two-set home.

## Fringe Areas

Get the Best Reception with a



Brach Air General

The only antenna that's laboratory tested and guaranteed to give you highest signal strength... plus withstanding high winds and ice loading. Don't accept a substitute. Brach antennas are guaranteed to give you better reception than you're now getting or your money back! Let me give you full details... today!



BRACH MANUFACTURING CORP. 210 CENTRAL AVENUE • NEWARK 4, N. J.

▼ Antenna design is constantly improving. Family needs and desires are constantly changing. Mailings such as those shown on this page can be the means of bringing the two together, thereby stimulating extra dealer business in TV accessories.

▲ Performance is always the thing. Where an antenna is not giving the most effective reception, especially in fringe areas, the market is always ripe for a new antenna sale.

TO EACH HIS OWN...

## TV SET



At last—peace and pleasure at favorite program time! With 2 sets in the home—everybody's happy! Of course up to now a second set has meant a second expensive installation. Well, not any more—with a simple, low-cost Brach Multi-Set coupler you can also operate that second set—from your old antenna installation—and reduce interference at the same time!

**Come in and see a demonstration!**



BRACH MANUFACTURING CORP. 210 CENTRAL AVENUE • NEWARK 4, N. J. U.S.A.

## It's time to change your OLD ANTENNA!



At last—peace and pleasure at favorite program time! With 2 sets in the home—everybody's happy. Of course up to now a second set has meant a second expensive installation with a simple.



BRACH MANUFACTURING CORP. 210 CENTRAL AVENUE • NEWARK 4, N. J.

# Fringe Areas Hold Vast Potential for TV Sales

## THESE 3 VEE-D-X FRINGE AREA SALESMEN

WILL HELP YOU GET YOUR SHARE!

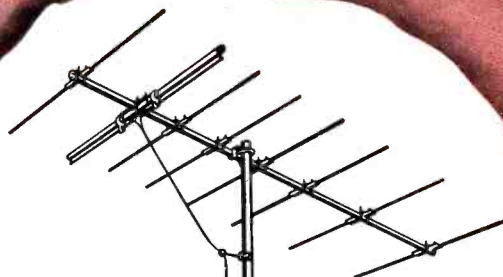

NEW VEE-D-X

*Long John*

Provides 41%  
More Gain Than  
The Best  
5 Element Yagi

You can lick those twin demons of fringe area reception—'snow' and 'flop-over'—with this sensational new, extra powerful 8 element Yagi. Produces as much gain as a double stacked Yagi array! Yet it costs less, is easier to install, and provides better roof-top appearance. Has famous VEE-D-X pre-assembled construction.

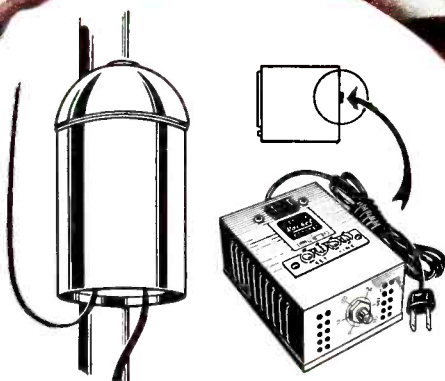

### NEW ROCKET BOOSTER

This single channel mast-mounted booster provides powerful 18 db gain. Amplifies signal at antenna height where most favorable signal-to-noise ratio exists. Uses only single 300 ohm transmission line. Has two components — (1) the mast-mounted booster, and (2) a control unit which fits snugly against back of TV set.

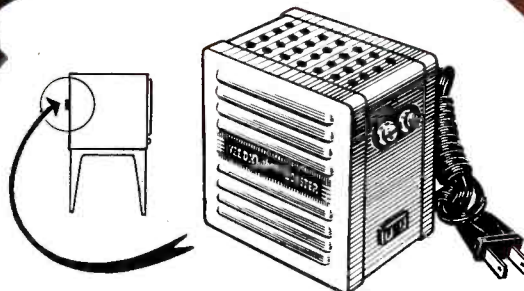

### OUTBOARD BOOSTER

The original single channel outboard type booster. Packs a powerful gain which provides brilliant picture quality in fringe areas. Easily and quickly installed by your maintenance men. Both-ersome tuning completely eliminated.

**REMEMBER . . .** for the **ULTIMATE IN SINGLE CHANNEL RECEPTION**—install Long John plus the new Outboard Booster or the mast-mounted Rocket Booster. In **EXTREME FRINGE AREAS** both boosters can be used in combination for added gain.

**MAIL THIS COUPON.** It will bring you added information on how to get your share of the fringe area market.

THE LaPOINTE-PLASCOMOLD CORP. • WINDSOR LOCKS, CONN.

Gentlemen:  
Send me full information on Long John . . .  
Rocket Booster . . . Outboard Booster . . .

NAME.....  
ADDRESS.....  
CITY.....ZONE.....STATE.....

**VEE-D-X** MAKERS OF  
THE WORLD'S  
MOST POWERFUL  
ANTENNA SYSTEMS

## Improving Sales Receptivity of Old Customers

(Continued from Page 56)

says, "It is our policy to recommend that our customers do not trade in their old small-screen TV sets, but keep them as a second set in the children's room, operating both sets from this new coupler."

Mrs. Smith: "Well, yes, but I don't think my husband wants to buy a big-screen set at this time."

Salesman: "How about this—suppose I leave this large-screen TV set in your house for a few days, at no obligation, so you and your husband can determine whether or not you will get real enjoyment from a new large screen TV set."

### Follow-up

Experience has shown that once a TV set owner views a number of programs on a large screen set in comparison to the performance of his small-screen set, he is usually a buyer on the field salesman's next visit to the home. An evening visit with Mr. Smith in which the salesman meets Mr. Smith's objections head on and overcomes them honestly but forcefully, will conclude a successful sale.

The new dealer who has no list of small-screen TV customers, and the

dealer who confines his activities to inside selling, can take advantage of provocative direct-mail postcard ideas.

Dealers must stop trying to get broader market for TV merchandise by price reductions alone. They have developed a big market with millions of TV set owners. Now, they can sell this market again by making the better home a "two-set home" and by making old customers aware of new TV set improvements and modern installations.

### Wide Support for Michigan Service Group

The Television Service Association of Michigan, formed some two years ago, is finding support for its aims and program from varying sources.

Manufacturers, TV stations, Detroit newspapers, and other segments of the industry have recently expressed support of the aims of the service organization. Reports by special committees have indicated that set makers, parts jobbers and others demonstrated a willingness financially to support the

TSA's program. This centers about the education of the public, especially that segment owning sets and the general improvement of industry public relations. Such public relations would find the support of newspapers and TV stations in the area.

Non-member firms are expressing more and more interest in TSA and are demonstrating this by indicating a desire to join the organization proper. At a recent meeting in Detroit's Northern Y.M.C.A., Louis Wolfgang, Poly-Tek Radio & TV Service Co., acting president, addressed an open meeting. In addition to a goodly portion of the regular membership, some 40 non-member firms were represented, many of them expressing an interest in joining the organization.

The direction in which the organization takes steps for the benefit of the membership is best illustrated by a recent meeting of the business management-customers relations committee. This committee decided to prepare a study program for management, intended to offer specific information on the operation of a television service business, including accounting methods and taxation.

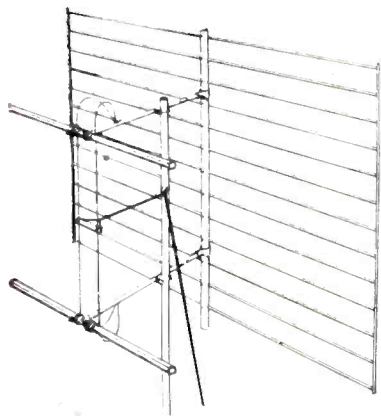

This type antenna is now being used by the largest TV service organizations for all their fringe area installations.

Leading TV manufacturers, who operate their own service departments, have found the Super-Vision to be the only antenna which fits into their rough installations to eliminate ghost and DX problems.

# SUPER-VISION TELEVISION ANTENNA

## Unbeatable for Fringe Area and DX

### ONLY TELEVISION ANTENNA WITH A MONEY-BACK GUARANTEE

LIST PRICE

**\$34.95**

Less Mast

1. Excellent for fringe area and DX receiving and broad band receiving and high gain on all channels—2 through 13.
2. Ghost problems reduced or eliminated due to excellent pattern.
3. Clearer pictures up to 125 miles or more from the station.
4. Provides 10 DB or more gain on high channels where gain is most needed.
5. Has excellent front to back ratio on all channels. Eliminates co-channel interference.
6. Minimizes interference: Airplane Flutter — Diathermy and Ignition — F.M. — Neon Signs — X-Ray — Industrial — Etc.
7. Eliminates double stacked arrays, and out-performs 2 bay yagis on low band and 4 bay yagis on high channels.
8. Only one transmission line necessary.
9. No worry over possible channel changes on either high or low channels.
10. It can be tipped without tilting the mast — to take advantage of the horizontal wave lengths.

## DAVIS ELECTRONICS

Manufacturers of Quality Electronic Equipment

3047 WEST OLYMPIC BLVD.

LOS ANGELES 6, CALIFORNIA



anybody can make claims . . . we back them up!



**GUARANTEED PERFORMANCE OR YOUR MONEY BACK!**

Yes, your money back if this booster does not give you as fine a picture as any booster on the market!

- (1) New, balanced input and output circuits for greatest gain. (2) Built-in power transformer (not AC-DC) with long-life selenium rectifier. (3) Utilizes finest turret tuner ever designed. (4) Fine tuning control. (5) Smart metal cabinet finished in wear-resisting mahogany enamel. (6) Pilot light illuminates selected channel.

See your nearest National distributor

TVB-2BX television booster \$39.95 list



### Booster by Vee-D-X

Mfd. by LaPointe-Plascomold Corp., Windsor Locks, Conn.

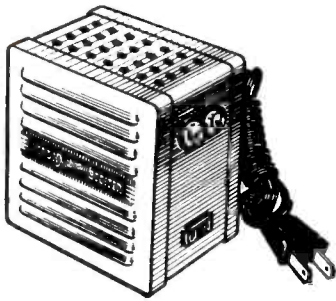

Attaching inconspicuously to the back panel of any television set, this booster is designed to increase the strength of incoming signals automatically without use of manual tuning controls. Turns on and off with set. Signal strength pre-amplified as much as 18 db. with full 5 megacycle band width. Push-pull cross neutralized amplifier for preventing oscillation.

Say you saw it in *Radio & Television Journal*, March, 1952

### JFD Indoor Antenna

Mfd. by JFD Manufacturing Co., Inc., 6101 Sixteenth Ave., Brooklyn 4, N. Y.



This indoor television antenna, companion to the "Panorama" and "Standard," has two three-section telescoping dipoles of extruded aircraft aluminum. Dipoles may be set in any position. A ratchet contour inside the molded Bakelite housing provides a firm hold and prevents tipping.

### Baker TV Tower

Manufactured by Baker Manufacturing Co., Evansville, Wisconsin



The self-supporting tower and telescoping mast come either separately or as a complete unit. All steel parts are heavily galvanized. Tower foot fits any roof, mast clamps fit any mast up to two inches. The tower has a built-in ladder which provides firm footing for erecting and adjusting. Telescoping mast allows one man to make a straight-up assembly.

Say you saw it in *Radio & Television Journal*, March, 1952

## PENN TELEVISION PRODUCTS ARE ENGINEERED FOR BETTER, LONGER LASTING ANTENNA INSTALLATIONS



**PRA-148**  
Peak Roof Mount.  
Takes masts from 3/4" to 2"

**Exclusive Patented Features**  
**TONGUE FOR MAST HOLDER**  
Serves as a strong supporting base for mast.  
**LOCKING BEARING**  
Enables mast to be locked and secured in any position.



**PRA-150**  
Mount  
arches over crown tile of peak roofs. Takes masts from 1" to 2"



**BMA-136**  
Universal Base Mount.  
Takes masts from 3/4" to 1 1/2"



**GRA-140**  
Floating Guy Wire Ring & Collar.  
Takes masts up to 1 3/8"  
**GRA-141** takes masts up to 1 3/4"



**BMA-138**  
Heavy Duty Base Mount.  
Takes masts from 1" to 2"

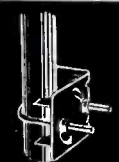

**BM-133**  
Base Mount with slide adjustment.



**CMA-500**, Pair of Chimney Mount Brackets with 2-12-ft. lengths of galvanized steel strapping. **CMA-500 SS**—same with stainless steel strapping.

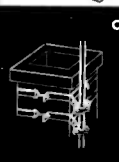

**CMS-333**, Pair of Chimney Mounts. Heavy gauge steel, hot dipped galvanized. **CMA-684**—same in heavy gauge aluminum.



**TC-313**  
TwinTena. Permits 2 TV sets to connect to one antenna.



**Hiloswitch**  
**TS-587**  
3-channel antenna transfer switch.

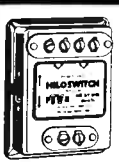

**TS-551**  
Hiloswitch 2-channel antenna transfer switch.

## PENN TELEVISION PRODUCTS CO.

3336-40 Frankford Ave., Phila. 34, Pa.

### Another New PENN TV PRODUCT!

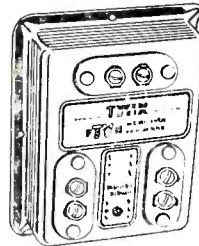

#### TC-374 TwinTena

A deluxe 2-set antenna coupler—permits two TV sets with 300 OHM input to be connected to one antenna—allows simultaneous reception on both sets, on or off, with no interference from either. Actual DB measurements on accurate instruments show stronger signal strength with the TC-374 as compared to other antenna couplers priced three-times higher.

Write for price list and catalogue on the complete PENN TELEVISION PRODUCTS line.

## South River NEWS

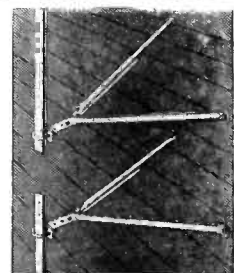

**24" WALL BRACKET Model WB-24**

Heavy gauge, embossed steel, hot-dip, galvanized finish. One-piece construction and 16" spread make it easy to install. Easy to fasten to wall studs. Fits all size masts up to 1 1/2" O.D. With hardware. (Available in 12", 15" and 18" sizes as well.)

South River Antenna Mounting Accessories are carried by every leading TV Parts Jobber from coast to coast.

New catalog mailed to all Dealers and Service Men.

Write, if you haven't received yours!

**SOUTH RIVER METAL PRODUCTS CO., INC.**  
SOUTH RIVER, N. J.

PIONEER AND OUTSTANDING PRODUCER OF FINEST LINE OF ANTENNA MOUNTS

# The TRIO ROTATOR

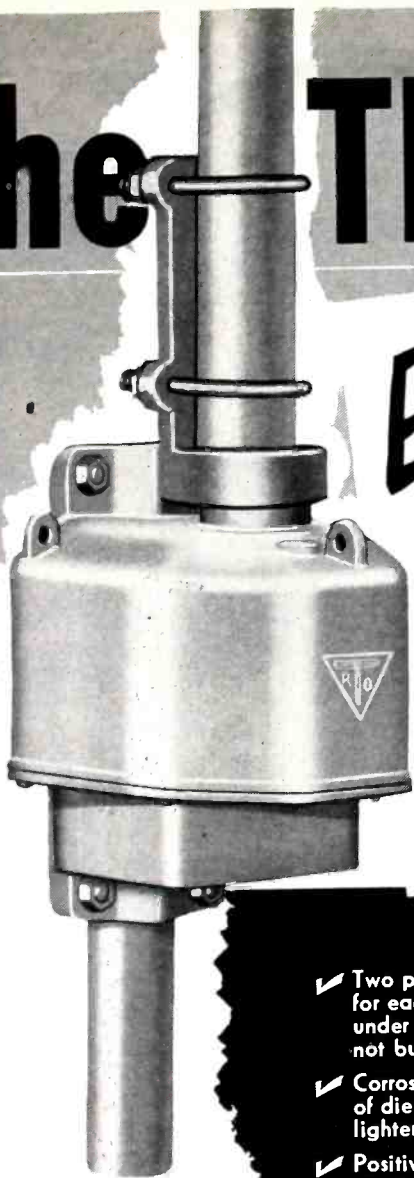

*Easy to Sell!*

It's easy to sell a product with as many plus features to talk about as the TRIO ROTATOR. In design, in construction, appearance; it is by far the outstanding TV antenna rotator in the market today!

*Stays Sold!*

In addition to providing a powerful sales story, the features listed below are your assurance of complete customer satisfaction: Assurance that the TRIO ROTATOR will give dependable performance year in and year out — in all kinds of weather!

- ✓ Two powerful 24 volt motors used — one for each direction of rotation. Each motor under load only fraction of time — will not burn out!
- ✓ Corrosion resisting, weatherproof housing of die-cast aluminum for greater strength, lighter weight, perfect alignment of parts!
- ✓ Positive electrical stops at ends of 360° rotation prevent damaging or twisting of leads!
- ✓ Will support heavy TV arrays — even in 80 MPH winds!
- ✓ Permanently lubricated with special grease that functions perfectly in high and low temperature extremes!
- ✓ Ball-bearing end thrusts on all shafts, including motor! Main shaft vertical load carried on large oversized "Oilite" self-lubricating bearing!
- ✓ All motors, shafts and gears mounted on a rugged, one-piece casting for true alignment and longer life!
- ✓ 1 1/16" diameter tool steel main shaft and mast holder will withstand 4500 inch/pounds bending moment!
- ✓ Rotator and mast holder fits any pipe size up to 2" OD!
- ✓ Precision built to extremely close tolerances!



*Smartly Styled*

## DIRECTION INDICATOR

The TRIO Direction Indicator is housed in a sturdy plastic cabinet of graceful lines. It is a beautiful instrument that will blend harmoniously with any furniture style.

Utmost ease in selecting the desired antenna direction is provided by a new "finger tip" control that operates at a light touch and the easy-to-read dial face that clearly and instantly indicates the exact antenna position.



**FULLY TESTED  
BEFORE  
SHIPMENT**

Each TRIO ROTATOR is thoroughly factory tested to the equivalent of 3 months of constant operation. This, plus an additional torque test guarantees each unit to be perfect in every detail of assembly.

The TRIO ROTATOR's sound design and construction has been proven by three years of extensive field testing under every extreme of weather.

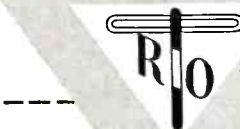

**TRIO** Manufacturing Company  
GRIGGSVILLE, ILLINOIS

A black and white photograph of a man wearing a cowboy hat and a plaid shirt, looking down at a sign. The sign is black with white text that reads "Better Television Picture Quality".

**Better  
Television  
Picture Quality**

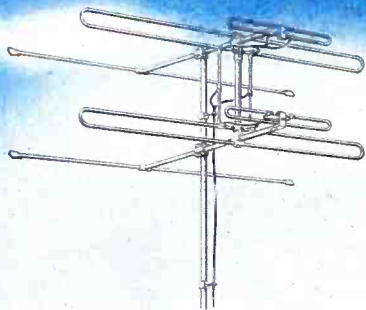

*this*  
**Book** →



... contains information never before available in a concise, easy to read form. It presents a complete discussion of the various factors and conditions which affect television reception and the reasons for good TV pictures.

Featured in this book is a detailed comparison, complete with illustrations and graphs, of the various types of antennas, their characteristics and performance under given conditions. Presented in a clear, factual manner, the performance data and comparative information contained in this review has been compiled from the test reports and published literature of manufacturers of the various types antennas.

This book also reviews the problem of coordinating the antenna with the location, the use of rotators, television reception in the "fringe" areas and the advisability of installing lightning arrestors.

Your Authorized Amphenol Distributor has a free copy of this book waiting for you — ask for yours today!

**AMPHENOL**

**AMERICAN PHENOLIC CORPORATION**  
1830 SOUTH 54TH AVENUE • CHICAGO 50, ILLINOIS

### Kenwood's Mounting Bracket

Mfd. by Kenwood Engineering Co.,  
Kenilworth, N. J.

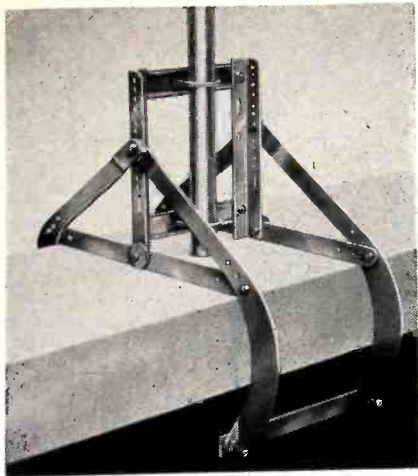

A sturdy frame with four clawlike members to clear a coping and extend to a wall make up this new parapet mounting bracket. It is designed for antenna masts up to 1½ inches in diameter. Claws are of heavy gauge steel. Adjustable cam for any contour adjustment. Can be installed on walls up to 13½ inches in thickness.

Say you saw it in *Radio & Television Journal*, March, 1952

### Brach Lightning Arrester

Mfd. by Brach Manufacturing Co.,  
Newark, N. J.

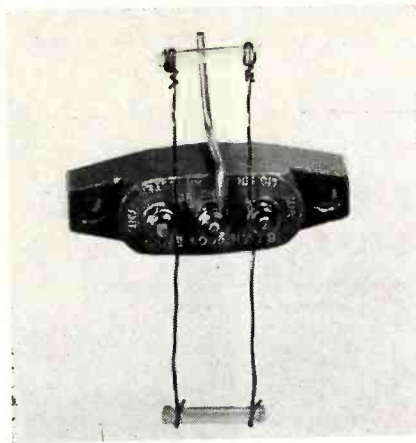

This lightning arrester for open-wire transmission lines uses a rare gas tube in which the charges are carried to electrodes sealed into tube, where they are dissipated before damaging TV receiver equipment. Designed for outdoor installation, it comes with mounting hardware.

Say you saw it in *Radio & Television Journal*, March, 1952

### Booster by National

Mfd. by National Co., Inc.,  
Malden, Mass.

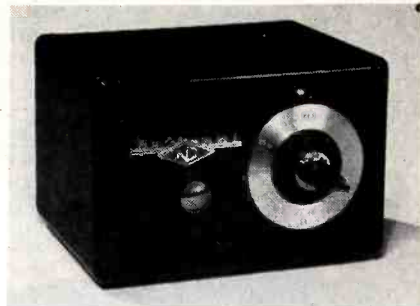

A television booster which features new, balanced input and output for greatest gain. Has built-in power transformer with selenium rectifier. Uses turret tuner. Pilot light illuminates the selected channel when the booster is put into operation and channel selectivity begins. Tuning is through fine tuning control. The booster is housed in a metal cabinet which is finished in wear-resistant mahogany enamel.

Say you saw it in *Radio & Television Journal*, March, 1952

## Fringe Areas!

**Brach Air General gives more gain than a stacked yagi, on every TV channel!**

Tested... best performance. Strongest construction. Air General, Brach TA-450 is the only antenna tested to give you highest gain... withstand high winds, and ice loading. Has non-hygroscopic high-impact insulators; rugged triangular construction; quick rig assembly... and other exclusive features. Guaranteed highest DB gain on all channels... better than any yagi. Order today!

**FREE** Send for new booklet, "How to get the most out of fringe area installations" by Ira Kamen, leading TV antenna authority.



**MANUFACTURING CORP.**  
200 Central Ave., Newark 4, N. J.

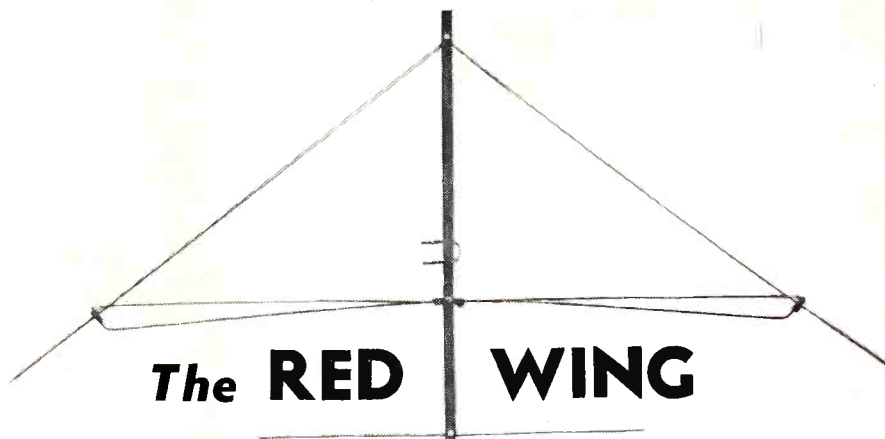

## The RED WING

# Television's SMALLEST SUCCESSFUL Antenna

# \$4.45

list

Manufactured by

## TELEVISION ASSOCIATES

140 Pennsylvania Ave.

Manchester, N. H.

## Freeze Lifting Will Spurt Antenna Demand

If the ban of TV station construction is soon lifted by the Federal Communications Commission (see page 94), the demand for antennas will be greatly increased as a result of the opening up of new television areas. This means that a real shortage may result because of the NPA's (National Production Authority) restrictions on the use of scarce aluminum and copper.

## Only the **OAK BOOSTER** GIVES YOU ALL THESE FEATURES:



- Highest gain of any booster.
- Dual input and output.
- Automatic On-Off.
- Gain adjustable from front knob.
- Variable bandwidth, controllable from front panel.
- New "Q" multiplier circuit increases gain.
- Mallory inductor controls interference and reduces noise to a minimum.

Lists for only **\$39.95**

Write for information, discounts and name of nearest jobber

**OAK ELECTRONICS**

150 Oak Street Buffalo, N. Y.

**INTRODUCING**

THE NEW AMAZING

**FRETARAY**

**TV**  
*Antenna*

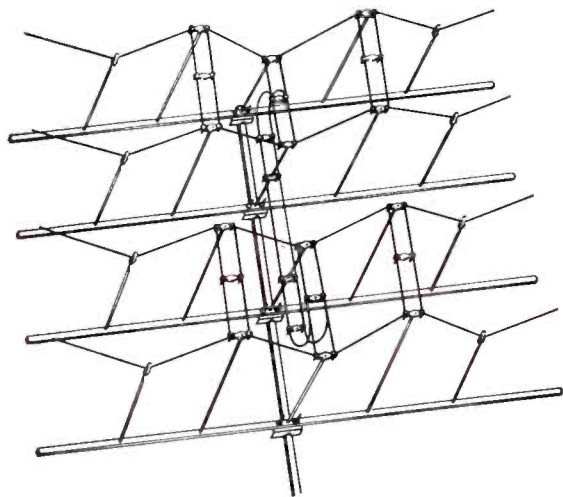

The Fretaray is the first actual broadband colinear array that retains high gain on all channels and sets the pace for new developments in television antennas. No other antenna is necessary with the fretaray and only one transmission line is needed. Just unpack, tighten, and mount. The performance of the fretaray will sell itself.

FOR  
*Matchless*  
FRINGE AREA  
RECEPTION

Exciting - new - different

Light weight steady  
construction

High gain

No assembly

One antenna  
for all channels

Unpack - tighten - mount

**FRETCO**  
INCORPORATED

1041 FORBES STREET  
PITTSBURGH 19, PENNSYLVANIA

## Tele-Ex-Pand TV Tower

Mfd. by Tele-Ex-Pand Products Sales Corp.,  
National Bank Bldg., Berwick, Pa.

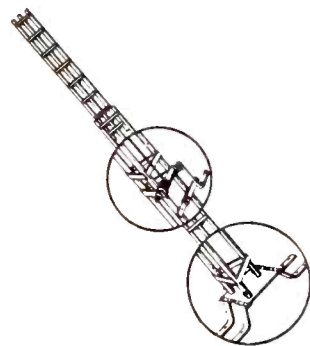

This television tower comes in the following four model sizes: 10-foot collapsed expands to 18 feet; 15-foot expands to 28 feet; 20-foot expands to 38 feet and to 55 feet. Adaptable to various uses, the tower expands, section on section. Mounted on pick-up or panel truck it can serve a dealer as a probe tower.

Say you saw it in *Radio & Television Journal*, March, 1952

## Penn TV Mount

Mfd. by Penn Television Products Co.,  
Philadelphia 34, Pa.

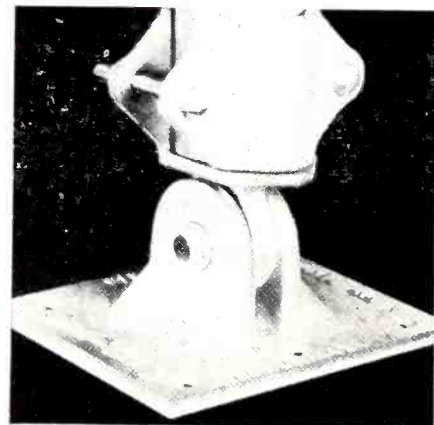

A heavy cast aluminum universal roof mount, with special alloy to give extra strength, this mount is built large and heavy to handle heavier type masts. Patented bearing permits locking in any position with turn of bolt. Swivels in any position, ready for use. Gives firm support to masts of from one to two inches.

Say you saw it in *Radio & Television Journal*, March, 1952

# the tower servicemen dreamed up!

the TEL-A-RAY

## SWING-OVER \* TOWER

A serviceman's dream — an antenna tower that swings over to the ground for servicing — now being produced by Tel-a-Ray! The Swing-Over Tower makes all other types obsolete because it is the easiest tower for servicing ever made.

Built from steel angles with welded construction, the Swing-Over Tower is guaranteed to withstand wind and weather.

Yet one man can lower the tower top to the ground, or raise it, in just three minutes. Competitively priced and guaranteed, the Swing-Over Tower will be your biggest item in 1952.

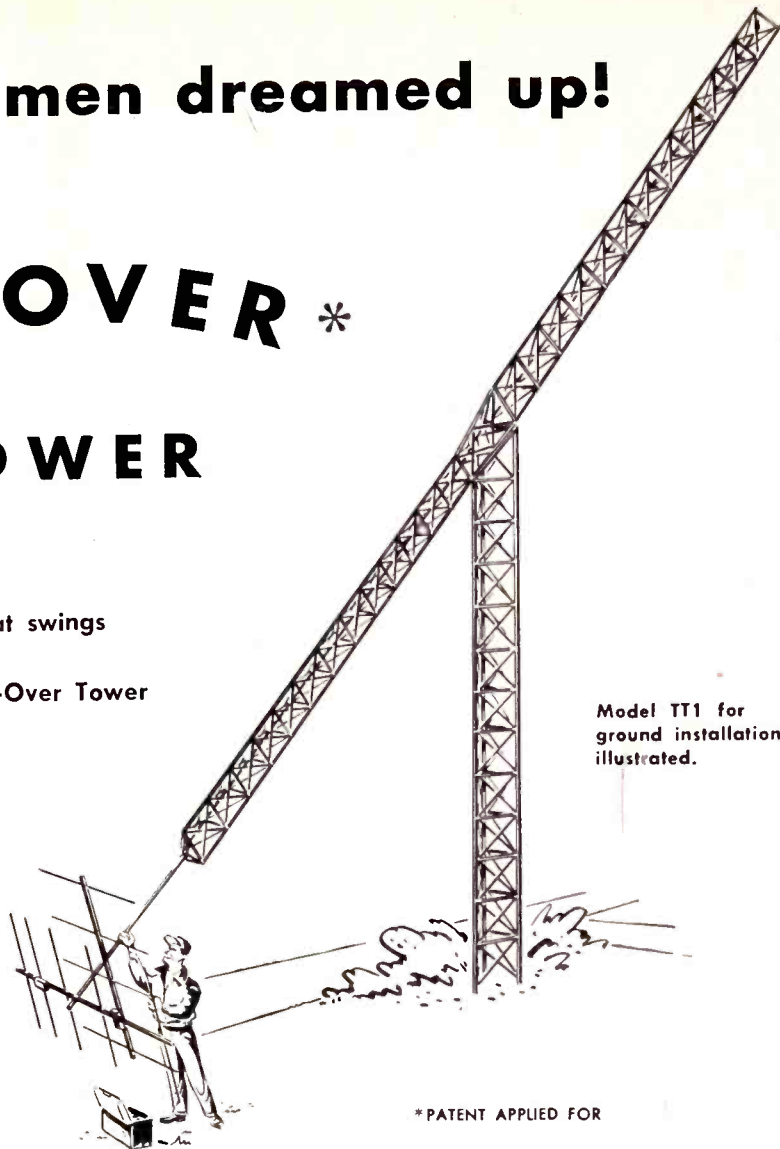

Model TT1 for ground installations illustrated.

\*PATENT APPLIED FOR

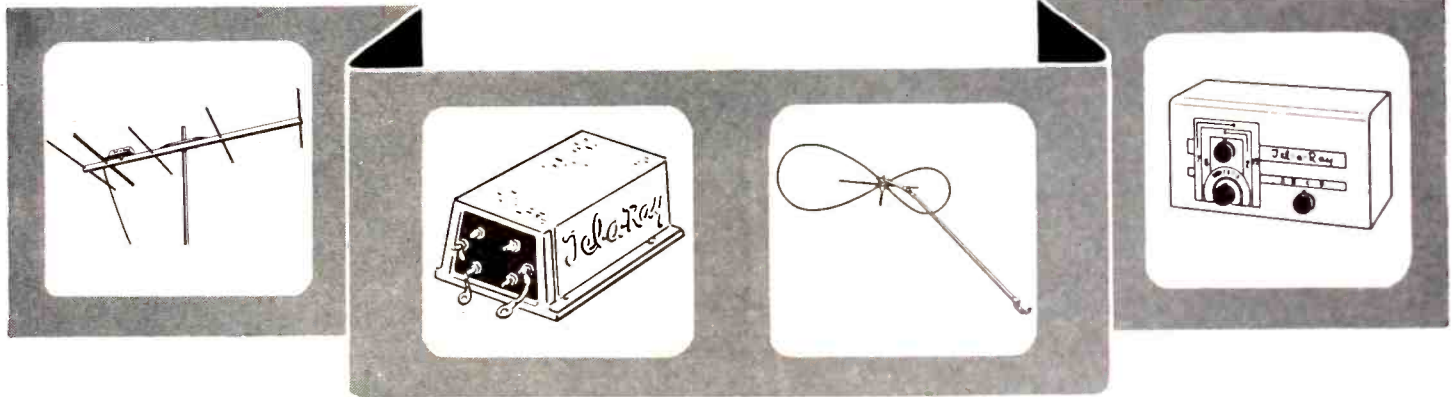

These Tel-a-Ray products are bringing more and better reception to television viewers every day . . . and bigger profits to their dealers: Left: The Model T antenna pulls in good reception up to 200 miles away! Cannot rust or corrode. Perfect for all fringe area reception. Left center: To complement the Model T antenna, the only antenna-mounted, low-cost preamplifier on the market, the model TB. High signal gain, low noise ratio make it outstanding.

Right center: The low-priced Butterfly antenna . . . receives 13 channels and FM radio in primary areas . . . completely guaranteed . . . swivel-mount permits erection anywhere! Right: The new Switching Booster (Model PTB1) — for areas where more than one channel can be received with separate antennas. Switches channels and antennas with one knob. Four antenna inputs. Furnishes high gain from antenna and voltage for four preamplifiers. A necessity in the fringes.

**WRITE TODAY FOR COMPLETE INFORMATION**

**Tel-a-Ray**  
ENTERPRISES, INCORPORATED  
BOX 332S  
HENDERSON, KENTUCKY



TRADEMARK

## Bogen's TV Booster

Mfd. by David Bogen Co., Inc.  
663 Broadway, New York 12, N. Y.

One control on this new TV booster tunes continuously from channel 2 to 13. "Off" position disconnects booster and connects set to antenna, ready for tuning. Two tubes and selenium rectifier; push-pull triode amplifier; twin lead supplied. Comes in mahogany hammertone metal cabinet with tan and ivory markings.

Say you saw it in *Radio & Television Journal*, March, 1952

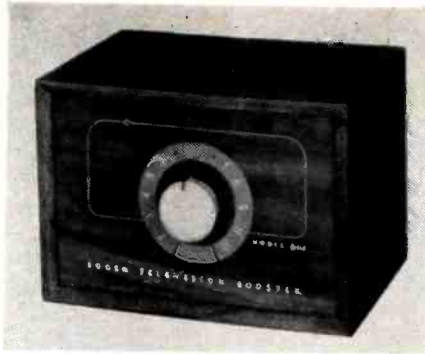

## Turner Booster

Manufactured by Turner Co.,  
Cedar Rapids, Iowa



With the 'Cascode' circuit, featuring low noise factor, this new television booster covers all TV channels and has continuous tuning over both high and low frequency bands. Terminal strip accommodates either 75-ohm coaxial or 300-ohm twin-lead transmission lines. Complete with twin-lead lines.

Say you saw it in *Radio & Television Journal*, March, 1952

## RMS's "Pix-Eye"

Mfd. by Radio Merchandise Sales, Inc.  
1165 Southern Blvd., New York, N. Y.



A new test instrument which permits check of picture tube and receiver circuits, the "Pix-Eye" can be plugged into the CRT socket and indications on the eye tube can guide the service technician. When it has established the fact that the receiver is operating properly and that H. V. is present, the set is operated with the CRT connected. If the tube shows no raster, no variation of brightness or contrast, or no video, defectiveness of the CRT can be readily established. Housed in a protective shield, the new device has instructions enclosed. An extension is available whereby the device can be used at the front of the set.

Say you saw it in *Radio & Television Journal*, March, 1952

Presenting the . . .

## GOODENOW CONSOLETTTE BASE

Jobber Territories Open

- Shipped ready to use.
- Mahogany finish
- 21" high: Available in following sizes:  
18x21; 21x21; 21x24; 24x24; 24x26; 26x26
- Supplied with casters.
- Carries the well known GOODENOW guarantee.
- The 21x21 retails profitably at . . . \$19.95
- Finished with hot lacquer
- 3-tone grill cloth
- (with door, at small extra cost)

And still making sales records is the  
GOODENOW TURNSTILE TV TABLE

Gives full support on 360 degree turns, with non-tilt support all around. In Mahogany, blonde lined oak or walnut. 21", 24", 26" square tops. The 21" lists at \$19.95.

. . . See Your Jobber or Write Direct

**GOODENOW MANUFACTURING CO.**  
1405 E. 28th Street Erie, Pa.

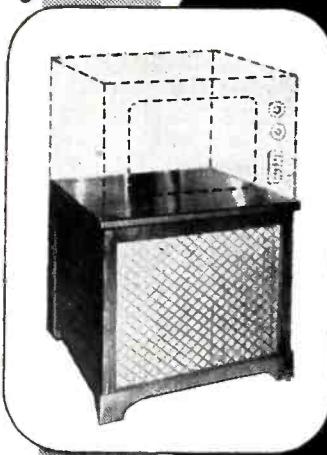

**SENSATIONAL RESULTS!**

**THE ONLY TRUE**

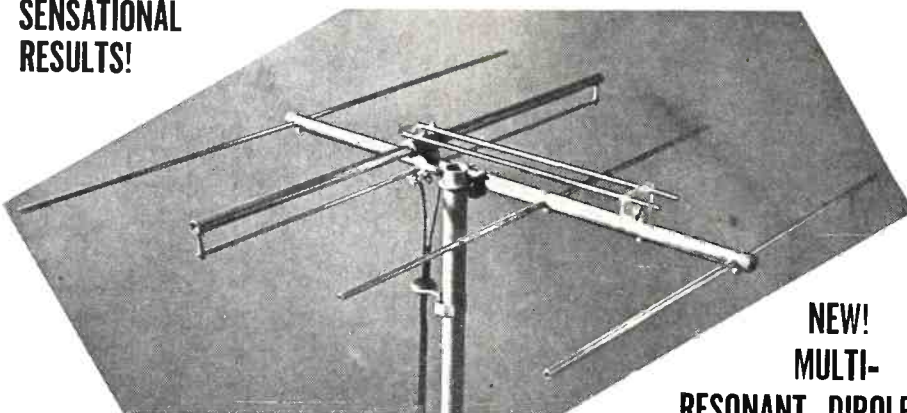

**NEW! MULTI-RESONANT DIPOLE**  
PAT. PENDING

## COMBINATION YAGI ANTENNA

Now! for the first time—a TV antenna with all these powerful advantages.

- Just a few Yagi antennas cover the entire high and low bands.
- All the elements work in their true fashion and do not double in purpose, such as a driven element acting as a parasitic with a loss of efficiency.
- When the multi-resonant dipole is incorporated in the Yagi antenna as a driven element the antenna assumes the aspect of two or more separate Yagi antennas in one.
- It eliminates troublesome and frequency sensitive phasing lines.
- It can be peaked in performance to any number of channels if desired, since it is not restricted to just a few channels as is the case of modified designs.
- In relation to size and gain, it is unequalled.
- It is light, rigid, and easy to install.

The following models and their peaked channels are K-36 (channels 3 & 6); K-45 (channels 4 & 5); K-79 (channels 7 & 9); K-113 (channels 11 & 13). This antenna also responds to adjacent channels. Additional channels combinations can be made with the same outstanding features, to meet the requirements of almost any territory.

The Multi Resonant Dipole Combination Yagi Antenna is the only true answer to difficult reception problems. Order today from your jobber or write for prices and descriptive folder.

**WELLS & WINEGARD**

TELEVISION ACCESSORY MFGS.  
BURLINGTON, IOWA



**B-T 2-Outlet Unit**

Mfd. by Blonder-Tongue Laboratories, Inc.,  
38 North 2nd Ave., Mt. Vernon, N. Y.

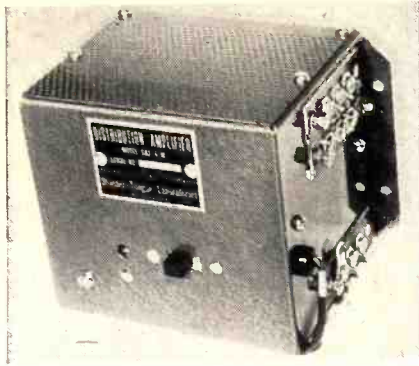

Featuring two isolated TV set outlets and a thorough line output, this two-outlet distribution amplifier is suited for use in master antenna systems of any size and for the two-set home. Provides full electronic isolation. Can be used in series by interconnecting them with 75-ohm line. Amplifier is housed in gray, hamertone finish metal cabinet.

Say you saw it in *Radio & Television Journal*, March, 1952

**New Finney Antenna**

Manufactured by Finney Corp.,  
4612 Clair Ave., Cleveland, Ohio

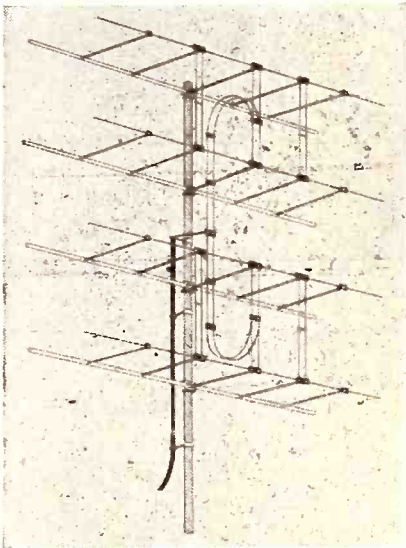

A TV Co-Lateral antenna featuring special co-linear arrangement of elements, 12 driven and 12 parasitic on the high band, eight driven and four parasitic on the low band. Arrangement produces narrow patterns, with high gain and high signal-to-noise ratio. Has one transmission line.

Say you saw it in *Radio & Television Journal*, March, 1952

**New Phoenix Antenna**

Mfd. by Phoenix Electronics, Inc.,  
Lawrence, Mass.

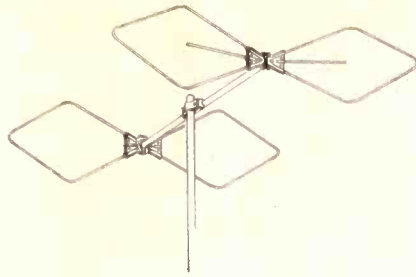

With a mast clamp which prevents turning, canting or breaking, this new type PAR-8 double loop television antenna provides coverage on all channels. Designed for quick, easy installation, for long life, and for fringe area reception.

Say you saw it in *Radio & Television Journal*, March, 1952

**Vico's New Antenna**

Manufactured by Video Industries Co.,  
42 Palmer Place, Port Chester, N. Y.

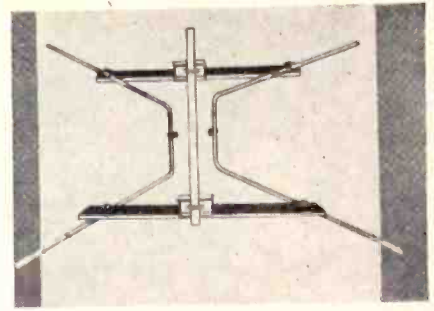

Reinforced with corrosion-proof aluminum elements, this new Vico antenna can be raised to a height of 18 feet without the use of guy wires. Simple assembly features "slide-lock" system, with no loose hardware.

**A STAR PERFORMANCE!**

**EUREKA**

**EUREKA TELEVISION and TUBE CORPORATION**.....Write today! for full information on all round and rectangular tubes!

.....**Manufacturers of Cathode-Ray Tubes and Electronic Products**  
69 Fifth Avenue, Hawthorne, New Jersey.....Telephone Hawthorne 7-3907

### TV Associates Antenna

Manufactured by Television Associates,  
140 Pennsylvania Ave., Manchester, N. H.

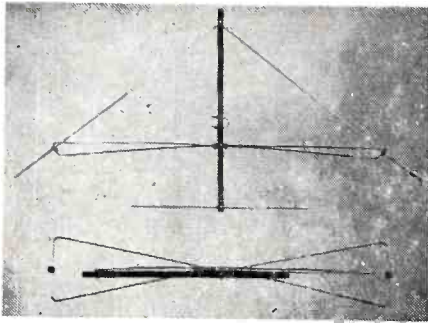

This outdoor television antenna is a lightweight model. It weighs one and one-quarter pounds. Named the "Red Wing," it is an inline type. Of aluminum construction throughout, it is the latest small-type antenna made by this manufacturer. Available immediately through jobbers.

Say you saw it in *Radio & Television Journal*, March, 1952

### New Trio Indicator

Manufactured by Trio Mfg. Co.,  
Griggsville, Ill.



This direction indicator provides a new "finger tip" control for selecting desired antenna direction. Operates at light touch and has easy-to-read dial for instant identification of antenna position. Cabinet is plastic. It is designed for use with this firm's rotor, which features two motors, one for each direction, ball-bearing end thrusts on all shafts, and one-piece casting.

Say you saw it in *Radio & Television Journal*, March, 1952

### New Davis Antenna

Manufactured by Davis Electronics,  
3047 W. Olympic Blvd., Los Angeles 6, Calif.

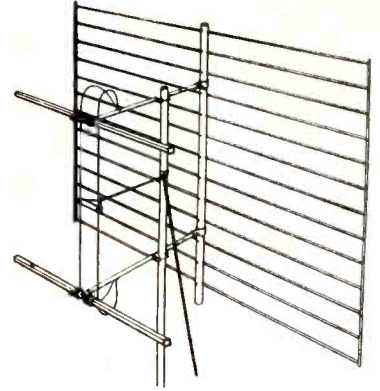

Designed for fringe area and DX receiving, this new television antenna provides high gain on channels 2 to 13. Provides 10 DB or more on high channels. Requires only one transmission line. Constructed to reduce interference such as diathermy, X-ray, FM, neon signs, airplane flutter and the like.

Say you saw it in *Radio & Television Journal*, March, 1952

## IT'S HERE! THE EASY TO ERECT **ENERGY** HYDRAULIC TELEVISION MAST

### NO GUY WIRES NECESSARY

An all hydraulic sectional mast extended with hand or power pump. Mast constructed of cold drawn seamless steel tubing. Cadmium plated for permanent rust protection.

### EASY INSTALLATION

ENERGY Masts can be installed in a short time, either clamped to side of building or set in concrete away from building, then raised and lowered hydraulically as service requires. Weight of 60 foot mast is 330 pounds, 22 feet in length collapsed.

Hand or power pumps can be furnished.

- One mast can serve many outlets.
- Mast will withstand 100-mile wind.
- Manufactured in two sections—40 feet and three sections—60 feet.
- Also recommended for two-way taxi and "Ham" radio installations.



### IDEAL FOR PORTABLE DEMONSTRATION ANTENNA

Smooth quick operation, ideal for commercial car demonstration. For any test location, can be set up in a few minutes.

Write today for literature and prices.

**ENERGY FARM**  
EQUIPMENT CO.  
Monticello, Iowa.

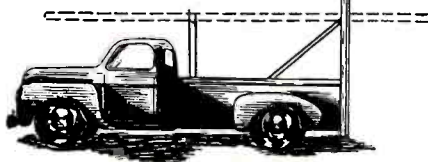

## NEW LEAD-IN SUPPORTS THAT GIVE BETTER TELEVISION and FM RECEPTION!

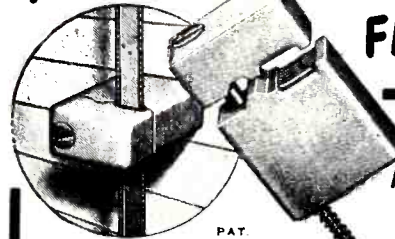

PAT.  
APPLIED  
FOR  
No. 9418

### OTHER ANTENNA AND LEAD-IN ACCESSORIES



No. 1925  
Insulated Screw Eye.  
Overall length 7-1/4",  
5/16" insulator hole.



No. 1961  
Split Bridge Ring Insulated  
Screw Eye. Overall  
length 3-5/8", 5/8" in-  
sulator hole, 1/4" di-  
agonal slot.

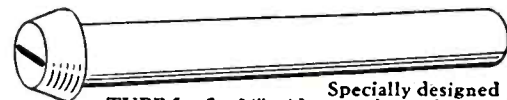

Specially designed  
TUBE for flat 3/8" wide 300 ohm twin-wire  
TV-FM Lead-in Conductors. Outside diameter 1/16"—  
fits hole made by standard 3/4" drill bit. Finest electrical  
porcelain, rectangular hole prevents conductor  
from twisting. Write for folder.

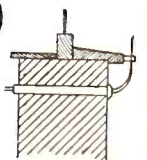

**Porcelain Products, Inc.**  
FINDLAY, OHIO



TIM ALEXANDER

# Motorola



MAX SCHINKE

# Admiral



FRANK SMOLEK

# ZENITH



FLOYD MAKSTEIN

# Emerson



NORM COOPER

# hallicrafters



DON ANDERSON

# Hoffman

# Simpson ELECTRIC COMPANY

5200 West Kinzie Street • Chicago 44, Illinois • Phone: COLUMBUS 1-1221

In Canada: Bach-Simpson, Ltd., London Ontario

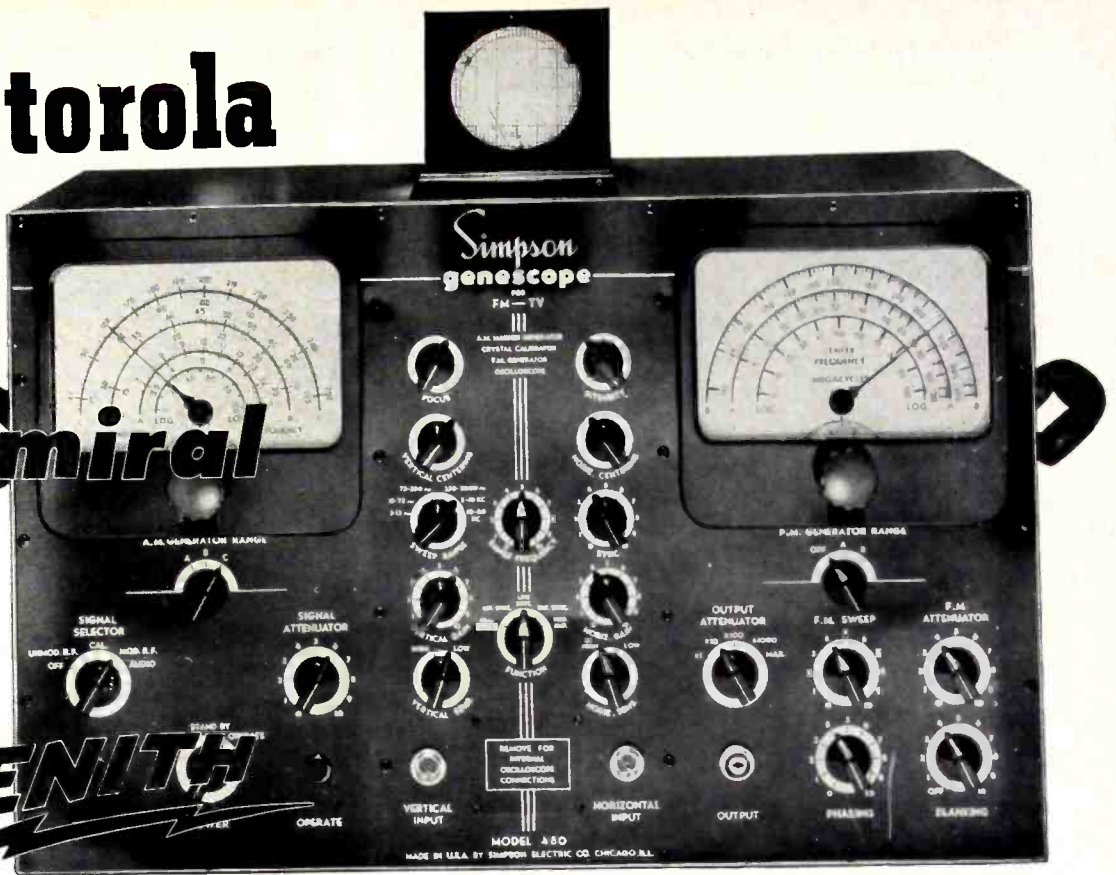

LEADING EXPERTS  
RECOMMEND

## Simpson Model 480 GENESCOPE for TV-FM Servicing

These leading manufacturer's service managers agree — the Simpson Model 480 Genescope is perfectly designed for proper testing, servicing and alignment of all TV and FM receivers!

### THE SIMPSON MODEL 479 TV-FM SIGNAL GENERATOR

Exactly the same circuits, ranges and functions as the Model 480, with the exception of the oscilloscope.



BURTON BROWNE ADVERTISING

**Electro-Voice Booster**

Manufactured by Electro-Voice,  
Buchanan, Michigan

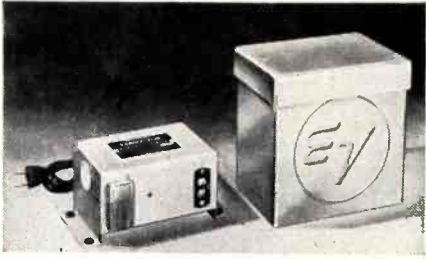

Named the "Tenna-Top," this new antenna-mounted television booster has four amplifiers, arranged as two 2-stage (two on the high band, two on the low). Turns on and off automatically with TV switch. Designed to provide all usable gain, and to minimize snow. Uses single twin-lead line; operates AC. Booster unit is 7¼" by 7½" by 6". Junction box is 6¾" by 3½" by 4½".

Say you saw it in *Radio & Television Journal*, March, 1952

**Tel-a-Ray's New Antenna**

Mfd. by Tel-a-Ray Enterprises, Inc.,  
Henderson, Kentucky

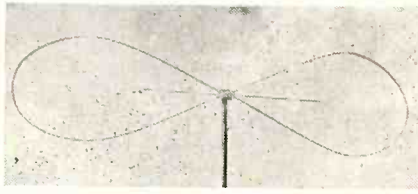

The "Butterfly" is a new high-gain television antenna for the primary TV signal area. Has an ease-of-action swivel which can be locked after any adjustment. Three-way bracket allows for attachment on window ledge, roof or similar location. For use outside primary signal area, this antenna is supplied with one-, two-, or four-bay arrays with an interconnecting line.

Say you saw it in *Radio & Television Journal*, March, 1952

**R-Phillips' "Long Ranger"**

Mfd. by Roger-Phillips Research Labs.,  
717 N. Lake Ave., Pasadena 6, Calif.

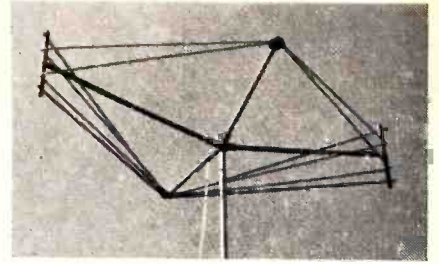

Designed for high and low band reception, the "Long Ranger" is of rhombic design. Comes preassembled, with elaborate assembly procedure enclosed indicating correct positioning of shorting bar, dressing of transmission line, and stacking. Covers channels 2 to 13. Is lightweight and directional. Uses 150, 300 or 500 ohm open line.

Say you saw it in *Radio & Television Journal*, March, 1952



# TELE-EX-PAND

## Deluxe Series

### TV TOWERS

When You Install!!!

Use The Best - Use Tele-Ex-Pand

ENGINEERED . . . WITH THE FUTURE IN MIND . . .  
IDEAL FOR USE AS:

- (1) PERMANENT HOME INSTALLATIONS . . . . .  
From the ground up with Tele-Ex-Pand is by far the easiest and safest way to install.
- (2) AS A PROBE TOWER . . . . .  
Mounted on a Pick-up or panel truck, at a cost the dealer can afford to pay.
- (3) AS A DEPENDABLE INSTALLATION FOR HAM OPERATORS AND SHORTWAVE INSTALLATIONS . . . . .  
Taxicab Companies, Fire Departments and Police Units, are but a few in this field.
- (4) UN-PARALLELED FOR 'COMMUNITY TOWER' USE . . . . .  
Where mountainous terrain must be overcome. Tele-Ex-Pand can be used effectively, one to each channel to be received.
- (5) ADAPTABILITY FOR USE AS SUPPORTING STAND-ARDS FOR FLOOD LIGHTS AT DRIVE-INS, USED CAR LOTS, AND DRIVING RANGES . . . . .

Write Us, or Contact Your Nearest Jobber for Prices

FOUR MODELS	
	Collapsed    Expanded
M-20	- 10 ft.    18 ft.
M-30	- 15 ft.    28 ft.
M-40	- 20 ft.    38 ft.
M-60	- 20 ft.    55 ft.



TELE-EX-PAND PRODUCTS SALES CORP.    BERWICK NATIONAL BANK BLDG.  
BERWICK, PENNA.

## NOW IN PRODUCTION

Famous-For-Quality

# Jersey Specialty

300-OHM Twin Lead TV Wire

20-100 Mil Web	20-55 Mil Web
20 80 Mil Web	22-55 Mil Web

20 and 22 gauge pure copper  
and  
4-Conductor Rotor Wire

**IMPORTANT NOTICE**

Expanded sales force now covering entire country. Write for representative appointment in your state.

*Write for descriptive circular and quotations*



## JERSEY SPECIALTY CO.

LITTLE FALLS, NEW JERSEY

All Phones: Little Falls 4-0784, 1404, 1405

# CONSUMER DEMAND



## MAKES THE TURNER TV BOOSTER A RED HOT PROFIT ITEM!

When Jack Jones installs a Turner Booster in a fringe-area home it doesn't take long for the word to get around . . . "Jack Jones has the best reception in town!" When that happens, brother, make sure you're stocked up on the Turner Booster!

Simple but effective word-of-mouth advertising will sell more Turner Boosters for you than all the direct mail, newspaper space or radio time you can buy.

In city after city, TV installers are turning to the Turner Booster — recommending it to solve their knottiest fringe area reception problems. They have discovered that Turner's low-noise-level Cascode circuit stabilizes the picture, reduces noise and snow to a minimum, and produces a good picture when many other boosters are unable to even lock the picture in!

Place an order with your jobber or write direct. You'll soon be convinced the Turner Booster is the hottest profit item leaving your shelves.

List price.....\$57.50

### THE TURNER COMPANY

901 17th Street N.E., Cedar Rapids, Iowa

IN CANADA:  
Canadian Marconi Co., Ltd.  
Toronto, Ont., and Branches

EXPORT:  
Ad. Auriema, Inc.  
89 Broad St., New York 4



# Directory of Manufacturers

*A comprehensive guide of firms manufacturing Antennas, Towers, Boosters, TV Installation Accessories, Hardware, Masts, Mounts.*

**Key to Listing:** 1. ANTENNAS  
2. TOWERS  
3. BOOSTERS  
4. INSTALLATION ACCESSORIES, HDWE, MASTS, MOUNTS

<b>AERONICS, INC.</b> 134-14 Franklin Ave., Flushing, N. Y.	1	<b>ANCHOR RADIO CORP.</b> 2215 S. St. Louis Ave., Chicago 23, Ill.	3	<b>BELDEN MFG. CO.</b> 4647 W. Van Buren St., Chicago, Ill.	4
<b>AIR-UP TOWERS CO.</b> 350 E. Broadway Muskegon Heights, Mich.	2	<b>ANDREW CORPORATION</b> 363 East 75th St., Chicago 19, Ill.	1	<b>BEST-VUE PRODUCTS</b> 240 N. 10th St., Brooklyn, N. Y.	1
<b>ALL CHANNEL ANTENNA CORP.</b> 70-07 Queens Blvd., Woodside, L. I., N. Y.	1	<b>ANDREW CORP.</b> 421 Seventh Ave., New York 1, N. Y.	1	<b>BIRNBACH RADIO CO.</b> 139 Hudson St., New York, N. Y.	4
<b>ALPRODCO, INC.</b> Mineral Wells, Texas Kempton, Ind	2	<b>APPROVED ELECTRONIC INSTRUMENTS CORP.</b> 142 Liberty St., New York, N. Y.	2-3	<b>BLONDER-TONGUE LABS.</b> 38 N. 2nd St., Mount Vernon, N. Y.	3
<b>ALLIANCE MFG. CO.</b> Alliance, Ohio	3	<b>ASTATIC CORP.</b> Conneaut, Ohio	3	<b>DAVID BOGEN CO., INC.</b> 663 Broadway, New York, N. Y.	3
<b>AMERICAN PHENOLIC CORP.</b> 1830 So. 54th Ave., Cicero 50, Ill.	1, 4	<b>BAKER MFG. CO.</b> Evansville, Wisc.	2	<b>L. S. BRACH MFG. CORP.</b> 200 Central Ave., Newark 4, N. J.	1-4
<b>AMPLITEL, INC.</b> 362 W. 57th St., New York, N. Y.	1	<b>BAND-IT CO., INC.</b> 2536 Walnut St., Denver 5, Colo.	4	<b>BROOKLYN TELEVISION CO.</b> 76 So. 8th St., Brooklyn, N. Y.	1
<b>AMY, ACEVES &amp; KING, INC.</b> 11 West 42nd St., New York 18, N. Y.	1	<b>BARB CITY INDUSTRIES, INC.</b> 1150 So. 4th St., DeKalb, Ill.	1	<b>BUD RADIO, INC.</b> 2118 E. 55th St., Cleveland, Ohio	3
				<b>CAMBURN, INC.</b> 32-40 57th St., Woodside, L. I., N. Y.	1
				<b>CAMBURN SALES &amp; MFG. CO.</b> 392 W. Michigan Ave., Battle Creek, Mich.	1
				<b>CAPITAL ELECTRIC CO.</b> 120 E. McCarty St., Jefferson City, Mo.	1
				<b>CASS MACHINE CO.</b> 691 Antoinette St., Detroit 2, Mich.	1-4
				<b>CHANNEL-MASTER CORP.</b> Naponoch Road, Ellenville, N. Y.	1
				<b>CIRCLE X CORP.</b> 500 Market St., Perth Amboy, N. J.	1
				<b>CLEAR BEAM ANTENNA CO.</b> 102 Prospect, Burbank, Calif.	1
				<b>COMMONWEALTH UTILITIES CO.</b> 512 S. Michigan Ave., Chicago 5, Ill.	1
				<b>COMMUNICATION COIL CO.</b> 2839 N. Narragansett Ave., Chicago 34, Ill	1
				<b>COMMUNICATIONS MEASUREMENTS LABS.</b> 120 Greenwich St., New York, N. Y.	1
				<b>DAVIS ELECTRONICS</b> 3047 W. Olympic Blvd., Los Angeles 6, Calif.	1
				<b>DELSON MFG. CO.</b> 126 Eleventh Ave., New York 11, N. Y.	1
				<b>EASY-UP TOWER CO.</b> 3800 Kinzie Ave., Racine, Wisc.	1-2
				<b>ELECTRO-VOICE, INC.</b> Buchanan, Mich.	3
				<b>ENERGY FARM EQUIPMENT CO.</b> Monticello, Iowa	2
				<b>EPCO ELECTRONICS</b> 140 Liberty St., New York, N. Y.	4
				<b>FEDERAL TELEVISION CORP.</b> 137 Duane St., New York 13, N. Y.	3
				<b>FERRO ELECTRIC PRODUCTS, INC.</b> Kirkland, Ill.	1

## Do Your Fringe Installations Suffer From *W-i-r-e-i-t-i-s*?

**SYMPTOMS:**

- Tangled power cables from TV set, Boosters and Rotators congesting living room.
- Multiple switching operations to get everything working at same time.

**Rx: STANLEY Power Control Box Model 60**  
Take it on each installation.

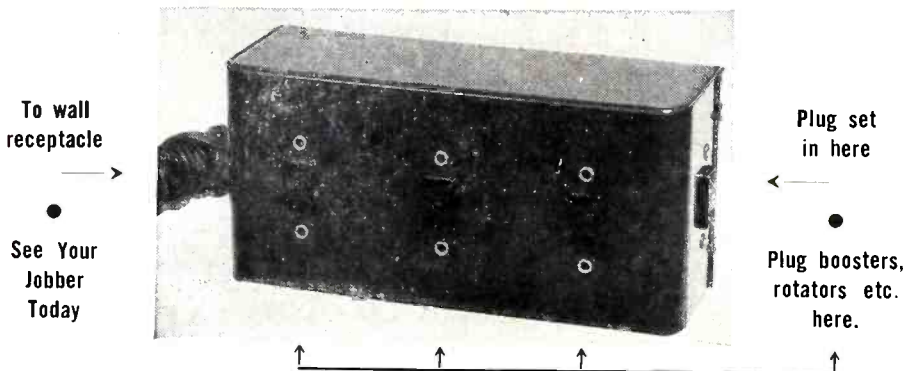

**SIMPLE OPERATION:**  
Turning power switch of receiver to the "on" position activates all accessories. Power Control Box easily mounts on back set.

**POWER CONTROL Box Model 60 — List \$5.95**

\* Disease generally found in fringe area installations.

# STANLEY SALES

110 E. FIRST STREET TV, ELECTRONICS MANUFACTURERS OWENSBORO, KENTUCKY

**VICO ANTENNAS**  
TOPS IN FRINGE AREAS  
Write for Catalogue  
**VIDEO INDUSTRIES COMPANY**  
42 Palmer Place Port Chester, N. Y.

(Continued on Page 74)

THE PICTURE WITH THE

**Bendix**  
FRONT-ROW  
**Television**

BILLION DOLLAR BACKGROUND

# Bendix Magic Interlace

Give Them 30 Seconds to Watch It . . .

## AND STAND BY TO WRITE THE ORDER!



An automobile is sold by letting the prospect *drive it* . . . a radio is sold by letting the prospect *hear it* . . . a television set is sold by letting the prospect **WATCH IT!**

And that's why the Bendix picture looks so good these days. Magic Interlace—a new electronic miracle—makes Bendix\* TV a natural for demonstrations. The picture is so much sharper, and so much more life-like that it is almost like seeing television for the first time. Make a thirty second comparison test against any other brand and see for yourself. You'll be convinced and so will your customers.

\*REG. U.S. PAT. OFF.

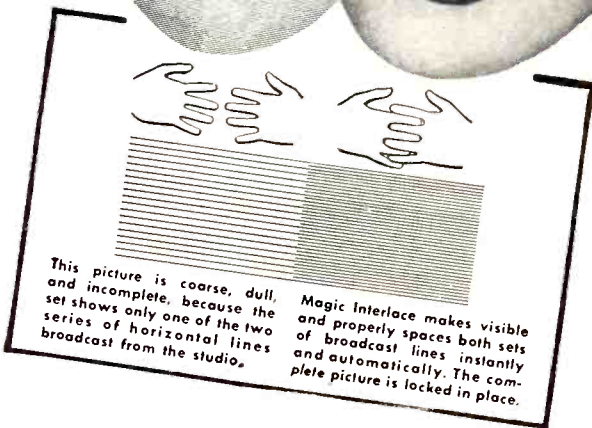

KATE SMITH.  
FIRST LADY  
OF TELEVISION



20L2—The big 20" picture and magnificent cabinetry of this model will appeal to the most discriminating buyers.



20K2—this high-quality model has a 20" rectangular, inclined non-reflecting picture tube with Magic Interlace and easy tuning.

### Do Business with **Bendix**—IT PAYS!



**THE PICTURE WITH THE BILLION DOLLAR BACKGROUND**

AVIATION CORPORATION HAS DESIGNED AND BUILT BILLIONS OF DOLLARS WORTH OF RADIO, TELEVISION, AUTOMOTIVE, RAILROAD, MARINE, AVIATION, AND INDUSTRIAL EQUIPMENT, INCLUDING ELECTRONIC DEVICES FOR SUCH ADVANCED FIELDS AS RADAR AND GUIDED MISSILES. FAMOUS FOR RELIABILITY, IN EVERY MAJOR INDUSTRY, THE BENDIX NAME GIVES YOU THE FINEST PLEDGE OF QUALITY IN TELEVISION.

BENDIX RADIO TELEVISION AND BROADCAST RECEIVER DIVISION • BALTIMORE 4, MARYLAND

# Directory of Manufacturers

(Continued from Page 72)

<b>THE FINNEY CO.</b> 4612 St. Clair Ave., Cleveland 3, Ohio	1	<b>KAY-TOWNES ANTENNA CO.</b> Box 586 Rome, Georgia	1-2	<b>PENN TEL. PROD. CO.</b> 3336 Frankford Ave., Philadelphia 34, Pa.	4
<b>M. M. FLERON &amp; SON, INC.</b> 113 North Broad St., Trenton, N. J.	1	<b>KENWOOD ENGINEERING</b> 265 Colfax Ave., Kenilworth, N. J.	4	<b>PHILSON MFG. CO.</b> 66 Sackett St., Brooklyn, N. Y.	1
<b>FRETCO TELEVISION CO., INC.</b> 1041 Forbes St., Pittsburgh 19, Pa.	1-4	<b>KNEPPER AIRCRAFT SERVICE</b> (Aero Tower Division) 1018 Linden St., Allentown, Pa.	2	<b>PHOENIX ELECTRONICS</b> Lawrence, Mass.	4
<b>GADGETS, INC.</b> 3629 N. Dixie Drive, Dayton 5, Ohio	1	<b>LA-POINTE PLASCOMOLD CORP.</b> Windsor Locks, Conn.	1-3	<b>PLYMOUTH ELECTRONIC CORP.</b> 50 Kingsbury St., Worcester 10, Mass.	4
<b>GENERAL CEMENT MFG. CO</b> 919 Taylor St., Rockford, Ill.	1-4	<b>LOUIS BROS.</b> 3543 East 16th St., Los Angeles, Calif.	1	<b>PORCELAIN PRODUCTS, INC.</b> Findlay, Ohio	4
<b>DON GOOD, INC.</b> 1014 Fair Oaks Ave., So. Pasadena, Calif.	4	<b>MARINO RADIO CO.</b> 203 Greenwich St., New York, N. Y.	1	<b>PRECISION PLASTIC PRODUCTS, INC.</b> 628 W. Lake St., Chicago 6, Ill.	1
<b>GONSET CO.</b> 801 S. Main St., Burbank, Calif.	1	<b>MARS-HALL, INC.</b> 920 Porter Bldg., Kansas City 2, Mo.	1	<b>PREMAX PRODUCTS</b> (Division. Chisholm-Ryder) College & Highland Aves., Niagara Falls, N. Y.	1-4
<b>HAUGEN MFG. CO.</b> 412 So. Front St., Mankato, Minn.	4	<b>MARVIN RADIO-TELEVISION</b> Buckeye at 89th St., Cleveland 4, Ohio	4	<b>RADIART CORP.</b> 3571 W. 62nd St., Cleveland 2, Ohio	1
<b>HI-LO TV ANTENNA CORP.</b> 3540 N. Ravenswood Ave., Chicago 13, Ill.	1	<b>METALACE CORP.</b> 2101 Grand Concourse, Bronx 53, N. Y.	4	<b>RADION MFG. CO.</b> 1130 W. Wisconsin Ave., Chicago 14, Ill.	1
<b>HI-PAR PRODUCTS CO.</b> 347 Lunenburg St., Fitchburg, Mass.	1	<b>MILLER TV ANTENNA CO.</b> 6806 Fountain Ave., Los Angeles, Calif.	1	<b>RADIO MERCHANDISE SALES</b> 1165 Southern Blvd., Bronx, N. Y.	3-4
<b>HY-LITE STUDIOS</b> 242 E. 137th St., Bronx, N. Y.	1	<b>MILNER MFG. CO.</b> Jackson, Miss.	2	<b>REGENCY (DIV. I. D. E. A. INC.)</b> 55 North New Jersey St., Indianapolis 4, Ind.	3
<b>IE MFG. CO.</b> 325 N. Hoyne Ave., Chicago, Ill.	4	<b>MODERN-AIRE MFG. CO.</b> 4436 W. Roosevelt Road, Chicago 24, Ill.	4	<b>ROGER-PHILLIPS RESEARCH LABS.</b> 717 N. Lake Ave., Pasadena 6, Calif.	1
<b>INDUSTRIAL TELEVISION, INC.</b> 359 Lexington Ave., Clifton, N. J.	3	<b>MUELLER ELECTRIC CO.</b> 1583 East 31st St., Cleveland 14, Ohio	4	<b>WALTER L. SCHOTT CO.</b> 3225 Exposition Place, Los Angeles 18, Calif.	1
<b>INSULINE CORP. OF AMERICA</b> 36-02 35th Ave., Long Island City 1, N. Y.	1	<b>NATIONAL ELECTRONICS MFG. CDRP.</b> 4202 Vernon Blvd., Long Island City, N. Y.	1	<b>NORMAN M. SEWELL, INC.</b> Box 752, Lansdale, Pa.	2
<b>JFD MFG. CO.</b> 6101-6123 16th Ave., Brooklyn 4, N. Y.	1-3-4	<b>NATIONAL COMPANY</b> Malden, Mass.	3	<b>SHORE ENGINEERING, INC.</b> 232 West Ave., Long Branch, N. J.	1
<b>JERROLD ELECTRONICS CORP.</b> 26th & Dickenson St., Philadelphia 7, Pa.	1-3	<b>OAK ELECTRONICS</b> 150 Oak St., Buffalo, N. Y.	3	<b>F. W. SICKLES CO.</b> Chicopee, Mass.	4
<b>JERSEY SPECIALTY CO.</b> Little Falls, N. J.	4	<b>OAK RIDGE ANTENNA CO.</b> 37-01 Vernon Blvd., Long Island City, N. Y.	1-4	<b>MARK SIMPSON MFG. CO., INC.</b> 32-28 49th St., Long Island City 3, N. Y.	3
<b>J &amp; A TELEVISION &amp; MFG. CO.</b> 5066 Broadway, Chicago 40, Ill.	1	<b>PEERLESS PRODUCTS INDUSTRIES</b> 812 N. Pulaski St., Chicago 51, Ill.	1	<b>S-C LABORATORIES, INC.</b> 37 George St., Newark 5, N. J.	1
<b>JONTZ MFG. CO.</b> 1101 E. McKinley Ave., Mishawaka, Indiana	2-4	<b>PENN BOILER &amp; BURNER MFG. CO.</b> Fruitville Rd., Lancaster, Pa.	1-2-4	<b>SNYDER MFG. CO.</b> 2218 W. Ontario St., Philadelphia 40, Pa.	1
				<b>SONAR RADIO CO.</b> 59 Myrtle Ave., Brooklyn, N. Y.	3
				<b>SONIC INDUSTRIES, INC.</b> 221 W. 17th St., New York 11, N. Y.	3

(Continued on Page 76)

**Kenco Mounts**  
...are engineered  
for the JOB!  
.....  
**KENWOOD ENGINEERING CO., Inc.**  
265 Colfax Avenue  
Kenilworth, N. J.



**KENCO  
EAVE  
MOUNTS**

Easily mounted on hanging rafters or trim boards of eave. Eliminates need for drilling into brick or masonry walls. Ideal for buildings with extended roofs. Hot dip galvanized.

Available in 3 sizes:

- Model # 135 . . . . . 22" Eave Mount
- Model # 136 . . . . . 28" Eave Mount
- Model # 137 . . . . . 48" Eave Mount

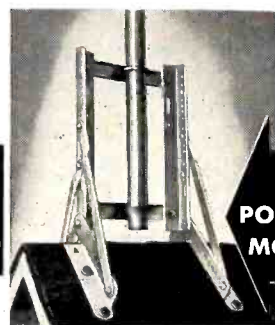

**ALL  
POSITION  
MOUNTS**

A strong, self supporting mount for peak, slope, side wall, corner or flat mountings. Positive locking braces eliminate need for guy wires in many installations. No blocking or shimming necessary.

- Model # 105 . . . . . For masts up to 1 1/2"
- Model # 101 . . . . . For masts up to 2"

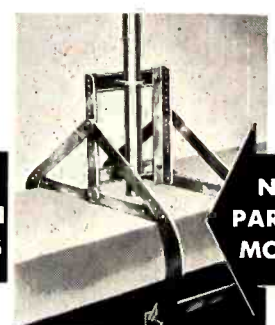

**NEW  
PARAPET  
MOUNT**

The KENCO Parapet Mount gives positive anchorage to apartment house walls without damage to building. Powerful clamping action insures safe installations. Shipped assembled. Quickly installed. Hot dip galvanized.

- Model # 106 . . . . .
- For walls up to 1 3/4" thick.



**NEWS! NOW ON 17" SYLVANIA SETS, TOO!**

**HALOLIGHT\***  
**THE FRAME OF LIGHT**  
**THAT'S KINDER TO YOUR EYES!**



The ADAMS—17" Mahogany Console with HALOLIGHT. Designed by Sundberg-Ferar, this superb cabinet is worthy of the finest home. A long list of Sylvania-engineered features make this Movie-Clear® receiver a sure-fire seller.



The McKINLEY—Stunning 17" Console with Doors, featuring HALOLIGHT. Here is a Movie-Clear® receiver in a gold-trimmed cabinet with slim, modern lines. A dream of beauty and TV power! In Blonde or Mahogany.

THE FRAME OF LIGHT that's kinder to your eyes is now available on 17" Sylvania TV sets as well as on 20" sets.

This means that the market for HALOLIGHT has been broadened by popular demand. Now within the reach of millions more.

Since Sylvania first applied the scientific principle of "Surround Lighting" to the face of a television set in July, 1951, HALOLIGHT has been the No. 1 feature of the television industry . . . the sensation of retail selling of TV sets.

In a store-window, HALOLIGHT attracts crowds and builds traffic. On the floor, it's a stand-out—the only TV set that looks different, is different, sells itself!

Ask your distributor to show you HALOLIGHT built into both 17" and 20" Sylvania TV sets—NOW!

\*Sylvania Trademark



The LINCOLN—DeLuxe 17" Television, Radio-Phonograph Combination with HALOLIGHT. Pull-out, all-speed record player and a generous size album compartment. Your customers will love this concert grand of home entertainment. In Mahogany or Blonde.



The JEFFERSON—20" Mahogany Console with Doors, featuring HALOLIGHT. A magnificent instrument in a handsome Hepplewhite cabinet—styled by Cedric Errol Millspaugh. Here is HALOLIGHT Television that sells on sight!

**SCIENCE MAKES IT BETTER!**

**SYLVANIA**  
**TELEVISION**

**Truly Modern Radios by SYLVANIA**

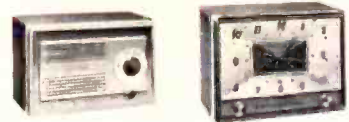

NEW, colorful, dependable—in colors to suit every taste and decor.

Radio-Clock wakes you to music, turns itself off when you sleep, controls any appliance.

Trim, modern Table Radio, like Radio-Clock, has an unusually large speaker and a built-in antenna.

Real sales-winners, both of them—and big volume builders for your store!

TELEVISION SETS; RADIO TUBES; TELEVISION PICTURE TUBES; ELECTRONIC PRODUCTS; ELECTRONIC TEST EQUIPMENT; FLUORESCENT LAMPS, FIXTURES, SIGN TUBING. WIRING DEVICES, LIGHT BULBS; PHOTOLAMPS; RADIOS. SYLVANIA ELECTRIC PRODUCTS INC., RADIO & TELEVISION DIVISION, 254 RANO STREET, BUFFALO 7, NEW YORK

# Directory of Manufacturers

<b>SOUTH RIVER</b> 46-48 Jackson St., South River, N. J.	4	<b>THOMPSON PRODUCTS, INC.</b> 2196 Clarkwood Rd., Cleveland 3, Ohio	1	<b>WALNUT MACHINE CO.</b> 1529 South Walnut St., South Bend 14, Ind.	1, 4
<b>SPIRLING PRODUCTS CO.</b> 60 Grand St., New York, N. Y.	1	<b>TOWERS CORP.</b> 3332 E. 55th St., Cleveland 4, Ohio	4	<b>WARD PRODUCTS CO.</b> 1523 East 45th St., Cleveland, Ohio	1
<b>SQUARE-ROOT MFG. CORP.</b> 391 Saw Mill River Rd., Yonkers, N. Y.	1	<b>TRICRAFT PRODUCTS CO.</b> 1535 No. Ashland Ave., Chicago 22, Ill.	1	<b>WELLS &amp; WINEGARD</b> Burlington, Iowa	1
<b>STANDARD COIL PRODS. CO. INC.</b> 2329 No. Pulaski Road, Chicago 39, Ill.	3	<b>TRIO MFG. CO.</b> Griggsville, Ill.	1-2-3	<b>WIND TURBINE CO.</b> West Chester, Pa.	1-2
<b>STANLEY SALES CO.</b> 600 West 3rd St., Owensboro, Ky.	3	<b>TRU-WORTH PRODUCTS CO., INC.</b> 5401 Berks St., Philadelphia, Pa.	1	<b>WOODLAND MFG. CO.</b> 416 Woodland Ave., Toledo 2, Ohio	1
<b>TECHNICAL APPLIANCE CORP.</b> Sherburne, N. Y.	1-3	<b>THE TURNER CO.</b> Cedar Rapids, Iowa	3	<b>THE WORKSHOP ASSOCIATES</b> 135 Crescent Rd., Needham 94, Mass.	1
<b>TEL-A-RAY ENTERPRISES, INC.</b> Box 332, Henderson, Ky.	1	<b>TV PRODUCTS</b> 152 Sanford St., Brooklyn, N. Y.	4	<b>MANUEL ZIMBEROFF &amp; ASSOCIATES</b> 514 Diversey Parkway, Chicago 14, Ill.	1
<b>TELE-CLEAR CORP.</b> 185 N. Wabash Ave., Chicago 1, Ill.	1	<b>TV WIRE PRODUCTS</b> 102 Prospect, Burbank, Calif.	4		
<b>TELE-TRONICS, INC.</b> 5738 Elston Ave., Chicago 30, Ill.	1	<b>U. H. F. RESONATOR CO.</b> 224 Seventh St., Racine, Wisc.	1		
<b>TELEVEX MFG. CO.</b> 1031 E. Olympic Blvd., Los Angeles, Calif.	1	<b>UNIVERSAL YONKERS CORP.</b> 137 Alexander St., Yonkers 2, N. Y.	1		
<b>TELEVISION ASSOCIATES</b> 140 Pennsylvania Ave., Manchester, New Hampshire	1	<b>VERI-BEST TEL. PRODUCTS, INC.</b> 655 Main St., Westbury, L. I., N. Y.	1		
<b>TELE-EX-PAND PRODUCTS SALES CORP.</b> P. O. Box 392, Berwick, Pa.	1	<b>VIDEO ACCESSORY MFG. CO.</b> 1410 E. 11th St., Tulsa 10, Okla.	4		
<b>TELREX, INC.</b> 26 Neptune Highway, Asbury Park 8, N. J.	1	<b>VIDEO ASSOCIATES</b> 1821 Adams St., Toledo 2, Ohio	1		

**Cracked plastic cabinets** on radio or TV receivers may be easily and neatly repaired by (1) applying carbon tetrachloride along the crack on the inside of the cabinet, (2) applying radio cement the full length of the crack, and (3) placing one-inch gauze bandage over the crack. Then press smoothly and apply a little more cement on top of the bandage. While drying, use a weight to keep the crack closed tightly.

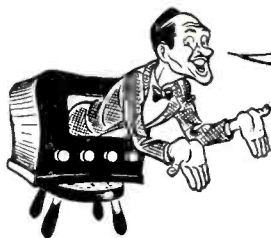

**PHOENIX GIVES  
EXTRA GAIN  
FOR MORE  
LIFELIKE  
PICTURES!**

**Phoenix Antennas Go Up Faster—Stay Up Longer!**

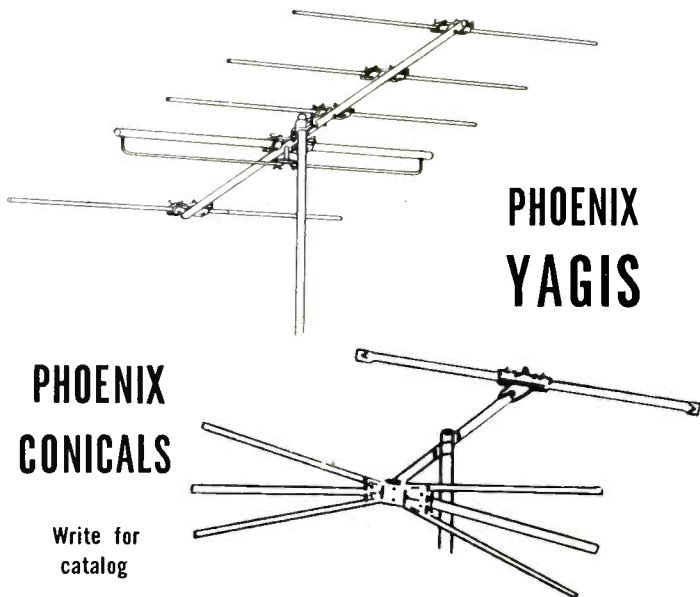

**PHOENIX  
YAGIS**

**PHOENIX  
CONICALS**

Write for  
catalog

**PHOENIX ELECTRONICS, Inc.** LAWRENCE MASS.

## Chicago Proclaims "Electronics Week" as Honor to Parts Show

The week of May 18th, 1952 has officially been proclaimed as "Electronics Week" in Chicago to coincide with and honor the two major industry shows, the Electronic Parts Show and the Audio Fair which are both being held there that week. In sending the proclamation to the Radar-Radio Industries of Chicago, Inc., Mayor Martin H. Kennelly said that he expects this group to act as unofficial hosts to the thousands of industry leaders who converge on Chicago during the week of May 18th.

Eight trade groups, including the five co-sponsors of the Electronic Parts Show, will be represented in Chicago during the week. The Show sponsors include: The Radio Television Manufacturers Association; the National Electronic Distributors Association; the Association of Electronic Parts and Equipment Manufacturers; the West Coast Electronic Manufacturers Association and the Sales Managers Club Eastern Division.

### Channel Master Mount

Mfd. by Channel Master Corp.,  
Napanoch Road, Ellenville, N. Y.

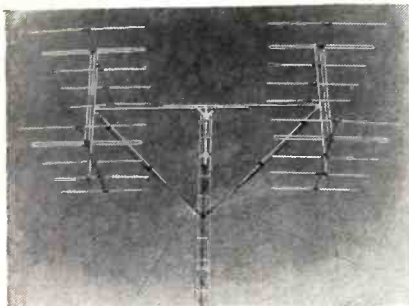

The "Super Mount" is a ready-made mounting structure designed to permit side-by-side stacking of four antenna. Possible mounting include: four low-band Yagis for a single channel; two pair of Yagis for two different channels, and any combination of broad-band and Yagi antennas on one mount. A four-bay array of this firm's Z-Match Yagis installed on this mount is considered able to produce more than 15 DB gain on the low band.

Say you saw it in *Radio & Television Journal*, March, 1952

### Amplitel's Amplifier

Distributed by Amplitel, Inc.,  
362 West 57th St., New York, N. Y.

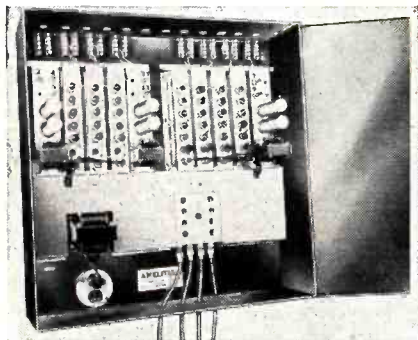

This amplifier for a master antenna system is designed to operate at from 250 to 5,000 microvolts, is stagger-tuned, with strips provided for low and high bands. Channel strips use four 6AQ5s and a 6AQ5 or 6AN5 in the output stage. Output and voltage at final tube plate approximately one volt. High-channel strip uses five 6AK5s and one 6AN5. Mixing unit of band-pass filters, from which outputs are fed to common buss. This is distribution system source of power.

Say you saw it in *Radio & Television Journal*, March, 1952

### Taco Twin-driven Yagi

Mfd. by Technical Appliance Corp.,  
Sherburne, N. Y.

This Super 980 antenna was designed for the extreme fringe areas. Containing a five-element design twin-driven Yagi, the antenna consists of three parasitic elements, two directors, one reflector, and two driven elements. High front-to-back ratio is helpful in areas affected by co-channel interference.

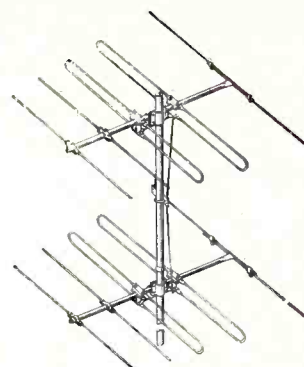

## Keep Picture Quality UP Keep Service Calls DOWN



JUST PRESS THE BUTTON,  
SPRAY IT ON —  
NO SPECIAL  
EQUIPMENT NEEDED!

### Spray on antenna and lead-in terminals

Krylon prevents corrosion and pitting, even in salt-spray areas. It seals antennas and connections in a waterproof acrylic (not vinyl) blanket. (When aluminum finish is desirable, use special aluminum Krylon.)

### Spray on high voltage circuits

Spray Krylon on the high voltage coil and insulation . . . in the socket of the high voltage rectifier . . . on component parts of rectifier circuit. Helps prevent corona because of its high dielectric strength.

Two types — clear and non-conducting aluminum. Both have exactly the same qualities. Packed in 12 oz. aerosol spray cans. List prices: \$1.95 clear, \$2.25 aluminum. Also available in gallons for application by brushing or dipping. See your jobber, or write direct.

**KRYLON, INC., Dept. 2603**  
2601 No. Broad St., Philadelphia 32, Pa.

Advertised in  
"The Saturday  
Evening Post"

**THE ACRYLIC SPRAY THAT PREVENTS TV TROUBLE**

## CBS Uses RCA's Tricolor Tube to Demonstrate All-Electronic Color System

Early this month the Columbia Broadcasting System demonstrated for the first time an all-electronic system of color television operating with the CBS color television system. The experimental receiver employed an RCA all-electronic color tube, and therefore eliminated the need for any moving mechanical parts, which was one of the drawbacks of the rotating disc system. The demonstration took place at the annual Convention of Radio Engineers at New York's Grand Central Palace.

Although the demonstration seemed to remove the mechanical features of the CBS color system, many observers at the show remarked that the system still remained "incompatible" because it does not permit the reception of color pictures in black-and-white without some kind of adaptor to the receiver.

The showing was of particular interest because it brought together, even if momentarily, the two arch-opponents of competing color systems. According to Adrian

Murphy, President of CBS Laboratories Division, "This demonstration shows the complete flexibility of the CBS color television system. Although the all-electronic system today uses the RCA tube, the CBS system can use any type of color tube yet conceived, including the so-called 'Lawrence' tube."

But RCA's vice president Dr. C. B. Jolliffe countered with: "Use of the RCA tricolor tube by the Columbia Broadcasting System proves what RCA has been saying for many years—that the mechanical disk is outmoded and obsolete. But even with a tricolor tube instead of a spinning disk, the CBS color television system remains incompatible.

CBS, by using RCA developments, such as the tricolor tube, is moving step by step toward the practical color television system developed by RCA. But CBS must still take the most important step, and that is to abandon its incompatible system and adopt the RCA system which is completely compatible."

## Novel New Display For Sylvania's Halolight

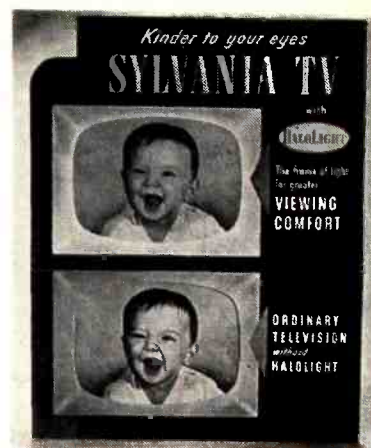

*In this new illuminated display for counter or window, the Halolight feature of Sylvania's television sets is dramatically presented. Identical translucent screens, simulating images on a TV tube, are lighted alternately from behind to show how Halolight makes the upper picture seem brighter and larger than the lower picture, which has the opaque framing of the ordinary TV set.*

## Hoffman 24-inch TV

Manufactured by Hoffman Radio Corp., 3761 South Hill St., Los Angeles, Calif.



Featured in this custom television console is a 24-inch picture tube. Twenty tubes, plus two rectifiers, are used in the set. Automatic gain control; front picture controls; color adapter plug; 12-inch concert-type speaker. Hand-finished cabinet is in white oak.

*Say you saw it in Radio & Television Journal March, 1952*

## THE MOST COMPLETE LINE OF TV CABINETS IN THE COUNTRY

River Edge... superb quality by skilled craftsmen. All cabinets are custom made, all with hand-rubbed finishes... table models, open face consoles, combinations, with bars, sliding doors, swivel bases, and many other fine features.

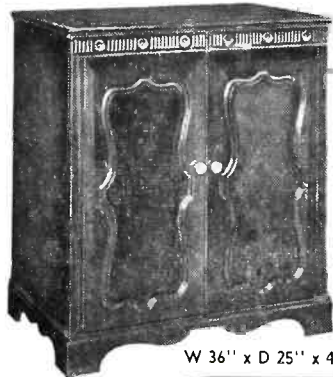

W 36" x D 25" x 41"

A typical example is the M-111 shown, which will accommodate up to 24" tube with or without record drawer, made of solid mahogany and mahogany veneers. A complete line of conversion cabinets available with adaptable masks made to fit all name brand chassis. River Edge Industries defies all competition with complete price range retailing from \$40 to \$400.

### Write for catalog

New territories open for Representatives, Distributors and Jobbers.

## RIVER EDGE INDUSTRIES

River Edge, New Jersey, ORadell 8-0900  
N. Y. Showroom: 192 Lexington Ave., CHickering 4-2120



*How come you  
sell so many  
picture  
tubes,  
Sam?*



"I'm using the CBS-Hytron Easy Budget Plan, Joe. My CBS-Hytron distributor gave it to me."

"Tell me more."

"Well, CBS-Hytron's Plan helps me sell TV picture tubes and service to many a customer who just doesn't have \$50 cash. Now I make sales I'd lose otherwise. My customer pays for the job painlessly a few dollars a month. Yet I get my cash right away — and can discount my bills with my distributor."

"Fine! How does it work, Sam?"

"Simple. I introduce my customer to the finance company authorized by CBS-Hytron. The finance company does the rest. Acts as my credit department to secure me against losses. Takes care of all the details . . . paper work, collections, etc. My customer gets his tube and I get my cash — at once."

"That's swell, Sam. Now I can see why you always have plenty of working capital."

"That's right. And talk about service! This CBS-Hytron Easy Budget Plan has even brought me immediate cash from old accounts I'd written off as bad debts. CBS-Hytron is perfectly willing, too, that my regular budget loans include my service work and other components besides CBS-Hytron tubes. I owe my CBS-Hytron distributor a vote of thanks for letting me in on this wonderful Plan."

"Fair enough! I've sure been losing sales I shouldn't, Sam. I need the CBS-Hytron Easy Budget Plan. CBS-Hytron tubes are tops, too. Thanks for the tip. I'll see my CBS-Hytron distributor today."



**SAVE THE SALE** No need for you to miss a single profitable picture-tube sale . . . just because your customer does not have the cash. Get the details on this original CBS-Hytron service for you. See your CBS-Hytron jobber . . . or mail this coupon . . . today!



MAIN OFFICE: SALEM, MASSACHUSETTS

HYTRON RADIO & ELECTRONICS CO.  
SALEM, MASSACHUSETTS

Please rush me details on the CBS-Hytron Easy Budget Plan.

NAME \_\_\_\_\_ (Please print)

STREET \_\_\_\_\_

CITY \_\_\_\_\_ STATE \_\_\_\_\_

## "We Have to Sell Ourselves Out of the Woods"

By H. B. Price, Vice President

National Appliance & Radio-TV Dealers Association

You have to create customer magnets and you have to dare to be different if you expect to get your full share of the television-radio-appliance business this year. Too often we dealers tend to think of customers in terms of mass rather than as individuals. That's rather unflattering. Our customer thinks of us as his partner in planning her home. Let's make her feel she's important to us.

Finding new prospects is no more a fixed, pre-set pattern of action than finding a new location for uranium. Go to the same old places with the same old methods and you'll find you're in territory your competitors reached first and mined over pretty thoroughly. Dare to be different though, and they'll come panting onto the scene, order books in hand, long after you've left that ground for more fertile territory.

There are three basic types of dealers: (1) The Merchandising Type—This operation depends on volume, spends a great deal of money advertising, has a Class A exposure to customer traffic, depends on short profit leaders to build volume and has no

out-of-store salesmen activity; (2) Strictly Specialty—Probably situated so that newspaper advertising is too expensive for their market coverage, must go out after business, pay higher commissions and depends on specialized services to compete with larger competitors, and, (3) Combination of the Two—Uses inside and outside activity properly balanced.

There is room for all three types, but you must recognize the category in which you belong. Trying to operate out of character could be costly. First, you must qualify your operation and plan your program. Second, acquire and train adequate sales personnel. It is here we have failed so miserably. Our future hangs on this and you must be willing to take time to bring into your organization men who can sell and who have vision and who will work for mutually better profits and greater security.

We can't buy or finagle ourselves out of the existing problems. We will have to sell ourselves out of the woods. You have a lot at stake — mainly to recapture the confidence of your public and suppliers and to rebuild confidence in yourselves.

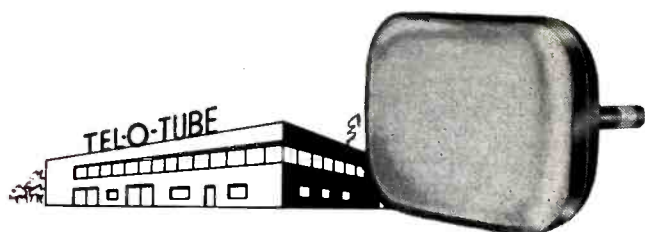

# TEL O TUBE

The World's Finest Television Picture Tube

10 to 20 inches Round and Rectangular

## Electrostatic Focus Tubes

Send Today For Complete Specifications

**TEL-O-TUBE CORPORATION OF AMERICA**

E. PATERSON NEW JERSEY

Sales Office: Tel-O-Tube Sales Corporation

580 5th Ave. New York 19, N. Y.

### A SHORT, SHORT STORY . . . .

## "HOW TO MAKE MONEY AND INFLUENCE SALES"

BY TRANS-VUE - JACKSON

1. You buy at "direct from factory" prices!
2. You eliminate middleman's profits . . . they're yours!
3. You sell for less than other brands!
4. You have greater mark-up than on any other line!
5. You buy the finest engineering possible!
6. You sell the smartest furniture!



You buy and sell the finest television obtainable—at prices that are incomparable—anywhere—by anybody.

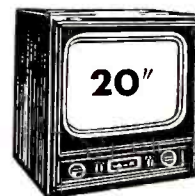

**YOU MAKE MONEY WITH TRANS-VUE-JACKSON!**

## TRANS VUE-JACKSON

500 E. 40th St.

CHICAGO 15

Manufacturers of Customized Television

## Committee of Manufacturers and NPA Review 1952 Outlook for Antennas

IF television dealers show a willingness to buy antennas made from substitute materials, the estimated 1952 demand for eight to 11 million antennas can be met, according to a report issued by the Antenna Manufacturers Industry Advisory Committee after a recent meeting with the National Production Authority, U. S. Department of Commerce.

NPA admitted that the antenna industry has displayed much ingenuity in finding alternates for scarce aluminum and copper. But there has been slow public acceptance of such functional substitutes as wood masts and cross bars (silver-plated or incorporating a conductive element), plastics, fibre glass rods and steel. Committee members pointed out that this placed those manufacturers using such materials at a serious competitive disadvantage.

These same committee members stressed that unless NPA issues a conservation order imposing limitations on the industry as a whole, this competitive disadvantage will continue.

Growing popularity of TV in the fringe areas where difficult reception requires the use of two to five "bays" to obtain good images on the TV screen was cited by the committee as a significant contributing factor in the total demand estimate. Members noted in such areas a trend away from all-band antennas to antennas with bays tuned to specific channels.

The estimate of the 1952 demand of eight to 11 million antennas was reached by committee members, who surmised that antenna replacements would be needed for half the four to five million TV sets installed before 1950. They added to this figure an estimate of six to eight million new antennas.

NPA's calculation of the number of TV receivers, one factor which governs antenna production, which can be made with anticipated 1952 allotments of controlled materials was set at three to four million units. This figure is more conservative than the antenna representatives' fore-

cast of the demand for new antennas.

According to NPA figures, of the 16 to 17 million TV sets now in use, slightly more than five million were made in 1951, about seven and one-half million in 1950, and from four to five million before 1950.

In a breakdown of antenna types, NPA pointed out that 60 per cent of production of television antennas goes for outdoor installation, 30 per cent for indoor use, and 10 per cent for incorporation within the receiving sets.

Since allotments of steel, copper, and aluminum are figured on the base period as the first half of 1950, the committee protested that the growth factor made this period unsatisfactory, advocating the whole year of 1950 or 1951, or even a recent high production quarterly period. Committee members pointed out that antenna production lags by three or four months behind TV receiver set production.

NPA stressed the need to increase conservation of aluminum for the rest of the year until greater production of this scarce metal is available.

Conservation measures discussed included the possibility of limiting use of tubular aluminum to components (thus excluding masts), reduction in diameter and wall thickness of elements, use of alternate materials or design, and limitation of maximum aluminum use in a bay of two and a half pounds.

Several manufacturers reported their practice already meets the suggested bay maximum. Two have abandoned the use of aluminum foundry castings and are using steel stampings instead. One producer reported that by standardizing his product he has reduced his materials waste from seven per cent to a tenth of one per cent, and has cut his aluminum usage from an average of 3.1 pounds per antenna to less than one pound.

It was admitted that lifting of the TV station construction freeze by the FCC would radically alter antenna demand.

**SO IMPORTANT** — it was  
Featured in Special Article  
in

**The New York Times**

Jan. 28, 1952

FREE copy  
of article on request

### UNIT REACTIVATES TV PICTURE TUBES

Small Electronic Device Tests  
Sets at Home and May Add  
Year or More of Use

By T. R. KENNEDY Jr.

A small electronic device that can be applied to home television receivers to test and reactivate the picture tube without removing it from the set, resulting in renewed brightness in many and continued useful life, has been placed on the market for the first time by a New York manufacturer.

In some cases, it was said, the picture tube may be made almost as good as new and given as much as a year's useful life before replacement is necessary. The instrument is small and compact. It weighs three pounds, is as large as the average lunch box, costs little and is simple to operate. Picture tubes, some of them now and never in a receiver, have shown remarkable improvement in brilliance and definition after a few minutes of reactivation in the last few days.

Although the principle of its operation is not new—cathode-ray tube manufacturers have used it for years in the initial making of picture tubes—its incorporation

The almost immediate urgent need for such an instrument, which also soon may be produced in kit form for home assembly, is apparent. Eight to ten million TV picture tubes, Transvision engineers estimate, have now been in use for three to four years or more, and "probably are in need of test and reactivation to 'renew' their brightness." Unfortunately, their loss of brightness, it was pointed out, seldom can be detected short of comparing the old tubes with new ones in lately produced sets.

Furthermore, picture tubes in their original state may have lost some of their brightness, which has been described as a "kind of aging process" to which all large cathode-ray tubes and similar devices are subject. Such tubes, in the current sizes most in use today, cost from \$25 to \$55.

New picture tubes can be tested and reactivated without removing them from their cartons, and tubes in TV sets without removing them from the receivers. It is done by attaching a standard picture-tube socket to the new instrument, turning a switch on the tester-reactivator, and noting the glow of a small neon bulb as a condition of the tube is indicated directly on a dial of the tester, which is plugged into an AC home electric socket. The receiver, meanwhile, is not turned on.

In some cases the test and reactivation is accomplished in less than a minute.

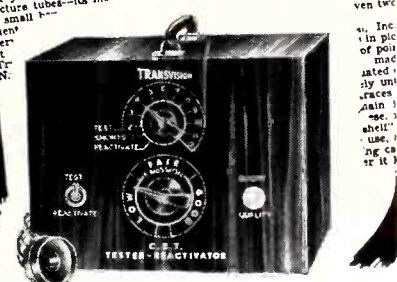

## TRANSVISION CR TUBE TESTER - REACTIVATOR

performs 2 vital functions:

- Tests Picture Tubes
- Renews Brightness of Many Dim Picture Tubes

It's a **TESTER**:

Without removing picture tube from set, you apply this precise instrument to:—

- Measure Cathode emission
- Locate shorts between elements
- Locate high resistance shorts or leakage as high as 3 megohms

It's a **REACTIVATOR**

for dim CR Picture Tubes

Revives dim TV Picture Tubes, without removal of tubes from sets. Works on a great many tubes with low light output, if there's no mechanical defect in tube. 110 V—60 cycles. Portable, weighs only 3 lbs. One or two applications pays for instrument.

**SATISFACTION GUARANTEED** \$19<sup>95</sup>  
or money refunded if you return the instrument in 10 days in good condition. **NET**

—RUSH THIS COUPON—

TRANSVISION, INC.

DEPT. RJ3 NEW ROCHELLE, N. Y.

( ) Send me CR Tube Tester-Reactivator(s).

( ) Enclosed find \$\_\_\_ deposit. Balance C.O.D.

( ) Enclosed find \$\_\_\_ in full. Send prepaid.

Name \_\_\_\_\_

Address \_\_\_\_\_

City \_\_\_\_\_ State \_\_\_\_\_

# Charlie Schultz Sez: "Give Them What They Want"

(Continued from Page 29)

to demand from its dynamic director. Cutting through in an "L" shape from its original store at 106 Prince Street, the store expanded by adding much additional space fronting on Morton Street. For the convenience of his customers, for their comfort and their good will, Charlie Schultz had air conditioning installed throughout the store.

Early in the program, it was decided that only the top names would be carried by the Prince Range store.

## Aggressive Selling

Today most retailers are beginning to realize, if they haven't already, that the day of "order-taking" is gone, that aggressive selling is necessary to turn inventory into profits. The Prince Range store never was an "order-taking" store. Charlie Schultz's salesmen know how to sell, know how to develop the qualities and good points of every piece of merchandise on the Prince Range floors. They know what the customer wants to know about the features of products. They know because Charlie Schultz has made it important that they know, and his constant insistence on their "knowing their goods" has paid off. Frequently Charlie

Schultz receives letters from satisfied customers thanking him for the treatment accorded them by Prince Range salesmen. Invariably they express a continued interest in the store and assure him they will be back in the future when they have other product needs.

Salesmen at Prince Range receive substantial salaries plus special bonus monies for stepped-up sales. They are not mere order-takers. They know how to cater to human wants and needs and are powerful closers. Irving Friedman, general manager of the store, keeps the sales organization constantly on its toes. A series of semi-monthly sales meetings are held to key timely sales efforts and to lay plans for various special and seasonal sales concentration drives. At weekly meetings executives and sales people make a point of exchanging information. Twenty-two salesmen round out the sales organization at the Prince Range store. For the development of leads stirred up by television, radio and newspaper advertising plus those created by billboards and telephone directory ads, a group of outside salesmen is employed. Elsewhere throughout the State several hundred indirect salesmen on commission, with routes

and leads of their own, are constantly pushing Prince Range products and the Prince Range name.

## Service Efficiency

Recognizing that an efficient service organization is the heart and main-spring of the store itself, Charlie Schultz insists that his service operation be without equal. Having for many years offered one of the widest selection of gas and electric ranges in the Newark area, the firm soon discovered that the answer to good service was specialization, and now has three range experts on its staff. Charlie Schultz follows the same pattern of technical competence in developing his television service staff. Under Arthur Luft, service manager, are shop men, technicians, antenna teams and trucks. Four girls handle service calls and routing details. The staff knows that Charlie Schultz insists only good work is acceptable. No shoddy installations can get by.

At Prince Range for the future the merchandising slogan is "keep on your toes and sell." And Charlie Schultz insists that his whole organization remember that every person whether he comes from the far end of New Jersey or from Brooklyn is "his customer."

## Personalities

"THE appliance business is not very much different from the television and radio business," believes Walter J. Daily, who as vice-president of the Lewyt Corporation has helped powerfully to convert the vacuum cleaner into an appliance which dealers could merchandise successfully. Daily's ruddy, healthy complexion and strong, friendly handshake belie the fact that he has been in sales for many years and has an abiding faith in the dealer and his ability to move products into customers homes providing "we give him the information and the enthusiasm to do the job."

The number of labor-saving appliances in the home such as dishwashers, vacuum cleaners and automatic clothes washers is constantly increasing, and one of the reasons is television, says Daily.

(Continued on Page 86)

## IN SALESMANSHIP





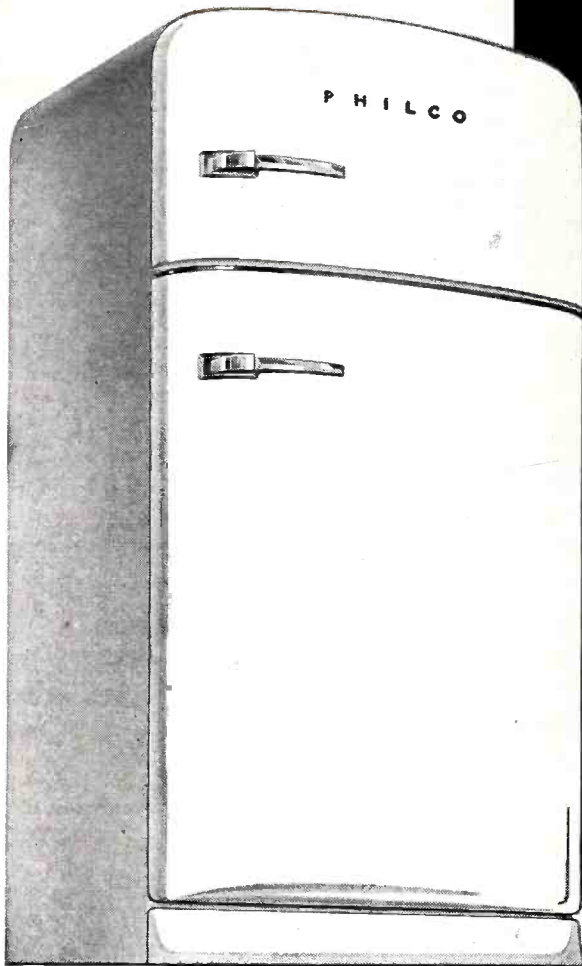

*Now at  
Precedent-Shattering  
New Low  
Prices!*

**PHILCO**  
**Two-Door Refrigerators**  
**with Automatic Defrost are**  
**sweeping the country**



The returns are in . . . from distributors and dealers everywhere, the enthusiastic word is that Philco is offering in 1952 the greatest merchandising package in the industry . . . *the two most wanted features in one superior quality refrigerator—TWO DOORS WITH AUTOMATIC DEFROST . . . at prices lower than competitive single door refrigerators . . . and up to \$100 less than other two-door refrigerators!*

Built to the highest Philco quality standards, these Super Powered Advanced Design refrigerators are an engineering and merchandising triumph. True automatic defrost . . . huge freezer space for up to 70 pounds of frozen foods . . . deluxe in service and convenience from top to bottom.

And remember, Philco offers not one but a choice of two-door models . . . a complete new line for '52 . . . in large quantity shipments. Now, Philco dealers exclusively can provide two-door refrigerator luxury and convenience at volume market prices! Get your share of this profitable market.

*Profit Packed—  
Feature Packed—  
Value Packed—*



**PHILCO TWO-DOOR REFRIGERATORS WITH AUTOMATIC DEFROST FOR '52**



• Perfecting plans for the 1952 NEDA Convention and Manufacturers' Conference are: seated left to right, L. B. Calamaras, executive v-p NEDA; Aaron Lippman, 1952 chairman; and Albert Steinberg, Philadelphia. Standing, left to right, are: A. C. Stallman, Ithaca; H. D. Stark, Minneapolis; D. W. Mack, Scranton; M. Green, Philadelphia, and B. C. Deadman, Green Bay, Wisc.



• Capehart signs on a new Texas distributor. Ralph Ness, district appliance manager, Graybar Electric Co., Inc., Dallas, inks a distributor franchise as, left to right, L. J. Collins, Capehart's director of sales, and Ed Grimes, Graybar's radio-TV manager, look on.

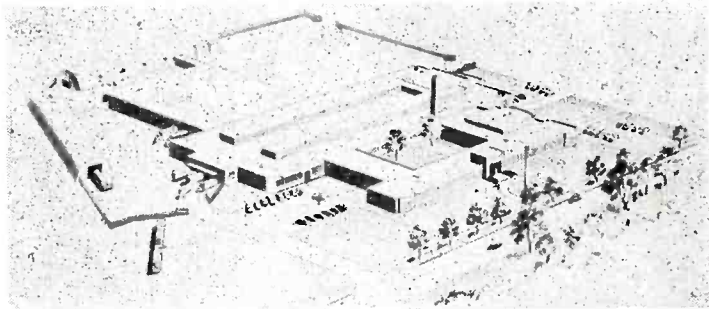

• Plant expansion at Sentinel Radio Corp. added 49,500 feet of production floor space. Included was main factory extension providing straight-line TV assembly, one of which runs 1,848 feet. Civilian and defense production is expected to run over \$30 million for next 12 months.

**RTJ**

*Journal*



• S. M. Fassler, manager of advertising and sales promotion, General Electric's receiver department, shows enthusiasm for the new window display, which commemorates the firm's 25 years in TV.



• At a countrywide series of recent meetings, distributors were shown the new look in Raytheon radios by, left to right, G. L. Hartman and William Helt, general sales manager and assistant general sales manager, Belmont Radio.



• Both Lou Schiffner, seated, general manager of Morris Distributing Co., Scranton, Pa., and William Griffin, district manager for the Hallicrafters Co., seem pleased over the appointment of the Scranton firm as exclusive area distributor.



• Phalanx of speed kings poised on the ice at Grossinger's Hotel and Country Club. Center of huddle, McDermott, Red Sox hurler, supported by Sid Pariser, president, and Marty Betty, sales manager, RMS.



• Above is the new home of Press Wireless Mfg. Co., Inc., Rockville, Conn., recent acquisition of LaPointe Plascomold Corp. Modern, 4-story brick building adds 156,000 feet of manufacturing space.

Camera

RTJ



• For developing snap-on removable bezel and safety glass, Arthur Eisenkramer, left, staff engineer at Emerson, receives cash award from R. T. Capodanno, director of firm's engineering.



• Patrons of New York's Roxy Theater have been treated to this foyer-presentation of DuMont's 30-inch Royal Sovereign for the past six months. TV fare supplements film attractions.

## Personalities in Salesmanship

(Continued from Page 82)

Television makes such strong demands upon the time of the housewife (and the man in the home) that both have come to feel the need and worth of labor-saving equipment in the home.

But aside from the fact that television can serve as a spark-plug for all the other products in the dealer's store, Daily is of the opinion that the television-appliance business is essentially "showbizness" and this means that the successful dealer is the one who is able to interest the buyer or potential buyer in whatever he is selling.

Phrased another way, it means transferring the enthusiasm and conviction of the seller to the buyer. Showmanship in selling is the method whereby such a transfer takes place, and it may involve advertising, good public relations, good store design and location, efficient buying and stock control, modern personnel practices, or all of these.

The goal of the dealer who aims at retail success is not a simple one, says Daily, who points out that the dealer's problems are complex today because he has so many items to sell that he no longer is thoroughly familiar with any of them.

And thoroughness is one of Daily's major approaches to doing business. It is also one of the big reasons why Lewyt has carved so large a slice of the vacuum cleaner business for itself in so short a time.

It was Alex Lewyt and Walter Daily who made so thorough an analysis of the vacuum cleaner market and its relationship to the television and appliance dealer, that their conclusions turned into diamond-studded possibilities.

Daily, who began in the vacuum business with Premier many years ago, and then worked his way up through every grade of merchandising, advertising and sales, serving with Bendix for four years before joining Lewyt in 1947, has always been a keen student of changes in sales trends and consumer buying habits. He knew, for instance, that in the decade beginning with the 1930's, there began a transition from the

house-to-house pattern of selling because when people spent a considerable sum of money for an appliance, they felt they wanted to trade with the local merchant whom they knew and could see after the sale for service.

This led him to a strong conviction that the dealer who could sell radios and refrigerators and washing machines could also earn a place for himself in the \$300 million a year vacuum cleaner business. This conviction, of course, was more than an intelligent guess—it was based on solid research, and then followed up by powerful and imaginative promotions such as the "Market Place," which for the first time provided the dealer with a convenient area in which he and his salesmen could demonstrate a Lewyt cleaner. And since a good demonstration is the heart of the sale, the Market Place became a huge success.

Daily, whose diminutive stature belies that he was intercollegiate wrestling champion at Yale, Class of 1917, still continues to use the tactics of the athlete and wrestler in tackling new problems. First he carefully analyzes his opponent, the problem; then he figures out his strategy (plans his holds) and then goes to work with sure courage and strong grip. "A good salesman can get five names from a customer and each of these persons can supply five more."

Daily is a great one for promotions at the dealer level, because he knows from experience that a dealer who uses a window display will sell about three times as many units during a promotion as the dealer who does not use one. "The dealer who uses a window display and fully-equipped store display will out-sell a dealer who uses neither a window display nor a store display by a margin of eight to one," he maintains.

Whether it be free premiums which dealers give to prospects (and arrange for home demonstrations later) or using the telephone as a sales tool, Walter Daily is always preaching the gospel of aggressive salesmanship, or "showsalesmanship" as he calls it.

## New "Sleepytimer" Display



Two Arvin "Sleepytimer" clock-radios can be shown to advantage in this new 23-inch-high display designed for use on dealer counters, in windows or on shelves. One set is placed on floor of the display, the other fits into tilted shelf built into the piece.

## New Regency Booster

Mfd. by Regency Division, I. D. E. A., Inc.,  
55 New Jersey St., Indianapolis 4, Ind.

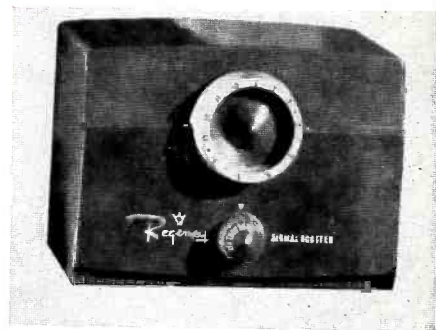

Modern styling is featured in this new television signal booster which incorporates the design highlights of previous television booster models manufactured by this firm: contra-wound bifilar coils with push-pull triode to give balanced circuit; internal impedance matching an input accommodates either 300-ohm parallel line or 73-ohm coaxial cable. Gold-colored metal panel for dial face has given way to simplified dial.

Say you saw it in *Radio & Television Journal*, March, 1952

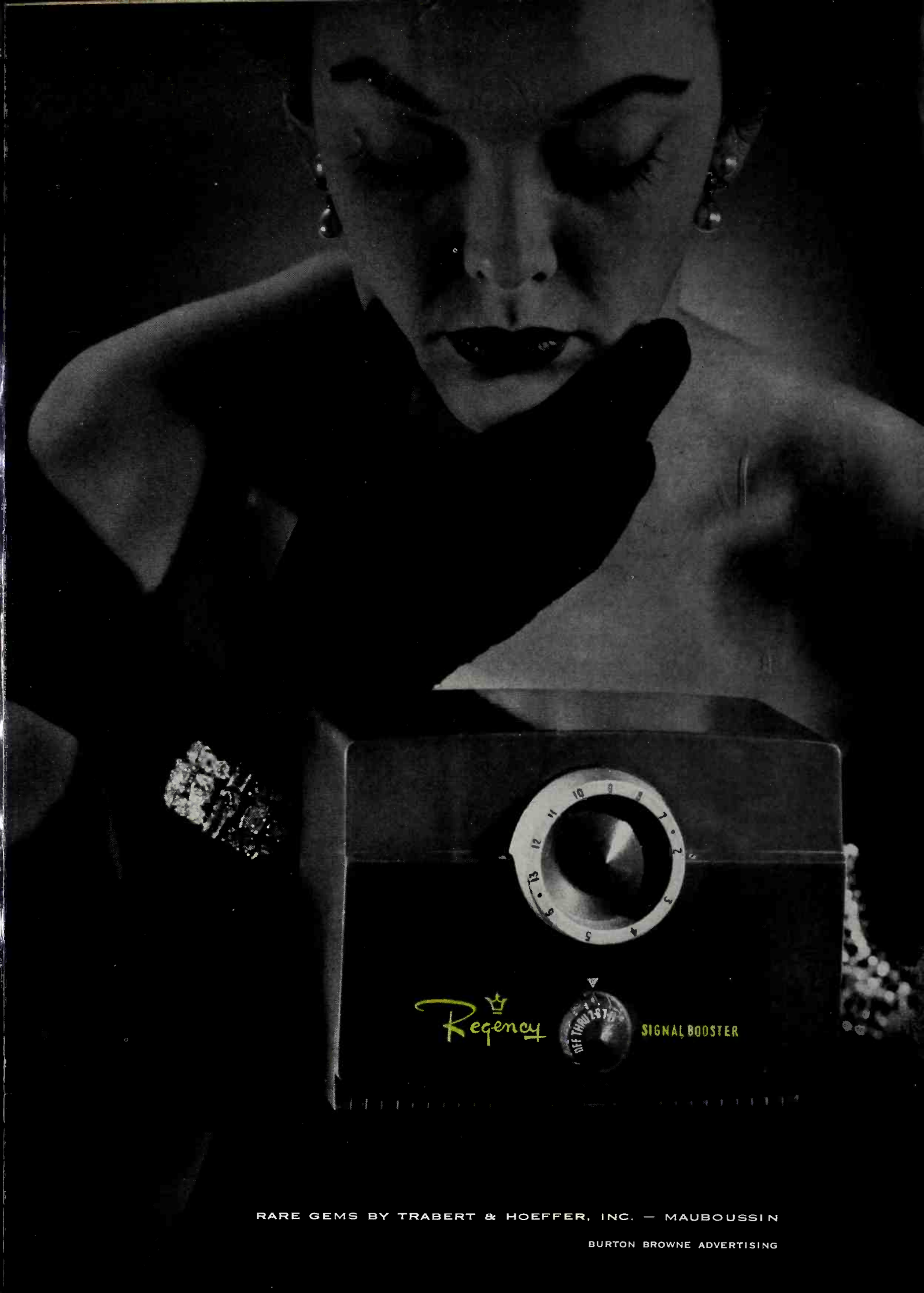

*Regency*

OFF THROUGH

SIGNAL BOOSTER

RARE GEMS BY TRABERT & HOEFFER, INC. — MAUBOUSSIN

BURTON BROWNE ADVERTISING

### New Radios by Jewel

Manufactured by Jewel Radio Corp.,  
10-40 45th Ave., Long Island City 1, N. Y.

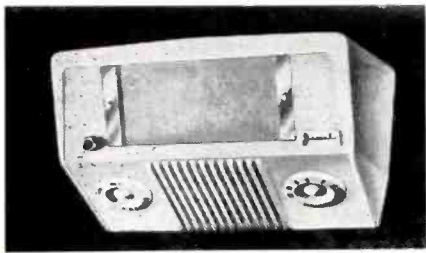

Dual-purpose radio for use on headboard bed or as table model, this new item operates on AC/DC, has superheterodyne circuit. Alnico V PM speaker; built-in 'Duraloop' antenna; high gain iron core IF transformer. Plastic cabinet comes in seven pastel colors.

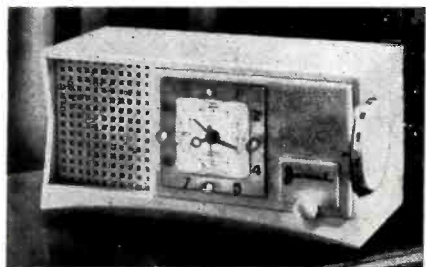

Five tubes including rectifier are used in this clock radio with superheterodyne circuit. Speaker is Alnico V PM. Clock is Sessions self-starting. Turns radio on and off at preset times. Also turns on buzzer alarm ten minutes after radio starts playing, or for waking with radio silenced. Say you saw it in *Radio & Television Journal* March, 1952

### Para-Flux Reproducer

Manufactured by Radio-Music Corp.,  
80 South Water St., Port Chester, N. Y.

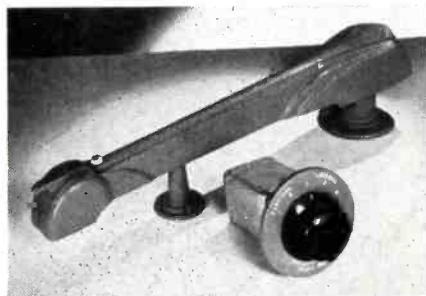

This reproducer is designed to reproduce lateral records, vertical cut transcriptions and LP microgrooves. For use with RMC turntable, featuring silent operation. Catalogue is available on request.

Say you saw it in *Radio & Television Journal* March, 1952

### New Emerson Radio

Mfd. by Emerson Radio & Phono. Corp.,  
111 Eighth Ave., N. Y.

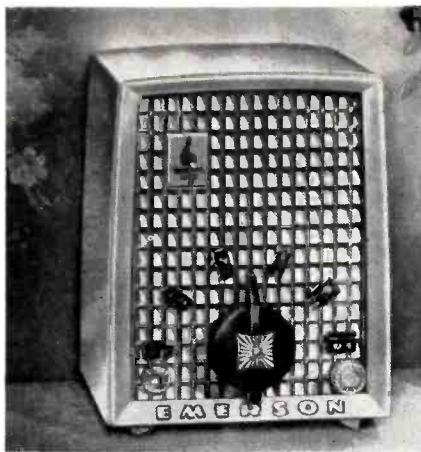

An AC/DC radio designed to incorporate big-set performance in a miniature radio. Cabinet measures 4 7/8 inches wide, 6 1/2 inches high and 4 7/8 inches deep. Uses built-in Ferrite bar loop antenna. Molded of plastic, the cabinets come in assorted solid and pastel colors.

Say you saw it in *Radio & Television Journal* March, 1952

### Hudson's Jr. Juke

Mfd. by Hudson Electronics Corp.,  
110 East 3rd. St., Mt. Vernon, N. Y.



This Jr. Juke console is available either in three-speed model or single-speed model. When phonograph is turned on the light shines through port-holes covered with fuzzy-wuzzy decals, also lighting up record compartment. Jack knife hinge prevents cover from being pushed back too far. Console is available either in ivory or blue lacquer.

Say you saw it in *Radio & Television Journal* March, 1952

### Two Motorola Radios

Manufactured by Motorola, Inc.,  
4545 Augusta Blvd., Chicago 51, Ill.



This town and country portable radio operates on AC or DC current, as well as on self-contained battery pack. Features three gang tuning and extra powerful reception. Plastic grille cloth front, hinged to fold flush into case. Portable is available in maroon, forest green or gray plastic.



Modern styling is accented by a transparent dial on top of the cabinet in this new table model radio. Perforated front serves as grille for oval dynamic speaker. Circuit features improved automatic volume control and distance-reception antenna. Model is available in walnut plastic, ivory or maroon.

Say you saw it in *Radio & Television Journal* March, 1952

### Trans Vue-Jackson Phono

Manufactured by Trans Vue-Jackson,  
500 E. 40th St., Chicago 15, Ill.



An electrically amplified phonograph in durable hard finish plastic. Has 2-tube electrical "Power Pac" amplifier. Plays 78-rpm records only. Operates on 117 volts, 60 cycles, AC only.

Say you saw it in *Radio & Television Journal* March, 1952

# How's this for long distance TV reception?

SCOTTSBLUFF,  
NEBRASKA



965 Miles

HOUSTON,  
TEX.

1,060 Miles

DETROIT, MICH.

1,484 Miles

BALTIMORE, MD.

1,795 Miles

MIAMI, FLA.

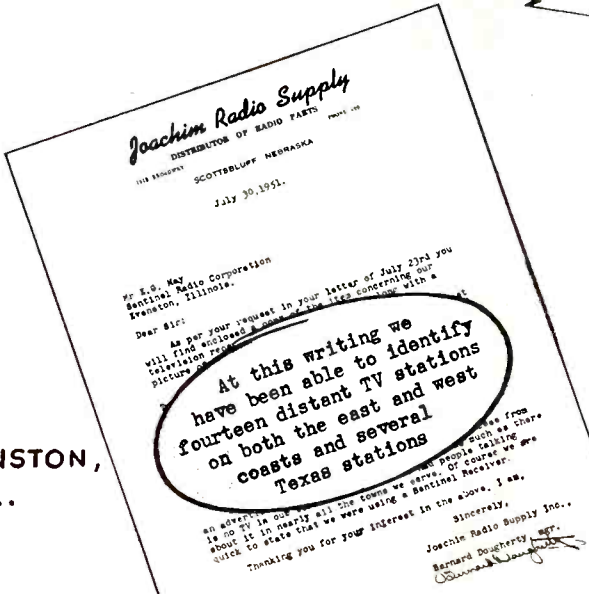

**Sentinel** received this letter from its Scottsbluff, Neb., distributor last summer, with a newspaper clipping and photographs to substantiate it.

Sentinel does not promise you any such miracles, but, Sentinel DOES promise outstanding performance in normal fringe areas. Sentinel invites you to make field tests under the most adverse conditions. See for yourself, in these days of easy claims, why Sentinel stresses PERFORMANCE, not promises!

Call your Sentinel distributor or write direct to Sentinel TODAY.



Above: Model 449-TVM—21" screen. Cylindrical face tube. Mahogany, with superbly matched TURN-table optional.



At Left: Model 447-TVM—17" screen. Mahogany, with stunningly matched TURN-table optional.

# Sentinel Television

SENTINEL RADIO CORPORATION • EVANSTON • ILLINOIS

### New Oxford Speaker

Manufactured by Oxford Electric Corp.,  
3911 S. Michigan Ave., Chicago 15, Ill.

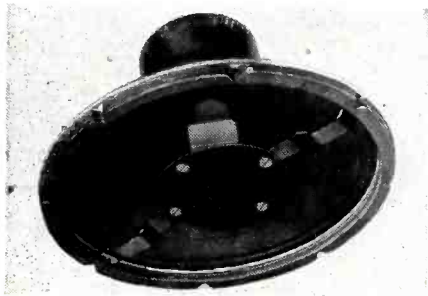

Latest development of this firm is the 12-inch coaxial speaker, designed for AM, FM and TV receivers, as well as for monitoring, recording and other sound installations. Frequency range is 65 to 15,000 C.P.S.; network crossover at 4,000 cycles; power rating 10 to 12 watts; input impedance 8 ohms.

Say you saw it in *Radio & Television Journal* March, 1952

### New Philharmonic TV

Mfd. by Philharmonic Radio & TV Corp.,  
New Brunswick, N. J.



Designed for improved fringe area reception, this console television receiver features a 24-inch black face picture tube. An open face model, it is available in mahogany and blonde. Eight-inch speaker; electromagnetic focus, Casco tuner. Cabinet is provided with a set of casters.

Say you saw it in *Radio & Television Journal* March, 1952

### New River Edge TV

Manufactured by River Edge Industries,  
5 River Edge Road, River Edge, N. J.



One of the leading models in this firm's new line, the P-80 features fine cabinetry craftsmanship in modern design. Available in seven wood finishes, record changer drawer, and bar if desired. Comes with 20-inch or 24-inch picture tube.

Say you saw it in *Radio & Television Journal* March, 1952

*"Positively Amazing Performance!"*

Is what they are all saying about the new ALL-CHANNEL

## GONSET "RADARRAY"

"Model C"

High gain and front-to-back ratio on all 12 channels. No side lobes. Ideally suited where maximum gain is required on several channels, or where ghosts, co-channel or adjacent channel interference problems exist in combination. Eliminates or greatly reduces oscillator interference troubles.

Ruggedly constructed yet light enough to be used on a rotator. Another engineering achievement by the originator of prefabricated open-wire line for T-V. Write for our "Fringe Area" brochure.

Ask Your Jobber or Write Us Today

GONSET CO. 801 S. MAIN ST BURBANK, CALIF.

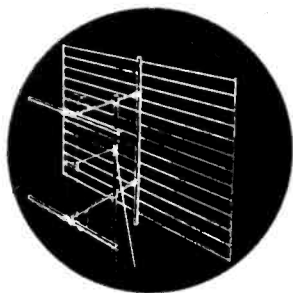

### Ingenious Consolette Base

Manufactured by Goodenow Mfg. Company,  
1405 E. 28th St., Erie, Pa.

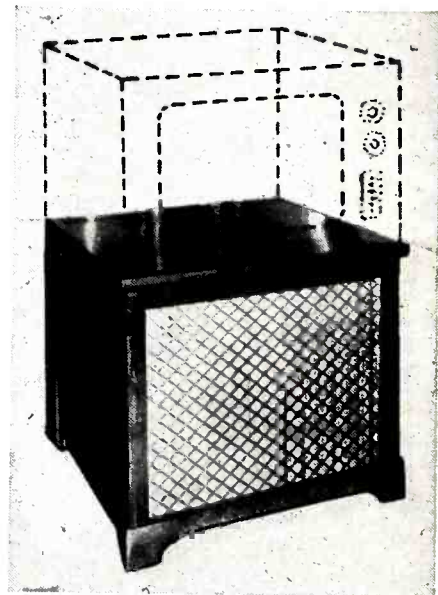

This new consolette base for television is shipped ready for use and requires no assembling. Cabinet is finished with hot lacquer, and is available in mahogany. Grill cloth is multi-toned, and casters make it entirely movable. Base is also available with doors at extra cost.

Say you saw it in *Radio & Television Journal*, March, 1952

## GOOD NEWS!!

Due to the demands of Distributors, Dealers and Friends for the Junior Juke Line, Hudson announces the addition of several new Juvenile models.

The complete new Junior Juke Line will be shown for the first time at the Toy Fair, Room 921, New Yorker Hotel, New York City, March 9th to 19th, 1952, inclusive.

Hudson's reputation has been established on high quality, unusual designs and coverings, and you will find these features in the new models now being introduced.

We look forward to seeing you.

Write for our free catalogue, showing the complete Hudson line of portable phonographs and portable radio-phonographs.

## HUDSON ELECTRONICS CORPORATION

110 East Third Street

Mount Vernon, New York



# IT'S RED HOT

## G-E 20 INCH — \$299.95\*



GET set—get *this* set—for sizzling sales. Here is the one 20-inch TV set that offers—for only \$299.95\*—the power of the General Electric name and all the famous G-E selling points. More picture per dollar than ever. Reserve power that adds 40% to your sales territory. Proved outstanding in side-by-side comparisons. *Genuine mahogany* veneered cabinetry. Costs less to service, say independent/service companies. It's a 25th Anniversary Value from the makers of the world's first home TV set! Model 20T2. Call your G-E TV distributor—now!

General Electric Co., Receiver Dept., Syracuse, N. Y.



### BLACK-DAYLITE TELEVISION

#### NEW 20-INCH G-E CONSOLE

Concealed swivel casters for easy moving, easy cleaning—an *extra* G-E sales point! *Genuine mahogany* veneered cabinet. UHF plug-in. 12" G-E speaker. Model 20C105.

Now \$349.95\*

Also available in *natural blond* veneered wood.  
Model 20C106.



*\*Includes picture tube and parts warranty, but not Federal Excise Tax. Prices and terms subject to change without notice, slightly higher West and South.*

*You can put your confidence in—*

# GENERAL ELECTRIC

## Sound Handbook Offered Free to RTJ Readers

An attractive, interesting and informative manual which tells all about "Hi-Fi" sound installations, public address systems and answers questions relating to all aspects of speakers is now being made available to readers of Radio & Television JOURNAL. The manual, which was prepared by one of the leading authorities in the sound field, describes in detail how to select and install loudspeakers and related equipment. The combination handbook and catalogue should be of particular interest to distributors, dealers, and servicemen and salesmen who want to develop a highly profitable sideline of sound installations tied in with their service and custom departments. While the manual is complete, the language used is non-technical, thereby enabling easy understanding. The booklet is



free and may be obtained by writing on your business stationery to The Editor, Radio & Television JOURNAL, 1270 Sixth Avenue, New York 20, N. Y. Mention that you would like your free copy of the Loudspeaker Technilog.

## Wining and Dining at NEDA—REP Dinner



One of the largest turnouts of distributors and sales reps gathered on January 26 to attend the second annual NEDA-REP dinner and dance at New York's Hotel Commodore. The affair was sponsored jointly by the members of the New York Chapter of the National Electronic Distributors Association and the New York Chapter of the "Representatives." As usual, the affair was characterized by good humor and good fellowship, a "representative" amount of liquid refreshment and speeches by Jules Bressler, Charlie Olstein and James Pickett. Among other NEDA and "REP" officials attending

were: Harry Finkelstein, secretary-treasurer of NEDA, Rubin Green, REP vice president, William Green, REP secretary-treasurer, Wally Shulan, Joe De Mambro, president of the Boston chapter of NEDA. Besides the dinner and the speeches, the group enjoyed a floor show which illustrated acrobatically how the human body can give competition to any electronic gadget. The entire affair was arranged by a joint NEDA-REP committee composed of Milton Fischer, Rubin Green, from NEDA, and Jules Bressler, Dan Bittan and James Pickett from the REPS.

## How Many of These Mistakes in Advertising Do You Make?

A great many dealers have often complained that while they would like to advertise, and know that advertising is the lubricant that builds business volume, they are afraid to plunge into advertising in a big way for fear that they might miss the mark and so waste their money. The fact that this problem is a real one and requires solution, especially in a period of sharp competition such as now prevails, was brought out recently when one of the top executives of a west coast television company struck out at some of the more common advertising ills which beset the industry today.

The speaker (Robert S. Bell, vice-president of the Packard-Bell Company of Los Angeles, said that "without advertising there would not be one-tenth of the television sets in American homes that there are today." Warming up to his subject, he pointed out that advertising pays off very handsomely when it is properly used, but how to use it properly is where the skill lies. He went on to list three general groups of mistakes which experience has shown are made in advertising, particularly in newspaper advertising:

1. "Shotgun advertising"—splitting the budget over too many small ads.
2. Forgetting to advertise the right product.
3. Selling prices, rather than features and advantages customers want.

The fault with "shotgun advertising" is that scattered, small advertising is usually a failure even when expenditures are extensive, and usually happens when the budget is split over many types of media. An easy and successful way of overcoming this type of advertising ailment, says Mr. Bell, is by employing elephant gun advertising—which means large ads with a maximum of continuity. Another of the pitfalls of advertising is that it is easy to become entangled in the mechanics of an ad to the extent that the sales talk about the product itself has been forgotten. It should be remembered, to quote a famous authority on the subject, that "Selling a product through advertising is no more nor less than the transfer of a sincere conviction from seller to buyer."

Selling the price rather than the product is a mistake still perpetrated in the television industry, and the way to correct this habit is by hard work and determination to sell a product on its virtues and its features.

# 3

big talking points

to help you sell

## RCA Room Air Conditioners

### RCA Factory Service

Only RCA offers coast-to-coast, direct-to-consumer Factory Service . . . positive assurance to your customers that every RCA Room Air Conditioner will be installed properly and continue to deliver dependable, care-free performance.

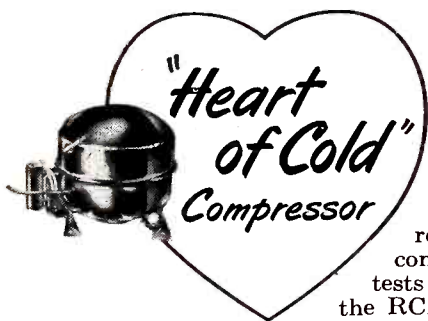

### Top Cooling Capacity

Relief from summer heat is one of the major reasons why people buy air conditioners. In comparative tests among competitive units, the RCA "Heart-of-Cold" Compressor rated tops in efficient cooling capacity! 5-year warranty on the lifetime hermetically sealed cooling system.



### Greater Air Flow

Another thing customers want . . . plenty of air circulation! The RCA "Airflow" Grille was especially designed and engineered to provide widest, fullest air flow to all parts of the room . . . and only RCA has it!

**\* P. S.** RCA Factory Service also means that you make full profit on every unit you sell. You are relieved of all responsibility. No installation problems! No parts inventory to carry! No service calls to eat into your profit!

## RCA VICTOR DIVISION

RADIO CORPORATION OF AMERICA



RCA makes your Customer's home a better place to live!

# Twenty-One New TV Areas to "Unfreeze" in 1952; Predict Set Sales Will Jump 750,000 to 1,660,000

A television industry study, presented recently to the Board of Directors of the Radio-Television Manufacturers Association, predicts that expansion of TV broadcasting to cities not now covered will not be delayed by defense production restriction, when the "freeze" on new stations is lifted by the Federal Communications Commission. This and other findings associated with the lifting of the "freeze" were obtained by a "task force" committee operating under the jurisdiction of RTMA's Television Committee.

The report shows: Material requirements for transmitters, studio equipment and antennas through the middle of 1953 can be met from present manufacturers' inventories and current al-

location of materials without asking for increased allocations. According to the report there are 28 transmitters already delivered to prospective broadcasters, 20 in manufacturers' stock and 154 in process, for which materials are assured.

By making use of presently existing structures and buildings, the requirements for construction material needed for new stations can be reduced to amounts presently allowed under NPA regulations. The increased demand for television receivers may exceed presently programmed production. A continuation of first quarter NPA allotments of critical materials would permit extension of TV service to more persons in more areas.

Based upon a "realistic schedule," according to the committee, construction

permits for 140 new television stations would be issued by the F. C. C. by the end of 1952 and 190 more by the end of 1953. It is estimated that half of these would be for UHF transmitters, and the remainder for VHF. The prediction was also made that 22 new VHF stations, but no UHF stations would go on the air during 1952, 21 of them in cities not now served with television. During 1953, says the committee, 117 new stations would go on the air with 64 in the UHF range. Using both "optimistic and pessimistic" projections, the committee estimates that consumer demand for television receivers will be increased between 750,000 and 1,660,000 sets in the second half of 1952 and the first half of 1953 by the lifting of the "freeze."

● *Present and proposed network routes (Bell coaxial, Bell microwave and independent) and present and future television allocations as envisioned by present FCC plans. Allocations are approximate only, the plans being so made as to provide flexibility.*

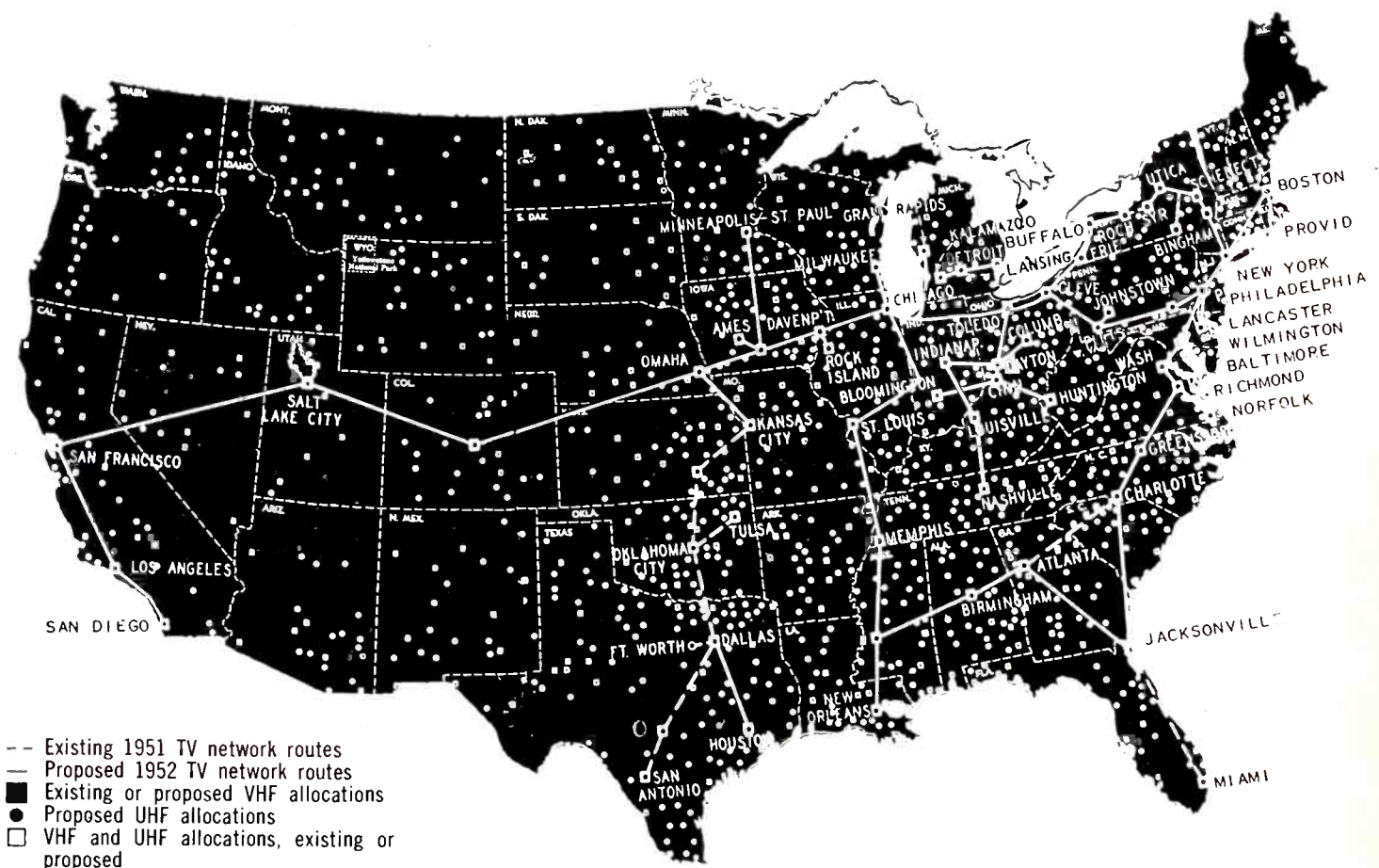

## NEWS AND NOTES OF MANUFACTURERS AND DISTRIBUTORS

● Brig. General David Sarnoff, chairman of the board, **Radio Corp. of America**, Camden, N. J., has released RCA's 32nd annual report, which places the firm's gross income from sales of products and services in 1951 at \$598,955,000. This compares with \$586,393,000 reported in 1950. Net profits were \$31,193,000 in 1951, compared with \$46,250,000 in 1950. These earnings were equivalent to \$2.02 per share of common stock, and represented 5.2 per cent of gross income. Earnings in 1950 were equivalent to \$3.10 per share of common stock, or 7.9 per cent of gross income.

● Hugo Sundberg, vice-president and general manager, **Oxford Electric Corp.**, Chicago, Ill., has been assigned to direct future sales policies of the firm, according to J. C. Ceader, president. Mr. Sundberg has been in the speaker industry for 23 years. He will be assisted by W. B. Barnes and V. E. Wollang, assistant sales managers of the firm.

● **Stromberg-Carlson Co.**, Rochester, N. Y. reports net earnings of \$685,777 for the year 1951, amounting to \$1.66 per share of common stock, after payment of preferred dividends. Total volume for the year was \$33,632,495. At a recent board meeting, the regular quarterly dividend of 50 cents per share on preferred and 25 cents per share on common stock were declared, payable April 1 to stockholders of record March 10.

● Albert D. Leban, Philadelphia manufacturers sales agent, has been appointed representative for **Radio Merchandise Sales**, N. Y., covering eastern Pennsylvania, southern New Jersey, Maryland, and Washington, D. C. Henry Lavin Associates are now representing RMS in all of New England. In the southeastern area of the

country, Hoyt Giddings has joined Grady Duckett, sales representative in that area.

● Consolidated net earnings of \$9,586,833, equivalent to \$4.97 per share, on net sales of \$185,925,058 in 1951, were announced recently by **Admiral Corp.**, Chicago, Ill. This compared with total sales for 1950 of \$230,397,661 and net earnings of \$18,767,554, or \$9.73 per share on 1,928,000 shares of capital stock outstanding. Corporate income taxes for 1951 amounted to \$9,138,788, or \$4.74 per share. As of December 31, 1951, Admiral's net worth increased to \$40,409,844 from \$32,751,011 at the end of the preceding year. Net working capital increased to \$27,361,637 in 1951 from \$21,931,846.

● D. H. Cogan, president, **CBS-Columbia, Inc.**, Brooklyn, N. Y., manufacturing subsidiary of the Columbia Broadcasting System announced that the appointment of Albert Axelrod recently as senior engineer in the advanced development laboratories of CBS-Columbia was one phase in an expansion program underway. Enlargement of the engineering department under the supervision of Leopold M. Kay, vice-president in charge of engineering was the first of many in the program prior to the moving of CBS-Columbia television and radio production lines to the new plant in Long Island City.

● To house its rapidly growing communications and electronic division, **Motorola, Inc.**, Chicago, Ill., has purchased a new 200,000-square-foot plant for \$1,250,000, completing the division's relocation. Paul V. Galvin, Motorola president announced recently that the firm's 2-way radio division is now operating from its new quarters, at 4501 Augusta Blvd., Chicago, in

the vicinity of the firm's main radio and TV plant. Consolidating all activities of the communications and electronics division, the newly-purchased plant has been renovated to include 2-way mobile and fixed-station radio, microwave relay, and carrier-control engineering, production and sales.

● A regular quarterly cash dividend of 35 cents per share of \$5 par value capital stock was declared recently by the directors of the **Stewart-Warner Corp.**, Chicago, Ill. It was payable March 8, 1952 to stockholders of record at the close of business February 15, 1952. These payment and record dates coincide with those of the 35 cent extra cash dividend declared by the Stewart-Warner board on December 26, 1951.

● "Radio now is entering a new era of continuing growth and one in which we will see quality attain its highest level," Robert W. Galvin, executive vice-president of **Motorola, Inc.**, Chicago, Ill., told distributors and salesmen at the firm's recent national radio convention. He branded the notion that TV means the end of radio as a popular fancy, noting that the increase in radio ownership in the past 12 months has come to approximately 10 million sets. He used this and other figures to demonstrate why Motorola was introducing an entire new 1952 line of home, automobile and portable radios. He noted that a spectacular gain was registered by radio in rural areas, and that secondary and portable sets were on the increase in American homes.

● The 1952 Winter Sales Conference of **Radio Merchandise Sales**, N. Y., was held recently at the Grossinger Hotel and Country Club, N. Y. Sales personnel and representatives were shown a variety of products, including three new antennas for urban, semi-fringe and fringe television areas. TV tube servicing kits and tool kits were also shown, and promotional plans for the months ahead were thoroughly outlined.



Featuring the Widest Selection of Magnificent Television Cabinets in the Most Beautiful Woods and Hand Rubbed Finishes. Created by Masters of the Trade, in Modern, Chinese, and Traditional Styles. Available in All Sizes, including 24". Ranging from Consolettes to Large Consoles. Inquiries Invited.

Descriptive Literature on Request

Manufacturers Representative  
**TELEVISION COMPANY OF AMERICA**

Showrooms

192 Lexington Ave.

MU 4-5347

New York, N. Y.



# New Appointments

Saxon in new RCA post, Selsby to direct Haydon sales, Gordy to Majestic branch, Wasson and Whitmore in realigned American Phenolic spots, Messing joins Philharmonic, Shiplett service manager at Bendix, Salisbury controller of Crosley Distributing, M. D. Burns in new Sylvania post, Cushway joins Crescent



Raymond W. Saxon

• Raymond W. Saxon, formerly staff assistant to J. B. Elliott, vice-president in charge of consumer products, **RCA Victor Division**, RCA, Camden, N. J., has been appointed general sales manager of

the Home Instrument Department. He will be responsible for the coordination of sales and styling, and for the analysis of consumer trends. Mr Saxon joined RCA Victor in 1940.

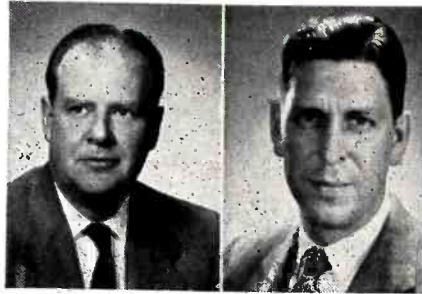

Walter B. Wasson Ray Whitmore

• In a realignment of its industrial sales staff in New York State, **American Phenolic Corp.**, Chicago, Ill., has placed Walter B. Wasson, factory-trained sales engineer, as district sales manager in the Syracuse office. Ray Whitmore, also a factory-trained sales engineer, has been made district sales manager for New York City with new offices in the Empire State Building.

• L. M. Salisbury has been appointed controller of the **Crosley Distributing Corp.**, Cincinnati, Ohio. Mr. Salisbury has been manager of the Crosley Division's business management department for the past three years and has had extensive experience in branch operations in the appliance and electronic fields.



L. M. Salisbury



Ben Selsby

• Ben Selsby, sales director of Haygren Electronic Mfg., Inc., has been named to direct the national sales program of the **Haydon Products Corp.**, Brooklyn, N. Y. The firm manu-

factures television masts and Mr. Selsby has rounded out his national distribution representatives.

• Stanley I. Messing has been appointed manager of the government contract division of **Philharmonic Radio & Television Corp.**, New Brunswick, N. J. Mr. Messing was formerly with Starrett Television Corp., and prior to that was with the Lansdale tube plant of Philco Corp.



Stanley I. Messing

• Matthew D. Burns has been named general manager of the radio tube division of **Sylvania Electric Products, Inc.**, with headquarters in Emporium, Pa. Mr. Burns will have charge of production, engineering, purchasing and other activities of the division's plants in nine communities of four states. He has been in radio tube manufacturing since 1921.



Matthew D. Burns



Sanford M. Gordy

• Sanford M. Gordy has been appointed general manager of the New York distributing branch of **Majestic Radio & Television**, Division of the Wilcox-Gay Corp. Mr. Gordy joined the Ma-

jestic organization recently after a 10-year association with Ludwig Baumann, N. Y. In his new post he will manage the New York branch for Majestic, and will supervise sales activities on Wilcox-Gay recorders.

• L. D. Shiplett has been named service manager, **Bendix Television and Broadcast Receiver Division**, Bendix Aviation Corp., Baltimore, Md. With Bendix Radio for the past 11 years, Mr. Shiplett was an inspection supervisor in the communications division prior to being assistant service manager in the television division.



L. D. Shiplett

• Charles P. Cushway, formerly executive vice-president of Webster-Chicago Corp., has joined **Crescent Industries, Inc.**, Chicago, Ill., as vice president and chairman of the advisory board. Mr. Cushway will direct Crescent's expanding operations in the jobber-dealer field, in this country and abroad, including a reorganization of the firm's sales effort on a district representative basis.



Chas. P. Cushway

## St. Louis Distributor Moves to New Quarters

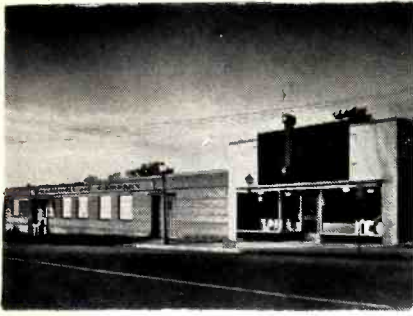

• Broadwell & Co., St. Louis wholesale distributors, have moved from 3005 Locust-St. to new and larger quarters at 3643 Delmar Blvd. Among the many major lines carried by the firm are Arvin Television and Radio products. The company was organized in 1949, with James P. Broadwell as president, Ralph W. Lay as vice-president and sales manager, and Norman J. Broadwell as secretary-treasurer. The St. Louis trading area covered by the firm includes the eastern half of the state of Missouri and the southern half of the state of Illinois.



Wm. J. Slawson

• William J. Slawson has been appointed distributor sales manager of **Brach Mfg. Corp.**, Newark, N. J. Mr. Slawson has been associated with the electronic industry for nine years

and was formerly with John F. Rider Publisher, Inc. He will direct the sale and promotion of Brach products through the firm's distributor organization.



James N. Ryan, Jr.

• James N. Ryan, Jr. has been named sales manager of **Steelman Phonograph & Radio Co., Inc.**, N. Y. Formerly assistant general sales manager of Tele-

tone Radio Corp., Mr. Ryan will initially contact the firm's distributors throughout the nation and outline promotional plans. He will direct sales and advertising in his new post.

## Figure in Crosley Sales Reorganization



W. A. Blees



E. W. Gaughan



J. W. Craig



F. F. Duggan

The broad expansion of the lines of products now sold by the Crosley Division, Avco Mfg. Corp., Cincinnati, Ohio, has necessitated the creation of two separate sales organizations, accord-

ing to John W. Craig, Avco vice-president and Crosley general manager.

Effective immediately, Mr. Craig made known, there will be a complete sales organization for refrigerators and appliances, and one for television and radio. Both sales organizations will be under the direction of W. A. Blees, vice-president of Avco in charge of Crosley sales. Assistant general manager, L. F. Cramer, will coordinate TV and radio functions, and Inwood Smith, assistant general sales manager, will assist the general manager on special assignments.

On the heels of Craig's announcement of the creation of two separate sales organizations, W. A. Blees made known the appointment of two new general sales managers, to head the new organizations. F. F. Duggan, who recently joined Crosley after serving as general sales manager of the American Kitchens Division of Avco, was named to head refrigerators and appliances. E. W. Gaughan, formerly Crosley eastern divisional sales manager, was named to head the television and radio organization.

Simultaneously Blees announced these other appointments to his staff, headquarters Cincinnati: R. K. White, assistant general sales manager in charge of coordinating general advertising, promotional, and public relations activities, and R. H. Schneberger, general service manager.

H. E. McCullough, who has been manager of the television sales section, has been made field sales manager for television and radio under Mr. Gaughan, in the new reorganization. M. R. Rodger has been appointed western divisional sales manager for appliances and T. H. Mason eastern divisional sales manager for appliances.

The expansion of the Crosley field sales organization for appliances, which will report directly to Rodgers and Mason, includes the appointment of the following five regional managers on appliances: F. D. O'Sullivan, N. Y.; L. R. Walker, Atlanta; J. E. Shelton, Chicago; R. O. Adkison, Kansas City, and C. E. Germaine, San Francisco.

### C R Tubes Improving



G. R. Sommers

New television picture tube screen improvements are contributing to better TV set performance, according to an announcement by George R. Sommers, general sales manager, radio and television picture tube division, Sylvania Electric Products, Inc.

"The improved screens," Sommers reports, "provide greater brightness and eliminate discoloration during entire tube life. The new screens are especially effective in providing better pictures when tubes are operated with anode voltages lower than 14,000 volts."

The development by Sylvania of screen materials with better balanced chemical properties has principally contributed to the improved results, according to Sommers. These are now being used in all picture tubes made by the firm, every type TV picture tube manufactured being supplied with the improved screens. They include glass types available in both standard round and rectangular bulb shapes, with cylindrical or spherical faces.

### Healthy Corpse

During the year 1951 there was an increase in radio ownership of more than 10 million sets. This impressive sales figure was racked up during a period when television was all-the-rage, and is therefore even more remarkable. Of course, all this probably comes as a surprise to those who predicted the early demise of the radio business as a result of TV's inroads. But to those hardy souls who have seen and studied the industrial history of motion pictures, the phonograph and the automobile, it is known that each great new medium or invention which has come along in American industry has not killed the other's growth but has established a secure place for itself on its own merits.

In this great, big, wide world, there is a place for everything, and the sales figures on radio in 1951 prove that television, while creating a stupendous market for itself, did not eliminate radio's unique position which has been built up over a period of three decades. To paraphrase Mark Twain's famous remark: "It seems that radio's death has been greatly exaggerated."

### Sales Clinic

One of the boasts of this industry is that it epitomizes progress. Nothing ever stands still. Every product is constantly being improved as new and wonderful electronic developments stream continuously from manufacturers' research laboratories.

But most of this progress has been on the technical and engineering level. This left a significant gap on the sales end where little research has been done. Now, however, this is being remedied by a series of Television Sales Clinics, initiated by the RCA Victor Division to help the industry's salesmen keep their techniques in step with the products they sell.

While it is true that selling will always contain elements of an art, it is nevertheless also true that modern sales techniques demand a planned and scientific approach if they are to successfully bridge the gap of an alert public which wants an intelligent presentation of the facts before it spends its money. RCA's approach to this problem comes as a welcome start to the hit-or-miss sales pattern which heretofore has been all too prevalent.

## ADVERTISERS' INDEX

ADMIRAL CORP. _____	50, 51	RADIO CORP. OF AMERICA _____	93
Agency: Cruttenden & Eger		Room Air Conditioners	
ALPRODCO, INC. _____	49	Agency: Al Paul Lefton Co., Inc.	
Agency: Paul J. Steffen Co.		RADIO MERCHANDISE SALES, INC. Fourth Cover	
AMERICAN PHENOLIC CORP. _____	62	Agency: Reid Associates	
Agency: Burton Browne Adv.		RADION CORP. _____	45
ANCHOR RADIO CORP. _____	54, 55	Agency: Calkins & Holden	
Agency: Symonds, MacKenzie & Co., Inc.		RIDER, JOHN F. PUBLISHING CO. _____	46
ANDREA RADIO CORP. _____	9	Agency: Conti Advertising Co.	
Agency: Royal & De Guzman		RIVER EDGE INDUSTRIES _____	78
ARVIN INDUSTRIES, INC. _____	15	Agency: Pace Adv. Agency, Inc.	
Agency: Roche, Williams & Cleary, Inc.		SENTINAL RADIO CORP. _____	89
BENDIX AVIATION CORP. _____	73	Agency: W. W. Garrison & Co.	
Agency: MacManus, John & Adams, Inc.		SIMPSON ELECTRIC CO. _____	69
BLONDER-TONGUE LABORATORIES, INC _____	42	Agency: Burton Browne Adv.	
Agency: Shappe-Wilkes, Inc.		SOUTH RIVER METAL PRODUCTS CO., INC. 60	
BRACH MFG. CO. _____	63	Agency: Art-Copy Advertising Agency	
Agency: Conti Adv.		STANLEY SALES CORP. _____	72
CBS-COLUMBIA, INC. _____	25	Agency: C. & D. Adv.	
Agency: Bennett, Walther & Menadier, Inc.		STROMBERG-CARLSON CO. _____	27
CROSLLEY DIVISION—AVCO MFG. CORP. _____	Third Cover	Agency: Federal Adv.	
Agency: Benton & Bowles, Inc.		SYLVANIA ELECTRIC PRODUCTS, INC. _____	75
DAVIS ELECTRONICS _____	58	Television Div.	
Agency: Clark Collard Adv.		Agency: Roy S. Durstine, Inc.	
DUMONT, ALLEN B. LABS., INC. _____	33	TECHNICAL APPLIANCE CORP. _____	47
Agency: Campbell-Ewald Co.		Agency: Austin C. Lescarboura & Staff	
ELECTRO-VOICE, INC. _____	36	TEL-A-RAY ENTERPRISES, INC. _____	65
Agency: Henry H. Teplitz Adv.		Agency: Keller-Crescent Co.	
EMERSON RADIO & PHONO. CORP. _____	22, 23	TELE KING CORP. _____	7
Agency: Grady & Wagner Co.		Agency: Jos. Katz Co.	
ENERGY FARM EQUIP. CO. _____	68	TELE-EX-PAND PRODUCTS SALES CORP. _____	70
Agency: Peterson Adv.		TEL-O-TUBE CORP. OF AMERICA _____	80
EUREKA TELEVISION & TUBE CORP. _____	67	Agency: Salow & Associates, Adv.	
Agency: Harry Belfor		TELEVISION ASSOCIATES _____	63
FINNEY CORP. _____	48	TELEVISION CO. OF AMERICA _____	95
Agency: Allied Advertising Agency, Inc.		TRANS-VUE-JACKSON CORP. _____	80
FRETCO, INC. _____	64	Agency: The Filmore Co., Inc.	
Agency: DiFonzo Advertising		TRANVISION _____	81
GENERAL ELECTRIC CO. _____	91	Agency: H. J. Gold Adv.	
Agency: Maxon, Inc.		TRIO MFG. CO. _____	61
HALLICRAFTERS CO. _____	3	Agency: Rudolph Bartz Adv.	
Agency: Sorensen & Co.		TURNER CO. _____	71
GONSET CO. _____	90	Agency: W. D. Lyon Co.	
GOODENOW MFG. CO. _____	66	VIDEO INDUSTRIES CO. _____	72
HI-LO ANTENNA CORP. _____	53	WALNUT MACHINE CO. _____	52
Agency: Sander Rodkin Adv.		WELLS & WINEGARD _____	66
HUDSON ELECTRONICS CORP. _____	90	Agency: Weyher Adv.	
HYTRON RADIO & ELECTRONICS CO. _____	79	ZENITH RADIO CORP. _____	5
Agency: Bennett, Walther & Menadier, Inc.		Agency: Critchfield & Co.	
I. D. E. A. (REGENCY) _____	87		
Agency: Burton Browne Adv.			
JFD MFG. CO. _____	43		
JERSEY SPECIALTY CO. _____	70		
Agency: George Gero			
JEWEL RADIO CORP. _____	19		
Agency: C. L. Miller Co.			
JONTZ MFG. CO. _____	46		
KENWOOD ENGINEERING CO., INC. _____	74		
Agency: Harry Belfor			
LAPOINTE-PLASCOMOLD CORP. _____	57		
Agency: F. W. Prella Co.			
KRYLON, INC. _____	77		
Agency: Gray & Rogers Adv.			
MERIT TRANSFORMER CORP. _____	Second Cover		
Agency: Burton Browne Adv.			
MOTOROLA, INC. _____	10, 11, 12, 13		
Agency: Gourfain-Cobb Adv.			
NATIONAL CO. _____	59		
Agency: John C. Dowd, Inc.			
OAK ELECTRONICS CO. _____	64		
PENN TV PRODUCTS CO. _____	60		
Agency: Ed Shapiro Adv.			
PHILCO CORP. _____	83		
Agency: Hutchins Adv.			
PHOENIX ELECTRONICS, INC. _____	76		
Agency: Milton Richards Adv.			
PORCELAIN PRODUCTS, INC. _____	68		
PREMAX PRODUCTS _____	52		
Agency: Norton Adv.			
RADIO CORP. OF AMERICA _____	30, 31		
Home Instrument			
Agency: J. Walter Thompson Co.			

without  
advertising



many of the products advertised  
in this paper might not  
have been developed!



# CROSLEY gives you the most colorful sales approach in 1952 radios!

WHEN Crosley put its name on color radios, America's retailers were given a new, powerful selling appeal for radio-merchandising: color-styling to please every taste—enhance every room! This year, Crosley strengthens its first-place hold in radio color-styling with a complete range of colors at no extra cost on all radio models. Add Crosley's matchless performance and reputation for dependability and you have the springboard to large volume in small radios—with Crosley.

*For style-leadership  
performance-leadership  
value-leadership*

**CROSLEY SETS THE PACE  
FOR 1952 RADIO SALES**

## CROSLEY "RIVIERA" PORTABLE

A "Cash-And-Carry" Favorite for Power and Beauty!

This mighty "mite" is just a fraction over 5 pounds. Batteries, AC or DC current. Large speaker gives full theater tone. Five smart two-toned models. Retractable handle.



## CROSLEY FM-AM RADIO

Doubly Appealing to Your Radio Prospects!

Supersensitive to give better reception . . . both FM and AM. Ruggedly constructed. Handsomely styled. Pin-point, drift-free tuning. AC/DC. Blue, Maroon, Green, Tan.



**CROSLEY "COLORADIO"**

Started the trend to color in radios.

Designed as an integral part of home furnishings. Distinguished by its richness of tone and specially engineered features. Connections for record player. White, Ebony, Chartreuse, Maroon, Aqua, Green.



**CROSLEY "CLOCK" RADIO**

Most beautiful Clock-Radio in America.

Has everything your customers want in a Clock-Radio, plus superb color styling. Fine automatic clock! Tone-engineered radio. White, Chartreuse, Maroon, Blue, Green, Bronze.

*Have you seen it?  
...Crosley's sensational new  
self-service radio display  
...it's boosting radio sales!  
Ask your Crosley Distributor*

**CROSLEY**

Division  Cincinnati 25, Ohio

**Better Products for Happier Living**

Radios . . . Television . . . Shelvador® Refrigerators  
Shelvador® Freezers . . . Sinks . . . Food Waste Disposers  
Electric Ranges . . . Electric Water Heaters  
Steel Kitchen Cabinets . . . Room Air Conditioners

**AGAIN RMS IS FIRST WITH**

# **An Outstanding New Development For TV Servicing...**

## **RMS PIX-EYE**

MODEL TE-5

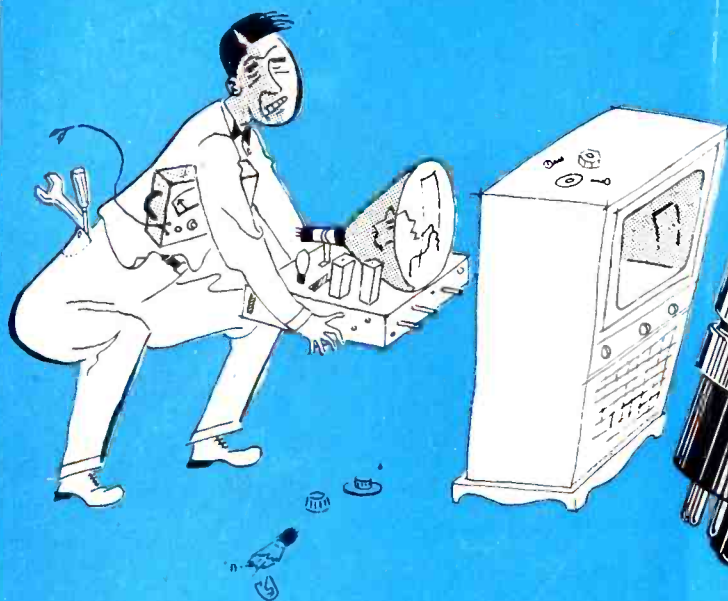

**FOR  
ON-THE-SPOT  
TESTING OF  
PICTURE TUBE  
AND VITAL  
RECEIVER  
CIRCUITS**

**With RMS Pix-Eye . . . make instant check of  
brightness control circuits • contrast control  
circuits • video circuits • low voltage  
circuits • filament voltage circuits**

The danger and extra labor in handling TV picture tubes is eliminated . . . with Pix-Eye on the job. Simply plug the instrument into the CRT socket . . . let it help you analyze the picture tube for shorts, intermittents and opens . . . and give you instant check of vital receiver circuits. For greater convenience in working at the front of the set, use extension unit, model EX-5. Take Pix-Eye on the call; keep one at the bench.

**SEE YOUR LOCAL RMS JOBBER TODAY!**

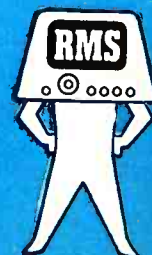

**RADIO MERCHANTISE SALES INC. New York 59, N. Y.**