

RTJ

Radio & TELEVISION JOURNAL



**don't go COLOR BLIND
on TV selling now!**



OCTOBER 1949

Sec. 34.66, P. L. & R.
U. S. POSTAGE
PAID
NEW YORK, N. Y.
Permit No. 10521

From: RADIO & TELEVISION JOURNAL
A KOLBE PUBLICATION
RKO BUILDING, RADIO CITY, 1270 SIXTH AVE.
NEW YORK 20, N. Y.
RETURN POSTAGE GUARANTEED
Postmaster: If undeliverable FOR ANY REASON, notify sender.
Returning reason, on FORM 3517, postage for which is guaranteed.

Compare!

CIRCLE-X TV ANTENNA TO ANY OTHER TV ANTENNA

The mechanical and electrical construction of Circle-X antenna is unsurpassed. No other type of antenna combines all the features that are engineered into the Circle-X.

	One type Antenna for all jobs	Low Installation Cost	Light Weight	Rigidity	One Wire Lead-in	High Gain	Wide Angle Reception	No High Frequency Head	Eliminates Ghosts	Eliminates Service Recalls
Circle X	X	X	X	X	X	X	X	X	X	X
Brand A		X		X		X				
Brand B				X	X	X	X			X
Brand C				X	X					
Brand D				X				X		
Brand E				X		X				
Brand F		X	X	X		X				

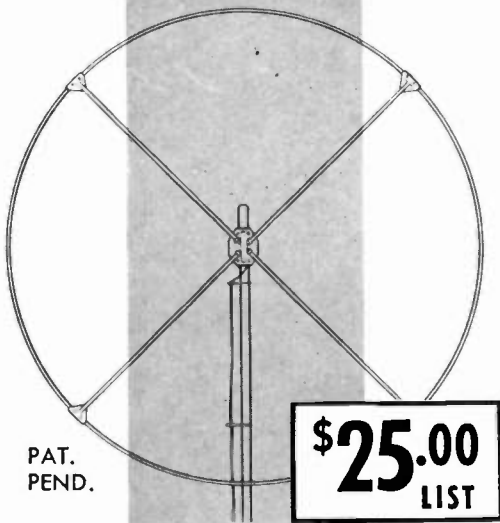

The high gain of the Circle-X is equal to stacked arrays. It is made of the light weight corrosion resistant aluminum alloys that have been used for many years, exposed to salt spray and other adverse atmospheric conditions.

The Circle-X gives clearer, sharper pictures on all channels (no high frequency head needed). It eliminates the necessity of having a rotor or reflectors. It is perfectly matched to 72,150 and 300 ohm receiver input circuits.

Use a Circle-X on your next tough TV installation. Installations have been made 125 miles from transmitting stations and the reception has been ghost free with clear, sharp pictures.

Save Money by using the Circle-X.

DEALERS:

DEALERS: Air Express or Parcel Post Special Delivery direct from factory to you thru your jobber, if he cannot supply you with the Circle-X from his stock. Your order will be shipped the same day it is received.

Write To
CIRCLE-X ANTENNA CORPORATION
504 MARKET ST., PERTH AMBOY, N. J.



**THIS MACHINE
IS NOT
FOR SALE!**



**BUT EVERY SHELDON TELEVISION PICTURE TUBE, CAREFULLY INSPECTED IN IT,
IS FOR SALE.**

This electronic testing device enables us to make 12 vital checks for quality . . .

- | | | |
|--------------------------|---------------------|--------------------------|
| 1—Heater Current | 5—Cathode Emission | 9—Brightness |
| 2—Beam Current | 6—Grid Current | 10—Color Temperature |
| 3—Gas | 7—Grid Cut-off | 11—Visual Screen Defects |
| 4—Heater Cathode Leakage | 8—Voltage Breakdown | 12—Visual Bulb Defects |

All these tests are in addition to many other standard inspections to maintain Sheldon's high standard of picture tube quality. To a viewer, this quality means:

- | | |
|---|--|
| 1—Round-the-clock viewing without eyestrain or glare. | 2—Black is Black, White is White—and between—All the Natural Intermediate Shading. |
|---|--|

It will pay you to get complete details about the superior quality found in every 10 BP4, 12 LP4, 16 HP4 and 16 LP4 flat-face all-glass Sheldon Picture Tube. **WRITE TODAY.**

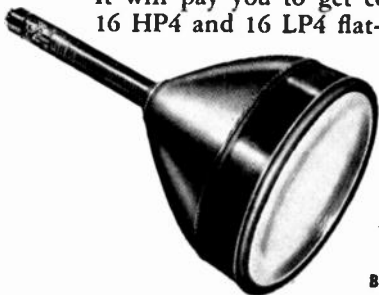

**A Sheldon Television Picture Tube
MAKES ANY SET BETTER!**

SHELDON ELECTRIC CO., Division of Allied Electric Products, Inc.

68-98 Colt Street, Irvington 11, N. J.

Branch Office & Warehouses: Chicago 6, Ill., 626 W. Jackson Blvd. • Los Angeles 6, Cal., 2359 West Pico Blvd.

TELEVISION PICTURE TUBES • CATHODE RAY TUBES • FLUORESCENT LAMP STARTERS AND LAMP HOLDERS • SHELDON REFLECTOR AND INFRA-RED LAMPS
PHOTOFLOOD AND PHOTOSPOT LAMPS • SPRING-ACTION PLUGS • TAPMASTER EXTENSION CORD SETS AND CUBE TAPS • RECTIFIER BULBS

OCTOBER • 1949

VOL. 66

No. 10

Television • Radio • Appliances • Records-Component Parts



Publisher
ALEX H. KOLBE

Editor
NAT BOOLHACK

Associate Editor
JOHN A. RICHARDS

Business Department
AARON LAFER

Art Director
VINCENT T. COSTELLO

Circulation Manager
MARY LOUISE KAUFFMAN

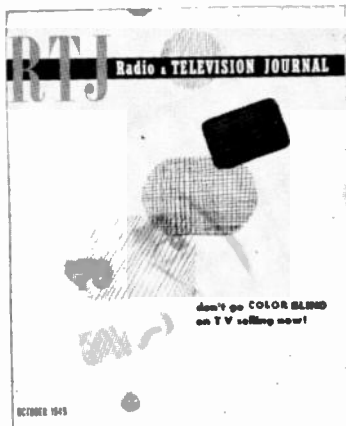

The Cover Dealers who are letting apprehension over pending FCC "color" rulings blind their salesmanship are also cooking their own goose—but good. See pages 20 and 21 in this issue.

Member of



OVER 30,000

Controlled Circulation Audit, Inc.

IN THIS ISSUE

Television Roundup	6, 8
A concise review of the month's significant happenings in radio and television.	
An Interview with the President of Stromberg-Carlson Co.	8, 14
TV Magnifiers VS Large Screen Sets	13
An analysis of the television enlarger market in the face of powerful competition from large-screen receivers.	
There's No Shortage of Business Provided You Go After It with Plenty of Punch	18
Don't Go "Color" Blind on TV Salesmanship	20, 21
Waiting for the FCC's color ruling should not hamstring the sale of monochrome TV sets	
Getting Your Share of Commercial Television Business	22, 23
Some pointers on how to increase sales of large-screen, projection television to public places.	
Illustrated Industry News	26, 27
Photographic highlights of industry events.	
Let's Understand the Needle Business	48



DEPARTMENTS

Picture Page	26, 27
News and Notes of Manufacturers and Distributors	30
New Products	36-46
(Radios, Television, Consoles, Phonographs, TV Accessories)	
Appointments	53
Editorial	54
Advertiser's Index	54

RADIO & TELEVISION JOURNAL with which is combined RADIO & APPLIANCE JOURNAL and ELECTRIC APPLIANCE JOURNAL is the complete business magazine for retail dealers who buy and sell Radios, Television Receivers, Appliances, Phonographs, Records, Master Servicing Component Parts; and is published monthly for Radio & Appliance Dealers, Jobbers, and Service Men by Kolbe Publications, Inc., Radio City, 1270 Sixth Avenue, New York 20, N. Y. Phone: Circle 7-5842. Alex H. Kolbe, President and Treasurer. Subscription: \$3.00 per year in U. S. A., its possessions, South America, Canada and all other countries \$4.00 per year payable in American currency in advance. Price 35 cents per copy. No material in RADIO & TELEVISION JOURNAL may be reprinted without consent of publisher.

Printed in U.S.A.

all dealers who want televisions HOTTEST line

say
Motorola!

DEALERS EVERYWHERE are saying . . . "We've been waiting for a line like this new Motorola 1950 line — now we can settle down and do business with confidence."



where value
is the measure
Motorola
is your
choice

PHONE — WIRE
your Motorola
distributor today



Only Motorola has the 8½" screen . . .
TV's biggest dollar-for-dollar VALUE!



Standout value for BUDGET buyers
. . . 7" tube — new BROADVIEW
screen!



Gorgeous wood cabinet console . . .
10" screen — low price — big value!



12½" Motorola BROADVIEW screen
. . . More picture for less money!



11 new inventions and improve-
ments highlight new "Masterpiece"
series! Giant 12½" and 16" pictures!



MOTOROLA INC. • 4545 Augusta Blvd. • Chicago 51

TELEVISION ROUNDUP

Compatibility

The hearings on color television which opened on September 26 at the Federal Communications Commission in Washington, and which will continue for several weeks, are momentous to the entire industry. The decisions arrived at will set the pattern for all future developments on color TV. Therefore RMA's president Raymond C. Cosgrove's opening statement to the FCC was especially significant. Cosgrove asked the FCC to take the first official step toward color by decreeing that it would approve no system that would make obsolete the millions of receiver sets now in the hands of the public. (See feature article entitled "Don't Go Color Blind on TV Selling Now" in this issue of RTJ.)

"No system for broadcasting color has been proved by field tests to be ready for commercial use yet, and, therefore, no standards should be adopted until that is done," said Mr. Cosgrove, pointing out that the central point in the entire color question is the principle of compatibility. If a non-compatible color system is approved existing sets would be rendered obsolete because they could not receive color broadcasts even in black and white unless they are radically altered. "Compatibility" means that the millions of receivers now in use, and which the public will continue to purchase, will be able, without any extra cost or inconvenience, to receive in black-and-white, all programs transmitted over the air, whether they be transmitted in color, or in black-and-white.

Radio-Television Week

Three forms of advertising material for use during National Radio & Television Week, October 30-November 5, is being made available to the nation's television and radio dealers. These consist of full-page advertising mats, for joint or local sponsorship, radio spots, and posters. This year marks the 29th anniversary of the radio industry, and for the first time, TV will be linked with radio in the celebration. Theme of the anniversary falls into three main categories this year:

1. "See—and hear the world of talent brought to your home by television." (This is for use in TV areas only)
2. "Listen—enjoy the world's greatest talent—with a new, finer radio—today." (This slogan is for use anywhere). It features both AM-FM

A TV Set Every Twenty-two Seconds



Two main television chassis assembly lines in the world's largest TV assembly plant. The Allen B. DuMont East Paterson plant spreads over 58 acres, nine and one-half of which is the main plant. Some 391,000 square feet of factory space make up the main plant. Bought for \$1,350,000, conversion to TV assembly operations cost \$750,000. At full capacity the plant will produce one TV receiver every 22 seconds.

and radio-phonograph receivers and again carries the famous slogan: "A radio for every room—a radio for everyone—everywhere."

3. "Enjoy the greatest array of talent you've ever heard—or seen." (This is to be used wherever both TV and radio facilities are available)

Smart dealers will take full advantage of this opportunity to cooperate with broadcasters in the promotion of National Radio & Television Week. Make this well-timed celebration work for you; arrange special window displays and advertisements.

What TV Customers Want

Exactly what does a prospective buyer of a television set really look for before he decides to plunk down his dough? One midwest sales executive has some of the answers to this perplexing question. The customer looks at: Brand Name—Is the set under consideration of tried, tested and proven quality? Style and Design—Does the set incorporate the style, quality and cabinetry found in other sets of com-

parable price? Screen Size—Does the receiver under consideration have the new expanded screen and does it produce clear undistorted pictures? Sound System—Does the set have the amplification and speaker quality to assure crystal clear, static-free reception? Long Range Reception—Will the set enable purchasers living in "fringe areas" to receive clear pictures? Additional Accessories—Does the set under consideration incorporate FM - AM radio and phonograph?

These are the factors most often considered by the buyer, plus the largest single factor of price. If TV makers can give the customers all this and price too . . . without taking the "guts" out of the set, well, then we'd like to see the dealer not spoil the whole package by giving away his margin with it.

New Life

Earlier this year, the perennial mourners were moaning that the appliance business was dead and someone ought to bury it. But the industry re-

(Continued on page 8)

DU MONT UP 120% OVER LAST YEAR

Substantial gains were chalked up by the Allen B. Du Mont Laboratories in the first 6 months of 1949 as compared with the corresponding period last year. In the face of a generally declining television market the Allen B. Du Mont Laboratories showed spectacular gains.

WHAT IS BEHIND DU MONT'S SUCCESS?

1. Technical leadership, in developing the outstanding television receivers.
2. Public recognition as shown by DuMont's great reputation for performance and dependability.
3. A sound merchandising policy which has made DuMont the most coveted franchise in television.
4. The fact that DuMont is in all phases of television—and *only* in television.

DU MONT *First with the finest in Television*

TV ROUNDUP

(Continued from page 6)

tused to be buried so quickly. Instead, the leading manufacturers started all-out sales campaigns which have proved so successful that on some lines supply shortages are back again. These pleasant facts were disclosed in a survey by the Journal of Commerce, which points out that reasons for the strong comeback are: (1) liberal credit terms to buyers, and special sales inducements, including elimination of down-payments on installment sales, provision for meter payments; (2) stepped-up advertising and sales efforts by manufacturers and distributors, and (3) depletion of distributors' and manufacturers' inventories. Other reasons given are the torrid weather this Summer, which had a terrific effect on refrigerator and fan sales, plus a growing public belief that no further important price cuts are in the cards for the immediate future. Remember that the population of the country keeps growing too, especially the number of new family units.

Boon to All Sales

We've been saying all along that television would prove to be a vast force for selling all types of products. TV's power to demonstrate is the reason for this, of course, and now the appliance people are saying the same thing. An increasing number of TV programs this Fall are being planned for the afternoon hours to catch housewives' attention while they are busy getting the evening meal ready. The theme will be labor-saving, sanitation, freedom from drudgery for women. It marks a return to the "reason-why" selling of the thirties, only this time "see-why" will be coupled with "reason-why."

August TV Production Reaches New Monthly Mark

Television receiver production during August reached a new high, following a Summer decline, as manufacturers prepared for an expected brisk fall and winter trade. RMA member-companies reported the manufacture of 185,706 TV sets during a five-week period between Aug. 1 and Sept. 2. Total industry production, it is estimated, exceeded 200,000 television receivers for the period indicated. This output is the highest since last March when the same manufacturers reported production of 182,361 TV sets, also during a five-week period. FM-AM set production also took an upward spurt with 64,179 receivers reported for August as against 23,843 in July.

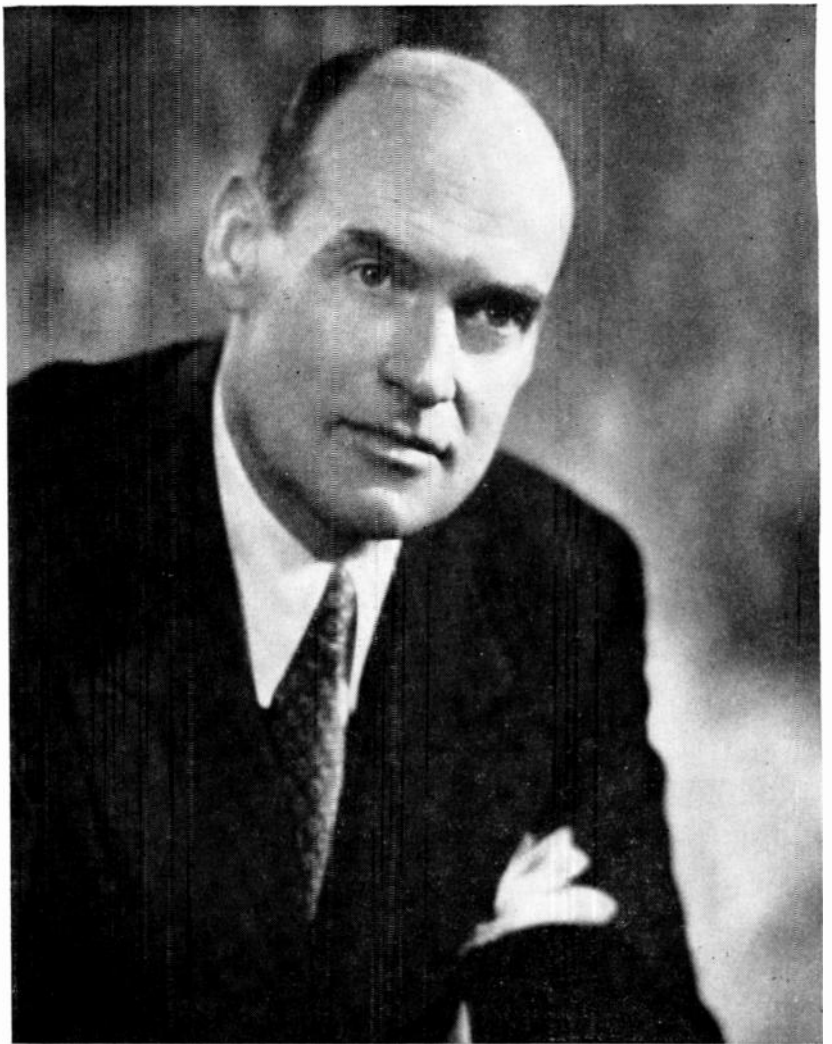

An Interview With Robert C. Tait
By Nat Boolhack

HE'S a tall, thin spare man. Robert C. Tait, president of the Stromberg-Carlson Company stands over six feet four inches in his stockinged feet. When he bends over to take a swipe at a golf ball, he has to stoop quite a bit, but don't let that stoop fool you—the drive is hard, straight and to the point.

Robert Tait assumed the post as head man over at Stromberg-Carlson in Rochester some six months ago. In that short period of time, he has taken the staid, conservative Stromberg-Carlson plant and infused it with a new feeling of motion and direction which is causing many old-timers in the radio industry to say: "Better watch Stromberg from here on: their walls may be covered with ivy but that fellow Tait won't let any ivy grow under that company's feet."

"Big Bob", as he is affectionately known to his host of friends both within and outside the plant, came to Stromberg from Pittsburgh where he held a high executive post with the Mellon

Bank. Although primarily an economist and banker, Bob Tait admits that he is a hybrid when it comes to business management. Notwithstanding his manner of calm detachment which bespeaks the professor of economics, Bob Tait has a zest for grappling with tangible problems. He showed this trait soon after assuming the helm at Stromberg-Carlson when he realized that his primary task was to institute a comprehensive study of the plant and all its ramifications from a completely objective viewpoint to determine where it could be improved. It was a task which required cold, scientific thinking because reorganization always soon reaches the point where it begins to cross the human factor, and Bob's natural warmheartedness was a liability rather than an asset in a situation such as this.

But Robert Tait had come to Stromberg to "do a job" and this analysis soon disclosed that the former divisional organization of the company

(Continued on page 14)

TOP VALUE

with a big **PLUS**

New Stromberg-Carlson Brentwood

at **\$359^{95*}** with

compartment for 45 RPM changer!

- ★ EXPANDED 12 ½-INCH TUBE
- ★ LOCKED-IN CLARITY
- ★ SUPERB TONE ON 12" SPEAKER
- ★ DECORATOR-DESIGNED CABINET

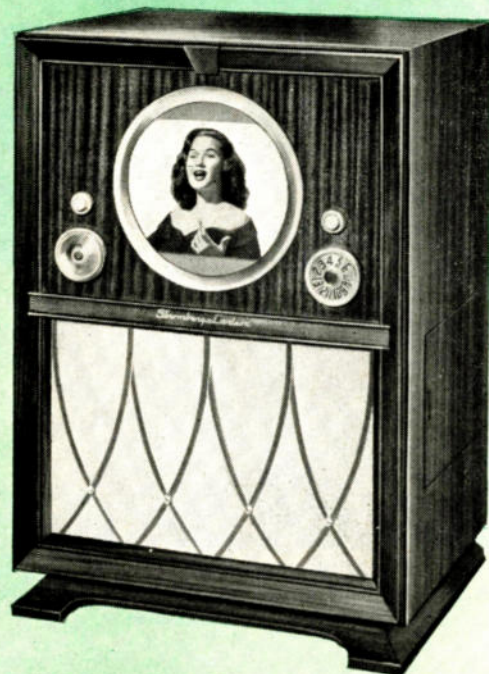

THE BRENTWOOD Smart cabinet, in selected mahogany veneers, #TC-125-LM. (Also in blond avodiré veneers, #TC-125-LA . . . \$369.95*)

*Plus installation and \$1.37 excise tax.
Slightly higher in South and West.

STROMBERG-CARLSON again brings you what the public wants most—outstanding value at a price well within reach of a majority of customers!

And again, Stromberg-Carlson gives you an extra selling feature to help close sales. In this new Brentwood, it's the side-door 45 rpm changer compartment—that practically makes a combination of the console at minimum price!

As for the television, it is unsurpassed for brilliance and definition, for excellent performance even in critical, distant and fringe areas.

With its 12-inch speaker, simplified tuning, beautifully executed cabinet and attractive price, the Brentwood has *sales clinchers by the half dozen!* Your order placed now will insure early delivery.

See it better



Hear it better

STROMBERG-CARLSON

THERE IS NOTHING FINER

Stromberg-Carlson Company, Rochester 3, N. Y.—In Canada, Stromberg-Carlson Co., Ltd., Toronto



New RCA 16-inch direct-view television tube fills gap between popular 10-inch tubes and the projection-type receivers.

***"Inside story" of a bigger, brighter
picture on your television screen***

The screen on which you are accustomed to seeing television is the face of an electron tube—on which electrons “paint” pictures in motion.

And the size of the picture, unless projected, is determined by the size of the tube.

Working to give you *bigger, brighter* pictures, RCA engineers and scientists developed a new way to make large, direct-view television tubes. They found a

method of “welding” large areas of glass and metal... while keeping a vacuum-tight seal!

Using this development—ideally suited to mass production—RCA can now build television tubes of light, tough metal... using polished glass for the face, or “screen.”

An achievement of research

Development of this new television tube is a continuation of *basic television research* which

began at RCA Laboratories. Such leadership in science and engineering adds *value beyond price* to any product or service of RCA and RCA Victor.

. . .

Examples of the newest advances in radio, television, and electronics—in action—may be seen at RCA Exhibition Hall, 36 West 49th Street, New York. Admission is free. Radio Corporation of America, Radio City, New York 20.



RADIO CORPORATION of AMERICA
World Leader in Radio — First in Television

STORE TRAFFIC

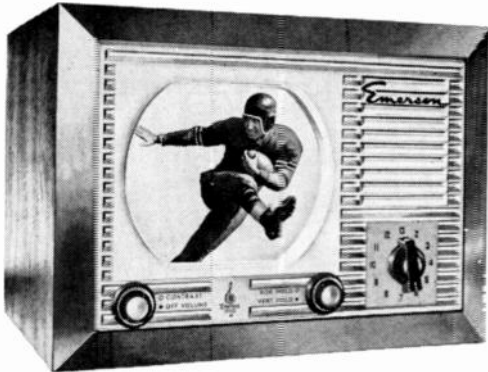

Emerson ^{ULTRA WAVE} Television

← **BIG-PICTURE TELEVISION FOR AC or DC CURRENT!** New 1950 Model 639. Rock-Bottom Priced at . . . **\$129⁹⁵**

LIFE-SIZE 16" TELEVISION. New → 1950 Model 631. At a New Unbelievably Low Price **\$329⁵⁰**

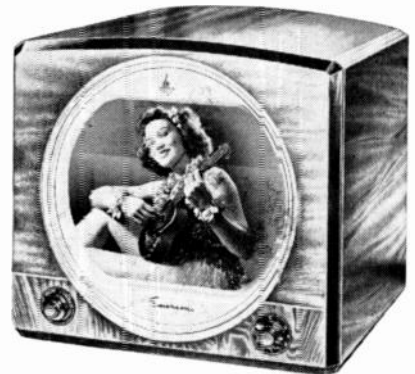

TURNOVER



← **BIGGEST VALUE** In Small Radio. AC-DC Compact Model 587 . . . **\$14⁹⁵**

THREE-WAY PORTABLE, Alligator-Grained Plastic Cabinet, Super-Powered. Model 559 **\$24⁹⁵**
less batteries



PROFITS

EMERSON'S SMARTER STYLING, FINER PERFORMANCE, LOWEST PRICES ASSURE GREATER TRAFFIC, TURNOVER AND PROFITS FOR EMERSON DEALERS



Emerson Radio and Television

Emerson Radio and Phonograph Corporation, New York 11, N. Y.

Reg. T. M.

Fastest

moving 1950 line!

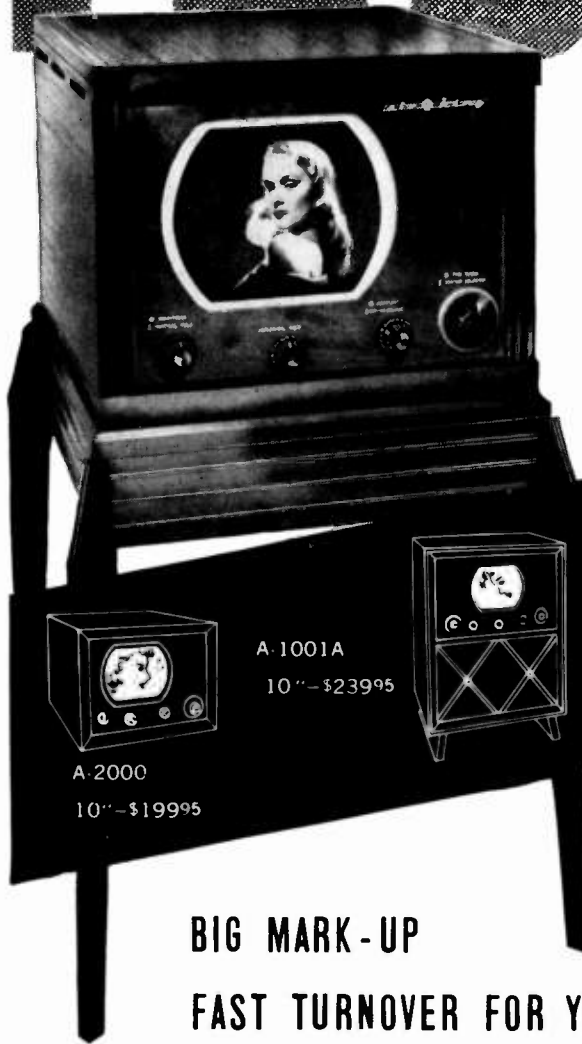

A-2010
10"—\$189⁹⁵

A-2002
12½"—\$269⁹⁵

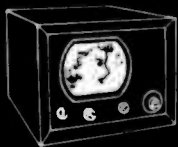

A-2000
10"—\$199⁹⁵

A-1001A
10"—\$239⁹⁵



A-2001
12½"—\$239⁹⁵

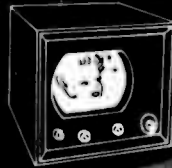

A-1016
16"—\$399⁹⁵



**BIG MARK-UP
FAST TURNOVER FOR YOU
LIST PRICES GUARANTEED 60 DAYS**

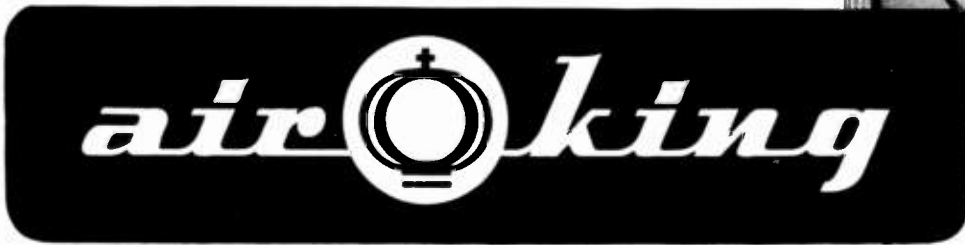

has everything

AIR KING PRODUCTS CO., INC. • 170-53rd St., Brooklyn 32. N.Y.

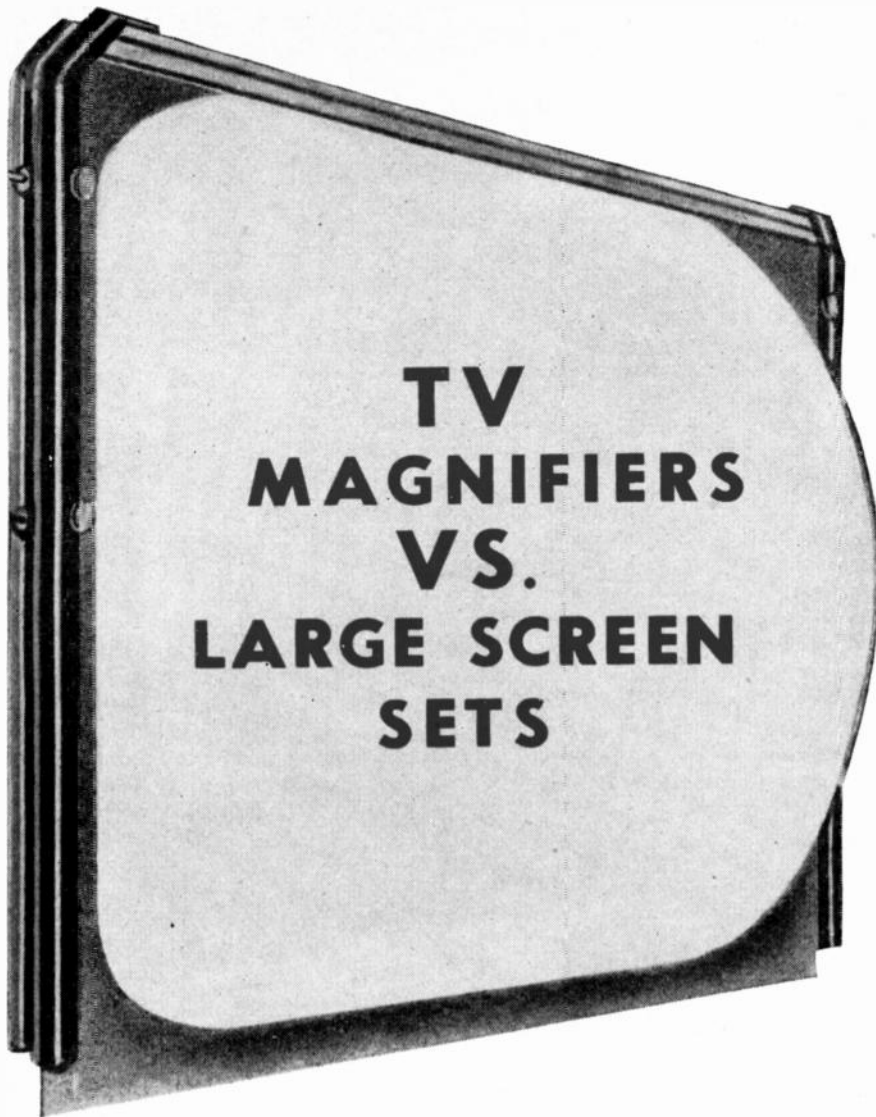

TV MAGNIFIERS VS. LARGE SCREEN SETS

With the daily increased production of large-size direct-view TV tubes and the consistent downward price trend of these large size tubes, the need and desirability for magnifying lenses poses a question of trend or necessity. In the case of the 7-inch and 10-inch TV tubes, the lens serves the purpose of enlarging a clear definite image to the equivalent of a 12-inch and 16-inch tube, also adding a practical third dimension. This is accomplished with a minimum of cost and an infinitesimal loss of side view angle. The American Medical Association and other accepted agencies of this type have recommended that a TV screen be viewed from an angle of not more than 30 degrees on each side. Therefore this decrease of side angle is beneficial to the viewer.

In the case of the 12-inch and 16-inch direct tubes, it is my opinion that it is absolutely necessary to use a lens to eliminate the loss of clarity and sharpness which becomes more aggravated as the size of direct tube increases. A good lens or magnifier made in accordance with present optical standards gives breadth, depth and pro-

nouncement to direct-view tubes, in addition to magnification.

Optical Requirements

The selling, introducing and pioneering of TV lenses has already been done.



THE AUTHOR Myron J. Greenwald, vice-president in charge of sales, Celomat Corp., N. Y., speaks with authority on a timely TV subject.

sometimes with ill effect. Many manufacturers attempted to make magnifiers without regard to the optical requirements that are necessary to achieve the perfection necessary for optimum results. The necessary research and technical knowledge was not available to these manufacturers; consequently they were able to make a cheap but very ineffective magnifier.

Manufacturers who were interested only in obtaining sales, placed the entire lens industry in a precarious position for a short period. The lens business has now so stabilized itself that only manufacturers of optically perfect products have the acceptance and recognition of the television industry.

Merchandising and selling lenses at this time has changed in certain respects and the customer today must be shown. The lens must be intelligently presented in the same manner as any other competitive merchandise.

1. The magnifier has been enclosed in a package with an aerial and a television set and successfully sold as one unit. This type of merchandising increases the unit sale, has good promotional and advertising possibilities and also increases the profit.
2. The magnifier has been displayed on sets or a magnifier display which shows how the lenses look and work on a television set and also demonstrates the brackets. In many cases the lenses sell themselves with the use of this silent salesman.
3. Many live wire dealers canvassed customers to whom they had previously sold a television set, leaving the lens for approval on the customers set. In approximately 75 per cent of the cases this has resulted in a sale, and in many cases their neighbors seeing the lens work also purchased one.

The dealer must realize that with a practical and necessary item such as the lens, he has a chance to make a legitimate mark up without price cutting, whereas he may have to cut the price of a set to sell it. In most cases the magnifier sells at list.

The production figures of television manufacturers show that the largest selling set at this time is the 10-inch; next is the 12½-inch and then the 16-inch. This makes the case for the magnifier much stronger as it can be used to greater advantage in both the 10-inch and the 12½-inch set.

Incidentally, preliminary research
(Continued on page 14)

An Interview With Robert C. Tait

along horizontal lines had many weaknesses. Stromberg-Carlson is one of the pioneers in the radio industry and it developed through the years, adding new divisions and interests. Bob Tait found that there were horizontal organizations on production, sales, engineering and finance covering the manufacture of such widely differing products as telephone instruments, components, automatic switching systems, sound equipment, and radio and television receivers.

It soon became evident that the sale, engineering, manufacturing and financing of telephonic instruments and equipment are all completely dissimilar from those same functions in the highly competitive radio-television field. The telephone and automatic switchboard equipment field is characterized by a slow steady pace where inventory turnover is slow, compared with the radio-television business — the fastest moving industry the nation has ever witnessed.

Bob saw the radio-television field as it really is today: an industry moving with such speed from the time a new design is out of the laboratory to the time the finished product is off the lines and shipped to distributors and dealers, that to be caught off balance for even a matter of days might mean the difference between a successful line or a flop. Bob Tait quickly realized that inventory in radio and television *must* be repaid if any company was to survive. This recognition of a central truth in this industry did not mean that Tait was embarking his company on a price competitive "rat race" where he would try to keep pace with every price slash instituted by other manufacturers; it did mean that he was acutely aware of the ever-present time factor in the selling of television receivers, and the new reorganization completed last Summer served to completely separate the radio-television division of the company from its other varied interests.

With a new vertical organizational system functioning, Bob Tait now turned his attention to an analysis of the Stromberg-Carlson Company itself, its place in the industry, its strengths and weaknesses.

This industrial soul-searching brought to light a number of essential facts which were requisite to the formulation of a plan of action. It also pointed the way to Stromberg's estimate of its own place in the industry, and we might suggest that if other television manufacturers embarked upon similar evaluations of their own positions in this remarkable industry, there

might result less confusion and less distress to both distributors and dealers.

Bob realized that Stromberg's greatest asset lay in its reputation for quality merchandise—a reputation developed over more than a quarter of a century—a reputation that must be lived up to and developed even further. This did not mean, said Tait to a group of the company's distributors at the first national postwar convention recently, that Stromberg-Carlson should try to shoot for the carriage trade in the TV industry or direct its product fire only toward the top cream of the market. Neither did it mean, said Tait, that Stromberg should attempt to make the cheapest, skimpiest set and slug it out on the lowest price level. The truth was somewhere in between these two extremes for Stromberg, and Bob Tait dedicated himself and the company to giving the best quality available in each of the price classes in which they chose to compete—in other words, to give the greatest *real* value.

Sober Comment

Bob Tait also has some sober comments when it comes to a discussion about future developments in television, particularly in regard to UHF and color. As in everything he does, Tait's thinking about this is predicated on cold research. Recently, Ralph Hackbusch, president of the Canadian Stromberg-Carlson subsidiary in Toronto traveled throughout the country, talking with leading engineers and research laboratories in the television field. Hackbusch reported that in his considered opinion, UHF is still a long way off, and color an even more distant prospect. No one has yet designed a high powered transmitter or a power tube capable of generating sufficient power in UHF to provide adequate coverage. Tuners, adapters, converters and antennas present additional problems. It all added up, said the experts to Hackbusch, that there will be no commercial broadcast on UHF for at least two to three years, with color coming sometime after that.

But when it comes to a discussion of general economic conditions, Bob Tait is really in his own element and doesn't require the assistance of any technical experts. The recession felt in television and every other industry last Summer (it was called everything from a depression to a 'rolling recession') was foreseen by many perspicacious individuals. In fact, someone has said that it was the best advertised recession in our economic history, and when it finally materialized last June, it was

rough only to those who expected the honeymoon to never end. Another leader in the television field said recently, "I'm glad about what happened last Summer . . . it took some of the fat off. After all, you can't go on eating whipped cream all the time; occasionally a fellow needs some lean meat."

Many are of the opinion that the television merchant had too much lean meat in recent months, and the big question is what's ahead?

"Big Bob" has some sharp comments on what's ahead, and as head of one of the leading firms in this business, he's staking a good deal on his beliefs. This will be a relatively short economic setback, says Tait, pointing out that the total income of this nation is still enormous, greater than anything we dared hope for before the war. The savings of our people are still increasing and are still available for the purchase of consumer goods, provided they can be stimulated to purchase. Calling the turn on a general business upswing next year, Bob really glows with enthusiasm when he predicts that our amazing new television industry is virtually depression-proof. "Stop worrying about general economics and get your share of this Fall's business," Tait recently told his distributors, adding grimly, "Somebody else is going to get it if we don't."

Why Bob Tait ever left the comparative quiet and serenity of a bank to devote himself to a seemingly unanswerable lot of television problems only he can answer. But one thing is certain . . . the devotion to his new task is so thorough and complete that it is having a refreshing effect on the entire industry.

TV MAGNIFIERS vs. LARGE SCREENS

(Continued from page 13)

with color transmission has proved that the reception of color through the same magnifier currently used in black and white reproduces full and rich tones of the entire spectrum. Consequently, the same lens will serve as effectively when color transmission becomes available.

It is the opinion of the writer that TV lenses will be sold in greater quantities if the dealer will intelligently present the lenses and show that with the use of the lens a clear image can be magnified to a brilliant clear large picture with a three dimensional effect. This can only be obtained with a magnifying lens.

Admiral

FIRST

in television because of values like this

New Wonder Set

with **10"** picture tube



Now! To boom your fall sales. A sensational new Wonder Set from Admiral! An unequalled value . . . a fast seller . . . a traffic builder!

Value leaders like this have made Admiral first in television. During the first six months of this year Admiral dealers across the nation sold more Admiral television combinations than all other makes combined. Think of it! More than 57% of the entire industry output was built by Admiral and sold by Admiral dealers.

Buyer-preference for Admiral television is sweeping the nation. So phone or wire your distributor without delay. Quantities of this new Wonder Set are limited. Act today. Admiral Corporation, Chicago 47, Ill.

- ★ 10" Picture Tube with Full Vision Screen
- ★ Pictures Clear as the Movies
- ★ Revolutionary New Superpowered "20X" Chassis
- ★ Built-in Directional Roto-Scope Antenna
- ★ The Only Built-in Antenna That's Directional
- ★ See! Hear! On Television! "Stop the Music" ABC-TV Network, Thursday, 8 PM, EST

NEW 1950 TABLE MODEL
\$ 169⁹⁵
20X11
EBONY

Fed. tax \$1.40
Prices slightly higher south
and west . . . subject to change without notice.



**ONLY RCA VICTOR
HAS THE
"GOLDEN THROAT"**

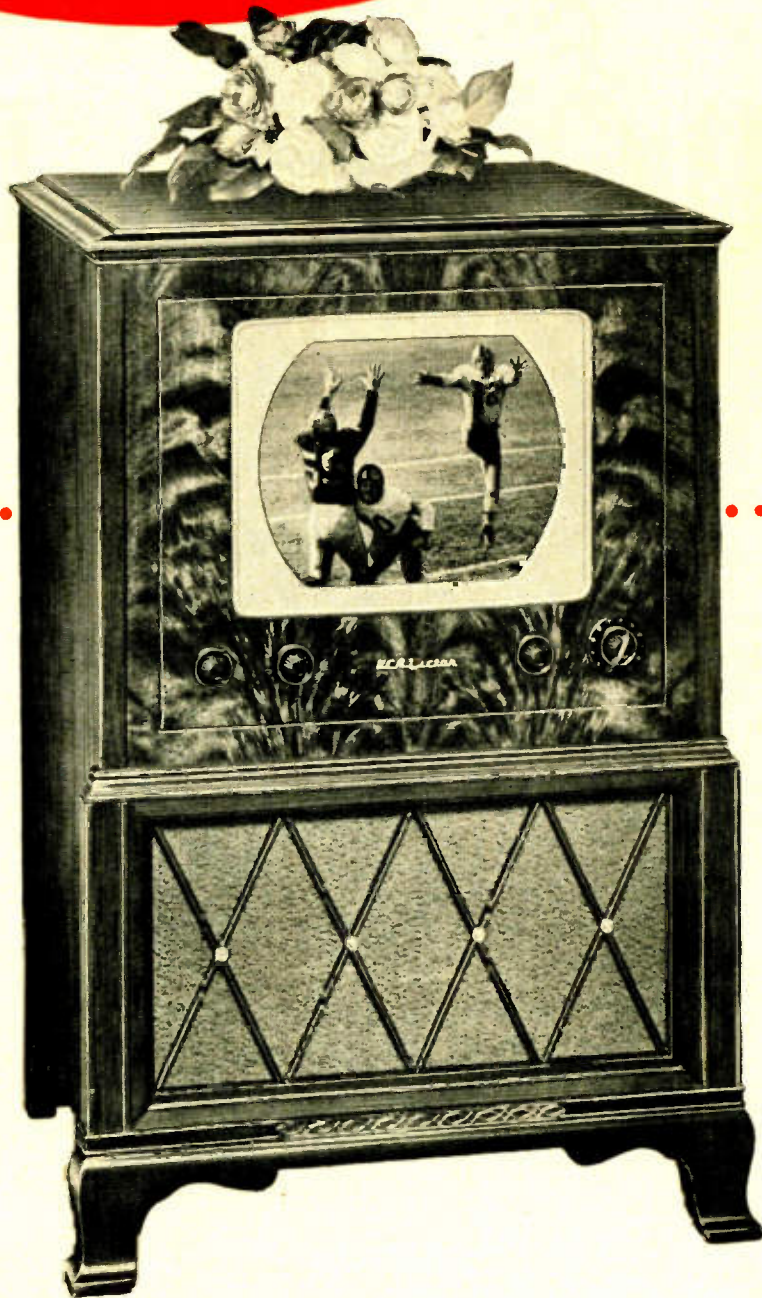

It gives your customers tops
in football . . . It gives you
tops in profits!

the RCA VICTOR 9TC247!

If your customers are looking for
a television set to bring their fa-
vorite football games right into
their homes . . . show them the
RCA Victor 9TC247!

They'll go for that large 12½-
inch picture tube, with pictures
locked in tune by the Eye Witness
Picture Synchronizer—*plus* rich,
mellow tone through the famous
"Golden Throat." All this in a
lovely Traditional console cabinet
that will make a handsome addi-
tion to any home!

The 9TC247, like all RCA Victor
instruments, has fast turnover be-
cause it offers your customers
highest possible quality at a fair
price. *Sell the entire RCA Victor
line for more satisfied customers . . .
greater profits!*

RCA VICTOR



DIVISION OF RADIO CORPORATION OF AMERICA

Radio & Television JOURNAL • October, 1949

Here's why your profits are greater with this RCA VICTOR

*Higher quality and outstanding selling points of
ALL RCA VICTOR instruments keep turnover high!*

Football fans are perfect prospects for Model 9TC247



**REFEREE'S VIEW OF
EVERY PLAY ON BIG
12½-INCH PICTURE TUBE—**

Be sure to demonstrate to your football fan customers how they'll have a luxury 50-yard line seat for the game *right in their own home* with the RCA Victor 9TC247.

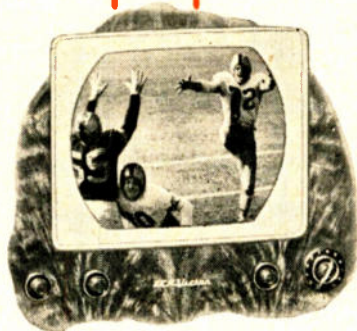

**THOSE BRIGHT, CLEAR, STEADY
EYE-WITNESS PICTURES!—**

Show customers how they catch *every* play with pictures *locked in tune* by the Eye Witness Picture Synchronizer . . . an RCA Victor exclusive development. And demonstrate how they'll hear it described in the incomparable vibrant voice of the "Golden Throat."

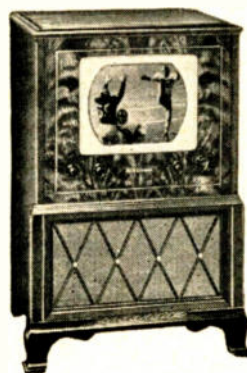

**CHARMING PERIOD
CONSOLE CABINET—**

Sell it as a lovely addition to *any* home. For in the 9TC247 cabinet, RCA Victor stylists have duplicated the rare dignity, beauty and grace found only in the Traditional mode of furniture design. In mahogany, walnut or blond finish.



*Don't forget
your
"Sell-up" Set!*

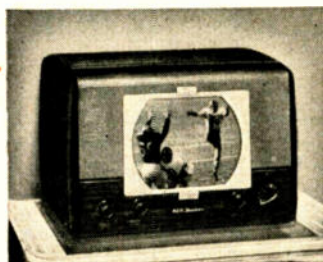

It's the 9T246 . . . RCA Victor's Anniversary Model. The same high quality that has made RCA Victor America's favorite television. The unbelievably low *special* price makes it your store-wide sales leader. You can make it your Number One "Sell-up" Set to the *more profitable* 9TC247.

**ONLY RCA VICTOR MAKES THE VICTROLA
"Victrola"—T. M. Reg. U. S. Pat. Off.**

RCA VICTOR—World Leader in Radio . . . First in Recorded Music . . . First in Television

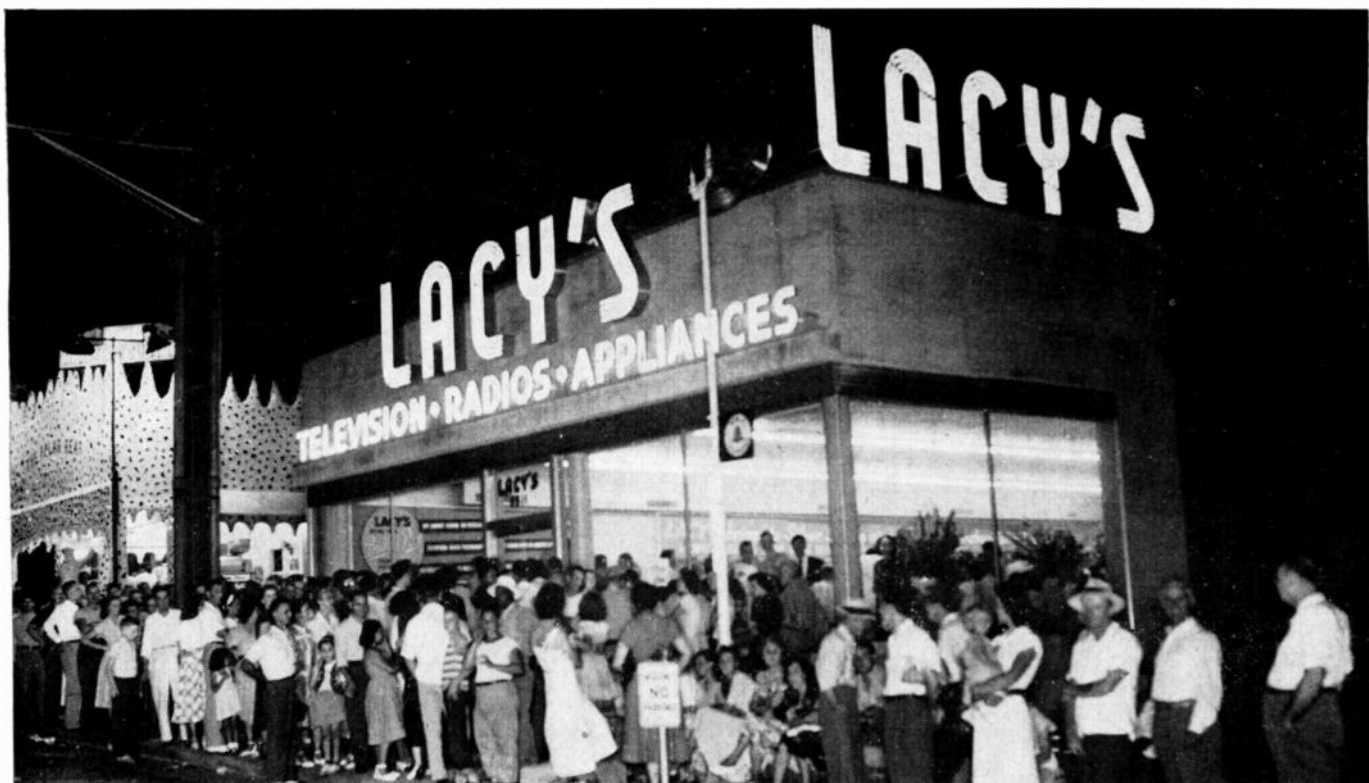

● Crowds like this, attracted by a \$1,500 door prize, really bought at this Lacey store opening.

There's No Shortage of Business

Provided You Go After It with Plenty of Punch

There's no shortage on new business if you go after it with plenty of punch with outstanding merchandise values and bring your goods within easy range of the customer's pocketbook and residence. Lacy's in Washington proved that theory of merchandising in the opening of their fifth television, radio and appliance store.

The new Lacy's is located at 8511 Fenton Street, Silver Spring, Md.—a Washington suburb that has grown to city proportions within the last five years. The new store is across the street from The Hecht Company and within a block of Silver Spring's two main traffic arteries. Also, it is close to free parking areas that accommodate over 1,000 cars.

Timed Promotion

The first publicity on the new store appeared two days prior to the opening with a page in a suburban shopping news. In rapid-fire succession, page-size ads appeared in the remaining suburban papers and all metropolitan papers. Spot announcements went out on radio stations and appeared on television. Local taxicabs carried bumper placards. Handbills were

passed out in Silver Spring parking areas.

The main publicity theme centered on a vast two-day sale at the Silver Spring store plus an announcement of over \$1,500 in door prizes to be given away on Saturday, the second day of the opening. A purchase or attendance at the actual drawing was not required for eligibility to win. Each door prize ticket had to be filled in with the entrant's name and address.

Value Sales Mount

Close to 1,000 people moved through the entrance in the first hour the store was open. Over 12,000 people visited the store within the first two days. First line of reasoning for such a large interest might refer to the valuable door prizes Lacy's was giving away. Undoubtedly they helped. However, these customers had "buy" on the mind for the close of Friday's business totaled a sensational figure. Saturday, with a few hours more of selling, showed an even larger figure. Buying was heavy in all departments with television leading. There was much credit buying, but Lacy's makes a strong bid for deferred payment, budget buying. Such items as \$3.50 alarm clocks at

99¢ were gobbled up and disappeared completely from the shelves. There was keen interest in a Bendix automatic washing machine at \$149.95 and television made a big showing with a 16-inch tube set for \$229.95 as the main attraction.

Solid Merchandising

There is nothing new in the tactics Lacy's used in their opening. Unquestionably low-price television will arouse interest at any time. However, the over all success in this case can be traced to Lacy's offer of worthwhile values in all departments. Also, bringing all elements of publicity into proper focus at the right time helped to produce results that were very, very satisfying.

Lacy's new store contains 6,500 square feet of selling space. The first floor is devoted to television, radio and small appliances. Also, the store offices are on the first floor. Downstairs has been turned over to white goods, including refrigerators, washers, ironers, freezers, driers, heating units and kitchen cabinet units. The front and part of one side has full depth windows that give a full view of the interior from the street. Exterior signs include two very large neon name signs.

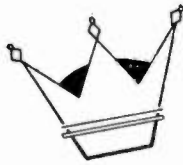

Tele King's

NEW '50 LINE

IS

SENSATIONAL



**BEST SET BY FAR...
for PERFORMANCE...
BEAUTY... VALUE...**

145 square inch eye-filling picture • Direct view screen • Supremely attractive wood mahogany cabinet • Designed for any decor • Teleramic picture with Tele Lock for brilliantly clear, steady viewing • Automatic frequency and gain control • Simplified operation • TV at its very best.

\$349⁹⁵

Plus Excise Tax

16" CONSOLE MODEL C816

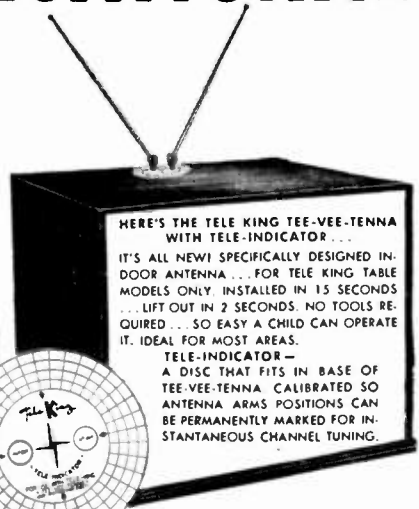

HERE'S THE TELE KING TEE-VEE-TENNA WITH TELE-INDICATOR...

IT'S ALL NEW! SPECIFICALLY DESIGNED IN-DOOR ANTENNA... FOR TELE KING TABLE MODELS ONLY. INSTALLED IN 15 SECONDS... LIFT OUT IN 2 SECONDS. NO TOOLS REQUIRED... SO EASY A CHILD CAN OPERATE IT. IDEAL FOR MOST AREAS.

TELE-INDICATOR— A DISC THAT FITS IN BASE OF TEE-VEE-TENNA. CALIBRATED SO ANTENNA ARMS POSITIONS CAN BE PERMANENTLY MARKED FOR INSTANTANEOUS CHANNEL TUNING.

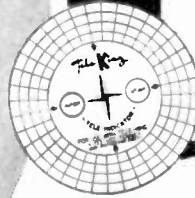

**145 SQUARE INCHES...
16" DIRECT VIEW SCREEN!**

Magnificent table model • Master designed wood mahogany cabinet • Finest components • Amazing TELERAMIC picture • Automatic gain control • Simplified operation.

16" TABLE MODEL T610



**FOR GIANT SALES...
91 SQUARE INCH
DIRECT VIEW SCREEN**

Designed wood mahogany cabinet • Brilliant Teleramic picture • Superior components • Automatic frequency control circuit.

\$319⁹⁵

Plus Excise Tax

12 1/2" TABLE MODEL T712

\$219⁹⁵

PLUS EXCISE TAX

**TERRIFIC SET...
FOR TERRIFIC SALES**

Gorgeous wood mahogany cabinet • Expanded 61 square inch DIRECT VIEW Teleramic picture • Tele Lock • All channel reception • Precision performance.

\$179⁹⁵

PLUS EXCISE TAX

10" TABLE MODEL T510



THE SHOWPIECE OF THE HOME

Tele King CORP.

601 WEST 26th STREET • NEW YORK, N. Y.

Prices slightly higher in west and south.



Don't Go **Color** TV Salesman

Stop reaching for the brass ring on that color merry-go-round and ring up sales on monochrome sets now.

COLOR has become the brass ring on a sober FCC ride. From a handful of aspirants seeking color television licenses, the number grabbing for the brass ring has swelled to over a half dozen staid enthusiasts for individual systems. There are others with negative sentiments about color television, also. One thing is certain, however. None of the prospective licensees will come up with approval until the FCC duly processes all applications, conducts cross-examination, sees demonstrations and finally makes the momentous decision on color. That may not be until next Spring. Meanwhile, the whole industry has let itself be caught with a case of the color shakes. The brass ring that is color flickers before everyone's eyes, until the whole issue has become a whirling color spectrum. Color, color, color! It has become worse than a kaleidoscope, blinding principals in the industry to the facts as they really are. In short, too many people

in too many places have gone 'color' blind. All to the detriment of the industry. And worst of all, too many dealers have gone 'color' blind where it hurts most—on television salesmanship.

What Are the Untinted Facts?

It is true that color television has become the number one topic on the question parade. But the facts do not warrant a topsy-turvy attitude to developments in color. Above all, they should not have dealers shaking in their boots because of the uncertainties which color stimulates in the industry. Such trembling in the face of the developments in the color situation is too easily transmitted to the consuming public. If for no other reason, dealers should have a firm and complete grasp of facts about color television and what it means to their individual operations.

The fever created by the present FCC hearings, which will decide the fate of

color for another indeterminate span in the future, is somewhat similar to that which a few in the industry must have felt back in March, 1947. At that time, color was ruled against and black-and-white television felt its first great push. Such FCC hearings had dated back to 1940 and beyond. In the early rulings the FCC informed the industry that the number of channels were not adequate for a national television system. Expansion by the industry continued, nevertheless, and by 1947 the industry was poised for its skyrocketing ride. A rash of applications for television facilities swamped the facilities of the 12 channels allocated, all within two years, and last October the FCC had to clamp a freeze on new station grants. Now the channel situation has been heaped upon the color situation, calling for further FCC rulings to insure future stability within the manufacturing and distributing segments of the television industry, and



From Green & Green's store on Pico Boulevard, Los Angeles, to the Times Square stores in New York, dealers throughout the Nation have a golden market for present monochrome television receivers. The color merry-go-round should not ham-

per the sale of these sets, for the danger of obsolescence, no matter what the future color rulings, is nil. Dealers should beware lest the color question completely blunt their salesmanship.

also for the protection of the investments made by present television owners.

The Protagonists

In the vanguard of prospective color licensees, who have perfected some form of color TV system, has been the Columbia Broadcasting System. CBS

Blind on ship

narrowly missed a favorable ruling in March, 1947, after which time the existing monochrome system catapulted the infant television industry along the high road of prosperity. Since then the broadcasting system has kept the pressure on, further perfecting its system to the point where the Joint Technical Advisory Committee of the Institute of Radio Engineers and the Radio Manufacturers Association proclaimed the CBS system to be in a further state of readiness than any other color system. The joint committee made known that the CBS 6-megacycle color television system is adjustable to the present black-and-white system with the aid of an adapter. It was CBS with its color system that pushed color television out of the laboratory by giving it a closed-circuit debut before the recent Atlantic City convention of the American Medical Association. On 20 specially built receivers some 1,000 doctors at a time were able to watch operations as they occurred on the operating table. The existence of a practical color system, even though of a closed-circuit type, did not portend a color system that would be available to the public. But

it has kept the pressure on the FCC for some new ruling.

The announcement by RCA that it had perfected a color system has also contributed to speeding a decision. RCA's system permits present receivers to receive color programs in monochrome or in color through an adapter, and allows for new color receivers to pick up color programs. Six other systems are compatible, or able to be used by existing television receivers for black-and-white reception without adjustment. One of these is Color Television, Inc., with a 6-megacycle system. One other is a 12-megacycle CBS system, and three other 6-megacycle systems are not identified. Figuring in the current FCC hearings too, however, are Dr. Leon Rubenstein, who proposed a color system of his own recently and Dr. Charles Willar Geer, University of So. California professor who claims he has a tube which can convert a set for color reception. The Philco Corp. and the Allen B. DuMont Laboratories, Inc. will also figure in the hearings.

Color in Time

Elaborate and extensive field tests of the various color television systems will determine the fate of color within the

next half year or so. One segment of the television industry is quite vociferous about the imperfect state of development of existing color TV systems. Dr. Allen B. DuMont believes color television is many years away. There are other industry leaders who hold a similar view. Dealers from Times Square to Pico Boulevard, Los Angeles, may have their individual views on the developments in color television systems. But for them to succumb to a paralysis while awaiting the latest developments, the latest FCC rulings, and the latest production line changes would be a fatal blow to their individual operations. In the face of possible basic changes within the television industry, and at a time when color may make dealers completely blind to promising sales, every dealer can look forward to prospering from television's Golden Age if . . . if he will fortify his salesmanship and that of his entire sales force.

Salesmanship Shortage

By the close of this year, the television industry's production figures will rest in a niche somewhere between the 2½-million to 3-million sets mark. This
(Continued on page 24)



The humming television industry is bubbling over with a variety of offerings, for almost any taste and any occasion. This Motorola portable is one of many receivers designed for special markets.

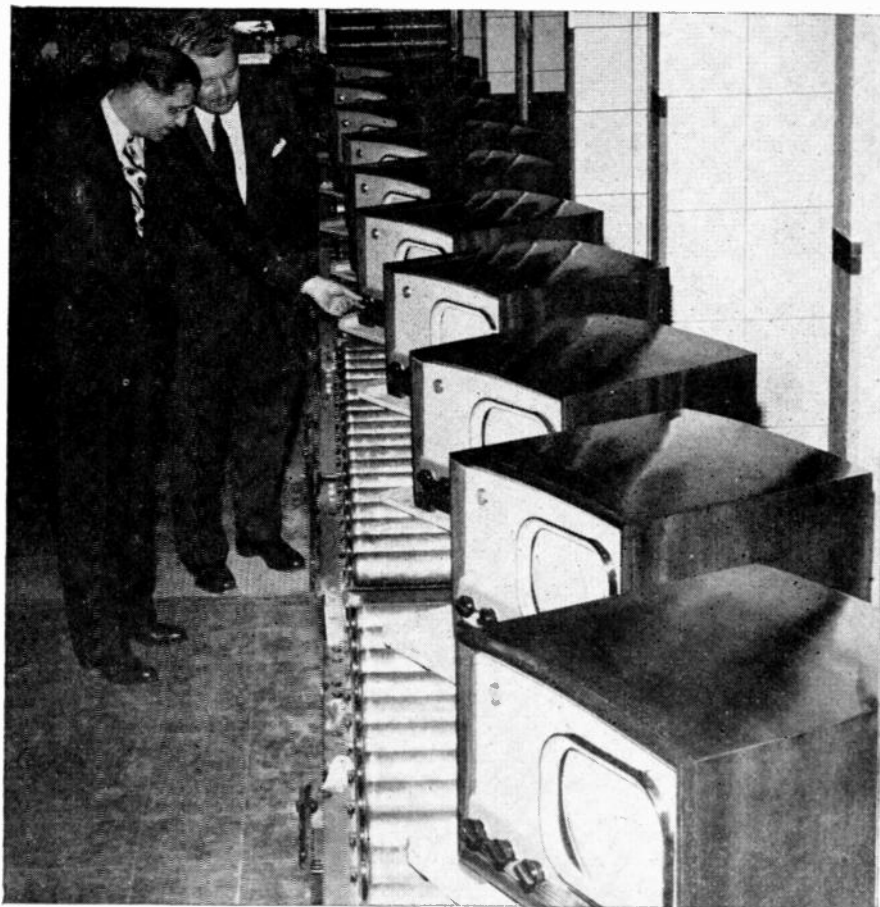

These sets moving off a General Electric Co. assembly line attest to the productive capacity of the television industry. After about two and one-half years, the productive might is revealed in the 185,706 sets reported made in August, 1949. Dealer salesmanship cannot flutter in the face of pending color rulings if selling is to keep pace with the flow of TV sets reaching the market.



● **Television in public places attracts bigger crowds, makes them stay longer, booms business. Use this appeal.**

About the Author

Alex Brown, who wrote the accompanying article for us, has had an extensive background in merchandising. Formerly with Pilot Radio and Davega Stores, he is now general sales manager



for Trad Television Corp., a firm which specializes in making large screen receivers for public viewing. Mr. Brown believes that the market for large screen public sets is almost as great as for home receivers. He also believes that the dealer is the man who should get this extra business.

Getting Your Share of Commercial TV Business

There's Plenty of Dealer Profit in the Vast Public-Location Television Field

SOMETHING quite interesting, particularly to the dealer who thinks in terms of new profit sources, is happening in a television market which we call the public location television field. These public locations include restaurants, clubs, and other places where crowds gather. This thing of interest is that owners of these public places are being made aware, and have consequently realized, that the home type television set, regardless of the picture tube size, has become obsolete due to the introduction of a large-screen projection type TV receiver. The fact that a four-foot by three-foot picture, or a two and one-quarter foot by three-foot picture converts a restaurant into a television theater is dawning on the more progressive owners of public places who are jealous of their position in the community, and who can still remember the new thrill that was given

their patrons when a TV receiver was originally installed.

As recently as a few months ago, bar and grill owners, for instance, were divided in their opinions regarding the value of television as either a service or a business builder. For some unknown reason some felt that television acted detrimentally, while others saw TV as an essential service rather than a device to create sales. The more progressive owners of public places, however, understood that the interest in television in a place such as theirs began to diminish directly in proportion to the number of sets placed in homes. As home-type TV prices declined, bottled beer sales picked up. Which meant that the demand for television in the tavern had declined considerably. It was all a logical sequence of events. Where people had flocked into all of these public places to see television as

a new thrill, it had, until the introduction of the new large-screen projection type receivers, become commonplace.

Move to Projection

These aforementioned progressive restaurant owners, who were among the first to install television, and who remembered the happy music of the cash register, are now installing these new large-screen projection-type TV sets. Such receivers automatically make obsolete all the home-type television sets in the places of competitors and converts an establishment into a television theater.

The fact that television programs will soon be appearing on the screens in movies, will undoubtedly have some impact on places such as restaurants, which consider themselves a factor in providing television reception of good quality in the community.

It can be readily seen, therefore, that the installation of a large-screen projection-type television receiver will certainly mitigate the situation, and, in fact, because of the difference in the physical dimensions of the auditorium in a theater and the size of a restaurant, provide, perhaps, a television picture with images directly in proportion in size to those appearing on a full size movie screen.

There are many dealers who are or were engaged in selling TV to these public places. These dealers who were responsible for the thousands of TV sets that were sold to these places are missing huge profits by not making the large screen projection-type television story known to their customers. Other dealers not aggressively engaged in outside selling in the initial stages in the opening of the television market, now have the opportunity to engage in a part of television receiver retailing which could prove to be more profitable than their home-type television departments.

For Large-Screen Profits

All of the aforementioned provides a new opportunity for the aggressive dealer to identify himself with a real money-maker. It is important to a dealer that he sell the make of large-screen projection-type receiver that has embodied in its design all the requirements that are peculiar to the needs of these public places. These requirements may be: single-knob control for rapid handling (to make it easy for the bartender to tune the receiver and handle customers); operation by a remote control which can be placed as far from the picture cabinet as desired; chassis design and arrangements of the type which makes for instantaneous servicing, and over-all physical design



● No matter where crowds gather public television appeals to young and old

for easy and complete installation. These requirements, all necessary to the public location television market assures the dealer that his customers will purchase the best receiver, for their purpose, in the television field.

It should, therefore, be obvious that the large-screen projection-type receiver has opened new profit sources. The wise dealer who is looking for a hedge against a rapidly narrowing profit margin in the home TV market, will do something about getting a share of this new television bonanza.

There is no limit to the sales prospects large-screen projection has opened up in the public-viewing market. Customers are found in an ever-widening circle. The tavern that first offered television to its customers is now in the market for a second and third set, a larger screen size. Lounges and recreation centers, hotels, clubs and fraternal organizations all come within the scope of this expanding and profitable area of merchandising. Dealers can profitably become commercial television conscious.

How to Go After That Profitable, Commercial Television Market

- Make a survey of your immediate neighborhood. List all bars, restaurants, schools, churches, lodges, fraternities.
- Hire an "outside" sales force to visit the aforementioned places. The sales force may consist of one good man or several. The purpose is to have him personally visit every potential customer to discuss how big screen TV will help him in his business or any other activity in which he or the organization he represents may be engaged. (Just consider television's potential for the school, or the Church social, or the lodge. The surface hasn't even been touched.)
- Arrange for a live demonstration on the prospect's own premises. This is most important. If it's a bar, make your demonstration on a Saturday afternoon when there are good football games, or on the night of a big fight. In that way, the customer can see what big screen television will actually do for his business.
- Follow through with stories of how installations have improved business in competitive places. Remember, the restaurant or bar owner buys television for business reasons, not for his own enjoyment. He's interested in what large screen TV will do for his cash register.

Don't Go Color Blind on TV

means that the distribution system will have opportunity to move the greatest number of television receivers ever produced in a single year by the television industry. And it means that the dealer and his salesmen will have to gird themselves for this tremendous task.

If any dealer has any doubts about the role of salesmanship in promoting the well-being of the television industry, a glance at the recent study by Fortune Magazine on the importance of salesmanship should wipe away those doubts. Among other things the Fortune article emphasizes that one serious remaining shortage in the economy is creative salesmanship. It also points out that sales training programs and budgets for such training are vital to prosperous operations. For those dealers who are cutting corners on expenses, therefore, lopping off sales training is not the way to bigger profits. Top-flight salesmanship is now a keener need than ever before because consumers are conditioned to wariness of depression years, favor saving, and buy with great caution. Every television salesman should therefore have all the attributes of a professional. He must bulge with self-confidence and must remain aggressive in the face of all sales resistance, real or imaginary. He must know his product, know his programs, know the fundamentals of television operations. He must be aware of all promotions, advertising and publicity which are aiding him in selling. He must know his customers, and must be able to evaluate the needs of each. The smallest item contributing to a good demonstration must be an integral

(Continued from page 21)

part of his selling plan—spacious, comfortable demonstration area, an attractive, spic-and-span display, and a properly adjusted set. No appeal should be too minor to ignore when selling, from a child's taste for Howdy-Doody to a woman's whim to have a set fit in with the interior decorating of her home.

Suggestion Selling

In the country and in the city, in hamlets and towns, in the heart of metropolitan areas and the hinterlands, salespeople have been found lacking in the most basic selling approach—suggestion selling. It is not a fallacy in salesmanship that is the exclusive province of television salesmen. Throughout every industry the same lack of professional selling sticks out like a sore thumb. But the television industry, even as it enters its Golden Age, is beset by distractions. These distractions are nothing but growing pains. The industry felt them before, has felt them ever since the green light was flashed for monochrome TV in March, 1947. Aggressive merchants left no stone unturned to cash in on the marvelous new product then, even when the industry was taking its first unsteady and faltering steps. On the eve of other momentous rulings which will determine the fate of the industry in the years ahead, dealers can keep their financial footing by not letting 'color' blind their salesmanship. And they will also see to it that color does not blind their salesmen, who comprise the driving force which keeps the industry true on its course toward a predicted listing as one of the Nation's top 10 industries.

Signs of Sheldon's Expansion

THEY SAID,
"It can't be done"

When we began to offer 10,000 shares of our stock at \$3 per share we were sure that the stock market would be in a panic. We were wrong. We were right. We were professional men and women, and other people with average incomes. We were sure that there were enough small people willing to supply venture capital to finance a small manufacturing corporation.

We were advised "It can't be done." But 200 people bought the first 10,000 shares direct from the Company within the very first week of our underwriting. About 200 of those were employees of the Company. We are offering the remaining 50,000 shares for sale at the same price.

WHEN YOU BUY ALLIED ELECTRIC PRODUCTS INC. STOCK, YOU OWN A STOCKHOLDER'S INTEREST IN THESE NATIONALLY KNOWN PRODUCTS.

Sheldon
FLUORESCENT STARTERS

Sheldon
"FLASH"
FLUORESCENT STARTERS

Sheldon
MILK BOTT HEAT LAMPS

Sheldon
MILK BOTT HEAT LAMPS

Sheldon
MILK BOTT HEAT LAMPS

ALLIED ELECTRIC PRODUCTS INC.
1000 CENT STREET
IRVINGTON, N. J.

Sheldon
NATURAL IMAGE
SOFT FLUO
Picture Tube

Just write for a prospectus... *John H. Dunlop*...
P. S. We will tell you, in a subsequent advertisement, "how we made out."

Crosley's \$2,000,000 Giveaway

On September 28, 32 armed guards and attendants walked into the Grand Ballroom of the Hotel Commodore, N. Y., bearing more than two tons of one dollar bills. The green stuff was the \$2,000,000 slated for the spectacular contest sponsored by the Crosley Division, Avco Manufacturing Co., Cincinnati, Ohio. The million in \$1 bills was promptly deposited in a giant, 14-foot tall Shelvador refrigerator which has a storage capacity of over 100 cubic feet.

The Shelvador full of money was a symbol of value of the cash, complete steel kitchens and refrigerators which Crosley, its distributors and dealers will give away in a contest due to open October 15 and continue through November 30. As many as 6,500 dealers are participating in the contest, which is being backed up with an advertising and promotion campaign on a national scale. Each participating dealer will announce the names of three prominent citizens of his community to serve as judges for his local contest, and, where dealers are numerous in metropolitan areas, each dealer will have a board of judges, with the Crosley distributor of the area coordinating the activities of participants.

W. A. Bles, Avco vice-president and Crosley general manager announced the contest in an 87-city phone hookup to 1,000 Crosley sales representatives, conducted the press showing in New York and believes the campaign is "so bold, so big and so startling that it will take the public by storm."

ONLY **STARRETT** OFFERS
DISCOUNTS up to 40%
 AND THE MOST SENSATIONAL
 PROMOTIONS IN AMERICA!

Full Page, Full Color Advertising in
 Your Area...in the American Weekly—

gets you the
 "mass market"

Fortune, Saturday Evening Post, New
 Yorker, Field & Stream, Town &
 Country, Times Magazine, Journal of
 Commerce, Wall Street Journal and
 Gourmet—

gets you the
 "big ticket" market!

**Protected Profits for
 Franchised Dealers
 assured by...**

Starrett

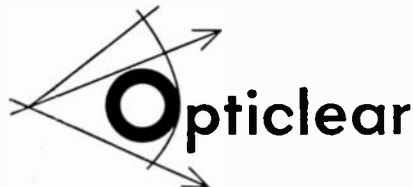

TELEVISION

with exclusive scientifically **FILM-FREED***
 picture tube, and built-in antenna.

*Patent Pending

America's most complete price range
\$249.95 to \$1295.00

Federal tax additional
 Prices slightly higher in West.

Don't let the other fellow get here first...write, wire, phone at our expense for full details NOW!

STARRETT TELEVISION CORP., 601 West 26th St., New York 1, N. Y.



A miniature, two-way Motorola radio puts this Miami mounted patrolman on an equal footing with the radio squad car. Unit is a "Handle-Talkie," developed by Motorola during the war. Miami police plan to use 13 of the miniature radios for regular duty assignments.

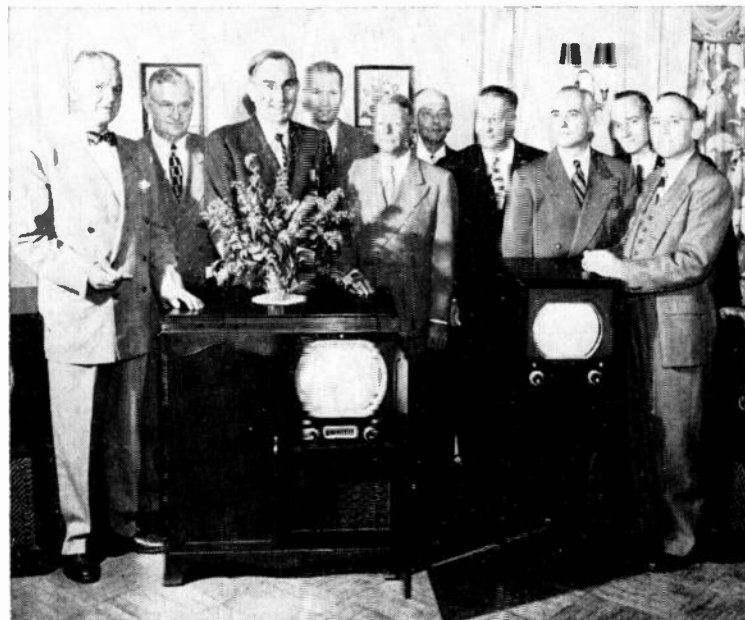

At the recent preview of the new Sylvania TV sets, Bayside, L. I.: L. to R., D. H. Tyson, controller; W. E. Poor, bd. chrmn.; H. W. Zimmer, G. R. Holden, R. H. Bishop, VPs; J. S. Learoyd, secty.; L. Bagg, Colonial sales mgr.; H. R. Shaw, chief engineer, J. Quick, Colonial exec.-v-pres. and Dr. R. M. Bowie, mgr. Sylvania lab.



Five hundred retailers and sales people turned out at a Kansas City meeting to hear the details of RCA Victor's latest merchandising and advertising promotion plans for its newest television receivers.



Emerson Radio Export and Canadian Fairbanks-Morse officers at Toronto National Exhibition of the Emerson radio and television lines. L. to R., Max Abrams, president; Joseph Katten, VP-gen. mgr., Emerson Radio Export, and H. C. Rindfleisch, Canadian Fairbanks-Morse Co., Ltd.

Nathan Chirelstein (holding phone), president of Sheldon Electric Co., TV tube manufacturer, Irvington, N. J., contemplates deluge of orders pouring in for his new, improved television tube. At right, one step in tube manufacture at Sheldon.

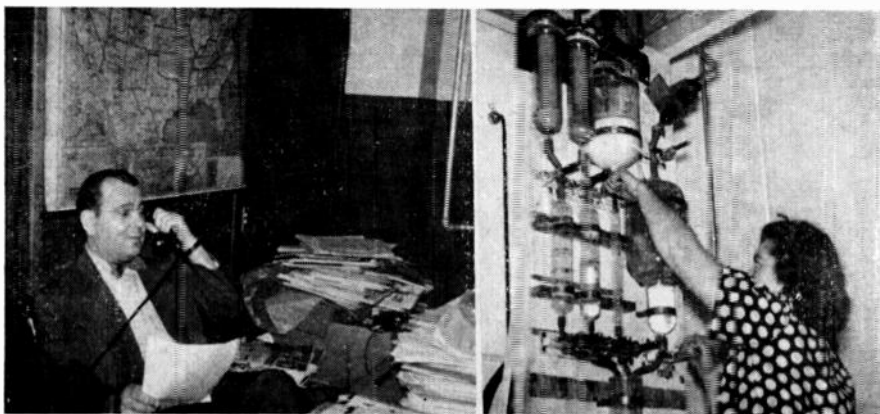

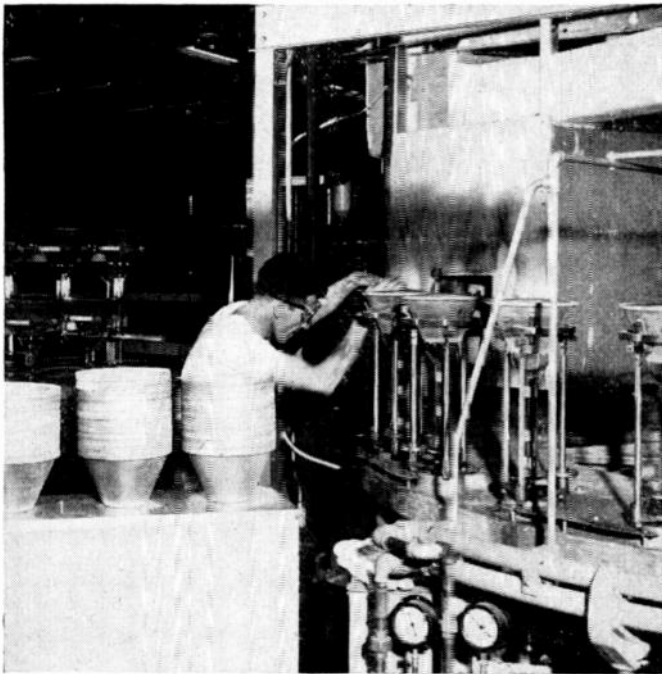

Making an 8 1/2-inch metal, electromagnetic, television picture tube at Electronics Park. GE claims tube, first in industry, gives 50 per cent more picture area than 7-inch tube. The firm is spending over a million dollars to modernize tube manufacturing and engineering facilities in Syracuse.

So great is the West Coast demand for its TV sets that Olympic Radio & Television, Inc., long Island City, N. Y., has taken to shipping sets to the Coast by air. Air deliveries, like this arriving in Los Angeles, supplement regular carload shipments and help fill the many back orders for Olympic sets.

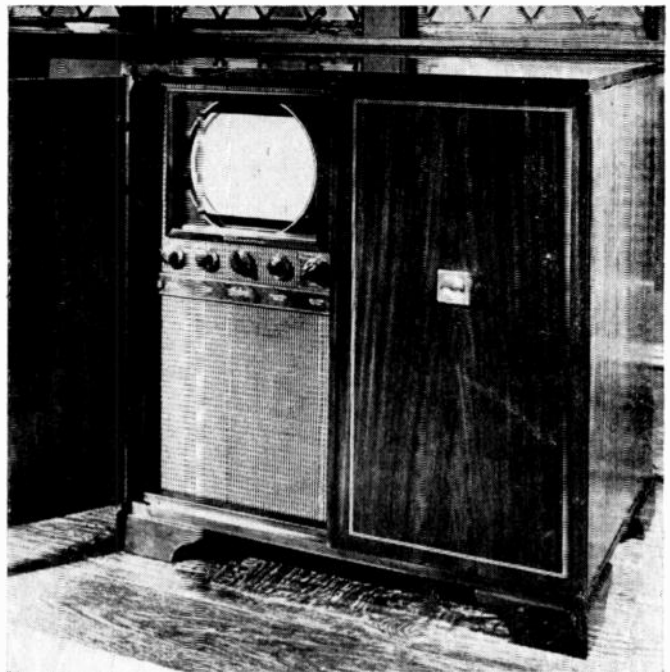

Lumite woven plastic grille is the latest feature of the loud-speaker section of Westinghouse Electric Corp. TV-radio sets. The woven plastic fabric aids tone transmission, is durable, stainproof and easy to clean. Set also has an electronic magnifier to expand screen to full circle.

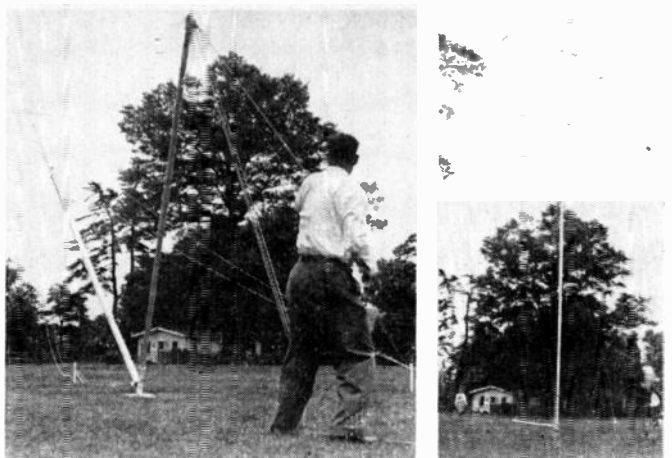
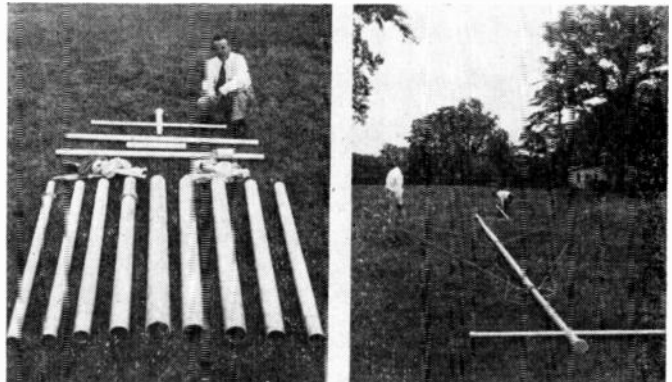

Not an aerialist exhibition but an antenna mast. Made by Special Purchase Products Co., N. Y., the sectional mast rises up to 90 feet above the ground, and is made of plywood tubing—Woundwood. Upper left: mast and erection sections for 60-foot antenna, guy lines, block and fall, base, boom socket and stakes. Upper right: mast assembled, boom is inserted in socket. Lower left: pulling boom to horizontal raises mast to vertical stand. Lower right: guy lines tight, mast stands erect above interference sources.

Tele-tone's **Big 3** SENSATIONAL

1 "BUILT-IN-ANTENNA"

IN MODEL TV-255

**LARGE 10" SCREEN
62 SQUARE INCHES**

Here it is . . . "Built-in-Antenna" . . . No installation required in most areas . . . Super-sensitive tuner for easy reception . . . Simplified controls . . . Improved picture lock for image perfection . . . and all

Model TV-255—Acoustically perfected mahogany high lustre finish plastic cabinet . . . \$169.95 plus excise tax.

Model TV-256 in hand-rubbed, high polish finish mahogany veneers . . . \$189.95 plus excise tax.



for only

\$149⁹⁵

plus excise tax

Model TV-254 only

2 "NO-GLARE"

BLACK TUBE

**16" DIRECT VIEW TUBE
145 SQUARE INCHES**

Now . . . the new "No-Glare" black picture tube. Sharp, but glareless pictures. No more eye-strain even after hours of viewing. Here's that extra "plus" for added TV enjoyment.

Model TV-286W in hand rubbed American walnut veneer cabinet . . . \$299.95 plus excise tax

Model TV-286M in hand rubbed high polish finish Honduras Mahogany veneer cabinet (pictured) . . . \$319.95 plus excise tax



as low as **\$299⁹⁵**
plus excise tax

THE GREATEST TV STORY EVER TOLD!

FIRST AGAIN...

Tele-tone

12½" TV LINE

is the country's outstanding buy for
QUALITY . . . DESIGN . . . PERFORM-
ANCE and LOW, LOW PRICE.

There is no better value
at any level.



LOW PRICE as low as
3 12½ IN. SCREEN **\$199.95** plus excise tax
BIG 92 SQUARE IN. PICTURE



**CHECK THESE SENSATIONALLY
PRICED 12½" SETS . . .**

- ✓ TV-287W—Table model in hand-rubbed, high polish finish walnut veneers.....\$199.95*
- ✓ TV-287M—Table model in hand-rubbed, high polish finish Honduras Mahogany veneers \$219.95*
- ✓ TV-288 —Table model (pictured above) in hand rubbed, high polish finish Honduras Mahogany veneers\$229.95*
- ✓ TV-284W—Console in hand-rubbed, high polish finish walnut veneers\$249.95*
- ✓ TV-284M—Console in hand-rubbed, high polish finish, Honduras Mahogany veneers (pictured at left)\$259.95*

*plus excise tax

Prices slightly higher in Southwest and Far West

Tele-tone
RADIO CORPORATION

540 WEST 58th STREET • NEW YORK CITY, N. Y.

as low as **\$249.95**
plus excise tax

NEWS AND NOTES OF MANUFACTURERS AND DISTRIBUTORS

● An increased demand for its low-priced radios has made it necessary for **Jewel Radio Corp.** to move its plant to a new location, where expanded facilities were available. The firm is now at 10-40 45th Ave., Long Island City, occupying over 20,000 square feet of space, with assembly lines equipped to turn out several thousand receivers a day.

● In line with its new price guarantee policy, **Starrett Television Corp.**, N. Y., has forwarded a special bulletin to its dealers, outlining the new policy. Guaranteed is a 30-day notice of any price reduction after December 1st. Full credit on all sets inventoried on the dealer's floor at the time of any reduction prior to December 1st, is also provided. The policy was inaugurated to give dealers maximum sales cooperation and to aid retail sales.

● **Capehart-Farnsworth Corp.**, Fort Wayne, Indiana, subsidiary of I.T.&T., has appointed the following distributors: Federal Distributing Co., Inc., Kansas City, to handle Capehart products in Kansas and Missouri, and Mytelka & Rose, Inc., Newark, N. J., for northern New Jersey.

● **Sylvania Television** has named Victor H. Meyer & Co., Inc., 312 Fifth Ave., N. Y., its metropolitan New York distributor. The firm has been a distributor of radios and electrical appliances for over 25 years.

● **Allen B. DuMont Laboratories, Inc.**, N. Y., has appointed two new distributors in the middle-western and Texas territories. General Utilities Corp., 647 W. Virginia St., Milwaukee, Wisc. for the Milwaukee area, and S. H. Lynch Co., 2101 Pacific St., Dallas, for that territory in Texas.

● The board of directors of **Emerson Radio & Phonograph Corp.**, N. Y., declared a regular quarterly dividend of 30 cents per share on 800,000 shares outstanding, payable October 15, 1949, to stockholders of record at the close of business October 5.

● John Bentia, sales manager, **Alliance Manufacturing Co.**, Alliance, Ohio, TV antenna rotator manufacturing firm, has just completed an introductory tour of television cities in Ohio. Initial jobber and dealer meetings in Cleveland, Toledo, Columbus, Cincinnati and Dayton were successful. Alliance's fall merchandising campaign was explained in detail at the meetings.

● **Bendix Radio & Television**, Baltimore, Md., has selected Moe Brothers Wilwaukee Co., 1119 N. Water St., Milwaukee, Wisc., as district merchandiser covering Wisconsin, except for several counties bordering Minnesota. The Moe Co. was founded over 10 years ago, and L. T. Hammond is president.

NEW LEAD-IN SUPPORTS THAT GIVE BETTER TELEVISION and FM RECEPTION!

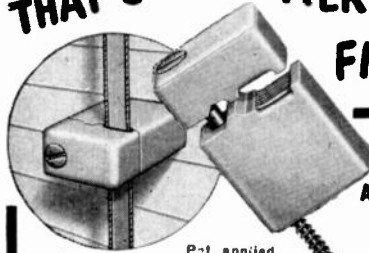

P-t. applied for No. 941R

Two major causes of TV Black-out, FM Fadeout are eliminated with Porcelain Products' exclusively designed lead-in supports. They give rigid support preventing lead-in wire from twisting in wind or going slack; short circuits are stopped by giving quick moisture drainage at support yet wire is held firmly without injury to insulation. Made of highest quality porcelain, resistant to weather extremes, factory assembled, screws rust-proofed, no maintenance, low initial cost. For all popular types of lead-in cables.

WRITE FOR FOLDER

OTHER ANTENNA AND LEAD-IN ACCESSORIES

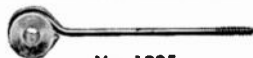

No. 1925 Insulated Screw Eye, Overall length 7-1/4", 5/16" insulator hole.



No. 1961 Split Bridle Ring Insulated Screw Eye, Overall length 3-5/8", 5/8" insulator hole, 1/4" diagonal slot.



No. 500 Antenna Strain Insulator, Brown glaze porcelain, size 2-1/8" x 1-9/16", 3/8" hole.

Porcelain Products, Inc.
FINDLAY, OHIO



Announces . . .

NEW SALES! NEW PROFITS!

the New 1950 line of PRECISION ENGINEERED SPEAKER CONES & VOICE COIL ASSEMBLIES, VOICE COILS, FIELD COILS AND ACCESSORIES.

AND SOMETHING NEW!!! . . . PROFESSIONAL type "SPEAKER ACCESSORIES KITS" to SAVE TIME & MONEY for every SERVICEMAN.

	SURE-FIRE SELLERS !!	List Price
Kit A—Speaker Cone Assortment . . . indispensable to every radio shop. 12 osstd. 4" to 12" top quality moulded and free-edge (magnetic incl.). Less voice coils. Kit of 12		\$3.49
Kit B—SPEAKER REPAIR KIT . . . Designed for QUICK, EASY & CHEAP repair jobs. Contains: 25 osstd. rings, 10 spiders, 25 voice coil forms, 3 yds. felt strip, 20 chamois leather segments, kit of shims, tube speaker cement and Instruction Sheet. ALL FOR ONLY		3.95
"COMBINATION KIT" . . . Contains both Kits A & B		6.49
Kit C—SPEAKER SPIDER KIT . . . Handy assortment of popular sizes used in standard speakers. Includes: Dustproof, Cup, Inside & Center Mtg. Kit of 20		2.75
Kit D—SPEAKER CEMENT & SOLVENT . . . All-purpose, fast-drying cement & thinner. 3 oz. bottle of each with brush		1.20
Kit E—CONE CENTERING SHIMS . . . 4 thicknesses, color-coded. All in leatherette case. Kit of 16 shims65
Kit F—SPEAKER CONE RINGS . . . 50 osstd. cardboard mtg. rings, 3" to 12". Kit of 50		2.25

USUAL TRADE DISCOUNTS

SPEAKER REPAIR PROBLEM??? . . . Try LEOTONE'S FACTORY SPEAKER REPAIR SERVICE for PROMPTNESS with a 6 MONTH GUARANTEE!!! . . . Specialists on those "Hard-to-Replace" and High Fidelity speakers.

"A BETTER CONE—BUY LEOTONE"

LEOTONE RADIO COMPANY
65 DEY STREET NEW YORK 7, N. Y.

DEALERS: Here's your
sure-fire hedge against
the narrowing profit
margins in the home
television market.



NEW! BIG EXTRA PROFITS

IT'S *tradioVision*

Theatre
Size
Television
4 feet X 3 feet
picture



Sales come fast and easy to clubs,
schools, taverns, restaurants, social
organizations, and all other places
where crowds gather! Tradiovision
is easy to demonstrate! Easy to sell!
Easy to install and service!



Everyone enjoys Tradiovision 4 feet x 3 feet television pictures in the Criterion Theatre lounge—one of the many hundreds of theatres, clubs and other places where crowds gather that feature Tradiovision. Sales comes fast and easy to all such places.



Jack Dempsey's Broadway Restaurant and Bar becomes a television theatre with Tradiovision — and Jack pays for his set out of the extra profits it brings in. Taverns and clubs are "naturals" for Tradiovision theatre size television!

Here's a great opportunity for you to identify yourself with a real money-maker. You sell Tradiovision for big extra profits because Tradiovision sets feature:

- Two models — P 13 (4 feet x 3 feet picture). P 14 (3 feet x 2¼ feet picture).
- Remote control operated — with single knob for rapid handling. (to make it easy for the owner to tune the receiver and handle customers.)
- FM radio with dual speakers for high quality audio — built in to Tradiovision Models.
- Chassis designed as isolated circuit units, plugged in to each other, making instantaneous servicing possible.
- RCA licensed — the greatest name in television! Most advanced engineering development in picture brightness.

With Tradiovision you give your customers the best receiver in the television field! Your community Tradiovision franchise may still be available. Write today for profit details.

TRAD TELEVISION CORP.

377 Fourth Avenue • New York 16, New York • MUrray Hill 3-9757

Further RCA Expansion

Television set production was expanded to a third plant of the RCA Victor division, Radio Corp. of America, when new equipment was installed in the Bloomington, Ind., factory recently, facilities at that location being converted to TV use. One third of the 226,000 square feet of manufacturing space at Bloomington is being initially devoted to TV set production, thereby making it the third RCA plant, along with Camden and Indianapolis, to be devoted to meeting the increasing de-

mand for RCA Victor's television receivers. Additional space will be allocated for TV at Bloomington as such room is required. In addition to TV receivers, the Bloomington plant is slated to manufacture all the intricate TV tuners or selector switches required both for its own production and for that of its sister plant in Indianapolis. H. G. Baker, general manager of RCA's home instrument department, viewed the half million dollars going into these new facilities as RCA's faith "in the continuing growth and stability of the television industry."

Co "X" 20 Antenna

Manufactured by Best Vue Products,
247 Centre St., N. Y.

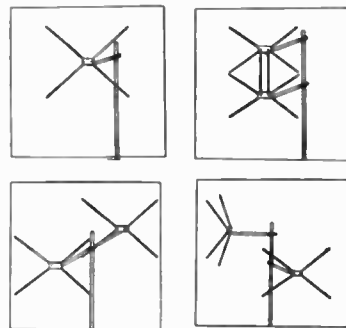

This is a multi-purpose conical TV antenna especially designed to meet any installation problem. It can easily be adapted for high and low frequency, dipole and reflector, stacked array, or separate installations. Constructed for broad response over the entire band, the manufacturer states this antenna brings in both the high and low frequencies with maximum efficiency. Other features are: high forward gain, lightning assembly and installation, use on 72, 150 or 300 ohm transmission lines and maximum signal pickup.

Say you saw it in *Radio & Television Journal*, October, 1949

SELL APPEAL WITH A "S" CAPITAL "S"



DUOTONE'S DAYLIGHT TELEVISION ENLARGING LENS!

A SMASH HIT WITH YOUR CUSTOMERS

because . . .

- ★ It's easy to attach to any television set.
- ★ Fits console or table models.
- ★ Makes image **FOUR TIMES BIGGER.**
- ★ No eyestrain! No glare! No distortion!
- ★ More contrast! Sharper outlines!
- ★ Wide angle view! 3-dimensional impression!

BIGGER PROFITS FOR YOU

because . . .

- ★ Duotone Daylight lens is available in all sizes.
- ★ Lens available tinted or clear.
- ★ Generous dealer discounts are our policy!

LENS PRICES start as low as \$12.95

Also Available . . . FILTERS

★ Duotone Daylight Television Filters scientifically tinted for maximum clarity, heightened contrast, elimination of eyestrain. 7" \$2.00, 10" \$3.50, 12" \$5.00, 15" or 16" \$7.50.

CONTACT YOUR DISTRIBUTOR OR DUOTONE DIRECT

THE **DUOTONE** COMPANY, INC.
799 Broadway New York 3, N. Y.

MAKERS OF THE FAMOUS DUOTONE NEEDLES

ATTENTION

South River Chimney Mounts are patent protected

U. S. Patent 2482575

Write for the new South River Catalog illustrating complete line of television accessories including the

NEW THRIFT CHIMNEY MOUNT Model T20

Low List Price

\$2.50 complete

and the **NEW 3" WALL BRACKET Model T3**

Low List Price

\$1.00 complete

SOUTH RIVER METAL PRODUCTS CO., Inc.

Dept. RJ, 17 Obert Street
South River, N. J.

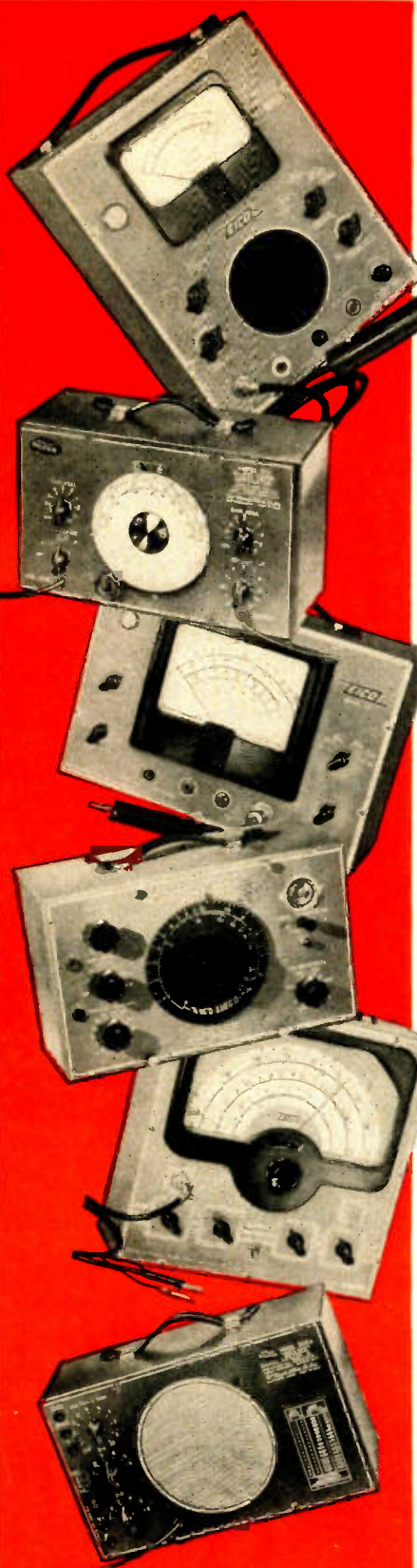

YOU JUST CAN'T SERVICE F.M. and T.V. BY **EAR!**

Or any Quality A.M. radio
— for that matter

2 Minutes . . . Reading Time
Benefits . . . for a Life Time

TODAY, modern time and labor-saving Test Equipment is a **MUST** to do the servicing job that brings satisfied customers *back* to you . . . and eliminates costly "callbacks" . . . in short, to be profitable, jobs must be done *right* the first time.

The days of "Servicing-by-Ear" are gone . . . only the alert, aggressive and properly-equipped technician can thrive and make money. Any Radio Serviceman, anywhere in the U.S.A., can now own new, up-to-date Test Equipment . . . *plus* many luxury items for his home, office, or hobby . . . *At No Cost* . . . through the famous N.U. DEALER EQUIPMENT PLAN . . . the only Plan that gives you this opportunity!

Since 1933, successful servicemen from every state in the Union have built their businesses around the 84,000 pieces of Equipment awarded them through the N.U. Dealer Equipment Plan . . . they earned them without any special effort . . . simply through their usual day-by-day purchases of N.U. Radio Tubes.

**ONLY YOUR N.U. DISTRIBUTOR
CAN OFFER YOU THE N.U. PLAN**

TEST EQUIPMENT: Ask him *today* to tell you how you can equip your shop, store or office.



LUXURY GIFTS: Mail the coupon below for the **FREE** 16-page fully-illustrated catalog.

Select the Test Equipment of your own choice from your N.U. Distributor's large, diversified stock . . . tell him you want to go on the N.U. Dealer Equipment Plan . . . get on-the-spot delivery of the Equipment . . . now you're on your way to a sounder, more profitable career in FM-TV and AM servicing.

Remember too National Union's help to the Service Engineer does not stop with Equipment. Each N.U. Tube, like the thoroughbred it is, best displays its 20 years of fine laboratory breeding, under the most severe operating conditions. No wonder N.U. Tubes are known throughout the industry as the Premium Quality Tube.

Free! Fully Illustrated
Luxury Gifts Catalog

NATIONAL UNION RADIO CORP.
356 Scotland Road, Orange, N. J.
Send me the FREE Luxury Gift Catalog and tell
me more about the N.U. Dealer Equipment Plan.

Name _____

Street Address _____

City _____ Zone _____ State _____

My Parts Distributor is: _____

For Prompt Action . . . Mail Today!



NATIONAL UNION RADIO CORPORATION

ORANGE, NEW JERSEY

RECEIVING TUBES • TRANSMITTING TUBES • CATHODE RAY TUBES • TELEVISION TUBES • SPECIAL PURPOSE TUBES
PHOTOTUBES • BALLASTS • BATTERIES • CAPACITORS • PANEL LAMPS • VIBRATORS • VOLUME CONTROLS

Television Neurosis

Have customers told you their television sets are acting up lately? They may be neurotic. TV sets, according to engineers at Motorola, have been developing anti-social tendencies just like people, so don't be surprised if your repair man recommends a session on the psychiatrist's couch.

Pursuing this parallel further, the engineers point out that people get confused through numerous conflicts and can't tell a good impulse from a bad one. Television sets likewise get confused when static and man-made electrical interference gets mixed up with the sight and sound signals. Result—weird noises from the loudspeaker and pictures with shakes. The Motorola experts point out that the company's new 1950 line of television sets are not at all neurotic because new circuits have eliminated such unpleasant tendencies. Now, if the experts would work on producing a new, simplified model of Homo Sapiens then maybe many of modern neurotic characteristics would disappear too . . . and with it a lot of the fun of life.

About That TV Service Contract

Since the status of the service company and dealer with reference to the New York State Insurance Law on television servicing contracts has raised an important issue, the remarks of Gerard I. Nierenberg, attorney for the Associated Radio-TV Servicemen of New York, made in a recent issue of ARSNY News are of prime importance.

Mr. Nierenberg held several conferences with Alfred Bohlinger, deputy superintendent, New York State Insurance Department. He discovered that not all original service contracts or renewals are automatically violations of the insurance law and therefore illegal. The question is just which forms of contracts are valid. Mr. Nierenberg has this to report:

"The Insurance Department has informed me that any service contract or renewal thereof made by a service organization, and a renewal service contract made by a manufacturer or dealer, pursuant to which a service organization, manufacturer or dealer agrees to a fixed fee or charge to make one or

more specified inspections and place a television receiver in good working order, and make such further inspections and repairs which may be required during the terms of the contract, (this) will be construed as valid provided that the contract may not include replacement of parts, shall be limited to repair of parts necessitated by normal use, and must exclude repairs necessitated by external causes and hazards."

These same rules regarding the legality or illegality of television service contracts are to be applied in passing upon service contracts for other appliances, machines, equipment or devices, to be used in the home or at business.

Keeping in mind the interpretation offered by the New York State Insurance Department, ARSNY has devised a contract which complies in all respects with this interpretation. Dealers who are interested in obtaining further information on the subject are encouraged to write Mr. Nierenberg or to contact ARSNY.

NOW you can STEP-UP your TV sales!

TVD-8-DISTRIBUTION UNIT

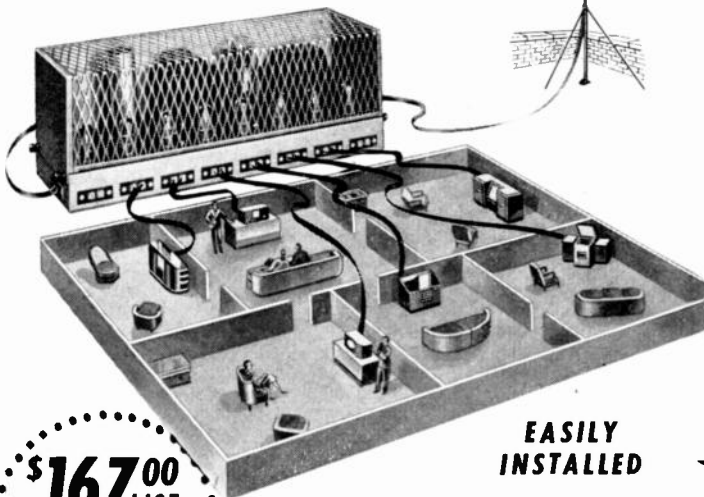

\$167.00
LIST
WRITE FOR
DEALER NET

EASILY
INSTALLED

Permits 8 Non-interfering Set Operations from Single Antenna... Prevents Interference Between Receivers

Gentlemen—this is one you won't want to miss—the answer to the TV dealer's demonstration problem! This set-up will operate 1 to 8 TV sets of any make at one time on a single antenna without inter-set interference. Leading set manufacturers now recommend it. There is less attenuation than with resistive distribution networks. It's compact, priced complete with tubes, easy to install, beautifully engineered by specialists. Order NOW!

Electro

**ENGINEERING AND
MANUFACTURING CO.**

627 W. Alexandrine, Detroit 1, Mich.

REPORTS COAST TO COAST SAY

Trans-Vue Sets



The first of multiple...
 were...
 designed...
 for use...
 commercial...
 locations...

Trans-Vue...
 sets...
 designed...
 for use...
 commercial...
 locations...

Commercial

"Trans-Vue is Television...
 Trans-Vue is Terrific!"

TO LARGER QUARTERS

Commercial and Home Television, Inc.
 has moved to larger quarters...
 located at 1120 N. LaSalle Ave.
 Chicago, Ill. The new quarters...
 are more spacious and better equipped...
 for the handling of the company's...
 growing business.

in Television for Restaurants

Commercial and Home Television, Inc.
 has developed a new line of...
 television sets specifically designed...
 for use in restaurants, hotels, and...
 other public places. These sets...
 feature a built-in speaker and...
 are designed for easy installation...
 and maintenance.

SALES ARE SOARING
 PROFITS POURING IN



The Trans-Vue "Entertainer", first in commercial television, is specifically engineered and designed for use in commercial locations to bring bigger and better television to you and your customers

Trans-Vue "Entertainer" gives your customers these 12 big feature "Firsts":

- 1 First with COMMERCIAL TELEVISION!
- 2 First with "SPLIT UNIT TELEVISION"!
- 3 First with AUTOMATIC "LOCKED-IN" TUNING!
- 4 First with "DIRECT IMAGE" COMMERCIAL TELEVISION!
- 5 First with EQUAL SOUND DISTRIBUTION TELEVISION!
- 6 First with EXTRA AUDIO AMPLIFICATION!
- 7 First with SIMPLIFIED TELEVISION CONTROL!
- 8 First with "ALL-ANGLE" 360 DEGREE VISIBILITY!
- 9 First with DIRECT VIEW CATHODE RAY TUBES!
- 10 First with "ANGLE COMPENSATION"!
- 11 First with CABINETS DESIGNED FOR COMMERCIAL USE!
- 12 First with POLAROID ONE-WAY FILTER!

All this means bigger sales, bigger profits for you...
 in the Trans-Vue "Entertainer"!

WRITE... WIRE... OR PHONE

TRANSLATE THESE TRANS-VUE "FIRSTS" INTO IMMEDIATE PROFITS

Trans-Vue

CORP.
 1139-41 S. WABASH AVE.
 CHICAGO 5, ILLINOIS

RTJ

Radios
Television

New Products

Consoles
Recorders



Phonographs
TV Accessories

Motorola's "Raeburn"

Manufactured by Motorola, Inc.,
4545 Augusta Blvd., Chicago 51, Ill.



Two simple controls and engineering that includes 11 new inventions and improvements are featured in this Masterpiece Series by this firm. The new 12½-inch tube is claimed to have up to 93 per cent increased brightness. UHF position is on band-switch. Built-in antenna provides reception in all but fringe areas. Cabinet in 18th Century mahogany.

Say you saw it in *Radio & Television Journal*, October, 1949

Industrial's New "Century"

Manufactured by Industrial Television, Inc.,
359 Lexington Ave., Clifton, N. J.

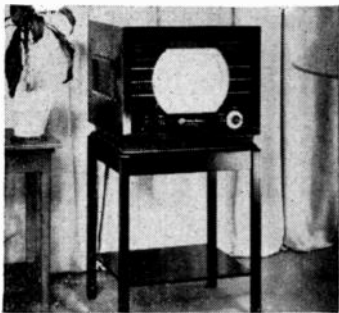

Equipped with a new, non-directional, built-in antenna, this new table model eliminates the need for outdoor antennas and any movement of set to improve performance. Picture tube is 12½-inch type. Has inter-carrier sound and automatic gain control circuits.

Say you saw it in *Radio & Television Journal*, October, 1949

Table TV by Philco

Manufactured by Philco Corp.,
Tioga & C Streets, Philadelphia, Pa.



For tuning the built-in antenna to each of the 12 television channels, this table model television receiver has a simple control. Aerial installation in eight out of 10 locations is not deemed necessary. Screen is 97 square inches in size. Cabinet reflects contemporary styling and is in striped mahogany veneers with leather finish.

Say you saw it in *Radio & Television Journal*, October, 1949

Electro's TV System

Manufactured by Electro Engineering & Mfg. Co., 627 W. Alexandrine, Detroit 1, Mich.

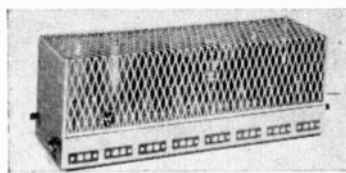

A television receiver distributing system which operates from one to eight receivers from one antenna. Operates from a 115 volt, 60 cycle supply line. Balanced 300 ohm input and output facilities avoids transmission line mismatch. Suited to display rooms or multiple dwellings.

Say you saw it in *Radio & Television Journal*, October, 1949

"Sheffield" by DuMont

Manufactured by Allen B. DuMont Labs, Inc.,
515 Madison Ave., New York



With a 12½-inch cathode-ray tube which yields an 85-square-inch picture, this console, finished in mahogany veneers, has improved electronic circuits for fringe area reception. Has a full-range FM radio. Cabinet is 27 inches wide, 39¾ inches high and 20¼ inches deep.

Say you saw it in *Radio & Television Journal*, October, 1949

Sylvania Table TV

Manufactured by Sylvania Television,
1280 Main St., Buffalo 9, N. Y.



A mahogany table model television receiver which uses a 10-inch picture tube and has a 63-square-inch screen. Has built-in antenna. FM high-fidelity sound circuits, continuous tuner, 10,000-volt electron beam, and triple-locked pictures.

Say you saw it in *Radio & Television Journal*, October, 1949

Stromberg-C's "Brentwood"

Manufactured by Stromberg-Carlson Co.,
Rochester, N. Y.

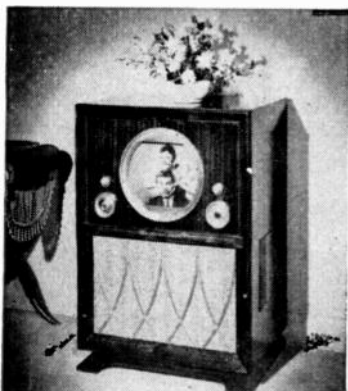

This console television receiver has an 89-square-inch picture screen on a 12½-inch cathode-ray tube. Has convenient visible controls and a precision-engineered audio system with 12-inch speaker. Side door compartment allows addition of 45-rpm changer, which is not furnished as standard equipment.

Say you saw it in *Radio & Television Journal*, October, 1949

Starrett's "John Hancock"

Manufactured by Starrett Television Corp.,
601 West 26th St., New York 1, N. Y.



With cabinet made in imported and domestic bleached, mahogany, walnut, or ebony, this console combination features a 16-inch picture and 36 tubes, including four rectifiers and the cathode-ray tube. Incorporates AM-FM sound, and record changer for all three speeds. Dual speakers powered by a 12-inch, PM, Alnico speaker. Automatic tuning for switching from AM, FM, TV or phonograph.

Say you saw it in *Radio & Television Journal*, October, 1949

Stewart-Warner Combo

Manufactured by Stewart-Warner Corp.,
1826 Diversey Pkwy., Chicago 14, Ill.



In a traditional cabinet finished in mahogany, this combination uses Protelgram and provides a 230-square-inch picture. Has 12-inch PM speaker for TV, AM, FM and phonograph sound. Also has 31 tubes plus seven rectifiers, a simplified control panel, and a turret tuner adjustable for reception of proposed UHF channels without a converter. Phonograph plays all size records and operates on three speeds.

Say you saw it in *Radio & Television Journal*, October, 1949

Hallicrafters' 19-inch TV

Manufactured by the Hallicrafters Co.,
4401 W. Fifth Ave., Chicago, Ill.

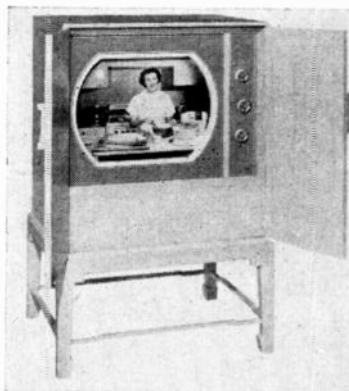

Featuring a 19-inch cathode-ray tube which gives a 203-square-inch picture is the latest in this firm's line of television receivers. Chest has Chinese influence, oak veneer and fruitwood finish. Console is 28 inches wide, 44 inches high and 22½ inches deep.

Say you saw it in *Radio & Television Journal*, October, 1949

**MORE NEW PRODUCTS
ON FOLLOWING PAGES**

New TV by Admiral

Manufactured by Admiral Corp.,
3800 W. Cortland St., Chicago 47, Ill.



An adaptation of the plastic "Wonder Set," this television console model has a 10-inch picture screen. Set is all plastic, making it stain-proof and mar-proof. Has a built-in, directional, "Roto-Scope" antenna, automatic gain control and an inter-carrier sound system for the elimination of microphonics.

Say you saw it in *Radio & Television Journal*, October, 1949

Zenith's "St. Regis"

Manufactured by Zenith Radio Corp.,
6001 W. Dickens Ave., Chicago 39, Ill.



For its 165-square-inch Giant Circle screen, this television console utilizes a Giant C tube. Set has 25 tubes, plus cathode-ray, and three rectifiers. Five tuned circuits for each channel are also incorporated in the receiver. Has gated automatic gain control and Zenith-Armstrong FM circuit. Cabinet comes in genuine Honduras mahogany veneers.

Say you saw it in *Radio & Television Journal*, October, 1949

Mars "Hampshire"

Manufactured by Mars Television, Inc.,
29-05 40th Road, Long Island City 1, N. Y.



Standing 50 inches high, this combination console uses an all-glass, 16-inch tube for a 148-square-inch picture. Has 40 tubes, 32 for the television section and eight for the radio. Uses a 12-inch speaker. Webster three-speed record changer plays all records, fully automatic. Cabinet is in hand-rubbed mahogany.

Say you saw it in *Radio & Television Journal*, October, 1949

Trav-Ler TV Console

Manufactured by Trav-Ler Radio Corp.,
571 W. Jackson Blvd., Chicago 6, Ill.



Providing a 145-square-inch picture from a 16-inch direct-view tube, this television console incorporates automatic gain control, inter-carrier sound and automatic lock-in picture circuits. Has 21 tubes and two rectifiers, in addition to the picture tube. Also uses full range FM sound circuit and PM Alnico V speaker. Cabinet is in mahogany finish.

Say you saw it in *Radio & Television Journal*, October, 1949

Console TV by RCA

Manufactured by RCA Victor Division,
Camden, N. J.

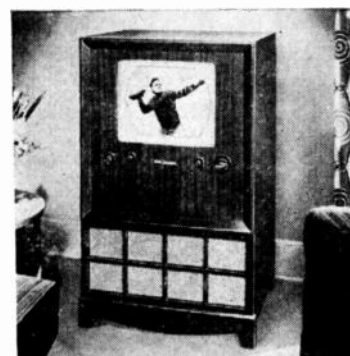

This console has a 12½-inch cathode-ray tube, features contemporary styling in walnut or mahogany finishes. Has a 12-inch speaker and simplified tuning. A jewel-light at the base indicates when the set has been left on. Set is equipped with a phono-jack, making it possible to attach a record player at the back of the console.

Say you saw it in *Radio & Television Journal*, October, 1949

Model 935

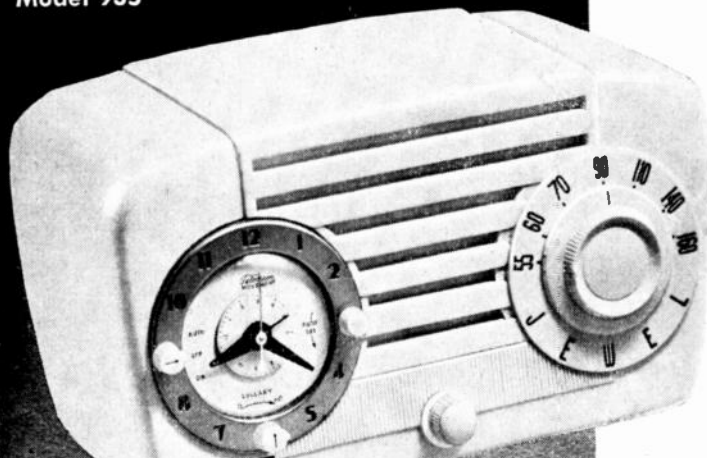

HERE'S
THE
LULLABY
SWITCH!

Turns off Wakemaster
automatically
when you retire



Order today! Some territories still
available to distributors and reps.

JEWEL Wakemaster

with
TELECHRON ALARM MOVEMENT
and LULLABY SWITCH

NOW!

ONLY \$29.95*
IN WALNUT
\$31.95*
IN IVORY

THE MODERN WAY to go to sleep . . . the pleasant way to wake up. With one setting, the Wakemaster lulls you to sleep, then shuts itself off at a time you select. Wakes you to music or news next morning . . . buzzes an insistent reminder ten minutes later if you're still in bed. A Telechron sweep-second clock . . . a DURALOOP equipped superhet radio . . . an electronic reminder. Use them together or independently of each other.

*Slightly higher west of Rockies.
Prices subject to change without notice.



JEWEL RADIO CORPORATION
10-40 45th AVE., LONG ISLAND CITY 1, N. Y.
Cable Address: JEWELRAD, New York

YOU CAN'T LOSE!

THE NEW

Capehart-IT&T

ASSOCIATION

DEALS YOU THIS PAT HAND

A YOU WIN
 with the powerful sales appeal of two world-famous names—Capehart and Farnsworth. And back of them the financial strength and the extensive research and manufacturing facilities of International Telephone & Telegraph Corporation.

K YOU WIN
 by being known as headquarters for the highest quality television and phonograph-radio instruments in your community.

Q YOU WIN
 with the assurance of steadily mounting sales built on Capehart performance and customer satisfaction.

J YOU WIN
 with the support of new, dramatic national and local advertising created to sell Capeharts for you in today's competitive markets.

10 YOU WIN
 with Capehart's policy of allowing discounts which permit a profit on merchandise that is sensibly priced to sell. Prices range from \$269.50 to \$1745.00.*

GET IN TOUCH
 with your nearest Capehart distributor. Or, if you are a distributor, call on us direct. There are still a few choice franchises available.

*Western prices slightly higher

AN IT&T ASSOCIATE

Capehart-Farnsworth

CORPORATION • Fort Wayne, Indiana

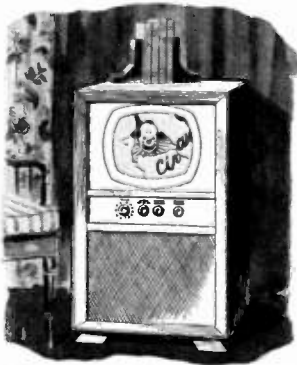

THE CAPEHART Prelude—For the small home this compact television set provides both economy of space and investment—with a clear, brilliant image and Capehart's true tonal fidelity. Rich mahogany finish. Polatenna (built-in aerial).



THE CAPEHART Symphony—For spacious homes Capehart provides the Symphony. Television with 16 inch picture. AM-FM radio and the Capehart record changer which plays all types of records automatically. Ample record space.

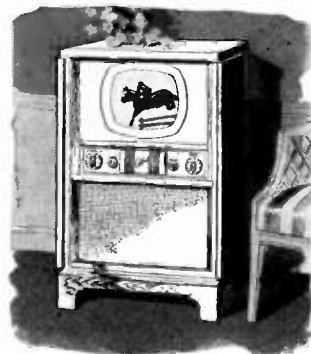

THE CAPEHART Overture—Capehart's Regency styling for those who prefer modest size with luxurious cabinetry. Rock-steady pictures—brilliant and clear—plus unmatched fidelity of tone. Television, AM-FM service. Polatenna (built-in aerial).

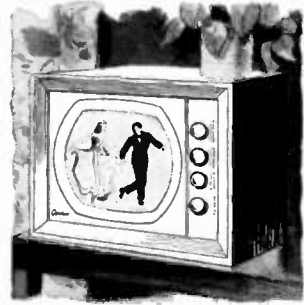

THE CAPEHART Minuet. Capehart's unique Minuet has its own distinctive charm. Modestly priced, it provides a sharp, clear picture in a compact cabinet. Sound is in the Capehart tradition of excellence. Polatenna (built-in aerial).

**IT'S HERE!
IT'S NEW!**

SYLVANIA

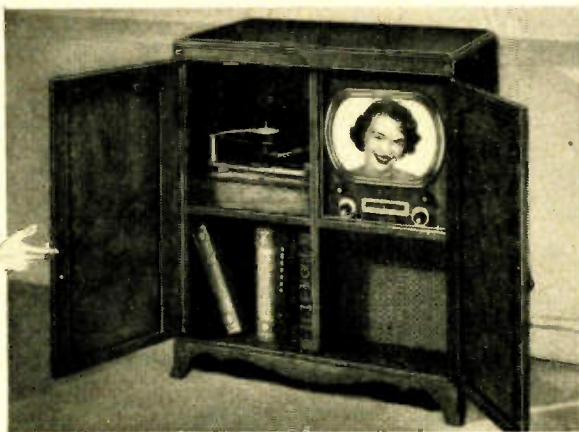

Sylvania 6-way Mahogany Console Combination # 128.
12½" tube... AM-FM radio... 3-speed automatic record changer.

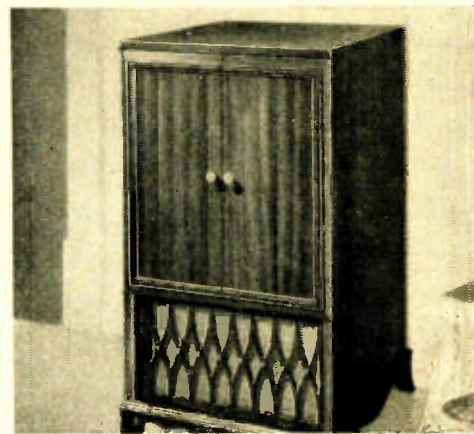

Sylvania 16" Mahogany Console # 090.
16" tube... FM sound... plug-in for record player.



Sylvania 6-way Mahogany Console Combination # 076.
10" tube... AM-FM radio... 3-speed automatic record changer.



Sylvania 12½" Mahogany Console # 114.
12½" tube... FM sound... plug-in for record player.

SEE the difference in **SYLVANIA** MOVIE CLEAR **TELEVISION!**



Sharper contrast! Finer detail! Sylvania's "Needle-Point" electron beam *brings out more detail more clearly!* **Steadier pictures!** New Sylvania "Triple Lock" makes pictures stay put, stay rock-steady *even under adverse conditions!* **Minimum picture interference!** Sylvania's shielded "Coaxial" lead-in eliminates "picture static."

HEAR the difference in **SYLVANIA** MOVIE CLEAR **TELEVISION!**

FM high-fidelity circuits with wide-range speaker and "Audio-Balanced" tone control! **"Intercarrier Sound"** eliminates "howls," "microphonic noise," and "acoustic feedbacks"! **Sound locked in with picture!** Sound automatically maintains its volume and quality no matter how often you switch channels!



COMPARE —
Close your eyes and compare Sylvania FM sound with the sound of any other fine television set!

**MOVIE
CLEAR***

TELEVISION

**MORE
PROFITS
FOR
YOU!**



Sylvania 10" Mahogany Console # 113.
10" tube . . . FM sound . . . plug-in for record player.



Sylvania 12 1/2" Mahogany Table Model # 125.
12 1/2" tube . . . FM sound . . . matching table optional.



Sylvania 10" Mahogany Table Model # 073.
10" tube . . . FM sound . . . matching table optional.



Sylvania 10" Blonde Table Model # 124.
10" tube . . . FM sound . . . matching table optional.



The Most **Sellable** Television on the Market—
that's **SYLVANIA** **MOVIE CLEAR** **TELEVISION!**

Styled right for you and your customers!
A model to please every customer, every model's
a fast-mover! Keeps inventories low!

Priced right for you and your customers! Low
prices for big sales—high markup for big profits!

**Sensational new "Pay-back" service
contract!** Exclusive Sylvania contract gives your
customers *cash refunds* for service they don't
use! That's a powerful selling tool—exclusive
with *Movie-clear* Television!

AND *Movie-clear* Tele-
vision will be advertised,
merchandised, by big,
consistent sales pro-
motion campaigns aimed
at your local customers!
Contact your Sylvania
Television distributor
today!

*TRADE MARK

SYLVANIA TELEVISION

MANUFACTURED BY COLONIAL RADIO CORPORATION
1280 MAIN STREET, BUFFALO 9, N. Y.

A Subsidiary of Sylvania Electric Products Inc. Manufacturers of Cathode Ray Tubes; Electronic Devices; Fluorescent Lamps, Fixtures, Wiring Devices; Electric Light Bulbs; Photolamps; Radio and Television Receivers.

Atwater 16-inch TV

Manufactured by Atwater Television Co.,
360 Furman St., Brooklyn 2, N. Y.

A new direct-view television console with a 16-inch tube and a 140-square-inch screen. Has FM radio and phonograph attachment. Uses 22 tubes and a 10-inch speaker. Console cabinet comes in mahogany.

Say you saw it in *Radio & Television Journal*, October, 1949



Wilcox-Gay Combo

Manufactured by Wilcox-Gay Corp.,
Charlotte, Michigan

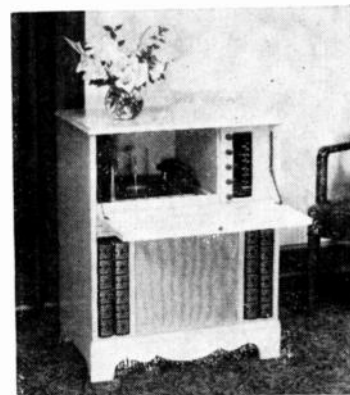

A combination AM-FM radio combination which has a three-speed automatic record changer. The instrument features a 12-inch speaker and the record changer plays all sizes and speeds of phonograph records automatically. Console is in blond or dark mahogany finish.

Say you saw it in *Radio & Television Journal*, October, 1949

National TV Console

Manufactured by the National Company,
Malden, Mass.



Featuring a 12½-inch picture tube, this television console has a 10-inch speaker for sound reproduction and has a cabinet of hand-rubbed mahogany veneer. Kinescope and deflection yoke are mounted inversely for removal of chassis without disturbing picture tube assembly.

Say you saw it in *Radio & Television Journal*, October, 1949

DEWALD presents a new TV SET with a BUILT-IN ANTENNA



HIGH-DEFINITION MODEL DT-160 with 16 inch Picture Tube

This handsome table model is available in Walnut or Mahogany cabinet, 24 x 20½ x 23½" deep. It's "tops" in performance — clearer, brighter, steadier pictures plus dependable performance and extra power for reception even in fringe areas.

The complete DeWALD TELEVISION and RADIO line means more satisfied customers, more sales, more profits for you. Now available.

AT NEW LOW PRICES

JOBBERS — REPRESENTATIVES

Some choice territories now available
Write for full information

Proven Quality for Over a Quarter-Century

in
RADIO
and
TELEVISION

for
SOMETHING
BETTER,
it's

DEWALD

DEWALD RADIO MFG. Corp. 35-15 37th Ave., Long Island City 1, N. Y

CONICAL TV RECORD BREAKER



Matches any ohm wire. All channels 1 to 13.
No booster required. Lightweight—approx. 7 lbs.
Immediate delivery.

Users report up to 300 miles reception.

\$11.75 DOUBLE STACK
8V-TV LIST \$37.95

\$5.75 SINGLE STACK
4V-TV LIST \$18.95

NO JOBBERS. ORDER DIRECT.
20% DEPOSIT ON ALL C.O.D. ORDERS

RAYTRON—441 Summit—Toledo, Ohio



411 CVM
The finest in television... gives clear-as-a-bell pictures of 82 square inches.

409 TVM
Full 140 square inch picture... perfectly matched with rich FM sound. Sure-fire sales-maker!

406 TVM
Sells on sight! Crystal clear, undistorted picture—fully 12% larger than the ordinary 12" picture size.

407 TVM
Big 16 inch with 140 square inch screen. Amazingly life-like pictures. Period Style Mahogany Console. Priced right.

401 TVM
More for your TV dollar! A full 60 square inches of picture. In a beautiful hand rubbed mahogany cabinet.

top of the heap

PROFIT WISE, PERFORMANCE, TOO!

PROFIT-WISE . . . Sentinel is your line. Sensational models that sell . . . that make you money. There's a table model or console and a picture size to please every buyer . . . you make sales and profits when you have Sentinel on the floor.

PERFORMANCE-WISE . . . too, Sentinel is your line. Known for a generation as builders of fine radio. Sentinel now brings you the best in TELEVISION. You can depend on Sentinel performance to sell for you . . . to stay sold.

400 TV
Eye-catching portable! In luggage style leather grain case. 12 channel operation.

Sentinel Radio and Television EVANSTON, ILLINOIS

And Sentinel's new, profitable, full line radios!

314-I—Sound money-maker! Simplified slide-rule dial, automatic volume control makes tuning-in quick and easy.



316—3-way personal portable. Light-weight. 4" Personality Colors. Exciting in tan, red, white or green.



333-W—FM-AM at a price that sells! Built-in antenna. Loaded with sales appeal! Ideal for that extra radio, in any home.



331-W—Priced for volume sales! Radio's grandest achievement in design and engineering. A little beauty.



332-I—Super sensitive for long-range reception... Full range tone control. Beautiful walnut finish plastic.



Sonic Booster

Manufactured by Sonic Industries, Inc.,
221 West 17th St., New York City, N. Y.

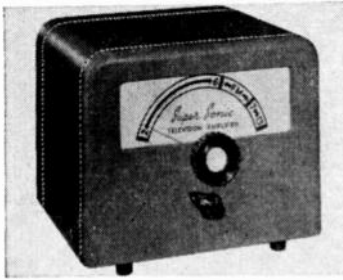

Two units are combined in this one instrument, a new television booster and FM tuner. A self-powered pre-amplifier, the combination booster and tuner picks up weak signals and strengthens television pictures, blending them with accurate FM sound reception. Helps eliminate interference and ghosts. Cabinet has illuminated dial and is covered in brown leatherette.

Say you saw it in *Radio & Television Journal*, October, 1949

Astatic TV Booster

Manufactured by the Astatic Corporation,
Conneaut, Ohio

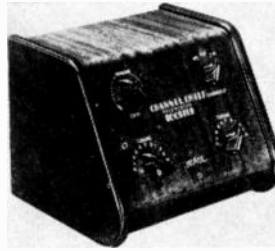

Uses four tubes and has high gain said to cover all television channels uniformly. Features dual tuning controls and variable gain control. Self-contained power supply operates from 115 volt, 60 cycle AC power line. On-off switch allows booster to be switched in or out of circuit at will. Cabinet is mahogany finish.

Say you saw it in *Radio & Television Journal*, October, 1949

Raytron Antenna

Manufactured by Raytron Manufacturing Co.,
441 Summit St., Toledo, Ohio



A hi-gain television antenna that matches any ohm wire. Covers channels one to 13. No booster is required. Weighs approximately seven lbs. Comes complete with center mast.

Say you saw it in *Radio & Television Journal*, October, 1949

WARNING!

A sharp, but timely warning to old-timers among radio service men that the "Youngsters" coming into the business, fresh out of colleges and technical schools, would be taking their jobs from them unless they take the necessary steps to make themselves as "competent as their new competition" was issued recently by Tim Alexander, Chairman of the RMA Service Committee.

Pointing out that the "screw driver and plier" serviceman has no permanent place in television, and that adequate test equipment and knowledge of its use is as important to the television technician as the x-ray machine is to the surgeon, Mr. Alexander said, "If you are a mediocre television man who can repair a set only by slow, plodding, tenacious work—watch out! Pretty soon one of these 'youngsters' will open a store across the street from you. By virtue of his better training and greater skill he will be able to do the job in one-quarter of the time. He will be paid twice as much per hour as you get, but the customer will still get off at half price."

He advised the "old-timers" to go to school again for the latest methods of servicing information to protect their jobs.

2-in-1 RMS
LIGHTNING
ARRESTOR



TAKES TWIN LEAD
OR COAXIAL CABLE!

NO WIRE STRIPPING
ON 300 OHM

NO INPUT LOSS

- carbon pile resistor type built to conform with building and insurance code.
- flexible metal straps and with hardware for quick, simple mounting.
- adaptable for all other radio applications.
- individually packaged for convenient handling.



Model LA-1



RADIO MERCHANDISE SALES, INC.
350 Westchester Avenue New York 55, N. Y.

**IT'S
SYLVANIA
AGAIN!**

**ION TRAP IN SYLVANIA
TELEVISION TUBES
ASSURES HUNDREDS
OF HOURS FREE FROM
SCREEN BURNS**



HERE'S HOW IT WORKS...

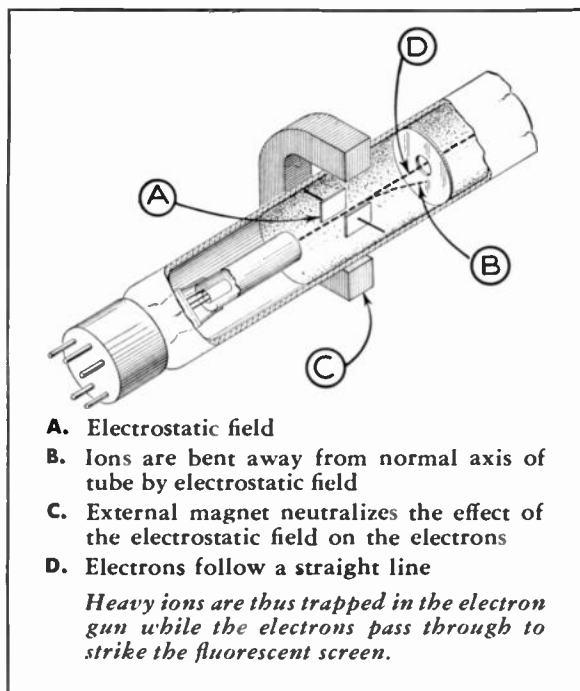

Owners of television sets equipped with Sylvania Television Picture Tubes report their screens still bright and unblemished after more than 1000 hours' use. Much credit for this top quality performance belongs to Sylvania scientists who hold the basic patents on the magic "ion trap." With this device these scientists prevented destruction of the fluorescent screen by heavy ion bombardment. So successful is this ion trap that now many other major TV tube makers are using it under agreements with Sylvania.

These same Sylvania Television Tube scientists are now developing shorter large-screen picture tubes and special tubes for uhf television. Their continued research makes the Sylvania label your guarantee of the newest and finest in television picture tubes. Sylvania has a complete line of all-glass and glass-metal types for television and general purpose cathode ray applications. They are available now from your Sylvania Distributor.

Write for free characteristics and TV set complement chart. Advertising Department, Box R-2810, Emporium, Pa.

**SYLVANIA
ELECTRIC**

RADIO TUBES; CATHODE RAY TUBES; ELECTRONIC DEVICES; FLUORESCENT LAMPS, FIXTURES, WIRING DEVICES, SIGN TUBING; LIGHT BULBS; PHOTOLAMPS

Why Decision on Color is Vital

"There is a vast difference between the television industry and other industries. In other fields, when a new model is put on the market, the consumer has a free choice between keeping his old model or buying the new. The new one may be better, but the old one at least will work. But a television set is a useless thing by itself. . . . It becomes of value only to the extent that it receives a picture and a sound accompaniment—only, in other words, as it brings education and entertainment into the home.

"In order to receive this service each set must be synchronized with the transmitting station. This necessitates the fixing of definite standards by the FCC to which all transmitting and receiving apparatus must conform. Otherwise chaos would prevail. These facts set the television industry apart as to the way in which it moves from one major phase of scientific development to another. The establishment of standards for color television will set the pattern for years to come. It is therefore essential that they permit the finest performance that now can be foreseen. Nothing less than this should be accepted."

—Raymond C. Cosgrove, president, Radio Manufacturers Association in a statement to the Federal Communications Commission on September 26, 1949.

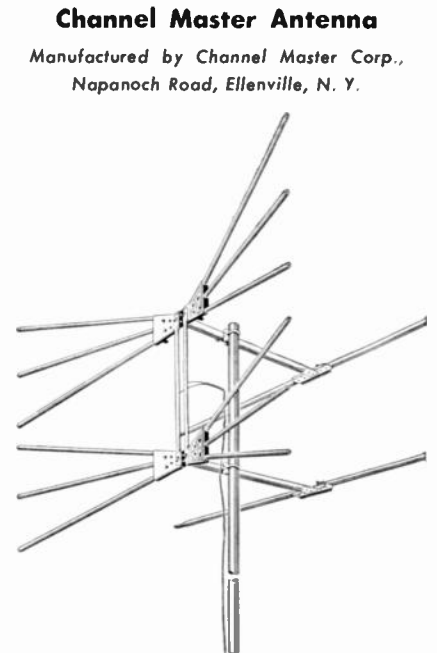

The Fan Flector is an antenna combining two principles of antenna engineering, fan type elements for uniform high impedance, and V-type alignment of these elements for narrow lobe, high gain characteristics on the high band. Single bay, stacked Fan Flector and double stacked Fan Flector models are available.

Alliance TENNA-ROTOR Sells with Television!



1,000,000 Demonstrations!
3,000,000 Viewers!
22 TV Cities
EACH WEEK!

● Compelling one-minute television films are doing a big selling job on the Alliance Tenna-Rotor! Viewers actually see how Tenna-Rotor makes a cloudy image come up sharp and clear. Every TV set owner wants to reach out—overcome interference—get more stations! Alliance films are timed with top programs to deliver a maximum TV audience!



CHECK YOUR STATION HERE!

Atlanta WAGA-TV WSB	Chicago WBKB WNBQ	Dayton WLW-D	Milwaukee WTMJ-TV	Pittsburgh WDTV
Baltimore WMAR-TV	Cincinnati WKRC-TV WLW-T	Detroit WJBK-TV WWJ-TV	New Haven WNHC-TV	Providence WJAR-TV
Boston WBZ-TV WNAC-TV	Cleveland WEWS WNBK	Indianapolis WFBM-TV	New York WATV WNBT	St. Louis KSD-TV
Buffalo WBEN-TV	Columbus WLW-C	Lancaster WGAL-TV	Philadelphia WCAU WPTZ	Toledo WSPD-TV
	Louisville WAVE-TV			Washington WNBW

The trend is to Tenna-Rotor. Tie in with this television advertising now!
 Alliance Tenna-Rotor Comes with a One Year Guarantee!

ALLIANCE MANUFACTURING COMPANY • ALLIANCE, OHIO

Export Department: 401 Broadway, New York, N. Y. U. S. A.



TWIN SCREW TYPE STAND-OFF INSULATOR

Strong, dependable—improves performance, cuts losses! One piece, rust proof steel.

300-OHM TRANSMISSION LINE

Weather-resistant, heavy, pure Polyethylene jacket. Ultra low loss—gives maximum signal transmission. 100' carton; 500' and 1000' reels.

PHOENIX ELECTRONICS, INC.
 Lawrence, Mass.

AT LEADING JOBBERS
 Write for folder V of complete line of television accessories.

"An inferior set with a good antenna will always outperform a better set with a poor antenna." From FM-TV Magazine, June 1949.



SELL A TV PICTURE
... for Customer Satisfaction !

FOR CUSTOMERS.....

An inadequate antenna sacrifices more than 10% of the TV picture quality. The customer wants the best TV picture reception. He depends on the TV dealer for a TV set at the price he can afford and for an antenna that is the best on the market.

FOR SALES.....

SEE-ABILITY IS SELL-ABILITY and the better the TV picture, the more satisfied the set owner will be. "When you sell a picture, you build customer satisfaction." And customer satisfaction sells more TV sets.

FOR INFORMATION.....

It takes selling punch and selling knowledge to put the most into a selling talk that will sell the potential TV viewer. American Phenolic Corporation has prepared "Sell a TV PICTURE", a comprehensive 16 page sales manual to help you sell TV.



**SINGLE BAY
 INLINE TV ANTENNA
 MODEL 114-005**

Operates over all channels and covers both high and low bands.

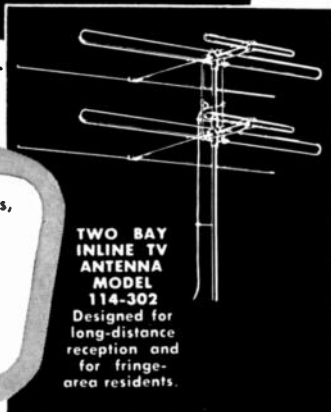

**TWO BAY
 INLINE TV ANTENNA
 MODEL 114-302**
 Designed for long-distance reception and for fringe-area residents.



For proved effectiveness, specify
AMPHENOL
INLINE ANTENNAS

--- THIS BOOK IS FOR YOU

"Sell a TV PICTURE" gives exact, scientific TV data in carefully chosen terms that are easily understood. Write today and ask for your free copy of "Sell a TV PICTURE"; AMERICAN PHENOLIC CORPORATION, 1830 SO. 54TH AVENUE, CHICAGO 50, ILL.



AMPHENOL
—INLINE—
ANTENNAS

AMERICAN PHENOLIC CORPORATION 1830 SO. 54TH AVENUE • CHICAGO 50, ILLINOIS

Let's Understand the Needle Business

By H. H. BORCHARDT
President, Recoton Corp.

Even though the phoneedle business is a lucrative one, the rewards which some dealers should be reaping from this sometimes-neglected side of their businesses nowhere nearly approaches the sales phonograph needles piled up in prewar days. Those dealers who devote adequate display space and promote phoneedles with the same insight they apply to other products have discovered that the sale of phonograph needles more than pays for the rent of a store. Other dealers carry these small items because they are a necessary evil. They are less enthusiastic about devoting display space to phoneedles and very often do not bother about promoting them, even in a small way. These are the dealers who are missing out on the profits which needles can bring to anyone who has a phonograph and record department in his radio and television store.

High Inventory Skids

The happenings which have, no doubt, soured some dealers on phoneedles were those which were partly under their control, partly not. Lulled

into expecting continued prosperity in the postwar years, many dealers continued to build up their product inventories. Needles were included along with everything else. After buying everything and anything they could lay their hands on, these dealers suddenly found they had piled their inventories too high. Even though they tried desperately to narrow down their stocks to a point where they had the most desirable items available, they still had brands which were not widely accepted. In desperation, they tried shoving these down customers' throats.

But money suddenly became tight, and wary consumers were just as suddenly gripped by conservative buying habits. In the face of this shift, aggressive merchandisers adjusted their selling sights and began promoting 25-cent, 50-cent and \$1.00 needles, continuing to do a large needle volume. Diehard dealers, on the other hand, tried to derive profits from existing stocks, not purchasing and promoting needles in this price range. Consequently sales dropped, and with them profits. When the returns on needles dropped, such delinquent dealers let that side of their business fritter away completely, thus throwing phoneedle profits out the window.

Understanding the Business

Why did these dealers refuse to buy and promote the popularly priced needles from which they could derive large profits from volume sales? The answer is that they did not understand the needle business. They ignored an important fact about phonograph needles. They simply forgot that until some new method is discovered whereby recorded sound is transmitted to a loudspeaker, phoneedles will continue to be a lucrative business. In fact, if recent surveys are any indication, the phoneedle business will continue to increase in sales volume and in total profits.

Many years of testing has definitely proved that the use of a screw-machined, turned steel needle is the finest means of reproducing the widest frequency from a recording. Theoretically, then, the only needle which should be used is such a steel needle. Unfortunately, however, the steel needle does not have a long life and other types, lasting longer, have been developed to overcome the objections of customers who deplore constant changing of needles. A growing factor in the needle business is the cartridge containing a replaceable, built-in needle.

Service and Suggestion

Dealers who enjoy a thriving record business from their phonograph-records department have been quick to realize that stocking replacement cartridges containing needles can be a sales booster. Like the elaborate service department, taking care of minor replacements encourages customers to feel complete confidence in a dealer. This may mean the difference between a sale of a larger item and no sale at all. It may be the stimulus for a return call and another purchase. If a dealer can make a fuss over an item as small as a phoneedle, customers feel, he certainly will be just as elaborate in servicing phonographs, radios and television sets.

And a dealer who has had the foresight to stock not only the cartridge replacements, now in greater and greater demand, but also 10-cent and 25-cent steel needles, along with popularly priced 50-cent and \$1.00 osmium alloy tipped needles, will discover that he really has a lucrative little business within a business. He will realize that phoneedles are not just a necessary evil, but that they are a profitable and necessary part of his operations.

Best Vue Scores Again with the NEW SENSATIONAL CO"X"20

THE FIRST TRULY MULTI-PURPOSE CONICAL TV ANTENNA

- Meets any installation problem
- Broad response over entire band
- Brings in high & low frequencies with maximum efficiency
- Use on 72, 150, or 300 ohm lines
- Lightning assembly & installation
- High forward gain

1. **High & Low Frequency**
Individually oriented dipoles for signals coming from different directions — excellent for locations midway between cities.



2. **Dipole & Reflector**
As a directional array, minimizes unwanted signals from the sides & eliminates ghosts.

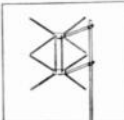

3. **Stacked Array**
As a stacked array the CO"X"20 provides extra high gain in weak signal areas.



4. **Separate Installations**
Can be converted into 2 simple, high gain, all-channel conical antennas for use in primary areas.

REPRESENTATIVE & JOBBER
INQUIRIES INVITED
Write, Wire or Phone for
Further Information

Best Vue Products
Mfrs. Fast Assembly Antennas
247 Centre St., New York 13, N. Y.

NEED
HELP?

TRAINED
MEN
AVAILABLE

Solve your trained manpower shortage by employing C.T.I. graduates. These men have completed a rigid course of training. What they've learned has been practical, because most of their training period was spent in the shop. We probably have graduates from your area. Write for prospectus on available men. (No employment fees).

**COMMERCIAL TRADES
INSTITUTE**

1400 Greenleaf
Dept. P104-10, Chicago 26

Here's an eye opener

**THAT'S
STEPPING
UP
SALES!**



THE ALL NEW WESTINGHOUSE 242

**GIVES BIG PICTURE PERFORMANCE
AT SMALL PICTURE PRICE . . .**

18½-inch image from a 12½-inch tube.

The sensational Electronic Magnifier is a sales feature that's simple to demonstrate, exciting to see, and the best sales clincher in television today!

Ask your Westinghouse Radio distributor for a demonstration of the great Westinghouse 242 features, and other new talked-about Westinghouse TV sets.



A flip of
the knob turns reg-
ular size picture to

GIANT CLOSE-UP

HOME RADIO DIVISION • WESTINGHOUSE ELECTRIC CORPORATION • SUNBURY, PA.

YOU CAN BE SURE...IF IT'S Westinghouse

Uses Nationwide TV Hook-Up to Sell "Tenna-Rotor"

Using television to sell their Alliance Tenna-Rotor—a television antenna rotating device—the Alliance Manufacturing Company is appearing with a regularly scheduled series of six television sound films over most of the major television stations. Each film is an actual demonstration of the product. The opener starts right out with a typical action view of an Alliance Tenna-Rotor, turning a television antenna on a housetop. Then the scene shifts to the living room where a close-up of a television screen, together with a viewer who is operating the Tenna-Rotor, is shown. The demonstration is clear and convincing—it shows fuzzy reproduction of a television picture and how the image comes up sharp and clear with the simple flick of a lever located at the set.

Each film has all of the qualities which make for sustained interest. There is variety, change of pace and action! The continuity is expertly handled and the sound is perfectly synchronized with the scenes.

The Alliance films made their first appearance on the air in New York over WNBT and in Cleveland over WEWS and WNBK, back in the early part of June. At present more than 22 television stations in most of the major Metropolitan centers east of the Mississippi have regular schedules going well into the fall and into 1950 on Alliance Tenna-Rotor. One-minute spots have been selected at strategic places—for example, spots adjacent to or participating in major league ball games, local and network shows, sports reviews and wherever adjacencies can be secured which provide a maximum evening audience. In Detroit and Pitts-



Planning Alliance's campaign: standing, l. to r., Miles McKearney, Foster & Davies ad agency; Jack Treacy, NBC spot sales; seated, l. to r., John Bentia, Alliance sales manager; H. Gallagher, WNBK, and H. Sweitzer, Alliance sales.

burgh, Alliance immediately precedes and follows the Notre Dame games. In Cleveland, they precede all home games with the Cleveland Indians. In Baltimore, they follow the Baltimore Orioles and over WATV in the Greater New York area, Alliance has spots close to the evening broadcasts of both the Brooklyn Dodgers games, as well as the two Yankee farm clubs—the Newark Bears and the Jersey City Giants.

Fall programming will include more appearances adjacent to regular evening network shows and at the present time Alliance is preparing some cooperative films for dealer tie-ins. The advertising agency, Foster & Davies, Inc., of Cleveland, which supervised the production and distribution of the

Tenna-Rotor films, made a careful analysis of many one-minute spot television commercials. This analysis revealed that too many commercials were static—lacked interest and did not provide sufficient variety. By using six films instead of one or two, with different scenes on each unit, the interest is maintained at a high level. The films are rotated each night. In this manner the deadly monotony so common to some television films is avoided. Each spot provides a 5-second margin for dealer tie-in or station write-in. New films will also be available for cooperative dealer tie-in advertising.

The results so far indicate that it pays to demonstrate a television product through the medium of television.



An
American
Pioneer in
Television

Rembrandt

REG. U.S. PAT. OFF.

presents

Dual Eye Appeal

Master in the Art
of Television



REMBRANDT television sets—hand-crafted for faultless reception—
 . . . treat your eyes with superb cabinet masterpieces in
 large, direct-vision, view screen. (12½", 15½", 19" table
 models and consoles.)
 . . . treat your eyes with superb cabinet masterpieces in
 hand-finished Mahogany, Walnut, Bland Mahogany, Knotty Pine,
 Maple, Oak or Chinese Postels.
 Continuous tuning for all 13 channels and entire FM bands auto-
 matically locked-in pictures.
**ALL REMBRANDT TELEVISION SETS EMBODY THE FINEST IN
 FM RADIO**

DISTRIBUTORS: A Few Choice Areas Available

REMINGTON RADIO CORPORATION
 White Plains, N. Y.

THE ONE AND ONLY TRADE-WIDE GUIDE

TRADE-IN DATA ON ALL MAKES OF HOUSEHOLD REFRIGERATORS MARKETED NATIONALLY SINCE 1928

- ADMIRAL
- APEX
- BELLEVILLE
- CAVALIER
- CHILRITE
- COLDSPOT
- COOLERATOR
- COPELAND
- CROSLLEY
- DALCO
- DAYTON
- ELECTROLUX
- FAIRBANKS-MORSE
- FIRESTONE
- FRIGIDAIRE
- GALE
- GENERAL ELECTRIC
- GIBSON
- GILFILLAN
- GRINNELL
- HOTPOINT
- JEWETT
- KELVINATOR
- LEONARD
- LIBERTY
- MAYFLOWER
- MERCHANT & EVANS
- MONTGOMERY WARD
- NORGE
- O'KEEFE & MERRITT
- PHILCO
- RICE
- SEACO
- SERVEL
- SPARTON
- STEWART-WARNER
- UNIVERSAL COOLER
- UNIVERSAL (LF&C)
- WESTINGHOUSE
- WILLIAMS ICE-O-MATIC

NEW! FREEZER SECTION INCLUDES DATA ON ALL MAKES OF HOUSEHOLD FREEZERS MARKETED NATIONALLY SINCE 1938

- ALCO
- AMANA
- AMC
- AMERICAN
- ARCTIC TRUNK
- ATLANTIC
- BEALL
- BEN BAR
- BEN-HUR
- BISHOP
- BTC
- CARRIER
- COLDSPOT
- COOLERATOR
- CO-OP
- CORONADO
- DEEFPREEZE
- ESKIMO FREEZE
- FIRESTONE
- FREEZ-ALL
- FRIGID KING
- FRIGIDAIRE
- FROSTAIR
- GENERAL ELECTRIC
- GIBSON
- GROSS
- HARDERFREEZ
- HOTPOINT
- IDEAL
- KELVINATOR
- KOLDMASTER
- LEONARD
- LOCKERATOR
- LOUDON
- MARQUETTE
- MARVEL
- MASTERFREEZE
- MAYTAG
- ORLEY
- PAK-A-WAY
- PANELECTRIC
- PHILCO
- QUICFREZ
- QUILLEN
- STANZERO
- SUB-ZERO
- VICTOR
- WHITING
- ZEROSAFE

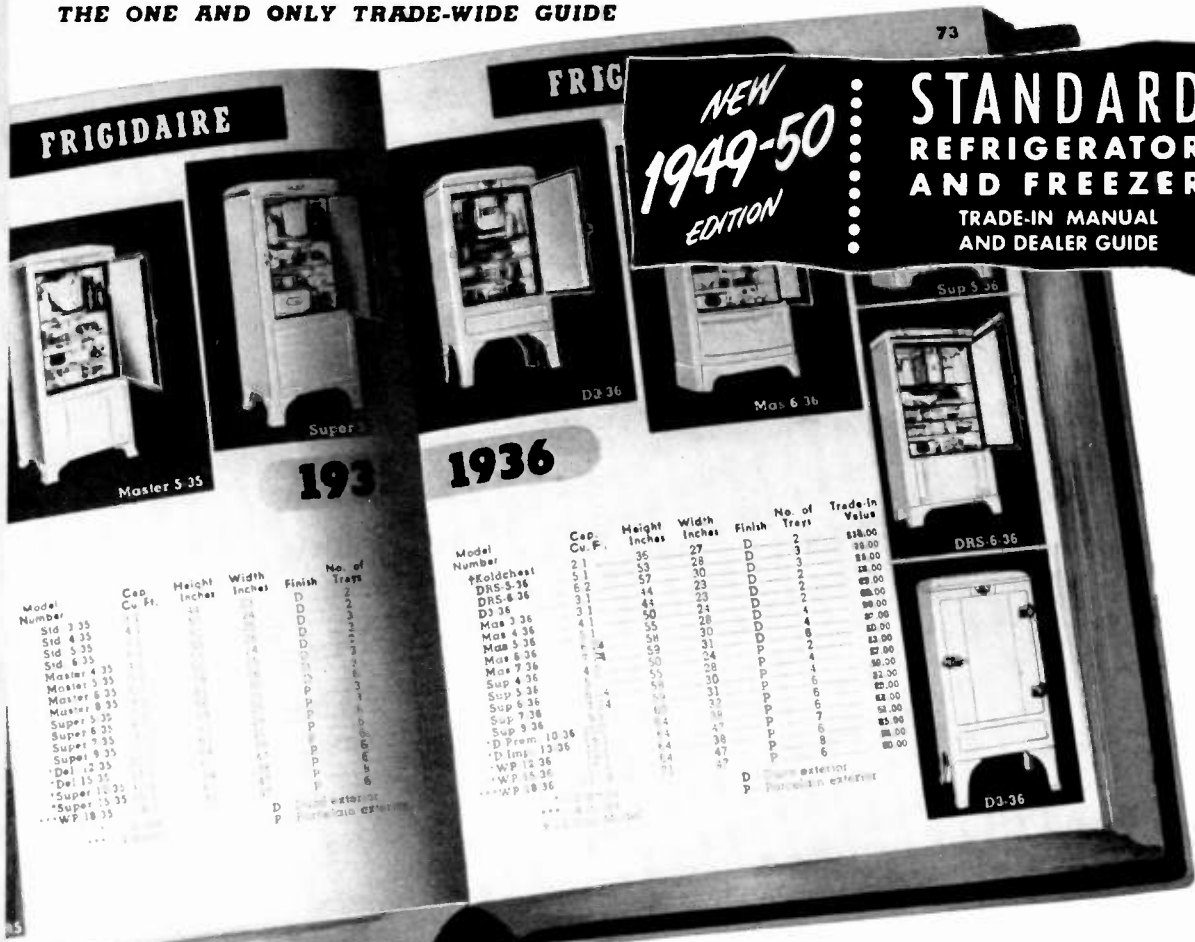

- More than 1200 photographs
- More than 3500 detailed listings
- Authentic trade-in valuations
- Operating information on Merchandising, Promotion and Reconditioning

Use the Standard Trade-In Manual for correct identifications and sound valuations.

Arranged and indexed for quick reference.

The internationally accepted trade-in authority on refrigerators! The standard reference source throughout the United States and 27 foreign countries. USED by retailers, service operators, associations, power companies, wholesalers, manufacturers, exporters, banks, publishers, economists, government agencies, libraries—in fact, everyone who is interested in household refrigerator and freezer market data.

Standard Refrigerator and Freezer Trade-In Manual and Dealer Guide—1949-1950 Edition—Case-bound, covered in washable green cloth, gold stamped. Pocket size, 4 1/4 x 6 1/4 inches. Lithographed, with more than 1200 photographic illustrations, 320 pages. Price—per copy—\$10.00 (U.S.A.). Foreign Price—\$12.50.

Quantity price list available on request.



PROTECT YOUR REFRIGERATOR AND FREEZER PROFITS!

All appraisals have been revised to reflect current market factors.

BE PREPARED FOR YOUR 1949 REPLACEMENT SALES

ORDER YOUR 1949-1950 STANDARD TRADE-IN MANUALS NOW!

Radio & Television Journal, 1270 Sixth Ave., New York 20, N. Y. Please send me at once:

_____ copies of 1949-1950 Standard Refrigerator & Freezer Trade-In Manual @ \$10.00* each. (Outside U.S.A. \$12.50.) * N.Y.C. orders, please add 2% N.Y.C. Sales Tax

Name _____
 Company _____
 Street Address _____
 City _____ Zone _____ State _____

Enclosed find check or money order for \$_____ in full payment.



© Copyrighted 1949 by Nelda Publications, Inc.

Recordis

GIVES YOU

2 QUALITY PRODUCTS

TO MULTIPLY SALES
TO BOOST PROFITS

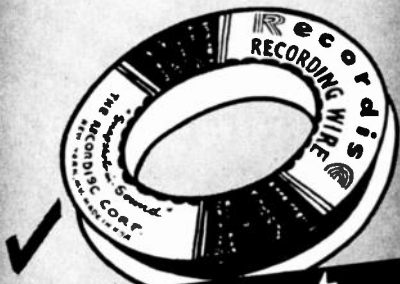

Super-Tone
REG. U.S. PAT. OFF.
RECORDING WIRE

Backed by the greatest name in home and professional recording, all RECORDISC products are your sure guides to customer satisfaction and steady, repeat sales.



WORLD-FAMOUS
HOME RECORDING
BLANKS

SEND FOR THE NEW
COMPLETE RECORDISC CATALOG

"You Take No Risk With Recordis"

THE
Recordis
CORP.

395 Broadway, New York 13, N. Y.

"Gold Rush" Promotion

As a climax to a big year of parts and accessory promotional activity, the Philco Accessory Division is currently engaged in its greatest of the "Forty-Niner" series of "Gold Rush Promotions" for dealers. The drive is characterized by the slogan "Final Drive for Big Nuggets" and runs through November 30, 1949. Outstanding part of the promotion is a series of opportunities for dealers and servicemen to buy Philco parts and accessories at exceptionally favorable prices.

New Dealer TV Manual

In a 16-page "Manual of Experience," published by the National Association of Electrical Distributors, the television dealer's installation and service problems have been analyzed and presented in a manner to show constructive procedures. The manual, according to Charles G. Pyle, managing director of NEWA, deals with every important aspect of installation and service. It is "intended to act as a guide to prospective television receiver dealers or as an instrument through which existing dealers can improve their present mode of operation."

ANOTHER NEW LEADER from the PROFIT-PROVEN PENTRON LINE



PENTRON
Aureo-Sonic
TAPE RECORDER
RADIO COMBINATION

NEW 2-IN-1

TAPE RECORDER-RADIO

Exclusive features, high fidelity, smart appearance, easy portability give this new Pentron Tape Recorder-Radio unequalled sales appeal. Hundreds of uses assure more prospects. Ideal for homes, schools, churches, broadcast studios, business. An invaluable aid in all forms of audio education, entertainment and demonstrations. Record conferences, radio programs, special events, inventories, research, etc.

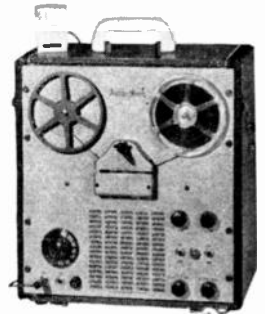

LIST PRICE
\$199.50
SLIGHTLY HIGHER
WEST OF ROCKIES

EXCLUSIVE FEATURES

- Tape Recorder records, plays back own radio and mike
- Superhet. Radio highly selective, built-in antenna
- Rewind Speed 20 to 1
- Power Output—5 Watts
- Frequency Response—60 to 8000 cps
- Recording Time—1 Hour
- Tape Speed—7 1/2" per Second
- Cabinet—2-Tone Simulated alligator, white plastic trim

Cash In On This Faster-Selling, Higher-Profit Line!

COMBINATION WIRE RECORDER • RADIO • PHONO — TAPE
RECORDER — RADIO — WIRE RECORDER — TAPE RECORDER

THE PENTRON CORP., 611 W. DIVISION ST., CHICAGO 10, ILL.

NEED REPRESENTATION?

IRVING B. SHURACK, Inc.

MANUFACTURERS REPRESENTATIVES

RADIO, TELEVISION ELECTRIC APPLIANCES

1133 BROADWAY

New York, N. Y.

**INTERESTED IN SECURING ADDITIONAL
LINES FOR NEW YORK AREA**

New Appointments

Seidel to VP post at RCA, Pokrass, Berliant and Bell in new positions with Tele King, Truesdell sales manager at Zenith, Weston, Rondell and Crossland in recent appointments at GE, Lyman national sales manager for DuMont, A. Norden, Jr. heads new division at Cornish Wire.

• Robert A. Seidel has been named vice-president in charge of distribution, RCA Victor division, Camden, N. J. Mr. Seidel was formerly vice-president and comptroller, W. T. Grant Co., which he joined in 1940, and has been an active member of the National Retail Dry Goods Association board of directors. He will make his headquarters at Camden.



ROBERT A. SEIDEL

New Officials Take Helm at Tele King

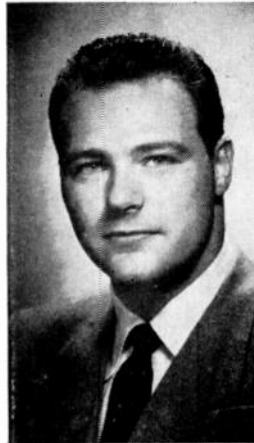

HARVEY POKRASS



EDWARD BERLIANT

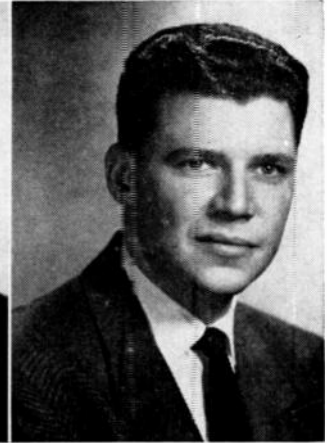

CALVIN E. BELL

• Leonard C. Truesdell has been named to the post of sales manager for household radio and television, Zenith Radio Corp., Chicago, Ill. Mr. Truesdell has been in the radio and appliance field since 1923. He directed



LEONARD C. TRUESDELL

• The board of directors, Tele King Corp., announced the appointment of Harvey Pokrass as president of the firm, also naming Edward Berliant executive vice-president and Calvin E. Bell secretary. A graduate electrical engineer, Mr. Pokrass has served as secretary-treasurer and vice-president of Tele King, and was an officer in the Kehr Warehouse Co. and the Flash Delivery Corp. before that. Mr. Berliant, 25 years in the field, is also general manager of the Tele King Corp. of New Jersey, and was formerly with Fada Radio & Electric Co. and with Krich Radisco. Mr. Bell has served as assistant sales manager of Tele King, and was formerly with R. H. Macy Co.

the entry of Bendix Aviation into the field of home radios and television, and recently rebuilt Hotpoint's national sales organization.

• F. A. Lyman has been appointed assistant national sales manager, receiver sales division, Allen B. DuMont Laboratories, Inc., N. Y. Mr. Lyman was formerly advertising manager of the Leo Meyberg Co., L. A., and has been in the radio-television business since 1941.

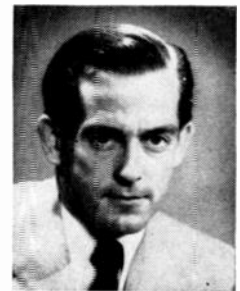

F. A. LYMAN

In Key Sales Posts at General Electric



D. E. WESTON



J. W. RONDELL



G. O. CROSSLAND

• D. E. Weston has been appointed merchandising manager of the receiver division General Electric Co., Electronics Park, N. Y. Formerly assistant television receiver sales manager, Mr. Weston has been with the firm since 1937. J. W. Rondell, former sales manager of GE table and portable radios, has been named assistant to the general sales manager, GE's electronics department, and G. O. Crossland has been assigned the post of sales manager of radios for the receiver division. Mr. Crossland formerly was sales manager of console radios.

• Alexander Norden, Jr. has been appointed to head a new division, the wired assemblies division, of Cornish Wire Co., Inc., 15 Park Row, N. Y. The division is to design, engineer and manufacture staple and specialized wire for manufacturers of radio, television and appliances.

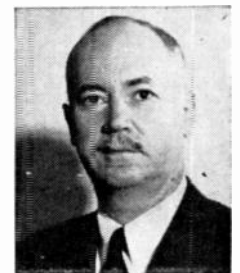

ALEXANDER NORDEN, Jr.



OCTOBER • 1949 • VOL. 66 • No. 10

Can Fair Trade Help the Radio-Television Industry?

Everybody loves a bargain . . . hates to be deceived while getting it. Every businessman loves a profit . . . hates to be bankrupted while seeking it. Predatory price-cutting of the kind we have seen in this industry in recent months affects both the consumer and the dealer. We (as well as other publications serving this field) have talked, scolded, preached and warned about the dire effects of unrestricted price-cutting, but nothing sensational has happened. The practice still continues with varying degrees of virulence throughout the industry. At the risk of belaboring the point, we're going to give you some additional facts about price-cutting and what might be done to mitigate its admitted evils.

The attack on prices at the retail level first became a major problem during the depression years of the 'Thirties' and led to the enactment of Fair Trade Laws in 45 states and Federal enabling legislation known as the Miller-Tydings Act. Since then, the related problems of price-cutting and fair trade have been batted back and forth by the courts and various industries with varying degrees of success. But before we can fully understand what fair trade might mean to the burgeoning television industry, we need first to comprehend the nature and economics of price-cutting, the motives behind it, and the effects on manufacturers, distributors and the public.

What Really Brings Prices Down?

Mass production, sustained and nourished by the life blood of mass distribution, the two are interdependent. Mass production reduces the cost of goods at the plant. Mass distribution, efficiently and with increasing economy, brings them to market. Mass production simply cannot be achieved without mass distribution. Mass distribution is not possible except under extraordinary circumstances of public need and demand) unless distributors believe their services are likely to yield them a profit.

Who Fixes Prices?

In the United States, the public—either as citizens or as consumers. The anti-trust laws offer protection against price-fixing monopoly; in the open market place, the consumer is queen. She has the freedom of choice to select from among products of similar class which may be offered at widely differing prices: she can pay much or little, as she pleases. To highlight this fact, surveying our own field of television, there are today almost 90 manufacturers of TV receivers, producing sets of every conceivable type and price. This is truly a competitive business, and, as Mr. Justice Brandeis observed years ago:

"The independent producer is engaged in business open to competition. He establishes the price at his peril—the peril that, if he sets it too high, either the consumer will not buy, or, if the article is nevertheless popular, the high profits will invite even more competition."

Who Loses from Price-Cutting?

1. The consuming public. Most of us like to believe we can outwit the price-cutter by buying only the "loss leaders" which he offers; but the law of averages is against us since we cannot be expert judges of all types of merchandise, our sense of value becomes distorted by fake prices on nationally branded and advertised products with which we have become familiar.

2. The responsible merchant. His legitimate business is undercut, and his reputation may be permanently clouded by an unjust and often temporary price comparison.

3. The manufacturer. He has invested large sums in developing and manufacturing a good product, and other large sums in creating public demand for it.

From every conceivable standpoint, price-cutting is injurious to every segment of the radio and television industry, and, if permitted to continue without abatement, will cause vast injury to the continued and stable growth of television. We believe that Fair Trading, properly understood and practiced, offers the solution to this great problem. We'll have more to say on how Fair Trade can be administered in our industry.

ADMIRAL CORPORATION	15
<i>Agency: Cruttenden & Eger Adv.</i>	
AIR KING PRODUCTS COMPANY	12
<i>Agency: Joseph Katz Company</i>	
ALLIANCE MFG. CO.	46
<i>Agency: Foster & Davies, Inc.</i>	
AMERICAN PHENOLIC CORP.	47
<i>Agency: Burton Browne Adv.</i>	
BEST-VUE PRODUCTS	48
<i>Agency: Shaw-Shon, Inc.</i>	
CAPEHART-FARNSWORTH CORP.	39
<i>Agency: J. M. Mathes</i>	
COMMERCIAL TRADES INSTITUTE	48
<i>Agency: Advertising Co. of America</i>	
DE WALD RADIO MFG. CO.	42
<i>Agency: Morton M. Magidson</i>	
ALLEN B. DU MONT LABS., INC.	7
<i>Agency: Buchanan & Co., Inc.</i>	
DUOTONE COMPANY	32
<i>Agency: Peter Hilton, Inc.</i>	
ELECTRO ENG. & MFG. COMPANY	34
<i>Agency: Wolfe-Jickling-Dox & Conkey</i>	
EMERSON RADIO & PHONOGRAPH CORP.	11
<i>Agency: Foote, Cone & Belding</i>	
JEWEL RADIO CORPORATION	38
<i>Agency: Harold A. Jacobs Co.</i>	
LEOTONE RADIO CO.	30
<i>Agency: Direct</i>	
MECK INDUSTRIES, INC.	Fourth Cover
<i>Agency: Frank C. Nahser, Inc.</i>	
MOTOROLA, INC.	5
<i>Agency: Gourfain-Cobb Adv.</i>	
NATIONAL UNION RADIO CORP.	33
<i>Agency: The Van Dine Agency</i>	
NOBLITT-SPARKS INDUSTRIES, INC.	Third Cover
<i>Agency: Roche, Williams & Cleary, Inc.</i>	
NELDA PUBLICATIONS, INC.	51
<i>Agency: Louis J. Albert Adv.</i>	
THE PENTRON CORP.	52
<i>Agency: Gotsch & De Ville Adv.</i>	
PHOENIX ELECTRONICS	46
<i>Agency: Milton Richards</i>	
PORCELAIN PRODUCTS, INC.	30
<i>Agency: Beeson-Faller-Reichert, Inc.</i>	
RADIO CORP. OF AMERICA	10, 16, 17
<i>Agency: J. Walter Thompson</i>	
RADIO MERCHANDISE SALES	44
<i>Agency: Nottingham & Phaneuf, Inc.</i>	
RECORDISC CORPORATION	52
<i>Agency: Cromwell Advertising</i>	
REMINGTON RADIO CORP.	50
<i>Agency: Direct</i>	
RAYTRON	42
<i>Agency: Direct</i>	
SENTINEL RADIO CORP.	43
<i>Agency: W. W. Garrison and Co.</i>	
SHELDON ELECTRIC CO.	3
<i>Agency: Corbin Adv.</i>	
SOUTH RIVER METAL PROD. CO.	32
<i>Agency: Art-Copy Adv.</i>	
STARRETT TELEVISION CORP.	25
<i>Agency: Ray-Hirsch Co., Inc.</i>	
STROMBERG-CARLSON COMPANY	9
<i>Agency: Federal Adv.</i>	
SYLVANIA ELEC. PROD.	45
<i>Agency: Newell-Emmett Co.</i>	
SYLVANIA TELEVISION	40, 41
<i>Agency: Kenyon & Eckhardt, Inc.</i>	
TELE KING CORP.	19
<i>Agency: Leland K. Howe Assoc. Inc.</i>	
TELE-TONE RADIO CORP.	28, 29
<i>Agency: Moore & Hamm, Inc.</i>	
TRAD TELEVISION	31
<i>Agency: Eastern Adv.</i>	
TRANS-VUE CORPORATION	25
<i>Agency: Harry J. Lazarus & Co.</i>	
WELIN INDUSTRIES	Second Cover
<i>Agency: Homer Harding</i>	
WESTINGHOUSE ELEC. CORP.	49
<i>Agency: Fuller & Smith & Ross, Inc.</i>	

Sell the TV that
has EVERYTHING!

ARVIN



VISIBLE VALUE

TELEVISION

ARVIN
Visible Value
TELEVISION

You can SEE the difference!

TV buyers are getting wiser every day. They are insisting on top value. You can give it to them with ARVIN—easier tuning; brighter, clearer, steadier pictures; largest possible pictures on each size screen; cabinets of exceptional beauty! AND top profits to you!



\$249.50*

Plus Federal Tax

MODEL 3121TM

12½" Screen Table Model

This sensational Arvin 12½" screen table model is your answer to the demand for larger TV screens at popular prices. Over 92 sq. in. of undistorted picture; super-powered Arvin chassis gets station easily, even in fringe areas. Only two groups of visible controls; a child can tune it. Highest FM tone fidelity! Table to match at small extra cost.



\$249.50*

Plus Federal Tax

MODEL 3101CM

10" Screen Mahogany Console

Check all TV lines and see how many offer a beautiful 10" screen console in genuine mahogany at anywhere near Arvin's low price! Your customers will go for Arvin's simplified tuning, the sharp, clear eye-level picture—"locked in" by Arvin's MAGIC MODERATOR.

MODEL 3100TM—10" screen table model, Mahogany finish \$219.50* (Blond slightly higher)



MODEL 3120CM—12½" SCREEN CONSOLE

Superb 12½" screen mahogany console shows over 92 sq. in. of undistorted picture—gives you a definite value advantage! Its eye-level convenience and "no squat" tuning should enable you to "sell up" many customers from the 12½" table model. Highest **\$299.50*** FM tone fidelity.

Plus Federal Tax

MODEL 3160CM—16" SCREEN CONSOLE

Here is the value of all TV values! Giant 16" direct view picture tube offers sharp, clear, Arvin-quality picture measuring full 14½" by 11½"! Every bit of action visible across a large room. Plus all the other "exclusives" that make Arvin so **\$399.50*** much easier to sell.

Plus Federal Tax



**AVAILABLE IN LIMITED QUANTITIES. NEW AREAS OPENING EVERY WEEK.
GET PROFITABLE FRANCHISE DETAILS NOW!**

Radio and Television Division

NOBLITT-SPARKS INDUSTRIES, INC.

COLUMBUS, INDIANA

*Slightly higher in Zone 2

**ANOTHER SENSATIONAL
MECK TELEVISION VALUE**

Big 10 inch tube
only \$**139⁹⁰** RETAIL
65 sq. in. DAYLIGHT PICTURE



Hand-Rubbed Mahogany Cabinet

Rock-bottom price for top quality television with big margin that will build your profits. Has every feature your customers want at the price they want to pay. Model XN-752, \$139.90



Low Prices – Big Margins. Get on the Meck Profit Line

JOHN MECK INDUSTRIES, INC.
Plymouth, Indiana



16" Tube, 145 Square Inch Screen, Mahogany Console,
Only \$29900

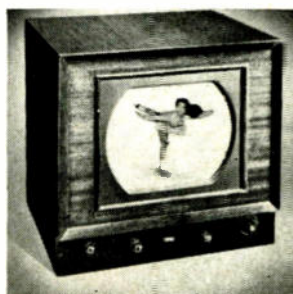

16" Tube, Tabletop, 145 Square Inch Screen, Mahogany Cabinet
Only \$27900

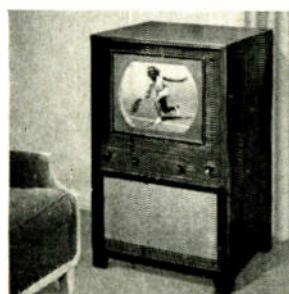

12½" Tube, 96 Square Inch Screen, Mahogany Console,
Only \$24900



12½" Tube, Tabletop, 96 Square Inch Screen, Mahogany Cabinet
Only \$21900