

Combining
**ELECTRIC
APPLIANCE
JOURNAL**

JULY, 1946

RADIO & *Television* **JOURNAL.**



MR. WM. T. SCHONING
Nat'l Elect. Dist. Assn.



MR. CHAS. PYLE
Nat'l Electrical Wholesalers'
Assn.



MR. CLIF SIMPSON
Man. Dir. Nat'l Electrical
Retailers' Assn.



MR. DAVID KRANTZ
Chairman, Philadelphia
Radio Servicemen's Assn.



MR. HERMAN RUBIN
Ex Officio Pres., Appliance
Dealers' Assn. of Philadelphia



MR. E. C. DENNISON
Pres., Menongahela Radio
Assn., Morgantown, Va.

The
**RADIO & APPLIANCE
INDUSTRIES'**
Official
ASSOCIATION
PUBLICATION

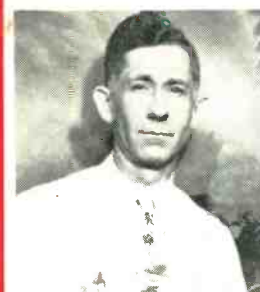

MR. SCOTT ADAMS
Pres., Radio Service Dealers'
Assn., Huntington, W. Va.



MR. E. J. BALCOM
Pres., Tulsa Radio Service
Assn., Tulsa, Okla.



MR. C. E. HEITKAMP
Pres., Greensboro Radio
Assn., Greensboro, N. C.



MR. R. E. ENGSTRAND
Sec., Wichita Radio Service
Dealers' Assn., Wichita, Kan.



MR. H. LEVE
Vice Pres., Massachusetts
Radio Tech. Guild

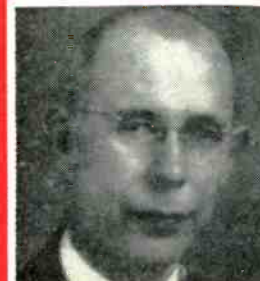

MR. A. E. KUHNHAUSEN
Pres., Northwest Retail Appl.
Dealers' Assn.

THORENS

MADE IN SWITZERLAND

CABINET CHANGER #856



Add this handsome cabinet changer to your radio set and transform it into a radio-phonograph combination of brilliant tone qualities, adding beauty to any room. The changer slides out like a drawer for easy loading. Plays eight mixed records in any order. Rejects any record desired, goes on to next. Repeats part or whole if desired. Pauses between records. Hinged tone-arm for easy needle change. Crystal pick-up, AC motor 100 to 250 volts, 50 to 60 cycles.

PLAYS 10" AND 12"
RECORDS MIXED



REPEATS



REJECTS



PAUSES

THORENS PHONOGRAPH #625A

Spring wound portable equipped with worm-gear drive motor. One motion starts record and sets tone arm in place. Automatically stops at end of record. Speed regulator, needle cup and record rack. Plays 10 and 12 inch records, weighs 11 pounds. Assorted colors. Imported from Switzerland.

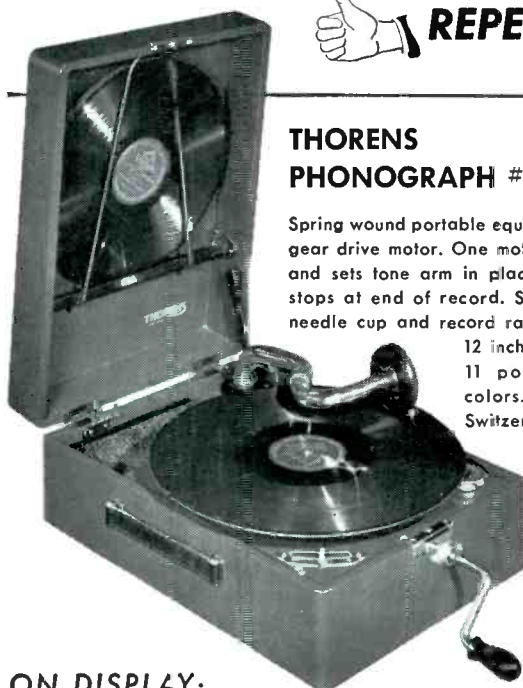

WORLD'S SMALLEST PORTABLE PHONOGRAPH

This Thorens is carried like a camera, weighs only four pounds. Plays 10 and 12 inch records with fine melodious quality. Assorted colors. 11" x 4 3/4" x 2". Imported from Switzerland.

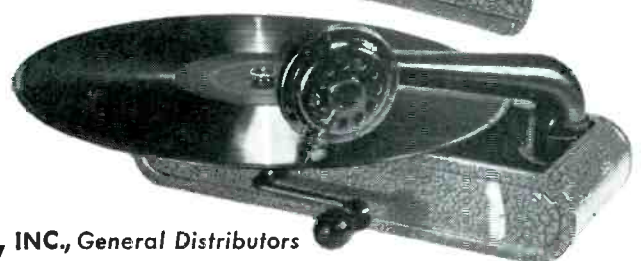
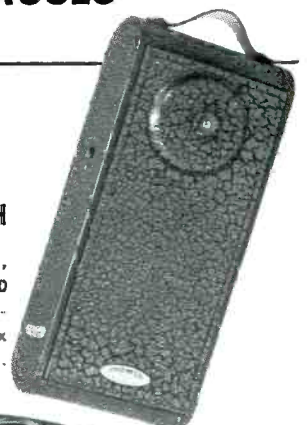

ON DISPLAY:

NATIONAL ASSN. OF MUSIC MERCHANTS
PALMER HOUSE, ROOM # 877, BOOTH # 48, JULY 15-18

REXON, INC., General Distributors
295 FIFTH AVENUE, NEW YORK 16, N. Y.

SERVICE DEPT. AND WAREHOUSE: 122 FIFTH AVENUE, NEW YORK 11

ON EXHIBIT!

Farnsworth's Newest Models

INCLUDING

- **New — TELEVISION**
- **New — FM Phonograph-Radio**
- **New — Chairside Phonograph-Radio**
- **New — Table Model Radio**

AT

**National Association of
Music Merchants
Convention and Trade Show**

July 15th, 16th, 17th, 18th
Room 801, Palmer House, Chicago

AND

JULY FURNITURE MARKET

July 8th through July 20th
Space 535B
(Permanent location)
American Furniture Mart, Chicago

We look forward to seeing every Farnsworth dealer who attends these shows. Dealers will be just as enthusiastic about the new models as they are about the Farnsworth Automatic Record Changer and those models already received. Farnsworth Television & Radio Corporation, Fort Wayne 1, Indiana.

FARNSWORTH TELEVISION • RADIO
PHONOGRAPH-RADIO

Farnsworth Radio and Television Receivers and Transmitters • Aircraft Radio Equipment • Farnsworth Television Tubes • Halstead Mobile Communications and Traffic Control Systems for Rail and Highway • The Farnsworth Phonograph-Radio • The Capehart • The Panamuse by Capehart

RADIO & TELEVISION JOURNAL, JULY, 1946

RADIO & TELEVISION JOURNAL

Contents

MAL PARKS

Editor

MARION DOOLEY

Managing Editor

IZ ZAM.....Technical Editor
B. F. HOLLEY.....Washington Editor
JIMMY KENT.....Merchandising Editor
FRED MERISH.....Management Editor
GORDON CHAMBERS.....West Coast Editor
E. H. COOKE.....Canadian Editor
BETTY BORIN.....Circulation Manager

COVER BY CULLEN RAPP

ALEX H. KOLBE

Publisher

IRVING N. COOPER
 Eastern Advertising Manager
 1270 SIXTH AVENUE
 New York 20, N. Y.
 Circle 7-5842

BRANCH OFFICES:

20 EAST JACKSON BLVD.
 Chicago 4, Illinois
 Harrison 6360

412 WEST 6th STREET
 Los Angeles 14, Calif.
 Vandyke 8815
FREDERICK STERN, Manager

EUROPEAN OFFICE:

6 RUE DE PASCAL
 Brussels, Belgium
JULIAN BLOCK, Manager

JULY FEATURES

RMA CONVENTION RE-ELECTS COSGROVE	8
MUSIC MERCHANTS HOLD 45th ANNUAL MEETING	16
REMINISCING IN RADIO	24
JOURNAL EDITOR MC's ADA OUTING	27
THIS UTILITY HELPS DEALERS SELL	28
SPOTLIGHT ON RADIOS	48
SHOBE MODERNIZES	36
MUSIC DEALERS CAN SELL APPLIANCES	42

ELECTRIC APPLIANCE JOURNAL

SPOTLIGHT ON RADIOS	46
OVER THE TOP ON OPENING DAY!	50
NEW PRODUCTS	55

MASTER SERVICING

FUNCTION AND ALIGNMENT OF FM LIMITER AND DISCRIMINATOR.....	58
THE QUESTION BOX	63
RADIO AND APPLIANCE ASSOCIATIONS' DIRECTORY	64

DEPARTMENTS

25 YEARS AGO	6	RECORD RELEASES	40
DEALER DOINGS	10	NEWS	68
EDITORIALLY SPEAKING	12	ADVERTISERS' INDEX	73
PICTURE PARADE	14	JOURNAL'S END	74

Volume
60

RADIO Television JOURNAL combines Master Servicing, and is published monthly for Radio-Television Dealers, Servicemen and Jobbers by Kolpar Publications, Inc., Radio City, 1270 Sixth Ave., New York (20), N. Y. Phone Circle 7-5842, Alex Kolbe, Pres. and Treas.; Mal Parks, Vice-Pres. and Gen. Mgr. Price 25c per copy. Printed in USA.

Number
7

What makes people say, "There is nothing finer than a Stromberg-Carlson"?

Is it Stromberg-Carlson's 52 years in electrical communication? Or Stromberg-Carlson's first-hand knowledge of broadcasting, gained from operating its own stations, WHAM and WHFM?

Or the fact that Stromberg-Carlson was the first line of fully-perfected FM radio receivers offered the public in 1939? Or Stromberg-Carlson's extensive participation in wartime research and specialized production?

These are just incidents — background. What the public thinks of as superior in Stromberg-Carlson is *performance* — a fidelity of reception and of reproduction that rivals the concert hall itself.



SEE YOU AT THE N. A. M. M.!

You are most cordially invited to visit Stromberg-Carlson's display of their full line at the National Association of Music Merchant's Convention at the Palmer House, Chicago, July 15-18, 1946.

STROMBERG-CARLSON

ROCHESTER 3, NEW YORK

RADIOS, RADIO-PHONOGRAPHS, TELEVISION, SOUND EQUIPMENT AND INDUSTRIAL SYSTEMS, TELEPHONES, SWITCHBOARDS, AND INTERCOMMUNICATION SYSTEMS

RADIO & TELEVISION JOURNAL, JULY, 1946



The **EIGHTEENTH CENTURY**, Model 1121 PF, provides splendid reception on all standard broadcast, on both the present and newly approved FM bands, and on spread-band short wave, as well as exquisite reproduction from records. Exclusive "full-floating" speaker mounting. Engineered for wire recording.

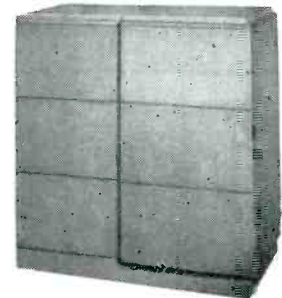

The **FUTURA**, Model 1121 M1, gives splendid reception on standard broadcast, on the present and the newly approved FM bands, and on spread-band short wave as well, thanks to its precision-engineered audio system and the exclusive "full floating" speaker mounting. Astounding fidelity in record reproduction. Engineered for wire recording.



The **NOCTURNE**, Model 1101 HW, is a smartly designed, excellent table radio with 6 tubes, including rectifier. It is noted for its unusually fine reception and extreme selectivity on standard broadcast. A 3-gang condenser gives it "big radio" performance. And a powerful Alnico 5 permanent-magnet dynamic speaker and correct acoustical design assure ample volume and excellent tone.

DUAL TRIMMERS

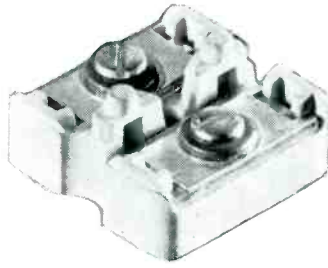

IMMEDIATE SHIPMENTS

Values 80 mmf to 200 mmf max. 11/16" highest quality ceramic base. Best grade India mica. All parts cadmium plated. Treated for minimum drift.

FOR MAXIMUM CIRCUIT Q SPECIFY
I. E. L.

Industrial Electronics Laboratories Inc.

NORRIS AND CARLISLE STREETS
Philadelphia 21, Pa.

Consulting Engineering and Specialized Manufacturing
of Electronic Controls, Measuring Equipment and Relays.

Amazing power

SUPER-GAIN CIRCUIT

- CLEAR FULL TONE
SCIENTIFICALLY DESIGNED
"VOICE CHAMBER"
- SIMPLE SMART LINES
BEAUTIFULLY STYLED METAL CASE
- EXPENSIVE REFINEMENTS
PLANETARY DRIVE
PLEXIGLAS DIAL
EXCITING COLORS

Electone
1947
THE ENGINEERED RADIO
Under Twenty-Five Dollars

*Brings in distant
stations you
never knew
existed..*

NORTHEASTERN ENGINEERING, Inc.
MANCHESTER NEW HAMPSHIRE

ENGINEERS AND MANUFACTURERS OF THE BEST IN ELECTRICAL AND ELECTRONIC EQUIPMENT



The lead article in the Journal twenty five years ago has a novel idea to boost record sales. They contend that records naturally deteriorate after too many playings, and their tone is sadly damaged by overuse. Consequently, they recommend that old records be broken, and new ones bought in their place. The author even suggests that the dealer institute some sort of record inspecting system. "Why shouldn't some bright young lady, who knows music and knows records, be able to get into a home, look over the stock of a hundred records, and then tell the owner that 15 of them should be replaced with new ones." There is no hint that this idea was ever carried out, and we feel the "bright young lady" might meet a doubtful reception in many homes.

* * *

The picture spread of the Journal shows the storefront of the newly established store, Lyon & Healy, on the north side of Chicago. The window display includes a large floor lamp, complete with fringed lampshade, and an early model of the Victrola. The Victrola, which stands almost as high as the lamp, has a cascade of records propped up against one side.

* * *

In recognition of the fact that summer is the ideal time to promote the sale of portable record players, the Journal carried a one page feature on "Window-Featuring the Portable." One window was called "Aboard the Yacht." In the words of the writer: "Across the center a miniature lake was sunk. Floating over the lake was a large model of a real yacht, on board which was a life-size young man in white duck and an attractive young woman in an outing suit. A portable phonograph was set up on the front part of the yacht."

An enterprising dealer in Brooklyn, tried this idea: "One dollar pays for a phonograph all summer. Pay full purchase price now, and machine will be despatched to your summer home. Return instrument in the fall and pay \$1.00. Then have full purchase price charged to a cabinet model."

* * *

A quarter page ad advocated the use of the Tonar record brush, for preserving records. According to the copy, "The stiff nap of the

brush gets into the record grooves. It **CLEANS** instead of sliding over the surface. The brush is so treated with a secret process that it polishes the sound waves of the record and doubles its playing life."

The idea of "polishing a sound wave" is indeed unique, and we would like to see a sample of this particular brush.

* * *

A new manufacturer entered the phonograph field in July, 1921. The *Recreator Phonograph Company* set up shop with a factory in Long Island City. They proposed to make a quality product, with several innovations including a wooden tone-arm. Officers of the company include: Jules Perrault, president; Henry Lube, vice president; and Austin O'Toole, treasurer.

* * *

Another news note stated that "A Buick roadster, emblazoned with the trade mark of the Victor Talking Machine Company . . . Victor dog and all . . . now takes A. M. Hersee of the Eastern sales force upon his business trips. Recently, manager Herbert Shoemaker and Mr. Hersee took the car over a thousand mile jaunt. Mr. Shoemaker declares that he found marked signs of business recovery, particularly in the Northern section . . . Vermont, New Hampshire and Northwestern Massachusetts."

* * *

The July Journal announced a new model, Number 300, to the Victor line. According to the copy, "This model is of the console type, while at the same time it does not abandon the very definite features that characterize the standard Victrola. It is low and broad, but retains the typical Victrola lid in the middle of the top, which is gracefully curved, and it has also the bulge acanthus leaf scroll legs. The list price is given as \$250." Even in these days of inflation, that \$250 reminds us that prices of radios and phonographs have certainly gone down over the years.

* * *

A page advertisement for Okeh records listed the following new releases of 1921. "My Man," "Dear Little Shamrock" with John McCormack; "Paper Doll"; "In a Monastery Garden"; and "Ain't We Got Fun." Popular releases were classified as fox trots or one steps, interspersed with a few waltzes.

* * *

The Melody National Sales Company of Chicago announces a new portable, weighing only eighteen pounds. The size was listed as 8 by 13 by 15, and its tone was claimed the equal of a \$200 machine. It also boasted a removable tone arm and winding key for customer convenience.

(Continued on page 52)



June

June Lear advertisements reached millions of readers of national magazines. Here's another in the steady campaign that runs from coast to coast and tells about the new Lear Home Radios.

With Lear's enviable reputation in aircraft radio—plus the performance of these handsome new sets themselves—public acceptance is growing by leaps and bounds.

This is one of the reasons dealers find the Lear Franchise so desirable. To get all the other reasons and know all the advantages, write for full information to LEAR, Incorporated, Home Radio Sales and Merchandising Division, 110 Ionia Avenue, N. W., Grand Rapids 2, Mich.

The Lear company's complete radio line includes: portable, console, and aircraft radios; vacuum tube and electronic; and a complete line of accessories.

For more than twenty years Lear has made aircraft radios that have to be made with fine precision and utmost skill.

This is the kind of manufacture Lear knows. And it is the fact that you find the new Lear Home radios you can buy for your home.

Lear Home Radios are designed with an eye to the future and with forethought into existing trends. They're built with the advanced design and construction craftsmanship that you know so well.

You can see some of the new Lear Radios at your Lear dealer's store. Others are on the way. And when you see them and hear them, we know you'll be glad you waited for a Lear Radio. LEAR, Incorporated, Home Radio Sales and Merchandising Division, 110 Ionia Ave., N. W., Grand Rapids 2, Michigan.

LEAR The Name We Fly By

LEAR RADIO

R. M. A. Convention Re-Elects Cosgrove

President Cosgrove "Drafted" for Third Term

Here are the RMA Officers, 1946-1947:

President: R. C. Cosgrove of Cincinnati, reelected.

Vice President and Chairman of Set Division: Henry C. Bonfig of Chicago, succeeding E. A. Nicholas of Fort Wayne, Ind.

Vice President and Chairman of Tube Division: M. F. Balcom of Emporium, Pa., reelected.

Vice President: Fred R. Lack of New York City, succeeding George Lewis of Newark, N. J.

Vice President and Chairman of Parts Division: J. J. Kahn of Chicago, succeeding R. C. Sprague of North Adams, Mass.

Vice President: Allen Shoup of Chicago, succeeding Thos. A. White of Chicago.

Treasurer: Leslie F. Muter of Chicago, reelected eighth term.

Executive Vice President-General Manager and Secretary: Bond Geddes of Washington, reelected.

General Counsel: John W. Van Allen of Buffalo, reelected

New RMA Directors

W. J. Barkley of Cedar Rapids, Ia.

Henry C. Bonfig of Chicago, Ill.

Lloyd H. Coffin of Salem, Mass.

George R. Haase of St. Charles, Ill.

Lloyd A. Hammarlund of New York, N. Y.

Larry F. Hardy of Philadelphia, Pa.

W. P. Hilliard of Baltimore, Md.

Harold C. Mattes of Chicago, Ill.

A. D. Plamondon, Jr., of Chicago, Ill.

Allen Shoup of Chicago, Ill.

Ross D. Siragusa of Chicago, Ill.

C. M. Srebroff of Long Island City, N. Y.

J. Hall Stackpole of St. Marys, Pa.

Action to promote radio production, to surmount critical material shortages and other difficulties, and widespread demands for release of the industry from OPA control featured the twenty-second annual convention and membership meetings for the Radio Manufacturers Association during a score of meetings, June 11-13 at the Stevens Hotel, Chicago. Immediate appointment was arranged of an RMA Production Problems Committee to deal with the numerous special and general industry conditions.

Convention Highlights

"Drafted" for a third term as President of the Association was R. C. Cosgrove, vice president and general manager of The Crosley Corporation, Cincinnati, Ohio. Mr. Cosgrove was reelected and inaugurated in the presence of the RMA membership in the Stevens Hotel Grand Ball Room, Thursday, June 13, and was presented with a trout fishing kit on behalf of the RMA Board of Directors, by former President and now Treasurer Leslie F. Muter.

President Cosgrove and other industry leaders, during the many RMA convention meetings, urged decontrol of the radio industry from OPA, and Mr. Cosgrove stated that such release might occur in sixty days or so.

"We are going to continue to have troubles," President Cosgrove told the industry leaders, "with terrific waste of time and money until we have complete decontrol of the radio business. Control of such a large and complex industry is simply impossible and when we put arbitrary controls on it, the results are that the public has paid more, receives poorer quality and has obtained only a fraction of the number of radio



sets which we would have had without OPA."

OPA decontrol also was urged by Robert C. Sprague, president of Sprague Electric Co., North Adams, Mass., and retiring chairman of the RMA Parts Division. He and other speakers at the many industry meetings also stressed the critical shortage of copper, wood for cabinets, tin, tungsten, steel and other materials.

Increasing production of tubes was predicted by Vice President M. F. Balcom of Sylvania Electric Products, Inc., Emporium, Pa., chairman of the RMA Tube Division, in one of the convention addresses.

Director Ben Abrams, president of Emerson Radio & Phonograph Corp., New York and chairman of the RMA-OPA Liaison Committee, told the convention that while receiving set production was now virtually at a normal prewar level, there are difficult material shortages. Mr. Abrams urged the industry to diversify its home receivers and also to promote television and other new electronic services.

Two meetings of the RMA Board of Directors were held along with membership meetings of the Set, Tube, Transmitter, Parts and Amplifier & Sound Equipment Divisions of the Association for the election of officers, directors and to reorganize RMA activities for the coming year.

Official convention guests included E. E. Smallwood, chief of the OPA radio unit; Joel Hawkins, chief of the CPA radio section, and representatives of the Army, Navy and allied industry organizations.

Another Triumph

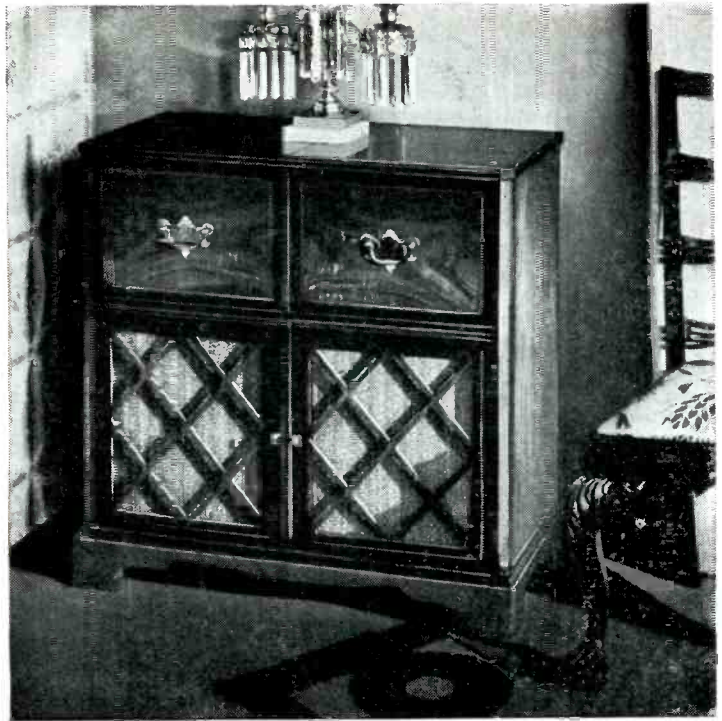

- A TRIUMPH IN RECORD REPRODUCTION**
- A TRIUMPH IN NATURAL COLOR TONE**
- A TRIUMPH IN COMPETITIVE VALUE**

HERE IT IS—the great #326 G-E radio-phonograph that can be demonstrated more dramatically than any combination in history! Both records and radio sound as though real human beings were just behind the grille playing or singing their hearts out! The amazing G-E Electronic Reproducer spells good-bye to the old fashioned needle—and “natural color tone” glorifies both radio programs and recorded music.



Best-Seen Radio Advertising in radio history (Starch Report), appearing in four colors in such leading magazines as Life, Look, Collier's, and the Saturday Evening Post pre-sells your customers on this triumphant combination.

Sensational New G-E Electronic Reproducer



This great new invention recreates music on an electronic wave—reveals new beauties in even the most familiar records.



Retractable Stylus can be dropped on the record—even scraped across the record grooves—and no harm done because it withdraws *instantly*.

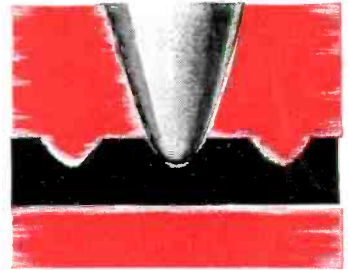

Permanent Sapphire Stylus rides the walls of the record groove, instead of digging into the bottom. Finer tone—virtually eliminates wear and tear.

SEE YOUR G-E DISTRIBUTOR—QUICK!

Model #326 G-E radio-phonographs demonstrate so dramatically and are such outstanding value that they will sell 10 times faster than they can be produced. There's no time to lose. Place your order for this triumphant combination **TODAY!** See your G-E Radio Distributor or write Electronics Department, General Electric Company, Bridgeport, Connecticut.



Cat-Quick Record Changer plays 10 twelve inch or 12 ten inch records. Its all-new design makes it quiet—sturdy—and unusually dependable.



More Record Storage Space than you used to sell in radio-phonographs costing twice as much. Generous record compartment holds 118 records.

THE FIRST AND GREATEST NAME IN ELECTRONICS

GENERAL ELECTRIC

PORTABLES • TABLE MODELS • CONSOLES • FARM SETS • AUTOMATIC PHONOGRAPH COMBINATIONS • TELEVISION
 RADIO & TELEVISION JOURNAL, JULY, 1946

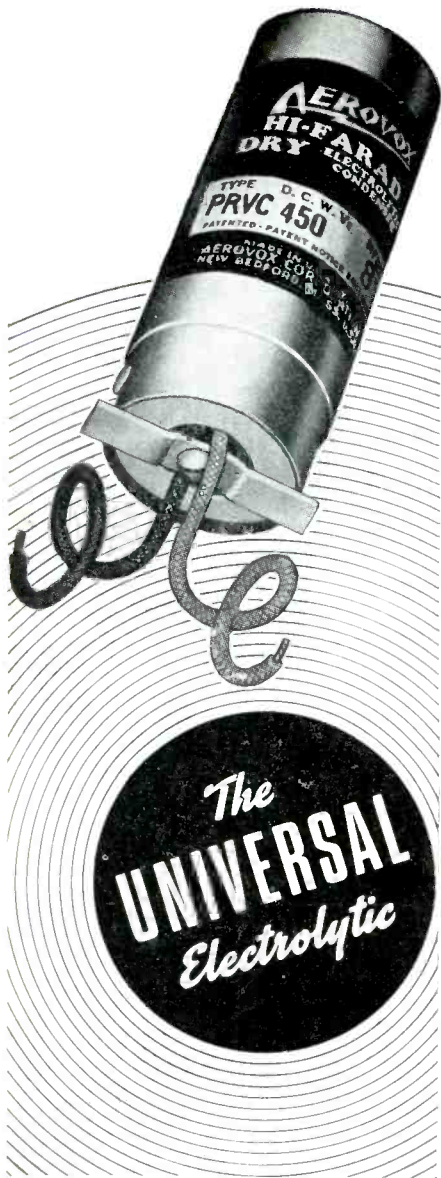

• Heretofore offered only in cardboard-case container, this type is now available in an aluminum can—the postwar Aerovox Type PRVC.

This truly universal replacement electrolytic readily doubles for twist-prong, spade-lug and screw-base types. To install, center screw is removed, metal cleat slipped off, wire leads passed through mounting hole, and metal cleat and screw now replaced from underside of chassis and tightly drawn up. Insulated positive and negative wire leads. Multiple sections have concentrically-wound sections with common negative. In all popular voltages and capacitances.

• **Ask Our Jobber . . .**

Ask for Aerovox Type PRVC metal-can cleat-mounting electrolytics. Have a stock on hand for your rush jobs. Ask for postwar catalog. Or write us.

AEROVOX
Capacitors
 INDIVIDUALLY TESTED
 AEROVOX CORP., NEW BEDFORD, MASS., U. S. A.
 In Canada: AEROVOX CANADA LTD., HAMILTON, ONT.
 Export: 13 E. 40 ST., NEW YORK 16, N. Y. Cable: 'ARLAB'

DEALER

The new Mueller Home and Auto Supply store, carrying full lines of General Electric and other appliances, has been opened at Presa and St. Mary's in San Antonio, Texas. William Campbell is general manager, and Jules DuBus is electrical appliance manager.

* * *

In line with their recently announced intention to enter the radio and electrical appliance field in a big way, the Roth-Schlenger organization of Newark, is remodeling its chain of twenty-two R & S retail stores in northern New Jersey. Twelve stores have already been enlarged and set up to provide for proper display of refrigerators, washers, radios and traffic appliances. The entire chain is now handling such traffic appliances as are coming through, and major lines are being added as fast as stores can be modernized to afford proper display.

* * *

Claud Stutts has opened the Kemah Electric Shop, with a complete line of electrical appliances and equipment, on Fourth Street in Kemah, Texas. He was recently discharged from the army.

* * *

Labiche's Modern Home Appliance Store, one of the largest in the south, was formally opened in New Orleans, on June 5 at 906 Gravier Street. Abert Labiche, vice president, and Theodore Eckert, manager, were hosts for the occasion. The new store will handle every kind of electrical appliance obtainable. The lines of more than 50 American manufacturers were on display for the formal opening, which featured a modern kitchen built into the store.

* * *

Macy's, New York's famous department store, opened a new department devoted exclusively to the sale of Government-surplus radio equipment. Under the super-

vision of David Davis, corporate buyer for the Macy chain, the new department is located on the fifth floor of the store. Using an advertisement in the New York Times to announce the opening, Macy's asserted that it has sent its "experts to tap the source . . . the distributing agencies of the War Assets Corporation." The ad continued by stating that the men came back with a steady supply of those hard to get "cathode ray tubes, transmitters, keys, and receivers." The department is staffed entirely by radio hams.

* * *

Farners Brothers, newest local appliance store, has opened for business at the corner of 23rd Street and Avenue N at Galveston, Texas. They will handle the full Westinghouse line of electrical appliances, in addition to Decca, Victor and Capitol records.

* * *

The Knoxville Music Center, Inc., is being opened at 215 South Gay Street, in Knoxville, Tenn. R. S. Jones is general manager; Carl Sloan heads the band instruments and piano departments; U. S. Jones is in charge of radio and sheet music department; and Charlie Gilbert heads the record department.

* * *

Plans for remodeling a one story building at Tulane and Carrollton avenues for a modern electrical appliance and hardware store have been announced by C. G. Staubiz, who will operate the New Orleans store. The modernization will include new front, floors, walls, ceiling and lighting fixtures.

* * *

Wolf, Kubly & Hirsig's new record and appliance shop was opened early in June in Madison, Wisconsin. The new setup occupies two stores in the Burdick & Murray department store building.

D O I N G S

The record shop is 55 feet by 20 feet, with an overall space of 11,000 square feet. The appliance shop is 20 feet by 60 feet, with a basement average about 2,000 square feet of selling space. Both stores have been decorated with soft blue walls and accoustically retreaded ceiling, fluorescent lighting being used wherever possible. In the record shop, three continuous rows of fluorescent lighting are used, and every seven feet a spot light is inserted for high-lighting interior displays.

* * *

William Zale, vice president of the Zale Jewelry Company, has announced that the firm will open a modern jewelry and electric appliance store, the nineteenth in their group, in the new Oak Cliff shopping center now under construction in Dallas. Harold Shackman will be manager of the new store.

* * *

Transfer of Paul Owens, who has been manager of the B. F. Goodrich store in Paducah, Kentucky, for 18 months, to take the company's store at Little Rock, Arkansas, has been announced recently. Richard Ragland will take over as manager in Paducah.

* * *

Fire following an explosion did \$35,000 worth of damage to the store and stock of the Carfagna Appliance Company in Turtle Creek, Penna. According to the police Chief, W. J. Whalen, the fire destroyed furniture and electric appliances in the store owned by Henry Carfagna.

* * *

A week long "exposition" was used by E. W. Edwards & Son, downtown department store in Syracuse, to introduce its home appliance center in the next door annex building. Features were exhibits and demonstrations of household equipment, including a

novelty display of a wire recorder, to allow customers to hear playbacks of their own voices. Tickets were distributed for daily awarding of door prizes. Refrigerators, home freezer units, electric ranges, radios and phonographs, vacuums, coffee-makers, sunlamps, heaters, irons and cookers, as well as complete laundry rooms with washers and ironers were on the floor. Easy Washing Machine Corporation of Syracuse, contributed a historical display of Easy washers dating from a plunger model made in 1877 up to its 1946 Spindrier.

* * *

Southern Hardware & Electrical Corp. of Alexandria has been chartered to deal in hardware and electrical equipment with authorized maximum capital of \$50,000, and with Robert B. Murphy of Alexandria as president.

* * *

Barham Clothing Co., of Memphis, one of the five stores owned in Tennessee and Alabama by Henry T. Barham, announces it will introduce a line of Westinghouse electrical appliances in the store when they become available. Mr. Barham plans soon to open several other stores in the Mid-south.

* * *

With authorized capital of \$50,000, Kingstree Refrigerator & Locker Co. has been granted a charter from Secretary of State Blackwell in Kingstree, S. C. Bruce M. Heniford is president and treasurer; M. D. Heniford, vice-president; John F. Heniford, secretary.

* * *

The Stigler Furniture & Appliance Co. was opened in Stigler, Okla., by Edwin W. White, an ex-Army captain, with the help of Hercul Dobyns as purchasing agent temporary sales manager.

Featured in the initial advertising were Bendix products.

**BUILD
YOUR LINE
AROUND**

*Smooth
Power*



For quick starting, uniform speed and quietness, equip your new phonographs and record-changers with *Smooth Power* motors. From the wide and modern GI line, accurately and carefully built, you can select exactly the right motors for your needs.

Then you'll be sure of giving your customers that smooth, all 'round performance that builds good will . . . and sales. For motors you can always depend upon, *standardize on Smooth Power.*

**THE GENERAL
INDUSTRIES co.**

DEPT. MT • ELYRIA, OHIO



EDITORIAL

I AM becoming greatly concerned over a situation which, in the final analysis, will affect all radio and appliance dealers and servicemen. I am referring to the deluge of malicious statements that are currently being circulated about your Radio & Television Journal by one rival publication.

During its 30 years of publishing history, Radio & Television Journal, formerly the Talking Machine Journal, has tried hard to live up to the ethics of responsible business paper journalism. And, it has always had as its primary goal the lifting of standards in the industry which it has been privileged to serve longer than any other radio trade paper.

But readers and advertisers alike are now constantly being bombarded with hysterical and unscrupulous statements which, while directed primarily against Radio & Television Journal will, we sincerely believe, hurt the standing of all business publications in this field.

Just as one rotten apple can spoil a barrel, so the type of thinking exemplified by these tactics, if allowed to continue, will degrade not only the business papers serving the radio and appliance fields but will cheapen the prestige now enjoyed by the industry and all of us who have its future sincerely at heart.

Everyone welcomes good, clean and honest competition. But, when one publication, and we will name names if we are forced to, descends into the gutter of below-the-belt, vicious, lying and untruthful propaganda to stem the tide which is running against them, we feel it is high time for the ethical business leaders in this industry to call them to terms.

There are other good and useful radio and appliance publications but, none serves the same purpose as Radio & Television Journal. Because it is the oldest publication in the field, it is able to serve the entire radio and appliance industry as an independent journal of opinion.

And, its distinctive purpose and policy has given Radio & Television Journal the prestige, character and responsibility which allows it to express the community of interest represented by all those in these fields.

Mal Parks

DON'T MISS Bendix Radio AT THE SUMMER MARKET!



Bendix Radio
 PERMANENT DISPLAY
 SPACE 545D • FIFTH FLOOR
 JULY 8 to 20
 AMERICAN FURNITURE MART
 CHICAGO

SEE THE FIRST SHOWING OF
Bendix Radio FM RADIO-PHONOGRAPHS
 AND OTHER FAMOUS *Bendix Radio Firsts!*



BENDIX RADIO DIVISION, BENDIX AVIATION CORPORATION
 BALTIMORE 4, MARYLAND



Picture Parade...



Four-year-old Pat Eby, wakes up to music with the new G.E. clock-radio. Clock and radio work together to act as an alarm or a tune on the radio.



Carol Radio's new portable, The Playmate, weighs only six pounds and makes the ideal vacation companion. Size: 9" x 7" x 4 1/2".



Brightening up the Madison Square Garden broadcast of Philco's Breakfast Club were two circus beauties, who along with the refrigerators, were all shined up for the occasion.



Fred Allen isn't too sure he approves of television. Well, you have to look at Benny, too. Fred is shown in front of RCA's large-screen home receiver.



W. C. Johnson, Admiral Corporation manager of field activities, presents an Admiral radio-phonograph to film star, Jane Russell.

HAVE YOU SEEN . . . HAVE YOU HEARD
 THE PROVOCATIVE, THE EXCITING
Merry-Go-Sound
 PHONOGRAPHS AND RECORDS

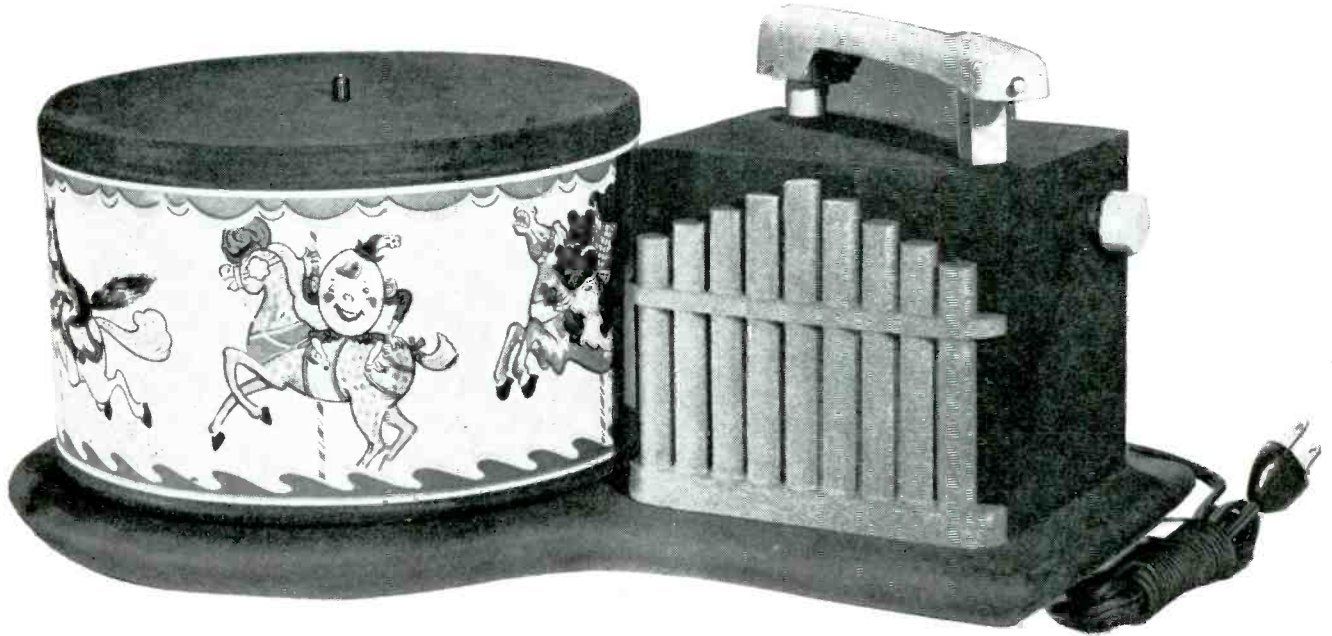

The Merry-Go-Sound electronic child's phonograph is no toy—it's a high fidelity electrically amplified record player, superior in tone quality to more expensive adult phonographs. It will play 7 inch, 10 inch or 12 inch records—nursery rhymes, dance music or symphonies with concert hall clarity. The turntable revolves in carousel fashion. The colorful "carousel" is scratch-proof and washable. Made of metal, plastics and wood.

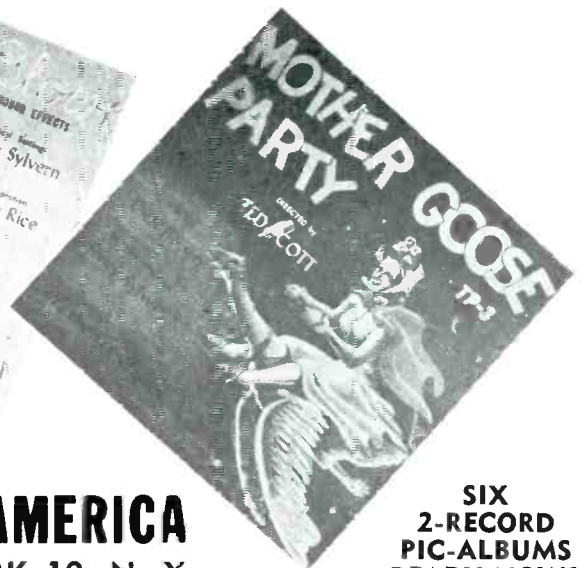
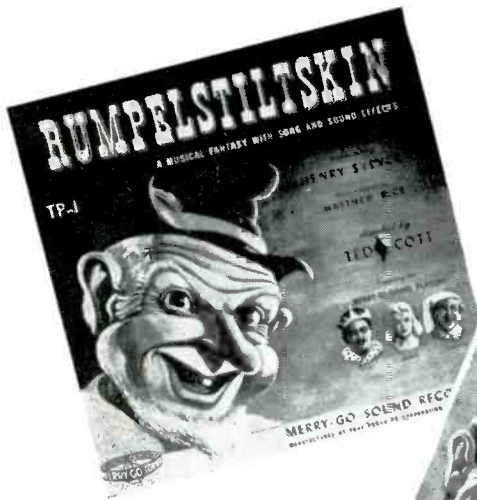

These are the most exciting records you have ever heard. Write today for a catalog and the name of your distributor.

TONE PRODUCTS CORP. OF AMERICA
 351 FOURTH AVENUE NEW YORK 10, N. Y.

**SIX
 2-RECORD
 PIC-ALBUMS
 READY NOW!**

MUSIC MERCHANTS HOLD



E. R. McDUFF
President
N.A.M.M.



Representatives of the RADIO & TELEVISION JOURNAL will be on hand this year to greet their old friends and make new ones at the 44th annual convention of the National Association of Music Merchants beginning on July 14th in Chicago.

The RADIO & TELEVISION JOURNAL, which was founded in 1916 as "The Talking Machine Journal," is the oldest publication serving the radio industry.

At the convention, the JOURNAL will maintain a large staff in Booth 66 to assure complete coverage of the five-day activities.

A general air of excitement and expectancy will enhance this largest in a national series of meetings, exhibits and social functions of the NAMM, at which many of the items displayed will be making their "grand entrance" before the public's eye.

Due to military restrictions and the necessities of safety, a previous preview has been prevented, the war among other things being responsible for much of the evidence of progress which will be noted.

Exhibitors are expected to reach the record number of 200, and the totaled guest list will be at least 6,000.

President E. R. McDuff (also president of the Grinnell Bros. store, Detroit, Mich.) will tender the opening welcome, when the present Board of Control convenes on Sunday afternoon at three o'clock in dining room four of The Palmer House, official headquarters for the conclave.

Facilities for exhibitors, however, will not be confined to the one hotel, but will extend to the Stevens, the Blackstone, Sherman, Morrison, Continental and others.

Other events in their scheduled order of occurrence will be as follows:

The directors will hold their elections at a luncheon meeting at 12:30 p.m. Monday in the Red Lacquer Room of The Palmer House. Voting ballots will be available in the adjoining foyer prior to the meeting. Twenty-four new members are to be named.

L. G. LaMair, president of Lyon & Healy, Inc., Chicago, is nominating committee chairman.

Merchandising clinics will commence on Tuesday at 9 a.m. They will include one on music promotion, for which Russell D. Wells, president of the Charles E. Wells Music Co., Denver, Colo., will be chairman; one on expense control, headed by



R. B. WELLS
Music Promotion



HARRY CALLAWAY
Phonograph Records



RADIO & TELEVISION JOURNAL, JULY, 1946

45th ANNUAL MEETING

W. Howard Beasley, president, Whittle Music Co., Dallas, Tex.; and one on phonograph booth records, under the chairmanship of Harry Callaway, vice president, the Thearle Music Co., Santiago, Calif. These clinics will take place in third floor dining room nine, the Red Lacquer Room and main ballroom, respectively.

Also in the Red Lacquer Room on Tuesday, a luncheon will be given by the Association in honor of members of the press.

A tea for the women guests, planned for this day, will be at 3 p.m. in the ballroom. Richardson Wright, editor of "House and Garden" magazine, will speak on "Music in the Home."

On Wednesday, from 9 a.m. until noon, the sales training conference will be conducted in the Red Lacquer Room under the direction of George H. Beasley, president, the Beasley Music Co., Texarkana, Ark.

Mr. Beasley will give an explanation of how the Association's Manual was prepared.

Trade association meetings will be held on both Tuesday and Wednesday, and will begin with a National Association of Musical Merchandise Wholesalers' directors' meeting to be followed by a general session of all the members.

Musical Merchandise Manufacturers' Association will convene at 3 p.m. on Tuesday and 9 a.m. on Wednesday. National Piano Manufacturers' Association will have a breakfast meeting Tuesday at 9 a.m., and its regular annual meeting will be at 10 a.m. Wednesday. A luncheon will be given at 12:30 p.m. in the Crystal Room.

National Band Instrument Manufacturers' Association will meet at 10 a.m. on Wednesday.

A preconvention announcement discloses that the exhibits will be closed Wednesday morning in order to avert confusion with these gatherings.

Thursday's merchandising clinics will include one on school cooperation in the ballroom in charge of Ray F. Erhlandson, vice president and general manager, San Antonio Music Co., San Antonio, Texas; sheet music, chairmanned by Robert H. Schmitt, president, Paul A. Schmitt Music Co., Minneapolis, Minn., in private dining room nine, third floor; store service clinic, directed by Jerome F. Murphy, president, M. Steinert & Son, Boston, Mass., in the Red Lacquer Room.

The new Board will convene at 12:30 p.m. Thursday for luncheon and officers' elections, and at 6:30 that evening the concluding banquet and informal dance will be held.



W. A. MILLS
Executive Secretary
N.A.M.M.



R. H. SCHMITT
Sheet Music



RAY ERLANDSON
School Cooperation

GUIDE OF EXHIBITS AT CHICAGO

For your convenience, we are publishing this listing of those who will exhibit at the NAMM Convention and Trade Show in Chicago the week of July 15th through 18th.

ADMIRAL CORP.

Booth 6 . . . phonographs and radios. Richard A. Graver in charge.

AERO NEEDLE CO.

Booth 83 . . . Aeropoint needles. E. H. Miller in charge.

ANSLEY RADIO CORP.

Rooms 860-861 . . . radio-phonograph combinations. Arthur C. Ansley in charge.

APOLLO RECORDS, INC.

Booth 53 . . . phonograph records. Frank J. Marks in charge.

ARA, INC.

Booth 99 . . . record releases, display material and dealer helps; in attendance, national sales mgr., Shelby York and Bruce Altman, sales promotion director.

BARD, J. F.

Booths 76-77 . . . needles, records, blank discs, portable phonographs.

BIBLETONE CO.

Booth 45 . . . children records (10 inch) in three-color books. Arthur Becker, Charles Becker and Roger Becker, in attendance.

BLACK & WHITE RECORDING CO.

Booth 55 . . . records. Ann Koblitz in charge.

BOETSCH BROS.

Room 887 . . . handwound portable phonographs. George Boetsch in charge.

BONOT CO.

Booths 12-13 . . . phonograph needles. E. B. Murphy in charge.

BURKAW ELECTRIC CO.

Rooms 897-898 . . . Jerry L. Herald will demonstrate a new home-recording instrument.

CADET RECORD CO.

Booth 76 . . . popular records and albums under the registered trademark names Cadet, Corax, Dial, Jump, Mastertone, Sunset, Indie and Index. In attendance, Jack Riley, President; Jim Olson, Chicago sales manager, and Larry Rook of Mastertone records.

CAPEHART CO., THE

Room 801 . . . radio-phonograph combinations. In attendance, Ernest H. Vogel, E. A. Nicholas, I. C. Hunter, and John S. Garceau.

CAPITOL RECORDS, INC.

Booths 58-59 . . . records and needles. Glenn E. Wallachs in charge.

COLUMBIA RECORDING CORP.

Booths 24, 25, 26 . . . records and needles. Joe Lucas, Chicago district mgr., in charge. Others in attendance, Neff Runyon, Paul Southard, Jack Heim, Ken McAllister, Bus Gross and Jeff Wilson.

COSMO RECORDS, INC.

Booth 54 . . . records. Eddie Heller in charge.

DECCA DISTRIBUTING CORP.

Booths 20-21 . . . records, needles and portable phonographs. S. C. Schulz in charge.

DELUXE RECORD DISTRIBUTING CO.

Booths 60-61 . . . records. Jules Braun in charge.

DUOTONE CO., INC.

Booth 44 . . . phonograph needles, recording blanks, recording heads and recording fluids. Stephen Nestor, pres., in charge, assisted by William A. Boeger, Jr., Gen. Sales Mgr., Anthony Beck and Lyle Markham.

(Continued on page 20)

UNITONE... *A Really Fine Radio!*

Modern cabinet styling, fine acoustical performance, maximum sensitivity and clear channel selectivity give Unitone Radio powerful sales ammunition. For the proof of the pudding get Circuit Measurements from our Engineers.

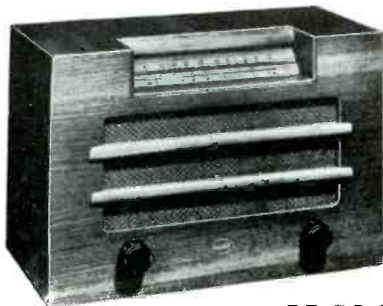

MODEL 88
5 Tube, 2 Band, A-C, D-C. Original Higher Fidelity Feedback, Alnico V Speaker.

Model 102 CA
Radio-Phonograph, 7 tubes, Push-pull Output. With Seeburg Automatic Changer new Higher Fidelity Audio Circuit.



Makers of superior 5, 6, 7 tube, one and two Band Receivers . . . 3 way Portable Radios, Record Players and Combinations.

UNION ELECTRONICS CORP.

38-01 Queens Boulevard

Long Island City, New York

ZENITH DOES IT AGAIN!



Scoops the Field

WITH THE SENSATIONAL NEW ZENITH TRANS-OCEANIC CLIPPER

STANDARD AND SHORT WAVE PORTABLE

Dealers all over America are telling us that this new Zenith Trans-Oceanic Clipper portable is far and away the most outstanding portable ever built. And no wonder—for it's literally loaded with features that attract—appeal—sell! For example, it plays anywhere—in *planes, trains, boats, motor cars* . . . it has a four-button Radiorgan tone control, pop-up Waverod, 5 short wave bands, Short Wave Wavemagnet . . . and it's just as beautiful in appearance as in performance. This Clipper portable is typical of the merchandise Zenith gives its dealers to sell—and only Zenith builds the Clipper!

Visit our exhibit at the N.A.M.M. Trade Show, July 15-18, Room 864, Palmer House, Chicago

Zenith Radio Corporation, Chicago 39, Illinois
Backed By 30 Years of Know-How In Radionics Exclusively

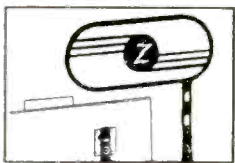

Removable Wavemagnet

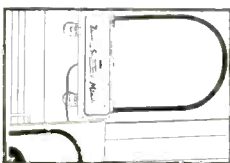

Short Wave Wavemagnet

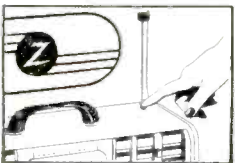

Pop-Up Waverod

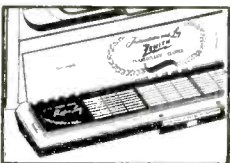

Instruction Log Panel

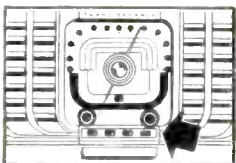

Radiorgan Tone Control

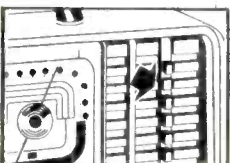

5 Short Wave Bands

(Continued from page 18)

ELECTRONIC CORP. OF AMERICA

Booth 14 . . . radios, Pianotune, Typatune. Jack Geartner in charge. ELECTROVOX CO., INC.

Booth 37 . . . needles, dealer sales helps. Ernest M. Ward, Chicago

sales representative will be in charge. Robert and Lowell Walcott, heads of this firm are expected to attend together with Roy Dally, chief design engineer.

EXCLUSIVE RECORDS

Booths 64, 79 . . . records. Leon Rene in charge.

FAVORITE MFG. CO.

Booths 31, 62, 63 . . . records, needles, blank discs and portable phonographs. Charles Kroneberger in charge.

GAMBLE HINGED MUSIC CO.

Room 876 . . . wire recorders, portable phonographs, radio-phonograph combinations, music vending machines, jobbing service on music of all publishers. In attendance, Eugene E. Gamble, Wayne Horwath, Bernard F. Pliska, A. W. Krueding.

GAROD RADIO CORP.

Room 892 . . . radios, portable phonographs and radio-phonograph combinations. Louis Silver in charge. GEM PHONO MFG. CO.

Booths 38-39 . . . needles. Jack Bergman in charge.

GENERAL ELECTRIC CO.

(Musaphonic Div.)

Booth 68; Rooms 890-891 . . . radio-phonograph combinations. G. S. Peterson in charge.

INTERNATIONAL MERIT PROD. CORP.

Booth 18 . . . needles. In attendance, Ed. M. Bieber, Harold Wilber and T. R. Garry.

KEYNOTE RECORDING, INC.

Booth 82 . . . record releases. In attendance, Eric Bernay, Don Campbell.

KING RECORD CO.

Booth 81 . . . records. Sidney Nathan in charge.

MANOR RECORD CO.

Booth 67 . . . records. Irving Ber- man in charge.

MELODY RECORD SUPPLY, INC.

Booths 92-93 . . . children's records, kiddies' phonographs and novelties, records. Mortimer Kline in charge.

MERCURY RADIO & TELEVISION CORP.

Booths 90-91; Room 776 . . . record releases. I. B. Green in charge. MICROTONE CO.

Booths 9-10 . . . needles. See Bonot Co. listing, a subsidiary. MUSICRAFT CORP.

Booths 41, 42, 43 . . . records. In attendance, Peter Hilton, president; Oliver Sabin, vice president in charge of sales; Lee Savin, sales manager; M. M. (Mike) Elliott, and James H. Martin, Chicago district manager.

MUSITRON CO.

Booths 49-50 . . . electric portable phonographs. G. E. Rissman in charge.

PERMO, INC.

Booths 73-74 . . . needles, counter and window displays, jobber and

(Continued on page 22)

Room 887

Birch
PHONOGRAPHS

the complete line, including Handwind, Electric and Record-Changer Portables will be on display in room 887 at the Convention.

This famous line of Phonographs, as usual, is setting the pace in better design, better tone and exclusive features.

On hand to greet you and demonstrate the line, will be

GEORGE BOETSCH
LEWIS E. DORFMAN
WILBUR R. LIGHT

BOETSCH BROS. 221 EAST 144th ST. NEW YORK 51, N. Y.

NATIONWIDE

THE SWING'S TO TELE-TONE!

THERE'S nothing localized or sectionalized about TELE-TONE's sweeping popularity. From Maine to California, Oregon to Florida, the enthusiastic praises come—from dealers and radio buyers alike—for TELE-TONE's superlative beauty, top flight performance. So much so that today, nothing finer can be said of any table model radio than: "It's a TELE-TONE." Which is worth remembering—for now as well as later.

Tele-tone

"In Tune With The World"

TELE-TONE RADIO CORPORATION, 609 West 51st St., New York 19
Producers of Small Radios and Small Radio-Phonographs Exclusively



MODEL 109—Compact (AC-DC) TUTONE PLASTIC. 5" Alnico No. 5 speaker Slide rule, full-vision dial, etc.



MODEL 131—Compact (AC-DC) Superb all-wood cabinet of striped veneers. 5" Alnico No. 5 speaker. Slide rule full-vision dial, etc.

MODEL 133 — Automatic Radio-phono combination. 8 tubes (AC) All wood, leatherette covered. Powerful with beautiful tone quality. Tone control, radio-phono switch, slide rule, full-vision dial. Plays 10" and 12" records.



WE'LL SEE YOU IN CHICAGO—PALMER HOUSE—JULY 11 to 18

(Continued from page 20)

dealer helps. Eugene C. Steffens in charge.

PEANSTIEHL CHEMICAL CO.

Booth 56 . . . needles. R. B. White in charge.

PHILCO RADIO & TEL. CORP.

Rooms 894-895 . . . radio-phonograph combinations. John F. Gilligan in charge.

PRESTO RECORDING CORP.

Rooms 879-880 . . . model K portable recorder; model L portable play-back; cutting and play-back needles, recording discs. In attendance, Ralph C. Powell, vice president in charge of sales and Leroy W. Beier, midwestern sales representative.

RADIO & TELEVISION, INC.

Room 878 . . . radio-phonograph combinations and portable phonographs. H. L. Weisburg in charge.

RADIO CORP. OF AMERICA
(RCA Victor Div.)

Booths 15-16; Room 813; Private Dining Room 14 . . . phonograph and radio-phonograph combinations. Jack M. Williams in charge.

RADIO & TELEVISION JOURNAL

Booth 66 . . . complimentary copies of the Industry's Oldest Radio Dealer publication and Official bureau of information for those seeking immediate contacts with manufacturers and wholesalers of phonographs, records, phonograph supplies, radio-phonograph combinations, radios, radio parts manufacturers, electronic and communication equipment and parts thereof. In attendance, Alex H. Kolbe and Mal Parks.

RECORDISC CORP.

Booth 96 . . . needles and blank discs. Sidney S. Gould in charge.

RECORD PLATE CO.

Booth 77 . . . "record plates" to catalog, index and individualize records and record albums. O. Morrey Smith in charge.

REXON, INC.

Booth 48; Room 877 . . . portable phonographs, record changers. In attendance, J. Schwalbe, president and John Fischer, sales manager.

SAVOY RECORD CO.

Booth 39 . . . records. Herman Lubinsky in charge.

SONORA RADIO CO.

Booths 94-95 . . . records and radios. In attendance, Joseph Gerl, president; Ed Harris, Gen. Sales Mgr.; Milton R. Benjamin, Sales Mgr., record div.; Marie Ruebens, recording director; Fred C. Collins and Gerald Ross.

SOUTHERN MUSIC CO.

Room 778 . . . portable phonographs, records, needles, sheet music, instruction books, band folios, musical instruments and accessories, teaching material. Milton Fink in charge.

STROMBERG-CARLSON CO.

Private Dining Room 17 . . . wire recordings, radio-phonograph combinations; phonographs. In attendance, Cliff J. Hunt, Gen. Sales Mgr.; Stanley Manson, Adv. and Sales Promotion Director.

TELETONE RADIO CORP.

Room 865 . . . portable phonographs, radios and radio-phonograph combinations. John S. Mills, General Sales Manager in charge, assisted by E. J. Cavanaugh.

UNITED LOOSE LEAF CORP.

Booth 72 . . . record albums. In attendance, Manual A. Freberg and Ben Freifield.

WATERS CONLEY CO.

Booth 11; Room 862 . . . portable phonographs. Wayne Davis in charge.

WILCOX-GAY CORP.

Room 810 . . . home recorders, discs, needles. In attendance, Warren H. Hasemeier, Gerald E. Murphy, Ward C. Haynes, Herbert C. Stroh, Claire S. Blakeslee and E. Morey.

ZENITH RADIO CORP.

Room 864 . . . radio-phonograph combinations, phonographs. Ed R. Taylor in charge. Also in attendance, Henry Bonfig, vice president in charge of sales.

Approved by Bureau
of Marine Inspection
U. S. Coast Guard

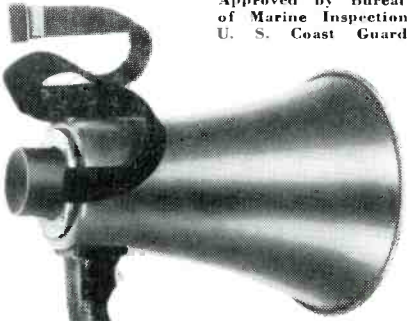

TAYBERN

"POWER VOICE"

PORTABLE ELECTRIC MEGAPHONE

- EASY TO USE
- POWERFUL

- WEATHER-PROOF
- COMPACT

**Manufactured for All Civilian Uses in Full Accordance With
the Exacting Standards Maintained for the U. S. Maritime
Commission and the War Shipping Administration.**

<ul style="list-style-type: none"> Paging Race Tracks Coast Guard Army Navy Shipyards Docks Boat Clubs Tug-Boats 	<ul style="list-style-type: none"> Airports Auctioneers Lecturers Life Guards Fishing Boats Railroad Yards Truck Loading Swimming Pools Gymnasiums 	<ul style="list-style-type: none"> Emergency Crews Athletic Events Merchant Marine Passenger Vessels Industrial Yards Fire Fighters Police Depts. Factories Armories 	<ul style="list-style-type: none"> Construction Gangs Schools and Colleges Political Gatherings And for Many Other Uses.
---	---	---	--

IMMEDIATE DELIVERY!



TAYBERN

EQUIPMENT COMPANY

120 Greenwich St., New York 6, N. Y.
Electronic Equipment Manufacturers

ARVIN Top Flight RADIOS

Mass MARKET ATTRACTION!

A floor combination with the fine quality and the low price to sell the mass market.

Powerful, SELECTIVE RADIO!

Six tubes including rectifier. Superheterodyne with many fine radio features for the money.

Automatic RECORD CHANGER!

A really dependable changer—performs smoothly and beautifully. Plays twelve 10" or ten 12" records.



Splendid TONE FOR RADIO OR RECORDS!

Acoustically balanced for better reproduction from large, heavy-duty PM speaker.

Beautiful MAHOGANY VENEER CABINET!

Trim and dainty, it fits beautifully into any living room. Plenty of record storage space.

HERE'S *Mass Market* SALES APPEAL!

The big mass of your radio prospects have modest family budgets. They want dependable, top flight quality in radios — at prices they can afford. With the Arvin big-demand line, you can show more people what they want — sell more radios and make more money. For example . . . this floor combination in the expanding Arvin line—Model 665—has the quality and the price to sell the mass market. Your radio sales set-up will never be complete until you have ARVINS!

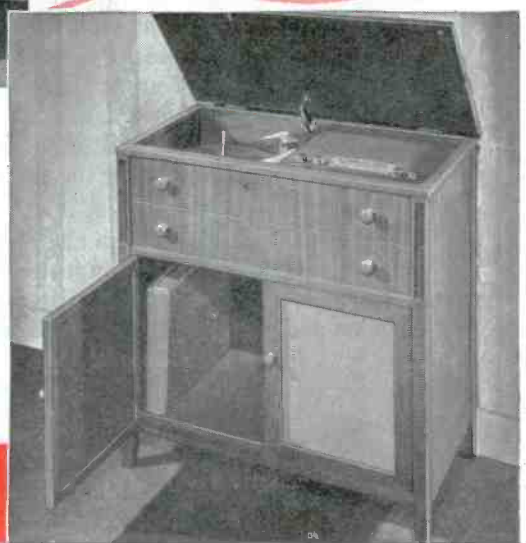

ARVIN is the name on many fine products from NOBLITT-SPARKS INDUSTRIES, INC. • COLUMBUS, INDIANA

REMINISCING IN RADIO

Here we inaugurate a new monthly feature which, we feel, will prove of absorbing interest to you. As the oldest monthly publication serving radio and appliance dealers your RADIO & TELEVISION JOURNAL is honored to have the privilege of serving a good many thousand readers who have subscribed for over 25 years. We hope that you will like this feature and will welcome your comments on it.

So I'm an old-timer, because I was around and had been dried off behind the ears when radio made its bow commercially! Maybe so, but remember that only twenty-five "short years" have passed since that time. True enough, radio has progressed in that period far beyond the "norm" for most industrial efforts.

It was in 1923 that I owned my first radio and, incidentally, it was one of the first "complete" sets on the market . . . a Crosley one-tuber with a 201-A tube worth \$6.00. A friend of mine told me to take good care of the tube as they were "scarce as hen's teeth" and were being bootlegged at much higher prices, in certain spots. I was delighted with my set, even though I had to buy an "A" and "B" battery, also a pair of headphones. In fact, I bought two pairs of headphones and by ingeniously hooking them together by an exclusive method of my own, a friend could listen with me. Shortly after I got the set, the first play was put on the air (from Chicago, anyway), "Abie's Irish Rose". It was a direct broadcast from the stage of a local theater and was very good, even though some of the actors at times said their lines too far away from a mike.

To go back even further, for a moment, it was about a year prior to my actually securing my set that Al. Kendrick, sales manager for Brunswick Phonograph Co. invited me to witness a sort of secret "something special" at night, in the Brunswick general offices. This proved to be the receiving of a broadcast of part of an operatic score, from the Auditorium theatre, three blocks or so away. However, when we were told that there were "absolutely no wires" connecting the equipment, we thought it was pretty wonderful.

Around this time I was western manager for Glad Henderson's self-same publication in which this appears. I thought I saw an opportunity for the talking machine and general music store to sell the new

marvel radio. Lyon & Healy were jobbers of the Victrola, and I told Leslie Wiswell, their wholesale manager what I thought. He stated emphatically that he didn't agree with me that the music store would be the big outlet for radio receivers because, at that time, everyone was "rolling their own" . . . making radio sets out of "certain parts and lots of baling wire". But, without pretending any clairvoyance in the matter, I persisted in the feeling that RADIO and MUSIC were synonymous, commercially. I called, among other places, at the offices of The Burgess Battery Co. to suggest they advertise their already famous "B" batteries to the talking machine dealer through my publication. I could tell that the advertising manager thought I was slightly, or greatly "off my top". However, I persisted, and a year later got a 12-page contract from Burgess. I didn't know then that, many years later, I was to enjoy a fine friendship with the inventor, the late Dr. C. F. Burgess and would be the advertising agent for a number of the Burgess companies.

Soon I was interesting many other "radio outfits" in going after the talking machine dealer business. One of the first of the "combinations" that I recall as emanating from the west, besides Brunswick, was the "Phonoradio", put out by Wasmuth-Goodrich Co. a furniture concern in Peru, Ind. It was a good job, in fact good enough to be backed, even then, with pages in The Saturday Evening Post. One of the problems, then, was to give good demonstrations, because radio broadcasting was very "sketchy" and nonchalant. A great amount of the stuff on the air was ad libbed; the "personalities" were mostly "song and patter" artists, with the exception, of course, of a few straight singers of established reputation who were brought into the picture. To jump ahead as regards the matter of broadcasting, I remember, as late as 1928 when

This month's reminiscence is contributed by Mr. Duane Wanamaker, president, Duane Wanamaker Advertising, Chicago, who has contributed much to the merchandising and marketing miracles enjoyed by the radio industry during the past 25 years.

I was on a business trip for my company, Grigsby-Grunow. In both Dallas and San Antonio, Texas, the leading stations invited me to come over "almost anytime during the day" and "say something over the air". I said: What shall I talk about?" The answer was "Oh, anything you care to talk about, and . . . just talk as long as you feel like talking". Incidentally, in both cities I offered a radio set free for the most interesting letter I received. Even though my broadcast occurred in the morning, over both stations, I received several hundred letters.

One day in 1926 I called on a firm by the name of Grigsby-Grunow Co., who were just starting to make a B Battery Eliminator. My call resulted in an advertising contract. Fred Williams, later with other leading radio organizations, was the sales manager. I don't think the company expected the tremendously favorable reception that was accorded their products almost from the beginning. Fred, as I understood it, was working on an overwrite of so much per eliminator. I also understood that, for quite awhile, he made money "by the bucketful", more money than anyone else around the place received, not even excluding the president.

Of course, the eliminator in question was "Majestic". How did the name become "Majestic", instead of "Monarch" or something else? Well, everyone put the name of their choice in a hat. The name drawn out first was "Majestic"; and it will probably go down in history as one of the most glamorous trade names that ever was.

After I had contacted the Majestic organization a time or two, I was sitting in my office one day when I received a call from Mr. B. J. Grigsby, president of the company, inviting me to the Union League club for lunch. After lunch, I was the new advertising manager for Grigsby-Grunow Co. When I went out there I had a small desk in a corner, in the back, with an old-fashioned single bulb, green-shaded light over my desk. A few months later, it looked as if I might not even have that. The B eliminator was "dying on its feet", due to the advent of the AC tube. It was then that Messrs. Grunow and Grigsby decided to go into the radio set business. Do I need to say that everyone . . . well, almost everyone . . . predicted dire things would happen, said they were "as crazy as loons". The story of Majestic is too well known for me to bore you with it here. Just in passing, it might be of some small interest to mention my own little personal thrill of handling a five million dollar advertising budget in our "big year"!



Rembrandt
by
REMINGTON

REMINGTON RADIO CORPORATION
WHITE PLAINS, N. Y.

JFD NEW "BIG 4" SERVICEMEN'S BASIC KIT!



A Great New TIMESAVER For Radio Servicemen
FOUR Basic Radio Service Kits in ONE Package

SPECIAL SERVICEMEN'S COST **\$18.00** LIST PRICE \$33.35

For Radio Servicemen Starting a Repair Business . . .
For Established Radio Servicemen Who want to Save Time and Energy . . .

These 4 Popular JFD Kits have everything needed for 25% of all radio service work.

1. **B25A Belt Kit.** Assortment of 25 Dial Belts in Metal Container. Includes FREE 64-page JFD Servicemen's Manual, listing belts for more than 1500 set models.
2. **SC25 Dial Cable & Cord Kit.** Contains 5 Metal Speaks of fast-moving dial cables and cords.
3. **770 Ballast Kit.** Contains five JFD Improved Aircooled AC-DC Adjustable Ballasts. Suitable for more than 95% of all ballast tube replacements.
4. **BP-100-MC Plug Assortment.** 100 radio battery plugs, in 25 different popular types. Sturdy Metal Container. Includes FREE Battery plug folder with technical data and schematic diagrams of all plug types.

COMBINATION List Price Value, \$33.35 Model "Big 4" Servicemen's SPECIAL Net Price \$18.00

Here's what we mean by a hard-hitting **WALCO** sales campaign!

PACKAGING...



DISPLAY...



DIRECT MAIL...



DEALER HELPS...



WALCO "400"
FLOATING JEWEL
RETAILS **\$2.50**

WALCO "400"
RUBY JEWEL
RETAILS **\$2.00**

WALCO "400"
PRECIOUS METAL
RETAILS **\$1.50**



**Designed for highest fidelity
... primed for greatest sales!**

Every possible selling help is yours! Full color, compact dispenser displays, window streamers, booth signs, consumer literature, leatherette counter pieces and the WALCO extra dividend of free needles for your booths.

When you offer WALCO phono needles to your customers—it's a sure sale! Just mention that WALCO needles are the choice of leading phono manufacturers for installation

in new instruments . . . that the great names in radios use WALCO for perfect reproduction. Remember, there's a WALCO needle for every price range—from 50¢ to \$5.00 and every needle, whatever the price, features the famous WALCO "bent shank" for highest fidelity and "floating action" for minimum record wear. ELECTROVOX COMPANY, INC., 31 Fulton St., Newark 2, New Jersey.

Get your free record booth needles today; if you're in Chicago for the Music Trade Show, see the complete WALCO line at Booth 37



JOURNAL EDITOR WILL M. C. CEREMONIES OF A. D. A. OUTING

Several hundred guests will assemble at the Green Valley Country Club in Philadelphia on the first annual outing of the Appliance Dealers' Association of Philadelphia on Tuesday, August 13th, 1946.

RADIO & TELEVISION JOURNAL Editor Mal Parks was unanimously selected by the Entertainment Committee to be the official Master of Ceremonies of the affair which will start at approximately 1 P.M. The Green Valley Country Club, located at 6900 Bridge Avenue, Philadelphia, is one of the finest places of its kind in the east, and the members and guests of the Appliance Dealers' Association of Philadelphia have been guaranteed the time of their

lives by the officials of the group.

Highlighting the diversissements will be a bathing beauty contest to select "Miss Philadelphia," who will represent the city at the Miss America Beauty Contest to be held later in the year at Atlantic City. The main judge at this event will be Journal Editor Mal Parks, who has been deluged with requests from Philadelphians for the opportunity of assisting him in this arduous and exacting task of picking out the reigning beauty of the City of Philadelphia.

The outing will include the usual events such as soft ball games, sack races, three-legged races, and the other good, old-fashioned sports events which add

enjoyment to any similar gathering. After these have been concluded, there will be dinner starting with steamed clams, and winding up with charcoal broiled steaks, lemonade, ice cream and cake. After dinner, there will be dancing with a nationally-known nine piece orchestra providing music.

Key speaker at the event will be Judge Adrian Bonelli, who is well known in the field of jurisprudence for the clarity of his understanding and the astuteness of his decisions. Judge Bonelli is in great demand as a speaker and the guests and members of the Appliance Dealers' Association of Philadelphia are fortunate in having his acceptance.

Designed for YOU



Model No. 314

BEACHCOMBER

A portable phonograph with a Garand spring wind motor. Battery operated amplifier with 3 tube push-pull output. Crystal phon pickup and 5" permanent magnetic speaker. Lightweight solid plywood cabinet with Leatherette cover in choice of colors. Plays 10" or 12" records with cover closed.

49.95

Fed. Tax Included



Model No. 311

VAGABOND

AC operated phonograph containing a 5" permanent magnetic speaker and a 3 tube amplifier. Crystal pick-up and heavy duty turntable. choice of colors. Equalizer for new improved tone control.

38.95

Fed. Tax Included

LINCOLN ELECTRONICS CORPORATION
653 11th AVENUE, NEW YORK 19, N. Y.

Today many dealers are facing stiff competition from powerful utilities. Here's the story of one utility that is specifically organized to sell for the dealer!

UTILITY HELPS DEALERS SELL

by MARION A. DOOLEY

Managing Editor, Radio & Television Journal

Dealer X was speaking disconsolately to his new salesman: "Today, Jim, you've really got a tough selling job on your hands. People want new radios and washing machines . . . but half the time we haven't got them. We build up the demand, and then have to go back on our word, 'cause we can't get the stuff. And on top of all that, we have to fight the utilities! Most of those darn companies are selling appliances, too!"

Unfortunately, this picture is not particularly exaggerated, and the dealers' life is far from happy. At present, there is little that can be done about the tight supply picture, but there is good news about competition from utility companies. Not all utilities are operating against the best interests of retailers . . . as a matter of fact, one such organization is doing everything possible to help the dealer. The Consolidated Edison Company of New York is actually SELLING APPLIANCES FOR THE DEALER, and letting the dealer take 100% of the profits. They do all the preliminary ground work of selling, including display, sales helps, storage rooms and actual sales talks . . . then the signed order of the customer is delivered to the cooperating dealer nearest the customer. Sounds almost too good to be true, but the plan is actually in operation among hundreds of appliance dealers in New York City and its vicinity. If one big utility can afford to adopt such a program, it seems obvious that others could do the same sort of thing in other cities of the country. It is up to the individual dealers to promote this plan wherever possible, and to convert dangerous competitors into powerful allies.

Here are the highlights of the plan. As stated before, Consolidated takes full responsibility for the sale. The manufacturer or retailer who agrees to the plan ships a certain quantity of appliances to Consolidated for display and demonstration pur-

poses. Consolidated then displays these models to the best advantage, and does everything in its power to complete the sale.

In order to benefit from the plan the dealer must:

1. Own or operate and maintain an appliance retail store or separate retail appliance department in accordance with such standards as may be established by the Consolidated Company.

2. To carry a representative stock from among the standard makes of appliances. This stock shall include, to the extent available, and as selected by the cooperating appliance dealer, the appliances for which Consolidated is authorized to take orders as agent.

3. To authorize Consolidated, as agent, to solicit orders for the account of the cooperating appliance dealer (who, in respect of each separate order, shall be designated in accordance with the provisions of the plan), and to accept such orders for appliance which shall have been assigned to such cooperating appliance dealer, and to complete the sale and delivery thereof in accordance with the terms of such order.

4. To perform each and all of the provisions of this plan.

Boiled down into everyday language, all this adds up to the advantage of the dealer. In the first place, only accredited dealers are eligible, which in itself helps to force the fly-by-night operator out of business. Even more important, dealers must carry standard brands. This too helps the dealer fight against the flood of nameless, stencil brands of radios and appliances that consume thousands of consumers dollars every year. Naturally, a certain proportion of your customers are inveterate bargain hunters . . . they will shop all over town for the cheapest article, and will buy doubtful brands

(Continued on next page)

simply because they are less expensive. The Consolidated plan, however, operates in direct opposition to stencil brands, and many dealers have been saved from stocking indifferent appliances by obtaining the benefits of Consolidated's streamlined selling methods.

The last two points outline the actual operation of the plan. They state that the dealer must appoint Consolidated as agent for its appliances, and must take the responsibility for completing the sale, and delivering the goods. Thus, Consolidated does all the ground work of the sale, leads the prospect right up to the point of sale, gets his signed order, and then passes the order over to the nearest cooperating dealer. They do the work, foot the bill, and the dealer gets the profits.

Upon closer examination, the plan yields several more points that are laid down for the benefit of the dealer and the manufacturer. For example, Consolidated is careful not to play favorites, and each manufacturer is given an equal opportunity for the display of its products. Appliances are rotated among the various showrooms of the company, and special care is taken to keep things on an equitable basis. These appliances are all samples, and the dealers provide the actual models that are sold. In order to make sure no hitches occur, the dealers are always kept informed of the type and quantity of appliances currently on display in the Consolidated showroom. Thus when Consolidated makes a sale, the dealer is sure to have the merchandise on hand for delivery. If for some reason, it is impossible to complete the sale, the responsibility lies with the dealer.

In each case, the completed sale is handed over to the dealer who is located nearest to the home of the purchaser. Of course, this system has to allow for the comparatively larger amount of business done by department stores, and Consolidated Edison has set up a different routine to accommodate appliance departments of large stores. One day a week, all orders are consigned to a department store. Department stores are listed in alphabetical order, and the orders are rotated. In this way, business is shared equally among the various department stores, and care is taken to see that they do not receive a lion's share of the total business.

On the question of finances, all money for advertising, display and demonstration shall be shared by Consolidated and participating manufacturers and distributors.

Here is an exact check list of the requirements a dealer must have to qualify for the plan. They are the usual attributes of a legitimate, serious retailer, but they rule out small, makeshift organizations:

The dealer shall:

1. Occupy a premises listed as a store for retail trade within the territory served by the Consolidated Edison Company of New York, Inc. with
 - a) At least one show window.

- b) Floor space for display of gas and/or electric appliances.

- c) Facilities or provisions for repair service ordinarily carried on by dealers.

- d) If the dealer be a department store, requirements (b) and (c) must be included in a separate appliance department.

2. Carry a representative stock from among the standard makes of appliances.

This stock shall include, to the extent available, and as selected by the cooperating appliance dealer the appliances for which Consolidated is authorized to take orders as agent and for the account of cooperating appliance dealers under this plan, and pursuant to arrangements between Consolidated and participating manufacturers and distributors.

3. Provide appliance delivery to customers.

4. Employ necessary personnel to perform functions described in 1, 2 and 3.

5. Maintain and operate store in a business-like condition.

6. Offer on all electrical and/or gas appliances at least one of the standard deferred payment plans and accept orders on basis of such terms as are effective with orders taken by Consolidated for the account of the dealers. In the case of department store dealers selling for cash only, the requirement of deferred payments is waived.

7. Agree and warrant not to deliver any appliances to a customer on an order taken by the Consolidated Edison company unless title to such appliance is vested in the cooperating appliance dealer free and clear of all liens and encumbrances whatsoever.

8. Certify that the equipment listed in the dealer's premises by Consolidated's representative is equipment which is normally carried by the dealer in stock, and is not on loan from any other dealer or distributor.

9. Display prominently in his place of business the cooperating appliance dealer emblem so long as he shall continue to be a cooperating appliance dealer.

10. Agree that connection of any gas appliances sold and installed by the dealer will be performed by a licensed plumber.

Thus the Consolidated Edison Company has blue-printed a workable, simple plan, whereby they and the dealer gain more business. Through the sale of an increased number of appliances, the utility naturally gets greater profits, and the dealer receives 100% of the profits of each sale. The plan is apparently foolproof, and has been operating successfully in the metropolitan area of New York for several years. It not only eliminates dangerous big-business competition from a utility . . . it extends a hearty helping hand to every dealer willing to cooperate.

Similar systems could easily be established in all parts of the country. The plan is simple to follow, and Edison will be glad to supply details to any dealer interested.

Here's How Radio Industry Says "OK"

TO FEDERAL'S NEW MINIATURE SELENIUM RECTIFIER

TYPE-403D2625



HALF MILLION ALREADY ON ORDER!

NOW being used in radio receivers, voltage multipliers, speech amplifiers, PA systems, electronic organs, business machines — wherever a low-voltage low-current d-c source is required — replacing type 117Z6-117Z3 and other rectifier tubes.

The "landslide" of orders which followed the announcement of this new rectifier means just one thing — another outstanding contribution which fills a great need in the electronic industry. Now, in hundreds of applications, this 5-plate rectifier stack is proving its value — in money saved, reduced assembly time, new space savings, longer life, instant starting. It measures only 1¼ x 1½ x ⅜ inches, and will go into restricted spaces where a tube and socket won't fit.

Though miniature in size, this rectifier embodies "full-scale" quality throughout, with **Center-Contact** construction and all of the other features which have made Federal Selenium Rectifiers the standard of quality in the industry. They're available now — in quantity. Write to department 2200 for prices and data.

CHARACTERISTICS:
Type 403D2625 Rectifier

Maximum RMS Voltage	130 volts
Maximum Inverse Voltage	380 volts
Maximum Peak Current	1200 ma.
Maximum RMS Current	325 ma.
Maximum DC Output	100 ma.
Approximate Rectifier Drop	5 volts

Federal Telephone and Radio Corporation

In Canada:—Federal Electric Manufacturing Company, Ltd., Montreal
Export Distributors—International Standard Electric Corporation



Newark 1,
New Jersey

STOP SUMMER SLUMP with

Replacement Record Changer

Answering popular demand from radio dealers and servicemen, Admiral Corporation, 3800 Cortland St., Chicago, now offers



the "Childproof" automatic record changer in a new unit suitable for replacing the many record changers that have worn out during the war years. The new replacement unit has all the features of the changer built into Admiral combinations — trouble-free mechanism, with only three moving parts during the change cycle . . . fool-proof tone arm that may be moved at any time without damage . . . 5-second record changing time .

"Low Boy" Record Player



Response from retailers who have seen Western Sound & Electric Laboratories' new "Low Boy" automatic record player is said to be "enthusiastic." Ready for immediate delivery now, Western predicts that this Model WE-100-AW will be a leader. Featuring a new acoustical loading principle — an 8 inch P.M. speaker projects sound horizontally through the base of the cabinet — the model is finished in a mahogany veneer cabinet.

Table-Size Radio-Phonograph

Combining a six-tube AC-DC standard band radio receiver with

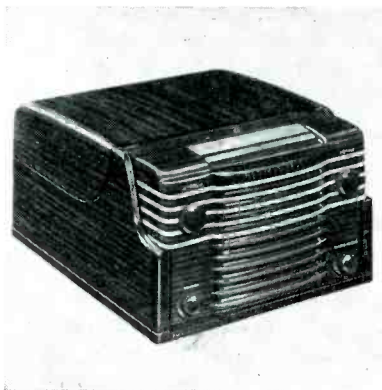

a fully automatic phonograph in a mahogany veneer cabinet, the new Model H-122 table-size Duo-combination is announced by the Westinghouse Electric Corporation. The receiver, which forms the front section of the new unit, can be removed for independent use. The automatic record changer, under a top-raising lid, accommodates twelve 10-inch or ten 12-inch discs. Special features include a built-in loop antenna, a continuously variable tone control, a phase-inverter tube, and a highly efficient push-pull output circuit for high quality reproduction with ample volume. The new model is 9 inches high, 14 $\frac{3}{4}$ inches wide and 19 inches deep.

Table Model



Table model 561, manufactured by Lear, Inc., 230 East Ohio St., Chicago, is housed in a cabinet of hand-rubbed genuine mahogany. It has five tubes, high quality permanent magnet Alnico No. 5 dynamic speaker, single-band standard broadcast, a built-in loop with outside aerial connection. The model has full vision angle-mounted illuminated dial. It is 88 inches by 10 inches by 6 $\frac{1}{2}$ inches, and retails for \$31.50. Simplicity of design makes it fit into the environment of any room with every type of furniture. Chassis is strong, of rugged construction, cadmium plating with precision workmanship.

Portable Phonograph



A new portable phonograph has been introduced by Major Electronics Company, Inc., 197 Wil-

these "SELLING" SPECIALS

liam Street, New York, The model has a three tube amplifier that has quality tone, and a new light-weight crystal pickup. The case is made of simulated alligator, which comes in blue, brown and tan. The new phonograph is made of light-weight materials for easy portability.

Plastic Set

Table model Learadio No. 563 is housed in ivory plastic, and retails for \$25.50. The case has full-visibility dial, rounded top corners,

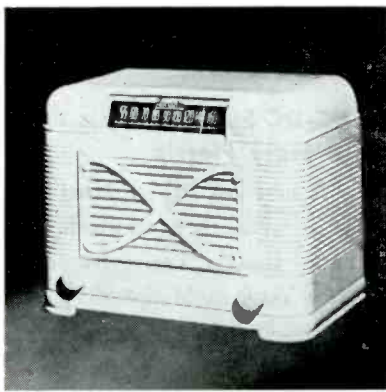

fluted design running along front edge and side, and a speaker panel with a graceful X pattern. It has five tubes, and a high quality Alnico permanent dynamic speaker. There is a built-in loop with provision for outside aerial connection. For further information write direct to manufacturer: Lear, Inc., 230 East Ohio, Street, Chicago.

Motorola Record Player

Galvin Manufacturing Corporation, 4545 Augusta Blvd., Chicago, announces a new record player. The model uses Hawley-processed pressed fibre for the "wrap-around" or base. Developed by the army, the material has lightness and flexibility. The wireless record player plays through any



radio; has Floating Action which silently handles ten 10 inch or eight 12 inch records, and has the newly designed record release spindle that permits easy placement and removal of records.

The Beachcomber

A new portable, battery phonograph has been announced by Lincoln Electronics Corporation, 653 Eleventh Avenue, New York 19.



Called "The Beachcomber," it has a hand wind motor and battery operated amplifier. Plays 10 or 12 inch records with the cover closed. Incorporating a heavy duty 5 inch P.M. speaker with Alnico V magnet, it has three tubes, volume control and lightweight crystal pickup. The cabinet is made of three ply veneer, covered with beach canvas. "A" battery life of 150 hours, "B" battery life of 300.

Portable Electronic Phonograph

A new addition to the "Rogers Majestic" and "De Forest" lines has been announced by W. T. Burnham, general sales manager of Rogers Majestic Limited. It is



a neat, compact portable electronic phonograph complete with its own amplifier and 6 by 4 inch oval speaker and may be played open or closed. There is a record carrying compartment, container for needles and the whole unit closes up into what looks like a weekend bag.

It is compact and, weighting under 18 pounds, is easy to carry.



THE NEW SUMMER
STROMBERG-CARLSON PORTABLE

(See story on next page)

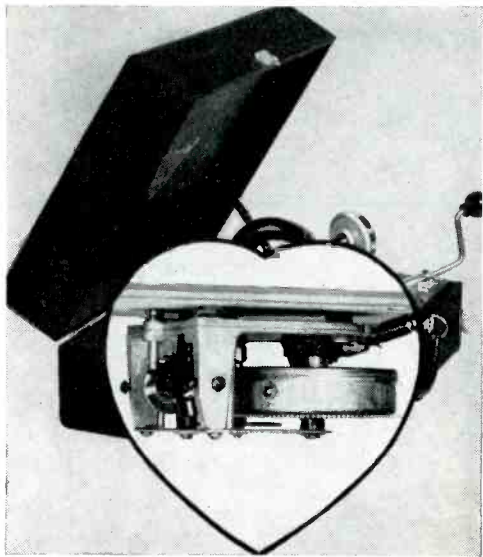

the **HEART**
OF ANY
PHONOGRAPH
IS ITS
MOTOR!

BEAUTY of design is but one feature of "THOMPSON PORTABLES" . . . even more important is the quality construction of the THOMPSON motor . . . the very heart of the instrument.

THOMPSON MOTORS are sturdily constructed of heavy steel base plates; heavy brass gears and pinions; massive power spring which permits playing of three ten-inch records at one winding (almost twice the spring capacity of the average popular spring-wound phonograph).

THOMPSON CASES are made of thoroughly cured three-eighths inch wood, covered with Genuine Keratol patented fabric. Fitted with durable plastic handle, sturdy brass hinges, locks and protective corner plates. Other features of extra refinement are: Chrome plated arm and reproducer . . . Chrome needle cup with spring-hinge cover . . . Record-holder for 12 records.

A Proud Ancestry!

The H. C. THOMPSON COMPANY has been manufacturing special precision movements since 1878 . . . more than sixty-five years of "know how" go into the making of each THOMPSON Phonograph Motor!

Western Union . . . Westinghouse . . . General Electric . . . Autocall and many others who demand "split-second" timing traditionally turn to The H. C. THOMPSON CO. for their requirements.

Constantly "in step" with modern developments, The H. C. THOMPSON CO. supplied radar parts to the Sylvania Electric Products Corporation and time fuses to the U. S. Signal Corps during the recent war. Currently they supply "Stop-Timers" (accurate to within one-fifth second) to leading national radio stations. *Quality and Accuracy Since 1878.*

We will be represented at the Music Trades Convention, beginning July 15th

Southern MUSIC-CO.

830 EAST HOUSTON STREET • SAN ANTONIO, TEXAS

Summer Portable By Stromberg Carlson

To round out its full line of 1946 radio receivers, the Stromberg-Carlson Company, Rochester, N. Y., introduced "The Vagabond," a new distinctive portable. The Vagabond contains six tubes, including rectifier, is fully equipped for AC-DC or battery operation. Its smart carrying case, attractively covered with maroon leather-finish fabric with gray trim, is inspired by high style, modern luggage. The Vagabond is a superheterodyne receiver with an unusually large and powerful speaker for its compact size. The receiver's 5½ inch Alnico speaker is a permanent magnet dynamic type. It measures 11½ by 13 by 6¾ inches and weighs 15 pounds with batteries.

AC-DC Superhet In Ivory Plastic

A new AC-DC superhet, with 5 tubes, has been introduced by Fada Radio, Long Island City, New York as Model 605W. It has

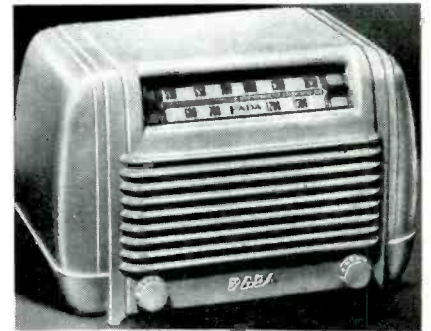

FADA MODEL 605 W

one wave band, covering American Broadcasts. There are 5 tuned circuits, automatic volume control, diode low distortion detector, and a power output of 2 watts. Incorporates Fada-Scope high efficiency loop antenna. Size: 10½ in. wide, 6½ in. high, and 6 in. deep. The set weighs five pounds, and has an OPA approved price of \$23.95. For shipping weight in a carton, add one and one-half pounds.

at last... the first real postwar cabinet design



BACKED BY THE FIRST *NEW* SALES IDEA!

Would you wrap rubies in burlap? Could you make a hit with a '46 motor in a Model "T" body? Then why sell modern, postwar radio engineering principles in anything but the most modern, postwar cabinet on the market today? And that is what Electromatic offers you in the Coluratone Combination.



FUTURAMIC DESIGN by ARTEK PASCOE!

When you think of 18th Century Drawing Rooms, you think of Chippendale. But when you think of 1946 and the future, the name is Artek Pascoe. Don't take our word for it! Ask the decorators who "know". Naturally, when we set out to build a real postwar radio cabinet, we went to Artek Pascoe. And here you see the result... the Futuramic Cabinet, especially designed and manufactured for ELECTROMATIC by Artek Pascoe.

NO PEEL... NO WARP... PERMANENT-BOND VENEERS!

The hard core wood and beautiful walnut veneers used in the Electromatic Cabinets are bonded together by high frequency induction heating, the most advanced process. Anyone with a home near the seashore, or a spot for a radio cabinet near an open window, will be mighty glad to hear that neither dampness, nor ruin will warp, split, or peel the beautiful hand-finished veneers.



MODEL 606A
Available with detachable legs, which are furnished separately.

ELECTROMATIC COLURATONE* AUDIO-AMPLIFIER SYSTEM!

Who but Electromatic—the company that has specialized in building table model radios and phonographs—could pack so many high-priced features into one medium-priced set? The COLURATONE AUDIO-AMPLIFIER SYSTEM, an exclusive Electromatic development, permits the reproduction of tones that are lost in ordinary sets. With COLURATONE you hear true tone—the deep resounding basses of the kettle drums and the clean sharp highs of the flute—without fuzz or distortion! Look below at the list of honest-to-goodness selling points your salesman can talk up.



MODEL 606A ELECTROMATIC AUTOMATIC RADIO-PHONOGRAPH COMBINATION



FEATURES:

- FUTURAMIC DESIGN BY ARTEK PASCOE • PERMANENT-BOND VENEERS... NON-PEELING... NON-WARPING • COLURATONE AUDIO-AMPLIFIER SYSTEM FOR CONSOLE TONE QUALITY • TRAVELITE INDICATOR INCREASES STATION SELECTOR EFFICIENCY • RECORD CHANGER ACCOMMODATES TEN 12-INCH OR TWELVE 10-INCH RECORDS

Write today for the full details on this outstanding automatic combination radio- and quickly converted to chair-side model with detachable legs furnished separately. Deliveries start July first on a first come - first serve basis.



You might think you have enough of a promotion in the Artek Pascoe name... the national and newspaper advertising... the counter circulars and self-sales tags... the brilliant technical features. But we've added a "something else" that will be a sure-fire selling idea!

THE ELECTROMATIC PIANO TEST!

Even if you have only basic selling knowledge about electronic equipment, you surely realize that it is most difficult to reproduce the tones of the piano because of its wide range. We have no fear of this reproduction on the ELECTROMATIC COLURATONE. When it goes on display on your floor, you will receive a recording of Greig's Piano Concerto, as played by a world-famous artist. The record has been prepared with convincing commentary by Andre Baruch, the well known radio announcer, on the quality of the ELECTROMATIC COLURATONE COMBINATION. Be sure to use it with every demonstration—nothing can be more convincing than this self-salesman!

*Coluratone—copyright pending

ELECTROMATIC—TOPS IN TABLE TOP COMBINATIONS AND CONSOLETTES

ELECTROMATIC

MANUFACTURING CORPORATION

88 University Pl., New York, N. Y.

Factories in Yonkers and New York City

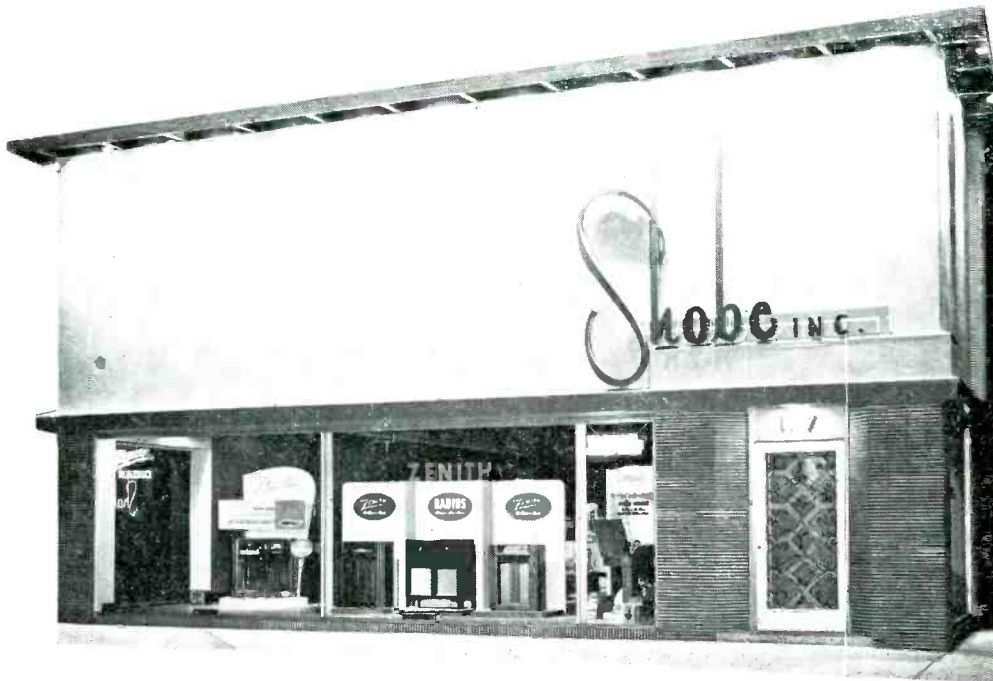

Shobe

Modernizes

Acting on his belief that a dealer needs a modern store in which to sell modern merchandise, N. S. (Cy) Shobe recently set the pattern for dealers in his territory by reconverting a building at 1117 Union Avenue into one of the most modern merchandise distributing establishments in the City.

A "face lifting" operation provided a spacious display window across the front, giving passers-by

an unobstructed view into the interior. An unusual door, done in red and white, is at the extreme right of the building keeping the display window space unbroken. The firm's name is strikingly imposed over the door in large, red illuminated letters and effective indirect lighting makes the building as outstanding after dark as during the day. Modern, attractive, different, Shobe, Inc., a Zenith Radio distributor, commands attention and customer appeal.

Cy Shobe has built his distributor business around the fact that he will not tolerate "back door"

selling. He has brought his sincerity home to dealers by posting a \$1,000 warranty not to sell any product which it distributes except through authorized, franchised dealers. Should any dealer cite a violation of this code by the management of Shobe, Inc., the firm offers to forfeit the \$1,000, making it payable to any established charity of the complaining dealer's own choosing.

In line with his modern merchandising, Shobe publishes twice monthly a house magazine called "The Topflighter," which goes to all Shobe dealers.



Cy Shobe listens as Ed Taylor of Zenith plays the Cobra Record Changer.



Al Haire, of Double H Sales Company, Ed Taylor and Wilbur Ray, Shobe Sales Manager, talk over Shobe's Dealer Magazine, Topflighter.

"HIS MASTER'S VOICE"...

the history of a famous Trade Mark



1 "His Master's Voice"

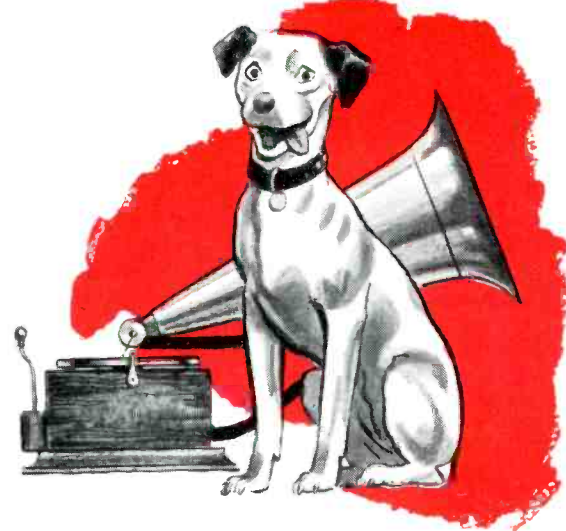

2 "Hello! Lots of people don't know it but my name is NIPPER. I was a real dog who really recognized 'His Master's Voice' back in 1898."



3 "But what made me immortal, was that my master (a painter fellow named Francis Barraud) caught sight of me listening one day . . ."

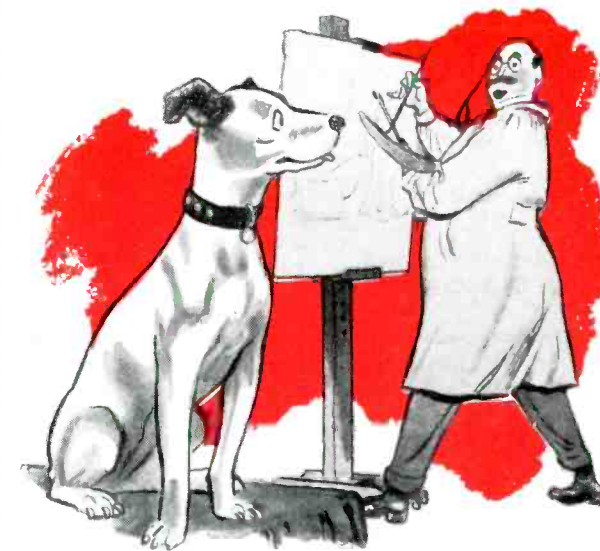

4 "And then I had to do the hardest work of my life—*posing!* If there's one thing I don't like to do, it's to sit still . . . But I did it for hours!"

T. M. Reg. U. S. Pat. Off.



5 "Then they took Mr. Barraud's painting of me and ran it as a Victrola* advertisement . . . I was started on my career to world fame!"

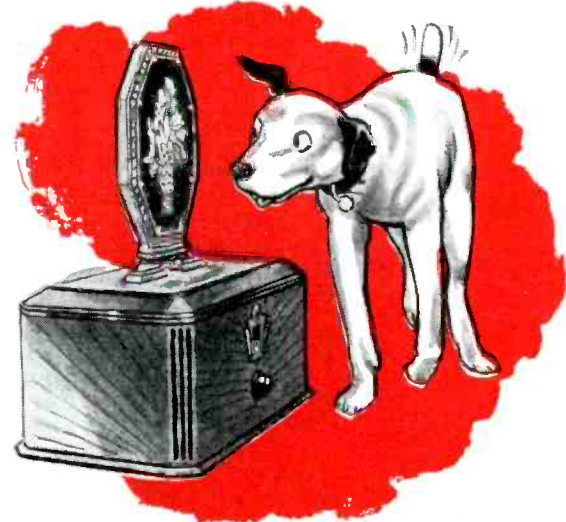

6 "Next, another kind of 'music box' came along—a radio made by RCA. Then when RCA merged with Victor—in 1929, I became *even more famous!*"



7 "So today you have something that never was dreamed of! You have the real-life TONE of the new RCA Victor 'Golden Throat.'"

"There are four table radios—including a set with short wave that can 'pull in' stations 12,000 miles away! And a battery radio you can plug in and run on AC if you want to. MY favorite is the 'Personal'—it's the tiniest, neatest portable RCA Victor ever made!

"Then, there's an automatic radio-phonograph that's nearly 1/3 smaller than the prewar table model. And, two console radios that make 'His Master's Voice' more real than ever!"



8 "Don't take my word for it—hear the 'Golden Throat' for yourself. Let your customers hear it! Every RCA Victor instrument has the 'Golden Throat!'"

ONLY RCA VICTOR MAKES THE VICTROLA*
*Victrola—T.M. Reg. U.S. Pat. Off.

  **RCA VICTOR**

RADIO CORPORATION OF AMERICA

RADIO & TELEVISION JOURNAL

is

P R E F E R R E D

by

Radio, Appliance & Service Association Leaders

***Read what these Industry Association Officers say
about RADIO & TELEVISION JOURNAL'S Assn. activities.***

E. J. Balcom, President, Tulsa Radio Service Association . . .

"Your articles have helped radio men organize . . . bringing about more cooperation between shops . . . whereas before there was a constant struggle against each other. As president of the Tulsa Radio Service Assn., I can personally vouch for the use and value of your tips. . . ."

Ted J. Telaak, President, Radio Technicians' Association, Inc., Buffalo, N. Y. . . .

"In my opinion the RADIO & TELEVISION JOURNAL is the foremost medium for presenting the opinions of various Associations throughout the United States, and it was particularly instrumental in presenting the facts during the much discussed "serviceman licensing" controversy. On behalf of the Buffalo Radio Technicians' Assn., congratulations for a job well done in the past. . . . I feel certain that this Association Activities Department will increase the value of your magazine in the future."

Dave Krantz, Chairman, Philadelphia Radio Service Men's Association . . .

"In the past few years, the radio service technician has realized that he should have some voice in today's electronic industry. . . . In turning to organization, he has found the salvation of the individual radio serviceman. . . . Your magazine has been the foremost exponent of its kind . . . aiding the servicemen . . . and taking his problems to heart. . . . A great deal of thanks for your fine work. . . . May it continue!"

C. E. Heitkamp, President, Radio and Electronic Technicians' Association, Greensboro, N. C. . . .

"The future of the radio and television technician in carrying out the purpose of his association has been guided to a large extent by the efforts of the RADIO & TELEVISION JOURNAL, and there is every reason to believe that such help will be continued. Speaking in behalf of the Greensboro Association, please accept my thanks."

Scott Adams, President, Radio Technicians' Association, Huntington, W. Va. . . .

"The RADIO & TELEVISION JOURNAL has served association work in this country more than any other publication . . . and in getting servicemen's organizations started. May its good work continue in forming a national group in the not too dim distant future."

E. G. Dennison, President, Monongahela Radio Association, Inc. . . .

"Thanks for a swell magazine and a job well done during the days in which we were disbanded and going our several ways individually. We would be lacking in gratitude indeed if we failed to express our appreciation. . . . Since most Radio Service Dealer associations found it difficult or impossible to remain active during the past chaotic years, their memberships have leaned heavily on RADIO & TELEVISION JOURNAL . . . and the help and trade information which you pack into each issue. . . ."

*No other radio, appliance or service publication reaches as
many association officials and members as*

RADIO & TELEVISION JOURNAL

1270 Sixth Avenue

New York 20, N. Y.

The oldest dealer publication — 1916 to 1946

RECORD RELEASES

We bring you the latest record releases for the summer season.

ARA

Rimsky-Korsakoff's music—From "Fandango", Teddy Lynch

ASCH

- 1001 Impressions—James P. Johnson, piano solo
Boogie Stride
- 1008 Song in My Soul—Coleman Hawkins
This and That
- 500 Girl of My Dreams—Jerry Jerome
Rainbow Blues
- 508 St. Louis Blues—Jerry Jerome
Riff
- 627 Railroad Whistle—Woody Guthrie
Lolly Lo
- 50 Liberation of Paris (English and
French)—Orson Welles
- 53 Private Life of Adam and Eve
(French)
- 5302 Red Army Songs
- 343 Songs by Lead Belly
- 345 Wayfaring Stranger—Burl Ives
- 356 Art Tatum, piano solos
- 364 Richard Dyer-Bennett
- 365 Original Memphis Five
- 400 Traditional Jewish Folk Songs and
Dances
- 410 Frontier Ballads
- 454 Poems by Langston Hughes
- 455 Strictly G.I.
- 600 Strange Fruit—Kenneth Spencer
Beloved Comrade

COLUMBIA

- 36979 Love on a Greyhound Bus—Kay
Kyser & Orchestra with Lcyann Polk
and The Campus Kids

All the Time—From "No Leave, No
Love", Michael Douglas

- 36980 Ashby de la Zooch—Tommy Tucker
Time, vocal chorus by Don Brown
and The Three Two Timers
Pin Marin

- 36901 There's a Palace Down in Dallas—
Happy Perryman and his Happy-Go-
Lucky Mountaineers
Don't Feel Sorry for Me

DECCA

DA-453 What So Proudly We Hail—
Bing Crosby

DA-23579 The Star-Spangled Banner—With
John Scott Trotter & Orchestra,
Max Terr's Mixed Chorus

DA-23580 God Bless America

DA-23581 Ballad for Americans—With Ken
Darby Singers and Decca Con-
cert Orchestra, directed by Vic-
Young

A-467 Fred Waring Music, Cole Porter
songs

23582 Jelly Jelly—Josh White, guitar,
bass and drums
Back Water Blues

DELUXE

Rumba at the Waldorf—Emil
Coleman (Slater's "Time to
Sleep" Album)

DISC

5026 Blue Skies—Mary Lou Williams
Man I Love

5027 These Foolish Things—Mary Lou Wil-
liams
Lonely Moment

2001 Blue for Norman—Jazz at the Phil-
harmonic, Vol. 2

2002 I Can't Get Started—Jazz at the
Philharmonic, Vol. 2

PROCESS

504 Keep Your Hands Up Stranger—The
Beaver Valley Singers
Prairie Gal

20-1885 Somewhere in the Night—From
"Three Little Girls in Blue", Betty
Rhodes

RCA

20-1886 What Has She Got—Betty Rhodes
This is Always
I'd be Lost Without You

20-1878 Doin' What Comes Natur'ly—
From "Annie Get Your Gun",
Freddy Martin & Orchestra with
Glenn Hughes and Martin Men
Blue Champagne

46-001 They Say It's Wonderful — Al
Goodman & Orchestra with Max-
ine
I Got Lost in His Arms

20-1877 Surrender—Perry Como with Russ
Case & Orchestra
More Than You Know

20-1891 No Variety Blues—Louis Armstrong
Whatta Ya Gonna Do

20-1875 You're an Old Lady—Sonnyboy
Williamson, harmonic and instru-
mental accompaniment
Early in the Morning

DM-1050 Bach: Brandenburg Concertos
No. 3 and 4; Prelude in E—Bos-
ton Symphony, Serge Koussevitsky

Album From "Madama Butterfly", Puccini
—Camilla Williams

K-1 From "The Red Mill", Victor Her-
bert—Al Goodman and Orchestra

Album "A Salute to Vincent Youmans"—
Russ Case & Orchestra

11-0224 Where's My Bess—From Gersh-
win's "Porgy and Bess", James
Melton with duo-pianists, David
Saperton and Bert Sheffer
All Through the Day—From "Cen-
tennial Summer"

11-9175 From "La Traviata", Verdi—"Ah!
Dite Alla Giovine" and "Impo-
nete", Licia Albanese and Robert
Merrill, Victor Orchestra, Frieder
Weissman

11-0173 Der Nussbaum—Marian Anderson,
with Franz Rupp at piano
Stille Tranen

DISC HIGH FIDELITY RECORDING...

... with less than 5 per cent
losses . . . sets the national standard for quality
recording. Complete catalog of:

Authentic Folk Music - Jazz - Rare Classics

DISC COMPANY OF AMERICA

117 W. 46th St., New York 19, N. Y.

Official record producers for the Franco-American Cultural Exchange and
for the USSR Alpha Latin American Records

Four Firms Indicted As Condenser 'Trust'

WASHINGTON, July 9.—Attorney General Tom C. Clark today announced the indictment of four New York and New Jersey firms and six individuals on charges of violating the antitrust laws in the production of variable condensers.

The indictment was returned by a Trenton, N. J., federal grand jury. It charged conspiracy to fix prices and monopolize the production and distribution of the devices, which are used in radios for tuning in stations. The alleged practices, according to Assistant Attorney General Wendell Berge, have retarded reconversion in the radio industry and have contributed to the existing shortage of home sets.

Named in the indictment were: General Instrument Corp., Abraham Blumenkrantz, president, and Samuel Cohen, board chairman, all of Elizabeth, N. J.; Radio Condenser Co., Stanley S. Cramer, president, and Russel E. Cramer, vice president, all of Camden, N. J.; Variable Condenser Corp. Charles Hyman, president, and Nathan Hyman, vice president, all of Brooklyn, N. Y.; Condenser Development Corp., Newark, N. J., patent holding company in which Blumenkrantz, Cohen and the two Cramers were officers and directors.

Alexander Heads Motorola Service, Parts Dept.

Tim Alexander, who handled Galvin Mfg. Corporation's wartime government heater contracts and contract terminations, is now managing the new Motorola Service and Parts Department.

He joined Motorola in 1937 as Home Set Service Manager and in 1940 became assistant to Walter Stellher, vice president of Motorola Home Products Division.

His present program calls for a field service group for dealer and distributor assistance and for a television education program. He will also reactivate the over eight thousand Motorola authorized service station group, as well as supervise the publications and parts department.

THE BELL RINGS

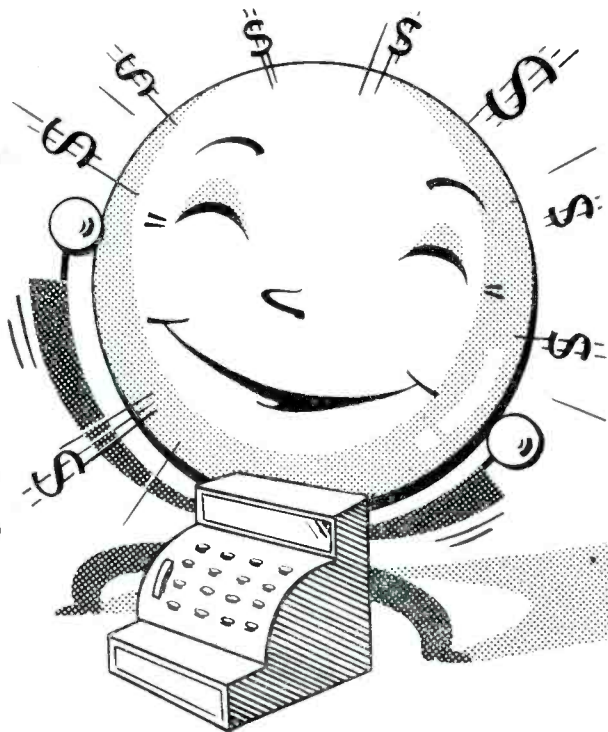

more consistently for merchants who stock

RECORDISC HOME RECORDING BLANKS

Made by . . . backed by . . . the world's largest manufacturer of home recording blanks. And known, admired and desired by thousands of amateur and professional recording enthusiasts.

Bond base, aluminum base and steel base . . . of superior quality . . . at lowest prices. Your Recordisc distributor will gladly show you how a Recordisc Department can be built into a major division of your store.

SEE US AT BOOTH 96
PALMER HOUSE HOTEL
JULY 15-18



THE RECORDISC CORP.

395 BROADWAY, NEW YORK 13, N. Y. • CABLE ADDRESS: RECORDISC, NEW YORK, N. Y.
EXPORT DEPT. ROYAL NATIONAL COMPANY, INC., 89 BROAD STREET, NEW YORK

When residents of Rochester, N. Y., start thinking about a new range or refrigerator—and who isn't these days?—many of them say, "Well, let's go down and see what's on display at the Hoffman Music Shop."

This old, established firm is representative of the many music businesses in the country which have gone into the appliance field and found it profitable. Hoffman's diverged to an appliance line back in 1926, when the youthful radio industry began to loom as a threat to sales of musical instruments and phonographs. When the music business slumped in the early 1930s, this store was firmly enough entrenched in appliance selling, that for several years it went out of the music business entirely.

Today, the old name remains as a reminder of the genesis of the business back in 1911 in a small Joseph Avenue shop. But if the late Samuel J. Hoffman, who founded the firm, were to return today, he would be greeted with a great contrast. Instead of the humble music shop he founded, he would discover the business bearing his name securely established as a combination music-appliance business in new, modern quarters at 468 Goodman Street North. Indirect lighting and modern interior decorating effectively set off the rows of gleaming appliances and the banks of phonograph records in gay albums, converting the store into a merchandising "palace" that would have amazed, delighted, and possibly confused the old music shop proprietor.

Musical merchandise, however, has not been forgotten by the founder's son, Harold Hoffman, present corporation president and

This striking window display of the Hoffman Music Store shows how musical merchandise and appliances can be tastefully combined to develop larger volume for each.



MUSIC STORES CAN

by R. R. McGuire

manager. Musical supplies — chiefly phonograph recordings—now comprise only about 20 per cent of the firm's business, but Mr. Hoffman expects the volume to increase, possibly close to 50 per cent, when musical instruments once again are distributed in quantity.

"Yes, we're still in the music business," said Mr. Hoffman, "but we've found over a 20-year period that the music-appliance combination is a good one and we expect to do business in these combined lines for a long time to come."

Strangely enough, the device that put the Hoffmans into the appliance business, also brought them back to a combination with music after the store had turned exclusively to appliance sales. Mr. Hoffman describes the evolution as follows:

"We saw the music picture beginning to fade when radio came in, and by 1926, our record and instrument sales had begun the decline that eventually took us out of the music business completely.

"Foreseeing this development, we started to look around for other lines to bulwark our business. The appliance line looked

good, and a friend of my father's, who was then a factory representative for the Gain-A-Day Washer, persuaded us to take over a dealership in his product. This we did, and when that item moved successfully, we gradually entered other lines — small appliances, stoves, and finally refrigerators."

By the early 1930's, the inroads of the burgeoning radio industry had virtually killed the record and musical instrument trade, and the Hoffman Music Shop became an appliance store. The name, and the original interest in music, however, were retained and in 1938-39, the firm went back into the music business. Re-entry into music lines resulted chiefly from the new interest in music and in improved recordings stimulated and developed by radio. And the advantage of a combination business was emphasized during the recent war years when the sale of recordings did much to sustain the business in the absence of other musical and appliance merchandise.

In running a combination music-appliance business, the most important precaution to observe is to keep each department separate, Mr. Hoffman has concluded as the result of his experience.

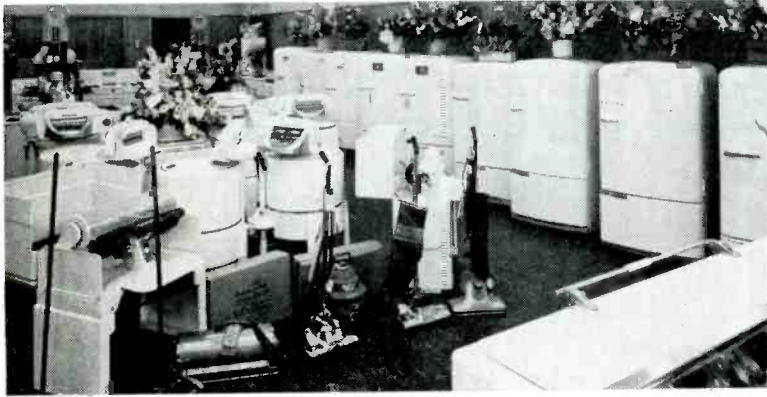

SELL APPLIANCES

"The merchandising of musical supplies and appliances is specialty selling and demands salesmen who are specialists in their line," he said. "You can't develop a successful business by trying to develop jack-of-all-trades who bounce from one department to the other."

Some doubling up has been necessary during the war years, but the basic policy at Hoffman's is to give each department free rein to develop and expand as a separate enterprise, without allowing the friendly rivalry to be disruptive of company harmony and cooperation.

But while the departments are handled as distinct units, it must be remembered that the floor traffic attracted to the store makes *both* departments. Hoffman's has found that its music customers are its appliance customers, and vice versa. And the management has concluded that developing a good floor traffic is one of the secrets to successful operation of either a music store or an appliance store, or a combination of both.

This premise was borne out in the firm's move to its new store. Before the move to the new loca-

tion, a good business had been built up in the old store across the street, which in its present vacant state now looks like a "hole in the wall" in contrast. After the move, it was discovered that the store's floor traffic had increased greatly—probably as much as 1,000 per cent. Unfortunately, the appliances were display models only, and no test could be made of the resultant increase in business. Sales of phonograph recordings, however, are indicative of the end product of this increased floor traffic — this business, always a healthy line at Hoffman's, has doubled since the move.

"If anyone had told me, 24 hours before we moved, that the results would be so gratifying, I would have thought they were crazy," said Mr. Hoffman.

The company endeavors to stock a complete line of appliances and music supplies. In addition, it deals in Parker and Eversharp pens and pencils and a few other small lines which go with the major merchandise.

Standard lines which the firm has been carrying for years include the complete Philco line, Westinghouse Hotpoint, and Kelvinator. Other major lines car-

ried are: Magic Chef, Norge, Quality, Stromberg-Carlson, RCA, Maytag, ABC, Admiral, Mixmaster, Toastmaster, Sunbeam, and others.

One interesting phenomenon of the current appliance merchandising scene is the great customer demand for items they've never even seen, and frequently which the merchandiser himself has never seen. "No one in town had seen the electric garbage disposal unit until the local gas and electric company displayed them in model kitchens recently," explained Mr. Hoffman. "Yet we had inquiries on this appliance three months before the kitchens opened.

"Time was when we could keep up with the new products by advance notices from the manufacturers of the opening of a nation-wide advertising campaign, but that's all changed in these topsy-turvy times. The other day a woman came into the store looking for a popular make range which she said had a full utility shelf. And after 35 years in the business, I had to confess to her that I'd never even heard of it!"

Mr. Hoffman believes that this active interest on the part of the housewife in the new and marvelous appliances of the Atomic Age, combined with new and improved magazines dedicated to home beautification and improvement, augurs heavy and continued demand for the modern appliances for a long time to come.

After his long experience in the appliance field, Mr. Hoffman has concluded that the best merchandising policy for this line is dependable service. "We stand back of everything we sell, and our business has been built up on that policy," he said.

Many regular appliance stores would envy this spacious display which is the appliance half of the Hoffman Music Shop as it appeared on opening recently in a new location.

OUR PRICES REMAIN THE SAME!!

FOR IMMEDIATE DELIVERY!! "TOWN and COUNTRY" ELECTRIC IRON

SCORING A NATION-WIDE SWEEP . . .

ELECTRIC THERMO-BROILER

With Thermostat Indicator

FIRST LIFETIME GUARANTEE IN APPLIANCE HISTORY!



LIST PRICE
(Less Cord)
\$19.57

Includes Excise Tax
O.P.A. Approved

- Complete portable electric unit
- Bakes — Grills — Fries — Broils — Toasts
- High-finish heavy gauge aluminum
- Solid maple handles
- All parts rust-proofed
- All parts removable for easy cleaning
- Heat range 400 to 1000 watts
- Full size — holds whole fowl
- Approved by Board of Fire Underwriters when requested



LIST PRICE
(Less Cord)
\$10.99

Includes Excise Tax
O.P.A. Approved



LIST PRICE
(Less Cord)
\$5.99

Includes Excise Tax
O.P.A. Approved

FOR HOME COUNTRY TRAVEL

It's a little bulldog of an iron! . . . compact enough to tuck into luggage . . . but with husky construction and heating capacity for a whole family's wash! It's the streamlined, compact iron women want — a profitable volume seller you can cash in on.

- Drop forged polished steel sole plate — smooth-ground — chrome plated.
- Detachable handle.
- Hammered finish, highly polished cast aluminum housing.
- Coiled nichrome wire heating element — encased in CORDURITE, a product of wartime research — recognized as today's more perfect insulating material — exclusive with "Thermo" Products.
- Packed in individual carton. Weight 3 lbs. 12 cartons in master carton, weight 37 lbs.
- LIFETIME GUARANTEE! In accordance with certificate furnished with each iron.

Announcing THERMO-MATIC ELECTRIC IRONS

The Fully Automatic Electric Iron with Life-Time Service Guaranteed

Here is the iron that the trade and public have been waiting for . . . features that will make it a leading seller in any market . . . a product that will keep our increased facilities humming to meet the demand.

- ← Approximate weight 3½ pounds.
- ← 7 "heat stations" on the dial.
- ← Can be regulated for nylon, rayon, silk, wool, cotton, linen and off.
- ← Can be shut off without taking plug from wall.
- ← 6-foot U.L. approved attached cord set.
- ← Streamlined plastic handle with thumb rest.
- ← Chrome plated with special alloy sole plate.
- ← Designed with heat break between casing and sole plate.
- ← Air flow control keeps thermal switch at maximum efficiency.
- ← Life-Time service guarantee at \$.35 cost.
- ← Light weight saves 25% ironing time.
- ← Heat range up to 1,000 watts.

Distributors being appointed in all key markets. DEALERS:

Write for name of distributor in your territory.

Watch for Thermo-Matic Toaster and Electrochef Roaster

THERMO-BROILER CO.

23 Flatbush Avenue

Brooklyn 17, N. Y.

(Continued from page 43)

"We gladly refund the purchase price on any item we've sold on which the customer has a justified complaint. In fact, we lean over backwards to recognize complaints, and have recognized claims which we felt strongly had little justification. These expenditures are charged to advertising, and we feel that the resultant good will is worth it."

Repeat customers form the bulwark of this Rochester business as a direct result of this policy. Third generation customers are now coming into the shop, some of whose ancestors were served by Mr. Hoffman when he started working as a boy of nine in his father's store.

The Hoffman Music Shop does not go in for novelty promotion schemes, or "fancy" advertising ventures to attract customers. In addition to its tested policy of standing behind its merchandise and providing modern display facilities and specialist-salesmen, the only promotional activity engaged in at present is regular advertising in the local newspapers, which effectively cover the city and suburban areas. A radio advertising program will be launched when merchandise begins to flow in sufficient quantity.

The sight of merchandise coming in from the manufacturers is one of the main thrills that Mr. Hoffman gets out of the merchandising business these lean and difficult days. After 35 years, he finds some of the other aspects of merchandising rather routine, and, like everyone else, he finds that running a business in these parlous times is a real problem and a headache. In addition to the problem of obtaining articles to sell, he has noted an equally difficult job in satisfying the post-war customer.

"Everybody's got money these days, and they're not happy unless they can spend it," he said. "Consequently they can't under-

stand why many items are available only for display, or they can't understand the simple arithmetic involved in distributing three lonely radios among 200 customers. Actually, I think we've created more ill will than good will in our efforts to be fair about distributing the thin trickle of merchandise we're getting these days. And, what's worse, there's absolutely nothing we can do about it."

"Of course," he added, "we're not expecting to do much this year, so we won't be too disappointed. However, we're not returning to the old war-time policy of buying up a lot of junk just to have something to sell and keep our personnel busy. We're not putting any junk in our new store—we'd rather strip our display space bare first."

An important feature of the Hoffman shop is its service de-

partment. "I wouldn't attempt to run an appliance store without an adequate service department," said Mr. Hoffman.

This department consists of three all-around mechanics, a shop in the basement of the store, and one service truck. At present, the unit handles the installations and provides the servicing for the appliances, phonographs and radios sold by the company. Very little outside work is handled. "We don't turn down any business that comes in, but we don't go out after it," explained the service manager, "We have enough servicing of our own, and it's still difficult to get adequate parts and replacement units."

The service department has always shown a profit, even without the aid of much outside work. Its work is largely responsible for insuring the firm's basic policy of satisfactory service.

NOT MERELY AS GOOD AS THE OTHERS ... BUT BETTER THAN ALL OTHERS!

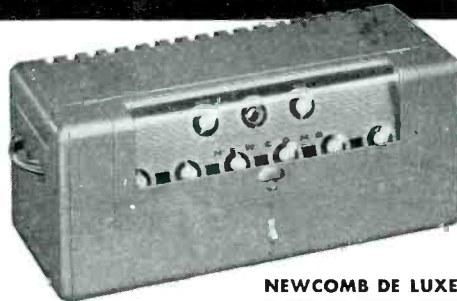

NEWCOMB DE LUXE
K-SERIES AMPLIFIER

SIMPLIFIED ... CONTROLLED OPERATION
... The Newcomb clear-view, plastic keylock control panel cover prevents unauthorized misadjustments. An expert may adjust controls and lock them in. An outside power switch turns system on and off. No curious "dial-twister" can disturb its operation.

THE KEYLOCK cover is another of the many features that make the name Newcomb outstanding in the sound equipment field. Designed for the postwar quality market, Newcomb amplifiers are unexcelled in the true reproduction of music and voice. *Without reservation...* Newcomb sound equipment will give finer, longer, more trouble-free service than any other system on the market today. Write for information.

T H E S O U N D O F Q U A L I T Y

Newcomb

AUDIO PRODUCTS CO.

MANUFACTURERS

DEPT. H 2815 S. HILL STREET, LOS ANGELES 7, CALIFORNIA

FADA

The
RADIO
of
TO-MORROW
TO-DAY!



1000 SERIES
6 TUBES



652 SERIES
6 TUBES

TOPS

- **IN BEAUTY**
- **IN DURABILITY**

Yes . . . "Tops" is the word for FADA. The FADA line of radios, brilliantly designed for beauty of appearance and precision made for beauty of tone, emphasizes the accuracy of our slogan, "The Radio of Tomorrow . . . Today."

And, back of the unmatched consumer acceptance of FADA's "radios of tomorrow" is the amazing durability of the FADA radio of yesterday. In every town and every city in the land there are FADA radios in everyday use . . . radios that have given ten, fifteen or twenty years of brilliant service.

Small wonder that these hundreds of thousands of satisfied users look forward to getting one of the new FADA receivers, equipped with Sensitive-Tone for finer, clearer reception.

Small wonder that FADA good-will, augmented year after year since broadcasting began, is your assurance of rapid, continuous sale of FADA radios for many years to come!



FADA 6 tube models are equipped with the new FADA "Sensitive-Tone" . . . assuring greater sensitivity and clearer reception.

PLACE YOUR FAITH IN

FADA Radio

Famous Since Broadcasting Began!

FADA RADIO AND ELECTRIC COMPANY, INC., LONG ISLAND CITY, N. Y.

electric APPLIANCE JOURNAL



The Cover

This youngster is safe from burns, since her mother has installed a PRESTELINE electric range. The cooking units are in a row across the back of the range out of reach and out of danger. PRESTELINE ranges are a product of the Pressed Steel Car Company, Inc.

JULY

1946



APPLIANCE CENTER *SPOTLIGHTS* RADIOS

by

Ethel Corbitt Pitkin

Radios occupy a prominent place in the new Appliance Center recently opened by Bannon's department store, Saint Paul, Minnesota, the first completed unit of the store's large expansion program.

The new Appliance Center is adjacent to the main Bannon store and accessible to it through a spacious archway. A main street entrance leads directly to the Center, which is original in design and which is unusual in layout, lighting and color schemes.

To obtain maximum display for merchandise, the front was replaced entirely by glass, even to the doors, which invite passers-by in for closer examination of the merchandise displayed.

Curtain walls, indirect lighting, and a color scheme which combines varied harmonious colors and contrasting sections are vitally effective in setting off the merchandise. The color backgrounds make each group of appliances stand out from the others in their own setting.

Here's how one appliance store has turned the spotlight on radios . . . despite the current shortage of sets. Clever display, and modern layouts have made radios the feature attraction of the Appliance Center, opened by Bannon's Department Store, St. Paul.

Merchandise can be spotted with lights as well as illuminated by lighting along the edge of the wall above the displays, concealed by the curtain effect wall-construction.

Banks of appliances are displayed along the sides of the selling floor, and special display nooks are arranged. There is a center group of unique display units which hold small appliances, down the middle of the room.

Samples of many makes of radios the store will handle are assembled at the front of the store, on one of the blonde-finished, chrome edged, circular-end display units which add to the streamlined effect of the new Center. Other samples are shown at the front of the store on a group of modernistic shelves built with a wall background. It is also, one of the first groups of merchandise to meet the eye.

The main radio department, however, is in the downstairs store, reached by broad winding stairs at the rear of the street floor. The same type of decoration and lighting are carried out here as on the street floor, although even greater brightness of color is used because the down-stairs section lacks the glass front of the upstairs section. Sunshine yellow, soldier blue, rust in the background of the shelves is used.

"Color and lighting", said Mr. R. T. Denning, manager of the Appliance Center, "are the two factors which create in the customer a receptive mood. They are both excellent salesmen. We have taken advantage of modern research in both of these helps for salesmanship and feel that, so

far as setting goes, we are ready for the post war trade in our lines."

Fluted glass walls add to the attractiveness of the department and give it distinction. These are used at the foot of the stairway, and again to form partitions to the listening booths in the modern record department at the front of the downstairs store.

The cost of remodeling the new Appliance Center approximated \$60,000. Its opening was attended by thousands of persons, including the Governor of the state, Ed. Thye, who gave a talk and cut the cord which held the large glass doors, to signal the opening. A loud speaker carried the ceremonies up and down Seventh street, one of the principal business streets of the city. There was a fifteen minute program in front of the store. Many specially invited guests were present.

During the building period, Bannon's centered advertising on this new project, while calling attention also to the complete new expansion program of the store in all departments. Large advertisements showed the exterior of the building as it was planned. In addition, huge signs on the front boarding that was necessary during the remodeling called attention to what was going on and told what the store was to house.

Such consistent advertising had its effect in pulling people to the store as soon as it was completed. The finished product lives up so well to what was advertised that already business is remarkable, held back only by restriction in amounts of merchandise available.

The main radio department of the new Center is located in the downstairs department of the store where decorations are carried out in blonde-finish, chrome edging, and colorings running to "sunshine" yellow and other bright shades, forming a light background against which radios are accentuated. Fluted glass walls add to the attractiveness of the department and give it distinction. These are used at the foot of the stairway, and again to form partitions to the listening booths in the modern record department at the front of the downstairs store.

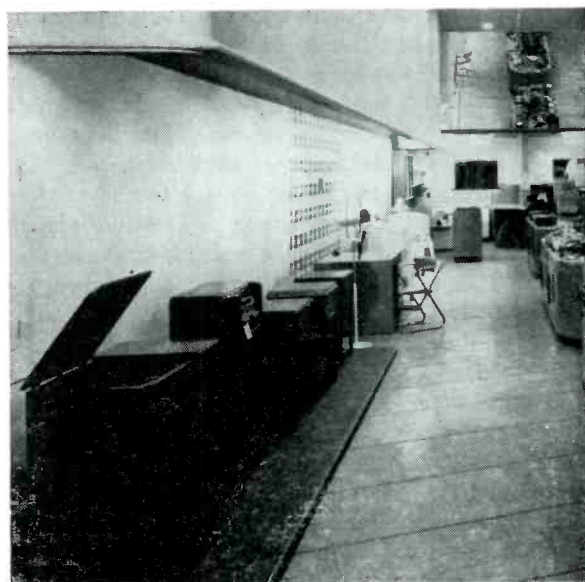

OVER THE TOP



On Opening Day!

With the keyword, "Everything Electrical", for his guiding motto, Kenneth C. Spitzer, who has been associated with the electrical business since 1922 and the field of radio since 1919, opened the doors of one of Atlantic City's most modern radio and electrical appliance stores.

On April 11, the people residing at the popular resort city were officially welcomed into the modern brick and concrete fireproof store containing 5200 square feet, of which 3200 square feet is used for show-room space. Show space, so carefully planned and utilized, that it can be said with justification that not an inch of available floor is neglected.

Being located in the center of a city known as the "World's Playground" and being simultaneously noted as a haven for conventioners from all sections of the country, Mr. Spitzer realized from the outset when plans for the store were being formulated, that if his enterprise was to be a success, he must live up to the name foisted upon the resort city by America's cross-section of people. He vowed to make his establishment a place where the public would find it a pleasure to buy. A showplace is

what he planned and a showplace is the result.

Upon entering the store through spacious glass doors, the customer is instantly aware of the methodical order of merchandise on display. Working samples of hard-to-get table top portable ironers, electric clothes dryers, washing machines, refrigerators and deep freezers along with imitation mantels, vacuum cleaners and floor lamps are plugged into myriads of floor sockets to assure instantaneous working demonstrations.

It was noted on opening day that the relative spaciousness of the Spitzer Store proved awe-inspiring to many who had been used to entering old-type outmoded appliance stores with a hodge-podge of merchandise in disarray.

"What the American consumer has been reading about in electrical appliances during the war years, we intend to give them in this post-war era," said Mr. Spitzer. "It is tiresome for the customer as well as for the dealer to always be gazing at ads and catalogues with a wistful eye and being informed that the product desired is not yet available. A glance at production statistics will prove with a

note of encouragement that manufacturing is now underway and should soon hit full stride. I tell the customer sincerely that the longest an order should take to be filled is ten weeks."

Featuring the complete line of Hotpoint appliances, the vast showroom is full of ranges, hot water heaters, sinks, dishwashers, disposal units as well as irons, toasters, clocks, bottle warmers, roasters and numerous other items which the home maker craves today. Outright sales are being transacted for most items displayed, but some scarcer appliances must still be ordered to be delivered when manufacture permits their availability.

This phase of today's selling too, has been handled with finesse by Mr. Spitzer, who declared: "Consumer's orders will be filled on a numerical system so as to insure fairness to all who buy. The policy of 'First come, first served', will be the prevailing one, for not only does a method of this type simplify bookkeeping and office work, but it serves the dual purpose of building up public confidence and morale."

With an instinctive grasp of modern selling methods coupled with foresight regarding the electrical world's future, Mr. Spitzer initiated in his place of business what is claimed to be the first such lighting installation in an Atlantic Avenue store. It is the new Cold Cathode lighting of the tubular variety, designed and installed by K.C. Spitzer and his staff of electricians. The cathodes, arranged around the ceiling in such a manner as to permit no irksome dark corners or shadowed floor space, represent an outstanding bit of useful advertising in themselves. Walls, painted a bright hue, add to the attractiveness of the interior and tend to facilitate eye comfort. The new cathode lighting was also used in the outside sign, which was also designed

by Mr. Spitzer, and constructed by a local sign company.

He started planning his new store shortly after V-J day, following his service of more than 3½ years as a civilian employe of the War Department. During the height of the war he served one year as radar and electronics instructor at Camp Evans, Bellmawr, N. J. where radar contact with the moon made recent history.

To announce the grand opening of the new store, Mr. Spitzer had placed in the local paper the day preceding opening, a full two-page spread carrying welcomes and well wishes of companies and contractors who had worked on the new business site, along with the congratulation of well known city merchants. Beside these felicitations were cuts of the new store, pictures of model kitchens and laundry rooms, and a full list of appliances to be stocked by the store. "The clincher," as Mr. Spitzer smilingly phrased it, "was the insertion of an 'opening special' ad, offering to the first 150 customers on opening day, the much sought-after Liberty door chimes. Complete with transformer, they were sold for \$4.95 ready to be installed. The regular list price was \$7.00 and they went like the proverbial 'hot-cakes'."

Future plans now being formulated call for the construction of two fully equipped model kitchens and one laundry room against the rear wall of the store. The models will be planned to varying degrees of equipment and will be priced systematically to fit the pocketbooks of all.

In the rear of the building, which overall has a frontage of 44 feet along the resort's main and famous Atlantic Avenue, running 100 feet back along Fleming avenue, a fully equipped service

(Continued on page 52)

●

This over-all view of Spitzer's store shows the careful arrangement of appliances that leaves plenty of room for customer inspection. Heavier appliances are placed along the walls, while traffic items are isolated in the center of the floor.

Such items are easily accessible from all sides, making it possible for a great number of customers to view them simultaneously. The entire effect is light and airy, and is well stocked without being crowded or confused.

●



department is maintained and staffed by trained, competent experts in the electrical and radio fields. Work, such as electrical contracting and installation of cold cathode lighting in local industrial and commercial establishments will be assured good results, for to further re-enforce the manufacturers' guarantee on all electrical and radio merchandise, a well equipped service department will stand behind all equipment and products sold. Mr. Spitzer, himself, supervises all service and construction work.

Radio work and radio improvement having always been a favorite interest to Kenneth Spitzer; his store is well stocked with radios of all major makes with standard and FM range, while television sets will be placed on the floor as soon as they start to flow from the production lines.

When that first influx of customers and prospective consumers began the morning of April 11, Mr. Spitzer was on hand to extend his personal greetings, and to guide them through the maze of appliances on display. The intricacies of some war-born electrical appliances warranted explanation, and if the opening day's receipts can be judged as an indicative barometer of the future, then the Modern electrical appliance store of Kenneth C. Spitzer is destined toward post-war success.

25 YEARS AGO

(Continued from page 7)

The Stewart Talking Machine Company of Indianapolis offered free tinted photographs of McCormack as record selling aids. Their stock also included well known artists such as Gallicurci, Kreisler and Schumann-Heink. Dealers were urged to send immediately for these portraits, while the supply lasted.

* * *

One dealer writes to the Answer Man, H. E. Speare: "I'm rearranging my store this summer. Would it be best to have the record sales counter in the very front of the store, or to have a small reception lobby there where instruments could be shown, and put the record counter back among the booths?" Mr. Speare replied: "Have your record counter as near the door as you possibly can. It has been proven conclusively that quick service and accessibility to the street will sell records. Do not under any circumstances put your record department back out of sight."

* * *

Glad Henderson's editorial comments: "About 500 new talking machine dealers have entered business within the past six months. True, this is not as many as last year, but the character of houses going into the field makes us believe that this group of dealers represents nearly twice as much value as a permanent asset to the industry. This proves that the industry is in much better shape than we imagine, and that the live dealer will always succeed no matter when he opens, or where."

* * *

Fact that the Government had asked a talking machine company to pay "close to \$75,000 additional taxes for the year 1917" was viewed as "unfair" by the Journal, and it was suggested that a "law might be passed giving the Government one year to check up reports, so that everyone would know his tax to be right."

* * *

And finally, editorially, merchants and manufacturers were requested to attend "every convention and outing that you can this summer. Conventions," it was advised, "are often exchange stations for getting new trains of thought and ideas on business. Going to a convention is like going to school for a couple of days and getting polished for the fall season—which is bound to be big."

RADIO & TELEVISION JOURNAL, JULY, 1946

THE SLATE RECORD PLAYER

- 100/120 volts A.C., 60 cycle, 78-79 RPM
- Shure Crystal Pickup, Type P-93, 3/4 oz. Needle Pressure Pickup Response—30-10,000 CPS
- Precious Point Needle, 10,000 play
- One-piece drawn aluminum Case, Hammered Brown Lacquer finish
- On-Off Power Switch (mounted in base)

The use of aluminum and plastics (turntable) prevents any setting-up of magnetic fields to affect the operation of the player which is entirely hum-free.

Overall Dimension: 12" x 10" x 3 3/4". Weight: 6 lb. (packed).



List Price
\$17.95

Dealers
Net Price \$11.58
Incl. Fed. Exc. Tax.

APPROVED SIGNAL GENERATOR

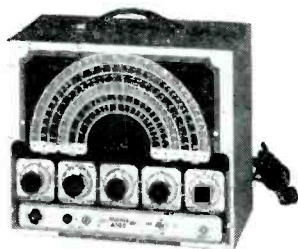

Model A-100

6 RF BANDS
100 to 310 Kc
320 to 1000 Kc
1000 to 3200 Kc
3.2 to 10.5 Mc
10.5 to 26 Mc
21 to 52 Mc

440 Standard Audio Frequency (same as WWV)
Internal modulation at 440 cycles (same as WWV).
External modulation possible from 40-30,000 cycles.

\$47.00 Net

POCKET SIZE VOLT-OHM MILLIAMETER

An Approved Electronic Instrument
DC Volts: 15-150-300-1500. AC Volts: 15-150-1500. Milliamperes: 1.5-15-150. DC Resistance: 3000-300,000 ohms. Net \$18.75

We will ship pre-paid if cash is remitted with order. 20 per cent deposit with order balance C.O.D.

SLATE & COMPANY

2553 WEBSTER AVE. Dept. J NEW YORK 58, N. Y.

Watch "FAVORITE" for the FAVORITES!



No. 1476

MUSIC BOX CAROUSEL

A "sweetheart" of an item. Any child will love this delightful gift. Turns like a real carousel as it plays music. Beautifully lithographed cut-outs of children on horses—a colorful, musical practical toy. Size: Base 10½" diam., 12½" high.

LIST PRICE \$16.25

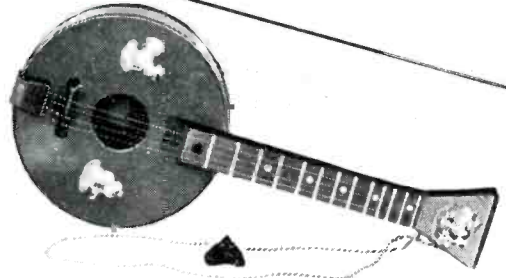

No. 1470 TOY BANJO

Popular kiddie instrument. All metal, including 4 strings and pick. Individually boxed. Size: 14" long; 6½" wide.

LIST PRICE \$1.10



No. 900 METAL MUSIC POWDER BOXES

Lovely spun aluminum box. Includes powder puff.

LIST PRICE \$7.95

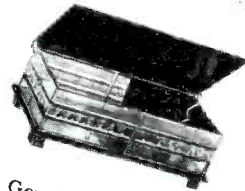

No. 1456 MUSIC BOX

Gorgeous! Genuine Lucite throughout. Rich looking. Smart for cigarettes and jewelry. Black colored top and legs. Amber hand-embossed sides 8" x 4" x 2¾".

LIST PRICE \$14.95

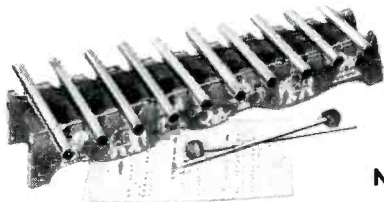

No. 1436

XYLOPHONE

Fast-selling musical toy. 10 musical bars perfectly tuned. Includes song sheets and pair of mallets.

LIST PRICE \$3.35

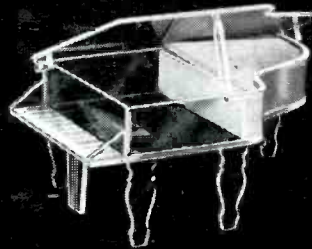

No. 1406

CLEAR LUCITE PIANO

Popular item! Ideal for cigarettes or jewelry. Lovely ornament.

LIST PRICE \$13.95

YOU'LL FIND IT AT "FAVORITE"

Favorite features a full line of record changers, phonographs, recording blanks, electric motors and pick ups, record albums, record cases, record cabinets and main springs—tone arms and reproducers. Also a complete line of phonograph needles, recording accessories, microphones and music boxes and replacement parts for most all makes of phonograph motors.

- New lines at Favorite
- Asch-Stimson, Kismet and Verne Records
- Steelman Electric Phonograph

No. 1423-12 12-KEY WOOD PIANO

Sturdy, educational toy. Has colorful whimsical decal decoration on top.

LIST PRICE \$3.35

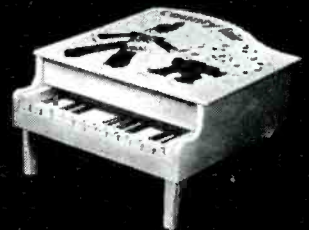

DON'T MISS OUR BOOTHS — Nos. 31, 62, 63 — AT THE CONVENTION

Mr. M. Reese will be in charge with six assistants. Drop over—for a pleasant "get-together." We'll be seeing you.

ESTABLISHED 1913

Telephone
GRamercy 7-6969

The Favorite Mfg. Co.

MANUFACTURERS AND DISTRIBUTORS

105-107 East 12th St., New York 3, N. Y.

Cable Address
FAVOGRAM

Amphenol

provides the link in

AM

FM

TV

A complete range of electronic components to serve the entire range of frequencies in use today.



- As the emphasis in communications development shifts more and more to the higher frequencies — notably FM and Television — the electrical circuits and the component parts involved require ever greater accuracy in performance. Amphenol engineers have always worked to help push forward the frontiers of the science of electronics — the unrivalled production facilities of Amphenol have supplied the quality components required by new developments in this field.
- Among the newest Amphenol products that will be of interest to amateurs and to manufacturers of elec-

tronic equipment are: electrically better Hi-Q tube sockets, octal angle sockets for cathode ray and other tubes — Twin-Lead parallel transmission line — several FM receiving antennas — new cables, including some special ones for Television color cameras and for Facsimile work. Write for complete information.

AMERICAN PHENOLIC CORPORATION

CHICAGO 50, ILLINOIS

In Canada • Amphenol Limited • Toronto



AMPHENOL

COAXIAL CABLES AND CONNECTORS • INDUSTRIAL CONNECTORS, FITTINGS AND CONDUIT • ANTENNAS • RADIO COMPONENTS • PLASTICS FOR ELECTRONICS

PARTS ON PARADE

Apex Washer

An automatic washing machine with an entirely new cleansing action has been announced by The Apex Electrical Manufacturing Company, 1070 E. 152nd St., Cleveland, Ohio.

The Apex automatic employs what best can be described as a "bouncing basket" for completely cleansing clothes through a 4 cycle



process of washing, rinsing, drying and fluffing, in place of either the cylinder or agitator type of action used in other washing machines.

The clothes are inserted through a top opening into a perforated aluminum and magnesium basket, which is equipped with a series of smooth, rounded baffles. When the machine is in the washing phase of the cleansing cycle, the basket bounces vigorously but does not revolve.

New Alarm

The E. Ingraham Company of Bristol, Connecticut, are now producing a "1-2-3 alarm" which rings one, two, and three soft-toned bell sequences until shut off.

This Lyric, Model SA-14 Electric Alarm is the first number in the new Sentinel line of clocks and watches produced by Ingraham. It is 4¼ inches high, with die-



cast silver plated case and silver finished dial with legible black numerals. It is self-starting, and the motor is completely sealed in oil, assuring a silent clock of long life. Modern and beautiful in design, Lyric fits in perfectly with any bedroom interior.

Shaver Booster



Plans for the manufacture and marketing of a new invention said to greatly increase the efficiency of an electric shaver have been announced by Edward J. Scheribel & Company, of Minneapolis.

Invented by Charles Zipper, of Minneapolis, the device has been

named the Zipper Power Booster. According to its inventor, the Zipper Power Booster plugs into the usual power outlet and the shaver, in turn, is plugged into the Zipper Power Booster.

Designed to retail at \$6.50.

Astor Stove

The stove presented by Astor is spun glass insulated to prevent charring and burning of the cord. The ceiling price is \$4.45 and the stove unit measures ten inches in



diameter. It operates on 660 watts AC, DC. The stove too is made of spun aluminum which is guaranteed not to rust or peel. Astor is a trade name for Union Products Manufacturing Company, 35 Park Place, New York.

Console Ironer

The console ironer, model 147, manufactured by the Horton Manufacturing Company, 731 Osage Street, Fort Wayne, is advertised as completely new in every way. It unfolds to the correct height, which means comfort in operation. Due to its higher, steadier heat, it insures speedier ironing. A single feathertouch control lever starts, stops and presses. Many special features are incorporated: large 26 inch roll, full 6 inch diameter, both ends open, twin thermostatic dials, pilot light, two end tables, an accessible central emergency safety release, permanent lubrication, and hermetically sealed motor. The ironer has long, graceful

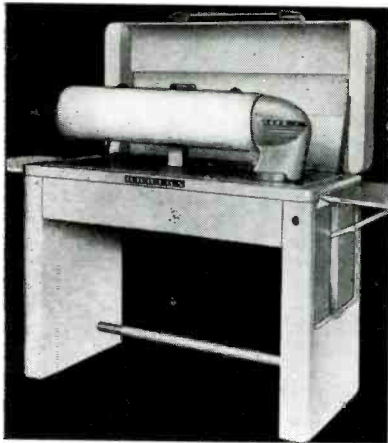

lines, and is covered with white enamel.

Family Size Pasteurizer

The Guard-It Manufacturing Co., Chicago, has just announced a "family-size" home milk pasteurizer with 2-gallon capacity and electrical heating and agitation. It will be sold through established dealers and jobbers on a nationwide basis.

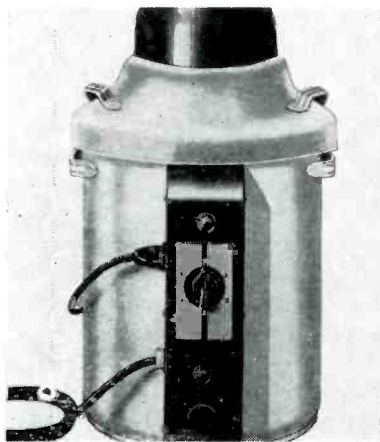

The Guard-It Home Pasteurizer is designed to meet this need. It sells for about \$45; operates electrically from an ordinary 60-cycle, 110-volt line; provides automatic timing and temperature control and uniform heating features comparable to commercial units. It conforms to U. S. Public Health Service requirements for proper pasteurization. The unit is marketed as the Safeguard Home Milk Pasteurizer.

Water Heater

An extremely wide range of possible applications in homes, cottages, service stations, professional offices, beauty shops, etc., is claimed for a new line of small-capacity automatic electric water heaters being marketed by Modohome Products, Inc., of Bourbon, Indiana. The units are made of stainless steel throughout and are furnished in three sizes with capacities of 3, 5 and 7½ gallons; the smaller size retailing for \$44.50 plus Tax and the larger heaters for \$49.50 (Tax \$2.97) and \$59.50 (plus Tax of \$3.57) respectively. According to the



manufacturer, users have found the capacities of the heaters adequate because of their unusually quick heat-recovery and high heat-retention of the tanks. Stainless steel eliminates the possibility of rust or corrosion and adds to the life of the heater. All the units operate on 110-115 v. alternating current, and are available for immediate shipment. They are easily installed with standard pipe fittings, and fit in small spaces under cabinet sinks, lavatories, on shelves, etc.

• **Ted McElroy**
 World's Largest Manufacturer of
 Wireless Telegraphic Apparatus
 COMPLETE CENTRAL OFFICE EQUIPMENT
McElroy Manufacturing Corp.
 82 Brookline Avenue • Boston, Massachusetts

Electric Heater

The Astor Line also features an electric heater, the only one with the safety lock of engaging teeth that holds with a bulldog grip and cannot slip. It has a nine inch cord attachment. The ceiling price is \$8.95. Size 19½ inches high, 14½ inch diameter bowl. It operates on 1,000 watt on AC or DC current. Immediate delivery is guaranteed on the heaters.

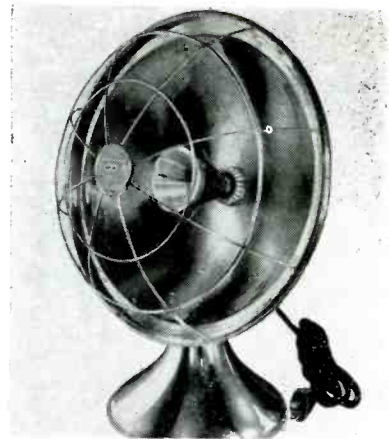

Radio Manufacturers

Established exporter with pre-war connections in foreign countries will handle your exports. Cash payments in New York. Will develop regular sales for 1 and 2 band sets.

Box 58

WANTED

MANUFACTURERS: What electrical appliances and specialties have you for the home, and for gifts? Can you make deliveries promptly? Aggressive sales organization is equipped to give you QUICK national distribution plus profitable export business. Well-financed, excellent trade references.

MAUFAR, Inc.

303 West 42nd Street
 New York 18, N. Y.

Master Servicing

A SECTION OF RADIO & TELEVISION JOURNAL

In This Issue

Function and Alignment
of F.M. Limiter
and Discriminator

The Question Box

Radio & Electric
Appliance
Associations
Directory

JULY
1946

New Home of Masco

Thanks to your cooperation we are now installed in our newly erected and completely modern building where we will be able to serve you with ever better models and increased production.

Please send all correspondence to us at our new address...

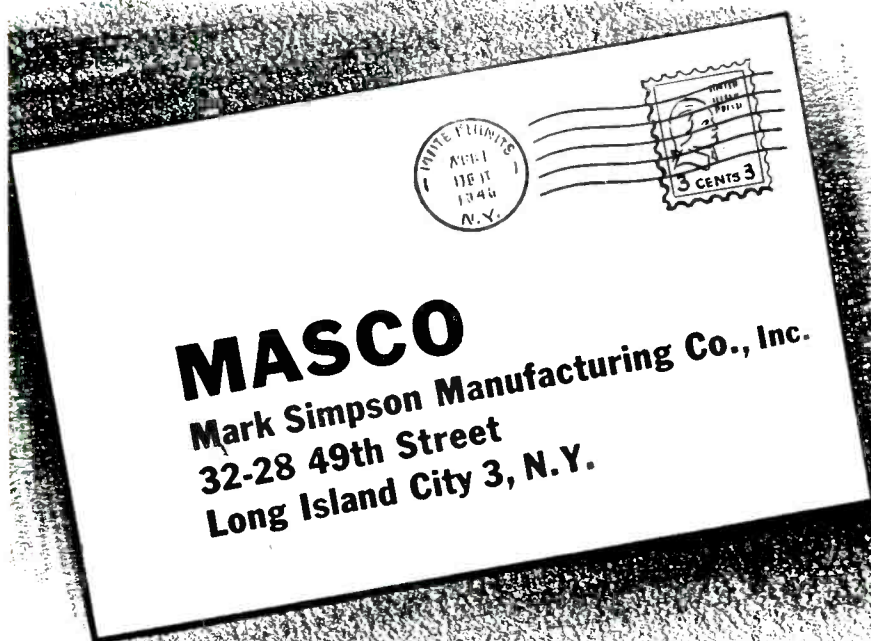

Consideration of Frequency Modulation broadcasting systems shows that the problem of modulation is greatly simplified. The circuits for phase modulation, deviation increase, are on the whole more stable and the overall transmitting equipment is less complicated than that necessary for Amplitude Modulation.

Consideration of the F-M receiver, however, shows that the reverse is true. Although, as we shall see, frequency-modulation signals may be brought in by receivers of the ordinary superhet, super-regenerative and T.R.F. design, under certain conditions, — to reap the full benefits of F-M transmission, the receiver must be specially constructed in the following respects:

The higher operating frequencies of F-M (from 88 to 108 megacycles) necessitate concomitant changes in the radio-frequency, mixer and intermediate-frequency circuits.

These circuits must be designed to accept a wider bandwidth for optimum sensitivity. The inclusion of special loudspeakers for the higher audio frequencies is not uncommon.

The incorporation of a "limiter" device to erase all noise and interference modulation from the constant-amplitude carrier before it arrives at the detector.

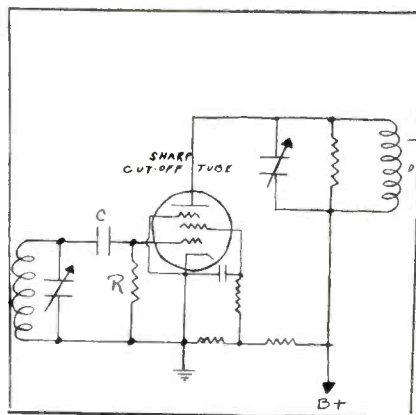

Figure 1. Typical F-M limited circuit. R, grid leak resistor, is usually about 50,000 to 200,000 ohms. C, grid leak condenser, is between 30 to 60 mmfd.

Function and Alignment of F. M. Limiter and Discriminator

This exclusive, accurate and authoritative exposition of the function and alignment of F-M limiter and discriminator is so important that we feel you will want to file it for future reference.

by Iz Zam

The incorporation of a "frequency-change detector" instead of the familiar "amplitude-change detector,"—the so-called discriminator or slope filter, which converts frequency variations into amplitude variations.

The above-mentioned factors account for the F-M receiver being more critical than the A-M. Specifically, it is the heterodyne oscillator and the discriminator circuits that are the most critical and that call for special care in the alignment procedure.

As has been mentioned above, the action of the limiter is to ensure the elimination of any possible variation in the F-M signal before it reaches the discriminator. The limiter tube is operated as an I-F stage, with proper limiting action dependent upon the correct selection of values for the plate and screen-grid voltages and for the grid leak resistor and capacitor. The latter behave as in the conventional detector; since there exists no cathode bias for

the stage, the positive half of each input cycle will cause grid current of flow, which in turn builds up a bias voltage across the grid resistor and thus reduces the plate current. The absence of an R-F bypass capacitor in the plate circuit will cause the waveform of the input voltage to appear in the output.

The plate and screen-grid voltages are selected to be on the low order of 45 to 75 volts (and sometimes 10 to 30 volts), in order to limit the peak value to which the developed signal in the plate circuit can rise: up to a pre-determined value of input signal voltage, the limiter's output will increase with an increase in signal amplitude; but once the input signal exceeds that value, the tube becomes overloaded, and the output from the plate circuit will remain constant. Thus, for satisfactory operation, the strength of the input voltages to the limiter must always be great enough to saturate the tube so that the tops and bot-

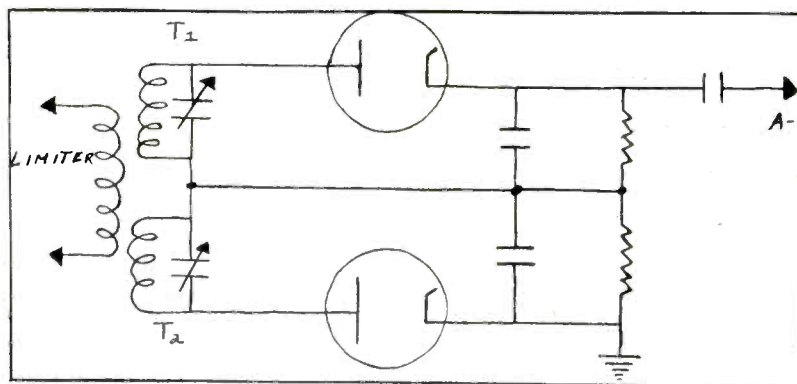

Figure 2. The Travis discriminator. Each "tank" is peaked to one of the two end frequencies of the I.F. pass-band.

toms of the waves will be clipped off.

Conventional values for the grid resistor range from 0.25 to 1 megohm; and the capacitor is rather small, usually in the neighborhood of .0001 microfarads. The use of small time constants tends to enhance the reduction of noise modulation, but when the input voltage to the limiter is high, small time constants also act objectionably against the constant output characteristic of the limiter. The use of larger time constants tends to make for better regulation, but then noise crashes can attain objectionable greater influence over the input signal. The design of single-stage limiters is always a compromise between the two methods. (See Fig. 1.)

The Discriminator

A basic form of circuit which can be employed to convert frequency variations to amplitude variations is the single "off-tuned" resonant circuit. The primary tank circuit is broadly tuned to the carrier frequency; the secondary tank has a sharper resonance curve and is deliberately mis-tuned to one side of its curve (see Figs. 2 and 3), the point of mis-tuning being the "operating point." Thus, a frequency deviation above that point will cause an increase in current in the secondary tank, and a deviation below that point will cause a corresponding decrease in current. The secondary tank voltage is applied across a standard amplitude-modulation type of detector, and the output of the detector will vary in accordance with the modulation—the amplitude of the variation will be proportional to the deviation of the signal, and the rate of the variation will be equal to the modulation frequency. (This explains how the conventional A-M receiver may sometimes bring in F-M signals.)

Only a small part of the resonance curve is linear so that, when this principle of demodulation is used, it is common to find the

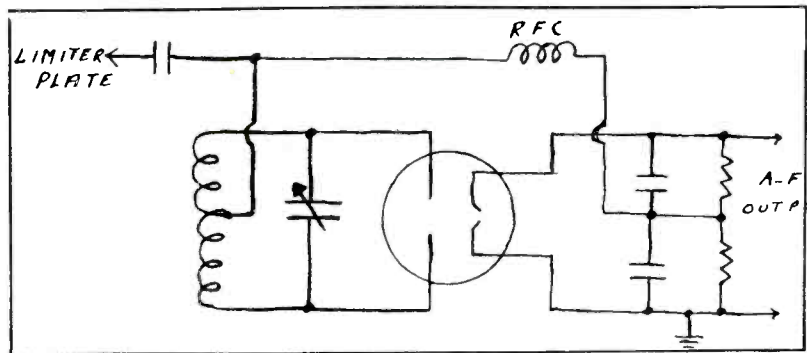

Figure 6. The Foster-Seeley discriminator.

presence of another secondary tank circuit, which has its resonant and "operating point" frequencies on the other side of the carrier. This is the Travis discriminator (Figs. 3, 4 and 5). Considering the transmitter deviation to be 75 KC either side of the carrier resting frequency, the resonant frequencies of the Travis tuned secondaries are spaced slightly more than 75 KC apart. Connected so that their output voltages are additive algebraically, the two secondaries produce a voltage variation that is about twice that of a single "off-tuned" resonant circuit. The two-diode circuit arrangement is called a differential rectifier. When the non-modulation I-F carrier is presented to this circuit, the voltages developed across each of the resistors are equal and opposite, and the resultant sum is zero voltage. When the modulated carrier is received, — the signal is varying above and below the I-F mid-frequency—then the individual voltages across each resistor become unequal, and the resultant voltage across the two series resistors is one which is equal to the difference between the two individual voltages, and which has the polarity of the larger individual voltage. The curve showing the relationship between discriminator voltage output and frequency is Fig. 5.

The Foster-Seeley Discriminator

The greater cost of, and number of adjustments for, three tuned circuits for a discriminator prompted engineers to seek another demodulation principle. The Foster-Seeley circuit, using two

(Continued on page 62)

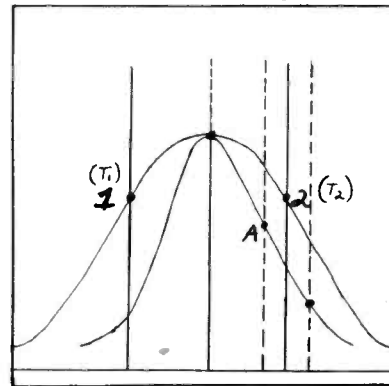

Figure 5. "A" shows the operating point for the single off-tuned circuit. "1" and "2" show the operating points for the Travis circuit, and when added together, they give rise to the "S" curve of Figure 5.

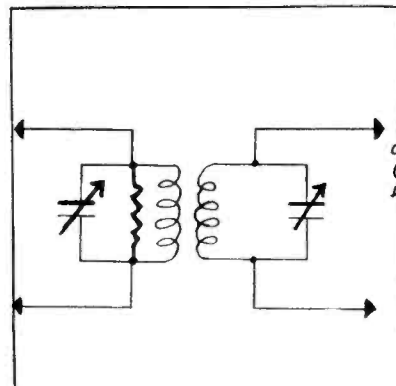

Figure 4. A single "off-tuned" resonant circuit. The primary tank is broadly tuned to the I-F carrier. The secondary is sharply tuned.

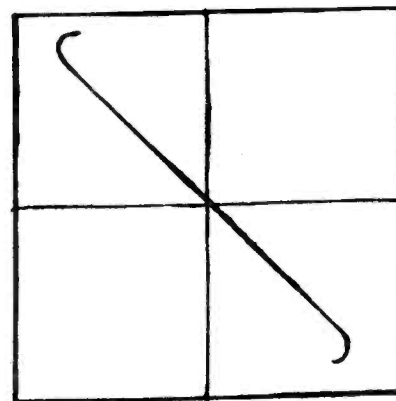

Figure 3. Discriminator voltage versus frequency.

Raytheon ANNOUNCES



JUST OFF THE PRESS!

The most complete, most carefully-indexed, most usable and informative catalog of war surplus electronic equipment yet offered! Describes more than 5000 items, with specifications and PRICES. . . .

**SEND FOR
CATALOG
TODAY!**

... A READY SUPPLY OF ELECTRONIC EQUIPMENT and COMPONENT PARTS

available for immediate delivery
to wholesalers, retailers and manufacturers

Here is merchandise you need. Electronic merchandise you can sell at a profit, with or without further processing. And there's plenty of it! Enough to "plug the gap" until your normal sources of supply can replenish your shelves and stockrooms.



Excellence in Electronics

It's Army and Navy gear—now being returned to the regular channels of trade by the War Assets Administrator. Acting as agent, Raytheon has a plentiful supply for you—together with a carefully indexed, easy-to-choose-from catalog that's literally bursting with news about the kind of goods you *want, need, and can obtain* right away. *Send for this catalog*—it means business for you. Good business, ready business, profitable business.

Most of the equipment is in the communications field—but there are large supplies of components too, electrical and electronic parts that you and your customers can

find immediate use for. It's all in the catalog—carefully described—priced—easy to find and easy to order. And of course it's all top-quality equipment, made to Government specifications by America's finest electronic manufacturers.

You'll be missing a bet if you don't take immediate advantage of this opportunity to *sell merchandise at a profit*. The market is hungry for this equipment. The business is there. Get your share of it.

Sending for the Raytheon catalog is the first step. Do that at once. Then get in touch with Raytheon for technical advice and merchandising plans for speedy action.

RAYTHEON MANUFACTURING COMPANY

Acting as Agent of the
War Assets Administrator under Contract No. 51A-3-46
60 East 42nd Street, New York
West Coast Office: 2802 N. Figueroa St., Los Angeles 31, Cal.



RAYTHEON MANUFACTURING COMPANY

60 East 42nd Street, New York 17, N. Y. RTJ-7

GENTLEMEN: Send your new Catalog of salable and immediately-available items of war surplus electronic equipment to

Name

Firm Name

Street Address

City State

F M

(Continued from page 59)

tuned circuits, is based upon the phase relationships that pertain in a transformer having a tuned secondary.

Between the limiter and detector, a special I-F coupling transformer is used; the discriminator secondary is center-tapped and is connected to the plate side of the primary through a blocking condenser, whose impedance is deliberately small compared to that of the RFC. For r-f, then, the primary circuit is in series with each half of the secondary to ground.

Both the primary and secondary are tuned to resonance in the center of the I-F pass-band. Whenever such is the case in transformers, at the resonant frequency the secondary voltage is 90 degrees

out of phase with primary voltage. Now, the voltage applied to the diodes is of two components—that produced by inductive coupling, and that introduced into the secondary's mid-point through the blocking condenser. At resonance, then, because of the method of connection referred to, the rectified load currents through the series resistors are of equal magnitude and opposite polarity, and there is no audio output. But, when the signal's frequency varies above and below resonance, then the secondary becomes respectively capacitive and inductive in behavior, and then the 90-degree phase relationship between primary and secondary no longer exists. During off-resonance, one of the diode's voltages will lag behind the other; so that, at a given moment, in a cycle, the voltage on one of the diode plates is greater

than that on the other. Thus the resultant voltages applied to the diodes are no longer equal, and the output voltage is then the difference between the individual voltages across each of the series load resistors.

Alignment

Because of the higher operating frequencies and the greater effect that temperature changes, tubage, etc., have upon frequency drift, a good rule to follow in alignment is to allow for a sufficient warming-up period prior to the making of any adjustments. Thirty minutes is a safe duration. And this applies to both the signal generator and the receiver.

The test instruments needed are a signal generator covering frequencies in the vicinity of 4.3 megacycles (the I-F resting frequency), and a low-current ammeter having 0-500 microampere, or more sensitive, movement.

The objective is to ensure that the I-F transformers and the tuned discriminator tanks, in that order, have a pass-band of 75 KC above and below the I-F mid-frequency of 4.3 megacycles—that is, a pass-band from 4.225 to 4.375 megacycles.

The ammeter is inserted in series with the limiter grid leak resistor and ground; the current of the limiter tube will be approximately 30 to 100 micro-amperes.

The signal generator is set to 4.375 megacycles and connected between grid and ground of the converter tube, the control grid having first been freed of its associated tank. Then the stages are aligned for maximum reading on the meter by variation of the trimmers.

It is well to watch out for feedback or oscillation in the I-F stages when so tuning them; and this is easily accomplished by periodically cutting off the signal generator and noting whether any reading on the ammeter is then obtained; *any* meter reading means oscillation, and should be checked before proceeding.

A Handy SALESKIT FOR RADIO SERVICEMEN

A real saleshelp exclusively for Radio Servicemen... the Jensen Phonograph Needle Saleskit is just the thing for demonstrating fine needles. What's more, Jensen needles augment your work, assure full, clear tone of the instruments you repair, make all records sound better.

Colorful, convenient, compact... the Saleskit slips easily into your pocket. Take it on service calls. It contains 3 Jensen Concert Needles retailing at \$1 each and 3 Jensen Genuine Sapphire Needles at \$2.50 each.

Available NOW at your jobber. WRITE TODAY for complete details and our better than usual discount to servicemen.



JENSEN INDUSTRIES, INC.
329 SOUTH WOOD STREET
CHICAGO 12 ILLINOIS

? The Question Box ?

How to "Trouble-Shoot" Common Servicing Problems.

Question: I can't get rid of motorboating in an Atwater Kent 206 that I have. Turning the volume control to maximum develops an intermittent whistle. All voltages check slightly higher than normal.

Answer: The filter condenser should be carefully re-checked. Loss of capacity in any one of the sections can cause the trouble. Replacement of the whole condenser unit with an 8-8-8-mfd 450-volt capacitor should remove the noise and restore all voltages to normal.

Question: Several type 35Z5-GT/G tubes I have show burned out pilot lamp sections. Can you give me a good way to restore function of this section with minimum adjustments?

Answer: Connect a 5-ohm, one watt resistor across pins 2 and 3. This will restore pilot light operation with no change in the normal filament voltage values.

Question: I have three Emerson Three-Way Portables on hand, all with the complaint of audio oscillation. Checking of shielding hasn't availed. All condensers seem okay.

Answer: Our experience has shown that this model exhibits audio regeneration when the filament filter condenser becomes partially or completely open; this is so because all the tube filaments are hooked up in series with the cathode of the amplifier section of the 117P7 tube which, of course, contains audio-frequency currents. Replacement of the filter condenser removes the fault.

Question: Can you give me a satisfactory method for replacing the 50Y6-GT/G—one that applies to available types and needs the least amount of adjustment?

Answer: The 45Z5-GT/G is probably the best substitution. Change the 50-socket to accomo-

date the half-wave rectifier plate, keeping the number three hole empty. Connect a 50-ohm, five watt resistor in series with the tube filaments. Connect the speaker field in series with the 35-cathode, as is conventional.

Question: My Emerson Three-Way Portable will play okay for a half hour, then go into distortion. Some of the resistors are a little high, but not enough to bother. The filters seem okay. Can you suggest something I should try?

Answer: Suspect the 117P7 tube. The internal grid impedance may have risen, or the input grid coupling resistor may be too high. Try connecting a 50,000 ohm resistor in parallel with the present

grid resistor. This may decrease the volume somewhat, but should remove the distortion.

Question: A good many of the sets I service come in with "intermittent" troubles. I waste a lot of time keeping the sets on and waiting for the trouble to show up. Is there any way I can speed up the process?

Answer: Our own experience has been that parts or circuits suspected of being intermittent can be brought to show themselves more quickly by overheating them, preferably with an all-round safe means as a cloth swathing the interior of the chassis. Caution: Such overheating should be undertaken for short periods only.



Raytheon tubes give peak performance. They have been built to this high level of maintained quality through continual testing and research by a company that is recognized everywhere as one of the advanced guard leading the way into the new era of electronics.



Excellence in Electronics
RADIO RECEIVING TUBE DIVISION
NEWTON, MASS. • CHICAGO

RADIO & APPLIANCE

ARIZONA

PHOENIX—*Phoenix Radio & Electronics Club*. Pres., Robert Culver, Culver Radio Service, 231 N. 1st Ave.; Vice Pres., Hurley Lowry, Lowry Service Co., 3rd Ave. and Roosevelt; Sec'y, Dick Wilhelm, Radio Parts of Arizona, 36 W. Madison.

TUCSON—*Radio Servicemen's Association*, 2216 6th Ave. Pres., Howard Klaiiss, 2216 S. 6th Ave.; Sec'y, Charles Sabor, 557 N. 4th Ave.

CALIFORNIA

LOS ANGELES—*Radio Electronic Service Association of Los Angeles*, 1914 S. Vermont Ave., Pres., Jerry Costigan; Sec'y, Sy Cooper.

LONG BEACH—*Long Beach Radio Technicians' Association*, P. O. Box 3085, E. Long Beach Station, Long Beach 4. Pres., Mel Mattox; Vice Pres., P. N. Nibbelin; Sec'y, M. McNeil; Treas., Bob Hayden.

SAN JOSE—*Santa Clara County Gas and Electric Appliance Association of San Jose*. Pres., Frank Acardi, c/o Nathan Dohrman Co.; Sec'y, E. M. Britton, c/o Pac. Gas and Electric Co.

CONNECTICUT

BRIDGEPORT—*Bridgeport Radio Service Association*. Pres., Thomas Cafora; Sec'y, Peter Laruslso.

WATERBURY—*Independent Radiomen of Waterbury*. Pres., J. Leo Phelan, RFD 3; Sec'y, James A. Nash, 629 E. Main St.

FLORIDA

ST. PETERSBURG—*St. Petersburg Electrical Dealers' Association*, P. O. Box 4042. Pres., E. G. Peters, Gulf Radio Sales, Inc., 216 4th St., N.; Sec'y, E. B. Brant, Florida Power Corp., P. O. Box 4042.

GEORGIA

ATLANTA—*Atlanta Electrical Association*, 353-361 Peachtree Arcade Bldg. Pres., Robert B. Shelley; Sec'y, L. I. Austin.

ILLINOIS

DECATUR—*Radio Association of Macon County*. Pres., P. R. Hollingsworth, 753 N. Water St.; Sec'y, W. A. Moore, 640 N. Main St.

INDIANA

EVANSVILLE—*The Radio Servicemen's Association, Incorporated*, 321 E. Iowa St. (c/o Victor J. Wolf), Evansville 11. Pres., William J. Hammer; Sec'y-Treas., Victor J. Wolf.

SOUTH BEND—*The Radio and Electronic Technicians' Association of Indiana, Incorporated*, Commercial Sound & Radio Co., 528 E. Colfax Ave., South Bend. Pres., John Lackman, Sr.; Sec'y-Treas., Albert Lear. Est., 1942. Meetings, semi-monthly. Membership, 60 (bonafide); 100 (associate).

IOWA

DES MOINES—*Electronic Association of Des Moines*, 845 42nd St. (c/o R. M. Evans), Pres., Harold Robbins; Sec'y-Treas., Robert M. Evans.

OTTUMWA—*Radio Technicians' Association of Ottumwa*. Pres., Dwight King; Sec'y, Fred Swanson, Cass & W. 2nd St.

KANSAS

TOPEKA—*Radio Electronic Technicians' Association*, Box 636. Pres., Douglas Darnall, 611 Quincy St.; Sec'y, C. L. St. Clair, 806 Forest St.

WICHITA—*Radio Service Dealers' Association*, 1619 E. Douglas. Pres., Art Koop; Sec'y, W. A. Alderman.

LOUISIANA

NEW ORLEANS—*Radio Dealers' Association of New Orleans*, c/o New Orleans Public Service, Inc., 317 Bayonne St. Sec'y, Al Lindauer.

MARYLAND

BALTIMORE—*Radio Service Association of Baltimore*, 1133 Harford Ave., Baltimore 2. Pres., J. Wong; Sec'y, M. Steinour; Treas., E. A. Smith.

MASSACHUSETTS

BOSTON—*Radio Technicians Guild*, 1082 Commonwealth Ave. Pres., Alfred Saunders; Sec'y, Alfred Turner. *Electric Institute of Boston, Incorporated*, 80 Boylston St., Boston 16. Pres., Frank L. Nason.

CAMBRIDGE—*Radio Technicians Guild*. Sec'y, H. Levy, 483 Cambridge St., Allston.

MICHIGAN

FLINT—*Radio & Appliance Dealers' Association*, c/o Flint Chamber of Commerce. Pres., Forrest Boswell; Sec'y, John Wernicke.

Radio and Television Journal's Association Activities Department is happy to present the first in a series of listings of radio associations throughout the country. This is not a complete listing, and

ASSOCIATIONS DIRECTORY

KALAMAZOO—*The Radio Technicians' Association of Kalamazoo*, Conference Room, YMCA Bldg., Box 773. Pres., Frank G. Rector; Sec'y, Seth E. Lover; Treas., Clifford P. Bennett. Established, April 30, 1935. Meetings, 1st and 3rd Mondays each month.

MINNESOTA

MINNEAPOLIS—*Radio Servicemen of America, Minneapolis Chapter*. Pres. J. R. Trovall (of Northern States Radio Service), 1010 2nd Ave., S.; Vice Pres., Clyde West (of Stewart and West Radio), 2526 Central Ave., N. W.; Sec'y, Forest Reine, 3200 Colfax Ave., N.

The Appliance Dealers' Association, Incorporated, 234 Foshay Tower. Pres., Ray Volkenant; Sec'y, C. T. Stephenson.

The Association of Radio and Television Service, Incorporated, 1100 First National Bank Bldg. Pres., Miles Chadwick; Vice Pres., C. W. Smith; Sec'y, D. A. Morken; Treas., Lee Horning.

North Central Electrical Industries. Promotion Manager, A. H. Kessler; Sec'y-Mgr., William Ritt, 234 Forshay Tower.

ST. PAUL—*Radio Servicemen of America*. (Currently organizing).

NEBRASKA

OMAHA—*Iowa Electrical Council, Incorporated*, 1306-7 Woodmen of the World Bldg., Omaha 2. Pres., H. G. Carlson, Electric Fixture and Supply Co., 1210 Harney; Sec'y-Treas., A. V. Sorenson, Midwest Equipment Co., 1112 Farnam.

NEW YORK

BINGHAMTON—*Radio & Appliance Service Group*, Electric Council, Chamber of Commerce. Chairman, Kenneth Chapel.

BUFFALO—*Radio Technicians' Association, Incorporated*, 657 Broadway, Buffalo 12. Pres., Ted Trelaak, Nat'l Serv. Co., 57 Broadway, Buffalo 12; Vice Pres., N. Leone, Niagara Radio Service, 490 Niagara St., Buffalo 1; Sec'y, Clarence Jax, Acme Radio Service, 1141 Main St., Buffalo 9; Treas., Nelson K. Malotte, Malotte

Radio Serv., 3198 Bailey Ave., Buffalo 15.

JAMESTOWN—*The Association of Radio Service Engineers*, Hotel Jamestown. Pres., Leo Burt, 622 E. 2nd St., Sec'y, Win Ayres, 305 W. 3rd St.

NEW YORK—*National Electrical Wholesalers' Association*, 500 5th Ave., New York 18.

PORT EWEN—*Kingston Radio Servicemen's Association*, c/o Light Radio Store, Bayard St.

ROCHESTER—*Radio Technicians' Guild of Rochester*, Rochester Gas and Electric Bldg., East Ave. Pres., David Boyce, 169 Steko Ave.; Vice Pres., Francis Holland, 506 Glenwood Ave.; Past Pres., Bert Lewis, 22 Thornton Rd.; Sec'y, William E. Brewerton, 229 Malden St.; Treas., William Frenzel, 34 Wren St.; Sergeant-at-Arms, J. Brown, 471 Hudson St. Established, 1939. Meetings, 1st and 3rd Tuesdays each month. Dues, \$10.00, per year. Membership, 40. Rochester Electrical Association. Sec'y, Harry Kramer.

NORTH CAROLINA

GREENSBORO—*Radio and Electronics Technicians' Association*. Pres., C. E. Heitkamp, 206 Isabel St.; Sec'y, E. B. Shore, 422 W. Gaston St.

OHIO

AKRON—*Akron Radio Technicians' Association*, 41 S. High St. Pres., Jack Gritton, 1689 Coventry St.; Sec'y, Del Bruner, 24 Byers Ave.

COLUMBUS—*Associated Radio Service Dealers*, 2552 N. High St. (Graham & Colton), Columbus 2. Pres., Leo Loudner, Bexley-Loudner Electric Co., 2507 E. Main St.; Vice Pres., James Long; Sec'y, Fred Colton; Treas., Francis Gibb. Electrical Dealers' Association of Columbus. Pres., Bill Hoermle; Sec'y, Bob Boyland (both of Hoermle's, 1844 Parsons Ave., Columbus.)

DAYTON—*The Gas & Electric League of Dayton*, 203 Gibbons Realty Bldg., 4 W. 3rd St., Dayton 2. Pres., R. R. Hollister, Hollister Elec., Inc., 27 E. 2nd St.; Sec'y-Treas., William Coughlen, Jr., c/o Gibbons Realty Bldg.

OKLAHOMA

OKLAHOMA CITY—*Oklahoma City Radio Service Association, Auto Radio Clinic*, 1110 W. Main. Pres., E. B. Cones, 2529 N. W. 27th St.; Sec'y, H. T. Fish, 20 S. E. 38th St.

TULSA—*Tulsa Radio Service Association*. Pres., E. J. Balcom, 1223 N. Elwood; Vice Pres., Max Cunningham, 116 W. 11th; C. W. Speaks, 2444 E. 1st.

we urge all Association secretaries to send in pertinent facts about their organizations so that we can give national publicity to their activities.

OREGON

PORTLAND—*Northwest Retail Appliance Dealers' Association*, 617 S. W. 3rd Ave., Portland 5. Pres., A. E. Kuhnhausen; Sec'y, E. H. Bremer. *Radio Research Club of Portland*, c/o M. M. Saelens, 323 N. W. 6th.

PENNSYLVANIA

ALLENTOWN—*Lehigh Valley Radio Service Association*. Pres., Phil Rothstein, RD I, Easton; Sec'y, Ed Droxler, 1044 3rd St., Fullerton.

PHILADELPHIA—*Appliance Dealers' Association of Philadelphia*, Bellevue-Stratford Hotel. Pres., Richard Balch; 1st Vice Pres., Albert Reiner; 2nd Vice Pres., Morris Davis; Sec'y, Charles Rosenthal; Ex Eec'y, Morris Popolow; Treas., Morris Bass. Established Nov., 1945. Meetings, 2nd Tuesday each month. Dues, \$25.00. Membership, 212. Directors are: Sam Perlman, chairman; Charles Carson, George Levin, Sam Passon, Frank Taylor, Sam Goldberg, Sam Tomarchio, William Grass, Fred Brown, Alex Gettlin, Albert Groff.

Electrical Association of Philadelphia, Architects Bldg., 17th and Sansom Sts. Pres., H. B. Bryans; Man. Dir., John A. Morrison.

Philadelphia Housewares Club. Pres., Herbert Morton.

Philadelphia Radio Servicemen's Association, 1643 S. Wilton St. Pres., Dave Krantz, 2109 S. 7th St.; Sec'y, Fred Keil, 3303 W. Queen Lane; Vice Pres., Peter Rapigani; Treas., Stan Myers. *Retail Record Dealers' Association of Greater Philadelphia*. Chairman, Dave Krantz, 2109 S. 7th St.; Vice Pres., I. Walker; Sec'y, Margaret Burger; Treas., Joe Weinstein.

PITTSBURGH—*The Radio Servicemen's Association of Pittsburgh*, 513 Station St., Wilmerding. Sec'y, William Irlam.

WILLIAMSPORT—*Associated Radio Servicemen of Central Pennsylvania*. Pres., Gordon Phipps, 1555 Overbrook Rd.; Sec'y, John Barosophy, 408 Campbell St.

TEXAS

DALLAS—*Dallas Radio Service Association*, c/o B. A. Blanton, 721 S. Beckley.

WASHINGTON

EVERETT—*Everett Radio Servicemen's Club*. Pres., M. H. Nunley, 1120 1st St., Snohomish, Wash.; Sec'y-Treas., Walt Olson, 2006 Broadway, Everett.

WEST VIRGINIA

HUNTINGTON—*The Association of Radio Technicians*, 314-316 11th St. Pres., Scott Adams. 617 Adams St.; Sec'y-Treas., F. D. Garber, 509 W. 9th Ave.

MORGANTOWN—*Monongahela Radio Association*, Box 344. Pres., E. G. Dennison, Rievesville; Sec'y, E. H. Flowers, Box 344, Morgantown.

CANADA

EDMONTON—*Associate Radio Technicians of Alberta*, Edmonton Branch, Edmonton, Alberta. Pres., George Wade, 10166 102nd St.; Sec'y, F. A. Niel, 10125 100 A St.

CALGARY—*Associated Radio Technicians of Alberta*, Calgary Branch, Calgary, Alberta. Pres., J. Howells, 608 Centre St.; Sec'y, W. Read, 2085 14th St.

LETHBRIDGE—*Associated Radio Technicians of Alberta*, Lethbridge Branch, Lethbridge, Alberta. Pres., Charles Kerr, Kepler's Radio; Sec'y, Albert Potoski, H. R. Carson, Ltd.

BELLEVILLE—*Radio Electronic Technicians' Association*, Belleville, Ontario. Pres., Harry Fletcher, Picton, Ontario; Sec'y, George E. Fralick, 32 Bridge St., E.

VANCOUVER—*Associated Radio Technicians of British Columbia*, 918 Rogers Bldg., Vancouver. Pres., E. W. Munton, 1542 Marine Dr., Hollyburn, B. C.; Sec'y, A. T. Johns, 219 Lonsdale Ave., N. Vancouver; Treas., M. J. Lennox, 3114 W. 20th, Vancouver. Established 1928 (incorporated under Societies Act of B. C. in 1934). Membership, 125. (Branch chapters in Victoria and Nanaimo, B. C.)

Canadian Electronic Wholesalers' Association (Western), 951 Seymour St., Vancouver. Pres., Arnot M. Clark, Vancouver; Vice Pres., K. Cairns, Winnipeg, Man.; Sec'y-Treas., W. D. Mann, Vancouver. Directors are: J. Smalley, Jr., Alberta, Calgary; A. Fairburn, Sask., Regina. Membership covers four Western Provinces of Canada.

RADIO & TELEVISION JOURNAL, JULY, 1946



TOTE LITE

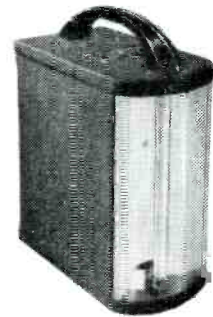

An important announcement regarding Radio and Television

Mr. Henry "Hank" Halperin, whose achievements in the radio industry are widely known, is now at the head of Paramount Industries, Inc. of New York.

Paramount Industries has successfully marketed TOTELITE, the first portable fluorescent light and TOTEGRILL, portable all-steel outdoor grill.

The Television and Radio Divisions of Paramount Industries are readying for the market sight and sound receiving sets, taking full advantage of the electronic advances made during the war years.

These sets will not compromise with the past. They will have no equal in the present. They will set the pace in the future.

TOTE-GRILL



During the NAMM Convention, Mr. Halperin will be at the Blackstone Hotel, Chicago, from July 14 to 18.



TRADE NEWS

Accurate reports about People and Events in the Industry.

Microtone Features "The Record Log"

A practical packaging idea record lovers will recognize immediately as answering a long-felt want, has been developed by the Microtone Company, 114 Manhattan St., Stamford, for its Silver Sapphire needle.

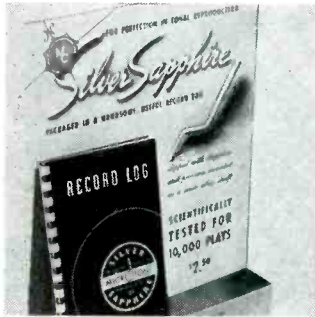

Instead of the usual box which is inevitably thrown away, each Silver Sapphire is attached to the cover of "The Record Log," a booklet designed for simple, fast cataloging of records and albums.

On the first index page, a brief introduction explains three ways for indexing records by Composer Groups, Individual Performers or Orchestra Leaders—though several other methods may be employed with equal facility. And its twenty-four pages—numbered, ruled and lined for quick reference—provide ample space for sizeable record libraries.

All in all, this handsome, plastic-bound Record Log with simulated pin-seal leather cover is an item every record fan will want to own, to say nothing of the needle itself. For the Silver Sapphire will give 10,000 plays reproducing faithfully every delicate tone, with a minimum of surface noise and record wear.

Display Room of New ECA Plant

Central focus of the modern display rooms of Electronic Corporation of America at its new plant is this full scale store window. The display rooms, laboratory and production facilities of ECA's new plant covering a square block at 170 - 53rd St., Brooklyn, were shown to a

group of more than 400 leading dealers who attended the opening ceremonies as part of the 300th anniversary of Brooklyn.

Jack Geartner, sales manager for ECA Radios explained that the display window with sliding doors was built so that the company could develop displays, photograph them and make them available for use by its franchised dealers. The central item in this window is a chairside Radio-phonograph combination with phonograph compartment opening either to the left or right offered in mahogany or walnut finishes at an OPA approved price of \$136.50. This set was in production on the day of the visit and could be seen coming off the line.

Also shown in this window is the 7 tube plastic table model at \$35.75 which has proved an instant success. The company is also making 5 and 7 tube table model radio-phonograph combinations with both manual and automatic record players. Mr. Geartner emphasized that this first display built for the showing is based on the company's experience that the windows that sell the most radios are the ones that display the most. The unusual attention paid by the leading dealers present seemed to prove Mr. Geartner's thesis.

Alfred Hitchcock "Spellbound" By Motorola "Playboy"

When Alfred Hitchcock, Republic Studio director, flew to England recently, the famous suspense specialist was presented with a Motorola "Playboy" portable radio for enter-

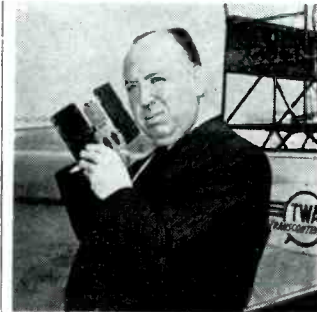

tainment en route.

Mr. Hitchcock's first reaction was one of skepticism that so small a unit had sufficient power to perform high in a plane. His doubts were dispelled, however, when the brownie-camera sized receiver began to play, giving rich tones and more than adequate volume.

Mr. Hitchcock said of the Galvin Manufacturing Corporation's gift. "It's a fine little set. It is almost unbelievable that such a tiny instrument should produce such beautiful music."

What modest Mr. Hitchcock might have said was, "Beyond a SHADOW OF A DOUBT the Motorola 'Playboy' has the EASY VIRTUE of receiving WALTZES FROM VIENNA and speeches by FOREIGN CORRESPONDENTS with equal clarity. Even if stranded in a LIFEBOAT, with this little radio I'd be less than 39 STEPS from civilization. Frankly, I'm SPELLBOUND."

Anthony B. Cassidy Sales Director

Anthony B. Cassidy has been appointed Director of Appliance Sales of The Yale & Towne

Manufacturing Company which has announced the addition of electric home appliances to its world famous line of locks, door closers, builders' hardware, and materials handling equipment produced in its plants in Stamford, Conn., Philadelphia, Chicago, North Chicago, Canada and Great Britain.

Yale's first traffic appliance is the patented "Tip-Toe" automatic iron, which will be manufactured in its Buffalo plant.

Mr. Cassidy is establishing Yale's national electric appliance sales headquarters in the Empire State Building, New York. For the past three years he has been developing Yale & Towne's new consumer products marketing program as assistant to the president, W. Gibson Carey, Jr.

9,603,000 Families Considering Television Sets

A possible market potential for home television receivers which may reach nearly 10 million sets during the next five or six years providing telecast facilities are made available in all urban areas was revealed June 18 by Frank Mansfield, director of sales research for Sylvania Electric Products Inc. He based his report on the answers given by home radio listeners, 28% of which are now located within range of existing television transmitters. "The public," he said, "was asked if it wanted television; what price it thought it would pay for a home receiver; and results it would expect from the set."

"26.6% of the urban families interviewed said they definitely planned to buy a television receiver," he continued, and "and 18.5% were considering television but had not definitely made up their minds. In other words 45.1% or possibly, 9,603,000 families are considering the purchase of a home television set. These possible prospects are pretty evenly distributed in different income groups. The only significant drop is in families with normal annual income of less than \$1,000."

When asked how much they thought they would pay for a



television receiver, Mansfield stated that 58.9% said they would pay from \$100 to \$249 and 31.0% said they would pay from \$250 to \$500. Only 3.4% said they would pay less than \$100 while 5.9% appeared to be willing to pay more than \$500. The average price for all families interested in the purchase of a television set was in the \$250-\$500 range.

Commenting on what the public expects from a television receiver, Mansfield said that a set designed for four people viewing at one time apparently filled the average need of about 80% of the families. He based this opinion on the finding of the survey which indicated that 78.1% of those interviewed stated that two to four people will want to watch a television show. 12.2% said five persons.

"In spite of the fact that color television exists only in the laboratory state," Mansfield continued, "there appears to be three prospects who want color television to one stating he wants black and white only. Desire for color decreases as income decreases and only one out of five of those who want it say they will pay over \$100 extra for it."

Motorola to Invade Car Heater Field

Announcement of a revolutionary new type gasoline heater was made by Galvin Manufacturing Corporation, makers of Motorola Radio for Home and Car. Company spokesmen assert that the new Motorola Gasoline Car Heater—entirely new in principle, performance and design—will be as dramatic a step forward in the field of automotive necessities as was the advent of the self starter.

Vice President E. H. Wavering, who heads the new Car Heater department at Motorola, stated that the new heater will represent a drastic departure from current auto heater design. Mr. Wavering emphasized that the most important of these features are patentable and therefore—exclusive with Motorola.

HOTPOINT'S ALL ELECTRIC KITCHEN



These young women have been "keeping house" in a typical war veteran's housing all-electric kitchen. Edison General Electric (Hotpoint) Appliance company officials said that an initial allocation of 1,000 such ensembles is now in the process of being shipped to veterans' housing across the nation. The appliance group in the background retails for less than \$450 in all parts of the nation, an announcement said.

The new Motorola Gasoline Heater will be marketed through present Motorola distributors, but it will be manufactured at a separate five-story plant in Chicago. Manufacture and distribution of the new heaters will be handled by a completely separate department.

It comes to the market fully tested and approved, not only in extensive laboratory experiments over a period of years, but by actual application. The heater in principle was used extensively by the Armed Forces during the war for heating trailers and Quonset huts and for pre-heating airplane and tank engines in the Aleutians and in sub-zero European winter fighting.

Borg-Warner Buys Air Products, Inc.

Howard E. Blood, president of the Norge division of Borg-Warner Corp., announces completion of negotiations for the purchase of the Air Products, Inc., Chattanooga, Tenn., plant, and transfer of title from the War Assets Administration. This brings to a total of five the number of factories to be devoted to the exclusive production of the Norge line of household appliances.

The new plant will be employed for the production of a new-type hermetic compressor unit to be used in household and commercial refrigerating devices, according to Mr. Blood. This output, he said, will aug-

ment that of the Norge factory in Muskegon, Mich.

Mr. Blood also announced that the plant's operations will be under the supervision of O. H. Shenstone, manager of the Muskegon factory, but Theron F. Gifford will be Chattanooga manager. Mr. Gifford formerly was assistant manager of Muskegon.

Situated one and one-half miles from the heart of Chattanooga, the property is located on the bank of the Tennessee River and is served by a spur of the Southern Railway which extends directly into the building. It consists of 17 acres of land and a modern brick and steel factory building equipped with daylight windows. The building is 820 feet long by 120 feet wide and contains approximately 10,000 square feet of floor space.

Electronic Laboratories Expands Sales Outlets

An expansion of sales outlets for Electronic Laboratories, Inc., of Indianapolis, was announced by Walter E. Peek, vice-president, with new offices opening in the United States, Canada and the territory of Hawaii.

Serviceing the Rocky Mountain states sales district will be Ronald Bowen, former Army major, with ten years' experience in the radio and electronic field. Bowen will have offices at 1886 South Humboldt street, in Denver, Colo.

As representatives for Electronic Laboratories in the southeastern seaboard states, the James Millar Associates will open a new office in Asheville, N. C., headed by J. E. Joyner. Operating from Chicago, B. G. Twyman, 6406 North Fairfield ave., will represent the firm in St. Louis and eastern Missouri.

New offices opened for Electronic Laboratories in Seattle, Wash., and Portland, Ore., by A. V. Rodman will be under the supervision of Myron and Jack Mitchell. The Portland office will be located at 316 NW 12th street.

The Stromberg-Carlson company of Canada with offices in Toronto, Ontario, will have charge of eastern Canada, while Electronic Laboratories of Canada, with offices in Vancouver, British Columbia, will cover western Canada.

First Electronic Laboratories sales office outside the continental limits of the United States, will be opened in Honolulu, T. H.

Headed by Marc Donnelly, ex-Army colonel, and formerly a resident of Indianapolis, the office will be located in the Aloha building in Honolulu, island of Oahu.

G.E. Announces Video Plans

General Electric's plans for production of black-and-white television receivers and television transmitting equipment were announced recently in a letter to the company's distributors and to broadcasters across the nation.

G.E. expects to make the first television receivers available to the public in August or September in areas where stations are now operating or will soon be on the air. This model will use the ten-inch direct-view picture tube. It will also incorporate the standard broadcast band. No price was announced for the set but it is expected to be around three hundred dollars.

Other sets for black-and-white picture reception will follow shortly thereafter and will be of the projection as well as direct-view types. All these television sets will be made at the Bridgeport, Conn., plant.

General Electric television transmitters and related studio equipment are now being manufactured in the G.E. factory at Syracuse, N. Y.

PRESTELINE RANGE AT FURNITURE MART

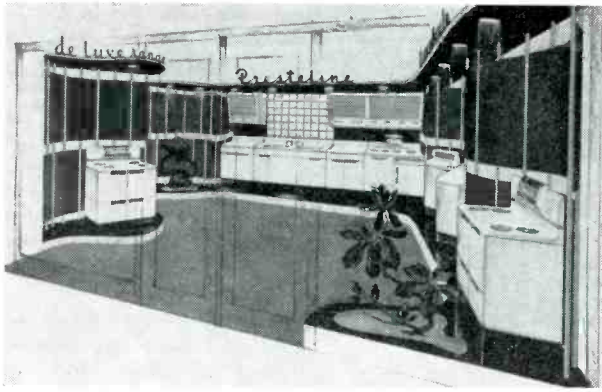

Buyers coming to the July Market are in for some pleasant surprises when they visit the PRESTELINE display in the Furniture Mart. The above reproduction in black and white reveals some of the novel innovations planned for their display by Henry Glass, one of the country's foremost designers.

Shown for the first time will be the new PRESTELINE DeLuxe Electric Range, styled by Henry Glass to bring a new note of charm to the modern kitchen. The treatment of the control panel on the backsplash is strikingly new. The panel is inclined at a slight angle from the backsplash to provide maximum visibility of the controls.

Philco Freezers Feature Low Prices

In the first step of a long-range program to provide frozen foods storage for every home, Philco Corporation has just established prices on its 2½ and 5 foot freezers that are by far the lowest of any large national-brand manufacturer, it was announced recently by Thomas A. Kennally, vice president of Philco.

Model AH25, a 2½ foot freezer is priced at \$149.50 anywhere in the United States, and the AH51, a five-foot freezer, is priced at \$199.50.

Orders for 100,000 Philco Freezers were already placed by distributors and dealers even before prices were announced. After seeing the freezers, dealers and their customers have guessed that prices would average anywhere from \$75 to \$100 more than Philco is charging, Mr. Kennally indicated.

Light from a concealed fluorescent bulb passes through translucent panels to illumine the controls with a soft, muted glow. Light from this same concealed bulb also illumines the top of the range.

Outstanding features of the new DeLuxe Range are: choice of surface cooking arrangements—either the divided top, with two cooking units at each side, or conventional top with four units grouped together; seven-heat surface cooking units; two ovens; full automatic control with selector switch for control of oven, deep-well cooker, or one of the two appliance outlets; warming compartment and one storage drawer.

"We are offering these new freezers to the public at the lowest possible prices even in the face of rising costs, as part of our long-established policy to bring new Philco developments within the reach of every family," Mr. Kennally pointed out.

G.E. Radio Clock Gets Final Check-up

Shown here is the final test of General Electric clock radio receivers now in production at the company's Bridgeport, Conn., plant. The new receiver will automatically wake you with your own brand of music. And for heavy sleepers, the set has an auxiliary resonator that sounds a few minutes after your "wake up" music comes on.

Here's how the "wake up" feature works. Before retiring, you tune in your favorite radio station, adjust the volume as desired, set the clock in the receiver as you would the ordinary alarm. Finally, you turn

the alarm selector control. This turns the radio off for the evening. The clock continues to operate. At the appointed "wake up" hour the clock turns the radio on and you are supposed to awaken. If it's been a tough night and you decided before retiring that you will need the resonator and have set that too—well, you get the double-barreled effect a few minutes after the radio music has been turned on.

You don't have to use the "wake up" radio resonator. The clock and radio work independently of one another, or in conjunction. You decide the operation.

The clock-radio operates on regular house current. It has four tubes, comes in a plastic case, and weighs about 5 pounds. It's about the size of a small loaf of bread.

Ad Man Joins General Electric

Fred A. Parnell has been appointed advertising and sales promotion manager for the General Electric Company's Receiver Division here. The announcement was made by Paul L. Chamberlain, manager of sales for the division.

As an account manager at Maxon, Inc., in New York, Mr. Parnell for the past year has supervised the G-E Receiver Division's advertising and sales promotion handled by the agency.

Mr. Parnell entered the agency field in 1941 after more than 12 years in advertising and sales work with General Electric, where he had served as sales manager for the G-E Home Bureau, and was advertising manager of the Construction Materials Division.

Three-Way Fluorescent Light Control

A three-way ballast fluorescent light control, featuring instant-starting transformer, is now on exhibit at Universal Sound Corp., Empire State Bldg., N. Y. C. Advantages of the control are: control of light output from 100% to 50% to 25% intensity; elimination of "blinks"; marked increase of lamp-life; savings in power costs; high light of efficiency; elimination of starters, starter switches and starter sockets; simplified construction. Wm. F. McEvoy, president, announces that these controls can be ordered now for summer delivery.

Lamont to Bendix As Sales Engineer

L. C. Truesdell, general manager for Radio and Television Bendix Radio Division, Bendix Aviation Corporation, has announced the appointment of M. B. Lamont as products manager in charge of electrical detail in radio, FM, and television. During the war Lamont served as expert and consultant to the War Department on communications, radar and guided-missiles in the North African and the China-Burma-India Theatres.

Mr. Lamont has recently associated with Philco Corporation with whom he has had wide experience in home radio. He was one of the pioneers in perfecting auto radio.

Truesdell cited Lamont's appointment as another step in the Bendix Radio leadership program, which is accounting for one of the leading lines in the household radio industry.



G-E's NEW MUSICAL CLOCK

RADIO & TELEVISION JOURNAL, JULY, 1946

Deepfreeze Eastern Regional Sales Manager Announced

The appointment of Donald L. Davison as the new Deepfreeze Eastern Regional Sales Manager has been announced by F. F.



Duggan, General Sales Manager, Deepfreeze Division, Motor Products Corporation, North Chicago, Illinois.

Mr. Davison will make his headquarters in New York with responsibilities embracing the Boston, New York and Philadelphia districts.

Mr. Davison's previous connections included responsible positions with Westinghouse Electric & Manufacturing Company as well as the Crosley Corporation. During the war he successfully operated as an independent Manufacturer's agent.

RCA Victor Creates New Distribution Department

Creation of a Distribution Department, to establish and direct RCA Victor's distribution policies and methods and to act in an advisory capacity on general sales policies, was announced today by Frank M. Folsom, Executive Vice President in charge of the RCA Victor Division, Radio Corporation of America. At the same time, Walter M. Norton, director of the Education and Training Division, was named director of this new department.

The distribution department will be responsible for the activities of the Market Research Division, Education and Training Division, RCA Victor Regional Managers and the RCA Victor Distributing Corporation. In addition the Department will provide consulting service to RCA Victor distributors for their assistance in financial, administrative and procedural problems.

Manual Announced

Distribution of the Evans 1946 home heater and water heater service manual is announced by C. C. Van Wagoner, Service Manager of the Heating and Appliance Division of Evans Products Company, Detroit. Copies of the manual are available to all distributors and dealers at a small nominal fee.

The 46 page manual, bound in blue leatherette and illustrated with 82 photographs and illustrations, contains, in addition to sections on installation and servicing, chapters on the basic theory of combustion, causes and corrections of heat losses in homes, methods of determining heat loss, functioning of chimneys and drafts, and a chart of United States climatic conditions. The climatic chart lists average, lowest, and design temperatures, and prevailing wind direction and average velocity in each state.

The manual contains 12 pages devoted to correct installation, illustrated with 21 photographs and sketches, and a four-page supplement on the operation of oil control valves. Data sheets for Evans 1938-1946 home heaters and water heaters give model numbers, BTU output, burner size, cubic centimeters of oil flow per minute at high and low fires, and draft on high fire.

Pad Shown At Housewares Show



Explaining postwar heating pad improvements at the Housewares Show held recently at Atlantic City, Matt R. Vee (center), Pittsburgh representative for Casco Products Corporation, discusses exclusive features of the new automatic heating pad now

under production at the Casco plant at Bridgeport, Conn. to W. A. Stafford, (l.) Modern Distributors, Inc., Huntington, W. Va., and Paul Erler, (r.) Joseph Horne Co., Pittsburgh, Pa. The Wetproof heating pad with 30 positive heat control and nite-lite switch was featured in a special display booth exhibited by Casco, makers of electrical appliances and automotive accessories.

Heroes Receive Emerson Radio Sets

The heroes of Bastogne who visited the Emerson Radio and Phonograph Corporation's factory one year ago, no longer have to worry about new radio sets. Benjamin Abrams, president of Emerson Radio and Phonograph Corporation, this week fulfilled his promise made to the eight heroes of Bastogne when they

visited the radio factory shortly after their heroic stand. At that time Mr. Abrams promised to send radios, just as soon as they were available, to each of the fighting men. Eight radios were shipped out this week in keeping with that promise.

The eight veterans, members of the isolated 101st Airborne Division, helped write one of the epics of the war at Bastogne, Belgium, when they withstood the Nazi horde surrounding their position. It will be recalled, they were surrounded by the enemy and held out for two weeks before being rescued by the late General Patton's 3rd Army. Shortly after being relieved, the veterans, in charge of Captain Edward W. Cissel of Elizabeth, N. J., were ferried home by plane to tour war plants at which time they were guided through the Emerson factory by Mr. Abrams.

We CUSHIONED this spindle

TO PROTECT RECORDS

On any single-post record changer, there's a weight of about six pounds on the spindle ledge when the changer is loaded. When the machine changes records, this weight falls on the bottom record of the remaining stack. The resulting shock ordinarily causes excessive record wear. But the exclusive Webster cushioned spindle absorbs shock—"babies" records. Webster changers effectively protect records—avoid chipped edges and excessive center hole wear.

WEBSTER Automatic Record Changers

The Choice of Music Lovers



Model 50



WEBSTER CHICAGO

5610 Bloomingdale Avenue, CHICAGO 39, ILLINOIS
32 years of Continuous Successful Manufacturing

New Gen. Control 5-Position Switch

General Control Co., 1200 Soldiers Field Road, Boston 34, Mass., announces the new Model MCF, a 5-position cam-lever switch, designed especially for ease in assembly and wiring. The two features which provide this are single hole mounting of the switch frame to the panel and single bolt assembly of the contact block to the switch frame. The single bolt assembly (a General Control patented feature, permits soldering of the wiring to the contacts to be done where it is most convenient: away from other units, even at a bench if desired.

The switch is locking or non-locking in all positions except the center position, which is always locking. The motion of the switch from the center to all switching positions is straight line. This, plus the

positive roller action, results in maximum ease of operation.

The fine silver contacts are permanently riveted to nickel-plated, phosphor-bronze contact springs, and all parts are non-corrosive to assure long life. The contacts are rated at 10 amperes, 125 volts, AC (non-inductive load).

The MCF is especially designed for those applications in the electronic and communications field where it is imperative that only the desired circuit—of several—is closed.

McKnew Heads Westinghouse Home Radio Service

Appointment of W. H. McKnew, a veteran of more than 16 years' service in the home radio and sound movie fields, as service manager of the Westinghouse Home Radio Division, has been announced



A banquet at the Penn-Harris Hotel marked the re-opening of the Pierce-Phelps Harrisburg office. About 400 dealers from the Central Pennsylvania area attended the event.

by Harold B. Donley, manager of the Division.

Mr. McKnew, a lieutenant commander in the U. S. Naval Reserve, recently transferred to inactive status, served from 1942 to 1945 as Resident Inspector of Naval Material at the Westinghouse Industrial Electronics and X-ray Divisions in Baltimore.

In his new capacity he will head nationwide service facilities of the Home Radio Division from headquarters in Sunbury, Pa.

Haines Resigns From Raytheon

E. Ralph Haines, assistant manager of distributor sales for the Raytheon Manufacturing Company, Newton, Mass., has resigned his position, it was revealed recently.

He started with Raytheon Manufacturing Company in 1935 in their middle western territory. In 1941 he became assistant manager of distributor sales. During the war he handled contact bids, contracts and negotiations with the Army and Navy. He also represented Raytheon on the Radio Tube Advisory Committee of the War Production Board in Washington, D. C. He returned to his position as assistant manager of distributor sales six months ago.

H. A. Renholm President RCA Victor Distributing Corp.

Harold A. Renholm, who has been merchandising RCA and Victor products for almost 30 years, has been appointed president of the RCA Victor Distributing Corporation, Chicago, it was announced by Frank M. Folsom, executive vice president in charge of the RCA Victor Division, under whose supervision the distributing corporation operates.

Prior to his appointment, Mr. Renholm was executive vice president and general manager of the RCA Victor Distributing Corporation. He has been associated with the RCA Victor organization since 1918 when he joined H. S. Smer Brothers in operating two large exclusive Victor retail agencies in outlying Chicago.

In 1927 Mr. Renholm joined the sales staff of the old Chicago Talking Machine Company, Victor wholesalers for the Midwest area.

CRL Announces Personnel Changes

Two men were appointed to important positions in engineering at Centralab recently. They are Robert L. Wolff and Rolland R. Roup.

Mr. Wolff was named chief radio and electronics engineer and replaces H. W. Rubinstein.

Mr. Roup, who replaces G. Milton Ehlers as chief ceramic engineer, came to Centralab in 1933.

**THE CHOICE OF MUSIC LOVERS
EVERYWHERE . . .**



**THE NEW
APEX
ELECTRIC PHONOGRAPHS**

- HIGH QUALITY
- SATISFIED CUSTOMERS
- TERRITORIAL PROTECTION
- RELIABLE DELIVERIES
- EXTRA PROFITS

**SEE AND HEAR THE NEW,
EXQUISITELY DESIGNED APEX LINE
JULY 14-18, PALMER HOUSE, CHICAGO**

**SID JOFFEE — MAX ZIMMER
REPRESENTING**

**APEX RADIO & TELEVISION CORP.
192 LEXINGTON AVE. • NEW YORK CITY**

ADVERTISERS' INDEX

July, 1946

AEROVOX CORPORATION Agency: Austin S. Lescarbourea & Staff	10	MAUFAR, INC. Agency: Direct	56
AMERICAN PHENOLIC CORPORATION Agency: Burton Browne Adv.	54	NEWCOMB AUDIO PRODUCTS CO. Agency: Gail Hall Adv.	45
APEX INDUSTRIES Agency: Retail Furniture Adv. Inst.	72	NOBLITT-SPARKS INDUSTRIES, INC. Agency: Sidiner & Van Riper, Inc.	23
ARA, INC. Agency: Ruthrauff & Ryan, Inc.	75	NORTHEASTERN ENGINEERING, INC. Agency: Direct	6
BENDIX AVIATION CORP. Agency: MacManus, John & Adams, Inc.	13	PERMO, INC. Agency: William Hoffman & Associates	76
BOETSCH BROS. Agency: Drummond McKay Co.	20	PARAMOUNT INDUSTRIES Agency: Blaine-Thompson Co., Inc.	67
DISC CO. OF AMERICA Agency: Direct	40	RCA VICTOR DIVISION (Instruments) Agency: J. Walter Thompson	38-9
ELECTROMATIC MFG. CORP. Agency: Reiss Advt.	35	RAYTHEON MANUFACTURING COMPANY Agency: Burton Browne Adv.	63
ELECTROVOX CO. Agency: George Homer Martin Associates	26	RAYTHEON MFG. CO. Agency: J. M. Mathes	60-61
FADA RADIO AND ELECTRIC CO. Agency: Sternfield-Godley, Inc.	46	REXON, INC. Agency: Anderson, Davis & Platte, Inc.	2
FARNSWORTH TELEVISION AND RADIO CORP. Agency: N. W. Ayer & Son, Inc.	3	RECORDISC CORPORATION Agency: Shappe-Wilkes, Inc.	41
FAVORITE MFG. CO. Agency: Atlantic Advt. Agency	53	REMINGTON RADIO CORP. Agency: Kermin-Thall	25
FEDERAL TELEPHONE AND RADIO CO. Agency: Rickard & Co., Inc.	31	MARK SIMPSON MANUFACTURING COMPANY Agency: Edward Hamburger Adv. Co.	57
GENERAL ELECTRIC CO. Agency: Maxon, Inc.	9	SLATE & COMPANY Agency: Mitchell Adv. Agency	52
GENERAL INDUSTRIES CO. Agency: Fuller & Smith & Ross, Inc.	11	STROMBERG CARLSON COMPANY Agency: McCann-Erickson, Inc.	5
INDUSTRIAL ELECTRONICS LABORATORIES, INC. Agency: Direct	6	SOUTHERN MUSIC CO. Agency: Pitluk Advertising Co.	34
JFD MFG. CO. Agency: Direct	25	TAYBERN EQUIPMENT CO. Agency: Direct	22
JENSEN INDUSTRIES, INC. Agency: Allan D. Parsons	62	TELETONE RADIO CO. Agency: B. D. Iola Co., Inc.	21
LEAR, INC. Agency: Kudner Agency	7	THERMO-BROILER CO., INC. Agency: Sternfield-Godley	44
LINCOLN ELECTRONICS CORP. Agency: Sternfield-Godley, Inc.	27	TONE PRODUCTS CORP. OF AMERICA Agency: Direct	15
McELROY MFG. CO. Agency: Shappe-Wilkes, Inc.	56	UNION ELECTRONICS CORP. Agency: Burke & Wayburn	18
		WEBSTER-CHICAGO CORP. Agency: William Hoffman Associates	71
		ZENITH RADIO CORPORATION Agency: Critchfield & Company	19



Journal's End

By Mal Parks

... Hi there folks, it's sure mighty nice to be back here visiting with you again this month even if it is a hot Sunday afternoon... Played hooky for the bass season and here I am way up state sitting on a porch watching the other fellows out there in the lake stringing up their small mouths as fast as they can throw their hooks in the water... Oh well, some of us have to work and it might as well be me...

... Grand visit with Central Radio's **R. D. Butchart**, here from Detroit to talk about organizing the radio dealers and service dealers in their town... They are thinking of reviving the association in which so many of them have put in so much work and effort... The fellows were nice enough to appoint Mr. Butchart to have me to come to work with them on the meetings... Will bring you more details later. meanwhile, all you fellows in the Detroit area who don't belong to the association now, contact Mr. Butchart at Central Radio and he'll give you more details...

... Aside to Forest Hill's **Monroe J. Wolfe** and **Leo Friedman** of the Temple of Music... Your suggestions are in order and I appreciate them... We'll get to work on a plan right away and I hope that you like the way that we work them out...

... Down to visit with Emerson's **Ben Abrams** and looked over their new Television set models... talked with Ben and found out that his youngest daughter Cynthia is just two, like our own Harriet Ann, and his Marjorie, who was just recently married, is about the same age as good old Mal, Jr... Talked about the old days, and it's mighty nice to know that, although he has reached such a high position in business and finance, Ben still remembers the old days when he walked in Prospect Park with Alex... Some of the "Johnny - come - lately's" whose money seems to have gone to their heads, could well emulate his unassuming friendliness...

... Wonder who first said: "Women are not realists or they would laugh at their men, not love them..."

... Oh yes, I have also been asked to tell you that there is a very good job open for an assistant national sales manager at one of the big radio companies which will pay up to \$10,000 to start... If you really have the stuff, drop me a note telling me the full details about your past experience, and I will put you in touch with the company...

... Associated Radio's **Herb Brennan**, in for a visit from Tampa, and wish you could all have sat in on the discussion on the dealers' present day problems... like the rest of us, Herb would like to know why gasoline service stations can get radios, automatic washers, refrigerators, and other items ahead of accredited dealers...

... Swell letter from **Leon Ferguson**, of Memphis, Tennessee's Radio Music Center, telling us about the shoddy way in which manufacturers are assembling and shipping their products today... Leon's letter is typical of many we receive and it seems to us that manufacturers should check on their shipping departments because the volume of complaints about breakage in transit is increasing each day...

... Swell letter from Hockett-Cowan Music Co.'s **C. F. Cowan** of Fresno, California... Mr. Cowan points out that something has to be done about discounts because, if things keep on, a lot of radio and appliance dealers will not be able to stand the gaff... his letter was so good we assigned one of our staff writers on the coast to bring you the sort of article which you will want and which we will publish in a future issue...

... Gosh, ... here we are at the end of the column, and if this month's visit is a little bit confused, just remember that it's hard to bring you these little items and still keep our eyes on the fellow out there who has hooked at least five small mouths in the last half hour... what with the bass season now being open, and the fish running heavy now at Montauk Point, I guess that I'm not going to be able to do much work, so, if I'm not in the office, just jump in your car and come up so we can get in a little fishing together... Until then, thanks again for everything and so long, see you soon...

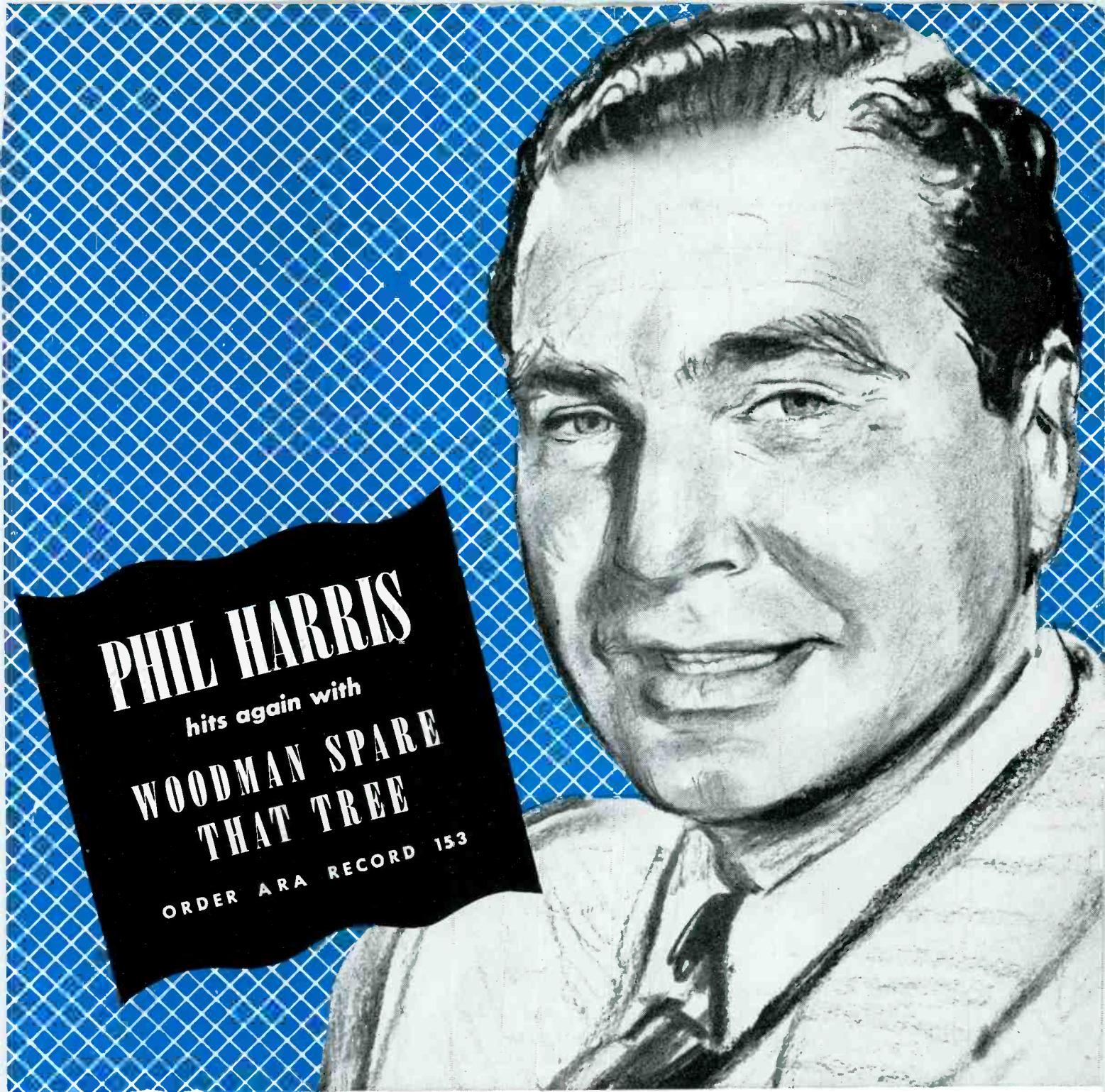

PHIL HARRIS

hits again with

**WOODMAN SPARE
THAT TREE**

ORDER ARA RECORD 153

ARA, the extra-profit major, offers you the perfect combination of extra-profit tunes plus extra-profit artists. Write for release lists of our latest recordings by such "big-name" artists as, PHIL HARRIS, HOAGY CARMICHAEL, LIONEL BARRYMORE, LOU BRING, GINNY SIMMS, ART TATUM, SMILEY BURNETTE, PAGE CAVANAUGH TRIO, JUDY CANOVA, EARL HINES, GEORGE JESSEL, JAN SAVITT, CHU CHU MARTINEZ, CASS COUNTY BOYS, FERDE GROFE, and many others.

ARA, Inc., Dept. RJ-1, 5655 Wilshire Blvd., Los Angeles 36, Calif

SEE US AT BOOTH 99, AT THE PALMER HOUSE HOTEL, JULY 15-18.

