

The RADIO ENGINEERS' DIGEST



JANUARY 1946

VOL. 2, No. 6

F. Scher

. . . CONTENTS . . .

Resistance Measurement at High Impulse Voltages	<i>Electronics</i>	1
Wave Guides	<i>Radio News</i>	5
Crystal-Controlled Oscillators	<i>Service</i>	11
Principles of Loran in Position Location	<i>Electronic Industries</i>	17
The TBA Plan for Television Channel Allocations	<i>Television</i>	22
An FM Phono Pickup	<i>Radio-Craft</i>	25
Shipborne Radar	<i>Communications</i>	27
Crystal Control in the New Ham Bands	<i>QST</i>	31
What's Being Read This Month		34

PUBLISHED BY REEVES-ELY LABORATORIES, INC.

www.americanradiohistory.com



THE RADIO ENGINEERS' DIGEST

JOHN F. C. MOORE, *Editor*

Copyright 1946 by Reeves-Ely Laboratories, Inc.

Vol. 2, No. 6

January 1946

Published monthly at New York, N. Y., by Reeves-Ely Laboratories, Inc.
comprising the following operating divisions and subsidiaries:

AMERICAN TRANSFORMER COMPANY, NEWARK, N. J.
HUDSON AMERICAN CORPORATION, NEW YORK, N. Y.
REEVES SOUND LABORATORIES, NEW YORK, N. Y.
WARING PRODUCTS CORPORATION, NEW YORK, N. Y.
THE WINSTED HARDWARE MANUFACTURING COMPANY, WINSTED, CONN.

For free distribution to our friends in the radio and electronics industries

Editorial Office, 25 West 43rd Street, New York 18, N. Y.

Printed by Criterion Products Corporation, New York, N. Y., U. S. A.

RESISTANCE MEASUREMENT AT HIGH IMPULSE VOLTAGES

Commonly used methods of measuring resistance cannot predict the effect of voltage coefficient on resistors subjected to high impulse voltages. The decreased resistance caused by impulses such as ignition voltages can be determined by the technique described.

Reprinted from *Electronics*
By *Scott L. Shive*
Radio Engineer
Signal Corps Ground Signal Agency
Detroit Signal Laboratory
Detroit, Mich.

COMPOSITION-TYPE resistors are ordinarily possessed of a voltage coefficient characterized by decreasing resistance as the voltage applied to the element increases. The rate of resistance drop with increasing voltage is dependent upon physical characteristics of the resistor such as, for example, the ingredients comprising the mix and the physical size in relation to the resistance value.

PROBLEM OF HIGH VOLTAGE

The suppression effectiveness of a resistor element applied to a high-tension ignition circuit is a function not necessarily of the resistance at low voltages, such as would normally be used in an ohmmeter circuit, but of the resistance at the instant of spark-plug discharge when the full high voltage of the system is impressed momentarily across the suppressor. The general range of ignition voltages is considered to be approximately from 5,000 volts to 12,000 volts, with the majority of motor vehicles normally operating near the lower limit.

The measurement at low voltage of any given resistor sample is a relatively simple matter. A number of adequate methods are available and generally applicable for the condition under which the applied voltage does not greatly exceed the rated voltage of the sample, or under which the measurement can be made quickly enough so that appreciable heating of the sample does not occur. However, it is evident that commonly employed methods cannot be used where measurements are to be made with applied voltages of 5,000 to 12,000 volts and where the resistor element is a composition carbon suppressor rated at 10,000 ohms and $\frac{1}{2}$ watt.

High voltages may be applied to the resistor element in question only momentarily if a serious heating effect is to be avoided. Thus a pulse of the desired peak value must be generated. As well as being of extremely short duration, it is desirable that the pulse be relatively free of higher harmonics and consequently approximately sinusoidal in wave form, yet capable of being reproduced accurately and repeatedly.

GENERATION OF PULSE

Essentially, the procedure for generating voltage pulses of the desired characteristics is to discharge a capacitor through the primary winding of a suitable step-up transformer. The resulting voltage wave appearing across the secondary winding is

Copyrighted 1945, (all rights reserved) by McGraw-Hill Publishing Co., Inc.
330 West 42nd Street, N. Y. C.
(*Electronics*, November 1945)

actually a rapidly damped wave train of relatively short duration. The initial half-cycle will, with the use of proper circuit elements, reach a peak value of several thousand volts and be eminently satisfactory for the purpose of high-voltage resistance measurements.

One specific circuit is shown in Fig. 1. In this, the pulse is generated by closing the key, thereby discharging a $4\mu\text{f}$ capacitor through the primary of a 3-kva, 60-cycle power transformer. A pulse of approximately 12,000 volts peak is developed across the loaded transformer secondary when the capacitor is charged to the full 1,000 volts just prior to discharge. The transformer windings consist of a 110-volt primary and a 3000-volt secondary.

The d-c power supply may be any source that is variable over the range from zero to approximately 1,000 volts and capable of withstanding a current drain sufficient to charge a $4\mu\text{f}$ capacitor to 1,000 volts through a 10,000-ohm resistor once every second.

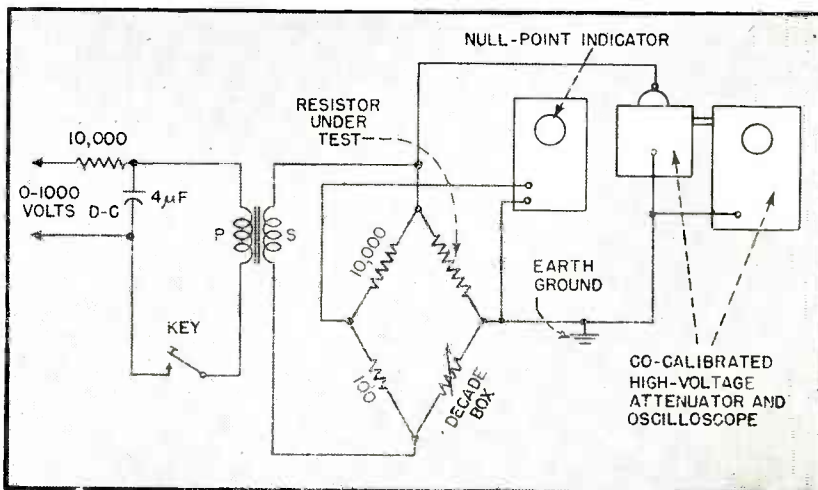

Fig. 1. Circuit for measuring the resistance of a suppressor subjected to high impulse voltage. One oscilloscope is employed as an indicator of the balance point of the bridge and the other for measurement of the peak voltage applied to the sample.

RESISTANCE MEASURING CIRCUIT

The measurement is accomplished by use of the Wheatstone bridge circuit, one arm of which is the resistor sample under test. The high voltage pulse is impressed across the entire bridge, and a balance is obtained by adjusting the variable arm. The null, or balance point, is indicated by the trace on an oscilloscope connected across the bridge at points diagonally opposite the high-voltage pulse connections.

A measure of the peak voltage of the pulses impressed across the test sample is obtained from the height of the trace on the screen of a second oscilloscope, calibrated in conjunction with a high-voltage attenuator.

With reference again to the diagram of Fig. 1, the two fixed arms of the bridge circuit are 10,000 ohms and 100 ohms respectively. These are wire wound resistors which have zero voltage coefficient. The variable arm consists of a decade box, also of wirewound elements, whose setting at balance is exactly 1/100 of the test sample

resistance. The null-point indicating oscilloscope used here is a 3 inch R.C.A. Model 155-A, while the pulse measuring system is composed of a DuMont oscilloscope, type No. 208, and a specially co-calibrated Rowe Research Laboratory high-voltage attenuator, type No. CA-211.

OPERATING PROCEDURE AND PRECAUTIONS

After connecting the resistor sample into the bridge circuit, the output of the d-c supply is adjusted until the desired pulse voltage, as indicated on the pulse-measuring scope, is applied across the test sample. During this and the subsequent procedure, the pulses should be produced at a rate not exceeding one per second in order to avoid appreciable heating of the sample and in order that the capacitor may become completely charged between discharges, thus assuring identical amplitudes for successive pulses.

With the desired pulse voltage obtained, the decade box used as the variable arm of the bridge is adjusted to produce balance. For the particular fixed arm resistance values used herein, the resistance of the unknown test sample at the selected voltage is then 100 times the decade-box setting.

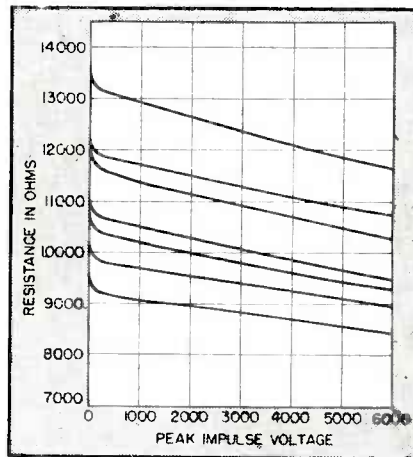

Fig. 2. Typical curves of resistance as a function of high impulse voltages, for samples of composition-type resistors. The nominal rating of the resistors is 10,000 ohms, one watt.

The bridge circuit is considered balanced for the setting at which the overall height of the trace on the null-point indicating oscilloscope is either zero or minimum. The height will be zero or nearly so when the test sample has little or no voltage coefficient, but for resistors with any appreciable degree of nonlinearity, the overall height of the trace cannot be reduced to zero and the null point becomes somewhat more difficult to detect.

INDICATOR TRACE

The effect of voltage coefficient or nonlinearity is to introduce a third harmonic into the current wave in the side of the bridge circuit containing the sample. This harmonic, depending in amplitude upon the degree of the nonlinearity, appears in the voltage wave across the terminals of the null-point indicator and cannot be balanced out. Hence the balance point in this case is taken to be that at which the fundamental of the first half-cycle of the pulse wave train is balanced out, and

nothing but harmonics remain in the oscilloscope trace. The fundamental is identified by a long tail extending well above or below the zero line and rapidly decreasing, as balance is approached from the high side, until finally at balance it disappears into the traces of the harmonics.

It will generally be found most satisfactory to operate the null-indicating oscilloscope with a horizontal sweep of approximately $\frac{1}{4}$ inch and from 200 to 300 cps.

The fixed arms of the bridge may be composed of inductive wire-wound resistors. The inductance so introduced has only a negligible effect on the accuracy of measurement at the frequency of the pulse wave. A 10,000 ohm wirewound resistor, with zero-voltage coefficient when measured at 10,000 volts, reads within 0.5 percent of its resistance at 6 volts d-c.

TYPICAL RESULTS

Figure 2 shows typical curves of resistance plotted against high impulse voltage obtained for representative samples of composition carbon-type suppressors nominally rated 10,000 ohms at one watt. The curves are seen to be relatively straight lines, from approximately 1,000 volts on up, with a constant negative slope. Thus for these samples, the resistance drop at high impulse voltages is approximately directly proportional to the peak value of voltage.



200% INCREASE IN COMFORT

The electric stabilizer which insured deadly aiming of guns as battle tanks plunged over rough terrain has led to development of a stabilizer for railroad coaches. In tests it has stepped up riding comfort by as much as 200%.

WAVE GUIDES

Reprinted from Radio News, Radio-Electronic Engineering Edition
By S. J. Mallory

Non-technical discussion of advantages and possibilities of wave guides for piping television programs.

A WELL recognized major problem confronting television engineers is that of providing links between cities for television network broadcasting. In the case of radio, network programs are sent over ordinary telephone lines to the many community radio stations. Television pictures, however, cannot be transmitted over existing lines.

A limited solution to this problem is a network of coaxial cables similar to those in use by the Bell System to provide telephone circuits between New York and Philadelphia and between Minneapolis and Stevens Point. These cables, however, have a capacity of only one television channel each. Shortly before the war, engineers found that by eliminating the center conductor of a coaxial cable it could carry much higher radio frequencies with remarkably little loss. Using these high frequencies, the number of available radio and television channels increases accordingly.

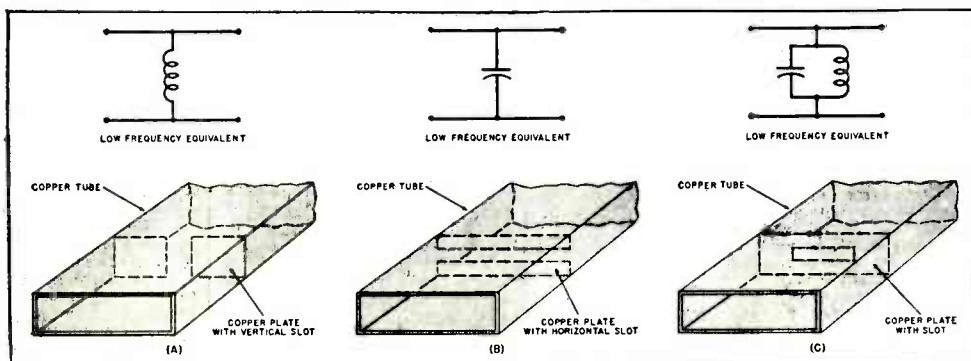

Fig. 1. Well-known low-frequency circuit elements can be simulated by placing a slotted metal plate across the inside of a wave guide. (A) With a slit across the short side, an inductive effect is obtained. (B) A capacitive effect may be had by placing the slit across the long side. (C) By employing a slotted plate, the wave-guide iris represents a shunt resonant circuit.

This new hollow transmission line is known as a wave guide. It may be of circular, square, rectangular, or other cross-section. Early work was carried on with the use of circular wave guides. Later, rectangular guides were found to have advantages for some purposes.

A single half-inch diameter wave guide could carry every television program in the country if need be. These wave-guide transmission lines between cities could carry television over the mountains and under the rivers to all the peoples of the United States as they are now served by ordinary network radio programs.

Copyright 1945, Ziff-Davis Publishing Co., 185 No. Wabash Ave., Chicago, Ill.
(Radio News, Radio-Electronic Engineering Edition, December 1945)

Within the city, wave guides could serve as a reliable medium through which television would reach additional thousands. Theaters could have a wave-guide connection with the main distributing system and the audience could see the news as it happens. Apartment dwellers could have the television piped in like water and their receiver could select any of several picture entertainments without concern of high buildings between the desired station and their cozy living rooms. Newspaper photographers could sit in their office studios and select their news shots from any of the half dozen news service television pictures "piped" from the scenes of the actual happening. All this over the small pipe we call a wave guide.

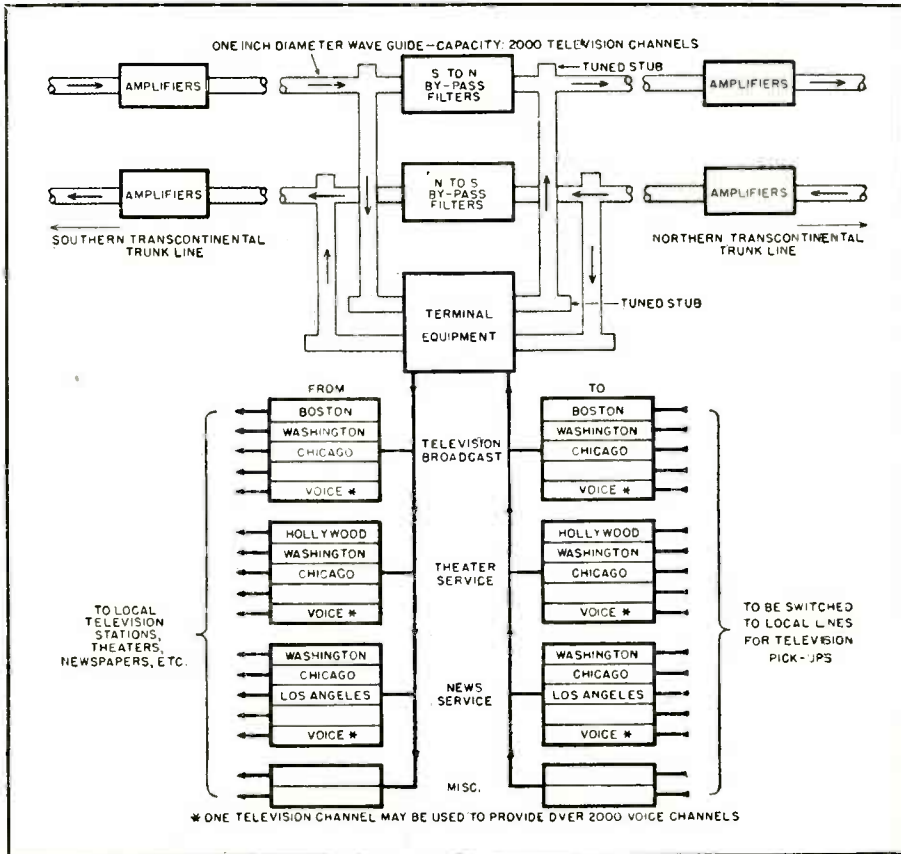

A typical television distribution terminal for a wave-guide transmission line.

All this and more was made possible when two American engineers working independently announced almost simultaneously the discovery that radio waves of frequencies thousands of times as high as those used for regular broadcast purposes could be transmitted through pipes or tubes even when filled with an insulating material. Pipes when used for this purpose are known as wave guides.

Why not use an ordinary pair of parallel wires to transmit these high frequency signals? Ordinary two wire lines are suitable for use at low frequencies, but at ultra-high frequencies the capacity between the conductors gives too great an attenuation and, furthermore, the waves would radiate from the wires and be lost in space.

Coaxial cables which are in common use are in reality merely a form of parallel wires with the difference that one conductor is tubular and wholly encloses the

second conductor. The inner conductor is supported on small insulators and is concentric with the outer conductor. This construction prevents loss of high-frequency energy by radiation but does not overcome the capacitive losses.

The transmission of electric waves through a hollow pipe is contrary to our ordinary conception of conveying electricity in that no return conductor is provided. However, these waves may be compared to the radio waves which are sent out from an ordinary radio transmitting antenna. In actual practice the waves to be sent through a wave guide are launched from a small antenna placed a quarter wavelength from the end of the wave guide. The transmitting ground is the wave guide proper.

Electromagnetic waves of a wavelength greater than about twice the diameter of a round wave guide will not flow through the guide. This wavelength is known as the cut-off point. The frequency corresponding to this wavelength is known as f_c .

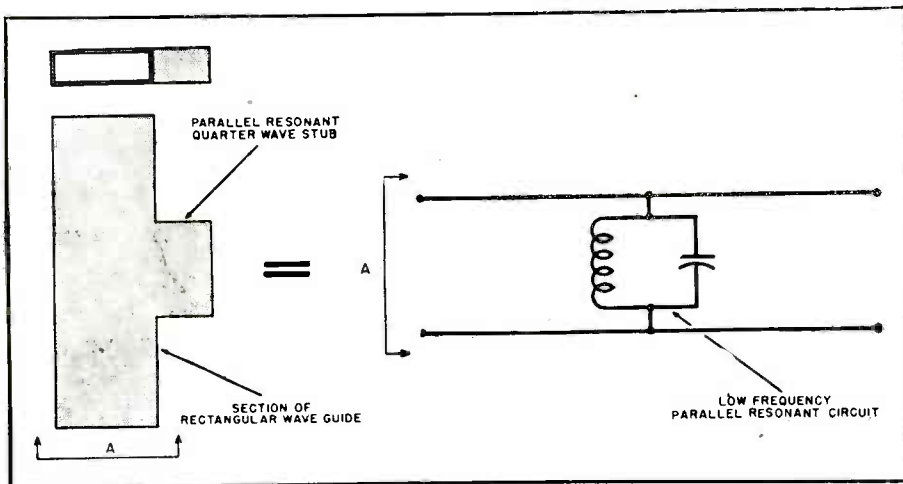

Fig. 2. A section of wave guide one-quarter wavelength long, connected to the side of a waveguide transmission line, is equivalent to connecting a parallel resonant circuit across a low-frequency two-wire line.

the cut-off frequency, or the critical frequency. All higher frequencies or shorter wavelengths can be transmitted through the wave guide. The critical frequency of a wave guide of rectangular cross section is determined by the larger of the two cross-sectional dimensions. The smaller dimension determines the amount of power the wave guide will handle. A $\frac{1}{4}$ " x 2" wave guide will transmit a 5 cm. wave of a fair amount of power.

Various appliances and fixtures have been developed for use with wave guides. These fixtures or plumbing, as they are often referred to, are analogous to familiar circuit components used in low frequency radio or electrical circuits.

A thin metal plate mounted across the inside of a wave guide may be cut or altered to simulate well known low frequency circuit elements. A slit cut across center of the plate parallel to the short side and leaving a small window will react as an inductance (Fig. 1A). A similar opening made parallel to the long side acts as a capacitive reactance (Fig. 1B). A combination of the two can be designed to act as a parallel resonant circuit with an infinite shunt impedance (Fig. 1C).

A small section of wave guide about a quarter of a wavelength long and connected to the side of the main guide behaves as a shunt resonant circuit with a high shunt impedance (Fig. 2). If the stub is a half wavelength long, it presents a short

circuit across the main wave guide (Fig. 4). Various other implements and devices are used to make measurements and to perform the duties of ordinary low-frequency circuit components.

Early work on wave guides was hampered considerably by the non-existence of tubes that would generate more than very small amounts of power at wavelengths short enough for use with wave guides of a practical size. Early tubes used for this purpose were usually of the positive-grid, negative-plate type known as Barkhausen oscillators (Fig. 3). Other types used were velocity modulation oscillators with resonant metal cavities mounted on the tube, and magnetrons which operate in the field of a powerful magnet.

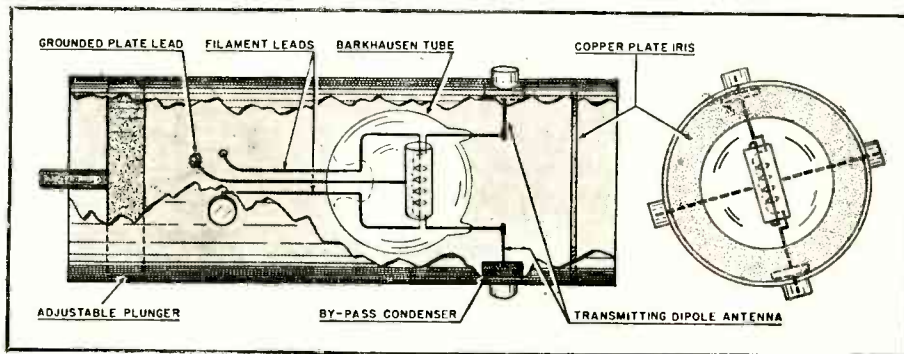

Fig. 3. A Barkhausen-type oscillator mounted in a resonant cavity is suitable for generating electric waves to travel through a circular wave guide.

The I.R.E. Proceedings for March, 1944 published a reprint of an article which appeared in volume 10, 1940, of *Journal of Technical Physics* (Russian), indicating that Russian scientists have developed magnetrons capable of furnishing as much as 300 watts at a wavelength of 9 cm. and 2 watts at 2.6 cm wavelength. These latter waves could be transmitted through a wave guide of little more than half an inch in diameter. (*Much higher power is used in American radar equipment. Ed.*)

How does all this affect the future of television? In order to answer this question, let us discuss television requirements briefly.

One objective sought in a television broadcast is to make available a picture that is as distinct and clear as possible; that is, the detail must be sharp. You all have had the undesirable experience of taking a snap-shot and of having the picture appear fuzzy and slightly out-of-focus. In order to produce a sharp television picture, the picture is broken up into thousands of small parts, over 350,000 parts in some cases, and each tiny segment is transmitted individually. This 350,000 segment picture is repeated 30 times each second. In order to perform this stupendous task it is necessary to transmit television pictures at very high frequencies.

The Federal Communications Commission allots a radio frequency band six million cycles wide to each television station as compared with the ten thousand cycle band allotted each radio broadcast station. A single television station occupies a band of frequencies six times greater than the combined frequency bands of all the radio broadcast stations in the U.S.

Future prospects of color television indicate the necessity of a band six million cycles wide for each color transmitted. Hence it was necessary to allot the television stations a portion of the frequency spectrum far removed from the normal broadcast band. This is the 50 to 300 million cycle region heretofore used only for experimental purposes.

A peculiar change takes place in radio waves at these high frequencies however, and, unlike the familiar broadcast radio, ultra-high frequency radio waves will not carry signals much farther than the horizon. These waves are similar to light waves in that respect. This means that a television transmitter located even as high as the Empire State Bldg. can be received no farther than 50 to 60 miles distant and furthermore it is unusual to have a 1000 foot tower so conveniently available. Thus, television "listeners" located a relatively short distance away may not be able to receive the broadcasts.

Complete coverage of an area is, therefore, possible only by means of a network of stations. One deterring factor that has held up the establishment of networks is the lack of available facilities for transmitting the television pictures between stations. Existing telephone lines cannot be used because they are not capable of transmitting the high frequencies necessary for good television pictures. A special kind of transmission line will have to be installed linking the stations of such a network.

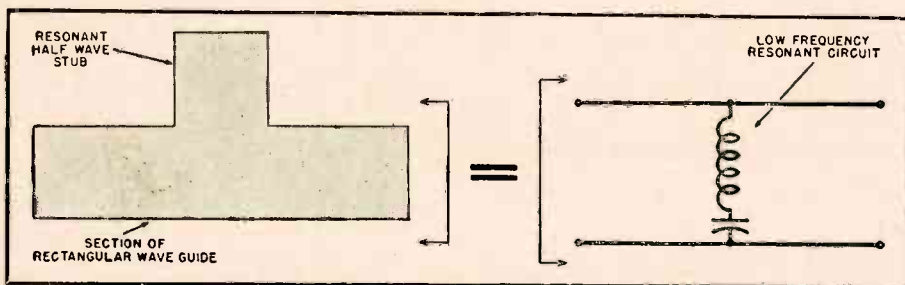

Fig. 4. A half-wavelength of wave guide connected to a section of wave-guide transmission line presents a shunt short-circuit at the frequency of resonance.

Wave guides offer a solution to this problem. A frequency band sufficiently wide to transmit one or several television pictures with the associated sound channels and control circuits could easily be handled over a single wave guide.

Another peculiarity of the high-frequency waves used in television broadcasting is that they will not pass through large structures such as skyscrapers, large apartment houses, elevated railroads, and the like. Such structures will cast a rather well-defined shadow in which the reception will be either poor or non-existent. Poor reception may be evidenced by such phenomena as fading of the picture or multiple appearances of the picture lurking in the background. These latter are known as *ghosts*. Troubles of this sort are mainly experienced in densely populated areas and could be overcome by supplying these receivers from a central distributing point through a special type of transmission line such as a wave guide.

One other limiting factor to television, as it is at present, has to do with picking up programs at locations other than at the main studio. Special feeder lines must be used for transmitting these pictures between the scene of the entertainment and transmitting station or stations. Most of the present-day programs originate in studios connected to the transmitter by single channel coaxial cable transmission lines. Portable radio systems are sometimes used in place of the transmission line in special cases but these may not be practical to use in the quick shifting news broadcasts and around-the-town scenes which will make up the programs of the future.

The desirable conditions of course would be those where the television program could be picked up at any location. You will want to be able to see Rita Hayworth

when she arrives at the Grand Central Station, the *Bums* making a winning home-run, and our future Presidents making their inaugural speeches. Not only you, but everyone else in the United States, would like to be able to have a ringside seat at these events.

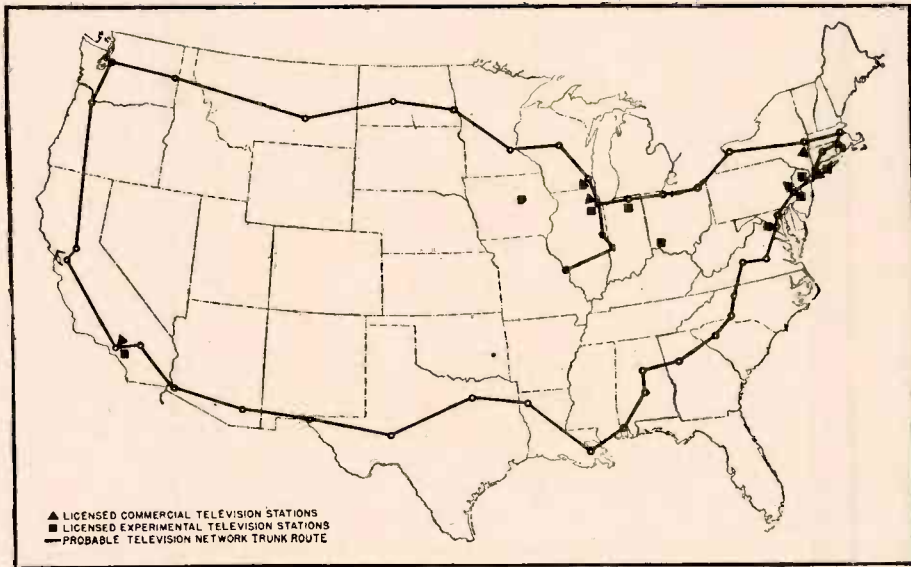

Nation-wide map of the various television stations (commercial and experimental) and the possible path of cross-country television network trunk routes.

Television is straining at the leash, ready now to surge into the American way of living and as Niles Trammell, President of the NBC, stated recently in the New York Times, "Television promises to be the greatest medium of mass communication yet evolved, with unparalleled opportunities for entertainment and education."

The use of wave guides may be the answer to obtaining for us, at an earlier date, the full realization of the benefits of television for all the peoples of these United States.

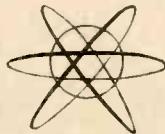

There is nothing so powerful as truth, — and often nothing so strange.

DANIEL WEBSTER

CRYSTAL-CONTROLLED OSCILLATORS

Reprinted from Service

By J. George Stewart

IN many types of post-war receivers crystal-controlled oscillators will be quite an important feature. The extensive use of these oscillators in Army-Navy equipment has developed crystal manufacture to the point where they are economically feasible

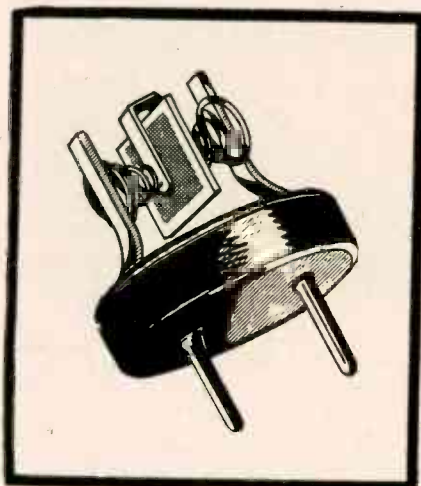

Fig. 1. A crystal unit in its holder, with the cover removed. The two springs serve to hold the electrodes against the crystal surface (Courtesy Crystal Research Laboratories)

for mass production. At the winter IRE meeting last January, we were shown a receiver which tuned the entire b-c band through the use of push-button crystal oscillators.

Most of the new f-m receivers will use crystal-controlled oscillators. Stability requirements in the newly assigned v-h-f band will create a need for double super-heterodyning, in which one of the fixed oscillators will probably be crystal controlled.

In the past most Service Men have had little opportunity to work with crystal-controlled oscillators, since their use has been restricted to transmitters and fixed frequency receivers.

PHYSICAL PROPERTIES OF CRYSTALS

Physically, the quartz crystal is less than an inch square and only several thousandths of an inch thick. This crystal is *sandwiched* between two small, flat squares of metal, called electrodes, which serve as surface contacts. Spring pressure is usually applied to these metal squares to hold them firmly in place, and leads are brought out from these electrodes to external pins or contacts. The entire assembly

is housed in a unit called the crystal holder. This has been the practice in the past. However, cost economy factors in receiver design may change the form of crystal holder, so that a simpler device embodying the same principles may be used.

ELECTRICAL CRYSTAL PROPERTIES

The crystal may be likened to a two-plate condenser, with the crystal acting as the dielectric, Fig. 1.

Electrically, the crystal is equivalent to a high Q , parallel resonant-tuned circuit, whose frequency is largely determined by the physical dimensions of the quartz crystal. Its electrical equivalent is shown in Fig. 2, where L , C and R are the series electrical constants of the crystal unit, and C_H represents the capacitance between the metal electrodes, with the crystal acting as the dielectric. C_1 represents the series capacitance between the crystal proper, and the electrodes.

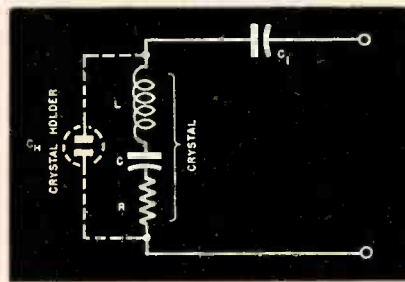

Fig. 2. The electrical equivalent of the crystal and its holder. In effect, the crystal is a series-resonant circuit, consisting of L , C , and R , with the capacitance of the holder across the entire system C_1 represents the series capacitance between the crystal proper, and the electrodes.

CRYSTAL OPERATION

When an electrical current of approximately resonant frequency is applied across the crystal, sympathetic vibrations are set up in the crystal structure. This vibration, in turn, causes large voltages to appear between the electrodes. For this reason, the crystal may be used in place of an LC element in the grid circuit of an oscillator to supply the necessary grid driving voltage. Since the physical dimensions of the crystal are constant, and do not expand appreciably with heat, and since these same dimensions determine the frequency of operation, in the same way that the dimensions of a tuning fork determine its audible frequency, it can be seen that a high degree of frequency stability is thus obtained.

GRID CIRCUIT ACTIVITY

When installed in the grid circuit of an oscillator, the value of C_H is further increased by the input capacitance of the tube, and the capacitance of the associated wiring. The resultant influence on the crystal frequency is quite small, and insofar as related to receivers, may be considered negligible.

CRYSTAL OUTPUTS

Crystal units are capable of delivering large values of r-f voltage, depending on the tube used, and the circuit voltages. However, in receiver applications, the amount of power required is small, and the circuit components reflect this in their size.

Any of several standard circuits may be employed using a crystal as the frequency-controlling element. Three typical circuits are shown in Fig. 3a, b, and c.

TRIODE-CRYSTAL OSCILLATORS

In Fig. 3a is shown a triode-crystal oscillator in its simplest form. This circuit is essentially a tuned-plate tuned-grid oscillator, with the feedback supplied by the grid-plate capacitance of the tube. Since the crystal itself is a discontinuous d-c circuit, the grid of the tube is returned to ground through the resistor R_1 . This resistor serves a second purpose, since it also limits the r-f current in the grid circuit. This grid current limitation is important, since the permissible current through the crystal must be kept below the crystal rating, else the crystal may be punctured and rendered inoperative. Expressed another way, the activity of the crystal is a function of the r-f voltage across it. If this voltage exceeds the limits of the crystal, the overactivity will shatter the crystal. Therefore, decreasing the value of the grid resistor reduces the current through the crystal. In Fig. 3a the cathode has been returned to ground, so that the grid bias is a function of the grid current which creates the bias across the grid resistor.

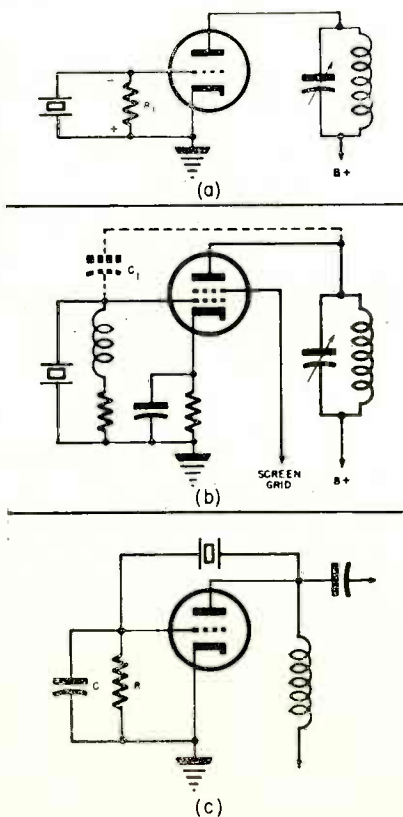

Fig. 3. Three circuits employing crystals for frequency control. In a, a triode circuit in its simplest form is shown. In b, we have a pentode circuit, while c shows the Pierce oscillator, which does not require a resonant circuit in the plate.

PENTODE CIRCUIT

In Fig. 3b a pentode has been substituted for the triode. Since the gain of a pentode is higher than that of a triode, less grid excitation is needed. The feedback from the plate to the grid has been reduced by the lower g-p capacitance inherent in the pentode structure. If this capacitance is too low, an external coupling capacitor

represented by C , is added, so that sufficient feedback is available. The size of the grid resistor for pentode crystal oscillators is usually 20,000 ohms or less. Since the lower value of resistor may shunt the crystal too effectively, and prevent oscillation, a r-f choke is usually added in series with the resistor. The choke supplies the necessary a-c impedance to reduce the shunting effect of the resistor, at the same time introducing a negligible amount of d-c resistance. Where cathode bias is used, the size of the grid resistor is reduced.

CRYSTAL EXCITATION

The crystal excitation is a direct function of the plate and screen voltages used, and they must be watched carefully to make sure that they are not excessive. Since power is not important in a receiver, high value grid resistors, and low grid and plate voltages may be used.

Fig. 4. A method for doubling the frequency of the crystal circuit. The first r-f transformer is tuned to the crystal frequency, while L_2C_2 is tuned to twice the crystal frequency.

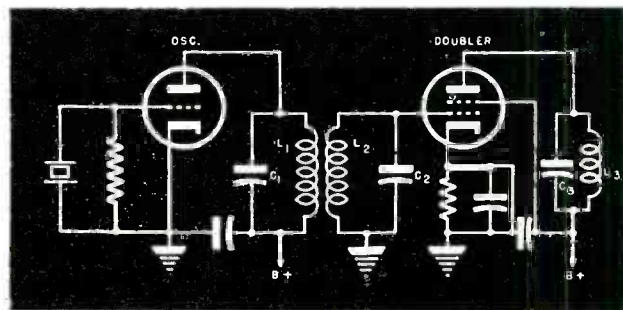

PIERCE OSCILLATORS

Fig. 3c shows a third method of crystal control for frequency stability, the Pierce oscillator circuit. A triode is used, although a pentode may be used too. Here, the crystal is used as the coupling element between the plate and grid circuits. Note that the plate circuit is untuned. Its use in a circuit of this type is similar to a crystal filter, in which only resonant voltages are passed by the crystal, the crystal performing as a series resonant circuit. For all other frequencies, the crystal acts as a pure capacitor. C_1 and the crystal may be considered as a load across the output of the tube. Therefore increasing the value of C_1 increases the load across the output circuit and the resultant grid current. Because of its position in the circuit the crystal is subject to high voltage strains. Therefore the plate voltage of Pierce oscillators is usually lower than for other crystal circuits.

HARMONIC OSCILLATORS

Fundamental frequency operation of crystal oscillators is limited by crystal size to about 15 mc. Crystals for frequencies above 6 or 7 mc are very expensive. To overcome this condition, the crystal may be cut to operate on a mechanical harmonic of its fundamental frequency, or may be employed in a circuit where some harmonic of the fundamental frequency of the crystal is amplified. When the crystal is operated on a mechanical harmonic of its fundamental frequency, the resonant circuit in the plate of the oscillator is tuned to the desired harmonic. The crystal then behaves as though it were oscillating fundamentally at the harmonic frequency. When the crystal is used to drive the frequency multiplier, the crystal first oscillates at its fundamental frequency. This fundamental frequency is then used to drive the multiplier stage. Sometimes, where the desired frequency is quite high, both methods are used concurrently.

FREQUENCY MULTIPLIER

Fig. 4 shows a typical crystal oscillator and frequency multiplier. In this circuit, L_1C_1 and L_2C_2 are tuned to the crystal frequency. L_3C_3 is tuned to twice the crystal frequency. Thus, the output of the doubler stage is twice the fundamental or crystal frequency.

TRI-TET CIRCUITS

This same principle may be so used that only one tube is necessary for both operations. For example, the crystal oscillator may be one-half of a twin triode, and the doubler may be the other half. Or, a pentode may be used, as shown in Fig. 5. This circuit is known as the *tri-tet*. Here, the control grid, cathode, and screen grid perform as a triode-crystal oscillator. The screen grid serves as the plate of the triode. The plate of the tube is then used as the multiplier, with L_2C_2 tuned to the desired harmonic. This circuit is usually used where even multiples of the fundamental frequency are desired. The circuit of Fig. 6 is used where odd multiples of the fundamental frequency are desired. This circuit is known as the *grid-plate* oscillator. The essential difference between the two circuits is that in Fig. 5 the crystal is returned to ground through the resonant circuit L_1C_1 , whereas in Fig. 6 the crystal is returned to ground directly.

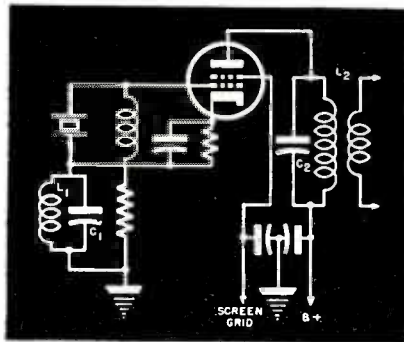

Fig. 5. A crystal frequency multiplier using one tube. L_1C_1 is tuned to the crystal frequency, while L_2C_2 is tuned to a multiple of this frequency. This circuit is used where even multiples of the crystal frequency are desired.

RESONANT CIRCUIT AND CATHODE RETURN

Actually, the circuit of Fig. 6 is a Pierce oscillator, since the screen grid, which is being used as the plate of a triode oscillator, and the crystal return, are connected together through their common ground terminals. Since the cathode of a tube may be considered as a continuation of the plate circuit, the placing of the resonant circuit in the cathode return does not change the relationship, other than placing the actual plate of the tube at r-f ground.

OSCILLATOR TUNING

All crystal oscillators are tuned in essentially the same way. Fig. 7 shows a typical plate-current characteristic for a crystal oscillator. When the oscillator is in the non-oscillating stage, the plate current will be found to be at some high level. As the plate-tank tuning capacitor is tuned from minimum capacitance, the plate current will dip as shown in Fig. 7; the current decreases slowly until it reaches some minimum value, and then rises sharply. The maximum oscillation will take place at the point of minimum plate current. However, for stability purposes, it is

best to operate the crystal oscillator at some point about halfway between maximum and minimum plate current. This point of operation also limits the amount of r-f current in the crystal, and will help prolong its useful life.

CAUSES OF NON-OSCILLATION

If the crystal oscillator stops oscillating, the cause may be traced to physical and electrical problems.

For instance, dirt on the crystal faces will interfere with oscillation. To clean crystals, carbon tetrachloride should be used. The faces of the crystal should be immersed in the liquid and then carefully dried on some lint-free cloth. The faces of the crystal should never be touched with the fingers, since a light film of grease is thus deposited on the crystal impairing its performance. The crystal should always be picked up by its edges, and care should be exercised not to chip the edges. The electrodes should receive similar care, since dirt or grease on their faces will produce the same effects as they would on the crystal.

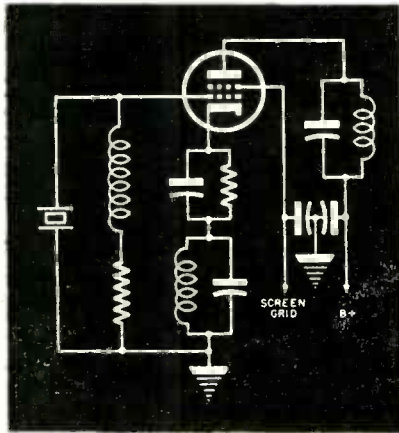

Fig. 6. This multiplier circuit is used where odd multiples of the crystal frequency are desired. The crystal portion of the circuit is essentially a Pierce oscillator, with the screen grid acting as the plate of a triode oscillator.

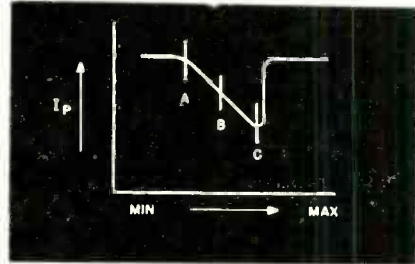

Fig. 7. Plate current characteristic of a crystal oscillator. For stability requirements, the circuit is tuned so that the current is in the vicinity of point B. This also prolongs the life of the crystal.

TIGHT COUPLING

If the crystal oscillator is coupled too tightly to the load, oscillations will cease. This condition will be rare in receivers, but is mentioned here in case some variable coupling method is used.

OTHER SOURCES OF TROUBLE

Detuning of the plate tank circuit is another source of trouble. The cure is obvious. All bypasses and coupling capacitors should be checked if some unusual condition appears. For example, an open g-p coupling capacitor, or if a variable coupling capacitor is used, a low value of coupling capacitance will prevent oscillations from starting. An open screen-grid bypass, or a reduction in its value, may cause excessive excitation of the crystal. Another cause of excessive excitation is high bias. This should be checked with a v-t voltmeter in the grid circuit. For other troubles, the crystal-controlled oscillator may be treated in the same manner as any oscillator.

PRINCIPLES OF LORAN IN POSITION LOCATION

Reprinted from *Electronic Industries*
By *Richard W. Kenyon*

War developed navigational aid permits surface ships or aircraft to locate themselves accurately by radio signal

The name Loran is derived from LONG RANGE Navigation and is descriptive of a system that enables a surface ship or an aircraft to determine its position by radio, without the necessity of radio transmissions from the craft itself.

A complete Loran system consists of a number of pairs of pulse transmitters located on the coast-line, and a receiver and indicator on the ship or aircraft. As in radar, the Loran system depends upon the fact that radio signals travel with a constant velocity. The distance between the shore transmitter and the receiver therefore is directly proportional to the time required for the reception of the signal. Position is determined by comparing arrival times of received pulses of radio frequency energy with charts prepared for the particular area which correlate time and position.

OPERATING PRINCIPLE

If two Loran transmitting stations, separated by several hundred miles, emit omni-directional signals, it is obvious that if signal pulses were transmitted at the same instant and received at the same time, the surface ship must be located somewhere on the perpendicular bisector of the baseline between the stations. When the travel time of the signals is not equal, then the ship is closer to one transmitter than to the other and the navigator must consult charts supplied for the particular area.

Loran transmitters, as indicated in Fig. 1, are the foci of a family of hyperbolas drawn as lines of constant time difference between the received pulses. Loran receivers and indicators measure directly the difference in time of arrival of radio signals from a pair of Loran transmitting stations.

In the simple example given, an ambiguity arises as to what point on the hyperbola the ship is located. The situation may be clarified by the introduction of a second pair of Loran transmitters, which will provide a second line of position. The intersection of the two lines of position determines a "fix," as shown in Fig. 1.

The shore transmitters in a Loran system send pulses of identical shape timed to have a repetition rate near 30 CPS. In practice the pulses from a pair of stations, known as a master station and a slave station, are not transmitted simultaneously. The slave station signal is delayed a finite amount so that it will always arrive last at a receiver. The amount of delay needs to be at least equal to the radio signal travel time of the baseline between the two stations, but usually is considerably more. This delay eliminates the ambiguity mentioned in the previous paragraph.

The frequencies used for transmission are less than 5 mc. Ranges of 500 to 700 nautical miles may be expected during the daytime, and up to 1400 nautical miles at night.

Sky wave transmission is depended upon for the additional night range. This leads to complex pulse patterns. Instead of single pulses, as in the case of ground wave reception, a train of pulses will result from ionosphere reflection. The first pulse of a train is the ground wave signal, which must be used for accuracy in position determination.

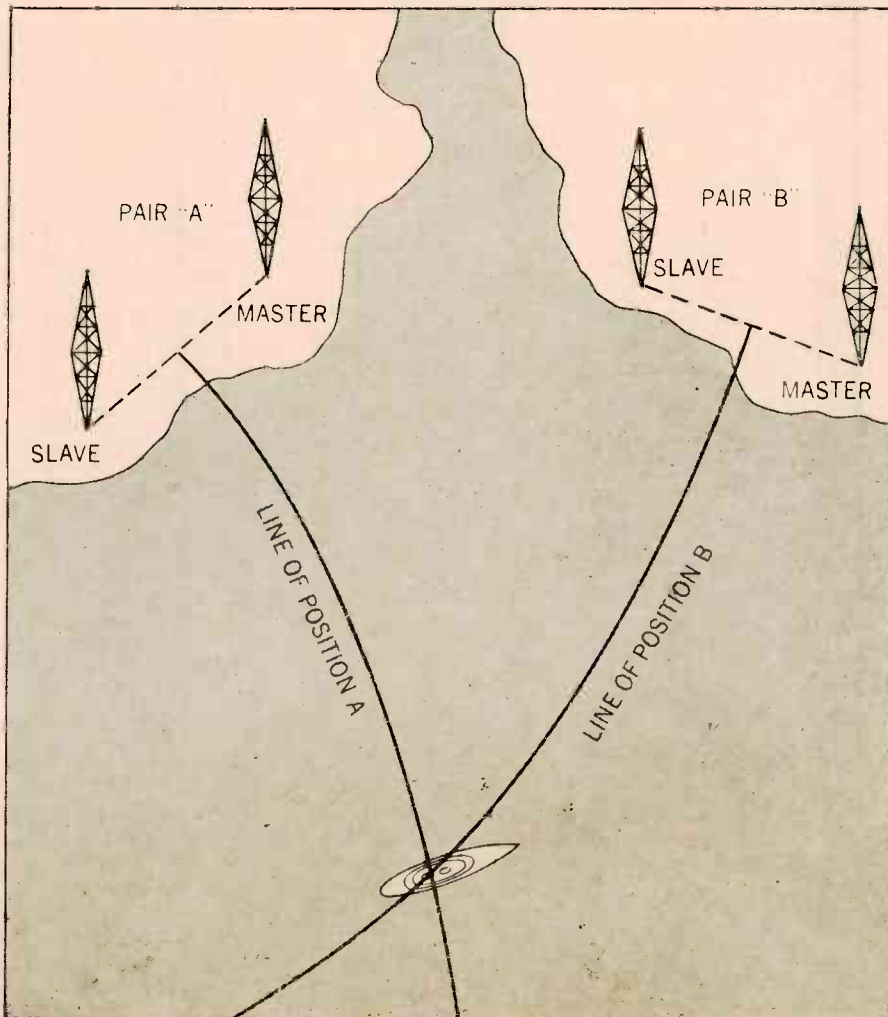

Fig. 1. Hyperbolic curves connecting points with an equal time difference of pulse arrival, show path on which craft might be located on map. A fix is obtained by intersection of two curves.

The Loran indicator measures the time of arrival of the radio signals from the transmitters. A superheterodyne receiver, conventional in design, introduces the signals into the indicator. The receiver is 80 kc wide, and has a gain of about 10^7 . A separate tube controls the receiver gain from the indicator control panel. A functional block diagram of the receiver indicator is shown in Fig. 2.

The indicator is a cathode ray oscillograph with two horizontal sweeps displaced one above the other. The upper horizontal trace is for the master station pulse while the lower trace shows the slave pulses.

The vertically displaced horizontal traces permit convenient comparison of time differences between master station or A pulse and the slave or B pulse. The left end of the lower or B trace represents the same time instant as the right end of the upper trace.

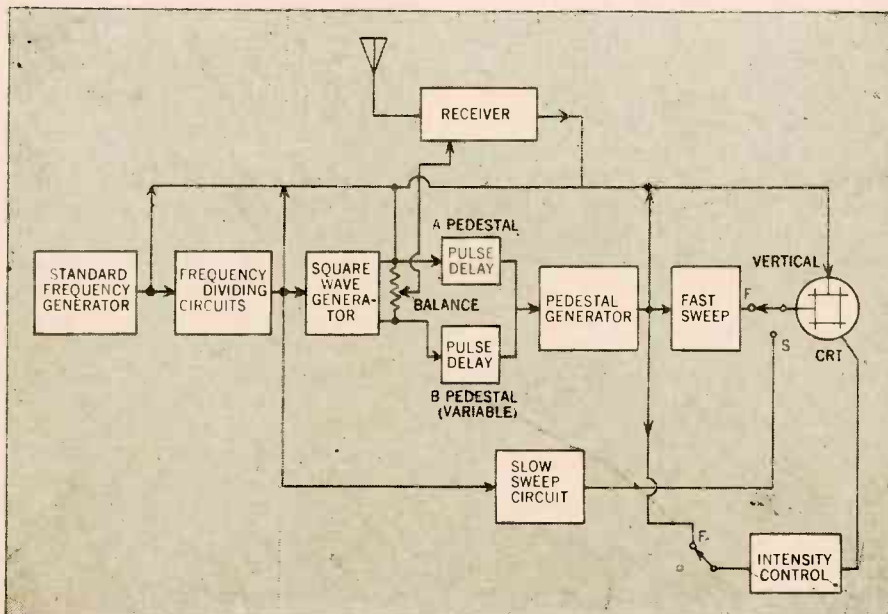
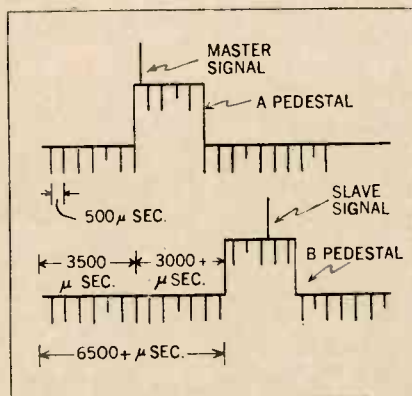

Fig. 2. This is a block diagram of a typical Loran receiver, which converts the time intervals between pulses to a highly precise positional displacement on a cathode ray tube viewing screen.

A system of internally generated pulses applied to the vertical deflection plates of the indicator act as time markers and permit measurement of interval between A and B pulses.

The standard frequency generator is crystal controlled at 100 kc. The output of this stage is applied to the frequency divider circuits which are of the blocking oscillator type. The resulting sharp pulses are superimposed on the trace at 10, 50,

Fig. 3. Here is shown a typical screen pattern in which the two pulses are received on pedestals to form two parallel horizontal traces.



and 500 microsecond intervals. Output pulses from the frequency divider circuits are used to trip the slow-sweep circuit, thereby providing an oscilloscope horizontal sweep of exactly twice the pulse repetition rate of the transmitter. A square wave generator produces a square wave of one-half the sweep frequency. This output is impressed in the vertical deflection plates of the oscilloscope to separate the two horizontal traces.

The square wave output is also applied to A and B pedestal delay circuits. The pulses from the A and B delay circuits time a pedestal generator which produces a "step" on each horizontal trace. The length of this pedestal is variable from 225 to 2500 microseconds, depending on the measurement desired. The A pedestal is fixed in position while the B has a variable time delay range with respect to A of approximately 10,000 microseconds.

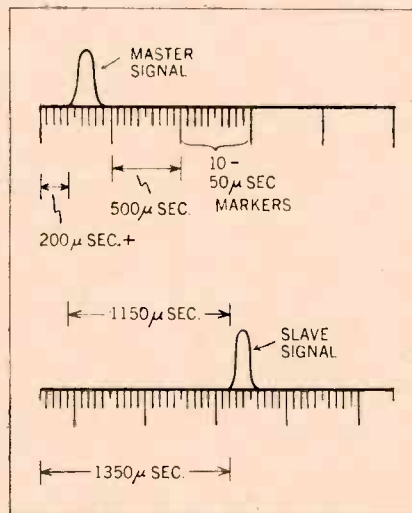

Fig. 4. The pattern of these pedestals is expanded for more precise determination of time displacements in computation of position.

The purpose of the pedestal on each trace is to create a "time zone" into which the A and B pulse can be placed by manipulation of the position of the B pedestal. Once these time zones are established, they can be treated separately by using a fast sweep to expand the pedestal time interval across the cathode ray screen for more accurate measurements.

The fast sweep circuit produces a sweep voltage in which amplitude varies almost linearly with the time occupied by the pedestals. In the fast sweep position only the tops of the pedestals appear on the oscilloscope screen.

MAKING A READING

A typical oscilloscope pattern of a Loran indicator is shown in Fig. 3. The long downward pulses are 500 microsecond markers. When the two signal pulses appear on the screen the object is to "stop" one on the A pedestal and the other on the B pedestal. The master station pulse is on the A trace or pedestal; the slave station pulse appears on the B trace. These signals can be stopped since the transmitter and receiver-indicator pulse rates are synchronized. When the signal is halted in the "B" pedestal, the time difference of the two signals can be read on the oscil-

oscope screen. First approximation readings are made from the left edge of the A pedestal to the left edge of the B pedestal. In Fig. 3, the time between left edge of A pedestal and B pedestal is $300 \mu \text{ sec}$.

Expansion of the sweep (Fig. 4) allows only the pedestal tops to be examined at full scale. Fig. 4 shows a total of five 500-microsecond markers and intermediate 50-microsecond markers. Examination of Fig. 4 shows that the time between slave and master signals is 1150 microseconds to the last 50-microsecond marker.

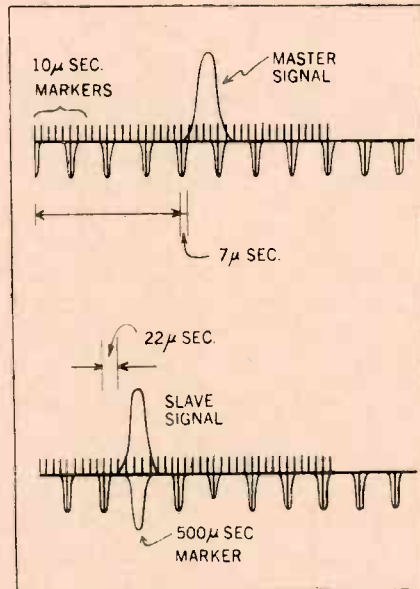

Fig. 5 shows further enlargement of the particular 500 microsecond interval, with expansions made by the oscilloscope sweep.

A further expansion (Fig. 5) of the sweep reveals the 50-microsecond intervals. This shows a time difference of 22 minus 7 or 15 microseconds. The total time difference of signals is therefore 4165 microseconds. This operation must then be repeated on a second pair of signals to determine a position fix.



THE TBA PLAN FOR TELEVISION CHANNEL ALLOCATIONS

Reprinted from *Television*

An analysis of the proposals put forth by this industry organization and why they are practical from an engineering point of view.

By *Will Baltin, Secretary-Treasurer*

WHEN the Television Broadcasters Association, Inc., presented to the Federal Communications Commission its "Industry Allocation Plan" for broad distribution of commercial television channels, it took a step in the right *direction*.

As a matter of fact the logical answer to distribution of 13 commercial channels over a wide area to an avalanche of applicants was to move in the same *direction* in which standard broadcasting moved years ago.

For example, with AM broadcasters clamoring for the same assignment of channels in adjacent areas of the east, midwest and farwest back in radio's early days, the FCC was faced with the dilemma of either insisting that these applicants share time on the air or arrange their antennae in such a way as to eliminate interference.

The answer—and rightfully so—was found in employing directional antennae. The commercial impracticality of time-sharing was established early in radio's history when such procedure was attempted. The era of networks proved its utter hopelessness.

Hence, the answer to channel assignments for television, like radio, may be found in "antenna directivity." Such a policy permits a minimum of 401 high-powered television stations in 135 of the first 140 major metropolitan districts of the United States.

The Engineering Committee of TBA had been giving careful study to various methods of channel distribution for several weeks prior to the FCC hearing on allocations last October. The problem was to create a competitive service for most major markets within the narrow confines of a 13-channel arrangement.

The task did not prove insuperable. History has a way of repeating itself and it was found that by applying the measure of "directivity" employed in standard broadcasting to television, more service to a greater number of people could result. A simple solution, yet one that might very well have been overlooked in an anxious quest for the right answer.

As Colonel William A. Roberts, Washington counsel for TBA, told the Commission at the hearing: "There is nothing untried or new in the method suggested. The

principles of certain directional antenna installations of a simple nature are thoroughly understood and accepted, and the Engineers of the Association have merely proposed the substitution of these directional characteristics in suitable instances for the reduction of power to the level of community stations, or the complete elimination of the use of channels by reason of unrestricted interference."

ANALYSIS OF PROPOSALS

Actually, what did the TBA proposal mean in terms of providing wider television service where the demand for channel assignment was greatest?

1. It meant that 59 more television stations could go on the air with high-powered transmitters than was possible under an allocation proposal recommended by the FCC.

2. It meant that cities like New Haven, Trenton, Lancaster and others could have television stations of power equal to those of New York City and Philadelphia without depriving larger metropolitan cities of sufficient channels to make possible a truly competitive service.

3. It meant that a commercial television service might be developed more quickly by permitting a greater number of applicants to enter the field now in the prime metropolitan, as well as the secondary metropolitan districts.

Although the TBA plan indicated the 401 high-powered stations were possible in 135 of the first 140 market areas, it made no attempt to show how many hundreds of more stations—high-powered and community—are possible elsewhere in the nation. The number is sizeable.

Dr. Thomas T. Goldsmith, Jr., a member of the Engineering Committee of TBA, in explaining the allocation proposal, told the Commission that the plan was the result of "progressive studies considering the technical requirements, the market considerations and the public service factors leading to a practical television industry."

He explained that the total of metropolitan high-powered stations provided for by the FCC was 342 for the first 140 markets, while the TBA industry plan provided 401 station assignments. New York City, for example, gained three high-powered stations in the TBA plan; Chicago gained two and Lancaster, which failed to be listed for assignment in the FCC proposal, got one station in the TBA proposal.

Dr. Goldsmith said that the use of directional antennae was suggested for only 48 out of the 401 proposed assignments under the TBA plan, in many cases antennae of simple design.

He emphasized the fact that the industry plan "provides high-powered stations in greater quantities in areas which can initiate and sustain a television service" without depriving adjacent districts of less populated sections of local television stations.

Another member of the Association's Engineering Committee, William S. Duttera, supplied the Commission with carefully drawn charts to show how effective directional antennae might be.

COVERAGE FIGURES

Duttera indicated, as did Dr. Goldsmith and Colonel Roberts, that "no complicated or unused directional antenna system has been considered." He submitted several charts showing the service areas of television stations as affected by co-channel and adjacent channel stations. (See Figs. 1 and 3.)

In order to outline the potentialities of the use of directive dipoles, Duttera cited as an example the coverage that might be obtained in the Trenton and Wilmington

metropolitan areas if stations in these cities were to operate on the same frequency. (This is shown in Fig. No. 2. The interference contour is a dashed line in both cases.) Both cities are only 57 miles apart, yet with each employing a full-powered metropolitan transmitter, combined with directivity in antenna design, the metropolitan districts of both, with some additional adjacent areas, could be provided with a television service.

Duttera advised the FCC that "no attempt has been made to determine the ultimate possible, nor can any such determination be made at the present time." He added that much depends on "further development of directional transmission; a greater knowledge of propagation; utilization of shielding effects of mountainous terrain; developments in the receiver antenna; satellites, and upon the possible use of directional receiving antennae."



THIMBLEFUL OF PRECISION

Ball bearings so tiny that 321 complete sets can be held in a thimble are used in precision mechanisms such as barometers and electrical instruments for aircraft.

AN FM PHONO PICKUP

Reprinted from Radio-Craft
By Nathaniel Rhita

CONSTRUCTION details of an FM pickup whose output could be received directly on an FM receiver were given in the 1944 Reference Annual. It was shown that such a device makes possible better fidelity than conventional phono pickups.

More improvements have been made in this field, the latest being a push-pull phonograph pickup recently disclosed by Alexis Badmaieff and assigned to RCA*. Not only does this instrument completely cover the audio range and far beyond, but its output is much higher. The wear on the record is practically negligible, and it includes a safety device which prevents needle damage should it be accidentally dropped on a record.

The basic hookup is given in Fig. 1. Tube A is a high-frequency oscillator. B is a discriminator tube whose peak frequency is displaced somewhat as shown in Fig. 2. The oscillator frequency F_c is adjusted to the steep portion of the discriminator's frequency characteristic. The pickup is shown as a dual capacitance, the stylus being grounded. Vibration of the latter in response to a recording causes it to alternately increase and decrease the frequency of the oscillator and discriminator in opposite phase.

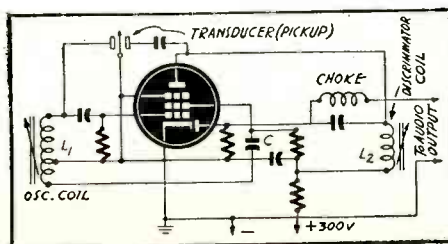
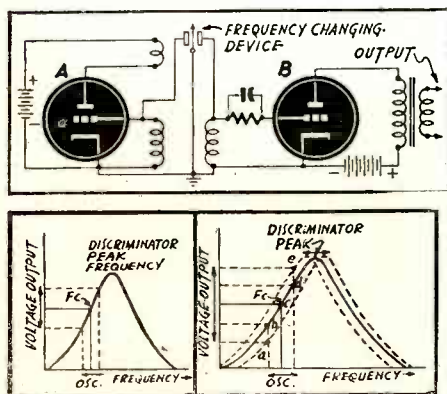

Fig. 1 (Top, Left). Basic circuit of the new FM pickup.

Figs. 2 and 3 (Left). How modulation takes place.

Fig. 4 (Above). A simple one-tube pickup circuit.

The result is explained in Fig. 3. When the stylus moves to the left it decreases the oscillator frequency and simultaneously increases the discriminator resonant frequency. The first changes the operating point from c to b , while the second shifts the entire discriminator curve to the right, therefore fixing the operating point at a . Likewise, when the stylus moves to the right, the operating point will be found at e .

Not only is the output doubled as a result of this double change, but the push-pull effect also cancels out even-harmonic distortion which might otherwise occur.

A still more simplified circuit is that of Fig. 4, where only a single tube of the 6SF7 or similar type may be used. L_1 is a tapped oscillator coil for the tube, which is electron-coupled. L_2 is the discriminator coil. The output of the latter is applied to a diode plate through a fixed condenser. It is rectified, filtered and applied to an audio amplifier. The tube suppressor is used as an electrostatic shield.

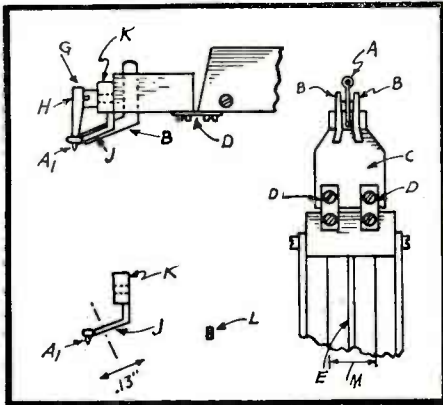

Fig. 5. Mechanical features of the design.

Typical design of such an instrument may follow Fig. 5, where several views are shown. The sapphire stylus is mounted at the end of a steel wire bent as shown and mounted on a brass block. The side view shows only one fixed plate, but of course there are two, one on each side of the steel wire and mounted on a bakelite block. The use of a viscoloid strip between the stylus and mounting screws was necessary to suppress resonance in the stylus support wire.

The pickup head is connected to the main tone arm by means of two spring plates which permit mounting in the proper vertical direction and also prevent damage to the unit should it be dropped on a record. Two transmission lines, one from each fixed plate, are placed in channels in the tone arm which is mounted directly on the chassis of the circuit by means of the usual pivot.

By way of illustration, several dimensions of the parts are given. With a device of this general construction an unusually good frequency curve was obtained.

This FM circuit is not limited to record pickups. It may be used for cutting records or as a push-pull condenser microphone. Since it operates on a principle of small displacements, it can likewise find application in measuring vibration, pressure, etc.

* Patent No. 2,371,373

DESIGN AND PERFORMANCE DATA

Oscillator coil	7 turns tapped at 2
Oscillator frequency	between 30 and 60 Mc.
Discriminator coil	5 turns
Frequency deviation	120 Kc.
Stylus pressure	.33 ounce
Hiss output	7 Db. below ordinary pickups
Resonant frequency	21,000 cycles

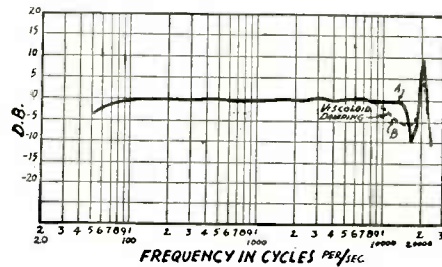

Fig. 6. The frequency response curve is flat.

SHIPBORNE RADAR

Reprinted from *Communications*

By *G. E. M. Bertram*

Chief Engineer

Radar Division

Raytheon Manufacturing Co.

WHILE the basic design features of land and sea radar systems are similar, their special wartime applications demanded many unusual features. This was particularly true of shipborne radar, which actually is a fixed-mobile unit, with extreme sensitivity, and unusually rugged marine construction.

One of these units, the SO radar, consisted of five sections: Transmitter-receiver, indicator and accessory control units, rectifier power unit, motor alternator-modulator unit and the antenna.

The ship's 24-volt d-c system is used as a primary supply to operate a shunt-wound motor which, in turn, drives an alternator generating high-frequency power at 115 volts. This a-c output system serves to power the complete radar system.

In the alternator-modulator, the potential is stepped up to approximately 8 kv, half-wave rectified, and fed to a pulse line. The a-c voltage charging this pulse line has a frequency of approximately 400 cycles. A synchronized rotary spark gap is utilized to discharge the line. Thus for each cycle of a-c the line is charged, then discharged by the firing of the gap, resulting in one-microsecond 8-kv pulses being fed through a coaxial cable, from the modulator unit to the transmitter.

A small amount of the high-frequency one-microsecond pulse voltage is also fed to the indicator. This synchronizes the radial sweep of the PPI with the transmitted pulse. It also serves to trigger the accessory control unit and to operate a PPI unblanking circuit.

In the transmitter, the one microsecond high-voltage pulses are applied to a r-f oscillator at a power input of approximately 250 kw and a repetition rate of 400 cps. Once each repetition cycle, microwave energy is generated for a period of one microsecond and fed to the antenna via a waveguide and radiated into space. The antenna reflector concentrates and reradiates the energy in a narrow beam.

Energy reflected back to the antenna from targets, enters the receiver via a TR box (duplexing cavity). This unit is merely an electronic switching arrangement which effectively changes the antenna from the transmitter to the receiver while the transmitter is off.

The receiver comprises a wide-band superheterodyne, detector and video amplifier. The output is delivered through a coaxial cable to the indicator as a rectified video signal. Here, the video signal is again amplified and fed to the control grid of the PPI, finally appearing on the screen as a small bright spot.

As the antenna rotates through 360° the radial sweep on the PPI does likewise and in exact synchronization with the antenna. This means that the outer dial on the tube may be calibrated in degrees and will, therefore, give precise bearing data.

Because of the synchronization of the radial sweep to the transmitted pulse, the distance of the target echo from the center of the screen is directly proportional

to the distance of the target from the antenna. Calibrated markers can be superimposed on the face of the PPI which will generate marker rings. From these concentric rings approximate ranges can be derived. The accessory control unit generates an accurate range mark which also appears on the PPI screen. When the range crank on this unit is rotated, this range mark moves out along the trace and when the mark coincides with the echo to be ranged, accurate range may be read directly from a dial mechanism which is coupled to the range crank.

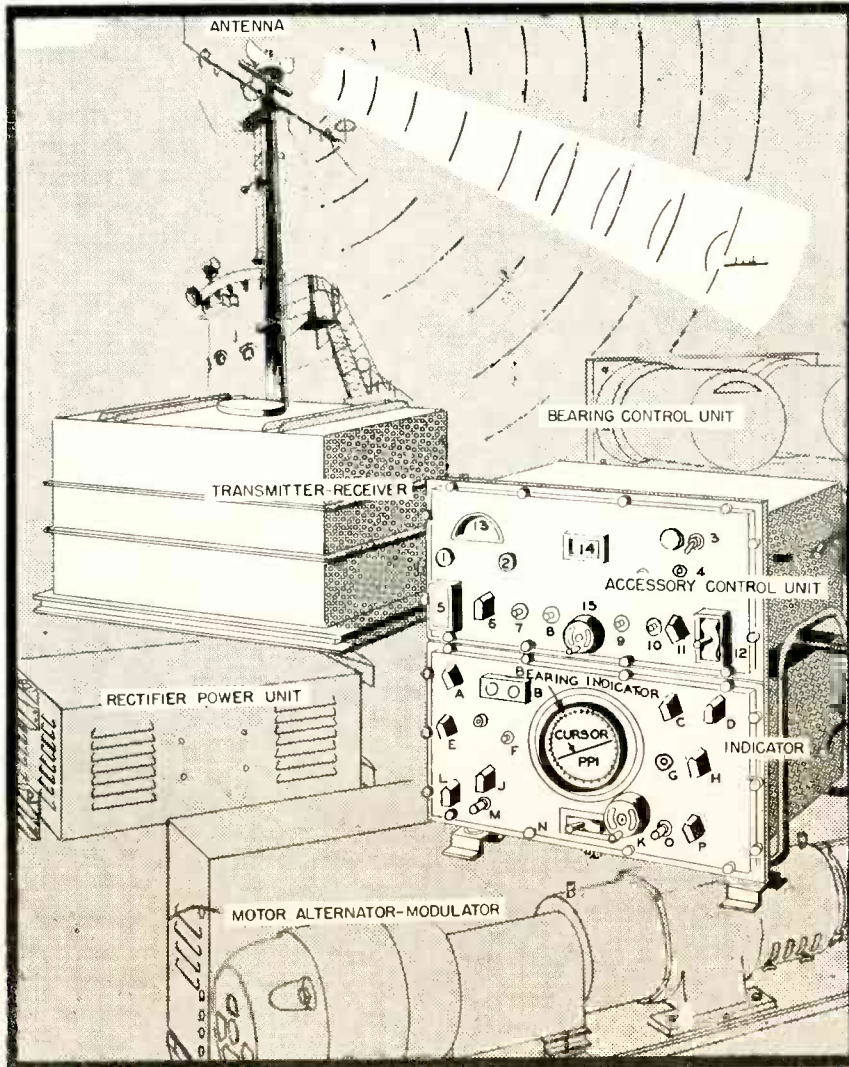

Setup of shipborne radar equipment. Plan position indicator controls: A, off-on, main switch for equipment; B, stop-start, main switch for modulator (turned on after set has warmed up); C, gain, controls receiver gain; D, marks, controls marker intensity; E, N-E normal-emergency, controls transmitter plate voltage for emergency operation; F, sw-1 (sweep length), adjusts sweep speed; G, tune set, controls receiver tuning (dual) by coarse adjustment of local circuits; H, tune, controls receiver tuning by vernier adjustment of plate voltage of local circuits; J, range, selects range 4-20-80 miles; K, bearing crank, adjusts bearing cursor; L, pilot, controls pilot light intensity; M, int, (intensity), controls PPI intensity; N, ccw-off-cw (counterclockwise-clockwise), controls direction of antenna rotation; O, focus, controls PPI focus, and P, center, adjusts PPI spot centering. Accessory control unit: 1, gain, controls echo box gain; 2, tune, tunes echo box, using meter resonance indicator; 3, ship heading flash, controls ship heading flash; 4, gain, special gain; 5, tune, switches meter from line voltage to echo box resonance indication; and 6, pilot, controls pilot light intensity.

It is a normal procedure to tune the equipment for optimum reception of surrounding targets. However, an echo box (resonance chamber) is supplied with each installation and may be used for tuning in the absence of targets.

The echo box is a resonant chamber which can be tuned to resonate at the transmitted frequency. The unit itself provides a high- Q tuned circuit in which oscillations persist for some time after the transmitted pulse stops. These oscillations are fed back into the wave-guide, through the duplexing cavity into the receiver, thus simulating echoes received from an actual target.

Operation of SO radar is not complicated, despite the large number of controls. After the set is turned on and permitted a normal warmup period, a start button is pressed. To avoid this delay a *normal-emergency* switch is provided.

Assuming the various semi-permanent and range adjustments to be in order, the intensity control is set for moderate brilliance of a spot appearing at the center-point of the PPI.

The gain control may be advanced to full for maximum output from the receiver. The receiver-tune knob is set to approximately mid-scale. The *marks* control is turned up until marker dots of moderate brilliance appear along the trace on the PPI. The space between each dot represents a specific distance depending on which one of the range settings is used.

When one particular target is to be observed, the antenna is brought to bear on it, using the antenna motor switch which has a clockwise and counter-clockwise position. The tune control is adjusted for maximum brilliance of the signal appearing on the PPI. If the target is at close range, the center control is used. Adjustment of this control regulates the starting point of the PPI trace, and prevents the center-point spot from overlapping and blocking out any signals from the nearby target. It does not affect the distance between range marks.

The sweep-length control is used to contract or expand the PPI sweep. Assuming we desire to closely follow a selected area, expanding the sweep length permits emphasis of details. It does not, however, change the range distance represented between the marker circles (the circles created by the marker dots rotating around the face of the PPI).

To determine the bearing of an obstacle, a bearing crank is used. Rotating the crank, moves the hairline around the PPI. By setting the hairline on the target and reading the azimuth scale around the PPI, the bearing may be read directly in degrees.

If the ship is equipped with a flux-gate or similar compass, the radar may be equipped with a true-relative bearing indicator. Selection of the desired reading will cause a *flash* trace to indicate either true or relative heading, of the antenna. The trace flashes once each revolution, only when the *flash* switch is turned on. On installations not equipped with special compasses, when turned on, the flash will always occur at zero degrees.

The range crank controls the range marker on the PPI. When the marker control is turned up, the ranging marker appears, forming a circle as it rotates around the face of the PPI. If the antenna is not rotating, it will of course, merely appear as a spot. The position of this marker is made to coincide with the target. The cranking of the range control automatically changes the range readings on the dial, and when lined up will give the range in yards. Practice in handling the equipments permits the entire sequence of steps in less than a minute. It is important to avoid confusion over the two different markers on the PPI. One set of four, forms the fixed distance markers. The other, a single marker which may be varied, is used to range on the object being scanned.

Since shipborne radar also has postwar commercial navigation applications, active development was initiated many months ago. As a result a simplified navigational radar design was completed recently. This comprises three units . . . antenna, transmitter-receiver, and indicator . . . the first two of which may be combined when the antenna is not mounted on the masthead. The weatherproof indicator unit is but little larger than the over-all dimensions of the PPI. It has a binacle-type mounting that permits installation at any convenient position and at any angle.

Available accessories include repeaters (remote indicators), the attachment for obtaining true-bearing readings in addition to the standard relative-bearing readings, and an echo box. Provision is also made for the reception of radar beacon signals.

The commercial model is designed to operate from shipboard 115-volt power source and has a power consumption not exceeding 2 kva. The expected maximum range is 15-20 miles for large surface objects such as ships, or 4-6 miles for small objects such as bell buoys. The minimum range is 100 yards from the antenna. Four range scales will be provided, 1½, 5, 15, and 50 miles. Range marks will permit ranges to be read with an accuracy of about 2%. Bearing accuracy will be within 2°.



*To have striven, to have made an effort, to have been true to certain ideals —
this alone is worth the struggle.*

SIR WILLIAM OSLER

CRYSTAL CONTROL IN THE NEW HAM BANDS

Reprinted from Q S T
By John Holmbeck,* W9KZO

How to Get to the 144-, 50- and 21-Mc. Bands with 1.75-, 3.5- and 7-Mc. Band Crystals.

IT IS well known by now that the FCC table of proposed amateur frequencies includes some higher-frequency bands which are not in even-harmonic relationship with the lower-frequency bands, and yet they are frequencies at which the use of crystal control may be desirable.

A little meditating and consequent doodling with figures discloses some interesting conclusions which should prove useful to a lot of us in solving frequency-control problems in the proposed new amateur bands around 21 and 144 Mc. Three major problems which have been worked out by the author are those of getting crystal control on the 144-Mc. and 50-Mc. bands and using any crystal in the 7-Mc. band for control in the proposed 21-Mc. band, all making use of crystals now in the 1.75-Mc. band.

THE 144-Mc. BAND

Since the new 144-Mc. band is not related to our lower-frequency bands by convenient harmonics, crystal control with crystals useful also in other bands looks a little messy, but by applying a little fourth-grade math and some superhet theory, a multitude of solutions and practical possibilities make themselves evident. So let's see what we have.

First, the maximum practical fundamental frequency of most crystal cuts is in the vicinity of 10 to 12 Mc. To obtain a rough estimate of the number of times we must multiply our crystal frequency to hit that band, let's divide 144 by about 10, giving us 14.4. This is not a very convenient number for frequency multiplying but it is very close to 16 which is an ideal number. So, dividing 144 by 16 we get 9 Mc. and by dividing 148 by 16 we get 9.25.

The next problem is that of getting to 9 Mc. with crystals now in other bands without changing their frequencies. By delving into superhet theory we find the statement that if two alternating voltages of different frequencies are applied to a non-linear impedance, the result is not only the two original frequencies but also their sum and difference, and we can select any one of the four we wish by an appropriate tuned circuit. In words of one syllable, this means that if we feed two frequencies into a mixer tube, we can get their sum and difference from the output.

We also want to find a use for those 1.75-Mc. crystals. If we combine the output of a 2-Mc. crystal with that from a 7-Mc. crystal, we can get to 9 Mc. and a 2-Mc. rock combined with a 7250-ke. slab will give us 9.25 Mc. Thus, by means of a couple of quadruplers we can hit the edges of the 114-Mc. band. Another advantage of a 2-Mc. crystal is that its harmonics are very useful for band-edge spotting. The following list will show examples of a few possible combinations and their results.

* A.P.O. 218, c/o Postmaster, New York

<i>Crystal Frequencies</i>	<i>Output Frequency</i>
2000 kc. + 7000 to 7250 kc.	144 to 148 Mc.
1950 kc. + 7050 to 7300 kc.	144 to 148 Mc.
1915 kc. + 7085 to 7300 kc.	144 to 147.44 Mc.
1750 kc. + 7250 to 7300 kc.	144 to 144.8 Mc.

Of course, you can work out plenty of others to suit your own crystals. The block diagram of Fig. 1 may be of some help in getting the idea.

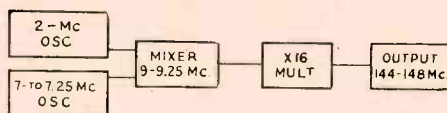

Fig. 1. Block diagrams showing how 2-Mc. crystals in combination with crystals in the 7-Mc. band may be used to control transmitter output at 144 to 148 Mc.

With these combinations, it is obvious that our 7-Mc. crystals are as useful as ever for 7, 14 and 28 Mc. and, we hope, for the 21-Mc. band. Besides that, our 1.75-Mc. rocks are good for operation in the 3.5- and 7-Mc. bands, which gives us even more possibilities. Two 1.75-Mc. crystals can be used by quadrupling one into the 7-Mc. band before feeding to the mixer and a doubled 3.5-Mc. crystal will do as well. Using two 160-meter crystals, with certain combinations of them, by exchanging their places, another spot in the 144-Mc. range is available.

Excellent frequency stability can be had by using crystals with opposing temperature coefficients, since drift of one may be used to compensate somewhat for the other one. One good combination is an X-cut on 40 (negative temperature coefficient) and a Y-cut on 160 (positive temperature coefficient). Since the cycles-per-degree-per-megacycle drift of a Y-cut often is about four times that of an X-cut, and since the "megacycle" factor of the X-cut is about four times that of the Y, it all cancels out nicely.

50-54 Mc.

Several combinations will give crystal control in the 50-54-Mc. band. For instance, the edges can be reached by using 3.5- and 4-Mc. crystals in conjunction with a 2-Mc. slab. The sums will be 5.5 and 6 Mc. of which the 50- to 54-Mc. band is the 9th harmonic which may be reached by tripling twice. Other combinations are shown in the table on the following page.

<i>Crystal Frequencies</i>	<i>Mixer Output</i>	<i>Multiplication After Mixer</i>	<i>Output Frequencies</i>
7 to 7.3 Mc. — 2 Mc.	5 to 5.3 Mc.	(5) (2)	50 to 53 Mc.
7 to 7.3 Mc. + 1.75 Mc.	8.75 to 9.05 Mc.	(3) (2)	52.5 to 54 Mc.
7 to 7.3 Mc. — 1.75 Mc.	5.25 to 5.55 Mc.	(5) (2)	52.5 to 54 Mc.
7 to 7.3 Mc. — 4 Mc.	3 to 3.3 Mc.	(4) (4)	50 to 53.5 Mc.
7 to 7.3 Mc. + 3.5 Mc.	10.5 to 10.8 Mc.	(5)	53 to 54 Mc.
3.5 to 4 Mc. + 2 Mc.	5.5 to 6 Mc.	(3) (3)	50 to 54 Mc.
3.5 to 4 Mc. — 2 Mc.	1.5 to 2 Mc.	(4) (4) (2)	50 to 54 Mc.

THE 21-Mc. BAND

Now for using more of our 40-meter rocks in the 21-Mc. band for which we are hoping. By tripling from 40, if the new range is 21 to 21.5, only crystals from 7000 to about 7166 will hit the band, and a lot of us have crystals higher than that. Going back to grammar-school math, we find that if we want to get to the new frequency by quadrupling, we must start between 5250 and 5385. The following table and the block diagram of Fig. 2 will show how it is done a lot faster than verbose rambling.

<i>Crystal Frequencies</i>	<i>Output Frequency</i>
2000 kc. + 7250 to 7300 kc.	21 to 21.2 Mc.
1950 kc. + 7200 to 7300 kc.	21 to 21.4 Mc.
1915 kc. + 7165 to 7300 kc.	21 to 21.5 Mc.
1750 kc. + 7000 to 7135 kc.	21 to 21.5 Mc.

It will be noted that the 1915-kc. crystal is useful in obtaining complete coverage of the 21-Mc. band, and almost complete coverage of the 144-Mc. band as well, when used in conjunction with existing 7-Mc. band crystals. Also, in heterodyning to 21 Mc., use is made of crystals above 7165 kc., while straight tripling makes use of those below 7165 kc.

The proud possessor of a v.f. crystal is in a good spot. If he gets to 21 Mc. by tripling—assuming he can shift 5 kc. at 7 Mc. his shift is 15 kc. at 21 Mc., but if he beats back to 5.25 and quadruples, he can shift 20 kc. Of course with this system, 80 and 160-meter crystals can be used by multiplying down to 40 before feeding to the mixer.

FREQUENCY MODULATION

These examples are intended only to give you ideas you can work out in detail yourselves. Another handy use for the heterodyne idea will be in f.m. Here is the reason. At the present time, reactance-tube modulators are the most practical for ham work, and the less deviating the oscillator has to do, the easier it is to keep it linear. So, if we want to get enough deviation in the output frequency, we've got to multiply the output of the oscillator frequency several times. However, since it is also easier to get a given number of kilocycles deviation of the oscillator at the higher frequencies, it is to our advantage to both heterodyne and multiply.

Thus, if we beat the f.m. oscillator with a rock to get a lower frequency and we still do not disturb our deviation, then we can multiply more times to hit a given band. Also by using a crystal which drifts in the same direction as the modulated oscillator, the frequency stability is greatly improved.

This dope is not intended to be the complete story; it's just to remind us of a few practical possibilities of the heterodyne principle. Good use can be made of receiver tubes which are designed to be mixers. Tubes like the 6K8 make good oscillator-mixers, or a 6N7 may be operated, both oscillators feeding into a 6L7 or 6SA7. The use of low power required by these tubes presents the advantage of low crystal current which means less temperature drift. The disadvantage of needing a lot of power amplification and frequency multiplication can be overcome by using the new television tubes with their excellent power gains. Coil switching is no difficulty with the small parts permissible, in fact pretuned circuits can be switched right along with the crystals or the use of a Pierce oscillator will save a lot of grief.

Fig. 2. Diagram showing the heterodyne arrangement which may be used to obtain crystal-controlled output at 21 Mc from 2- and 7-Mc. crystals. Cutting off the low-frequency oscillator makes the mixer an isolating amplifier for straight-through operation when desired for simple frequency multiplication.

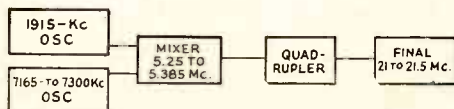

There is another point to be welcomed by the c.w.-v.f.o. bug. It is highly undesirable to key a self-excited oscillator, but for break-in work we can't have the oscillator or its harmonics fall on the spot where we want to copy. So if we beat a rock against an e.c.o. we can keep the e.c.o. off the receiver frequency but leave it on and key the crystal oscillator which can be tuned up and almost forgotten. Also the power required by either oscillator is almost nil. A 6K8 is ideal for this; the oscillator section is perfect for crystals, and by putting plenty of bias on the signal grid it need pull no power from the e.c.o.

WHAT'S BEING READ THIS MONTH

As a regular feature of our magazine, we take pleasure in presenting each month a complete list of the articles which have appeared in the current issues of the leading trade and professional magazines. The list for this month is as follows:

COMMUNICATIONS (December 1945)

STEPPING UP FROM $\frac{1}{4}$ KW TO 5 KW	A. E. Griffiths
Description of new KOTA Transmitter in Black Hills of South Dakota	
A SIMPLIFIED METHOD OF WAVE ANALYSIS	W. L. Cassell
A REPORT ON THE 1945 ROCHESTER FALL MEETING	Lewis Winner
A Coaxial Modification of the Butterfly Circuit (E. E. Cross)	
High-Quality Sound Recording on Magnetic Wire (L. C. Holmes)	
Field Intensities Beyond Line of Sight at 45.5 and 91 MC (C. W. Carnahan)	
Comments on Existing Television Systems From a Measurement Viewpoint (J. Minter)	
MEASUREMENT OF AMPLIFIER INPUT IMPEDANCE	D. L. Waidelich
RADAR COUNTERMEASURES	Ralph G. Peters
ATTENUATION TEST EQUIPMENT FOR V-H-F TRANSMISSION LINES	
F. A. Muller and K. Zimmerman	
RAILROAD RADIO COMMUNICATIONS	Robert A. Clark, Jr.
VOLTAGE-REGULATED POWER SUPPLIES (Part II)	
G. Edward Hamilton and Theodore Maiman	
MULTIPLE WIRE RECORDING	Russel J. Tinkham

C Q (January 1946)

HANDY TALKING ON THE 144-MC BAND	William H. Vogel, Jr.
KNOW YOUR METER	Richard E. Nebel
SELF-SUPPORTING ANTENNA MAST	William Kessler
FLEXIBLE SHAFTING IN AMATEUR RIGS	Lawrence Le Kashman
ON THE BEAM	Robert L. Rod
HIGH OUTPUT TRANSMITTER-RECEIVER	B. W. Southwell
RADIO AMATEUR'S WORKSHEET, NO. 8-POTENTIOMETERS; MULTI-PHASE COMMUNICATION	

ELECTRICAL COMMUNICATION (Volume 22, 1945, Number 4)

- 200-KILOWATT HIGH-FREQUENCY BROADCAST TRANSMITTERS *H. Romander*
- ARMY AIR FORCES' PORTABLE INSTRUMENT LANDING SYSTEM *Sidney Pickles*
- APPLICATIONS OF HIGH-FREQUENCY SOLID-DIELECTRIC FLEXIBLE
LINES TO RADIO EQUIPMENT *H. Busignies*
- ROTARY AUTOMATIC EQUIPMENT TO BE INSTALLED IN LEXINGTON,
KENTUCKY, AND ROCHESTER, NEW YORK
- TROPICAL MOISTURE AND FUNGI: PROBLEMS AND SOLUTIONS
E. S. McLarn, Harry Oster, Henry Kolin, and A. Neumann
- TWENTY YEARS OF TELEPHONY IN SPAIN *O. C. Bagwell and J. J. Parsons*
- STANDARD TELEPHONES AND CABLES PTY. LTD., AUSTRALIA—
50th ANNIVERSARY *J. Clarke*
- SIMULTANEOUS USE OF CENTIMETER WAVES AND FREQUENCY
MODULATION *A. G. Clavier and V. Altovsky*
- THYRATRONS AND THEIR APPLICATIONS TO RADIO ENGINEERING *A. J. Maddock*
- THE MEASURED CHARACTERISTICS OF SOME ELECTROSTATIC
ELECTRON LENSES—DISCUSSION

ELECTRONICS (January 1946)

- RADAR COUNTERMEASURES**
Equipment for detecting and jamming enemy radars
- RADAR ON 50 CENTIMETERS** *Harold A. Zahl and John W. Marchetti*
First of two articles describing the TPS-3, a 600-mc unit of significant design
- VEHICULAR-MOUNTED MINE DETECTOR** *H. G. Doll, M. Lebourg, G. K. Miller*
Detection of a mine automatically sets the brakes of a jeep travelling at 8 mph
- THE MPG-1 RADAR** *H. A. Straus, L. J. Rueger, C. A. Wert, S. J. Reisman,
M. Taylor, R. J. Davis, and J. H. Taylor*
Transmitting, r-f, receiver and antenna-positioning system details
- 2,660-MC TRAIN COMMUNICATION SYSTEM** *E. A. Dahl*
Details of microwave f-m system to be installed on Rock Island Railroad
- CAPACITOR-CHARGING RECTIFIER** *H. J. Bichsel*
Experimental determination of design criteria for fastest charging
of large capacitor bank
- CAVITY MAGNETRONS**
Microwave pulse generators capable of producing four million watts
peak power at 3000 mc

ELECTRONICS (January 1946) continued

- SUPERSONIC FLAW DETECTOR* *Ralph B. De Lano*
Industrial device permits nondestructive locating of minute flaws
in castings and other solid objects
- MINIMUM ATTENUATION IN AIR-CORE WAVEGUIDES* *Edwin N. Phillips*
Tabulation of design equations and graphical procedure for quickly
finding optimum conditions
- PICKUP WITH LOW MECHANICAL IMPEDANCE* *Henry P. Kalmus*
Light stiff moving element, which requires small tracking weight,
amplitude modulates an oscillator
- PULSE RESPONSE OF DIODE VOLTMETERS* *Allan Easton*
Corrections necessary for peak-reading voltmeter used to measure
pulse amplitude
- ELECTRONIC A-C VOLTAGE REGULATOR* *L. Dale Harris*
Vacuum-tube circuit absorbs fluctuations in line voltage, permitting
calibration of a-c instruments
- BRIDGING AMPLIFIER FOR F-M MONITORING* *George E. Beggs, Jr.*
Push-pull all-triode amplifier with good transient and frequency
response characteristics
- BETATRON PULSING SYSTEM* *I. Paul and T. J. Wang*
Circuit employs thyratron and ignitron to give 1,000-ampere pulse
as capacitor discharges through orbit-shift coils
- IMPEDANCE-ADMITTANCE CONVERSION CHART* *Robert C. Paine*
A short cut for speeding computation of value of impedances in parallel

ELECTRONIC INDUSTRIES (January 1946)

- AUTOMATIC POSITIONING CONTROL MECHANISMS* *R. W. May & N. H. Hale*
Autotune equipment uses effectively for rapid readjustment of multifrequency
transmitters has industry applications
- 1946 RADIO STATISTICS*
Radio-electronic output and complete home set census
How production and use compare during past 24 years
- ULTRASONIC VIBRATIONS REVEAL HIDDEN FLAWS*
Process provides method of detecting flaws and discontinuities in wide
variety of metals and extruded products
- THEORY OF MAGNETRON TUBES AND THEIR USES* *H Gregory Shea*
The action of the magnetron can be compared crudely to that of a
synchronous generator with an electron rotor
- PROPOSED TEST COILS*
Tentative standards for testing permeability and Q of powdered iron
core slugs $\frac{3}{8}$ in. in diameter and $\frac{3}{4}$ in. long

ELECTRONIC INDUSTRIES (January 1946) continued

- BRAIN WAVE RECORDS IN MEDICAL DIAGNOSIS*..... *Franklin Offner, Ph.D.*
Electronic equipment for diagnosis and research provides useful tool
for modernized studies of mental aberrations
- LABORATORY KEYHOLE*
Current Research that Forecasts Future Electronic Developments
- PHASITRON CONVERTS FROM AM TO FM DIRECTLY*
Considerable simplification of FM transmitter circuits is achieved
in one envelope by deflection of an electron sheet
- THE TRON FAMILY*
A dictionary of many well-known and not so well-known tubes and other elec-
tronic devices having a common suffix—compiled by W. C. White, GE Co.
- CASE STUDIES OF RF HEATING*
Modern methods of using high frequency heating
- LENS ABBERATIONS IN PICTURE PROJECTION*..... *Angelo Montani*
Fundamental principles of optics underlying methods of computing
refractive systems for television equipment
- NEW POWER OPERATED SENSITIVE RECORDER*..... *Dr. Paul G. Weiller*
Use of tube-controlled shaded pole motor drive to follow up movements
of a sensitive instrument provides rapid operation
- PHOSPHORS AND THEIR BEHAVIOR IN TELEVISION*..... *Irving Krushel*
Part 2 of a study of the manufacture, applications and properties of
phosphors in relation to television needs

FM AND TELEVISION (December 1945)

- WHAT'S NEW THIS MONTH*
Railroad Radio — Globe Wireless, Ltd. — Color Television
- PROGRESS REPORT ON RAILROAD FM*..... *Arnold Nygren*
- THE PHASITRON MODULATOR TUBE*..... *Dr. Robert Adler*
- CATHODE-RAY TUBES*..... *Dr. P. S. Christaldi and I. E. Lempert*
- TEMCO 250-WATT FM TRANSMITTER*..... *Samuel L. Sack*
- FM HANDBOOK — Chapter 8, concluded*..... *Burt Zimet*

PROCEEDINGS OF THE I. R. E. AND WAVES AND ELECTRONS (January 1946)

Proceedings Section

- 1946 *Frederick B. Llewellyn*
- A NEW METHOD OF AMPLIFYING WITH HIGH EFFICIENCY A CARRIER
WAVE MODULATED BY A VOICE WAVE*..... *S. T. Fisher*
- THE TRANSVERSE ELECTRIC MODES IN COAXIAL CAVITIES*
Robert A. Kirkman and Morris Kline
- RADIO-FREQUENCY SPECTRUM ANALYZERS*..... *Everard M. Williams*
- PRINCIPAL AND COMPLEMENTARY WAVES IN ANTENNAS*..... *S. A. Schelkunoff*
- PROBE ERROR IN STANDING-WAVE DETECTORS*
William Altar, P. B. Marshall, and L. P. Hunter
- DISCUSSION ON "PHASE INVERTER"* by *D. L. Drukey*..... *C. B. Fisher and D. L. Drukey*

PROCEEDINGS OF THE I. R. E. AND WAVES AND ELECTRONS (January 1946) Waves and Electrons Section

WAVES AND ELECTRONS	Alfred N. Goldsmith
ELECTRONICS AND COMMUNICATIONS	W. L. Everitt
BENJAMIN E. SHACKELFORD—BOARD OF DIRECTORS, 1945-1947	
PREPARATION AND PUBLICATION OF I.R.E. PAPERS	Helen M. Stote
AN ULTRA-HIGH-FREQUENCY RADIO RANGE WITH SECTOR IDENTIFICATION AND SIMULTANEOUS VOICE	A. Alford, A. Kandoian, F. J. Lundburg, and C. B. Watts, Jr.
A SIMPLE OPTICAL METHOD FOR THE SYNTHESIS AND EVALUATION OF TELEVISION IMAGES	R. E. Graham and F. W. Reynolds
PROBLEMS IN THE MANUFACTURE OF ULTRA-HIGH-FREQUENCY SOLID-DIELECTRIC CABLE	A. J. Warner

Q S T (January 1946)

QRM	Paul Robbiano, W6PKM
The Electronic Life Saver—Part I	
DUPLEX PHONE ON 5300 MEGACYCLES	Reuben Merchant, W2LFG and A. E. Harrison, W6BMS
WVW	
CHRISTMAS, 1944	S/Sgt. R. H. Newkirk, W9BRD
A NEW F.M. DETECTOR CIRCUIT	
THE HALF-RHOMBIC ANTENNA	Capt. John H. Mullaney, SC, W4HGU
A SMALL OSCILLOSCOPE USING THE 913	E. M. McCormick
EXTENDED-RANGE TELEVISION RECEPTION	Marshall P. Wilder, W2JLK
Part II	
THE BRIGHT NEW WORLD—OF SUNSPOTS	Commander E. H. Conklin, USNR, W3JUX
THE "LITTLE GEM II"	Byron Goodman, W1JPE
IN QST 25 YEARS AGO THIS MONTH	
HINTS AND KINKS	
Link Coupled Modulator—V.H.F. Modulator with A2 and A3	
THE WORLD ABOVE 50 MC.	
LORAN	Alexander A. McKenzie, W1BPI
The Latest in Navigational Aids—Part II	
HOW'S DX?	
LISTENING IN ON THE STARS	Oswald G. Villard, Jr., W6QYT, ex-W1DMV
THE CRYSTAL BALL	
A RADIO-FREQUENCY AUTO-RESONATOR	Pfc. John F. Clemens, W9ERN

RADIO (December 1945)

NEW VIBRATING REED MAGNETIC PICKUP	Richard G. Leitner
IRREGULARITIES IN RADIO TRANSMISSION, PART 1	Oliver P. Ferrell
DRY-CONTACT RECTIFIERS FOR RADIO APPLICATIONS	Goeffrey Herbert
RADIO INSULATING MATERIALS, PART 4	Albert H. Postle
CHART—LOSS DUE TO SHUNT RESISTANCE INSERTED BETWEEN MATCHED SOURCE AND SINK	
FM-FAX "SKYROCKET" ANTENNA	
RADIO DESIGN WORKSHEET, No. 43	
Notes on the Reception of Vertically Polarized Electromagnetic Waves; Some Notes on Circuit Shielding	

RADIO CRAFT (January 1946)

<i>RADIO-ELECTRONICS MONTHLY REVIEW</i>	
LORAN-RADIO NAVIGATION AID	E. F. Brissie
RADIO ON BUS LINES	S. R. Winters
<i>RADIO TARGET PLANES</i>	
SHORTWAVE DIATHERMY	Jonathan M. Oxley
ELEMENTS OF RADAR, PART II	Jordan McQuay
RADIO OPPORTUNITIES	E. A. Witten
SERVICE SANS INSTRUMENTS	Virgil R. Sears
A. C. VOLTAGE MEASUREMENTS	Oscar E. Carlson
144-MC RADIO	I. Queen
A.S.C. RADIO	E. Aisberg
PORTABLE PHONO-RADIO	John F. Millar
HI-FI AMPLIFIER CONTEST	J. W. Straede
SIGNAL GENERATOR COVERS ALL BANDS	Bob White

RADIO NEWS (January 1946)

INTRODUCTION TO U.H.F. FREQUENCY MEASUREMENTS	Guy Dexter
135 TO 500 MC. SIGNAL GENERATOR	
.....	John Wonsowicz, W9DUT and Herbert S. Brier, W9EGQ
UNUSUAL TRANSMITTER FOR 28-54 MC.	Rufus P. Turner, W1AY
INTERNATIONAL SHORT-WAVE	Kenneth R. Boord
R.F. CHOKES AT U.H.F.	W. J. Stolze
A SIMPLE REMOTE TUNING DEVICE FOR RECEIVERS	Capt. E. L. Hannum, Jr.
THE ARMY'S RADIO RELAY EQUIPMENT	Andrew R. Boone
FM IN CANADA	Dorothy Holloway
FROM STUDIO TO MASTER CONTROL	Henry J. Seitz
LISTENING TO THE WORLD	Christopher Cross
RESISTANCE MEASUREMENTS	Shepherd Litt, W2LCC
R.F.-I.F.-A.F. SIGNAL TRACER	Vincent Cavaleri
TELEVISION SWEEP OSCILLATORS	Edward M. Noll
PRACTICAL RADIO COURSE	Alfred A. Ghirardi
TELEVISION FOR URBANIZED AREAS	George Duvall
RADIO OPERATED AIRPLANE	S. R. Winters
IMPROVED SOUND REPRODUCER	Christian A. Volf
THE SIGNAL CORPS ON - AND IN - THE AIR	

RADIO NEWS—Radio-Electronic Engineering Edition (January 1946)

DESIGN OF HIGH-FREQUENCY RELAY SYSTEMS	Robert Endall
TWO-DECADE ELECTRONIC COUNTER	A. N. Moerman
STUDIO ACOUSTICS	R. H. Bolt
HIGH-FREQUENCY MEASUREMENTS	D. B. Sinclair
BASIC WAVE-GUIDE PRINCIPLES	Russ Trivison

SERVICE (December 1945)

<i>AUTOMATIC NOISE LIMITERS</i>	<i>Thomas T. Donald</i>
<i>AVC-DETECTOR-AF SYSTEMS</i>	<i>Robert L. Martin</i>
<i>CROSS MODULATION, BEAT NOTES AND R-F WHISTLES</i>	<i>A. M. Ross</i>
<i>INTERSTATION NOISE SUPPRESSION SYSTEMS</i>	<i>J. George Stewart</i>
<i>OLD TIMER'S CORNER</i>	
<i>POSTWAR RECEIVERS</i>	
<i>SER-CUITS</i>	<i>Henry Howard</i>
<i>SERVICING HELPS</i>	
<i>SERVICING THE OSCILLOGRAPH</i>	<i>S. J. Murcek</i>
Part VI	
<i>SUB-MINIATURES</i>	<i>Roger Etton</i>
Tube Data	
<i>350 SPEAKER P-A SYSTEM</i>	
<i>VOLUME AND TONE CONTROL RESISTORS</i>	<i>Alfred A. Ghirardi</i>
Part X of a Series on Receiver Components	

TELEVISION (January 1946)

<i>STATUS OF INDUSTRY - 28 HOUR PROGRAM WEEK</i>	<i>Frederick A. Kugel</i>
<i>COMMISSIONER JETT RESTATES HIS VIEWS ON DUAL SYSTEM</i>	<i>Dorothy Holloway</i>
<i>TELEVISION ADVERTISING - TELEVISION OUTLOOK IN BOSTON</i>	<i>Gilbert Winsfield</i>
<i>LONG SHOTS AND CLOSE UPS</i>	<i>H. G. Christianson</i>
<i>STATION EQUIPMENT: FILM PROJECTION EQUIPMENT</i>	<i>James L. Caddigan</i>

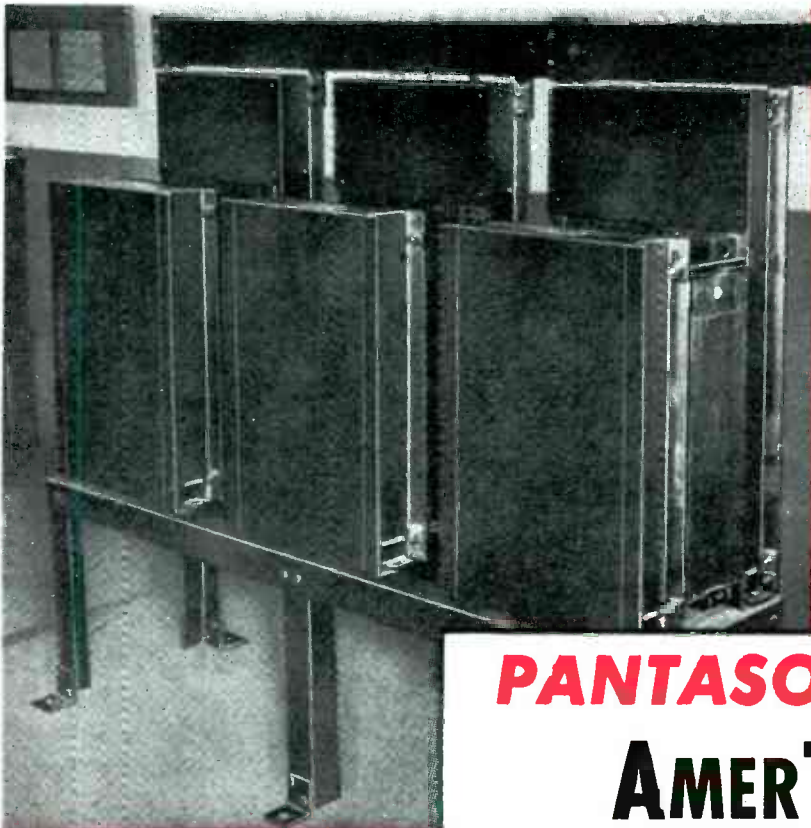

PANTASOTE finds

AMERTRAN

DRY-TYPE

TRANSFORMERS

a Natural for Plant Distribution

The Pantasote Company's Passaic, N. J., plant is replacing a combination D.C.-A.C. system with an all A.C. system. Continuity of service during the changeover was a problem. Three AmerTran 37.5 KVA Dry Type Transformers were installed. At present these AmerTrans supply part of the lighting load, also 80 HP 3 phase 240 V. A.C. for power purposes. Eventually the AmerTrans will take the entire plant lighting load.

AMERICAN TRANSFORMER COMPANY

178 Emmet Street

• Newark 5, New Jersey

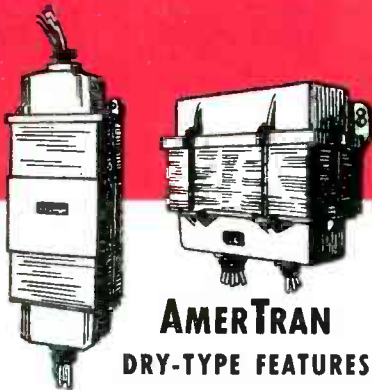

AMERTRAN
DRY-TYPE FEATURES

Compact and durable. Installed, indoors or outdoors, out of the way — in corners, on pillars, shelves, beams, ceilings—at load centers. Wide variety of ratings.

No maintenance; no piping; no liquid. Safe, clean efficient.

**Pioneer Manufacturers
of Transformers, Reactors
and Rectifiers for Electronics
and Power Transmission**

AMERTRAN

MANUFACTURING SINCE 1901 AT NEWARK, N. J.

HUDSON AMERICAN... *Aristocrats of* MARINE RADIO TELEPHONES



The "MARINER"



The "MASTER MARINER"



The "PRIVATEER"

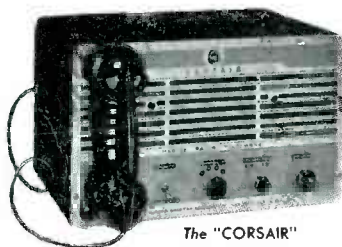

The "CORSAIR"

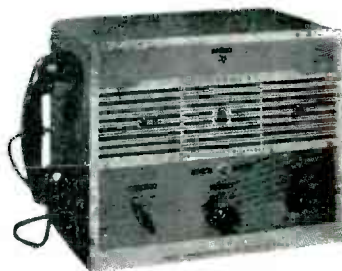

The "SEAFARER"

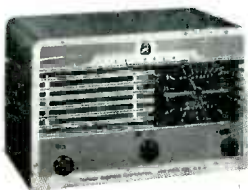

The "CLIPPER"
Marine Radio Receiver

SIX NEW HUDSON MODELS

Here is Hudson American's completely new line. New in styling—new in design—new in superb performance—new in conception of what a Marine Radio Telephone should be and do—and built by a company with a solid background of many years of pioneering in this specialized field.

Etched chromium and blue enameled panels for beautiful appearance—modern circuit design for high efficiency and economy of power—simplified controls for utmost ease of operation—tropicalized and rustproofed for long trouble-free life. These features and many more are integral parts of every Hudson American Marine Radio Telephone.

The modern craft is Radio Telephone equipped. The modern Radio Telephone is Hudson. Hudson should be your choice.

Write for detailed information M 1

HUDSON AMERICAN CORPORATION

A subsidiary of Reeves-Ely Laboratories, Inc.

25 WEST 43rd STREET, NEW YORK 18, N. Y.

Y 1

