

# *The* RADIO ENGINEERS' DIGEST



OCTOBER 1945

VOL. 2, No. 3

## CONTENTS

Audio Oscillators and Their Applications	<i>Radio News</i>	1
A Decibel Nomograph	<i>Radio-Craft</i>	6
Remote Tuning with Reactance Tubes	<i>Electronics</i>	8
Producing Nearly Constant Alternating Voltages for Calibration	<i>Communications</i>	11
Railroad Radio Communication On The V.H.F's.	<i>Radio</i>	15
Second Detector and AVC Systems	<i>Service</i>	23
How Microphones Work	<i>Q S T</i>	29
What's Being Read This Month		35

PUBLISHED BY REEVES-ELY LABORATORIES, INC.

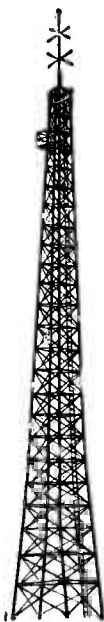

# THE RADIO ENGINEERS' DIGEST

JOHN F. C. MOORE, *Editor*

Copyright 1945 by Reeves-Ely Laboratories, Inc.

Vol. 2, No. 3

October 1945

Published monthly at New York, N. Y., by Reeves-Ely Laboratories, Inc.,  
comprising the following operating divisions and subsidiaries:

AMERICAN TRANSFORMER COMPANY, Newark, N. J.  
HUDSON AMERICAN CORPORATION, New York, N. Y.  
REEVES SOUND LABORATORIES, New York, N. Y.  
WARING PRODUCTS CORPORATION, New York, N. Y.  
THE WINSTED HARDWARE MANUFACTURING COMPANY. Winsted, Conn.

For free distribution to our friends in the radio and electronics industries

Editorial Office, 25 West 43rd Street, New York 18, N. Y.

Printed by Criterion Products Corporation, New York, N. Y., U. S. A.

# AUDIO OSCILLATORS AND THEIR APPLICATIONS

Reprinted from Radio News

By J. C. Hoadley

The audio oscillator is an indispensable test instrument for either the home or the laboratory

**A**N AUDIO oscillator is one of the most versatile pieces of equipment which is within the reach of the majority of radio repairmen, amateurs, and laboratory workers. Its uses are manifold.

An audio oscillator is essentially a generator of sinusoidal audio frequency voltage, i.e., those frequencies which the human ear can perceive. This range is generally 20 c.p.s. to 20,000 c.p.s., although some so-called audio oscillators go as high as 200,000 c.p.s. More generally the range immediately above audibility, i.e., 20,000 c.p.s., is referred to as supersonic.

There are many types of audio oscillators, including "beat-frequency" or "heterodyne" type, Wien bridge, parallel T network, resistance stabilized, and even our old friend the Hartley oscillator which may be used to generate audio frequencies. There are a host of others, but the most frequently used are the beat-frequency and Wien bridge RC types.

The beat-frequency oscillator consists of two radio frequency oscillators, usually operating in the neighborhood of 100 kc., being beat together in a detector. The frequency of one is varied, which results in a beat frequency from zero cycles-per-second to forty kilocycles or more. This type, if properly designed, may be accurately calibrated, possesses low distortion, and has the big advantage that a large frequency range may be covered on one rotation of the frequency dial, and the output is very constant.

The Wien bridge, or RC oscillator, consists of a degenerative amplifier in which the frequency of oscillation is determined by a resistance-capacity network that provides regenerative coupling between the input and output. Means is usually provided to maintain the output voltage constant, and may take the shape of a small lamp which is placed in the cathode circuit of one of the tubes. Its "variable resistance with current" characteristic provides an "automatic volume control" effect and is very effective in maintaining the output of the oscillator constant. The Wien bridge has the advantages that it is inexpensive to build, is very stable, and has unusually low distortion by virtue of its large amount of degeneration.

There are many excellent models of both types on the market, or those who would like to build their own can refer to the simple models described in the May and December 1943 issues of RADIO NEWS.

One of the most typical uses of the audio oscillator is in the determination of the frequency response characteristics of an audio amplifier. The oscillator output is introduced into one of the amplifier's inputs and the oscillator's output voltage is held constant. The amplifier is now terminated in a suitable resistive load across which is connected an a.c. voltmeter.

Incidentally, a.c. voltmeters of the copper-oxide rectifier type do not have a flat response characteristic. They are prone to fall off at the high frequencies. Fig. 2 shows the actual response characteristic of a typical unit. The response is uniform up to 1000 cycles-per-second, and then it falls off, being down almost 50

per-cent at 30,000 c.p.s. This curve was obtained by connecting the voltmeter to an audio oscillator to which was also connected an oscilloscope. The amplitude of the waveform on the scope-tube was held constant with the oscillator output voltage control and the meter read for different frequencies. As the oscilloscope has nearly perfect frequency response at these relatively low frequencies, the curve is quite accurate. The frequency is varied in small steps and the output voltage at each frequency is noted.

The values obtained are recorded and when all the values desired are obtained, a curve is drawn on semi-log graph paper. This is graph paper which has linear graduations along its Y axis and logarithmic graduation along its X axis.

In Fig. 1 is a series of response curves for a typical amplifier with high and low boost tone controls. This particular amplifier has a five-position switch for adjusting the tonal response. It is readily noted from the graph that the boosts occur at 4000, 5000, 8000 and above 15,000 c.p.s. Note also the change in the low frequency curve when the control was advanced to full boost, i.e., the frequency at which it boosted was lowered from 90 c.p.s. to 50 c.p.s. The curve of the amplifier with no compensation is noted just below the first series of curves. This curve was plotted in volts as a db. curve would have appeared in a relatively straight line.

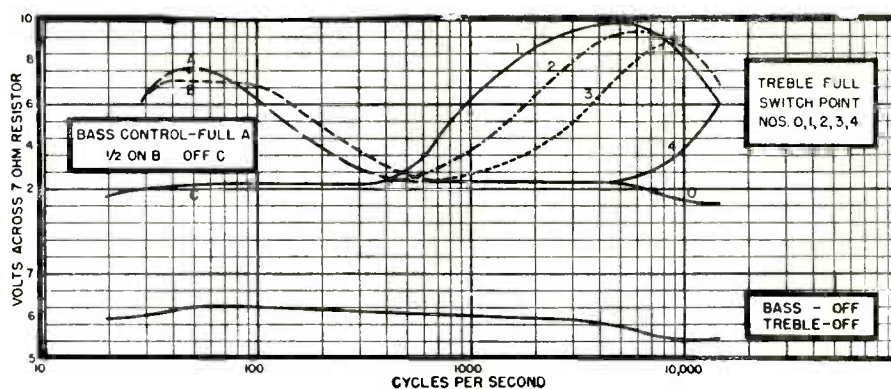

Fig. 1. Response curves of an audio amplifier with both bass and treble tone controls. An audio oscillator was a must in plotting these curves.

With the oscillator then as a check on the finished results, special response curves may be imparted to audio systems to compensate for deficiencies in pickups, speakers, records, and acoustic conditions which are undesirable. Also, special sound effects can be created. Of course, the audio oscillator may be connected to the amplifier with the speaker connected, and the oscillator varied; any resonant conditions of a room or auditorium will be immediately apparent as the critical frequency is found. That frequency might then be subdued in the amplifier with a filter network.

Another common use for the audio oscillator is to modulate a radio frequency signal generator. This, then, provides a private broadcasting station whose signal frequency may be varied and whose audible frequency may be varied too. We may now measure the response characteristics of the entire radio receiver from antenna to loud speaker. Here we may find that the high frequency response is suffering because of a sharp intermediate frequency amplifier which is cutting side bands and attenuating the higher frequencies. If we have sensitivity to spare, we may stagger the i.f. trimmer condensers so as to provide a wider band pass, or we may introduce a compensating high frequency boost in the audio system, or both.

If we add a distortion analyzer to our setup, we may measure the distortion of the audio system or the distortion of the whole receiver. Distortion analyzers are rather complex pieces of equipment, but one may be improvised. If an electronic

switch is so connected as to alternately impress the output of the oscillator and then the output of the receiver, on the vertical plates of an oscilloscope, any difference between the two superimposed sine waves will be a measure of the distortion of the whole receiver.

The turns ratio of a transformer may be measured by connecting the oscillator output to the primary and measuring the applied primary voltage and the induced secondary voltage. The turns ratio is proportional to the two voltages. ( $E_1/E_2 = T_1/T_2$ .) The response of the transformer may also be determined, but care must be taken to see that first, the output impedance of the oscillator must equal or be lower than the primary impedance of the transformer, and the secondary must be loaded with the proper resistance to accurately simulate the load imparted to it in the circuit it was designed to be used in.

Rattles in loud speakers are a disturbing item which may be located with the audio oscillator as can rattles and resonances in baffles. The oscillator is either connected to the speaker directly if it has a low impedance output, or through an amplifier. The frequency is varied until the rattle is heard. This technique is particularly advantageous where the rattles occur at only one frequency. They are usually quite easily removed when they may be induced at will and studied at leisure. Some common causes are loose voice coils, partially cemented paper patches on the cone, and taut voice coil leads.

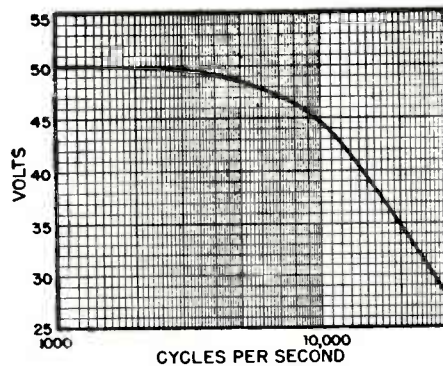

*Fig. 2. Frequency response characteristic of a copper-oxide rectifier-type a.c. voltmeter. Its accuracy is dependable over 1000 cycles. It is advisable to employ a v.t.v.m. type meter when making frequency measurements.*

Loose mounting bolts on the speaker and the output transformer cause annoying, hard to find rattles. The author has even run into a case of a loose high note deflector which was the cause of a very hard to find rattle. Cabinets contribute their share of rattles and resonances, which are easily located with an audio oscillator. The cure is either a brace in the proper place or some sound-absorbing material such as celotex or hair-felt added where it will eliminate the offending vibrations.

While on the subject of vibrations, an important use of our oscillator is that of a power source for a stroboscopic light source. If we connect a neon lamp to the output of the oscillator and the voltage is high enough to fire the lamp, we have a stroboscopic light source.

With a reflector placed in back of the lamp, we have a device which operates in a manner similar to that of stroboscopic method of determining the correct speed of a phonograph turntable. The stroboscope discs are relatively common. They are placed on the turntable and the light from a 50- or 60-cycle lamp is allowed to

shine thereupon. The disc is marked with the proper number of lines around its circumference, so that when the turntable is revolving at 78.26 r.p.m., the lines appear to stand still. This is a partial illusion, however, as the lines move while the lamp is off, and the lamp comes on when they arrive at a certain position. This gives the illusion that they stand still. A sine wave is not as ideal a wave form as a saw tooth for this service but will be adequate for some work.

Speaker cones may be inspected while in motion as they may be made to appear to stop or move very slowly forward or backward by varying the frequency. Similarly, vibration in cabinets and also machinery may be stopped and inspected.

In conjunction with a recorder, a frequency response test record may be made which is indispensable for testing and developing phonograph pickups. A record of this type is useful in providing a pickup with the proper compensating networks so as to properly play back transcriptions with special response characteristics, introduced to meet special conditions. If a single frequency is recorded, then the speed constancy of a phonograph turntable may be determined.

If the constant frequency record is played back through an amplifier and mixed with the oscillator's output, any variation or wow will be apparent at a low frequency beat. Also, the turntable speed may be adjusted precisely to the speed which will allow the finished record to produce a frequency identical with the oscillator. This will, in effect, compensate for recording and playback speed variations due to loading of the motor.

An interesting item which works both ways is an audio frequency standard. If a Wien bridge audio oscillator, whose output is several watts or so at 110 volts, is connected to an electric clock and the frequency is adjusted to 60 cycles; you have an accurate frequency source which can be checked by time signals periodically. Or you have an accurate clock if you check the frequency of the oscillator against WWV's standard frequency broadcasts. This, of course, is not as accurate as the elaborate standards which use a temperature compensated crystal whose frequency is divided down to 1000 c.p.s. and runs a special 1000 cycle clock, but if line voltage variations are not too great and temperature extremes reasonable, it is fairly accurate.

For other purposes, our clock may be made to run at other speeds. The average electric clock will run at frequencies from 50 c.p.s. to 120 c.p.s. so their motors can be used with our oscillator to power, for instance, some tone wheels in an electronic organ. The frequency could, in this case, be varied to place an octave of tone wheels driven by the clock motor in tune with some other instrument. The well-known Hammond electric organ uses tone wheels driven by an electric clock type motor which takes advantage of its synchronous properties to keep the organ always in tune.

A system could be worked out, for instance, which included a synchronous motor, and an audio oscillator for a power source, which in the presence of varying loads on the motor changes the frequency of the oscillator, which would in turn change the motor speed and compensate for the greater or lesser load. This would constitute an ideal system for a phonograph or recording motor.

The slip in a synchronous motor could be determined by magnetizing the end of its shaft and placing a coil with an iron core near the magnetized spot. When the shaft is rotated, a frequency would be generated. If this frequency were beat with the supply source frequency of the motor, a beat frequency would result. This beat frequency could be measured by introducing it into one set of plates of an oscilloscope and our audio oscillator introduced into the other plates. Observation of the resulting Lissajous patterns would give us the exact value. The speed of the motor could be determined by comparing the pickup coils' output directly with

that of the oscillator on an oscilloscope or by the zero beat method with earphones and an amplifier.

An unusual application is one where two audio oscillators have their frequency determining dials mechanically coupled to two intermittently moving shafts. The outputs may be connected to a servo motor, and the system would then become an electro-mechanical differential. The servo motor would tend to move as the sum or difference of the two shafts' incremental rotations.

The author has found his audio oscillator one of his most useful pieces of equipment over a period of years, both in radio service work and in electronic research. There seems to be no end of new uses. Perhaps this article has suggested a new application to you.

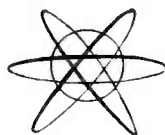

#### WAR DEVICE TO AID FARMER

*Smoke generators, an electrical industry development which created the American "secret weapon" of artificial fog used so successfully in the battle of Europe, will have an important peacetime application in distributing insecticides in farms and orchards.*

# A DECIBEL NOMOGRAPH

Reprinted from Radio-Craft

By Nathaniel Rhita

This "equivalent to an infinite number of charts" calculates gains or losses in decibels from the voltage input-output ratios

**M**ANY problems may be solved by graphical means. An advantage of such representations is the bird's-eye view which results. To connect two variables it is common to plot a chart which is a line or curve, every point of which indicates one variable in terms of the other. Charts may be designed to correlate frequency vs. dial setting, antenna length vs. reactance, plate voltage vs. plate current, etc.

Another type of graph is the nomograph which is useful in certain types of problems. This is usually designed to contain three lines or curves, each calibrated in terms of a variable. The nomograph differs from the ordinary chart in that the reader supplies his own indication by the use of a straight-edge, preferably a celluloid ruler or other transparent straight-edge.

Suppose we wish to show the variation of three quantities: Two may be shown on a chart, but there is no way of showing the third, which will have to be assumed constant. We would need an infinite number of curves on our chart, each corresponding to some value of the third variable. A nomograph is therefore equal to an infinite number of graphs. This is the key to its usefulness.

A useful nomograph is that relating DB gain or loss to voltage or power ratio. The three variables are input, output and decibels. In the figure, the left-hand scale is calibrated in values from 1 microvolt to 100 volts in two sections, A and B. The right-hand scale indicates from one-half volt to 500 volts. The center scale shows decibels in two sections, C corresponding to A and D corresponding to B.

As the nomograph stands it indicates voltage gain or loss, but since current varies directly with voltage in any constant impedance circuit, amperes may be substituted for volts and microamperes for microvolts. To extend to power values the center scale must be divided by two for all readings.

To work out a problem, connect the larger of the two voltages, currents or powers at scale E with the smaller at either A or B by means of the ruler. If the output is larger there is a gain, otherwise a loss. The answer is read off at C or D.

Five lines are shown on the figure as examples.

1—We wish to find the voltage gain of an audio amplifier. Making measurements with a V.T.V.M. we find the output is 55 volts when the input is .15 volts. There is a GAIN of 51.3 DB (Line A).

2—We have an R.F. tuner and after repairing and aligning we wish to find its amplification. Applying a signal generator to an artificial antenna we find an output of 3 volts when 1600 microvolts is measured at the input. The GAIN is 6.5 DB (Line B).

3—How much attenuation must we use to obtain an output of .51 volts when 20 volts is applied to the attenuator? All impedances are assumed matched. We must design an attenuator to have a 31.9 DB loss (Line C). The same line may be used to show the output when the input and the attenuation are known.

4—As mentioned before, power calculations are the same except that the DB scale is read off as one-half its value. The catalog lists a particular amplifier as having 10 watts output. What is its power gain (above 6 milliwatts)? Connect 10 at E with 6000 at A. The gain is 64.2 divided by 2, equals 32.1 DB (Line D).



5—Another useful transformation is that of percentage to decibel loss. Amplifiers are sometimes rated in percentage distortion or noise and sometimes in DB down from the rated output. Only two variables are concerned, percentage and decibels. To operate, the ruler is kept fixed against the bottom indication of the left-hand scale at all times. Percentage is read at E, while DB down is read at D. A particular amplifier is known to have 2% distortion. How many DB is this below rated output? The answer is 17 DB below (Line E).

The nomograph below is suitable for most practical purposes. For greater accuracy, a photostatic enlargement of any convenient size may be employed.

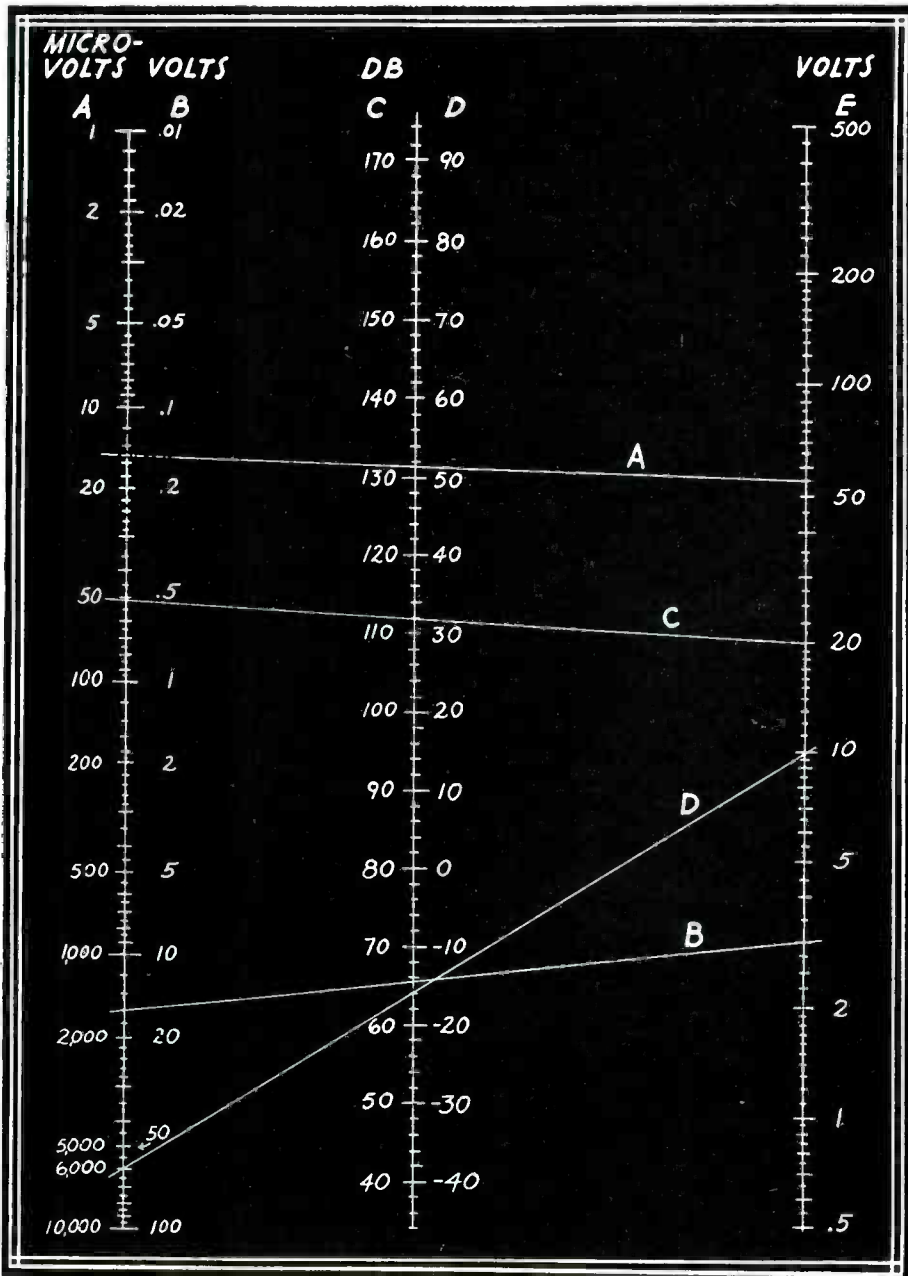

# REMOTE TUNING WITH REACTANCE TUBES

Reprinted from *Electronics*

By *H. B. Bard, Jr.*

Radio Engineering Aide  
U. S. Immigration Service  
Los Angeles, Calif.

Remotely-located radio receivers are tuned over a limited band by means of reactance tubes connected across their oscillator tank circuits. The reactance tubes are controlled by direct voltages applied over connecting telephone lines

**I**N MOST radio receiving stations involving remotely controlled equipment it is desirable to be able to exercise at least a limited amount of tuning from the control location. Transmitter frequencies will vary slightly within the permissible tolerance allowed. In order to compensate for such slight variations it is necessary to shift the receiver frequencies slightly to provide optimum reception.

Several means have been utilized in the past, such as motor-driven tuning capacitors, stepping relays which switch in various crystals or capacitors, and the transmission of i-f signals over telephone lines. Each of these systems has its merits but from the constructional standpoint they are complicated mechanically or electrically, or do not provide continuous variation of the controlled frequency.

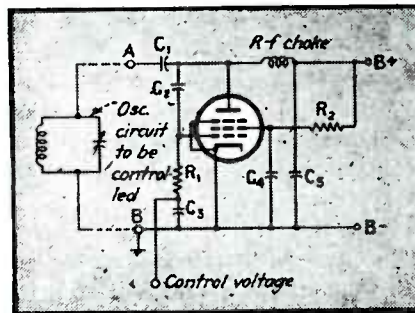

Fig. 1. Fundamental reactance-tube tuning circuit

## BASIC PRINCIPLE

An electronic, continuous, and simple means of control can be achieved by utilizing a reactance-tube circuit. Such a circuit is one in which a direct-current or voltage variation is converted into a variation in impedance at the output terminals. The impedance variation may be either capacitive or inductive, depending upon the component parts used in the circuit, and is achieved by the use of a tube that draws from its load either a leading or lagging current with reference to the impressed voltage.

Copyrighted 1945, (all rights reserved) by McGraw-Hill Publishing Co., Inc.  
330 W. 42nd Street, New York City  
(*Electronics*, August 1945)

The use of reactance tubes is common in the automatic-frequency-control circuits of receivers and in the modulators used in some types of frequency-modulated radio transmitters.

Figure 1 shows a basic reactance tube circuit in which a change in d-c voltage on the control grid, through  $R_1$ , produces a reactance change between points  $A$  and  $B$ . Capacitor  $C_1$  is a blocking capacitor,  $C_2$  is a phase splitting capacitor, and  $C_3, C_4,$  and  $C_5$  are bypass capacitors. Resistor  $R_2$  merely drops screen voltage to a desirable value.

Points  $A$  and  $B$  are attached to the circuit over which control is desired. In the example under discussion in this instance, a receiver oscillator is to be controlled and therefore  $AB$  is connected across the oscillator tank circuit. Inasmuch as the impedance presented at  $AB$  may have a resistive term, there will be some loading of the oscillator circuit by the control tube. The magnitude of the resistive term diminishes as the phase difference between the grid voltage and the impressed voltage at  $AB$  approaches ninety degrees.

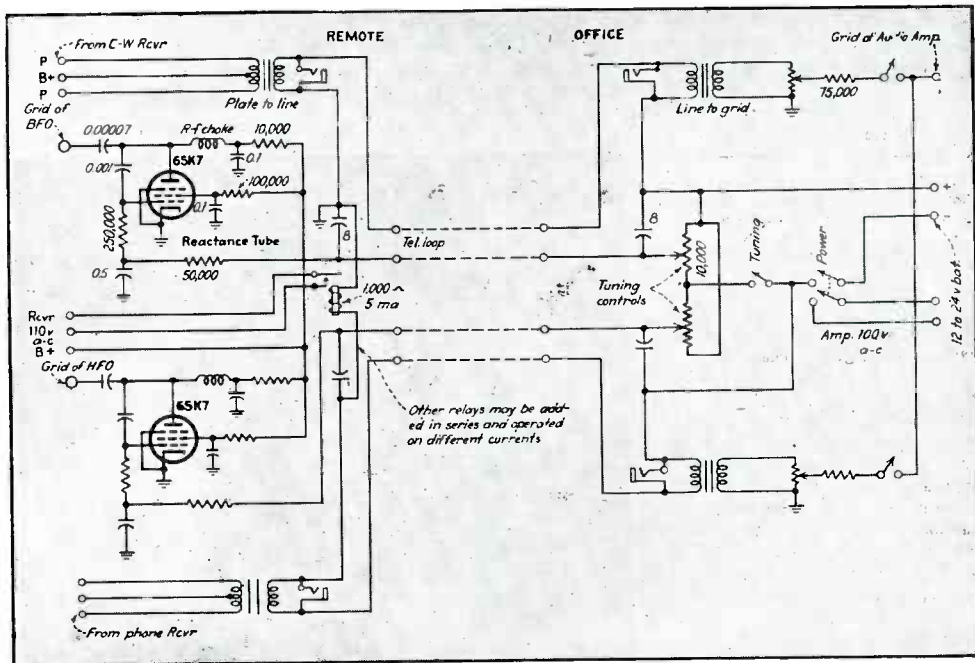

Fig. 2. Remote-tuning arrangement suitable for handling two receivers. Addition of other relays and another potentiometer permits a number of variations discussed in the text

C-W VS. VOICE RECEPTION

When tuning a receiver by means of the reactance-tube circuit several different methods may be used. Where reception is limited to voice signals it is necessary to control the high-frequency oscillator, but for the reception of C-W telegraph signals the control may be applied to the beat-frequency oscillator and the high-frequency oscillator may be crystal controlled.

The range of frequency variation at 5 mc when the high-frequency oscillator is controlled may be as high as 30 kc with a 12-volt bias variation. When the control is applied to the beat-frequency oscillator at 465 kc the available variation in beat note is approximately 10 kc each side of zero beat for a total bias

variation of 12 volts. The amount of variation, or control, is largely determined by the amount that the grid bias on the reactance tube is varied and the value of the coupling capacitor  $C_1$ ; the larger this capacitor the greater the control.

#### CIRCUIT VARIATION

Figure 2 shows schematically a typical installation in which two receivers are remotely controlled over two telephone lines. Closing the dpst power switch at the office turns on the office amplifier and also turns on the remote receivers. Closing the tuning switch at the office applies bias to the two remotely located reactance tubes. Variation of the tuning-control potentiometers changes the output reactance on the two reactance tubes and accomplishes the desired tuning. Audio output of the two receivers is fed back to the office over the associated telephone lines and applied to the office amplifier input through potentiometers and spst switches providing individual control.

In this instance one remote receiver is used for c-w reception and the other for voice and therefore one reactance tube controls a beat-frequency oscillator while the other controls a high-frequency oscillator, as previously outlined. Where both c-w and voice are to be received with one receiver it is a simple matter to arrange remote switching of a reactance tube from beat-frequency oscillator to high-frequency oscillator or vice versa. In such instances additional relays are connected in series with the power relay and adjusted to pull up at different currents. An additional potentiometer included in the relay battery circuit permits suitable currents to be selected.



#### BROADCASTING PATENT IN 1871

*The first radio broadcasting patent in the United States was granted to Edison in 1871. "Signalling between distant points can be carried on by induction without the use of wires connecting such distant points," his application stated.*

# PRODUCING NEARLY CONSTANT ALTERNATING VOLTAGES FOR CALIBRATION

Reprinted from Communications

By William Stockman

Stockholm, Sweden

Voltage stabilization circuit, used to maintain an alternating voltage nearly constant, uses a pair of diodes as amplitude limiters and a special neutralization circuit. The amplitude can be preset to desirable value by means of a direct voltage source

IF THE power line voltage remains constant it may be utilized directly for calibration purposes. When there are non-permissible variations in the line voltage, however, some sort of voltage-regulating circuit must be employed before the line voltage can be utilized as a calibration source. One simple method of obtaining a constant calibration voltage is to use an *iron-hydrogene*\*\* resistance. The voltage drop across the resistor provides the desirable calibration voltage. However, it is sometimes more convenient to obtain the alternating voltage from a source of constant direct voltage. This can be done by means of a rotating capacitor, or by means of the rotating commutator, Figure 1.

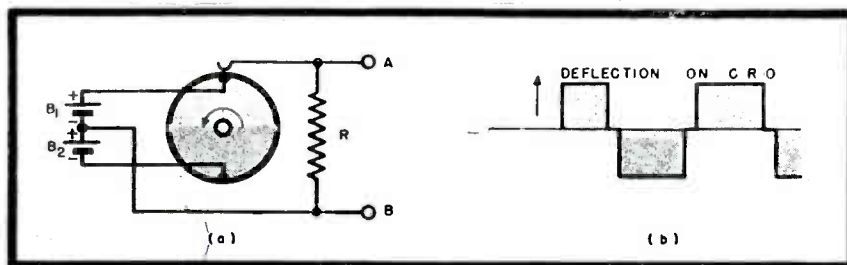

Fig. 1. Commutator arrangement for the generation of a modified square-wave of constant amplitude. Curve in (b) is the square-wave curve plotted from the screen of a cro used in a piezoelectric combustion-engine indicator built by the writer.

## NON-SINUSOIDAL WAVE FORMS

Most devices used for constant calibration voltage produces a non-sinusoidal wave form. This is not a serious limitation, however, since the peak value is the reference quantity.

\*\* Resistance unit, in use in Europe, resembling our ballast tube in action. Device contains a thin iron filament in a glass bulb containing hydrogen. Resistance varies so as to maintain current constant. Calibration voltage is then obtained across a fixed resistance in series with the *iron-hydrogen* resistance.

### ROTATING COMMUTATOR

The rotating commutator method has been used effectively when rotating parts are not objectionable.<sup>1</sup> When this method is used to calibrate an amplifier in a cathode-ray oscillograph the amplifier must pass the square-wave without seriously changing its shape.

### VOLTAGE SOURCES

Therefore the commutator speed must be chosen to meet this requirement. The direct-voltage sources  $B_1$  and  $B_2$  may be dry cells or storage batteries, and for many purposes a single battery is sufficient. A reduced square-wave voltage may be obtained by means of a tap on the resistor  $R$ .

The speed of rotation does not have to be very constant and it is therefore possible to replace the driving motor by some sort of a push-button arrangement.

### DIODE VOLTAGE STABILIZER

The calibration voltage source developed by the writer is shown in Figure 2. The arrangement with two clipping diodes is well known in the field of control circuits, and is employed, for example, in the General Radio square-wave generator, 769-A. The system shown in Figure 2 has, in addition, a compensation circuit that provides better stabilization and also improves the wave-form of the calibration voltage. Component-value development, particularly  $R_2$ , afforded this interesting effect.

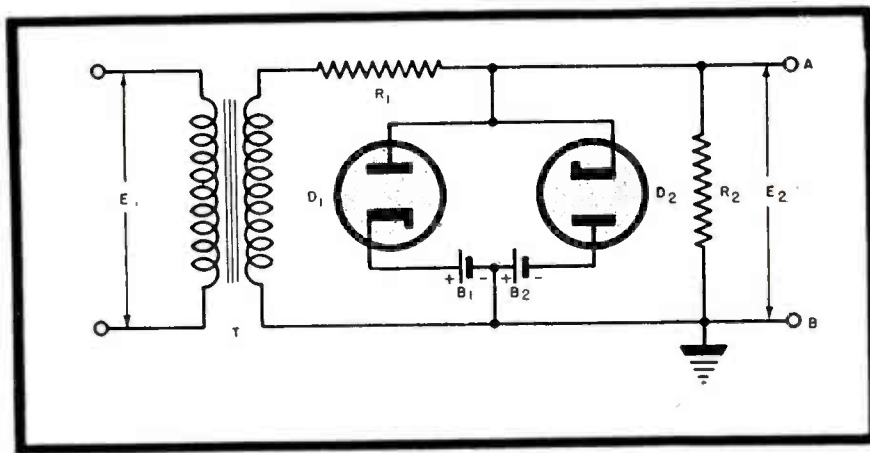

Fig. 2. Alternating voltage stabilizer. The secondary voltage of the transformer is approximately 60 volts rms and the Resistor  $R_1$  one megohm. For the value of  $R_2$  see Figure 3

### CIRCUIT DATA

In the circuit,  $E_1$  is the line voltage and  $E_2$  the desired calibration voltage.  $T$  is a line transformer, and  $D_1$   $D_2$  a double diode of a commercially available type, such as 6H6. The batteries  $B_1$  and  $B_2$  are bias sources, and  $R_1$  and  $R_2$  are fixed resistors. If  $R_2$  were infinitely large, the voltage  $E_2$  would be a squarewave with the amplitude determined by the value of the bias voltages, and by other factors. The clipping takes place because of the excessive voltage drops in  $R_1$  during the periods of conduction.

<sup>1</sup> Beale and Stansfield, *The Standard-Sunbary Engine Indicator*, Engineer; December 13, 20 and 27, 1935.

<sup>2</sup> The curve in Figure 1 is the square-wave curve plotted from the screen of the cro used in piezoelectric combustion-engine indicator built by the writer.

## CALIBRATION VOLTAGE CURVES

Figure 3 shows various curves for the stabilized calibration voltage  $E_2$  versus the line voltage  $E_1$ . Curve 1, obtained for a large value of  $R_2$ , one megohm, represents conditions when  $R_2$  is infinitely large. The stabilization is poor and the waveform rectangular. It can be seen that an increase in  $E_1$  causes a decrease in  $E_2$ . This is because the heater voltage of the diodes, which is obtained from the line varies with the line voltage  $E_1$ . When the cathodes are heated from a storage battery, curve 2 is obtained. We note that the stabilization effect is much better than in curve 1;  $E_2$  now varies only 1% when  $E$  varies 10%, and the variations are in the same direction.

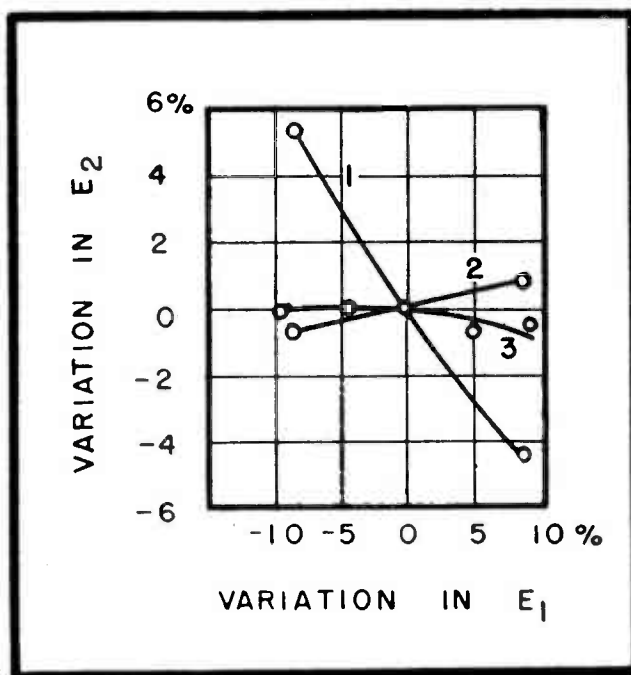

Fig. 3. Various degrees of stabilization obtained with the arrangement in Figure 2. Curve 1 represents conditions when the diode heaters are fed from the line and curve 2 when they are fed from a direct voltage source;  $R_2$  in both cases being one megohm. Curve 3 illustrates the line heating with  $R_2=20,000$  ohms; the proper value for neutralization

## NEUTRALIZATION CIRCUIT

Using the voltage from the line for the heaters provides a very practical arrangement. There are methods available for improving stabilization on line-heated filaments. If a potentiometer,  $R_1$   $R_2$ , were employed without any clipping diodes, and if  $R_2$  were so small that  $E_2$  remained at the same order of magnitude as previously, we would have sinusoidal calibration voltage, varying in the same direction as the line voltage remaining unstabilized. The variation is therefore opposite in sign to the one represented by the curve 1. Then the combined effects of the non-linear potentiometer  $R_1$  . . .  $D_1$ ,  $D_2$ , and the linear potentiometer  $R_1$  . . .  $R_2$ , in combination, would give an essentially sinusoidal waveform and a calibration voltage almost independent of line-voltage variations. Measurements performed by the writer prove that such an action is obtained; curve 3 represents one possible combination of component values. Equilibrium was obtained at all measured points.

It should be noted that curve 3 does not represent the best possible result, but still yields a variation of only 1% in  $E_2$  for a variation of 10% in  $E_1$ . The desired calibration voltage in this case was 1.5 volts, while the actual value was 1.54 volts at normal line voltage. The emf of each bias dry cell was 1.58 volts and there was a variation in bias voltage of  $\pm 0.01$  volt due to charging of the dry cells during the interval of calibration.

#### DISCUSSION OF RESULTS

Measurement of the heater voltage revealed that the diodes were operated with a heater voltage 5% below the value recommended by the tube manufacturer. Since the heater voltage was obtained from the line it may be expected that the general nature of curve 1 should show up in curve 3.

#### ERROR SOURCE

A source of error in the calibration voltage is the gradual charging of the dry cells employed as bias batteries.<sup>3</sup> The charging effect is created by the weak diode currents. The slight effect it has on the accuracy of the calibration may be removed if the diode plate circuits are closed only at the instant of calibration. With reference to rapid variations in line voltage, an error may be introduced due to the thermal inertia of the diode cathodes. This source of error is generally not serious and the arrangement with direct heater voltage, curve 2 in Figure 3, is always available as a substitute in difficult cases.

---

<sup>3</sup> It is known that dry batteries may be charged to some extent and in this way may be made useful during a longer period of time.



*In science the credit goes to the man who convinces the world, not to the man to whom the idea first occurs.*

SIR WILLIAM OSLER



# RAILROAD RADIO COMMUNICATION ON THE V.H.F.'s.

Reprinted from Radio

By T. W. Wigton

Supervisor of Electronics

Chicago, Burlington & Quincy Railroad Company

This article describes the problems encountered and how they were overcome in establishing a satisfactory railroad communication system

**E**ARLY IN 1944, the Burlington Railroad began extensive tests of two-way radio communication. Because much had already been done to develop the results which might have been expected in the lower frequencies, we selected 156 megacycles for these tests and conducted all experiments and concentrated our entire efforts at or near this frequency.

The Railroad's program called for a number of definite decisions to be based on our findings. First, and of great importance, we were interested in determining the dependability of radio communication at these frequencies, the necessary power for a desired range and the design of equipment which would best be adapted to withstand locomotive vibration and other conditions not likely to be encountered anywhere but on a railroad. In addition to the actual radio experiments and from an operating point of view, the Railroad Management was eager to determine the useful possibilities and methods to which two-way radio communication might be applied in operating a long freight train to an added advantage, also in the expediting of switching movements in large freight terminals. There were potential possibilities, all of which required further test and application to make them a reality.

To the best of our knowledge, the use of frequencies above 150 megacycles, prior to our experiments, had never been used commercially to any great extent, for ground communication. As a result, the work we were about to undertake was strictly research. After six months of constant use and test, most problems were solved along with others not first anticipated.

With the cooperation of engineers of the Bendix Radio Division of Bendix Aviation Corporation, and using several of their VHF transmitters and receivers, we equipped a group of Diesel locomotives and thereby established a field laboratory in which to demonstrate the actual working conditions to which the equipment will be subjected during normal operations.

## ANTENNAS

Using a few fundamental facts gained from experience on 40 megacycles and lower frequencies, many mysterious behaviors encountered became susceptible to reasonable explanation. Thus the clues to many questions as to the type of feed and type of antennas in general became clearer and many false conclusions were avoided. Very strong signal strengths have prevailed at all times within line-of-sight (horizon distance in miles equal to 1.22 times the square root of the antenna height in feet). At many points several miles beyond this distance, excellent signal strengths have been observed with consistency. This may be a function of ionosphere refraction.

The fixed station with a power input of 15 watts (amplitude modulated) is located on the top floor of the Burlington General Office Building. A suitable

telescoping pole supports the "old reliable" half-wave vertical doublet antenna 305 feet above the street level. The location of the control station was chosen based on two important facts. First, the height gained without complicated antenna structure and second, the location in respect to the traversed area of terminal switch engine movements. All switching movements are confined to a south and west direction in respect to the location of the control station. This desirable condition almost immediately suggested added economy in transmitter power input by the use of a directional antenna system.

Many different types of directional arrays have been tried with excellent results. It would be difficult and perhaps incorrect to make a definite statement as to which type of antenna proved the most effective. Briefly, however, the different antennas tried, such as the square corner reflector, four element parasitic arrays, collinear Sterbas, and horizontal rhombics, followed true to past proven performances so many times described in various magazines and engineering books. Without question, the horizontal terminated rhombic gave the greatest signal gain of any of the directional antennas. It consisted of eight wave lengths per leg, fed through a quarter-wave matching section by a 72 ohm co-axial line. The one serious objection was that the resulting beam became too sharp for practical use. As a result, the required signal strength at six or eight miles distant and 45 degrees off the end was too low for satisfactory and dependable communication. This could have been corrected but further difficulties were later experienced.

Prior to the rhombic, all antennas, both mobile and on the fixed station were vertically polarized. At speeds upward of 15 MPH, rapid fade or sometimes termed signal flutter had been experienced in areas of low signal voltage but at no time became serious enough to warrant study or correction. The flutter became faster as the mobile unit speed increased. With horizontal polarization on the mobile unit and using the horizontal rhombic, at a given point in line with the directivity of the antenna, the overall signal strength was several db better than any of the other arrays mentioned. It was further proven, in spite of the increased signal strength, at any speed above 8 or 10 MPH, transmission, due to signal flutter becomes unintelligible.

An explanation of this phenomenon can perhaps best be given by the fact that the mobile unit was closely surrounded by numerous buildings and poles spaced along the right-of-way adjacent to the tracks. It becomes a point of discussion as to whether this may be a function of multiple patch reflection but actually the reason for this condition predominating with horizontal polarization still appears to be unsolved and one requiring further study.

Various types of mobile antennas have been given intensive study and trial. Unfortunately we are definitely limited to a maximum antenna height above the locomotive roof. Obviously this limitation is governed by overhead structures such as bridges, signal towers and viaducts. The antenna height proper is, of course, dependent upon the locomotive height above the rail. Allowable heights on the Burlington range from 17 inches to 27 inches above the roof surface. At 156 megacycles a half-wave antenna in free space is approximately 35 inches long. This dictates one of two types of antennas, either a quarter-wave Marconi or some form of capacity loaded vertical.

The first tests began using a quarter-wave vertical rod ground plane antenna fed against ground by an unbalanced co-axial line. Matching a concentric line to a vertical quarter-wave radiator has definite limitations. It is difficult and impractical to examine properly a concentric line for standing waves. Any radiation from such a line (due to current unbalance or mismatch) will tend to combine with the antenna radiation and result in raising the vertical angle of radiation. This is a condition we do not want at 156 megacycles.

After a month of experimenting with the ground plane antenna it became evident that a more efficient radiator of some description was necessary to cover

the required range with a dependable signal. It was apparent that the basic answer was in securing a closer match between the co-ax and antenna, using a quarter-wave radiator with more radiation by the antenna itself and less in the stub and line. Numerous configurations and feed methods resulted. These included a form of co-axial antenna popular in the 40 megacycle police installations, but modified with the lower half in the horizontal plane. Many other modified antennas commonly employed on the lower frequencies, slightly modified, were also tried, with none too good results.

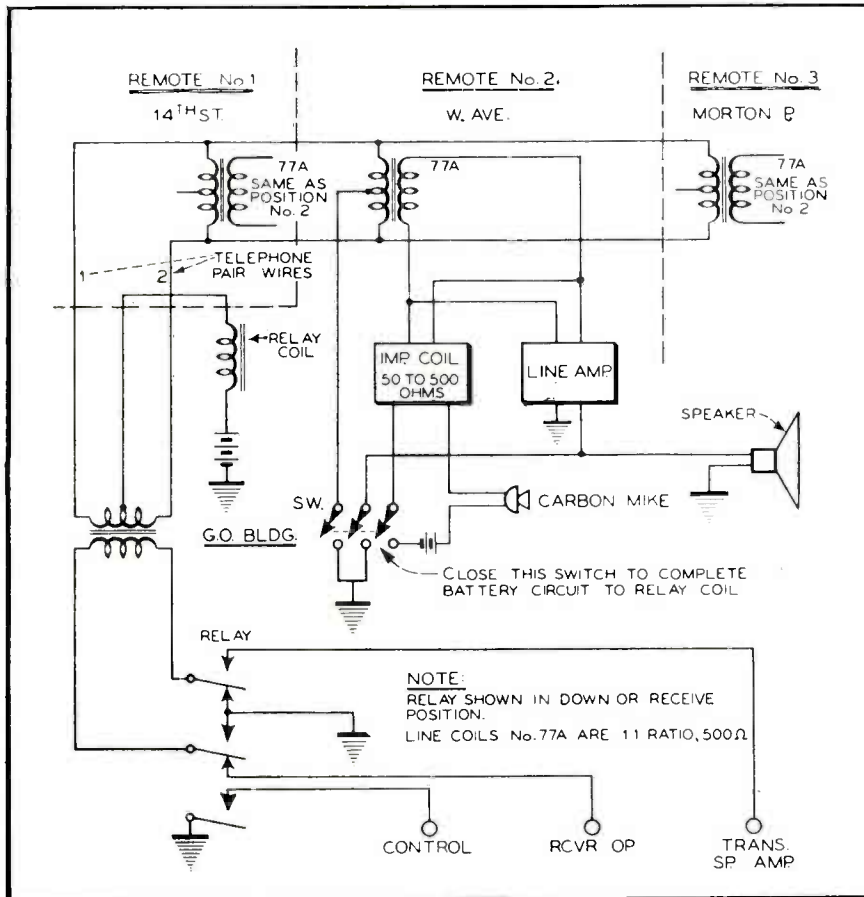

*Schematic of remote control setup for C. B. & Q. radio installation*

As a result of many experiments the answer, at the time of this writing, appears to be a capacity loaded vertical radiator matched at the base of the antenna by an adjustable quarter-wave horizontal stub. In reality the resultant antenna resembles the voltage fed zeppelin often used on the lower frequencies. Capacity loading of the vertical radiator is done by an adjustable disc, 12 inches in diameter, and capable of being moved up or down to any given fixed point on the vertical radiator. Tuning of this antenna became very simple after a few basic principles were put in practice. Briefly, the antennas are pruned by maximum field strength indication. It proved interesting to note that maximum field strength is not a function of maximum power input based on plate current times plate voltage. In pruning this type of quarter-wave vertical, the plate current can easily be brought to twice normal by careful adjustment of the matching stub lengths. Resonance usually is found at or near a quarter wave. At this point, with the 12 inch disc at the ex-

treme far end, a field strength reading is taken. As the disc is lowered the plate current begins to fall and the field strength rises. Moving the loading disc further down the radiator will cause continual rise in field strength and decrease of plate current to a point where resonance is found and the reverse condition will begin.

It has been found with similar antennas of this type using a quarter-wave radiator loaded to an electrical half-wave by capacity to ground, the radiation resistance and radiation efficiency is greatly dependent upon the actual point on the radiator where the loading disc is placed. Maximum field strength resulted with the disc placed approximately  $1/20$  wavelength below the top of the vertical radiator.

As mentioned before, this particular antenna is serving our need very well. The height above the locomotive roof is within limits and the overall radiation efficiency is ample to cover our desired range with several microvolts of signal to spare on the fringe of the talking circuit. Further experiments, no doubt, will bring to light some form of antenna far superior to this particular one developed, or any thought of thus far.

#### **TRANSMITTER AND RECEIVER**

The transmitter and receiver units used in all of these tests were designed and manufactured by the Bendix Co. for the use of the Army air forces. For this reason the description here can only be high-lighted.

The transmitter and receiver are nothing more than straightforward design. The transmitters are amplitude modulated, employing a crystal controlled doubling oscillator at a frequency near 8000 kc, capacity coupled to the associated frequency tripler stages driving the final push-pull r-f amplifier. Plate power input to the final amplifier averages 15 watts working into a 55 ohm antenna load.

The receiver consists of one r-f stage, crystal controlled oscillator, 1st detector, three 12 megacycle i-f stages, 2nd detector, and audio amplifier with two watts of audio power. On first thought, two watts of audio does not seem quite enough power to overcome the noise of a railroad engine cab but it proves ample power for good loud speaker volume, overriding all cab noises except the whistle. This is not objectionable due to the short duration of the whistle blasts.

The necessity of generating the various voltages needed in radio equipment presents a problem on a railroad caboose or engine. There are many ways to accomplish the task but to standardize on any one method is rather difficult. The ideal arrangement calls for quick and simple interchangeable units to facilitate occasional repairs. Diesel locomotives, to which our experiments have been confined, maintain 30-volt lead batteries, some 64 volts and still a third 120 volts. A distinct advantage is the almost unlimited current supply available but efficiency is also an important item.

Among various railroads there have been long discussions about what the most practical attack on primary power might be. It was first generally agreed to adopt 110 volts a. c. as a primary power on all engines and cabooses to operate the radio equipment. This would satisfy standardization of all radio units and each would be readily interchangeable with one another. It did seem, however, a round about way to run a rotary converter, d.c. to a.c., then through the power transformer into rectifiers for the necessary d-c voltages. This represented two pieces of equipment to accomplish one purpose. To do the entire job in one operation required a dynamotor capable of three d-c output voltages; namely, plate positive, grid bias negative and filament voltage. At the present writing we have had dependable operation with such type of machine. It delivers the three necessary output voltages in one small compact unit and has only one disadvantage, that the motor end obviously must match the battery voltage of the different locomotive

battery supplies. This is easily solved and still requires only three different types of dynamotors to protect the three battery voltages.

In the past there has been no necessity for providing a source of electric power on the caboose of a freight train. Marker lights have been the kerosene type lantern which are dependable and require little maintenance. The installation of radio equipment on these cars creates a necessity for some form of power. This power must also be dependable and available both while the car is in motion and during periods when the train takes a siding or for some reason is delayed for an indefinite

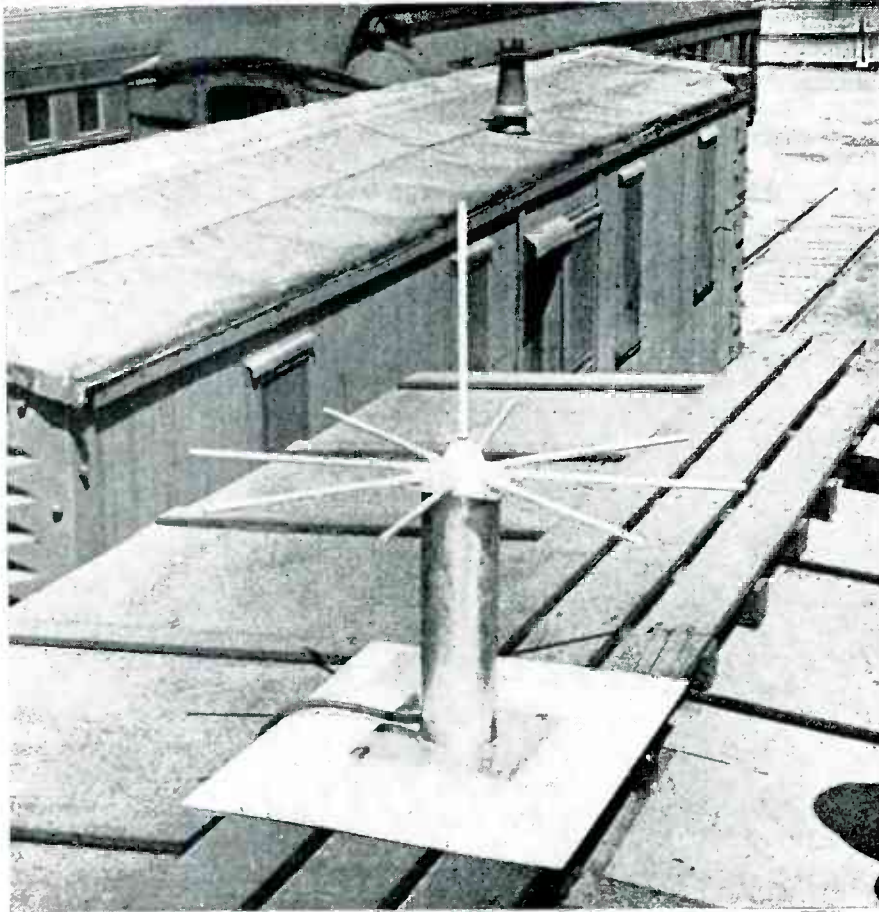

*156-megacycle quarter-wave ground plane vertical antenna*

period of time. Generation of this power might be done by equipping the car with a strong battery and axle-driven charging generator. Another possible source of power might be a generator driven by a propane gas internal combustion engine unit mounted on the roof of the car. With this type of installation we might very well eliminate bulky storage batteries but whether an engine of this kind would be entirely dependable in all kinds of weather and conditions remains to be seen. Actually the problem of how and where to get this power is not a serious one but requires careful planning in order to meet the necessary requirements. Foremost in these requirements is 100 per cent availability and dependability. As mentioned before, primary power on all locomotives is already available.

The entire locomotive and caboose radio units must be capable of withstand-

ing severe shock, both up and down, forward and backward. This requirement is due to slack action encountered in long freight trains as a result of four to six inches of slack between each car. Consider a hundred car freight train, the engine starting to pull forward; before the entire slack has been pulled the engine is moving perhaps 3 MPH. When all of this slack is taken up, the caboose will be required to accelerate from 0 to 3 MPH instantly. In order to retard some of this shock to the radio equipment it has been provided with rubber shock mounts. After several thousand miles of operation with conditions like this, some form of trouble might be expected. We have, however, experienced no difficulty or had any equipment failures due to violent shock or vibration, thus far, after covering approximately 18,000 miles of actual operation.

#### *EMPLOYMENT OF THE VHF'S*

Frequencies in this region of the spectrum are essentially propagated over a line-of-sight path, with some exception under certain conditions, as brought out before. However, basing future railroad operations on line-of-sight propagation, it becomes practical to assign several stations to the same frequency with much less geographical separation and still maintain a minimum of mutual interference. As a result the station per channel ratio is greater than would be possible on the lower frequencies. In view of the recent F.C.C. frequency allocations (between 152 and 162 megacycles, 60 channels, each 60 kc wide) for railroad use, stations in slightly separated localities can be assigned to the same channel, thus adequate room for railroad radio is provided for a long time to come.

Perhaps there is some question of the necessity for communication beyond line-of-sight on a railroad. In the distant future this need may develop as the use of radio communication becomes better established on moving trains. In the event of such a future requirement it would become necessary, and certainly feasible, to install automatic relay repeaters at necessary intervals to cover the longer distances. This type of transmission might be somewhat more costly but still more dependable than some lower frequency channel direct transmission, due to the behavior of wave propagation.

Radio communication activities on the Burlington Railroad have to date been confined to short distances (1 to 20 miles) and there appears to be no immediate necessity of any long distance communication conducted by radio. If and when such occasion should arise it would not be too difficult to accomplish satisfactory communication over any distance desired by the use of relay transmitters and receivers at the necessary intervals.

#### *AMPLITUDE OR FREQUENCY MODULATION*

Lengthy debates have resulted among the different railroad's communication engineers concerning merits of FM over AM and vice versa. As mentioned before, the Burlington tests have been strictly AM, so perhaps we are not fully qualified to pass judgement. However, it might be well to cite a thought or two and remain neutral.

During the past fourteen months, in the course of many cross-country tests, we have encountered and experienced many severe electrical storms. Using AM equipment we were able to maintain perfect communication at all times. During a nearby lightning flash, slight shock excitation could be noticed in the receiver output but far too low in amplitude to interrupt the voice modulation to any extent. This same condition has also been noticed with low signal to noise ratio with the transmitter and receiver separated by a distance of 15 or 20 miles.

The mention of atmospheric interference may lead to the question of man-made electrical disturbances on frequencies above 150 megacycles. Extensive tests were conducted with the thought in mind to determine what, if any, electrical devices or motors might cause trouble. Diesel electric locomotives of the type used on these tests have numerous d-c circuits and motors. Voltages range from 30 to 1000 volts. In some instances the radio receivers and transmitters have necessarily been mounted directly over and close to the field and commutator of the main direct current generator. This generator produces a large field and at maximum speeds, develops in excess of 800 volts at several hundred amperes. This obviously is a natural source of noise generation. Filtering of such equipment would become an engineering problem and added expense. It is very evident, however, the resonant output frequency of this machine and those associated with it is far separated from the VHF's. With temporary installations made, which themselves invited noise pickup, there never occurred any trace of noise that was audible in the receiver output.

The inherent characteristic of FM signals, i.e., the stronger signal prevailing over the weaker one, might not be desirable from an operating point of view, if several engines should be working in close proximity. Consider a group of 20 radio equipped locomotives working within a 30 mile radius. Obviously the channel will at times be crowded with general orders and instructions at which time any one certain engine might necessarily have some form of emergency requiring immediate contact with its home base. If this same engine happened to be on or near the fringe of the circuit where low signal strength prevailed, he would be unable to break in or attract attention and as a result his radio would be useless. This condition would be less liable to occur when using AM. Though his signal would be low, a heterodyne or beat (due to slight frequency differences) would result, which would, undoubtedly, attract the home base operator's attention.

It is apparent that satisfactory radio communication can be handled with amplitude modulation, thereby relieving the necessity of wider and more channels that would be required for suitable frequency modulated equipment.

### **REMOTE OPERATION**

As mentioned before, the fixed station equipment is located on the top floor of the Burlington General Office Building. All of the experimental antennas are fed by co-axial cable from the transmitter room to the roof. This is an ideal condition in being able to have some 300 feet elevation with the transmitter and receiver in close proximity of the antenna itself, with minimum of r-f power loss in a short transmission line.

All communication and orders to the mobile units from the yardmasters at outlying terminals is handled through a 500-ohm physical telephone pair to the fixed station transmitter. At the present time there are three remote operating positions, viz., the passenger terminal yards, the freight delivery and make-up yards, and the freight inbound and outbound terminal.

There are many advantages gained by control of this kind. Any number of additional remote points can be readily set up by merely providing a drop pair into the office of "yard shanty" along the right of way where contact with the engines is desired. In this way, one radio transmitter and associated equipment handles the work of several.

Control of the fixed station transmitter is accomplished by using a simplex coil shunted across the telephone pair wires. When the circuit is idle, the receiver output is across the line continuously. At such time that any mobile unit desires contact, he addresses his call to the yard office concerned with his message. Each

yard office is equipped with a standard desk telephone and push-to-talk switch. The function of the push-to-talk switch merely places the simplex coil center tap at ground potential and energizes the receive-transmit relay of the radio transmitter. To prevent crosstalk within the telephone cable, the audio gain on the line is held to within minus one or minus two db and brought back up to loud speaker volume at each remote point by a standard line amplifier. Our farthest point of control is nine miles from the radio transmitter. It might be expected that line levels would vary to some extent in relation to the lengths of the line, however, modulation of the carrier is maintained very near 100 per cent without the use of speech amplifiers or line pads at any of the remote stations.

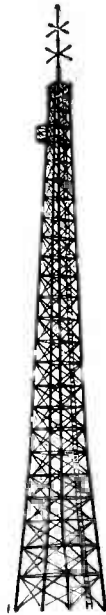

#### POWER LEAKS ELIMINATED

*A new clamp has been devised to improve the efficiency of power feeder connections for electrically-operated machinery. Power leaks, resulting from less effective connections, are eliminated.*



## SECOND DETECTOR AND AVC SYSTEMS

Reprinted from *Service*

By *Robert L. Martin*

**I**N THE modern receiver, the second detector and avc system play quite an important role. The second detector demodulates the incoming signals, reproducing the original program that modulated the transmitter. The avc (automatic volume control) system automatically biases an amplifier in proportion to the strength of the signal so as to keep a constant volume level at the loudspeaker; avc is sometimes referred to as agc, automatic gain control, the more precise term since the gain is being directly controlled, the volume indirectly.

Detection of amplitude-modulated waves may be brought about by operating the detector on a curved part of its current/voltage characteristic (the portions where Ohm's law is not obeyed) or by complete rectification at cut-off. Triode and pentode detectors may be operated as grid-leak detectors or as bias or plate detectors. The grid-leak detector, as shown in Fig. 1, is the most sensitive and economical type. Here, the grid acts like a diode plate and the grid leak as the diode load resistor of a modern, conventional diode detector. The demodulated signal appears across the grid leak and condenser. The tube also amplifies the signal, and thus the tube really acts as detector and amplifier. The carrier and sidebands are also amplified but they are eliminated by an r-f bypass condenser in the plate circuit which offers a low impedance to r-f but has a negligible effect on the a-f.

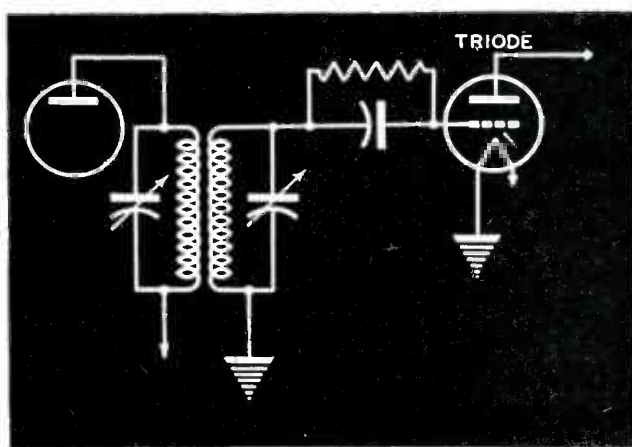
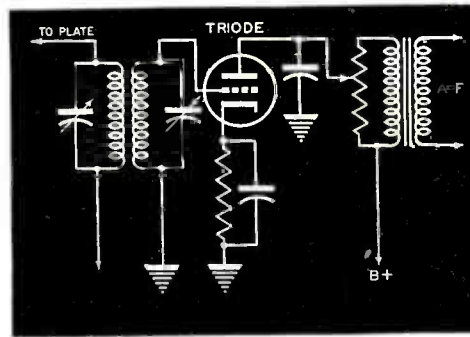

*Fig. 1. . . Grid-leak detector system — the most sensitive of the detector systems*

The disadvantages of the grid-leak detector are mainly its non-linearity and loading effects on the tuned circuit. The former is by far the more important. The detector operates approximately on a square-law curve where the output voltage is nearly proportional to the square of the input voltage. This leads to considerable second harmonic distortion which increases with the per cent modulation. Strong

signals cause overloading of the tube as a class A amplifier which leads to worse distortion. Therefore an r-f volume control must be employed to limit the detector voltage.

Normal values of grid leak and condenser are 1 megohm and 250 mmfd. Higher leak values provide more sensitivity to low voltages (weak signals) but attenuate the high frequencies causing a loss of treble. These and other effects are



*Figs. 2. (above) and 3 (below). Fig. 2. . . Bias or plate detector with high-value self-bias resistor. Fig. 3. . . Early method of obtaining avc by using triode and C bias divider.*

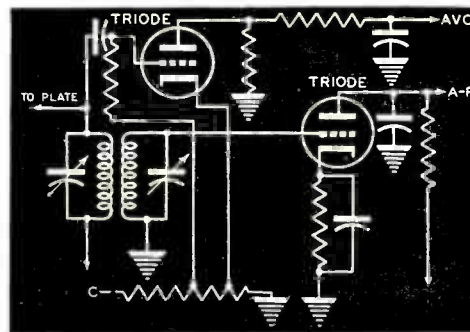

further discussed under diode detectors in this article. The grid-leak detector, operating on zero bias, uses a low plate voltage. When triodes were used with audio transformers it was difficult to get a sizeable step-up ratio and a good match at the same time because the low plate voltage gave a high plate resistance. With high gain pentodes and resistance coupling this is not a problem.

### BIAS DETECTORS

Fig. 2 shows a triode used as a bias detector, also called plate or power detector because detection takes place in the plate circuit and more output power and voltage is available than in grid-leak detectors. The bias detector has a high value cathode-bias resistor which causes the tube to be operated near its cut-off point. Since this type detector carries both r-f and a-f, the resistor must have an a-f, bypass, 1 mfd or more. A plate r-f bypass condenser of about 100 mmfd is used to keep the unwanted r-f components out of the audio transformer. Fig. 2 also shows one method of audio volume control which was often used with plate detectors.

Because bias detectors operate at high values of bias, they are adapted to handling much larger signal voltages than grid-leak detectors and are less subject to overload distortion. Another good feature resulting from the high bias is the high input impedance which imposes no loading on the tuned circuit feeding the

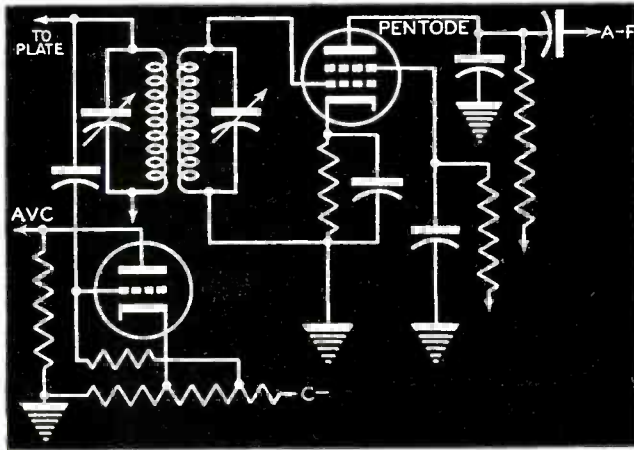
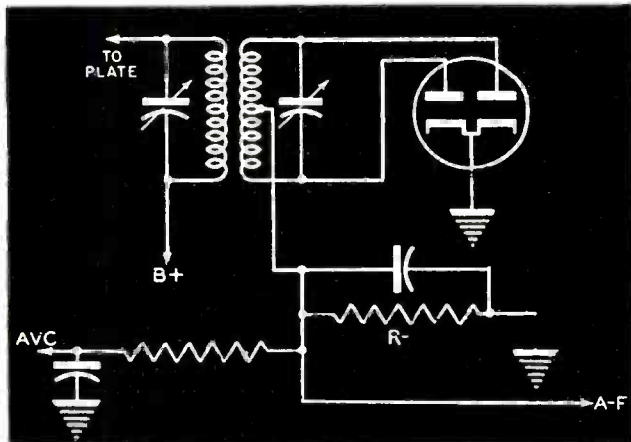

Fig. 4. (above). Tetrode or pentode-bias detector. This method offers a high-voltage output

Fig. 5 (below) Full-wave diode-detector delivering audio voltage plus avc.



detector. Still another feature, of particular interest to the Service Man, is the fact that due to the curvature of the tube's characteristic, the plate current increases as the signal increases. This is useful in tuning or judging signal strength. It should be noted that, in grid-leak detectors, the signal causes a decrease in average plate current because the tube is working at zero bias and at the opposite end of its characteristic (with opposite curvature) from the bias detector. High-resistance tetrode or pentode tubes make very good bias detectors when used with resistance or impedance coupling to the audio amplifier. In Fig. 4 we have such a circuit using a pentode.

### AVC SYSTEMS

Fig. 3 shows an early method of obtaining avc through the use of a triode coupled to the plate of the final i-f amplifier. The plate and grid voltage for the triode are derived from a bleeder resistor in the negative high-voltage lead, so that positive B is at ground potential. The tube is operated as a class B amplifier near cut-off so that when a signal is received, the average plate current increases (exactly like the bias detector) causing a voltage drop across the plate-load resistor. This drop, being more negative with respect to ground as the signal increases, may be utilized as avc bias to control the gain of one or more amplifiers to maintain a constant volume.

### DETECTOR-AVC CIRCUITS

In Fig. 5 appears a combined detector and avc system using the first type tube developed for this purpose, the 6H6. This tube is a full-wave rectifier which supplies a full-wave audio signal across  $R_1$ , the diode-load resistor. It has long been an

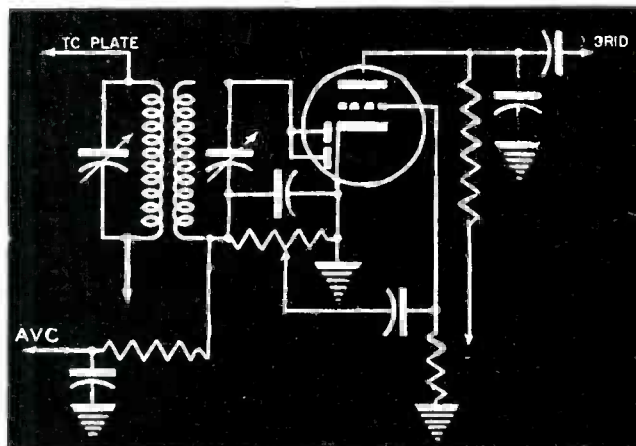

Fig. 6. . . .The most popular type of diode detector, with diodes in parallel.

obsession of the writer that this should represent the ideal detector, but somehow or other aural demonstrations fail to reveal the difference between full-wave and the conventional half-wave performance. It is hard to reconcile the extensive theory required for a thorough understanding of diode-detector operation and the simplicity of its circuit. In this article a brief analysis will be offered. The avc action is simpler, and therefore we'll approach that analysis first.

### DIODE-LOAD RESISTOR

In this system, the rectified r-f signal appears across the diode-load resistor which is shunted by a particular value of capacitor for proper detector action, as we will see later. This capacitor acts as an r-f filter so that, at the high side of the diode-load resistor, we have the demodulated, or detected audio signal. In Fig. 5, it is a full-wave signal; in Fig. 6, half-wave. But, in both cases, the high side of the resistor has a negative d-c polarity compared to the low side, which is grounded. Any voltage to be used for avc must be pure d-c, or direct voltage without any pulsations; hence the series resistor and shunt capacitor which comprise the





# HOW MICROPHONES WORK

Reprinted from QST

By Albert Kahn,\* W9KYM

## A Discussion of Various Types of Voice Pick-Ups

This article constitutes a discussion of the fundamental principles upon which several of the various types of microphones operate. In addition, some suggestions are given for selecting the proper kind of mike for a given application.

**I**N OPERATING practice, c.w. and 'phone have a lot in common. In both, signals must be easy and pleasant to listen to; they must get through QRM and QRN; and they should convey not only words but the personality of the operator. In the same manner that an x.p.d.c. note with well-spaced characters and a rhythmic swing makes a c.w. station "the one you'd like to sked," a pleasant, well-modulated voice gives a 'phone station that something which makes it stand out from the others on the band as desirable to work. These qualities will, in the final analysis, give a ham a "they-want-to-work-you" signal. Aside from more answers to a CQ, the QSOs will have a better chance of developing into real friendships as a result of putting more personality on the carrier.

### FIDELITY

It has been said that there is no need for "high fidelity" in an amateur transmitter. "After all, what we need is speech, not music!" Such thinking ignores some pretty important factors. Quality is important. Speech is a very complex collection of sounds, and intelligibility may be greatly impaired by loss or over-emphasis or other distortion of some of those sounds. For instance, "harmonic distortion," such as frequently appears in common carbon microphones in the form of strong harmonics generated within the microphone itself, produces one of the most unpleasant varieties of distortion. Also, of course, such harmonics are serious wasters of valuable r.f. energy and creators of aggravated sideband interference. The desired objective of an amateur 'phone transmitter is not to put maximum signal strength into a distant receiver but to put in a maximum of *intelligibility*, in a pleasant-to-listen-to voice. Many a low-power 'phone has proved astonishingly effective because its speech quality was extraordinarily good. High intelligibility and a "pleasant" voice often may accomplish more than would a boost in power and this can be achieved only with the aid of a microphone which does a good job on its initial end of the circuit.

Unlike brass pounding, where an operator pounds or wiggles a key, the 'phone ham actually does nothing to the microphone. He talks to the air and the air, in turn, actuates the microphone. Accordingly, in any discussion of sound pick-up practice, we must consider the action of a sound wave on the microphone.

Fig. 1 is a picture of the coupling between the sound source, *P* (the ham's mouth), and the microphone, *M*, located at a distance away, *R*. Although the radiated

\* President, Electrovoice, Inc., South Bend 24, Ind.

sound is hemispherical, we are concerned only with the segment of sound shown in Fig. 2. The rest is radiated into space or reflected. (If the amount reflected is too great it messes up the calculations as well as the signal on the air.)

Emitted sound expands equally in all directions, decreasing in intensity by the square of the distance. For simplicity, we are neglecting losses from absorption, etc.) This means that the voltage output will halve or the level will drop 6 db. every

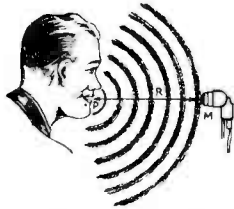

Fig. 1. Hemispherical pattern set up by sound wave from speaker's voice.

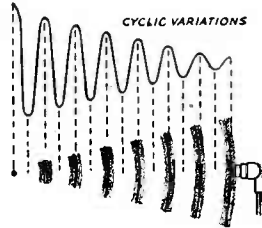

Fig. 2. Section of sound pattern which actuates the microphone.

time the distance  $R$  is doubled. The increase of  $R$  directly increases reverberation pick-up, since there is always an existing ratio of direct-to-reflected-sound. This can be a serious source of distortion despite otherwise excellent audio equipment. The size of the room, the amount of soft material and wall and floor material of course will govern the workable distance to a conventional pressure microphone. Unidirectional or bidirectional microphones will increase this working distance by a factor of 1.7 and will be discussed later.

#### PRESSURE MICROPHONES

The pressure type of microphone has the widest use. By definition, it is one which produces voltage directly proportional to the sound pressure applied. The back of the microphone is always closed to prevent the sound from striking the back of the diaphragm in improper phase relationship. Fig. 3-A shows a single-frequency sound wave, with the pressure component leading, striking the diaphragm. This pressure displaces the diaphragm from its normal position to that indicated

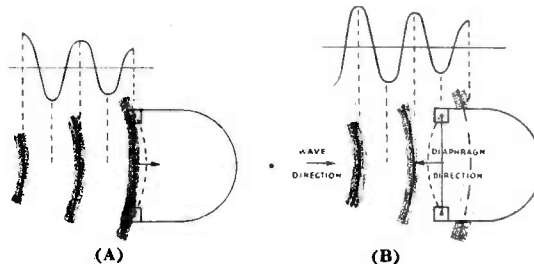

Fig. 3—A Microphone diaphragm under pressure from sound wave. —B Diaphragm position under a "rarity" or absence of pressure. The shaded dashed line represents the part of the wave which is passing the microphone indicating that the wave direction and direction of diaphragm movement are opposite.

by the dotted line and this movement is transmitted to a moving coil, crystal, carbon granules, or a condenser plate. At the next half cycle, the diaphragm position is shown by Fig. 3-B. At this instant, the wave has passed on and there is a rarity of pressure in front and the diaphragm springs back, through equilibrium, in the outward position. At the conclusion of the cycle it returns to rest in its normal position.

Since the pressure of a sound wave is equal in all directions, a sound wave from any direction will actuate the diaphragm. Fig. 4-A shows sound originating from



the side and exerting side pressure on the diaphragm. Whenever the wavelength of sound from an angle is short compared to the diaphragm width, there are several points of pressure and of rarefaction which cause irregular movement of the diaphragm. For highest-fidelity angular pick-up, the diaphragm therefore should be kept small. However, in actual practice too small a diaphragm lowers the output and usually a compromise is made. Fig. 4-B illustrates sound striking the microphone from the rear and energizing the diaphragm. This is true only, however, at the low and middle frequencies; the high frequencies travel in a beam and are accordingly deflected.

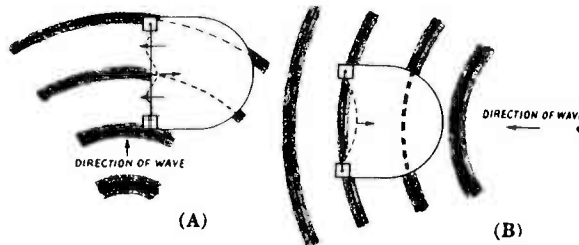

Fig. 4—A Diaphragm movement under wave approaching at right angles to plane of diaphragm. —B Wave approaching from the rear of the microphone.

An ideal diaphragm is one which follows perfectly, in physical movement, the sound pressure applied and thereby provides an accurate voltage image, as shown in Fig. 5-A. Fig. 5-B illustrates a badly overloaded diaphragm of a moving-coil microphone which reaches its elastic limit before the sound pressure has reached maximum amplitude. Pressure and diaphragm movement start at normal and expand to the elastic limit of the diaphragm. At this point the pressure continues to increase but the diaphragm comes slowly to rest in its displaced position until the sound wave is on the decay side of the cycle and then it returns in phase with it. The electrical output, meanwhile, follows the velocity of the diaphragm or voice coil and, while the diaphragm is at rest, the voltage drops, approaching zero. As the diaphragm returns at high velocity through equilibrium, an electrical surge is created in reverse polarity and a counterpart of the wave appears on the other half of the cycle. This sort of wave form is extremely abundant in harmonics, more odd than even. This action commonly is known as "flasting" and often results from speaking in too loud a voice directly into the microphone, particularly if it is designed for normal pick-up at, say, six inches to a foot away. Several microphones are commercially made for close work but few if any can be used for both close and distant pick-up with satisfactory results.

Pressure microphones are the closest approach to an all-around instrument. They maintain their inherent frequency response at various distances from the sound source and they can be built as a dynamic, condenser, crystal, carbon, or a ribbon with a closed back. Since the diaphragm can be made stiff, they are not, as a rule, too susceptible to breath or wind noise. They are semi-non-directional and can be used for group pick-up when room reverberation permits. Relatively high efficiency and excellent frequency characteristics can be secured with correct design.

#### VELOCITY MICROPHONES

The velocity microphone is of the type which is responsive to the pressure gradient or the difference between the instantaneous sound pressure on the front and back of the ribbon or diaphragm. Fig. 6-A illustrates a conventional velocity microphone looking directly at the interior assembly. The ribbon is loosely sus-

pended between the pole pieces which also serve as baffles. Variations in sound pressure move it through the magnetic field set up by a permanent magnet attached to the pole pieces, inducing a voltage in the ribbon. Fig. 6-B is a bird's-eye view of the same assembly showing the ribbon, pole pieces, and the magnetic lines.

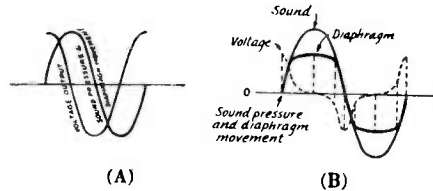

Fig. 5—A Curves showing relationship between diaphragm pressure and output for ideal conditions. —B The same for a badly overloaded diaphragm.

Fig. 7-A is a picture of the ribbon being actuated by a single sound wave at the top half of the cycle, with the pressure component leading. For simplicity, it has a wavelength of less than one-fourth the distance around the pole pieces. For lower frequencies, actually there is a pressure on both sides of the ribbon and the microphone responds to the difference in pressures, the pressure gradient.

The ribbon moves through the magnetic field, cuts the lines of force, and a voltage is induced in the ribbon which is the electrical image of the sound wave. As the wave progresses a half cycle it passes around the pole pieces and at the instant of passing (Fig. 7-B) there is pressure from the rear and a rarity of air at the front. Since the ribbon is loosely suspended without any inherent spring and resonating below audibility, it floats back, following the difference in pressure between the front and the back — just as simple as that.

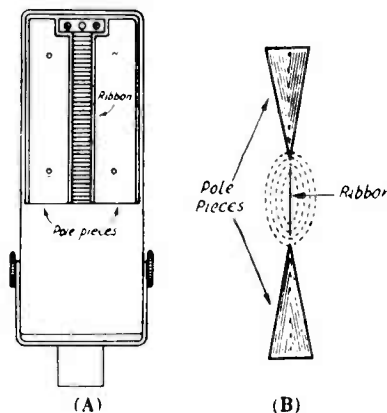

Fig. 6—A Constructional elements of a velocity microphone. —B A cross-sectional view of the pole pieces and ribbon as viewed from the top. The dotted lines represent magnetic flux.

In the design, it is necessary to determine the desired upper-frequency response and make the pole pieces, or baffles, the correct width. There is a direct relationship between baffle width and upper frequency cut-off since the high frequencies which are physically close together do not have time to get around a wide pole piece before the next one is on its heels. Narrow poles require higher magnetic energization for a given level since there is less collection of sound and therefore less movement of the ribbon. The baffles should be slightly less than one-half wavelength at the highest frequency to be reproduced. Thus you can measure the frequency

response of a velocity microphone with a ruler, assuming no introduced distortion by the ribbon, coupling transformer, or sound reflection within the case.

The velocity microphone, it is seen, is bidirectional because if sound enters at the side, there is equal pressure on both sides of the ribbon and therefore no movement can result. Fig. 8 is a picture of the directional characteristics of a velocity microphone. The sound entering directly into the front or back gives maximum output, sound from the side producing zero output. As the sound strikes it from an angle, there is a corresponding decrease in level which may be represented by drawing a line (dotted) from angular to direct sound. If the angle adjoining the top of the angular sound angle is kept a right angle, the output will be graphically represented by the length of the lines, or, if you remember your

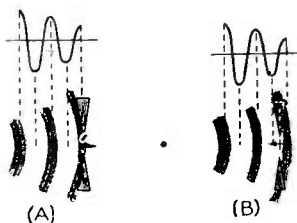

Fig. 7. Movement of velocity-microphone ribbon in respect to wave direction.

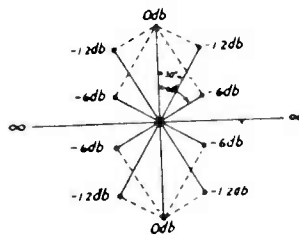

Fig. 8. Directional characteristics of a velocity microphone.

trig, the output will vary as the cosine of the formed angle. The frequency response for all practical purposes will remain constant at all angles of sound incidence — there will be just a drop in level.

This bidirectivity can be put to work to reduce reverberation since the attenuation at the sides decreases random sound pick-up by 5 db. It can be oriented so that the sides face objectional noise (XYL and jr. ops?). It can be used between two persons and “worked to” from front and back with equal pick-up. As the ribbon in the conventional type is loosely suspended it will follow even extreme sound pressures without blasting and without the harmonic generation shown in Fig. 5.

The velocity microphone must not be worked too close to the sound source since there is a shift in phase between particle velocity and sound pressure at close distance which causes a substantial rise in the low-frequency response. Popular-priced velocity microphones are lower in output than their pressure counterparts and require higher-gain speech amplifiers and better input shielding.

#### THE DIFFERENTIAL MICROPHONE

The third type of microphone, the differential, was covered completely in the December, 1943, issue of *QST*.<sup>1</sup> This has proved to be extremely useful for overcoming high ambient noise in nearly all military applications. Already it has been used widely for all types of communication in the aircraft, railroad, industrial, and emergency service fields.

Unidirectional microphones are a fourth type but in reality they are combinations of pressure and velocity elements which are operated together in such phase relationship that sound pressure adds from the front and cancels from the back. This has been done successfully in both dual- and single-head instruments. These provide a 5 db. reduction in random noise and are highly desirable in “live” rooms, especially where the undesired sound strikes the microphone from the rear.

Research has provided a wide choice of microphones and intelligence in selection and use is therefore more necessary than ever. The carbon microphone (pressure or differential type) has been widely used for military application and does provide high articulation. In addition, the modern version is durable and has high output. The chief disadvantage is high harmonic distortion, especially, in the single-button variety, which makes it less pleasant to listen to and is not in

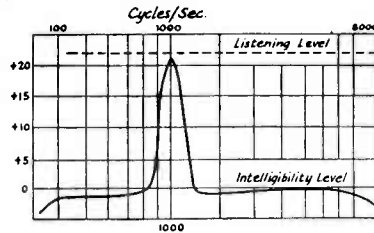

Fig. 9. A hypothetical curve illustrating how a peak lowers the effective listening level.

keeping with modern 'phone-station standards, except possibly in mobile use where high-level signals and light-weight equipment are of extreme importance.

Laboratory articulation tests have proven quite conclusively that a flat response curve between 200 and 4000 c.p.s. is ideal for communication service. Peaks in the frequency response lower the effective intelligibility at the receiving end as indicated by Fig. 9. In this instance the energy in the peak does not represent intelligibility but limits the receiver volume to the point of overload caused by the peak, yet if the peak is removed, the entire spectrum can be substantially raised. This same reasoning also can be applied to the rest of the transmitting and receiving equipment.

There will be a wide variety of microphones waiting for the radio amateur after the war. Wise choice of the appropriate type and correct use will put new sparkle in the QSO of Tomorrow.

<sup>1</sup> Beekley, "A Differential Microphone," *QST*, Dec. 1943, p. 36.



## WHAT'S BEING READ THIS MONTH

As a regular feature of our magazine, we take pleasure in presenting each month a complete list of the articles which have appeared in the current issues of the leading trade and professional magazines. The list for this month is as follows:

### COMMUNICATIONS (September 1945)

#### AERONAUTICAL COMMUNICATIONS

Airline V-H-F F-M System.....*T. W. Hall*

#### BROADCAST TRANSMITTERS

Stepping up Transmitter Power from 500-w to 1-kw.....*Lawrence A. Reilly*

#### FILTER DESIGN

Effect of Coil Q on Filter Performance.....*Paul Selgin*

#### V-H-F COMPONENTS

Coil Design for V-H-F.....*Art. H. Meyerson*

#### V-H-F OSCILLATORS

Crystal Oscillators in F-M and Television.....*Sidney X. Shore*

#### SOUND ENGINEERING

Acoustic Feedback Reduction by Increased  
Directivity in Megaphones.....*Arthur J. Sanial*

#### RESISTIVE NETWORKS

Resistive Attenuators, Pads and Networks — Part VIII.....*Paul B. Wright*

### C Q (October 1945)

#### EXCITERS FOR THE NEW AMATEUR BANDS

Juggling 80-meter crystals to hit 52.5-54 mc and cover the  
rest of the bands up to 148 megacycles.....*Herbert S. Brier, W9EGQ*

#### BALANCED R-F IMPEDANCE MEASURING SET

A versatile instrument for measuring the impedances of  
two-wire fed antennas.....*Frank C. Jones, W6AJF*

#### GET ON THE AIR WITH AN MOPA

A 60-watt rig for 112 and 144 megacycle operation.....*Howard A. Bowman, W6QIR*

#### FREQUENCY METER AND HARMONIC OSCILLATOR

A versatile unit with excellent design and constructional  
features.....*Alston M. Wheelden, W2NYZ*

#### 'ROUND-THE-WORLD TIME CHART

#### ANTENNA CONSTRUCTION HINTS

Elements of antenna technique.....*W. H. Anderson, VE3AAZ*

#### RADIO AMATEUR'S WORKSHEET, NO. 5: COUPLING OF TUNED RADIO FREQUENCY CIRCUITS; AUTOMATIC FIDELITY CONTROL

MORE ON TIME.....*Athan Cosmas*

**ELECTRONICS (October 1945)***RADAR WARFARE*

The technical factors behind the uses of the electric device contributing most to victory

*FINGERTIP CONTROL FOR FORMATION FLYING*

Newest accessory for C-I electronic autopilot permits effortless maneuvering of largest bombers.....*D. G. Taylor and G. Voikent*

*VHF MULTIPLE-RELAY TELEVISION NETWORK*

Description of a chain through which video programs originating in Washington are telecast in Philadelphia.....*F. J. Bingley*

*THE TECHNICAL BASIS OF ATOMIC EXPLOSIVES*

Production and use of uranium-235 and plutonium

*CRACK DETECTOR FOR PRODUCTION TESTING*

The instrument makes use of skin effect to determine the presence and depth of cracks in metals.....*John H. Jupe*

*DESIGN OF STABLE HETERODYNE OSCILLATORS*

Proper design of the variable capacitor minimizes effect of temperature changes on frequency.....*John B. Moore*

*AUTOMATIC FADER*

Complete or partial fading of a program is accomplished without the use of motors.....*Dan Hunter*

*MICROWAVE TECHNIQUES*

Transmitter and receiver designs insuring adequate stability are discussed.....*Frederick A. Jenks*

*BRIDGE NULL INDICATOR*

New circuit provides sensitivity with overload protection and a visual indication of output.....*E. W. Herold*

*COAXIAL CABLE TESTS*

Production testing by substitution in bridge or resonant circuits.....*Perry H. Ware*

*INDUSTRIAL TEST EQUIPMENT DESIGN*

Why circuit analyzers used for heavy field-duty fail, and how to avoid it.....*Ted Powell*

*CRYSTAL-TUNED F-M RECEIVERS*

Advantages of quartz crystals in oscillators stage include high stability, easy alignment, and precise tuning.....*William Maron*

*GRAPHICAL ANALYSIS OF COMPLEX WAVES*

Arithmetic combined with 6, 8, or 12 measurements gives equation and amplitudes of harmonics up to the sixth.....*Larry S. Cole*

*REACTOR MEASUREMENTS*

Circuit for measuring electrical parameters of iron-core inductors.....*Howard L. Daniels*

*TRANSMISSION LINES AS TUNING ELEMENTS*

Graphical determination of line length and shunting capacitance for resonance.....*H. E. Newell, Jr.*

**ELECTRONIC INDUSTRIES (October 1945)***STRAIN ANALYZING AND RECORDING INSTRUMENTS*

Practical schemes developed include inductance and resistance type gages with results recorded on moving film.....*Claude M. Hathaway*

*MODERN RADIO PRODUCTION*

Viewing some of the laboratory and factory methods in the Cedar Rapids plant of the Collins Radio Co.

*IMPROVING RECORDINGS*

How to get the most out of phonograph records including a new design for a volume expander to increase "presence".....*Norman C. Pickering*

*INCENTIVE PAY FOR ELECTRONIC ENGINEERS*

Compensation plans based upon individual achievements and inventions as well as company prosperity. Rewards for technical men comparable to earnings of sales and other executives.....*Dr. J. A. Stobbe*

*TELEVISION REFLECTIONS FROM AIRPLANES**SOUND STUDIO DESIGN**TECHNIC OF ANTENNA GAIN MEASUREMENTS*

Standing wave ratio obtained by means of slotted line used to correct power input to antenna under test.....*G. Glinski*

*GENERATION OF ATOMIC POWER FROM ELEMENTS*

Electronic principles familiar to tube engineers are of vital importance in the development of nuclear energy.....*H. Gregory Shea*

*THRU THE LABORATORY KEYHOLE**PRACTICAL PROBLEMS OF CRYSTAL DIMENSIONING*

A systematic approach to methods that will result in reducing differences under conditions otherwise standard.....*C. W. Franklin*

*ARMY AND NAVY RADAR*

Electrical echoes can be in either horizontal and shown on oscillograph tubes in either horizontal and vertical or circular patterns

*ENGINEERING DETAILS OF OWI 200 KW UNITS*

Technical data and constructional features of fully modulated inverted amplifier operating at 6.22 mc.....*Hugo Romander*

*ENGINEERING BRITISH B-48 WALKIE TALKIES*

Technical features of Americanized design for combined mobile transmitter-receiver developed for military liason

*MOBILE TELE CONTROL**TUBES ON THE JOB**AIRLOOP ANTENNA*

**FM AND TELEVISION (September 1945)***WHAT'S NEW THIS MONTH*

ESPRI report on emergency communications

*NOTES ON FM BROADCASTING*.....D. W. Gellerup*THE FACTS ABOUT 10-KW. FM TRANSMITTERS*.....Milton B. Sleeper*FACSIMILE DISPATCH & REPORT SYSTEM. PART 2*.....Milton Aiden*PROPOSED RULES FOR FM BROADCASTING*

Official FCC text

*PHASE AND FREQUENCY MODULATION*.....Ralph S. Hawkins*TELEVISION CONTROL ROOM ON WHEELS*.....Klaus Landsberg**PROCEEDINGS OF THE I. R. E. (October 1945)***RESPONSIBILITY OF THE RADIO ENGINEER TO THE ENGINEERING PROFESSION*.....H. W. Sundius*KEITH HENNEY: BOARD OF DIRECTORS — 1945-1947**I.R.E. SPECIAL COMMITTEE ON OBTAINING MEMBERSHIP**TALENTS AND VOLUNTEER SERVICE*.....E. Finley Carter*VACUUM-TUBE RADIO-FREQUENCY-GENERATOR CHARACTERISTICS AND APPLICATION TO INDUCTION-HEATING PROBLEMS*.....T. P. Kinn*A 60-KILOWATT HIGH-FREQUENCY TRANSOCEANIC-RADIOTELEPHONE AMPLIFIER*.....C. F. P. Rose*STUDY OF ULTRA-HIGH-FREQUENCY TUBES BY DIMENSIONAL ANALYSIS*.....G. J. Lehmann and A. R. Vallarino*LOW-FREQUENCY COMPENSATION OF VIDEO-FREQUENCY AMPLIFIERS*.....M. J. Larsen*THE DESIGN OF BROAD-BAND AIRCRAFT-ANTENNA SYSTEMS*.....F. D. Bennett, P. D. Coleman, and A. S. Meier*CATHODE-COUPLED WIDE-BAND AMPLIFIERS*.....G. C. Sziklai and A. C. Schroeder*BAND-PASS BRIDGE-T NETWORK FOR TELEVISION INTERMEDIATE-FREQUENCY AMPLIFIERS*.....G. C. Sziklai and A. C. Schroeder*ELECTRON TRANSIT TIME IN TIME-VARYING FIELDS*.....Arthur B. Bronwell*DISCUSSION ON "THE THEORY OF TRANSMISSION LINES" BY EDWARD N. DINGLEY, JR.*.....Fred J. Heath and Edward N. Dingley, Jr.**RADIO (September 1945)***DESIGN CONSIDERATIONS IN SMALL RECEIVERS*.....A. C. Matthews*EFFECT OF DIELECTRIC MATERIALS ON INDUCTOR PERFORMANCE*.....A. C. Thompson*MODERN QUARTZ CRYSTAL PRODUCTION, PART 2*.....Richard E. Nebel*RECENT TRENDS IN PRECISION RESISTOR DESIGN*.....A. P. Howard*FREQUENCY CONVERSION IN SUPERHETERODYNES*.....M. A. Charles*RECENT RADIO INVENTIONS —*

Device for measuring Peak Currents; Coupling Device; Radio Altimeter and Panoramic Reception System; D-C Voltage Amplifier; Phase Angle Indicator; Homing Autopilot for Aircraft; Stabilized Oscillator; Frequency Modulation Detector

*RADIO DESIGN WORKSHEET, NO. 40: INDUCTIVE BALANCE ANTI-NOISE CIRCUIT**CHART-INCREASE IN LOSS OF RESISTANCE PAD OF 500-OMH ITERATIVE IMPEDANCE DUE TO TERMINATION MISMATCH*



**RADIO-CRAFT (October 1945)**

THE RADIO BOMB DID EXIST	
RADAR — SECRET WEAPON NO. 1.....	Fred Shumanian
ELECTRONIC NAVIGATOR	
STRATOVISION	
B-29 ELECTRONIC GUN CONTROL TESTS.....	T. E. Holland
HOW RADAR OPERATES	
MICROWAVES, PART III.....	Major Eugene E. Skinner
TAXIS HAVE TWO-WAY RADIO	
"DESIGN ENGINEERS" OF THE U. S. FORCES.....	Captain M. M. Carothers
NAZI MORALE RADIO.....	Alan Jay
BROADCAST EQUIPMENT, PART XII.....	Don C. Hoefler
DETECTOR CIRCUITS, PART III.....	Robert F. Scott
TUBE REPLACEMENTS, PART IV.....	I. Queen
TUBE REJUVENATION.....	Myron G. Albin
SCRAMBLED SPEECH FOR RADIOPHONES.....	John B. Parchman
A WALNUT MICROPHONE.....	Carl Burkett
A COMBINATION TO-TEST PANEL.....	Charles H. McElroy
POCKET-SIZE TUBE TESTER.....	Homer L. Davidson
A BALANCED V.T.V.M.....	Wm. B. Miller

**RADIO NEWS (October 1945)**

THE OSCILLOSCOPE APPLIED TO TRANSMITTER CHECKING.....	Morris Eddy and Arthur Howard
112MC. CRYSTAL-CONTROLLED TRANSMITTER.....	L. G. Morey, W9KBO
INTERNATIONAL SHORT-WAVE.....	Kenneth R. Boord
ULTRASONIC COMMUNICATIONS.....	Robert G. Rowe
HAMFESTERS PICNIC	
THE ROAD TO HAMDOM.....	S/Sgt. George Mobus, W9UAO
Q. T. C.....	Carl Coleman
TEMPERATURE CONTROL IN THE DESIGN OF STABLE OSCILLATORS.....	Lyle C. Tyler
CAPTURED 1000 WATT JAP TRANSMITTER	
4-CHANNEL MIXER FOR YOUR AMPLIFIER.....	David A. King
NEW TYPE SIGNAL TRACER.....	Shephard S. Litt, 2LCC
ELECTROLYTIC CAPACITOR CHECKER.....	Rufus P. Turner
PRACTICAL RADIO COURSE.....	Alfred A. Ghirardi
VIDEO AMPLIFIERS.....	Edward M. Noll
REACHING THE RURALIST.....	John Latimer
RADAR — THE SILENT WEAPON OF WORLD WAR 2	
PRACTICAL RADAR.....	Jordan McQuay
RADAR PLOTS THE INVASION.....	Eugene Mason
FOR THE RECORD	
SPOT RADIO NEWS	
TRAINING WITH VISUAL AIDS.....	Carl E. Winter
ELECTRONIC TIMERS.....	Samuel A. Proctor
TUNING FORK MULTIVIBRATOR.....	Cpl. Hayward L. Talley

**RADIO NEWS Radio-Electronic Engineering Edition (Oct. 1945)**

<i>ELECTRONICS IN NON-DESTRUCTIVE TESTING OF MATERIALS</i> .....	Robert Endall
<i>WASHINGTON TO PHILADELPHIA TELEVISION RELAY NETWORK</i> .....	N. F. Smith
<i>MAXIMUM POWER TRANSFER</i> .....	Myril B. Reed
<i>ELECTRONIC SERVO SYSTEM</i> .....	E. J. Thompson
<i>ELECTROMAGNETIC OSCILLOGRAPHS</i> .....	C. M. Hathaway
<i>GRAPHICAL CALCULATOR FOR DIRECTIONAL ANTENNAS</i> .....	Roger W. Hodgkins
<i>BESSEL-FUNCTION GRAPHS</i> .....	R. A. Whiteman

**SERVICE (September 1945)**

<i>C-R OSCILLOGRAPHS Applications — Servicing, Part III</i> .....	S. J. Murcek
<i>F-M LIMITERS</i> .....	J. George Stewart
<i>MARINE P-A SYSTEMS</i> .....	Martinn W. Elliott
<i>OLD TIMER'S CORNER</i>	
<i>RECEIVER INPUT CIRCUITS</i> .....	L. E. Edwards
<i>SER-CUITS</i> .....	Henry Howard
<i>SERVICING HELPS</i> .....	Frank L. Keene
<i>VOLUME AND TONE CONTROL RESISTORS</i>	
<i>PART 7 OF A SERIES ON RECEIVER COMPONENTS</i> .....	Alfred A. Ghirardi

**TELEVISION (October 1945)**

<i>COMMISSIONERS PORTER, JETT AND DURR ON ALLOCATIONS</i> .....	Dorothy Holloway
<i>SMALL STATION OPERATION</i> .....	Philip Merryman
<i>MADAMOISELLE TRIES OUT TELEVISION</i> .....	Mary Gannon
<i>TELEVISION OUTLOOK IN CHICAGO</i> .....	Frederick A. Kugel
<i>LONG SHOTS AND CLOSE UPS</i> .....	Hal G. Christensen
<i>ONE MAN'S RELECTIONS</i> .....	Dr. Alfred N. Goldsmith
<i>PROGRAMMING</i>	

# IT'S THE EXTRA POINT THAT COUNTS



Failure to make that *extra* point accounted for the loss of over 20% of America's key football games last year!

Failure to chalk up extra points by buying Victory Bonds now to build the peace is stopping short of the goal. Victory Bonds tackle our post-war problems. They hold the line against rising prices, and guard the recovery of our wounded.

And Victory Bonds carry you over the goal to a secure and brighter future.

**BUY that extra bond!**  
**BUILD that Better Future!**

# HUDSON AMERICAN

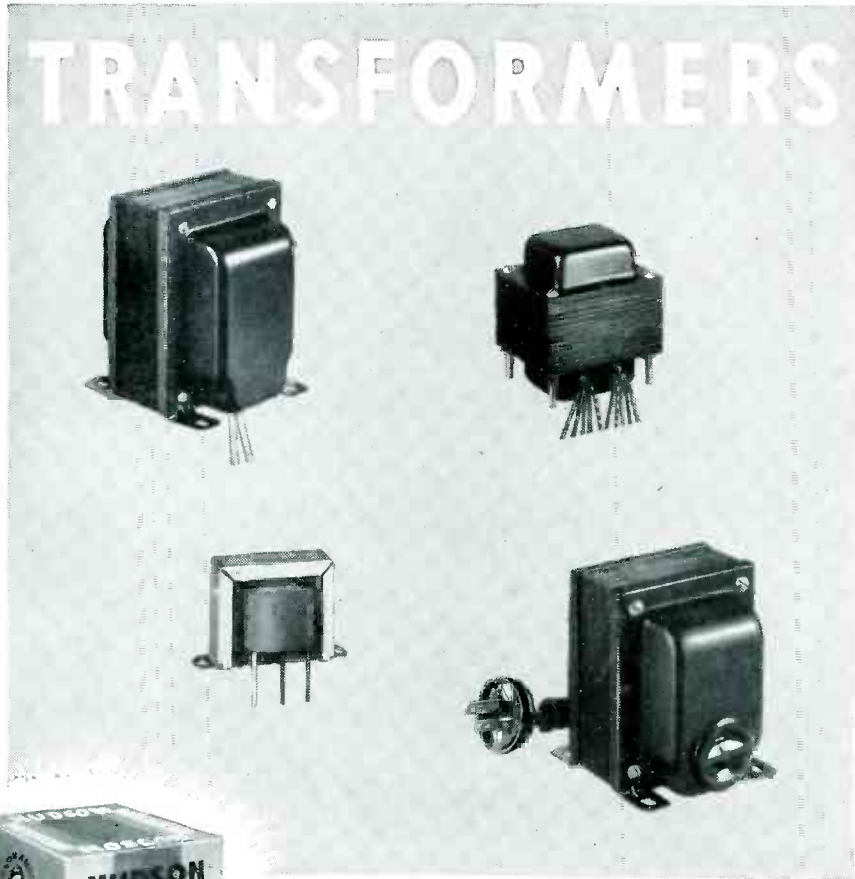

Look for this distinctive package



## FOR GENERAL PURPOSE AND REPLACEMENT USE IN RADIO AND ELECTRONIC EQUIPMENT

HUDSON AMERICAN'S engineering experience in designing and manufacturing high quality transformers extends over a period of more than 20 years.

HUDSON AMERICAN'S up-to-date facilities include the most modern coil producing machinery available—vacuum impregnating equipment for wax or varnish and completely automatic production test apparatus. HUDSON AMERICAN Transformers are precisely wound—meticulously assembled—thoroughly impregnated and carefully finished. Continuous inspection and quality control insure maximum uniformity.

For dependability and economy, specify HUDSON AMERICAN Transformers for your radio and electronic requirements. They cost no more than ordinary transformers.

*Write for catalog 1045*

## HUDSON AMERICAN CORPORATION

*(A subsidiary of Reeves-Ely Laboratories, Inc.)*

25 WEST 43rd STREET, NEW YORK 18, N. Y.