

# The RADIO ENGINEERS' DIGEST

MARCH 1945

VOL. 1, No. 8

## .. CONTENTS ..

Low Voltage Receiver.....	<i>Electronic Industries</i>	1
Common Carrier Radio Relay Systems.....	<i>FM and Television</i>	5
Radio Equipment for the Personal Plane.....	<i>Aero Digest</i>	9
Fading Effects at High Frequencies.....	<i>Electronics</i>	12
Electronics Puts New Health Instruments In Medical Kits.....		23
Magnetic Phonograph Pickups.....	<i>Radio</i>	24
Super Photo-Timer.....	<i>Radio-Craft</i>	29
What's Being Read This Month.....		32

Published by THE HUDSON AMERICAN CORPORATION

## *The American Way of Life*

As Americans one and all we believe in our country. We believe in the American way of life which has made our nation great.

That way of life now stands challenged as never before in our history. And it means a fight to the finish if our way is to prevail.

We have been quick to meet this challenge with courage and with skill. We have raised a mighty armed force and have forged the tools of war.

We have done a splendid job thus far, but we must not stop at that. If we slow down now before the finish, we will only prolong the job. We will make it longer and costlier than it need be otherwise.

But if we keep right in there pitching, we will reach our goal at last. And we will have the satisfaction of knowing that we have played a vital part in the greatest fight for freedom that the world has ever known.

## THE RADIO ENGINEERS' DIGEST

JOHN F. C. MOORE, *Editor*

### *Advisory Board*

PHILIP GREENSTEIN

Assistant Professor of Electrical Engineering,  
New York University

CARL NEITZERT

Assistant Professor of Electrical Engineering,  
Stevens Institute of Technology

Copyright 1945 by The Hudson American Corporation

Vol. 1, No. 8

March, 1945

Published monthly at New York, N. Y., by The Hudson American Corporation  
For free distribution to its friends in the radio and electronics industries

Editorial Office, 25 West 43rd Street, New York 18, N. Y.

Printed by Criterion Products Corporation, New York, N. Y., U. S. A.

# LOW VOLTAGE RECEIVER

Reprinted from *Electronic Industries*

By *Joseph Lorch*

*Research Engineer, Harvey-Wells Communications, Inc., Southbridge, Mass.*

Design considerations in the construction of equipment to operate from 24-volt battery as sole source of power

**A** GREAT amount of development work has been carried out in recent months on radio equipment using "B" voltages ranging from 12 to 32 volts. It has been conclusively shown that satisfactory operation of receivers, amplifiers, small transmitters and other electronic devices can be obtained with plate and screen voltages of this order.

Up to the present time by far the greatest amount of low voltage equipment has been developed for aircraft use. This is not surprising since very often a small difference in size and weight of a piece of apparatus will determine whether or not it can be carried in the already crowded plane. Weight and size considerations will assume even greater importance in small private airplanes of postwar production. Commercial airlines, too, will prefer light weight radio equipment since each and every pound saved in equipment will increase the pay load by that amount.

There are many other fields in which low voltage equipment eventually will play an important part. To mention but a few of the important ones: home radio for farm use, communication systems for railways and receiving equipment for small seacraft will greatly benefit by this development.

Successful construction of low voltage radio equipment depends upon three factors:

1. Correct choice of tubes.
2. Full utilization of the supply voltage by proper dimensioning of all components apt to cause undesired voltage losses in plate and screen circuits.
3. Special treatment of bias circuits in order to maintain tube uniformity.

Amazing as it may seem, only in the case of power output tubes was the design of new tubes required in order to provide acceptable performance. All other functions can be fulfilled by existing tube types that originally were introduced for use at higher voltages. This does not mean that all tube types operating satisfactorily at higher plate and screen voltages, other than output tubes, can be used to advantage at these low voltages. It has rather been established that in order to obtain optimum performance the selection of proper tube types becomes of paramount importance.

In the frame of this discussion a sensitive receiver circuit will be described that has been tried out in practice. Specific circuit considerations and problems

of tube selection will be pointed out. Sufficient information will be included to enable the reader to modify the circuit for his particular requirements.

The receiver, of which a schematic diagram is shown in Fig. 1, was developed for an aircraft application and uses a 24-volt aircraft battery as its sole source of power. By proper selection of component parts the total weight is kept below three pounds. Under flight conditions (battery voltage of 28 volts) the sensitivity is better than 5 microvolts for 50 milliwatts power output.

#### Power Output

The maximum power output obtained with the circuit shown ranges from 200 to 250 milliwatts at approximately 10 percent distortion. Means of increasing the power output to 600 milliwatts are also described. The total power consumption at 28 v is 20 watts. The receiver is designed to operate satisfactorily under supply voltage variations from 22 v to 32 v. Basically, the circuit employs the superheterodyne principle using a total of five tubes.

The frequency band ranges from 200 to 400 kc permitting reception of the low frequency "beacon" and weather stations. The intermediate frequency amplifier operates at 90 kc. By proper choice of tuning components other frequencies

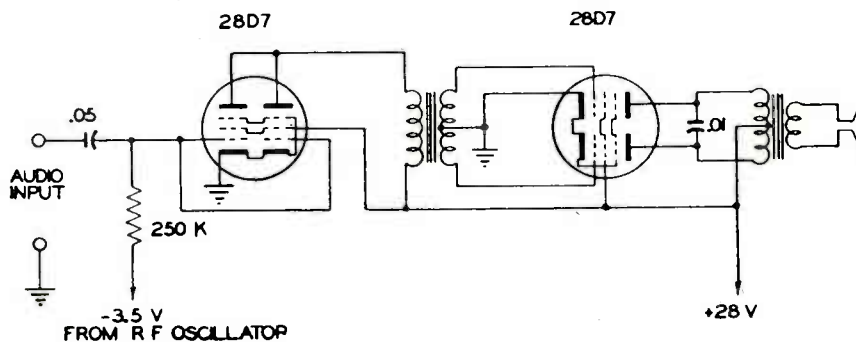

Fig. 2—An arrangement such as this may be used to boost power output to about 600 milliwatts

up to the ultra high frequency region can be covered. Tests performed by the writer at frequencies up to 100 megacycles indicate that no ill effects arise from the use of low supply voltages at such high frequencies. The reader intending to build a low voltage receiver from the material furnished in this discussion may, therefore, select any frequency band or a number of frequency bands of greatest interest to him.

The tube types and their respective functions are as follows:

Tube type	Function
12SK7.....	RF amplifier
12SA7.....	Oscillator and mixer.
12SK7.....	IF amplifier
12SR7.....	2nd detector, avc generator, and 1st audio amplifier
28D7.....	Power output stage

The 12SK7 was chosen as RF and IF amplifier for several reasons. While at 28 v its transconductance is not quite as high as that of some other types available, the variation in transconductance from tube to tube is very small resulting in little change in performance in case of tube replacement. In addition, a relatively small variation of transconductance is experienced under supply voltage fluctuations. This feature is of importance wherever storage batteries are used, in order to insure satisfactory receiver sensitivity should the battery voltage drop to a low

value. Furthermore, the 12SK7 maintains very desirable remote cut-off characteristics at low supply voltages, an important factor when automatic volume control is employed.

The 12SA7 used displays substantially the desirable features mentioned for the 12SK7. In addition, it represents a stable oscillator at low voltages. In order to obtain the required amount of excitation it is necessary to move the cathode tap considerably higher on the oscillator coil than normally recommended. While, as a thumb rule, for the 12SA7 the cathode tap should occur one-tenth the total number of turns from the ground end of the coil, for correct excitation at 28 v "B" supply the winding should be tapped at one-quarter the total number of turns. This, incidentally, represents the only departure in coil design from normal practice.

The second detector and the means of obtaining avg voltage are entirely conventional. However, the first audio amplifier is by necessity a low Mu triode (12RS7). While one would at first assume that better results could be obtained when using a high Mu triode, experience has shown that consistent sensitivities from tube to tube cannot be obtained if a high Mu triode is used. This behavior is caused by the effect of varying amounts of contact potential which may develop grid bias sufficiently high to cause almost complete cut-off in the amplifier. For low Mu triodes this impairment is considerably less evident.

The power amplifier is a Sylvania type 28D7. This type of tube, specifically designed for low voltage use combines two power pentode systems in one envelope which in the particular application here described are operated in parallel in Class "A1" (plate impedance—2000 ohms). The resistor inserted in series with the heater protects the tube should the supply voltage ever exceed 28 volts. In order fully to utilize the available plate supply voltage of 28 volts two precautions are taken:

1. The dc resistance of the primary winding of the output transformer is kept extremely low (approximately 50 ohms) resulting in a very low voltage drop across this winding.
2. The necessary bias voltage of 3.5 volts is introduced as "C" bias obtained from a voltage divider in the grid circuit of the RF oscillator. If the tube were self-biased the effective plate voltage would be decreased from 28 volts to 24.5 volts thus causing an appreciable drop in power output.

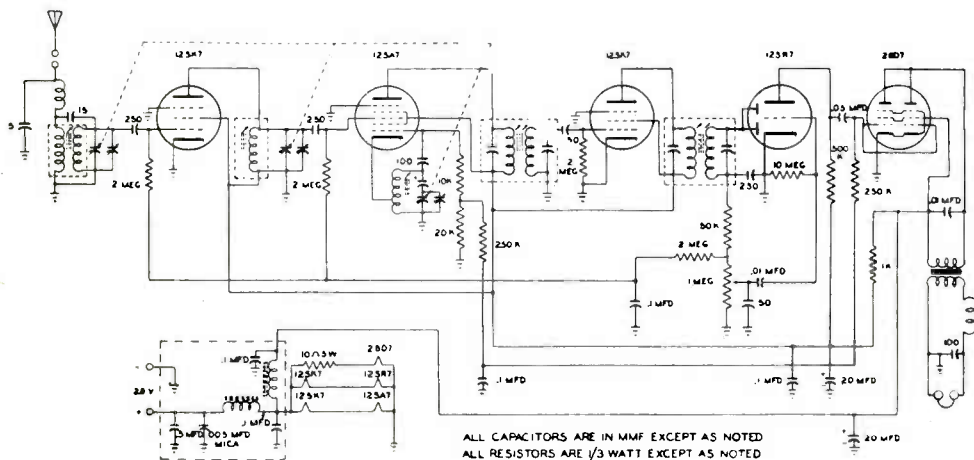

Fig. 1—By proper selection of components, this receiver, operating from 24-volt aircraft battery, can weigh under three pounds. Sensitivity is 5 microvolts and output 50 milliwatts though output can be increased to 600 milliwatts as shown in Fig. 2.

No cathode bias is applied to any tube in this receiver. Instead, grid leak bias was found to create better tube uniformity and, at the same time, permit optimum tube operation. The RF amplifier and mixer tubes are supplied with avc voltage through their respective grid leaks, the avc voltage being generated in the second detector.

#### *Interference Prevention*

Since the receiver is supplied by storage batteries which may be charged during periods of reception, elaborate precautions are taken to prevent generator hash from entering the receiver through the power supply leads, the antenna and the phone leads. In addition to the general considerations governing the design of such filters it is important that the dc resistance of all chokes involved be kept as low as possible. Thus, the dc resistance of the common supply filter choke does not exceed .2 ohms, and that of the "B" filter choke measures about 10 ohms, both filters using polyiron cores.

The filter chokes used in the antenna and phone circuits consist of ten turns wound on 5 megohm,  $\frac{1}{2}$ w resistors. Besides the hash filters a ripple filter is required for the "B" supply voltage of all tubes except the output tube. The ripple filter, in this case consisting of 1000 ohm series resistor in the "B" line, by-passed by 20 mfd electrolytic condensers is highly essential for a receiver deriving its "B" supply directly from a storage battery under charge.

The audio power output of 200 to 250 milliwatts is ample for phone reception. It is sufficient for modest requirements of loud speaker reception, especially if a high efficiency speaker is used. When higher values of power output are desired Class "A2" operation will do the trick. As shown in Fig. 2, the audio signal is applied to the control grids of the driver, consisting of the two pentode systems of a 28D7 tube connected in parallel. The plate circuit of the driver works into an interstage transformer which in turn feeds another 28D7 tube operating in push-pull. The primary to  $\frac{1}{2}$  secondary impedance ratio of the interstage transformer is 6 to 1 for optimum working conditions, the load impedance of the driver being 2000 ohms. The plate-to-plate load impedance of the output stage is 1500 ohms. This arrangement will provide a maximum power output of approximately 600 milliwatts.

While this discussion has thus far only concerned itself with supply voltages around 28 volts it is worth mentioning that equipment operating from 14 volt supplies entirely feasible. The performance, especially the power output obtainable, is naturally somewhat lower than for 28 volts supplies. Since at this writing no special output tubes for 14 volts operation are commercially available as yet, it is necessary to use power output tubes designed for higher voltages.

The 6U6GT has been found to be most useful in this application. However, in order to obtain sufficient power output it is necessary to use two tubes of this type connected in parallel. The sensitivity of a receiver equivalent to the one shown in Fig. 1, but using six tubes including two 6U6GT output tubes, is better than 10 microvolts for 6 milliwatts output and the maximum power output obtainable is approximately 35 milliwatts and 80 milliwatts for Class "A1" and Class "A2" operation respectively, at reasonably low harmonic distortion. While a power output of this order is no longer recommended for satisfactory loud speaker reception it is still very usable for phone operation and even several headsets may be used simultaneously.

While low voltage radio equipment is still in its early stages of development it is already causing a considerable amount of interest. It would be given an even greater impetus should the radio tube industry succeed in designing output tubes capable of delivering larger amounts of power than now obtainable.

# COMMON CARRIER RADIO RELAY SYSTEMS

Reprinted from *FM AND TELEVISION*

By *Dr. Ralph Bown\**

## Plans for development of systems to carry Multiplex Telephony, Television, and Sound Programs

OVER THE first 25 years of its service life, radio telephony has evolved toward ever higher frequencies. At each frequency advance new uses for the benefit of the public have been opened, and in each major advance the telephone companies have taken a leading part. The war developments of the 1917-18 were followed by country-wide broadcasting. The short-wave discoveries of the mid-twenties led to world-wide public telephone service and international broadcasting. Development of ultra-short-wave techniques brought FM and television broadcasting, marine, mobile, and military radio telephony, and point-to-point multiplex radio telephone extensions of the wire network. In the large expanses of microwave frequency space now opened before us by the electronic developments of more recent years, the use of radio relays for overland transmission as a supplement or alternative to wires or cables is clearly foreshadowed.

The present view among radio and telephone engineers is that microwave radio relaying offers a very promising method of obtaining broad-band transmission circuits for multiplex telephony, television, and similar services furnished by telephone companies. It is important to have this question thoroughly tested in actual practice, so that the facts may be fully developed in the engineering, economic, and service aspects. For this reason, the Bell System has undertaken a large program of research and experimental trial of microwave radio relay systems, and is now engaged in the establishment of an experimental system between New York and Boston.

Our purpose is to engineer and build this system as soundly as possible, to try it out carefully under actual service conditions, and to learn as thoroughly as we can by experience what are the advantages and disadvantages of this method of transmission for use in communication services. We want to be in a position to proceed in accordance with the conclusions reached by our research and experience. If the radio relay system will enable us to give better service or to reduce the cost, we would hope to employ it as far as it is justified under the circumstances then prevailing.

With such a program in mind, I want to develop the frequency needs for radio relay transmission as we see them, and I can do that best by giving first a brief résumé of the technical situation:

In present types of broad-band wire facilities such as coaxial cable, the signals are severely attenuated as they go along the line, and vacuum tube amplifiers or repeaters are placed at intervals of 5 or 10 miles to renew or relay the signals. In microwave radio relay systems, the highly directive radio beams carry the signals across country in line-of-sight spans, so that relaying amplifier stations are placed about every 25 to 35 miles. These radio relay stations are not little amplifier

\*Director of Research, Bell Telephone Laboratories, 463 West St., New York City. A statement delivered at the FCC Allocations Hearing.

Copyright 1944, FM Company, 511 Fifth Avenue, N. Y. C.  
(*FM and Television*, November 1944)

boxes which can be stowed in roadway manholes or other small space. They are relatively large and expensive structures, involving elevated precision antennas, and the housing, maintenance, and power-supply problems characteristic of small, isolated radio stations. The comparative economic factors cannot be estimated satisfactorily at this stage of research and development, but there is a good chance that the microwave radio method of broad-band transmission will prove in. Performance, i. e., transmission quality, reliability, and flexibility, is obviously a very important factor in any comparison with wire transmission. This can be ascertained only by extensive development and trial.

At these very high frequencies, the radio transmission path itself places no material limitations on band width. This fact sometimes leads people to jump to the conclusion that radio relays can inherently carry broader-band signals than wire systems. Actually on either type of system the most definite band limitations are imposed by the cumulative effect of the multiplicity of amplifier stages required in a long circuit to overcome the attenuation, and only careful trial and engineering study will show the comparative merits of the two types on this score.

The radio relay system is characterized by an entirely different kind of vulnerability to interruption by storms, fires, or accidents than are wire systems. Crippling damage must occur at the relay stations in order to affect service. The long jumps in between contain no man-made structures to suffer damage. On the other hand, radio antenna structures may be more exposed to damage by storm or sleet than cable facilities, especially where cables are underground.

Whether microwave radio transmission will be affected by weather variations to a greater extent than wire transmission is yet to be determined, but it seems clear that, whatever the effect, it will be quite a different one. All these factors indicate the desirability of using both broad band cable and microwave radio developments to give the most flexible and reliable network for serving the needs of the country.

The frequencies best adapted for microwave radio relay systems are believed to be from about 500 mc. on up to 20,000 mc. or more. At the present time, there is a greater variety of suitable electronic tools available at the lower end of this broad expanse, while toward the higher end it is more easily possible to obtain the advantages of directivity. A natural trend of development therefore would be to start experimentation at the lower frequencies and progress upward as knowledge of the art permits. The American Telephone and Telegraph Company and Bell Telephone Laboratories are looking toward carrying on research to explore the merits of this entire frequency territory.

The channel width which will be required in radio relaying has been the subject of some discussion. Obviously the width depends upon the signals being transmitted and the technique employed. While sooner or later it will be necessary to consider much wider bands, it seems appropriate to assume for the immediate present that a signal frequency band up to about 5 mc. is what most systems will be called upon to transmit. This would accommodate either television or a multiplex group of telephone circuits. Straight-forward modulation of such a band onto a microwave carrier frequency by amplitude modulation, or frequency or phase modulation, or other method will result in sidebands having a minimum spread of  $\pm 5$  mc. from the carrier, or a total minimum band of 10 mc.

Frequency control at these extremely high frequencies is not easy, and a variation of  $\pm 1$  or 2 mc. may not be unreasonable for some time to come. Some guard band is also necessary and, furthermore, not all methods of modulation can achieve the minimum sidebands assumed above. Based on this reasoning, it seems sensible to suggest 20 mc. as the minimum or unit channel width for broad-band transmission of the kind here envisioned, with the expectation that more than one unit channel may be required for some kinds of experimentation and for wider-band signals such, for example as high definition or color television.



In a radio relay system, at each station, the incoming signal is amplified and its frequency changed so that the retransmission will not interfere with the reception. Under favorable conditions, the frequency change at the next relay point can be back to the original frequency so that each channel is used every other span, and only two channels are necessary to relay a signal as far as may be desired in one direction. For the unfavorable condition where spurious, longer-distance transmission can occur, causing one station to interfere with another on the same frequency several spans removed in the chain, each channel can be reused only every third or fourth span, so that more than two channels are required for each signal carried through the system. To be sure, if such spurious transmission is avoidable and, in addition, if it were possible to use at the repeater station two antennas of such directivity that the transmitter could not fire back materially into the receiver, operating on the same frequency, one channel would suffice for relaying each signal. Under present conditions, two channels for each one-way signal transmission is a good median assumption. Since there must be transmission in both directions, we conclude that four radio channels are needed to make up a complete broad band communication circuit.

The ultimate communication load capacity which can be expected from a given microwave band is an important question. The use of extremely high frequencies and sharply directive transmission tends to reduce interference, so that frequencies can be used over and over again. If sound engineering is applied to the whole problem, the set of frequencies needed for a 100- or 200-mile circuit should be adequate for the extension of that circuit to much longer distances and, by branching to wider areas, thereby creating a comprehensive network. Using the same frequencies simultaneously on several routes branching out of a common point is a nice problem in antenna refinement, station locations, and power levels, requiring a great deal of detail system-design coordination. In such congested cases, the use of wires and cables in solving the terminal and toll entrance problems may be necessary to conserve radio frequency space.

If the hopes we entertain for the success of the experimental system between New York and Boston are realized, the radio relay type of transmission may well become an important feature of the communications system of the future. Therefore, we believe the frequency requirements to be provided for at this time should be based on assumed minimum traffic requirements for important routes in the nationwide network. As a practical matter, 5 broad-band circuits is the smallest number that would be considered reasonable on routes likely to be developed in a 5- to 10-year period. With no provision for spares, 5 circuits would allow, for example, 3 television circuits and 2 multiplex groups of telephone circuits.

Viewed now from the development engineer's standpoint, this turns out to be a size of circuit-group which fits in well with an economical layout of radio apparatus. It is expected that a set of channels aggregating about 400 mc. wide can be passed as a solid block through one radio antenna system, so that an economical design is probable. When fully used, 400 mc. should yield 20 unit-channels each 20 mc. wide. As was worked out above, 4 channels are needed for each 2-way broad-band circuit, so these 20 channels should give 5 circuits. Thus, from both minimum traffic and development standpoints, this seems to be a conservative and practical beginning.

Since these are minimum figures, and since we are as yet quite uncertain which frequency range will prove to be best for this service, it is important to allow two such blocks, one near 2,000 mc. and another near 4,000 mc. At still higher frequencies, around 12,000 mc. provision should be made for a larger block 1,000 mc. wide, in order to give adequate room for experimentation and possible commercial development in the next 5 to 10 years.

Specifically, it is our recommendation that the following reservations of fre-

quencies be made to care for the probable needs of multiplex telephony, television and sound programs and similar services in public telephone systems:

20 channels each 20 mc. wide, constituting a band 400 mc. wide from 1,900 to 2,300 mc.

20 channels each 20 mc. wide, constituting a band 400 mc. wide from 4,000 to 4,400 mc.

A space 10,000 mc. wide, lying between 11,500 and 12,500 mc.

It is also our suggestion that ten to fifteen percent of the space above 13,000 mc. should be reserved to permit experimentation and to meet the future public telephone system requirements for this type of radio service.

While no specific suggestion is here made for the reservation of frequencies in the region of 6,000 to 8,000 mc., it might become necessary to go into this range, particularly if crowding by other services curtailed use of the 2,000-mc. band, or if the bands near or above 12,000 mc. proved unsuitable for relay purposes.

The bands of frequencies recommended herein are considered conservative since, with current methods, they might be severely taxed by a moderate development of net work television service. While we may optimistically expect developments of the future to increase the carrying capacity of these bands, we must expect that the load will grow too.



#### Electronic Role on Battleship

*More than 1,600 electronic tubes serve a battleship; an aircraft carrier must have 1,550, according to the Navy.*

# RADIO EQUIPMENT FOR THE PERSONAL PLANE

Reprinted from Aero Digest

By Major William P. Lear, CAP

IT IS pretty generally agreed that after the war there will be a greatly increased amount of private flying, although authorities vary widely in their predictions as to just how much there will be. One of them suggests that five years after the close of hostilities we shall have 200,000 planes in the air above America.

Much planning is being done in the meantime to provide facilities for feeder lines, non-scheduled commercial traffic and the privately owned airplane used for pleasure, suburban commutation and week-end trips. The traveling salesman who once waited at lonely railroad junctions for belated trains will see the day when he can jump into his plane and shorten his route by hours or days. "Do you own your own car?" the employer asks the candidate for a sales route. Tomorrow the question is likely to be, "Do you own your own plane?"

## *Plans for Post-War Aviation*

Much planning is being done to meet this change in the travel habits of an air-minded people. Pennsylvania, for instance, is seeking legislation to provide landing areas so that every village of a thousand people or more will have access to either an airport or a landing strip. Michigan's Board of Aeronautics is planning a survey preliminary to providing adequate facilities for that great aircraft area of which Detroit is the heart. And so keen and hardheaded a manufacturer as Henry Kaiser is suggesting a plan for building 5000 terminals for personal airplane operators, to be ready six months after the war.

The CAA, too, is discussing plans for the relaxation of its regulations for the benefit of the private flyer, while aircraft manufacturers are advertising planes of such simplicity of design and reasonableness of price that they will be available for every post-war family.

The moment a buyer gets one of these new planes he begins to wonder about radio equipment, and having qualified with the CAA inspectors, he casts about for such information as can be found on which to base the purchase of equipment.

First of all, the owner of the personal plane wants the three basic elements of radio. The first is a simple radio range receiver (200-400 kc). This is the "ears for the pilot," with which to navigate the whole CAA radio range system. With it he can receive traffic control instructions from the Authority's radio range stations, and special messages radioed over the CAA Communications system. With it he can also make use of the numerous radio ranges and airport localizers maintained by our armed forces. With such a receiver the pilot is equipped to navigate in "contact" weather, on or off the airways, and to land at all traffic controlled airports.

Having thus provided himself with the ears of the pilot, he will next want the "voice of the pilot," in the form of a communications transmitter. This is for flying in adverse weather, over or through the overcast, or to operate under

flight plan regulations. It need not cost much more than the receiver, and will enable him to operate on the itinerant aircraft frequencies.

Of course, he will first have to secure a station license for the transmitter from the Federal Communications Commission, and must pass a rather simple operator's test before he can operate it. This will take a little time and effort, but is well worth his while. With this equipment he can fly with greater confidence and safety, and in weather that he could not otherwise attempt.

### *Radio Direction Finder*

The third item of radio equipment that he will want is a radio direction finder. This will supply much needed "eyes for the pilot." The simplest type of finder is the manually-operated aural-null loop. This is operated in conjunction with the radio range receiver. Equipped with it he can take his own radio bearings on all radio range stations and marine radio beacons, all of which operate within the range of his 200-400 kc equipment. It is especially useful in off-the-airways flying.

With a duplicate receiver, powered by dry cells, and the two connected with a single headset jack, uninterrupted contact can be maintained with both the range station and the tower. Besides providing the pilot with all-important help in making instrument approaches, the auxiliary receiver will bring him safely to his destination in case of power failure.

There is a wide range of prices today for aircraft radio apparatus. This is governed, of course, by its complexity and utility. Receivers can be had with direct or remote control, and with various types of receiving range and accuracy of tuning, such as pretuned frequencies for airport traffic control, and simultaneous radio range filters which permit reception of either course signals, or broadcasts, or both.

Direction finders range all the way from the simple, manually-operated loop, to which we have referred, to complex, fully-automatic unidirectional instruments that cost as much as an entire small plane and engine.

One of the first things to bear in mind is that the performance of an aircraft radio is only as good as its installation, no matter how simple or how complex the apparatus may be. The pilot should make sure that he has selected the apparatus best suited to the type of plane in which it is to be installed, and adapted to the kind of flying he proposes to do.

Before proceeding with the installation, a rough wiring diagram should be prepared, showing the location of the wiring and the inter-connection of the items to be installed. This includes the one or more antennae required, together with antenna selector switches, circuit fuses, etc. The governing factor for the success of the installation is the antenna system. The best type of antenna for the receiver is the "whip" or "spike" antenna. Install it below, rather than above the fuselage, if possible, and as close to the receiver as you can.

### *Antenna for the Transmitter*

A separate antenna should be installed for the transmitter. One of the most elementary forms consists of two horizontal wires, supported by tension springs, between the top of the vertical fin and two sub masts located near the wing tips.

By far, the most versatile antenna system is a properly weighted retractable trailing antenna, called a "reel antenna." It is a reel or drum containing about 100 feet of flexible stranded copper wire which the operator pays out to optimum length, to obtain most efficient transmission.

For purposes of installation, radio receivers all fall into one of three classes—direct control, partial remote control, and full remote control. Most receivers

are of the direct control type. These are small and usually can be mounted on the instrument board, or below it on a bracket at the pilot's side. Or they can be placed above the windshield. The power unit is either a power pack consisting of a dry cell battery or a vibrator or dynamotor unit which converts the current from the storage batteries into alternating current of the desired voltage and amperage.

The power unit is usually installed under the pilot's seat or under the floor, with connections between the radio apparatus and its antenna, and between the component units of the apparatus, made as short as possible.

In order to prevent ignition interference, all electrical wiring and accessories must be shielded in metal conduits or metal boxes; and to prevent re-radiated interference the entire structure of the airplane must be bonded together into one electrical whole. Modern airplanes are usually bonded at the time of construction, so that there is little for the radio service man to do except to bond the engine mount to the airframe. This is done by soldering a piece of metal braid with pigtailed ends across the rubber shock absorbers.

We are an air-minded people, and are growing more so every day. Instrument flying, once a mystery quite beyond the comprehension of most of us, is something to which we are steadily growing accustomed. As a nation, I predict we are going to take to the air like ducks to water. We may be a bit slow about it, perhaps, at first. But we shall take it up in ever-increasing numbers and with ever-increasing enthusiasm. It is necessary that those of us who are now in the aeronautical field should recognize the irresistible trend of the mass of our American people.



#### Boston-Los Angeles Television

*Approximately 7,000 miles of coaxial cable between Boston and Los Angeles will be used to carry simultaneously 480 different telephone channels and television pictures after the war.*

# FADING EFFECTS at HIGH FREQUENCIES

Reprinted from Electronics

By John B. Moore

RCA Communications, Inc.

New York, N. Y.

**Commercial communications services operating between 4 and 24 Mc are adversely affected by field-strength variations of less than one minute duration. The precise nature of the problem depends upon the type of service. Practical methods of minimizing drop-outs, distortion and errors are reviewed.**

**T**HE FIELD strength of a distant transmitter operating at frequencies between 4 and 24 Mc may vary over a wide range. Diurnal and seasonal variations, and slow shifts with the sunspot cycle, may be largely if not entirely overcome by the proper choice of carrier frequencies. There remains, however, the problem of insuring satisfactory reception during short-period variations, commonly called fading.

This problem is of particular importance to the commercial communications services, including telegraph, printing telegraph, picture transmission and facsimile, telephone and program services. All are adversely affected in one way or another by fading. No single solution for all types of fading and services has yet been disclosed or put into commercial use.

It is the purpose of this paper to give a coordinated picture of the general problem, the methods of attack employed so far, and the advantages or disadvantages of each method. Violent interruptions or drop-outs lasting from several minutes to several hours or days, caused by terrestrial magnetic disturbances or sun spot activity, will not be dealt with.

## *Types of Fading*

Short-period variations in the signal delivered by the receiving antenna may be of several kinds. The term *fading* will be taken to include any such variation which has a time duration—from normal to subnormal or abnormal and back to normal—of less than one minute roughly speaking, and generally less than one second. The various types will be identified by their outstanding characteristics and effects.

The simplest case is that in which the carrier and all modulation sidebands vary in intensity simultaneously and in the same proportion. This may be a 20 db drop (10 to 1 in field intensity), or considerably greater. Regardless of the depth to which the signal fades, carrier and sidebands retain their original relative strengths. The signal becomes weak, and may even drop below the noise level, but there is no noticeable distortion.

Theoretically at least, this simple type of fading—in amplitude or depth only—may be caused either by: (1) a change in the reflection or refraction of a single ray by the ionized layer then effective in propagating the signal to the receiving point; or (2) out-of-phase addition, and thereby partial cancellation,

of two or more rays arriving over paths of slightly different apparent lengths. Such out-of-phase arrival of two or more rays at the receiving antenna gives rise to a number of different effects.

The interference pattern resulting from the out-of-phase arrival of two or more rays sweeps across any given point at which a receiving antenna may be located. At a given instant, and for any specific and discrete frequency, areas or bands of maximum and minimum field intensity just above the surface of the earth (at antenna height) will occur along the direction of propagation as shown

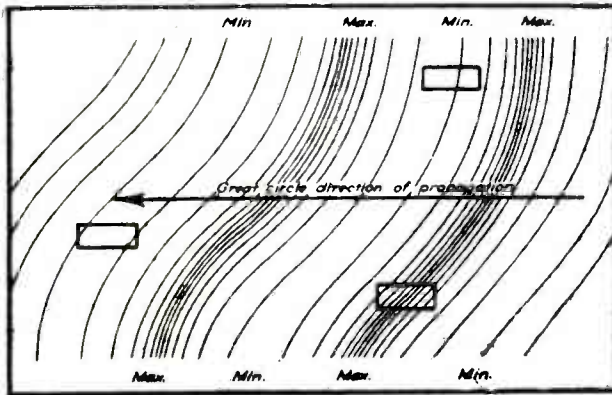

Fig. 1—A typical interference pattern, showing areas or bands of maximum and minimum field intensity. Antennas arranged for space diversity reception are shown as boxes

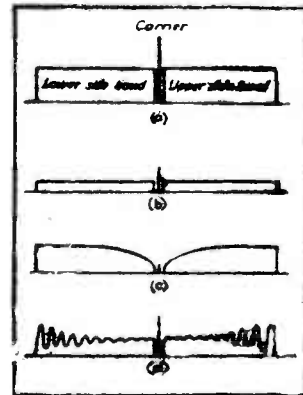

Fig. 2—General types of fading: (a) normal signal; (b) distortionless and non-selective fade; (c) selective fading of a carrier; (d) selective fading of sidebands

in Fig. 1. Generally, the slower the fading the greater the area covered by any one such maximum or minimum.

The interference pattern also sweeps across the frequency spectrum, the frequency separation between maxima and minima varying greatly. Here again, the slower the fading the more widely separated the maxima and minima.

In view of the statements just made, we may say that slow fading generally covers a large geographical area and a wide band of frequencies.

As the fading becomes more rapid, due to the interference patterns—space and frequency—sweeping across the surface of the earth and across the frequency spectrum, the areas of maxima and minima apparently become smaller and the separations between frequencies having simultaneous maximum and minimum field strengths also become less. Under such conditions not only are there rapid variations in field strength of all frequencies within a particular band, but also different discrete frequencies, or very narrow bands of frequencies, do not fade in unison. The result is so-called *selective fading*.

Another effect resulting from simultaneous arrival of two or more rays over paths of appreciably different length is encountered when the time-of-arrival of the rays differs by an amount—measured in milli-seconds—which is appreciable compared to the time of duration of a telegraph dot or of a small element in material being transmitted by radio-photo (facsimile). This is commonly referred to as the *multi-path* effect.

*Effects of Fading*

The practical effects of the various type of fading shown in Fig. 2 can best

be discussed in relation to specific types of radio-communication service. A convenient classification, for this purpose, is:

- (1) Slow-speed telegraphy
- (2) High-speed telegraphy and multiplex
- (3) Radio-photo or facsimile
- (4) Telephone and program services

This classification is based on speeds, or band widths, required.

(1) Slow-speed telegraphy is affected chiefly by the slower type of fading, in which the predominant factor is simultaneous variation of the received field strength of the carrier and all necessary sidebands.

Taking the arbitrary upper limit of 20 dots or square cycles per second for this class of service, and considering that the third harmonic of the fundamental keying frequency is all that is needed for reasonably good envelope formation of the dots and dashes, we see that the total band width involves only  $3 \times 20$ , or

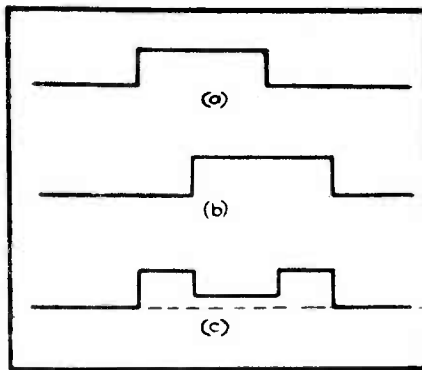

Fig. 3—A "split", showing the effect of multi-path propagation on the formation of a high-speed telegraph dot. (a) The first signal received; (b) the delayed ray signal; (c) the resultant

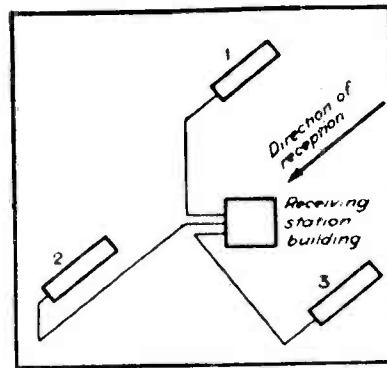

Fig. 4—A space diversity antenna layout. Three directive antennas (shown as rectangles) are placed a number of wavelengths apart, at the corners of an isosceles triangle

60 cps. Observation has shown that such sidebands seldom, if ever, fade differently than the carrier with which they are associated. So-called selective fading therefore is not a serious factor in this type of service.

Multi-path propagation normally does not bother such slow-speed service. The time duration of a dot, at 50 words per minute, is 25 milliseconds. Difference in time arrival, as between two or more rays, normally runs to a maximum of only about 3 milli-seconds. An exception is the occasional case of long-delayed echos, the delay of which is comparable to or greater than the time duration of a telegraph dot or similar signalling element.

(2) High-speed telegraphy includes high-speed Morse or printer operations and multiplex services in which keying speeds may run to 200 dots per second (square cycles per second). At such speed the time duration of a telegraph dot or multiplex keying element amounts to only 2.5 milli-seconds.

It will be apparent, from statements made in preceding paragraphs, that multi-path propagation can seriously interfere with such high-speed telegraphic transmissions. A delayed signal, arriving over a longer path, will result in a dot being elongated, the overall effect being to make the mark/ space ratio not 50/50 but perhaps as heavy as 90/10 or even 100/0. Satisfactory reception and transcription then becomes extremely difficult or impossible.



Another effect, due to the multi-path propagation, is cancellation of portions of a dot. A common form of malformation, or *split*, is due to out-of-phase addition during the time when both the initial and the delayed rays are being received, the resulting signal dot then consisting of an initial short pulse due to the ray which arrived first, a period of very low or practically zero signal strength during the overlapping of the received rays, and a final short pulse due to the delayed ray only. The resultant is shown in Fig. 3. The duration and depth of the split, in a dot, depends upon the speed of telegraphic transmission the relative amount of delay between rays arriving, and relative phases and amplitudes of the arriving rays.

Selective fading may affect envelope formation when the fundamental and necessary harmonics of the keying frequency run to  $200 \times 3$  or 600 cps or higher. That is, sidebands removed this far from the carrier may, under conditions of extreme selective fading, fade differently than does the carrier, and an originally rectangular envelope shape will suffer malformation.

(3) Radio-photo and facsimile keying speeds and sideband frequencies generally run considerably higher than for high-speed telegraphic service. Roughly, we may set an upper limit of 3000 cps for systems now in use. Such transmissions obviously will be adversely affected by general fading in depth, by multi-path propagation, and by selective fading. The effects, as observed in the recorded picture, may be streaks, widened or elongated elements of the picture subject matter, and loss of detail.

(4) Telephone and program service sidebands require some 3000 or 5000 cps, respectively. General fading, in depth only, reduces the modulation/noise ratio. Depending upon the action of the receiving system and equipment, this may produce a falling and rising level of modulation output (from the loudspeaker) or a rising and falling noise level.

Selective fading produces distortion having characteristics which depend both on the nature of the selective fading and on the type of receiving system and equipment used. One particularly bothersome type of distortion occurs when the carrier fades but the sidebands remain. The upper and lower sidebands, in the case of double-side-band transmission, then beat only with each other instead of with the carrier. The resulting second-harmonic products are, as is well known, a very annoying form of distortion of the original and intended speech or music.

#### *Reducing the Effects of Fading*

The most commonly used method for combatting and minimizing the undesirable effects of fading is automatic gain control (agc), known in some types of equipment is automatic volume control (avc). This method maintains a reasonably constant reference level for any speech or music modulation. It is effective against the slower, general fading in which the carrier and all sidebands fade essentially in unison and in the same proportion.

If the agc system is designed to act too rapidly, it will follow the lower modulation frequencies and actually, to a considerable degree, remove these modulation components from the final output signal delivered to a loudspeaker or other utilization device or circuit. This action is sometimes referred to as demodulation of the carrier. (This use of the term *demodulation* should not be confused with final rectification, or detection, to which the term demodulation often and unfortunately is applied.)

Automatic gain control to take care of general fading of the slower type, is usually used in combination with other methods that are described in following sections. For convenience, these methods are listed here:

Frequency diversity  
 Space diversity  
 Polarization diversity  
 Ray selection and diversity  
 Limiting  
 Frequency and phase modulation  
 Exalted-carrier receivers  
 Single-side-band.

These general methods will be taken up, separately, in following sections.

### *Frequency Diversity*

This general method derives its name from the diversity, or difference, of fading that often exists on frequencies which may be separated by as little as 500 cps or less. While the basic principle has rather wide possibilities, its practical application has, for various reasons, been pretty much limited to telegraphic

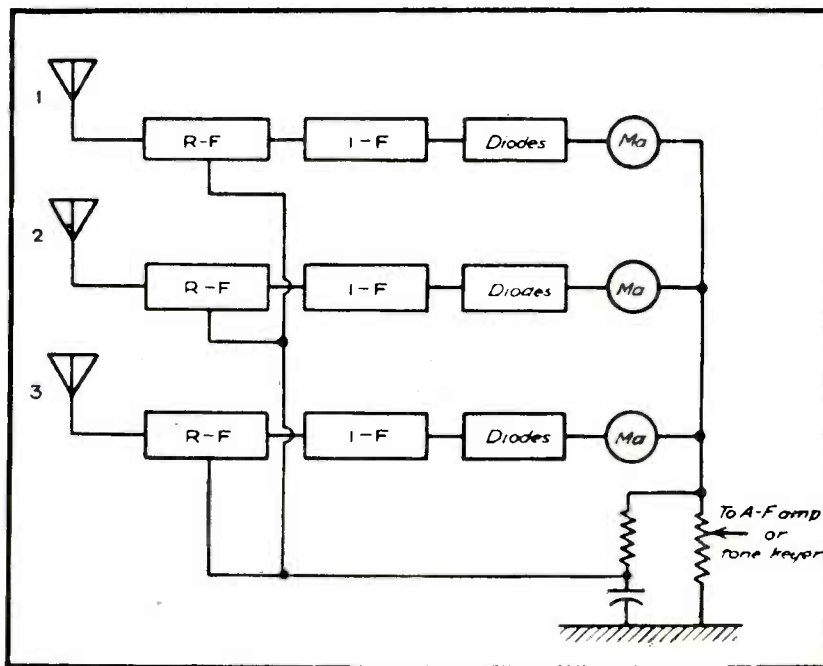

Fig. 5—In this space diversity reception system the rectified output of three receivers is combined, operating the keyer and also supplying bias for automatic gain control

services in which the transmission of intelligence is accomplished by keying an r-f carrier on and off. The simplest and probably most widely used system or method has as its purpose the improvement of radio-telegraphic communication without resort to elaborate and expensive receiving systems and equipment. This particular method will be described, by way of illustration.

In the radio transmitter, the carrier frequency is varied or modulated in any manner which will produce sidebands extending roughly 1 kc each side of the carrier. A common method of accomplishing this is to phase-modulate the master oscillator by means of a tone frequency in the neighborhood of 600 cps. The resulting distribution of energy, in side band frequencies on each side of the carrier,

is determined by the degree of modulation. A limited number of sidebands, spaced 600 cps, is a practical compromise between the wide separation desirable for obtaining the maximum benefits of diversity of fading on the one hand, and the disadvantages of interference to signals on adjacent channels on the other. However, distribution of the total available power between the carrier and a large number of discrete sideband frequencies means less power, and therefore less field intensity, on any one frequency.

Rapid fading which would chop or split characters, in the case of a pure c-w carrier, also manifests itself as selective fading which sweeps across the frequency spectrum. At the receiving station, therefore, the adverse effects of such fading are minimized by the employment of frequency diversity—the reception of a number of separate frequencies instead of a pure carrier.

### *Space Diversity*

This system makes use of the diversity of fading existing at geographically separated points, specifically at receiving antennas which are spaced a number of wave-lengths from one another. Due to the fact that the system does not depend upon or require any special type of signal, but may be used for reception of all types of high-frequency signals and services, it has been widely adopted.

Three antennas generally are used, as shown in Fig. 4. They may be of any type, directional or not, and are placed at the corners of an isosceles triangle. The exact shape and orientation of this base triangle with respect to the desired direction of reception is not critical.

Generally speaking, spacing between the several antennas should be greater for use at the lower frequencies than at the higher frequencies for good diversity performance. A figure of about ten wave lengths or a compromise of about 1000 feet is generally to be recommended, although diversity of fading can be observed between antennas spaced much less than this. However, the greater the spacing, the slower the fading on which diversity action can be expected to be obtained.

In such systems a transmission line of a type having low inherent pickup conducts the r-f signal voltages from each antenna to a separate receiver. The outputs from these three receivers then are either combined or switched, the object being to insure that the utilized output signal will at any and every instant be derived either wholly or chiefly from the antenna at which the best signal-to-noise ratio exists at that instant.

In telegraph service, and others that similarly employ on-off keying of the carrier, general practice is to combine the rectified outputs from the final detectors of the several receivers. This combined, rectified output controls a keying tube or tubes and also supplies bias voltage for automatic gain control as shown in Fig. 5. The purpose of combining after final rectification is to insure that the outputs from the several receivers will always be additive. If combining in the r-f or i-f portions of the equipment is attempted, addition and cancellation effects will be experienced due to the varying phase relationships between the several signals. This would, in effect, create another interference pattern.

Proper use of this diversity system and action, together with age to handle slow and area-wide fading, results in a great improvement in reliability and accuracy of telegraphic communication. This is due to the fact that at practically every instant, during the useful period of the day for any given signal, the field strength seldom simultaneously drops to the noise level at all three antennas. Drop-outs, splits and fills are thereby prevented from appearing in the final output signal delivered by the system and equipment.

In telephone and program services, and in others which employ variable depth of amplitude modulation rather than on-off keying, application and use of

the space diversity principle is attended by certain complications not met in the case of telegraph service. This is due to the fact that the audio-frequency modulation envelopes of the several signals, delivered by the separate antennas and their receivers, vary in phase. That is, their phases vary with relation to each other as the field-interference pattern sweeps across the antenna locations. Combining two or more such rectified, modulated outputs of approximately equal strengths but out of phase results in a distorted output if the phase differences are very great.

The usual arrangement of equipment for space diversity reception of amplitude modulated (phone) signals, applies a common age to all three receivers. Control voltage is derived from the final rectified and combined output of the three receivers normally employed. The purpose of this common age voltage is to insure that at each and every moment the receiver getting the strongest signal from its antenna will contribute most to the combined output.

If this were the only selecting action, the contributions made by the individual receivers would be proportional to their input signals received, at the moment, from their respective antennas. Actually, however, there is also a considerable degree of inherent switching action, caused by operation of the final diodes of the several receivers into their common load circuit in which the combining of outputs is accomplished. This action is to completely cut off the output or contribution from the diodes of one or two receivers when the output from another rises appreciably above them. As a result of the common age, and also of the diode action described, a ratio of antenna voltages of as little as two to one (or less) may result in the entire output signal, in the combining circuit, being supplied by one receiver momentarily having the strongest antenna signal.

The result of this switching action is that distortion occurs only at those instants when the signal delivered by one antenna is increasing in strength and that delivered by another antenna is decreasing in strength and the two momentarily are about equal in amplitude but differ in phase. This effect is minimized by reducing the value of the differential, between the two signals, required to effectively switch; that is, by cutting off the weaker and permitting the stronger to contribute the entire output current present in the combining circuit. Reduc-

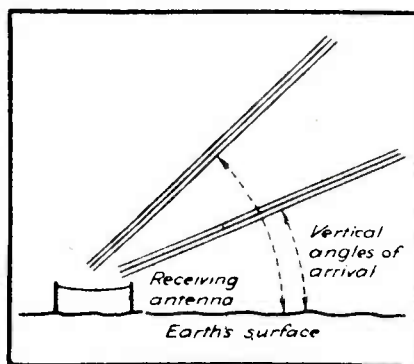

Fig. 6—"Bundles" or groups of rays frequently arrive at the receiving point at different angles. Antenna systems having variable vertical selectivity reduce trouble from this source

tion of the required differential results in more rapid switching, and thereby reduces the time duration of the distortion that is experienced.

Proper use of space diversity action, together with age, insures the best possible signal-to-noise ratio at every instant, and maintains that ratio at a more nearly constant value than is possible by the use of a single receiver. On very

rapid fading, which may also be quite deep, the second and third receivers fill in during those very brief but rapidly occurring instants when the signal from the first antenna is practically zero.

#### *Polarization Diversity*

Where space is not available for the erection of antennas separated by some hundreds of feet, use can be made of polarization diversity reception. The fact that the polarization of a received wave does not remain constant, but varies from horizontal to vertical and to other skew angles, makes it possible to obtain the benefits of diversity of fading by using one horizontal doublet and one vertical doublet (or other type antenna), both antennas being located at the same spot. Two separate receivers are used, in the same manner as for space diversity reception. The improvement to be expected is, however, considerably less.

#### *Ray Selection and Diversity*

As has been pointed out, long-distance propagation of high-frequency signals does not take place over but a single path at any given instant. Angle of incidence of two or more rays, or bundles of rays, can be observed and measured, as shown in Fig. 6. By selecting only one of these rays, or small bundles of rays, the effects of ray interference can be greatly reduced.

The so-called *Musa* (multiple-unit steerable antenna) system, developed by the Bell Telephone Laboratories, accomplishes this. The antenna system and its associated equipment are designed to effectively pick out any one ray, or small bundle of rays, by means of extremely sharp vertical directivity which can be adjusted to the desired angle. When it is thus possible to pick out only a single ray, the field-interference pattern previously discussed is no longer such a source of trouble. Large variations in the vertical angle of arrival must, of course, be followed by adjustment of the vertical directivity of the system. Where the signal is arriving simultaneously over two paths that differ sufficiently in their vertical angle of arrival, each can be selected separately and the two combined or switched for obtaining what may be termed ray diversity or path diversity.

A detailed description of the antenna system, and of the receiving equipment, is given in a reference cited at the end of this paper. Briefly, the antenna system consists of some twelve separate antennas of the rhombic type, erected in a straight line pointing in the direction of the desired reception. Rather elaborate provisions are made in the receiving building for properly phasing the signals received from the separate antennas. Adjustment of this phasing is the means employed to produce the sharply directive and adjustable vertical pattern desired.

#### *Limiting*

Limiting, by means of non-linear circuit elements such as biased or over-driven vacuum tubes, has relatively little value as a means of reducing the effects of fading except when used in combination with other methods.

In receivers used for telegraph service, employing on-off keying of the carrier, limiting may be used to handle small variations still remaining after the use of agc and diversity reception of any type. Care must be taken, however, not to depend on limiting to such an extent that preceding stages of amplification and frequency conversion are overloaded. If this is not guarded against, various types of spurious interference are apt to be experienced.

In the reception of signals employing variable depth of amplitude modulation, such as telephone signals, limiting obviously cannot be used.

In systems employing frequency or phase modulation rather than variable depth of amplitude modulation, limiting is used to eliminate or minimize amplitude variations still existing after the use of agc.

### Frequency or Phase Modulation

The use of frequency, or phase modulation as a means of reducing the effects of fading has as its purpose the elimination of amplitude variations in the received r-f signal. Since intelligence is transmitted by varying the frequency or phase, and not the amplitude, it is obvious that limiting can be made use of in the receiving equipment. Some of the variations still existing after the use of agc can thus be eliminated.

Selective fading, due to its random effects on the numerous sidebands that make up a frequency or phase-modulated signal, results in rather serious distortion of modulation such as speech or music. The system therefore does not improve reception which is bothered primarily by selective fading.

It is of interest to note, in dealing with frequency modulation and phase modulation, that certain conditions of propagation partially convert these types of modulation into amplitude variations. One very annoying manifestation of this is the conversion of frequency or phase modulation at power-supply frequencies

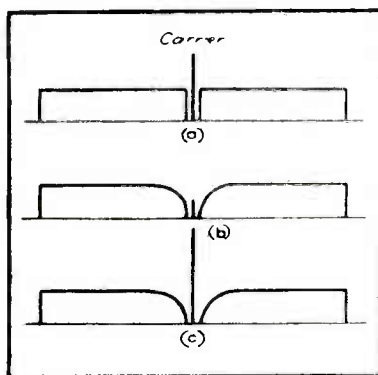

Fig. 7—Principle of exalted carrier receiving system.  
 (a) normal signal; (b) selective fade of carrier;  
 (c) carrier exalted or reinforced at the receiver

(hum) into what is effectively amplitude modulation of the received signal. This results in a rising and falling hum level in the a-f output of the receiver. This resultant level of hum may be considerably higher than that measured at the transmitter.

Radio-photo or facsimile services nowadays use some form of frequency modulation almost exclusively. This is applied either to the r-f carrier or to a tone-frequency sub-carrier which then is used to modulate the r-f carrier of a telephone-type transmitter employing any desired system—amplitude, frequency or phase—for modulating its r-f carrier. Advantages of this application lie in the fact that limiting may be applied, in the radio receiving equipment in one case and in the radio-photo terminal equipment in the other case, to eliminate streaks caused by amplitude fading.

The frequency-modulated sub-carrier system permits the use of standard phone transmitters and receivers.

Frequency or phase modulation of the r-f carrier itself simplifies the modulation problem in the transmitter, particularly in those cases in which a given transmitter must be used for either telegraph or telephone services, or their equivalents, on short notice. It also, however, complicates the design of the receiving equipment.

*Exalted-Carrier Receivers*

Selective fading often reduces the amplitude of the carrier, yet at the same time leaves most of the sidebands at their normal amplitudes. The result is second-harmonic distortion due to the absence of a carrier and the resultant beating of one set of sidebands against the other. The exalted-carrier type of receiver prevents this sort of distortion, by maintaining the carrier at a high level at all times as shown in Fig. 7. Carrier voltage at the final rectifier or detector is maintained at such a high level that the effective percentage of modulation can not exceed 100 percent. Actually, the figure is more like 50 percent or even 30 percent maximum.

*Fig. 8—Seven-unit telegraph code used to prevent printing of wrong letters due to signal malformation*

	1	2	3	4	5	6	7
A							
B							
C							
D							
E							
F							
G							
H							
I							
J							
K							
L							
M							
N							
O							
P							
Q							
R							
S							
T							
U							
V							
W							
X							
Y							
Z							
&							
.							
SHIFT							
UNSR							
BELL							
SPACE							
LINE							
-							
/							

In general, two different methods may be employed for obtaining the desired result. In one, the frequency of a local oscillator is automatically held to within plus or minus a few cps, or less, of the frequency of the incoming carrier signal. In the other general method, the incoming signal itself supplies the required carrier which is filtered, amplified, and then re-combined with the sidebands. The same net result may be obtained by the use of a sharply selective i-f system which emphasizes or exalts the carrier and at the same time uniformly reduces the relative amplitude of all sidebands.

The use of a single receiver of this type for reception of amplitude modulated phone signals results in virtually complete elimination of the second-harmonic distortion that otherwise is caused by selective fading of the carrier. To take care of the slower, general fading, it is necessary to supplement the exalted-carrier method with some other system such as space-diversity reception.

### *Single-side-band System*

Complete suppression or elimination of one set of sidebands (upper or lower) and partial suppression of the transmitted carrier, as employed in some phone services, is not intended primarily for reduction of fading effects. Since the system necessarily employs an exalted-carrier receiver, however, it gives the improvement described above.

### *Special Code System*

In view of the apparent impossibility of completely overcoming all types of fading at all times, the problem of providing reliable telegraphic communication has been attacked from another angle. This is to develop a code or system of communication which will tolerate any reasonable malformation of the signal, yet which will not cause an incorrect letter or character to be recorded on the received copy.

This attack has been primarily aimed at development of printing telegraph services. The so-called 5-unit code, for printer service, is so constituted and arranged that the dropping out of one or more impulses (marking bands) by fading, or the accidental filling-in of spaces by static or interference, will result in the printing of an incorrect letter or character. To prevent such errors, or *transpositions*, there has been developed a code and system which will print a special error indicator sign when the incoming signal has suffered mutilation.

A printing-telegraph code in which each selecting combination consists of only three marking elements, out of a total of seven available per character, provides the required performance. This code is shown in Fig. 8. If either fewer or more than three marking or selecting impulses are received, the receiving machine prints the special error indicator sign. Fading can not, therefore, result in errors or transpositions,—only the special error indicator sign being recorded in such cases.

### *Summary*

It is apparent, from the data given in the preceding sections, that no one method constitutes a complete solution to the problem of fading and its undesirable effects on signals. It also will be apparent that different combinations of the basic methods must be used for different types of service. The particular combination best suited to any given service and circuit depends upon the type and quality of service required and also upon the total cost justified by the business to be handled.

### BIBLIOGRAPHY

- (1) Beverage, H. H. and Peterson, H. O., Diversity Receiving System of RCA Communications, Inc. for Radiotelegraphy, *Proc. IRE*, April 1931.
- (2) Peterson, H. O., Beverage, H. H. and Moore, J. B., Diversity Telephone Receiving System of RCA Communications, Inc., *Proc. IRE*, April 1931.
- (3) Moore, J. B., Recent Developments in Diversity Receiving Equipment, *RCA Review*, July 1937.
- (4) Polkinghorn, F. A., A Single-Sideband Musa Receiving System for Commercial Operation on Transatlantic Radio Telephone Circuits, *BSTJ*, April 1940.
- (5) Roetken, A. A., A single-Sideband Receiver for Shortwave Telephone Service, *Proc. IRE*, Dec. 1938.
- (6) U. S. Patent 2,183,147, re-issued Re 22,394, Printing Telegraph System, Moore, J. B. and Mathes, R. E.



## ELECTRONICS PUTS NEW HEALTH INSTRUMENTS IN MEDICAL KITS

**P**OSTWAR medicine—bright with promise—may owe much of its accomplishment to new applications of electronics.

Due to it, physicians now have a brilliant array of diagnostic, surgical and curative instruments vastly stepping up the potentials of medicine.

Electrical manufacturers point out that the following are a few of the electronic-improved devices:

**ELECTRONIC STETHOSCOPE**—This gives an immensely wider range in investigating heart action than formerly was obtainable, and makes possible detecting “heart-muscle fatigue” never recorded by the old-style stethoscope.

### FOR DIFFICULT CASES

**MODERN ELECTROCARDIOGRAPH**—This instrument—which was begun without the aid of electronics, but now relies heavily upon it—allows the “reading” and “charting” of heart action. It is a precision instrument, used in difficult cases to check the information first indicated by the stethoscope.

**ELECTROENCEPHALOGRAPH**—Only recently developed, this instrument does for the brain what the electrocardiograph does for the heart—permits the reading and charting of its action to reveal the presence and course of disease.

**ELECTRON MICROSCOPE**—The spectacular industrial applications seemingly have overshadowed the medical usages—but medical researchers believe the giant microscope’s potentiality is very great. By it, a specimen can be magnified as much as 100,000 times.

### IDENTIFIES THE ATOMS

**ELECTRON MICROANALYZER**—An accessory to the electron microscope, the analyzer facilitates the high-speed chemical analysis of “ultra-microscopic” bits of matter. It enables the identifying of atoms in a particle 1/100,000th of an inch in diameter.

**ULTRA-VIOLET LAMP**—From treating the common cold to attacking stubborn cases of dermatitis, the ultra-violet lamp affords help. When penicillin—latest, greatest life-saver of this century—is being manufactured, the lamp is used to throw a “zone” of radiation and protection over the room in which the flasks of mold are being cultured. (The air in the room is cleansed electronically.) The lamp’s best-known use is in sick rooms, where it destroys fully half the germs. Pharmacists can fill prescriptions under its germ-killing rays.

### WAR SURGERY INSTRUMENT

**ELECTRONIC PROBE**—Primarily a war surgery instrument, saving lives into the thousands, the probe—now used to remove shrapnel and bullets from the body—will be useful in much peacetime surgery as well.

**ELECTRODE**—A cutting tool used in surgery, the electrode produces coagulation as it cuts, reducing bleeding and the necessity of “tying off” blood vessels. It also cauterizes.

**X-RAY APPLICATIONS**—The manifold uses of X-ray have been well publicized. One form is a powerful weapon against cancer; another takes pictures of diseased areas of the body to expedite diagnosis. The portable field X-ray is a development of World War II.

### FEVER AND SHOCK THERAPY

**ELECTRONIC HEATING**—High-frequency induction heating is used for therapeutic (curative) application either to specific organs and muscles or to the entire body. In the latter case, it is known as “fever therapy,” a technique whereby high temperature is artificially induced to kill disease.

**ELECTRIC SHOCK THERAPY INSTRUMENTS**—Electric shock as a weapon against dementia praecox and other mental ills now is as well known as the famous insulin shock and metrazol shock treatments. Evidence is accumulating that it has great value—sometimes bringing apparent virtual recovery, at other times resulting in improvement.

# MAGNETIC PHONOGRAPH PICKUPS

Reprinted from Radio

By Roy Dally

Consulting Engineer, Electrovox Corporation

## An analysis of the characteristics of magnetic pickups and their application in reproducing apparatus

**T**HE magnetic pickup made possible the change from acoustic phonographs to the electrically amplified type, bringing with it improvements that had always been the dream of every phonograph engineer. Accurately controlled volume level, power output limited only by the amplifier used, greatly increased frequency range and controlled tonal effects were only a few of the advantages gained.

Early types of magnetic pickups were all very similar in design, operating at vertical pressures averaging about 6 oz. They were usually large and unwieldy, with great masses of weight attached for counterbalancing,—in general, a far cry from present-day designs operating at less than 1 oz. pressure. However, they paved the way for the modern phonograph, and still have advantages for specific applications where other types of pickups have proved inadequate.

### *Pickup Design*

*Fig. 1* illustrates the most conventional type of design. Both pole pieces and armature were machined or formed from soft iron or high permeability alloys. The armature, in an approximate shape of a cross, had section "A" machined or swaged to a cylindrical shape, about which were fitted rubber sleeves, to act as bearings, the pole pieces were so shaped as to retain and compress the rubber bearings when assembled to a back plate (not shown), which permitted the armature to reciprocate in an approximate lateral plane only, indicated by the double arrow.

The magnet was a permanent horse-shoe type, tungsten in early designs, and cobalt alloys in later models.

A coil of wire surrounded the armature, being spaced to permit the armature to move, and held rigidly in the pole piece assembly. The impedance of the device was determined by the number of turns of wire used, high impedance pickups having as much as 10,000 turns of #44 EN wire, with a resulting impedance at 1000 cycles of about 50,000 ohms.

Air gaps existed on each side of the armature and the upper pole piece tips, which varied with different designs from .008" to .018" each. However, when once determined for a particular design, these were held very closely by means of assembly gages.

Since a decided magnetic attraction existed between the armature and the pole piece tips, some means was necessary to center the armature in the air gap by overcoming the attraction, but which would permit the armature to reciprocate between the tips when driven by the record groove. The material most commonly used for such a centering block was gum rubber and, later, a loaded rubber stock. The centering block was slotted to receive the free end of the armature, and was

in turn clamped to the pole piece assembly in such a manner that it could be moved laterally, thus centering the armature in the air gap.

An equivalent fixed air gap existed between the lower part of the armature and the lower pole piece tips, through the rubber bearings. There was no metal-to-metal contact between the armature and the pole pieces.

In operation, the armature reciprocated between pole piece faces 1 and 2, varying alternately first one and then the other air gap. Thus, when the armature was nearer to 1, a greater number of lines of force appeared through the armature between 1 and 4, since the reluctance between the north and south poles of the magnet was smallest for that magnetic path. When the armature approached face 2, conditions were reversed, the lines of force through the armature were also reversed, being predominant between 2 and 3, and current was generated in the turns of wire due to the reversal of flux through the armature.

Now that we have a general picture of a simple magnetic pickup, let us consider certain design considerations necessary for desirable characteristics.

### *Design Considerations*

Voltage output is dependent on flux density, saturation, the number of turns of wire in the coil, and velocity. By velocity is meant the speed at which the armature travels as it reciprocates in the air gap. Flux density is dependent on the magnet used and the reluctance of the air-metal circuit between the magnet poles. Only one precaution need be observed with respect to flux density, namely, that the armature must not be saturated at any time. Saturation would result in distortion, and would particularly affect the dynamic range and response of the pickup.

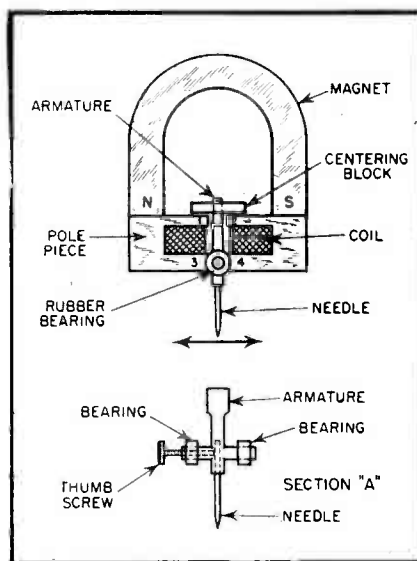

*Fig. 1. Diagram of conventional type of magnetic pickup*

Fortunately, this condition is rarely encountered, since the air gaps are usually sufficient to prevent it, but in attempting unusual designs, it is well to keep saturation in mind.

Increasing the number of turns of wire does not result in a proportionate increase in voltage, since the resistance of each turn increases as the turns become larger, but in any practical design, a worth while gain may be had.

Velocity, when considered from a pickup standpoint is not a variable to be tampered with indiscriminately. It may be changed in any one design by increasing the ratio of the distances between the bearing and needle point, and the bearing and upper air gap, so that for a given distance of travel of the needle point, the armature between the upper pole faces will travel a greater distance, but such practice invariably results in greater difficulties with armature resonance, to be discussed later. Good design practice calls for a ratio of about 1 to 1.

Voltage output is the simplest of the design problems to deal with, since adequate gain is available in any good amplifier, at little or no cost. Very worth while savings may be effected by using low cost materials in the pickup design, resulting in low flux density and less output, and letting the amplifier carry on from there.

### *Resonance*

As is usual with all electro-mechanical devices covering a wide frequency range, we come to the important problem of mechanical resonance. This has been discussed at some length in previous articles,<sup>1,2</sup> in connection with tone arms and crystal cartridges. The resonance conditions encountered in a magnetic pickup, however, are much more severe than in a crystal cartridge, because of the fact that the armature must have low magnetic reluctance and for a given mass, such metals and alloys exceed by far the weight of aluminum and magnesium used in making chucks for cartridge. In order to obtain a frequency range beyond 5000 cycles without resonance peaks or cut-offs, a great deal of thought must be given the armature, striving for the lowest possible mass and greatest stiffness.

With a few exceptions there has been a notable reluctance to break away from the conventional design as shown in *Fig. 1.*, and this design is definitely limited mechanically when one begins to think in terms of response to 10,000 cycles, and tracking pressures of less than 1 oz. The prime reason for lack of improved design may be traced directly to the insistence of magnetic pickup users that the voltage output be kept relatively high. 2.5 to 3.0 volts RMS at 1000 cycles was not unusual at tracking pressures of 6 oz. Gradual refinements over a period of years resulted in tracking pressure being reduced to about 2.5 oz., and approximately .5 volts output.

### *Vertical Inertia*

In considering further reduction of pressure, the problem of vertical inertia, discussed in the article on tone arm design, becomes of prime importance. While it is simple enough to reduce the effective vertical pressure of the system by counterbalancing, either by spring or weight, such counterbalancing in no way decreases vertical inertia, quite to the contrary, weight counterbalancing increases it. Therefore, in order to avoid groove skipping, particularly in coin-operated phonographs, the total mass and weight of the tone arm and pickup must be kept at a minimum. This in turn means a lighter, smaller magnet, as well as attention to every detail in order to save weight, and the inevitable result must be decreased voltage output. In addition, a pickup mechanism cannot be made to track at low pressures unless it has a suitably high compliance, which can be obtained only by small light moving parts, a minimum of damping and centering resistance, and a good bearing system. Therefore, every improvement in tracking, frequency range, and quality must be made at the expense of voltage output. If users of magnetic pickups would be content with approximately 0.1 volt output, very definite improvements could be made in magnetic pickup design.

A two-fold problem exists in centering and damping a magnetic pickup. Maintaining the armature in the magnetic center of the air gap, and yet permit-

<sup>1</sup> Tone Arm Design, *Dally*, RADIO, July, 1944.

<sup>2</sup> Crystal Phonograph Pickups, *Dally*, RADIO, September, 1944.

ting it to move freely when driven by the groove, is a condition requiring a tough, resilient system, unaffected by humidity and temperature changes, and showing little change of characteristics over long periods of time. In addition, the armature must be adequately damped to overcome resonant peaks and transient response. Unfortunately, the requirements of a good centering material and an efficient damping material are very much in opposition with each other. The very nature of damping material requires that it be soft and with a minimum of resilience. Obviously, such could not be used for centering.

### Centering

Probably the simplest, most efficient, and least expensive means of centering is pure gum rubber. It may be applied mechanically in a number of ways, the only precaution being that it be used generously, and not in small blocks, which tend to age much more rapidly. But such centering is useless, from a damping standpoint, since rubber so used lacks that ability to a marked degree. Damping

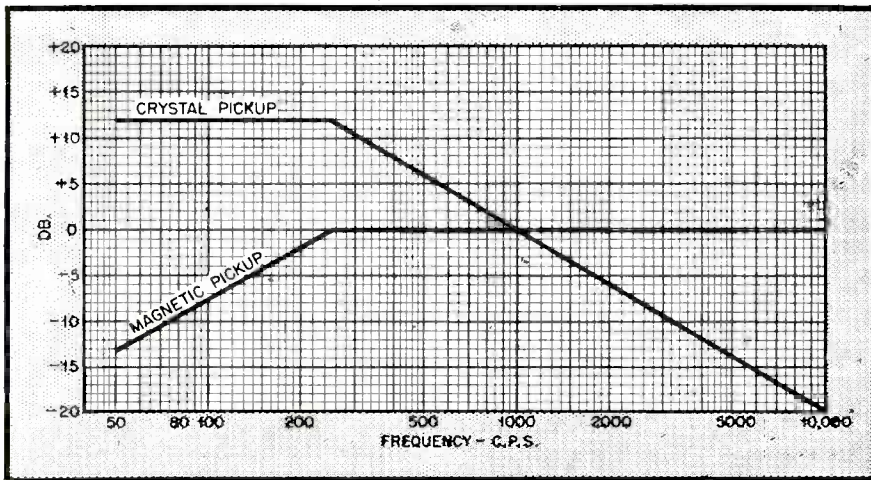

Fig. 2. Comparative theoretical response curves of crystal and magnetic pickups

must then be applied separately, using a material having the desired qualities. Both centering and damping may be applied in compression or shear, however compression is preferable, since in shear, a portion of the material is necessarily carried with the armature, and thus adds to the mass and weight of the moving system. This in spite of the fact that damping in shear is more effective.

Much research has been done in attempting to obtain better damping materials. Many compositions have been tried, some borrowed from other industries, and a few satisfactory compromises have been found. It is possible to both center and damp with one material, but such material never has both properties to a satisfactory degree, and failure can result if precautions are not taken from a mechanical standpoint. In addition, materials having good damping qualities are invariably subject to severe changes in characteristics with changes of temperature. Increased temperature results in decreased damping efficiency, and resonant peaks appear in the pickup response.

It is to be hoped that among the many new materials being produced today, a more suitable damping medium will be found, particularly with respect to temperature effects.

### Bearings

There is little to be said about bearing systems. Rubber has been used in the majority of designs, being simple, effective, and inexpensive. Knife-edge

bearings have been used successfully, and result in long operating life, but have the disadvantages of added cost, mechanical noise, and aggravation of resonance problems. A combination of rubber and knife edge has also been used, but with little success. If a rubber bearing system is to be utilized, precautions should be taken to see that pure gum stock or its equivalent is used, and that the walls of the tubing or sheet be as thin as practical. Excessive wall thickness will result in loose play of the armature at the bearings, becoming more pronounced in effect as the frequency increases, low efficiency and distortion can only result.

The magnetic pickup differs from a crystal device in that the voltage output is proportional to velocity. Reference to *Fig. 2* illustrates the comparison between theoretically perfect crystal and magnetic pickups. A perfect magnetic pickup would reproduce the magnetic recording head characteristic, since both are proportional to velocity. The loss of bass response below 250 cycles is due to the constant amplitude recording characteristic of commercial home type records, made necessary to avoid break through between adjacent groove walls.

Unfortunately, the magnetic pickup cannot be compensated so readily as the crystal, as illustrated in the article<sup>2</sup> on crystal pickups. Similar adequate networks would require the use of large iron-cored inductances and large capacitors, whose cost and space requirements would be prohibitive. It is much simpler to make the necessary compensations in the amplifier circuits, wherein suitable bass compensation may be had with little cost.

#### *Moving Coil Types*

Moving coil, or dynamic types of pickups have been designed, with varying success. They differ essentially from the armature type in that a coil of wire is movably suspended in an air gap and, when driven by the record groove, cuts lines of force existing through it, with a resultant generation of current proportional to velocity. The inherent drawback is reduction of weight in the moving system, which compels the use of very few turns of wire, as few as one turn being used. Since such a device would have very low impedance, it must be coupled through a suitable transformer for maximum efficiency. The transformer, in turn, is expensive and tends to aggravate hum pickup problems since it must be located closely to the pickup, to avoid excessive losses.

A distinct advantage, however, is that there is no centering problem because, by use of proper materials, there exists no magnetic attraction between the moving system and the pole piece assembly.

Successful moving coil systems have been expensive, delicately made, and suitable for use under exacting conditions, where they give a splendid account of themselves. It is not at all impossible, however, that the design may be applied to routine phonograph requirements with success.

The magnetic pickup has been neglected to a large degree since the general acceptance of the crystal types. However, it has demonstrated its dependability under adverse operating conditions where crystals are inadequate, and is by no means obsolete. General acceptance of low voltage outputs could result in some startling improvements that might well place it at the head of desired pickup types.

# SUPER PHOTO-TIMER

Reprinted from Radio-Craft

## Revolutionizes X-Ray Photofluorographic Technique

**A**N ALL-ELECTRIC photo-timing device enables X-ray technicians to make photofluorographs automatically with the absolute assurance that each exposure will be perfect. This development permits substitution of cheap photofluorographs (photographs of the light image formed by X-rays on a fluorescent screen) for the large and expensive X-ray photographs on 14- by 17-inch film. A new field in public health service may thereby be opened up (*Radio-Craft*, December, 1944).

The principle was first utilized by Dr. Russel E. Morgan under the direction of Dr. Paul C. Hodges, Director of Radiology (X-ray technique) at the University of Chicago, and is currently being commercialized by Westinghouse. Fig. 1 shows the rough details of its action. It is a standard X-ray fluoroscopic apparatus, with the addition of electronic equipment in the lower part of the photo-fluorographic hood.

X-rays from the tube pass through the object to be examined and are turned into light upon striking the screen. Thus an image varying in density according to the opacity of the object to X-rays is formed. This image is photographed in

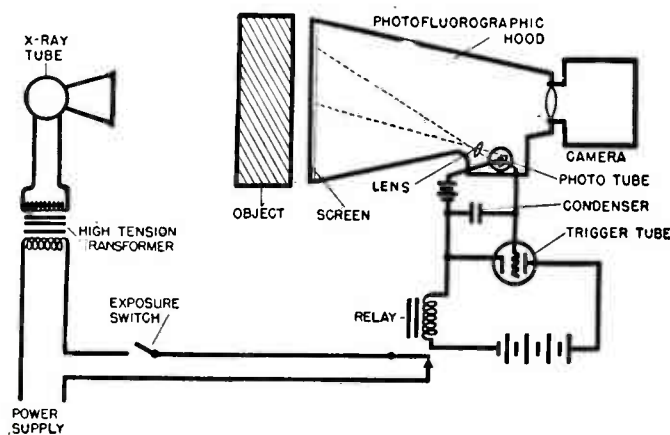

Fig. 1 — Graphic explanation of the electronic photo-timer's operation. "Object" is the body of a subject being examined

the ordinary way by the camera. Meanwhile the lens focuses part of the light on the screen onto a phototube. As light reaches the tube, its infinitely high resistance drops, permitting more or less current to flow from the battery, according to the amount of light reaching it. It will be seen that the tube is in the grid circuit of a thyratron used as a trigger tube. As current flows through the phototube, the condenser is charged and the grid voltage rises. At a certain voltage, the tube fires and the relay is opened, stopping the exposure. The size of the condenser controls the time required to charge to the firing point for given quantity of light.

Copyright 1945, Radcraft Publications, Inc., 25 W. Broadway, N. Y. C.  
(*Radio-Craft*, February 1945)

### An Automatic Method

Exposure timing, which formerly was an involved process for each exposure, becomes fully automatic once a preliminary adjustment is made by means of a control on the timer. This permits making denser or thinner negatives according to the technician's preference or the conditions under which work is done.

By the old individual-exposure method the time of exposure or voltage applied to the X-ray tube were varied. Unexpected voltage variations during the exposure of a negative might affect results, which were in the long run dependent on the technician's judgment. With the electronic control, the current through the X-ray tube is set at some particular value, but variations of current (or voltage) are of no consequence, and the exposure time is allowed to vary over a range from  $1/20$  to  $1/5$  of a second. Only a very rough kilovoltage adjustment is made, based on an estimate of subject size, and the thickness of the subject need not be measured. Using the timer, therefore, the procedure involves merely the positioning of the subject, a rough kilovoltage adjustment in accordance with a quick visual classification, and the touching of an exposure switch. The increased operating efficiency is evident in this comparison. Moreover, since the phototube is affected only by the light intensity from the scanned section of the screen, uniformly good exposures are insured regardless of the thickness of the object or of irregularities within it. A skilled technician cannot compensate for invisible, unknown internal irregularities, but the photoelectric timer can, since it is only affected by the light intensity on the fluorescent screen.

### Details of the Camera

The essential parts of the phototube camera are the focusing lens, the photoelectric multiplier tube, a condenser, a resistance, and a gas triode trigger tube. (Fig. 2, left side) The phototube assembly is mounted beneath the photofluorographic hood, and the lens scans a representative, rectangular area of fluorescent screen. In chest photofluorography this area,  $9\frac{1}{2}$  inches in the horizontal direction and  $3\frac{3}{4}$  inches in the vertical, coincides with the portions of the upper lobes of the right and left lungs because they are representative areas of the subject's chest.

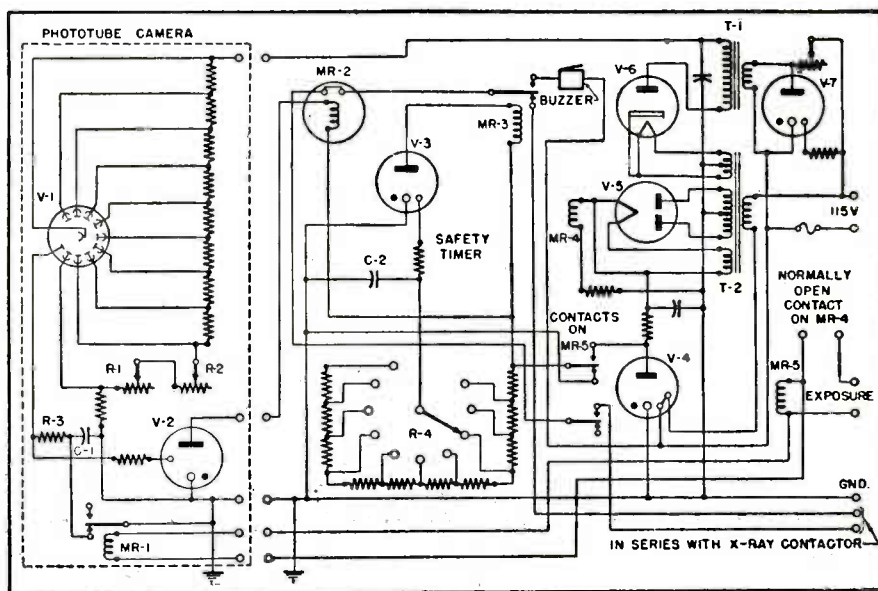

Fig. 2. — Diagram of the entire unit.



The multiplier tube has nine stages of amplification, providing a 400,000 to 2,000,000 gain. From 800 to 1000 volts between cathode and ground are furnished by the power supply unit. There is 150 to 200 volts from anode to the ground. These ranges are provided to compensate for variations in tube sensitivities. Power is supplied to the timer by two transformers. One transformer furnishes regulated voltage to the photoelectric tube; the other serves the remaining circuit tubes. The main X-ray control switch turns on the timer power as well as the X-ray tube filament supply.

The density of the exposed film can be adjusted in accordance with the preference of the radiologist. A density control mounted on the phototube camera assembly varies the voltage between the eighth and ninth dynodes through a resistor and may be locked by means of the lock nut.

Initiation of the exposure occurs on closing the exposure switch. A current flows in the phototube circuit, creating a potential across a resistor and capacitor. The resistor is included to compensate for the relay drop-out time—about 1/60 of a second. The trigger tube fires at 70 volts and its resulting plate current energizes a relay which opens the main X-ray contactors in the X-ray control and ends the exposure. In preparation for the next exposure, a shorting relay by-passes to ground any charge left on the condenser.

#### *The Safety Circuit*

A safety timer, consisting of a trigger tube, an adjustable resistance, a condenser, two relays, and a buzzer, protects the X-ray unit against any failure of the unit and against excessively long exposures which might exceed the rating of the X-ray tube and cause damage to it. A relay opens the X-ray transformer primary before exposure time reaches the danger point. The safety unit is mounted in a case with the power supply for the phototube camera. A complete schematic is seen in Fig. 2.

The value of miniature chest photofluorography, rendered more efficient by the phototimer which insures uniform exposures, lies not only in conserving manpower by finding the tubercular individual while he can still be easily cured, but also in finding thousands of totally unsuspected carriers of disease who are spreading tuberculosis.

Since the cost of 14 x 17 X-ray film was a limiting economical factor in mass surveys, a method which decreased cost was necessary. The use of miniature films on rolls already represents a considerable economy, for the film cost of such an exposure is one cent as against sixty cents for a 14 x 17 film. The phototimer contributes a further saving because a given crew of technicians can handle twice as many subjects as heretofore—a 100 percent increase in efficiency—and because uniform exposure is obtained regardless of internal variations, eliminating repetitions.

The industrial application of the electronic timer should be as effective for the same reasons. Whether similar objects are moving rapidly on a conveyor or whether a variety of irregular objects must be X-rayed, the electronic timer will provide uniform exposures quickly and efficiently.

## WHAT'S BEING READ THIS MONTH

For our readers' information, we take pleasure in presenting the following list of articles which have appeared in the most recent issues of the leading trade and professional magazines:

### COMMUNICATIONS (February 1945)

#### SOUND ENGINEERING

A War Correspondent's Recorder at BBC.....*W. J. Lloyd and D. E. L. Schorter*

#### INSTRUMENT DESIGN AND APPLICATION

A General-Purpose Impedance Bridge Simplified Switching Circuit.....*P. M. Honnell*

#### ENGINEERING CONFERENCE REVIEW

A Report on the IRE Winter Technical Meeting.....*Lewis Winner*

Instrument Approach and Landing Systems.....*Lieut. Col. P. L. Moseley*

Self-Contained Triode Transmitter.....*J. E. Gorham, Maj. H. A. Zohl, G. F. Rouse*

Exalted Carrier A-M/P-M Reception.....*Murray G. Crosby*

Reflex Oscillators.....*J. R. Pierce*

Multiples Systems.....*Charles R. Burrows, Alfred Decino*

V-H-F Tetrodes.....*Clayton E. Murdock*

#### TELEVISION ENGINEERING

Television relays.....*H. B. Fancker*

#### CIRCUIT ANALYSIS

Supply Voltage Effect on Transitron Performance.....*Cledo Brunetti*

R-F Pentodes as Transitron Oscillators.....*E Kohler*

3-Cycles-Per-Second.....*Geo. J. Nelson*

#### TRANSMITTING TUBE DESIGN AND APPLICATION

External Anode Triodes(*Part II*).....*A. James Ebel*

### ELECTRONICS (March 1945)

#### TWO IMPORTANT JOBS

Radio operator-gunner in a U. S. Army bomber is a busy man indeed

#### THE FCC ALLOCATION PLAN

An appraisal of the technical and economic significance of the 25 to 30,000-Mc proposal

#### A SQUARE-LOOP F-M ANTENNA

A 44.5-Mc radiator is built around the top of an a-m station tower.....*John P. Taylor*

#### INDUCTION HARDENING

Rotation of work during rapid heating produces uniform case-hardening without soft spots.....*Otto Weitman*

#### DIRECT-READING COLOR DENSITOMETER

Nine-stage multiplier phototube provides sufficient sensitivity to check color film at three wavelengths.....*Monroe H. Sweet*

#### ENGINEERING ASPECTS OF TELEVISION PROGRAMMING

Many more cameras per studio are needed to provide frequent viewpoint changes.....*Virginia Meyer Bradley*

#### TRACKING ANGLE IN PHONOGRAPH PICKUPS

Procedure for determining optimum offset angle and needle overhang of tone arm to minimize distortion.....*B. B. Bauer*

**ELECTRONICS (March 1945) Continued**

- EFFECTS OF HUMIDITY ON TERMINAL-STRIP DESIGN**  
Design and layout techniques to minimize leakage due to high humidity effects.....*Louis L. George*
- FREQUENCY-RESPONSE CURVE TRACER**  
Unit combines artificial voice and driven pen to chart frequency characteristics of acoustical equipment.....*H. B. Shaper*
- IMPROVED ELECTRON GUN FOR C-R TUBES**  
Zero first-anode current design simplifies power supply, gives sharper focus.....*L. F. Swedlund*
- CATHODE-RAY NULL DETECTOR FOR WIEN BRIDGE**  
Method of using a c-r tube as a phase detector in a Wien bridge circuit.....*Charles Markey*
- CONTOURS OF CAPACITOR PLATES**  
Method of calculating capacitor plate contour to give desired capacitance variation.....*L. J. McDonald*
- THE CAA INSTRUMENT LANDING SYSTEM — PART II**  
Technical details of runway localizer transmitter, and effects of buildings and hills on performance.....*Peter Caporale*
- ZERO PHASE SHIFT AMPLIFIER**  
Phase-shift correction by conventional high and low-frequency compensation and negative feedback.....*L. R. Malling*
- TRANSMISSION-LINE CALCULATOR**  
Relation of load impedance to standing-wave ratio and distance to first voltage minimum.....*Robert C. Paine*
- DISCRIMINATOR LINEARITY**  
Theoretical criteria, derived from equations for resonant and coupled circuits.....*L. B. Arguinbau*
- BAND-PASS FILTER DESIGN**  
Band-pass filter design tables for use with reactance slide-rule.....*C. J. Merchant*
- CHICAGO CONFERENCE ON INDUCTION AND DIELECTRIC HEATING**  
1945 WINTER TECHNICAL MEETING OF THE IRE

**ELECTRONIC INDUSTRIES (March 1945)**

- DC SATURABLE REACTORS FOR CONTROL PURPOSES**.....*Harry Holubow*
- ELECTRONIC TACHOMETER**
- ENGINEERING DOUBLE SUPERHET RECEIVERS**.....*John D. Reid, Jr.*
- IRE STAGES LARGEST TECHNICAL MEETING**
- \$1000 EDITORIAL AWARD**
- FACTORY SHORTCUTS**
- PE TUBE SMOKE SENSING**.....*Gilbert R. Sonbergh*
- "TALKIES"**
- GASKET PRESSURE METER**.....*George H. Pfetterle*
- VHF HOMING DEVICE**
- TUBES ON THE JOB**
- DIATHERMY PROBLEMS**
- STUDY ELECTRONIC HEAT**

**FM AND TELEVISION (February 1945)**

- FINAL DECISION ON FM FREQUENCIES**  
Effects upon the Radio Industry
- VHF TETRODE FOR MEDIUM POWER OUTPUT**.....*Clayton E. Murdock*
- 15,000 CYCLES FOR ALL NETWORKS**  
Explaining the Network Map
- BETTER WAYS TO MEET LISTENERS' NEEDS**.....*Milton B. Sleeper*
- FM HANDBOOK**.....*René T. Hemmes*

**PROCEEDINGS OF THE I.R.E. (March 1945)**

- POSTWAR ENGINEERING DEFENSE AGAINST AGGRESSION*.....Joseph R. Redman
- IVAN STODDARD COGGESHALL*
- RADIO PROGRESS DURING 1944*.....I.R.E. Technical Committee
- RADIO-RELAY-SYSTEM DEVELOPMENT*.....C. W. Hansell
- TRANSIENT RESPONSE*.....H. E. Kalbmann, R. E. Spencer, and C. P. Singer
- I.R.E BUILDING FUND*
- INSTITUTE NEWS AND RADIO NOTES*
- BOARD OF DIRECTORS*
- EXECUTIVE COMMITTEE*
- CEDAR RAPIDS SECTION*
- CORRESPONDENCE:*
- "FREQUENCY AND PHASE MODULATION,"*.....D. L. Jaffe and Dale Pollack
- "CALCULATOR FOR DIRECTIVE ARRAYS"*.....J. G. Rountree
- "BALANCED AMPLIFIERS"*.....Franklin Offner
- "QUALITY-CONTROL ENGINEERING"*.....George W. Purnell
- POSTWAR RADIO-AND-ELECTRONIC PROSPECTS*
- RADIO-AND-ELECTRONIC WARTIME ACHIEVEMENTS*
- TELEVISION AS SERVICE TO THE PUBLIC*
- WARTIME ELECTRONIC DEVELOPMENTS HOLD PEACETIME PROMISE*
- LOOKING AHEAD TO COLOR AND ULTRA-HIGH-FREQUENCY TELEVISION*
- TELEVISION NETWORKS*

**RADIO (February 1945)**

- VELOCITY MODULATION TUBES*
- A discussion of the theory of velocity modulation and of the manner in which various types of velocity modulation tubes function.....M. G. Bell
- REQUIREMENTS IN BROADCAST ANTENNA AND GROUND SYSTEMS*
- The various factors affecting the design of broadcast antenna and ground systems are discussed, and data are presented to guide the designer in meeting the problems involved.....Harold E. Ennes
- FM RECEIVER DESIGN, PART I*
- In this series of article, the author discusses the various factors entering into the design and testing of f-m receivers.....A. C. Matthews
- TRANSMISSION LINE IMPEDANCE MATCHING CHART*
- How to compute transmission line stubs and coupling links with the aid of charts.....Robert C. Paine
- NOTE ON MEASURING COUPLING COEFFICIENT*
- A simplified method of determining the coupling coefficient between two magnetically coupled inductors is described.....Lieut. Col. P. M. Honnell
- RADIO DESIGN WORKSHEET: No. 33 — EXTRANEIOUS ROOTS*
- THE TERMINOLOGY OF ELECTROMAGNETIC THEORY, PART 8*
- Definitions of terms commonly used in microwave theory
- RADIO BIBLIOGRAPHY: AIRCRAFT RADIO, PART VI*.....F. X. Rottenmeyer

**RADIO CRAFT (March 1945)**

ELECTRONIC FLIGHT CONTROL.....	Raymond Lewis
B-29 ELECTRONIC GUNSIGHT	
PLANE TEMPERATURE ELECTRON CONTROL.....	R. H. Whempner
AUTO COMPASS AIDS BOMBING	
VOTES BY RADIO.....	T. R. Kennedy
A HEAT-VARIABLE RESISTOR	
TWO COMPACT SETS.....	G. L. Keirstad
RADIO JOCKEY.....	Eric Leslie
SENSITIVE ALARM SYSTEM	
POSTWAR RADIO NEWSPRINTER	
GROUNDING-GRID AMPLIFIERS.....	Stuart T. Black
BROADCAST EQUIPMENT, PART VII.....	Don C. Hoffler
SPEECH AMPLIFIERS, PART VI.....	Robert F. Scott
RECORDING ON WIRE.....	I. Queen
HIGH FIDELITY.....	McMurdo Silver
INTERCOMMUNICATORS.....	M. N. Beitman
PHONOGRAPH "BUZZ" CURE	
METER ADAPTION.....	Alfred Shortcut
CIRCUIT EQUALIZATION.....	Robert Smith
RADIO HEADPHONE CIRCUITS.....	John Kearney
A SEVEN-TUBE SUPER.....	Edwin Bohr
NEW IDEA IN DETECTOR CIRCUITS.....	W. T. Counalser

**RADIO NEWS (March 1945)**

THE PIANO OF THE FUTURE.....	Stanley Kempner
SERVICING AUTO RADIOS.....	Milton S. Kiver
PROPOSED FREQUENCY ALLOCATIONS, 25,000 Kc. TO 30,000,000 Kc.	
COMMUNICATIONS AIRBORNE.....	Capt. Edward J. Flynn
DESIGN OF TELEVISION RECEIVERS.....	A. D. Sobel
SERVICEMEN ARE ORGANIZING.....	Bert Dale
SERVICEMEN'S MULTIMETER.....	Walter C. Hunter
FACSIMILE TRANSMITTER AND RECEIVER	
RADIO INDUSTRY GOES TO PRESS.....	I. M. Carroll
TELEVISION TRANSMITTING EQUIPMENT.....	Edward M. Noll
SINE-SQUARE WAVE OSCILLATOR.....	McMurdo Silver
THE SAGA OF THE VACUUM TUBE.....	Gerald F. J. Tyne
NEWS FROM OVERSEAS.....	Kenneth R. Porter
PRACTICAL RADIO COURSE.....	Alfred A. Ghirardi
INSTALLATION AND MAINTENANCE OF NAVY ELECTRONIC EQUIPMENT	
PASEDENA POLICE ADOPT HANDIE-TALKIE	

**RADIO NEWS Radio Electronic Engineering Edition (March 1945)**

ELECTRONIC MOTOR CONTROL.....	Robert Endall
ANALYSIS OF NOISE FIGURE.....	S. J. Mallory
INDUSTRIAL APPLICATION OF ELECTRON TUBES.....	John DeWitt
MULTICHANNEL PILOT CRYSTAL OSCILLATOR.....	William Maron
PULSE GENERATING CIRCUITS.....	M. H. Shamos
X-RAY ABSORPTION.....	Dr. M. Iona
A NEW V.H.F. TETRODE.....	Clayton E. Murdock
PROPOSED FREQUENCY ALLOCATION CHART	

**SERVICE (February 1945)***AUTO SET DIAL CORD INSTALLATION NOTES*

For Chrysler C-1708; Ford F-1740; Lincoln L-1760, 1761; Studebaker S-1722, S-1726

*CRYSTAL PICKUPS*

Data for 17 RCA types

*HIGH-FIDELITY RECORDED-MUSIC REPRODUCTION*.....Willard Moody

*HIRING SERVICE MEN*.....Charles and H. A. Middleton

*OLD TIMER'S CORNER*

*POST WAR RECEIVER COMPONENTS AND ACCESSORIES*....Donald Philips

*SERVICE HELPS*.....Edward Arthur

*SER-CUITS* ..... Henry Howard

**TELEVISION (March 1945)**

*N.B.C. AND MADISON SQUARE GARDEN*....Robert E. Shelby and Harold P. See

*C.B.S. LIGHTING*.....Worthington Miner

*THE TASK OF THE TELEVISION DIRECTOR*.....Herb Leder

*W.O.R. PRESENTS*.....Bob Emory

*ONE MAN'S REFLECTIONS*.....Dr. Alfred N. Goldsmith



**KEEP YOUR RED CROSS  
AT HIS SIDE**

