

APRIL, 1934

Radio Engineering

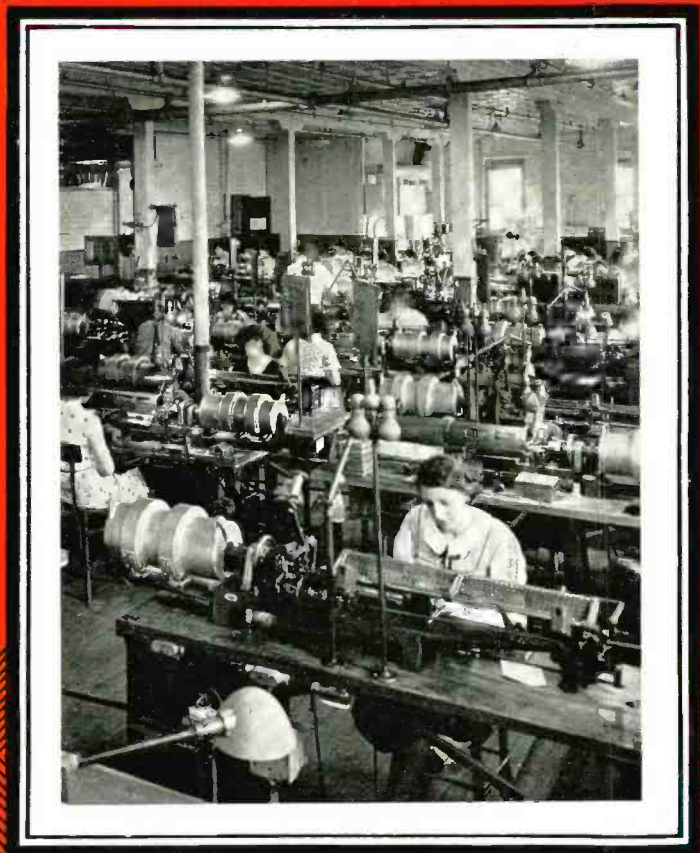
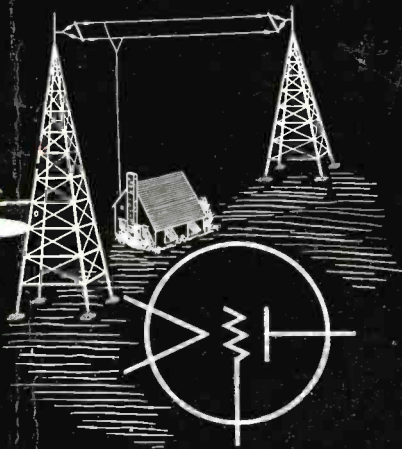

VOL. XIV

NO. 4



The Journal of the
Radio and Allied Industries

SVEA METAL



Swedish Iron &

17 Battery Place



Steel Corporation

New York City



For more than a quarter of a century suppliers of high grade metals to the foremost electrical equipment manufacturers.

LOOK TO RCA FOR PROGRESSIVE TUBE DEVELOPMENT

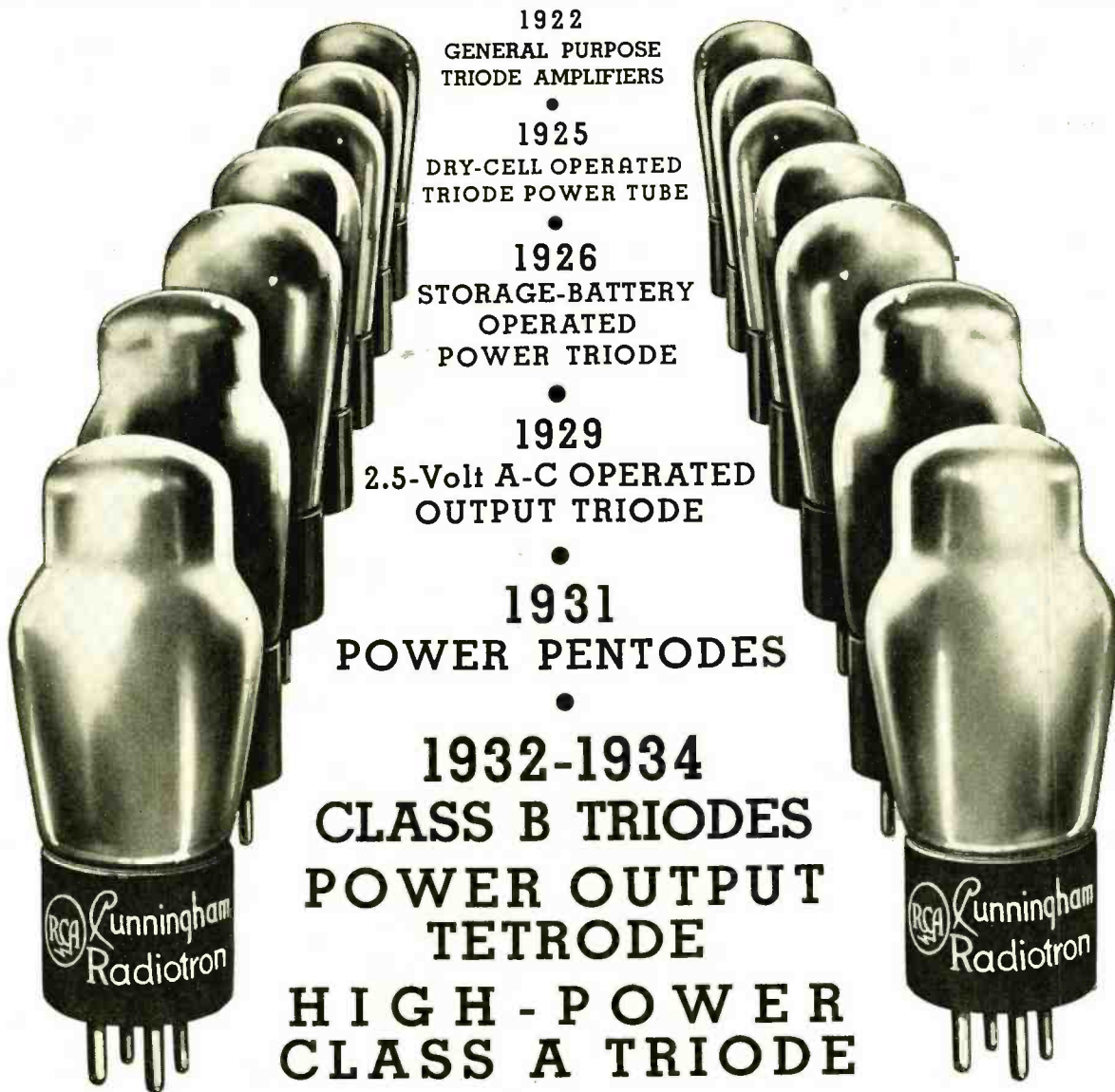

1922
GENERAL PURPOSE
TRIODE AMPLIFIERS

1925
DRY-CELL OPERATED
TRIODE POWER TUBE

1926
STORAGE-BATTERY
OPERATED
POWER TRIODE

1929
2.5-Volt A-C OPERATED
OUTPUT TRIODE

1931
POWER PENTODES

1932-1934
CLASS B TRIODES
POWER OUTPUT
TETRODE
HIGH-POWER
CLASS A TRIODE



THE MOTIVE behind these RCA developments in
AUDIO-FREQUENCY POWER-AMPLIFIER TUBES:
better receiver performance at lower cost!

RCA RADIOTRON CO., INC.

HARRISON *A Radio Corporation of America Subsidiary* NEW JERSEY

RADIO ENGINEERING

Reg. U. S. Patent Office

Editor
M. L. MUHLEMAN

Member
Audit Bureau of Circulations

Associate Editor
RAY D. RETTENMEYER

Vol. XIV

APRIL, 1934

Number 4

CONTENTS

	PAGE
COVER ILLUSTRATION	
BANK OF VACUUM TUBE GRID WINDING MACHINES	
EDITORIAL	4
LINEAR CLASS B. AMPLIFIERS.....By George H. Miller	13
ANTENNA MEASURING SET.....By W. B. Lodge	14
CATHODE-RAY TUBES.....	17
KNOXVILLE POLICE RADIO SYSTEM.....Milburne O. Sharpe	18
DESIGN OF WIDE RANGE AUDIO TRANSFORMERS	
By I. A. Mitchell	22
COILS AND CIRCUITS.....By Howard J. Benner	24
WIRE IN TUBES.....By C. A. Laise and J. Kurtz	29
HIGH-FIDELITY RECEIVERS.....By A. Gerard Hanley	30
HIGH-FIDELITY MONITORING.....By J. P. Taylor	32

DEPARTMENTS

COMMUNICATION AND BROADCAST ENGINEERING	
<i>A Chronological History of Electrical Communication— Telegraph, Telephone and Radio.....</i>	6
NEWS OF THE INDUSTRY.....	38
NEW PRODUCTS.....	40

"ALL-WAVE" STANDARDS

AN IMPORTANT MATTER to come before the RMA Board of Directors at its meeting in Chicago on April 18, is promulgation of standards, defining the nomenclature and frequency ranges for "all wave," "short wave," standard and other receivers.

Recommendations for names and frequency ranges to be applied to the "all wave" and other receivers were made at a meeting on March 24 in New York of the RMA receiver Committee, of which E. T. Dickey of Camden, N. J., is chairman. The recommendations of the nomenclature and frequency ranges of the standards and other receivers will be transmitted to the RMA Board of Directors by Chairman Virgil M. Graham of the Association's engineering division, and after adoption by the RMA Board of Directors will be promulgated for the guidance of the trade and the public.

BRYAN S. DAVIS
President

JAS A. WALKER
Secretary

Published Monthly by the

Bryan Davis Publishing Co., Inc.

19 East 47th Street
New York City

SANFORD R. COWAN
Advertising Manager

A. B. CARLSEN
Circulation Manager

Chicago Office—919 N. Michigan Ave.—L. F. McClure, Mgr.

Cleveland Office—10515 Wilbur Ave.—J. C. Munn, Mgr.

San Francisco Office—155 Sansome St.—R. J. Birch, Mgr.

Los Angeles Office—846 S. Broadway—R. J. Birch, Mgr.

St. Louis Office—505 Star Bldg.—F. J. Wright, Mgr.

Wellington, New Zealand—Tearo Book Depot.

Melbourne, Australia—McGill's Agency.

Entered as second class matter August 26, 1931, at the Post Office at New York, N. Y., under Act of March 3, 1879. Yearly subscription rate \$2.00 in United States. \$3.00 in Canada and foreign countries.

radio engineers test and approve

CLAROSTAT PRODUCTS

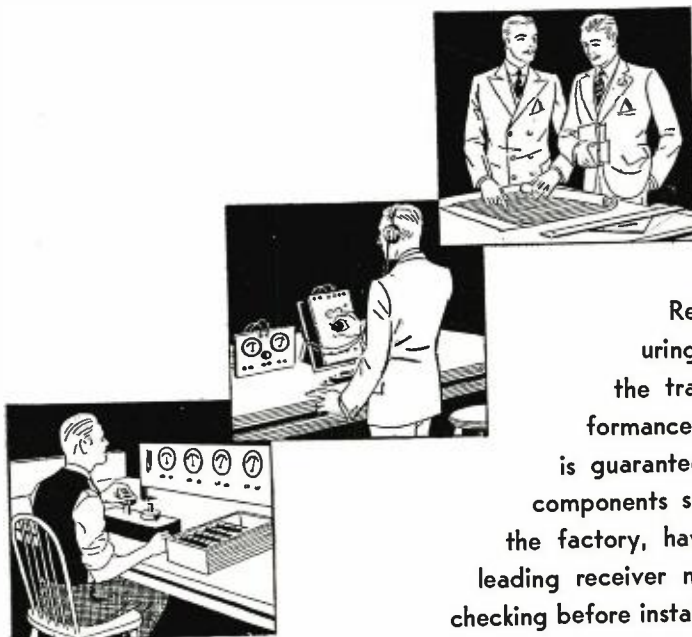

There is no room for guess work in a Radio Receiver manufacturing plant. Modern measuring instruments, checking components, plus the trained mind, determine radio receiver performance in advance. The certainty of performance is guaranteed in a measure by the reliability of the components supplier. Clarostat Products, pre-tested at the factory, have won the approval of practically every leading receiver manufacturer. Clarostats need no further checking before installation.

For all modern radios

new and improved CLAROSTAT FLEXIBLE RESISTORS

— UNEQUALLED IN STRENGTH AND ACCURACY —

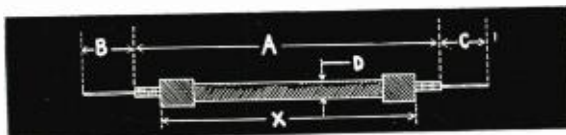

"X" Directly proportional to watt dissipation.
Type "FX"—Watts per inch = one-half. "D" = 1/4 inch.
Type "FY"—Watts per inch = one. "D" = 1/4 inch.

"A" = "X" ± 1/2 inch.
"B" = "C" = 2 inches. (Std.)
All linear dimensions ± 1/8 inch.

RESISTANCE TOLERANCE: ± 5% and not more than 1% change of original value when entire resistor is wound upon a 3/8 inch diameter arbor.

TENSILE STRENGTH:
Type "FX"—not less than 50 lbs.
Type "FY"—not less than 100 lbs.

WATT RATING: Continuous.

TERMINALS: No. 24 B & S tin-coated copper wire.

CODE USED:
1" "FX", 500—Type "FX," 1 watt, 500 ohms.
4" "FY", 250—Type "FY," 4 watts, 250 ohms.

STANDARD STOCK:
All popular resistance values and sizes "FX."

Clarostat engineers have perfected a new series of flexible resistors of superior quality at prices competitive with carbon resistors.

In design they are trim. In accuracy, the commercial tolerance is maintained at ±5%. In ruggedness and tensile strength, their new design permits them to exceed R.M.A. requirements from 250% to 500%. The R.M.A. color code for resistance values is used throughout. Production facilities permit unlimited quantities on short notice.

Try them—samples will be sent free to responsible parties. State resistance values desired in ordering your samples.

We solicit inquiries on mass production or special resistor problems, for radio, sound, communication or industrial application.

NEW CONTROL REPLACEMENT GUIDE UPON REQUEST

CLAROSTAT MFG. CO., Inc.

285 North 6th Street

Brooklyn, N. Y.

"AD-A-SWITCH" was originated by Clarostat



EDITORIAL

VACUUM TUBES

IN THE COURSE OF THE history of radio development it has occurred to many that at some place along the way it might have been more advantageous and more in the favor of progress had engineering thought taken another path. What might have been the fruits of investigations entirely free of the influence of engineering thought at any given period?

It is axiomatic in the field of letters that a new literary style can be created only by completely breaking away from the thread of influence woven by the early masters of the art in this country and abroad. The same axiom may be extended to any field of endeavor and there is no denying that a man is more apt to build upon old and tried foundations than start anew from the very ground.

These conjectures regarding what might have been are ever-recurrent and the day will never come when man is absolutely sure of his way. Yet, standing out as a brilliant contradiction to the axioms centering about the paths of progress is the vacuum tube. Conceived in its elemental form shortly after the birth of radio, it has steadfastly held its ground against all comers. The basic thread of thought has been fed ever since by the best minds in the engineering field with the result that the present-day tube hardly bears a scientific resemblance to the original valve.

The strength of the influence of the vacuum tube on engineering minds is the astounding correctness of the underlying principle. Rather than being a mere development, the principle is a vein of thought of astronomical vastness as yet hardly tapped.

The element of certainty surrounding the vacuum tube has had a direct bearing upon radio engineering development. Our receivers, our transmitters, our automatic

equipment, have been built around the tube. The vacuum tube has also become the nucleus of practically all modern measuring systems. It is the central foundation of the radio industry and will remain so.

More recently the vacuum tube has influenced the design of receivers and transmitters, mainly through the ability of the engineers to model a tube to most any desired set of specifications. Where at one time receiver and transmitter design were restricted by fixed tube characteristics it is now common for the engineer to decide first what the scope of his equipment must be and fit the tube to these requirements. That this should continue as the accepted method of equipment design seems quite logical since the engineer cannot obtain the same flexibility and extent in characteristics with other components as he can with the tube. The tube, therefore, must take up the slack.

The practice of producing custom-made tubes for the benefit of the equipment designer favors progress, but works a hardship on the tube manufacturer and tube seller. There are at present over two hundred tube types, including the hard-glass group. The moratorium called to protect the supplier and the seller of tubes has put a stop to what had nearly become a senseless program, and has also given the designer of transmitting, receiving and measuring equipment sufficient time to learn something about the tubes available. The result is that many tube types have been entirely discarded by the design engineer and those now in use have been narrowed down to a mere handful.

In the meantime many worthy improvements have been made in tube design. New materials and new methods of manufacture have contributed to tube efficiency, and the end is not yet. As higher percentages of efficiency are reached it will be possible—as it is, to an extent, now—to use effectively a single tube type for a number of specific purposes. It is possible, therefore, that increases in tube efficiency, and improved methods of design, will prevent another flood of tubes such as we have recently experienced.

SUMMERILL

NICKEL

SEAMLESS

TUBING

IN SEAMLESS NICKEL CATHODE TUBING—

THE SUMMERILL CASE

packed for shipment



The scientific care used in making SUMMERILL SEAMLESS TUBING extends to the shipping case, a container constructed to insure the tubes against damage in transit. There is no waste through crushing or bending. Each tube arrives in perfect condition, just as it was when packed.

What factors influence your selection of a source of supply?

Aren't you interested primarily in *Chemical Purity, Material Density, Mechanical Accuracy* and *Service Dependability*?

If so, the Summerill Tubing Company is your logical source. They have studied the requirements of the trade, know what is needed and are prepared to deliver on short notice *in any volume*.

SUMMERILL TUBING COMPANY

"SPECIALISTS IN TUBING SPECIALTIES"

BRIDGEPORT, *Montgomery County*, PA. • PHILADELPHIA DISTRICT

COMMUNICATION and BROADCAST ENGINEERING

Published Monthly

A Chronological History

of electrical communication

—telegraph, telephone and radio

This history began with the January 1, 1932, issue of RADIO ENGINEERING. The items are numbered chronologically, beginning at 2000 B.C., and will be continued down to modern times. The history records important dates, discoveries, inventions, necrology and statistics, with numerous contemporary chronological tie-in references to events in associated scientific development. The material was compiled by Donald McNicol.

PART XXVIII

1906 (Continued)

- (1103) For radio purposes R. A. Fessenden, at Brant Rock, Mass., employs a generator of one-half kw capacity, operating at 75,000 cycles.
- (1104) The West Jersey and Seashore Railway, commencing in July, is operated by means of electric power. The third-rail system is used, with a direct-current voltage of 675.
- (1105) The first long distance electric power transmission lines of the Niagara Power Company's system are placed in service on July 7. The generators are of 7,500 kw capacity each. Three-phase, 25-cycle current at 12,000 volts is stepped up to 62,500 volts.
- (1106) Fessenden succeeds in telephoning a distance of eleven miles by means of wireless telephone apparatus.
- (1107) The tantalum filament electric lamp is brought out, in the United States.
- (1108) The Argentine Marconi Company is formed (August) to operate the Marconi wireless system in Argentina and Uruguay.
- (1109) The first New York Central Railroad train to be hauled by electric power moves from High Bridge to Grand Central Terminal, New York, September 30. An electric locomotive operating on 600-volts d.c., is employed.
- (1110) Acheson, in America, discovers a process of producing fine, pure graphite.
- (1111) Samuel Sheldon is elected president of the A. I. E. E.
- (1112) Edward J. Nally becomes vice-president and general manager of the Postal Telegraph-Cable Company, New York. (Continued in this position until 1913.)
- (1113) During the year, 200,000 tantalum filament electric lamps are marketed in America.

1907

- (1114) The Association of Iron and Steel Engineers organized at Pittsburgh, Penna.
- (1115) The Society of Wireless Telegraph Engineers organized at Boston, Mass.
- (1116) The printing telegraph system developed by Professor Rowland, in the United States, is placed in service on a number of trunk circuits of the Postal Telegraph-Cable Company.
- (1117) Minor M. Davis succeeds Francis W. Jones as chief engineer of the Postal Telegraph-Cable Company.

- (1118) The Engineering Building, the new national headquarters of the national engineering societies, 33 West 39th, Street, New York, is dedicated April 16.
- (1119) The first train operated by means of an electric locomotive on the New York, New Haven and Hartford Railroad, arrives at Grand Central Terminal, New York, May 11.
- (1120) The Erie Railroad Company runs its first electrically drawn train into Rochester, N. Y., January 22. Power at 60,000 volts, single-phase, 25-cycles, is delivered from a power station ninety miles from the railroad line.
- (1121) For radio signaling purposes a 100,000-cycle electric generator of one k.w. capacity is constructed, in America.
- (1122) Tungsten filament electric lamps are introduced commercially in America. During the year 52,471 lamps are marketed.
- (1123) Theodore N. Vail returns from retirement and becomes president of the American Telephone and Telegraph Company.
- (1124) The various Bell Telephone Companies absorb 458,000 telephone subscriber stations previously owned and operated by independent telephone companies.
- (1125) H. G. Stott is elected president of the A. I. E. E.
- (1126) Alexander Graham Bell receives the John Fritz medal in recognition of his inventions in telephony.
- (1127) The Barclay-Buckingham printing telegraph system is extensively employed on the lines of the Western Union Telegraph Company.
- (1128) A nationwide telegraphers' strike takes place in the United States, lasting through July, August and September.
- (1129) The Marconi company announces the opening of transatlantic commercial wireless telegraph service (October 17) to be transacted through a station at Glace Bay, Nova Scotia, and a station at Clifden, Ireland.
- (1130) In the United States there are in operation 3,462 commercial central electric stations, employing 42,066 persons, and having in operation 9,778 electric generators. Municipally owned central electric stations number 1,252, with 5,556 employees, and having in service 2,395 electric generators.
- (1131) In the United States there are 175 telephone systems (companies) belonging to the American Telephone and Telegraph Company, operating 8,947,266 miles of wire and 3,132,063 telephone stations (subscribers' stations.) There are 22,796 independent telephone companies (non-Bell systems) operating 4,052,103 miles of wire and 2,986,515 telephone stations.
- (1132) American cable manufacturers produce telephone cables having 600 pairs of No. 22 gage copper wires.
- (1133) In the United States there are 15,527 public telephone exchanges.
- (1134) In the United States twenty-five commercial telegraph companies operate 1,577,773 miles of wire. The total income for telegraph companies is \$51,583,868 and the expenses \$41,879,613 for the year 1907. 1,047,458 miles of wire are operated single Morse; 239,278. Morse duplex; 266,337, quadruplex, and 24,888 miles by machine or automatic systems.

(To be continued)

An open letter to manufacturers of Auto Radio Sets and Controls

THE S.S. WHITE
INDUSTRIAL DIVISION

DENTAL MANUFACTURING CO.
152 West 42nd Street, New York

TELEPHONE WISCONSIN-7-3510
CABLE ADDRESS "FLEXWHITE" NEW YORK
MEMBER-MOTOR & EQUIPMENT ASSOCIATION
MEMBER-AERO CHAMBER OF COMMERCE

FLEXIBLE SHAFTING • RUBBER • FINE STEEL CUTTING INSTRUMENTS • GOLD • SILVER • PLATINUM AND ALLOYS • RESISTANCE UNITS

Gentlemen:

Auto Radios in 1933 had a big year. Over 600,000 sets were sold. Close to 100 per cent were of the flexible shaft operated remote control type.

Every indication points to an even bigger demand in 1934. And practically all sets will again be flexible shaft controlled. Auto Radio Manufacturers and Dealers will always favor this type of set because it can be installed in any car new or old, which means an unlimited market; and because it offers no installation problem, for the receiver can be located anywhere in the car, yet the control will always be where for safety's sake it should be - right under the driver's hand.

Now, to get and to hold your share of this business there are two things you must be sure of: (1) that the flexible shafts you use, fully meet all requirements; (2) that your source of supply can be depended upon for deliveries, particularly when the demand is at its peak - and without any let down in shaft quality. You are sure on both counts when you use S.S. WHITE Remote Control Flexible Shafts.

The active season is right ahead. Get set for it. We'll be glad to send you a sample of our special remote control shaft and casing. WRITE for it - today.

Yours very truly,

The S. S. WHITE Dental Mfg. Co.
INDUSTRIAL DIVISION

These are actual size pictures of S.S.W. No. 150L53 Flexible Shafts and No. 170A1 Casing, which were developed to meet the specific requirements of auto radio control. Note the square and octagonal swaged shaft ends, and the enlarged casing end, features originated and patented by S. S. WHITE. Note how small the casing is. It permits a neat, unobtrusive installation. You cannot appreciate how smooth, effortless and sensitive tuning with a flexible shaft can be until you have tried the No. 150L53 shaft.

— *Watch for it!*

Design data on ultra short wave Transmitters and Receivers—

More articles on High Fidelity Receivers and Broadcasting—

Station synchronization and Directional Broadcasting—

Additional material on short wave and all-wave Receiver Design.

New components for 1934 Receivers.

Tube Design and circuit applications.

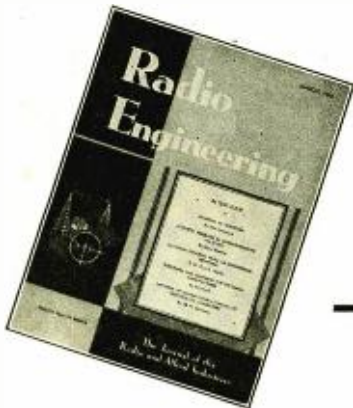

— In May Radio Engineering

Extra copies of the May number will be available at the Radio Engineering Exhibit Room at the I. R. E. Convention, Hotel Benjamin Franklin, Philadelphia (May 28 to 30.)

Paid A. B. C. Circulation over 5,000.

Total monthly Distribution over 6,000.

Advertising Space Reservations should be made at once.
Copy for May number accepted until May 10th.

TUNGSTEN— KULGRID "C" STRANDED (PRONOUNCED "COOL GRID") —WELDS

Reduces Production Costs By Eliminating Rejections In The Manufacture of Electronic, Neon and Hard Glass Tubes!

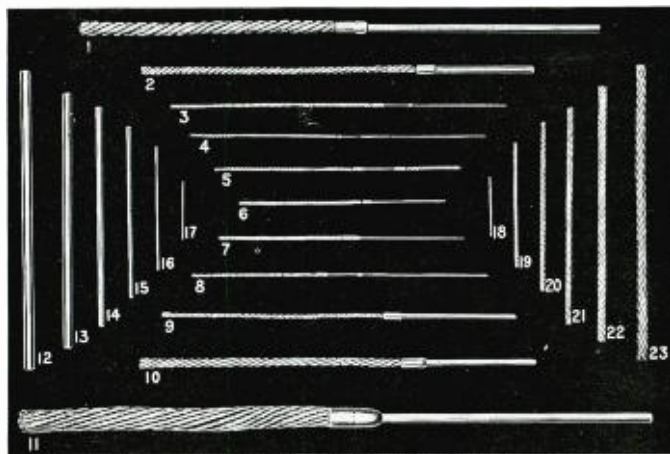

KULGRID "C" WELDS ILLUSTRATED

No.	KULGRID STRAND (diameter)	TUNGSTEN ROD (diameter)	ALLOY
1	7 x 41 x .012	.250	
2	7 x 24 x .010	.150	
3	19 x .010	.040	.050 Nickel
4	12 x .010	.030	.040 "
5	19 x .010	.050	19 x .010 "
6	19 x .010	.050	
7	7 x 6 x .010	.080	
8	19 x .010	.040	.040 Moly
9	7 x 7 x .012	.100	
10	7 x 37 x .010	.200	
11	19 x 7 x .018	.325	

No.	TUNGSTEN ROD (diameter)	No.	STRAND Kulgrid "C"
12	.250	18	12 x .010
13	.187	19	19 x .012
14	.125	20	7 x 6 x .010
15	.080	21	7 x 7 x .012
16	.040	22	7 x 24 x .010
17	.030	23	7 x 37 x .010

ANY Combination and size of Kulgrid, Tungsten, Molybdenum, or Nickel can be supplied to your specifications in cut pieces or finished welds.

**CALLITE
PRODUCTS DIV.**
UNION CITY NEW JERSEY

KULGRID "C" STRAND

- Does not oxidize or flake under high temperatures during beading, stem making, sealing-in and exhaust operations.
- Does not get brittle. Strands once welded *stay welded* and remain flexible at all times.
- Welds easily and permanently with Tungsten. *All strands bond firmly* to Tungsten producing welds of lower resistance.

Kulgrid Wire Applications

KULGRID "C" WIRE

Designed for use as lateral grid supports. Maintains rigidity and better alignment than copper. Highly conductive core and non-corrosive sleeve lowers operating temperatures and reduces grid emission. Welds readily to Nickel.

KULGRID "I" WIRE

Designed for use as grid wire proper for round grids. Elongation 10 to 18%. Breaking strength .9 to 1.15 kg.*

KULGRID "S" WIRE

Designed for use as grid wire proper for flat grids. Elongation 10 to 20%. Breaking strength 1.0 to 1.4 kg.*

* Measured on .005" diameter wire.

CALLITE PRODUCTS DIV. R.E.4
Union City, New Jersey

Gentlemen:—Please send to me, without cost or obligation, samples of KULGRID "C" TUNGSTEN Welds; KULGRID "C" "I"-"S" GRID WIRE (state type and series) in the following specifications:

	STRAND DIA. and length	TUNGSTEN ROD, dia. and length
<input type="checkbox"/> Tungsten—Kulgrid "C" Strand Weld
<input type="checkbox"/> Kulgrid "C" Grid Wire
<input type="checkbox"/> Kulgrid "I" Grid Wire
<input type="checkbox"/> Kulgrid "S" Grid Wire

I do not want your representative to call.

NAME

ADDRESS

COMPANY

High Fidelity Speakers

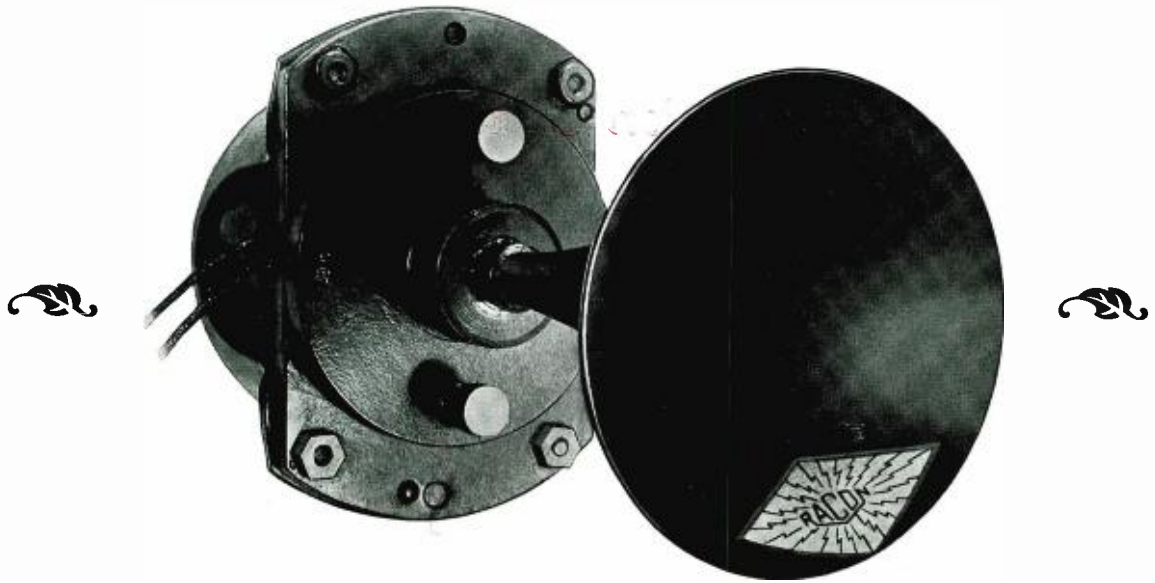

• • • • • **R a c o n**
is equipped to furnish TWEETERS
in *Quantity* to Radio Receiver
Manufacturers!

For 1934 HIGH FIDELITY in radio broadcast reproduction is the paramount issue. The RACON High-Frequency Loudspeaker makes possible a quality and fidelity never before obtainable from home receivers.

To facilitate the application of the "Tweeter" to production lines, a special manufacturer's model is available. Its response has been equalized to "air-conditions" and its design is such that it can be economically applied to big production models. A sample will be sent gladly to established manufacturers requesting it by letter or wire.

RACON ELECTRIC CO. INC.

52 EAST 19th STREET
LONDON, ENGLAND

NEW YORK CITY
TORONTO, CANADA

Sales Offices in Principal Cities

L A M I N A T E D B A K E L I T E S H E E T S · R O D S · T U B E S

SMOOTH production schedules are largely dependent upon materials with uniform machining qualities. Synthane laminated bakelite machines readily. It is applicable to widely diversified electrical and mechanical uses. And with Synthane the purchaser buys more than a material. He buys Synthane service also—an assurance of prompt,



intelligent and accurate handling of requirements. Samples for testing sent free on request.

F A B R I C A T E D P A R T S · S I L E N T S T A B I L I Z E D G E A R M A T E R I A L



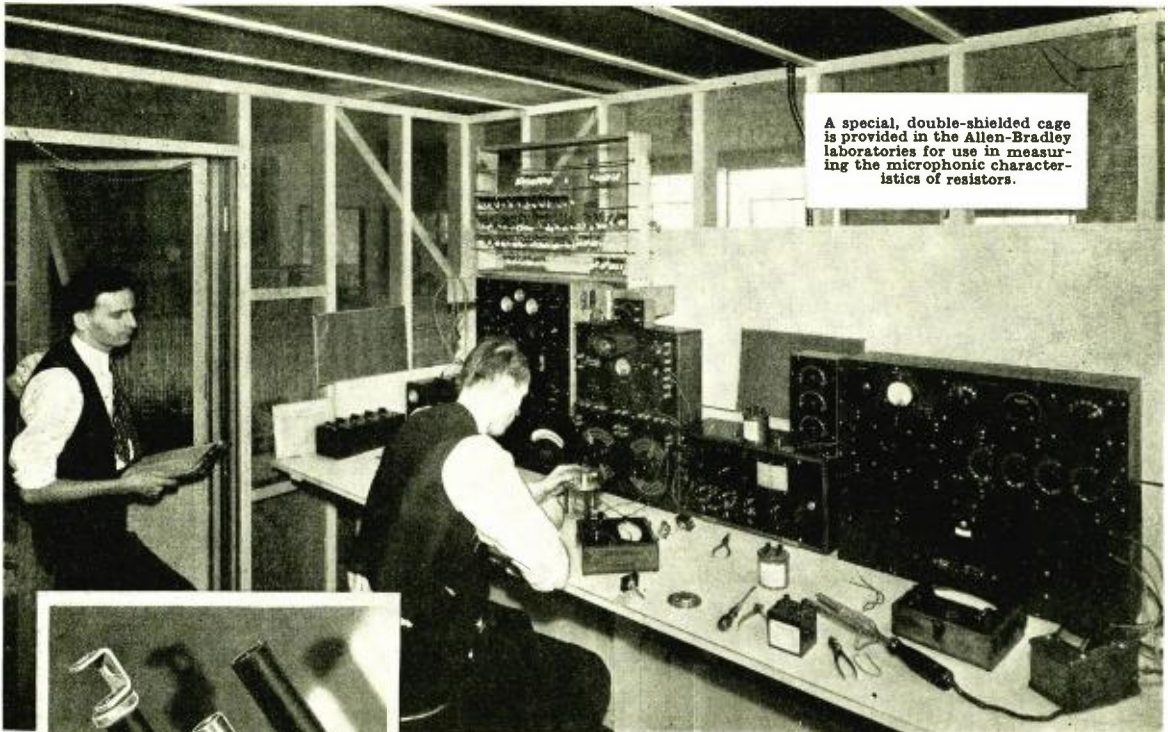

A special, double-shielded cage is provided in the Allen-Bradley laboratories for use in measuring the microphonic characteristics of resistors.



SPARK PLUG RESISTORS
Allen-Bradley Suppressors remain permanent in resistance even after long, abusive automotive service.



BRADLEYUNITS
Bradleyunits are solid molded resistors unaffected by temperature, moisture, or age.



BRADLEYOMETERS
The Bradleyometer can be arranged to provide any resistance-rotation curve.

The Secret of Allen-Bradley Quality is "laboratory control" over production

The quality of Allen-Bradley Resistors is no accident!

In addition to the usual routine tests in production, the manufacture of Allen-Bradley Fixed and Adjustable Resistors is continually supervised under critical engineering and laboratory controls.

For instance, the high gain amplifiers used in measuring the microphonic characteristics of resistors are carefully shielded from stray fields by being operated in specially shielded cages as illustrated above.

In the manufacture of any product, the quality of that product can be determined only if precision measurement equipment is available. Progress is possible only when the actual merit of the product can be accurately evaluated. Allen-Bradley quality and progress in the resistor art have been achieved through the use of such precision measurement equipment, the design of which, in many cases, is entirely original.

Get an Allen-Bradley quotation on your next resistor order.



Allen-Bradley

General Offices: 126 W. Greenfield Ave., Milwaukee, Wis.

RADIO ENGINEERING

FOR APRIL, 1934

Linear Class B Amplifiers

By **GEORGE H. MILLER, HOWELL BROADCASTING CO.**

WHILE MUCH HAS been written on the subject of Class B radio-frequency power amplifiers, as used in broadcast transmission, it has been the experience of the writer that some confusion exists among operating personnel as to the exact relationship which exists between the power input, power output, and efficiency of this widely used type of amplifier. It is the object of this article to explain the very important relationship between grid input voltage and tube efficiency, and to point out some of the detrimental results which can be obtained by disregarding this relation.

LINEARITY OF AMPLIFIER

The most important consideration in any power amplifier used for amplifying modulated waves is its linearity. This, of course, requires that the r-f output current in load shall increase directly as the grid excitation voltage; i.e., a linear relation should exist between them. The power output, then, will vary as the square of the input grid voltage E_g . However, another important consideration is that the d-c plate current I_p should also bear a linear relation to the grid voltage. If this is the case the power input to the tube increases directly as the grid voltage, and we have a condition where the power output increases twice as fast as the power input.

It is very obvious that to obtain the above results the power output divided by the power input, or conversion efficiency, must also bear a linear relation to the grid voltage. In this case then, we must operate on the center of the linear portion of the efficiency curve in exactly the same manner as is done in the case of the E_g - I_p characteristic when considering the carrier setting in the adjustment of Class B amplifiers. This follows from the fact that any departure from linearity in the efficiency

- The operation of linear Class B amplifiers and the relationship existing between power input, power output, and the general efficiency of the system applied to radio-frequency circuits.

curve results in a similar departure of the output current characteristic. The upper limit in efficiency is the limiting factor in the operation of the tube.

HYPOTHETICAL CONDITION

Referring to Fig. 1 we find an ideal condition for a Class B power amplifier showing a linear dynamic characteristic between grid voltage and (1) d-c plate current, (2) power input, and (3) efficiency, where:

I_p = d-c plate current
 P_i = Power input
 P_o = Power output
 E = Efficiency in %
 E_g = Grid voltage
 P_d = Plate dissipation

If we assume conditions as indicated, we find that the power output, as shown by the dotted curve, would follow the square law, while the d-c plate current,

power input, and efficiency would be linear. The latter values are drawn so as to be represented by a single line for convenience. At any point on E_g the power output would be (1) the product of P_i and E , and (2) the difference between P_i and P_d .

The power lost in the tube in the form of plate dissipation is the difference between P_i and P_o and is represented by the shaded area between the two curves. If we wished to amplify 100 per cent modulated radio-frequency power it would be necessary to excite the grid of this amplifier to a point half way up the E_g - I_p characteristic, which also corresponds to the point of half maximum efficiency. When set at this point the amplitude of the carrier voltage could be swung from zero to twice its unmodulated value. It should be noted that at the carrier setting given, the power output is one-quarter its maximum value.

CARRIER EFFICIENCY

It is apparent from Fig. 1 that if we attempted to increase the carrier efficiency by raising the operating point to some point above the center, it would be necessary to reduce the modulation percentage, since it would be no longer possible to swing the d-c plate current to twice its normal value, or the power output to four times its normal carrier value. Failure to reduce modulation percentage would of course result in amplitude distortion on positive modulation peaks. This distortion could also

(Continued on page 16)

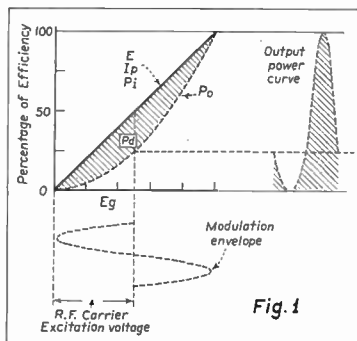

Illustrating an ideal condition for a Class B power amplifier.

ANTENNA MEASURING SET

By W. B. LODGE, ASST. CHIEF ENGINEER, CBS

THE IMPEDANCE OF the transmitting antenna and its transmission line are two of the most important constants in the equipment of a radio broadcasting station. Knowing these values, it is possible for the engineer to determine the power actually delivered to the antenna by the transmitter, the constants of the coils or condensers necessary to tune the antenna to resonance, and the proper method to follow in coupling together the antenna, the transmission line, and the transmitter. These problems must be solved during the lining-up period of a radio station.

In the case of a low-powered transmitter, a cut and try procedure is satisfactory. But when the radio engineer is faced with the installation of a modern, high powered radio transmitter which must operate at the highest efficiency possible, the requirements are more rigid. Approximations which might be overlooked in the adjustment of a smaller transmitter would then result in the loss of many kilowatts of valuable radio-frequency power and the probability of burnout or damage to expensive equipment.

ANTENNA MEASURING EQUIPMENT

To date there has been available no compact field equipment for use in antenna and transmission line work. Due largely to this lack of equipment, radio engineers familiar with this type of work require anywhere from two to eight weeks to properly adjust the radiating equipment of a high powered broadcast transmitter. Furthermore, if the problem is complicated by the re-

- Details of a unit for measuring the resistive and reactive components of antenna and transmission line impedance, and the terminating impedance at antenna end of transmission line

quirements of a directive antenna system, or the reduction of harmonic radiation, longer periods of adjustment may be necessary before the station is ready for year in and year out operation. Therefore, engineering expenses of such work become quite appreciable.

With the engineering of a large number of radio transmitters under the supervision of New York headquarters, the technical department of the Columbia Broadcasting System found it necessary to develop a convenient and accurate antenna measuring set.

The set is designed to measure the impedance of any antenna from .1 to .9 wavelengths long, giving the resistive and reactive components. It may also be used to determine the characteristic impedance and the electrical length of two-wire or concentric tube radio-frequency transmission lines. And, what is probably the greatest time saver, this unit also measures the terminating impedance at the antenna end of the transmission line. All of these values must be determined to properly engineer a large broadcast installation.

Not only is the antenna resistance required in calculating the antenna input power, but also the reactance of the antenna must be known to determine the elements of the T and π circuits whose

simplicity and efficiency are forcing acceptance in coupling the antenna to the transmission line. The surge impedance of the transmission line must also be known in designing the coupling equipment, and in addition if the installation involves a directional antenna the electrical length of the line must be measured.

The above factors are extensively treated in theoretical papers, and this theory is an essential background for the engineer who must install and adjust a modern antenna system. However, in practice the engineer does not have before him a straightforward problem on paper. Usually, he faces a compact coupling house at the end of a transmission line, which structure is filled with a miscellaneous assortment of coils and condensers whose constants are considerably in doubt. A copper wire or a steel tower reaches up from beside the coupling house into the space through which the output of the radio transmitter must be radiated. There are two things this radio engineer must do. First he must terminate the transmission line in its own impedance, and second he must send the full licensed power of the transmitter into the antenna. He is then getting the maximum number of millivolts per meter and the highest efficiency obtainable, unless he can experiment with the design of the antenna itself. Theory cannot tell him to what impedance he has adjusted the coupling equipment at the end of the line, nor can it tell him the efficiency at which the entire transmitting plant is operating. In this work the engineer must rely upon the available measuring equipment.

Adequate antenna measuring equipment is of such vital interest to the radio engineer that a description of the Model 2 CBS antenna set is presented here.

DESCRIPTION OF ANTENNA MEASURING SET

This set is designed to measure the impedance of any radio frequency network whose resistive component does not exceed 1000 ohms. The frequency range is 500 kc. to 1800 kc, and the

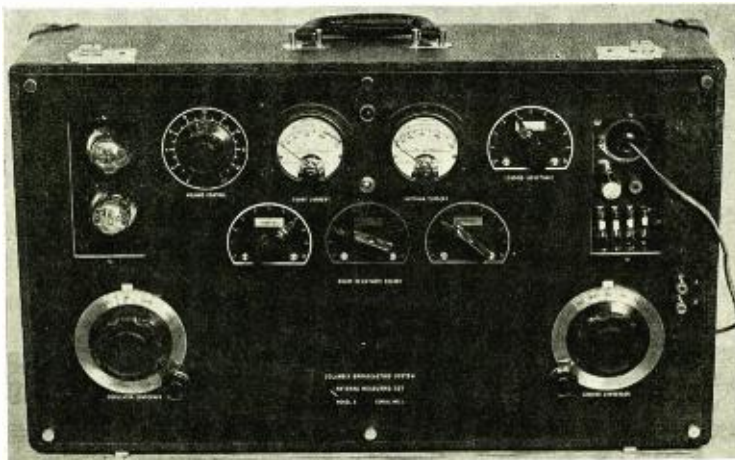

Fig. 3. Front view of the antenna measuring unit.

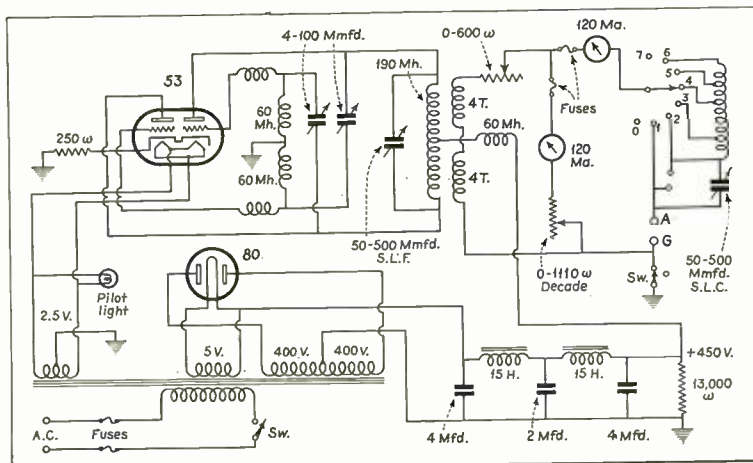

Fig. 1. Complete circuit of the antenna measuring equipment.

unit is a-c operated, requiring 100 watts at 110 volts and 60 cycles. In particular it is possible to determine the components of impedance. $Z = R \pm j X$, of a transmitting antenna or transmission line.

The complete schematic diagram, Fig. 1, shows the circuit arrangement of the set. Fundamentally, it consists of a balanced oscillator (using the two triodes of a type 53 tube) whose tank coil is loosely coupled to the measuring equipment. A rheostat in series with the pickup coil controls the r-f current in this equipment. The measuring circuit consists of two branches. They receive the same r-f voltage and are adjusted until their currents are equal. One branch consists of three decade resistors, and the other includes the unknown impedance and means of tuning it to resonance. A 120 ma. r-f milliammeter indicates the current in each branch. These instruments are protected with instrument fuses whose blow-point is 150 ma.

The rear view of the panel is shown in Fig. 2. The tube compartment, oscillator tuning condenser, r-f chokes, and grid coupling condensers are shown to the right. While the power transformer and filter are at bottom center, with the decade resistors directly above them. The oscillator tank coil, with the pickup coil inside it, is mounted at top center, and behind it are the two r-f milliammeters. The r-f volume control is between the meters and the tube compartment. To the left are the fuse and terminal compartment, the loading condenser, and loading coil and its tap switch.

Fig. 3 shows the set ready for operation. Tube changes and all necessary adjustments can be made from the front of the panel. A panel light plugs into a jack on the fuse panel where it receives 2.5 volts from the filament bus. The two fuses to the right, protecting the a-c sup-

ply, in Fig. 3 are of 2 ampere rating. The two fuses to the left are special $\frac{1}{8}$ -ampere units, of 1.5 ohms resistance, the one to the left being in the decade resistance circuit, the second from the left in the antenna circuit.

A pair of binding posts on the fuse panel is connected across the loading condenser, which has a maximum value of 500 mmf. Additional condenser may be paralleled across it by means of these binding posts, and if a calibrated variable condenser, insulated from ground, is required, turning the switch marked "Loading Inductance" to 0 or to 7 disconnects the loading condenser from other circuit elements, and makes it available at the binding posts.

MEASUREMENTS OF RESISTANCE AND REACTANCE

First remove the cover plates from compartments at each end of panel—the set should never be operated with the tube compartment covered, as the tubes dissipate sixty watts. Now place a 52 in the upper socket, and an 80 in the lower socket. With

$$R_D = R_A + R_L$$

the toggle switch in the up (off) position, connect the power cable to a 110-volt a-c supply, and turn the volume control to "0". This will give a minimum r-f current. Throw the toggle switch to the down (on) position (there is a pilot light directly above the switch). Set the oscillator tuning condenser to the frequency at which it is desired to measure the antenna. Although a calibration chart is shown, it is, however, advisable to check the frequency with a wavemeter. Then connect the antenna and ground to their respective binding posts, "A" and "G". The small s.p.s.t. switch in the fuse compartment should remain closed during antenna measurements, as it connects the common ground of the set to the binding post "G" in the measuring circuit. The same procedure should be followed for grounded concentric transmission lines, while for two-wire transmission lines the grounding switch should be open, since this "floats" the measuring equipment with respect to ground.

Now tune the antenna to resonance. If the antenna is exactly $\frac{1}{4}$ wave and requires no loading, the switch marked "Loading Inductance" is set on step 1 (the schematic diagram of Fig. 1 shows the wiring of this switch). An antenna whose reactance component is not zero may be tuned by a suitable choice of coil and condenser.

With the antenna tuned to resonance, adjust the shunt resistance until the two r-f milliammeters indicate the same current. Readjust the antenna tuning until the minimum shunt resistance for equal current in the two branches is obtained, thus eliminating the effect of the inductance of the pickup coil and control rheostat. The resistance decade (R_D) is then equal to the antenna resistance (R_A) plus the resistance of the loading coil and condenser (R_L).

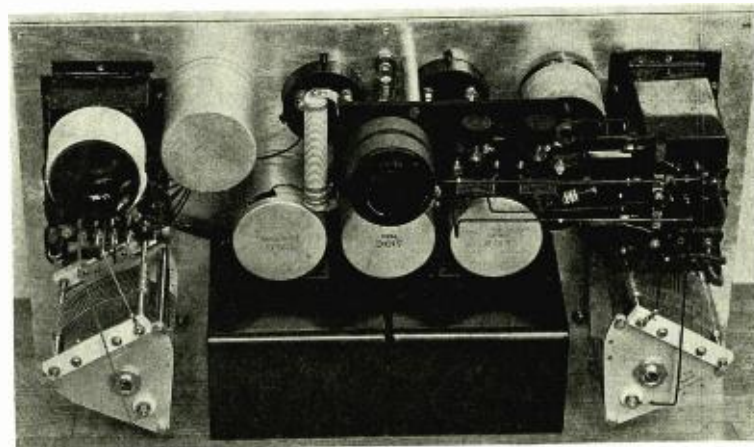

Fig. 2. Rear view of panel. The tubes are in the right-hand compartment.

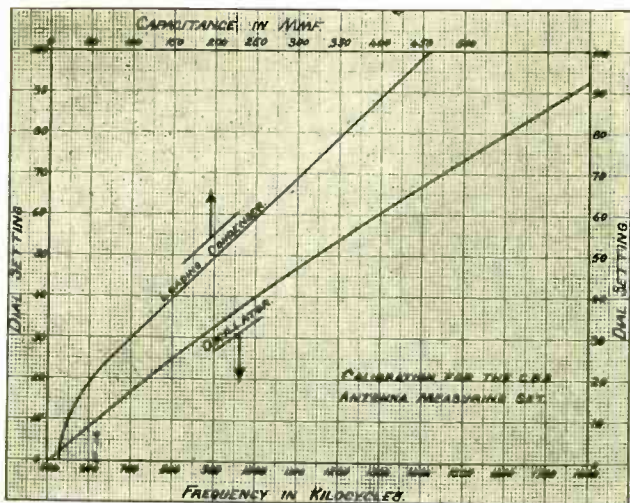

Fig. 4. Calibration chart for the antenna measuring set.

Note the dial setting (S_1) of the loading condenser, and connect a jumper between the binding posts "A" and "G". After retuning the loading circuit to resonance by means of the condenser, note this second dial setting (S_2) of the loading condenser. Again adjust the shunt resistance until the two milliammeters read alike. The decade setting is then equal to R_L , and the antenna resistance is given by:

$$R_A = R_D - R_L$$

and the reactive component of the antenna impedance is given by:

$$X_A = X_2 - X_1$$

where X_2 is the reactance of the loading condenser corresponding to S_2 at the frequency in question, and X_1 corresponds to S_1 ; a calibration of the loading condenser also being shown.

TRANSMISSION LINE MEASUREMENTS

For ungrounded transmission lines, open the small s.p.s.t. switch in the fuse compartment, and operate the set as described above if it is desired to measure R and X. To measure impedance, set the tap switch marked "Loading Inductance" on step 1. The set is then ready to operate under the ammeter-voltmeter method, in which impedance is determined from Ohm's law:

$$Z = \frac{E}{I}$$

Set the shunt decade resistance at some convenient value, R, and connect the transmission line to "A" and "G". Record the shunt current, I_s , and the transmission line current, I_A , as shown by the two r-f milliammeters. The r-f voltage across the resistance is $I_s R$, and the fuse and milliammeter add 7 ohms to R. It may then be shown that:

$$Z = \frac{I_s}{I_A} (R + 7) - 7$$

Measure the impedance as described

with the far end of the transmission line first open and then short circuited, and call these two values of impedance Z_{oc} and Z_{sc} respectively, the surge impedance is then given by:

$$Z_0 = \sqrt{Z_{oc} Z_{sc}}$$

and the electrical length by:

$$\theta = \tan^{-1} \sqrt{\frac{Z_{sc}}{Z_{oc}}}$$

CLASS B AMPLIFIERS

(Continued from page 13)

be produced by reducing the point of maximum efficiency, such as might result in a change of load resistance without a corresponding change in excitation adjustment. The maximum carrier efficiency, then, is limited to one-half the peak efficiency, and in the ideal case shown in Fig. 1 would be 50 per cent. During modulation the efficiency shifts from zero to maximum during each audio-frequency cycle. An examination of the shaded area in Fig. 1 will also disclose the fact that the plate dissipation decreases on either positive or negative modulation peaks.

During sustained modulation the average plate dissipation likewise decreases. Since the average power input during modulation is the same as that for carrier only, it follows that the average power output increases by an amount equal to the decrease in plate dissipation. It can be shown that for 100 per cent sustained modulation the average power output in load increases 50 per cent. This increase in power output can be noted by the increased area on the positive halves of the power curve shown to the right in Fig. 1.

In actual practice, none of the ideal linear characteristics mentioned above are actually obtained. The Ep-Ip static

characteristic never presents a straight line, the plate current being limited by space charge effects. The maximum efficiency is theoretically 78.5 per cent and it is likewise impossible to realize this value in actual practice. Values between 60 and 70 per cent are about the maximum obtainable. The linearity of the Ep-Efficiency curve is governed by many factors and invariably departs from this condition as the point of maximum efficiency is approached. The many factors which effect the linearity of this type of amplifier are closely related and are too involved to discuss here.

Fig. 2 shows characteristics which may be obtained in actual practice. In this case the upper limit in efficiency occurs when the value of minimum plate voltage approaches the maximum grid voltage and grid current becomes excessive. At this point any increase in current from the plate supply is carried by the grid and the limit of operation is reached in the case shown in Fig. 2.

Beyond this point the grid dissipates excessive power, as shown by the heavily shaded area, and the danger point is reached in the operation of the tube.

PERMISSIBLE EFFICIENCY

It is apparent that the useful portion of this characteristic lies between zero and approximately 60 per cent efficiency, which shows a substantially linear relation to Eg. The maximum safe carrier efficiency would be 30 per cent for a 100 per cent modulated grid exciting voltage. An examination of Fig. 2 gives a visual picture of the relation between power input and output as the modulation cycle traverses its course. A carrier efficiency of about 33 per cent is in general the maximum obtainable in present-day operation and any excess in this upper limit might well be eyed with suspicion, since it represents either amplitude distortion or insufficient modulation. It is generally advisable to run at the lowest figure which the safe tube capacity allows. A value of 25 per cent is not uncommon in many broadcast transmitters.

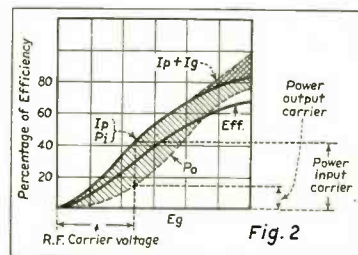

Illustrating the permissible efficiency of a Class B linear amplifier.

Knoxville Police

By **MILBURNE O. SHARPE**

CHIEF ENGINEER, WPFO



FIG. 1. UNIT CONTAINING THE SPEECH INPUT EQUIPMENT, HIGH-FREQUENCY RECEIVER, MONITORING AMPLIFIER AND POWER SUPPLY

"CALLING CRUISER NUMBER 100! Calling cruiser number 100!" Thus Knoxville's new RCA-Victor 250-watt police radio transmitter was introduced into the war against crime in East Tennessee on Saturday, May 20, 1933, at 2 P.M. From that time until midnight, May 31, a total of 538 emergency transmissions were broadcast to the seven city cruising cars and the four county cruising cars. Since that date the city has increased its radio equipped cars to fifteen, and the county has ten. In addition to these mobile units, there are approximately twenty station house receivers in Knoxville and Knox County, and at least one is to be placed in each of the fourteen surrounding counties, all of which will be a part of the system as it is now set up. At the present time an attempt is being made to equip all motorcycles of the entire Tennessee State Motor Patrol with radio receivers, to be served by all the police radio stations in the State.

Table I shows that for the part of 1933 during which WPFO was in operation, a total of 12,685 emergency calls were broadcast, of which number 10,469 were dispatched to city cars. The total time for the city cars to answer these calls was 25,013 minutes, or an average of 2.4 minutes per call. Considering the fact that each car must patrol an area of approximately five square miles, we think this is a very good record.

The total area WPFO is now attempting to serve is 5,900 square miles, with a population figure of 454,324. This population figure at first limited the installation to a power output of 250 watts. However, because of the increased population in Knox and Anderson Counties due to the tremendous influx of Tennessee Valley Authority executives, engineers and workers, the Federal Radio Commission has granted permission to use the entire output power of 500 watts.

TABLE I.

	June	July	Aug.	Sept.	Oct.	Nov.	Dec.	Total
County Cars	114	180	179	130	122	94	101	920
All Cars	160	209	235	191	180	133	169	1297
City Cars	1931	1646	1654	1263	1385	1254	1516	10469
Time On Run	3534	3810	4112	4019	3216	2810	3512	25013
Average	2.54	2.31	2.48	2.47	2.32	2.25	2.32	2.4
Out of Service	23518	27722	27035	27557	23414	22124	26254	177524
Average	17.0	16.9	16.3	17.0	16.8	17.6	17.3	16.9
Arrests	351	374	308	405	301	284	313	2336

The Norris Dam Site is located in Anderson County, about twenty miles airline distance from the transmitter, and with the increased power of the station, can easily be covered with a good radio signal, day or night.

The longest airline distance to a station house receiver is 54 miles, which is a rather large figure for an installation of this kind, and we do not yet know definitely just how this is going to work out.

TRANSMITTER EQUIPMENT

The equipment consists of an RCA-Victor type 40TA speech input amplifier, the regulation model ET3670 100-watt police broadcast transmitter unit, and a type UT4199 500-watt high-level modulator-amplifier unit. The output of this latter unit is fed through a two-wire transmission line to the terminating equipment located at the base of the tower. The tower itself is the new Blaw-Knox one-quarter wave vertical radiator, designed for the transmitter frequency of 2470 kilocycles.

The speech input equipment, the local audio-frequency signal oscillator, high-frequency receiver, monitoring amplifier, test jacks and switches, and the signal light switches (to be explained later) are all mounted with their power supplies on the rack shown in Fig. 1. Fig. 2 shows the 100-watt oscillator-buffer unit as well as the 500-watt high-level modulator-amplifier unit. Fig. 3 gives a view of the tower, looking up.

The entire plant and studio equipment is located at Police headquarters, in the same room with the Desk Sergeant, permitting the minimum of time elapse between the receipt of calls and their dispatch over the air. From all outward appearances, one would not expect a location such as this to be entirely satisfactory for the plant equipment, since it is low compared with much of the city, and is near and surrounded by numerous structures and power lines. Two other sites were selected for trial, but after comprehensive field strength measurements had been made on this one, using the experimental 100-watt transmitter W4XE, the present location was accepted. At an average distance of about 3 miles, the field strength is 10,000 microvolts per meter; at an average distance of about 18 miles this strength dropped to about 100 microvolts per meter, but still is sufficient to produce good volume in the receivers. These measurements were made when the transmitter power output was only 250 watts. With the 500 watts we are now using, we expect proportionately greater signal strength at all locations.

A block diagram of the entire set-up is shown in Fig. 4. The double-button microphone is fed into a —24a push-pull stage, followed by a —45 push-pull stage, then into an 845 push-pull stage, which acts as a driver for the 203a Class B modulators. Push-pull amplification has been employed throughout the entire transmitter in the audio-frequency circuits, and in the

Radio System

- A description of the complete communication system employed by the Knoxville Police Department, with some interesting data on the antenna and control systems, the dispatch system, and the methods of servicing the mobile equipment

power amplifier stage. Type 210 tubes are used in the oscillator and first buffer amplifier stages, followed by two stages of 211 buffer amplification. The output of the second 211 amplifier feeds into the 203a power amplifier. In this stage, for full 500-watt output, six 203a tubes are employed, as shown in the figure. For 400-watt operation, two of these tubes are removed, one from each side of the push-pull circuit. By a reduction in plate voltages, and a corresponding reduction of excitation voltage, the power output can be further reduced to almost any desired value. However, for 100-watt or less power into the antenna, it is desirable that only the ET3670 100-watt unit be used. When operating at 400-watts or less, two of the four 203a modulator tubes are also removed, since the remaining two of these tubes in the Class B modulator circuit provide ample power for full 100 per cent modulation.

A novel feature of the type 40TA speech input amplifier, which is entirely a-c operated, is the method of supplying microphone current. This is accomplished by connecting the microphone across a dropping resistor in the plate circuit of the —45 second amplifier stage. When the switch is in the "on" position, the B potential is applied to the tubes, allowing normal current flow. When the switch is in the "off" position, a large biasing resistor is cut into the circuit, dropping the plate current of all the tubes almost to zero, due to the high negative bias imposed on the tube grids. Since there can be no voltage drop across a resistor without current flow, the voltage is automatically removed from the microphone circuit.

RELAY SYSTEMS

A volume level indicator calibrated in db serves to monitor the output of the amplifier, which has an overall gain of about 54 db. Full 100 per cent modulation of the carrier is obtained with plus 10 db output from the —45 stage. Provision is made in this stage, also, for

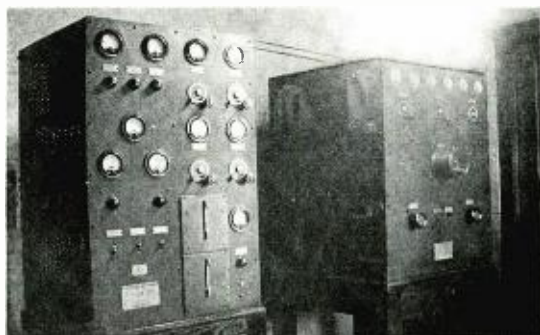

FIG. 2. THE 100-WATT OSCILLATOR-BUFFER UNIT, AND THE 500-WATT HIGH LEVEL MODULATOR-AMPLIFIER UNIT AT STATION WPFO.



FIG. 3. LOOKING UP THROUGH THE LATTICE-WORK QUARTER-WAVE VERTICAL RADIATOR OF STATION WPFO

operating one or more monitoring speakers from the amplifier, by means of coupling condensers, without interfering with its normal operation. A switch at the left of the panel, within easy reach of the operator, controls the operation of the entire transmitter, through a system of relays. When the switch is closed to the lower position, (1) the input circuits are connected to the microphone, (2) the bias resistor is shorted, putting the amplifier into operation and supplying microphone current, and (3) a remote relay operates, starting the transmitter.

When the switch is closed to the upper position, (1) the input circuits are connected to the external line terminals, (2) the bias resistor is shorted, putting the amplifier into operation, and (3) the remote relay operates, starting the transmitter. This provides for pickup from a distant source if such procedure should be necessary. In our case, the external line terminals are connected to the local audio-frequency oscillator, whose tone signal is used to call attention to a message about to be broadcast.

In actual operation, the switch is closed first to the upper position, sending out the tone signal. It is then flipped to the lower position where it is allowed to remain until the message has been broadcast, after which it is again moved to the upper position for the "end of transmission" signal. To remove the transmitter carrier from the air, the switch is moved to the center, or "off" position.

Coming now to the 100-watt oscillator-exciter unit, we look first at the crystal oscillators. Duplicate crystals are used, each with individual temperature control equipment. These crystals are ground in such a manner that their variation in frequency with temperature is only about 50 cycles per degree Centigrade. Inasmuch as our frequency deviation allowance is plus or minus 0.04 per cent, or 988 cycles, we could allow the temperature to change a maximum of 20 degrees in either direction before we would be operating in violation of present regulations. However, tests have shown that the operating temperature is being maintained to within better than 0.5 degree. While speaking of the crystals and oscillator circuit, it might be mentioned that our frequency will be changed from 2470 kilocycles, as at present, to 2474 kilocycles on and after May 1, 1934, due to changes in the regulations which abolish the frequency

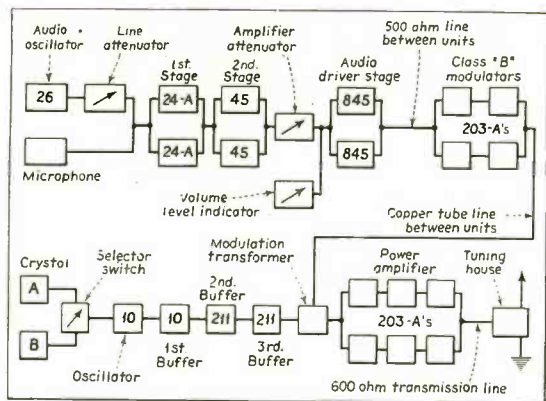

FIG. 4. A BLOCK DIAGRAM OF THE ENTIRE SET-UP OF THE KNOXVILLE POLICE TRANSMITTER SYSTEM.

channel of 2470 kilocycles. The oscillator circuit uses the well-known type 210 tube, operating with only 160 volts on the plate, with a current of 0.038 ampere. Operation at these values results in an extremely stable oscillator circuit.

The 210 oscillator circuit is followed by a 210 buffer stage, operating at considerably higher plate voltage and current. Two more buffer stages employing 211 tubes follow the 210 amplifier. Energy is fed through an inductively-coupled transmission line to the input circuits of the 203a power amplifier stage in the larger unit. This transmission line may be seen in Figs. 2A and 2B at the top of the transmitter units.

In addition to the circuits mentioned, the exciter unit contains the push-pull 845 audio-frequency driver amplifier, the output of which is fed through a shielded conduit line to the modulators in the succeeding unit. All tubes in the exciter unit are automatically biased, assuring correct operating adjustment under the slight voltage changes sometimes encountered. The power supply comes from a 220-volt single phase source, and is rectified by two 866 mercury vapor tubes connected in a full-wave rectifier circuit, and followed by a suitable choke and condenser filter arrangement. The maximum d-c voltage employed in this unit is 1250. The side shields operate interlock switches, removing all high voltage from the unit when the shields are removed for any reason.

The high level modulator-amplifier unit uses six type 203a tubes connected in a parallel push-pull tuned grid-tuned plate circuit. Class B modulation is employed, four type 203a tubes providing plenty of power to modulate the carrier a full 100 per cent. The power amplifier tubes operate at a potential of 1100 volts, and the modulators at a plate voltage of about 1450. The modulator plate current, unmodulated, is adjusted to a value of 0.125 ampere, while under full excitation reaches a value of 0.650 ampere.

POWER SUPPLY

The power supply for this unit is from a 220-volt, three-phase source, and is rectified by three type 872 mercury tubes connected in a half-wave rectifier circuit. These rectifiers are followed by a choke and condenser filter circuit, as in the exciter unit. Bias voltage for all the tubes in this unit is secured from a Tungar 16x897 mercury vapor rectifier tube, followed by an extremely effective filter circuit. A time delay relay prevents application of the high voltage to the rectifiers until their filaments have reached the proper operating

temperature. The high voltage power supply to the exciter unit is applied through interlocking relays in the power amplifier unit, acting as a further protection. An overload relay, mounted on the front panel of the 500-watt unit, serves to remove all high voltage from the entire transmitter in case any circuit should draw an excessive current.

A rather interesting experience was encountered with the application of this overload relay. One day, as the carrier was turned on, a loud crackle came from the direction of the power amplifier stage, and the overload relay immediately removed all voltage from the transmitter. A close inspection of all components failed to reveal any short circuit or other trouble. The relay was reset, and the operating switch turned "on" again. Crack! A similar occurrence. Another inspection did not discover the trouble. It was only by leaving the operating switch in the "on" position, and watching the amplifier stage while pushing in the overload relay that the trouble was discovered. A quite ordinary house fly had chosen to alight between the rotor and stator plates of one of the neutralizing condensers. Its body was large enough to provide a current path for the high voltage between the plates, with the consequent opening of the relay, to say nothing of the electrocution of the fly!

Now, to get back to the subject at hand. In actual operation, the filaments of all the mercury vapor tubes are left at full voltage, 24 hours a day, the filament supply on the other tubes being closed when the remote operating switch is closed. Under these conditions of "stand-by" operation, the power drain on the supply is about 300 watts. The total drain when the transmitter is under full excitation is about 4 kilowatts.

The output of the power amplifier is inductively coupled to the 600-ohm transmission line. The line to the tuning house equipment is approximately 100 feet long, with one right-angle bend it was impossible to avoid. So far as we can tell, this bend has not interfered with the efficient operation of the line, although it is not good practice. The antenna is connected by a copper tube feeder to the transmission line terminating equipment. The Blaw-Knox vertical radiator has a resistance of 45 ohms at 2470 kilocycles. The unmodulated antenna current is 3.35 amperes. The ground connections of all units are bonded together, and to the connecting conduit. A double wire is run from this system to a maze of wires buried beneath the tower, forming an efficient ground network.

RECEIVERS

Getting down to the present receivers, these are nine-tube RCA-Victor superheterodynes with a tuning range of 1572 to 2508 kilocycles. They combine high selectivity and sensitivity with good tone quality and the efficiency of Class B amplification. Automatic volume control is included as a very necessary feature for this class of work. The control unit contains the station selector, battery switch, and the manual volume control. Convenient mounting on the steering column is provided. The tuning control is locked with the exception of a very small vernier adjustment, after the receiver has once been tuned to the desired frequency. A permanent type dynamic speaker is employed, giving good quality reproduction, and adding nothing to the current drain from the car battery.

The plate supply for the receiver consists of a small, and very efficient, dynamotor and filter system. Two small 22.5 volt C batteries are required for bias on the Class B amplifier, consisting of two 112-A tubes. The

entire receiver including the dynamotor, requires only 4.35 amperes current from the car battery. Protection of all units is afforded by fuses; the one for the A battery being mounted on the under side of the control box.

BATTERIES

Even with the small current drain of 4.35 amperes, it has been found necessary to install new heavy-duty batteries and heavy-duty generators to eliminate the cost and expense of changing batteries frequently. Present indications are, too, that it would be desirable to decrease the size of the generator pulley, causing them to run at a higher rate of speed, and consequently begin charging at a considerably lower rate of speed than at present. At night, especially, when the cars are cruising at low speeds with radio, lights (and in the winter, car heaters), all in use, the generator will not charge enough to make up for this additional drain.

When the receiving sets were first installed, all cars were provided with plate type antennas mounted underneath the car. Due to the limited size of these antennas, and the unavoidable shielding effect of being mounted so close to the frame of the car, it is found advisable to replace this type antenna with a wire screen in the top of the car. This has been found to be much more effective, especially on those cars which cruise at fairly long distances from the transmitting station.

From an operators' standpoint, police operation will be found to be quite a lot different from anything most of them will have encountered, especially in those installations where the operators are required to do the actual dispatching. In our case, all calls from outside came to the Desk Sergeant, whose office is combined with the broadcast transmitter room. Those calls to be broadcast are given orally to the operator, who makes note of them and dispatches them as soon as possible. Car assignment is made by the Desk Sergeant, but all logs of transmission are kept by the operators. Needless to say, it is necessary for the person making the car assignments to be thoroughly familiar with the entire area to be served, to know the territory each zone includes, and the number of cars available in each zone at any particular time. As an aid in keeping tab on the cars, and to save the Desk Sergeant the time and trouble of asking the operator which cars are busy each time he wants to make an assignment, we have worked out a scheme using an illuminated map of the city with the zones outlined on it. We have six territorial zones, and an additional uptown zone which includes a part of five of the territorial zones. These areas have been outlined in red upon a map of the city, and each has been assigned a number. Within each of these territorial zones has been drawn a blue line, roughly outlining the normal cruising route of the cars in that zone. Naturally, the cars do not always patrol the same beat, but follow it as a general route. In the center of each zone, around the number, has been mounted three signal lights. No illumination in a zone indicates that no cars are cruising or are on assignment in that particular zone. A green signal indicates that one or more cars are cruising, and are available to answer calls. A red light indicates that one or more of the cars are out on assignments, and are out of service as far as taking other calls is concerned. Since we are at present using only one car at a time in each zone, no confusion arises from the fact that there is only one signal lamp for one or more cars. If all the cars in the zone are on assignments, the green light is turned off, leaving only the red one illuminated. If it becomes necessary to answer another call in that zone, the call is given to

a reserve car, which may be cruising in the additional uptown zone. The reserve car red light is then turned on, and an amber light shows the zone to which the car has been sent.

Experience has already taught us that this scheme has been of great assistance as a time saver and in keeping the location of the cars before us, enabling faster assignments. The map is shown in Fig. 5. As can be seen, the components are few, and easily assembled. In addition to the map and its mounting, all that is necessary is the required number of pilot brackets and bulbs, a small 2.5-volt step-down transformer, a multi-wire cable, the number of switches to perform the various combinations and a panel large enough to mount the switches.

The correct method of making the various connections can be devised in a few moments, and since every installation of this kind would probably vary considerably, the wiring diagram of the one we are using is not shown.

SERVICE DIFFICULTIES

As the transmitter is kept on the air 24 hours a day, it is necessary to employ three full-time operators, each working an 8-hour shift. One relief operator is also employed. Duties consist mainly of message dispatching and maintaining log sheets and reports, and this fact sometimes complicates operation of the station, since a car will be forced to come in for servicing just at a time when numerous calls are waiting to be dispatched, and more coming in all the time. When such occasions do arise, it is necessary for the operator to grab some tools and a tester and go outside to look at the car. It



FIG. 5. THE ELECTRICALLY OPERATED MAP OF KNOXVILLE WHICH IS OF GREAT ASSISTANCE IN LOCATING CRUISER CARS AND EXPEDITING ASSIGNMENTS.

has often happened that the operator will have to make a number of trips back inside to dispatch messages before the servicing can be completed. We hope to get these conditions corrected soon, however, and do not anticipate a great amount of trouble on that account.

Considerable improvement in the functioning of the police department is noticed since the introduction of the radio system. Figures are not available to completely check the results, before and after, but all members of the department feel that much better conditions are now prevalent. At this time, each car has an area of about 5 square miles to protect, and experience has already shown the need to decrease this area.

Readers may be interested to know the WPF0 has received verifications of reception from 31 states and 2 provinces in Canada, all of them reporting good signals with excellent modulation and very little fading. This would be extremely good news to many entertainment broadcasters, no doubt, but we would like to be able to concentrate this distant radiation closer to the ground, and keep it within the 5,900 square miles we are attempting to serve.

Design of Wide-Range

By **I. A. MITCHELL**

CHIEF ENGINEER, UNITED TRANSFORMER CORP.

THE GRADUAL IMPROVEMENT in the fidelity of electro-acoustic devices during the past few years has made necessary a corresponding improvement in the fidelity of the accompanying audio systems. It is a known fact that the frequency characteristic of a well-designed audio amplifier is almost entirely controlled by its audio transformers; and for high-fidelity reproduction audio transformers are required with negligible discrimination from 30 to 15,000 cycles. Some of the difficulties encountered in developing such transformers are indicated below.

QUALITY DESIGN CONSIDERATIONS

In the design of quality audio transformers, five major factors must be

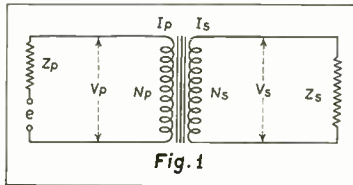

Electrical circuit of an ideal transformer, with 100-percent efficiency.

carefully considered. These factors, in the order of their commercial importance, may be listed as follows:

1. Uniform frequency response
2. Low wave-form distortion or phase shift
3. Thorough shielding
4. Dependability
5. Flexibility

As the scope of this article is limited, frequency characteristic alone will be covered. However, it is well to note that the improvement of frequency range has some bearing on all other factors, that is:

(A) In attempting to reduce frequency discrimination by reducing leakage reactances, distributed capacitances, and by the operation of core materials at low flux densities, both wave-form distortion and phase shift are reduced considerably.

(B) Due to the greater range of frequency transmission, both magnetic and electrostatic pickup become quite objectionable. The transformers, whose frequency curves are illustrated, were housed in a casting having five times the permeability of normal cast iron. When transformers are operating at low levels, it is also essential to have a

secondary inner metallic shield to minimize electrostatic pickup.

(C) Considerable improvement in frequency range of a standard transformer can often be obtained by reducing the thickness of insulation between windings, thus reducing the leakage reactance; or by no or poor impregnation of the windings, thus reducing distributed capacitance. This is false economy and engineering of the worst order. Coils should be vacuum impregnated and so sealed that no adverse humidity conditions can affect them. Winding insulations should be capable of withstanding at least twice the maximum peak potential possible in practice.

(D) In attempting to obtain a number of impedance combinations from one transformer, so that flexibility in service is assured, variation in frequency range will be obtained unless accurate precautions are taken. It is essential that for all impedances available, almost complete coupling of the windings be maintained. This can be done. The transformer whose frequency characteristic is shown in Fig. 5 has six primary impedances and six secondary impedances, the impedance range in both cases being 10 to 1, yet to 25,000 cycles not 0.5 db change in loss is obtained for any impedance combination.

IMPEDANCE RATIOS

Inherently a transformer is a device presenting a means of transferring power from one circuit to another without any direct connection between these circuits. In simple form, we illustrate in Fig. 1 an ideal transformer; that is, a transformer having 100 per cent efficiency. In such a case the power de-

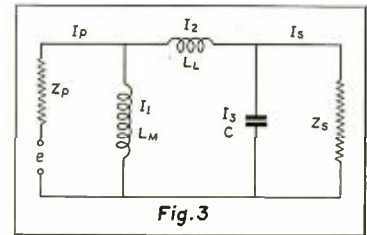

A simplification of the equivalent transformer circuit shown in Fig. 2B.

livered to the input will equal the power taken from the secondary or:

$$(1) \quad V_p I_p = V_s I_s$$

The basic characteristic formula of a transformer is:

$$(2) \quad \frac{V_p}{V_s} = \frac{N_p}{N_s}$$

combining (1) and (2) we obtain

$$(3) \quad \frac{I_s}{I_p} = \frac{N_p}{N_s}$$

Knowing that

$$(4) \quad V_s = I_s Z_s$$

we can substitute (2) and (3), obtaining

$$V_p \frac{N_s}{N_p} = \frac{I_p N_p}{N_s} Z_s$$

Therefore

$$\frac{V_p}{I_p} = Z_p = \left(\frac{N_p}{N_s} \right)^2 Z_s$$

This result indicates that the impedance ratio of a transformer is directly proportional to the square of the turns, and is the base upon which all impedance matching is done in audio transformers.

EQUIVALENT T NETWORK

Unfortunately, in practice, transformers which are 100 per cent efficient are not obtainable. A physical transformer

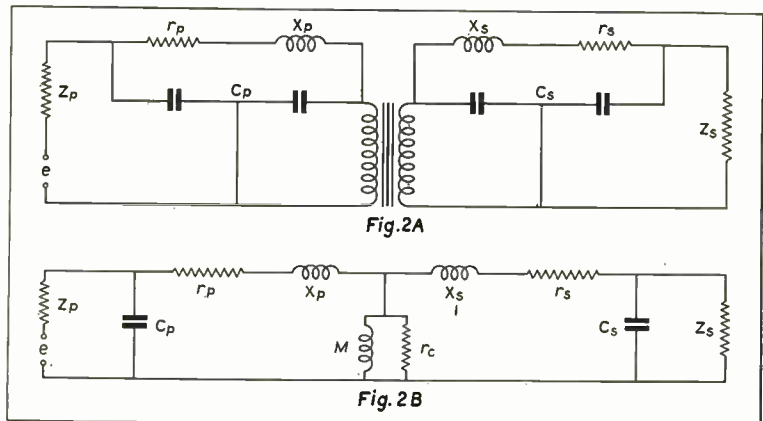

Fig. 2A illustrates a physical transformer. In Fig. 2B is shown the equivalent T network of the same transformer.

Audio Transformers

is illustrated in Fig. 2-A and its equivalent T network in circuit is shown in Fig. 2-B. Here r_p and r_s are respectively the primary and secondary resistances; X_p and X_s are respectively the primary and secondary leakage reactances; C_p and C_s are respectively the distributed capacitances of the primary and secondary and their attendant circuits. In a physical transformer, M is not infinite, as some current is taken through the primary circuit with the secondary open. This is the current required to set up the flux in the core. Power is also absorbed in r_e which includes the $I^2 R$ losses in the coil windings and a small amount of loss occasioned by the eddy current losses and

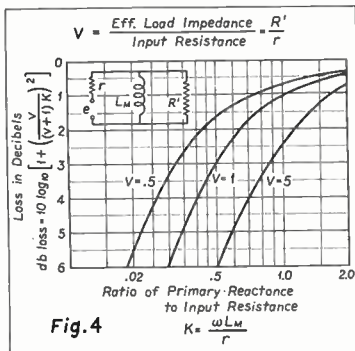

Fig. 4 Curves showing the loss due to the shunting effect of the primary of a transformer.

hysteresis losses in the core. These core losses can be reduced to an inconsiderable value if quality core materials such as the nickel iron alloys and powdered iron are used. The winding resistances are generally of small magnitude and, having no frequency discrimination, can normally be eliminated. This allows us to simplify our equivalent circuit still further as per Fig. 3, where the leakage reactance L_1 and distributed capacitance C is lumped.

UNIFORM FREQUENCY TRANSMISSION

It is apparent that for uniform frequency transmission in this circuit, I_s should be constant regardless of frequency. If all the impedances in this circuit were non-inductive, such would be the case. Unfortunately the impedance of an inductance varies directly as frequency and the impedance of a reactance inversely to frequency. It is therefore seen that as the frequency is reduced the impedance of L_m will also be decreased and I_1 will be increased. This shunting effect of the primary inductance is the main factor controlling the low-frequency response of a transformer. Obviously the reactance of the transformer primary should be high

- An article giving special consideration to the design factors in wide-range audio transformers for high-fidelity amplifying equipment

as compared to the source impedance Z_p at the lowest frequency at which it is to function efficiently.

A curve showing the loss due to the shunting effect of the primary of a transformer is illustrated in Fig. 4. As an example of the use of this curve, let us assume source and load impedances of 500 ohms. At the frequency at which the primary reactance is 325 ohms, there would be a 2-db loss. In other words, to design a transformer having a loss of 2 db at 20 cycles, the primary inductance would have to be such as to offer an impedance of 325 ohms at 20 cycles.

COUPLING

Examining Fig. 4 once more, it is seen that as the frequency increases L_1 increases in impedance. This naturally throws a series loss in the secondary circuit such that I_2 and the following current I_s and I_a are reduced. The leakage inductance L_1 is due to imperfect flux coupling between the primary and secondary. If the coefficient of coupling in the above transformer were .995, the leakage would be .5 per cent. This would be at 20 cycles .5 per cent of 325 ohms, or 1.625 ohms. At this frequency it is evident that the leakage reactance loss is negligible. However the impedance of L_1 at 20,000 cycles, varying directly with frequency, would be 1,625 ohms. Naturally in a 500-ohm

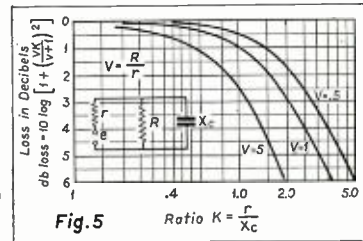

Fig. 5 Curves showing the loss due to distributed capacity in an audio-frequency circuit.

circuit this would be a very great loss.

The distributed capacity C is again effective only at the higher frequencies. Similar to the primary it is purely a shunting effect varying with frequency. Fig. 5 illustrates the loss due to distributed capacity in an audio circuit. If source and load impedances were 100,000 ohms each, it would require only 300 mmfd. to cause a loss of 2 db at 10,000 cycles.

Summarizing the above, we note that on the whole, there are three major factors governing the range of audio transformers; namely, primary inductance, distributed capacitance, leakage reactance.

POINT OF BALANCE

To increase primary inductance on a given core structure, it is necessary to increase the turns in the windings. Un-

(Continued on page 34)

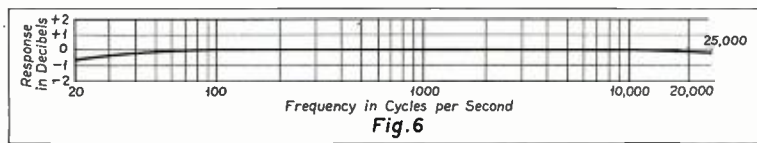

Fig. 6 Characteristic curve of a line-matching transformer

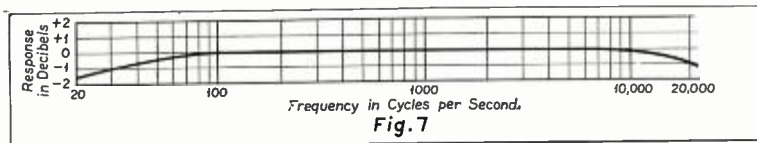

Fig. 7 Characteristic curve of an output transformer, with coupling exceeding .999.

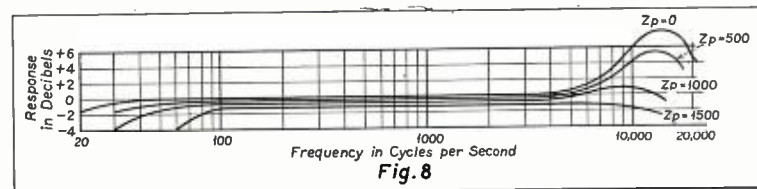

Fig. 8 Variation in frequency characteristic against source impedance for a line-to-grid transformer.

COILS and CIRCUITS

By **HOWARD J. BENNER**

CHIEF ENGINEER, F. W. SICKLES CO.

SEVERAL YEARS AGO a coil was not considered efficient unless it was space wound with heavy wire on a large diameter form. This idea was shown to be unsound by the two-layer, bank-wound coil, which proved to be very efficient especially when wound with litzendraht wire. This was one of the first steps in reducing the size of coils. Shortly after the appearance of the two-layer bank coils, the midget receivers were introduced to the market, creating a demand for smaller units and resulting in the application of the universal type coil to the carrier-frequency section of the receivers. However, the four-layer bank coil, which is not only small but also compares favorably with the larger units, replaced the two-layer units.

Fig. 1 shows a direct comparison of the coils designed for the same purpose.

- A. Is a four-layer, bank-wound coil.
- B. Is a single-layer coil used several years ago.
- C. Is a universal wound coil.
- D. Is a two-layer, bank-wound coil.

Fig. 2 shows a comparison of the Q of the coils pictured in Fig. 1. It can readily be seen that a great deal of progress has been made in reducing the

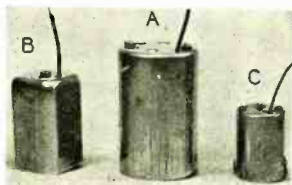
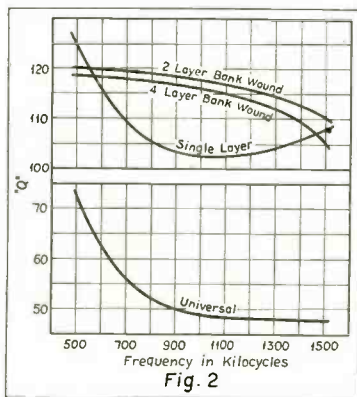

Fig. 3. Showing relative sizes of an old and new i-f unit, and a unit for midget sets.

size of coils, while still maintaining their quality.

I-F TRANSFORMERS

The intermediate-frequency transformers were another very important unit where the reduction of size was necessary. These units have been developed to the extent that usable stage gains of 125 are easily obtained. The midget and all-wave receivers have popularized the intermediate frequencies around 450 kc but gain and selectivity at that frequency was quite a problem.



A comparison of the "Q" of the four coils pictured in Fig. 1.

Despite this fact, however, the use of litzendraht wire in winding the coils and a thorough study of the effect of form factor on the Q has resulted in highly efficient units.

Fig. 3 shows the comparison in size of a unit used extensively a few years ago, a more modern unit used today, and also a midget intermediate-frequency transformer. Coil A is a double-tuned unit whose shield measures $2\frac{1}{8}'' \times 3\frac{1}{4}''$. Coil B is also a double-tuned unit, but its shield measures only $1\frac{3}{8}'' \times 2\frac{3}{8}''$, and coil C is a single-tuned unit with a shield measuring $1\frac{1}{4}'' \times 1\frac{3}{4}''$.

In the more modern receivers, especially those covering the higher frequency bands, extremely high i-f gain is convenient when little gain can be

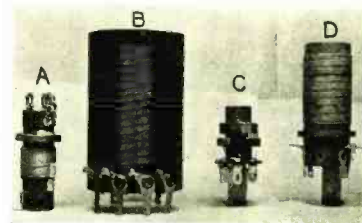

Fig. 1. Showing the relative sizes of four-layer, single-layer, universal, and two-layer coils.

obtained at the carrier frequency, over-all intermediate-frequency sensitivities of 10 to 15 microvolts being required under the above conditions. Many receivers employ r-f stages to increase their overall sensitivity, thus permitting lower intermediate-frequency gain, which results in a quieter receiver with a higher image ratio. However, the intermediate frequencies around 450 kc are generally used for two reasons, one being that a higher image ratio is acquired and the other being that there is less oscillator-detector circuit reaction. This reaction is generally encountered at high frequencies where the resonance of the detector and oscillator are very close to each other, and it results in the detector stage controlling the tuning frequency rather than the oscillator. Perfect tracking of a receiver is very difficult where this action occurs.

SHIELDING

The shielding of coils is also a very serious problem and, as will be seen, image ratio is directly affected by it. Certain precautions must be taken to maintain a high image ratio, and there are two ways to keep this ratio high.

1. Using high-Q coils in the pre-selector ahead of the first detector.

2. By using image suppression. These suppression schemes have been used by some manufacturers but, due to the critical adjustment required, have proved more or less unsatisfactory.

The following shows the effect of shielding with respect to the image ratios in a receiver using similar coils in different size shields. The circuit

Band	Frequencies	No. of Bands
A. Broadcast	540-1500 kc	1
B. All-Wave	150-375 kc 540 kc-21.5 mc	5
C. All-Wave minus Long-Wave band	540 kc-21.5 mc	4
D. Broadcast, Police and Amateur bands	540-4000 kc	2
E. Broadcast and High-Frequency bands	540-1600 kc 5.5-16.5 mc	2
F. Broadcast and Long-Wave bands	150-375 kc 540-1600 kc	2
G. Broadcast, Long-Wave and High-Frequency bands	150-375 kc 540-1600 kc 5.5-16.5 mc	3

used was a receiver with a 175-kc intermediate frequency. The antenna coil was of the high-impedance type with a coupling capacity of approximately 15 mmfd. This fed a type 58 tube. The r-f stage used impedance coupling with approximately 15-mmfd coupling capacity feeding into a 2A7 first detector. Both antenna and r-f coils were wound with solid wire.

On coils of the above description with a 1 3/8" diameter shield the average image ratio for the 1500-550 kc band was approximately 4500. By changing the shield to 2 1/8" diameter the image ratio was increased to approximately 8000.

Since the midget receivers being built today do not have room for coils in shields whose diameter is 2 1/8", an extensive study of Q versus form factor in smaller shields was put under way. Although too lengthy to discuss in this article, it was found that image ratio as high as those of the coils in the 2 1/8" diameter shield can easily be obtained in a 1 3/8" shield, the adjacent channel selectivity being, in general, taken care of by the intermediate frequency.

MULTI-BAND RECEIVERS

In the accompanying table is listed the band arrangements of the latest type receivers showing that the trend of receivers is toward the addition of one or more bands to the usual 1500-550 kc range. These multi-band receivers become rather complicated, due to the switching arrangement and numerous trimmers required to do a good job of tracking.

The circuit arrangement of receivers covering 4 or 5 bands can be divided into the following four types:

1. As shown in Fig. 4, using 2 r-f stages for the highest frequency band, and one r-f stage on all others.
2. Using one r-f stage for all bands.
3. Using a band-pass preselector for all bands.

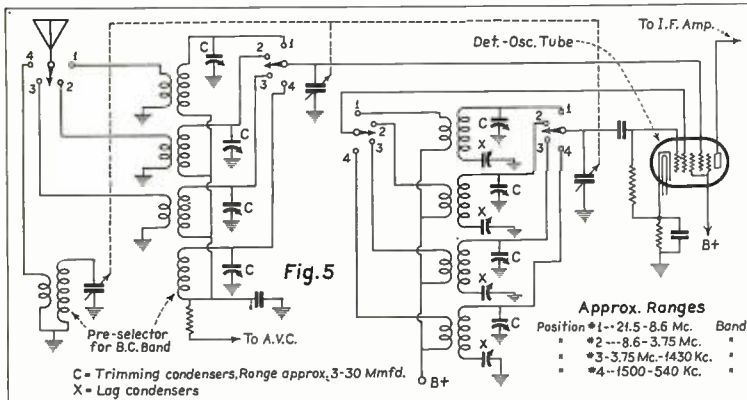

Showing arrangement using pre-selector for broadcast band and single coil for all other high-frequency bands.

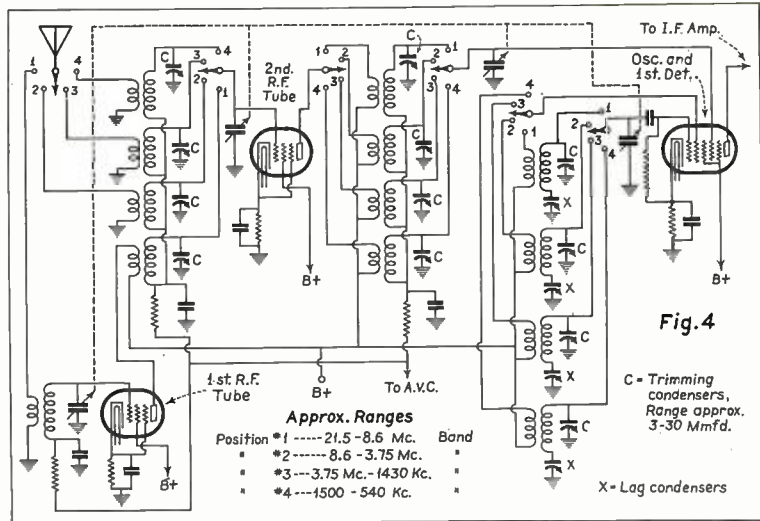

Arrangement using two r-f stages for the highest frequency band and one stage for all other bands.

THE DATA ON COILS, COIL DESIGN, AND CIRCUITS, PRESENTED ON THESE PAGES IS OF PARTICULAR INTEREST AT THIS TIME WHEN ENGINEERS ARE ABSORBED WITH THE DESIGN OF RECEIVERS OF GREATER AUDIO- AND RADIO-FREQUENCY RANGE. OF PARTICULAR MOMENT ARE THE PROBLEMS SURROUNDING THE DESIGN OF DUAL-WAVE AND ALL-WAVE RECEIVERS WHICH HAVE THE PUBLIC EYE. THE GENERAL CHARACTERISTICS OF RADIO-FREQUENCY AND INTERMEDIATE-FREQUENCY COILS IS OF ADDED INTEREST.

4. As shown in Fig. 5, using a band-pass preselector for broadcast band and single coils for all high-frequency bands.

PRESELECTION CIRCUITS

As can be seen in Fig. 4, preselection is obtained on all bands resulting in a fair image ratio although very little gain is had from the coils at higher frequencies. These type receivers require a tremendous amount of engineering work before they may be released for a productive receiver, although some of the larger manufacturers are turning out receivers of this type which perform very well.

The simplest form of an all-wave receiver, from the set manufacturers' standpoint, has a band-pass preselector for the 1500-550 kc band which affords an excellent image ratio, and three high-frequency bands having a single coil in the carrier frequency circuits. This is shown in Fig. 5. Although the image ratio on the high-frequency bands is not very high, this type receiver has been generally accepted by numerous radio manufacturers.

As a variation of the grid switching circuit shown in Fig. 4, Fig. 6 shows the preselector circuit of a two-gang receiver using series coils. This type receiver is quite satisfactory although tracking is a more difficult problem, but even this may easily be remedied by the addition of a variable trimming condenser in the detector circuit.

Another variation from the grid switching and the series coil type circuits is shown in Fig. 7. It is the shunt coil type generally used in two-band receivers. The theory of two coils in parallel is that the effective inductance will be a little less or a little more than the inductance of the smaller coil, depending whether the mutual is

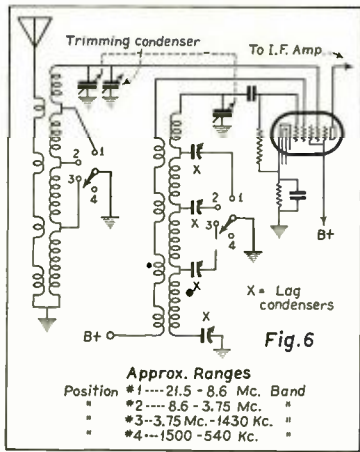

Showing series coil arrangement of an all-wave receiver.

aiding or bucking. The Q of two coils in parallel is generally that of the coil with the lower inductance, therefore a very efficient receiver can be made with this type circuit.

AUTOMATIC VOLUME CONTROL

Practically all the modern receivers employ automatic volume control which tends to maintain a constant signal level of stations whose field strength varies, and which also prevents overloading when tuning to strong carriers. In general, the principle is that the volume level is set by a control in the audio circuit of the receiver, the carrier wave biasing back the tubes the amount of which depends on the carrier strength. Therefore, the actual amplification of

the stages under control will vary proportionally with the input signal, tending to keep the r-f signal constant on the second detector tube. The signal is then rectified and amplified in the conventional manner.

Hum, due in part to lengthy leads and pickup in the second detector, is a serious problem in AVC circuits, thus opening a place for the application of one of the newer type tubes, the 2B7 or the 6B7. The 6B7 tube contains a pentode section and two diode plates with a common cathode. The 2B7 may readily be used as an intermediate-frequency amplifying tube and the diode plates used for automatic volume control. This system has several advantages, one of the most important being from a hum standpoint. As the AVC is taking place in an r-f tube, rather than in a tube where audio amplification takes place, very little hum pickup is encountered.

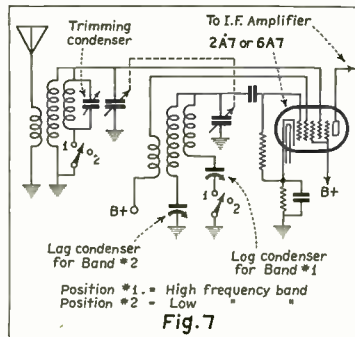

Showing shunt coil arrangement for dual-wave receivers.

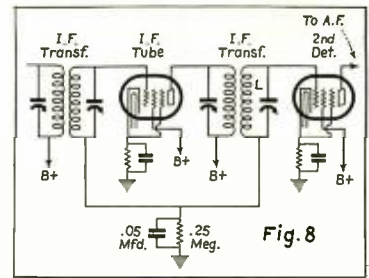

Circuit arrangement for the prevention of overload in a superheterodyne receiver.

OVERLOAD PREVENTION SYSTEM

Another very practical kink that can be employed in some receivers that do not have automatic volume control is an overload prevention system. This system requires but two parts, a resistor and a condenser, connected in series with the ground return of the second detector and i-f coil, when used in a superheterodyne circuit; or in a t-r-f receiver, the two parts are connected in the ground return of the detector and previous r-f coil.

Fig. 8 shows the application to a superheterodyne circuit. The principle is quite simple. When a signal that is strong enough to overload is applied, the detector tube draws grid current. This current flows from cathode to ground, then through resistor R and coil L, back to the grid, causing a voltage drop across resistor R which in turn biases back both the detector and tube under control. This system although not 100 per cent perfect, proves to be very effective when turning to a strong carrier.

CATHODE-RAY TUBES

(Continued from page 17)

By means of the cathode-ray tube, the resultant pattern is traced upon the screen. Conversely, from this pattern the frequency and phase relations of the two deflecting voltages can be determined. Where, in addition, the wave form is known for one of the deflecting voltages, the wave form of the other can readily be obtained by graphical analysis.

FREQUENCY DETERMINATION

When the cathode-ray oscillograph is used for calibrating purposes, frequency ratios of less than 10:1 can be readily determined by visual inspection of the image. For frequency ratios greater than 10:1, the complexity of the pattern makes visual determination difficult, generally requiring the use of a photograph. In general, the standard frequency selected should be one whose multiples and submultiples will cover the desired range and provide the simplest patterns.

In examining Lissajou's figures, one should consider them as the side view

or elevation of a picture traced on a glass cylinder on which the observer may view the wave as it travels around the cylinder. The illusion is clearest when the whole figure rotates slowly. Fig. 6 is a simple single line pattern having a frequency ratio of 6:1. With a base frequency of 60 cycles this pattern would be the picture of 360 cycles, or with a base frequency of 100, the picture of 600 cycles. The frequency ratio is determined by counting the peaks of the waves in the horizontal plane and the number of end loops which in this case is one; hence a frequency ratio of 6:1. Again, Fig. 8 has 16 peaks and is a three-line pattern, indicating a frequency ratio of 16:3.

Figs. 6, 7, and 8 illustrate patterns as they generally appear on the fluorescent screen. Figs. 3, 4, and 5 are shown as pictures whose appearance suggests that the pattern has been developed on a plane.

OPTIONAL METHOD

An optional method for determining the frequency ratio is that of counting the number of peaks on a given figure

with the horizontal lines of intersection on the figure instead of with the number of loops at the end of the figure. A study of some of the patterns will make this clear.

When waves having frequency ratios greater than 10:1 are compared, accurate determinations may be difficult with the front and back portions of the figures in the same horizontal plane. To separate the front and back portions, the figures can be displaced to show either on an ellipse or a circle. For an ellipse, for example, a phase-splitting device consisting of a resistance and a capacity is employed. The resistance is connected across one set of deflection plates and the capacitance across the other.

It can, then, be easily seen why the cathode-ray tube and its application to the oscillograph has caused such widespread interest, for it has greatly facilitated not only the study of electrical wave shapes and transients, but also the measurement of modulation, adjustment of radio receivers, determination of peak voltages, the tracing of vacuum tube characteristics, and many similar operations.

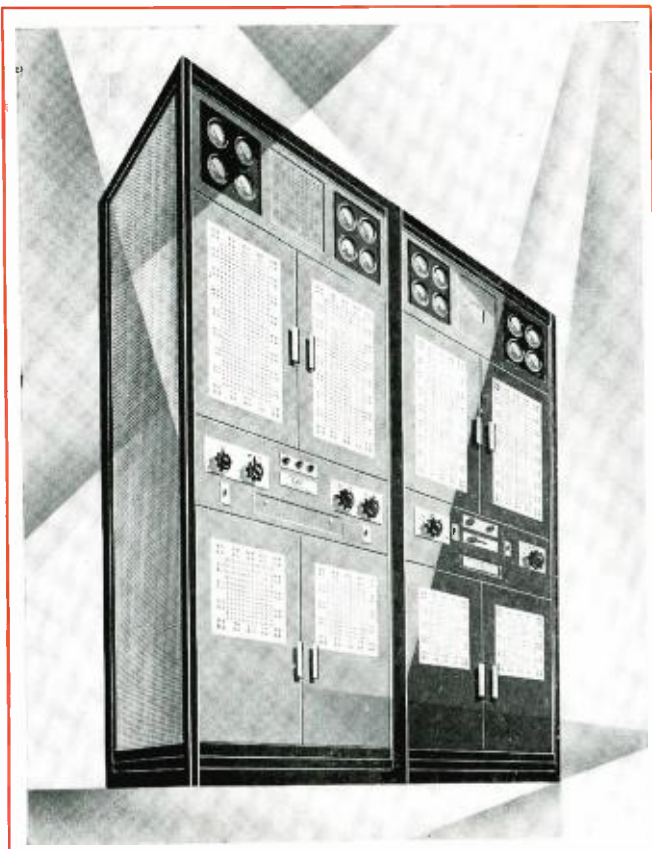

A Deluxe Transmitter at Low Initial Cost and Low Operating Cost

The MODERN RCA VICTOR

One K. W. TRANSMITTER

Type "1 D"

RADIO HEADQUARTERS takes pride in introducing this advanced-design one-k.w. broadcast transmitter, in anticipation of the great improvements being made in broadcast receiving sets, and the general trend towards extended audio frequency range of microphones and remote pickup telephone lines.

NOTE THESE OUTSTANDING FEATURES:

ECONOMICAL—EFFICIENT

Uses Efficient High Level Class B Modulation, Low Installation Cost. Lowest Operating Cost of Any Standard Transmitter, Air-Cooled Radiotrons Only.

COMPLETELY EQUIPPED

Built-in Cathode Ray Modulation Indicator, High Fidelity Speaker, Dummy Antenna, Radio Harmonic Suppressors.

HIGHEST FIDELITY

Uniform Frequency Response, Minimum Audio Harmonic Content, Even at 100% Modulation.

SIMPLE TO INSTALL and OPERATE

No Generators or Water Cooling Equipment, Entirely Self-Contained and AC Operated, Unitary Line Voltage Control, Complete Metering, Automatic Starting.

ADVANCED MECHANICAL DESIGN

Complete Shielding, Plug-in Crystal Units with Heater Chamber, Relay and Oscillator in Duplicate, Centralized Controls.

MODERN APPEARANCE

Designed According to Dynamic Symmetry, Finished in White Metal and Tones of Gray.



RCA VICTOR CO., INC.

Camden, N. J., U. S. A., "Radio Headquarters"

New York: 153 E. 24th St. Chicago: 111 N. Canal St. San Francisco: 235 Montgomery St.

Dallas: Santa Fe Bldg. Atlanta: 144 Walton St., N. W.

BRANCH OFFICES IN: Rio de Janeiro—Yokohama—Shanghai—Buenos Aires—Santiago (Chile)

RCA VICTOR HIGH FIDELITY SPEECH INPUT EQUIPMENT *for* BROADCAST STUDIOS

The demand for this new line of Broadcast Studio and Control Equipment is adequate assurance that it fulfills definitely the requirements set by the ever advancing standards of the broadcasting industry.

TYPE 44-AP VELOCITY MICROPHONE

- Uniform Frequency Response
- Uniform Directivity
- The Microphone without a Diaphragm.
- Has earned instant popularity through its outstanding performance.

TYPE 41-B PRE-AMPLIFIER

- Designed to insure full realization of the High Fidelity and greater artistry made possible by the use of the Velocity Microphone.

TYPE 46-A FOUR POSITION MIXER PANEL

- For use with high quality microphones
- Balanced variable ladder network—Positive contact
- Absolute minimum of noise.

WRITE THE NEAREST OFFICE FOR DESCRIPTIVE BULLETIN AND PRICE QUOTATIONS.



TYPE 40-C PROGRAM AMPLIFIER

- Complete AC operation
- Self-contained volume indicator
- Power Supply for Pre-Amplifiers and Auxiliary Microphone
- An all purpose Amplifier

TYPE AA-4194-B MONITORING AMPLIFIER

- Another completely AC operated amplifier designed especially for use with high quality monitoring speakers.

REMOTE CONTROL UNIT

for operation with AA-4194-B Monitoring Amplifier



RCA VICTOR COMPANY, Inc.

CAMDEN, N. J., U. S. A.

"Radio Headquarters"

NEW YORK: 153 E. 24th St.

DALLAS: Santa Fe Building

CHICAGO: 111 N. Canal St.

SAN FRANCISCO: 235 Montgomery St.

ATLANTA: 144 Walton St., N.W.

WIRE in Tubes

By **C. A. LAISE** and **J. KURTZ**
 PRESIDENT and CHIEF ENGINEER, CALLITE PRODUCTS

● Through the use of new metals and metal alloys for grids, element supports, and leads, the efficiency of modern vacuum tubes may be substantially increased.

THE DEVELOPMENT OF the multi-grid tubes and also other types of hard glass electronic devices has placed added responsibility on the material suppliers in order to meet the more exacting demands of the newer operating conditions.

During the past year a new series of composite wires with special properties have been developed. These wires, made under special processes, go a long way toward solving some of the tube manufacturing problems, and likewise permit greater efficiency from vacuum tubes of both the receiving and transmitting types.

GRID SUPPORTS

It is highly important that the grids in power and transmitting tubes, and in some receiving tubes, be made of a material having high heat conductivity so that the operating temperature of the grid assembly may be kept within reasonable limits. Since the temperature

bears a direct relation to grid emissions, a grid assembly of high heat conductivity is a decided advantage.

To this end a special composite wire has been developed which consists of an inner core of copper alloy perfectly bonded to a nickel sleeve. It is principally adapted for use in grid construction as side rods, and aside from its high heat conductivity, provides a greater degree of alignment than plain copper, due to the stiffening and supporting action of the outer nickel sleeve.

GRID WIRE

A second type of wire, with a special iron alloy core bonded to a nickel sleeve, has been designed for use as the grid wire proper for round grids. A third type of wire, for flat grids, has also been developed. This type has a steel alloy core bonded to a nickel sleeve and provides greater rigidity.

All three wires can be made either hard drawn or soft annealed, having an elongation of 10 to 20% and a breaking strength of 1.0 to 1.45 kilograms based on a wire .005" in diameter. They show remarkable resistance to corrosion and oxidation, and are weldable to each other and to nickel and other related metals.

LEAD-IN WIRE

An important requirement in the manufacture of vacuum tubes has been a stranded wire which does not oxidize readily at the high temperatures necessary in the successive steps of production such as beading, stem making, sealing in, and exhaust. This newly developed composite wire, known as Kulgrid "C," has the necessary high heat and electrical conductivity for efficient operation when used in conjunction with tungsten in the manufacture of hard glass electronic tubes.

With many types of stranded wire used with tungsten rod for lead-in purposes, excessive oxidation takes place. The oxide flakes off and deposits itself in the press which is very objectionable and may even lead to stem leakage. Frequently the strand becomes brittle and cannot be shaped or formed, and it will therefore fall off at or prior to the basing operation.



Fig. 5. Tungsten rod to copper strand; no sleeve. Showing the weakness of the weld. 50 x.

Fig. 6. Tungsten rod to composite strand; no sleeve. This shows the strong, well-balanced weld when composite strand is used. 50 x.



In attempting to solve this problem it was found that the composite wire previously described as having an inner core of copper alloy bonded to a nickel sleeve, when stranded into a flexible cable, had none of the objectionable points of regular copper strand. Since the nickel sleeving on each strand does not oxidize readily, flake deposits in the tube press are practically eliminated. Moreover, the composite strand does not

(Continued on page 36)



Fig. 1. Tungsten rod to stranded copper with nickel sleeve. 50 x.

Fig. 2. Enlarged view of above showing crystallization of tungsten when copper strand is used. 200 x.

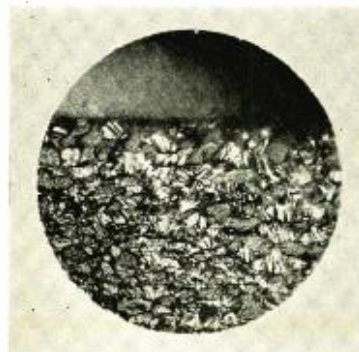

Fig. 3. Tungsten rod to stranded composite wire with nickel sleeve. 50 x.

Fig. 4. Enlarged view of above showing no crystallization of tungsten when composite strand is used. 200 x.



High-Fidelity RECEIVERS

By A. GERARD HANLEY

PART 2

THE LARGE NUMBER of services now available in the spectrum from 150 to 20,000 kc make all-wave receivers highly desirable for the average listener. Moreover, the popularity which multi-band receivers are now enjoying would make it appear probable that there will shortly be some difficulty in merchandizing single-band receivers. Much valuable information and considerable entertainment is available at frequencies above or below the broadcast band. It would, therefore, appear that there is considerable appeal to all-wave receivers.

GROUNDING ANTENNAS

It is the usual custom to employ grounded antennas of less than a quarter wavelength for broadcast reception. At first glance it seems that the same considerations should apply for all frequency bands and that the band switch might be employed to switch between some four or five antennas.

If grounded antennas longer than a quarter-wave are employed, a certain amount of directivity is, of course, unavoidable. Since a quarter-wave antenna at 20,000 kc (15 M.) is only 12.5 feet in length, it is obvious that the amount of energy that would be abstracted from incident waves would, in the usual case, be entirely too small for practical use. The antenna commonly employed with all-wave receivers is of the order of 75 to 100 feet in length. While such an arrangement does possess some directivity at short wavelengths, it is ordinarily far more satisfactory than a shorter antenna. The disposition of the antenna in the vertical and horizontal planes is ordinarily not very important, since signals arriving from distant transmitters nearly always have vertically and horizontally polarized components. The important consideration is, of course, a sufficiently large induced voltage and this is proportional to the product of the field strength, the cosine of the angle between the plane of polarization of the incident wave and the antenna, and the cosine of the angle between the wave front and the direction of the antenna. That is:

$$E = e \cos \alpha \cos \beta$$

- Covering the problems of noise, cross-modulation, image frequency and wide-band selectivity in high-fidelity receivers—with some notes on all-wave circuits with respect to their use in future receivers.

Antenna coupling systems are now generally available to couple the receiver to a distant and well constructed antenna. The success of such systems, which generally employ aperiodic coupling transformers and a transmission line in reducing man-made static, is too well known to need comment here. Suffice it to say that few if any of them are entirely satisfactory over the entire spectrum covered by all-wave receivers.

ANTENNA STEP-UP AND NOISE

In the design of any radio receiver it is good practice to proportion the components and characteristics such that the receiver sensitivity is limited by thermal noise from the antenna tuned circuit. This noise voltage is proportional to the square root of the tuned circuit impedance (i.e. L/CR), to the square root of the absolute temperature, and to the square root of the acceptance band of the receiver. For a temperature of 30 degrees Centigrade, a bandwidth of 16,000, and a first circuit impedance at resonance of 50,000 ohms, the noise voltage applied to the grid of the first tube is about 3 microvolts. Now:

$$Z = \frac{L}{CR} = \frac{Q}{\omega C}$$

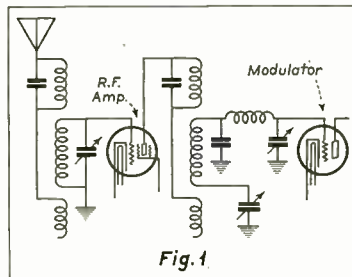

Fig. 1

Use of three tuned circuits preceding the modulator for the reduction of cross-modulation and improvement in signal to first-circuit noise ratio.

Voltage step-up from the antenna is proportional to Q . Therefore the factors which tend to increase the voltage step-up also tend to increase first-circuit noise. However, the former increases as the first power of Q and the latter as the square root of Q , so that best results will be obtained with high- Q input circuits. Maximum antenna step-up is, of course, of great importance in obtaining a good signal-to-noise ratio. Hence it would be desirable to tune the antenna if this were practicable. Unfortunately in receivers which must be operated with antennas of varying length and which must be tuned over a wide frequency band this is impractical without an additional tuning control. The permissible Q of the first tuned circuit is also limited by the band width requirements, a wide band requiring a lower Q than a narrow band. It is, as a result, always necessary to effect the best compromise.

CROSS MODULATION

Cross modulation is due to third-order terms in the r-f amplifier or first detector. When a variable- μ tube is used as the i-f amplifier¹, cross modulation will nearly always take place in the first detector. It has been shown² that cross modulation is proportional to the square of the amplitude of the unwanted signal and to the percentage modulation of the unwanted signal. If all cross modulation occurs in the first detector, it appears that any amplification of the unwanted signal before it reaches the first detector serves to make matters worse.

From this standpoint, r-f amplifica-

¹S. Ballentine and H. A. Snow "Reduction Of Distortion And Crosstalk In Radio Receivers By Means Of Variable Mu Tetrodes"—Proc. I. R. E., Vol. 18, pp. 2102, Dec., 1930.

²F. A. Polkinghorn "Short Wave Transoceanic Telephone Receiving Equipment"—Proc. Radio Club of America," Vol. 9, No. 11, pp. 62, Dec., 1932.

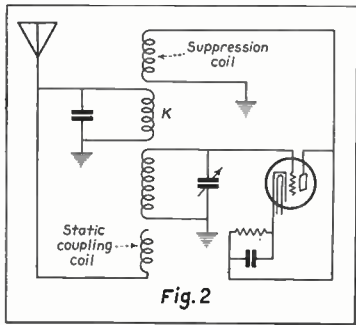

Effective circuit for increasing image suppression through voltage cancellation.

tion is undesirable. On the other hand, we know that r-f amplification helps considerably in increasing the ratio of signal to first-circuit noise. Obviously we are again forced to accept a compromise. This condition is usually met by using the circuit of Fig. 1 or its equivalent. In this case, a single tuned circuit is employed to couple the antenna to the r-f amplifier and two tuned coupled circuits are employed to couple the r-f amplifier to the first detector or modulator. Such a circuit gives a good signal-to-noise ratio and in addition provides considerable discrimination to the unwanted signal. Of course, a loss of 6 to 10 db is inevitable in the tuned coupled circuits but this is more than compensated by the gain of the r-f amplifier. Had the two tuned coupled circuits been used ahead of the amplifier a loss of 6 to 10 db in the ratio of signal to first-circuit noise would have occurred without any more discrimination to the unwanted signal than that of Fig. 1.

IMAGE FREQUENCY

Another reason for three tuned circuits between the antenna and the first detector lies in the attenuation of the image frequency. This may best be illustrated by an example. Suppose the signal frequency is 1000 kc and the oscillator frequency is 1175 kc. Then an unwanted signal of 1350 kc. appearing on the first detector input would produce a beat note which would fall in the band of the i-f amplifier together with the wanted signal. An attenuation of 1000 to 10,000 times to the image frequency is usually required by a good design.

One very common and effective circuit arrangement for increasing image suppression is shown in Fig. 2. The image frequency which appears in the plate circuit of the r-f amplifier causes a current to flow through the suppression coil, in which the signal frequency, the oscillator frequency, and the image frequency appear. Now the voltage transferred to the coil K will increase in direct proportion to frequency. Since the oscillator frequency is usually

higher than the signal frequency, the image frequency will be higher than the oscillator frequency, and hence the image frequency voltage transferred to coil K will be larger than the others. Since all these voltages are so phased by poling the suppression coil that they subtract from the original signal, the subtraction from the image frequency can be relatively great without seriously reducing the signal.

Another method of increasing suppression of the image frequency lies in the use of a tuned circuit coupled to the antenna and tracked with the oscillator tuning condenser. This circuit acts like a wave trap to suppress the image and if properly tracked is probably the most effective method of image frequency suppression. Such an arrangement is illustrated in Fig. 3. The latter suppression circuit should have as high a Q as is practical.

About a year ago the use of image frequency suppression networks was very common. They are not so common today because of certain difficulties inherent in particular types and due to the fact that a good tuned circuit costs but little more and is in some cases more effective. The arrangement shown in Fig. 2 may actually decrease image suppression at certain frequencies because too much energy is fed back to coil K; i.e., more than is required to balance the image response. This is due largely to the decrease in selectivity of radio-frequency tuned circuits at the high-frequency end of the spectrum. If properly proportioned with respect to the constants of the tuned circuits, they may add considerably to the image suppression and in high-fidelity receivers are probably justified if three tuned radio-frequency circuits are used.

CHOICE OF INTERMEDIATE FREQUENCY

The choice of the intermediate frequency is again a compromise. Much has already been written on this subject and it is largely affected by specific design so that a treatment of the matter here is largely outside the scope of this series of articles. A few of the considerations involved in this matter, however, are:

1. The intermediate frequency should not approach too close to the frequency of any nearby transmitter which might lay down sufficient field to ride through the amplifier.
2. The higher the intermediate frequency the more difficult it becomes to obtain high selectivity and high gain.
3. The higher the intermediate frequency the less the danger of image response.
4. The higher the intermediate frequency, the greater the trouble likely to be encountered from intermediate-frequency harmonics being fed from

the second detector or the intermediate frequency amplifier circuits back into the first detector. The obvious reason for this lies in the fact that the amplitude of the lower harmonics is usually greater than that of the higher harmonics.

5. The higher the intermediate frequency the less the possibility of interference from two stations whose frequency separation is equal to the intermediate frequency.

COUPLING OF TUNED CIRCUITS

It is usually necessary in wide-band receivers to use something more than sufficient coupling between the successive tuned circuits of the i-f amplifier. Since the tuning is fixed, it is more or less immaterial whether inductive or capacitive coupling is used. If the bandwidth is adjustable in steps it is usually more convenient to use capacity coupling; if it is to be continually variable, inductive coupling is usually more practical; and it is usual practice to couple two identical circuits which are tuned to the same frequency. We have for sufficient coupling where K is the coefficient of coupling and M is the mutual coupling impedance (see Fig. 4):

$$wM = \frac{\sqrt{R_1 R_2}}{M I}$$

$$K = \frac{M}{\sqrt{L_1 L_2}} = \frac{1}{\sqrt{Q_1 Q_2}}$$

Now if $Q_1 = Q_2 = 100$, $K = 1\%$. As the coupling is increased beyond critical, the response becomes lower and flatter and finally separates into a two-humped curve with a valley between. Actually the two humps begin to be apparent at about 1.5 times sufficient coupling (i.e., at 1.5% for the case cited above, and the frequency between humps is substantially independent of the circuit resistance if high Q circuits are employed, so that the approximate relation between frequency at unity power factor F_1 and resonant frequency F_0 is nearly:

$$\frac{F_1}{F_0} = \frac{1}{\sqrt{1 \pm K}}$$

The secondary currents at the humps
(Continued on page 36)

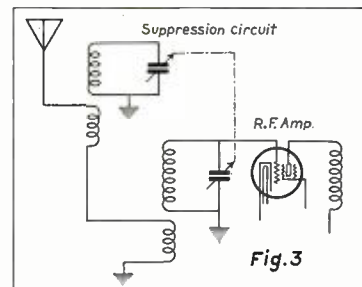

An image suppressor tracked with the oscillator tuned circuit, and functioning as a wave trap.

High-Fidelity MONITORING

By J. P. TAYLOR

FAVORITE THEORY OF broadcast engineering: that transmitter standards should be kept several years ahead of receiver development. Favorite delusion: that they are. Thus, whenever the near-advent of high-fidelity receivers is discussed, the average station engineer smugly remarks that he is all set for them. But is he?

Receiver engineers are skeptical. In the course of development work they have built, in the laboratory, receivers capable of almost perfect fidelity. And they have used these receivers to compare the quality of broadcast transmissions. Their observations are interesting and illuminating. They mark most disparagingly the stations using inferior equipment. But this, of course, was expected. What was not, is the variation in quality among stations using comparable-equipment, and even among various programs of the same station. There is an import to this which should give pause to the holier-than-thou broadcaster.

INADEQUATE MONITORING

Mr. J. E. Young, in his recent article* pointed out the premium which the widespread use of high-fidelity receivers would place on transmitters with low harmonic and phase distortion, increased dynamic range, etc. And, in general, these factors explain the difference between correctly and incorrectly designed transmitters which is so noticeable with high-fidelity receivers. The following discussion, therefore, will concern only the second difference which has been noted; namely, that between stations

*High-fidelity Transmitters, RADIO ENGINEERING, March, 1934.

- A discussion of the inadequacy of the average broadcast monitoring system now in use, and a description of a new high-fidelity system having a response from 30 to 14,000 cycles.

Fig. 1. The amplifier of a perfected high-fidelity monitoring system having response from 30 to 14,000 cycles.

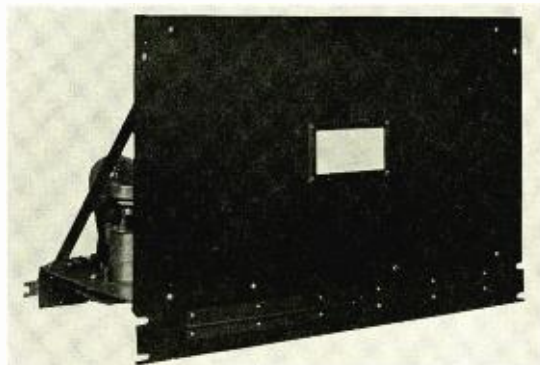

having comparative equipment of the better class.

A majority of the larger broadcast stations, and many of the smaller ones, have equipment capable of reproducing a range of 50 to 8,000 cycles. The engineers of these stations will show you frequency characteristics of speech input and transmitter which are beautifully straight. Listening to these stations on a receiver with a useful upper limit of 4000 or 5000 cycles they all appear to have about the same quality. Yet, when a receiver with a range extending to 8000 cycles is used the quality of these stations is found to vary widely—some being very good, others very bad. The question is, why, if the frequency characteristics of these are flat, should the added octave make this difference?

An incident which occurred not long ago in a network station indicates the answer. Just a few evenings after they had completed installation of complete new studio equipment, the operators of this station were surprised to hear a

high-pitched whistle coming in over the network program. When it continued, they opened the Morse wire and checked the other stations on the net. None of them were getting it. Finally they checked the key-station, which at first denied, but on checking admitted, that the whistle was originating in their equipment. It was going out over the net and was undoubtedly being put on the air by most of the stations. It could not have been much above 5,000 cycles, and yet only one of the stations on the network had a monitoring speaker in which it could be detected!

This incident might have happened on almost any network, for the monitoring systems of the stations in question were typical of those used in nine out of ten broadcast stations. That the monitoring system should be the most cheaply constructed item in almost every station is a distressing indictment of broadcasting, but it is a fact which anyone acquainted among stations will confirm. Manufacturers have time and again seen stations spend thousands for speech input equipment only to turn around and construct their own monitoring system out of parts purchased at the nearest cut-rate salvage store. Apparently it has never occurred to the engineers of these stations that in so doing they were actually using, at a vital point in their plant, parts, such as loudspeakers, which

had been previously discarded as obsolete by receiver manufacturers. Other stations are using monitoring equipment which they installed several years ago, and are seemingly unaware that, although it may well have been the best available then, it is now hopelessly obsolete. A few stations are still using cone type magnetic speakers. All in all, probably not one station in ten has an up-to-date monitoring system.

DEAF BROADCASTING

It is hardly necessary to point out the impossibility of properly monitoring a 6,000- or 8,000-cycle transmission with a 4,000-cycle monitoring system. A flat frequency characteristic of speech input and transmitting equipment is a necessary, but not a sufficient, condition for high-quality presentations. Without wishing to discredit the frequency curves which engineers so proudly display, it is nevertheless, well to remember that these invariably start at the microphone input.

Because they are seldom equipped to make sound measurements, station engineers must usually assume microphone characteristics at the manufacturer's estimate. Such characteristics are often incorrectly or unfairly measured. At the best they are, of necessity, measured under special conditions (as, for instance, in a sound-deadened room or in the open air) and are, therefore, subject to correction when otherwise used. Moreover, published curves are average curves, and it is only in the most recent types of microphones that individual units can be relied upon to hold closely to the average.

Studio acoustics, once much neglected, are now conceded an importance equal to that of frequency characteristics. Certain acoustic rules are known and can be applied. But for the most part acoustics are still experimental and the final judgment is still that of the ear.

The effect of placement (arrangement of artists) introduces a third uncertainty. Properly speaking it depends on the directional characteristics of the microphone and the reverberation characteristics of the studio. But the relations are not sufficiently understood to permit of arbitrary placing. It is almost always necessary to try several arrangements in order to arrive at the best.

There are, then, at least three important factors affecting transmission quality; namely, microphones, acoustics and placement on which the engineer has no check except that of his ear—and his ear can be no better than his monitoring speaker.

In addition there are other factors on which the engineer can check dur-

ing silent hours, but for control of which during program he must depend chiefly on aural monitoring. In this category are extraneous noises (fader noises, hum, spurious oscillations, etc.) and overloading in the microphone or line amplifiers.

With so many transmission variables entirely dependent on it, a broadcaster without an adequate monitoring system is like a deaf violinist—he may own a Stradivarius, and he may have someone to tune it up for him, but his chances of an artistic presentation are still poor.

Many of the stations which are "deaf broadcasting" are already distinguishable—they are the ones which usually sound better with the receiver tone control turned to exclude the treble. This is an impairment which will be greatly accentuated by high-fidelity receivers. It, therefore, behooves these stations to make plans for improving their aural monitoring systems.

A HIGH-FIDELITY SYSTEM

For those stations which are faced with the immediate necessity of bringing their monitoring system up-to-date, and who wish to provide at the same time for the extended requirements of high-fidelity broadcasting, monitoring systems of remarkably improved fidelity are available.

Chief criticisms of old monitoring systems were: first, limited frequency range, and second, overload distortion. Chief reasons were: first, lack of wide-range loudspeakers; second, amplifier

designs incapable of sufficient output, and third, poor matching of component parts.

One improved system, used in the Radio City studios of NBC, and in the new CBS Playhouse, overcomes each of these difficulties in turn. The loudspeakers employed are of a newly developed type having a frequency range nearly double that of previous types. The final amplifier stage, incorporating four 45's in a push-pull parallel arrangement, provides, without overloading, several times the power usually available. Most important of all it has been designed not by parts but as an integrated system properly matched throughout, thus assuring best possible over-all results.

As a result of these new features the response of this monitoring system from amplifier input to speaker output (loudspeaker sound pressure) is practically flat over the range of 60 to 8,000 cycles, while the useful output actually extends from 30 to 14,000 cycles. This is a range which has never before been even approached in a monitor of standard manufacture. Worthy of note is the fact that the whole range is covered by each speaker, the two units used being identical. This is simpler, more effective, and far more practical than the use of two or three speakers of different frequency characteristics.

The amplifier has an undistorted power output of 10 watts, considerably more than would ordinarily be used, but the insurance against overload is even



Fig. 2. The mounted amplifier tilted forward to show accessibility.

greater, for the final amplifier stage, operating Class A Prime, is capable of providing 25 watts on peaks without noticeable distortion. And for average program material, the noticeable overload point is actually 25 watts with complete protection against introduction of distortion in the monitoring system itself. Thus full volume range is added to full frequency range.

CONSTRUCTION

Convenience and accessibility have been stressed in the mechanical design of this monitoring system. The amplifier is shown in Fig. 1. In addition to the amplifier and speakers, there is a remote control unit. Full control of the monitoring system is placed in this unit, four push-buttons controlling a power relay and a motor driven volume control located in the amplifier unit.

The amplifier itself is assembled on a standard 19" panel and finished in the usual manner. Unusual, though, is the hinged arrangement which allows the upper section of the panel to be swung forward, along with the sub-panel, thus giving access both to tubes and to the

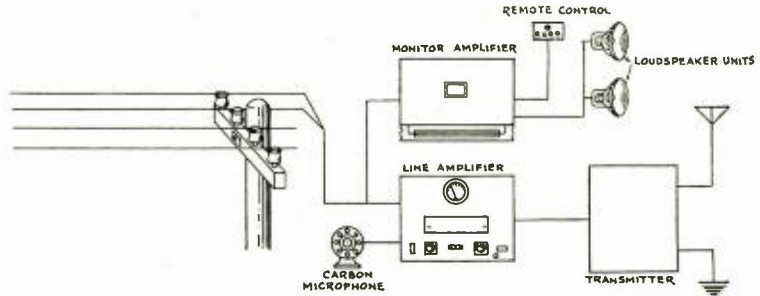

Fig. 4. Simplified schematic for monitoring system of transmitter control room.

bottom of the sub-panel. The advantages of this easy accessibility are evident from Fig. 2. The amplifier employs a 57 in the first stage, a 59 in the second stage, and four 45s in the third stage. As it is primarily a bridging amplifier the input impedance is high, being approximately 20,000 ohms. Output impedances of 15, 30 and 500 ohms are provided. The overall gain of the amplifiers is 40 db.

In order to make the system complete in itself, a rectifier power supply is built into the amplifier. The unit is designed

for operation from a 110-120 volt, 50-60 cycle line.

The 10" speakers are of standard shape and appearance. They may be mounted on a baffle in a console or in the wall as desired.

FLEXIBILITY

The descriptions of this monitoring system would not be complete without a word regarding its flexibility. There are an increasing number of points in the broadcast station where monitoring is regularly or occasionally required. The special features of this system together with the fact that it is self-contained make it easily adaptable for use at any of these points. In Fig. 3 and Fig. 4 are shown typical arrangements for studio and transmitter control rooms. The diagrams are, of course, simplified, though in practice the amplifier inputs would probably be terminated on a jack panel, ready to be plugged in at any appropriate point. Other applications will be apparent to every broadcaster. It is, for instance, ideal for the clients' audition room—the remote control being particularly appropriate at this point.

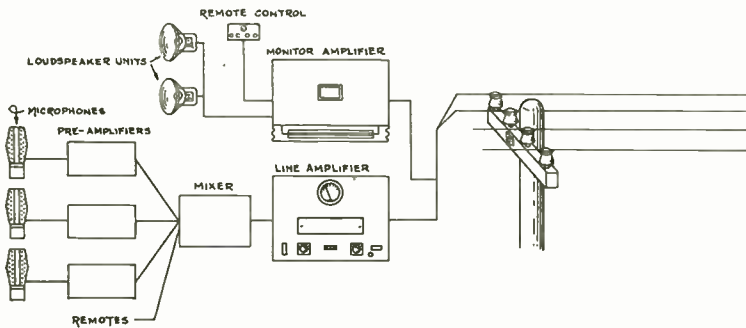

Fig. 3. Simplified schematic for monitoring system of studio control room.

DESIGN OF WIDE-RANGE AUDIO TRANSFORMERS

(Continued from page 23)

fortunately this at the same time increases the distributed capacitance and leakage reactance. It is therefore apparent that in attempting to improve low-frequency response we must sacrifice highs, or vice versa. The choice of a balance point depends solely upon the application. However, it has also been found possible to increase the coil inductance by improving the core material so that it has a higher permeability at the flux densities involved. Research in this field has developed the nickel-iron and other magnetic alloys. The reduction of leakage reactance and distributed capacitance is quite involved. Toroidal and semi-toroidal transformer

structures reduce flux leakage and consequent poor coupling, but in addition to this many coil structures require accurate and multiple interleaving of coils. How high this can be extended is seen in the frequency characteristic of the standard line-matching transformer illustrated in Fig. 6. The coupling in this transformer exceeds .999. The frequency run of a well-designed output transformer is illustrated in Fig. 7.

DISTRIBUTED CAPACITANCE

Distributed capacitance can be divided up into three cumulative effects: turn-to-turn capacitance, layer-to-layer capacitance, and coil-to-coil capacitance. In a well-designed coil the layer-to-layer factor is most important. To keep this at a low value, coils can be sectionalized so that the layer length is kept low. However, this must be done very care-

fully so as not to increase the leakage reactance. On transformers in which the distributed capacitance is of appreciable effect, such as windings in low-level grid circuits, resonant effects will generally occur in the secondary such that an increase in amplification is obtained at certain frequencies. This is often an advantage providing the distributed capacitance is low enough to effect resonance at a relatively high frequency. Both load resistance and source impedance affect this resonance. Fig. 8 illustrates variation in frequency characteristic against source impedance.

On the whole, reviewing the frequency curves illustrated, it is readily apparent that transformer design has advanced sufficiently to make possible the commercial production of audio units with a frequency range of 30 to 15,000 cycles.



WHY

ARMCO ELECTRICAL SHEETS

will reduce your costs . . .



HIGHER SPACE FACTOR—The uniform flatness of all Armco electrical grades insures a better space factor—particularly important in building electrical machinery.

LONGER DIE LIFE—Armco electrical sheets have a clean surface, are free from scale, which, with other important factors, insure longer die life and greater shop economies.

BETTER MAGNETIC QUALITIES—These are important in improving the electrical efficiency of motors, generators, transformers and other electrical apparatus.



There is an Armco electrical sheet grade that will reduce practically every loss encountered in the fabrication or performance of electrical apparatus • Armco, a pioneer in the development of electrical steel, devotes one large plant solely to the production of these special sheets. Special and highly modern equipment in the plant and laboratory are under the close supervision of highly skilled men of long experience. • Let us prove the good qualities of Armco Electrical Sheets to you. A note to the address below will put a trained Armco Engineer at your service immediately.



MONEY-SAVING USES FOR ARMCO ELECTRICAL SHEETS

Distribution Transformers Power Transformers Chokes
Audio Transformers A-C and D-C Motors and Generators

THE AMERICAN ROLLING MILL COMPANY

Executive Offices: Middletown, Ohio

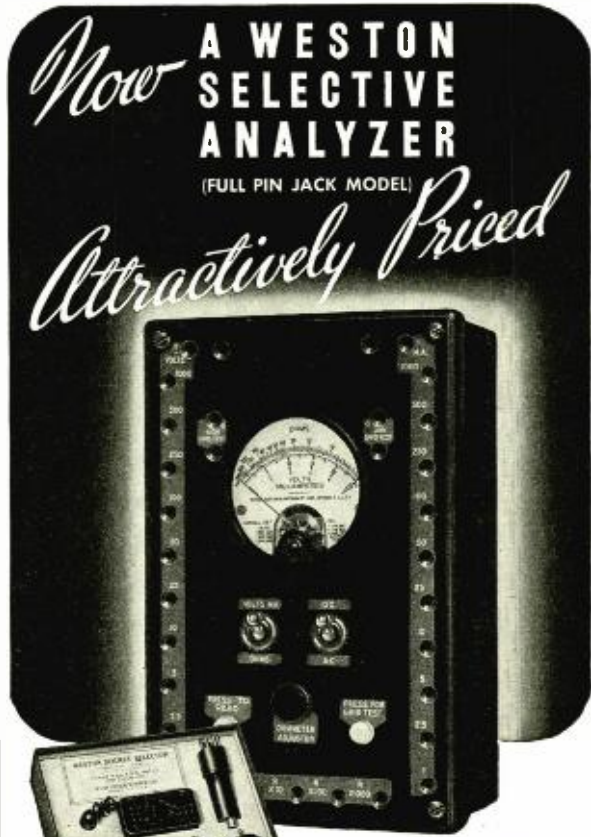

WESTON Model 667 SELECTIVE ANALYZER — with Model 666 Type 1A Socket Selector Set.

Service men, everywhere, will welcome this news: A Weston Selective Analyzer . . . using the Weston method which banished analyzer obsolescence . . . is now available priced to suit all pocketbooks.

Model 667 is identical in size with other Weston Standardized Service Units. It contains all the necessary voltage, current and resistance ranges. All ranges are brought out to pin-jacks, eliminating the range-changing switch. It is furnished with the improved Weston Socket Selector Set . . . Model 666 type 1A . . . making it truly universal in its capacity to analyze radio receivers.

You will want complete information on this attractively priced Weston Analyzer and other Weston equipment. Return the coupon today . . . Weston Electrical Instrument Corporation, 604 Frelinghuysen Avenue, Newark, New Jersey.

WESTON Radio Instruments

Weston Electrical Instrument Corporation
604 Frelinghuysen Ave., Newark, N. J.

Send Name _____
Bulletin on Weston Address _____
Radio Instruments. City and State _____

or frequencies of unity power factor is given by the relation:

$$I_1 = \frac{E}{Z_1 + \frac{(wM)^2}{Z_2}}$$

and:
$$I_2 = -j \frac{wMI_1}{Z_2}$$

Where: $Z_1 = R_1 + j(wL_1 - 1/wC_1)$
 $Z_2 = R_2 + j(wL_2 - 1/wC_2)$

When one of the coupled circuits is misaligned or when regeneration occurs, the behavior illustrated in Fig. 4 occurs. Using high-Q coils gives very pronounced humps when the circuits are overcoupled.

BANDWIDTH

If the bandwidth is defined as the frequency increment between the humps, then the width of the band is given by:

$$\frac{\Delta F}{F_0} = \frac{\sqrt{1+K} - \sqrt{1-K}}{\sqrt{1-K^2}}$$

And if K is very small, as is usually the case, this reduces to:

$$\frac{\Delta F}{F_0} = K$$

That is, the width of the acceptance band expressed as a percentage of the midband frequency is very closely proportional to the coefficient of coupling. In general it is desired that the response at the two humps and at the center of the band be nearly equal. This condition is realized to a first approximation when:

$$K = \frac{1.5}{\sqrt{Q_1 Q_2}}$$

Again if $Q_1 = Q_2$, which in general is the case, then it appears that the Q required to give nearly uniform response is inversely proportional to the coefficient of coupling, that is:

$$Q_1 = Q_2 = \frac{1.5}{K} = \frac{1.5 F_0}{\Delta F}$$

If E_1 is the voltage applied to the primary, and E_2 is the voltage across the secondary condenser C_2 , then for the condition of uniform response:

$$\frac{E_2}{E_1} = \frac{Q}{2}$$

Which is to say that response at resonance is down 6 db over that of an identical single tuned circuit. Or viewed

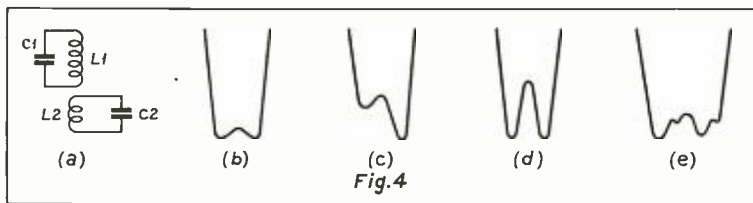

Effect of regeneration and high-Q coils in overcoupled circuits.

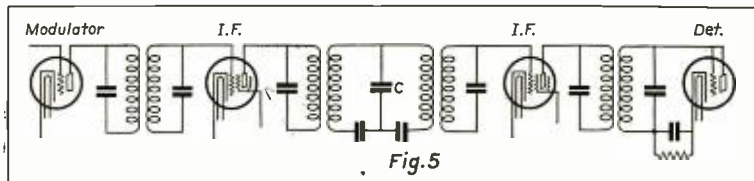

An intermediate-frequency amplifier with eight tuned circuits, with capacitive coupling between two of the stages, designed for an i-f band of 16 kilocycles.

in another manner, the impedance facing the plate of the preceding tube is half that of a single identical tuned circuit; which is equivalent to saying that the gain is reduced 6 db, since for r-f pentodes, the gain is given by:

$$A = G_m \frac{L}{CR}$$

However, the slope of the curve is decidedly steeper than would be obtained with single tuned circuits.

SELECTIVITY

Most of the closeup selectivity and nearly all of the receiver amplification is obtained in the i-f amplifier—usually two r-f pentodes will provide sufficient gain. In this case, then, six tuned circuits would result, and under ordinary circumstances this would be sufficient. However, if an i-f band of 16 kc is used, at least eight tuned circuits should be used. This can be had as shown in Fig. 5, in which capacitive coupling is employed between two of the tuned circuits; though in some cases this capacity might be replaced with an i-f amplifier tube.

Since most of amplification of the receiver will be due to the intermediate-frequency amplifier, some consideration must be given to the maximum stable gain possible with the circuit arrangements used. Assuming effective shielding of the various components, as well as proper bypassing of supply circuits, elimination of common ground returns and other common impedances, the gain will be limited by the effective control grid-plate capacities of the tubes. Since these capacities are effectively in series, the overall effective feedback ca-

capacity of the amplifier will be $\frac{c}{n}$, if c

is the effective control grid-plate capacity of any one tube, and n is the number of stages. It has been shown³

that the limiting amplification is given by the relation:

$$u = \sqrt{\frac{G_m}{wC} + 1} + 1$$

where C is in farads, G_m in mhos, and u is the effective amplification. This relation expresses the maximum stable amplification per stage, but by proper substitution for u, G_m , and C, the proper amplification for the amplifier may be obtained.

³“Characteristics Of Shielded Grid Piotrons”—A. W. Hull and N. H. Williams, *Phy. Rev.*, Vol. 27, pp. 449, April 1926.

(To be continued)

WIRE IN TUBES

(Continued from page 29)

become brittle when subjected to excessive heat with the result that there is very little lead breakage.

The subject of welds was also given consideration and a photomicrographic study was made of various types of tungsten welds using the composite strand wire as compared with regular copper strand. The tungsten used was from the same lot, the welds made under the same conditions, the only difference being the type of strand used.

The photomicrographics of Figs. 1 and 2 show the result of a weld between a tungsten rod and stranded copper with a nickel sleeve. Considerable re-crystallization is apparent in Fig. 1, and is quite obvious in Fig. 2.

The photomicrographics of Figs. 3 and 4 show the same sort of weld between a tungsten rod and the composite strand with nickel sleeve. It will be particularly noted from Fig. 4 that practically no crystallization of the tungsten has taken place. Compare this with Fig. 2.

A study was also made of the relative strength of such welds. Fig. 5 shows a tungsten rod welded to a copper strand without a nickel sleeve. The weakness in the weld is apparent. In Fig. 6 is shown a tungsten rod welded to the composite strand, also without a nickel sleeve. It is apparent that the two metals more readily weld together, with the composite strand flowing uniformly about the tungsten, forming a fillet all around which adds to the strength.



SHIPPING PROBLEMS ELIMINATED BY RAILWAY EXPRESS

No matter what you want to ship, Railway Express will answer your shipping problems. At your convenience and at your very door, in principal cities and towns, a Railway Express truck will call and take your shipments away to be rushed to the consignee at passenger train speed. Whether it be one shipment or five hundred—it makes no difference to Railway Express. Absolute safety and careful handling during transit are assured throughout. We give a receipt on collection and take a receipt at delivery—a twofold guarantee of safety and swiftness.

Railway Express service is inexpensive, too, and saves you much in convenience, worry and time. Telephone your local Railway Express agent who will be glad to give you information, rates, and service.

The best there is in transportation

SERVING THE NATION FOR 95 YEARS

RAILWAY EXPRESS

AGENCY, Inc.

NATION-WIDE SERVICE

UTC

Presents

Linear Standard Audio Components in a new HIGH FIDELITY A.C. Operated 2A3 Power Amplifier

Ideal for broadcast, recording, and public address applications.

Used by the leaders in sound and film recording. Ideal as a studio amplifier for Broadcast Stations. Will drive output amplifiers modulating up to 250 watts A.F. into R.F. stage.

Designed to Meet the Most Rigorous Requirements for Maximum Tonal Fidelity



Plate Filament and Bias Supply



Audio Amplifier

SPECIFICATIONS:

MAIN POWER AMPLIFIER

Input will match 50, 125, 200, 250, 333, and 500 ohms lines.
Output will match 500, 333, 250, 200, 125, 50, 30, 20, 15, 10, 7.5, 5, 2.5 and 1.2 ohms.
Three balanced push pull stages. Tubes used: 4—36, 2—2A3, 1—5Z3, 1—82.
Stable fixed C bias for output stage.
Undistorted class A output 15 watts.
Gain: plus 80 DB.
Flat frequency response from 30 to 15,000 cycles.
Trap resonant filter rectifier circuit increases filtering efficiency 400%.
Audio and power sections on separate drilled, heavy gauge metal decks.
Completed sections may be used either for vertical rack mounting or installed in portable oak cases.
All LS audio filter and power components fully shielded and doubly sealed against adverse tropical climatic conditions.

UTC Linear Standard components used are:

- 1—LS-12—Multiple input lines to push pull grids.
- 2—LS-22—Push pull 56 plates to push pull grids.
- 1—LS-55—Fixed bias 2A3 plates to broadcast and voice coil lines.
- 1—LS-90—Trap resonant smoothing choke.
- 1—LS-91—Trap resonant input choke.
- 1—LS-94—High inductance C bias choke.
- 1—LS-70—Heavy duty plate, filament and C bias supply transformer.

LIST PRICE \$136.00, NET TO DEALER \$81.00.

Complete set drilled metal decks for audio and power sections.

LIST PRICE \$16.50, NET TO DEALERS \$9.90.

The New U-1000-B Bulletin Is Ready



Send For Your
FREE Copy Today

16 PAGES OF VALUABLE DATA
COVERING NEWLY DESIGNED
AND TESTED HIGH FIDELITY AND
WIDE RANGE AMPLIFIER CIRCUITS

UNITED TRANSFORMER CORP.
264-266 CANAL STREET NEW YORK, N. Y.

NEWS OF THE INDUSTRY

RELIANCE VARIABLE CONDENSERS

The Reliance Die and Stamping Co., 1260 Clybourn Ave., Chicago, Ill., are producing new variable condensers which will be available in 2, 3, and 4 section units of various capacities, including the 370 and 420 mmfd. for t-r-f, and oscillator condensers with cut rotors for the 175 and 465 kc intermediate-frequencies.

The mechanical construction is a distinct departure from conventional design and yet is interchangeable electrically and mechanically with competitive makes of variable condensers, they state.

AUDIOLA BECOMES FAIRBANKS-MORSE SUBSIDIARY

The Audiola Radio Company of Chicago has, through an arrangement just completed, become a wholly owned subsidiary corporation of Fairbanks, Morse & Co. The acquisition of this pioneer radio organization by Fairbanks-Morse means an expansion of the Audiola Company, not only in the field of radio receivers, but also for the manufacture and sale of electric refrigerators and washing machines, it is stated.

Mr. Mortimer Frankel remains with Audiola as General Manager.

Sales offices of the subsidiary corporation will be maintained for the present at the usual address, 430 South Green Street, Chicago.

BRAND WITH LINCOLN RADIO

The Lincoln Radio Corporation takes the pleasure of announcing the new association of Mr. Jean J. Brand as Chief Engineer. For the past four years, Mr. Brand has been affiliated with the Howard Radio Co., as Chief Engineer.

WESTINGHOUSE MODULATOR BOOKLET

A booklet full of useful operating data telling how to measure modulation accurately so as to prevent distortion, over-modulation and other inherent troubles of poorly designed and improperly operated phone rigs has recently been issued by the Westinghouse Electric and Manufacturing Company. Copies may be obtained from the nearest dealer or direct from the advertising department, East Pittsburgh.

INDUCTIVE INTERFERENCE BULLETIN

The Radio Branch of the Department of Marine, Dominion of Canada, have just issued Supplement A to Bulletin No. 2 on Radio Inductive Interference. Copies of this supplement may be obtained from The Kings Printer, Ottawa, at 15 cents each. Copies of bulletin No. 2, Radio Inductive Interference, published January, 1932, may also be obtained at 35 cents each.

ARLAB SPEAKERS

The Arlab Manufacturing Co., 1250 North Paulina St., Chicago, Ill., have recently issued a bulletin giving specifications on their dynamic and magnetic speakers. The following are included: Midget 5-inch, Arlab 6-inch, Deluxe 6-inch, 8½-inch Radio Speaker, 11-inch Radio and P-A, 14-inch (all dynamics), Arlab Special Trumpet Unit, and Arlab Magnetic Speakers.

ISOLANTITE MOVES N. Y. OFFICE

Isolantite Inc., announces the removal of its New York Sales Office from 75 Varick Street, to 233 Broadway, New York City. Their new telephone number is REctor 2-9274.

UNION SHAFTING BOOKLET

A booklet has recently been issued on "Union" cold finished shafting. In addition, "Union" turned and polished shafting, special finish shafting, and precision shafting are included. Much valuable information, such as the physical properties, straightness, warpage, surface finish, tolerances, keyseating, and a list of the other products manufactured by the Union Drawn Steel Co., Massillon, Ohio, is also given.

VACUUM PUMP BULLETIN

Bulletin No. 10 on Cenco high vacuum pumps, gages, and accessories includes valuable information on the special pumps produced by the Central Scientific Company, 460 East Ohio Street, Chicago, Ill. Among those included in this publication are the Cenco-Hyvac, Cenco-Megavac, Cenco-Megavac (motor driven), Cenco-Hypervac, and Cenco-Aristovac pumps. A complete description and specifications are given with each. Copies may be obtained from the Central Scientific Company.

NEW GRAMMES BROCHURE

L. F. Grammes & Sons, Inc., manufacturers for over fifty years of numerous types of metal products, have released an attractive brochure dealing with the latest creations of Grammes craftsmen. This brochure may be obtained free upon request to the manufacturer.

Illustrated in the brochure are the many types of radio bezels, escutcheons and name plates which this company supplies to the radio field. Grammes & Sons have also been manufacturing radio dials for quite some time and will announce in the near future a new airplane type dial with indirect lighting.

RAILWAY EXPRESS AND WESTERN UNION COOPERATE

Express packages are now being accepted at local Western Union telegraph offices or, on call by telephone or call box signal, will be picked up by telegraph messengers, as a result of a combination of services recently consummated between the Railway Express Agency and the telegraph company.

Selected telegraph offices in cities and towns where the express company maintains collection and delivery service are being equipped for the receiving of shipments.

Telegraph messengers can be summoned by telephone to private homes and offices to pick up packages up to 20 pounds in weight and \$250 in value. They are authorized to take shipments for forwarding by Rail or Air Express service; to accept them with charges prepaid or collect and to give receipts. There will be no extra charge for messenger service.

This added convenience to the public for forwarding packages will not in any way curtail the regular vehicle service of the Railway Express in any of the cities and towns where it has been introduced. Express trucks will still make regular collection and delivery of shipments, large or small, on scheduled calls or on request by telephone or other notification to the local express office.

SYLVANIA RESIDENT ENGINEERS

Hygrade Sylvania Corporation now maintains resident engineers out in the field for the closest cooperation with radio set manufacturers and others in the matching of tubes and circuits. Charles W. Shaw, more familiarly known as Bill Shaw, who handles the sales of Sylvania tubes to set manufacturers, has three engineers constantly at his disposal for the technical end of his job. Walter Jones, who works out of the company's plant at Emporium, Pa., heads up the Commercial Engineering Division and is very well known to the trade. In fact, Mr. Jones has represented Sylvania in this capacity for a number of years. Cooperating with Mr. Jones and located in New York, is George Connor, who, in addition to the metropolitan area also covers New England and New Jersey. Charles Marshall is stationed at Chicago and handles the Middle West. Many technical problems are now solved at the set manufacturer's plant or laboratory, in a minimum time and with a minimum of trouble and expense to customers.

NEW WESTINGHOUSE MANAGER

Walter C. Evans, Manager of the Chicopee Falls Radio Division of Westinghouse, has just announced the appointment of C. J. Burnside as Manager of the Radio Engineering Department of that plant. R. L. Davis, former manager of this department, will devote his full time to various important radio development work.

Police and aircraft radio apparatus are the chief radio products of the plant. A substantial amount of Government radio business is also handled annually. Mr. Burnside's duties will concern the design and manufacture of all these devices.

Mr. Burnside was graduated in 1924 from South Dakota School of Mines. Since then he has been associated with the radio departments of Westinghouse.

CURTIS HAS NEW REPRESENTATIVES

The Curtis Condenser Corp., 3601 West 140th St., Cleveland, Ohio, manufacturers of electrolytic condensers, announce the appointment of David M. Kasson and Associates, 159 Fifth Ave., N. Y. C., and W. B. Pray Sales Company, 89 State Street, Boston, Mass., as their representatives to the New York Metropolitan Area and the New England States respectively.

G. E. PAY INCREASE

A 10 per cent pay increase to all General Electric employes receiving \$2600 or under, either on salary or hourly rate, effective April 1, was announced by Gerard Swope, president of the company, March 30.

The increase affects between 38,000 and 40,000 employes and increases the company payroll \$3,500,000 to \$4,000,000 per year.

The Vacuum Tube Industry

has been served by

Isolantite

since the inception of A. C.
operated tubes

NEW applications for vacuum tubes daily increase the problems to be solved by Tube Engineers. The trend toward higher and higher frequencies has created insulation problems many of which have been solved by ISOLANTITE.* There are many and varied applications for ISOLANTITE in vacuum tube design. Let us help you with your insulation problems.

Isolantite Inc.

BELLEVILLE NEW JERSEY

New York Sales Offices: 233 Broadway

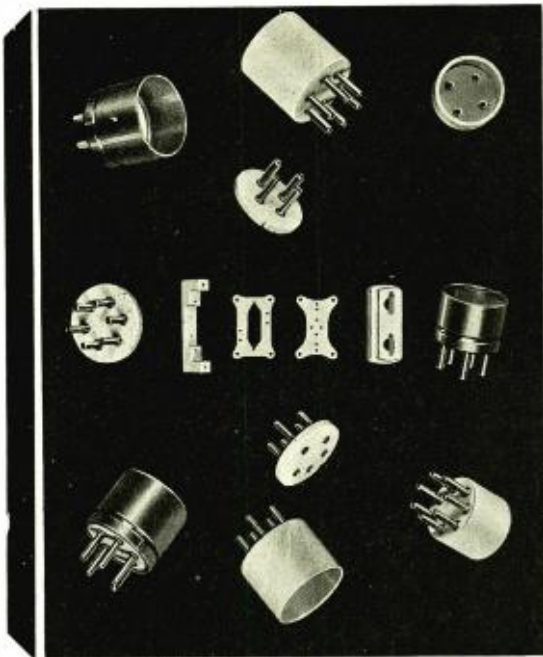

*Isolantite is the trade name of products manufactured by Isolantite, Inc. Do not confuse Isolantite with other ceramic bodies lacking in electrical characteristics and mechanical strength but of similar appearances.

Now you can build your chassis
with **NO SPACE PROVISION
FOR SHIELDING**

... and then add **GOAT SHIELDS**
as needed

The form-fitting feature of Goat Shields enables the builder to take advantage of every available saving in chassis space, and still make it possible to add tube shielding when subsequent tests on the complete job indicate where such shielding is necessary or desired.

In other words, it is not necessary to redesign a set for shielding, because Goat Shields require no extra space.

With the ever-increasing demand for greater fidelity in tone reproduction, and the consequent necessity for noise reduction, the better shielding effectiveness of Goat Shields is finding wider and wider acceptance by leading manufacturers of midgets, compacts and auto radio.

Goat offers all these advantages at a very low cost for shielding. Ask for complete information and samples.



Photograph (approximately 1/4 size) showing the space relation between a standard tube and a Goat Modern Form-Fitting Tube Shield. Half of the shield has been removed in order to show the relative sizes more clearly.



GOAT RADIO TUBE PARTS, INC.
314 Dean Street Brooklyn, N. Y.

NEW PRODUCTS

EGERT MICRO-VERNIER DIAL

Wireless Egert Engineering, Inc., 179 Varick St., New York, N. Y., have introduced a unique vernier dial especially intended for use on laboratory instruments, and by small instrument manufacturers, amateurs, experimenters and set builders.



The dial, illustrated on this page, is said to read accurately to 0.1 of one division at any point on the scale. It has a double-throw vernier pointer so that readings may be clockwise or counter-clockwise. It provides a spread of 270 degrees on the dial for a 180-degree condenser.

The dial ratio is 7.5 to 1 and it is said that the unit is absolutely free from backlash. Provision is made for mounting condensers directly on the dial itself, rather than on the panel. Both the scale and pointer are made of metal to prevent any inaccuracy in reading due to shrinkage of the scale.

AMERTRAN TRANSFORMER-COMMUTATOR VOLTAGE REGULATOR

The transformer-commutator principle for voltage control in alternating-current circuits is described for the first time in the latest publication (Bulletin No. 1175) of the American Transformer Company, 178 Emmet St., Newark, N. J. Seven illustrations of typical AmerTran Voltage Regulators and two basic circuit diagrams accompany the text.

This new type of voltage regulator provides small increments of voltage without sudden changes and without interrupting the circuit, equalling all other types of equipment for flexibility and smoothness of control. It may be designed to regulate up to 100 percent of the input voltage in steps of 1.2 volts or less, or it may be built to cover a smaller voltage range if desired. The equipment is available for manual, semi-automatic or full-automatic operation and may be constructed for either indoor or outdoor use.

Important among the stated advantages of the AmerTran Voltage Regulator is its high electrical efficiency which equals that

of a transformer of equal size. In addition, this type of regulator has practically no effect upon power factor, very low exciting current and does not cause wave distortion or interference to radio receivers. The equipment requires a minimum amount of maintenance and is designed to give many years of continuous service.

The AmerTran Voltage Regulator is now available in sizes from 0.25 to 200 kva. (equivalent transformer capacity), for single- or three-phase circuits, and for controlling potentials up to 2400 volts. Types have been developed for automatic regulation of feeder circuits, for controlling input voltage to broadcast transmitters, rectifiers, testing transformers, electric furnaces, and electric soldering equipment, and for many miscellaneous voltage control problems.

In the radio industry a large number of AmerTran Voltage Regulators are being used by vacuum-tube manufacturers for controlling voltage to equipment such as aging racks, life test racks and high-frequency furnaces. In broadcasting stations regulators are being used to maintain the input voltage to plate transformers at a constant value and to reduce power without shutting down the transmitter.

NEW C. R. C. SWITCHES

A new, inexpensive short-wave switch, small in size yet very flexible and efficient, is now being made by C. R. C., Incorporated, at Beloit, Wisconsin. It is known as the C.R.C. Model 1200.



Heavy silver-plated wiping contacts, positive indexing action, low contact resistance, absolutely noiseless operation, low capacity between circuits and to ground, and single hole mounting are among the important features given.

Any circuit combination from single pole twelve position to four pole three position can be furnished.

BAKELITE INSULATING MATERIAL

The Bakelite Corporation, of Bound Brook, New Jersey, have recently developed a special material for electrical insulation and to be used where low dielectric loss is desirable. This mineral filled material has the following physical properties

Specific Gravity.....	1.9
Weight Per Cubic Inch.....	1.1 oz.
Shock Resistance.....	2.68 ft. lbs.
Dielectric Strength.....	640 VPM—inst.
Dielectric Strength.....	400 VPM—step.
Tensile Strength.....	6100 lbs. per sq. in.

Power Factor:
 Audio Frequency (1000 cycles).... 1.3%
 Phase Angle..... 0.75 degree

Radio Frequency (1,000,000 cycles)	0.75%
Phase Angle.....	0.43 degree
Specific Inductive Capacity.....	5.0

Transverse Strength:
 Modulus of Elasticity..... 5,500,000
 Modulus of Rupture...9,300 lbs. per sq. in.
 Resistance Surface (West. Elec.

Test).....	475 megohms
Volume Resistivity.....	1.0 x 10 ¹⁴ ohms

Water Absorption:
 24 Hours..... 0.002%
 48 Hours..... 0.007%
 144 Hours..... 0.025%

This new material is particularly adapted to the molding of tube bases.

UTC AUDIO TRANSFORMERS

UTC Linear Standard audio components meet the most rigorous requirements for maximum tonal fidelity, state their manufacturers, the United Transformer Corporation, 264-266 Canal St., N. Y. C. In addition, these units, as their name implies, are said to be linear from 20 to 20,000 cycles.

The units are housed in balanced high permeability shields and have, as an added precaution, their own inner metallic shields distinctly separated from the enclosed case.

The UTC Linear Standard series of audio components now includes low-level transformers to match velocity, voice coil, and crystal microphones; and coupling, mixing and matching transformers for standard RCA and W. E. tubes. Standard designs are also available on Class A and Class B output transformers for power outputs of from 1 to 5000 watts. Another item is their new linear audio reactors which have a high "Q," and are ideal for equalizing and filter networks.

BRUNO PA-2 MICROPHONE

Bruno Laboratories, of 20 West 22nd St., New York, N. Y., have introduced a low priced Ribbon Velocity Microphone to meet the requirements of Public Address equipment builders and users. This new microphone, known as model number PA-2, affords a high fidelity and better frequency response over the audio range, it is stated.

This Velocity Microphone is ruggedly built and is not affected by humidity changes or atmospheric conditions. It is ideal for outdoor use.



The impedance of this unit is 200 ohms, but other impedances can be furnished to specifications.

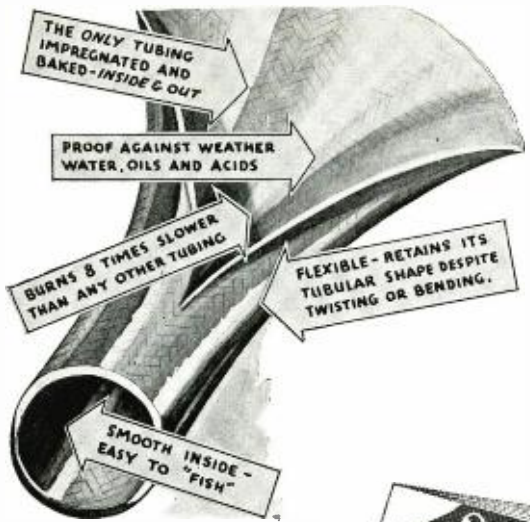

*Turbo Oil Tubing—impregnated inside and out. The finest made. Never gets brittle, maintains tubular shape, slow burning and acid proof.

*Turbo Saturated Sleeving—extremely high voltage breakdown resistance. Ideal for radio sub panels, transmitting equipment, flexible resistors, etc.

*Turbo Varnished Cloth—in rolls, tapes and cut to size. Also varnished Paper. Silk.

*Trade Mark Registered



radio manufacturers

insist on

TURBO* TUBING

MAGNETO GRADE
RADIO GRADE
SATURATED SLEEVING

New developments, auto receivers, high-frequency circuits, communication apparatus, flexible resistors, etc., require flexible insulating tubing in increasing quantities.

Dependable, efficient and rugged "spaghetti" that always meets the specifications set for it will reduce manufacturers' production costs by eliminating waste and rejections.

Our 14 years of experience supplying leading receiver and parts manufacturers with tubing and sleeving is an important reason why "Radio Manufacturers Insist on Turbo Tubing."

A complete line of all types, in all sizes, maintained in stock at all times.

Our new catalog No. 10 and samples of *Turbo Tubing (state type, color and size desired) will be sent free upon request.

WM. BRAND & CO.

268 Fourth Ave. New York City, N. Y.

Dependable Sensational Performance!

BUD

Laboratory-Built
P. A. Equipment

**5 DAYS
FREE
Trial**

Try **BUD Sound Equipment** For Five Days **Absolutely Free!**

**ELECTRO-DYNAMIC UNITS
DOUBLE BUTTON CARBON
MICROPHONES · 4 & 6 FT.
ALL ALUMINUM TRUMPETS
FIELD EXCITERS · AIR COLUMN
HORNS · LOW AND HIGH
FREQUENCY UNITS FOR WIDE
RANGE THEATRE USE**

We invite careful, critical inspection of our entire line of BUD laboratory-built sound equipment. We suggest that you conduct your own comparative test. We CHALLENGE you to duplicate BUD performance and BUD DEPENDABILITY AT ANY PRICE! Write today for descriptive literature and prices and details of our FREE FIVE DAY TRIAL offer.

BUD SPEAKER CO.
1127 JACKSON ST.
TOLEDO, OHIO-U.S.A.

HK

354

**NEW
GAMMATRON**

A REAL
TRANSMITTING
TUBE

●
Rated Output
100 WATTS
●

Write for folder

HEINTZ AND KAUFMAN
SINCE 1919 LTD RADIO ENGINEERS AND MFRS.
311 California Street, San Francisco, California

PROCTOR

Piezo Phonograph Reproducer



Uniform Response
Extended Frequency
Range, High and
Low
Unequalled Mechan-
ical Design and Con-
struction
Non-Resonant
Freely Damped
Minimum Record
Wear
Calibrated Needle
Pressure Scale
Non-Magnetic

Write for
Bulletin R-1

Especially adapted for use in Broadcasting Stations, Sound Studios and Theatres where a high degree of fidelity and consistent performance must be maintained. Reproduces Acetate and Aluminum Records with a minimum of wear on the record or the needle.

B. A. PROCTOR CO., Inc., 17 West 60th St., N. Y.
DESIGNERS AND MANUFACTURERS OF RECORDING AND SOUND
EQUIPMENT

— CORRECTION —
in the March advertisement of
BRUNO LABORATORIES
through a typographical error
it was stated that the fre-
quency response range of
**BRUNO RV3 HIGH FIDELITY
VELOCITY MICROPHONE**
was 30 to 1400 cycles
The correct frequency range is
30 to 14000 cycles
BRUNO LABORATORIES
20-26 WEST 22nd STREET NEW YORK CITY

PIEZO ELECTRIC CRYSTALS

All "Scientific Radio Service Crystals" . . .
are accurately ground to an accuracy better than
.03% on equipment tested regularly by U. S.
Bureau of Standards, Standard Frequency Signals

**BROADCAST AND
COMMERCIAL BANDS**
Broadcast Band Crystals mounted in
our Standard Holder and ground to
our usual high degree of accuracy
now \$35.00 each. Mounted in our
NEW Isolantite Metal Metal Crys-
tal Holder \$45.00. Prices for other
bands quoted upon application.

AMATEUR BAND
Scientific Radio Service Crystals
ground to within FIVE Kilo-Cycles
of your specified frequency in
either 80 or 160 meter bands \$15.00
each. Mounted in our Standard
Holder \$5.00 additional. Accurate
calibration with each crystal.

Superior by Comparison—Prompt Shipments Assured

SCIENTIFIC RADIO SERVICE

"The Crystal Specialists" Since 1925

124 JACKSON AVE., UNIVERSITY PARK, HYATTSVILLE, MD.
Dept. RE-4

EMBOSSED METAL ESCUTCHEONS
OF ALL KINDS, ETCHED PANELS AND SCALES. SMALL
METAL STAMPINGS. If it's made of metal consult.

L. F. GRAMMES & SONS, Inc. 350 UNION ST. ALLENTOWN, PA.

University Course in RADIO COMMUNICATION

Open to high school graduates. Complete in 9 months.
High standard of instruction and equipment. Fall term
opens September 14.

UNIVERSITY OF WISCONSIN

Extension Division
623 W. State Street Milwaukee, Wis.

BLILEY PIEZO-ELECTRIC CRYSTALS

FOR USE IN RADIO
Transmitters - Receivers - Monitors - Standards
Supplied to any frequency from 20Kcs to 15,000Kcs.
Send for price list and descriptive circular.



BLILEY PIEZO-ELECTRIC CO.

237 Union Station Bldg. Erie, Pa.

FUSES

INSTRUMENT
Precision—
1/100 amp. up
RADIO
HIGH VOLTAGE
AUTO
AIRCRAFT
Anti-Vibration
LITTELFUSE LABS.
4505 Ravenswood Ave.
CHICAGO, ILL.

High Grade New and Used

ELECTRON TUBE EQUIPMENT

Vacuum Pumps, Stem, Sealing, Flare and Basing Ma-
chines; Welders, Blowers, Rheostats, Transformers, etc.
Specialists in Equipment and Methods for Manufacture of Neon
Tubes, Radio Tubes, Incandescent Lamps, Photo Cells, X-ray
Tubes, etc.

Write for Bulletin Showing Savings from 20% to 80%

KAHLE ENGINEERING CO.

360 Manhattan Ave.
Union City, N. J.

When You Renew Your Subscription to RADIO ENGINEERING

Remember the Group Rate — \$1.00 a year for
four or more subscriptions.

Regular Rate—\$2.00 a year in U. S. A.—\$3.00 in foreign countries

INDEX TO ADVERTISERS

Allen-Bradley Co. 12	Isolantite, Inc. 39	Sickles Co., The F. W. Third Cover
American Rolling Mill Co., The 35	Kahle Engineering Co. 42	Sumnerhill Tubing Co. 5
Bentley, Harris Mfg. Co. 43	Littelfuse Laboratories 42	Swedish Iron & Steel Corp. Second Cover
Bliley Piezo-Electric Co. 42	Muter Company, The 43	Synthane Corp. 11
Brand & Co., Wm. 41	Proctor Company, Inc., B. A. 42	Thomas & Skinner Steel Products Co. 43
Bruno Laboratories 42	Racon Elec. Co., Inc. 10	United Transformer Corp. 37
Bud Speaker Company 41	Railway Express Agency, Inc. 37	University of Wisconsin 42
Callite Products Co. 9	RCA Radiotron Co., Inc. 1	Weston Elec. Inst. Corp. 35
Capitol Radio Eng. Inst. 43	RCA Victor Co., Inc. 27, 28	White Dental Mfg. Co., Inc. S. S. . . . 7
Central Radio Laboratories 44	Scientific Radio Service 42	Zlerick Mfg. Co., F. R. 43
Clarostat Mfg. Co. 3	Shakeproof Lock Washer Co. 44	Zophar Mills, Inc. 43
Goat Radio Tube Parts, Inc. 39		
Grammes & Sons, Inc., L. F. 42		
Heintz and Kaufman, Ltd. 41		
Hygrade Sylvania Corp., Back Cover		

I Closed Up My Shop . . . and went to school—

It took nerve to close up my radio service shop and go to the C. R. E. I. residence school . . . but I made up my mind to train myself for a real radio job. Today I'm on the way, my confidence in C. R. E. I. has been rewarded . . . just like hundreds of other fellow graduates who recognize the limits of experience and appreciate the advantages of TECHNICAL TRAINING for success in Radio.



3 Convenient Plans of Study . . .

Write for Our New Complimentary Catalog

With pictures and full details of our courses and laboratories.

C. R. E. I. training covers every type of Radio Engineering, and is presented in our famous One Year Residence Course . . . Home Study Course . . . or Combination Residence-Home Study Course. Full details given on request.

**CAPITOL
ENGINEERING**



**RADIO
INSTITUTE**

Dept. RE-4

14th and Park Road, N.W. Washington, D. C.

For Your Experimental Department

A tube of 500 assorted lugs and terminals — hot tinned for easy soldering.

Price \$1.00



We are also prepared to handle production stampings.

Write Us for
Quotations

F. R. ZIERICK MFG. COMPANY

Bronx Lehigh Bldg., 385 Gerard Ave., New York, N. Y.

LAMINATIONS

for Audio & Power Transformers
SPECIALIZED METHODS — YEARS OF EXPERIENCE
Wide Variety of Stock Standard Sizes

Dimension and Price Sheets on request

We Also Make

PERMANENT MAGNETS—DIES—TOOLS—
METAL STAMPINGS

Facilities for prompt service



**Thomas & Skinner
Steel Products Co.**

1100 to 1120
E. Twenty-Third St.
INDIANAPOLIS, IND.

APRIL, 1934

Yours . . . for the asking!

Bentley, Harris' booklet and
sample card on **SLEEVING**
and **FLEXIBLE TUBING**
is ready!

SIZE
NUMBER

BH

TO TAKE
O & S BARE WIRE

20



20

16



16



14

Every executive, engineer
and production man will
find this booklet helpful!

• Write for Your Free Copy Today •

BENTLEY, HARRIS MFG. COMPANY
CONSHOHOCKEN, PENNA.

• WAXES

• COMPOUNDS

• VARNISHES

For Insulation of Condensers

Transformers, coils, power packs, pot heads, sockets, wiring devices, wet and dry batteries, etc. Also WAX SATURATORS for braided wire and tape. WAXES for radio parts. Compounds made to your own specifications if you prefer.

• ZOPHAR MILLS, INC.

FOUNDED 1848

MEMBERS OF N.R.A.

Court, Lorraine and Creamer Sts., Brooklyn, N. Y.

Agents: Ralph B. Clark, 2907 Calumet Ave., Toledo, Ohio

H. A. B. Saeve Co., San Francisco, Seattle, New Orleans

CANDOHMS

ARMoured WIRE WOUND RESISTORS

WILL LOWER YOUR COSTS

OVER SEVEN MILLION IN USE
MAY WE SAMPLE AND QUOTE

THE MUTER COMPANY

1255 So. Michigan Ave.

Chicago, Ill.

Page 43

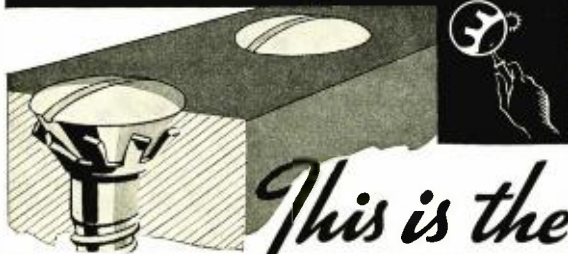
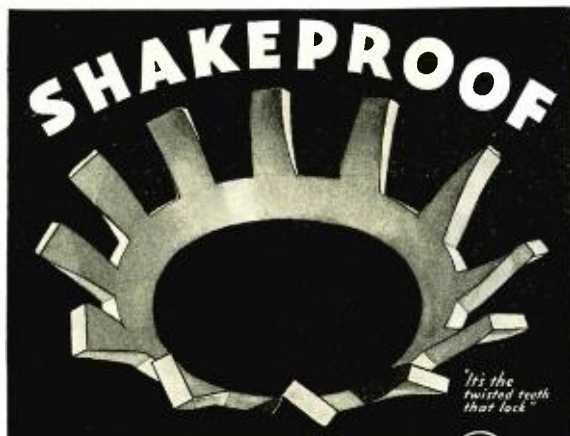

This is the Perfect way to Lock Countersunk Screws

THE worry of how to keep countersunk screws from working loose need bother you no longer. Simply put a Shakeproof Countersunk Lock Washer under every screw and, even if exposed to intense vibration, they will not back out. The twisted, hardened steel teeth bite into both screw head and the side of the screw hole, forming a positive lock that keeps the screw in position permanently. Test this modern locking method in your own shop—send for free samples today!



Send today for your free copy of this complete Shakeproof Catalog. Explains thoroughly the many advantages that Shakeproof offers—also shows new patented Shakeproof products.

SHAKEPROOF Lock Washer Company

(Division of Illinois Tool Works)
2509 N. Keeler Ave. Chicago, Ill.



U. S. Pat. 1,419,564—1,664,122—1,497,554—1,782,337—Other Pat. Pending—Foreign Pat.

“Ah,
my dear
Watson;



THERE'S no mystery about the popularity of this new RADIOHM for replacement jobs. You'll detect it at once... for it offers smoother, easier, better attenuation than ever before. Try a RADIOHM on that next job.

Note the protecting metal strip that “makes contact” with the resistance strip—noiselessly, smoothly, surely.

Central Radio Laboratories
Milwaukee, Wis.



Every Radio Service Man should be a member of the Institute of Radio Service Men

Centralab RADIOHM

COILS

To the receiver manufacturer—large or small—and to the manufacturing laboratory, the SICKLES COMPANY offers increased coil manufacturing facilities.

- Universal windings for compactness.
- Two layer bank windings for high Q .
- Four layer bank windings for compactness and high Q .
- Special I.F. windings for 456 and 370 KC that make possible selectivities comparable to 175 KC I.F. transformers.

Increased production facilities insure prompt delivery. Added laboratory equipment guarantees accuracy and quality.

Enlarged engineering staff develops new coil data.

THE F. W. SICKLES CO.

SPRINGFIELD, MASS.

MANUFACTURERS OF RADIO COILS SINCE 1922

Export Department: 116 Broad Street, New York, N. Y.

Cable Address: Auriema, New York



TYPE 5000-IF TRANSFORMER

Adjusting condensers side by side. No mechanical interaction. Shield $1\frac{3}{8}$ " square. Especially suitable for auto radio. Insulated trimming screws.

AND ROUNDING OUT A LINE WITH A CYLINDRICAL TRIMMER



TYPE 6000-IF TRANSFORMER

Adjusting condensers in same plane. New type of trimmer. Round can $1\frac{7}{16}$ " diameter. Insulated trimming screws.

AND A DE LUXE ASSEMBLY WHERE HIGHEST QUALITY IS PARAMOUNT.

ALL TYPES AVAILABLE FOR SINGLE TUNED, DOUBLE TUNED OR COMPOSITE UNITS.

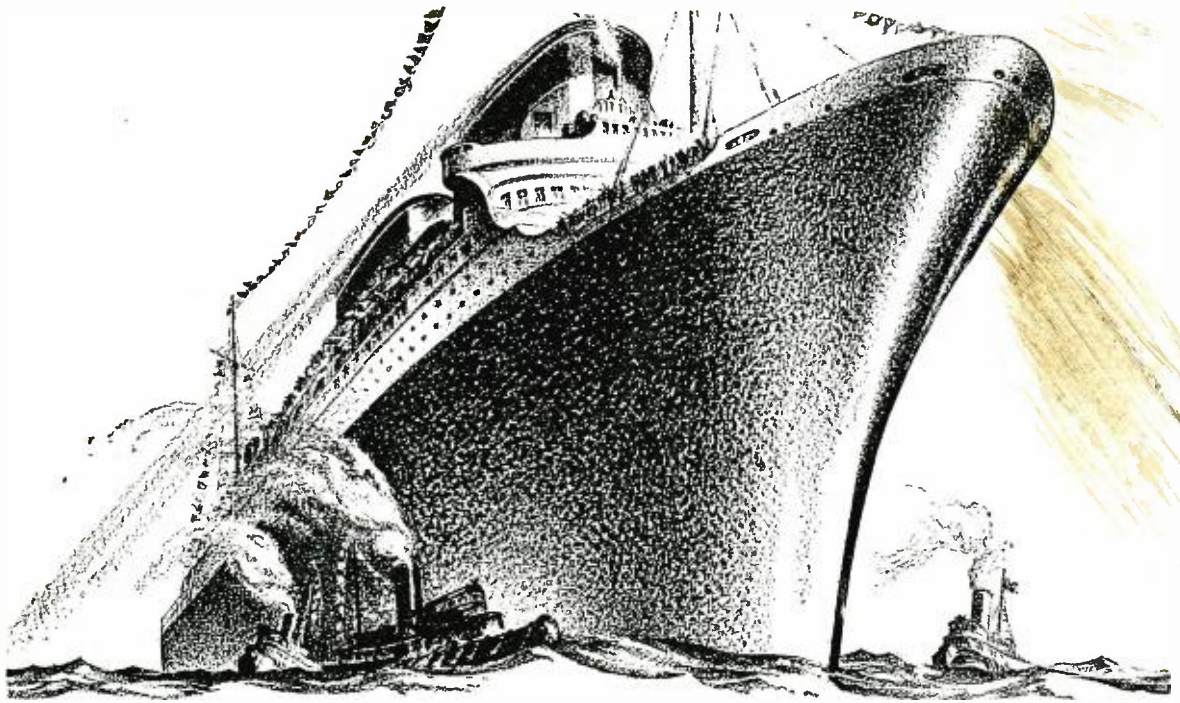

MAIDEN VOYAGE

● A new ship's reputation for comfort . . . speed . . . performance . . . is either made or broken on her trial run. It is then that the public's favor must be won!

Radio sets face a similar critical trial whenever they are demonstrated. Naturally, no effort can be spared to design or select every feature of the set for finest results.

That is why leading set manufacturers come to Sylvania for tubes to be used in original equipment. They know their sets will perform best with tubes that have been tested and proved for their own circuits!

Sylvania Tubes are built by one of the world's largest companies specializing in electric vacuum tubes. Hygrade Sylvania pioneered in the development of the efficient 6.3 volt tubes that made automobile radios prac-

tical. Later, Sylvania engineers were instrumental in perfecting the complete 6.3 volt group for general use. And in the sciences of radio transmission and electronics, also, Sylvania has made outstanding contributions.

Set manufacturers are invited to consult Sylvania engineers and avail themselves of Sylvania's complete Circuit Laboratory in solving their circuit and design problems. No obligation incurred.

Dealers and jobbers handling Sylvania tubes benefit from the support of the financial, engineering and sales departments of a company whose financial rating has always been AaA1.

Write for full details. Hygrade Sylvania Corporation, Emporium, Penna.



Sylvania

(Reg. U. S. Pat. Off.)



THE SET-TESTED RADIO TUBE