

Tenth Year of Service

RADIO ENGINEERING

Vol. X FEBRUARY, 1930 No. 2

IN THIS ISSUE

|||||

APPLICATION OF SCREEN-GRID TUBES TO AUDIO-FREQUENCY AMPLIFIERS

(Page Twenty-Nine)

By John J. Glauber

A NEW TYPE FOUR-ELEMENT TUBE

(Page Thirty-Four)

By H. F. Dalpayrat

SOLDER-PLATING IN RADIO MANUFACTURING

(Page Thirty-Six)

By John P. Arnold

INTERFERENCE FROM POWER LINES

(Page Forty)

By Clyde L. Farrar

A REMOTE CONTROL SELECTOR SYSTEM

(Page Forty-Two)

By Elmer E. Burns

PRODUCTION TRENDS IN THE RADIO INDUSTRY

(Page Forty-Five)

By Austin C. Lescarbourea

|||||

Sold only by subscription
\$2.00 per year



The Journal of the Radio Industry

This NEW clear Thinking--Hard Fast--In New Directions

It's Here--Right Now--Everywhere
Sweeping into Every Industry

Something is happening - - Headed "Upward."

Moving Faster - - Spreading Deeper.

Permanent - - Nothing can stop it now.

Industry's Next Great Stage is Starting

THE new prosperity, now preparing, will be based on new thinking, new ways, new thoroughness. New conditions are ahead of us. Some are here now. Production-thinking and equipment-thinking are sharper, faster, more complete. And with a stronger will to mesh perfectly with every aim and problem of business.

* * *

Just the hint of a business dip was enough. Even if it is over by the time you read this, the fast, keen, fresh thinking that it started is going on. It is getting more momentum. Its results in business and industry will be permanent. The new direction of industry's advance is being determined right now.

Already you feel it everywhere. Nothing escapes the sharp scrutiny of this new thinking. Methods, materials, equipment, designs, models, old ways, old slots, old neglects of opportunities, old "leech wastes"; all are in the crucible now.

From top to bottom in industry the best thought of all workers is being enlisted by executives.

* * *

The Fact-Sheets of Industry aim to help the scope and thoroughness of the new thinking, by supplying it with practical material; facts that every executive and every worker may find useful now. Facts no worker can do

Write NOW. There is no charge. First of FACT-SHEETS of INDUSTRY, now in preparation, will be mailed free to ANY Worker, any Executive, if quick.

State work you do, your company's product or business: and whether request is for self. Address; Librarian (S-2), National Vulcanized Fibre Company, Wilmington, Del. (Card will do).

without, if he looks ahead and wants to be in step with his company's new aims and efforts.

* * *

The publication of this, the first of the Fact-Sheets of Industry, is the start of a plan which, when at its full growth, will supply freely to thinking workers in ALL levels of industry, practical knowledge which hitherto has not been readily accessible; facts from many other industries which may stimulate their own productive thinking; and which, (though they affect practically every business, every department and every worker), are usually known only in part and only by a limited group of specialists in each industry.

* * *

As a movement in line with national measures for further improvement of business conditions and of the circuit of producing, earning, consuming, equipping, etc.;—and as the initial step in this democratizing of inter-industry knowledge (which, under present conditions, is more needed by thinking workers, and can yield more important results than ever before);—all expenses of issuing the first of the Fact-Sheets of Industry are being borne by The National Vulcanized Fibre Company and its various divisions and associated industries.

NVF

NATIONAL VULCANIZED FIBRE COMPANY



NEW *Equipment and Resources* >>> *for* **BETTER SERVICE** •

▲
FORMICA constantly adds to its equipment and resources to provide better service for the electrical and radio trade.

During the past year, over 50,000 feet of floor space was added to the Formica factory. Many new machines have been installed including a very much longer sheet press.

This equipment is located near the center of industry where quick deliveries can be made to manufacturers everywhere over the shortest average haul.

*Send your blue prints for quotations
on fabricated parts*

▼
THE FORMICA INSULATION COMPANY
4626 Spring Grove Avenue CINCINNATI, OHIO

• **FORMICA** •



RADIO ENGINEERING

Reg. U. S. Patent Office

Member, Audit Bureau of Circulations

Editor

M. L. MUHLEMAN

Western Editor
EVANS E. PLUMMER

Advisory Editor
DONALD McNICOL

Associate Editor
AUSTIN C. LESCARBOURA

Vol. X

February 1930

Number 2

Contents

	PAGE
Announcement	4
Impressions and Expressions, <i>By Austin C. Lescarbourea, Associate Editor</i>	26
Application of Screen-Grid Tubes to Audio-Frequency Amplifiers..... <i>By John J. Glauber</i>	29
Discussion on Glauber Paper..... <i>By Dr. Ellsworth D. Cook</i>	32
An American Pentode.....	33
A New Type Four-Element Tube, <i>By Henri Francois Dalpayrat</i>	34
Solder-Plating in Radio Manufacturing, <i>By John P. Arnold</i>	36
The Serviceman Speaks..... <i>By Austin C. Lescarbourea</i>	37
Interference from Power Lines..... <i>By Clyde L. Farrar</i>	40
A Remote Control Selector System..... <i>By Elmer E. Burns</i>	42
Revising the -99 Type Tube, <i>By Allen B. DuMont and V. O. Allen</i>	43
Production Trends in the Radio Industry, <i>By Austin C. Lescarbourea</i>	45
Public-Address and Centralized Radio Systems. Part IV, <i>By E. W. D'Arcy</i>	49

Departments

The Trend of Invention.....	53
News of the Industry.....	54
New Developments of the Month.....	60
Buyers' Directory.....	82
Index of Advertisers.....	88

Progress in Accommodating Radio to Air Transport Industry

By Thorp Hiscock

Chief of Communication of the Boeing System

DURING the past year considerable progress was made in the accommodating of radio to the needs of the air transport industry. Under proper regulations the orderly use and allocation of aviation channels was provided. Sufficient of these channels were set up to allow proper operation of aircraft communication in the interests of the protection of life and property. Much work has been done in cooperation with the Federal Radio Commission, Department of Commerce, Bureau of Standards, and Army and Navy to standardize equipment and installations as well as provide channels where all services could obtain adequate protection.

Perhaps the greatest immediate progress in the development of radio for aeronautical purposes has been shown by the Department of Commerce Airways Division under the leadership of Captain F. C. Hingsburg. During the last year the Department of Commerce weather broadcast stations have been established on the transcontinental airways from Boston to San Francisco, and the circuit from Los Angeles to Seattle is almost completed. These stations work in the 1000 meter band, and broadcast weather forecasts and local weather conditions to flyers as often as at 30-minute intervals.

In addition, the Department of Commerce has installed radio range or beacon stations at approximately 200-mile intervals to assure flyers the ability of staying on the airways.

Published Monthly by

Bryan Davis Publishing Co., Inc.

Publishing
AVIATION ENGINEERING
RADIO ENGINEERING
PROJECTION ENGINEERING

Publication Office—Lyon Block—Albany, N. Y.
Chicago Office—333 No. Michigan Ave.—Charles Farrell—Mgr.
Cleveland Office—10,515 Wilbur Ave.—James Munn—Mgr.
San Francisco Office—318 Kohl Bldg. { Cupit and Birch—Mgrs.
Los Angeles Office—846 So. Broadway

Bryan S. Davis,
President
James A. Walker,
Secretary
E. M. Bacon,
Advertising Manager

52 Vanderbilt Ave.
New York City

Entered as second class matter at the post office at Albany, N. Y., January 9, 1925, under the act of March 3, 1879.

Yearly subscription rate \$2.00 in U. S. and Canada; \$3.00 in foreign countries.

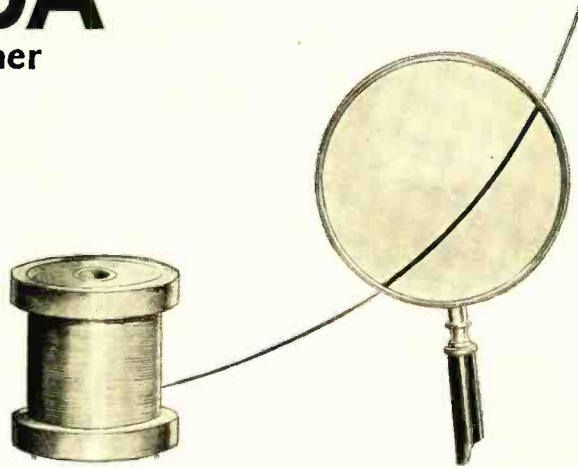

Magnet Wire

"as fine as a human hair"

ANACONDA manufactures Maring Process magnet wire in all standard forms, the smallest size (.0027. No. 42 B & S) being equal in thickness to a human hair. Specialized experience and equipment make possible such precision.

From rods of pure electrolytic copper, produced under Anaconda supervision, the wire is drawn to A. S. T. M. specifications. A dozen exacting tests safeguard quality throughout the finishing processes. All wire is gauged for size at a final inspection before it is weighed and wrapped.

Anaconda offers a dependable service on magnet wire and on a complete line of wire and cable products. Let us discuss your 1930 requirements with you now.



Anaconda safeguards quality from mine to consumer—provides a nationwide service, prompt, dependable, complete.

ANACONDA WIRE & CABLE COMPANY

General Offices: 25 Broadway, New York
Chicago Offices: 111 West Washington St.

Magnet Wire Mills at
Muskegon, Mich.; Anderson, Ind.; Sycamore, Ill.

Sales Offices in Principal Cities



Donald McNicol, Past President of the I. R. E., Now Editorial Director of Radio Engineering

Donald McNicol, Fel. A. I. E. E., Fel. I. R. E., who for some years past has been Advisory Editor of *Radio Engineering* will, in March, 1930, actively take up the work of editing the publication.

Mr. McNicol has been closely identified with radio engineering since the beginning of the science in this country, and is a past president of the Institute of Radio Engineers. He is the author of hundreds of technical papers on radio, including the extensive work: *The Engineering Rise in Radio*, which had

a wide reading in all parts of the world, and which appeared serially in *Radio Engineering* during 1928 and 1929.

He was for four years chairman of the Committee on Communication, American Institute of Electrical Engineers, and for eight years a member of the publication committee of that Institute. He is internationally known in radio and communication circles and is the author of four standard text-books on communication subjects.

Prominent radio manufacturers assemble their receivers this easier, quicker way

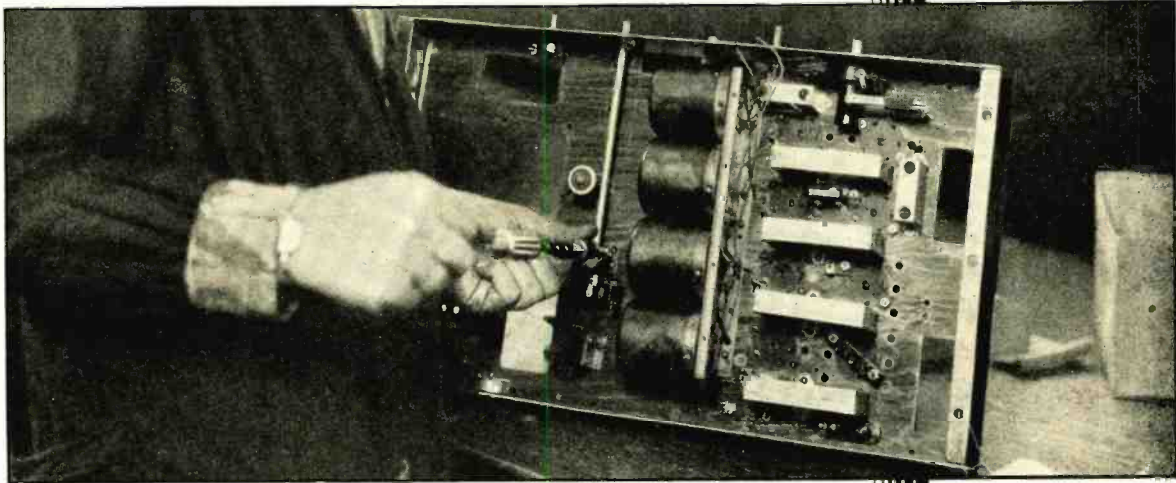

Self-tapping Screws cut time, cost and troubles on radio assemblies

Radios bearing such famous names as Philco, Stromberg-Carlson, Edison, Colonial, U. S. Radio and Television and Kolster are assembled with Hardened Self-tapping Sheet Metal Screws.

Radio manufacturers find that these unique Screws are valuable assistants in keeping costs down and production up. No other means of fastening parts securely to a chassis is so easy, quick and economical. For instance, by adopting Self-tapping Screws the Philadelphia Storage Battery Co. eliminated 44 troublesome tapping operations on each Philco receiver, and in addition, effected a saving of \$16,000 a year in time and labor.

With these Screws any unskilled workman can make a secure fastening in a single operation. No tapping necessary . . . no tapping plates required. No nuts to run on in hard-to-get-at places. Just turn a Self-tapping Screw into a drilled or pierced hole . . . it will hold as securely as a machine screw fastening, and it will not loosen as readily under vibration.

If you make fastenings to sheet metal don't fail to use the coupon. It will bring proper samples for trial on your own assemblies.

PARKER-KALON CORP., Dept. L, 190-198 Varick St., NEW YORK

PARKER-KALON
TYPE
HARDENED Z SELF-TAPPING
Sheet Metal Screws

APR. 1, 1919—NO. 1298232—MAR. 26, 1922—NO. 1411184
 PATENTED AUG. 14, 1923—NO. 1465146—FEB. 10, 1925—NO. 1526162 OTHERS PENDING

These Screws Tap their own thread

Simply turn a Self-tapping Screw into a drilled or punched hole. It taps its own thread in the metal as you turn it in—binding the sections securely together.

Test them for—

Among the many applications for which radio manufacturers use these Self-tapping Screws are: Fastening padding, power, by-pass and neutralizer condensers; condenser braces; power chokes; power and push-pull transformers; volume control shields; shield plates; wire clamps. Try them for similar assemblies.

Please send me samples of Hardened Self-tapping Screws. I want to try them out for:

Name _____

Address _____

New!

EBY PARTS

in Laminated Bakelite

SOCKETS

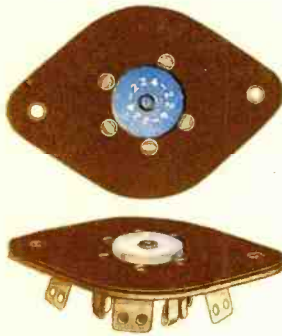

MODEL 5-27 UY

Available in any marking desired.
3500 Volts lowest breakdown point under normal conditions; 3100 volts after exposure to 90% humidity for forty-eight hours.
Mounting holes on 1-27/32" centers.
Also available in UX type.

Assembled with *two* bakelite punchings. The top plate, in addition to completely insulating the contact eyelets in accordance with approved Underwriters' Standards, also acts as a bakelite barrier between the contacts, and minimizes the chances of breakdown. Built-in guide for tube prongs. Each socket marked with number of tube to be inserted. Two eyelet assembly.



Close-up of new EBY contact plug. Punched from highest grade .012" phosphor bronze tinned in sheets. Delivers positive wiping contact at top and bottom of both sides of tube prongs. Two holes in soldering lug.

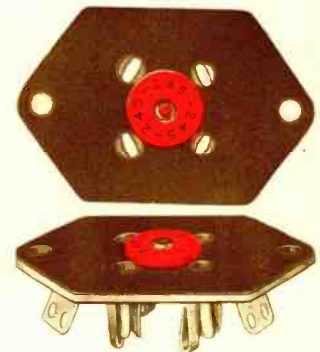

MODEL 5-9 UX

Available in any marking desired.
3100 Volts lowest breakdown point under normal conditions; 2700 volts after exposure to 90% humidity for forty-eight hours.
Mounting holes on 1-9/16" centers.
Not available in UY type.

BINDING POST STRIPS

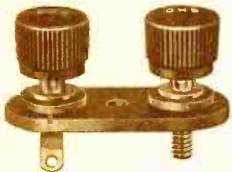

No. 2710

Assembled with posts marked ANT and GND. Ground post automatically grounded to panel and antenna post insulated. Two posts with engraved non-removable tops completely assembled and insulated with one eyelet, one nut and one soldered connection.

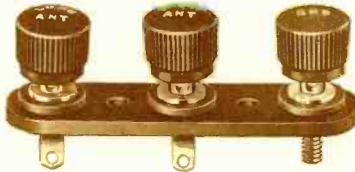

No. 2700

Assembled with posts marked LONG ANT, SHORT ANT and GND. Ground post automatically grounded to panel and both antenna posts insulated. Quick, easy and economical way to assemble and insulate three posts with engraved non-removable tops.

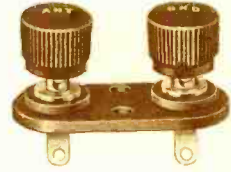

No. 2720

Assembled with two posts with non-removable tops engraved ANT and GND arranged so that both posts are insulated when unit is mounted on panel with one eyelet. Also available assembled with posts marked as desired.

TIP JACK STRIPS



TWIN JACKS

Two eyelets and two soldered connections completely assembled, insulate and mark these two jacks. Available marked PHONO, SPEAKER and FIELD. Mount sub-panel.

EBY Laminated Bakelite Tip Jack Strips are assembled with new contact prongs which deliver a positive wiping contact at the top and bottom of both sides of standard phone tips. Tips can't wobble when inserted.

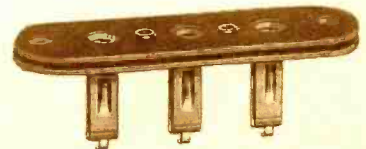

TRIPLE JACKS

Two eyelets and three soldered connections completely assemble, insulate and mark these three jacks. Available marked per specifications. Mount sub-panel.

The H. H. EBY MFG. CO., Inc.
22nd Street and Lehigh Avenue,
Philadelphia, Pa.

A New **EBY** Idea

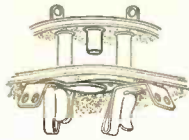

in

Plugs and Receptacles

For speaker field and voice coil connections

Two contacts short when plug is withdrawn



Base held in top of plug by small ring. Solder cable leads to lugs at top of prongs. Avoid expensive wire-stripping and soldering operation required when leads are threaded into prongs.

A brand new idea to protect filter condensers and resistors when speaker field and voice coil connections are broken.

In sets where the field coil of the speaker is part of the filter circuit, the voltage surge, when the speaker is disconnected and this much of the load is removed, may damage the condensers. In "bleeder" circuits, it may also damage resistors. By using the two contacts which short when the plug is removed for field connections, the chances of damage are minimized.



Base held in top of plug by small ring. Solder cable leads to lugs at top of prongs. Avoid expensive wire-stripping and soldering operation required when leads are threaded into prongs.

Approved by Underwriters

The EBY method of shorting two of the contacts when the plug is removed makes the prongs of the plug inaccessible while they are making contact. This feature and the excellent insulation of the plug have induced the Underwriters' Laboratories to approve this device.

For Use with Pentode Tube

Looking into the future a little, the EBY Model 2080 Plug and Receptacle has still another important application. It is ideal for speaker connections in sets using the Pentode tube. When this tube is used, field connections, when they are broken, MUST be shorted to prevent damage to the tube. All the more reason for adopting this unit as standard now!



Two of the contacts in this receptacle short when the plug is removed. Prongs of plug are, therefore, inaccessible even when receptacle is mounted flush on panel. No recessing necessary.



Two of the contacts in this receptacle short when the plug is removed. Prongs of plug are, therefore, inaccessible even when receptacle is mounted flush on panel. No recessing necessary.

Separate Plugs

Here's a plug similar in construction to the Model 2080 Plug, illustrated and described above, with the base arranged to fit into standard UX and UY sockets. When standard UX and UY sockets are used as receptacles, the contacts do not short when the plug is removed, but this plug provides a safe, economical way to make speaker field and voice coil connections. The plug is available with either four or five prongs.



Four prong plug arranged for use with standard UX sockets. Base held in top of plug by small ring. Solder cable leads directly to lugs at top of prongs. No threading leads.



Five prong plug arranged for use with standard UY sockets. Base held in top of plug by small ring. Solder cable leads directly to lugs at top of prongs. No threading leads.

The H. H. EBY MFG. CO., Inc.
22nd Street and Lehigh Avenue
Philadelphia, Pa.

THE NEW HOME OF SPRAGUE CONDENSERS · NORTH ADAMS, MASS.

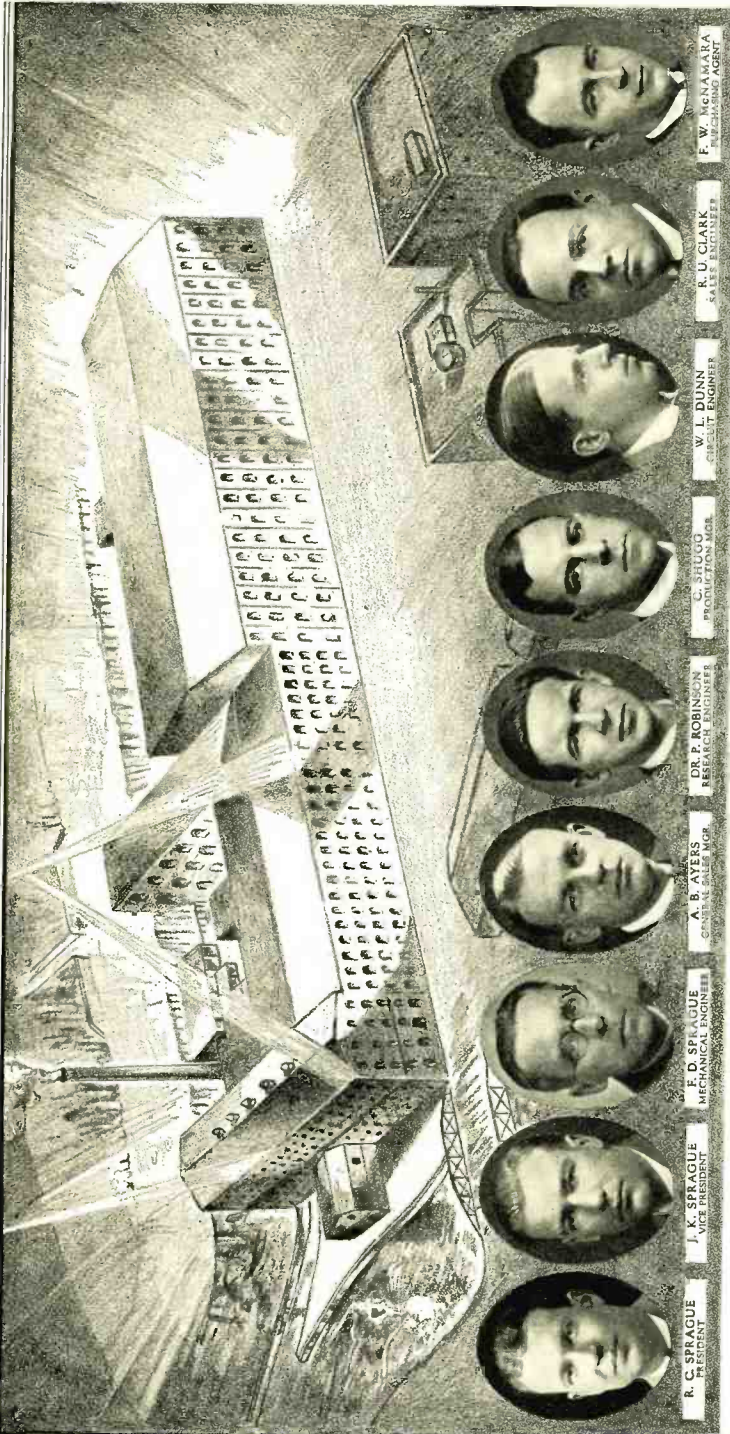

GENTLEMEN

**HAVE YOU A
CONDENSER
PROBLEM** *in your
lab?*
IF SO *we can
help you.*
WE HAVE
very extensive
RESEARCH LABS
headed by
CAPABLE ENGINEERS
*specializing in the
application and production
of*
**ELECTROLYTIC and
PAPER CONDENSERS**
TO
**HELP DESIGN AND
PRODUCE A-1
FILTER SYSTEMS
AT A LOWER COST.
HOW ABOUT
PRODUCTION?**
120,000 SQUARE FEET
in our new
PLANT *devoted entirely
to the manufacture of
condensers.*
WE ARE ONE SPECIALIST
it costs nothing
TO CONSULT.
**YOU ARE both
JUDGE and
JURY.**
**HOW ABOUT
A TRIAL?**

SPRAGUE SPECIALTIES COMPANY QUINCY, MASSACHUSETTS

SOME SPRAGUE ELECTROLYTIC OR PAPER CONDENSER.
WILL SOLVE YOUR CONDENSER PROBLEMS



MAKE YOUR OWN DIE CASTINGS

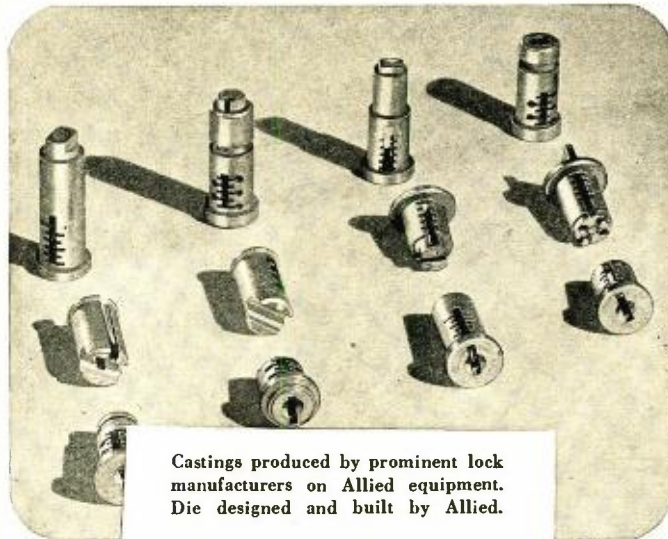

With Production—Accuracy & Finish Guaranteed by Allied.

Allied offers the advantages of even greater die casting economies.

By installing Allied Die Casting Machines, using the same dies in use for them at the Allied plant, manufacturers can produce their own die castings at still lower costs, with production, accuracy and fine finish guaranteed.

This installation includes complete engineering service in every phase of the art. Additional dies and carefully formulated alloys are always available and the entire Allied organization is at your command for consultation at all times.

A number of our customers, whose initial requirements were

produced in our plant, but whose later volume warranted the production of their own die castings are now operating Allied Die Casting Machines in their own plant under this plan.

Allied offers its customers even more than the high speed production of finer die castings, in which accuracy, strength, fine finish and low cost are inherent qualities.

The Allied Process and installation plan present the opportunity to utilize the economies of Allied Die Castings *NOW* — with the probability of even greater economies through the eventual operation of your own plant.



ALLIED DIE CASTING CORP.

LONG ISLAND CITY, N. Y.

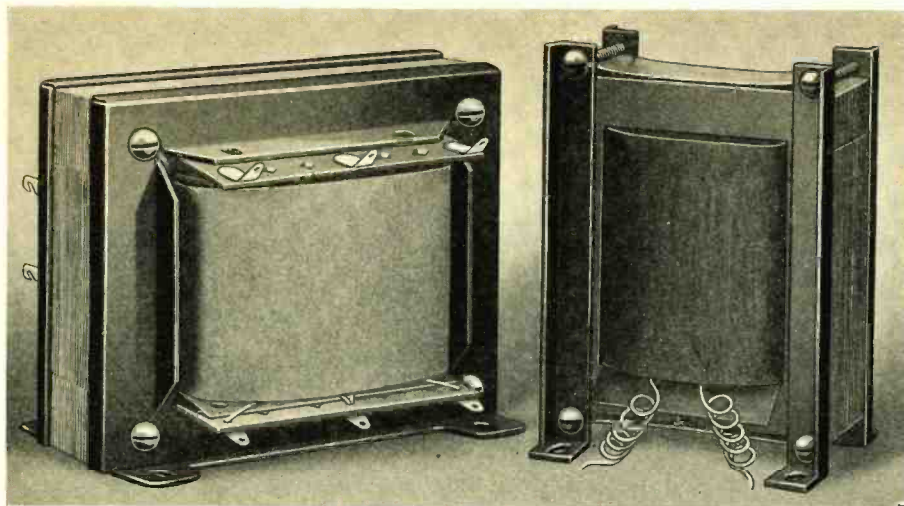

Jefferson Power Transformer and Choke for use with 245 power and 224 or 227 amplifier tubes.

Jefferson Standardization Solves Transformer Problems for All Set Manufacturers

A Reliable Source of Supply

The Jefferson policy assures dependable delivery . . . even in peak periods. Besides this important and often vital matter of sure delivery, Jefferson service includes the assistance of a corps of trained electrical engineers who are ready, if need be, to go right into your own plant and assist your own engineers in the solution of your power and amplification problems.

Now any receiving set manufacturer, no matter how small, may obtain Jefferson quality audio and power transformers and chokes. Through standardization, Jefferson can give all manufacturers the same high quality which was restricted heretofore to large producers of receiving sets.

Jefferson electrical units have proved their superior quality by many years' use in the sets of the largest and representative manufacturers. Jefferson engineers have co-operated with receiver manufacturers and aided them in the solution of their audio and power problems.

Jefferson progressiveness in the field of radio transformer development was demonstrated when the 245 power and 224 amplifier tubes were still in the experimental stage. Jefferson engineers anticipated the new electrical problems to be met and developed transformers, chokes and audios to work with these new tubes. And like other Jefferson transformer developments, they won the endorsement of quality set manufacturers.

Whether you are a large or small producer, insure the success of your set, from an electrical standpoint, by using Jefferson quality standardized units. Complete information and prices on request.

JEFFERSON ELECTRIC COMPANY
1592 S. Laffin St., Chicago, Ill.

JEFFERSON

AUDIO and POWER TRANSFORMERS and CHOKES



SOLVED!



We are happy to announce the solution of all problems in connection with the assembled 224 shield, through a new method of assembling which results in a completed part that is mechanically and electrically perfect, improved in appearance, and more economical in manufacture because shrinkage is practically eliminated.

Screen is formed into cylinder over mandril; seam solidly clinched. Cylinder is clamped to disc by expanding it into a seam under pressure. No spot welding with its inaccurate forming, loose joints, sloppy appearance.



Patent Applied for

The highest-quality materials are used throughout. Mesh strip has selvaged edge and will not fuse or split under high temperatures. We can also supply it with perforated nickel cylinder in place of the screen.

Manufactured accurately, and it reaches you accurate because packed in special containers. At your end, each part can go from its box right into the tube, removing all worry from this element of the difficult 224 tube. All of which, we beg you to note, has been *proven* in *production*. May we submit samples? Or answer questions?



GOAT RADIO TUBE PARTS, INC.

33 - 35th ST., BUSH TERMINAL BLDG. No 5
BROOKLYN, N.Y.



The new Dubilier aerial condenser is beautifully encased in

DUREZ!

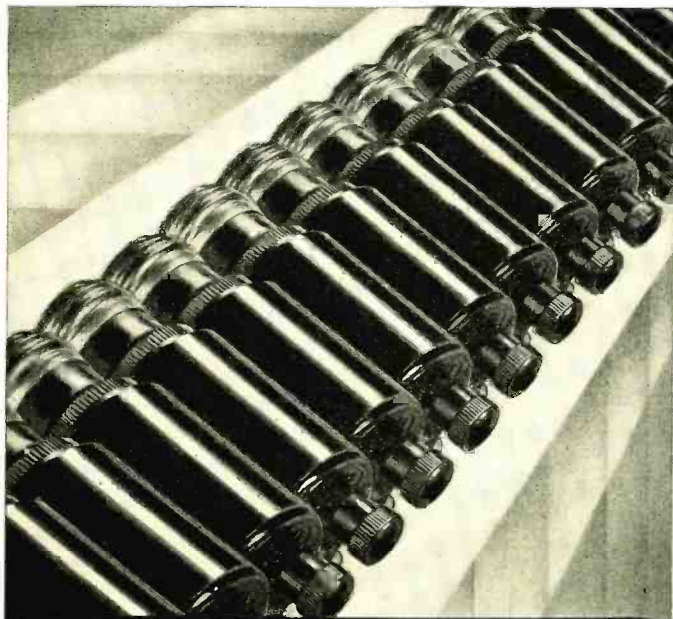

DUREZ
★ ONE, or a MILLION just like it



Write for this free booklet, "Do It With Durez." Contains complete information about Durez . . . physical and dielectric properties, color ranges, and scores of possible applications.

THE selection of Durez by radio manufacturers is seldom based on hearsay. Before they adopt the perfect molding compound, they insist upon their own rigid tests! Fair enough. *Those very tests have meant the success of Durez!* After carefully considering other materials, the Dubilier Condenser Corporation, New York, selected Durez for the beautiful modern case on the new light-socket aerial!

Why was Durez selected? . . . The socket case must be durable. Durez is hard, strong, tough, non-brittle! It must be properly insulated. Durez has high dielectric properties! *Attractive.* Durez comes in jet black, and in all practical colors and combinations of colors! *Uniform!* Every Durez part is alike, whether you make one, a hundred or a million! *And the socket case must be economical, in large quantities.* Durez comes from the mold finished, in one operation!

In that one operation, studs may be imbedded, threads and holes made, lettering molded. Threads will fit tightly, seat easily. Lettering will be sharp and distinct. . . Durez has other advantages. Light. Seldom splits or cracks. Resists acids, heat, moisture, oil, rust and corrosion. Not affected by warping nor changes in temperature. Finish permanent. And adaptable to countless products and parts!

Submit Durez to our own tests. Compare it with your present material—its ease and economy of manufacture, its durability, beauty and final economy. Whatever you make, whatever you plan to make, you owe it to yourself to investigate Durez. Write to General Plastics, Inc., at 25 E. Walck Road, North Tonawanda, N. Y. Also New York, Chicago, San Francisco, Los Angeles.



EVOLUTION



SCOVILL began the manufacture of radio condensers when the radio industry was in its infancy. It was brave pioneering back in those days of condenser development and had it not been for fundamental engineering science and manufacturing skill we feel sure that radio would just be emerging from swaddling clothes. The condenser is both the eye and the pulse of the set. There is no more graphic presentation to the engineering mind of Scovill's contributions to condenser development than to compare our first commercial effort with our product of today.

Scovill is proud of service in this direction and hopes to continue for many years its association with those leaders in the radio field who insist upon Scovill condensers.

SCOVILL
MANUFACTURING COMPANY
WATERBURY, CONNECTICUT



IN EVERY TUBE GILBY

GILBY Salvage Mesh, Gilby Filament Wire— these are the manufacturer's assurance for satisfactory performance of his tubes. Gilby products are the results of exhaustive research, the culmination of engineering skill and efficiency.

The solid, even edges of Gilby Salvage Mesh simplify welding operations and lend unusual strength to the product. The mesh is interlocked. It may be supplied within .005 plus or minus as specified. Patent Applications fully protect this material and the tube of which it is a part.

Gilby Filament Wire is recognized by many leading manufacturers as The Standard. Look for the large diameter aluminum spool, it's a Gilby Feature!

GILBY WIRE COMPANY

Wilbur B. Driver, President
NEWARK, NEW JERSEY

We will be glad to send samples of these products and to have an opportunity to work with your engineering department.

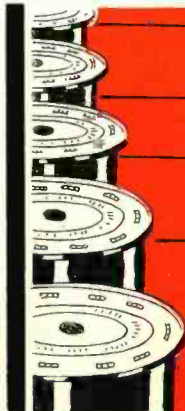

Smooth... silent ... **POWER**

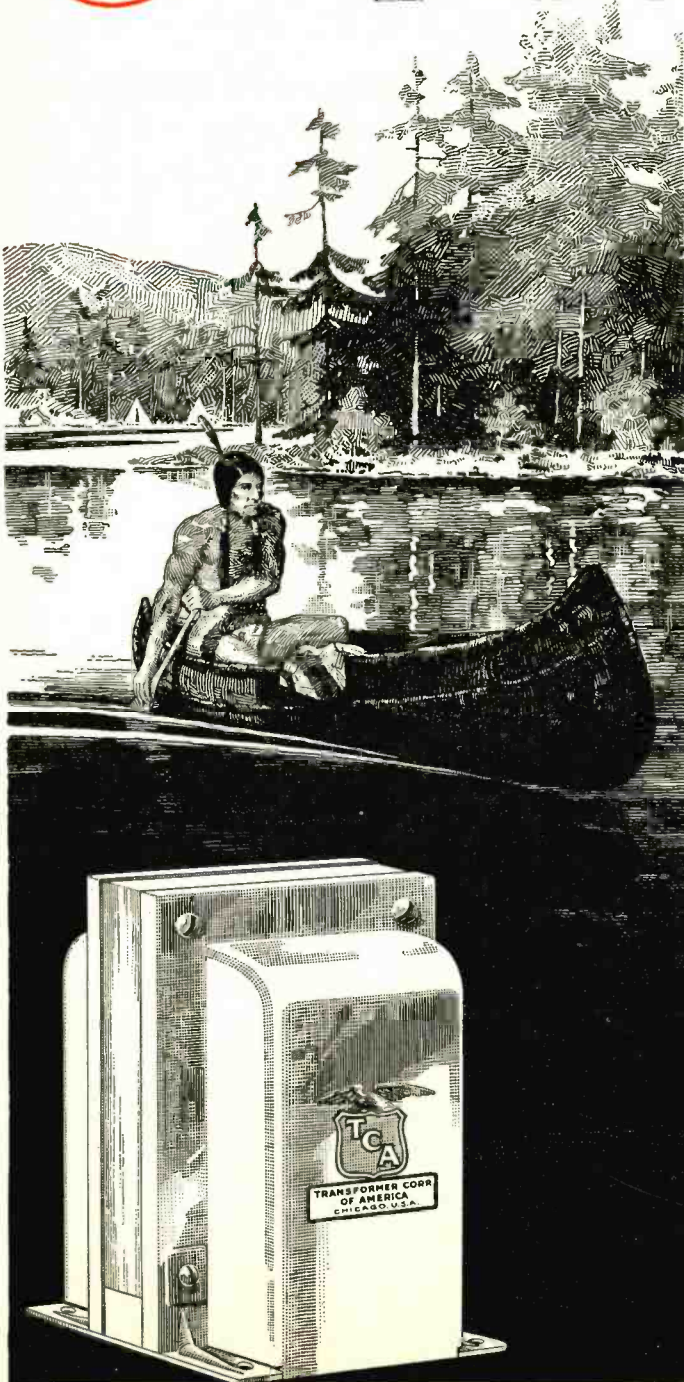

A steady, unwavering flow of energy, smooth and silent, has been the dream and the despair of radio engineers throughout the history of the A. C. Set. In these power-supply transformers, developed by T·C·A, the dream has become a reality.

Any power-pack must of necessity have adequate capacity to handle the set . . . but the quality of the output of the transformer and filter circuit is a hidden "fourth dimension" that puts real value into a radio receiver. This smooth quiet power is a composite result of scientific design, fine materials and skilled workmanship.

Only scrupulous control of every manufacturing process and minute oversight of every operation makes possible such a result on a volume production basis.

- Power Transformers**
- Power Packs**
- Audio Transformers**
- Chokes**
- Dynamic Speakers**

Engineering co-operation gladly furnished to meet your special requirements.

**TRANSFORMER CORPORATION
OF AMERICA**
2301-2319 S. Keeler Ave., Chicago, Ill.



THE METAL THAT IS "TUNED" TO RADIO

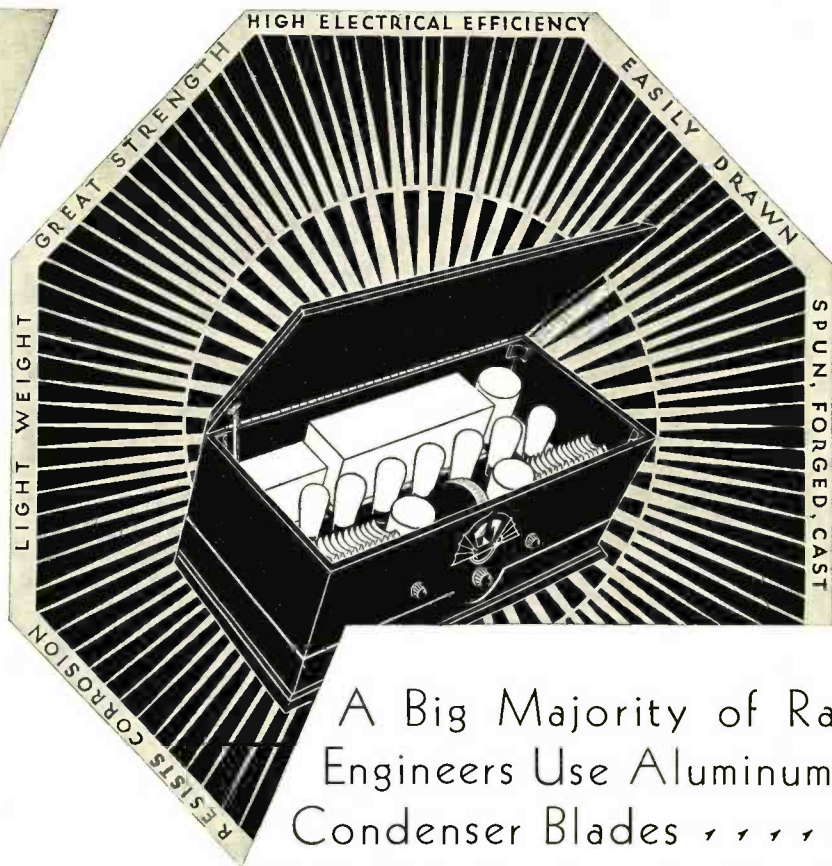

A Big Majority of Radio Engineers Use Aluminum For Condenser Blades

Use Alcoa Aluminum for condensers and your judgment is backed by the majority—by many of the keenest minds in the industry. Alcoa Aluminum condenser blades give you razor edged selectivity and greater clarity of tone.

The special Alcoa Aluminum Sheet developed for condenser blades has a gauge of split-hair tolerance limited to .001 inches. There is a total variation within one sheet never exceeding .0005 inches. Alcoa Aluminum has the highest electrical conductivity, weight for weight, of any metal used for set building.

Due to the extreme lightness Alcoa Aluminum rotor blades give easier tuning and quicker response—place less strain on the installation. Because they weigh $\frac{1}{8}$ as much as other metals commonly used, they minimize the danger of misalignment, if sets receive rough handling in shipment.

Alcoa Aluminum in its many forms is highly resistant to corrosion. It is non-magnetic. It keeps its bright, silvery appearance, an added factor in selling. Alcoa Aluminum in sheets proves the most satisfactory material not only for condenser blades but also for shields.

Rolled into foil, it makes the finest fixed condensers. It can also be cast and supplied in form of castings and of wire.

Our nearest office will gladly supply you with specific data on the application of Alcoa Aluminum for any radio construction purposes that you may have in mind. ALUMINUM COMPANY of AMERICA; 2468 Oliver Building, PITTSBURGH, PA. Offices in 19 Principal American Cities.



ALCOA ALUMINUM

From now on—



THE set manufacturer to stay in business will be the one who plays safe by refusing to take the risk of using parts of uncertain performance or dependability. When competition whets its blade and selling costs go up, it becomes increasingly important to hold assembly costs as low as possible.

Take mica condensers for example. Unless capacity ratings are accurate, a terrible burden is thrown on the inspection department and "rejects" pile up until

they exceed the stock of usable condensers on hand. It doesn't require much imagination to picture what happens to production costs under such circumstances.

When you order Sangamo Condensers you need not make over-allowances for "rejects." The reliability of Sangamo ratings is attested to by a number of nationally known radio manufacturers.

And Sangamo is equally reliable as a source of supply.

SANGAMO High Voltage Condensers

Tested at 5000 volts d. c. and 3500 a. c. and built to Sangamo standards, known throughout the radio world, amateurs, commercial men and manufacturers have learned to depend on Sangamo High Voltage Condensers. Accurately rated and adequately tested—these condensers offer the maximum protection in high voltage, high frequency circuits.

SANGAMO ELECTRIC CO.

SPRINGFIELD, ILLINOIS, U. S. A.

Manufacturers of Precision Electrical Apparatus for 30 Years



See Reverse
Side

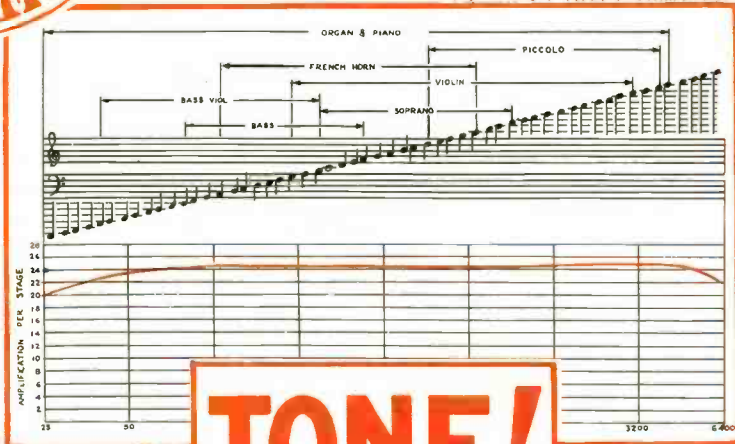
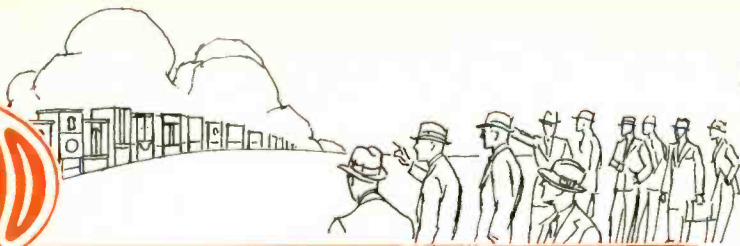

TONE!

Curve of Type "A" Sangamo Straight Audio Transformer showing uniformity of amplification at all audible frequencies.

What happens out on the "skirmish line"?

When your set goes up to the front line to meet prospective buyers—does it have an outstanding strategic advantage over competition or is it just a "long, hard pull" for your dealers?

Radio receivers must satisfy two different types of buyers. One is the amateurs who not only know the difference between good and indifferent performance but who understand what causes the difference. They are also an important recommending factor in the final purchase of all receivers.

The other type is not technical-minded but regards a radio receiver simply as a musical instrument.

To both classes *tone quality* is all-important. When a dealer tells an amateur that your set has Sangamo Transformers in the "audio end" he *knows* that the tone will be right. He also has more confidence in your set all the way through because he knows that no manufacturer who uses Sangamo Transformers will jeopardize their performance by using inferior parts elsewhere in the set. When equipped with Sangamo Transformers, your set need only be demonstrated to sell those who judge by ear alone.

Sangamo "A" Line Transformers are built for the custom set maker or manufacturer who wants a "tone" advantage over competition. The cost is slightly higher but is more than offset by the increased salability of the receiver.

"A" Line Transformers

Type A straight audio amplification, list price, \$10.00

Type B Push-pull Input Transformer for all tubes, list price, 12.00

Type C-171 Push-pull Output, for 171 or 250 type power tubes with cone speaker list price, 12.00

Type D-210, same as C except for 210 and 112 power tubes list price, 12.00

Type H-171, Push-pull Output for 171 or 250 power tubes for Dynamic Speaker list price, 12.00

Type G-210, same as type H except for 210 and 112 tubes, list price, 12.00

Type F Plate Impedance for use as a choke to prevent oscillation and for impedance coupled amplifiers, list price, 5.00





Unusual facilities for furnishing transformers with or without cases ready for mounting and quick assembly with the receiver. Prices on application.



PIN THIS TO YOUR LETTERHEAD AND MAIL
SANGAMO ELECTRIC CO.
Springfield, Illinois, U. S. A., Dept. R942

- (For manufacturers) I am interested in engineering data regarding your transformers and condensers.
- (For set builders) Please send circulars describing your apparatus and latest audio hook-ups. I inclose 10c to cover cost of mailing.

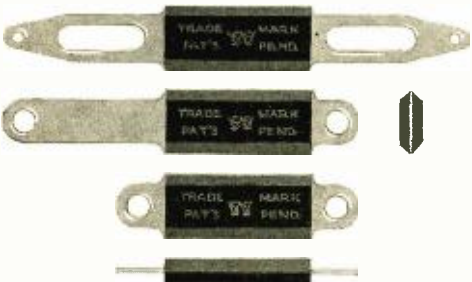
S. S. White Molded Resistance Units

Types Manufactured <i>Illustrations Full Size</i>	Type No. and Description	Normal Wattage and Mfg. Range	Engineering Data
	No. 16X Tubular type. Fits standard mountings.	1 watt 2000 ohms to 10 megohms and higher.	Construction —Molded. Material —Vulcanized mixture of rubber and conducting material. Finished units non-hygroscopic.
	No. 65X Wire pigtail type with tinned copper leads 1½" long, furnished straight or bent to shape.	1 watt 2000 ohms to 10 megohms and higher.	End Caps —Nickel-plated brass, molded in material. Lugs —Tinned copper molded in, insuring an intimate and firm attachment to the resistance material. Mfg. Tolerance —To specifications. Finished units doubly tested in insure accuracy.
	No. 25X No. 50X No. 40X Small flat type, compact, supplied with lugs as shown or to special design. Also furnished bent in shapes required for assembling.	1 watt 2000 ohms to 10 megohms and higher.	Durability —Their strength insures them against breakage. Resistance value is permanent. If overloaded, resistance increases with rise in temperature and prevents self-destruction; when cool will return to original resistance. Operation —Absolutely noiseless and fool proof against damage from excessively high voltages such as condenser discharges, etc. Severe noise tests indicate that they can be guaranteed against noisy operation.
	No. 15X Hexagonal type with threaded ends.	1.25 watts 1500 ohms to 10 megohms and higher.	Use —Are exceptionally suited for resistance-coupled amplifiers, grid leaks, voltage regulators, laboratory instruments, etc.
	No. 70X Flat, heavy duty type. Furnished with lugs as shown or to specifications. Thickness 5/32".	3 watts 1000 ohms to 10 megohms and higher.	

WHEN lives depend on reliable radio equipment it is essential that only the best material be used in its manufacture. After extensive laboratory tests the Pan American Airways chose the S. S. W. Resistance Units for the resistance-coupling in radio receivers now installed on all Pan American Transport planes. Stewart Warner, R. C. A. Communications, Wireless

Specialty, General Electric, and others are also users of S. S. W. Resistance Units.

The best in resistance units is now available to manufacturers of radio receivers, transmitters, and audio amplifying systems at attractive prices.

Manufacturers are invited to write for quotations on their requirements.

The S. S. White Dental Mfg. Co.

INDUSTRIAL DIVISION

152 West 42nd Street

New York, N. Y.



COILS OF POLYMET QUALITY

{ THAT three-fold Polymet policy—Quality, Service, and Dependability—which appeals to 80% of the RCA licensees, will prove equally advantageous to you. }

The Coilton Division of Polymet is a modern expansion of the oldest exclusive coil-winding plant in the electrical industry. New buildings, machinery and equipment, with close engineering supervision of production, insure an exactness of coil performance justifying the designs of engineers and the judgment of purchasing agents.

Coil specifications, submitted to Polymet, have prompt attention, careful fabrication, dependable delivery.

Coilton Division (*Coil Windings exclusively*)
Easton, Pa.

Strand & Sweet Division (*Magnet Wire exclusively*)
Winsted, Conn.

Address all communications to

Polymet Manufacturing Corporation

839-C E. 134th St. New York City

World's Largest Manufacturers of Radio Essentials

**Coils • Resistors • Condensers
Magnet Wire • Transformers
• Volume Controls •**

COILS FOR

- Power Transformers
- Audio Transformers
- Magnetic Speakers
- Dynamic Speakers
- Speaker Filters
- Magnetic Actions
- Ignition Devices
- X-ray Apparatus
- Small Armatures
- Chokes, Horns, etc.



With EVEREADY RAYTHEON 4-PILLAR Tubes, you can get the MOST from your present radio receiver

PEOPLE in all parts of the country are telling of the greater power, increased distance, improved tone, and quick action of these remarkable new tubes. The reason is that

Eveready Raytheons are built stronger—immune to the bumps and jolts of shipment and handling. They come to you in as perfect condition as when they leave our laboratory test room.

types. At your dealer's. He also has the famous B-H tube for "B" eliminator units.

NATIONAL CARBON CO., INC.
General Offices: New York, N. Y.
Branches: Chicago, Kansas City, New York,
San Francisco.

Unit of **UCE** and Carbon
Union Carbide Corporation



Showing the exclusive, patented Eveready Raytheon 4-Pillar construction. Note the sturdy four-cornered glass stem, the four heavy wire supports, and the bracing by a stiff mica sheet at the top.

The Eveready Raytheon 4-Pillar construction is exclusive and patented. Examine the illustration at the bottom of this page. See how the elements of this tube are anchored at eight points.

This is of particular importance in tubes of the 280 rectifier and 224 screen-grid type which have heavier elements, and in tubes used for push-pull audio amplification, where uniform characteristics are most essential. Eveready Raytheon 4-Pillar Tubes come in all



Eveready Raytheon Screen-Grid Tubes, ER 224. The weight of the four large elements in this type of tube makes the exclusive Eveready Raytheon 4-pillar construction vitally important.



Trade-marks



**hundreds of radios
daily demonstrate value
of MICARTA insulation**

PERFORMANCE of a superior character distinguishes the thousands of radio sets manufactured daily in which Micarta insulation is used. Sensitivity, selectivity and tonal qualities depend upon unimpaired insulation.

The finest instruments usually have antenna and oscillator coils wound on Micarta tubing. Tip-jacks, trimmer condensers, connector plates, terminal strips, sub and tube-panels, and other parts are readily made from Micarta sheets.

Micarta has high dielectric and mechanical strength, and will not warp, splinter or absorb moisture.

The Micarta Fabricators Inc. are offering you the advantages of their broad experience in the fabrication of Micarta into finished parts. The preparation of dies, the punching of plate stock, the punching and threading of tubing, the intricacies of process lettering and engraving require knowledge acquired only after years of practice.

For information write to:

Micarta Fabricators, Inc.
233 Spring Street 500 South Peoria Street
New York, N. Y. Chicago, Ill.



WESTINGHOUSE ELECTRIC & MFG. COMPANY
EAST PITTSBURGH PENNSYLVANIA
SALES OFFICES AND SERVICE SHOPS IN ALL
PRINCIPAL CITIES OF THE UNITED STATES

Westinghouse

T 30901



Smooth flowing POWER!



THIS shows the exclusive rocking disc construction of Centralab volume control. "R" is the resistance. Contact disc "D" has only a rocking action on the resistance. Pressure arm "P" together with shaft and bushing is fully insulated.

LIKE a deep smoothly flowing stream the volume control on your radio, if it is a CENTRALAB, delivers a constant, uninterrupted flow of power that results in the purest, finest tone.

The most famous American radios are CENTRALAB equipped. Is yours?



This is the action of the usual wire wound control after it has been in use for some time . . . like dragging a stick over a cobblestone pavement.



The tailor uses the same principle as Centralab. He does not want to ruin the garment by placing the iron on it so he places a cloth in between. Centralab controls can not ruin the resistance because the rocking disc is in between the pressure arm and the resistance.

Write for our Free Booklet "Volume and Voltage Controls—Their Uses."

Centralab

CENTRAL RADIO  LABORATORIES

Dept. 212 B., 16 Keefe Ave.

Milwaukee, Wis.

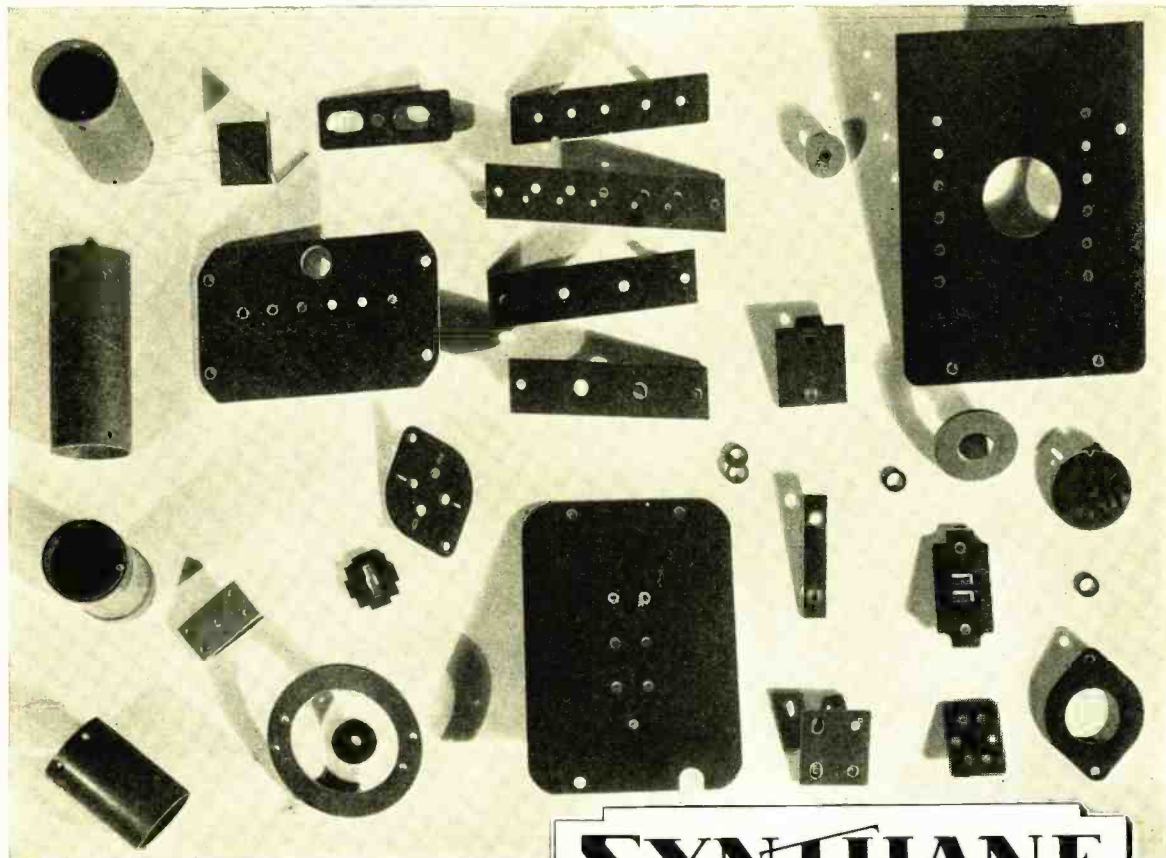

SYNTHANE

Laminated Bakelite

Is Made Especially For You

No matter whether you make parts or complete sets, you will find Synthane, uniform laminated Bakelite particularly adaptable to your specifications.

These standard grades of Synthane (designated by the new N. E. M. A. nomenclature), together with supplementary grades for special applications, cover every requirement of the radio industry. It will pay you to test Synthane and prove to yourself its uniform superiority of performance under all conditions.

GRADE X . . . FOR GENERAL USE:

Paper base, furnished in Natural, Chocolate Brown surface natural core, and Black surface natural core.

Thickness from .015 inch and up; punches up to 1-32 inch cold, and when heated, to greater thicknesses, machines readily.

GRADE XP . . . ESPECIALLY MADE FOR PUNCHING OPERATIONS:

Specially processed paper base material for punching operations, furnished in Natural; Chocolate Brown with natural core; Black surface natural core; Solid Black; Chocolate Brown with shiny or satin finish.

Punches and shears cold up to 3-32 inch; punches and shears in thicker sizes depending on the design of the die and temperature of material.

GRADE XX . . . FOR EXTREMELY LOW MOISTURE ABSORPTION AND FINE MACHINING:

Paper base, furnished in Natural and Black. Thickness from .015 inch up. Machines readily. Low Moisture Absorption.

GRADE C . . . FOR EXCEPTIONAL STRUCTURAL STRENGTH:

Canvas base, furnished in Natural and Black.

For application where highly resilient insulation is required. Punches readily. Structural qualities make it usable where high tensile and transverse strength is required, in connection with good insulating properties, widely used for its mechanical properties.

GRADE L . . . FOR FINE MACHINING:

Linen base, furnished in Natural and Black. Thickness from .015 inch up, but usually required not over 1/8 inch. Applicable for fine machining.

Variations from these standard grades are made to suit individual requirements. A grade of Synthane, once established to your specifications, will be uniformly the same in all subsequent shipments.

We invite you to send specifications for samples.

SYNTHANE

CORPORATION OAKS · PENNA

NEW YORK, CHICAGO, CLEVELAND, SAN FRANCISCO

Sheets, Rods, Tubes, Fabricated Parts

MERSHON
ELECTROLYTIC
CONDENSER



Why

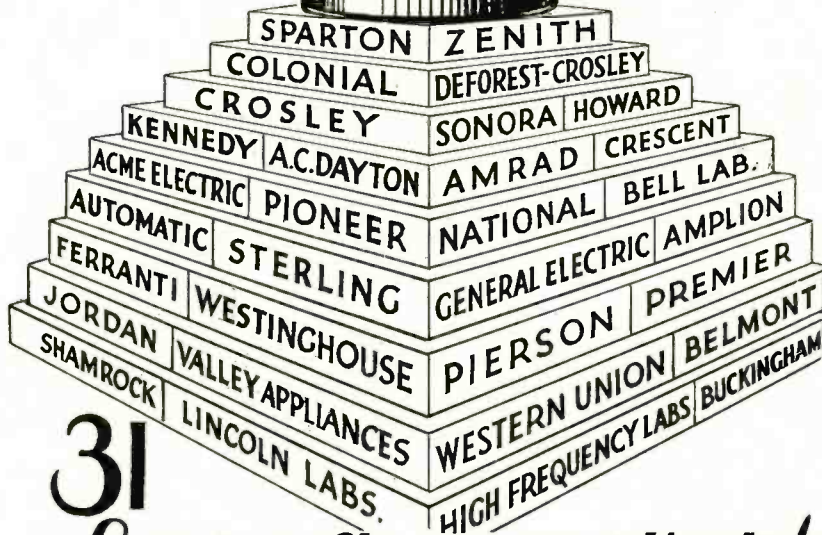

31
Leaders Choose and Use It!

Thirty-one leading radio manufacturers specify the Mershon Electrolytic Condenser as standard equipment.

It has enormous capacity in small space
—72 MFD. in 32 cubic inches.

- saves weight
- self-healing
- humless

The Mershon costs less per microfarad than ordinary condensers, is practically indestructible and makes possible a reduction in size and weight of chassis while assuring uninterrupted efficiency.

The experience records of manufacturers using the Mershon Condenser as well as those of our own laboratories are available to engineers in designing their new Power Packs. Bulletins, diagrams and a consulting service are yours for the asking. Write today.

SELF-HEALING

Mershon Department R-1
THE AMRAD CORPORATION
Medford Hillside Mass.
Please send full information about the
Mershon Condenser to:
Name
Address

IMPRESSIONS *and* EXPRESSIONS

By

AUSTIN C. LESCARBOURA

Why Should Radio Be Different?

WHERE are those remarkable opportunities for radio men which we hear so much about? That is the theme song of the choir that greets anyone who attempts to mention remarkable radio opportunities in public speech or print. There are tens of thousands of so-called radio men ready to lynch the enthusiastic radio speaker or writer, in thought if not in deed.

Well, we have personally looked into the situation. We have gone over a batch of requests received from various radio and allied industries seeking competent men for good positions. And we have gone over the examination papers of many applicants for such positions. The painful truth which we must tell at this time is that radio industries, as well as industries borrowing from the radio technique, have gone beyond the haywire, soldering iron and pliers stage. The handyman of yesteryear has no place in the radio work of today.

Does a diploma in medicine, law, journalism, engineering or chemistry qualify its recipient to a top-notch, outstanding, splendidly remunerated position? Certainly not! A diploma is merely an invitation to roll up one's sleeves and begin learning the real thing through practical experience. Why should radio be any different? Why should radio graduates seek top-notch positions without first obtaining practical experience?

There is no shortage of radio opportunities. The main trouble just now is a very serious shortage of men who know their radio. If those who would find fault with radio opportunities would first of all analyze themselves critically, or at least take the examination for one of those good jobs, they would soon learn where the trouble rests.

Business Picks Up

THINGS are looking up in the radio industry. During the past thirty days we have noticed revived activity in many organizations, mainly along the line of a healthy flow of orders. Vacuum tube manufacturers particularly are getting closer to a normal basis for this time of the year, several of them reporting sales better than 50 per cent of their usual volume. Radio sets and accessories are selling, too, at an estimated 35 to 50 per cent of normal volume.

It is obvious that the industry is intent on disposing of its large inventory before plunging into new production, although on all sides we note the customary engineering and designing activities. The most excellent products offered the public during the past season, have set a high mark for the forthcoming season's offerings. Engineers have a real task before them, but, fully aware of that fact, they can be counted upon to exceed all previous engineering and production achievements.

Sales organizations are being rebuilt, or at least strengthened, from the general sales manager to the ultimate dealer. Merchandising plans are being revised and made more attractive than ever. Servicing organizations are being perfected.

Who knows but that the temporary lull just passed through may prove the greatest possible blessing in disguise, since a young and impetuous industry, hitherto unable to rest for breath and thought, has for once been able to engage in some solid thinking?

Price Slashing and Instalment Buying

THERE is a sad echo these days to the frantic price-slashing parties that have been going on in the radio set field. We refer to the situation of the radio dealer in the small town, where good trade and good-will have been painstakingly built up, only to be smashed overnight by the near-sighted policies of radio set manufacturers bent on seeking the easiest way out of a dull market, usually at the suggestion of a sales force too weak to go out and fight for business.

The situation we have unearthed works out as follows: Dealer A sells the latest radio set to Customer B, who pays 20 per cent down and assumes a purchase contract for the balance on monthly instalments. Customer B is delighted. He feels he has had his money's worth, even at full list price. Dealer A has made a clean sale and money. Manufacturer C, of that set, is also happy, as is Jobber D. Three months have passed, as they say in the movies. Manufacturer C, probably inspired by Jobber D, is worried about his increasing inventory, due to over-production on the one hand, and to a weak selling force on the other. Upon the advice of his sales manager, he drops the price to half or less.

Now let us flash to the small town. Customer B, who has paid probably a third so far on his radio, reads the advertisements to learn that his set is being offered at 50 per cent of the original price. Why, he asks himself in indignant rage, should he play sucker? Why continue to pay off at the original price? Why not cancel the contract, return the set to the dealer, and buy at the new cut rate? And so he does, with sad results for the dealer, who is money out of pocket, in bad with the finance company, and rapidly losing prestige as an honest merchant.

When will the radio manufacturers learn what their price-slashing orgies lead to? Answer: When they become far-sighted instead of near-sighted.

The Zero Hour Approaches

THE radio industry cannot be censured for desiring to dispose of its inventories before proceeding to the next season's products. However, we note that many materials and parts manufacturers are compelled to stand by, waiting for orders that are bound to come, while the shelves are being cleared off.

Once more, therefore, we are face to face with the greatest curse of our infant radio industry, namely, seasonable and rush production schedules. Materials and parts purveyors fully expect their many bright prospects to materialize overnight into a veritable avalanche of orders. They await the zero hour, backed by more equipment and provisions for the necessary operating personnel, than ever before. Meanwhile, however, they are relatively inactive.

Would it not be the part of good business to be ordering materials and parts at this time? Admitting, as we have, that the shelves have not yet been cleared of last season's products, would it not be possible to place orders for the materials and parts which will be required for the next season's products? In many instances the designs and specifications have been completed. Surely better prices and better terms can be obtained now, when the supply exceeds the demand, than in a few months when every radio manufacturer will be calling frantically for materials and parts, with demand overwhelming supply.

All Worthy of the Name

de Forest

REG. U. S. PAT. OFF.



AUDION 511



AUDION 422A

The new D. C.
Screen Grid
Audion for
Portable Sets

The De Forest reputation for engineering skill and painstaking precision has been zealously guarded in the production of all De Forest receiving and transmitting Audions. The De Forest Engineering staff is continually bringing out new developments which will be announced from time to time in this publication.

Transmitting Audions

- 510—15 Watt Oscillator.
- *503A—50 Watt Oscillator and R. F. Power Amplifier.
- *511—50 Watt Oscillator, R. F. Amplifier, Modulator or R. F. Power Amplifier.
- *545—50 Watt A. F. Amplifier and Modulator.
- 552—75 Watt Oscillator and R. F. Amplifier.
- 504A—250 Watt Oscillator, Modulator or R. F. Power Amplifier.
- 500—500 Watt Special Oscillator.
- 520B—5000 Watt Oscillator and R. F. Power Amplifier—water cooled.
- 565—7½ Watt Screen Grid R. F. Amplifier.
- 560—75 Watt Screen Grid R. F. Amplifier.
- 561—500 Watt Screen Grid R. F. Amplifier
- *566—A half-wave hot cathode, mercury vapor rectifier. Medium Current.
- 572—A half-wave hot cathode, mercury vapor rectifier. Heavy Current.
- 601—Vision Neon Lamp.
- 602—Photo Electric Cell.

422—Long life, oxide-coated filament which insures ample emission. Interchangeable with standard—22 type tubes but with a higher actual gain per stage because of lower plate resistance and high mutual conductance. Non-microphonic, because of special design of filament and rigidly supported elements.

*422A—Valuable for portable installations. Filament rating .06 amp. at 3.3 volts. Operating characteristics and life same as 422.

*499—Non-microphonic long-life—99 type tube. Valuable for portable work. Sturdy and uniform. Containing the special oxide-coated filament standard with all De Forest receiving Audions.

*503A—An improved “50 watter” interchangeable with standard—03A types. Especially valuable as a medium power, self-excited oscillator or radio frequency power amplifier.

*511—Audion 511 is similar in construction to 503A but also suitable as an audio-frequency amplifier as well as an oscillator and radio frequency power amplifier. Interchangeable with standard—11 types.

*545—Designed especially as a modulator or audio-frequency power amplifier. Interchangeable with standard—45 type Transmitting tubes.

*566—A high grade hot-cathode mercury vapor rectifier. Especially designed to prevent breakdown between anode and filament. Filament rating 2.50 volts at 5 amps. Max. inverse peak, 7500 volts.

For further information consult
your local dealer or address—

DE FOREST RADIO CO.
Passaic New Jersey

Receiving Audions

- 401A—Detector-Amplifier.
- 410—Power Amplifier.
- 412A—Detector - Amplifier, Power Amplifier.
- *422—Standard D. C. Screen Grid Amplifier.
- *422A—A 60 m.a. D. C. Screen Grid Detector-Amplifier.
- 424—A. C. Screen Grid Amplifier.
- 426—Amplifier (A. C. Filament).
- 427—Detector-Amplifier (A. C. Heater Type).
- 440—High Mu Audion.
- 445—A. C. Power Amplifier.
- 471A—Power Amplifier, Last Audio Stage.
- 471B—Power Amplifier, Last Audio Stage.
- 480—Full Wave Rectifier (125 M. A.).
- 481—Half Wave Rectifier (110 M. A.).
- 450—Power Amplifier.
- *499—60 m.a. General Purpose.

WHAT DO YOU DEMAND IN LAMINATED PRODUCTS?

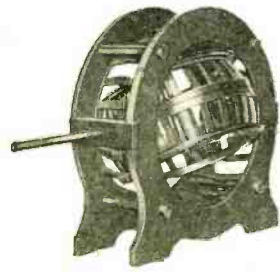
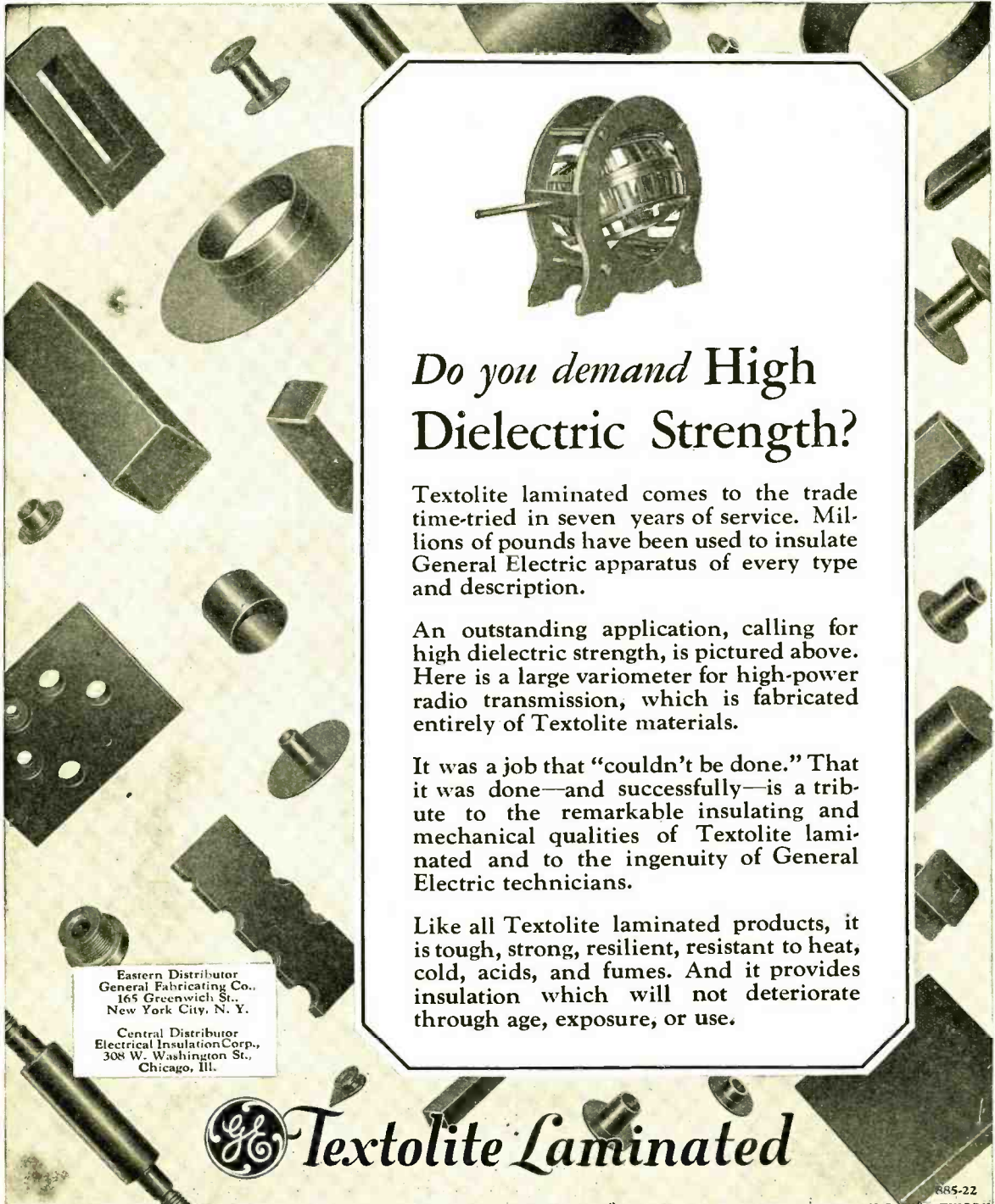

Do you demand High Dielectric Strength?

Textolite laminated comes to the trade time-tried in seven years of service. Millions of pounds have been used to insulate General Electric apparatus of every type and description.

An outstanding application, calling for high dielectric strength, is pictured above. Here is a large variometer for high-power radio transmission, which is fabricated entirely of Textolite materials.

It was a job that "couldn't be done." That it was done—and successfully—is a tribute to the remarkable insulating and mechanical qualities of Textolite laminated and to the ingenuity of General Electric technicians.

Like all Textolite laminated products, it is tough, strong, resilient, resistant to heat, cold, acids, and fumes. And it provides insulation which will not deteriorate through age, exposure, or use.

Eastern Distributor
General Fabricating Co.,
165 Greenwich St.,
New York City, N. Y.

Central Distributor
Electrical Insulation Corp.,
308 W. Washington St.,
Chicago, Ill.

 *Textolite Laminated*

JOIN US IN THE GENERAL ELECTRIC HOUR, BROADCAST EVERY SATURDAY AT 9 P.M., E.S.T. ON A NATION-WIDE N.B.C. NETWORK

GENERAL ELECTRIC

GENERAL ELECTRIC COMPANY, SCHENECTADY, N. Y., SALES OFFICES IN PRINCIPAL CITIES

885-22



Application of Screen Grid Tubes to Audio Frequency Amplifiers[†]

Relative to the Construction of Proper Circuits Suitable to the Characteristics of the Typical Screen-Grid Tube

By John J. Glauber *

THE advent of the photo-cell, condenser microphone, and other minute voltage generators has made it imperative to develop audio-frequency amplifiers possessing a high overall amplification, so that devices requiring considerable voltage or power may be operated by them. Such amplifiers employ many stages in cascade, and are therefore cumbersome and costly. It is the purpose of this paper to show how the screen-grid tube may be applied to such amplifiers.

The discussion will be limited to the type 24 a-c. screen-grid tube when used so that the grid nearer the cathode is the control electrode, the outer or screen grid having a fixed positive d-c. potential with respect to the cathode. The deleterious effects produced at the higher frequencies, due to the high amplification factor and the large interelectrode capacity existing between the plate and the adjacent control grid excludes its use as a space charge tube.

Fig. 1 shows the variation of amplification factor, plate resistance and mutual conductance with screen-grid voltage, ($E_{gc} = -1.5$ volts, $E_p = 180$ volts). By varying the screen-grid potential the tube characteristics may be changed materially. It is important to determine that particular value of screen potential necessary to give maximum amplification. Since a vacuum tube may be considered as an a-c. generator having a very high internal resistance, its voltage output will be a function of the impedance of the load. For maximum voltage output it is necessary to make the load impedance as high as possible. The circuit for such a device is shown in Fig. 2.

Where:

- μ = amplification factor of tube
- e_c = a-c. input voltage to tube

[†] Delivered before the Radio Club of America, December 11, 1929.

* Engineering Dept., Pacent Electric Company.

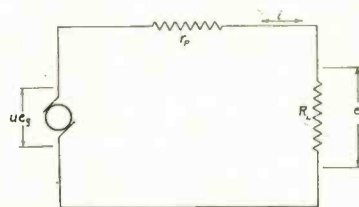

Figure 2

- μe_c = voltage generated in plate circuit
 - γ_p = internal resistance
 - R_L = load impedance, taken as pure resistance for simplicity
 - e_L = output voltage
- It may be shown that
- $$\frac{e_L}{e_c} = \frac{\mu R_L}{\gamma_p + R_L} = A \quad (1)$$

where A represents the stage voltage amplification. Since it is more difficult to measure the plate resistance of high-impedance tubes than the amplification factor and mutual conductance (G_m) it is desirable to eliminate γ_p from equation (1). It may be shown that the mutual conductance of a vacuum tube, i. e., the change in plate current

produced by a change in grid voltage is

$$G_m = \frac{\mu}{\gamma_p} \quad (2)$$

Substituting equation (2) in equation (1)

$$A = \frac{\mu G_m R_L}{\mu + G_m R_L} \quad (3)$$

Equation (3) is accurate up to 10,000 cycles per second, above which a correction must be applied for the reactance in shunt with R_L due to the interelectrode capacity between plate and screen grid. The screen is at the potential of the cathode as far as a-c. is concerned, since a large bypass condenser is always used between cathode and screen. The reactance in shunt with R_L will reduce the amplification per stage A.

By substituting various values in equation (3) for R_L and values of μ and G_m corresponding to various shield potentials from Fig. 1 a family of curves showing the relationship existing between the amplification per stage and shield potential was plotted and is shown in Fig. 3. The maximum amplification obtainable in-

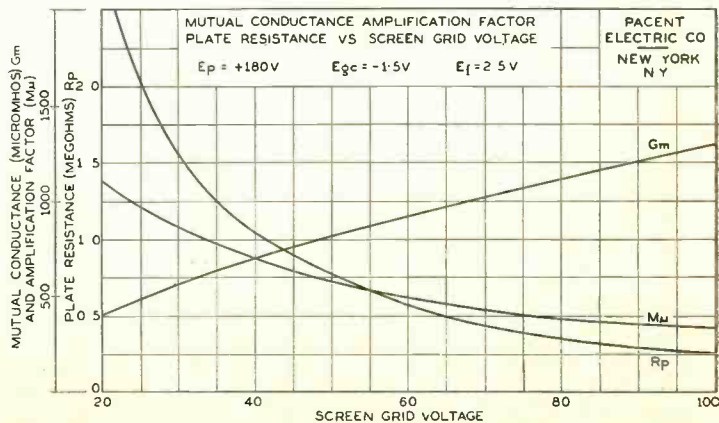

Figure 1

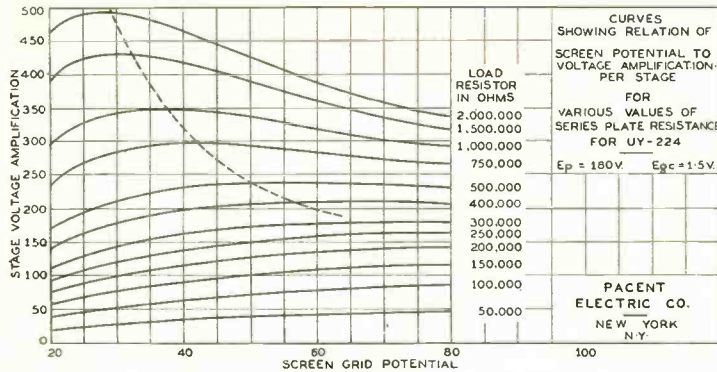

Figure 3

sistance and, for each value of load resistor there is a definite shield potential for maximum amplification.

To determine the d-c. operating point a family of curves showing the relationship between plate potential in volts (E_p) and plate current in milliamperes (I_p) for shield potentials (E_{gs}) of 20, 30 and 40 volts, for a constant control-grid bias of negative 1.5 volts, is shown in Fig. 4. With 500 volts assumed as the available potential at the source, load lines of 0.5, 0.75, 1.0, 1.5 and 2.0 megohms were drawn. The slope is the reciprocal of the resistance expressed in ohms. If projected to the right all load lines would intersect the X-axis at $E_b = 500$ volts. The 1.5 and 2.0 megohm lines intersect the E_p - I_p curves shown where the plate voltage is equal to or less than or but slightly greater than the screen potential. In this region the relation between E_p and I_p is non-linear and varies considerably for different tubes of the same type. If curves were plotted for control-grid biases less than and greater than negative 1.5 volts, for each value of shield potential shown, curves parallel to those shown would have been obtained. That is, there would be a family of three parallel curves for each value of shield potential. For distortionless amplification it is essential that the load line intersect the particular family at which it is desired to operate, at points having the same slope. This obtains at the higher plate potentials where the E_p - I_p curves are substantially linear. For the UY-224 the plate potential should not be less than 135 volts. The point of intersection of the load line with the E_p - I_p curve may be shifted by decreasing the screen potential, by increasing the control-grid bias or by increasing the plate supply voltage. To obtain maximum amplification from the 2-megohm resistor requires $E_{gs} = 30$, $E_p = 180$ and $I_p = 0.81$. The plate supply voltage required would be $E_b = 1800$ volts. The 1.5 megohm load would require $E_b = 1395$ volts. The 1 megohm load requires $E_{gs} = 37.5$ volts for maximum amplification (see Fig. 3). It would also intersect the E_p - I_p curve in the unstable region (see Fig. 4). Exami-

nation discloses that it intersects the E_p - I_p curve for $E_{gs} = 20$ at $E_p = 180$ volts. This is a desirable operating point and the decrease in amplification from the maximum obtainable is not sufficient to warrant increasing the plate supply voltage to 1385 volts.

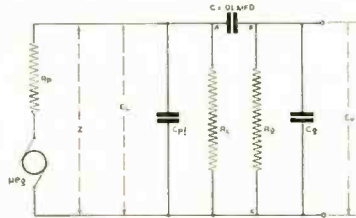

Figure 5

Thus far only a pure resistance to determine the operating point has been considered. To be of any use the output must be coupled to a succeeding tube or device. Since the impedance in the plate circuit determines the a-c. amplification, it is important to know the impedance of the coupling system over the useful frequency

range. The output of the tube may be coupled without further voltage amplification to a power tube, or if greater amplification is required, to one or more stages in cascade and then into a power tube. It will be assumed that the output of the screen-grid tube is to be coupled to the input of a type '27 tube.

The high plate impedance of the screen-grid tube excludes transformer or impedance coupling. Only resistance and direct coupling remain. Since direct coupling is merely a simplification of resistance coupling, and as it usually gives a much poorer frequency response over the audio range, (due to the high input capacity of the following tube) when high values of load resistance are used, the analysis of the coupling system will be limited to the conventional method of resistance coupling. The equivalent of such a circuit is shown in Fig. 5.

Where:

- $\mu e_g, \gamma_{p'}$, E_L and R_L are as for Fig. 2
- C_{pt} = output capacity of tube (approx. 12 mmf.)
- C = coupling condenser (.01 mf.)
- R_g = grid resistor
- C_s = input capacity of succeeding tube (approx. 39 mmf. for UY-227)
- E_o = voltage applied to succeeding tube
- Z = impedance in output circuit of generator

For such a network the impedance

$$Z = \frac{R_L [1 + j \omega R_g (C_g + C)]}{1 - \omega^2 R_L R_g (C_g C_{pt} + C_{pt} C + C_g C) + j \omega (R_g C_g + R_g C + R_L C_{pt} + R_L C)}$$

Rationalizing and collecting terms

$$Z = \frac{R_L [1 + \omega^2 R_g \{ R_g (C_g + C)^2 + R_L C^2 \}]}{1 + \omega^4 R_L^2 R_g^2 (C_g C_{pt} + C_{pt} C + C_g C)^2 + \omega^2 [R_g^2 (C_g + C)^2 + R_L^2 (C_{pt} + C)^2 + 2 C_g C_{pt} C + C_g^2 C + C_{pt} C^2 + C_g C^2]} + 2 R_g R_L C^2]$$

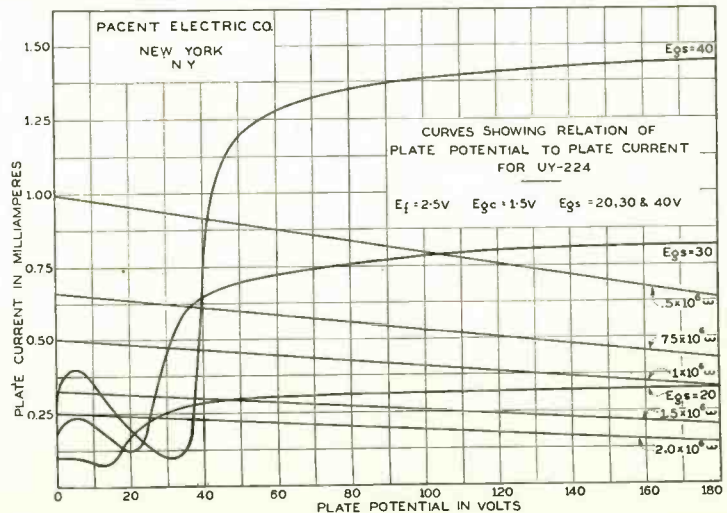

Figure 4

C_{pt} and C_g are usually negligible compared to C , the resistive and reactive components of Z become:

$$R_s = \frac{R_L [1 + \omega^2 R_g C^2 (R_g + R_L)]}{1 + \omega^4 R_L^2 R_g^2 C^2 (C_{pt} + C_g)^2 + \omega^2 C^2 (R_g + R_L)^2} \quad (4)$$

$$-jX_s = \frac{-jR_L [\omega R_L C + \omega^3 R_L R_g^2 C^2 (C_{pt} + C_g)]}{1 + \omega^4 R_L^2 R_g^2 C^2 (C_{pt} + C_g)^2 + \omega^2 C^2 (R_g + R_L)^2} \quad (5)$$

$$Z = R_s - jX_s$$

Both components vary with frequency. For given values of R_L and R_g the capacities C_{pt} and C_g are important factors in determining the value of Z at the higher frequencies, while C is important in determining the value of Z at the lower frequencies. If $C_g = 0 = C_{pt}$, equations (4) and (5) become

$$R_s = \frac{R_L R_g}{R_g + R_L} \quad (6)$$

$$-jX_s = \frac{-jR_L^2}{\omega C (R_g + R_L)^2} \quad (7)$$

when C is large.

In Fig. 6 are plotted curves, computed from Eq. (4) and (5), of the impedance Z of Fig. 5 for a few combinations of R_L , R_g and C_g ; the constants being given in the figure. The

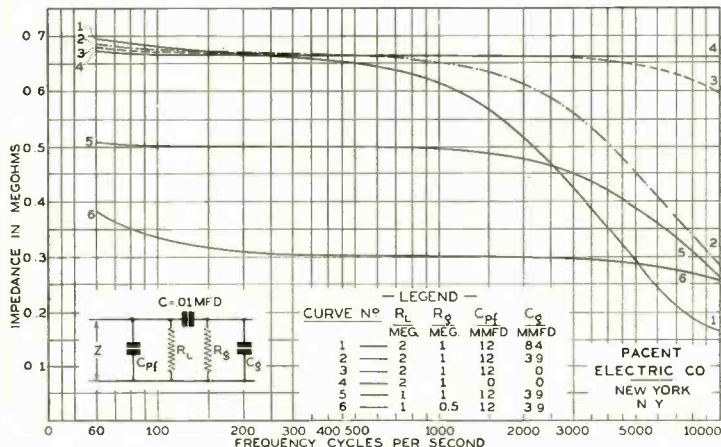

Figure 6

ideal frequency-impedance characteristic is a straight line of zero slope. The higher the impedance the greater will be the amplification obtainable. It is important to note how the impedance varies from the ideal with high values of R_L and R_g when C_{pt} and C_g are present. The ideal characteristic is shown by curve 4 and was computed for $C_{pt} = 0 = C_g$. Curve 3 was computed for $C_g = 0$ and $C_{pt} = 12$ mmf. Comparing curves 1, 2, and 3, which differ only in the value of C_g the reduction in impedance at the higher frequencies due to the input capacity C_g of the 27-type tube is shown. For a three-element tube,

$$C_g = C_{pt} + C_{gp} \left(\frac{\mu R_L}{R_L + \gamma_p} + 1 \right)$$

where:

C_{gp} = direct grid to cathode capacity

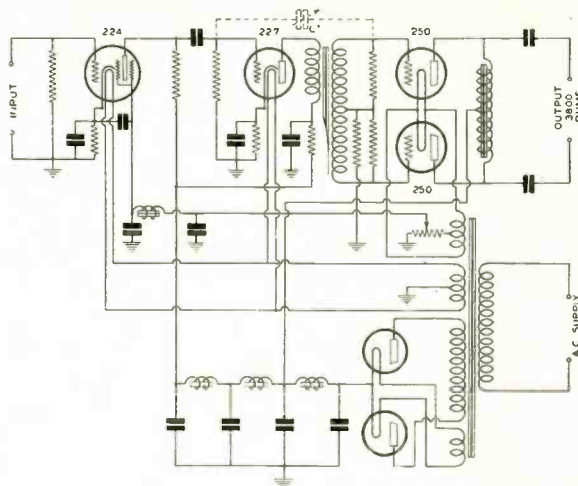

Fig. 8. Complete circuit diagram of an amplifier. Incorporating a screen-grid tube resistance coupled to a 27 tube.

C_{pk} = direct grid to plate capacity
 R_L is assumed to be large compared to r_p .

For a 27 tube C_g is approximately 30 mmf. However, due to the socket and wiring capacities this may, if care is not exercised, be increased to 100 mmf. To approach the ideal fre-

quency-impedance characteristic the values of R and R_g should be so chosen that each is less than the capacitive reactance in shunt with it at the highest frequency to be reproduced. In Fig. 7 is shown the computed amplification, obtained by substituting Z for R_L in equation (3), for the UY-224 if the optimum value of screen potential for $R_L = 1$ megohm were used ($E_{gs} = 37.5$) and for the actual potential used ($E_{gs} = 20$) for values of $R_g = 0.5$ and 1 megohm. The dash-line curves shown at the low-frequency end of each solid line curve is the amplification available at E_o , Fig. 5. This is the amplification available across the input circuit of the following stage. This was obtained by multiplying E_L by the ratio of the impedances BC to AC. Above 500 cycles the coupling condenser reactance is negligible compared to R_g and from there on the dash and solid line curves coincide. The dot-dash curve is the actual amplification obtained from test for $R_L = 1$ and $R_g = 0.5$ megohm. A variable frequency input was fed to the control grid of the UY-224, the output voltage E_o being measured by a high input impedance vacuum-tube voltmeter. The prox-

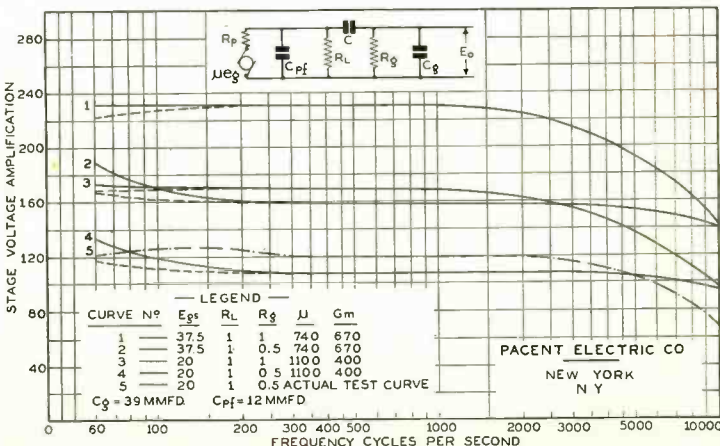

Figure 7

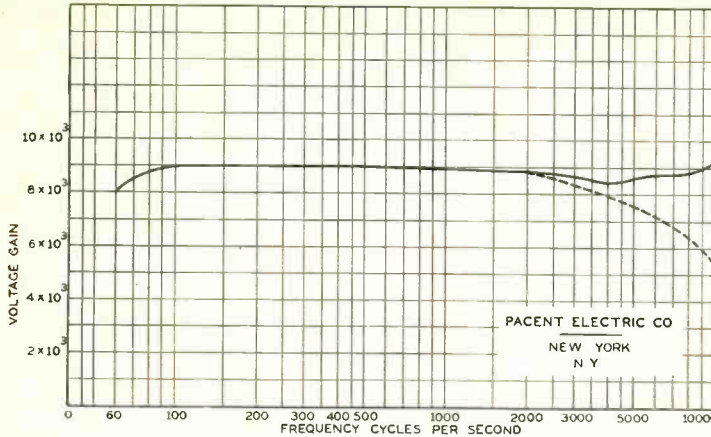

Figure 9

imity of the test curve to the computed curve for identical values of R_L and R_g shows the accuracy with which the gain of a tube and its coupling system may be computed. The more rapid falling off at the higher frequencies is due to stray capacities unaccounted for in the computed results.

Fig. 8 is the complete circuit diagram of an amplifier incorporating a screen-grid tube resistance coupled to a UY-27, the output of which is transformer coupled to a pair of UX-250's in push-pull. An over-all voltage gain of 9000 was obtained. The simplicity of the circuit is of interest. It was found that the gain of this amplifier varied considerably for different screen-grid tubes of the same type. This was due to the wide variation in the screen currents of these tubes which materially affects their operating characteristics. To obtain a uniform gain it was found necessary to adjust the screen-grid potential slightly for different tubes. The screen potential is obtained from the 84-volt bias of the output tubes and the screen voltage is adjustable. A filter in the screen-grid circuit eliminates any a-c. which may be due to the filament center-tap being eccentric.

The dash-line curve of Fig. 9, which, below 2000 cycles coincides with the full-line curve, shows the frequency characteristic of such an amplifier. The deficiency at the high end is not bad and it may be remedied, as shown by the full-line curve, by the introduction of a small condenser C' shown in dotted lines in Fig. 8. This provides regeneration at the higher frequencies. Too great a value of C' will produce sustained oscillations at an audible frequency. This is extremely undesirable and care must be taken to make C' as small as possible. It is important in using such a device to connect it to the grid of the push-pull tube in phase with the grid to which the energy is to be fed back to. This may be determined by trial. If the improper grid is connected a greater suppression of the higher frequencies will be had than if no con-

denser were used. The above means of increasing the gain at the higher frequencies is of laboratory interest only as the adjustment of C' is too critical to be incorporated in commercial amplifiers. It is possible to neutralize the input capacity of the UY-27 but this entails additional expense. The input capacities of the push-pull tubes are readily neutralized by inter-connecting through small variable capacities the grid of each tube to the plate circuit of the other tube.

The resistors between grid and ground of each push-pull tube, although not essential, are used to make the input circuit practically a pure resistance.

For stable operation careful shielding is advisable. In shielding, care must be exercised to keep the grid-to-plate, grid-to-ground and plate-to-ground capacities at an absolute minimum.

Screen-grid tubes may be operated in push-pull. It is advisable in such cases to provide an adjustment for varying the screen potential as described above, for each screen-grid tube, so as to equalize their characteristics.

In conclusion, the writer wishes to express his appreciation of the assistance rendered by the *Engineering Department of the Pacent Electric Company.*

DISCUSSION ON GLAUBER PAPER

HERE is a well-defined tendency toward the use of a single stage in the audio-frequency amplifier of present-day receivers. That this is good engineering is evidenced by the quality curves of several well-designed receivers using only one audio stage, their freedom from acoustical regeneration and the decreased detector distortion due to the unavoidable use of a power detector. When a screen-grid tube is used as a detector, the engineer is face to face with the problems of voltage amplification by means of a high impedance tube. Many receiver designers

have accepted the screen-grid detector tube as an audio-frequency amplifier for phonograph combinations. Mr. Glauber's practical work has a particular significance to these engineers and it is in this connection that probably the greatest use of this kind of an amplifier will be found.

When the screen-grid tube is coupled by the conventional resistor-condenser combination to the power stage, it may not be amiss to caution the designer about the stability of the bias on the power stage. Because of the high internal impedance of the screen-grid tube, high impedance coupling units must be used to obtain sufficient voltage amplification. If a high resistance grid coupling member is used to put bias on the grid of the power stage, there is a danger from that kind of grid current which flows from the grid and effectively opposes the applied bias. This reduces the effective bias, thereby increasing the plate current. With certain tubes, the action gets worse and eventually ruins the power tube.

There is another problem mentioned in this paper which needs some amplification in view of some misconceptions which appear to exist. The conclusions reached by some who are enthusiastic for such a system, indicate that it has been assumed that coupling means referred to as "direct coupling" (as opposed to the resistor-condenser

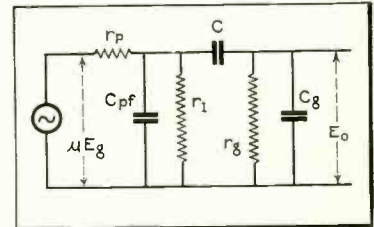

Figure 10

coupling means), acts as a pure resistance. This is not true at high frequencies. Even if the capacities across the various parts of the voltage dividing resistance which supplies the several stages of this type of amplifier were negligible, there remains the input capacity of the various tubes. If this could be avoided elsewhere, it can hardly be avoided in coupling the last screen-grid tube to the power stage, particularly if this stage is made up of three-element tubes.

The possibility of employing regeneration to obtain improved high-frequency response has been pointed out. While this may be done, it should be remembered that its use may be a source of trouble in a radio receiver which has to endure the vagaries of manufacture. Variations between units and tolerances in the construction of the set, decrease the amount of permissible regeneration from that allowable in a laboratory set-up.

For many years, I have been using a simple trick in calculating the amplification of resistance- and impedance-coupled amplifiers. Because of the simplification involved, the method and results will be briefly illustrated using the author's nomenclature as far as possible. The equivalent circuit used by the author is as shown in Fig. 10.

This circuit may be redrawn by considering the effective impedance of ($C_{p\tau}$) and (r_1), and (C_k) and (r_k) respectively as parallel network. The other circuit elements are generalized as shown in Fig. 11.

Now, the effective amplification of the stage is:

$$\mu_o = \left[\frac{E_o}{E_1} \right] \left[\frac{E_1}{E_g} \right] = \left[\mu \left(\frac{Z_1 Z_g}{Z_1 Z_1 + Z_1 Z_2 + |Z_1 Z_2} \right) \right]$$

Where:

$$Z_2 = (Z_g + Z_c) \text{ and } Z_o = (-j |X_o|)$$

A simplification results in calculating the reciprocal of the percentage amplification $\left(\frac{\mu_o}{\mu} \right)$. This step eliminates all rationalization and results in

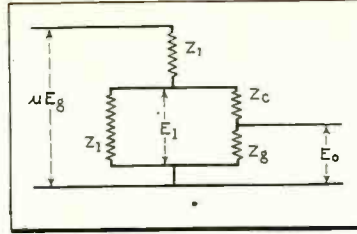

Figure 11

a relatively simple vector expression whose magnitude may then be evaluated. The reciprocal of its magnitude is the desired result. Thus from the above expression:

$$\frac{\mu}{\mu_o} = \left(\frac{Z_1}{Z_g} + \frac{Z_2}{Z_g} + \frac{Z_1 Z_2}{Z_1 Z_g} \right)$$

Where:

$$Z_1 = \left(\frac{r_1}{1 + j \frac{r_1}{|X_{cp}|}} \right)$$

$$\frac{Z_2}{Z_g} = \left(1 + \frac{Z_c}{Z_g} \right) = \left[1 - j \left(\frac{|X_{cl}|}{r_g} \right) \left(1 + j \frac{r_g}{|X_{cg}|} \right) \right]$$

Hence:

$$\frac{\mu}{\mu_o} = \left\{ 1 + \frac{r_p}{r_g} + \frac{r_p}{r_1} + \frac{|X_o|}{|X_{cg}|} + \frac{r_p}{r_1} \frac{|X_o|}{|X_{cg}|} \right\} + j \left\{ \frac{r_p}{|X_{cg}|} + \frac{r_p}{|X_{cp}|} + \frac{r_p}{X_{cp}} \frac{|X_o|}{|X_{cg}|} - \frac{|X_{cl}|}{r_g} \right\} + \frac{r_p}{r_g} \frac{|X_o|}{|X_{cp}|} - \frac{r_p}{r_1} \frac{|X_{cl}|}{r_g}$$

In employing this equation, consider that portion to the left in direct line with the section above.

It will be observed that the real part of this expression is independent of frequency while three terms of the imaginary part vary directly with frequency and the remaining two vary inversely with frequency. Calculation from this equation is a comparatively simple matter. It is to be remembered that the symbols (X) are real numbers without sign.

The absolute magnitude may now be found and by dividing the amplification factor of the tube under those conditions by this number, the effective voltage amplification of that stage is known. The simplicity of this method of calculation is evident and because of this, its inclusion in this discussion is felt to be well warranted.

DR. ELLSWORTH D. COOK,
United Research Corp.

An American Pentode

New Five-Element Tube With Space Charge Grid Has Lower Plate Resistance and Increased Amplification Factor

IN the laboratories of the CeCo Manufacturing Company, Providence, R. I., tube engineers working under the direction of N. O. Williams, vice-president and works manager, after months of experimentation have perfected an a-c. pentode.

Double Screen-Grid

The new tube is a sort of double screen-grid, having a screen around the plate, as is the case with the screen-grid of the present; also another screen between the control grid and the cathode. The insertion of this second screen permits a greatly increased amplification; three to four times as great as the screen-grid.

For comparison, the following average characteristics of the type 224 tube are:

- Amplification factor 420
- Plate resistance 400,000 ohms
- Mutual conductance, 1.050 micromhos at E_p 180, E_g -1.5, E screen 75

The gain per stage when using a 224 tube may be computed from the widely known equation.

$$A = G_m \frac{R_p R_x}{R_p + R_x}$$

where A is voltage gain

G_m is mutual conductance

R_p is plate resistance in ohms

R_x is impedance in plate circuit

Applying the pentode tube constants of column (1) (right) in this equation and comparing them with the theo-

retical gain from a 224 tube under the same conditions, the relative gains are in the ratio of 1 for the type 224 to 1.23 for the pentode. For two stages, the ratio becomes 1 to 1.5.

Examination of the values given in the table of characteristics shows that the constants of the pentode vary greatly as the operating conditions are changed.

In (1) the space charge grid potential is 10 volts; in (2) it is 20 volts. The change has reduced the plate resistance much further than it decreased the amplification factor, a higher mutual conductance resulting. It will be noted that plate current, screen current and space charge current have moved to higher values, so high in fact as to have a serious effect on the life of the tube.

From (1) to (3) the screen-grid voltage was decreased from 180 to 135

volts, other electrode potentials remaining fixed as in (1). The results were marked increases in amplification factor and in plate resistance, the latter climbing relatively faster and giving a much lower mutual conductance. Less plate current and less screen current were taken but the current to the space charged grid suffered an increase.

Control grid to plate capacity is about 90% higher than that of the 224 tube. Input capacity-control grid to cathode, space charge grid and screen in parallel is double the value found in the 224 as is also the output capacity.

The tube performs admirably as a radio-frequency amplifier, using a tuned impedance in the plate circuit. Also, it is a very satisfactory audio amplifier, especially well suited for use in the now famous Loftin-White direct-coupled circuit.

Average Characteristics of A.C. Pentode

	(1)	(2)	(3)	(4)
Heater volts	2.5	2.5	2.5	2.5
Heater amperes	7.75	1.75	1.75	1.75
Control grid volts	-1.5	-1.5	-1.5	-1.5
Space charge grid volts	+10	20	10	20
Screen-grid volts	+180	180	135	135
Plate volts	250	250	250	250
Amplification factor	575	540	740	750
Plate resistance-ohms	285,000	100,000	380,000	300,000
Mutual Conductance-micromhos	2,000	3,000	1,930	2,500
Plate current ma.	4.1	6.0	1.7	2.6
Screen current ma.	0.8	0.9	0.5	0.2
Space charge current ma.	3.0	10.0	5.0	12.0

A New Type Four-Element Tube

A Tube Employing a Screening Member Out of Line With the Effective Electron Path but Functioning Much the Same as the Usual Screen-Grid

By Henri Francois Dalpayrat

THE tube to be described has a number of unique features but the main feature lies in the construction and placement of a fourth element. This element tends to reduce the space charge in the tube when used under ordinary conditions but can be employed for other uses, as will be explained later.

The following theoretical discussion will serve to delineate the purposes of the tube:

Space Charge

It is well known that the positive charge on the anode of any radio

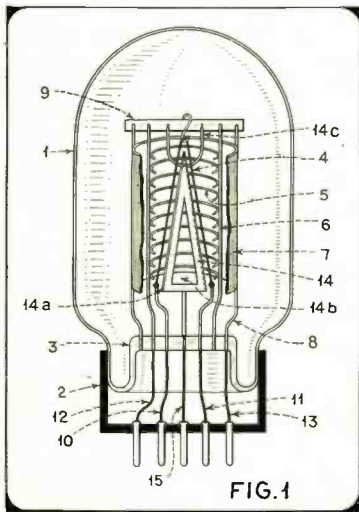

General details of the tube described in this article. The fourth element is shown at 14.

vacuum tube does not attract all the electrons which are emitted from the cathode. The number of electrons emitted depends on the cathode temperature and also on the uniformity of heat distribution along the surface of the cathode. Thus, if the cathode consists of an ordinary filament, this filament is likely to be cooler near the supports than in the central section. The result of this is that electrons are liberated from different portions of the cathode at different velocities. The lower velocity electrons shoot off into space for only a small distance and are likely to return to the cathode. However, they cannot re-enter into the cathode as they are repelled by the negative charge thereof. These electrons, however, form a kind of a cloud around the filament which is known as the space charge and this space charge blocks the progress of other

electrons and prevents them from reaching the plate. Only the electrons having a velocity high enough to pass through this charge cloud, will reach the plate and even some of these are likely to be screened off by the cloud and returned into the space charge. Moreover, the electrons which finally do reach the plate, do so at a reduced speed due to the obstruction of the space charge, resulting in a higher resistance through the tube.

It is evident that if the space charge can be substantially reduced, the controlling elements in the tube would be more effective in exercising a complete control over the electron stream.

In the tube to be described means are provided for substantially overcoming the space charge effect without, at the same time, interfering with the main flow of electron to the anode.

Also, means are provided to utilize an auxiliary flow of electrons from the cathode to an auxiliary electrode.

The tube is so designed that the auxiliary electrode is made to follow closely the configuration of the cathode.

Factors Under Consideration

It is estimated that over 85% of the voltage applied to the anode in an ordinary tube serves to overcome the repulsion due to the space charge, while the remaining 15% or even less serves to establish the electronic current. Therefore, if the space charge is removed, only 15% of the anode voltage will be necessary to pass the same current. Therefore, if the original plate voltage is maintained, the amplification factor is greatly increased. Theoretically, the amplification factor of the tube would be thus raised from about 6 or 8 to perhaps 130 or 150. Values even as high as 300 may be expected from a tube of this type, if all of the losses are reduced to a minimum.

The effect of the space charge in repelling the electrons and screening

them from the anode, is a constant factor which is not affected by the incoming signal. This screening causes a load on the tube and is a cause of its inefficiency. Therefore, the main object is to remove as much of this negative space charge hovering around the cathode as possible and do it in such a way that no obstruction is placed in the path of the main electron flow. This is accomplished by introducing a small metallic plate in the immediate vicinity of the cathode and preferably under it, but following the shape of the cathode and placed as near as possible to its surface.

It will be seen that when a suitable potential is applied to such a special electrode, it will attract the electrons which normally would constitute the space charge and will therefore minimize the tendency for creating space charge. This attraction of electrons will, of course, exist in spite of the fact that the auxiliary electrode is located under the cathode outside of the main path of electrons where the normal space charge would accumulate. Arrangements are known where the auxiliary electrode to eliminate the space charge is introduced into the main path but by the present arrangement of the electrode, the space charge can be minimized and at the same time, the main path of the electron flow remains unobstructed. On the other hand, such a location of the auxiliary electrode permits an application to this electrode of sufficiently high voltage to attract a considerable percentage of electron emission and thus make it suitable for stabilizing or amplifying purposes. A potential of similar value applied to a space charge electrode located in the main path would, of course, have rendered the tube ineffective and, therefore, in all the previous uses of such a space charge electrode located in the main path, it has been usual to apply an extremely small positive potential to

Here are shown alternative arrangements and designs for the four elements.

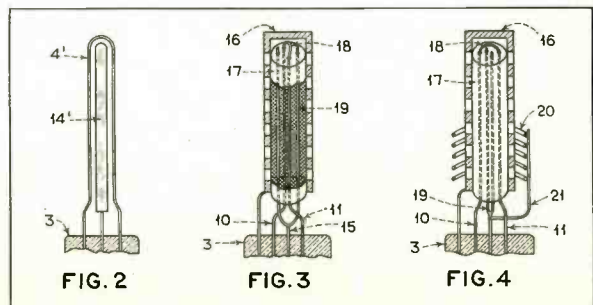

Solder-Plating in Radio Manufacturing

Description of Equipment for the Electroplating of Parts to be Soldered

By John P. Arnold

THE assemblage of radio receivers, their components and accessories as well, involves soldering processes which have for their object the union of similar or dissimilar metals in such a manner that the joints are not only mechanically secure but also electrically conducting. The whole art of soldering well does not demand any particular skill but it does require some experience, and the capacity of unskilled labor employed for this work varies between extremes which may be represented by the scrupulous workman who slowly turns out an excellent job and the slipshod pieceworker who rapidly produces work that often goes no further than the factory inspector.

The usual apparatus for solder-plating is shown in Fig. 1. The outer container is the immersing tank, of about 60-gallon capacity, which may be either of wood, earthenware or lead sheathed with rubber, bakelite or celluloid in order not to share in the chemical activity which takes place during the electroplating process. A perforated bakelite barrel, about 15 in. long and 12 in. inside diameter, containing the parts to be plated, is fixed to a shaft which, when the barrel is immersed in the electrolyte, can be rotated by suitable machinery. Means are also provided to disengage the driving machinery and to tilt the shaft in order to remove the barrel from the tank. The part of the shaft which extends down into the solution

Two metal bars are placed along the length of the tank on each side of the barrel and are connected electrically. The anodes, composed of hard solder (about 50 parts tin and 50 parts lead) are hung from these bars and depend into the electrolyte. These anodes, 20 in. number, are moulded in bars 20 in. long and of elliptical cross-section of 2 and 4 ins. along each diameter. The other (cathode) connection is made through the revolving shaft into the bakelite barrel where metal studs on the interior surface make contact with the parts to be plated.

Standard electroplating apparatus is used for the work. In operation a 6-v., 100-ampere generator supplies a plating current of about 50 amperes at 4 volts through the electrolyte. The current density is estimated at about 26 amperes per public foot of cathode surface. The process takes place at room temperatures and the time required to plate 1000 to 3000 small parts is about ten minutes.

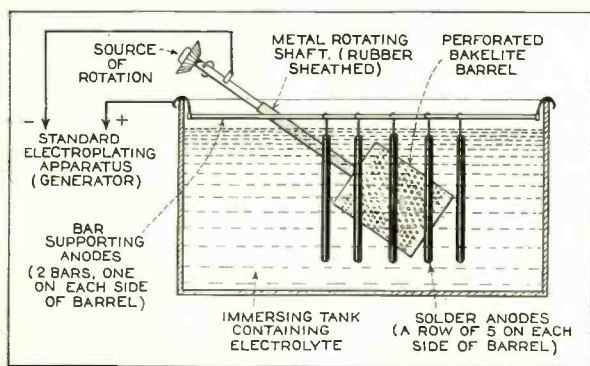

Fig. 1. Details and arrangement of the apparatus for solder-plating. The formula for the electrolyte is given in the text.

Preparing Parts for Plating

The parts which are to be plated must be first prepared by dipping in gasoline or other oil solvent; then given an alkali wash in hot caustic potash solution, after which they are rinsed with water and dipped in a "spent acid" neutralizing bath. They are again rinsed with water and ready to be placed in the barrel. After the plating has been completed, the parts must once more be washed with water and then dipped in the alkali bath. Finally they are rinsed both in hot and cold water and moisture is removed by a hot-air dryer. The material is usually handled in wire baskets and with scoops.

It will be understood, of course, that various departures from the method described may be necessary due to the type of the material to be plated. For example, one may wish to plate only a part of the material placed in the barrel. In this case, the parts which are not to take the solder deposit may be "stopped out" by a coating of some non-conducting substance, such as copal varnish.

After the solder-plated parts are delivered to the workman he has nothing further to do than to weld the connection with a hot iron, thus dispensing with fluxes which are the usual causes of a badly finished piece of work. The irons must, of course, be tinned and additional solder may be employed to make a heavier and firmer joint. The appearance of the

(Continued on page 39)

As the technique of soldering also involves several preparatory steps, e. g., the removal of dirt, grease, and oxide from the metals, the tinning of these parts, etc., it is expedient to relieve the workmen who do the actual soldering of these preliminary operations, for these steps are not only time-consuming but are also those which require the most skill on the part of the man who handles the iron.

Electroplating Process

It is ordinarily the practice to clean the metallic parts and dip these in the molten alloy before the pieces reach the workmen. Solder-dipping, however, is not a very satisfactory method in its present stage of development; hence the electroplating process, which will be described in this article, is rapidly finding favor with manufacturers whose plants operate on large production schedules, not only because of its time- and labor-saving advantages, but also on account of the excellence of the finished work.

must also be protected with a rubber or bakelite coating.

Formula for Electrolyte

A suitable formula for the electrolyte is as follows: for heavy plating, 63 ounces of hydrofluoric acid, 37 of lead carbonate, and 24 of boric acid per gallon of water; for light plating, these ingredients to two gallons of water. A 50% concentration of hydrofluoric acid should be used.

The electrolyte is first prepared by filling the tank to about one-third of its capacity, and the hydrofluoric acid is added to this, after which the boric acid is thrown in. The lead carbonate (white lead) is made into a paste with water and slowly added to the solution. (The operator should be extremely careful to avoid breathing the fumes which are given off at this stage of the mixing.) The electrolyte, which will have a specific gravity of between 1100 and 1200, is now thoroughly mixed and as much of the sediment as possible removed. To rejuvenate the electrolyte the various components and water may be added from time to time.

The Serviceman Speaks

In Which We Go to the Last Link in the Radio Industry and Learn How to Sell Radio Sets and Keep Them Sold

By Austin C. Lescarboura

Mem. I.R.E. Mem. A.I.E.E.

SEVERAL months ago we conducted a survey among radio manufacturers, securing their collective opinions on the servicing situation, as well as their suggestions as to ways in which not only they but also jobbers and dealers could facilitate the selling and servicing of sets. The article, which appeared in these columns as a result, included an account of the methods of the various manufacturers in servicing their sets. It would seem, from their statements, as though the manufacturer had done all in his power; all else was in the hands of the dealer and his service staff.

However, we have attained that mature age when we always assume that there are two sides to any argument. Accordingly, instead of calling our survey complete, we have sought the other side. Button-holing the serviceman, we forced him to be seated and tell us the story of servicing from his point of view. We expected it to be entirely different from the story as told by the manufacturer. We were not disappointed. The manufacturer might do well to listen in on the complaints and suggestions of the serviceman.

The City Dealer

According to the small-town serviceman, the large city dealer "gets away with murder." He sells hundreds of sets and does not know his customer's personality. His idea is to sell the set and then forget the purchaser. If the set is in need of repair, the purchaser is referred to the manufacturers. If the purchaser insists on service by the dealer from whom the set was purchased, some underpaid high-school boy or house electrician is sent to service the set. In many cases the large city dealers are radio departments or department stores. They are essentially merchandising establishments, not electrical repair shops. Having no service department, needing none since they sell so many sets and can maintain a fair reputation even though they ignore the customer after cashing his check, the city dealer can undersell the small-town dealer. Many small-town inhabitants enter their local dealer's store, listen to the various sets on display, select one, and ask the price. Given the list price, the prospective purchaser says: "But the So and So Department Store in town is asking less for the same set."

"And if anything goes wrong with it after it is in your home," inquires the local dealer, "will they send their man up to fix it?" The chances are small.

Nevertheless, the prospective purchaser is likely to buy at the city store and then ask the local dealer to service the set free of charge under the manufacturer's guarantee. This is manifestly unfair. Whereas the city dealer can stress tone quality as the selling feature, the small-town dealer must emphasize service. Knowing the purchaser personally, meeting him on the street almost daily, the small-town dealer must give the purchaser perfect service. He cannot ignore the purchaser after the set is installed.

Furthermore, the public has gotten away from the tinkering stage. It is interested only in programs and their perfect reception. Most sets are now enclosed, only the tubes showing. Purchasers are inclined to a hands-off policy. If anything goes wrong, they immediately call the serviceman. For these reasons the small-town dealer's first thought is on service. For him it is more important even than merchandising.

Two types of people walk into the dealer's shop. The one kind has heard a friend's set, or has been influenced by advertising or general reputation. He knows what make he wants and asks for it. The other type just wants a radio. He tries them all. He asks questions. Such prospective buyers are influenced to no small degree by the advice of the dealer. They usually purchase that which he recommends. And, since service is guaranteed for a certain time after installation, it is only natural that the dealer will push that make which requires least servicing, or which can be serviced most easily due to jobber and manufacturer cooperation.

Whether or not they know it, many manufacturers are on probation this year. Dealers are carrying as many as a dozen different makes of sets. At the end of a year or so, those which are most in demand and require the least service will continue to be carried in stock. The others will be thrown out. Dealers will refuse to carry them any longer, preferring to handle a few lines that they know are good. Manufacturers should do their utmost to sell themselves to the dealers during this probation period.

The Serviceman's Complaints

The serviceman has many complaints to make to the manufacturer. Only a very few manufacturers send service notes to the dealer. Such notes may be sent to the jobber, but for some reason or other they never reach those who can use them—the dealer and his

service force. The servicemen are forced to beg and hammer the manufacturer for notes. And then, what do they get? One set of notes, for a dealer who may have eight or ten servicemen in the field. For their own good, manufacturers should take the initiative in sending service data. And such literature should be sent to all dealers, whether or not they handle the manufacturer's sets. The dealer can get notes for his own sets with ease. But he is often called on to service sets which he does not handle. In order to keep his sets in good condition, the manufacturer should get his notes in the hands of all dealers and servicemen.

The servicemen agree with most manufacturers that sets should be serviced in the field wherever possible, and not returned to the factory. This saves time, shipping expense, and break-downs due to improper packing and handling. Such practice also places personal responsibility on one person, the serviceman, and eliminates passing the buck of responsibility. But in order to be efficiently serviced in the field, it is essential that the manufacturers send their own field men to the dealers to give their servicemen pointers, suggestions, and data. Some of the manufacturers of higher priced sets do so. Many fail to meet this very important need.

The serviceman's chief complaint as to the present-day sets with which he comes in contact, is poor construction. The parts seem fairly good, but the assembly and inspection seem to be of a low order. Perhaps this is due to conveyor-belt methods and unskilled assemblers. Time is the all-important element on the conveyor belt. This seems to be reflected in the construction. The enormous demand for sets during the past year has speeded up production. The seasonal aspect of radio production, with a consequent turnover of labor, is not conducive to standardized and efficient construction.

The intense competition among manufacturers and the tremendous quantities of sets produced has put the emphasis, not on quality, but on saving a fraction of a cent per unit on parts, and a fraction of a second on assembly. These fractions, multiplied by the number of sets turned out, save the manufacturer thousands of dollars—so he thinks. But with a 90-day guarantee the savings, and additional money besides, to say nothing of reputation loss, are expended in replacing parts which were defective in the first place, or ruined through faulty assembly.

bly. Usually these minute unit savings are made at the cost of construction or materials. In the long run, it does not pay.

Receiver Ratings

Another phase called to our attention is skimping on ratings. In the highly competitive merchandising that obtains today, many manufacturers are compelled to build to a price and not to a service standard. Factors of safety are reduced to a dangerous point. Sets are being used more hours per day than ever before. A conservative estimate places the average use of a set at five hours a day. Unless properly rated and constructed, such continuous use heats the set and causes burn-outs and short circuits.

Most calls for the serviceman are a result of defective tubes. Many manufacturers will sigh in relief at this statement and point with pride to their sets, saying, "There you are, it's not the set, it's the tubes." Defective tubes may be caused by mishandling on the part of the consumer or in transit, placing tubes in the wrong sockets, or with the power on, causing overloading in case all the prongs do not contact at once, faulty sockets, or inherently defective tubes. Service calls may be traced to all these causes. But, according to the serviceman, many of the tubes are inherently bad. Tolerances seem to have been widened in many cases; tubes are not as uniformly good as formerly. The tube which causes the most trouble is the -80 rectifier. Until recently, it was not made to withstand the work which it has been called upon to do in the usual -45 push-pull set. It has been greatly overworked. Tube manufacturers are beginning to realize this point and make sturdier -80 tubes. But they are still the leading trouble-makers.

Other faults that the serviceman finds after ringing the bell, and installing himself in the parlor, to the discomfort of the family that expected to be able to listen in on the evening's feature programs, are a-c. hum, burned-out power packs, rattles in the dynamic speaker, and bent automatic tuners. Resistors and voltage dividers are also troublesome, as well as noisy volume controls. Condensers have been known to short and power packs to burn within a few hours after installation of a set. And within two days, any and all the above mentioned disasters are liable to befall the radio set purchaser.

At a later date the serviceman is apt to be called in to correct burned-out tubes, faulty filter condensers and resistors which have worn out or changed value.

It would seem from the foregoing that there is nothing intrinsically sound in the modern set. The other side of the serviceman's story shows that rarely do sets need readjustments. Tuning condensers do not short. Contacts remain clean. Audio transformers no longer burn out. If these defects have been overcome in produc-

tion, so can the others. And until they are, the manufacturer should aid the dealer and serviceman in the repair of sets.

Re-shipping Slow

Sets returned to the manufacturer seem to stay in his hands too long. Meanwhile the dealer loses time, lacks the use of the set for display, demonstration and sale, and the money invested in that set is temporarily tied up to no advantage. The manufacturer ships his new sets fast. They bring him in money. But in the case of parts in exchange for defective ones, the manufacturer takes his own sweet time in sending them along.

The manufacturer sends his salesman around to the dealer, who orders enough sets to meet his demand. The sets arrive *pronto*, among them a few bad ones. There seems to be a "cluck" or two in every large shipment. They are returned. Their repair and re-shipment, or the sending on of others to take their place, takes several times as long as the original shipment. In the meantime, the manufacturer expects the dealer to keep buying more sets. Why should he tie up his capital in this way, especially since every new batch of sets ordered is liable to contain another "cluck" which must be returned and not sent back for weeks or months to come? This practice on the part of manufacturers is most unfair to the dealer, who must hold the bag. And of all people, the dealer is least in the position to hold the bag for the radio industry, since he has the smallest working capital, the largest overhead (in proportion to income) and many expenses incidental to sales (service.) Many a dealer has servicemen continually on the run repairing brand new sets.

The serviceman finds it easy to get replacement parts for sets that he handles as a dealer. But if he should switch over to handling other sets, it is all he can do to get parts for the sets he has let go. Or for sets he never did handle.

New Parts for Old Sets

Automobile manufacturers realize their responsibility to purchasers of their cars. Bring a 1910 Ford in for servicing. You will not be laughed at. You will not be told that parts for that model have long since gone out of existence. They can still be had. The same is true of other reliable makes. Even though the car is no longer made, as in the case of the Maxwell, a sufficient supply of parts is kept on hand to effect repairs and replacements. So long as there is a car of his on the road, the manufacturer feels it his duty to keep parts for it in stock. The same should be true of radio manufacturers. Unfortunately, their attitude on the matter is different.

An actual example of the attitude of the manufacturer is the case of a set that required one particular make of tube. The set was faulty. No litera-

ture on the set was available. The manufacturer asked that it be returned. This was done. One week, two weeks, three weeks elapsed. The set was not returned. Finally came a letter stating that if the dealer wished the set repaired, he would have to furnish the tubes. In the words of Milt Cross, "Is dis a system?"

Manufacturers do not continue making or storing parts for sets they no longer produce. Not only do they discontinue parts, but they discontinue service literature on sets more than two years old. At least, such is the practice in most cases. Both in the construction of their product and in the parts side of the game, manufacturers seem to hope that their sets will wear out soon and the parts will not be forthcoming, so forcing the owners to buy new sets. They will be forced to buy new sets, of course. But be assured, they will not be repeat orders. And the purchaser will not be fooled twice into buying sets whose models and parts are discontinued.

Manufacturers seem indisposed to carry spare parts stocks. Perhaps they dislike to tie up capital in stock. Perhaps they feel that with a newly designed set they will be caught with parts which they cannot get off their shelves. Still, they all recommend that the dealer and serviceman carry such stocks. And since the dealer handles more than one make, it would mean carrying a tremendous stock of parts—parts for all the sets he carries and services. This is absurd. Besides, why should the dealer stock parts when he sees that the manufacturer is unwilling to take a chance doing the same thing. Again, the manufacturer wants the dealer to hold the bag. This is not playing the game. Instead of referring the dealer and serviceman to the manufacturer of each individual part, from whom the dealer has to purchase in small quantities and gets little and slow service since the parts manufacturer prefers to handle only large quantities, the set manufacturer should carry a complete line of parts, which he can buy cheaply in large quantities. Then the dealer can stock from the set manufacturer, getting all the parts for any one set from one source—the manufacturer of that set.

The Dealer's Service Department

The manufacturer looks for dealers who are, first and foremost, merchandisers. Too often, he cares little about the service department of the dealer who handles his line. This is the wrong attitude. Again, an analogy with the automobile industry is in order. The garage that wants to have the agency for a nationally-known make of car, must guarantee the employment of mechanics who know that make of car from bumper to bumper. The car manufacturer inspects the dealer's service department, and only after convincing himself that the concern can properly service his car will he give it the agency.

Radio manufacturers should likewise insist on their dealers having more than average service departments. Somehow they seem to think that radio sets are slot-machine merchandise, to be handled by merchants only—department stores, music stores, hardware stores, furniture stores—anyone who can sell. This is wrong. And it will be increasingly wrong as time goes on and the sales of sets depend more on service. As in the case of automobiles, he who sells should be able to service.

Just as automobile manufacturers design and make special test and repair apparatus for use in servicing their cars, and insist on the use of such apparatus by their dealers' service departments, so radio set manufacturers should make test equipment by which every part of their individual sets may be tested. Some manufacturers claim that such apparatus is abused in the hands of incompetent servicemen, or servicemen who handle other sets than their own and use their apparatus on other sets, or change their apparatus for such use. The serviceman is anxiously looking for such equipment. And manufacturers who realize that repeat sales as well as many new ones depend on proper servicing, will not only supply such equipment to servicemen, but positively demand that service departments of dealers handling their sets use such equipment in servicing their sets.

Less Servicing, Greater Sales

On the whole, servicing is a liability, not an asset. The dealer loses money on his service department, due to manufacturer guarantees. The money he loses on service must be made up from increased sales. The dealer will boost the set that requires the least expense in the form of servicing after installation, or that can be most satisfactorily serviced.

The progressive manufacturer will use this legitimate form of advertising and good-will to the best advantage. He will assemble and inspect his set as rigidly as possible, realizing that a little added cost at the initial factory end will save him much later in defective parts and free repair. Good-will alone would make it worth while to be more careful. He will send all dealers, whether or not they handle his sets, literature on servicing his sets, notices in model changes, new circuits, and other improvements as they occur. He will not wait for the dealer or serviceman to come to him. He will carry a stock of spare parts, not only for his present models, but for every model he ever made, so long as any are still in use. He will take pride in the long life of his sets, and help the serviceman to that end. He will insist on the maintenance of good service departments by his dealers. He will insist that they carry parts, but will enable the dealers to get all the parts from

the manufacturer's stock. He will be as much concerned with servicing the set after it is sold as he was in making the original sale.

This manufacturer will thrive.

The Serviceman Knows

The manufacturer may be surprised at the statements herein made. He has perfected his design in the laboratory, his production in the factory. Be that as it may, they are still paying off according to performance in the field. The most competent authority of set characteristics in the field is the serviceman. The set manufacturer might do well to make a periodic survey of his dealers and servicemen to find out from them what parts of their sets require most attention. They could learn much that would be of value in production, design and assembly. The opinions and ideas of the serviceman more nearly represent those of the consumer than those of the manufacturer. And since, in the last analysis, the public *must* be served, the serviceman's ideas, incorporated in the set, would gain the good-will of the dealer, who would be a walking advertisement of the set, entering every prospective purchaser's home, his story believed and his opinion respected and acted upon. In the serviceman's hands is the fate of the manufacturer. Let the manufacturer take cognizance of the fact.

A NEW TYPE FOUR-ELEMENT TUBE

(Continued from page 35)

Uses of Fourth Element

If it is desired to decrease the electronic flow from filament to plate, the fourth element (auxiliary electrode) may be connected to a source of high positive potential of such magnitude that this fourth element will attract more electrons than the plate. On the other hand, if it is desired to increase the electronic flow from filament to plate, a potential may be applied to the fourth element—just sufficient to remove the accumulation of the negative electrons around the filament forming the space charge. On removal of this space charge, as already explained above, the amplification of the tube is increased enormously. The fourth element may also be connected to a tuning circuit in such a way that its potential is modulated or varied by the plate circuit. These voltage variations may then be applied to another circuit to be further amplified. The fourth element may also be used for neutralizing purposes. This is done by providing a coupling relation between the auxiliary electrode and the plate and arranging this coupling relation to exercise a suitable action for stabilizing oscillations. For this purpose, the coil 29 may be also used with reversed connection to the one shown. Under such condition, the complete oscillation control circuit is closed

through the internal capacity existing between the fourth element and the filament and also the capacity between the filament and the grid and the plate, and these capacities are then adjusted in order to obtain the desired result. This adjustment may be carried out during the manufacture of the tube. For example, the capacity between the fourth element and the grid could be made equal to the capacity between the grid and plate or any other desired relation. This capacity can be very easily increased by turning over the edges of the metallic plate constituting the fourth electrode as in Figs. 1 and 2 (as shown at 14a of Fig. 1) or by increasing the size of the external control parts 20 of Fig. 4. This tube may be further used to reduce or eliminate what is known as audio resonance when a vacuum tube is applied to audio-frequency amplifiers. Such audio resonance is generally caused by inductance of the coupling transformer, its distributed capacity and the relation of this capacity to the tube capacity. Such effect may sometimes be sufficient to cause the circuit to sing or also to distort the higher notes of the speech or music transmitted, causing a sort of buzzing noise. The usual manner to overcome this, is by introducing a high resistance across the secondary winding of the coupling transformers, that is, by introducing losses and reducing the volume of sound. The system described, how-

ever, does not introduce any resistance. If it is only necessary to apply a counter-electromotive force through a separate winding to the transformer to be connected to the auxiliary electrode and, in this way, oppose resonance conditions. Such a connection is for instance, illustrated in Fig. 6 where the transformer, consisting of coils 23 and 31, is shown to have an iron core 37 and be suitable for audio-frequency amplification. We are not restricted, however, to this particular connection as the result may be attained by a different connection, coupling the fourth electrode to either the plate or the grid circuit.

SOLDER-PLATING

(Continued from page 36)

solder-plated article is a dull grey and the more tin in the composition of the anodes the lighter it becomes. The material may also be polished to improve its appearance.

In conclusion, it should be mentioned that the forgoing comparison between solder-dipping and solder-plating should not be construed to mean that solder-dipping should be superseded by the latter process in all cases or that that method is incapable of further improvement. Solder-dipping is probably the quicker means, but the quality of the finished work is not great.

Interference From Power Lines

Much Interference is Traceable to Inherent Operating Conditions

*By Clyde L. Farrar**

RADIO interference, its elimination or reduction is proving to be one of the most troublesome and costly problems that is facing the power companies. This is especially true of the smaller companies which have extensive transmission lines, and these lines must be built as economically as possible.

Radio engineers have in general believed that interference experienced from power systems is due to defective equipment. This is true of interference experienced on potentials of 22,000 volts and less, but for potentials above this value, radio interference does not necessarily mean defective equipment. It is this latter form of interference that the writer wishes to treat. The first form of interference has been extensively studied and the remedies are known. The interference due to defective equipment is in most cases easily traced by the radio man.

Causes of Interference

The most troublesome transmission lines are those operating at 66,000 volts and insulated with pin-type insulators. In general these lines are inherently noisy and at the present time no single cheap and effective method of overcoming this interference has been developed, although some promising methods have been proposed. The main causes of this interference experienced on the high-tension lines are:

(a) Loose tie wires, (b) loose insulator pins, (especially due to the use of cemented steel pins), (c) overstressed insulator, (d) loose hardware on the pole, (e) grounded down wires on poles, (f) dirty insulators.

Loose tie wires are a constant source of trouble from a radio standpoint. This interference is due to the fact that at 66,000 volts, even a small conductor takes an appreciable charging current and unless this tie wire is in intimate contact with the conductor, this charging current will take place through air, which of course results in a spark.

This item of loose tie wires places a large financial burden on the power company as the action of wind will soon loosen up a tight line. Loose tie wires on the porcelain also are a great source of interference. This interference is due to the fact that the insulator is essentially the dielectric between the plates of a condenser formed by the transmission lines as one plate and the ground as the other plate. The capacitance of the average 66 K. V. pin-type insulator using the

MR. FARRAR has been conducting tests for Power Companies in an attempt to determine the various sources of "radio interference" from power lines. The article presented here covers the results of the tests.

It is of more than passing interest to learn that a large percentage of the interference from high-tension power lines has nothing whatsoever to do with defective equipment. It is due to inherent operating conditions and, as Mr. Farrar points out, there is little chance of eliminating the troublesome factors until radio and power engineers cooperate in the matter.—EDITOR.

usual tie and metal pin is approximately 10 mmf. Hence, under a voltage of 38 K. V. (line to ground) the charging current is .14 milliampere. The insulator must then pass this charging current from the line to the ground and unless this charging current is uniformly distributed interference will result.

At the present time very few insulators having these characteristics have been tried out on a transmission line. Obtaining an equal distribution of charging current at the tie wire groove is very difficult, if not impossible with the normal type of line construction, as this distribution of charging current will not be uniform unless the tie wire is in intimate contact with the tie wire groove and exerts an equal pressure at all points in the groove. This statement is also true for the conductor groove.

Tests have shown that a tie made by a careful workman will cause interference at about 28 K. V. between conductor and ground. As the voltage between conductor and ground of a 66,000 K. V. live wire connected and neutral grounded is approximately 38 K. V. interference will be experienced. Special ties made by placing copper braid between the tie wire and tie wire groove and between the conductor and conductor groove have resulted in a tie that was free from interference, providing the pinhole and pin were likewise treated to insure good contact between the pin and the porcelain. This procedure is not economically justified as the expense is very high, amounting to approximately \$1200 a mile if the work is carefully done, (and unless carefully done will make the line worse since the charging current of the insulator is increased and trouble due to the pinhole will be increased).

In most places weathering will re-

duce the effectiveness very quickly. Also it is doubtful that this treatment can be effectively done with hot-line tools, and any remedy to be effective must be applicable to hot-line tool work.

Metallized Insulator Heads

Some insulator manufacturing companies are metallizing the insulator head at the wire and conductor groove. The pinhole is also metallized and in some cases a machined thread is cut. At the present time these insulators cost about 25% more than a standard insulator. In many cases this expense would wipe out the profits on a line, as the replacing of the insulator on an existing line would represent an added investment of about 25% to 30% of the original investment. In one power company investigated by the writer this insulator replacement would represent an outlay of approximately \$1,500,000.

The ability of these insulators to withstand weathering is problematical and for this reason the use of these types of insulators cannot be justified until sufficient time has elapsed to determine their resistance to weathering. Metallic paints have been suggested as a means of reducing the insulator interference. However, the life of paint is very short and if partial weathering should cause the paint to chip, destructive arcing (from a radio viewpoint) would occur and a noisy line would result.

The voltage gradient over the common types of insulators leaves much to be desired. This is illustrated by the fact that in wet weather insulator interference is greatly reduced if not eliminated. This is probably due to the fact that with the increased leakage current, the voltage gradient becomes uniform, and is reduced at the insulator head where normally it is extremely high (this reduced voltage gradient is not high enough to support sparking); also more effective contact is made between the conductor and insulator.

The assembly of multi-section insulators must be so controlled that no air films are interposed in the path of the charging current. Unless this precaution is made arcing between porcelain may occur, especially in those parts of the insulator subjected to high electrostatic stresses.

Loose Hardware

Loose hardware in a transmission line contributes radio interference because every piece of metal on the pole—unless it is at ground potential by being connected to the down wire—will accumulate a sufficient charge to raise its voltage

*Associate Professor, Electrical Engineering, University of Arkansas.

above ground to a high value. The writer has seen cases where a spark $\frac{1}{8}$ -in. long has been maintained between a $\frac{3}{8}$ -in. bolt and a down wire. The remedy for this condition is a periodic tightening of all hardware. This simple precaution will increase the maintenance cost of a line from 25 to 40%.

The interference experienced by loose hardware varies directly with the charging current. Hence anything that will reduce this charging current will reduce the interference from loose hardware. The methods of reducing the charging current is to eliminate the down lead on the pole, and by the use of low-capacity insulators. The treated insulators mentioned before increase this charging current and would increase any interference from this cause.

In many cases it is not advisable to eliminate the down lead on the pole due to the pole shattering in areas subjected to severe lightning storms. Their use on an undergrounded line, (that is, a line having no ground or static wire carried on the pole structure) is often debated and on those systems which are not exposed to severe storms can probably be eliminated.

The question of the effect of the ground wire or wires has not, to the writer's knowledge, been definitely determined although in pin-type lines the ground wire probably increases the interference due to the insulator and reduces the interference due to loose hardware.

Interference Area

A question of great interest to the power companies is how far this interference is transmitted along a transmission line. As far as the writer knows, no definite maximum distance has been determined although some companies have reported cases of trouble being transmitted 200 miles.

In a test conducted, a known interference was placed on the line and measurements were made along the line at a distance of 22 miles from the source of trouble. Little reduction in interference was noted. From this it can be seen that the line as a whole must be treated in order that this interference be reduced.

The fact that the line to be cleared must be treated as a whole is the feature that is most discouraging to the power company. This is especially true if there is a large amount of inter-connection which means that an extensive reconstruction program must be undertaken.

This interference usually does not extend to a greater distance than 250-400 feet from a transmission line. A typical distribution is shown by Fig. I.

In many of the smaller towns and in the rural districts the primary and secondary distribution lines are carried on the same poles as the high tension lines (in many cases such small towns

and rural districts would not be served economically with power unless the transmission lines also served to carry the distribution lines.) These distribution lines, due to their proximity to the high-tension lines, have interference induced on them. This interference is then distributed over the distribution system. The distance this interference is transmitted over the system is generally much less than that in the high-tension line although the author has traced interference for 18 miles along a rural line.

A.C. and D.C. Sets

The modern a-c. set is especially susceptible to this type of interference. As a matter of fact it has been found that many cases of interference originated when the customer substituted a-c. sets for d.-c. sets. This interference seems to be due to the pickup between the alternating-current wiring in the set and the antenna system.

That the interference experienced by high-tension lines (66 K. V. pin-type insulator as the suspension type can be made relatively free from interference at a low cost) is an inherent operating condition and not one due to defective insulators and equipment (although these can cause interference) does not seem to be understood by radio engineers, and it is only during the last few months that this has been realized by the power companies. Cases are on record where power companies have rebuilt existing lines, using the best of material and the most careful workmanship and after the new line was placed in service the reduction in interference was negligible. One test made on an isolated line showed no reduction, as measured by a field strength set, when the line was worked over very carefully by a crew of linemen.

We may summarize by saying that interference may be expected within a lateral area of 250-400 feet from a high-tension, pin-type insulator transmission line, and as long as economy dictates this type of construction no relief can be expected for some time unless the radio manufacturers design a double antenna balancing tuning arrangement which will balance out this interference.

That the power companies are not

standing idly by is shown by the cost sheets of the power companies; one of the smaller western companies has found the direct cost of finding trouble amounting to over \$25,000 a year, while the indirect charges easily double this figure.

Interference Level

It is very doubtful that the interference level in the smaller towns fed from high-tension lines can be economically reduced below 1 to 5 microvolts per meter. If a ratio of 40 to 1 is maintained between station strength and the interference for good reception, the radio manufacturers are placing an undue burden upon the power companies by increasing the sensitiveness of their sets. The author has investigated many cases of reported trouble due solely to the fact that the customer could not operate full volume on stations 1000 miles away.

Considerable interference is also experienced from substations, especially of the indoor type. This is especially true of the older substations using bushings which are of old design. Again this interference is due to discharges between the conductors and non-conductors, or between conductors not normally in the circuit but in the intense electrostatic field, and as a result have relatively high potentials with respect to nearby conductors.

In many cases the elimination of trouble from substations means rebuilding, and since substations in the smaller sizes with between \$20 and \$40 per kw. the elimination of substation interference must be approached with great caution.

Engineering Cooperation Necessary

If the interference from high-tension pin-types transmission lines is to be solved in an economical manner it must be done through the close cooperation of the radio engineer and the power engineer. It is, perhaps unfortunately, true that transmission lines are still built according to economic conditions. If conditions do not warrant the construction of a line free from radio interference, the community will suffer for want of service

(Continued on page 44)

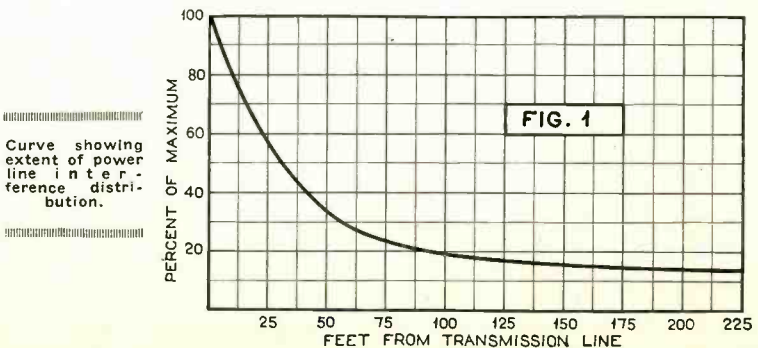

A Remote Control Selector System

An Improved Arrangement Employing a Vacuum-Tube Voltmeter as the Means of Operation

By Elmer E. Burns

THE vacuum-tube voltmeter is a device which responds to a voltage applied to its grid circuit by a surge of plate current if the applied voltage swings over sufficiently in the positive direction. If the voltmeter is connected across the output of a receiving set such a voltage change occurs at resonance with received signals and the voltmeter responds with a surge of plate current.

Radio control of mechanical devices such as directing the movements of an airplane or even operating a visible or audible signal makes use of the vacuum-tube voltmeter. In such devices the grid bias of the vacuum-tube is given such a value that the plate current is zero when no signal is being received. The surge of plate current caused by the control signal actuates a relay and the contact current of the relay operates the mechanism.

The vacuum-tube voltmeter method of remote control of a radio receiving set works out very simply. The motor which is to be controlled is, of course, that which turns the condenser gang. The relay must stop the motor at resonance and at the same time lock itself so that the condenser will be held at this point until the movement is again started by the remote control switch or push-button. The voltmeter does the tuning. The remote control switch simply throws the voltmeter into action. There is no juggling of push-buttons nor is there any pre-selection. By means of one main control switch or push-button all stations that are broadcasting and that could be tuned in by hand with sufficient volume for good reception can be brought in one after the other. By means of a station selector switch the voltmeter can be set to operate for a particular station so that it will bring in that station and no other. A number of selector switches can be provided for the user's favorite stations and these can be very small so that the remote control panel need not be

larger than the palm of one's hand. Any number of control panels can be installed connected in multiple so that the set can be controlled from any one of a number of rooms.

Details of System

Now as to details. To secure a high voltage for the operation of the voltmeter a step-up transformer is used with its primary connected across the output of the receiving circuit. The primary has high impedance so that it does not consume an appreciable amount of energy. The secondary is connected to the grid circuit of the voltmeter tube. The sensitivity of the device depends on the turns ratio. This should be 1 to 8 or preferably 1 to 10. Fig. 1 is a schematic diagram of the circuit. Fig. 2 shows the relay and its connections. When a current of sufficient strength flows through the relay coil the armature is drawn in. This movement breaks the motor circuit and at the same time opens the plate circuit and closes a circuit leading from the high potential terminal of the power unit through the relay coil and a resistor to ground. This locks the relay. The remote control switch simply opens this circuit allowing the armature to spring back. This movement opens the locking circuit at the relay contacts, closes the plate circuit and the motor circuit and the voltmeter is again ready for action. The relay that I am using is sensitive to 1.5 milliamperes. It is a standard production job and is inexpensive.

By using a heater type tube and connecting the remote control leads between cathode and ground these leads are placed at ground potential. Since the current through these leads is the plate current of the tube which normally does not go above five milliamperes—never above ten and that only for a brief interval—a very small wire can be used. No. 30 is large enough. Even a smaller wire could be used so far as the current is con-

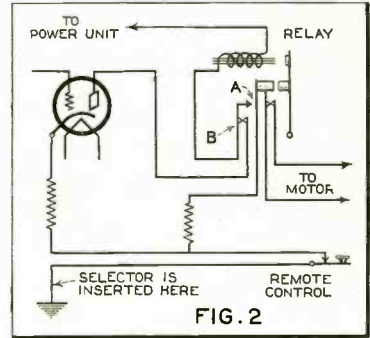

The relay connections. A is the contact for the locking circuit; B is the contact for the plate circuit. These two contacts are of the "make-before-break" type.

cerned. It is only a question of mechanical strength. Since the leads are actually at ground potential there is no difficulty in regard to Underwriters' requirements.

A simple reversing mechanism allows the motor to run continuously in one direction while the condenser gang reverses at the end of each 180-degree movement. A good induction motor of about 1/100 or 1/200 horsepower is suitable.

Stopping at Resonance Peak

The problem of stopping at the resonance peak becomes simple in the case of a receiving set having a band-pass effect and uniform selectivity over the scale. The best sets from now on will have practically uniform selectivity combined with band-pass tuning. There are such sets now on the market as I know from experience with one particular set made by a well-known manufacturer. To go to the resonance peak it is necessary to control the overhang of the motor. The motor current is cut off just as the tuning unit enters the resonance curve. The motor armature must make a certain definite number of revolutions after the current is cut off. This can be adjusted once for all by a simple device which controls the rotational inertia of the armature. A rod attached to the motor shaft at a right angle carries two weights with set screws. These weights are adjusted to give the right moment of inertia and locked in position.

The Selector

Now a little more about the selector. It is desirable to have matters arranged so that any one of a few favorite stations can be brought in simply by pressing a button for the station desired. Suppose there are

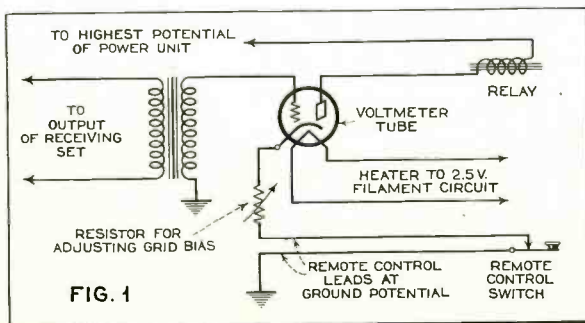

Schematic diagram of the vacuum-tube voltmeter circuit for remote control of radio receiver.

eight stations on the selector. Eight contacts are mounted in position for resonance one for each station. Call these the selector contacts. A single contact is carried by the dial. Contact is made for each station over a band slightly wider than the ten kilocycle band, say 15 or 20 kc. Suppose station number one is desired. Selector switch number one is closed. The circuit for this station is then open only at the selector contact. When this contact is closed by the movement of the dial the plate circuit is closed and the voltmeter is ready for action. If the station is broadcasting the voltmeter will operate and stop the motor. It will not stop for any other station because the plate circuit is open for all other stations. The selector does not stop the motor. It simply throws the voltmeter into action over a small band covering that of the station.

One selector switch answers for as many stations as are desired. The switch is mounted to rotate over a dial. When the switch is turned to the "off" position the set is turned off. The call letters of the stations on the selector are marked on the dial. It is only necessary to turn the switch to the letters for the station desired (see Fig. 3). This movement turns the set on and adjusts the tuner so that it will bring in that station and no other. The tuning is not done with the dial but

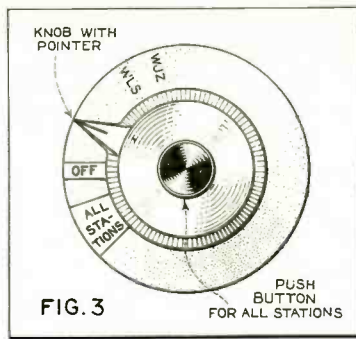

FIG. 3
Details of dial used at the remote control end of the line.

the proper connections are made for the station desired by simply turning the switch and the station is tuned in by the action of the voltmeter. If the switch is turned to the point marked "all stations," the selector is cut out and then all stations that will come in with sufficient volume for good reception can be brought in by means of the push-button in the center of the knob. The remote control dial need not be more than two inches in diameter. This is all that is needed for complete remote control provided the set has automatic volume control. If there is no automatic volume control a remote volume control is needed.

How does it work from the user's point of view? Suppose he wants a certain one of his favorite stations. He simply turns the switch to the call letters for that station. Suppose the station is not broadcasting at that moment. He can sit down and forget about it. The tuner will keep on going and when the station does start to broadcast will tune it in. Next the listener decides that he wants another station that is on the selector. He turns the switch to the letters for that station. The first station is cut out and the second station comes in. Next the listener decides he would like to get some stations that are not on the selector. He turns the switch to the position marked "all stations" and uses the push-button on the center of the dial bringing in all the stations one after another. He may go to another room and do the same thing with another remote control dial which has its contacts connected in multiple with the first.

It should be added that no special modification of a set is necessary as connection to the condenser shaft can be made by means of a belt, the motor being placed above or below according to the space available. Instead of modifying a set to adapt it to remote control the vacuum-tube voltmeter system can be modified to a very great extent to adapt it to the requirements of any particular set.

Revising the -99 Type Tube

New Type of Filament for Dry Cell Tube Eliminates Usual Faults

*By Allen B. DuMont and V. O. Allen**

IN theory, at least, the radio industry made no mistake when it introduced the -99 or dry cell all-purpose radio tube. At a time when the socket-power operation of radio sets was still more or less a dream, and the sloppy storage battery held the center of the stage, the dry battery radio set was certainly a step

* Engineering Dept., DeForest Radio Co.

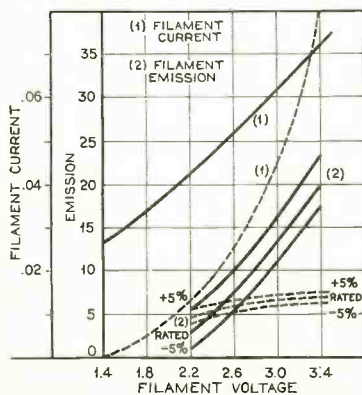

FIG. 1
Curves of the new tube are in full lines; those of the common type -99 tube in dotted lines.

in advance. And even after the advent of socket-power radio, the need of a dry cell tube for the portable and the rural radio sets still had to be met by the radio industry.

Disadvantages

Unfortunately, practice is quite another matter. In the case of the -99 tube, the beautiful theory was soon exploded by practical considerations. Due to its uncertain emission arising from a very limited amount of active material or thoria in the thoriated tungsten filament of very modest dimensions, the -99 tube proved a keen disappointment in many instances. It is a fact that the -99 tube has been the greatest gamble in the radio tube market. The buyer could never be sure that a tube was good, bad or indifferent, when taken out of its carton; and even if the tube happened to perform satisfactorily for a time, its life was a questionable matter.

Another disadvantage of the -99 type tube has been along mechanical lines. It is at best a frail construction with decided microphonic characteristics.

All in all, the -99 type tube has not been a success, which accounts for the unpopularity of radio sets employing this type of tube and for their early

appearance among the job-lot sets on the Radio Rialto otherwise known as Cortlandt Street Bargain Row.

Yet today, as before, there is serious need for a satisfactory dry cell radio tube. The portable radio set has great possibilities, if it can be made to operate economically. The rural home is still waiting for a satisfactory radio

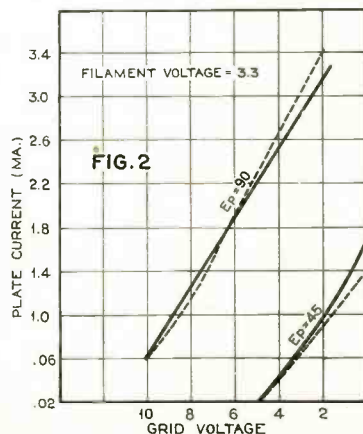
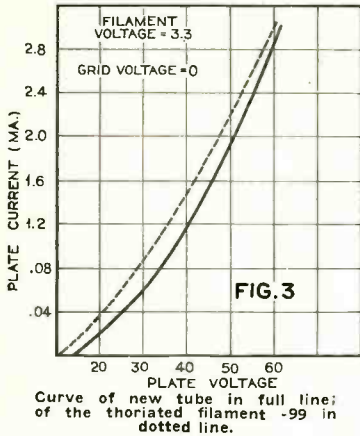

FIG. 2
Curves of the new tube are in full lines; those of the common type -99 tube in dotted lines.

set, in the absence of an a-c. supply. With these facts in mind, and taking advantage of a breathing spell in the radio industry, our engineering staff recently turned to an exhaustive study of the -99 type tube. First of all, we have determined the shortcomings of the usual -99 tube, both qualitatively and quantitatively. Then we have set to work on designing a new tube while retaining the essential electrical characteristics of the -99 type, so as to safeguard the investment made by the public in so many radio sets employing that tube.

New Type Filament

The principal disadvantages of the earlier -99 type tube were its exceedingly short life, its microphonic ten-



encies, its inability to withstand slight mechanical shocks, and its critical filament voltage. In general, these weaknesses could be traced to the use of a thoriated tungsten filament, which of necessity had to be of very small cross-sectional area. Also, the process involved in its manufacture had a tendency to render this filament brittle. It was apparent to us, therefore, that the entire solution of the problem depended upon the substitution of a new type of filament that would permit of a greater cross-sectional area and more uniform electron emission. After considerable research, we decided upon the combination of an oxide-coated filament with a special alloy base metal. By means of this filament, it is possible to increase the diameter of the filament approximately three times and still have a tube that draws only 60 milli-amperes of filament current, with the same general operating characteristics as the conventional -99 tube. The electronic emission of the filament of this new tube is approximately three times greater than the usual -99 tube. The low operating temperature of the filament enables the tube to maintain its output over a considerable period of time. Also, because of the lower operating temperature of the oxide coated filament with special alloy base, the wire does not become brittle with use.

Emission curve of the new dry-cell tube plotted against hours.

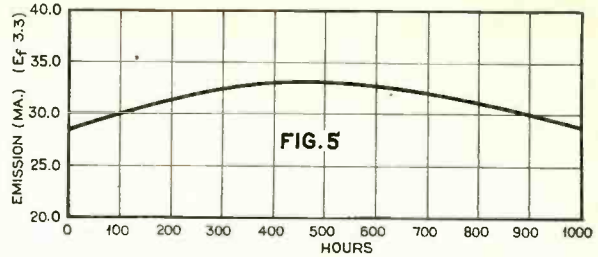

In analyzing the comparative merits of the new tube and the usual type, the accompanying series of curves was obtained. Fig. 1 shows a comparison between the thoriated tungsten filament and the oxide coated filament, operating at various voltages. Curves 1 are comparisons of the filament current, while curves 2 are comparisons of the emission at various voltages. It will be noted that the emission of the oxide coated type is considerably in excess of that of the thoriated tungsten type. In Fig. 2 the curves represent grid voltage versus plate current. In this respect the two types are quite similar. Fig 3 shows the difference between the two types of filament with regard to plate current at various plate voltages.

Fig. 4 shows the amplification factor, plate resistance and mutual conductance as a function of the plate voltage. It will be observed that the characteristics of the oxide coated type in the operating range of voltages, is considerably better. That is to say, the amplification constant is higher, the plate resistance is lower, and the mutual conductance is appreciably higher.

In Fig. 5 the emission life is shown. It will be noticed that there is very little falling off in the emission for the first 1000 hours.

The various features brought out in the accompanying curves make the new tube particularly well adapted to rural

and portable battery sets. Also, the new tube will be found most useful in laboratory standards, where it is advisable to enclose all components including tubes and batteries in shielded cases. Although the new tube is interchangeable with present types on the market, even greater output can be obtained by having the circuit particularly designed for it.

INTERFERENCE FROM POWER LINES

(Continued from page 41)

or the rates will of necessity be raised to pay for the increased cost of lines. In many districts under-insulated lines (from a radio standpoint) have given good service for long periods of years, in some cases deriving a considerable portion of their insulation from the wooden cross-arms.

The question now confronting the power companies is how far are they justified in going in eliminating this interference, with the meagre amount of engineering data at their command. It is hoped that the radio engineer will become acquainted with the problem of the power company and that the literature sent out by them will not lead the radio dealer to believe that all forms of interference can be eliminated by replacing defective equipment.

No power engineer feels justified in recommending an outlay totalling thousands of dollars when the propagation of radio waves over networks is so little understood as it is at the present time. Use is being made of the data collected in studying carrier current transmission and the most promising fields of endeavor is in making use of these data. The line of approach most promising is to isolate a section of line which is traversing a thickly populated area by means of choke coils and to rebuild the line between the choke coils with suspension insulators of the ball and socket type. That this is expensive no one will question and since it is expensive this remedy should be applied only after careful investigation.

The lack of a standard of reference is a distinct drawback to the free interchange of operating experiences. Standards should be set up in order that definite responsibility be fixed. This would enable the power companies to spend money in making effective cures that is now spent in making dealers' trouble calls.

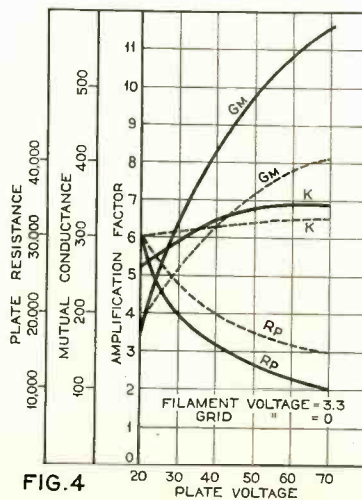

Production Trends in the Radio Industry

A Survey Concerning the Purchase of Parts, Assembly, and Influences Upon Design and Production

By Austin C. Lescarbourea

Mem. I.R.E., Mem. A.I.E.E.

MUCH has been written concerning Radio the Science. A visit to the laboratories in which the many intricate devices of radio are invented and designed, gives ample proof of the scientific nature of radio. The great transmitting stations give added weight to the theory that radio is a science.

We have also heard and read much of Radio the Art. Not an art, exactly, but the machinery of art. As a competitor of the stage and screen, as the employer of thousands of artists, actors, singers, musicians, radio may well be considered as an art. A visit to the broadcasting studios in the evening will convince even the skeptics on this point.

We have also learned to think of Radio in terms of an Industry. Radio receivers, like automobiles, are made by mass production, thousands at a time, on conveyor belts; nationally advertised brands competing for the public dollar, each claiming some exclusive feature, each being made in yearly models, shown at national radio shows. Figures are given as proof of the high standing of radio among the industries of the nation. A visit to the large factories devoted to the manufacture of radio receivers aids in stimulating the impression of radio as a huge industry. Wherefore it might be well to go inside some of these factories and compare their methods to those of factories turning out other much sought after commodities, discovering the efficiency which is the keynote of success in any industry. Of course, we were unable to visit over 200 factories in person, so we made the survey by sending the manufacturers questionnaires, from which we have gathered our evidence.

Manufacturers and Assemblers

In most industries, manufacturers manufacture. That seems self-evident. But in the radio field, many manufacturers of radio receivers are little more than assemblers. They buy, not raw material, but most of the parts which comprise their finished products. Nor do they buy all the parts from a common manufacturer. So decentralized is this matter of buying parts from many manufacturers and fitting them together into a receiver, that cause for comment is urgent.

The manufacturer of a particular part desires, for the sake of economy, to standardize his product. The set manufacturer should adopt his assembly to suit the standardized part. As

to other part manufacturers, whose products are also inherent components of the finished product, let them take care of themselves. They can suit their products to his.

On the other hand we have the set manufacturer, who does not want to invest in machinery and labor to manufacture parts for his set, since radio engineering continually changes the features, and would necessitate quick obsolescence of his plant. He wants to buy cheaply from a parts manufacturer, whose product is also sold to other set manufacturers like himself. The set manufacturer has two alternatives. He can either accept the parts manufacturer's standardized product, in which case the part is so different than that supplied to the other set makers, or he can have the parts manufacturer produce to his own specifications, in which case the unit price of the part will rise.

Some set manufacturers are engaged in associated lines, which they have been making since pre-radio days. Thus, the Bosch Magneto, Stromberg-Carlson, Victor, Atwater-Kent and other set manufacturers have for years been manufacturing products, which, slightly modified, are essential parts of the modern radio receiver. Naturally, these companies continue to manufacture the parts which they have been producing, and for which they have a market outside their own sets. They also incorporate those parts that they make in the radio receivers which bear their names. Many factors enter

into the question. What parts if any shall I, a set manufacturer, produce, and which parts shall I buy from parts manufacturers? By manufacturing his own parts the set manufacturer can obtain exclusive features in his receiver. But unless he has an outlet for these parts, larger than his own demand for them for incorporation in his radio sets, they are liable to cost more than if bought outside. Practically no two manufacturers have exactly the same set-up for production. Some have elected to do no fabricating whatsoever, preferring to devote their entire attention to assembly processes. On the opposite extreme is the manufacturer who endeavors to build every component entering into his finished receiver. And there are the many manufacturers who take the middle of the road, sometimes walking a little to the left or to the right.

Large Parts Production

It cannot be said that any one course of procedure is right and all the others wrong. There are instances of successful manufacture with no parts production and with the production of almost all the parts. As hinted before, many factors enter into a decision to manufacture parts, or to purchase them. An outstanding example of successful production under a system where many parts are manufactured is that of Stromberg-Carlson. Since they are interested not only in radio, but also in associated industries, they have found it expedient to manufacture, for use in their sets—and for sale outside

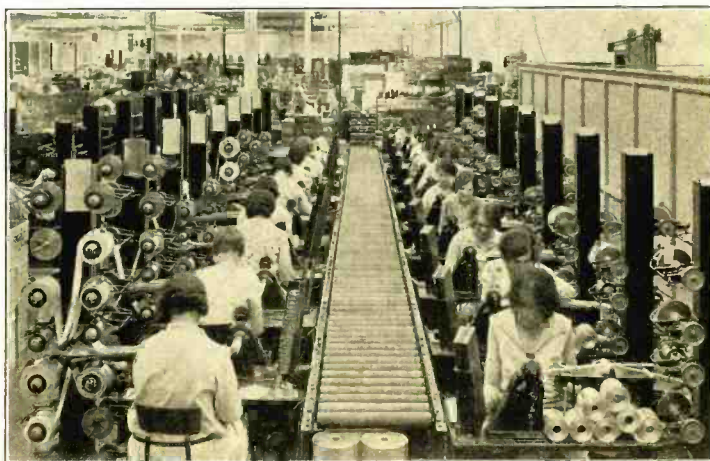

It has been said that the successful all-electric radio sets of today are built on a paper foundation—satisfactory filter condensers. Here is the way Stromberg-Carlson makes its paper condensers.

their organization—audio transformers, by-pass and filter capacitors, r-f. tuning coils, filter inductors, phonograph jacks, switching keys, vacuum-tube sockets, electrodynamic speaker assemblies, wire and cordage, power transformers, phonograph pickups and tone arms, chassis frameworks, shields and cabinets.

On the other hand, Stromberg-Carlson purchases in accordance to its specifications power transformers, volume control potentiometers, fixed resistors, "on-off" switches, connecting cord caps, power outlets standard to the electrical industry, etched dials and name plates, and vacuum tubes.

The other extreme may be represented by Stewart-Warner, which concern manufactures complete receivers and speakers only, including the parts entering into the construction of these products with the exception of the raw material, and such standard items as fixed and variable condensers and carbon rod resistors. Since this company relies to such a large degree on materials manufactured outside its own plant, it must, to guarantee quality, keep strict vigilance over the production of parts by others. All condensers are built to its exact specifications, and tested before being put into stock. This procedure they find necessary, since standard products are rarely suited to the company's particular needs, and are expensive due to exclusive specifications. This close supervision of parts manufactured elsewhere, narrows the material difference between inside and outside parts production. There remains only the question of cost. And although the part manufactured outside must realize a profit to its manufacturer as well as to the set manufacturer, mass production, even where special specifications must be adhered to, cheapens the price of the product to such an extent as to make it not worth while for some set manufacturers to produce.

Outside Purchasing of Standard Parts

The Colin B. Kennedy Corporation takes the stand that it is best to buy standard parts that meet its specifications wherever possible, since such parts can be obtained cheaper and of better quality from specialists, than if they were produced by the set manufacturer. In its present models, Kennedy produces all stampings, shields, etc., because they cannot be obtained elsewhere to conform to the peculiar requirements. The company also produces its own frequency transformers to obtain the uniformity which it claims is lacking in those manufactured by outside sources. The advantage of standardized parts is the possibility of buying on smaller commitments than if the article were made for one manufacturer's particular use. This the Kennedy people do in regard to loudspeakers, finding the standard product entirely satisfactory.

The Sonora Phonograph Company manufactures punch press parts, coils, cabinets, and cables. The company's production does not justify large investments in tools and special fixtures for the manufacture of other parts. Loudspeakers, condensers, transformers, and shielding cans, all standard items, slightly changed to meet particular requirements, are purchased, in the belief that for quantities less than 100,000 they can be bought from suppliers who produce in large quantities, more economically than they can be manufactured, considering tool costs.

The Crosley organization manufactures a very large proportion of the parts it uses in its sets, with the exception of parts requiring machine tool operations.

The foregoing examples show the trend in manufacturing and purchasing parts for assembly. Those concerns which engage in affiliated industries

seem able to manufacture parts more cheaply than buying them. Companies devoted entirely or almost entirely to radio find it more expedient to purchase parts, especially standard equipment and items requiring tooling.

Cooperative Purchasing

Since so many parts are purchased from parts manufacturers, most of the parts are standard or changed only slightly to meet the requirements of the individual manufacturer, the idea presents itself that a great saving might be effected by the cooperative buying of these standard parts, particularly such items as switches, coils, wire, dials and sockets. Yet, strange to relate, only one of the many manufacturers questioned thought that a saving could be effected. The reason for the negative replies is, firstly, that the individual purchasers buy in such huge quantities that they get the rock bottom prices as it is, and secondly, that the manufacture of parts outside is usually done to specifications, precluding the manufacture of any one part in tremendous quantities all alike for many set manufacturers, which would be necessary for cooperative buying and a lowering of price. We are inclined to question the correctness of these answers. In the first place, if the individual manufacturer buys in such huge quantities, he might better manufacture the parts himself. In any case, from the parts manufacturer's angle, he may sell huge quantities of his product to one set producer, but that producer is still only one of many customers. If he sells hundreds of thousands to one firm he must sell millions all told. The amount of a product purchased by an individual concern has, of itself, little bearing on the possible economy of cooperative buying. And if most of these parts are made to specification, and such procedure fails to admit of cooperative buying, it might be well for the set manufacturers to get together and standardize the part so that they can purchase cooperatively and at a large reduction in price. The Crosley Radio Corporation alone thinks that a saving could be effected, and is, in fact, considering such a move.

Production Schedules

Radio has achieved for itself the reputation of most uneven production schedules. It is almost as seasonal an industry as Christmas cards. A period of production speeded up to a 24-hour day, the hiring of new operators at high wages, operators unskilled in their work, inefficient until broken in, is followed by a period of laying off the operators just as they are attaining efficiency, losing the investment represented in their training, letting the plant stand idle for months at a time, or producing at such a lowered rate as to increase unit cost to fabulous figures. And in the meantime, having to store the sets made in the rush period and left unsold, rental of stor-

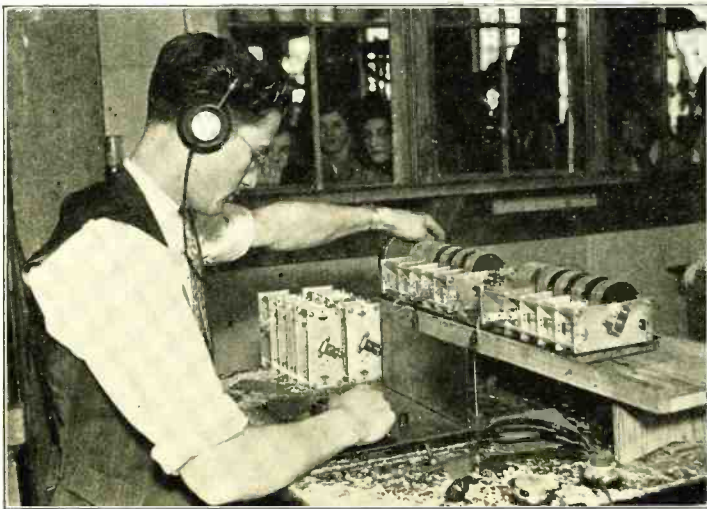

The single-control radio tuner—the seemingly impossible thing in the days of multi-dial radio—has been made possible by ingenious condenser calibration devices. Here is the way the Zenith Radio Corp. matches up condensers in gangs.

age space and obsolescence of the sets. Radio is probably the most wasteful, ill-organized production in the world. And it avails nothing. Even the storage of vast quantities of sets after the rush is over in no way aids the jobber and dealer to get deliveries. When they want deliveries, there are not enough sets to go round. When the holiday season is past the manufacturer is stuck with thousands of sets. Most certainly there is something rotten in the Radio Industry. Of course, the set manufacturers do not want to hold the bag for the industry, but this they are doing nevertheless. One firm will carry nothing in stock, producing only on customers' orders. Another will not stock ahead of demand or absolute shipping date. The last few months have shown the set manufacturers the folly of closing their eyes to a possible decline in demand. At least one concern now professes to a more steady production schedule, with a reduction only when changing from one model to another. Nevertheless, the frequent and radical changes in radio design makes even production hazardous. In this respect, while big production crowded into shorter periods is more expensive, it lessens the possibility of accumulating slow-moving inventories.

Flexible Production

Another problem is to balance the increased efficiency of even production against over- or under-production due to a wrongly estimated market. Perhaps the ideal system is moderate production the year round but a sufficiently flexible organization to permit a rapid increase should the demand warrant. And of course, the rapid changes in radio design tend to the manufacture of no more sets than the immediate market calls for. In view of which fact it is difficult to see how so many manufacturers could have so far forgotten themselves as to over-produce, as they have this past season. Perhaps it was a case that each manufacturer, seeing his competitors producing in enormous quantities, was afraid to be left behind, and decided to follow suit. As a result, at least one well-known manufacturer is now paying storage for 75,000 sets, which are growing more obsolete every day. Only "fools rush in where angels fear to tread." Q.E.D.

Leaving this sore spot of the radio industry let us return once more to production and such. Many manufacturers use mass production methods, conveyor belts, and the employment of many operators and few craftsmen. The operators, having such specialized tasks, and working from a conveyor belt, are not particularly interested in the quality of the product. Speed is the pass word of Production. For which reason inspection becomes more important than ever. For the most part, set manufacturers agree that inspection should not be under the direct supervision of or paid by Production. Of course, the production depart-



Here is the Crosley Radio Corporation's shipping room, where, by means of a carousel conveyor, radio sets can be carried to waiting freight cars at the rate of 580 per hour.

ment maintains a few inspectors along the assembly lines, but in general a separate factory superintendent can maintain better quality, since speed and cheapness of production are not the criterions on which he holds his job. In many cases, a compromise is effected between speed of production and absolute perfection of materials and assembly. However, competition is forcing the strictest possible inspection in order to sell at all. In some plants there is a separate inspection department, answerable to the Chief Engineer, or the General Manager of the company. This is necessary where most of the operators are on a piece-work basis and where sales departments demand faster production than is consistent with rigid inspection.

One manufacturer's production department is cut in half, the Factory Superintendent having charge of Production, and the Production Engineer working independently of the factory superintendent, having charge of Inspection. As a general rule, it seems better to divorce Inspection from Production, making it subject to the General Manager of the Company or the Engineering Department.

In the good old days of radio, programs were only an excuse for the existence of a station. The DX fan desired plenty of station announcements, and receivers that could get the greatest possible number of stations in the shortest time. But things have changed since then. The great strides made in the broadcast program field and the wearing off of the first pride of long-distance reception has caused a demand for greater selectivity, even at the cost of sensitivity. The ever-increasing number of stations operating very close to each other helped this trend.

Public Trend

Asking the radio manufacturers their opinions on the public trend, we find that although the initial pur-

chaser is still concerned with the matter of getting distant stations, the novelty soon wears off, and he prefers to get a few stations with a minimum of interference. Stromberg-Carlson believes that while the urban population is satisfied to get a few nearby powerful stations, the rural population prefers a distant powerful station with better programs, to a nearby one. That company reports a demand for receivers with sufficiently high sensitivity to insure good daylight reception of fairly distant stations and good DX work under favorable night conditions. In the opinion of the Sonora Company the public seems to prefer sets with sufficiently high sensitivity to obtain good daytime reception even at the cost of interference at night.

Sales methods have in many instances changed from stressing the quality of the set as a whole to stressing some one feature of the set. Often, the stressed feature is an adjective, by which the entire performance of the set is characterized; sometimes it is a new time- and effort-saving contraption; sometimes it is a rather irrelevant point, having nothing to do with sound reproduction. Seldom, anymore, is it an engineering feature. Having observed this change in advertising and selling, we sought to learn if these selling points originated in the minds of the advertising and sales departments and were incorporated in the set because of their sales value, or were taken by the advertising and sales departments from the finished set, as designed and produced under the sole direction of the engineers. About half the manufacturers admit the influence of sales and advertising departments in the incorporation of selling points in their sets. The other half deny any such thing. Sonora says that the advertising department does influence production, though the nature of the selling feature to be incorporated in the set is

left to the discretion of the engineering department. In the Stromberg-Carlson plant both engineers and sales departments confer before incorporating any new ideas. Pure sales novelties are not catered to. The Alden Manufacturing Company dogmatically insists that by all means the sales department should specify selling points since "articles not designed to sell will not sell." Rather a sweeping statement. But every man has his own opinion. Stewart-Warner claims that the selling features stressed by its advertising and sales departments were picked from the finished receiver, which was made without recourse to selling ideas. Let us call the battle a tie, one side professing to build to engineers' specifications only and letting the advertising department pick out what they can from the finished product, the other side professing a progressive attitude by catering to the public's desires as seen through the eyes of the sales department. So be it.

Influence of Serviceman

Of course, having asked whether or not sales and advertising influenced design and production, we could not stop there. We had to ask about the influence of the serviceman, either the dealer's or the manufacturer's. The serviceman in our opinion, and we state this before looking at the opinions of the manufacturers, is a most important factor, and should have a voice in the design and production of the sets he services, since he knows how the set behaves in the field better than the manufacturer. He knows what parts need the most servicing in each make. Manufacturers would do well to heed his words of wisdom, gain his good-will, and at one and the same time, improve their sets and aid their sales.

Now let us see what the manufac-

turers have to say. We win—at least on paper. Most of the manufacturers do take the advice of servicemen in designing new models. At least so they state. Knowing a thing or two about the servicing situation, we are inclined to shake a grain of salt upon the tail of the unbounded enthusiasm with which some of the manufacturers profess to look upon the serviceman. One company keeps records of all suggestions made by its servicemen or those of its dealers. Another company uses the field experience of its dealers' servicemen in designing new sets and controlling production. Another firm professes to getting very little constructive criticism from servicemen, and several other firms either do not ask for suggestions from the field, or have such faith in the omniscience of their factory engineers that they look with disdain upon any information originating outside the factory or the laboratory.

Standardization

In conclusion, a few side remarks may not be inappropriate. Differences in production methods seem to be diminishing rapidly, and standardization becoming the order of the day. A further standardization should now take place not only in methods but in parts required for assembly. As an example, standardization of type and size of choke and transformer laminations would tend to a lowering cost of coils and laminations to both parts and set manufacturer. Now that weekly improvements of great magnitude are no longer forthcoming, the improvements being slower and less spectacular, the trend should be not so much to the insertion of selling points as the concentration of over-all performance. As an example, mentioned by a manufacturer, a loudspeaker should be made more efficient, considering sound out-

put to electrical input, this in turn allowing smaller power outputs from the audio system, which in turn will simplify and reduce the expense of the power plant, filtering, etc. Another suggestion, which is already on the way to fulfillment, is the elimination of firms who are in the radio business only to profit from the sale of stock. Also the dissemination of information as to stock on hand, oversupply, etc. May we extend best wishes for success to the R.M.A. which is now conducting such activity? More time should be allowed for the designing of parts. The present system of waiting until the last minute prior to the trade show, is mighty expensive. Better to anticipate the market trend.

Radio manufacturers should consider themselves collectively as well as individually. Instead of trying to make all the sets that the country can consume, each manufacturer should bear in mind the fact that thousands of sets are being manufactured and sold by other firms.

The Ohio Carbon Company has the right idea in mind when it advocates the determination of sales quotas by the manufacturers so as not to entail a terrific peak production.

Under the present conditions where radio sales are confined largely to the holiday season, it is not difficult to understand the reasons for attempting to build the entire season's requirements in a few weeks' time. But it would be a wonderful improvement for the radio industry in general if the manufacture of the parts and sets could be spread over an entire year. The first move would necessitate the spreading of sales over a twelve months' period instead of a six weeks' period. Assuming that this could be done, the manufacturer of a radio set would have ample time in which to lay out a definite program. His manufacturing and engineering forces could be brought down to a minimum but permanent figure. The unnecessary cost of increased factory space, equipment, labor and overhead, that goes with the present idea of making a year's requirements in a few months' time, would be conserved and this surplus expended over a period of a year much more judiciously, tending to strengthen the industry as a whole. Under the conditions existing at the present time, raw materials are frequently purchased at the highest price levels, top prices are paid for labor when it is at a premium, a great deal of equipment is bought and paid for and becomes obsolete before it ever produces a dollar's worth of merchandise, and finally when the season draws near a close sets are dumped on the market by the hundreds of thousands. In addition to the financial considerations that are involved it stands to reason that the quality of the product that is ground out like sausage in a short manufacturing season cannot compare to that same product

(Continued on page 52)



A view of a section of the radio set plant of the American Bosch Magneto Corp.

Public-Address and Centralized Radio Systems

IV. Mixer Circuits and Electromagnetic Reproducers

By E. W. D'Arcy

IN Fig. 18-A is shown a constant input and output impedance mixer control which is the ideal type mixer as the impedance of the mixer control remains constant despite any given variation of attenuation. Very excellent impedance matching can be obtained with this system and any given variation in attenuation of individual volume controls will not affect the setting of the others. This paralleled arrangement is used quite extensively where jacks are inserted in the combined output of the mixer transformer and volume control so that each individual circuit may be transferred from its position feeding into its amplifier to an emergency amplifier by means of patch cords. There are some drawbacks to this circuit, however, in that the image impedance of the load does not match that of the individual mixer circuits and, therefore, some distortion is caused by this effect. A preferable system of connecting these controls is shown in Fig. 18-B where they operate in series with each other. The same flexibility pertaining to the transfer of microphone circuits to spare amplifiers can be obtained with little additional complication. In the circuit of Fig. 18-B the ultimate in impedance constancy is realized as the manipulation of any individual gain control will not affect the level at which any other is operating—and since all the impedances are matched up as shown, distortion from this cause is elimin-

ated. This type of volume control has not been on the market for long.

A detailed mixer diagram is shown in Fig. 19, wherein flexibility is used with regard to the use of emergency amplifiers and an additional pad can be cut in and varied for background accompaniment of music on program announcements. This is a very necessary feature in broadcasting at the present time as almost every program has its theme song. The jack position shown allows the use of any one microphone circuit and its patching onto the duplicate amplifier position for emergency use in case of amplifier trouble.

Reproducers

An entire text book could be written on phonograph reproducers. The author, therefore, is limited in regards to the amount of material which can be concentrated in the space available on this subject. Consequently, it will be necessary to skip some detail on any particular phase, concentrating on the salient points of interest.

It might possibly be of some assistance to the reader in the understanding of the latter parts of this article to retain in his mind the primary requirements of reproducers as set forth at this time.

- (1) High unit efficiency of electrical output to mechanical driving force.
- (2) Permanent maintenance of characteristics.
- (3) Linear output

$$\frac{V^1}{V^2} = \frac{E^1}{E^2}$$

V^1 = Initial needle actuation
 V^2 = Different needle actuation
 E^1 = Initial output
 E^2 = Different output

- (4) Minimum wearing force on bottom of record groove.
- (5) Minimum wearing force on sides of record groove.
- (6) Maximum effective coupling of needle point to record groove.
- (7) Allowable variation from right angles of the reproducer with respect to the recording groove.
- (8) Maximum effective inertia of reproducer-head with respect to record groove.

The author will base the following discussion on the premises heretofore stated.

1. High unit efficient of electrical output to mechanical driving force: Very little explanation is needed of the first

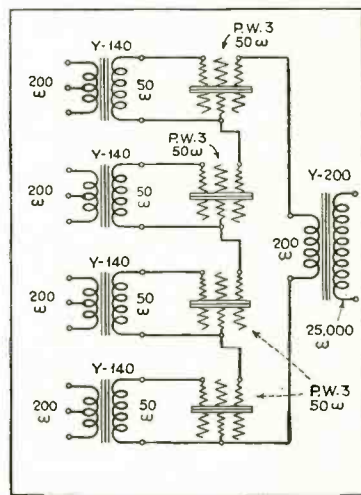

Fig. 18-B. Circuit of mixer with the controls connected in series.

requirement mentioned, as it is quite obvious that this states and sums up any further detailed statement as to reproducer mechanics and allows of no argument, in that the efficiency of any device can be determined if the power input is divided into the power output. In the case of a reproducer, the upper limit of power input is determined by the maximum load possible to place on the record groove without causing excessive wear. Therefore, all relative comparisons of reproducers should be determined, not by their peak output, but rather the efficiency as expressed in the formula here given:

Electrical output in relative units

Driving force in relative units

2. Permanent maintenance of characteristics: As can be readily realized, permanence of characteristics is an extremely important item in any reproducer and should be one of the first things considered. This is not the case in several of the reproducers now on the market for the following reasons:

Damping

Rubber is used quite extensively in the majority of reproducers now on the market, and in most cases not very wisely. The intelligent use of rubber can probably be excused in view of the prevailing prices possible to obtain for reproducers. It is also possible to obtain a reasonable life for a reproducer if the effect of rubber on the overall characteristics of the device is reduced to a minor factor. However, in some types now available, the

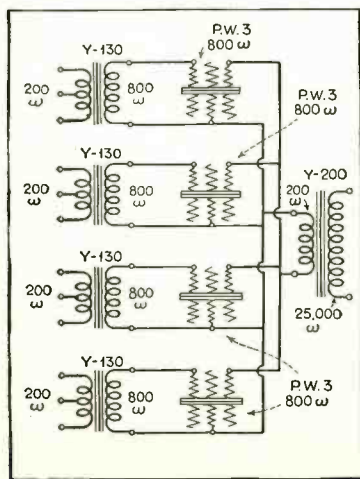

Fig. 18-B. Circuit of a constant input and output impedance mixer control.

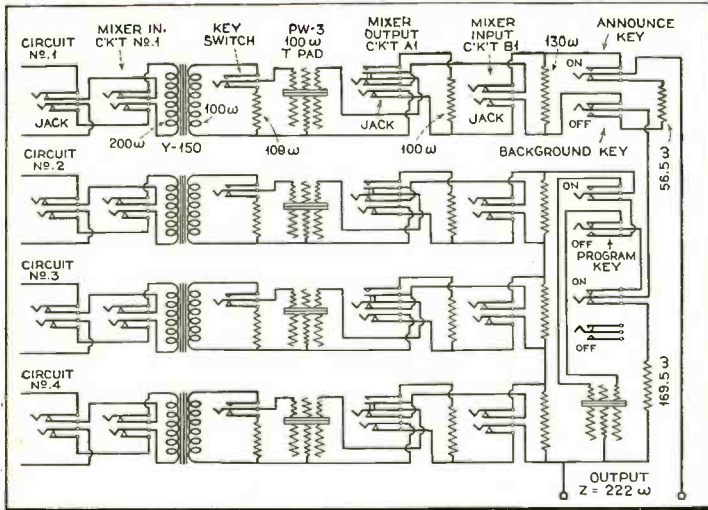

Fig. 19. Circuit diagram of mixer system to be used with emergency amplifiers. An additional pad can be cut in and varied for background accompaniment.

rubber is relied upon for the entire satisfactory operation of the reproducers, and it is the author's intention to point to a few representative types of reproducers and point out a few of the errors in designing them.

The ideal reproducer should require no other damping than that actually producing energy. It is impossible, with the types of reproducers now current, to obtain this result without the use of some additional damping to assist the record vibration in returning the armature to its non-excited position, due to armature weight and magnetic instability. We can, however, reduce this effect to a minimum by proper design of reproducers and for purposes of illustration have shown several representative types which, by process of evolution, illustrate the development of reproducers using rubber.

In Fig. 20 is shown a type quite familiar a few years ago. In this type the pivotal point of the needle and armature is located below the lower armature gap. As can readily be seen, with this system the effect of the damping is multiplied through the leverage of the distance between the armature end and the pivot point, as compared to the distance between the

needle point and pivot point. Therefore, when sufficient damping is introduced to overcome any magnetic attraction of either pole piece for the armature, it results in an unusually high degree of needle point impedance with resultant reliance on the rubber for operation and causing excessive record wear.

In Fig. 21, a type is shown in which the leverage action between the applied damping and needle point is decreased considerably due to mounting of the pivot in the lower gap, thereby fixing the necessary damping at a much lower figure, and resulting in much less reliance on the rubber due to decreased damping required on the armature to insure armature stability.

In Fig. 22, a type of reproducer is shown using an entirely different principle of operation which insures stability of performance in so far as damping is concerned, as the pivot point is constructed integrally with the armature and damping applied both by the torsion steel pivot support and damping applied in the form of oil of a low viscosity pressed against this torsion steel by the forces of gravity. The illustration is sufficiently clear to show the operation of this reproducer.

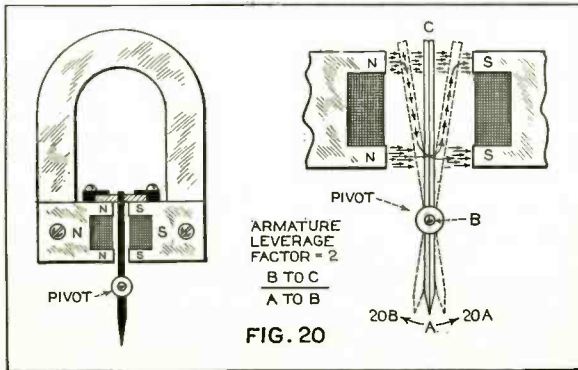

FIG. 20

This is the type now supplied with the better class of sound installation.

In Fig. 24, a type of reproducer is shown which uses rubber blocks for damping. By reason of the short armature, due to smallness of the armature coil—the impedance of this device being approximately 50 ohms—an extremely favorable leverage action is obtained. While the armature is very small, it is operated at high flux density and its output, therefore, is as high as several of the more highly damped types, and its factor of efficiency, as defined in section I, is extremely high.

Magnet Life

The subject of the permanence of different types of steel has been very ably covered by Mr. George Crouse in previous issues of this magazine. Therefore, we will confine ourselves to the effect of construction on magnet life.

In this respect it could be said that the smaller the air gaps, and consequently the higher flux density the armature operates at, the longer the life of the permanent magnet.

In Fig. 20, in order to obtain good results, a considerable gap distance is required, consequently operating the

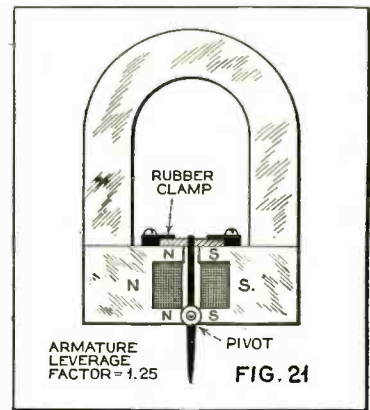

A pickup with decreased leverage action.

armature at a lower flux density with resultant inefficiency and considerable magnetic leakage.

In Fig. 22, the gap distance is extremely small and the armature core in the coils is of a high permeability; therefore, the drain on the magnet is inconsiderable.

In Fig. 23, in so far as magnetic leakage is concerned, any loss can be disregarded as the two magnets form a complete magnetic circuit. The armature, however, is operated at an extremely low flux density, which in turn requires a larger armature with resultant increased record wear and armature instability.

In Fig. 24, the armature is very small and operates at a higher flux density, which means that the gap distance is decreased considerably with resultant increase in magnet life.

The use of rubber in pivots is tolerable as the rubber can be placed un-

Details of an early form of electromagnetic pickup and the principle on which it functions.

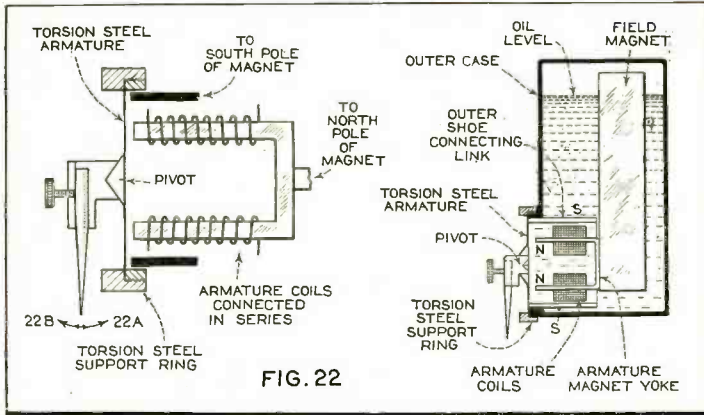

Details of the form of pickup used extensively in commercial work.

der considerable pressure, and even in the event of hardening will maintain a permanent seat for the pivot. In this respect it is far superior to an assembly where reliance is placed on the two pivot points, with all the likelihood of their improper adjustment.

In Fig. 22, the pivot is a torsion steel disc clamped in a frame with the pivotal point in the shape of strengthening across the face of the disc. This system is the last word in permanence as the likelihood of the torsion steel aging under normal conditions is unlikely.

Electro-Mechanics of Types

At this time, since the subject of the theory around which the different types of pickups operate is closely related with the life of the pickup, the author wishes to digress from the exact subject of permanent characteristics.

In Fig. 20, the theory of its operation is illustrated. The unexcited position of the armature lies directly between the two pole-pieces. When the armature is moved to the direction indicated the flux moves from the upper north shoe of the pole-piece in two directions, namely, across the air gap to the upper south pole and a portion is diverged, due to the lower magnetic impedances, through the armature to the lower south pole. In the reversed excitation position, the flux moves across the lower gap and some portion is diverged to the upper south pole gap, thus realigning the direction of the lines of force through the coil and producing electrical energy. The only difficulty with this particular mechanical design is that when the armature is energized in one direction, it also moves the magnetic pivot point in such a direction as to assist in decreasing the magnetic flow with a resultant decrease in possible output.

In Fig. 21, the same electromagnetic action takes place, but due to moving the mechanical pivot point up to where it coincides with the magnetic pivot, full advantage is taken of the magnetic flux moving back and forth through the armature.

In Fig. 22, the principle is basically changed, as the direction of the flux does not change through the armature, but operates in the following manner: The drawing shown in Fig. 22 is considerably exaggerated to show the theory around which this pickup operates. One might call this particular theory one of flux disparagement. As shown, with the needle moved in the line in-

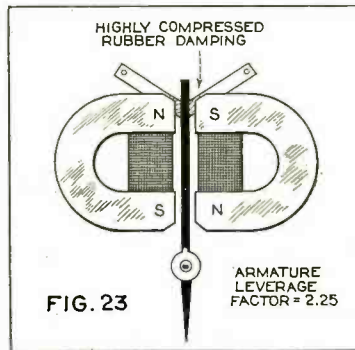

The armature of this pickup operates at low flux density.

dicated, the direction of the magnetic flux is from the north pole through the base of the armature coil supports, which incidentally is of high permeability material, and then through the armature coil cores in direct proportion to the difference of the armature and pivot angles. In the case shown the lower coil would be energized considerably more than the upper one and when the direction of needle movement is changed there occurs a realignment of the magnetic flux through the two coils. This realignment produces the electrical energy. This type of construction is far superior to any other now used, as one can quite readily see, especially since it is possible to design the armature coils to operate with a short magnetic path through a high permeability material.

In Fig. 23, the theory is somewhat similar to that of Fig. 20, in that a complete reversal of the flux in the armature is depended upon to procure energy. The author should modify this

statement, as any decrease or increase of flux will also cause generated energy. One of the difficulties with this particular type, so far as theory goes, is the fact that the magnetic pivot and mechanical pivot are not in the same location, so the same difficulty is experienced as with the type shown in Fig. 20, with the additional disadvantage that when the armature is disturbed from its neutral position, attraction to either side increases rapidly, resulting in a highly unstable armature with a resultant increase in damping required. Also, the armature necessarily has to be of considerable length in order to obtain any kind of an efficient flux strength.

The theory around which Fig. 24 operates is the same as Fig. 21, so no further explanation is required of it.

3. Linear output: Another point which is of a great deal of importance and not frequently discussed is that of linear output. In other words, for a given percentage increase in needle deflection, the electrical output should be increased the same amount.

This point is of great importance in any reproducing system, and so many factors enter into consideration in the design of pickups to mitigate against this result, such as saturated armatures, insufficient magnet strength in proportion to the armature used, and magnet shoes of very poor permeability. No accurate data can be calculated on this effect, but by means of the exciting device shown in Fig. 25, accurate measurements can be made, and very useful data compiled. The reproducer illustrated in Fig. 24 has been designed with this result in mind.

4. Wear on bottom of record groove: This effect is dependent upon the required weight to allow successful reproduction of the lower frequencies by the reproducer mechanism used, and is entirely dependent upon the type of armature system for its magnitude. A highly damped armature, while at the same time causing excessive wear on the side of the grooves, also causes more wear on the bottom of the groove in order to obtain good coupling between the needle point and record groove due to increased weight.

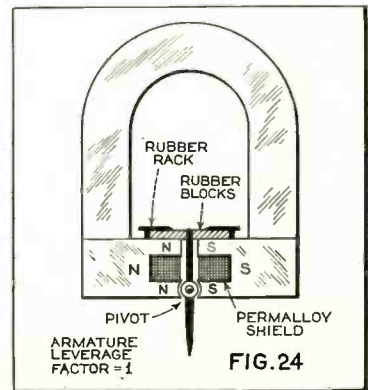

A pickup using rubber blocks for damping.

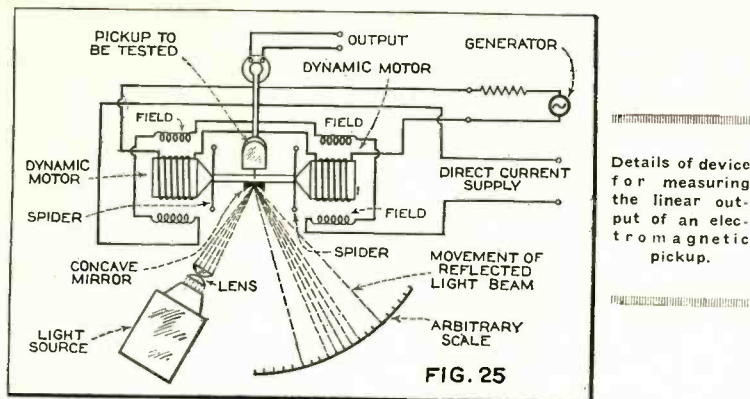

Details of device for measuring the linear output of an electromagnetic pickup.

5. *Wear on side of record groove:* This condition is dependent upon the armature system used also, as a highly damped armature possesses a high period of inertia, and one can readily see the impossibility of obtaining any kind of overall efficiency out of a device which furnishes the main load to the sides of the record groove by means of damping instead of useful magnetic load. In the system shown in Figs. 21, 22 and 24, the ability to deliver good response with relatively low damping is noticeable, and therefore record wear is reduced considerably.

The oil-damped assembly in Fig. 22, is possibly the most efficient type yet evolved in so far as minimum record wear is concerned, and can be held up as a model to work from in this regard.

6. *Maximum effective coupling of needle point with record groove:* This particular subject has a very definite and concrete place in any discussion on reproducers, as it sums up all of our points pertaining to efficiency under one heading.

If our driving mechanism impedance is too high or the reproducer head weight too low, the lower frequency register instead of being reproduced with clarity will cause considerable trouble due to the needle point not making a perfect juncture with the recorded frequencies. The angle of the needle with relation to the record groove also calls for application of this rule. Practice has dictated a needle angle of between 65 and 70 degrees for maximum efficiency in this respect, and all reproducers should operate in this manner for correct needle coupling. A reproducer which might show a relatively high output at the lower frequencies would still be worthless if the needle impedance were too high for correct coupling with the record groove.

The question of needles also comes under this heading and it has been the author's experience that reproduction is considerably damaged instead of improved if the needle is extremely sturdy but with a sharp taper on the end instead of a gradual one. Reliance should not be placed entirely on the abrasive content of the record for

wearing the needle to a correct junction as both reproduction and the record suffer in the process. In the past record manufacturers have been able to "fill" a record by the simple expedient of varying the number of grooves per inch. This policy will undoubtedly have to be discontinued with the present demand for better reproduction, and a standard width groove will be established.

7. *Allowable maximum variation from right angles of the reproducer with respect to the record groove:* This particular item is of some importance, although a compromise must be effected between the desirable amount of inertia in the reproducer head and angular discrepancy tolerable with respect to the record groove. Any system which operates to maintain right angle operation of the reproducer with respect to the record groove must necessarily have a quadrangle construction with the head placed in a short side of the quadrangle and bearings at each corner of it. This system has some theoretical superiority over a simple head support, but a great amount of difficulty is experienced in

maintaining enough mass inertia of the entire arm assembly to allow good response at large amplitudes without vibration of the entire tone arm and the resultant reflected distortion due to resonant points in the tone arm assembly. No difficulty will be experienced with respect to angular discrepancy in regards to the record groove if the arm is made long enough and centered in a position where the maximum error from a true right angle with respect to the record groove does not exceed 15 degrees.

8. *Maximum effective inertia of reproducer head with respect to amplitudes reproduced:* This is one of the most important points in successful reproduction and one of the least discussed. The illustration given in Fig. 22, illustrates intelligent application of this knowledge as it is quite obvious that the only thing which we should actuate is the armature of the reproducer and not the reproducer head itself. The inertia, or impedance of the reproducer head assembly, should be infinite for theoretical perfection. The limiting factor is the maximum weight that the record groove can pull in an arc without the needle point creeping up the sides of the record groove away from the line of applied force. This in turn is directly related with the extent of the damping applied to the armature and the resultant increased effort exerted on its part to assist in lifting the needle from its true seat. Therefore, instead of making a tone arm as light as possible, it should be made as heavy as possible with respect to mass weight. The type illustrated in Fig. 22, while having a needle pressure of only 4 ounces, still possesses a mass weight of the rotating reproducer support of 22 ounces, which affords some idea as to the mass period possible with this type of unit without introducing any tendency for the needle to jump its track even at the heaviest amplitudes.

(To be continued)

PRODUCTION TRENDS

(Continued from page 48)

if it were manufactured by an industry sailing along on an even keel over a twelve months' period. Finally, a manufacturer turning out 25,000 sets in a year's time, for instance, would have the advantage of the time factor to assist him in better judgment which is so necessary and which under the present altogether too short season often proves to be wrong. Today's practice makes it necessary for a radio manufacturer to decide today what he is going to start doing tomorrow and which most likely will have proved later on to be the wrong move. Still he cannot help himself. He hasn't the time.

Rome wasn't built in a day, the automobile business didn't grow up over night, and it is ridiculous for anyone to think that the radio business is any different. Let's keep radio plants going from the first of January

until the thirty-first of December on a lower but steadier output than we have in the past. It is a good deal better to have a moderately sized factory working steadily twelve months of the year than a gigantic plant that for six or eight weeks during the year is swarming with workers running around helter-skelter and pell-mell over each other and then to have this big plant absolutely idle the balance of the year. The short season is very unfair to the labor that builds the sets since it works man-power almost to the breaking point during a comparatively few weeks of the year only to have the dismal nightmare of being laid off stare it in the face. To just as great an extent it is just as unfair to the men whose finances are being used in the industry. It would be far better for the industry as a whole to lay out a sane sales campaign that covers the entire year and then confine manufacturing to that sort of a program.



The Trend of Invention

By RICHARDS & GEIER

PATENT AND TRADE MARK ATTORNEYS 274 MADISON AVE NEW YORK CITY



SOUND ACTUATED AND PRODUCING DEVICE

Lee de Forest, of New York, N. Y., Assignor by Mesne Assignments, to General Talking Pictures Corporation, a Corporation of Delaware. U. S. Patent No. 1,738,988. (Issued December 10, 1929.)

One of the objects of this invention is the production of a microphonic or loud-speaking device designed especially for use in electric recording of and reproducing from sound records.

In a sound reproducing device of the type described, an elongated container having a relatively small cross-section, said container having an enlarged conical portion at one end forming a horn, two liquids of different density in surface contacts in said container at least one of said liquids being open to the atmosphere through said conical portion, a terminal in each liquid and means for impressing varying electrical currents on said terminals to produce sounds in accordance with the varying electrical currents causing physical displacement of the liquids in said container whereby the atmosphere in contact therewith is subjected to rarefactions and compressions.

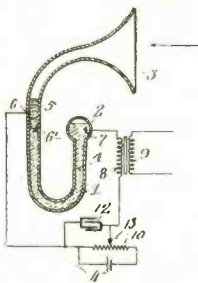

Electrodynamic Device

Albert L. Thuras, of New York, N. Y., assignor to Bell Telephone Laboratories, Incorporated, of New York, N. Y., a Corporation of New York. U. S. Patent No. 1,729,806. (Issued October 1, 1929.)

This invention relates to electrodynamic devices and more particularly to the movable element of such devices.

An object of the invention is to increase the efficiency of electrodynamic devices which are employed as the driving systems of acoustic devices.



PIEZO-ELECTRIC INTERFERENCE ELIMINATOR

Herman A. Affel, of Ridgewood, New Jersey, Assignor to American Telephone and Telegraph Company, a Corporation of New York. U. S. Patent No. 1,739,494. (Issued December 17, 1929.)

This invention relates to transmission systems and particularly to arrangements in such systems for eliminating interference.

The method of suppressing an alternating-current wave of definite frequency by means of a piezo-electric device of substantially different frequency, which consists in heating the alternating-current wave of definite frequency with another wave so as to produce a third wave having a frequency characteristic of the piezo-electric device, whereupon the piezo-electric device becomes absorbent to said third wave.

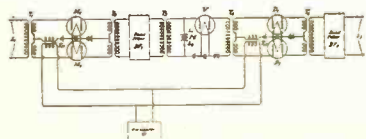

Free books on patent and trade-mark law can be obtained by our readers upon request to Radio Engineering or direct to Richards & Geier. Copies of the patents described on this page may be obtained through the above-mentioned firm of patent attorneys.

Free books on patent and trade-mark law can be obtained by our readers upon request to Radio Engineering or direct to Richards & Geier. Copies of the patents described on this page may be obtained through the above-mentioned firm of patent attorneys.

WIRED RADIO SYSTEM

Albert H. Taylor, of Washington, District of Columbia, Assignor to Wired Radio, Inc., of New York, N. Y., a Corporation of Delaware. U. S. Patent No. 1,739,773. (Issued December 17, 1929.)

One of the objects of this invention is to provide a wired radio broadcasting system where the transmission frequencies are maintained constant and operated in such relation that there will be no interference between the channels.

In a wired radio broadcasting system the combination of a line wire distribution circuit, a polyphase transmitter of high-frequency electrical signals connected with said line wire distribution circuit, a plurality of receivers connected with said line wire distribution circuit for selectively receiving the energy

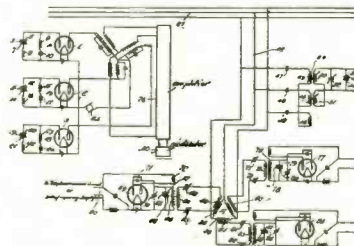

Impressed upon said line wire distribution circuit said transmitter, and piezo electric control elements ground to the same frequency located in each phase of said transmitter and at each of said receivers for controlling said circuits at the same operating frequency.

SOUND-AMPLIFYING SYSTEM

Harold Green, of London, England, Assignor to Celebritone, Limited, of London, England, a British Company. U. S. Patent No. 1,734,944. (Issued November 5, 1929.)

This invention relates to sound amplifying systems and particularly to those for use in theatres, auditoriums and the like. In such places, where an organ is frequently required as part of or supplementary to an orchestra, it may be possible to install only a small reed-organ because of the cost of a large pipe-organ and other considerations.

In combination with an organ, an electrical system for amplifying the sound comprising a microphone

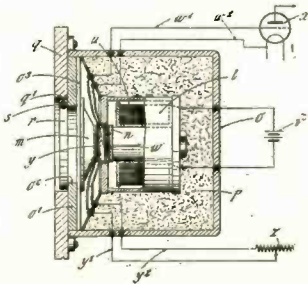

having means damping the audio-frequency vibrations generated therein; a reproducer connected with the microphone and adapted to magnify the damped vibrations thereto transmitted; and a soundproof container for the microphone connected with the organ and having a single size-controllable opening disposed toward said organ to admit sound only from the latter.

SOUND-TRANSMITTING APPARATUS

Ernst Wilckens, of Berlin, Germany. U. S. Patent No. 1,737,346. (Issued November 26, 1929.)

The present invention relates to apparatus for emitting acoustical signals in gaseous or liquid media,



and more particularly to that type in which the liquid or gaseous operating agent is supplied through a nozzle to a vibratory diaphragm for generating the necessary fluctuations in pressure by variation in volume.

PHOTO ELECTRIC TUBE

Herbert E. Metcalf, of San Leandro, California. Assignor to The Magnavox Company, of Oakland, California, a Corporation of Arizona. U. S. Patent No. 1,738,957. (Issued December 10, 1929.)

This invention relates to apparatus for use in wireless or wire communications and commercial use for the rectification, amplification and generation of either low- or high-frequency oscillations.

In a two-electrode vacuum tube having an evacuated vessel and double terminal anode, the latter having

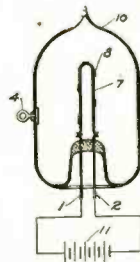

deposited thereon a volatile material sensitive to the action of light, the step of heating the anode to cause the volatile material to be vaporized and deposited in the form of a sensitive film upon the inner wall of the vessel, whereby to form a light sensitive cathode.

RADIO DIAL CONTROL

Henry A. Ziola, of Toledo, Ohio. U. S. Patent No. 1,734,068 (Issued November 5, 1929.)

This invention relates to a radio dial control, particularly to indicating means operable simultaneously with the controlling mechanism of a radio receiving apparatus.

In a radio dial control, a wheel member, means for rotating the wheel member, an endless band having interlocking contact with said wheel member and provided with indicia, a wave controlling means,

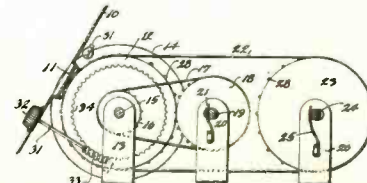

a reduced pinion secured to the shaft of said wheel member, a larger pinion secured to the shaft of the wave controlling means a drive connection of the said pinions, and means for separating said pinions to maintain proper relation of the driving connection.

NEWS OF THE INDUSTRY

RMA TRADE SHOW PLANS AT ATLANTIC CITY

PLANS are maturing for the great annual radio industry events, the Annual Convention and Trade Show of the Radio Manufacturers Association at Atlantic City, during the week of June 2d. More than 30,000 persons connected with or interested in radio manufacturing and radio merchandising attended this event last year at Chicago and the Radio Manufacturers Association's management, with the assistance of Atlantic City officials, are completing plans for a record-breaking assemblage next June of all radio interests.

Atlantic City will be host to the Sixth Annual RMA convention and the Fourth Trade Show. Also there will be national gatherings of affiliated radio industry organizations, the National Federation of Radio Associations, the Radio Wholesalers Association, the organizations of radio dealers and jobbers, and other radio organizations.

Reduced railroad rates of one and one-half fares are being secured for the Atlantic City gathering.

Hotel rates will be reasonable. This is assured by the Atlantic City municipal authorities, the Hotel Association of the seashore resort, and by specific contract with the Radio Manufacturers Association. The Atlantic City hotels have agreed to establish the same rates for rooms as prevailed in their published rates for the same week of June, 1929, so that trade show visitors will be insured against any increase in rates for hotel accommodations during the week of June 2d.

The Trade Show, convention meetings and annual banquet all will be held in the new mammoth \$15,000,000 civic auditorium on the boardwalk. The setting for the Trade Show and convention is unique. The \$15,000,000 auditorium, 350 ft. wide and 650 ft. deep, is the last word in modern convention hall construction. In addition to the great exhibition floor, which is large enough to hold a football or baseball game, the auditorium houses a mammoth stage, 110 ft. by 85 ft., and also has the largest pipe-organ, of 32,000 pipes, in the world. There are many adjacent rooms for convention and committee meetings in the Auditorium, which is convenient to the great string of boardwalk hotels, and all will be teeming with the life of the radio industry during the week of June 2d.

The Atlantic City radio events will come just after the opening, on Decoration Day, of the seashore resort as the "playground of the world." All of the attractions on the shore, piers, golf courses, etc., will be in full swing, and afford opportunity for complete enjoyment by all of the radio host of the pleasure facilities at Atlantic City. The Trade Show this year will afford all visitors, their wives and families, an unusual opportunity to combine a vacation with a visit to the Trade Show. And an unusually large attendance of feminine visitors is expected for whom special entertainment features are being planned. In addition, there will be many special radio events, including the annual RMA banquet and the many meetings of the various radio organizations being arranged.

Radio dealers and jobbers, as well as manufac-

turers, from all parts of the United States, are expected to gather at Atlantic City.

Railroad facilities at Atlantic City are unexcelled, with 99 trains daily, and special trains are already being planned from New England, the middle western, southern, and also far western centers. As this is the first RMA Trade Show and Convention in the east, it is possible for many radio jobbers and dealers to attend who have not been able to visit the last three great radio gatherings at Chicago.

There will be 85,000 square feet of exhibition space available for the Trade Show in the mammoth auditorium. The principal displays will be on the main floor. This great acreage, 45,000 square feet, will be used for exhibition booths. In addition, there are 40,000 square feet immediately adjacent in which will be erected 200 sound-proof demonstration booths. These will be temporary but guaranteed sound-proof installations, a rather unusual feature never before possible at the Trade Show. The booths will make immediate demonstrations available to visitors just off the exhibition floor.

The contracts for show space are now being issued to members of the Radio Manufacturers Association, and the space assignments will be made about March 1st. The 85,000 feet of exhibition space compares with 30,000 square feet available at the RMA Trade Show last year, and with the 19,000 square feet occupied during the first highly successful RMA Trade Show in 1927.

Invitations to 35,000 radio jobbers and dealers of this country and also Canada will be sent soon, and manufacturers are already making plans for the entertainment of their sales and distributing organizations.

Each day during the week of June 2nd there will be constant and varied entertainments for the industry guests. There will be luncheons, dinners, theatre parties, as well as the premier event, the Annual RMA Banquet. The banquet will be held on Wednesday evening, June 4th, in the great ballroom of the Atlantic City Auditorium, which seat 5,000 persons, assuring the largest RMA banquet ever held and probably the largest ever held in the United States. Last year the RMA banquet broke all records for affairs of this kind, with more than 2,300 guests, and even these accommodations were insufficient. The great ballroom in the Atlantic City Auditorium is expected to hold between three and four thousand guests, when the curtain rises on the night of June 4th. Broadcast facilities of Station WPG, the municipal station at Atlantic City and in the Auditorium, which is on the network of the National Broadcasting Company and is one of the most modern broadcasting stations in the country, are available to the RMA.

Opening business sessions of the Radio Manufacturers Association and also of the National Federation of Radio Associations and the Radio Wholesalers Association will be held early in the week of June 2nd. Many industry leaders will speak at the business sessions, and the annual convention of the Radio Manufacturers Association will elect officers for the next year and transact much other important business. Problems incidental to radio manufacturing,

distributing, engineering and merchandising will receive attention at many national group gatherings.

The Sixth Annual RMA Convention and business sessions will be presided over by Mr. H. B. Richmond of Cambridge, Mass., President of the RMA, and there will be open sessions for the discussion of radio problems.

Plans for the Trade Show are in charge of Mr. Jess B. Hawley, Chairman of the RMA Show Committee, and the show again will be managed by Herrmann & Irwin, with Mr. G. Clayton Irwin, Jr., as director.

The authorities of Atlantic City, including Mayor Ruffin, the Hotel Association and the Auditorium Management, including Lincoln G. Dickey, Director General, and Albert H. Skean, Convention Manager, are cooperating with RMA officers to make the Atlantic City meeting the greatest in radio history.

Special Parts and Raw Materials Section

An entire special section in the 1930 Radio Manufacturers' Association sponsored public shows, the Radio World's Fair, in New York, and the Chicago Radio Show, Chicago, will be devoted exclusively to the display of parts and raw materials which enter into set and radio apparatus construction.

Decision to include such a section in the forthcoming public shows was made by G. Clayton Irwin, Jr., general manager, after he had conferred with a large majority of RMA members, both east and west. The idea was inspired by public comments at the 1929 New York and Chicago shows and by dealers who insisted that the public is interested in the quality of the things "inside the box."

The entire industry was checked by Mr. Irwin to make certain that the whole distributing end of the radio business as well as the suppliers saw and admitted the virtue of an impressive exhibition of parts and raw materials.

"Major set makers are also heartily in accord with plans for the project," said Mr. Irwin. "They realize that a separate department in the show, given over to the parts and materials with which their sets are constructed, will do much to drive home the lesson that quality in set construction means quality in reception."

The show management intends to cooperate with the exhibitors in the Parts and Raw Materials Section to the end that this division of the show will hold its own in general interest and worth. "Live" exhibits, instead of so-called "dead" exhibits will be urged, both to hold attention and to impart information.

In all probability an assembly table, in reduced size, will be constructed, since in no other way can thousands and thousands of radio prospects be impressed with the great care exercised in bringing the accurately constructed parts into a complete whole—the radio set in the home.

"The education of the public in the manner provided by the Parts and Raw Material Section," according to Mr. Irwin, "is the most positive means of getting over the story of quality, care, and precision in manufacture—the kind of promotion that pays the most dividends."

Larger amounts of inter-manufacturer business is done at the public shows than is generally supposed. At the conclusion of the 1929 Chicago Radio Show, William Alley, RMA Merchandising Director, interviewed many of the parts makers and reported at that time:

"Manufacturers who took leadership in designing apparatus found themselves in a position to close contracts with leading receiver manufacturers who exhibited at the Coliseum."

RADIO EDUCATION ON INCREASE

An optimistic confidence in the future of radio is expressed in the increasing demands for practical training and scientific education. Ambitious men, convinced this vocation is a promising one, are looking to the schools and colleges of the country for scientific instruction in this field, educators find.

The constantly increasing demand is shown in the records of the department of engineering extension of the Pennsylvania State College, which, since 1923, has offered home-study courses in radio. With a present enrollment of over a thousand home-study students in radio, this department has found necessary the preparation of a new course for advanced students, instituted to cover the newer developments in broadcasting systems.

Preparatory to the advanced courses there is instruction in Elementary Radio and Radio Construction and Repair. The advanced study now announced stresses radio broadcasting, communication, telephone, fading and atmospheric disturbances.

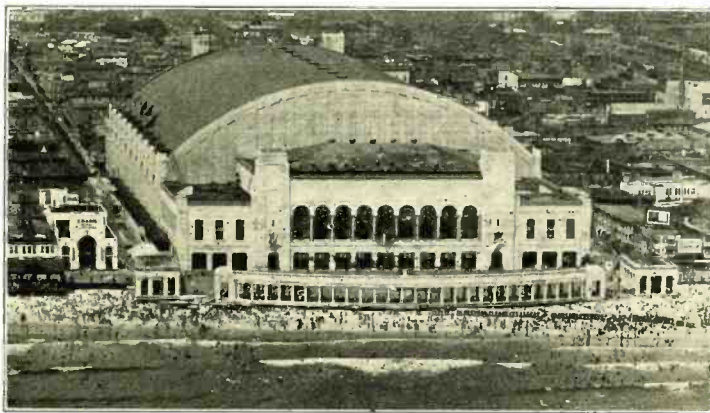

The mammoth Civic Auditorium, on the boardwalk, at Atlantic City, where the Annual RMA Trade Show and Convention will be held.

Packed like **EGGS**



THE Dudlo policy of care and precision follows through to final destination. Not only are Dudlo coils designed, manufactured and inspected with the utmost care, but even the packing and shipping is such as to insure their arrival in perfect condition, irrespective of distance or mode of transportation.

Like so many eggs, every coil has its individual compartment separated by corrugated board. The completed case is then telescoped into an outer shipping container of heavy corrugated construction, giving double protection against damage in handling while in transit.

Dudlo was the first to adopt this method of packing which has saved thousands of dollars and an untold amount of trouble and inconvenience for coil users the world over.

DUDLO MANUFACTURING COMPANY, FORT WAYNE, INDIANA
Division of General Cable Corporation

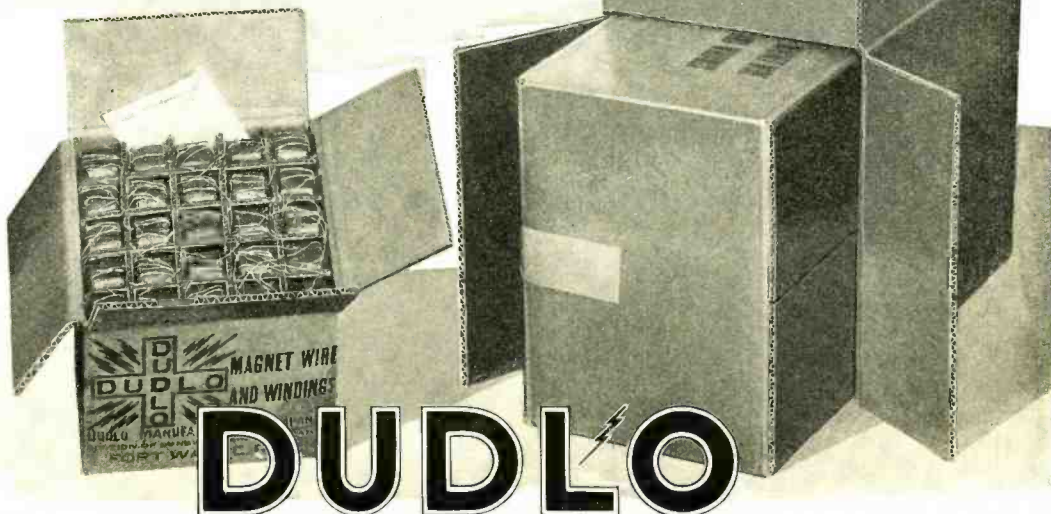
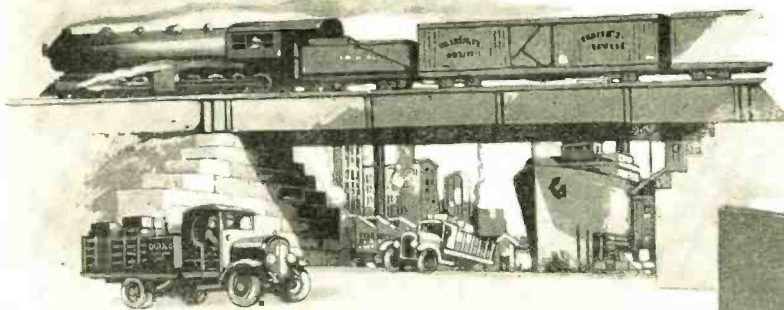

H. A. BEACH WITH STROMBERG-CARLSON

According to word received from the Stromberg-Carlson Telephone Manufacturing Company at Rochester, N. Y., George A. Scoville, Vice-President, in charge of sales, has appointed Harry A. Beach as manager of the Radio Department of that organization. The appointment of Mr. Beach in this capacity is seen in radio circles as a part of the company's program to secure wider distribution of its radio products.

The selection of Mr. Beach for this important post was, it is believed, influenced by reason of his long experience in the higher-priced merchandise field and because of his extraordinary contact with dealers throughout the country.

His past experience was almost exclusively with organizations operating in the medium and higher-priced fields and includes a period of more than twelve years with the Victor Talking Machine Company. With this firm, he served for approximately



H. A. BEACH

eight years in an executive capacity, and of this period he spent five years as manager of the Traveling Department. At the conclusion of his association with the Victor organization, he became Eastern Sales Manager for the Brunswick-Balke-Collender Company, which post he held for three years. Following this connection he assumed the duties of vice-president in charge of sales for the Earle Radio Company and discharged those duties with credit for more than three years.

A. T. HAUGH WITH VALLEY

Mr. Arthur T. Haugh, former President of the Radio Manufacturers' Association and well-known in the radio and automotive industries, has just been elected vice-president in charge of Merchandising of Valley Appliances, Inc., manufacturers of the Symington Reproducer, Rochester, N. Y. Details of future plans are expected to be announced within the next thirty days.

W. L. DUNN WITH SPRAGUE

Mr. W. L. Dunn, former chief engineer of Colonial Radio Corporation, has joined the Sprague Specialties Company as head of the Engineering Department.

Mr. Dunn will be in charge of research work and it is felt that his experience in the designing of radio receivers will be of great assistance in helping the company to determine how they can further improve and adapt their products for use in radio circuits.

NEW CUNNINGHAM APPOINTMENTS

Executive appointments announced recently by E. T. Cunningham, Inc., advance H. C. Brown to the position of assistant sales manager, and Arthur J. McGittrick to that of resident manager with headquarters at Washington, D. C.

Mr. Brown takes over his new duties after having served more than eighteen years in the electrical industry, during part of which time he acted as national secretary of the National Electrical Contractors Association (now the Association of Electricians, International).

RCA-VICTOR APPOINTMENTS

E. E. Shumaker, President of RCA-Victor Company, Inc., has announced the appointment of E. K. MacEwan as secretary of the new company. Francis S. Kane and Walter H. Hunt become assistant secre-

aries. Paul G. McCollum is appointed assistant comptroller and Robert P. Alexander, Eugene F. Haines and Cornelius G. Terwilliger, assistant treasurers.

Mr. MacEwan, the new secretary, has been associated with the Victor Talking Machine Company since it was incorporated in 1901. He worked in the experimental department until 1911 when he became a member of the secretary's staff. In 1920 he was appointed secretary of the Victor Talking Machine Company.

NEW KOLSTER "PATENT POLICY"

Rudolph Spreckels, Chairman of the Board of Kolster Radio Corporation, has announced the inauguration of a policy on the part of Kolster Radio to license other manufacturers under certain of its patents in the broadcast receiver field through the execution of a patent license agreement with Scoville Manufacturing Company of Waterbury, Conn.

This license will permit the Scoville Manufacturing Company to manufacture condensers for radio receivers under a patent of Dr. Kolster's relating to condenser design and construction through the payment of suitable royalties to Federal Telegraph Company, a wholly-owned subsidiary of Kolster Radio Corporation.

Mr. Spreckels further stated that Kolster was in negotiation with more than thirty other radio manufacturers covering the granting of licenses under this and other patents controlled by Kolster subsidiaries.

PEERLESS JOINS GENERAL CABLE

Purchase of the Peerless Insulated Wire and Cable Company of Pennington, New Jersey, is announced by General Cable Corporation.

The Peerless Brand of Weatherproof Wire, because of its construction has built an excellent reputation for quality among the largest users of weatherproof wire, who have recognized in its certain durable qualities inherent in its construction and method of fabrication.

The manufacture of Peerless Brand, embodying this special construction, will be continued at Pennington under the personal direction of its former management, who will now have at their command the research facilities and production experience of General Cable.

The Pennington plant will be operated as a part of the Standard Underground Cable Company division of General Cable Corporation.

Sales of Peerless brand of weatherproof wire manufactured at Pennington will be in the name of the Standard Underground Cable Company division of General Cable Corporation with the brand name, "Peerless," as well as the familiar construction continued.

Peerless brand will also be available through the other divisions of General Cable.

BUDWORTH, INC., AFFILIATED WITH STROMBERG-CARLSON

Through recently completed negotiations between the Stromberg-Carlson Telephone Manufacturing Company, Rochester, New York, and Budworth, Inc., New York City, designers and builders of special amplifying and remote control systems, the Budworth organization has become affiliated with Stromberg-Carlson. It has been announced. Stromberg-Carlson, it is understood, secures the rights to all inventions and laboratory work of Budworth, Inc., prominent among which is the radio remote control system, developed by T. F. Budworth and Arthur P. Davis, which is fully perfected and has been in service in the field for several years. Under this agreement Budworth, Inc., also receives the rights to use certain patents held by the Stromberg-Carlson Company. Budworth, Inc., will have the advantage of additional working capital, to meet the demands of a rapidly expanding business, as well as receiving the benefit of the Stromberg-Carlson sales and services organization.

R. H. WOODFORD JOINS CROSELY AS SALES MANAGER

Powel Crosley, Jr., president of the Crosley Radio Corporation, has announced the appointment of R. H. Woodford as general sales manager, succeeding Neal E. Newman, resigned. Mr. Woodford assumed his new duties on Jan. 6.

With twenty years' experience in the radio-music field behind him, Mr. Woodford is exceptionally well qualified for his new position. For the past five years he was general sales manager of the radio division of the Stewart-Warner Co. His previous experience included a year with Liberty Magazine, Eastern office; a year as sales manager of the Wahl-Eversharp Co.; seven years as Cincinnati branch manager of the Columbia Graphophone Co.; and eleven years with the American Piano Co. He handled outside sales for the latter organization and played an important part in the introduction of the Ampico piano to the music public.

RCA VICTOR MANUFACTURING AND SALES STRUCTURE

Mr. Edward E. Shumaker, president of the RCA Victor Company, has made the following statement to the press:

"To correct an erroneous impression which was created in some quarters, I would say that the RCA

Victor Company, the stock of which is owned 50 per cent by the RCA, 30 per cent by the General Electric Company, and 20 per cent by the Westinghouse Electric & Manufacturing Company, will manufacture at its Camden, N. J., plant all the radio broadcast receiving sets, loudspeakers, accessories, etc., which were formerly manufactured by the General Electric and Westinghouse companies. The RCA Victor Company, where all these activities have been concentrated, will distribute its products not only through the distributing channels of the Radio Corporation and the Victor Talking Machine Company, but also through the distributing channels of the General Electric and Westinghouse companies. The arrangement effected with the General Electric and Westinghouse companies whereby their vast facilities of national distribution will be at the service of the RCA Victor Company will, it is confidently expected, increase the volume of production of the Camden plant and make the products of the RCA Victor Company even more readily available to all parts of this country."

BOOKLET DESCRIBES USE OF BAND FILTER TUNING

In an unusually interesting manner, the story of the development of the new Hammarlund "band filter" tuning method and its incorporation into the special Hammarlund receiver, the HIQ-30, is told in a 48-page booklet, titled, "HIQ-30 Manual," recently released by the Hammarlund Manufacturing Company, 424 West 33rd Street, New York City.

This manual, which is procurable at twenty-five cents the copy, is also replete with curves and pertinent circuit data, as well as descriptions of power supplies for use with band filter tuning receivers.

R. B. LACEY APPOINTED GENERAL SALES MANAGER OF PERRYMAN

R. B. Lacey has been appointed General Sales Manager of the Perryman Electric Co., Inc., according to a recent announcement by H. B. Foster, Vice-President of that organization.

For the past three years Mr. Lacey, better known to the trade as "Bob," has been western Sales Manager of the Perryman Company, with his headquarters at Chicago. In this position he initiated a sales policy for field operation which has proved so successful that it will be extended under his direction throughout the country during the coming year.

Years of contact with jobbers and dealers have endowed "Bob" Lacey with a thorough understanding and sympathy for the problems of the trade. He knows from first-hand experience the difficulties by which every jobber is confronted, because Lacey him-



R. B. LACEY

self was a jobber for seven years. Previous to this, he was Sales Manager of the Western Steel Works, Sales Manager of the AutoSCOPE Company and the CleareSCOPE Company and the Staver Motor Car Company.

L. W. CHUBB MADE ASSISTANT TO VICE-PRESIDENT RADIO-VICTOR CORPORATION OF AMERICA

L. Warrington Chubb, manager of the radio engineering department of the Westinghouse Electric and Manufacturing Company at East Pittsburgh, Pa., has been appointed first assistant to the vice-president in charge of engineering of the new Radio-Victor Corporation of America. His headquarters will be in Camden, New Jersey.

Mr. Chubb has been manager of the Westinghouse Radio Department since its founding in 1920. Before that he was active in development and research work for the company.

Your Contact Spring Problems Solved

with

THE reasons which have prompted the foremost Radio and Electrical Manufacturers to standardize on RIVERSIDE Phosphor Bronze for their Contact Springs are definite and can easily be understood.

Briefly, experienced Electrical Engineers have found that this organization — because of its extensive research activities into the peculiar properties of Phosphor Bronze — has the experience and ability necessary for the successful performance of these two important tasks:

1. To determine the precise alloy and temper which will produce the best results in accordance with the fabrication and performance of even the most intricate contact spring.
2. To produce this metal to such specifications and keep it absolutely uniform on all succeeding orders.

If you have problems involving the use of Phosphor Bronze just inform us of their nature and our laboratories will make their recommendations promptly.

RIVERSIDE PHOSPHOR BRONZE, either tinned or untinned, can be supplied in every variety of sheets, rods and wire

THE RIVERSIDE METAL CO.
RIVERSIDE, Burlington County, NEW JERSEY

**SPECIALISTS IN THE MANUFACTURE OF
PHOSPHOR BRONZE AND NICKEL SILVER SINCE 1897**

New York: 15 Maiden Lane
Boston: 80 Federal Street



Chicago: 549 W. Wash. Blvd.
Cleveland: 2036 E. 22nd St.

RIVERSIDE Phosphor Bronze

RCA LICENSES TRIAD

Negotiations between the Radio Corporation of America and the Triad Mfg. Co., of Pawtucket, R. I., makers of Triad Radio Tubes, which have been in progress for some time, have culminated in the licensing of the Triad Mfg. Co., by the RCA, General Electric Co. and Westinghouse Electric Company to manufacture radio tubes under all patents now controlled by them and to manufacture under any future patents which may be granted to these companies.

NEW WAGNER CHICAGO OFFICE

Wagner Electric Corporation announces the removal of its Chicago sales office and service station to 1933 Indiana Avenue.

NEW RADIO MANUAL

The first and only public printing of the officers' radio manual used by the Signal Corps of the United States Army, entitled "Theory of Radio Communication," by Lieut. John T. Filgate, has just been completed by the Radio Design Publishing Company, 103 Broadway, Brooklyn, N. Y. As issued in limited number in the service this manual is a mimeographed pamphlet; as sold by the new publishers it is a handsome stiff-covered volume, containing 251 pages and more than 200 illustrations. The retail price is \$2.00.

"Theory of Radio Communication" represents more than four years of work on the part of Lieut. Filgate, who for a long time was an instructor at the Army Signal School at Fort Monmouth, N. J. Although intended for use by Army officers, little of its contents is devoted to purely military signalling, the book being a general treatise on radio for the more advanced students of the art.

NEW INCA APPOINTMENTS

The Inca Manufacturing Corporation of Fort Wayne has announced the appointments of two men widely known to the trade in the copper wire industry as additions to the Inca organization.

Mr. Paul Stauffer becomes eastern manager for Inca, with headquarters at Newark, New Jersey. Mr. Stauffer enjoys an unbroken record of many years of service in the copper wire industry.

R. A. Connor joins the sales and engineering staff of the Inca organization at Fort Wayne. Like Mr. Stauffer, Mr. Connor has a long record of service to his credit in the industry. Mr. Connor had previously been associated for many years with Mr. George A. Jacobs, president and founder of the Inca Manufacturing Corporation. Both of these appointments are effective at once.

CROSLY INVADES SOUTH AFRICA

The Crosley Radio Corporation of Cincinnati, Ohio, announces the appointment of H. Polliack & Co., Ltd., as distributors for Crosley products in South Africa. This company has branches in Johannesburg, Durban and Cape Town and a dealer following in practically every town in the Union of South Africa.

R.S.M.A. PLANS EXPANSION

At a meeting of the Board of Directors of the Radio Service Managers Ass'n held at its headquarters, 1400 Broadway, New York City, a resolution was passed providing for the expansion of the R.S.M.A. through the organization of branch associations in other large cities.

Service managers who are interested in forming such an association in their locality, are urged to communicate with Mr. Grover C. Kircunof, executive secretary of the R.S.M.A., who will be pleased to supply any information that may be required.

The executive office of the R.S.M.A. will supply branch associations with complete sets of examination questions and answers as well as all necessary forms such as certification cards, office record cards, etc., at a very nominal cost and will supply, for local distribution to members, necessary copies of "The Radio Service Man" which is the official publication of the Radio Service Managers Association and will be issued monthly by that organization.

All non-resident members of record of the R.S.M.A. will have their membership transferred to the branch association that is nearest to their homes. All certification cards issued to servicemen who are associate members of the R.S.M.A. or any of its branch organizations will be interchangeable so that one who has passed his examination in one city and secured his certification card can go to another city and through that card be reasonably sure of securing employment.

Each branch organization will have one official representative for each 25 members enrolled, who will attend the annual meeting of the R.S.M.A. and have full power to vote on all questions at that meeting. There will also be one contributing editor appointed by each branch who will gather and pass upon all news items or other matter that may be of interest to the radio service field and forward all such material to the home office of the R.S.M.A. in New York City.

The fee to be paid by branch associations shall be \$1.00 per member per year with a fixed minimum of \$25.00. Local officers will be elected by each branch organization and each branch will be a unit unto itself, responsible only to the main body. No financial responsibility will be assumed for such branch organizations by the main body or any other branch association.

All branch associations will be subject to the By-Laws of the Radio Service Managers Association.

R.S.M.A. TAKES LARGER QUARTERS

Having outgrown its executive office at 1400 Broadway, New York City, the Radio Service Managers Association is now located in larger quarters at 324 West 42nd Street, just west of 8th Avenue and little over a block from Times Square, New York City.

R.S.M.A. TO ISSUE PUBLICATION

The Radio Service Managers Association as an additional service to its members have issued an association magazine which will be sent to members of the association as an additional part of their membership rights. The publication which will carry complete details of all meetings and lectures of the association.

SPIRO SELECTED BY SPEED

A. D. Strathy, Director of Sales for the Cable Radio Tube Corp., of Brooklyn, has announced the appointment of Mury Spiro, 1207 Race St. Philadelphia, as territorial representative for Speed Tubes.

NEW PAASCHE HEADQUARTERS

Paasche Airbrush Company announced, effective October 1st, larger and more modern quarters for their New York Sales and Service branch to be located at 103 Lafayette St., New York City—Telephone Canal 4768-D. The largely increased demand for Paasche Airbrushes in the Eastern territory made necessary this splendid ground floor location close to all subway stations, which can be conveniently reached from all inner-city points. Mr. L. J. Dagon continues as Branch Manager, assisted by Messrs. H. A. Schwarz, Louis Straub, P. R. Ford, and G. M. Theuret, a competent office force and with the added facilities of this larger and better office, the service rendered by the New York Staff of the Paasche Airbrush Co. will set new and even higher standards for Paasche customers in Connecticut, Rhode Island, New Jersey and New York. A complete stock of Paasche Equipment will be constantly maintained at this new address.

Following the increase in their New York City and Philadelphia Branch offices and as a further important step in the expansion of their sales organization, the Paasche Airbrush Co. announces an increase in the personnel of their Cleveland, Ohio, branch.

H. V. Schweitzer and J. G. Newman have been added as salesmen. Mr. D. Borde-Nielsen continues as Branch Manager. A larger sales and display room have been opened at 722 Perry-Payne Bldg.—Telephone Main 5560. A complete stock of equipment will now be maintained at this new address for quick service to the many Paasche customers in this territory.

BOSCH CONTROVERSIES TERMINATED

Elihu Root, Jr. as counsel for the American Bosch Magneto Corporation, and Hiram E. Todd, counsel for Robert Bosch Magneto Co., Inc. have announced the settlement of all litigations and controversies between American Bosch Magneto Corporation, of Springfield, Massachusetts, and the Robert Bosch interests, including Robert Bosch Aktiengesellschaft, of Stuttgart, Germany, and Robert Bosch Magneto Company, Inc., of Long Island City, New York. This settlement brings to an end ten years of bitter controversy and numerous litigations between the companies, not only in the United States, but also in France, England, and other parts of the world. The settlement agreements were recently signed in Paris by all the parties interested.

AMERICAN BOSCH ENTERS ITALY

American Bosch Magneto Corporation of Springfield, Mass. has just concluded an agreement with Fabbrica Italiana Magneti Marelli, of Milan, Italy for an initial period of five years, to cover the manufacture and sale of radio sets and other radio products in Italy and other European countries. This agreement is of broad scope, inasmuch as it relates to the interchange of designs, inventions and manufacturing processes for production of such products, and also to advertising, selling and servicing.

It is expected that Magneti Marelli will, as a result of this agreement, quickly get into quantity production of radio sets and loudspeakers similar to those of American design, which have been increasing greatly in popularity in Italy. Not only does American Bosch expect to sell considerable radio materials and parts to Magneti Marelli, but to receive valuable rights and large royalties starting early next year.

NEW KOLSTER ADVERTISING MANAGER

Kolster Radio Corporation announces the appointment of Corson Kneezel as their advertising manager. Mr. Kneezel formerly was associated with Evans, Kip, & Hackett, Inc. of New York, N. Y. and previous to that with the Foster & Kleiser Company on the Pacific Coast.

A NEW BROADCASTER AT BOTTOM OF YOUR DIAL

Down at the very bottom of your dial, or below the 200-meter limit of the usual broadcast band, there is a new station to be tuned in. It is W2XCD, which turns out to be the experimental radio telephone station of the DeForest Radio Company at Lassaie, N. J.

On Tuesday evening, December 17th, Station W2XCD first went on the air with a test program, using only 50 watts. Reception with good loudspeaker volume and excellent tone quality was reported as far as Philadelphia. The power is to be increased until the full 5000-watt rating, granted in the license, is attained.

Station W2XCD broadcasts on a wavelength of 187 meters, or 1604 kilocycles, from 8 to 10 P. M. every evening. In the near future, this station is to be used to transmit the vocal and sound accompaniment for the Jenkins radiomovies or radiovision pictures transmitted from W2XCR at Jersey City. The combined reception of sound and sight signals at the home end, by means of a standard broadcast receiver and the special radiovision equipment, will constitute synchronized sound pictures or radio talkies. A demonstration of this complete radio entertainment is to be made in Newark, N. J., early in January. Both stations are now on the air every day except Sunday, from 8 to 10 P. M.

It is interesting to note that 10 different makes of standard radio receivers have been capable of tuning in the signals of W2XCD, on 187 meters. Another purpose of the DeForest experimental telephone transmitter is to test and develop DeForest transmitting tubes under practical operating conditions.

ESCO INCREASES PLANT SPACE

The Electric Specialty Company of Stamford, Connecticut, is increasing its manufacturing capacity approximately 40% by the erection of a two-story steel and brick addition to its plant in Stamford.

Their business has made a substantial and conservative growth every year since the organization of the Company in 1913. Sales for 1929 will exceed those of their best year, 1928, by about 40%.

FISKE NOW GENERAL SALES MANAGER OF GOLD SEAL

Edward R. Fiske, formerly General Field Supervisor of the Gold Seal Electrical Co., has been promoted to the position of General Sales Manager.

Ed Fiske has been in the radio field a number of years, having been with the CeCo organization, as Assistant Sales Manager, for nearly four years, and by the way is now celebrating his first anniversary with Gold Seal. He attended the Post-Graduate Electrical Course at Harvard University, which, plus his years of practical experience, makes him well informed on the modern trend in radio merchandising.

A RECORD IN RECORDING

(A Simple Drama)

Since all recording has to do with records, those engaged in such work are continually dealing with new records. It might also be said that many records are broken.

However, a new slant on the record and recording situation came to our attention the other day from Sound Studios of New York, Inc. It was a sunny morning, and Phil Cook got up at eight instead of noon. Folding his orange pajamas neatly over the foot of his bed, he proceeded to shower, shave, and dress. He phoned once more. "All well in readiness. How many could he make in one day? Oh, about eight. That's what most of them do, six or eight. Any more was too fatiguing on the artist. That flattered Mr. Cook's ego. He is very fond of his ego. Mr. Cook smiled into the telephone. Yes, he was an artist. Proof, his cane, his tie, his suit, his spats. Yes, he was an artist. But to get up at eight every day for—All well. Forty-eight records at eight a day, that makes six days (set up at eight in the morning for a whole week? Impossible! Preposterous! Yes, that was the word, preposterous. He would do it all in one day. A few minutes later Mr. Cook might have been seen hurrying through 57th Street to Sound Studios. Determination was in his every step. "Preposterous," he kept mumbling to himself.

Arriving at the Studios Mr. Cook set about making records. He worked all morning and all afternoon. When the day had ended he went home and waited. Several days later the records came. There were forty-eight. Good. The mail also brought a letter from Sound Studios, stating that he had broken a record. The heart belonging to Mr. Cook sank. Only his belt held it up. He would have to get up at eight again, and he had already set his alarm back to the usual noon hour. But he had not dropped the package. The forty-eight were all there. He counted again. Sure enough, there were none missing. Then what did the letter mean? It went on to say that he had made a new record. That would be forty-nine. Again he counted them. Again there were forty-eight. By this time Mr. Cook was visibly confused. He sat down. He cooled off. He thought. He got an adding machine. It did not help.

That night as he lay in bed, just dozing off, a thought came to Mr. Cook. Mr. Cook is like that. Thoughts always come when he is not thinking. He jumped out of bed. In his orange pajamas he turned on the light. (These were the same orange pajamas, for the week had not yet ended.) He searched for the letter, and what is more, found it. It said that he had made forty-eight recordings, more than anyone had ever made in one day. Ah, at last the light. More than anyone had ever made in one day. That broke the old—Mr. Cook began to smile. He threw the adding machine out of the window, smushing through the roof of his own automobile. It was all as plain as day now. He had made forty-eight recordings and one record.

Mr. Cook returned to his slumbers.



**LARGE - SMALL - THICK - THIN
PRESSED METAL PARTS**

*Stampings
Any Metal
Any Purpose
Any Quantity*

**THE METAL SPECIALTY
CO.**
1533 Riverside Drive
CINCINNATI OHIO

NEW DEVELOPMENTS OF THE MONTH

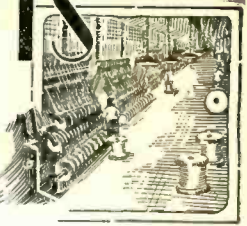
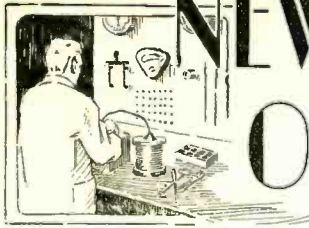

DE FOREST 422-A AUDION

With the requirements of a successful portable radio set as well as a rural radio set in mind, the DeForest engineering staff has developed a new dry-battery type of d-c. screen-grid tube. The DeForest Radio Company of Passaic, N. J., has just introduced this tube, which is known as the DeForest 422-A Audion.

Instead of the thoriated tungsten filament employed in the usual -22 d-c. screen-grid tube, the DeForest 422-A Audion employs an oxide-coated filament of approximately three times the usual cross-sectional area. While the usual filament emission for the -22 type is rated at 15 milliamperes as the passing mark, the DeForest 422-A has an emission averaging 50 milliamperes, with a passing mark of 25. The filament draws only 60 milliamperes at 3.3 volts, as compared with 132 milliamperes for the usual -22 type. The heavy filament, with its oxide coating, makes for a practically non-microphonic tube, and one with positive and ample emission during a long period of service. The other characteristics of the 422-A Audion are plate voltage, 135; screen-grid voltage, 45; control grid, -3; mutual conductance, 465 microns.

NEW PAASCHE AIRBRUSH

The Paasche Airbrush Company, 1909 Diversey Parkway, Chicago, Illinois, announce a multiple head airbrush, which they predict will be exceedingly popular with manufacturers of radio cabinets and complete sets. It is known as the UAT Multiple Head Airbrush and has an operating lever which swings into three positions, thumb action, finger action or hand action, which is a new and exclusive Paasche feature. It operates on a very small air compression requiring only from 1/2 to 2 cubic feet of free air per minute at low air pressure of 2 to 40 pounds.

Multiplehead Airbrush with 1 pint and 1 quart size pressure feed cup interchangeable on one cover. The 5 different types of airbrush in five sizes provide the widest working range. Based on its utility, finish workmanship and better materials, the price is very low.

The manufacturers claim that this airbrush will operate at maximum efficiency with minimum volume and pressure at the lowest operating cost of any similar airbrush. Among the many uses it has are the spraying of parts and retouching of cabinets.

Type UAT is also made in larger sizes, UBT and UCT for faster and larger work with heavier colors.

BOSCH RADIO NOW AVAILABLE FOR MOTOR-CARS

The American Bosch Magneto Corporation of Springfield, Mass., builders of precision automotive electrical devices for a long period of years, announced and displayed for the first time during the New York Automobile Show, its New Bosch Motor-Car Radio. The new radio receiver is a precision-built instrument, carefully engineered for automobile installation, either at time of manufacture of the vehicle or later. The receiver utilizes the screen-grid type tubes, thoroughly shielded from outside interferences and from the electrical system of the automobile. Receiver and cone-type electromagnetic speaker are contained in one small compact unit which is mounted out of sight on the dash, behind the instrument panel. A solid shaft operates the receiver from an unobtrusive tuning control unit which can be mounted in any convenient position on the dash.

This control unit, no larger than a man's hand, contains a key switch to prevent unauthorized operation in the absence of the owner. One knob controls the single dial; the other controls volume. The station selector dial is electrically lighted independently of other lights on the car and tuning is made easier through the use of the Bosch Line-O-Lite dial.

The receiver operates from the storage battery of the car and from dry cell "B" batteries which are carried in a weather-proof steel container mounted underneath the car. No mutilation of the dash, top, or upholstery is necessary in the installation of Bosch Motor-Car Radio. The aerial is not contained in the roof of the car. A new type of antenna is employed.

The list price of the set, complete with tubes, batteries and loudspeaker, is \$140.

DEVELOPMENT IN METALLIZED RESISTORS

A major development in the production and application of metallized resistors is announced by the engineering department of the International Resistance Company of Philadelphia, Pa.

Extensive research conducted by Dr. Harold Pender and his co-workers has resulted in increasing the safety factor of metallized resistors under load by increasing the area of the filament several times. With modifications in the coating material used, they are in position to produce metallized units at the same cost, but with three or four times the safety factor of their present units.

For example, the 1-watt units have been placed in load tests up to the point of 8 to 15 watts, at which load the heat becomes so intense that the end caps melt off, showing that they reach a temperature of well over 400 deg. F. The conducting filament itself, however, is not damaged, and the change of resistance at this extremely high load is surprisingly low. This enables them to make their present ratings of resistors with a much greater margin of safety.

The new filament is made in a continuous operation, instead of in several operations on various machines, as heretofore.

ELECTRO-ACOUSTIC SCREEN-GRID POWER AMPLIFIER

As a result of much scientific research and development in sound and transmitting equipment, the Electro Acoustic Products Co. of Chicago presents a new amplifier, known as the EA-6S, for public-address and sound projection.

The frequency range of this amplifier, it is said, extends from 30 cycles to over 10,000 cycles—consequently the overtones or harmonic frequencies which are so vital in the construction of natural sound are retained. Resistance coupling is used in this amplifier as in all Electro-Acoustic Products Company amplifiers. The frequency range is extremely flat, free from transformer resonance so commonly characteristic of transformer-coupled amplifiers.

With the use of the screen-grid tube in the first stage of amplification a very high voltage gain is obtained. Sufficient gain is available to operate directly from the secondary of a microphone transformer without using a preliminary microphone amplifier. The input impedance of the amplifier is constantly 500,000 ohms at all frequencies. This is a very distinct advantage as there is no distortion possible resulting from improper impedance "matching" or "reflection." Also any type pickup may be used without regard to its impedance—either phonograph, microphone or radio. The quality is always the same regardless of where the volume control is set. There is no loss of high frequencies when the volume control is turned down.

A variable scratch filter as well as volume control is incorporated in this unit. With the aid of this device the surface noise of records may be greatly diminished without impairing the tone quality. The volume control is smooth and regular in operation.

Field current of 50 milliamperes for one or two dynamic speakers is available from the unit when desired.

The power output is in excess of five watts of undistorted energy. The output impedance is 2000 ohms. Special output impedance can be provided.

Five tubes are employed—one -24, one -26, one -50 and two -81 type.

The physical dimensions of the steel case which houses condensers, transformers, etc., is 17 1/2 inches long, 9 1/2 inches high and 12 inches wide.

When desirable two or more EA-6S amplifiers may be connected in parallel. This is often advantageous in installing equipment in apartment houses and hospitals.

JANETTE MOTOR-DRIVEN SPEED REDUCER

The Janette Motor-Driven Speed Reducer, which is designed especially for talking motion-picture work, is equipped with a 1/4 h.p. motor, single phase, mounted on a common base with a speed reduction unit. On one end of the motor, the end away from the Speed Reducer, there is a heavy steel flywheel mounted on the motor shaft. The purpose of this is to give the motor a constant speed despite fluctuations in the voltage of the line current. This is highly

important, inasmuch as the countershaft must turn exactly 33 1/3 R.P.M., and to do this, the motor must always turn exactly 1750 R.P.M. There is a triple reduction in the gear reducing unit, giving a final speed of 33 1/3 R.P.M. on the countershaft. This countershaft is mounted vertically, extending upward out of the gear box. Near the top of the countershaft, there is mounted a disc 4" in diameter. In common practice, a large, heavy disc is placed on this 4" disc, and the talking picture record in turn mounted on this large disc.

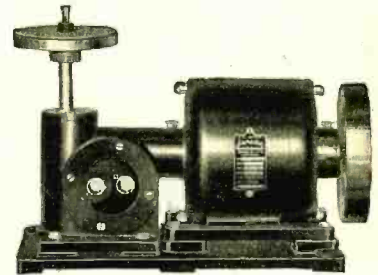

The Janette Motor-Driven Speed Reducer.

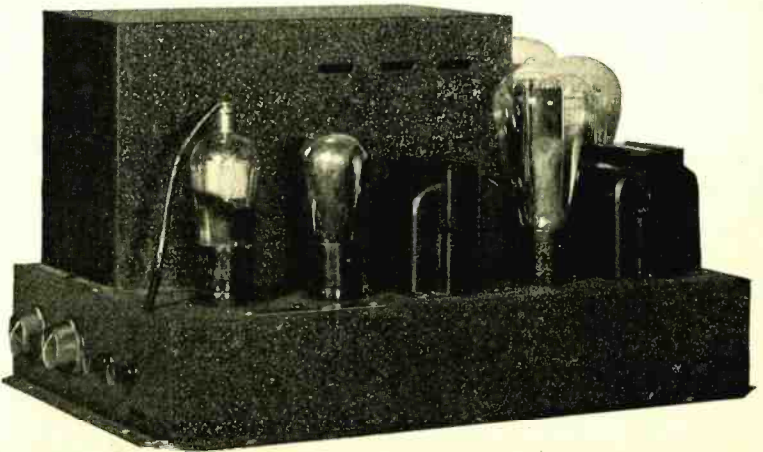

The New Electro-Acoustic Screen-Grid Power Amplifier.

4th RMA Trade Show

ATLANTIC CITY AUDITORIUM

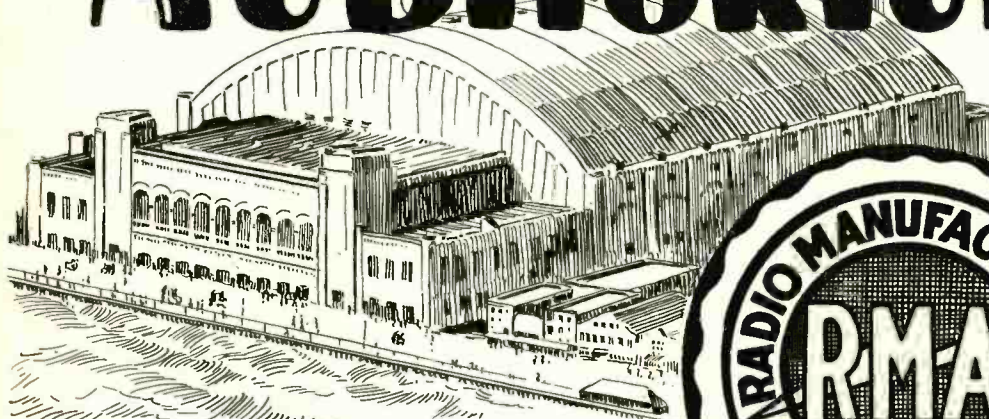

JUNE 2 to 6th

In
Connection With the 6th Annual R.M.A. Convention and the Federated Radio Trade Assn. Convention

The fourth annual R.M.A. trade show will be held this June in Atlantic City, the playground of America, the country's pre-eminent convention city. It will be the largest trade show in the history of the radio industry, twice as large as last year's Chicago show.

Atlantic City offers more hotels, better accommodations, more to see, hear and do—this is the one trade show you cannot afford to miss.

The Atlantic City Auditorium, facing the boardwalk and cooled by the breezes of the Atlantic ocean, is the largest convention hall in the country. All exhibition booths and demonstration rooms will be under one roof, on one floor,

making it easy to get a comprehensive view of the entire trade show.

The June trade show marks the beginning of radio's new year. The most responsible manufacturers exhibit and demonstrate their latest models and accessories on this occasion. It behooves everyone connected with the radio industry to visit the trade show this year, which will be the most interesting and important radio gathering ever convened.

Hotel reservations should be made through the Atlantic City Convention Bureau, Atlantic City, New Jersey. Invitation credentials for the trade show will be mailed to the trade about May 1st.

REDUCED ROUND TRIP RATES ON ALL RAILROADS.

Radio Manufacturers' Association Trade Show, Room 1904 Times Bldg., N. Y.

Under Direction of U. J. Hermann and G. Clayton Irwin, Jr.

ELECTRAD MANUFACTURERS' TYPE SUPER TONATROL

Something really new in a high-voltage volume control device was announced by Electrad, Inc. six months ago under the name "Super-Tonatrol." Now Electrad presents the Model "B" Super Tonatrol which is particularly adapted for use by manufacturers on account of its compact size and clever arrangement, whereby if desired two completely isolated circuits may be controlled by one shaft. Single control units also are supplied.

Both the Model "A" and Model "B" Super Tonatrol (Model "B" illustrated here) have the same general construction and operating characteristics. The contact is a pure silver multiple type which literally floats over the resistance element with amazing smoothness and which actually grows smoother with use, owing to a microscopic deposit of silver from the contact on the resistance element. The specially developed resistance element itself is fused at high temperature to the surface of a vitreous enameled metal plate. The result is greater permanence and accuracy of resistance values and more rapid heat dissipation.

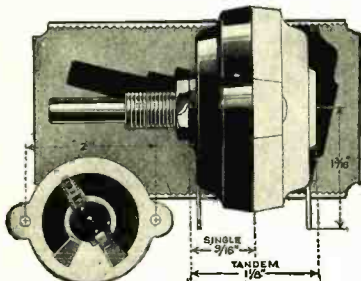

Electrad Manufacturers' Type Super Tonatrol.

As an indication of its remarkable endurance, it is stated that laboratory tests equivalent to more than ten years' average use, failed to produce any material signs of wear or variation in resistance value and a practical immunity to changes in temperature and humidity.

An advantage offered by the dual or tandem type Super Tonatrol is that a tapered resistance can be used in the antenna circuit, while a uniform resistance, operated for the same shaft can control the grid circuits. The resistance variation in the antenna circuit is extremely small during the first half of the knob rotation which assures smoother control of powerful signals.

Model "B" has a handsome molded bakelite cover and dissipates three watts. Either single or dual units are supplied in Model "B" and both models are available in all usual resistance ratings or tapered curves.

Electrad offers to send to any manufacturer, without obligation, a test sample and technical data on either model Super Tonatrol.

NEW TYPE SUPERIOR RESISTOR

A new development by the Superior Resistor Corp., 334 Badger Avenue, Newark, N. J., is their Type AT-50 and BT-10 wire-wound resistor. This unit was designed to meet the demand for a resistor that could be mounted directly on a metal or other panel without the use of separate insulated mounting.

The resistor is wound on the usual Lavie bobbin but has a shoulder turned on either end to form an insulating mounting for the complete unit. It may be secured to the panel by the use of a No. 6 screw.

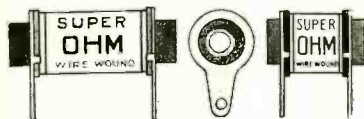

New "Superior" Resistor.

The uses to which a unit of this type can be put will readily be appreciated by those interested in the design of sound-picture projection, television, screen-grid circuits, vacuum-tube voltmeters, radio receivers, etc.

Resistance values from .25 ohm to 2 megohms, with an accuracy of 1%, or less if desired, may be obtained. From .25 ohm to 100,000 ohms the bobbin is 3/8-in. long by 1/2-in. in diameter and will safely carry 1/2 watt. The higher values, up to 2 megohms, are wound 1 1/4-in. long bobbins and will safely carry 1 watt.

From the above it is evident that these resistors will make ideal units for fader and volume controls, grid bias, plate resistors, and in fact will be found to fill a long-felt want for many other purposes than those mentioned above.

ARCTURUS ANNOUNCES D-C. LINE OF TUBES

The Arcturus Radio Tube Company, of Newark, New Jersey, adds to its a-c. radio vacuum tube line with a complete complement of battery type tubes, according to their announcement.

The addition to the Arcturus tubes consists of d-c. designs incorporating original engineering developments on standard types for all battery receivers, designated as types 012A, 101A, 099, 122 and 071A. These are, respectively, semi-power amplifier, standard r-f., a-f. amplifier and detector, dry cell low current, screen-grid and power amplifier types.

LOUDSPEAKER FOR AUTOMOBILE RADIO RECEIVERS

A loudspeaker developed especially for use in connection with automobile radio sets, has just been placed on the market by the Amplion Corporation of America. It is known as the Amplion model (AV) Automobile Chassis Speaker.

This new speaker, although extremely compact and light, is very powerful and can furnish enormous volume. It utilizes a small but high-powered magnetic unit of the balanced armature type. Due to the special steel used, an intense magnetic field is maintained. The unit is mounted on an aluminum foundation, in such a position that the drive pin actuates the cone from the inside. The cone is approximately 7-in. in diameter and the depth of the entire speaker chassis is only 3 1/2-in. A special aluminumized cloth is used for the cone material and it is claimed that this accounts, to a great extent, for the clear natural tone quality of the speaker.

The periphery of the cone is securely fastened to a light wood frame. The ends of the aluminum support, which holds the unit, are also fastened to the wood frame. The entire chassis, with the unit, weighs only 15 ounces. While the speaker may be mounted in any desired position, it is generally placed behind the automobile instrument board, so that the latter acts as a baffle.

DE FOREST 499 TYPE AUDION

After considerable research and engineering development, a satisfactory -99 type or dry-cell audion tube is now introduced as the DeForest 499 Audion by the DeForest Radio Company of Passaic, N. J.

The DeForest 499 Audion differs from the usual -99 type tube mainly in filament. It employs an oxide-coated filament of about three times the cross-sectional area of the usual thoriated tungsten filament, while the omission is approximately four times that obtained with thoriated tungsten. Instead of a very limited amount of active material with uncertain emission and life, the oxide-coated filament provides positive, copious and uniform emission over a long period of service. The use of a larger filament also results in a non-microphonic tube. The mutual conductance of the DeForest 499 Audion is 600 as against the usual 475, resulting in better amplifying properties. Otherwise, the characteristics are those of the standard -99, namely, 3.3 volts for the filament, 90 volts for the plate, and -4.5 volts for the grid.

NEW WESTINGHOUSE BATTERY CHARGER

A new Rectox rectifier for charging batteries by means of copper oxide rectification is announced by the Westinghouse Electric and Manufacturing Company, East Pittsburgh, Pa. Employing the copper oxide principle this charger presents a simple, safe, and satisfactory means for charging storage batteries in all applications.

The leading feature of the Rectox charger is the fact that there are no parts to wear out or replace, with the exception of fuses which protect both the a-c. and d-c. circuits. No chemicals or acids are used, and there is no danger of explosion or corroding fumes.

PRESTO ELECTROMAGNETIC PICKUP

The illustration shows the latest type of electromagnetic pickup, known as the Projectionist Model, developed by the Presto Machine Products Co., 70 Washington St., Brooklyn, N. Y., and which was designed to meet the special practical considerations involved in theatre and similar auditorium applications.

It is pointed out by this firm that it has been the preeminent source of sound reproduction develop-



The new Presto Electromagnetic Pickup.

ment in the independent phonograph industry for more than a decade and that its latest product has been based on the highest practical efficiency factor that could be coordinated with a maximum of quality.

The result is claimed to be a pickup that is really a musical instrument through the application of which a realism of tone unsurpassed is available throughout the entire chromatic scale. A ball bearing base and pivot construction of smooth action and permanent alignment were designed to withstand rough professional use. There is provided an adjustment for needle pressure weight for 33 1/3 r. p. m. records, and the head or unit can be instantly replaced, mechanically and electrically, without need of tools. Low or high impedance units can be supplied to match given amplifiers and specially designed units to increase sharpness in speech enunciation are available.

As special equipment for synchronized turntables this model appears thoroughly engineered and reflects practical knowledge of the projection booth.

THE NEW AMPLION "EXCITER"

While it is true that numerous developments in the radio art have been responsible, to a great extent, for present-day talking motion pictures, it is equally true that the "talkies" in turn, have been an important factor in the improvement of existing radio apparatus.

The new Amplion exciter is an example of the way in which the highly specialized "talkie" demand has speeded up the perfection of radio apparatus. This exciter is a recent development of the research laboratories of the Amplion Corporation of America. The function of the exciter is to furnish direct-current excitation for the fields of dynamic speakers. With the older types, it was necessary to place the exciter near the speaker, and one exciter was required for every two units.

In this latest Amplion product, one exciter can be used to operate as many as four giant dynamic units. The new exciter can be located in the projection room with the amplifying units, since a comparatively high direct-current voltage is available to overcome voltage drop to the speakers on the stage.

The improved exciter utilizes a novel type of full-wave, gas-filled rectifier tube, built on the Tungar principle, but with standard UX base. The new exciter will deliver quite a variety of voltages, giving a maximum direct-current voltage of 28 volts at a load of 2 1/2 amperes. The full-wave characteristics of this device, plus the extremely high capacity filter condensers, insure the attainment of the desired steady humless operation.

The exciter is housed in a compact, air-cooled, black metal case, similar to the one used for the older model Amplion exciter. However, the new design has an opening in the top of the case, which permits easy access to the rectifier tube, for replacement purposes.

NEW "POWERIZER" ELECTRICAL PICKUP

As another perfected and strong link in the chain of units that go to make up amplifying and sound distributing installations known as Powerizer Systems, the Radio Receptor Company of New York City now announces a precision electrical pickup. This device employs a special pickup head developed by the General Electric Company for the Radio Receptor Company's use. It is claimed to have a uniform frequency response of from 40 to 6000 cycles, or sufficient range for the faithful reproduction of recorded music. As proof of the sturdy design and construction of this pickup, it has withstood a 10-hour life test on the vibrometer, or scientific yardstick of electrical pickup life, as contrasted with a half hour for the usual pickup. The electrical resistance is 49 ohms. The pickup head is mounted on an arm which rides on a ball-bearing swivel, and carries a sliding weight so as to adjust the stylus bearing pressure for best results with any record.

NEW EAGLE PLUG

Eagle Electric Mfg. Co., Inc. of 59-79 Hall Street, Brooklyn, N. Y., announces that their new bakelite appliance plug, No. 750, is now in production and ready for delivery.

With its beautiful symmetry of design, sturdy construction and assembly with phosphor bronze contact clip to insure good electrical connection, it is expected to prove very popular with the trade.

Sample sent on request. Intended retail price 20c each.

STATEMENTS ARE STATEMENTS FACT'S ARE FACT'S

AND CANNOT BE DISPROVED

IT IS A FACT	OUR CONDENSERS SATISFY, AND OUR CUSTOMERS STAY WITH US YEAR AFTER YEAR.
IT IS A FACT	WE MAKE AS GOOD A CONDENSER AS MONEY CAN BUY AND AT COMPETITIVE PRICES.
IT IS A FACT	EVERYTHING WE MANUFACTURE IS MADE ON SOUND CONSERVATIVE ENGINEERING PRINCIPLES.
IT IS A FACT	A CHAIN IS AS STRONG AS ITS WEAKEST LINK.
IT IS A FACT	IF YOU USE CONDENSERS THEY ARE ONE OF YOUR LINKS.
IT IS A FACT	IF YOU USE CONDENSERS YOU CANNOT AFFORD TO TAKE A CHANCE.
IT IS A FACT	WE GUARANTEE FOR A DEFINITE PERIOD OF TIME EVERY PRODUCT WE MANUFACTURE WHICH INCLUDES:

POWER AMPLIFIERS, POWER PACKS AND IGNITION SYSTEMS AS WELL AS CONDENSER'S

EVERY EXPERIENCE YOU HAVE WITH US WILL DRAW YOU CLOSER TO THIS HIGHLY SATISFACTORY AND DEPENDABLE SOURCE OF SUPPLY.

EXECUTIVE OFFICES:
616 S. MICHIGAN AVE.,
CHICAGO, ILL.

THOMAS ENGINEERING & MANUFACTURING CO.
FACTORY AND LABORATORIES:
ST. CHARLES, ILL.

A Phenolic Laminated Insulation

A product in which dielectric strength, non-absorption, acid-resistance and other requirements for high efficiency meet the exacting standards of its producer — THE GENERAL ELECTRIC COMPANY — America's great institution in Electrical Manufacturing and Research.



Textolite Laminated

Valuable Specifications for Radio Insulation

Our Engineers have prepared specifications covering the use of Phenolic Laminated Insulation on Radio Sets.

These specifications are the result of exhaustive laboratory experiments to determine the exact types and grades of TEXTOLITE necessary to prevent loss of power and changes in operating characteristics due to humidity variations and other abnormal conditions. Requests on business stationery for these specifications will be given prompt attention.

ELECTRICAL INSULATION CORPORATION 308 W. Washington St.
CHICAGO ILLINOIS
DETROIT OFFICE—53 Marston Court. MILWAUKEE OFFICE—114 Wisconsin Ave.

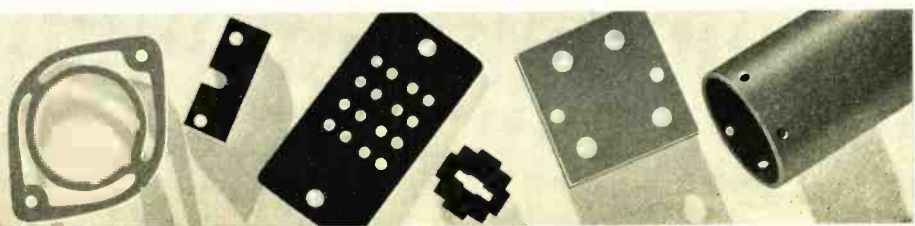



Programs in 7 seconds by your watch!

BUYERS WANT THIS KIND OF ACTION

by GEORGE LEWIS

Vice-President, Arcturus Radio Tube Company

Good performance is required to sell radio sets these days. Buyers are critical. They do more "shopping." The efficient set is the set that makes a lasting "first impression."

That's where Arcturus Radio Tubes can be a big help. They act quick—bringing in programs in 7 seconds *by the watch!* The demonstration gets away to a good start. Another important point about Arcturus Tubes is their exclusive construction which minimizes hum and inherent tube noises. And they hold the world's record for long life.

These are three good reasons why Arcturus Tubes are demanded by prominent set engineers and are standard equipment in many leading sets. It's a fact that the unique design and construction of Arcturus Tubes insures the best possible set performance under all conditions.

ARCTURUS RADIO TUBE COMPANY
NEWARK, N. J.

ARCTURUS

BLUE LONG LIFE
RADIO TUBES



▶▶▶ HIGH-QUALITY, DEPENDABLE TUBES FOR TALKING PICTURES AND TELEVISION



EVEREADY Raytheon Television Tubes are the result of our extensive research and experience in this new science. Their construction is along the same advanced lines which give all Eveready Raytheon Tubes their well-known superior performance.

The Eveready Raytheon Foto-Cell is a long-life, sensitive, quick-response transmitting tube for talking pictures. Used also in television. It is made in several types for different requirements. Foto-Cells to special specifications will be made at reasonable prices.

The Eveready Raytheon Kino-Lamp for television reception is the first tube developed commercially which will work with all systems. Uniform glow over the entire plate, perfect reproductive qualities without the need of mirrors or ground glass, tested performance . . . are features which make this tube outstanding.

Correspondence is invited from every one interested in television and talking pictures.

NATIONAL CARBON COMPANY, INC.

General Offices: New York, N. Y.

Branches: Chicago, Kansas City, New York, San Francisco.

Unit of Union Carbide **UCC** and Carbon Corporation



Trade-marks



HOLED-TITE
TRADE MARK NEW YORK

Radio Tube Pads

are in almost universal use by leading tube manufacturers. R.C.A., Ce-Co., Cunningham, and over two score more.

WHY?

—Because this packing pad prevents breakage.

“Come backs” from customers are avoided. Even “unseen” damage is prevented—the kind that does not actually break the glass, but distorts the character of the tube.

Holed-Tite packing pads have replaced all types of tube packing, because: (1) They cost less; (2) permit use of smaller shipping containers, another saving; (3) cut down and simplify the operations in packing; (4) save valuable storage space in factory; (5) are clean, never mussy.

For packing any size radio tube in any quantity. Our Packing Engineers will gladly help solve your packing problems.

HOLED-TITE PACKING CORP.

100 East 42nd St., New York City
(Affiliated with International Paper Co.)

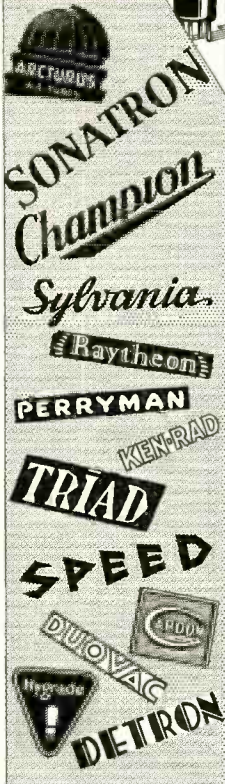

“Good tubes must be packed right.”

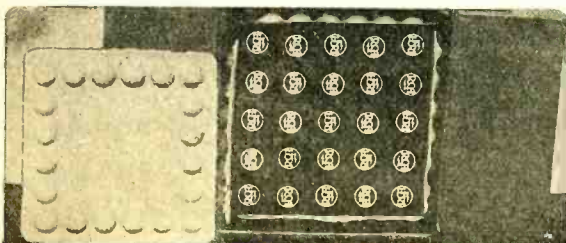

The
DAYRAD
RADIO SET
ANALYZER

The answer to your service problems is embodied in this compact and light-weight instrument.

Performs every necessary test on radio sets, power packs, screen grid circuits, etc. Tests both plates of type '80 rectifier tubes separately. Will also test total current in Raytheon tube circuits.

D.C. METER RANGES—20/100 Milliampères, 20/100/200/600 Volts (1000 Ohms per Volt).

A.C. METER RANGES—4/8/160/800 Volts. Only one selector switch to operate. Both UY and UX sockets on the panel. Self contained continuity test. Carrying case is of genuine moulded Bakelite. Equipped with either Weston or Jewell Meters.

DEALER'S NET PRICE **\$58.50**

Day-Rad Catalog of new line of instruments just off the press—Write now

THE RADIO PRODUCTS CO.
DAYTON, OHIO

The
**SCREEN
 GRID**
 tube

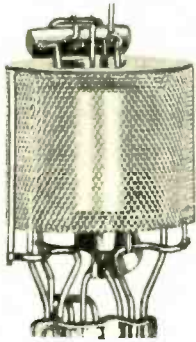

easier to make with
FANSTEEL TANTALUM

PRODUCTION of the popular "224" brings problems which have worried more than one able engineer. Many of these troubles disappear with the use of a better metal—developed by Fansteel Tantalum!

Here is a metal, easily formed, woven and welded, that holds its shape permanently at high temperatures. That requires less de-gassing than any other metal and this can be done at much lower temperatures. That has little or no susceptibility to contact potential. Requires no pre-cleaning or annealing — saving an operation which often repays the cost of the metal.

Other advantages — more uniform tube characteristics, less waste, decreased rejections, increased production, lowered manufacturing costs. Obviously, the use of this superior metal is profitable. Write today for full information and prices.

Profitable uses for Tantalum and other Fansteel Metals—Molybdenum and Alloys—are suggested in our booklet "Rare Metals." We'll gladly send a copy on request.

**FANSTEEL PRODUCTS
 COMPANY, Inc.
 NORTH CHICAGO, ILLINOIS**



**LONG LIFE, RELIABILITY,
 EFFICIENCY**

**EVEREADY
 RAYTHEON
 B-H**

**THE ORIGINAL GASEOUS
 RECTIFYING TUBE FOR
 "B"-ELIMINATOR UNITS**



Eveready Raytheon B-H Rectifying Tube—standard for "B" Power Units 125 m.a., 300 volts.

THE Eveready Raytheon B-H Tube uses ionized helium instead of a filament. This gas supplies millions of electrons a second—over and over. It makes a rectifying tube of long life and sustained voltage.

The large majority of "B"-eliminators are designed to use the B-H tube . . . and it is standard in more than 100 makes. If you use such a unit, put a new Eveready Raytheon B-H in it, and notice the great improvement.

Note to experimenters: If you require a source of steady, powerful D. C., you will find the B-H tube an efficient, heavy-duty rectifier.

NATIONAL CARBON COMPANY, INC.

General Offices: New York, N. Y.

Branches: Chicago, Kansas City, New York, San Francisco

Unit of Union Carbide **UCC** and Carbon Corporation



Trade-marks

TIME--the best proof of QUALITY

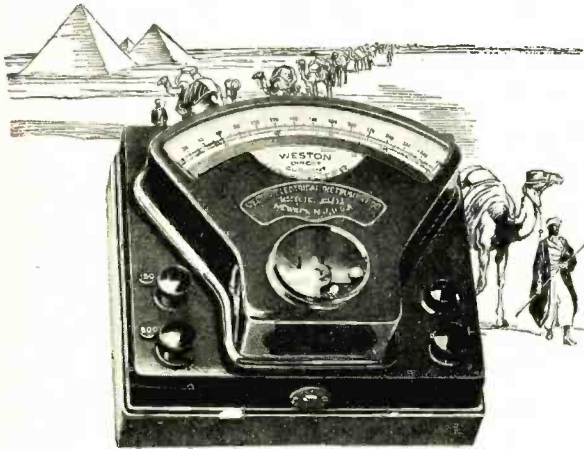

D. C. MODEL ONE—the pioneer of all modern instruments for electrical measurement. They have stood the test of more than forty years of continuous service, proof of permanent accuracy and unparalleled quality.

SWINGING round in the great cycle of centuries the world has progressed from ancient alchemy to positive science. The last phase of this metamorphosis has come with magic suddenness. In a single decade an era of dynamic development has sprung from a long succession of years of imperceptible change. And then, out of this static condition—like the unheralded appearance of a comet—there has come a veritable galaxy of scientific, industrial and commercial achievements of unusual brilliance.

Men are again building pyramids, but the original motive is lacking except for the same objective of permanence and security. No longer are mammoth monuments erected by the masses for the glory of a few. In the new order it is the few who are devoting their genius, and often without glory, to the building of memorials which will benefit all humanity. White power, electricity, has taken the place of black magic and the medium of visualization and control is electrical measurement. In this modern art the pioneer and master mind was Weston.

Today, the designs of his creation are the standards of the world. Weston instruments are perennially young. Time takes little toll of their exquisitely fashioned movements. Like the construction of the pyramids, they possess the secret of permanence.



WESTON ELECTRICAL INSTRUMENT CORP.
612 Frelinghuysen Avenue Newark, N. J.

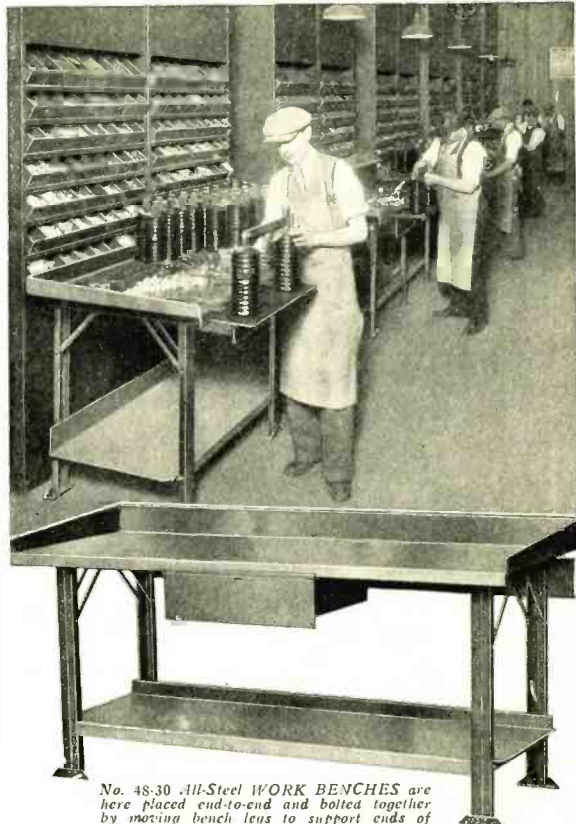

No. 48-30 All-Steel WORK BENCHES are here placed end-to-end and bolted together by moving bench legs to support ends of adjoining units. Also, SMALL PARTS RECEPTACLES on wall—a "special" job.

Tuned to the Tempo of Today!

PRODUCTION today is largely a matter of speed. Raw materials must pass from their sources of supply, after fabrication into the finished product, to the user in the shortest possible time.

Speed in production is dependent upon many things: Convenience—Saving of Space—Adaptability—Accessibility—Minimum Waste Motion—these are but a few.

You will find that ANGLE STEEL EQUIPMENT permits your plant to produce more and better work at lessened costs. Over 250 items from which to choose in Catalog "C-RE". Write for your copy.

The standard No. 48-30 WORK BENCH is fairly indicative of the usability and versatility of ANGLE STEEL EQUIPMENT. Built in 48, 60 or 72 inch widths; 30 inches deep; 34 inches high. All-steel construction, angle and sheet steel. Olive green lacquer finish. Shipped K.D.

Catalog "C-RE" illustrates and describes over 250 items, as: Benches, Bench Legs, Bins (Drill & Reamer), Cabinets, Chairs, Desks, Tables, Etc.

MAIL THE COUPON BELOW!

Angle Steel Equipment ALL-STEEL

PERMANENCE IN STEEL **ECONOMICAL • SANITARY • DURABLE**

Mail for Catalog

ANGLE STEEL STOOO CO.,
Plainwell, Mich.

Send Representative
 Send Catalog "C-RE"

Name

Address

City..... State.....

*Satisfaction as to Quality—
Satisfaction as to Price—*

IGRAD FIXED CONDENSERS

of all sizes and combinations—to meet your specifications

By-Pass Units Filter Units
High Voltage Units

The quality is demonstrated by satisfactory performance for several years in many of the better sets. Let us figure on your specifications.

Igrad Condenser & Mfg. Co. *Home Office and
Factory* Rochester, N. Y.

CONDENSER SPECIALISTS

AARON, SIEDMAN & COMPANY
CHICAGO, ILL.

Representatives:
MARSHANK SALES COMPANY
LOS ANGELES, CALIF.
TRADE CONTACT CORP.
BOSTON, MASS.

STONER & HEATH, Inc.
NEW YORK, N. Y.

MANUFACTURERS OF

CARBONIZED

MESH
PLATES

NICKEL

CARBONIZED RIBBON

DISCS

SCREEN GRID
ASSEMBLED

GETTER CUPS

Superior Radio Tube Products
Unequaled in Quality and Precision

We Solicit Your Special Requirements.

NEWARK PLATE LABORATORIES
228 Jelliff Avenue,
NEWARK, N. J.

STANDARD SPOT WELDER

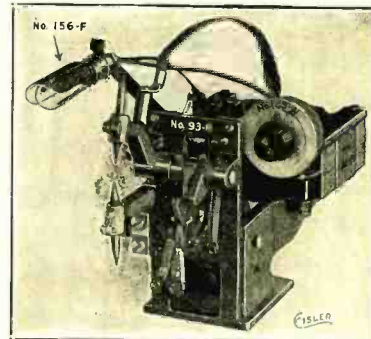

Machine No. 93-R

SPECIAL PRICE \$38.50

\$1.75 Additional for Complete Light Bracket

Increased production facilities enable Eisler Electric to offer these Standard Spot Welders at this new low price.

Machines are of proven merit, noted for extreme simplicity. In use by all Radio Tube Manufacturers.

EISLER ELECTRIC CORP.
Successor to the Eisler Engineering Co., Inc.
RADIO TUBE MACHINERY MANUFACTURERS
760 South Thirteenth St., Newark, N. J.



General Etching and Mfg. Co.
MANUFACTURERS OF
ETCHED AND LITHOGRAPHED METAL PRODUCTS
 3070-82 W. Grand Ave., Chicago, Ill.

— ART BRONZE —
ESCUTCHEONS

Simple or intricate formations. Excellent facilities in our large and modern plant



NAME PLATES
 Dials
 Wave Bands

Various etched, lithographed and embossed metal products and specialties

Send us your inquiries



*The DURHAM METALLIZED PRINCIPLE!
 THAT BE RIGHT!*

Nearly a hundred miles of DURHAM METALLIZED FILAMENT

used during peak months in 1929 in American Radio. The monthly volume of these units now employed by America's most important manufacturers of radio receivers, power amplifiers and allied products if laid end to end would nearly stretch from New York to Philadelphia. This tremendous volume and this widespread preference by competent radio engineers is conclusive proof that the Durham metallized principle **MUST** be right!

Engineering data and samples for testing gladly sent upon request. Please state rating in which you are interested.

DURHAM
 METALLIZED
RESISTORS & POWER OHMS

INTERNATIONAL RESISTANCE COMPANY
 2006 Chestnut St. Philadelphia, Pa.

WHERE CAN WE GET IT--?

Many times this question has been answered by the Cardwell Organization for

- The Westinghouse Elec. & Mfg. Co.
- General Elec. Co.
- Western Elec. Co.
- American Tel. & Tel. Co.
- Western Union Tel. Co.
- Radio Corp. of America
- Bell Tel. Laboratories
- Dept. of Commerce
- U. S. Navy
- Signal Corps
- Broadcasting Stations

AND SOME OF "WHAT THEY GOT!"

RELAYS

INDUCTANCES

TRANSFORMERS

CONDENSERS (Radio)

Variable and Fixed, for Transmitters and Receivers, Standard and Special

OIL DIELECTRIC CONDENSERS

For high voltages and high capacities

AUTOMATIC TELEGRAPH EQUIPMENT

RADIO RECEIVERS AND TRANSMITTERS

And component parts of all descriptions necessary for their construction

A Contract-Manufacturing department embracing all of our facilities for production is at your service, within limits guided by due consideration for the patent and manufacturing rights of others.

CARDWELL CONDENSERS

THE ALLEN D. CARDWELL MFG. CORPORATION
 81 PROSPECT STREET + + BROOKLYN, N.Y.



"THE STANDARD OF COMPARISON"

CENCO MEGAVAC PUMPS

FOR DEPENDABILITY *in high exhaustion*

Cenco Megavac Pumps have won undisputed leadership in the dependable exhaustion of these products:

Luminus Tube Signs

Radio Tubes
Thermos Bottles
Photo Electric Cells
Rectifier Tubes

X-Ray Tubes
Incandescent Lamps
Violet-Ray Apparatus
Mercury Switches

Mercury Vapor Lamps

Superior standards of precision in the preparation and fitting of all working parts have made Cenco Megavacs outstanding for reliability in long continuous service.

CENTRAL SCIENTIFIC COMPANY
460 E. Ohio Street Chicago, Ill.

4409

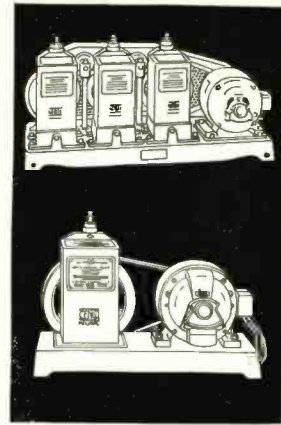

**A
GUARANTEED
FINAL VACUUM
OF .1 MICRON . .**

Cenco Megavacs are the fastest rotary oil pumps available today guaranteeing a final vacuum of .1 micron . . . They are made in two sizes, single and triple unit . . . Their application to modern industrial methods is comprehensively treated in the booklet, "High Vacuum Engineering." Write for your copy today—it's free!

Wire Cloth *of Nickel*

for Tube Manufacturers

The "Buffalo" Wire Cloth used for the screen grid tubes is woven carefully and accurately on our new improved looms.

Examine this better wire cloth before you place your next order. Samples and prices will be promptly sent on request.



Buffalo Wire Works Co., Inc.
(Formerly Scheelers Sons. Est. 1869)
588 Terrace, Buffalo, N. Y.



PYROXYLIN LACQUERS

As the oldest and largest manufacturers of pyroxylin lacquers in the world, we maintain complete control over basic raw materials and chemical processes, insuring absolute customer satisfaction through guaranteed uniformity in quality, results and economy.

The facilities of our Service Laboratory equip us to work out any finishing problem, and enable us to render you valuable assistance without cost.

THE ZAPON COMPANY, Stamford, Conn.

Stupakoff Refractory Tubing

High Dielectric Strength

Continuous exposure to temperatures over 3000° F. has no effect on "Stupakoff" tubes. They are impervious to gas, chemically inert, strong, tough, and resist deformation and thermal shocks.

We manufacture and carry IN STOCK about 600 SIZES of refractory porcelain tubing, from .015" O. D. to 2" O. D., and from 1/16" to 48" long. Very accurate dimensions are assured.

We would be glad to know your special needs, and confer with you on them.

Catalog and prices on request.

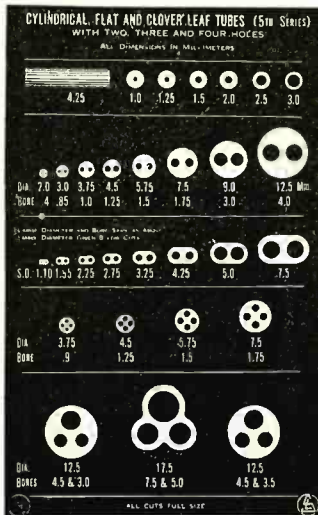

STUPAKOFF LABORATORIES, Inc.
6627 Hamilton Ave., Pittsburgh, Pa.

We also manufacture pure alumina, zirconia, magnesia, and other refractory tubing, with melting point ranges from 3300 to 5072 degrees.

A SCIENTIFIC CONTRIBUTION TO RADIO

POTTER ELECTRO-CHEMICAL FILTER CONDENSER

(EDELMAN PATENTS)

THE POTTER CO. R.L.2
1950 Sheridan Road, North Chicago, Ill.
Please send latest information on ELECTRO-CHEMICAL FILTER CONDENSERS.

Company Name.....
Address.....
City.....State.....
Name.....Title.....



Here is our New Type S. G. SHIELDED CONDENSER

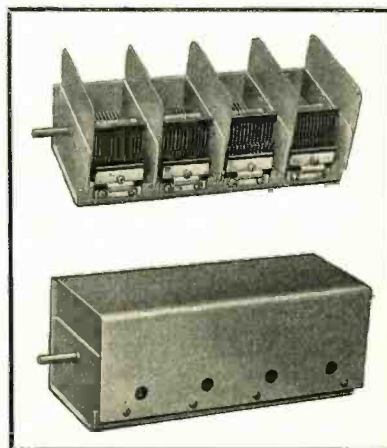

The completely shielded stators with section shields protruding beyond the grid ends of the stators eliminate every possibility of coupling—a much desired feature for 1930 set construction.

Minimum compensators of novel construction have a ground potential on the adjusting screw. This greatly facilitates balancing because the process of balancing is not affected by screw driver or hand capacity.

Bosses are arranged so that the condenser can be mounted either on bottom or side.

The heavy drawn dust proof cover completely encloses the unit. This gives additional rigidity to the entire assembly and makes a neat and compact job that improves the mechanical appearance of any set in which this new condenser is incorporated.

Write for a sample, prices and complete information

United Scientific Laboratories, Inc.
117 Fourth Avenue New York City
BRANCH OFFICES
St. Louis Boston Cincinnati Philadelphia
Chicago Minneapolis Los Angeles San Francisco
Canadian Offices: London, Ontario

GEN-ERAL COILS

Reg. U. S. Pat.

**CHOKE
COIL
CX 100**

Wound with No. 36 single silk covered wire.

Any number of turns desired up to 750.

CHICAGO
NEW YORK
LOS ANGELES



RADIO COILS

TO SPECIFICATIONS

Note—To those engineers who prefer bank wound coils we wish to advise that we will be able to handle your requirements and they may be specified for your production run of receivers.

LITZ WIRE

SPACED - BANKED - LAYER



SCREEN GRID COIL—R.F.B. 200

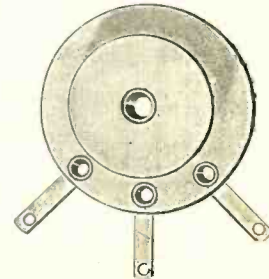

Tapped Choke Coil CX 101

GENERAL MANUFACTURING CO.

8066 South Chicago Ave., Chicago, Ill.

JOHNSON'S INDUSTRIAL TAPES

for better
RADIO
construction

THE use of Johnson's Industrial Tape has already become an important contribution to better radio construction. This is not because of its insulating properties only but by reason of its properties of perfect, permanent adhesion and non-corrosive action.

We are prepared to make many special coatings with varied ranges of cloth construction as well as our standard Industrial Tape and Jonflex Tape.

NO COST TO TEST IT

JOHNSON & JOHNSON, New Brunswick, N. J.
Please send free sample roll of Johnson's Industrial Tape.

Name _____
Company _____
Street and No. _____
City _____ State _____

**M.&W.C.^o
1876**

**LACQUERS
ENAMELS**

? NEW ?

Clear Crystal Lacquer
An Entirely **NEW** and **DIFFERENT** DECORATION.
Not an Oil Baking finish.
It **AIR DRIES** in less than one hour.
Its Beautiful Crystal Formation surpasses all the usual Decorative finishes.
Ideal for Polished Metal.

Your inquiry is invited.

Maas & Waldstein Company
Executive Offices and Plant, 438 Riverside Ave., Newark, N. J.
Chicago Office and Warehouse 1115 W. Washington Blvd.
Los Angeles Office and Warehouse 1214 Venice Blvd.

Which ?..

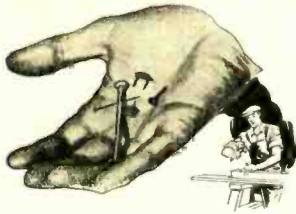

would you buy to nail a plank?

Our catalog is helpful

Hardwick, Hindle Catalog No. 429 fills the need for a terse Resistor manual. It shows styles, types of mountings—and gives clear Resistance Tables. May we send it?



No question about it, is there? One glance at a nail and you know its purpose; one glance at a nailing job, and you know which nail to use.

But **RESISTORS** are different. They demand specialized knowledge, specialized handling, specialized application.

We have organized a special Rush Order Department—and within 72 hours after your specifications reach us, we can have finished samples on their way to you.

We believe that we can produce exactly the Resistor equipment you need. In fact, we have proved just that in serving many of the country's largest users. May we include you?

RESISTORS

HARDWICK, HINDLE, Inc.

Sales: 122 Greenwich St., New York City
 Factory: 215 Emmet St., Newark, N. J.

The New "M-Q"

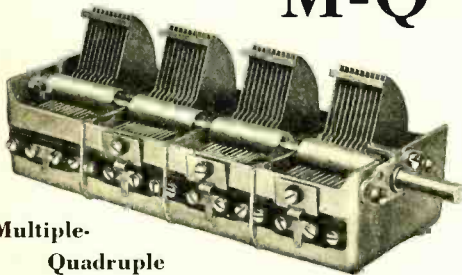

Multiple-
 Quadruple

HAMMARLUND For Manufacturers

HAMMARLUND Quality at a PRICE! A four-gang condenser with every feature a manufacturing asset. Stamina, accurate matching, fine finish and good looks—plus a price that appeals to careful buyers.

Write us your needs. Hammarlund cooperation and facilities are yours for the asking. Address Dept. RE2.

HAMMARLUND MANUFACTURING CO.
 424-438 W. 33rd St., New York

For Better Radio
Hammarlund
 PRECISION
 PRODUCTS

NEW



THEY ALL LIKE IT!

The advantages of Corwico Super-Braidite are so outstanding as to make an instant appeal to everyone interested in the manufacture of radio sets.

The Engineer Likes Super-Braidite

Because of the increased voltage breakdown and the possibility of controlling this voltage breakdown between practical limits.

The Production Manager Likes Super-Braidite

Because of its ease in handling, Super-Braidite is readily stripped back by our model "A" Stripper or with any Automatic Stripper, thus speeding up production and cutting costs.

The Sales Manager Likes Super-Braidite

Because Super-Braidite adds to the mechanical appearance of the set. The neat appearing, glossy insulation is flameproof and does not bunch up nor fray when pushed back. Soldered joints are neat and clean.

The Purchasing Agent Likes Super-Braidite

Because he can pass on to the production department a superior product without increased cost.

Corwico Super-Braidite is made with both solid and stranded core in 15 different color combinations.

With Corwico Super-Braidite we furnish our Model "A" Stripping Machines for use in your plant. Write for a sample of Super-Braidite and full particulars.

More Than A Wire—
 A Hook-up Service

CORNISH WIRE COMPANY
 INCORPORATED

30 Church St., New York City



LEHMAIER, SCHWARTZ & Co., INC.

511 to 541 West Twenty-fifth Street, N. Y. C.
Manufacturers

We also supply HEAVY LEAD or ALUMINUM FOILS for Dry or Chemical "A" Condensers.

CONDENSER FOILS

TIN LEAD ALUMINUM COMPOSITION

ESTABLISHED IN 1878, we are proud of the fact that since the inception of paper condensers, we have supplied the major portion of all the foil used in their manufacture; whether these condensers were for RADIO, TELEPHONE, IGNITION OR POWER FACTOR CORRECTION.

"The recognized Standard by which all other Condenser Foil is Judged"

Change D.C. to A.C. With JANETTE Rotary Converters

Thousands of Janette Rotary Converter installations all over the world prove conclusively that the problem of how to operate A. C. radios on direct current has been solved.

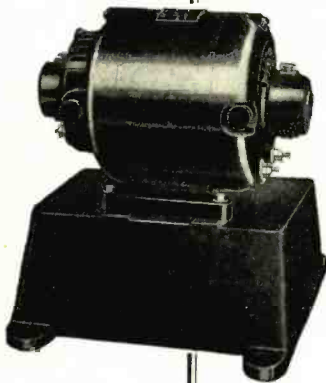

Janette Rotary Converters are quiet, reliable and reasonably priced. An exclusive Janette Filter eliminates hum or ripple, assuring reception equally as good as though the power were derived from an A.C. line.

Write for Bulletin
729-C

Janette Manufacturing Co.
550 West Monroe Street, Chicago
Singer Bldg., 149 Broadway, New York, N. Y. Real Estate Trust Bldg., Philadelphia.

CROWE Escutcheons *in* the Modern Vogue



We have dies for stock shapes of escutcheons and windows, which may be utilized with little or no die cost. Blue prints of these dies will be submitted upon request.

Crowe Production Methods assure Radio Manufacturers of prompt deliveries and guarantee the same careful attention to all jobs, whether large or small runs.

The escutcheon shown above is coin embossed. We also produce a great variety of etched escutcheons. When comparatively small runs are required or where changes in names are necessary for jobbers and dealers, the use of etched escutcheons is advised.

CROWE NAME PLATE & MANUFACTURING CO.
1750 Grace Street, Chicago, Illinois

FELT

WASHERS, GASKETS, STRIPS, PACKINGS
Write for Catalog and Sample Card
THE BOOTH FELT CO., INC.

481-491 194th Street
Brooklyn, N. Y.

737 Sherman Street
Chicago, Ill.

WIRE

ALPHA

Quality wire for every type of hook-up "Alphex" a slip back braided hook-up wire made under a patented process.

Alpha "HITENSION" Wire (colored Rubber)

BARE-TINNED-ENAMELED-RUBBER COVERED

—CABLES TO SPECIFICATION—

ALPHA WIRE CORPORATION
520 Broadway, New York City

ALPHA

TUBE MANUFACTURERS

Write us regarding—Automatic Hot Cut Flare Machines, Automatic Exhaust Machines, Baach-International Compound High Vacuum Pumps, and other high production radio tube making equipment—

INTERNATIONAL MACHINE WORKS, Inc.
527-529 Thirty-Second St., Union City, New Jersey

WAXES and COMPOUNDS

Impregnating, sealing, filling
Made to individual specifications

Write to

COCHRANE CHEMICAL CO.
430 Danforth Ave. Jersey City, N. J.

An Announcement

We take this opportunity to inform the condenser manufacturers that Mr. C. M. Polland, Chief Chemist and Engineer of our Czechoslovakian mills, will be in the United States during the months of February and March. Mr. Polland will be pleased to extend his assistance to all manufacturers in improving their laboratories, suggesting proper equipment, etc., with a view toward standardizing methods of raw material inspection.

We request those interested in this service to notify us so that mutually convenient appointments may be arranged.

The Old Masters Paper & Pulp Corp.

154 Nassau Street,
New York City.

22 West Monroe Street,
Chicago, Ill.

ALUMINUM SHEET FOR THE RADIO INDUSTRY

Special radio sheet for condenser plates and for shielding.

Aluminum-alloy castings for radio and other purposes.

Fairmont Manufacturing Co.
FAIRMONT, W. VA.

Branch offices at

52 Vanderbilt Ave. New York
Monadnock Block Chicago
General Motors Bldg. Detroit

You can forget the Condensers, if they are DUBILIER'S



PL—1927

Capacity... .004 Mfd.
Current... 150 Amms.
Volts Effective 25,000
Frequency... 400 K. C.
Another example of Dubilier advances in mica dielectric power-type condenser-units. A condenser measuring 16 inches by 12½ inches x 12½ inches height.

THE RICHEST experience in condenser-work possible to any organization in the industry.

This is the thing beyond—the added element of value—that goes with each Dubilier job.

Manufacturers profit by including Dubilier condensers in their designs. Good condensers are a big factor in the success of new sets.

ANNOUNCING!! A new untuned radio frequency transformer! One for use with the Screen-grid tube which is extraordinarily effective over the entire wave-band.

Inquiries from interested manufacturers are invited.

Dubilier CONDENSER CORPORATION

342 Madison Avenue, New York, N. Y.

KESTER FLUX-CORE SOLDER

FLUX IN POCKETS SOLDER WALL

Ready to Use

ECONOMY

Needs only Heat

Kester for economy. Saves the time and labor ordinarily spent in searching for, handling, and applying a separate flux. For every phase of industrial soldering, use Kester, the solder with the flux right in the core.

In choosing the most efficient and profitable solder for your needs, consult the Kester research department. Our engineers will analyze the soldering requirements of your production and maintenance departments, and supply a special solder from our enormous line of 48,000 cored wire items. This authoritative service imposes no obligations; investigate it promptly.

KESTER SOLDER CO.,
4224 Wrightwood Ave., Chicago, Ill.
Established 1899—Formerly Chicago Solder Co.

KESTER
FLUX-CORE
SOLDER

ACID-CORE
ROSIN-CORE
PASTE-CORE

METAL MENDER
RADIO SOLDER

Type 360 Test Oscillator

One of the new test oscillators for the radio service laboratory is now ready. It will deliver a modulated radio-frequency voltage at any point in the broadcast band (500 to 1500 kilocycles) and at 175 and 180 kilocycles. The tuning control is calibrated with an accuracy of 2 per cent.

The Type 360 Test Oscillator is intended to be used for neutralizing, ganging, and tuning of the radio-frequency stages in a receiver, and it is fitted with an output voltmeter for indicating the best adjustment.

Price \$110.00

General Radio Company
30 State Street Cambridge, Mass.

AEROVOX BUILT BETTER CONDENSERS AND RESISTORS

Moulded Mica Condensers Standard for R. F. Circuits

THE fact that moulded mica condensers, as a class, will give best results in radio frequency circuits is universally accepted as standard practice in engineering circles.

But to get best results—accuracy, minimum dielectric losses and freedom from change under the influence of varying temperature, weather and chemical action—the capacity unit must be carefully constructed, accurately measured and securely sealed in its bakelite housing.

In Aerovox Moulded Mica Condensers—made in a variety of shapes and sizes to suit the requirements of receiver manufacturers and experimenters—only the best grade of India Ruby Mica, pure tinfoil plates and high quality bakelite are employed. The capacity of the elements is pre-determined and accurately adjusted to the desired value, the units are thoroughly impregnated and moulded in bakelite—safe against the action of time and weather.

Send for Complete Catalog

Complete specifications of all Aerovox units, including filter, bypass and mica condensers, Pyrohm, wire-wound and Lavite resistors will be sent free of charge on request.

AEROVOX WIRELESS CORP.
76 Washington Street, Brooklyn, N. Y.
PRODUCTS THAT ENDURE



ROOSEVELT HOTEL

PENN AVENUE AT SIXTH STREET
600 ROOMS
IN THE CENTRE
OF THE TRIANGLE

OVER 300 **3** A DAY
ROOMS AT **AND LESS**

All with Shower or Tub
DOUBLE ~ \$1.00
A DAY EXTRA

**GARAGE IN
CONNECTION**

*Famous for Food ~
At Reasonable Prices*
L. FRED KLOOZ, Pres.



PITTSBURGH

*Opens Mid-August
in New York*

The HOTEL GOVERNOR CLINTON

OPPOSITE PENNSYLVANIA R. R. STATION

New York's new hotel truly expressive of the greatest city. 1200 pleasant rooms each with Servidor, bath, circulating ice water and radio provisions.

Rooms from \$3.00 General Manager
E. G. KILL,



31ST STREET 7TH AVENUE

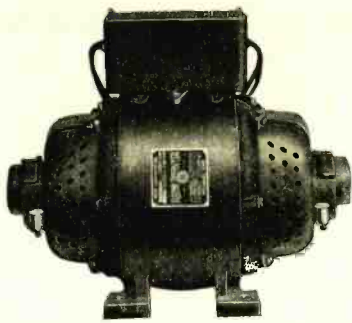

Dynamotor with Filter for Radio Receivers
MACHINES for OPERATING 60-CYCLE A. C. RADIO RECEIVERS, LOUD SPEAKERS and PHONOGRAPHS from DIRECT CURRENT LIGHTING SOCKETS WITHOUT OBJECTIONABLE NOISES OF ANY KIND

The dynamotors and motor generators are suitable for radio receivers and for combination instruments containing phonographs and receivers. Filters are usually required. The dynamotors and motor generators with filters give as good or better results than are obtained from ordinary 60-cycle lighting sockets. They are furnished completely assembled and connected and are very easily installed.

These machines are furnished with wool-packed bearings which require very little attention, and are very quiet running.

ELECTRIC SPECIALTY COMPANY

411 South Street

Stamford, Conn.

Mixer Controls,
Constant Impedance Faders, Volume Controls and Transformers for Speech Input and associated equipment.

Write for Bulletins K1-K2-L1 and M1 describing this apparatus

D'Arcy Laboratories

205 West Wacker Drive

Chicago, Illinois

The ELECTRAD Super-TONATROL for MANUFACTURERS

The new Model "B" combines the time-tested Super-TONATROL operating characteristics and longer life with the greater compactness desirable in modern receivers.

Single or dual units (operating on one shaft) can be made to all usual specifications.

175 Varick Street, New York

ELECTRAD INC.

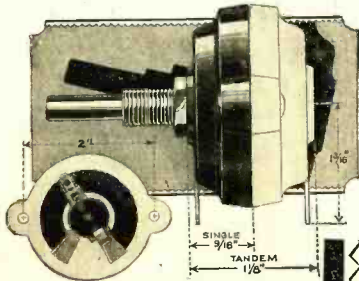

Write Dept. RE-2 for Data and Blueprint

3-watt dissipation — Isolated circuits — Resistance element fused to enameled metal plate — Pure silver contact — Bakelite case — Lighter, smaller, sturdier.



CONDENSER TISSUES

NO Radio set is any better than its weakest link, and the weakest link is very often a filter Condenser. No Condenser is any better than the thin strips of Insulating Tissue which separate the layers of metal foil. A pinhole or a speck of metal in the Condenser Tissue means a breakdown of the Condenser, with the entire set put out of commission.

DEXSTAR Condenser Paper is regarded by Radio experts as being the highest grade Insulating Tissue ever made—the freest from defects, the most uniform in quality, the most lasting under exacting and unusual requirements. DEXSTAR Condenser Tissue is the specialized product of a paper mill which has excelled in Tissue Paper production for three generations.

RADIO designers and builders should have the assurance that Condensers which they use are made with DEXSTAR Condenser Tissues. It is insurance against many radio troubles. The leading Condenser manufacturers are now using DEXSTAR Condenser Tissues exclusively.

C. H. DEXTER & SONS, INC.
Makers of Highest Grade Thin Papers
WINDSOR LOCKS, CONN.

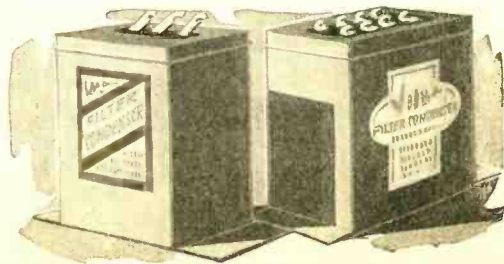

JENKINS & ADAIR, INC.
VARIABLE ATTENUATOR
 Types GA-200 & GA-500

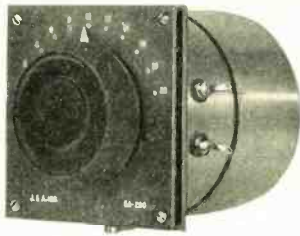

For Use in Broadcasting Station, Control Room, Studio, Sound Stage, Recording Room and Laboratory.

In an audio circuit between an output and an input of equal impedance, it is often desirable to place a variable volume controlling device which is calibrated, and which in itself produces no distortion. This takes the form of an H-type resistance network, and has long been familiar in telephone practice.

The Jenkins & Adair Variable Attenuators are variable H-type networks, ranging from 0 to 20 DB. in steps of 2 DB. They are highly accurate instruments, making them suitable for laboratory measurements as well as commercial broadcast and recording work. Two types are built, adapted to 200 ohm and 500 ohm circuits. They are identical in size and mechanical construction as well as in price. They are very heavily built, and good for years of hard service.

Price (in U.S.A.)..... **\$85.00**
 F.o.b. Chicago.

Send for Bulletin No. 10 giving full description and uses.

JENKINS & ADAIR, INC.
ENGINEERS

3333 Belmont Ave., Chicago, U. S. A.

British Office: 76 Old Hall St. Liverpool, England.
 French Office: 16 Rue de Cheateaudun, Asnieres, France.

POWER AMPLIFIERS

MODEL 245

adapted to phonographs for home use or other places where low power efficient amplifier is desired. Maximum output—1700 Milli-watts.



MODEL 250

for theatres, public halls, etc. Maximum output 4,700 milli-watts. A standard double button microphone may be used.

Both models are resistance coupled two stage amplifiers using a screen grid tube in the first stage. Will meet the most exacting tone quality requirements.

H. J. L. LABORATORIES
 800 N. Clark St. Chicago, Ill.

HIGH FREQUENCY BOMBARDING MACHINERY

\$200.00 to \$1500.00

- Gaps with silver..... \$5.00, \$7.50, \$10.00
- Tungsten Gaps..... \$5.00, \$10.00, \$15.00
- Transformers, 1 1/4 KV. 3500 volts..... \$22.50
- All sizes of bombarding coils..... \$5.00
- Repairing of Gaps (turning and cleaning)..... \$1.25
- Re-silvering of Gaps (silver solder)..... \$4.50, \$7.00

Now is the time to put your bombarding machinery in shape. Write us regarding your bombarding needs.

FRANK CSERWENKA
Manufacturer of Bombarding Machines
 35 MONROE ST. PASSAIC, N. J.
 Telephone: Passaic 9692

THE Radio industry has contributed much to the development of Aviation.

Radio Beacons, Radio Altimeters, Receiving and Sending Units, Remote Control—these and other Radio devices have been adapted to aeronautical use by Radio Engineers.

Aviation Engineering, in addition to covering the engineering developments in aircraft—also covers the radio engineering contributions—“the eyes and ears of Aviation.”



Aviation Engineering **IS NOT** Sold on Newsstands

Bryan Davis Publishing Co.
 52 Vanderbilt Ave., N. Y. City

Enter my subscription to AVIATION ENGINEERING for { 1 yr. at \$2.00 / 2 yrs. at \$3.00

Name

Address

City State

Please check classification: Engineer Airport
 Technician Manufacturer

RADIO FREQUENCY CHOKE



Self-supporting space-wound coils, wound on automatic machines to the exact number of turns you specify. Precision inductances for quantity production.

COILS AND COIL WINDING MACHINERY
MEISSNER MANUFACTURING COMPANY
 522 S. Clinton St. Chicago, Ill.

MODERN RADIO Requires AMPERITE Line Voltage Control

Successful electric radio operation depends on steady voltage. Up to 30 per cent line fluctuation in every community makes AMPERITE Control necessary. Saves tubes—improves tone—reduces service costs.

FREE—Useful AMPERITE Bulletin and list of AMPERITE-equipped radios. Write Dept. RE2



AMPERITE Corporation
 561 BROADWAY, NEW YORK

AMPERITE
 Self-Adjusting
 LINE VOLTAGE CONTROL

These are a Few of the articles appearing in *Projection Engineering*



- Transmission of Sound..... by James R. Cameron
- Technique of Sound-Picture Projection..... by J. Garrick Eisenberg
- Effects of Seating on Theatre Acoustics..... by W. Keith Friend
- How and Why the Fader..... by Horatio Lamson
- Facts about Filters..... by John Rider
- Television, as a Distinct Unit..... by D. E. Replogle
- Reproducing Machine for Picture and Sound..... by H. Pfannenstiehl
- Acoustics of Motion Picture Theatres..... by John S. Parkinson
- Tinted Films for Sound Positives..... by Lloyd A. Jones
- Television in the Making..... by Austin C. Lescarboursa
- Rotating the Wax for Sound Pictures..... by L. A. Elmer



**Keep Pace With Developments in Talking Movies
and Television**

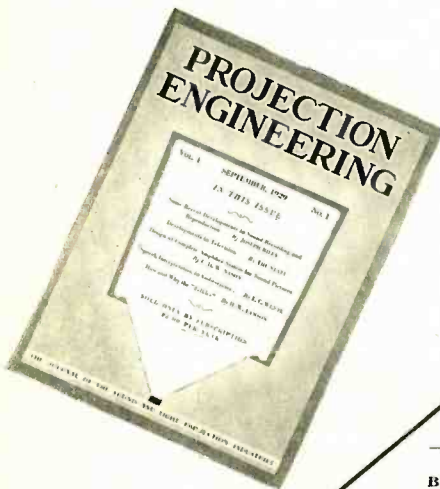

**PROJECTION ENGINEERING
IS NOT SOLD ON NEWSSTANDS
SUBSCRIBE NOW!!**

BRYAN DAVIS PUBLISHING CO., Inc.
52 Vanderbilt Avenue, New York City

➔ **Please Check Your
Classification**

Enclosed find \$2.00 for which enter my subscription
for **PROJECTION ENGINEERING** for one year
two years

- Manufacturer**
(Including executives, plant superintendents, foremen, purchasing agents, etc.)
- Engineer**
- Technician**
- Producer**
- Distributor**
- Theatre**
- Projectionist**

Name.....

Address.....

Town and State.....

“ EXTRA SPECIALS FOR SET BUILDERS — DEALERS — SERVICE STATIONS ”

Thoradson Power Transformer 150 watt—800 volts center tap—5 volts Fil. to carry 2 amp. (shipping weight 12 lbs.).....	\$3.25 ea.
UNCASED—filter condensers: for general repair and power pack work:	
1 mfd.—150 D.C. Working voltage.....	\$0.30 ea.
2 mfd.—150 D.C. Working voltage.....	.40 "
4 mfd.—150 D.C. Working voltage.....	.60 "

"Send for list of special priced radio items."

W. K. SKIDMORE & CO., 17 Warren Street, New York F.O.B. New York.

AEROVOX or DUBILIER filter block 7 mfd.....	\$2.50 ea.
DUBILIER—4 mfd. filter condenser 600 volts D.C. volts.....	1.75 "
R. C. A.—2 mfd. filter condenser 250 volts D.C. volts.....	.35 "

"Many other filter condensers at very low prices."

Thoradson Double Choke. 18 henry—250 mills. Each choke has 2000 volt insulation; Res. 108½ ohms.....	\$4.95 ea.
--	------------

(Shipping weight 14 lbs.)

WE offer to manufacturers interested in

EXPORT

the services of a dependable organization, well established in the entire foreign field

AD. AURIEMA, INC.

Manufacturers' Export Managers

116 Broad Street, New York, N. Y.

ALHAMBRA

LOUD SPEAKER PAPER

Alhambra Paper gives absolutely uniform resonance and imparts the utmost in tone quality.

Write us about your requirements

THE SEYMOUR CO.,
323 W. 16th St., New York City

CORE LAMINATIONS

for Audio & Power Transformers — Chokes

Annealed Nickel Alloy.
Hymu (High Permeability) a new grade
Silicon Steel for Audio.

A large variety of standard shapes carried in stock. Special designs stamped to your order.

Our BOOKLET on LAMINATIONS (sent on request) gives specifications of Stock Standard Shapes, and contains much data of value to the designer—and buyer.

Lamination Stamping Company

764 Windsor Street, Hartford, Conn.

BARE AND TINNED COPPER WIRE

*For All Purposes
Fine Sizes Our Specialty*

SPARGO WIRE COMPANY

ROME, NEW YORK
Established 1885

TUBE MACHINERY

Our new factory enables us to render prompt service on all types of vacuum tube machinery, including—

- Vacuum Pumps, single and compound
- Automatic Hot Cut-off Flare Machines
- 24-Position Automatic Exhaust Machines

ARROW MANUFACTURING & MACHINE CO., Inc.

912 Savoye St., North Bergen, N. J.



GEARS

IN STOCK—IMMEDIATE DELIVERY

Gears, speed reducers, sprockets, thrust bearings, flexible couplings, pulleys, etc. A complete line is carried in our Chicago stock. Can also quote on special gears of any kind. Send us your blue prints and inquiries. Write for Catalog No. 200.

CHICAGO GEAR WORKS

769-773 W. Jackson Blvd. Chicago, Ill.



MICROPHONES

All kinds from \$10 to \$300

For Public Address, etc., list..... \$25
Standard Broadcast Model, list..... \$75
Condenser Models for Film and Record Work.
By \$250.00, \$300.00

Also Desk and Floor Stands, Covers, Cords, etc.

EXPERT MICROPHONE REPAIRS

UNIVERSAL MICROPHONE CO., LTD.

Inglewood, Calif.

Export Rep. at Ad. Aurema, Inc. 116 Broad St., N. Y. C.

Chicago: Fred Carner Co., 126 N. Clinton St.
San Francisco: C. C. Lanevin Co., 274 Brannon St.

LAMINATIONS

IN ALL TYPES FOR AUDIO AND POWER TRANSFORMERS—CHOKES

In Stock for Immediate Delivery
Expert Tool and Die Making—Metal Stamping

Let us quote prices on quantity you require.

WILLOR MFG. CORP.

117 Mercer St., N. Y. C.

WIRE

STRAND—Antennae (plain or enameled)—Double Galvanized.
WIRE—Antennae (plain or enameled). Connecting and Ground (Rubber covered, braided or plain).
BUS BAR—Litzendraht-Loop.
MAGNET (Cotton or Silk).

John A. Roebling's Sons Co., Trenton, N. J.

TESTING OF RADIO APPARATUS

Permeability and Hysteresis Curves of iron samples.
Condensers tested for life, voltage breakdown, leakage, etc.
Input and output curves of socket power devices—Oscillograms.

80th St. and East End Ave. **ELECTRICAL TESTING LABORATORIES** New York, N. Y.

The Most Fascinating Radio Book of the Year!



FREE with the NEW RADIO NEWS

THE thrill of the Short Waves! It's like the invention of radio all over again. If you've ever decoded messages straight from South Africa or Australia—if you've ever known the kick of getting Europe or Little America direct—if you've ever had S. W. chats with friends hundreds of miles away, then you know what we mean.

The Short Waves are opening up a tremendous new field of amazing possibilities. An entirely new world of experimenting, of thrills, of new experiences with these miraculous S. Ws. lies ahead.

Because you and thousands of other radio men want to keep posted on all the latest wrinkles on Short Waves, the Technical Staff of RADIO NEWS has especially prepared a complete new up-to-the-minute SHORT WAVE MANUAL.

Crowded with chapters especially written by that foremost Short Wave authority, Lieut. W. H. Wenstrom, this volume represents the last word in authentic Short Wave data. You will be fascinated with such chapters as:—

- Breaking into Amateur Transmitting
- S-W Transmitter for the Average Home and Purse
- A Portable S-W Transmitter and Multiwave Receiver
- For Real Thrills Get Down in the Amateur Wave Bands
- Ready for a Short-Wave Chat
- Getting the Most from Your S-W Transmitter
- Some Experiments on Ultra-High Frequencies
- Short-Wave Stations of the World.

It is one thing to pound the key of a short-wave transmitter and hope to high heaven that your signals are "getting out." It is another thing to understand intelligently the conditions under which it is accomplished and how to get the most out of your Short Wave work. Here's the Manual that gives you the complete and latest dope, just the book you want!

Why It's Yours FREE!

RADIO NEWS has many thousands more readers than any other radio magazine. But we feel there are still a few of you radio men who have been so close to your work that you don't realize what you are missing.

That's why, although we will sell thousands of these SHORT WAVE MANUALS for a substantial price, for a limited time you can have a copy entirely FREE as an inducement to read RADIO NEWS.

Here's the magazine that tells you all about the newest receivers, all about the latest discoveries in servicing and handling radio parts and sets—and then goes beyond all that to give you the vital radio news of the whole world in a terse, business-like way that demands reading by every man whose interest lies in radio.

If the Federal Radio Commission makes a new ruling—if an Austrian inventor designs an improved tube—if a new discovery in television occurs in Greece or even Patagonia, you'll find it all explained in RADIO NEWS.

That is why we say with emphasis—if it's radio news, it's in RADIO NEWS. Here's the magazine for the man who wants to see with modern vision the future trends and developments of radio's rapid progress.

Send for FREE S-W Book NOW!

To introduce the NEW RADIO NEWS to you, we will send you the next Eleven Big Numbers, almost a full year subscription, for only \$2—and will ship you the new 1930 SHORT WAVE MANUAL, postpaid, ENTIRELY FREE! You save 75c on the newsstand price of RADIO NEWS and get this invaluable S. W. volume without cost! Risk nothing—Mail coupon TODAY!

Mail Coupon Before It's Too Late!

The NEW RADIO NEWS, Dept. 230-RE,
MACKINNON-FLY PUBLICATIONS, Inc.
381 Fourth Avenue, New York, N. Y.

Gentlemen: Send me, ENTIRELY FREE, postpaid, the new 1930 SHORT WAVE MANUAL, and enter my subscription for the next Eleven Big Issues of the NEW RADIO NEWS at only \$2 when I enclose (regular newsstand price \$2.75). I understand you will cheerfully refund my \$2 and I may keep the S. W. MANUAL if I am not perfectly satisfied after reading the first issue.

Name

Address

City & State

Are you a Service man ? Engineer ? Dealer ? Experimentor

Present subscription will be extended from expiration.

Buyers Directory of Materials and Apparatus

Readers interested in products not listed in these columns are invited to tell us of their wants, and we will inform the proper manufacturers. Address Readers' Information Bureau.

Addresses of companies listed below, can be found in their advertisement—see index on page 88

- ADAPTERS:**
Lynch, Arthur H., Inc.
- ALUMINUM:**
Aluminum Co. of America
Fairmont Manufacturing Co.
- ALUMINUM, SHEET:**
Fairmont Mfg. Co.
- AMMETERS:**
Ferranti, Inc.
General Electric Co.
General Radio Co.
Jewell Elec. Inst. Co.
Weston Elec. Instrument Corp.
- AMPLIFIERS, POWER:**
Ferranti, Inc.
G. M. Laboratories, Inc.
General Amplifier Co.
General Radio Co.
H. J. L. Laboratories
Radio Receptor Co., Inc.
Samson Elec. Co.
- ANTENNAE, LAMP SOCKET:**
Dubilier Condenser Mfg. Co.
Electrad, Inc.
- ARRESTERS, LIGHTNING:**
Jewell Elec. Inst. Co.
- BASES, SPEAKER:**
American Felt Co.
Booth Felt Co.
Western Felt Company
- BASES, VACUUM TUBE:**
(See Tube Parts)
- BATTERY COMPOUNDS:**
Mitchell Rand Mfg. Co.
- BEARINGS, RADIALL:**
Chicago Gear Works
- BENCHES, STEEL WORK:**
Standard Pressed Steel Co.
- BINDING POSTS:**
General Radio Co.
- BRACKETS, ANGLE:**
Electrad, Inc.
Scovill Mfg. Co.
- BRASS:**
National-Harris Wire Co.
Scovill Mfg. Co.
- BROADCAST STATION EQUIP'T:**
Cardwell, Allen D., Mfg. Co.
Ferranti, Inc.
General Radio Co.
Jenkins & Adair, Inc.
- BUTTS:**
Scovill Mfg. Co.
- CABINETS, METAL:**
Aluminum Co. of America
Metal Specialty Co.
- CASTINGS:**
Fairmont Mfg. Co.
- CELLS, PHOTOELECTRIC:**
National Carbon Co., Inc.
- CEMENT, LOUD SPEAKER:**
Maas & Waldstein Co.
- CENTRALIZED RADIO SYSTEMS:**
Ferranti, Inc.
Samson Elec. Co.
- CHASSES**
Aluminum Co. of America
Metal Specialty Co.
- CHOKES, AUDIO FREQUENCY:**
American Transformer Co.
Ferranti, Inc.
General Radio Co.
Jefferson Electric Co.
Polymet Mfg. Co.
Thordarson Elec. Mfg. Co.
Transformer Co. of Amer.
- CHOKES, RADIO FREQUENCY:**
Cardwell, Allen D., Mfg. Co.
General Radio Co.
Hammarlund Mfg. Co., Inc.
Meissner Mfg. Co.
Samson Elec. Co.
- CHOKES, POWER:**
American Transformer Co.
Dongan Elec. Mfg. Co.
Ferranti, Inc.
General Radio Co.
Jefferson Electric Co.
Polymet Mfg. Corp.
Transformer Corp. of Amer.
- CLAMPS, GROUND:**
Scovill Mfg. Co.
- CLIPS, SPRING:**
Electrad, Inc.
Scovill Mfg. Co.
- COIL FORMS:**
General Radio Co.
- COIL WINDING:**
Acme Wire Co.
Dudlo Mfg. Co.
Inca Mfg. Co.
Melssner Mfg. Co.
Polymet Mfg. Corp.
Rome Wire Co.
- COILS, CHOKE:**
Acme Wire Co.
Dudlo Mfg. Co.
Ferranti, Inc.
Jefferson Electric Co.
Polymet Mfg. Corp.
Rome Wire Co.
Westinghouse Elec. & Mfg. Co.
- COILS, IMPEDANCE:**
Acme Wire Co.
Dudlo Mfg. Co.
Ferranti, Inc.
Polymet Mfg. Corp.
Rome Wire Co.
- COILS, INDUCTANCE:**
Acme Wire Co.
Cardwell, Allen D., Mfg. Co.
General Radio Co.
Hammarlund Mfg. Co.
Inca Mfg. Co.
Rome Wire Co.
- COILS, MAGNET:**
Acme Wire Co.
Dudlo Mfg. Co.
Inca Mfg. Co.
Polymet Mfg. Corp.
Rome Wire Co.
- COILS, SHORT WAVE:**
General Radio Co.
Hammarlund Mfg. Co.
- COILS, TRANSFORMER:**
Acme Wire Co.
Dudlo Mfg. Co.
Polymet Mfg. Corp.
Rome Wire Co.
- CONDENSER PARTS:**
Aluminum Co. of America
Ferranti, Inc.
Metal Specialty Co.
Scovill Mfg. Co.
- CONDENSERS, BY-PASS:**
Acme Wire Co.
Aerovox Wireless Corp.
Amrad Co.
Condenser Corp. of America
Dongan Electric Mfg. Co.
Dubilier Condenser Mfg. Co.
Electrad, Inc.
Ferranti, Inc.
Igrad Condenser & Mfg. Co., Inc.
Polymet Mfg. Corp.
Potter Co., The
Sprague Specialties Co.
Thomas Engineering & Mfg. Co.
- CONDENSERS, ELECTRO-LYTIC:**
Amrad Corporation
Sprague Specialties Co.
- CONDENSERS, FILTER:**
Acme Wire Co.
Aerovox Wireless Corp.
Amrad Co.
Condenser Corp. of America
Dongan Electric Mfg. Co.
Dubilier Condenser Mfg. Co.
Igrad Condenser & Mfg. Co., Inc.
Polymet Mfg. Corp.
Potter Co., The
Sprague Specialties Co.
Thomas Engineering & Mfg. Co.
- CONDENSERS, FIXED:**
Acme Wire Co.
Aerovox Wireless Corp.
Amrad Co.
Condenser Corp. of America
Dongan Electric Mfg. Co.
Dubilier Condenser Mfg. Co.
Electrad, Inc.
Polymet Mfg. Corp.
Potter Co., The
Sprague Specialties Co.
Thomas Engineering & Mfg. Co.
- CONDENSERS, MIDGET:**
Cardwell, Allen D. Mfg. Co.
General Radio Co.
Hammarlund Mfg. Co.
Polymet Mfg. Co.
Scovill Mfg. Co.
Sprague Specialties Co.
United Scientific Laboratories
- CONDENSERS, MULTIPLE:**
Cardwell, Allen D. Mfg. Co.
Hammarlund Mfg. Co.
Scovill Mfg. Co.
United Scientific Laboratories
- CONDENSERS, NEUTRALIZ-ING:**
Hammarlund Mfg. Co., Inc.
Polymet Mfg. Corp.
- CONDENSERS, VARIABLE TRANSMITTING:**
Cardwell, Allen D. Mfg. Co.
General Radio Co.
Hammarlund Mfg. Co.
- CONDENSERS, VARIABLE:**
Cardwell, Allen D. Mfg. Co.
Frost, Herbert H., Inc.
General Radio Co.
Hammarlund Mfg. Co.
Scovill Mfg. Co.
United Scientific Laboratories
- CONNECTORS:**
Cornish Wire Co.
Scovill Mfg. Co.
- CONTROLS, CURRENT:**
Allen Bradley Co.
Central Radio Laboratories
Polymet Mfg. Corp.
Shalleross Mfg. Co.
- CONTROLS, VOLUME:**
Allen Bradley Co.
Central Radio Laboratories
Claroostat Co.
Electrad, Inc.
Ferranti, Inc.
Polymet Mfg. Corp.
Radio Receptor Co., Inc.
- CONVERTERS:**
Cardwell, Allen D., Co.
Electric Specialty Co.
- CONVERTERS, ROTARY:**
Electric Specialty Co.
Janette Mfg. Co.
- COPPER:**
Scovill Mfg. Co.
- CORDS, EXTENSION:**
Acme Wire Co.
Anaconda Wire & Cable Co.
Cornish Wire Co.
Polymet Mfg. Co.
- COUPLINGS, FLEXIBLE:**
Chicago Gear Works
Hammarlund Mfg. Co., Inc.
- CURRENT CONTROLS, AUTO-MATIC:**
Radiall Co.
- CUSHIONS, SPEAKERS:**
Western Felt Co.
- DIALS:**
Crowe Nameplate & Mfg. Co.
General Etching & Mfg. Co.
Hammarlund Mfg. Co.
Scovill Mfg. Co.
United Scientific Laboratories
- DIALS, DRUM:**
Hammarlund Mfg. Co.
United Scientific Laboratories
- DIE-CASTINGS:**
Allied Die-Casting Corp.
- DIES:**
Willor Mfg. Corp.
- DYNAMOTORS:**
Electric Specialty Co.
- ESCAPESONS:**
Crowe Nameplate & Mfg. Co.
General Etching & Mfg. Co.
Scovill Mfg. Co.
- EXPORT:**
Ad. Aurlrema, Inc.
- FELT, ACOUSTICAL:**
American Felt Co.
Booth Felt Co.
Western Felt Co.
- FELT, PACKING:**
American Felt Co.
Booth Felt Co.
Western Felt Co.
- FILAMENTS:**
(See Tube Parts)
- FILAMENT CONTROLS, AUTO-MATIC:**
Lynch, Arthur H., Inc.
Polymet Mfg. Corp.
Radiall Co.
- FOIL:**
Aluminum Co. of America
Lelmaier, Schwartz & Co., Inc.
- FRICTION TAPES:**
Mitchell Rand Mfg. Co.
- GALVANOMETERS:**
Ferranti, Inc.
General Electric Co.
General Radio Co.
Jewell Elec. Inst. Co.
Westinghouse Elec. & Mfg. Co.
- GEARS:**
Chicago Gear Works
- GENERATORS:**
Electric Specialty Co.
Janette Mfg. Co.
- GETTER MATERIAL:**
(See Tube Parts)
- GRID LEAKS:**
(See Resistances, Fixed)
- HEADPHONES:**
Amplion Co. of Amer.
- HINGES:**
Scovill Mfg. Co.
- HORNS:**
Amplion Co. of Amer.
- INDUCTANCES, TRANSMITTING:**
General Radio Co.

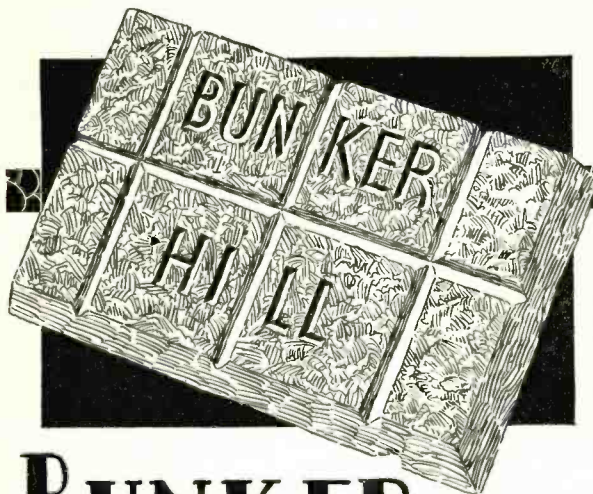

BUNKER HILL

99.99+ % ZINC

BUNKER HILL Zinc

In Die Casting Alloys
 10% Increased Tensile Strength
 100% Increased Elongation
 50% Increased Impact Resistance
 3—Times longer Steam Test Life

In Brass Making
 Greater percentage reduction by rolling between anneals.
 Reduction in stress-corrosion cracking, due to low lead content.
 Decreased brittleness, account minimum cadmium content.

In Galvanizing
 More flexible coating, insured by minimum lead and cadmium content.
 Increased corrosion protection account of purer zinc coating.

As Ribbon Zinc
 Increased softness and ductility.
 Greater corrosion resistance.

In Nickel Silver
 Higher drawing and spinning qualities.

The Remarkable New Die Casting Metal

Every die caster who has longed for a better zinc to gain additional markets at no extra cost now has that opportunity pounding at his door.

Bunker Hill Zinc will make die castings that cut "creep" to the minimum and will not "hot short" in the making. Add to this the extra advantages of increased hardness, tensile strength, ductility and impact resistance and you'll realize there's no better die casting zinc today.

Bunker Hill's 99.99+ % Purity varies less than 1/100th of 1% (month in and month out) and actually costs less to use than lower grades. Be sure it's "Bunker Hill," that's all.

ST. JOSEPH LEAD CO.

Sales Office: 250 Park Ave., New York

Telephone: Eldorado 8191

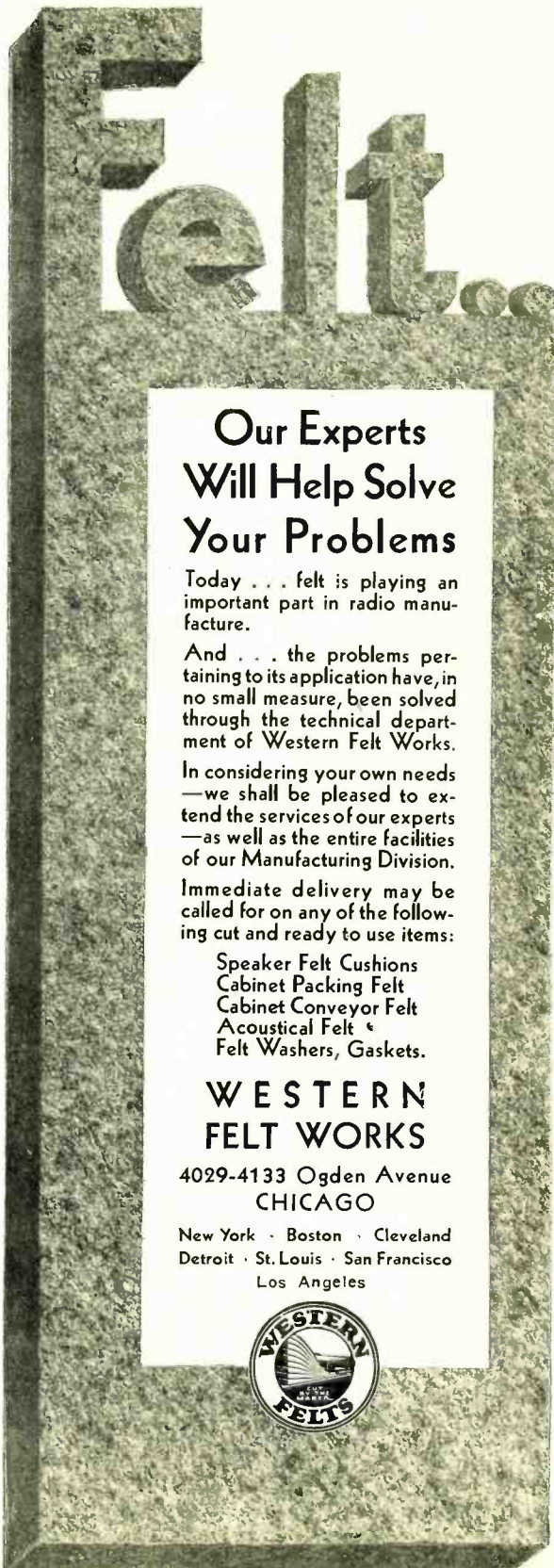

Our Experts Will Help Solve Your Problems

Today . . . felt is playing an important part in radio manufacture.

And . . . the problems pertaining to its application have, in no small measure, been solved through the technical department of Western Felt Works.

In considering your own needs — we shall be pleased to extend the services of our experts — as well as the entire facilities of our Manufacturing Division.

Immediate delivery may be called for on any of the following cut and ready to use items:

- Speaker Felt Cushions
- Cabinet Packing Felt
- Cabinet Conveyor Felt
- Acoustical Felt
- Felt Washers, Gaskets.

WESTERN FELT WORKS

4029-4133 Ogden Avenue
 CHICAGO

New York · Boston · Cleveland
 Detroit · St. Louis · San Francisco
 Los Angeles



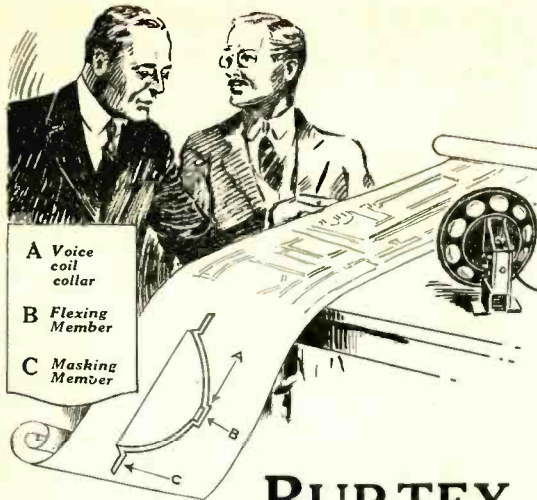

BURTEX DIAPHRAGMS

to your specifications



BURTEX Diaphragms stand pre-eminent both for quality of reproduction and efficiency in construction. The finest engineering demands Burtex installation.

Made of one-piece construction, BURTEX is lighter and stronger than any paper material—it is impervious to any climatic change.

The voice coil collar and mask are integral parts of the Diaphragm—the collar being used as both a flexing and mounting device, saving the cost of the cone in assembly.

BURTEX Diaphragms are made in a large variety of sizes. Special designs can be made to suit your requirements. For your future diaphragm orders—Specify BURTEX!

These and other leading radio manufacturers have been specifying BURTEX to their complete satisfaction . . . they know from past experience they can depend on BURTEX performance.

VICTOR
KOLSTER
BRANDES
CROSLY
ALL
AMERICAN
BEST
HERALD
KOLEKNIK
STROMBERG-
CARLSON

STEVENS-SIBLEY
Electric
PHONOGRAPH
MOTOR

should be specified for electric pickups and electric reproduction of records.
For — 80 r.p.m. and 33 1/3 r.p.m.

Stevens Manufacturing Corp.

42-48 Spring Street - Newark, N. J.

- INDUSTRIAL TAPES:**
Johnson and Johnson
- INSTRUMENTS, ELECTRICAL:**
Ferranti, Inc.
General Electric Co.
Jewell Elec. Inst. Co.
Westinghouse Elec. & Mfg. Co.
- INSULATION LAMINATED:**
Electrical Insulation Corp.
Formica Insulation Co.
General Electric Co.
National Vulcanized Fibre Co.
Synthane Corp.
- INSULATION, MOULDED:**
Bakelite Corp.
Formica Insulation Co.
General Electric Co.
General Plastics Co.
Monowatt Elec. Corp.
National Vulcanized Fibre Co.
Synthane Corp.
- INSULATION, VARNISHED:**
Acme Wire Co.
Mitchell Rand Mfg. Co.
- JACKS:**
Carter Radio Co.
Electrad, Inc.
General Radio Co.
- KITS, TESTING:**
(See Testing Kits)
General Radio Co.
Jewell Elec. Inst. Co.
- LABORATORIES, TESTING:**
Electrical Testing Labs.
Wireless Egert Engineering, Inc.
- LACQUER, WOOD:**
Maas & Waldstein Co.
- LACQUER, METAL:**
Maas & Waldstein Co.
- LACQUER, ENAMEL:**
Maas & Waldstein Co.
- LAMINATIONS:**
Lamination Stamping Co.
Willor Mfg. Corp.
- LAMPS, MINIATURE:**
National Carbon Co., Inc.
- LAMPS, PANEL:**
National Carbon Co., Inc.
- LAMPS, SOUND RECORDING:**
G. M. Laboratories, Inc.
- LEAD-INS:**
Electrad, Inc.
- LOCK WASHERS:**
Shakeproof Lock Washer Co.
- LIGNS:**
Scovill Mfg. Co.
Shakeproof Lock Washer Co.
- MACHINERY, TUBE:**
American Transformer Co.
Arrow Mfg. & Machine Co., Inc.
Frank Cswervenka Engineering Co., The
Central Scientific Labs.
Eisler Electric Co.
Int'l Machinery Works, Inc.
Lepele High Frequency Labs.
- MACHINES, SPECIAL:**
Willor Mfg. Corp.
- MAGNESIUM:**
Aluminum Co. of America.
- METAL RADIO PARTS:**
The Metal Specialty Co.
- METALS, RARE:**
Fansteel Products Co., Inc.
American Electro Metal Corp.
- METERS:**
Ferranti, Inc.
General Electric Co.
Jewell Elec. Inst. Co.
Weston Elec. Instr. Co.
- MICROPHONES:**
Amplion Co. of America
Electro-Acoustic Prod. Co.
Jenkins & Adair, Inc.
Radio Receptor Co., Inc.
Universal Microphone Co.
- MOLDING MATERIALS**
(See Insulation, Moulded)
- MOTORS:**
Electric Specialty Co.
- MOTOR-GENERATORS:**
Electric Specialty Co.
- MOUNTINGS, RESISTANCE:**
Electrad, Inc.
Lynch Mfg. Co., Inc.
Polymet Mfg. Corp.
- NAMEPLATES:**
Crowe Nameplate & Mfg. Co.
General Etching & Mfg. Co.
Scovill Mfg. Co.
- NICKLE SILVER:**
National-Harris Wire Co.
Riverside Metal Co., The
- NUTS:**
Shakeproof Lock Washer Co.
- OHMMETERS:**
General Radio Co.
Weston Elec. Instr. Co.
- OSCILLOGRAPH:**
The Belmont Corp., Ltd.
General Radio Co.
- PACKING PADS, CABINET:**
American Felt Co.
Booth Felt Co.
Western Felt Co.
- PACKING MATERIAL:**
Holed-Tite Packing, Inc.
- PANELS, COMPOSITION:**
(See Insulation, Moulded)
- PANELS, METAL:**
Aluminum Co. of America
Metal Specialty Co.
Radio Receptor Co., Inc.
Scovill Mfg. Co.
- PAPER, CONDENSED:**
Dexter, C. E. & Sons, Inc.
The Old Masters Paper & Pulp Corp.
- PAPER, CONE SPEAKER:**
Seymour Co.
- PARTS, SCREW MACHINE:**
Standard Pressed Steel Co.
- PHONOGRAPH MOTORS:**
(See Motors)
- PHOSPHOR BRONZE:**
Baltimore Brass Co.
National-Harris Wire Co.
Riverside Metal Co.
- PHOTOELECTRIC CELLS:**
(See Cells)
- PICK-UPS, PHONOGRAPH:**
Amplion Co. of Amer.
Electro-Acoustic Prod. Co.
Hardwick, Hindie, Inc.
Jensen Co.
- PLATES, OUTLET:**
Carter Radio Co.
- PLUGS, ATTACHMENT:**
Carter Radio Co.
General Radio Co.
Polymet Mfg. Corp.
Rodale Mfg. Co.
- POTENTIOMETERS:**
Allen-Bradley Co.
Central Radio Laboratories
Electrad, Inc.
General Radio Co.
Polymet Mfg. Corp.
United Scientific Laboratories
- POWER UNITS, A-1:**
Jefferson Electric Co.
Radio Receptor Co., Inc.
- POWER UNITS, B-1:**
Dongan Elec. Mfg. Co.
General Radio Co.
Jefferson Electric Co.
Thordarson Electric Mfg. Co.
- POWER UNITS, A-B-O:**
Dongan Elec. Mfg. Co.
General Radio Co.
Jefferson Electric Co.
Thordarson Electric Mfg. Co.
- POWER UNITS, PARTS FOR:**
Acme Wire Co.
American Transformer Co.
Dongan Elec. Mfg. Co.
Ferranti, Inc.
General Radio Co.
Jefferson Electric Co.
Lynch, Arthur H., Inc.
Polymet Mfg. Corp.
Thordarson Electric Mfg. Co.
Transformer Co. of Amer.
- PRESSED METAL PARTS:**
The Metal Specialty Co.
- PUBLIC ADDRESS SYSTEMS:**
Radio Receptor Co., Inc.
Samson Elec. Co.
- PULLEYS:**
Chicago Gear Works

- PUMPS, HIGH VACUUM:**
Arrow Mfg. & Machine Co., Inc.
Central Scientific Co.
Eisler Elec. Corp.
Int'l Machine Works, Inc.
- PUNCHINGS:**
Aluminum Co. of America
The Metal Specialty Co.
Scovill Mfg. Co.
- PUNCHINGS, BAKELITE:**
Electrical Insulation Corp.
- RECEPTACLES, WALL:**
Carter Radio Co.
Rodaie Mfg. Co.
- RECORD CHANGERS:**
Krasberg Tool & Mfg. Co.
- REGULATORS, VOLTAGE:**
Central Radio Laboratories
Clarostat Co.
DeJur-Amsco Co.
Polymet Mfg. Corp.
Radiall Co.
- RELAYS:**
Cardwell, Allen D., Mfg. Co.
Leach Relay Co.
- REPRODUCERS, TALKING
MOTION PICTURES:**
The Beltone Corp., Ltd.
- RESISTANCES, FIXED:**
Aerovox Wireless Corp.
Allen-Bradley Co.
Central Radio Laboratories
Clarostat Mfg. Co.
DeJur-Amsco Co.
Electrad, Inc.
Electro-Motive Co.
Ferranti, Inc.
Frost, Herbert H.
General Electric Co.
Hardwick, Hindle Inc.
International Resistance Co.
Lynch, Arthur H., Inc.
Polymet Mfg. Corp.
Superior Resistor Corp.
The S. S. White Dental Mfg. Co.
- RESISTANCES, VARIABLE:**
Allen-Bradley Co.
Central Radio Laboratories
Clarostat Mfg. Co.
Electrad, Inc.
Frost, Herbert H.
General Electric Co.
Hardwick, Hindle, Inc.
International Resistance Co.
Lynch, Arthur H., Inc.
Polymet Mfg. Corp.
Shalldross Mfg. Co.
- RETORTS:**
Allen-Bradley Co.
Central Radio Laboratories
Electrad, Inc.
Frost, Herbert H.
General Radio Co.
Polymet Mfg. Corp.
United Scientific Laboratories
Westinghouse Elec. & Mfg. Co.
- SCREW MACHINE PRODUCTS:**
Aluminum Co. of America
National Vulcanized Fibre Co.
Scovill Mfg. Co.
Standard Pressed Steel Co.
Synthane Corp.
- SCREWS, HARDENED SELF-
TAPPING:**
Parker-Kalon Corp.
- SCREWS, DRIVE, HARDENED
METALLIC:**
Parker-Kalon Corp.
- SEALING COMPOUNDS:**
Candv & Co.
Cochrane Chemical Company
Mitchell Rand Mfg. Co.
- SHIELDING, METAL:**
Aluminum Co. of America
Hammarlund Mfg. Co., Inc.
- SHIELDS, TUBE:**
Carter Radio Co.
- SHORT WAVE APPARATUS:**
Cardwell, Allen D., Co.
General Radio Co.
Hammarlund Mfg. Co., Inc.
Lynch, Arthur H., Inc.
- SOCKETS, TUBE:**
Frost, Herbert H.
General Radio Co.
Lynch, Arthur H., Inc.
- SOLDER:**
Amplion Corp. of Amer.
Kester Solder Co.
Jensen Radio Mfg. Co.
Oxford Radio Corp.
Rola Co., The
- SPAGHETTI:**
(See Wire, Spaghetth).
- SPEAKER PARTS, METAL:**
The Metal Specialty Co.
- SPEAKERS:**
Amplion Corp. of Amer.
Electro-Acoustic Prod. Co.
Jensen Radio Mfg. Co.
Potter Co., The
Rola Co., The
Transformer Co. of Amer.
- SPROCKETS:**
Chicago Gear Works
- STAMPINGS, METAL:**
Aluminum Co. of America
Metal Specialty Co.
Scovill Mfg. Co.
- SUBPANELS:**
Formica Ins. Co.
General Radio Co.
National Vulcanized Fibre Co.
- SWITCHES:**
Electrad, Inc.
Ferranti, Inc.
Rodaie Mfg. Co.
- TABLES, STEEL WORK:**
Angle Steel Stool Co.
Standard Pressed Steel Co.
- TAPES, FRICTION:**
Mitchell Rand Mfg. Co.
- TELEVISION PARTS:**
Allen-Bradley Co.
Clarostat Co., Inc.
Lynch, Arthur H., Inc.
Shalldross Mfg. Co.
- TESTERS, B-ELIMINATOR:**
General Radio Co.
Jewell Electrical Inst. Co.
- TESTERS, TUBE:**
Ferranti, Inc.
General Radio Co.
Jewell Elec. Inst. Co.
Weston Elec. Inst. Co.
- TESTING INSTRUMENTS:**
Ferranti, Inc.
General Electric Co.
General Radio Co.
Jewell Elec. Inst. Co.
Radio Products Co.
Westinghouse Elec. & Mfg. Co.
Weston Elec. Instrument Corp.
- TESTING KITS:**
General Radio Co.
Jewell Elec. Inst. Co.
Weston Elec. Inst. Co.
- TESTING LABORATORIES:**
Electrical Testing Labs.
- TIN COATED METAL:**
Baltimore Brass Co.
- TOOLS:**
Willor Mfg. Corp.
- TRANSFORMERS, AUDIO:**
American Transformer Co.
Dongan Elec. Mfg. Co.
Ferranti, Ltd.
General Radio Co.
Jefferson Electric Co.
Radio Receptor Co., Inc.
Samson Elec. Co.
Thordarson Electric Mfg. Co.
Transformer Corp. of America
- TRANSFORMERS,
B-POWER UNIT:**
American Transformer Co.
Dongan Elec. Mfg. Co.
Ferranti, Ltd.
General Radio Co.
Jefferson Electric Co.
Radio Receptor Co., Inc.
Samson Elec. Co.
Thordarson Electric Mfg. Co.
Transformer Corp. of America
- TRANSFORMERS, BROADCAST
STATION:**
Ferranti, Inc.
Radio Receptor Co., Inc.
Samson Electric Co.
- TRANSFORMER CASES,
METAL:**
Metal Specialty Co.
- TRANSFORMERS, FILAMENT
HEATING:**
Dongan Elec. Mfg. Co.
General Radio Co.
Jefferson Electric Co.
Thordarson Electric Mfg. Co.
Transformer Corp. of America
- TRANSFORMERS, OUTPUT:**
Dongan Elec. Mfg. Co.
Ferranti, Ltd.
General Radio Co.
Jefferson Electric Co.
Radio Receptor Co., Inc.
Samson Elec. Co.
Thordarson Electric Mfg. Co.
Transformer Corp. of America

NEW AUDIOS for OLD SETS

A profitable business for service stations is the installation of tone quality by replacing inferior units with THORDARSON REPLACEMENT TRANSFORMERS.

The chief difference between this year's sets and last year's, between high priced sets and cheap ones, is the difference in audio amplification. This is the difference which the set OWNER HEARS.

R-100 Straight Audio, \$2.25

R-101 Input Push-Pull, 3.50

AT ALL JOBBERS

THORDARSON

THORDARSON ELECTRIC MFG. CO.
Huron, Kingsbury and Larrabee Streets * CHICAGO, ILLINOIS

Something New Liquid Porcelain Coated Voltage Dividers



Our Engineers have developed a new process of coating with liquid porcelain, producing a voltage divider that is water-proof, acid-proof, oil-proof and fire-proof. This coating is baked at the low temperature of 150 degrees F., which will not injure the wire by setting up oxidization, insuring longer life.

EDISON BASED OR REGULAR VOLTAGE TYPES

Super Ohms Types AT-50 and BT-10

Actual Size

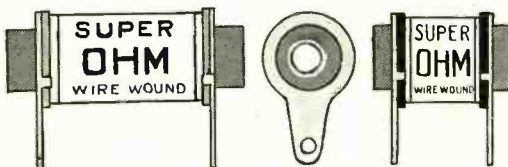

Just the Resistor for Your Volume and
Fader Controls.

1 Ohm to 100,000 Ohms

Tolerances 1% plus or minus rated value.
Temperature Co-efficient .0001. These SUPER OHMS are supplied with center hole to clear No. 6 screw and have their own insulating washers of 1/8" Lavite shoulder that projects below lugs or flexible leads. Ideal for mounting on metal base.

BAKELITE STRIP RESISTORS TYPE ST

Actual Size

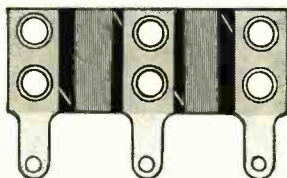

A complete line of Bakelite Resistors to meet the most exacting requirements.

SAMPLES SHIPPED 24 HOURS AFTER
RECEIPT OF SPECIFICATIONS

Resistors of Every Description

SUPERIOR RESISTOR CORP.

334 Badger Ave.

Newark, N. J.

- TRANSFORMERS, POWER:**
American Transformer Co.
Dongan Elec. Mfg. Co.
Ferranti, Ltd.
General Radio Co.
Jefferson Electric Co.
Polymet Mfg. Co.
Radio Receptor Co., Inc.
Samson Elec. Co.
Thordarson Electric Mfg. Co.
Transformer Corp. of America
- TRANSFORMERS, E. F., TUNED:**
Cardwell, Allen D. Mfg. Co.
Hammarlund Mfg. Co., Inc.
- TRANSFORMERS, STEP-DOWN:**
Amplion Corp. of Amer.
Radio Receptor Co., Inc.
- TUBE MACHINERY:**
See (Machinery, Tube.)
- TUBE PACKING:**
Holed-Tite Packing, Inc.
- TUBE PARTS:**
American Electro Metal Corp.
Callite Products Co., Inc.
Cleveland Wire Cloth & Mfg. Co.
Engineering Co., The
Fansteel Products Co., Inc.
General Plastics, Inc.
Gilby Wire Co.
Goat Radio Tube Parts Inc.
Lepel High Freq. Labs.
Nat'l.-Harris Wire Co.
Newark Plate Laboratories
Newark Wire Cloth Company
Synthane Corp., Inc.
(See Parts, Tube.)
- TUBE TESTERS:**
(See Testers, Tube)
- TUBES, A. C.:**
Arcturus Radio Co.
Cable Radio Tube Co.
De Forest Radio Co.
Hyvac Radio Tube Co.
Marvin Radio Tube Corp.
National Carbon Co., Inc.
Perryman Electric Co.
Sylvania Products Co.
Televoal Corp.
- TUBES, RECTIFIER:**
Arcturus Radio Co.
Cable Radio Tube Co.
De Forest Radio Co.
Hyvac Radio Tube Co.
National Carbon Co., Inc.
Perryman Electric Co.
Sylvania Products Co.
Televoal Corp.
- TUBES, SCREEN GRID:**
Arcturus Radio Co.
Cable Radio Tube Co.
De Forest Radio Co.
Hyvac Radio Tube Co.
National Carbon Co., Inc.
Perryman Electric Co.
Sylvania Products Co.
Televoal Corp.
- TUBES, TELEVISION**
See (Cells, Photoelectric.)
- TUBING, NICKEL:**
National-Harris Wire Co.
- TUBING, REFRACTORY:**
Stupakoff Labs, Inc.
- TUBING, VARNISHED:**
Alpha Wire Corp.
Mitchell Rand Mfg. Co.
- UNITS, SPEAKER:**
Amplion Corp.
Jensen Radio Mfg. Co.
Rola Co.
Wright DeCoster, Inc.
- UNIVERSAL JOINTS:**
Chicago Gear Works
- VARNISH:**
Maas & Waldstein Co.
Mitchell Rand Mfg. Co.
- VOLTAGE REGULATORS:**
(See Regulators)
- VOLTMETERS, A. C.:**
Ferranti, Inc.
General Electric Co.
General Radio Co.
Jewell Elec. Inst. Co.
Weston Elec. Instrument Corp.
- VOLTMETERS, D. C.:**
Ferranti, Inc.
General Electric Co.
General Radio Co.
Jewell Elec. Inst. Co.
Weston Elec. Instrument Corp.
- WASHERS:**
American Felt Co.
Aluminum Co. of America
Booth Felt Co.
Electrical Insulation Corp.
Scovill Mfg. Co.
Shakeproof Lock Washer Co.
Synthane Corp.
Western Felt Co.

- WAXES, IMPREGNATING:**
Candy and Co.
Cochrane Chemical Company
Mitchell Rand Mfg. Co.
- WAXES, INSULATING:**
Candy and Co.
Cochrane Chemical Company
Mitchell Rand Mfg. Co.
- WAXES, SEALING:**
Candy and Co.
Cochrane Chemical Co.
Mitchell Rand Mfg. Co.
- WIRE, ANTENNA:**
Acme Wire Co.
Alpha Wire Corp.
Anaconda Wire & Cable Co.
Cornish Wire Co.
Dudlo Mfg. Corp.
National Vulcanized Fibre Co.
Roebbling, J. A., Sons Co.
Rome Wire Co.
- WIRE BALLAST:**
National-Harris Wire Co.
- WIRE, BARE & TINNED COPPER:**
Alpha Wire Corp.
Anaconda Wire & Cable Co.
Cornish Wire Co.
Dudlo Mfg. Corp.
Roebbling, J. A., Sons, Co.
Rome Wire Co.
Spargo Wire Co.
- WIRE, COTTON COVERED:**
Acme Wire Co.
Anaconda Wire & Cable Co.
Alpha Wire Corp.
Dudlo Mfg. Corp.
Polymet Mfg. Corp.
Roebbling, J. A., Sons Co.
Rome Wire Co.
- WIRE, ENAMELED COPPER:**
Acme Wire Co.
Alpha Wire Corp.
Anaconda Wire & Cable Co.
Cornish Wire Co.
Dudlo Mfg. Corp.
Polymet Mfg. Corp.
Roebbling, J. A., Sons Co.
Rome Wire Co.
- WIRE, FILAMENT:**
American Electro Metal Corp.
Callite Products Co., Inc.
Cornish Wire Co.
Fansteel Products Co., Inc.
Gilby Wire Co.
National-Harris Wire Co.
- WIRE, HOOK-UP:**
Acme Wire Co.
Alpha Wire Corp.
Cornish Wire Co.
Dudlo Mfg. Co.
Roebbling, J. A., Sons, Co.
Rome Wire Co.
- WIRE, LITZENDRAHT:**
Dudlo Mfg. Corp.
Roebbling, J. A., Sons Co.
Rome Wire Co.
- WIRE, MAGNET:**
Acme Wire Co.
Anaconda Wire & Cable Co.
Dudlo Mfg. Corp.
Inca Manufacturing Co.
Polymet Mfg. Corp.
Rome Wire Co.
- WIRE, MOLYBDENUM:**
American Electro Metal Corp.
Callite Products Co., Inc.
Fansteel Products Co., Inc.
- WIRE, PIGTAIL:**
Dudlo Mfg. Corp.
Roebbling, J. A., Sons Co.
Rome Wire Co.
- WIRE, RESISTANCE**
Alloy Metal Wire Co.
Anaconda Wire & Cable Co.
Fansteel Products Co., Inc.
Gilby Wire Co.
National-Harris Wire Co.
- WIRE, SILK COVERED:**
Acme Wire Co.
Alpha Wire Corp.
Anaconda Wire & Cable Co.
Cornish Wire Co.
Radio Wire Corp.
Roebbling, J. A., Sons Co.
Rome Wire Co.
- WIRE, SPAGHETTI:**
Acme Wire Co.
Alpha Wire Corp.
Cornish Wire Co.
Mitchell Rand Mfg. Co.
Rome Wire Co.
- WIRE, TANTALUM:**
Fansteel Products Co., Inc.
- WIRE, TINNED COPPER:**
Alpha Wire Corp.
Anaconda Wire & Cable Co.
Dudlo Mfg. Corp.
Roebbling, J. A., Sons, Co.
Rome Wire Co.
- ZINC:**
St. Joseph Lead Co.

OUR OIL PROCESS
CONDENSERS ARE
EQUALLY SUITABLE
FOR POWER OR
RADIO APPLICA-
TION.

LET US AID YOU
WITH YOUR SPECI-
FICATIONS.



CONDENSER CORPORATION OF AMERICA

259-271 CORNELISON AVE.,
JERSEY CITY, N. J.

The Ekko Co.
Daily News Bldg.
Chicago, Ill.

W. C. Laing
Southern Ohio Bank Bldg.
Cincinnati, Ohio

HERE IT IS



Grab it!

DON'T be satisfied with just "getting-by." Take advantage of this real opportunity.

A new world for the electragist is opening its gates. Enter this new and anxious market for sound system installations. Theatres, dance halls, auditoriums, stadiums, train and bus terminals, and over fifty more actual fields . . . as yet hardly scratched. All there for you.

Just think of it, if you can qualify, there's a golden opportunity to obtain a distributor-contractor franchise with territorial protection. We know our business and can teach you. This is one of the oldest and most experienced organizations of audio engineering of its kind.

So sit down right now and write for your copy of "Amplified Opportunities."

RADIO RECEPTOR Co., Inc.

110 Seventh Avenue, New York City

Licensed by Radio Corporation of America
and Associated Companies



Good music, clearly reproduced and distributed with proper attention to acoustical effects is the major attraction at Scott's Roller Skating Rink, Buffalo, N. Y. Installation by Buffalo Radio Engineering Laboratories. Includes microphone, phonograph, Powerizer Amplifiers (1 No. 171-A and 2 No. 250-A) with six Wright Do Coster speakers.

R. E.-2-30

**POWERIZER
SOUND SYSTEMS**

DEPENDABLE

**QUALITY — UNIFORMITY
SERVICE**

ON

WAXES — & — MELTABLE

**INSULATING and WEATHER-
PROOFING COMPOUNDS**

WAXES—All kinds.

IMPREGNATIONS—Condensers, Coils, Rubber-Covered and Weather-Proofed Wire, Telephone and Electrical Cables, Etc.

SEALING COMPOUNDS—Coils, Condensers, Batteries (Wet & Dry), Pot Heads, Cables, Wiring Devices and Specials.

FINISHING—All grades of Weather Proof and Rubber-Covered Wire.

SPECIAL COMPOUNDS



Candy & Company
WAXES



35th St. & Maplewood Ave.
Chicago, Ill.
"For over 35 yrs."

ACME WIRE PRODUCTS

**Parvolt Filter and By-Pass Condensers
Coils — Magnet Wire Wound
Varnished Insulations
Magnet Wire — All Insulations**

All products made to Recognized Commercial Standards, including those of:
National Electric Mfrs. Assn.
Radio Manufacturers Assn.
American Society for Testing Materials

For 25 years manufacturers and suppliers to the largest and most discriminating users.

THE ACME WIRE CO.

NEW HAVEN, CONN.

Branch Offices

New York Cleveland
52 Vanderbilt Ave. Guardian Bldg.
Chicago
842 N. Michigan Ave.

INDEX OF ADVERTISERS

	PAGE		PAGE
Acme Wire Co. The.....	88	Fairmont Mfg. Co.....	75
Ad. Auriema, Inc.....	80	Fansteel Products Co., Inc.....	66
Aerovox Wireless Corp.....	76	Formica Insulation Co.....	1
Allen-Bradley Co.....	90		
Allied Die Casting Corp.....	9	G	
Aluminum Co. of America.....	16	General Electric Co.....	28
Alpha Wire Corp.....	74	General Etching & Mfg. Co.....	69
Amperite Corp.....	78	General Mfg. Co.....	73
Amrad Corporation.....	24	General Plastics, Inc.....	12
Anaconda Wire & Cable Co.....	3	General Radio Co.....	76
Angle Steel Stool Co.....	67	Gilby Wire Co.....	14
Arcturus Radio Tube Co.....	64	Goat Radio Tube Parts, Inc.....	11
Arrow Mfg. & Mach. Co., Inc.....	80		
		H	
B		Hammarlund Mfg. Co.....	73
Bakelite Corp.....	Back Cover	Hardwick, Hindle, Inc.....	73
Booth Felt Co., The.....	74	H. J. L. Laboratories.....	78
Buffalo Wire Works Co., Inc.....	70	Holed-Tite Packing Corp.....	65
Buyers Directory.....	82, 84, 85, 86		
		I	
C		Igrad Condenser Mfg. Co.....	68
Candy & Co.....	88	Int'l. Machine Works, Inc.....	74
Cardwell, Allen D. Mfg. Co.....	69	Int'l. Resistance Co.....	69
Central Radio Laboratories.....	23		
Central Scientific Company.....	70	J	
Chicago Gear Works.....	80	Janette Mfg. Co.....	74
Chirostat Mfg. Co., Inc.....	74	Jefferson Elec. Co.....	10
Cochrane Chemical Co.....	74	Jenkins & Adair, Inc.....	78
Condenser Corp. of America.....	87	Johnson & Johnson.....	72
Cornish Wire Co.....	73		
Crowe Name Plate & Mfg. Co.....	74	K	
Cswervenka, Frank.....	78	Kestor Solder Co.....	75
D		L	
D'Arcy Laboratories.....	77	Lamination Stamping Co.....	80
DeForest Radio Co.....	27	Lehmaier, Schwartz & Co., Inc.....	74
Dexter, C. H. & Sons, Inc.....	77		
Dongan Elec. Mfg. Co.....	Third Cover	M	
Dubilier Condenser Corp.....	75	Maas & Waldstein Co.....	72
Dudlo Mfg. Co.....	55	Meissner Mfg. Co.....	78
		Metal Specialty Co., The.....	59
E			
Icby, H. H. Mfg. Co., The.....	6, 7	N	
Eisler Electric Corp.....	68	National Carbon Co., Inc.....	21, 64, 66
Electrad, Inc.....	77	National Vul. Fibre Co.....	Second Cover
Electrical Insulation Corp.....	63	Newark Plate Laboratories.....	68
Electric Specialty Co.....	77		
Electrical Testing Labs.....	80		
		O	
		Old Masters Paper & Pulp Corp., The.....	75
		P	
		Parker-Kalon Corp.....	5
		Polvmet Mfg. Corp.....	20
		Potter Co., The.....	71
		R	
		Radio Manufacturers' Association.....	61
		Radio Products Co.....	65
		Radio Receptor Co., Inc.....	87
		Riverside Metal Co., The.....	57
		Roebing, J. A. Sons Co.....	80
		S	
		Saugamo Elec. Co.....	17, 18
		Scovill Mfg. Co.....	13
		Seymour Co., The.....	80
		Shakeproof Lock Washer Co.....	90
		Shidmore Co., W. K.....	80
		Spargo Wire Co.....	80
		Sprague Specialties Co.....	8
		Stevens Mfg. Corp.....	84
		St. Joseph Lead Corp.....	83
		Stupakoff Labs., Inc.....	71
		Superior Resistor Corp.....	86
		Synthane Corp., Inc.....	25
		T	
		Thomas Eng. & Mfg. Co.....	63
		Thorndarson Electric Mfg. Co.....	85
		Transformer Corp. of America.....	15
		U	
		Universal Microphone Co., Ltd.....	80
		United Scientific Labs.....	71
		W	
		Western Felt Co.....	83
		Westinghouse Elec. & Mfg. Co.....	22
		Weston Elec. Instrument Corp.....	67
		White Dental Mfg. Co., The S. S.....	19
		Willor Mfg. Corp.....	80
		Z	
		Zapon Co., The.....	70

Volume Control INSURANCE!

SORRY to bother you! An insurance man is hardly popular these days. Of course you are fed up on insurance.

But our *Volume Control Insurance* is something entirely new in insurances. It gives you maximum protection, yet it doesn't cost you a cent! How?

Here's our story: If you check up with your jobbers and dealers, you will find that the greatest source of service troubles, aside from the use and misuse of tubes, is faulty volume controls. Our *Volume Control Insurance* covers you on tone distortion, unsatisfactory volume control, and volume control replacements. And a *Volume Control Insurance* is virtually issued to you when you include in your radio assembly the

Wire-Wound Volume Control CLAROSTAT

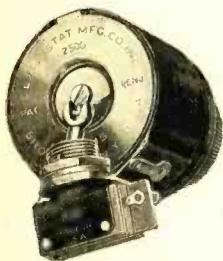

Switch Type

Yes, here it is in perfected form—the ideal volume control—a real *Volume Control Insurance*. We have specialized in variable resistors for years past. We developed the best compression type variable resistor and specialized in that type for several years. Then we developed a line of fixed resistors. For two years we have worked on a satisfactory wire-wound volume control, with one design after the other subjected to gruelling tests, and with no end of special winding equipment. And at last we have the answer.

The new **WIRE-WOUND VOLUME CONTROL CLAROSTAT** is compact, simple, silent, smooth, foolproof and long-lived. It is matched to your exact resistance requirements. The bakelite casing, with metal end plate, protects winding and contact member from dirt and dust and tampering. The turns cannot slip or short circuit.

But best of all, it is matched to your needs. We have developed special winding equipment for variable spacing of turns, as well as tapered support strips. We can provide volume controls, rheostats or potentiometers which positively match any resistance curve you may desire, thereby providing true

control of any circuit. Our machines permit of handling the finest resistance wire, so that our units can be made in resistance values up to 50,000 ohms.

Here is a laboratory product, a precision instrument, an ideal device. But the installation of a battery of special and costly winding machines enables us to produce these devices in any quantity to meet your demands. And the price is right—for quality merchandise—with *Volume Control Insurance*.

And don't overlook line voltage insurance in the form of the CLAROSTAT LINE BALLAST, the perfected and inexpensive method of regulating line voltage automatically, now employed in the better type socket-power radio sets. It costs little, but saves much. Your assembly is not complete without this 1930 feature.

WRITE for technical data regarding the wire-wound CLAROSTAT and the Line Ballast CLAROSTAT. If you are a radio manufacturer or designing engineer, send us your specifications and we shall gladly supply the necessary samples for your examination and tests.

Clarostat Manufacturing Company, Inc.

Specialists in Radio Aids

282 North Sixth Street

::

::

::

Brooklyn, N. Y.



Duo Type

Remember there's a **CLAROSTAT** for Every Purpose

PRODUCTS USE

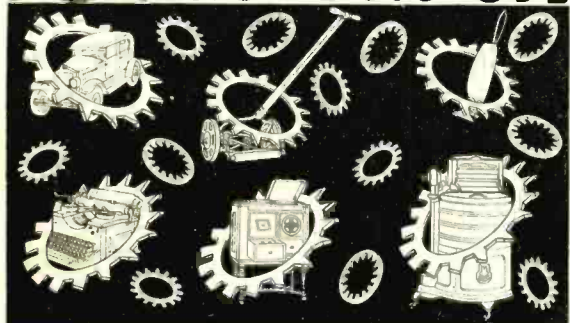

SHAKEPROOF

All over the town — all over the country—on automobiles and electric refrigerators—on radio sets and vacuum cleaners — on machine tools and kitchen stoves—wherever there is a bolt to come loose—wherever there is a nut to lock—you will find **SHAKEPROOF**. Big manufacturers—medium sized manufacturers—small manufacturers alike are unanimous in their adoption of **SHAKEPROOF**, not only because they hold and won't let go, but because they speed up production, save on bolt lengths and cut costs as well. There is a place on your product for **SHAKEPROOF**. You are paying for **SHAKEPROOF** whether you are using them or not. Write for samples and prove this to your entire satisfaction.

SHAKEPROOF

Lock Washer Company

[Division of Illinois Tool Works]

2509 North Keeler Avenue Chicago, Illinois

WRITE FOR SAMPLES

MILLIONS of Bradleyunits

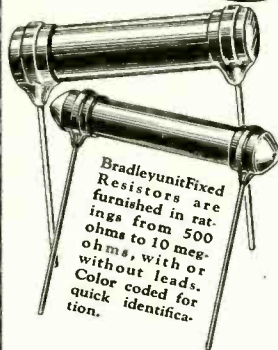

In Radio Sets TODAY

Bradleyunit Fixed Resistors are furnished in ratings from 500 ohms to 10 megohms, with or without leads. Color coded for quick identification.

MANUFACTURERS of leading radio receivers are using millions of Bradleyunits for grid leaks and plate coupling resistors, because Bradleyunits are absolutely noiseless in performance. In radio sets, Bradleyunits are specified because their accurate rating is unaffected by temperature, moisture and age. In production, Bradleyunits are preferred because they are not fragile. There are no breakage losses. You too can benefit by standardizing on Bradleyunit Solid Molded Resistors.

Write for complete information and prices, today!



The huge Allen-Bradley plant at Milwaukee provides unlimited research and production facilities.

ALLEN-BRADLEY CO. 279 Greenfield Ave. Milwaukee, Wis.

Allen-Bradley
PERFECT RADIO **AB** RESISTORS.



ONE conspicuously — successful radio manufacturer, whose name is a by-word in America, has risen to the position because he insists upon building his product as well as he knows how to build it. In that plant any suggestion that a few cents can be saved, by buying parts or materials not thoroughly approved, is quickly frowned upon.

Permanency in a fast-changing industry can be attained only by building a genuine and accumulative good-will over a period of years.

You will secure in Dongan Power Parts the most recent development that will stand the acid test of performance. Not the lowest in price — but the finest Power Parts that can be made by an organization which has devoted twenty years to the single purpose of designing and building fine transformers.

A Message to Amplifier and Service Engineers

These parts are widely used in the season's most successful Models. For satisfactory 245 Tube performance make sure by using Dongan Parts.

Check or money order guarantees delivery.

No. 994 P. A. Transformer.....	\$12.00
No. 2189 Push Pull Output Transformer.....	\$12.00
with No. 2142 Push Pull Input Transformer.....	\$ 4.50
or No. 3107 Straight Output Transformer.....	\$12.00
with No. 2158 Audio Transformer.....	\$ 4.50
D-946 Standard Condenser Unit.....	\$22.50
No. 5554 Double Choke (use in Filter Circuit).....	\$11.00
No. 2124 Transformer (Radio and Phonograph Amplification)	\$ 6.00

DONGAN ELECTRIC MANUFACTURING CO.

2991-3001 Franklin St., Detroit





Bakelite Molded multi-plug and socket. Made by Howard B. Jones. Chicago, Ill.

Sturdy, compact multi-plug and socket accurately formed of Bakelite Molded

AN interesting example of the use of Bakelite Molded to simplify design and assembly, is presented by the Jones multi-plug and socket. The plugs are solid blocks of Bakelite Molded, approximately $\frac{1}{2}$ inch thick, sixteen of them being completed in a multiple cavity mold at one closing of the press. Accurately positioned holes for the blades, and the index numerals

are formed in the mold. Eight of the Bakelite Molded socket blocks are completed in a second multiple cavity mold. These socket blocks which are 1 inch by $1\frac{1}{8}$ inches in cross section, have accurately dimensioned slots for the contact blades, holes for the position pins, and index numerals formed in the mold. No subsequent drilling or machining are required.

Bakelite Engineering Service.—Intimate knowledge of thousands of varied applications of Bakelite Materials combined with twenty years' experience in the development of phenol resinoids for radio uses provides a valuable background for the cooperation offered by our engineers and research laboratories. Write for Booklet 38M, "Bakelite Molded."

BAKELITE CORPORATION

247 Park Avenue, New York, N. Y. Chicago Office: 635 W. 22nd Street
BAKELITE CORP. OF CANADA, LTD. 163 Dufferin St., Toronto, Ontario, Canada

BAKELITE

REGISTERED

U. S. PAT. OFF.



THE MATERIAL OF A THOUSAND USES

"The registered Trade Mark and Symbol shown above may be used only on products made from materials manufactured by Bakelite Corporation. Under the capital 'B' is the numerical sign for infinity, of unlimited quantity. It symbolizes the infinite number of present and future uses of Bakelite Corporation's products."